

Information:					
17	NPL Documents	Ref13.pdf	36157	no	1
Warnings:					
Information:					
18	NPL Documents	Ref14.pdf	206143	no	2
Warnings:					
Information:					
19	NPL Documents	Ref15.pdf	124745	no	3
Warnings:					
Information:					
20	NPL Documents	Ref16.pdf	16709	no	1
Warnings:					
Information:					
21	NPL Documents	Ref17.pdf	166548	no	4
Warnings:					
Information:					
22	NPL Documents	Ref18.pdf	60465	no	1
Warnings:					
Information:					
23	NPL Documents	Ref19.pdf	27941	no	1
Warnings:					
Information:					
24	NPL Documents	Ref20.pdf	27597	no	1
Warnings:					
Information:					
25	NPL Documents	Ref21.pdf	25393	no	1
Warnings:					

Information:					
26	Miscellaneous Incoming Letter	transmittal.pdf	29149	no	1
Warnings:					
Information:					
27	Fee Worksheet (PTO-06)	fee-info.pdf	8272	no	2
Warnings:					
Information:					
Total Files Size (in bytes):			3049449		
<p>This Acknowledgement Receipt evidences receipt on the noted date by the USPTO of the indicated documents, characterized by the applicant, and including page counts, where applicable. It serves as evidence of receipt similar to a Post Card, as described in MPEP 503.</p> <p><u>New Applications Under 35 U.S.C. 111</u> If a new application is being filed and the application includes the necessary components for a filing date (see 37 CFR 1.53(b)-(d) and MPEP 506), a Filing Receipt (37 CFR 1.54) will be issued in due course and the date shown on this Acknowledgement Receipt will establish the filing date of the application.</p> <p><u>National Stage of an International Application under 35 U.S.C. 371</u> If a timely submission to enter the national stage of an international application is compliant with the conditions of 35 U.S.C. 371 and other applicable requirements a Form PCT/DO/EO/903 indicating acceptance of the application as a national stage submission under 35 U.S.C. 371 will be issued in addition to the Filing Receipt, in due course.</p> <p><u>New International Application Filed with the USPTO as a Receiving Office</u> If a new international application is being filed and the international application includes the necessary components for an international filing date (see PCT Article 11 and MPEP 1810), a Notification of the International Application Number and of the International Filing Date (Form PCT/RO/105) will be issued in due course, subject to prescriptions concerning national security, and the date shown on this Acknowledgement Receipt will establish the international filing date of the application.</p>					

IN THE UNITED STATES PATENT AND TRADEMARK OFFICE

Applicant: Ira M. Marlowe
Serial No.: 10/316,961
Filed: 12/11/2002
Title: AUDIO DEVICE INTEGRATION SYSTEM

Examiner: Kurr, Jason R.

Art Unit: 2615

Mail Stop RCE
Commissioner for Patents
P.O. Box 1450
Alexandria, VA 22313-1450

RESPONSE

Sir:

This is a response to the outstanding Office Action dated April 19 2007, on the above-identified application. The time period for response extends to and includes July 19, 2007.

Amendments to the Claims begin on page 2 of this response.

Remarks begin on page 26 of this response.

AMENDMENTS TO THE CLAIMS

1. (Currently Amended) An audio device integration system comprising:

a car stereo;

an after-market audio device external to the car stereo;

an interface connected between the car stereo and the after-market audio device for channeling audio signals to the car stereo from the after-market audio device, the interface including:

means for remotely controlling the after-market audio device using the car stereo by receiving a control command from the car stereo in a format incompatible with the after-market audio device, processing the control command into a formatted command compatible with the after-market audio device, and transmitting the formatted command to the after-market audio device for execution thereby;

means for receiving data from the after-market audio device in a format incompatible with the car stereo, processing the data into formatted data compatible with the car stereo, and transmitting the formatted data to the car stereo for display thereby;

and

means for switching to one or more auxiliary input sources connected to the interface.

2. (Previously Presented) The apparatus of claim 1, wherein the car stereo is an Original Equipment Manufacturer (OEM) car stereo.

3. (Original) The apparatus of claim 1, wherein the car stereo is an after-market car stereo.

4. (Previously Presented) The apparatus of claim 1, wherein the after-market audio device comprises a CD player, CD changer, MP3 player, Digital Audio Broadcast (DAB) receiver, or satellite receiver.

5. (Previously Presented) The apparatus of claim 1, wherein the interface further comprises a plug-and-play mode for automatically detecting a device type of the after-market audio device and integrating the after-market audio device based upon the device type.

6. (Currently Amended) The apparatus of claim 1, wherein the interface generates a ~~CD player~~ device presence signal for maintaining the car stereo in a state responsive to processed data and audio signals.

7. (Original) The apparatus of claim 1, wherein the data comprises track and time information.

8. (Original) The apparatus of claim 1, wherein the data comprises song title and artist information.
9. (Original) The apparatus of claim 1, wherein the data comprises channel number and channel name information.
10. (Original) The apparatus of claim 1, wherein the data comprises video information.
11. (Previously Presented) The apparatus of claim 1, wherein the formatted data is displayed as a menu on a display of the car stereo.
12. (Previously Presented) The apparatus of claim 1, wherein the display of the car stereo comprises a graphic panel.
13. (Original) The apparatus of claim 1, wherein the commands are input by a user using one or more control buttons or presets on the car stereo.
14. (Cancelled)
15. (Previously Presented) The apparatus of claim 1, wherein audio signals from the one or more auxiliary input sources are selectively channeled to the car stereo by the interface.

16. (Previously Presented) The apparatus of claim 1, wherein a user can select between the one or more auxiliary input sources by depressing keys on the car stereo.
17. (Previously Presented) The apparatus of claim 1, wherein a user can select one of the auxiliary input sources by entering a disc number at the car stereo.
18. (Previously Presented) The apparatus of claim 1, wherein a user can select one of the auxiliary input sources by entering a track number at the car stereo.
19. (Previously Presented) The apparatus of claim 1, wherein a user can select one of the auxiliary input sources by entering both disc and track numbers at the car stereo.
20. (Previously Presented) The apparatus of claim 1, wherein a user can select between the audio device and the one or more auxiliary input sources by entering a sequence at the car stereo.
21. (Original) The apparatus of claim 20, wherein the sequence comprises a track up selection followed by a track down selection.
22. (Original) The apparatus of claim 1, further comprising a second interface connected to the first interface for providing a plurality of auxiliary input sources.
23. (Original) The apparatus of claim 22, wherein both the first interface and the second interface are controllable using the car stereo.

24. (Currently Amended) An audio device integration system comprising:

a car stereo;

a plurality of auxiliary input sources;

an interface connected between the car stereo and the plurality of auxiliary input sources for channeling audio from at least one of the plurality of auxiliary input sources, the interface including:

means for remotely controlling at least one of the plurality of auxiliary input sources using the car stereo by receiving a control command from the car stereo in a format incompatible with the at least one of the plurality of auxiliary input sources, processing the control command into a formatted control command compatible with the at least one of the plurality of auxiliary input sources, and transmitting the formatted control command to the at least one of the plurality of auxiliary input sources for execution thereby;

means for receiving data from the at least one of the plurality of auxiliary input sources in a format incompatible with the car stereo, processing the data into formatted data compatible with the car stereo, and transmitting the formatted data to the car stereo for display thereby; and

means for selecting one of the plurality of auxiliary input sources from the car stereo.

25. (Original) The apparatus of claim 24, wherein the means for selecting one of the plurality of auxiliary input sources comprises a disc or track selection entered by a user using control buttons of the car stereo.

26. (Previously Presented) The apparatus of claim 24, wherein the audio device at least one of the plurality of auxiliary input sources comprises a CD player, CD changer, MP3 player, satellite receiver, or a Digital Audio Broadcast (DAB) receiver.

27. (Previously Presented) The apparatus of claim 24, wherein a device type of the at least one of the plurality of auxiliary input sources is automatically detected by the interface and the at least one of the plurality of auxiliary input sources is automatically integrated with the car stereo based upon the device type.

28. (Original) The apparatus of claim 24, wherein the interface is switchable into an auxiliary input mode by issuing a control sequence at the car stereo.

29. (Original) The apparatus of claim 28, wherein the control sequence comprises a track up command followed by a track down command.

30. (Currently Amended) A method for integrating an after-market device with a car stereo comprising:

connecting an interface to the car stereo, the after-market device to the interface, and an auxiliary input source to the interface;

remotely controlling the after-market device using the car stereo by:

receiving control commands from the car stereo at the interface in a format incompatible with the after-market device; and

processing the control commands into formatted control commands compatible with the after-market device and dispatching the formatted control commands to the after-market device;

receiving data in a format incompatible with the car stereo and audio from the after-market device at the interface;

processing the data into formatted data compatible with the car stereo and dispatching the audio and formatted data to the car stereo;

displaying the formatted data on the car stereo and playing the audio through the car stereo; and

playing audio from the ~~auxiliary input source~~ after-market device through the car stereo.

31. (Original) The method of claim 30, wherein the step of receiving data from the device comprises retrieving CD track and time information from the device.

32. (Original) The method of claim 30, wherein the step of receiving data from the device comprises retrieving MP3 song, title, track, and time information from the device.

33. (Original) The method of claim 30, wherein the step of receiving data from the device comprises retrieving channel number, channel name, artist, and song information from the device.

34. (Original) The method of claim 30, wherein the step of receiving data from the device comprises retrieving video information from the device.

35. (Previously Presented) The method of claim 30, wherein the step of displaying the formatted data comprises displaying the data in an LCD panel.

36. (Previously Presented) The method of claim 30, wherein the step of displaying the formatted data comprises displaying the data in a graphical user interface at the car stereo.

37. (Previously Presented) The method of claim 30, wherein the step of displaying formatted data comprises displaying video at the car stereo.

38. (Previously Presented) The method of claim 30, wherein the step of connecting the after-market device to the interface comprises connecting a CD player, CD changer, MP3 player, satellite receiver, or a Digital Audio Broadcast (DAB) receiver to the interface.

39. (Cancelled)

40. (Previously Presented) The method of claim 30, further comprising receiving a selection command from the car stereo and channeling data and audio from the auxiliary input source to the interface in response to the selection command.

41. (Original) The method of claim 40, further comprising processing the data from the auxiliary input source for display on the car stereo.

42. (Currently Amended) An apparatus for docking a portable device for integration with a car stereo comprising:

a storage area remote from a car stereo for storing the portable device;

a docking portion within the storage area for communicating and physically mating with the portable device;

a data port in communication with the docking portion, the data port connectable with a device for integrating the portable device with the car stereo; and

an interface connected to the data port and to the car stereo, the interface channeling audio from the portable device to the car stereo, the interface including means for remotely controlling the portable device using the car stereo by processing control commands generated by the car stereo in a format incompatible with the portable device into formatted control commands compatible with the portable device, and dispatching the formatted control commands to the portable device for execution thereby.

43. (Previously Presented) The apparatus of claim 42, wherein the storage area further comprises a top member, a bottom member, and a hinge interconnecting the top member and the bottom member at an edge thereof.

44. (Previously Presented) The apparatus of claim 42, wherein the data port comprises an RS-232 or Universal Serial Bus (USB) port.

45. (Previously Presented) The apparatus of claim 42, wherein the storage area further comprises a top portion and a bottom portion defining a sleeve for holding the portable audio device.

46. (Previously Presented) The apparatus of claim 43, further comprising a clasp for retaining the top and bottom members in a closed position.

47. (Currently Amended) A method of integrating an after-market device with an Original Equipment Manufacturer (OEM) or after-market car stereo comprising:

connecting the after-market device to an interface;

connecting the interface to a car stereo;

determining whether the car stereo is an OEM car stereo or an after-market car stereo;

generating and transmitting a device presence signal to the car stereo to maintain the car stereo in an operational state responsive to external signals, signals generated by the after-market device, the device presence signal based upon the car stereo;

channeling audio signals from the after-market device to the car stereo using the interface.

48. (Previously Presented) The method of claim 47, further comprising receiving control commands from the car stereo at the interface in a format incompatible with the after-market device.

49. (Original) The method of claim 48, further comprising converting the control commands into a format recognizable by the after-market audio device.

50. (Original) The method of claim 49, further comprising dispatching formatted commands to the after-market audio device for execution thereby.

51. (Previously Presented) The method of claim 47, further comprising converting data received at the interface from the after-market audio device in a format incompatible with the car stereo into a format compatible with the car stereo.

52. (Original) The method of claim 51, further comprising displaying formatted data on the car stereo.

53. (Original) The method of claim 52, wherein the step of displaying formatted data comprises displaying channel numbers, channel names, titles, tracks, song names, or artist names on the car stereo.

54. (Original) The method of claim 52, wherein the step of displaying formatted data comprises displaying video on the car stereo.

55. (Currently Amended) An audio device integration system comprising:

a car stereo;

a portable MP3 player external to the car stereo;

an interface connected between the car stereo and the portable MP3 player, the interface including:

means for generating a device presence signal and transmitting the signal to the car stereo to maintain the car stereo in an operational state;

means for remotely controlling the MP3 player using the car stereo by receiving a control command from the car stereo in a format incompatible with the MP3 player, processing the control command into a formatted control command compatible with the MP3 player, and transmitting the formatted control command to the MP3 player for execution thereby; and

means for transmitting audio from the portable MP3 player to the car stereo.

56. (Previously Presented) The apparatus of claim 55, wherein the car stereo is an Original Equipment Manufacturer (OEM) car stereo.

57. (Previously Presented) The apparatus of claim 55, wherein the car stereo is an after-market car stereo.

58. (Cancelled)

59. (Previously Presented) The system of claim 55, wherein the interface further includes means for receiving data from the MP3 player in a format incompatible with the car stereo, processing the data into formatted data compatible with the car stereo, and transmitting the formatted data to the car stereo for display thereby.

60. (Previously Presented) The apparatus of claim 59, wherein the data comprises track and time information.

61. (Previously Presented) The apparatus of claim 59, wherein the data comprises song title and artist information.

62. (Previously Presented) The apparatus of claim 59, wherein the commands are input by a user using one or more control buttons or presets on the car stereo.

63. (Currently Amended) An audio device integration system comprising:

a car stereo;

a satellite radio receiver external to the car stereo;

an interface connected between the car stereo and the satellite radio receiver, the interface including:

means for generating a device presence signal and transmitting the signal to the car stereo to maintain the car stereo in an operational state;

means for remotely controlling the satellite radio receiver using the car stereo by receiving a control command from the car stereo in a format incompatible with the satellite radio receiver, processing the control command into a formatted control command compatible with the satellite radio receiver, and transmitting the formatted control command to the satellite radio receiver for execution thereby; and

means for transmitting audio from the satellite radio receiver to the car stereo.

64. (Previously Presented) The apparatus of claim 63, wherein the car stereo is an Original Equipment Manufacturer (OEM) car stereo.

65. (Previously Presented) The apparatus of claim 63, wherein the car stereo is an after-market car stereo.

66. (Cancelled)

67. (Previously Presented) The system of claim 63, wherein the interface further includes means for receiving data from the satellite radio receiver in a format incompatible with the car stereo, processing the data into formatted data compatible with the car stereo, and transmitting the formatted data to the car stereo for display thereby.

68. (Previously Presented) The apparatus of claim 67, wherein the data comprises track and time information.

69. (Previously Presented) The apparatus of claim 67, wherein the data comprises song title and artist information.

70. (Previously Presented) The apparatus of claim 67, wherein the data comprises a channel number and a channel name.

71. (Previously Presented) The apparatus of claim 67, wherein the commands are input by a user using one or more control buttons or presets on the car stereo.

72. (Currently Amended) An audio device integration system comprising:

a car stereo;

a digital audio broadcast receiver external to the car stereo;

an interface connected between the car stereo and the digital audio broadcast receiver, the interface including:

means for generating a device presence signal and transmitting the signal to the car stereo to maintain the car stereo in an operational state;

means for remotely controlling the digital audio broadcast receiver using the car stereo by receiving a control command from the car stereo in a format incompatible with the digital audio broadcast receiver, processing the control command into a formatted control command compatible with the digital audio broadcast receiver, and transmitting the formatted control command to the digital audio broadcast receiver for execution thereby; and

means for transmitting audio from the digital audio broadcast receiver to the car stereo.

73. (Previously Presented) The apparatus of claim 72, wherein the car stereo is an Original Equipment Manufacturer (OEM) car stereo.

74. (Previously Presented) The apparatus of claim 72, wherein the car stereo is an after-market car stereo.

75. (Cancelled)

76. (Previously Presented) The system of claim 72, wherein the interface further includes means for receiving data from the digital audio broadcast receiver in a format incompatible with the car stereo, processing the incompatible data into formatted data compatible with the car stereo, and transmitting the formatted data to the car stereo for display thereby.

77. (Previously Presented) The apparatus of claim 76, wherein the data comprises track and time information.

78. (Previously Presented) The apparatus of claim 76, wherein the data comprises song title and artist information.

79. (Previously Presented) The apparatus of claim 76, wherein the data comprises a channel number and a channel name.

80. (Previously Presented) The apparatus of claim 76, wherein the commands are input by a user using one or more control buttons or presets on the car stereo.

81. (Currently Amended) A device for integrating video information for use with a car stereo, comprising:

a car stereo;

a an after-market video device external to the car stereo;

an interface connected between the car stereo and the after-market video device, the interface including:

means for generating a device presence signal and transmitting the signal to the car stereo to maintain the car stereo in an operational state; state responsive to signals generated by the after-market video device; and

means for transmitting video information from the after-market video device to the car stereo.

82. (Previously Presented) The device of claim 81, further comprising means for converting the video information into a format compatible with the car stereo.

83. (Currently Amended) An audio device integration system comprising:

a car stereo;

a portable audio device external to the car stereo;

an interface connected between the car stereo and the portable audio device, the interface including:

means for generating a device presence signal and transmitting the signal to the car stereo to maintain the car stereo in an operational state;

means for remotely controlling the portable audio device using the car stereo by receiving a control command from the car stereo in a format incompatible with the portable audio device, processing the control command into a formatted control command compatible with the portable audio device, and transmitting the formatted control command to the portable audio device for execution thereby; and

means for transmitting audio from the portable audio device to the car stereo.

84. (Previously Presented) The apparatus of claim 83, wherein the portable audio device comprises a portable CD player.

85. (Previously Presented) The apparatus of claim 83, wherein the portable audio device comprises a portable MP3 player.

86. (Previously Presented) The apparatus of claim 83, wherein the portable audio device comprises a portable satellite receiver.

87. (Previously Presented) The apparatus of claim 83, wherein the portable audio device comprises a portable Digital Audio Broadcast (DAB) receiver.

88. (Previously Presented) The apparatus of Claim 1, further comprising a bus connection established between the after-market audio device and the interface.

89. (Previously Presented) The apparatus of Claim 88, wherein the bus connection comprises a Universal Serial Bus (USB) connection.

90. (Previously Presented) The apparatus of Claim 24, further comprising a bus connection established between the at least one of the plurality of auxiliary input sources and the interface.

91. (Previously Presented) The apparatus of Claim 90, wherein the bus connection comprises a Universal Serial Bus (USB) connection.

92. (Previously Presented) The apparatus of Claim 55, further comprising a bus connection established between the MP3 player and the interface.

93. (Previously Presented) The apparatus of Claim 92, wherein the bus connection comprises a Universal Serial Bus (USB) connection.

94. (Previously Presented) The apparatus of Claim 63, further comprising a bus connection established between the satellite radio receiver and the interface.

95. (Previously Presented) The apparatus of Claim 94, wherein the bus connection comprises a Universal Serial Bus (USB) connection.

96. (Previously Presented) The apparatus of Claim 72, further comprising a bus connection established between the digital audio broadcast receiver and the interface.

97. (Previously Presented) The apparatus of Claim 96, wherein the bus connection comprises a Universal Serial Bus (USB) connection.

98. (Previously Presented) The apparatus of Claim 81, further comprising a bus connection established between the video device and the interface.

99. (Previously Presented) The apparatus of Claim 98, wherein the bus connection comprises a Universal Serial Bus (USB) connection.

100. (Previously Presented) The apparatus of Claim 83, further comprising a bus connection established between the portable audio device and the interface.

101. (Previously Presented) The apparatus of Claim 100, wherein the bus connection comprises a Universal Serial Bus (USB) connection.

102. (Previously Presented) The apparatus of Claim 81, wherein the interface further comprises means for receiving a control signal from the car stereo in a format incompatible with the video device, processing the control signal into a formatted control signal compatible with the video device, and transmitting the formatted control signal to the video device for execution thereby.

103. (Previously Presented) The apparatus of Claim 102, wherein the interface further comprises means for receiving data from the video device incompatible with the car stereo, processing the data into formatted data compatible with the car stereo, and transmitting the formatted data to the car stereo for display thereon.

104. (Currently Amended) An audio device integration system, comprising:

a car stereo;

a an after-market, line-level audio source external to the car stereo; and

an interface connected between the car stereo and the after-market, line level audio source, the interface including:

means for generating and transmitting a device presence signal to the car stereo to maintain the car stereo in an operational state; ~~and~~ state responsive to signals generated by the after-market, line-level audio source; and

means for transmitting audio from the after-market, line-level audio source to the car stereo.

REMARKS

Applicant submits this response to the outstanding Office Action on the above-identified application. Applicant has amended the claims, as set forth herein, and respectfully submits that the application, as amended, is in condition for allowance.

Applicant has amended independent Claims 1, 24, 30, 42, 47, 55, 63, 72, 81, 83, and 104, and dependent Claim 6, to further define the present invention. For the reasons set forth below, Applicant submits that the pending claims are patentable over the cited references, taken alone or in any combination.

I. SUMMARY OF THE INVENTION

Applicant's claimed invention relates generally to an audio device integration system for integrating one or more after-market audio devices external to a car stereo (and, normally, not compatible with the car stereo), such as an MP3 player, a satellite radio receiver, digital audio broadcast (DAB) receiver, or one or more auxiliary input sources, for use with an Original Equipment Manufacturer (OEM) or after-market car stereo system. The invention allows an external device which is ordinarily incompatible with an OEM or after-market car stereo system to be integrated therewith, such that the OEM or after-market car stereo system can be used to control the external device, and audio and/or video from the external device can be channeled to the car stereo. Integration is achieved by the interface of the present invention by receiving an incompatible control command from the car stereo, processing the incompatible control command into a formatted control command compatible with the external device, and transmitting the formatted control command to the external device for execution thereby.

Additionally, incompatible data from the external device, such as track number, time, song name, artist name, video information, and other data, is received by the interface of the present invention, processed into formatted data compatible with the car stereo, and transmitted to the car stereo for display thereby. As a result, external devices which are ordinarily alien to and inoperable with an existing car stereo system can be integrated for use with such systems, while remote command and control capabilities (e.g., using the controls of the car stereo system) are provided.

II. SUMMARY OF THE REFERENCES CITED IN THE OFFICE ACTION

Applicant submits that the pending claims are patentable over the references cited in the Office Action, taken alone or in combination. Specifically, Applicant submits that the pending claims are patentable over U.S. Patent No. 6,163,079 to Miyazaki, et al., U.S. Patent No. 6,653,948 to Kunimatsu, et al., U.S. Patent No. 6,608,399 to McConnell, et al., U.S. Patent No. 6,993,615 to Falcon, U.S. Patent Application Publication No. 2002/0085730 to Holland, U.S. Patent No. 6,591,085 to Grady, U.S. Patent No. 6,346,917 to Fuchs, et al., and U.S. Patent No. 6,374,177 to Lee, et al., taken alone or in any combination.

Miyazaki, et al. discloses a user-operable system for a vehicle which includes a central control unit and one or more detachable units which can be connected to one or more connectors positioned at various locations in the vehicle. In the first embodiment, the central control unit comprises an audio control unit, and the detachable unit includes a disk changer, a switch unit, and a multiplex control unit. In the second embodiment, the central control unit comprises a car navigation control unit, and the detachable unit includes a disk changer, a switch unit, and a

liquid crystal screen and an associated switch and speaker, wherein the disk changer uploads map data to the car navigation control unit. In the third embodiment, the central control unit includes an air conditioner control unit and the detachable unit includes a switch unit for controlling an air conditioner.

Kunimatsu, et al. discloses a vehicle-mounted display system for allowing operation of a plurality of screens with many functions. The invention allows a user to select a screen from a plurality of screens, and the screen is displayed across the entire surface of the display panel, along with an operation menu which is superimposed over the selected screen.

McConnell, et al. discloses a universal docking station for a vehicle with various electronic feature modules which are custom-designed for docking in the universal docking station. The modules include a custom-designed MP3 player, a tire pressure monitor, a satellite programming receiver, a vehicle security module, an electronic map module, a display feature module, a gas station speed pass module, a remote, keyless entry receiver module, a vehicle lighting controller module, a camera module, a radar detector module, a power line controller module, a garage door opener module, a digital media player module, a global positioning system (GPS) module, a BlueTooth linking module, and a breathalyzer module. A video display could be provided with the docking station for displaying video information.

Falcon discloses a portable computing device which is operable with an appliance, such as a car stereo. The car stereo includes a docking portion which receives the portable computing device. The portable computing device functions as a display for the car stereo, and allows a

user to control the car stereo. The portable computing device includes a configuration module which identifies the type of appliance to which the portable computing device is connected. The appliance includes a type module which sends a data packet to the portable computing device. The data packet is utilized by the configuration module to determine the type of the appliance. The portable computing device generates a screen which is customized to the type of the appliance.

Holland discloses a briefcase with an integrated loudspeaker system. The briefcase can store an electronic device. The loudspeaker system includes an amplifier which can be connected to the electronic device.

Grady discloses an FM transmitter and power supply / charging station for an MP3 player. The FM transmitter transmits audio from the MP3 player to a nearby FM receiver. A docking cavity is provided in the station for receiving the MP3 player.

Fuchs, et al. discloses a method for installing an antenna system external to a vehicle.

Lee, et al. discloses a method and apparatus for providing navigational services in a wireless communication device. The apparatus includes an Internet radio which can be installed in a vehicle. The radio includes an interactive display panel and a communications device, such as a multi-band receiver, a GPS receiver, an infrared (IrDA) receiver, or a gateway receiver, for allowing the radio to obtain data from an external network. Navigational services can be

provided to the user, and navigational updates can be obtained using the communications device. Geographic advertising and other content can be provided to the user.

III. ARGUMENT

Applicant submits that none of the cited references, taken alone or in any combination, teach or suggest providing an audio device integration system which allows an external, after-market device to communicate with and to be remotely controlled using an existing car stereo system.

A. None of the Cited References, Taken Alone or in Any Combination, Teach or Suggest Providing Remote Control of an External Audio or Video Device By A Normally Incompatible Car Stereo

In view of Applicant's amendments to independent Claims 1, 24, and 30, Applicant respectfully submits that Claims 1-4, 6, 10-13, 15-26, 28-30, 34-38, 40-41, 82, 88-89, 90-91, and 102-103, which were rejected as being obvious over Miyazaki, et al. in view of Kunimatsu, et al. and McConnell, et al., are patentable over these references.

The Office Action concedes that neither Miyazaki, et al. nor Kunimatsu, et al. disclose the claimed feature of an audio device integration system which includes **means for remotely controlling an external, after-market device using a car stereo by receiving a control command from the car stereo in a format incompatible with a device external to the car stereo, processing the control command into a formatted command compatible with the external device, and transmitting the formatted command to the external device for execution thereby, as set forth in independent Claims 1 and 24, and similar limitations set forth in independent method Claim 30 and dependent Claim 82.** Although the Office Action points to

column 4, lines 7-19 of McConnell, et al. as disclosing this feature, neither this excerpt, nor the entirety of McConnell, et al., discloses this feature, as specifically set forth in independent Claims 1, 24, and 30 and dependent Claim 82.

McConnell, et al. briefly mentions a controller 14 (see FIG. 1) which “includes suitable circuitry and/or programming to perform power conditioning, filtering, and data protocol translation. Controller circuit 14 operates as a gateway for supply of electrical power (conditioned) and communication of data between the vehicle’s electrical and signal distribution system 15, such [as] a multiplexed data wire or power line, and particular feature modules coupled to rack 12.” However, McConnell, et al. makes no mention of allowing a car stereo system to control an ordinarily incompatible external device, but only discloses custom-designed, native, digital audio player and satellite receiver modules that can be docked with the docking station disclosed therein. These modules are only disclosed in McConnell, et al. as sending audio to a “vehicle speaker system” (see col. 7, line 50), and there is no mention of remotely controlling any of these modules by a car stereo. Put simply, because McConnell, et al. fails whatsoever to disclose allowing a car stereo to remotely control one of the modules, it necessarily fails to disclose receiving an incompatible control command from a car stereo, processing same into a format compatible with an external, after-market device, and transmitting same to the device for execution thereby, as required by the claims.

Indeed, in connection with the digital audio and satellite receiver modules disclosed in McConnell, et al., only audio signals are disclosed as being transmitted to a vehicle speaker system. Thus, McConnell, et al. merely contemplates *sending only audio to the car audio*

system. No disclosure is provided relating to control commands flowing in the opposite direction, i.e., from the car stereo to the external audio or video device. As such, McConnell, et al. is absent any disclosure relating to issuing control commands at the car stereo for controlling a device external to the car stereo, much less processing *incompatible* control commands issued at the car stereo so that they can be used to remotely control the external device. Accordingly, Applicant submits that independent Claims 1, 24, and 30 and their respective dependent claims, which include all of the limitations of Claims 1, 24, and 30, as well as dependent Claim 82, are patentable over Miyazaki, et al., Kunimatsu, et al., and McConnell, et al., taken alone or in combination.

For similar reasons, Applicant submits that Claims 5, 7-9, 27, 31-33, and 52-54 are patentable over Miyazaki, et al. in view of Kunimatsu, et al., McConnell, et al., and Falcon. Claims 5, 7-9, 27, and 31-33, by virtue of their dependency on independent Claims 1, 24, and 30, each recite the aforementioned limitations of remotely controlling an external device using a car stereo by receiving a control command from a car stereo in a format incompatible with an external device, processing the control command into a format compatible with the external device, and dispatching the processed command to the external device for execution thereby. As discussed above, neither Miyazaki, et al., Kunimatsu, et al., nor McConnell, et al., taken alone or in combination, teach or suggest such limitations.

Falcon is likewise deficient. Falcon fails whatsoever to disclose allowing a car stereo to remotely control a normally incompatible, after-market, external audio or video device using a car stereo by processing incompatible control commands from the car stereo at the interface into

commands that are compatible with an after-market, external device, and transmitting same to the external, after-market device for execution thereby. Rather, it merely discloses a customized car radio which is specifically designed to receive the portable computer disclosed therein. There is clearly no disclosure of the portable computer being incompatible with the car stereo (since the car stereo is specifically designed for use with the portable computer), nor is there any disclosure of the car stereo being capable of remotely controlling a normally incompatible, after-market device external thereto. As such, Applicants submit that Claims 5, 7-9, 27, and 31-33 are patentable over Miyazaki, et al., Kunimatsu, et al., McConnell, et al. and Falcon, taken alone or in any combination.

Applicant also submits that dependent Claims 52-54, which recite limitations directed to receiving incompatible data from an after-market device at an interface, processing the data into a format compatible with a car stereo, and transmitting same to the car stereo for display thereon, are patentable over Miyazaki, et al. in view of Kunimatsu, et al., McConnell, et al., and Falcon, taken alone or in any combination. None of these references are concerned with receiving information from an after-market device, much less processing same into a format compatible with a car stereo for display thereon. Indeed, each of the external devices disclosed in these references are native (i.e., custom-designed) products which are already compatible with the car stereo. They clearly are not after-market products, and there is no disclosure of retrieving incompatible information from an after-market product and processing same for display on a car stereo. As such, Applicant submits that Claims 52-54 are patentable over the cited references, taken alone or in any combination.

Applicant also submits that Claims 42-46, 48-51, 55-57, 59-65, 67-74, 76-80, 83-87, 92-97, and 100-103, which were rejected as being obvious over various combinations of the remaining references cited in the Office Action in view of McConnell, et al., are patentable over these references. In connection with these claims, the Office Action cites McConnell, et al. as disclosing the claimed feature of remotely controlling an external device using a car stereo by receiving incompatible control commands from a car stereo, processing same into a format compatible with an external audio or video device, and dispatching same to the external device for execution thereby. As discussed above, McConnell, et al. is devoid of such a feature, and Miyazaki, et al., Kunimatsu, et al., and Falcon, taken alone or in any combination, fail to cure this deficiency. The remaining references, i.e., Holland, Grady, Fuchs, and Lee, are similarly deficient. Holland relates only to a briefcase with an integrated loudspeaker, and is absent any disclosure relating to an interface between a car stereo system and an external audio or video device. Grady merely discloses a docking station with an FM transmitter, and fails whatsoever to disclose an interface which allows for remote control of an external audio or video device using a normally incompatible car stereo. Lee, et al. is concerned only with providing navigational services on a wireless communications device, and is unconcerned with processing incompatible commands from a car stereo system for remotely controlling an external audio or video device. Fuchs, et al. only relates to an antenna, and is entirely unconcerned with an interface connected between a car stereo system and an external audio or video device. As such, Applicant submits that Claims 42-46, 48-51, 55-57, 59-65, 67-74, 76-80, 83-87, 92-97, and 100-103 are patentable over Holland, Grady, Fuchs, and Lee, taken alone or in any combination with Miyazaki, et al., Kunimatsu, et al., McConnell, et al. and Falcon.

B. None of the Cited References, Taken Alone or in Any Combination, Teach or Suggest Generating and Transmitting a Device Presence Signal to Maintain a Car Stereo in a State Responsive to Signals Generated by an After-Market External Device

In view of Applicant's amendments to independent Claims 47, 81, and 104, Applicant submits that Claims 47, 81, 98-99, and 104, which were rejected as being anticipated by Miyazaki, et al., or obvious over Miyazaki, et al. in view of Falcon or Kunimatsu, et al., are patentable over these references. An important feature of the present invention, as set forth in amended Claims 47, 81, 98-99, and 104, is the ability of the integration system of the present invention to maintain an existing car stereo in a state responsive to signals generated by an after-market external device, including an after-market audio or video device or an after-market, line-level audio source, by generating and transmitting a device presence signal to the car stereo which is based upon the car stereo. Ordinarily, if an after-market device is connected to an existing car stereo system, the car stereo system does not recognize the after-market device and is unresponsive to such a device. The present invention thus allows non-native, after-market devices to be integrated for use with an existing car stereo system because it prevents the car stereo system from being unresponsive when such devices are connected, via the present invention, to the car stereo system.

Neither Miyazaki, et al., Falcon, nor Kunimatsu, et al., taken alone or in any combination, teach or suggest **generating and transmitting a device presence signal to maintain a car stereo in an operational state responsive to signals generated by an after-market device or an after-market, line-level source**, as required by Claims 47, 81, 98-99, and 104. Miyazaki, et al. is entirely unconcerned with maintaining a car stereo in a state responsive to signals generated

by an external, *after-market device*. Miyazaki, et al. merely discloses sending multiplexed instruction data from an audio switch unit to one or more electric equipment units (reference numeral 40A) positioned in a car. However, the equipment units are native (i.e., specifically designed) for use with the system disclosed in Miyazaki, et al. Indeed, each equipment unit includes a specially-designed wiring harness which is configured for use only with custom-designed connectors positioned throughout a vehicle. As such, since these components are native and are custom-designed for each other, Miyazaki, et al. is absent any disclosure relating to an interface for integrating external, after-market devices for use with an existing car stereo.

Still further, although the Office Action points to element number 38 in FIG. 1 of Miyazaki, et al. as disclosing the interface recited in the claims, element number 38 is nothing more than a vehicle-side connector with no internal electronics whatsoever for generating and transmitting a device presence signal to a car stereo. It clearly is not an interface positioned between and in communication with an after-market, external device and a car stereo, much less an interface which generates and transmits a device presence signal to a car stereo to maintain communication between the car stereo and the after-market, external device, as required by Claims 47, 81, 98-99, and 104. Additionally, although the Office Action points to the multiplex element 42 of FIGS. 1 and 2, col. 4, lines 51-67, and col. 5, lines 1-31 of Miyazaki, et al., these excerpts only very broadly disclose exchanging multiplexed data between its audio control unit and the electric equipment units disclosed therein. However, the electric equipment units of Miyazaki, et al. do not send a signal to the audio control unit to maintain a car stereo in a state responsive to signals generated by an external, *after-market device*, as the Office Action improperly concludes. Such a signal is not disclosed in Miyazaki, et al., nor is any required,

because the components of Miyazaki, et al. are custom-designed to communicate with each other. Put simply, the electric equipment units are native components that are designed to work with a custom-designed audio control unit, and are not after-market components that ordinarily cannot communicate with an existing car stereo.

Falcon and Kunimatsu, et al. fail to remedy the deficiencies of Miyazaki, et al. Falcon does not disclose generating and transmitting a device presence signal to maintain a car stereo in an operational state responsive to signals generated by a non-native device. Rather, it merely discloses a customized car radio which is specifically designed to receive the portable computer disclosed therein. The portable computer includes a software configuration module which determines the type of appliance in which it is docked (e.g., a furnace, an air conditioner, a humidifier, a clock radio, a refrigeration appliance, a freezer, an oven, a range, a car stereo, etc.), and presents an appropriate user interface on its screen based upon the detected type of appliance. However, since the appliances are specifically designed to operate with and be responsive to the portable computer, there is no disclosure of the portable computer of Falcon generating and transmitting a device presence signal to a car stereo to maintain it in a state responsive to signals generated by an external, ordinarily incompatible, after-market device. Kunimatsu, et al. merely discloses a vehicle-mounted display system, and is unconcerned with an integration device that allows for communication between by car stereo and an after-market device by sending a device presence signal to the car stereo. As such, Applicant submits that Claims 47, 81, 98-99, and 104 are patentable over Miyazaki, et al., Falcon, and Kunimatsu, et al., taken alone or in any combination.

IV. CONCLUSION

All issues raised in the Office Action are believed to have been addressed. Claims 1, 6, 24, 30, 42, 47, 55, 63, 72, 81, 83, and 104 were amended, and Claims 1-13, 15-38, 40-57, 59-65, 67-74, and 76-104 are pending and are in condition for allowance. No new matter has been added. Reexamination is requested and favorable action solicited.

Respectfully submitted,

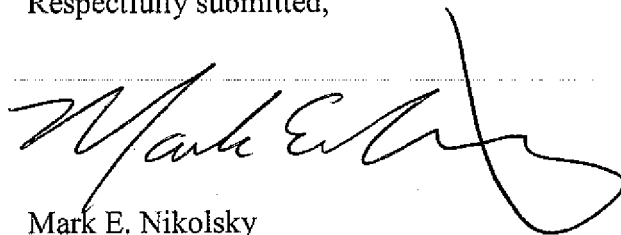

Date:

6/28/2007

Mark E. Nikolsky
Reg. No. 48,319
McCarter & English, LLP
Four Gateway Center
100 Mulberry Street
Newark, NJ 07102-4056
Tel.: 973-639-6987
Fax.: 973-297-6624

EAST Search History

Ref #	Hits	Search Query	DBs	Default Operator	Plurals	Time Stamp
L1	707	381/86.ccls.	US-PGPUB; USPAT	OR	OFF	2007/07/07 17:03
L2	4788	307/10.1	US-PGPUB; USPAT	OR	OFF	2007/07/07 17:03
L3	1969	307/9.1	US-PGPUB; USPAT	OR	OFF	2007/07/07 17:03
L4	290	340/825.25.ccls.	US-PGPUB; USPAT	OR	OFF	2007/07/07 17:11
L5	3	("5794164" "6052603" "6058319"). pn.	US-PGPUB; USPAT	OR	OFF	2007/07/07 17:18
L6	1	"20020197954".pn.	US-PGPUB; USPAT	OR	OFF	2007/07/07 17:18

UNITED STATES PATENT AND TRADEMARK OFFICE

UNITED STATES DEPARTMENT OF COMMERCE
 United States Patent and Trademark Office
 Address: COMMISSIONER FOR PATENTS
 P.O. Box 1450
 Alexandria, Virginia 22313-1450
 www.uspto.gov

APPLICATION NO.	FILING DATE	FIRST NAMED INVENTOR	ATTORNEY DOCKET NO.	CONFIRMATION NO.
10/316,961	12/11/2002	Ira Marlowe	9809/1	4879

7590 07/12/2007
 MICHAEL R FRISCIA
 MCCARTER & ENGLISH
 FOUR GATEWAY CENTER
 100 MULBERRY STREET
 NEWARK, NJ 07102

EXAMINER

KURR, JASON RICHARD

ART UNIT	PAPER NUMBER
2615	

2615

MAIL DATE	DELIVERY MODE
07/12/2007	PAPER

07/12/2007

PAPER

Please find below and/or attached an Office communication concerning this application or proceeding.

The time period for reply, if any, is set in the attached communication.

Office Action Summary

Application No. 10/316,961	Applicant(s) MARLOWE, IRA	
Examiner Jason R. Kurr	Art Unit 2615	

-- The MAILING DATE of this communication appears on the cover sheet with the correspondence address --

Period for Reply

A SHORTENED STATUTORY PERIOD FOR REPLY IS SET TO EXPIRE 3 MONTH(S) OR THIRTY (30) DAYS, WHICHEVER IS LONGER, FROM THE MAILING DATE OF THIS COMMUNICATION.

- Extensions of time may be available under the provisions of 37 CFR 1.136(a). In no event, however, may a reply be timely filed after SIX (6) MONTHS from the mailing date of this communication.
- If NO period for reply is specified above, the maximum statutory period will apply and will expire SIX (6) MONTHS from the mailing date of this communication.
- Failure to reply within the set or extended period for reply will, by statute, cause the application to become ABANDONED (35 U.S.C. § 133). Any reply received by the Office later than three months after the mailing date of this communication, even if timely filed, may reduce any earned patent term adjustment. See 37 CFR 1.704(b).

Status

- 1) Responsive to communication(s) filed on 28 June 2007.
- 2a) This action is FINAL.
- 2b) This action is non-final.
- 3) Since this application is in condition for allowance except for formal matters, prosecution as to the merits is closed in accordance with the practice under *Ex parte Quayle*, 1935 C.D. 11, 453 O.G. 213.

Disposition of Claims

- 4) Claim(s) 1-13, 15-38, 40-57, 59-65 and 67-104 is/are pending in the application.
 - 4a) Of the above claim(s) _____ is/are withdrawn from consideration.
- 5) Claim(s) _____ is/are allowed.
- 6) Claim(s) 1-13, 15-38, 40-57, 59-65 and 67-104 is/are rejected.
- 7) Claim(s) _____ is/are objected to.
- 8) Claim(s) _____ are subject to restriction and/or election requirement.

Application Papers

- 9) The specification is objected to by the Examiner.
- 10) The drawing(s) filed on _____ is/are: a) accepted or b) objected to by the Examiner.
Applicant may not request that any objection to the drawing(s) be held in abeyance. See 37 CFR 1.85(a).
Replacement drawing sheet(s) including the correction is required if the drawing(s) is objected to. See 37 CFR 1.121(d).
- 11) The oath or declaration is objected to by the Examiner. Note the attached Office Action or form PTO-152.

Priority under 35 U.S.C. § 119

- 12) Acknowledgment is made of a claim for foreign priority under 35 U.S.C. § 119(a)-(d) or (f).
 - a) All b) Some * c) None of:
 - 1. Certified copies of the priority documents have been received.
 - 2. Certified copies of the priority documents have been received in Application No. _____.
 - 3. Copies of the certified copies of the priority documents have been received in this National Stage application from the International Bureau (PCT Rule 17.2(a)).

* See the attached detailed Office action for a list of the certified copies not received.

Attachment(s)

- 1) Notice of References Cited (PTO-892)
- 2) Notice of Draftsperson's Patent Drawing Review (PTO-948)
- 3) Information Disclosure Statement(s) (PTO/SB/08)
Paper No(s)/Mail Date 6/28/07.
- 4) Interview Summary (PTO-413)
Paper No(s)/Mail Date. _____
- 5) Notice of Informal Patent Application
- 6) Other: _____

DETAILED ACTION

Claim Rejections - 35 USC § 102

The following is a quotation of the appropriate paragraphs of 35 U.S.C. 102 that form the basis for the rejections under this section made in this Office action:

A person shall be entitled to a patent unless –

(b) the invention was patented or described in a printed publication in this or a foreign country or in public use or on sale in this country, more than one year prior to the date of application for patent in the United States.

Claim 104 is rejected under 35 U.S.C. 102(b) as being anticipated by Miyazaki et al (US 6,163,079).

With respect to claim 104, Miyazaki discloses an audio device integration system, comprising: a car stereo (fig.1 #32, col.4 ln.6-7); an after-market, line-level audio source (fig.2 #40A) external to the car stereo; and an interface (fig.1,2 #38) connected between the car stereo and the after-market, line level audio source, the interface including: means (fig.2 #42) for generating and transmitting a device presence signal to the car stereo to maintain the car stereo in an operational state responsive to signals generated by the after-market, line level audio source (col.4 ln.54-57); and means (fig.1 "Ls") for transmitting audio from the after-market line-level audio source to the car stereo.

Claim Rejections - 35 USC § 103

Art Unit: 2615

The following is a quotation of 35 U.S.C. 103(a) which forms the basis for all obviousness rejections set forth in this Office action:

(a) A patent may not be obtained though the invention is not identically disclosed or described as set forth in section 102 of this title, if the differences between the subject matter sought to be patented and the prior art are such that the subject matter as a whole would have been obvious at the time the invention was made to a person having ordinary skill in the art to which said subject matter pertains. Patentability shall not be negated by the manner in which the invention was made.

Claims 1-4,6,10-13,15-26,28-30,34-38,40-41,82,88-89,90-91 and 102-103 are rejected under 35 U.S.C. 103(a) as being unpatentable over Miyazaki et al (US 6,163,079) in view of Kunimatsu et al (US 6,653,948 B1) and in further view of McConnell et al (US 6,608,399 B2).

With respect to claim 1, Miyazaki discloses an audio device integration system comprising: a car stereo (fig.1 #32, col.4 ln.6-7); an after-market audio device (fig.2 #40A) external to the car stereo; an interface (fig.1,2 #38,) connected between the car stereo and the after-market audio device for channeling audio signals to the car stereo from the after-market audio device (col.2 ln.5-16), the interface including: means (fig.2 #32,42) for remotely controlling the after-market audio device using the car stereo by receiving a control command from the car stereo, processing the control command, and transmitting the command to the after-market audio device for execution thereby (col.4 ln.51-67, col.5 ln.1-31); and means (fig.2, #42) for receiving data from the after-market audio device, processing the data, and transmitting the data to the car stereo (col.4 ln.51-67, col.5 ln.1-31); and means (fig.2 #43) for switching to one or more auxiliary input sources connected to the interface (col.4 ln.54-57).

Miyazaki does not disclose expressly wherein the means for receiving a control command from the car stereo and the means for receiving data from the after-market device include the capability of processing data from an incompatible form between devices into a compatible format that allows each device to function by executing the compatible formatted command.

McConnell discloses means (fig.1) for receiving incompatible data from vehicle devices, that formats the data into a compatible form, which allows communication between the devices (col.4 ln.7-19 "data protocol translation").

Art Unit: 2615

At the time of the invention it would have been obvious to a person of ordinary skill in the art to use the means of McConnell to format the data being transmitted between the audio control and peripheral devices along the multiplex signal line of Miyazaki.

The motivation for doing so would have been to allow a user of the invention of Miyazaki to incorporate peripheral devices in the vehicles electrical system that do not contain a multiplex control unit as depicted in figure 2 #42. This would allow a user to use peripheral devices that are not pre-configured to be used with the system of Miyazaki.

Miyazaki does not disclose expressly wherein the means for receiving data from the after-market device includes the capability of displaying data on a display of the car stereo, however does disclose the processing of data including "a radio/CD selection instruction, a station selection instruction, a volume control instruction, etc. (col.4 ln.51-66). Miyazaki also teaches a navigation system (fig.4 #28) with a visual display (fig.4 #47) as an auxiliary device.

Kunimatsu teaches a navigation system (fig.1 #14) that is combined with an audio system (fig.1 #18) to provide information to a display (fig.1 #12).

At the time of the invention it would have been obvious to a person of ordinary skill in the art to combine the audio and navigation systems of Miyazaki into one unit that displays information to a visual display as taught by Kunimatsu.

The motivation for doing so would have been to allow a user, who is seated near the car stereo to view the control instructions sent from the auxiliary device, such

Art Unit: 2615

as volume, selected station, or selected CD. This would also allow the user to make desirable changes to the settings of the auxiliary device by merely controlling the car stereo. Hence, now the system of Miyazaki not only displays navigation information but also information pertaining to the audio system such as the data disclosed in column 4 lines 51-66.

With respect to claim 2, Miyazaki discloses the apparatus of claim 1, wherein the car stereo is an Original Equipment Manufacturer (OEM) car stereo (col.1 ln.12-36).

With respect to claim 3, Miyazaki discloses the apparatus of claim 1, however does not disclose expressly wherein the car stereo is an after-market car stereo. Miyazaki discloses a system for connecting auxiliary devices to a vehicles control system, however does not make the distinction that the control system is replaceable by an after-market control, such as an after-market car stereo to replace the factory stereo control components. Official Notice is taken that after-market car stereos are well known in the art, and the invention of Miyazaki is not limited to interacting with only factory stereo components. At the time of the invention it would have been obvious that a user of Miyazaki's invention could replace the factory stereo with an after-market unit and continue to achieve the same results. The motivation for using an after-market unit would have been to upgrade the vehicles sound system. These upgrades could include features such as, bass and stereophonic outputs, or mp3 and satellite capabilities.

Art Unit: 2615

With respect to claim 4, Miyazaki discloses the apparatus of claim 1, wherein the after-market audio device comprises a CD player, CD changer (fig.2 #44), MP3 player, Digital Audio Broadcast (DAB) receiver, or satellite receiver.

With respect to claim 6, Miyazaki discloses the apparatus of claim 1, wherein the interface generates a device presence signal for maintaining the car stereo in a state responsive to processed data and audio signals (col.4 ln.54-66).

With respect to claim 10, Miyazaki discloses the apparatus of claim 1, wherein the data comprises video information (col.5 ln.24-31).

With respect to claim 11, Miyazaki discloses the apparatus of claim 1, however does not disclose expressly wherein the formatted data is displayed as a menu on the display of the car stereo. It is implied that the system of Miyazaki includes a screen to display the navigation information, however it is not disclosed wherein this information is provided as a menu.

Kunimatsu discloses a combined navigation/audio system that displays a menu of data (fig.3B).

At the time of the invention it would have been obvious to a person of ordinary skill in the art to use the combined navigation and audio system of Kunimatsu as the navigation and audio units of Miyazaki. This would provide a menu of options for a user to select.

Art Unit: 2615

The motivation for providing the data in the form of a menu, as does Kunimatsu, would have been to simplify the controls of the system of Miyazaki, by providing an easily viewable set of options.

With respect to claim 12, Miyazaki discloses the apparatus of claim 1, however does not disclose expressly wherein the display of the car stereo comprises a graphic panel. Miyazaki discloses wherein the navigation unit (fig.4 #28,40B) comprises a graphic panel (fig.4 #47).

Kunimatsu discloses a vehicle mounted display system (fig.1 #12) that is integrated with a navigation unit (fig.1 #14) and an audio system (fig.1 #18), wherein the system includes a graphic panel (fig.1 #20).

At the time of the invention it would have been obvious to a person of ordinary skill in the art to use the combined navigation and audio system of Kunimatsu as the navigation and audio units of Miyazaki. It is well known in the art that touch-screen panels are commonly found in vehicles for the purpose of controlling and displaying both navigation and audio information, as evidenced by Kunimatsu.

The motivation for using a combined unit would have been to supply a system with one set of controls, which would ultimately simplify the operation of the system. Also, a system with one display and one set of controls (being the touch-screen display) would greatly reduce the required area of mounting space, hence allowing the system to be implemented in smaller vehicles.

With respect to claim 13, Miyazaki discloses the apparatus of claim 1, wherein the commands are input by a user using one or more control buttons or presets on the car stereo. It is implied that the audio control unit of Miyazaki contains control buttons or presets to control the functions disclosed on column 4 lines 57-60. Without control buttons or presets, it would not be possible for a user to control these disclosed functions.

With respect to claim 15, Miyazaki discloses the apparatus of claim 1, wherein audio signals from the one or more auxiliary input sources are selectively channeled to the car stereo by the interface (col.4 ln.63-67, col.5 ln.1-4).

With respect to claim 16, Miyazaki discloses the apparatus of claim 1, however does not disclose expressly wherein a user can select between the one or more auxiliary input sources by depressing keys on the car stereo. Miyazaki discloses wherein the control unit is connected to a disk changer (fig.3 #44). Official Notice is taken that it is well known in the art that car stereo units have keys for selecting disks (auxiliary input sources) from a CD changer. It would have been obvious to a person of ordinary skill in the art to use keys for the selection of disks in the changer on the audio control unit (fig.3 #32) of Miyazaki. The motivation for doing so would have been to select a CD to play without having to manually access the disk changer.

With respect to claim 17, Miyazaki discloses the apparatus of claim 1, however does not disclose expressly wherein a user can select one of the auxiliary input sources by entering a disc number at the car stereo. Miyazaki discloses wherein the control unit is connected to a disk changer (fig.3 #44). Official Notice is taken that it is well known in the art that car stereo units have keys for selecting disks (auxiliary input sources) from a CD changer. These keys are known to be associated with a disk number that corresponds to a disk in the changer. It would have been obvious to a person of ordinary skill in the art to use keys with disk numbers for the selection of disks in the changer on the audio control unit (fig.3 #32) of Miyazaki. The motivation for doing so would have been to select a CD to play without having to manually access the disk changer.

With respect to claim 18, Miyazaki discloses the apparatus of claim 1, however does not disclose expressly wherein a user can select one of the auxiliary input sources by entering a track number at the car stereo. Miyazaki discloses wherein the control unit is connected to a disk changer (fig.3 #44). Official Notice is taken that it is well known in the art that car stereo units have means to enter a track number of a CD in a CD changer. It would have been obvious to a person of ordinary skill in the art to enter track numbers on the audio control unit (fig.3 #32) of Miyazaki for the selection of a track of a disk in the changer. The motivation for doing so would have been to select an audio track to play without having to manually access the disk changer.

Art Unit: 2615

With respect to claim 19, Miyazaki discloses the apparatus of claim 1, however does not disclose expressly wherein a user can select one of the auxiliary input sources by entering both disc and track numbers at the car stereo. Miyazaki discloses wherein the control unit is connected to a disk changer (fig.3 #44). Official Notice is taken that it is well known in the art that car stereo units have means to enter both disk and track numbers to select an audio track in a CD changer. It would have been obvious to a person of ordinary skill in the art to enter both disk and track numbers on the audio control unit (fig.3 #32) of Miyazaki for the selection of a track of a disk in the changer. The motivation for doing so would have been to select an audio track to play without having to manually access the disk changer.

With respect to claim 20, Miyazaki discloses the apparatus of claim 1, however does not disclose expressly wherein a user can select between the audio device and the one or more auxiliary input sources by entering a sequence at the car stereo. Miyazaki discloses wherein the control unit is connected to a disk changer (fig.3 #44). Official Notice is taken that it is well known in the art that car stereo units have means to enter a sequence, such as disk and track number, to select an audio track in a CD changer. It would have been obvious to a person of ordinary skill in the art to enter a sequence, such as disk and track numbers on the audio control unit (fig.3 #32) of Miyazaki for the selection of a track of a disk in the changer. The motivation for doing so would have been to select an audio track to play without having to manually access

Art Unit: 2615

the disk changer.

With respect to claim 21, Miyazaki discloses the apparatus of claim 20, however does not disclose expressly wherein the sequence comprises a track up selection followed by a track down selection. Official Notice is taken that is well known in the art that track up and down commands are common on most CD players and disk changers. It would have been obvious to a person of ordinary skill in the art to use these commands in the control of the CD changer of Miyazaki. The motivation for doing so would have been to allow a user to pan through the tracks until a desired track is found.

With respect to claim 22, Miyazaki discloses the apparatus of claim 1, further comprising a second interface (fig.1 #38) connected to (fig.1 "Ls,Lb") the first interface (fig.1 #38) for providing a plurality of auxiliary input sources.

With respect to claim 23, Miyazaki discloses the apparatus of claim 22, wherein both the first interface and the second interface are controllable using the car stereo (col.6 ln.28-32).

With respect to claim 24, Miyazaki discloses an audio device integration system comprising: a car stereo (fig.1 #32, col.4 ln.6-7); a plurality of auxiliary input sources (fig.2 #40A, fig.4 #40B); an interface (fig.1 #38) connected between the car stereo and the plurality of auxiliary input sources (col.2 ln.5-16) for channeling audio from at least

Art Unit: 2615

one of the plurality of auxiliary input sources, the interface including; means (fig.2 #32,42) for remotely controlling at least one of the plurality of auxiliary input sources using the car stereo by receiving a control command from the car stereo, processing the control command, and transmitting the command to the after-market audio device for execution thereby (col.4 ln.51-67, col.5 ln.1-31); and means (fig.2, #42) for receiving data from the after-market audio device, processing the data, and transmitting the data to the car stereo (col.4 ln.51-67, col.5 ln.1-31); and means (fig.2 #43) for selecting one of the plurality of auxiliary input sources from the car stereo (col.4 ln.54-57).

Miyazaki does not disclose expressly wherein the means for receiving a control command from the car stereo and the means for receiving data from the after-market device include the capability of processing data from an incompatible form between devices into a compatible format that allows each device to function by executing the compatible formatted command.

McConnell discloses means (fig.1) for receiving incompatible data from vehicle devices, that formats the data into a compatible form that allows communication between the devices (col.4 ln.7-19 "data protocol translation").

At the time of the invention it would have been obvious to a person of ordinary skill in the art to use the means of McConnell to format the data being transmitted between the audio control and peripheral devices along the multiplex signal line of Miyazaki.

The motivation for doing so would have been to allow a user of the invention of Miyazaki to incorporate peripheral devices in the vehicles electrical system that do not

Art Unit: 2615

contain a multiplex control unit as depicted in figure 2 #42. This would allow a user to use peripheral devices that are not pre-configured to be used with the system of Miyazaki.

Miyazaki does not disclose expressly wherein the means for receiving data includes the capability of displaying data on a display of the car stereo, however does disclose the processing of data including "a radio/CD selection instruction, a station selection instruction, a volume control instruction, etc. (col.4 ln.51-66). Miyazaki also teaches a navigation system (fig.4 #28) with a visual display (fig.4 #47) as an auxiliary device.

Kunimatsu teaches a navigation system (fig.1 #14) that is combined with an audio system (fig.1 #18) to provide information to a display (fig.1 #12).

At the time of the invention it would have been obvious to a person of ordinary skill in the art to combine the audio and navigation systems of Miyazaki into one unit that displays information to a visual display as taught by Kunimatsu.

The motivation for doing so would have been to allow a user, who is seated near the car stereo to view the control instructions sent from the auxiliary device, such as volume, selected station, or selected CD. This would also allow the user to make desirable changes to the settings of the auxiliary device by merely controlling the car stereo. Hence, now the system of Miyazaki not only displays navigation information but also information pertaining to the audio system such as the data disclosed in column 4 lines 51-66.

Art Unit: 2615

With respect to claim 25, Miyazaki discloses the apparatus of claim 24, however does not disclose expressly wherein a user can select one of the auxiliary input sources by entering both disc and track numbers at the car stereo. Miyazaki discloses wherein the control unit is connected to a disk changer (fig.3 #44). Official Notice is taken that it is well known in the art that car stereo units have means such as buttons to enter both disk and track numbers to select an audio track in a CD changer. It would have been obvious to a person of ordinary skill in the art to enter both disk and track numbers on the audio control unit (fig.3 #32) of Miyazaki for the selection of a track of a disk in the changer. The motivation for doing so would have been to select an audio track to play without having to manually access the disk changer.

With respect to claim 26, Miyazaki discloses the apparatus of claim 24, wherein at least one of the plurality of auxiliary input sources comprises a CD player, CD changer (fig.2 #44), MP3 player, satellite receiver, or a Digital Audio Broadcast (DAB) receiver.

With respect to claim 28, Miyazaki discloses the apparatus of claim 24, however does not disclose expressly wherein the interface is switchable into an auxiliary input mode by issuing a control sequence at the car stereo. Miyazaki discloses wherein the control unit is connected to a disk changer (fig.3 #44). Official Notice is taken that it is well known in the art that car stereo units have means to enter a sequence, such as disk and track number, to select an audio track in a CD changer. It would have been

Art Unit: 2615

obvious to a person of ordinary skill in the art to enter a sequence to switch the interface into an auxiliary input mode, such as disk and track numbers on the audio control unit (fig.3 #32) of Miyazaki for the selection of a track of a disk in the changer. The motivation for doing so would have been to select an audio track to play without having to manually access the disk changer.

With respect to claim 29, Miyazaki discloses the apparatus of claim 28, wherein the control sequence comprises a track up command followed by a track down command. Official Notice is taken that is well known in the art that track up and down commands are common on most CD players and disk changers. It would have been obvious to a person of ordinary skill in the art to use these commands in the control of the CD changer of Miyazaki. The motivation for doing so would have been to allow a user to pan through the tracks until a desired track is found.

With respect to claim 30, Miyazaki discloses a method for integrating an after-market device (fig.2 #40A) with a car stereo (fig.1 #32, col.4 ln.6-7) comprising: connecting an interface (fig.1 #38) to the car stereo, the after-market device to the interface, and an auxiliary input source (fig.1 #38) to the interface (col.2 ln.5-16); remotely controlling the after-market device using the car stereo by: receiving control commands from the car stereo at the interface; and processing the control commands and dispatching processed control commands to the after-market device; receiving data and audio from the after-market device at the interface; processing the data into a

Art Unit: 2615

second format compatible with the car stereo and dispatching the audio and processed data to the car stereo (col.4 ln.51-67, col.5 ln.1-4), and playing audio from the after-market device through the car stereo (fig.3 #30).

Miyazaki does not disclose expressly wherein the control commands are in a format incompatible with the after-market device, where the commands are processed into a format compatible to both the car stereo and the after-market device.

McConnell discloses means (fig.1) for receiving incompatible data from vehicle devices, that formats the data into a compatible form in order to allow communication between the devices (col.4 ln.7-19 "data protocol translation").

At the time of the invention it would have been obvious to a person of ordinary skill in the art to use the means of McConnell to format the data being transmitted between the audio control and peripheral devices along the multiplex signal line of Miyazaki.

The motivation for doing so would have been to allow a user of the invention of Miyazaki to incorporate peripheral devices in the vehicles electrical system that do not contain a multiplex control unit as depicted in figure 2 #42. This would allow a user to use peripheral devices that are not pre-configured to be used with the system of Miyazaki.

Miyazaki does not disclose expressly wherein the system displays processed data on a display of the car stereo, however does disclose the processing of data including "a radio/CD selection instruction, a station selection instruction, a volume

Art Unit: 2615

control instruction, etc. (col.4 ln.51-66). Miyazaki also teaches a navigation system (fig.4 #28) with a visual display (fig.4 #47) as an auxiliary device.

Kunimatsu teaches a navigation system (fig.1 #14) that is combined with an audio system (fig.1 #18) to provide information to a display (fig.1 #12).

At the time of the invention it would have been obvious to a person of ordinary skill in the art to combine the audio and navigation systems of Miyazaki into one unit that displays information to a visual display as taught by Kunimatsu.

The motivation for doing so would have been to allow a user, who is seated near the car stereo to view the control instructions sent from the auxiliary device, such as volume, selected station, or selected CD. This would also allow the user to make desirable changes to the settings of the auxiliary device by merely controlling the car stereo. Hence, now the system of Miyazaki not only displays navigation information but also information pertaining to the audio system such as the data disclosed in column 4 lines 51-66.

With respect to claim 34, Miyazaki discloses the method of claim 30, wherein the step of receiving data from the device comprises retrieving video information from the device (col.5 ln.24-31).

With respect to claim 35, Miyazaki discloses the method of claim 30, wherein the step of displaying the formatted data comprises displaying the data in an LCD panel

Art Unit: 2615

(fig.4 #47).

With respect to claim 36, Miyazaki discloses the method of claim 30 in view of Kunimatsu, wherein the step of displaying the formatted data comprises displaying the data in a graphical user interface at the car stereo (Kunimatsu: fig.1).

With respect to claim 37, Miyazaki discloses the method of claim 30 in view of Kunimatsu, wherein the step of displaying formatted data comprises displaying video at the car stereo (Kunimatsu: fig.1, fig.3A).

With respect to claim 38, Miyazaki discloses the method of claim 30, wherein the step of connecting the after-market device to the interface comprises connecting a CD player, CD changer (fig.3 #44), MP3 player, satellite receiver, or Digital Audio Broadcast (DAB) receiver to the interface.

With respect to claim 40, Miyazaki discloses the method of claim 30, however does not disclose expressly further comprising receiving a selection command from the car stereo and channeling data and audio from the auxiliary input source to the interface in response to the selection command. Miyazaki discloses wherein the control unit is connected to a disk changer (fig.3 #44). Official Notice is taken that it is well known in the art that car stereo units have means to select an audio tracks and disks in a CD changer. It would have been obvious to a person of ordinary skill in the art to send a

Art Unit: 2615

selection command to the interface when an auxiliary unit such as a disk changer is connected. The motivation for doing so would have been to select an audio track to play without having to manually access the disk changer.

With respect to claim 41, Miyazaki discloses the method of claim 40 in view of Kunimatsu, further comprising processing the data from the auxiliary input source for display on the car stereo (Kunimatsu: col.5 ln.56-62).

With respect to claim 82, Miyazaki discloses the device of claim 81 in view of Kunimatsu, further comprising means for converting the video information into a format compatible with the car stereo (Kunimatsu: fig.1 #44).

Art Unit: 2615

Miyazaki does not disclose expressly wherein the control commands are in a format incompatible with the after-market device, where the commands are processed into a format compatible to both the car stereo and the after-market device.

McConnell discloses means (fig.1) for receiving incompatible data from vehicle devices, that formats the data into a compatible form in order to allow communication between the devices (col.4 ln.7-19 "data protocol translation").

At the time of the invention it would have been obvious to a person of ordinary skill in the art to use the means of McConnell to format the data being transmitted between the audio control and peripheral devices along the multiplex signal line of Miyazaki.

The motivation for doing so would have been to allow a user of the invention of Miyazaki to incorporate peripheral devices in the vehicles electrical system that do not contain a multiplex control unit as depicted in figure 2 #42. This would allow a user to use peripheral devices that are not pre-configured to be used with the system of Miyazaki.

With respect to claims 88-91, Miyazaki discloses the apparatus of claims 1 and 24, however does not disclose expressly wherein the connection between the auxiliary/after-market device and the interface comprises a bus or USB connection.

Official Notice is taken that bus and USB connections were well known in the art to connect devices for the purpose of exchanging data. At the time of the invention it would have been obvious to a person of ordinary skill in the art to use a USB connection

Art Unit: 2615

to attach external devices to the audio system of Miyazaki. The motivation for doing so would have been to allow a user to make use of the plug and play capabilities of a USB connection.

With respect to claim 102, Miyazaki discloses the apparatus of claim 81, wherein the interface further comprises means (fig.2 #42) for receiving a control signal from the car stereo, processing the control signal, and transmitting the control signal to the auxiliary device (col.4 ln.51-67, col.5 ln.1-31).

Miyazaki does not disclose expressly wherein the means for receiving a control signal from the car stereo includes the capability of processing data from an incompatible form between devices into a compatible format that allows each device to function by executing the compatible formatted command.

McConnell discloses means (fig.1) for receiving incompatible data from vehicle devices, that formats the data into a compatible form that allows communication between the devices (col.4 ln.7-19 "data protocol translation").

At the time of the invention it would have been obvious to a person of ordinary skill in the art to use the means of McConnell to format the data being transmitted between the audio control and peripheral devices along the multiplex signal line of Miyazaki.

The motivation for doing so would have been to allow a user of the invention of Miyazaki to incorporate peripheral devices in the vehicles electrical system that do not contain a multiplex control unit as depicted in figure 2 #42. This would allow a user to

Art Unit: 2615

use peripheral devices that are not pre-configured to be used with the system of Miyazaki.

With respect to claim 103, Miyazaki discloses the apparatus of claim 81, wherein the interface further comprises means (fig.2 #42) for receiving a data from the auxiliary device (Kunimatsu's video device, see claim 81), processing the control signal, and transmitting the control signal to the auxiliary device (col.4 ln.51-67, col.5 ln.1-31).

Miyazaki does not disclose expressly wherein the means for receiving a control signal from the car stereo includes the capability of processing data from an incompatible form between devices into a compatible format that allows each device to function by executing the compatible formatted command.

McConnell discloses means (fig.1) for receiving incompatible data from vehicle devices, that formats the data into a compatible form that allows communication between the devices (col.4 ln.7-19 "data protocol translation").

At the time of the invention it would have been obvious to a person of ordinary skill in the art to use the means of McConnell to format the data being transmitted between the audio control and peripheral devices along the multiplex signal line of Miyazaki.

The motivation for doing so would have been to allow a user of the invention of Miyazaki to incorporate peripheral devices in the vehicles electrical system that do not contain a multiplex control unit as depicted in figure 2 #42. This would allow a user to

Art Unit: 2615

use peripheral devices that are not pre-configured to be used with the system of Miyazaki.

Claims 5,7-9,27,31-33 and 52-54 are rejected under 35 U.S.C. 103(a) as being unpatentable over Miyazaki et al (US 6,163,079) in view of Kunimatsu et al (US 6,653,948 B1) in view of McConnell et al (US 6,608,399 B2) and in further view of Falcon (US 6,993,615 B2).

With respect to claim 5, Miyazaki discloses the apparatus of claim 1, however does not disclose expressly wherein the interface further comprises a plug-and-play mode for automatically detecting a device type of the after-market audio device and integrating the after-market audio device based upon the device type.

Falcon discloses an external audio device (fig.4 #102) that interfaces with a car stereo (fig.4 #200) wherein the interfacing of the devices comprises a plug-and-play mode for automatically detecting a device type of the audio device and integrating the audio device based upon the device type (col.4 ln.25-42).

At the time of the invention it would have been obvious to a person of ordinary skill in the art to automatically detect and integrate the external audio devices of Miyazaki with the audio control unit as is accomplished in the interfacing of Falcon.

The motivation for doing so would have been to provide a user-friendly system that does not require resetting control configurations each time a new auxiliary device is connected to or in communication with the audio control.

With respect to claims 7-9, Miyazaki discloses the apparatus of claim 1, however does not disclose expressly wherein the data comprises "track and time information", "song title and artist information", "channel number and channel information".

Falcon discloses an external audio device (fig.4 #102) that interfaces with a car stereo (fig.4 #200) wherein the interfacing information of the devices comprises "track

Art Unit: 2615

and time information" (col.8 ln.20-26), "song title and artist information" (col.8 ln.26-30), "channel number and channel information" (col.6 ln.41-47).

At the time of the invention it would have been obvious to a person of ordinary skill in the art to include the interfacing information disclosed by Falcon in the data exchanged by Miyazaki.

The motivation for doing so would have been to provide the audio control unit with information pertaining to the operation of the auxiliary devices. This would allow the audio control to present this information to a user located in the front of the vehicle, hence allowing a user to view and control the reproduction of information without leaving his or her seat.

With respect to claim 27, Miyazaki discloses the apparatus of claim 24, however does not disclose expressly wherein a device type of the at least one of the plurality of auxiliary input sources is automatically detected by the interface and the at least one of the plurality of auxiliary input sources is automatically integrated with the car stereo based upon the device type.

Falcon discloses an external audio device (fig.4 #102) that interfaces with a car stereo (fig.4 #200) wherein the interfacing of the devices comprises automatically detecting a device type of the audio device and automatically integrating the device with the car stereo based upon the device type (col.4 ln.25-42).

At the time of the invention it would have been obvious to a person of ordinary skill in the art to automatically detect and integrate the external audio devices of Miyazaki with the audio control unit as is accomplished in the interfacing of Falcon.

The motivation for doing so would have been to provide a user-friendly system that does not require resetting control configurations each time a new auxiliary device is connected to or in communication with the audio control.

With respect to claims 31-33, Miyazaki discloses the apparatus of claim 30, however does not disclose expressly wherein the data comprises "track and time information", "MP3 song, title, track, and time information", "channel number, channel name, artist, and song information".

Falcon discloses an external audio device (fig.4 #102) that interfaces with a car stereo (fig.4 #200) wherein the interfacing information of the devices comprises "track and time information" (col.8 ln.20-26), "MP3 song, title, track, and time information" (col.8 ln.20-30), "channel number, channel name, artist, and song information" (col.6 ln.41-47, col.8 ln.18-40).

At the time of the invention it would have been obvious to a person of ordinary skill in the art to include the interfacing information disclosed by Falcon in the data exchanged by Miyazaki.

The motivation for doing so would have been to provide the audio control unit with information pertaining to the operation of the auxiliary devices. This would allow the audio control to present this information to a user located in the front of the vehicle,

Art Unit: 2615

hence allowing a user to view and control the reproduction of information without leaving his or her seat.

With respect to claim 52, Miyazaki discloses the method of claim 51, however does not disclose expressly further comprising displaying formatted data on the car stereo.

Kunimatsu teaches a navigation system (fig.1 #14) that is combined with an audio system (fig.1 #18) to provide information to a display (fig.1 #12).

At the time of the invention it would have been obvious to a person of ordinary skill in the art to combine the audio and navigation systems of Miyazaki into one unit that displays the formatted data to a visual display as taught by Kunimatsu.

The motivation for doing so would have been to allow a user, who is seated near the car stereo to view the control instructions sent from the auxiliary device, such as volume, selected station, or selected CD. This would also allow the user to make desirable changes to the settings of the auxiliary device by merely controlling the car stereo. Hence, now the system of Miyazaki not only displays navigation information but also information pertaining to the audio system such as the data disclosed in column 4 lines 51-66.

With respect to claim 53, Miyazaki discloses the method of claim 52 in view of Kunimatsu, however does not disclose expressly wherein displayed formatted data

Art Unit: 2615

comprises; channel numbers, channel names, titles, tracks, song names, or artist names on the car stereo.

Falcon discloses an external audio device (fig.4 #102) that interfaces with a car stereo (fig.4 #200) wherein the interfacing information of the devices comprises channel numbers, channel names, titles, tracks, song names, or artist names on the car stereo (col.8 ln.20-40).

At the time of the invention it would have been obvious to a person of ordinary skill in the art to include the interfacing information disclosed by Falcon in the data to be displayed the combination of Kunimatsu and Miyazaki.

The motivation for doing so would have been to graphically provide the user with information pertaining the operation of the auxiliary device.

With respect to claim 54, Miyazaki discloses the method of claim 52 in view of Kunimatsu, wherein the step of displaying formatted data comprises displaying video on the car stereo (Kunimatsu: col.5 ln.41-44).

Claims 42,45,83-84 and 100-103 are rejected under 35 U.S.C. 103(a) as being unpatentable over Miyazaki et al (US 6,163,079) in view of McConnell et al (US 6,608,399 B2).

With respect to claim 42, Miyazaki discloses an apparatus for docking a portable device (fig.2 #40A) for integration with a car stereo comprising: a storage area (fig.7

Art Unit: 2615

#50, col.2 ln.29-42) remote from a car stereo for storing the portable device; a docking portion (fig.2 #4C) within the storage area for communicating and physically mating with the portable device; a data port (fig.1 "Ls") in communication with the docking portion (fig.2 #4C), the data port connectable with a device (fig.2 #42) for integrating the portable device with the car stereo; and an interface (fig.2 #38) connected to the data port and to the car stereo, the interface channeling audio from the portable device to the car stereo, the interface including means for remotely controlling the portable device using the car stereo (fig.2 #32) processing control commands generated by the car stereo, and dispatching the commands to the portable device for execution thereby (col.4 ln.51-67, col.5 ln.1-31).

Miyazaki does not disclose expressly wherein the control commands are in a format incompatible with the after-market device, where the commands are processed into a format compatible to both the car stereo and the after-market device.

McConnell discloses means (fig.1) for receiving incompatible data from vehicle devices, that formats the data into a compatible form in order to allow communication between the devices (col.4 ln.7-19 "data protocol translation").

At the time of the invention it would have been obvious to a person of ordinary skill in the art to use the means of McConnell to format the data being transmitted between the audio control and peripheral devices along the multiplex signal line of Miyazaki.

The motivation for doing so would have been to allow a user of the invention of Miyazaki to incorporate peripheral devices in the vehicles electrical system that do not

Art Unit: 2615

contain a multiplex control unit as depicted in figure 2 #42. This would allow a user to use peripheral devices that are not pre-configured to be used with the system of Miyazaki.

With respect to claim 45, Miyazaki discloses the apparatus of claim 42, wherein the storage area further comprises a top portion (fig.14 #17) and a bottom portion (fig.14 #50) defining a sleeve (fig.14 #41) for holding the portable device.

With respect to claim 83, Miyazaki discloses an audio device integration system comprising: a car stereo (fig.1 #32); a portable audio device external to the car stereo (fig.2 #40A); an interface (fig.1 #38) connected between the car stereo and the portable audio device, the interface including; means (fig.2 #42) for generating a device presence signal and transmitting the signal to the car stereo to maintain the car stereo in an operational state (col.4 ln.54-66); means (fig.2 #32) for remotely controlling the portable audio device using the car stereo by receiving a control command from the car stereo, processing the control command, and transmitting the control command (col.4 ln.51-67, col.5 ln.1-31); and means (fig.1 "Ls") for transmitting audio from the portable audio device to the car stereo.

Art Unit: 2615

Miyazaki does not disclose expressly wherein the control commands are in a format incompatible with the after-market device, where the commands are processed into a format compatible to both the car stereo and the after-market device.

McConnell discloses means (fig.1) for receiving incompatible data from vehicle devices, that formats the data into a compatible form in order to allow communication between the devices (col.4 ln.7-19 "data protocol translation").

At the time of the invention it would have been obvious to a person of ordinary skill in the art to use the means of McConnell to format the data being transmitted between the audio control and peripheral devices along the multiplex signal line of Miyazaki.

The motivation for doing so would have been to allow a user of the invention of Miyazaki to incorporate peripheral devices in the vehicles electrical system that do not contain a multiplex control unit as depicted in figure 2 #42. This would allow a user to use peripheral devices that are not pre-configured to be used with the system of Miyazaki.

With respect to claim 84, Miyazaki discloses the apparatus of claim 83, wherein the portable audio device comprises a portable CD player (fig.2 #44).

Art Unit: 2615

With respect to claims 100 and 101, Miyazaki discloses the apparatus of claim 83, however does not disclose expressly wherein the connection between the portable audio device and the interface comprises a bus or USB connection.

Official Notice is taken that bus and USB connections were well known in the art to connect devices for the purpose of exchanging data. At the time of the invention it would have been obvious to a person of ordinary skill in the art to use a USB connection to attach external devices to the audio system of Miyazaki. The motivation for doing so would have been to allow a user to make use of the plug and play capabilities of a USB connection.

Claim 47 is rejected under 35 U.S.C. 103(a) as being unpatentable over Miyazaki et al (US 6,163,079) in view of Falcon (US 6,993,615 B2).

With respect to claim 47, Miyazaki discloses a method of integrating an after-market device (fig.2 #40A) with an Original Equipment Manufacturer (OEM) or after-market car stereo (fig.1 #32) comprising: connecting the after-market device to an interface (fig.1 #38); connecting the interface to a car stereo; generating and transmitting a device presence signal to the car stereo to maintain the car stereo in an operational state responsive to signals generated by the after-market device (col.4 ln.54-57), the device presences signal based upon the car stereo; channeling audio signals from the after-market device to the car stereo using the interface (col.4 ln.51-67, col.5 ln.1-4).

Miyazaki does not disclose expressly wherein the method determines whether the car stereo is an OEM car stereo or an after-market car stereo.

Falcon discloses a method of interfacing an after-market device (fig.4 #102) with a car stereo (fig.4 #200), wherein the method includes determining the type of the car stereo (col.4 ln.25-42).

At the time of the invention it would have been obvious to a person of ordinary skill in the art to use the method of Falcon to determine the type of car stereo used in the invention of Miyazaki, whether it be an OEM car stereo or an after-market car stereo.

The motivation for doing so would have been to supply the auxiliary devices of Miyazaki with information pertaining to the capabilities of the currently installed control

Art Unit: 2615

unit. This would ultimately allow the system to take advantage of any options provided in an after-market device not consistent with OEM devices, or vice versa.

Claims 55-57,85 and 92-93 are rejected under 35 U.S.C. 103(a) as being unpatentable over Miyazaki et al (US 6,163,079) in view of Grady (US 6,591,085 B1) and in further view of McConnell et al (US 6,608,399 B2).

With respect to claim 55, Miyazaki discloses an audio device integration system comprising: a car stereo (fig.1 #32); an auxiliary device (fig.2 #40A) external to the car stereo; an interface (fig.1 #38) connected between the car stereo and the auxiliary device, the interface including; means (fig.2 #42) for generating a device presence signal and transmitting the signal to the car stereo to maintain the car stereo in an operational state (col.4 ln.54-63); means (fig.2 #32,42) for remotely controlling the MP3 player using the car stereo by receiving a control command from the car stereo, processing the control command, and transmitting the control command to the auxiliary device (col.4 ln.51-67, col.5 ln.1-31); and means (fig.1 "Ls") for transmitting audio from the auxiliary device to the car stereo.

Art Unit: 2615

Miyazaki does not disclose expressly wherein the means for receiving a control command from the car stereo and the means for receiving data from the after-market device include the capability of processing data from an incompatible form between devices into a compatible format that allows each device to function by executing the compatible formatted command.

McConnell discloses means (fig.1) for receiving incompatible data from vehicle devices, that formats the data into a compatible form that allows communication between the devices (col.4 ln.7-19 "data protocol translation").

At the time of the invention it would have been obvious to a person of ordinary skill in the art to use the means of McConnell to format the data being transmitted between the audio control and peripheral devices along the multiplex signal line of Miyazaki.

The motivation for doing so would have been to allow a user of the invention of Miyazaki to incorporate peripheral devices in the vehicles electrical system that do not contain a multiplex control unit as depicted in figure 2 #42. This would allow a user to use peripheral devices that are not pre-configured to be used with the system of Miyazaki.

Miyazaki does not disclose expressly wherein the auxiliary device is a portable MP3 player.

Grady discloses an MP3 player (fig.8 #56) external to a car stereo (fig.8 #68) that is in communication with the stereo (col.5 ln.55-64).

Art Unit: 2615

At the time of the invention it would have been obvious to a person of ordinary skill in the art to use an MP3 player such as the one disclosed by Grady as the auxiliary device of Miyazaki.

The motivation for doing so would have been to allow a user of the system of Miyazaki to reproduce sound from an MP3 into the vehicle environment.

With respect to claim 56, Miyazaki discloses the apparatus of claim 55, wherein the car stereo is an Original Equipment Manufacturer (OEM) car stereo (col.1 ln.12-36).

With respect to claim 57, Miyazaki discloses the apparatus of claim 55, however does not disclose expressly wherein the car stereo is an after-market car stereo. Miyazaki discloses a system for connecting auxiliary devices to a vehicles control system, however does not make the distinction that the control system is replaceable by an after-market control, such as an after-market car stereo to replace the factory stereo control components. Official Notice is taken that after-market car stereos are well known in the art, and the invention of Miyazaki is not limited to interacting with only factory stereo components. At the time of the invention it would have been obvious that a user of Miyazaki's invention could replace the factory stereo with an after-market unit and continue to achieve the same results. The motivation for using an after-market unit would have been to upgrade the vehicles sound system. These upgrades could include features such as, bass and stereophonic outputs, or mp3 and satellite capabilities.

Art Unit: 2615

With respect to claim 85, Miyazaki discloses the apparatus of claim 83, however does not disclose expressly wherein the portable audio device is a portable MP3 player.

Grady discloses an MP3 player (fig.8 #56) external to a car stereo (fig.8 #68) that is in communication with the stereo (col.5 ln.55-64).

At the time of the invention it would have been obvious to a person of ordinary skill in the art to use an MP3 player such as the one disclosed by Grady as the auxiliary device of Miyazaki.

The motivation for doing so would have been to allow a user of the system of Miyazaki to reproduce sound from an MP3 into the vehicle environment.

With respect to claims 92 and 93, Miyazaki discloses the apparatus of claim 55, however does not disclose expressly wherein the connection between the auxiliary/after-market device and the interface comprises a bus or USB connection.

Official Notice is taken that bus and USB connections were well known in the art to connect devices for the purpose of exchanging data. At the time of the invention it would have been obvious to a person of ordinary skill in the art to use a USB connection to attach external devices to the audio system of Miyazaki. The motivation for doing so would have been to allow a user to make use of the plug and play capabilities of a USB connection.

Claims 63-65,86 and 94-95 are rejected under 35 U.S.C. 103(a) as being unpatentable over Miyazaki et al (US 6,163,079) in view of Fuchs et al (US 6,346,917 B1) and in further view of McConnell et al (US 6,608,399 B2).

With respect to claim 63, Miyazaki discloses an audio device integration system comprising: a car stereo (fig.1 #32); an auxiliary device external (fig.2 #40A) to the car stereo; an interface (fig.1 #38) connected between the car stereo and the auxiliary device, the interface including: means (fig.2 #42) for generating a device presence signal and transmitting the signal to the car stereo to maintain the car stereo in an operational state (col.4 ln.54-63); means (fig.2 #32,42) for remotely controlling the satellite radio receiver using the car stereo by receiving a control command from the car stereo, processing the control command, and transmitting the control command to the

Art Unit: 2615

auxiliary device (col.4 ln.51-67, col.5 ln.1-31); and means (fig.1 "Ls") for transmitting audio from the auxiliary device to the car stereo.

Miyazaki does not disclose expressly wherein the means for receiving a control command from the car stereo includes the capability of processing data from an incompatible form between devices into a compatible format that allows each device to function by executing the compatible formatted command.

McConnell discloses means (fig.1) for receiving incompatible data from vehicle devices, that formats the data into a compatible form that allows communication between the devices (col.4 ln.7-19 "data protocol translation").

At the time of the invention it would have been obvious to a person of ordinary skill in the art to use the means of McConnell to format the data being transmitted between the audio control and peripheral devices along the multiplex signal line of Miyazaki.

The motivation for doing so would have been to allow a user of the invention of Miyazaki to incorporate peripheral devices in the vehicles electrical system that do not contain a multiplex control unit as depicted in figure 2 #42. This would allow a user to use peripheral devices that are not pre-configured to be used with the system of Miyazaki.

Miyazaki does not disclose expressly wherein the auxiliary device is a satellite radio receiver.

Fuchs discloses a satellite radio receiver (fig.4 #30) external to a car stereo that is in communication with the stereo (col.1 ln.51-62).

Art Unit: 2615

At the time of the invention it would have been obvious to a person of ordinary skill in the art to use a satellite radio receiver such as the one disclosed by Fuchs as the auxiliary device of Miyazaki.

The motivation for doing so would have been to allow a user of the system of Miyazaki to reproduce sound from a satellite broadcast into the vehicle environment.

With respect to claim 64, Miyazaki discloses the apparatus of claim 63, wherein the car stereo is an Original Equipment Manufacturer (OEM) car stereo (col.1 ln.12-36).

With respect to claim 65, Miyazaki discloses the apparatus of claim 63, however does not disclose expressly wherein the car stereo is an after-market car stereo. Miyazaki discloses a system for connecting auxiliary devices to a vehicles control system, however does not make the distinction that the control system is replaceable by an after-market control, such as an after-market car stereo to replace the factory stereo control components. Official Notice is taken that after-market car stereos are well known in the art, and the invention of Miyazaki is not limited to interacting with only factory stereo components. At the time of the invention it would have been obvious that a user of Miyazaki's invention could replace the factory stereo with an after-market unit and continue to achieve the same results. The motivation for using an after-market unit would have been to upgrade the vehicles sound system. These upgrades could include features such as, bass and stereophonic outputs, or mp3 and satellite capabilities.

Art Unit: 2615

With respect to claim 86, Miyazaki discloses the apparatus of claim 83, however does not disclose expressly wherein the portable device is a portable satellite radio receiver.

Fuchs discloses a portable satellite radio receiver (fig.4 #30) external to a car stereo that is in communication with the stereo (col.1 ln.51-62).

At the time of the invention it would have been obvious to a person of ordinary skill in the art to use a satellite radio receiver such as the one disclosed by Fuchs as the auxiliary device of Miyazaki.

The motivation for doing so would have been to allow a user of the system of Miyazaki to reproduce sound from a satellite broadcast into the vehicle environment.

With respect to claims 94 and 95, Miyazaki discloses the apparatus of claim 63, however does not disclose expressly wherein the connection between the auxiliary/after-market device and the interface comprises a bus or USB connection.

Official Notice is taken that bus and USB connections were well known in the art to connect devices for the purpose of exchanging data. At the time of the invention it would have been obvious to a person of ordinary skill in the art to use a USB connection to attach external devices to the audio system of Miyazaki. The motivation for doing so would have been to allow a user to make use of the plug and play capabilities of a USB connection.

Claims 72-74,87 and 96-97 are rejected under 35 U.S.C. 103(a) as being unpatentable over Miyazaki et al (US 6,163,079) in view of Lee et al (US 6,374,177B1) and in further view of McConnell et al (US 6,608,399 B2).

With respect to claim 72, Miyazaki discloses an audio device integration system comprising: a car stereo (fig.1 #32); an auxiliary device external (fig.2 #40A) to the car stereo; an interface (fig.1 #38) connected between the car stereo and the auxiliary device, the interface including: means (fig.2 #42) for generating a device presence signal and transmitting the signal to the car stereo to maintain the car stereo in an operational state (col.4 ln.54-63); means (fig.2 #32) for remotely controlling the digital audio broadcast receiver using the car stereo by receiving a control command from the car stereo, processing the control command and transmitting the command to the

Art Unit: 2615

auxiliary device (col.4 ln.51-67, col.5 ln.1-31); and means (fig.1 "Ls") for transmitting audio from the auxiliary device to the car stereo.

Miyazaki does not disclose expressly wherein the means for receiving a control command from the car stereo includes the capability of processing data from an incompatible form between devices into a compatible format that allows each device to function by executing the compatible formatted command.

McConnell discloses means (fig.1) for receiving incompatible data from vehicle devices, that formats the data into a compatible form that allows communication between the devices (col.4 ln.7-19 "data protocol translation").

At the time of the invention it would have been obvious to a person of ordinary skill in the art to use the means of McConnell to format the data being transmitted between the audio control and peripheral devices along the multiplex signal line of Miyazaki.

The motivation for doing so would have been to allow a user of the invention of Miyazaki to incorporate peripheral devices in the vehicles electrical system that do not contain a multiplex control unit as depicted in figure 2 #42. This would allow a user to use peripheral devices that are not pre-configured to be used with the system of Miyazaki.

Miyazaki does not disclose expressly wherein the auxiliary device is a digital audio broadcast receiver.

Lee discloses a digital audio broadcast receiver (fig.2 #100) external to an audio control (fig.2 #90) that is in communication with the stereo (col.8 ln.25-50).

Art Unit: 2615

At the time of the invention it would have been obvious to a person of ordinary skill in the art to use a satellite radio receiver such as the one disclosed by Lee as the auxiliary device of Miyazaki.

The motivation for doing so would have been to allow a user of the system of Miyazaki to reproduce sound from a digital audio broadcast into the vehicle environment such as a streaming audio file.

With respect to claim 73, Miyazaki discloses the apparatus of claim 72, wherein the car stereo is an Original Equipment Manufacturer (OEM) car stereo (col.1 ln.12-36).

Art Unit: 2615

With respect to claim 74, Miyazaki discloses the apparatus of claim 72, however does not disclose expressly wherein the car stereo is an after-market car stereo. Miyazaki discloses a system for connecting auxiliary devices to a vehicles control system, however does not make the distinction that the control system is replaceable by an after-market control, such as an after-market car stereo to replace the factory stereo control components. Official Notice is taken that after-market car stereos are well known in the art, and the invention of Miyazaki is not limited to interacting with only factory stereo components. At the time of the invention it would have been obvious that a user of Miyazaki's invention could replace the factory stereo with an after-market unit and continue to achieve the same results. The motivation for using an after-market unit would have been to upgrade the vehicles sound system. These upgrades could include features such as, bass and stereophonic outputs, or mp3 and satellite capabilities.

With respect to claim 87, Miyazaki discloses the apparatus of claim 83, however does not disclose expressly wherein the portable audio device comprises a portable digital audio broadcast receiver.

Lee discloses a digital audio broadcast receiver (fig.2 #100) external to an audio control (fig.2 #90) that is in communication with the stereo (col.8 ln.25-50).

At the time of the invention it would have been obvious to a person of ordinary skill in the art to use a satellite radio receiver such as the one disclosed by Lee as the auxiliary device of Miyazaki.

Art Unit: 2615

The motivation for doing so would have been to allow a user of the system of Miyazaki to reproduce sound from a digital audio broadcast into the vehicle environment such as a streaming audio file.

With respect to claims 96 and 97, Miyazaki discloses the apparatus of claim 72, however does not disclose expressly wherein the connection between the auxiliary/after-market device and the interface comprises a bus or USB connection.

Official Notice is taken that bus and USB connections were well known in the art to connect devices for the purpose of exchanging data. At the time of the invention it would have been obvious to a person of ordinary skill in the art to use a USB connection to attach external devices to the audio system of Miyazaki. The motivation for doing so would have been to allow a user to make use of the plug and play capabilities of a USB connection.

Claims 81 and 98-99 are rejected under 35 U.S.C. 103(a) as being unpatentable over Miyazaki et al (US 6,163,079) in view of Kunimatsu et al (US 6,653,948 B1).

With respect to claim 81, Miyazaki discloses a device for information for use with a car stereo, comprising: a car stereo (fig.1 #32); an auxiliary device external to the car stereo (fig.2 #40A); an interface (fig.1 #38) connected between the car stereo and the auxiliary device, the interface including; means (fig.2 #42) for generating a device

Art Unit: 2615

presence signal and transmitting the signal to the car stereo to maintain the car stereo in an operational state (col.4 ln.54-63); and means (fig.1 "Ls") for transmitting information from the auxiliary device to the car stereo.

Art Unit: 2615

Miyazaki does not disclose expressly wherein the auxiliary device is an after-market video device, however does teach a navigation system (fig.4 #28) with a visual display (fig.4 #47) as an auxiliary device.

Kunimatsu teaches a navigation system (fig.1 #14) that is combined with an audio system (fig.1 #18) and a video system (fig.1 #44,50,52) to provide information to a display (fig.1 #12).

At the time of the invention it would have been obvious to a person of ordinary skill in the art to combine the audio, and navigation systems of Miyazaki into one after-market unit that displays information to a visual display as taught by Kunimatsu. It would also have been obvious to a person of ordinary skill in the art to include the video system disclosed by Kunimatsu in the system of Miyazaki.

The motivation for doing so would have been to allow a user, who is seated near the car stereo to view the control instructions sent from the auxiliary device, such as volume, selected station, or selected CD. This would also allow the user to make desirable changes to the settings of the auxiliary device by merely controlling the car stereo. Hence, now the system of Miyazaki not only displays navigation information but also information pertaining to the audio system such as the data disclosed in column 4 lines 51-66. This would also provide a user with the option to view television broadcasts.

Art Unit: 2615

With respect to claims 98 and 99, Miyazaki discloses the apparatus of claim 81, however does not disclose expressly wherein the connection between the video device and the interface comprises a bus or USB connection.

Official Notice is taken that bus and USB connections were well known in the art to connect devices for the purpose of exchanging data. At the time of the invention it would have been obvious to a person of ordinary skill in the art to use a USB connection to attach external devices to the audio system of Miyazaki. The motivation for doing so would have been to allow a user to make use of the plug and play capabilities of a USB connection.

Claims 43 and 46 are rejected under 35 U.S.C. 103(a) as being unpatentable over Miyazaki et al (US 6,163,079) in view of McConnell et al (US 6,608,399 B2) and in further view of Holland (US 2002/0085730 A1).

Art Unit: 2615

With respect to claim 43, Miyazaki discloses the apparatus of claim 42, wherein the storage area further comprises a top member (fig.14 #17), bottom member (fig.14 #50). Miyazaki does not disclose expressly wherein the top member and the bottom member are interconnected at an edge by a hinge.

Holland discloses an apparatus for docking with a portable device further comprising a hinge (pg.1 [0009]) for connecting a top member (fig.2 #5) and a bottom member (fig.2 #3) at an edge.

At the time of the invention it would have been obvious to a person of ordinary skill in the art to use the hinge of Holland to connect the top and bottom portions of Miyazaki.

The motivation for doing so would have been to provide a closable lid to the protective case (Miyazaki: fig.14 #50). This would provide a case that does not have to slide in and out of a vehicle compartment but rather opens on the hinge, hence allowing for after market installation due to a lack in the need for a manufactured vehicle compartment.

With respect to claim 46, Miyazaki discloses the apparatus of claim 43 in view of Holland, further comprising a clasp (Holland: fig.4 #9) for retaining the top and bottom members in a closed position (Holland: pg.2 [0024][0025]).

Claims 44 and 48-51 are rejected under 35 U.S.C. 103(a) as being unpatentable over Miyazaki et al (US 6,163,079) in view of Falcon (US 6,993,615 B2) and in further view of McConnell et al (US 6,608,399 B2).

With respect to claim 44, Miyazaki discloses the apparatus of claim 42, however does not disclose expressly wherein the data port comprises an RS-232 or Universal Serial Bus (USB) port.

Falcon discloses a car stereo (fig.4 #200) with USB ports (fig.4 #216) for the connection of peripheral devices (col.8 ln.6-7).

At the time of the invention it would have been obvious to a person of ordinary skill in the art to use the USB ports of Falcon as the data ports of Miyazaki.

The motivation for doing so would have been to provide the system of Miyazaki with a plug and play option that is consistent with USB connections.

Art Unit: 2615

With respect to claim 48, Miyazaki discloses the method of claim 47, further comprising receiving control commands from the car stereo at the interface (col.4 ln.51-67, col.5 ln.1-4).

Miyazaki does not disclose expressly wherein the control commands are in a format incompatible with the after-market device, where the commands are processed into a format compatible to both the car stereo and the after-market device.

McConnell discloses means (fig.1) for receiving incompatible data from vehicle devices, that formats the data into a compatible form in order to allow communication between the devices (col.4 ln.7-19 "data protocol translation").

At the time of the invention it would have been obvious to a person of ordinary skill in the art to use the means of McConnell to format the data being transmitted between the audio control and peripheral devices along the multiplex signal line of Miyazaki.

The motivation for doing so would have been to allow a user of the invention of Miyazaki to incorporate peripheral devices in the vehicles electrical system that do not contain a multiplex control unit as depicted in figure 2 #42. This would allow a user to use peripheral devices that are not pre-configured to be used with the system of Miyazaki.

With respect to claim 49, Miyazaki discloses the method of claim 48, further comprising converting the control commands into a format recognizable by the after-market audio device. It is implied, that in order for the car stereo and after-market

Art Unit: 2615

devices of Miyazaki to interact with each other properly, the control commands must be converted into formats recognizable by each device.

With respect to claim 50, Miyazaki discloses the method of claim 49, further comprising dispatching formatted commands to the after-market audio device for execution thereby (col.4 ln.63-67 col.5 ln.1-4).

With respect to claim 51, Miyazaki discloses the method of claim 47, however does not disclose expressly converting data received at the interface from the after-market audio device in a format incompatible with the car stereo into a format compatible with the car stereo.

McConnell discloses means (fig.1) for receiving incompatible data from vehicle devices, that formats the data into a compatible form in order to allow communication between the devices (col.4 ln.7-19 "data protocol translation").

At the time of the invention it would have been obvious to a person of ordinary skill in the art to use the means of McConnell to format the data being transmitted between the audio control and peripheral devices along the multiplex signal line of Miyazaki.

The motivation for doing so would have been to allow a user of the invention of Miyazaki to incorporate peripheral devices in the vehicles electrical system that do not contain a multiplex control unit as depicted in figure 2 #42. This would allow a user to

Art Unit: 2615

use peripheral devices that are not pre-configured to be used with the system of Miyazaki.

Claims 59 and 62 are rejected under 35 U.S.C. 103(a) as being unpatentable over Miyazaki et al (US 6,163,079) in view of McConnell et al (US 6,608,399 B2) in view of Grady (US 6,591,085 B1) and in further view of Kunimatsu et al (US 6,653,948 B1).

With respect to claim 59, Miyazaki discloses the system of claim 55 as modified by McConnell and Grady, wherein the interface further includes means for receiving data from the MP3 player in a format incompatible with the car stereo, processing the data into formatted data compatible with the car stereo, and transmitting the formatted data to the car stereo.

Art Unit: 2615

Miyazaki does not disclose expressly wherein the means for receiving data includes the capability of displaying data on a display of the car stereo, however does disclose the processing of data including "a radio/CD selection instruction, a station selection instruction, a volume control instruction, etc. (col.4 ln.51-66). Miyazaki also teaches a navigation system (fig.4 #28) with a visual display (fig.4 #47) as an auxiliary device.

Kunimatsu teaches a navigation system (fig.1 #14) that is combined with an audio system (fig.1 #18) to provide information to a display (fig.1 #12).

At the time of the invention it would have been obvious to a person of ordinary skill in the art to combine the audio and navigation systems of Miyazaki into one unit that displays information to a visual display as taught by Kunimatsu. This would ultimately give the system of Miyazaki the capability of displaying graphically information received from any auxiliary devices, such as an MP3 player.

The motivation for doing so would have been to allow a user, who is seated near the car stereo to view the control instructions sent from the auxiliary device, such as volume, selected station, or selected CD. This would also allow the user to make desirable changes to the settings of the auxiliary device by merely controlling the car stereo. Hence, now the system of Miyazaki not only displays navigation information but also information pertaining to the audio system such as the data disclosed in column 4 lines 51-66.

Art Unit: 2615

With respect to claim 62, Miyazaki discloses the apparatus of claim 59, wherein the commands are input by a user using one or more control buttons or presets on the car stereo. It is implied that the audio control unit of Miyazaki contains control buttons or presets to control the functions disclosed on column 4 lines 57-60. Without control buttons or presets, it would not be possible for a user to control these disclosed functions.

Claims 60-61 rejected under 35 U.S.C. 103(a) as being unpatentable over Miyazaki et al (US 6,163,079) in view of McConnell et al (US 6,608,399 B2) in view of Grady (US 6,591,085 B1) in view of Kunimatsu et al (US 6,653,948 B1) and in further view of Falcon (US 6,993,615 B2).

With respect to claims 60-61, Miyazaki discloses the apparatus of claim 59 in view of Kunimatsu, however does not disclose expressly wherein displayed formatted data comprises; track and time information and song title and artist information.

Art Unit: 2615

Falcon discloses an external audio device (fig.4 #102) that interfaces with a car stereo (fig.4 #200) wherein the interfacing information of the devices comprises track and time information and song title and artist information (col.8 ln.20-40).

At the time of the invention it would have been obvious to a person of ordinary skill in the art to include the interfacing information disclosed by Falcon in the data to be displayed the combination of Kunimatsu and Miyazaki.

The motivation for doing so would have been to graphically provide the user with information pertaining the operation of the MP3 player.

Claims 67 and 71 are rejected under 35 U.S.C. 103(a) as being unpatentable over Miyazaki et al (US 6,163,079) in view of Fuchs et al (US 6,346,917 B1) in view of McConnell et al (US 6,608,399 B2) and in further view of Kunimatsu et al (US 6,653,948 B1).

With respect to claim 67, Miyazaki discloses the system of claim 63 as modified by McConnell and Fuchs, wherein the interface further includes means for receiving data from the satellite radio receiver in a format incompatible with the car stereo, processing the data into formatted data compatible with the car stereo, and transmitting the formatted data to the car stereo.

Miyazaki does not disclose expressly wherein the means for processing data includes the capability of displaying data on a display of the car stereo, however does disclose the processing of data including "a radio/CD selection instruction, a station

Art Unit: 2615

selection instruction, a volume control instruction, etc. (col.4 ln.51-66). Miyazaki also teaches a navigation system (fig.4 #28) with a visual display (fig.4 #47) as an auxiliary device.

Kunimatsu teaches a navigation system (fig.1 #14) that is combined with an audio system (fig.1 #18) to provide information to a display (fig.1 #12).

At the time of the invention it would have been obvious to a person of ordinary skill in the art to combine the audio and navigation systems of Miyazaki into one unit that displays information to a visual display as taught by Kunimatsu. This would ultimately give the system of Miyazaki the capability of displaying graphically information received from any auxiliary devices, such as a satellite radio receiver.

The motivation for doing so would have been to allow a user, who is seated near the car stereo to view the control instructions sent from the auxiliary device, such as volume, selected station, or selected CD. This would also allow the user to make desirable changes to the settings of the auxiliary device by merely controlling the car stereo. Hence, now the system of Miyazaki not only displays navigation information but also information pertaining to the audio system such as the data disclosed in column 4 lines 51-66.

With respect to claim 71, Miyazaki discloses the apparatus of claim 67, wherein the commands are input by a user using one or more control buttons or presets on the car stereo. It is implied that the audio control unit of Miyazaki contains control buttons or presets to control the functions disclosed on column 4 lines 57-60. Without control

Art Unit: 2615

buttons or presets, it would not be possible for a user to control these disclosed functions.

Claims 68-70 are rejected under 35 U.S.C. 103(a) as being unpatentable over Miyazaki et al (US 6,163,079) in view of Fuchs et al (US 6,346,917 B1) in view of McConnell et al (US 6,608,399 B2) in view of Kunimatsu et al (US 6,653,948 B1) and in further view of Falcon (US 6,993,615 B2).

With respect to claims 68-70, Miyazaki discloses the apparatus of claim 67 in view of Kunimatsu, however does not disclose expressly wherein displayed formatted data comprises; track and time information and song title and artist information, channel number and a channel name.

Falcon discloses an external audio device (fig.4 #102) that interfaces with a car stereo (fig.4 #200) wherein the interfacing information of the devices comprises track and time information and song title and artist information, channel number and a channel name (col.8 ln.20-40).

At the time of the invention it would have been obvious to a person of ordinary skill in the art to include the interfacing information disclosed by Falcon in the data to be displayed the combination of Kunimatsu and Miyazaki.

The motivation for doing so would have been to graphically provide the user with information pertaining the operation of the satellite radio receiver.

Art Unit: 2615

Claims 76 and 80 are rejected under 35 U.S.C. 103(a) as being unpatentable over Miyazaki et al (US 6,163,079) in view of Lee et al (US 6,374,177 B1) in view of McConnell et al (US 6,608,399 B2) and in further view of Kunimatsu et al (US 6,653,948 B1).

With respect to claim 76, Miyazaki discloses the system of claim 72 as modified by McConnell and Lee, wherein the interface further includes means for receiving data from the digital audio broadcast receiver in a format incompatible with the car stereo, processing the data into formatted data compatible with the car stereo, and transmitting the formatted data to the car stereo.

Miyazaki does not disclose expressly wherein the means for processing data includes the capability of displaying data on a display of the car stereo, however does disclose the processing of data including "a radio/CD selection instruction, a station selection instruction, a volume control instruction, etc. (col.4 ln.51-66). Miyazaki also teaches a navigation system (fig.4 #28) with a visual display (fig.4 #47) as an auxiliary device.

Kunimatsu teaches a navigation system (fig.1 #14) that is combined with an audio system (fig.1 #18) to provide information to a display (fig.1 #12).

At the time of the invention it would have been obvious to a person of ordinary skill in the art to combine the audio and navigation systems of Miyazaki into one unit that displays information to a visual display as taught by Kunimatsu. This would

Art Unit: 2615

ultimately give the system of Miyazaki the capability of displaying graphically information received from any auxiliary devices, such as a digital audio broadcast receiver.

The motivation for doing so would have been to allow a user, who is seated near the car stereo to view the control instructions sent from the auxiliary device, such as volume, selected station, or selected CD. This would also allow the user to make desirable changes to the settings of the auxiliary device by merely controlling the car stereo. Hence, now the system of Miyazaki not only displays navigation information but also information pertaining to the audio system such as the data disclosed in column 4 lines 51-66.

With respect to claim 80, Miyazaki discloses the apparatus of claim 76, wherein the commands are input by a user using one or more control buttons or presets on the car stereo. It is implied that the audio control unit of Miyazaki contains control buttons or presets to control the functions disclosed on column 4 lines 57-60. Without control buttons or presets, it would not be possible for a user to control these disclosed functions.

Claims 77-79 are rejected under 35 U.S.C. 103(a) as being unpatentable over Miyazaki et al (US 6,163,079) in view of Lee et al (US 6,374,177 B1) in view of Kunimatsu et al (US 6,653,948 B1) in view of McConnell et al (US 6,608,399 B2) and in further view of Falcon (US 6,993,615 B2).

Art Unit: 2615

With respect to claims 77-79, Miyazaki discloses the apparatus of claim 76 in view of Kunimatsu, however does not disclose expressly wherein displayed formatted data comprises; track and time information and song title and artist information, channel number and a channel name.

Falcon discloses an external audio device (fig.4 #102) that interfaces with a car stereo (fig.4 #200) wherein the interfacing information of the devices comprises track and time information and song title and artist information, channel number and a channel name (col.8 ln.20-40).

At the time of the invention it would have been obvious to a person of ordinary skill in the art to include the interfacing information disclosed by Falcon in the data to be displayed the combination of Kunimatsu and Miyazaki.

The motivation for doing so would have been to graphically provide the user with information pertaining the operation of the digital audio broadcast receiver.

Response to Arguments

Applicant's arguments filed June 28, 2007 have been fully considered but they are not persuasive.

With respect to claims 1, 24 and 30 the Applicant argues that McConnell does not disclose remotely controlling an external, after-market device using a car stereo by receiving a control from the car stereo. The Examiner would like to note that McConnell has not been relied upon to anticipate this claimed feature. The above action cites Miyazaki as teaching a bi-directional communication between the car stereo and after-

Art Unit: 2615

market devices through a multiplex signal path (Miyazaki: col.4 ln.51-67, col.5 ln.1-31).

The combination of Miyazaki with McConnell has been relied upon to show that it would have been obvious to use the "data protocol translation" of McConnell (col.4 ln.7-19) in the invention of Miyazaki for the purpose of allowing communication between incompatible devices.

With respect to claims 47, 81 and 104, the Applicant argues that the Miyazaki reference does not teach wherein the system "generates a device presence signal to the car stereo to maintain the car stereo in an operational state responsive to external signals". The Examiner disagrees with this assertion. Miyazaki teaches in column 4 lines 54-67, that when switch unit #43 is operated, a multiplex signal ("device presence signal") containing instruction data is sent to the audio control unit ("car stereo").

Miyazaki continues to teach that this multiplex signal may contain instructions pertaining to an on/off changeover instruction, hence informing the audio control of the present operational state of the detachable unit #40A. It is implied that the audio control unit stays in a responsive state to the multiplex signal, so when an instruction from the multiplex control unit transmits data containing an "on" instruction the audio control unit may respond, or else the audio control unit would never recognize the presence of the detachable unit.

Art Unit: 2615

Conclusion

Any inquiry concerning this communication or earlier communications from the examiner should be directed to Jason R. Kurr whose telephone number is (571) 272-0552. The examiner can normally be reached on M-F 10:00am to 6:30pm.

If attempts to reach the examiner by telephone are unsuccessful, the examiner's supervisor, Vivian Chin can be reached on (571) 273-7848. The fax phone number for the organization where this application or proceeding is assigned is 571-273-8300.

Information regarding the status of an application may be obtained from the Patent Application Information Retrieval (PAIR) system. Status information for published applications may be obtained from either Private PAIR or Public PAIR. Status information for unpublished applications is available through Private PAIR only. For more information about the PAIR system, see <http://pair-direct.uspto.gov>. Should you have questions on access to the Private PAIR system, contact the Electronic Business Center (EBC) at 866-217-9197 (toll-free). If you would like assistance from a USPTO Customer Service Representative or access to the automated information system, call 800-786-9199 (IN USA OR CANADA) or 571-272-1000.

JK

JK

PING LEE
PRIMARY EXAMINER

Under the Paperwork Reduction Act of 1995, no persons are required to respond to a collection of information unless it contains a valid OMB control number.

Substitute for form 1449/PTO INFORMATION DISCLOSURE STATEMENT BY APPLICANT (Use as many sheets as necessary)		<i>Complete if Known</i>	
		Application Number	10/316,961
		Filing Date	12/11/2002
		First Named Inventor	Ira Marlowe
		Art Unit	2615
		Examiner Name	Jason Kurr
Sheet 1	of 3	Attorney Docket Number	99879-00005

NON PATENT LITERATURE DOCUMENTS			
Examiner Initials*	Cite No. ¹	Include name of the author (in CAPITAL LETTERS), title of the article (when appropriate), title of the item (book, magazine, journal, serial, symposium, catalog, etc.), date, page(s), volume-issue number(s), publisher, city and/or country where published.	T ²
/JK/	1	GILROY, AMY, "Blitz Safe Bows New SkyLink," This Week in Consumer Electronics (TWICE), November 24, 2003.	
/JK/	2	GILROY, AMY, "XM Exceeds Forecasts," This Week in Consumer Electronics (TWICE), November 24, 2003.	
/JK/	3	"BlitzSafe News," http://www.blitzsafe.com/blitz_news/news031124/body_news031124.html , November 24, 2003	
/JK/	4	"XM Satellite Radio Introduces XM Direct," http://www.blitzsafe.com/blitz_news/news031117/body_news031117.html , November 17, 2003.	
/JK/	5	"Digital Audio Radio," http://www.blitzsafe.com/blitz_news/news052003a/body_news052003a.html , 2003.	
/JK/	6	"BlitzSafe Winner of 2003 Autosound Grand Prix Accessories Supplier of the Year," Audiovideo Magazine, March 3, 2003.	
/JK/	7	"BlitzSafe Releases World's First XM Satellite Radio, Auxillary and CD Interfaces for Landrover 'Freelander 2003'," http://www.blitzsafe.com/blitz_news/news092002b/body_news09002b.html , September 16, 2002.	
/JK/	8	"BlitzSafe Releases World's First XM Satellite Radio, Auxiliary and CD Interfaces for Lexus," http://www.blitzsafe.com/blitz_news/news092002a/body_news092002a.html , September 14, 2002.	
/JK/	9	Pohlmann, et al. "Satellite Radio A to Z," http://www.blitzsafe.com/blitz_news/news072002a/body_news072002a.html , 2002.	
/JK/	10	"BlitzSafe Launches XM and Six Interfaces for the 'Mini Cooper'," http://www.blitzsafe.com/blitz_news/news062002a/body_news062002a.html , June 25, 2002.	

Examiner Signature	/Jason Kurr/	Date Considered	07/07/2007
--------------------	--------------	-----------------	------------

*EXAMINER: Initial if reference considered, whether or not citation is in conformance with MPEP 809. Draw line through citation if not in conformance and not considered. Include copy of this form with next communication to applicant.

¹ Applicant's unique citation designation number (optional). ² Applicant is to place a check mark here if English language Translation is attached. This collection of information is required by 37 CFR 1.98. The information is required to obtain or retain a benefit by the public which is to file (and by the USPTO to process) an application. Confidentiality is governed by 35 U.S.C. 122 and 37 CFR 1.14. This collection is estimated to take 2 hours to complete, including gathering, preparing, and submitting the completed application form to the USPTO. Time will vary depending upon the individual case. Any comments on the amount of time you require to complete this form and/or suggestions for reducing this burden, should be sent to the Chief Information Officer, U.S. Patent and Trademark Office, P.O. Box 1450, Alexandria, VA 22313-1450. DO NOT SEND FEES OR COMPLETED FORMS TO THIS ADDRESS. SEND TO: Commissioner for Patents, P.O. Box 1450, Alexandria, VA 22313-1450.

If you need assistance in completing the form, call 1-800-PTO-9199 (1-800-786-9199) and select option 2.

Under the Paperwork Reduction Act of 1995, no persons are required to respond to a collection of information unless it contains a valid OMB control number.

Substitute for form 1449/PTO INFORMATION DISCLOSURE STATEMENT BY APPLICANT (Use as many sheets as necessary)		Complete if Known	
		Application Number	10/316,961
		Filing Date	12/11/2002
		First Named Inventor	Ira Marlowe
		Art Unit	2615
		Examiner Name	Jason Kurr
Sheet 2	of 3	Attorney Docket Number	99879-00005

NON PATENT LITERATURE DOCUMENTS			
Examiner Initials*	Cite No. ¹	Include name of the author (in CAPITAL LETTERS), title of the article (when appropriate), title of the item (book, magazine, journal, serial, symposium, catalog, etc.), date, page(s), volume-issue number(s), publisher, city and/or country where published.	T ²
/JK/	11	"Digital Connect," Mobile Electronics, May, 2002.	
/JK/	12	SOLOMON, BRETT, "Selling 12V: OEM Integration," Dealerscope, May, 2002.	
/JK/	13	"XM Xtra:," Mobile Entertainment, April/May, 2002.	
/JK/	14	"Blitzsafe Introduces New Line of XM Digital Connect Cables," The 12 Volt News, February 20, 2002.	
/JK/	15	"XM Radio Losses Mount As Do Subscribers," http://www.blitzsafe.com/blitz_news/news012002d/body_news012002d.html , January 24, 2002.	
/JK/	16	"Blitzsafe Expects 3 Mil. XM Subscribers Within Three Years," http://www.blitzsafe.com/blitz_news/news012002c/body_news012002c.html , January, 2002.	
/JK/	17	"XM Signs Over 30,000 Subscribers in First 8 Weeks," XM Radio, January 7, 2002.	
/JK/	18	'BlitzSafe Unveils the First DVD Interface," Automeia, February, 1999.	
/JK/	19	"MBALP V.2A2 CD Changer Converter Mercedes Benz Model for 1997 and 1996," http://www.blitzsafe.com/blitz_news/pr02111996/body_pr02111996.html , June 11, 1996.	
/JK/	20	"CD Changer Converter - Porsche Model Year 1996," http://www.blitzsafe.com/blitz_news/pr02071996/body_pr02071996.html , February 7, 1996.	

Examiner Signature	/Jason Kurr/	Date Considered	07/07/2007
--------------------	--------------	-----------------	------------

*EXAMINER: Initial if reference considered, whether or not citation is in conformance with MPEP 609. Draw line through citation if not in conformance and not considered. Include copy of this form with next communication to applicant.
¹ Applicant's unique citation designation number (optional). ² Applicant is to place a check mark here if English language Translation is attached.
 This collection of information is required by 37 CFR 1.98. The information is required to obtain or retain a benefit by the public which is to file (and by the USPTO to process) an application. Confidentiality is governed by 35 U.S.C. 122 and 37 CFR 1.14. This collection is estimated to take 2 hours to complete, including gathering, preparing, and submitting the completed application form to the USPTO. Time will vary depending upon the individual case. Any comments on the amount of time you require to complete this form and/or suggestions for reducing this burden, should be sent to the Chief Information Officer, U.S. Patent and Trademark Office, P.O. Box 1450, Alexandria, VA 22313-1450. DO NOT SEND FEES OR COMPLETED FORMS TO THIS ADDRESS. SEND TO: Commissioner for Patents, P.O. Box 1450, Alexandria, VA 22313-1450.

If you need assistance in completing the form, call 1-800-PTO-9199 (1-800-786-9199) and select option 2.

Under the Paperwork Reduction Act of 1995, no persons are required to respond to a collection of information unless it contains a valid OMB control number.

Substitute for form 1449/PTO INFORMATION DISCLOSURE STATEMENT BY APPLICANT (Use as many sheets as necessary)		Complete if Known	
		Application Number	10/316,961
		Filing Date	12/11/2002
		First Named Inventor	Ira Marlowe
		Art Unit	2615
		Examiner Name	Jason Kurr
		Attorney Docket Number	99879-00005
Sheet	3	of	3

NON PATENT LITERATURE DOCUMENTS			
Examiner Initials*	Cite No. ¹	Include name of the author (in CAPITAL LETTERS), title of the article (when appropriate), title of the item (book, magazine, journal, serial, symposium, catalog, etc.), date, page(s), volume-issue number(s), publisher, city and/or country where published.	T ²
/JK/	21	"CD Changer Converter - Mercedes Benz 1996 MY," http://www.blitzsafe.com/blitz_news/pr08231995/body_pr08231995.html , August 23, 1995.	

Examiner Signature	/Jason Kurr/	Date Considered	07/07/2007
--------------------	--------------	-----------------	------------

*EXAMINER: Initial if reference considered, whether or not citation is in conformance with MPEP 609. Draw line through citation if not in conformance and not considered. Include copy of this form with next communication to applicant.
¹ Applicant's unique citation designation number (optional). ² Applicant is to place a check mark here if English language Translation is attached.
 This collection of information is required by 37 CFR 1.98. The information is required to obtain or retain a benefit by the public which is to file (and by the USPTO to process) an application. Confidentiality is governed by 35 U.S.C. 122 and 37 CFR 1.14. This collection is estimated to take 2 hours to complete, including gathering, preparing, and submitting the completed application form to the USPTO. Time will vary depending upon the individual case. Any comments on the amount of time you require to complete this form and/or suggestions for reducing this burden, should be sent to the Chief Information Officer, U.S. Patent and Trademark Office, P.O. Box 1450, Alexandria, VA 22313-1450. **DO NOT SEND FEES OR COMPLETED FORMS TO THIS ADDRESS. SEND TO: Commissioner for Patents, P.O. Box 1450, Alexandria, VA 22313-1450.**

If you need assistance in completing the form, call 1-800-PTO-9199 (1-800-786-9199) and select option 2.

Under the Paperwork Reduction Act of 1995, no persons are required to respond to a collection of information unless it contains a valid OMB control number.

Substitute for form 1449/PTO INFORMATION DISCLOSURE STATEMENT BY APPLICANT <i>(Use as many sheets as necessary)</i>	Complete if Known	
	Application Number	10/732,909
	Filing Date	12/10/2003
	First Named Inventor	Ira Marlowe
	Art Unit	2615
	Examiner Name	Jason Kurr
Attorney Docket Number	99879-00005	
Sheet 1 of 1		

U. S. PATENT DOCUMENTS						
Examiner Initials*	Cite No. ¹	Document Number		Publication Date MM-DD-YYYY	Name of Patentee or Applicant of Cited Document	Pages, Columns, Lines, Where Relevant Passages or Relevant Figures Appear
		Number-Kind Code ² (if known)				
/JK/	22	US-	5,794,164	08/11/1998	Beckert, et al.	
/JK/	23	US-	6,052,603	04/18/2000	Kinazalov, et al.	
/JK/	24	US-	6,058,319	05/02/2000	Sadler	
/JK/	25	US-	2002/0197954	12/26/2002	Schmitt, et al.	
		US-				
		US-				
		US-				
		US-				
		US-				
		US-				
		US-				
		US-				
		US-				
		US-				
		US-				
		US-				
		US-				
		US-				
		US-				
		US-				
		US-				

FOREIGN PATENT DOCUMENTS							
Examiner Initials*	Cite No. ¹	Foreign Patent Document		Publication Date MM-DD-YYYY	Name of Patentee or Applicant of Cited Document	Pages, Columns, Lines, Where Relevant Passages Or Relevant Figures Appear	T ⁶
		Country Code ³ -Number ⁴ -Kind Code ⁵ (if known)					

Examiner Signature	/Jason Kurr/	Date Considered	07/07/2007
--------------------	--------------	-----------------	------------

¹EXAMINER: Initial if reference considered, whether or not citation is in conformance with MPEP 609. Draw line through citation if not in conformance and not considered. Include copy of this form with next communication to applicant. ² Applicant's unique citation designation number (optional). ³ See Kinds Codes of USPTO Patent Documents at www.uspto.gov or MPEP 901.04. ⁴ Enter Office that issued the document, by the two-letter code (WIPO Standard ST.3). ⁵ For Japanese patent documents, the indication of the year of the reign of the Emperor must precede the serial number of the patent document. ⁶ Kind of document by the appropriate symbols as indicated on the document under WIPO Standard ST.16 if possible. ⁷ Applicant is to place a check mark here if English language translation is attached.

This collection of information is required by 37 CFR 1.97 and 1.98. The information is required to obtain or retain a benefit by the public which is to file (and by the USPTO to process) an application. Confidentiality is governed by 35 U.S.C. 122 and 37 CFR 1.14. This collection is estimated to take 2 hours to complete, including gathering, preparing, and submitting the completed application form to the USPTO. Time will vary depending upon the individual case. Any comments on the amount of time you require to complete this form and/or suggestions for reducing this burden, should be sent to the Chief Information Officer, U.S. Patent and Trademark Office, P.O. Box 1450, Alexandria, VA 22313-1450. DO NOT SEND FEES OR COMPLETED FORMS TO THIS ADDRESS. SEND TO: Commissioner for Patents, P.O. Box 1450, Alexandria, VA 22313-1450.

If you need assistance in completing the form, call 1-800-PTO-9199 (1-800-786-9199) and select option 2.

Index of Claims



Application/Control No.

10/316,961

Examiner

Jason R. Kurr

Applicant(s)/Patent under Reexamination

MARLOWE, IRA

Art Unit

2615

√	Rejected
=	Allowed

-	(Through numeral) Cancelled
+	Restricted

N	Non-Elected
I	Interference

A	Appeal
O	Objected

Final	Claim	Date			
	Original	5/29/06	11/7/06	4/12/07	7/7/07
	1	√	√	√	√
	2	√	√	√	√
	3	√	√	√	√
	4	√	√	√	√
	5	√	√	√	√
	6	√	√	√	√
	7	√	√	√	√
	8	√	√	√	√
	9	√	√	√	√
	10	√	√	√	√
	11	√	√	√	√
	12	√	√	√	√
	13	√	√	√	√
	14	-	-	-	-
	15	√	√	√	√
	16	√	√	√	√
	17	√	√	√	√
	18	√	√	√	√
	19	√	√	√	√
	20	√	√	√	√
	21	√	√	√	√
	22	√	√	√	√
	23	√	√	√	√
	24	√	√	√	√
	25	√	√	√	√
	26	√	√	√	√
	27	√	√	√	√
	28	√	√	√	√
	29	√	√	√	√
	30	√	√	√	√
	31	√	√	√	√
	32	√	√	√	√
	33	√	√	√	√
	34	√	√	√	√
	35	√	√	√	√
	36	√	√	√	√
	37	√	√	√	√
	38	√	√	√	√
	39	-	-	-	-
	40	√	√	√	√
	41	√	√	√	√
	42	√	√	√	√
	43	√	√	√	√
	44	√	√	√	√
	45	√	√	√	√
	46	√	√	√	√
	47	√	√	√	√
	48	√	√	√	√
	49	√	√	√	√
	50	√	√	√	√

Final	Claim	Date			
	Original	5/29/06	11/7/06	4/12/07	7/7/07
	51	√	√	√	√
	52	√	√	√	√
	53	√	√	√	√
	54	√	√	√	√
	55	√	√	√	√
	56	√	√	√	√
	57	√	√	√	√
	58	√	√	-	-
	59	√	√	√	√
	60	√	√	√	√
	61	√	√	√	√
	62	√	√	√	√
	63	√	√	√	√
	64	√	√	√	√
	65	√	√	√	√
	66	√	√	√	√
	67	√	√	√	√
	68	√	√	√	√
	69	√	√	√	√
	70	√	√	√	√
	71	√	√	√	√
	72	√	√	√	√
	73	√	√	√	√
	74	√	√	√	√
	75	√	√	-	-
	76	√	√	√	√
	77	√	√	√	√
	78	√	√	√	√
	79	√	√	√	√
	80	√	√	√	√
	81	√	√	√	√
	82	√	√	√	√
	83	√	√	√	√
	84	√	√	√	√
	85	√	√	√	√
	86	√	√	√	√
	87	√	√	√	√
	88	√	√	√	√
	89	√	√	√	√
	90	√	√	√	√
	91	√	√	√	√
	92	√	√	√	√
	93	√	√	√	√
	94	√	√	√	√
	95	√	√	√	√
	96	√	√	√	√
	97	√	√	√	√
	98	√	√	√	√
	99	√	√	√	√
	100	√	√	√	√

Final	Claim	Date	
	Original	4/12/07	7/7/07
	101	√	√
	102	√	√
	103	√	√
	104	√	√
	105		
	106		
	107		
	108		
	109		
	110		
	111		
	112		
	113		
	114		
	115		
	116		
	117		
	118		
	119		
	120		
	121		
	122		
	123		
	124		
	125		
	126		
	127		
	128		
	129		
	130		
	131		
	132		
	133		
	134		
	135		
	136		
	137		
	138		
	139		
	140		
	141		
	142		
	143		
	144		
	145		
	146		
	147		
	148		
	149		
	150		

Search Notes



Application/Control No.	Applicant(s)/Patent under Reexamination	
10/316,961	MARLOWE, IRA	
Examiner	Art Unit	
Jason R. Kurr	2615	

SEARCHED			
Class	Subclass	Date	Examiner
381	86	5/24/2006	JK
307	9.1,10.1	10/4/2006	JK
340	825.25	10/4/2006	JK
307	10.1	3/7/2007	JK
Update	Above	7/7/2007	JK

SEARCH NOTES (INCLUDING SEARCH STRATEGY)		
	DATE	EXMR
Searched, car stereo's and interfacing with auxiliary audio devices	5/24/2006	JK
Searched (digital audio broadcasting) DAB	5/29/2006	JK
Searched: mp3 players, interfacing, DAB digital audio broadcasts, satellite radio	11/7/2006	JK
Searched new IDS (2/16/07) and continuation applications	3/7/2007	JK

INTERFERENCE SEARCHED			
Class	Subclass	Date	Examiner

IN THE UNITED STATES PATENT AND TRADEMARK OFFICE

Applicant: Ira M. Marlowe
Serial No.: 10/316,961
Filed: 12/11/2002
Title: AUDIO DEVICE INTEGRATION SYSTEM

Examiner: Kurr, Jason R.

Art Unit: 2615

Mail Stop Amendment
Commissioner for Patents
P.O. Box 1450
Alexandria, VA 22313-1450

RESPONSE

Sir: _____

This is a response to the outstanding Office Action dated July 12, 2007. The time period for response extends to and includes October 12, 2007.

Amendments to the Claims begin on page 2 of this response.

Remarks begin on page 29 of this response.

AMENDMENTS TO THE CLAIMS

1. (Currently Amended) An audio device integration system comprising:

a first connector electrically connectable to a car stereo;

a second connector electrically connectable to an after-market audio device external to the a car stereo;

a third connector electrically connectable to one or more auxiliary input sources external to a car stereo and an after-market audio device;

an interface connected between the ear stereo and the after market audio device the first and second electrical connectors for channeling audio signals to the a car stereo from the an after-market audio device, the interface including: including a microcontroller in electrical communication with the first and second electrical connectors, the microcontroller programmed to execute:

means for a first code portion for remotely controlling the an after-market audio device using the a car stereo by receiving a control command from the a car stereo through the first connector in a format incompatible with the an after-market audio device, processing the a received control command into a formatted command compatible with the an after-market audio device, and transmitting the a formatted command to the

an after-market audio device through the second connector for execution thereby; by an after-market audio device;

means a second code portion for receiving data from the an after-market audio device through the second connector in a format incompatible with the a car stereo, processing the received data into formatted data compatible with the a car stereo, and transmitting the formatted data to the a car stereo through the first connector for display thereby; and by a car stereo; and

means a third code portion for switching to one or more auxiliary input sources connected to the interface. third electrical connector.

2. (Currently Amended) The apparatus of claim 1, ~~wherein the car stereo is~~ further comprising an Original Equipment Manufacturer (OEM) car stereo. stereo connected to the first electrical connector.

3. (Currently Amended) The apparatus of claim 1, ~~wherein the car stereo is~~ further comprising an after-market car stereo. stereo connected to the first electrical connector.

4. (Currently Amended) The apparatus of claim 1, ~~wherein the after-market audio device comprises~~ further comprising a CD player, CD changer, MP3 player, Digital Audio Broadcast (DAB) receiver, or satellite receiver. receiver connected to the second electrical connector.

5. (Currently Amended) The apparatus of claim 1, wherein the interface further comprises a plug-and-play mode for automatically detecting a device type of ~~the~~ an after-market audio device connected to the second electrical connector and integrating ~~the~~ an after-market audio device based upon the device type.

6. (Currently Amended) The apparatus of claim 1, wherein the interface generates a device presence signal for maintaining ~~the~~ a car stereo in a state responsive to processed data and audio signals.

7. (Currently Amended) The apparatus of claim 1, wherein the ~~data comprises~~ second code portion processes data generated by an after-market audio device including track and time information.

8. (Currently Amended) The apparatus of claim 1, wherein the ~~data comprises~~ second code portion processes data generated by an after-market audio device including song title and artist information.

9. (Currently Amended) The apparatus of claim 1, wherein the ~~data comprises~~ second code portion processes data generated by an after-market audio device including channel number and channel name information.

10. (Currently Amended) The apparatus of claim 1, wherein the ~~data comprises~~ interface processes video information. information generated by an after-market audio device.

11. (Currently Amended) The apparatus of claim 1, wherein ~~the~~ formatted data is displayed as a menu on a display of ~~the~~ a car stereo.
12. (Currently Amended) The apparatus of claim ~~1~~, 11, wherein the display ~~of the car stereo~~ comprises a graphic panel.
13. (Currently Amended) The apparatus of claim 1, wherein ~~the~~ commands are input by a user using one or more control buttons or presets on ~~the~~ a car stereo.
14. (Cancelled)
15. (Currently Amended) The apparatus of claim 1, wherein audio signals from ~~the~~ one or more auxiliary input sources are selectively channeled to the car stereo by the interface.
16. (Currently Amended) The apparatus of claim 1, wherein a user can select between ~~the~~ one or more auxiliary input sources by depressing keys on ~~the~~ a car stereo.
17. (Currently Amended) The apparatus of claim 1, wherein a user can select one of the auxiliary input sources by entering a disc number at ~~the~~ a car stereo.
18. (Currently Amended) The apparatus of claim 1, wherein a user can select one of the auxiliary input sources by entering a track number at ~~the~~ a car stereo.

19. (Currently Amended) The apparatus of claim 1, wherein a user can select one of the auxiliary input sources by entering both disc and track numbers at ~~the~~ a car stereo.

20. (Currently Amended) The apparatus of claim 1, wherein a user can select between ~~the~~ an audio device and ~~the~~ one or more auxiliary input sources by entering a sequence at ~~the~~ a car stereo.

21. (Original) The apparatus of claim 20, wherein the sequence comprises a track up selection followed by a track down selection.

22. (Original) The apparatus of claim 1, further comprising a second interface connected to the first interface for providing a plurality of auxiliary input sources.

23. (Currently Amended) The apparatus of claim 22, wherein both the first interface and the second interface are controllable using ~~the~~ a car stereo.

24. (Currently Amended) An audio device integration system comprising:

a first electrical connector connectable to a car stereo;

a plurality of auxiliary electrical connectors connectable to a plurality of auxiliary input sources;

an interface connected between ~~the car stereo~~ and the first electrical connector and the plurality of auxiliary ~~input sources~~ electrical connectors for channeling audio from at least one of the a plurality of auxiliary input sources; sources to a car stereo, the interface ~~including~~: including a microcontroller in electrical communication with the first electrical connector and the plurality of auxiliary electrical connectors, the microcontroller programmed to execute:

means a first code portion for remotely controlling at least one of the a plurality of auxiliary input sources using the a car stereo by receiving a control command from the a car stereo through the first electrical connector in a format incompatible with the at least one of the a plurality of auxiliary input sources, processing the a received control command into a formatted control command compatible with the at least one of the a plurality of auxiliary input sources, and transmitting the a formatted control command to the at least one of the a plurality of auxiliary input sources through at least one of the plurality of auxiliary electrical connectors for execution ~~thereby~~; by the at least one of a plurality of auxiliary input sources;

~~means~~ a second code portion for receiving data from the at least one of the a plurality of auxiliary input sources through at least one of the plurality of auxiliary electrical connectors in a format incompatible with the a car stereo, processing the received data into formatted data compatible with the a car stereo, and transmitting the formatted data to the a car stereo through the first electrical connector for display ~~thereby~~; and by a car stereo; and

means a third code portion for selecting one of ~~the~~ a plurality of auxiliary input sources from ~~the~~ a car stereo.

25. (Currently Amended) The apparatus of claim 24, wherein the ~~means~~ third code portion for selecting one of ~~the~~ a plurality of auxiliary input sources ~~comprises~~ processes a disc or track selection entered by a user using control buttons of ~~the~~ a car stereo. stereo to select one of a plurality of auxiliary input sources.

26. (Currently Amended) The apparatus of claim 24, wherein ~~the audio device at least one of the plurality of auxiliary input sources comprises~~ further comprising a CD player, CD changer, MP3 player, satellite receiver, or a Digital Audio Broadcast (DAB) ~~receiver.~~ receiver connected to one of the plurality of auxiliary electrical connectors.

27. (Currently Amended) The apparatus of claim 24, wherein a device type of ~~the~~ at least one of ~~the~~ a plurality of auxiliary input sources is automatically detected by the interface and ~~the~~ at least one of ~~the~~ a plurality of auxiliary input sources is automatically integrated with ~~the~~ a car stereo based upon the device type.

28. (Currently Amended) The apparatus of claim 24, wherein the interface is switchable into an auxiliary input mode by issuing a control sequence at ~~the~~ a car stereo.

29. (Original) The apparatus of claim 28, wherein the control sequence comprises a track up command followed by a track down command.

30. (Currently Amended) A method for integrating an after-market device with a car stereo comprising:

providing an interface having a first electrical connector connectable to a car stereo, a second electrical connector connectable to an after-market device external to a car stereo, a third electrical connector connectable to an auxiliary input source, and a microcontroller positioned within the interface;

connecting an interface to the first electrical connector to a car stereo, the second electrical connector to an after-market device to the interface, external to a car stereo, and the third electrical connector to an auxiliary input source to the interface; external to a car stereo and an after-market device;

remotely controlling the after-market device using the car stereo by:

receiving control commands from the car stereo at the interface through the first electrical connector in a format incompatible with the after-market device; and

processing the control commands into formatted control commands compatible with the after-market device using a first code portion executed by the microcontroller and dispatching the formatted control commands to the after-market device; device through the second electrical connection;

receiving data in a format incompatible with the car stereo through the second electrical connector and audio from the after-market device at the interface;

processing the data into formatted data compatible with the car stereo using a second code portion executed by the microcontroller and dispatching the audio and formatted data to the car stereo; stereo through the first electrical connector;

displaying the formatted data on the car stereo and playing the audio through the car stereo; and

playing audio from the after-market device through the car stereo.

31. (Original) The method of claim 30, wherein the step of receiving data from the device comprises retrieving CD track and time information from the device.

32. (Original) The method of claim 30, wherein the step of receiving data from the device comprises retrieving MP3 song, title, track, and time information from the device.

33. (Original) The method of claim 30, wherein the step of receiving data from the device comprises retrieving channel number, channel name, artist, and song information from the device.

34. (Original) The method of claim 30, wherein the step of receiving data from the device comprises retrieving video information from the device.

35. (Previously Presented) The method of claim 30, wherein the step of displaying the formatted data comprises displaying the data in an LCD panel.

36. (Previously Presented) The method of claim 30, wherein the step of displaying the formatted data comprises displaying the data in a graphical user interface at the car stereo.

37. (Previously Presented) The method of claim 30, wherein the step of displaying formatted data comprises displaying video at the car stereo.

38. (Currently Amended) The method of claim 30, wherein the step of connecting the after-market device to the ~~interface~~ second electrical connector comprises connecting a CD player, CD changer, MP3 player, satellite receiver, or a Digital Audio Broadcast (DAB) receiver to the ~~interface~~ second electrical connector.

39. (Cancelled)

40. (Previously Presented) The method of claim 30, further comprising receiving a selection command from the car stereo and channeling data and audio from the auxiliary input source to the interface in response to the selection command.

41. (Original) The method of claim 40, further comprising processing the data from the auxiliary input source for display on the car stereo.

42. (Currently Amended) An apparatus for docking a portable device for integration with a car stereo comprising:

a storage area remote from a car stereo for storing ~~the~~ a portable device;

a docking portion within the storage area for communicating and physically mating with ~~the~~ a portable device;

a data port in communication with the docking portion, the data port connectable with a device for integrating ~~the~~ a portable device with ~~the~~ a car stereo; and

an interface connected to the data port and to ~~the~~ a car stereo, the interface channeling audio from ~~the~~ a portable device to ~~the~~ a car stereo, the interface including a microcontroller in electrical communication with a portable device through the data port and a car stereo, the microcontroller executing means program code for remotely controlling ~~the~~ a portable device using ~~the~~ a car stereo by processing control commands generated by ~~the~~ a car stereo in a format incompatible with ~~the~~ a portable device into formatted control commands compatible with ~~the~~ a portable device, and dispatching ~~the~~ a formatted control commands to ~~the~~ a portable device for execution thereby.

43. (Previously Presented) The apparatus of claim 42, wherein the storage area further comprises a top member, a bottom member, and a hinge interconnecting the top member and the bottom member at an edge thereof.

44. (Previously Presented) The apparatus of claim 42, wherein the data port comprises an RS-232 or Universal Serial Bus (USB) port.

45. (Currently Amended) The apparatus of claim 42, wherein the storage area further comprises a top portion and a bottom portion defining a sleeve for holding ~~the~~ a portable device.

46. (Previously Presented) The apparatus of claim 43, further comprising a clasp for retaining the top and bottom members in a closed position.

47. (Currently Amended) A method of integrating an after-market device with an Original Equipment Manufacturer (OEM) or after-market car stereo comprising:

providing an interface having a first electrical connector, a second electrical connector, and a microcontroller positioned in the interface and in electrical communication with the first and second electrical connectors;

connecting the after-market device to ~~an interface;~~ the first electrical connector;

connecting the second electrical connector ~~interface~~ to a car stereo;

determining whether the car stereo is an OEM car stereo or an after-market car stereo;

generating and transmitting a device presence signal to the car stereo using a first code portion executed by the microcontroller to maintain the car stereo in an operational state responsive to signals generated by the after-market device, the device presence signal based upon the car stereo; and

channeling audio signals from the after-market device to the car stereo using the interface.

48. (Previously Presented) The method of claim 47, further comprising receiving control commands from the car stereo at the interface in a format incompatible with the after-market device.

49. (Currently Amended) The method of claim 48, further comprising converting the control commands into a format recognizable by the after-market audio ~~device~~. device using a second code portion executed by the microcontroller.

50. (Original) The method of claim 49, further comprising dispatching formatted commands to the after-market audio device for execution thereby.

51. (Currently Amended) The method of claim 47, further comprising converting data received at the interface from the after-market audio device in a format incompatible with the car stereo into a format compatible with the car stereo; stereo using a third code portion executed by the microcontroller.

52. (Original) The method of claim 51, further comprising displaying formatted data on the car stereo.

53. (Original) The method of claim 52, wherein the step of displaying formatted data comprises displaying channel numbers, channel names, titles, tracks, song names, or artist names on the car stereo.

54. (Original) The method of claim 52, wherein the step of displaying formatted data comprises displaying video on the car stereo.

55. (Currently Amended) An audio device integration system comprising:

a first electrical connector connectable to a car stereo;

a second electrical connector connectable to a portable MP3 player external to the a car stereo;

an interface connected between the car stereo and the portable MP3 player, the first and second electrical connectors for transmitting audio from a portable MP3 player to a car stereo, the interface including: including a microcontroller in electrical communication with the first and second electrical connectors, the microcontroller executing:

means a first code portion for generating a device presence signal and transmitting the signal to the a car stereo to maintain the a car stereo in an operational state; and

means a second code portion for remotely controlling the an MP3 player using the a car stereo by receiving a control command from the a car stereo through the first electrical connector in a format incompatible with the an MP3 player, processing the a received control command into a formatted control command compatible with the an MP3 player, and transmitting the a formatted control command to the an MP3 player through the second electrical connector for execution thereby; and by an MP3 player.

means for transmitting audio from the portable MP3 player to the car stereo.

56. (Currently Amended) The apparatus of claim 55, ~~wherein the car stereo is~~ further comprising an Original Equipment Manufacturer (OEM) car stereo. stereo connected to the first electrical connector.

57. (Currently Amended) The apparatus of claim 55, ~~wherein the car stereo is~~ further comprising an after-market car stereo. stereo connected to the first electrical connector.

58. (Cancelled)

59. (Currently Amended) The system of claim 55, wherein the ~~interface further includes~~ means microcontroller executes a third code portion for receiving data from ~~the an~~ MP3 player in a format incompatible with ~~the a~~ car stereo, processing ~~the received~~ data into formatted data compatible with ~~the a~~ car stereo, and transmitting ~~the formatted~~ data to ~~the a~~ car stereo for display thereby.

60. (Currently Amended) The apparatus of claim 59, wherein the ~~data comprises~~ third code portion processes data generated by an MP3 player including track and time information.

61. (Currently Amended) The apparatus of claim 59, wherein the ~~data comprises~~ third code portion processes data generated by an MP3 player including song title and artist information.

62. (Currently Amended) The apparatus of claim 59, wherein ~~the~~ commands are input by a user using one or more control buttons or presets on ~~the a~~ car stereo.

63. (Currently Amended) An audio device integration system comprising:

a first electrical connector connectable to a car stereo;

a second electrical connector connectable to a satellite radio receiver external to the a car stereo;

~~an interface connected between the car stereo and the satellite radio receiver;~~ first and second electrical connectors for transmitting audio from a satellite radio receiver to a car stereo,
~~the interface including;~~ including a microcontroller in electrical communication with the first and second electrical connectors, the microcontroller executing:

~~means~~ a first code portion for generating a device presence signal and transmitting the signal to ~~the a~~ a car stereo to maintain ~~the a~~ a car stereo in an operational state; and

~~means~~ a second code portion for remotely controlling ~~the a~~ a satellite radio receiver using ~~the a~~ a car stereo by receiving a control command from ~~the a~~ a car stereo through the first electrical connector in a format incompatible with ~~the a~~ a satellite radio receiver, processing ~~the a~~ a received control command into a formatted control command compatible with ~~the a~~ a satellite radio receiver, and transmitting ~~the a~~ a formatted control command to the satellite radio receiver through the second electrical connector for execution ~~thereby;~~ and by a satellite radio receiver.

~~means for transmitting audio from the satellite radio receiver to the car stereo.~~

64. (Currently Amended) The apparatus of claim 63, ~~wherein the car stereo is further comprising an Original Equipment Manufacturer (OEM) car stereo;~~ stereo connected to the first electrical connector.

65. (Currently Amended) The apparatus of claim 63, ~~wherein the car stereo is further comprising an after-market car stereo;~~ stereo connected to the first electrical connector.

66. (Cancelled)

67. (Currently Amended) The system of claim 63, wherein the ~~interface further includes means~~ microcontroller executes a third code portion for receiving data from ~~the~~ a satellite radio receiver in a format incompatible with ~~the~~ a car stereo, processing ~~the~~ received data into formatted data compatible with ~~the~~ a car stereo, and transmitting ~~the~~ formatted data to ~~the~~ a car stereo for display thereby.

68. (Currently Amended) The apparatus of claim 67, wherein the ~~data comprises~~ third code portion processes data generated by a satellite radio receiver including track and time information.

69. (Currently Amended) The apparatus of claim 67, wherein the ~~data comprises~~ third code portion processes data generated by a satellite radio receiver including song title and artist information.

70. (Currently Amended) The apparatus of claim 67, wherein the ~~data comprises~~ third code portion processes data generated by a satellite radio receiver including a channel number and a channel name.

71. (Currently Amended) The apparatus of claim 67, wherein ~~the~~ commands are input by a user using one or more control buttons or presets on ~~the~~ a car stereo.

72. (Currently Amended) An audio device integration system comprising:

a first electrical connector connectable to a car stereo;

a second electrical connector connectable to a digital audio broadcast receiver external to the a car stereo;

an interface connected between the ear stereo and the digital audio broadcast receiver, first and second electrical connectors for transmitting audio from a digital audio broadcast receiver to a car stereo, the interface including: including a microcontroller in electrical communication with the first and second electrical connectors, the microcontroller executing:

means a first code portion for generating a device presence signal and transmitting the signal to the a car stereo to maintain the a car stereo in an operational state; and

~~means~~ a second code portion for remotely controlling ~~the~~ a digital audio broadcast receiver using ~~the~~ a car stereo by receiving a control command from ~~the~~ a car stereo through the first electrical connector in a format incompatible with ~~the~~ a digital audio broadcast receiver, processing ~~the~~ a received control command into a formatted control command compatible with ~~the~~ a digital audio broadcast receiver, and transmitting ~~the~~ a formatted control command to ~~the~~ a digital audio broadcast receiver through the second electrical connector for execution ~~thereby; and by a digital audio broadcast receiver.~~

~~means for transmitting audio from the digital audio broadcast receiver to the car stereo.~~

73. (Currently Amended) The apparatus of claim 72, ~~wherein the car stereo is further comprising an Original Equipment Manufacturer (OEM) car stereo.~~ stereo connected to the first electrical connector.

74. (Currently Amended) The apparatus of claim 72, ~~wherein the car stereo is further comprising an after-market car stereo.~~ stereo connected to the first electrical connector.

75. (Cancelled)

76. (Currently Amended) The system of claim 72, wherein the ~~interface further includes~~ ~~means~~ the microcontroller executes a third code portion for receiving data from ~~the~~ a digital audio broadcast receiver in a format incompatible with ~~the~~ a car stereo, processing ~~the~~

incompatible data into formatted data compatible with ~~the~~ a car stereo, and transmitting the formatted data to ~~the~~ a car stereo for display thereby.

77. (Currently Amended) The apparatus of claim 76, wherein the ~~data comprises~~ third code portion processes data generated by the digital audio broadcast receiver including track and time information.

78. (Currently Amended) The apparatus of claim 76, wherein the ~~data comprises~~ third code portion processes data generated by the digital audio broadcast receiver including song title and artist information.

79. (Currently Amended) The apparatus of claim 76, wherein the ~~data comprises~~ third code portion processes data generated by the digital audio broadcast receiver including a channel number and a channel name.

80. (Currently Amended) The apparatus of claim 76, wherein ~~the~~ commands are input by a user using one or more control buttons or presets on ~~the~~ a car stereo.

81. (Currently Amended) A device for integrating video information for use with a car stereo, comprising:

a first electrical connector connectable to a car stereo;

a second electrical connector connectable to an after-market video device external to the
a car stereo;

an interface connected between the ear stereo and the after market video device, first and
second electrical connectors for transmitting video information from an after-market video
device to a car stereo, the interface including: including a microcontroller in electrical
communication with the first and second electrical connectors, the microcontroller executing:

means a first code portion for generating a device presence signal and transmitting
the signal to ~~the~~ a car stereo through the first electrical connector to maintain ~~the~~ a car
stereo in an operational state responsive to signals generated by ~~the~~ an after-market video
device; ~~and~~ device.

~~means for transmitting video information from the after market video device to~~
~~the car stereo.~~

82. (Currently Amended) The device of claim 81, further comprising means for converting
the video information into a format compatible with ~~the~~ a car stereo.

83. (Previously Presented) An audio device integration system comprising:

a car stereo;

a portable audio device external to the car stereo;

an interface connected between the car stereo and the portable audio device, the interface including:

means for generating a device presence signal and transmitting the signal to the car stereo to maintain the car stereo in an operational state;

means for remotely controlling the portable audio device using the car stereo by receiving a control command from the car stereo in a format incompatible with the portable audio device, processing the control command into a formatted control command compatible with the portable audio device, and transmitting the formatted control command to the portable audio device for execution thereby; and

means for transmitting audio from the portable audio device to the car stereo.

84. (Previously Presented) The apparatus of claim 83, wherein the portable audio device comprises a portable CD player.

85. (Previously Presented) The apparatus of claim 83, wherein the portable audio device comprises a portable MP3 player.

86. (Previously Presented) The apparatus of claim 83, wherein the portable audio device comprises a portable satellite receiver.

87. (Previously Presented) The apparatus of claim 83, wherein the portable audio device comprises a portable Digital Audio Broadcast (DAB) receiver.

88. (Currently Amended) The apparatus of Claim 1, ~~further comprising~~ wherein the second electrical connector comprises a bus connection established between ~~the~~ an after-market audio device and the interface.

89. (Previously Presented) The apparatus of Claim 88, wherein the bus connection comprises a Universal Serial Bus (USB) connection.

90. (Currently Amended) The apparatus of Claim 24, ~~further comprising~~ wherein at least one of the plurality of auxiliary input connectors comprises a bus connection established between ~~the~~ at least one of ~~the~~ a plurality of auxiliary input sources and the interface.

91. (Previously Presented) The apparatus of Claim 90, wherein the bus connection comprises a Universal Serial Bus (USB) connection.

92. (Currently Amended) The apparatus of Claim 55, ~~further comprising~~ wherein the second electrical connector comprises a bus connection established between ~~the~~ an MP3 player and the interface.

93. (Previously Presented) The apparatus of Claim 92, wherein the bus connection comprises a Universal Serial Bus (USB) connection.

94. (Currently Amended) The apparatus of Claim 63, ~~further comprising~~ wherein the second electrical connector comprises a bus connection established between ~~the~~ a satellite radio receiver and the interface.

95. (Previously Presented) The apparatus of Claim 94, wherein the bus connection comprises a Universal Serial Bus (USB) connection.

96. (Currently Amended) The apparatus of Claim 72, ~~further comprising~~ wherein the second electrical connector comprises a bus connection established between ~~the~~ a digital audio broadcast receiver and the interface.

97. (Previously Presented) The apparatus of Claim 96, wherein the bus connection comprises a Universal Serial Bus (USB) connection.

98. (Currently Amended) The apparatus of Claim 81, ~~further comprising~~ wherein the second electrical connection comprises a bus connection established between ~~the~~ a video device and the interface.

99. (Previously Presented) The apparatus of Claim 98, wherein the bus connection comprises a Universal Serial Bus (USB) connection.

100. (Currently Amended) The apparatus of Claim 83, ~~further comprising~~ wherein the second electrical connector comprises a bus connection established between the a portable audio device and the interface.

101. (Previously Presented) The apparatus of Claim 100, wherein the bus connection comprises a Universal Serial Bus (USB) connection.

102. (Currently Amended) The apparatus of Claim 81, wherein the ~~interface further comprises means~~ microcontroller executes a second code portion for receiving a control signal from ~~the a~~ a car stereo in a format incompatible with ~~the a~~ a video device, processing ~~the a~~ received control signal into a formatted control signal compatible with ~~the a~~ a video device, and transmitting ~~the a~~ a formatted control signal to ~~the a~~ a video device for execution thereby.

103. (Currently Amended) The apparatus of Claim 102, wherein the ~~interface further comprises means~~ microcontroller executes a third code portion for receiving data from ~~the a~~ a video device incompatible with ~~the a~~ a car stereo, processing ~~the received~~ received data into formatted data compatible with ~~the a~~ a car stereo, and transmitting ~~the~~ the formatted data to ~~the a~~ a car stereo for display thereon.

104. (Currently Amended) An audio device integration system, comprising:

a first electrical connector electrically connectable to a car stereo;

a second electrical connector electrically connectable to an after-market, line-level audio source external to the a car stereo; and

an interface connected between the car stereo and the after-market, line level audio source; first and second electrical connectors for transmitting audio from an after-market, line level audio source to a car stereo, the interface ~~including:~~ including a microcontroller in electrical communication with the first and second electrical connectors, the microcontroller executing:

means a first code portion for generating and transmitting a device presence signal to the a car stereo through the first electrical connector to maintain the a car stereo in an operational state responsive to signals generated by the an after-market, line-level audio source; and source.

means for transmitting audio from the after-market, line-level audio source to the car stereo.

REMARKS

Applicant submits this response to the outstanding Office Action on the above-identified application. Applicant has amended the claims, as set forth herein, and respectfully submits that the application, as amended, is in condition for allowance.

As summarized below, Applicant has amended independent Claims 1, 24, 30, 42, 47, 55, 63, 72, 81, and 104 to overcome the rejections raised in the Office Action and to further define the present invention. Applicant has also amended dependent Claims 2-13, 15-20, 23, 25-28, 38, 45, 49, 51, 56-57, 59-62, 64-65, 67-71, 73-74, 76-80, 82, 88, 90, 92, 94, 96, 98, 100, and 102-103 to further define the present invention, to address minor informalities, and to provide consistency with the amended independent claims.

For purposes of brevity, summaries of Applicant's invention and the cited references (i.e., U.S. Patent No. 6,1632,079 to Miyazaki, et al.; U.S. Patent No. 6,653,948 to Kunimatsu, et al.; U.S. Patent No. 6,993,615 to Falcon; U.S. Patent No. 6,608,399 to McConnell, et al.; U.S. Patent No. 6,591,085 to Grady; U.S. Patent No. 6,346,917 to Fuchs, et al.; and U.S. Patent No. 6,374,177 to Lee, et al.) were provided in Applicant's previous responses, and are not repeated herein.

Applicant submits that amended independent Claim 1 is patentable over Miyazaki, et al., Kunimatsu, et al., and McConnell, et al., taken alone or in any combination. None of these references, taken alone or in combination, teach or suggest the features of amended independent Claim 1, which recites an audio device integration system which includes a **first connector**

electrically connectable to a car stereo, a **second connector** electrically connectable to an after-market audio device external to a car stereo, a **third connector** electrically connectable to one or more auxiliary input sources external to a car stereo and an after-market audio device, and an interface connected between the first and second electrical connectors for channeling audio signals to a car stereo from an after-market audio device. This claim was also amended to recite that the interface includes a **microcontroller in electrical communication with the first and second electrical connectors**, and that the microcontroller is **programmed to execute:**

a first code portion for remotely controlling an after-market audio device using a car stereo by receiving a control command from a car stereo through the first connector in a format incompatible with an after-market audio device, processing a received control command into a formatted command compatible with an after-market audio device, and transmitting a formatted command to an after-market audio device through the second connector for execution by an after-market audio device;

a second code portion for receiving data from an after-market audio device through the second connector in a format incompatible with a car stereo, processing received data into formatted data compatible with a car stereo, and transmitting formatted data to a car stereo through the first connector for display by a car stereo; and

a third code portion for switching to one or more auxiliary input sources connected to the third electrical connector.

Importantly, neither Miyazaki, et al., Kunimatsu, et al., nor McConnell, et al., taken alone or in combination, teach or suggest providing an interface having a programmed microcontroller, wherein a code portion is executed by the microcontroller for receiving an incompatible control command issued a car stereo through a first electrical connector connected to the interface, processing the incompatible control command into a formatted control command compatible with an after-market audio device, and transmitting the formatted control command to an after-market audio device through a second electrical connector connected to the interface, as required by Claim 1. The electric equipment units of Miyazaki, et al. only include a multiplex control unit for controlling a remotely-positioned device, such as a disk changer. Miyazaki, et al. is entirely absent any disclosure relating to an interface connectable between a car stereo and an after-market audio device via first and second electrical connectors, much less an interface which includes a microcontroller programmed to execute a code portion for processing incompatible control commands transmitted to the interface from a car stereo through a first electrical connector into formatted commands compatible with an after-market device, and transmitting processed commands to an after-market device through a second electrical connector. Simply put, the system of Miyazaki, et al. has nothing to do with processing incompatible control commands at an interface using a programmed microcontroller. This is because the devices of Miyazaki, et al. are already compatible with each other.

Kunimatsu, et al. fails to cure the remedies of Miyazaki, et al. It, too, is wholly devoid of any disclosure relating to an interface connectable between a car stereo and an after-market audio device via first and second electrical connectors, much less an interface which includes a microcontroller programmed to execute a code portion for processing incompatible control

commands transmitted to the interface from a car stereo through a first electrical connector into formatted commands compatible with an after-market device, and transmitting processed commands to an after-market device through a second electrical connector. Again, the system of Kunimatsu, et al. includes components which are already compatible with each other. There is no need to process incompatible control commands issued at a car stereo.

McConnell, et al. fails to cure the deficiencies of Miyazaki, et al. and Kunimatsu, et al. It does not teach an interface having first and second connectors connectable to a car stereo and an after-market audio device, much less an interface having a microcontroller programmed to execute a code portion for processing incompatible control commands issued at a stereo into a format compatible with an after-market audio device. Miyazaki, et al. only discloses “data protocol translation.” This term is not defined in Miyazaki, et al., and there is no description as to what “protocols” are capable of being translated. It is silent on this point, and is thus deficient as a reference. It is a far stretch to suggest that mere mention of these words in McConnell, et al. constitute disclosure of the concept of processing an incompatible control command from a car stereo for the purpose of controlling an external, after-market device. Certainly, McConnell, et al. does not disclose an interface having a microcontroller programmed in the specific manner recited in amended independent Claim 1. Thus, the resulting combination of Miyazaki, et al., Kunimatsu, et al., and McConnell, et al. fails to disclose each element of amended independent Claim 1. Moreover, one of ordinary skill in the art would not be motivated to combine the teachings of McConnell, et al. with Miyazaki, et al. and Kunimatsu, et al., since, as discussed above, the components disclosed in Miyazaki, et al. and Kunimatsu, et al. are already native to and compatible with each other.

Additionally, none of these references, taken alone or in combination, teach or suggest a programmed microcontroller which executes a second code portion for receiving data from an after-market audio device through the second electrical connector, processing received data into formatted data compatible with a car stereo, and transmitting formatted data to a car stereo through the first electrical connector, as specifically required by amended Claim 1. Further, neither Miyazaki, et al., Kunimatsu, et al., nor McConnell, et al., taken alone or in any combination teach or suggest a microcontroller programmed to execute a third code portion for switching to one or more auxiliary input sources connected to the third electrical connector, as specifically recited in amended Claim 1. As such, Applicant submits that independent Claim 1 and Claims 2-13, 15-20, and 23, which depend from amended independent Claim 1 and contain all of the limitations thereof, are patentable over Miyazaki, et al., Kunimatsu, et al., and McConnell, et al. There is simply no disclosure of any of the devices of Miyazaki, et al., Kunimatsu, et al., or McConnell, et al. having a programmed microcontroller which allows for the processing of data generated by an after-market device into a format compatible with a car stereo, or a programmed microcontroller which allows for switching to one or more auxiliary devices connected to a third connector of an interface.

The majority of the remaining independent claims (i.e., Claims 24, 30, 42, 47, 55, 63, 72, 81, and 104) were amended to include limitations similar to those appearing in amended independent Claim 1.

Specifically, independent Claim 24 was amended to recite an interface having a first connector connectable to a car stereo, a plurality of auxiliary electrical connectors connectable to

a plurality of auxiliary input sources, and a microcontroller programmed to execute code features similar to those recited in Claim 1. Independent Claim 30 was amended to method of integrating an after-market device which includes the step of providing an interface having a first electrical connector connectable to a car stereo, a second electrical connector connectable to an after-market device external to a car stereo, a third electrical connector connectable to an auxiliary input source, and a microcontroller, as well as process steps similar to the code features recited in Claim 1. Independent Claim 42 was amended to recite that the interface includes a microcontroller in communication with a portable device through the data port of the docking station and in communication with a car stereo, which executes a code portion for remotely controlling a portable device docked within the docking station. Independent Claim 47 was amended to recite the step of providing an interface having a first electrical connector, a second electrical connector, and a microcontroller positioned within the interface, as well as the step of generating and transmitting a device presence signal to the car stereo using a first code portion executed by the microcontroller. Independent Claims 55, 63, and 72 were amended to recite an interface having first and second connectors (one of which is connectable to a car stereo, the other of which is connectable to at least one external, after-market device, such as an MP3 player, a satellite radio receiver, or a digital audio broadcast receiver) and a microcontroller programmed to execute code features similar to the features recited in Claim 1. Independent Claims 81 and 104 were amended to recite a first electrical connector connectable to a car stereo, a second electrical connector connectable to an after-market video device (Claim 81) or to a line-level audio source (Claim 104), and an a microcontroller positioned in the interface which executes program code for generating and transmitting a device presence signal to a car stereo to

maintain a car stereo in an operational state responsive to an after-market video device (Claim 81) or a line-level audio source (Claim 104).

For the same reasons as those stated above, the remaining claims (i.e., independent Claims 24, 30, 42, 47, 55, 63, 72, 81, and 104 and their associated dependent claims) are patentable over Miyazaki, et al., Kunimatsu, et al., and McConnell, et al., taken alone or in any combination. These claims are also patentable over the remaining references cited in the Office Action (i.e., Falcon, Grady, Fuchs, et al., and Lee, et al.), taken alone or in any combination with Miyazaki, et al., Kunimatsu, et al., and/or McConnell, et al., as none of these references are concerned with providing an interface having two or more electrical connectors for connection with a car stereo and at least one after-market, external device, nor are they even remotely concerned with an interface which includes a microcontroller programmed to execute the code features recited in the remaining claims. As such, Applicant submits that remaining Claims 24-29, 30-38, 40-57, 59-65, 67-74, and 76-82, and 88-104 are patentable over the cited references, taken alone or in any combination.

Applicant respectfully traverses the rejection of independent Claim 83 as being obvious over Miyazaki, et al. in view of McConnell, et al. Claim 83 recites an audio device integration system which includes a car stereo, a portable audio device external to a car stereo, and an interface connected between the car stereo and the portable audio device, which includes means for generating a device presence signal and transmitting a signal to a car stereo to maintain the car stereo in an operational state, and **means for remotely controlling the portable audio device using the car stereo by receiving a control command from the car stereo in a format**

incompatible with the portable audio device, processing the control command into a formatted control command compatible with the portable audio device, and transmitting the formatted control command to the portable device for execution thereby.... Neither Miyazaki, et al. nor McConnel, et al., taken alone or in combination, teach or suggest such features.

First, one of ordinary skill in the art would not be motivated to combine the system of Miyazaki, et al. with the system of McConnell, et al. As discussed above, the components of Miyazaki, et al. are compatible with each other. The ability to integrate an incompatible, non-native device is not disclosed or even contemplated, because the components of Miyazaki, et al. are native and interoperable with each other. As such, one would not be motivated to combine the “data protocol translation” feature of McConnell, et al. into the system of Miyazaki, et al. since there is absolutely no disclosed need in Miyazaki, et al. to process incompatible signals.

Second, the combination of Miyazaki, et al. with McConnell, et al. still does not teach or suggest each element of Claim 83. Claim 83 specifically recites an interface which processes incompatible control commands from a car stereo into formatted control commands that can be executed by a portable device external to a car stereo. Both Miyazaki, et al. and McConnell, et al. are devoid of such features, taken alone or in combination. As acknowledged in the Office Action, Miyazaki, et al. fails to disclose processing incompatible control commands issued from a car stereo. McConnell, et al. is likewise deficient, in that it does not disclose processing incompatible control commands issued from a car stereo. That McConnell, et al. mentions the words “data protocol translation” is immaterial. The term is not defined in McConnell, et al.,

and the very words themselves only describe translation of data protocols, not control commands issued from a car stereo. Thus, the resulting combination of Miyazaki, et al. with the "data protocol translation" feature of McConnell, et al. fails to teach or suggest each element of independent Claim 83. As such, Applicant submits that independent Claim 83 and Claims 84-87, which depend from Claim 83 and contain all of the limitations thereof, are patentable over the cited references. Applicant also submits that none of the remaining cited references, taken alone or in any combination with Miyazaki, et al. and/or McConnell, et al., teach or suggest the features of amended independent Claim 83 and Claims 84-87 depending therefrom.

All issues raised in the Office Action are believed to have been addressed. Claims 1, 2-13, 15-20, 23-28, 30, 38, 42, 45, 47, 49, 51, 55-57, 59-65, 67-74, 76-82, 88, 90, 92, 94, 96, 98, 100, and 102-104 were amended. No new matter is believed to have been added. Claims 1-13, 15-38, 40-57, 59-65, 67-74, and 76-104 are pending and are in condition for allowance. Reexamination is requested and favorable action solicited.

Date:

9/6/2007

Respectfully submitted,

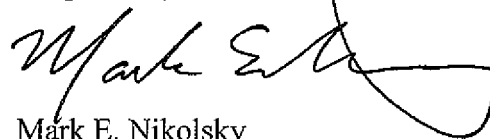

Mark E. Nikolsky
Reg. No. 48,319
McCarter & English, LLP
Four Gateway Center
100 Mulberry Street
Newark, NJ 07102-4056
Tel.: 973-639-6987
Fax.: 973-297-6624

IN THE UNITED STATES PATENT AND TRADEMARK OFFICE

Customer No. 27614

Mail Stop Amendment
Commissioner for Patents
P.O. Box 1450
Alexandria, VA 22313-1450

Re: Our file: 99879-00005 Examiner: Kurr, Jason R.
Applicant: Ira M. Marlowe Art Unit: 2615
Serial No.: 10/316,961
Filing Date: 12/11/2002
Title: Audio Device Integration System

Sir:

Enclosed for filing in the United States Patent and Trademark Office is the following:

1. Response to Office Action
2. Transmittal Sheet

CONDITIONAL PETITION

If any extension of time is required for the submission of the above-identified items, Applicant requests that this be considered a petition therefor. Please charge any additional charges or any other charges relating to this matter, or credit any overpayment, to the Deposit Account of the writer, **Account No. 503571**. A duplicate copy of this letter is enclosed.

9/6/2007
Date

Respectfully submitted,



Mark E. Nikolsky
Registration No. 48,319
McCarter & English, LLP
Four Gateway Center
100 Mulberry Street
Newark, NJ 07102
Tel: (973) 639-6987
Fax: (973) 297-6624

CERTIFICATE OF ELECTRONIC FILING

I hereby certify that this correspondence is being electronically filed with the United States Patent and Trademark Office (via EFS-Web) on 9/6/2007.

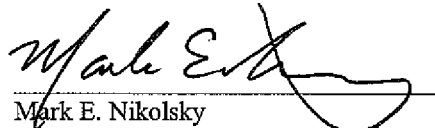

Mark E. Nikolsky

Electronic Acknowledgement Receipt

EFS ID:	2167948
Application Number:	10316961
International Application Number:	
Confirmation Number:	4879
Title of Invention:	Audio device integration system
First Named Inventor/Applicant Name:	Ira Marlowe
Correspondence Address:	MICHAEL R FRISCIA MCCARTER & ENGLISH FOUR GATEWAY CENTER 100 MULBERRY STREET NEWARK NJ 07102 US 9734364499 -
Filer:	Mark E. Nikolsky
Filer Authorized By:	
Attorney Docket Number:	9809/1
Receipt Date:	06-SEP-2007
Filing Date:	11-DEC-2002
Time Stamp:	20:18:25
Application Type:	Utility under 35 USC 111(a)

Payment information:

Submitted with Payment	no
------------------------	----

File Listing:

Document Number	Document Description	File Name	File Size(Bytes) /Message Digest	Multi Part /.zip	Pages (if appl.)
1	Amendment - After Non-Final Rejection	Response.pdf	995334 bb85e553b571d7a029d3f5e7bf79f91718b91e30	no	37

Warnings:

Information:

2	Miscellaneous Incoming Letter	Transmittal_Sheet.pdf	25677 ef904696361b65e0580ac453472ab32bc554eb70	no	1
---	-------------------------------	-----------------------	---	----	---

Warnings:

Information:

Total Files Size (in bytes):			1021011		
-------------------------------------	--	--	---------	--	--

This Acknowledgement Receipt evidences receipt on the noted date by the USPTO of the indicated documents, characterized by the applicant, and including page counts, where applicable. It serves as evidence of receipt similar to a Post Card, as described in MPEP 503.

New Applications Under 35 U.S.C. 111

If a new application is being filed and the application includes the necessary components for a filing date (see 37 CFR 1.53(b)-(d) and MPEP 506), a Filing Receipt (37 CFR 1.54) will be issued in due course and the date shown on this Acknowledgement Receipt will establish the filing date of the application.

National Stage of an International Application under 35 U.S.C. 371

If a timely submission to enter the national stage of an international application is compliant with the conditions of 35 U.S.C. 371 and other applicable requirements a Form PCT/DO/EO/903 indicating acceptance of the application as a national stage submission under 35 U.S.C. 371 will be issued in addition to the Filing Receipt, in due course.

New International Application Filed with the USPTO as a Receiving Office

If a new international application is being filed and the international application includes the necessary components for an international filing date (see PCT Article 11 and MPEP 1810), a Notification of the International Application Number and of the International Filing Date (Form PCT/RO/105) will be issued in due course, subject to prescriptions concerning national security, and the date shown on this Acknowledgement Receipt will establish the international filing date of the application.

PATENT APPLICATION FEE DETERMINATION RECORD
Effective December 8, 2004

Application or Docket Number

10/316900

CLAIMS AS FILED - PART I

	(Column 1)	(Column 2)
TOTAL CLAIMS		
FOR	NUMBER FILED	NUMBER EXTRA
TOTAL CHARGEABLE CLAIMS	minus 20 =	
INDEPENDENT CLAIMS	minus 3 =	
MULTIPLE DEPENDENT CLAIM PRESENT <input type="checkbox"/>		

* If the difference in column 1 is less than zero, enter "0" in column 2

CLAIMS AS AMENDED - PART II

AMENDMENT A	(Column 1)	(Column 2)	(Column 3)
	CLAIMS REMAINING AFTER AMENDMENT	HIGHEST NUMBER PREVIOUSLY PAID FOR	PRESENT EXTRA
	2/16/07		
Total	99	Minus	87 = 12
Independent	99	Minus	10 = 89
FIRST PRESENTATION OF MULTIPLE DEPENDENT CLAIM <input type="checkbox"/>			

AMENDMENT B	(Column 1)	(Column 2)	(Column 3)
	CLAIMS REMAINING AFTER AMENDMENT	HIGHEST NUMBER PREVIOUSLY PAID FOR	PRESENT EXTRA
	9/6/07		
Total	99	Minus	99 = 0
Independent	99	Minus	11 = 88
FIRST PRESENTATION OF MULTIPLE DEPENDENT CLAIM <input type="checkbox"/>			

AMENDMENT C	(Column 1)	(Column 2)	(Column 3)
	CLAIMS REMAINING AFTER AMENDMENT	HIGHEST NUMBER PREVIOUSLY PAID FOR	PRESENT EXTRA
Total		Minus	
Independent		Minus	
FIRST PRESENTATION OF MULTIPLE DEPENDENT CLAIM <input type="checkbox"/>			

* If the entry in column 1 is less than the entry in column 2, write "0" in column 3.
 ** If the "Highest Number Previously Paid For" IN THIS SPACE is less than 20, enter "20".
 *** If the "Highest Number Previously Paid For" IN THIS SPACE is less than 3, enter "3".
 The "Highest Number Previously Paid For" (Total or Independent) is the highest number found in the appropriate box in column 1.

SMALL ENTITY TYPE

OR OTHER THAN SMALL ENTITY

RATE	FEE	OR	RATE	FEE
BASIC FEE	395 ⁰⁰		BASIC FEE	790 ⁰⁰
X\$ 25=			X\$50=	
X100=			X200=	
+180=			+360=	
TOTAL			TOTAL	790.00

SMALL ENTITY TYPE

OR OTHER THAN SMALL ENTITY

RATE	ADDITIONAL FEE	OR	RATE	ADDITIONAL FEE
X\$ 25=	395 ⁰⁰		X\$50=	
X100=	100 ⁰⁰		X200=	
+180=			+360=	
TOTAL ADDIT. FEE			TOTAL ADDIT. FEE	

RATE	ADDITIONAL FEE	OR	RATE	ADDITIONAL FEE
X\$ 25=			X\$50=	
X100=			X200=	
+180=			+360=	
TOTAL ADDIT. FEE			TOTAL ADDIT. FEE	

RATE	ADDITIONAL FEE	OR	RATE	ADDITIONAL FEE
X\$ 25=			X\$50=	
X100=			X200=	
+180=			+360=	
TOTAL ADDIT. FEE			TOTAL ADDIT. FEE	

130

EAST Search History

Ref #	Hits	Search Query	DBs	Default Operator	Plurals	Time Stamp
L1	3	09/445778	US-PGPUB; USPAT	OR	OFF	2008/02/07 14:49
S1	632	381/86.ccls.	US-PGPUB; USPAT	OR	OFF	2008/01/23 16:41
S12 8	2	09/923280	US-PGPUB; USPAT	OR	OFF	2008/01/08 14:43
S12 9	3726	integrat\$3 same (auxiliary peripheral) with (stereo main head master)	US-PGPUB; USPAT	OR	OFF	2008/01/08 14:44
S13 0	9146	integrat\$3 same (auxiliary peripheral) same (stereo main head master)	US-PGPUB; USPAT	OR	OFF	2008/01/08 14:45
S13 1	1723	S130 and (vehicle car automobile)	US-PGPUB; USPAT	OR	ON	2008/01/08 14:45
S13 2	1222	S131 and ((@ad @rlad)<="20021211")	US-PGPUB; USPAT	OR	ON	2008/01/08 15:30
S13 3	330	S132 and audio	US-PGPUB; USPAT	OR	ON	2008/01/08 14:46
S13 4	266	S133 and display	US-PGPUB; USPAT	OR	ON	2008/01/08 15:29
S13 5	476	340/825.24,825.25.ccls.	US-PGPUB; USPAT	OR	ON	2008/01/08 15:30
S13 6	86	S135 and (vehicle car automobile)	US-PGPUB; USPAT	OR	ON	2008/01/08 15:30
S13 7	72	S136 and ((@ad @rlad)<="20021211")	US-PGPUB; USPAT	OR	ON	2008/01/08 15:30
S13 8	627	455/345.ccls.	US-PGPUB; USPAT	OR	OFF	2008/01/23 16:45
S13 9	732	455/345,346.ccls.	US-PGPUB; USPAT	OR	OFF	2008/01/23 16:45
S14 0	489	S139 and ((@ad @rlad)<="20021211")	US-PGPUB; USPAT	OR	OFF	2008/01/23 16:54
S14 1	4	"09698918"	US-PGPUB; USPAT	OR	OFF	2008/01/23 16:56
S14 2	6	("6380978" "6337913" "6300880" "6301367" "6134223" "5793413").pn.	US-PGPUB; USPAT	OR	OFF	2008/01/23 16:59
S14 3	1	"5610822".pn.	US-PGPUB; USPAT	OR	OFF	2008/01/23 17:21
S14 4	13	S139 and ((data format) near (conversion convert))	US-PGPUB; USPAT	OR	OFF	2008/01/23 17:22



UNITED STATES PATENT AND TRADEMARK OFFICE

UNITED STATES DEPARTMENT OF COMMERCE
United States Patent and Trademark Office
Address: COMMISSIONER FOR PATENTS
P.O. Box 1450
Alexandria, Virginia 22313-1450
www.uspto.gov

4

APPLICATION NO.	FILING DATE	FIRST NAMED INVENTOR	ATTORNEY DOCKET NO.	CONFIRMATION NO.
10/316,961	12/11/2002	Ira Marlowe	9809/1	4879

7590 02/20/2008
 MICHAEL R FRISCIA
 MCCARTER & ENGLISH
 FOUR GATEWAY CENTER
 100 MULBERRY STREET
 NEWARK, NJ 07102

EXAMINER

KURR, JASON RICHARD

ART UNIT	PAPER NUMBER
2615	

MAIL DATE	DELIVERY MODE
02/20/2008	PAPER

Please find below and/or attached an Office communication concerning this application or proceeding.

The time period for reply, if any, is set in the attached communication.

Office Action Summary	Application No. 10/316,961	Applicant(s) MARLOWE, IRA	
	Examiner Jason R. Kurr	Art Unit 2615	

-- The MAILING DATE of this communication appears on the cover sheet with the correspondence address --

Period for Reply

A SHORTENED STATUTORY PERIOD FOR REPLY IS SET TO EXPIRE 3 MONTH(S) OR THIRTY (30) DAYS, WHICHEVER IS LONGER, FROM THE MAILING DATE OF THIS COMMUNICATION.

- Extensions of time may be available under the provisions of 37 CFR 1.136(a). In no event, however, may a reply be timely filed after SIX (6) MONTHS from the mailing date of this communication.
- If NO period for reply is specified above, the maximum statutory period will apply and will expire SIX (6) MONTHS from the mailing date of this communication.
- Failure to reply within the set or extended period for reply will, by statute, cause the application to become ABANDONED (35 U.S.C. § 133). Any reply received by the Office later than three months after the mailing date of this communication, even if timely filed, may reduce any earned patent term adjustment. See 37 CFR 1.704(b).

Status

- 1) Responsive to communication(s) filed on 06 September 2007.
- 2a) This action is **FINAL**.
- 2b) This action is non-final.
- 3) Since this application is in condition for allowance except for formal matters, prosecution as to the merits is closed in accordance with the practice under *Ex parte Quayle*, 1935 C.D. 11, 453 O.G. 213.

Disposition of Claims

- 4) Claim(s) 1-13, 15-38, 40-57, 59-65 and 67-104 is/are pending in the application.
 - 4a) Of the above claim(s) _____ is/are withdrawn from consideration.
- 5) Claim(s) _____ is/are allowed.
- 6) Claim(s) 1-13, 15-38, 40-57, 59-65 and 67-104 is/are rejected.
- 7) Claim(s) _____ is/are objected to.
- 8) Claim(s) _____ are subject to restriction and/or election requirement.

Application Papers

- 9) The specification is objected to by the Examiner.
- 10) The drawing(s) filed on _____ is/are: a) accepted or b) objected to by the Examiner.
Applicant may not request that any objection to the drawing(s) be held in abeyance. See 37 CFR 1.85(a).
Replacement drawing sheet(s) including the correction is required if the drawing(s) is objected to. See 37 CFR 1.121(d).
- 11) The oath or declaration is objected to by the Examiner. Note the attached Office Action or form PTO-152.

Priority under 35 U.S.C. § 119

- 12) Acknowledgment is made of a claim for foreign priority under 35 U.S.C. § 119(a)-(d) or (f).
 - a) All b) Some * c) None of:
 - 1. Certified copies of the priority documents have been received.
 - 2. Certified copies of the priority documents have been received in Application No. _____.
 - 3. Copies of the certified copies of the priority documents have been received in this National Stage application from the International Bureau (PCT Rule 17.2(a)).

* See the attached detailed Office action for a list of the certified copies not received.

Attachment(s)

- 1) Notice of References Cited (PTO-892)
- 2) Notice of Draftsperson's Patent Drawing Review (PTO-948)
- 3) Information Disclosure Statement(s) (PTO/SB/08)
Paper No(s)/Mail Date _____
- 4) Interview Summary (PTO-413)
Paper No(s)/Mail Date. _____
- 5) Notice of Informal Patent Application
- 6) Other: _____

DETAILED ACTION

Claim Objections

Claim 100 is objected to because of the following informalities:

Claim 100 discloses "the second electrical connector", there is a lack of antecedent basis for this limitation within the claim.

Appropriate correction is required.

Claim Rejections - 35 USC § 112

The following is a quotation of the second paragraph of 35 U.S.C. 112:

The specification shall conclude with one or more claims particularly pointing out and distinctly claiming the subject matter which the applicant regards as his invention.

Claims 1-3, 6, 11, 13, 16-20, 23-25, 27-28, 30, 42, 55-57, 59, 62-65, 67, 71-74, 76, 80-82, 102-104 are rejected under 35 U.S.C. 112, second paragraph, as being indefinite for failing to particularly point out and distinctly claim the subject matter which applicant regards as the invention.

With respect to claims 1, 6, 11, 13, 16-20, 23-25, 27-28, 30, 42, 55, 59, 62-63, 67, 71-72, 76, 80-82, 102-104 the Applicant has amended the term "the car stereo" to read "a car stereo" throughout the claim language. By doing this, it is unclear to the Examiner as to which car stereo the claim is referring. Are there multiple car stereos? For example, claim 1 discloses "a first connector electrically connectable to a car stereo",..., "an interface connected between the first and second electrical connectors for channeling audio signals to a car stereo". From this disclosure it is impossible to

Art Unit: 2615

determine where the audio signals are being channeled, thus rendering the claim as indefinite.

With respect to claims 2-3, 56-57, 64-65, and 73-74 the claims disclose "the apparatus of claim 1, further comprising an OEM car stereo/ after-market car stereo". The term "further comprising" implies that these types of car stereos are in addition to the car stereo of claim 1. There is no support for a multiple car stereo system in the Applicant's disclosure.

Claim Rejections - 35 USC § 103

The following is a quotation of 35 U.S.C. 103(a) which forms the basis for all obviousness rejections set forth in this Office action:

(a) A patent may not be obtained though the invention is not identically disclosed or described as set forth in section 102 of this title, if the differences between the subject matter sought to be patented and the prior art are such that the subject matter as a whole would have been obvious at the time the invention was made to a person having ordinary skill in the art to which said subject matter pertains. Patentability shall not be negated by the manner in which the invention was made.

Claims 1-6, 10-13, 15-30, 34-35, 37-38, 40-41, 47-52, 54-57, 59, 62, 81-82, 88-93, 98-99 and 102-104 are rejected under 35 U.S.C. 103(a) as being unpatentable over Owens et al (US 2002/0084910 A1) in view of Beckert et al (US 6,175,789 B1).

With respect claim 1, Owens discloses an audio device integration system comprising: a first connector (fig.1 #32) electrically connectable to a car stereo (fig.1 #10); a second connector (fig.8 "L1,R1,V1") electrically connectable to an after-market audio device (fig.1 #44,46,48) external to a car stereo (pg.2 [0032] ln.9-11); a third

Art Unit: 2615

connector (fig.1 #12) electrically connectable to one or more auxiliary input sources (fig.1 #13) external to a car stereo and an after-market audio device (pg.2 [0025] ln.3-6); an interface (fig.1 #30,40) connected between the first and second electrical connectors for channeling audio signals to a car stereo from an after-market audio device (pg.2 [0032]), wherein the interface remotely controls at least one of a plurality of auxiliary sources using a car stereo by receiving a control command from a car stereo through the first connector (pg.2 [0028]), transmitting a control command to at least one of a plurality of auxiliary input sources through at least one of the plurality of auxiliary electrical connectors for execution by at least one of a plurality of auxiliary input sources (pg.1 [0006]); receiving data from one of a plurality of auxiliary input sources through at least one of the plurality of auxiliary electrical connectors, and transmitting the data to a car stereo through the first electrical connector for display by a car stereo (pg.3 [0035]); and selecting one of a plurality of auxiliary input sources from a car stereo (pg.2 [0026]).

Owens does not disclose expressly wherein the interface comprises a microcontroller programmed to execute code portions to process control commands into compatible formats between the car stereo and after-market devices.

Beckert discloses a vehicle computer interface system in cooperation with a vehicles audio system that allows for the operation of incompatible devices wherein the interface includes a microcontroller (fig.2 #64) in electrical communication with the car stereo (fig.2 #60) and after-market devices (fig.2 #74,78,80), the microcontroller programmed to execute: a first code portion for remotely controlling (col.4 ln.22-31) an after-market audio device using a car stereo by receiving a control command from a car

Art Unit: 2615

stereo through the first connector in a format incompatible with an after-market audio device, processing a received control command into a formatted command compatible with an after-market audio device, and transmitting a formatted command to an after-market audio device through the second connector for execution by an after-market audio device (col.1 ln.63-67, col.2 ln.1-30); a second code portion for receiving data from an after-market audio device through the second connector in a format incompatible with a car stereo, processing received data into formatted data compatible with a car stereo (col.3 ln.41-67, col.4 ln.1-7), and transmitting formatted data to a car stereo through the first connector for display by a car stereo (col.4 ln.17-22); and a third code portion for switching to one or more auxiliary input sources connected to the third electrical connector (col.5 ln.28-37,56-62).

At the time of the invention it would have been obvious to include the compatibility processing of Beckert in the interface of Owens. The motivation for doing so would have been to allow the use of after-market devices that do not rely on the same format as the car stereo.

With respect to claim 2, Owens discloses the apparatus of claim 1, however does not disclose expressly further comprising an Original Equipment Manufacturer (OEM) car stereo connected to the first electrical connector. The after-market car stereo (fig.1 #10) of Owens contains the master microprocessor that performs the systems selection functions of auxiliary units (pg.2 [0034]) wherein this microprocessor is not available in an OEM car stereo. Beckert discloses a system wherein the interface processing

Art Unit: 2615

occurs in a unit (fig.2 #64,62) separate from the car stereo (fig.2 #60). At the time of the invention it would have been obvious to a person of ordinary skill in the art that the master microprocessor that controls the interfacing functions of Owens could have been located within an external unit to the car stereo as taught by Beckert, such as the A/V interface module (fig.1 #30). The motivation for doing so would have been to allow a user to integrate auxiliary and after-market devices with the factory (OEM) car stereo.

With respect to claim 3, Owens discloses the apparatus of claim 1, further comprising an after-market car stereo (pg.2 [0025] ln.1-3).

With respect to claim 4, Owens discloses the apparatus of claim 1, further comprising a CD player (fig.1 #10), CD changer (fig.2 #15), MP3 player, Digital Audio Broadcast (DAB) receiver, or satellite receiver.

With respect to claim 5, Owens discloses the apparatus of claim 1, wherein the interface further comprises a plug-and-play mode for automatically detecting a device type of an after-market audio device connected to the second electrical connector and integrating an after-market audio device based upon the device type (pg.2 [0034]).

With respect to claim 6, Owens discloses the apparatus of claim 1, wherein the interface generates a device presence signal for maintaining the car stereo in a state responsive to processed data and audio signals (pg.2 [0034]). It is clear that as the

Art Unit: 2615

master microprocessor polls system the peripheral modules respond with a presence signal containing information pertaining to their status.

With respect to claim 10, Owens discloses the apparatus of claim 1, wherein the interface processes video information generated by an after-market audio device (pg.2 [0032]).

With respect to claim 11, Owens discloses the apparatus of claim 1, however does not disclose expressly wherein formatted data is displayed as a menu on the display of the car stereo. Owens discloses wherein an auxiliary input could be an MP3 player (pg.2 [0025] ln.3-5). Official Notice is taken that it is well known in the art that car stereo head units have the function of displaying menus of files stored in an attached MP3 player. At the time of the invention it would have been obvious to a person of ordinary skill in the art to allow the head unit (fig.1 #10) of Owens to display a menu of the audio files stored in attached auxiliary source such as an MP3 player. The motivation for providing the stored audio files in the form of a menu on the head unit would have been to provide a simple display to a user of the available audio options for sound reproduction.

With respect to claim 12, Owens discloses the apparatus of claim 11, wherein the display comprises a graphic panel (fig.10 #21, pg.3 [0035]).

Art Unit: 2615

With respect to claim 13, Owens discloses the apparatus of claim 1, wherein the commands are input by a user using one or more control buttons or presets on a car stereo (fig.10 #27,28, pg.3 [0038-0039]).

With respect to claim 15, Owens discloses the apparatus of claim 1, wherein audio signals from the one or more auxiliary input sources are selectively channeled to the car stereo by the interface (pg.2 [0032]).

With respect to claim 16, Owens discloses the apparatus of claim 1, wherein a user can select between the one or more auxiliary input sources by depressing keys on a car stereo (pg.3 [0039], "mode button", "A/V source").

With respect to claim 17, Owens discloses the apparatus of claim 1, wherein a user can select one of the auxiliary input sources by entering a disc number at a car stereo (pg.3 col.2 ln.1-4).

With respect to claim 18, Owens discloses the apparatus of claim 1, wherein a user can select one of the auxiliary input sources by entering a track number at a car stereo (pg.3 [0039] ln.7-11).

Art Unit: 2615

With respect to claim 19, Owens discloses the apparatus of claim 1, wherein a user can select one of the auxiliary input sources by entering both disc and track numbers at a car stereo (pg.3 [0039]).

With respect to claim 20, Owens discloses the apparatus of claim 1, wherein a user can select between the audio device and the one or more auxiliary input sources by entering a sequence at a car stereo (pg.3 [0037-0039]).

With respect to claim 21, Owens discloses the apparatus of claim 20, wherein the sequence comprises a track up selection followed by a track down selection (pg.3 [0039] ln.3-5).

With respect to claim 22, Owens discloses the apparatus of claim 1, further comprising a second interface (fig.1 #30) connected to the first interface (fig.1 #40) for providing a plurality of auxiliary input sources.

With respect to claim 23, Owens discloses the apparatus of claim 22, wherein both the first interface and the second interface are controllable using a car stereo (pg.1 [0006]).

With respect to claim 24, Owens discloses an audio device integration system comprising: a first electrical connector (fig.1 #32) connectable to a car stereo (fig.1 #10);

Art Unit: 2615

a plurality of auxiliary electrical connectors (fig.8 "L1-L3,R1-R3,V1-V3") connectable to a plurality of auxiliary input sources (fig.1 #44,46,48); an interface (fig.1 #30,40) connected between the first electrical connector and the plurality of auxiliary electrical connectors for channeling audio from at least one of a plurality of auxiliary input sources to a car stereo (pg.2 [0032]), wherein the interface remotely controls at least one of a plurality of auxiliary sources using a car stereo by receiving a control command from a car stereo through the first connector (pg.2 [0028]), transmitting a control command to at least one of a plurality of auxiliary input sources through at least one of the plurality of auxiliary electrical connectors for execution by at least one of a plurality of auxiliary input sources (pg.1 [0006]); receiving data from one of a plurality of auxiliary input sources through at least one of the plurality of auxiliary electrical connectors, and transmitting the data to a car stereo through the first electrical connector for display by a car stereo (pg.3 [0035]); and selecting one of a plurality of auxiliary input sources from a car stereo (pg.2 [0026]).

Owens does not disclose expressly wherein the interface comprises a microcontroller programmed to execute code portions to process control commands into compatible formats between the car stereo and after-market devices.

Beckert discloses a vehicle computer interface system in cooperation with a vehicles audio system that allows for the operation of incompatible devices wherein the interface includes a microcontroller (fig.2 #64) in electrical communication with the car stereo (fig.2 #60) and after-market devices (fig.2 #74,78,80), the microcontroller programmed to execute: a first code portion for remotely controlling (col.4 ln.22-31) an

Art Unit: 2615

after-market audio device using a car stereo by receiving a control command from a car stereo through the first connector in a format incompatible with an after-market audio device, processing a received control command into a formatted command compatible with an after-market audio device, and transmitting a formatted command to an after-market audio device through the second connector for execution by an after-market audio device (col.1 ln.63-67, col.2 ln.1-30); a second code portion for receiving data from an after-market audio device through the second connector in a format incompatible with a car stereo, processing received data into formatted data compatible with a car stereo (col.3 ln.41-67, col.4 ln.1-7), and transmitting formatted data to a car stereo through the first connector for display by a car stereo (col.4 ln.17-22); and a third code portion for switching to one or more auxiliary input sources connected to the third electrical connector (col.5 ln.28-37,56-62).

At the time of the invention it would have been obvious to include the compatibility processing of Beckert in the interface of Owens. The motivation for doing so would have been to allow the use of after-market devices that do not rely on the same format as the car stereo.

With respect to claim 25, Owens discloses the apparatus of claim 24, wherein the third code portion for selecting one of a plurality of auxiliary input sources processes a disc or track selection entered by a user control buttons of a car stereo to select one of a plurality of auxiliary input sources (pg.3 [0039]).

Art Unit: 2615

With respect to claim 26, Owens discloses the apparatus of claim 24, further comprising a CD player, CD changer (fig.1 #15), MP3 player, satellite receiver, or a Digital Audio Broadcast (DAB) receiver connected to one of the plurality of auxiliary electrical connectors.

With respect to claim 27, Owens discloses the apparatus of claim 24, wherein a device type of at least one of a plurality of auxiliary input sources is automatically detected by the interface and at least one of a plurality of auxiliary input sources is automatically integrated with a car stereo based upon the device type (pg.2 [0034]).

With respect to claim 28, Owens discloses the apparatus of claim 24, wherein the interface is switchable into an auxiliary input mode by issuing a control sequence at a car stereo (pg.3 [0039] ln.1-3).

With respect to claim 29, Owens discloses the apparatus of claim 28, wherein the control sequence comprises a track up command followed by a track down command (pg.3 [0039] ln.3-5).

With respect to claim 30, Owens discloses a method for integrating an after-market device with a car stereo comprising: providing an interface (fig.1 #30,40) having a first electrical connector (fig.1 #32) connectable to a car stereo (fig.1 #10), a second electrical connector (fig.1 "V1,L1,R1") connectable to an after-market device (fig.1

Art Unit: 2615

#44,46,48) external to a car stereo (pg.2 [0032] ln.9-11), a third electrical connector (fig.1 "V2,L2,R2") connectable to an auxiliary input source (fig.1 #44,46,48); connecting the first electrical connector to a car stereo (fig.1 #18,32), the second electrical connector to an after-market device external to a car stereo (fig.8, fig.1), and the third electrical connector to an auxiliary input source external to a car stereo and after-market device (fig.1,fig.8); remotely controlling the after-market device using the car stereo by: receiving control commands from the car stereo at the interface through the first electrical connector; and processing the control commands and dispatching processed control commands to the after-market device through the second electrical connection (pg.1 [0006]); receiving data through the second electrical connector and audio from the after-market device at the interface; processing the data and dispatching the audio and processed data to the car stereo through the first electrical connector (pg.2 [0032]); displaying the data on the car stereo and playing the audio through the car stereo (pg.3 [0035]), and playing audio from the after-market device through the car stereo (pg.2 [0032] ln.13-17).

Owens does not disclose expressly wherein the interface comprises a microcontroller programmed to execute code portions to process control commands into compatible formats between the car stereo and after-market devices.

Beckert discloses a vehicle computer interface system in cooperation with a vehicles audio system that allows for the operation of incompatible devices wherein the interface includes a microcontroller (fig.2 #64) in electrical communication with the car stereo (fig.2 #60) and after-market devices (fig.2 #74,78,80), the microcontroller

Art Unit: 2615

programmed to execute: a first code portion for remotely controlling (col.4 ln.22-31) an after-market audio device using a car stereo by receiving a control command from a car stereo through the first connector in a format incompatible with an after-market audio device, processing a received control command into a formatted command compatible with an after-market audio device, and transmitting a formatted command to an after-market audio device through the second connector for execution by an after-market audio device (col.1 ln.63-67, col.2 ln.1-30); a second code portion for receiving data from an after-market audio device through the second connector in a format incompatible with a car stereo, processing received data into formatted data compatible with a car stereo (col.3 ln.41-67, col.4 ln.1-7), and transmitting formatted data to a car stereo through the first connector for display by a car stereo (col.4 ln.17-22); and a third code portion for switching to one or more auxiliary input sources connected to the third electrical connector (col.5 ln.28-37,56-62).

At the time of the invention it would have been obvious to include the compatibility processing of Beckert in the interface of Owens. The motivation for doing so would have been to allow the use of after-market devices that do not rely on the same format as the car stereo.

With respect to claim 34, Owens discloses the method of claim 30, wherein the step of receiving data from the device comprises retrieving video information from the device (pg.2 [0032]).

With respect to claim 35, Owens discloses the method of claim 30, wherein the step of displaying the formatted data comprises displaying the data in an LCD panel (fig.10 #21, pg. 3 [0035]).

With respect to claim 37, Owens discloses the method of claim 30, wherein the step of displaying formatted data comprises displaying video at the car stereo (pg.2 [0032]).

With respect to claim 38, Owens discloses the method of claim 30, wherein the step of connecting the after-market device to the second electrical connector comprises connecting a CD player, CD changer (fig.1 #15), MP3 player, satellite receiver, or Digital Audio Broadcast (DAB) receiver to the second electrical connector. It is clear that any audio device that outputs right or left channel outputs may be connected to the inputs (fig.8 "R1-R3,L1-L3") of the A/V source selector.

With respect to claim 40, Owens discloses the method of claim 30, further comprising receiving a selection command from the car stereo and channeling data and audio from the auxiliary input source to the interface in response to the selection command (pg.3 [0039] ln.1-3).

Art Unit: 2615

With respect to claim 41, Owens discloses the method of claim 40, further comprising processing the data from the auxiliary input source for display on the car stereo (pg.2-3 [0034-0035]).

With respect to claim 47, Owens discloses a method of integrating an after-market device with an Original Equipment Manufacturer (OEM) or after-market car stereo comprising: providing an interface having a first electrical connector, a second electrical connector, and a bus positioned in the interface and in electrical communication with the first and second electrical connectors; connecting the after-market device to the first electrical connector; connecting the second electrical connector to a car stereo; generating and transmitting a device presence signal to the car stereo to maintain the car stereo in an operational state responsive to signals generated by the after-market device, the device presences signal based upon the car stereo; and channeling audio signals from the after-market device to the car stereo using the interface.

Owens does not disclose expressly wherein a microcontroller is positioned with the interface, however does teach that a microcontroller (fig.9 "master processor") is positioned within the car stereo (fig.1 #10). This microprocessor controls the communication between the after-market devices and the car stereo through interface units (fig.1 #30,40).

Beckert discloses a vehicle computer interface system in cooperation with a vehicles audio system that allows for the operation of incompatible devices wherein an

Art Unit: 2615

interface includes a microcontroller (fig.2 #64) in electrical communication with the car stereo (fig.2 #60) and after-market devices (fig.2 #74,78,80). At the time of the invention it would have been obvious to a person of ordinary skill in the art that the micro-processing of Owens (i.e. polling the system to see the status of peripheral devices [0034]) may occur within the interface device as performed by Beckert. The motivation for doing so would have been to allow a user to keep the OEM car stereo unit while continuing to be able to add accessories to the car audio system.

Owens does not disclose expressly wherein the method determines whether the car stereo is an OEM car stereo or an after-market car stereo, however in light of the teachings of Beckert, Owens may poll the audio system from microcontroller within the interface to determine the status of the car stereo for the purpose of integrating with peripheral devices.

With respect to claim 48, Owens discloses the method of claim 47 in view of Beckert, further comprising receiving control commands from the car stereo at the interface in a format incompatible with the after-market device (Beckert: col.1 ln.63-67, col.2 ln.1-6).

With respect to claim 49, Owens discloses the method of claim 48, further comprising converting the control commands into a format recognizable by the after-market audio device using a second code portion executed by the microcontroller (Beckert: col.3 ln.42-67, col.4 ln.1-7).

With respect to claim 50, Owens discloses the method of claim 49, further comprising dispatching formatted commands to the after-market audio device for execution thereby (pg.1 [0006]).

With respect to claim 51, Owens discloses the method of claim 47, further comprising converting data received at the interface from the after-market audio device in a format incompatible with the car stereo into a format compatible with the car stereo using a third code portion executed by the microcontroller (Beckert: col.3 ln.42-67, col.4 ln.1-7).

With respect to claim 52, Owens discloses the method of claim 51, further comprising displaying formatted data on the car stereo (Beckert: col.4 ln.17-32).

With respect to claim 54, Owens discloses the method of claim 52, wherein the step of displaying formatted data comprises displaying video on the car stereo (pg.3 [0035]).

With respect claim 55, Owens discloses an audio device integration system comprising: a first connector (fig.1 #32) electrically connectable to a car stereo (fig.1 #10); a second connector (fig.8 "L1,R1,V1") electrically connectable to a portable MP3 player (pg.2 [0025] ln.3-6) external to a car stereo (pg.2 [0032] ln.9-11); an interface

Art Unit: 2615

(fig.1 #30,40) connected between the first and second electrical connectors for transmitting audio from a portable MP3 player to a car stereo (pg.2 [0032]), the interface generating a device presence signal and transmitting the signal to a car stereo to maintain a car stereo in an operational state (pg.2 [0034]), wherein the interface remotely controls the MP3 player using a car stereo by receiving a control command from a car stereo through the first connector (pg.2 [0028]), transmitting a control command to an MP3 player through the second electrical connector for execution by an MP3 player (pg.1 [0006]). The disclosure of Owens describes the MP3 player as being connected to auxiliary jack #12, however it is implied that an audio device with audio outputs "R" and "L" channel may be connected to the inputs of A/V source selector #40.

Owens does not disclose expressly wherein the interface comprises a microcontroller programmed to execute code portions to process control commands into compatible formats between the car stereo and after-market devices.

Beckert discloses a vehicle computer interface system in cooperation with a vehicles audio system that allows for the operation of incompatible devices wherein the interface includes a microcontroller (fig.2 #64) in electrical communication with the car stereo (fig.2 #60) and after-market devices (fig.2 #74,78,80), the microcontroller programmed to execute: a first code portion for remotely controlling (col.4 ln.22-31) an after-market audio device using a car stereo by receiving a control command from a car stereo through the first connector in a format incompatible with an after-market audio device, processing a received control command into a formatted command compatible with an after-market audio device, and transmitting a formatted command to an after-

Art Unit: 2615

market audio device through the second connector for execution by an after-market audio device (col.1 ln.63-67, col.2 ln.1-30); a second code portion for receiving data from an after-market audio device through the second connector in a format incompatible with a car stereo, processing received data into formatted data compatible with a car stereo (col.3 ln.41-67, col.4 ln.1-7), and transmitting formatted data to a car stereo through the first connector for display by a car stereo (col.4 ln.17-22); and a third code portion for switching to one or more auxiliary input sources connected to the third electrical connector (col.5 ln.28-37,56-62).

At the time of the invention it would have been obvious to include the compatibility processing of Beckert in the interface of Owens. The motivation for doing so would have been to allow the use of after-market devices that do not rely on the same format as the car stereo.

With respect to claim 56, Owens discloses the apparatus of claim 55, however does not disclose expressly further comprising an Original Equipment Manufacturer (OEM) car stereo connected to the first electrical connector. The after-market car stereo (fig.1 #10) of Owens contains the master microprocessor that performs the systems selection functions of auxiliary units (pg.2 [0034]) wherein this microprocessor is not available in an OEM car stereo. Beckert discloses a system wherein the interface processing occurs in a unit (fig.2 #64,62) separate from the car stereo (fig.2 #60). At the time of the invention it would have been obvious to a person of ordinary skill in the art that the master microprocessor that controls the interfacing functions of Owens could

Art Unit: 2615

have been located within an external unit to the car stereo as taught by Beckert, such as the AV interface module (fig.1 #30). The motivation for doing so would have been to allow a user to integrate auxiliary and after-market devices with the factory (OEM) car stereo.

With respect to claim 57, Owens discloses the apparatus of claim 55, further comprising an after-market car stereo connected to the first electrical connector (pg.2 [0025] ln.1-3).

With respect to claim 59, Owens discloses the system of claim 55 in view of Beckert, wherein the microcontroller executes a third code portion for receiving data from an MP3 player in a format incompatible with a car stereo, processing received data into formatted data compatible with the car stereo, and transmitting the formatted data to a car stereo (Beckert: col.4 ln.17-32).

With respect to claim 62, Owens discloses the apparatus of claim 59, wherein commands are input by a user using one or more control buttons or presets on a car stereo (pg.3 [0037-0039]).

With respect to claim 81, Owens discloses a device for integrating video information for use with a car stereo, comprising: a first electrical connector (fig.1 #32) connectable to a car stereo (fig.1 #10); a second electrical connector (fig.8 "L1,R1,V1")

Art Unit: 2615

connectable to an after-market video device (fig.1 #44,46,48) external to the car stereo; an interface (fig.1 #30,40) connected between the first and second electrical connectors for transmitting video information from an after market video device to a monitor (pg.2 [0032]), the interface including means for generating a device presence signal and transmitting the signal to a car stereo through the first electrical connector to maintain the car stereo in an operational state responsive to signals generated by an after-market video device (pg.2 [0034]).

Owens does not disclose expressly wherein video information is transmitted to the car stereo or wherein the interface contains a microcontroller.

Beckert discloses a system interface that includes a microcontroller (fig.2 #62) that processed video data into a format compatible (col.3 ln.42-67, col.4 ln.1-7) to be displayed on a car stereo (fig.2 #60)(col.4 ln.17-32). At the time of the invention it would have been obvious to a person of ordinary skill in the art to use the interface of Beckert in the system of Owens. The motivation for doing so would have been to display video signals on the screen of the car stereo from the after market video devices.

With respect to claim 82, Owens discloses the device of claim 81, further comprising means for converting the video information into a format compatible with the car stereo (Beckert: col.4 ln.17-32).

Art Unit: 2615

With respect to claim 88, Owens discloses the apparatus of claims 1, wherein the second electrical connector comprises a bus connection established between an after-market audio device and the interface (pg.2 [0025]).

With respect to claim 89, Owens discloses the apparatus of claim 88, however does not disclose expressly wherein the connection between the bus connection comprises a Universal Serial Bus (USB) connection.

Official Notice is taken that bus and USB connections were well known in the art to connect devices for the purpose of exchanging data. At the time of the invention it would have been obvious to a person of ordinary skill in the art to use a USB connection to attach external devices to the audio system of Owens. The motivation for doing so would have been to allow a user to make use of the plug and play capabilities of a USB connection.

With respect to claim 90, Owens discloses the apparatus of claims 24, wherein at least one of the plurality of auxiliary input connectors comprises a bus connection established between at least one of a plurality of auxiliary input sources and the interface (pg.2 [0025]).

With respect to claim 91, Owens discloses the apparatus of claim 90, however does not disclose expressly wherein the connection between the bus connection comprises a Universal Serial Bus (USB) connection.

Official Notice is taken that bus and USB connections were well known in the art to connect devices for the purpose of exchanging data. At the time of the invention it would have been obvious to a person of ordinary skill in the art to use a USB connection to attach external devices to the audio system of Owens. The motivation for doing so would have been to allow a user to make use of the plug and play capabilities of a USB connection.

With respect to claim 92, Owens discloses the apparatus of claims 55, wherein the second electrical connector comprises a bus connection established between the MP3 player and the interface (pg.2 [0025]).

With respect to claim 93, Owens discloses the apparatus of claim 92, however does not disclose expressly wherein the connection between the bus connection comprises a Universal Serial Bus (USB) connection.

Official Notice is taken that bus and USB connections were well known in the art to connect devices for the purpose of exchanging data. At the time of the invention it would have been obvious to a person of ordinary skill in the art to use a USB connection to attach external devices to the audio system of Owens. The motivation for doing so would have been to allow a user to make use of the plug and play capabilities of a USB connection.

With respect to claim 98, Owens discloses the apparatus of claims 81, wherein the second electrical connector comprises a bus connection established between a video device and the interface (pg.2 [0025]).

With respect to claim 99, Owens discloses the apparatus of claim 98, however does not disclose expressly wherein the connection between the bus connection comprises a Universal Serial Bus (USB) connection.

Official Notice is taken that bus and USB connections were well known in the art to connect devices for the purpose of exchanging data. At the time of the invention it would have been obvious to a person of ordinary skill in the art to use a USB connection to attach external devices to the audio system of Owens. The motivation for doing so would have been to allow a user to make use of the plug and play capabilities of a USB connection.

With respect to claim 102, Owens discloses the apparatus of claim 81, wherein the microcontroller executes a second code portion for receiving a control signal from a car stereo in a format incompatible with a video device, processing a received control signal into a formatted control signal compatible with a video device, and transmitting a formatted control signal to a video device for execution thereby (col.1 ln.63-67, col.2 ln.1-7).

With respect to claim 103, Owens discloses the apparatus of claim 102, wherein the microcontroller executes a third code portion for receiving a data from a video device incompatible with a car stereo, processing received data into formatted data compatible with a car stereo, and transmitting formatted data to a car stereo for display thereon (Beckert: col.3 ln.42-67, col.4 ln.1-7,17-32).

With respect to claim 104, Owens discloses an audio device integration system, comprising: a first electrical connector (fig.1 #32) electrically connectable to a car stereo (fig.1 #10); a second electrical connector (fig.8 "L1,R1,V1") electrically connectable to an after-market, line-level audio source (fig.1 #44,46,48) external to a car stereo (pg.2 [0032] ln.9-11); and an interface (fig.1 #30,40) connected between the first and second electrical connectors for transmitting audio from an after-market, line level audio source to a car stereo (pg.2 [0032]), a microcontroller in electrical communication with the first and second electrical connectors, the microcontroller executing: a first code portion for generating and transmitting a device presence signal to a car stereo through the first electrical connector to maintain a car stereo in an operational state responsive to signals generated by an after-market, line level audio source (pg.2 [0034]).

Owens does not disclose expressly wherein the microcontroller is within the interface. The after-market car stereo (fig.1 #10) of Owens contains the master microprocessor that performs the systems selection functions of after-market devices (pg.2 [0034]) wherein this microprocessor is not available in an OEM car stereo.

Art Unit: 2615

Beckert discloses a system wherein the interface processing occurs in a unit (fig.2 #64,62) separate from the car stereo (fig.2 #60). At the time of the invention it would have been obvious to a person of ordinary skill in the art that the master microprocessor that controls the interfacing functions of Owens could have been located within an external unit to the car stereo as taught by Beckert, such as the A/V interface module (fig.1 #30). The motivation for doing so would have been to allow a user to integrate auxiliary and after-market devices with the factory (OEM) car stereo.

Claims 7-9, 31-33, 53 and 60-61 are rejected under 35 U.S.C. 103(a) as being unpatentable over Owens et al (US 2002/0084910 A1) in view of Beckert et al (US 6,175,789 B1) and in further view of Falcon (US 6,993,615 B2).

With respect to claims 7-9, 31-33, 53, 60-61 Owens discloses the apparatus of claims 1, 30, 52, 59 in view of Beckert, however does not disclose expressly wherein the second code portion processes data generated by an aftermarket audio device including "track and time information", "song title and artist information", or "channel number and channel information".

Falcon discloses an external audio device (fig.4 #102) that interfaces with a car stereo (fig.4 #200) wherein the interfacing information of the devices comprises "track and time information" (col.8 ln.20-26), "song title and artist information" (col.8 ln.26-30), "channel number and channel information" (col.6 ln.41-47).

Art Unit: 2615

At the time of the invention it would have been obvious to a person of ordinary skill in the art to include the interfacing information disclosed by Falcon in the data exchanged by Beckert.

The motivation for doing so would have been to provide the audio control unit with information pertaining to the operation of the auxiliary devices. This would allow the audio control to present this information to a user located in the front of the vehicle, hence allowing a user to view and control the reproduction of information without leaving his or her seat.

Claim 36 is rejected under 35 U.S.C. 103(a) as being unpatentable over Owens et al (US 2002/0084910 A1) in view of Beckert et al (US 6,175,789 B1) and in further view of Kunimatsu et al (US 6,653,948 B1).

With respect to claim 36, Owens discloses the method of claim 30, however does not disclose expressly wherein the step of displaying the formatted data comprises displaying the data in a graphical user interface at the car stereo.

Kunimatsu discloses a graphical user interface to be mounted within a vehicle, wherein data is displayed as easily selectable screens. At the time of the invention it would have been obvious to a person of ordinary skill in the art to use the GUI of Kunimatsu in place of the LCD screen of Owens. The motivation for doing so would have been to provide the user with an interactive display for the simple selection of audio sources and audio tracks.

Claims 42, 44 and 45 are rejected under 35 U.S.C. 103(a) as being unpatentable over Beckert et al (US 6,175,789 B1) in view of Miyazaki et al (US 6,163,079).

With respect to claim 42, Beckert discloses an apparatus for docking a portable device (fig.2 #78,74) for integration with a car stereo comprising: an interface (fig.2 #62) connected to the data port (fig.2 #70) and to a car stereo (fig.2 #60), the interface channeling audio from a portable device to a car stereo (col.5 ln.27-37), the interface including a microcontroller in electrical communication with a portable device through the data port and a car stereo (fig.3 #92, col.5 ln.56-62), the microcontroller executing program code for remotely controlling a portable device using a car stereo by

Art Unit: 2615

processing control commands generated by a car stereo in a format incompatible with a portable device into formatted control commands compatible with a portable device, and dispatching formatted control commands to a portable device for execution thereby (col.1 ln.63-67, col.2 ln.1-6, col.3 ln.42-67, col.4 ln.1-7).

Beckert does not disclose expressly a storage area remote from the car stereo for storing the portable device.

Miyazaki discloses a storage area (fig.7 #50, col.2 ln.29-42) remote from a car stereo for storing a portable device; a docking portion (fig.2 #4C) within the storage area for communicating and physically mating with the portable device; a data port (fig.1 "Ls") in communication with the docking portion (fig.2 #4C), the data port connectable with a device (fig.2 #42) for integrating the portable device with a car stereo. At the time of the invention it would have been obvious to a person of ordinary skill in the art to use the storage areas with accompanying docks to mount or store the portable devices of Beckert. The motivation for doing so would have been to protect the portable device from damage during travel.

With respect to claim 44, Beckert discloses the apparatus of claim 42, wherein the data port comprises an RS-232 or Universal Serial Bus (USB) port (fig.2 #70).

With respect to claim 45, Beckert discloses the apparatus of claim 42 in view of Miyazaki, wherein the storage area further comprises a top portion (Miyazaki : fig.14

Art Unit: 2615

#17) and a bottom portion (Miyazaki: fig.14 #50) defining a sleeve (Miyazaki: fig.14 #41) for holding the portable device.

Claims 43 and 46 are rejected under 35 U.S.C. 103(a) as being unpatentable over Beckert et al (US 6,175,789 B1) in view of Miyazaki et al (US 6,163,079) and in further view of Holland (US 2002/0085730 A1).

With respect to claim 43, Beckert discloses the apparatus of claim 42 in view of Miyazaki, wherein the storage area further comprises a top member (fig.14 #17), bottom member (fig.14 #50). Miyazaki does not disclose expressly wherein the top member and the bottom member are interconnected at an edge by a hinge.

Holland discloses an apparatus for docking with a portable device further comprising a hinge (pg.1 [0009]) for connecting a top member (fig.2 #5) and a bottom member (fig.2 #3) at an edge.

At the time of the invention it would have been obvious to a person of ordinary skill in the art to use the hinge of Holland to connect the top and bottom portions of Miyazaki.

The motivation for doing so would have been to provide a closable lid to the protective case (Miyazaki: fig.14 #50). This would provide a case that does not have to slide in and out of a vehicle compartment but rather opens on the hinge, hence allowing for after market installation due to a lack in the need for a manufactured vehicle compartment.

With respect to claim 46, Beckert discloses the apparatus of claim 43 in view of Holland, further comprising a clasp (Holland: fig.4 #9) for retaining the top and bottom members in a closed position (Holland: pg.2 [0024][0025]).

Claims 63-65, 67, 71 and 94-95 are rejected under 35 U.S.C. 103(a) as being unpatentable over Owens et al (US 2002/0084910 A1) in view of Beckert et al (US 6,175,789 B1) and in further view of Lazzeroni et al (US 2003/0026440 A1).

With respect claim 63, Owens discloses an audio device integration system comprising: a first connector (fig.1 #32) electrically connectable to a car stereo (fig.1 #10); a second connector (fig.8 "L1,R1,V1") electrically connectable to an after-market audio device external to a car stereo (pg.2 [0032] ln.9-11); an interface (fig.1 #30,40) connected between the first and second electrical connectors for transmitting audio from the after-market audio device to a car stereo (pg.2 [0032]), the interface generating a device presence signal and transmitting the signal to a car stereo to maintain a car stereo in an operational state (pg.2 [0034]), wherein the interface remotely controls the after-market audio device using a car stereo by receiving a control command from a car stereo through the first connector (pg.2 [0028]), transmitting a control command to an after-market audio device through the second electrical connector for execution by an MP3 player (pg.1 [0006]).

Owens does not disclose expressly wherein the interface comprises a microcontroller programmed to execute code portions to process control commands into compatible formats between the car stereo and after-market devices.

Beckert discloses a vehicle computer interface system in cooperation with a vehicles audio system that allows for the operation of incompatible devices wherein the interface includes a microcontroller (fig.2 #64) in electrical communication with the car stereo (fig.2 #60) and after-market devices (fig.2 #74,78,80), the microcontroller programmed to execute: a first code portion for remotely controlling (col.4 ln.22-31) an after-market audio device using a car stereo by receiving a control command from a car stereo through the first connector in a format incompatible with an after-market audio device, processing a received control command into a formatted command compatible with an after-market audio device, and transmitting a formatted command to an after-market audio device through the second connector for execution by an after-market audio device (col.1 ln.63-67, col.2 ln.1-30); a second code portion for receiving data from an after-market audio device through the second connector in a format incompatible with a car stereo, processing received data into formatted data compatible with a car stereo (col.3 ln.41-67, col.4 ln.1-7), and transmitting formatted data to a car stereo through the first connector for display by a car stereo (col.4 ln.17-22); and a third code portion for switching to one or more auxiliary input sources connected to the third electrical connector (col.5 ln.28-37,56-62).

At the time of the invention it would have been obvious to include the compatibility processing of Beckert in the interface of Owens. The motivation for doing

Art Unit: 2615

so would have been to allow the use of after-market devices that do not rely on the same format as the car stereo.

Owens does not disclose expressly wherein the after-market audio device is a satellite radio receiver.

Lazzeroni discloses a vehicle audio switching system that allows for the connection of multiple after-market audio devices to a vehicles stereo (see Abstract), wherein an after-market device is a satellite radio receiver (fig.1 #112). At the time of the invention it would have been obvious to a person of ordinary skill in the art to use the satellite radio receiver of Lazzeroni as an after-market device in the invention of Owens.

With respect to claim 64, Owens discloses the apparatus of claim 63, however does not disclose expressly further comprising an Original Equipment Manufacturer (OEM) car stereo connected to the first electrical connector. The after-market car stereo (fig.1 #10) of Owens contains the master microprocessor that performs the systems selection functions of auxiliary units (pg.2 [0034]) wherein this microprocessor is not available in an OEM car stereo. Beckert discloses a system wherein the interface processing occurs in a unit (fig.2 #64,62) separate from the car stereo (fig.2 #60). At the time of the invention it would have been obvious to a person of ordinary skill in the art that the master microprocessor that controls the interfacing functions of Owens could have been located within an external unit to the car stereo as taught by Beckert, such as the A/V interface module (fig.1 #30). The motivation for doing so would have been to

Art Unit: 2615

allow a user to integrate auxiliary and after-market devices with the factory (OEM) car stereo.

With respect to claim 65, Owens discloses the apparatus of claim 63, wherein the car stereo is an after-market car stereo connected to the first electrical connector (pg.2 [0025] ln.1-3).

With respect to claim 67, Owens discloses the system of claim 55 in view of Beckert, wherein the microcontroller executes a third code portion for receiving data from an MP3 player in a format incompatible with a car stereo, processing received data into formatted data compatible with the car stereo, and transmitting the formatted data to a car stereo (Beckert: col.4 ln.17-32).

With respect to claim 71, Owens discloses the apparatus of claim 67, wherein the commands are input by a user using one or more control buttons or presets on the car stereo (pg.3 [0039]).

With respect to claim 94, Owens discloses the apparatus of claims 63, wherein the second electrical connector comprises a bus connection established between a satellite radio receiver and the interface (pg.2 [0025]).

With respect to claim 95, Owens discloses the apparatus of claim 94, however does not disclose expressly wherein the connection between the bus connection comprises a Universal Serial Bus (USB) connection.

Official Notice is taken that bus and USB connections were well known in the art to connect devices for the purpose of exchanging data. At the time of the invention it would have been obvious to a person of ordinary skill in the art to use a USB connection to attach external devices to the audio system of Owens. The motivation for doing so would have been to allow a user to make use of the plug and play capabilities of a USB connection.

Claims 68-70 are rejected under 35 U.S.C. 103(a) as being unpatentable over Owens et al (US 2002/0084910 A1) in view of Beckert et al (US 6,175,789 B1) in view of Lazzeroni et al (US 2003/0026440 A1) and in further view of Falcon (US 6,993,615 B2).

With respect to claims 68-70 Owens discloses the apparatus of claim 67 in view of Beckert, however does not disclose expressly wherein the third code portion processes data generated by a satellite radio receiver including "track and time information", "song title and artist information", or "channel number and channel information".

Falcon discloses an external audio device (fig.4 #102) that interfaces with a car stereo (fig.4 #200) wherein the interfacing information of the devices comprises "track

Art Unit: 2615

and time information" (col.8 ln.20-26), "song title and artist information" (col.8 ln.26-30), "channel number and channel information" (col.6 ln.41-47).

At the time of the invention it would have been obvious to a person of ordinary skill in the art to include the interfacing information disclosed by Falcon in the data exchanged by Beckert.

The motivation for doing so would have been to provide the audio control unit with information pertaining to the operation of the auxiliary devices. This would allow the audio control to present this information to a user located in the front of the vehicle, hence allowing a user to view and control the reproduction of information without leaving his or her seat.

Claims 72-74, 76, 80 and 96-97 are rejected under 35 U.S.C. 103(a) as being unpatentable over Owens et al (US 2002/0084910 A1) in view of Beckert et al (US 6,175,789 B1) and in further view of Lee et al (US 6,374,177B1).

With respect claim 72, Owens discloses an audio device integration system comprising: a first connector (fig.1 #32) electrically connectable to a car stereo (fig.1 #10); a second connector (fig.8 "L1,R1,V1") electrically connectable to an after-market audio device external to a car stereo (pg.2 [0032] ln.9-11); an interface (fig.1 #30,40) connected between the first and second electrical connectors for transmitting audio from the after-market audio device to a car stereo (pg.2 [0032]), the interface generating a device presence signal and transmitting the signal to a car stereo to maintain a car

Art Unit: 2615

stereo in an operational state (pg.2 [0034]), wherein the interface remotely controls the after-market audio device using a car stereo by receiving a control command from a car stereo through the first connector (pg.2 [0028]), transmitting a control command to an after-market audio device through the second electrical connector for execution by an MP3 player (pg.1 [0006]).

Owens does not disclose expressly wherein the interface comprises a microcontroller programmed to execute code portions to process control commands into compatible formats between the car stereo and after-market devices.

Beckert discloses a vehicle computer interface system in cooperation with a vehicles audio system that allows for the operation of incompatible devices wherein the interface includes a microcontroller (fig.2 #64) in electrical communication with the car stereo (fig.2 #60) and after-market devices (fig.2 #74,78,80), the microcontroller programmed to execute: a first code portion for remotely controlling (col.4 ln.22-31) an after-market audio device using a car stereo by receiving a control command from a car stereo through the first connector in a format incompatible with an after-market audio device, processing a received control command into a formatted command compatible with an after-market audio device, and transmitting a formatted command to an after-market audio device through the second connector for execution by an after-market audio device (col.1 ln.63-67, col.2 ln.1-30); a second code portion for receiving data from an after-market audio device through the second connector in a format incompatible with a car stereo, processing received data into formatted data compatible with a car stereo (col.3 ln.41-67, col.4 ln.1-7), and transmitting formatted data to a car

Art Unit: 2615

stereo through the first connector for display by a car stereo (col.4 ln.17-22); and a third code portion for switching to one or more auxiliary input sources connected to the third electrical connector (col.5 ln.28-37,56-62).

At the time of the invention it would have been obvious to include the compatibility processing of Beckert in the interface of Owens. The motivation for doing so would have been to allow the use of after-market devices that do not rely on the same format as the car stereo.

Owens does not disclose expressly wherein the auxiliary device is a digital audio broadcast receiver.

Lee discloses a digital audio broadcast receiver (fig.2 #100) external to an audio control (fig.2 #90) that is in communication with the stereo (col.8 ln.25-50). At the time of the invention it would have been obvious to a person of ordinary skill in the art to use a satellite radio receiver such as the one disclosed by Lee as the auxiliary device of Owens. The motivation for doing so would have been to allow a user of the system of Owens to reproduce sound from a digital audio broadcast into the vehicle environment such as a streaming audio file.

With respect to claim 73, Owens discloses the apparatus of claim 72, however does not disclose expressly wherein the car stereo is an Original Equipment Manufacturer (OEM) car stereo connected to the first electrical connector. The after-market car stereo (fig.1 #10) of Owens contains the master microprocessor that performs the systems selection functions of auxiliary units (pg.2 [0034]) wherein this

Art Unit: 2615

microprocessor is not available in an OEM car stereo. Beckert discloses a system wherein the interface processing occurs in a unit (fig.2 #64,62) separate from the car stereo (fig.2 #60). At the time of the invention it would have been obvious to a person of ordinary skill in the art that the master microprocessor that controls the interfacing functions of Owens could have been located within an external unit to the car stereo as taught by Beckert, such as the A/V interface module (fig.1 #30). The motivation for doing so would have been to allow a user to integrate auxiliary and after-market devices with the factory (OEM) car stereo.

With respect to claim 74, Miyazaki discloses the apparatus of claim 72, further comprising an after-market car stereo connected to the first electrical connector (pg.2 [0025] ln.1-3).

With respect to claim 76, Owens discloses the system of claim 72 in view of Beckert, wherein the microcontroller executes a third code portion for receiving data from a digital audio broadcast receiver in a format incompatible with a car stereo, processing received data into formatted data compatible with the car stereo, and transmitting the formatted data to a car stereo for display thereby (Beckert: col.4 ln.17-32).

With respect to claim 80, Owens discloses the apparatus of claim 76, wherein the commands are input by a user using one or more control buttons or presets on the car stereo (pg.3 [0039]).

With respect to claim 96, Owens discloses the apparatus of claims 72, wherein the second electrical connector comprises a bus connection established between a digital audio broadcast receiver and the interface (pg.2 [0025]).

With respect to claim 97, Owens discloses the apparatus of claim 96, however does not disclose expressly wherein the connection between the bus connection comprises a Universal Serial Bus (USB) connection.

Official Notice is taken that bus and USB connections were well known in the art to connect devices for the purpose of exchanging data. At the time of the invention it would have been obvious to a person of ordinary skill in the art to use a USB connection to attach external devices to the audio system of Owens. The motivation for doing so would have been to allow a user to make use of the plug and play capabilities of a USB connection.

Claims 77-79 are rejected under 35 U.S.C. 103(a) as being unpatentable over Owens et al (US 2002/0084910 A1) in view of Beckert et al (US 6,175,789 B1) in view of Lee et al (US 6,374,177B1) and in further view of Falcon (US 6,993,615 B2).

With respect to claims 77-79 Owens discloses the apparatus of claim 76 in view of Beckert, however does not disclose expressly wherein the third code portion processes data generated by a satellite radio receiver including "track and time information", "song title and artist information", or "channel number and channel information".

Falcon discloses an external audio device (fig.4 #102) that interfaces with a car stereo (fig.4 #200) wherein the interfacing information of the devices comprises "track and time information" (col.8 ln.20-26), "song title and artist information" (col.8 ln.26-30), "channel number and channel information" (col.6 ln.41-47).

At the time of the invention it would have been obvious to a person of ordinary skill in the art to include the interfacing information disclosed by Falcon in the data exchanged by Beckert.

The motivation for doing so would have been to provide the audio control unit with information pertaining to the operation of the auxiliary devices. This would allow the audio control to present this information to a user located in the front of the vehicle, hence allowing a user to view and control the reproduction of information without leaving his or her seat.

Claims 83-84 and 100-101 are rejected under 35 U.S.C. 103(a) as being unpatentable over Miyazaki et al (US 6,163,079) in view of McConnell et al (US 6,608,399 B2)

With respect to claim 83, Miyazaki discloses an audio device integration system comprising: a car stereo (fig.1 #32); a portable audio device external to the car stereo (fig.2 #40A); an interface (fig.1 #38) connected between the car stereo and the portable audio device, the interface including; means (fig.2 #42) for generating a device presence signal and transmitting the signal to the car stereo to maintain the car stereo in an operational state (col.4 ln.54-66); means (fig.2 #32) for remotely controlling the portable audio device using the car stereo by receiving a control command from the car stereo, processing the control command, and transmitting the control command (col.4 ln.51-67, col.5 ln.1-31); and means (fig.1 "Ls") for transmitting audio from the portable audio device to the car stereo.

Miyazaki does not disclose expressly wherein the control commands are in a format incompatible with the after-market device, where the commands are processed into a format compatible to both the car stereo and the after-market device.

McConnell discloses means (fig.1) for receiving incompatible data from vehicle devices, that formats the data into a compatible form in order to allow communication between the devices (col.4 ln.7-19 "data protocol translation").

At the time of the invention it would have been obvious to a person of ordinary skill in the art to use the means of McConnell to format the data being transmitted between the audio control and peripheral devices along the multiplex signal line of Miyazaki.

Art Unit: 2615

The motivation for doing so would have been to allow a user of the invention of Miyazaki to incorporate peripheral devices in the vehicles electrical system that do not contain a multiplex control unit as depicted in figure 2 #42. This would allow a user to use peripheral devices that are not pre-configured to be used with the system of Miyazaki.

With respect to claim 84, Miyazaki discloses the apparatus of claim 83, wherein the portable audio device comprises a portable CD player (fig.2 #44).

With respect to claims 100 and 101, Miyazaki discloses the apparatus of claim 83, however does not disclose expressly wherein the connection between the portable audio device and the interface comprises a bus or USB connection.

Official Notice is taken that bus and USB connections were well known in the art to connect devices for the purpose of exchanging data. At the time of the invention it would have been obvious to a person of ordinary skill in the art to use a USB connection to attach external devices to the audio system of Miyazaki. The motivation for doing so would have been to allow a user to make use of the plug and play capabilities of a USB connection.

Claim 85 is rejected under 35 U.S.C. 103(a) as being unpatentable over Miyazaki et al (US 6,163,079) in view of McConnell et al (US 6,608,399 B2) and in further view of Grady (US 6,591,085 B1).

With respect to claim 85, Miyazaki discloses the apparatus of claim 83, however does not disclose expressly wherein the portable audio device is a portable MP3 player.

Grady discloses an MP3 player (fig.8 #56) external to a car stereo (fig.8 #68) that is in communication with the stereo (col.5 ln.55-64).

At the time of the invention it would have been obvious to a person of ordinary skill in the art to use an MP3 player such as the one disclosed by Grady as the auxiliary device of Miyazaki.

The motivation for doing so would have been to allow a user of the system of Miyazaki to reproduce sound from an MP3 into the vehicle environment.

Claim 86 is rejected under 35 U.S.C. 103(a) as being unpatentable over Miyazaki et al (US 6,163,079) in view of McConnell et al (US 6,608,399 B2) and in further view of Fuchs et al (US 6,346,917 B1).

With respect to claim 86, Miyazaki discloses the apparatus of claim 83, however does not disclose expressly wherein the portable device is a portable satellite radio receiver.

Fuchs discloses a portable satellite radio receiver (fig.4 #30) external to a car stereo that is in communication with the stereo (col.1 ln.51-62).

Art Unit: 2615

At the time of the invention it would have been obvious to a person of ordinary skill in the art to use a satellite radio receiver such as the one disclosed by Fuchs as the auxiliary device of Miyazaki.

The motivation for doing so would have been to allow a user of the system of Miyazaki to reproduce sound from a satellite broadcast into the vehicle environment.

Claim 87 is rejected under 35 U.S.C. 103(a) as being unpatentable over Miyazaki et al (US 6,163,079) in view of McConnell et al (US 6,608,399 B2) and in further view of Lee et al (US 6,374,177 B1).

With respect to claim 87, Miyazaki discloses the apparatus of claim 83, however does not disclose expressly wherein the portable audio device comprises a portable digital audio broadcast receiver.

Lee discloses a digital audio broadcast receiver (fig.2 #100) external to an audio control (fig.2 #90) that is in communication with the stereo (col.8 ln.25-50).

At the time of the invention it would have been obvious to a person of ordinary skill in the art to use a satellite radio receiver such as the one disclosed by Lee as the auxiliary device of Miyazaki.

The motivation for doing so would have been to allow a user of the system of Miyazaki to reproduce sound from a digital audio broadcast into the vehicle environment such as a streaming audio file.

Response to Arguments

Applicant's arguments with respect to claims 1-82 and 100-104 have been considered but are moot in view of the new ground(s) of rejection.

Applicant's arguments filed September 6, 2007 have been fully considered but they are not persuasive.

With respect to claim 83 the Applicant argues that one of ordinary skill in the art would not have been motivated to combine the system of Miyazaki with the system of McConnell. The Applicant argues that there would not be a need to include the "data protocol translation" of McConnell in the invention of Miyazaki because the components of Miyazaki are native and interoperable with each other. The Examiner would like to note that the combination of references was made to show that it would have been obvious to one of ordinary skill in the art to make the system of Miyazaki compatible with components operating on different formats, and such could be realized through the data protocol translation of McConnell. The motivation for performing such a combination would have been to introduce alien components to the native system.

Conclusion

Applicant's amendment necessitated the new ground(s) of rejection presented in this Office action. Accordingly, **THIS ACTION IS MADE FINAL**. See MPEP § 706.07(a). Applicant is reminded of the extension of time policy as set forth in 37 CFR 1.136(a).

Art Unit: 2615

A shortened statutory period for reply to this final action is set to expire THREE MONTHS from the mailing date of this action. In the event a first reply is filed within TWO MONTHS of the mailing date of this final action and the advisory action is not mailed until after the end of the THREE-MONTH shortened statutory period, then the shortened statutory period will expire on the date the advisory action is mailed, and any extension fee pursuant to 37 CFR 1.136(a) will be calculated from the mailing date of the advisory action. In no event, however, will the statutory period for reply expire later than SIX MONTHS from the date of this final action.

Any inquiry concerning this communication or earlier communications from the examiner should be directed to Jason R. Kurr whose telephone number is (571) 272-0552. The examiner can normally be reached on M-F 10:00am to 6:30pm.

If attempts to reach the examiner by telephone are unsuccessful, the examiner's supervisor, Vivian Chin can be reached on (571) 273-7848. The fax phone number for the organization where this application or proceeding is assigned is 571-273-8300.

Information regarding the status of an application may be obtained from the Patent Application Information Retrieval (PAIR) system. Status information for published applications may be obtained from either Private PAIR or Public PAIR. Status information for unpublished applications is available through Private PAIR only. For more information about the PAIR system, see <http://pair-direct.uspto.gov>. Should you have questions on access to the Private PAIR system, contact the Electronic Business Center (EBC) at 866-217-9197 (toll-free). If you would like assistance from a

Art Unit: 2615

USPTO Customer Service Representative or access to the automated information system, call 800-786-9199 (IN USA OR CANADA) or 571-272-1000.

JK
JK



VIVIAN CHIN

SUPERVISORY PATENT EXAMINER

Notice of References Cited	Application/Control No. 10/316,961	Applicant(s)/Patent Under Reexamination MARLOWE, IRA	
	Examiner Jason R. Kurr	Art Unit 2615	Page 1 of 1

U.S. PATENT DOCUMENTS

*	Document Number Country Code-Number-Kind Code	Date MM-YYYY	Name	Classification
*	A US-2002/0084910 A1	07-2002	Owens et al.	340/825.24
*	B US-2003/0026440 A1	02-2003	Lazzeroni et al.	381/86
*	C US-6,175,789 B1	01-2001	Beckert et al.	701/33
	D US-			
	E US-			
	F US-			
	G US-			
	H US-			
	I US-			
	J US-			
	K US-			
	L US-			
	M US-			

FOREIGN PATENT DOCUMENTS

*	Document Number Country Code-Number-Kind Code	Date MM-YYYY	Country	Name	Classification
	N				
	O				
	P				
	Q				
	R				
	S				
	T				

NON-PATENT DOCUMENTS

*	Include as applicable: Author, Title Date, Publisher, Edition or Volume, Pertinent Pages)
U	
V	
W	
X	

*A copy of this reference is not being furnished with this Office action. (See MPEP § 707.05(a).)
Dates in MM-YYYY format are publication dates. Classifications may be US or foreign.

Index of Claims



Application/Control No.

10/316,961

Examiner

Jason R. Kurr

Applicant(s)/Patent under Reexamination

MARLOWE, IRA

Art Unit

2615

✓	Rejected
=	Allowed

-	(Through numeral) Cancelled
+	Restricted

N	Non-Elected
I	Interference

A	Appeal
O	Objected

Final	Claim	Date					
	Original	5/29/06	11/7/06	4/12/07	7/7/07	2/7/08	
	1	✓	✓	✓	✓	✓	
	2	✓	✓	✓	✓	✓	
	3	✓	✓	✓	✓	✓	
	4	✓	✓	✓	✓	✓	
	5	✓	✓	✓	✓	✓	
	6	✓	✓	✓	✓	✓	
	7	✓	✓	✓	✓	✓	
	8	✓	✓	✓	✓	✓	
	9	✓	✓	✓	✓	✓	
	10	✓	✓	✓	✓	✓	
	11	✓	✓	✓	✓	✓	
	12	✓	✓	✓	✓	✓	
	13	✓	✓	✓	✓	✓	
	14	-	-	-	-	-	
	15	✓	✓	✓	✓	✓	
	16	✓	✓	✓	✓	✓	
	17	✓	✓	✓	✓	✓	
	18	✓	✓	✓	✓	✓	
	19	✓	✓	✓	✓	✓	
	20	✓	✓	✓	✓	✓	
	21	✓	✓	✓	✓	✓	
	22	✓	✓	✓	✓	✓	
	23	✓	✓	✓	✓	✓	
	24	✓	✓	✓	✓	✓	
	25	✓	✓	✓	✓	✓	
	26	✓	✓	✓	✓	✓	
	27	✓	✓	✓	✓	✓	
	28	✓	✓	✓	✓	✓	
	29	✓	✓	✓	✓	✓	
	30	✓	✓	✓	✓	✓	
	31	✓	✓	✓	✓	✓	
	32	✓	✓	✓	✓	✓	
	33	✓	✓	✓	✓	✓	
	34	✓	✓	✓	✓	✓	
	35	✓	✓	✓	✓	✓	
	36	✓	✓	✓	✓	✓	
	37	✓	✓	✓	✓	✓	
	38	✓	✓	✓	✓	✓	
	39	-	-	-	-	-	
	40	✓	✓	✓	✓	✓	
	41	✓	✓	✓	✓	✓	
	42	✓	✓	✓	✓	✓	
	43	✓	✓	✓	✓	✓	
	44	✓	✓	✓	✓	✓	
	45	✓	✓	✓	✓	✓	
	46	✓	✓	✓	✓	✓	
	47	✓	✓	✓	✓	✓	
	48	✓	✓	✓	✓	✓	
	49	✓	✓	✓	✓	✓	
	50	✓	✓	✓	✓	✓	

Final	Claim	Date					
	Original	5/29/06	11/7/06	4/12/07	7/7/07	2/7/08	
	51	✓	✓	✓	✓	✓	
	52	✓	✓	✓	✓	✓	
	53	✓	✓	✓	✓	✓	
	54	✓	✓	✓	✓	✓	
	55	✓	✓	✓	✓	✓	
	56	✓	✓	✓	✓	✓	
	57	✓	✓	✓	✓	✓	
	58	✓	✓	-	-	-	
	59	✓	✓	✓	✓	✓	
	60	✓	✓	✓	✓	✓	
	61	✓	✓	✓	✓	✓	
	62	✓	✓	✓	✓	✓	
	63	✓	✓	✓	✓	✓	
	64	✓	✓	✓	✓	✓	
	65	✓	✓	✓	✓	✓	
	66	✓	✓	✓	✓	✓	
	67	✓	✓	✓	✓	✓	
	68	✓	✓	✓	✓	✓	
	69	✓	✓	✓	✓	✓	
	70	✓	✓	✓	✓	✓	
	71	✓	✓	✓	✓	✓	
	72	✓	✓	✓	✓	✓	
	73	✓	✓	✓	✓	✓	
	74	✓	✓	✓	✓	✓	
	75	✓	✓	-	-	-	
	76	✓	✓	✓	✓	✓	
	77	✓	✓	✓	✓	✓	
	78	✓	✓	✓	✓	✓	
	79	✓	✓	✓	✓	✓	
	80	✓	✓	✓	✓	✓	
	81	✓	✓	✓	✓	✓	
	82	✓	✓	✓	✓	✓	
	83	✓	✓	✓	✓	✓	
	84	✓	✓	✓	✓	✓	
	85	✓	✓	✓	✓	✓	
	86	✓	✓	✓	✓	✓	
	87	✓	✓	✓	✓	✓	
	88	✓	✓	✓	✓	✓	
	89	✓	✓	✓	✓	✓	
	90	✓	✓	✓	✓	✓	
	91	✓	✓	✓	✓	✓	
	92	✓	✓	✓	✓	✓	
	93	✓	✓	✓	✓	✓	
	94	✓	✓	✓	✓	✓	
	95	✓	✓	✓	✓	✓	
	96	✓	✓	✓	✓	✓	
	97	✓	✓	✓	✓	✓	
	98	✓	✓	✓	✓	✓	
	99	✓	✓	✓	✓	✓	
	100	✓	✓	✓	✓	✓	

Final	Claim	Date		
	Original	4/12/07	7/7/07	2/7/08
	101	✓	✓	✓
	102	✓	✓	✓
	103	✓	✓	✓
	104	✓	✓	✓
	105			
	106			
	107			
	108			
	109			
	110			
	111			
	112			
	113			
	114			
	115			
	116			
	117			
	118			
	119			
	120			
	121			
	122			
	123			
	124			
	125			
	126			
	127			
	128			
	129			
	130			
	131			
	132			
	133			
	134			
	135			
	136			
	137			
	138			
	139			
	140			
	141			
	142			
	143			
	144			
	145			
	146			
	147			
	148			
	149			
	150			

Search Notes



Application/Control No.

10/316,961

Examiner

Jason R. Kurr

Applicant(s)/Patent under Reexamination

MARLOWE, IRA

Art Unit

2615

SEARCHED

Class	Subclass	Date	Examiner
381	86	5/24/2006	JK
307	9.1,10.1	10/4/2006	JK
340	825.25	10/4/2006	JK
307	10.1	3/7/2007	JK
Update	Above	7/7/2007	JK
340	825.24	1/8/2008	JK
700	94	1/8/2008	JK
455	345,346	1/23/2008	JK

INTERFERENCE SEARCHED

Class	Subclass	Date	Examiner

**SEARCH NOTES
(INCLUDING SEARCH STRATEGY)**

	DATE	EXMR
Searched, car stereo's and interfacing with auxiliary audio devices	5/24/2006	JK
Searched (digital audio broadcasting) DAB	5/29/2006	JK
Searched: mp3 players, interfacing, DAB digital audio broadcasts, satellite radio	11/7/2006	JK
Searched new IDS (2/16/07) and continuation applications	3/7/2007	JK
Searched (format conversions) w/ control and auxiliary units or after market units	1/23/2008	JK
Consulted: Dan Sellers + Andrew Flanders 700/94 Ping Lee, Xu Mei, suggested 455/3.06,345,346 and 710 docking stations	1/8/2008	JK



UNITED STATES PATENT AND TRADEMARK OFFICE

UNITED STATES DEPARTMENT OF COMMERCE
United States Patent and Trademark Office
Address: COMMISSIONER FOR PATENTS
P.O. Box 1450
Alexandria, Virginia 22313-1450
www.uspto.gov

APPLICATION NO.	FILING DATE	FIRST NAMED INVENTOR	ATTORNEY DOCKET NO.	CONFIRMATION NO.
10/316,961	12/11/2002	Ira Marlowe	9809/1	4879

7590 04/09/2008
MICHAEL R FRISCIA
MCCARTER & ENGLISH
FOUR GATEWAY CENTER
100 MULBERRY STREET
NEWARK, NJ 07102

EXAMINER

KURR, JASON RICHARD

ART UNIT	PAPER NUMBER
----------	--------------

2615

MAIL DATE	DELIVERY MODE
-----------	---------------

04/09/2008

PAPER

Please find below and/or attached an Office communication concerning this application or proceeding.

The time period for reply, if any, is set in the attached communication.

Interview Summary	Application No. 10/316,961	Applicant(s) MARLOWE, IRA	
	Examiner JASON R. KURR	Art Unit 2615	

All participants (applicant, applicant's representative, PTO personnel):

(1) JASON R. KURR. (3)_____.

(2) Mark E. Nikolsky. (4)_____.

Date of Interview: 02 March 2008.

Type: a) Telephonic b) Video Conference
c) Personal [copy given to: 1) applicant 2) applicant's representative]

Exhibit shown or demonstration conducted: d) Yes e) No.
If Yes, brief description: _____.

Claim(s) discussed: 1,24,30,42,47,55,63,72,81,83 and 104.

Identification of prior art discussed: Owens et al (US 2002/0084910 A1), Beckert et al (US 6,175,789 B1).

Agreement with respect to the claims f) was reached. g) was not reached. h) N/A.

Substance of Interview including description of the general nature of what was agreed to if an agreement was reached, or any other comments: Applicant discussed possible claim amendments and how they would relate to the prior art.

(A fuller description, if necessary, and a copy of the amendments which the examiner agreed would render the claims allowable, if available, must be attached. Also, where no copy of the amendments that would render the claims allowable is available, a summary thereof must be attached.)

THE FORMAL WRITTEN REPLY TO THE LAST OFFICE ACTION MUST INCLUDE THE SUBSTANCE OF THE INTERVIEW. (See MPEP Section 713.04). If a reply to the last Office action has already been filed, APPLICANT IS GIVEN A NON-EXTENDABLE PERIOD OF THE LONGER OF ONE MONTH OR THIRTY DAYS FROM THIS INTERVIEW DATE, OR THE MAILING DATE OF THIS INTERVIEW SUMMARY FORM, WHICHEVER IS LATER, TO FILE A STATEMENT OF THE SUBSTANCE OF THE INTERVIEW. See Summary of Record of Interview requirements on reverse side or on attached sheet.

/Vivian Chin/
Supervisory Patent Examiner

Examiner Note: You must sign this form unless it is an Attachment to a signed Office action.

Examiner's signature, if required

Application Number



Application/Control No.

10/316,961

Applicant(s)/Patent under Reexamination

MARLOWE, IRA

Examiner

JASON R. KURR

Art Unit

2615



UNITED STATES PATENT AND TRADEMARK OFFICE

UNITED STATES DEPARTMENT OF COMMERCE
United States Patent and Trademark Office
Address: COMMISSIONER FOR PATENTS
P.O. Box 1450
Alexandria, Virginia 22313-1450
www.uspto.gov

APPLICATION NO.	FILING DATE	FIRST NAMED INVENTOR	ATTORNEY DOCKET NO.	CONFIRMATION NO.
10/316,961	12/11/2002	Ira Marlowe	9809/1	4879

7590 04/21/2008
MICHAEL R FRISCIA
MCCARTER & ENGLISH
FOUR GATEWAY CENTER
100 MULBERRY STREET
NEWARK, NJ 07102

EXAMINER

KURR, JASON RICHARD

ART UNIT PAPER NUMBER

2615

MAIL DATE DELIVERY MODE

04/21/2008

PAPER

Please find below and/or attached an Office communication concerning this application or proceeding.

The time period for reply, if any, is set in the attached communication.

Interview Summary	Application No. 10/316,961	Applicant(s) MARLOWE, IRA	
	Examiner JASON R. KURR	Art Unit 2615	

All participants (applicant, applicant's representative, PTO personnel):

(1) JASON R. KURR. (3)_____.

(2) Mark E. Nikolsky. (4)_____.

Date of Interview: 02 April 2008.

Type: a) Telephonic b) Video Conference
c) Personal [copy given to: 1) applicant 2) applicant's representative]

Exhibit shown or demonstration conducted: d) Yes e) No.
If Yes, brief description: _____.

Claim(s) discussed: 1,24,30,42,47,55,63,72,81,83 and 104.

Identification of prior art discussed: Owens et al (US 2002/0084910 A1), Beckert et al (US 6,175,789 B1).

Agreement with respect to the claims f) was reached. g) was not reached. h) N/A.

Substance of Interview including description of the general nature of what was agreed to if an agreement was reached, or any other comments: Applicant discussed possible claim amendments and how they would overcome the above identified prior art.

(A fuller description, if necessary, and a copy of the amendments which the examiner agreed would render the claims allowable, if available, must be attached. Also, where no copy of the amendments that would render the claims allowable is available, a summary thereof must be attached.)

THE FORMAL WRITTEN REPLY TO THE LAST OFFICE ACTION MUST INCLUDE THE SUBSTANCE OF THE INTERVIEW. (See MPEP Section 713.04). If a reply to the last Office action has already been filed, APPLICANT IS GIVEN A NON-EXTENDABLE PERIOD OF THE LONGER OF ONE MONTH OR THIRTY DAYS FROM THIS INTERVIEW DATE, OR THE MAILING DATE OF THIS INTERVIEW SUMMARY FORM, WHICHEVER IS LATER, TO FILE A STATEMENT OF THE SUBSTANCE OF THE INTERVIEW. See Summary of Record of Interview requirements on reverse side or on attached sheet.

/Vivian Chin/
Supervisory Patent Examiner

Examiner's signature, if required

Examiner Note: You must sign this form unless it is an Attachment to a signed Office action.

Summary of Record of Interview Requirements

Manual of Patent Examining Procedure (MPEP), Section 713.04, Substance of Interview Must be Made of Record

A complete written statement as to the substance of any face-to-face, video conference, or telephone interview with regard to an application must be made of record in the application whether or not an agreement with the examiner was reached at the interview.

Title 37 Code of Federal Regulations (CFR) § 1.133 Interviews Paragraph (b)

In every instance where reconsideration is requested in view of an interview with an examiner, a complete written statement of the reasons presented at the interview as warranting favorable action must be filed by the applicant. An interview does not remove the necessity for reply to Office action as specified in §§ 1.111, 1.135. (35 U.S.C. 132)

37 CFR §1.2 Business to be transacted in writing.

All business with the Patent or Trademark Office should be transacted in writing. The personal attendance of applicants or their attorneys or agents at the Patent and Trademark Office is unnecessary. The action of the Patent and Trademark Office will be based exclusively on the written record in the Office. No attention will be paid to any alleged oral promise, stipulation, or understanding in relation to which there is disagreement or doubt.

The action of the Patent and Trademark Office cannot be based exclusively on the written record in the Office if that record is itself incomplete through the failure to record the substance of interviews.

It is the responsibility of the applicant or the attorney or agent to make the substance of an interview of record in the application file, unless the examiner indicates he or she will do so. It is the examiner's responsibility to see that such a record is made and to correct material inaccuracies which bear directly on the question of patentability.

Examiners must complete an Interview Summary Form for each interview held where a matter of substance has been discussed during the interview by checking the appropriate boxes and filling in the blanks. Discussions regarding only procedural matters, directed solely to restriction requirements for which interview recordation is otherwise provided for in Section 812.01 of the Manual of Patent Examining Procedure, or pointing out typographical errors or unreadable script in Office actions or the like, are excluded from the interview recordation procedures below. Where the substance of an interview is completely recorded in an Examiners Amendment, no separate Interview Summary Record is required.

The Interview Summary Form shall be given an appropriate Paper No., placed in the right hand portion of the file, and listed on the "Contents" section of the file wrapper. In a personal interview, a duplicate of the Form is given to the applicant (or attorney or agent) at the conclusion of the interview. In the case of a telephone or video-conference interview, the copy is mailed to the applicant's correspondence address either with or prior to the next official communication. If additional correspondence from the examiner is not likely before an allowance or if other circumstances dictate, the Form should be mailed promptly after the interview rather than with the next official communication.

The Form provides for recordation of the following information:

- Application Number (Series Code and Serial Number)
- Name of applicant
- Name of examiner
- Date of interview
- Type of interview (telephonic, video-conference, or personal)
- Name of participant(s) (applicant, attorney or agent, examiner, other PTO personnel, etc.)
- An indication whether or not an exhibit was shown or a demonstration conducted
- An identification of the specific prior art discussed
- An indication whether an agreement was reached and if so, a description of the general nature of the agreement (may be by attachment of a copy of amendments or claims agreed as being allowable). Note: Agreement as to allowability is tentative and does not restrict further action by the examiner to the contrary.
- The signature of the examiner who conducted the interview (if Form is not an attachment to a signed Office action)

It is desirable that the examiner orally remind the applicant of his or her obligation to record the substance of the interview of each case. It should be noted, however, that the Interview Summary Form will not normally be considered a complete and proper recordation of the interview unless it includes, or is supplemented by the applicant or the examiner to include, all of the applicable items required below concerning the substance of the interview.

A complete and proper recordation of the substance of any interview should include at least the following applicable items:

- 1) A brief description of the nature of any exhibit shown or any demonstration conducted,
- 2) an identification of the claims discussed,
- 3) an identification of the specific prior art discussed,
- 4) an identification of the principal proposed amendments of a substantive nature discussed, unless these are already described on the Interview Summary Form completed by the Examiner,
- 5) a brief identification of the general thrust of the principal arguments presented to the examiner,
(The identification of arguments need not be lengthy or elaborate. A verbatim or highly detailed description of the arguments is not required. The identification of the arguments is sufficient if the general nature or thrust of the principal arguments made to the examiner can be understood in the context of the application file. Of course, the applicant may desire to emphasize and fully describe those arguments which he or she feels were or might be persuasive to the examiner.)
- 6) a general indication of any other pertinent matters discussed, and
- 7) if appropriate, the general results or outcome of the interview unless already described in the Interview Summary Form completed by the examiner.

Examiners are expected to carefully review the applicant's record of the substance of an interview. If the record is not complete and accurate, the examiner will give the applicant an extendable one month time period to correct the record.

Examiner to Check for Accuracy

If the claims are allowable for other reasons of record, the examiner should send a letter setting forth the examiner's version of the statement attributed to him or her. If the record is complete and accurate, the examiner should place the indication, "Interview Record OK" on the paper recording the substance of the interview along with the date and the examiner's initials.

Examiners' Note:

This is a corrected version of a previously mailed "Interview Summary" Paper No. 20080402. The Examiner has changed the date of the interview, the personal copy given to check box, and the substance of the interview at the request of the Applicant.

Application Number



Application/Control No.

10/316,961

Applicant(s)/Patent under Reexamination

MARLOWE, IRA

Examiner

JASON R. KURR

Art Unit

2615

Under the Paperwork Reduction Act of 1995, no persons are required to respond to a collection of information unless it displays a valid OMB control number.

Request For Continued Examination (RCE) Transmittal

Address to:
Mail Stop RCE
Commissioner for Patents
P.O. Box 1450
Alexandria, VA 22313-1450

Application Number	10/316,961
Filing Date	12/11/2002
First Named Inventor	Ira Marlowe
Art Unit	2615
Examiner Name	Kurr, Jason R.
Attorney Docket Number	99879-00005

This is a Request for Continued Examination (RCE) under 37 CFR 1.114 of the above-identified application.

Request for Continued Examination (RCE) practice under 37 CFR 1.114 does not apply to any utility or plant application filed prior to June 8, 1995, or to any design application. See Instruction Sheet for RCEs (not to be submitted to the USPTO) on page 2.

1. **Submission required under 37 CFR 1.114** Note: If the RCE is proper, any previously filed unentered amendments and amendments enclosed with the RCE will be entered in the order in which they were filed unless applicant instructs otherwise. If applicant does not wish to have any previously filed unentered amendment(s) entered, applicant must request non-entry of such amendment(s).
- a. Previously submitted. If a final Office action is outstanding, any amendments filed after the final Office action may be considered as a submission even if this box is not checked.
- i. Consider the arguments in the Appeal Brief or Reply Brief previously filed on _____
- ii. Other _____
- b. Enclosed
- i. Amendment/Reply iii. Information Disclosure Statement (IDS)
- ii. Affidavit(s)/Declaration(s) iv. Other _____
2. **Miscellaneous**
- a. Suspension of action on the above-identified application is requested under 37 CFR 1.103(c) for a period of _____ months. (Period of suspension shall not exceed 3 months; Fee under 37 CFR 1.17(i) required)
- b. Other _____
3. **Fees** The RCE fee under 37 CFR 1.17(e) is required by 37 CFR 1.114 when the RCE is filed.
- a. The Director is hereby authorized to charge the following fees, any underpayment of fees, or credit any overpayments to Deposit Account No. 503571. I have enclosed a duplicate copy of this sheet.
- i. RCE fee required under 37 CFR 1.17(e)
- ii. Extension of time fee (37 CFR 1.136 and 1.17)
- iii. Other _____
- b. Check in the amount of \$ _____ enclosed
- c. Payment by credit card (Form PTO-2038 enclosed)

WARNING: Information on this form may become public. Credit card information should not be included on this form. Provide credit card information and authorization on PTO-2038.

SIGNATURE OF APPLICANT, ATTORNEY, OR AGENT REQUIRED

Signature	<i>Mark E. Nikolsky</i>	Date	4/24/2008
Name (Print / Type)	Mark E. Nikolsky	Registration No.	48,319

CERTIFICATE OF MAILING OR TRANSMISSION

I hereby certify that this correspondence is being deposited with the United States Postal Service with sufficient postage as first class mail in an envelope addressed to: Mail Stop RCE, Commissioner For Patents, P.O. Box 1450, Alexandria, VA 22313-1450 or facsimile transmitted to the U.S. Patent and Trademark Office on the date shown below.

Signature		Date	
Name (Print / Type)		Date	

This collection of information is required by 37 CFR 1.114. The information is required to obtain or retain a benefit by the public which is to file (and by the USPTO to process) an application. Confidentiality is governed by 35 U.S.C. 122 and 37 CFR 1.11 and 1.14. This collection is estimated to take 12 minutes to complete, including gathering, preparing, and submitting the completed application form to the USPTO. Time will vary depending upon the individual case. Any comments on the amount of time you require to complete this form and/or suggestions for reducing the burden, should be sent to the Chief Information Officer, U.S. Patent and Trademark Office, U.S. Department of Commerce, P.O. Box 1450, Alexandria, VA 22313-1450. DO NOT SEND FEES OR COMPLETED FORMS TO THIS ADDRESS. SEND TO: Mail Stop RCE, Commissioner for Patents, P.O. Box 1450, Alexandria, VA 22313-1450.

IN THE UNITED STATES PATENT AND TRADEMARK OFFICE

Applicant: Ira M. Marlowe
Serial No.: 10/316,961
Filed: 12/11/2002
Title: AUDIO DEVICE INTEGRATION SYSTEM

Examiner: Kurr, Jason R.

Art Unit: 2615

Mail Stop Amendment
Commissioner for Patents
P.O. Box 1450
Alexandria, VA 22313-1450

RESPONSE

Sir:

This is a response to the outstanding Office Action dated February 20, 2008. The Office Action was made final. The time period for response extends to and includes May 20, 2008.

Amendments to the Claims begin on page 2 of this response.

Remarks begin on page 29 of this response.

AMENDMENTS TO THE CLAIMS

1. (Currently Amended) An audio device integration system comprising:

a first connector electrically connectable to a car stereo;

a second connector electrically connectable to an after-market audio device external to a the car stereo;

a third connector electrically connectable to one or more auxiliary input sources external to a the car stereo and ~~an~~ the after-market audio device;

an interface connected between ~~the~~ said first and second electrical connectors for channeling audio signals to a the car stereo from ~~an~~ the after-market audio device, ~~the~~ said interface including a microcontroller in electrical communication with ~~the~~ said first and second electrical connectors, ~~the~~ said microcontroller ~~programmed~~ pre-programmed to execute:

a first pre-programmed code portion for remotely controlling ~~an~~ the after-market audio device using a the car stereo by receiving a control command from a the car stereo through ~~the~~ said first connector in a format incompatible with ~~an~~ the after-market audio device, processing a the received control command into a formatted command compatible with ~~an~~ the after-market audio device, and transmitting a the formatted command to ~~an~~ the after-market audio device through ~~the~~ said second connector for execution by ~~an~~ the after-market audio device;

a second pre-programmed code portion for receiving data from ~~an~~ the after-market audio device through ~~the~~ the said second connector in a format incompatible with a the car stereo, processing the received data into formatted data compatible with a the car stereo, and transmitting the formatted data to a the car stereo through ~~the~~ the said first connector for display by a the car stereo; and

a third pre-programmed code portion for switching to one or more auxiliary input sources connected to ~~the~~ the said third electrical connector.

2. (Currently Amended) The apparatus of claim 1, wherein the car stereo further ~~comprising~~ comprises an Original Equipment Manufacturer (OEM) car stereo connected to ~~the~~ the said first electrical connector.

3. (Currently Amended) The apparatus of claim 1, wherein the car stereo further ~~comprising~~ comprises an after-market car stereo connected to ~~the~~ the said first electrical connector.

4. (Currently Amended) The apparatus of claim 1, wherein the after-market audio device further ~~comprising~~ comprises a CD player, CD changer, MP3 player, Digital Audio Broadcast (DAB) receiver, or satellite receiver connected to ~~the~~ the said second electrical connector.

5. (Currently Amended) The apparatus of claim 1, wherein ~~the~~ said interface further comprises a plug-and-play mode for automatically detecting a device type of ~~an~~ the after-market audio device connected to ~~the~~ said second electrical connector and integrating ~~an~~ the after-market audio device based upon the device type.

6. (Currently Amended) The apparatus of claim 1, wherein ~~the~~ said interface generates a device presence signal for maintaining a the car stereo in a state responsive to processed data and audio signals.

7. (Currently Amended) The apparatus of claim 1, wherein ~~the~~ said second pre-programmed code portion processes data generated by ~~an~~ the after-market audio device including track and time information.

8. (Currently Amended) The apparatus of claim 1, wherein ~~the~~ said second pre-programmed code portion processes data generated by ~~an~~ the after-market audio device including song title and artist information.

9. (Currently Amended) The apparatus of claim 1, wherein ~~the~~ said second pre-programmed code portion processes data generated by ~~an~~ the after-market audio device including channel number and channel name information.

10. (Currently Amended) The apparatus of claim 1, wherein ~~the~~ said interface processes video information generated by ~~an~~ the after-market audio device.

11. (Currently Amended) The apparatus of claim 1, wherein the formatted data is displayed as a menu on a display of a the car stereo.

12. (Previously Presented) The apparatus of claim 11, wherein the display comprises a graphic panel.

13. (Currently Amended) The apparatus of claim 1, wherein commands are input by a user using one or more control buttons or presets on a the car stereo.

14. (Cancelled)

15. (Currently Amended) The apparatus of claim 1, wherein audio signals from the one or more auxiliary input sources are selectively channeled to the car stereo by the said interface.

16. (Currently Amended) The apparatus of claim 1, wherein a user can select between the one or more auxiliary input sources by depressing keys on a the car stereo.

17. (Currently Amended) The apparatus of claim 1, wherein a user can select one of the auxiliary input sources by entering a disc number at a the car stereo.

18. (Currently Amended) The apparatus of claim 1, wherein a user can select one of the auxiliary input sources by entering a track number at a the car stereo.

19. (Currently Amended) The apparatus of claim 1, wherein a user can select one of the auxiliary input sources by entering both disc and track numbers at a the car stereo.

20. (Currently Amended) The apparatus of claim 1, wherein a user can select between ~~an~~ the audio device and the one or more auxiliary input sources by entering a sequence at a the car stereo.

21. (Original) The apparatus of claim 20, wherein the sequence comprises a track up selection followed by a track down selection.

22. (Currently Amended) The apparatus of claim 1, further comprising a second interface connected to ~~the first~~ said interface for providing a plurality of auxiliary input sources.

23. (Currently Amended) The apparatus of claim 22, wherein both ~~the first~~ said interface and ~~the~~ said second interface are controllable using a the car stereo.

24. (Currently Amended) An audio device integration system comprising:

a first electrical connector connectable to a car stereo;

a plurality of auxiliary electrical connectors connectable to a plurality of auxiliary input sources;

an interface connected between ~~the~~ said first electrical connector and ~~the~~ said plurality of auxiliary electrical connectors for channeling audio from at least one of a the plurality of auxiliary input sources to a the car stereo, ~~the~~ said interface including a microcontroller in electrical communication with ~~the~~ said first electrical connector and ~~the~~ said plurality of auxiliary electrical connectors, ~~the~~ said microcontroller ~~programmed~~ pre-programmed to execute:

a first pre-programmed code portion for remotely controlling at least one of a the plurality of auxiliary input sources using a the car stereo by receiving a control command from a the car stereo through ~~the~~ said first electrical connector in a format incompatible with at least one of a the plurality of auxiliary input sources, processing a received control command into a formatted control command compatible with at least one of a the plurality of auxiliary input sources, and transmitting a formatted control command to at least one of a the plurality of auxiliary input sources through at least one of ~~the~~ said plurality of auxiliary electrical connectors for execution by ~~the~~ at least one of a the plurality of auxiliary input sources;

a second pre-programmed code portion for receiving data from at least one of a the plurality of auxiliary input sources through at least one of ~~the~~ said plurality of auxiliary electrical connectors in a format incompatible with a the car stereo, processing the received data into formatted data compatible with a the car stereo, and transmitting the formatted data to a the car stereo through ~~the~~ said first electrical connector for display by a the car stereo; and

a third pre-programmed code portion for selecting one of a the plurality of auxiliary input sources from a the car stereo.

25. (Currently Amended) The apparatus of claim 24, wherein the third pre-programmed code portion for selecting one of a the plurality of auxiliary input sources processes a disc or track selection entered by a user using control buttons of a the car stereo to select one of a the plurality of auxiliary input sources.

26. (Currently Amended) The apparatus of claim 24, ~~further comprising~~ wherein at least one of the plurality of auxiliary input sources comprises a CD player, CD changer, MP3 player, satellite receiver, or a Digital Audio Broadcast (DAB) receiver connected to one of said plurality of auxiliary electrical connectors.

27. (Currently Amended) The apparatus of claim 24, wherein a device type of at least one of a the plurality of auxiliary input sources is automatically detected by the said interface and ~~the~~ at least one of a the plurality of auxiliary input sources is automatically integrated with a the car stereo based upon the device type.

28. (Currently Amended) The apparatus of claim 24, wherein the interface is switchable into an auxiliary input mode by issuing a control sequence at a the car stereo.

29. (Original) The apparatus of claim 28, wherein the control sequence comprises a track up command followed by a track down command.

30. (Currently Amended) A method for integrating an after-market device with a car stereo comprising:

providing an interface having a first electrical connector connectable to a car stereo, a second electrical connector connectable to an after-market device external to a the car stereo, a third electrical connector connectable to an auxiliary input source, and a pre-programmed microcontroller positioned within the said interface;

connecting the said first electrical connector to a the car stereo, the said second electrical connector to ~~an~~ the after-market device external to a the car stereo, and the said third electrical connector to ~~an~~ the auxiliary input source external to a the car stereo and ~~an~~ the after-market device;

remotely controlling the after-market device using the car stereo by:

receiving control commands from the car stereo at the interface through the said first electrical connector in a format incompatible with the after-market device; and

processing the control commands into formatted control commands compatible with the after-market device using a first pre-programmed code portion pre-programmed into and executed by ~~the~~ said microcontroller and dispatching the formatted control commands to the after-market device through ~~the~~ said second electrical connection;

receiving data in a format incompatible with the car stereo through ~~the~~ said second electrical connector and audio from the after-market device at the interface;

processing the data into formatted data compatible with the car stereo using a second pre-programmed code portion pre-programmed into and executed by the microcontroller and dispatching the audio and formatted data to the car stereo through ~~the~~ said first electrical connector;

displaying the formatted data on the car stereo and playing the audio through the car stereo; and

playing audio from the after-market device through the car stereo.

31. (Original) The method of claim 30, wherein the step of receiving data from the device comprises retrieving CD track and time information from the device.

32. (Original) The method of claim 30, wherein the step of receiving data from the device comprises retrieving MP3 song, title, track, and time information from the device.

33. (Original) The method of claim 30, wherein the step of receiving data from the device comprises retrieving channel number, channel name, artist, and song information from the device.

34. (Original) The method of claim 30, wherein the step of receiving data from the device comprises retrieving video information from the device.

35. (Previously Presented) The method of claim 30, wherein the step of displaying the formatted data comprises displaying the data in an LCD panel.

36. (Previously Presented) The method of claim 30, wherein the step of displaying the formatted data comprises displaying the data in a graphical user interface at the car stereo.

37. (Previously Presented) The method of claim 30, wherein the step of displaying formatted data comprises displaying video at the car stereo.

38. (Currently Amended) The method of claim 30, wherein the step of connecting the after-market device to the said second electrical connector comprises connecting a CD player, CD changer, MP3 player, satellite receiver, or a Digital Audio Broadcast (DAB) receiver to the said second electrical connector.

39. (Cancelled)

40. (Currently Amended) The method of claim 30, further comprising receiving a selection command from the car stereo and channeling data and audio from the auxiliary input source to ~~the~~ the said interface in response to the selection command.

41. (Original) The method of claim 40, further comprising processing the data from the auxiliary input source for display on the car stereo.

42. (Currently Amended) An apparatus for docking a portable device for integration with a car stereo comprising:

a storage area remote from a car stereo for storing a the portable device;

a docking portion within the storage area for communicating and physically mating with a the portable device;

a data port in communication with the docking portion, the data port connectable with a device for integrating a the portable device with a the car stereo; and

an interface connected to ~~the~~ the said data port and to a the car stereo, ~~the~~ the said interface channeling audio from a the portable device to a the car stereo, ~~the~~ the said interface including a

microcontroller in electrical communication with a the portable device through the said data port and a the car stereo, the said microcontroller ~~executing~~ pre-programmed to execute first program code for remotely controlling a the portable device using a the car stereo by processing control commands generated by a the car stereo in a format incompatible with a the portable device into formatted control commands compatible with a the portable device, and dispatching formatted control commands to a the portable device for execution thereby.

43. (Currently Amended) The apparatus of claim 42, wherein the said storage area further comprises a top member, a bottom member, and a hinge interconnecting the said top member and the said bottom member at an edge thereof.

44. (Previously Presented) The apparatus of claim 42, wherein the data port comprises an RS-232 or Universal Serial Bus (USB) port.

45. (Currently Amended) The apparatus of claim 42, wherein the storage area further comprises a top portion and a bottom portion defining a sleeve for holding a the portable device.

46. (Currently Amended) The apparatus of claim 43, further comprising a clasp for retaining the said top and bottom members in a closed position.

47. (Currently Amended) A method of integrating an after-market device with an Original Equipment Manufacturer (OEM) or after-market car stereo comprising:

providing an interface having a first electrical connector, a second electrical connector, and a microcontroller positioned in the said interface and in electrical communication with the said first and second electrical connectors;

connecting the after-market device to the said first electrical connector;

connecting the said second electrical connector to a the car stereo;

determining whether the car stereo is an OEM car stereo or an after-market car stereo;

generating and transmitting a device presence signal to the car stereo using a first code portion pre-programmed into and executed by the microcontroller to maintain the car stereo in an operational state responsive to signals generated by the after-market device, the device presence signal based upon the car stereo; and

channeling audio signals from the after-market device to the car stereo using the said interface.

48. (Currently Amended) The method of claim 47, further comprising receiving control commands from the car stereo at the said interface in a format incompatible with the after-market device.

49. (Currently Amended) The method of claim 48, further comprising converting the control commands into a format recognizable by the after-market audio device using a second code portion pre-programmed into and executed by the microcontroller.

50. (Original) The method of claim 49, further comprising dispatching formatted commands to the after-market audio device for execution thereby.

51. (Currently Amended) The method of claim 47, further comprising converting data received at the interface from the after-market audio device in a format incompatible with the car stereo into a format compatible with the car stereo using a third code portion pre-programmed into and executed by the microcontroller.

52. (Original) The method of claim 51, further comprising displaying formatted data on the car stereo.

53. (Original) The method of claim 52, wherein the step of displaying formatted data comprises displaying channel numbers, channel names, titles, tracks, song names, or artist names on the car stereo.

54. (Original) The method of claim 52, wherein the step of displaying formatted data comprises displaying video on the car stereo.

55. (Currently Amended) An audio device integration system comprising:

a first electrical connector connectable to a car stereo;

a second electrical connector connectable to a portable MP3 player external to a the car stereo;

an interface connected between the said first and second electrical connectors for transmitting audio from a portable MP3 player to a car stereo, the said interface including a microcontroller in electrical communication with the said first and second electrical connectors, the said microcontroller ~~executing:~~ pre-programmed to execute:

a first pre-programmed code portion for generating a device presence signal and transmitting the signal to a the car stereo to maintain a the car stereo in an operational state; and

a second pre-programmed code portion for remotely controlling ~~an~~ the MP3 player using a the car stereo by receiving a control command from a the car stereo through the said first electrical connector in a format incompatible with ~~an~~ the MP3 player, processing a the control command into a formatted control command compatible with ~~an~~ the MP3 player, and transmitting a the formatted control command to ~~an~~ the MP3 player through the said second electrical connector for execution by ~~an~~ the MP3 player.

56. (Currently Amended) The apparatus of claim 55, wherein the car stereo further ~~comprising~~ comprises an Original Equipment Manufacturer (OEM) car stereo, stereo connected to the first electrical connector.

57. (Currently Amended) The apparatus of claim 55, wherein the car stereo further ~~comprising~~ comprises an after-market car stereo connected to the first electrical connector.

58. (Cancelled)

59. (Currently Amended) The system of claim 55, wherein ~~the~~ said microcontroller ~~executes~~ is pre-programmed to execute a third code portion for receiving data from ~~an~~ the MP3 player in a format incompatible with a the car stereo, processing received data into formatted data compatible with a the car stereo, and transmitting formatted data to a the car stereo for display thereby.

60. (Currently Amended) The apparatus of claim 59, wherein ~~the~~ said third code portion processes data generated by ~~an~~ the MP3 player including track and time information.

61. (Currently Amended) The apparatus of claim 59, wherein ~~the~~ said third code portion processes data generated by ~~an~~ the MP3 player including song title and artist information.

62. (Currently Amended) The apparatus of claim 59, wherein commands are input by a user using one or more control buttons or presets on a the car stereo.

63. (Currently Amended) An audio device integration system comprising:

a first electrical connector connectable to a car stereo;

a second electrical connector connectable to a satellite radio receiver external to a the car stereo;

an interface connected between ~~the~~ said first and second electrical connectors for transmitting audio from a satellite radio receiver to a car stereo, the interface including a microcontroller in electrical communication with ~~the~~ said first and second electrical connectors, ~~the~~ said microcontroller ~~executing:~~ pre-programmed to execute:

a first pre-programmed code portion for generating a device presence signal and transmitting the signal to a the car stereo to maintain a the car stereo in an operational state; and

a second pre-programmed code portion for remotely controlling a the satellite radio receiver using a the car stereo by receiving a control command from a the car stereo through the said first electrical connector in a format incompatible with a the satellite radio receiver, processing a received control command into a formatted control command compatible with a the satellite radio receiver, and transmitting a the formatted control command to the satellite radio receiver through ~~the~~ said second electrical connector for execution by a the satellite radio receiver.

64. (Currently Amended) The apparatus of claim 63, wherein the car stereo further comprising comprises an Original Equipment Manufacturer (OEM) car stereo connected to ~~the~~ said first electrical connector.

65. (Currently Amended) The apparatus of claim 63, wherein the car stereo further comprising comprises an after-market car stereo connected to ~~the~~ said first electrical connector.

66. (Cancelled)

67. (Currently Amended) The system of claim 63, wherein ~~the~~ said microcontroller ~~executes~~ is pre-programmed to execute a third code portion for receiving data from a the satellite radio receiver in a format incompatible with a the car stereo, processing received data into formatted data compatible with a the car stereo, and transmitting formatted data to a the car stereo for display thereby.

68. (Currently Amended) The apparatus of claim 67, wherein ~~the~~ said third code portion processes data generated by a the satellite radio receiver including track and time information.

69. (Currently Amended) The apparatus of claim 67, wherein ~~the~~ said third code portion processes data generated by a the satellite radio receiver including song title and artist information.

70. (Currently Amended) The apparatus of claim 67, wherein ~~the~~ said third code portion processes data generated by a the satellite radio receiver including a channel number and a channel name.

71. (Currently Amended) The apparatus of claim 67, wherein commands are input by a user using one or more control buttons or presets on a the car stereo.

72. (Currently Amended) An audio device integration system comprising:

a first electrical connector connectable to a car stereo;

a second electrical connector connectable to a digital audio broadcast receiver external to a the car stereo;

an interface connected between ~~the~~ said first and second electrical connectors for transmitting audio from a the digital audio broadcast receiver to a the car stereo, ~~the~~ said interface including a microcontroller in electrical communication with ~~the~~ said first and second electrical connectors, ~~the~~ said microcontroller ~~executing;~~ pre-programmed to execute:

a first pre-programmed code portion for generating a device presence signal and transmitting the signal to a the car stereo to maintain a the car stereo in an operational state; and

a second pre-programmed code portion for remotely controlling a the digital audio broadcast receiver using a the car stereo by receiving a control command from a the car stereo through ~~the~~ said first electrical connector in a format incompatible with a the digital audio broadcast receiver, processing a received control command into a formatted control command compatible with a the digital audio broadcast receiver, and transmitting a the formatted control command to a the digital audio broadcast receiver through ~~the~~ said second electrical connector for execution by a the digital audio broadcast receiver.

73. (Currently Amended) The apparatus of claim 72, wherein the car stereo further comprising comprises an Original Equipment Manufacturer (OEM) car stereo connected to ~~the~~ said first electrical connector.

74. (Currently Amended) The apparatus of claim 72, wherein the car stereo further comprising comprises an after-market car stereo connected to ~~the~~ said first electrical connector.

75. (Cancelled)

76. (Currently Amended) The system of claim 72, wherein ~~the~~ said microcontroller executes is pre-programmed to execute a third code portion for receiving data from a the digital audio broadcast receiver in a format incompatible with a the car stereo, processing incompatible

data into formatted data compatible with a the car stereo, and transmitting formatted data to a the car stereo for display thereby.

77. (Currently Amended) The apparatus of claim 76, wherein ~~the~~ said third code portion processes data generated by the digital audio broadcast receiver including track and time information.

78. (Currently Amended) The apparatus of claim 76, wherein ~~the~~ said third code portion processes data generated by the digital audio broadcast receiver including song title and artist information.

79. (Currently Amended) The apparatus of claim 76, wherein ~~the~~ said third code portion processes data generated by the digital audio broadcast receiver including a channel number and a channel name.

80. (Currently Amended) The apparatus of claim 76, wherein commands are input by a user using one or more control buttons or presets on a the car stereo.

81. (Currently Amended) A device for integrating video information for use with a car stereo, comprising:

a first electrical connector connectable to a car stereo;

a second electrical connector connectable to an after-market video device external to a the car stereo;

an interface connected between the said first and second electrical connectors for transmitting video information from ~~an~~ the after-market video device to a the car stereo, the interface including a microcontroller in electrical communication with ~~the~~ said first and second electrical connectors, ~~the said~~ said microcontroller ~~executing:~~ pre-programmed to execute:

a first pre-programmed code portion for generating a device presence signal and transmitting the signal to a the car stereo through ~~the~~ said first electrical connector to maintain a the car stereo in an operational state responsive to signals generated by ~~an~~ the after-market video device.

82. (Currently Amended) The device of claim 81, further comprising means for converting video information into a format compatible with a the car stereo.

83. (Currently Amended) An audio device integration system comprising:

a car stereo;

a portable audio device external to the car stereo;

an interface connected between the car stereo and the portable audio device, the interface ~~including~~ including a microcontroller pre-programmed to execute:

first pre-programmed means for generating a device presence signal and transmitting the signal to the car stereo to maintain the car stereo in an operational state;

second pre-programmed means for remotely controlling the portable audio device using the car stereo by receiving a control command from the car stereo in a format incompatible with the portable audio device, processing the control command into a formatted control command compatible with the portable audio device, and transmitting the formatted control command to the portable audio device for execution thereby; and

means for transmitting audio from the portable audio device to the car stereo.

84. (Previously Presented) The apparatus of claim 83, wherein the portable audio device comprises a portable CD player.

85. (Previously Presented) The apparatus of claim 83, wherein the portable audio device comprises a portable MP3 player.

86. (Previously Presented) The apparatus of claim 83, wherein the portable audio device comprises a portable satellite receiver.

87. (Previously Presented) The apparatus of claim 83, wherein the portable audio device comprises a portable Digital Audio Broadcast (DAB) receiver.

88. (Currently Amended) The apparatus of claim 1, ~~wherein the second electrical connector comprises~~ further comprising a bus connection established between ~~an~~ the after-market audio device and ~~the~~ said interface.

89. (Previously Presented) The apparatus of claim 88, wherein the bus connection comprises a Universal Serial Bus (USB) connection.

90. (Currently Amended) The apparatus of claim 24, wherein at least one of the plurality of auxiliary input connectors comprises a bus connection established between at least one of a the plurality of auxiliary input sources and ~~the~~ said interface.

91. (Previously Presented) The apparatus of claim 90, wherein the bus connection comprises a Universal Serial Bus (USB) connection.

92. (Currently Amended) The apparatus of claim 55, ~~wherein the second electrical connector comprises~~ further comprising a bus connection established between ~~an~~ the MP3 player and ~~the~~ said interface.

93. (Previously Presented) The apparatus of claim 92, wherein the bus connection comprises a Universal Serial Bus (USB) connection.

94. (Currently Amended) The apparatus of claim 63, ~~wherein the second electrical connector comprises~~ further comprising a bus connection established between a the satellite radio receiver and ~~the~~ said interface.

95. (Previously Presented) The apparatus of claim 94, wherein the bus connection comprises a Universal Serial Bus (USB) connection.

96. (Currently Amended) The apparatus of claim 72, ~~wherein the second electrical connector comprises~~ further comprising a bus connection established between a the digital audio broadcast receiver and ~~the~~ said interface.

97. (Previously Presented) The apparatus of claim 96, wherein the bus connection comprises a Universal Serial Bus (USB) connection.

98. (Currently Amended) The apparatus of claim 81, ~~wherein the second electrical connection comprises~~ further comprising a bus connection established between a the video device and ~~the~~ said interface.

99. (Previously Presented) The apparatus of claim 98, wherein the bus connection comprises a Universal Serial Bus (USB) connection.

100. (Currently Amended) The apparatus of claim 83, wherein the second electrical connector comprises further comprising a bus connection established between a the portable audio device and the said interface.

101. (Previously Presented) The apparatus of claim 100, wherein the bus connection comprises a Universal Serial Bus (USB) connection.

102. (Currently Amended) The apparatus of claim 81, wherein ~~the~~ said microcontroller ~~executes~~ is pre-programmed to execute a second code portion for receiving a control signal from a the car stereo in a format incompatible with a the video device, processing a received control signal into a formatted control signal compatible with a the video device, and transmitting a the formatted control signal to a the video device for execution thereby.

103. (Currently Amended) The apparatus of claim 102, wherein ~~the~~ said microcontroller ~~executes~~ is pre-programmed to execute a third code portion for receiving data from a the video device incompatible with a the car stereo, processing received data into formatted data compatible with a the car stereo, and transmitting formatted data to a the car stereo for display thereon.

104. (Currently Amended) An audio device integration system, comprising:

a first electrical connector electrically connectable to a car stereo;

a second electrical connector electrically connectable to an after-market, line-level audio source external to a the car stereo; and

an interface connected between ~~the~~ said first and second electrical connectors for transmitting audio from ~~an~~ the after-market, line level audio source to a the car stereo, ~~the~~ said interface including a microcontroller in electrical communication with ~~the~~ said first and second electrical connectors, ~~the~~ said microcontroller ~~executing:~~ pre-programmed to execute:

a first pre-programmed code portion for generating and transmitting a device presence signal to a the car stereo through ~~the~~ said first electrical connector to maintain a the car stereo in an operational state responsive to signals generated by the ~~an~~ after-market, line-level audio source.

REMARKS

Attorney for Applicant has carefully reviewed the outstanding final Office Action on the above-identified application. Applicant has amended the claims, as set forth herein, and respectfully submits that the application, as amended, is in condition for allowance. A Request for Continued Examination (RCE) is being filed herewith.

Attorney for Application would like to thank Examiner Jason Kurr for the courtesies extended in a personal interview conducted with the Examiner on April 2, 2008.

In the personal interview, the references cited in the Office Action were discussed, as well as amendments to the claims. In particular, amendments to the claims to differentiate over the new primary references Owens, et al. and Beckert, et al., were discussed.

Applicant notes that the Interview Summary dated April 9, 2008 incorrectly indicated the date of the personal interview as March 2, 2008. It also incorrectly indicated that a personal copy of the Interview Summary was given to the undersigned, and did not reflect in the Substance of the Interview Summary that claim amendments were discussed which would overcome the cited references. The undersigned contacted Examiner Kurr to indicate these discrepancies, and it was agreed that the Examiner would issue another Interview Summary correcting the foregoing. To this end, a new Interview Summary, dated April 21, 2008, was prepared, which reflects the foregoing corrections.

In the interview, it was agreed that independent Claim 1 and its associated dependent Claims 2-13 and 15-23 would overcome the references cited in the Office Action if amended to recite that the microcontroller of the interface of the present invention is “**pre-programmed to execute** a first **pre-programmed** code portion for remotely controlling an after-market audio device... ; a second **pre-programmed** code portion for receiving data from an after-market audio device...; and a third **pre-programmed** code portion for switching between one or more auxiliary input sources....” In particular, at the interview, it was discussed that neither of the primary references (i.e., Owens, et al. and Beckert, et al.), nor any of the remaining references, taken alone or in combination, teach or suggest providing an interface having a pre-programmed microcontroller which executes pre-programmed code portions for integrating an after-market device for use with a car stereo. As such, Applicant believes that Claims 1-13 and 15-23 are in condition for allowance.

Claims 1-11, 13, 15-20, and 22-23 were also amended to overcome the rejections in the Office Action under 35 U.S.C. § 112 with respect to usage of the words “a” and “the,” to provide antecedent basis, and to address matters of form. Applicant has also introduced the word “said” into the claims to refer to elements which are positively claimed, and used the word “the” to refer to elements which are not positively claimed.

Applicant has also amended independent Claim 24 in a manner similar to the foregoing amendments to independent Claim 1. Specifically, independent Claim 24 was amended to recite that the interface of the present invention includes a microcontroller which is **pre-programmed to execute** first, second, and third **pre-programmed** code portions. Claims 24-28 were also

amended to overcome the rejections in the Office Action under 35 U.S.C. § 112, to provide antecedent basis, and to address matters of form. Accordingly, Applicant submits that Claims 24-29 are in condition for allowance.

Applicant has amended independent Claims 30 and 83 in a manner similar to independent Claims 1 and 24, in that Claims 30 and 83 now recite that the microcontroller is **pre-programmed to execute** first and second **pre-programmed** code portions. Claims 30, 38, 40, 83, 88, 90, 92, 94, 96, 98, 100, and 102-103 were also amended to overcome the rejections in the Office Action under 35 U.S.C. § 112, to provide antecedent basis, and to address matters of form. Accordingly, Applicant submits that Claims 30-41 and 83-103 are in condition for allowance.

Applicant has amended independent Claims 42, 55, 63, and 72 in a similar fashion, so that they now recite that the microcontroller is **pre-programmed to execute** a ... **pre-programmed** code portion for remotely controlling a device external to a car stereo. Claims 42-43, 45-46, 55-57, 59-65, 67-74, and 76-80 were also amended to overcome the rejections in the Office Action under 35 U.S.C. § 112, to provide antecedent basis, and to address matters of form. As such, Applicant submits that Claims 42-46, 55-57, 59-65, 67-74, and 76-80 are in condition for allowance.

Applicant has amended independent Claims 47, 81, and 104 to recite that the microcontroller is **pre-programmed to execute** a first **pre-programmed** code portion for generating a device presence signal ... to maintain a car stereo in a responsive state. Claims 47-

49, 51, 81-82, and 104 were also amended to overcome the rejections in the Office Action under 35 U.S.C. § 112, to provide antecedent basis, and to address matters of form. Accordingly, Applicant submits that Claims 47-54, 81-82, and 104 are in condition for allowance.

All issues raised in the Office Action are believed to have been addressed. Claims 1-11, 13, 15-20, 22-28, 30, 38, 40, 42-43, 45-49, 51, 55-57, 59-65, 67-74, 76-83, 88, 90, 92, 94, 96, 98, 100, and 102-104 were amended. No new matter is believed to have been added. Claims 1-13, 15-38, 40-57, 59-65, 67-74, and 76-104 are pending and are in condition for allowance. Reexamination is requested and favorable action solicited.

Respectfully submitted,



Mark E. Nikolsky
Reg. No. 48,319
McCarter & English, LLP
Four Gateway Center
100 Mulberry Street
Newark, NJ 07102-4056
Tel.: 973-639-6987
Fax.: 973-297-6624

Date: 4/21/2008

**TRANSMITTAL OF INFORMATION DISCLOSURE STATEMENT
(Under 37 CFR 1.97(b) or 1.97(c))**

Docket No.
99879-00005

In Re Application Of: **Ira Marlowe**

Application No.	Filing Date	Examiner	Customer No.	Group Art Unit	Confirmation No.
10/316,961	12/11/2002	Kurr, Jason R.	27614	2615	4879

Title: **Audio Device Integration System**

Address to:
**Commissioner for Patents
P.O. Box 1450
Alexandria, VA 22313-1450**

37 CFR 1.97(b)

1. The Information Disclosure Statement submitted herewith is being filed within three months of the filing of a national application other than a continued prosecution application under 37 CFR 1.53(d); within three months of the date of entry of the national stage as set forth in 37 CFR 1.491 in an international application; before the mailing of a first Office Action on the merits, or before the mailing of a first Office Action after the filing of a request for continued examination under 37 CFR 1.114.

37 CFR 1.97(c)

2. The Information Disclosure Statement submitted herewith is being filed after the period specified in 37 CFR 1.97(b), provided that the Information Disclosure Statement is filed before the mailing date of a Final Action under 37 CFR 1.113, a Notice of Allowance under 37 CFR 1.311, or an Action that otherwise closes prosecution in the application, and is accompanied by one of:
- the statement specified in 37 CFR 1.97(e);
- OR**
- the fee set forth in 37 CFR 1.17(p).

TRANSMITTAL OF INFORMATION DISCLOSURE STATEMENT
(Under 37 CFR 1.97(b) or 1.97(c))

Docket No.
99879-00005

In Re Application of: **Ira Marlowe**

Application No.	Filing Date	Examiner	Customer No.	Group Art Unit	Confirmation No.
10/316,961	12/11/2002	Kurr, Jason R.	27614	2615	4879

Title: **Audio Device Integration System**

Payment of Fee

(Only complete if Applicant elects to pay the fee set forth in 37 CFR 1.17(p))

- A check in the amount of _____ is attached.
- The Director is hereby authorized to charge and credit Deposit Account No. 503571 as described below.
 - Charge the amount of _____
 - Credit any overpayment.
 - Charge any additional fee required.
- Payment by credit card. Form PTO-2038 is attached.

WARNING: Information on this form may become public. Credit card information should not be included on this form. Provide credit card information and authorization on PTO-2038.

Certificate of Transmission by Facsimile*

I certify that this document and authorization to charge deposit account is being facsimile transmitted to the United States Patent and Trademark Office (Fa

(Date)

Signature

Typed or Printed Name of Person Signing Certificate

Certificate of Mailing by First Class Mail

I hereby certify that this correspondence is being deposited with the United States Postal Service with sufficient postage as first class mail in an envelope addressed to "Commissioner for Patents, P.O. Box 1450, Alexandria, VA 22313-1450" [37 CFR 1.8(a)] on

(Date)

Signature of Person Mailing Correspondence

Typed or Printed Name of Person Mailing Certificate

***This certificate may only be used if paying by deposit account.**

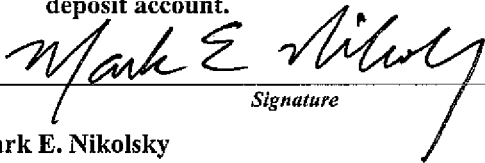
Signature

Dated: 4/21/2008

Mark E. Nikolsky
Registration No. 48,319
McCarter & English, LLP
Four Gateway Center
100 Mulberry Street
Newark, NJ 07102
Tel: (973) 639-6987
Fax: (973) 297-6624

CC:

Under the Paperwork Reduction Act of 1995, no persons are required to respond to a collection of information unless it contains a valid OMB control number.

Substitute for form 1449/PTO

**INFORMATION DISCLOSURE
STATEMENT BY APPLICANT**

(Use as many sheets as necessary)

Complete if Known

Sheet 1 of 3

Application Number	10/316,961
Filing Date	12/11/2002
First Named Inventor	Ira Marlowe
Art Unit	2615
Examiner Name	Kurr, Jason R.
Attorney Docket Number	99879-00005

U. S. PATENT DOCUMENTS						
Examiner initials*	Cite No. ¹	Document Number		Publication Date MM-DD-YYYY	Name of Patentee or Applicant of Cited Document	Pages, Columns, Lines, Where Relevant Passages or Relevant Figures Appear
		Number-Kind Code ² (if known)				
	1	US-	6,529,804	03/04/2003	Draggon, et al.	
	2	US-	6,058,319	05/02/2000	Sadler	
	3	US-	6,052,603	04/18/2000	Kinzalow, et al.	
	4	US-	5,794,164	08/11/1998	Beckert, et al.	
	5	US-	2004/0145457	07/29/2004	Schofield, et al.	
	6	US-	2004/0266336	12/30/2004	Patsiokas, et al.	
	7	US-	2002/0197954	12/26/2002	Schmitt, et al.	
	8	US-	2004/0151327	08/05/2004	Marlowe	
	9	US-	2005/0239434	10/27/2005	Marlowe	
	10	US-	2007/0015486	01/18/2007	Marlowe	
	11	US-	2007/0293183	12/20/2007	Marlowe	
		US-				
		US-				
		US-				
		US-				
		US-				
		US-				
		US-				
		US-				

FOREIGN PATENT DOCUMENTS							
Examiner Initials*	Cite No. ¹	Foreign Patent Document		Publication Date MM-DD-YYYY	Name of Patentee or Applicant of Cited Document	Pages, Columns, Lines, Where Relevant Passages Or Relevant Figures Appear	T ³
		Country Code ⁴ Number ⁴ Kind Code ⁵ (if known)					
	12	WO	2008/002954	01/03/2008	Ira Marlowe		
	13	WO	2006/094281	09/08/2006	Ira Marlowe		
	14	WO	2004/053722	06/24/2004	BlitzSafe of America, Inc		
	15	KR	1020010035788 English Abstract	05/07/2001	Gyu Jin Park		
	16	KR	1020010059192 English Abstract	07/06/2001	Hyundai Motor Company		

Examiner Signature	Date Considered
--------------------	-----------------

*EXAMINER: Initial if reference considered, whether or not citation is in conformance with MPEP 609. Draw line through citation if not in conformance and not considered. Include copy of this form with next communication to applicant. ¹ Applicant's unique citation designation number (optional). ² See Kinds Codes of USPTO Patent Documents at www.uspto.gov or MPEP 901.04. ³ Enter Office that issued the document, by the two-letter code (WIPO Standard ST.3). ⁴ For Japanese patent documents, the indication of the year of the reign of the Emperor must precede the serial number of the patent document. ⁵ Kind of document by the appropriate symbols as indicated on the document under WIPO Standard ST.16 if possible. ⁶ Applicant is to place a check mark here if English language translation is attached.

This collection of information is required by 37 CFR 1.97 and 1.98. The information is required to obtain or retain a benefit by the public which is to file (and by the USPTO to process) an application. Confidentiality is governed by 35 U.S.C. 122 and 37 CFR 1.14. This collection is estimated to take 2 hours to complete, including gathering, preparing, and submitting the completed application form to the USPTO. Time will vary depending upon the individual case. Any comments on the amount of time you require to complete this form and/or suggestions for reducing this burden, should be sent to the Chief Information Officer, U.S. Patent and Trademark Office, P.O. Box 1450, Alexandria, VA 22313-1450. DO NOT SEND FEES OR COMPLETED FORMS TO THIS ADDRESS. SEND TO: Commissioner for Patents, P.O. Box 1450, Alexandria, VA 22313-1450.

If you need assistance in completing the form, call 1-800-PTO-9199 (1-800-786-9199) and select option 2.

Under the Paperwork Reduction Act of 1995, no persons are required to respond to a collection of information unless it contains a valid OMB control number.

Substitute for form 1449/PTO INFORMATION DISCLOSURE STATEMENT BY APPLICANT <i>(Use as many sheets as necessary)</i>		Complete if Known	
		Application Number	10/316,961
		Filing Date	12/11/2002
		First Named Inventor	Ira Marlowe
		Art Unit	2615
		Examiner Name	Kurr, Jason R.
Sheet 2	of 3	Attorney Docket Number	99879-00005

NON PATENT LITERATURE DOCUMENTS			
Examiner Initials*	Cite No. ¹	Include name of the author (in CAPITAL LETTERS), title of the article (when appropriate), title of the item (book, magazine, journal, serial, symposium, catalog, etc.), date, page(s), volume-issue number(s), publisher, city and/or country where published.	T ²
	17	Copy of Office Action dated August 8, 2006, from co-pending Application Serial No.: 10/732,909 (29 pages)	
	18	Copy of Interview Summary dated December 15, 2006, from co-pending Application Serial No.: 10/732,909 (3 pages)	
	19	Copy of Interview Summary dated January 3, 2007, from co-pending Application Serial No.: 10/732,909 (3 pages)	
	20	Copy of Office Action dated April 20, 2007, from co-pending Application Serial No.: 10/732,909 (20 pages)	
	21	Copy of Office Action dated October 3, 2007, from co-pending Application Serial No.: 10/732,909 (28 pages)	
	22	Copy of Interview Summary dated October 26, 2007, from co-pending Application Serial No.: 10/732,909 (3 pages)	
	23	International Search Report of the International Searching Authority mailed May 12, 2004, issued in connection with International Patent Appln. No. PCT/US03/39493 (4 pages)	
	24	International Search Report of the International Searching Authority mailed Sept. 24, 2007, issued in connection with International Patent Appln. No. PCT/US06/008043 (4 pages)	
	25	Written Opinion of the International Searching Authority mailed Sept. 24, 2007, issued in connection with International Patent Appln. No. PCT/US06/008043 (5 pages)	
	26	International Preliminary Report on Patentability issued Oct. 16, 2007, issued in connection with International Patent Appln. No. PCT/US06/008043 (1 page)	

Examiner Signature	Date Considered
--------------------	-----------------

*EXAMINER: Initial if reference considered, whether or not citation is in conformance with MPEP 609. Draw line through citation if not in conformance and not considered. Include copy of this form with next communication to applicant.

¹ Applicant's unique citation designation number (optional). ² Applicant is to place a check mark here if English language Translation is attached. This collection of information is required by 37 CFR 1.98. The information is required to obtain or retain a benefit by the public which is to file (and by the USPTO to process) an application. Confidentiality is governed by 35 U.S.C. 122 and 37 CFR 1.14. This collection is estimated to take 2 hours to complete, including gathering, preparing, and submitting the completed application form to the USPTO. Time will vary depending upon the individual case. Any comments on the amount of time you require to complete this form and/or suggestions for reducing this burden, should be sent to the Chief Information Officer, U.S. Patent and Trademark Office, P.O. Box 1450, Alexandria, VA 22313-1450. DO NOT SEND FEES OR COMPLETED FORMS TO THIS ADDRESS. SEND TO: Commissioner for Patents, P.O. Box 1450, Alexandria, VA 22313-1450.

If you need assistance in completing the form, call 1-800-PTO-9199 (1-800-786-9199) and select option 2.

Under the Paperwork Reduction Act of 1995, no persons are required to respond to a collection of information unless it contains a valid OMB control number.

Substitute for form 1449/PTO INFORMATION DISCLOSURE STATEMENT BY APPLICANT (Use as many sheets as necessary)				Complete if Known			
				Application Number		10/316,961	
				Filing Date		12/11/2002	
				First Named Inventor		Ira Marlowe	
				Art Unit		2615	
				Examiner Name		Kurr, Jason R.	
Sheet	3	of	3	Attorney Docket Number		99879-00005	

NON PATENT LITERATURE DOCUMENTS			
Examiner Initials*	Cite No. ¹	Include name of the author (in CAPITAL LETTERS), title of the article (when appropriate), title of the item (book, magazine, journal, serial, symposium, catalog, etc.), date, page(s), volume-issue number(s), publisher, city and/or country where published.	T ²
	27	Russian Official Action with translation, issued by the Patent Office of the Russian Federation on Dec. 24, 2007, in connection with Russian App. No. 2006101060 (21 pages)	
	28	Written Opinion, mailed by the Australian Patent Office on Aug. 28, 2007, in connection with Singapore App. No. 200601303-1 (6 pages)	

Examiner Signature	Date Considered
--------------------	-----------------

*EXAMINER: Initial if reference considered, whether or not citation is in conformance with MPEP 609. Draw line through citation if not in conformance and not considered. Include copy of this form with next communication to applicant.
 1 Applicant's unique citation designation number (optional). 2 Applicant is to place a check mark here if English language Translation is attached.
 This collection of information is required by 37 CFR 1.98. The information is required to obtain or retain a benefit by the public which is to file (and by the USPTO to process) an application. Confidentiality is governed by 35 U.S.C. 122 and 37 CFR 1.14. This collection is estimated to take 2 hours to complete, including gathering, preparing, and submitting the completed application form to the USPTO. Time will vary depending upon the individual case. Any comments on the amount of time you require to complete this form and/or suggestions for reducing this burden, should be sent to the Chief Information Officer, U.S. Patent and Trademark Office, P.O. Box 1450, Alexandria, VA 22313-1450. DO NOT SEND FEES OR COMPLETED FORMS TO THIS ADDRESS. SEND TO: Commissioner for Patents, P.O. Box 1450, Alexandria, VA 22313-1450.

If you need assistance in completing the form, call 1-800-PTO-9199 (1-800-786-9199) and select option 2.

(19) World Intellectual Property Organization
International Bureau



(43) International Publication Date
3 January 2008 (03.01.2008)

PCT

(10) International Publication Number
WO 2008/002954 A2

- (51) International Patent Classification:
H05K 11/02 (2006.01) H04B 1/06 (2006.01)
- (21) International Application Number:
PCT/US2007/072182
- (22) International Filing Date: 27 June 2007 (27.06.2007)
- (25) Filing Language: English
- (26) Publication Language: English
- (30) Priority Data:
11/475,847 27 June 2006 (27.06.2006) US
11/805,799 24 May 2007 (24.05.2007) US

AT, AU, AZ, BA, BB, BG, BH, BR, BW, BY, BZ, CA, CH, CN, CO, CR, CU, CZ, DE, DK, DM, DO, DZ, EC, EE, EG, ES, FI, GB, GD, GE, GH, GM, GT, HN, HR, HU, ID, IL, IN, IS, JP, KE, KG, KM, KN, KP, KR, KZ, LA, LC, LK, LR, LS, LT, LU, LY, MA, MD, ME, MG, MK, MN, MW, MX, MY, MZ, NA, NG, NI, NO, NZ, OM, PG, PH, PL, PT, RO, RS, RU, SC, SD, SE, SG, SK, SL, SM, SV, SY, TJ, TM, TN, TR, TT, TZ, UA, UG, US, UZ, VC, VN, ZA, ZM, ZW.

- (71) Applicant and
- (72) Inventor: MARLOWE, Ira [US/US]; 6403 Hilltop Court, Fort Lee, NJ 07102 (US).

(84) Designated States (unless otherwise indicated, for every kind of regional protection available): ARIPO (BW, GH, GM, KE, LS, MW, MZ, NA, SD, SL, SZ, TZ, UG, ZM, ZW), Eurasian (AM, AZ, BY, KG, KZ, MD, RU, TJ, TM), European (AT, BE, BG, CH, CY, CZ, DE, DK, EE, ES, FI, FR, GB, GR, HU, IE, IS, IT, LT, LU, LV, MC, MT, NL, PL, PT, RO, SE, SI, SK, TR), OAPI (BF, BJ, CF, CG, CI, CM, GA, GN, GQ, GW, ML, MR, NE, SN, TD, TG).

- (74) Agent: FRISCIA, Michael, R.; Mccarter & English, LLP, Four Gateway Center, 100 Mulberry Street, Newark, NJ 07102 (US).

Published:
— without international search report and to be republished upon receipt of that report

- (81) Designated States (unless otherwise indicated, for every kind of national protection available): AE, AG, AL, AM,

For two-letter codes and other abbreviations, refer to the "Guidance Notes on Codes and Abbreviations" appearing at the beginning of each regular issue of the PCT Gazette.



WO 2008/002954 A2

(54) Title: MULTIMEDIA DEVICE INTEGRATION SYSTEM

(57) Abstract: A multimedia device integration system is provided. One or more after-market audio or video devices, such as a CD player, CD changer, digital media device, satellite receiver, DAB receiver, video device, digital camera, cellular telephone, portable navigation device, or any other device or combinations thereof, is integrated for use with an existing OEM or after-market car stereo or video system, wherein control commands can be issued at the car stereo or video system and data from the after-market device can be displayed on the car stereo or video system. Instructions generated at the car stereo or video system are received, processed, converted into a format recognizable by the after-market device, and dispatched to the after-market device for execution. Information from the after-market device is converted into a format recognizable by the car stereo or video system, and dispatched to the car stereo or video system for display thereon. The integration subsystem could be provided as an integrated circuit that can be installed in a car audiovisual system or a portable audiovisual device. A wireless or inductive battery charging circuit could be provided for wirelessly or inductively charging a battery of a portable after-market device.

MULTIMEDIA DEVICE INTEGRATION SYSTEM

SPECIFICATIONBACKGROUND OF THE INVENTIONFIELD OF THE INVENTION

The present invention relates to a multimedia device integration system. More specifically, the present invention relates to a multimedia device integration system for integrating after-market components such as satellite receivers, CD players, CD changers, digital media devices (*e.g.*, MP3 players, MP4 players, WMV players, Apple iPod devices, portable media centers, and other devices), Digital Audio Broadcast (DAB) receivers, auxiliary audio sources, video devices (*e.g.*, DVD players), cellular telephones, and other devices for use with factory-installed (OEM) or after-market car stereo and video systems.

RELATED ART

Automobile audio systems have continued to advance in complexity and the number of options available to automobile purchasers. Early audio systems offered a simple AM and/or FM tuner, and perhaps an analog tape deck for allowing cassettes, 8-tracks, and other types of tapes to be played while driving. Such early systems were closed, in that external devices could not be easily integrated therewith.

With advances in digital technology, CD players have been included with automobile audio systems. Original Equipment Manufacturers (OEMs) often produce car stereos having CD players and/or changers for allowing CDs to be played while driving. However, such systems often include proprietary buses and protocols that do not allow after-market audio systems, such as satellite receivers (*e.g.*, XM satellite tuners), digital audio broadcast (DAB) receivers, digital media players (*e.g.*, Apple iPod, MP3, MP4, WMV, etc.), CD changers, auxiliary input sources, video devices (*e.g.*, DVD players), cellular telephones, and the like, to be easily integrated therewith. Thus, automobile purchasers are frequently forced to either entirely replace the OEM audio system, or use same throughout the life of the vehicle or the duration of ownership. Even if the OEM radio is replaced with an after-market radio, the after-market radio also frequently is not operable with an external device.

A particular problem with integrating after-market audio and video systems with existing car stereo and video systems is that signals generated by both systems are in proprietary formats, and are not capable of being processed by the after-market system. Additionally, signals generated by the after-market system are also in a proprietary format that is not recognizable by the car stereo or video system. Thus, in order to integrate after-market systems with existing car stereo and video systems, it is necessary to convert signals between such systems.

It is known in the art to provide one or more expansion modules for OEM and after-market car stereos for allowing external audio products to be integrated with the car stereo. However, such expansion modules only operate with and allow integration of external audio products manufactured by the same manufacturer as the OEM / after-market car stereo. For example, a satellite receiver manufactured by PIONEER, Inc., cannot be integrated with an OEM car radio manufactured by TOYOTA or an after-market car radio manufactured by CLARION, Inc. Thus, existing expansion modules only serve the limited purpose of integrating equipment by the same manufacturer as the car stereo. Thus, it would be desirable to provide an integration system that allows any audio device of any manufacture to be integrated with any OEM or after-market radio system. Further, radio-frequency (RF) transmitters and cassette tape adapters have been developed for allowing music from a device external to a car radio, such as a portable CD player, to be played through the car radio using the FM receiver or the cassette deck of the radio. However, such systems are often prone to interference, and do not provide high fidelity.

Moreover, it would be desirable to provide an integration system that not only achieves integration of various audio and video devices that are alien to a given OEM or after-market car stereo or video system, but also allows for information to be exchanged between the after-market device and the car stereo or video system. For example, it would be desirable to provide a system wherein station, track, time, and song information can be retrieved from the after-market device, formatted, and transmitted to the car stereo or video system for display thereby, such as at an LCD panel of the car stereo or on one or more display panels of a car video system. Such information could be transmitted and displayed on both hardwired car stereo and video systems (*e.g.*, radios installed in dashboards or at other locations within the car), or integrated for display on one or more software or graphically-driven radio systems operable with graphical display panels.

Additionally, it would be desirable to provide a multimedia device integration system that allows a user to control more than one device, such as a CD or satellite receiver and one or more auxiliary sources, and to quickly and conveniently switch between same using the existing controls of the car stereo or video system. Still further, it would be desirable to provide a multimedia device integration system that allows for wireless integration of portable devices for use with car audio and/or video systems, wherein full remote control of the portable device is provided at the controls of the car system.

Accordingly, the present invention addresses these needs by providing a multimedia device integration system that allows a plurality of after-market devices, such as CD players, CD changers, digital media devices (*e.g.*, MP3 players, MP4 players, Apple iPod, WMV players, portable media centers, and other devices), satellite receivers, DAB receivers, auxiliary input sources, video devices (*e.g.*, DVD players), cellular telephones, digital cameras, portable navigation devices, or any combination thereof, to be integrated into existing car stereo and video systems while allowing information to be displayed on, and control to be provided from, the car stereo or video system.

SUMMARY OF THE INVENTION

The present invention relates to a multimedia device integration system. One or more after-market audio devices, such as CD players, CD changers, digital media devices (*e.g.*, MP3 players, MP4 players, WMV players, Apple iPod devices, portable media centers), digital cameras, satellite receivers (*e.g.*, XM or Sirius receivers), digital audio broadcast (DAB) receivers, portable navigation devices, or auxiliary input sources, can be connected to and operate with an existing stereo system in an automobile, such as an OEM car stereo system or an after-market car stereo system installed in the automobile. The integration system connects to and interacts with the car stereo at any available port of the car stereo, such as a CD input port, a satellite input, or other known type of connection. If the car stereo system is an after-market car stereo system, the present invention generates a signal that is sent to the car stereo to keep same in an operational state and responsive to external data and signals. Commands generated at the control panel are received by the present invention and converted into a format recognizable by the after-market device. The formatted commands are executed by the after-market device, and audio therefrom is channeled to the car stereo. Information from the after-market device is received by the present invention, converted into a format recognizable by the car stereo, and forwarded to the car stereo for display thereby. The formatted information could include information relating to a CD or MP3 track being played, channel, song, and artist information from a satellite receiver or DAB receiver, or video information from one or more external devices connected to the present invention. The information can be presented as one or more menus, textual, or graphical prompts for display on an LCD display of the radio, allowing interaction with the user at the radio. A docking port may be provided for allowing portable external audio devices to be connected to the interface of the present invention.

In an embodiment of the present invention, a dual-input device is provided for integrating both an external audio device and an auxiliary input with an OEM or after-market car stereo. The user can select between the external audio device and the auxiliary input using the controls of the car stereo. The invention can automatically detect the type of device connected to the auxiliary input, and integrate same with the car stereo.

In another embodiment of the present invention, an interface is provided for integrating a plurality of auxiliary input sources with an existing car stereo system. A user can select between the auxiliary sources using the control panel of the car stereo. One or

more after-market audio devices can be integrated with the auxiliary input sources, and a user can switch between the audio device and the auxiliary input sources using the car stereo. Devices connected to the auxiliary input sources are inter-operable with the car stereo, and are capable of exchanging commands and data via the interface.

In another embodiment of the present invention, an interface is provided for integrating an external device for use with a car stereo or video system, wherein the interface is positioned within the car stereo or video system. The system comprises a car stereo or video system; an after-market device external to the car stereo or video system; an interface positioned within the car stereo or video system and connected between the car stereo or video system and the after-market device for exchanging data and audio or video signals between the car stereo or video system and the after-market device; means for processing and dispatching commands for controlling the after-market device from the car stereo or video system in a format compatible with the after-market device; and means for processing and displaying data from the after-market device on a display of the car stereo or video system in a format compatible with the car stereo or video system. The after-market device could comprise one or more of a CD changer, CD player, satellite receiver (*e.g.*, XM or Sirius), digital media device (*e.g.*, MP3, MP4, WMV, or Apple iPod device), video device (*e.g.*, DVD player), cellular telephone, or any combination thereof.

In another embodiment of the present invention, an interface is provided for integrating a cellular telephone for use with a car stereo or video system. The system comprises a car stereo or video system; a cellular telephone external to the car stereo or video system; an interface connected between the car stereo or video system and the cellular telephone for exchanging data and audio or video signals between the car stereo or video system and the cellular telephone; means for processing and dispatching commands for controlling the cellular telephone from the car stereo or video system in a format compatible with the cellular telephone; and means for processing and displaying data from the cellular telephone on a display of the car stereo or video system in a format compatible with the car stereo or video system.

In another embodiment of the present invention, an interface is provided for integrating an external video system for use with a car video system. The system comprises a car video system; an after-market video device external to the car video

system; an interface connected between the car video system and the after-market video device for exchanging data, audio, and video signals between the car video system and the after-market video device; means for processing and dispatching commands for controlling the after-market video device from the car video system in a format compatible with the after-market video device; and means for processing and displaying data from the after-market video device on a display of the car video system in a format compatible with the car video system.

The present invention also provides an interface for integrating a plurality of after-market devices for use with a car stereo or video system using a single interface. In one embodiment, the system comprises an interface in electrical communication with a car stereo or video system and an after-market device; a plurality of configuration jumpers in the interface for specifying a first device type corresponding to the car stereo or video system and a second device type corresponding to the after-market device; and a plurality of protocol conversion software blocks stored in memory in the interface for converting signals from the after-market device into a first format compatible with the car stereo or video system and for converting signals from the car stereo or video system into a second format compatible with the after-market device, wherein at least one of the protocol conversion software blocks are selected by the interface using settings of the plurality of configuration jumpers. In another embodiment, the system comprises an interface in electrical communication with a car stereo or video system and an after-market device; first and second wiring harnesses attached to the interface, wherein the first wiring harness includes a first electrical configuration corresponding to the car stereo or video system and the second wiring harness includes a second electrical configuration corresponding to the after-market device; and a plurality of protocol conversion software blocks stored in memory in the interface for converting signals from the after-market device into a first format compatible with the car stereo or video system and for converting signals from the car stereo or video system into a second format compatible with the after-market device, wherein at least one of the protocol conversion software blocks are selected by the interface using the first and second electrical configurations of the first and second wiring harnesses. A plurality of wiring harnesses can be provided for integrating a plurality of devices.

The present invention also provides a method for integrating an after-market device for use with a car stereo or video system, comprising the steps of interconnecting the car stereo or video system and the after-market device with an interface; determining a first device type corresponding to the car stereo or video system and a second device type corresponding to the after-market device; loading a protocol conversion software block from memory in the interface using the first and second device types; converting signals from the after-market device into a first format compatible with the car stereo or video system using the protocol conversion software block; and converting signals from the car stereo or video system into a second format compatible with the after-market device using the protocol conversion software block.

The present invention further provides a multimedia device integration system that allows for the wireless integration of a portable audio and/or video device with a car audio and/or video system. The portable device could comprise a CD changer, CD player, satellite receiver (*e.g.*, XM or Sirius), digital media device (*e.g.*, MP3, MP4, WMV, or Apple iPod device), video device (*e.g.*, DVD player), or a cellular telephone. The portable device includes a wireless interface and an integration subsystem positioned within the portable device. The wireless interface establishes a wireless communications channel between the portable device and the car system, and allows for the wireless exchange of control commands, data, video, and audio signals between the portable device and the car system. The integration module receives control commands issued at the car system and transmitted over the wireless channel, processes same into a format compatible with the portable device, and dispatches same to the portable device for execution thereby. The integration module also receives data from the portable device (including, but not limited to, track information, song information, artist information, time information, and other related information), processes the data into a format compatible with the car system, and transmits same over the wireless channel to the car system for display thereon. Optionally, the integration module could be positioned within the car system.

The integration module could also include a voice recognition subsystem for acquiring spoken commands from a user, converting same into control commands compatible with the portable device, and dispatching the processed control commands to the portable device for execution thereby. The voice commands could be received at the

car audio and/or video system (i.e., using a microphone connected to the car audio and/or video system or some other vehicle component), or at the portable device (i.e., using a microphone connected to or forming a part of the portable device). Additionally, the integration module could include a speech synthesizer for generating synthesized speech for conveying data generated by the portable device to a user. The synthesized speech could be channeled to the car audio and/or video system by the integration module to be played through the car audio and/or video system.

The present invention further provides a multimedia device integration system that allows for the integration of a portable audio and/or video device with a car audio and/or video system using a docking slot provided in the car system. The portable device includes an integration module positioned within the portable device and an external interface for allowing electrical communication with the car system via the docking slot. Optionally, the integration module could be positioned within the car audio or video system. The integration module could also include a voice recognition subsystem for acquiring spoken commands from a user, converting same into control commands compatible with the portable device, and dispatching the processed control commands to the portable device for execution thereby. Additionally, the integration module could include a speech synthesizer for generating synthesized speech for conveying data generated by the portable device to a user.

The present invention also provides a multimedia device integration system which allows a digital camera, such as a still digital camera or a digital video camera, to be integrated for use with an existing car audiovisual system. Data, video, and/or audio from the digital camera is received by the interface, processed into a format compatible with the car audiovisual system, and transmitted thereto for display on and/or playing through the car audiovisual system. Control commands for controlling the digital camera, which can be issued at the car audiovisual system, are received by the interface, processed into a format compatible with the digital camera, and transmitted thereto for execution by the digital camera.

The present invention also provides a multimedia device integration system which allows a portable navigation device, such as a portable GPS receiver, to be integrated for use with an existing car audiovisual system. Data, video, and/or audio from the portable navigation device is received by the interface, processed into a format compatible with the

car audiovisual system, and transmitted thereto for display on and/or playing through the car audiovisual system. Control commands for controlling the portable navigation device, which can be issued at the car audiovisual system, are received by the interface, processed into a format compatible with the portable navigation device, and transmitted thereto for execution by the portable navigation device.

The present invention also provides an interface integrated circuit that allows for the integration of an external portable audio and/or video device with a car audiovisual system, and which can be installed within the car audiovisual system. The interface integrated circuit could communicate with the portable audio and/or video device using one or more communications ports or a wireless transceiver. A manufacturer of a car audiovisual system could be provided with the interface integrated circuit and an electrical schematic for installing same. The interface integrated circuit could be provided with pre-installed firmware for converting data, audio, and/or video signals generated by the portable audio and/or video device into a format compatible with the car audiovisual system, and for converting control commands issued by the car audiovisual system into a format compatible with the portable audio and/or video device for execution thereby. The integrated circuit could also be installed in the portable audio and/or video device, or it could be embodied as a software product which is functionally equivalent to the integrated circuit and which is executed by an existing microprocessor of either the car audiovisual system or the portable audio and/or video device.

BRIEF DESCRIPTION OF THE DRAWINGS

These and other important features of the present invention will be apparent from the following Detailed Description of the Invention, taken in connection with the accompanying drawings, in which:

FIG. 1 is a block diagram showing the multimedia device integration system of the present invention.

FIG. 2A is a block diagram showing an alternate embodiment of the multimedia device integration system of the present invention, wherein a CD player is integrated with a car radio.

FIG. 2B is a block diagram showing an alternate embodiment of the multimedia device integration system of the present invention, wherein a MP3 player is integrated with a car radio.

FIG. 2C is a block diagram showing an alternate embodiment of the multimedia device integration system of the present invention, wherein a satellite or DAB receiver is integrated with a car radio.

FIG. 2D is a block diagram showing an alternate embodiment of the multimedia device integration system of the present invention, wherein a plurality of auxiliary input sources are integrated with a car radio.

FIG. 2E is a block diagram showing an alternate embodiment of the multimedia device integration system of the present invention, wherein a CD player and a plurality of auxiliary input sources are integrated with a car radio.

FIG. 2F is a block diagram showing an alternate embodiment of the present invention, wherein a satellite or DAB receiver and a plurality of auxiliary input source are integrated with a car radio.

FIG. 2G is a block diagram showing an alternate embodiment of the present invention, wherein a MP3 player and a plurality of auxiliary input sources are integrated with a car radio.

FIG. 2H is a block diagram showing an alternate embodiment of the present invention, wherein a plurality of auxiliary interfaces and an audio device are integrated with a car stereo.

FIG. 3A is a circuit diagram showing a device according to the present invention for integrating a CD player or an auxiliary input source with a car radio.

FIG. 3B is a circuit diagram showing a device according to the present invention for integrating both a CD player and an auxiliary input source with a car radio, wherein the CD player and the auxiliary input are switchable by a user.

FIG. 3C is a circuit diagram showing a device according to the present invention for integrating a plurality of auxiliary input sources with a car radio.

FIG. 3D is a circuit diagram showing a device according to the present invention for integrating a satellite or DAB receiver with a car radio.

FIG. 4A is a flowchart showing processing logic according to the present invention for integrating a CD player with a car radio.

FIG. 4B is a flowchart showing processing logic according to the present invention for integrating a MP3 player with a car radio.

FIG. 4C is a flowchart showing processing logic according to the present invention for integrating a satellite receiver with a car radio.

FIG. 4D is a flowchart showing processing logic according to the present invention for integrating a plurality of auxiliary input sources with a car radio.

FIG. 4E is a flowchart showing processing logic according to the present invention for integrating a CD player and one or more auxiliary input sources with a car radio.

FIG. 4F is a flowchart showing processing logic according to the present invention for integrating a satellite or DAB receiver and one or more auxiliary input sources with a car radio.

FIG. 4G is a flowchart showing processing logic according to the present invention for integrating a MP3 player and one or more auxiliary input sources with a car stereo.

FIG. 5 is a flowchart showing processing logic according to the present invention for allowing a user to switch between an after-market audio device and one or more auxiliary input sources.

FIG. 6 is a flowchart showing processing logic according to the present invention for determining and handling various device types connected to the auxiliary input ports of the invention.

FIG. 7A is a perspective view of a docking station according to the present invention for retaining an audio device within a car.

FIG. 7B is an end view of the docking station of **FIG. 7A**.

FIGS. 8A-8B are perspective views of another embodiment of the docking station of the present invention, which includes the multimedia device integration system of the present invention incorporated therewith.

FIG. 9 is a block diagram showing the components of the docking station of **FIGS. 8A-8B**.

FIG. 10 is a block diagram showing an alternate embodiment of the multimedia device integration system of the present invention, wherein the interface is incorporated within a car stereo or car video system.

FIG. 11A is a diagram showing an alternate embodiment of the multimedia device integration system of the present invention for integrating a cellular telephone for use with a car stereo or video system; **FIG. 11b** is a flowchart showing processing logic for integrating a cellular telephone for use with a car stereo or video system.

FIG. 12A is a diagram showing an alternate embodiment of the multimedia device integration system of the present invention for integrating an after-market video device for use with a car video system; **FIG. 12B** is a flowchart showing processing logic for integrating an after-market video device for use with a car video system.

FIG. 13A is a block diagram showing an alternate embodiment of the multimedia device integration system of the present invention, wherein configuration jumpers and protocol conversion software blocks are provided for integrating after-market devices of various types using a single interface.

FIG. 13B is a block diagram showing an alternate embodiment of the multimedia device integration system of the present invention, wherein wiring harnesses and protocol conversion software blocks are provided for integrating after-market devices of various types using a single interface.

FIG. 14 is a flowchart showing processing logic of the multimedia device integration system of the present invention for integrating after-market devices of various types using a single interface.

FIG. 15 is a flowchart showing processing logic of the multimedia device integration system of the present invention for allowing a user to specify one or more after-market device types for integration using a single interface.

FIG. 16 is a flowchart showing processing logic of the multimedia device integration system of the present invention for allowing a user to quickly navigate through

a list of songs on one or more after-market devices using the controls of a car stereo or video system.

FIG. 17 is a diagram showing another embodiment of the present invention, wherein a plurality of external devices are integrated using a single interface.

FIG. 18 is a diagram showing another embodiment of the present invention, wherein wireless integration is provided between a car audio and/or video system and a portable audio and/or video device using a wireless transceiver and an integration module positioned within the portable device.

FIG. 19 is a diagram showing another embodiment of the present invention, wherein wireless integration is provided between a car audio and/or video system and a portable audio and/or video device using a wireless transceiver and an integration module positioned within the car audio and/or video system.

FIG. 20 is a diagram showing another embodiment of the present invention, wherein a docking slot is provided in a car audio and/or video system for receiving a portable audio and/or video device, and an integration module is positioned within the portable device.

FIG. 21 is a diagram showing another embodiment of the present invention, wherein a docking slot is provided in a car audio and/or video system for receiving a portable audio and/or video device, and an integration module is positioned within the car audio and/or video system.

FIG. 22 is a diagram showing another embodiment of the present invention, wherein wireless integration is provided between a car audio and/or video system and a portable audio and/or video device, and the portable device includes an integration module having speech synthesis and recognition capabilities.

FIG. 23 is a diagram showing another embodiment of the present invention, wherein wireless integration is provided between a car audio and/or video system and a portable audio and/or video device, and the car audio and/or video system includes an integration module having speech synthesis and recognition capabilities.

FIG. 24 is a flowchart showing processing logic according to the present invention for wirelessly integrating a portable audio and/or video device for use with a car audio or video system.

FIG. 25A is a diagram showing another embodiment of the multimedia device integration system of the present invention for integrating a digital camera for use with a car audiovisual system; **FIG. 25B** is a flowchart showing processing logic for integrating the digital camera for use with the car audiovisual system.

FIG. 26A is a diagram showing another embodiment of the multimedia device integration system of the present invention for integrating a portable navigation device for use with a car audiovisual system; **FIG. 26B** is a flowchart showing processing logic for integrating the portable navigation device for use with the car audiovisual system.

FIG. 27 is a diagram showing another embodiment of the multimedia device integration system of the present invention, wherein the integration system is provided as an integrated circuit installed within a car audiovisual system.

DETAILED DESCRIPTION OF THE INVENTION

The present invention relates to a multimedia device integration system. One or more after-market devices, such as a CD player, CD changer, digital media player (*e.g.*, MP3 player, MP4 player, WMV player, Apple iPod, portable media center, or other device), satellite receiver, digital audio broadcast (DAB) receiver, video device (*e.g.*, DVD player), cellular telephone, or the like, can be integrated with an existing car radio or car video device, such as an OEM or after-market car stereo or video system. Control of the after-market device is enabled using the car stereo or car video system, and information from the after-market device, such as channel, artist, track, time, song, and other information, is retrieved from the after-market device, processed, and forwarded to the car stereo or car video system for display thereon. The information channeled to the car stereo or video system can include video from the external device, as well as graphical and menu-based information. A user can review and interact with information via the car stereo. Commands from the car stereo or video system are received, processed by the present invention into a format recognizable by the after-market device, and transmitted thereto for execution. One or more auxiliary input channels can be integrated by the present invention with the car stereo or video system. The user can switch between one or more after-market devices and one or more auxiliary input channels using the control panel buttons of the car stereo or video system.

As used herein, the term “integration” or “integrated” is intended to mean connecting one or more external devices or inputs to an existing car stereo or video system via an interface, processing and handling signals, audio, and/or video information, allowing a user to control the devices via the car stereo or video system, and displaying data from the devices on the car stereo or video system. Thus, for example, integration of a CD player with a car stereo system allows for the CD player to be remotely controlled via the control panel of the stereo system, and data from the CD player to be sent to the display of the stereo. Of course, control of after-market devices can be provided at locations other than the control panel of the car stereo or video system without departing from the spirit or scope of the present invention. Further, as used herein, the term “interoperable” is intended to mean allowing the external audio or video device to receive and process commands that have been formatted by the interface of the present invention, as well as allowing a car stereo or video system to display information that is generated by

the external audio or video device and processed by the present invention. Additionally, by the term “inter-operable,” it is meant allowing a device that is alien to the environment of an existing OEM or after-market car stereo or video system to be utilized thereby.

Also, as used herein, the terms “car stereo” and “car radio” are used interchangeably and are intended to include all presently existing car stereos, radios, video systems, such as physical devices that are present at any location within a vehicle, in addition to software and/or graphically- or display-driven receivers. An example of such a receiver is a software-driven receiver that operates on a universal LCD panel within a vehicle and is operable by a user via a graphical user interface displayed on the universal LCD panel. Further, any future receiver, whether a hardwired or a software/graphical receiver operable on one or more displays, is considered within the definition of the terms “car stereo” and “car radio,” as used herein, and is within the spirit and scope of the present invention. Moreover, the term “car” is not limited to any specific type of automobile, but rather, includes all automobiles. Additionally, by the term “after-market,” it is meant any device not installed by a manufacturer at the time of sale of the car.

FIG. 1 is a block diagram showing the multimedia device integration (or interface) system of the present invention, generally indicated at **20**. A plurality of devices and auxiliary inputs can be connected to the interface **20**, and integrated with an OEM or after-market car radio **10**. A CD player or changer **15** can be integrated with the radio **10** via interface **20**. A satellite radio or DAB receiver **25**, such as an XM or Sirius radio satellite receiver or DAB receiver known in the art, could be integrated with the radio **10**, via the interface **20**. Further, an MP3 player **30** could also be integrated with the radio **10** via interface **20**. The MP3 player **30** could be any known digital media device, such as an Apple iPod or any other digital media device. Moreover, a plurality of auxiliary input sources, illustratively indicated as auxiliary input sources **35** (comprising input sources 1 through n , n being any number), could also be integrated with the car radio **10** via interface **20**. Optionally, a control head **12**, such as that commonly used with after-market CD changers and other similar devices, could be integrated with the car radio **10** via interface **20**, for controlling any of the car radio **10**, CD player/changer **15**, satellite/DAB receiver **25**, MP3 player **30**, and auxiliary input sources **35**. Thus, as can be readily appreciated, the interface **20** of the present invention allows for the integration of a multitude of devices and inputs with an OEM or after-market car radio or stereo.

FIG. 2A is a block diagram of an alternate embodiment of the multimedia device interface system of the present invention, wherein a CD player/changer **15** is integrated with an OEM or after-market car radio **10**. The CD player **15** is electrically connected with the interface **20**, and exchanges data and audio signals therewith. The interface **20** is electrically connected with the car radio **10**, and exchanges data and audio signals therewith. In a preferred embodiment of the present invention, the car radio **10** includes a display **13** (such as an alphanumeric, electroluminescent display) for displaying information, and a plurality of control panel buttons **14** that normally operate to control the radio **10**. The interface **20** allows the CD player **15** to be controlled by the control buttons **14** of the radio **10**. Further, the interface **20** allows information from the CD player **15**, such as track, disc, time, and song information, to be retrieved therefrom, processed and formatted by the interface **20**, sent to the display **13** of the radio **10**.

Importantly, the interface **20** allows for the remote control of the CD player **15** from the radio **10** (e.g., the CD player **15** could be located in the trunk of a car, while the radio **10** is mounted on the dashboard of the car). Thus, for example, one or more discs stored within the CD player **15** can be remotely selected by a user from the radio **10**, and tracks on one or more of the discs can be selected therefrom. Moreover, standard CD operational commands, such as pause, play, stop, fast forward, rewind, track forward, and track reverse (among other commands) can be remotely entered at the control panel buttons **14** of the radio **10** for remotely controlling the CD player **15**.

FIG. 2B is a block diagram showing an alternate embodiment of the present invention, wherein an MP3 player **30** is integrated with an OEM or after-market car radio **10** via interface **20**. As mentioned earlier, the interface **20** of the present invention allows for a plurality of disparate audio devices to be integrated with an existing car radio for use therewith. Thus, as shown in **FIG. 2B**, remote control of the MP3 player **30** via radio **10** is provided for via interface **20**. The MP3 player **30** is electronically interconnected with the interface **20**, which itself is electrically interconnected with the car radio **10**. The interface **20** allows data and audio signals to be exchanged between the MP3 player **30** and the car radio **10**, and processes and formats signals accordingly so that instructions and data from the radio **10** are processable by the MP3 player **30**, and vice versa. Operational commands, such as track selection, pause, play, stop, fast forward, rewind, and other commands, are entered via the control panel buttons **14** of car radio **10**, processed by the

interface **20**, and formatted for execution by the MP3 player **30**. Data from the MP3 player, such as track, time, and song information, is received by the interface **20**, processed thereby, and sent to the radio **10** for display on display **13**. Audio from the MP3 player **30** is selectively forwarded by the interface **20** to the radio **10** for playing.

FIG. 2C is a block diagram showing an alternate embodiment of the present invention, wherein a satellite receiver or DAB receiver **25** is integrated with an OEM or after-market car radio **10** via the interface **20**. Satellite/DAB receiver **25** can be any satellite radio receiver known in the art, such as XM or Sirius, or any DAB receiver known in the art. The satellite/DAB receiver **25** is electrically interconnected with the interface **20**, which itself is electrically interconnected with the car radio **10**. The satellite/DAB receiver **25** is remotely operable by the control panel buttons **14** of the radio **10**. Commands from the radio **10** are received by the interface **20**, processed and formatted thereby, and dispatched to the satellite/DAB receiver **25** for execution thereby. Information from the satellite/DAB receiver **25**, including time, station, and song information, is received by the interface **20**, processed, and transmitted to the radio **10** for display on display **13**. Further, audio from the satellite/DAB receiver **25** is selectively forwarded by the interface **20** for playing by the radio **10**.

FIG. 2D is a block diagram showing an alternate embodiment of the present invention, wherein one or more auxiliary input sources **35** are integrated with an OEM or after-market car radio **10**. The auxiliary inputs **35** can be connected to analog sources, or can be digitally coupled with one or more audio devices, such as after-market CD players, CD changers, MP3 players, satellite receivers, DAB receivers, and the like, and integrated with an existing car stereo. Preferably, four auxiliary input sources are connectable with the interface **20**, but any number of auxiliary input sources could be included. Audio from the auxiliary input sources **35** is selectively forwarded to the radio **10** under command of the user. As will be discussed herein in greater detail, a user can select a desired input source from the auxiliary input sources **35** by depressing one or more of the control panel buttons **14** of the radio **10**. The interface **20** receives the command initiated from the control panel, processes same, and connects the corresponding input source from the auxiliary input sources **35** to allow audio therefrom to be forwarded to the radio **10** for playing. Further, the interface **20** determines the type of audio devices connected to the auxiliary input ports **35**, and integrates same with the car stereo **10**.

As mentioned previously, the present invention allows one or more external audio devices to be integrated with an existing OEM or after-market car stereo, along with one or more auxiliary input sources, and the user can select between these sources using the controls of the car stereo. Such “dual input” capability allows operation with devices connected to either of the inputs of the device, or both. Importantly, the device can operate in “plug and play” mode, wherein any device connected to one of the inputs is automatically detected by the present invention, its device type determined, and the device automatically integrated with an existing OEM or after-market car stereo. Thus, the present invention is not dependent any specific device type to be connected therewith to operate. For example, a user can first purchase a CD changer, plug same into a dual interface, and use same with the car stereo. At a point later in time, the user could purchase an XM tuner, plug same into the device, and the tuner will automatically be detected and integrated with the car stereo, allowing the user to select from and operate both devices from the car stereo. It should be noted that such plug and play capability is not limited to a dual input device, but is provided for in every embodiment of the present invention. The dual-input configuration of the present invention is illustrated in **FIGS. 2E-2H** and described below.

FIG. 2E is a block diagram showing an alternate embodiment of the present invention, wherein an external CD player/changer **15** and one or more auxiliary input sources **35** are integrated with an OEM or after-market car stereo **10**. Both the CD player **15** and one or more of the auxiliary input sources **35** are electrically interconnected with the interface **20**, which, in turn, is electrically interconnected to the radio **10**. Using the controls **14** of the radio **10**, a user can select between the CD player **15** and one or more of the inputs **35** to selectively channel audio from these sources to the radio. The command to select from one of these sources is received by the interface **20**, processed thereby, and the corresponding source is channeled to the radio **10** by the interface **20**. As will be discussed later in greater detail, the interface **20** contains internal processing logic for selecting between these sources.

FIG. 2F is a block diagram of an alternate embodiment of the present invention, wherein a satellite receiver or DAB receiver and one or more auxiliary input sources are integrated by the interface **20** with an OEM or after-market car radio **10**. Similar to the embodiment of the present invention illustrated in **FIG. 2E** and described earlier, the

interface **20** allows a user to select between the satellite/DAB receiver **25** and one or more of the auxiliary input sources **35** using the controls **14** of the radio **10**. The interface **20** contains processing logic, described in greater detail below, for allowing switching between the satellite/DAB receiver **25** and one or more of the auxiliary input sources **35**.

FIG. 2G is a block diagram of an alternate embodiment of the present invention, wherein a MP3 player **30** and one or more auxiliary input sources **35** are integrated by the interface **20** with an OEM or after-market car radio **10**. Similar to the embodiments of the present invention illustrated in **FIGS. 2E** and **2F** and described earlier, the interface **20** allows a user to select between the MP3 player **30** and one or more of the auxiliary input sources **35** using the controls **14** of the radio **10**. The interface **20** contains processing logic, as will be discussed later in greater detail, for allowing switching between the MP3 player **30** and one or more of the auxiliary input sources **35**.

FIG. 2H is a block diagram showing an alternate embodiment of the present invention, wherein a plurality of auxiliary interfaces **40** and **44** and an audio device **17** are integrated with an OEM or after-market car stereo **10**. Importantly, the present invention can be expanded to allow a plurality of auxiliary inputs to be connected to the car stereo **10** in a tree-like fashion. Thus, as can be seen in **FIG. 2H**, a first auxiliary interface **40** is connected to the interface **20**, and allows data and audio from the ports **42** to be exchanged with the car radio **10**. Connected to one of the ports **42** is another auxiliary interface **44**, which, in turn, provides a plurality of input ports **46**. Any device connected to any of the ports **42** or **46** can be integrated with the car radio **10**. Further, any device connected to the ports **42** or **46** can be inter-operable with the car radio **10**, allowing commands to be entered from the car radio **10** (*e.g.*, such as via the control panel **14**) for commanding the device, and information from the device to be displayed by the car radio **10**. Conceivably, by configuring the interfaces **40**, **44**, and successive interfaces in a tree configuration, any number of devices can be integrated using the present invention.

The various embodiments of the present invention described above and shown in **FIGS. 1** through **2H** are illustrative in nature and are not intended to limit the spirit or scope of the present invention. Indeed, any conceivable audio device or input source, in any desired combination, can be integrated by the present invention into existing car stereo systems. Further, it is conceivable that not only can data and audio signals be exchanged between the car stereo and any external device, but also video information that can be

captured by the present invention, processed thereby, and transmitted to the car stereo for display thereby and interaction with a user thereat.

Various circuit configurations can be employed to carry out the present invention. Examples of such configurations are described below and shown in **FIGS. 3A-3D**.

FIG. 3A is an illustrative circuit diagram according to the present invention for integrating a CD player or an auxiliary input source with an existing car stereo system. A plurality of ports **J1C1**, **J2A1**, **X2**, **RCH**, and **LCH** are provided for allowing connection of the interface system of the present invention between an existing car radio, an after-market CD player or changer, or an auxiliary input source. Each of these ports could be embodied by any suitable electrical connector known in the art. Port **J1C1** connects to the input port of an OEM car radio, such as that manufactured by TOYOTA, Inc. Conceivably, port **J1C1** could be modified to allow connection to the input port of an after-market car radio. Ports **J2A1**, **X2**, **RCH**, and **LCH** connect to an after-market CD changer, such as that manufactured by PANASONIC, Inc., or to an auxiliary input source.

Microcontroller **U1** is in electrical communication with each of the ports **J1C1**, **J2A1**, and **X2**, and provides functionality for integrating the CD player or auxiliary input source connected to the ports **J2A1**, **X2**, **RCH**, and **LCH**. For example, microcontroller **U1** receives control commands, such as button or key sequences, initiated by a user at control panel of the car radio and received at the connector **J1C1**, processes and formats same, and dispatches the formatted commands to the CD player or auxiliary input source via connector **J2A1**. Additionally, the microcontroller **U1** receives information provided by the CD player or auxiliary input source via connector **J2A1**, processes and formats same, and transmits the formatted data to the car stereo via connector **J1C1** for display on the display of the car stereo. Audio signals provided at the ports **J2A1**, **X2**, **RCH** and **LCH** is selectively channeled to the car radio at port **J1C1** under control of one or more user commands and processing logic, as will be discussed in greater detail, embedded within microcontroller **U1**.

In a preferred embodiment of the present invention, the microcontroller **U1** comprises the 16F628 microcontroller manufactured by MICROCHIP, Inc. The 16F628 chip is a CMOS, flash-based, 8-bit microcontroller having an internal, 4 MHz internal oscillator, 128 bytes of EEPROM data memory, a capture/compare/PWM, a USART, 2 comparators, and a programmable voltage reference. Of course, any suitable

microcontroller known in the art can be substituted for microcontroller **U1** without departing from the spirit or scope of the present invention.

A plurality of discrete components, such as resistors **R1** through **R13**, diodes **D1** through **D4**, capacitors **C1** and **C2**, and oscillator **Y1**, among other components, are provided for interfacing the microcontroller **U1** with the hardware connected to the connectors **J1C1**, **J2A1**, **X2**, **RCH**, and **LCH**. These components, as will be readily appreciated to one of ordinary skill in the art, can be arranged as desired to accommodate a variety of microcontrollers, and the numbers and types of discrete components can be varied to accommodate other similar controllers. Thus, the circuit shown in **FIG. 3A** and described herein is illustrative in nature, and modifications thereof are considered to be within the spirit and scope of the present invention.

FIG. 3B is a diagram showing an illustrative circuit configuration according to the present invention, wherein one or more after-market CD changers / players and an auxiliary input source are integrated with an existing car stereo, and wherein the user can select between the CD changer/player and the auxiliary input using the controls of the car stereo. A plurality of connectors are provided, illustratively indicated as ports **J4A**, **J4B**, **J3**, **J5L1**, **J5R1**, **J1**, and **J2**. Ports **J4A**, **J4B**, and **J3** allow the audio device interface system of the present invention to be connected to one or more existing car stereos, such as an OEM car stereo or an after-market car stereo. Each of these ports could be embodied by any suitable electrical connector known in the art. For example, ports **J4A** and **J4B** can be connected to an OEM car stereo manufactured by BMW, Inc. Port **J3** can be connected to a car stereo manufactured by LANDROVER, Inc. Of course, any number of car stereos, by any manufacturer, could be provided. Ports **J1** and **J2** allow connection to an after-market CD changer or player, such as that manufactured by ALPINE, Inc., and an auxiliary input source. Optionally, ports **J5L1** and **J5R1** allow integration of a standard analog (line-level) source. Of course, a single standalone CD player or auxiliary input source could be connected to either of ports **J1** or **J2**.

Microcontroller **DD1** is in electrical communication with each of the ports **J4A**, **J4B**, **J3**, **J5L1**, **J5R1**, **J1**, and **J2**, and provides functionality for integrating the CD player and auxiliary input source connected to the ports **J1** and **J2** with the car stereo connected to the ports **J4A** and **J4B** or **J3**. For example, microcontroller **DD1** receives control commands, such as button or key sequences, initiated by a user at control panel of the car

radio and received at the connectors **J4A** and **J4B** or **J3**, processes and formats same, and dispatches the formatted commands to the CD player and auxiliary input source via connectors **J1** or **J2**. Additionally, the microcontroller **DD1** receives information provided by the CD player and auxiliary input source via connectors **J1** or **J2**, processes and formats same, and transmits the formatted data to the car stereo via connectors **J4A** and **J4B** or **J3** for display on the display of the car stereo. Further, the microcontroller **DD1** controls multiplexer **DA3** to allow selection between the CD player/changer and the auxiliary input. Audio signals provided at the ports **J1**, **J2**, **J5L1** and **J5R1** is selectively channeled to the car radio at ports **J4A** and **J4B** or **J3** under control of one or more user commands and processing logic, as will be discussed in greater detail, embedded within microcontroller **DD1**.

In a preferred embodiment of the present invention, the microcontroller **DD1** comprises the 16F872 microcontroller manufactured by MICROCHIP, Inc. The 16F872 chip is a CMOS, flash-based, 8-bit microcontroller having 64 bytes of EEPROM data memory, self-programming capability, an ICD, 5 channels of 10 bit Analog-to-Digital (A/D) converters, 2 timers, capture/compare/PWM functions, a USART, and a synchronous serial port configurable as either a 3-wire serial peripheral interface or a 2-wire inter-integrated circuit bus. Of course, any suitable microcontroller known in the art can be substituted for microcontroller **DD1** without departing from the spirit or scope of the present invention. Additionally, in a preferred embodiment of the present invention, the multiplexer **DA3** comprises the CD4053 triple, two-channel analog multiplexer/demultiplexer manufactured by FAIRCHILD SEMICONDUCTOR, Inc. Any other suitable multiplexer can be substituted for **DA3** without departing from the spirit or scope of the present invention.

A plurality of discrete components, such as resistors **R1** through **R18**, diodes **D1** through **D3**, capacitors **C1-C11**, and **G1-G3**, transistors **Q1-Q3**, transformers **T1** and **T2**, amplifiers **LCH:A** and **LCH:B**, oscillator **XTAL1**, among other components, are provided for interfacing the microcontroller **DD1** and the multiplexer **DA3** with the hardware connected to the connectors **J4A**, **J4B**, **J3**, **J5L1**, **J5R1**, **J1**, and **J2**. These components, as will be readily appreciated to one of ordinary skill in the art, can be arranged as desired to accommodate a variety of microcontrollers and multiplexers, and the numbers and types of discrete components can be varied to accommodate other similar

controllers and multiplexers. Thus, the circuit shown in **FIG. 3B** and described herein is illustrative in nature, and modifications thereof are considered to be within the spirit and scope of the present invention.

FIG. 3C is a diagram showing an illustrative circuit configuration for integrating a plurality of auxiliary inputs using the controls of the car stereo. A plurality of connectors are provided, illustratively indicated as ports **J1**, **RCH1**, **LCH1**, **RCH2**, **LCH2**, **RCH3**, **LCH3**, **RCH4**, and **LCH4**. Port **J1** allows the multimedia device integration system of the present invention to be connected to one or more existing car stereos. Each of these ports could be embodied by any suitable electrical connector known in the art. For example, port **J1** could be connected to an OEM car stereo manufactured by HONDA, Inc., or any other manufacturer. Ports **RCH1**, **LCH1**, **RCH2**, **LCH2**, **RCH3**, **LCH3**, **RCH4**, and **LCH4** allow connection with the left and right channels of four auxiliary input sources. Of course, any number of auxiliary input sources and ports/connectors could be provided.

Microcontroller **U1** is in electrical communication with each of the ports **J1**, **RCH1**, **LCH1**, **RCH2**, **LCH2**, **RCH3**, **LCH3**, **RCH4**, and **LCH4**, and provides functionality for integrating one or more auxiliary input sources connected to the ports **RCH1**, **LCH1**, **RCH2**, **LCH2**, **RCH3**, **LCH3**, **RCH4**, and **LCH4** with the car stereo connected to the port **J1**. Further, the microcontroller **U1** controls multiplexers **DA3** and **DA4** to allow selection amongst any of the auxiliary inputs using the controls of the car stereo. Audio signals provided at the ports **RCH1**, **LCH1**, **RCH2**, **LCH2**, **RCH3**, **LCH3**, **RCH4**, and **LCH4** are selectively channeled to the car radio at port **J1** under control of one or more user commands and processing logic, as will be discussed in greater detail, embedded within microcontroller **U1**. In a preferred embodiment of the present invention, the microcontroller **U1** comprises the 16F872 microcontroller discussed earlier. Additionally, in a preferred embodiment of the present invention, the multiplexers **DA3** and **DA4** comprises the CD4053 triple, two-channel analog multiplexer/demultiplexer, discussed earlier. Any other suitable microcontroller and multiplexers can be substituted for **U1**, **DA3**, and **DA4** without departing from the spirit or scope of the present invention.

A plurality of discrete components, such as resistors **R1** through **R15**, diodes **D1** through **D3**, capacitors **C1-C5**, transistors **Q1-Q2**, amplifiers **DA1:A** and **DA1:B**, and oscillator **Y1**, among other components, are provided for interfacing the microcontroller

U1 and the multiplexers **DA3** and **DA4** with the hardware connected to the ports **J1**, **RCH1**, **LCH1**, **RCH2**, **LCH2**, **RCH3**, **LCH3**, **RCH4**, and **LCH4**. These components, as will be readily appreciated to one of ordinary skill in the art, can be arranged as desired to accommodate a variety of microcontrollers and multiplexers, and the numbers and types of discrete components can be varied to accommodate other similar controllers and multiplexers. Thus, the circuit shown in **FIG. 3C** and described herein is illustrative in nature, and modifications thereof are considered to be within the spirit and scope of the present invention.

FIG. 3D is an illustrative circuit diagram according to the present invention for integrating a satellite receiver with an existing OEM or after-market car stereo system. Ports **J1** and **J2** are provided for allowing connection of the integration system of the present invention between an existing car radio and a satellite receiver. These ports could be embodied by any suitable electrical connector known in the art. Port **J2** connects to the input port of an existing car radio, such as that manufactured by KENWOOD, Inc. Port **J1** connects to an after-market satellite receiver, such as that manufactured by PIONEER, Inc.

Microcontroller **U1** is in electrical communication with each of the ports **J1** and **J2**, and provides functionality for integrating the satellite receiver connected to the port **J1** with the car stereo connected to the port **J2**. For example, microcontroller **U1** receives control commands, such as button or key sequences, initiated by a user at control panel of the car radio and received at the connector **J2**, processes and formats same, and dispatches the formatted commands to the satellite receiver via connector **J2**. Additionally, the microcontroller **U1** receives information provided by the satellite receiver via connector **J1**, processes and formats same, and transmits the formatted data to the car stereo via connector **J2** for display on the display of the car stereo. Audio signals provided at the port **J1** is selectively channeled to the car radio at port **J2** under control of one or more user commands and processing logic, as will be discussed in greater detail, embedded within microcontroller **U1**.

In a preferred embodiment of the present invention, the microcontroller **U1** comprises the 16F873 microcontroller manufactured by MICROCHIP, Inc. The 16F873 chip is a CMOS, flash-based, 8-bit microcontroller having 128 bytes of EEPROM data memory, self-programming capability, an ICD, 5 channels of 10 bit Analog-to-Digital (A/D) converters, 2 timers, 2 capture/compare/PWM functions, a synchronous serial port

that can be configured as either a 3-wire serial peripheral interface or a 2-wire inter-integrated circuit bus, and a USART. Of course, any suitable microcontroller known in the art can be substituted for microcontroller **U1** without departing from the spirit or scope of the present invention.

A plurality of discrete components, such as resistors **R1** through **R7**, capacitors **C1** and **C2**, and amplifier **A1**, among other components, are provided for interfacing the microcontroller **U1** with the hardware connected to the connectors **J1** and **J2**. These components, as will be readily appreciated to one of ordinary skill in the art, can be arranged as desired to accommodate a variety of microcontrollers, and the numbers and types of discrete components can be varied to accommodate other similar controllers. Thus, the circuit shown in **FIG. 3D** and described herein is illustrative in nature, and modifications thereof are considered to be within the spirit and scope of the present invention.

FIGS. 4A through **6** are flowcharts showing processing logic according to the present invention. Such logic can be embodied as software and/or instructions stored in a read-only memory circuit (*e.g.*, and EEPROM circuit), or other similar device. In a preferred embodiment of the present invention, the processing logic described herein is stored in one or more microcontrollers, such as the microcontrollers discussed earlier with reference to **FIGS. 3A-3D**. Of course, any other suitable means for storing the processing logic of the present invention can be employed.

FIG. 4A is a flowchart showing processing logic, indicated generally at **100**, for integrating a CD player or changer with an existing OEM or after-market car stereo system. Beginning in step **100**, a determination is made as to whether the existing car stereo is powered on. If a negative determination is made, step **104** is invoked, wherein the present invention enters a standby mode and waits for the car stereo to be powered on. If a positive determination is made, step **106** is invoked, wherein a second determination is made as to whether the car stereo is in a state responsive to signals external to the car stereo. If a negative determination is made, step **106** is re-invoked.

If a positive determination is made in step **106**, a CD handling process, indicated as block **108**, is invoked, allowing the CD player/changer to exchange data and audio signals with any existing car stereo system. Beginning in step **110**, a signal is generated by the present invention indicating that a CD player/changer is present, and the signal is

continuously transmitted to the car stereo. Importantly, this signal prevents the car stereo from shutting off, entering a sleep mode, or otherwise being unresponsive to signals and/or data from an external source. If the car radio is an OEM car radio, the CD player presence signal need not be generated. Further, the signal need not be limited to a CD player device presence signal, but rather, could be any type of device presence signal (*e.g.*, MP3 player device presence signal, satellite receiver presence signal, video device presence signal, cellular telephone presence signal, or any other type of device presence signal). Concurrently with step 110, or within a short period of time before or after the execution of step 110, steps 112 and 114 are invoked. In step 112, the audio channels of the CD player/changer are connected (channeled) to the car stereo system, allowing audio from the CD player/changer to be played through the car stereo. In step 114, data is retrieved by the present invention from the CD player/changer, including track and time information, formatted, and transmitted to the car stereo for display by the car stereo. Thus, information produced by the external CD player/changer can be quickly and conveniently viewed by a driver by merely viewing the display of the car stereo. After steps 110, 112, and 114 have been executed, control passes to step 116.

In steps 116, the present invention monitors the control panel buttons of the car stereo for CD operational commands. Examples of such commands include track forward, track reverse, play, stop, fast forward, rewind, track program, random track play, and other similar commands. In step 118, if a command is not detected, step 116 is re-invoked. Otherwise, if a command is received, step 118 invokes step 120, wherein the received command is converted into a format recognizable by the CD player/changer connected to the present invention. For example, in this step, a command issued from a GM car radio is converted into a format recognizable by a CD player/changer manufactured by ALPINE, Inc. Any conceivable command from any type of car radio can be formatted for use by a CD player/changer of any type or manufacture. Once the command has been formatted, step 122 is invoked, wherein the formatted command is transmitted to the CD player/changer and executed. Step 110 is then re-invoked, so that additional processing can occur.

FIG. 4B is a flowchart showing processing logic, indicated generally at 130, for integrating an MP3 player with an existing car stereo system. Examples of MP3 players that can be integrated by the present invention include, but are not limited to, the Apple

iPod and other types of digital media devices. Beginning in step **132**, a determination is made as to whether the existing car stereo is powered on. If a negative determination is made, step **134** is invoked, wherein the present invention enters a standby mode and waits for the car stereo to be powered on. If a positive determination is made, step **136** is invoked, wherein a second determination is made as to whether the car stereo is in a state responsive to signals external to the car stereo. If a negative determination is made, step **136** is re-invoked.

If a positive determination is made in step **136**, an MP3 handling process, indicated as block **138**, is invoked, allowing the MP3 player to exchange data and audio signals with any existing car stereo system. Beginning in step **140**, a signal is generated by the present invention indicating that an MP3 player is present, and the signal is continuously transmitted to the car stereo. Importantly, this signal prevents the car stereo from shutting off, entering a sleep mode, or otherwise being unresponsive to signals and/or data from an external source. In step **142**, the audio channels of the MP3 player are connected (channeled) to the car stereo system, allowing audio from the MP3 player to be played through the car stereo. In step **144**, data is retrieved by the present invention from the MP3 player, including track, time, title, and song information, formatted, and transmitted to the car stereo for display by the car stereo. Thus, information produced by the MP3 player can be quickly and conveniently viewed by a driver by merely viewing the display of the car stereo. After steps **140**, **142**, and **144** have been executed, control passes to step **146**.

In steps **146**, the present invention monitors the control panel buttons of the car stereo for MP3 operational commands. Examples of such commands include track forward, track reverse, play, stop, fast forward, rewind, track program, random track play, and other similar commands. In step **148**, if a command is not detected, step **146** is re-invoked. Otherwise, if a command is received, step **148** invokes step **150**, wherein the received command is converted into a format recognizable by the MP3 player connected to the present invention. For example, in this step, a command issued from a HONDA car radio is converted into a format recognizable by an MP3 player manufactured by PANASONIC, Inc. Any conceivable command from any type of car radio can be formatted for use by an MP3 player of any type or manufacture. Once the command has been formatted, step **152** is invoked, wherein the formatted command is transmitted to the

MP3 player and executed. Step **140** is then re-invoked, so that additional processing can occur.

FIG. 4C is a flowchart showing processing logic, indicated generally at **160**, for integrating a satellite receiver or a DAB receiver with an existing car stereo system. Beginning in step **162**, a determination is made as to whether the existing car stereo is powered on. If a negative determination is made, step **164** is invoked, wherein the present invention enters a standby mode and waits for the car stereo to be powered on. If a positive determination is made, step **166** is invoked, wherein a second determination is made as to whether the car stereo is in a state responsive to signals external to the car stereo. If a negative determination is made, step **166** is re-invoked.

If a positive determination is made in step **166**, a satellite/DAB receiver handling process, indicated as block **168**, is invoked, allowing the satellite/DAB receiver to exchange data and audio signals with any existing car stereo system. Beginning in step **170**, a signal is generated by the present invention indicating that a satellite or DAB receiver is present, and the signal is continuously transmitted to the car stereo. Importantly, this signal prevents the car stereo from shutting off, entering a sleep mode, or otherwise being unresponsive to signals and/or data from an external source. In step **172**, the audio channels of the satellite/DAB receiver are connected (channeled) to the car stereo system, allowing audio from the satellite receiver or DAB receiver to be played through the car stereo. In step **174**, data is retrieved by the present invention from the satellite/DAB receiver, including channel number, channel name, artist name, song time, and song title, formatted, and transmitted to the car stereo for display by the car stereo. The information could be presented in one or more menus, or via a graphical interface viewable and manipulable by the user at the car stereo. Thus, information produced by the receiver can be quickly and conveniently viewed by a driver by merely viewing the display of the car stereo. After steps **170**, **172**, and **174** have been executed, control passes to step **176**.

In steps **176**, the present invention monitors the control panel buttons of the car stereo for satellite/DAB receiver operational commands. Examples of such commands include station up, station down, station memory program, and other similar commands. In step **178**, if a command is not detected, step **176** is re-invoked. Otherwise, if a command is received, step **178** invokes step **180**, wherein the received command is

converted into a format recognizable by the satellite/DAB receiver connected to the present invention. For example, in this step, a command issued from a FORD car radio is converted into a format recognizable by a satellite receiver manufactured by PIONEER, Inc. Any conceivable command from any type of car radio can be formatted for use by a satellite/DAB receiver of any type or manufacture. Once the command has been formatted, step **182** is invoked, wherein the formatted command is transmitted to the satellite/DAB receiver and executed. Step **170** is then re-invoked, so that additional processing can occur.

FIG. 4D is a flowchart showing processing logic, indicated generally at **190**, for integrating a plurality of auxiliary input sources with a car radio. Beginning in step **192**, a determination is made as to whether the existing car stereo is powered on. If a negative determination is made, step **194** is invoked, wherein the present invention enters a standby mode and waits for the car stereo to be powered on. If a positive determination is made, step **196** is invoked, wherein a second determination is made as to whether the car stereo is in a state responsive to signals external to the car stereo. If a negative determination is made, step **196** is re-invoked.

If a positive determination is made in step **196**, an auxiliary input handling process, indicated as block **198**, is invoked, allowing one or more auxiliary inputs to be connected (channeled) to the car stereo. Further, if a plurality of auxiliary inputs exist, the logic of block **198** allows a user to select a desired input from the plurality of inputs. Beginning in step **200**, a signal is generated by the present invention indicating that an external device is present, and the signal is continuously transmitted to the car stereo. Importantly, this signal prevents the car stereo from shutting off, entering a sleep mode, or otherwise being unresponsive to signals and/or data from an external source. Then, in step **202**, the control panel buttons of the car stereo are monitored.

In a preferred embodiment of the present invention, each of the one or more auxiliary input sources are selectable by selecting a CD disc number on the control panel of the car radio. Thus, in step **204**, a determination is made as to whether the first disc number has been selected. If a positive determination is made, step **206** is invoked, wherein the first auxiliary input source is connected (channeled) to the car stereo. If a negative determination is made, step **208** is invoked, wherein a second determination is made as to whether the second disc number has been selected. If a positive determination

is made, step **210** is invoked, wherein the second auxiliary input source is connected (channeled) to the car stereo. If a negative determination is made, step **212** is invoked, wherein a third determination is made as to whether the third disc number has been selected. If a positive determination is made, step **214** is invoked, wherein the third auxiliary input source is connected (channeled) to the car stereo. If a negative determination is made, step **216** is invoked, wherein a fourth determination is made as to whether the fourth disc number has been selected. If a positive determination is made, step **218** is invoked, wherein the fourth auxiliary input source is connected (channeled) to the car stereo. If a negative determination is made, step **200** is re-invoked, and the process disclosed for block **198** repeated. Further, if any of steps **206**, **210**, **214**, or **218** are executed, then step **200** is re-invoked and block **198** repeated.

The process disclosed in block **198** allows a user to select from one of four auxiliary input sources using the control buttons of the car stereo. Of course, the number of auxiliary input sources connectable with and selectable by the present invention can be expanded to any desired number. Thus, for example, 6 auxiliary input sources could be provided and switched using corresponding selection key(s) or keystroke(s) on the control panel of the radio. Moreover, any desired keystroke, selection sequence, or button(s) on the control panel of the radio, or elsewhere, can be utilized to select from the auxiliary input sources without departing from the spirit or scope of the present invention.

FIG. 4E is a flowchart showing processing logic, indicated generally at **220**, for integrating a CD player and one or more auxiliary input sources with a car radio. Beginning in step **222**, a determination is made as to whether the existing car stereo is powered on. If a negative determination is made, step **224** is invoked, wherein the present invention enters a standby mode and waits for the car stereo to be powered on. If a positive determination is made, step **226** is invoked, wherein a second determination is made as to whether the car stereo is in a state responsive to signals external to the cars stereo. If a negative determination is made, step **226** is re-invoked.

If a positive determination is made in step **226**, then step **228** is invoked, wherein a signal is generated by the present invention indicating that an external device is present, and the signal is continuously transmitted to the car stereo. Importantly, this signal prevents the car stereo from shutting off, entering a sleep mode, or otherwise being unresponsive to signals and/or data from an external source. Then, in step **230**, a

determination is made as to whether a CD player is present (*i.e.*, whether an external CD player or changer is connected to the multimedia device integration system of the present invention). If a positive determination is made, steps **231** and **232** are invoked. In step **231**, the logic of block **108** of **FIG. 4A** (the CD handling process), described earlier, is invoked, so that the CD player/changer can be integrated with the car stereo and utilized by a user. In step **232**, a sensing mode is initiated, wherein the present invention monitors for a selection sequence (as will be discussed in greater detail) initiated by the user at the control panel of the car stereo for switching from the external CD player/changer to one or more auxiliary input sources. Step **234** is then invoked, wherein a determination is made as to whether such a sequence has been initiated. If a negative determination is made, step **234** re-invokes step **228**, so that further processing can occur. Otherwise, if a positive determination is made (*i.e.*, the user desires to switch from the external CD player/changer to one of the auxiliary input sources), step **236** is invoked, wherein the audio channels of the CD player/changer are disconnected from the car stereo. Then, step **238** is invoked, wherein the logic of block **198** of **FIG. 4D** (the auxiliary input handling process), discussed earlier, is executed, allowing the user to select from one of the auxiliary input sources. In the event that a negative determination is made in step **230** (no external CD player/changer is connected to the present invention), then step **238** is invoked, and the system goes into auxiliary mode. The user can then select from one or more auxiliary input sources using the controls of the radio.

FIG. 4F is a flowchart showing processing logic, indicated generally at **240**, for integrating a satellite receiver or DAB receiver and one or more auxiliary input sources with a car radio. Beginning in step **242**, a determination is made as to whether the existing car stereo is powered on. If a negative determination is made, step **244** is invoked, wherein the present invention enters a standby mode and waits for the car stereo to be powered on. If a positive determination is made, step **246** is invoked, wherein a second determination is made as to whether the car stereo is in a state responsive to signals external to the car stereo. If a negative determination is made, step **246** is re-invoked.

If a positive determination is made in step **246**, then step **248** is invoked, wherein a signal is generated by the present invention indicating that an external device is present, and the signal is continuously transmitted to the car stereo. Importantly, this signal prevents the car stereo from shutting off, entering a sleep mode, or otherwise being

unresponsive to signals and/or data from an external source. Then, in step **250**, a determination is made as to whether a satellite receiver or DAB receiver is present (*i.e.*, whether an external satellite receiver or DAB receiver is connected to the multimedia device integration system of the present invention). If a positive determination is made, steps **251** and **252** are invoked. In step **251**, the logic of block **168** of **FIG. 4C** (the satellite/DAB receiver handling process), described earlier, is invoked, so that the satellite receiver can be integrated with the car stereo and utilized by a user. In step **252**, a sensing mode is initiated, wherein the present invention monitors for a selection sequence (as will be discussed in greater detail) initiated by the user at the control panel of the car stereo for switching from the external satellite receiver to one or more auxiliary input sources. Step **254** is then invoked, wherein a determination is made as to whether such a sequence has been initiated. If a negative determination is made, step **254** re-invokes step **258**, so that further processing can occur. Otherwise, if a positive determination is made (*i.e.*, the user desires to switch from the external satellite/DAB receiver to one of the auxiliary input sources), step **256** is invoked, wherein the audio channels of the satellite receiver are disconnected from the car stereo. Then, step **258** is invoked, wherein the logic of block **198** of **FIG. 4D** (the auxiliary input handling process), discussed earlier, is executed, allowing the user to select from one of the auxiliary input sources. In the event that a negative determination is made in step **250** (no external satellite/DAB receiver is connected to the present invention), then step **258** is invoked, and the system goes into auxiliary mode. The user can then select from one or more auxiliary input sources using the controls of the radio.

FIG. 4G is a flowchart showing processing logic according to the present invention for integrating an MP3 player and one or more auxiliary input sources with a car stereo. Beginning in step **262**, a determination is made as to whether the existing car stereo is powered on. If a negative determination is made, step **264** is invoked, wherein the present invention enters a standby mode and waits for the car stereo to be powered on. If a positive determination is made, step **266** is invoked, wherein a second determination is made as to whether the car stereo is in a state responsive to signals external to the car stereo. If a negative determination is made, step **266** is re-invoked.

If a positive determination is made in step **266**, then step **268** is invoked, wherein a signal is generated by the present invention indicating that an external device is present,

and the signal is continuously transmitted to the car stereo. Importantly, this signal prevents the car stereo from shutting off, entering a sleep mode, or otherwise being unresponsive to signals and/or data from an external source. Then, in step **270**, a determination is made as to whether an MP3 player is present (*i.e.*, whether an external MP3 player is connected to the multimedia device integration system of the present invention). If a positive determination is made, steps **271** and **272** are invoked. In step **271**, the logic of block **138** of **FIG. 4B** (the MP3 handling process), described earlier, is invoked, so that the CD player/changer can be integrated with the car stereo and utilized by a user. In step **272**, a sensing mode is initiated, wherein the present invention monitors for a selection sequence (as will be discussed in greater detail) initiated by the user at the control panel of the car stereo for switching from the external CD player/changer to one or more auxiliary input sources. Step **274** is then invoked, wherein a determination is made as to whether such a sequence has been initiated. If a negative determination is made, step **274** re-invokes step **278**, so that further processing can occur. Otherwise, if a positive determination is made (*i.e.*, the user desires to switch from the external MP3 player to one of the auxiliary input sources), step **276** is invoked, wherein the audio channels of the MP3 player are disconnected from the car stereo. Then, step **278** is invoked, wherein the logic of block **198** of **FIG. 4D** (the auxiliary input handling process), discussed earlier, is executed, allowing the user to select from one of the auxiliary input sources. In the event that a negative determination is made in step **270** (no external MP3 player is connected to the present invention), then step **278** is invoked, and the system goes into auxiliary mode. The user can then select from one or more auxiliary input sources using the controls of the radio.

As mentioned previously, to enable integration, the present invention contains logic for converting command signals issued from an after-market or OEM car stereo into a format compatible with one or more external audio devices connected to the present invention. Such logic can be applied to convert any car stereo signal for use with any external device. For purposes of illustration, a sample code portion is shown in **Table 1**, below, for converting control signals from a BMW car stereo into a format understandable by a CD changer:

Table 1

```

; =====
;   Radio requests changer to STOP (exit PLAY mode)
;   Decoding 6805183801004C message
;   =====

```

```

Encode_RD_stop_msg:

```

```

    movlw 0x68
    xorwf BMW_Recv_buff,W
    skpz
    return

    movlw 0x05
    xorwf BMW_Recv_buff+1,W
    skpz
    return

    movlw 0x18
    xorwf BMW_Recv_buff+2,W
    skpz
    return

    movlw 0x38
    xorwf BMW_Recv_buff+3,W
    skpz
    return

    movlw 0x01
    xorwf BMW_Recv_buff+4,W
    skpz
    return

    tstf  BMW_Recv_buff+5
    skpz
    return

    movlw 0x4C
    xorwf BMW_Recv_buff+6,W

```

```
    skipz
    return

    bsf    BMW_Recv_STOP_msg
    return
```

The code portion shown in **Table 1** receives a STOP command issued by a BMW stereo, in a format proprietary to BMW stereos. Preferably, the received command is stored in a first buffer, such as `BMW_Recv_buff`. The procedure “Encode_RD_stop_msg” repetitively applies an XOR function to the STOP command, resulting in a new command that is in a format compatible with the after-market CD player. The command is then stored in an output buffer for dispatching to the CD player.

Additionally, the present invention contains logic for retrieving information from an after-market audio device, and converting same into a format compatible with the car stereo for display thereby. Such logic can be applied to convert any data from the external device for display on the car stereo. For purposes of illustration, a sample code portion is shown in **Table 2**, below, for converting data from a CD changer into a format understandable by a BMW car stereo:

Table 2

```

; =====
; Changer replies with STOP confirmation
; Encoding 180A68390002003F0001027D message
; =====

Load_CD_stop_msg:
    movlw 0x18
    movwf BMW_Send_buff

    movlw 0x0A
    movwf BMW_Send_buff+1

    movlw 0x68
    movwf BMW_Send_buff+2

    movlw 0x39
    movwf BMW_Send_buff+3

    movlw 0x00           ;current status_XX=00, power off
    movwf BMW_Send_buff+4

    movlw 0x02           ;current status_YY=02, power off
    movwf BMW_Send_buff+5

    clrf  BMW_Send_buff+6 ;separate field, always =0

    movfw BMW_MM_stat    ;current status_MM , magazine config
    movwf BMW_Send_buff+7

    clrf  BMW_Send_buff+8 ;separate field, always =0

    movfw BMW_DD_stat    ;current status_DD , current disc
    movwf BMW_Send_buff+9

    movfw BMW_TT_stat    ;current status_TT , current track
    movwf BMW_Send_buff+10

    xorwf BMW_Send_buff+9,W ;calculate check sum
    xorwf BMW_Send_buff+8,W
    xorwf BMW_Send_buff+7,W
    xorwf BMW_Send_buff+6,W
    xorwf BMW_Send_buff+5,W
    xorwf BMW_Send_buff+4,W
    xorwf BMW_Send_buff+3,W
    xorwf BMW_Send_buff+2,W
    xorwf BMW_Send_buff+1,W
    xorwf BMW_Send_buff,W

    movwf BMW_Send_buff+11 ;store check sum
    movlw D'12'           ;12 bytes total
    movwf BMW_Send_cnt
    bsf   BMW_Send_on     ;ready to send
    return

```

The code portion shown in **Table 2** receives a STOP confirmation message from the CD player, in a format proprietary to the CD player. Preferably, the received command is stored in a first buffer, such as BMW_Send_buff. The procedure “Load_CD_stop_msg” retrieves status information, magazine information, current disc, and current track information from the CD changer, and constructs a response containing this information. Then, a checksum is calculated and stored in another buffer. The response and checksum are in a format compatible with the BMW stereo, and are ready for dispatching to the car stereo.

The present invention also includes logic for converting signals from an OEM car stereo system for use with a digital media device such as an MP3, MP4, or Apple iPod player. Shown below are code samples for allowing commands and data to be exchanged between a Ford car stereo and an Apple iPod device:

Table 3

```
//decoding Ford "play" command :41-C0-80-CA-01+

    if ( ACP_rx_ready == ON ) {
        ACP_rx_ready = OFF;
        ACP_rx_taddr = ACP_rx_buff[1];
        ACP_rx_saddr = ACP_rx_buff[2];
        ACP_rx_data1 = ACP_rx_buff[3];
        ACP_rx_data2 = ACP_rx_buff[4];
        ACP_rx_data3 = ACP_rx_buff[5];
        if ( (ACP_rx_saddr == 0x80) ) {
            switch ( ACP_rx_taddr ) {
                case 0xC0:
                    if ( ACP_rx_data1 == 0xCA ) {
                        if ( ACP_rx_data2 ==
0x01 ) {
                            flags.ACP_play_req
= 1;
                        }
                    }
                    break;
                }
            }
            break;
        }
    }
```

In the code portion shown in **Table 3**, a “Play” command selected by a user at the controls of a Ford OEM car stereo is received, and portions of the command are stored in one or more buffer arrays. Then, as shown below in **Table 4**, the decoded portions of the

command stored in the one or more buffer arrays are used to construct a “Play/Pause” command in a format compatible with the Apple iPod device, and the command is sent to the Apple iPod for execution thereby:

Table 4

```
// encoding iPod "play/pause" command 0xFF 0x55 0x03 0x02 0x00 0x01 0xFA

    if ( iPod_play_req == ON ) {
        iPod_play_req = OFF;
        iPod_tx_data[0] = 0x55;
        iPod_tx_data[1] = 0x03;
        iPod_tx_data[2] = 0x02;
        iPod_tx_data[3] = 0x00;
        iPod_tx_data[4] = 0x01;
        iPod_tx_counter = 5;
        iPod_tx_ready = ON;
    }
```

While the code portions shown in **Tables 1-2** are implemented using assembler language, and the code portions shown in **Tables 3-4** are implemented using the C programming language, it is to be expressly understood that any low or high level language known in the art could be utilized without departing from the spirit or scope of the invention. It will be appreciated that various other code portions can be developed for converting signals from any after-market or OEM car stereo for use by an after-market external audio device, and vice versa.

FIG. 5 is a flowchart showing processing logic, indicated generally at **300** for allowing a user to switch between an after-market audio device, and one or more auxiliary input sources. As was discussed earlier, the present invention allows a user to switch from one or more connected audio devices, such as an external CD player/changer, MP3 player, satellite receiver, DAB receiver, or the like, and activate one or more auxiliary input sources. A selection sequence, initiated by the user at the control panel of the car stereo, allows such switching. Beginning in step **302**, the buttons of the control panel are monitored. In step **304**, a determination is made as to whether a “Track Up” button or sequence has been initiated by the user. The “Track Up” button or sequence can for a CD player, MP3 player, or any other device. If a negative determination is made, step **306** is invoked, wherein the sensed button or sequence is processed in accordance with the present invention and dispatched to the external audio device for execution. Then, step **302** is re-invoked, so that additional buttons or sequences can be monitored.

In the event that a positive determination is made in step **304**, step **308** is invoked, wherein the present invention waits for a predetermined period of time while monitoring the control panel buttons for additional buttons or sequences. In a preferred embodiment of the present invention, the predetermined period of time is 750 milliseconds, but of course, other time durations are considered within the spirit and scope of the present invention. In step **310**, a determination is made as to whether the user has initiated a “Track Down” button or sequence at the control panel of the car stereo within the predetermined time period. These sequences can be used for a CD player, MP3 player, or any other device. If a negative determination is made, step **312** is invoked. In step **312**, a determination is made as to whether a timeout has occurred (*e.g.*, whether the predetermined period of time has expired). If a negative determination is made, step **308** is re-invoked. Otherwise, if a positive determination is made, step **312** invokes step **306**, so that any buttons or key sequences initiated by the user that are not a “Track Down” command are processed in accordance with the present invention and dispatched to the audio device for execution.

In the event that a positive determination is made in step **310** (a “Track Down” button or sequence has been initiated within the predetermined time period), then step **314** is invoked. In step **314**, the audio channels of the audio device are disconnected, and then step **316** is invoked. In step **316**, the logic of block **198** of **FIG. 4D** (the auxiliary input handling process), discussed earlier, is invoked, so that the user can select from one of the auxiliary input sources in accordance with the present invention. Thus, at this point in time, the system has switched, under user control, from the audio device to a desired auxiliary input. Although the foregoing description of the process **300** has been described with reference to “Track Up” and “Track Down” buttons or commands initiated by the user, it is to be expressly understood that any desired key sequence, keystroke, button depress, or any other action, can be sensed in accordance with the present invention and utilized for switching modes.

When operating in auxiliary mode, the present invention provides an indication on the display of the car stereo corresponding to such mode. For example, the CD number could be displayed as “1”, and the track number displayed as “99,” thus indicating to the user that the system is operating in auxiliary mode and that audio and data is being supplied from an auxiliary input source. Of course, any other indication could be

generated and displayed on the display of the car stereo, such as a graphical display (*e.g.*, an icon) or textual prompt.

FIG. 6 is a flowchart showing processing logic, indicated generally at **320**, for determining and handling various device types connected to the auxiliary input ports of the invention. The present invention can sense device types connected to the auxiliary input ports, and can integrate same with the car stereo using the procedures discussed earlier. Beginning in step **322**, the control panel buttons of the car stereo are monitored for a button or sequence initiated by the user corresponding to an auxiliary input selection (such as the disc number method discussed earlier with reference to **FIG. 4D**). In response to an auxiliary input selection, step **324** is invoked, wherein the type of device connected to the selected auxiliary input is sensed by the present invention. Then, step **326** is invoked.

In step **326**, a determination is made as to whether the device connected to the auxiliary input is a CD player/changer. If a positive determination is made, step **328** is invoked, wherein the logic of block **108** of **FIG. 4A** (the CD handling process), discussed earlier, is executed, and the CD player is integrated with the car stereo. If a negative determination is made in step **326**, then step **330** is invoked. In step **330**, a determination is made as to whether the device connected to the auxiliary input is an MP3 player. If a positive determination is made, step **334** is invoked, wherein the logic of block **138** of **FIG. 4B** (the MP3 handling process), discussed earlier, is executed, and the MP3 player is integrated with the car stereo. If a negative determination is made in step **330**, then step **336** is invoked. In step **336**, a determination is made as to whether the device connected to the auxiliary input is a satellite receiver or a DAB receiver. If a positive determination is made, step **338** is invoked, wherein the logic of block **168** of **FIG. 4C** (the satellite/DAB receiver handling process), discussed earlier, is executed, and the satellite receiver is integrated with the car stereo. If a negative determination is made in step **336**, step **322** is re-invoked, so that additional auxiliary input selections can be monitored and processed accordingly. Of course, process **320** can be expanded to allow other types of devices connected to the auxiliary inputs of the present invention to be integrated with the car stereo.

The present invention can be expanded for allowing video information generated by an external device to be integrated with the display of an existing OEM or after-market car stereo. In such a mode, the invention accepts RGB (red/green/blue) input signals from

the external device, and converts same to composite signals. The composite signals are then forwarded to the car stereo for display thereby, such as on an LCD panel of the stereo. Additionally, the present invention can accept composite input signals from an external device, and convert same to RGB signals for display on the car stereo. Further, information from the external device can be formatted and presented to the user in one or more graphical user interfaces or menus capable of being viewed and manipulated on the car stereo.

FIG. 7A is a perspective view of a docking station **400** according to the present invention for retaining an audio device within a car. Importantly, the present invention can be adapted to allow portable audio devices to be integrated with an existing car stereo. The docking station **400** allows such portable devices to be conveniently docked and integrated with the car stereo. The docking station **400** includes a top portion **402** hingedly connected at a rear portion **408** to a bottom portion **404**, preferably in a clam-like configuration. A portable audio device **410**, such as the SKYFI radio distributed by DELPHI, Inc., is physically and electrically connected with the docking portion **412**, and contained within the station **100**. A clasp **406** can be provided for holding the top and bottom portions in a closed position to retain the device **410**. Optionally, a video device could also be docked using the docking station **400**, and tabs **413** can be provided for holding the docking station **400** in place against a portion of a car. Conceivably, the docking station **400** could take any form, such as a sleeve-like device for receiving and retaining a portable audio device and having a docking portion for electrically and mechanically mating with the audio device. It should be noted that the docking station **400** could be formed without the top portion **402**.

FIG. 7B is an end view showing the rear portion **408** of the docking station **400** of **FIG. 7A**. A hinge **414** connects the top portion and the bottom portions of the docking station **400**. A data port **416** is provided for interfacing with the audio device docked within the station **400**, and is in electrical communication therewith. In a preferred embodiment of the present invention, the data port **416** is an RS-232 serial or USB data port that allows for the transmission of data with the audio device, and which connects with the multimedia device integration system of the present invention for integrating the audio device with an OEM or after-market car stereo. Any known bus technology can be utilized to interface with any portable audio or video device contained within the docking

station **400**, such as FIREWIRE, D2B, MOST, CAN, USB/USB2, IE Bus, T Bus, I Bus, or any other bus technology known in the art. It should be noted that the present invention can be operated without a docking station, *i.e.*, a portable audio or video device can be plugged directly into the present invention for integration with a car stereo or video system.

FIGS. 8A-8B are perspective views of another embodiment of the docking station of the present invention, indicated generally at **500**, which includes the multimedia device integration system of the present invention, indicated generally at **540**, incorporated therewith. As shown in **FIG. 8A**, the docking station **500** includes a base portion **530**, a bottom member **515** interconnected with the base portion **530** at an edge thereof, and a top member **510** hingedly interconnected at an edge to the base portion **530**. The top member **510** and the bottom member **515** define a cavity for docking and storing a portable audio device **520**, which could be a portable CD player, MP3 player, satellite (*e.g.*, XM, SIRIUS, or other type) tuner, or any other portable audio device. The docking station **500** would be configured to accommodate a specific device, such as an IPOD from Apple Computer, Inc., or any other portable device.

The multimedia device integration system **540**, in the form of a circuit board, is housed within the base portion **530** and performs the integration functions discussed herein for integrating the portable device **520** with an existing car stereo or car video system. The integration system **540** is in communication with the portable device **520** via a connector **550**, which is connected to a port on the device **520**, and a cable **555** interconnected between the connector **550** and the integration system **540**. The connector **550** could be any suitable connector and can vary according to the device type. For example, a MOLEX, USB, or any other connector could be used, depending on the portable device. The integration system **540** is electrically connected with a car stereo or car video system by cable **560**. Alternatively, the integration system could wirelessly communicate with the car stereo or car video system. A transmitter could be used at the integration system to communicate with a receiver at the car stereo or car video system. Where automobiles include Bluetooth systems, such systems can be used to communicate with the integration system. As can be readily appreciated, the docking station **500** provides a convenient device for docking, storing, and integrating a portable device for use

with a car stereo. Further, the docking station **500** could be positioned at any desired location within a vehicle, including, but not limited to, the vehicle trunk.

As shown in **FIG. 8B**, the top member **510** can be opened in the general direction indicated by arrow **A** to allow for access to the portable audio device **520**. In this fashion, the device **520** can be quickly accessed for any desired purpose, such as for inserting and removing the device **520** from the docking station **500**, as well as for providing access to the controls of the device **520**.

FIG. 9 is a block diagram showing the components of the docking station of **FIGS. 8A-8B**. The docking station **500** houses both a portable audio or video device **520** and a multimedia device integration system (or interface) **540**. The shape and configuration of the docking station **500** can be varied as desired without departing from the spirit or scope of the present invention.

The integration system of the present invention provides for control of a portable audio or video device, or other device, through the controls of the car stereo or video system system. As such, controls on the steering wheel, where present, may also be used to control the portable audio device or other device. Further, in all embodiments of the present invention, communication between the after-market device and a car stereo or video system can be accomplished using known wireless technologies, such as Bluetooth.

FIG. 10 is a block diagram showing an alternate embodiment of the multimedia device integration system of the present invention, indicated generally at **600**, wherein the interface **630** is incorporated within a car stereo or car video system **610**. The interface **630** is in electrical communication with the control panel buttons **620**, display **615**, and associated control circuitry **625** of the car stereo or video system **610**. The interface **630** could be manufactured on a separate printed circuit board positioned within the stereo or video system **610**, or on one or more existing circuit boards of the stereo or video system **610**. An after-market device **635** can be put into electrical communication with the interface **630** via a port or connection on the car stereo or video system **610**, and integrated for use with the car stereo or video system **610**.

The device **635** can be controlled using the control panel buttons **620** of the car stereo or video system **610**, and information from the device **635** is formatted by the interface **630** and displayed in the display **615** of the car stereo or video system **610**. Additionally, control commands generated at the car stereo or car video device **610** are

converted by the interface **630** into a format (protocol) compatible with the multimedia device **635**, and are dispatched thereto for execution. A plurality of multimedia devices could be integrated using the interface **630**, as well as one or more auxiliary input sources **640**. The after-market device **635** could comprise any audio, video, or telecommunications device, including, but not limited to, a CD player, CD changer, digital media player (*e.g.*, MP3 player, MP4 player, WMV player, Apple iPod, or any other player), satellite radio (*e.g.*, XM, Sirius, Delphi, etc.), video device (*e.g.*, DVD player), cellular telephone, or any other type of device or combinations thereof. Additionally, one or more interfaces could be connected to the interface **630** (“daisy-chained”) to allow multiple products to be integrated. The device **600** could include one or more of the circuits disclosed in **FIGS. 3A-3D** and modified depending upon the type of the after-market device **635**.

FIG. 11A is a diagram showing an alternate embodiment of the present invention, indicated generally at **645**, wherein a cellular telephone **670** is integrated for use with a car stereo. The telephone **670** is in electrical communication with the interface **665**, which receives data from the cellular telephone and formats same for displaying on the display **650** of the car stereo or video system **660**. Commands for controlling the telephone **670** can be entered using the control panel buttons **655** of the car stereo or video system **660**. The commands are processed by the interface **665**, converted into a format (protocol) compatible with the telephone **670**, and transmitted to the telephone **670** for processing thereby.

Additionally, audio and video from the telephone **670** can be channeled to the car stereo or video system **660** via the interface **665** and played through the speakers and/or display **650** of the car stereo or video system **660**. For example, if the telephone **670** is provided with the ability to download songs or music, such songs or music can be selected using the car stereo or video system **660** and played therethrough using the interface **665**. Further, the telephone **670** could be provided with the ability to receive live and/or streamed audio and/or video signals (*e.g.*, via QuickTime or RealSystem streaming files, or a live radio signal received by the telephone), satellite audio (*e.g.*, XM or SIRIUS satellite radio signals, received by a satellite-capable cellular telephone), mobile television (*e.g.*, “amp’d” mobile), or navigational information (*e.g.*, via the Global Positioning System (GPS)), which can be selected using the car stereo or video system **660** and played

thereon (both audio and video) using the interface **665**. For example, if the telephone **670** is equipped to receive SIRIUS satellite digital audio signals, a user could be presented with a menu of available channels that can be displayed and selected using the car stereo or video system **660**, which causes corresponding audio signals to be played through speakers of the car stereo or video system **660**. It is also noted that navigational and map data received by the telephone **670**, including, but not limited to, Global Positioning System (GPS) maps and road / driving maps (e.g., Google driving / road maps, Telnv maps, etc.), can be displayed on the car stereo or video system **660**. Additionally, other types of data, such as restaurant menus accessed by the telephone **670**, could be displayed on the car stereo or video system **660**.

It should be noted that control of the cellular telephone could be provided using one or more displays (e.g., LCD) of a car video system. Moreover, control of the cellular telephone **670** is not limited to the use of buttons on the car stereo or video system **660**, and indeed, a software or graphically-driven menu or interface can be used to control the cellular telephone. The device **645** could include one or more of the circuits disclosed in **FIGS. 3A-3D** and modified for use with the cellular telephone **670**.

FIG. 11b is a flowchart showing processing logic, indicated generally at **647**, for integrating a cellular telephone with a car radio. Beginning in step **649**, a determination is made as to whether the existing car stereo is powered on. If a negative determination is made, step **651** is invoked, wherein the present invention enters a standby mode and waits for the car stereo to be powered on. If a positive determination is made, step **653** is invoked, wherein a second determination is made as to whether the car stereo is in a state responsive to signals external to the car stereo. If a negative determination is made, step **649** is re-invoked.

If a positive determination is made in step **653**, a cellular telephone handling process, indicated as block **661**, is invoked. Beginning in step **654**, a signal is generated by the present invention indicating that a cellular telephone is present, and the signal is continuously transmitted to the car stereo. Importantly, this signal prevents the car stereo from shutting off, entering a sleep mode, or otherwise being unresponsive to signals and/or data from an external source. In step **657**, the audio channels of the cellular telephone are connected (channeled) to the car stereo system, allowing audio from the cellular telephone to be played through the car stereo. Video signals from the cellular telephone could also

be processed in accordance with the present invention (e.g., RGB to composite signal conversion, or vice-versa), and the processed video could be sent by the interface to the car stereo system for display thereby. In step **659**, data is retrieved by the present invention from the cellular telephone, such as song information corresponding to one or more songs downloaded onto the cellular telephone, satellite radio channel, artist name, genre, etc. After steps **654**, **657**, and **659** have been executed, control passes to step **663**.

In steps **663**, the present invention monitors the control panel buttons of the car stereo for cellular telephone operational commands. In step **664**, if a command is not detected, step **663** is re-invoked. Otherwise, if a command is received, step **663** invokes step **667**, wherein the received command is converted into a format recognizable by the cellular telephone connected to the present invention. Once the command has been formatted, step **669** is invoked, wherein the formatted command is transmitted to the cellular telephone and executed. Step **654** is then re-invoked, so that additional processing can occur.

FIG. 12A is a diagram showing an alternate embodiment of the present invention, indicated generally at **675**, wherein an after-market video device **695** is integrated for use with a car video system **685**. In particular, the interface **675** allows a non-native video device **695** (i.e., a device which is alien to a car video system) to be used interchangeably with a car video system **685**. The after-market video device **695** could comprise a portable DVD player, digital video (DV) camera, digital camera, rear-view camera, or any other video device. The interface **690** receives output video signals from the device **695**, and converts same for display on one or more displays **680** (e.g., LCD seat-back displays in a minivan, fold-down displays mounted on the roof of a vehicle, vehicle navigation displays, etc.) of the car video system **685**. The output signals could be transmitted via a wired or a wireless connection to the interface **690**. The interface **690** could convert between composite and red/green/blue (RGB) video signals, and vice versa, using commercially-available video format conversion chips such as the TDA8315, TDA4570, TDA3567, TDA3566A, and TDA3569A video conversion chips manufactured by Philips Corp., and the AL251 and AL250 video conversion chips manufactured by Averlogic Technologies, Inc., or any other suitable video conversion chips. Commands issued by a user using the car video system **685** or display(s) **680** for controlling the device **695** are received by the interface **690**, converted into a format compatible with the device **695**, and transmitted

thereto for processing. The device **675** could include one or more of the circuits disclosed in **FIGS. 3A-3D** and modified for use with the video device **695**.

FIG. 12B is a flowchart showing processing logic, indicated generally at **671**, for integrating an after-market video device with a car video system. Beginning in step **673**, a determination is made as to whether the existing car video system is powered on. If a negative determination is made, step **674** is invoked, wherein the present invention enters a standby mode and waits for the car video system to be powered on. If a positive determination is made, step **677** is invoked, wherein a second determination is made as to whether the car video system is in a state responsive to signals external to the car video system. If a negative determination is made, step **673** is re-invoked.

If a positive determination is made in step **677**, an after-market video device handling process, indicated as block **687**, is invoked. Beginning in step **679**, a signal is generated by the present invention indicating that an external device is present, and the signal is continuously transmitted to the car video system. Importantly, this signal prevents the car video system from shutting off, entering a sleep mode, or otherwise being unresponsive to signals and/or data from an external source. In step **681**, the audio and video channels of the after-market device are connected (channeled) to the car video system, allowing audio and video from the after-market device to be played through the car video system. In step **684**, the display(s) of the car video system are updated with data from the after-market device. After steps **679**, **681**, and **684** have been executed, control passes to step **683**.

In step **683**, the present invention monitors the car video system for after-market video device operational commands. In step **689**, if a command is not detected, step **683** is re-invoked. Otherwise, if a command is received, step **689** invokes step **691**, wherein the received command is converted into a format recognizable by the after-market video device connected to the present invention. Once the command has been formatted, step **693** is invoked, wherein the formatted command is transmitted to the after-market video device and executed. Step **679** is then re-invoked, so that additional processing can occur.

FIG. 13A is a block diagram showing an alternate embodiment of the multimedia device integration system **710** of the present invention, wherein configuration jumpers **720** and protocol conversion software blocks **724** are provided for integrating after-market devices of various types using a single interface. The jumpers **720** can be set to a plurality

of different settings, each of which corresponds to an after-market device of a specific type (*e.g.*, CD changer, CD player, digital media player, satellite radio, video device, cellular telephone, etc.) or from a specific manufacturer. Additionally, the jumpers **720** can be used to specify one or more device or manufacturer types for the car stereo or video system **705**. The settings of the configuration jumpers **720** correspond to one or more protocol conversion software blocks **724** stored in memory (*e.g.*, programmable flash memory, ROM, EEPROM, etc.) **725** of the interface **710**. Each of the software blocks **724** controls the interface circuitry **715** and contains instructions for converting data from the device **707** into a format compatible with the car stereo or video system **705**, and vice versa. For example, a first block could contain software for allowing communication between an Apple iPod and an in-dash car stereo manufactured by Sony, and a second block could contain software for allowing communication between a DVD player and a car video system. Any desired number of blocks could be stored in the memory **725** and can be selected as desired by the user via configuration jumpers **720**. As such, a single interface **710** can be used for integrating numerous devices of various types and manufactures for use with one or more car stereo or video systems. The device **710** could include one or more of the circuits shown in **FIGS. 3A-3D**, with modifications depending upon the device types of the devices **705** and **707**.

FIG. 13B is a block diagram showing an alternate embodiment of the multimedia device integration system of the present invention, wherein wiring harnesses **727** and **728** and protocol conversion software blocks **729** are provided for integrating multimedia devices of various types using a single interface **726**. In this embodiment, the electrical configurations (pinouts) of each of the harnesses **727** and **728** correspond to car stereo / video systems and after-market devices of specific types and made by specific manufacturers (*e.g.*, harness **727** could correspond to a BMW car stereo, and harness **728** could correspond to an ALPINE satellite tuner). The electrical configurations (pinouts) of the harnesses are utilized by the interface **726** to retrieve a specific protocol conversion software block **729** that allows communication between the devices. The interface **726** could be provided with a plurality of protocol conversion software blocks pre-loaded into memory in the interface, and could be provided with any desired harnesses. The interface **726** could include one or more of the circuits shown in **FIGS. 3A-3D**, with modification

depending upon the device types of the devices attached to the wiring harnesses 727 and 728.

FIG. 14 is a flowchart showing processing logic, indicated generally at 730, of the multimedia device integration system of the present invention for integrating after-market devices of various types using a single interface. In step 735, the interface determines types of devices that are connected thereto, including the car stereo or video system and one or more after-market devices to be integrated therewith. This could be achieved by the configuration jumper settings or the harness types connected to the interface and discussed with respect to **FIGS. 13A** and **13B**. Then, in step 740, a protocol conversion software block is selected from blocks of conversion software (*e.g.*, from the blocks 725 and 729 shown in **FIGS. 13A** and **13B**). In step 745, instructions are converted using the selected conversion block to allow the car stereo or video system to operate with the multimedia device.

FIG. 15 is a flowchart showing processing logic, indicated generally at 750, of the multimedia device integration system of the present invention for allowing a user to specify one or more after-market device types for integration using a single interface. In step 770, a user is provided with one or more lists of devices to be integrated, which are displayed on the display 760 of the car stereo or video device 755. Then, in step 775, using the buttons 765 of the car video device, the user can specify the type of multimedia device to be integrated (*e.g.*, by scrolling through the lists). Additionally, the device type could be specified using a graphical or software menu displayed on the car stereo or car video system. In step 780, a determination is made as to whether a timeout has occurred (*e.g.*, the user has not selected a device type within a predetermined period of time). If a positive determination is made, step 785 occurs, wherein a protocol conversion software block is selected from memory corresponding to the last device type displayed by the car stereo or video system. If a negative determination is made, step 790 is invoked, wherein a determination is made as to whether the user has specified a device type. If a negative determination is made, step 775 is re-invoked so that the user can specify a device type. If a positive determination is made, step 795 is invoked, wherein a protocol conversion software block is selected from memory corresponding to the device specified by the user. In step 800, the protocol conversion software block is mapped to a logical address in memory. Then, in step 805, instructions to be exchanged between the car stereo or video

system and the after-market device are converted using the software block to allow communication between the devices using compatible formats. Accordingly, the logic of **FIG. 15** allows a single interface having multiple protocol conversion software blocks to be used integrate a plurality of after-market devices with a car stereo or video system.

FIG. 16 is a flowchart showing processing logic of the multimedia device integration system of the present invention, indicated generally at **810**, for allowing a user to quickly navigate through a list of songs on one or more after-market devices using the controls of a car stereo or video system (fast navigation technique). This method allows a user to quickly select a song from a list of songs available on an after-market device for playing on the car stereo or video system, and could be applied for use with any type of after-market device, including, but not limited to, a digital media player such as an MP3 player or Apple iPod player. Beginning in step **812**, a user is provided with a list of alphanumeric characters on a display of the car stereo or video system. This list could include the letters A through Z, as well as the numbers 0 through 9. In step **814**, the user can specify a desired alphanumeric character, which can be specified by scrolling through the list using one or more controls of the car stereo or video system and pressing a button once the desired character has been highlighted, or optionally, if an alphanumeric keypad (or touchscreen interface) is provided on the car stereo or video system, the user can directly enter the desired alphanumeric character.

When the desired alphanumeric character has been specified, in step **816** a remote database is queried using the alphanumeric character. The remote database could comprise a list of songs stored in one or more after-market devices integrated by the present invention for use with the car stereo or video system. In step **818**, a list of potentially matching songs is retrieved from the database and presented on the display of the car stereo or video system for perusal by the user. For example, if the user specified the letter "A," the list could include all songs in the remote database having titles (or artists) beginning with the letter "A." In step **820**, a determination is made as to whether a desired song appears in the list and is immediately viewable by the user, without requiring the user to scroll through the list. If a positive determination is made, step **822** is invoked, wherein the desired song is selected by the user and retrieved from the after-market device for playing on the car stereo or video system.

In the event that a negative determination is made in step **820**, step **824** is invoked, wherein the user can specify an additional alphanumeric character using the car stereo or video system. For example, if the user initially specified the letter “A” and the desired song is not visible in the list of songs without scrolling, the user can refine the query by adding an additional alphanumeric character. Thus, for example, the user can specify the letters “AN” to search for songs having titles (or artists) beginning with the letters “AN.” In step **826**, the remote database of the after-market device is queried using the specified letters. In step **828**, a list of potential matches is presented to the user at the car stereo or video system. In step **830**, a determination is made as to whether the desired song appears in the list and is immediately viewable without requiring the user to scroll through the list. If a positive determination is made, step **822** is invoked, wherein the user can select the desired song for retrieval from the after-market device and playing on the car stereo or video system. If a negative determination is made, step **832** is invoked, wherein a determination is made as to whether a threshold number of alphanumeric characters has been specified by the user. For example, a maximum threshold of 3 alphanumeric characters could be specified, or any other desired number. If a negative determination is made, steps **824-832** are re-invoked in the manner disclosed herein to allow the user to specify additional alphanumeric characters for querying the remote database. If a positive determination is made (threshold met), then processing terminates and the user must scroll through the list of retrieved songs or repeat the processing disclosed in **FIG. 16** to begin a new query.

FIG. 17 is a diagram showing another embodiment of the present invention, indicated generally at **850**, wherein a plurality of external devices are integrated using a single interface **852**. Any desired number or combination of devices can be integrated for use with a car stereo or video system using the interface **852**. The interface **852** houses a plurality of ports **858** for connecting any desired number of external devices, and a port **856** for connection with a car stereo or video system. The ports **858** and **856** could be any suitable type of input port, and could vary depending upon the types of devices to be integrated. Additionally, the interface **852** includes integration electronics **854**, which could include any desired electronics disclosed herein for integrating a plurality of external devices.

As shown in **FIG. 17**, a CD player **860**, a digital media device **862**, a satellite tuner **864**, a video device **866**, a cellular phone **868**, and an auxiliary input **870** are connected to the interface **852** and integrated for use with a car stereo or video system. The CD player **860** could comprise any desired CD player or changer. The digital media device **862** could comprise any portable digital media device, such as an Apple iPod, MP3 player, MP4, player, WMV player, portable music center, or any other desired device. The satellite tuner **864** could comprise any desired satellite tuner, such as an XM or Sirius tuner. The video device **866** could comprise any desired video device, such as a DVD player. The cellular phone **868** could comprise any cellular telephone capable of downloading and storing music or video files. The auxiliary input **870** could comprise any desired external device. Any desired number of interfaces **852** could be interconnected (“daisy-chained”). Further, the interface **852** could form part of an existing car stereo or video system. Control of the external devices connected to the interface **852** is provided through the car stereo or video system.

FIG. 18 is a diagram showing another embodiment of the present invention, indicated generally at **900**, wherein wireless integration is provided between a car audio and/or video system **910** and a portable audio and/or video device **924**. The car system **910** could be any OEM or after-market car audio and/or video system. The portable device **924** could comprise a CD player, CD changer, digital media player (*e.g.*, MP3 player, MP4 player, WMV player, Apple iPod, Apple video iPod), portable media center, portable media player, satellite receiver, digital audio broadcast (DAB) receiver (also commonly referred to as a high-definition (HD) radio receiver), video device (*e.g.*, DVD player or digital media player, such as the SONY PSP digital media player), cellular telephone, or any other portable device.

The car system **910** includes system electronics **912** (*e.g.*, circuitry and components provided by an OEM or after-market car audio and/or video system manufacturer), a display **918**, a control panel **920** (*e.g.*, buttons, touch screen display, etc.) for allowing user interaction and control, and a wireless interface or transceiver **916**. The wireless interface **916** could comprise an AT76C551 Bluetooth transceiver manufactured by Atmel, Inc., which includes a Bluetooth baseband controller with an integrated digital signal processor (DSP), and an AT7024 2.4 - 2.5 GHz band RF front end transceiver manufactured by Atmel, Inc., which includes a low-noise amplifier and transmit / receive

switch driver. Any other suitable wireless transceiver (e.g., IEEE 802.11a, 802.11b, or 802.11g) could also be substituted. The display **918** could comprise any display associated with the car system **910**, including, but not limited to, a display panel, a seat-back display, a dashboard display, an LCD or plasma display, or any other display in a car or associated with a car audio and/or video system, positioned anywhere within a vehicle.

The portable device **924** includes device electronics **934** (e.g., circuitry and components provided by the portable device manufacturer), a wireless interface or transceiver **926**, and an integration subsystem or module **932** positioned within the portable device **924**. Optionally, the wireless interface **926** could be positioned external to the portable device **924**. The wireless interface **926** is identical to the wireless interface **916**, and both interfaces **916** and **926** establish a wireless communications channel or link **922** between the car system **910** and the portable device **924**.

The integration subsystem **932** receives control commands that are issued at the car system **910** and wirelessly transmitted to the portable device **924** via the wireless communications link **922**, processes the commands into a format compatible with the device electronics **934** of the portable device **924**, and dispatches same to the device electronics **934** for execution thereby, so as to provide remote, wireless control of the portable device **924** using the car system **910**. For example, a "Play" command could be entered at the car system **910** (which could be a BMW car stereo), wirelessly transmitted to the portable device **924** (which could be an Apple iPod), converted by the integration subsystem **932** into a format recognizable by the device electronics **934**, and executed thereby. The integration subsystem **932** also receives data generated by the device electronics **934** (including, but not limited to, track information, artist information, song title, time information, etc.), processes same into a format compatible with the car system **910**, and transmits the processed data to the car system **910** using the wireless link **922** for display thereon using the display **918**. For example, playlists or other data generated by the portable device **924** could be processed by the integration subsystem **932** into a format compatible with the car system **910**, and wirelessly transmitted thereto for display on the display **918**.

Audio and video information generated by the portable device **924** can be transmitted digitally to the car system **910** using the wireless link **922**. This information could also be transmitted via one or more analog RF carrier signals, using suitable digital-

to-analog and analog-to-digital conversion circuitry known in the art. The integration subsystem **932** could also include conversion circuitry (*e.g.*, using the video format conversion chips discussed above with respect to **FIG. 12A**) for converting video information generated by the portable device **924** for display on the display **918** of the car system **910** (*e.g.*, by converting composite video signals to red, green, and blue (RGB) video signals, or vice versa). It should be noted that the integration subsystem **932** could also be utilized to process data, video, and audio information provided by the portable device **924** where the portable device **924** is connected to the Internet (*e.g.*, via a wireless Internet connection established by a cellular telephone). In such circumstances, the display **918** of the car system **910** would function as an Internet browser, and the controls **920** of the car system **910** could be utilized to navigate the Internet.

The integration subsystem **932** contains circuitry similar to the circuitry disclosed in the various embodiments of the present invention discussed herein, and could include a PIC16F872 or PIC16F873 microcontroller manufactured by Microchip, Inc. and programmed in accordance with the flowchart discussed below with respect to **FIG. 24**. Additionally, the integration subsystem **932** generates a device presence signal for maintaining the car system **910** in a state responsive to the portable device **924**. It should be noted that a non-wireless connection **930** could be provided between optional external interfaces ports **914** and **928** of the car system **910** and the portable device **924**, respectively, using any suitable wired connection type such as serial, FIREWIRE, CAN/CAN2, USB/USB2, IE Bus, T Bus, I Bus, or any other connection, to allow for wired integration between the car system **910** and the portable device **924**. Additionally, the non-wireless connection **930** could include a fiber-optic connection, such as a D2B or MOST fiber-optic connection. The device presence can be transmitted to the car system **910** using the wireless link **922** or, optionally, the non-wireless connection **930**.

FIG. 19 is a diagram showing another embodiment of the present invention, indicated generally at **1000**, wherein wireless integration is provided between a car audio and/or video system **1010** and a portable audio and/or video device **1024**. The components shown in **FIG. 19** are identical to the components shown in **FIG. 18**, and reference numerals of corresponding components have been increased by 100. In this embodiment, the integration subsystem **1032** is positioned internally within the car system **1010**, which also includes system electronics **1012**, wireless interface **1016**, display **1018**,

control panel **1020**, and, optionally, external interface port **1014**. The portable device **1024** includes a wireless interface **1026** in communication with device electronics **1034**, and optionally, an external interface port **1028** for communicating with the external interface port **1014** of the car system **1010** via non-wireless connection **1030**.

FIG. 20 is a diagram showing another embodiment of the present invention, indicated generally at **1100**, wherein a docking slot **1140** is provided in a car audio and/or video system **1110** for receiving a portable audio and/or video device **1124**. The car system **1110** includes system electronics **1112** (e.g., circuitry and components provided by an OEM or after-market car audio or video system manufacturer), a display **1118**, and a control panel **1120**. The portable device **1124** includes an integration subsystem or module **1132**, device electronics **1134** (e.g., circuitry and components provided by the manufacturer of the portable device **1124**) and an external interface port **1142** that interfaces with the docking slot **1140** to allow electrical communication between the integration subsystem **1132** of the car system **1110** and the device electronics **1134** of the portable device **1124**. The electrical connection formed by the external interface port **1142** and the docking slot **1140** could include a FIREWIRE, CAN/CAN2, USB/USB2, IE Bus, T Bus, or I Bus connection, or any other suitable connection type. Additionally, a fiber-optic connection could be formed between the external interface port **1142** and the docking slot **1140**, using a D2B, MOST, or other suitable fiber-optic connection.

The portable device **1124** is inserted into the docking slot **1140** in the general direction indicated by arrow **A**. Once docked, the integration subsystem **1132** processes control commands issued at the car system **1110** into a format compatible with the portable device **1124**, and processes data generated by the portable device **1124** into a format compatible with the car system **1110** in the manner described herein. Audio and video signals generated by the portable device **1124** are channeled by the integration subsystem **1132** to the system electronics **1112**, for playing through the car system **1110**. The portable device **1124** could comprise a digital media player (e.g., MP3 player, MP4 player, WMV player, Apple iPod, Apple video iPod, or other device), a portable media center, a portable media player, a satellite receiver, a digital audio broadcast (DAB) receiver or high-definition (HD) radio receiver, a portable video device, a cellular telephone, or any other portable device.

FIG. 21 is a diagram showing another embodiment of the present invention, indicated generally at **1200**, wherein a docking slot **1240** is provided in a car audio and/or video system **1210** for receiving a portable audio and/or video device **1224**. The components shown in **FIG. 21** are identical to those disclosed in **FIG. 20**, and reference numerals of corresponding components have been increased by 100. In this embodiment, the integration subsystem **1232** is positioned within the car system **1210**, which also includes system electronics **1212**, display **1218**, and control panel **1220**. The portable device **1224** includes device electronics **1234** and an external interface port **1242** for interfacing with the docking slot **1240** and providing electrical (and/or optical) communication with the integration subsystem **1232**.

FIG. 22 is a diagram showing another embodiment of the present invention, indicated generally at **1300**, wherein wireless integration is provided between a car audio and/or video system **1310** and a portable audio and/or video device **1324**, and voice synthesis and speech recognition capabilities are provided. More particularly, the portable device **1324** includes an integration subsystem or module **1332** having a voice recognition subsystem **1336** and a speech synthesizer **1338**. As with the embodiments discussed earlier with respect to **FIGS. 18-19**, the car system **1310** includes system electronics **1312** (*e.g.*, circuitry and components provided by an OEM or after-market car audio or video system manufacturer), an optional external interface port **1314**, a wireless interface or transceiver **1316** (which could be a Bluetooth or other suitable wireless transceiver), a display **1318**, and a control panel **1320**.

The portable device **1324** could comprise a CD player, CD changer, digital media player (*e.g.*, MP3 player, MP4 player, WMV player, Apple iPod, Apple video iPod, or other device), portable media center, portable media player, satellite receiver, digital audio broadcast (DAB) receiver, high-definition (HD) radio receiver, video device (*e.g.*, DVD player or digital media player, such as the SONY PSP digital media player), cellular telephone, or any other portable device. The portable device **1324** includes a wireless interface **1326** which communicates with the wireless interface **1316** to provide a wireless communications channel or link **1322**, an optional external interface port **1328** for providing a non-wireless connection **1330** with the external interface port **1314** (which could include any suitable wired connection, such as FIREWIRE, CAN/CAN2, USB/USB2, IE Bus, T Bus, I Bus, etc., or any suitable optical connection, such as D2B or

MOST), device electronics **1334**, and optional external audio output **1340** and optional external audio input **1342**.

The voice recognition subsystem **1336** of the integration subsystem **1332** could comprise the HM2007 speech recognition processor manufactured by Hualon Microelectric Corporation, the VRP6679 speech recognition processor manufactured by Oki, Inc., or any other suitable speech recognition processor. The voice recognition subsystem **1336** receives control commands that are spoken by a user and are transmitted to the portable device **1324** via the wireless link **1322** or the non-wireless connection **1330** (where the car system **1310** another vehicle component connected to the car system **1310** includes a microphone for receiving voice commands). Optionally, a microphone could be connected to the external audio input **1342** of the portable device **1324** for receiving voice commands. Any desired, spoken commands could be received by the integration subsystem **1332** and processed by the voice recognition subsystem **1336** into a format compatible with the device electronics **1334** of the portable device **1324** for execution thereby. For example, a user could speak a desired artist name, whereupon the voice recognition subsystem **1336** processes the spoken artist name into a digital format, passes the processed artist name to the integration subsystem **1332**, and the integration subsystem **1332** constructs a query command and passes the query command to the device electronics **1334** along with the processed artist name to the device electronics **1334**. The device electronics **1334** then queries the portable device **1324** for all songs (e.g., by searching ID3 tags associated with each song and stored in the portable device **1324**) having a matching artist name. The resulting list is then passed to the integration subsystem **1332**, whereupon the information is processed into a format compatible with the car system **1310**. Then, the information is transmitted to the car system **1310** via the wireless link **1322** or the non-wireless connection **1330** for display on the display **1318** of the car system **1310**.

Voice recognition could also be used to retrieve other media files, such as video clips that are stored on the portable device **1324**. Such files, one retrieved, could then be processed by the integration subsystem **1332** in the manner described herein, transmitted to the car system **1310** (via the wireless link **1322** or the non-wireless connection **1330**), and displayed on the display **1318** of the car system **1310**. An index of such files could

also be generated by the integration subsystem **1332** for quick browsing and retrieval using car system **1310** or voice commands.

The speech synthesizer **1338** provides synthesized speech corresponding to data produced by the portable device **1324**. For example, track lists, artist names, song titles, and other information (e.g., video clip titles, movie titles, etc.) could be retrieved from the portable device **1324** by the integration subsystem **1332** (e.g., in response to a command issued by the user at the car system **1310** or a spoken command processed by the voice recognition subsystem **1336**), and synthesized speech corresponding to the retrieved information could be generated by the speech synthesizer **1338** using known text-to-speech software. The speech synthesizer **1338** could include the RC 8650 or RC 8660 speech synthesis chipsets manufactured by RC Systems, Inc., or any other suitable speech synthesizers. Synthesized speech could be transmitted to the car system **1310** via the wireless link **1322** or the non-wireless connection **1330** and played through the car system **1310**, or optionally, the speech could be channeled to an external device via the optional external audio output **1340**. It should be noted that the voice recognition subsystem **1336** and the speech synthesizer **1338** could be formed on a single integrated circuit forming part of the integration subsystem **1332**. Additionally, the integration subsystem **1332** provides full control of the portable device **1324** using the car system **1310** and exchange of data, audio, and video signals between the portable device **1324** and the car system **1310**, in the manner described herein.

FIG. 23 is a diagram showing another embodiment of the present invention, indicated generally at **1400**, wherein wireless integration is provide between a car audio and/or video system **1410** and a portable audio and/or video device **1424** and voice recognition and speech synthesis capabilities are provided. The components shown in **FIG. 23** are functionally identical to the components shown in **FIG. 22**, and reference numerals of corresponding components have been increased by 100. In this embodiment, the integration subsystem **1432** is positioned in the car system **1410**, which includes system electronics **1412**, an optional external interface port **1414**, a wireless interface **1416**, a display **1418**, and a control panel **1420**. The integration subsystem **1432** includes a voice recognition subsystem **1436** and a speech synthesizer **1438**, which provide the voice recognition and speech synthesis capabilities described above with reference to **FIG. 22**. The portable device **1424** includes a wireless interface **1426**, and optional external

interface port **1428**, device electronics **1434**, an optional external audio output port **1440**, and an optional external audio input port **1442**.

FIG. 24 is a flowchart showing processing logic according to the present invention, indicated generally at **1450**, for wirelessly integrating a portable audio and/or video device for use with a car audio and/or video system. In step **1452**, a wireless link is established between the portable device and the car audio and/or video system. As discussed above, the wireless link could be any suitable wireless communications link, such as a Bluetooth wireless link, an IEEE 802.11 link, or any other suitable link. In step **1454**, the car audio and/or video system type is determined, such as the manufacturer name and/or model identifier. In step **1456**, the portable audio and/or video device type is identified, such as the manufacturer name and/or model identifier. In step **1458**, a protocol conversion software block is loaded from memory, based upon the corresponding device types of the car audio and/or video system and the portable audio and/or video device. The protocol conversion software block includes code for converting commands issued at the car audio and/or video system into a format compatible with the portable audio and/or video device, as well as code for converting data generated by the portable audio and/or video device into a format compatible with the car audio and/or video system.

In step **1460**, data generated by the portable audio and/or video device is processed by the protocol conversion software block. Then, in step **1466**, the processed data is transmitted to the car audio and/or video system for display thereon, using the wireless link. In step **1462**, audio and/or video signal generated by the portable audio and/or video device are channeled to the car audio and/or video system using the wireless link. In step **1464**, a determination is made as to whether commands from the car audio and/or video system are to be processed. If a negative determination is made, step **1458** is re-invoked. Otherwise, step **1468** is invoked, wherein the commands are processed using the protocol conversion software block. Then, in step **1470**, the processed commands are transmitted to the car audio and/or video system using the wireless link. Step **1458** is then re-invoked, so that additional processing can occur.

Importantly, the present invention allows video files in any format (including video clips, movies, pictures, etc.) that are stored on a portable device to be displayed on one or more displays of a car audio and/or video system, and playback of such files to be controlled using the car audio and/or video system. Examples of such files include, but

are not limited to, MPEG, WMV, AVI, JPEG, GIF, TIFF, MP4, or any other suitable video format. Such files could be stored on a cell phone, a portable media center, a portable media player, or any other portable device which is integrated by the present invention (through a wired or wireless connection) for use with a car audio and/or video system. Thus, for example, a video clip downloaded to a cellular telephone or a video clip stored on a portable device (e.g., an Apple video iPod) can be displayed on one or more displays of a car audio and/or video system. Further, the present invention allows for live video streams, such as live television video received by a cellular telephone or other portable device, to be displayed on one or more displays of the car audio and/or video system.

FIG. 25A is a diagram showing another embodiment of the present invention, indicated generally at **1500**, wherein a digital camera **1515** is integrated for use with a car audiovisual system **1505**. The digital camera **1515** could comprise any commercially-available digital still or video camera, such as a point-and-shoot or single-lens-reflex (SLR) digital camera. The digital camera **1515** is in electrical communication with the interface **1510** via any suitable electrical connection, such as USB, USB2, Firewire (IEEE 1394), etc., or any suitable wireless connection, such as BLUETOOTH, IEEE 802.11 (WiFi), etc. The interface **1510** receives data from the digital camera **1515** (such photographs or video clips) and formats same for displaying on a display **1520** of the car audiovisual system **1505**. Instructions for controlling the digital camera **1515** can be entered using the control panel buttons **1525** of the car audiovisual system **1505**. The instructions are processed by the interface **1510**, converted into a format (protocol) compatible with the digital camera **1515**, and transmitted to the digital camera **1515** for processing thereby. Output signals from the digital camera **1515** containing still images, full motion video, or multimedia data can be channeled to the car audiovisual system **1505** via the interface **1510** and played through the display **1520** and/or speakers of the car audiovisual system **1505**. For example, a video file stored in the digital camera **1515** can be selected using the control panel buttons **1525**, which causes the digital camera **1515** to produce corresponding output signals that are processed by the interface **1510**, transmitted to the car audiovisual system **1505**, and displayed on the display **1520**. It should be noted that control of the digital camera **1515** can be performed using buttons on the car audiovisual system **1505**, or a software or graphically-driven menu or interface, such as a

touch screen, as well as controls on the digital camera **1515** itself. The interface **1510** could include one or more of the circuits disclosed herein and modified for use with the digital camera **1515**, including, but not limited to a microcontroller programmed in accordance with the present invention as well as a video processing integrated circuit for converting video signals from the camera **1515** into video signals compatible with the car audiovisual system **1505**.

FIG. 25B is a flowchart showing processing logic, indicated generally at **1530**, for integrating a digital camera with a car audiovisual system. Beginning at step **1535**, a determination is made as to whether the existing car audiovisual system is powered on. If a negative determination is made, step **1540** is invoked, wherein the present invention enters a standby mode and waits for the car audiovisual system to be powered on. If a positive determination is made, step **1545** is invoked, wherein a second determination is made as to whether the car audiovisual system is in a state responsive to signals external to the car audiovisual system. If a negative determination is made, step **1535** is re-invoked.

If a positive determination is made in step **1545**, a digital camera handling process, indicated as block **1565**, is invoked. Beginning in step **1550**, a signal is generated by the present invention indicating that a digital camera is present, and the signal is continuously transmitted to the car audiovisual system. Importantly, this signal prevents the car audiovisual system from shutting off, entering a sleep mode, or otherwise being unresponsive to signals and/or data from an external source. In step **1555**, video and/or audio channels of the digital camera are connected (channeled) to the car audiovisual system. In step **1560**, data is retrieved by the present invention from the digital camera, such as title information corresponding to one or more files stored in the digital camera. For example, a list of files stored on the digital camera is presented on the display of the car audiovisual system for selection by a user. The user can then select a file, which could include a picture (.jpg, .gif, .tiff, etc.) or a video file (.wmv, .mpg, etc.), using the controls of the car audiovisual system, and display same on the display of the car audiovisual system. If conversion of the video signal is required, the present invention could convert the signal using any suitable video conversion circuitry (e.g., composite-to-RGB signal conversion, and/or vice versa) prior to displaying the signal on a display of the car audiovisual system. After steps **1550**, **1555**, and **1560** have been executed, control passes to step **1570**.

In step **1570**, the present invention monitors the control panel buttons of the car audiovisual system for digital camera operational instructions. In step **1575**, if an instruction is not detected, step **1570** is re-invoked. Otherwise, if an instruction is received, step **1580** is invoked, wherein the received instruction is converted into a format recognizable by the digital camera connected to the present invention. For example, after a user selects a particular file name presented on the display, an instruction to output video signals that correspond to the selected file is generated. Once the instruction has been formatted, step **1585** is invoked, wherein the formatted instruction is transmitted to the digital camera and executed thereby. Step **1550** is then re-invoked, so that additional processing can occur.

FIG. 26A is a diagram showing another embodiment of the present invention, indicated generally at **1600**, wherein a portable navigation device **1615** (e.g., a Garmin or Tom Tom GPS receiver, etc.) is integrated for use with a car audiovisual system **1605**. The portable navigation device **1615** is in electrical communication (e.g., wired or wireless communication, as discussed hereinabove using any suitable wired or wireless connection methodology) with the interface **1610**, which receives data from the portable navigation device **1615** and formats same for displaying on a display **1620** of the car audiovisual system **1605**. Instructions for controlling the portable navigation device **1615** can be entered using control panel buttons **1625** of the car audiovisual system **1605**. The instructions are processed by the interface **1610**, converted into a format (protocol) compatible with the portable navigation device **1615**, and transmitted to the portable navigation device **1615** for processing thereby. Maps and audio cues from the portable navigation device **1615** can be channeled to the car audiovisual system **1605** via the interface **1610** and played through the display **1620** and/or speakers of the car audiovisual system **1605**. For example, a driving destination may be specified using the control panel buttons **1625**, which causes a digital map file (or a portion thereof) stored in the portable navigation device **1615** to be presented on the display **1620**, and speech-synthesized driving instructions (generated by the portable navigation device **1615**) to be played through speakers of the car audiovisual system **1605**. It should be noted that control of the portable navigation device **1615** can be performed using buttons on the car audiovisual system **1605**, or a software or graphically-driven menu or interface, such as a touch screen, as well as controls on the portable navigation device **1615** itself. One or more interfaces

could be connected to the interface **1610** (“daisy-chained”) to allow multiple products to be integrated. The device **1600** could include one or more of the circuits disclosed herein and modified for use with the portable navigation device **1615**.

FIG. 26B is a flowchart showing processing logic, indicated generally at **1630**, for integrating a portable navigation device with a car audiovisual system. Beginning in step **1635**, a determination is made as to whether the existing car audiovisual system is powered on. If a negative determination is made, step **1640** is invoked, wherein the present invention enters a standby mode and waits for the car audiovisual system to be powered on. If a positive determination is made, step **1645** is invoked, wherein a second determination is made as to whether the car audiovisual system is in a state responsive to signals external to the car audiovisual system. If a negative determination is made, step **1635** is re-invoked.

If a positive determination is made in step **1645**, a portable navigation device handling process, indicated as block **1665**, is invoked. Beginning in step **1650**, a signal is generated by the present invention indicating that a portable navigation device is present, and the signal is continuously transmitted to the car audiovisual system. Importantly, this signal prevents the car audiovisual system from shutting off, entering a sleep mode, or otherwise being unresponsive to signals and/or data from an external source.

In step **1655**, video and/or audio channels of the portable navigation device are connected (channeled) to the car audiovisual system. In step **1660**, data is retrieved by the present invention from the portable navigation device, such as a menu for specifying a driving destination, and presented on the display of the car audiovisual system. After steps **1650**, **1655**, and **1660** have been executed, control passes to step **1670**.

In step **1670**, the present invention monitors the control panel buttons of the car audiovisual system for portable navigation device operational instructions. In step **1675**, if an instruction is not detected, step **1670** is re-invoked. Otherwise, if an instruction is received, step **1680** is invoked, wherein the received instruction is converted into a format recognizable by the portable navigation device connected to the present invention. For example, an instruction for displaying driving directions to a driving destination could be issued from the car audiovisual system and converted into a format compatible with the portable navigation device. Once the instruction has been formatted, step **1685** is invoked,

wherein the formatted instruction is transmitted to the portable navigation device and executed thereby. Step **1650** is then re-invoked, so that additional processing can occur.

FIG. 27 is a diagram showing another embodiment of the present invention, indicated generally at **1700**, wherein the integration system of the present is embodied as an interface integrated circuit **1725** (e.g., a microcontroller) that could be supplied to a manufacturer of a car audiovisual system **1705** and installed within the car audiovisual system **1705**, at the time of manufacture of the car audiovisual system **1705** or thereafter. The integrated circuit **1725** could be fabricated as a single microchip, or a collection of associated microchips (e.g., a chipset). The integrated circuit **1725** is in electrical communication with the car audiovisual system electronics **1710** and an associated display **1715** and control panel buttons **1720**. The interface integrated circuit **1725** is also in electrical communication with a communications port **1730** (e.g., FIREWIRE, CAN/CAN2, USB/USB2, IE Bus, T Bus, I Bus, MOST, or D2B) which could be formed integrally with the car audiovisual system **1705**, e.g., accessible as a port on the front panel of the car audiovisual system **1705** (such as a USB port), or at some other location in a vehicle external to the car audiovisual system **1705** but in electrical communication therewith. Optionally, the interface integrated circuit **1725** could be in electrical communication with a wireless transceiver **1735** (e.g., Bluetooth, IEEE 802.11, WiFi, WiMAX, EVDO, Wireless USB, or HyperLAN) and or one or more auxiliary communications ports **1740**, which could support the same or a different type of communications protocol as communications port **1730**. The wireless transceiver **1735** allows wireless communication of data, audio, and/or video between the interface integrated circuit **1725** and the portable music player **1745**.

A portable music player **1745** could be plugged directly into the communications port **1730** (e.g., using a USB or firewire connection) thereby placing the portable music player **1745** in electrical communication with the interface integrated circuit **1725**. The interface integrated circuit **1725** receives data, audio, and/or video from the portable music player **1745** through the communications port **1730** and formats the data for display on and/or playing through the car audiovisual system **1705**. Instructions for controlling the portable music player **1745** can be entered using the control panel buttons **1720** of the car audiovisual system **1705**. The instructions are processed by the interface integrated circuit **1725**, converted into a format (protocol) compatible with the portable music player **1745**,

and transmitted through the communications port **1730** to the portable music player **1745** for processing thereby. Audio from the portable music player **1745** can be channeled to the car audiovisual system **1705** via the interface integrated circuit **1725** and played through the display **1715** and/or speakers of the car audiovisual system **1705**.

A music file stored in the portable music player **1745** may be selected using the control panel buttons **1720**, which causes corresponding audio signals from the portable music player **1745** to be played through speakers of the car audiovisual system **1705**. It should be noted that control of the portable music player **1745** is not limited to the use of buttons on the car stereo or video system **1720**, and indeed, a software or graphically-driven menu or interface can be used to control the portable music player **1745**. The car audiovisual system **1705** could include one or more of the circuits disclosed herein and modified for use with the portable music player **1740**.

It should also be noted that a manufacturer of audiovisual system **1705** could be provided with protocol conversion software built into the interface integrated circuit **1725** and a schematic diagram with instructions for installing the interface integrated circuit **1725** into existing car audiovisual **1705** systems. Alternatively, a functional equivalent of the interface integrated circuit **1725** could be provided in the form of a protocol conversion software product or a firmware upgrade, which is loaded into an existing car audiovisual system and used by a microprocessor therein to allow integration with third-party devices. In this case, the existing car audiovisual system would include a data port or a wireless transceiver for communicating with third-party devices. Optionally, the interface integrated circuit **1725** could be sold to portable device manufacturers and implemented within portable audio and/or video devices. Alternatively, a functional equivalent of the interface integrated circuit **1725** could be provided in the form of a protocol conversion software product or a firmware upgrade, which is loaded into an existing portable and/or video device and used by a microprocessor therein to allow integration with third-party devices, such as an existing car audiovisual system.

In all embodiments of the present invention, the interface could allow audio and/or video signals generated by a car audiovisual system (whether from a live signal received by the car audiovisual system or from a stored medium) to be ported from the car audiovisual system to a portable audio and/or video device for recording same in the portable device. For example, a live radio signal received by the car audiovisual system

(e.g., a live FM station or a live satellite station) could be ported by the interface of the present invention to the portable device (via a wired or wireless connection) and recorded (“ripped”) on the portable audio and/or video device in a suitable format, such as one or more MP3 files. Further, the interface allows audio and/or video signals generated by a portable audio and/or video device (whether from a live signal received by the portable device or from a stored medium) to be ported from the portable device to the car audiovisual system for recording same using the car audiovisual system.

The interface of the present invention could include circuitry for wirelessly charging a battery of a portable audio or video device. For example, the interface could include an inductive battery charging circuit which transmits electrical power to the portable device using induction, when the device is located near the interface. In such circumstances, the portable device would also include a corresponding inductive circuit which receives the transmitted electrical power and applies same to the battery of the portable device. Such a circuit could operate in a “trickle charge” mode, wherein a low voltage and amperage electrical current is delivered to the battery of the portable device over time to charge a battery. Also, transmission of power from the interface to the portable device could be accomplished through the use of radio frequency (RF) transmissions between the interface and the portable device. In situations where the interface is installed in a car audio or video system (as discussed herein), a wireless battery charging circuit could also be installed in the car audio or video system.

Having thus described the invention in detail, it is to be understood that the foregoing description is not intended to limit the spirit and scope thereof.

CLAIMSWhat is claimed is:

1. A multimedia device integration system comprising:
 - a car audio system having a display associated therewith;
 - a portable device external to the car audio system;
 - a first wireless interface in communication with the car audio system;
 - a second wireless interface in communication with the portable device, the first and second wireless interfaces establishing a wireless communications link between the car audio system and the portable device; and
 - an integration subsystem for generating a device presence signal for maintaining the car audio system in a state responsive to the portable device, wherein the integration subsystem transmits the device presence signal to the car audio system, channels audio from the portable device to the car audio system using the wireless communications link, processes video information generated by the portable device into a format compatible with the car audio system, and transmits the processed video information to the car audio system using the wireless communications link for displaying the processed video information on the display of the car audio system.
2. The system of Claim 1, wherein the integration subsystem processes data generated by the portable device into a format compatible with the car audio system and displays the processed data on the display of the car audio system.
3. The system of Claim 1, wherein the integration subsystem receives control commands issued at the car audio system and transmitted over the wireless communications link, processes the commands into a format compatible with the portable device, and dispatches the processed commands to the portable device for execution thereby.
4. The system of Claim 1, wherein the integration subsystem further comprises a voice recognition subsystem for processing spoken control commands issued by a user.

5. The system of Claim 4, wherein the integration subsystem retrieves an audio file or a video file from the portable device in response to a spoken command.
6. The system of Claim 4, wherein the integration subsystem further comprises a speech synthesizer for generating synthesized speech corresponding to data generated by the portable device.
7. The system of Claim 1, wherein the car audio system comprises an OEM car audio system.
8. The system of Claim 1, wherein the car audio system comprises an after-market car audio system.
9. The system of Claim 1, wherein the portable device comprises a portable receiver.
10. The system of Claim 10, wherein the portable receiver comprises a digital audio broadcast (DAB) receiver, a high-definition (HD) radio receiver, or a satellite receiver.
11. The system of Claim 1, wherein the portable device comprises a portable digital media player.
12. The system of Claim 11, wherein the portable digital media player comprises a video device, a portable media center, a portable media player, an MP3 player, an MP4 player, a WMV player, an Apple iPod, or an Apple video iPod.
13. The system of Claim 1, wherein the portable device comprises a cellular telephone.
14. The system of Claim 1, further comprising a non-wireless connection established between the car audio system and the portable device for exchanging data, commands, audio and video signals between the car audio system and the portable device.
15. The system of Claim 1, wherein the integration subsystem is positioned within the portable device.
16. The system of Claim 1, wherein the integration subsystem is positioned within the car audio system.

17. The system of Claim 1, wherein the video information comprises a video file stored on the portable device.
18. The system of Claim 1, wherein the video information comprises a picture stored on the portable device.
19. The system of Claim 1, wherein the video information comprises a television signal received by the portable device.
20. A multimedia device integration system comprising:
- a car video system having a display associated therewith;
 - a portable device external to the car video system;
 - a first wireless interface in communication with the car video system;
 - a second wireless interface in communication with the portable device, the first and second wireless interfaces establishing a wireless communications link between the car video system and the portable device; and
 - an integration subsystem for generating a device presence signal for maintaining the car video system in a state responsive to the portable device, wherein the integration subsystem transmits the device presence signal to the car video system, channels audio from the portable device to the car video system using the wireless communications link, processes video information generated by the portable device into a format compatible with the car video system, and transmits the processed video information to the car video system using the wireless communications link for displaying the processed video information on the display of the car video system.
21. The system of Claim 20, wherein the integration subsystem processes data generated by the portable device into a format compatible with the car video system and displays the processed data on the display of the car video system.
22. The system of Claim 20, wherein the integration subsystem receives control commands issued at the car video system and transmitted over the wireless communications link, processes the commands into a format compatible with the portable

device, and dispatches the processed commands to the portable device for execution thereby.

23. The system of Claim 20, wherein the integration subsystem further comprises a voice recognition subsystem for processing spoken control commands issued by a user.

24. The system of Claim 23, wherein the integration subsystem retrieves an audio file or a video file from the portable device in response to a spoken command.

25. The system of Claim 23, wherein the integration subsystem further comprises a speech synthesizer for generating synthesized speech corresponding to data generated by the portable device.

26. The system of Claim 20, wherein the car video system comprises an OEM car video system.

27. The system of Claim 20, wherein the car video system comprises an after-market car video system.

28. The system of Claim 20, wherein the portable device comprises a portable receiver.

29. The system of Claim 28, wherein the portable receiver comprises a digital audio broadcast (DAB) receiver, a high-definition (HD) radio receiver, or a satellite receiver.

30. The system of Claim 20, wherein the portable device comprises a portable digital media player.

31. The system of Claim 30, wherein the portable digital media player comprises a video device, a portable media center, a portable media player, an MP3 player, an MP4 player, a WMV player, an Apple iPod, or an Apple video iPod.

32. The system of Claim 20, wherein the portable device comprises a cellular telephone.

33. The system of Claim 20, further comprising a non-wireless connection established between the car video system and the portable device for exchanging data, commands, audio and video signals between the car video system and the portable device.

34. The system of Claim 20, wherein the integration subsystem is positioned within the portable device.

35. The system of Claim 20, wherein the integration subsystem is positioned within the car video system.

36. The system of Claim 20, wherein the video information comprises a video file stored on the portable device.

37. The system of Claim 20, wherein the video information comprises a picture stored on the portable device.

38. The system of Claim 20, wherein the video information comprises a television signal received by the portable device.

39. A multimedia device integration system comprising:

a car audio system;

a portable device external to the car audio system;

a docking slot formed in the car audio system for receiving the portable device and establishing electrical communication between the car audio system and the portable device; and

an integration subsystem for generating a device presence signal for maintaining the car audio system in a state responsive to the portable device, wherein the integration subsystem receives data generated by the portable device, processes the data into a format compatible with the car audio system, and transmits the processed data, the device presence signal, and audio signals to the car audio system.

40. The system of Claim 39, wherein the processed data is displayed on a display of the car audio system.

41. The system of Claim 39, wherein the integration subsystem processes a video file stored on the portable device into a format compatible with the car audio system and transmits the video file to the car audio system for displaying the video file on a display of the car audio system.

42. The system of Claim 39, wherein the integration subsystem receives control commands issued at the car audio system, processes the commands into a format compatible with the portable device, and dispatches the processed commands to the portable device for execution thereby.

43. The system of Claim 39, wherein the integration subsystem further comprises a voice recognition subsystem for processing spoken control commands issued by a user.

44. The system of Claim 43, wherein the integration subsystem retrieves an audio file or a video file from the portable device in response to a spoken command.

45. The system of Claim 43, wherein the integration subsystem further comprises a speech synthesizer for generating synthesized speech corresponding to data generated by the portable device.

46. The system of Claim 39, wherein the car audio system comprises an OEM car audio system.

47. The system of Claim 39, wherein the car audio system comprises an after-market car audio system.

48. The system of Claim 39, wherein the portable device comprises a portable receiver.

49. The system of Claim 48, wherein the portable receiver comprises a digital audio broadcast (DAB) receiver, a high-definition (HD) radio receiver, or a satellite receiver.

50. The system of Claim 39, wherein the portable device comprises a portable digital media player.

51. The system of Claim 50, wherein the portable digital media player comprises a video device, a portable media center, a portable media player, an MP3 player, an MP4 player, a WMV player, an Apple iPod, or an Apple video iPod.

52. The system of Claim 39, wherein the portable device comprises a cellular telephone.

53. The system of Claim 39, wherein the integration subsystem is positioned within the portable device.

54. The system of Claim 39, wherein the integration subsystem is positioned within the car audio system.

55. A multimedia device integration system comprising:

a car video system;

a portable device external to the car video system;

a docking slot formed in the car video system for receiving the portable device and establishing electrical communication between the car video system and the portable device; and

an integration subsystem for generating a device presence signal for maintaining the car video system in a state responsive to the portable device, wherein the integration subsystem receives data generated by the portable device, processes the data into a format compatible with the car video system, and transmits the processed data, the device presence signal, audio signals, and video signals to the car video system.

56. The system of Claim 55, wherein the processed data is displayed on a display of the car video system.

57. The system of Claim 55, wherein the integration subsystem processes a video file stored on the portable device into a format compatible with the car video system and transmits the video file to the car video system for displaying the video file on a display of the car video system.

58. The system of Claim 55, wherein the integration subsystem receives control commands issued at the car video system, processes the commands into a format compatible with the portable device, and dispatches the processed commands to the portable device for execution thereby.

59. The system of Claim 55, wherein the integration subsystem further comprises a voice recognition subsystem for processing spoken control commands issued by a user.

60. The system of Claim 59, wherein the integration subsystem retrieves an audio file or a video file from the portable device in response to a spoken command.
61. The system of Claim 59, wherein the integration subsystem further comprises a speech synthesizer for generating synthesized speech corresponding to data generated by the portable device.
62. The system of Claim 55, wherein the car video system comprises an OEM car video system.
63. The system of Claim 55, wherein the car video system comprises an after-market car video system.
64. The system of Claim 55, wherein the portable device comprises a portable receiver.
65. The system of Claim 64, wherein the portable receiver comprises a digital audio broadcast (DAB) receiver, a high-definition (HD) radio receiver, or a satellite receiver.
66. The system of Claim 55, wherein the portable device comprises a portable digital media player.
67. The system of Claim 66, wherein the portable digital media player comprises a video device, a portable media center, a portable media player, an MP3 player, an MP4 player, a WMV player, an Apple iPod, or an Apple video iPod.
68. The system of Claim 55, wherein the portable device comprises a cellular telephone.
69. The system of Claim 55, wherein the integration subsystem is positioned within the portable device.
70. The system of Claim 55, wherein the integration subsystem is positioned within the car video system.

71. A method for wirelessly integrating a portable device for use with a car audio system comprising:

establishing a wireless communications link between the car audio system and the portable device;

generating a device presence signal for maintaining the car audio system in a state responsive to the portable device;

transmitting the device presence signal to the car audio system over the wireless communications link;

processing video information generated by the portable device into a format compatible with the car audio system;

transmitting the processed video information and audio signals generated by the portable device to the car audio system over the wireless communications link;

displaying the processed video information on a display of the car audio system;
and

playing the audio signals over the car audio system.

72. The method of Claim 71, further comprising processing data generated by the portable device into a format compatible with the car audio system.

73. The method of Claim 72, further comprising transmitting the processed data over the wireless communications link to the car audio system.

74. The method of Claim 73, further comprising displaying the processed data on a display of the car audio system.

75. The method of Claim 71, further comprising transmitting control commands issued by a user at the car audio system over the wireless communications link.

76. The method of Claim 75, further comprising receiving the control commands at the portable device and processing the control commands into a format compatible with the portable device.

77. The method of Claim 76, further comprising dispatching the processed control commands to the portable device for execution thereby.

78. The method of Claim 71, further comprising receiving spoken control commands with a voice recognition subsystem and processing the spoken control commands into a format compatible with the portable device.

79. The method of Claim 78, further comprising dispatching the processed control commands to the portable device for execution thereby.

80. The method of Claim 71, further comprising generating synthesized speech corresponding to data generated by the portable device.

81. A method for wirelessly integrating a portable device for use with a car video system comprising:

establishing a wireless communications link between the car video system and the portable device;

generating a device presence signal for maintaining the car video system in a state responsive to the portable device;

transmitting the device presence signal to the car video system over the wireless communications link;

processing video information generated by the portable device into a format compatible with the car video system;

transmitting the processed video information and audio signals generated by the portable device to the car video system over the wireless communications link;

displaying the processed video information on a display of the car video system;
and

playing the audio signals over the car video system.

82. The method of Claim 81, further comprising processing data generated by the portable device into a format compatible with the car video system.

83. The method of Claim 82, further comprising transmitting the processed data over the wireless communications link to the car video system.

84. The method of Claim 83, further comprising displaying the processed data on a display of the car video system.

85. The method of Claim 81, further comprising transmitting control commands issued by a user at the car video system over the wireless communications link.

86. The method of Claim 85, further comprising receiving the control commands at the portable device and processing the control commands into a format compatible with the portable device.

87. The method of Claim 86, further comprising dispatching the processed control commands to the portable device for execution thereby.

88. The method of Claim 81, further comprising receiving spoken control commands with a voice recognition subsystem and processing the spoken control commands into a format compatible with the portable device.

89. The method of Claim 88, further comprising dispatching the processed control commands to the portable device for execution thereby.

90. The method of Claim 81, further comprising generating synthesized speech corresponding to data generated by the portable device.

91. A docking station for docking and integrating a portable device for use with a car stereo, comprising:

a base portion;

a bottom member connected to the base portion;

a top member removably connected to the base portion, the base portion, bottom member, and top member defining a cavity for receiving a portable device; and

an integration device connected to the base portion for integrating the portable device with a car stereo.

92. A multimedia device integration system comprising:

a car audiovisual system having a display associated therewith;

a cellular telephone external to the car audiovisual system, the cellular telephone including a receiver for receiving a broadcast radio transmission transmitted to the cellular telephone; and

an interface in communication with the car audiovisual system and the cellular telephone, wherein the interface generates and transmits a device presence signal to the car audiovisual system to maintain same in a state responsive to the cellular telephone, processes the broadcast radio transmission received by the cellular telephone into a format compatible with the car audiovisual system, and transmits the processed broadcast radio transmission to the car audiovisual system for playing thereby.

93. The multimedia device integration system of Claim 92, wherein the broadcast radio transmission comprises a satellite radio transmission received by the cellular telephone.

94. The multimedia device integration system of Claim 92, wherein the broadcast radio transmission comprises a live radio transmission from a radio station.

95. The multimedia device integration system of Claim 92, wherein the broadcast radio transmission comprises a streamed audio transmission received by the cellular telephone.

96. The multimedia device integration system of Claim 92, wherein the broadcast radio transmission comprises a video transmission received by the cellular telephone.

97. The multimedia device integration system of Claim 96, wherein the video transmission comprises a live video transmission.

98. The multimedia device integration system of Claim 96, wherein the video transmission comprises a streamed video transmission.

99. The multimedia device integration system of Claim 96, wherein the interface processes the video transmission into a format compatible with the car audiovisual system and transmits the processed video transmission to the car audiovisual system for display thereon.

100. The multimedia device integration system of Claim 92, wherein the interface receives control commands issued at the car audiovisual system, processes the control commands into a format compatible with the cellular telephone, and transmits processed control commands to the cellular telephone for execution thereby.

101. The multimedia device integration system of Claim 92, wherein the interface processes navigational information received by the cellular telephone into a format compatible with the car audiovisual system, and transmits processed navigational information to the car audiovisual system for display thereon.

102. The multimedia device integration system of Claim 101, wherein the navigational information comprises a road map.

103. The multimedia device integration system of Claim 101, wherein the navigational information comprises a Global Positioning System (GPS) map.

104. A multimedia device integration system comprising:

a car audiovisual system;

a digital camera external to the car audiovisual system; and

an interface in electrical communication with the car audiovisual system and the digital camera, wherein the interface generates and transmits a device presence signal to the car audiovisual system to maintain same in a state responsive to the digital camera, processes output signals generated by the digital camera into a format compatible with the car audiovisual system, and transmits the processed output signals to the car audiovisual system for display thereby.

105. The multimedia device integration system of Claim 104, wherein the interface transmits audio signals generated by the digital camera device to the car audiovisual system for playing thereby.

106. The multimedia device integration system of Claim 104, wherein the interface receives control commands issued at the car audiovisual system, processes the control commands into a format compatible with the digital camera, and transmits processed control commands to the digital camera for execution thereby.

107. The multimedia device integration system of Claim 104, wherein the output signal comprises a still video image.

108. The multimedia device integration system of Claim 104, wherein the output signal comprises a full motion video clip.

109. The multimedia device integration system of Claim 104, wherein the output signal comprises a live video signal.

110. The multimedia device integration system of Claim 104, wherein the output signal comprises a streaming video signal.

111. A multimedia device integration system comprising:

a car audiovisual system;

a portable navigation device external to the car audiovisual system;

an interface in electrical communication with the car audiovisual system and the portable navigation device, wherein the interface processes video and data signals generated by the portable navigation device into a format compatible with the car audiovisual system, and transmits the processed video and data signals to the car audiovisual system for display thereby.

112. The multimedia device integration system of Claim 111, wherein the interface receives control commands issued at the car audiovisual system, processes the control commands into a format compatible with the portable navigation device, and transmits processed control commands to the portable navigation device for execution thereby.

113. The multimedia device integration system of Claim 111, wherein the portable navigation system comprises a portable Global Positioning System (GPS) device.

114. The multimedia device integration system of Claim 111, wherein the video signals comprise a map generated by the portable navigation device and displayed on the car audiovisual system.

115. The multimedia device integration system of Claim 111, wherein the interface transmits audio signals generated by the portable navigation device to the car audiovisual system for playing thereby.

116. The multimedia device integration system of Claim 115, wherein the audio signals comprise synthesized speech generated by the portable navigation device.

117. A multimedia device integration system, comprising:

a car audiovisual system;

an after-market, portable audiovisual device external to the car audiovisual system;

and

an interface integrated circuit installed in the portable audiovisual device and in communication with the car audiovisual system and the portable audiovisual device, the interface integrated circuit generating and transmitting a device presence signal for maintaining the car audiovisual signal in a state responsive to the portable audiovisual device and transmitting audio signals from the portable audiovisual device to the car audiovisual system for playing thereon.

118. The system of Claim 117, wherein the interface integrated circuit receives control commands issued at the car audiovisual system, processes the control commands into a format compatible with the portable audiovisual device, and transmits processed control commands to the portable audiovisual device for execution thereby.

119. The system of Claim 117, wherein the interface integrated circuit receives data generated by the portable audiovisual device, processes the data into a format compatible with the car audiovisual system, and transmits processed data to the portable audiovisual device for display thereby.

120. The system of Claim 117, wherein the interface integrated circuit receives video signals generated by the portable audiovisual device, processes the video signals into a

format compatible with the car audiovisual device, and transmits processed video signals to the car audiovisual device for display thereby.

121. The system of Claim 117, further comprising a communications port operatively associated with the interface integrated circuit and allowing communications between the interface integrated circuit and the portable audiovisual device.

122. The system of Claim 121, wherein the communications port comprises a Universal Serial Bus (USB) port.

123. The system of Claim 117, further comprising a wireless transceiver operatively associated with the interface integrated circuit and allowing wireless communications between the interface integrated circuit and the portable audiovisual device.

124. The system of Claim 123, wherein the wireless transceiver comprises a WiFi, Bluetooth, or IEEE 802.11 transceiver.

125. The system of Claim 117, wherein the integrated circuit transmits audio signals generated by the portable audiovisual device to the car audiovisual system for recording by the car audiovisual system.

126. The system of Claim 117, wherein the integrated circuit transmits audio signals generated by the car audiovisual system to the portable audiovisual device for recording by the portable audiovisual device.

127. The system of Claim 117, wherein the integrated circuit transmits video signals generated by the portable audiovisual device to the car audiovisual system for recording by the car audiovisual system.

128. The system of Claim 117, wherein the integrated circuit transmits video signals generated by the car audiovisual system to the portable audiovisual device for recording by the portable audiovisual device.

129. The system of Claim 117, wherein the integrated circuit comprises a single microchip.

130. The system of Claim 117, wherein the integrated circuit comprises a chipset.

131. The system of Claim 117, wherein the integrated circuit comprises a microprocessor of the car audiovisual system.

132. A multimedia device integration system, comprising:

a car audiovisual system;

an after-market, portable audiovisual device external to the car audiovisual system;

and

an interface integrated circuit installed in the car audiovisual system and in communication with the car audiovisual system and the portable audiovisual device, the interface integrated circuit generating and transmitting a device presence signal for maintaining the car audiovisual system in a state responsive to the portable audiovisual device and transmitting audio signals from the portable audiovisual device to the car audiovisual system for playing thereby.

133. The system of Claim 132, wherein the interface integrated circuit receives control commands issued at the car audiovisual system, processes the control commands into a format compatible with the portable audiovisual device, and transmits processed control commands to the portable audiovisual device for execution thereby.

134. The system of Claim 132, wherein the interface integrated circuit receives data generated by the portable audiovisual device, processes the data into a format compatible with the car audiovisual system, and transmits processed data to the portable audiovisual device for display thereby.

135. The system of Claim 132, wherein the interface integrated circuit receives video signals generated by the portable audiovisual device, processes the video signals into a format compatible with the car audiovisual device, and transmits processed video signals to the car audiovisual device for display thereby.

136. The system of Claim 132, further comprising a communications port operatively associated with the interface integrated circuit and allowing communications between the interface integrated circuit and the portable audiovisual device.

137. The system of Claim 136, wherein the communications port comprises a Universal Serial Bus (USB) port.

138. The system of Claim 132, further comprising a wireless transceiver operatively associated with the interface integrated circuit and allowing wireless communications between the interface integrated circuit and the portable audiovisual device.

139. The system of Claim 138, wherein the wireless transceiver comprises a WiFi, Bluetooth, or IEEE 802.11 transceiver.

140. The system of Claim 132, wherein the integrated circuit transmits audio signals generated by the portable audiovisual device to the car audiovisual system for recording by the car audiovisual system.

141. The system of Claim 132, wherein the integrated circuit transmits audio signals generated by the car audiovisual system to the portable audiovisual device for recording by the portable audiovisual device.

142. The system of Claim 132, wherein the integrated circuit transmits video signals generated by the portable audiovisual device to the car audiovisual system for recording by the car audiovisual system.

143. The system of Claim 132, wherein the integrated circuit transmits video signals generated by the car audiovisual system to the portable audiovisual device for recording by the portable audiovisual device.

144. The system of Claim 142, wherein the integrated circuit comprises a single microchip.

145. The system of Claim 142, wherein the integrated circuit comprises a chipset.

146. The system of Claim 132, wherein the integrated circuit comprises a microprocessor of the car audiovisual system.

147. A multimedia device integration system comprising:
a car audiovisual system;

a portable audio device external to the car audiovisual system;

an interface in communication with the car audiovisual system and the portable audio device, the interface generating and transmitting a device presence signal to the car audiovisual system to maintain the car audiovisual system in a state responsive to the portable audio device, the interface transmitting audio signals from the portable audio device to the car audiovisual system; and

a charging circuit for inductively charging a battery of the portable audio device

148. The multimedia device integration system of Claim 147, wherein the charging circuit comprises a first inductive charging circuit operatively associated with the interface and a second inductive charging circuit operatively associated with the portable audio device, the first and second inductive charging circuits inductively coupled to each other to transmit electrical power therebetween.

149. The multimedia device integration system of Claim 147, wherein the interface receives video signals from the portable audio device, processes same into a format compatible with the car audiovisual system, and transmits processed video signals to the car audiovisual system for display thereby.

150. The multimedia device integration system of Claim 147, wherein the interface receives control commands issued at the car audiovisual system, processes same into a format compatible with the portable audio device, and transmits processed control commands to the portable audio device for execution thereby.

151. A multimedia device integration system comprising:

a car audiovisual system;

a portable audio device external to the car audiovisual system;

an interface in communication with the car audiovisual system and the portable audio device, the interface generating and transmitting a device presence signal to the car audiovisual system to maintain the car audiovisual system in a state responsive to the portable audio device, the interface transmitting audio signals from the portable audio device to the car audiovisual system; and

a charging circuit for wirelessly charging a battery of the portable audio device

152. The multimedia device integration system of Claim 151, wherein the charging circuit comprises a first wireless charging circuit operatively associated with the interface and a second wireless charging circuit operatively associated with the portable audio device, the first and second wireless charging circuits wirelessly coupled to each other to transmit electrical power therebetween.

153. The multimedia device integration system of Claim 151, wherein the interface receives video signals from the portable audio device, processes same into a format compatible with the car audiovisual system, and transmits processed video signals to the car audiovisual system for display thereby.

154. The multimedia device integration system of Claim 151, wherein the interface receives control commands issued at the car audiovisual system, processes same into a format compatible with the portable audio device, and transmits processed control commands to the portable audio device for execution thereby.

1/41

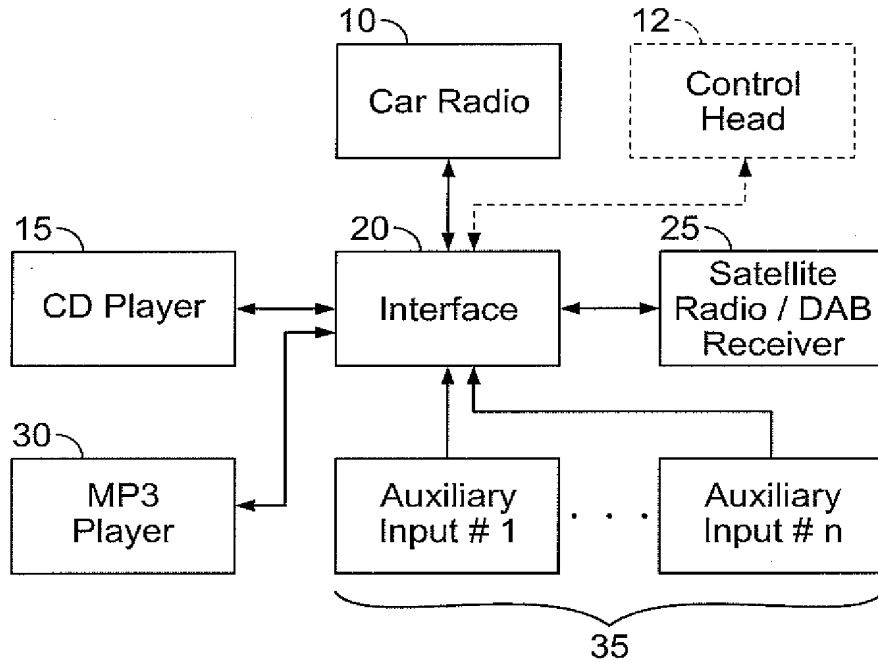

FIG. 1

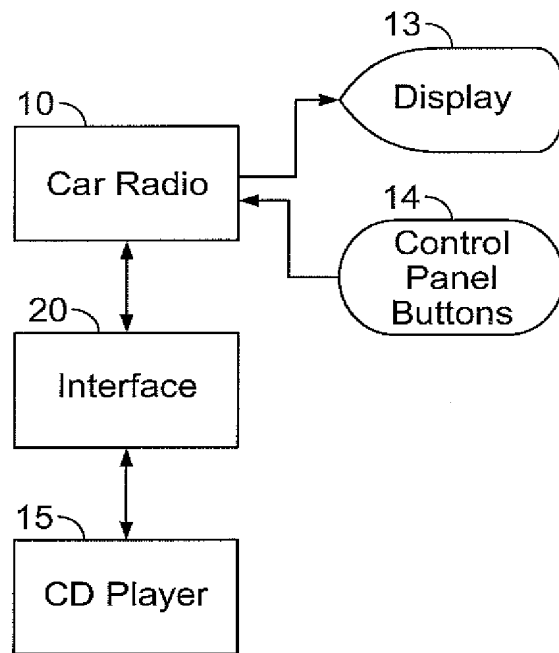

FIG. 2A

2/41

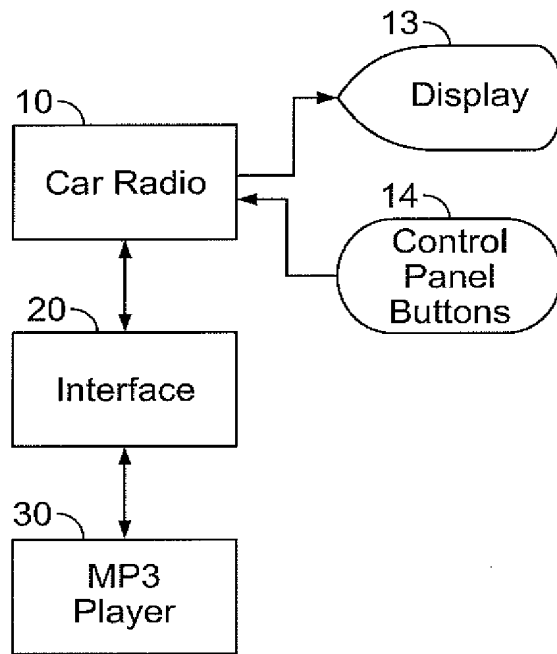

FIG. 2B

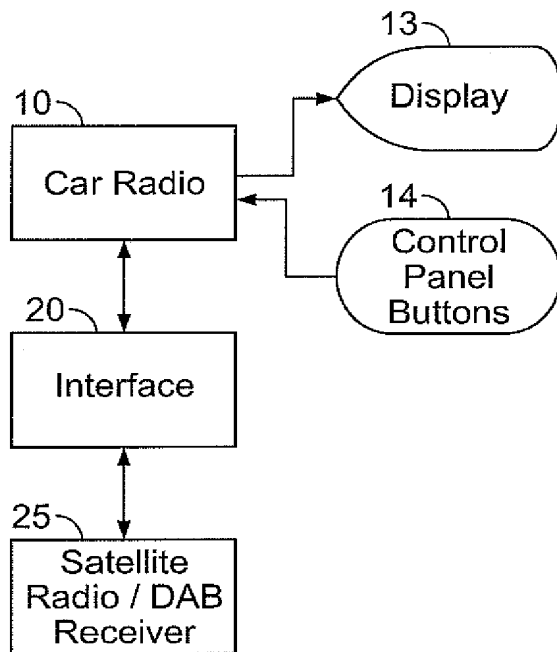

FIG. 2C

3/41

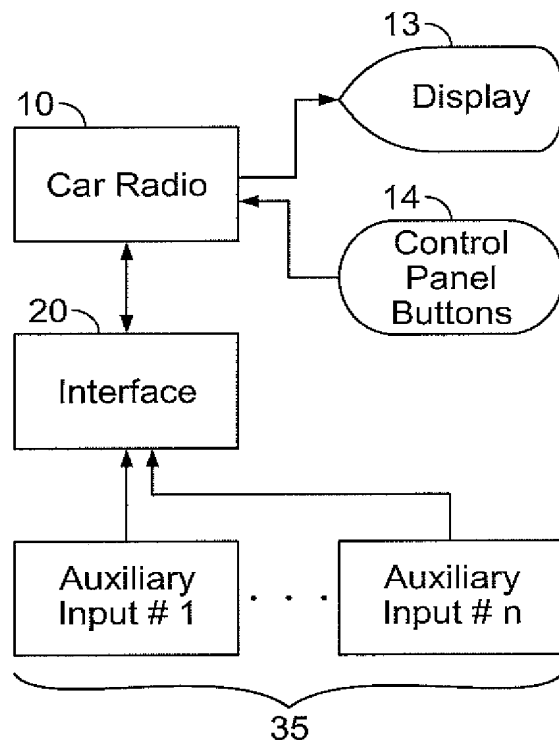

FIG. 2D

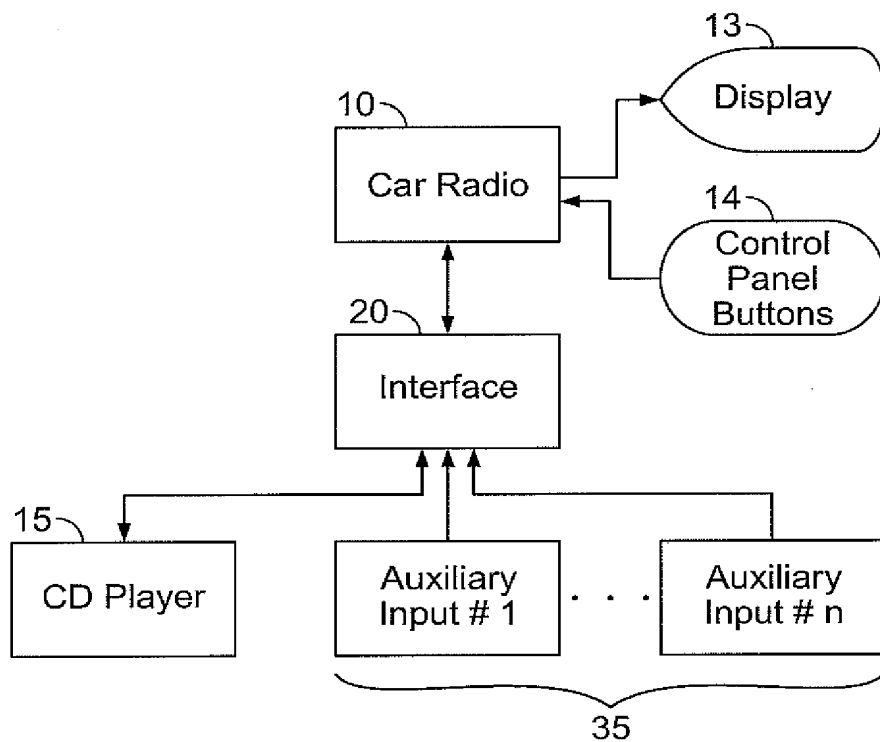

FIG. 2E

4/41

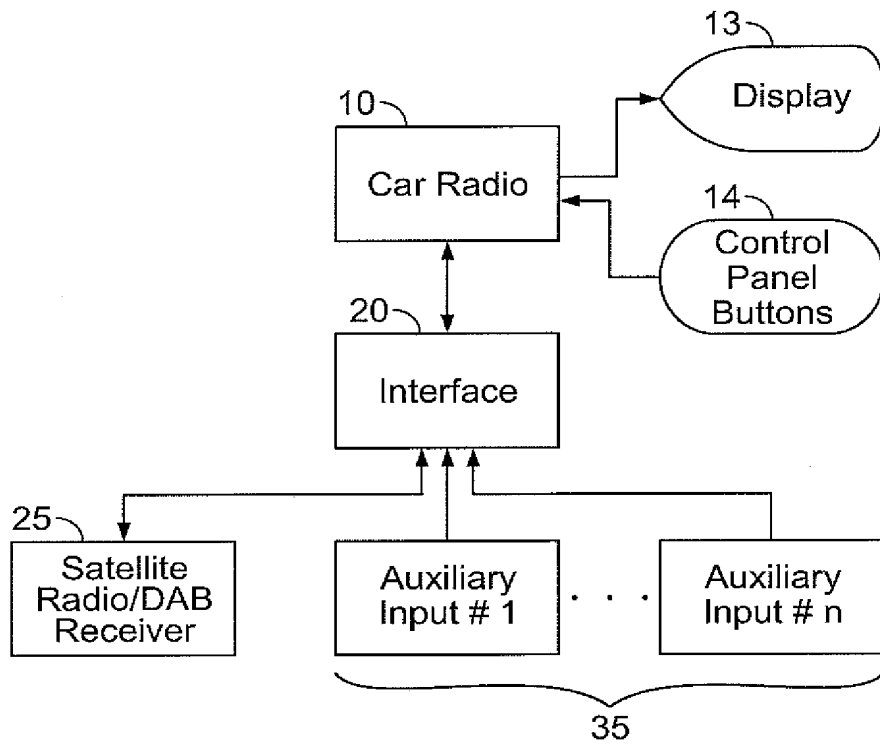

FIG. 2F

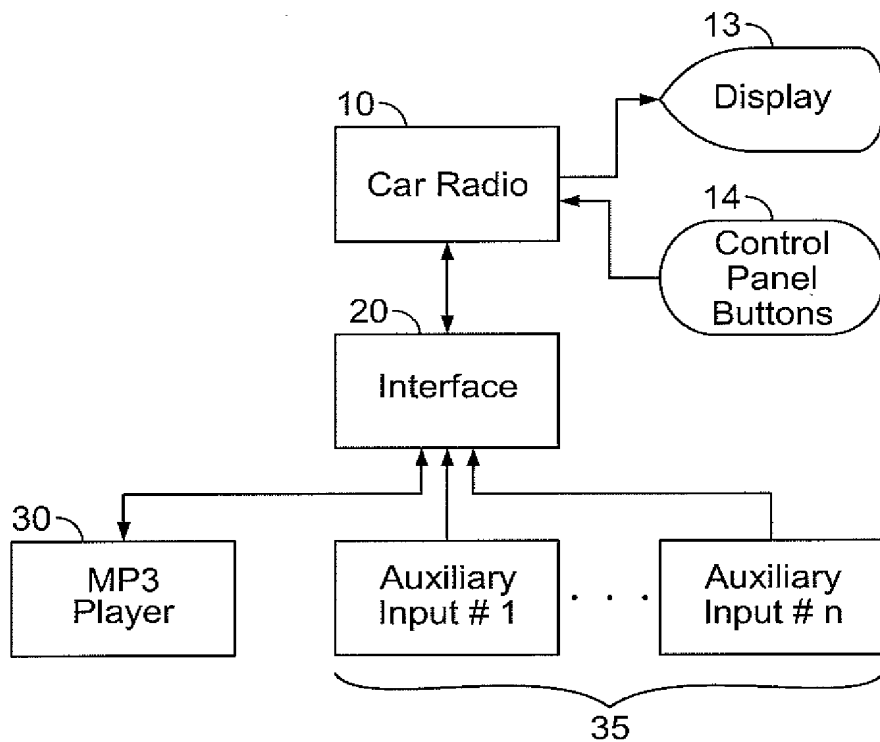

FIG. 2G

5/41

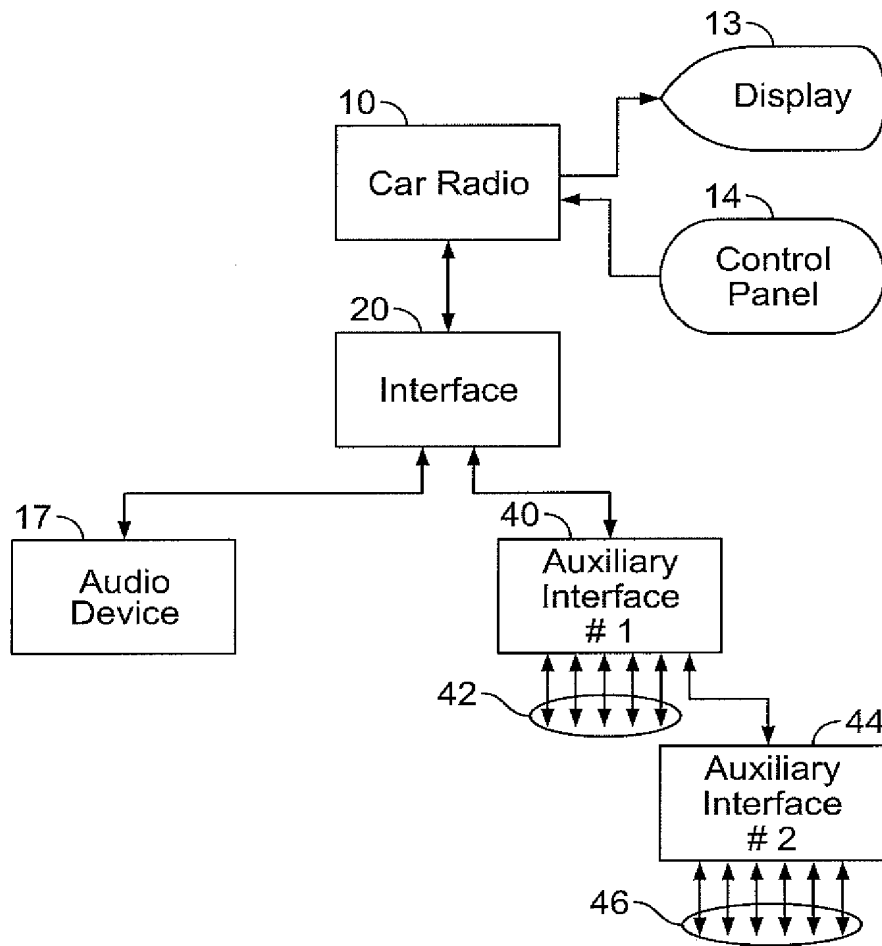
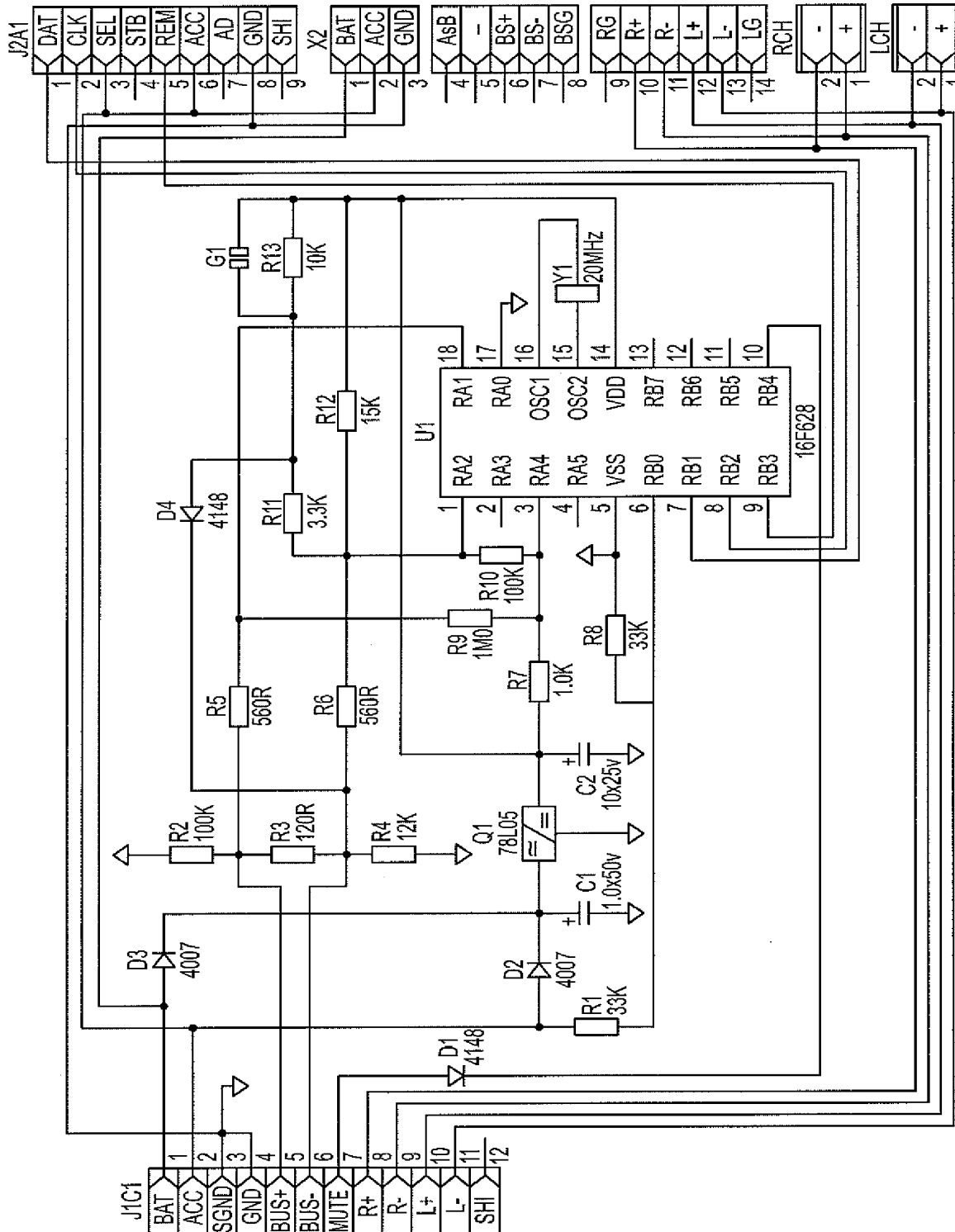

FIG. 2H

6/41



7/41

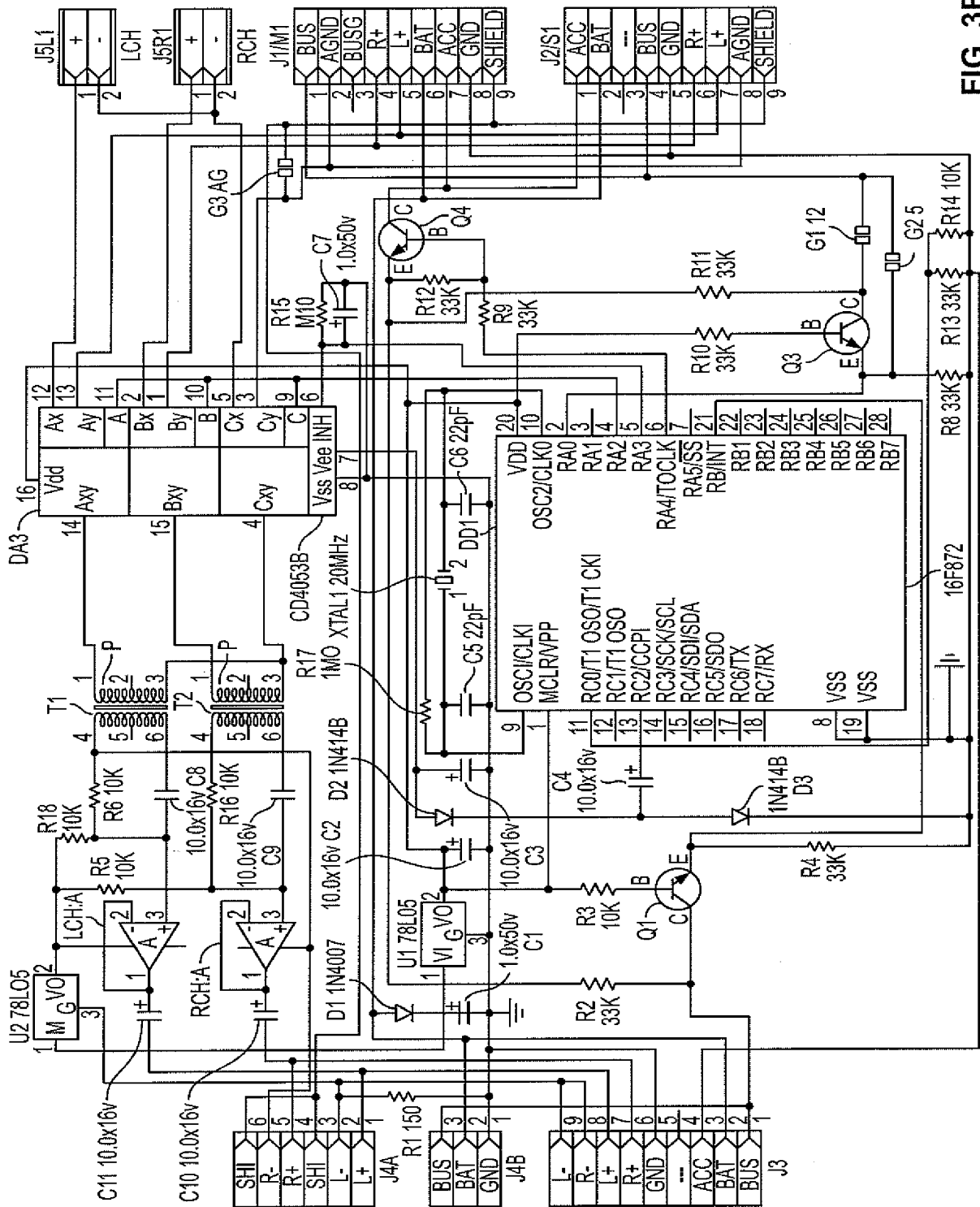
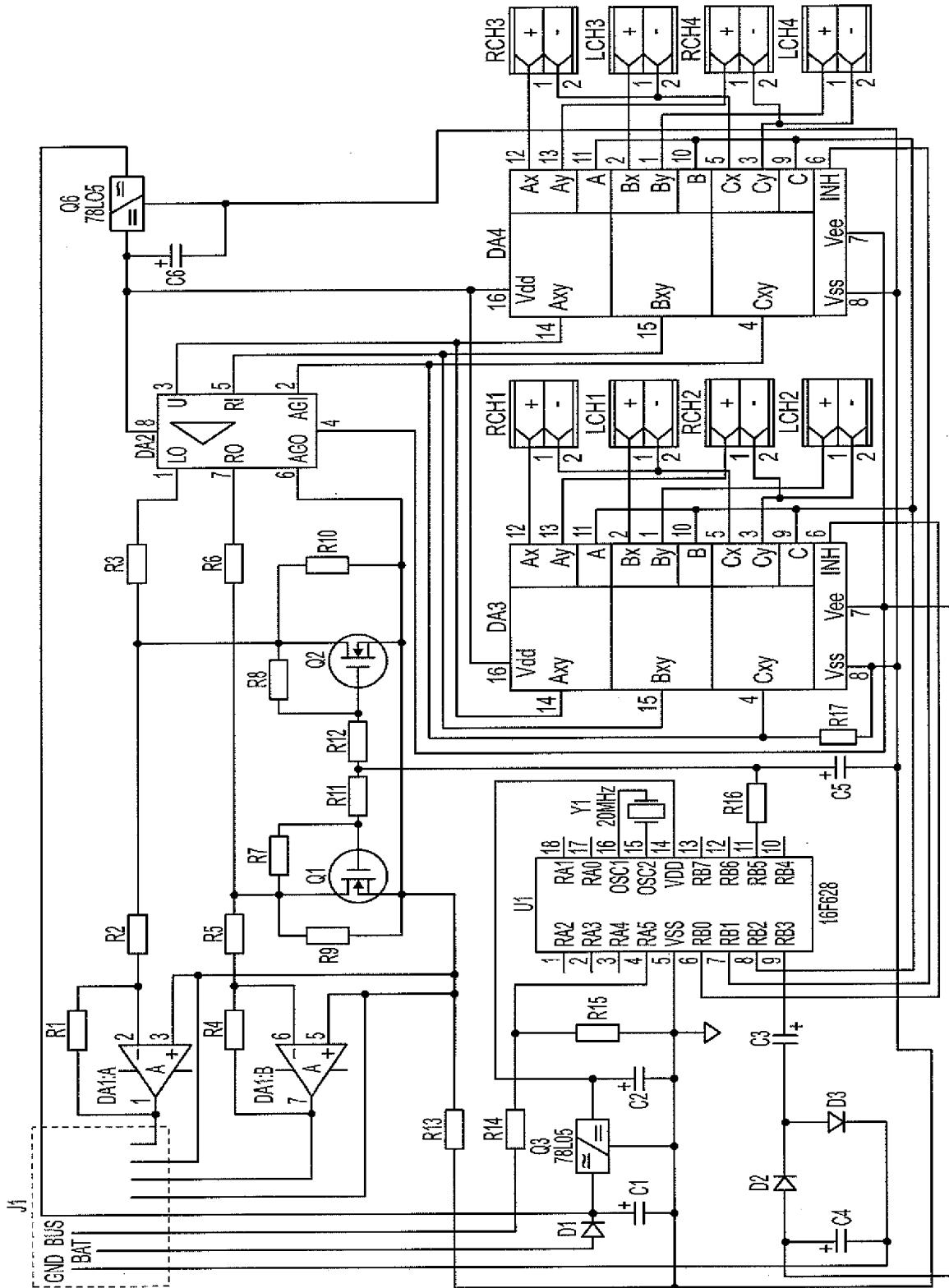
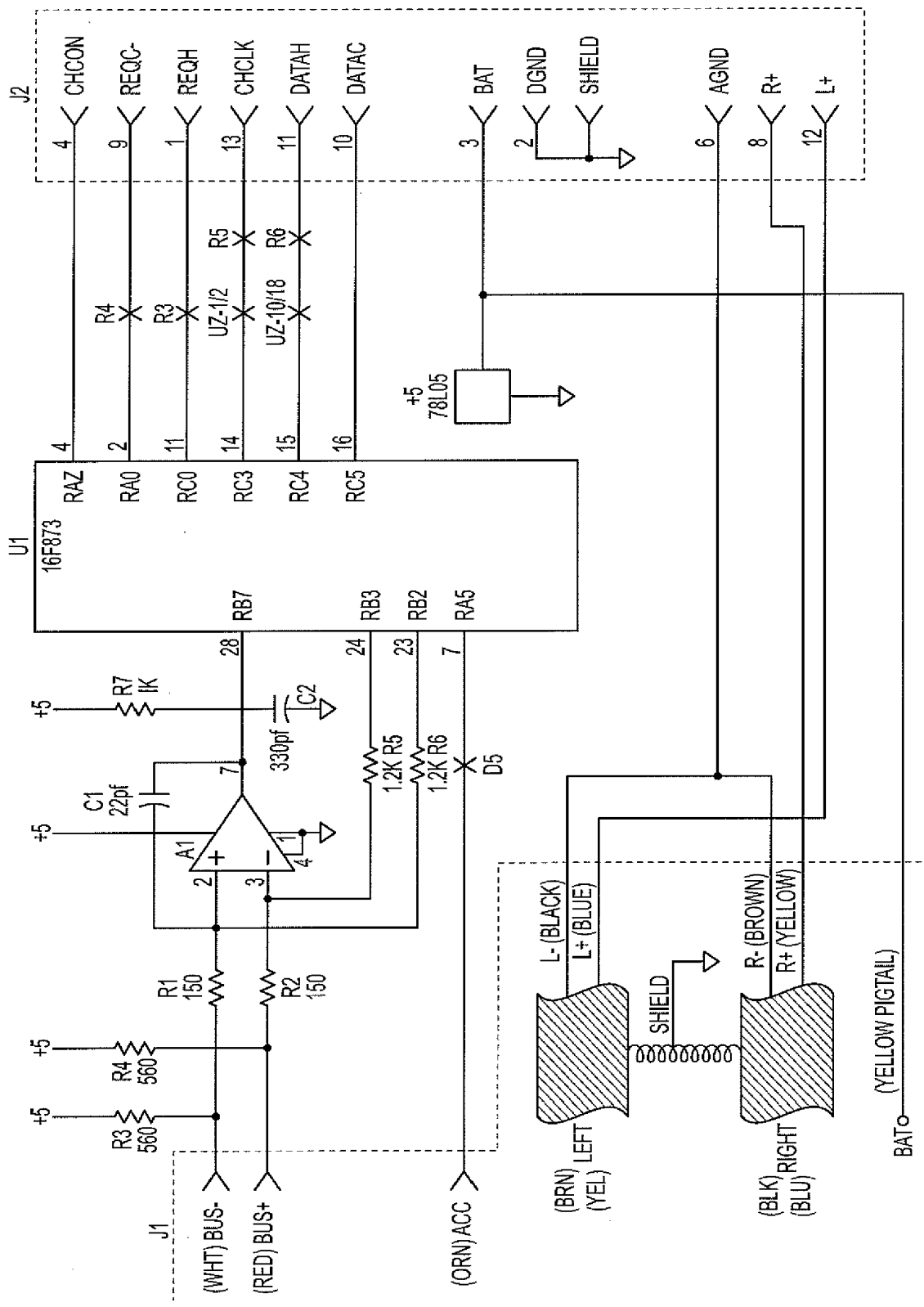

FIG. 3B

8/41



9/41



10/41

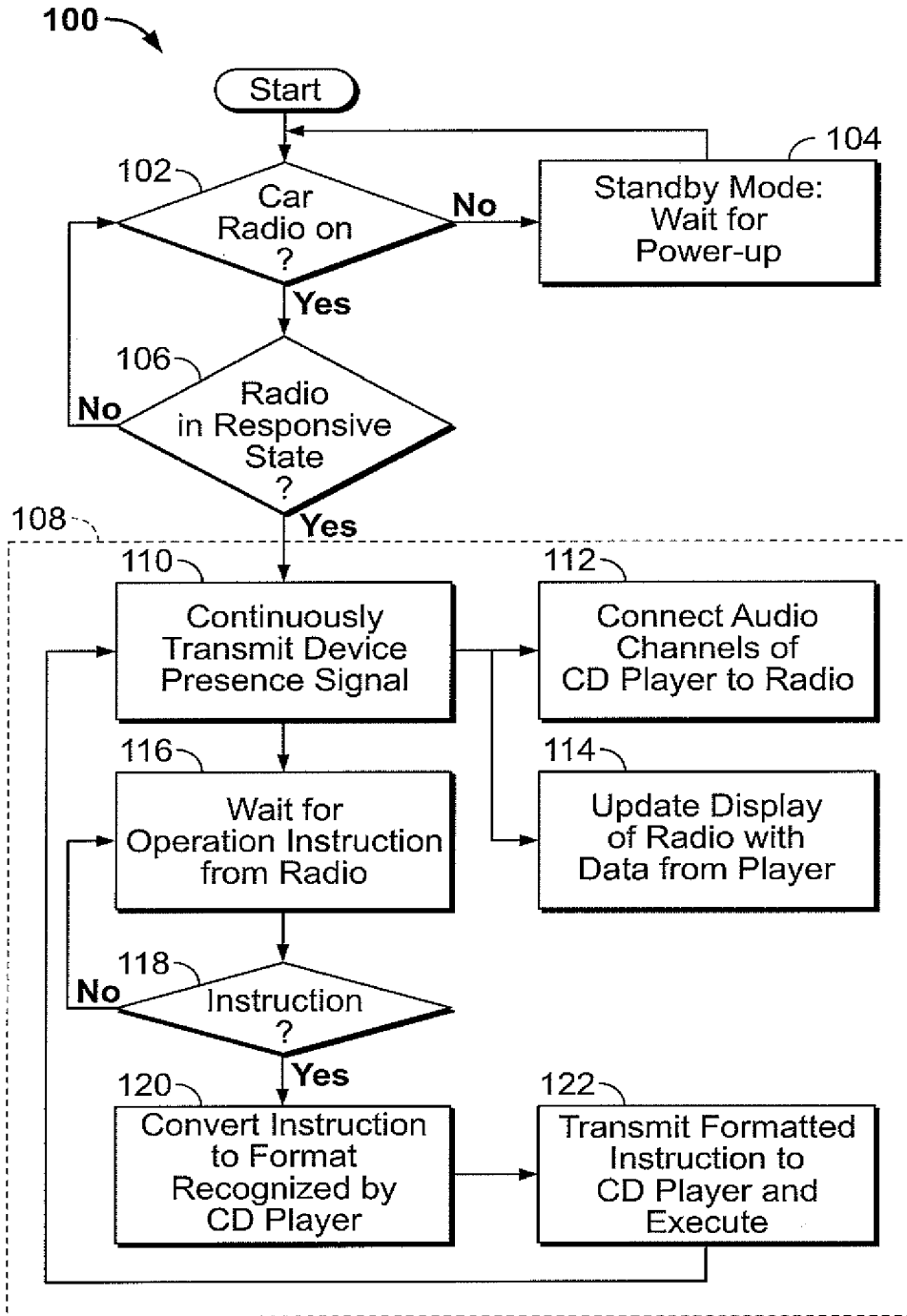

FIG. 4A

11/41

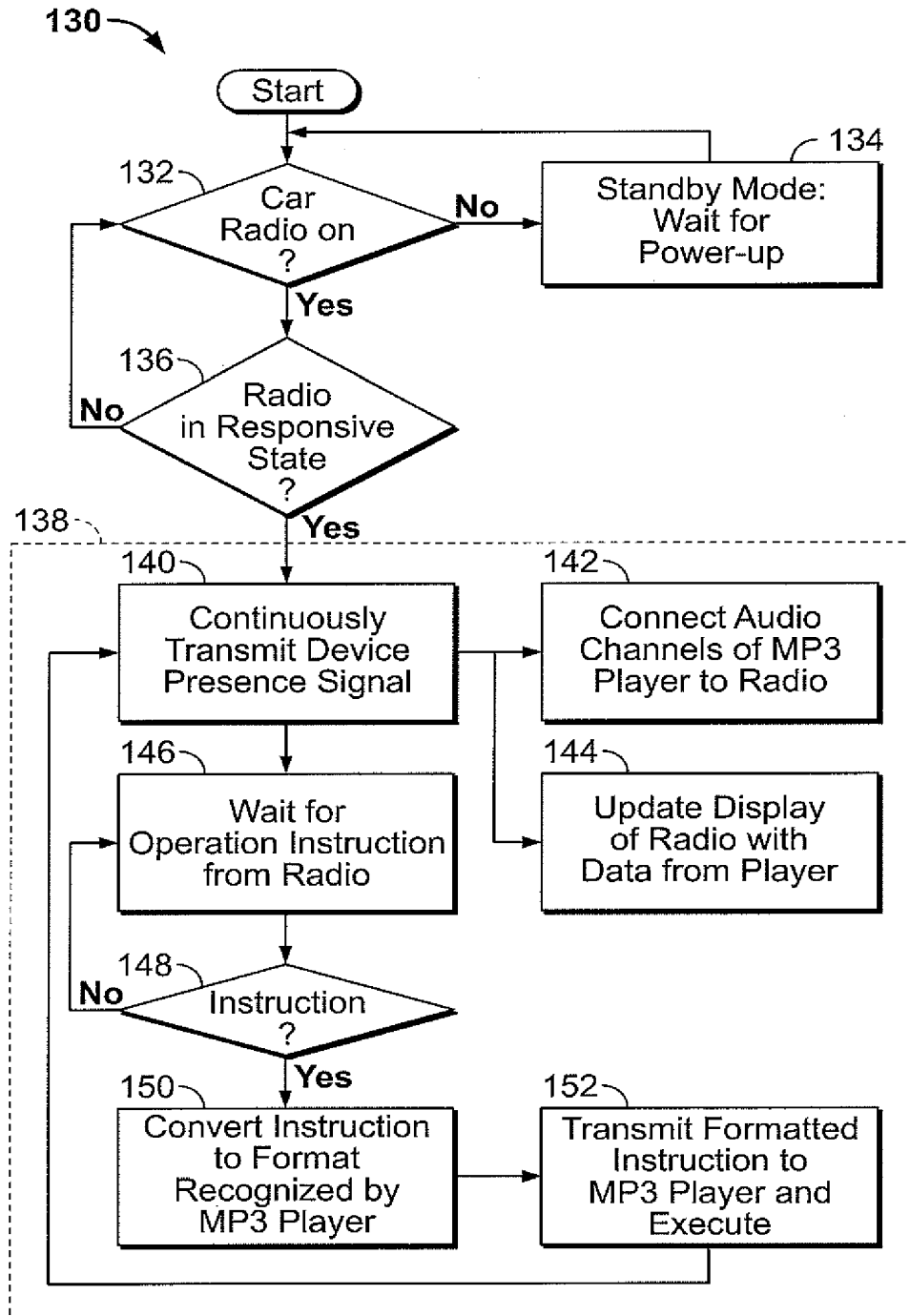

FIG. 4B

12/41

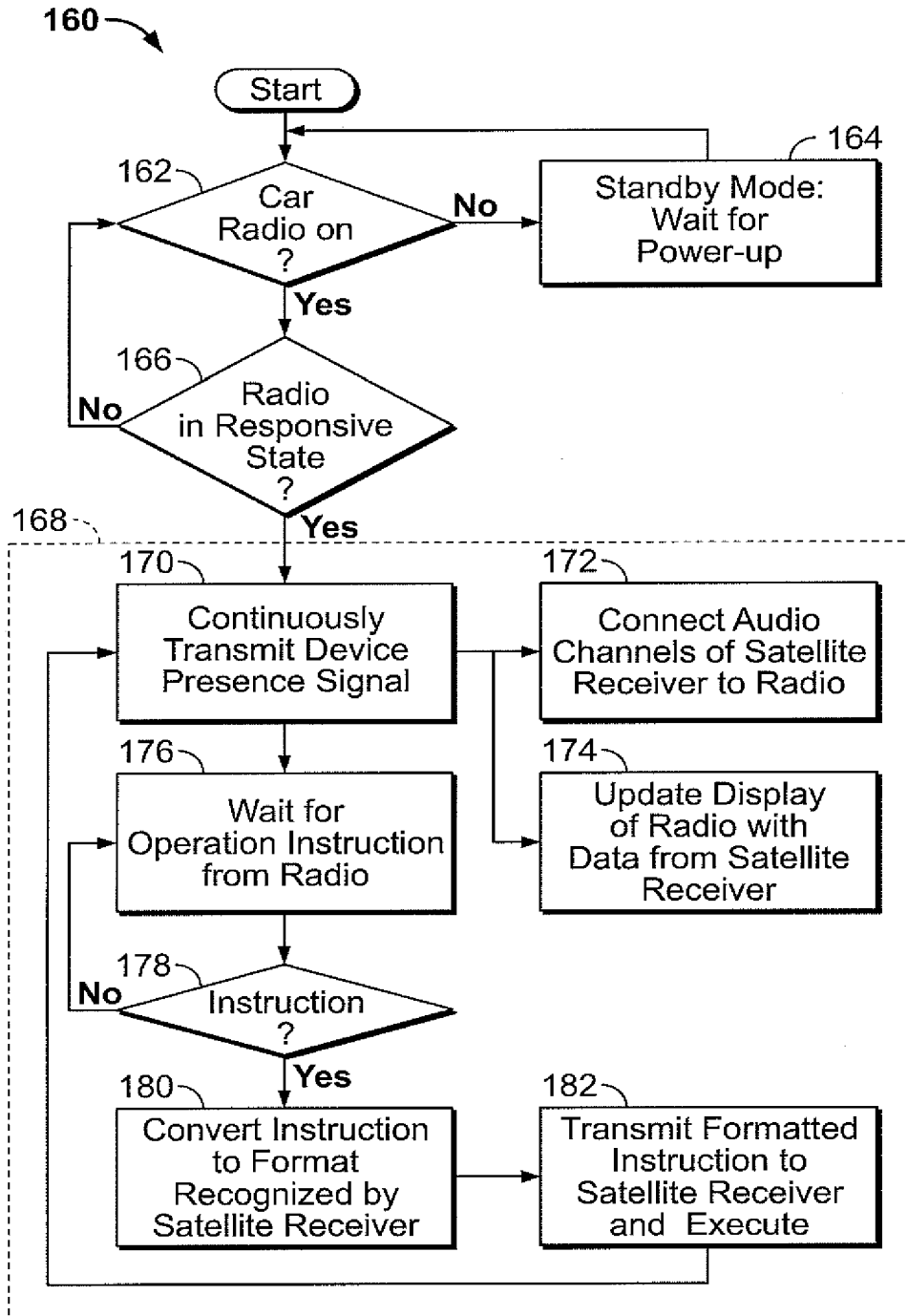

FIG. 4C

13/41

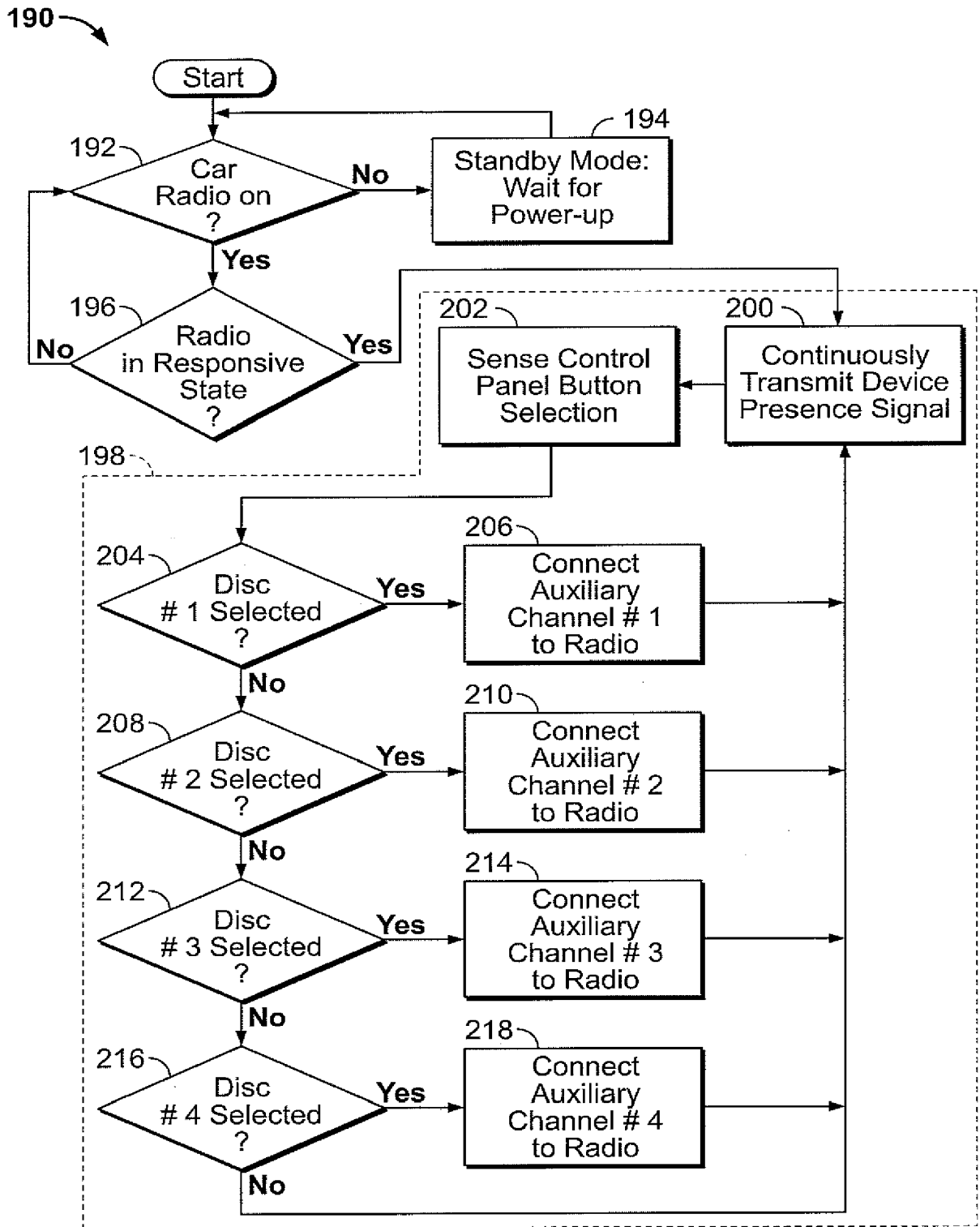

FIG. 4D

14/41

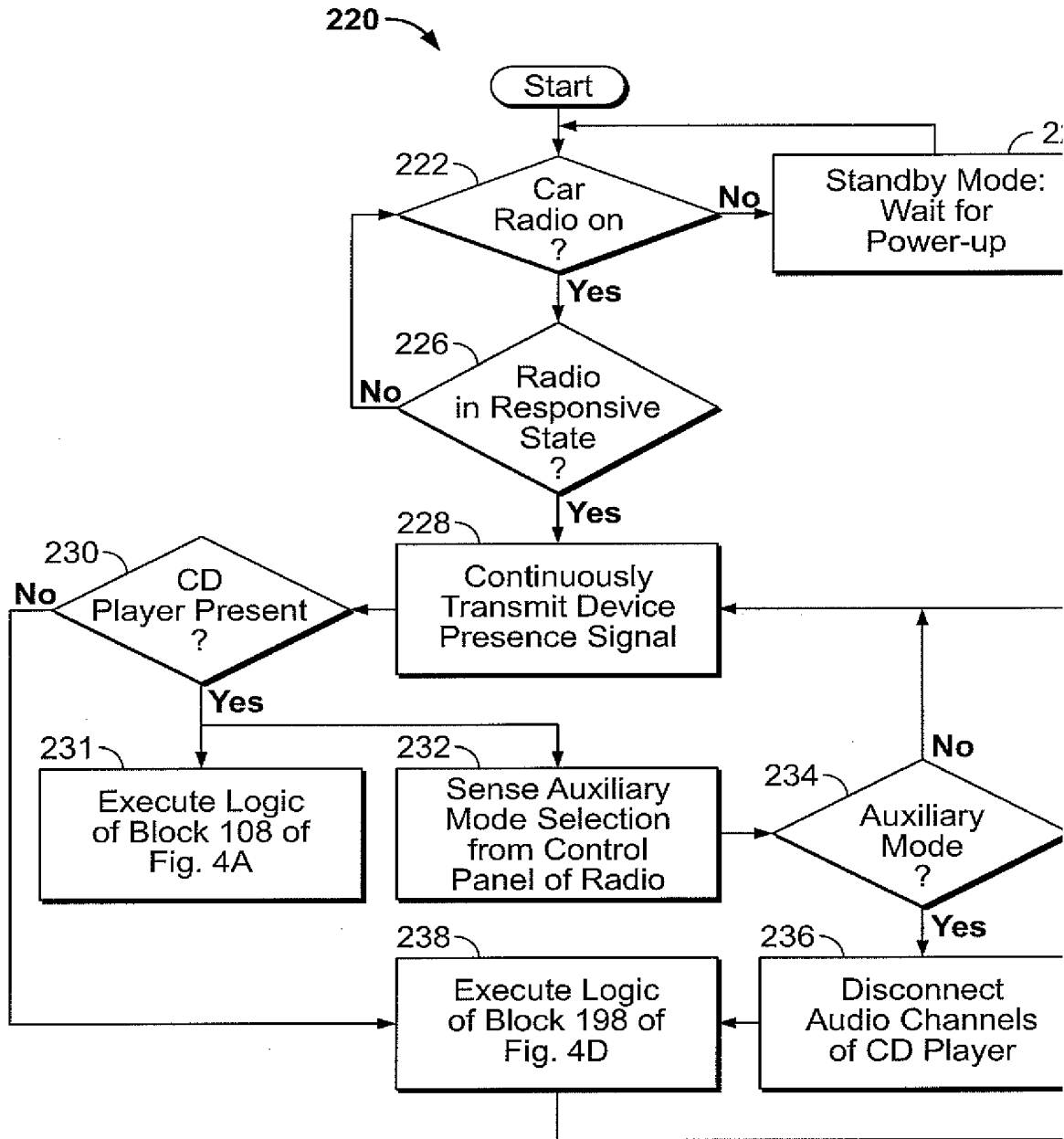

FIG. 4E

15/41

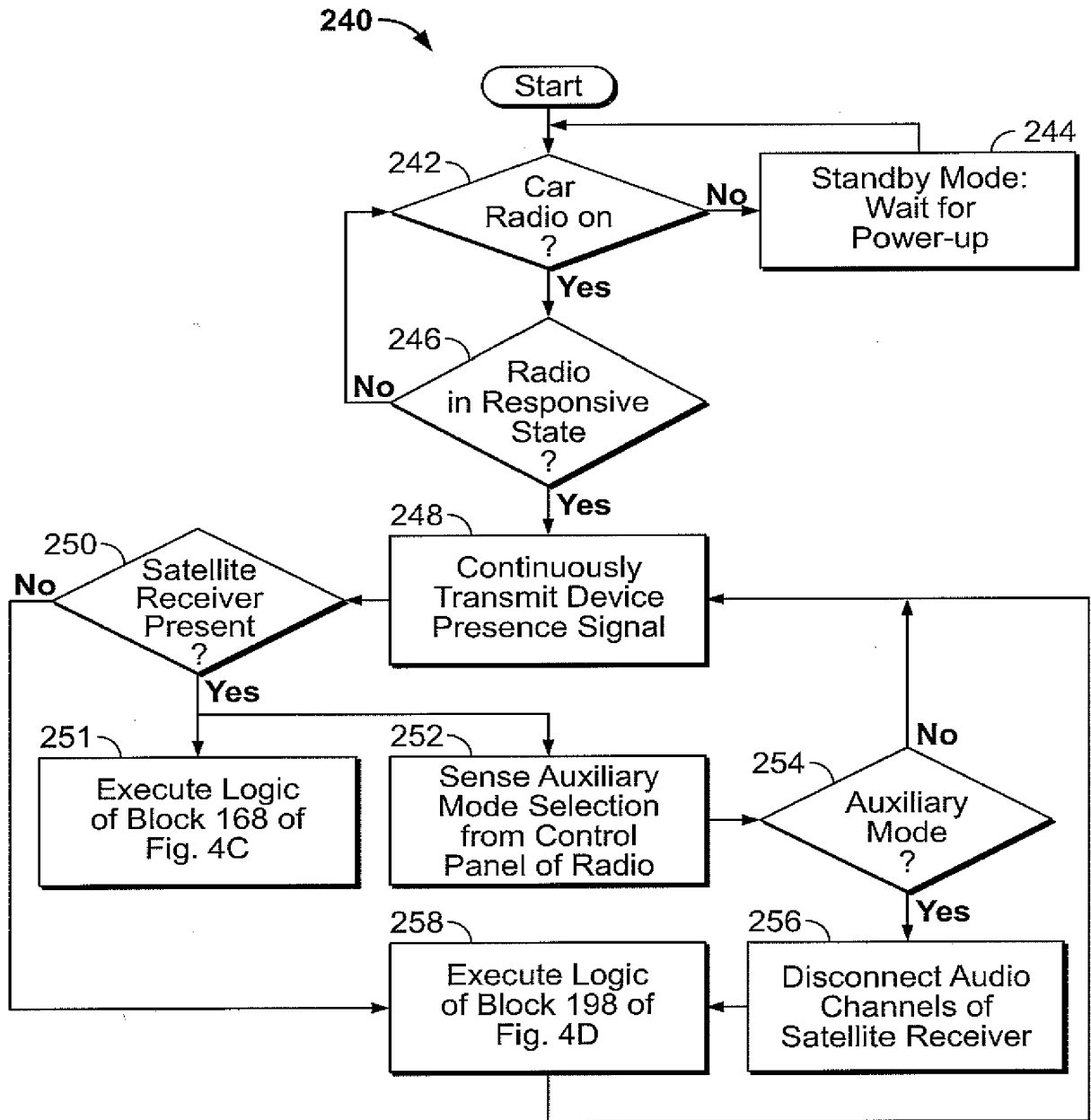

FIG. 4F

16/41

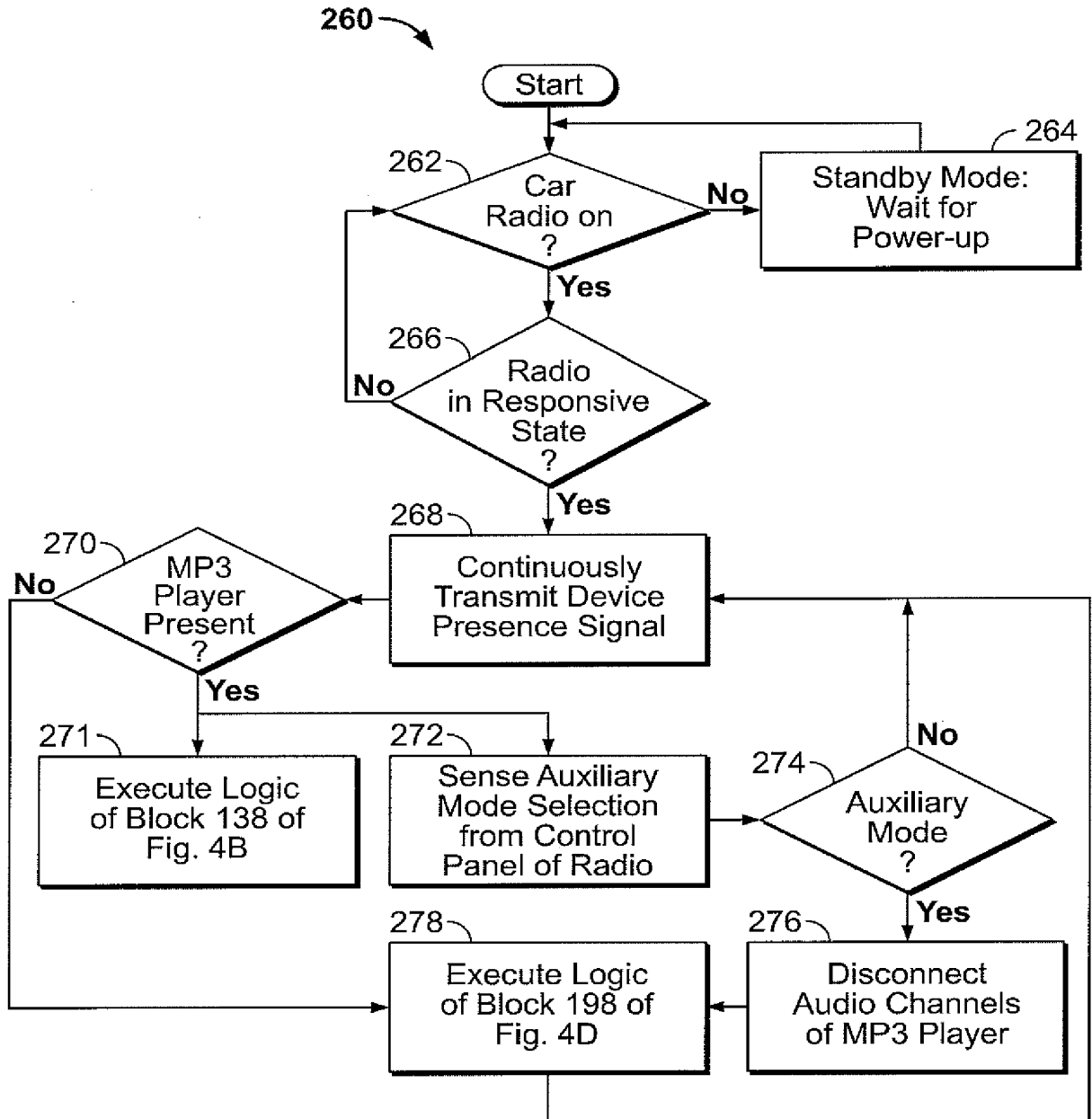

FIG. 4G

17/41

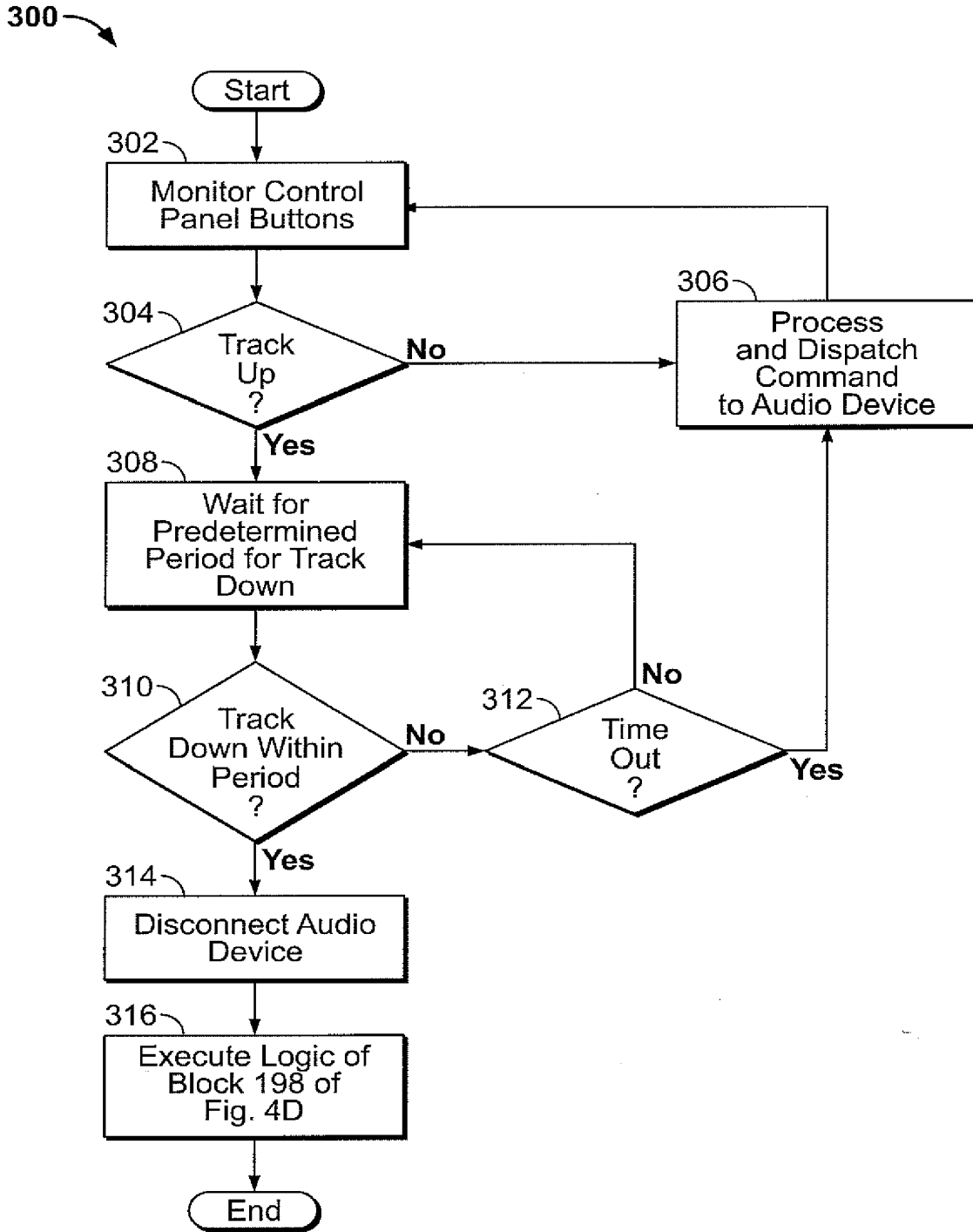

FIG. 5

18/41

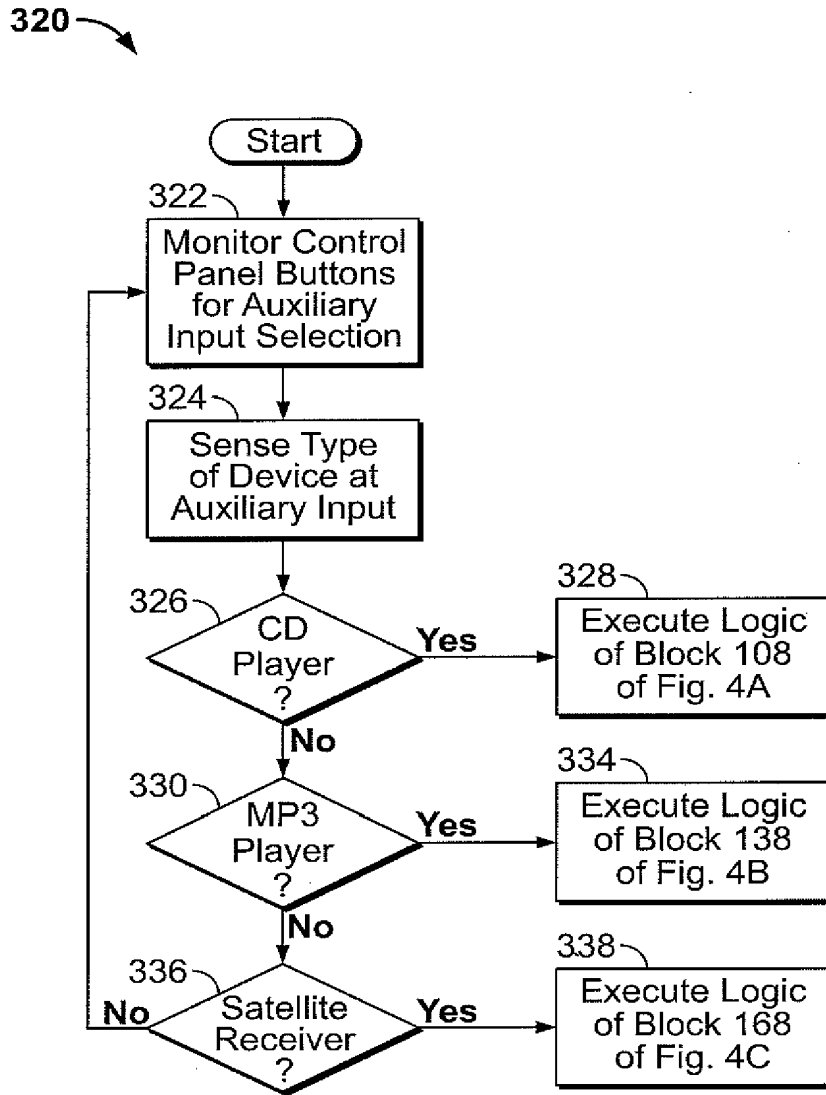

FIG. 6

19/41

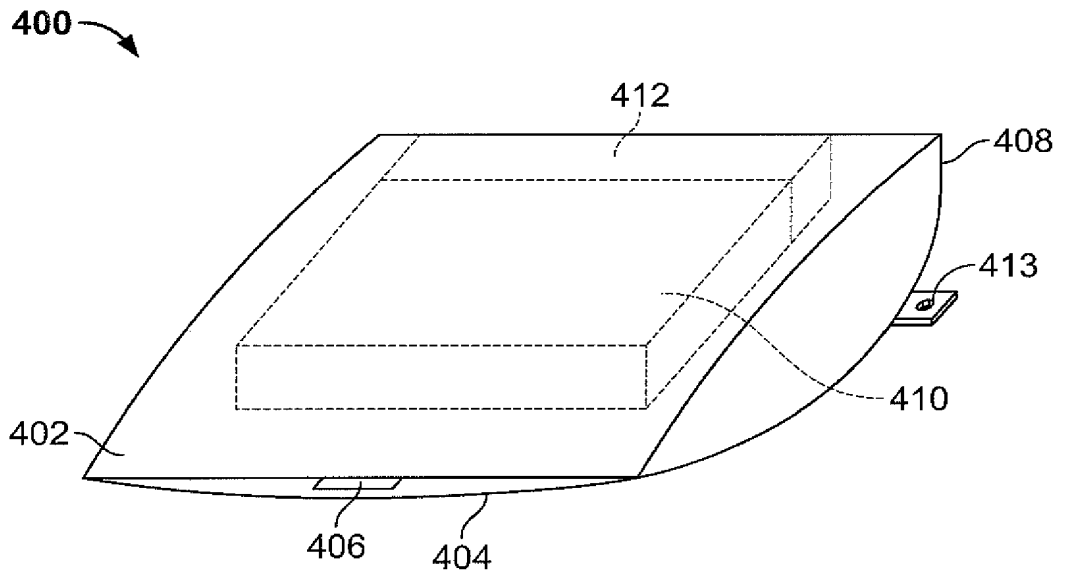

FIG. 7A

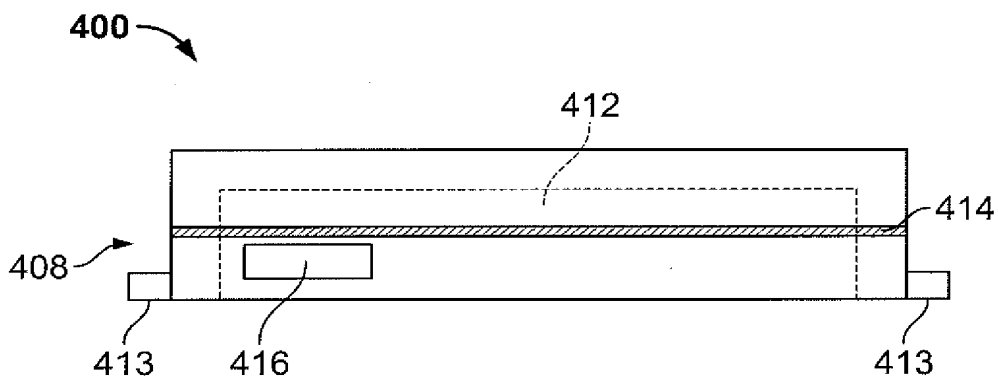

FIG. 7B

20/41

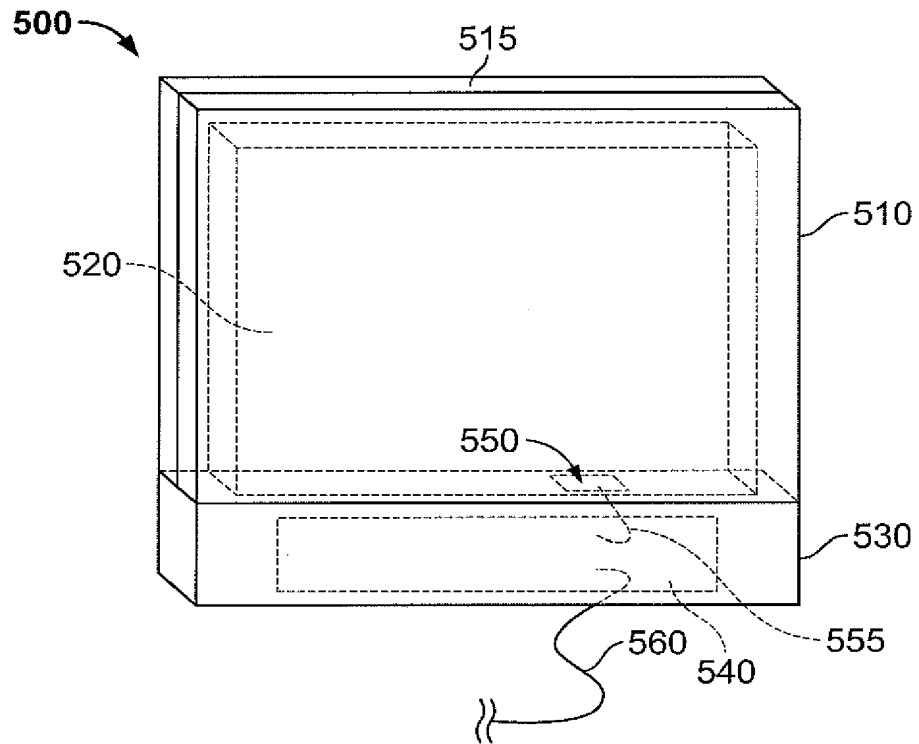

FIG. 8A

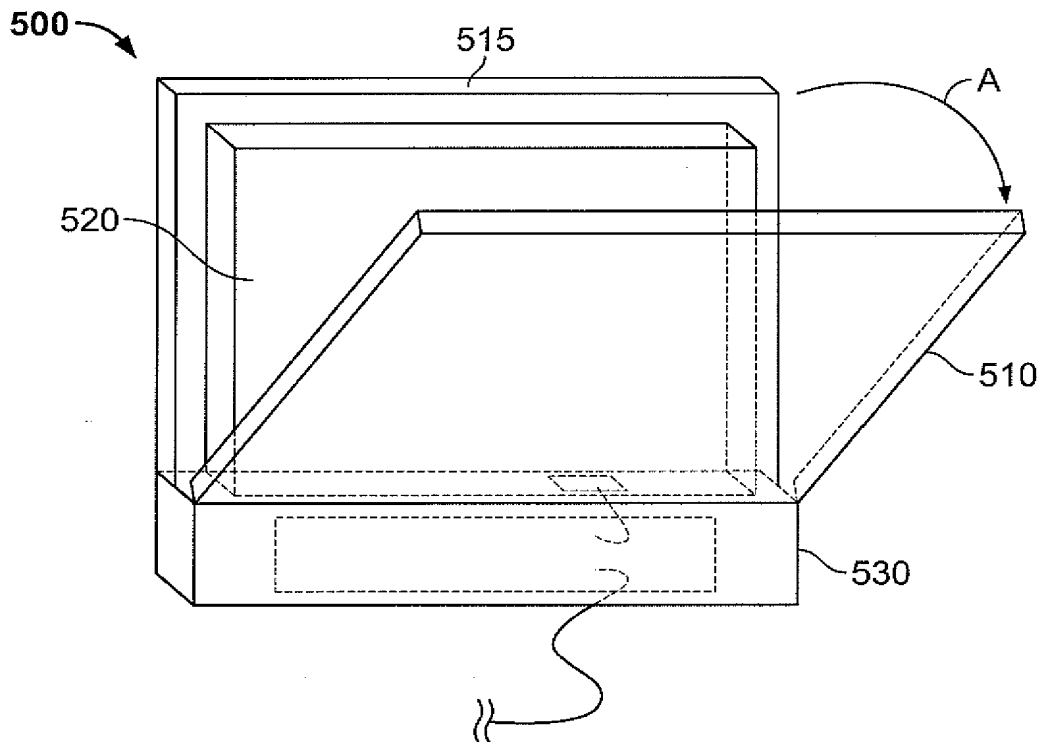

FIG. 8B

21/41

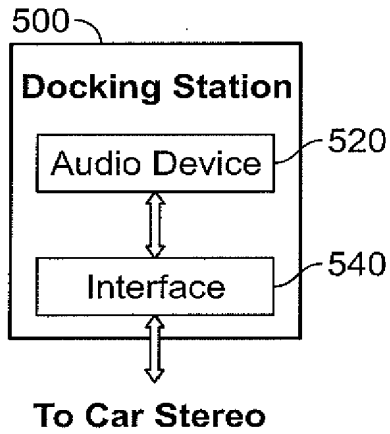

FIG. 9

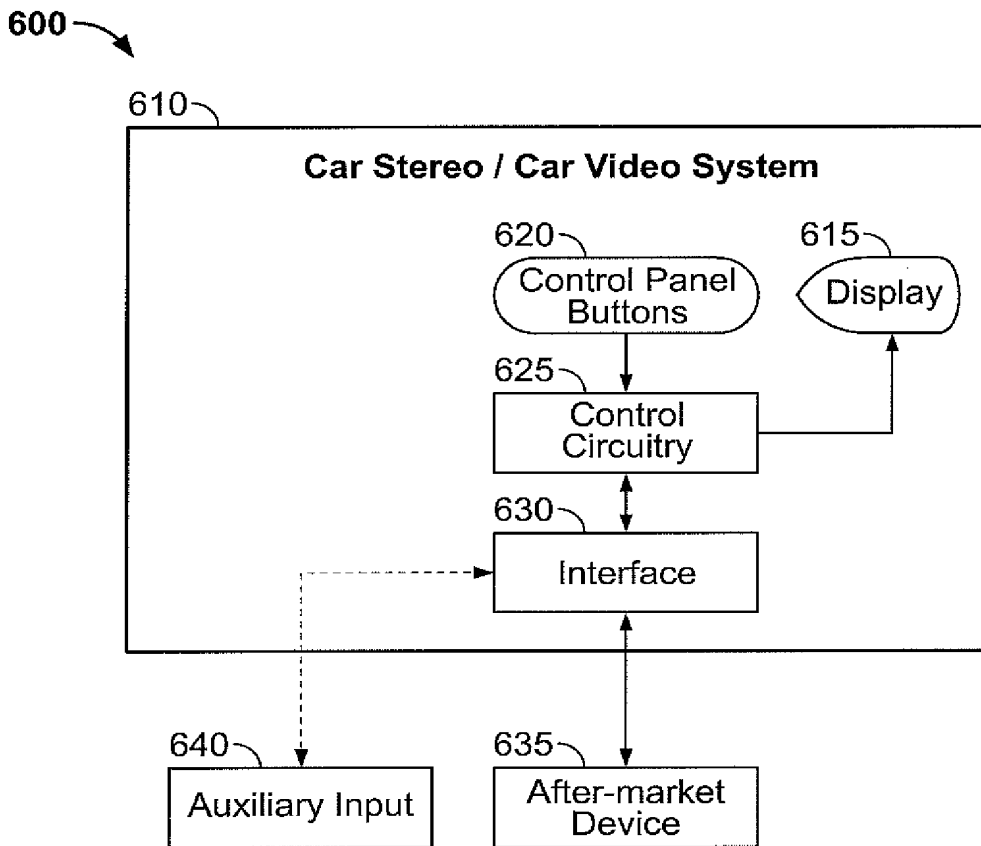

FIG. 10

22/41

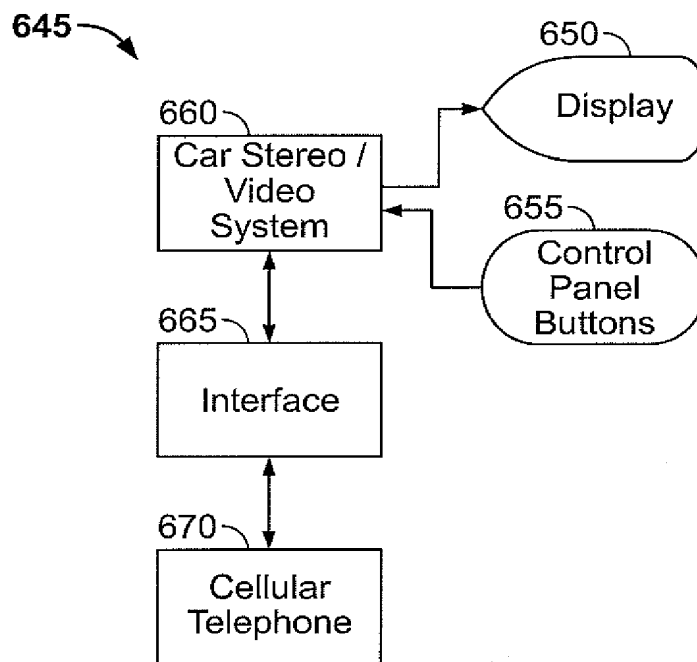

FIG. 11A

23/41

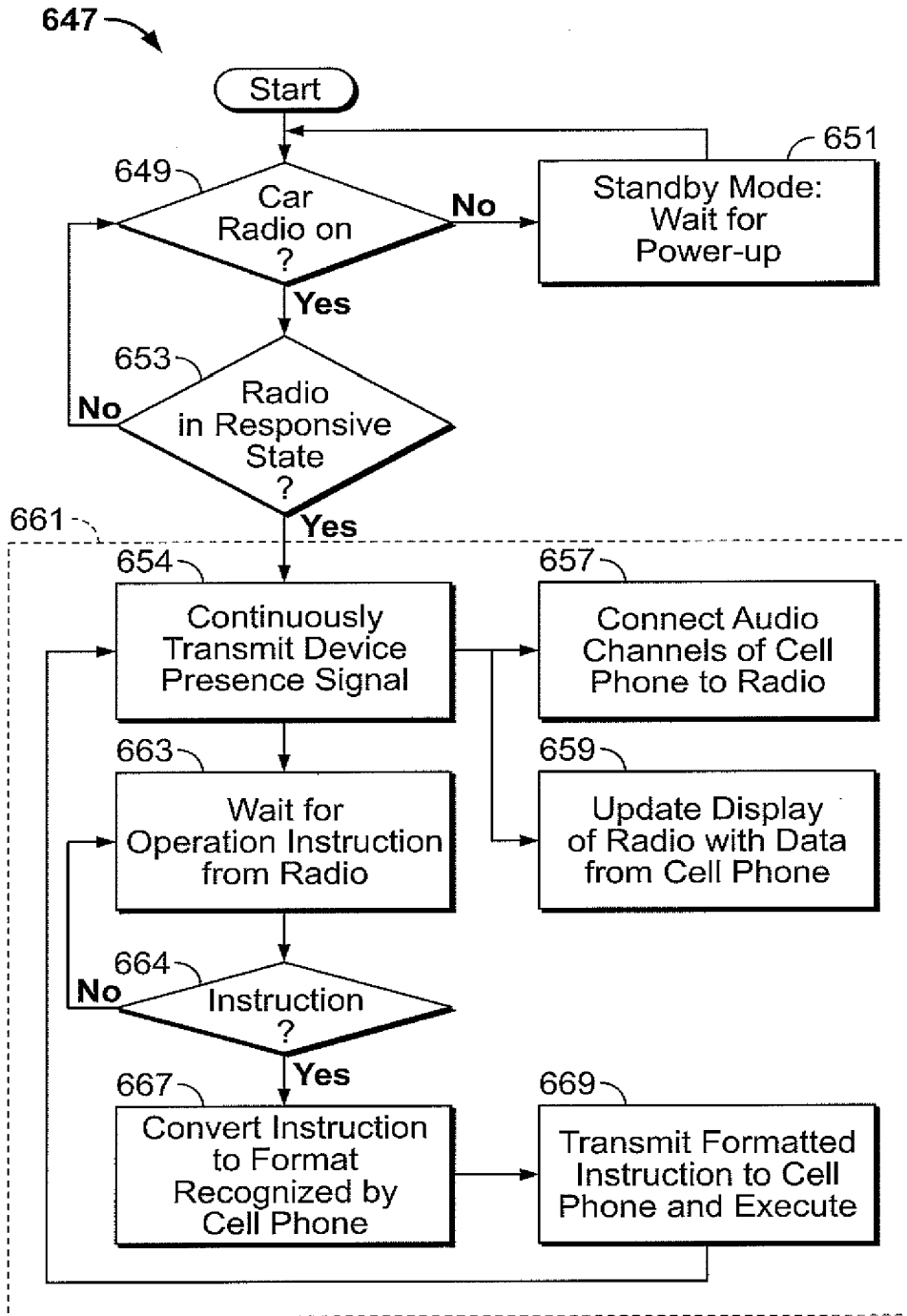

FIG. 11B

24/41

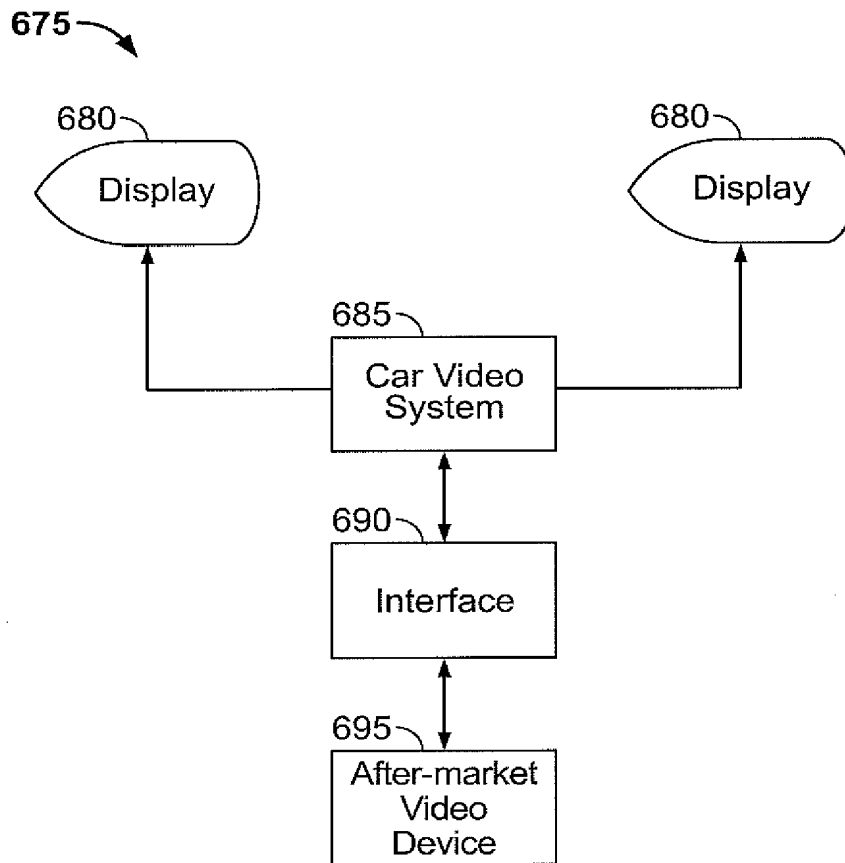

FIG. 12A

25/41

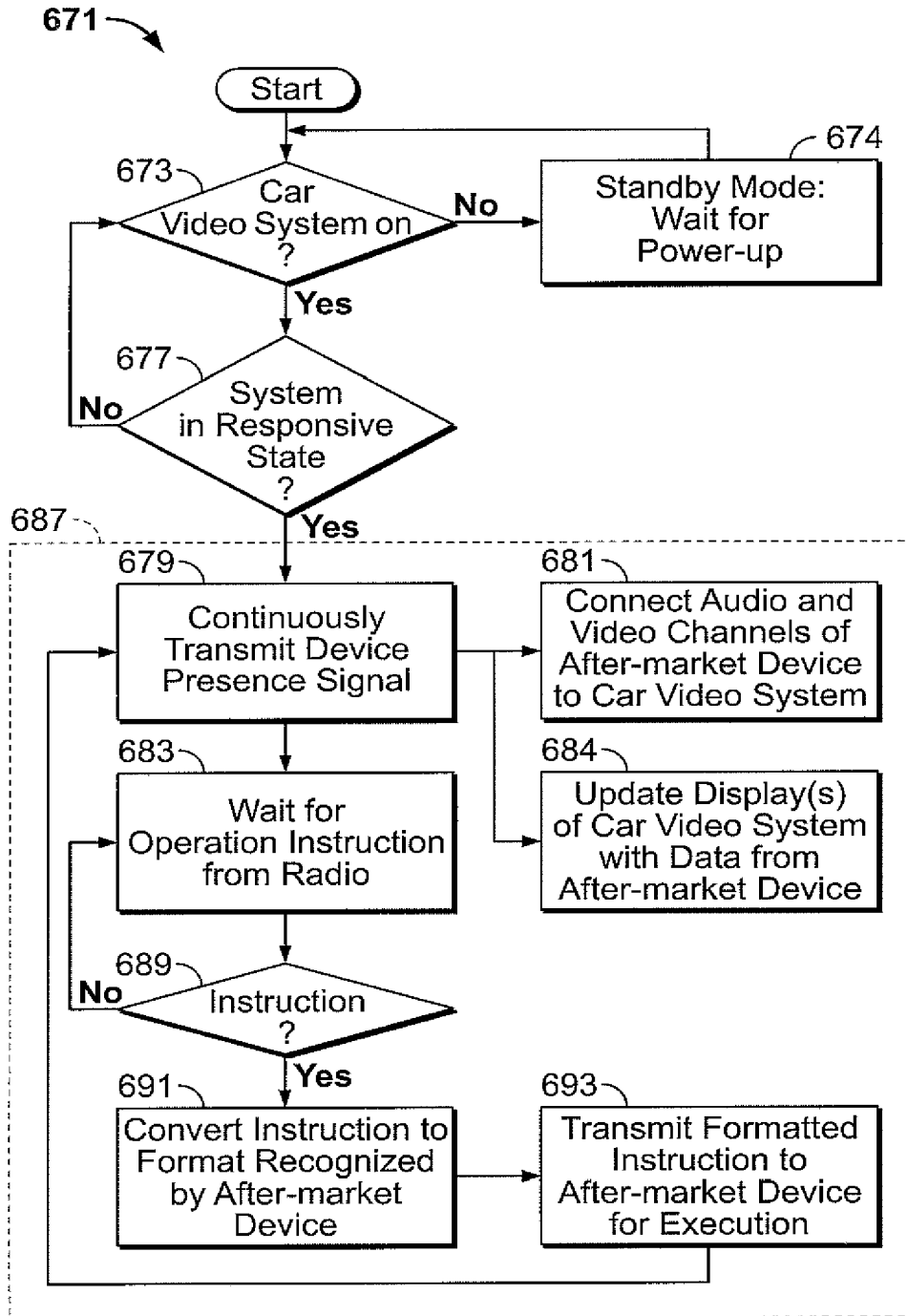

FIG. 12B

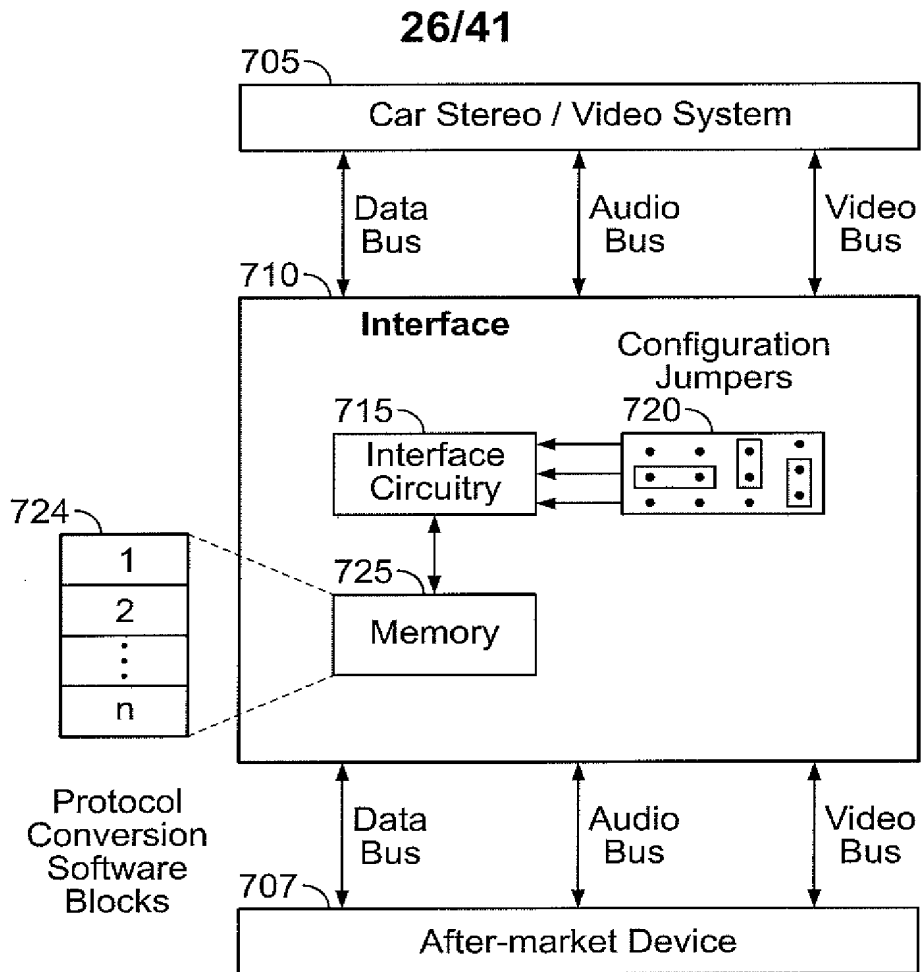

FIG. 13A

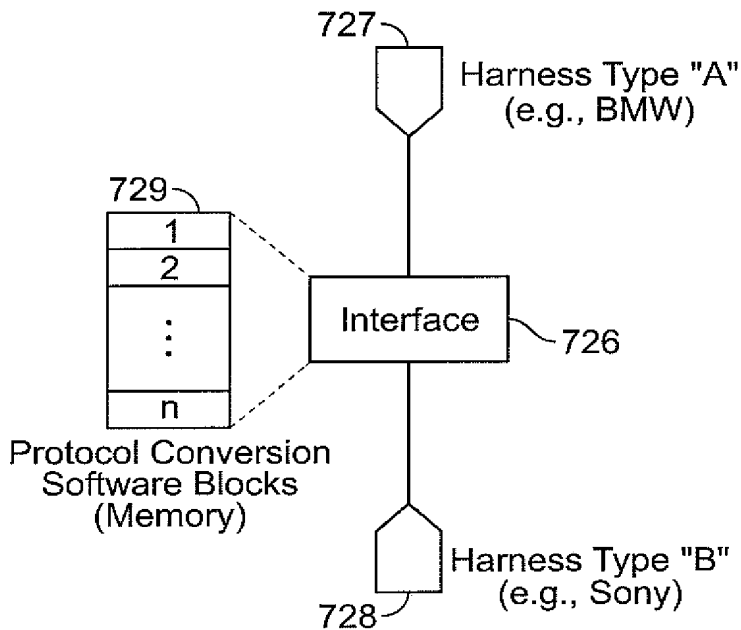

FIG. 13B

27/41

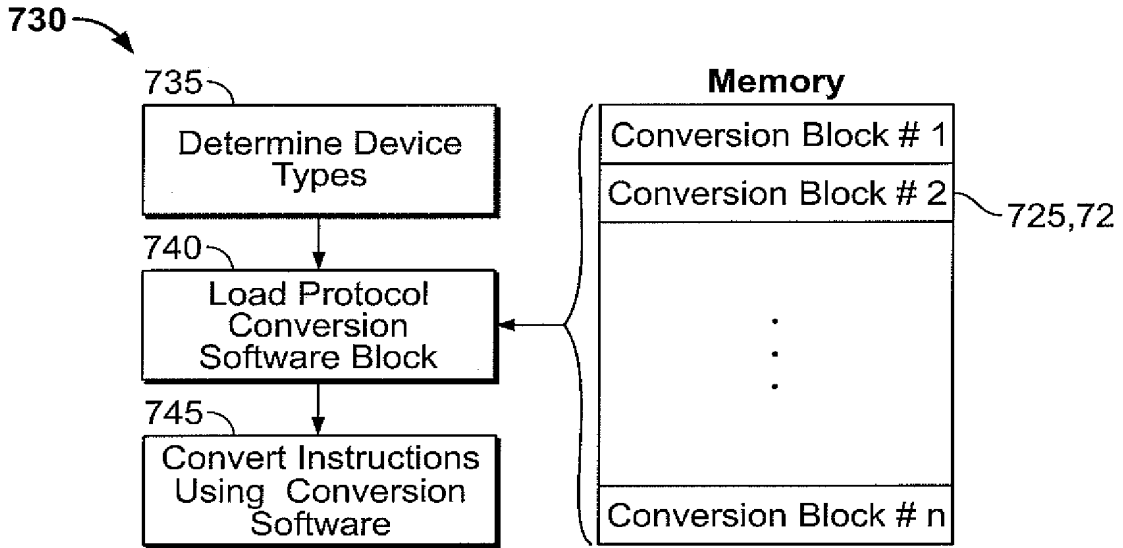

FIG. 14

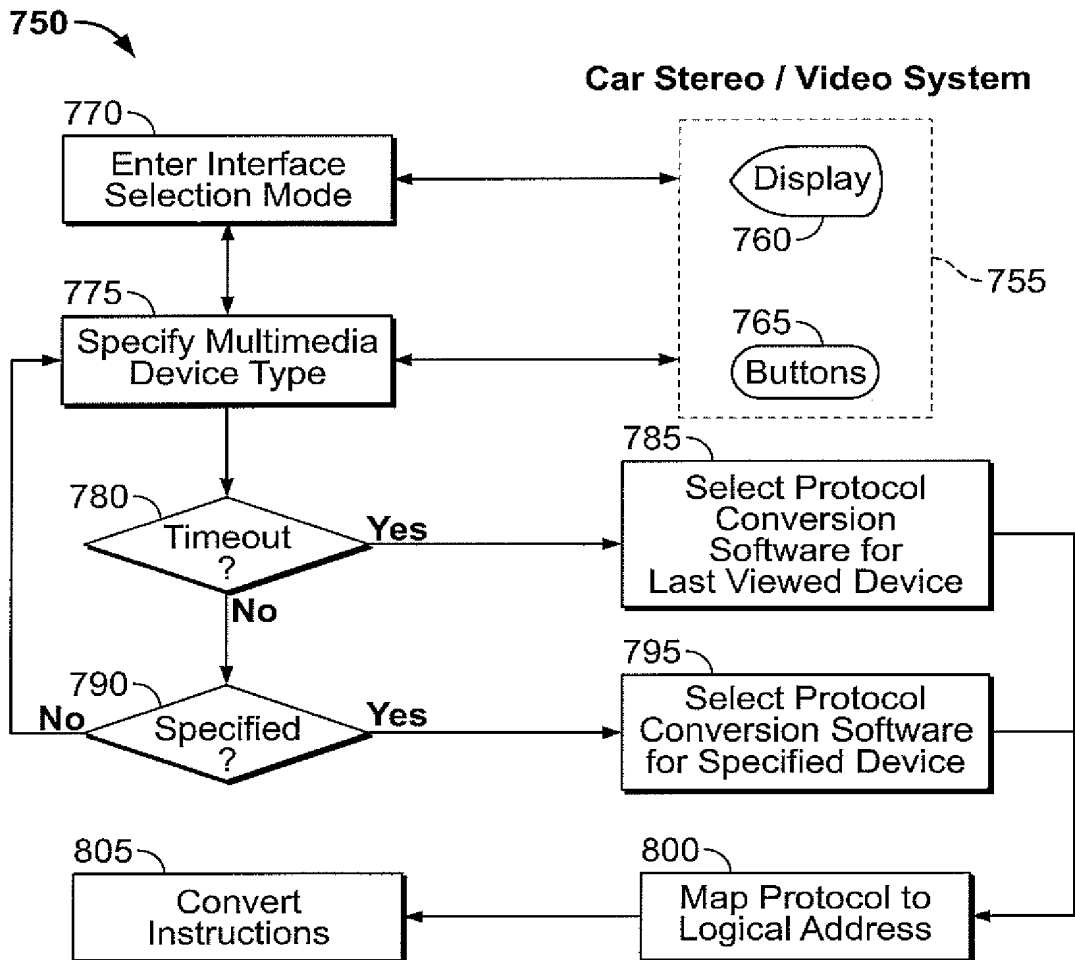

FIG. 15

28/41

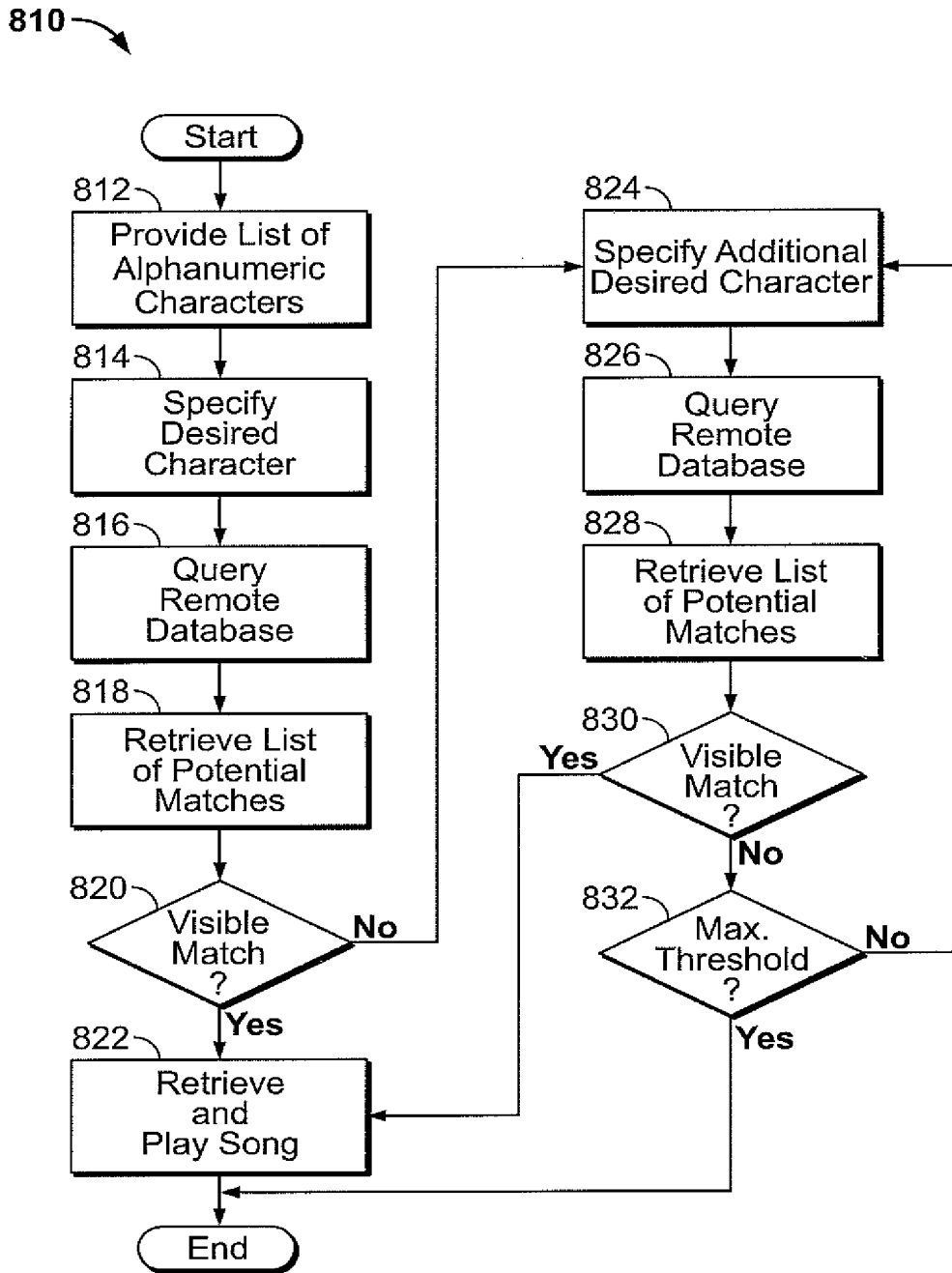

FIG. 16

29/41

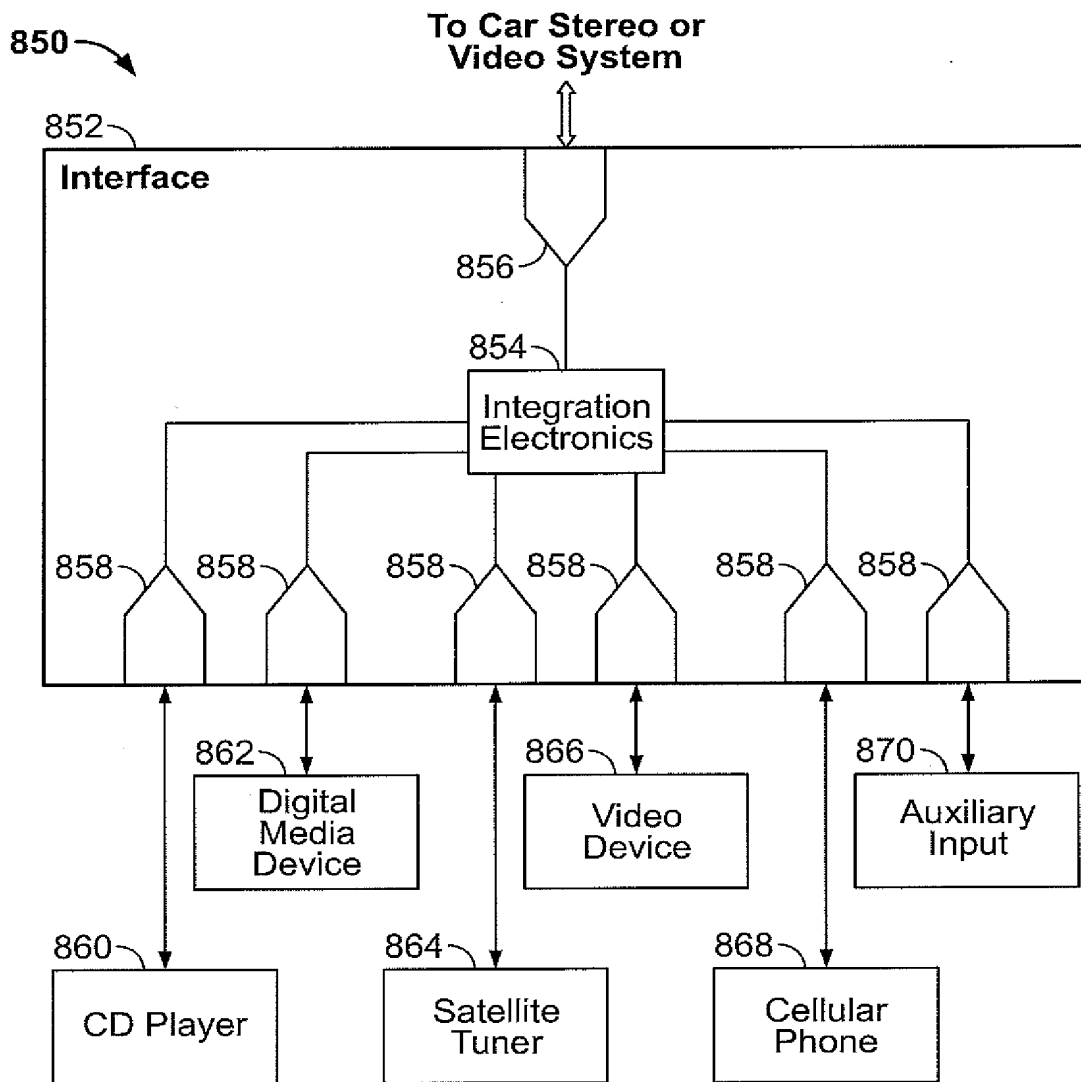

FIG. 17

30/41

900

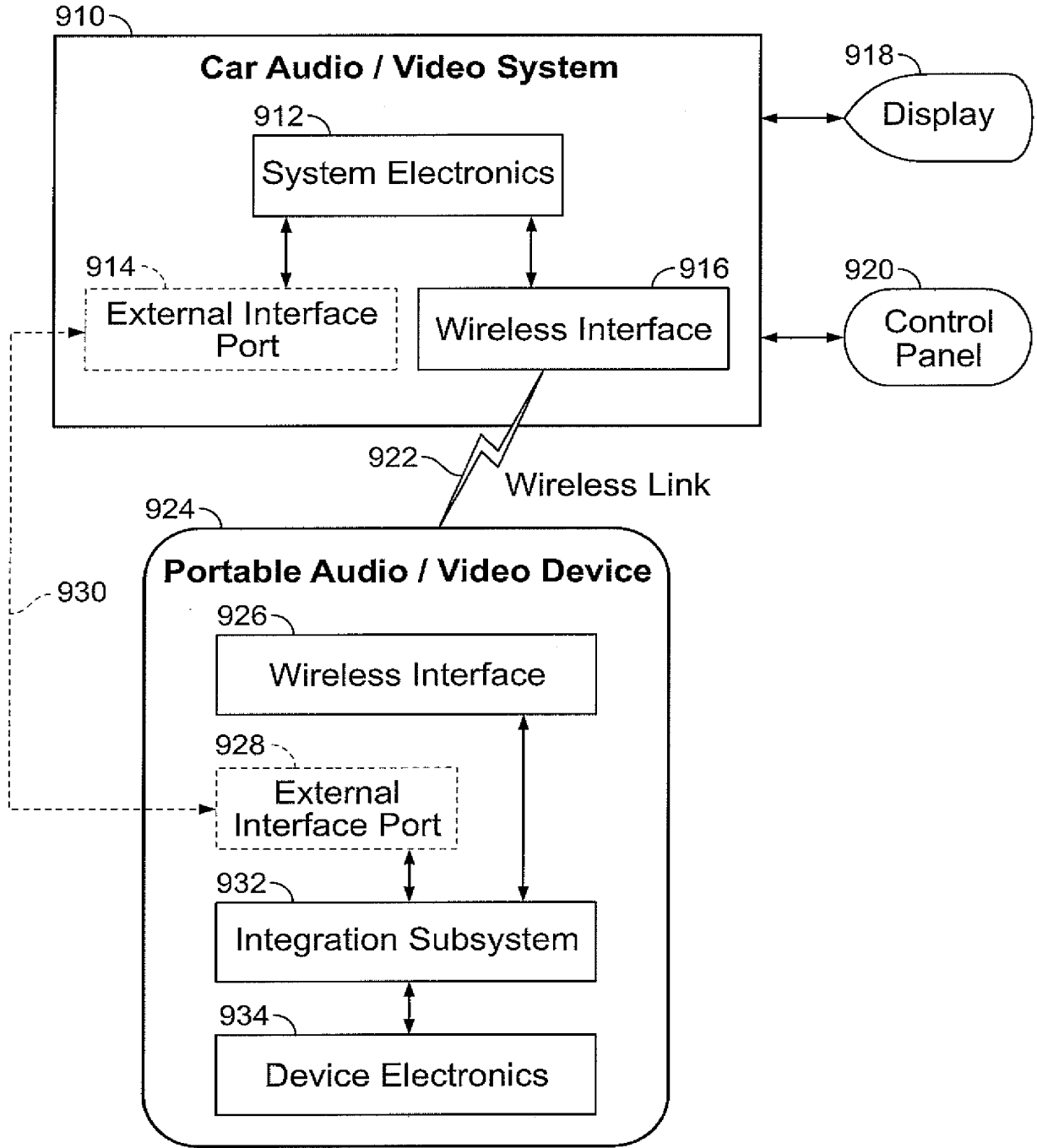

FIG. 18

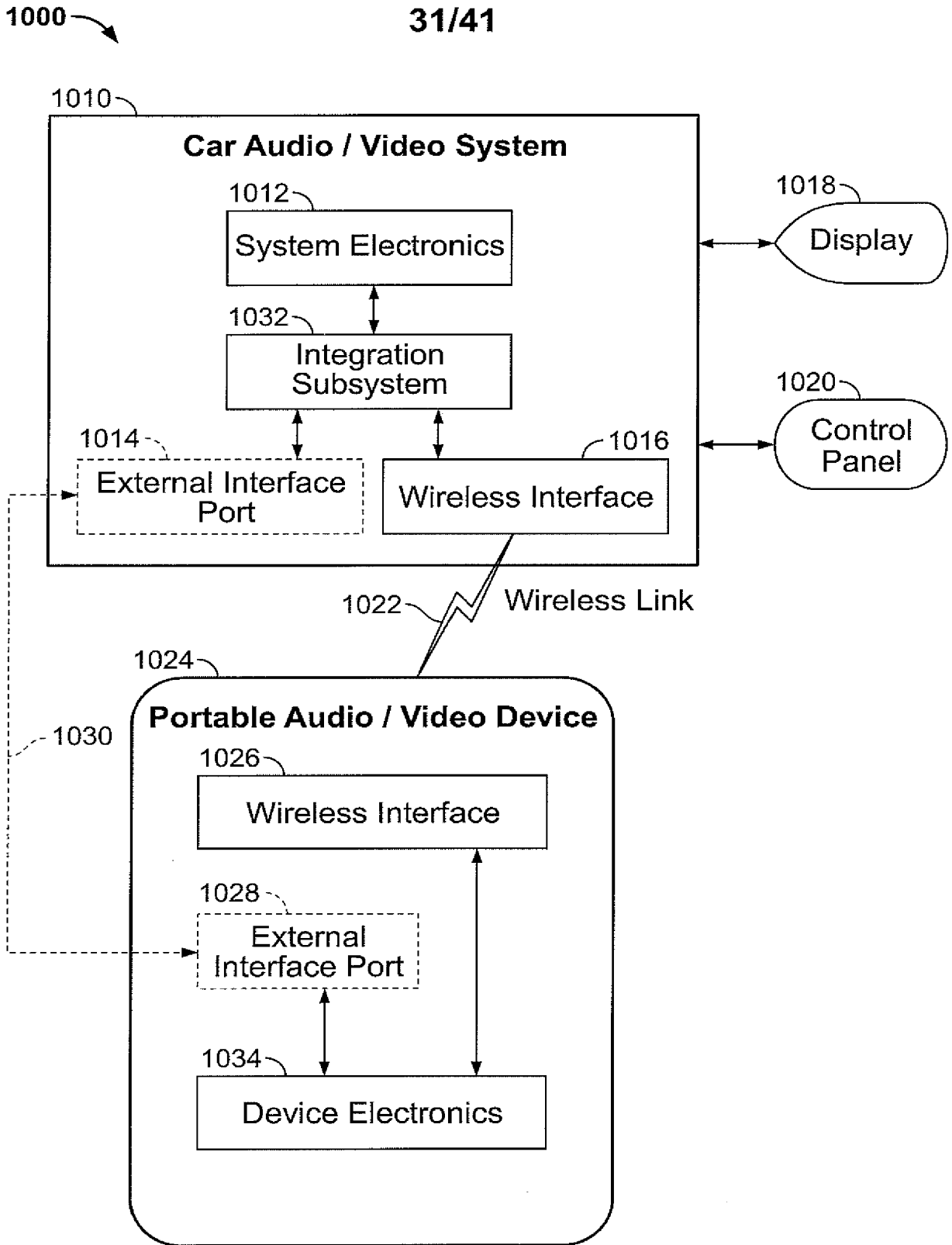

FIG. 19

32/41

1100

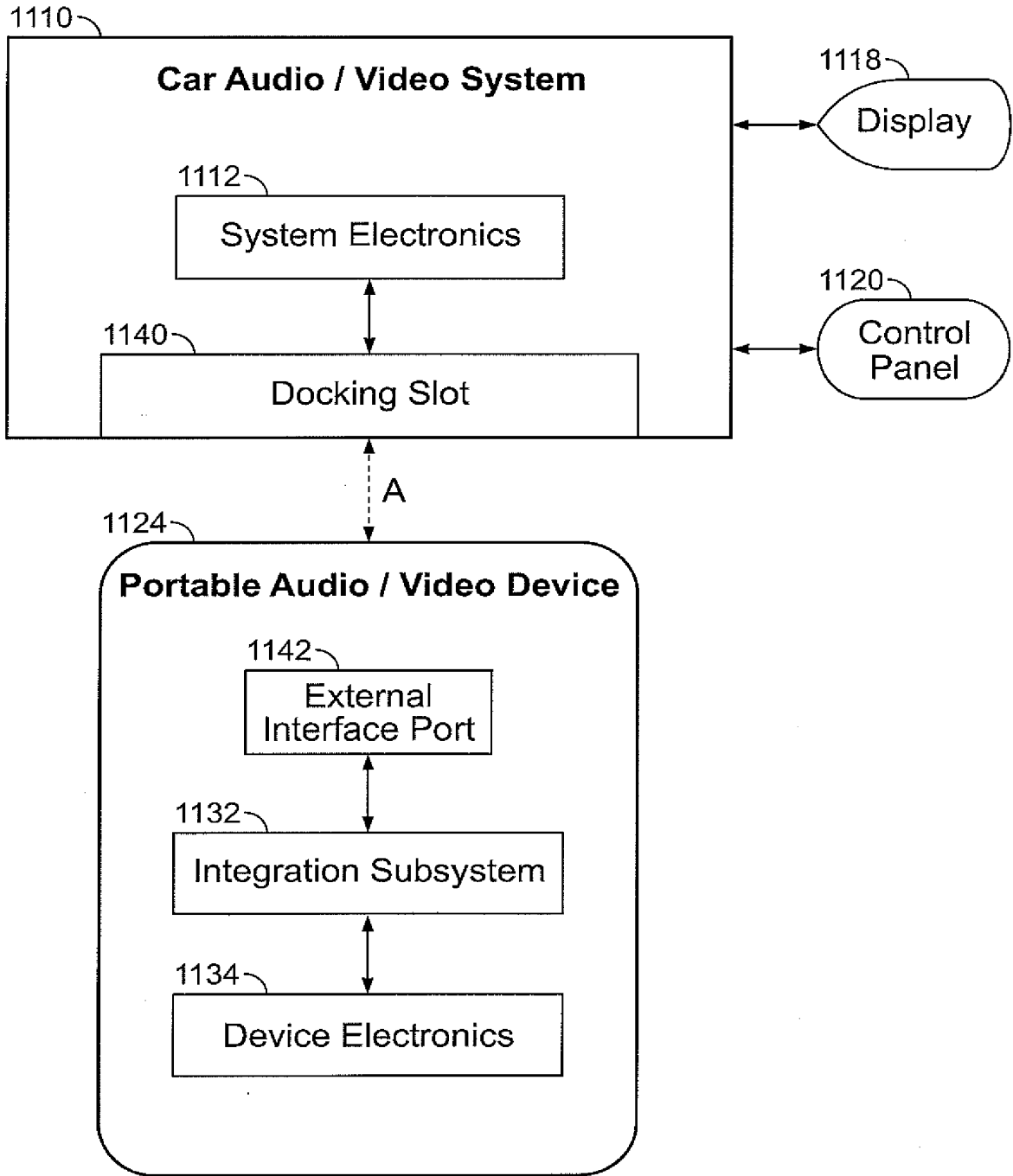

FIG. 20

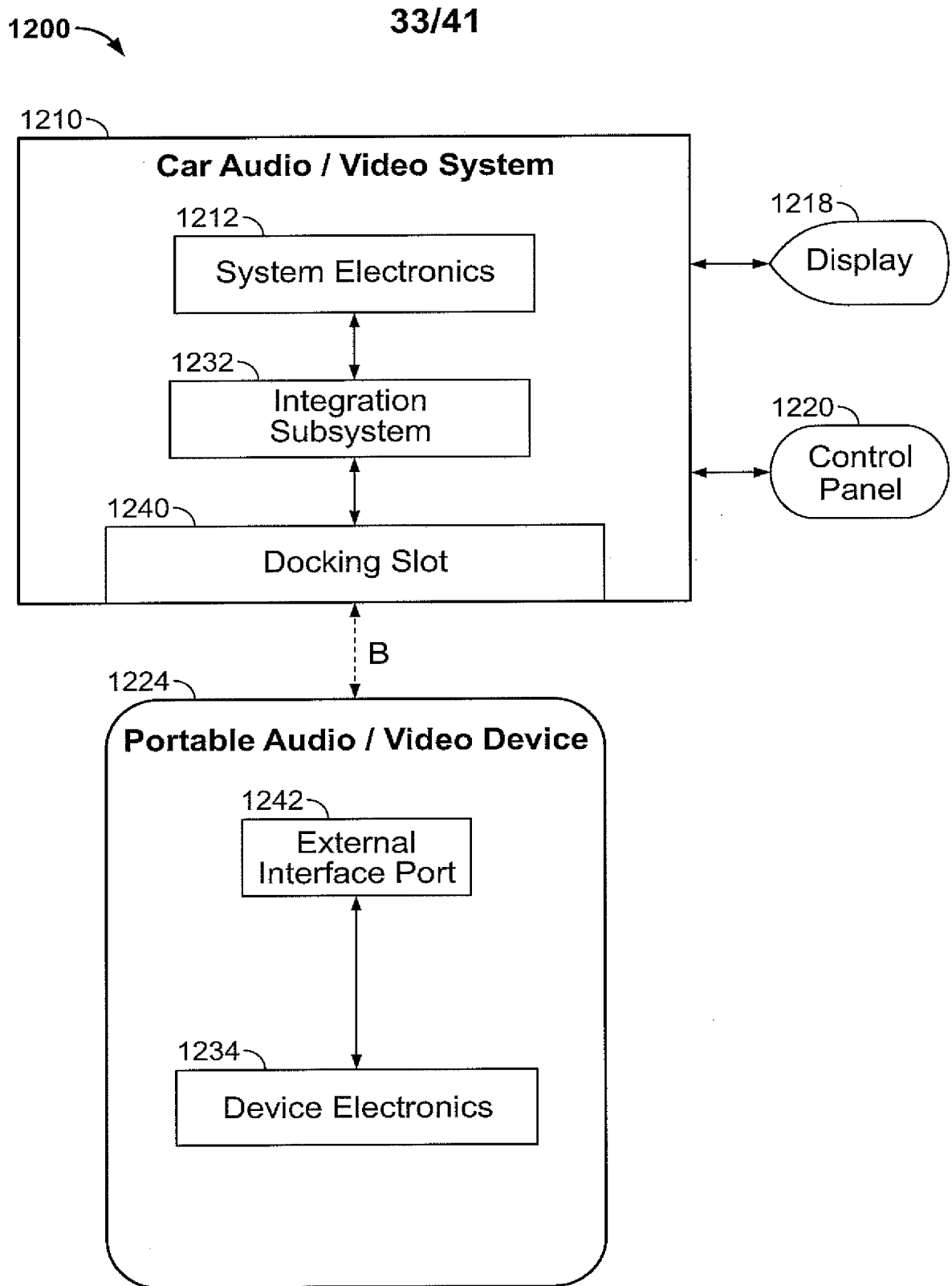

FIG. 21

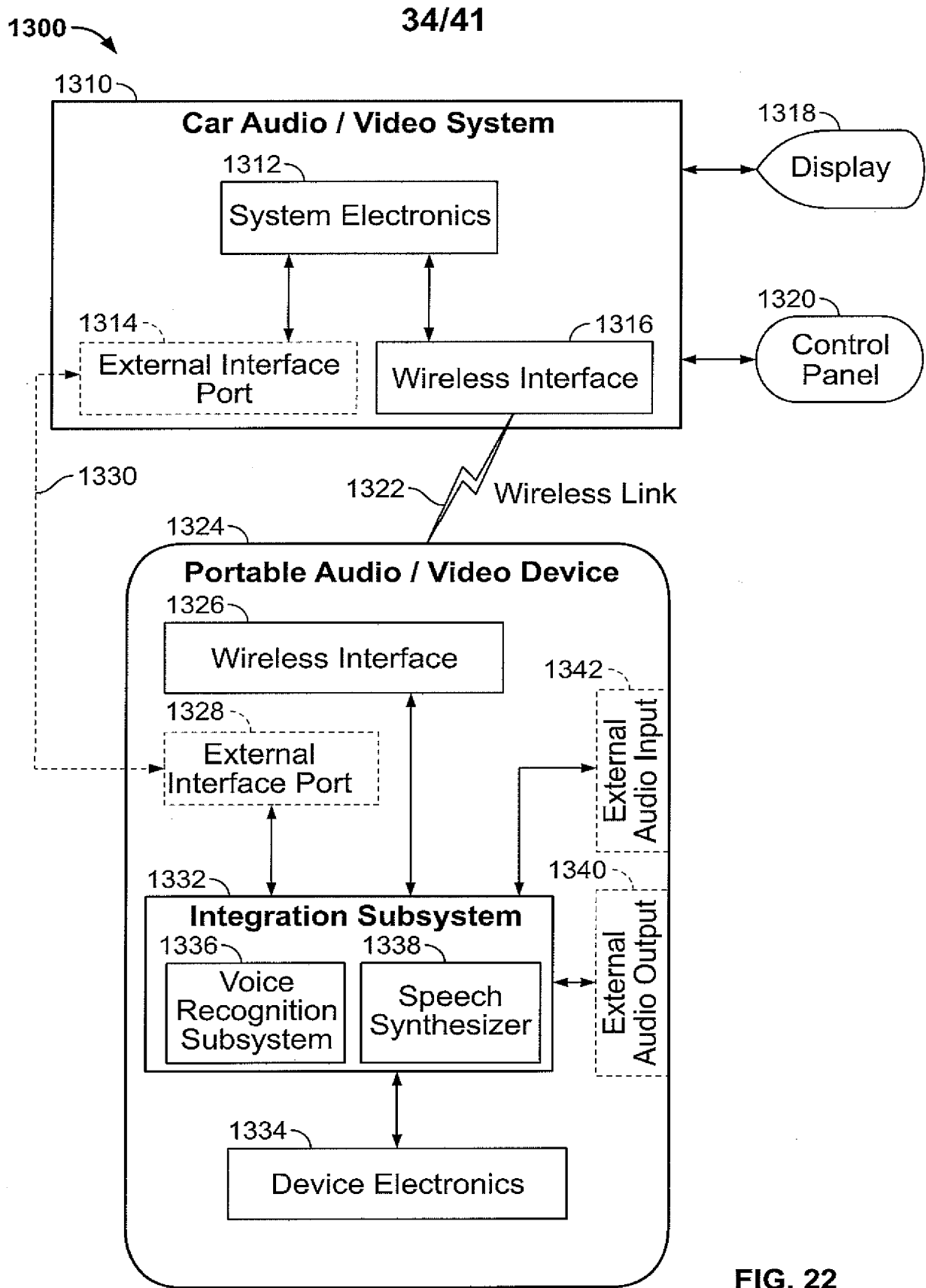

FIG. 22

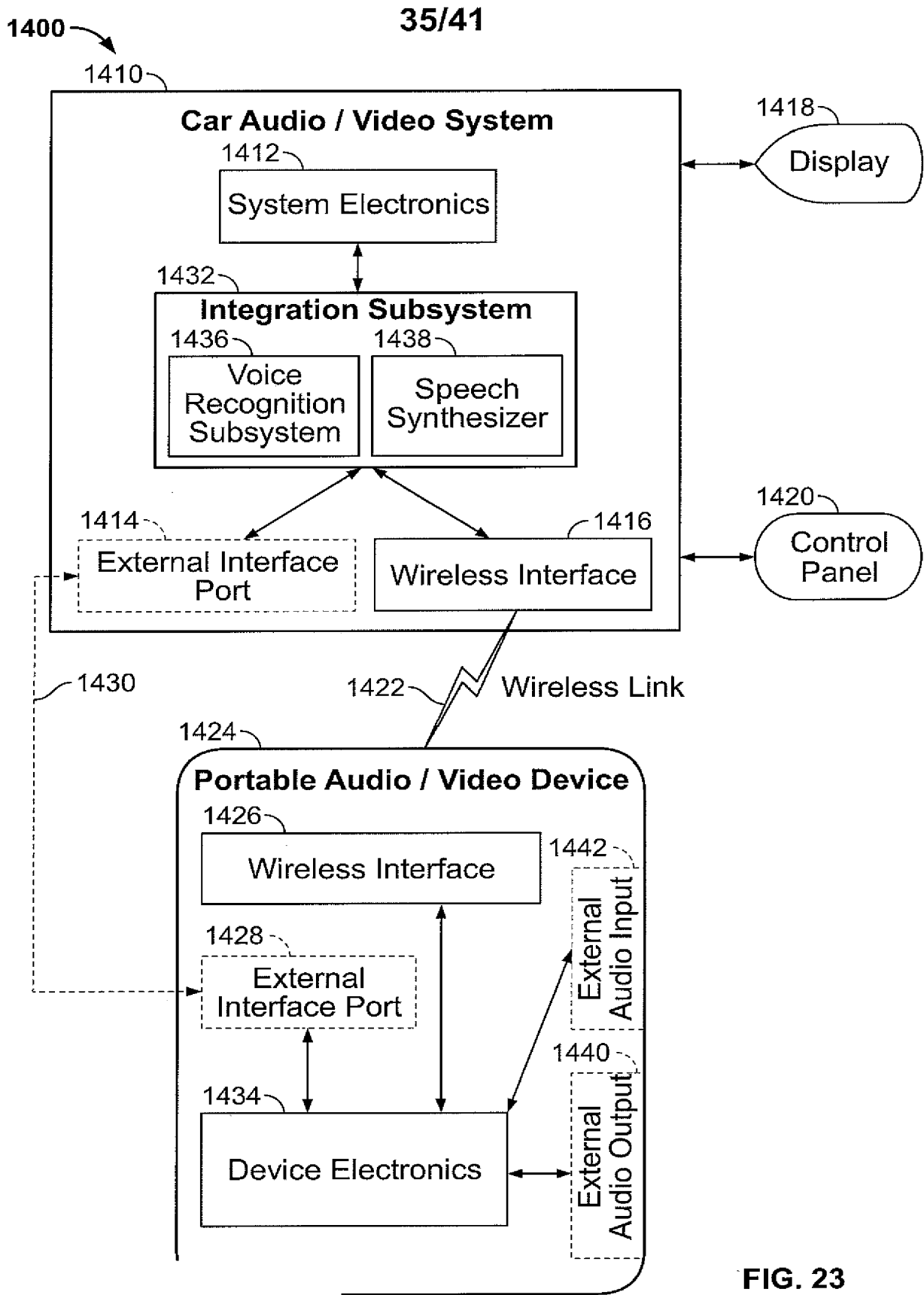

FIG. 23

1450 ↗

36/41

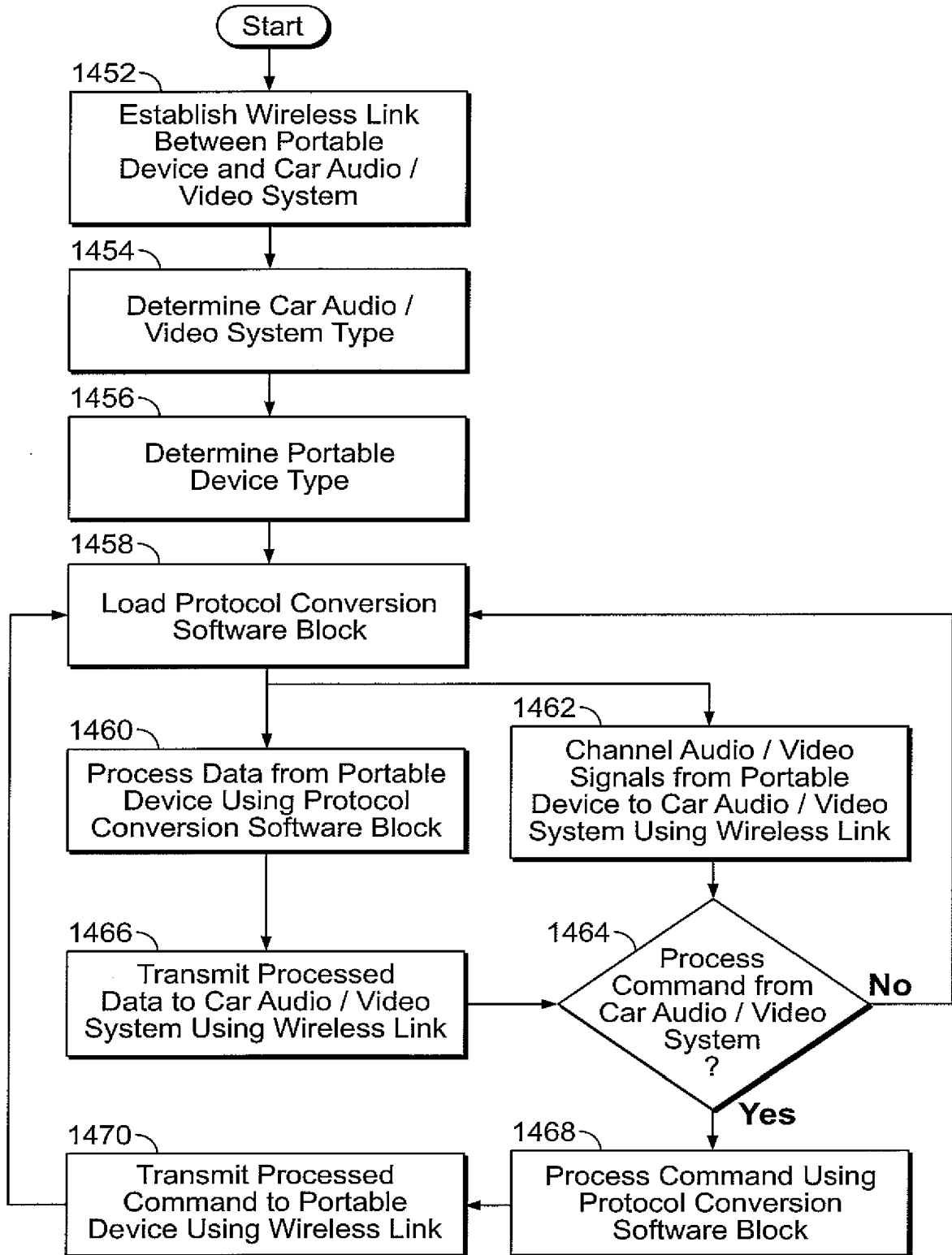

FIG. 24

37/41

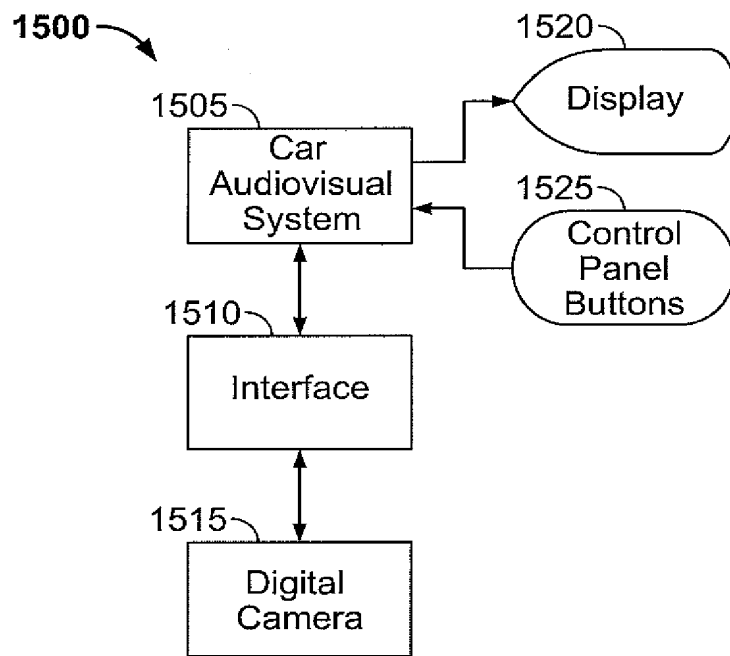

FIG. 25A

38/41

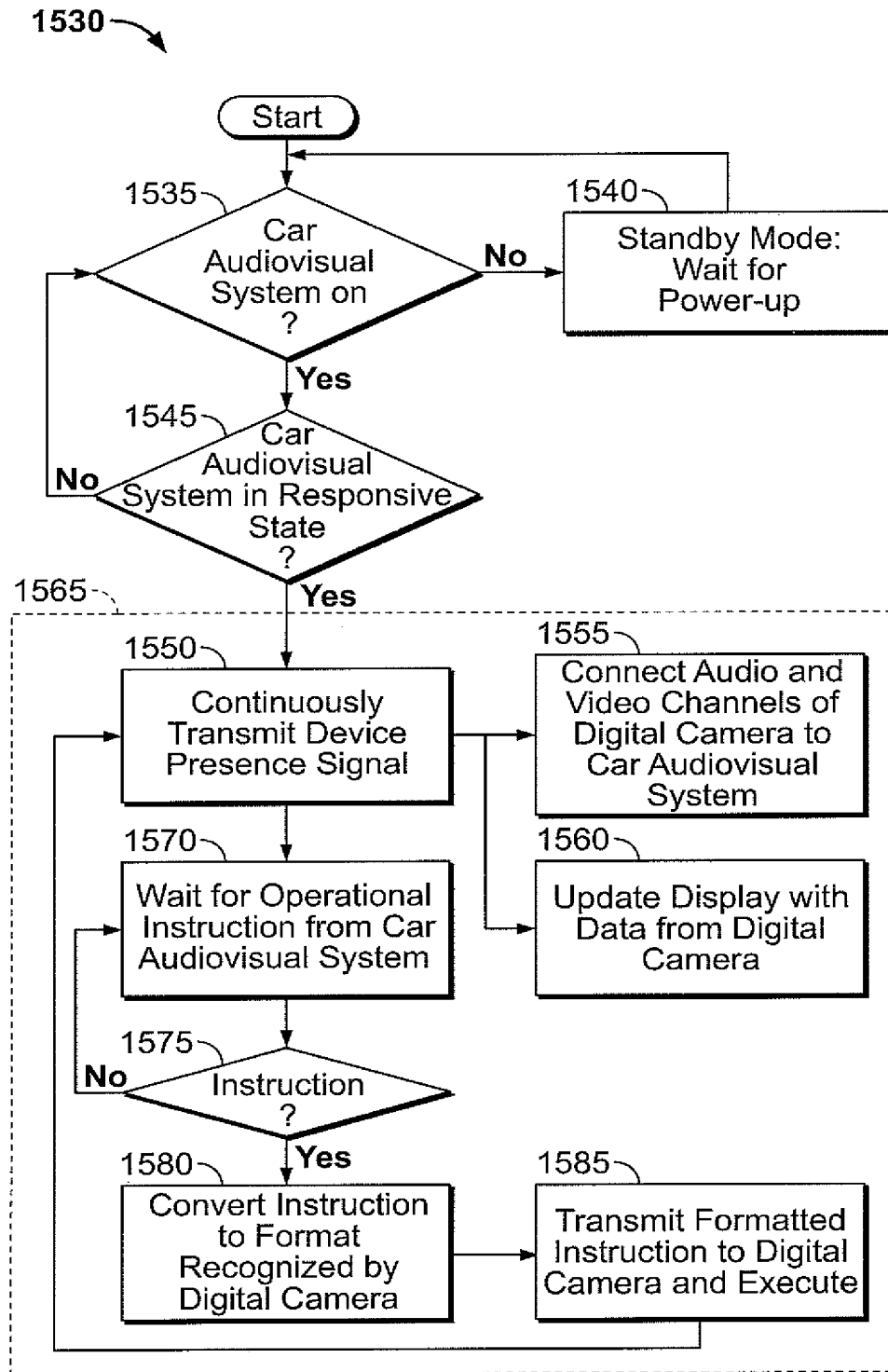

FIG. 25B

39/41

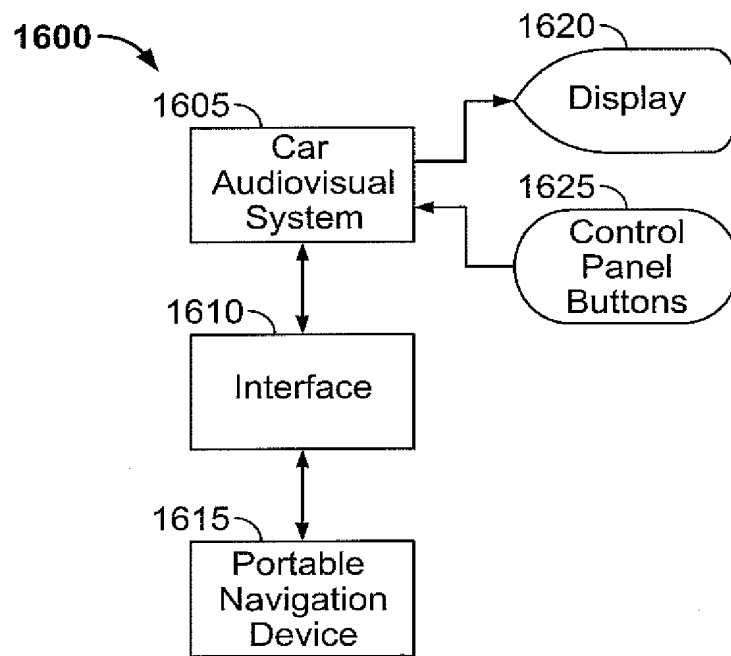

FIG. 26A

40/41

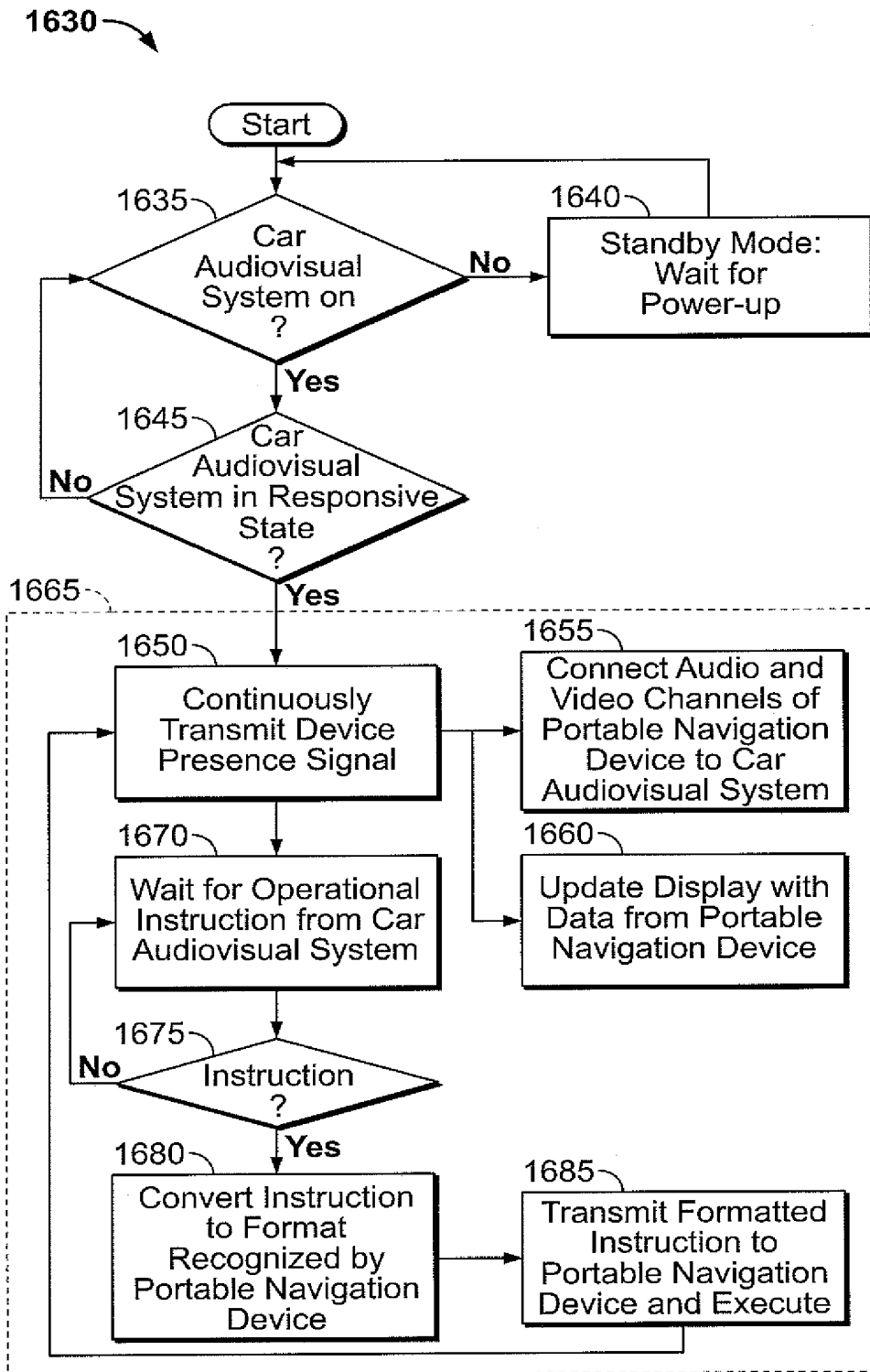

FIG. 26B

41/41

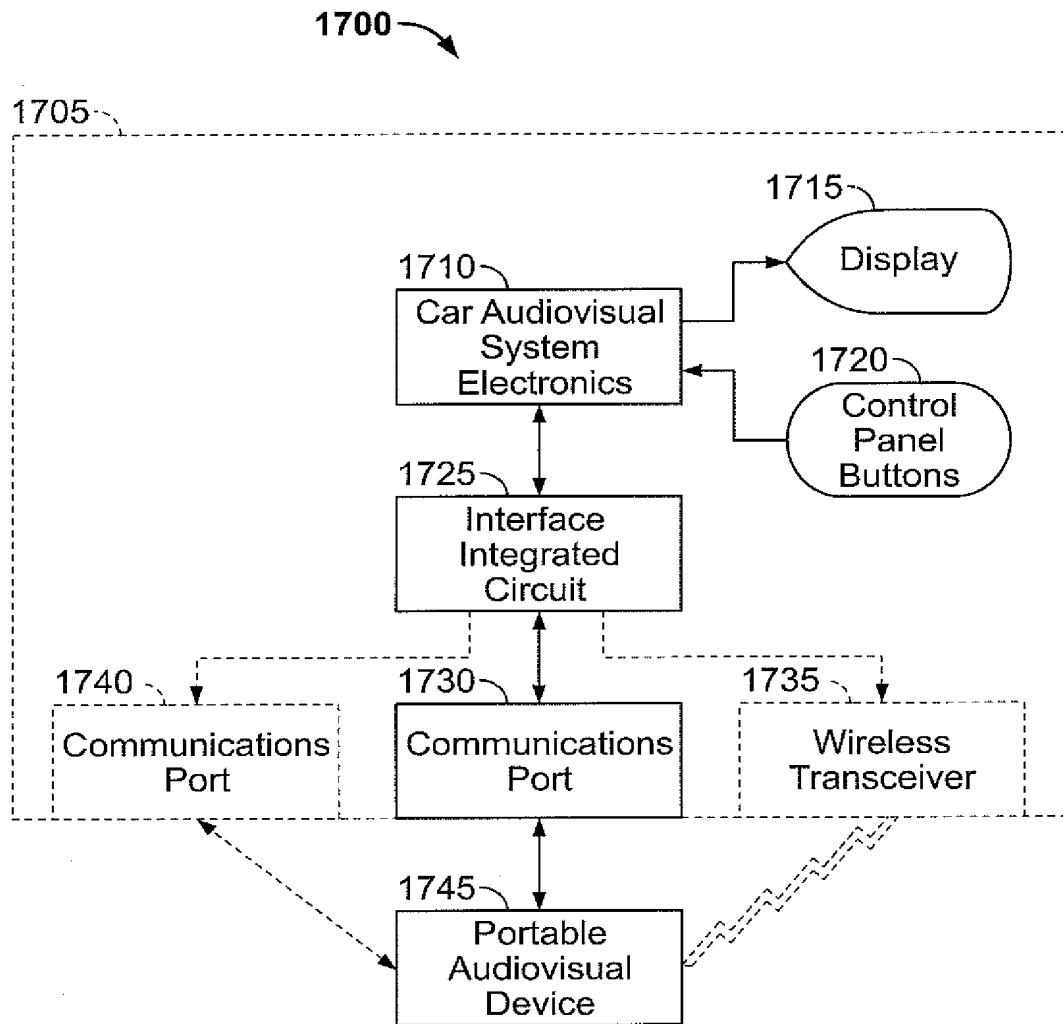

FIG.27

(19) World Intellectual Property Organization
International Bureau



(43) International Publication Date
8 September 2006 (08.09.2006)

PCT

(10) International Publication Number
WO 2006/094281 A2

(51) International Patent Classification: Not classified

(21) International Application Number:
PCT/US2006/008043

(22) International Filing Date: 3 March 2006 (03.03.2006)

(25) Filing Language: English

(26) Publication Language: English

(30) Priority Data:
11/071,667 3 March 2005 (03.03.2005) US

(71) Applicant: MARLOWE, Ira [US/US]; 6403 Hilltop Court, Fort Lee, NJ 07024 (US).

(74) Agent: FRISCIA, Michael; McCarter & English, LLP, Four Gateway Center, 100 Mulberry Street, Newark, NJ 07102 (US).

(81) Designated States (unless otherwise indicated, for every kind of national protection available): AE, AG, AL, AM, AT, AU, AZ, BA, BB, BG, BR, BW, BY, BZ, CA, CH, CN,

CO, CR, CU, CZ, DE, DK, DM, DZ, EC, EE, EG, ES, FI, GB, GD, GE, GH, GM, HR, HU, ID, IL, IN, IS, JP, KE, KG, KM, KN, KP, KR, KZ, LC, LK, LR, LS, LT, LU, LV, LY, MA, MD, MG, MK, MN, MW, MX, MZ, NA, NG, NI, NO, NZ, OM, PG, PH, PL, PT, RO, RU, SC, SD, SE, SG, SK, SL, SM, SY, TJ, TM, TN, TR, TT, TZ, UA, UG, US, UZ, VC, VN, YU, ZA, ZM, ZW.

(84) Designated States (unless otherwise indicated, for every kind of regional protection available): ARIPO (BW, GH, GM, KE, LS, MW, MZ, NA, SD, SL, SZ, TZ, UG, ZM, ZW), Eurasian (AM, AZ, BY, KG, KZ, MD, RU, TJ, TM), European (AT, BE, BG, CH, CY, CZ, DE, DK, EE, ES, FI, FR, GB, GR, HU, IE, IS, IT, LT, LU, LV, MC, NL, PL, PT, RO, SE, SI, SK, TR), OAPI (BF, BJ, CF, CG, CI, CM, GA, GN, GQ, GW, ML, MR, NE, SN, TD, TG).

Published:
— without international search report and to be republished upon receipt of that report

For two-letter codes and other abbreviations, refer to the "Guidance Notes on Codes and Abbreviations" appearing at the beginning of each regular issue of the PCT Gazette.

(54) Title: MULTIMEDIA DEVICE INTEGRATION SYSTEM

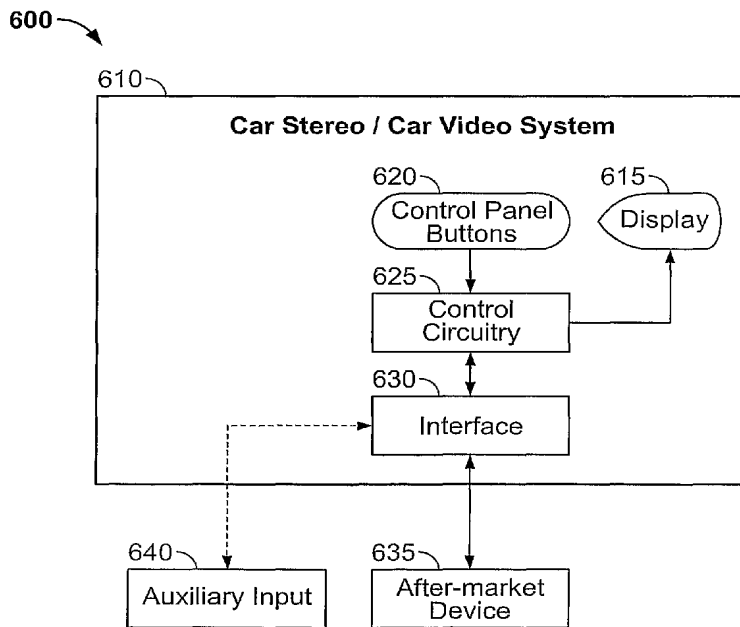

(57) Abstract: An multimedia device integration system is provided. One or more after-market audio or video devices, such as a CD player, CD changer, digital media device {e.g., MP3 player, MP4 player, WMV player, Apple iPod, portable music center, or other device) satellite receiver {e.g., XM or Sirius receiver}, DAB receiver, video device {e.g., DVD player}, cellular telephone, or any other device or combinations thereof, is integrated for use with an existing OEM or after-market car stereo or video system, wherein control commands can be issued at the car stereo or video system and data from the after-market device can be displayed on the car stereo or video system. Control commands generated at the car stereo or video system are received, processed, converted into a format recognizable by the after-market device, and dispatched to the after-market device for execution. Information from the after-market

device is converted into a format recognizable by the car stereo or video system, and dispatched to the car stereo or video system for display thereon. One or more auxiliary input sources can be integrated with the car stereo or video system, and selected using the controls of the car stereo or video system. A docking station is provided for docking a portable audio or video device for integration with the car stereo or video system.

WO 2006/094281 A2

IN THE UNITED STATES PATENT AND TRADEMARK OFFICE

INVENTOR: IRA MARLOWE

5 TITLE: MULTIMEDIA DEVICE INTEGRATION
SYSTEMSPECIFICATION

10

BACKGROUND OF THE INVENTIONFIELD OF THE INVENTION

15 The present invention relates to a multimedia device integration system. More specifically, the present invention relates to a multimedia device integration system for integrating after-market components such as satellite receivers, CD players, CD changers, digital media devices (*e.g.*, MP3 players, MP4 players, WMV players, Apple iPod devices, portable media centers, and other devices),
20 Digital Audio Broadcast (DAB) receivers, auxiliary audio sources, video devices (*e.g.*, DVD players), cellular telephones, and other devices for use with factory-installed (OEM) or after-market car stereo and video systems.

RELATED ART

25 Automobile audio systems have continued to advance in complexity and the number of options available to automobile purchasers. Early audio systems offered a simple AM and/or FM tuner, and perhaps an analog tape deck for allowing cassettes, 8-tracks, and other types of tapes to be played while driving. Such early systems were closed, in that external devices could not be easily
30 integrated therewith.

With advances in digital technology, CD players have been included with automobile audio systems. Original Equipment Manufacturers (OEMs) often produce car stereos having CD players and/or changers for allowing CDs to be played while driving. However, such systems often include proprietary buses and protocols that do not allow after-market audio systems, such as satellite receivers (e.g., XM satellite tuners), digital audio broadcast (DAB) receivers, digital media players (e.g., Apple iPod, MP3, MP4, WMV, etc.), CD changers, auxiliary input sources, video devices (e.g., DVD players), cellular telephones, and the like, to be easily integrated therewith. Thus, automobile purchasers are frequently forced to either entirely replace the OEM audio system, or use same throughout the life of the vehicle or the duration of ownership. Even if the OEM radio is replaced with an after-market radio, the after-market radio also frequently is not operable with an external device.

A particular problem with integrating after-market audio and video systems with existing car stereo and video systems is that signals generated by both systems are in proprietary formats, and are not capable of being processed by the after-market system. Additionally, signals generated by the after-market system are also in a proprietary format that is not recognizable by the car stereo or video system. Thus, in order to integrate after-market systems with existing car stereo and video systems, it is necessary to convert signals between such systems.

It known in the art to provide one or more expansion modules for OEM and after-market car stereos for allowing external audio products to be integrated with the car stereo. However, such expansion modules only operate with and allow integration of external audio products manufactured by the same manufacturer as

the OEM / after-market car stereo. For example, a satellite receiver manufactured by PIONEER, Inc., cannot be integrated with an OEM car radio manufactured by TOYOTA or an after-market car radio manufactured by CLARION, Inc. Thus, existing expansion modules only serve the limited purpose of integrating
5 equipment by the same manufacturer as the car stereo. Thus, it would be desirable to provide an integration system that allows any audio device of any manufacture to be integrated with any OEM or after-market radio system. Further, radio-frequency (RF) transmitters and cassette tape adapters have been developed for allowing music from a device external to a car radio, such as a portable CD player,
10 to be played through the car radio using the FM receiver or the cassette deck of the radio. However, such systems are often prone to interference, and do not provide high fidelity.

Moreover, it would be desirable to provide an integration system that not only achieves integration of various audio and video devices that are alien to a
15 given OEM or after-market car stereo or video system, but also allows for information to be exchanged between the after-market device and the car stereo or video system. For example, it would be desirable to provide a system wherein station, track, time, and song information can be retrieved from the after-market device, formatted, and transmitted to the car stereo or video system for display
20 thereby, such as at an LCD panel of the car stereo or on one or more display panels of a car video system. Such information could be transmitted and displayed on both hardwired car stereo and video systems (*e.g.*, radios installed in dashboards or at other locations within the car), or integrated for display on one or more software or graphically-driven radio systems operable with graphical display panels.

Additionally, it would be desirable to provide a multimedia device integration system that allows a user to control more than one device, such as a CD or satellite receiver and one or more auxiliary sources, and to quickly and conveniently switch between same using the existing controls of the car stereo or video system.

5 Accordingly, the present invention addresses these needs by providing a multimedia device integration system that allows a plurality of after-market devices, such as CD players, CD changers, digital media devices (*e.g.*, MP3 players, MP4 players, Apple iPod, WMV players, portable media centers, and other devices), satellite receivers, DAB receivers, auxiliary input sources, video
10 devices (*e.g.*, DVD players), cellular telephones, or any combination thereof, to be integrated into existing car stereo and video systems while allowing information to be displayed on, and control to be provided from, the car stereo or video system.

SUMMARY OF THE INVENTION

The present invention relates to a multimedia device integration system. One or more after-market audio devices, such as CD players, CD changers, digital media devices (*e.g.*, MP3 players, MP4 players, WMV players, Apple iPod devices, portable media centers, and other devices), satellite receivers (*e.g.*, XM or Sirius receivers), digital audio broadcast (DAB) receiver, or auxiliary input sources, can be connected to and operate with an existing stereo system in an automobile, such as an OEM car stereo system or an after-market car stereo system installed in the automobile. The integration system connects to and interacts with the car stereo at any available port of the car stereo, such as a CD input port, a satellite input, or other known type of connection. If the car stereo system is an after-market car stereo system, the present invention generates a signal that is sent to the car stereo to keep same in an operational state and responsive to external data and signals. Commands generated at the control panel are received by the present invention and converted into a format recognizable by the after-market device. The formatted commands are executed by the after-market device, and audio therefrom is channeled to the car stereo. Information from the after-market device is received by the present invention, converted into a format recognizable by the car stereo, and forwarded to the car stereo for display thereby. The formatted information could include information relating to a CD or MP3 track being played, channel, song, and artist information from a satellite receiver or DAB receiver, or video information from one or more external devices connected to the present invention. The information can be presented as one or more menus, textual, or graphical prompts for display on an LCD display of the radio, allowing

interaction with the user at the radio. A docking port may be provided for allowing portable external audio devices to be connected to the interface of the present invention.

In an embodiment of the present invention, a dual-input device is provided
5 for integrating both an external audio device and an auxiliary input with an OEM or after-market car stereo. The user can select between the external audio device and the auxiliary input using the controls of the car stereo. The invention can automatically detect the type of device connected to the auxiliary input, and integrate same with the car stereo.

10 In another embodiment of the present invention, an interface is provided for integrating a plurality of auxiliary input sources with an existing car stereo system. A user can select between the auxiliary sources using the control panel of the car stereo. One or more after-market audio devices can be integrated with the auxiliary input sources, and a user can switch between the audio device and the
15 auxiliary input sources using the car stereo. Devices connected to the auxiliary input sources are inter-operable with the car stereo, and are capable of exchanging commands and data via the interface.

In another embodiment of the present invention, an interface is provided for integrating an external device for use with a car stereo or video system, wherein
20 the interface is positioned within the car stereo or video system. The system comprises a car stereo or video system; an after-market device external to the car stereo or video system; an interface positioned within the car stereo or video system and connected between the car stereo or video system and the after-market device for exchanging data and audio or video signals between the car stereo or

video system and the after-market device; means for processing and dispatching commands for controlling the after-market device from the car stereo or video system in a format compatible with the after-market device; and means for processing and displaying data from the after-market device on a display of the car stereo or video system in a format compatible with the car stereo or video system. 5 The after-market device could comprise one or more of a CD changer, CD player, satellite receiver (*e.g.*, XM or Sirius), digital media device (*e.g.*, MP3, MP4, WMV, or Apple iPod device), video device (*e.g.*, DVD player), cellular telephone, or any combination thereof.

10 In another embodiment of the present invention, an interface is provided for integrating a cellular telephone for use with a car stereo or video system. The system comprises a car stereo or video system; a cellular telephone external to the car stereo or video system; an interface connected between the car stereo or video system and the cellular telephone for exchanging data and audio or video signals 15 between the car stereo or video system and the cellular telephone; means for processing and dispatching commands for controlling the cellular telephone from the car stereo or video system in a format compatible with the cellular telephone; and means for processing and displaying data from the cellular telephone on a display of the car stereo or video system in a format compatible with the car stereo 20 or video system.

In another embodiment of the present invention, an interface is provided for integrating an external video system for use with a car video system. The system comprises a car video system; an after-market video device external to the car

video system; an interface connected between the car video system and the after-market video device for exchanging data, audio, and video signals between the car video system and the after-market video device; means for processing and dispatching commands for controlling the after-market video device from the car video system in a format compatible with the after-market video device; and means
5 for processing and displaying data from the after-market video device on a display of the car video system in a format compatible with the car video system.

The present invention also provides an interface for integrating a plurality of after-market devices for use with a car stereo or video system using a single
10 interface. In one embodiment, the system comprises an interface in electrical communication with a car stereo or video system and an after-market device; a plurality of configuration jumpers in the interface for specifying a first device type corresponding to the car stereo or video system and a second device type corresponding to the after-market device; and a plurality of protocol conversion
15 software blocks stored in memory in the interface for converting signals from the after-market device into a first format compatible with the car stereo or video system and for converting signals from the car stereo or video system into a second format compatible with the after-market device, wherein at least one of the protocol conversion software blocks are selected by the interface using settings of
20 the plurality of configuration jumpers. In another embodiment, the system comprises an interface in electrical communication with a car stereo or video system and an after-market device; first and second wiring harnesses attached to the interface, wherein the first wiring harness includes a first electrical configuration corresponding to the car stereo or video system and the second

wiring harness includes a second electrical configuration corresponding to the after-market device; and a plurality of protocol conversion software blocks stored in memory in the interface for converting signals from the after-market device into a first format compatible with the car stereo or video system and for converting
5 signals from the car stereo or video system into a second format compatible with the after-market device, wherein at least one of the protocol conversion software blocks are selected by the interface using the first and second electrical configurations of the first and second wiring harnesses. A plurality of wiring harnesses can be provided for integrating a plurality of devices.

10 The present invention also provides a method for integrating an after-market device for use with a car stereo or video system, comprising the steps of interconnecting the car stereo or video system and the after-market device with an interface; determining a first device type corresponding to the car stereo or video system and a second device type corresponding to the after-market device; loading
15 a protocol conversion software block from memory in the interface using the first and second device types; converting signals from the after-market device into a first format compatible with the car stereo or video system using the protocol conversion software block; and converting signals from the car stereo or video system into a second format compatible with the after-market device using the
20 protocol conversion software block.

BRIEF DESCRIPTION OF THE DRAWINGS

These and other important objects and features of the invention will be apparent from the following Detailed Description of the Invention, taken in connection with the accompanying drawings, in which:

5 **FIG. 1** is a block diagram showing the multimedia device integration system of the present invention.

FIG. 2a is a block diagram showing an alternate embodiment of the multimedia device integration system of the present invention, wherein a CD player is integrated with a car radio.

10 **FIG. 2b** is a block diagram showing an alternate embodiment of the multimedia device integration system of the present invention, wherein a MP3 player is integrated with a car radio.

FIG. 2c is a block diagram showing an alternate embodiment of the multimedia device integration system of the present invention, wherein a satellite or DAB receiver is integrated with a car radio.

FIG. 2d is a block diagram showing an alternate embodiment of the multimedia device integration system of the present invention, wherein a plurality of auxiliary input sources are integrated with a car radio.

20 **FIG. 2e** is a block diagram showing an alternate embodiment of the multimedia device integration system of the present invention, wherein a CD player and a plurality of auxiliary input sources are integrated with a car radio.

FIG. 2f is a block diagram showing an alternate embodiment of the present invention, wherein a satellite or DAB receiver and a plurality of auxiliary input source are integrated with a car radio.

FIG. 2g is a block diagram showing an alternate embodiment of the present invention, wherein a MP3 player and a plurality of auxiliary input sources are integrated with a car radio.

5 **FIG. 2h** is a block diagram showing an alternate embodiment of the present invention, wherein a plurality of auxiliary interfaces and an audio device are integrated with a car stereo.

FIG. 3a is a circuit diagram showing a device according to the present invention for integrating a CD player or an auxiliary input source with a car radio.

10 **FIG. 3b** is a circuit diagram showing a device according to the present invention for integrating both a CD player and an auxiliary input source with a car radio, wherein the CD player and the auxiliary input are switchable by a user.

FIG. 3c is a circuit diagram showing a device according to the present invention for integrating a plurality of auxiliary input sources with a car radio.

15 **FIG. 3d** is a circuit diagram showing a device according to the present invention for integrating a satellite or DAB receiver with a car radio.

FIG. 4a is a flowchart showing processing logic according to the present invention for integrating a CD player with a car radio.

20 **FIG. 4b** is a flowchart showing processing logic according to the present invention for integrating a MP3 player with a car radio.

FIG. 4c is a flowchart showing processing logic according to the present invention for integrating a satellite receiver with a car radio.

FIG. 4d is a flowchart showing processing logic according to the present invention for integrating a plurality of auxiliary input sources with a car radio.

FIG. 4e is a flowchart showing processing logic according to the present invention for integrating a CD player and one or more auxiliary input sources with a car radio.

5 **FIG. 4f** is a flowchart showing processing logic according to the present invention for integrating a satellite or DAB receiver and one or more auxiliary input sources with a car radio.

10 **FIG. 4g** is a flowchart showing processing logic according to the present invention for integrating a MP3 player and one or more auxiliary input sources with a car stereo.

FIG. 5 is a flowchart showing processing logic according to the present invention for allowing a user to switch between an after-market audio device and one or more auxiliary input sources.

15 **FIG. 6** is a flowchart showing processing logic according to the present invention for determining and handling various device types connected to the auxiliary input ports of the invention.

FIG. 7a is a perspective view of a docking station according to the present invention for retaining an audio device within a car.

FIG. 7b is an end view of the docking station of **FIG. 7a**.

20 **FIGS. 8a-8b** are perspective views of another embodiment of the docking station of the present invention, which includes the multimedia device integration system of the present invention incorporated therewith.

FIG. 9 is a block diagram showing the components of the docking station of **FIGS. 8a-8b**.

FIG. 10 is a block diagram showing an alternate embodiment of the multimedia device integration system of the present invention, wherein the interface is incorporated within a car stereo or car video system.

5 **FIG. 11a** is a diagram showing an alternate embodiment of the multimedia device integration system of the present invention for integrating a cellular telephone for use with a car stereo or video system; **FIG. 11b** is a flowchart showing processing logic for integrating a cellular telephone for use with a car stereo or video system.

10 **FIG. 12a** is a diagram showing an alternate embodiment of the multimedia device integration system of the present invention for integrating an after-market video device for use with a car video system; **FIG. 12b** is a flowchart showing processing logic for integrating an after-market video device for use with a car video system.

15 **FIG. 13a** is a block diagram showing an alternate embodiment of the multimedia device integration system of the present invention, wherein configuration jumpers and protocol conversion software blocks are provided for integrating after-market devices of various types using a single interface.

20 **FIG. 13b** is a block diagram showing an alternate embodiment of the multimedia device integration system of the present invention, wherein wiring harnesses and protocol conversion software blocks are provided for integrating after-market devices of various types using a single interface.

FIG. 14 is a flowchart showing processing logic of the multimedia device integration system of the present invention for integrating after-market devices of various types using a single interface.

FIG. 15 is a flowchart showing processing logic of the multimedia device integration system of the present invention for allowing a user to specify one or more after-market device types for integration using a single interface.

FIG. 16 is a flowchart showing processing logic of the multimedia device integration system of the present invention for allowing a user to quickly navigate through a list of songs on one or more after-market devices using the controls of a car stereo or video system.

FIG. 17 is a diagram showing an another embodiment of the present invention, wherein a plurality of external devices are integrated using a single interface.

DETAILED DESCRIPTION OF THE INVENTION

The present invention relates to a multimedia device integration system. One or more after-market devices, such as a CD player, CD changer, digital media player (*e.g.*, MP3 player, MP4 player, WMV player, Apple iPod, portable media center, or other device), satellite receiver, digital audio broadcast (DAB) receiver, 5 video device (*e.g.*, DVD player), cellular telephone, or the like, can be integrated with an existing car radio or car video device, such as an OEM or after-market car stereo or video system. Control of the after-market device is enabled using the car stereo or car video system, and information from the after-market device, such as 10 channel, artist, track, time, song, and other information information, is retrieved from the after-market device, processed, and forwarded to the car stereo or car video system for display thereon. The information channeled to the car stereo or video system can include video from the external device, as well as graphical and menu-based information. A user can review and interact with information via the 15 car stereo. Commands from the car stereo or video system are received, processed by the present invention into a format recognizable by the after-market device device, and transmitted thereto for execution. One or more auxiliary input channels can be integrated by the present invention with the car stereo or video system. The user can switch between one or more after-market devices and one or 20 more auxiliary input channels using the control panel buttons of the car stereo or video system.

As used herein, the term “integration” or “integrated” is intended to mean connecting one or more external devices or inputs to an existing car stereo or video system via an interface, processing and handling signals, audio, and/or video

information, allowing a user to control the devices via the car stereo or video system, and displaying data from the devices on the car stereo or video system. Thus, for example, integration of a CD player with a car stereo system allows for the CD player to be remotely controlled via the control panel of the stereo system, and data from the CD player to be sent to the display of the stereo. Of course, control of after-market devices can be provided at locations other than the control panel of the car stereo or video system without departing from the spirit or scope of the present invention. Further, as used herein, the term “inter-operable” is intended to mean allowing the external audio or video device to receive and process commands that have been formatted by the interface of the present invention, as well as allowing a car stereo or video system to display information that is generated by the external audio or video device and processed by the present invention. Additionally, by the term “inter-operable,” it is meant allowing a device that is alien to the environment of an existing OEM or after-market car stereo or video system to be utilized thereby.

Also, as used herein, the terms “car stereo” and “car radio” are used interchangeably and are intended to include all presently existing car stereos, radios, video systems, such as physical devices that are present at any location within a vehicle, in addition to software and/or graphically- or display-driven receivers. An example of such a receiver is a software-driven receiver that operates on a universal LCD panel within a vehicle and is operable by a user via a graphical user interface displayed on the universal LCD panel. Further, any future receiver, whether a hardwired or a software/graphical receiver operable on one or more displays, is considered within the definition of the terms “car stereo” and “car

radio,” as used herein, and is within the spirit and scope of the present invention. Moreover, the term “car” is not limited to any specific type of automobile, but rather, includes all automobiles. Additionally, by the term “after-market,” it is meant any device not installed by a manufacturer at the time of sale of the car.

5 **FIG. 1** is a block diagram showing the multimedia device integration (or interface) system of the present invention, generally indicated at **20**. A plurality of devices and auxiliary inputs can be connected to the interface **20**, and integrated with an OEM or after-market car radio **10**. A CD player or changer **15** can be integrated with the radio **10** via interface **20**. A satellite radio or DAB receiver **25**,
10 such as an XM or Sirius radio satellite receiver or DAB receiver known in the art, could be integrated with the radio **10**, via the interface **20**. Further, an MP3 player **30** could also be integrated with the radio **10** via interface **20**. The MP3 player **30** could be any known digital media device, such as an Apple iPod or any other digital media device. Moreover, a plurality of auxiliary input sources, illustratively
15 indicated as auxiliary input sources **35** (comprising input sources 1 through n , n being any number), could also be integrated with the car radio **10** via interface **20**. Optionally, a control head **12**, such as that commonly used with after-market CD changers and other similar devices, could be integrated with the car radio **10** via interface **20**, for controlling any of the car radio **10**, CD player/changer **15**,
20 satellite/DAB receiver **25**, MP3 player **30**, and auxiliary input sources **35**. Thus, as can be readily appreciated, the interface **20** of the present invention allows for the integration of a multitude of devices and inputs with an OEM or after-market car radio or stereo.

FIG. 2a is a block diagram of an alternate embodiment of the multimedia device interface system of the present invention, wherein a CD player/changer **15** is integrated with an OEM or after-market car radio **10**. The CD player **15** is electrically connected with the interface **20**, and exchanges data and audio signals therewith. The interface **20** is electrically connected with the car radio **10**, and exchanges data and audio signals therewith. In a preferred embodiment of the present invention, the car radio **10** includes a display **13** (such as an alphanumeric, electroluminescent display) for displaying information, and a plurality of control panel buttons **14** that normally operate to control the radio **10**. The interface **20** allows the CD player **15** to be controlled by the control buttons **14** of the radio **10**. Further, the interface **20** allows information from the CD player **15**, such as track, disc, time, and song information, to be retrieved therefrom, processed and formatted by the interface **20**, sent to the display **13** of the radio **10**.

Importantly, the interface **20** allows for the remote control of the CD player **15** from the radio **10** (e.g., the CD player **15** could be located in the trunk of a car, while the radio **10** is mounted on the dashboard of the car). Thus, for example, one or more discs stored within the CD player **15** can be remotely selected by a user from the radio **10**, and tracks on one or more of the discs can be selected therefrom. Moreover, standard CD operational commands, such as pause, play, stop, fast forward, rewind, track forward, and track reverse (among other commands) can be remotely entered at the control panel buttons **14** of the radio **10** for remotely controlling the CD player **15**.

FIG. 2b is a block diagram showing an alternate embodiment of the present invention, wherein an MP3 player **30** is integrated with an OEM or after-market

car radio 10 via interface 20. As mentioned earlier, the interface 20 of the present invention allows for a plurality of disparate audio devices to be integrated with an existing car radio for use therewith. Thus, as shown in FIG. 2b, remote control of the MP3 player 30 via radio 10 is provided for via interface 20. The MP3 player 5 30 is electronically interconnected with the interface 20, which itself is electrically interconnected with the car radio 10. The interface 20 allows data and audio signals to be exchanged between the MP3 player 30 and the car radio 10, and processes and formats signals accordingly so that instructions and data from the radio 10 are processable by the MP3 player 30, and vice versa. Operational 10 commands, such as track selection, pause, play, stop, fast forward, rewind, and other commands, are entered via the control panel buttons 14 of car radio 10, processed by the interface 20, and formatted for execution by the MP3 player 30. Data from the MP3 player, such as track, time, and song information, is received by the interface 20, processed thereby, and sent to the radio 10 for display on 15 display 13. Audio from the MP3 player 30 is selectively forwarded by the interface 20 to the radio 10 for playing.

FIG. 2c is a block diagram showing an alternate embodiment of the present invention, wherein a satellite receiver or DAB receiver 25 is integrated with an OEM or after-market car radio 10 via the interface 20. Satellite/DAB receiver 25 20 can be any satellite radio receiver known in the art, such as XM or Sirius, or any DAB receiver known in the art. The satellite/DAB receiver 25 is electrically interconnected with the interface 20, which itself is electrically interconnected with the car radio 10. The satellite/DAB receiver 25 is remotely operable by the control panel buttons 14 of the radio 10. Commands from the radio 10 are received by the

interface **20**, processed and formatted thereby, and dispatched to the satellite/DAB receiver **25** for execution thereby. Information from the satellite/DAB receiver **25**, including time, station, and song information, is received by the interface **20**, processed, and transmitted to the radio **10** for display on display **13**. Further, audio
5 from the satellite/DAB receiver **25** is selectively forwarded by the interface **20** for playing by the radio **10**.

FIG. 2d is a block diagram showing an alternate embodiment of the present invention, wherein one or more auxiliary input sources **35** are integrated with an OEM or after-market car radio **10**. The auxiliary inputs **35** can be connected to
10 analog sources, or can be digitally coupled with one or more audio devices, such as after-market CD players, CD changers, MP3 players, satellite receivers, DAB receivers, and the like, and integrated with an existing car stereo. Preferably, four auxiliary input sources are connectable with the interface **20**, but any number of auxiliary input sources could be included. Audio from the auxiliary input sources
15 **35** is selectively forwarded to the radio **10** under command of the user. As will be discussed herein in greater detail, a user can select a desired input source from the auxiliary input sources **35** by depressing one or more of the control panel buttons **14** of the radio **10**. The interface **20** receives the command initiated from the control panel, processes same, and connects the corresponding input source from
20 the auxiliary input sources **35** to allow audio therefrom to be forwarded to the radio **10** for playing. Further, the interface **20** determines the type of audio devices connected to the auxiliary input ports **35**, and integrates same with the car stereo **10**.

As mentioned previously, the present invention allows one or more external audio devices to be integrated with an existing OEM or after-market car stereo, along with one or more auxiliary input sources, and the user can select between these sources using the controls of the car stereo. Such “dual input” capability
5 allows operation with devices connected to either of the inputs of the device, or both. Importantly, the device can operate in “plug and play” mode, wherein any device connected to one of the inputs is automatically detected by the present invention, its device type determined, and the device automatically integrated with an existing OEM or after-market car stereo. Thus, the present invention is not
10 dependent any specific device type to be connected therewith to operate. For example, a user can first purchase a CD changer, plug same into a dual interface, and use same with the car stereo. At a point later in time, the user could purchase an XM tuner, plug same into the device, and the tuner will automatically be detected and integrated with the car stereo, allowing the user to select from and
15 operate both devices from the car stereo. It should be noted that such plug and play capability is not limited to a dual input device, but is provided for in every embodiment of the present invention. The dual-input configuration of the present invention is illustrated in **FIGS. 2e-2h** and described below.

FIG. 2e is a block diagram showing an alternate embodiment of the present
20 invention, wherein an external CD player/changer **15** and one or more auxiliary input sources **35** are integrated with an OEM or after-market car stereo **10**. Both the CD player **15** and one or more of the auxiliary input sources **35** are electrically interconnected with the interface **20**, which, in turn, is electrically interconnected to the radio **10**. Using the controls **14** of the radio **10**, a user can select between the

CD player 15 and one or more of the inputs 35 to selectively channel audio from these sources to the radio. The command to select from one of these sources is received by the interface 20, processed thereby, and the corresponding source is channeled to the radio 10 by the interface 20. As will be discussed later in greater
5 detail, the interface 20 contains internal processing logic for selecting between these sources.

FIG. 2f is a block diagram of an alternate embodiment of the present invention, wherein a satellite receiver or DAB receiver and one or more auxiliary input sources are integrated by the interface 20 with an OEM or after-market car
10 radio 10. Similar to the embodiment of the present invention illustrated in FIG. 2e and described earlier, the interface 20 allows a user to select between the satellite/DAB receiver 25 and one or more of the auxiliary input sources 35 using the controls 14 of the radio 10. The interface 20 contains processing logic, described in greater detail below, for allowing switching between the satellite/DAB
15 receiver 25 and one or more of the auxiliary input sources 35.

FIG. 2g is a block diagram of an alternate embodiment of the present invention, wherein a MP3 player 30 and one or more auxiliary input sources 35 are integrated by the interface 20 with an OEM or after-market car radio 10. Similar to the embodiments of the present invention illustrated in FIGS. 2e and 2f and
20 described earlier, the interface 20 allows a user to select between the MP3 player 30 and one or more of the auxiliary input sources 35 using the controls 14 of the radio 10. The interface 20 contains processing logic, as will be discussed later in greater detail, for allowing switching between the MP3 player 30 and one or more of the auxiliary input sources 35.

FIG. 2h is a block diagram showing an alternate embodiment of the present invention, wherein a plurality of auxiliary interfaces **40** and **44** and an audio device **17** are integrated with an OEM or after-market car stereo **10**. Importantly, the present invention can be expanded to allow a plurality of auxiliary inputs to be
5 connected to the car stereo **10** in a tree-like fashion. Thus, as can be seen in **FIG. 2h**, a first auxiliary interface **40** is connected to the interface **20**, and allows data and audio from the ports **42** to be exchanged with the car radio **10**. Connected to one of the ports **42** is another auxiliary interface **44**, which, in turn, provides a plurality of input ports **46**. Any device connected to any of the ports **42** or **46** can
10 be integrated with the car radio **10**. Further, any device connected to the ports **42** or **46** can be inter-operable with the car radio **10**, allowing commands to be entered from the car radio **10** (e.g., such as via the control panel **14**) for commanding the device, and information from the device to be displayed by the car radio **10**. Conceivably, by configuring the interfaces **40**, **44**, and successive interfaces in a
15 tree configuration, any number of devices can be integrated using the present invention.

The various embodiments of the present invention described above and shown in **FIGS. 1** through **2h** are illustrative in nature and are not intended to limit the spirit or scope of the present invention. Indeed, any conceivable audio device
20 or input source, in any desired combination, can be integrated by the present invention into existing car stereo systems. Further, it is conceivable that not only can data and audio signals be exchanged between the car stereo and any external device, but also video information that can be captured by the present invention,

processed thereby, and transmitted to the car stereo for display thereby and interaction with a user thereat.

Various circuit configurations can be employed to carry out the present invention. Examples of such configurations are described below and shown in

5 **FIGS. 3a-3d.**

FIG. 3a is an illustrative circuit diagram according to the present invention for integrating a CD player or an auxiliary input source with an existing car stereo system. A plurality of ports **J1C1**, **J2A1**, **X2**, **RCH**, and **LCH** are provided for allowing connection of the interface system of the present invention between an
10 existing car radio, an after-market CD player or changer, or an auxiliary input source. Each of these ports could be embodied by any suitable electrical connector known in the art. Port **J1C1** connects to the input port of an OEM car radio, such as that manufactured by TOYOTA, Inc. Conceivably, port **J1C1** could be modified to allow connection to the input port of an after-market car radio. Ports
15 **J2A1**, **X2**, **RCH**, and **LCH** connect to an after-market CD changer, such as that manufactured by PANASONIC, Inc., or to an auxiliary input source.

Microcontroller **U1** is in electrical communication with each of the ports **J1C1**, **J2A1**, and **X2**, and provides functionality for integrating the CD player or auxiliary input source connected to the ports **J2A1**, **X2**, **RCH**, and **LCH**. For
20 example, microcontroller **U1** receives control commands, such as button or key sequences, initiated by a user at control panel of the car radio and received at the connector **J1C1**, processes and formats same, and dispatches the formatted commands to the CD player or auxiliary input source via connector **J2A1**. Additionally, the microcontroller **U1** receives information provided by the CD

player or auxiliary input source via connector **J2A1**, processes and formats same, and transmits the formatted data to the car stereo via connector **J1C1** for display on the display of the car stereo. Audio signals provided at the ports **J2A1**, **X2**, **RCH** and **LCH** is selectively channeled to the car radio at port **J1C1** under control
5 of one or more user commands and processing logic, as will be discussed in greater detail, embedded within microcontroller **U1**.

In a preferred embodiment of the present invention, the microcontroller **U1** comprises the 16F628 microcontroller manufactured by MICROCHIP, Inc. The 16F628 chip is a CMOS, flash-based, 8-bit microcontroller having an internal, 4
10 MHz internal oscillator, 128 bytes of EEPROM data memory, a capture/compare/PWM, a USART, 2 comparators, and a programmable voltage reference. Of course, any suitable microcontroller known in the art can be substituted for microcontroller **U1** without departing from the spirit or scope of the present invention.

15 A plurality of discrete components, such as resistors **R1** through **R13**, diodes **D1** through **D4**, capacitors **C1** and **C2**, and oscillator **Y1**, among other components, are provided for interfacing the microcontroller **U1** with the hardware connected to the connectors **J1C1**, **J2A1**, **X2**, **RCH**, and **LCH**. These components, as will be readily appreciated to one of ordinary skill in the art, can be
20 arranged as desired to accommodate a variety of microcontrollers, and the numbers and types of discrete components can be varied to accommodate other similar controllers. Thus, the circuit shown in **FIG. 3a** and described herein is illustrative in nature, and modifications thereof are considered to be within the spirit and scope of the present invention.

FIG. 3b is a diagram showing an illustrative circuit configuration according to the present invention, wherein one or more after-market CD changers / players and an auxiliary input source are integrated with an existing car stereo, and wherein the user can select between the CD changer/player and the auxiliary input using the controls of the car stereo. A plurality of connectors are provided, illustratively indicated as ports **J4A**, **J4B**, **J3**, **J5L1**, **J5R1**, **J1**, and **J2**. Ports **J4A**, **J4B**, and **J3** allow the audio device interface system of the present invention to be connected to one or more existing car stereos, such as an OEM car stereo or an after-market car stereo. Each of these ports could be embodied by any suitable electrical connector known in the art. For example, ports **J4A** and **J4B** can be connected to an OEM car stereo manufactured by BMW, Inc. Port **J3** can be connected to a car stereo manufactured by LANDROVER, Inc. Of course, any number of car stereos, by any manufacturer, could be provided. Ports **J1** and **J2** allow connection to an after-market CD changer or player, such as that manufactured by ALPINE, Inc., and an auxiliary input source. Optionally, ports **J5L1** and **J5R1** allow integration of a standard analog (line-level) source. Of course, a single standalone CD player or auxiliary input source could be connected to either of ports **J1** or **J2**.

Microcontroller **DD1** is in electrical communication with each of the ports **J4A**, **J4B**, **J3**, **J5L1**, **J5R1**, **J1**, and **J2**, and provides functionality for integrating the CD player and auxiliary input source connected to the ports **J1** and **J2** with the car stereo connected to the ports **J4A** and **J4B** or **J3**. For example, microcontroller **DD1** receives control commands, such as button or key sequences, initiated by a user at control panel of the car radio and received at the connectors **J4A** and **J4B**

or **J3**, processes and formats same, and dispatches the formatted commands to the CD player and auxiliary input source via connectors **J1** or **J2**. Additionally, the microcontroller **DD1** receives information provided by the CD player and auxiliary input source via connectors **J1** or **J2**, processes and formats same, and transmits
5 the formatted data to the car stereo via connectors **J4A** and **J4B** or **J3** for display on the display of the car stereo. Further, the microcontroller **DD1** controls multiplexer **DA3** to allow selection between the CD player/changer and the auxiliary input. Audio signals provided at the ports **J1**, **J2**, **J5L1** and **J5R1** is selectively channeled to the car radio at ports **J4A** and **J4B** or **J3** under control of
10 one or more user commands and processing logic, as will be discussed in greater detail, embedded within microcontroller **DD1**.

In a preferred embodiment of the present invention, the microcontroller **DD1** comprises the 16F872 microcontroller manufactured by MICROCHIP, Inc. The 16F872 chip is a CMOS, flash-based, 8-bit microcontroller having 64 bytes of
15 EEPROM data memory, self-programming capability, an ICD, 5 channels of 10 bit Analog-to-Digital (A/D) converters, 2 timers, capture/compare/PWM functions, a USART, and a synchronous serial port configurable as either a 3-wire serial peripheral interface or a 2-wire inter-integrated circuit bus. Of course, any suitable microcontroller known in the art can be substituted for microcontroller **DD1**
20 without departing from the spirit or scope of the present invention. Additionally, in a preferred embodiment of the present invention, the multiplexer **DA3** comprises the CD4053 triple, two-channel analog multiplexer/demultiplexer manufactured by FAIRCHILD SEMICONDUCTOR, Inc. Any other suitable

multiplexer can be substituted for **DA3** without departing from the spirit or scope of the present invention.

A plurality of discrete components, such as resistors **R1** through **R18**, diodes **D1** through **D3**, capacitors **C1-C11**, and **G1-G3**, transistors **Q1-Q3**,
5 transformers **T1** and **T2**, amplifiers **LCH:A** and **LCH:B**, oscillator **XTAL1**, among other components, are provided for interfacing the microcontroller **DD1** and the multiplexer **DA3** with the hardware connected to the connectors **J4A**, **J4B**, **J3**, **J5L1**, **J5R1**, **J1**, and **J2**. These components, as will be readily appreciated to one of ordinary skill in the art, can be arranged as desired to accommodate a
10 variety of microcontrollers and multiplexers, and the numbers and types of discrete components can be varied to accommodate other similar controllers and multiplexers. Thus, the circuit shown in **FIG. 3b** and described herein is illustrative in nature, and modifications thereof are considered to be within the spirit and scope of the present invention.

15 **FIG. 3c** is a diagram showing an illustrative circuit configuration for integrating a plurality of auxiliary inputs using the controls of the car stereo. A plurality of connectors are provided, illustratively indicated as ports **J1**, **RCH1**, **LCH1**, **RCH2**, **LCH2**, **RCH3**, **LCH3**, **RCH4**, and **LCH4**. Port **J1** allows the multimedia device integration system of the present invention to be connected to
20 one or more existing car stereos. Each of these ports could be embodied by any suitable electrical connector known in the art. For example, port **J1** could be connected to an OEM car stereo manufactured by HONDA, Inc., or any other manufacturer. Ports **RCH1**, **LCH1**, **RCH2**, **LCH2**, **RCH3**, **LCH3**, **RCH4**, and **LCH4** allow connection with the left and right channels of four auxiliary input

sources. Of course, any number of auxiliary input sources and ports/connectors could be provided.

Microcontroller **U1** is in electrical communication with each of the ports **J1**, **RCH1**, **LCH1**, **RCH2**, **LCH2**, **RCH3**, **LCH3**, **RCH4**, and **LCH4**, and provides functionality for integrating one or more auxiliary input sources connected to the ports **RCH1**, **LCH1**, **RCH2**, **LCH2**, **RCH3**, **LCH3**, **RCH4**, and **LCH4** with the car stereo connected to the port **J1**. Further, the microcontroller **U1** controls multiplexers **DA3** and **DA4** to allow selection amongst any of the auxiliary inputs using the controls of the car stereo. Audio signals provided at the ports **RCH1**, **LCH1**, **RCH2**, **LCH2**, **RCH3**, **LCH3**, **RCH4**, and **LCH4** are selectively channeled to the car radio at port **J1** under control of one or more user commands and processing logic, as will be discussed in greater detail, embedded within microcontroller **U1**. In a preferred embodiment of the present invention, the microcontroller **U1** comprises the 16F872 microcontroller discussed earlier. Additionally, in a preferred embodiment of the present invention, the multiplexers **DA3** and **DA4** comprises the CD4053 triple, two-channel analog multiplexer/demultiplexer, discussed earlier. Any other suitable microcontroller and multiplexers can be substituted for **U1**, **DA3**, and **DA4** without departing from the spirit or scope of the present invention.

A plurality of discrete components, such as resistors **R1** through **R15**, diodes **D1** through **D3**, capacitors **C1-C5**, transistors **Q1-Q2**, amplifiers **DA1:A** and **DA1:B**, and oscillator **Y1**, among other components, are provided for interfacing the microcontroller **U1** and the multiplexers **DA3** and **DA4** with the hardware connected to the ports **J1**, **RCH1**, **LCH1**, **RCH2**, **LCH2**, **RCH3**,

LCH3, **RCH4**, and **LCH4**. These components, as will be readily appreciated to one of ordinary skill in the art, can be arranged as desired to accommodate a variety of microcontrollers and multiplexers, and the numbers and types of discrete components can be varied to accommodate other similar controllers and
5 multiplexers. Thus, the circuit shown in **FIG. 3c** and described herein is illustrative in nature, and modifications thereof are considered to be within the spirit and scope of the present invention.

FIG. 3d is an illustrative circuit diagram according to the present invention for integrating a satellite receiver with an existing OEM or after-market car stereo
10 system. Ports **J1** and **J2** are provided for allowing connection of the integration system of the present invention between an existing car radio and a satellite receiver. These ports could be embodied by any suitable electrical connector known in the art. Port **J2** connects to the input port of an existing car radio, such as that manufactured by KENWOOD, Inc. Port **1** connects to an after-market
15 satellite receiver, such as that manufactured by PIONEER, Inc.

Microcontroller **U1** is in electrical communication with each of the ports **J1** and **J2**, and provides functionality for integrating the satellite receiver connected to the port **J1** with the car stereo connected to the port **J2**. For example, microcontroller **U1** receives control commands, such as button or key sequences,
20 initiated by a user at control panel of the car radio and received at the connector **J2**, processes and formats same, and dispatches the formatted commands to the satellite receiver via connector **J2**. Additionally, the microcontroller **U1** receives information provided by the satellite receiver via connector **J1**, processes and formats same, and transmits the formatted data to the car stereo via connector **J2**

for display on the display of the car stereo. Audio signals provided at the port **J1** is selectively channeled to the car radio at port **J2** under control of one or more user commands and processing logic, as will be discussed in greater detail, embedded within microcontroller **U1**.

5 In a preferred embodiment of the present invention, the microcontroller **U1** comprises the 16F873 microcontroller manufactured by MICROCHIP, Inc. The 16F873 chip is a CMOS, flash-based, 8-bit microcontroller having 128 bytes of EEPROM data memory, self-programming capability, an ICD, 5 channels of 10 bit Analog-to-Digital (A/D) converters, 2 timers, 2 capture/compare/PWM functions,
10 a synchronous serial port that can be configured as either a 3-wire serial peripheral interface or a 2-wire inter-integrated circuit bus, and a USART. Of course, any suitable microcontroller known in the art can be substituted for microcontroller **U1** without departing from the spirit or scope of the present invention.

15 A plurality of discrete components, such as resistors **R1** through **R7**, capacitors **C1** and **C2**, and amplifier **A1**, among other components, are provided for interfacing the microcontroller **U1** with the hardware connected to the connectors **J1** and **J2**. These components, as will be readily appreciated to one of ordinary skill in the art, can be arranged as desired to accommodate a variety of
20 microcontrollers, and the numbers and types of discrete components can be varied to accommodate other similar controllers. Thus, the circuit shown in **FIG. 3d** and described herein is illustrative in nature, and modifications thereof are considered to be within the spirit and scope of the present invention.

FIGS. 4a through **6** are flowcharts showing processing logic according to the present invention. Such logic can be embodied as software and/or instructions stored in a read-only memory circuit (*e.g.*, and EEPROM circuit), or other similar device. In a preferred embodiment of the present invention, the processing logic
5 described herein is stored in one or more microcontrollers, such as the microcontrollers discussed earlier with reference to **FIGS. 3a-3d**. Of course, any other suitable means for storing the processing logic of the present invention can be employed.

FIG. 4a is a flowchart showing processing logic, indicated generally at
10 **100**, for integrating a CD player or changer with an existing OEM or after-market car stereo system. Beginning in step **100**, a determination is made as to whether the existing car stereo is powered on. If a negative determination is made, step **104** is invoked, wherein the present invention enters a standby mode and waits for the car stereo to be powered on. If a positive determination is made, step **106** is
15 invoked, wherein a second determination is made as to whether the car stereo is in a state responsive to signals external to the car stereo. If a negative determination is made, step **106** is re-invoked.

If a positive determination is made in step **106**, a CD handling process, indicated as block **108**, is invoked, allowing the CD player/changer to exchange
20 data and audio signals with any existing car stereo system. Beginning in step **110**, a signal is generated by the present invention indicating that a CD player/changer is present, and the signal is continuously transmitted to the car stereo. Importantly, this signal prevents the car stereo from shutting off, entering a sleep mode, or otherwise being unresponsive to signals and/or data from an external source. If the

car radio is an OEM car radio, the CD player presence signal need not be generated. Further, the signal need not be limited to a CD player device presence signal, but rather, could be any type of device presence signal (e.g., MP3 player device presence signal, satellite receiver presence signal, video device presence signal, cellular telephone presence signal, or any other type of device presence signal). Concurrently with step 110, or within a short period of time before or after the execution of step 110, steps 112 and 114 are invoked. In step 112, the audio channels of the CD player/changer are connected (channeled) to the car stereo system, allowing audio from the CD player/changer to be played through the car stereo. In step 114, data is retrieved by the present invention from the CD player/changer, including track and time information, formatted, and transmitted to the car stereo for display by the car stereo. Thus, information produced by the external CD player/changer can be quickly and conveniently viewed by a driver by merely viewing the display of the car stereo. After steps 110, 112, and 114 have been executed, control passes to step 116.

In steps 116, the present invention monitors the control panel buttons of the car stereo for CD operational commands. Examples of such commands include track forward, track reverse, play, stop, fast forward, rewind, track program, random track play, and other similar commands. In step 118, if a command is not detected, step 116 is re-invoked. Otherwise, if a command is received, step 118 invokes step 120, wherein the received command is converted into a format recognizable by the CD player/changer connected to the present invention. For example, in this step, a command issued from a GM car radio is converted into a format recognizable by a CD player/changer manufactured by ALPINE, Inc. Any

conceivable command from any type of car radio can be formatted for use by a CD player/changer of any type or manufacture. Once the command has been formatted, step 122 is invoked, wherein the formatted command is transmitted to the CD player/changer and executed. Step 110 is then re-invoked, so that
5 additional processing can occur.

FIG. 4b is a flowchart showing processing logic, indicated generally at 130, for integrating an MP3 player with an existing car stereo system. Examples of MP3 players that can be integrated by the present invention include, but are not limited to, the Apple iPod and other types of digital media devices. Beginning in
10 step 132, a determination is made as to whether the existing car stereo is powered on. If a negative determination is made, step 134 is invoked, wherein the present invention enters a standby mode and waits for the car stereo to be powered on. If a positive determination is made, step 136 is invoked, wherein a second determination is made as to whether the car stereo is in a state responsive to signals
15 external to the car stereo. If a negative determination is made, step 136 is re-invoked.

If a positive determination is made in step 136, an MP3 handling process, indicated as block 138, is invoked, allowing the MP3 player to exchange data and audio signals with any existing car stereo system. Beginning in step 140, a signal
20 is generated by the present invention indicating that an MP3 player is present, and the signal is continuously transmitted to the car stereo. Importantly, this signal prevents the car stereo from shutting off, entering a sleep mode, or otherwise being unresponsive to signals and/or data from an external source. In step 142, the audio channels of the MP3 player are connected (channeled) to the car stereo system,

allowing audio from the MP3 player to be played through the car stereo. In step 144, data is retrieved by the present invention from the MP3 player, including track, time, title, and song information, formatted, and transmitted to the car stereo for display by the car stereo. Thus, information produced by the MP3 player can
5 be quickly and conveniently viewed by a driver by merely viewing the display of the car stereo. After steps 140, 142, and 144 have been executed, control passes to step 146.

In steps 146, the present invention monitors the control panel buttons of the car stereo for MP3 operational commands. Examples of such commands include
10 track forward, track reverse, play, stop, fast forward, rewind, track program, random track play, and other similar commands. In step 148, if a command is not detected, step 146 is re-invoked. Otherwise, if a command is received, step 148 invokes step 150, wherein the received command is converted into a format recognizable by the MP3 player connected to the present invention. For example,
15 in this step, a command issued from a HONDA car radio is converted into a format recognizable by an MP3 player manufactured by PANASONIC, Inc. Any conceivable command from any type of car radio can be formatted for use by an MP3 player of any type or manufacture. Once the command has been formatted, step 152 is invoked, wherein the formatted command is transmitted to the MP3
20 player and executed. Step 140 is then re-invoked, so that additional processing can occur.

FIG. 4c is a flowchart showing processing logic, indicated generally at 160, for integrating a satellite receiver or a DAB receiver with an existing car stereo system. Beginning in step 162, a determination is made as to whether the

existing car stereo is powered on. If a negative determination is made, step 164 is invoked, wherein the present invention enters a standby mode and waits for the car stereo to be powered on. If a positive determination is made, step 166 is invoked, wherein a second determination is made as to whether the car stereo is in a state responsive to signals external to the car stereo. If a negative determination is made, step 166 is re-invoked.

If a positive determination is made in step 166, a satellite/DAB receiver handling process, indicated as block 168, is invoked, allowing the satellite/DAB receiver to exchange data and audio signals with any existing car stereo system.

Beginning in step 170, a signal is generated by the present invention indicating that a satellite or DAB receiver is present, and the signal is continuously transmitted to the car stereo. Importantly, this signal prevents the car stereo from shutting off, entering a sleep mode, or otherwise being unresponsive to signals and/or data from an external source. In step 172, the audio channels of the satellite/DAB receiver are connected (channeled) to the car stereo system, allowing audio from the satellite receiver or DAB receiver to be played through the car stereo. In step 174, data is retrieved by the present invention from the satellite/DAB receiver, including channel number, channel name, artist name, song time, and song title, formatted, and transmitted to the car stereo for display by the car stereo. The information could be presented in one or more menus, or via a graphical interface viewable and manipulable by the user at the car stereo. Thus, information produced by the receiver can be quickly and conveniently viewed by a driver by merely viewing the display of the car stereo. After steps 170, 172, and 174 have been executed, control passes to step 176.

In steps 176, the present invention monitors the control panel buttons of the car stereo for satellite/DAB receiver operational commands. Examples of such commands include station up, station down, station memory program, and other similar commands. In step 178, if a command is not detected, step 176 is re-
5 invoked. Otherwise, if a command is received, step 178 invokes step 180, wherein the received command is converted into a format recognizable by the satellite/DAB receiver connected to the present invention. For example, in this step, a command issued from a FORD car radio is converted into a format recognizable by a satellite receiver manufactured by PIONEER, Inc. Any conceivable command from any
10 type of car radio can be formatted for use by a satellite/DAB receiver of any type or manufacture. Once the command has been formatted, step 182 is invoked, wherein the formatted command is transmitted to the satellite/DAB receiver and executed. Step 170 is then re-invoked, so that additional processing can occur.

FIG. 4d is a flowchart showing processing logic, indicated generally at
15 **190**, for integrating a plurality of auxiliary input sources with a car radio. Beginning in step 192, a determination is made as to whether the existing car stereo is powered on. If a negative determination is made, step 194 is invoked, wherein the present invention enters a standby mode and waits for the car stereo to be powered on. If a positive determination is made, step 196 is invoked, wherein a
20 second determination is made as to whether the car stereo is in a state responsive to signals external to the car stereo. If a negative determination is made, step 196 is re-invoked.

If a positive determination is made in step 196, an auxiliary input handling process, indicated as block 198, is invoked, allowing one or more auxiliary inputs

to be connected (channeled) to the car stereo. Further, if a plurality of auxiliary inputs exist, the logic of block 198 allows a user to select a desired input from the plurality of inputs. Beginning in step 200, a signal is generated by the present invention indicating that an external device is present, and the signal is
5 continuously transmitted to the car stereo. Importantly, this signal prevents the car stereo from shutting off, entering a sleep mode, or otherwise being unresponsive to signals and/or data from an external source. Then, in step 202, the control panel buttons of the car stereo are monitored.

In a preferred embodiment of the present invention, each of the one or more
10 auxiliary input sources are selectable by selecting a CD disc number on the control panel of the car radio. Thus, in step 204, a determination is made as to whether the first disc number has been selected. If a positive determination is made, step 206 is invoked, wherein the first auxiliary input source is connected (channeled) to the car stereo. If a negative determination is made, step 208 is invoked, wherein a second
15 determination is made as to whether the second disc number has been selected. If a positive determination is made, step 210 is invoked, wherein the second auxiliary input source is connected (channeled) to the car stereo. If a negative determination is made, step 212 is invoked, wherein a third determination is made as to whether the third disc number has been selected. If a positive determination is made, step
20 214 is invoked, wherein the third auxiliary input source is connected (channeled) to the car stereo. If a negative determination is made, step 216 is invoked, wherein a fourth determination is made as to whether the fourth disc number has been selected. If a positive determination is made, step 218 is invoked, wherein the fourth auxiliary input source is connected (channeled) to the car stereo. If a

negative determination is made, step 200 is re-invoked, and the process disclosed for block 198 repeated. Further, if any of steps 206, 210, 214, or 218 are executed, then step 200 is re-invoked and block 198 repeated.

The process disclosed in block 198 allows a user to select from one of four
5 auxiliary input sources using the control buttons of the car stereo. Of course, the number of auxiliary input sources connectable with and selectable by the present invention can be expanded to any desired number. Thus, for example, 6 auxiliary input sources could be provided and switched using corresponding selection key(s) or keystroke(s) on the control panel of the radio. Moreover, any desired keystroke,
10 selection sequence, or button(s) on the control panel of the radio, or elsewhere, can be utilized to select from the auxiliary input sources without departing from the spirit or scope of the present invention.

FIG. 4e is a flowchart showing processing logic, indicated generally at 220, for integrating a CD player and one or more auxiliary input sources with a car
15 radio. Beginning in step 222, a determination is made as to whether the existing car stereo is powered on. If a negative determination is made, step 224 is invoked, wherein the present invention enters a standby mode and waits for the car stereo to be powered on. If a positive determination is made, step 226 is invoked, wherein a second determination is made as to whether the car stereo is in a state responsive to
20 signals external to the cars stereo. If a negative determination is made, step 226 is re-invoked.

If a positive determination is made in step 226, then step 228 is invoked, wherein a signal is generated by the present invention indicating that an external device is present, and the signal is continuously transmitted to the car stereo.

Importantly, this signal prevents the car stereo from shutting off, entering a sleep mode, or otherwise being unresponsive to signals and/or data from an external source. Then, in step 230, a determination is made as to whether a CD player is present (*i.e.*, whether an external CD player or changer is connected to the multimedia device integration system of the present invention). If a positive determination is made, steps 231 and 232 are invoked. In step 231, the logic of block 108 of FIG. 4a (the CD handling process), described earlier, is invoked, so that the CD player/changer can be integrated with the car stereo and utilized by a user. In step 232, a sensing mode is initiated, wherein the present invention monitors for a selection sequence (as will be discussed in greater detail) initiated by the user at the control panel of the car stereo for switching from the external CD player/changer to one or more auxiliary input sources. Step 234 is then invoked, wherein a determination is made as to whether such a sequence has been initiated. If a negative determination is made, step 234 re-invokes step 228, so that further processing can occur. Otherwise, if a positive determination is made (*i.e.*, the user desires to switch from the external CD player/changer to one of the auxiliary input sources), step 236 is invoked, wherein the audio channels of the CD player/changer are disconnected from the car stereo. Then, step 238 is invoked, wherein the logic of block 198 of FIG. 4d (the auxiliary input handling process), discussed earlier, is executed, allowing the user to select from one of the auxiliary input sources. In the event that a negative determination is made in step 230 (no external CD player/changer is connected to the present invention), then step 238 is invoked, and the system goes into auxiliary mode. The user can then select from one or more auxiliary input sources using the controls of the radio.

FIG. 4f is a flowchart showing processing logic, indicated generally at **240**, for integrating a satellite receiver or DAB receiver and one or more auxiliary input sources with a car radio. Beginning in step **242**, a determination is made as to whether the existing car stereo is powered on. If a negative determination is made, step **244** is invoked, wherein the present invention enters a standby mode and waits for the car stereo to be powered on. If a positive determination is made, step **246** is invoked, wherein a second determination is made as to whether the car stereo is in a state responsive to signals external to the car stereo. If a negative determination is made, step **246** is re-invoked.

If a positive determination is made in step **246**, then step **248** is invoked, wherein a signal is generated by the present invention indicating that an external device is present, and the signal is continuously transmitted to the car stereo. Importantly, this signal prevents the car stereo from shutting off, entering a sleep mode, or otherwise being unresponsive to signals and/or data from an external source. Then, in step **250**, a determination is made as to whether a satellite receiver or DAB receiver is present (*i.e.*, whether an external satellite receiver or DAB receiver is connected to the multimedia device integration system of the present invention). If a positive determination is made, steps **251** and **252** are invoked. In step **251**, the logic of block **168** of **FIG. 4c** (the satellite/DAB receiver handling process), described earlier, is invoked, so that the satellite receiver can be integrated with the car stereo and utilized by a user. In step **252**, a sensing mode is initiated, wherein the present invention monitors for a selection sequence (as will be discussed in greater detail) initiated by the user at the control panel of the car stereo for switching from the external satellite receiver to one or more auxiliary

input sources. Step 254 is then invoked, wherein a determination is made as to whether such a sequence has been initiated. If a negative determination is made, step 254 re-invokes step 258, so that further processing can occur. Otherwise, if a positive determination is made (*i.e.*, the user desires to switch from the external
5 satellite/DAB receiver to one of the auxiliary input sources), step 256 is invoked, wherein the audio channels of the satellite receiver are disconnected from the car stereo. Then, step 258 is invoked, wherein the logic of block 198 of FIG. 4d (the auxiliary input handling process), discussed earlier, is executed, allowing the user to select from one of the auxiliary input sources. In the event that a negative
10 determination is made in step 250 (no external satellite/DAB receiver is connected to the present invention), then step 258 is invoked, and the system goes into auxiliary mode. The user can then select from one or more auxiliary input sources using the controls of the radio.

FIG. 4g is a flowchart showing processing logic according to the present
15 invention for integrating an MP3 player and one or more auxiliary input sources with a car stereo. Beginning in step 262, a determination is made as to whether the existing car stereo is powered on. If a negative determination is made, step 264 is invoked, wherein the present invention enters a standby mode and waits for the car stereo to be powered on. If a positive determination is made, step 266 is invoked,
20 wherein a second determination is made as to whether the car stereo is in a state responsive to signals external to the car stereo. If a negative determination is made, step 266 is re-invoked.

If a positive determination is made in step 266, then step 268 is invoked, wherein a signal is generated by the present invention indicating that an external

device is present, and the signal is continuously transmitted to the car stereo. Importantly, this signal prevents the car stereo from shutting off, entering a sleep mode, or otherwise being unresponsive to signals and/or data from an external source. Then, in step 270, a determination is made as to whether an MP3 player is present (*i.e.*, whether an external MP3 player is connected to the multimedia device integration system of the present invention). If a positive determination is made, steps 271 and 272 are invoked. In step 271, the logic of block 138 of FIG. 4b (the MP3 handling process), described earlier, is invoked, so that the MP3 player can be integrated with the car stereo and utilized by a user. In step 272, a sensing mode is initiated, wherein the present invention monitors for a selection sequence (as will be discussed in greater detail) initiated by the user at the control panel of the car stereo for switching from the external MP3 player to one or more auxiliary input sources. Step 274 is then invoked, wherein a determination is made as to whether such a sequence has been initiated. If a negative determination is made, step 274 re-invokes step 278, so that further processing can occur. Otherwise, if a positive determination is made (*i.e.*, the user desires to switch from the external MP3 player to one of the auxiliary input sources), step 276 is invoked, wherein the audio channels of the MP3 player are disconnected from the car stereo. Then, step 278 is invoked, wherein the logic of block 198 of FIG. 4d (the auxiliary input handling process), discussed earlier, is executed, allowing the user to select from one of the auxiliary input sources. In the event that a negative determination is made in step 270 (no external MP3 player is connected to the present invention), then step 278 is invoked, and the system goes into auxiliary mode. The user can then select from one or more auxiliary input sources using the controls of the radio.

As mentioned previously, to enable integration, the present invention contains logic for converting command signals issued from an after-market or OEM car stereo into a format compatible with one or more external audio devices connected to the present invention. Such logic can be applied to convert any car stereo signal for use with any external device. For purposes of illustration, a sample code portion is shown in **Table 1**, below, for converting control signals from a BMW car stereo into a format understandable by a CD changer:

Table 1

```

10      ;      =====
      ;      Radio requests changer to STOP (exit PLAY mode)
      ;      Decoding 6805183801004C message
      ;      =====

15      Encode_RD_stop_msg:

      movlw 0x68
      xorwf BMW_Recv_buff,W
      skpz
      return

20      movlw 0x05
      xorwf BMW_Recv_buff+1,W
      skpz
      return

25      movlw 0x18
      xorwf BMW_Recv_buff+2,W
      skpz
      return

30      movlw 0x38
      xorwf BMW_Recv_buff+3,W
      skpz
      return

35      movlw 0x01
      xorwf BMW_Recv_buff+4,W
      skpz
      return

40      tstf  BMW_Recv_buff+5
      skpz
      return

45      movlw 0x4C
      xorwf BMW_Recv_buff+6,W

```

```

    skpz
    return

    bsf   BMW_Recv_STOP_msg
    return
    
```

The code portion shown in **Table 1** receives a STOP command issued by a BMW stereo, in a format proprietary to BMW stereos. Preferably, the received command is stored in a first buffer, such as BMW_Recv_buff. The procedure “Encode_RD_stop_msg” repetitively applies an XOR function to the STOP command, resulting in a new command that is in a format compatible with the after-market CD player. The command is then stored in an output buffer for dispatching to the CD player.

Additionally, the present invention contains logic for retrieving information from an after-market audio device, and converting same into a format compatible with the car stereo for display thereby. Such logic can be applied to convert any data from the external device for display on the car stereo. For purposes of illustration, a sample code portion is shown in **Table 2**, below, for converting data from a CD changer into a format understandable by a BMW car stereo:

Table 2

```

; =====
; Changer replies with STOP confirmation
; Encoding 180A68390002003F0001027D message
; =====

Load_CD_stop_msg:
    movlw 0x18
    movwf BMW_Send_buff

    movlw 0x0A
    movwf BMW_Send_buff+1

    movlw 0x68
    movwf BMW_Send_buff+2

    movlw 0x39
    
```

```

movwf BMW_Send_buff+3
5  off      movlw 0x00          ;current status_XX=00, power
      movwf BMW_Send_buff+4
      off      movlw 0x02          ;current status_YY=02, power
10      movwf BMW_Send_buff+5
      clrfs BMW_Send_buff+6      ;separate field, always =0
      movfw BMW_MM_stat         ;current status_MM , magazine
15  config  movwf BMW_Send_buff+7
      clrfs BMW_Send_buff+8      ;separate field, always =0
20  disc    movfw BMW_DD_stat     ;current status_DD , current
      movwf BMW_Send_buff+9
      movfw BMW_TT_stat         ;current status_TT , current
25  track   movwf BMW_Send_buff+10
      xorwf BMW_Send_buff+9,W    ;calculate check sum
      xorwf BMW_Send_buff+8,W
      xorwf BMW_Send_buff+7,W
30      xorwf BMW_Send_buff+6,W
      xorwf BMW_Send_buff+5,W
      xorwf BMW_Send_buff+4,W
      xorwf BMW_Send_buff+3,W
      xorwf BMW_Send_buff+2,W
35      xorwf BMW_Send_buff+1,W
      xorwf BMW_Send_buff,W
      movwf BMW_Send_buff+11    ;store check sum
      movlw D'12'              ;12 bytes total
40      movwf BMW_Send_cnt
      bsf   BMW_Send_on        ;ready to send
      return

```

The code portion shown in **Table 2** receives a STOP confirmation message
45 from the CD player, in a format proprietary to the CD player. Preferably, the
received command is stored in a first buffer, such as BMW_Send_buff. The
procedure "Load_CD_stop_msg" retrieves status information, magazine
information, current disc, and current track information from the CD changer, and
constructs a response containing this information. Then, a checksum is calculated

and stored in another buffer. The response and checksum are in a format compatible with the BMW stereo, and are ready for dispatching to the car stereo.

The present invention also includes logic for converting signals from an OEM car stereo system for use with a digital media device such as an MP3, MP4,
5 or Apple iPod player. Shown below are code samples for allowing commands and data to be exchanged between a Ford car stereo and an Apple iPod device:

Table 3

```

//decoding Ford "play" command :41-C0-80-CA-01+
10     if ( ACP_rx_ready == ON ) {
        ACP_rx_ready = OFF;
        ACP_rx_taddr = ACP_rx_buff[1];
        ACP_rx_saddr = ACP_rx_buff[2];
        ACP_rx_data1 = ACP_rx_buff[3];
15     ACP_rx_data2 = ACP_rx_buff[4];
        ACP_rx_data3 = ACP_rx_buff[5];
        if ( (ACP_rx_saddr == 0x80) ) {
            switch ( ACP_rx_taddr ) {
                case 0xC0:
20                 if ( ACP_rx_data1 == 0xCA)
                    {
                        if ( ACP_rx_data2
25 == 0x01 ) {
                            flags.ACP_play_req = 1;
                                }
                                break;
                                    }
                                    break;
50
30     }
        }
    }

```

In the code portion shown in **Table 3**, a "Play" command selected by a user
35 at the controls of a Ford OEM car stereo is received, and portions of the command are stored in one or more buffer arrays. Then, as shown below in **Table 4**, the decoded portions of the command stored in the one or more buffer arrays are used to construct a "Play/Pause" command in a format compatible with the Apple iPod device, and the command is sent to the Apple iPod for execution thereby:

Table 4

```

// encoding iPod "play/pause" command 0xFF 0x55 0x03 0x02 0x00
0x01 0xFA
5      if ( iPod_play_req == ON ) {
          iPod_play_req = OFF;
          iPod_tx_data[0] = 0x55;
          iPod_tx_data[1] = 0x03;
          iPod_tx_data[2] = 0x02;
10     iPod_tx_data[3] = 0x00;
          iPod_tx_data[4] = 0x01;
          iPod_tx_counter = 5;
          iPod_tx_ready = ON;
15     }

```

While the code portions shown in **Tables 1-2** are implemented using assembler language, and the code portions shown in **Tables 3-4** are implemented using the C programming language, it is to be expressly understood that any low or high level language known in the art could be utilized without departing from the spirit or scope of the invention. It will be appreciated that various other code portions can be developed for converting signals from any after-market or OEM car stereo for use by an after-market external audio device, and vice versa.

FIG. 5 is a flowchart showing processing logic, indicated generally at **300** for allowing a user to switch between an after-market audio device, and one or more auxiliary input sources. As was discussed earlier, the present invention allows a user to switch from one or more connected audio devices, such as an external CD player/changer, MP3 player, satellite receiver, DAB receiver, or the like, and activate one or more auxiliary input sources. A selection sequence, initiated by the user at the control panel of the car stereo, allows such switching. Beginning in step **302**, the buttons of the control panel are monitored. In step **304**, a determination is made as to whether a "Track Up" button or sequence has been

initiated by the user. The “Track Up” button or sequence can for a CD player, MP3 player, or any other device. If a negative determination is made, step 306 is invoked, wherein the sensed button or sequence is processed in accordance with the present invention and dispatched to the external audio device for execution.

5 Then, step 302 is re-invoked, so that additional buttons or sequences can be monitored.

In the event that a positive determination is made in step 304, step 308 is invoked, wherein the present invention waits for a predetermined period of time while monitoring the control panel buttons for additional buttons or sequences. In

10 a preferred embodiment of the present invention, the predetermined period of time is 750 milliseconds, but of course, other time durations are considered within the spirit and scope of the present invention. In step 310, a determination is made as to whether the user has initiated a “Track Down” button or sequence at the control panel of the car stereo within the predetermined time period. These sequences can

15 be used for a CD player, MP3 player, or any other device. If a negative determination is made, step 312 is invoked. In step 312, a determination is made as to whether a timeout has occurred (*e.g.*, whether the predetermined period of time has expired). If a negative determination is made, step 308 is re-invoked. Otherwise, if a positive determination is made, step 312 invokes step 306, so that

20 any buttons or key sequences initiated by the user that are not a “Track Down” command are processed in accordance with the present invention and dispatched to the audio device for execution.

In the event that a positive determination is made in step 310 (a “Track Down” button or sequence has been initiated within the predetermined time

period), then step 314 is invoked. In step 314, the audio channels of the audio device are disconnected, and then step 316 is invoked. In step 316, the logic of block 198 of FIG. 4d (the auxiliary input handling process), discussed earlier, is invoked, so that the user can select from one of the auxiliary input sources in accordance with the present invention. Thus, at this point in time, the system has switched, under user control, from the audio device to a desired auxiliary input. Although the foregoing description of the process 300 has been described with reference to “Track Up” and “Track Down” buttons or commands initiated by the user, it is to be expressly understood that any desired key sequence, keystroke, button depress, or any other action, can be sensed in accordance with the present invention and utilized for switching modes.

When operating in auxiliary mode, the present invention provides an indication on the display of the car stereo corresponding to such mode. For example, the CD number could be displayed as “1”, and the track number displayed as “99,” thus indicating to the user that the system is operating in auxiliary mode and that audio and data is being supplied from an auxiliary input source. Of course, any other indication could be generated and displayed on the display of the car stereo, such as a graphical display (*e.g.*, an icon) or textual prompt.

FIG. 6 is a flowchart showing processing logic, indicated generally at 320, for determining and handling various device types connected to the auxiliary input ports of the invention. The present invention can sense device types connected to the auxiliary input ports, and can integrate same with the car stereo using the procedures discussed earlier. Beginning in step 322, the control panel buttons of

the car stereo are monitored for a button or sequence initiated by the user corresponding to an auxiliary input selection (such as the disc number method discussed earlier with reference to **FIG. 4d**). In response to an auxiliary input selection, step **324** is invoked, wherein the type of device connected to the selected
5 auxiliary input is sensed by the present invention. Then, step **326** is invoked.

In step **326**, a determination is made as to whether the device connected to the auxiliary input is a CD player/changer. If a positive determination is made, step **328** is invoked, wherein the logic of block **108** of **FIG. 4a** (the CD handling process), discussed earlier, is executed, and the CD player is integrated with the
10 stereo. If a negative determination is made in step **326**, then step **330** is invoked. In step **330**, a determination is made as to whether the device connected to the auxiliary input is an MP3 player. If a positive determination is made, step **334** is invoked, wherein the logic of block **138** of **FIG. 4b** (the MP3 handling process), discussed earlier, is executed, and the MP3 player is integrated with the car stereo.
15 If a negative determination is made in step **330**, then step **336** is invoked. In step **336**, a determination is made as to whether the device connected to the auxiliary input is a satellite receiver or a DAB receiver. If a positive determination is made, step **338** is invoked, wherein the logic of block **168** of **FIG. 4c** (the satellite/DAB receiver handling process), discussed earlier, is executed, and the satellite receiver
20 is integrated with the car stereo. If a negative determination is made in step **336**, step **322** is re-invoked, so that additional auxiliary input selections can be monitored and processed accordingly. Of course, process **320** can be expanded to allow other types of devices connected to the auxiliary inputs of the present invention to be integrated with the car stereo.

The present invention can be expanded for allowing video information generated by an external device to be integrated with the display of an existing OEM or after-market car stereo. In such a mode, the invention accepts RGB (red/green/blue) input signals from the external device, and converts same to composite signals. The composite signals are then forwarded to the car stereo for display thereby, such as on an LCD panel of the stereo. Additionally, the present invention can accept composite input signals from an external device, and convert same to RGB signals for display on the car stereo. Further, information from the external device can be formatted and presented to the user in one or more graphical user interfaces or menus capable of being viewed and manipulated on the car stereo.

FIG. 7a is a perspective view of a docking station **400** according to the present invention for retaining an audio device within a car. Importantly, the present invention can be adapted to allow portable audio devices to be integrated with an existing car stereo. The docking station **400** allows such portable devices to be conveniently docked and integrated with the car stereo. The docking station **400** includes a top portion **402** hingedly connected at a rear portion **408** to a bottom portion **404**, preferably in a clam-like configuration. A portable audio device **410**, such as the SKYFI radio distributed by DELPHI, Inc., is physically and electrically connected with the docking portion **412**, and contained within the station **100**. A clasp **406** can be provided for holding the top and bottom portions in a closed position to retain the device **410**. Optionally, a video device could also be docked using the docking station **400**, and tabs **413** can be provided for holding the docking station **400** in place against a portion of a car. Conceivably, the docking

station 400 could take any form, such as a sleeve-like device for receiving and retaining a portable audio device and having a docking portion for electrically and mechanically mating with the audio device.

FIG. 7b is an end view showing the rear portion 408 of the docking station 400 of **FIG. 7a**. A hinge 414 connects the top portion and the bottom portions of the docking station 400. A data port 416 is provided for interfacing with the audio device docked within the station 400, and is in electrical communication therewith. In a preferred embodiment of the present invention, the data port 416 is an RS-232 serial or USB data port that allows for the transmission of data with the audio device, and which connects with the multimedia device integration system of the present invention for integrating the audio device with an OEM or after-market car stereo. Any known bus technology can be utilized to interface with any portable audio or video device contained within the docking station 400, such as FIREWIRE, D2B, MOST, CAN, USB/USB2, IE Bus, T Bus, I Bus, or any other bus technology known in the art. It should be noted that the present invention can be operated without a docking station, *i.e.*, a portable audio or video device can be plugged directly into the present invention for integration with a car stereo or video system.

FIGS. 8a-8b are perspective views of another embodiment of the docking station of the present invention, indicated generally at 500, which includes the multimedia device integration system of the present invention, indicated generally at 540, incorporated therewith. As shown in **FIG. 8a**, the docking station 500 includes a base portion 530, a bottom member 515 interconnected with the base portion 530 at an edge thereof, and a top member 510 hingedly interconnected at

an edge to the base portion 530. The top member 510 and the bottom member 515 define a cavity for docking and storing a portable audio device 520, which could be a portable CD player, MP3 player, satellite (*e.g.*, XM, SIRIUS, or other type) tuner, or any other portable audio device. The docking station 500 would be
5 configured to accommodate a specific device, such as an IPOD from Apple Computer, Inc., or any other portable device.

The multimedia device integration system 540, in the form of a circuit board, is housed within the base portion 530 and performs the integration functions discussed herein for integrating the portable device 520 with an existing car stereo
10 or car video system. The integration system 540 is in communication with the portable device 520 via a connector 550, which is connected to a port on the device 520, and a cable 555 interconnected between the connector 550 and the integration system 540. The connector 550 could be any suitable connector and can vary according to the device type. For example, a MOLEX, USB, or any other
15 connector could be used, depending on the portable device. The integration system 540 is electrically connected with a car stereo or car video system by cable 560. Alternatively, the integration system could wirelessly communicate with the car stereo or car video system. A transmitter could be used at the integration system to communicate with a receiver at the car stereo or car video system. Where
20 automobiles include Bluetooth systems, such systems can be used to communicate with the integration system. As can be readily appreciated, the docking station 500 provides a convenient device for docking, storing, and integrating a portable device for use with a car stereo. Further, the docking station 500 could be positioned at

any desired location within a vehicle, including, but not limited to, the vehicle trunk.

As shown in **FIG. 8b**, the top member **510** can be opened in the general direction indicated by arrow **A** to allow for access to the portable audio device **520**.

5 In this fashion, the device **520** can be quickly accessed for any desired purpose, such as for inserting and removing the device **520** from the docking station **500**, as well as for providing access to the controls of the device **520**.

FIG. 9 is a block diagram showing the components of the docking station of **FIGS. 8a-8b**. The docking station **500** houses both a portable audio or video
10 device **520** and a multimedia device integration system (or interface) **540**. The shape and configuration of the docking station **500** can be varied as desired without departing from the spirit or scope of the present invention.

The integration system of the present invention provides for control of a portable audio or video device, or other device, through the controls of the car
15 stereo or video system system. As such, controls on the steering wheel, where present, may also be used to control the portable audio device or other device. Further, in all embodiments of the present invention, communication between the after-market device and a car stereo or video system can be accomplished using known wireless technologies, such as Bluetooth.

20 **FIG. 10** is a block diagram showing an alternate embodiment of the multimedia device integration system of the present invention, indicated generally at **600**, wherein the interface **630** is incorporated within a car stereo or car video system **610**. The interface **630** is in electrical communication with the control panel buttons **620**, display **615**, and associated control circuitry **625** of the car

stereo or video system 610. The interface 630 could be manufactured on a separate printed circuit board positioned within the stereo or video system 610, or on one or more existing circuit boards of the stereo or video system 610. An after-market device 635 can be put into electrical communication with the interface 630 via a
5 port or connection on the car stereo or video system 610, and integrated for use with the car stereo or video system 610.

The device 635 can be controlled using the control panel buttons 620 of the car stereo or video system 610, and information from the device 635 is formatted by the interface 630 and displayed in the display 615 of the car stereo or video
10 system 610. Additionally, control commands generated at the car stereo or car video device 610 are converted by the interface 630 into a format (protocol) compatible with the multimedia device 635, and are dispatched thereto for execution. A plurality of multimedia devices could be intergrated using the interface 630, as well as one or more auxiliary input sources 640. The after-market
15 device 635 could comprise any audio, video, or telecommunications device, including, but not limited to, a CD player, CD changer, digital media player (*e.g.*, MP3 player, MP4 player, WMV player, Apple iPod, or any other player), satellite radio (*e.g.*, XM, Sirius, Delphi, etc.), video device (*e.g.*, DVD player), cellular telephone, or any other type of device or combinations thereof. Additionally, one
20 or more interfaces could be connected to the interface 630 (“daisy-chained”) to allow multiple products to be integrated. The device 600 could include one or more of the circuits disclosed in FIGS. 3a-3d and modified depending upon the type of the after-market device 635.

FIG. 11a is a diagram showing an alternate embodiment of the present invention, indicated generally at **645**, wherein a cellular telephone **670** is intergrated for use with a car stereo. The telephone **670** is in electrical communication with the interface **665**, which receives data from the cellular telephone and formats same for displaying on the display **650** of the car stereo or video system **660**. Commands for controlling the telephone **670** can be entered using the control panel buttons **655** of the car stereo or video system **660**. The commands are processed by the interface **665**, converted into a format (protocol) compatible with the telephone **670**, and transmitted to the telephone **670** for processing thereby. Additionally, audio from the telephone **670** can be channeled to the car stereo or video system **660** via the interface **665** and played through the speakers of the car stereo or video system **660**. For example, if the telephone **670** is provided with the ability to download songs or music, such songs or music can be selected using the car stereo or video system **660** and played therethrough using the interface **665**. It should be noted that control of the cellular telephone could be provided using one or more displays (*e.g.*, LCD) of a car video system. Moreover, control of the cellular telephone **670** is not limited to the use of buttons on the car stereo or video ststem **660**, and indeed, a software or graphically-driven menu or interface can be used to control the cellular telephone. The device **645** could include one or more of the circuits disclosed in **FIGS. 3a-3d** and modified for use with the cellular telephone **670**.

FIG. 11b is a flowchart showing processing logic, indicated generally at **647**, for integrating a cellular telephone with a car radio. Beginning in step **649**, a determination is made as to whether the existing car stereo is powered on. If a

negative determination is made, step 651 is invoked, wherein the present invention enters a standby mode and waits for the car stereo to be powered on. If a positive determination is made, step 653 is invoked, wherein a second determination is made as to whether the car stereo is in a state responsive to signals external to the car stereo. If a negative determination is made, step 649 is re-invoked.

If a positive determination is made in step 653, a cellular telephone handling process, indicated as block 661, is invoked. Beginning in step 654, a signal is generated by the present invention indicating that a cellular telephone is present, and the signal is continuously transmitted to the car stereo. Importantly, this signal prevents the car stereo from shutting off, entering a sleep mode, or otherwise being unresponsive to signals and/or data from an external source. In step 657, the audio channels of the cellular telephone are connected (channeled) to the car stereo system, allowing audio from the cellular telephone to be played through the car stereo. In step 659, data is retrieved by the present invention from the cellular telephone, such as song information corresponding to one or more songs downloaded onto the cellular telephone. After steps 654, 657, and 659 have been executed, control passes to step 663.

In steps 663, the present invention monitors the control panel buttons of the car stereo for cellular telephone operational commands. In step 664, if a command is not detected, step 663 is re-invoked. Otherwise, if a command is received, step 663 invokes step 667, wherein the received command is converted into a format recognizable by the cellular telephone connected to the present invention. Once the command has been formatted, step 669 is invoked, wherein the formatted

command is transmitted to the cellular telephone and executed. Step 654 is then re-invoked, so that additional processing can occur.

FIG. 12a is a diagram showing an alternate embodiment of the present invention, indicated generally at 675, wherein an after-market video device 695 is integrated for use with a car video system 685. The after-market video device 695 could comprise a portable DVD player, digital video (DV) camera, digital camera, or any other video device. The interface 690 receives output video signals from the device 695, and converts same for display on one or more displays 680 (e.g., LCD seat-back displays in a minivan, fold-down displays mounted on the roof of a vehicle, vehicle navigation displays, etc.) of the car video system 685. The interface 690 could convert between composite and red/green/blue (RGB) video signals, and vice versa, using commercially-available video format conversion chips such as the TDA8315, TDA4570, TDA3567, TDA3566A, and TDA3569A video conversion chips manufactured by Philips Corp., and the AL251 and AL250 video conversion chips manufactured by Averlogic Technologies, Inc., or any other suitable video conversion chips. Commands issued by a user using the car video system 685 or display(s) 680 for controlling the device 695 are received by the interface 690, converted into a format compatible with the device 695, and transmitted thereto for processing. The device 675 could include one or more of the circuits disclosed in FIGS. 3a-3d and modified for use with the video device 695.

FIG. 12b is a flowchart showing processing logic, indicated generally at 671, for integrating an after-market video device with a car video system. Beginning in step 673, a determination is made as to whether the existing car video

system is powered on. If a negative determination is made, step 674 is invoked, wherein the present invention enters a standby mode and waits for the car video system to be powered on. If a positive determination is made, step 677 is invoked, wherein a second determination is made as to whether the car video system is in a
5 state responsive to signals external to the car video system. If a negative determination is made, step 673 is re-invoked.

If a positive determination is made in step 677, an after-market video device handling process, indicated as block 687, is invoked. Beginning in step 679, a signal is generated by the present invention indicating that an external
10 device is present, and the signal is continuously transmitted to the car video system. Importantly, this signal prevents the car video system from shutting off, entering a sleep mode, or otherwise being unresponsive to signals and/or data from an external source. In step 681, the audio and video channels of the after-market device are connected (channeled) to the car video system, allowing audio and
15 video from the after-market device to be played through the car video system. In step 684, the display(s) of the car video system are updated with data from the after-market device. After steps 679, 681, and 684 have been executed, control passes to step 683.

In step 683, the present invention monitors the car video system for after-
20 market video device operational commands. In step 689, if a command is not detected, step 683 is re-invoked. Otherwise, if a command is received, step 689 invokes step 691, wherein the received command is converted into a format recognizable by the after-market video device connected to the present invention. Once the command has been formatted, step 693 is invoked, wherein the formatted

command is transmitted to the after-market video device and executed. Step 679 is then re-invoked, so that additional processing can occur.

FIG. 13a is a block diagram showing an alternate embodiment of the multimedia device integration system 710 of the present invention, wherein
5 configuration jumpers 720 and protocol conversion software blocks 724 are provided for integrating after-market devices of various types using a single interface. The jumpers 720 can be set to a plurality of different settings, each of which corresponds to an after-market device of a specific type (*e.g.*, CD changer, CD player, digital media player, satellite radio, video device, cellular telephone,
10 *etc.*) or from a specific manufacturer. Additionally, the jumpers 720 can be used to specify one or more device or manufacturer types for the car stereo or video system 705. The settings of the configuration jumpers 720 correspond to one or more protocol conversion software blocks 724 stored in memory (*e.g.*, programmable flash memory, ROM, EEPROM, *etc.*) 725 of the interface 710.
15 Each of the software blocks 724 controls the interface circuitry 715 and contains instructions for converting data from the device 707 into a format compatible with the car stereo or video system 705, and vice versa. For example, a first block could contain software for allowing communication between an Apple iPod and an in-dash car stereo manufactured by Sony, and a second block could contain software
20 for allowing communication between a DVD player and a car video system. Any desired number of blocks could be stored in the memory 725 and can be selected as desired by the user via configuration jumpers 720. As such, a single interface 710 can be used for integrating numerous devices of various types and manufactures for use with one or more car stereo or video systems. The device 710 could

include one or more of the circuits shown in **FIGS. 3a-3d**, with modifications depending upon the device types of the devices **705** and **707**.

FIG. 13b is a block diagram showing an alternate embodiment of the multimedia device integration system of the present invention, wherein wiring
5 harnesses **727** and **728** and protocol conversion software blocks **729** are provided for integrating multimedia devices of various types using a single interface **726**. In this embodiment, the electrical configurations (pinouts) of each of the harnesses **727** and **728** correspond to car stereo / video systems and after-market devices of specific types and made by specific manufacturers (*e.g.*, harness **727** could
10 correspond to a BMW car stereo, and harness **728** could correspond to an ALPINE satellite tuner). The electrical configurations (pinouts) of the harnesses are utilized by the interface **726** to retrieve a specific protocol conversion software block **729** that allows communication between the devices. The interface **726** could be provided with a plurality of protocol conversion software blocks pre-loaded into
15 memory in the interface, and could be provided with any desired harnesses. The interface **726** could include one or more of the circuits shown in **FIGS. 3a-3d**, with modification depending upon the device types of the devices attached to the wiring harnesses **727** and **728**.

FIG. 14 is a flowchart showing processing logic, indicated generally at
20 **730**, of the multimedia device integration system of the present invention for integrating after-market devices of various types using a single interface. In step **735**, the interface determines types of devices that are connected thereto, including the car stereo or video system and one or more after-market devices to be integrated therewith. This could be achieved by the configuration jumper settings

or the harness types connected to the interface and discussed with respect to **FIGS. 13a and 13b**. Then, in step **740**, a protocol conversion software block is selected from blocks of conversion software (e.g., from the blocks **725** and **729** shown in **FIGS. 13a and 13b**). In step **745**, instructions are converted using the selected
5 conversion block to allow the car stereo or video system to operate with the multimedia device.

FIG. 15 is a flowchart showing processing logic, indicated generally at **750**, of the multimedia device integration system of the present invention for allowing a user to specify one or more after-market device types for integration
10 using a single interface. In step **770**, a user is provided with one or more lists of devices to be integrated, which are displayed on the display **760** of the car stereo or video device **755**. Then, in step **775**, using the buttons **765** of the car video device, the user can specify the type of multimedia device to be integrated (e.g., by scrolling through the lists). Additionally, the device type could be specified using
15 a graphical or software menu displayed on the car stereo or car video system. In step **780**, a determination is made as to whether a timeout has occurred (e.g., the user has not selected a device type within a predetermined period of time). If a positive determination is made, step **785** occurs, wherein a protocol conversion software block is selected from memory corresponding to the last device type
20 displayed by the car stereo or video system. If a negative determination is made, step **790** is invoked, wherein a determination is made as to whether the user has specified a device type. If a negative determination is made, step **775** is re-invoked so that the user can specify a device type. If a positive determination is made, step **795** is invoked, wherein a protocol conversion software block is selected from

memory corresponding to the device specified by the user. In step 800, the protocol conversion software block is mapped to a logical address in memory. Then, in step 805, instructions to be exchanged between the car stereo or video system and the after-market device are converted using the software block to allow
5 communication between the devices using compatible formats. Accordingly, the logic of FIG. 15 allows a single interface having multiple protocol conversion software blocks to be used integrate a plurality of after-market devices with a car stereo or video system.

FIG. 16 is a flowchart showing processing logic of the multimedia device integration system of the present invention, indicated generally at 810, for allowing
10 a user to quickly navigate through a list of songs on one or more after-market devices using the controls of a car stereo or video system (fast navigation technique). This method allows a user to quickly select a song from a list of songs available on an after-market device for playing on the car stereo or video system,
15 and could be applied for use with any type of after-market device, including, but not limited to, a digital media player such as an MP3 player or Apple iPod player. Beginning in step 812, a user is provided with a list of alphanumeric characters on a display of the car stereo or video system. This list could include the letters A through Z, as well as the numbers 0 through 9. In step 814, the user can specify a
20 desired alphanumeric character, which can be specified by scrolling through the list using one or more controls of the car stereo or video system and pressing a button once the desired character has been highlighted, or optionally, if an alphanumeric keypad (or touchscreen interface) is provided on the car stereo or video system, the user can directly enter the desired alphanumeric character.

When the desired alphanumeric character has been specified, in step **816** a remote database is queried using the alphanumeric character. The remote database could comprise a list of songs stored in one or more after-market devices integrated
5 by the present invention for use with the car stereo or video system. In step **818**, a list of potentially matching songs is retrieved from the database and presented on the display of the car stereo or video system for perusal by the user. For example, if the user specified the letter "A," the list could include all songs in the remote database having titles (or artists) beginning with the letter "A." In step **820**, a
10 determination is made as to whether a desired song appears in the list and is immediately viewable by the user, without requiring the user to scroll through the list. If a positive determination is made, step **822** is invoked, wherein the desired song is selected by the user and retrieved from the after-market device for playing on the car stereo or video system.

15 In the event that a negative determination is made in step **820**, step **824** is invoked, wherein the user can specify an additional alphanumeric character using the car stereo or video system. For example, if the user initially specified the letter "A" and the desired song is not visible in the list of songs without scrolling, the user can refine the query by adding an additional alphanumeric character. Thus,
20 for example, the user can specify the letters "AN" to search for songs having titles (or artists) beginning with the letters "AN." In step **826**, the remote database of the after-market device is queried using the specified letters. In step **828**, a list of potential matches is presented to the user at the car stereo or video system. In step **830**, a determination is made as to whether the desired song appears in the list and

is immediately viewable without requiring the user to scroll through the list. If a positive determination is made, step 822 is invoked, wherein the user can select the desired song for retrieval from the after-market device and playing on the car stereo or video system. If a negative determination is made, step 832 is invoked, wherein a determination is made as to whether a threshold number of alphanumeric characters has been specified by the user. For example, a maximum threshold of 3 alphanumeric characters could be specified, or any other desired number. If a negative determination is made, steps 824-832 are re-invoked in the manner disclosed herein to allow the user to specify additional alphanumeric characters for querying the remote database. If a positive determination is made (threshold met), then processing terminates and the user must scroll through the list of retrieved songs or repeat the processing disclosed in FIG. 16 to begin a new query.

FIG. 17 is a diagram showing another embodiment of the present invention, indicated generally at 850, wherein a plurality of external devices are integrated using a single interface 852. Any desired number or combination of devices can be integrated for use with a car stereo or video system using the interface 852. The interface 852 houses a plurality of ports 858 for connecting any desired number of external devices, and a port 856 for connection with a car stereo or video system. The ports 858 and 856 could be any suitable type of input port, and could vary depending upon the types of devices to be integrated. Additionally, the interface 852 includes integration electronics 854, which could include any desired electronics disclosed herein for integrating a plurality of external devices.

As shown in FIG. 17, a CD player 860, a digital media device 862, a satellite tuner 864, a video device 866, a cellular phone 868, and an auxiliary input 870 are connected to the interface 852 and integrated for use with a car stereo or video system. The CD player 860 could comprise any desired CD player or video system. The CD player 860 could comprise any desired CD player or
5 changer. The digital media device 862 could comprise any portable digital media device, such as an Apple iPod, MP3 player, MP4, player, WMV player, portable music center, or any other desired device. The satellite tuner 864 could comprise any desired satellite tuner, such as an XM or Sirius tuner. The video device 866 could comprise any desired video device, such as a DVD player. The cellular
10 phone 868 could comprise any cellular telephone capable of downloading and storing music or video files. The auxiliary input 870 could comprise any desired external device. Any desired number of interfaces 852 could be interconnected (“daisy-chained”). Further, the interface 852 could form part of an existing car stereo or video system. Control of the external devices connected to the interface
15 852 is provided through the car stereo or video system.

Having thus described the invention in detail, it is to be understood that the foregoing description is not intended to limit the spirit and scope thereof.

CLAIMSWhat is claimed is:

1. A multimedia device integration system comprising:

a car stereo system;

5 an after-market device external to the car stereo system;

an interface positioned within the car stereo system and connected between
the car stereo system and the after-market device for exchanging data and audio
signals between the car stereo system and the after-market device;

means for processing and dispatching commands for controlling the after-
10 market device from the car stereo system in a format compatible with the after-
market device; and

means for processing and displaying data from the after-market device on a display
of the car stereo system in a format compatible with the car stereo system.
2. The apparatus of claim 1, wherein the after-market device comprises a CD
15 player, CD changer, digital media player, Digital Audio Broadcast (DAB) receiver,
satellite receiver, or a cellular telephone.
3. The apparatus of claim 2, wherein the digital media player comprises an
MP3 player, an MP4 player, WMV player, or an Apple iPod.
4. The apparatus of claim 1, further comprising one or more auxiliary input
20 sources connected to the interface.

5. A multimedia device integration system comprising:
- a car stereo system;
 - a cellular telephone external to the car stereo system;
- 5 an interface connected between the car stereo system and the cellular telephone for exchanging data and audio signals between the car stereo system and the cellular telephone;
- means for processing and dispatching commands for controlling the cellular telephone from the car stereo system in a format compatible with the cellular
- 10 telephone; and
- means for processing and displaying data from the cellular telephone on a display of the car stereo system in a format compatible with the car stereo system.
6. The apparatus of claim 5, further comprising songs or music downloadable through the cellular telephone.
- 15 7. The apparatus of claim 6, wherein the songs or music are playable through the car stereo system using the interface.
8. A multimedia device integration system comprising:
- a car video system;
 - a cellular telephone external to the car video system;

an interface connected between the car video system and the cellular telephone for exchanging data, audio, and video signals between the car video system and the cellular telephone;

means for processing and dispatching commands for controlling the cellular telephone from the car video system in a format compatible with the cellular telephone; and

means for processing and displaying data from the cellular telephone on a display of the car video system in a format compatible with the car video system.

9. The apparatus of claim 8, further comprising songs or music downloadable through the cellular telephone.

10. The apparatus of claim 9, wherein the songs or music are playable through the car video system using the interface.

11. A multimedia device integration system comprising:

a car video system;

15 an after-market video device external to the car video system;

an interface connected between the car video system and the after-market video device for exchanging data, audio, and video signals between the car video system and the after-market video device;

means for processing and dispatching commands for controlling the after-market video device from the car video system in a format compatible with the after-market video device; and

means for processing and displaying data from the after-market video device on a display of the car video system in a format compatible with the car video system.

12. The apparatus of claim 11, wherein the after-market video device
5 comprises a DVD player.

13. The apparatus of claim 11, wherein the interface is positioned within the car video system.

14. A multimedia device integration system comprising:

an interface in electrical communication with a car stereo system and an
10 after-market device;

a plurality of configuration jumpers in the interface for specifying a first device type corresponding to the car stereo system and a second device type corresponding to the after-market device; and

a plurality of protocol conversion software blocks stored in memory in the
15 interface for converting signals from the after-market device into a first format compatible with the car stereo system and for converting signals from the car stereo system into a second format compatible with the after-market device, wherein at least one of the protocol conversion software blocks are selected by the interface using settings of the plurality of configuration jumpers.

15. The system of claim 14, wherein the plurality of protocol conversion software blocks allow a plurality of after-market devices to integrated with the car stereo system.

16. The system of claim 14, wherein the plurality of configuration jumpers are
5 settable by a user.

17. A multimedia device integration system comprising:

an interface in electrical communication with a car video system and an after-market device;

a plurality of configuration jumpers in the interface for specifying a first
10 device type corresponding to the car video system and a second device type corresponding to the after-market device; and

a plurality of protocol conversion software blocks stored in memory in the interface for converting signals from the after-market device into a first format compatible with the car video system and for converting signals from the car video
15 system into a second format compatible with the after-market device, wherein at least one of the protocol conversion software blocks are selected by the interface using settings of the plurality of configuration jumpers.

18. The system of claim 17, wherein the plurality of protocol conversion software blocks allow a plurality of after-market devices to integrated with the car
20 video system.

19. The system of claim 17, wherein the plurality of configuration jumpers are settable by a user.

20. A multimedia device integration system comprising:

an interface in electrical communication with a car stereo system and an
5 after-market device;

first and second wiring harnesses attached to the interface, wherein the first wiring harness includes a first electrical configuration corresponding to the car stereo system and the second wiring harness includes a second electrical configuration corresponding to the after-market device; and

10 a plurality of protocol conversion software blocks stored in memory in the interface for converting signals from the after-market device into a first format compatible with the car stereo system and for converting signals from the car stereo system into a second format compatible with the after-market device, wherein at least one of the protocol conversion software blocks are selected by the
15 interface using the first and second electrical configurations of the first and second wiring harnesses.

21. The system of claim 20, further comprising a plurality of wiring harnesses corresponding to additional device types and connectable to the interface.

22. A multimedia device integration system comprising:

20 an interface in electrical communication with a car video system and an after-market device;

first and second wiring harnesses attached to the interface, wherein the first wiring harness includes a first electrical configuration corresponding to the car video system and the second wiring harness includes a second electrical configuration corresponding to the after-market device; and

5 a plurality of protocol conversion software blocks stored in memory in the interface for converting signals from the after-market device into a first format compatible with the car video system and for converting signals from the car video system into a second format compatible with the after-market device, wherein at least one of the protocol conversion software blocks are selected by the interface
10 using the first and second electrical configurations of the first and second wiring harnesses.

23. The system of claim 22, further comprising a plurality of wiring harnesses corresponding to additional device types and connectable to the interface.

24. A method for integrating an after-market device for use with a car stereo
15 system comprising:

interconnecting the car stereo system and the after-market device with an interface;

determining a first device type corresponding to the car stereo system and a second device type corresponding to the after-market device;

20 loading a protocol conversion software block from memory in the interface using the first and second device types;

converting signals from the after-market device into a first format compatible with the car stereo system using the protocol conversion software block;

converting signals from the car stereo system into a second format
5 compatible with the after-market device using the protocol conversion software block; and

exchanging converted signals between the car stereo system and the after-market device.

25. The method of claim 24, wherein the step of determining the first and
10 second device types comprises determining jumper settings of the interface, wherein the jumper settings correspond to the first and second device types.

26. The method of claim 24, wherein the step of determining the first and second device types comprises determining electrical configurations of wiring harnesses attached to the interface, wherein the electrical configurations
15 correspond to the first and second device types.

27. The method of claim 24, wherein the step of determining the first and second device types comprises allowing the user to specify a device type of the after-market device using the car stereo system.

28. A method for integrating an after-market device for use with a car video system comprising:

interconnecting the car video system and the after-market device with an interface;

5 determining a first device type corresponding to the car video system and a second device type corresponding to the after-market device;

loading a protocol conversion software block from memory in the interface using the first and second device types;

10 converting signals from the after-market device into a first format compatible with the car video system using the protocol conversion software block;

converting signals from the car video system into a second format compatible with the after-market device using the protocol conversion software block; and

15 exchanging converted signals between the car video system and the after-market device.

29. The method of claim 28, wherein the step of determining the first and second device types comprises determining jumper settings of the interface, wherein the jumper settings correspond to the first and second device types.