

SOUNDGATE®

EXHIBIT #	<u>19</u>
DATE	_____
DEPONENT	_____
 PROFESSIONAL REPORTERS	800.376.1006

SUMMER 2002

Daimler Exhibit 1014

Why SoundGate® Dealers have the edge...

The technology in today's automobiles is more sophisticated than that found in any laptop computer. At SoundGate we believe that although challenging, these new technologies are full of opportunities for mobile electronic retailers across the nation. This philosophy, combined with the advantages we discuss below, are the reason SoundGate Dealers continue to be the leaders in aftermarket OEM-Integration.

...Rob Putman, Founder and President



Product engineered to a higher standard...

The SoundGate product line is designed to be the strongest link in your mobile audio system. Surface mount technology, 1% industrial grade components, meticulous assembly, and superior quality control assure mobile audio dealers and installers a level of performance and reliability unsurpassed in the industry.



INTRA MOSFET found in the Intra/SoundGate Intelligent Circuit Breakers

Innovative solutions that keep your bays busy and profitable...

High-tech solutions are a necessity for adding the latest aftermarket high-performance equipment to today's and tomorrow's vehicles. We stay highly-tuned to the trends in the automotive industry in an effort to have important products ready for our dealers by the time the cars show up on the streets. We thrive on providing dealers with cutting edge solutions to keep bays busy and profitable.

New technologies...

This catalog presents new technologies that are timely and important for the Mobile Electronics Retailer. SoundGate's new line of Auxiliary Input Interfaces allow the installation of a myriad of aftermarket add-ons, in a plug-and-play manner. The ICB-series circuit breakers, using a patented MOSFET technology, have the power to make today's archaic fuses and circuit breakers obsolete.

You'll also find an expanding line of interfaces that allow control of XM and Sirius Satellite Radio receivers directly from factory radios with CD changer control capability! These interfaces not only get rid of the FM modulator, but also the external receiver control keypad!



The best technical support in the industry...

SoundGate technicians are not only highly qualified installers themselves, but they have access to the largest resource of 12-volt information in the industry.



Having helped thousands of installers find the right wire color, locate factory amplifiers, or take the noise out of a problematic installation, SoundGate technicians are as important to the SoundGate philosophy as the product line itself. Getting information to SoundGate dealers quickly and accurately is all in a day's work for them...another example of how SoundGate gives your shop the edge.



Customer service determined to keep you satisfied...

During those instances when you need to know the status of an order, or need a simple question answered, our dedicated Customer Service Staff is here to give you the answer in a quick, concise manner. Expertly trained to be knowledgeable about every step of the SoundGate Customer Satisfaction Pledge, these experts will keep you moving down the road.



A word about value...

Having been in the Industry for twenty-two years now, I've seen how under-performing products erode customer satisfaction and confidence, and your profits. That's why SoundGate product isn't presented or sold as a commodity item. We build the best product possible, so that once correctly installed, it will last the life of the car... and longer! Thank you for your support ...Rob

INDEX

CD Changers Interfaces	8 - 12	Trigger Devices	20
Steering Wheel Control Interfaces	9 - 13	Filter Devices	20
The BAYSX (Basics) line	14 - 15	Diagnostic and Test Equipment	21
Factory Radio Replacements	16 - 17	Application Guide	22 - 44
OnStar Interfaces	16 - 17	Application Guide Notes	
Line Output Converters	18 - 19	and Footnotes	45 - 51

Copyright © 2002 SOUNDGATE®
SOUNDGATE® is a registered trademark of The Putman Group, Inc. All rights reserved. All other trademarks are the property of their respective owners.

Shipping Address:
730 E. Burkitt St.
Sheridan, WY 82801
Mailing Address:
PO Box 6689
Sheridan, WY 82801

Monday-Friday 8:00 am to 5:00 pm (MST)

Toll-free Ordering 888-760-4707 Technical Support 307-674-4707
Customer Service 888-760-4707 Toll-free Fax 866-674-4819

KICKER000111

THE SOUNDGATE DOCKING STATION...

By eliminating FM modulators, and inputting your favorite source directly into the CD changer port, the SDS1 allows your systems to sound their best!

The addition of aftermarket components to factory audio systems is one of the fastest-growing segments of the aftermarket industry. This is a trend that will continue to grow at an accelerated rate in the coming years. The new "SoundGate Docking Station", the SDS1, is the most exciting product to come along in this segment of the industry!

Imagine, the SDS1 allows you to add not one, but two audio sources directly to the CD changer input port of almost any factory, or aftermarket radio! Think of the possibilities - Satellite radio and DVD/Video at the same time! Or, how about Satellite radio and an MP3 jukebox at the same time - just use your imagination! *World wide patents pending!*

Rock It!



**Dock It!
Lock It,**



It's as easy as 1-2-3! The SDS1 docking cables allow the SDS1 to be plugged into almost any factory radio (CD changer compatible), or to most any aftermarket receiver or CD player (see listings at right). Remember, the SDS1 requires a CD changer to be connected to the radio in use.

A simple momentary contact switch (with LED status indicator) allows the owner to switch between CD Changer, Aux input #1, and Aux input #2. For those instances when a CD changer is not installed, SoundGate offers a growing line of Auxiliary Input Interfaces, shown in the panel below.

No CD Changer present? With the vehicles listed at right, it's no problem!

Allows Direct Audio Input Of DVD, MP3, Satellite Radio or Game Consoles into the vehicle's CD Changer port

Some customers want the fast, simple input of a second audio source while *not* using an FM modulator. SoundGate's vehicle-specific auxiliary input interfaces provide a direct, pre-amp level input of any external audio source! So, if your customer wants Satellite radio, MP3, or DVD input into their factory radio, these are the solutions for you.

Models listed at right, available now ...more coming soon!

Allows the direct audio input of DVD, MP3, Satellite Radio or Game Consoles!

One cable (sold separately) required per installation

SoundGate's Docking Station principle is easy to sell, and to understand... The SDS1, shown at right, is capable of working with any factory or aftermarket radio that is CD changer control capable. The SDS1 has two sets of RCA inputs. The Docking cables adapt the SDS1 interface module to the individual audio systems listed below. One cable is required per vehicle. A control cable, part of each docking cable, utilizes a momentary push-button switch and an LED status indicator. The switch and LED are mounted within the operator's reach and allow the user to select "Input 1", "Input 2", or "CD Changer".



The SDS1 "Docking Station" with DOCKVW1 plugged in.

(DOCKVW1 shown)

Choose one cable to use with your SoundGate Docking Station...

One for a particular car, or...

AUDI 1998-2002	#DOCKAUDI	KIA 1998-2002	#DOCKKIA
BMW 1996-2002	#DOCKBMW	MAZDA 1998-2002	#DOCKMAZD
CHRYSLER 1998-2001	#DOCKCHRY1	MITSUBISHI 1998-2002	#DOCKMITS
CHRYSLER 2002	#DOCKCHRY2	NISSAN 1998-2002	#DOCKNISS
CHRYSLER 1996-2001	#DOCKCHRY3	SUBARU 1998-2002	#DOCKSUBA
FORD 1995-2002	#DOCKFORD	TOYOTA 1998-2002	#DOCKTOYO
GM1 1998-2002	#DOCKGM1	VOLKSWAGEN 1998-2002	#DOCKVW1
GM2 1998-2002	#DOCKGM2	VOLKSWAGEN 1998-2002	#DOCKVW2
HONDA 1998-2002	#DOCKHOND1	VOLVO (C, V) 1998-2002	#DOCKVOLV1
HONDA 1992-1997	#DOCKHOND2	VOLVO (S) 1998-2002	#DOCKVOLV2

Please see the SoundGate Application Guide beginning on page 23 for more specific information.

One for an aftermarket radio

ALPINE	#DOCKALPINE
AUDIOVOX	#DOCKAVOX
BLAUPUNKT	#DOCKBLAU
CLARION	#DOCKCLAR
ECLIPSE	#DOCKECLIP
JVC	#DOCKJVC
KENWOOD	#DOCKKNWD
PANASONIC	#DOCKPANA
PIONEER	#DOCKPIO
SONY	#DOCKSONY

Please note that cable offerings are expanding all the time. Please call for the latest updates.

#AUXBMW
BMW 1996-02
LandRover 2000-02

#AUXCHRY
Chrysler 1998-02

#AUXFORD
Ford 1995-02

#AUXVW
VW & Audi
1998-02



AUXVW Shown

SoundGate's "Aux" series of interfaces allow one auxiliary source to be input directly into the factory CD changer port. With these interfaces a CD changer cannot be used. Quickly add MP3, satellite radio, or even a portable cassette for those owners with factory in-dash single play CD players.

MOBILE INTELLIGENCE™ INTELLIGENT POWER

SoundGate® and Intra Technologies® usher in a new era of charging system protection for automobiles. Designed and built around Intra Technologies®' patented MOSFET switch, capable

of handling up to 1000 amperes of current, this product literally re-invents the state-of-the-art in battery supply and charging system protection!

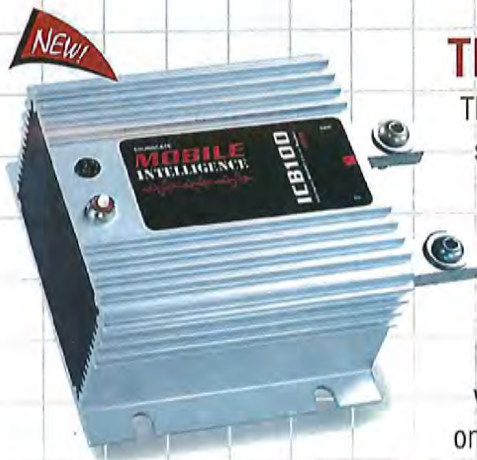

The ICB-series

The ICB-series of intelligent circuit breakers ensure that your system will get all the power your alternator and batteries can supply. Compare this to a fuse that actually limits power as current increases (in photo at right increased resistance of the fuse created enough heat to melt the fuseholder!).

Check out the features of this patented technology and see what an ICB could mean for you on the competition circuit.



Fuses, fresh or fried, become obsolete

#ICB100
100-amp disconnect

#ICB250
250-amp disconnect

#ICB500
500-amp disconnect

#ICB1000
1000-amp disconnect

- **Programmed Short-Circuit Disconnect Setpoints**
- **Manual Pushbutton Disconnect of the Circuit Breaker**
via a momentary contact switch at the breaker, or remotely via an optional harness.
- **Semi-Automatic Capacitor-Bank Charging**
The ICB circuit breakers have the unique ability to recharge a capacitor bank without having to use a resistor. A special startup sequence allows any ICB breaker to directly charge capacitor banks - a real time-saver at competitions.
- **Automatic Disconnect via a High-Temperature Disconnect Setpoint**

- **Control via a Keyless Entry System**
Protect the sound system during valet parking, or when dropping the vehicle off for routine servicing (requires optional 'ICB remote cable' shown at right, and SoundGate "TrigPlus").
- **LED Status Indicators**
Two LED status indicators, controlled by the microprocessor, provide the owner with the status of the circuit breaker under all operating conditions. Status modes include "On Status", "Off Status", "Over Temperature", "Current Overload", and "Short Circuit".



Optional ICB remote cable #ICBCABLE

Specifications	Unit	ICB100	ICB250	ICB500	ICB1000	Comments
Continuous Current	Amperes	100	150	200	300	Maximum Continuous Current
Over Current Disconnect	Amperes	100	250	500	1000	Maximum current for 15 seconds
Short Circuit Disconnect	Amperes	200	500	1000	2000	Less than 5ms
Nominal RDS (on)	Milliohms	0.7	0.4	0.3	0.2	

There are always exciting developments at SoundGate - the latest of which is Team SoundGate. The "Mobile Intelligence"

line was created for SoundGate's competition-specific devices. You'll see this line grow over time to offer some of the most innovative point-producing products on the Competition Circuit.

TEAM SOUNDGATE®



The ICB-series of Intelligent Circuit Breakers are the key components in today's Mobile Intelligence lineup, but hold onto

your eardrums... more revolutionary additions to the line are on the horizon! Call today for details on how to become a "Team SoundGate" member, along with the cool benefits doing so can bring you!

MANAGEMENT FOR CARS AND BOATS...brought to you by SOUNDGATE®

Designed especially for the marine environment, these power management devices by Intra use the same MOSFET technology as the ICB-series circuit breaker. From the simple operation of the

LVD (low voltage disconnect), to the sophisticated protection of the IPM (intelligent power manager), these devices are equally at home in the fastest boat, or the simplest pleasure cruiser.



Run accessory loads with the engine off... without worry!

LVD70

SoundGate introduces the Low Voltage Disconnect (LVD) - an intelligent, low-cost switch that allows you to run accessory loads (e.g. audio system, etc.) in your car or boat without risk of exhausting the starting battery. Each LVD monitors battery voltage and automatically disconnects the circuit at a predetermined setpoint. You always preserve enough power to restart your engine - reducing the need for a jump start, whether at dock or miles from port in your boat, or in your car listening to tunes at your favorite hang-out!

#LVD70 (shown)
Disconnect @ 12.1 volts
(70 amp capability)
#LVD100
Disconnect @ 12.1 volts
(100 amp capability)

- **Jump Start Protection**
Significantly reduces the need for jump starting
- **70 or 100 Amp Current Ratings**
handles all but the largest of loads
- **Extends Battery Life**
Charging and discharging batteries shortens life
- **Easy Installation**
Easily installed near the battery
- **Small, lightweight**
Unobtrusive, silent, never needs maintenance, fully automatic
- **Audible Alarm**
included alarm warns user of impending circuit shutdown.
- **Nickel plated**
The nickel plating of the LVD's guarantee maximum performance for the life of the product.
- **Coming Soon...**
LVD 150 and LVD 200

IPM70

SoundGate introduces the Intelligent Power Manager (IPM70) - a sophisticated load management device that monitors the state of charge of the battery, or batteries. Upon sensing that available current is not great enough for engine starting, the IPM70 will disconnect the battery from the load.

The IPM70's transponder system only allows starting of the vehicle when the included key fob is within five feet of the transponder. Any attempted start without the key fob will completely disconnect the vehicle from the battery - a great security benefit for boats, or even motorcycles!



Designed especially for the Marine Market
Revolutionary Safety and Security on the Water!

#IPM70
Automatic disconnect
(70 amp capability),
with transponder

- **Jump Start Protection**
Sophisticated jump-start prevention - monitors battery charge state - not just voltage.
- **70 Amp Current Rating**
Suitable for all but the argest of loads
- **Extends Battery Life**
Charging and discharging batteries shortens life
- **Easy Installation**
Easily installed near the battery in series with the negative battery lead.
- **Nickel plated**
The nickel plating of the LVD's guarantee maximum performance for the life of the product.
- **Security Transponder**
Prevents unauthorized starting or hot-wiring of the vehicle.

ALPINE CD CHANGER INTERFACES

BMW

Add M-Bus Alpine CD changers to any changer control BMW radio, even if Navigation-equipped!

#ABMW35V5

Digital Interface (cable not required)



3-SERIES, M-Series, Z-Series

- 1996 - 2002 (excluding 1996 318i)

5-SERIES (including X5)

- 1997 - 2002 vehicles that do not include factory DSP audio systems.

7-SERIES

- September of 1998 - 2001 vehicles without factory DSP audio systems.

DSP solutions coming this Summer!

Chrysler

Works with all rounded style radios - including the new square-plug Liberty, 2002 Ram, etc. And if your customer's car has steering wheel audio controls, our interface allows perfect control of the changer via the steering wheel buttons.

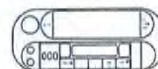

#ACR2V3 - Digital Interface (cable sold separately)

#CRCBLDIN - DIN-style cable for 1998 thru 2001 vehicles

#CRCBLSQ - Square-style cable for 2002 vehicles

Note: For older, rectangular-style radios, see #ALPMSTR on following page.

CHRYSLER

- Concord 99-02
- LHS 1999-02
- 300M 99-02
- PT Cruiser 01-02
- Sebring 01-02
- Town & Country 01-02
- Voyager 01-02

DODGE

- Caravan 01-02
- Dakota 01-02
- Durango 01-02
- Intrepid 98-02
- Neon 99-02
- Stratus 01-02

JEEP

- Grand Cherokee 99-02
- Liberty 2002

Ford, Lincoln, Mercury, Jaguar S-type

Works flawlessly with In-Dash CD players, and factory navigation systems - choose one cable shown at right to go along with the ALFD1V5, and you're on your way.



#ALFD1V5

Digital Interface

(cable, listed at right, required and sold separately)

Start with the ALFD1V5, choose the cable for your application and you've got a plug-and-play CD changer installation for any changer control capable Ford vehicle from 1995-2002.

FC1 cable

For cars that are equipped with factory CD changer cables (some Lincolns, an option on Windstars). #FC1

FC2 cable

T-harness at radio location to interface 1995-1998 vehicles. #FC2

FC3 cable

T-harness at rear amp/tuner to interface 1996-2002 Taurus and others with Distributed Audio Systems (DAS). #FC3

FC4 cable

Cable harness for Cougar, Focus, and Jaguar S-type. Plugs directly into rear of factory radio. (Not all CD related voice commands are supported on voice recognition equipped vehicles) #FC4

FC5 cable

T-harness at radio to interface 1998 Ford Combo radios & most 1999 - 2002 Ford CD changer-capable radios. #FC5

Interface and cable installations are illustrated on page 51 in the notes section of this catalog

Nissan, Infiniti



Finally, a reliable, trouble-free method of adding Alpine M-Bus changers to 1998 thru 2002 Nissans and Infinitis. Full functionality, even if the vehicle has steering wheel audio controls!

#ALNS1 - Digital Interface (cable included)

NISSAN

- All 1998-2002
- excluding 2002 Altima

INFINITI

- All 1998-2002

Land Rover



Add M-Bus Alpine CD changers to 1998-2002 Land Rovers with changer control radios!

RANGE ROVER and DISCOVERY

#ABMW35V5 - Digital Interface (one cable required, listed below, sold separately)

#RVRCLD - Range Rover/Discovery cable

FREELANDER

#ABMW35V5 - Digital Interface (one cable required, listed below, sold separately)

#RVRCLF - Freelander (with navigation) cable

If vehicle is not equipped with factory navigation, see ALFD1V5, shown directly above.

Toyota



Here's one you've all been waiting for. Seamlessly add Alpine changers to 1998 thru 2002 Toyotas - even when navigation, or steering-wheel-control-equipped.

#ALTOY1 - Digital Interface (cable included)

TOYOTA

- All 1998-2002 (excluding Matrix)

ALPINE CD CHANGER INTERFACES

The Alpine interfaces listed are to be used with the Alpine M-bus changers (models CHM-S600, 611, 620, 630)

Volkswagen, Audi

With our factory match connector, you will be able to quickly add an 6-disc

Alpine M-Bus CD changer to any changer-capable 1998-2002 Volkswagen (excluding Bose), or to any 1998-2002 Audi!

#ALVW1 - Digital Interface (cable required, listed below, sold separately)

#VWCBLR - VW Cable (Plugs into factory changer cable)

#VWCBLF - VW Cable (Plugs into factory radio)

#VWCBLA - Audi Cable (Plugs into Audi factory cable)

VOLKSWAGEN

- 1998-02 all with changer control radio (excluding Bose systems).

AUDI

- 1998-02 all with changer control radio

Note: 99-01 radio's may require re-programming by vehicle dealer to accept this changer.



ALPMSTR

A single ALPMSTR interface allows you to add Alpine CD changers to six different car makes with the simple switch of a cable.

Keep a few of the ALPMSTRs in stock, and a couple of each of the cables listed below, and you can add CD changers to a wide range of vehicles!

#ALPMSTR - Digital Interface (cable, listed below, required and sold separately)



CHRYSLER 1996-01

Chrysler products to ALPMSTR interface cable. Radio must have "disc up" & "disc down" on 1 & 5 radio presets.

#ALPMCR1



HONDA/ACURA 1998-02

Honda or Acura to ALPMSTR interface cable. All models.

#ALPMHD1



JAGUAR 1996-97

Jaguar to ALPMSTR interface cable.

#ALPMJG1



MERCEDES BENZ mid-1995-98

Mercedes Benz to ALPMSTR interface cable. Except ML320. Radio model #'s BE 1692, CM2296, CM2396 (on back of radio).

#ALPMMB1



VOLVO 1996-02

Volvo to ALPMSTR interface cable. All models except

1999-2002 S80 and V70, or 2001-02 S40, S60 or S70.

#ALPMVL1

1999 cable

Changer cables - non electronic



HONDA / ACURA 1992-97

Connect Alpine M-bus 6-Disc CD changers to 1992 thru 1997 Hondas and Acuras. Connects at factory radio. #ALHN1



MERCEDES 1994-mid 95

Connect Alpine M-bus 6-Disc CD changers to 1994 thru mid 95 Mercedes. Connects to factory changer cable in rear of vehicle. Radio model #'s BE1492, CM2294 (on back of the radio). #ALMB2



MAZDA 1994-96

Connect Alpine M-bus 6-Disc CD changers to 1994 thru 1996 Mazdas. Connects in rear of vehicle at factory changer cable. #ALMZ1



VOLVO 1991-95

Connect Alpine M-bus 6-Disc CD changers to 1991-95 Volvos. Connects at factory radio. #ALVOL1

The REMOTE1.5 Steering Wheel Control Interface for ALPINE

Today's customers don't want to forfeit any of the features that come with their cars - losing the factory steering wheel controls with the upgrade to an aftermarket receiver or CD player can often mean losing the sale. The SoundGate "REMOTE1.5" lets you add Alpine receivers and CD players to almost any General Motors or Chrysler Corporation vehicle.

Don't settle for lesser-performing imitations, use SoundGate - the inventor of steering wheel control interfaces.



The SoundGate REMOTE1.5 lets you retain the use of General Motors or Chrysler Corporation factory steering-wheel audio controls when installing any Alpine receiver or CD Player. Remote 1.5 has been upgraded to allow simultaneous use of remote port on rear of receiver, and of Alpine's wireless handheld remote.

#REMOTE1.5

- 1993-02 General Motors vehicles with steering wheel audio controls.
- 1994-98 Chrysler Corporation vehicles with steering wheel audio controls.

Toll-Free Ordering | 888-760-4707

KICKER000117

9

KENWOOD CD CHANGER INTERFACES

BMW

Effortlessly add 6 or 10-disc changers to the 1996 thru 2002 BMWs listed below.

#KBMWV5 - Digital Interface (cable not required)

- | | |
|--|---|
| 3-SERIES, M-Series, Z-Series
- 1996-2002 (excluding 1996 318i) | 7-SERIES
- September of 1998-2001 vehicles without factory DSP audio systems. |
|--|---|

DSP solutions coming this Summer!



Chrysler

Works with all rounded style radios, including the Jeep Liberty and 2002 Ram truck with the new square-style changer plug. And if your customer's car has steering wheel audio controls our interface allows perfect control of the changer via the steering wheel buttons.

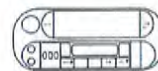

- #KNCR2V3 - Digital Interface (cable required, listed below, sold separately)
- #CRCBLDIN - DIN-style plug for 1998 thru 2001 vehicles
- #CRCBLSQ - Square-style plug for 2002 vehicles

- ### CHRYSLER
- Concord 99-02
 - LHS 1999-02
 - 300M 99-02
 - PT Cruiser 01-02
 - Sebring 01-02
 - Town & Country 01-02
 - Voyager 01-02

- ### DODGE
- Caravan 01-02
 - Dakota 01-02
 - Durango 01-02
 - Intrepid 98-02
 - Neon 99-02
 - Stratus 01-02

- ### JEEP
- Grand Cherokee 99-02
 - Liberty 2002

Ford, Lincoln, Mercury, Jaguar S-type



Take advantage of the millions of Fords on the road by installing a Kenwood 6 or 10-disc changer via our totally awesome digital interface, and one of our matching plug-n-play harnesses - shown below.

#KNFD1V5 - Digital Interface (cable required, listed below, sold separately)

Start with the KND1V5, choose the cable for your application and you've got a plug-and-play CD changer installation for any changer control capable Ford vehicle from 1995-2002.

- FC1 cable**
For cars that are equipped with factory CD changer cables (some Lincolns, an option on Windstars). #FC1
- FC2 cable**
T-harness at radio location to interface 1995-1998 vehicles. #FC2
- FC3 cable**
T-harness at rear amp/tuner to interface 1996-2002 Taurus and others with Distributed Audio Systems (DAS). #FC3

- FC4 cable**
Cable harness for Cougar, Focus, and Jaguar S-type. Plugs directly into rear of factory radio. (Not all CD related voice commands are supported recognition equipped vehicles) #FC4
- FC5 cable**
T-harness at radio to interface 1998 Ford Combo radios & most 1999 - 2002 Ford CD changer-capable radios. #FC5
- Interface and cable installations are illustrated on page 51 in the notes section of this catalog

Land Rover



Add Kenwood CD changers to 1998-2002 Land Rovers with changer control radios!

- ### RANGE ROVER and DISCOVERY
- #KBMWV5 - Digital Interface (one cable required, listed below, sold separately)
 - #RVRCLD - Range Rover/Discovery cable
- ### FREELANDER
- #KBMWV5 - Digital Interface (cable required, listed below, sold separately)
 - #RVRCLF - Freelander (with navigation) cable. See KNFD1V5 for non-Nav vehicles

PIONEER CD CHANGER INTERFACES WITH XM RADIO CONTROL!

Satellite Radio is the radio of the future, and what could be better than CD changer interfaces from SoundGate that can control XM Satellite Radio receivers?

This "best of both worlds" scenario can be found in the Pioneer CD Changer Interfaces listed on these two pages.

Connect a Pioneer CD changer, and an XM Satellite receiver to these interfaces and the owner can switch between listening and control of the CD changer or of the XM Satellite Radio receiver! Please note that when in XM Satellite Radio mode, artist and title information is not displayed on factory radio.



(PIOTOY1 shown)

BMW

Add a Pioneer 6 or 12-disc changer, and an XM satellite receiver directly to the CD changer input of the BMWs listed below! #PIOBMW1 - Digital Interface (cable not required)

- | | |
|--|---|
| 3-SERIES, M-Series, Z-Series
- 1996-2002 (excluding 1996 318i) | 7-SERIES
- September of 1998-2001 vehicles without factory DSP audio systems. |
|--|---|
- 5-SERIES (including X5)
- 1997-2002 vehicles that do not include factory DSP audio systems.

DSP solutions coming this Summer! KICKER000118

10 www.soundgate.com

KENWOOD CD CHANGER INTERFACES

The Kenwood interfaces listed are to be used with Kenwood changers (models numbers KDC-C667, C665, C717 and C715)

Toyota

Toyota has hit a home run with most of its recent vehicle introductions. Let SoundGate drive you to new profit opportunities with its incredible new KNT0Y1 for use in all 1998 thru 2002 vehicles. 6 and 10-disc compatible.

#KNT0Y1 - Digital Interface (cable included)



Volkswagen, Audi

SoundGate provides the ultimate in flexibility with its KNVW1 interface. Use with one of three separate cables... cable #VWCBLR plugs into the factory cable, #VWCBLF plugs into the rear of the factory radio, and #VWCBLA is for use with Audis. Compatible with all 1998 thru 2002, except VW with Bose.

#KNVW1 - Digital Interface (cable required, listed below, sold separately)

#VWCBLR - VW Cable (Plugs into factory changer cable)

#VWCBLF - VW Cable (Plugs into factory radio)

#VWCBLA - Audi Cable (Plugs into Audi factory cable)



TOYOTA

- 1998-02 all with changer control radio (excluding Matrix)
- No additional cables needed

VOLKSWAGEN and AUDI

- 1998-02 all with changer control radio (except Bose in VW)

Note: 99-01 radios may need reprogramming by Volkswagen dealer to accept this changer.

The REMOTE1.5 Steering Wheel Control Interface for KENWOOD and PIONEER

Today's customers don't want to forfeit any of the features that come with their cars - losing the factory steering wheel controls with the upgrade to an aftermarket receiver or CD player can often mean losing the sale. The SoundGate "REMOTE1.5" lets you add Kenwood or Pioneer receivers and CD players (excluding video units, and Excelon MP3) to almost any General Motors or Chrysler Corporation vehicle. Don't settle for lesser-performing imitations, use SoundGate - the inventor of steering wheel control interfaces.



The SoundGate REMOTE1.5 lets you retain the use of General Motors or Chrysler Corporation factory steering-wheel audio controls when installing Kenwood or Pioneer receivers or CD players equipped with an infrared remote eye!

#REMOTE1.5

- 1993-02 General Motors vehicles with steering wheel audio controls.
- 1994-98 Chrysler Corporation vehicles with steering wheel audio controls.

The Pioneer interfaces listed are to be used with any Pioneer P-bus type changers

PIONEER CD CHANGER INTERFACES WITH XM RADIO CONTROL!

Ford

Coming soon will be an all new SoundGate interface for connecting Pioneer 6 or 12-disc CD changers and XM satellite receivers to 1995 thru 2002 Fords.

Stay tuned for release information!

#PIOFD1 - Digital Interface (cable required, sold separately, listed on page 51)

Toyota

We all know how popular Toyotas are... SoundGate now gives you the opportunity to install 6 or 12 disc changers in all 1998 thru 2002 Toyotas, and control XM satellite radio receivers with the same interface! Think of the possibilities!

#PIOTOY1 - Digital Interface (cable included)

TOYOTA • All Models 1998 thru 2002 (excluding Matrix)

Volkswagen, Audi

An all new SoundGate interface for adding Pioneer 6 or 12-disc CD changers and XM satellite radio receivers to 1998 thru 2002 Volkswagens and Audis!

#PIOVW1 - Digital Interface (cable required, sold separately)

Toll-Free Ordering: 888-760-6707

SONY CD CHANGER INTERFACES

The Sony interfaces listed are to be used with all Sony Uni-Link changers

BMW

SoundGate re-introduces its hugely popular Sony to BMW CD Changer Interface. Works with most 1996 thru 2002 BMWs! No additional cables needed.

#SNBMWV5 - Digital Interface (cable not required)

3-SERIES, M-Series, Z-Series

- 1996 - 2002 (excluding 1996 318i)

5-SERIES (including X5)

- 1997 - 2002 vehicles that do not include factory DSP audio systems.



DSP solutions coming this Summer!

7-SERIES

- September of 1998 - 2001 vehicles without factory DSP audio systems.

Toyota

What could go together better than Sony and Toyota? We think not much! SoundGate's new SNT0Y1 gives you perfect control of 6 and 10-disc Sony changers when connected to any 1998 thru 2002 Toyota! No additional cables needed.

#SNT0Y1 -

Digital Interface (cable included)



TOYOTA

• 1998-02 all with changer control radio (excluding Matrix)

Ford, Lincoln, Mercury, Jaguar S-type

After a long absence from the marketplace, SoundGate is very pleased to announce the re-introduction of its Sony to Ford

CD changer interface! Upgraded with all the latest programming and audio improvements for Sony's new changers, these interfaces are guaranteed to literally fly out your install bays.

#SNFD1V5 - Digital Interface (cable required, listed at right, sold separately)



Start with the SNFD1V5, choose the cable for your application and you've got a plug-and-play CD changer installation for any changer control capable Ford vehicle from 1995-2002.

FC1 cable

For cars that are equipped with factory CD changer cables (some Lincolns, an option on Windstars). #FC1

FC2 cable

T-harness at radio location to interface a 1995-1998 vehicles. #FC2

FC3 cable

T-harness at rear amp/tuner to interface 1996-2002 Taurus and others with Distributed Audio Systems (DAS). #FC3

FC4 cable

Cable harness for Cougar, Focus, and Jaguar S-type. Plugs directly into rear of factory radio. (Not all CD related voice commands are supported recognition equipped vehicles) #FC4

FC5 cable

T-harness at radio to interface 1998 Ford Combo radios & most 1999 - 2002 Ford CD changer-capable radios. #FC5

Interface and cable installations are illustrated on page 51 in the notes section of this catalog

LandRover

Add Sony CD changers to 1998-2002 Land Rovers with changer control radios!



RANGE ROVER and DISCOVERY

#SNBMWV5 - Digital Interface (one cable required, listed below, sold separately)

#RVRCBLD - Range Rover/Discovery cable

FREELANDER

#SNBMWV5 - Digital Interface (cable required, listed below, sold separately)

#RVRCBLF - Freelander (with navigation) cable. See SNFD1V5 for non-nav vel

Volkswagen, Audi

SoundGate is pleased to bring Volkswagens and Audis into the install bays of Sony dealers. Use with one of three separate cables... cable #VWCBLR plugs into the factory VW cable, #VWCBLF plugs into the rear of the factory VW radio, and #VWCBLA is for use with Audis. Compatible with all 1998 thru 2002 vehicles, except VW with Bose.

#SNVW1 - Digital Interface (cable required, listed at right, sold separately)



VOLKSWAGEN and AUDI

• 1998-02 all with changer control radio (except Bose in VW)

Note: 99-01 radios may need reprogramming by vehicle dealer to accept this changer.

#SNVW1 - Digital Interface

(cable required, listed below, sold separately)

#VWCBLR - VW Cable (Plugs into factory changer cable)

#VWCBLF - VW Cable (Plugs into factory radio)

#VWCBLA - Audi Cable (Plugs into Audi factory cable)

SONY STEERING WHEEL CONTROL INTERFACES

These are the interfaces that started the steering wheel control interface revolution... back in 1994! Since then, thousands of happy customers have made the switch to a new Sony receiver or CD player, and retained the use of

their factory steering wheel controls. Don't lose out on valuable sales. SoundGate's Sony-specific steering wheel control interfaces are pre-programmed - just connect them and drive away... it's that simple!

Ford to Sony

The SoundGate FRDSW2 lets you retain the use of the factory dashboard, or rear-seat audio controls on many Ford Motor Company vehicles when installing any SONY RM-X2S, or RMX-4S compatible receiver or CD player (including the SONY ES product line)! You need the FRDSW2 if your shop installs in any of the vehicles listed at right:



#FRDSW2

General Motors to Sony

The SoundGate GMSW1 lets you retain the use of the factory steering-wheel audio controls on General Motors vehicles listed at right when installing any SONY RM-X2S or RM-X4S compatible receiver or CD player (including the SONY ES product line)!



#GMSW1

Chrysler to Sony

The SoundGate CRSW1 lets you retain the use of Chrysler Corporation factory steering-wheel audio controls when installing any SONY RM-X2S or RM-X4S compatible receiver or CD player (including the SONY ES product line)! Remember, on Chrysler Corporation vehicles, the audio pushbuttons are on the rear of the steering wheel!



#CRSW1

VANS*

Aerostar	1996-97
Econoline	1994-96
Windstar	1994-97
MERCURY	
Villager	1993-95
NISSAN	
Quest	1993-95

CARS

FORD	
Taurus	1992-95
MERCURY	
Sable	1992-95

* Rear speaker on - off function is not duplicated upon radio replacement.

BUICK

Skylark	1997-99
---------	---------

CADILLAC

Escalade	1999-02
----------	---------

CHEVROLET

Blazer	1997-02
Camaro	1994-02
Impala	2000-02
Lumina	1995-00
Monte Carlo	2000-02
Monte Carlo	1995-99

BUICK

S10 Pickup	2000-02
Venture	2000-02
Venture	1999

GMC

Jimmy	1998-02
-------	---------

OLDSMOBILE

Alero	1999-02
Bravada	1999-00
Silhouette	1994-99
Silhouette	2000-02

PONTIAC

Bonneville	2000-02
Bonneville	1996-99
Firebird	1993-02
Grand Am	1996-02
Grand Prix	1994-02
Montana	2000-02
Montana	1999
Sunfire	1996-99
Transport	1996-98

CHRYSLER

1999-00 Town and Country

DODGE

1999-00 Caravan
1999-00 Dakota
1999-00 Durango
1999-01 Ram Pickup

JEEP

1997-98 Grand Cherokee

PLYMOUTH

1998-01 Prowler

The CRSW1 works with rectangular style Chrysler radios.

Not entirely sure which interface you need?

The SoundGate Application Guide begins on page 23 and contains information on over 1500 vehicles.

BAYSX

Optimize Your Install Ba

We know it's not necessary to always have every one of our parts on hand. There are a few items, however, that we feel are so important, that no bay should be without them. They are the SoundGate "BAYSX (Basics)".

This is our guarantee to you:
Stock each of our 12 BAYSX products... If you have a car that comes into your bay that you can't deal with, using our BAYSX parts, call us first so that we can tell you how to make the install work. If together, we can't make it work over the phone, we'll GIVE YOU one of our GENSWEEP signal generators. We're so confident in our product and in our technical support that we can make this offer to you.

Take us up on it!

LOC4

The LOC4 is the audiophiles' choice for adding amplifiers to factory systems. This 2-channel Line Output Converter has two sets of inputs that will give you 1.5 or 4 Volts RMS output. It is designed to connect to a speaker level signal source. The LOC4 does not use transformers, power resistors or potentiometers - assuring the customer of the highest performance in the industry - frequency response is flat from 17Hz to 23kHz, and beyond! Design parameters require mounting as close to the source unit as possible.

LOCHVA

The LOCHVA is a 2-channel, high-voltage-output, Line Output Converter for connection to a speaker level signal source. It provides complete DC isolation, adjustable gain, infrasonic filter, and a frequency response within 3dB from 20Hz to 20kHz.

LOCPREA

The LOCPREA is a high performance, high quality, Line Output Converter designed to connect to factory pre-amp level signal sources - this is the type of signal found between most factory radios and factory amplifiers. This 2-channel LOC has complete DC isolation, high input impedance, high voltage output, an infrasonic filter, and slight bass boost which add up to an awesome sounding system. Frequency response is flat from 20Hz to 20kHz, plus or minus 3db.

LOCB

The LOCB is part of the SoundGate Audiophile series of interfaces, and is the ultimate solution for adding amplifiers to factory Bose® systems, Ford Premium systems, Toyota and Lexus differential systems - almost any factory amplified system. This 2-channel Line Output Converter is designed to connect to the pre-amp level leads of the factory system (before the factory amplifier) and is a fully active device which can accept input signals from 350mV to almost 6 Volts, and give you 2.5 Volts RMS output. With no transformers, potentiometers or power resistors, you get a frequency response of 17Hz to 23kHz as well as a high signal-to-noise ratio.

PWR1

Quite a few earlier model year vehicles with amplified systems, and some non-amplified systems have chassis grounded speaker wiring. The PWR1 is the interface for these systems. It eliminates speaker-damaging DC offset, protecting the factory amplifiers, tweeters and midrange drivers. Set screw type connectors make for easy installation. See the SoundGate resource guide for specific applications.

OEM4A

The OEM4A is a high-performance, adjustable, 4-channel, radio replacement interface designed to seamlessly integrate new receivers or CD players into virtually all factory amplified systems. Our universal pigtail leads, allow you to use the factory-match connectors your shop already stocks. With separate gain adjustments for front and rear, and it's wide range of adjustment, it will easily handle any of today's receivers, CD players or multi-media units, including today's high-power MOSFET's. With full DC isolation, proprietary transformers and no power resistors your customer gets a 20Hz to 20kHz frequency response with no noise! Handles up to 80 watts per channel! See the SoundGate resource guide for specific applications.



TRIGSPKR

The TRIGSPKR converts a speaker level signal into a remote wake-up signal. This means you do not have to run a remote lead back to the radio location when the vehicle is not equipped with a factory turn-on lead. With its high input impedance, even the most sensitive system will not be affected by it.

TRIGLOHD

Quite a few of today's vehicles (Ford Premium and Lexus, for example), have a factory amplifier wake-up circuit that operates between 5 and 9 Volts. The TRIGLOHD will trigger on any input voltage between 2 and 30 Volts and give you a 12 Volt, 1 Amp capacity turn-on signal. This eliminates connecting the turn-on lead for new amplifier(s) to an ignition source with the resulting noise problems that method can create.

IS02

The IS02 is a 2-channel isolator that completely DC isolates two components in a sound system. With a frequency response of 20Hz to 20kHz, it is the best noise isolator on the market. If you've installed what should be an awesome-sounding system only to have it ruined by system hiss, pops, clicks or CD tracking-type noise, this unit will fix the problems.



FLTR25TE

The FLTR25TE is a high quality, high performance electronic filter (active design) that utilizes a toroid choke. Designed by David Navone, the undisputed authority on solving noise problems in car audio systems, the FLTR25TE is the most effective noise filter on the market.

REMOTE1.5

The REMOTE1.5 allows you to replace the factory radio in select General Motors and Chrysler Corporation vehicles and retain the use of the factory steering wheel audio controls, when installing select Alpine, Kenwood, Pioneer or JVC receivers or CD players that are infrared remote control capable. With select Alpine units, you can simply plug the REMOTE1.5 into the remote control port on the rear of the Alpine radio eliminating the need to mount the infrared emitter in front of the radio. See the SoundGate resource guide for specific applications. The 1.5 update allow the infrared eye on the front of Alpine units to work in conjunction with the remote port on the rear of the units.

STARMOD2V2

The STARMOD2V2 interface allows you to replace the factory radio in select General Motors vehicles with OnStar® and retain the functionality of the OnStar® system. The STARMOD2V2 has a sophisticated automatic trigger circuit that detects when an OnStar® communication occurs, automatically waking up the STARMOD amplifier. It is also equipped with a relay that will allow you to broadcast the incoming OnStar® communication over one speaker of the vehicle. See the SoundGate® resource Guide for specific application information. Prewired with factory match connector.



All of the products in the BAYSX program are also available individually, and can be found on the pages listed below.

The BAYSX (Basics)

LOC4	page 18
LOCHVA	page 18
LOCPREA	page 19
LOCB	page 19
PWR1	page 17
OEM4A	page 16
TRIGSPKR	page 20
TRIGLOHD	page 20
IS02	page 20
FLTR25TE	page 20
REMOTE1.5	page 13
STARMOD2V2	page 16



STARMOD's and DIGISTAR's

General Motors has paved America's roads with the popular OnStar® system. We believe these types of systems will become standard equipment in most vehicles, presenting new challenges for the aftermarket. True to SoundGate form, however, we evaluated the technology and the impact on installers, and set to work developing solutions.

Note: Some 2002 vehicles may require the use of #AVM1 - (shown here). Listed on page 19



The STARMOD's and DIGISTAR's are the beginning of an entire line of digital interfaces for databus-equipped vehicles.



FACTORY RADIO REPLACEMENT INTERFACES

OEM4A

- Integrate new receivers or CD players (including high-powered MOSFETs) into factory amplified systems with one universal interface!
- The 4-channel OEM4A uses simple pigtail leads for speaker level inputs and outputs so you can use the wiring harnesses that your shop already stocks.



MOSFET Ready

#OEM4A

OEM2

- Are you installing a new receiver or CD player and want to keep the use of just one of the factory amps?
- Is just one or two of your customer's Bose-amplified speakers bad?
- Use the 2-channel OEM2 to retain the use of factory amps while bypassing ones that may be bad!



MOSFET Ready

#OEM2

MOSFET's are great...

just be sure to use an OEM4A for trouble-free installations

If you're interfacing MOSFET-output radios with factory amplifiers, chances are you've run up against some obstacles. The overall gain capability of these new radios is high enough that most head unit replacement interfaces cannot adequately attenuate the outputs. When interfacing MOSFET output radios with factory amplifiers, use our OEM4A (left) to create the perfect match. A second possible problem with MOSFET-output radios is the amount of current they require to operate at their full potential. Look at the battery and ignition-lead wiring of every car you install one of these powerhouses into. If the factory wiring is 18 gauge or smaller (most are now 22 gauge), use the simple diagram above to ensure an adequate supply of voltage and current to the new unit.

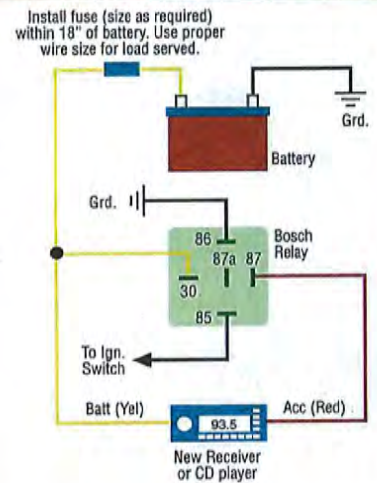

Hi-Power to Common-Ground Interfaces - audiophile sound quality for customers that want the best!

Installing today's high powered receivers and CD players into cars with common-grounded wiring is a time consuming job. To do it right, new speaker wiring has to be run to each common-grounded speaker.

SoundGate's floating-to-common-ground interfaces eliminate running new speaker wiring in cars... saving you time.

FLT1

- For non-amplified systems, or for common-grounded speaker wiring that is not chassis grounded
- Maintains full high-power receiver output and provides a 3dB bass boost below 85 Hz

#FLT1



4 channel non-chassis-grounded systems

PWR1

- For use in many cars with chassis-grounded speaker wiring
- Eliminates speaker-damaging DC offset - protects delicate tweeters and midrange drivers
- Set screw type connectors for the easiest installation

#PWR1



4 channel For chassis-grounded systems

...and so are the interfacing solutions from SoundGate!

STARMOD1V2

SoundGate's "V2" versions of its original STARMOD's now include the factory 9-pin harness, making these units a true plug-n-play install in certain vehicles. STARMOD1V2 should be used if doing a full system install with new amplifiers, etc. A separate speaker, not included, broadcasts the OnStar messaging. A mute output mutes the new receiver upon OnStar use.

#STARMOD1V2

STARMOD2V2

STARMOD2V2 should be used in those instances in which a simple radio swap is being performed. The built-in relay network of the STARMOD2V2 allows one factory speaker to broadcast the OnStar messaging. A mute output mutes the new receiver upon OnStar use.

#STARMOD2V2

STARMOD2

STARMOD2 does not have the factory 9-pin harness attached. This unit is designed for use in non-General Motors vehicles (Audi, Saab, Volvo, Acura) which utilize OnStar, or in those GM cars which use a 24 or 32-pin factory harness. A mute output lead mutes the new receiver. A built-in relay network allows OnStar messaging to be broadcast over one factory speaker.

#STARMOD2

DIGISTAR1

Coming early this Summer, SoundGate's new DIGISTAR interfaces will represent the final design iteration of OnStar integration. DIGISTAR1 is designed to rebroadcast OnStar messaging through a separate speaker, not included, when a full system replacement is being done (new amps, etc.). DigiStar1 triggers off of the vehicle's digital command language.

#DIGISTAR1

DIGISTAR2

DIGISTAR2 has a built-in relay network that allows OnStar messaging to play through one of the vehicle's factory speakers. A mute output lead allows the new receiver to be muted during OnStar messaging. DigiStar2 triggers off of the vehicle's digital command language.

#DIGISTAR2

...designed to be the strongest link in your aftermarket system!

Plug and Play for 1997-2002 Corvettes...only from SoundGate!

The Bose® systems in the new 'C5' Corvettes (1997-2002) are totally different from any other factory Bose® system. SoundGate's GMCRV1 lets you add high-power receivers or CD players to these cars in minutes!



- Built-in 120 Hz high-pass crossovers for the front 3 1/2" factory speakers.
- Electronic, lo-pass interface flawlessly matches the new receiver or CD player to the Bose subwoofer amps located in each door.
- Plug-and-play factory-match connectors turn this former installation headache into a ten-minute slam dunk!

#GMCRV1



The legendary performance and reliability of the SoundGate line really shine in our factory radio replacement interfaces. Unique in their abilities, design, and construction, these interfaces provide you with quick, solid solutions for extraordinary sounding systems. Don't settle for cheap imitations... these are the originals, and the best.

FORD PREMIUM SYSTEMS

- Add new receivers or CD players with speaker level outputs (4x45 watt max.).
- Gain and impedance levels perfectly matched to the Ford amplifiers - no noise, no distortion, perfect gain structures.
- Full bandwidth frequency response
- Bring Explorer JBL, Mustang Mach-460, and other Ford premium systems alive with CD source units & full dynamic range.
- Pre-wired with factory match harness connectors - simply plug it in and move on to your next install!
- Note: See OEM4A for MOSFET installations



FRD2

1988-94 Ford vehicles - including 1994-00 Mustang Mach 460 #FRD2



FRD2 Connectors

BOSE SYSTEMS

- Hardwired factory-match connectors - no sub-assembly required.
- Fully active design. Squeezes the best performance out of factory Bose systems.
- No adjustments - each unit tailored to a specific Bose system. Correct gain and impedance levels designed-in. No potentiometers means guaranteed performance for the life of the product.
- Special noise suppression for Camaros and Firebirds
- Note: See OEM4A for MOSFET installations



GMB1

1989-96 GM vehicles

#GMB1



GMB1 Connector



GMB2 Connectors



GMB2

up to 1985 GM vehicles and 1985-89 Corvette

#GMB2

LINE OUTPUT CONVERTERS - use after factory amplifier

TYPE 1
Installations:

Adding new amplifiers to factory radios should be an easy task. Right? Well, if you've tried using a so-called 'universal' line output convertor (LOC), you've probably run into the same problems installers nationwide have encountered: hiss, noise, overheated amps and radios, and not enough gain. Worse yet, we've all encountered the factory radio with the output stages destroyed by trying to drive a power resistor inside an LOC.

LOC4

When we set out to design the ultimate passive line output convertor 7 years ago, little did we realize that we were designing a classic. Our LOC4 has become the defacto standard for installations where sound quality has to be its absolute best. Designed to be connected after an amplifier (either built into the radio, or outboard) the LOC4 must be mounted as close to the source unit as possible. If you are adding an amplifier at the pre-amp stage of a system (before the factory amplifier) please see our LOCB on the next page - it's the active-design big brother to the LOC4. **Rated for up to 80 watts! Flat from 17Hz to 23kHz!**
#LOC4



2
channel



LOC2 / LOC3FR - Auto Wake Up!

We had a huge number of requests for a line output converter that could do it all - high voltage output, an auto-trigger circuit to wake up the new amp - even a built in crossover! These are the units that answer all those needs. LOC2 gives 100 Hz lo-pass output and LOC3FR provides full-range output. Designed around the same audio circuit as our world-famous LOC4 shown above, both units include infrasonic filters and set-screw inputs for the easiest installation. **Rated for up to 80 watts!**
#LOC2 - 100Hz lo-pass output
#LOC3FR - Full-range output



Setting System Gain Levels - it's time well spent.



One of the biggest mistakes still being made in today's installations is that of not properly setting the gain controls on the finished system. We all get rushed trying to get that job out the door. But please, don't overlook this most important step!

1. Turn your amplifier and Line Output Convertor gain controls all the way down, then open them just a very small amount.
2. Next, turn the system on and turn the radio to its maximum volume on the knob, or until distortion is just heard. If distortion is heard decrease the volume setting until it goes away.
3. Turn the gain control on the next component in the signal chain up until the same result is achieved as in step 2.
4. Continue on down the chain until you reach the amplifier. As a final step turn the gain control on the amplifier(s) up until the system is playing at the maximum desired volume level. Following these steps maximizes signal-to-noise ratio and minimizes noise in the system!

SoundGate solves these problems in two ways; number one, we have line output converters that are designed correctly, and two, we also know exactly which car to use them in, and on what wires! If you've been frustrated trying to use so-called universal line output converters, give us a call. We'll solve your interfacing problems.

LOCHV4A

Our line of transformer-based line output converters solidly trounce every other device on the market when it comes to out-and-out performance (except for our own "Audophile-Series" of course!). Some companies make claims of exceptional frequency response. But, have you ever seen one of their devices tested under actual operating conditions? It's easy to show good frequency response when load impedance on the LOC is varied, but these loads don't exist in the real world.

Our 4-channel LOCHV4A uses our custom-wound transformers, custom support circuitry, and high quality potentiometers. We don't use power resistors - those things that melt most LOC's into a pile of plastic goo. Instead, we use extremely high input impedance. **Rated for up to 85 watts!** If you've tried the rest, come try the best... your ears will hear the difference!

- High voltage output • Complete DC isolation
- Response flat from 20 Hz to 20 KHz under real-world load impedance!

#LOCHV4A



4
channel

LOCHVA

A 2-channel version of our popular 4-channel LOCHV4A shown above. Exactly the same performance in a design perfectly suited for adding sub amps. **Rated for up to 85 watts!**

#LOCHVA



LOCSUBA

Add a sub in record time. This adjustable output, lo-pass (100 Hz crossover) LOC gives hi-voltage output, an infrasonic filter, and bass boost centered at 50 Hz. The same high-performance design as our LOCHVA and LOCHV4A, but with the crossover built in! LOCSUBA is perfectly suited for keeping the factory subwoofer working in newer Fords when you're replacing the factory radio. SoundGate's awesome "TechLab" data sheets you how to do it - wire-by-wire (faxed on demand) **Rated for up to 85 w**

#LOCSUBA



LOCA

Need an adjustable LOC to fit anyone's budget? The LOCA is your answer. Great frequency response, full DC isolation, and great reliability in a small, easy-to-use package. The LOCA can only be connected after the amplification stage of the system - either after the internally-amplified radio, or after the factory amplifier.

#LOCA



LINE OUTPUT CONVERTERS - use before factory amplifier

TYPE 2
Installations

LOCB

When you're adding amplifiers to factory-amplified systems and you want the ultimate in performance, you have to intercept the factory wiring between the radio and the factory amplifier - this is where the cleanest signal is found. But, doing this with just any LOC can spell disaster - if you hook up an LOC that uses power resistors at this point in the wiring you'll probably fry the outputs of the factory radio. SoundGate knows these details, and knows how to correctly add amplification at this point in the signal chain. The LOCB is the active-circuit-design big brother of our LOC4. This monster will give you 2.5 volts RMS output - regardless of the input voltage - even if its as low as 350 millivolts! It's the ultimate statement of performance in LOC's... period! Flat from 17Hz to 23kHz! #LOCB



LOCPREA

This passive-design LOC has the same ultra-high input impedance as our LOCB. However, here we use transformers to maintain complete DC isolation between components. If you've got an extremely noisy vehicle, or just can't mount the LOCs directly behind the radio, the LOCPREA is for you. Full DC isolation, full-bandwidth frequency response, high voltage output, an infrasonic filter, and a slight bass boost add up to an awesome way of adding amps to almost any system that is factory-amplified. Response is flat within 3 db from 20 Hz to 20 KHz. The passive design of the LOCPREA means it can't be used in systems where AC voltage is very low (some Toyota and Lexus systems, for example) - for those installs latch on to our LOCB shown at left. #LOCPREA



Trouble deciding which LOC to use? SoundGate makes it easy.

Type 1 Installations:

Type 1 interfaces are designed to be connected to the leads of an existing pair of speakers, or can be used to replace the speakers entirely. If the factory system is amplified, Type 1 interfaces are to be installed only after the factory amplifier.

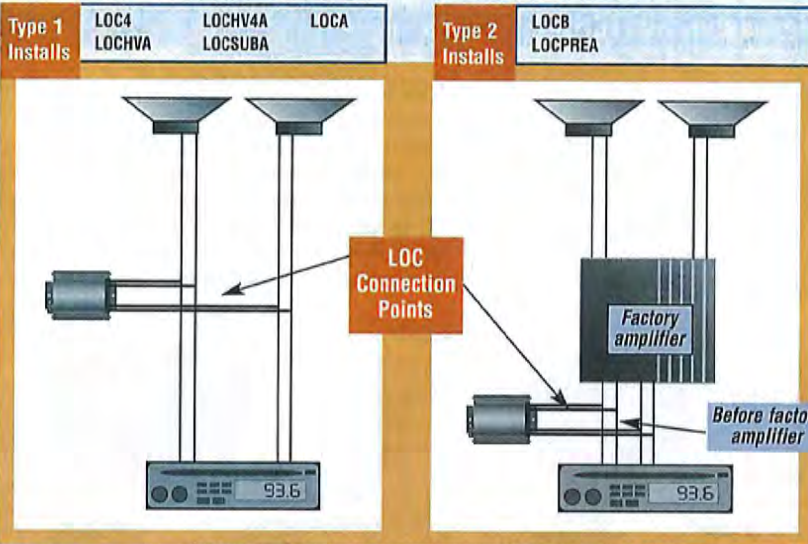

Type 2 Installations:

Type 2 interfaces are specifically designed for use with factory radios that feed into factory amplifiers. These interfaces are designed to be connected either directly at the output of the factory radio, or at the INPUT of the factory amplifier. They can be used to simply add a subwoofer amp, or to replace the factory amplifiers.

SPECIALTY interfaces

AVM2

The AVM2 is a two-channel version of our popular AVM4, shown at right. Both the AVM2 and AVM4 have low source impedance and are easily capable of driving a set of headphones, or even small speakers. We use the AVM2 as a single headphone driver, as a pre-amp booster in certain OnStar installations, and as a master volume control for limos and boats.

#AVM2 - stereo device

#AVM1 - Single-channel device available for OnStar installations



AVM4

In our travels this year, speaking with dealers, one request kept coming up: Dealers needed a device that would level-match components in an audio/video system. Sony Playstations and Nintendo Gameboys were driving installers nuts! The low output levels of MP3 devices were another problem area. The AVM4 not only performs this level-matching function, but it can also be used as a headphone amplifier for two sets of headphones (each with its own volume control!).

#AVM4



LD2

Are you building competition systems, or performing multi-amp installations? If so, the LD2's 30 volt isolated power supply can increase the level of a signal up to a maximum of 12dB. In other words a 2 volt output deck can be turned into an 8-volt RMS monster! The second knob on the LD2 allows bass to be boosted by up to 15dB - perfect for use in SPL contests! Check out these specs: 9.6 volts maximum signal level, greater than 120 dB of dynamic range, a source impedance of only 50 ohms, soft turn-on and delayed turnoff, and isolation at 3 KHz of greater than 200,000 ohms! It's the Best! **Warning** - Speaker damage can occur if mis-used.

#LD2

KICKER000127



FINE-TUNING ACCESSORIES

Turn-on and Turn-off pops are culprits that installers deal with every day. SoundGate has a solution for curing nearly every instance of turn-on and turn-off pop. Study the trigger devices on this page carefully, paying special attention to our TRIGLOHD - this unit gives installers the proper method for waking up amplifiers in Ford Premium Sound systems, Infinitis, Lexus, and all other cars that use low-voltage factory trip leads.

TRIGOFF

Delayed amp turnoff timer (trigger lead device). For the hardest to solve turn-off pop problems. If your system is noisy during turn-off, this device gives you the remedy. Every shop should stock at least one!

#TRIGOFF



TRIGSPKR

TRIGSPKR converts a speaker lead to a remote wake-up signal. Quit running wake-up leads clear back to the radio. Simply connect to a speaker, and save a bunch of time!

#TRIGSPKR



TRIGLOHD

Low voltage trip - 2 to 30 volts in, 12 volts out, 1 amp capability. Finally, a way to add amps to Ford Premium sound systems - without turn-on or turn-off pop!

#TRIGLOHD



TRIGRCA

System turn-off pop eliminator. Do you have a noisy source unit that's causing pops? Install our TRIGRCA in the RCA signal path and stop the pop before it gets to your amps!

#TRIGRCA



TRIGDLYA

Adjustable amp turn-on delay. For those instances in which a turn-on pop is coming from the source unit or is being caused by the timing functions of the factory head unit's wakeup lead.

#TRIGDLYA



ISOLATORS, NOISE decoupler, SWITCHING devices

SoundGate's line of Isolation devices allow a shop to produce totally noise-free installations, time after time. The best installation techniques can't solve isolation problems that are inherent in an aftermarket car audio component. The differences in voltage potential between two different car audio components mounted at different ends

ISO2

Our ISO2 completely DC isolates two components in a sound system. If you've installed what should be an awesome-sounding system only to have it ruined by system hiss, pops, clicks, or CD tracking-type noise, this unit will completely eliminate them! This is a high-performance version of our DCPL2, at right.

#ISO2



of the vehicle can spell problems for components that haven't been optimally designed. SoundGate now makes the hiss, pop, and click problems of these types of installations a thing of the past. Also, our A/B switch allows two different RCA output devices to be hooked up to the same amplification system.

ISO4

The same high-quality, custom-built components as our ISO2 in a 4-channel version! Both our ISO2, and ISO4, have extended lower frequency response (compared to our budget-minded DCPL2), and higher voltage capabilities - perfect for those high-voltage-output competition head units.

#ISO4



DCPL2

A less expensive alternative to our ISO2 and ISO4, the DCPL2 is a signal decoupler that completely DC isolates two components in a sound system. Eliminate hiss, pops, and CD tracking type noises in the least expensive systems.

#DCPL2



ABSWC1

Do you have a customer that wants to add an MP3 player or portable CD to an existing amplified system? If so, the ABSWC1 is the answer. Switches between two source units quietly and reliably!

No noise!

#ABSWC1



USE FOR HOOKING UP MP3 PLAYERS!

FILTER devices

Noise filters are not typically thought of as very high-tech devices. In most cases we try not to use them. However, there come those times when you just have to use a filter to eliminate noise in the system. We decided that if filters are needed we should make sure that you

FLTR10E

Electronic noise filter, 10 amp peak (active design for ultimate filtering capability).

#FLTR10E



PERFECT FOR RECEIVERS OR SMALL AMPS

FLTR25E

Electronic noise filter, 25 amp peak (active design for exceptional filtering capability).

#FLTR25E



FOR AMPLIFIER INSTALLATIONS

have the best. Our filters have been designed by Dave Navone, the undisputed authority on solving all types of noise problems in car audio systems. If you need noise filters, we absolutely guarantee these to be the best.

FLTR25TE

Electronic noise filter, 25 amp peak (active design with toroid, for ultimate filtering capability).

#FLTR25TE



THE ULTIMATE NOISE FILTER

TEST DISCS

Until these CDs came along there was no way to quickly and accurately set up an automotive sound system without using some very high-end and expensive pieces of test equipment. Engineered and produced using state-of-the-art equipment, these discs are a must-have for any installer concerned with getting systems set up quickly and correctly.

CD101 lets you measure the reference level of components, test the reproduction quality of a system when driven with very low levels, and check speaker polarity. Also included are low frequency tests for checking rattling or buzzing panels in a car, and low frequency bursts for testing sub systems.

#CD101

CD102 is the tool for testing and evaluating the staging and imaging of a system. One and a half years in the making, this disc has been used as judging software, and is indispensable in determining correct speaker placement.

#CD102

CD103 - "My Disc" contains 86 tracks. Learn what distortion really means in a system. Optimize the overall gain structure of a complete system, check speaker polarity (used with PLR1), check imaging, evaluate the noise floor of the system, and others!

#CD103

CD104 The ultimate amplifier-level setting tool!

#CD104

CD105 - "Your Disc" was produced for the audio retailer, technician, or consumer as a sales and training aid. It is intended to make it easier to demonstrate and evaluate some of the more difficult to explain characteristics and specifications of an audio system. This disc demonstrates differences in: 1) Car wind, road and tire noise, 2) Spectral balance, 3) Crossover separation, 4) System noise, 5) and Distortion. A 'must-have' for retailers!

#CD105



CAR AUDIO BOOKS



In keeping with the SoundGate philosophy of "never stop learning", we've made the Richard Clark and David Navone publications available to our dealers. We feel these publications are invaluable when it comes to expanding your knowledge of "how things work, and if they don't...why not?" Yet another way to give yourself the edge.

A2TBBOOK

Over 800 pages of the most thoroughly-researched technical information concerning car audio in existence. Written by Richard Clark, Dave Navone, and a host of contributing writers, this volume will get you up to speed on almost any technical subject you can imagine that concerns car audio. Everything from the most basic principles of electricity, to high end concepts concerning acoustics. A MUST-HAVE for all shops.

#A2TBBOOK

ALTBOOK

Every installer has faced that dreaded sound when the car is started for the first time. Alternator whine can be a confusing problem to diagnose and solve. This book, written by the country's authority on noise problems in car audio systems, Dave Navone, explains what alternator noise is, and how to get rid of it. A fully illustrated resource that should be a part of every installer's tool box.

#ALTBOOK

SECRETS BOOK

Everyone knows how big the Soundoff scene is, and this book should be a first read by anyone contemplating building a new system, or tuning an existing one up for the next contest. Richard Clark's presence on the competition circuit is legendary, and he and David Navone's workshops on high-end car audio are the most valuable ever presented in our industry. Get one copy for yourself, and additional copies for every one of your customers involved in SPL, or sound-quality contests!

#SECRETSBK



DIAGNOSTIC AND TEST EQUIPMENT

GEN1K

The GEN1K produces a 1KHz sine wave through both speaker level and RCA outputs. A calibrated knob adjusts the pre-amp level signal from zero up to 3 volts RMS. With this feature the GEN1K can be used to optimally set amplifier levels in a system. Using the GEN1K's speaker level outputs, speaker wires can be easily located and tested.

#GEN1K



GENADJ

The GENADJ provides multiple frequency outputs of 50, 100, 200, 400, and 800 Hz. The alligator-clipped leads can drive a speaker up to an 8-volt peak-to-peak level. The RCA output is user adjustable from zero, up to 3 volts. Use this device to find exactly where noise is entering a system by driving each component of the system with the GENADJ. Also use to test speaker leads.

#GENADJ



GENSWEEP

The new GENSWEEP is a variable-frequency (20 Hz to 2 KHz) version of our GENADJ shown below left. 0 - 8v output peak-to-peak. This unit is perfect for full-range systems, where the GENADJ is better-suited for use in electronically crossed-over systems.

#GENSWEEP



PLR1

The PLR1 is the unit to use for checking speaker polarity. The first step after completing any system install should be a polarity check. Use the PLR1 along with track 23 on CD103 to check every speaker in the system. The affordable solution for guaranteeing your systems get off to the right start.

#PLR1



SOUNDGATE® 2002 Application Guide

MAKE and MODEL	YEARS	VEHICLE IDENTIFIER/QUALIFIER	INSTALL NOTES (pgs 44-52)	RECEIVER INSTALLATIONS (see part #)	RECEIVER FOOTNOTES	REAR ONSTAR (see part #)	CO CHANGER INTERFACE APPLICATIONS AND FOOTNOTES (see part #)	AUXILIARY INPUT INTERFACES (see part #)	STEERING WHEEL CONTROL INTERFACE APPLICATIONS AND FOOTNOTES (see part #)	AMPLIFIER INSTALLATION APPLICATIONS AND FOOTNOTES (Line output converter required)	FACTORY AMPLIFIER LOCATION	
A4S4 (cont.)	1994-00	With factory Bose system	#15	CEMAA	(R1, R5, R6)		ALVYKXNWT with YWZBLA (CA)	SOS1 with DOCKAUDI (D1) or ALUAW (D2)	Type 2 (L0C8 or L0CPREA)	Type 2 (L0C8 or L0CPREA)	G	
		With factory Concert Sound system	#15	CEMAA	(R1, R5, R6)		ALVYKXNWT with YWZBLA (CA)	SOS1 with DOCKAUDI (D1) or ALUAW (D2)	Type 2 (L0C8 or L0CPREA)	Type 2 (L0C8 or L0CPREA)	E	
	1996-97	With factory Bose system	#15	CEMAA	(R1, R5, R6)		Factory only			Type 2 (L0C8 or L0CPREA)	G	
		With factory Concert Sound system	#15	CEMAA	(R1, R5, R6)		Factory only			Type 2 (L0C8 or L0CPREA)	E	
	A6S6	2002	With factory Bose system	#15	CEMAA	(R1, R2, R5)	SterilMod	ALVYKXNWT with YWZBLA (CA)	SOS1 with DOCKAUDI (D1) or ALUAW (D2)	Type 1	Type 2 (L0C8 or L0CPREA)	F
			With factory Gamma system	#15	CEMAA	(R1, R2, R5)	SterilMod	ALVYKXNWT with YWZBLA (CA)	SOS1 with DOCKAUDI (D1) or ALUAW (D2)	Type 1	Type 2 (L0C8 or L0CPREA)	F
		1998-01	With factory Bose system	#15	CEMAA	(R1, R2, R5)		ALVYKXNWT with YWZBLA (CA)	SOS1 with DOCKAUDI (D1) or ALUAW (D2)	Type 1	Type 2 (L0C8 or L0CPREA)	F
			With factory Gamma system	#15	CEMAA	(R1, R2, R5)		ALVYKXNWT with YWZBLA (CA)	SOS1 with DOCKAUDI (D1) or ALUAW (D2)	Type 1	Type 2 (L0C8 or L0CPREA)	F
	A6S8	1995-97	With factory Bose system	#15	CEMAA	(R1, R2, R5)		Factory only			Type 2 (L0C8 or L0CPREA)	sub only
			With factory Bose system, without Nav	#15	CEMAA	(R1, R2, R5)	SterilMod	ALVYKXNWT with YWZBLA (CA)	SOS1 with DOCKAUDI (D1) or ALUAW (D2)	Type 2 (L0C8 or L0CPREA)	Type 2 (L0C8 or L0CPREA)	F
2002		With factory Bose system, with Nav	#15	CEMAA	(R1, R2, R5)	SterilMod	ALVYKXNWT with YWZBLA (CA)	SOS1 with DOCKAUDI (D1) or ALUAW (D2)	Type 1	Type 1	F	
2000-01		With factory Bose system, with Nav	#15	CEMAA	(R1, R2, R5)	SterilMod	ALVYKXNWT with YWZBLA (CA)	SOS1 with DOCKAUDI (D1) or ALUAW (D2)	Type 1	Type 2 (L0C8 or L0CPREA)	F	
A6S9	1999-99	With factory Bose system	#15	CEMAA	(R1, R2, R5)		Not Recommended			Type 1	F	
		With factory Bose system, with Nav	#15	CEMAA	(R1, R2, R5)		Not Recommended			Type 1 or 2	F	
	1999-99	With factory Bose system	#15	CEMAA	(R1, R2, R5)		Factory only			Type 1 or 2	F	
		With factory Bose system	#15	CEMAA	(R1, R2, R5)		Factory only			Type 1 or 2	F	
A6S10	2001-02	With factory Bose system	#15	CEMAA	(R1, R2, R5)	SterilMod	ALVYKXNWT with YWZBLA (CA)	SOS1 with DOCKAUDI (D1) or ALUAW (D2)	Type 1 or 2	Type 1 or 2	F	
		With 5-speaker system	#15	CEMAA	(R1, R2, R5)		ALVYKXNWT with YWZBLA (CA)	SOS1 with DOCKAUDI (D1) or ALUAW (D2)	Type 1 or 2	Type 1 or 2	F	
	1999-99	With 5-speaker Bose System	#15	CEMAA	(R1, R2, R5)		ALVYKXNWT with YWZBLA (CA)	SOS1 with DOCKAUDI (D1) or ALUAW (D2)	Type 1	Type 1	F	
		With 5-speaker Bose System	#15	CEMAA	(R1, R2, R5)		ALVYKXNWT with YWZBLA (CA)	SOS1 with DOCKAUDI (D1) or ALUAW (D2)	Type 1	Type 1	F	
A6S11	1994-98	AI	#14	CEMAA	(R1, R5)	SterilMod	ALVYKXNWT with YWZBLA (CA)	SOS1 with DOCKAUDI (D1) or ALUAW (D2)	Type 1 or 2 (L0C8 or L0CPREA)	Type 1 or 2 (L0C8 or L0CPREA)	E - right side	
	1999-02	Without Bose system	#14	CEMAA	(R1, R5)		ALVYKXNWT with YWZBLA (CA)	SOS1 with DOCKAUDI (D1) or ALUAW (D2)	Type 1	Type 1	none	
	1999-02	Without Bose system	#14	CEMAA	(R1, R5)		ALVYKXNWT with YWZBLA (CA)	SOS1 with DOCKAUDI (D1) or ALUAW (D2)	Type 1	Type 1	none	
	1999-02	Without Bose system	#14	CEMAA	(R1, R5)		ALVYKXNWT with YWZBLA (CA)	SOS1 with DOCKAUDI (D1) or ALUAW (D2)	Type 1	Type 1	none	
BMW	3-Series (AI, except sedan) including M and Z series	2002	With Harmon Karbon system	CEMAA	(R1, R5)		ABMKSXNMPPOBMSIBMWS/F5S (C1, C4)	SOS1 with DOCKBMW (D1) or ALUBMW (D2)	Type 1	Type 1	G	
			Without Harmon Karbon system	CEMAA	(R1, R5)		ABMKSXNMPPOBMSIBMWS/F5S (C1, C4)	SOS1 with DOCKBMW (D1) or ALUBMW (D2)	Type 1	Type 1	G	
		2001	With Harmon Karbon system	CEMAA	(R1, R5)		ABMKSXNMPPOBMSIBMWS/F5S (C1, C4)	SOS1 with DOCKBMW (D1) or ALUBMW (D2)	Type 1	Type 1	G	
			Without Harmon Karbon system	CEMAA	(R1, R5)		ABMKSXNMPPOBMSIBMWS/F5S (C1, C4)	SOS1 with DOCKBMW (D1) or ALUBMW (D2)	Type 1	Type 1	G	
		1999-00	With Harmon Karbon system	CEMAA	(R1, R5)		ABMKSXNMPPOBMSIBMWS/F5S (C1, C4)	SOS1 with DOCKBMW (D1) or ALUBMW (D2)	Type 1	Type 1	G	
			Without Harmon Karbon system	CEMAA	(R1, R5)		ABMKSXNMPPOBMSIBMWS/F5S (C1, C4)	SOS1 with DOCKBMW (D1) or ALUBMW (D2)	Type 1	Type 1	G	
		2002	With Harmon Karbon system	CEMAA	(R1, R5)		ABMKSXNMPPOBMSIBMWS/F5S (C1, C4)	SOS1 with DOCKBMW (D1) or ALUBMW (D2)	Type 1	Type 1	G	
			Without Harmon Karbon system	CEMAA	(R1, R5)		ABMKSXNMPPOBMSIBMWS/F5S (C1, C4)	SOS1 with DOCKBMW (D1) or ALUBMW (D2)	Type 1	Type 1	G	
		1999-01	With Harmon Karbon system	CEMAA	(R1, R5)		ABMKSXNMPPOBMSIBMWS/F5S (C1, C4)	SOS1 with DOCKBMW (D1) or ALUBMW (D2)	Type 1	Type 1	G	
			Without Harmon Karbon system	CEMAA	(R1, R5)		ABMKSXNMPPOBMSIBMWS/F5S (C1, C4)	SOS1 with DOCKBMW (D1) or ALUBMW (D2)	Type 1	Type 1	G	
3-Series (AI)	1996-98	With Harmon Karbon system	CEMAA	(R1, R5)		ABMKSXNMPPOBMSIBMWS/F5S (C1, C4)	SOS1 with DOCKBMW (D1) or ALUBMW (D2)	Type 1	Type 1	G		
		Without Harmon Karbon system	CEMAA	(R1, R5)		ABMKSXNMPPOBMSIBMWS/F5S (C1, C4)	SOS1 with DOCKBMW (D1) or ALUBMW (D2)	Type 1	Type 1	G		
	1996-98	AI	CEMAA	(R2)		Factory only				Type 1	E	
	1995-98	AI	CEMAA	(R1, R5)		Factory only				Type 1	G	
3-Series (AI)	1995-94	AI	CEMAA	(R3)		Note #15				Type 1	G	
	1999	With 4-speaker factory system	RT1	(R5)						Type 1	none	
	1997-99	With 6-speaker factory system	PWR1	(R5)						Type 1	G	
	1995-98	AI	PWR1	(R2)						Type 1	G	
5-Series	2002	With factory Harmon	#15	CEMAA	(R1, R5)		ABMKSXNMPPOBMSIBMWS/F5S (C1, C4)	SOS1 with DOCKBMW (D1) or ALUBMW (D2)	Type 1	Type 1	G	
		Without factory Harmon	#15	CEMAA	(R1, R5)		ABMKSXNMPPOBMSIBMWS/F5S (C1, C4)	SOS1 with DOCKBMW (D1) or ALUBMW (D2)	Type 1	Type 1	G	
	1997-01	With DSP	Call for details	(R10)		Factory Only				Call for details	G	
	1995-98	Without DSP	Without DSP	(R10)		1995-98 Factory Only				Type 2 (L0C8 only)	G	
5-Series (AI)	1995-98	AI	CEMAA	(R5)						Type 1	none	
	1997-99	AI	PWR1	(R3)						Type 1	none	
	1997-99	AI	CEMAA	(R10)						Type 1	none	
	2002	Information forthcoming	#15	CEMAA	(R10)		ABMKSXNMPPOBMSIBMWS/F5S (C1, C4)	SOS1 with DOCKBMW (D1) or ALUBMW (D2)	Type 1	Type 1	G	
7-Series	1995-98	Without DSP	Without DSP	(R10)		Factory Only				Call for details	G	
	1995-98	With DSP	With DSP	(R10)		Factory Only				Type 1	E	
	1995-98	AI thru Aug. 98	AI thru Aug. 98	(R3)		Factory only				Type 1	none	
	1996-94	AI	PWR1	(R3)		Factory only				Type 1	none	
X5	2002	Sport Utility		CEMAA	(R1, R5)		ABMKSXNMPPOBMSIBMWS/F5S (C1, C4)	SOS1 with DOCKBMW (D1) or ALUBMW (D2)	Type 1	Type 1	G	
	2004-01	Sport Utility without DSP		CEMAA	(R1, R5)		ABMKSXNMPPOBMSIBMWS/F5S (C1, C4)	SOS1 with DOCKBMW (D1) or ALUBMW (D2)	Type 1	Type 1	G	

KICKER000132

SOUNDGATE® 2002 Application Guide

MAKE and MODEL	YEARS	VEHICLE IDENTIFIER/ EQUALIFIER	INSTALL NOTES (pgs 44-52)	RECEIVER INSTALLATIONS use part #	RECEIVER FOOTNOTES	REMAIN ONSTAR use part #	CD CHANGER INTERFACE APPLICATIONS AND FOOTNOTES use part #	AUXILIARY INPUT INTERFACES use part #	STEERING WHEEL CONTROL INTERFACE APPLICATIONS AND FOOTNOTES use part #	AMPLIFIER INSTALLATION APPLICATIONS AND FOOTNOTES (Use output connector required)	FACTORY AMPLIFIER LOCATION
25 (cont)	2000-01	Sport Utility with DSP		Call for details	(R10)	Factory Only	Call for details		Call for details		G
	2001-02	With Harman/Kardon system		CEM4A	(R1, R6)	Factory changer is standard equipment (CS)			Type 1		G
BUICK	Century	With factory Base system	#19, 25	CEM4A	(R1, R6)	StarMod (S9-20)		SSS1 with DOCK3GMZ (S9-00) (D1)	REMOUELS	Type 2 (LOC8 or LOC9R)	E
		Without Base system	#19, 25	Interface not needed		StarMod (S9-20)		SSS1 with DOCK3GMZ (S9-00) (D1)	REMOUELS	Type 1	none
ELECTRA	1997-98	AI	#37	GMB1	(R1, R6, R11)					Type 1	none
		Without factory Base system	#37	Interface not needed						Type 2 (LOC8 only)	none
LACAZA	2000-02	AI	#19, 20, 25, 26, 32, 63	Not Recommended		StarMod (T1)		SSS1 with DOCK3GMZ (S9-00) (D1)	Not recommended	Type 1	none
		Without factory Base system	#25 (S9-39)	Interface not needed		StarMod (S9-20)		SSS1 with DOCK3GMZ (S9-00) (D1)	REMOUELS	Type 1	none
Park Avenue or Ultra	1997-02	With 6-speaker system	#25	CEM4A	(R1, R6)	StarMod (S9-20)		SSS1 with DOCK3GMZ (S9-00) (D1)	REMOUELS	Type 1	none
		With 9-speaker system	#21, 23, 25	Do Not Use Interface		StarMod (S9-20)		SSS1 with DOCK3GMZ (S9-00) (D1)	REMOUELS	Type 1 or 2	none
Regal	1998-98	AI	#37	GMB1	(R1, R6, R11)					Type 1	none
		Without factory Base system	#37	Interface not needed						Type 2 (LOC8 only)	none
Riviera	1998-98	AI	#37	GMB1	(R1, R6, R11)					Type 1	none
		Without factory Base system	#37	Interface not needed						Type 2 (LOC8 only)	none
Road	1998-97	Without CPT screen	#37	CEM4A	(R1, R6)					Type 1	none
		Without factory sub	#19, 20, 25	Interface not needed		StarMod		SSS1 with DOCK3GMZ (S9-00) (D1)	REMOUELS	Type 1	none
Rendezvous	2002	With 10-speaker system	#25, 26, 28	CEM4A	(R1, R6)	StarMod (T1)		SSS1 with DOCK3GMZ (S9-00) (D1)	REMOUELS or GMSWT	Type 1	none
		Without factory Base system	#25, 26, 28	Interface not needed		StarMod (T1)		SSS1 with DOCK3GMZ (S9-00) (D1)	REMOUELS or GMSWT	Type 1	none
Skyline	1997-98	AI	#37	CEM4A	(R1, R6)	StarMod (S9-20)		SSS1 with DOCK3GMZ (D1)	REMOUELS	Type 1 or 2	E
		Without factory Base system	#37	Interface not needed				SSS1 with DOCK3GMZ (D1)	REMOUELS	Type 1 or 2	none
Somerset	1998-97	AI	#37	GMB1	(R1, R6, R11)					Type 1	none
		Without factory Base system	#37	Interface not needed						Type 2 (LOC8 only)	none
Suzuki	1997-98	AI	#37	GMB1	(R1, R6, R11)					Type 1	none
		Without factory Base system	#37	Interface not needed						Type 2 (LOC8 only)	none
Taurus	1997-98	AI	#37	GMB1	(R1, R6, R11)					Type 1	none
		Without factory Base system	#37	Interface not needed						Type 2 (LOC8 only)	none
Taurus	1998-98	AI	#37	GMB1	(R1, R6, R11)					Type 1	none
		Without factory Base system	#37	Interface not needed						Type 2 (LOC8 only)	none
Taurus	1999-00	AI	#37	GMB1	(R1, R6, R11)					Type 1	none
		Without factory Base system	#37	Interface not needed						Type 2 (LOC8 only)	none
Taurus	2000-01	AI	#37	GMB1	(R1, R6, R11)					Type 1	none
		Without factory Base system	#37	Interface not needed						Type 2 (LOC8 only)	none
Taurus	2001-02	AI	#37	GMB1	(R1, R6, R11)					Type 1	none
		Without factory Base system	#37	Interface not needed						Type 2 (LOC8 only)	none
Taurus	2002	AI	#37	GMB1	(R1, R6, R11)					Type 1	none
		Without factory Base system	#37	Interface not needed						Type 2 (LOC8 only)	none
Taurus	2003	AI	#37	GMB1	(R1, R6, R11)					Type 1	none
		Without factory Base system	#37	Interface not needed						Type 2 (LOC8 only)	none
Taurus	2004	AI	#37	GMB1	(R1, R6, R11)					Type 1	none
		Without factory Base system	#37	Interface not needed						Type 2 (LOC8 only)	none
Taurus	2005	AI	#37	GMB1	(R1, R6, R11)					Type 1	none
		Without factory Base system	#37	Interface not needed						Type 2 (LOC8 only)	none
Taurus	2006	AI	#37	GMB1	(R1, R6, R11)					Type 1	none
		Without factory Base system	#37	Interface not needed						Type 2 (LOC8 only)	none
Taurus	2007	AI	#37	GMB1	(R1, R6, R11)					Type 1	none
		Without factory Base system	#37	Interface not needed						Type 2 (LOC8 only)	none
Taurus	2008	AI	#37	GMB1	(R1, R6, R11)					Type 1	none
		Without factory Base system	#37	Interface not needed						Type 2 (LOC8 only)	none
Taurus	2009	AI	#37	GMB1	(R1, R6, R11)					Type 1	none
		Without factory Base system	#37	Interface not needed						Type 2 (LOC8 only)	none
Taurus	2010	AI	#37	GMB1	(R1, R6, R11)					Type 1	none
		Without factory Base system	#37	Interface not needed						Type 2 (LOC8 only)	none
Taurus	2011	AI	#37	GMB1	(R1, R6, R11)					Type 1	none
		Without factory Base system	#37	Interface not needed						Type 2 (LOC8 only)	none
Taurus	2012	AI	#37	GMB1	(R1, R6, R11)					Type 1	none
		Without factory Base system	#37	Interface not needed						Type 2 (LOC8 only)	none
Taurus	2013	AI	#37	GMB1	(R1, R6, R11)					Type 1	none
		Without factory Base system	#37	Interface not needed						Type 2 (LOC8 only)	none
Taurus	2014	AI	#37	GMB1	(R1, R6, R11)					Type 1	none
		Without factory Base system	#37	Interface not needed						Type 2 (LOC8 only)	none
Taurus	2015	AI	#37	GMB1	(R1, R6, R11)					Type 1	none
		Without factory Base system	#37	Interface not needed						Type 2 (LOC8 only)	none
Taurus	2016	AI	#37	GMB1	(R1, R6, R11)					Type 1	none
		Without factory Base system	#37	Interface not needed						Type 2 (LOC8 only)	none
Taurus	2017	AI	#37	GMB1	(R1, R6, R11)					Type 1	none
		Without factory Base system	#37	Interface not needed						Type 2 (LOC8 only)	none
Taurus	2018	AI	#37	GMB1	(R1, R6, R11)					Type 1	none
		Without factory Base system	#37	Interface not needed						Type 2 (LOC8 only)	none
Taurus	2019	AI	#37	GMB1	(R1, R6, R11)					Type 1	none
		Without factory Base system	#37	Interface not needed						Type 2 (LOC8 only)	none
Taurus	2020	AI	#37	GMB1	(R1, R6, R11)					Type 1	none
		Without factory Base system	#37	Interface not needed						Type 2 (LOC8 only)	none
Taurus	2021	AI	#37	GMB1	(R1, R6, R11)					Type 1	none
		Without factory Base system	#37	Interface not needed						Type 2 (LOC8 only)	none
Taurus	2022	AI	#37	GMB1	(R1, R6, R11)					Type 1	none
		Without factory Base system	#37	Interface not needed						Type 2 (LOC8 only)	none
Taurus	2023	AI	#37	GMB1	(R1, R6, R11)					Type 1	none
		Without factory Base system	#37	Interface not needed						Type 2 (LOC8 only)	none
Taurus	2024	AI	#37	GMB1	(R1, R6, R11)					Type 1	none
		Without factory Base system	#37	Interface not needed						Type 2 (LOC8 only)	none
Taurus	2025	AI	#37	GMB1	(R1, R6, R11)					Type 1	none
		Without factory Base system	#37	Interface not needed						Type 2 (LOC8 only)	none
Taurus	2026	AI	#37	GMB1	(R1, R6, R11)					Type 1	none
		Without factory Base system	#37	Interface not needed						Type 2 (LOC8 only)	none
Taurus	2027	AI	#37	GMB1	(R1, R6, R11)					Type 1	none
		Without factory Base system	#37	Interface not needed						Type 2 (LOC8 only)	none
Taurus	2028	AI	#37	GMB1	(R1, R6, R11)					Type 1	none
		Without factory Base system	#37	Interface not needed						Type 2 (LOC8 only)	none
Taurus	2029	AI	#37	GMB1	(R1, R6, R11)					Type 1	none
		Without factory Base system	#37	Interface not needed						Type 2 (LOC8 only)	none
Taurus	2030	AI	#37	GMB1	(R1, R6, R11)					Type 1	none
		Without factory Base system	#37	Interface not needed						Type 2 (LOC8 only)	none
Taurus	2031	AI	#37	GMB1	(R1, R6, R11)					Type 1	none
		Without factory Base system	#37	Interface not needed						Type 2 (LOC8 only)	none
Taurus	2032	AI	#37	GMB1	(R1, R6, R11)					Type 1	none
		Without factory Base system	#37	Interface not needed						Type 2 (LOC8 only)	none
Taurus	2033	AI	#37	GMB1	(R1, R6, R11)					Type 1	none
		Without factory Base system	#37	Interface not needed						Type 2 (LOC8 only)	none
Taurus	2034	AI	#37	GMB1	(R1, R6, R11)					Type 1	none
		Without factory Base system	#37	Interface not needed						Type 2 (LOC8 only)	none
Taurus	2035	AI	#37	GMB1	(R1, R6, R11)					Type 1	none
		Without factory Base system	#37	Interface not needed						Type 2 (LOC8 only)	none
Taurus	2036	AI	#37	GMB1	(R1, R6, R11)					Type 1	none
		Without factory Base system	#37	Interface not needed						Type 2 (LOC8 only)	none
Taurus	2037	AI	#37	GMB1	(R1, R6, R11)					Type 1	none
		Without factory Base system	#37	Interface not needed						Type 2 (LOC8 only)	none
Taurus	2038	AI	#37	GMB1	(R1, R6, R11)					Type 1	none
		Without factory Base system	#37	Interface not needed						Type 2 (LOC8 only)	none
Taurus	2039	AI	#37	GMB1	(R1, R6, R11)					Type 1	none
		Without factory Base system	#37	Interface not needed						Type 2 (LOC8 only)	none
Taurus	2040	AI	#37	GMB1	(R1, R6, R11)					Type 1	none
		Without factory Base system	#37	Interface not needed						Type 2 (LOC8 only)	none
Taurus	2041	AI	#37	GMB1	(R1, R6, R11)					Type 1	none
		Without factory Base system	#37	Interface not needed						Type 2 (LOC8 only)	none
Taurus	2042	AI	#37	GMB1	(R1, R6, R11)					Type 1	none
		Without factory Base system	#37	Interface not needed						Type 2 (LOC8 only)	none
Taurus	2043	AI	#37	GMB1	(R1, R6, R11)					Type 1	none
		Without factory Base system	#37	Interface not needed						Type 2 (LOC8 only)	none
Taurus	2044	AI	#37	GMB1	(R1, R6, R11)					Type 1	none
		Without factory Base system	#37	Interface not needed						Type 2 (LOC8 only)	none
Taurus	2045	AI	#37	GMB1	(R1, R6, R11)					Type 1	none
		Without factory Base system	#37	Interface not needed						Type 2 (LOC8 only)	none
Taurus	2046	AI	#37	GMB1	(R1, R6, R11)					Type 1	none
		Without factory Base system	#37	Interface not needed						Type 2 (LOC8 only)	none
Taurus	2047	AI	#37	GMB1	(R1, R6, R11)					Type 1	none
		Without factory Base system	#37	Interface not needed						Type 2 (LOC8 only)	none
Taurus	2048	AI	#37	GMB1	(R1, R6, R11)						

SOUNDGATE® 2002 Application Guide

MAKE and MODEL	YEARS	VEHICLE IDENTIFIER/ QUALIFIER	INSTALL NOTES (pgs 44-52)	RECEIVER INSTALLATIONS use part #	RECEIVER FOOTNOTES use part #	RETAIN ONSTAR use part #	CD CHANGER INTERFACE APPLICATIONS AND FOOTNOTES use part #	STEERING WHEEL CONTROL INTERFACE APPLICATIONS AND FOOTNOTES use part #	AUXILIARY INPUT INTERFACES use part #	AMPLIFIER INSTALLATION APPLICATIONS AND FOOTNOTES (Line output converter required)	FACTORY AMPLIFIER LOCATION
Deville (cont)	1990-96	With factory Bose system Without factory Bose system	#37, 25 (B6)	GMB1 Interface not needed	(R1, R6, R11)		REMO1E1.5 (R6 only)	Type 2 (L0C8 only)		Type 1 (L0C8 only)	none
Eldorado	1990-92	With 4-speaker non-Bose system	#25, 26	Interface not needed		StarMod (T1)	Not recommended	Type 1		Type 1	none
	1990-92	With 4-speaker Bose system	#26	Not recommended			Not recommended	Type 1		Type 1	E cent
	1992-95	With factory Bose system	#22, 37	GMB1	(R1, R6, R11)			Type 2 (L0C8 only)		Type 2 (L0C8 only)	none
	1995-91	Without factory Bose system	#37	Interface not needed				Type 1		Type 1	none
Escalade	1995-91	With factory Bose system	#37	Interface not needed				Type 1		Type 1	none
	1995-91	Without factory Bose system	#37	Interface not needed				Type 2 (L0C8 only)		Type 2 (L0C8 only)	none
	2001-02	With 4-speaker Bose audio system	#25	Interface not needed		StarMod (T2)		Type 1		Type 1	none
	2001-02	With 4-speaker (dual) system	#25, 28	CEM4A	(R1, R6)	StarMod (T2)		Type 1 or 2		Type 1 or 2	A
Essex	1999-00	With Bose audio system	#25, 28	CEM4A	(R1, R6)	StarMod (T2)		Type 1 or 2		Type 1 or 2	G
	1999-00	With luxury audio system	#25	GMB1	(R1, R6, R11)			Type 2 (L0C8 only)		Type 2 (L0C8 only)	K
	1999-00	With Bose audio system	#25	Interface not needed				Type 1		Type 1	A
	2002	With amplified system	#37	CEM4A	(R1, R6)	StarMod (T2)		REMO1E1.5 or GMSW1		Type 1	C
Fleewood and Brookwood	1992-95	With factory Bose system	#37	GMB1	(R1, R6, R11)			Type 2 (L0C8 only)		Type 2 (L0C8 only)	E
	1992-95	Without factory Bose system	#37	Interface not needed				Type 1		Type 1	none
	2000-02	Call SoundGate before Starting	#19, 20, 24, 25, 26					Type 1		Type 1	E
	1999-99	Call SoundGate before Starting	#19, 20, 24, 25, 26					Type 1		Type 1	E
Gazer	1992-95	With factory Bose system	#37, 22	GMB1 (R2-3S)	(R1, R6, R11)			Type 2 (L0C8 only)		Type 2 (L0C8 only)	E
	1992-95	Without factory Bose system	#37, 22	Interface not needed				Type 1		Type 1	I
	1999-91	With factory Bose system	#37	GMB1	(R1, R6, R11)			Type 2 (L0C8 only)		Type 2 (L0C8 only)	I
	1999-91	Without factory Bose system	#37	Interface not needed				Type 1		Type 1	none
CHEVROLET	1990-92	All	#28, 50	Interface not needed				Type 1		Type 1	G (sub)
	2002	With amplified system		CEM4A	(R1, R6)	StarMod (T2)		Type 1		Type 1	C
	1990-92	With factory Bose system	#25	CEM4A	(R1, R6)	StarMod (R4-01)		REMO1E1.5 or GMSW1		Type 1 or 2	K
	1990-92	Without factory Bose system	#25	Interface not needed				REMO1E1.5 or GMSW1		Type 1	none
	1992-97	All		Interface not needed				REMO1E1.5 or GMSW1 (R7 only)		Type 1	none
	1990-91	With amplified system		CEM4A	(R1, R6)			Type 1 or 2		Type 1 or 2	J
	1997-02	With 8-speaker Monsoon system	#17	Do Not Use Interface				REMO1E1.5 or GMSW1		Type 1 or 2 (A6)	F
	1994-95	Without Monsoon system (4 speakers)	#35	Interface not needed				REMO1E1.5 or GMSW1		Type 1	none
	1994-95	With factory Bose system	#10, 37	GMB1	(R1, R6, R11)			REMO1E1.5 or GMSW1		Type 2 (L0C8 only)	I
	1990-93	Without factory Bose system		Interface not needed				REMO1E1.5 or GMSW1		Type 1	none
	1990-93	With factory Bose system	#10, 37	GMB1	(R1, R6, R11)			Type 2 (L0C8 only)		Type 2 (L0C8 only)	I
	1991-98	Without factory Bose system	#37	Interface not needed				Type 1		Type 1	none
Caprice	1991-93	With factory Bose system	#37	GMB2	(R1, R6, R11)			Type 2 (L0C8 only)		Type 2 (L0C8 only)	G
	1991-93	Without factory Bose system	#37	Interface not needed				Type 1		Type 1	none
	1991-93	With factory Bose system	#37	CEM4A	(R1, R6)			Type 2 (L0C8 only)		Type 2 (L0C8 only)	E
Cavalier	2002	Without Bose system	#25	Interface not needed				Type 1		Type 1	none
	2002	With Monsoon audio system	#25	CEM4A	(R1, R6)	StarMod (T1)		Type 1 or 2 (A6)		Type 1 or 2 (A6)	E
	2000-01	Without Monsoon audio system	#18, 26	Interface not needed				Type 1		Type 1	none
	2000-01	With Monsoon audio system	#18, 26	Interface not needed				Type 1		Type 1	none
1999-99	All	With Monsoon audio system	#18, 26	CEM4A	(R1, R6)			Type 1 or 2 (A6)		Type 1 or 2 (A6)	E
	All	Without Monsoon audio system	#18, 26	Interface not needed				Type 1		Type 1	none
1997	All	Without Monsoon audio system	#18, 26	Interface not needed			REMO1E1.5		Type 1	Type 1	none
1997	All	With Monsoon audio system	#18, 26	Interface not needed			REMO1E1.5		Type 1	Type 1	none

KICKER000134

SOUNDGATE® 2002 Application Guide

MAKE and MODEL	YEARS	VEHICLE IDENTIFIER/ QUALIFIER	INSTALL NOTES (pgs 44-52)	RECEIVER INSTALLATIONS use part #	RECEIVER FOOTNOTES (R1, R6)	RETAIN ONSTAR use part #	CD CHANGER INTERFACE APPLICATIONS AND FOOTNOTES use part #	AUXILIARY INPUT INTERFACES use part #	STEERING WHEEL CONTROL INTERFACE APPLICATIONS AND FOOTNOTES (Line output converter required) use part #	AMPLIFIER INSTALLATION APPLICATIONS AND FOOTNOTES	FACTORY AMPLIFIER LOCATION
Corvette	1991-92	With factory Bose system		Without factory Bose system	Without factory Bose system						
	1990-96	Without factory Bose system		Without factory Bose system	Without factory Bose system						
	1985-89	Without factory Bose system		Without factory Bose system	Without factory Bose system						
Express	1994	Without factory Bose system		Without factory Bose system	Without factory Bose system						
	2002	Without factory Bose system		Without factory Bose system	Without factory Bose system						
	1999-01	Without factory Bose system		Without factory Bose system	Without factory Bose system						
Impala	2000-02	Without factory Bose system		Without factory Bose system	Without factory Bose system						
	2000	Without factory Bose system		Without factory Bose system	Without factory Bose system						
Lumina	1995-99	Without factory Bose system		Without factory Bose system	Without factory Bose system						
	1991-94	Without factory Bose system		Without factory Bose system	Without factory Bose system						
Malibu	2001-02	Without factory Bose system		Without factory Bose system	Without factory Bose system						
	1998-00	Without factory Bose system		Without factory Bose system	Without factory Bose system						
Metro	1999-01	Without factory Bose system		Without factory Bose system	Without factory Bose system						
Monte Carlo	2002	Without factory Bose system		Without factory Bose system	Without factory Bose system						
	2000-01	Without factory Bose system		Without factory Bose system	Without factory Bose system						
Pickup Heavy Duty	1995-99	Without factory Bose system		Without factory Bose system	Without factory Bose system						
Pickup CK	1998-02	Without factory Bose system		Without factory Bose system	Without factory Bose system						
Pickup S10	1999-01	Without factory Bose system		Without factory Bose system	Without factory Bose system						
Pickup Silverado	1998-01	Without factory Bose system		Without factory Bose system	Without factory Bose system						
	1998-02	Without factory Bose system		Without factory Bose system	Without factory Bose system						
Prism	2001-02	Without factory Bose system		Without factory Bose system	Without factory Bose system						
Silverado	2000	Without factory Bose system		Without factory Bose system	Without factory Bose system						
	1999	Without factory Bose system		Without factory Bose system	Without factory Bose system						
	1998-01	Without factory Bose system		Without factory Bose system	Without factory Bose system						
	1998-02	Without factory Bose system		Without factory Bose system	Without factory Bose system						
Truck	1998-02	Without factory Bose system		Without factory Bose system	Without factory Bose system						

KICKER000135

SOUNDGATE® 2002 Application Guide

MAKE and MODEL	YEARS	VEHICLE IDENTIFIER/QUALIFIER	INSTALL NOTES (pgt 44-52)	RECEIVER INSTALLATIONS use part #	RECEIVER FOOTNOTES	RETAIN ONSTAR use part #	CO-CHANGER INTERFACE APPLICATIONS AND FOOTNOTES use part #	AUXILIARY INPUT INTERFACES use part #	STEERING WHEEL CONTROL INTERFACE APPLICATIONS AND FOOTNOTES use part #	AMPLIFIER INSTALLATION APPLICATIONS AND FOOTNOTES (Line output converter required)	FACTORY AMPLIFIER LOCATION
Truckster	2002	With Base Without Base	#55	DEM44 Interface not needed	(R1, R6)		Information Interfacing			Type 1	F
Vanite	1994-02	All with video system All without video system	#51, #2 #52	See Note #51 Interface not needed	Standard (T1)			SOS1 with DDC03M1 (94-99) (D1) SOS1 with DDC03M1 (94-99) (D1)	REMOTE1.5 or GSNW1 REMOTE1.5 or GSNW1	Type 1 Type 1	none none
CHRYSLER											
300M	2002	With Base audio system (4-speaker) With midline audio system (6-speaker) With infinity I audio system (8-speaker) With infinity II audio system (10-speaker)	#45 #45 #45 #45	Interface not needed DEM44 DEM44 DEM44	(R1, R6) (R1, R6) (R1, R6) (R1, R6)		AC03G or NMC02G with CREL30 (C3) AC03G or NMC02G with CREL30 (C3) AC03G or NMC02G with CREL30 (C3) AC03G or NMC02G with CREL30 (C3)	SOS1 with DDC03Y2 (D1) or AU03CHY (D2) SOS1 with DDC03Y2 (D1) or AU03CHY (D2) SOS1 with DDC03Y2 (D1) or AU03CHY (D2) SOS1 with DDC03Y2 (D1) or AU03CHY (D2)		Type 1 Type 1 Type 1 Type 1	none H-120 watt F-240 watt F-360 watt
	1994-01	With Base audio system (4-speaker) With midline audio system (6-speaker) With infinity I system (8-speaker) With infinity II system (10-speaker)	#45 (D1) #45 (D1) #45 (D1) #45 (D1)	Interface not needed DEM44 DEM44 DEM44	(R1, R6) (R1, R6) (R1, R6) (R1, R6)		AC03G or NMC02G with CREL30 (C3) AC03G or NMC02G with CREL30 (C3) AC03G or NMC02G with CREL30 (C3) AC03G or NMC02G with CREL30 (C3)	SOS1 with DDC03Y1 (D1) or AU03CHY (D2) SOS1 with DDC03Y1 (D1) or AU03CHY (D2) SOS1 with DDC03Y1 (D1) or AU03CHY (D2) SOS1 with DDC03Y1 (D1) or AU03CHY (D2)		Type 1 Type 1 Type 1 Type 1	none H-120 watt F-240 watt F-360 watt
Cirrus	1994-00	With infinity audio system (6-speaker) Without infinity system (4-speaker)	#45 (D1) Without infinity system (4-speaker)	DEM44 Interface not needed	(R1, R6) (R1, R6)		ALPM1R with ALPM1R1 (C3) ALPM1R with ALPM1R1 (C3)	SOS1 with DDC03Y3 (D1) SOS1 with DDC03Y3 (D1)		Type 1 Type 1	D none
Concorde	2002	With Base audio system (4-speaker) With midline audio system (6-speaker) With infinity I audio system (8-speaker) With infinity II system (10-speaker)	#45 #45 #45 #45	Interface not needed DEM44 DEM44 DEM44	(R1, R6) (R1, R6) (R1, R6) (R1, R6)		AC03G or NMC02G with CREL30 (C3) AC03G or NMC02G with CREL30 (C3) AC03G or NMC02G with CREL30 (C3) AC03G or NMC02G with CREL30 (C3)	SOS1 with DDC03Y2 (D1) or AU03CHY (D2) SOS1 with DDC03Y2 (D1) or AU03CHY (D2) SOS1 with DDC03Y2 (D1) or AU03CHY (D2) SOS1 with DDC03Y2 (D1) or AU03CHY (D2)		Type 1 Type 1 Type 1 Type 1	none H-120 watt F-240 watt F-360 watt
	1994-01	With Base audio system (4-speaker) With midline audio system (6-speaker) With infinity I audio system (8-speaker) With infinity II system (10-speaker)	#45 (D1) #45 (D1) #45 (D1) #45 (D1)	Interface not needed DEM44 DEM44 DEM44	(R1, R6) (R1, R6) (R1, R6) (R1, R6)		AC03G or NMC02G with CREL30 (C3) AC03G or NMC02G with CREL30 (C3) AC03G or NMC02G with CREL30 (C3) AC03G or NMC02G with CREL30 (C3)	SOS1 with DDC03Y1 (D1) or AU03CHY (D2) SOS1 with DDC03Y1 (D1) or AU03CHY (D2) SOS1 with DDC03Y1 (D1) or AU03CHY (D2) SOS1 with DDC03Y1 (D1) or AU03CHY (D2)		Type 1 Type 1 Type 1 Type 1	none H-120 watt F-240 watt F-360 watt
	1994-97	With infinity sound system With amplifier switch required in dash	#45 (D1) With amplifier switch required in dash	DEM44 PW1R	(R1, R6) (R6)		ALPM1R with ALPM1R1 (94-97) (C3) ALPM1R with ALPM1R1 (94-97) (C3)	SOS1 with DDC03Y1 (D1) or AU03CHY (D2) SOS1 with DDC03Y3 (94-97) (D1)		Type 1 or 2 Type 1	F-360 watt Glosscode E
Lebaran	1994-95	With infinity sound system	With infinity sound system	PW1R	(R6)			SOS1 with DDC03Y2 (D1) or AU03CHY (D2)		Type 1	G
LKS	2002	With Base audio system (4-speaker) With midline audio system (6-speaker) With infinity I audio system (8-speaker) With infinity II system (10-speaker)	#45 #45 #45 #45	Interface not needed DEM44 DEM44 DEM44	(R1, R6) (R1, R6) (R1, R6) (R1, R6)		AC03G or NMC02G with CREL30 (C3) AC03G or NMC02G with CREL30 (C3) AC03G or NMC02G with CREL30 (C3) AC03G or NMC02G with CREL30 (C3)	SOS1 with DDC03Y2 (D1) or AU03CHY (D2) SOS1 with DDC03Y2 (D1) or AU03CHY (D2) SOS1 with DDC03Y2 (D1) or AU03CHY (D2) SOS1 with DDC03Y2 (D1) or AU03CHY (D2)		Type 1 Type 1 Type 1 Type 1	none H-120 watt F-240 watt F-360 watt
	1994-01	With Base audio system (4-speaker) With midline audio system (6-speaker) With infinity I audio system (8-speaker) With infinity II system (10-speaker)	#45 (D1) #45 (D1) #45 (D1) #45 (D1)	Interface not needed DEM44 DEM44 DEM44	(R1, R6) (R1, R6) (R1, R6) (R1, R6)		AC03G or NMC02G with CREL30 (C3) AC03G or NMC02G with CREL30 (C3) AC03G or NMC02G with CREL30 (C3) AC03G or NMC02G with CREL30 (C3)	SOS1 with DDC03Y1 (D1) or AU03CHY (D2) SOS1 with DDC03Y1 (D1) or AU03CHY (D2) SOS1 with DDC03Y1 (D1) or AU03CHY (D2) SOS1 with DDC03Y1 (D1) or AU03CHY (D2)		Type 1 Type 1 Type 1 Type 1	none H-120 watt F-240 watt F-360 watt
	1994-98	All	All	DEM44	(R1, R6)		ALPM1R with ALPM1R1 (C3)	SOS1 with DDC03Y3 (D1)		Type 1	F
	1994-97	With infinity sound system	With infinity sound system	DEM44	(R1, R6)			SOS1 with DDC03Y2 (D1) or AU03CHY (D2)		Type 1 or 2	G
Neon	2002	All	All	DEM44	(R1, R6)			SOS1 with DDC03Y1 (D1) or AU03CHY (D2)		Type 1	none
New Yorker	1994-95	With infinity sound system	With infinity sound system	DEM44	(R1, R6)			SOS1 with DDC03Y1 (D1) or AU03CHY (D2)		Type 1	none
	1991-93	With infinity sound system	With infinity sound system	PW1R				SOS1 with DDC03Y3 (94-99) (D1)		Type 1	E
PT Cruiser	2002	All (6-speaker)	All (6-speaker)	DEM44				SOS1 with DDC03Y2 (D1) or AU03CHY (D2)		Type 1	none
Saving	2002	With base-level audio system With Premium Bold audio system	With base-level audio system With Premium Bold audio system	Interface not needed Interface not needed			AC03G or NMC02G with CREL30 (C3) AC03G or NMC02G with CREL30 (C3)	SOS1 with DDC03Y1 (D1) or AU03CHY (D2) SOS1 with DDC03Y1 (D1) or AU03CHY (D2)		Type 1 Type 1	none D
Trim & Country Van	2002	With infinity sound system Without infinity sound system	With infinity sound system Without infinity sound system	DEM44 Interface not needed	(R1, R6) (R6, D)		AC03G or NMC02G with CREL30 (C3) AC03G or NMC02G with CREL30 (C3)	SOS1 with DDC03Y2 (D1) or AU03CHY (D2) SOS1 with DDC03Y1 (D1) or AU03CHY (D2)		Type 1 or 2 Type 1	none none
	2001	With infinity sound system	With infinity sound system	DEM44	(R1, R6)		AC03G or NMC02G with CREL30 (C3)	SOS1 with DDC03Y1 (D1) or AU03CHY (D2)		Type 1 or 2	none
	1994-00	Without infinity sound system	Without infinity sound system	DEM44	(R1, R6)		AC03G or NMC02G with CREL30 (C3) ALPM1R with ALPM1R1 (C3)	SOS1 with DDC03Y1 (D1) or AU03CHY (D2) SOS1 with DDC03Y3 (D1)	REMOTE1.5 or GSNW1 (94-00)	Type 1 or 2	none

KICKER000136

SOUNDGATE® 2002 Application Guide

MAKE and MODEL	YEARS	VEHICLE IDENTIFIER/QUALIFIER	INSTALL NOTES (pgs 44-52)	RECEIVER INSTALLATIONS use part #	RECEIVER FOOTNOTES	RETAIN ONSTAR use part #	CD CHANGER INTERFACE APPLICATIONS and FOOTNOTES use part #	AUXILIARY INPUT INTERFACES use part #	STEERING WHEEL CONTROL INTERFACE APPLICATIONS and FOOTNOTES use part #	AMPLIFIER INSTALLATION APPLICATIONS and FOOTNOTES (Line output converter required)	FACTORY AMPLIFIER LOCATION
Isuzu & Country Van (cont)	1995-00	Without Infinity sound system		Interface not needed	RS-10		ALPNSIR with ALPMSRI (C3)	SOS1 with DOCKCR12 (D1)	REMOTE1.5 or CSWMT (99-00)	Type 1	none
	1999-05	With Infinity sound system		PWR1	(R6)					Type 1	
Voyager	2002	With Infinity sound system	#45	CE14A	(R1, R6)		AP2RS or KNCR2RS with CRCLSO (C3)	SOS1 with DOCKCR12 (D1) or AUOCHRY (D2)		Type 1 or 2	
		Without Infinity sound system		Interface not needed	RS-10		AP2RS or KNCR2RS with CRCLSO (C3)	SOS1 with DOCKCR12 (D1) or AUOCHRY (D2)		Type 1	none
DAEWOO	1995-02	All		Interface not needed			Not a factory option			Type 1	none
Leganza	1999-02	All		Interface not needed			Not a factory option			Type 1	none
Nubira	1999-02	All		Interface not needed			Not a factory option			Type 1	none
Avezer	1995-99	With Infinity system		CE14A	(R1, R6)		ALPNSIR with ALPMSRI (96-99) (C3)	SOS1 with DOCKCR12 (96-99) (D1)		Type 1	E
Caravan	2002	With Infinity sound system	#45	CE14A	(R1, R6)		AP2RS or KNCR2RS with CRCLSO (C3)	SOS1 with DOCKCR12 (D1) or AUOCHRY (D2)		Type 1 or 2	
		Without Infinity sound system		Interface not needed	RS-10		AP2RS or KNCR2RS with CRCLSO (C3)	SOS1 with DOCKCR12 (D1) or AUOCHRY (D2)		Type 1	none
	2001	With Infinity sound system	#45	CE14A	(R1, R6)		AP2RS or KNCR2RS with CRCLSO (C3)	SOS1 with DOCKCR12 (D1) or AUOCHRY (D2)		Type 1 or 2	
		Without Infinity sound system		Interface not needed	RS-10		AP2RS or KNCR2RS with CRCLSO (C3)	SOS1 with DOCKCR12 (D1) or AUOCHRY (D2)		Type 1	none
	1995-00	With Infinity sound system		CE14A	(R1, R6)		ALPNSIR with ALPMSRI (C3)	REMOTE1.5 or CSWMT (99-00)		Type 1 or 2	
		Without Infinity sound system		Interface not needed	RS-10		ALPNSIR with ALPMSRI (99-00)	REMOTE1.5 or CSWMT (99-00)		Type 1	none
	1987-95	With Infinity sound system		PWR1	(R6)					Type 1	
	1984-86	All		RLT	(R3)					Type 1	
Delata	2002	With Infinity sound system	#45	CE14A	(R1, R6)		AP2RS or KNCR2RS with CRCLSO (C3)	SOS1 with DOCKCR12 (D1) or AUOCHRY (D2)		Type 1	N
		Without Infinity sound system		Interface not needed			AP2RS or KNCR2RS with CRCLSO (C3)	SOS1 with DOCKCR12 (D1) or AUOCHRY (D2)		Type 1	none
	2001	With Infinity sound system	#45	CE14A	(R1, R6)		AP2RS or KNCR2RS with CRCLSO (C3)	SOS1 with DOCKCR12 (D1) or AUOCHRY (D2)		Type 1	N
		Without Infinity sound system		Interface not needed			AP2RS or KNCR2RS with CRCLSO (C3)	SOS1 with DOCKCR12 (D1) or AUOCHRY (D2)		Type 1	none
	1994-00	All		Interface not needed			ALPMSIR with ALPMSRI (96-00) (C3)	SOS1 with DOCKCR12 (96-00) (D1)	REMOTE1.5 or CSWMT (99-00)	Type 1	none
	1987-88	Without factory receiver		RLT	(R3)					Type 1	none
Daytona	1989-93	With Infinity sound system		PWR1	(R6)					Type 1	
Durango	2002	With Base-level system (4-speaker)		Interface not needed			AP2RS or KNCR2RS with CRCLSO (C3)	SOS1 with DOCKCR12 (D1) or AUOCHRY (D2)		Type 1	none
		With Infinity sound system (8-speaker)	#45	CE14A	(R1, R6)		AP2RS or KNCR2RS with CRCLSO (C3)	SOS1 with DOCKCR12 (D1) or AUOCHRY (D2)		Type 1	N-100 watt
	2001	With Base-level system (4-speaker)		Interface not needed			AP2RS or KNCR2RS with CRCLSO (C3)	SOS1 with DOCKCR12 (D1) or AUOCHRY (D2)		Type 1	none
		With Infinity sound system (8-speaker)	#45	CE14A	(R1, R6)		AP2RS or KNCR2RS with CRCLSO (C3)	SOS1 with DOCKCR12 (D1) or AUOCHRY (D2)		Type 1	N-100 watt
	1996-00	With Base-level system (4-speaker)		Interface not needed			ALPMSIR with ALPMSRI (C3)	REMOTE1.5 or CSWMT (99-00)		Type 1	none
		With Infinity sound system (8-speaker)		CE14A	(R1, R6)		ALPMSIR with ALPMSRI (C3)	REMOTE1.5 or CSWMT (99-00)		Type 1	N-100 watt
Durazny	1988-93	With Infinity sound system		PWR1	(R6)					Type 1	
Intrepid	2002	With Base audio system (4-speaker)		Interface not needed			AP2RS or KNCR2RS with CRCLSO (C3)	SOS1 with DOCKCR12 (D1) or AUOCHRY (D2)		Type 1	none
		With midline audio system (6-speaker)	#45	CE14A	(R1, R6)		AP2RS or KNCR2RS with CRCLSO (C3)	SOS1 with DOCKCR12 (D1) or AUOCHRY (D2)		Type 1	N-120 watt
		With Infinity I audio system (8-speaker)	#45	CE14A	(R1, R6)		AP2RS or KNCR2RS with CRCLSO (C3)	SOS1 with DOCKCR12 (D1) or AUOCHRY (D2)		Type 1	F-240 watt
		With Infinity II system (10-speaker)	#45	CE14A	(R1, R6)		AP2RS or KNCR2RS with CRCLSO (C3)	SOS1 with DOCKCR12 (D1) or AUOCHRY (D2)		Type 1	F-360 watt
	1998-01	With Base audio system (4-speaker)		Interface not needed			AP2RS or KNCR2RS with CRCLSO (C3)	SOS1 with DOCKCR12 (D1) or AUOCHRY (D2)		Type 1	none
		With midline audio system (6-speaker)	#45 (D1)	CE14A	(R1, R6)		AP2RS or KNCR2RS with CRCLSO (C3)	SOS1 with DOCKCR12 (D1) or AUOCHRY (D2)		Type 1	N-120 watt
		With Infinity I audio system (8-speaker)	#45 (D1)	CE14A	(R1, R6)		AP2RS or KNCR2RS with CRCLSO (C3)	SOS1 with DOCKCR12 (D1) or AUOCHRY (D2)		Type 1	F-240 watt
		With Infinity II system (10-speaker)	#45 (D1)	CE14A	(R1, R6)		AP2RS or KNCR2RS with CRCLSO (C3)	SOS1 with DOCKCR12 (D1) or AUOCHRY (D2)		Type 1	F-360 watt
	1993-97	With Infinity sound system		CE14A	(R1, R6)		ALPMSIR with ALPMSRI (96-97) (C3)	SOS1 with DOCKCR12 (96-97) (D1)		Type 1	6
Neon	2002	All		Interface not needed			AP2RS or KNCR2RS with CRCLSO (C3)	SOS1 with DOCKCR12 (D1) or AUOCHRY (D2)		Type 1	none
	2000-01	All		Interface not needed			AP2RS or KNCR2RS with CRCLSO (C3)	SOS1 with DOCKCR12 (D1) or AUOCHRY (D2)		Type 1	none
	1997-99	All		Interface not needed			Not available			Type 1	none
Pickup (1500)	2002	With Infinity sound system	#45	CE14A	(R1, R6)		AP2RS or KNCR2RS with CRCLSO (C3)	SOS1 with DOCKCR12 (D1) or AUOCHRY (D2)		Type 1	none
		Without Infinity sound system		Interface not needed			AP2RS or KNCR2RS with CRCLSO (C3)	SOS1 with DOCKCR12 (D1) or AUOCHRY (D2)		Type 1	none
Pickup (2500, 3500)	2002	Without Infinity sound system		Interface not needed			ALPMSIR with ALPMSRI (96-99) (C3)	SOS1 with DOCKCR12 (96-99) (D1)		Type 1	none
		With Infinity sound system	#45	CE14A	(R1, R6)		ALPMSIR with ALPMSRI (96-01) (C3)	SOS1 with DOCKCR12 (96-01) (D1)	REMOTE1.5 or CSWMT (99-01)	Type 1	C
Polyp (1500, 2500, 3500)	1994-01	Without Infinity sound system		Interface not needed			ALPMSIR with ALPMSRI (96-01) (C3)	SOS1 with DOCKCR12 (96-01) (D1)	REMOTE1.5 or CSWMT (99-01)	Type 1	none
		With Infinity sound system		CE14A	(R1, R6)		ALPMSIR with ALPMSRI (96-01) (C3)	SOS1 with DOCKCR12 (96-01) (D1)	REMOTE1.5 or CSWMT (99-01)	Type 1	none
Ramcharger	1984-87	All		RLT	(R3)					Type 1	none
Shadow	1989-94	With factory receiver and four speakers		RLT	(R3)					Type 1	none
Spirit	1990-95	With Infinity sound system		PWR1	(R6)					Type 1	

KICKER000137

SOUNDGATE® 2002 Application Guide

MAKE and MODEL	YEARS	VEHICLE IDENTIFIER/ QUALIFIER	INSTALL NOTES (pgs 44-52)	RECEIVER INSTALLATIONS use part #	RECEIVER FOOTNOTES	RETAIN ONSTAR use part #	CD CHANGER INTERFACE APPLICATIONS and FOOTNOTES use part #	AUXILIARY INPUT INTERFACES use part #	STEERING WHEEL CONTROL INTERFACE APPLICATIONS and FOOTNOTES use part #	AMPLIFIER INSTALLATION APPLICATIONS and FOOTNOTES (Line output converter required)	FACTORY AMPLIFIER LOCATION
Subaru	1991-96	With Infinity sound system	#41	MITSUBISHI	(R7)				MITSUBISHI or Type 1 (A1)	6	none
Subaru	2002	Without Infinity sound system		Interface not needed						Type 1	none
		With base-level audio system	#45	GENMA	(R1, R6)		APRSG or MDCR2G with CROB.SD (C3)	SOS1 with DDCR2G (D1) or AUOCR2Y (D2)	Type 1	none	D
		With base-level audio system	#45	Interface not needed			APRSG or MDCR2G with CROB.SD (C3)	SOS1 with DDCR2G (D1) or AUOCR2Y (D2)	Type 1	none	none
		With Premium Gold audio system (5-speaker)		GENMA	(R1, R6)		APRSG or MDCR2G with CROB.LIN (C3)	SOS1 with DDCR2G (D1) or AUOCR2Y (D2)	Type 1	none	D
Van (Full size)	1999-02	Without Infinity system (5-speaker)		Interface not needed (R8)			ALPM18R with ALPMCR1 (C3)	SOS1 with DDCR2G (D1)	Type 1	none	none
		With Infinity audio system (5-speaker)		GENMA	(R1, R6)		ALPM18R with ALPMCR1 (C3)	SOS1 with DDCR2G (D1)	Type 1	none	C, 12whatt
Year	2000-02	With battery receiver and four speakers		PL71	(R3)		ALPM18R with ALPMCR1 (C3)	SOS1 with DDCR2G (D1)	Type 1	none	none
		All - Alpine audio system		8-pin Alpine DIN					Type 1	6	
EAGLE	1989-99	With Infinity sound system		MITSUBISHI	(R7)				MITSUBISHI or Type 1 (A1)	D	none
Eagle	1993-97	Without Infinity sound system		Interface not needed						Type 1	none
		With Infinity sound system		GENMA	(R8)		ALPM18R with ALPMCR1 (R6-97) (C3)	SOS1 with DDCR2G (R6-97) (D1)	Type 1 or 2	G	none
FERRARI	All Models	Without Infinity sound system		Interface not needed			ALPM18R with ALPMCR1 (R6-97) (C3)	SOS1 with DDCR2G (R6-97) (D1)	Type 1	none	none
		With factory CD changer controls							Type 1		
FORD	1996-97	With the word Automatic on tape door	#4	FR02	(R1, R6, R11)				FR03R2	Type 1 or 2 (LOC8 only)	A
		Without word Automatic on tape door		PL71	(R6)				FR03R2	Type 1	none
Aspire	1994-97	With Premium Sound System, or with Factory CD player	#4	Interface not needed						Type 1	none
		Without word Automatic on tape door or with factory CD		FR02	(R1, R6, R11)					Type 1 or 2 (LOC8 only)	G
Bronco II	1991-91	All		Interface not needed	(R6)					Type 1	none
		With "toggle" type volume control on factory receiver		FR02	(R1, R6, R11)					Type 1 or 2 (LOC8 only)	G
Contour	1995-00	With rotary type volume knob		PWR1	(R6)					Type 1	none
		With amplifier in mono-speaker location		GEN2	(R5)					Type 1	B
Country Squire	1988	With rotary volume knob on factory receiver, 6 factory speakers		Interface not needed						Type 1 or 2 (LOC8 only)	C
		All		PWR1	(R2)					Type 1	none
Crown Victoria	1994-02	All		Interface not needed	(R2)					Type 1	none
		With CD-changer controls on radio or in-dash CD. This is factory DAS (distributed audio system - LUD)	#3, 35	Interface not needed			SNF01 or ALFD1 or KNFD1, with FCS (C7)	SOS1 with DDCR2G (D1) or AUOFORD (D2, D4)	Type 1	none	none
Econoline	1999-02	Without word Automatic on tape door	#4 (B1)	FR02	(R1, R6, R11)					Type 1 or 2 (LOC8 only)	E
		With Premium sound system		Interface not needed			SNF01 or ALFD1 or KNFD1, with FCS (C3)	SOS1 with DDCR2G (D1) or AUOFORD (D2, D4)	Type 1	none	none
Econoline	1997	Without Premium sound system		Interface not needed	(R1, R6)					Type 1	none
		With Premium sound system		Interface not needed			SNF01 or ALFD1 or KNFD1, with FCS (C3)	SOS1 with DDCR2G (D1) or AUOFORD (D2, D4)	Type 1	none	none

KICKER000138

SOUNDGATE® 2002 Application Guide

MAKE and MODEL	YEARS	VEHICLE IDENTIFIER/ QUALIFIER	INSTALL NOTES (pgs 44-52)	RECEIVER INSTALLATIONS use part #	RECEIVER FOOTNOTES	RETAIN ONSTAR use part #	CD CHANGER INTERFACE APPLICATIONS AND FOOTNOTES use part #	AUXILIARY INPUT INTERFACES use part #	STEERING WHEEL CONTROL INTERFACE APPLICATIONS AND FOOTNOTES use part #	AMPLIFIER INSTALLATION APPLICATIONS AND FOOTNOTES (Use output connector required)	FACTORY AMPLIFIER LOCATION
Econoline (cont)	1997		#4	OEUMA	(R1, R6)		SXF01 or ALU01 or NRP01, with FZ2 (C3)	SXS1 with DOCKPARD (D1) or AUOFFORD (D2, D4)	FRUSWZ	Type 1 or 2 (LOCB only)	N
	1994-95	With the word Automatic on the tape door, or with factory CD	#4	FR02	(R1, R6, R11)				FRUSWZ	Type 1 or 2 (LOCB only)	N
		Without word Automatic on tape door		Interface not needed					FRUSWZ	Type 1	none
	1992-93	With Premium Sound System		PWR1	(R2)					Type 1	none
		With factory Premium Sound System		FL1	(R2)					Type 1	none
	1989-91	All		PWR1	(R1, R6)					Type 1	none
	1985-88	With Premium Sound System		OEUMA	(R1, R2, R6)					Type 1	B
	2001-02	With base audio system		Interface not needed						Type 1	none
		With 104-line audio system		Interface not needed						Type 1	F sub
		With 104-line audio system		Interface not needed						Type 1	F sub
		With 104-line audio system		Interface not needed						Type 1	none
Escort/D2	1987-92	Without words Premium Sound on tape door	#14				SXF01 or ALU01 or NRP01, with FZ2 (C3)	SXS1 with DOCKPARD (D1) or AUOFFORD (D2, D4)		Type 1	none
		With Premium Sound System	#4, 14	OEUMA	(R1, R6)		SXF01 or ALU01 or NRP01, with FZ2 (C3)	SXS1 with DOCKPARD (D1) or AUOFFORD (D2, D4)		Type 1 or 2 (LOCB only)	J
	1994-95	With cassette and amp under dashboard	#4	FR02	(R1, R6, R11)					Type 1 or 2 (LOCB only)	B
	1992-95	With factory CD player	#4 (94-95)	FR02	(R1, R6, R11)					Type 1 or 2 (LOCB only)	B
	1993	With factory cassette player		PWR1	(R1, R6)					Type 1	B
	1992-93	With factory cassette player, without amplifier beneath the dashboard		PWR1	(R1, R6)					Type 1	none
	1991	With words Premium Sound on grille		PWR1	(R2)					Type 1	none
	1989-90	All		PWR1	(R1, R6)					Type 1	none
	1986-88	With Premium Sound System		OEUMA	(R1, R2, R6)					Type 1	B
		Without amplifier switch on dash		FL1	(R2)					Type 1	none
Emerson	2000-02	All, if subwoofer equipped call for info.	#35	Interface not needed			SXF01 or ALU01 or NRP01, with FZ5 (C3)	SXS1 with DOCKPARD (D1) or AUOFFORD (D2, D4)		Type 1	none
Expedition	1995-02	All, if subwoofer equipped call for info.	#35	Interface not needed			SXF01 or ALU01 or NRP01, with FZ5 (C3)	SXS1 with DOCKPARD (D1) or AUOFFORD (D2, D4)		Type 1	none
	1997-98	All		OEUMA	(R1, R6)					Type 1 or 2 (LOCB only)	B
	2001-02	All, if subwoofer equipped call for info.	#4, 35	Interface not needed			SXF01 or ALU01 or NRP01, with FZ5 (C3)	SXS1 with DOCKPARD (D1) or AUOFFORD (D2, D4)		Type 1	F (sub)
		All, if subwoofer equipped call for info.	#4, 35	Interface not needed			SXF01 or ALU01 or NRP01, with FZ5 (C3)	SXS1 with DOCKPARD (D1) or AUOFFORD (D2, D4)		Type 1	F (sub)
	1998	With factory CD/cassette combination radio, if subwoofer equipped call for info.		Interface not needed			SXF01 or ALU01 or NRP01, with FZ5 (C3)	SXS1 with DOCKPARD (D1) or AUOFFORD (D2, D4)		Type 1	none
		With CD changer controls on radio, or with in-dash CD. If equipped with subwoofer (AUR), call for details	#4	OEUMA	(R1, R6)		SXF01 or ALU01 or NRP01, with FZ2 (C3)	SXS1 with DOCKPARD (D1) or AUOFFORD (D2, D4)		Type 1 or 2 (LOCB only)	F
		With JBL Audio System. This is factory DAS (distributed audio system-LOD) (see note #3).	#4, 4 (sub amp)	Interface not needed			SXF01 or ALU01 or NRP01, with FZ2 (C3)	SXS1 with DOCKPARD (D1) or AUOFFORD (D2, D4)		Type 1	none
		With AM/FM only - no cassette		LOCUBA (for sub)			SXF01 or ALU01 or NRP01, with FZ2 (C7)	SXS1 with DOCKPARD (D1) or AUOFFORD (D2, D4)		Type 1	F
	1995-97	With JBL Audio System. This is factory DAS (distributed audio system-LOD) (see note #3).	#4, 4 (sub amp)	Interface not needed			SXF01 or ALU01 or NRP01, with FZ2 (C3)	SXS1 with DOCKPARD (D1) or AUOFFORD (D2, D4)		Type 1	none
		Without JBL system (with CD-changer controls on factory cassette), or with in-dash CD player	#4	OEUMA	(R1, R6)		SXF01 or ALU01 or NRP01, with FZ2 (C3)	SXS1 with DOCKPARD (D1) or AUOFFORD (D2, D4)		Type 1 or 2 (LOCB only)	F
		Cassette only (without factory CD-changer controls), or AM/FM only.		Interface not needed						Type 1	none
	1993-94	With the letters DMR on the factory tape door, or with JBL		FR02	(R1, R6, R11)					Type 2 (LOCB only)	F
		Without letters DMR on tape door		Interface not needed						Type 1	none
	1991-92	With 104-line volume knob		FR02	(R1, R6, R11)					Type 1 or 2 (LOCB only)	F
		With rotary type volume knob		PWR1	(R1, R6)					Type 1	none
Focus	2000-02	All without Som-brandled system		Interface not needed			SXF01 or ALU01 or NRP01, with FZ4 (C1, C3)	SXS1 with DOCKPARD (D1) or AUOFFORD (D2, D4)		Type 1	none
		All with Som-brandled system		Interface not needed			See (in-link direct)	SXS1 with DOCKPARD (D1)		Type 1	none
HW-40	1997	With CD-changer controls on cassette	#4	OEUMA	(R1, R6)		SXF01 or ALU01 or NRP01, with FZ2 (C3)	SXS1 with DOCKPARD (D1) or AUOFFORD (D2, D4)		Type 1 or 2 (LOCB only)	B
LTD	1995-96	With premium sound system		PWR1	(R2)					Type 1	none
LTD Crown Victoria	1998-99	With rotary volume knob on factory receiver, 6 factory speakers		FR02	(R1, R6, R11)					Type 2 (LOCB only)	E
				PWR1	(R2)					Type 1	none

KICKER000139

SOUNDGATE® 2002 Application Guide

MAKE and MODEL	YEARS	VEHICLE IDENTIFIER/ QUALIFIER	INSTALL NOTES (pgs 44-52)	RECEIVER INSTALLATIONS use part #	RECEIVER FOOTNOTES use part #	RETAIN ONSTAR use part #	CD CHANGER INTERFACE APPLICATIONS AND FOOTNOTES use part #	AUXILIARY INPUT INTERFACES use part #	STEERING WHEEL CONTROL INTERFACE APPLICATIONS AND FOOTNOTES use part #	AMPLIFIER INSTALLATION APPLICATIONS AND FOOTNOTES (Use origin comment required)	FACTORY AMPLIFIER LOCATION
LTD Crown Victoria (cont.)	1987	With 5-speaker factory system		PWR1	(R2)				Type 1		
	1986	With 5-speaker factory system		CEM2	(R4)				Type 1		
	1986	With digital or analog receiver and Premium Sound System		CEM2	(R4)				Type 1		E
	2001-02	With Premium audio system		Interface not needed					Type 1		none
Mustang	1986	With Mach 480 system	#4, 44	LOCSUBA (for sub)					Type 1 or 2 (LOCS only)		E sub
	1994-00	With factory AM/FM receiver and cassette player	#4	FR02	(R1, R6, R11)				Type 1 or 2 (LOCS only)		B
	1993	With the Mach-480 sound system	#4	FR02	(R1, R6, R11)				Type 1 or 2 (LOCS only)		B, E
	1987-92	With factory cassette or CD player		FR02	(R1, R6, R11)				Type 1 or 2 (LOCS only)		B
	1985-86	With 5-speaker factory system		PWR1	(R2, R6)				Type 1		B
	1985-86	With amplifier located in the dash		PWR1	(R2, R6)				Type 1		B
Pickup, F-Series	2001-02	All	#4S	Interface not needed			SMP1 or ALF01 or KNP01, with FCS (C3)	S0S1 with DOCK0RD (D1) or AUW0RD (D2, D4)	Type 1		F sub
	1999-00	All		Interface not needed			SMP1 or ALF01 or KNP01, with FCS (C3)	S0S1 with DOCK0RD (D1) or AUW0RD (D2, D4)	Type 1		none
	1997-98	Without CD-changer controls, or AM/FM only.		Interface not needed					Type 1		none
Ford	1994-95	With CD-changer controls on radio	#4	CEM4A	(R1, R5)		SMP1 or ALF01 or KNP01, with FCS (C3)	S0S1 with DOCK0RD (D1) or AUW0RD (D2, D4)	Type 1 or 2 (LOCS only)		C
	1994-95	With the word Automatic on the tape door, or with factory CD	#4	FR02	(R1, R6, R11)				Type 1 or 2 (LOCS only)		C
	1987-93	All		Interface not needed					Type 1		none
	1987-88	All		FL11					Type 1		none
	1987-88	All		FL11	(R2)				Type 1		none
	1995-02	All	#4 (S4-S7)	FR02	(R1, R6, R11)		SMP1 or ALF01 or KNP01, with FCS (C3)	S0S1 with DOCK0RD (D1) or AUW0RD (D2, D4)	Type 1		none
	1995-02	With factory cassette or CD player (less use of EQ, if equipped)		FR02	(R1, R6, R11)				Type 1 or 2 (LOCS only)		A, F
	1995-02	All		Interface not needed					Type 1		none
	1991	All		Interface not needed					Type 1		none
	1987	Without CD-changer controls on factory radio, or AM/FM only.		Interface not needed					Type 1		none
Pony	1995-97	With CD-changer controls on factory cassette	#4	CEM4A	(R1, R6)		SMP1 or ALF01 or KNP01, with FCS (C3)	S0S1 with DOCK0RD (D1) or AUW0RD (D2, D4)	Type 1 or 2 (LOCS only)		C
	1993-94	With the word Automatic on the tape door, or with factory CD	#4 (S4)	FR02	(R1, R6, R11)				Type 1 or 2 (LOCS only)		C
	1985-88	Without word Automatic on tape door		Interface not needed					Type 1		none
	1985-88	With Premium Sound System		CEM2	(R5)				Type 1		B
	1985	With Premium Sound System		CEM2	(R5)				Type 1		B
	2001-02	All	#3, 14	Call for details	(R4)				Type 1		B
	1985-89	All - Without JBL Audio System	#3, 14	Call for details			SMP1 or ALF01 or KNP01, with FCS (C7)	S0S1 with DOCK0RD (D1) or AUW0RD (D2, D4)	Type 1		G (RCU)
	1982-95	With word Automatic on the tape door	#4 (S4-S5)	FR02	(R1, R6, R11)				Type 1		G (RCU)
	1982-95	Without word Automatic on tape door		FR02	(R1, R6, R11)				Type 1 or 2 (LOCS only)		E
	Tempra	1986-91	With AM/FM tuner only—no cassette		PWR1					FR0S12	
1986-91		With "twee" type volume control		FR02	(R1, R6, R11)				FR0S12		none
1986-91		With rotary volume control		PWR1	(R6)				FR0S12		none
1986-87		With word's Premium Sound on speaker grille		PWR1	(R2)				Type 1		E
Tempra	1987-94	All	#4 (S4)	CEM4A	(R1, R2, R6)				Type 1		E
	1984-86	With factory CD, amplifier, switch, or amplifier beneath rear deck		PWR1	(R2)				Type 1		E
Thunderbird	2002	Information forthcoming							Type 1 or 2 (LOCS only)		E
	1994-97	With word Automatic on tape door, or with factory in-dash CD	#4	FR02	(R1, R6, R11)				Type 1		none
		Without word Automatic on tape door		Interface not needed					Type 1		none

KICKER000140

SOUNDGATE® 2002 Application Guide

MAKE and MODEL	YEARS	VEHICLE IDENTIFIER/ QUALIFIER	INSTALL NOTES (pgs 44-52)	RECEIVER INSTALLATIONS use part #	RECEIVER FOOTNOTES	RETRAK ONSTAR use part #	CD CHANGER INTERFACE APPLICATIONS AND FOOTNOTES use part #	AUXILIARY INPUT INTERFACES use part #	STEERING WHEEL CONTROL INTERFACE APPLICATIONS AND FOOTNOTES use part #	AMPLIFIER INSTALLATION APPLICATIONS AND FOOTNOTES (Line output converter required)	FACTORY AMPLIFIER LOCATION
Thunderbolt (cont.)											
	1988-93	With "Toggle" type volume control on factory receiver		FR02	(R1, R6, R11)					Type 1 or 2 (LOOS only)	E
		With Rotary volume control knob		PWR1						Type 1	none
	1987	With 6-speaker factory system			(R2)					Type 1	B
	1985-87	With Factory Equalizer		PWR1	(R2)					Type 1	E
	1985	With analog receiver and factory amplifier in trunk		PWR1	(R2)					Type 1	E
Windstar	2001-02	All		Interface not needed			SWP1 or ALP10 or ALP101, with F55 (C3)	SOS1 with DOCKSMT (D1) or ALDFORD (D2, D4)		Type 1	none
	1999-00	All		Interface not needed			SWP10 or ALP101 or ALP101, with F55 (C3)	SOS1 with DOCKSMT (D1) or ALDFORD (D2, D4)		Type 1	none
	1994-98	With the word Automatic on the tape door, or with factory in-deck CD	#4	FR02	(R1, R6, R11)			FR05WZ		Type 1 or 2 (LOOS only)	B
		Without word Automatic on tape door								Type 1	none
GMC											
Denali /XL Denali	2001-02	With Standard Base System	#28	DEM4A	(R1, R6)	StarMod (T2)		SOS1 with DOCKSMT (D1)	REMOTE1.5 or GMSMT	Type 1 or LOOS	G
	1998-00	With Standard Base System	#25, 28	DEM4A	(R1, R6)	StarMod		SOS1 with DOCKSMT (D1)	REMOTE1.5 or GMSMT	Type 1 or 2 (LOOS only)	G
	2002	With Base	#56	DEM4A	(R1, R6)			SOS1 with DOCKSMT (D1)		Type 1	F
		Without Base								Type 1	none
Jimmy/Envoy	1998-01	With 6-speaker system	#25	DEM4A	(R1, R6)	StarMod		SOS1 with DOCKSMT (D1)	REMOTE1.5 or GMSMT	Type 1 or 2 (LOOS only)	K
		Without factory amplifier (base auto)				StarMod		SOS1 with DOCKSMT (D1)	REMOTE1.5 or GMSMT	Type 1	none
	1995-97	All		Interface not needed				SOS1 with DOCKSMT (D1)		Type 1	none
Pickup CK	1998-02	All		Interface not needed		StarMod (T2)		SOS1 with DOCKSMT (D1)		Type 1	none
	1995-1997	All		Interface not needed				SOS1 with DOCKSMT (D1)		Type 1	none
Safari van	2000-02	Without Speed Compensated Volume		Interface not needed		StarMod (T2)		SOS1 with DOCKSMT (D1)		Type 1	none
		With Speed Compensated Volume		Interface not needed				SOS1 with DOCKSMT (D1)		Type 1	G (dash)
	1998-99	With 6-speaker system		Interface not needed				SOS1 with DOCKSMT (D1)		Type 1	none
		With 8-speaker system		Interface not needed				SOS1 with DOCKSMT (D1)		Type 1	G (dash)
Sierra full size van	1998-02	All		Interface not needed				SOS1 with DOCKSMT (D1)		Type 1	none
Sierra HD	2001-02	All	#25	Interface not needed		StarMod (T2)		SOS1 with DOCKSMT (D1)		Type 1	none
Sierra pickup	2002	All		Interface not needed		StarMod (T1)		SOS1 with DOCKSMT (D1)		Type 1	none
	1999-01	All	#25 (199 only)	Interface not needed		StarMod		SOS1 with DOCKSMT (D1)		Type 1	none
Sierra van pickup	1998-01	All		Interface not needed				SOS1 with DOCKSMT (D1)	REMOTE1.5 or GMSMT	Type 1	none
Silverado	1999	With subwoofer in center console	#25, 28	DEM4A	(R1, R6)	StarMod		SOS1 with DOCKSMT (D1)		Type 1	K
		Without subwoofer in console	#25, 28			StarMod		SOS1 with DOCKSMT (D1)		Type 1	A
	1995-98	All		Interface not needed				SOS1 with DOCKSMT (D1)		Type 1	A (optional)
Yukon	2001-02	All (9-speaker system)	#25, 28	Interface not needed		StarMod (T2)		SOS1 with DOCKSMT (D1)		Type 1	C
	2000	With subwoofer in Left Rear	#25, 28	Interface not needed		StarMod		SOS1 with DOCKSMT (D1)		Type 1	C
		With 4-speaker base-level system		Interface not needed				SOS1 with DOCKSMT (D1)		Type 1	none
	1999	With subwoofer in center console	#25, 28	Interface not needed		StarMod		SOS1 with DOCKSMT (D1)		Type 1	K
		Without subwoofer in console	#25	DEM4A	(R1, R6)	StarMod		SOS1 with DOCKSMT (D1)		Type 1	A
	1995-98	All		Interface not needed				SOS1 with DOCKSMT (D1)		Type 1	J
Yukon XL	2001-02	All (9-speaker system)	#25, 28	Interface not needed		StarMod (T2)		SOS1 with DOCKSMT (D1)		Type 1 or 2 (LOOS only)	C
	2000	With 3-speaker system	#25, 28	Interface not needed		StarMod		SOS1 with DOCKSMT (D1)		Type 1	C
		With 4-speaker system	#25	Interface not needed		StarMod		SOS1 with DOCKSMT (D1)		Type 1	none
HONDA											
Accord	2001-02	All		Interface not needed			ALPNSTR with ALPH101 (CA)	SOS1 with DOCKSMT (D1)		Type 1	none
	1998-00	All		Interface not needed			ALPNSTR with ALPH101 (CA)	SOS1 with DOCKSMT (D1)		Type 1	none
	1992-97	With factory Base system		DEM4A	(R1, R6)		ALPH1, (C3)			Type 1 or 2 (LOOS only)	none
		Without Base system					ALPH1, (C3)			Type 1	none
	1989-91	With factory Base system		DEM4A	(R1, R6)					Type 2 (LOOS or LOCPREA)	I
		Without Base system								Type 1	none
Civic	2001-02	All		Interface not needed			ALPNSTR with ALPH101 (CA)	SOS1 with DOCKSMT (D1)		Type 1	none
	1998-00	All	#25	Interface not needed			ALPNSTR with ALPH101 (CA)	SOS1 with DOCKSMT (D1)		Type 1	none
	1992-97	All	#25	Interface not needed			ALPH1, (C3)			Type 1	none
CRV	2002			Interface not needed						Type 1	none

SOUNDGATE® 2002 Application Guide

MAKE and MODEL	YEARS	VEHICLE IDENTIFIER/ QUALIFIER	INSTALL NOTES (pp. 44-52)	RECEIVER INSTALLATIONS use part #	RECEIVER FOOTNOTES	RETAIN ONSTAR use part #	CO CHANGER INTERFACE APPLICATIONS AND FOOTNOTES use part #	AUXILIARY INPUT INTERFACES use part #	STEERING WHEEL CONTROL INTERFACE APPLICATIONS AND FOOTNOTES use part #	AMPLIFIER INSTALLATION APPLICATIONS AND FOOTNOTES (Line output converter required)	FACTORY AMPLIFIER LOCATION
CW (cont.)	1995-01	All		Interface not needed			ALPNSTR with ALPNM01 (CA)	SOSI with DOCKHND (D1)	Type 1	none	none
Isuzu	2000-02	All		Interface not needed			ALPNSTR with ALPNM01 (CA)	SOSI with DOCKHND (D1)	Type 1	none	none
Copsey	2001-02	All	With factory Navigation system	StarMod to integrate Star Unit			ALPNSTR with ALPNM01 (CA)	SOSI with DOCKHND (D1)	Type 1	none	none
Passport	1995-02	All		Interface not needed			ALPNSTR with ALPNM01 (CA)	SOSI with DOCKHND (D1)	Type 1	none	none
Proble	2001-02	All		Interface not needed			ALPNSTR with ALPNM01 (CA)	SOSI with DOCKHND (D1)	Type 1	E (usb)	E (usb)
	1999-00	All		Interface not needed			ALPNSTR with ALPNM01 (CA)	SOSI with DOCKHND (D1)	Type 1	E (usb)	E (usb)
	1997	All		Interface not needed			ALPNM1 (C3)		Type 1	none	none
	1992-96	S, S, SR		Interface not needed			ALPNM1 (C3)		Type 1	none	none
	1995-96	VTEC SR-Y		Interface not needed			ALPNM1 (C3)		Type 1	E (usb)	E (usb)
S2000	2001-02	All		Interface not needed			ALPNSTR with ALPNM01 (CA)	SOSI with DOCKHND (D1)	Type 1	none	none
	2000	All		Interface not needed			ALPNSTR with ALPNM01 (CA)	SOSI with DOCKHND (D1)	Type 1	none	none
HYUNDAI											
Accent	2002	Information forthcoming							Type 1		
Elantra	2002	Information forthcoming							Type 1		
Santa Fe	2002	Information forthcoming							Type 1		
Sonata	2002	Information forthcoming							Type 1		F
Tiburon	2002	Information forthcoming							Type 1		
X3500	2002	Information forthcoming							Type 1		
X3550	2002	Information forthcoming							Type 1		
INFINITI											
EQ0	1996-02	With factory Bose system		EQM4A	(R1, R6)		ALN51	SOSI with DOCKN55 (D1)	Type 1 or Type 2		
	1997	All		EQM4A	(R1, R6)				Type 1		
	1990-96	All		FJ11	(R5)				Type 1		E
IQ5	2002	Information forthcoming		EQM4A	(R1, R6)		ALN51	SOSI with DOCKN55 (D1)	Type 1 or Type 2		
IQ0	1998-01	With factory Bose system		EQM4A	(R1, R6)		ALN51	SOSI with DOCKN55 (D1)	Type 1		E
	1996-97	Without factory Bose system		EQM4A	(R1, R6)				Type 2 (LDC8 or LDCPREN)		F
	2001-02	All	#59				ALN51	SOSI with DOCKN55 (D1)	Type 1		none
IQ30	1995-97	All		EQM4A	(R1, R6)				Type 1		
	1990-94	Sedan with Bose system		EQM4A	(R1, R6)				Type 2 (LDC8 emb)		F
		Without factory Bose system							Type 1		none
MQ0	1991-02	With factory Bose system		EQM4A	(R1, R6)				Type 2 (LDC8 emb)		F
	1990	Without factory Bose system							Type 1		none
		Without factory Bose system		EQM4A	(R1, R6)				Type 2 (LDC8 emb)		F
		Without factory Bose system							Type 1		none
Q45	2002	Information forthcoming		EQM4A	(R1, R6)		ALN51	SOSI with DOCKN55 (D1)	Type 1		
	1999-01	With factory Bose System		EQM4A	(R1, R6)		ALN51	SOSI with DOCKN55 (D1)	Type 2 (LDC8 or LDCPREN)		F
		Without factory Bose system							Type 1		none
	1997-98	With factory Bose System		EQM4A	(R1, R6)		ALN51 (R9)	SOSI with DOCKN55 (R9) (D1)	Type 2 (LDC8 or LDCPREN)		F
		Without factory Bose system					ALN51 (R9)	SOSI with DOCKN55 (R9) (D1)	Type 1		none
	1994-96	With factory Bose system		EQM4A	(R1, R6)				Type 2 (LDC8 emb)		F
		Without factory Bose system							Type 1		none
	1990-93	With factory Bose system	63A	EQM4A	(R1, R6)				Type 2 (LDC8 or LDCPREN)		L, E
		Without factory Bose system							Type 1		none
QK4	2000-02	All					ALN51	SOSI with DOCKN55 (D1)	Type 1		none
	1999-99	All					ALN51	SOSI with DOCKN55 (D1)	Type 1		none
	1997	Without factory Bose system		EQM4A	(R1, R6)				Type 2 (LDC8 or LDCPREN)		F
		Without factory Bose system							Type 1		none
Qx4m	2002	All - Information forthcoming							Type 1		
RoadSport	2002	Information forthcoming							Type 1		
KICKER000142											
ISUZU											
Ascari	2002	All - Information forthcoming							Type 1		
RoadSport	2002	Information forthcoming							Type 1		

SOUNDGATE® 2002 Application Guide

MAKE and MODEL	YEARS	VEHICLE IDENTIFIER/ QUALIFIER	INSTALL NOTES (pgs 44-52)	RECEIVER INSTALLATIONS see part #	RECEIVER FOOTNOTES	REMAIN ONSTAR see part #	CD CHANGER INTERFACE APPLICATIONS AND FOOTNOTES see part #	AUXILIARY INPUT INTERFACES see part #	STEERING WHEEL CONTROL INTERFACE APPLICATIONS AND FOOTNOTES see part #	AMPLIFIER INSTALLATION APPLICATIONS AND FOOTNOTES (Line output converter required)	FACTORY AMPLIFIER LOCATION
JAGUAR											
Traverse	2002	Kamachi - Information forking									
Velocross	2001	AI - Information forking									
S-Type	1999-02	AI	#4, #6	LOCHINA/LOSSIBA			SF601 or AL501 or NW01 with F24, C1, C4	S051 with DOCP080 (D1) or AU0500 (D2, D4)	Type 1		E subs. & det. ch.
X-Type	2002	Information forking					ALP15TR with ALP15C1, C4		Type 1		C
AI Models	1999-01	AI		PR01 (R1, R6)			ALP15TR with ALP15C1, C4		Type 1		C
	1996	X112 with main factory system		FL1 (R7)			<i>copy Above</i>		Type 1 or 2		none
		X16 with speaker system		Interface not needed			<i>copy Above</i>		Type 1		none
	1997-95	AI		CEM4A (R1, R6)			Alpine In-Bus Direct		Type 1		C
JEEP											
Cherokee	1995-01	AI		Interface not needed			ALP15TR with ALP15C1, C3	S051 with DOCK070 (D1) or AU0500 (D2)	Type 1		none
Cherokee XJ	1994-95	AI		RL1 (R3)					Type 1		none
Grand Cherokee	2002	With Infinity sound system		CEM4A (R1, R6)			ALP20G or NU020G with DOCK050 (C3)	S051 with DOCK070 (D1) or AU0500 (D2)	Type 1		H
	1999-01	With Infinity sound system		CEM4A (R1, R6)			ALP20G or NU020G with DOCK050 (C3)	S051 with DOCK070 (D1) or AU0500 (D2)	Type 1		H
	1998-99	Without Infinity sound system		CEM4A (R1, R6)			ALP15TR with ALP15C1, C4	S051 with DOCK070 (D1) or AU0500 (D2)	Type 1		H
	2002	AI		Interface not needed			ALP20G or NU020G with DOCK050 (C3)	S051 with DOCK070 (D1) or AU0500 (D2)	Type 1		none
Wrangler	1995-02	AI		Interface not needed			ALP15TR with ALP15C1, C3	S051 with DOCK070 (D1) or AU0500 (D2)	Type 1		none
KIA											
Optima	2001-02	With AMFM/CD With AMFM/Cassette only		CEM4A (R1, R6)			Met a factory option		Type 1 or 2		120Watt
Pio	2001-02	AI		Interface not needed			Met a factory option		Type 1		none
Sedona	2002	AI		Interface not needed			Met a factory option		Type 1		none
Sedona	1994-02	AI		Interface not needed			Met a factory option		Type 1		none
Spectra	2000-02	AI		Interface not needed			Factory only	S051 With DOCK06A (D1)	Type 1		none
Sportage	1995-02	AI		Interface not needed			Factory only	S051 With DOCK06A (D1)	Type 1		none
LAND ROVER											
AI Models	1997-94	With factory CD changer controls	#15	CEM4A (R1, R6)			Pioneer CD/AM/FM Direct		Type 1		F
Defender	1995-98	With factory CD changer controls	#15	CEM4A (R1, R6)			Carion Direct		Type 1		D
	1994-95	AI	#15	CEM4A (R1, R6)					Type 1		D
Discovery	2000-02	AI	#15	CEM4A (R1, R6)			RIVRBLD with ABWMS01G or KBMW03 or SBMW (C3)	S051 with DOCK06W (D5) or AL06W (D6)	Type 1		F
	1999-99	AI		CEM4A (R1, R6)					Type 1		F
Freelander	2002	Information forking		CEM4A (R1, R6)			RIVRBLD with ABWMS01G or KBMW03 or SBMW (C3)	S051 with DOCK06W (D5) or AL06W (D6)	Type 1		F
Range Rover	2000-02	AI		CEM4A (R1, R6)			RIVRBLD with ABWMS01G or KBMW03 or SBMW (C3)	S051 with DOCK06W (D5) or AL06W (D6)	Type 1		D
	1997-99	AI		CEM4A (R1, R6)					Type 1		F
LEXUS											
SC430	2002	Information forking	#3	Interface not needed					Type 1		H
SC300/400	1999-00	With factory Navigation, with Hakamichi		Not Recommended					Type 1		C
		With factory Navigation, with Hakamichi		Not Recommended					Type 1		F
	1999-95	With Hakamichi factory system		CEM4A (R1, R6)					Type 2 (LO03 or LO0P6A)		F
		W/ Pioneer factory system, no CD button		Interface not needed					Type 1		D
		W/ Pioneer factory system, w/ CD button		CEM4A (R1, R6)					Type 1		D
ES300	2002	Information forking	#3	Interface not needed					Type 1 or 2 (LO03 only)		C
ES300/300	1997-95	AI		Interface not needed					Type 1		D
	1990-96	With double DIN radio		Interface not needed					Type 2 (LO03 or LO0P6A)		D
	1990-91	With single DIN radio		Interface not needed					Type 2 (LO03 or LO0P6A)		D
GS400	1999-95	AI without Navigation system		CEM4A (R1, R6)					Type 1		D
GS300/430	2000-02	Information forking	#3, #40	Interface not needed					Type 2 (LO03 or LO0P6A)		D
LS300	2002	Information forking	#3	Interface not needed					Type 1		D
LS430	2002	Information forking	#3	Interface not needed					Type 1		D
LS400	1999-95	With Hakamichi factory system		Interface not needed					Type 1		D
	1999-95	With Pioneer factory system		Interface not needed					Type 1		L
RX300/RX400	2000-01	AI		CEM4A (R1, R6)					Type 1		L
	1997-99	With Pioneer factory system		CEM4A (R1, R6)					Type 1		L

Handwritten: 5/11/05 SC97

Handwritten: 2-Subamp Air Behind Air seat

SOUNDGATE® 2002 Application Guide

MAKE and MODEL	YEARS	VEHICLE IDENTIFIER/ QUALIFIER	INSTALL NOTES (pgs. 44-52)	RECEIVER INSTALLATIONS use part #	RECEIVER FOOTNOTES (R1, R6, R11)	RETAIN ONSTAR use part #	CD CHANGER INTERFACE APPLICATIONS AND FOOTNOTES use part #	AUXILIARY INPUT INTERFACES use part #	STEERING WHEEL CONTROL INTERFACE APPLICATIONS AND FOOTNOTES use part #	AMPLIFIER INSTALLATION APPLICATIONS AND FOOTNOTES (Line output converter required)	FACTORY AMPLIFIER LOCATION
EXACTO	2003-01	All		CEHMA	(R1, R6)				Type 1	D	
	1994-99	With Premium system		CEHMA	(R1, R6)				Type 1	L	
LINCOLN	Continental		#1, 36, 47	LOCUSBA (for subs)			SNF01 or ALF01 or KNF01, with FCS (C3)	SOS1 with DOCKFORD (D1) or AUFORD (D2, D4)	Type 1	E sub	
			#1, 36	LOCUSBA (for subs)			SNF01 or ALF01 or KNF01, with FCS (C3)	SOS1 with DOCKFORD (D1) or AUFORD (D2, D4)	Type 1	none	
			#3	Call for details					Type 1	E	
				as above					Type 1	E	
				FR02	(R1, R6, R11)				Type 1 or 2 (LOC8 only)	G	
				CEM2	(R1)				Type 1	E	
	LS	2000-02	All	LOCUSBA			SNF01 or ALF01 or KNF01, with FCS (C3)	SOS1 with DOCKFORD (D1) or AUFORD (D2, D4)	Type 1	E sub, B headsets	
			#36, 48, 65	FR02	(R1, R6, R11)				Type 1 or 2 (LOC8 only)	none	
	Mark VII	1993-92	All	FR02	(R1, R6, R11)				Type 1 or 2 (LOC8 only)	E	
			With "toggle" type volume control on factory receiver		(R1, R6, R11)				Type 1 or 2 (LOC8 only)	E	
Ford	1994-97	All	CEM2	(R1)					Type 1	E	
	1995-98	With CD changer controls on factory radio		CEM4A	(R1, R6)		SNF01 or ALF01 or KNF01, with FCS (C3)	SOS1 with DOCKFORD (D1) or AUFORD (D2, D4)	Type 1 or 2 (LOC8 only)	E	
	1993-94	All	FR02	(R1, R6, R11)					Type 1 or 2 (LOC8 only)	B or E	
	Navigator	1999-02	All, II speaker-equipped call for details #35	Interface not needed					Type 1	none	
			With factory CD-changer controls		(R1, R6)				Type 1 or 2 (LOC8 only)	A	
	Trim Car	2001-02	All	Interface not needed					Type 1	E sub	
			With factory CD-changer controls #36	Interface not needed					Type 1	none	
			With factory DMS (distributed audio system - LUX) No interface available #3	Interface not needed					Type 1	E	
				FR02	(R1, R6, R11)				Type 1 or 2 (LOC8 only)	E	
			With "toggle" type volume control on factory receiver		(R1, R6, R11)				Type 1	E	
MAZDA	1994-97	All	CEM2	(R1)					Type 1	E	
	929	1992-96	With 12-speaker system	CEM4A	(R1, R6)				Type 2 (LOC8 or LOC8EA)	E	
	626	1994-02	With factory Bose system	CEM4A	(R1, R6)				Type 2 (LOC8 or LOC8EA)	E	
			rear amp	Interface not needed	(R6)				Type 1	B	
	Mitsubishi	2000-02	With Bose system	CEM4A	(R1, R6)			SOS1 with DOCKMAZD (D1)	Type 2 (LOC8 or LOC8EA)	B	
			Without Bose sound system	Interface not needed	(R6)				Type 1	none	
			With factory removable face radio	Interface not needed	(R6)				Type 1	none	
				Interface not needed	(R6)		Same Direct	SOS1 with DOCKMAZD (D1)	Type 1	none	
				Interface not needed	(R1, R6)				Type 1 or 2	E	
			#42	CEM4A	(R1, R6)				Type 1	none	
Mazda	1994-97	Without Bose sound system	Interface not needed	CEM4A	(R1, R6)				Type 2 (LOC8 or LOC8EA)	none	
		With factory Bose system	Interface not needed	CEM4A	(R1, R6)				Type 1	none	
	MPV	2002	Information forthcoming	Interface not needed					Type 1	none	
				Interface not needed	(R6)				Type 1	none	
			With factory removable face radio	Interface not needed	(R1, R6, R11)				Type 1 or 2 (LOC8 only)	F	
	Mitsubishi	1993-94	With the Indus DMR on the factory receiver face door	FR02	(R1, R6, R11)				Type 1 or 2 (LOC8 only)	F	
			With "toggle" type volume control on factory receiver	FR02	(R1, R6, R11)				Type 1 or 2 (LOC8 only)	F	
	Pickup	1999-02	With factory CD-changer controls	Interface not needed	(R6)			SOS1 with DOCKFORD (D1) or AUFORD (D2, D4)	Type 1	none	
		1997	With factory CD-changer controls	CEM4A	(R1, R6)			SOS1 with DOCKFORD (D1) or AUFORD (D2, D4)	Type 1 or 2 (LOC8 only)	none	
			Without CD-changer controls, or AM/FM only (no cassette)	Interface not needed					Type 1	none	
	1995-96	With CD-changer controls on factory cassette	CEM4A	(R1, R6)			SOS1 with DOCKFORD (D1) or AUFORD (D2, D4)	Type 1 or 2 (LOC8 only)			
	1994	With the word Automatic on the tape door, or with factory CD	FR02	(R1, R6, R11)				Type 1 or 2 (LOC8 only)			
Protege 5	2002	Information forthcoming					SOS1 with DOCKMAZD (D1)				

KICKER000144

SOUNDGATE® 2002 Application Guide

MAKE and MODEL	YEARS	VEHICLE IDENTIFIER/QUALIFIER	INSTALL NOTES (pgs 44-52)	RECEIVER INSTALLATIONS (see part #)	RECEIVER FOOTNOTES	REMAIN ONSTAR (see part #)	CD CHANGER INTERFACE APPLICATIONS AND FOOTNOTES (see part #)	AUXILIARY INPUT INTERFACES (see part #)	STEERING WHEEL CONTROL INTERFACE APPLICATIONS AND FOOTNOTES (Use output converter required)	AMPLIFIER INSTALLATION APPLICATIONS AND FOOTNOTES (Use output converter required)	FACTORY AMPLIFIER LOCATION
Prolog (cont.)	1985-91	With factory removable base radio		Interface not needed	(R)	Scam Direct		SOS1 with DOCKMAD2 (S9-F1) (D1)	Type 1	none	none
Thule	2001-02	With base audio system		Interface not needed				SOS1 with DOCKMAD2 (D1)	Type 1	none	none
		With Mid-line audio system		Interface not needed				SOS1 with DOCKMAD2 (D1)	Type 1	F sub	F sub
		With In-dash radio (in-dash F-66)	F56	Interface not needed				SOS1 with DOCKMAD2 (D1)	Type 1	F sub	F sub
FX7	1992-95	With factory base system		Interface not needed	(R)		ALM21 (84-95) (CA)		Type 2 (L003 or L0CPRA)		I
	1995-97	Press see note #7	F7						Type 1		
MERCEDES											
C200, C40, C320	2001-02	All (other units) with base system	F54	See Note F54			BRMRC1 (C3)		Type 1 (A2)		F
		All (other units) without base system	F54	See Note F54			BRMRC1 (C3)		Type 1		none
C-Class (rest of)	1999-00	All (other units)	F54	See Note F54			BRMRF1 with BFC/BKT (C3)		Type 1 (A2)		G
CL320, CL430	1999-02	All (other units)	F54	See Note F54			BRMRF1 with BFC/BKT (C3)		Type 1 (A2)		none
E200W30, E55	2001-02	All (other units)	F54	See Note F54			BRMRF1 with BFC/BKT (C3)		Type 2 (L003 or L0CPRA)		F
	1999-00	All (other units)	F54	See Note F54			BRMRF1 with BFC/BKT (C3)		Type 1 or 2		G
M.L.200, M.L.420	2001-02	All (other units)	F54	See Note F54			BRMRF1 with BFC/BKT (C3)		Type 1		none
	2000	All (other units)	F54	See Note F54			BRMRF1 with BFC/BKT (C3)		Type 1		none
	1999-99	With base system		DEBMA	(R1, R6)		BRMRS1 (C3)		Type 1		none
		Without base system		Interface not needed			BRMRS1 (C3)		Type 1 (A2)		G
S430, S500, S600	2000-02	All (other units)	F54	See Note F54			BRMRF1 with BFC/BKT (C3)		Type 1		none
S130, S160	2000-02	All (other units)	F54	See Note F54			BRMRF1 (C3)		Type 1 or 2		M
SL320, SL420	2000-02	All		DEBMA	(R1, R6)		BRMRF1 (C3)		Type 1		M
	1998-99	All		DEBMA	(R1, R6)		ALPMS1 with ALPMS1 (88 only) (CA)		Type 1		M
All Models	1995-98	All (except 98 M.L.)		DEBMA	(R1, R6)		ALPMS1 with ALPMS1 (CA)		Type 2 (L003 or L0CPRA)		G
	1992-95	All		Call for details			ALM21 (84-mid 95) (CA)		Type 1		E
	1995-99	Call for details tech. Sheet							Type 1		E
MERCURY											
Capri	1985-96	With factory amplifier in dash		CEM2	(R4)				Type 1		none
		Without amplifier located in dash		PMR1	(R2)				Type 1		none
	1983-84	Without amplifier switch beside factory receiver		FL1	(R2)				Type 1		none
Capri XR2	1993-94	With amplifier switch beside factory receiver		PMR1	(R2)				Type 1		none
		Without word Automatic on tape door	#4 (94)	FR02	(R1, R6, R11)				Type 1 or 2 (L003 only)		none
	1991-93	With "toggle" type volume control on factory receiver		FR02	(R1, R6, R11)				Type 1		none
Colony Park	1998	With rotary volume knob on factory radio		PMR1	(R2)				Type 1		none
		With rotary volume knob on factory receiver & factory speakers		PMR1	(R2)				Type 1		none
Cougar	1995-97	With set factory speakers		PMR1	(R2)			SMS1 with DOCKMAD2 (D1) or ALDFORD (D2, D4)	Type 1		none
	1994-97	With word Automatic on tape door, or with factory in-dash CD	#4	FR02	(R1, R6, R11)				Type 1		none
	1988	With "toggle" type volume control		FR02	(R1, R6, R11)				Type 1 or 2 (L003 only)		E
	1985-87	With rotary volume knob on factory radio		PMR1	(R2)				Type 1		none
		With factory Equalizer or 6-speaker system		PMR1	(R2)				Type 1		none
Grand Marquis	1998-02	All	Note #3	Interface not needed			SMS1 or ALD1 or MRF01 with F55 (C3)		Type 1		none
	1995-97	With CD-changer controls on factory radio, or factory CD. This is factory DAS (distributed audio system - DAS)		Interface not needed			SMS1 or ALD1 or MRF01, with F55 (C3)		Type 1		none
	1995-97	Without CD-changer controls on factory radio, or on factory in-dash CD.		Interface not needed			SMS1 or ALD1 or MRF01, with F55 (C7)		Type 1		none
	1992-94	With word Automatic on the tape door	#4 (94)	FR02	(R1, R6, R11)				Type 1 or 2 (L003 only)		E

KICKER000145

SOUNDGATE® 2002 Application Guide

MAKE and MODEL	YEARS	VEHICLE IDENTIFIER/ QUALIFIER	INSTALL NOTES (pgs. 44-52)	RECEIVER INSTALLATIONS use part #	RECEIVER FOOTNOTES	RETAIN ONSTAR use part #	CD CHANGER INTERFACE APPLICATIONS AND FOOTNOTES use part #	AUXILIARY INPUT INTERFACES use part #	STEERING WHEEL CONTROL INTERFACE APPLICATIONS AND FOOTNOTES use part #	AMPLIFIER INSTALLATION APPLICATIONS AND FOOTNOTES (Line output converter required)	FACTORY AMPLIFIER LOCATION
Grand Marquis (cont.)	1992-94	Without word Automatic on base door		Interface not needed						Type 1	none
	1994-98	With rotary volume control and factory amplifier in the trunk		PWR1	(R2)					Type 1	E
	1994-97	With rotary volume control and amplifier behind left rear trim		PWR1	(R2)					Type 1	G
	1994-97	With another on underside of rear deck		PWR1	(R2)					Type 1	E
	1994-97	Without digital factory receiver, amplifier behind rear quarter trim		DEM2	(R4)					Type 1	G
Mountaineer	1999-02	With Mach audio system. If equipped with subwoofer, call for details	#4, 36	LOCUS10A to keep factory sub			SMEF1 or ALFD1 or KWFD1, with FCS (C3)	SOS1 with DOCKFORD (D1) or AUWFD0 (D2, D4)		Type 1 or 2 (LOC8 only)	F, RCU & sub
		Without Premium sound system	#4	DEM4A	(R1, R6)		SMEF1 or ALFD1 or KWFD1, with FCS (C5)	SOS1 with DOCKFORD (D1) or AUWFD0 (D2, D4)		Type 1 or 2 (LOC8 only)	F
		Without Premium sound system	#4	Interface not needed			SMEF1 or ALFD1 or KWFD1, with FCS (C7)	SOS1 with DOCKFORD (D1) or AUWFD0 (D2, D4)		Type 1	none
	1997-98	Cassette only w/ CD changer controls	#4	DEM4A	(R1, R6)		SMEF1 or ALFD1 or KWFD1, with FCS (C3)	SOS1 with DOCKFORD (D1) or AUWFD0 (D2, D4)		Type 1 or 2 (LOC8 only)	F
	Without CD-changer controls on factory radio, or AM/FM only		Interface not needed						Type 1	none	
	1999-07	With all system. This is factory DAS (distributed audio system - LUX). No interface available.	#3, 4, 36	LOCUS10A to keep factory sub			SMEF1 or ALFD1 or KWFD1, with FCS (C7)	SOS1 with DOCKFORD (D1) or AUWFD0 (D2, D4)		Type 1	F
Mustang	1992-94	With premium sound or speaker grilles	#4	FR02	(R1, R6, R11)					Type 1 or 2 (LOC8 only)	E
	2004-02	All	#3, 14	Call for details			SMEF1 or ALFD1 or KWFD1, with FCS (C7)	SOS1 with DOCKFORD (D1) or AUWFD0 (D2, D4)		Type 1	G
	1995-99	All	#3, 14	Call for details			SMEF1 or ALFD1 or KWFD1, with FCS (C7)	SOS1 with DOCKFORD (D1) or AUWFD0 (D2, D4)		Type 1	G
	1992-95	With word Automatic on tape door	#1 (94-95)	FR02	(R1, R6, R11)			SMEF1 or ALFD1 or KWFD1, with FCS (C7)	FR02MP	Type 1 or 2 (LOC8 only)	E
	Without word Automatic on tape door		PWR1	(R1, R6)				FR02MZ	Type 1	none	
	With AM/FM tuner only — no cassette		PWR1	(R1, R6)				FR02MZ	Type 1	none	
	With "boost" type volume control	#4	FR02	(R1, R6, R11)				FR02MZ	Type 1 or 2 (LOC8 only)	E	
	With rotary volume control and factory amplifier in the trunk		PWR1	(R1, R6)					Type 1	E	
	With rotary volume control and amplifier behind left rear trim		PWR1	(R1, R6)					Type 1	G	
Tazer	1997-94	All	#4 (94)	DEM4A	(R1, R6)					Type 1	E
	1995-95	With factory EQ, or amplifier located on underside of rear deck		PWR1	(R1, R6)					Type 1	E
	1995	With factory digital receiver, but without factory equalizer		PWR1	(R1, R6)					Type 1	none
Tracer	1997-02	Without words Premium Sound on tape door	#4	Interface not needed			SMEF1 or ALFD1 or KWFD1, with FCS (C3)	SOS1 with DOCKFORD (D1) or AUWFD0 (D2, D4)		Type 1	none
		With Premium Sound System	#4, 14	DEM4A	(R1, R6)					Type 1 or 2 (LOC8 only)	E
	1993-95	With cassette, and amplifier under dashboard, or with factory CD	#1 (94-95)	FR02	(R1, R6, R11)					Type 1 or 2 (LOC8 only)	B
Villager	1993	With factory cassette player, with amp		PWR1	(R1, R6)					Type 1	none
	1997-92	With words Premium Sound on grille		PWR1	(R2)					Type 1	none
	2001-02	Without factory video system		Interface not needed			SMEF1 or ALFD1 or KWFD1, with FCS (C3)	SOS1 with DOCKFORD (D1) or AUWFD0 (D2, D4)		Type 1	none
	1999-00	All	Without factory video system	Interface not needed			SMEF1 or ALFD1 or KWFD1, with FCS (C3)	SOS1 with DOCKFORD (D1) or AUWFD0 (D2, D4)		Type 1	none
	1999-98	All	DEM4A	(R1, R6)			SMEF1 or ALFD1 or KWFD1, with FCS (C3)	SOS1 with DOCKFORD (D1) or AUWFD0 (D2, D4)		Type 1 or 2 (LOC8 only)	G
	1993-95	With the word Automatic on the tape door, or with factory CD	#4 (94-95)	FR02	(R1, R6, R11)			FR02MZ		Type 1 or 2 (LOC8 only)	G
MITSUBISHI	3000GT	All	DEM4A	(R1, R6)						Type 2 (LOC8 or LOCPEEN)	G
	Diamond	1992-02	With Infinity Sound System	MITSPOVR	(R7)					MITSAMP or Type 1 (A1)	D
		Without Infinity Sound System	Interface not needed							Type 1	none
	Ecipex	1995-02	With Infinity Sound System	MITSPOVR	(R7)					MITSAMP or Type 1 (A1)	D
	Without Infinity Sound System	Interface not needed							Type 1	none	
Delant	1996-02	With Infinity Sound System	MITSPOVR	(R7)				FR02MZ		MITSAMP or Type 1 (A1)	D

KICKER000146

SOUNDGATE® 2002 Application Guide

NAME and MODEL	YEARS	VEHICLE IDENTIFIER/ QUALIFIER	INSTALL NOTES (pgs 44-52)	RECEIVER INSTALLATIONS use part #	RECEIVER FOOTNOTES	RETAIN ONSTAR use part #	CD CHANGER INTERFACE APPLICATIONS AND FOOTNOTES use part #	AUXILIARY INPUT INTERFACES use part #	STEERING WHEEL CONTROL INTERFACE APPLICATIONS and FOOTNOTES (Line output converter required)	AMPLIFIER INSTALLATION APPLICATIONS and FOOTNOTES	FACTORY AMPLIFIER LOCATION
Savant (cont.)	1989-92	Without Infinity Sound System		Interface not needed				SST1 With DOCKMITS (D1)	Type 1	none	none
Lancer	2002	Information forthcoming		FL1	(R4)				Type 1	none	none
Mercury Mar	1983-86	AI							Type 1	none	none
Mirage	2002	Information forthcoming							Type 1	none	none
Mustang	1987-92	With Infinity Sound System		MITSQDR	(P7)			SST1 With DOCKMITS (D1)	MITSAMP or Type 1 (A1)	D	D
		Without Infinity Sound System		Interface not needed				SST1 With DOCKMITS (D1)	Type 1	none	none
	1988	AI		Call for details				SST1 With DOCKMITS (D1)	Type 1	F	F
NISSAN											
240SX	1985-88	With factory CD player		PWR1	(R5)			SST1 with DOCKMITS (98-99) (D1)	Type 1	none	none
300ZX	1989-95	With factory Bose system		OE4MA	(R1, R6)				Type 2 (LOC8 only)	1	1
	1984-89	AI		FL1	(R5)				Type 1	none	none
350Z	2003	Information forthcoming							Type 1	none	none
Altima	2002	With base-level 6-speaker system		Interface not needed	(R6)				Type 1	none	none
		With Bose Audio System							Type 1 or 2 (LOC8 only)		
		With 6-disc in-dash changer									
1999-01	AI	With factory CD player, or tweeters mounted in the 4-pillars		OE4MA	(R1, R6)			SST1 with DOCKMITS (D1)	Type 1	E	E
1993-97	AI			PWR1	(R1, R6)				Type 1		
Frontier	1989-92	AI		OE4MA	(R1, R6)				Type 1		
Maxima	2000-02	With Navigation system		ALN1 (C3)					Type 1 or 2 (LOC8 only)		
		With 7-speaker factory Bose system		ALN1 (C3)					Type 1		
		With 7-speaker non-Bose system		OE4MA	(R1, R6)			SST1 with DOCKMITS (D1)	Type 1 or 2 (LOC8 only)	E	E
		With 6-speaker non-Bose system		Interface not needed					Type 1	none	none
1995-99	With factory Bose system			OE4MA	(R1, R6)			SST1 with DOCKMITS (D1)	Type 1	none	none
		Without factory Bose system		Interface not needed				SST1 with DOCKMITS (98-99) (D1)	Type 1	none	none
1991-94	With factory Bose system			OE4MA	(R1, R6)			SST1 with DOCKMITS (98-99) (D1)	Type 2 (LOC8 only)	none	none
		Without factory Bose system		Interface not needed					Type 2 (LOC8 only)	none	none
1989-90	With factory Bose system			OE4MA	(R1, R6)				Type 2 (LOC8 only)	none	none
		Without factory Bose system		Interface not needed					Type 2 (LOC8 only)	none	none
1983-92	Without factory Bose system			Interface not needed					Type 1	none	none
Pathfinder	1996-02	Without factory Bose system	#5	Interface not needed				SST1 with DOCKMITS (98-99) (D1)	Type 2 (LOC8 only)	none	none
		With 4, 6, or 8-speaker systems	#5	Interface not needed	(R1, R6)			SST1 with DOCKMITS (98-99) (D1)	Type 2 (LOC8 only)	none	none
1993-95	With 4, 6, or 8-speaker systems		#5	OE4MA	(R1, R6)				Type 1	F	F
2001-02	With factory video system			Read note #5					Type 1		
		Without factory video system		Not recommended					Type 1		
1999-00	AI	Without factory video system		Interface not needed				SST1 with DOCKMITS (D1) or ALMPRO (D2, D4)	Type 1	none	none
1999-98	With Premium sound system			Interface not needed				SST1 with DOCKMITS (D1) or ALMPRO (D2, D4)	Type 1	none	none
		Without Premium sound system		OE4MA	(R1, R6)			SST1 with DOCKMITS (D1) or ALMPRO (D2, D4)	Type 2 (LOC8 only)	6	6
1994-95	With factory cassette or CD player			Interface not needed				SST1 with DOCKMITS (D1) or ALMPRO (D2, D4)	Type 1	none	none
1993	With the word Automatic on tape door			FR02	(R1, R6, R11)			FR02	Type 2 (LOC8 only)	none	none
		With the word Automatic on tape door		FR02	(R1, R6, R11)			FR02	Type 2 (LOC8 only)	none	none
		Without the word Automatic on tape door		Interface not needed					Type 1		
Sentra	2002	Information forthcoming							Type 1		
SE-R	2002	Information forthcoming							Type 1		
Sanza	1985-87	With built-in AM/FM cassette		FL1	(R2)			SST1 with DOCKMITS (D1)	Type 1	none	none
Sentra	2000-02	With in-dash AM/FM CD player		Interface not needed	(R6)			SST1 with DOCKMITS (D1)	LOPHM Only	none	none
88 or 98	1994-99	AI	#5 (98 only)	Interface not needed				SST1 with DOCKMITS (98-99) (D1)	Type 1	none	none
98 or Regency	1988-90	With factory Bose system	#9	GM01	(R1, R6, R11)				Type 2 (LOC8 only)	1	1
		Without factory Bose system		Interface not needed					Type 1	none	none
1986-88	With factory Bose system		#7	GM02	(R1, R6, R11)				Type 2 (LOC8 only)	1	1
		Without factory Bose system		Interface not needed					Type 1	none	none
Acherra	1997-99	AI	#4	Interface not needed				SST1 with DOCKMITS (98-99) (D1)	REMO1E1.5 (S1)	none	none
Alto	2001-02	With AM/FM Cassette with 6-speaker	#5	Interface not needed				SST1 with DOCKMITS (D1)	REMO1E1.5	none	none
		With AM/FM Cassette/CD 6-speaker	#6	Interface not needed				SST1 with DOCKMITS (D1)	REMO1E1.5 or BANSWI	6	6
1999-00	With 8-speaker system (factory sub)		#7, 29	Interface not needed				SST1 with DOCKMITS (D1)	REMO1E1.5 or BANSWI	6 (sub)	6 (sub)
		With 4 or 6-speaker system		Interface not needed				SST1 with DOCKMITS (D1)	Type 1	none	none

SOUNDGATE® 2002 Application Guide

MAKE and MODEL	YEARS	VEHICLE IDENTIFIER/ QUALIFIER	INSTALL NOTES (pgs 44-52)	RECEIVER INSTALLATIONS use part #	RECEIVER FOOTNOTES	RETAIN ONSTAR use part #	CD CHANGER INTERFACE APPLICATIONS AND FOOTNOTES use part #	STEERING WHEEL CONTROL INTERFACE APPLICATIONS AND FOOTNOTES use part #	AUXILIARY INPUT INTERFACES use part #	AMPLIFIER INSTALLATION APPLICATIONS AND FOOTNOTES (Line output converter required)	FACTORY AMPLIFIER LOCATION
Bonneville (cont.)	1996	AI		Interface not needed				REMOVALS or GUSWH	SISI with DOCKSIZM (01)	Type 1	none
	1992-95	AI	#3	Interface not needed				REMOVALS	REMOVALS	Type 1	sub amp only
Freight	1987-91	With factory base system	#3	GMR2	(R1, R6, R11)			REMOVALS or GUSWH	SISI with DOCKSIZM (01)	Type 2 (LODB only)	I
	1997-02	With Mosconi System (10-speaker)	#17	Interface not needed				REMOVALS or GUSWH	SISI with DOCKSIZM (01)	Type 1 or 2 (A6)	G
		With base-level system (4-speaker)		Interface not needed				REMOVALS or GUSWH	SISI with DOCKSIZM (01)	Type 1	none
	1995-96	AI		Interface not needed				REMOVALS or GUSWH	SISI with DOCKSIZM (01)	Type 1	none
1993-94	AI						REMOVALS		Type 1	none	
1996-88	With factory subwoofer switch and subwoofer on light on dash. Note #1			Interface not needed					Type 1		
Grand Am	2001-02	With 5-speaker system	#26	Interface not needed	Starbord (T1)			REMOVALS or GUSWH	SISI with DOCKSIZM (01)	Type 1	none
		With 3-speaker system	#26, #23, #30	Interface not needed	Starbord (T1)			REMOVALS or GUSWH	SISI with DOCKSIZM (01)	Type 1	G
	1994-01	AI	#3	Interface not needed	Starbord			REMOVALS or GUSWH	SISI with DOCKSIZM (01)	Type 1	G
	1995-98	AI	#4	Interface not needed				REMOVALS or GUSWH	SISI with DOCKSIZM (01)	Type 1	none
Grand Prix	1999-02	With factory base system (8-speaker)	#25, #30	CEMA	(R1, R6)	Starbord (09-02)		REMOVALS or GUSWH	SISI with DOCKSIZM (01)	Type 2 (A6)	E
		Without factory base system (5-speaker)	#25 (09-00)	Interface not needed	Starbord (09-02)			REMOVALS or GUSWH	SISI with DOCKSIZM (01)	Type 1	none
	1994-97	AI		CEMA	(R1, R6)			REMOVALS or GUSWH	SISI with DOCKSIZM (09-97) (01)	Type 1	G
Montana	1998	With factory auto switch on dashboard	#1							Type 1	E
	1999-02	All without factory video system	#20, #25, #2	Interface not needed	Starbord			REMOVALS or GUSWH	SISI with DOCKSIZM (01)	Type 1	none
		AI with factory video system	#31, #25, #2	#31	Starbord			REMOVALS or GUSWH	SISI with DOCKSIZM (09) (01)	Type 1	none
	2000-02	Without Mosconi auto system. IMPORTANT!! - See Note #18 for an important warning concerning the advantages in this vehicle!	#18, #26	Interface not needed	Starbord (T1)					Type 1	none
Santita		With Mosconi auto system. IMPORTANT!! - See Note #18 for an important warning concerning the advantages in this vehicle!	#18, #26	CEMA	(R1, R6)					Type 1 or 2 (A6)	E
	1999-99	AI		Interface not needed					SISI with DOCKSIZM (09-99) (01)	Type 1	none
	1998	AI without factory video system	#20, #25 (08)	Interface not needed	Starbord			REMOVALS or GUSWH	SISI with DOCKSIZM (01)	Type 1	none
	1995-97	AI with factory video system	#31					REMOVALS or GUSWH	SISI with DOCKSIZM (01)	Type 1	none
	1995	AI		Interface not needed	(R6)			REMOVALS		Type 1	none
Vibe	1994	AI		Interface not needed	(R6)			REMOVALS		Type 1	none
	2003	AI		CEMA	(R1, R6)			REMOVALS		Type 1	none
	2002	All with factory installation AI without factory navigation		Call for details Call for details						Type 1 or Type 2	
	1994-01	AI		Call for details						Type 1	
	1994-95	All without equalizer, non-Berlin AI with equalizer, non-Berlin radio With Berlin radio		Interface not needed Bypass EQ CEMA (R1, R6)	(R6) (R6) (R1, R6)					Type 1 Type 1 Type 2 (LODB or LOCPREA) Type 2 (LODB or LOCPREA)	none none D D
SAAB	1995-88	AI with factory amplifiers		CEMA (R1, R6)	(R1, R6)					Type 1	D
	2001-02	Information forthcoming								Type 1 or Type 2	B
	1999-00	AI		CEM2						Type 1	
	2002	Information forthcoming			Starbord					Type 1	
	1999-01	AI								Type 1	
AI Models	1992-99	AI		CEM2	(R5)	Chassis Direct				Type 1	D
	1999-00	AI		CEM2		Chassis Direct				Type 1	
	1992-98	With factory CD changer controls				Chassis Direct				Type 1	
	1994-99	AI			(R10)					Type 1	B.H
1992-93	AI		Interface not needed	(R4)					Type 1	none	

KICKER000149

SOUNDGATE® 2002 Application Guide

MAKE and MODEL	YEARS	VEHICLE IDENTIFIER/ QUALIFIER	INSTALL NOTES (pp. 44-52)	RECEIVER INSTALLATIONS use part #	RECEIVER FOOTNOTES	RETAIN ONSTAR use part #	CO CHAMBER INTERFACE APPLICATIONS AND FOOTNOTES use part #	AUXILIARY INPUT INTERFACES use part #	STEERING WHEEL CONTROL INTERFACE APPLICATIONS AND FOOTNOTES use part #	AMPLIFIER INSTALLATION APPLICATIONS AND FOOTNOTES (Line output converter required)	FACTORY AMPLIFIER LOCATION
SATURN											
L Series	2001-02	Base and optional system		Interface not needed						Type 1	
		Advanced system		DEMMA (R1, R6)						Type 1	
S Series	1999-02	Base and optional system		Interface not needed						Type 1	
		Advanced system		DEMMA (R1, R6)						Type 1	
Vue	2002	Base and optional system		Interface not needed						Type 1	
		Advanced system		DEMMA (R1, R6)						Type 1	
SUBARU											
Brid	1992-97	All		FL1	(R3)					Type 1	none
Forester	2002	Information forthcoming		Interface not needed				SIST with DOCSUBA (D1)		Type 1	none
	1999-2001	Information forthcoming		Interface not needed				SIST with DOCSUBA (D1)		Type 1	none
Impreza	2002	Information forthcoming		Interface not needed				SIST with DOCSUBA (D1)		Type 1	none
	1999-2001	Information forthcoming		FL1	(R3)			SIST with DOCSUBA (D1)		Type 1	none
Justy	1998	All		FL1	(R3)			SIST with DOCSUBA (D1)		Type 1	none
Legacy	2002	Information forthcoming		Interface not needed				SIST with DOCSUBA (D1)		Type 1	none
	1999-2001	Information forthcoming		Interface not needed				SIST with DOCSUBA (D1)		Type 1	none
Outback	2002	Information forthcoming		Interface not needed				SIST with DOCSUBA (D1)		Type 1	none
	1999-2001	Information forthcoming		Interface not needed				SIST with DOCSUBA (D1)		Type 1	none
XT Coupe	1995-91	All		FL1	(R3)			SIST with DOCSUBA (D1)		Type 1	none
	2001-02	Information forthcoming		FL1	(R3)			SIST with DOCSUBA (D1)		Type 1	none
SUZUKI											
Astro	2002	Information forthcoming		FL1	(R3)			Alpine M-Bus Direct		Type 1	none
	1995-99	With Alpine factory radio		FL1	(R3)			Cluson Direct		Type 1	none
	1995-99	With Cluson factory radio		FL1	(R3)					Type 1	none
Escalade	2000-02	Information forthcoming		Interface not needed						Type 1	none
Grand Vitara	2000-02	Information forthcoming		FL1	(R3)					Type 1	none
Samurai	1999-95	All		Interface not needed						Type 1	none
	1992-94	All		Interface not needed						Type 1	none
	1992-94	All		FL1	(R3)			Cluson Direct (with Cluson radio)		Type 1	none
	2000-02	Information forthcoming		Interface not needed						Type 1	none
TOYOTA											
4-Runner	2002	With 4-speaker system		Interface not needed				ANTOY1 or SNTOY1, PTOY1		Type 1	none
		With 6-speaker system		DEMMA (R1, R6)				SIST with DOCKTOY (D1)		Type 1	none
	1999-01	With 6-speaker system		DEMMA (R1, R6)				SIST with DOCKTOY (D1)		Type 1	B
		With 4-speaker system		Interface not needed	(R6)			ANTOY1 or SNTOY1, PTOY1		Type 1	C
	1991-98	With 50004 or 51703 radio		DEMMA (R1, R6)				SIST with DOCKTOY (D1)		Type 1	none
		Without 50004 or 51703 radio		Interface not needed	(R6)			SIST with DOCKTOY, 98 and up (D1)		Type 2 (LOC8 or LOC9A)	B
	2001-02	With 4 or 6-speaker system		Interface not needed	(R6)			SIST with DOCKTOY, 98 and up (D1)		Type 1	none
		With 7-speaker Premium system		DEMMA (R1, R6)				SIST with DOCKTOY (D1)		Type 1 or 2	none
	1995-00	With 7-speaker system		DEMMA (R1, R6)				SIST with DOCKTOY (D1)		Type 2 (LOC8 or LOC9A)	C
		With 4-speaker system		Interface not needed	(R6)			SIST with DOCKTOY, 98 and up (D1)		Type 1	none
Camry	2002	Information forthcoming		DEMMA (R1, R6)				SIST with DOCKTOY, 98 and up (D1)		Type 1	C
	1997-01	With 5-speaker system		Interface not needed	(R6)			SIST with DOCKTOY, 98 and up (D1)		Type 1	none
	1992-96	With 4-speaker system		Interface not needed	(R6)			SIST with DOCKTOY, 98 and up (D1)		Type 1	none
		With 50004, 51703, 18004, A11708 radios		DEMMA (R1, R6)				SIST with DOCKTOY, 98 and up (D1)		Type 2 (LOC8 or LOC9A)	D
	2000-02	With 6-speaker one-antenna system		Interface not needed	(R6)			SIST with DOCKTOY (D1)		Type 1	none
		With 6-speaker amplified system		DEMMA (R1, R6)				SIST with DOCKTOY (D1)		Type 1 or 2	C
	1999-98	With 18004 or 11708 radios		DEMMA (R1, R6)				SIST with DOCKTOY, 98 and up (D1)		Type 2 (LOC8 or LOC9A)	D
		Without 18004 or 11708 radios		Interface not needed	(R6)			SIST with DOCKTOY, 98 and up (D1)		Type 1	none
Celica GT	1994-96	With 6- or 8-speaker system		DEMMA (R1, R4, R6)				SIST with DOCKTOY, 98 and up (D1)		Type 1 or 2	B, J
Corolla	2002	Information forthcoming		Interface not needed	(R6)					Type 1	none
	1992-95	All		Interface not needed	(R6)					Type 1	none

2000-02
CH9191

KICKER000150

SOUNDGATE® 2002 Application Guide

MAKE and MODEL	YEARS	VEHICLE IDENTIFIER/ QUALIFIER	INSTALL NOTES (pgs 44-52)	RECEIVER INSTALLATIONS	RECEIVER FOOTNOTES	REMAIN ONSTAR use part #	CD CHANGER INTERFACE APPLICATIONS AND FOOTNOTES use part #	AUXILIARY INPUT INTERFACES use part #	STEERING WHEEL CONTROL INTERFACE APPLICATIONS AND FOOTNOTES use part #	AMPLIFIER INSTALLATION AMPLIFIER AND FOOTNOTES (Line output center required)	FACTORY AMPLIFIER LOCATION
Edo	2000-02	All		Interface not needed				S/S1 with DOCKTOY (D1)	Type 1	none	
Highlander	2002	All		CEM4A	(R1, R6)			S/S1 with DOCKTOY (D1)	Type 1 or 2	H	
Landcruiser	2002	With Navigation system		Interface not needed				S/S1 with DOCKTOY (D1)	Type 1	Call for details	
		With 7-speaker system		CEM4A	(R1, R6)			S/S1 with DOCKTOY (D1)	Type 1	D	
	1997-00	All with amplified system		LOC9HA	(R7)			S/S1 with DOCKTOY (D1)	Type 1 or 2	C	
	1997-96	With radio #52624	#8	CEM4A	(R1, R6)			S/S1 with DOCKTOY (D1)	Type 1	C	
		Without radio #52604		Interface not needed	(R8)				Type 1	none	
Matrix	2002	Information forthcoming		Interface not needed				S/S1 with DOCKTOY (D1)	Type 1	none	
MP2	2000-02	All		CEM4A	(R1, R6)			S/S1 with DOCKTOY (D1)	Type 2 (A1)	F, G	
	1997-96	With 50904 or 51703 radios		Interface not needed	(R4)				Type 2 (A1)	none	
		Without 50904 or 51703 radios		Interface not needed	(R4)				Type 1	none	
Prado	1992-95	All		Interface not needed	(R4)				Type 1	none	
Pilotop	1997-98	Standard Cab		Interface not needed	(R8)			S/S1 with DOCKTOY (D1)	Type 1	none	
		Extended Cab		CEM4A	(R1, R6)			S/S1 with DOCKTOY (D1)	Type 1	B	
Primo	1997	All		CEM4A	(R1, R6)			S/S1 with DOCKTOY (D1)	Type 1 or 2	C, F sub	
	1994-96	With 16555 or 11709 radio		CEM4A	(R1, R6)			S/S1 with DOCKTOY (D1)	Type 1 or 2	C	
		Without 16555 or 11709 radio		Interface not needed	(R8)				Type 1 or 2	none	
	1991-93	All		Interface not needed					Type 1	none	
Prus	2002	Information forthcoming		Interface not needed				S/S1 with DOCKTOY (D1)	Type 1	none	
RAH4	1996-02	All		Interface not needed				S/S1 with DOCKTOY (D1)	Type 1	none	
Sajona	2002	With 6-speaker system		CEM4A	(R1, R6)			S/S1 with DOCKTOY (D1)	Type 1 or 2	B, K	
		With 10-speaker system		Interface not needed				S/S1 with DOCKTOY (D1)	Type 1	none	
Sansa	2002	With 6-speaker system		CEM4A	(R1, R6)			S/S1 with DOCKTOY (D1)	Type 1 or 2	B	
		With 8-speaker system		Interface not needed				S/S1 with DOCKTOY (D1)	Type 1	none	
	1999-01	With 6-speaker system		CEM4A	(R1, R6)			S/S1 with DOCKTOY (D1)	Type 1 or 2	B	
		With 8-speaker system		Interface not needed				S/S1 with DOCKTOY (D1)	Type 1 or 2	D	
Sobara	2000-02	With 4 or 6-speaker system		CEM4A	(R1, R6)			S/S1 with DOCKTOY (D1)	Type 1	none	
		With 7-speaker Premium system		Interface not needed				S/S1 with DOCKTOY (D1)	Type 1 or 2	D	
	1999	With 6-speaker non-amplified system		CEM4A	(R1, R6)			S/S1 with DOCKTOY (D1)	Type 1	none	
		With 8-speaker amplified system		Interface not needed				S/S1 with DOCKTOY (D1)	Type 1 or 2	D	
Suzuki	1997-96	All		CEM4A	(R1, R6)			S/S1 with DOCKTOY (D1)	Type 1	D	
Tered	1995-98	All		Interface not needed				S/S1 with DOCKTOY (D1)	Type 1	none	
Turbo	2001-02	With 6-speaker amplified system		CEM4A	(R1, R6)			S/S1 with DOCKTOY (D1)	Type 1 or 2	B	
		With 8-speaker non-amplified system		Interface not needed				S/S1 with DOCKTOY (D1)	Type 1	none	
T100/Exams	1995-02	All		Interface not needed	(R8)			S/S1 with DOCKTOY (D1)	Type 1	none	
VOLKSWAGEN											
New Beetle	1999-02	All		Interface not needed				S/S1 with DOCKTOY (D1, D2) or AUXW (D2)	Type 1	none	
Cabrio	2002	Information forthcoming		Interface not needed				S/S1 with DOCKWAF, DOCKWAF (D1, D2) or AUXW (D2)	Type 1	none	
Europe	1995-02	All		Interface not needed				S/S1 with DOCKWAF, DOCKWAF (D1, D2) or AUXW (D2)	Type 1	none	
Golf	2000-02	With Monsoon system	#17 - Call for info by fax	Interface not needed				S/S1 with DOCKWAF, DOCKWAF (D1, D2) or AUXW (D2)	Type 1	none	
		Without Monsoon system		Call for info by fax				S/S1 with DOCKWAF, DOCKWAF (D1, D2) or AUXW (D2)	Type 1	none	
	1999	All		Interface not needed				S/S1 with DOCKWAF, DOCKWAF (D1, D2) or AUXW (D2)	Type 1	none	
	1998	With factory Base system		CEM4A	(R1, R6)			S/S1 with DOCKWAF, DOCKWAF (D1, D2) or AUXW (D2)	Type 1 or 2	none	
		Without factory Base system		Interface not needed				S/S1 with DOCKWAF, DOCKWAF (D1, D2) or AUXW (D2)	Type 1	none	
	1997	With factory Base system		CEM4A	(R1, R6)			S/S1 with DOCKWAF, DOCKWAF (D1, D2) or AUXW (D2)	Type 1 or 2	none	
		Without factory Base system		Interface not needed				S/S1 with DOCKWAF, DOCKWAF (D1, D2) or AUXW (D2)	Type 1	none	
	1993-96	All		Interface not needed				S/S1 with DOCKTOY (D1)	Type 1	none	

KICKER000151

SOUNDGATE® 2002 Application Guide

NAME and MODEL	YEARS	VEHICLE IDENTIFIER/ QUANTIFIER	INSTALL NOTES (pgs 44-52)	RECEIVER INSTALLATIONS use part #	RECEIVER FOOTNOTES	RETAIN ONSTAR use part #	CO CHARGER INTERFACE APPLICATIONS AND FOOTNOTES use part #	AUXILIARY INPUT INTERFACES use part #	STEERING WHEEL CONTROL INTERFACE APPLICATIONS AND FOOTNOTES use part #	AMPLIFIER INSTALLATION APPLICATIONS AND FOOTNOTES (Line output converter required)	FACTORY AMPLIFIER LOCATION
Call (local)	1989-92	Without Active system		Interface not needed	(R6, R8)					Type 1	
	1985-91	With Active system	#12	Interface not needed	(R6, R8)					Type 1	
	1987-88	Without Active system		PWR1	(R3)					Type 1	none
Jeep	2000-02	With Mission system	#17 - Call for info by fax	Interface not needed			ALUHI or KNHWI with VWICBLR (C4)	SOS1 with DOCKWME, DOCKWR (D1, D3) or ALUWV (D2)		Type 1	none
		Without Mission system	Call for info by fax	Interface not needed			ALUHI or KNHWI with VWICBLR (C4), VWICBLF (C3)	SOS1 with DOCKWME, DOCKWR (D1, D3) or ALUWV (D2)		Type 1	
	1999	AI		Interface not needed			ALUHI or KNHWI with VWICBLR (C4), VWICBLF (C3)	SOS1 with DOCKWME, DOCKWR (D1, D3) or ALUWV (D2)		Type 1	
	1997-98	With factory Bose system		CEMAA	(R1, R6)		Not Available	SOS1 with DOCKWME, DOCKWR (D1, D3) or ALUWV (D2) (SB only)		Type 1 or 2	
		Without factory Bose system		Interface not needed			ALUHI or KNHWI with VWICBLR (C4), VWICBLF (C3)	SOS1 with DOCKWME, DOCKWR (D1, D3) or ALUWV (D2)		Type 1	
	1992-95	AI		Interface not needed						Type 1	
	1987-91	With Active system	#12	Interface not needed	(R6, R8)		ALUHI or KNHWI with VWICBLR (C4), VWICBLF (C3)	SOS1 with DOCKWME, DOCKWR (D1, D3) or ALUWV (D2)		Type 1	
		With Mission system	#17 - Call for info by fax	Interface not needed			ALUHI or KNHWI with VWICBLR (C4), VWICBLF (C3)	SOS1 with DOCKWME, DOCKWR (D1, D3) or ALUWV (D2)		Type 1	
		Without Mission system	Call for info by fax	Interface not needed			ALUHI or KNHWI with VWICBLR (C4), VWICBLF (C3)	SOS1 with DOCKWME, DOCKWR (D1, D3) or ALUWV (D2)		Type 1	
	1999	With factory Bose system	Call for info by fax	CEMAA	(R1, R6)		Factory only	SOS1 with DOCKWME, DOCKWR (D1, D3) or ALUWV (D2)		Type 1 or 2	
		Without factory Bose system		Interface not needed			ALUHI or KNHWI with VWICBLR (C4), VWICBLF (C3)	SOS1 with DOCKWME, DOCKWR (D1, D3) or ALUWV (D2)		Type 1	
	1993-97	AI		Interface not needed						Type 1	
	1991-92	With Active system	#12	Interface not needed	(R6, R8)					Type 1	
		Without Active system		Interface not needed						Type 1	
VOLVO											
C70 Convertible Coupe	2000-02	With AMFM/CO, or 3-Disc changer, Dolby Pro. 10 speaker system		CEMAA	(R1, R6)		ALPNSTR with ALPMA1, (C3)	SOS1 Call for cable requirements (D1)		Type 1 or 2	400 watt
		With AMFM/CO, or 3-Disc changer, Dolby Pro. 12 speaker system		CEMAA	(R1, R6)		ALPNSTR with ALPMA1, (C3)	SOS1 Call for cable requirements (D1)		Type 1 or 2	400 watt
	1999-05	With AMFM/CO (Std. Equipment)		CEMAA	(R1, R6)		ALPNSTR with ALPMA1, (C3)	SOS1 Call for cable requirements (D1)		Type 1	
		With Dolby Pro Logic		CEMAA	(R1, R6)		ALPNSTR with ALPMA1, (C3)	SOS1 Call for cable requirements (D1)		Type 1 or 2	
	2001-02	With AMFM/Cassette, 6-speaker		Interface not needed			Factory only	SOS1 Call for cable requirements (D1)		Type 1	none
		With AMFM/CO, 6-speaker		CEMAA	(R1, R6)		Factory only	SOS1 Call for cable requirements (D1)		Type 1 or 2	100 watt
	2000	With AMFM/Cassette (Std. Equipment)		Interface not needed			ALPNSTR with ALPMA1, (C3)	SOS1 Call for cable requirements (D1)		Type 1	none
S70	2000	AI		Interface not needed			ALPNSTR with ALPMA1, (C3)	SOS1 Call for cable requirements (D1)		Type 1	
70-Series	1998-99	AI		Interface not needed			ALPNSTR with ALPMA1, (C3)	SOS1 Call for cable requirements (D1)		Type 1	none
S80	2001-02	With AMFM/Cassette, 6-speaker		Interface not needed	(R1, R6)		Factory only	SOS1 Call for cable requirements (D1)		Type 1 or 2	none
		With AMFM/4-Disc changer/10-speaker		CEMAA	(R1, R6)		Factory only	SOS1 Call for cable requirements (D1)		Type 1	200 watt
	1999-00	With 6-speaker system		CEMAA	(R1, R6)		Factory only	SOS1 Call for cable requirements (D1)		Type 1	0
		With 8-speaker system		Interface not needed			Factory only	SOS1 Call for cable requirements (D1)		Type 1	none
S90	1999	AI		Interface not needed			ALPNSTR with ALPMA1, (C3)	SOS1 Call for cable requirements (D1)		Type 1	none
V40	2000-02	With AMFM/Cassette, 7-speaker		Interface not needed			ALPNSTR with ALPMA1, (C3)	SOS1 Call for cable requirements (D1)		Type 1	none
		With AMFM/CO, 7-speaker		CEMAA	(R1, R6)		ALPNSTR with ALPMA1, (C3)	SOS1 Call for cable requirements (D1)		Type 1 or 2	200 watt
V70	2001-02	With AMFM/Cassette, 6-speaker		Interface not needed			Factory only	SOS1 Call for cable requirements (D1)		Type 1	none
	1998-99	AI		Interface not needed			Factory only	SOS1 Call for cable requirements (D1)		Type 1	none
V70 T5	2001-02	With AMFM/Cassette, 6-speaker		Interface not needed			Factory only	SOS1 Call for cable requirements (D1)		Type 1	none
		With AMFM/4-Disc changer/Dolby Pro		CEMAA	(R1, R6)		Factory only	SOS1 Call for cable requirements (D1)		Type 1 or 2	200 watt
XJ, XJZ wagon	2002	With AMFM/Cassette, 6-speaker		Interface not needed			Factory only	SOS1 Call for cable requirements (D1)		Type 1	none
		With AMFM/CO, 6-speaker		CEMAA	(R1, R6)		Factory only	SOS1 Call for cable requirements (D1)		Type 1 or 2	100 watt
		With AMFM/4-Disc changer/Dolby Pro		CEMAA	(R1, R6)		Factory only	SOS1 Call for cable requirements (D1)		Type 1 or 2	200 watt
All Models	1998-97	AI		Interface not needed			ALPNSTR with ALPMA1, (C3)	SOS1 Call for cable requirements (D1)		Type 1	
	1991-95	AI		Interface not needed			AVOLV1, (C3)	SOS1 Call for cable requirements (D1)		Type 1	

*too only
too only*

Note #1 - An Important Warning concerning General Motors Vehicle Installations:

General Motors vehicles (Non-Bose equipped) equipped with a dash-board-mounted subwoofer switch, or "subwoofer on" indicator light are equipped with a subwoofer amplifier. This amp draws its power from the power antenna lead of the factory radio. If installing an aftermarket receiver or CD player in one of these vehicles, ISOLATE THE POWER ANTENNA TRIP LEAD OF THE NEW HEAD UNIT FROM THE CAR'S POWER ANTENNA LEAD using a Bosch, or similar relay: not doing so will damage the new receiver's power antenna, or amplifier wake-up lead.

Note #2 - Explanation of Ford/Lincoln/Mercury warning:

In 1988 Ford Motor Company vehicles started using a 9-volt trip signal to wake-up their factory PSA-B (Premium Sound) amplifiers. In 1995 the voltage level of the amplifier wake-up lead dropped to 5 volts (Lexus also started using a 5-volt signal in 1996). Many aftermarket amplifiers will not wake-up with this low-voltage signal. Using the LOC2 or LOC3FR is a perfect solution/selling point (auto wake-up feature) for adding amplifiers to these vehicles. If not using the SoundGate LOC2 or LOC3FR, it will be necessary to use SoundGate TRIGLOHD to convert the 5, or 9-volt signal to 12 volts. Also, if adding an amplifier using the amplifier's high-level inputs, intersect the signal leads for the amplifier input after the factory amplifier, not at the radio. The radio only provides 660 millivolts of drive voltage to the factory amplifiers.

Note #3 - Ford's Distributed-Audio Systems (digital/analog LUX systems) and Lexus with Mark Levinson:

Ford Motor Company's Distributed-Audio Systems (DAS) are unique to 1995-98 "JBL" systems, and other Ford Motor Company vehicles as noted in this application guide. In these systems (and in Lexus, Mark Levinson) there are only two channels of audio transferred from the dashboard controls (FCU - front control unit), to the tuner/pre-amp/amplifier module (RCU-rear control unit) mounted in the rear of the vehicle. These two channels are converted to four inside the RCU and are controlled via digital commands from the FCU. Because there is no way to integrate four channels of audio into the input of the RCU, an interface cannot be made. If adding a new receiver or CD player to these vehicles, the entire factory system will have to be bypassed. A SoundGate LOC5UBA can be used to retain the factory subwoofer (where so equipped).

Note #4 - Ford head units with low voltage amplifier turn-on circuitry:

A 570-ohm resistor must be installed between the amplifier wake-up lead of the new receiver and the amp turn-on lead of this vehicle. Not doing so will result in distortion in the audio system.

Note #5 - 1989-92 Nissan Maximas w/O Bose Systems

and 1993-95 Pathfinders with 4, 6, or 8-speaker systems: Maxima: An amplifier located under the left side of the luggage compartment powers both rear speakers. This amplifier has floating inputs and

receives its signals from the speaker wire plug at the rear of the radio. The Brown, with black stripe, wire of the rear speaker plug is the turn-on wire for this amp. Connect this wire to the "amp-on" or "power antenna" wire of the new receiver.

Pathfinders: 4-speaker system - amplifier is mounted behind radio. Connect the Brown/white stripe wire of the rear speaker plug to the remote turn on lead of the new receiver. Connect high power speaker leads of new receiver direct to new harness.

6 or 8-speaker system - amplifiers are mounted behind right rear quarter trim. Connect Pink wire of factory rear speaker plug to remote trigger lead of new receiver. Connect high power speaker leads of new receiver direct to new harness. If installing a MOSFET deck, use an OEM4A.

Note #6 - 1990-94 Audi V8s with Bose systems:

An aftermarket receiver or CD player with high-voltage RCA outputs (4 or 5 volts) can be connected, and directly interfaced into the Audi V8s without using an interface. Simply solder RCA connectors to a Scosche, Metra, or similar Audi harness. Ground the car's common amplifier return to the rear of the new receiver.

Note #7 - 1989-92 Mazda RX7s with door speakers:

The door speakers in these cars are woofers that are powered by an amplifier that will be located under the driver's side of the dash (without passive shoulder belts), or under the passenger's side (with passive shoulder belts). The amp can be bypassed by simply unplugging the input and output connectors at the amp, and then plugging the two connectors into one another.

Note #8 - 1991-96 Toyota Landcruisers with six or eight-speaker systems:

The amplifier for these systems is located to the right of the glovebox. An aftermarket harness plugged into the output connector of this amp will bypass the amp. If the vehicle is equipped with the factory subs they will continue to operate.

Note #9 - 1984 General Motors vehicles with Bose systems:

In late 1984 General Motors made a change to the Bose systems in their automobiles. The change consisted of switching from a 4-channel, balanced receiver output, to a 4-channel, common-grounded receiver output (WARNING! This is not the same type of output as an aftermarket low-power, common-grounded output). General Motors does not have any records indicating exactly when these changes were made (as referenced to automobile serial numbers). When using a SoundGate #GMB2 or OEM4A in any 1984 automobile (as noted in this application guide) you must inspect the wiring harness at the rear of the factory receiver. You will see the speaker harnesses (blue and white connectors) wired in one of two ways. If six wires enter each connector harness an aftermarket high-power receiver can be wired directly to the Bose amplifiers via the car's harness. If the car you're working on has five wires entering each connector, you will need to use the SoundGate #GMB2 or OEM4A for any aftermarket receiver or CD player installation.

Note #10 - Reserved for future use.

Note #11 - 1990 - 93 Chevrolet Corvette factory service bulletin: General Motors has issued a service bulletin for aftermarket receivers or CD players installed in 1990-93 Corvettes. Please call SoundGate at 307-674-4707 for a copy of the bulletin if performing this installation.

Note #12 - 1989 - 90 Volkswagens with "Aktiv" audio systems:

The wiring of the Volkswagen "Aktiv" systems changed in the 1989-1990 model years. In 1989 Jettas with VIN #s starting with, and higher than 1G KW400001, and 1990 Golfs and Jettas made in Mexico with VIN #s starting with 1G LM007400, the car's speaker wiring changed to a five-wire, common-negative-type at the radio harness. In these instances the amplifier in the door powers all six speakers in the car, and the pre-amp outputs of a new receiver can be used to interface. In cars built before the above years and VIN numbers, the dash and rear speakers were powered off of the radio, and only the door speakers were amplified by the amplifier located in each door. In these applications the speaker connector at the dash will have eight wires, and the speaker leads of the new receiver can be used for interfacing. Jettas with Bose systems: SoundGate dealers have properly interfaced new head units into the Jetta Bose systems by simply using an aftermarket harness wired off of the new receiver's speaker output leads. One dealer reported a slight turn and turn off pop, but this was probably a result of a bias problem in the outputs of the new receiver. A second dealer reported that there were no turn on or turn off pops, and that the gain structure was correct.

Note #13 - Reserved for future use.

Note #14 - 1996 - 2002 Ford Taurus and Mercury Sable:

Ford Taurus, Mercury Sables, and Ford Escorts are equipped with radios termed "ICP" by Ford. Replacing these oval radios will require a "like-designed" kit available through Scosche or Metra. The Taurus and Sable, in addition, will require a wiring harness to extend the new receiver's speaker wiring to the amplifier/tuner module located in the trunk (in front of spare tire in wagons).

Note #15 - Land Rover audio systems:

Land Rover audio systems will be found to be wired in one of two ways. One type uses an eight-wire speaker harness. The second uses a five-wire harness at the radio location. Both of these systems are 'common-grounded'. To properly interface a new receiver into these vehicles, use a new receiver that incorporates high-power speaker level outputs. Connect these outputs to a SoundGate OEM4A for proper signal integration into the factory amplifiers. All factory speakers and amplifiers will work as with the factory radio.

Note #16 - Headliner speakers in Acura Vigor:

The two-channel amplifier located behind the factory radio on the non-Bose-equipped Acura Vigors powers the overhead speakers located in the headliner. Replacing the factory radio will result in the loss of these speakers. An RCA output from the new radio can be used to drive the

input of this amplifier. The balance of the car's speakers are powered directly off of the factory, or new radio's speaker-level outputs.

Note #17 - Chevrolet Camaros, Pontiac Firebirds and Volkswagens with Monsoon systems:

Firebirds, Camaros and Volkswagens equipped with Monsoon audio systems are easily integrated with. When replacing the factory radio, simply wire all eight speaker leads of the new receiver to a Metra or Scosche harness and simply plug the harness into the car. Attempting to use an interface in these vehicles will result in the factory amplifier not turning on. The factory amplifier uses current sensing as a turn-on signal. If adding an aftermarket amplifier to the system, a SoundGate trigger device (TRIGSPKR) will be required to provide the new amplifier with a wake-up lead. We do not recommend using radios with high-power "Mostef" outputs in these vehicles.

Note #18 - Pontiac Sunfire and Chevrolet Cavalier airbag warning: 1999 thru 2002 model year Chevrolet Cavaliers and 1999 thru 2002 Pontiac Sunfires are subject to a very important warning from General Motors. GM service information states that both airbags must be deactivated before attempting radio removal. Unhooking the battery does not accomplish deactivation. Call SoundGate at 307-674-4707, and we will fax you the airbag deactivation instructions. Instructions differ between 1999 thru 2000 model year vehicles, and 2001 thru 2002 model year cars.

Note #19 - Hiss problems using FM modulators on 1999 thru 2002 model year General Motors cars:

This vehicle is equipped with General Motors "Adaptive Reception System". This system consists of a front windshield antenna, and a rear window antenna. Both antennas feed their respective signals into a Radio Antenna Module (antenna amplifier). The Radio Antenna Module has a variable gain feature that can be adjusted at a General Motors dealership using a scan tool. This adjustment serves to maximize the radio reception for rural, or urban areas (similar to a distance/local switch). **WARNING!** If you are connecting an FM-modulated CD changer to this vehicle, you may experience a large amount of hiss when listening to the CD changer. If this is the case, the vehicle will need to be taken to a dealership and the Radio Antenna Module will need to be adjusted to the urban (city) setting.

Note #20 - Lack of ignition leads in 1999 thru 2002 model year GM vehicles:

The harness connector for the factory radio in this vehicle does not contain an ignition lead. An ignition source for the new receiver or CD player will have to be obtained from a separate connector at the dash location.

Note #21 - Factory amps using current sensing for "wake-up" signals:

The factory amplifier in this vehicle utilizes current-sensing for its turn-on (wake-up) signal. Using an interface in this vehicle will prevent the factory amplifier from turning on.

Note #22 - General Motors vehicles with remote-mounted tuner/amplifier boxes:

When adding a new receiver to this vehicle, the interface will not be used at the radio location in the dashboard. In this vehicle the radio unit in the dashboard is simply a keypad. Two channels of audio exit this unit and are input into a Radio Interface Module that is located in a secondary location in the vehicle. The Radio Interface Module converts the two channels of audio into four channels. The tuner for the vehicle is also part of this Radio Interface Module. If adding a new receiver to this vehicle an antenna extension cable will need to be run from the Radio Interface Module location to the dashboard. The speaker leads will also have to be extended from the dashboard to the Radio Interface Module.

The Radio Interface Module locations are:

1. Cadillac Catera - beneath rear deck
2. Cadillac Seville and Eldorado - right rear quarter panel beside power antenna.
3. 1989 - 91 Chevrolet Corvette - above the passenger's legs behind the dashboard.
4. 1992 - 96 Corvette - right rear storage compartment behind the passenger seat.
5. 1989-96 Cadillac Fleetwood/Brougham - In dashboard left of radio.

Note #23 - Factory amplifiers using active crossovers:

The amplifier(s) in this vehicle contain active crossover networks. If replacing the factory amplifier, new crossovers will have to be added to each pair of speaker leads to prevent damage to the midrange and tweeter drivers.

Note #24 - General Motors vehicles with amplifiers integrated into the Class 2 serial data-bus:

The amplifier in this vehicle is electrically integrated into the rest of the vehicle and cannot be removed unless the entire sound system is replaced. This factory amplifier also uses built-in, active crossover networks. If adding full-range amplifiers to this vehicle, the outputs of the factory amp need to be summed into a full-range signal using SoundGate LOCHVA line output converters. Call SoundGate at 307-674-4707 for details.

Note #25 - General Motors "On-Star" system:

This vehicle may be equipped with General Motors "OnStar" system. If replacing the factory radio, the OnStar system will not operate unless a SoundGate "STARMOD" interface is used. The STARMOD is needed to ensure un-interrupted incoming messaging from the OnStar center. Eliminating or affecting the operation of the OnStar system creates serious liability concerns for the Mobile Electronics Industry. Please call SoundGate at 307-674-4707 for additional details.

Note #26 - Chime Warnings in certain General Motors vehicles using the Class 2 serial data-bus:

This vehicle utilizes General Motor's Class 2 Serial Data Bus. In this vehicle the warning chimes for the entire vehicle (seat belt, headlights on, door ajar, etc.) are transmitted through the factory radio or amplifier and then through the car's speakers. Removing the factory radio or amplifier (if equipped) will disable these chimes. SoundGate will have a chime interface module in the near future to bring these chime functions back. Until this module becomes available it is a liability to the installing dealer if the chimes are disabled. We can provide a bypass procedure to make the chimes work, until the new interface is introduced. Please call for details.

Note #27 - General Motors ignition leads obtained via park lamp circuit:

This vehicle obtains its factory ignition lead voltage via the park lamp circuit. A circuit inside the radio senses voltage on the park lamp circuit, to instruct the radio that the car is in a started condition, or that the key is in the on position.

- 2000-02 Impala. Park Lamp circuit is "B4" pin (gray wire) of 24-pin connector.

- 2000-02 Monte Carlo. Park Lamp circuit is "B4" pin (gray wire) of 24-pin connector.

Note #28 - General Motors sport utility vehicles with rear-seat audio control panels:

When replacing the factory radios in General Motors utility vehicles with rear-seat audio controls, the new radio will be wired into the audio path using the new receiver's high power speaker leads. The rear seat headphone jacks will continue to operate with the installation of the aftermarket receiver.

Note #29 - Factory amplifier in Oldsmobile Alero:

According to General Motors schematics for this vehicle, the rear speakers are a 3-voice-coil design. Speaker size is 6 x 9. We assume that dual voice coils are used for the 6 x 9 driver and that the third set of voice coils is used for direct feed to a coaxial tweeter. The factory amplifier (located on driver's side rear quarter panel) feeds only the second set of voice coils on the 6 x 9's.

Note #30 - Bi-amplified factory speakers:

One or more pairs of speakers in this vehicle may be bi-amplified. If replacing with aftermarket speakers, individual tweeter/midrange, or tweeter/woofer combinations should be used as a replacement.

Note #31 - General Motors minivans with factory video systems:

General Motors minivans equipped with the factory video system for rear-seat passengers use a unique head unit, along with an "auxiliary video module". This factory receiver/cd/cassette allows front seat passengers to listen to one source (e.g. cassette), while rear seat passengers listen to either the same source, or to the video system either through the rear speakers, or through headphones. Indications are that the factory radio uses an "output level control" to adjust the output level of the rear audio signals during rear-seat headphone use. Due to the

unique design of, and integration of the factory radio into, the video system, please call SoundGate at 307-674-4707 for further information on how to integrate an aftermarket receiver/CD player into this vehicle. Allow four to five extra hours labor for this installation.

Note #32 - 2000-2002 Pontiac Bonneville, 2001-2002 Oldsmobile Aurora, 2000-2002 Buick LeSabre:

These vehicles present many obstacles to installers. These include:
1. A ribbon type cable that plugs into the rear of the radio, instead of a standard molex-type connector. This looks like a computer-type ribbon cable, but cannot be soldered into, or modified.

2. General Motors Class 2 serial data-bus - This data bus connects 15 different modules within the vehicle, including the factory radio and factory CD changer. Disconnecting more than one module from the data-bus causes serious operational problems in the vehicle. If putting a new receiver in this vehicle, keep the factory radio plugged into the factory cable and remote-mount the factory radio in a hidden location. Speaker/amplifier wires can be intersected at the driver's side kickpanel location.

Note #33 - General Motors vehicles with dual-voice coil rear speakers:

This vehicle utilizes a separate amplifier, which feeds a second set of voice coils on the rear speakers. Some General Motors vehicles will include a 'bass gain' control slide switch on the dashboard, which allows driver control of bass boost. Replacement speakers must be dual-voice-coil design to retain this feature.

Note #34 - Vehicles with 2-ohm or 10-ohm speakers:

These vehicles use speakers that are not 4-ohm impedance:

- 1996-98 Pontiac Grand AM and 1996-98 Buick Skylark w/4-speaker system: All speakers 10-ohm
- 1996-98 Pontiac Grand AM, 1996-98 Buick Skylark, and 1997-99 Oldsmobile Achieva w/component front speakers. Front speakers are parallel and present a 2-ohm load. Rear speakers are 10-ohm.
- 1997-02 Pontiac Firebirds and Chevrolet Camaros with non-Monsoon system. Rear speakers are 10-ohm. With Monsoon system: Subwoofers are 2-ohm, front midranges are 2-ohm.
- 1989-93 Infiniti Q45 With Bose: Rear speakers are 2-ohm

Note #35 - 2000-2002 model year BMWs with Motorola StarTAC cellular phone wiring:

The 2000-2002 model-year BMW 5-Series (starting with January, 2000 production), are pre-wired for a Motorola StarTAC cellular phone. The power connector for this phone is identical to 3-pin round/power/data-bus lead for the CD changer. The 3-pin CD changer plug has the brown ground lead in the #1 pin location (refer to numbers molded into plug). The cellular phone connector has the brown ground lead in the #2 pin location.

WARNING! - Plugging the cellular phone power connector into our BMW CD Changer interface will result in damage to the interface - this is not covered under warranty. A warning notice is packaged with each ABMW35V4, KBMWV4, and SNBMWV4 informing installers of this danger.

Note #36 - 1998 thru 2002 Fords with factory subwoofer:

The listed Ford Motor Company vehicles with factory subwoofers utilize a separate subwoofer connector harness directly at the rear of the factory radio. This 8-pin connector directly feeds the subwoofer amplifier. If replacing the factory receiver in one of these vehicles, please call SoundGate tech. support at 307-674-4707 for information on how to retain use of the factory subwoofer with an aftermarket receiver. A SoundGate LCSUBA will be required to make this conversion work correctly.

Note #37 - General Motors Bose systems turn-on relays:
General Motors vehicles equipped with Bose systems utilize a relay to wake-up the Bose amplifiers, and to activate the power antenna. This relay typically will start malfunctioning after 5 or 6 years of use. If customer complains of his/her Bose system frequently shutting down, replace relay (factory part# 1407-8902).

Note #38 - General Motors vehicles which use the factory radio to program various functions throughout the vehicle:
The factory radio in these vehicles is used to program various convenience and security functions within the vehicle. If the factory radio is removed or replaced, the ability to set these functions will be disabled. At press time, SoundGate did not have information on whether removing the radio causes other operational problems within the vehicle.

Note #39 - IMPORTANT! - All 1999 thru 2002 model year General Motors vehicles:

General Motors has issued an airbag warning document (#645519) warning of a potential, very serious problem when disconnecting and reconnecting factory radios in the above model year vehicles. Paraphrasing the GM document: "Class 2 Serial Data Communication allows control modules... the instrument panel cluster, the radio... to exchange information.... Typically, the PCM broadcasts a portion of the VIN, while another module broadcasts another portion of the VIN. This information is compared by the SDM in order to ensure installation is in the correct vehicle. When the broadcast VIN does not match the VIN stored within the SDM, the following can occur:

- DTC B1001 Option Configuration Error is set and **deployment of the airbags is inhibited**....
- SoundGate's interpretation of this bulletin is that a removal of the factory radio, or possibly just unplugging it and then cycling the ignition key can cause this error code to be set. A disabling of the airbag system is, of course, a legal liability for those involved in causing this action.
- To ensure that the airbag system in the above listed cars is not disabled during any work that is performed on these vehicles, please follow this procedure:

- Before ANY work is performed, sit in the drivers seat and turn the vehicle off.
- Turn the ignition key to the 'ON' position. Count the number of times that the airbag indicator on the dashboard flashes (GM states the indicator should flash 7 times). If you are unsure of the number of flashes, repeat the test.

3. Complete the work/installation on the vehicle.

4. After work is completed, once again sit in the driver's seat and repeat steps #1 and #2.

5. **IMPORTANT!** The airbag warning indicator MUST flash exactly the same number of times as it did before the installation was begun. If the airbag indicator flashes a different number of times as during the pre-installation test, do not release the vehicle to the customer. Immediately contact your local GM dealership for the procedure necessary to ensure proper airbag operation. SoundGate strongly recommends that this procedure be added to any pre-installation inspection forms that are currently used by the installing dealer.

The customer should be present for the pre-installation test (steps #1 and #2), then should also witness the post-installation test confirming the correct airbag indicator flash sequence. The customer should sign this form, verifying this test. If a dealership is presently not using pre-installation inspection forms, we strongly recommend this procedure be started.

Note #40 - Factory CD Changer signals input directly into factory amplifiers:

In these vehicles, the factory CD changer signal is input directly into the factory amplifier. Removing, or replacing the factory amplifier will disable use of the factory changer. Aftermarket amplifiers can be added to the system through the use of SoundGate LOCHVAs, used after the factory amplifier. Call SoundGate Technical Support at 307-674-4707 for details.

Note #41 - 1999-2002 Mercedes S-Class:

Mercedes S-Class vehicles use a fiber optic audio link between the factory radio and factory amplifier. Depending on the options present on the vehicle, replacement of the radio may not be possible. Please call SoundGate at 307-674-4707 for specific details on the vehicle you are working with.

Note #42 - 1999-2000 Mazda Millenia:

These model year Millenias present an operating condition on the amplifier turn-on lead that can damage aftermarket receivers and CD players. As the volume of the radio is increased, the current draw on the amplifier turn-on lead increases. This current draw will increase to where it either shuts down the turn-on lead of the aftermarket receiver, or damages it. We recommend isolating the turn-on lead of the vehicle through a relay to prevent damage to the new head unit.

Note #43 - 1990-94 BMW radio button sequence for determining changer use:

- Does radio have a "mode" button in upper left hand corner? If so, continue to step 2. If not, stop.
- With engine off, turn the ignition key to the "run" position.
- Make sure radio is off (For 1992-94 models turn radio on).
- While holding "program" button, press "mode" button. Display will show either "Pioneer", or "Alpine". If "Pioneer" displayed, old "M-bus" style Pioneer changer will plug in. Important - pins #12 and #13 are switched in the factory BMW cable. Either switch these two pins at the changer end of the factory cable, or use the 18" cable packaged with the Pioneer changer and plug the cable directly into the back of the factory radio.

Note #44 - Ford vehicles equipped with high-pass output factory radios:

These vehicles use an internally-amplified radio that utilizes high-pass output, high-power speaker leads. The radio is equipped with an 8-pin connector that outputs low-pass audio signals to the factory subwoofer. If replacing the factory radio, use a SoundGate LOCSUBA to keep the factory subwoofer operational. Contact SoundGate for a wiring diagram for this connector.

Note #45 - 2001-02 Daimler Chrysler vehicles with Infinity sound systems:

These vehicles utilize a digital signal to control the turn-on and turn-off of the factory amplifier. When replacing a factory radio, this digital trip function will have to be bypassed. Please call SoundGate at 307-674-4707 for details.

Note #46 - 1999 thru 2001 Volkswagens:

These vehicles utilize a digital-bus electrical system. It has been observed that numerous systems within the vehicle can operate improperly under certain circumstances. In one instance a burned-out turn signal bulb caused dashboards lights to flash erratically, caused headlights to turn on and off by themselves, and caused the headlights to turn on when the turn signals were activated. If you note any type of improper electrical system operation in these vehicles, make certain the customer takes the vehicle to a Volkswagen dealer for repair before beginning any type of audio or video work in the car.

Note #47 - 2001-02 Lincoln Continental:

These vehicles utilize a "virtual image" dashboard that displays information which includes radio operation information. The SCP databus used in this car is similar in operation to General Motors Class 2 Serial data bus. If factory radio is removed the display of radio information on the dashboard will be lost. The Ford Motor Company "Rescu" system operates through the factory radio and is similar in operation to the General Motors "OnStar" system.

Note #48 - 2001-02 Lincoln LS:

These cars are equipped with Lincoln's "Rescu" system (similar to General Motors "OnStar"). Removing the factory radio disables "Rescu". The battery for this vehicle is in the right rear corner of the trunk.

Note #49 - 2001-02 Ford F-Series Pickups:

Quad-cab versions of these vehicles may be equipped with a rear-seat entertainment system. This system uses an FM modulator to input its signal into the factory audio system.

Note #50 - General Motors vehicles with dual-source factory radios, and rear-seat audio controls (RSA):

The radios in these vehicles allow the rear seat passengers to listen to one source (AM/FM, or cassette), while the front seat passengers listen to a second, different music source. For example, the rear seat passengers may listen to the cassette or CD through headphones while the driver listens to the radio through the front speakers. The rear seat

passengers have control of the volume for each headphone. The primary radio controls always override the rear seat audio controls. The rear seat audio functions even when the radio is turned off.

Note #51 - Power Supply and Grounding Warning for all 1996 thru 2002 General Motors vehicles with Class 2 Serial Data Bus when installing aftermarket amplifiers:

When installing amplifiers in these vehicles it is strongly recommended that grounding points for the amplifier(s) be kept away from any factory electrical components (body computers), and/or wiring. GM service personnel have reported to us that amplifiers added to these vehicles should only be grounded at the battery. Not doing so can cause diagnostic trouble codes to be set within the Class 2 data bus, and can possibly cause damage to factory "PCM" module. Likewise, it is recommended that the B+ power supply for these amps only be taken directly from the battery. Taking battery power from existing wiring can cause excessive current draw, and cause the setting of diagnostic trouble codes (DTC's).

Note #53 - Security systems in 3-Series BMWs:

If removing the factory radio in 3-Series BMWs, check for the presence of a 1 1/2" long rear support stud on the rear of the radio. If the vehicle is equipped with a factory security system, this rear support stud acts as a trip mechanism for the radio theft feature of the security system. Removal of the factory radio in these vehicles will disable the remote door lock function of the security system. To remedy this, look for and locate the microswitch that is located behind the rear support bracket of the factory radio. Disconnect the electrical connector that is attached to this microswitch and the door locks will function normally.

Note #54 - Mercedes vehicles with fiber-optic systems:

Replacing the factory radios in these vehicles must be done on a case-by-case basis. Different options within the vehicle will determine how the integration or replacement is accomplished. If the factory cellular phone is present, the factory radio cannot be replaced. If the "Command" system is present, the factory radio cannot be replaced.

Note #55- Honda Civics with factory security system:

The security system in these vehicles is part of the factory radio. When replacing the factory radio perform the following steps:

1. Remove factory radio from dash. The faceplate of the factory radio can be removed - disconnecting a flat ribbon cable allows this.
2. Plug the security harness back into the factory radio and slide the radio back into the dash opening. Let the back of the radio slide towards the bottom of the dash. Keep lowering radio towards lower edge behind dashboard.
3. Two holes are present at the lower portion of the dashboard, on the rear side of the dash that line up with the rear support holes of the radio. Secure the radio to the dash using these holes and the rear support bracket of the radio.

Note #56 - 2002 Envoy's, Jimmys and Trailblazers:

The Bose audio systems in these vehicles are a distributed audio

system. The radio outputs a digital signal to the amplifier telling the amplifier to adjust volume, fade, balance, etc. There are four channels of audio out of the radio: there are four channels so that the rear seat passengers can listen to one source while the front seat occupants listen to a second source. If adding a new radio, an OEM4A can be used to input signal into the factory amplifier. If the factory radio is left in the vehicle using an extension harness, the steering wheel audio controls (volume) will continue to operate through the amplifier. If equipped with factory Bose systems, adding amplifiers must be done after the factory amplifier using Type 1 LOC's. LOC's cannot be added at the radio because the radio has a fixed output level.

Note #57 - The factory security control unit in this vehicle feeds 12 volts to the radio via the Yellow/Red wire. Connect this wire to ground via a 50 Kohm resistor.

Note #58 - The front speakers in this vehicle are powered directly from the factory radio. The rear speakers are powered from an amplifier mounted beneath the rear deck. Bypassing this amplifier requires running new wires from radio location to rear deck.

Note #59 - This Infiniti vehicle utilizes a distributed sound system. The tuner and pre-amp are located within the amplifier. Any replacement of the factory radio will require a complete bypass of the factory sound system.

Note #60 - 1998 and newer Volkswagens will use one of two wiring methods between the factory radio and factory amplifier: integrating new receivers or amplifiers into these vehicles does not require an interface. Please call SoundGate at 307-674-4707 for a faxable document on how to properly interface with these vehicles.

Note #61 - Factory radios with high-power, and low-level outputs: The factory radio in this vehicle feeds low-level audio signals to the subwoofer amplifier. The factory radio powers the balance of speakers in the vehicle via high power outputs.

Note #62 - General Motors OnStar systems integrated into Class 2 Serial databus: Communications between, and control of, the audio and OnStar systems takes place over the Class 2 serial databus. Factory radio must remain in the vehicle and connected to power, ground, and data wires in factory harness for Onstar to function properly.

Note #63 - General Motors vehicles with OnStar, and use of 'ribbon-type' cable at radio: Communications between, and control of, the audio and OnStar systems takes place over the Class 2 serial databus. Factory radio wiring harness is a ribbon cable and cannot be tapped, spliced, or extended.

Note #64 - The Bose system in this vehicle uses a 2-channel front output, a mono rear output, and a center-channel output. If you want to keep the center channel speaker, use LOCHVAs, or LOC4's after the amplifier. If not, use LOCB's at the radio.

Note #65 - Due to the physical and digital integration of the factory radio/navigation system into this vehicle, radio replacement is not recommended. For sound quality improvements we recommend replacing factory speakers and adding additional amplification.

Note #66 - Lincoln LS is equipped with amplified tweeters and subwoofers. Main speakers are powered from head unit. Jaguar S Type is equipped with amplified center channel speakers and subwoofers. These vehicles have an 8-pin connector on the rear of the radio with 4 wires feeding the center channel or tweeter amplifier and 4 wires feed-

ing the subwoofer amplifier. If adding a new receiver, a SoundGate LOCHVA will be required to properly interface the new receiver to the center channel/tweeter amplifier. An LOGSUBA will be required to properly interface the new receiver to the subwoofer amplifier. Call SoundGate technical support at 307-674-4707 for more information

FOOTNOTES RELATED TO COLUMNS IN APPLICATION GUIDE:

RECEIVER FOOTNOTES:

- R1** - This interface is designed to be connected to the new receiver's speaker lead outputs (not RCA).
- R2** - System is common-grounded front and rear.
- R3** - System is common-grounded left and right.
- R4** - System is common-grounded on front channels only.
- R5** - System is common-grounded on rear channels only.
- R6** - This interface retains the use of the factory amplifier(s).
- R7** - Use high voltage (2 volts or greater) RCA outputs from the new receiver to connect to the wiring harness of this car.
- R8** - Use speaker level outputs from the new receiver to connect to the wiring harness of this car.
- R9** - We recommend not replacing the receiver in this vehicle.
- R10** - Call SoundGate for details concerning head unit replacements in this vehicle (307-674-4707)
- R11** - If installing high power MOSFET-output receivers, use OEM4A.

CD CHANGER INTERFACE FOOTNOTES:

- C1** - Use of a 10-Disc CD changer in this vehicle will not allow direct access to discs 7 thru 10. Access to discs 1 thru 6 is as with factory changer. Radio will sequentially play discs 7 thru 10 after finishing disc 6.
- C3** - This interface plugs into the rear of the factory radio.
- C4** - This interface plugs into the factory changer cable in the rear of the vehicle.
- C5** - Some 99 and 2000 Volkswagens and Audis may require the car's computer/radio be reprogrammed to accept a CD changer (factory or aftermarket). If installing a CD changer into one of these vehicles, please contact your local dealer for costs associated with this reprogramming procedure.
- C6** - If the vehicle is equipped with a factory navigation system, an aftermarket CD changer cannot be added at this time.
- C7** - This interface plugs into the tuner box located in the rear of the vehicle.
- C8** - Radio must have "disc up" and "disc down" on the #1 and #5 presets. If radio has 6 presets and "Direct Disc Access" above the presets, you can only use a factory changer.

AUXILIARY INPUT INTERFACE FOOTNOTES:

- D1** - A factory CD changer must be present to use the SDS1 with the cable shown. If an aftermarket changer is present, see page 5 for a list of cables for aftermarket changers.
- D2** - This interface uses the CD changer input on the factory audio system. A CD changer cannot be used with this interface.
- D3** - DOCVWR "tee's" into the factory changer wiring in the trunk. DOCVWF "tee's" into the changer wiring behind the radio.
- D4** - AUXFORD interface requires FC1, FC2, FC3, FC4 or FC5 cable (sold separately) to complete installation. See the CD changer application section to determine which interface cable is required for your particular vehicle.
- D5** - A CD changer must be used in conjunction with this interface. For Discovery, and RVCBLD cable is required to complete the installation. Fjor Freelandr, an RVCBLF cable is required to complete the installation.
- D6** - This interface uses the CD changer input when a CD changer cannot be used when this interface is used.
- D7** - AUXCHRY interface requires additional cable to complete the installation.
98-01 - "rounded-style radio" use CRCBLDIN2
2002 - "rounded-style radio" use CRCBLSQ

ONSTAR-RELATED FOOTNOTES:

- T1** - The OnStar system in this vehicle communicates with the radio via the Class 2 serial data bus. The factory radio must remain in the vehicle and connected to power, ground, and data for the OnStar system to function properly. A SoundGate AVM1 may be required to boost the OnStar audio to an appropriate level to ensure proper operation of the STARMOD interface.
- T2** - SoundGate AVM1 must be used with STARMOD interface module

STEERING WHEEL CONTROL FOOTNOTES:

- S1** - This car is also equipped with steering-wheel mounted temperature and/or fan-speed controls. These functions are not translated with the use of this interface.
- S2** - Call SoundGate for details.

Type 1 Installations:

Type 1 interfaces are designed to be connected to the leads of an existing pair of speakers, or can be used to replace the speakers entirely. If the factory system is amplified, Type 1 interfaces are to be installed only after the factory amplifier.

TYPE 1 Use SoundGate part #'s
 LOCA LOCHVA LOCHWA LOCSUBA LOCHV4A LOCA
 LOCHVA LOCSUBA LOCA LOCHV4A LOCSUBA LOCA
 LOCHVA LOCSUBA LOCA LOCHV4A LOCSUBA LOCA

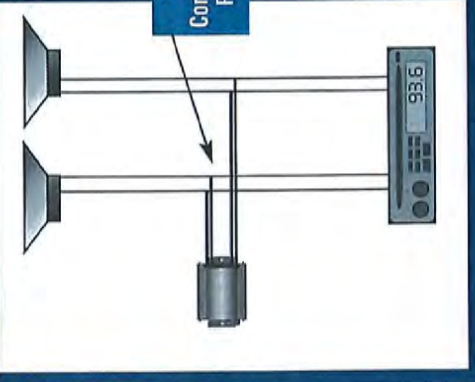

TYPE 2 Use SoundGate part #'s
 LOCB LOCPREA

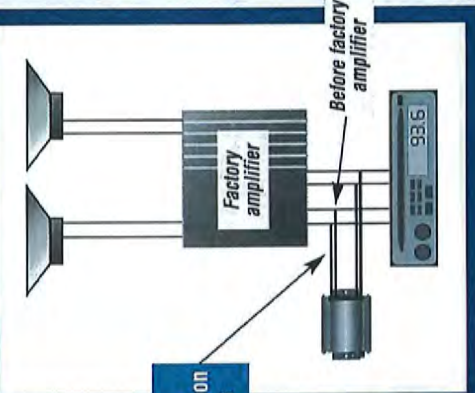

Type 2 Installations:

Type 2 interfaces are specifically designed for use with factory radios that feed into factory amplifiers. They are designed to be connected either directly at the **output of the factory radio**, or at the **INPUT of the factory amplifier**. They can be used to simply add a subwoofer amp, or to replace the factory amplifiers.

AMPLIFIER LOCATOR

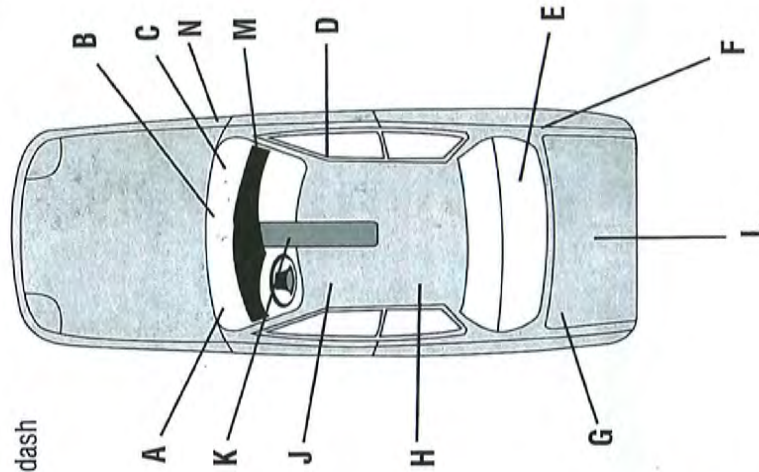

- A - Behind Driver's side of dash
- B - Behind or below factory radio
- C - Behind passenger's side of dash
- D - Below or to right of passenger's seat
- E - Attached to rear side of back seat, or to bottom or rear deck
- F - Behind right side trunk trim, or behind right rear quarterpanel
- G - Behind left side trunk trim, or behind left rear quarterpanel
- H - Beneath rear seat
- I - At each speaker
- J - Beneath Driver's seat
- K - Beneath Center Console
- L - Beneath carpet and/or floorpan of rear storage area, in center of vehicle
- M - Under passenger's side footwell
- N - Passenger's side kickpanel area

Adding an Amplifier/s:

- A1 - Use MITSAMP to replace the factory amplifier. To add an amplifier, use Type 1 interface and connect after the factory amplifier (speaker level).
- A2 - Amplifiers can only be added after the factory amplifier.
- A5 - Use of SoundGate TRIGLOHD is required to create wake-up lead.
- A6 - Use of SoundGate TRIGSPKR is required to create wake-up lead.

Helpful Hints:

It should be possible to accomplish any amplifier installation with a complete absence of alternator whine. Finding the cause of alternator whine is a logical, step-by-step procedure. The first step is making sure system gains are properly set. For the complete procedure please call SoundGate at 307-674-4707 for a bulletin outlining the how-to's.

SoundGate's Ford CD changer interface program made easy...

Choose the cable required for your vehicle, then combine it with any Alpine, Kenwood, Pioneer or Sony Interface for a plug-and-play CD changer installation.

#FC1 cable
For cars that are equipped with factory CD changer cables (some Lincolns, an option on Windstars).
#FC1



#FC2 cable
T-harness at radio location to interface to most 1995 - 1998 vehicles.
#FC2

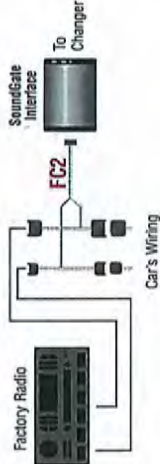

#FC3 cable
T-harness at rear amp/tuner to interface 1996 - 2002 Taurus and others with Distributed Audio Systems (DAS). #FC3

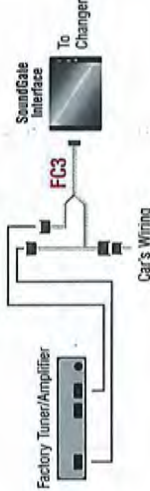

#FC4 cable
Cable harness for Cougar, Focus, and Jaguar S-type. Plugs directly into rear of factory radio.
(Not all CD related voice commands are supported on voice recognition equipped vehicles) #FC4



#FC5 cable
T-harness at radio to interface 1998 Ford Combo radios and most 1999 - 2002 Ford CD changer-capable radios.
#FC5

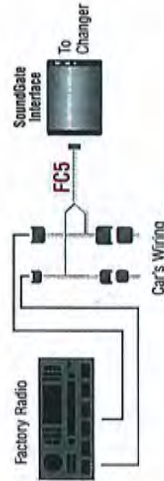

For instance...

If you have a 1999 Ford Taurus, and you want to install an Alpine CD changer, you would use the ALFD1V5 and an FC3 cable. If you have a 2000 Ford Focus and you want to install a Kenwood CD changer, you would use a KNFD1V5 and an FC4 cable. It's a modular program designed to keep your inventory costs down - just stock an interface or two along with one each of the cables listed above, and be able to work with nearly every Ford from 1995-2002 (excluding Mustang).

Don't let Bose® systems trip you up...

Most GM Bose systems that have a 2-piece main radio connector, have a common front/rear audio output. Examine the factory connector. If the wires at pin location 1 and 17 are bare (no insulation) or have clear insulation, then the system is a common front/rear ground audio system and you will need to interface with it accordingly.

Aftermarket 20-pin GM harnesses are designed for non-Bose systems (non-amplified), that have 4 positive and 4 negative speaker leads.

The SoundGate OEM4A Radio Replacement Interface is required to properly interface a new receiver with the Bose amplifier(s).

Connect the speaker outputs from the new receiver to the inputs of the SoundGate OEM4A. Connect the 4 positive audio outputs of the OEM4A to the 4 positive leads in the factory match connector. Combine the two front negative audio output leads from the OEM4A and connect to the common front lead in the factory match harness (in pin location #3). Combine the two rear negative audio output leads from the OEM4A and connect to the common rear lead in the factory match harnesses (pin location #19).

Make certain that you connect the shield drain wires at pin location #1 and #17 directly to a good bare metal chassis ground to prevent noise.

Pin#	Color	Description
1	Bare	Shield Drain Wire
2	Tan	Left Front (+)
3	See Note	Front Common (-)
4	Lt Grn	Right Front (+)
5	-	Not Used
6	-	Not Used
7	-	Not Used
8	-	Not Used
9	-	Not Used
10	-	Not Used
11	Orn	+12v. Batt
12	Yel	+12v. Ignition
13	Grn	Power Antenna
14	See Note	Dimming
15	-	Not Used
16	Blk	Ground
17	Bare	Shield drain wire
18	See Note	Right Rear (+)
19	See Note	Rear Common (-)
20	See Note	Left Rear (+)

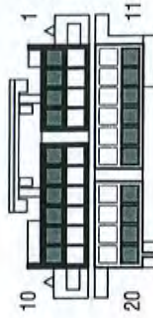

Note:
Wire colors vary greatly from make to make and vehicle to vehicle. Wire colors shown are the most common however, pin locations always take precedence over wire colors.

**CONSUMERS:
KNOW YOUR RIGHTS!**

**Federal law (the Magnuson-Moss
Warranty Act - Section 102c) says
you can purchase and install aftermarket
products in your new car without
voiding the car's warranty!**

**Manufacturers
(or authorized representatives)
cannot:**

**Condition a warranty on the purchase
and use of its own parts or services.**

**Refuse to honor a warranty unless
the manufacturer can show that an
aftermarket accessory is the cause of
a particular malfunction otherwise
covered by warranty.**

**For more information, contact
the Federal Trade Commission at
(202) 326-2222**

Dear Soundgate Team Member,

This guide is based on decades of combined experience and knowledge of the SoundGate Staff. We have made every effort to ensure that the information contained herein is accurate. However, mistakes can, and do, occur.

Please, if you see any mistakes in this guide, call us at our toll-free number (888-760-4707) so that we may reevaluate the information. We want to hear from you and make this guide as accurate and useful as possible!



Liability Disclaimer

This instruction booklet is based on carefully documented research at the time of publishing.

SoundGate®, The Putman Group, Inc., its subsidiaries, or Officers of the corporation cannot be held liable for damages or injuries caused by, or resulting from the use of this guide. Strictly adhere to all car manufacturer warnings that pertain to the disassembly, maintenance, or servicing of the vehicle and any of its associated parts or systems.

SoundGate® cannot be held responsible for discrepancies, or inconsistencies that may occur due to automobile manufacturing changes.

All rights reserved; reproduction or storage in whole or in part, electronic or otherwise, without written permission is strictly prohibited.

© Copyright 2002, The Putman Group, Inc. All Rights Reserved. SoundGate® is a registered trademark of The Putman Group, Inc.

Bose® is a registered trademark of The Bose Corporation.

StarTac is a registered trademark of Motorola. OnStar is a registered trademark of Onstar Corporation.

All other trademarks are the property of their respective owners.