



US005523589A

United States Patent [19]

[11] Patent Number: **5,523,589**

Edmond et al.

[45] Date of Patent: **Jun. 4, 1996**

[54] **VERTICAL GEOMETRY LIGHT EMITTING DIODE WITH GROUP III NITRIDE ACTIVE LAYER AND EXTENDED LIFETIME**

[75] Inventors: **John A. Edmond; Gary E. Bulman**, both of Cary; **Hua-Shuang Kong**, Raleigh; **Vladimir Dmitriev**, Fuquay-Varina, all of N.C.

[73] Assignee: **Cree Research, Inc.**, Durham, N.C.

[21] Appl. No.: **309,251**

[22] Filed: **Sep. 20, 1994**

[51] Int. Cl.⁶ **H01L 31/0312; H01L 33/00**

[52] U.S. Cl. **257/77; 257/96; 257/97; 257/103**

[58] Field of Search **257/77, 96, 97, 257/103; 372/43, 44, 45, 46**

[56] **References Cited**

U.S. PATENT DOCUMENTS

5,243,204	9/1993	Suzuki et al.	257/77
5,247,533	9/1993	Okazaki et al.	372/45
5,273,933	12/1993	Hatano et al.	437/127
5,290,393	3/1994	Nakamura	156/613
5,306,662	4/1994	Nakamura et al.	437/107
5,313,078	5/1994	Fujii et al.	257/77
5,338,944	8/1994	Edmond et al.	257/76
5,387,804	2/1995	Suzuki et al.	257/77
5,393,993	2/1995	Edmond et al.	257/77
5,416,342	5/1995	Edmond et al.	257/76
5,432,808	7/1995	Hatano et al.	372/45

FOREIGN PATENT DOCUMENTS

0541373A2 5/1993 European Pat. Off. .

OTHER PUBLICATIONS

V. A. Dmitriev, *SiC-Based Solid Solutions: Technology and Properties*, Springer Proceedings in Physics, vol. 56, 1992, pp. 3-14.

J. N. Kuznia et al., *Influence of Buffer Layers on the Deposition of High Quality Single Crystal GaN Over Sapphire Substrates*, J. Appl. Phys., vol. 73, No. 9, May 1993, pp. 4700-4702.

M. Asif Khan et al., *The Nature of Donor Conduction in n-GaN*, J. Appl. Phys., vol. 74, No. 9, Nov. 1993, pp. 5901-5903.

Isamu Akasaki et al., *Effects of AlN Buffer Layer on Crystallographic Structure and on Electrical and Optical Properties of GaN and Ga_{1-x}Al_xN (0<x≤0.4) Films Grown on Sapphire Substrate by MOVPE*, Journal of Crystal Growth, vol. 98, 1989, pp. 209-219.

Shuji Nakamura, *GaN Growth Using GaN Buffer Layer*, Japanese Journal of Applied Physics, vol. 30, No. 10A, Oct. 1991, pp. L1705-L1707.

Shuji Nakamura et al., *Candela-Class High-Brightness InGaN/AlGaN Double-Heterostructure Blue-Light-Emitting Diodes*, Appl. Phys. Lett., vol. 64, No. 13, Mar. 1994, pp. 1687-1689.

Shuji Nakamura, *InGaN/AlGaN Double-Heterostructure Blue LEDs* (undated).

Primary Examiner—Ngân V. Ngô

Attorney, Agent, or Firm—Bell, Seltzer, Park & Gibson

[57] **ABSTRACT**

A light emitting diode emits in the blue portion of the visible spectrum and is characterized by an extended lifetime. The light emitting diode comprises a conductive silicon carbide substrate; an ohmic contact to the silicon carbide substrate; a conductive buffer layer on the substrate and selected from the group consisting of gallium nitride, aluminum nitride, indium nitride, ternary Group III nitrides having the formula A_xB_{1-x}N, where A and B are Group III elements and where x is zero, one, or a fraction between zero and one, and alloys of silicon carbide with such ternary Group III nitrides; and a double heterostructure including a p-n junction on the buffer layer in which the active and heterostructure layers are selected from the group consisting of binary Group III nitrides and ternary Group III nitrides.

36 Claims, 4 Drawing Sheets

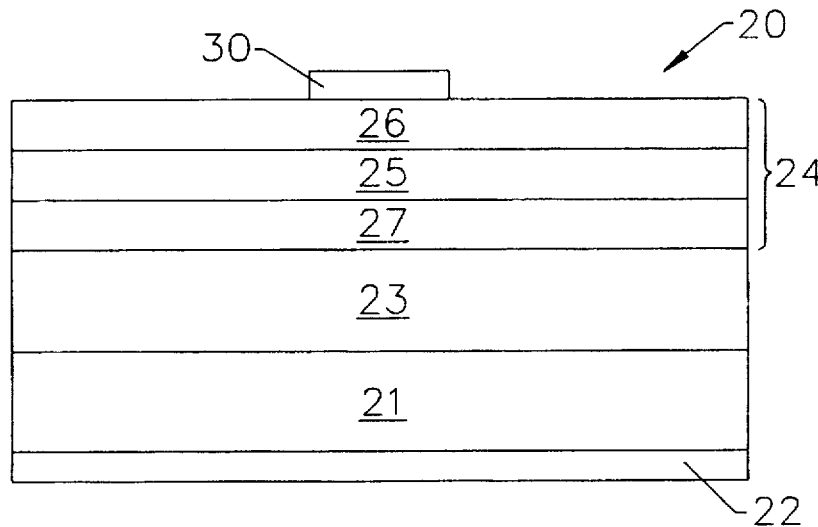

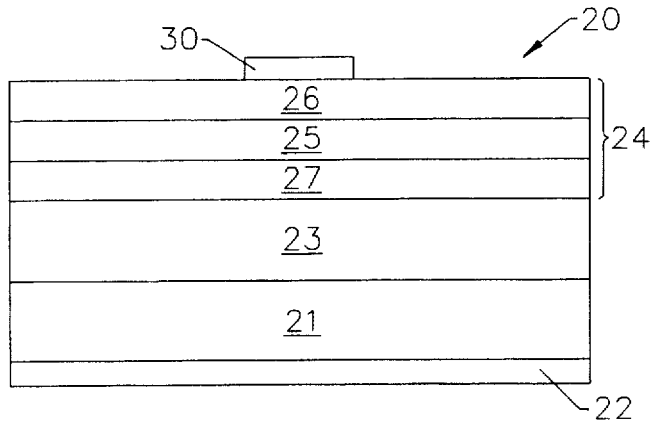

FIG. 1.

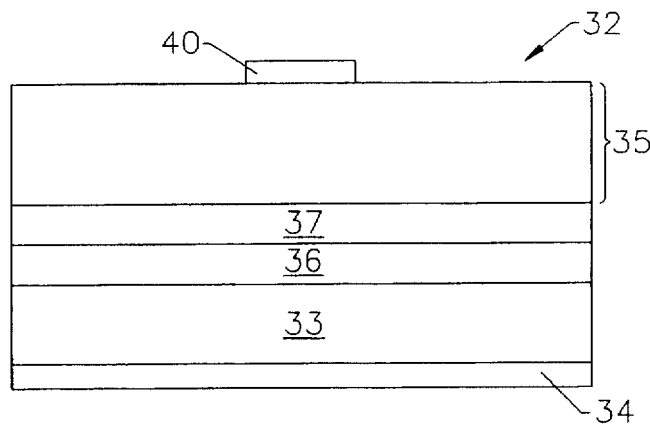

FIG. 2.

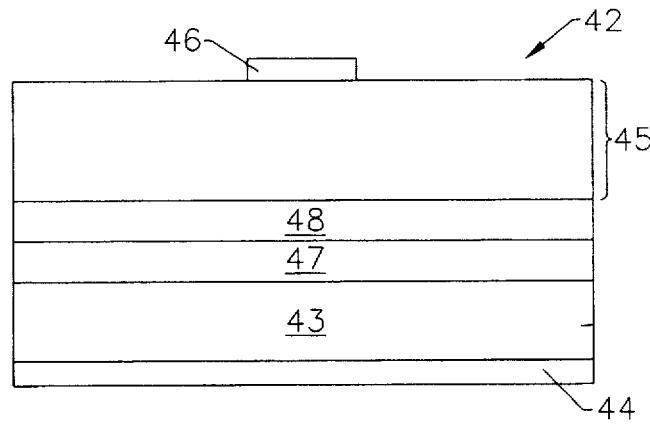

FIG. 3.

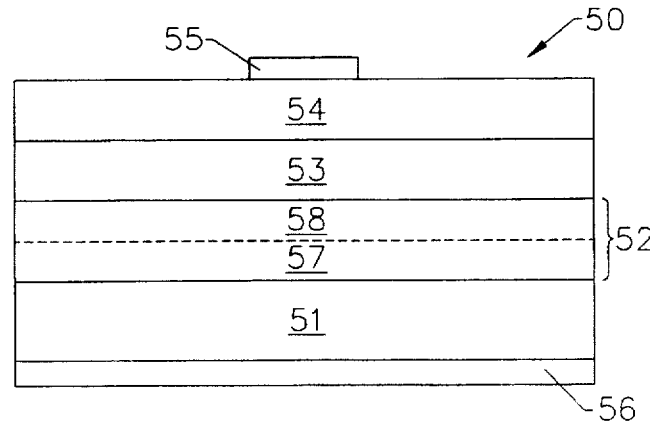

FIG. 4.

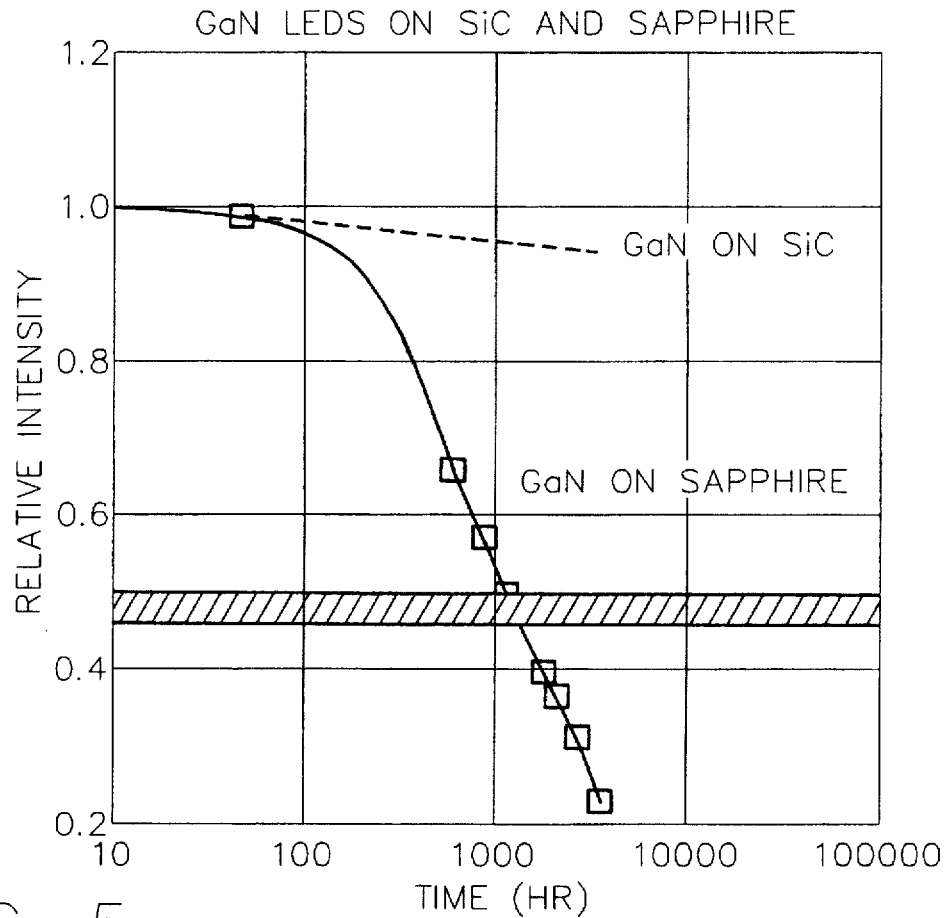

FIG. 5.

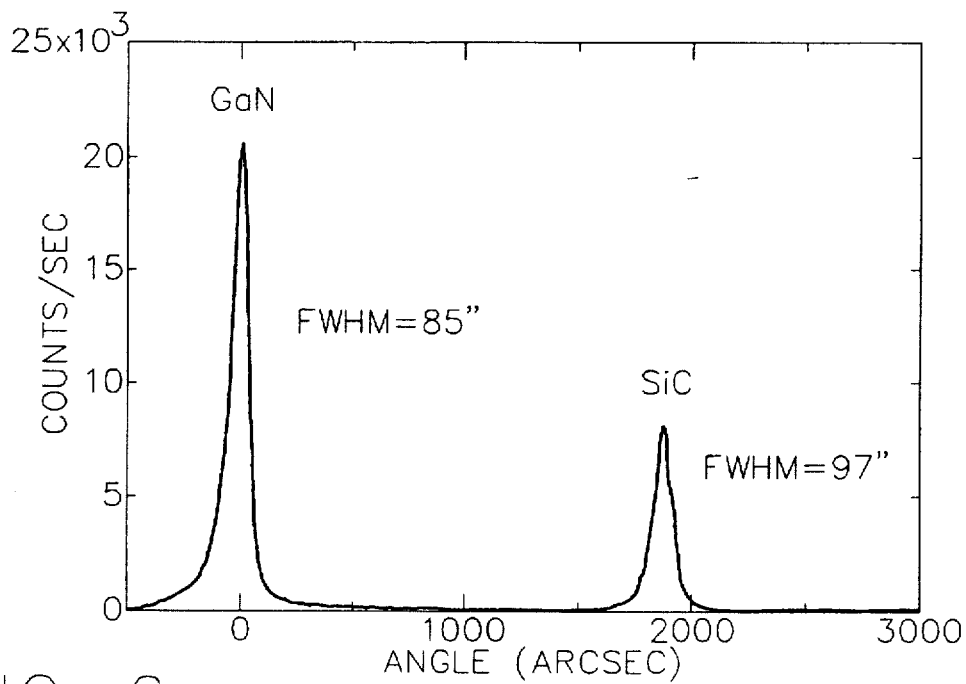

FIG. 6.

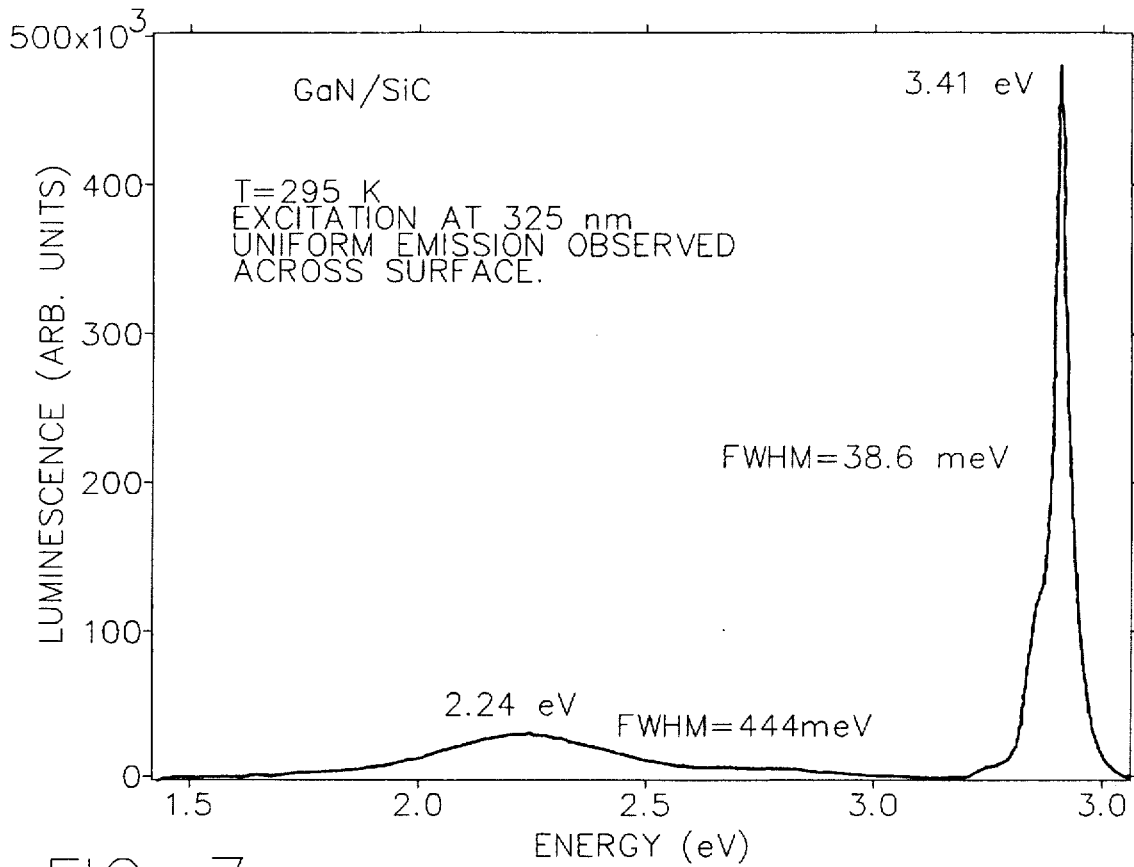

FIG. 7.

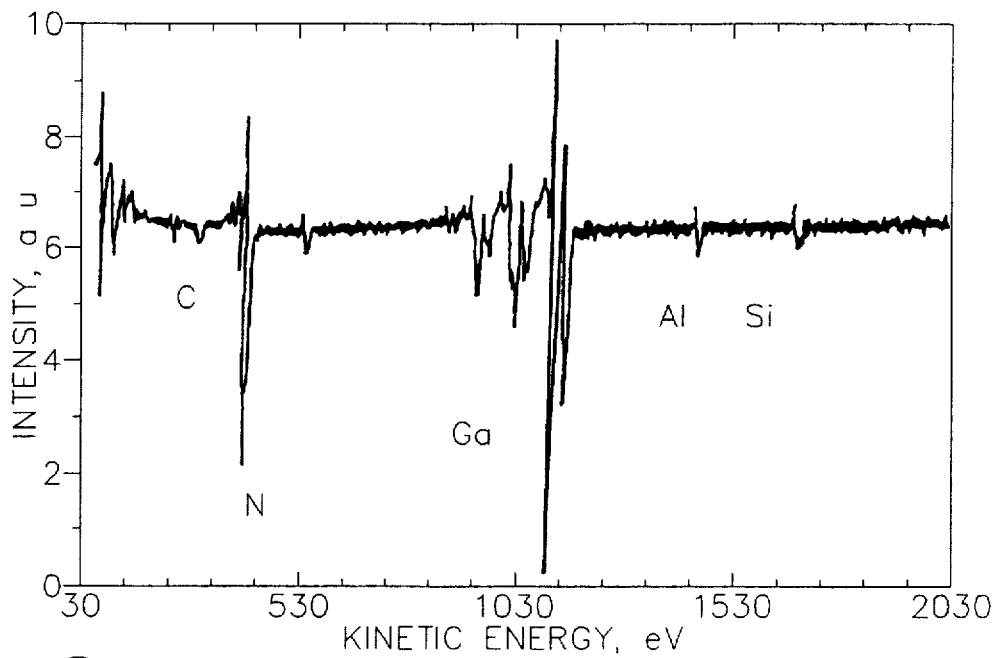

FIG. 8.

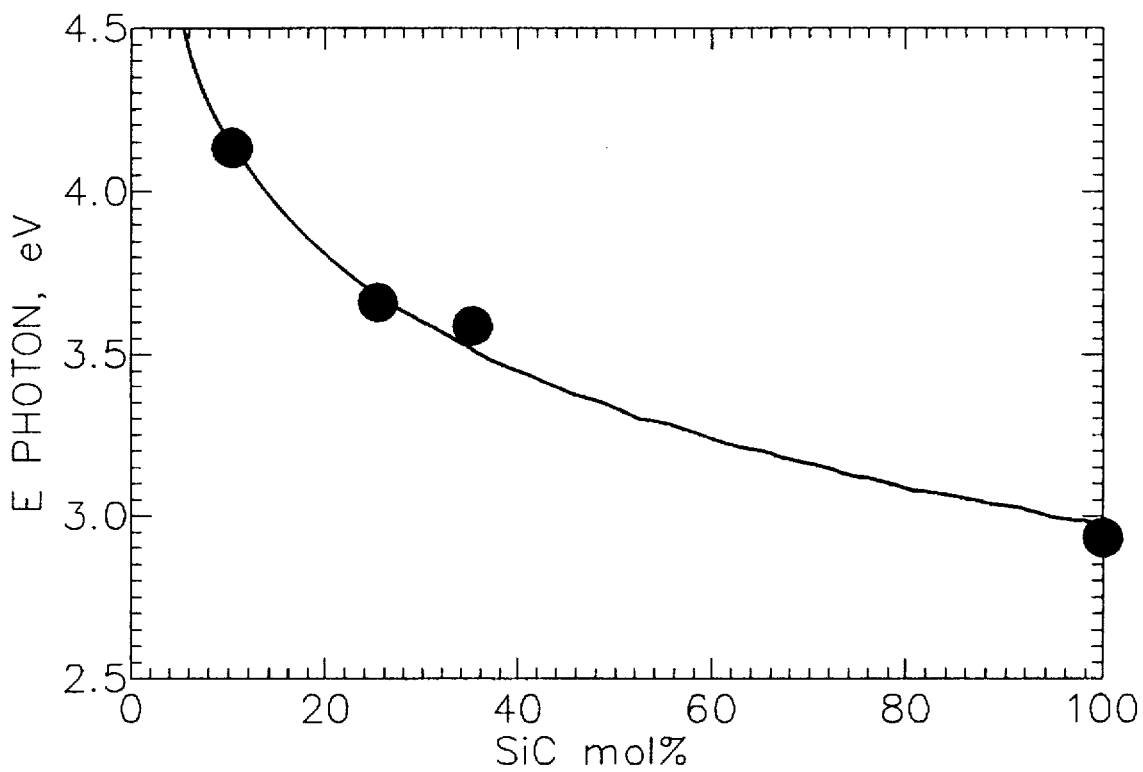

FIG. 9.

Explore Litigation Insights

Docket Alarm provides insights to develop a more informed litigation strategy and the peace of mind of knowing you're on top of things.

Real-Time Litigation Alerts



Keep your litigation team up-to-date with **real-time alerts** and advanced team management tools built for the enterprise, all while greatly reducing PACER spend.

Our comprehensive service means we can handle Federal, State, and Administrative courts across the country.

Advanced Docket Research



With over 230 million records, Docket Alarm's cloud-native docket research platform finds what other services can't. Coverage includes Federal, State, plus PTAB, TTAB, ITC and NLRB decisions, all in one place.

Identify arguments that have been successful in the past with full text, pinpoint searching. Link to case law cited within any court document via Fastcase.

Analytics At Your Fingertips



Learn what happened the last time a particular judge, opposing counsel or company faced cases similar to yours.

Advanced out-of-the-box PTAB and TTAB analytics are always at your fingertips.

API

Docket Alarm offers a powerful API (application programming interface) to developers that want to integrate case filings into their apps.

LAW FIRMS

Build custom dashboards for your attorneys and clients with live data direct from the court.

Automate many repetitive legal tasks like conflict checks, document management, and marketing.

FINANCIAL INSTITUTIONS

Litigation and bankruptcy checks for companies and debtors.

E-DISCOVERY AND LEGAL VENDORS

Sync your system to PACER to automate legal marketing.