

A23L0001-29 [I,A]; B01F0015-06 [I,A]; A23L0001-33 [I,A];  
A23L0001-326 [I,A]; B01D0021-30 [I,A]  
IPCR A23D0007-005 [I,A]; A23D0007-02 [I,A]; A23D0007-04 [I,A];  
A23L0001-29 [I,A]; A23L0001-326 [I,A]; A23L0001-33 [I,A];  
B01D0021-30 [I,A]; B01F0015-06 [I,A]

CAS INDEXING IS AVAILABLE FOR THIS PATENT.

L4 ANSWER 18 OF 27 USPATFULL on STN  
AN 2006:254989 USPATFULL  
TI Natural astaxanthin extract reduces dna oxidation  
IN Chew, Boon P., Pullman, WA, UNITED STATES  
Park, Jean Soon, Pullman, WA, UNITED STATES  
PI US 20060217445 A1 20060928  
AI US 2004-565717 A1 20040726 (10)  
WO 2004-US24314 20040726  
20060123 PCT 371 date  
PRAI US 2003-490121P 20030725 (60)  
DT Utility  
FS APPLICATION  
LN.CNT 1366  
INCL INCLM: 514/690.000  
INCLS: 514/763.000; 514/560.000  
NCL NCLM: 514/690.000  
NCLS: 514/560.000; 514/763.000  
IPC IPCI A61K0031-12 [I,A]; A61K0031-015 [I,A]  
IPCR A61K0031-12 [I,A]; A61K0031-015 [I,A]  
CAS INDEXING IS AVAILABLE FOR THIS PATENT.

L4 ANSWER 19 OF 27 USPATFULL on STN  
AN 2006:227598 USPATFULL  
TI Preventive or remedy for arthritis  
IN Kamiya, Toshikazu, Ibaraki, JAPAN  
Nakagiri, Ryusuke, Chapel Hill, NC, UNITED STATES  
PA Kyowa Hakko Kogyo Co., Ltd., Tokyo, JAPAN, 100-8185 (non-U.S.  
corporation)  
PI US 20060193962 A1 20060831  
AI US 2004-552526 A1 20040409 (10)  
WO 2004-JP5115 20040409  
20051011 PCT 371 date  
PRAI JP 2003-107405 20030411  
DT Utility  
FS APPLICATION  
LN.CNT 1047  
INCL INCLM: 426/615.000  
NCL NCLM: 426/615.000  
IPC IPCI A23L0001-212 [I,A]  
IPCR A23L0001-212 [I,A]; A23K0001-14 [I,A]; A23K0001-16 [I,A];  
A23L0001-30 [I,A]; A61K0031-7008 [I,A]; A61K0031-726 [I,A];  
A61K0036-00 [I,A]; A61K0036-185 [I,A]; A61P0019-02 [I,A]  
CAS INDEXING IS AVAILABLE FOR THIS PATENT.

L4 ANSWER 20 OF 27 USPATFULL on STN  
AN 2004:209092 USPATFULL  
TI Process for producing a plant extract containing plant powder  
IN Sakai, Yasushi, Tsukuba-shi, JAPAN  
Yokoo, Yoshiharu, Sagamihara-shi, JAPAN  
PI US 20040161524 A1 20040819  
US 7521079 B2 20090421  
AI US 2003-481519 A1 20031219 (10)  
WO 2002-JP6226 20020621  
PRAI JP 2001-188480 20010621  
DT Utility

FS APPLICATION  
LN.CNT 1479  
INCL INCLM: 426/655.000  
NCL NCLM: 426/655.000  
NCLS: 426/433.000; 426/594.000; 426/597.000  
IPC [7]  
IPCI A23L0001-28 [ICM,7]  
IPCI-2 A23L0001-28 [I,A]  
IPCR A23L0001-28 [I,A]; A23K0001-14 [I,A]; A23K0001-16 [I,A];  
A23L0001-30 [I,A]; A61K0036-185 [I,A]

L4 ANSWER 21 OF 27 USPATFULL on STN  
AN 2004:209046 USPATFULL  
TI Preventives or remedies for arthritis  
IN Nakagiri, Rysuke, Tokyo, JAPAN  
Kamiya, Toshikazu, Tsuchiura-shi, JAPAN  
Suda, Toshio, Sunto-gun, JAPAN  
Miki, Ichiro, Mishima-shi, JAPAN  
PI US 20040161478 A1 20040819  
AI US 2003-480044 A1 20031209 (10)  
WO 2002-JP5790 20020611  
PRAI JP 2001-181947 20010615  
JP 2002-70702 20020314

DT Utility  
FS APPLICATION  
LN.CNT 1301  
INCL INCLM: 424/725.000  
NCL NCLM: 424/725.000  
IPC [7]  
IPCI A61K0035-78 [ICM,7]  
IPCR A21D0002-36 [I,A]; A21D0013-08 [I,A]; A23K0001-14 [I,A];  
A23K0001-16 [I,A]; A23L0001-30 [I,A]; A61K0036-185 [I,A];  
A61P0019-02 [I,A]; A61P0029-00 [I,A]

L4 ANSWER 22 OF 27 USPATFULL on STN  
AN 2004:159281 USPATFULL  
TI Liver funcion protecting or ameliorating agent  
IN Sakai, Yasushi, Tsukuba-shi, JAPAN  
Kayahashi, Shun, Tsukuba-shi, JAPAN  
Hashizume, Erika, Tsukuba-shi, JAPAN  
Nakagiri, Ryusuke, Tokyo, JAPAN  
PI US 20040122085 A1 20040624  
US 7332522 B2 20080219  
AI US 2003-473867 A1 20031003 (10)  
WO 2002-JP3098 20020328

DT Utility  
FS APPLICATION  
LN.CNT 1146  
INCL INCLM: 514/470.000  
NCL NCLM: 514/457.000; 514/470.000  
NCLS: 514/470.000; 549/283.000  
IPC [7]  
IPCI A61K0031-365 [ICM,7]  
IPCI-2 A61K0031-34 [I,A]; A61K0031-343 [I,A]  
IPCR A61K0031-34 [I,A]; A23L0001-30 [I,A]; A61K0031-343 [I,A];  
A61K0031-365 [I,A]; A61K0031-366 [I,A]; A61P0001-16 [I,A];  
C07D0307-88 [I,A]; C07D0311-76 [I,A]

CAS INDEXING IS AVAILABLE FOR THIS PATENT.

L4 ANSWER 23 OF 27 USPATFULL on STN  
AN 2003:64375 USPATFULL  
TI Processes for extracting carotenoids and for preparing feed materials

IN Kagan, Michael, Jerusalem, ISRAEL  
Braun, Sergei, Zur Hadassa, ISRAEL  
PI US 20030044495 A1 20030306  
US 6818239 B2 20041116  
AI US 2002-172747 A1 20020617 (10)  
RLI Continuation of Ser. No. WO 2000-IL846, filed on 18 Dec 2000, UNKNOWN  
PRAI GB 1999-30194 19991221  
DT Utility  
FS APPLICATION  
LN.CNT 526  
INCL INCLM: 426/250.000  
NCL NCLM: 426/429.000; 426/250.000  
NCLS: 426/250.000; 426/253.000; 426/431.000; 426/478.000; 426/540.000  
IPC [7]  
IPCI A23L0001-27 [ICM,7]  
IPCI-2 A23L0001-28 [ICM,7]; A23L0001-27 [ICS,7]  
IPCR A23L0001-27 [I,A]; A23L0001-275 [I,A]; C07C0403-00 [I,A];  
C07C0403-24 [I,A]; C09B0061-00 [I,A]  
CAS INDEXING IS AVAILABLE FOR THIS PATENT.

L4 ANSWER 24 OF 27 USPATFULL on STN  
AN 2002:205917 USPATFULL  
TI Liver function protecting or improving agent  
IN Nakagiri, Ryusuke, Tsukuba-shi, JAPAN  
Kamiya, Toshikazu, Tsukuba-shi, JAPAN  
Hashizume, Erika, Tsukuba-shi, JAPAN  
Sakai, Yasushi, Inashiki-gun, JAPAN  
Kayahashi, Shun, Tsukuba-shi, JAPAN  
PI US 20020110605 A1 20020815  
AI US 2001-10154 A1 20011210 (10)  
PRAI JP 2000-375510 20001211  
DT Utility  
FS APPLICATION  
LN.CNT 1786  
INCL INCLM: 424/725.000  
NCL NCLM: 424/725.000  
IPC [7]  
IPCI A61K0035-78 [ICM,7]  
IPCR A21D0002-36 [I,A]; A21D0013-08 [I,A]; A23K0001-14 [I,A];  
A23K0001-16 [I,A]; A23L0001-212 [I,A]; A23L0001-30 [I,A];  
A61K0036-185 [I,A]; A61P0001-16 [I,A]  
CAS INDEXING IS AVAILABLE FOR THIS PATENT.

L4 ANSWER 25 OF 27 USPAT2 on STN  
AN 2004:209092 USPAT2  
TI Process for producing an extract of Hydrangea containing plant powder  
IN Sakai, Yasushi, Tsukuba, JAPAN  
Yokoo, Yoshiharu, Sagamihara, JAPAN  
PA Kyowa Hakko Kogyo Co., Ltd., Tokyo, JAPAN (non-U.S. corporation)  
PI US 7521079 B2 20090421  
WO 2003000074 20030301  
AI US 2002-481519 20020621 (10)  
WO 2002-JP6226 20020621  
20031219 PCT 371 date  
PRAI JP 2001-188480 20010621  
DT Utility  
FS GRANTED  
LN.CNT 1371  
INCL INCLM: 426/655.000  
INCLS: 426/594.000; 426/597.000; 426/433.000  
NCL NCLM: 426/655.000  
NCLS: 426/433.000; 426/594.000; 426/597.000

IPC IPCI A23L0001-28 [ICM,7]  
IPCI-2 A23L0001-28 [I,A]  
IPCR A23L0001-28 [I,A]; A23K0001-14 [I,A]; A23K0001-16 [I,A];  
A23L0001-30 [I,A]; A61K0036-185 [I,A]  
EXF 426/597; 426/433; 426/594

L4 ANSWER 26 OF 27 USPAT2 on STN  
AN 2004:159281 USPAT2  
TI Liver function protecting or ameliorating agent  
IN Sakai, Yasushi, Tsukuba, JAPAN  
Kayahashi, Shun, Tsukuba, JAPAN  
Hashizume, Erika, Tsukuba, JAPAN  
Nakagiri, Ryusuke, Tokyo, JAPAN  
PA Kyowa Hakko Kogyo Co., Ltd., Tokyo, JAPAN (non-U.S. corporation)  
PI US 7332522 B2 20080219  
WO 2002080904 20021017  
AI US 2002-473867 20020328 (10)  
WO 2002-JP3098 20020328  
20031003 PCT 371 date  
PRAI JP 2001-106600 20010405  
DT Utility  
FS GRANTED  
LN.CNT 1099  
INCL INCLM: 514/457.000  
INCLS: 514/470.000; 549/283.000  
NCL NCLM: 514/457.000; 514/470.000  
NCLS: 514/470.000; 549/283.000  
IPC IPCI A61K0031-365 [ICM,7]  
IPCI-2 A61K0031-34 [I,A]; A61K0031-343 [I,A]  
IPCR A61K0031-34 [I,A]; A23L0001-30 [I,A]; A61K0031-343 [I,A];  
A61K0031-365 [I,A]; A61K0031-366 [I,A]; A61P0001-16 [I,A];  
C07D0307-88 [I,A]; C07D0311-76 [I,A]  
EXF 549/283; 549/290; 549/307; 549/289; 514/457; 514/470  
CAS INDEXING IS AVAILABLE FOR THIS PATENT.

L4 ANSWER 27 OF 27 USPAT2 on STN  
AN 2003:64375 USPAT2  
TI Processes for extracting carotenoids and for preparing feed materials  
IN Kagan, Michael, Jerusalem, ISRAEL  
Braun, Sergei, Zur Hadassa, ISRAEL  
PA Fermentron Ltd., Jerusalem, ISRAEL (non-U.S. corporation)  
PI US 6818239 B2 20041116  
AI US 2002-172747 20020617 (10)  
RLI Continuation of Ser. No. WO 2000-IL846, filed on 18 Dec 2000  
PRAI GB 1999-30194 19991221  
DT Utility  
FS GRANTED  
LN.CNT 501  
INCL INCLM: 426/429.000  
INCLS: 426/431.000; 426/478.000; 426/250.000; 426/253.000; 426/540.000  
NCL NCLM: 426/429.000; 426/250.000  
NCLS: 426/250.000; 426/253.000; 426/431.000; 426/478.000; 426/540.000  
IPC [7]  
IPCI A23L0001-27 [ICM,7]  
IPCI-2 A23L0001-28 [ICM,7]; A23L0001-27 [ICS,7]  
IPCR A23L0001-27 [I,A]; A23L0001-275 [I,A]; C07C0403-00 [I,A];  
C07C0403-24 [I,A]; C09B0061-00 [I,A]  
EXF 426/807; 426/250; 426/253; 426/635; 426/425; 426/429; 426/430; 426/431;  
426/478; 426/540; 424/439; 424/451  
CAS INDEXING IS AVAILABLE FOR THIS PATENT.

=> d hist

(FILE 'HOME' ENTERED AT 15:15:33 ON 03 JAN 2012)

INDEX 'ADISCTI, ADISINSIGHT, ADISNEWS, AGRICOLA, ANABSTR, ANTE, AQUALINE, AQUASCI, BIOENG, BIOSIS, BIOTECHABS, BIOTECHDS, BIOTECHNO, CABA, CAPLUS, CEABA-VTB, CIN, CONFSCI, CROPB, CROPU, DDFB, DDFU, DGENE, DISSABS, DRUGB, DRUGU, EMBAL, EMBASE, ESBIOBASE, ...' ENTERED AT 15:15:47 ON 03 JAN 2012  
SEA KRILL AND OIL AND MEAL AND SUPERCRITICAL(P)EXTRACT? AND SOL

- 0\* FILE ADISNEWS
- 0\* FILE ANTE
- 0\* FILE AQUALINE
- 0\* FILE BIOENG
- 0\* FILE BIOTECHABS
- 0\* FILE BIOTECHDS
- 0\* FILE BIOTECHNO
- 0\* FILE CEABA-VTB
- 0\* FILE CIN
- 0\* FILE FOMAD
- 0\* FILE FROSTI
- 0\* FILE FSTA
- 1 FILE IFIPAT
- 0\* FILE KOSMET
- 0\* FILE NTIS
- 0\* FILE PASCAL
- 28 FILE USPATFULL
- 4 FILE USPAT2
- 0\* FILE WATER
- 1 FILE WPIDS
- 1 FILE WPINDEX

L1 QUE KRILL AND OIL AND MEAL AND SUPERCRITICAL(P)EXTRACT? AND SOL

FILE 'IFIPAT, USPATFULL, USPAT2' ENTERED AT 15:19:01 ON 03 JAN 2012

- L2 33 S L1
- L3 32 DUP REM L2 (1 DUPLICATE REMOVED)
- L4 27 S L3 AND DIOXIDE

=> logoff

ALL L# QUERIES AND ANSWER SETS ARE DELETED AT LOGOFF

LOGOFF? (Y)/N/HOLD:y

COST IN U.S. DOLLARS	SINCE FILE ENTRY	TOTAL SESSION
FULL ESTIMATED COST	43.57	47.51

STN INTERNATIONAL LOGOFF AT 15:21:58 ON 03 JAN 2012

# WEST Search History for Application 12057775

Creation Date: 2012010315:00

## Prior Art Searches

Query	DB	Op.	Plur.	Thes.	Date
"krill oil"	PGPB, USPT, USOC, EPAB, JPAB, DWPI, TDBD	OR	YES		01-03-2012
("krill oil" ) and "krill meal"	PGPB, USPT, USOC, EPAB, JPAB, DWPI, TDBD	OR	YES		01-03-2012
("krill oil" and "krill meal" ) and "supercritical fluid"	PGPB, USPT, USOC, EPAB, JPAB, DWPI, TDBD	OR	YES		01-03-2012
extract? and krill and oil and meal and supercritical	PGPB, USPT, USOC, EPAB, JPAB, DWPI, TDBD	OR	YES		01-03-2012
2004241249	PGPB	OR	YES		01-03-2012
200400241249	PGPB	OR	YES		01-03-2012
20040241249	PGPB	OR	YES		01-03-2012
(20040241249 ) and "supercritical"	PGPB	OR	YES		01-03-2012
(20040241249 ) and "solvent extraction"	PGPB	OR	YES		01-03-2012
(20040241249 ) and "extract"	PGPB	OR	YES		01-03-2012
(20040241249 and "extract" ) and "oil"	PGPB	OR	YES		01-03-2012
(20040241249 and "extract" and "oil" ) and "meal"	PGPB	OR	YES		01-03-2012
supercritical and extraction and krill	PGPB, USPT, USOC, EPAB, JPAB, DWPI, TDBD	OR	YES		01-03-2012
(supercritical and extraction and krill ) and co-solvent	PGPB, USPT, USOC, EPAB, JPAB, DWPI, TDBD	OR	YES		01-03-2012
(supercritical and extraction and krill and co-solvent ) and oil	PGPB, USPT, USOC, EPAB, JPAB, DWPI, TDBD	OR	YES		01-03-2012
supercritical and extraction and alcohol		OR	YES		01-03-2012

	PGPB, USPT, USOC, EPAB, JPAB, DWPI, TDBD				
<b>(supercritical and extraction and alcohol ) and monohydric</b>	PGPB, USPT, USOC, EPAB, JPAB, DWPI, TDBD	OR	YES		01-03-2012
<b>(supercritical and extraction and alcohol and monohydric ) and krill and meal</b>	PGPB, USPT, USOC, EPAB, JPAB, DWPI, TDBD	OR	YES		01-03-2012

Receipt date: 03/08/2011

12057775 - GAI: 1651

Doc code: IDS

Doc description: Information Disclosure Statement (IDS) Filed

Approved for use through 07/31/2012. OMB 0651-0031  
U.S. Patent and Trademark Office; U.S. DEPARTMENT OF COMMERCE

Under the Paperwork Reduction Act of 1995, no persons are required to respond to a collection of information unless it contains a valid OMB control number.

<b>INFORMATION DISCLOSURE STATEMENT BY APPLICANT</b> ( Not for submission under 37 CFR 1.99)	Application Number	12057775
	Filing Date	2008-03-28
	First Named Inventor	Inge Bruheim, et al.
	Art Unit	1651
	Examiner Name	Susan Marie Hanley
	Attorney Docket Number	NATNUT-14409/US-5/ORD

U.S. PATENTS							Remove
Examiner Initial*	Cite No	Patent Number	Kind Code <sup>1</sup>	Issue Date	Name of Patentee or Applicant of cited Document	Pages, Columns, Lines where Relevant Passages or Relevant Figures Appear	
	1						

If you wish to add additional U.S. Patent citation information please click the Add button. Add

U.S. PATENT APPLICATION PUBLICATIONS							Remove
Examiner Initial*	Cite No	Publication Number	Kind Code <sup>1</sup>	Publication Date	Name of Patentee or Applicant of cited Document	Pages, Columns, Lines where Relevant Passages or Relevant Figures Appear	
	1						

If you wish to add additional U.S. Published Application citation information please click the Add button. Add

FOREIGN PATENT DOCUMENTS								Remove
Examiner Initial*	Cite No	Foreign Document Number <sup>3</sup>	Country Code <sup>2</sup> j	Kind Code <sup>4</sup>	Publication Date	Name of Patentee or Applicant of cited Document	Pages, Columns, Lines where Relevant Passages or Relevant Figures Appear	T <sup>5</sup>
	1	2000/25608	WO		2000-05-11	NIPPON SUISAN KAISHA, LTD.		<input type="checkbox"/>
	2	2000/38708	WO		2000-07-06	PHAIRSON MEDICAL INC.		<input type="checkbox"/>
	3	2002/102394	WO		2002-12-27	NEPTUNE TECHNOLOGIES & BIORESS		<input type="checkbox"/>



Receipt date: 03/08/2011

Application Number	12057775	12057775 - GAU: 1651
Filing Date	2008-03-28	
First Named Inventor	Inge Bruheim, et al.	
Art Unit	1651	
Examiner Name	Susan Marie Hanley	
Attorney Docket Number	NATNUT-14409/US-5/ORD	

**INFORMATION DISCLOSURE  
STATEMENT BY APPLICANT**  
( Not for submission under 37 CFR 1.99)

4	2003/011873	WO		2003-02-13	NEPTUNE TECHNOLOGIES & BIORESSOURCES INC.	<input type="checkbox"/>
5	2005/004393	WO		2005-01-13	KONIN-KLIJKE PHILIPS ELECTRONICS N.V.	<input type="checkbox"/>
6	2005/037848	WO		2005-04-28	ENZYMOTEC LTD.	<input type="checkbox"/>
7	2005/038037	WO		2005-04-28	ENZYMOTEC INC.	<input type="checkbox"/>
8	2007/080514	WO		2007-07-19	KRILL A/S	<input type="checkbox"/>
9	2007/080515	WO		2007-07-19	AKER BIOMARINE ASA	<input type="checkbox"/>
10	2007/108702	WO		2007-09-27	AKER SEAFOODS HOLDING AS	<input type="checkbox"/>
11	2008/006607	WO		2008-01-17	NATTOPHARMA ASA	<input type="checkbox"/>
12	2008/117062	WO		2008-10-02	AKER BIOMARINE ASA	<input type="checkbox"/>
13	2009/027692	WO		2009-03-05	AKER BIOMARINE ASA	<input type="checkbox"/>
14	2001/028526	WO		2001-04-26	TRUFFINI & REGGE FARMACEUTICI	<input type="checkbox"/>

<b>Receipt date: 03/08/2011</b>  <b>INFORMATION DISCLOSURE STATEMENT BY APPLICANT</b> <b>( Not for submission under 37 CFR 1.99)</b>	Application Number		12057775	12057775 - GAU: 1651
	Filing Date		2008-03-28	
	First Named Inventor	Inge Bruheim, et al.		
	Art Unit		1651	
	Examiner Name	Susan Marie Hanley		
	Attorney Docket Number		NATNUT-14409/US-5/ORD	

15	2004/047554	WO		2004-06-10	PHARES PHARM RES NV	<input type="checkbox"/>
16	0973532	EP		2005-09-07	I.B.R ISRAELI BIOTECHNOLOGY RESEARCH LTD.	<input type="checkbox"/>
17	1123368	EP		2008-04-09	UNIVERSITE DE SHERBROOKE	<input type="checkbox"/>
18	1292294	EP		2009-03-18	ACCERA, INC.	<input type="checkbox"/>
19	2001/082928	WO		2001-11-08	HENDERSON	<input type="checkbox"/>
20	2003/013497	WO		2003-02-20	SUNTORY LIMITED	<input type="checkbox"/>
21	1419768	EP		2009-01-07	NEPTUNE TECHNOLOGIES & BIORESSOURCES, INC.	<input type="checkbox"/>
22	1385500	EP		2010-07-28	YEDA RESEARCH AND DEVELOPMENT CO. LTD	<input type="checkbox"/>
23	2002/083122	WO		2002-10-24	YEDA RESEARCH AND DEVELOPMENT CO. LTD	<input type="checkbox"/>
24	1392623	EP		2004-03-03	MARTEK BIOSCIENCES BOULDER CORPORATION	<input type="checkbox"/>
25	2002/092540	WO		2002-11-21	MARTEK BIOSCIENCES BOULDER CORPORATION	<input type="checkbox"/>

<b>Receipt date: 03/08/2011</b>  <b>INFORMATION DISCLOSURE STATEMENT BY APPLICANT</b> <b>( Not for submission under 37 CFR 1.99)</b>	Application Number		12057775	12057775 - GAU: 1651
	Filing Date		2008-03-28	
	First Named Inventor	Inge Bruheim, et al.		
	Art Unit		1651	
	Examiner Name	Susan Marie Hanley		
	Attorney Docket Number		NATNUT-14409/US-5/ORD	

26	1406641	EP		2009-01-07	NEPTUNE TECHNOLOGIES & BIORESSOURCES, INC.		<input type="checkbox"/>
27	2005/070411	WO		2005-08-04	BRUZZESE		<input type="checkbox"/>
28	1542670	EP		2005-06-22	SUNTORY LIMITED	Identical to WO2004028529	<input type="checkbox"/>
29	2004/028529	WO		2004-04-08	SUNTORY LIMITED		<input type="checkbox"/>
30	1743531	EP		2007-01-17	NIPPON SUISAN KAISHA, LTD		<input type="checkbox"/>
31	1631280	EP		2008-03-08	BTG INTERNATIONAL LIMITED		<input type="checkbox"/>
32	2004/100943	WO		2004-11-25	BTG INTERNATIONAL LIMITED		<input type="checkbox"/>
33	1660071	EP		2006-05-31	BTG INTERNATIONAL LIMITED		<input type="checkbox"/>
34	2005/018632	WO		2005-03-03	BTG INTERNATIONAL LIMITED		<input type="checkbox"/>
35	2006/030552	WO		2006-03-23	SUNTORY LIMITED		<input type="checkbox"/>
36	1689413	EP		2006-08-16	ENZYMOTEC LTD.		<input type="checkbox"/>

<b>INFORMATION DISCLOSURE STATEMENT BY APPLICANT</b> ( Not for submission under 37 CFR 1.99)	Application Number		12057775	12057775 - GAU: 1651
	Filing Date		2008-03-28	
	First Named Inventor	Inge Bruheim, et al.		
	Art Unit		1651	
	Examiner Name	Susan Marie Hanley		
	Attorney Docket Number		NATNUT-14409/US-5/ORD	

37	1706106	EP		2009-07-15	BRUZZESE	<input type="checkbox"/>
----	---------	----	--	------------	----------	--------------------------

If you wish to add additional Foreign Patent Document citation information please click the Add button

**NON-PATENT LITERATURE DOCUMENTS**

Examiner Initials*	Cite No	Include name of the author (in CAPITAL LETTERS), title of the article (when appropriate), title of the item (book, magazine, journal, serial, symposium, catalog, etc), date, pages(s), volume-issue number(s), publisher, city and/or country where published.	T <sup>5</sup>
	1	TAKAICHI et al., 2003, "Fatty Acids of astaxanthin esters in krill determined by mild mass spectrometry", Comparative Biochemistry and Physiology Part B, Biochemistry and Molecular Biology, Elsevier, Oxford, Vol. 136, 1 January 2003, p. 317-322;	<input type="checkbox"/>
	2	TANAKA et al., 2004, "Extraction of Phospholipids from Salmon Roe with Supercritical Carbon Dioxide and an Entrainer", J. Oleo Sci, 53(9): 417-424	<input type="checkbox"/>
	3	TANAKA et al., 2005, "Extraction of Phospholipids from Unused Natrual Resources with Supercritical Carbon Dioxide and an Entrainer", Journal of Oleo Science, Vol. 54(11): 569-576	<input type="checkbox"/>
	4	TODORIC et al., 2006, "Adipose tissue inflammation induced by high-fat diet in obese diabetic mice is prevented by n-3 polyunsaturated fatty acids", Diabetologia, 49(9): 2109-2119	<input type="checkbox"/>
	5	TOU et al., 2007, "Krill for human consumption: nutritional value and potential health benefits.", Nutrition Rev 65 (2):63-77	<input type="checkbox"/>
	6	TRAYHURN et al., 2004, "Adipokines: inflammation and the pleiotropic role of white adipose tissue", Br. J. Nutrition, 92(3): 347-355	<input type="checkbox"/>
	7	TREBBLE et al., 2003, "Inhibition of tumour necrosis factor-alpha and interleukin 6 production by mononuclear cells following dietary fish-oil supplementation in healthy men and response to antioxidant co-supplementation", Br. J. Nutrition, 90(2): 405-412	<input type="checkbox"/>
	8	UKKOLA et al., 2002, "Adiponectin: a link between excess adiposity and associated comorbidities?", J. Mol. Med., 80 (11): 696-702	<input type="checkbox"/>

<b>INFORMATION DISCLOSURE STATEMENT BY APPLICANT</b> ( Not for submission under 37 CFR 1.99)	Receipt date: 03/08/2011	Application Number	12057775	12057775 - GAU: 1651
	Filing Date	2008-03-28		
	First Named Inventor	Inge Bruheim, et al.		
	Art Unit	1651		
	Examiner Name	Susan Marie Hanley		
	Attorney Docket Number	NATNUT-14409/US-5/ORD		

9	VAN DER VEEN et al., 1971 "The Lipids of Krill (Euphausia Species) and Red Crab (Pleuroncodes Planipes)", Lipids, 6(7): 481-485	<input type="checkbox"/>
10	VIRTUE, et al. 1996, Reproductive trade-off in male Antarctic krill, Euphausia superba", Marine Biology, Volume 126, Number 3, Pages 521-527	<input type="checkbox"/>
11	YAMAGUCHI et al., 1983, "The Composition of Carotenoid Pigments in the Antarctic Krill Euphausia superba", Bulletin of the Japanese Society of Scientific Fisheries, 49(9): 1411-1415	<input type="checkbox"/>
12	YAMAGUCHI et al., 1986, "Supercritical Carbon Dioxide Extraction Of Oils From Antarctic Krill," Journal Of Agricultural And Food Chemistry, vol. 34, pp. 904-907	<input type="checkbox"/>
13	YANASE M; 1974, "Modification of a Russian method for separation of heat-coagulated protein from Antarctic krill", Database FSTA (online); International Food Information Service (IFIS); FRANKFURT-MAIN, DE	<input type="checkbox"/>
14	YEN et al., 1994, "Effect of dietary omega-3 and omega-6 fatty acid sources on PUVA-induced cutaneous toxicity and tumorigenesis in the hairless mouse", Arch. Dermatol. Res., 286(6): 331-6	<input type="checkbox"/>
15	DATABASE WPI Week 200682, Thomson Scientific, London, GB, 2006	<input type="checkbox"/>
16	ENGLISH ABSTRACT; JP 2003-531857; See abstract from corresponding WO 2001/082928 filed herewith	<input type="checkbox"/>
17	ENGLISH ABSTRACT; JP 2004-525180; See abstract from corresponding WO 2002/083122 filed herewith	<input type="checkbox"/>
18	ENGLISH ABSTRACT; JP 2006-528233; See abstract from corresponding WO 2004/100943 filed herewith	<input type="checkbox"/>
19	ENGLISH ABSTRACT; JP 2007-502805; See abstract from corresponding WO 2005/018632 filed herewith	<input type="checkbox"/>

<b>INFORMATION DISCLOSURE STATEMENT BY APPLICANT</b> ( Not for submission under 37 CFR 1.99)	Application Number		12057775	12057775 - GAU: 1651
	Filing Date		2008-03-28	
	First Named Inventor	Inge Bruheim, et al.		
	Art Unit	1651		
	Examiner Name	Susan Marie Hanley		
	Attorney Docket Number	NATNUT-14409/US-5/ORD		

20	ENGLISH ABSTRACT; JP 2007-509131; See abstract from corresponding WO 2005/037848 filed herewith	<input type="checkbox"/>
21	ENGLISH ABSTRACT; JP 2007-518764; See abstract from corresponding WO 2005/070411 filed herewith	<input type="checkbox"/>
22	ENGLISH ABSTRACT; JP 2004-536059; See abstract from corresponding WO 2002/09254 filed herewith	<input type="checkbox"/>
23	ENGLISH ABSTRACT; JP 2006-502196; See abstract from corresponding WO 2004/028529 filed herewith	<input type="checkbox"/>


If you wish to add additional non-patent literature document citation information please click the Add button

**EXAMINER SIGNATURE**

Examiner Signature	/Deborah Ware/	Date Considered	12/30/11
--------------------	----------------	-----------------	----------

\*EXAMINER: Initial if reference considered, whether or not citation is in conformance with MPEP 609. Draw line through a citation if not in conformance and not considered. Include copy of this form with next communication to applicant.

<sup>1</sup> See Kind Codes of USPTO Patent Documents at [www.USPTO.GOV](http://www.USPTO.GOV) or MPEP 901.04. <sup>2</sup> Enter office that issued the document, by the two-letter code (WIPO Standard ST.3). <sup>3</sup> For Japanese patent documents, the indication of the year of the reign of the Emperor must precede the serial number of the patent document. <sup>4</sup> Kind of document by the appropriate symbols as indicated on the document under WIPO Standard ST.16 if possible. <sup>5</sup> Applicant is to place a check mark here if English language translation is attached.


<b>Search Notes</b>  	<b>Application/Control No.</b>  12057775	<b>Applicant(s)/Patent Under Reexamination</b>  BRUHEIM ET AL.
	<b>Examiner</b>  DEBBIE K WARE	<b>Art Unit</b>  1651

<b>SEARCHED</b>			
<b>Class</b>	<b>Subclass</b>	<b>Date</b>	<b>Examiner</b>

<b>SEARCH NOTES</b>		
<b>Search Notes</b>	<b>Date</b>	<b>Examiner</b>
WEST, NPL and INV: see search history print out	12/2011-1/2012	DKW

<b>INTERFERENCE SEARCH</b>			
<b>Class</b>	<b>Subclass</b>	<b>Date</b>	<b>Examiner</b>

--	--

<b><i>Index of Claims</i></b> 	<b>Application/Control No.</b> 12057775	<b>Applicant(s)/Patent Under Reexamination</b> BRUHEIM ET AL.
	<b>Examiner</b> DEBBIE K WARE	<b>Art Unit</b> 1651

✓	<b>Rejected</b>
=	<b>Allowed</b>

-	<b>Cancelled</b>
÷	<b>Restricted</b>


N	<b>Non-Elected</b>
I	<b>Interference</b>

A	<b>Appeal</b>
O	<b>Objected</b>

Claims renumbered in the same order as presented by applicant
  CPA
  T.D.
  R.1.47

CLAIM		DATE							
Final	Original	09/08/2011	01/03/2012						
	1	÷	N						
	2	÷	N						
	3	÷	N						
	4	÷	N						
	5	÷	N						
	6	÷	N						
	7	÷	N						
	8	÷	N						
	9	÷	N						
	10	÷	N						
	11	÷	N						
	12	÷	N						
	13	÷	N						
	14	÷	N						
	15	÷	N						
	16	÷	N						
	17	÷	N						
	18	÷	N						
	19	÷	N						
	20	÷	N						
	21	÷	N						
	22	÷	N						
	23	÷	N						
	24	÷	N						
	25	÷	N						
	26	÷	N						
	27	÷	N						
	28	÷	N						
	29	÷	N						
	30	÷	N						
	31	÷	N						
	32	÷	N						
	33	÷	N						
	34	÷	N						
	35	÷	N						
	36	÷	N						



<b><i>Index of Claims</i></b>  	<b>Application/Control No.</b> 12057775	<b>Applicant(s)/Patent Under Reexamination</b> BRUHEIM ET AL.
	<b>Examiner</b> DEBBIE K WARE	<b>Art Unit</b> 1651

✓	<b>Rejected</b>
=	<b>Allowed</b>


-	<b>Cancelled</b>
÷	<b>Restricted</b>

N	<b>Non-Elected</b>
I	<b>Interference</b>

A	<b>Appeal</b>
O	<b>Objected</b>

Claims renumbered in the same order as presented by applicant
  CPA
  T.D.
  R.1.47

CLAIM		DATE							
Final	Original	09/08/2011	01/03/2012						
	37	÷	N						
	38	÷	N						
	39	÷	N						
	40	÷	N						
	41	÷	N						
	42	÷	N						
	43	÷	N						
	44	÷	N						
	45	÷	N						
	46	÷	N						
	47	÷	N						
	48	÷	N						
	49	÷	N						
	50	÷	✓						
	51	÷	✓						
	52	÷	✓						
	53	÷	✓						
	54	÷	✓						
	55	÷	✓						
	56	÷	N						
	57	÷	N						
	58	÷	N						
	59	÷	N						
	60	÷	N						
	61	÷	N						
	62	÷	N						
	63	÷	N						
	64	÷	N						
	65	÷	N						
	66	÷	N						
	67	÷	N						
	68	÷	N						
	69	÷	N						
	70	÷	N						
	71	÷	N						
	72	÷	N						

<b><i>Index of Claims</i></b>  	<b>Application/Control No.</b> 12057775	<b>Applicant(s)/Patent Under Reexamination</b> BRUHEIM ET AL.
	<b>Examiner</b> DEBBIE K WARE	<b>Art Unit</b> 1651

✓	<b>Rejected</b>
=	<b>Allowed</b>

-	<b>Cancelled</b>
÷	<b>Restricted</b>

N	<b>Non-Elected</b>
I	<b>Interference</b>

A	<b>Appeal</b>
O	<b>Objected</b>

Claims renumbered in the same order as presented by applicant
  CPA
  T.D.
  R.1.47

CLAIM		DATE							
Final	Original	09/08/2011	01/03/2012						
	73	÷	N						
	74	÷	N						
	75	÷	N						
	76	÷	N						
	77	÷	N						
	78	÷	N						
	79	÷	N						
	80	÷	N						
	81	÷	N						
	82	÷	N						
	83	÷	N						
	84	÷	N						
	85	÷	N						
	86	÷	N						
	87	÷	N						
	88	÷	N						
	89	÷	N						
	90	÷	N						

**IN THE UNITED STATES PATENT AND TRADEMARK OFFICE**

In re Application of:	Bruheim et al.	Art Unit:	1651
Serial No.:	12/057,775	Examiner:	Ware
Filed:	March 28, 2008	Confirmation:	1945
Entitled:	BIOEFFECTIVE KRIL OIL COMPOSITIONS		

**RESPONSE TO RESTRICTION REQUIREMENT  
MAILED SEPTEMBER 8, 2011**

**EFS WEB FILED**

Commissioner for Patents  
P.O. Box 1450  
Alexandria, Virginia 22313-1450

Examiner Ware:

This communication is responsive to the Office Action mailed September 8, 2011. The Commissioner is hereby authorized to charge any fees during the entire pendency of this application, including fees due under 37 C.F.R. §§ 1.16 and 1.17 that may be required, including any required extension of time fees, or credit any overpayment to Deposit Account 50-4302, referencing Attorney Docket No. **NATNUT-14409/US-5/ORD**. This paragraph is intended to be a CONSTRUCTIVE PETITION FOR EXTENSION OF TIME in accordance with 37 C.F.R. § 1.136(a)(3).

**IN THE CLAIMS**

1. (Withdrawn) A composition comprising:  
from about 3% to 10% ether phospholipids on a w/w basis;  
from about 35% to 50% non-ether phospholipids on w/w basis, so that the total amount of ether phospholipids and non-ether phospholipids in the composition is from about 48% to 60% on a w/w basis;  
from about 20% to 45% triglycerides on a w/w basis;  
and from about 400 to about 2500 mg/kg astaxanthin.
2. (Withdrawn) The composition of Claim 1, wherein said ether phospholipids are selected from the group consisting of alkylacylphosphatidylcholine, lyso-alkylacylphosphatidylcholine, alkylacylphosphatidylethanolamine, and combinations thereof.
3. (Withdrawn) The composition of Claim 1, wherein said ether lipids are greater than 90% alkylacylphosphatidylcholine.
4. (Withdrawn) The composition of Claim 1, wherein said non-ether phospholipids are selected from the group consisting of phosphatidylcholine, phosphatidylserine, phosphatidylethanolamine and combinations thereof.
5. (Withdrawn) The composition of Claim 1, wherein said composition comprises a blend of lipid fractions obtained from *Euphausia superba*.
6. (Withdrawn) The composition of Claim 1, wherein said composition comprises from about 25% to 30% omega-3 fatty acids as a percentage of total fatty acids and wherein from about 80% to 90% of said omega-3 fatty acids are attached to said phospholipids.
7. (Withdrawn) A capsule containing the composition of Claim 1.

8. (Withdrawn) A composition comprising:  
from about 3% to 10% ether phospholipids on a w/w basis; and  
from about 400 to about 2500 mg/kg astaxanthin.
  
9. (Withdrawn) The composition of Claim 8, further comprising from about 35% to 50% non-ether phospholipids on w/w basis, so that the total amount of ether phospholipids and non-ether phospholipids in the composition is from about 38% to 60% on a w/w basis.
  
10. (Withdrawn) The composition of Claim 8, further comprising from about 20% to 45% triglycerides on a w/w basis.
  
11. (Withdrawn) The composition of Claim 8, wherein said ether phospholipids are selected from the group consisting of alkylacylphosphatidylcholine, lyso-alkylacylphosphatidylcholine, alkylacylphosphatidylethanolamine, and combinations thereof.
  
12. (Withdrawn) The composition of Claim 11, wherein said ether lipids are greater than 90% alkylacylphosphatidylcholine.
  
13. (Withdrawn) The composition of Claim 8, wherein said non-ether phospholipids are selected from the group consisting of phosphatidylcholine, phosphatidylserine, phosphatidylethanolamine and combinations thereof.
  
14. (Withdrawn) The composition of Claim 8, wherein said composition comprises a blend of lipid fractions obtained from *Euphausia superba*.
  
15. (Withdrawn) The composition of Claim 10, wherein said composition comprises from about 25% to 30% omega-3 fatty acids as a percentage of total fatty acids and wherein from about 80% to 90% of said omega-3 fatty acids are attached to said phospholipids.
  
16. (Withdrawn) A capsule containing the composition of Claim 8.

17. (Withdrawn) A blended krill oil composition comprising:  
from about 45% to 55% w/w phospholipids;  
from about 20% to 45% w/w triglycerides;  
and from about 400 to about 2500 mg/kg astaxanthin.
18. (Withdrawn) The composition of Claim 17, wherein said blended krill oil product comprises a blend of lipid fractions obtained from *Euphausia superba*.
19. (Withdrawn) The composition of Claim 17, wherein said composition comprises from about 25% to 30% omega-3 fatty acids as a percentage of total fatty acids and wherein from about 80% to 90% of said omega-3 fatty acids are attached to said phospholipids.
20. (Withdrawn) A *Euphausia superba* krill oil composition comprising:  
from about 3% to about 10% w/w ether phospholipids;  
from about 27% to 50% w/w non-ether phospholipids so that the amount of total phospholipids in the composition is from about 30% to 60% w/w;  
from about 20% to 50% w/w triglycerides;  
from about 400 to about 2500 mg/kg astaxanthin; and  
from about 20% to 35% omega-3 fatty acids as a percentage of total fatty acids in said composition, wherein from about 70% to 95% of said omega-3 fatty acids are attached to said phospholipids.
21. (Withdrawn) A dietary supplement comprising encapsulated *Euphausia superba* krill oil comprising from about 3% to about 10% w/w ether phospholipids; from about 27% to 50% w/w non-ether phospholipids so that the amount of total phospholipids in the composition is from about 30% to 60% w/w; from about 20% to 50% w/w triglycerides; from about 400 to about 2500 mg/kg astaxanthin; and from about 20% to 35% omega-3 fatty acids as a percentage of total fatty acids in said composition, wherein from about 70% to 95% of said omega-3 fatty acids are attached to said phospholipids.

22. (Withdrawn) A method of making a *Euphausia superba* krill oil composition comprising:  
contacting *Euphausia superba* with a polar solvent to provide a polar extract comprising phospholipids;  
contacting *Euphausia superba* with a neutral solvent to provide a neutral extract comprising triglycerides and astaxanthin;  
combining said polar extract and said neutral extract to provide *Euphausia superba* krill oil from about 3% to about 10% w/w ether phospholipids; from about 27% to 50% w/w non-ether phospholipids so that the amount of total phospholipids in the composition is from about 30% to 60% w/w; from about 20% to 50% w/w triglycerides; from about 400 to about 2500 mg/kg astaxanthin; and from about 20% to 35% omega-3 fatty acids as a percentage of total fatty acids in said composition, wherein from about 70% to 95% of said omega-3 fatty acids are attached to said phospholipids.
23. (Withdrawn) The method of Claim 22, further comprising the step of encapsulating the *Euphausia superba* krill oil.
24. (Withdrawn) A *Euphausia superba* krill oil produced by the method of Claim 22.
25. (Withdrawn) A method of producing a dietary supplement comprising;  
contacting *Euphausia superba* with a polar solvent to provide an polar extract comprising phospholipids;  
contacting *Euphausia superba* with a neutral solvent to provide a neutral extract comprising triglycerides and astaxanthin;  
combining said polar extract and said neutral extract to provide *Euphausia superba* krill oil from about 3% to about 10% w/w ether phospholipids; from about 27% to 50% w/w non-ether phospholipids so that the amount of total phospholipids in the composition is from about 30% to 60% w/w; from about 20% to 50% w/w triglycerides; from about 400 to about 2500 mg/kg astaxanthin; and from about 20% to 35% omega-3 fatty acids as a percentage of total fatty acids in said composition, wherein from about 70% to 95% of said omega-3 fatty acids are attached to said phospholipids;  
encapsulating said *Euphausia superba* krill oil.

26. (Withdrawn) A composition comprising at least 65% (w/w) of phospholipids, said phospholipids characterized in containing at least 35% omega-3 fatty acid residues.
27. (Withdrawn) The composition according to claim 26, wherein the composition is derived from a marine or aquatic biomass.
28. (Withdrawn) The composition according to claim 26, wherein the composition is derived from krill.
29. (Withdrawn) The composition of Claim 26, wherein said composition comprises less than 2% free fatty acids.
30. (Withdrawn) The composition of Claim 26, wherein said composition comprises less than 10% triglycerides.
31. (Withdrawn) The composition of Claim 26, wherein said phospholipids comprise greater than 50% phosphatidylcholine.
32. (Withdrawn) The composition of Claim 26, wherein the composition comprises at least 500 mg/kg astaxanthin esters.
33. (Withdrawn) The composition of Claim 26, wherein the composition comprises at least 500 mg/kg astaxanthin esters and at least 36% (w/w) omega-3 fatty acids.
34. (Withdrawn) The composition of Claim 26, wherein the composition comprises less than about 0.5g/100g total cholesterol.
35. (Withdrawn) The composition of Claim 26, wherein the composition comprises less than about 0.45% arachidonic acid (w/w).



36. (Withdrawn) A krill lipid extract comprising at least 500 mg/kg astaxanthin esters and at least 36% (w/w) omega-3 fatty acids.
37. (Withdrawn) A krill lipid extract comprising at least 100 mg/kg astaxanthin esters, at least 20% (w/w) omega-3 fatty acids, and less than about 0.45% arachidonic acid (w/w).
38. (Withdrawn) A method comprising administering the composition of Claim 1 to a subject in an amount effective for reducing insulin resistance, reducing inflammation, improving blood lipid profile and reducing oxidative stress.
39. (Withdrawn) A krill lipid extract comprising greater than about 80% triglycerides and greater than about 90 mg/kg astaxanthin esters.
40. (Withdrawn) The krill lipid extract of Claim 39, characterized in containing from about 5% to about 15% omega-3 fatty acid residues.
41. (Withdrawn) The krill lipid extract of Claim 39, characterized in containing less than about 5% phospholipids.
42. (Withdrawn) The krill lipid extract of Claim 39, characterized in comprising from about 5% to about 10% cholesterol.
43. (Withdrawn) A krill meal composition comprising less than about 50g/kg total fat.
44. (Withdrawn) The krill meal composition of Claim 43 comprising from about 5 to about 20 mg/kg astaxanthin esters.
45. (Withdrawn) The krill meal composition of Claim 43 comprising greater than about 65% protein.

46. (Withdrawn) The krill meal composition of Claim 43 comprising greater than about 70% protein.
47. (Withdrawn) An animal feed comprising the krill meal of Claim 46.
48. (Withdrawn) A method of increasing flesh coloration in an aquatic species comprising feeding said aquatic species a composition comprising the krill meal of Claim 46.
49. (Withdrawn) A method of increasing growth and overall survival rate of aquatic species by feeding the krill meal of Claim 46.
50. (Original) A method of producing krill oil comprising:  
a) providing krill meal; and  
b) extracting oil from said krill meal.
51. (Original) The method of Claim 50, wherein said krill meal is produced from heat-treated krill.
52. (Original) The method of Claim 50, wherein said krill meal is stored prior to said extraction step.
53. (Original) The method of Claim 50, wherein said extracting step comprises extraction by supercritical fluid extraction.
54. (Original) The method of Claim 53, wherein said supercritical fluid extraction is a two step process comprising a first extraction step with carbon dioxide and from 1 to 10% of a co-solvent and a second extraction with carbon dioxide and from 10-30% of a co-solvent, wherein said co-solvent is a C<sub>1</sub>-C<sub>3</sub> monohydric alcohol.
55. (Original) An oil produced by the method of claim 50.

56. (Withdrawn) A method of production of krill oil comprising:
- a) providing fresh krill;
  - b) treating said fresh krill to denature lipases and phospholipases in said fresh krill to provide a denatured krill product; and
  - c) extracting oil from said denatured krill product.
57. (Withdrawn) The method of claim 56 in which the denaturation step comprises heating of said fresh krill.
58. (Withdrawn) The method of claim 56 in which the denaturation step comprises heating said fresh krill after grinding.
59. (Withdrawn) The method of claim 56, further comprising storing said denatured krill product at room temperature or below between the denaturation step and the extraction step.
60. (Withdrawn) The method of claim 56, wherein the enzyme denaturation step is achieved by application of heat.
61. (Withdrawn) The method of claim 56, wherein the extraction step comprises use of supercritical carbon dioxide, with or without use of a polar modifier.
62. (Withdrawn) The method of claim 56, wherein the extraction step comprises the use of ethanol.
63. (Withdrawn) The method of Claim 56, wherein the extraction step comprises ethanol extraction followed by acetone to precipitation of phospholipids.
64. (Withdrawn) The method of Claim 56, wherein said denatured krill product is a meal.
65. (Withdrawn) Oil produced by the method of Claim 56.

66. (Withdrawn) A composition comprising an oil extracted from krill having a phosphatidylcholine content of greater than about 50% (w/w).

67. (Withdrawn) The composition of Claim 66, wherein said oil has a phosphatidylcholine content of greater than about 70% (w/w).

68. (Withdrawn) The composition of Claim 66, wherein said oil has a phosphatidylcholine content of greater than about 80% (w/w).

69. (Withdrawn) The composition of Claim 66, wherein said composition comprises less than 2% free fatty acids.

70. (Withdrawn) The composition of Claim 66, wherein said composition comprises less than 10% triglycerides.

71. (Withdrawn) The composition of Claim 66, wherein the composition comprises at least 500 mg/kg astaxanthin esters.

72. (Withdrawn) The composition of Claim 66, wherein the composition comprises less than about 0.45% arachidonic acid (w/w).

73. (Withdrawn) A composition comprising odorless krill oil.

74. (Withdrawn) The composition of Claim 73, wherein said odorless krill oil comprises less than about 10 mg/kg (w/w) trimethylamine.

75. (Withdrawn) An odorless krill oil produced by the method comprising:  
extracting a neutral krill oil from a krill oil containing material by supercritical fluid extraction to provide a deodorized krill material, wherein said neutral krill oil contains odor causing compounds and  
extracting a polar krill oil from said deodorized krill material by supercritical fluid extraction with a polar entrainer to provide an essentially odorless krill oil.
76. (Withdrawn) A composition comprising krill oil containing less than about 70 micrograms/kilogram (w/w) astaxanthin esters.
77. (Withdrawn) The composition of claim 76, comprising less than about 50 micrograms/kilogram (w/w) astaxanthin esters.
78. (Withdrawn) The composition of claim 76, comprising less than about 20 micrograms/kilogram (w/w) astaxanthin esters.
79. (Withdrawn) The composition of claim 76, comprising less than about 5 micrograms/kilogram (w/w) astaxanthin esters.
80. (Withdrawn) A krill oil produced by the process comprising:  
pumping fresh krill from a trawl onto a ship, heating the krill to provide a krill material, and extracting oil from the krill material.
81. (Withdrawn) A method of reducing diet-induced hyperinsulinemia, insulin insensitivity, muscle mass hypertrophy, serum adiponectin reduction or hepatic steatosis comprising:  
in a subject exposed to a high fat diet, administering to said subject exposed to a high fat diet an effective amount of a krill oil composition under conditions such that a condition selected from the group consisting of diet-induced hyperinsulinemia, insulin insensitivity, muscle mass hypertrophy, serum adiponectin reduction and hepatic steatosis is reduced.

82. (Withdrawn) The method of Claim 81, wherein said effective amount of a krill oil composition is from 0.2 grams to 10 grams of said krill oil composition.

83. (Withdrawn) The method of Claim 81, wherein said krill oil composition comprises: from about 45% to 55% w/w phospholipids; from about 35% to 45% w/w triglycerides; and from about 400 to about 2500 mg/kg astaxanthin.

84. (Withdrawn) The method of Claim 81, wherein said krill oil composition comprises a blend of lipid fractions obtained from *Euphausia superba*.

85. (Withdrawn) A method of reducing diet-induced hyperinsulinemia, insulin insensitivity, muscle mass hypertrophy, serum adiponectin reduction or hepatic steatosis comprising in a subject consuming a high fat diet or a normal fat diet:

administering to said subject consuming a high fat diet or a normal fat diet an effective amount of a krill oil composition under conditions such that a condition selected from the group consisting of diet-induced hyperinsulinemia, insulin insensitivity, muscle mass hypertrophy, serum adiponectin reduction and hepatic steatosis is reduced.

86. (Withdrawn) A method of inducing diuresis in a subject comprising:  
administering to said subject an effective amount of a krill oil composition under conditions such that diuresis is induced.

87. (Withdrawn) A method of increasing muscle mass in a subject, comprising:  
administering to said subject an effective amount of a krill oil composition under conditions such that muscle mass is increased.

88. (Withdrawn) A method of decreasing protein catabolism in a subject, comprising:  
administering to said subject an effective amount of a krill oil composition under conditions such that protein catabolism is decreased.

89. (Withdrawn) A method of decreasing lipid content in the heart of a subject, comprising:  
administering to said subject an effective amount of a krill oil composition under  
conditions such that lipid content in the heart of the subject is decreased.

90. (Withdrawn) A method of decreasing lipid content in the liver of a subject, comprising:  
administering to said subject an effective amount of a krill oil composition under  
conditions such that lipid content in the liver of the subject is decreased.

**REMARKS**

All amendments and cancellation of claims are made without acquiescing to any of the Examiner's arguments or rejections, and solely for the purpose of expediting the patent application process in a manner consistent with the PTO's Patent Business Goals (PBG), and without waiving the right to prosecute the cancelled claims (or similar claims) in the future.

In the Restriction Requirement mailed August 30, 2011, the Examiner required election of one of the following groups:

- Group I (Claims 1-21)
- Group II (Claims 22-25)
- Group III (Claims 26-35)
- Group IV (Claims 36-37 and 39-42)
- Group V (Claims 38)
- Group VI (Claims 43-47)
- Group VII (Claims 48-49)
- Group VIII (Claims 50-55)
- Group IX (Claims 56-65)
- Group X (Claims 66-72)
- Group XI (Claims 73-75)
- Group XII (Claims 76-79)
- Group XIII (Claim 80)
- Group XIV (Claims 81-85)
- Group XV (Claim 86)
- Group XVI (Claim 87)
- Group XVII (Claim 88)
- Group XVIII (Claims 89-90).

Applicants elect Group VIII (Claims 50-55) without traverse.



**CONCLUSION**

If a telephone interview would aid in the prosecution of this application, the Examiner is encouraged to call the undersigned collect at (608) 662-1277.

Dated: October 31, 2011

/J. Mitchell Jones/

John Mitchell Jones  
Registration No. 44,174

Casimir Jones, S.C.  
2275 Deming Way, Suite 310  
Middleton, WI, 53562  
(608) 662-1277

## Electronic Patent Application Fee Transmittal

<b>Application Number:</b>	12057775
<b>Filing Date:</b>	28-Mar-2008
<b>Title of Invention:</b>	BIOEFFECTIVE KRILL OIL COMPOSITIONS
<b>First Named Inventor/Applicant Name:</b>	Inge Bruheim
<b>Filer:</b>	John Mitchell Jones/Vickie Hoeft
<b>Attorney Docket Number:</b>	NATNUT-14409/US-5/ORD

Filed as Large Entity

### Utility under 35 USC 111(a) Filing Fees

Description	Fee Code	Quantity	Amount	Sub-Total in USD(\$)
<b>Basic Filing:</b>				
<b>Pages:</b>				
<b>Claims:</b>				
<b>Miscellaneous-Filing:</b>				
<b>Petition:</b>				
<b>Patent-Appeals-and-Interference:</b>				
<b>Post-Allowance-and-Post-Issuance:</b>				
<b>Extension-of-Time:</b>				
Extension - 1 month with \$0 paid	1251			

Description	Fee Code	Quantity	Amount	Sub-Total in USD(\$)
<b>Miscellaneous:</b>				
<b>Total in USD (\$)</b>				<b>150</b>

## Electronic Acknowledgement Receipt

<b>EFS ID:</b>	11301699
<b>Application Number:</b>	12057775
<b>International Application Number:</b>	
<b>Confirmation Number:</b>	1945
<b>Title of Invention:</b>	BIOEFFECTIVE KRILL OIL COMPOSITIONS
<b>First Named Inventor/Applicant Name:</b>	Inge Bruheim
<b>Customer Number:</b>	72960
<b>Filer:</b>	John Mitchell Jones/Vickie Hoeft
<b>Filer Authorized By:</b>	John Mitchell Jones
<b>Attorney Docket Number:</b>	NATNUT-14409/US-5/ORD
<b>Receipt Date:</b>	31-OCT-2011
<b>Filing Date:</b>	28-MAR-2008
<b>Time Stamp:</b>	16:01:52
<b>Application Type:</b>	Utility under 35 USC 111(a)

### Payment information:

Submitted with Payment	yes
Payment Type	Deposit Account
Payment was successfully received in RAM	\$150
RAM confirmation Number	2700
Deposit Account	504302
Authorized User	

The Director of the USPTO is hereby authorized to charge indicated fees and credit any overpayment as follows:

Charge any Additional Fees required under 37 C.F.R. Section 1.16 (National application filing, search, and examination fees)

Charge any Additional Fees required under 37 C.F.R. Section 1.17 (Patent application filing, search, and examination fees)

Charge any Additional Fees required under 37 C.F.R. Section 1.19 (Document supply fees)

Charge any Additional Fees required under 37 C.F.R. Section 1.20 (Post Issuance fees)

Charge any Additional Fees required under 37 C.F.R. Section 1.21 (Miscellaneous fees and charges)

### File Listing:

Document Number	Document Description	File Name	File Size(Bytes)/ Message Digest	Multi Part /.zip	Pages (if appl.)
1		14409US5RRR10312011.pdf	107230 ffb3b7f73378fa06427136d63abacde164be9032	yes	15

#### Multipart Description/PDF files in .zip description

Document Description	Start	End
Response to Election / Restriction Filed	1	1
Claims	2	13
Applicant Arguments/Remarks Made in an Amendment	14	15

#### Warnings:

#### Information:

2	Fee Worksheet (SB06)	fee-info.pdf	30412 37604383c6f692c81a99ff9f1aba125524b02af1	no	2
---	----------------------	--------------	---	----	---

#### Warnings:

#### Information:

**Total Files Size (in bytes):** 137642

This Acknowledgement Receipt evidences receipt on the noted date by the USPTO of the indicated documents, characterized by the applicant, and including page counts, where applicable. It serves as evidence of receipt similar to a Post Card, as described in MPEP 503.

#### New Applications Under 35 U.S.C. 111

If a new application is being filed and the application includes the necessary components for a filing date (see 37 CFR 1.53(b)-(d) and MPEP 506), a Filing Receipt (37 CFR 1.54) will be issued in due course and the date shown on this Acknowledgement Receipt will establish the filing date of the application.

#### National Stage of an International Application under 35 U.S.C. 371

If a timely submission to enter the national stage of an international application is compliant with the conditions of 35 U.S.C. 371 and other applicable requirements a Form PCT/DO/EO/903 indicating acceptance of the application as a national stage submission under 35 U.S.C. 371 will be issued in addition to the Filing Receipt, in due course.

#### New International Application Filed with the USPTO as a Receiving Office

If a new international application is being filed and the international application includes the necessary components for an international filing date (see PCT Article 11 and MPEP 1810), a Notification of the International Application Number and of the International Filing Date (Form PCT/RO/105) will be issued in due course, subject to prescriptions concerning national security, and the date shown on this Acknowledgement Receipt will establish the international filing date of the application.

Under the Paperwork Reduction Act of 1995, no persons are required to respond to a collection of information unless it displays a valid OMB control number.

<b>PATENT APPLICATION FEE DETERMINATION RECORD</b> Substitute for Form PTO-875	Application or Docket Number <b>12/057,775</b>	Filing Date <b>03/28/2008</b>	<input type="checkbox"/> To be Mailed
---	---	----------------------------------	---------------------------------------

APPLICATION AS FILED – PART I			OTHER THAN SMALL ENTITY			
	(Column 1)	(Column 2)	SMALL ENTITY <input type="checkbox"/>	OR	SMALL ENTITY	
FOR	NUMBER FILED	NUMBER EXTRA	RATE (\$)	FEE (\$)	RATE (\$)	FEE (\$)
<input type="checkbox"/> BASIC FEE <small>(37 CFR 1.16(a), (b), or (c))</small>	N/A	N/A	N/A		N/A	
<input type="checkbox"/> SEARCH FEE <small>(37 CFR 1.16(k), (l), or (m))</small>	N/A	N/A	N/A		N/A	
<input type="checkbox"/> EXAMINATION FEE <small>(37 CFR 1.16(o), (p), or (q))</small>	N/A	N/A	N/A		N/A	
TOTAL CLAIMS <small>(37 CFR 1.16(j))</small>	minus 20 =	*	X \$ =	OR	X \$ =	
INDEPENDENT CLAIMS <small>(37 CFR 1.16(h))</small>	minus 3 =	*	X \$ =		X \$ =	
<input type="checkbox"/> APPLICATION SIZE FEE <small>(37 CFR 1.16(s))</small>	If the specification and drawings exceed 100 sheets of paper, the application size fee due is \$250 (\$125 for small entity) for each additional 50 sheets or fraction thereof. See 35 U.S.C. 41(a)(1)(G) and 37 CFR 1.16(s).					
<input type="checkbox"/> MULTIPLE DEPENDENT CLAIM PRESENT <small>(37 CFR 1.16(j))</small>						
* If the difference in column 1 is less than zero, enter "0" in column 2.			TOTAL		TOTAL	

APPLICATION AS AMENDED – PART II					OTHER THAN SMALL ENTITY			
	(Column 1)	(Column 2)	(Column 3)		SMALL ENTITY	OR	SMALL ENTITY	
AMENDMENT	10/31/2011	CLAIMS REMAINING AFTER AMENDMENT	HIGHEST NUMBER PREVIOUSLY PAID FOR	PRESENT EXTRA	RATE (\$)	ADDITIONAL FEE (\$)	RATE (\$)	ADDITIONAL FEE (\$)
	Total <small>(37 CFR 1.16(i))</small>	* 90	Minus ** 90	= 0	X \$ =		OR	X \$60= 0
	Independent <small>(37 CFR 1.16(h))</small>	* 9	Minus *** 25	= 0	X \$ =		OR	X \$250= 0
	<input type="checkbox"/> Application Size Fee <small>(37 CFR 1.16(s))</small>							
	<input type="checkbox"/> FIRST PRESENTATION OF MULTIPLE DEPENDENT CLAIM <small>(37 CFR 1.16(j))</small>						OR	
					TOTAL ADD'L FEE		OR	TOTAL ADD'L FEE 0

	(Column 1)	(Column 2)	(Column 3)		SMALL ENTITY	OR	SMALL ENTITY	
AMENDMENT		CLAIMS REMAINING AFTER AMENDMENT	HIGHEST NUMBER PREVIOUSLY PAID FOR	PRESENT EXTRA	RATE (\$)	ADDITIONAL FEE (\$)	RATE (\$)	ADDITIONAL FEE (\$)
	Total <small>(37 CFR 1.16(i))</small>	*	Minus **	=	X \$ =		OR	X \$ =
	Independent <small>(37 CFR 1.16(h))</small>	*	Minus ***	=	X \$ =		OR	X \$ =
	<input type="checkbox"/> Application Size Fee <small>(37 CFR 1.16(s))</small>							
	<input type="checkbox"/> FIRST PRESENTATION OF MULTIPLE DEPENDENT CLAIM <small>(37 CFR 1.16(j))</small>						OR	
					TOTAL ADD'L FEE		OR	TOTAL ADD'L FEE

\* If the entry in column 1 is less than the entry in column 2, write "0" in column 3.  
 \*\* If the "Highest Number Previously Paid For" IN THIS SPACE is less than 20, enter "20".  
 \*\*\* If the "Highest Number Previously Paid For" IN THIS SPACE is less than 3, enter "3".  
 The "Highest Number Previously Paid For" (Total or Independent) is the highest number found in the appropriate box in column 1.

Legal Instrument Examiner:  
 /ANGELONA JONES/

This collection of information is required by 37 CFR 1.16. The information is required to obtain or retain a benefit by the public which is to file (and by the USPTO to process) an application. Confidentiality is governed by 35 U.S.C. 122 and 37 CFR 1.14. This collection is estimated to take 12 minutes to complete, including gathering, preparing, and submitting the completed application form to the USPTO. Time will vary depending upon the individual case. Any comments on the amount of time you require to complete this form and/or suggestions for reducing this burden, should be sent to the Chief Information Officer, U.S. Patent and Trademark Office, U.S. Department of Commerce, P.O. Box 1450, Alexandria, VA 22313-1450. DO NOT SEND FEES OR COMPLETED FORMS TO THIS ADDRESS. **SEND TO: Commissioner for Patents, P.O. Box 1450, Alexandria, VA 22313-1450.**

If you need assistance in completing the form, call 1-800-PTO-9199 and select option 2.



UNITED STATES PATENT AND TRADEMARK OFFICE

UNITED STATES DEPARTMENT OF COMMERCE
United States Patent and Trademark Office
Address: COMMISSIONER FOR PATENTS
P.O. Box 1450
Alexandria, Virginia 22313-1450
www.uspto.gov

Table with 5 columns: APPLICATION NO., FILING DATE, FIRST NAMED INVENTOR, ATTORNEY DOCKET NO., CONFIRMATION NO.

12/057,775 03/28/2008 Inge Bruheim NATNUT-14409/US-5/ORD 1945

72960 7590 09/08/2011
Casimir Jones, S.C.
2275 DEMING WAY, SUITE 310
MIDDLETON, WI 53562

EXAMINER

WARE, DEBORAH K

ART UNIT PAPER NUMBER

1651

MAIL DATE DELIVERY MODE

09/08/2011 PAPER

Please find below and/or attached an Office communication concerning this application or proceeding.

The time period for reply, if any, is set in the attached communication.

**Office Action Summary**

<b>Application No.</b> 12/057,775	<b>Applicant(s)</b> BRUHEIM ET AL.	
<b>Examiner</b> DEBBIE K. WARE	<b>Art Unit</b> 1651	

-- The MAILING DATE of this communication appears on the cover sheet with the correspondence address --

**Period for Reply**

A SHORTENED STATUTORY PERIOD FOR REPLY IS SET TO EXPIRE 1 MONTH(S) OR THIRTY (30) DAYS, WHICHEVER IS LONGER, FROM THE MAILING DATE OF THIS COMMUNICATION.

- Extensions of time may be available under the provisions of 37 CFR 1.136(a). In no event, however, may a reply be timely filed after SIX (6) MONTHS from the mailing date of this communication.
- If NO period for reply is specified above, the maximum statutory period will apply and will expire SIX (6) MONTHS from the mailing date of this communication.
- Failure to reply within the set or extended period for reply will, by statute, cause the application to become ABANDONED (35 U.S.C. § 133). Any reply received by the Office later than three months after the mailing date of this communication, even if timely filed, may reduce any earned patent term adjustment. See 37 CFR 1.704(b).

**Status**

- 1)  Responsive to communication(s) filed on \_\_\_\_.
- 2a)  This action is **FINAL**.
- 2b)  This action is non-final.
- 3)  An election was made by the applicant in response to a restriction requirement set forth during the interview on \_\_\_\_; the restriction requirement and election have been incorporated into this action.
- 4)  Since this application is in condition for allowance except for formal matters, prosecution as to the merits is closed in accordance with the practice under *Ex parte Quayle*, 1935 C.D. 11, 453 O.G. 213.

**Disposition of Claims**

- 5)  Claim(s) 1-90 is/are pending in the application.  
5a) Of the above claim(s) \_\_\_\_ is/are withdrawn from consideration.
- 6)  Claim(s) \_\_\_\_ is/are allowed.
- 7)  Claim(s) \_\_\_\_ is/are rejected.
- 8)  Claim(s) \_\_\_\_ is/are objected to.
- 9)  Claim(s) 1-90 are subject to restriction and/or election requirement.

**Application Papers**

- 10)  The specification is objected to by the Examiner.
- 11)  The drawing(s) filed on \_\_\_\_ is/are: a)  accepted or b)  objected to by the Examiner.  
Applicant may not request that any objection to the drawing(s) be held in abeyance. See 37 CFR 1.85(a).  
Replacement drawing sheet(s) including the correction is required if the drawing(s) is objected to. See 37 CFR 1.121(d).
- 12)  The oath or declaration is objected to by the Examiner. Note the attached Office Action or form PTO-152.

**Priority under 35 U.S.C. § 119**

- 13)  Acknowledgment is made of a claim for foreign priority under 35 U.S.C. § 119(a)-(d) or (f).  
a)  All b)  Some \* c)  None of:  
1.  Certified copies of the priority documents have been received.  
2.  Certified copies of the priority documents have been received in Application No. \_\_\_\_.  
3.  Copies of the certified copies of the priority documents have been received in this National Stage application from the International Bureau (PCT Rule 17.2(a)).

\* See the attached detailed Office action for a list of the certified copies not received.

**Attachment(s)**

- 1)  Notice of References Cited (PTO-892)
- 2)  Notice of Draftperson's Patent Drawing Review (PTO-948)
- 3)  Information Disclosure Statement(s) (PTO/SB/08)  
Paper No(s)/Mail Date \_\_\_\_.
- 4)  Interview Summary (PTO-413)  
Paper No(s)/Mail Date \_\_\_\_.
- 5)  Notice of Informal Patent Application
- 6)  Other: \_\_\_\_.



***Election/Restrictions***

**DETAILED ACTION**

Restriction to one of the following inventions is required under 35 U.S.C. 121:

- I. Claims 1-21, drawn to a composition comprising ether and non-ether phospholipids, triglycerides and astaxanthin, classified in class 424, subclass 520.
- II. Claims 22-25, drawn to method of making krill oil using *Euphausia superba*, classified in class 435, subclass 325.
- III. Claims 26-35, drawn to a composition comprising phospholipids containing 35% omega-3 fatty acids, classified in class 510, subclass 468.
- IV. Claim 36-37 and 39-42, drawn to krill lipid extracts, classified in class 514, subclass 506.
- V. Claim 38, drawn to method of administering the composition to a subject for reducing insulin resistance, inflammation, blood lipids and oxidative stress, classified in class 530, subclass 303.
- VI. Claims 43-47, drawn to an animal feed, classified in class 426 , subclass 53.
- VII. Claims 48-49, drawn to method for treating aquatic species with krill meal, classified in class 119, subclass 200.
- VIII. Claims 50-55, drawn to method of producing krill oil from meal type, classified in class 426, subclass 114.

Art Unit: 1651

- IX. Claims 56-65, drawn to a method of production of krill oil, classified in class 424, subclass 538.
- X. Claims 66-72, drawn to a composition comprising oil extract having phosphatidylcholine, classified in class 554, subclass 79.
- XI. Claims 73-75, drawn to an odorless krill oil, classified in class 210, subclass 427 and 332.
- XII. Claims 76-79, drawn to krill oil composition comprising astaxanthin esters, classified in class 585, subclass 639.
- XIII. Claim 80, drawn to krill oil product by process using a ship trawl, classified in class 43, subclass 9.1.
- XIV. Claims 81-85, drawn to method of treating a subject consuming a high fat diet or normal fat diet, classified in class 436, subclass 13 and 71.
- XV. Claim 86, drawn to a method of inducing diuresis, classified in class 205, subclass 695.
- XVI. Claim 87, drawn to method of increasing muscle mass, classified in class 514, subclass 7.4.
- XVII. Claim 88, drawn to a method of decreasing protein catabolism, classified in class 424, subclass 283.1.
- XVIII. Claims 89-90, drawn to method of decreasing lipid content of heart and liver organs, classified in class 514, subclass 89.

The inventions are distinct, each from the other because of the following reasons:

Art Unit: 1651

Inventions II, VIII-IX and I, III-IV, VI, X-XI, XII-XIII are related as process of making and product made. The inventions are distinct if either or both of the following can be shown: (1) that the process as claimed can be used to make another and materially different product or (2) that the product as claimed can be made by another and materially different process (MPEP § 806.05(f)). In the instant case the products as claimed can be made by another and materially different process, such as by using live whole krill or by using meal of krill, or by using extract of krill or by using fish meal or synthetic or plant lipids and carotenoids, wherein the sources of lipid are subjected to solvent extraction or by ultrafiltration and chromatographic techniques. The products as claimed do not necessarily require the methods steps as claimed for making the individually claimed products. Therefore, there is two way distinctness between the methods of making and the products being made.

Inventions I, III-IV, VI, X-XI, XII and XIII are directed to related products. The related inventions are distinct if: (1) the inventions as claimed are either not capable of use together or can have a materially different design, mode of operation, function, or effect; (2) the inventions do not overlap in scope, i.e., are mutually exclusive; and (3) the inventions as claimed are not obvious variants. See MPEP § 806.05(j). In the instant case, the inventions as claimed have a materially different design and do not overlap or are mutually exclusive. Furthermore, the inventions as claimed do not encompass overlapping subject matter and there is nothing of record to show them to be obvious variants. Each of the products require their own specific ingredients for which to be

Art Unit: 1651

comprised by the claimed products and each group of product possess their own distinctness and thus, have two way distinctness from one another.

Inventions II, VIII and IX are directed to related methods of making. The related inventions are distinct if: (1) the inventions as claimed are either not capable of use together or can have a materially different design, mode of operation, function, or effect; (2) the inventions do not overlap in scope, i.e., are mutually exclusive; and (3) the inventions as claimed are not obvious variants. See MPEP § 806.05(j). In the instant case, the inventions as claimed for each of the methods have their own set of distinct process steps for carrying out each separate method to produce a different product. Thus, there is two way distinctness between each of the methods of making a separate and distinct product. Furthermore, the inventions as claimed do not encompass overlapping subject matter and there is nothing of record to show them to be obvious variants.

Inventions I, III-IV, VI, X-XI, XII-XIII and V, VII, XIV-XVIII are related as product and process of use. The inventions can be shown to be distinct if either or both of the following can be shown: (1) the process for using the product as claimed can be practiced with another materially different product or (2) the product as claimed can be used in a materially different process of using that product. See MPEP § 806.05(h). In the instant case the product as claimed can be used in a materially different process of using that product. The products are different and have different uses as claimed in the distinct processes of using the products as evidenced by the claimed subject matter.

Art Unit: 1651

Therefore, there is one way distinctness between the separate products and processes of using as claimed.

Inventions V, VII, XIV-XVII and XVIII are directed to related methods of using.

The related inventions are distinct if: (1) the inventions as claimed are either not capable of use together or can have a materially different design, mode of operation, function, or effect; (2) the inventions do not overlap in scope, i.e., are mutually exclusive; and (3) the inventions as claimed are not obvious variants. See MPEP § 806.05(j). In the instant case, the inventions as claimed the methods of using have a materially different mode of operation, function or effect. Furthermore, the inventions as claimed do not encompass overlapping subject matter and there is nothing of record to show them to be obvious variants. Each group of method claims is, therefore, distinct and separate from the other and possesses two way distinctness from each other.

Restriction for examination purposes as indicated is proper because all these inventions listed in this action are independent or distinct for the reasons given above and there would be a serious search and/or examination burden if restriction were not required because at least the following reason(s) apply:

(a) the inventions have acquired a separate status in the art in view of their different classification;

(b) the inventions have acquired a separate status in the art due to their recognized divergent subject matter;

Art Unit: 1651

(c) the inventions require a different field of search (for example, searching different classes/subclasses or electronic resources, or employing different search queries);

(d) the prior art applicable to one invention would not likely be applicable to another invention, and hence a reference which reads on one inventive group as presented above, will not necessarily read on another inventive group, see each of Groups I-VI and note their separate and distinct status of classification in the art.; and

(e) the inventions are likely to raise different non-prior art issues under 35 U.S.C. 101 and/or 35 U.S.C. 112, first paragraph.

The examiner has required restriction between product and process claims. Where applicant elects claims directed to the product, and the product claims are subsequently found allowable, withdrawn process claims that depend from or otherwise require all the limitations of the allowable product claim will be considered for rejoinder. All claims directed to a nonelected process invention must require all the limitations of an allowable product claim for that process invention to be rejoined.

In the event of rejoinder, the requirement for restriction between the product claims and the rejoined process claims will be withdrawn, and the rejoined process claims will be fully examined for patentability in accordance with 37 CFR 1.104. Thus, to be allowable, the rejoined claims must meet all criteria for patentability including the requirements of 35 U.S.C. 101, 102, 103 and 112. Until all claims to the elected product are found allowable, an otherwise proper restriction requirement between product claims and process claims may be maintained. Withdrawn process claims that are not

Art Unit: 1651

commensurate in scope with an allowable product claim will not be rejoined. See MPEP § 821.04(b). Additionally, in order to retain the right to rejoinder in accordance with the above policy, applicant is advised that the process claims should be amended during prosecution to require the limitations of the product claims. **Failure to do so may result in a loss of the right to rejoinder.** Further, note that the prohibition against double patenting rejections of 35 U.S.C. 121 does not apply where the restriction requirement is withdrawn by the examiner before the patent issues. See MPEP § 804.01.

**Applicant is advised that the reply to this requirement to be complete must include (i) an election of a invention to be examined even though the requirement may be traversed (37 CFR 1.143) and (ii) identification of the claims encompassing the elected invention.**

The election of an invention may be made with or without traverse. To reserve a right to petition, the election must be made with traverse. If the reply does not distinctly and specifically point out supposed errors in the restriction requirement, the election shall be treated as an election without traverse. Traversal must be presented at the time of election in order to be considered timely. Failure to timely traverse the requirement will result in the loss of right to petition under 37 CFR 1.144. If claims are added after the election, applicant must indicate which of these claims are readable upon the elected invention.

Should applicant traverse on the ground that the inventions are not patentably distinct, applicant should submit evidence or identify such evidence now of record showing the inventions to be obvious variants or clearly admit on the record that this is

Art Unit: 1651

the case. In either instance, if the examiner finds one of the inventions unpatentable over the prior art, the evidence or admission may be used in a rejection under 35 U.S.C. 103(a) of the other invention.

Applicant is reminded that upon the cancellation of claims to a non-elected invention, the inventorship must be amended in compliance with 37 CFR 1.48(b) if one or more of the currently named inventors is no longer an inventor of at least one claim remaining in the application. Any amendment of inventorship must be accompanied by a request under 37 CFR 1.48(b) and by the fee required under 37 CFR 1.17(i).

Any inquiry concerning this communication or earlier communications from the examiner should be directed to DEBBIE K. WARE whose telephone number is (571)272-0924. The examiner can normally be reached on 9:30-6:00.

If attempts to reach the examiner by telephone are unsuccessful, the examiner's supervisor, Mike Wityshyn can be reached on 571-272-0926. The fax phone number for the organization where this application or proceeding is assigned is 571-273-8300.



Art Unit: 1651

Information regarding the status of an application may be obtained from the Patent Application Information Retrieval (PAIR) system. Status information for published applications may be obtained from either Private PAIR or Public PAIR. Status information for unpublished applications is available through Private PAIR only. For more information about the PAIR system, see <http://pair-direct.uspto.gov>. Should you have questions on access to the Private PAIR system, contact the Electronic Business Center (EBC) at 866-217-9197 (toll-free). If you would like assistance from a USPTO Customer Service Representative or access to the automated information system, call 800-786-9199 (IN USA OR CANADA) or 571-272-1000.

/Deborah K. Ware/  
Deborah K. Ware  
Primary Examiner  
Art Unit 1651


**UNITED STATES PATENT AND TRADEMARK OFFICE**

UNITED STATES DEPARTMENT OF COMMERCE  
**United States Patent and Trademark Office**  
 Address: COMMISSIONER FOR PATENTS  
 P.O. Box 1450  
 Alexandria, Virginia 22313-1450  
 www.uspto.gov

**BIB DATA SHEET**
**CONFIRMATION NO. 1945**

SERIAL NUMBER	FILING or 371(c) DATE	CLASS	GROUP ART UNIT	ATTORNEY DOCKET NO.		
12/057,775	03/28/2008	424	1651	NATNUT-14409/US-5/OPD		
<b>APPLICANTS</b> Inge Bruheim, Volda, NORWAY; Mikko Griinari, Espoo, FINLAND; Snorre Tilseth, Bergen, NORWAY; Sebastiano Banni, Cagliari, ITALY; Jeffrey Stuart Cohn, Camperdown, AUSTRALIA; Daniele Mancinelli, Orsta, NORWAY;						
<b>** CONTINUING DATA *****</b> This appln claims benefit of 60/920,483 03/28/2007 and claims benefit of 60/975,058 09/25/2007 and claims benefit of 60/983,446 10/29/2007 and claims benefit of 61/024,072 01/28/2008						
<b>** FOREIGN APPLICATIONS *****</b>						
<b>** IF REQUIRED, FOREIGN FILING LICENSE GRANTED **</b> 04/14/2008						
Foreign Priority claimed 35 USC 119(a-d) conditions met Verified and Acknowledged	<input type="checkbox"/> Yes <input checked="" type="checkbox"/> No <input type="checkbox"/> Yes <input checked="" type="checkbox"/> No /DEBBIE K WARE/ Examiner's Signature	<input type="checkbox"/> Met after Allowance Initials	<b>STATE OR COUNTRY</b> NORWAY	<b>SHEETS DRAWINGS</b> 19	<b>TOTAL CLAIMS</b> 90	<b>INDEPENDENT CLAIMS</b> 26
<b>ADDRESS</b> Casimir Jones, S.C. 2275 DEMING WAY, SUITE 310 MIDDLETON, WI 53562 UNITED STATES						
<b>TITLE</b> BIOEFFECTIVE KRILL OIL COMPOSITIONS						
<b>FILING FEE RECEIVED</b> 9490	FEES: Authority has been given in Paper No. _____ to charge/credit DEPOSIT ACCOUNT No. _____ for following:		<input type="checkbox"/> All Fees <input type="checkbox"/> 1.16 Fees (Filing) <input type="checkbox"/> 1.17 Fees (Processing Ext. of time) <input type="checkbox"/> 1.18 Fees (Issue) <input type="checkbox"/> Other _____ <input type="checkbox"/> Credit			

<b>INFORMATION DISCLOSURE STATEMENT BY APPLICANT</b> ( Not for submission under 37 CFR 1.99)	Application Number		12057775	
	Filing Date		2008-03-28	
	First Named Inventor	Inge Bruheim		
	Art Unit		1636	
	Examiner Name			
	Attorney Docket Number		NATNUT-14409/US-5/ORD	

U.S.PATENTS							<input type="button" value="Remove"/>
Examiner Initial*	Cite No	Patent Number	Kind Code <sup>1</sup>	Issue Date	Name of Patentee or Applicant of cited Document	Pages,Columns,Lines where Relevant Passages or Relevant Figures Appear	
	1	4119619		1978-10-10	ROGOZHIN SERGEI VASILIEVICH et al.		
	2	5434183		1995-07-18	LARSSON-BACKSTROM		
	3	6537787		2003-03-25	GILDAS		
	4	6800299		2004-10-05	BEAUDOIN & MARTIN		
	5	5266564		1993-11-30	MODELELL et al		

If you wish to add additional U.S. Patent citation information please click the Add button.

U.S.PATENT APPLICATION PUBLICATIONS							<input type="button" value="Remove"/>
Examiner Initial*	Cite No	Publication Number	Kind Code <sup>1</sup>	Publication Date	Name of Patentee or Applicant of cited Document	Pages,Columns,Lines where Relevant Passages or Relevant Figures Appear	
	1	20030044495		2003-03-06	KAGAN and BRAUN		

**INFORMATION DISCLOSURE  
STATEMENT BY APPLICANT**  
( Not for submission under 37 CFR 1.99)

Application Number	12057775
Filing Date	2008-03-28
First Named Inventor	Inge Bruheim
Art Unit	1636
Examiner Name	
Attorney Docket Number	NATNUT-14409/US-5/ORD

2	20040241249	2004-12-02	SAMPALIS
---	-------------	------------	----------

If you wish to add additional U.S. Published Application citation information please click the Add button.

**FOREIGN PATENT DOCUMENTS**

Examiner Initial*	Cite No	Foreign Document Number <sup>3</sup>	Country Code <sup>2</sup> j	Kind Code <sup>4</sup>	Publication Date	Name of Patentee or Applicant of cited Document	Pages, Columns, Lines where Relevant Passages or Relevant Figures Appear	T <sup>5</sup>
	1	8701265	BR		1987-03-12	SATO		<input type="checkbox"/>
	2	1098900	CA		1981-04-07	ROGOZHIN, et al		<input type="checkbox"/>
	3	0609078	EP		1994-08-03	SCOTIA HOLDINGS PLC		<input type="checkbox"/>
	4	1127497	EP		2001-08-29	NIPPON SUISAN KAISHA LTD		<input type="checkbox"/>
	5	1406641	EP		2004-04-14	NEPTUNE TECHNOLOGIES & BIORESSOURCES INC.		<input type="checkbox"/>
	6	670306	EP		1995-06-09	NIPPON OIL CO. LTD		<input type="checkbox"/>
	7	2097014	GB		1982-10-27	BAIKOFF		<input type="checkbox"/>
	8	921537	GB		1999-06-09	PICKER NORDSTAR INC.		<input type="checkbox"/>

**INFORMATION DISCLOSURE  
STATEMENT BY APPLICANT**  
( Not for submission under 37 CFR 1.99)

Application Number		12057775
Filing Date		2008-03-28
First Named Inventor	Inge Bruheim	
Art Unit	1636	
Examiner Name		
Attorney Docket Number	NATNUT-14409/US-5/ORD	

9	02049091	JP		1990-02-19	SUNTORY LTD	<input type="checkbox"/>
10	2215351	JP		1990-08-28	TAIYO FISHERY CO LTD.	<input type="checkbox"/>
11	2524217	JP		1996-08-14	TAIYO FISHERY CO LTD.	<input type="checkbox"/>
12	2963152	JP		1992-02-25	CHLORINE ENG CORP LTD	<input type="checkbox"/>
13	2000/23546	WO		2000-04-27	UNIV SHERBROOKE	<input type="checkbox"/>
14	3081692	JP		1994-07-19	CHLORINE ENG CORP LTD	<input type="checkbox"/>
15	3344887	JP		1997-07-08	IKEDA SHOKKEN KK	<input type="checkbox"/>
16	3467794	JP		2003-09-05	NIPPON OIL & FATS CO LTD	<input type="checkbox"/>
17	3486778	JP		2003-10-31	GREEN CROSS CORP	<input type="checkbox"/>
18	3611222	JP		1997-08-05	CHLORINE ENG CORP LTD	<input type="checkbox"/>
19	3678317	JP		2005-05-20	CHLORINE ENG CORP LTD	<input type="checkbox"/>

**INFORMATION DISCLOSURE  
STATEMENT BY APPLICANT**  
( Not for submission under 37 CFR 1.99)

Application Number		12057775
Filing Date		2008-03-28
First Named Inventor	Inge Bruheim	
Art Unit	1636	
Examiner Name		
Attorney Docket Number	NATNUT-14409/US-5/ORD	

20	4012665	JP		1992-01-17	MATSUSHITA ELECTRIC IND CO LTD	<input type="checkbox"/>
21	61281159	JP		1986-12-11	SHISEIDO CO LTD; NIPPON SUISAN KAISHA LTD.	<input type="checkbox"/>
22	2001-158736	JP	A	2001-06-12	SNOW BRAND MILK PROD CO LTD	<input type="checkbox"/>
23	2003-003192	JP	A	2003-01-08	UNITIKA LTD	<input type="checkbox"/>
24	2003-048831	JP	A	2003-02-21	SUNTORY LTD	<input type="checkbox"/>
25	2003-146883	JP	A	2003-05-21	SNOW BRAND MILK PROD CO LTD	<input type="checkbox"/>
26	2003-531857	JP	A	2003-10-28	HENDERSON	<input type="checkbox"/>
27	2004-525180	JP	A	2004-08-19	YEDA RESEARCH AND DEVELOPMENT CO. LTD.	<input type="checkbox"/>
28	2004-536059	JP	A	2004-12-02	MARTEK BIOSCIENCES BOULDER CORPORATION	<input type="checkbox"/>
29	2005-245379	JP	A	2005-09-15	NIPPON SUISAN KAISHA LTD	<input type="checkbox"/>
30	2006-069948	JP	A	2006-03-16	HIROSE YUKIHIRO	<input type="checkbox"/>

**INFORMATION DISCLOSURE  
STATEMENT BY APPLICANT**  
( Not for submission under 37 CFR 1.99)

Application Number		12057775
Filing Date		2008-03-28
First Named Inventor	Inge Bruheim	
Art Unit	1636	
Examiner Name		
Attorney Docket Number	NATNUT-14409/US-5/ORD	

31	2006-083136	JP	A	2006-03-30	SUNTORY LTD		<input type="checkbox"/>
32	2006-290784	JP	A	2006-10-26	HIROSE YUKIHIRO		<input type="checkbox"/>
33	2006-316073	JP	A	2006-11-24	IBR ISRAELI BIOTECHNOLOGY RESEARCH LTD		<input type="checkbox"/>
34	2006-328014	JP	A	2006-12-07	HIROSE YUKIHIRO		<input type="checkbox"/>
35	2006-502196	JP	A	2006-01-19	SUNTORY LIMITED		<input type="checkbox"/>
36	2006-528233	JP	A	2006-12-14	BTG INTERNATIONAL LIMITED		<input type="checkbox"/>
37	2007-126455	JP	A	2007-05-24	FUJI CHEM IND CO LTD		<input type="checkbox"/>
38	2007-246404	JP	A	2007-09-27	SNOW BRAND MILK PROD CO LTD		<input type="checkbox"/>
39	2007-502805	JP	A	2007-02-15	BTG INTERNATIONAL LIMITED		<input type="checkbox"/>
40	2007-509131	JP	A	2007-04-12	ENZYMOTEC LTD.		<input type="checkbox"/>
41	2007-518764	JP	A	2007-07-12	BRUZZESE		<input type="checkbox"/>

**INFORMATION DISCLOSURE  
STATEMENT BY APPLICANT**  
( Not for submission under 37 CFR 1.99)

Application Number	12057775
Filing Date	2008-03-28
First Named Inventor	Inge Bruheim
Art Unit	1636
Examiner Name	
Attorney Docket Number	NATNUT-14409/US-5/ORD

42	220741	SU		1971-01-06	KRGUCHKOV		<input type="checkbox"/>
43	1986/06082	WO		1986-10-23	MAT-CON RADGIVENDE INGENIØRFIRMA A/S		<input type="checkbox"/>
44	1990/05765	WO		1990-05-31	MIKALSEN		<input type="checkbox"/>
45	1993/24142	WO		1993-12-09	PHAIRSON MEDICAL AB		<input type="checkbox"/>
46	1997/38585	WO		1997-10-23	THE UNIVERSITY OF BRITISH COLUMBIA		<input type="checkbox"/>
47	1997/39759	WO		1997-10-30	BRIGHAM AND WOMEN'S HOSPITAL		<input type="checkbox"/>
48	1998/34498	WO		1998-08-13	BIOZYME SYSTEMS INC.		<input type="checkbox"/>
49	1999/39589	WO		1999-08-12	BIOZYME SYSTEMS INC.		<input type="checkbox"/>

If you wish to add additional Foreign Patent Document citation information please click the Add button

**NON-PATENT LITERATURE DOCUMENTS**

Examiner Initials*	Cite No	Include name of the author (in CAPITAL LETTERS), title of the article (when appropriate), title of the item (book, magazine, journal, serial, symposium, catalog, etc), date, pages(s), volume-issue number(s), publisher, city and/or country where published.	T <sup>5</sup>
	1	ANDO and HATANO, 1988, "Isolation of apolipoproteins from carotenoid-carrying lipoprotein in the serum of chum salmon, <i>Oncorhynchus keta</i> ", J. Lipid Research, 29: 1264-1271	<input type="checkbox"/>



**INFORMATION DISCLOSURE  
STATEMENT BY APPLICANT**  
( Not for submission under 37 CFR 1.99)

Application Number		12057775
Filing Date		2008-03-28
First Named Inventor	Inge Bruheim	
Art Unit	1636	
Examiner Name		
Attorney Docket Number	NATNUT-14409/US-5/ORD	

2	AOI et al., 2003, "Astaxanthin limits exercise-induced skeletal and cardiac muscle damage in mice", <i>Antioxidants &amp; Redox Signaling</i> , 5(1): 139-44	<input type="checkbox"/>
3	BRITTON, 1985, "General Carotenoid Methods", <i>Methods in Enzymology</i> , Vol 111, pp. 113-149	<input type="checkbox"/>
4	CALDER, 2006, "n-3 polyunsaturated fatty acids, inflammation, and inflammatory diseases", <i>Am. J. Clin. Nutr.</i> , 83: 1505S	<input type="checkbox"/>
5	CHAREST et al., 2001, "Astaxanthin Extraction from Crawfish Shells by Supercritical CO2 with Ethanol as Cosolvent", <i>J. Aquatic Food Product Technology</i> , 10(3): 79-93	<input type="checkbox"/>
6	CHEN and MEYERS, 1982, "Extraction of Astaxanthin Pigment from Crawfish Waste Using a Soy Oil Process", <i>J. Food Sci.</i> , 47: 892-896	<input type="checkbox"/>
7	CLARKE, 1980, "The Biochemical Composition of Krill, <i>Euphausia superba</i> dana, from South Georgia", <i>J. Exp. Mar. Biol. Ecol.</i> , 43: 221-236	<input type="checkbox"/>
8	CZECZUGA, 1974, "Comparative Studies of Carotenoids in the Fauna of the Gullmar Fjord (Bohuslan, Sweden). II. Crustacea: <i>Eupagurus bernhardus</i> , <i>Hyas coarctatus</i> and <i>Upogebia deltaura</i> ", <i>Marine Biology</i> , 28: 95-98	<input type="checkbox"/>
9	DE RITTER and PURCELL, 1981, "Carotenoid Analytical Methods", <i>Carotenoids as Colorants and Vitamin A Precursors: Technological and Nutritional Applications</i> , pp 815-882	<input type="checkbox"/>
10	DEUTCH, 1995, "Menstrual pain in Danish women correlated with low n-3 polyunsaturated fatty acid intake", <i>Eur. J. Clin. Nutr.</i> , 49(7): 508-16	<input type="checkbox"/>
11	DIEZ et al., 2003, "The role of the novel adipocyte-derived hormone adiponectin in human disease", <i>Eur. J. Endocrinol.</i> , 148(3): 293-300	<input type="checkbox"/>
12	ELLINGSEN et al., 1987, "Biochemistry of the autolytic processes in Antarctic krill post mortem. Autoproteolysis." <i>Biochem. J.</i> 246, 295-305	<input type="checkbox"/>

**INFORMATION DISCLOSURE  
STATEMENT BY APPLICANT**  
( Not for submission under 37 CFR 1.99)

Application Number		12057775
Filing Date		2008-03-28
First Named Inventor	Inge Bruheim	
Art Unit	1636	
Examiner Name		
Attorney Docket Number	NATNUT-14409/US-5/ORD	

13	EMODI, 1978, "Carotenoids: Properties and Applications", Food Technology, 32(5): 38	<input type="checkbox"/>
14	FELIX-VALENZUELA et al., 2001, "Supercritical CO2/Ethanol Extraction of Astaxanthin from Blue Crab (Callinectes Sapidus) Shell Waste", Journal of Food Process Engineering, 24: 101-112	<input type="checkbox"/>
15	FOX and SCHEER, 1941, "Comparative Studies of the Pigments of Some Pacific Coast Echinoderms", The Biological Bulletin, 441-455	<input type="checkbox"/>
16	FRICKE, et al., 1984, "Lipid, Sterol and Fatty Acid Composition of Antarctic Krill (Euphausia superba Dana)", Lipids, 19 (11): 821-827	<input type="checkbox"/>
17	GEUSENS et al., 1994, "Long-term effect of omega-3 fatty acid supplementation in active rheumatoid arthritis. A 12-month, double-blind, controlled study", Arthritis Rheum., 37(6): 824-9	<input type="checkbox"/>
18	GILCHRIST and GREEN, 1960, "The Pigments of Artemia", Proceedings of the Royal Society, Series B Biological Sciences, Vol 152 No. 946, pp 118-136	<input type="checkbox"/>
19	GOODWIN and SRISUKH, 1949, "Some Observations on Astaxanthin Distribution in Marine Crustacea", Department of Biochemistry, University of Liverpool, pp. 268-270	<input type="checkbox"/>
20	GULYAEV and BUGROVA, 1976 "Removing fats from the protein paste "Okean". Konservnaya I Ovoshchesushil'naya Promyshlennost, (4), 37-8	<input type="checkbox"/>
21	HARDARDOTTIR and KINSELLA, 1988, "Extraction of Lipid and Cholesterol from Fish Muscle with Supercritical Fluids" Journal of Food Science, 53(6): 1656-1658	<input type="checkbox"/>
22	INTERNATIONAL AQUA FEED, 2006, Vol. 9	<input type="checkbox"/>
23	International Search Report and Written Opinion for PCT/GB2008/002934, Dated 2009-03-11	<input type="checkbox"/>

**INFORMATION DISCLOSURE  
STATEMENT BY APPLICANT**  
( Not for submission under 37 CFR 1.99)

Application Number	12057775
Filing Date	2008-03-28
First Named Inventor	Inge Bruheim
Art Unit	1636
Examiner Name	
Attorney Docket Number	NATNUT-14409/US-5/ORD

24	International Search Report and Written Opinion for PCT/IB2010/000512; dated 2010-06-24	<input type="checkbox"/>
25	International Search Report for PCT/IB2007/000098, dated: 2007-06-26	<input type="checkbox"/>
26	ITOH et al., 2007; "Increased adiponectin secretion by highly purified eicosapentaenoic acid in rodent models of obesity and human obese subjects", Arteriosclerosis, Thrombosis, and Vascular Biology; 27(9): 1918-1925	<input type="checkbox"/>
27	JOHNSON et al., 1978, "Simple Method for the Isolation of Astaxanthin from the Basidiomycetous Yeast Phaffia rhodozyma", Applied and Environmental Microbiology, 35(6): 1155-1159	<input type="checkbox"/>
28	KOLAKOWSKA, 1989, "Krill lipids after frozen storage of about one year in relation to storage time before freezing", Die Nahrung Food, 33(3): 241-244	<input type="checkbox"/>
29	KRIS-ETHERTON et al., 2002, "Fish Consumption, Fish Oil, Omega-3 Fatty Acids, and Cardiovascular Disease", Circulation, 106:2747-2757	<input type="checkbox"/>
30	KRISTENSEN et al., 1989, "Dietary supplementation with n-3 polyunsaturated fatty acids and human platelet function: a review with particular emphasis on implications for cardiovascular disease", J. Intern. Med. Suppl. 731:141-50	<input type="checkbox"/>
31	KUNESOVA et al., 2006, "The influence of n-3 polyunsaturated fatty acids and very low calorie diet during a short-term weight reducing regimen on weight loss and serum fatty acid composition in severely obese women", Physiol Res.; 55 (1):63-72	<input type="checkbox"/>
32	LAIGHT et al., 1999, "F2-isoprostane evidence of oxidant stress in the insulin resistant, obese Zucker rat: effects of vitamin E", Eur. J. Pharmacol. 377(1): 89-92	<input type="checkbox"/>
33	LAMBERTSON and BRAEKKAN, 1971, "Method of Analysis of Astaxanthin and its Occurrence in some Marine Products," J. Sci. Food. Agr., Vol 22(2): 99-101	<input type="checkbox"/>
34	LIBBY et al., 2006, "Inflammation and Atherothrombosis: From Population Biology and Bench Research to Clinical Practice", J. Amer. Coll. Card., 48 (9, Suppl. A): A33-A46	<input type="checkbox"/>

**INFORMATION DISCLOSURE  
STATEMENT BY APPLICANT**  
( Not for submission under 37 CFR 1.99)

Application Number		12057775
Filing Date		2008-03-28
First Named Inventor	Inge Bruheim	
Art Unit	1636	
Examiner Name		
Attorney Docket Number	NATNUT-14409/US-5/ORD	

35	LOPEZ et al., 2004, "Selective extraction of astaxanthin from crustaceans by use of supercritical carbon dioxide", Talanta, 64: 726-731	<input type="checkbox"/>
36	MANDEVILLE, 1991, "Isolation and Identification of Carotenoid Pigments, Lipids and Flavor Active Components from Raw Commercial Shrimp Waste", Food Biotechnology, 5(2): 185-195	<input type="checkbox"/>
37	MEYERS and BLIGH, 1981, "Characterization of Astaxanthin Pigments from Heat-Processed Crawfish Waste", J. Agric. Food Chem., 29: 505-508	<input type="checkbox"/>
38	MEYERS, 1977, "Using Crustacean Meals and Carotenoid-Fortified Diets", Feedstuffs, Vol. 49(19)	<input type="checkbox"/>
39	MEYERS, 1994, "Developments in world aquaculture, feed formulations, and role of carotenoids", Pure & Appl. Chem, Vol. 66(5): 1069-1076	<input type="checkbox"/>
40	MILLS et al., 1989, "Dietary N-6 and N-3 fatty acids and salt-induced hypertension in the borderline hypertensive rat", Lipids, 24(1): 17-24	<input type="checkbox"/>
41	MOATES and VAN BENTEM, 1990, "Separating out the value", Food Science and Technology Today, 4(4): 213-214	<input type="checkbox"/>
42	NIKOLAEVA, 1967 "Amino acid composition of protein-coagulate in krill", VNIRO, 63:161-4	<input type="checkbox"/>
43	PHLEGER, et al. (2002) "Interannual and between species comparison in the lipids, fatty acids, and sterols of Antarctic krill from the US AMLR Elephant Island survey area: 1997 and 1998". Comp Biochem Physiol 131B:733-747	<input type="checkbox"/>
44	POPP-SNIJDERS et al., 1987, "Dietary supplementation of omega-3 polyunsaturated fatty acids improves insulin sensitivity in non-insulin-dependent diabetes", Diabetes Res. 4(3): 141-7	<input type="checkbox"/>
45	SACHINDRA, 2006, "Recovery of carotenoids from shrimp waste in organic solvents", Waste Management, 26: 1092-1098	<input type="checkbox"/>

<b>INFORMATION DISCLOSURE STATEMENT BY APPLICANT</b> ( Not for submission under 37 CFR 1.99)	Application Number		12057775
	Filing Date		2008-03-28
	First Named Inventor	Inge Bruheim	
	Art Unit		1636
	Examiner Name		
	Attorney Docket Number		NATNUT-14409/US-5/ORD

46	SAETHER et al., 1986, "Lipids of North Atlantic krill", J Lipid Res., 27(3):274-85.	<input type="checkbox"/>
47	SHAHIDI et al., 1998, "Carotenoid Pigments in Seafoods and Aquaculture" Critical Reviews in Food Science, 38(1): 1-67	<input type="checkbox"/>
48	SIDEHU et al., 1970, "Biochemical Composition and Nutritive Value of Krill (Euphausia superb dana)", J. Sci Food Agr., Vol 21, 293-296	<input type="checkbox"/>
49	SIMOPOULOS, 1991, "Omega-3 fatty acids in health and disease and in growth and development", Am. Clin. Nutr. 54:438-63	<input type="checkbox"/>
50	SOMIYA, 1982, "Yellow lens' eyes of a stomiatoid deep-sea fish, Malacosteus niger", Proc. R. Soc. Lond., 215: 481-489	<input type="checkbox"/>

If you wish to add additional non-patent literature document citation information please click the Add button

**EXAMINER SIGNATURE**

Examiner Signature		Date Considered	
--------------------	--	-----------------	--

\*EXAMINER: Initial if reference considered, whether or not citation is in conformance with MPEP 609. Draw line through a citation if not in conformance and not considered. Include copy of this form with next communication to applicant.

<sup>1</sup> See Kind Codes of USPTO Patent Documents at [www.USPTO.GOV](http://www.USPTO.GOV) or MPEP 901.04. <sup>2</sup> Enter office that issued the document, by the two-letter code (WIPO Standard ST.3). <sup>3</sup> For Japanese patent documents, the indication of the year of the reign of the Emperor must precede the serial number of the patent document. <sup>4</sup> Kind of document by the appropriate symbols as indicated on the document under WIPO Standard ST.16 if possible. <sup>5</sup> Applicant is to place a check mark here if English language translation is attached.

<b>INFORMATION DISCLOSURE STATEMENT BY APPLICANT</b> ( Not for submission under 37 CFR 1.99)	Application Number	12057775
	Filing Date	2008-03-28
	First Named Inventor	Inge Bruheim
	Art Unit	1636
	Examiner Name	
	Attorney Docket Number	NATNUT-14409/US-5/ORD

**CERTIFICATION STATEMENT**

Please see 37 CFR 1.97 and 1.98 to make the appropriate selection(s):

That each item of information contained in the information disclosure statement was first cited in any communication from a foreign patent office in a counterpart foreign application not more than three months prior to the filing of the information disclosure statement. See 37 CFR 1.97(e)(1).

**OR**

That no item of information contained in the information disclosure statement was cited in a communication from a foreign patent office in a counterpart foreign application, and, to the knowledge of the person signing the certification after making reasonable inquiry, no item of information contained in the information disclosure statement was known to any individual designated in 37 CFR 1.56(c) more than three months prior to the filing of the information disclosure statement. See 37 CFR 1.97(e)(2).

- See attached certification statement.
- The fee set forth in 37 CFR 1.17 (p) has been submitted herewith.
- A certification statement is not submitted herewith.

**SIGNATURE**

A signature of the applicant or representative is required in accordance with CFR 1.33, 10.18. Please see CFR 1.4(d) for the form of the signature.

Signature	/J. Mitchell Jones/	Date (YYYY-MM-DD)	2011-03-04
Name/Print	J. Mitchell Jones	Registration Number	44,174

This collection of information is required by 37 CFR 1.97 and 1.98. The information is required to obtain or retain a benefit by the public which is to file (and by the USPTO to process) an application. Confidentiality is governed by 35 U.S.C. 122 and 37 CFR 1.14. This collection is estimated to take 1 hour to complete, including gathering, preparing and submitting the completed application form to the USPTO. Time will vary depending upon the individual case. Any comments on the amount of time you require to complete this form and/or suggestions for reducing this burden, should be sent to the Chief Information Officer, U.S. Patent and Trademark Office, U.S. Department of Commerce, P.O. Box 1450, Alexandria, VA 22313-1450. **DO NOT SEND FEES OR COMPLETED FORMS TO THIS ADDRESS. SEND TO: Commissioner for Patents, P.O. Box 1450, Alexandria, VA 22313-1450.**

## Privacy Act Statement

The Privacy Act of 1974 (P.L. 93-579) requires that you be given certain information in connection with your submission of the attached form related to a patent application or patent. Accordingly, pursuant to the requirements of the Act, please be advised that: (1) the general authority for the collection of this information is 35 U.S.C. 2(b)(2); (2) furnishing of the information solicited is voluntary; and (3) the principal purpose for which the information is used by the U.S. Patent and Trademark Office is to process and/or examine your submission related to a patent application or patent. If you do not furnish the requested information, the U.S. Patent and Trademark Office may not be able to process and/or examine your submission, which may result in termination of proceedings or abandonment of the application or expiration of the patent.

The information provided by you in this form will be subject to the following routine uses:

1. The information on this form will be treated confidentially to the extent allowed under the Freedom of Information Act (5 U.S.C. 552) and the Privacy Act (5 U.S.C. 552a). Records from this system of records may be disclosed to the Department of Justice to determine whether the Freedom of Information Act requires disclosure of these records.
2. A record from this system of records may be disclosed, as a routine use, in the course of presenting evidence to a court, magistrate, or administrative tribunal, including disclosures to opposing counsel in the course of settlement negotiations.
3. A record in this system of records may be disclosed, as a routine use, to a Member of Congress submitting a request involving an individual, to whom the record pertains, when the individual has requested assistance from the Member with respect to the subject matter of the record.
4. A record in this system of records may be disclosed, as a routine use, to a contractor of the Agency having need for the information in order to perform a contract. Recipients of information shall be required to comply with the requirements of the Privacy Act of 1974, as amended, pursuant to 5 U.S.C. 552a(m).
5. A record related to an International Application filed under the Patent Cooperation Treaty in this system of records may be disclosed, as a routine use, to the International Bureau of the World Intellectual Property Organization, pursuant to the Patent Cooperation Treaty.
6. A record in this system of records may be disclosed, as a routine use, to another federal agency for purposes of National Security review (35 U.S.C. 181) and for review pursuant to the Atomic Energy Act (42 U.S.C. 218(c)).
7. A record from this system of records may be disclosed, as a routine use, to the Administrator, General Services, or his/her designee, during an inspection of records conducted by GSA as part of that agency's responsibility to recommend improvements in records management practices and programs, under authority of 44 U.S.C. 2904 and 2906. Such disclosure shall be made in accordance with the GSA regulations governing inspection of records for this purpose, and any other relevant (i.e., GSA or Commerce) directive. Such disclosure shall not be used to make determinations about individuals.
8. A record from this system of records may be disclosed, as a routine use, to the public after either publication of the application pursuant to 35 U.S.C. 122(b) or issuance of a patent pursuant to 35 U.S.C. 151. Further, a record may be disclosed, subject to the limitations of 37 CFR 1.14, as a routine use, to the public if the record was filed in an application which became abandoned or in which the proceedings were terminated and which application is referenced by either a published application, an application open to public inspections or an issued patent.
9. A record from this system of records may be disclosed, as a routine use, to a Federal, State, or local law enforcement agency, if the USPTO becomes aware of a violation or potential violation of law or regulation.

## Electronic Acknowledgement Receipt

<b>EFS ID:</b>	9581496
<b>Application Number:</b>	12057775
<b>International Application Number:</b>	
<b>Confirmation Number:</b>	1945
<b>Title of Invention:</b>	BIOEFFECTIVE KRILL OIL COMPOSITIONS
<b>First Named Inventor/Applicant Name:</b>	Inge Bruheim
<b>Customer Number:</b>	72960
<b>Filer:</b>	John Mitchell Jones/Stephanie Filandrinos
<b>Filer Authorized By:</b>	John Mitchell Jones
<b>Attorney Docket Number:</b>	NATNUT-14409/US-5/ORD
<b>Receipt Date:</b>	08-MAR-2011
<b>Filing Date:</b>	28-MAR-2008
<b>Time Stamp:</b>	16:03:13
<b>Application Type:</b>	Utility under 35 USC 111(a)

### Payment information:

Submitted with Payment	no
------------------------	----

### File Listing:

Document Number	Document Description	File Name	File Size(Bytes)/ Message Digest	Multi Part /.zip	Pages (if appl.)
1	Transmittal Letter	14409US5ORD_IDSletter.pdf	73260 <small>f1a4d85386b5eb1ea8878beac82c0ae3a178bad0</small>	no	1

### Warnings:

### Information:



2	Foreign Reference	BR8701265.pdf	443659	no	13
			ca61b51d0124934d500e19d75c9d0a06d0f70ee6		
<b>Warnings:</b>					
<b>Information:</b>					
3	Foreign Reference	CA1098900.pdf	433645	no	10
			55b518a2adac9c958c839bd3b67b585aaa2b05e		
<b>Warnings:</b>					
<b>Information:</b>					
4	Foreign Reference	EP0609078.pdf	243242	no	19
			4456ef3193c05cd57807f97093d630831cb58be1		
<b>Warnings:</b>					
<b>Information:</b>					
5	Foreign Reference	EP1127497.pdf	129236	no	11
			0400ccd59c75b9d0d6af3c8af578a6e7d42443af		
<b>Warnings:</b>					
<b>Information:</b>					
6	Foreign Reference	EP1406641B1.pdf	113611	no	13
			004634ecf6dfca9cb183a0516f0bc45157009422		
<b>Warnings:</b>					
<b>Information:</b>					
7	Foreign Reference	EP670306.pdf	539670	no	9
			5aa537e67c7390c9d360ba6c05dfc88c3ff7a8c2		
<b>Warnings:</b>					
<b>Information:</b>					
8	Foreign Reference	GB921537A2.pdf	141569	no	10
			1a4780e1c014c15282f89b7a4742221ea7d4d4cd		
<b>Warnings:</b>					
<b>Information:</b>					
9	Foreign Reference	JP02049091.pdf	117217	no	3
			ebce63c8f5aeaf3660f381076339810a78dafc82		
<b>Warnings:</b>					
<b>Information:</b>					
10	Foreign Reference	JP02215351.pdf	268356	no	7
			3cecfb18ca6486d44a9357dc76cb11a6aa3fd40e		
<b>Warnings:</b>					
<b>Information:</b>					

11	Foreign Reference	GB2097014.pdf	49166	no	5
			4bd71f70693141079eaf06afae445a707f43671		
<b>Warnings:</b>					
<b>Information:</b>					
12	Foreign Reference	JP2524217.pdf	138676	no	1
			a96ef801909bfa9941acb15803cf232bd003e52f		
<b>Warnings:</b>					
<b>Information:</b>					
13	Foreign Reference	JP2963152.pdf	154291	no	2
			63be9e76decd95dec39a3eb2b73eb2cccd9196e4		
<b>Warnings:</b>					
<b>Information:</b>					
14	Foreign Reference	JP3081692.pdf	151666	no	1
			3f238bcd4967317155fb630e30c5893f0543264		
<b>Warnings:</b>					
<b>Information:</b>					
15	Foreign Reference	JP3344887.pdf	152246	no	1
			09e6f354bfdbae45c47967e88fa0506b103492b6		
<b>Warnings:</b>					
<b>Information:</b>					
16	Foreign Reference	JP3467794.pdf	143014	no	1
			b719d0be49f8c723f49c1cd311d6c17faa2ec9a7		
<b>Warnings:</b>					
<b>Information:</b>					
17	Foreign Reference	JP3486778.pdf	139432	no	1
			2a20878ea2ace5b77f7f031a2b625bf557837c8e		
<b>Warnings:</b>					
<b>Information:</b>					
18	Foreign Reference	JP3611222.pdf	138025	no	1
			2daba920ee25fd656cc641ccd0e5733d70a6336d		
<b>Warnings:</b>					
<b>Information:</b>					
19	Foreign Reference	JP3678317.pdf	151658	no	1
			97258811be3eee0e9f5ceb753af0d6645fbb8f97		
<b>Warnings:</b>					
<b>Information:</b>					

20	Foreign Reference	JP4012665.pdf	141356	no	2
			e9f0aa403bbe0b31c4654894313aadf90b0f5080		
<b>Warnings:</b>					
<b>Information:</b>					
21	Foreign Reference	JP61281159A.pdf	104337	no	3
			ae00769c5bfc26efd0e33fe27fd3bbe0786763f7		
<b>Warnings:</b>					
<b>Information:</b>					
22	Foreign Reference	JP2001-158736.pdf	138856	no	1
			e25880d560287060ba84df53c6592227dcff65b		
<b>Warnings:</b>					
<b>Information:</b>					
23	Foreign Reference	JP2003-003192.pdf	138462	no	1
			4caa22534936bd9c5f2e01c46a227b4b197ed351		
<b>Warnings:</b>					
<b>Information:</b>					
24	Foreign Reference	JP2003-048831.pdf	157445	no	1
			772e98473e688b5b50f17debebec398c5b49a7f0		
<b>Warnings:</b>					
<b>Information:</b>					
25	Foreign Reference	JP2003-146883.pdf	138882	no	1
			5dab1ff80024230ed192903da380785feb2cdabd3		
<b>Warnings:</b>					
<b>Information:</b>					
26	Foreign Reference	JP2005-245379.pdf	139119	no	1
			f6aa3a0adfd07ef1c74b14565f94c020206329bc		
<b>Warnings:</b>					
<b>Information:</b>					
27	Foreign Reference	JP2006-069948.pdf	131124	no	1
			85787a6f54c4b807d8805374da42860594f840c5		
<b>Warnings:</b>					
<b>Information:</b>					
28	Foreign Reference	JP2006-083136.pdf	152186	no	1
			630f057030c652bf9b01d30bc76e500c573338ac		
<b>Warnings:</b>					
<b>Information:</b>					

29	Foreign Reference	JP2006-290784.pdf	130633	no	1
			f675752dcd92b70b447bb31801bbb6ba59455646		
<b>Warnings:</b>					
<b>Information:</b>					
30	Foreign Reference	JP2006-316073.pdf	133516	no	2
			c10ffb526fd68a4ae94cc1bdd6155e2ef029c3d3		
<b>Warnings:</b>					
<b>Information:</b>					
31	Foreign Reference	JP2006-328014.pdf	129708	no	1
			13c23dff5ca2f030d6567a622888634b0255b65		
<b>Warnings:</b>					
<b>Information:</b>					
32	Foreign Reference	JP2007-126455.pdf	130855	no	2
			754967275a43cf72a1e3ed57e3d42fb2515f9f5		
<b>Warnings:</b>					
<b>Information:</b>					
33	Foreign Reference	JP2007-246404.pdf	128077	no	1
			1ebf6ed70152d068fb9ed668e60c45e915cf56c6		
<b>Warnings:</b>					
<b>Information:</b>					
34	Foreign Reference	SU220741-Translation.pdf	22077	no	1
			8280fffb5ecd7f2c1449f4c67610335e8b5c4855		
<b>Warnings:</b>					
<b>Information:</b>					
35	Foreign Reference	WO1986006082.pdf	676064	no	17
			19e015354650b71799e084e185e641354e23593f		
<b>Warnings:</b>					
<b>Information:</b>					
36	Foreign Reference	WO1990005765.pdf	525597	no	13
			f86c6603d0410873f650b970cc5308befec48484		
<b>Warnings:</b>					
<b>Information:</b>					
37	Foreign Reference	WO1993024142.pdf	3557206	no	83
			4d69e280bd394571cf34dd3e1efc966d04acf9e6		
<b>Warnings:</b>					
<b>Information:</b>					

38	Foreign Reference	WO1997038585.pdf	718651	no	19
			7502408689bec846c82bef6bdb8ab993ca528b7dd		
<b>Warnings:</b>					
<b>Information:</b>					
39	Foreign Reference	WO1997039759.pdf	640818	no	14
			00c3b9681b9b1aaa742788fcc97068d404f1709b		
<b>Warnings:</b>					
<b>Information:</b>					
40	Foreign Reference	WO1998034498.pdf	1833867	no	59
			dfc8bf6688a3de980c1c1d110d3040ea8627f9b4		
<b>Warnings:</b>					
<b>Information:</b>					
41	Foreign Reference	WO1999039589.pdf	1883493	no	59
			03bbe111d4f704995b1cd5981b36e2e9771391dc		
<b>Warnings:</b>					
<b>Information:</b>					
42	Foreign Reference	WO2000023546.pdf	3401573	no	58
			89a927c46b654d7756ad20fb4282b63306c6f097		
<b>Warnings:</b>					
<b>Information:</b>					
43	NPL Documents	ANDO_HATANO1988.pdf	1349428	no	8
			3dd6c538d77396562cc90774ab978c5a4a7dc8b9		
<b>Warnings:</b>					
<b>Information:</b>					
44	NPL Documents	AOI2003AntioxRedoxSignal.pdf	1060138	no	9
			d77ea2d1116903ab6aa010eb87809d837c2ab9bd		
<b>Warnings:</b>					
<b>Information:</b>					
45	NPL Documents	Britton1985MethEnzym113-49.pdf	698806	no	39
			55edd79c44e359c46714cfbe665024504ec4500f		
<b>Warnings:</b>					
The page size in the PDF is too large. The pages should be 8.5 x 11 or A4. If this PDF is submitted, the pages will be resized upon entry into the Image File Wrapper and may affect subsequent processing					
<b>Information:</b>					
46	NPL Documents	CALDER2006.pdf	395847	no	15

<b>Warnings:</b>					
<b>Information:</b>					
47	NPL Documents	Charest2001.pdf	959506 f30a0cab206edf2bec27379121dde4b68585c1a0	no	16
<b>Warnings:</b>					
<b>Information:</b>					
48	NPL Documents	Chen-Meyers1982JFoodSciVol47pp892-896.pdf	197011 58b4e495e50de7ac427467d11d70e5d4ad6ad60c	no	6
<b>Warnings:</b>					
The page size in the PDF is too large. The pages should be 8.5 x 11 or A4. If this PDF is submitted, the pages will be resized upon entry into the Image File Wrapper and may affect subsequent processing					
<b>Information:</b>					
49	NPL Documents	Clarke1980.pdf	1300027 0056c751110ea995607895d071c4fd5741c1d403	no	4
<b>Warnings:</b>					
<b>Information:</b>					
50	NPL Documents	Czczuga1974MarineBiology.pdf	347285 9477e179192b77837b81ab709918bbb0a2f4797	no	6
<b>Warnings:</b>					
<b>Information:</b>					
51	NPL Documents	DeRitter1981AcademicPress815-882.pdf	1307373 1176e1b065f16c610a3ce3f77266b4ebcdce1500	no	70
<b>Warnings:</b>					
The page size in the PDF is too large. The pages should be 8.5 x 11 or A4. If this PDF is submitted, the pages will be resized upon entry into the Image File Wrapper and may affect subsequent processing					
<b>Information:</b>					
52	NPL Documents	DEUTCH1995EurJClinNutr.pdf	504794 581e281c1efad1afb52dc6f553e02e79ab1a0851	no	11
<b>Warnings:</b>					
<b>Information:</b>					
53	NPL Documents	DIEZ2003EURJENDOCRIL.pdf	99839 7b5ecee986ddc21a589f0c42904e52ee07ec2f58	no	8
<b>Warnings:</b>					
<b>Information:</b>					
54	NPL Documents	Emodi1978.pdf	614241 373808bd3dd9286f1d994260468d956ca508585	no	8
<b>Warnings:</b>					

The page size in the PDF is too large. The pages should be 8.5 x 11 or A4. If this PDF is submitted, the pages will be resized upon entry into the Image File Wrapper and may affect subsequent processing

**Information:**

55	NPL Documents	FELIX-VALENZUELA2001.pdf	290840	no	14
			835797bb9ad332cac89c430720daed54472e8570		

**Warnings:**

The page size in the PDF is too large. The pages should be 8.5 x 11 or A4. If this PDF is submitted, the pages will be resized upon entry into the Image File Wrapper and may affect subsequent processing

**Information:**

56	NPL Documents	Fox1941.pdf	291204	no	16
			70e85e477711be02c4e9c1e488d07ec328bd900b		

**Warnings:**

The page size in the PDF is too large. The pages should be 8.5 x 11 or A4. If this PDF is submitted, the pages will be resized upon entry into the Image File Wrapper and may affect subsequent processing

**Information:**

57	NPL Documents	Fricke1984.pdf	195109	no	9
			53401eed6567b183c0d9da5aa0fa7ed8effbd687		

**Warnings:**

The page size in the PDF is too large. The pages should be 8.5 x 11 or A4. If this PDF is submitted, the pages will be resized upon entry into the Image File Wrapper and may affect subsequent processing

**Information:**

58	NPL Documents	GEUSENS1994ArthritisRheum.pdf	744430	no	8
			d01b78b441c484bd112687192351b8062957b92f		

**Warnings:**

**Information:**

59	NPL Documents	Gilchrist1960.pdf	2217750	no	21
			3de01800e44c617318d4ca886d2ab8f38213f55c		

**Warnings:**

**Information:**

60	Information Disclosure Statement (IDS) Filed (SB/08)	14409US5updated_IDS.pdf	617936	no	13
			34f8b8635cb262b18a87fc2f39c79f919dfdd5db		

**Warnings:**

**Information:**

<b>Total Files Size (in bytes):</b>			32067105		
-------------------------------------	--	--	----------	--	--

**This Acknowledgement Receipt evidences receipt on the noted date by the USPTO of the indicated documents, characterized by the applicant, and including page counts, where applicable. It serves as evidence of receipt similar to a Post Card, as described in MPEP 503.**

**New Applications Under 35 U.S.C. 111**

**If a new application is being filed and the application includes the necessary components for a filing date (see 37 CFR 1.53(b)-(d) and MPEP 506), a Filing Receipt (37 CFR 1.54) will be issued in due course and the date shown on this Acknowledgement Receipt will establish the filing date of the application.**

**National Stage of an International Application under 35 U.S.C. 371**

**If a timely submission to enter the national stage of an international application is compliant with the conditions of 35 U.S.C. 371 and other applicable requirements a Form PCT/DO/EO/903 indicating acceptance of the application as a national stage submission under 35 U.S.C. 371 will be issued in addition to the Filing Receipt, in due course.**

**New International Application Filed with the USPTO as a Receiving Office**

**If a new international application is being filed and the international application includes the necessary components for an international filing date (see PCT Article 11 and MPEP 1810), a Notification of the International Application Number and of the International Filing Date (Form PCT/RO/105) will be issued in due course, subject to prescriptions concerning national security, and the date shown on this Acknowledgement Receipt will establish the international filing date of the application.**



IN THE UNITED STATES PATENT AND TRADEMARK OFFICE

In re Application of:	Inge Bruheim, et al	Confirmation:	1945
Serial No.:	12/057,775	Group No.:	1636
Filed:	03-28-2008	Examiner:	TBD
Entitled:	<b>BIOEFFECTIVE KRILL OIL COMPOSITIONS</b>		

INFORMATION DISCLOSURE STATEMENT LETTER

EFS Web Filed  
Commissioner for Patents  
P.O. Box 1450  
Alexandria, VA 22313-1450

Sir or Madam:

The citations listed in the attached **IDS Form SB08A** may be material to the examination of the above-identified application, and are therefore submitted in compliance with the duty of disclosure defined in 37 C.F.R. §§ 1.56 and 1.97.

Applicants wish to bring to the Examiner’s attention that we are not providing copies of US Patents as instructed under 37 CFR 1.98(a)(2). The Examiner is requested to make these citations of official record in this application.

This Information Disclosure Statement under 37 C.F.R. §§ 1.56 and 1.97 is not to be construed as a representation that a search has been made, that additional information material to the examination of this application does not exist, or that any one or more of these citations constitutes prior art.

Applicants wish to bring to the Examiner’s attention that some references cited in this Information Disclosure Statement were listed on the International Search Report dated 07/16/2008 for International Application No. PCT/GB2008/001080, filed 03/28/2008; as well as the Examiner’s Report dated 06/11/2010 for Australian Patent Application No. 2008231570, filed 03/28/2008.

The Commissioner is hereby authorized to charge any required fees or credit any overpayments to Attorney Deposit Account No.: **50-4302**, referencing Attorney Docket No.: **NATNUT-14409/US-5/ORD**.

Dated: March 3, 2011

/J. Mitchell Jones/  
J. Mitchell Jones  
Registration No. 44,174  
CASIMIR JONES, S.C.  
2275 Deming Way, Suite 310  
Middleton, WI 53562  
608.662.1277

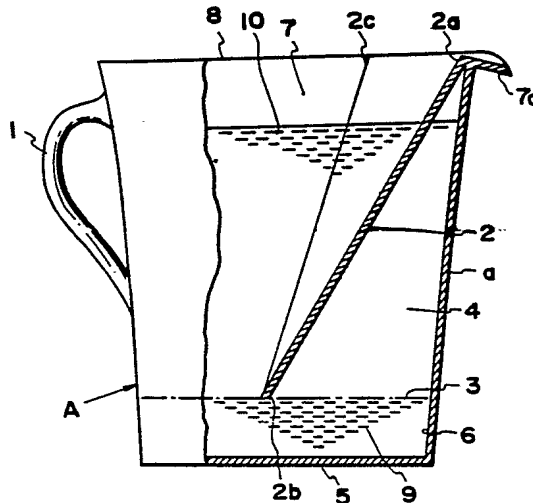


特許協力条約に基づいて公開された国際出願

<p>(51) 国際特許分類<sup>4</sup> A47J 43/28</p>	<p>A1</p>	<p>(11) 国際公開番号 WO 87/ 01265</p> <p>(43) 国際公開日 1987年3月12日 (12.03.87)</p>
<p>(21) 国際出願番号 PCT/JP86/00438                  (22) 国際出願日 1986年8月27日 (27. 08. 86)                  (31) 優先権主張番号 特願昭60-192480                  (32) 優先日 1985年8月31日 (31. 08. 85)                  (33) 優先権主張国 JP                  (71) 出願人: および                  (72) 発明者                  佐藤忠義 (SATO, Tadayoshi) [JP/JP]                  〒116 東京都荒川区町屋4丁目32番13号 Tokyo, (JP)                  (74) 代理人                  弁理士 佐々木秋市 (SASAKI, Akiichi)                  〒160 東京都新宿区西新宿1丁目3番3号榎本ビルディング 4階                  Tokyo, (JP)                  (81) 指定国                  DE, DE (欧州特許), DE (補助的実用新案), FR (欧州特許),                  GB (欧州特許), GB, IT (欧州特許), KR, US.                  添付公開書類 国際調査報告書</p>		

(54) Title: FILTER FOR TEMPURA OIL (SALAD OIL)

(54) 発明の名称 てんぷら油の濾過装置



(57) Abstract

A filter for tempura oil comprises a transparent vessel that is graduated to regulate the amount of water. An oil bath part and a water bath part are formed on the upper and lower sides of the graduation line. The oil bath part formed over the graduation line is provided with a liquid storage part separated by a partitioning wall protruded from the inner surface of the oil bath part to control the water not to flow into the oil bath part when the oil is drained. Impurities in the used oil are made to precipitate in the water in the water bath part, and the purified oil is made usable again.

(57) 要約

容器は透明であり、容器内部には水量を規制する目盛線を施してこの目盛線の上下に油槽室と水槽室とを区分し、かつ、目盛線より上方の油槽室に容器内面から突出した仕切壁で油を排出するときに油槽室に移動する水を規制し、貯める貯液室を設け、投入した使用油の不純物を水槽室の水に沈下させ浄化した油を再び使用可能にするてんぷら油等の濾過装置。

情報としての用途のみ

PCTに基づいて公開される国際出願のパンフレット第1頁にPCT加盟国を同定するために使用されるコード

AT	オーストリア	FR	フランス	VL	マリ
AU	オーストラリア	GA	ガボン	MR	モーリタニア
BB	バルバドス	GB	イギリス	MW	マラウイ
BE	ベルギー	HU	ハンガリー	NL	オランダ
BR	ブラジル	IT	イタリア	NO	ノルウエー
BG	ブルガリア	JP	日本	RO	ルーマニア
CF	中央アフリカ共和国	KP	朝鮮民主主義人民共和国	SD	スーダン
CG	コンゴ	KR	大韓民国	SE	スウェーデン
CH	スイス	LI	リヒテンシュタイン	SN	セネガル
CM	カメルーン	LK	スリランカ	SU	ソビエト連邦
DE	西ドイツ	LU	ルクセンブルグ	TD	チャード
DK	デンマーク	MC	モナコ	TG	トーゴ
FI	フィンランド	MG	マダガスカル	US	米国

## 明 細 書

## てんぷら油の濾過装置

## 技術分野

この発明はてんぷら、その他の揚物に使用された油から過酸化物及び臭い不純物等の汚れを水により分解、洗浄するてんぷら油等の濾過装置に関する。

## 背景技術

てんぷら、その他の揚物に一度使用された油は網体や濾過面を通して保存容器（油こし器）に保存され何度かくり返し使用される。油こし器の例は実公昭54-29584号に示され、こし網上に敷いた濾紙の上に更に載せる手網を備えたものが知られている。このように従来使用油は濾紙を使用して濾過して再使用しているが、いかに目の細かい濾紙を使用しても小さなカーボン、過酸化物、及び臭い不純物などの汚れは残り、何度か使用している間に色は黒くなり、酸化は著しく進んでしまう。このような油で揚げた揚物を食すると胸やけや吐気、頭痛などの現象が起こる。そこで本発明は水と油の分離性を利用して使用油から完全に小さなカーボンを取り除く事により油を透明に保ち酸化促進を遅らせ、油の再使用できる経済性を高めることを目的とする。又、本発明は濾過網や濾紙の濾過部品を省略して簡易に取扱いできる簡易構造の濾過容器を提供することを目的とする。

## 発明の開示

本発明は透明の濾過容器で底面から一定高さ位置に水量の

目盛線を設け、当該目盛線より上方の容器内部に内周面から突出した内壁で仕切られ、かつ、容器底に向けて開口した貯液室を設け、容器の目盛線の下方に水を、同上方に使用油を分離収容し、油中のカーボン等の不純物を水中に沈下せしめて水による濾過を行なうものである。これにより油を透明に保ち酸化促進を遅らせることができる。

#### 図面の簡単な説明

第1図はこの発明に係る好ましい濾過装置の断面を示す図であり、第2図は不純物を分離させ油のみを他の容器に移しかえる使用状態の濾過装置の断面図を示す図であり、第3図から第7図は内壁を変形した他の実施例の濾過装置の断面を示す図であり、第8図は内壁を有しない他の実施例の濾過装置の側面図である。

#### 発明を実施するための最良の形態

本発明をより詳細に述べるために以下添付図面に従つてこれを説明する。

第1図は濾過装置の容器の一部を切欠いて断面構造を示したもので、容器本体aは家庭で使用するに便利な握り部1をもつコップ形を示しているが、業務用に使用する場合は同一構成で大型に形成するものである。

濾過装置Aの容器本体aは透明素材でつくられた透明容器であり、底面5から一定の高さ位置に目盛線3を施し、容器内部を前記目盛線3の上方の油槽室7と、同下方の水槽室6とに区分する。目盛線3は水槽室6の水量を規制する。7aは油槽室7の注出部で容器Aの上面開口部の外周からくちば

し状に突出させる。注出部 7 a の巾中央には凹んだ流路を設けることもある。2 は油槽室 7 を部分的に横切る仕切壁で、この壁 2 により水槽室 6 の上部に大きな室である油槽室 7 と水槽室 6 より少し大きい収容室である貯液室 4 とを区分形成する。

仕切壁 2 の上端縁 2 a は前記注出部 7 a の内端に接続し、かつ、容器本体 A の上面開口部 8 の円周に沿って円弧状につながっている。仕切壁 2 の巾方向の外縁 2 c は容器本体 a の内周面に沿って下がる。仕切壁 2 の下端縁 2 b は目盛線 3 とほぼ同一平面上に位置づけ、かつ、油槽室 7 のほぼ中心部まで突出させて仕切壁 2 を傾斜面に形成する。仕切壁 2 と容器本体 a の外周面でかこまれた貯液室 4 は水槽室 6 側に開口する。かくして容器本体 a の水槽室 6 に目盛線 3 まで水 9 を満たし、次に汚れた油を油槽室 6 に投入すると比重の関係で油は水に浮いて水と混入する事はなく水と油が分離した状態で安定する。油に混入しているカーボン等の不純物は落下して水槽室 6 の水 9 に沈む。顕微鏡で覗くと目に見えないような小さなカーボンが静かに水に落下して様子を見ることが出来る。このようにして不純物を除去した油は透明になり、第 2 図に示すように容器本体 a を貯液室 4 側に低く傾ければ水 9 は水槽室 6 から貯液室 4 に移動して貯えられ、洗浄された油のみを油槽室 7 から他の保存容器 B にとり出すことができる。不純物を混入した水はその後に廃棄すれば良い。

第 3 図から第 7 図は他の実施例の濾過装置の一部を切欠いた断面図で仕切壁 2 及び貯液室 4 を変形した構造例を示す。

第 3 図においては仕切壁 2 は目盛線 3 より所定間隔をあけて上方に油槽室 7 の内周面から水平に突出し平面上半月板の形状を呈する。水槽室 6 から移動する水は仕切壁 2 で規制され、水槽室 6 の一部と所定間隔の空所の貯液室 4 に貯められる。

第 4 図、第 5 図は貯液室 4 を水平部 2 c と垂直部 2 d との内壁 2 で区分し、垂直部 2 d の下端を目盛線 3 に近設した。

第 6 図、第 7 図は容器本体 a の外周面自体を凹入したものを示している。

第 8 図は濾過装置 A の容器本体 a が大型の場合で、仕切壁を設けないうで目盛線 3 直上にコック C を設けて浄化された油を抜きとりできるようにした。

以上のようにこの発明は水と油の特性に着目し、容器本体 a の下部の水槽室 6 に水を入れ、上部の油槽室 7 に使用した油 10 を投入し、油中の不純物を水に落下させて浄化することができる。

#### 産業上の利用可能性

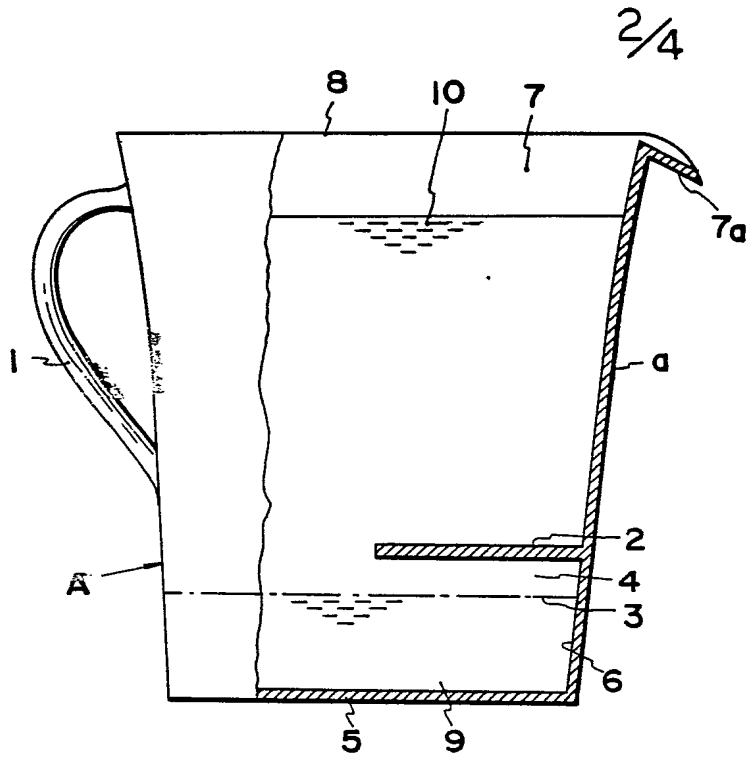
以上のようにこの発明に係る濾過装置は、使用油から完全に小さなカーボン等の不純物を取り除く事により油を透明に保ち酸化促進を遅らせることができ、従つて使用油を節約できる経済上有用なものである。又、構造が極めて簡単であり、濾紙等を使用しないので取扱上便利であり、しかも確實、かつ、安定した濾過効率を有するものである。

## 請 求 の 範 囲

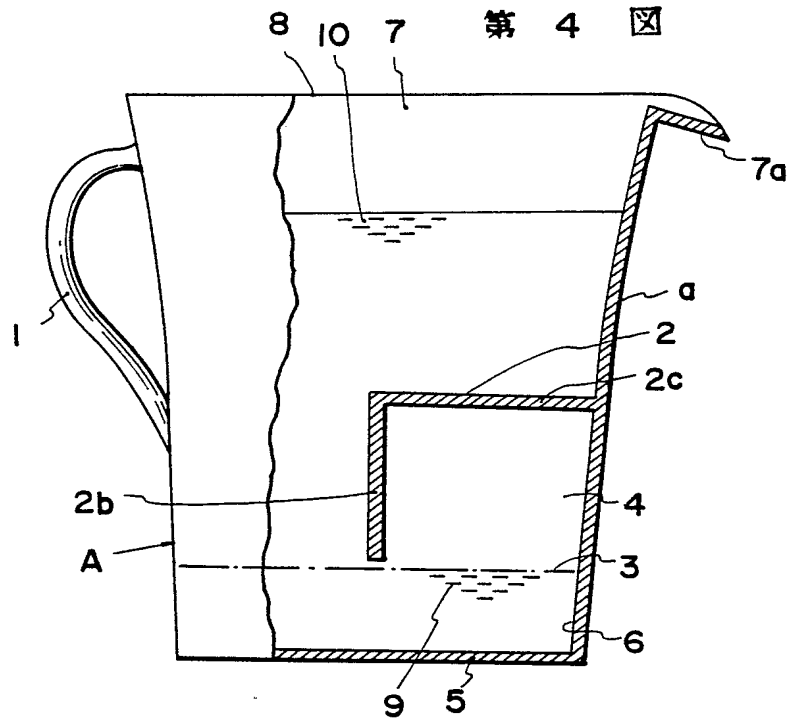
1. 透明な容器であつて、当該容器の外周面に底面から一定高さ位置に所定水量を規制する目盛線を施し、当該目盛線より下方に水槽室を、同上方に容器開口面に至る油槽室を連設して設け、水と使用された油とを目盛線の上下の槽に分離収容して油中のカーボン等不純物を水に沈下せしめ、かつ、前記油槽室に容器内面から内壁を突出し、この内壁にかこまれた貯液室を前記油槽室側に閉じ水槽室側に開口して設け、容器を傾けるときの水槽室から移動する水を貯液室に貯め、水で洗浄した油を容器外部にとり出すことを特徴とするてんぷら油等の濾過装置。
2. 容器内部を容器開口部の内周縁から目盛線上の内部中央に至る内壁で仕切り、目盛線上の油槽室に並べて水槽室に開口する貯液室を設けたことを特徴とする請求の範囲第1項記載の貯液室。
3. 容器内部を目盛線より所定高さ位置で容器内面から内部中央まで水平に突出した内壁で仕切り、水槽室の一部分を含んで貯液室とした請求の範囲第1項記載の貯液室。





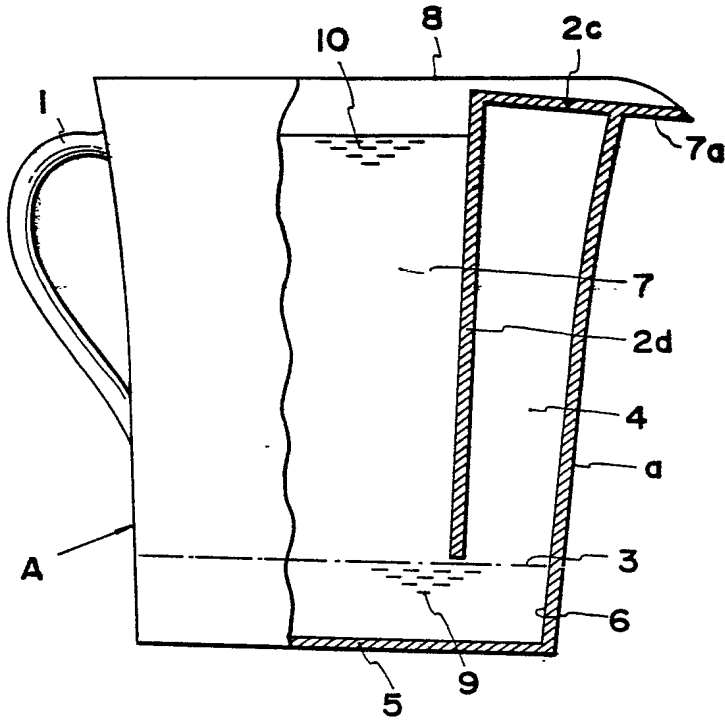


第 3 图

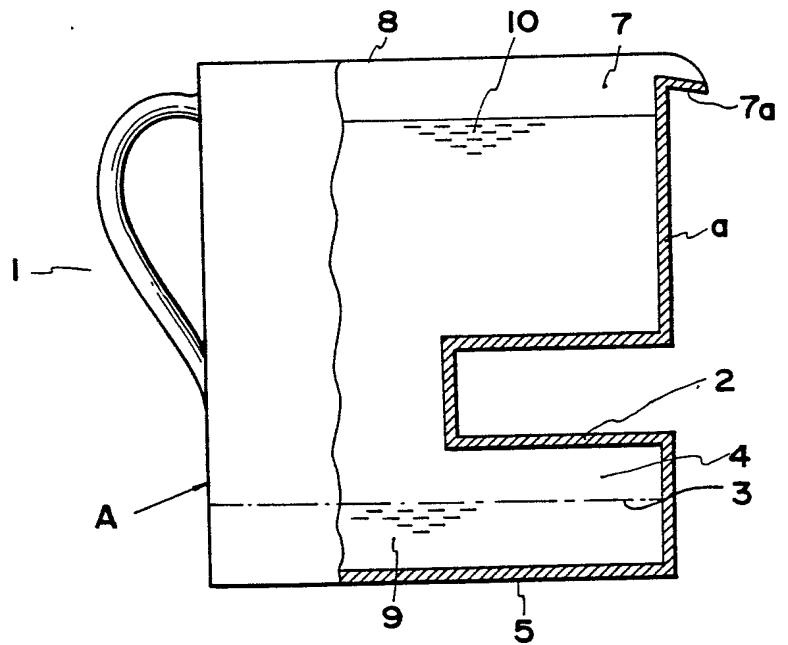


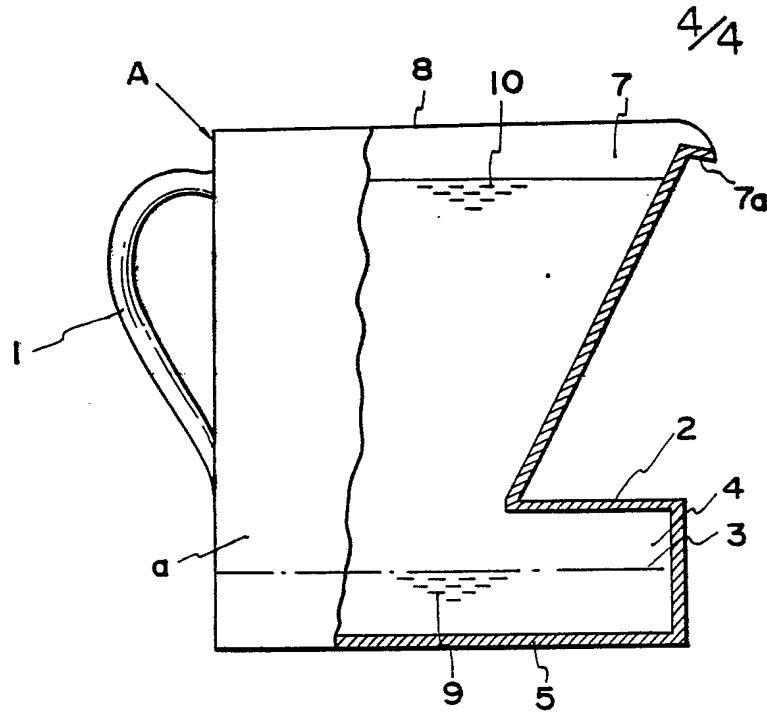
第 5 图

3/4



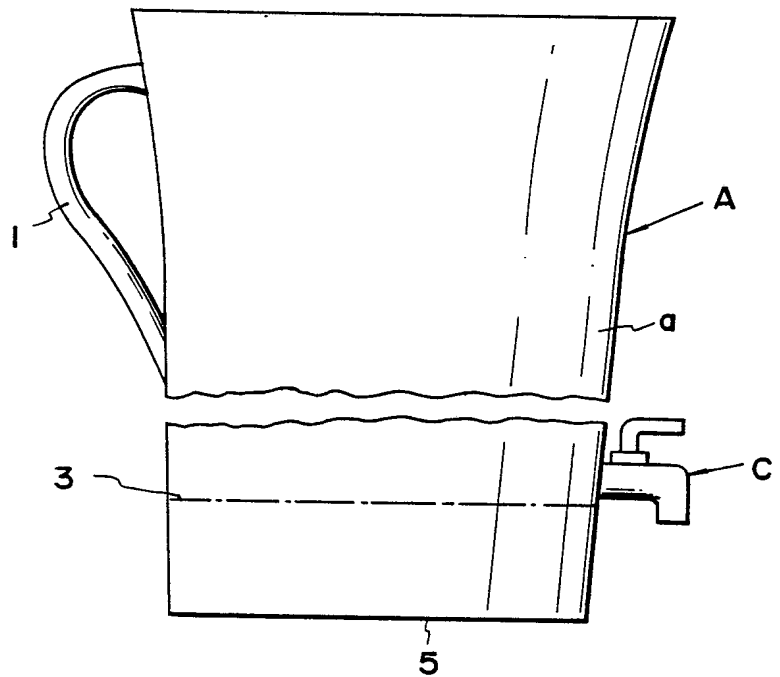
第 6 图





第 7 图

第 8 图



# INTERNATIONAL SEARCH REPORT

International Application No.

PCT/JP86/00438

<b>I. CLASSIFICATION OF SUBJECT MATTER</b> (if several classification symbols apply, indicate all) <sup>3</sup>		
According to International Patent Classification (IPC) or to both National Classification and IPC		
Int.Cl <sup>4</sup> A47J43/28		
<b>II. FIELDS SEARCHED</b>		
Minimum Documentation Searched <sup>4</sup>		
Classification System	Classification Symbols	
IPC	A47J43/28, B01D17/025-17/032	
Documentation Searched other than Minimum Documentation to the Extent that such Documents are Included in the Fields Searched <sup>4</sup>		
<b>III. DOCUMENTS CONSIDERED TO BE RELEVANT</b> <sup>14</sup>		
Category <sup>*</sup>	Citation of Document, <sup>16</sup> with indication, where appropriate, of the relevant passages <sup>17</sup>	Relevant to Claim No. <sup>18</sup>
Y	JP, U, 57-145348 (Nakama Fusamitsu) 10 March 1981 (10. 03. 81) (Family: none)	1-3
Y	JP, U, 56-151045 (Yoshizumi Tadao) 11 April 1980 (11. 04. 80) (Family: none)	1-3
Y	JP, U, 53-13967 (Okabe Magoichi) 14 July 1976 (14. 07. 76) (Family: none)	1-3
<p><sup>*</sup> Special categories of cited documents: <sup>14</sup></p> <p>"A" document defining the general state of the art which is not considered to be of particular relevance</p> <p>"E" earlier document but published on or after the international filing date</p> <p>"L" document which may throw doubts on priority claim(s) or which is cited to establish the publication date of another citation or other special reason (as specified)</p> <p>"O" document referring to an oral disclosure, use, exhibition or other means</p> <p>"P" document published prior to the international filing date but later than the priority date claimed</p> <p>"T" later document published after the international filing date or priority date and not in conflict with the application but cited to understand the principle or theory underlying the invention</p> <p>"X" document of particular relevance; the claimed invention cannot be considered novel or cannot be considered to involve an inventive step</p> <p>"Y" document of particular relevance; the claimed invention cannot be considered to involve an inventive step when the document is combined with one or more other such documents, such combination being obvious to a person skilled in the art</p> <p>"&amp;" document member of the same patent family</p>		
<b>IV. CERTIFICATION</b>		
Date of the Actual Completion of the International Search <sup>2</sup>	Date of Mailing of this International Search Report <sup>2</sup>	
November 12, 1986 (12.11.86)	December 1, 1986 (01.12.86)	
International Searching Authority <sup>1</sup>	Signature of Authorized Officer <sup>20</sup>	
Japanese Patent Office		

I. 発明の属する分野の分類		
国際特許分類 (IPC) <b>Int. Cl.</b> <b>A47J43/28</b>		
II. 国際調査を行った分野		
調 査 を 行 っ た 最 小 限 資 料		
分類体系	分類記号	
<b>IPC</b>	<b>A47J43/28, B01D17/025-17/032</b>	
最小限資料以外の資料で調査を行ったもの		
III. 関連する技術に関する文献		
引用文献の カテゴリー ※	引用文献名 及び一部の箇所が関連するときは、その関連する箇所の表示	請求の範囲の番号
<b>Y</b>	<b>JP, U, 57-145348 ( 中間房光 ) 10. 3月. 1981 ( 10. 03. 81 ) (ファミリーなし)</b>	<b>1-3</b>
<b>Y</b>	<b>JP, U, 56-151045 ( 吉住忠男 ) 11. 4月. 1980 ( 11. 04. 80 ) (ファミリーなし)</b>	<b>1-3</b>
<b>Y</b>	<b>JP, U, 53-13967 ( 岡部孫一 ) 14. 7月. 1976 ( 14. 07. 76 ) (ファミリーなし)</b>	<b>1-3</b>
<p>※引用文献のカテゴリー</p> <p>「A」 特に関連のある文献ではなく、一般的技術水準を示すもの                  「E」 先行文献ではあるが、国際出願日以後に公表されたもの                  「L」 優先権主張に疑義を提起する文献又は他の文献の発行日若しくは他の特別な理由を確立するために引用する文献 (理由を付す)                  「O」 口頭による開示、使用、展示等に言及する文献                  「P」 国際出願日前で、かつ優先権の主張の基礎となる出願の日の後に公表された文献</p> <p>「T」 国際出願日又は優先日の後に公表された文献であって出願と矛盾するものではなく、発明の原理又は理論の理解のために引用するもの                  「X」 特に関連のある文献であって、当該文献のみで発明の新規性又は進歩性がないと考えられるもの                  「Y」 特に関連のある文献であって、当該文献と他の1以上の文献との、当業者にとって自明である組合せによって進歩性がないと考えられるもの                  「&amp;」 同一パテントファミリーの文献</p>		
IV. 認 証		
国際調査を完了した日	<b>12. 11. 86</b>	国際調査報告の発送日 <b>01. 12. 86</b>
国際調査機関	日本国特許庁 (ISA/JP)	権限のある職員 <b>4 B 8 1 1 4</b> 特許庁審査官 <b>田 村 恵 理 子</b>

(11) (A) No. 1098900

(45) ISSUED 810407

(52) CLASS 260-129  
C.R. CL. 260-219;  
260-497

(51) INT. CL. <sup>2</sup> C07G 7/00, C08B 37/08

(19) (CA) **CANADIAN PATENT** (12)

(54) METHOD FOR THE PROCESSING OF KRILL TO PRODUCE PROTEIN,  
LIPIDS AND CHITIN

(72) Rogozhin, Sergei V.;  
Vainerman, Efim S.;  
Burmistrova, Ljubov M.;  
Davidovich, Jury A.;  
Ryashentsev, Vladimir J.;  
Kulakova, Valentina K.;  
Lagunov, Lev L.;  
Bykov, Vladimir P.,  
USSR

(73) Granted to Institut Elementoorganicheskikh Soedineny  
Akademii Nauk SSSR, USSR Vsesojuzny  
Nauchno-Issledovatel'sky Institut Rybnogo Khozyaistva  
I Okeanografii, VNIRO, USSR

(21) APPLICATION No. 293,095

(22) FILED 771214

No. OF CLAIMS 3 - NO DRAWING

DISTRIBUTED BY THE PATENT OFFICE, OTTAWA.  
CCA-274 (3-80)

293095

**1098900**

ABSTRACT OF THE DISCLOSURE

APR 7 1981

A<sup>1</sup>

The method for the processing of ~~krill~~<sup>krill</sup> to produce protein, lipids and chitin comprises emulsification of lipids by intensively stirring ~~krill~~<sup>krill</sup> in an aqueous medium. The resultant emulsion of lipids is separated from the ~~krill~~<sup>krill</sup> mass and from the ~~krill~~<sup>krill</sup> mass proteins are extracted at a pH of 10 to 12. The alkaline extract of proteins is separated from chitin integuments and protein is separated therefrom.



**1098900**

THE EMBODIMENTS OF THE INVENTION IN WHICH AN EXCLUSIVE PROPERTY OR PRIVILEGE IS CLAIMED ARE DEFINED AS FOLLOWS:

1. A method for the processing of krill to produce protein, lipids and chitin which comprises emulsification of lipids of krill in an aqueous medium; separation of the resultant emulsion of lipids from the krill mass; alkaline extraction of proteins from the krill mass at a pH of 10 to 12; separation of the alkaline extract of proteins from chitin integuments; separation of protein from the alkaline extract.

2. A method as claimed in claim 1, wherein emulsification is carried out in the presence of mineral salts.

3. A method as claimed in claim 1, wherein emulsification is carried out at a pH of the medium of 4.5 to 5.0.



METHOD FOR THE PROCESSING OF KRILL  
TO PRODUCE PROTEIN, LIPIDS AND CHITIN

The present invention relates to methods for the processing of krill to produce protein, lipids and chitin. Krill is a prospective source of food protein and other practically useful products such as chitin and lipids which find wide application in different branches of the national economy -- the food industry, textile and paint and varnish industry, in agriculture and medicine.

Known in the art is a method for the production of a proteinaceous nutritive substance from krill residing in comminuting and pressing fresh or frozen and then defrosted krill. The liquid separated during pressing is heated for 10 to 15 minutes at a temperature of 90 to 95°C for coagulation of proteins contained therein. The proteinaceous coagulate is separated from the broth by filtration or centrifugation to produce a mass which is used in the USSR under a trade name of the Okean protein paste.

A disadvantage of said method for the processing of krill is loss of nutritive substances, particularly protein, and an insufficiently full utilization of other components of krill. The broth containing a considerable amount of nutritive substances is not processed and is poured off. The yield of protein is 35 to 40%. It should be pointed out that the Okean paste is a perishable product and should be stored only when frozen at a temperature not exceeding -18°C for not more than 12 to 14 months. The thermally denatured protein contained in the Okean paste possesses low functional properties (foam-forming and gel-forming properties, a water-holding capacity, etc.) which makes its processing and use difficult.

The cake formed after pressing comprising a portion of the starting

proteins, lipids and chitin integuments can at present be processed and used only as feed meal.

Known in the art is a method for the production of a protein concentrate from frozen krill kept at a temperature of  $-20^{\circ}\text{C}$  comprising defrostation, comminution of krill, extraction with isopropanol with subsequent removal of the solvent, and drying under vacuum at  $70^{\circ}\text{C}$ .

Using the present method a proteinaceous concentrate is produced with a content of protein of 710 to 775%, lipids of 0.3%, and chitin of 5.8 to 6.4% (as calculated for dry substance). Said method has the following disadvantages. The use of organic solvent makes the production more difficult. In addition, the solvent itself and the process for the removal thereof may deteriorate the quality of the protein. The proteinaceous concentrate has a comparatively low content of protein and a high chitin content.

It is an object of the present invention to develop such a method for the processing of krill which would make it possible to produce protein, lipids and chitin with a high yield and quality.

The method for the processing krill to produce protein, lipids and chitin, according to the invention, is characterized in comprising emulsification of lipids of krill in an aqueous medium; separation of the emulsion of lipids from the krill mass; alkaline extraction of proteins from the krill mass at a pH of 10 to 12; separation of the protein extract produced from chitin integuments; separation of protein from the protein extract.

The invention makes it possible to obtain a protein product with a content of protein of up to 95% by weight as calculated for dry substance.

According to the invention, the first stage of the

processing of krill provides for extraction of lipids. This extraction of lipids is effected by emulsification using various techniques such as intensive stirring in an apparatus with a stirrer, or an ultrasonic method. Used as a medium in which emulsification is conducted is water or aqueous solutions of salts. To reduce losses of protein in the process of emulsification the pH of the emulsifying medium should be maintained within 4.5 to 5.0. In emulsification lipids are separated with a yield of up to 95% by weight.

10

The krill after separation of lipids therefrom is treated with an alkaline solution with a pH of 10 to 12 for extraction of proteins therefrom. A two-phase system is formed comprising an aqueous-alkaline solution containing protein, and a solid residue containing chitin integuments and other insoluble substances. The aqueous-alkaline solution containing protein is separated from the solid residue by filtration or centrifugation. Protein is separated from the resultant aqueous-alkaline solution by various methods, for example, by precipitation with alcohol or ultrafiltration, precipitation in the isoelectric point, or thermal coagulation. The isoelectric precipitation is carried out by food acids at a pH of 4 to 5. A curdled, easily settling precipitate of protein is formed which is separated and washed with 2 to 5 volumes of water. The washed precipitate is dried. As a result a product is obtained with a protein content of up to 95% by weight as calculated for dry substance.

20

Thus, the proposed method for the processing of krill makes it possible to produce such valuable substances as protein, lipids and chitin.

30

The simple technology and the availability of the reactants used make the process commercially profitable.

For a better understanding of the present invention

examples are presented below.

Example 1

In an apparatus with a capacity of 10 l provided with a stirrer there is placed 1 kg of krill which is filled with water and stirred at 1,000 rpm for 0.3 hour. The resultant emulsion of lipids is separated from the krill mass by filtration through a stainless steel screen having a mesh size of 1x1 mm. The krill mass is transferred to the vessel with a stirrer into which there is added 3 l of an aqueous solution of NaOH of such a concentration as to reach a pH of the mixture of 10 and stirred for half an hour. When krill is treated with alkali extraction of proteins takes place. The resultant extract of proteins is separated from the insoluble residue of chitin integuments by filtration through a metal screen with a mesh size of 1x1 mm and centrifuged at 25,000 rpm for 0.15 hour to remove impurities. To the purified extract of proteins there is added while stirring a 1-mole solution of HCl to reach a pH of 4.5, protein being precipitated. The precipitate is left to settle for 3 hours, thereafter it is separated from the liquid, washed with 3 liters of water and dried lyophilically. The protein product obtained in an amount of 50 g is a pale-pink odorless powder, having a moisture content of 10% by weight and comprising 85% by weight of protein and 2% by weight of lipids.

The residue of krill produced after separation of the extract of proteins is pressed to remove moisture and dried to produce 17 g of chitin integuments.

Example 2

The processing of krill is carried out in the same manner as in Example 1, except that emulsification of lipids is conducted in a 0.15 mole aqueous solution of sodium chloride at a pH of 4.5. The protein product obtained in an amount of 54 g has a moisture content of 12% and comprises 80% by weight of protein and 3% by weight of lipids.

chitin integuments.

Examples 3

The processing of krill is conducted in the same manner as in Example 1, except that emulsification of lipids is carried out for half an hour, and protein is precipitated from the alkaline extract by adding thereto a 1 mole solution of acetic acid. The resultant protein precipitate is washed with 5 volumes of water to produce 60 g of a protein product having a moisture content of 8% and comprising 85% by weight of protein, 5% by weight of lipids and 18 g of chitin integuments.

10

Example 4

The processing of krill is carried out in the same manner as in Example 1, except that precipitation of protein from the alkaline extract is conducted by adding thereto a 0.8 mole solution of sulfuric acid. The resultant precipitate of protein is washed with 3 volumes of water to produce 54 g of a protein product having a moisture content of 11% and comprising 80% by weight of protein and 5% by weight of lipids, and 24 g of chitin integuments.

20

Example 5

The processing of krill is conducted in the same manner as in Example 1, except that emulsification of lipids is conducted in an aqueous solution of salts -- 0.2 mole of NaCl; 0.03 mole of  $MgCl_2$ ; 0.01 mole of  $MgSO_4$ ; and 0.005 mole of  $CaSO_4$ .

The protein product obtained in an amount of 60 g has a moisture content of 10% and comprises 82% by weight of protein, 4.2% by weight of lipids, and 20 g of chitin integuments.

30

liquid, washed with 3 liters of water and dried lyophilically. The protein product obtained in an amount of 50 g is a pale-pink odorless powder, having a moisture content of 10% by weight and comprising 85% by weight of protein and 2% by weight of lipids.

A

The residue of ~~krill~~<sup>krill</sup> produced after separation of the extract of proteins is pressed to remove moisture and dried to produce 17 g of chitin integuments.

## Example 2

The processing of ~~krill~~<sup>krill</sup> is carried out in the same manner as in Example 1, except that emulsification of lipids is conducted in a 0.15 mole aqueous solution of sodium chloride at a pH of 4.5. The protein product obtained in an amount of 54 g has a moisture content of 12% and comprises 80% by weight of protein and 3% by weight of lipids, and 20 g of chitin integuments.

## Example 3

The processing of ~~krill~~<sup>krill</sup> is conducted in the same manner as in Example 1, except that emulsification of lipids is carried out for half an hour, and protein is precipitated from the alkaline extract by adding thereto a 1 mole solution of acetic acid. The resultant protein precipitate is washed with 5 volumes of water to produce 60 g of a protein product having a moisture content of 8% and comprising 85% by weight of protein, 5% by weight of lipids and 18 g

of chitin integuments.

Example 4

A

The processing of ~~krill~~<sup>krill</sup> is carried out in the same manner as in Example 1, except that precipitation of protein from the alkaline extract is conducted by adding thereto a 0.8 mole solution of sulfuric acid. The resultant precipitate of protein is washed with 3 volumes of water to produce 54 g of a protein product having a moisture content of 11% and comprising 80% by weight of protein and 5% by weight of lipids, and 24 g of chitin integuments.

Example 5

The processing of ~~krill~~<sup>krill</sup> is conducted in the same manner as in Example 1, except that emulsification of lipids is conducted in an aqueous solution of salts -- 0.2 mole of NaCl; 0.03 mole of MgCl<sub>2</sub>; 0.01 mole of MgSO<sub>4</sub>; and 0.005 mole of CaSO<sub>4</sub>.

The protein product obtained in an amount of 60 g has a moisture content of 10% and comprises 82% by weight of protein, 4.2% by weight of lipids, and 20 g of chitin integuments.





**EUROPEAN PATENT APPLICATION**

Application number : **94300599.1**

Int. Cl.<sup>5</sup> : **C07F 9/10, A61K 31/66,  
A61K 7/00, A23J 7/00,  
C07F 9/117**

Date of filing : **27.01.94**

Priority : **27.01.93 GB 9301629**

Representative : **Sturt, Clifford Mark et al  
J. MILLER & CO.  
34 Bedford Row  
Holborn  
London WC1R 4JH (GB)**

Date of publication of application :  
**03.08.94 Bulletin 94/31**

Designated Contracting States :  
**AT BE CH DE DK ES FR GB GR IE IT LI LU MC  
NL PT SE**

Applicant : **SCOTIA HOLDINGS PLC  
Efamol House  
Woodbridge Meadows  
Guildford Surrey GU1 1BA (GB)**

Inventor : **Horrobin, David Frederick, c/o Scotia  
Pharm. Ltd.  
Efamol House,  
Woodbridge Meadows  
Guildford, Surrey, GU1 1BA (GB)  
Inventor : McMordie, Austin, c/o Scotia Pharm.  
Ltd.  
Efamol House,  
Woodbridge Meadows  
Guildford, Surrey, GU1 1BA (GB)  
Inventor : Manku, Mehar Singh, c/o Scotia  
Pharm. Ltd.  
Efamol House,  
Woodbridge Meadows  
Guildford, Surrey, GU1 1BA (GB)**

**Formulations containing unsaturated fatty acids.**

A phospholipid comprising two different unsaturated fatty acids, the fatty acids being selected from the twelve n-6 and n-3 essential fatty acids, oleic acid, parinaric acid and combinic acid.

**EP 0 609 078 A1**

Unsaturated fatty acids, particularly the essential fatty acids (EFAs), shown in Table I below and certain others, have a range of possible medical uses.

Besides the essential fatty acids, there are more particularly oleic acid, parinaric acid and other fatty acids with conjugated double bonds, and columbinic acid, a fatty acid with non-conjugated bonds which, while not being an essential fatty acid, can correct many of the features of essential fatty acid deficiency. Parinaric acid is an 18:4 n-3 acid (9 cis, 11 trans, 13 trans, 15 cis); columbinic acid is an 18:3 n-6 acid (6, 9 cis, 13 trans).

The bodily conversions of the main series of EFAs appear in the table, which is:-

10

**TABLE 1**

15

n-6

n-3

20

18:2 delta-9,12  
(linoleic acid)

18:3 delta-9,12,15  
(alpha-linolenic acid)

delta-6 desaturase

25

18:3 delta-6,9,12  
(gamma-linolenic acid)

18:4 delta-6,9,12,15  
(stearidonic acid)

elongation

30

20:3 delta-8,11,14  
(dihomo-gamma-linolenic acid)

20:4 delta-8,11,14,17

delta-5 desaturase

35

20:4 delta-5,8,11,14  
(arachidonic acid)

20:5 delta-5,8,11,14,17  
(‘eicosapentaenoic acid’)

elongation

40

22:4 delta-7,10,13,16  
(adrenic acid)

22:5 delta-7,10,13,16,19

delta-4 desaturase

45

22:5 delta-4,7,10,13,16

22:6 delta-4,7,10,13,16,19  
(‘docosahexaenoic acid’)

50

The above pathways are not normally reversible nor, in man, are n-3 and n-6 series acids inter-convertible.

The acids, which in nature are of the all-cis configuration, are systematically named as derivatives of the corresponding octadecanoic, eicosanoic or docosanoic acids, e.g. delta-9, 12 octadecadienoic acid or delta-4, 7, 10, 13, 16, 19-docosahexaenoic acid, but numerical designations such as, correspondingly, 18:2 n-6 or 22:6 n-3 are convenient. Initials, for example, EPA for the 20:5 n-3 acid (eicosapentaenoic acid) or DHA for the 22:6 n-3 acid (docosahexaenoic acid), are also used but do not serve when n-3 and n-6 acids of the same chain length and degree of unsaturation exist as for example with the 22:5 acids. Trivial names in more or less common use in the n-6 series are as shown. Of the n-3 series only 18:3 n-3 has a commonly used trivial name,

alpha-linolenic acid, though the name stearidonic acid is coming into use for the 18:4 n-3 acid and the names eicosapentaenoic acid and docosahexaenoic acid as such are also used. The alpha isomer of linolenic acid was characterised earlier than gamma-linolenic acid and reference in the literature simply to linolenic acid, especially in the earlier literature, is to the alpha-acid.

Many of these fatty acids have actions which appear synergistic with one another. For example, gamma-linolenic acid (GLA) exerts one set of anti-inflammatory effects while eicosapentaenoic acid (EPA) exerts another set of anti-inflammatory effects. Many of the fatty acids are easily oxidised, while oleic acid exerts potent anti-oxidant effects. Arachidonic acid (AA) is an important constituent of cell membranes but can be harmful if converted to pro-inflammatory, pro-thrombotic and vasoconstrictor metabolites, such as thromboxane A<sub>2</sub> or leukotrienes: it is therefore useful to administer AA with a fatty acid which reduces its conversion to the harmful metabolites.

In most countries further, the guidelines for pharmaceutical products militate against ready acceptance of drugs which are mixtures of compounds, such as mixtures of fatty acids. It is therefore preferable to seek approval for single molecules.

It would therefore be desirable to have a vehicle, for administration of fatty acids, incorporating different fatty acids in the form of a single molecule, and we propose the use of phospholipids such as P-serine, P-choline, P-ethanolamine, or P-inositol (P-phosphotidyl), which have two sites at which fatty acids may be incorporated. Such phospholipids are close to the natural phospholipids and not therefore appropriate single molecules for delivery of two different fatty acids.

The invention thus makes use of phospholipids in which one site is occupied by one fatty acid and the other is occupied by a different fatty acid, particularly one which has an action additive to or synergistic with the first. The fatty acids may be prepared by chemical synthesis, or by extraction and purification from natural products, in each case by methods known in themselves, and may be incorporated into phospholipids by methods known in themselves.

The fatty acids to be used for preparation of the phospholipids are the twelve essential fatty acids shown in table 1, oleic acid, columbinic acid and parinaric acid.

Preferably there are present fatty acids selected from GLA, DGLA, AA, EPA and DHA.

Among fatty acids of particular interest are gamma-linolenic acid (GLA), dihomo-gamma-linolenic acid (DGLA), arachidonic acid (AA), eicosapentaenoic acid (EPA) and docosahexaenoic acid (DHA). Of particular interest therefore are phospholipids containing any of these particular fatty acids at both positions on the phospholipid, especially phospholipids containing the following pairs of fatty acids:-

- Gamma-linolenic acid (GLA) or dihomo-gamma-linolenic acid (DGLA) with arachidonic acid (AA)
- GLA or DGLA with eicosapentaenoic acid (EPA)
- GLA or DGLA with docosahexaenoic acid (DHA)
- AA with EPA
- AA with DHA
- EPA with DHA

Because of the inevitable limitations of the methods of synthesis and separation of the phospholipids, any phospholipid preparation made for use in pharmaceutical products or foods is likely in practice to be a mixture of different phospholipids. This invention therefore for preference covers situations in which the specified phospholipids make up at least 20%, preferably more than 40%, very preferably more than 70% and ideally more than 90% of the total phospholipid present.

The phospholipids may for example be used in the preparation of foods or skin care preparations or of pharmaceutical agents for oral, enteral, parenteral (intravenous, subcutaneous, intramuscular or any other such route), topical, rectal, vaginal or other route of administration. They may be desirably administered in pharmaceutical forms at doses of 1mg to 100g, preferably 100mg to 20g and very preferably 500mg to 4g of the specified phospholipid per day. When used in foods or preparations for enteral, parenteral or topical administration they may desirably be made into formulations containing by weight 0.01% to 60%, preferably 0.1% to 30% and very preferably 1% to 20% phospholipid of the specified phospholipid.

Suitable pharmaceutical dosage forms are for example a hard or soft gelatin capsule, a tablet, a pastille, a cream, a lotion or emulsions. A food may for example be a whip, a foam, a powder or a chocolate. For cosmetic use creams and the like may be used.

### **Synthetic routes to phospholipids**

Four classes of phospholipids are considered:

- I. phospholipid acids (PA)
- II. phosphatidylcholines (PC)

III. phosphatidylethanolamines (PE)

IV. phosphatidylserines (PS)

In all cases the target molecules are diacyl phospholipids .

Phospholipid synthesis can be divided into two approaches.

5 (i) phosphorylation first, then acylation

(ii) acylation first then phosphorylation

Phospholipid syntheses are usually considered as either partial synthetic routes or total synthetic routes. Partial synthesis takes advantage of naturally occurring phospholipids as starting materials while total synthesis usually starts with a glycerol derivative. For mixed acid phospholipid synthesis the second approach is  
10 generally more feasible.

### (I) Phosphatidic Acid Synthesis

#### (i) Phosphorylation step first

15

##### Method (a)

Glycerophosphatidic acid has been acylated with fatty acid anhydride in 60-80% yields. This route is suited to the synthesis of PA's with the same acyl group in both positions but may be adapted to mixed acid synthesis as for example at II (i)(a). Salts of the fatty acid in question are often added, to reduce the degree of cyclic phosphate formation and phosphate migration.

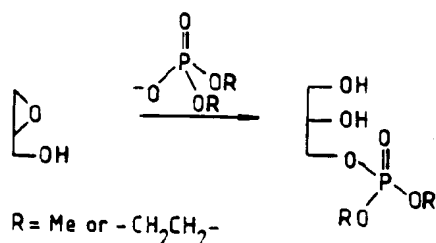
20

Glycerolphosphatidic acid has been prepared on a large scale (300g) by enzymatic phosphorylation of glycerol. The reaction, carried out in a fermenter, uses immobilised glycerol kinase, a catalytic amount of ATP and an enzymatic system for ATP regeneration. This is the most attractive route for the large scale production  
25 GPA.

Cyclic phosphate formation can be avoided if the phosphate group is in the form of a triester. GPA has been prepared by the reaction of sodium dihydrogen phosphate with glycidol and the following reaction may be used:-

30

35



40

The intermediate phosphotriester is then acylated with an acid chloride and conversion to the PA completed by removal of the phosphate protecting groups, for example by trimethylsilyl iodide.

##### Method (b)

45

PA's have been prepared in quantitative yield on a small scale by hydrolysis of PC's using phospholipase D (from *Streptomyces chromofliscus*).

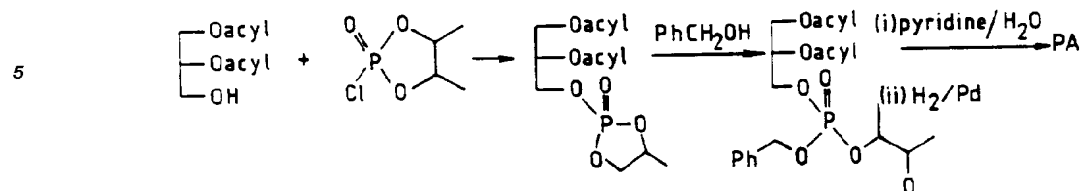
#### (ii) Acylation first

50

PA's have been prepared from the corresponding 1,2-diacylglycerol. This starting material is common to a number of the syntheses and method for its preparation are given below. The following are routes to the PA's using it.

55

## Method (a)



As given, this is suitable only for saturated acyl groups. However, choice of an alcohol other than benzyl alcohol expands the applicability of this route.

## Method (b)

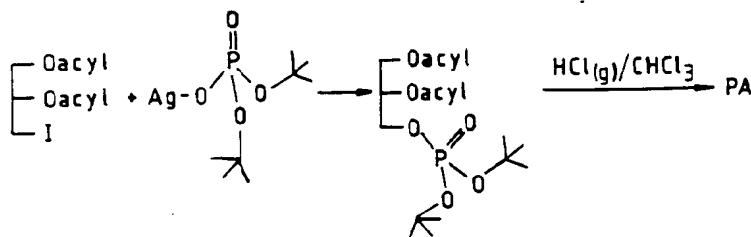
15

High yield (>90%) synthesis of PA is given by reaction of 1,2-diacylglycerol with  $\text{POCl}_3/\text{Et}_3\text{N}^6$ .

## Method (c)

20

25



30

This route solves the problem of acyl group migration provided the expense, and interaction of silver ions with polyunsaturated fatty acids, is acceptable.

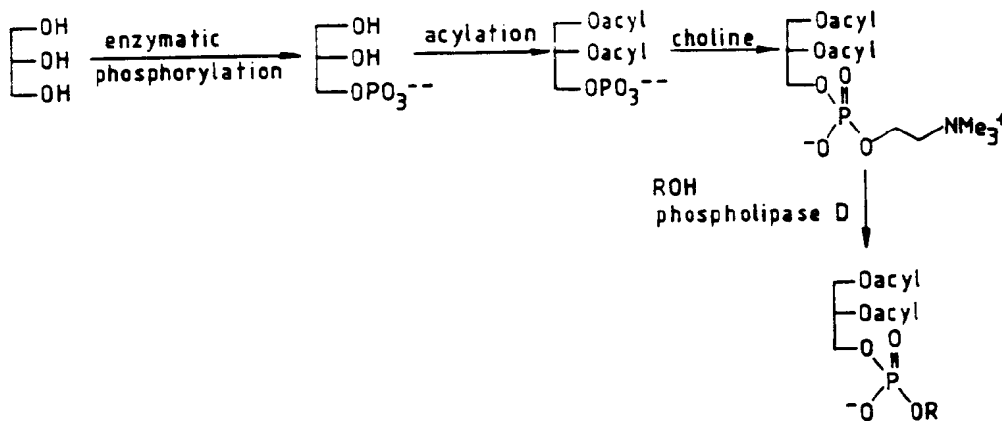
## Method (d)

35

40

45

50



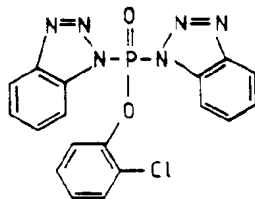
This gives same acid PA's, PC's and PS's as well as novel lipid phosphodiester. The initial phosphorylation uses glycerol as a starting material and produces glycerol phosphate (GPA) in good yields and in optically pure form. The method starts with the purification of GPA as a crystalline 4-N,N-dimethylaminopyridine salt and continues with acylation using fatty acid anhydride and conversion of the PA to PC. The final step is phospholipase D mediated transphosphatidyl reaction.

Method (e)

This uses a mild phosphorylating agent which does not lead to acyl group migration:-

5

10

(II) Phosphatidylcholine Synthesis

15

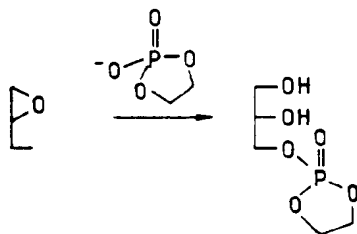
(i) Phosphorylation step firstMethod (a)

20

Glycerophosphatidyl choline has been acylated using a variety of yields ranging from 67 to 88%. The use of ultrasound reduces the reaction time. This route is limited to PC's with the same acyl group at C1 and C2. However, using any one of a number of phospholipase A<sub>2</sub> enzymes, followed by reacylation, mixed acid PC's can be prepared. Glycerophosphatidyl choline is commercially available and can also be readily prepared from egg yolk as a colourless crystalline cadmium chloride complex. A chemical synthesis is the opening of glycidol with a suitably protected phosphate.

25

30

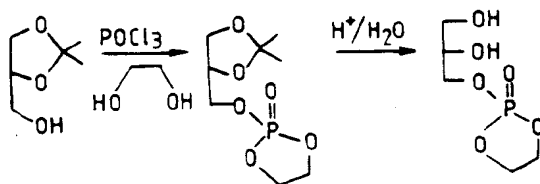


35

The phosphate diester is then acylated with fatty acid chloride and converted to PC by reaction with trimethylamine under anhydrous conditions. Alternatively, initial treatment with aqueous trimethylamine yields GPC which is then acylated as discussed above. This phosphotriester can also be easily prepared from solketal.

40

45



50

Alternatively, GPC can be prepared by reaction of solketal with phosphorus oxychloride followed by choline, with subsequent acid-catalysed removal of the acetonide group.

Method (b)

55

Synthesis of GPC or PC by the coupling of solketal or a 1,2-diacylglycerol and choline phosphate, the choline phosphate being prepared by enzymatic phosphorylation of choline.

Method (c)

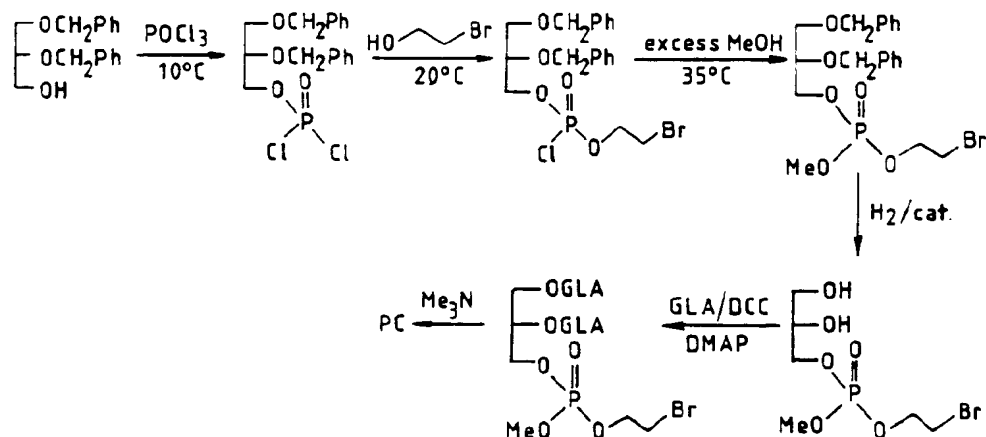
Cyclic phosphate formation is avoided by keeping the phosphate as a phosphotriester until a late stage. For example GPC protected as a triester is produced as follows:

5

10

15

20

Method (d)

PC's are prepared by exhaustive methylation of phosphatidylethanolamines.

25

Method (e)

PCs are prepared by reaction between PA's and choline under the influence of a phosphate activating agent as in II (i)(d) above. Trichloroacetonitrile and 2,4,6-triisopropylbenzenesulfonyl chloride can both be used.

30

Method (f)

Mixed acid PC's can be prepared by phospholipase  $A_2$ , mediated reacylation of lysophosphatidylcholine with oleic acid in toluene. Other acid derivatives and other reaction conditions can be used. Lipozyme can be used to mediate the selective esterification of GPC at the 1-position by an acid anhydride in 71% yield. For example in a synthesis comprising sequential use of these two enzymes.

35

(ii) Acylation first

40

There is a wide range of reagents for the conversion of a 1,2-diacylglycerol into a PC.

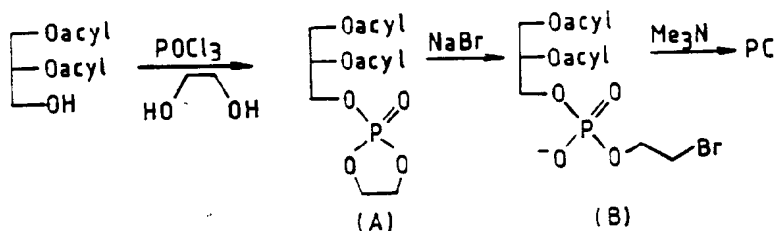
Method (a)

45

The simplest route is the reaction with phosphorus oxychloride followed by choline (as a chloride, tosylate or tetraphenylborate salt). A modification of this route is the use of ethane-1,2-diol in the place of choline and although this adds more steps to the synthesis, purification of the intermediate (A) is easier than direct PC purification.

50

55



Compound (A) can also be converted to a PC by reaction with trimethylamine. Preparation of mixed acid PC's involves phospholipase A<sub>2</sub> hydrolysis of (B) followed by reacylation with a second fatty acid anhydride in the presence of perchloric acid and subsequent treatment with trimethylamine. The function of the perchloric acid is to minimise acyl group migration. Reacylation of lysophosphatidylcholine is however chemically difficult because the hydroxyl group is very sterically crowded, which can lead to problems of acyl or phosphate migration under the forcing conditions needed for reacylation.

#### Method (b)

Phosphorylation with a suitably protected phosphoryl chloride to yield either intermediate (A) or (B) above is followed by reaction with trimethylamine.

#### Method (c)

This is the route as in II (i)(d) above

### (III) Phosphatidylethanolamine Synthesis

#### (i) Phosphorylation step first

##### Method (a)

Glycerophosphatidylethanolamine is commercially available, and though the amino group is an active nucleophile, thus interfering with the acylation step it can be used as a starting point for PE synthesis.

##### Method (b)

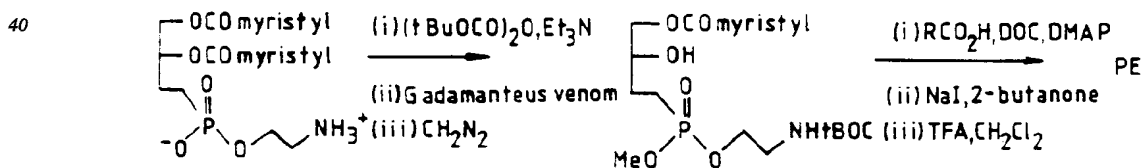
PE's are prepared from PC's by phospholipase D catalysed transphosphitylation.

##### Method (c)

Using 2,4,6-triisopropylbenzenesulfonyl chloride as an activating agent a protected form of ethanolamine is coupled to a PA. The protecting group subsequently removed.

##### Method (d)

Synthesis of mixed acid PE:-



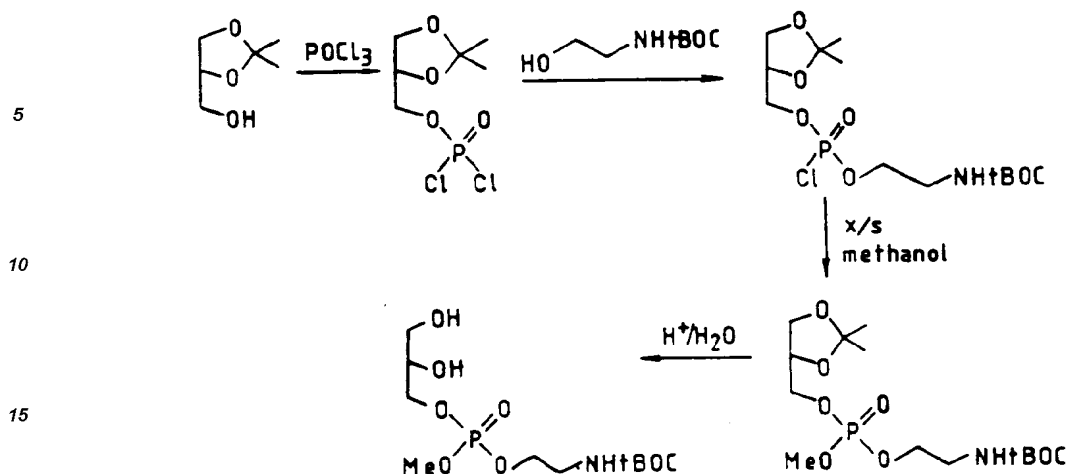
Protection of the phosphate as a methyl ester gives a good yield for acylation of the intermediate lysophosphatidylethanolamine.

##### Method (e)

A protected form of GPE is acylated. Starting from solketal, reaction with phosphorus oxychloride followed by N-protected ethanolamine and finally acid catalysed deacetonisation of the adduct yields protected GPE as a phosphodiester. An improvement to synthesis of protected GPE phosphoester as shown below:-

55





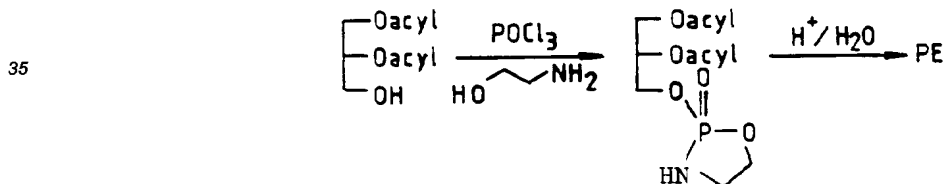
After acylation, removal of the methyl group is by using sodium iodide in butan-2-one.

Further, if N-t-BOC ethanolamine is O-phosphorylated it can be coupled (using either trichloroacetonitrile, DCC or 2,4,6-triisopropylbenzoyl chloride) with either a 1,2-diacylglycerol to yield a protected PE with solketal to yield (after removal of the acetonide group) protected GPE.

(ii) Acylation first

Method (a)

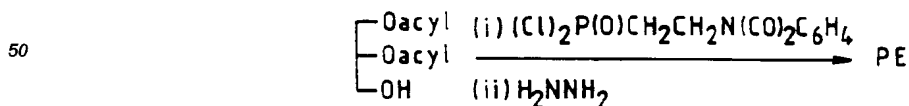
PE's can be prepared from 1,2-diacylglycerols by sequential addition of  $\text{POCl}_3$  and either ethanolamine or its N-t-BOC derivative. When free ethanolamine is used an oxazaphosphalane is formed. This is opened under very mild conditions (aqueous acetic acid; room temperature; 2h). The product PE precipitates from solution, thus making this method attractive for larger scale syntheses.



Method (b)

PE's have been prepared by reaction of glycerol iodohydrin diesters with a silver salt of a suitably protected ethanolaminephosphate. See PA synthesis method (c).

Method (c)



Method (d)

This is the route as in II (i)(d) above.

**(IV) Phosphatidylserine Synthesis****(i) Phosphorylation step first**5 **Method (a)**

Glycerophosphorylserine is commercially available. A protected form of GPS (N-phthaloyl derivative) has been prepared. After attachment of the acyl groups reaction with hydrazine yields PS.

10 **Method (b)**

PS has been prepared by enzyme-catalysed transphosphatidylation of PC in the presence of serine, phospholipase D (from Savoy cabbage leaves) in low yield. Using a *Streptomyces* phospholipase D preparation almost quantitative conversion is given.

15

**Method (c)**

Coupling of a PA and a protected serine derivative promoted by 2,4,6-triisopropylbenzenesulfonyl chloride yields PS's in 60-95% yields.

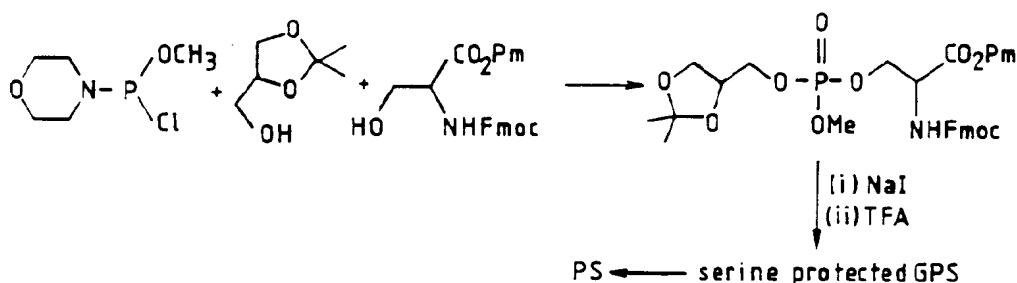
20

**Method (d)**

Glycerophosphatidylserine has been prepared from solketal using phosphoramidite methodology

25

30



35

**(ii) Acylation first****Method (a)**

40

Starting from a 1,2-diacylglycerol reaction with  $\text{POCl}_3$  followed by reaction of the intermediate phosphodichloridate with a protected serine derivative group PS's. Using a serine derivative protected only on the carboxyl group an intermediate oxazaphospholane is formed with undergoes facile cleavage.

**Method (b)**

45

This is the route as in II (i)(d) above.

**Preparation of 1,2-diacylglycerols**

50

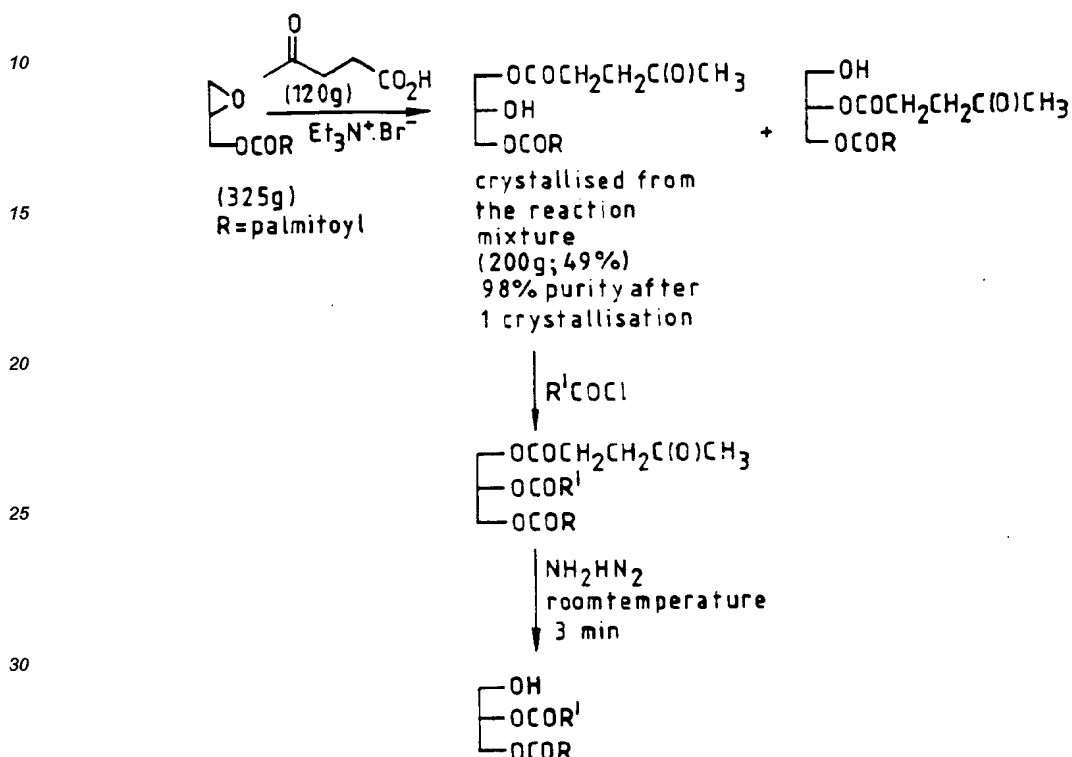
A requirement of phospholipid chemistry (and triglyceride chemistry) is the preparation of pure same-acid and mixed-acid 1,2-diacylglycerols, particularly large scale preparation. A problem is that 1,2-diglycerides tend to isomerise very easily to 1,3-diglycerides, complicating purification of the final phospholipid. There is wide variety of protecting groups that can be used. For example, the trityl group has been successfully used for small scale preparation of 1,2-diacylglycerols. It is removed under extremely mild conditions (column chromatography on silicic/boric acids) with the undesired sideproduct, triphenylmethanol, eluting before the diacylglycerol. An alternative procedure for the removal of the trityl group is reaction with boron trifluoride etherate, though triphenylmethanol has to be removed from the reaction product.

55

A very satisfactory route uses the levulinoyl protecting group. The route is as shown on the next page.

Very little acyl migration accompanies the deblocking procedure.

A second valuable protecting group is the tert-butyldimethylsilyl group. Removal of the silyl group using boron trifluoride-etherate is effected without problems of migration of the acetate group. The reaction is quenched with excess dry triethylamine, immediately adding the phosphorylating agent, thereby avoiding an aqueous work up.



Aqueous work up on a large scale allows time for acyl migration to occur. This particular silyl group is bulky enough to react with a 1-monoacylglycerol exclusively at the 3 position, whereas use of the trimethylsilyl group leads to a mixture of silythers at the 2 and 3 positions. The synthesis takes the following course:

- (i) reaction of RCO<sub>2</sub>H with glycidol to yield 1-monoacylglycerol
- (ii) reaction of the 1-monoacylglycerol with TBDMS-Cl to yield the 1-acyl-3-silyl glycerol
- (iii) reaction of this with R'COCl to yield 1-acyl-2-acyl'-3-silyl glycerol
- (iv) removal of the silyl group with BF<sub>3</sub>Et<sub>2</sub>O
- (v) quenching of excess boron trifluoride with excess triethylamine and reaction with the phosphorylating reagent of choice

### Synthesis of mixed acid phosphatidylcholines

#### Approach 1

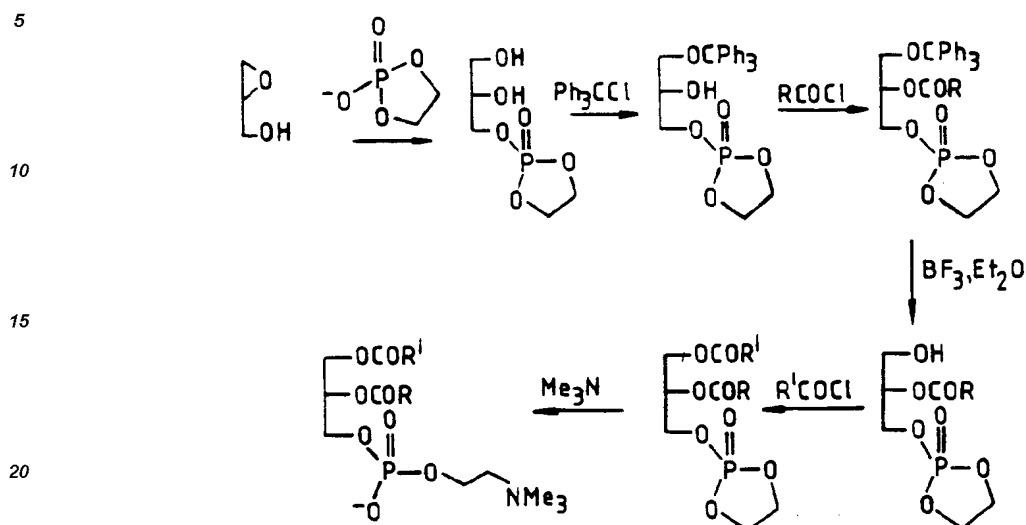
Regioselective hydrolysis of a same-acid diacylphosphatidylcholine with a phospholipase A<sub>2</sub> enzyme followed by reacylation with a different acid.

#### Approach 2

Phosphorylation of a pre-prepared 1,2-diacylglycerol. There is a wide range of methods for the small scale production of 1,2-diacylglycerols. Care needs to be taken to avoid formation of the 1,3-isomer as this complicates the purification of the final phosphatidylcholine.

Approach 3

The following:

Approach 4

25

Lipase mediated monoacylation (exclusively in the 1 position) of GPC has been reported using a vinyl ester of the desired fatty acid. The other product of this reaction is acetaldehyde which quickly evaporates out of the reaction mix. This means that under suitable conditions the lipase reaction is effectively irreversible.

Approach 5

30

Preparation of triglycerides by lipase catalysed exchange of the 1,3-acyl groups of a same-acid triglyceride with an excess of a fatty acid ester. This approach can be used to prepare a mixed acid phosphatidylcholine by starting with a same-acid PC and an excess of a simple ester of the desired fatty acid.

Synthesis of 1-(z,z,z-6,9,12-octadecatrienoyl)-2-(z-9-octadecenoyl)-rac-glycero-3-phosphocholine

35

(i) A mixture of solketal (3.3g, 25 mmol), tetrabutylammonium hydrogen sulfate (425mg, 1.25 mmol, 5 mol%), sodium hydroxide (6.0g, 150 mmol), 4-methoxybenzyl chloride (4.7g, 30 mmol), water (6 ml) and trans-1-2-dichloroethane (20ml) was stirred vigorously under reflux until tlc (10% acetone/hexane) showed the reaction to be complete (typically 3-7 hours). On completion the reaction mixture was cooled and diluted with water (20ml) and methylene chloride (20ml). The organic layer was separated and washed with water until the washings were neutral (4 x 30ml). The organic layer was dried ( $\text{MgSO}_4$ ) and concentrated to dryness. Purification by flash chromatography (8% acetone/hexane) yielded the fully protected glycerol as a colourless oil.

45

(ii) A mixture of the fully protected glycerol (vide supra) (1.0g), hydrochloric acid (1M, 10ml) and methanol (15ml) were stirred together at room temperature for 1 hour. (At this point the analysis (25 % ethyl acetate/hexane) showed complete disappearance of the starting material and the formation of one new spot corresponding to the product). The bulk of the solvent was removed, brine (20ml) was added and the product was extracted into methylene chloride (4 x 30ml). The combined extracts were dried ( $\text{MgSO}_4$ ) and concentrated to dryness. On standing under high vacuum the product crystallised. On one occasion it was purified by flash chromatography (3% methanol/methylene chloride) although this was not generally necessary. This monoprotected glycerol was the starting point for attachment of the fatty acids.

50

55

(iii) A solution of DCC (1.1g, 5.3 mmol) and DMAP (0.67g, 5.3mmol) in methylene chloride (10ml) was added to a solution of the monoprotected glycerol (1.0g, 4.7mmol) and GLA (98%, 1.24g, 4.4mmol) in methylene chloride (40ml) at  $0^\circ\text{C}$  under nitrogen. The reaction was stirred overnight, warming up to room temperature. As the reaction proceeded a precipitate of dicyclohexylurea formed. Hexane (60ml) was added to precipitate more dicyclohexylurea and the reaction was filtered and concentrated to dryness. Careful pur-

ification by flash chromatography (20% ethyl acetate/hexane) yielded the monoprotected 1-monoacylglycerol as a colourless oil. By tlc it was clear that it was not contaminated by any of the monoprotected 2-monoacylglycerol isomer.

(iv) A solution of DCC (0.72g, 3.45 mmol) and DMAP (0.36g, 2.92 mmol) in methylene chloride (10ml) was added to a solution of the monoprotected 1-monoacylglycerol (1.25g, 2.05 mmol) and OA (99%, 0.83g, 2.92 mmol) in methylene chloride (40ml) at room temperature under nitrogen. The reaction was stirred overnight. As the reaction proceeded to a precipitate of dicyclohexylurea formed. Hexane (60ml) was added to precipitate more dicyclohexylurea and the reaction was filtered and concentrated to dryness. Purification by flash chromatography (8% ethyl acetate/hexane) yielded the monoprotected diacylglycerol as a colourless oil.

(v) Bromodimethylborane (220 $\mu$ l, 2.2 mmol) was added by syringe to a solution of the monoprotected diacylglycerol (800mg, 1.1 mmol) in methylene chloride (20ml) at -78°C (external cooling by dry ice/acetone) under nitrogen. After 3 minutes at -78°C the reaction was quenched by the addition of diethyl ether (200ml). Tlc analysis (4% acetone/chloroform) indicated that the reaction had gone substantially towards completion. The mixture was washed with water (5 x 100ml), brine (100ml), dried (MgSO<sub>4</sub>) and concentrated to dryness. The product was used directly in the next step without any further purification.

(vi) A solution of the diacylglycerol (1.1 mmol) and triethylamine (210 $\mu$ l, 1.5 mmol) was cooled to 0°C. To this was added a solution of 2-chloro-1,3,2-dioxaphospholane-2-oxide (180mg, 1.25 mmol) in toluene (5ml). After 6 hours a further portion of the chlorophosphidate (150mg) was added and the mixture was stirred overnight, warming up to room temperature. Tlc analysis (20% ethyl acetate/toluene) showed almost complete disappearance of starting material and the formation of a new compound. The solvents were removed under reduced pressure and, after drying under vacuum at 45°C for several hours, the product was used directly in the next stage of the reaction.

(vii) A solution of trimethylamine in anhydrous acetonitrile (16g gas in 100ml) was prepared. The crude product from the previous step was dissolved in this solution (4ml) and transferred to a sealed tube. The tube was purged with nitrogen and heated at 65°C for 48 hours. The reaction was cooled. The mixture was two layers. The bottom layer was the phosphatidylcholine and the top layer solvent. The mixture was dissolved in chloroform, transferred to a round bottomed flask and concentrated to dryness. Purification by flash chromatography (chloroform: methanol: water 65:25:4) yielded the pure mixed acid phosphatidylcholine as a yellow waxy solid. Tlc analysis (chloroform: methanol: water 65:25:4) showed only one clean spot. A sample of the phospholipid was transmethylated and the fatty acid methyl esters determined by g.c.

#### **Synthesis of 1,2-di(z,z,z-6,9,12-octadecatrienoyl)-gn-glycerol-3-phosphocoline**

A mixture of crystalline L- $\alpha$ -glycerophosphorylcholine-cadmium chloride complex (from Sigma)(490mg; 1.1 mmol)(dried by evaporation from ethanol (2 x 30ml) and toluene (4x30ml), GLA acid chloride (890mg; 3 mmol) and 4-N,N-dimethylaminopyridine (370mg; 3 mmol) in methylene chloride (20ml) was stirred overnight under nitrogen at room temperature. Initially the reaction mixture was a dense suspension but after the overnight period it was an almost clear solution. Tlc analysis in two systems (1. chloroform/methanol/water: 65/25/4; 2. chloroform/methanol/ammonium hydroxide: 65/30/5) showed the presence of two new compounds. The major component had an R<sub>f</sub> value consistent with the desired product and the minor component was thought to be the corresponding lysophosphorylcholine. The reaction mixture was concentrated to dryness and suspended in methanol/chloroform/water : 5/4/1 (20ml). A dense white precipitate formed. The mixture was applied to a mixed resin ion exchange column (approximately 25ml each of Dowex 50x4-100 (H<sup>+</sup>form) and Dowex 1x2-100 (HO<sup>-</sup>form)). (This was to remove both the DMAP and the cadmium chloride). The phospholipid was eluted with methanol/chloroform/water : 5/4/1 (200ml) and the eluent was concentrated to dryness. Ethanol and toluene were added to aid complete removal of water. A solution of the crude mixture in methylene chloride was applied to a column of silica gel (20ml) which had previously been packed in methylene chloride. GLA was eluted with methylene chloride (250ml) and the product was then eluted with methanol/chloroform/water : 5/4/1. Fractions containing the pure product were pooled and concentrated. The residue was dissolved in methylene chloride, dried (magnesium sulfate), concentrated and finally dried under high vacuum. The product was a waxy solid which was homogenous by tlc analysis. At this stage no further analysis has been carried out. Yield = 310mg (86%).

An analogous procedure has been carried out using GLA acid and anhydride rather than GLA acid chloride. This gave a much better yield (72% with a 48 hour reaction period). However, this sample has not been used for testing.

5

10

15

20

25

30

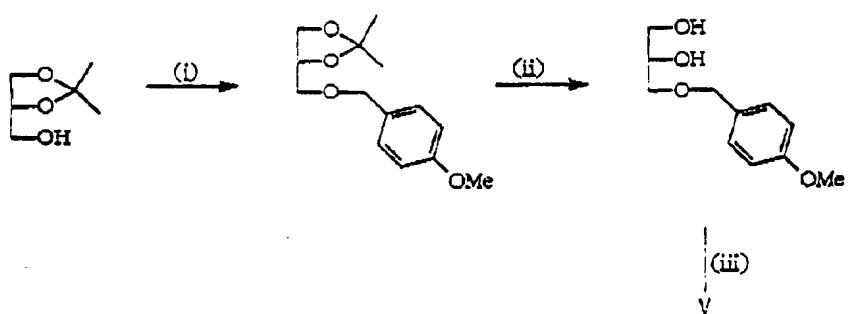
35

40

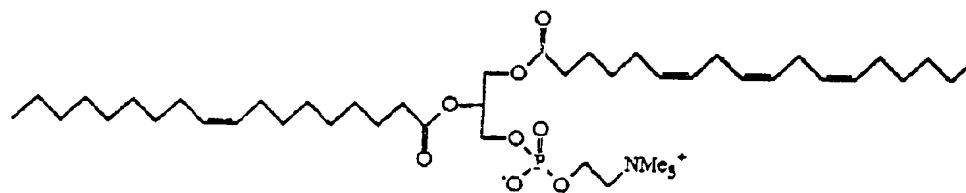
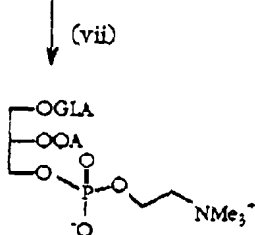
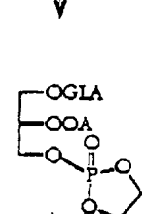
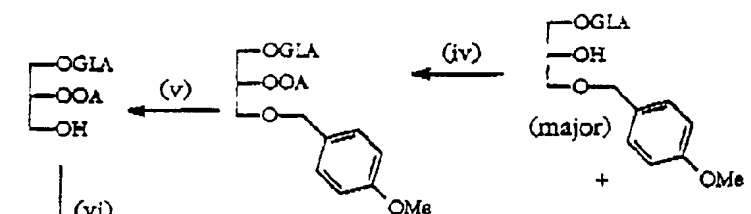
45

50

55



(iii)  
↓



1-(z,z,z-6,9,12-octadecatrienoyl)-2-(z-9-octadecenoyl)-rac-glycero-3-phosphocholine

**Claims**

- 5     **1.** A phospholipid comprising two different unsaturated fatty acids, the fatty acids being selected from the twelve n-6 and n-3 essential fatty acids, oleic acid, parinaric acid and columbinic acid.
- 2.** A phospholipid according to claim 1, wherein the fatty acids are selcted from GLA, DGLA, AA, EPA and DHA.
- 10    **3.** A phospholipid according to claim 1, wherein the fatty acids are in a combination selected from GLA or DGLA with AA, EPA or DHA; AA with EPA or DHA; and EPA with DHA.
- 4.** A phospholipid according to claim 1, 2 or 3, comprising serine, choline, ethanolamine or inositol.
- 15    **5.** A phospholipid according to any preceding claim when for therapeutic, nutritional or cosmetic use.
- 6.** A phospholipid according to claim 5 in the form of a composition in which the specified phospholipid forms, by weight, at least 20%, preferably more than 40%, very preferably more than 70% and ideally more than 90% of the total phospholipid present.
- 20    **7.** A phospholipid according to claim 5 in the form of a pharmaceutical or dietary composition suited to the administration of 1 mg to 100 g, preferably 100 mg to 20 g and very preferably 500 mg to 4 g of the specified phospholipid daily.
- 25    **8.** A phospholipid according to claim 5 in the form of a pharmaceutical, dietary or cosmetic composition comprising by weight 0.01 to 60%, preferably 0.2 to 30% and very preferably 1 to 20% of the specified phospholipid.

30

35

40

45

50

55



European Patent  
Office

EUROPEAN SEARCH REPORT

Application Number  
EP 94 30 0599

DOCUMENTS CONSIDERED TO BE RELEVANT			
Category	Citation of document with indication, where appropriate, of relevant passages	Relevant to claim	CLASSIFICATION OF THE APPLICATION (Int. Cl.5)
X	US-A-3 577 446 (SUMANAS RAKHIT) * the whole document *	1-8	C07F9/10 A61K31/66 A61K7/00 A23J7/00 C07F9/117
X	--- CHEMICAL ABSTRACTS, vol. 101, no. 3, 16 July 1984, Columbus, Ohio, US; abstract no. 023203, SCHMITZ B ET AL '1-trans-Parinaroyl phospholipids: synthesis and fast atom bombardment/electron impact mass spectrometric characterization' * abstract * & CHEM. PHYS. LIPIDS (CPLIA4,00093084);84; VOL.43 (2); PP.139-51 UNIV. BONN; INST. PHYSIOL. CHEM.; BONN; D-5300; FED. REP. GER. (DE)	1-4	
X	--- BIOCHEMISTRY (BICHAW,00062960);82; VOL.21 (22); PP.5685-9 WASHINGTON UNIV.;SCH. MED.; ST. LOUIS; 633110; MO; USA (US) Welti R et al 'Partition of parinaroyl phospholipid probes between solid and fluid phosphatidylcholine phases' * the whole document *	1-4	
X	--- BIOCHIM. BIOPHYS. ACTA (BBACAQ,00063002);82; VOL.713 (1); PP.73-9 UNIV. GUELPH; COLL. BIOL. SCI.; GUELPH; NIG 2W1; ON; CAN. (CA) Mahadevappa V G et al 'The molecular species composition of individual diacyl phospholipids in human platelets' * the whole document *	1-4	
The present search report has been drawn up for all claims			TECHNICAL FIELDS SEARCHED (Int.Cl.5)  C07F A61K A23J
Place of search THE HAGUE		Date of completion of the search 18 May 1994	Examiner Beslier, L
<p><b>CATEGORY OF CITED DOCUMENTS</b></p> <p>X : particularly relevant if taken alone                      Y : particularly relevant if combined with another document of the same category                      A : technological background                      O : non-written disclosure                      P : intermediate document</p> <p>T : theory or principle underlying the invention                      E : earlier patent document, but published on, or after the filing date                      D : document cited in the application                      I : document cited for other reasons                      .....                      &amp; : member of the same patent family, corresponding document</p>			

EPO FORM 1503 03.82 (P04C01)





European Patent  
Office

EUROPEAN SEARCH REPORT

Application Number  
EP 94 30 0599

DOCUMENTS CONSIDERED TO BE RELEVANT			
Category	Citation of document with indication, where appropriate, of relevant passages	Relevant to claim	CLASSIFICATION OF THE APPLICATION (Int.Cl.5)
X	BIOCHIM. BIOPHYS. ACTA (BBACAQ,00063002);92; VOL.1123 (1); PP.41-50 CENT. RECH. JOUY-EN-JOSAS;STN. RECH. NUTR.; JOUY-EN-JOSAS; FR. (FR) Menguy L et al 'Apparent relative retention of the phosphatidylethanolamine molecular species 18:0-20:5(n-3), 16:0-22:6(n-3) and the sum 16:0-20:4(n-6) plus 16:0-20:3(n-9) in the liver microsomes of pig on an essential fatty acid deficient diet***' * the whole document * ---	1-4	TECHNICAL FIELDS SEARCHED (Int.Cl.5)
X	J. NEUROCHEM. (JONRA9,00223042);90; VOL.55 (4); PP.1200-7 OREGON HEALTH SCI. UNIV.;DEP. MED.; PORTLAND; 97201; OR; USA (US) Lin D S et al 'Effects of dietary n-3 fatty acids on the phospholipid molecular species of monkey brain' * the whole document * ---	1-4	
X	BIOCHEM. CELL BIOL. (BCBIEQ,08298211);88; VOL.66 (11); PP.1163-8 UNIV. WEST. ONTARIO;DEP. BIOCHEM.; LONDON; N6A 5C1; ON; CAN. (CA) Ishinaga M et al 'Composition of phospholipid molecular species from mammary tumors' * the whole document * --- -/--	1-4	
The present search report has been drawn up for all claims			
Place of search THE HAGUE		Date of completion of the search 18 May 1994	Examiner Beslier, L
<b>CATEGORY OF CITED DOCUMENTS</b> X : particularly relevant if taken alone Y : particularly relevant if combined with another document of the same category A : technological background O : non-written disclosure P : intermediate document T : theory or principle underlying the invention E : earlier patent document, but published on, or after the filing date D : document cited in the application L : document cited for other reasons ..... & : member of the same patent family, corresponding document			

EPO FORM 1503 03.82 (POMC01)



European Patent  
Office

EUROPEAN SEARCH REPORT

Application Number  
EP 94 30 0599

DOCUMENTS CONSIDERED TO BE RELEVANT			
Category	Citation of document with indication, where appropriate, of relevant passages	Relevant to claim	CLASSIFICATION OF THE APPLICATION (Int.Cl.5)
X	BIOCHIM. BIOPHYS. ACTA (BBACAQ);76; VOL.450 (2); PP.210-24 UNIV. FLORENCE;INST. GEN. PATHOL.; FLORENCE; ITALY Fallani A et al 'Structural analysis of phosphatidylcholines of Yoshida ascites hepatoma and liver cells from host rats fed a control and an essential fatty acid-deficient diet***' * the whole document *	1-4	
Y	CHEMICAL ABSTRACTS, vol. 107, no. 23, 7 December 1987, Columbus, Ohio, US; abstract no. 218003, NOGUCHI Y ET AL 'Polymerizable glycerophospholipids' * abstract * & JP-A-86 129 190 (NIPPON OILS AND FATS CO., LTD.;JAPAN ) 17 June 1986	1-8	
Y	CHEMICAL ABSTRACTS, vol. 116, no. 6, 10 February 1992, Columbus, Ohio, US; abstract no. 046304, HIBINO H ET AL 'Infusion solutions containing stable lipids with highly unsaturated fatty acids' * abstract * & JP-A-91 153 628 (NIPPON OIL AND FATS CO., LTD.;JAPAN ) 1 July 1991 --- -/--	1-8	TECHNICAL FIELDS SEARCHED (Int.Cl.5)
The present search report has been drawn up for all claims			
Place of search THE HAGUE		Date of completion of the search 18 May 1994	Examiner Beslier, L
<p>CATEGORY OF CITED DOCUMENTS</p> <p>X : particularly relevant if taken alone Y : particularly relevant if combined with another document of the same category A : technological background O : non-written disclosure P : intermediate document</p> <p>T : theory or principle underlying the invention E : earlier patent document, but published on, or after the filing date D : document cited in the application L : document cited for other reasons ..... &amp; : member of the same patent family, corresponding document</p>			

EPO FORM 1503 03.82 (P04C01)



European Patent  
Office

EUROPEAN SEARCH REPORT

Application Number  
EP 94 30 0599

DOCUMENTS CONSIDERED TO BE RELEVANT				
Category	Citation of document with indication, where appropriate, of relevant passages	Relevant to claim	CLASSIFICATION OF THE APPLICATION (Int.Cl.5)	
Y	CHEMICAL ABSTRACTS, vol. 111, no. 17, 23 October 1989, Columbus, Ohio, US; abstract no. 154301, HIBINO H ET AL 'Preparation of phosphatidylcholines for drugs, foods, and cosmetics***' * abstract * & JP-A-88 225 387 (NIPPON OILS AND FATS CO., LTD.; JAPAN ) 20 September 1988 ----	1-8		
Y	CHEMICAL ABSTRACTS, vol. 112, no. 23, 4 June 1990, Columbus, Ohio, US; abstract no. 217461, HIBINO H ET AL 'Preparation of phosphatidylcholines by acylation of glycerophosphocholine' * abstract * & JP-A-89 311 087 (NIPPON OILS AND FATS CO., LTD.; JAPAN ) 15 December 1989 ----	1-8		
Y	EP-A-0 147 741 (A. NATTERMANN & CIE GMBH) * the whole document * ----	1-8		TECHNICAL FIELDS SEARCHED (Int.Cl.5)
Y	DE-A-33 47 269 (PEARSON & CO) * the whole document * ----	1-8		
Y	WO-A-89 03836 (BOARD OF REGENTS OF THE UNIVERSITY OF WASHINGTON) * the whole document * ----	1-8		
A	EP-A-0 296 751 (EFAMOL HOLDINGS PLC) * the whole document * -----	1-8		
The present search report has been drawn up for all claims				
Place of search		Date of completion of the search	Examiner	
THE HAGUE		18 May 1994	Beslier, L	
CATEGORY OF CITED DOCUMENTS		T : theory or principle underlying the invention E : earlier patent document, but published on, or after the filing date D : document cited in the application L : document cited for other reasons ..... & : member of the same patent family, corresponding document		
X : particularly relevant if taken alone Y : particularly relevant if combined with another document of the same category A : technological background O : non-written disclosure P : intermediate document				

EPO FORM 1503 03.82 (P04C01)



(12) **EUROPEAN PATENT APPLICATION**  
 published in accordance with Art. 158(3) EPC

(43) Date of publication:  
**29.08.2001 Bulletin 2001/35**

(51) Int Cl.7: **A23L 1/33**

(21) Application number: **99949411.5**

(86) International application number:  
**PCT/JP99/05892**

(22) Date of filing: **26.10.1999**

(87) International publication number:  
**WO 00/25608 (11.05.2000 Gazette 2000/19)**

(84) Designated Contracting States:  
**AT BE CH CY DE DK ES FI FR GB GR IE IT LI LU  
 MC NL PT SE**

• **SHIGEMATU, Yoshiaki**  
 Chiyoda-ku, Tokyo 100-0004 (JP)

(30) Priority: **02.11.1998 JP 31173098**

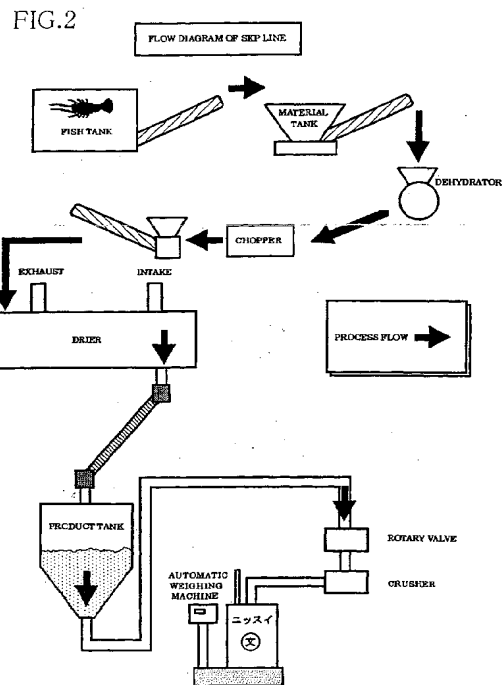
(74) Representative:  
**Leson, Thomas Johannes Alois, Dipl.-Ing. et al**  
**Tiedtke-Bühling-Kinne & Partner GbR,**  
**TBK-Patent,**  
**Bavariaring 4**  
**80336 München (DE)**

(71) Applicant: **Nippon Suisan Kaisha, Ltd.**  
**Tokyo 100-0004 (JP)**

(72) Inventors:  
 • **YOSHITOMI, Bunji, Nippon Suisan Kaisha, Ltd.**  
**Hachioji-shi, Tokyo 192-0906 (JP)**

(54) **DRY KRILL POWDER**

(57) A dried powdery and granular krill product containing all components of krill. The proteolytic enzymes originally contained in krill materials are perfectly disabled. The product is produced by a process including only heating as means for denaturing protein and disabling the proteolytic enzymes originally contained in krill materials. The product is produced by a process including no chemicals treatment to remove water and disable or inactivate the proteolytic enzymes in any production steps, and generating no wastewater. The production process comprises the steps of lightly dehydrating krill, coarsely crushing the krill, and drying the coarsely crushed krill under heating. Thus, water is removed from the krill by only heating, and degradation of the lipid in the krill product is prevented without using an anti-oxidant. Application fields are enlarged and the preservation characteristic is improved. The so-called zero-emission method and product, generating no wastes, are realized.



**Description**

BACKGROUND OF THE INVENTION

5 Field of the Invention

**[0001]** The present invention relates to a dried powdery and granular krill product which contains all components of krill and in which lipid degradation is sufficiently prevented with no need of an anti-oxidant.

10 Description of the Prior Art

**[0002]** Krill are animal plankton living primarily in the Arctic and Antarctic Oceans, and about 80 kinds of krill have been known up to date. Of those many kinds of krill, Antarctic Krill (*Euphasia superba*) living in the Antarctic Ocean are found in abundance as one of natural resources. Therefore, survey of the resource and development of the method of catching the krill have been extensively conducted in the period of 1970 to 1985, including studies for developing methods of processing the krill to be useful in practical applications.

**[0003]** Krill are comparable to fish, flesh and fowl in point of nutritive value, but there are several problems in processing the krill for practical applications. One of the problems is that krill lose freshness in short time. If krill are left to stand after being caught, the heads and chests of the krill start changing into black color in 1 - 2 hours even at a low atmospheric temperature of about 0 °C. Further, shells of the heads and chests of krill are so vulnerable to external pressure that the krill are easily broken down upon impacts applied at the time of catching, whereupon the enzymes present in the internal organs flow out and decompose muscles. Those phenomena occur under actions of the enzymes present in krill. It is thought that tyrosinase is responsible for the former color-changing phenomenon, and protease is responsible for the latter muscle-decomposing phenomenon.

**[0004]** Accordingly, those enzymes require to be disabled or inactivated when processing krill. In other words, it has been required immediately after catching krill to quickly freeze the krill down to below - 40 °C, thereby inactivating the enzymes, or to heat the krill up to above 80 °C, thereby disabling the enzymes, followed by preserving the krill.

**[0005]** Known krill products include raw frozen and peeled krill products which are subjected to quick freezing and then preserved in a frozen condition, boiled krill products which are heated and then preserved in a frozen condition, and krill meal which is heated and dried and then preserved at the normal temperature. The following Tables 1 and 2 list classifications of those products depending on how krill are processed, and features and points to be improved of the products.

**[0006]** The known products are used in various applications. However, because the products are transported from the Antarctic Ocean to Japan, the product price greatly depends on the transportation cost. There is hence a desire for extracting excellent characteristics of krill more efficiently and realizing krill products having a higher value added.

[Table 1]

Processing	Processing Object	Product Examples
Quick freezing, Preserve in frozen condition	Inactivate enzymes	Raw frozen and stripped krill
Heating, Preserve in frozen condition	Disable enzymes	Boiled krill
Heating & drying, Preserve at normal temperature	Disable enzymes	Krill meal

[Table 2]

Product Examples	Features	Points to be improved
Raw frozen and stripped krill	Products have flavor, taste and feeling of raw krill.	Remaining high water content and activity of enzymes necessitate storage and distribution in frozen state. Enzymes are activated upon thawing and product quality degrades. Drips flow out.
Boiled krill	Heating disables enzymes and makes protein stable to give meat-like feeling.	Flavor and taste components flow out during boiling. Cold chain is required because of high water content.

[Table 2] (continued)

Product Examples	Features	Points to be improved
Krill meal	Heating disables enzymes and makes protein stable. Meal can be stored at normal temp. because of low water content.	Digestibility lowers due to protein denaturation during heating. Water-soluble components flow out into stickwater.

**[0007]** Japanese Unexamined Patent Publication No. 57-11876 discloses a method of impeding activity of the proteolytic enzymes in krill and utilizing the krill as protein materials. With the disclosed method, a krill paste is degenerated with alcohol to effect fixation (denaturation) of protein and degeneration of the enzymes at the same time. The processed krill paste is then washed with water to remove alcohol. The disclosed method however has the following problems.

1. Water-soluble protein and low-molecular protein, which are not yet denatured, are removed together with alcohol during washing with water.
2. Free amino acids and extract components, which are taking in part of providing good taste, are also removed together with alcohol during washing with water.
3. Polar lipid is removed together with alcohol during washing with water. Most of the lipid in krill is phospholipid and is rich in polyunsaturated fatty acids (PUFAs). Thus these PUFAs are removed.
4. Alcohol can be recovered and reused, but an alcohol recovery system pushes up the cost. For the above reasons, the above-disclosed method has difficulties in realizing practical use.

**[0008]** Further, Japanese Unexamined Patent Publication No. 8-298967 discloses a method of producing dried shrimp granules. With this disclosed method, raw shrimps are crushed by a mincing apparatus (meat grinder) into the form of ground meat. The ground meat is then heated under agitation, followed by drying.

**[0009]** More specifically, according to the embodiment disclosed in the above Publication, shrimp materials are first crushed into the form of ground meat. The ground meat described in the embodiment includes not only the meat in the completely ground form, but also fragments of shrimps in the finely chopped form. Concretely, the above process is performed by a meat grinder which is used for producing mince or the like. Also according to the description in the embodiment, a maximum grain size representing the coarsely ground state is about 2 mm square. The shrimp materials thus processed are dried under heating to thereby provide dried shrimp granules. Considering specific properties of krill, however, it is inferred that even if krill are dried under heating after being processed in a similar manner as in the prior art, ground krill are very difficult to dry into a satisfactory condition.

**[0010]** From intensive studies, the inventors found that when krill are processed in a similar manner as in the prior art, lipid, protein and water contained in the krill are brought into an emulsified state, and the processed krill are very difficult to dry even with a heating and drying machine. Such a difficulty is related to the fact that most of the lipid in krill is phospholipid, as described above, and therefore emulsification is further increased. In other words, water in the krill is stabilized in structure with emulsification and becomes still harder to evaporate under heating.

**[0011]** In addition, when krill are crushed into the form of ground meat, the proteolytic enzymes present in the internal organs of the krill develop activity, and a temperature rise during the grinding process increases the activity of those enzymes. As a consequence, proteolysis in the krill is promoted and specific taste is deteriorated.

**[0012]** Moreover, when ground materials are dried by a heating and drying machine, the materials come into contact with a heating surface of the machine, and a coating(a layer) grows gradually. Then, there occurs finally such a phenomenon that the materials adhering to the heating surface are scorched. To prevent the occurrence of such a phenomenon, the heating surface of the machine must be scraped by a stirring vane or the like. Taking into account the structure and accuracy of the machine and an influence of thermal expansion of the machine under heating, however, it is very difficult to always keep constant a gap between the heating surface and the tip of the stirring vane. As a result, the materials cannot be avoided from being scorched, thus leading to a deterioration of flavor and taste and a lowering of digestibility.

SUMMARY OF THE INVENTION

**[0013]** An object of the present invention is therefore to effectively utilize krill as one of valuable aquatic resources, and to provide a dried powdery and granular krill product and a method of producing the dried powdery and granular krill product, which contains all components of krill and has a good preservation ability while activity of the enzymes in the krill is totally disabled.

**[0014]** The present invention resides in a dried powdery and granular krill product that contains all components of

krill. Because of containing all components of krill, the present product has a function capable of sufficiently preventing degradation of the lipid in the krill product without using an anti-oxidant. In the dried powdery and granular krill product, the proteolytic enzymes originally contained in krill materials are perfectly disabled. Accordingly, the present invention also resides in a dried powdery and granular krill product which contains all components of krill and in which the proteolytic enzymes originally contained in krill materials are perfectly disabled. The present product is produced by a process including only heating as means for denaturing protein and disabling the proteolytic enzymes originally contained in krill materials. Accordingly, the present invention further resides in a dried powdery and granular krill product which contains all components of krill, in which the proteolytic enzymes originally contained in krill materials are perfectly disabled, and which is produced by a process including only heating as means for denaturing protein and disabling the proteolytic enzymes originally contained in krill materials.

**[0015]** The dried powdery and granular krill product of the present invention is produced by a process including no chemicals treatment to remove water and disable or inactivate the proteolytic enzymes in any production steps, and generating no wastewater. The production process comprises the steps of lightly dehydrating krill, coarsely crushing the krill, and drying the coarsely crushed krill under heating.

**[0016]** The dried powdery and granular krill product of the present invention is subjected to no chemical treatment using chemicals, etc. in any production steps, and is processed by only heating. Also, there is no step in the production process in which wastewater is generated. Thus, water is removed from the krill by only heating. Moreover, application fields are enlarged and the preservation characteristic is improved. The so-called zero-emission method and product, generating no wastes, are realized.

**[0017]** The production method of the present invention comprises steps of removing seawater from krill, coarsely crushing the krill, and drying the coarsely crushed krill under heating. In the conventional process of producing krill meal, krill are first boiled in water in the same amount as the krill, and are then subjected to separation into solid and liquid components. The solid component is heated and dried using a drier. The liquid component obtained from the solid/liquid separation is called stickwater and preserved separately. For this reason, the conventional krill meal contains less water-soluble components than the krill product of the present invention, and therefore has disadvantages in not providing satisfactory flavor and taste in the extracted form, etc. and attractiveness of feed to fish under cultivation, etc. Further, the conventional production process is disadvantageous in that protein is excessively denatured by heating applied in both the boiling and heating/drying steps, and digestibility of the product is reduced.

#### BRIEF DESCRIPTION OF THE DRAWINGS

##### **[0018]**

Fig. 1 is a graph showing activity of the proteolytic enzymes remaining in raw krill and the product of the present invention; and

Fig. 2 is a schematic view of a production line for the product of the present invention.

#### DESCRIPTION OF THE PREFERRED EMBODIMENT

**[0019]** There are 80 or more kinds of krill as described above, but the kind of krill used in the present invention is not restricted. In addition to krill, mysids are also usable.

**[0020]** Krill primarily used in an embodiment are Antarctic Krill (*Euphasia superba*) which have been employed in industrial fields.

**[0021]** A production process will be described below.

**[0022]** Krill used as materials are put into a fish tank at once after being caught. The krill are then put in a dehydrator to remove seawater, etc. attaching to the krill surfaces. The type of the dehydrator is not particularly restricted, but outer shells of krill are so fragile that the shells are easily broken down under pressure of 40 - 140 g/cm<sup>2</sup> and the internal components flow out. Therefore, the type of the dehydrator is preferably selected so that an excessive physical load will not be applied to krill.

**[0023]** The dehydrated krill are chopped to improve thermal efficiency in the heating and drying process. The type of a machine used for chopping the krill is not particularly restricted. The grain size of the chopped krill is selected to a coarsely crushed state, i.e., about 1.5 - 2.5 cm square, at which outer shells and muscular tissues of the krill materials remain. This process can be performed with, e.g., a known mincing apparatus, which is usually employed for grinding meat into mince, by properly selecting the opening size of a perforated plate.

**[0024]** The chopped krill are dried under heating. The type of a machine for use in this process is also not particularly restricted. While a known heating and drying machine such as a steam type disk dryer, for example, can be used, the machine is preferably adjustable in heating time, heating temperature, degree of agitation, and so forth. Because the internal components of krill as one of natural resources change depending on the season, it is desired to adjust the

parameters of the machine in match with the change of the internal components of krill for obtaining products with constant quality.

5 [0025] The heating time and the heating temperature are set to such an extent that the muscular protein of krill and the proteolytic enzymes in krill are denatured and degenerated under heating, and that the water content is reduced down to below 10 % from a point of ensuring good preservation. It is important that the heating and drying process is not performed at overly high temperatures and for an overly long time, and is performed at the necessary lower limit values to satisfy the above-described conditions. Excessive heating lowers digestibility due to extreme denaturation, reduces astaxanthin, natural dye, present in krill, reduces vitamins, and oxidizes lipid. On the other hand, if heating is insufficient, activity of the proteolytic enzymes in krill remains, which leads to a deterioration of product quality. If the water content is over ten and several percents, the krill product gathers mold during preservation.

10 [0026] The dried krill are very fragile, including the shells, and therefore can be easily crushed any desired grain size.

[0027] The krill product of the present invention can be used as a main material of feed for cultured fish in place of fish powder, and in food applications it can be mixed as a shrimp taste seasoning in fish-paste products, etc.

15 [0028] In view of that the problem described above in connection with the prior art is attributable to crushing of raw materials into the form of ground meat, krill materials are first chopped into pieces having a size of 20 - 30 % of the body length (about 1.5 - 2.5 cm square) and are then put into a heating and drying machine in the present invention. As a result, the krill materials are avoided from being emulsified and the drying efficiency is enhanced. Further, strong activity of the proteolytic enzymes present in the internal organs of krill is suppressed and an adverse influence upon flavor and taste of the krill product is reduced. In addition, the chopped krill do not adhere to the heating surface and can be heated appropriately, thus greatly contributing to improvement of product quality.

20 [0029] Moreover, since the dried krill product obtained in accordance with the method of the present invention has a large grain size and maintains a fair part of shapes of the krill materials, it is also possible to produce products utilizing the shapes of the krill materials advantageously. Additionally, the dried krill can be simply crushed into a desired grain size as required.

25 [0030] Thus, it can be said that the present invention provides a dried product that has a different quality and is produced through a different process from those obtained with and described in the prior art, i.e., Japanese Unexamined Patent Publication No. 8-298967.

[0031] Fig. 1 shows comparatively activity of the proteolytic enzymes remaining in raw krill and the krill product of the present invention.

30 [0032] In the graph of Fig. 1, the activity of the remaining proteolytic enzymes is plotted at each period of reaction time based on a measurement index, i.e., the absorptivity at 440 nm, by using azocasein as a substrate. As will be seen from Fig. 1, the activity of the remaining proteolytic enzymes in the raw krill is increased with lapse of the reaction time, while the activity of the remaining proteolytic enzymes in the krill product of the present invention is hardly changed. This suggests that the proteolytic enzymes remain not alive in the krill product of the present invention and they are perfectly disabled in the production process, and that a possibility of quality deterioration of the krill product during the preservation is low.

[0033] Preservation characteristics of the krill product of the present invention will be described with reference to Tables 3 and 4 below.

40 [0034] For comparison, the results listed in Table 3 were obtained by preparing two groups of the krill product of the present invention, in one of which ethoxyquin that is most generally used as an anti-oxidant in meal, etc. was added to the krill product and in the other of which no ethoxyquin was added, and then measuring a change of product quality by using a degradation of the lipid as an index for a period of two months during which the two groups were preserved at 37 °C. To make distinct a difference in change occurred during the preservation, 300 ppm of ethoxyquin, which is double the amount added in usual cases, was added to the group added with ethoxyquin.

45 [0035] As will be seen from Table 3, a significant difference in change of the lipid was not found until the end of one month between the group added with no anti-oxidant and the group added with the anti-oxidant. Also, during the second month, oxidation proceeded slightly faster in the group added with no anti-oxidant than the group added with the anti-oxidant, but a significant difference was not found.

50 [0036] There are several indexes indicating a degree of lipid degradation. About the lipid in krill, particularly, the krill lipid having been extracted and refined, it is known that, during the preservation, a peroxide value hardly increases and only a carbonyl value increases. In other words, it is pointed out that degradation of the krill lipid differs in creation of oxides and progress rate of the decomposing reaction from those in general fish oil, etc.

55



[Table 3]

	Acid value		Peroxide value		Carbonyl value	
	no antioxidant *1	with antioxidant *2	no antioxidant	with antioxidant	no antioxidant	with antioxidant
Preservation start	18.1	19.2	1.8	4.1	67.6	60.5
After 1 month at 37 °C	21.9	22.6	6.0	7.0	75.6	81.3
After 2 months at 37 °C	21.3	23.6	10.7	6.2	93.5	78.6

\*1: No ethoxyquin added

\*2: 300 ppm of ethoxyquin added

**[0037]** Furthermore, as will be seen from Table 4, a phenomenon of the lipid degrading at apparently different rates during the preservation was found between the krill product of the present invention and a control prepared by perfectly removing all the water-soluble components originally present in krill from the krill product of the present invention. Although the material responsible for the above phenomenon is not yet known, it is believed that the water-soluble components originally present in krill have some anti-oxidizing action. For this reason, in the krill product of the present invention which contains all the components of krill in an enriched condition, lipid degradation can be prevented satisfactorily without using any anti-oxidant.

[Table 4]

	Peroxide value		Carbonyl value	
	product of invention	water-soluble components removed	product of invention	water-soluble components removed
Preservation start	0	0	69.5	87.7
After 1 month at 30 °C	0	0	53.9	71.7
After 3 months at 30 °C	0	0	63.0	76.9
After 6 months at 30 °C	6.9	10.5	89.1	142.3
After 12 months at 30 °C	11.8	20.7	127.1	202.6

<Example>

**[0038]** The present invention will be described in more detail in connection with Example. It should be understood that the present invention is limited in no way by the following Example.

Example 1

1. Process Flow Including Plant for Drying Krill

**[0039]** An outline of the process flow is as shown in Fig. 2. Krill materials are first conveyed by a krill supply apparatus from a fish tank to a material tank, and are then supplied to a dehydrator in a proper lot. The use of a dehydrator basically intends to remove seawater contained in the krill materials. Since it is expected that the amount of water

contained in krill varies depending on the materials, a diaphragm is adjusted to provide a proper dehydration rate, taking into account the performance of the dehydrator. The dehydrated materials are coarsely crushed by a chopper and are then supplied to a drier. The materials are boiled in the drier under heating with vapor, followed by further drying. At the time when reaching a predetermined water content, the drying is stopped and a resulting dried semifinished product is ejected. The dried semifinished product is conveyed to a product tank, and is then automatically packaged into bags in units of predetermined weight after passing a rotary valve, a crusher and so on.

**[0040]** The conventional production process for krill meal is represented by raw krill → boiling → centrifugal separation or solid/liquid separation → extraction of solid → drying → crushing → packaging. The liquid component was removed in the centrifugal separation step, and the useful components of krill contained in the liquid component were discarded. It can be said from one aspect that the krill meal was a product resulted from drying the sludge.

**[0041]** By contrast, the process flow for producing the krill product of the present invention is represented by raw krill → removal of water attached to krill → boiling → drying → crushing → packaging. The centrifugal separation step is not included. In the boiling and drying steps; the enzymes in krill are disabled and the krill components are stabilized through thermal degeneration. Thus, the components originally contained in the krill are all kept in the product without being discarded externally. An apparatus for implementing the above process is featured in omitting a step of squeezing boiled krill using a decanter or a press. The krill drying apparatus used in the present invention differs from the conventional meal producing apparatus in that a cooker and a drier are combined in an integral structure.

2. Component Analytical Values

**[0042]** Table 5 lists component analytical values of the krill product of the present invention. For comparison, Table 5 also lists component analytical values of the krill meal produced by the conventional process. In particular, the krill product of the present invention contains free amino acids as much as more than twice the amount contained in the conventional krill meal. The free amino acids deeply take part in developing flavor and taste of the product when eaten, attractant of feed to fish under cultivation, etc.

**[0043]** Since the squeezing step subsequent to boiling of the krill materials is omitted, the components developing flavor and taste are not lost and the krill product of the present invention has good flavor. Further, the production process of the present invention generates no appreciable wastewater and provides a high yield.

[Table 5]

	Krill meal	Product of invention
Water	6.5	8.3
Coarse protein (Free amino acid)	64.0 (2.9)	65.1 (7.54)
Coarse fat	7.0	7.0
Coarse ash	16.7	18.0
Coarse fiber	3.2	2.1

**[0044]** According to the present invention, a method is provided which can effectively utilize krill, as one of important aquatic resources, in a perfect manner without any loss due to efflux of krill components. The dried powdery and granular krill product obtained by the present invention contains all the components originally contained in the krill, and strong activity of the enzymes specific to the krill is disabled. Therefore, the krill product of the present invention can be widely applied to not only the feed industry, but also the food industry.

Claims

1. A dried powdery and granular krill product containing all components of krill.
2. A dried powdery and granular krill product according to Claim 1, wherein the proteolytic enzymes originally contained in krill materials are perfectly disabled.
3. A dried powdery and granular krill product according to Claim 1 or 2, wherein said product is produced by a process including only heating as means for denaturing protein and disabling the proteolytic enzymes originally contained in krill materials.

**EP 1 127 497 A1**

4. A dried powdery and granular krill product according to Claim 1, 2 or 3, wherein said product is produced by a process including no chemicals treatment to remove water and disable or inactivate the proteolytic enzymes in any production steps, and generating no wastewater.

5 5. A dried powdery and granular krill product according to any one of Claims 1 to 4, wherein said product is produced by a process comprising the steps of lightly dehydrating krill, coarsely crushing the krill, and drying the coarsely crushed krill under heating.

10

15

20

25

30

35

40

45

50

55

FIG.1

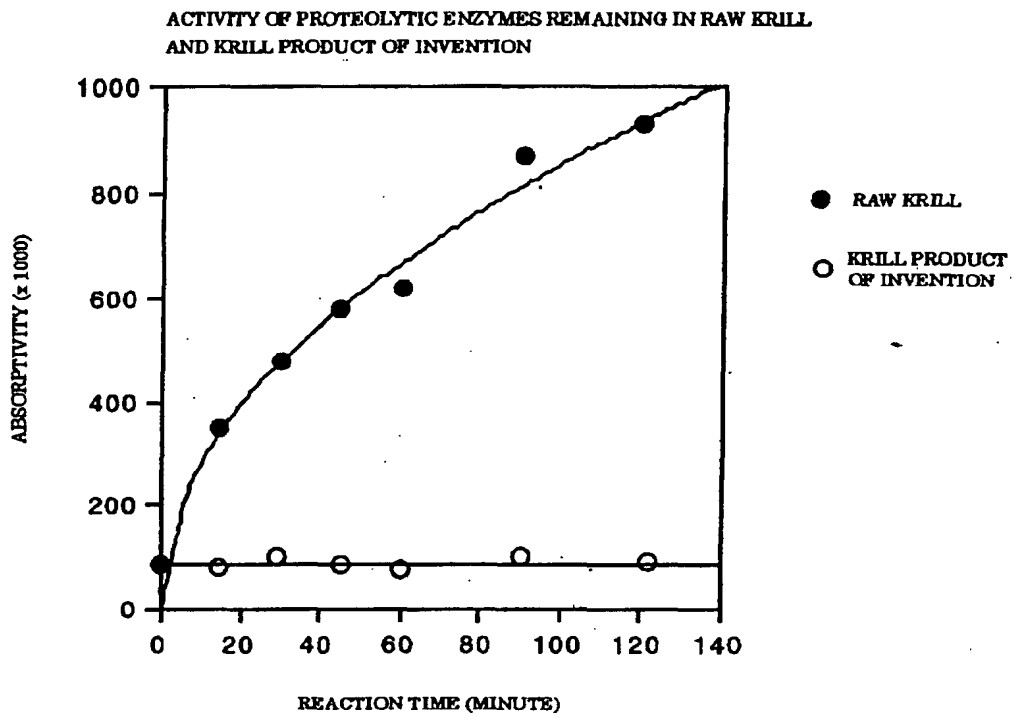
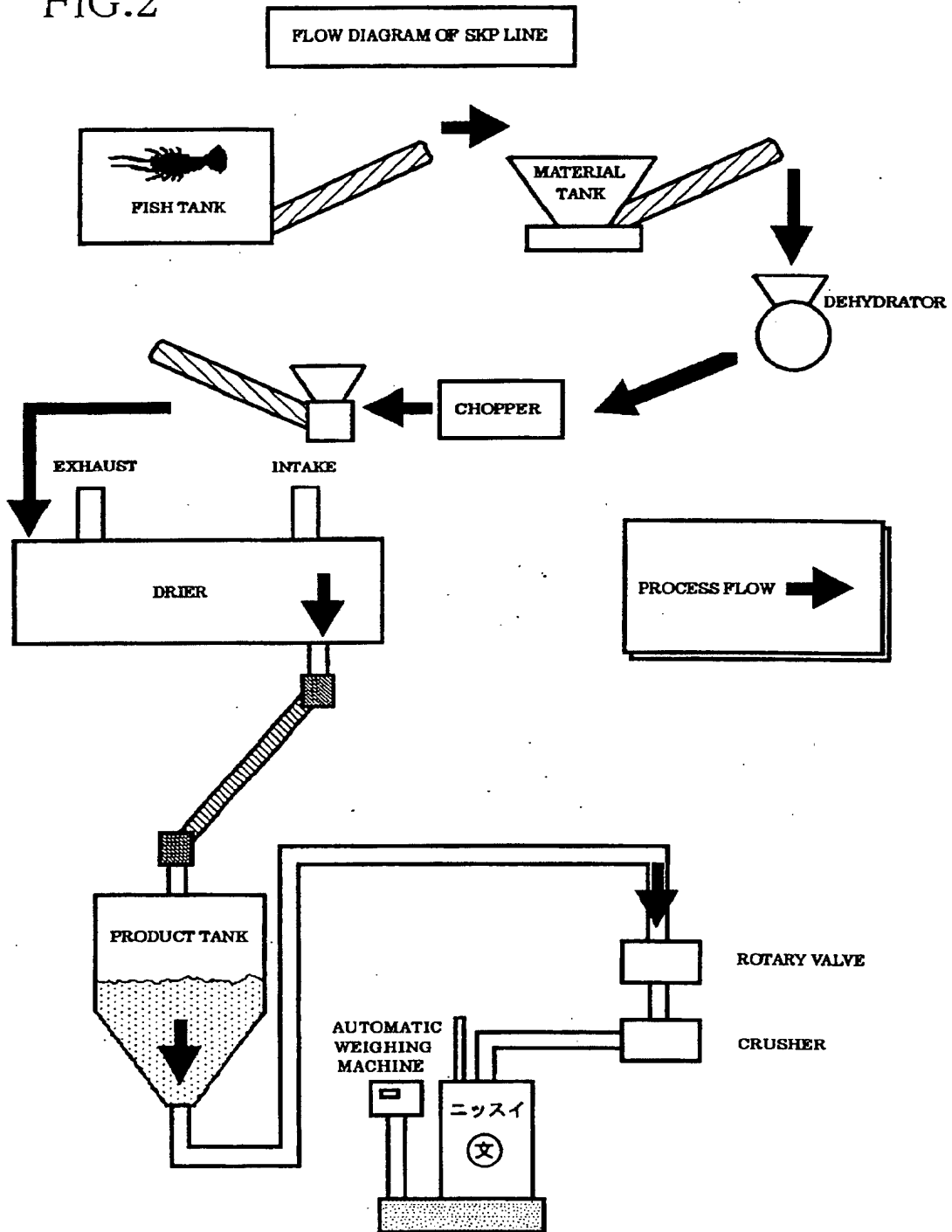


FIG.2



INTERNATIONAL SEARCH REPORT

International application No.

PCT/JP99/05892

<p>A. CLASSIFICATION OF SUBJECT MATTER Int.Cl.<sup>6</sup> A23L1/33</p> <p>According to International Patent Classification (IPC) or to both national classification and IPC</p>												
<p>B. FIELDS SEARCHED</p> <p>Minimum documentation searched (classification system followed by classification symbols) Int.Cl.<sup>6</sup> A23L1/33</p> <p>Documentation searched other than minimum documentation to the extent that such documents are included in the fields searched</p> <p>Electronic data base consulted during the international search (name of data base and, where practicable, search terms used)</p>												
<p>C. DOCUMENTS CONSIDERED TO BE RELEVANT</p> <table border="1"> <thead> <tr> <th>Category*</th> <th>Citation of document, with indication, where appropriate, of the relevant passages</th> <th>Relevant to claim No.</th> </tr> </thead> <tbody> <tr> <td>X</td> <td rowspan="2">JP, 51-22855, A (Daigo Takamura), 23 February, 1976 (23.02.76), Claims; column 3, the second line from the bottom to column 4, line 2 (Family: none)</td> <td>1-4</td> </tr> <tr> <td>Y</td> <td>5</td> </tr> <tr> <td>Y</td> <td>JP, 4-304862, A (Kabushiki Kaisha Nichiro), 28 October, 1992 (28.10.92), Claim 1 (Family: none)</td> <td>1</td> </tr> </tbody> </table>		Category*	Citation of document, with indication, where appropriate, of the relevant passages	Relevant to claim No.	X	JP, 51-22855, A (Daigo Takamura), 23 February, 1976 (23.02.76), Claims; column 3, the second line from the bottom to column 4, line 2 (Family: none)	1-4	Y	5	Y	JP, 4-304862, A (Kabushiki Kaisha Nichiro), 28 October, 1992 (28.10.92), Claim 1 (Family: none)	1
Category*	Citation of document, with indication, where appropriate, of the relevant passages	Relevant to claim No.										
X	JP, 51-22855, A (Daigo Takamura), 23 February, 1976 (23.02.76), Claims; column 3, the second line from the bottom to column 4, line 2 (Family: none)	1-4										
Y		5										
Y	JP, 4-304862, A (Kabushiki Kaisha Nichiro), 28 October, 1992 (28.10.92), Claim 1 (Family: none)	1										
<p><input type="checkbox"/> Further documents are listed in the continuation of Box C.      <input type="checkbox"/> See patent family annex.</p>												
<p>* Special categories of cited documents:                  "A" document defining the general state of the art which is not considered to be of particular relevance                  "E" earlier document but published on or after the international filing date                  "L" document which may throw doubts on priority claim(s) or which is cited to establish the publication date of another citation or other special reason (as specified)                  "O" document referring to an oral disclosure, use, exhibition or other means                  "P" document published prior to the international filing date but later than the priority date claimed                  "T" later document published after the international filing date or priority date and not in conflict with the application but cited to understand the principle or theory underlying the invention                  "X" document of particular relevance; the claimed invention cannot be considered novel or cannot be considered to involve an inventive step when the document is taken alone                  "Y" document of particular relevance; the claimed invention cannot be considered to involve an inventive step when the document is combined with one or more other such documents, such combination being obvious to a person skilled in the art                  "&amp;" document member of the same patent family             </p>												
<p>Date of the actual completion of the international search 12 November, 1999 (12.11.99)</p>												
<p>Date of mailing of the international search report 24 November, 1999 (24.11.99)</p>												
<p>Name and mailing address of the ISA/ Japanese Patent Office</p>												
<p>Authorized officer</p>												
<p>Facsimile No.</p>												
<p>Telephone No.</p>												

Form PCT/ISA/210 (second sheet) (July 1992)



(11) **EP 1 406 641 B1**

(12) **EUROPEAN PATENT SPECIFICATION**

(45) Date of publication and mention of the grant of the patent:  
**07.01.2009 Bulletin 2009/02**

(51) Int Cl.:  
**A61K 35/60<sup>(2006.01)</sup> A61K 31/23<sup>(2006.01)</sup>**  
**A61P 9/10<sup>(2006.01)</sup>**

(21) Application number: **02734945.5**

(86) International application number:  
**PCT/CA2002/000843**

(22) Date of filing: **07.06.2002**

(87) International publication number:  
**WO 2002/102394 (27.12.2002 Gazette 2002/52)**

(54) **KRILL EXTRACTS FOR PREVENTION AND/OR TREATMENT OF CARDIOVASCULAR DISEASES**

KRILLEXTRAKTE ZUR PRÄVENTION UND/ODER BEHANDLUNG VON HERZ-KREISLAUF-ERKRANKUNGEN

EXTRAITS À BASE DE KRILL POUR LA PREVENTION ET/OU LE TRAITEMENT DES MALADIES CARDIOVASCULAIRES

(84) Designated Contracting States:  
**AT BE CH CY DE DK ES FI FR GB GR IE IT LI LU MC NL PT SE TR**  
Designated Extension States:  
**AL LT LV MK RO SI**

(74) Representative: **Nargolwalla, Cyra**  
**Cabinet Plasseraud**  
**52 rue de la Victoire**  
**75440 Paris Cedex 09 (FR)**

(30) Priority: **18.06.2001 US 298383 P**

(56) References cited:  
**WO-A-00/23546**

(43) Date of publication of application:  
**14.04.2004 Bulletin 2004/16**

- DATABASE MEDLINE US NATIONAL LIBRARY OF MEDICINE (NLM), BETHESDA, MD, US; 1985, IAROSCHKIN A P ET AL: "Technochemical characterisitcs of canned Natural Antartic shrimp meat and its nutritive value" Database accession no. nlm4002685
- IKEDA I: "EFFECTS OF LONG-TERM FEEDING OF MARINE OILS WITH DIFFERENT POSITIONAL DISTRIBUTION OF EICOSAPENTAENOIC AND DOCOSAHEXAENOIC ACIDS ON LIPID METABOLISM, EICOSANOID PRODUCTION, AND PLATELET AGGREGATION IN HYPERCHOLESTEROLEMIC RATS" LIPIDS, vol. 33, no. 9, 1998, pages 897-904, XP009068910

(60) Divisional application:  
**08164524.4 / 1 997 498**

(73) Proprietor: **Neptune Technologies & Bioresources Inc.**  
**Laval,**  
**Quebec H7M 3Y2 (CA)**

(72) Inventor: **SAMPALIS, Tina**  
**Laval, Québec H7W 3J8 (CA)**

Note: Within nine months of the publication of the mention of the grant of the European patent in the European Patent Bulletin, any person may give notice to the European Patent Office of opposition to that patent, in accordance with the Implementing Regulations. Notice of opposition shall not be deemed to have been filed until the opposition fee has been paid. (Art. 99(1) European Patent Convention).

**EP 1 406 641 B1**

**Description****BACKGROUND OF THE INVENTION**5 Field of the Invention

**[0001]** This invention relates to multi-therapeutic extracts derived from krill and/or marine, which can prevent and/or treat several diseases.

10 Description of Prior Art

**[0002]** Krill is the common name for small, shrimp-like crustaceans, however not shrimp, that swarm in dense shoals, especially in Antarctic waters. It is one of the most important food source for fish, some kind of birds and especially for baleen whales as being an important source of protein. Krill is also a good source of omega-3 fatty acid, which are well known for their health benefits.

**[0003]** It is known in the art to use krill and/or marine enzymes for the treatment of a great variety of diseases in human and animals such as infections, inflammations, cancers, HIV/AIDS, pain, polyps, warts, hemorrhoids, plaque, wrinkles, thin hairs, allergic itch, anti-adhesion, eye disease, acne, cystic fibrosis and immune disorders including autoimmune disease and cancer.

**[0004]** It is also known in the art that krill and/or marine oil may be used for the treatment of autoimmune murine lupus and other autoimmune diseases and can also be used for treating cardiovascular diseases.

**[0005]** However, the krill and/or marine oil used for these treatments has only conserved its omega-3 fatty acids as active ingredients, which is a very small part of all the active ingredients of the krill and/or marine itself. This fact reduces the potential of the krill and/or marine oil as a treatment for these diseases.

**[0006]** There is an increasing demand for treatments using products derived from a natural source, therefore, it would be highly desirable to be provided with a krill and/or marine extract having an enhanced potential for prevention and/or treatment and/or management of disease.

**SUMMARY OF THE INVENTION**

**[0007]** In accordance with the present invention there is provided a composition for use in a method of prevention, therapy and/or treatment of several disease, the method comprising the administration of a therapeutically effective amount of krill oil to a patient.

**[0008]** In a preferred embodiment of the present invention the krill and oil is obtained from a process comprising the steps of:

(a) placing krill material in a ketone solvent, preferably acetone to achieve extraction of the soluble lipid fraction from the marine and/or aquatic animal material;

40 (b) separating the liquid and solid contents;

(c) recovering a first lipid rich fraction from the liquid contents by evaporation of the solvent present in the liquid contents;

45 (d) placing the solid contents in an organic solvent selected from the group of solvents consisting of alcohol, preferably ethanol, isopropanol or t-butanol and esters of acetic acid, preferably ethyl acetate to achieve extraction of the remaining soluble lipid fraction from the marine and/or aquatic material;

50 (e) separating the liquid and solid contents;

(f) recovering a second lipid rich fraction by evaporation of the solvent from the liquid contents; and

(g) recovering the solid contents.

55 **[0009]** In a preferred embodiment of the present invention, the krill and oil comprises Eicosapentanoic acid, Docosahexanoic acid, Phosphatidylcholine, Phosphatidylinositol, Phosphatidylserine, Phosphatidylethanolamine, Sphingomyelin,  $\alpha$ -tocopherol, all-trans retinol, Astaxanthin and flavonoid.

**[0010]** In another embodiment of the present invention, the krill oil comprises Eicosapentanoic acid, Docosahexanoic



acid, Linolenic acid, Alpha-linolenic acid, Linoleic acid, Arachidonic acid, Oleic acid, palmitic acid, palmitoleic acid, stearic acid, nervonic acid, Phosphatidylcholine, Phosphatidylinositol, Phosphatidylserine, Phosphatidylethanolamine, Sphingomyelin, Cholesterol, Triglycerides, Monoglycerides, a-tocopherol, all-trans retinol, Astaxanthin, Canthaxanthin,  $\beta$ -carotene, flavonoid, Zinc, Selenium, sodium, potassium and calcium.

5 **[0011]** In another embodiment of the present invention, the krill oil comprises Eicosapentanoic acid, Docosahexanoic acid, Linolenic acid, Alpha-linolenic acid, Linoleic acid, Arachidonic acid, Oleic acid, palmitic acid, palmitoleic acid, stearic acid, Phosphatidylcholine, Phosphatidylinositol, Phosphatidylserine, Phosphatidylethanolamine, Sphingomyelin, Cholesterol, Triglycerides, Monoglycerides, a-tocopherol, all-trans retinol, Astaxanthin, Canthaxanthin,  $\beta$ -carotene, Zinc and Selenium.

10 **[0012]** The diseases that can be treated and/or prevented by the method of the present invention are cardiovascular diseases.

**[0013]** In accordance with the present invention there is also provided a composition for the treatment and/or prevention and/or therapy of the previously mentioned diseases, the composition comprising a therapeutically effective amount of krill oil in association with a pharmaceutically acceptable carrier.

15 **[0014]** In accordance with the present invention, it is further provided the use of krill oil for the treatment and/or prevention and/or therapy of the previously mentioned diseases.

**[0015]** In accordance with the present invention, it is also provided the use of krill oil for the manufacture of a medicament for the treatment and/or prevention and/or therapy of the previously mentioned diseases.

20 **DETAILED DESCRIPTION OF THE INVENTION**

**[0016]** In accordance with the present invention, there is provided krill extract for prevention and/or treatment and/or therapy of several diseases.

25 **[0017]** A multi-therapeutic oil extract free of enzyme is derived from krill, found in any marine environment around the world, for example, the Antarctic ocean (*euphasia superba*), the Pacific ocean (*euphasia pacifica*), the Atlantic ocean, the Indian ocean, in particular coastal regions of Mauritius Island and/or Reunion Island of Madagascar, Canadian West Coast, Japanese Coast, St-Lawrence Gulf and Fundy Bay, and this oil extract is a free fatty acid lipid fraction.

**[0018]** The extraction process can be described as the following:

30 (a) Placing aquatic krill in a ketone solvent, preferably acetone, to achieve the extraction of grease from the krill and/or marine;

(b) Separating the liquid and the solid phases;

35 (c) Recovering a lipid rich fraction from the liquid phase obtained at step (b) by evaporation of the solvent present in the liquid phase;

40 (d) Placing the solid phase in an organic solvent, which can be alcohol, preferably ethanol, isopropanol or t-butanol, or esters of acetic acid, preferably ethyl acetate. This in order to extract the remaining soluble lipid fraction from the solid phase;

(e) Separating the liquid and the solid phases; and

45 (f) Recovering a lipid rich fraction from the liquid phase obtained at step (e) by evaporation of the solvent present in the liquid phase.

**[0019]** The active components of the enzyme-free krill and/or marine oil extract are:

lipids

50 **[0020]**

i) Omega-3:

55 i. Eicosapentanoic acid: >8g/100g

ii. Docosahexanoic acid: >2g/100g

iii. Linolenic acid: >0.10g/100g

iv. Alpha-linolenic acid: >0.3g/100g

5 **[0021]** In the preferred embodiment of the present invention, the Omega-3 are found in more than 30g/100g.

ii) Omega-6: i. Linoleic acid: >0.9g/100g

10 ii. Arachidonic acid: <0.45g/100g, preferably < 0.6g/100g

iii) Omega-9: i. Oleic acid: >5g/100g

iv) palmitic acid: >10g/100g

15 v) palmitoleic acid: 0.08g/100g

vi) stearic acid: > 0.5g/100g

### Phospholipids

20

#### **[0022]**

Phosphatidylcholine:>4.5g/100g

25 Phosphatidylinositol: >107mg/100g

Phosphatidylserine: >75 mg/100g

30 Phosphatidylethanolamine: >0.5g/100g

Sphingomyelin: >107mg/100g

### Neutral lipids

35

#### **[0023]**

Cholesterol: <3g/100g

40 Triglycerides: <55g/100g

Monoglycerides: >0.5g/100g

**[0024]** In another embodiment of the present invention, the neutral lipids of the krill and/or marine extract also comprises:

45 Diglycerides: >0.5g/100g

### Antioxydants

50

#### **[0025]**

$\alpha$ -tocopherol (vitamin E): >1.0 IU/100g

all-trans retinol (vitamin A): >1500 IU/100g

55  $\beta$ -carotene: > 3000  $\mu$ g/100 ml

**Pigments**

**[0026]**

5       Astaxanthin: >20 mg/100g  
       Canthaxanthin: > 2 mg/100g

**Metals**

10

**[0027]**

       Zinc: >0.1 mg/100g  
15       Selenium: >0.1 mg/100g

**[0028]** In another embodiment of the present invention, the krill and/or marine extract also comprises:

20       Flavonoids: >0.5mg/100g  
       Sodium: < 500mg/100g  
       Calcium: >0.1 mg/100g  
25       Potassium: >50mg/100g  
       Aluminum: < 8.5mg/100g  
       Protein: > 4g/100g  
30       Moisture and volatile matter: <0.8%

**[0029]** After characterization of the krill oil extract, it was determined that the extract contains less than 25 ppm of solvent residue from the extraction process.

35       The oil has the following stability indexes:

       Peroxide value: < 0.1 (mEq/kg)  
       Oil Stability index: < 0.1 after 50 hours at 97.8°C  
40       Saponification index: 70-180  
       Iodine value:60-130%

45       **[0030]** The present invention will be more readily understood by referring to the following examples which are given to illustrate the invention rather than to limit its scope.

**Example 1**

50       **Cardiovascular disease prevention and/or treatment**

**[0031]** Krill oil has been shown to decrease cholesterol *in vivo*. It also inhibits platelet adhesion and plaque formation and reduces vascular endothelial inflammation in a patient. It can offer hypertension prophylaxis. It prevents oxidation of low-density lipoprotein. It may have an inhibitory effect on the secretion of VLDL due to increased intracellular degradation of apo B-100. It also offers a post-myocardial infarction prophylaxis because of its ability to decrease CIII apolipoprotein B, to decrease CIII non-apolipoprotein B lipoproteins and to increase antithrombin III levels. Krill and/or marine oil is suitable for prophylactic usage against cardiovascular disease in human where cardiovascular disease relates to coronary artery disease, hyperlipidemia, hypertension, ischemic disease (relating to angina, myocardial inf-

arction, cerebral ischemia, shock without clinical or laboratory evidence of ischemia, arrhythmia)

[0032] To evaluate the effects of krill oil on the course of arteriosclerotic coronary artery disease and hyperlipidemia, a study was performed (prospective clinical trial, statistical significance  $p < 0.05$ ) with patients with known hyperlipidemia.

[0033] A group of 13 patients took krill oil concentrate gelules. Both fish oil and krill oil contained equal amounts of omega-3 fatty acids. Recommended dosage is of 1 to 6 capsules per day, each capsule containing 800 mg of oil. In this study, each patient took 6 capsules per day.

[0034] The patients were tested for LDL, HDL, Triglycerides, vital signs, CBC, SGOT/SGPT,  $\gamma$ -GT, ALP, Urea, Creatine, Glucose,  $K^+$ ,  $Na^+$ ,  $Ca^{2+}$  and total indirect bilirubin cholesterol before treatment and also at 2 months.

[0035] Table 1 is showing the results obtained from the previously described tests:

**Table 1**

Paired Samples Test								
Paired Differences								
Parameter tested	Mean	SD.	Std. Error Mean	95% Confidence Interval of the Difference		t-value	df	Sig. (2-tailed)
				Lower	Upper			
Cholesterol	.4954	.55800	.15476	.1582	.8326	3.201	12	.008
Triglycerides	.3538	.54543	.15127	.0242	.6834	2.339	12	.037
Triglycerides	.3538	.54543	.15127	.0242	.6834	2.339	12	.037
HDL	-.2108	.29859	.08281	-.3912	-.0303	-2.545	12	.026
HDL	-.2108	.29859	.08281	-.3912	-.0303	-2.545	12	.026
LDL	.2846	.47333	.13128	-.0014	.5706	2.168	12	.051
LDL	.2846	.47333	.13128	-.0014	.5706	2.168	12	.051
Chol / HDL	.3600	.53446	.14823	.0370	.6830	2.429	12	.032
Chol / HDL	.3600	.53446	.14823	.0370	.6830	2.429	12	.032

[0036] From the above, it was shown that a daily uptake of 1 to 4.8 g of krill extract was providing to the patients a cholesterol decrease in the range of 15%, a triglycerides decrease in the range of 15%, a HDL increase in the range of 8%, a LDL decrease in the range of 13% and a Cholesterol/HDL ratio decrease of 14%.

[0037] This shows that an uptake of krill extract has a beneficial effect on patient suffering from hyperlipidemia, which is known to be the primary causative factor of atherosclerosis.

[0038] The following example 2 to 11 are for reference purposes only.

**Example 2**

**Arthritis treatment**

[0039] Krill and/or marine oil offers symptomatic relief for Arthritis where arthritis relates to adult arthritis, Still's disease, polyarticular or pauciarticular juvenile rheumatoid arthritis, rheumatoid arthritis, osteoarthritis because it has been shown that it provides a clinical improvement in decreasing the number of tender joints and of analgesics consumed daily by decreasing the production of Interleukin-8 and Interleukin-1 in human patients. Patients with a bleeding tendency or severe psychiatric disease were excluded from the study.

[0040] To evaluate the effects of krill and/or marine oil supplementation on the clinical course of osteoarthritis, a study was performed (prospective clinical trial, statistical significance  $p < 0.05$ ) with patients diagnosed with and treated for osteoarthritis which is Active class I, II or III and having treatment with NSAIDs and/or analgesics for at least 3 months before enrollment.

[0041] A group of 13 patients took krill and/or marine oil concentrate capsules at a daily rate of 6 capsules of 800mg krill oil per capsule. The recommended dosage varies between 1 and 4.8 grams of pure krill extract per day. Patients were asked to follow a normal healthy diet consisting of 20% fat (less than 10% animal fat), 40% protein and 40% carbohydrates.

[0042] The inclusion criteria for the study are being aged between 50 and 65 years, both genders being admissible,

having a clinical diagnosis of primary osteoarthritis (mild to moderate) 6 to 12 months prior to study enrollment including pain and stiffness, radiographic confirmation of illness prior to enrollment. It also include evidence of measurable symptoms of OA for at least 3 months prior to study enrollment requiring the use of acetaminophen, anti-inflammatory agents or opioid analgesics. Patients were asked to stop the use of all "pain-killers" the week prior to initiation of the trial for wash-out purposes.

**[0043]** The Exclusion criteria were a severe osteoarthritis, unavoidable sustained use of NSAID's, aspirin or other medicines for anti-inflammatory use, use of topical analgesics within 4 weeks of randomization visit, steroid injection into either knee within past 3 months, initiation of physical therapy or muscle conditioning within 3 months, seafood allergies, use of anticoagulants or salicylates, alcohol consumption exceeding 3 mixed drinks per day, concurrent medical/arthritic disease that could confound or interfere with the evaluation of pain, prior surgery (including arthroscopy) of either knee, a known "secondary" cause of osteoarthritis.

**[0044]** Evaluation was based on daily dose of NSAIDs and/or analgesics and/or SAARDs, number of painful joints, number or swollen joints, duration of morning stiffness, visual analog scale (0-100) WOMACscale and SF36. Preliminary results have been obtained after 2 months. The number of NSAIDs and/or analgesics and/or SAARDs

**Table 2**

	Frequency	%	Valid %	Cumulative %
<b>No change</b>	3	23.1	23.1	23.1
<b>Pain relief</b>	10	76.9	76.9	100.0
<b>Total</b>	13	100.0	100.0	

**[0045]** This shows that ten out of 13 (76.9%) people reported a significant pain relief and improvement of flexibility of large joints (lower back, knees, shoulders)

**Example 3**

**Skin Cancer Prophylaxis**

**[0046]** Krill and/or marine oil has been shown to be a skin cancer prophylactic because of its retinol anti-carcinogenic effect, Astaxanthin anti-carcinogenic effect and its phospholipid anti-carcinogenic effect.

**[0047]** To evaluate the photoprotective potential of krill and/or marine oil against UVB-induced skin cancer, a study was performed on nude mice, preferably on C57BL6 Nude Congenic Mice - B6NU-T (heterozygotes) because of their proven susceptibility to skin cancer.

**[0048]** Groups were formed as follows: 48 fish oil: 16 with oral supplementation (po) 16 with local application, 16 with po and local application; 48 krill and/or marine oil: 16 with po, 16 with local application, 16 with po and local application. In order to establish efficacy of krill and/or marine oil for the prevention of skin cancer, the test was conducted as a randomized blind controlled trial (statistical significance  $p < 0.05$ ). Half of the mice have been treated orally or topically or both with oil containing 100% by weight krill and/or marine oil and the other half have been treated the same way with fish oil.

**[0049]** Nutrition was fat-free chow for the first week and was modified accordingly with the assigned group as described below for the following 2-20 weeks in the quantity of 1 ml of oil per day.

**[0050]** The mice were divided in six groups as follows:

Group A: fat-free chow with supplementation of fish oil (20% of total calories)

Group B: fat-free chow (100% of calories) + local application of fish oil 2 times per day

Group C: fat free chow with supplementation of fish oil (20% of total calories) + local application of soy oil 2 times per day

Group D: fat-free chow with supplementation of krill and/or marine oil (20% of total calories)

Group E: fat free chow (100% of calories) + local application of krill and/or marine oil 2 times per day

Group F: fat-free chow with supplementation or krill and/or marine oil (20% of total calories) + local application of

krill and/or marine oil 2 times per day

[0051] The mice had been submitted to UVB radiation using a fluorescent test lamp, emission spectrum 270-400 nm during weeks 2-20. The essay were performed during 30 minutes of UVB exposure per day and the test lamp was at a distance of 30 cm from the mice. At the end of the 20 weeks, or when malignant tumors had formed, mice were anesthetized with ether and sacrificed. Skin was examined blind by pathologists for signs of carcinogenesis.

[0052] The following tables (Tables 3-8) are showing the results obtained about the incidence of cancer when ultra-violet radiations are administered to mice's skin during 5 weeks.

Table 3

Krill extract Oral uptake					
		Frequency	Percent	Valid Percent	Cumulative Percent
Valid	Benign	14	87.5	87.5	87.5
	Cancer	2	12.5	12.5	100.0
	Total	16	100.0	100.0	

Table 4

Control Oral uptake					
		Frequency	Percent	Valid Percent	Cumulative Percent
Valid	Benign	14	87.5	87.5	87.5
	Cancer	2	12.5	12.5	100.0
	Total	16	100.0	100.0	

Table 5

Krill extract topical uptake					
		Frequency	Percent	Valid Percent	Cumulative Percent
Valid	BENIGN	16	100.0	100.0	100.0

Table 6

Control topical uptake					
		Frequency	Percent	Valid Percent	Cumulative Percent
Valid	BENIGN	5	31.3	31.3	31.3
	Cancer	11	68.8	68.8	100.0
	Total	16	100.0	100.0	

Table 7

Krill extract topical and oral uptake					
		Frequency	Percent	Valid Percent	Cumulative Percent
Valid	BENIGN	16	100.0	100.0	100.0

**Table 8**

<b>Control topical and oral uptake</b>					
		Frequency	Percent	Valid Percent	Cumulative Percent
Valid	BENIGN	10	62.5	62.5	62.5
	Cancer	6	37.5	37.5	100.0
	Total	16	100.0	100.0	

**[0053]** The results obtained shows that both oral and topical use of krill oil is effective for the protection of the skin against the harmful effects fo UVB radiation induced skin cancer.

#### **Example 4**

##### **Transdermal transport in therapeutic applications**

**[0054]** Krill and/or marine oil enhances transdermal transportation as a substrate for dermatological topical therapeutic applications. It may be used in dermatological treatments via creams, ointments, gels, lotions and oils. It may also be used in various therapeutic applications such as relating to anesthetic, corticosteroids, anti-inflammatory, antibiotic and ketolytic functions.

**[0055]** To evaluate the efficacy of krill and/or marine oil as a substrate for topical treatments and the speed of transdermal absorption of krill and/or marine alone or as a substrate, a study was performed as a randomized blind controlled trial on C57BL6 nude Congenic Mice - B6NUT (heterozygotes).

**[0056]** The results appearing in tables 5 and 6 are showing that topical treatment with krill oil facilitate the absorption of retinol and other antioxydants through the dermis which in turn result in significant photoprotective potential which in turn results in 100% protection from UVB induced skin cancer. In contrast, fish oil application with all-trans retinol resulted in 68.8% incidence of cancer.

#### **Example 5**

##### **Transdermal Transport for dermatological topical cosmetic applications**

**[0057]** Krill and/or marine oil can be used to enhance transdermal transportation as a substrate for dermatological topical cosmetic applications where cosmetic applications relate, to skin hydration, anti-wrinkle, keratolytics, peeling and mask via creams, ointments, gels, lotions or oils.

**[0058]** To evaluate the effects of Krill and/or marine oil in aging and facial wrinkles, a study was conducted as a prospective clinical trial on patients concerned about facial dryness and wrinkles. Those patients had no prognosis severely limited by other dermatological or non-dermatological condition, bleeding tendency or severe psychiatric disease.

**[0059]** 13 Healthy caucasian women with facial dryness or wrinkles have been included in this study. Women have been asked to take 6 capsules a day, each capsule containing 800 mg of krill extract. The recommended daily dosage is of about 1 to 4.8 g of krill extract.

**[0060]** Table 9 shows results obtained on skin hydration following the method previously described.

**Table 9**

<b>Changes in skin hydration</b>				
	Frequency	%	Valid %	Cumulative %
<b>No change</b>	4	30.8	30.8	30.8
<b>Hydration</b>	9	69.2	69.2	100.0
<b>Total</b>	13	100.0	100.0	

**[0061]** The results of the pilot study after 2 months indicate that nine out of 13 (69.2%) people reported a significant improvement of the hydration, texture and elasticity of the skin (face, hands and arms) in human patients.

**[0062]** Moreover, these results are also indicative that krill extract is useful for anti-wrinkle treatment. The mechanism

of all-trans retinol, which is included in the krill oil, as an anti-wrinkle works as follows:

- Regeneration and distinctive anti-inflammatory effects
- 5 - Improve blood irrigation
- Increases the epidermis regeneration by increasing the rate of cell division and turnover
- 10 - Accelerates the differentiation of keratin
- Regenerates the collagen
- Allows cells in the top layer of the skin, which are always being replaces, to mature more normally than untreated sun-damaged cells
- 15 - Reduces the activation of enzymes that break down the proteins collagen and elastin that provide structural support for the skin.

The results obtained with krill extract administered on a patient's skin show that the krill extract is having an anti-wrinkle effect by increasing the hydration and the mechanism above described.

**Example 6**

**Premenstrual syndrome**

[0063] Table 10 shows results obtained from the use of krill oil to reduce the pain and mood changes associated with premenstrual syndrome in women. Krill oil extract was administered to 7 women during 2 months. The women were taking 6 capsules of krill extract per day, each capsule containing 800 mg of krill oil. A recommended daily intake of krill oil is of about 1 to 4.8 grams. All participants were advised to continue with their usual nutrition habits and to refrain from initiating any restrictions in their diet. No serious side effects were reported.

[0064] All women enrolled reported noticeable emotional and/or physical discomfort 7 to 10 days prior to menstruation. A self-assessment visual analogue scale validated for the assessment of the premenstrual syndrome, ranging from 0 (no symptoms) to 10 (unbearable) was used as a primary outcome in order to evaluate the effect of krill extract on premenstrual discomfort.

[0065] Data analysis has been reported on 60% of the women participating in the study who have completed a two months regimen. The majority of the women (73.3%) showed a clinically significant reduction in both emotional and physical distress prior to menstruation (see Table 10).

**Table 10**

<b>Frequency distribution of the effect of krill extract on premenstrual syndrome symptomatology</b>			
<b>PMS symptoms</b>	<b>Frequency %</b>	<b>Valid %</b>	<b>Cumulative %</b>
<b>No change</b>	26.7	26.7	26.7
<b>Positive</b>	73.3	73.3	100.0
<b>Total</b>	100.0	100.0	

**Example 7**

**Diabetes**

[0066] 8 human patients were taking krill extract at the dosage of 6 capsules a day, each capsule containing 800 mg of krill extract, during 2 months. A recommended daily intake of krill oil is of about 1 to 4.8 grams. The Table 11 is showing the variation in the glucose tested for the patients after 2 months.



Table 11

Variation in glucose in patients							
Paired Differences							
Parameter tested	Mean	SD.	Std. Error Mean	95% Confidence Interval of the Difference	t-value	df	Sig. (2-tailed)
Glucose	.5778	.60369	.20123	.1137 - 1.0418	2.871	8	.021

**[0067]** A blood glucose decrease of 20% was obtained for the patients taking krill extract, which shows that an uptake of krill extract is controlling blood glucose content and therefore controlling diabetes in human patients.

**[0068]** While the invention has been described in connection with specific embodiments thereof, it will be understood that it is capable of further modifications and this application is intended to cover any variations, uses, or adaptations of the invention following, in general, the principles of the invention and including such departures from the present disclosure as come within known or customary practice within the art to which the invention pertains and as may be applied to the essential features hereinbefore set forth, and as follows in the scope of the appended claims.

## Claims

1. A composition comprising krill oil in association with a pharmaceutically acceptable carrier, for use in a method for decreasing cholesterol in a patient, wherein said krill oil is administered to the patient in a quantity in a range of 1 to 4.8 grams per day, wherein said krill oil is obtainable from a process comprising the steps of:
  - a) placing krill in a ketone solvent to achieve extraction of the soluble lipid fraction from said krill ;
  - b) separating the liquid and solid phases;
  - c) recovering a first lipid rich fraction from the liquid phase obtained at step (b) by evaporation of the solvent present in the liquid phase;
  - d) placing the solid phase in an organic solvent selected from the group consisting of alcohol and esters of acetic acid to achieve extraction of the remaining soluble lipid fraction from the solid phase ;
  - e) separating the liquid and solid phases; and
  - f) recovering a second lipid rich fraction from the liquid phase obtained at step (e) by evaporation of the solvent present in the liquid phase.
2. The composition according to claim 1, wherein the ketone solvent used in step (a) of the process is acetone.
3. The composition according to claim 1 or 2, wherein the organic solvent used in step (d) of the process is selected from the group consisting of ethanol, isopropanol and t-butanol.
4. The composition according to claim 1 or 2, wherein the organic solvent used in step (d) of the process is ethyl acetate.
5. The composition according to anyone of claims 1-4, wherein said quantity is 4.8 grams per day.
6. The composition according to anyone of claims 1-5, wherein said krill oil comprises Eicosapentanoic acid, Docosahexanoic acid, Phosphatidylcholine, Phosphatidylinositol, Phosphatidylserine, Phosphatidylethanolamine, Sphingomyelin,  $\alpha$ -tocopherol, all-trans retinol, Astaxanthin and flavonoid.
7. The composition according to anyone of claims 1-5, wherein said krill oil comprises Eicosapentanoic acid, Docosahexanoic acid, Linolenic acid, Alpha-linolenic acid, Linoleic acid, Arachidonic acid, oleic acid, palmitic acid, palmitoleic acid, stearic acid, nervonic acid, Phosphatidylcholine, Phosphatidylinositol, Phosphatidylserine, Phosphatidylethanolamine, Sphingomyelin, cholesterol, triglycerides, monoglycerides,  $\alpha$ -tocopherol, all-trans retinol, Astaxanthin, canthaxanthin,  $\beta$ -carotene flavonoid, zinc, selenium, sodium, potassium and calcium.
8. The composition according to anyone claims 1-7, wherein said composition is administered orally.

9. The composition according to anyone claims 1-8, wherein said patient is a patient suffering from hyperlipidemia.

### Patentansprüche

- 5
1. Zusammensetzung, aufweisend Krillöl, zusammen mit einem pharmazeutisch akzeptablen Träger, zur Verwendung in einem Verfahren zur Verringerung von Cholesterin bei einem Patienten, wobei das Krillöl dem Patienten in einer Menge in einem Bereich von 1 bis 4,8 Gramm pro Tag verabreicht wird, wobei das Krillöl erhältlich ist aus einem Verfahren, aufweisend die Schritte:
- 10
- a) Einbringen von Krill in ein Ketonlösungsmittel, um die Extraktion der löslichen Lipidfraktion aus dem Krill zu erreichen,
  - b) Trennen der flüssigen und festen Phasen,
  - 15 c) Wiedergewinnen einer ersten lipidreichen Fraktion aus der flüssigen Phase, die in Schritt b) erhalten wurde, durch Verdampfen des in der flüssigen Phase vorhandenen Lösungsmittels,
  - d) Einbringen der festen Phase in ein organisches Lösungsmittel, ausgewählt aus der Gruppe bestehend aus Alkohol und Estern von Essigsäure, um Extraktion der verbleibenden löslichen Lipidfraktion aus der festen Phase zu erreichen,
  - e) Trennen der flüssigen und festen Phasen, und
  - 20 f) Wiedergewinnen einer zweiten lipidreichen Fraktion aus der flüssigen Phase, die in Schritt (e) erhalten wurde, durch Verdampfen des in der flüssigen Phase vorhandenen Lösungsmittels.
2. Zusammensetzung gemäß Anspruch 1, wobei das in Schritt (a) des Verfahrens verwendete Ketonlösungsmittel Aceton ist.
- 25
3. Zusammensetzung gemäß Anspruch 1 oder 2, wobei das in Schritt (d) des Verfahrens verwendete organische Lösungsmittel ausgewählt wird aus der Gruppe bestehend aus Ethanol, Isopropanol und t-Butanol.
4. Zusammensetzung gemäß Anspruch 1 oder 2, wobei das in Schritt (d) des Verfahrens verwendete organische Lösungsmittel Ethylacetat ist.
- 30
5. Zusammensetzung gemäß irgendeinem der Ansprüche 1-4, wobei die Menge 4,8 Gramm pro Tag ist.
6. Zusammensetzung gemäß irgendeinem der Ansprüche 1-5, wobei das Krillöl Eicosapentansäure, Docosahexansäure, Phosphatidylcholin, Phosphatidylinositol, Phosphatidylserin, Phosphatidylethanolamin, Sphingomyelin,  $\alpha$ -Tocopherol, all-trans-Retinol, Astaxanthin und Flavonoid aufweist.
- 35
7. Zusammensetzung gemäß irgendeinem der Ansprüche 1-5, wobei das Krillöl Eicosapentansäure, Docosahexansäure, Linolensäure, alpha-Linolensäure, Linolsäure, Arachidonsäure, Oleinsäure, Palmitinsäure, Palmitoleinsäure, Stearinsäure, Nervensäure, Phosphatidylcholin, Phosphatidylinositol, Phosphatidylserin, Phosphatidylethanolamin, Sphingomyelin, Cholesterin, Triglyceride, Monoglyceride,  $\alpha$ -Tocopherol, all-trans-Retinol, Astaxanthin, Canthaxanthin,  $\beta$ -Karotin, Flavonoid, Zink, Selen, Natrium, Kalium und Kalzium aufweist.
- 40
8. Zusammensetzung gemäß irgendeinem der Ansprüche 1-7, wobei die Zusammensetzung oral verabreicht wird.
- 45
9. Zusammensetzung gemäß irgendeinem der Ansprüche 1-8, wobei der Patient ein Patient ist, der an Hyperlipidämie leidet.

### Revendications

- 50
1. Composition comprenant de l'huile de krill en association avec un véhicule pharmaceutiquement acceptable, pour une utilisation dans une méthode pour réduire le taux de cholestérol chez un patient, **caractérisée en ce que** ladite huile de krill est administrée au patient dans une quantité de 1 à 4,8 grammes par jour, ladite huile de krill étant susceptible d'être obtenue par un procédé comprenant les étapes de :
- 55
- a) mettre du krill dans un solvant cétonique pour réaliser une extraction de la fraction lipidique soluble dudit krill;
  - b) séparer la phase liquide de la phase solide;

## EP 1 406 641 B1

- c) récupérer une première fraction riche en lipides de la phase liquide obtenue à l'étape (b) par évaporation du solvant présent dans la phase liquide;
- d) mettre la phase solide dans un solvant organique choisi dans le groupe constitué d'alcool et d'esters d'acide acétique pour réaliser l'extraction de la fraction lipidique soluble restante de la phase solide;
- 5 e) séparer la phase liquide de la phase solide; et
- f) récupérer une seconde fraction riche en lipides de la phase liquide obtenue à l'étape(e) par évaporation du solvant présent dans la phase liquide.

- 10 2. Composition selon la revendication 1, **caractérisée en ce que** le solvant cétonique utilisé à l'étape (a) du procédé est l'acétone.
3. Composition selon la revendication 1 ou 2, **caractérisée en ce que** le solvant organique utilisé à l'étape (d) du procédé est choisi dans le groupe constitué de l'éthanol, l'isopropanol et le t-butanol.
- 15 4. Composition selon la revendication 1 ou 2, **caractérisée en ce que** le solvant organique utilisé à l'étape (d) du procédé est l'acétate d'éthyle.
5. Composition selon l'une quelconque des revendications 1 à 4, **caractérisée en ce que** ladite quantité est de 4.8 grammes par jour.
- 20 6. Composition selon l'une quelconque des revendications 1 à 5, **caractérisée en ce que** ladite huile de krill comprend de l'acide eicosapentaénoïque, de l'acide docosahexaénoïque, de la phosphatidylcoline, du phosphatidylinositol, de la phosphatidylsérine, de la phosphatidyléthanolamine, de la sphingomyéline, de l' $\alpha$ -tocophérol, du tout-trans rétinol, de l'astaxanthine et de la flavonoïde.
- 25 7. Composition selon l'une quelconque des revendications 1 à 5, **caractérisée en ce que** ladite huile de krill comprend de l'acide eicosapentaénoïque, de l'acide docosahexaénoïque, de l'acide linoléique, de l'acide  $\alpha$ -linoléique, de l'acide linoléique, de l'acide arachidonique, de l'acide oléique, de l'acide palmitique, de l'acide palmitoléique, de l'acide stéarique, de l'acide nervonique, de la phosphatidylcholine, du phosphatidylinositol, de la phosphatidylsérine, de la phosphatidyléthanolamine, de la sphingomyéline, du cholestérol, des triglycérides, des monoglycérides, de l' $\alpha$ -tocophérole, du tout-trans rétinol, de l'astaxanthine, de la cantaxanthine, du  $\beta$ -carotène, de la flavonoïde, du zinc, du sélénium, du sodium, du potassium et du calcium.
- 30 8. Composition selon l'une quelconque des revendications 1 à 7, **caractérisée en ce que** ladite composition est administrée oralement.
- 35 9. Composition selon l'une quelconque des revendications 1 à 8, **caractérisée en ce que** ledit patient est un patient souffrant d'hyperlipidémie.

40

45

50

55

19



Europäisches Patentamt  
European Patent Office  
Office européen des brevets



11 Publication number: **0 670 306 A1**

12

**EUROPEAN PATENT APPLICATION**

21 Application number: **95102933.9**

51 Int. Cl.<sup>6</sup>: **C07C 403/24, C12P 23/00**

22 Date of filing: **02.03.95**

30 Priority: **02.03.94 JP 32388/94**

71 Applicant: **NIPPON OIL CO. LTD.**  
**3-12, Nishi Shinbashi 1-chome**  
**Minato-ku**  
**Tokyo (JP)**

43 Date of publication of application:  
**06.09.95 Bulletin 95/36**

84 Designated Contracting States:  
**CH DE FR GB LI**

72 Inventor: **Kitaoka, Motomitsu**  
**3-23-1-504, Miyauchi,**  
**Nakahara-ku**  
**Kawasaki-shi,**  
**Kanagawa (JP)**  
Inventor: **Tsubokura, Akira**  
**2-228, Kosugi-cho,**  
**Nakahara-ku**  
**Kawasaki-shi,**  
**Kanagawa (JP)**  
Inventor: **Kiyota, Takashi**  
**94-9, Ichisawa-cho,**  
**Asahi-ku**  
**Yokohama-shi,**  
**Kanagawa (JP)**

74 Representative: **Cohausz & Florack**  
**Patentanwälte**  
**Kanzlerstrasse 8a**  
**D-40472 Düsseldorf (DE)**

54 **Process for extracting carotenoids.**

57 A process for extracting carotenoid compounds comprising the step of bringing a material containing the carotenoid compound into contact with a cyclic hydrophilic organic compound to extract the carotenoid compound from the material to the cyclic hydrophilic organic compound.

By this process, a carotenoid compound can be efficiently extracted resulting in an extract containing a high concentration of the carotenoid compound.

**EP 0 670 306 A1**

## BACKGROUND OF THE INVENTION

## 1. Field of Invention

5 The present invention relates to a process for extracting carotenoid compounds from a material which contains carotenoid compounds, and particularly to a process for extracting carotenoid compounds from a natural product such as microbial cells, algal cells, or tissues or organs of plants or animals.

## 2. Related Art

10

Carotenoid compounds are a group of red to yellow pigments which are widely distributed, in nature, in microbial cells, algal cells, and the tissues or organs of plants or animals. Recently, carotenoid compounds have been widely used, for example, in the field of food additives as coloring agents for foods and drinks, and as feed additives for coloring the meat, the skin, the eggs etc. of fish such as salmon or trout, and of poultry. In addition, carotenoid compounds are known to have an antioxidation action, and therefore promise to be useful as anti-oxidation agents. It has been found that certain carotenoid compounds have anti-cancer effects, and therefore promise to be useful as ingredients in pharmaceutical compositions.

15 Carotenoid compounds can be classified as those containing oxygen atom in its molecule, and those not containing oxygen atom, and the former are designated xanthophyll compounds. Among the xanthophyll compounds, astaxanthin, canthaxanthin, zeaxanthin etc. are industrially and synthetically produced. However, considering the trend of a preference for natural products it is becoming difficult to use the synthetic products as food additives and feed additives and also recently it is strongly sought to develop a process for production of natural carotenoid compounds in place of the chemically synthesized products.

20 Various technics for extraction of carotenoid compound from natural materials have been reported. For example,  $\beta$ -carotene not containing oxygen atom is extracted using petroleum ether etc. as a solvent. However, among carotenoid compounds, those including xanthophyll compounds cannot be efficiently extracted with said solvents. Further, since said solvents are immiscible with water, direct extraction of the xanthophyll compounds from a wet material is not possible.

30 On the other hand, it is known that xanthophyll compounds can be extracted with chlorinated hydrocarbons such as chloroform. However, since chlorinated hydrocarbons are toxic or involve potential environmental pollution they cannot, in practice, be used industrially as solvents in the production of foods and feeds. In addition, since they are immiscible with water, direct extraction of xanthophyll compounds from a wet material is impossible.

35 In addition, processes for extraction of carotenoid compounds with an organic solvent such as acetone, ethyl acetate etc. have been reported (see Japanese Unexamined Patent Publication (Kokai) Nos. 5-155,736; 1-202,261; and 58-88353). However, according to the reported processes, since the concentration of pigments in the extract is low, then a large amount of solvent is required and the extraction processes are highly disadvantageous as an industrial process.

## 40 SUMMARY OF THE INVENTION

The present inventors researched processes for extracting carotenoid compounds accumulated in microbial cells, algal cells, and tissues or organs of plants or animals, and as a result, found that carotenoid compounds can be efficiently extracted with a cyclic hydrophilic organic solvent to obtain an extract containing high concentration of the carotenoid compounds, and completed the present invention. In addition, the present invention is advantageous in that since the cyclic hydrophilic organic compounds used in the present invention are miscible with water, direct extraction of carotenoid compounds from a wet material is possible.

45 Accordingly, the present invention provides a process for extracting carotenoid compounds characterized by extracting carotenoid compounds from a material containing the carotenoid compounds with a cyclic hydrophilic organic compound. In this case, the cyclic hydrophilic organic compound may be used alone or in combination with an another organic solvent.

50 According to the present invention, the cyclic hydrophilic organic compounds used as solvents for extracting carotenoid compounds are preferably those compounds which have a 5-membered or 6-membered ring structure as the bone struction and contain one or more oxygen atoms and/or one or more nitrogen atoms in each molecule. The oxygen atom or nitrogen atom may be one which forms part of the ring structure or one which does not form part of the ring structure. The ring structure may have a side chain such as an alkyl group. The cyclic hydrophilic organic compounds used in the present invention are

preferably pyridine, tetrahydrofurane, dioxane, cyclohexanone, and the like.

According to the present invention, materials from which carotenoid compounds are to be extracted may be any materials which contain carotenoid compounds. Usually, microbial cells, algal cells, as well as tissues and organs of plants and animals are used. Specifically, there are used microbial cells obtainable by heterotrophically culturing a bacterium capable of producing a carotenoid compound such as E-396 (FERM BP-4283) or Corynebacterium SQH 348 (FERM BP-4284); microbial cells obtainable by heterotrophically culturing a yeast capable of producing a carotenoid compound such as Phaffia rhodozyma; algal cells obtainable by autotrophically culturing in the light an algae such as Haematococcus pluvialis or the genus Dunaliella; crustacea such as krill, crayfishes, crabs, lobsters etc; tissues of plants such as carrot; palm oil, and the like.

Among the microbial cells are preferably mentioned those which are obtained by culturing a bacterium, such as E-396 (FERM BP-4283), which has an ability to produce at least one carotenoid compound selected from the group consisting of astaxanthin, adonixanthin,  $\beta$ -carotene, achinenone, canthaxanthin and zeaxanthin in a medium containing components necessary for the growth, such as a carbon source, a nitrogen source and inorganic salts, as well as, if necessary, substances specially required by the cells, such as vitamins, amino acids, nucleotide bases, and separating the cells by centrifugation, filtration or the like to obtain cultured cells; or culturing a microorganism belonging to the genus Corynebacterium such as (Corynebacterium) SQH348 (FERM-BP-4284) in a medium containing components necessary for the growth of cells, such as a carbon source, a nitrogen source and inorganic salts, as well as, if necessary, substances specially required by the cells, such as vitamins, amino acids, nucleotide bases etc., and separating the cells by centrifugation, filtration etc. to obtain the cultured cells.

Although material containing any amount of a carotenoid compound may be used as a material to be subjected to extraction, preferably the material should contain at least 0.0001% by weight, preferably at least 0.001% by weight, and most preferably at least 0.01% by weight of carotenoid compounds. The upper limit of carotenoid content in a material to be subjected to the extraction is not critical.

Carotenoid compounds to be extracted include, for example, asaxanthin, canthaxanthin, zeaxanthin, adonixanthin, echinenone, cryptoxanthin, adonirubin, asteroidenone, rhodoxanthin, 3-hydroxy echinenone, astaxanthin ester,  $\beta$ -carotene,  $\alpha$ -carotene,  $\gamma$ -carotene, lycopene and the like, though the compounds are not limited to them. The present invention is especially useful for the extraction of xanthophyll compounds among carotenoid compounds, which are hardly extracted by conventional processes.

Cyclic hydrophilic organic compounds as extraction solvents may be used singly or in a combination of at least two compounds. A mixture of one or more cyclic hydrophilic organic compounds and another solvent can also be used.

Where one or more cyclic hydrophilic organic compounds are used in a combination with another organic solvent, the mixture should contain at least 10% by weight, preferably at least 40% by weight, and most preferably at least 60% by weight of a cyclic hydrophilic organic compound. Solvents used in the mixed solvent can be, for example, alcohols such as methanol, ethanol, propanol etc.; ketones such as acetone, methylethyl ketone, methyl isopropyl ketone etc.; ether such as diethyl ether, isopropyl ether etc.; esters such as ethyl acetate, butyl acetate etc.; aliphatic hydrocarbons such as hexane, heptane, cyclohexane, petroleum ether, etc.; aromatic hydrocarbons such as benzene, toluene, xylene etc.; chlorinated hydrocarbons such as dichloromethane, chloroform etc., and the like. The solvents are not limited to them above.

Usually, the extraction is carried out by bringing a material to be subjected to extraction into contact with a cyclic hydrophilic organic compound or a mixture of a cyclic hydrophilic organic compound and another solvent. More particularly, a material to be subjected to extraction is dispersed in a cyclic hydrophilic organic compound.

In an embodiment, the contact is made by mixing a material to be subjected to extraction with a cyclic hydrophilic organic compound and agitating or stirring the resulting mixture. During this operation, the carotenoid compounds is extracted from said material to the cyclic hydrophilic organic compounds. Next, the cyclic hydrophilic organic compound is separated from the mixture by any conventional procedure, such as centrifugation, filtration or the like, to obtain an extract containing the carotenoid compounds.

In another embodiment, a column is filled with a material to be subjected to extraction, and a cyclic hydrophilic organic compound or a mixture thereof with another solvent is passed through the column, to obtain an extract containing the carotenoid compounds.

A material to be subjected to extraction may be in a dry condition or a wet condition. Usually, the amount of a cyclic hydrophilic organic compound or a mixture thereof with another solvent is 0.2 to 1000 parts by weight, preferably 0.5 to 500 parts by weight, and most preferably 1 to 100 parts by weight, per 1 part by weight of a material to be subjected to extraction.

The extraction ratio of a carotenoid compounds by a cyclic hydrophilic organic compound or by a mixture of a cyclic hydrophilic organic compound and another solvent is usually at least 60%, and preferably at least 80%.

5 The extraction temperature is usually between -40 °C and 100 °C, preferably between -20 °C and 80 °C, and most preferably between 0 °C and 35 °C, though it being not limited these temperatures.

The extraction time is usually between one second and 100 hours, preferably between 30 seconds and 10 hours.

10 The extract containing carotenoid compound is treated to recover the carotenoid compound. Namely, the solvent in the extract is removed by a conventional procedure such as evaporation of the solvent, by lyophilization, vacuum evaporation, flash drying and the like to obtain the desired carotenoid compound in a dried form.

#### EXAMPLES

15 The present invention will be explained more definitely, by referring to the Examples.

##### Example 1

20 An astaxanthin and adonixanthin-producing strain of E-396 (FERM BP-4283 deposited with National Institute of Bioscience & Human Technology Agency of Industrial Science and Technology in Japan) was cultured in 3L of a medium comprising 20 g/L yeast extract, 30 g/L sucrose, 1.5 g/L KH<sub>2</sub>PO<sub>4</sub>, 1.5g Na<sub>2</sub>HPO<sub>4</sub>, 0.5 g/L MgSO<sub>4</sub> · 7H<sub>2</sub>O, 0.01 g/L Fe<sub>2</sub>(SO<sub>4</sub>)<sub>3</sub> · 7H<sub>2</sub>O, and 0.01 g/L CaCl<sub>2</sub> and adjusted with Na<sub>2</sub>SO<sub>4</sub> to a pH 7.0 for 5 days, and the culture was centrifuged to obtain 90g of wet cells. The wet cells contained 1.0 mg/g concentration of carotenoid compounds.

25 To 10g of the wet cells was added 10 mL of pyridine, and extraction was carried out by agitating the mixture for an hour, and to the separated cells was again added 10 mL pyridine, and the mixture was again agitated for an hour. The extraction was further repeated twice. The amount of carotenoid compounds extracted in each extraction is shown in Table 1. As a result, 95% of the total amount of carotenoid compounds was extracted in the first two extractions.

30

##### Example 2

The same procedure as described in Example 1 was repeated except that tetrahydrofurane was used in place of pyridine. The amount of carotenoid compounds extracted in each extraction is shown in Table 1. As a result, 97% of the total amount of carotenoid compounds was extracted in the first two extractions.

35

##### Example 3

40 The same procedure as described in Example 1 was repeated except that dioxane was used in place of pyridine. The amount of carotenoid compounds extracted in each extraction is shown in Table 1. As a result, 93% of the total amount of carotenoid compositions was extracted in the first two extractions.

##### Example 4

45 The same procedure as described in Example 1 was repeated except that cyclohexanone was used in place of pyridine. The amount of carotenoid compounds extracted in each extraction is shown in Table 2. As a result, 88% of the total amount of carotenoid compounds was extracted in the first two extractions.

##### Example 5

50

The same procedure as described in Example 1 was repeated except that a mixture of tetrahydrofurane and dioxane 1:1 was used in place of pyridine. The amount of carotenoid compounds extracted in each extraction is shown in Table 1. As a result, 96% of the total amount of carotenoid compounds was extracted in the first two extractions.

55

Example 6

5 The same procedure as described in Example 1 was repeated except that a mixture of tetrahydrofuran and cyclohexanone 1:1 was used in place of pyridine. The amount of carotenoid compounds extracted in each extraction is shown in Table 1. As a result, 94% of the total amount of carotenoid compounds was extracted in the first two extractions.

Example 7

10 The same procedure as described in Example 1 was repeated except that a mixture of tetrahydrofuran, dioxane and cyclohexanone 2:1:1 was used in place of pyridine. The amount of carotenoid compounds extracted in each extraction is shown in Table 1. As a result, 95% of the total amount of carotenoid compounds was extracted in the first two extractions.

15 Example 8

The same procedure as described in Example 1 was repeated except that a mixture of pyridine, tetrahydrofuran, dioxane and cyclohexanone 1:1:1:1 was used in place of pyridine. The amount of carotenoid compounds extracted in each extraction is shown in Table 1. As a result, 97% of the total amount of carotenoid compounds was extracted in the first two extractions.

Comparative Example 1

25 The same procedure as described in Example 1 was repeated except that acetone was used in place of pyridine. The amount of carotenoid compounds extracted in each extraction is shown in Table 1. As a result, only 52% of the total amount of the carotenoid compounds was extracted in the four extractions.

Comparative Example 2

30 The same procedure as described in Example 1 was repeated except that isopropanol was used in place of pyridine. The amount of carotenoid compounds extracted in each extraction is shown in Table 1. As a result, only 48% of the total amount of carotenoid compounds was extracted in the four extractions.

Comparative Example 3

35 The same procedure as described in Example 1 was repeated except that hexane was used in place of pyridine. As a result, no carotenoid compounds were extracted.

Comparative Example 4

40 The same procedure as described in Example 1 was repeated except that chloroform was used in place of pyridine. As a result, no carotenoid compounds were extracted.

45

50

55



Table 1

Amount of Carotenoid Compounds Extracted				
	Amount of carotenoid compounds extrate (mg)			
	First ext.	Second ext.	Third ext.	Fourth ext.
Example 1	6.1	3.4	0.3	0.1
Example 2	6.5	3.2	0.3	0.0
Example 3	5.9	3.4	0.4	0.1
Example 4	5.3	3.5	0.7	0.2
Example 5	6.3	3.3	0.3	0.0
Example 6	6.2	3.4	0.3	0.1
Example 7	6.6	2.9	0.2	0.0
Example 8	6.7	3.0	0.3	0.0
Comp. Example 1	0.8	3.6	0.9	0.2
Comp. Example 2	2.8	1.5	0.4	0.1
Comp. Example 3	0.0	0.0	0.0	0.0
Comp. Example 4	0.0	0.0	0.0	0.0

Examples 9 to 12

A canthaxanthin producer strain *Corynebacterium* sp. SQH 348 (FERM BP-4284) was cultured in 3L of a medium containing 30 g/L yeast extract, 10 g/L glucose, 1 mL/L soybean oil, 2.5 g/L  $\text{NH}_4\text{NO}_3$ , 1.5 g/L  $\text{KH}_2\text{PO}_4$ , 1.5 g/L  $\text{Na}_2\text{HPO}_4$ , 0.5 g/L  $\text{MgSO}_4 \cdot 7\text{H}_2\text{O}$ , 0.01 g/L  $\text{Fe}_2(\text{SO}_4)_3 \cdot 7\text{H}_2\text{O}$  and 0.01 g/L  $\text{CaCl}_2$ , adjusted to pH 8.0 with  $\text{CaCO}_3$ , for 7 days, and the culture was centrifuged to obtain 75g of wet cells. The wet cells contained 0.61 mg/g carotenoid compounds. Next, 10g of the wet cells was subjected to extractions as described in Examples 1 to 4 using different extraction solvents. The result is shown in Table 2.

Table 2

Amount of Carotenoid Compounds Extracted					
Extraction solvent		Amount of carotenoid compounds extracted			
		First ext.	Second ext.	Third ext.	Fourth ext.
Example 9	Pyridine	3.8	2.1	0.2	0.0
Example 10	Tetrahydrofurane	3.9	2.0	0.2	0.0
Example 11	Dioxane	3.5	2.2	0.3	0.1
Example 12	Cyclohexanone	3.1	2.4	0.5	0.1

Example 13

An astaxanthin producer yeast *Phaffia rhodozyma* was cultured in 3L of MYP medium for 10 days. After finishing the culture, the culture medium was centrifuged and the collected cells were lyophilized to obtain 23g of dry cells. The dry cells contained 0.86 mg/g of carotenoid compounds. 2g of the dry cells was mixed with 10 mL of pyridine in a glass homogenizer, and homogenized for 30 minutes. As a result, 1.60 mg (yield 93%) of the carotenoid compounds was extracted.

Example 14

The same procedure as described in Example 13 was repeated except that tetrahydrofurane was used in place of pyridine. As a result, 1.61 mg (yield 94%) of the carotenoid compounds was extracted.

5

Example 15

The same procedure as described in Example 13 was repeated except that dioxane was used in place of pyridine. As a result, 1.55 mg (yield 90%) of the carotenoid compounds was extracted.

10

Example 16

The same procedure as described in Example 13 was repeated except that cyclohexanone was used in place of pyridine. As a result, 1.51 mg (yield 88%) of the carotenoid compounds was extracted.

15

Example 17

Dried cells of an astaxanthin producer algae Haematococcus pluvialis were ground in a mortar, and 2g of the ground cells (carotenoid content 5.3 mg/g) were filled in a column, and pyridine was passed through in the column, at a flow rate of 0.5 mL/min., for 40 min. for extraction. As a result, 10.5 mg (yield 99%) of the carotenoid compounds was extracted.

20

Example 18

The same procedure as described in Example 17 was repeated except that tetrahydrofurane was used in place of pyridine. As a result, 10.3 mg (yield 97%) of the carotenoid compounds was extracted.

25

Example 19

The same procedure as described in Example 17 was repeated except that dioxane was used in place of pyridine. As a result, 10.4 mg (yield 98%) of the carotenoid compounds was extracted.

30

Example 20

The same procedure as described above was repeated except that cyclohexanone was used in place of pyridine. As a result, 10.1 mg (yield 95%) of the carotenoid compounds was extracted.

35

As can be seen from the above, according to the present invention, carotenoid compounds, especially xanthophyll compounds, can be efficiently extracted from a material containing the carotenoid compounds by using a cyclic hydrophilic organic compound as an extraction solvent to obtain an extract containing a high concentration of carotenoids.

40

**Claims**

1. A process for extracting a carotenoid compound comprising the step of:

45

bringing a material containing the carotenoid compound into contact with a cyclic hydrophilic organic compound so as to prepare a mixture of said material and said cyclic hydrophilic organic compound resulting in the extraction of the carotenoid compound from said material to said cyclic hydrophilic organic compound.

2. A process according to claim 1, further comprising the step of separating the cyclic hydrophilic organic compound containing the carotenoid compound from said mixture to obtain an extract.

50

3. A process according to claim 1, further comprising the step of removing the cyclic hydrophilic organic compound from the extract to recover the carotenoid compound.

55

4. A process according to claim 1, wherein the carotenoid compound to be extracted is a xanthophyll compound.

5. A process according to claim 1, wherein the cyclic hydrophilic organic compound is a solvent selected from the group consisting of pyridine, tetrahydrofurane, dioxane and cyclohexanon.
6. A process according to claim 1, wherein the cyclic hydrophilic organic compound is used in the form of a mixture of the cyclic hydrophilic organic compound and another solvent.
7. A process according to claim 6, wherein said another solvent is an organic solvent selected from the group consisting of methanol, ethanol, isopropanol, acetone, methyl ethyl ketone, methyl isopropyl ketone, diethyl ether, isopropyl ether, ethyl acetate, butyl acetate, hexane, heptane, cyclohexane, petroleum ether, benzene, toluene, xylene, dichloromethane and chloroform.
8. A process according to claim 1, wherein the material containing a carotenoid compound is selected from the group consisting of microbial cells, algal cells, plant tissue and animal tissue.
9. A process according to claim 8, wherein the cells are those of an organism belonging to the genus Corynebacterium, Phaffia, Haematococcus or Dunaliella.
10. A process according to claim 8, wherein the microbial cells are those of an organism belonging to the genus to which the astaxanthin and adonixanthin-producing strain E-396 (FERM BP-4283) belongs.
11. A process according to claim 10, wherein the microbial cells are those of the strain E-396 (FERM BP-4283).
12. A microbial strain E-396 (FERM BP-4283) capable of producing astaxanthin and adonixanthin.



DOCUMENTS CONSIDERED TO BE RELEVANT			
Category	Citation of document with indication, where appropriate, of relevant passages	Relevant to claim	CLASSIFICATION OF THE APPLICATION (Int.Cl.6)
X	DATABASE WPI Section Ch, Week 8830 Derwent Publications Ltd., London, GB; AN 90-380807 & JP-A-02 276 584 (OSAKA CHEM ALLOY KK) , 13 November 1990 * abstract * ---	1	C07C403/24 C12P23/00
X	DATABASE WPI Section Ch, Week 8830 Derwent Publications Ltd., London, GB; AN 88-209162 & JP-A-63 145 367 (MAZUREN KASEI KK) , 17 June 1988 * abstract * ---	1	
A D	EP-A-0 077 583 (ANIC S.P.A.) * claim 1 * & JP-A-58 088 353 ---	1,12	
P,A	WO-A-94 10140 (NATURAL CAROTENE CORPORATION) * claim 1 * ---	1	<b>TECHNICAL FIELDS            SEARCHED (Int.Cl.6)</b>  C07C C12P
A	CHEMICAL ABSTRACTS, vol. 112, no. 18, 1990 Columbus, Ohio, US; abstract no. 164947w, * abstract * & JP-A-01 290 659 (NIPPON TERPENE CHEMICAL CO., LTD.) 22 November 1989 ---	1	
A	L.F. FIESER AND M. FIESER 'organische chemie' 1968 , VERLAG CHEMIE , WEINHEIM * page 1577, line 33 - line 40 * -----	1	
The present search report has been drawn up for all claims			
Place of search		Date of completion of the search	Examiner
BERLIN		15 June 1995	Kapteyn, H
<b>CATEGORY OF CITED DOCUMENTS</b> X : particularly relevant if taken alone Y : particularly relevant if combined with another document of the same category A : technological background O : non-written disclosure P : intermediate document T : theory or principle underlying the invention E : earlier patent document, but published on, or after the filing date D : document cited in the application L : document cited for other reasons ..... & : member of the same patent family, corresponding document			

EPO FORM 1503 (01.82) (P/NC01)



Europäisches Patentamt  
European Patent Office  
Office européen des brevets



(11) EP 0 921 537 A2

(12) **EUROPEAN PATENT APPLICATION**

(43) Date of publication:  
09.06.1999 Bulletin 1999/23

(51) Int. Cl.<sup>6</sup>: H01F 7/20

(21) Application number: 98309985.4

(22) Date of filing: 04.12.1998

(84) Designated Contracting States:  
AT BE CH CY DE DK ES FI FR GB GR IE IT LI LU  
MC NL PT SE  
Designated Extension States:  
AL LT LV MK RO SI

(72) Inventors:  
• Englund, Rurik  
06100 Porvoo (FI)  
• Kinanen, Ilmari V.  
02210 Espoo (FI)  
• Lindholm, John-Erik M.  
01120 Vasterkog (FI)

(30) Priority: 05.12.1997 US 985935

(74) Representative: Waters, Jeffrey  
The General Electric Company, p.l.c.  
GEC Patent Department  
Waterhouse Lane  
Chelmsford, Essex CM1 2QX (GB)

(71) Applicant: Picker Nordstar Inc.  
00510 Helsinki (FI)

(54) **Magnet coil assembly**

(57) An MR imaging apparatus includes a magnet assembly having two generally opposed pole pieces (23). Current flowing in driver coils (14, 16) associated with each pole pieces generates a magnetic field in the imaging region. The driver coils include a conductor having beveled edges, the conductor being wound in a spiral fashion. A layer of electrical insulation is located between the conductor windings. A cooling member (10, 12) fabricated from bifilar wound tubing having a generally rectangular cross section is in thermal communication with each driver coil. Coolant flowing through the cooling member removes heat generated in the driver coils.

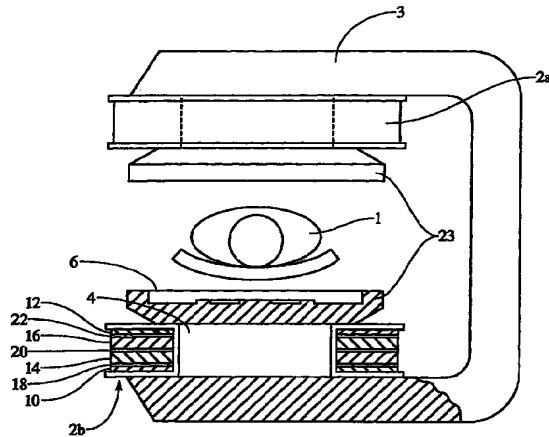


Fig.1

EP 0 921 537 A2

## Description

[0001] The present invention relates to magnet coil assemblies, and more particularly to driver coils and cooling techniques for use in resistive electromagnets. The present invention finds particular application in the field of magnetic resonance imaging (MRI).

[0002] MRI is widely used for imaging anatomical and other structures. A commonly used type of magnet for MRI systems is the superconducting type, which is capable of generating field strengths in the range of 0.5-2 Tesla (T). Superconducting magnets are, however, relatively expensive to manufacture and operate.

[0003] At lower fields, for example in the range of 0.1 to 0.3 T, resistive magnets are commonly used to produce magnetic fields for MRI applications. Resistive magnets typically include one more magnet driver coils operating in cooperation with a suitable magnet structure, the magnetic field strength being generally proportional to the current through the coils. A limitation on magnet performance, however, is the heat generated in the resistance of the driver coils. As a result, cooling systems have been used to remove this excess heat.

[0004] To provide the necessary cooling, annular cooling flanges or discs fabricated from a material such as aluminium have been placed in thermal contact with the magnet coils. Channels having a size and depth sufficient to accommodate and retain copper tubing having a round cross section have been included on one side of the cooling flange, which has had a thickness greater than that of the tubing. The channels and tubing are arranged in a bifilar wound pattern so that the inlet and outlet of the tubing are both accessible from the outer radius of the cooling flange. The cooling flanges have then been placed against the driver coils, with the tubing preferably on the side of the flange facing away from the magnet coil. In operation, a coolant such as water has been caused to flow through the tubing.

[0005] In practice, however, neither the surface of the driver coil nor surface of the cooling flange are perfectly flat. The resultant gaps degrade the thermal conductivity between the coil and flange. There have also been radial gaps between the channels and hence the turns of tubing, also reducing thermal efficiency.

[0006] In magnet systems having two driver coils on each pole of the magnet it has been necessary to use three cooling flanges. The structure associated with each pole has thus included a first cooling flange, a driver coil having its first side electrically insulated from but in thermal contact with the first cooling flange, a second cooling flange located between the second side of the first driver coil and first side of a second driver coil (the second cooling flange being in thermal contact with but electrically insulated from the driver coils), the second driver coil, and a third cooling flange electrically insulated from but in thermal contact with the second side of the second driver coil.

[0007] Driver coils have also included many turns of a

conductor such as aluminium arranged in a generally planar, disc-shaped coil. The conductor has had a rectangular cross-section, with the conductor wound or coiled from an inner to an outer radius in the form of an annulus or disc. To insulate between the multiple conductor turns, an anodized aluminium conductor has been used. A disadvantage of anodized aluminium, however, is its cost. A further disadvantage is that defects in the anodization may result in short circuits between coil turns, with a corresponding deleterious effect on magnet performance.

[0008] In accordance with a first aspect of the invention, a magnet coil assembly includes a generally planar driver coil. Current flowing through the driver coil causes heat to be generated. The assembly also includes tubing which contains the flow of coolant. The tubing has a substantially planar exterior portion which faces and is in thermal communication with the surface of the driver coil.

[0009] According to a more limited aspect of the invention, the tubing has a rectangular exterior cross section.

[0010] According to another more limited aspect of the invention, the tubing is wound to define a plurality of generally planar turns. A layer of thermally insulating material having a thickness less than that of the tubing may be located between the turns.

[0011] According to yet another more limited aspect of the invention, the tubing is bifilar wound.

[0012] According to another more limited aspect, the driver coil and the and the tubing are separated by a layer of electrical insulation which defines a plurality of holes. According to a still more limited aspect, an epoxy is located between the insulation and the driver coil.

[0013] According to another aspect of the invention, a magnet for use in MRI includes two pole pieces in an opposed relationship which define an imaging region. A driver coil and a material for defining a cooling passage are associated with the first pole piece. The material has a substantially planar portion facing and in thermal communication with the driver coil. A driver coil and material for defining a cooling passage are also associated with the second pole piece. The material has a substantially planar portion facing and in thermal communication with the driver coil associated with the second pole piece.

[0014] According to a more limited aspect of the invention, the driver coil associated with the first pole piece includes a conductor which has a generally rectangular cross section. An edge of the conductor which is adjacent to the material is beveled. According to a still more limited aspect, the conductor is wound to define a plurality of generally planar turns. The turns are separated by a layer of electrical insulation. According to a still more limited aspect, the electrical insulation does not extend past the edge of the conductor facing the material in thermal communication therewith.

[0015] According to another aspect of the invention, a

magnet coil assembly for use in magnetic resonance imaging includes a first driver coil and material which defines a cooling passage. The material has a substantially planar portion which faces and is in thermal communication with the first surface of the first driver coil. A second surface of the second driver coil is adjacent the second surface of the first driver coil. Material which defines a cooling passage and has a substantially planar portion faces and is in thermal communication with the first surface of the first driver coil.

[0016] One way of carrying out the invention will now be described in greater detail, by way of example, with reference to the accompanying drawings, in which:

Figure 1 depicts an MRI apparatus according to the present invention;

Figure 2 is an exploded view of a magnet coil assembly;

Figure 3 is a top view of a cooling member;

Figure 4 is a top view of a perforated insulating layer; and

Figure 5 is a sectional view of a portion of the windings of a driver coil along line 5-5 of Figure 2.

[0017] With reference to Figure 1, an MRI apparatus which produces images of the anatomy of patient 1 includes a generally C-shaped magnet body 3. The patient 1 is placed in an imaging region located between the pole pieces 23. Current flowing in the driver coils contained in coil assemblies 2a, 2b generates a magnetic field  $B_0$  in the imaging region. Necks 4 connect the pole pieces 23 to the body 3 of the magnet, thereby providing a return path for the body of the magnet.

[0018] Gradient coils 6 generate time-varying gradient magnetic fields, preferably in three orthogonal directions (e.g., x, y, z). As known in the art, the MRI apparatus 100 also includes RF transmit and receive coils (not shown) for exciting magnetic resonance of materials within the imaging region and detecting signals excited thereby. As is also conventional in the art, associated signal processing and computer apparatus generates and displays images of the internal anatomy of the patient on a CRT or other suitable monitor.

[0019] Figure 2 depicts the various components of the lower magnet coil assembly 2b, it being understood that lower magnet coil assembly 2b is also representative of the upper magnet coil assembly 2a.

[0020] With reference to Figure 1, 2, and 3, the magnet coil assembly 2b includes a pair of cooling members 10, 12, a pair of magnet coils 14, 16, and electrical insulation layers 18, 20, 22. Each cooling member 10 is fabricated from tubing wound in a generally planar annular configuration. The tubing is preferably copper tubing having an 8 x 12 mm rectangular exterior cross section

and is bifilar wound, with the 12 mm dimension of the tube running in the radial direction. Other materials and cross sections may also be used, provided that tubing is wound so that a substantially flat portion of the tubing cross section may be placed facing and in thermal contact with the magnet coil 14. Placed between each of the adjacent layers of tubing is thermal insulation such as PVC having a thickness of approximately 2 mm. Typical conductivity for a polymer such as PVC is approximately 0.3 w/mK. The tubing is wound so that adjacent turns of tubing are substantially adjacent, though separated by thermal insulation 28. The member has an inlet 24 through which a coolant such as water is introduced, and an outlet 26 from which the coolant exits after having flowed through the tubing. Mechanical spacers 29a, 29b are placed in the inner layers of the winding to account for spaces caused by the bend of the bifilar wound tubing and thus maintain the circularity of the cooling member 10.

[0021] An electrical insulation layer 18 is located between the cooling member 10 and the driver coil 14. The insulation layer 18 should provide a desired degree of electrical isolation consistent with good thermal communication between the cooling spiral 10 and the driver coil 14. With reference to Figure 4, the insulation layer 18 is of an annular shape and contains a plurality of perforations or holes 28. A uniform layer of epoxy adhesive is used to fasten the cooling member 10 to the driver coil 14. The epoxy preferably provides a high degree of thermal conductivity, which in practice means a high filler content, and a desired degree of electrical isolation. Because the insulation layer 18 contains numerous perforations 28, the epoxy layer joins the cooling member 10 and the driver coil 14 over a substantial portion of their surface. The epoxy preferably has a minimum of voids so as to maximize thermal communication between the cooling member 10 and the driver coil 14. To improve electrical isolation, the cooling member 10 may also be coated with a layer of lacquer.

[0022] With reference to Figures 2 and 5, a generally planar driver coil 14 contains a plurality of turns of a spiral-wound electrical conductor 30 such as aluminium. An electrical connection is made at one end of the conductor 30 at the inside of the spiral and at the other end at the outside of the spiral. A cross section of a portion of the driver coil 14 showing a representative portion of the coil windings is shown in Figure 5. While gaps are shown between the windings for ease of illustration, it will be appreciated that in practice the windings are substantially adjacent.

[0023] The conductor 30 is characterized by a generally rectangular cross section having beveled edges 32a and 32b. An electrical insulation layer 34 such as Mylar is placed between the turns of the conductor 30, thus preventing the turns from making electrical contact. The beveled surfaces prevent electrical contact near the upper and lower edges of the conductor 30 in the event that the vertical dimensions of the insulating layer 34 or

conductor 30 should vary or if the insulating layer 34 is not precisely positioned. In practice, the nominal dimensions of the bevels 32a, 32b and the height of the insulating layer 34 are chosen so that electrical insulation between the conductor 30 turns is achieved despite variations in the material and assembly techniques while preventing or minimizing protrusion of the insulating layer 34 beyond the vertical extent or edges of the conductor 30. This in turn facilitates thermal communication between the conductor and adjacent layers or structures such as the cooling member 10. In an arrangement where the conductor has a nominal height of 100 mm and a nominal thickness of 0.5 mm, satisfactory results have been achieved with bevels 32a, 32b having a height of 1 mm and a depth of 0.02 mm and an insulation layer 34 having a height of 100 mm.

**[0024]** An electrical insulation layer 20 is placed between the driver coils 14, 16. The insulation layer 18 is selected to provide a desired degree of electrical isolation between the driver coils 14, 16. The coils 14, 16 are bonded to the insulation layer using an epoxy. Of course, other arrangements, such as those described above in regard to insulation layer 18, may be used if improved thermal communication between driver coils 14, 16 is desired.

**[0025]** While the foregoing description has been directed primarily to cooling member 10, insulating layer 18, and driver coil 14, it will be appreciated that it applies equally to driver coil 16, insulating layer 22, and cooling member 22. After assembly, the entire structure is hermetically sealed using epoxy, a glass fibre laminate, or like technique.

**[0026]** In operation, a current source provides an electrical current to the magnet assemblies 2a, 2b so that a desired magnetic field  $B_0$  is generated, and coolant such as water is caused to flow through passages defined by the material of the cooling members 10, 12. Being relatively flexible, the cooling members may be placed in good thermal contact with the driver coils 12, 14 during the manufacturing process, for example by applying pressure during assembly. Thus, the system is relatively tolerant of variations in the surfaces of the cooling member and driver coils. Because protrusions of the relatively thermally insulating Mylar beyond the surface of the driver coils are minimized, thermal communication between the cooling members and the driver coils 12, 14 is further enhanced.

**[0027]** Although the cooling member has been described in terms of bifilar wound tubing, other configurations are possible. Thus, for example, coolant may be introduced to the cooling members through headers or manifolds, each feeding a plurality of cooling passages. In one embodiment, each cooling member includes a first inlet manifold and first exit manifold which are associated with a first plurality of cooling passages, and a second inlet manifold and second exit manifold which are associated with a second plurality of passages. The first and second passages are inter-

leaved, with the direction of coolant flow in opposite directions.

**[0028]** As will be appreciated, coolant entering the inlet side 24 of the cooling member is cooler than that exiting through the outlet 26. A particular advantage of the bifilar winding of the cooling member is that variation in temperature of the cooling member in the radial direction are minimized. This in turn minimizes variation in temperature of the driver coils 12, 14 in the radial direction. Effective thermal insulation between the individual turns in the cooling member also improves the thermal efficiency of the cooling member.

**[0029]** The invention has been described in relation to a C-shaped magnet apparatus. It will be appreciated that the invention can be used with other magnet configurations, such as the so-called four-poster type, the so-called H-form, or other configurations which provide a return path for the magnet flux.

**[0030]** A first advantage of the described embodiment is that improved thermal performance in a magnet system is provided while minimizing cost and complexity, including that of the cooling system. Another advantage is that improved thermal communication between the cooling member and the driver coil is provided. Not only can absolute temperature of the magnet coils be reduced, but also temperature gradients within the coils themselves can be minimized. Yet another advantage is that a separate cooling flange may be eliminated. Another advantage is that the turns of the magnet coil are insulated using a technique which avoids the disadvantages of the anodized approach but which does not degrade the performance of the cooling system.

**[0031]** The invention has been described with reference to the preferred embodiment. Obviously, modifications and alterations will occur to others upon reading an understanding the preceding description. It is intended that the invention be construed as including all such modifications an alterations insofar as they come within the scope of the appended claims or the equivalents thereof.

#### Claims

1. A magnet coil assembly comprising: a first generally planar driver coil (14, 16) having at least a first surface, heat being generated in the first driver coil in response to the flow of electrical current; and a first material (10, 12) defining a passage capable of containing the flow of a coolant therethrough which removes heat generated in the first driver coil, the first material having a substantially planar portion facing and in thermal communication with the first driver coil.
2. A coil assembly as claimed in claim 1, wherein the first material comprises tubing.
3. A coil assembly as claimed in claim 2, wherein the



tubing has a rectangular exterior cross section.

- 4. A coil assembly as claimed in claim 2 or claim 3, wherein the tubing is wound to define a plurality of generally planar turns. 5
- 5. A coil assembly as claimed in claim 4, including a layer of thermally insulating material (28) between the turns. 10
- 6. A coil assembly as claimed in claim 5, wherein the thermally insulating material (28) has a thickness less than that of the tubing.
- 7. A coil assembly as claimed in any one of claims 2 to 6, wherein the tubing is bifilar wound. 15
- 8. A coil assembly as claimed in any one of claims 1 to 7, wherein the first driver coil (14, 16) and the first material (10, 12) are separated by a layer of electrical insulation (18, 22), the layer of electrical insulation having a plurality of holes. 20
- 9. A coil assembly as claimed in claim 8, comprising adhesive between the layer of electrical insulation (18, 22) and the first driver coil (14, 16). 25
- 10. A coil assembly as claimed in claim 9, wherein the adhesive is an epoxy having a high thermal conductivity. 30
- 11. A coil assembly as claimed in any one of claims 1 to 10, wherein the coolant comprises water.
- 12. A coil assembly as claimed in any one of claims 1 to 11, wherein the first driver coil (14, 16) comprises a conductor (30) having a generally rectangular cross section, an edge of the conductor adjacent the first material having a bevel (32a, 32b). 35
- 13. A coil assembly as claimed in claim 12, wherein the conductor (30) is wound so as to define a plurality of generally planar turns and the turns are separated by a layer of electrical insulation (34). 40
- 14. A coil assembly as claimed in any one of claims 1 to 13, wherein the first material (10, 12) facing and in thermal communication with the first surface of the first driver coil defines a plurality of passages (24, 26). 45
- 15. A coil assembly as claimed in any one of claims 1 to 14, further including a second generally planar driver coil (14, 16) having at least a first surface, heat being generated in the second driver coil in response to the flow of electrical current; and a second material (10, 12) defining a passage capable of containing the flow of a coolant therethrough which 50

removes heat generated in the magnet coil, the second material having a substantially planar portion facing and in thermal communication with the second driver coil, wherein the first driver coil is associated with a first pole piece (23) and the second driver coil is associated with a second pole piece (23), the first and second pole pieces in an opposed relationship and defining an image region therebetween for use in magnetic resonance imaging.

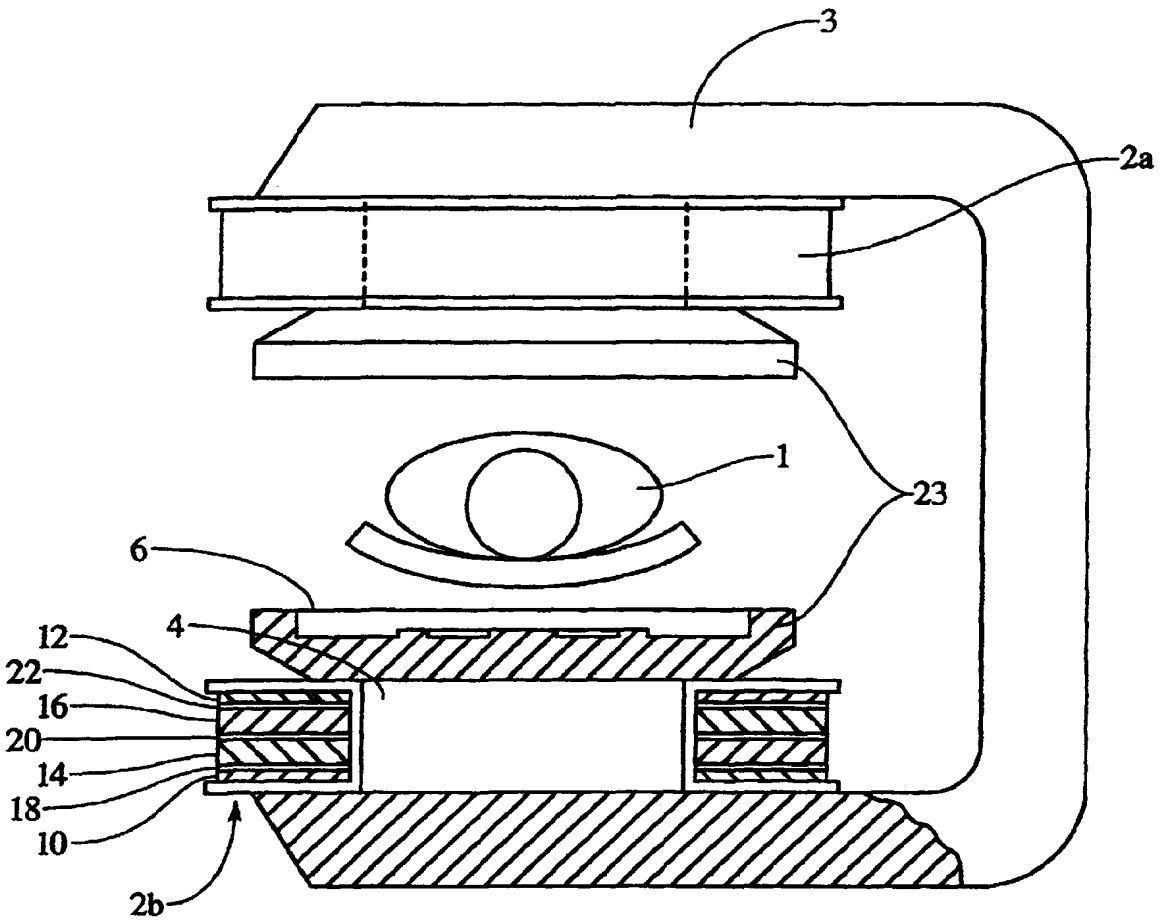
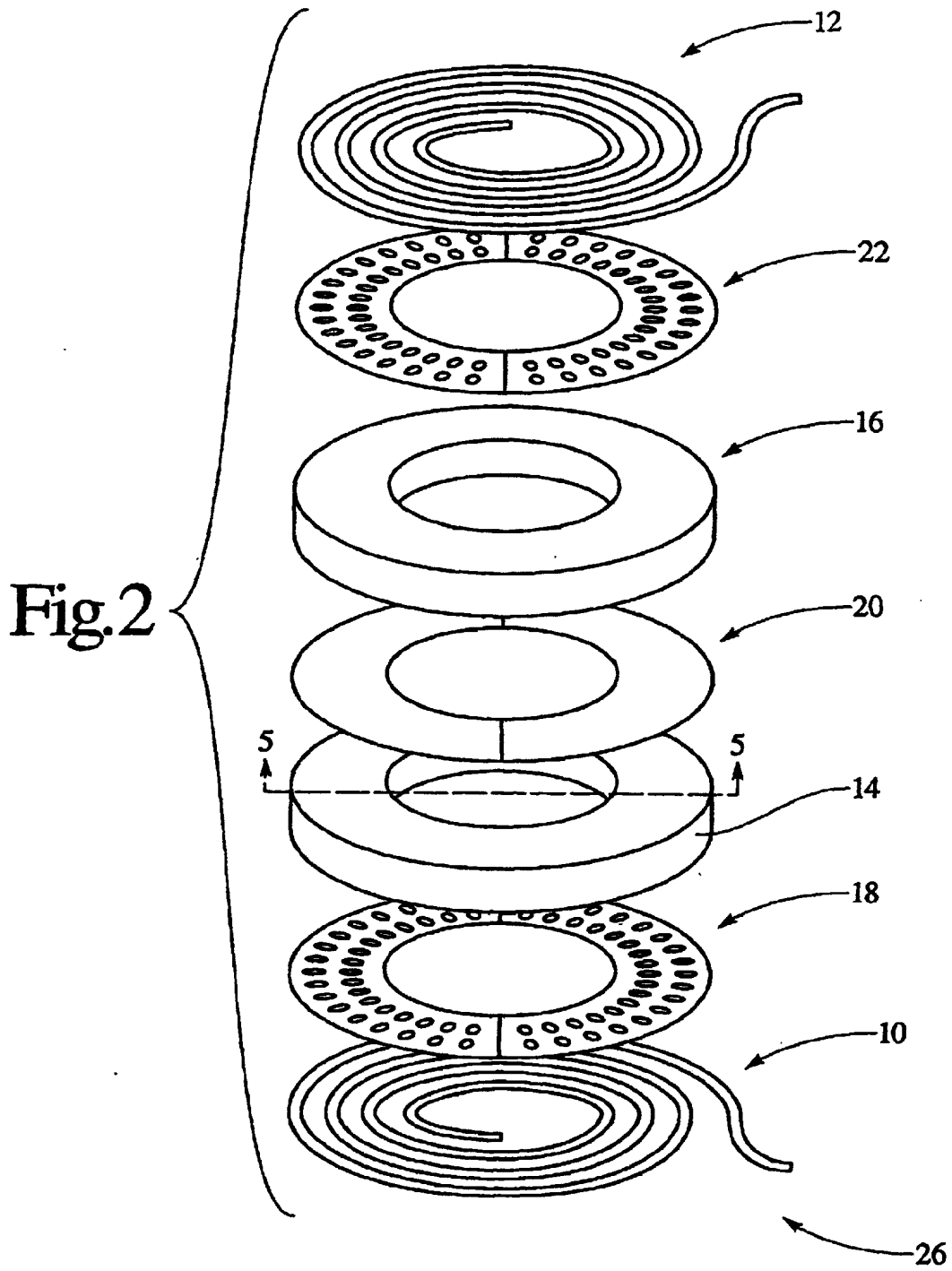


Fig.1



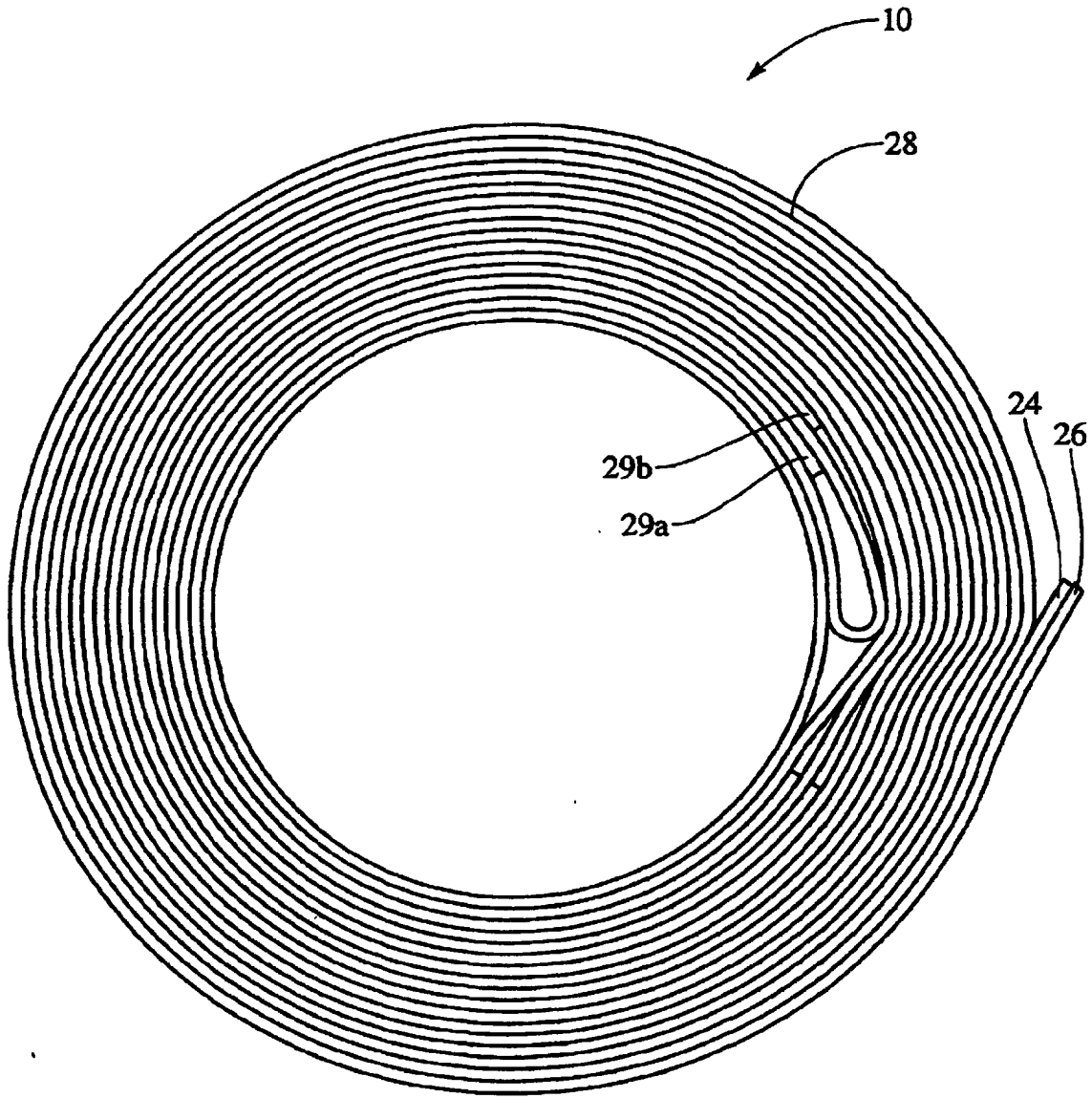


Fig. 3

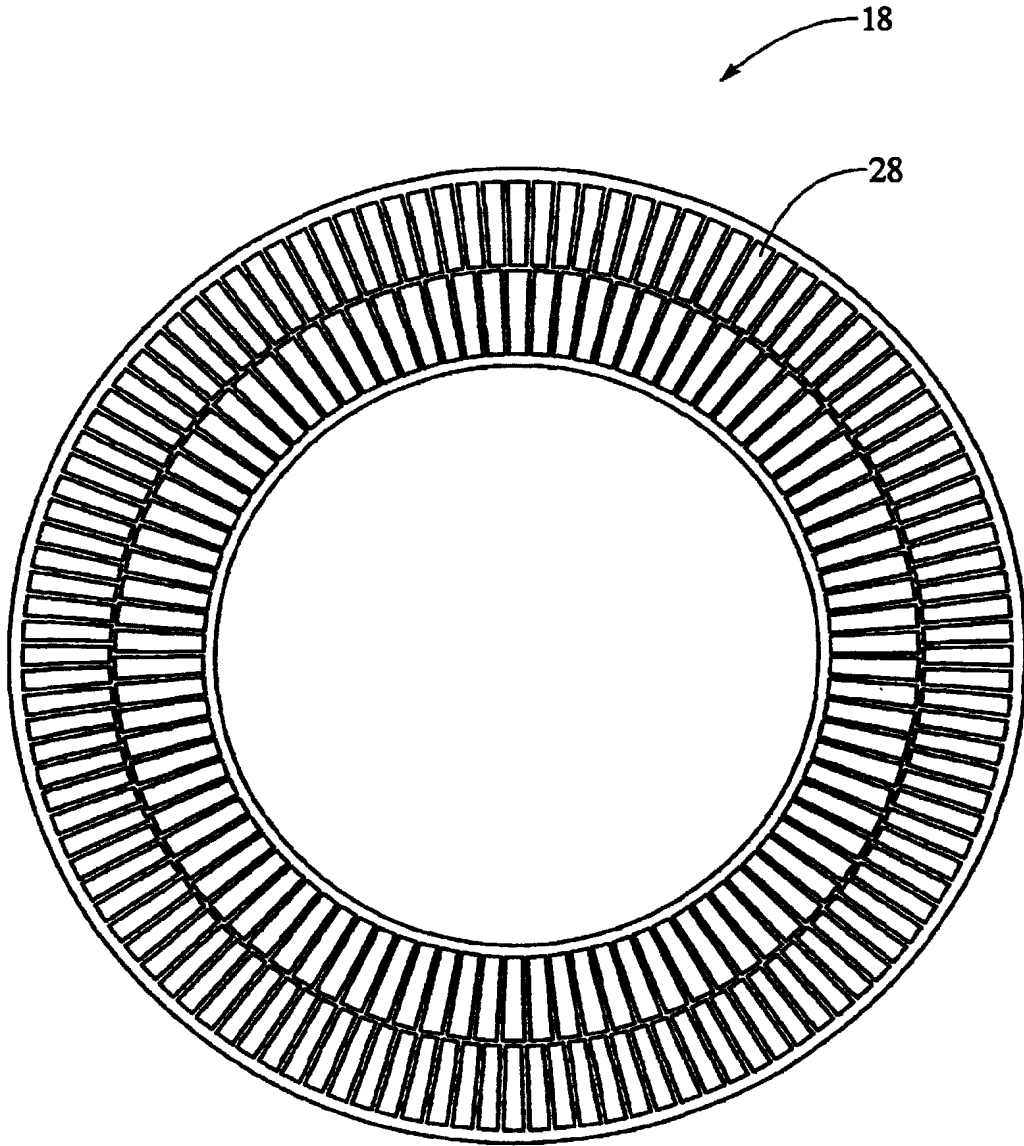


Fig. 4

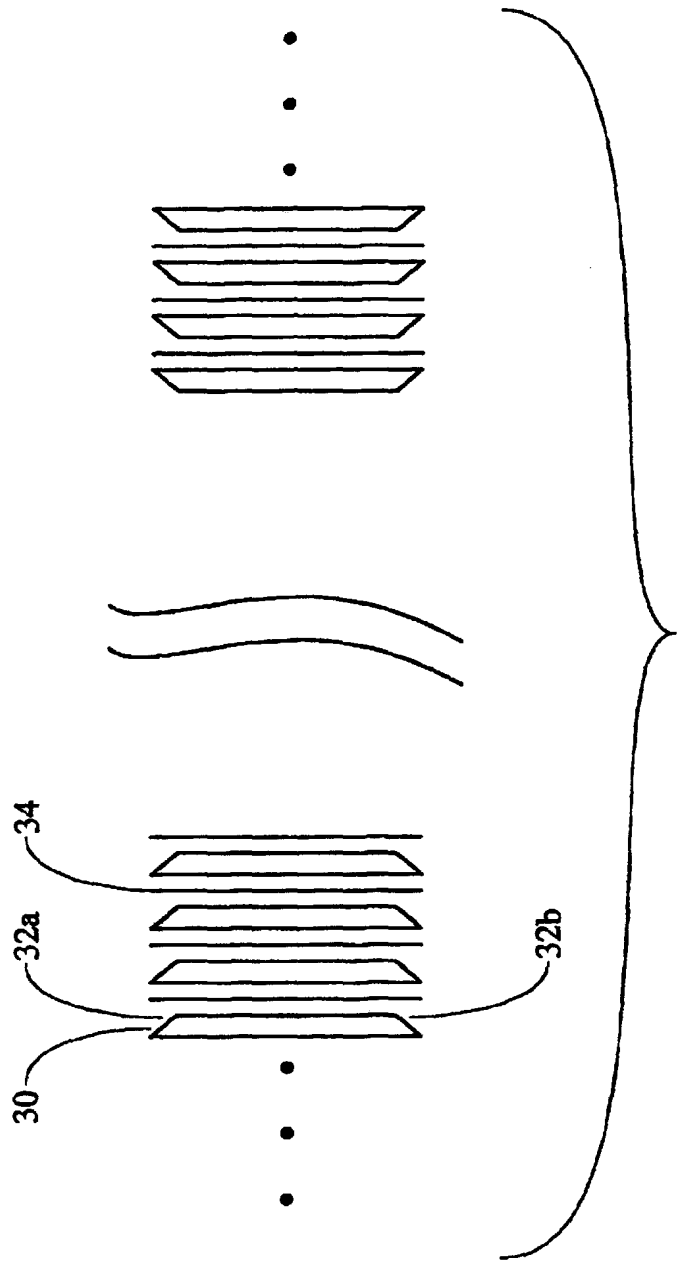


Fig. 5



## PATENT ABSTRACTS OF JAPAN

(11) Publication number: **02049091 A**  
 (43) Date of publication of application: **19.02.1990**

(51) Int. Cl. **C09K 15/08**  
 A23L 3/3499, A61K 7/00, A61K 31/12, A61K 31/12, A61K 31/12

(21) Application number: **63198947**  
 (22) Date of filing: **11.08.1988**

(71) Applicant: **SUNTORY LTD**  
 (72) Inventor: **UCHIUMI KOUZOU**  
**INOUE MASAYASU**  
**MIKI WATARU**  
**TANAKA TAKAHARU**  
**HIGUCHI NAOKI**

(54) **ASTAXANTHIN-CONTAINING COMPOSITION**

## (57) Abstract:

**PURPOSE:** To obtain the subject composition, containing astaxanthin (ester) as an active ingredient and capable of providing an antioxidant, medicine for protecting oxidative tissual disorder and anti-inflammatory agent.

**CONSTITUTION:** The objective composition contain-

ing astaxanthin consisting of a natural or synthetic product consisting of an extracted essence obtained by extracting red yeast, *Tigriopus japonicus* Mori (red water flea) or krill with ethanol, acetone, etc., and/or esters thereof, such as oleate, palmitate or stearate, as an active ingredient. Furthermore, culture conditions for producing the astaxanthin (ester) using the red yeast may be 15-27°C for 3-7 days under aerobic conditions and liquid pH of a culture medium is preferably kept at 4.0-9.5.

**COPYRIGHT:** (C)1990,JPO&Japio



# DELPHION



**RESEARCH**

**PRODUCTS**

**INSIDE DELPHION**

**Home** **My Account** **My Account** **My Account**

My Account

Search: Quick/Number Boolean Advanced Derwent

Help

## The Delphion Integrated View

Buy Now:  PDF | [File History](#) | [Other choices](#) Tools: Add to Work File:  Create new Work File  Add

View: [INPADOC](#) | Jump to:   Go to: [Derwent](#)  Email this to a friend

Title: **JP02049091A2: ASTAXANTHIN-CONTAINING COMPOSITION**

Derwent Title: Compsn. contg. astaxanthin as oxidation inhibitor - useful as vitamin E substitute and as food additive, medicament etc. [Derwent Record]

Country: **JP** Japan  
Kind: **A** (See also: [JP02619491B2](#))

Inventor: **UCHIUMI KOUZOU;**  
**INOUE MASAYASU;**  
**MIKI WATARU;**  
**TANAKA TAKAHARU;**  
**HIGUCHI NAOKI;**

Assignee: **SUNTORY LTD**  
[News, Profiles, Stocks and More about this company](#)

Published / Filed: **1990-02-19 / 1988-08-11**

Application Number: **JP1988000198947**

IPC Code: Advanced: **[A23L 3/3499](#); [A61K 31/12](#); [C09K 15/08](#);**  
Core: **[A23L 3/3463](#); [C09K 15/00](#);** more...  
IPC-7: **[A23L 3/3499](#); [A61K 7/00](#); [A61K 31/12](#); [C09K 15/08](#);**

Priority Number: **1988-08-11 JP1988000198947**

Abstract: **PURPOSE:** To obtain the subject composition, containing astaxanthin (ester) as an active ingredient and capable of providing an antioxidant, medicine for protecting oxidative tissual disorder and anti-inflammatory agent.

**CONSTITUTION:** The objective composition containing astaxanthin consisting of a natural or synthetic product consisting of an extracted essence obtained by extracting red yeast, *Tigriopus japonicus* Mori (red water flea) or krill with ethanol, acetone, etc., and/or esters thereof, such as oleate, palmitate or stearate, as an active ingredient. Furthermore, culture conditions for producing the astaxanthin (ester) using the red yeast may be 15-27°C for 3-7 days under aerobic conditions and liquid pH of a culture medium is preferably kept at 4.0-9.5.

COPYRIGHT: (C)1990,JPO&Japio

INPADOC Legal Status: None Buy Now: [Family Legal Status Report](#)

Family:

Buy PDF	Publication	Pub. Date	Filed	Title
<input checked="" type="checkbox"/>	<a href="#">JP02619491B2</a>	1997-06-11	1988-08-11	



View image

1 page



<input checked="" type="checkbox"/>	<b>JP02049091A2</b>	1990-02-19	1988-08-11	ASTAXANTHIN-CONTAINING COMPOSITION
2 family members shown above				

Forward References:

Go to Result Set: Forward references (3)

Buy PDF	Patent	Pub.Date	Inventor	Assignee	Title
	<a href="#">US7001611</a>	2006-02-21	Kiso; Yoshinobu	Suntory Limited	<a href="#">Compositions normalizing circadian rhythm</a>
	<a href="#">US6335015</a>	2002-01-01	Lignell; Ake	Astacarotene AB	<a href="#">Method of the prophylactic treatment of mastitis</a>
	<a href="#">US5871766</a>	1999-02-16	Hennekens; Charles H.	Brigham and Women's Hospital	<a href="#">Beta-carotene vitamin E therapy for inhibition of major vascular events</a>

Other Abstract Info:

[DERABS C90-096261](#) [DERC90-096261](#)



[Nominate this for the Gallery...](#)

Copyright © 1997-2007 The Thomson Corporation

[Subscriptions](#) | [Web Seminars](#) | [Privacy](#) | [Terms & Conditions](#) | [Site Map](#) | [Contact Us](#) | [Help](#)

# EUROPEAN PATENT OFFICE

## Patent Abstracts of Japan

PUBLICATION NUMBER : 02215351  
PUBLICATION DATE : 28-08-90

APPLICATION DATE : 14-02-89  
APPLICATION NUMBER : 01034846

APPLICANT : TAIYO FISHERY CO LTD;

INVENTOR : NONAKA MICHIO;

INT.CL. : A23J 7/00 A23L 1/30 A23L 1/33 A61K 31/685 A61K 37/22

TITLE : METHOD FOR COLLECTING KRILL PHOSPHOLIPID AND FUNCTIONAL FOOD AND NERVE FUNCTION IMPROVING AGENT HAVING NERVE FUNCTION IMPROVING EFFECT

ABSTRACT : PURPOSE: To obtain an useful phospholipid in high purity by fractionating an ethanol extracted total lipid of fresh krill dehydrated by vacuum freeze drying method to specific two ingredients using an absorption column chromatography and further isolating these ingredients using a fraction collector.

CONSTITUTION: A fresh krill is dehydrated to  $\leq 6\%$  water content using a vacuum freeze drying method. Then the dried krill is homogenized with ethanol to extract total lipid. The ethanol is removed as much as possible from the total lipid and the extracted total lipid is fractionated to soluble fraction and insoluble fraction using an acetone based solvent or hexane based solvent as eluate and then the solvent is cleaned from the insoluble fraction to give a crude phospholipid. Then the crude phospholipid is fractionated to phosphatidyl choline and phosphatidyl ethanolamine with an absorption column chromatography using ethanol based solvent, acetone based solvent or hexane based solvent as an eluate. Then each phospholipid ingredient is isolated therefrom in a high purity of about 90-95% by a fraction collector.

COPYRIGHT: (C)1990,JPO&Japio

⑩ 日本国特許庁 (JP)

⑪ 特許出願公開

⑫ 公開特許公報 (A) 平2-215351

⑬ Int. Cl.<sup>3</sup> 識別記号 庁内整理番号 ⑭ 公開 平成2年(1990)8月28日  
 A 23 J 7/00 6712-4B  
 A 23 L 1/30 8114-4B  
 1/33 A 2114-4B\*  
 B

審査請求 未請求 請求項の数 3 (全6頁)

⑮ 発明の名称 オキアミリン脂質の分取方法及び脳機能改善効果を有する機能性食品と脳機能改善剤

⑯ 特 願 平1-34846

⑰ 出 願 平1(1989)2月14日

⑱ 発 明 者 丸 山 一 輝 東京都中央区月島3丁目2番9号 大洋漁業株式会社大洋研究所内

⑲ 発 明 者 西 川 正 純 東京都中央区月島3丁目2番9号 大洋漁業株式会社大洋研究所内

⑳ 発 明 者 木 村 省 二 東京都中央区月島3丁目2番9号 大洋漁業株式会社大洋研究所内

㉑ 出 願 人 大洋漁業株式会社 東京都千代田区大手町1丁目1番2号

㉒ 代 理 人 弁理士 大津 洋夫

最終頁に続く

明 細 書

1. 発明の名称

オキアミリン脂質の分取方法及び脳機能改善効果を有する機能性食品と脳機能改善剤

2. 特許請求の範囲

(1) 生オキアミを真空凍結乾燥法により脱水したうえ、エタノールで総脂質を抽出し、得られた総脂質を、エタノール系溶媒、アセトン系溶媒、またはヘキサン系溶媒のいずれかを溶離液となし、シリカゲルを充填剤として、吸着カラムクロマトグラフィーを用いてホスファチジルコリンとホスファチジルエタノールアミンを分離し、これをフラクションコレクターにより単離するようにしたことを特徴とするオキアミリン脂質の分取方法。

(2) オキアミより単離したホスファチジルコリンもしくはホスファチジルエタノールアミンまたはこれらの誘導体のうち少なくとも一種以上を有効成分として食品基材に混入させるようにしたことを特徴とする脳機能改善効果を有する機能性食品。

品。

(3) オキアミより単離したホスファチジルコリンもしくはホスファチジルエタノールアミンまたはこれらの誘導体のうち少なくとも一種以上を有効成分として含有し構成させるようにしたことを特徴とする脳機能改善剤。

3. 発明の詳細な説明

「産業上の利用分野」

本発明は、オキアミからリン脂質を分離抽出する方法、特に、生体内において重要な生理活性を示すホスファチジルコリン及びホスファチジルエタノールアミンを単離する方法であり、こうして分取されたホスファチジルコリン及びホスファチジルエタノールアミン等が、食品としてまたは薬品として利用可能なものである点に特徴を有する技術に関する。

「従来技術」

最近、高齢化社会を迎えて、老人性痴呆症が大

きな社会問題になっている。老人性痴呆症は、神経系の障害を原因として起こるアルツハイマー型痴呆症と、脳血管障害を原因として起こる脳血管性痴呆症との二つの型に大別できる。前者のアルツハイマー型痴呆症の場合には、脳内の神経化学的な変化として、神経伝達物質であるアセチルコリンの生産が著しく低下していることが知られており、この病気の予防や治療法として、低下したコリン系の代謝を補給することにより生理機能を回復せんとすることが行なわれている。例えば、PCT特許出願公表昭56-500374号「レシチンを投与することにより病気を治療するための方法および組成物」、特開昭59-167514号「脳機能亢進剤組成物」、特開昭60-214734号「神経障害及び走化の治療組成物および治療方法」等がそれである。

即ち、コリン含有リン脂質であるホスファチジルコリンを摂取することにより、脳内にアセチルコリンを供給し、これによりアルツハイマー型痴呆症やその他の神経障害の予防と治療が期待され

ている。また、リン脂質の一種であるホスファチジルエタノールアミンはS-アデノシルメチオンニンからのメチル基移転反応によりホスファチジルコリンに変換される。従って、当該ホスファチジルエタノールアミンもアルツハイマー型痴呆症やその他の神経障害の予防と治療剤としての利用が期待されている。

ている。

本発明者は、特に、グリセリン脂質である、これらホスファチジルコリン及びホスファチジルエタノールアミンといったリン脂質に注目し、これを食品や薬品の原料として利用が可能な状態で工業的に分取する方法を研究開発せんとしたものである。

従来、天然物からリン脂質を工業的に精製する場合の原料といえば大豆が一般的であり、大豆リン脂質は主に健康食品等として、商品化されている。従来大豆リン脂質精製法は、まず原料大豆をクロロホルム・メタノール系の溶媒で総脂質を抽出し、次に当該総脂質をアセトンで分画し、可

溶性区分と不溶性区分に分ける。当該アセトン可溶性区分には中性脂質、コレステロール、遊離脂肪酸等が分画されており、またアセトン不溶性区分にはリン脂質が分画されている。そこで、次に、アセトン不溶性区分を90%エタノールで処理して、アルコールに溶けるホスファチジルコリンと不溶性のホスファチジルエタノールアミンとを得る。

「発明が解決しようとする問題点」  
しかし、上記のような、大豆を原料としたリン脂質の精製法の場合には、得られるホスファチジルコリン及びホスファチジルエタノールアミンとも純度が70%~80%程度であり、90%以上の高純度の精製物を得ることはなかなか困難であった。また、上記のように、クロロホルムメタノールを使用する方法は、いかに精製分画しても有害成分が残留している恐れがあるため、食品には使用しにくいという問題があった。

本発明者は、オキアミが豊富な蛋白質資源とし

て注目されているが、腐敗し易く、水分が多過ぎることから保存と運送にコストがかかり過ぎるとして、その有効な利用法が確立していないこと、また、オキアミにはリン脂質が多く含まれているが、この有効成分であるリン脂質に着目して付加価値が高く経済性のある高純度な機能性食品または医薬品等に利用しようとする技術開発が、いまだなされていないことに気が付いた。

そこで本発明者は、未利用の水産資源であるオキアミを原料として、これから有用なリン脂質を高純度で得ることができれば、オキアミの有効利用法として非常に有益であると考え、その精製法の研究開発を進め、完成したのが本発明である。

即ち、本発明は、オキアミを原料として、総脂質を分画し、得られた総脂質から高純度のホスファチジルコリン及びホスファチジルエタノールアミン等を精製単離することを特徴とする分取方法と、そうして得られた生理活性物質を用いて脳機能改善効果を有する機能性食品及び脳機能改善剤として利用する技術である。

## 「問題点を解決する手段」

本発明は、上記問題点を解決するため、次のような手段を採用したものである。

本発明は、生オキアミを真空凍結乾燥法により脱水したうえ、エタノールで総脂質を抽出し、得られた総脂質を、エタノール系溶媒、アセトン系溶媒、またはヘキサン系溶媒のいずれかを溶離液となし、シリカゲルを充填剤として、吸着カラムクロマトグラフィーを用いてリン脂質を分画し、これをフラクションコレクターにより単離するようになったことを特徴とするオキアミリン脂質の分取方法である。

第一工程：船内急速凍結生オキアミのブロック中には、90%以上が水分であるため、脱水方法が問題になる。そこで本発明では、吸着カラムクロマトグラフィーを用いた分取の前処理として、真空凍結乾燥装置を用いて脱水し乾燥オキアミとする。このとき水分含量が6%以下になるように脱水乾燥するのが望ましい。すると、水溶性蛋白質のエタノール抽出物への混入が抑制できるの

アミンなどのオキアミリン脂質を分取する方法である。

次は、上記の方法でオキアミより単離した高純度のホスファチジルコリンもしくはホスファチジルエタノールアミンがいずれも脳機能を改善する生理機能活性物質であるところに着目し、当該オキアミより単離した高純度のホスファチジルコリンもしくはホスファチジルエタノールアミンまたはこれらの誘導体のうち少なくとも一種以上を有効成分として食品基材に混入させるようにして脳機能改善効果を有する機能性食品とする。

また、オキアミより単離したホスファチジルコリンもしくはホスファチジルエタノールアミンまたはこれらの誘導体のうち少なくとも一種以上を有効成分として含有させるようにして脳機能改善剤となす。ここで、脳機能改善剤は、錠剤、カプセル、顆粒、液状などの形態として、薬品化することができるものである。

## 「作用」

で、分別成分の純度を高めることができる。

第二工程：第一工程により得られた乾燥オキアミをエタノールでホモジナイズして総脂質を抽出する。

第三工程：次に総脂質からエタノールを出来るだけ除去したうえ、アセトン系溶媒、またはヘキサン系溶媒のいずれかを溶離液となし、可溶区分と不溶区分とに分画する。例えば、アセトン系溶媒の場合には、リン脂質の大部分は不溶区分にあるので、これから溶媒を洗浄すれば、粗リン脂質が得られる。

第四工程：この粗リン脂質をエタノール系溶媒、アセトン系溶媒、またはヘキサン系溶媒のいずれかを溶離液となし、吸着カラムクロマトグラフィーを用いてホスファチジルコリンやホスファチジルエタノールアミンに分画し、これからフラクションコレクターにより各リン脂質成分を90%以上95%前後の高純度にて単離する。

本発明は、以上のようにして高純度のホスファチジルコリンもしくはホスファチジルエタノール

アルツハイマー型痴呆症の場合には、脳内の神経化学的な変化として、神経伝達物質であるアセチルコリンの生産が著しく低下していることが知られており、この病気の予防や治療法として、低下したコリン系の代謝を補給することにより生理機能を回復せんとすることが行なわれている。

特に、人の場合、コリンまたはコリンに解離する天然産出化合物レシチンを経口投与した場合、脳アセチルコリンの合成および放出を増進するのに十分な容量の血液コリン量の増加をもたらすと同時に、脳脊髄液のコリン量も増加する生理機能のあることが解っている。

従って、オキアミからリン脂質であるホスファチジルコリンをいかに効率良く、しかも安全性を保って抽出するか、それを食品または薬剤として摂取することにより、脳内にアセチルコリンを供給し、これによりアルツハイマー型痴呆症やその他の神経障害の予防と治療を期待しようとするのが本発明である。

## 「実施例」

以下、本発明を実施例に基づき詳細に説明する。

## &lt;実施例1.&gt;

船内急速凍結生オキアミ20Kgを真空乾燥装置を用いて水分含量4%前後になるまで乾燥させて乾燥オキアミ2.2Kgを得た。この原料である乾燥オキアミの脂質組成をイアトロスキャン法で分析した結果は、表1.の通りであった。

次に、こうして得た乾燥オキアミ2kgをエタノール40kgでホモジナイズして総脂質の抽出を行なった。その後、再抽出はエタノール20kgと同様に行なった。

抽出物である総脂質を濃縮して、できるだけエタノールを除去した後、当該総脂質をアセトンに溶解し、可溶区分と不溶区分に分画する。すると大部分のリン脂質は不溶区分に区画される。そこで、当該不溶区分に分画された物質にアセトン洗浄を数回繰り返して、粗リン脂質408gを得た。

20mlを自動注入した。溶離液はエタノール100%を流速30ml/minで流し、カラム恒温槽は40℃で、ピーク検出は紫外線吸収検出器(205μm)を用いてモニターしたところ、第1図に示したクロマトグラムが得られたので、最初のピークの分画区分をAとし、2番目の大きなピークの分画区分をBとしてフラクションコレクターを用いて分取した。分画区分Bのホスファチジルコリンの純度はイアトロスキャン法で分析したところ98%以上であった。1バッチのサイクルタイムは30分で、原料溶液を30分毎に自動充填して100サイクルで約50時間要して、乾燥オキアミ2kgから高純度ホスファチジルコリンを約239g分取した。

また、分画区分Aから同様に純度95%以上の高純度のホスファチジルエタノールアミンを約45g分取した。

## &lt;実施例2.&gt;

ウエクスラー方式の記憶ないし知能指数試験を

表1. 乾燥オキアミの脂質組成

脂質組成	重量%
ホスファチジルコリン	31.1
ホスファチジルエタノールアミン	7.5
トリグリセリド	43.2
遊離脂肪酸	6.5
その他	5.7

次に、前記粗リン脂質400gをエタノールに2000mlに溶解し、全自動分取型高速液体クロマトグラフィーに装着した分取カラム(カラム長さ×カラム径:50cm×50mm、断面積19.6cm<sup>2</sup>)に粒径10μmの球状シリカゲル(吸着剤)を充填したものに、1バッチ当たり

したところ記憶指数123であった記憶喪失にかかっている患者に、オキアミのから第1実施例にて分取した高純度ホスファチジルコリン(純度98%)を6週間に渡って1日3回食事毎に10gづつ食品に混入して経口投与した。

試験治療前と高純度ホスファチジルコリン摂取終了の6週間後に、患者からコリン測定用血液資料を採取しておき、血漿資料を分離し、凍結し、そしてそのコリン含量について慣用の放射性酵素法により分析した。その結果は、試験治療前採取した血液中の血漿コリン量が13.4±1.2ナノモル/mlであったのに対し、高純度ホスファチジルコリン投与から4時間後に得られた血液中の血漿コリン量が31.3±2.5ナノモル/mlに増加していた(P<0.01)。

しかも、高純度ホスファチジルコリン摂取の6週間後には、患者の記憶指数は、142に向上していた。

「効果」

特開平2-215351(5)

第1請求項に係る保護を受けようとする発明は、未利用の水産資源であるオキアミを原料として、これから有用なホスファチジルコリン及びホスファチシルエタノールアミンを90%以上という高純度で精製単離することができる分取方法である。この分取方法は、精製単離成分が高純度であるというだけでなく、その精製過程において、毒性を持った溶剤などが一切使用されていないので、安全性が高く、食品や薬品などにも安心して利用できる点に特徴がある。

また、第2請求項、第3請求項に係る特許を受けようとする発明は、そうして得られたオキアミン脂質であるホスファチジルコリン及びホスファチシルエタノールアミンには、アルツハイマー病の予防と治療が期待できる脳機能を改善するという生理機能を有しているため、これを利用して脳機能改善効果を有する機能性食品及び脳機能改善剤となすことができる。

第1図は本発明に係るクロマトグラムが得られた組成成分の分画表である。

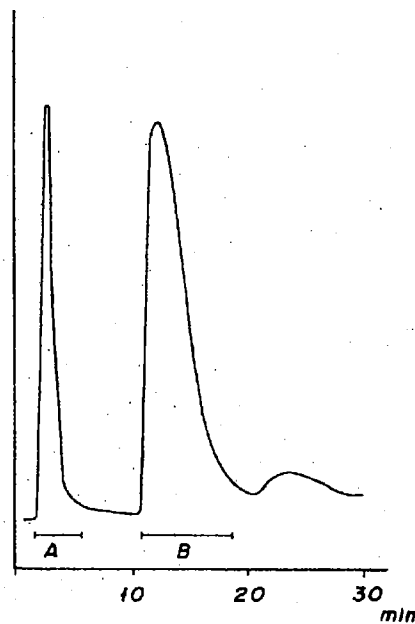
特許出願人 大洋漁業株式会社

代理人 弁理士 大津 洋 夫



4. 図面の簡単な説明

第 1 図



特開平2-215351(6)

第1頁の続き

@Int. Cl.<sup>5</sup>

A 61 K 31/685  
37/22

識別記号

AAM

庁内整理番号

7431-4C  
8615-4C

@発 明 者 野 中 道 夫 東京都中央区月島3丁目2番9号 大洋漁業株式会社大洋  
研究所内

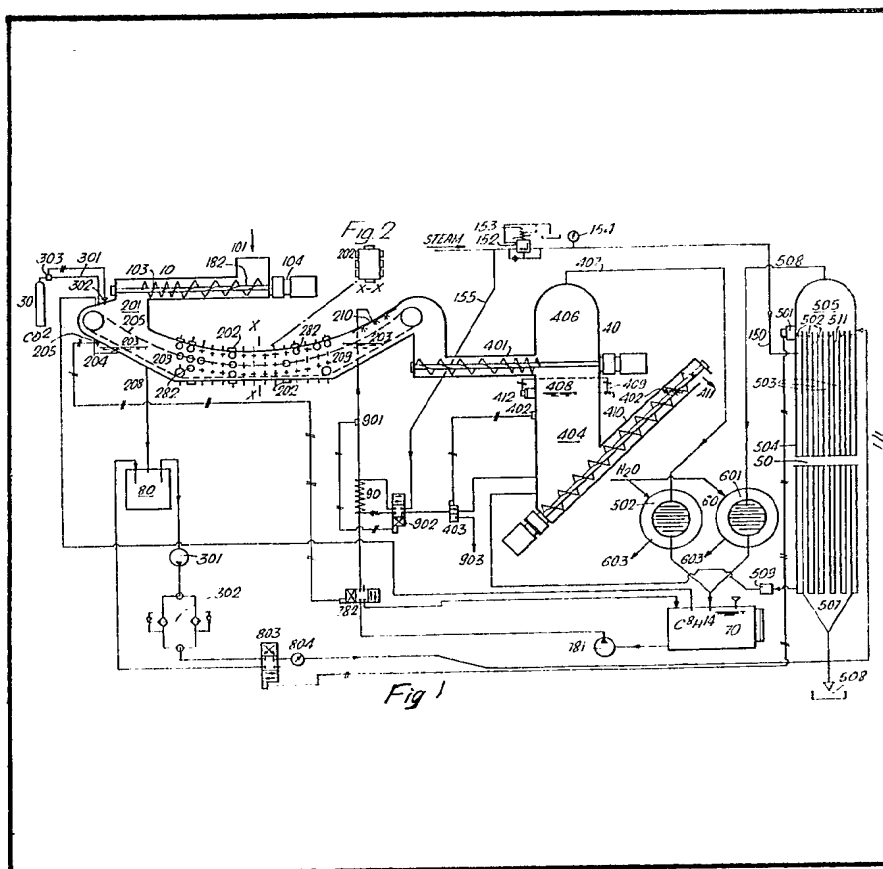


(21) Application No 8111677  
 (22) Date of filing 13 Apr 1981  
 (43) Application published 27 Oct 1982  
 (51) INT CL<sup>3</sup> C11B 1/10  
 (52) Domestic classification C5C 6A4 6C3 7  
 (56) Documents cited GB 0921537 GB 0634526  
 (58) Field of search C5C  
 (71) Applicant Eugene Marc Alexandre Baikoff, 1A Seng Mansions, Robin Road, Singapore 1025  
 (72) Inventor Eugene Marc Alexandre Baikoff  
 (74) Agents Michael Burnside & Partners, 2 Serjeants' Inn, Fleet Street, London, EC4Y 1HL

(54) **Ultrasonic extraction of vegetable oil**

(57) Enhanced recovery of vegetable oil, (e.g. palm oil) from oil bearing vegetal material is achieved by subjecting vegetal material immersed in a solvent (209) to a plurality of

intersecting acoustic fields distributed longitudinally and transversely through a vessel (20) for said solvent and vegetal material, said acoustic fields being generated by a plurality of ultrasonic transducers (202) arranged longitudinally and circumferentially of said vessel (20).



GB 2 097 014 A









## PATENT ABSTRACTS OF JAPAN

(11)Publication number : 02-049723

(43)Date of publication of application : 20.02.1990

---

(51)Int.Cl. A61K 31/20  
A23L 1/30  
// C07C 57/03

---

(21)Application number : 01-096821 (71)Applicant : TAIYO FISHERY CO LTD

(22)Date of filing : 17.04.1989 (72)Inventor : KIMURA SEIJI  
FUJIMOTO KENSHIRO  
NISHIKAWA MASAZUMI  
MARUYAMA KAZUTERU  
NONAKA MICHIO

---

(30)Priority

Priority number : 363 9478 Priority date : 18.04.1988 Priority country : JP

---

(54) ENCEPHALON FUNCTION IMPROVING COMPOSITION, LEARNING ABILITY ENHANCING AGENT, MEMORY ENHANCING AGENT, PREVENTIVE AND REMEDY FOR DEMENTIA OR FUNCTIONAL FOOD HAVING ENCEPHALON FUNCTION IMPROVING EFFECT

(57)Abstract:

PURPOSE: To obtain an encephalon function improving agent, title various kind of preparations or food having encephalon function improving effect containing docosahexaenoic acid or derivative thereof as an active ingredient.

CONSTITUTION: The title composition, preparation and food containing docosahexaenoic acid (C<sub>22</sub>H<sub>32</sub>O<sub>2</sub>) or derivative thereof as an active ingredient. As the derivative of docosahexaenoic acid, a fatty acid extracted from natural and fat oil, phospholipid, triglyceride or salt or amide thereof or ester obtained by alcoholysis, etc., is used. The above-mentioned composition can enhances encephalon function or restores nerve disorder and is useful as a raw material for drug or functional food.

## PATENT ABSTRACTS OF JAPAN

(11)Publication number : 04-057853

(43)Date of publication of application : 25.02.1992

(51)Int.Cl.

C09B 61/00

(21)Application number : 02-170549

(71)Applicant : CHLORINE ENG CORP LTD  
ITANO REITOU KK

(22)Date of filing : 28.06.1990

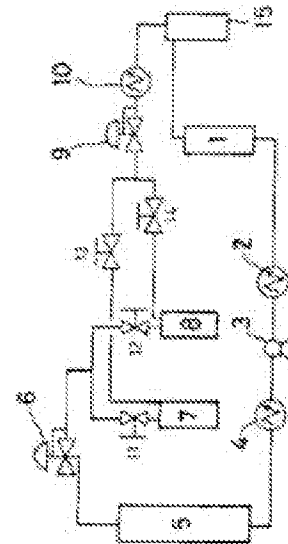
(72)Inventor : TOKUMORI TSUNEO  
SUMIDA YOKO  
TSUYAMA KOICHI  
KUNISHIRO IYOKO  
OKADA HARUO  
TANI TOSHIFUMI

(54) METHOD FOR EXTRACTING AND SEPARATING COLORING MATTER FROM KRILL

(57)Abstract:

**PURPOSE:** To prepare a reddish orange coloring matter having a high safety in a high concn. by extracting, with CO<sub>2</sub> in a supercritical state, krill shells of which the protein has been decomposed by a protease.

**CONSTITUTION:** Krill shells are treated with a protease to decompose the protein in the shells and the treatment product is filtered. The residue of filtration is dried to give treated shells having a water content of 6-8% and a mean particle size of 200 μm or lower. The treated shells are put into an extraction vessel 5. An extractant comprising a liq. CO<sub>2</sub> in an amt. of 30-40 pts.wt. based on one pt.wt. treated shells having a coloring matter concn. of 30 mg/100 g is supplied through a supercooling apparatus 2 to a pump 3, pressurized at the pump 3 to 100-250 kg/cm<sup>2</sup>, heated with a heat exchanger 4 to 35-40°C to bring it into a supercritical state, and transferred to the extraction vessel 5 to extract an oil in the treated shells. After the pressure of the oil-contg. CO<sub>2</sub> in the supercritical state is reduced to 40-60



kg/cm<sup>2</sup> with a pressure reducing valve 6, the CO<sub>2</sub> is delivered through a selector valve 11 to the first separating vessel 7 to separate the oil, and recycled through a selector valve 13, a pressure reducing valve 9, a condense 10, a water separator 15, and a storage vessel 1 to the extraction vessel 5. Then, selector valves 11 and 13 are closed while selector valves 12 and 14 are opened, and the CO<sub>2</sub> contg. the coloring matter is transferred to the second separating vessel 8, where the CO<sub>2</sub> is evaporated to give a coloring matter with a concn. of 2000-10000 mg/100g.



## PATENT ABSTRACTS OF JAPAN

(11)Publication number : 06-200179

(43)Date of publication of application : 19.07.1994

(51)Int.Cl. C09B 61/00  
C09B 67/54

(21)Application number : 03-314666 (71)Applicant : CHLORINE ENG CORP LTD  
ITANO REITOU KK

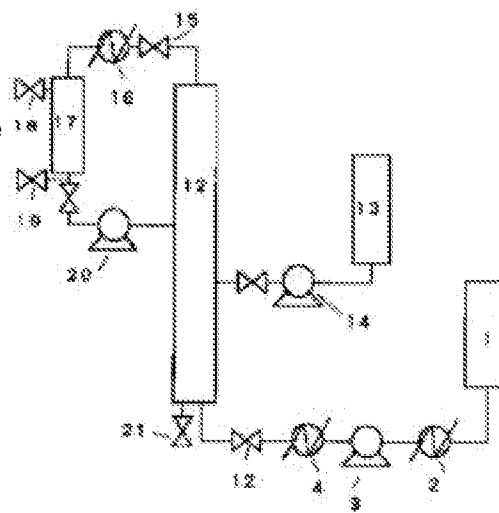
(22)Date of filing : 28.11.1991 (72)Inventor : TSUYAMA KOICHI  
MISHIMA KAYOKO  
TANI TOSHIFUMI  
YAMASHITA EIJI  
MANABE AKIYOSHI

### (54) METHOD FOR EXTRACTING AND SEPARATING PIGMENT FROM KRILL

(57)Abstract:

**PURPOSE:** To recover highly concentrated pigment from krill in high yield.

**CONSTITUTION:** Krill crust is put to extraction using carbon dioxide in a supercritical state to extract a mixture of oily component and pigment, and this mixture, while being refluxed, is subjected to extraction and separation using carbon dioxide in a supercritical state to separate the pigment from the oily component followed by concentrating the pigment. With this method, the aimed pigment of high concentration can be recovered in high yield with reduced amount of the pigment concomitant with the oily component.



## PATENT ABSTRACTS OF JAPAN

(11)Publication number : 09-176678

(43)Date of publication of application : 08.07.1997

(51)Int.Cl.

C11B 1/10

(21)Application number : 07-334576

(71)Applicant : IKEDA SHOKKEN KK

(22)Date of filing : 22.12.1995

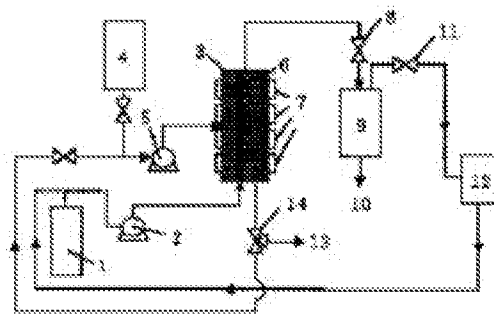
(72)Inventor : MIYAMOTO HIROSHI  
TAKAGAKI YASUYUKI  
MANSOU MITSUMASA

### (54) METHOD OF CONCENTRATION OF FAT OR OIL CONTAINING HIGHLY UNSATURATED ALIPHATIC ACID

(57)Abstract:

**PROBLEM TO BE SOLVED:** To provide a simple and effective method of concentration of a fat or oil contg. a highly unsaturated aliph. acid while keeping the unsaturated aliph. acid in the form of triglyceride.

**SOLUTION:** Around an extractor 3 are arranged four heaters 7 that can be regulated at any temp and controlled to make an increasing temp gradient from the bottom heater to the top heater, and regions of different carbon dioxide concentrations are formed within the extractor 3 thereby constituting a rectification function by supercritical fluid extraction. Consequently, if carbon dioxide in a supercritical state is supplied from under the extractor 3 and a feed 4 to be concentrated and separated is supplied to the extractor 3 through a pressurizing unit 5, a supercritical fluid contg. extract is drawn from the top of the extractor 3 and the objective raffinate 13 is obt'd. from the bottom.



## PATENT ABSTRACTS OF JAPAN

(11)Publication number : 06-256179

(43)Date of publication of application : 13.09.1994

(51)Int.Cl.

A61K 31/23  
A23L 1/30  
A61K 31/685

(21)Application number : 05-048176

(71)Applicant : NIPPON OIL & FATS CO LTD

(22)Date of filing : 09.03.1993

(72)Inventor : HIBINO HIDEHIKO

FUKUDA NOBUO

MATSUYOSHI SHIGERU

IRIKITA MASAMI

HASHIMOTO MASAOKI

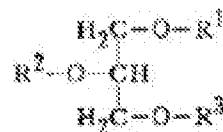
ISAKI YOSHINORI

### (54) LEARNING ABILITY IMPROVER

(57)Abstract:

PURPOSE: To obtain an improver low in toxicity, excellent in treating effect and safety and useful for senile dementia, etc., by including a specific diacylglycerol derivative as an active ingredient.

CONSTITUTION: The improver contains 1,2-diacyl-sn-glycerol derivative of the formula [R1 is 14-24C saturated or monoene fatty acid residue; R2 is arachidonic acid or eicosapentaenoic acid (residue); R3 is H, phosphorylcholine, phosphoryl- ethanolamine, phosphorylserine, phosphorylinositol or phosphoric acid group] as an active ingredient. The active ingredient is preferably orally administered in a dose of 50mg to 10g/60kg weight daily.



## PATENT ABSTRACTS OF JAPAN

(11)Publication number : 06-287138

(43)Date of publication of application : 11.10.1994

---

(51)Int.Cl.

A61K 31/23

---

(21)Application number : 05-077080

(71)Applicant : GREEN CROSS CORP:THE

(22)Date of filing : 02.04.1993

(72)Inventor : NISHIZAWA HIROYUKI

---

(54) AGENT FOR PREVENTION AND TREATMENT OF ALZHEIMER'S DISEASE

(57)Abstract:

**PURPOSE:** To obtain an agent for the prevention and treatment of Alzheimer's disease caused by the lowering of intracranial acetylcholine content by using a medium-chain fatty acid triglyceride containing 8-10C fatty acid as a main component.

**CONSTITUTION:** A medium-chain fatty acid triglyceride containing 8-10C fatty acid such as caprylic acid and capric acid as the constituent fatty acid is used as a main component of the objective agent for the prevention and treatment of Alzheimer's disease. The constituent free fatty acid of the agent passes through the blood-brain barrier into the cerebral spinal fluid and is metabolized in the brain cell to acetyl CoA. Excess acetyl CoA forms acetylcholine together with choline. The amount of the active component in the agent for prevention and treatment of Alzheimer's disease is preferably 5-15wt.%. The agent for the prevention and treatment of Alzheimer's disease is administered e.g. in the form of a fat emulsion. The emulsion is prepared from the above active component, an emulsifier such as phospholipid, water and arbitrary other additive components.

## PATENT ABSTRACTS OF JAPAN

(11)Publication number : 09-202891

(43)Date of publication of application : 05.08.1997

---

(51)Int.Cl. C11B 1/10  
C11B 3/00

---

(21)Application number : 08-012266 (71)Applicant : CHLORINE ENG CORP LTD  
IKEDA SHOKKEN KK

(22)Date of filing : 26.01.1996 (72)Inventor : TOKUMORI TSUNEO  
KATO AKIRA  
NAKANISHI KOICHI  
MIYAMOTO HIROSHI  
AOKI HIDEYUKI  
MANSOU MITSUMASA

---

(54) REDUCTION IN PEROXIDE IN OIL AND FAT CONTAINING HIGHLY UNSATURATED FATTY ACIDS

(57)Abstract:

PROBLEM TO BE SOLVED: To reduce a peroxide of an oil and fat usably as a material for foods, medicines, etc., without changing components from those of a feed raw material by extracting the oil and fat containing highly unsaturated fatty acids with a supercritical fluid in a specific extraction column and recovering the fraction from the overhead top of the extraction column.

SOLUTION: An oil and fat containing highly unsaturated fatty acids (e.g. a fatty acid containing  $\geq 10$ wt.% of  $\geq 18$ C highly unsaturated fatty acids having  $\geq 3$  unsaturated bonds, its lower alcohol ester or a glyceride thereof) is extracted and separated with a supercritical fluid in an extraction column having a temperature gradient in the height direction of the column to recover all the fractions from the overhead top of the extraction column. The extraction is preferably carried out at 35-100°C under 80-300 atm pressure.

## PATENT ABSTRACTS OF JAPAN

(11)Publication number : 09-310089

(43)Date of publication of application : 02.12.1997

(51)Int.Cl. C11B 7/00  
C07C 67/48  
C07C 69/587  
C11B 1/10  
C11C 1/08  
C11C 1/10  
// C07C 51/44  
C07C 57/03

(21)Application number : 08-125637

(71)Applicant : CHLORINE ENG CORP LTD

(22)Date of filing : 21.05.1996

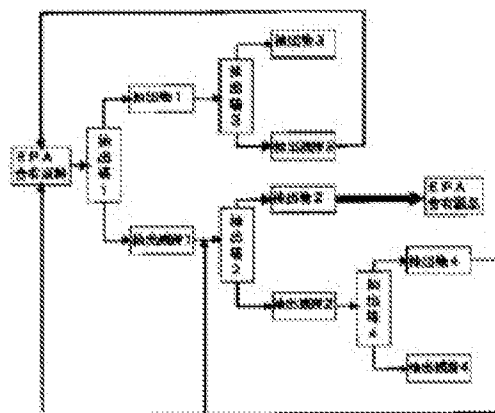
(72)Inventor : TOKUMORI TSUNEO  
KATO AKIRA  
NAKANISHI KOICHI

### (54) CONCENTRATION OF EICOSAPENTAENOIC ACID-CONTAINING MATERIAL

(57)Abstract:

PROBLEM TO BE SOLVED: To obtain highly pure eicosapentaenoic acid(EPA) from fatty acid esters.

SOLUTION: This method for concentrating an eicosapentaenoic acid- containing material comprises feeding an eicosapentaenoic acid-containing material into an extraction tower having a rectifying action, extracting the material with supercritical carbon dioxide to recover the first extract and the first extraction residue, similarly extracting the first extraction residue as a raw material, recovering the obtained second extract as an EPA-containing concentrate, separating and extracting the first extract and the second extraction residue, and further using extracts or extract residues having the same eicosapentaenoic acid contents as that of the raw material as extraction separation raw materials.



## PATENT ABSTRACTS OF JAPAN

(11)Publication number : 2000-351734

(43)Date of publication of application : 19.12.2000

---

(51)Int.Cl. A61K 38/54  
A61K 7/28  
A61P 1/00  
A61P 1/02  
A61P 1/04  
A61P 25/00  
A61P 27/00  
A61P 27/06  
A61P 29/00  
A61P 31/04  
A61P 31/18  
A61P 33/06  
A61P 35/00  
A61P 37/00

---

(21)Application number : 2000-147259 (71)Applicant : PHAIRSON MEDICAL AB

(22)Date of filing : 21.05.1993 (72)Inventor : LINDBLOM RAGNVALD  
DE FAIRE JOHAN

---

(30)Priority

Priority number : 92 9201628 Priority date : 22.05.1992 Priority country : SE

---

(54) NEW PHARMACEUTICAL USE OF KRILL ENZYME

(57)Abstract:

PROBLEM TO BE SOLVED: To obtain a medicine harmonizing with immune system, symbiotically interacting, attacking pathogeny and symptom, free from side effect, useful for therapy of plaque on a tooth by including a proteolytic enzyme separated from krill.

SOLUTION: This medicine includes a mixture of hydase including an enzyme originating from krill. In a preferable example of a preparative method of this medicine, distilled water is added to white krill or Euphausia superba in a ratio of 1:1, adding 0.02% of sodium azide and leaving standing for 6 hr. at 4°C. Then recovering aqueous phase by centrifugal separation and degreasing by adding ethyl acetate at 4°C. Recovering lower side aqueous phase, boiling and adding saturated ammonium sulfate to saturated state of 60%. Separating the product precipitate, dissolving in 0.05 mole phosphorus buffer solution of 0.05 mole sodium chloride (PBS) at pH 7.4 and then extracting the material by dialyzing to PBS. Multiple enzymes and a

single enzyme are recovered from the extracted material.





## PATENT ABSTRACTS OF JAPAN

(11) Publication number: **61281159 A**  
 (43) Date of publication of application: **11.12.1986**

(51) Int. Cl. **C09B 61/00**

(21) Application number: **50123170**  
 (22) Date of filing: **06.06.1985**

(71) Applicant: **SHISEIDO CO LTD**  
**NIPPON SUISAN KAISHA LTD**  
 (72) Inventor: **KUTSUNA YUTAKA**  
**MATSUOKA MASAHIRO**  
**FUJITA TAKAO**  
**SATAKE MIKIO**

## (54) PRODUCTION OF ORANGE PIGMENT

## (57) Abstract:

**PURPOSE:** To obtain an odorless pigment having bright orange color with stable color tone and free of after-smell, by extracting krill with a solvent, hydrogenating and hydrolyzing the unsaturated lipid other than the pigment in the extract, adding urea to the isolated fatty acid and removing the component by molecular distillation.

**CONSTITUTION:** Dried krill is extracted with an or-

ganic solvent such as n- hexane. A catalyst (preferably palladium oxide) is added to the resultant crude pigment liquid, and the unsaturated lipid other than the pigment in the crude liquid is selectively hydrogenated and then hydrolyzed with lipase. The isolated fatty acid is removed by the addition of urea and/or by the molecular distillation to obtain the objective orange pigment. The staining power of the pigment can be improved by concentrating and purifying the obtained pigment by column chromatography.

**USE:** Coloring of foods, cosmetics, etc.

**COPYRIGHT:** (C)1986, JPO&Japio



# DELPHION



**RESEARCH**

**PRODUCTS**

**INSIDE DELPHION**



[My Account](#)

Search: [Quick/Number](#) [Boolean](#) [Advanced](#) [Derwent](#)

[Help](#)

## The Delphion Integrated View

Buy Now:  PDF | [File History](#) | [Other choices](#)      Tools: Add to Work File: [Create new Work File](#)  [Add](#)

View: [INPADOC](#) | Jump to: [Top](#)  Go to: [Derwent](#)      [Email this to a friend](#)

**Title:** **JP61281159A2: PRODUCTION OF ORANGE PIGMENT**

**Derwent Title:** Mfg. orange colouring matter from euphausia solvent extract - by catalytic hydrogenation of co-existing unsatd. lipid, hydrolysis of reduced using lipase and removing liberated fatty acid  
[Derwent Record]

**Country:** JP Japan  
**Kind:** A (See also: [JP63040827B4](#))

**Inventor:** KUTSUNA YUTAKA;  
MATSUOKA MASAHIRO;  
FUJITA TAKAO;  
SATAKE MIKIO;

**Assignee:** SHISEIDO CO LTD  
NIPPON SUISAN KAISHA LTD  
[News, Profiles, Stocks and More about this company](#)

**Published / Filed:** 1986-12-11 / 1985-06-06

**Application Number:** JP1985000123170

**IPC Code:** Advanced: **C09B 61/00**;  
Core: more...  
IPC-7: **C09B 61/00**;

**Priority Number:** 1985-06-06 JP1985000123170

**Abstract:** PURPOSE: To obtain an odorless pigment having bright orange color with stable color tone and free of after-smell, by extracting krill with a solvent, hydrogenating and hydrolyzing the unsaturated lipid other than the pigment in the extract, adding urea to the isolated fatty acid and removing the component by molecular distillation.

CONSTITUTION: Dried krill is extracted with an organic solvent such as n- hexane. A catalyst (preferably palladium oxide) is added to the resultant crude pigment liquid, and the unsaturated lipid other than the pigment in the crude liquid is selectively hydrogenated and then hydrolyzed with lipase. The isolated fatty acid is removed by the addition of urea and/or by the molecular distillation to obtain the objective orange pigment. The staining power of the pigment can be improved by concentrating and purifying the obtained pigment by column chromatography.

USE: Coloring of foods, cosmetics, etc.

COPYRIGHT: (C)1986,JPO&Japio

**INPADOC Legal Status:** None      Buy Now: [Family Legal Status Report](#)



[View Image](#)

1 page

Family:

Buy PDF	Publication	Pub. Date	Filed	Title
<input checked="" type="checkbox"/>	JP63040827B4	1988-08-12	1985-06-06	DAIDAI SHOKUSHI KISONOSEIZOHO
<input checked="" type="checkbox"/>	JP61281159A2	1986-12-11	1985-06-06	PRODUCTION OF ORANGE PIGMENT
2 family members shown above				

Other Abstract Info:

CHEMABS 106(15)118476V CAN106(15)118476V [DERABS C87-025164](#) [DERC87-025164](#)



[Nominate this for the Gallery...](#)

Copyright © 1997-2007 The Thomson Corporation

[Subscriptions](#) | [Web Seminars](#) | [Privacy](#) | [Terms & Conditions](#) | [Site Map](#) | [Contact Us](#) | [Help](#)

## PATENT ABSTRACTS OF JAPAN

(11)Publication number : 2001-158736

(43)Date of publication of application : 12.06.2001

---

(51)Int.Cl. A61K 31/164  
A23L 1/30  
A61K 31/688  
A61K 31/7032  
A61P 19/00  
A61P 19/10

---

(21)Application number : 11-340211 (71)Applicant : SNOW BRAND MILK PROD CO  
LTD

(22)Date of filing : 30.11.1999 (72)Inventor : TAKADA YUKIHIRO  
MATSUBARA NORIYOSHI  
YANAGIDAIRA SHUICHI  
KAWAKAMI HIROSHI  
AOE SEIICHIRO

---

(54) AGENT FOR PREVENTING AND IMPROVING OSTEOARTHROPATHY

(57)Abstract:

PROBLEM TO BE SOLVED: To provide an agent for preventing and improving osteoarthropathy such as osteoporosis, fracture, lumbago and rheumatism, and to provide a drink, food or feed to which an effect for preventing and improving the osteoarthropathy is imparted.

SOLUTION: This agent for preventing or improving the osteoarthropathy, containing a sphingosine skeleton-containing compound such as ceramide, sphingomyelin, a sphingoglycolipid or ganglioside as an active ingredient, or containing the sphingosine skeleton-containing compound and further suitably one or more substances selected from calcium agents, vitamin D and vitamin K.

## PATENT ABSTRACTS OF JAPAN

(11)Publication number : 2003-003192

(43)Date of publication of application : 08.01.2003

---

(51)Int.Cl. C11B 11/00  
B01D 11/00  
C11B 1/10  
// A23L 1/30

---

(21)Application number : 2001-186515 (71)Applicant : UNITIKA LTD  
(22)Date of filing : 20.06.2001 (72)Inventor : MIYANISHI KENJI  
MUKAI KATSUYUKI  
ONO TAKAHIRO  
NAWA KAZUE

---

(54) METHOD FOR EXTRACTING SPHINGOLIPID OR SPHINGOGLYCOLIPID

(57)Abstract:

PROBLEM TO BE SOLVED: To provide a method for efficiently obtaining from animal/plant material sphingoglycolipids or the like having attracted public attention as a functional material for cosmetics and foods.

SOLUTION: The objective method for extracting sphingolipids or sphingoglycolipids from an animal/plant material is characterized by involving using carbon dioxide in a liquefied, subcritical or supercritical condition and another solvent in addition to the carbon dioxide.

# PATENT ABSTRACTS OF JAPAN

(11)Publication number : 2003-048831

(43)Date of publication of application : 21.02.2003

(51)Int.Cl. A61K 31/202  
 A23L 1/00  
 A23L 1/30  
 A23L 2/38  
 A23L 2/52  
 A61K 31/232  
 A61K 31/683  
 A61K 31/715  
 A61K 35/66  
 A61K 35/70  
 A61P 25/24  
 A61P 25/28

(21)Application number : 2001-235519

(71)Applicant : SUNTORY LTD

(22)Date of filing : 02.08.2001

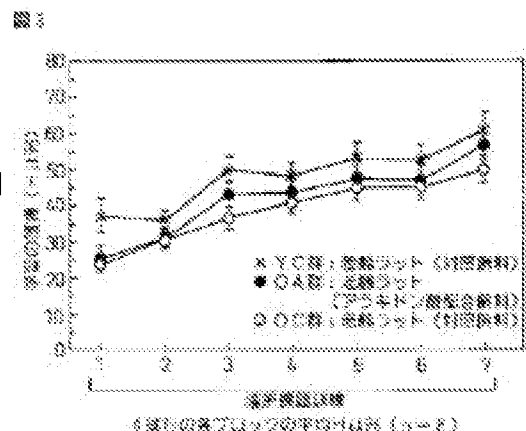
(72)Inventor : AKIMOTO KENGO  
 KAWASHIMA HIROSHI  
 ONO YOSHIKO  
 OKAICHI HIROSHIGE  
 OKAICHI YOKO

(54) COMPOSITION HAVING PREVENTING AND AMELIORATING ACTION ON SYMPTOM OR DISEASE CAUSED BY DECREASE IN BRAIN FUNCTION

(57)Abstract:

PROBLEM TO BE SOLVED: To obtain a composition having preventing or ameliorating action on symptoms or diseases caused by decrease in brain functions.

SOLUTION: This composition comprises arachidonic acid and/or a compound composed of arachidonic acid as a constituent fatty acid, especially an arachidonic acid ester, a triglyceride, a phospholipid or a glycolipid in which a part or the whole of a constituent fatty acid is arachidonic acid as an active ingredient.



## PATENT ABSTRACTS OF JAPAN

(11)Publication number : 2003-146883

(43)Date of publication of application : 21.05.2003

---

(51)Int.Cl. A61K 31/688  
A23L 1/30  
A23L 2/38  
A23L 2/52  
A61P 25/28

---

(21)Application number : 2001-341383 (71)Applicant : SNOW BRAND MILK PROD CO  
LTD

(22)Date of filing : 07.11.2001 (72)Inventor : TANAKA MIYAKO  
KAWAKAMI HIROSHI

---

### (54) PREVENTING AND TREATING AGENT FOR DEFECT OF MEMORY

(57)Abstract:

PROBLEM TO BE SOLVED: To provide a medicine, beverage and foods for preventing or treating Alzheimer type defect of memory.

SOLUTION: This preventing and treating agent for the Alzheimer type defect of memory is provided by using sphingomyelin as an active ingredient of the agent. Sphingomyelin has an effect for suppressing the reduction of a protein kinase C activity caused by aging and it is suggested that the compound is effective for preventing and treating the Alzheimer type defect of memory.

## PATENT ABSTRACTS OF JAPAN

(11)Publication number : 2005-245379

(43)Date of publication of application : 15.09.2005

---

(51)Int.Cl. A23L 1/33  
A23K 1/16  
A23L 1/30  
A61K 31/122  
A61K 31/202  
A61K 31/683  
A61K 35/56  
A61P 3/02

---

(21)Application number : 2004-063594 (71)Applicant : NIPPON SUISAN KAISHA LTD

(22)Date of filing : 08.03.2004 (72)Inventor : YOSHITOMI BUNJI

---

**(54) AGGREGATE OF EYEBALL OF CRUSTACEANS, METHOD FOR USING THE SAME, FOOD CONTAINING THE SAME, AND METHOD FOR PRODUCING THE SAME**

(57)Abstract:

PROBLEM TO BE SOLVED: To efficiently utilize crustaceans, especially krill, as resources, to efficiently recover fat-soluble effective substances, such as carotenoid, highly unsaturated fatty acid, and phospholipid, which are components of the crustaceans, and to utilize the substances.

SOLUTION: An aggregate is formed by collecting eyeballs of the crustaceans, so that the aggregate is used as a supply source of the carotenoid, the highly unsaturated fatty acid, and/or the phospholipid. A food or a dietary supplement contains the collected eyeballs, as they are, or a powdered product thereof and is used for supplying the carotenoid, the highly unsaturated fatty acid, and/or the phospholipid. The aggregate is produced by reducing a water content of the crustaceans to make the eyeballs bring into a state of being easily separated, and then giving physical impact thereto, so that the eyeballs are isolated and recovered. The krill or mysids are preferably used as the crustaceans.



## PATENT ABSTRACTS OF JAPAN

(11)Publication number : 2006-069948

(43)Date of publication of application : 16.03.2006

(51)Int.Cl.	<i>A61K 8/96</i>	<i>(2006. 01)</i>
	<i>A23L 1/30</i>	<i>(2006. 01)</i>
	<i>A61K 8/00</i>	<i>(2006. 01)</i>
	<i>A61Q 19/00</i>	<i>(2006. 01)</i>
	<i>A61K 35/56</i>	<i>(2006. 01)</i>
	<i>A61K 36/00</i>	<i>(2006. 01)</i>
	<i>A61P 17/16</i>	<i>(2006. 01)</i>

(21)Application number : 2004-254504      (71)Applicant : HIROSE YUKIHIRO

(22)Date of filing : 01.09.2004      (72)Inventor : HIROSE YUKIHIRO  
HIROSE KEIKO

### (54) ANTI-AGING COMPOSITION AND COSMETICS, BEVERAGES AND FOODS CONTAINING THE SAME

(57)Abstract:

PROBLEM TO BE SOLVED: To provide a composition having the function to prevent aging and provide cosmetics, beverages and foods containing the composition.

SOLUTION: (1) Soy bean extract, Igusa rush (*Juncus*) extract and krillbriitt extract is used as essential component, (2) Kusunohagasiwa (*Mallotus philippinensis* Mueller-Argoviensis) extract is added, (3) preferably, extracts selected from *Aloe vera*, *Momordicagrosvenorii*, *Eucommia ulmoides*, *Lepidiummee yenii*, *Avena sativa*, *Gentianella alboroccea*, *Hibiscus sabdariffa*, *Anethum grveolens*, *Calendula officinalis*, *Euphoria longana*, *Foeniculum vulgare*, *Thea sinensis*, *Mentha pulegium*, *Urtrea thunbergiana*, *Areca catechu*, *Fagopyrum tartaricum*, *Unearia gambir* and *Terminalia arjuna*, are added, (4) and further preferably these extracts are fermented with *Bacillus natto* and an extract is obtained from the fermentation mixture and is used as an anti-aging agent. The cosmetics, beverages and foods contain the anti-aging agent.



## PATENT ABSTRACTS OF JAPAN

(11)Publication number : 2006-290784

(43)Date of publication of application : 26.10.2006

(51)Int.Cl.	<i>A61K 36/00</i>	<i>(2006. 01)</i>
	<i>A23L 1/30</i>	<i>(2006. 01)</i>
	<i>A61K 35/56</i>	<i>(2006. 01)</i>
	<i>A61P 9/00</i>	<i>(2006. 01)</i>
	<i>A61P 21/00</i>	<i>(2006. 01)</i>

(21)Application number : 2005-112471      (71)Applicant : HIROSE YUKIHIRO

(22)Date of filing : 08.04.2005      (72)Inventor : HIROSE YUKIHIRO  
HIROSE KEIKO

### (54) COMPOSITION HAVING BLOODSTREAM AGGRAVATION-PREVENTING ACTION AND FOOD AND BEVERAGE CONTAINING THE SAME COMPOSITION

(57)Abstract:

**PROBLEM TO BE SOLVED:** To provide a composition effective in preventing bloodstream aggravation and preventing shoulder stiffness and lumbago and foods and beverages each containing the composition.

**SOLUTION:** The composition having bloodstream aggravation-preventing action contains one kind or a plurality of kinds of extracts selected from a fruit of peach, a fruit of Japanese plum and a root bark of tree peony and one kind or a plurality of kinds of extracts selected from rush, krill and soybean or the composition having bloodstream aggravation-preventing action contains extracts obtained by fermenting one kind or a plurality of kinds of extracts selected from a fruit of peach, a fruit of Japanese plum and a root bark of tree peony and one kind or a plurality of kinds of extracts selected from rush, krill and soybean with *Bacillus natto* as active ingredients. The foods and beverages each comprises the composition. The foods and beverages having effect for preventing lumbago and shoulder stiffness each comprises the composition.

## PATENT ABSTRACTS OF JAPAN

(11)Publication number : 2006-316073

(43)Date of publication of application : 24.11.2006

(51)Int.Cl.	<i>A61K 36/18</i>	<i>(2006. 01)</i>
	<i>A61K 35/56</i>	<i>(2006. 01)</i>
	<i>A61P 17/00</i>	<i>(2006. 01)</i>
	<i>A61P 17/18</i>	<i>(2006. 01)</i>
	<i>A61P 35/00</i>	<i>(2006. 01)</i>
	<i>A61P 17/14</i>	<i>(2006. 01)</i>
	<i>A61K 8/97</i>	<i>(2006. 01)</i>
	<i>A61K 8/98</i>	<i>(2006. 01)</i>
	<i>A61Q 19/00</i>	<i>(2006. 01)</i>
	<i>A61Q 19/04</i>	<i>(2006. 01)</i>
	<i>A61Q 19/08</i>	<i>(2006. 01)</i>
	<i>A61Q 7/00</i>	<i>(2006. 01)</i>
	<i>A61Q 5/00</i>	<i>(2006. 01)</i>

(21)Application number : 2006-234112      (71)Applicant : **IBR ISRAELI BIOTECHNOLOGY RESEARCH LTD**

(22)Date of filing : 30.08.2006      (72)Inventor : **SOUDANT ETIENNE  
BEZALEL LEA  
ZIV MEIRA  
PERRY INON**

### (30)Priority

Priority number : 1997 120291	Priority date : 23.02.1997	Priority country : IL
1997 120292	23.02.1997	IL
1997 121320	16.07.1997	IL

### (54) EXTRACT, PHARMACEUTICAL COMPOSITION, COSMETIC COMPOSITION, AND METHODS FOR PRODUCING THESE COMPOSITIONS

#### (57)Abstract:

**PROBLEM TO BE SOLVED:** To provide a cell or tissue extract which can inhibit the proliferation of cells or tissues.

**SOLUTION:** This extract obtained from processes comprising a process for preparing producer cells or producer tissues derived from an organism capable of entering a phase of dormancy, a process for inducing the cells or tissues into the phase of dormancy, and a process for obtaining a water-soluble fraction exhibiting a cell proliferation-inhibiting action

from the cells or tissues or media in which the cells or tissues are cultured, is characterized in that the efficacy of the cell proliferation-inhibiting action is reversible; the action is not exhibited or is little exhibited, when a fraction is similarly obtained from the cells or tissues in the phase of non-dormancy; the producer cells or producer tissues are cells or tissues obtained from the bulbs of Narcissus plant; and the organism is an organism belonging to the genus Artemia.

## PATENT ABSTRACTS OF JAPAN

(11)Publication number : 2006-328014

(43)Date of publication of application : 07.12.2006

(51)Int.Cl.	<i>A61K 35/56</i>	<i>(2006. 01)</i>
	<i>A23L 1/30</i>	<i>(2006. 01)</i>
	<i>A61K 8/96</i>	<i>(2006. 01)</i>
	<i>A61K 8/00</i>	<i>(2006. 01)</i>
	<i>A61Q 5/00</i>	<i>(2006. 01)</i>
	<i>A61K 35/74</i>	<i>(2006. 01)</i>
	<i>A61K 36/00</i>	<i>(2006. 01)</i>
	<i>A61P 9/00</i>	<i>(2006. 01)</i>
	<i>A61P 17/14</i>	<i>(2006. 01)</i>

(21)Application number : 2005-156483      (71)Applicant : HIROSE YUKIHIRO

(22)Date of filing : 30.05.2005      (72)Inventor : HIROSE YUKIHIRO  
HIROSE KEIKO

### (54) COMPOSITION HAVING PREVENTION ACTION ON BLOOD FLOW DETERIORATION

#### (57)Abstract:

PROBLEM TO BE SOLVED: To obtain a composition for effectively preventing blood flow deterioration and a food and beverage and a hair grower containing the same.

SOLUTION: The composition having a prevention action on blood flow deterioration comprises one or a plurality of essences selected from soybean, krill and rush and one or a plurality of essences selected from ginkgo leaves and petals of safflower as active ingredients. The composition having a prevention action on blood flow deterioration comprises an essence obtained by fermenting one or a plurality of essences selected from soybean, krill and rush and one or a plurality of essences selected from ginkgo leaves and petals of safflower with *Bacillus natto* as active ingredients. The food and beverage comprise the composition. The hair grower comprises the composition.

## PATENT ABSTRACTS OF JAPAN

(11)Publication number : 2007-126455

(43)Date of publication of application : 24.05.2007

(51)Int.Cl.

<i>A61K</i>	<i>31/122</i>	<i>(2006. 01)</i>
<i>A61K</i>	<i>35/56</i>	<i>(2006. 01)</i>
<i>A61K</i>	<i>35/60</i>	<i>(2006. 01)</i>
<i>A61K</i>	<i>36/02</i>	<i>(2006. 01)</i>
<i>A61K</i>	<i>36/06</i>	<i>(2006. 01)</i>
<i>A61K</i>	<i>35/74</i>	<i>(2006. 01)</i>
<i>A61K</i>	<i>36/00</i>	<i>(2006. 01)</i>
<i>A61P</i>	<i>25/24</i>	<i>(2006. 01)</i>
<i>A61P</i>	<i>25/28</i>	<i>(2006. 01)</i>
<i>A61P</i>	<i>25/18</i>	<i>(2006. 01)</i>
<i>A61P</i>	<i>25/02</i>	<i>(2006. 01)</i>
<i>A61P</i>	<i>25/14</i>	<i>(2006. 01)</i>
<i>A61P</i>	<i>25/16</i>	<i>(2006. 01)</i>
<i>A61P</i>	<i>25/00</i>	<i>(2006. 01)</i>
<i>A61P</i>	<i>31/18</i>	<i>(2006. 01)</i>
<i>A61P</i>	<i>5/14</i>	<i>(2006. 01)</i>
<i>A61P</i>	<i>25/30</i>	<i>(2006. 01)</i>
<i>A61P</i>	<i>25/22</i>	<i>(2006. 01)</i>
<i>A61P</i>	<i>9/10</i>	<i>(2006. 01)</i>
<i>A61P</i>	<i>9/12</i>	<i>(2006. 01)</i>
<i>A61P</i>	<i>35/00</i>	<i>(2006. 01)</i>
<i>A61P</i>	<i>3/10</i>	<i>(2006. 01)</i>
<i>A61P</i>	<i>3/06</i>	<i>(2006. 01)</i>
<i>A61P</i>	<i>29/00</i>	<i>(2006. 01)</i>
<i>A61P</i>	<i>19/06</i>	<i>(2006. 01)</i>
<i>A61P</i>	<i>11/00</i>	<i>(2006. 01)</i>
<i>A61P</i>	<i>1/04</i>	<i>(2006. 01)</i>
<i>A61P</i>	<i>1/16</i>	<i>(2006. 01)</i>
<i>A61P</i>	<i>1/18</i>	<i>(2006. 01)</i>
<i>A61P</i>	<i>13/12</i>	<i>(2006. 01)</i>
<i>A61P</i>	<i>27/12</i>	<i>(2006. 01)</i>
<i>A61P</i>	<i>37/08</i>	<i>(2006. 01)</i>
<i>A61P</i>	<i>9/00</i>	<i>(2006. 01)</i>
<i>A61P</i>	<i>7/00</i>	<i>(2006. 01)</i>
<i>A61P</i>	<i>9/02</i>	<i>(2006. 01)</i>
<i>A61P</i>	<i>1/12</i>	<i>(2006. 01)</i>
<i>A61P</i>	<i>1/10</i>	<i>(2006. 01)</i>
<i>A61P</i>	<i>7/12</i>	<i>(2006. 01)</i>
<i>A61P</i>	<i>21/00</i>	<i>(2006. 01)</i>
<i>A23L</i>	<i>1/30</i>	<i>(2006. 01)</i>

(21)Application number : 2006-275760 (71)Applicant : FUJI CHEM IND CO LTD

(22)Date of filing : 06.10.2006 (72)Inventor : TAKAHASHI JIRO

(30)Priority

Priority number : 2005295777    Priority date : 07.10.2005    Priority country : JP

---

**(54) CEREBRAL DYSFUNCTION IMPROVING AGENT**

(57)Abstract:

**PROBLEM TO BE SOLVED:** To provide medicines and foods and drinks, containing astaxanthin and/or an ester of the astaxanthin, excellent in improving and preventing effect for cerebral dysfunction, causing no side effect, high in safety, and capable of taken for a long term.

**SOLUTION:** The improving agents and the preventing agents for cerebral dysfunction, comprising alga Hematococcus extracts as an active ingredient, containing astaxanthin and/or an ester of the astaxanthin are provided. And, foods and drinks having improving effects and preventing effects of cerebral dysfunction, comprising the alga Hematococcus extracts as an active ingredient, containing astaxanthin and/or an ester of the astaxanthin are provided.





**Method for preparation of protein foodstuff from krill**

A method is offered for the preparation of a protein foodstuff from krill.

The method is realized in the following manner.

Raw krill that is freshly caught, or frozen and then defrosted, is rinsed with water, minced and pressed.

The liquid that is expressed during pressing, which looks like a pinkish-orange creamy mass, is heated to 90 – 95 °C for 10 – 15 min. During this process, the proteins coagulate to form a protein coagulate.

This latter is separated from the broth by filtration or centrifugation. The yield of protein coagulate is about 50 – 60% and of the broth is 50 – 40%, respectively, of the weight of the liquid expressed during pressing.

The protein coagulate and the broth obtained are used in cooking.

**Claim**

A method for the preparation of a protein foodstuff from krill wherein raw krill that is freshly caught or frozen and then defrosted is rinsed with water, minced and pressed, the liquid expressed during pressing is heated to 90 – 95 °C for 10 – 15 min in order to coagulate the proteins contained therein, and finally the coagulate that is the protein foodstuff is separated from the broth by filtration or centrifugation.



## INTERNATIONAL APPLICATION PUBLISHED UNDER THE PATENT COOPERATION TREATY (PCT)

<b>(51) International Patent Classification<sup>4</sup> :</b> <b>C08B 37/08, C12P 19/04, 19/26</b> <b>C09B 61/00</b>	<b>A1</b>	<b>(11) International Publication Number:      WO 86/ 06082</b> <b>(43) International Publication Date:   23 October 1986 (23.10.86)</b>
<b>(21) International Application Number:</b> PCT/DK86/00034 <b>(22) International Filing Date:</b> 9 April 1986 (09.04.86) <b>(31) Priority Application Number:</b> 1662/85 <b>(32) Priority Date:</b> 12 April 1985 (12.04.85) <b>(33) Priority Country:</b> DK  <b>(71) Applicant (for all designated States except US):</b> MAT- CON RÅDGIVENDE INGENIØRFIRMA A/S [DK/DK]; No. 45 Generatorvej, DK-2730 Herlev (DK). <b>(72) Inventor; and</b> <b>(75) Inventor/Applicant (for US only) :</b> JOENSEN, Jon, Olavur [DK/DK]; No. 4 Pilekæret, DK-2840 Holte (DK). <b>(74) Agent:</b> INTERNATIONALT PATENT-BUREAU; 12 Nybrogade, DK-1203 Copenhagen K (DK).		<b>(81) Designated States:</b> AT (European patent), AU, BE (Eu- ropean patent), BR, CH (European patent), DE (Eu- ropean patent), FR (European patent), GB (Euro- pean patent), IT (European patent), JP, LU (Euro- pean patent), NL (European patent), NO, SE (Euro- pean patent), SU, US.  <b>Published</b> <i>With international search report.</i>
<b>(54) Title:</b> A PROCESS FOR RECOVERING CHITIN FROM MATERIALS IN WHICH CHITIN OCCURS TO- GETHER WITH OR CONNECTED TO PROTEINACEOUS SUBSTANCES		
<b>(57) Abstract</b>  A process according to which chitin and possibly astaxanthin are recovered from chitin sources, particularly shrimp and krill shells, by demineralization with an acid and removal of protein using the enzymatic activity of fish viscera. The chitin-decomposing enzymatic activity of the fish viscera is suppressed by treatment of the viscera with acid at pH 1.2 to 2.5, preferably 1.5 to 2.5, prior to or during the removal of protein. The recovering may be effected in the presence of an oil, preferably from cod liver, extracting the astaxanthin.		

***FOR THE PURPOSES OF INFORMATION ONLY***

Codes used to identify States party to the PCT on the front pages of pamphlets publishing international applications under the PCT.

<b>AT</b> Austria	<b>GA</b> Gabon	<b>MR</b> Mauritania
<b>AU</b> Australia	<b>GB</b> United Kingdom	<b>MW</b> Malawi
<b>BB</b> Barbados	<b>HU</b> Hungary	<b>NL</b> Netherlands
<b>BE</b> Belgium	<b>IT</b> Italy	<b>NO</b> Norway
<b>BG</b> Bulgaria	<b>JP</b> Japan	<b>RO</b> Romania
<b>BR</b> Brazil	<b>KP</b> Democratic People's Republic of Korea	<b>SD</b> Sudan
<b>CF</b> Central African Republic	<b>KR</b> Republic of Korea	<b>SE</b> Sweden
<b>CG</b> Congo	<b>LI</b> Liechtenstein	<b>SN</b> Senegal
<b>CH</b> Switzerland	<b>LK</b> Sri Lanka	<b>SU</b> Soviet Union
<b>CM</b> Cameroon	<b>LU</b> Luxembourg	<b>TD</b> Chad
<b>DE</b> Germany, Federal Republic of	<b>MC</b> Monaco	<b>TG</b> Togo
<b>DK</b> Denmark	<b>MG</b> Madagascar	<b>US</b> United States of America
<b>FI</b> Finland	<b>ML</b> Mali	
<b>FR</b> France		

A process for recovering chitin from materials in which chitin occurs together with or connected to proteinaceous substances.

Chitin is a nitrogen-containing polymer carbohydrate occurring widespread in nature, in particular in shells of insects, crustaceans and molluscs, but also in certain fungi.

5 Chitin and chitosan (the latter may be obtained by deacetylation of chitin using strong bases) are used in various industries, e.g. as viscosity-increasing agents, gelforming agents, film-forming agents, ion exchangers and flocculants and for heavy metal removal,  
10 as suture materials and as wound healing agents.

In the most important sources of chitin, e.g. the shells of shrimps, krill and crabs, the chitin occurs together with and partly connected to proteinaceous substances. Said shells further contain a substantial  
15 amount of mineral substances, in particular calcium carbonate.

Moreover, many sources of chitin comprise the dyestuff astaxantin and derivatives thereof which are very valuable because they can be used in fodder for  
20 salmon or related fish.

Several attempts have been made to develop methods of the production of chitin or chitosan using the shells of marine crustaceans as starting material. Such shells are at present regarded as being the most  
25 important source of chitin, and the method according to the present invention is in the following described in connection with the processing thereof, in particular shells of shrimps and krill, but the process is generally applicable to all chitin sources from which protein  
30 has to be removed.

A common feature of the prior art methods is that the lime contained in the shells is removed by treatment with an acid, whereas it has been suggested removing the protein by treatment with a strong solution of sodium hydroxide or with enzymatic agents (pepsine from hog or fish). It has further been suggested dissolving the protein by proteolytic bacteria.

The removal of protein by means of sodium hydroxide or other strong bases has the disadvantage that a substantial part of the astaxanthin contained in the shells is lost and, moreover, a part of the chitin is hydrolyzed into chitosan which means that the obtained product is not pure.

The use of proteolytic bacteria involves a complicated procedure, and the removal of protein using enzymatic agents has not resulted in an efficient dissolving of the protein and has given a rather poor yield of astaxanthin.

A substantially higher yield of astaxanthin has been obtained by treating shrimp shells with silage prepared by treating cod viscera without lever, with formic acid and propionic acid to obtain pH 4.1-4.5 in the mixture, whereby pH was kept between 2.5 and 3.0 during the treatment of the shrimp shells. Said treatment resulted in an efficient dissolving of the protein, but simultaneously a substantial part of the chitin was decomposed, for which reason the chitin yield was unsatisfactory.

To separate the astaxanthin this has been extracted with an oil, e.g. soybean oil.

It has now been found that by treating fish viscera, preferably comminuted fish viscera, with an acid to achieve a pH between 1.2 and 2.5, the enzymatic activity of the viscera is effected in such a way that the chitin-decomposing activity is substantially suppressed, whereas the proteolytic activity only decreases

to a minor extent. It has further been found that said suppressing of the activity of chitin-decomposing enzymes is almost irreversible if the viscera are kept at a low pH for a prolonged period as is the case when they  
5 are ensiled. This means that with a silage of fish viscera of a pH between 1.5 and 2.5 a substantial increase of pH up to 4 is permissible during the treatment of the shrimp and krill shells and thereby an efficient proteolysis may be obtained without substantial decomposition  
10 of the chitin.

However, if fresh fish viscera is used instead of silage the proteolysis would be performed at a pH of 1.2 to 2.5.

Thus, the invention deals with a process for  
15 recovering chitin from materials in which chitin is present together with or connected to proteinaceous substances by demineralizing by means of an acid and removal of protein by exploiting the proteolytic activity of fish viscera, which process is characterized in that

- 20 a) an aqueous suspension is produced comprising the optionally minced chitin-containing material and the fish viscera which have possibly been pre-ensiled, ensuring that the fish viscera or the silage prepared therefrom act  
25 on the shells at a pH of 1.2 to 2.5, preferably 1.5 to 2.5, or the viscera have previously been ensiled at such a pH,
- b) the suspension is heated at a temperature between 25 and 50°C for a period between a few  
30 hours and four days, preferably  $\frac{1}{2}$  to 3 days, and

c) the suspension is separated to obtain at least  
(i) an aqueous phase containing dissolved hydrolyzed protein, and (ii) a sludge fraction containing the chitin substantially without proteins and mineral substances.

5 Between step b) and step c) it is preferred to carry out a partial neutralization and a heating of the suspension to inactivate the enzymes and microorganisms therein and to facilitate the subsequent separation.

10 Particularly in cases where fish viscera or silage thereof are not available in sufficient amount, it is advantageous to omit to carry out such an enzyme activating heating and to return part of the aqueous phase separated in step c) to step a). This permits the  
15 exploitation of the remaining proteolytic activity in the aqueous phase and the need for fish viscera or fish viscera silage is reduced.

Another way of reducing said need is to incorporate proteolytically active material derived from the  
20 animals constituting the chitin source into the suspension prepared in step a). By the extraction of chitin from shrimp shells it is possible to remove the raw "shrimp heads" comprising the shrimp viscera in which proteolytic activation occurs. Correspondingly, by the  
25 processing of krill all parts of the animals in raw comminuted form can be a constituent of the suspension prepared in step a). The protease contained in the comminuted krill thus contributes in the liberation the chitin shells from proteins and the yield of protein hydro-  
30 lysate of the process is enhanced by the materials derived from the meat parts of the krill.

Said separation at step c) of the process is preferably effected by using a decanter combined with a centrifugation. The sludge fraction obtained by centri-  
35 fugation and containing the chitin is washed repeatedly.



To improve the efficiency of the washing operations the chitin is pressed after each washing. Especially when sulfuric acid has been used for demineralization of the shells the pressing is important since it  
5 helps to remove the only slightly soluble calcium sulfate formed by the reaction of sulfuric acid with calcium compounds in the shells.

The purified product is dried to obtain a stable product. In a following process or as an alternative to  
10 said drying the chitin may be further treated, i.e. by heating with a strong base to achieve chitosan.

If the chitin-containing material used as starting material contains astaxanthin, this may be extracted by an oil, preferably in connection with a proteolytic  
15 treatment, and if so, the separation in step c) yields an oil fraction containing most of the astaxanthin from the starting material in addition to the aqueous fraction containing protein hydrolyzate and the sludge fraction containing the chitin. Said oil fraction is  
20 usually marketable without previous concentration of the astaxanthin therein.

In a preferred embodiment the astaxanthin is extracted using a marine oil provided by adding fish liver or other oil-containing parts of fish from which  
25 the oil is released as a result of the proteolytic activity of viscera, said oil being isolated as a separate fraction in step c) as explained above.

Alternatively, an oil such as soybean oil may be added, but to reduce costs it is often more advantageous  
30 to include fish liver, such as cod liver, or other oil-containing parts of fish when preparing the silage used in the process according to the invention, or to add cod liver or the like when preparing the suspension in step a). In both cases the proteolytic enzymes of the fish  
35 viscera cause such a decomposition of the oil-containing

tissue that the oil is liberated and afterwards separated in step c).

The aqueous phase obtained by the separation has a substantial content of protein hydrolysate and after  
5 an optional neutralization it may be used as a component in animal fodder, preferably in dried condition.

From the above it appears that an embodiment of the process is characterized in that the suspension in  
10 step a) is prepared using a silage previously produced from fish viscera and an inorganic acid and having a pH of 1.2 to 2.5, preferably 1.5 to 2.5. The fish viscera silage may also comprise a minor amount of organic acid to suppress growth of microorganisms. When such a previously  
15 manufactured silage is used, the pH of the suspension prepared in step a) may be higher than allowed when fresh viscera is used, but pH should not be higher than 4.

In another embodiment of the process the suspension is prepared in step a) by using fresh fish viscera  
20 and adjusting the pH of the suspension to 1.2 to 2.5, preferably 1.5 to 2.5.

When shrimp shells are used as a source of chitin the shells are collected in a shrimp peeling plant and are usually pressed to a solids content of 50%. Due to  
25 the high deterioration rate the shrimp shells will usually be preserved by adding a strong inorganic acid to obtain a pH-value less than 3, and thereby a simultaneous demineralization of the shells takes place. If the starting material is raw shrimp shells, the preservation is preferably effected at pH 1.2 to 2.5.  
30

Since the enzymatic activity of fish viscera and silage prepared therefrom varies substantially depending inter alia on the species of fish and the feed condition thereof as well as on the season and the age and storage  
35 temperature of the silage, it is not possible to indi-

cate exact limits for the ratio of chitin source to fish viscera or silage to be used. However, when the chitin source is shrimp shells, said ratio is generally between 1:1 and 1:10, typically from 1:2 to 1:5, the amount of 5 shrimp shells being calculated as a compacted material having about 50% solids.

Since particularly the astaxanthin is very liable to oxidation, care is usually taken to ensure that antioxidants be present during the process, said antioxidants being preferably introduced as early in the process as possible, viz. during the possible preceding silaging or preservation of the chitin source with acid and by the possible preceding processing of fish viscera to silage. When using fresh starting materials the anti-15 oxidants are added during the preparation of the suspension in step a). As antioxidants, conventional compounds may be used, e.g. butylhydroxyanisol.

To obtain a high purity of the chitin obtained as sludge fraction at the separation it might be suitable 20 to use a fish viscera silage previously freed from sludge, when preparing the suspension in step a).

The acid used in the possible preceding silaging or preservation of e.g. shrimp or krill shells and for obtaining the desired pH of the suspension, is hydro-25 chloric acid or sulfuric acid or any other strong acid.

The process according to the invention is further illustrated by means of the following embodiment example.

#### E X A M P L E

30 6 batches of silage are prepared by using approx. 500 kg liver and viscera from cod, 15 l, 50%, (w/w) sulfuric acid and 5 g butylhydroxyanisol (as antioxidant) for each batch. The sulfuric acid is added while the liver and viscera are subjected to the action of a 35 submerged mixer and blender in a 1000 l tub. Mixing and

blending is continued for 15 minutes whereupon the mixture is by pumping transferred to a tank wherein it is combined with the other five batches prepared in the same way.

5           The pH of the mixture is approx. 2.0.

The silage thus prepared is kept in the tank for two days during which it is intermittently agitated by means of a recycling pump.

10           To remove particulate material and sludge the silage is passed through a centrifugal decanter and pumped to a 5 m<sup>3</sup> spherical tank.

At this stage the liver and viscera silage (approx. 3000 kg) has the following approximate composition:

15	Oil	20% by weight
	Non-fat solids	11% by weight
	Protein	8% by weight
	Ash	2% by weight

20           Shells from a shrimp shelling machine have the following approximate composition (after drainage of water).

	Solids	20% by weight
	Protein	5% by weight
	Chitin	5% by weight
25	Fat	0,5% by weight
	Ash	6,5% by weight
	Astaxanthin	50 ppm.

30           Batches of each 250 kg shrimp shells are stirred with 600 liter water in a 1000 liter tub and 11 liter sulfuric acid (96% w/w) and 1 g butylhydroxyanisol is added. pH approx. 2.0.

35           When a sufficient amount of shrimp shells has been silaged in this way they are pumped to a screw press to produce 1500 kg press cake having approx. 40% solids. Said press cake has the following composition:

	Solids	40	% by weight
	Protein	15	% by weight
	Chitin	15	% by weight
	Fat	1,5%	by weight
5	Ash	6	% by weight
	Astaxanthin	150	ppm.

A substantial part of the calcium sulphate formed by reaction between the sulfuric acid and the calcium carbonate in the shells, is removed together with the  
10 press water.

This press water may be used for treating a further amount of shrimp shells to reduce consumption of sulfuric acid and to avoid discharging of the acid liquid to the environment.

15 The obtained press cake of acid treated shrimp shells is introduced into the spherical tank holding the liver and viscera ensilage into which the shells are suspended. The resulting suspension has a viscosity of 2-3000 cps. The pH is approx. 2.

20 The mixture is heated at 35°C by means of a heating coil through which water at 45°C is circulated. The mixture is agitated by pumping.

After having been heated at 35°C and agitated for two days the suspension is heated to 80°C by means of  
25 steam and is subsequently pumped to the screw press in which oil and an aqueous solution of hydrolysed protein are separated from the raw chitin. The liquid phase is treated in a decanter centrifuge to remove sludge and is thereafter separated by centrifugation into an oil  
30 fraction and a fraction of aqueous protein hydrolysate.

The oil contains 50-60% of the astaxanthin originally present in the shrimp shells, corresponding to approx. 200 ppm astaxanthin in the oil. The oil may be used as such for the preparation of fodder for salmon  
35 and related fish in which a reddish meat colour is desired.

The protein hydrolysate is evaporated and dried to obtain a product suitable as addition to fodder for cattle and poultry.

The press cake which comprises the chitin of the 5 shrimp shells is suspended in 2000 liter water at 80°C and the suspension is agitated by means of a pump for 15 minutes. The suspension is pumped to the press and the liquid phase obtained thereby is by means of a decanter and a centrifuge separated to recover a further amount 10 of astaxanthin containing oil. The aqueous phase from said separation is discharged.

The press cake of chitin is once more suspended in 2000 liter water at 80°C and 20 kg sodium carbonate is added. The suspension is agitated and the chitin 15 recovered again by means of the screw press.

In a similar way the chitin is rinsed once more using water without sodium carbonate and subsequently the rinsing is repeated adding 10 liter hydrochloric acid (30% w/w).

20 The obtained cake of chitin is finally washed with 2000 liter pure water, also at 80°C, and pressed again.

The resulting cake of chitin is dried using hot air to obtain 225 kg chitin having the following data:

25 Colour: white with a pale reddish tint  
Protein <0,5% by weight  
Oil <0,1% by weight  
Ash <0,5% by weight.

When a product of extremely low ash content is 30 desired a partially demineralized water is used in the washing process described above.

## PATENT CLAIMS

1. A process for recovering chitin from materials wherein chitin is present together with or connected to proteinaceous substances by demineralization with an acid and removal of protein by utilizing the proteolytic effect of fish viscera, characterized in that

- 5
- 10
- 15
- 20
- a) an aqueous suspension is produced comprising the optionally minced chitin-containing material and the fish viscera which have possibly been pre-ensiled, ensuring that the fish viscera or the silage prepared therefrom act on the shells at a pH of 1.2 to 2.5, preferably 1.5 to 2.5, or the viscera have previously been ensiled at such a pH,
  - b) the suspension is heated at a temperature between 25 and 50°C for a period between a few hours and four days, preferably  $\frac{1}{2}$  to 3 days, and
  - c) the suspension is separated to obtain at least (i) an aqueous phase containing dissolved hydrolyzed protein, and (ii) a sludge fraction containing the chitin substantially without proteins and mineral substances.

2. A process according to claim 1, by which a chitin-containing material is used comprising astaxanthin, characterized in that astaxanthin is extracted using a marine oil which is provided by using fish liver or other oil-containing parts of fish from which the oil is liberated by means of the proteolytic activity of the viscera, said oil being isolated as a separate fraction in step c).

3. A process according to claim 1 or 3, characterized in that the suspension in step a) is produced using a silage prepared from fish viscera and inorganic

acid and having a pH of 1.2 to 2.5, preferably 1.5 to 2.5, the pH of the suspension being adjusted to not more than 4.

4. A process according to claim 1 or 2, characterized in that the suspension is prepared in step a) by using fresh fish viscera and adjusting the pH thereof to 1.2 to 2.5, preferably 1.5 to 2.0.

5. A process according to any of the preceding claims, characterized in that the chitin source is shrimp shells whereby the ratio of said shells, calculated as compacted shrimp shells having approx. 50% solids, to fish viscera or silage thereof, amounts to from 10:1 to 1:2.

6. A process according to any of the preceding claims, characterized in that an antioxidant is applied to the suspension, said antioxidant being preferably added during the possible silaging of the chitin source and/or of the fish viscera.

7. A process according to any of the preceding claims, characterized in that a partial neutralization and heating of the suspension at 80 to 85°C to inactivate enzymes therein and to decrease the viscosity, is performed between step b) and step c).

8. A process according to claim 3, characterized in that the silage of fish viscera is previously freed from sludge.

9. A process according to any of the preceding claims, characterized in that the source of chitin is raw shrimp shells preserved with an acid to pH 1.2 to 2.5.

10. A process according to claims 1 to 6 and 8 to 9, characterized in that part of the aqueous phase separated in step c) is returned to step a).

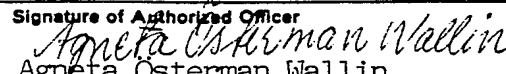
11. A process as claimed in any of the preceding claims, characterized in that in the preparation of the



suspension in step a) protease-containing parts of the animals serving as the chitin source are included.

# INTERNATIONAL SEARCH REPORT

International Application No **PCT/DK86/00034**

<b>I. CLASSIFICATION OF SUBJECT MATTER</b> (if several classification symbols apply, indicate all) <sup>6</sup>		
According to International Patent Classification (IPC) or to both National Classification and IPC <b>4</b>		
C 08 B 37/08, C 12 P 19/04, 19/26, C 09 B 61/00		
<b>II. FIELDS SEARCHED</b>		
Minimum Documentation Searched <sup>7</sup>		
<b>Classification System</b>	<b>Classification Symbols</b>	
IPC 2-4	C 08 B 37/08	
Documentation Searched other than Minimum Documentation to the Extent that such Documents are Included in the Fields Searched <sup>8</sup>		
SE, NO, DK, FI classes as above		
<b>III. DOCUMENTS CONSIDERED TO BE RELEVANT <sup>9</sup></b>		
<b>Category <sup>10</sup></b>	<b>Citation of Document, <sup>11</sup> with indication, where appropriate, of the relevant passages <sup>12</sup></b>	<b>Relevant to Claim No. <sup>13</sup></b>
Y	US, A, 4 505 936 (LOUISIANA STATE UNIVERSITY) 19 March 1985	2
Y	US, A, 3 906 112 (BIOPRODUCTS INC) 16 September 1975 & CA, 1044505	2
Y	NO, B, 147 365 (JAN RAA ET AL) 28 May 1982	2
A	US, A, 4 199 496 (Q P PENISTON ET AL) 22 April 1980	1
A	Chemical Abstracts, vol 98 (1983) abstract no 29 926	
A	Chemical Abstracts, vol 95 (1981) abstract no 112 049	
A	Chemical Abstracts, vol 90 (1979) abstract no 50 989	
	.../...	
<p><sup>10</sup> * Special categories of cited documents:</p> <p>"A" document defining the general state of the art which is not considered to be of particular relevance</p> <p>"E" earlier document but published on or after the international filing date</p> <p>"L" document which may throw doubts on priority claim(s) or which is cited to establish the publication date of another citation or other special reason (as specified)</p> <p>"O" document referring to an oral disclosure, use, exhibition or other means</p> <p>"P" document published prior to the international filing date but later than the priority date claimed</p> <p>"T" later document published after the international filing date or priority date and not in conflict with the application but cited to understand the principle or theory underlying the invention</p> <p>"X" document of particular relevance; the claimed invention cannot be considered novel or cannot be considered to involve an inventive step</p> <p>"Y" document of particular relevance; the claimed invention cannot be considered to involve an inventive step when the document is combined with one or more other such documents, such combination being obvious to a person skilled in the art.</p> <p>"&amp;" document member of the same patent family</p>		
<b>IV. CERTIFICATION</b>		
Date of the Actual Completion of the International Search	Date of Mailing of this International Search Report	
1986-06-26	1986 -07- 16	
International Searching Authority	Signature of Authorized Officer	
Swedish Patent Office	 Agneta Osterman Wallin	

III. DOCUMENTS CONSIDERED TO BE RELEVANT (CONTINUED FROM THE SECOND SHEET)		
Category *	Citation of Document, with indication, where appropriate, of the relevant passages	Relevant to Claim No
A	Chemical Abstracts, vol 87 (1977) abstract no 197 638	
A	Chemical Abstracts, vol 83 (1975) abstract no 106 55	
Y	Chemical Abstracts, vol 69 (1968) abstract no 59 578	1
Y	Chemical Abstract vol 102 (1985) abstract no 111 840	2,3,4
Y	Chemical Abstracts, vol 101 (1984) abstract no 71 145	2
Y	Chemical Abstracts, vol 96 (1982) abstract no 216 337	2,6
Y	Chemical Abstracts, vol 96 (1982) abstract no 198 142	2,6
A	Chemical Abstracts vol 88 (1978) abstract no 87 897	
A	Chemical Abstracts vol 88 (1978) abstract no 86 324	
A	Chemical Abstracts vol 78 (1973) abstract no 121 652	



## INTERNATIONAL APPLICATION PUBLISHED UNDER THE PATENT COOPERATION TREATY (PCT)

<b>(51) International Patent Classification <sup>5</sup> :</b>  <b>C09B 61/00, A23J 1/04</b>	<b>A1</b>	<b>(11) International Publication Number:</b> <b>WO 90/05765</b>  <b>(43) International Publication Date:</b> 31 May 1990 (31.05.90)
<b>(21) International Application Number:</b> PCT/NO89/00119 <b>(22) International Filing Date:</b> 15 November 1989 (15.11.89)  <b>(30) Priority data:</b> 885150 18 November 1988 (18.11.88) NO  <b>(71) Applicant:</b> MIKALSEN, Ester (heiress of the deceased inventor) [NO/NO]; N-6100 Volda (NO). <b>(72) Inventor:</b> MIKALSEN, Gunnar (deceased). <b>(74) Agent:</b> CURO AS; N-7094 Lundamo (NO).  <b>(81) Designated States:</b> AT (European patent), AU, BB, BE (European patent), BF (OAPI patent), BG, BJ (OAPI patent), BR, CF (OAPI patent), CG (OAPI patent), CH (European patent), CM (OAPI patent), DE (European patent), DK, FI, FR (European patent), GA (OAPI patent), GB (European patent), HU, IT (European patent), JP, KP, KR, LK, LU (European patent), MC, MG, ML (OAPI patent), MR (OAPI patent), MW, NL (European patent), SE (European patent), SN (OAPI patent), SU, TD (OAPI patent), TG (OAPI patent), US.		<b>Published</b> <i>With international search report.</i> <i>In English translation (filed in Norwegian).</i>
<b>(54) Title:</b> A PROCEDURE FOR THE PRODUCTION OF ASTAXANTHIN AND RELATED CAROTENOIDS, ASTAXANTHIN ESTERS, CHITIN, PROTEINS AND MEAT FROM PLANTS, ALGAE, BACTERIA, KRILL, SHRIMPS AND OTHER CRAYFISH AND CRUSTACEA		
<b>(57) Abstract</b>  A procedure is described for the production of astaxanthin and related carotenoids, astaxanthin esters, chitin, proteins and meat from plants, algae, bacteria, krill, shrimps and other crayfish and crustacea by extraction in boiling lye. The residue from the extraction is dried and dissolved in anhydride formic acid or another concentrated strong acid, filtered, then the filtrate has water added so that the purified chitin can be precipitated. Astaxanthin and related carotenoids, astaxanthin esters, chitin and proteins are removed from the extract either by acid precipitation or by cooling, removal and subsequent phase separation and purification.		

**FOR THE PURPOSES OF INFORMATION ONLY**

Codes used to identify States party to the PCT on the front pages of pamphlets publishing international applications under the PCT.

AT	Austria	ES	Spain	MG	Madagascar
AU	Australia	FI	Finland	ML	Mali
BB	Barbados	FR	France	MR	Mauritania
BE	Belgium	GA	Gabon	MW	Malawi
BF	Burkina Faso	GB	United Kingdom	NL	Netherlands
BG	Bulgaria	HU	Hungary	NO	Norway
BJ	Benin	IT	Italy	RO	Romania
BR	Brazil	JP	Japan	SD	Sudan
CA	Canada	KP	Democratic People's Republic of Korea	SE	Sweden
CF	Central African Republic	KR	Republic of Korea	SN	Senegal
CG	Congo	LI	Liechtenstein	SU	Soviet Union
CH	Switzerland	LK	Sri Lanka	TD	Chad
CM	Cameroon	LU	Luxembourg	TG	Togo
DE	Germany, Federal Republic of	MC	Monaco	US	United States of America
DK	Denmark				

A procedure for the production of astaxanthin and related carotenoids, astaxanthin esters, chitin, proteins and meat from plants, algae, bacteria, krill, shrimps and other crayfish and crustacea.

The present invention consists of a procedure for the production of astaxanthin and related carotenoids, astaxanthin esters, chitin, proteins and meat as according to claim 1.

5 Astaxanthin and related carotenoids are used in the fish farming industry today as dyes for colouring the fish meat of species which have red or pale red meat in natural habitats. During cultivation, there is no feed that contains enough dye to give this colour flesh to such fish. These  
10 dyes are produced today by fermenting algae and synthesizing from a fermentation mixture. This approach is both expensive and time-consuming and necessitates the processing of large volumes of fermentation mixture.

So far there has been no product to meet the need for  
15 an inexpensive industrial process for producing astaxanthin and related carotenoids for the fish farming industry and other applications for the colouring of foodstuffs. The present invention describes a procedure which enables astaxanthin and related carotenoids to be produced on an  
20 industrial basis much cheaper than with present day technology. At the same time, the present invention is based on the exploitation of natural resources that are unexploitable or which represent a waste disposal problem. These include Antarctic krill; plants, bacteria and algae;  
25 and waste from the commercial processing of the meat in species such as shrimps, crayfish and crustacea. The present invention also helps to utilize the above-mentioned natural resources better, by using more of the raw material, either by improving the degree of utilization through the  
30 production of the required products, or by utilizing the same raw material to produce other types of products. Thus

the present invention can for example be used to produce astaxanthin and related carotenoids astaxanthin esters, chitin, proteins and meat from Antarctic krill in a way that gives an extremely high degree of utilization of this raw  
5 material.

The shells of Antarctic krill are in addition the greatest unused source of protein in the world. However they cannot be used for feed or food because they contain too many toxic components such as fluorine and toxic heavy  
10 metals. With the means of production in the present invention, both the fluorine and the toxic heavy metals can be removed from the shells so that extensive use can be made of the proteins and chitin that can be produced from them.

These and other features of the invention become  
15 evident from the characterizing part of the Claims of Patent below.

The method in accordance with this invention will now be illustrated in greater detail by the following examples.

#### 20 Example 1, Krill

When the Antarctic krill is caught, the meat is squeezed out behind the cephalothorax using modified shrimp processing equipment. This extraction of the meat must be done within 3 to 4 hours of the time of catching to avoid  
25 contamination from the shell, head and cephalothorax which could affect the meat. As the autolysis of krill occurs very quickly and easily, this is another reason why the meat must be extracted within 4 hours of the time of the catch. After the meat has been squeezed out, it has to be kept at below  
30 40°C until it is processed. The contaminants in krill are mainly the fluorine in the shell and toxic heavy metals such as cadmium, mercury, lead and zinc. There are high concentrations of cadmium in the cephalothorax and the content of the head.

35 The further treatment of the rest of the krill after the meat has been extracted, i.e., the shell, cephalothorax and the head with its content, here termed krill shell, can take alternative forms.

## Alternative A:

- The krill shell is boiled in 1.0 N NaOH for 30 min. then the extract is separated from the residue. The residue is then again boiled in 1.0 N NaOH for 30 min. and extract is once more separated from the residue. The residue is dried in concentrated formic acid before being dissolved in anhydride formic acid or another strong concentrated acid, filtrated, then water is added to the filtrate to precipitate the purified chitin. The extracts from the two boilings are mixed and can either:
- 10 a: have an acid added until all astaxanthin and related carotenoids, astaxanthin esters, proteins are precipitated, whereupon the precipitate is separated from the solution by filtration or a similar process; or
  - 15 b: be removed to cool, after this the mixture is separated into three phases which are divided by floating off the phase with the lowest specific weight and decanting (or the equivalent) the phase with the intermediate specific weight from the phase with the highest specific weight; where the phase with the lowest specific weight is neutralized by the addition of an acid which causes the formation of two liquid phases, which are separated, and the oily phase which consists of astaxanthin esters is taken care of; where the phase with the highest specific weight is neutralized by an acid, and the solids consisting of astaxanthin and related carotenoids are filtered away and taken care of; and where the phase with the intermediate specific weight is neutralized and has marine oil,  $\text{Ca}^{2+}$ -ions,  $\text{S}^{2-}$ -ions and  $(\text{NH}_4)_2\text{HPO}_4$  for the precipitation of the fluorine and the heavy metal contaminants, where this precipitate is removed from the solution by floating or the equivalent, after this the solution is acidified prior to the precipitation of the purified proteins followed by the separation of these proteins from the solution by filtration or an equivalent method.



## Alternative B:

The krill shell is boiled in 0.01 N NaOH for 30 min. then the extract is separated from the residue. The residue is then again boiled in 0.01 N NaOH for 30 min. and the extract is once more separated from the residue. The residue is then again boiled this time in 1.0 N NaOH for 30 min. and the extract is again separated from the residue. The residue is dried in concentrated formic acid before being dissolved in anhydride formic acid or another strong concentrated acid, filtrated, then water is added to the filtrate to precipitate the purified chitin.

The extracts from the first two boilings in 0.01 N NaOH are mixed, neutralized and have the addition of marine oil,  $\text{Ca}^{2+}$ -ions,  $\text{S}^{2-}$ -ions and  $(\text{NH}_4)_2\text{HPO}_4$  for the precipitation of the fluorine and the heavy metal contaminants, where this precipitate is removed from the solution by floating or the equivalent, after this the solution is acidified prior to the precipitation of the purified proteins followed by the separation of these proteins from the solution by filtration or an equivalent method.

The extracts from the last two boilings in 1.0 N NaOH are mixed and can either:

- a: have an acid added until all astaxanthin and related carotenoids, astaxanthin esters, proteins are precipitated, whereupon the precipitate is separated from the solution by filtration or a similar process; or
- b: be placed to cool, after this the mixture is separated into three phases which are divided by floating off the phase with the lowest specific weight and decanting (or the equivalent) the phase with the intermediate specific weight from the phase with the highest specific weight; where the phase with the lowest specific weight is neutralized by the addition of an acid which causes the formation of two liquid phases, which are separated, and the oily phase consisting of

astaxanthin esters is taken care of; where the phase with the highest specific weight is neutralized by an acid and solids consisting of astaxanthin and related carotenoids are filtered away and taken care of; and where the phase with the intermediate specific weight is neutralized and followed by the addition of marine oil,  $\text{Ca}^{2+}$ -ions,  $\text{S}^{2-}$ -ions and  $(\text{NH}_4)_2\text{HPO}_4$  for the precipitation of the fluorine and the heavy metal contaminants, where this precipitate is removed from the solution by floating or the equivalent, after this the solution is acidified prior to the precipitation of the purified proteins followed by the separation of these proteins from the solution by filtration or an equivalent method.

15 Example 2, Plants, algae and bacteria

Astaxanthin can be produced from plants, algae and bacteria that contain this die in accordance with the procedure presented in this patent.

Plants, algae or bacteria or a mixture of these can be boiled for 30 min. in 1.0 N NaOH, after this the extract is separated from the residue of the plants, algae or bacteria and the extract is removed for cooling. During cooling the astaxanthin is separated and is deposited as sediment in the extract. The sediment is composed of astaxanthin and extract and these are separated by a known method.

Example 3, shrimps, crayfish and other crustacea

Shrimps, crayfish and crustacea differ from krill in that they are boiled before the meat is removed for consumption. The residue from the shrimps, crayfish and crustacea consists of shell, heads with contents and nonedible components, which can be processed in the same way as krill shell for the production of astaxanthin and related carotenoids, astaxanthin esters, proteins and chitin.

The above description only indicates the preferred means of applying the present invention. For specialists in the field it is obvious that various modifications can be made without exceeding the framework of the invention, which  
5 is delimited by the following claims of patent. The procedures which are indicated should therefore be considered as illustrative rather than restrictive.

## Claim of Patent:

1. A procedure for the production of astaxanthin and related carotenoids, astaxanthin esters, chitin, proteins and meat from plants, algae, bacteria, krill, shrimps and other crayfish and crustacea,

5 c h a r a c t e r i z e d by it consisting of the following steps:

1: extraction of proteins, astaxanthin and related carotenoids, and astaxanthin esters by boiling in lye,

2: residue from step 1 is dried in concentrated formic acid then dissolved in anhydride formic acid or another strong  
10 acid, filtered, then the filtrate has water added so as to allow the precipitation of the purified chitin,

3: recovery of astaxanthin and related carotenoids, astaxanthin esters, chitin and proteins from the extract in  
15 step 1 in one or more product fractions.

2. A procedure in accordance with Claim 1,  
c h a r a c t e r i z e d by the above-mentioned extraction occurring in two steps, where the mentioned lye is 1.0 N of a strong base, where the extracts from the two steps have an  
20 acid added until all astaxanthin, related carotenoids, astaxanthin esters and proteins are precipitated, after this the unprecipitated compounds are separated from the extracts in a product fraction by decanting and filtration or by equivalent methods or combination of methods.

25 3. A procedure in accordance with Claim 1,  
c h a r a c t e r i z e d by the above-mentioned extraction occurring in two steps, where the mentioned lye is 1.0 N of a strong base, where the extracts from the two steps are removed for cooling, whereupon the extracts are separated  
30 into three phases which are divided by floating off the phase with the lowest specific weight and decanting (or the equivalent) the phase with the intermediate specific weight from the phase with the highest specific weight; where the phase with the lowest specific weight is neutralized by the

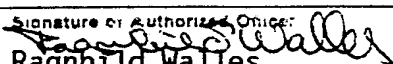
addition of an acid which causes the formation of two liquid phases, which are separated, and the oily phase consisting of astaxanthin esters is taken care of; where the phase with the highest specific weight is neutralized by an acid and  
5 solids consisting of astaxanthin and related carotenoids are filtered away and taken care of in a known manner; and where the phase with the intermediate specific weight is neutralized and followed by the addition of marine oil,  $\text{Ca}^{2+}$ -ions,  $\text{S}^{2-}$ -ions and  $(\text{NH}_4)_2\text{HPO}_4$  for the  
10 precipitation of  $\text{F}^-$ -ions and the heavy metal contaminants, where this precipitate is removed from the solution by floating or the equivalent, after this the solution is acidified prior to the precipitation of the purified proteins followed by the separation of these  
15 proteins from the solution by filtration or an equivalent method.

4. A procedure in accordance with Claim 1, characterized by the above-mentioned extraction occurring in four steps, where the mentioned lye in the  
20 first two steps is 0.01 N of a strong base, where the mentioned lye in the last two steps is 1.0 N of a strong base; where the extracts from the first two steps are neutralized and this is followed by the addition of marine oil,  $\text{Ca}^{2+}$ -ions,  $\text{S}^{2-}$ -ions and  $(\text{NH}_4)_2\text{HPO}_4$  for the  
25 precipitation of  $\text{F}^-$ -ions and the contaminants, where this precipitate is removed from the solution by floating or the equivalent, after this the solution is acidified prior to the precipitation of the purified proteins followed by the separation of these proteins from the solution by filtration  
30 or an equivalent method, where the extracts from the last two steps have an acid added until all astaxanthin, related carotenoids, astaxanthin esters and proteins are precipitated, after this the unprecipitated compounds are separated from the extracts in a product fraction by  
35 decanting and filtration or by equivalent methods or combination of methods.

5. A procedure in accordance with Claim 1, characterized by the above-mentioned extraction occurring in four steps, where the mentioned lye in the first two steps is 0.01 N of a strong base, where the mentioned lye in the last two steps is 1.0 N of a strong base; where the extracts from the first two steps are neutralized and this is followed by the addition of marine oil,  $\text{Ca}^{2+}$ -ions,  $\text{S}^{2-}$ -ions and  $(\text{NH}_4)_2\text{HPO}_4$  for the precipitation of  $\text{F}^-$ -ions and the contaminants, where this precipitate is removed from the solution by floating or the equivalent, after this the solution is acidified prior to the precipitation of the purified proteins followed by the separation of these proteins from the solution by filtration or an equivalent method, where the extracts from the last two steps are removed for cooling, whereupon the extracts are separated into three phases which are divided by floating off the phase with the lowest specific weight and decanting or the equivalent the phase with the intermediate specific weight from the phase with the highest specific weight; where the phase with the lowest specific weight is neutralized by the addition of an acid which causes the formation of two liquid phases, which are separated, and the oily phase consisting of astaxanthin esters is taken care of; where the phase with the highest specific weight is neutralized by an acid and solids consisting of astaxanthin and related carotenoids are filtered away and taken care of in a known manner; and where the phase with the intermediate specific weight is neutralized and followed by the addition of marine oil,  $\text{Ca}^{2+}$ -ions,  $\text{S}^{2-}$ -ions and  $(\text{NH}_4)_2\text{HPO}_4$  for the precipitation of  $\text{F}^-$ -ions and the heavy metal contaminants, where this precipitate is removed from the solution by floating or the equivalent, after this the solution is acidified prior to the precipitation of the purified proteins followed by the separation of these proteins from the solution.

# INTERNATIONAL SEARCH REPORT

International Application No. **PCT/NO 89/00119**

<b>I. CLASSIFICATION OF SUBJECT MATTER</b> (In several classification symbols apply, indicate all)		
According to International Patent Classification (IPC) or to both National Classification and IPC		
IPC5: C 09 B 61/00, A 23 J 1/04		
<b>II. FIELD OF SEARCH</b>		
Minimum Documentation Searched		
Classification	Classification symbol	
IPC5	C 09 B; C 07 K; A 23 J	
Documentation Searched other than Minimum Documentation (to the extent that such Documents are included in the Fields Searched)		
SE,DK,FI,NO classes as above		
<b>III. DOCUMENTS CONSIDERED TO BE RELEVANT*</b>		
Category*	Citation of Document, <sup>1)</sup> with indication, where appropriate, of the relevant passages <sup>12)</sup>	Relevant to Claim No. <sup>13)</sup>
X	US, A, 4505936 (MEYERS ET AL) 19 March 1985, see column 4, line 61 - column 5, line 9	1-2
	--	
X	GB, A, 1224172 (THE BRITISH PETROLEUM COMPANY LIMITED) 3 March 1971, see the whole document	1-2
	--	
	-----	
<p>* Special categories of cited documents: <sup>14)</sup></p> <p>"A" document defining the general state of the art which is not considered to be of particular relevance</p> <p>"E" earlier document but published on or after the international filing date</p> <p>"L" document which may throw doubts on priority claim(s) or which is cited to establish the publication date of another citation or other special reason (as specified)</p> <p>"O" document referring to an oral disclosure, use, exhibition or other means</p> <p>"P" document published prior to the international filing date but later than the priority date claim</p> <p>"T" later document published after the international filing date or priority date and not in conflict with the application but cited to understand the principle or theory underlying the invention</p> <p>"X" document of particular relevance; the claimed invention cannot be considered novel or cannot be considered to involve an inventive step</p> <p>"Y" document of particular relevance; the claimed invention cannot be considered to involve an inventive step when the document is combined with one or more other such documents, such combination being obvious to a person skilled in the art</p> <p>"Z" document member of the same patent family</p>		
<b>IV. CERTIFICATION</b>		
Date of the Actual Completion of the International Search	Date of mailing of this International Search Report	
20th February 1990	1990 -02- 23	
International Searching Authority	Signature of Authorized Officer	
SWEDISH PATENT OFFICE	 Ragnhild Wallies	

**ANNEX TO THE INTERNATIONAL SEARCH REPORT  
ON INTERNATIONAL PATENT APPLICATION NO. PCT/NO 89/00119**

This annex lists the patent family members relating to the patent documents cited in the above-mentioned international search report

Patent document cited in search report	Publication date	Patent family member(s)	Publication date
US-A- 4505936	19/03/85	NONE	
GB-A- 1224172	03/03/71	FR-A- 1567571	16/05/69
		BE-A- 716165	06/12/68

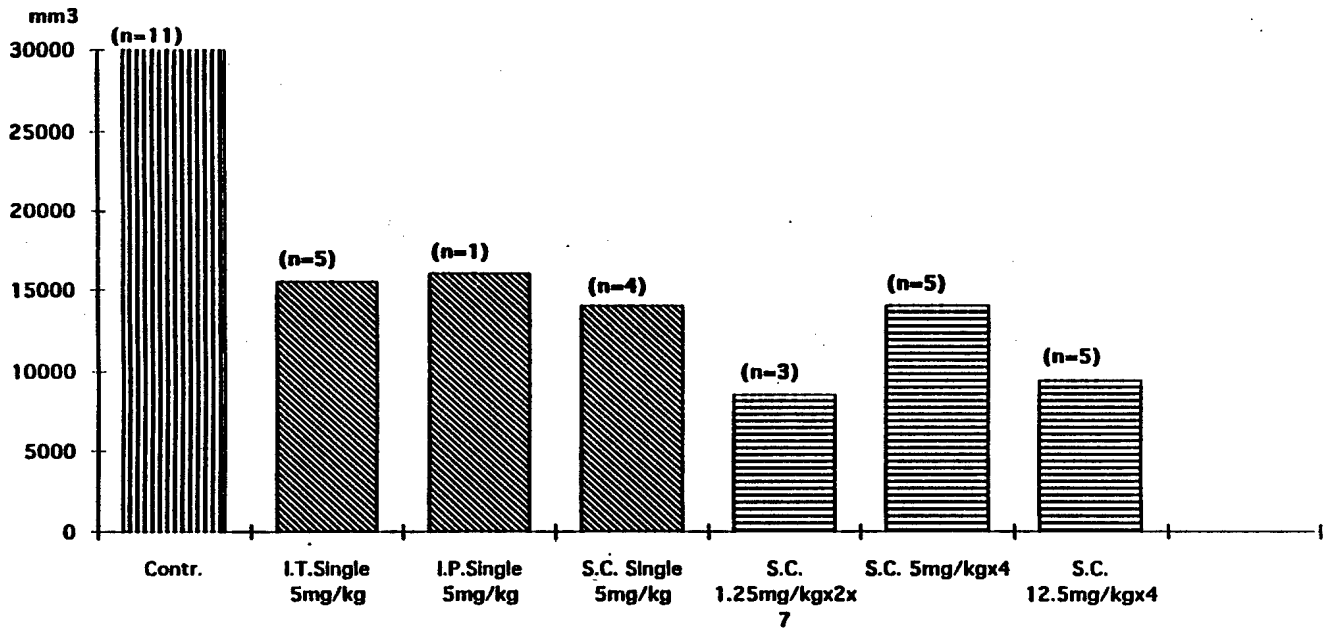




INTERNATIONAL APPLICATION PUBLISHED UNDER THE PATENT COOPERATION TREATY (PCT)

<p>(51) International Patent Classification <sup>5</sup> : <b>A61K 37/54, C12N 9/50</b></p>	<p><b>A1</b></p>	<p>(11) International Publication Number: <b>WO 93/24142</b> (43) International Publication Date: 9 December 1993 (09.12.93)</p>
<p>(21) International Application Number: PCT/SE93/00455 (22) International Filing Date: 21 May 1993 (21.05.93) (30) Priority data: 9201628-6 22 May 1992 (22.05.92) SE (71) Applicant (for all designated States except US): PHAIRSON MEDICAL AB [SE/SE]; Bruksförvaltarvägen 18, S-740 33 Vattholma (SE). (72) Inventors; and (75) Inventors/Applicants (for US only) : LINDBLOM, Ragnvald [SE/SE]; Alsäter, S-740 10 Almunge (SE). DE FAIRE, Johan [SE/SE]; Bruksförvaltarvägen 18, S-740 33 Vattholma (SE).</p>		<p>(74) Agents: PERNEBORG, Henry et al.; Uppsala Patentbyrå, Box 9013, S-750 09 Uppsala (SE). (81) Designated States: AT, AU, BB, BG, BR, CA, CH, CZ, DE, DK, ES, FI, GB, HU, JP, KP, KR, KZ, LK, LU, MG, MN, MW, NL, NO, NZ, PL, PT, RO, RU, SD, SE, SK, UA, US, VN, European patent (AT, BE, CH, DE, DK, ES, FR, GB, GR, IE, IT, LU, MC, NL, PT, SE), OAPI patent (BF, BJ, CF, CG, CI, CM, GA, GN, ML, MR, NE, SN, TD, TG).  Published With international search report.</p>

(54) Title: NEW PHARMACEUTICAL USES OF KRILL ENZYMES



(57) Abstract

Non-immunogenic enzyme compositions which have been isolated from antarctic krill and exhibit both endo- and exo-peptidase activity, are useful for the manufacture of medicaments and pharmaceutical compositions for the treatment of a great variety of diseases in humans and animals such as infections, inflammations, cancers, HIV/AIDS, pain, polyps, warts, hemorrhoids, plaque, wrinkles, thin hair, allergic itch, anti-adhesion, eye diseases such as cataract, glaucom, etc.

**FOR THE PURPOSES OF INFORMATION ONLY**

Codes used to identify States party to the PCT on the front pages of pamphlets publishing international applications under the PCT.

<b>AT</b>	Austria	<b>FR</b>	France	<b>MR</b>	Mauritania
<b>AU</b>	Australia	<b>GA</b>	Gabon	<b>MW</b>	Malawi
<b>BB</b>	Barbados	<b>GB</b>	United Kingdom	<b>NL</b>	Netherlands
<b>BE</b>	Belgium	<b>GN</b>	Guinea	<b>NO</b>	Norway
<b>BF</b>	Burkina Faso	<b>GR</b>	Greece	<b>NZ</b>	New Zealand
<b>BG</b>	Bulgaria	<b>HU</b>	Hungary	<b>PL</b>	Poland
<b>BJ</b>	Benin	<b>IE</b>	Ireland	<b>PT</b>	Portugal
<b>BR</b>	Brazil	<b>IT</b>	Italy	<b>RO</b>	Romania
<b>CA</b>	Canada	<b>JP</b>	Japan	<b>RU</b>	Russian Federation
<b>CF</b>	Central African Republic	<b>KP</b>	Democratic People's Republic of Korea	<b>SD</b>	Sudan
<b>CG</b>	Congo	<b>KR</b>	Republic of Korea	<b>SE</b>	Sweden
<b>CH</b>	Switzerland	<b>KZ</b>	Kazakhstan	<b>SK</b>	Slovak Republic
<b>CI</b>	Côte d'Ivoire	<b>LJ</b>	Liechtenstein	<b>SN</b>	Senegal
<b>CM</b>	Cameroon	<b>LK</b>	Sri Lanka	<b>SU</b>	Soviet Union
<b>CS</b>	Czechoslovakia	<b>LU</b>	Luxembourg	<b>TD</b>	Chad
<b>CZ</b>	Czech Republic	<b>MC</b>	Monaco	<b>TG</b>	Togo
<b>DE</b>	Germany	<b>MG</b>	Madagascar	<b>UA</b>	Ukraine
<b>DK</b>	Denmark	<b>ML</b>	Mali	<b>US</b>	United States of America
<b>ES</b>	Spain	<b>MN</b>	Mongolia	<b>VN</b>	Viet Nam
<b>FI</b>	Finland				

NEW PHARMACEUTICAL USES OF KRILL ENZYMES.Technical field

The present invention relates to new pharmaceutical uses of non-immunogenic proteinaceous substances and compositions which have enzymatic activity and which in a great number of clinical tests surprisingly have proven to provide a cure for an amazingly great variety of diseases. According to the the invention it is believed that these substances function in a phagocytosis-like manner, i.e. they seem to be able to distinguish between various particles and soluble matter regarded to be "normal" or "abnormal", respectively, in a particular environment or, differently expressed, seem to be able of recognizing, targeting and destroying divergent cells. It should, however, be emphasized that the invention is not intended to be restricted by any hypothetic mode of action expressed in the present specification.

Description of Prior Art

One traditional way of looking upon proteolytic enzymes for medical use is to use them for cleansing of non-healing wounds covered with proteinaceous structures - as an alternative to surgical debridement, mainly in elderly patients with ulcera caused by circulation insufficiencies. See e.g. US-A-4,801,451 and US-A-4,963,491, which disclose a mixture of exo- and endopeptidase enzymes which have been isolated from antarctic krill (*Euphasia superba*) and its use for cleaning purposes, both pharmaceutical cleaning (US-A-4,801,451) and non-pharmaceutical cleaning (US-A-4,963,491). The only disclosed pharmaceutical cleaning is enzymatic debridement, viz. enzymatic cleansing of necrotic wounds. Disclosed uses for non-pharmaceutical purposes are i.a. as laundering agents, for renovation of old paintings etc. WO 85/04809 discloses the use of enzymes from antarctic krill as a digestion promotor. EP-A1-0170115 discloses the use of krill as a thrombus dissolvent.

Enzymes and enzyme mixtures derived from antarctic krill have been isolated and extensively studied as regards their biological and biochemical properties. Various procedures for isolating these enzymes have also been developed. See e.g. Anheller J-E., Hellgren L., Karlstam B. and Vincent J. (1989): "Biochemical and biological profile of a new enzyme preparation from Antarctic krill (*E. superba*) suitable for debridement of ulcerative lesions", Arch. Dermatol. Res. 281, 105-110; Axelsen N.H., Kroll J. and Weeke B. (1973): "A manual of quantitative immunoelectrophoresis: methods and applications", Scan. J. Immu-

nol. 2, Suppl.; Bucht A. and Karlstam B. (1986): "Immunological characterization of three highly purified trypsin-like enzymes from Antarctic krill (*Euphausia superba*)", Biol. Chem. Hoppe-Seyler 367, 366 (Suppl.); Bucht A., Johansson, B. and Karlstam B. (1986): "Separation and identification of proteases from Antarctic  
5 krill (*Euphausia superba*)", 6th Int. Symp. HPLC Proteins, Peptides and Polynucleotides, Baden-Baden, pp. 34; Chen C.S., Yan T.R. and Chen H.Y. (1978): "Purification and properties of trypsin-like enzymes and a carboxypeptidase A from *Euphausia superba*", J. Food Biochem. 2, 349-366; Hellgren L., Karlstam B.,  
10 Mohr V. and Vincent J. (1991): "Krill enzymes - a new concept for efficient debridement of necrotic ulcers", Int. J. Dermatol. 30, 102-103; Karlstam B.: "Crossed immunoelectrophoretic krill analysis of proteins from Antarctic krill (*Euphausia superba*) with special reference to serine proteinases" (submitted for publication); Kimoto K.K., Kusama S. and Murakami K. (1983); "Purification and  
15 characterization of serine proteinases from *Euphausia superba*", Agric. Biol. Chem. 47, 529-534; Lowry O.H., Rosebrough N.J., Farr A.L. and Randal R.J. (1951): "Protein measurement with the Folin phenol reagent", J. Biol. Chem. 193, 265-275; Moore S. and Stein W.H. (1963): "Chromatographic determination of amino acids by the use of automatic recording equipment", Methods Enzymol. 6, 819-831; Osnes K.K. and Mohr V. (1985): "On the purification and characteriza-  
20 tion of three anionic serine-type peptide hydrolases from Antarctic krill, *Euphausia superba*", Comp. Biochem. Physiol. 82B, 607-619; and Osnes K.K. and Mohr V. (1986): "On the purification and characterization of exopeptidases from Antarctic krill, *Euphausia superba*", Comp. Biochem. Physiol. 83B, 445-458.

#### Background of the invention

25 Our immune system is always on guard and active and its main functions are to protect and to preserve the integrity of our body by taking care of foreign invaders, old and worn-out cells, divergent cells and soluble matters that are regarded to be abnormal in the specific environment.

30 Phagocytes, granulocytes, macrophages and NK-cells, are our "old immunocells" and their mode of action for protection and preservation is phagocytosis, i.e. engulfing for example a germ inside themselves and releasing lysosomal enzymes that will kill and decompose the germ.

35 Lymphocytes, T-cells and B-cells are our "new immunocells" and they present a variety of modes of action for protection and preservation. Some T-cells release toxins for killing of microbes, other deliver messages and control the

intensity of response and B-cells produce antibodies. The old and new cells interact in a complex interplay for optimal protection of our body.

In case of a tissue damage the granulocytes appear at site within a few minutes and they immediately start to attack foreign invaders, damaged cells etc. Within a few hours macrophages, NK-cells, and T-cells have responded to the chemotactic signals from granulocytes at work and they enter into the area. A sophisticated interplay starts for scavenging of damaged tissue to final healing.

The sign of an activated immune defence can be seen as an inflammation which is caused by leaking toxins from different immunocells and microbes and the inflammation is healthy as long as it is kept at a low level. Sometimes the immune defence gets over-activated and an acute inflammation appears that is causing more harm than good, and if protracted the inflammation may become chronic which might be the starting point of an autoimmune condition.

The main reason for inflammations going astray is microbial infections and despite the manifold actions of our immune defence, microbes have developed means of selfprotection that in the long run could lead to very hazardous conditions.

The microbes may disguise themselves to irrecognition for the immunocells or they may enter into cells, even immunocells, and live, multiply, and change the memory of their host-cells. Some cancers and AIDS and the severe complication of opportunistic infections of these diseases are examples of such microbial (mis-)behavior.

The pathogenesis of a disease is thus dependent on how well the immune system is functioning and normally it is in perfect balance for its tasks. Besides the microbial interference, drugs are the main cause of temporary and permanent suppression of the immune defence and much attention in pharmaceutical research is put in this direction.

#### Summary of the invention

The optimal drug would be a drug that acts in harmony and symbiotic interplay with the immune defence system and with a targeting at causes and symptoms without adverse reactions. The present invention provides novel pharmaceutical uses and novel pharmaceutical compositions which seem to have said properties. The means by which this is achieved involves the use of one or more proteolytic enzymes which have been isolated from antarctic krill (*Euphasia superba*). As mentioned above, such enzymes are known as such, and have also

been suggested for a few pharmaceutical uses. The results obtained when using said krill enzymes for the herein disclosed purposes could not be expected, and the results obtained are, indeed, unexpected. The means by which these results are achieved will be explained in the following Examples and the appended  
5 claims.

#### Preparation Example

As mentioned above, many procedures for isolating proteolytic enzymes from krill are already known, so the following is only one of many possible ways of preparing enzyme preparations which can be used according to the invention.

10 Deep frozen white Krill, Euphasia Superba, was thawed and homogenized. Distilled water was added at ratio of 1:1 (w/v) and 0.02% sodium azide and left for 6 hours at +4°C. The water phase was collected together with the centrifugate from meat/shell pieces, 9000 rpm for 40 minutes. The water phase was defatted with ethyl acetate at +4°C over night. The lower water phase was collected and  
15 evaporated for several hours.

Saturated ammonium sulphate solution was added to 60% saturation. The obtained precipitate was centrifugated at 9000 rpm for 40 minutes and then dissolved in 0.05M phosphate buffer, pH 7.4, 0.05M sodium chloride (PBS) and dialyzed against PBS, "crude extract".

20 The crude extract was applied to a Sephacryl 200 (Pharmacia, Sweden) column and protein fractions were collected at 280 nm absorbance and assayed for proteolytic activity. Active fractions were pooled and lyophilized. The combined active fractions will in the following interchangeably be called "Multi-Protein", "Multi-Enzyme", PHIM or PHIM 106.

25 The molecular weight range of isolated enzymes was determined by SDS-PAGE PAA4/30 (Pharmacia, Sweden). Minimum 6 bands were shown within the range of 18,000-40,000, specifically 24,000-34,000.

One fraction from the gel chromatography above showed both endo- and exopeptidase activities and the fraction was applied for further separation. It was  
30 shown that this fraction contained a possible single enzyme with a molecular weight of 26,000-32,000. It will in the following be called "Single-Protein", or "Single-Enzyme".

Neither the crude extract, nor the Multi-Protein, nor the Single-Protein showed any bacteriocidal effects in vitro, but possibly a bacteriostatic effect.

35 The normal temperature range of the enzymes in living shrimps is -5 to

-2°C. It is surprising to find that temperature optimum for the enzymes is +55°C at neutral pH and some enzymes are stable at 100°C for 1 hour.

#### Various characteristics of PHIM

In Figure 28 the temperature stability of PHIM, as prepared above, is shown, i.e. the percentage relative activity of PHIM (activity expressed as digested area of bovine casein; BioRad Protease Substrate Tablets; 30°C for 20 hours) as a function of time at the temperatures 10, 20, 30, 40, 50, 60 and 70°C. At 70°C the activity has decreased to below 25% after 2 hours whereas this takes at least 12 hours at 60°C. At 40°C a decrease of activity below 25% is seen after 11 days whereas the activity of PHIM at 30°C after 11 days is still about 100%.

In Figure 29 the temperature optimum is shown, i.e. the total proteolytic activity of PHIM (expressed in Casein equivalents in mm<sup>2</sup> as digested area of bovine casein; BioRad Protease Substrate Tablets; pH 7.0; 30°C for 24 hours) as a function of temperature. It is interesting to note that the optimum activity is obtained at 55°C.

In Figure 30 the pH stability of PHIM is shown, i.e. the percentage relative activity of PHIM (activity expressed as digested area of bovine casein; BioRad Protease Substrate Tablets; 30°C for 20 hours) as a function of time at different pH values. Reconstituted PHIM was kept at room temperature for 2 to 18 hours. At pH 3.5 and pH 11 there is a rather rapid decrease of activity already after a few hours whereas between pH 7.0 and pH 9.5 the activity is still above about 70% after 18 hours.

In Figure 31 the pH optimum of PHIM is shown, i.e. the total proteolytic activity of PHIM (expressed in Casein equivalents in mm<sup>2</sup> as digested area of bovine casein, BioRad Protease Substrate Tablets; 30°C for 16 hours) as a function of pH. It is noted that there is an optimum proteolytic activity at about pH 8.

In Figure 32 an in-vitro Dose-Activity curve of PHIM is shown, i.e. the total proteolytic activity of PHIM (expressed in Casein equivalents in mm<sup>2</sup> as digested area of bovine casein; BioRad Protease Substrate Gel Tablets; pH 7.0; 30°C for 24 hours). The protein concentration was measured according to Bradford, M., Anal. Biochem. 72, 248, 1976. The activity rapidly increases with increased doses of PHIM and reaches a maximum at about 1.5 mg of PHIM, the activity still having about the same value at 15 mg of PHIM.

### Clinical Examples

To illustrate the therapeutical effect obtained according to the invention, possible limitations and drawbacks in clinical practice, the enzymes and enzyme mixtures according to the invention were tested clinically for i.a. the following

5 indications:

- Infections
- Inflammations
- Dead and divergent cells
- Opportunistic infections
- 10 - Eye diseases
- Pain
- Cancer.

All studies were designed as pilot studies on small numbers of patients for the respective indication. To investigate the aim of study mostly topical wounds and affected sites were selected where visual inspection of clinical parameters could be performed.

In most of the cases the keyword for patient selection was "otherwise healthy patient", i.e. the focusing was made on the primary clinical problem situation and obvious underlying system factors were excluded to enable a good interpretation of results. A certain variety of general conditions and systemic factors are naturally included in this patient material since patients from the age of 20 to 85 years participated and indications from ambulatory "light" inflammation to hospitalized bed sore were included. Each test group for the respective indication constituted a rather homogeneous group regarding general conditions and underlying systemic factors.

### Brief description of the drawings

**Figures 1-4** are diagrams showing average exudation ratios, average erythema scoring, average swelling/oedema scoring and average pain for treatment of post-operative surgical wounds with Single- and Multi-Enzymes according to the invention.

**Figures 5 and 6** are diagrams showing average pain relief and inflammation scoring for 7 days' treatment of painful gum infections with Multi-Enzymes according to the invention.

**Figures 7 and 8** are diagrams showing erythema/swelling and pain sensation scoring for nine days' treatment of viral infections in the upper airways



with Multi-Enzyme according to the invention.

**Figures 9 and 10** are diagrams showing average time between urinations and pain relief scoring respectively for four days' treatment of urinary bladder and urethra infections with Multi-Enzyme according to the invention.

5 **Figure 11** is a diagram showing average pain relief over seven days' treatment of acute arthritis in race horses with Multi-Enzyme according to the invention.

**Figure 12** is a diagram showing the decomposing efficiency of Single-Enzyme on necrotic post-operative wounds.

10 **Figure 13** shows the Dose-Response curve of the Multi-Enzyme (PHIM) for the indication burns.

**Figure 14** shows Dose-Range intervals for the Multi-Enzyme (PHIM) for various indications.

15 **Figure 15** shows the maximal accumulated amount per kg body weight of Multi-Enzyme (PHIM) to reach a cure for various indications.

**Figure 16** shows the minimal accumulated amount per kg body weight of Multi-Enzyme (PHIM) to reach a cure for various indications.

**Figure 17** is a bar chart illustrating the effect of tumour treatment with a single injection (IT, IP and SC) of PHIM 106, compared with the control group.

20 **Figure 18** is similar to Fig. 17, but shows the result of repeated injection of PHIM 106 subcutaneously.

**Figure 19** is a bar chart illustrating the tumour volume for administration of PHIM 106 in varying doses and compared to the control.

25 **Figures 20 and 21** show histopathological sections of control rats in two different degrees of magnification.

**Figures 22 and 23** show sections corresponding to Figs. 20 and 21 but for rats treated according to the invention.

**Figures 24 and 25** are photos showing the tumours on an untreated control rat, and

30 **Figures 26 and 27** show corresponding photos of a rat treated with a single subcutaneous injection according to the invention.

**Figure 28** shows the temperature stability of PHIM, i.e. the percentage relative activity of PHIM versus the time at different temperatures.

35 **Figure 29** shows the temperature optimum of PHIM, i.e. the total proteolytic activity as a function of the temperature.

**Figure 30** shows the pH stability of PHIM, i.e. the percentage relative

activity versus the time at different pH values.

**Figure 31** shows the pH optimum of PHIM, i.e. the total proteolytic activity as a function of the pH.

**Figure 32** shows a Dose-Activity curve of PHIM, i.e. the total proteolytic activity as a function of the dose of PHIM.

#### Clinical Examples 1 to 10 - Infections

Infections and inflammations most often occur together and they show similar clinical signs, i.e. erythema, swelling, heat, oedema, exudation, pus, pain, necrotic tissues, and sometimes smell. These clinical signs were followed and recorded to evaluate the course of treatment and efficacies of the Single-Protein and Multi-Protein preparations according to the invention, as described above.

#### Example 1 - Post-operative surgical wounds

Totally 40 patients were included in this study and they were divided into two groups of 20 patients each, representing 41 post-op. abdominal (34) and thoracic (7) wounds. Single-Enzyme, 3 Casein-Units/ml, resp. Multi-Enzyme, 5 Casein- units/ml, preparations from Krill were tested in each group. Lyophilized white powder without preservatives or anti-microbial additives. To be reconstituted in 5 ml saline.

The patient material had an average age of  $52 \pm 16$  years, including 28 males and 12 females. The anti-microbial actions of the preparations were very good to excellent regarding clinical effects and efficiency. Within 5 days all infections were brought to a subclinical level and all obvious signs of clinical infections were gone. No notable difference between the two preparations could be observed. There were no obvious or suspected adverse reactions observed.

The results are summarized in Figures 1-4.

A suitable dose range for this indication is 0.01 to 100, preferably 1 to 25 mg per 100 cm<sup>2</sup>.

#### Example 2 - Small size burns

11 patients with smaller full thickness burns infected by *S. aureus* and *P. aeruginosa* not responding to antibiotics and silverdiazine cream were included in this study. 5 patients were treated with Single-Enzyme hydrocolloid cream, 3 Casein-Units/ml, and 6 patients with Multi-Enzyme solution, 5 Casein-Units/ml. Lyophilized white powder without preservatives or anti-microbial additives. Multi-Enzyme preparation: 1 ampoule to be reconstituted in 5 ml saline to a final

concentration of 5 Casein-Units/ml solution. Single-Enzyme preparation: 1 ampoule to be mixed with 5 ml of hydrocolloid gel to a final concentration of 3 Casein-Units/ml gel.

5 A suitable dose range for this indication is 0.01 to 100, preferably 1 to 25 mg per 100 cm<sup>2</sup>.

All wounds were completely free from all signs of infection within 5 days' treatment which was confirmed by MO-cultivation. Necrotic tissue, pus and fibrinous fibrils in the granulation tissue were effectively decomposed by both preparation and no perceptible difference in efficacy between the preparations  
10 could be observed. No adverse reactions could be noted from the preparations.

The test results are summarized in Table 1.

Table 1

**Compilation of Data  
for Small Size Burns**

Wound Nr./ Size (cm <sup>2</sup> )	Strain	MO-status before (10 <sup>6</sup> )	Visual percentage of Necr./Pus /Fibrin/Granul./Epith.		Preparation	Day of termIn.	MO-status after (10 <sup>6</sup> )	Visual percentage of Necr./Pus /Fibrin/Granul./Epith.		Healed day post-treatm.	
			Necr./Pus	Fibrin/Granul./Epith.				Necr./Pus	Fibrin/Granul./Epith.		
I 1.5	P. aerig.	16	20	60	Solution	3.5	4		30	70	3
II 4.0	P. aerig.	18	50	10	Gel	5.0			10	60	11
III 3.6	S. aureus	22	10	90	Gel	3.0			10	40	6
IV 2.4	P. aerig.	14	40	10	Gel	3.0				50	---
V 2.8	S. aureus	17		100	Solution	4.0				30	70
VI 1.9	S. aureus	16		100	Solution	2.5				20	80
VII 4.5	S. aureus	15	10	80	Gel	5.0			10	60	15
VIII 3.2	P. aerig.	12	40	40	Solution	3.0				60	40
IX 1.8	S. aureus	16	10	90	Solution	2.5				20	80
X 2.3	P. aerig.	17	30	30	Gel	3.5				40	60
XI 3.1	P. aerig.	20	30	30	Solution	5.0			10	80	10

### Example 3 - Painful gum infections

22 patients with acute or chronic gum infections/inflammations were included in this study. Lyophilized white powder without preservatives or anti-microbial additives. Multi-Enzyme preparation: 1 ampoule to be reconstituted in  
5 5 ml saline to a final concentration of 5 Casein-Units/ml solution.

Three times a day, morning, mid-day and evening, an ampoule was reconstituted in 5 ml tap water and the mouth cavity was rinsed for 5 minutes. No eating and drinking within 2 hours after treatment was allowed. The treatment went on for 7 days independent of results.

10 Pain relief was reported after 20 minutes' to 12 hours' treatment. Infections and inflammations vanished within 4 days and did not reoccur during the follow-up period of 3 weeks. No adverse reactions were reported.

The results are summarized in Figures 5 and 6.

15 A suitable dose range for this indication is 0.1 to 100, preferably 1 to 35 mg per treatment.

### Example 4 - Viral infections in the upper airways

11 patients with Influenza Virus infections and secondary bacterial infections in the upper airways (e.g. sinusitis) were included in this study.

20 Viral infections in the airways cause harm to the cilia and an inflammatory reaction is initiated with erythema, swelling and increased mucus-secretion. The harmed cilia can no longer wipe away inhaled bacteria and bacterial infections often become secondary complications to viral infections.

Other typical symptoms of viral infections are general state of illness, strong sense of fatigue, fever and general pain.

25 Viruses are dependent on host-cells for their survival and multiplication and it is a difficult task to kill a virus without harming/killing the host-cell.

Multi-Enzyme preparation: Lyophilized white powder without preservatives or anti-microbial additives was used. One ampoule to be reconstituted in 5 ml of saline to a final concentration of 5 Casein-Units per ml.

30 Approximately 0,25 ml of the test solution was sprayed in each nostril and the mouth-cavity was rinsed for 5 minutes with approx. 4.5 ml. The procedure was repeated three times daily and clinical parameters, erythema, swelling, mucus-secretion, pain and adverse reactions were recorded once daily.

35 The treatment was terminated when all signs of infection were gone but for no longer than 10 days.

8 patients were free from symptoms after 6 days' treatment and the remaining three patients after 9 days.

Pain relief was experienced in all patients and occurred within 2 hours to two days. Sputum became clear within three days in patients with purulent discharges. Erythema and swelling disappeared within 4 days.

The results are summarized in Figures 7 and 8. No adverse reactions were observed.

A suitable dose range for this indication is 0.1 to 100, preferably 1 to 35 mg per treatment.

#### 10                    Example 5 - Herpes Simplex infection in the mouth cavity

8 patients with relapsed Herpes Simplex blisters in mouth cavity were treated twice daily with mouth-wash. Lyophilized white powder without preservatives or anti-microbial additives. Multi-Enzyme: 1 ampoule to be reconstituted in 5 ml of saline to a final concentration of 5 Casein-Units/ml.

15                    An ampoule was prepared before each treatment and the mouth cavity was rinsed for 5 minutes with test solution. No eating or drinking was allowed within 2 hours after each treatment. The procedure was repeated twice daily and clinical parameters, erythema, swelling, pain and adverse reactions were recorded once daily.

20                    The treatment was terminated when all signs of infection were gone but for no longer than 10 days.

Pain relief was experienced within 2 hours after the first treatment and in some patients the pain recurred between treatments during the first two days but never thereafter.

25                    After 5 days all patients were free from symptoms and all blisters had healed. No adverse reactions were observed.

It appears from the above Examples 1 to 5 that bacterial, viral and fungal infections follow very similar courses of progress and all signs of infections and inflammations have vanished within 3-6 days. Even drug-resistant bacterial strains, such as *S. aureus* and *P. aeruginosa* in burns, and intra-cellular virus, such as Herpes Simplex, follow the same pattern. Gum infections and viral infections in the upper airways were also effectively treated only with rinsing of the mouth-cavity for totally 15 minutes per day for 5-7 days. The short effective time of action and the possible rinsing-away effect from saliva supports the hypothesis that the proteins from the test preparations have an ability to adhere

35

to cells or surfaces and to perform actions for much longer time than the actual treatment sequence. The identical observation was made in patients with extreme lacrimal secretion in eye infections.

5 A suitable dose range for this indication is 0.1 to 100, preferably 1 to 35 mg per treatment.

#### Example 6 - Infected decubitus ulcers

14 elderly patients with totally 18 decubitus on heels and lower back were included in this study. Lyophilized white powder without preservatives or antimicrobial additives. Multi-Enzyme preparation: 1 ampoule to be reconstituted in 10 5 ml saline to a final concentration of 5 Casein-Units/ml solution.

Ulcers were rinsed thoroughly with saline and emptied as far as possible before instillation of 5 ml Multi-Enzyme Solution into the ulcer and covered with semi-occlusive dressing. The procedure was repeated twice daily for 7 days and ulcers were inspected for inflammation, erythema, heat, swelling, necrotic tissue, 15 pus, pain and possible adverse reactions.

Infections were gone within 4 days' treatment. 6 wounds healed completely within 7 days and totally 11 within 14 days. 7 wounds did not heal due to the general conditions of the patients but the wounds showed some progress. No adverse reactions were observed.

20 A suitable dose range for this indication is 0.1 to 100, preferably 1 to 25 mg per 100 cm<sup>2</sup>.

#### Example 7 - Fistulae infections

The purpose of the study was to investigate the anti-microbial and decomposition efficacies and usefulness of Single-Protein and Multi-Protein preparations from Krill on anal fistulae. Lyophilized white powder without preservatives 25 or anti-microbial additives.

Single-Protein with both endo- and exopeptidase activities: 1 ampoule to be reconstituted in 5 ml of hydrogel to a final concentration of 3 Casein-Units/ml. Multi-Protein with a mixture of endo- and exopeptidase activities: 1 ampoule to 30 be reconstituted in 5 ml of hydrogel to a final concentration of 5 Casein-Units/ml.

The fistulae were rinsed with sterile solution and emptied as far as possible before instillation of Single-Protein Gel and Multi-Protein Gel, respectively. The procedure was repeated once daily and patients were inspected for erythema, heat, swelling, pus, pain and adverse reactions.

The treatment was terminated when all signs of infection and inflammation were gone but for no longer than 10 days.

2 + 2 patients with anal fistulae, with no passages to rectum, were included in this study and treated with Single-Protein and Multi-Protein gel preparations, respectively.

Total pain relief was reported within 48 hours and all signs of infections and inflammations were gone after 4 days.

All fistulae were healed on Day 6 to Day 9 and no recurrence was reported within 6 months' follow-up. No adverse reactions were observed.

It appears from the above Examples that complicated infections that generally are regarded by expertise to be very difficult to treat, such as anal fistulae and decubitus ulcera, were successfully treated and led to final healing in most of the cases within the time-frame of the respective study.

A suitable dose range for this indication is 0.01 to 100, preferably 1-25 mg per 100 cm<sup>2</sup>.

#### Example 8 - Eye infections

15 patients with purulent eye infections were treated twice daily with eye-drops of Multi-Enzyme preparation from Krill. (Lyophilized white powder without preservatives or anti-microbial additives. One ampoule of Multi-Enzyme to be reconstituted in 25 ml Water for Injection to a final concentration of 1 Casein-Unit/ml.) The infected eye was dropped morning and evening with two drops, approx. 0.4 ml, of the test solution. At each application the eye was inspected for erythema, swelling, pus, lacrimal secretion and possible adverse reactions.

The treatment was terminated when all signs of infection were gone but for no longer than 10 days.

All patients were free from infections within 3 days' treatment. Erythema and swelling around the eyes faded away within 2 days and excess lacrimal secretion ceased within 2 days as well. Instantly after the first application all patients experienced a smoothing feeling in the infected eye and irritation and tenderness around the eyes disappeared within a few minutes. No adverse reactions were reported.

It appears from the above Example that eye infections responded quickest to the treatment even though very low concentrations were used, 0.4 Casein-Units/treatment.

A suitable dose range for this indication is 0.01 to 50, preferably 0.1 to



5 mg per treatment.

#### Example 9 - Prophylactic treatment of post-op. wounds

Single-Enzyme and Multi-Enzyme preparations from Krill were tested against a sterile 0.9% NaCl control solution, as a prophylactic anti-microbial rinsing solution on post-op. wounds, totally 60 patients with 20 patients in each group.

Non-bleeding post-op. wounds, first treatment 6-12 hours post-op., were redressed twice daily with resp. solution. The wounds were rinsed thoroughly with resp. solution and covered with sterile gauze under semi-occlusive dressing. At each redressing the wounds were inspected for infection, inflammation, erythema, swelling, heat, necrotic tissue, fibrin, pus, bleeding, pain and possible adverse reactions.

Treatment was terminated when wounds were healed, >90% epithelialization, or when test or control treatments failed.

No post-op. clinical infections occurred in the groups treated with Single-Enzyme or Multi-Enzyme solutions nor were acute inflammation or erythema observed in any of the patients in these two groups. 18 wounds were healed within 10 days' treatment. No adverse reactions were observed.

In the control group 4 patients developed severe invasive infections and additional 2 patients had acute inflammation. Erythema, swelling and pain were frequent observations in this group. 14 wounds were healed within 10 days' treatment.

A suitable dose range for this indication is 0.01 to 100, preferably 1 to 25 mg per 100 cm<sup>2</sup>.

#### Example 10 - Urinary bladder and urethra infections

12 patients, only females, with painful urinary infections were included in this study. Lyophilized white powder without preservatives or anti-microbial additives. Multi-Enzyme preparation: 6 ampoules to be reconstituted in 50 ml saline to a final concentration of 3 Casein-Units/ml solution.

First discharge of urine from all patients was very turbid and second discharge was clear to weakly turbid.

Pain relief was instant and improved ability to retain urine was obvious after two days treatments. MO-samples confirmed no bacteria after 4 days' treatment and all treatments were terminated after 4 days. No adverse reactions

were observed.

The results are summarized in Figures 9 and 10. The average MO-status values are shown in Table 2.

Table 2

5 Average MO-status on 4 days treatment  
with Krill Multi-Enzyme preparation

	MO-status Before treatment	MO-status Day 2	MO-status Day 4
10	$1.4 \times 10^4$	$4.3 \times 10^3$	$<1.0 \times 10^2$
	100%	31%	<1%

15 It appears from the above Example that urinary bladder and urethra  
infections responded very well to instillation treatment, twice daily. After 2 days'  
treatment the acute signs of infection and inflammation had disappeared and  
after 4 days' treatment all patients were free from symptoms.

A suitable dose range for this indication is 0.1 to 200, preferably 1 to 50 mg  
per treatment.

20 Clinical Examples - Inflammations

Inflammations is a common feature in most of the studies and the reduc-  
tion of inflammation was similar in all indications. In 3 to 4 days inflammations  
were reduced to acceptable levels for a sound healing process. In the prophylactic  
study of post-op. wounds (Example 9) no inflammation occurred in the test  
25 groups. Cf. also Example 3 (acute or chronic gum infections/inflammations).

Example 11 - Inflamed horse joints

16 lame trotters with inflamed foreleg knees were included in this study.  
Lyophilized white powder without preservatives or anti-microbial additives. Multi-  
Enzyme preparation: 1 ampoules to be reconstituted in 10 ml Water for Injection  
30 to a final concentration of 2.5 Casein-Units/ml solution.

2 ml of Test Solution were injected into the painful joint on Day 1, 2, 4 and  
7. After injections the horses were observed for any instant adverse reactions or  
deteriorations in general conditions. The clinical parameters were observed once

daily.

9 cases responded with a quick pain relief, 30 minutes to 2 hours after the first treatment, 4 more cases within 6 hours and 2 more cases within 2 hours after the second injection. 1 case showed pain relief after the third injection and this case had an extreme swelling over the knee.

Heat and swelling were reduced rapidly and no signs of inflammation could be observed after two days for 15 of the included cases. No adverse reactions were observed.

The results are summarized in Figure 11.

It appears from the above Example that acute arthritis in race horses can be treated with intraarticular injections in a sequence treatment of 4 injections over 7 days. The clinical signs of inflammation were rapidly reduced and heat and swelling faded away within 2 days. One week post-treatment the horses were back on easy training.

A suitable dose range for this indication is 0.1 to 200, preferably 1 to 50 mg per treatment.

#### Clinical Examples 12-16 - Dead and Divergent Cells

Cf. also Examples 3, 4, 5 and 10.

#### Example 12 - Necrotic post-operative wounds

15 patients with necrotic wounds were treated with Single-Enzyme preparations from krill. Lyophilized white powder without preservatives or antimicrobial additives. To be reconstituted in 5 ml saline. Single-Enzyme preparation: 3 Casein-Units/ml.

Normal rinsing and wound toilet was performed prior to applying the Single-Enzyme. Twice daily an ampoule was diluted in 5 ml saline and poured onto a gauze dressing which covered the wound completely. The drained gauze was fixed to the wound by a self-adhesive semi-occlusive dressing. At every change of dressing the wound was visually inspected for erythema, oedema, bleeding, swelling, heat, exudation, pus, necrotic tissue, pain, smell, possible adverse reactions and general status of patient. The treatment was terminated when all necroses, fibrin, pus and blood clots were decomposed but for no longer than 7 days.

This patient material was heterogeneous with respect to the ethiology of

the wounds, i.e. scheduled operations, traumas, burns, shots and diabetes patients. All patients were treated poly-clinically twice a day. No adverse reaction were observed from the test preparations.

The results are summarized in Figure 12.

5 As can be seen from the above, necroses, fibrin, pus, blood clots, and plaques were effectively decomposed within a week and some wounds healed within a week. Burns, shots, and post-op. wounds in diabetes-patient initially showed very poor efficacy but at termination of the study, 7 days, the necroses were completely decomposed from underneath and what remained was only the  
10 top surfaces of the necroses, like a lid, and the wounds were partially healed within a week.

A suitable dose range for this indication is 0.01 to 100, preferably 1 to 25 mg per 100 cm<sup>2</sup>.

#### Example 13 - Decomposition of scar formation and keloids

15 The purpose of this study was to investigate the decomposing efficacy and usefulness of Multi-Protein preparation from Krill as an alternative to surgical revision. Lyophilized white powder without preservatives or anti-microbial additives. Multi-Protein with endo- and exopeptidase activities: 1 ampoule to be reconstituted in 5 ml Water for Injection to a final concentration of 5 Casein-  
20 Units/ml.

For every centimeter of the scar/keloid 0.2 ml of Multi-Protein solution was injected to a maximum volume of 1 ml per lesion and day. The procedure was repeated once daily and the scar/keloid was inspected for erythema, swelling, heat, bleeding, necroses and adverse reactions.

25 The treatment was terminated at 80% decomposition of scar/keloid but for no longer than 7 days.

Multi-Protein preparation was injected once daily into 5 facial scar formations and 3 keloid formations on hand and forearms.

30 Fibrinous scars were reduced to approx. 25% of their initial volumes and collagenous keloids to approx. 70% after 7 days' treatment. No adverse reactions could be observed during this trial.

As can be seen from the above intradermal and subcutaneous scar forma-  
35 tions and keloids were decomposed to 75% resp. 30% after 7 days' treatment with intratissual injections. In cosmetic corrections of scars and keloids the decomposi-  
tion must not be too quick and seldom more than 60-80% of the scars/keloids need

to be removed for best results. The skin and underlying tissues need to adapt slowly to the new situation if not other defects, such as wrinkles, shall occur.

A suitable dose range for this indication is 0.1 to 50, preferably 1 to 10 mg per treatment.

5

#### Example 14 - Psoriasis and dry eczema

Psoriasis plaques and dry eczema plaques were extremely easily decomposed with Hydrogel test preparations (Single-Enzyme) under semi-occlusive dressings. Within 24 hours the plaques were completely gone and the sensitive skin, especially in psoriasis patients, did not show any additional inflammation, irritation, or pain. On the contrary, the affected skin areas showed less inflammation after treatment but most of all the accessibility of steroid creams was improved when plaques were gone and much better effects could be observed from those preparations.

10 A suitable dose range for this indication is 0.01 to 100, preferably 1 to 15 25 mg per 100 cm<sup>2</sup>.

#### Example 15 - Dental plaque in dogs

The purpose of this study was to investigate the decomposing efficacy and usefulness of Multi-Protein preparation from Krill on dental plaque in a dog model. Lyophilized white powder without preservatives or anti-microbial additives. Multi-Protein with endo- and exopeptidase activities: 1 ampoule to be reconstituted in 5 ml of saline to a final concentration of 5 Casein-Units/ml.

20 The content from a freshly prepared ampoule was carefully painted over teeth and gingiva. The tongue was fixated for minimum 2 minutes and food and beverage were not allowed for 2 hours post-treatment. The treatment was repeated twice daily until all plaque was completely decomposed. The dogs were inspected for status of plaque, saliva secretion and adverse reactions once daily.

8 beagles with abnormal plaque formation due to special feeding and housing were included in this study. After 4 days all signs of plaque were gone and the study was terminated. No adverse reactions could be observed.

30 A suitable dose range for this indication is 0.1 to 100, preferably 1 to 35 mg per treatment.

#### Example 16 - Human dental plaque

The purpose of this study was to investigate the decomposing efficacy and

usefulness of Multi-Protein preparation from Krill on dental plaque. Lyophilized white powder without preservatives or anti-microbial additives. Multi-Protein with endo- and exopeptidase activities: 1 ampoule to be reconstituted in 5 ml of saline to a final concentration of 5 Casein-Units/ml.

5 An ampoule of Multi-Protein solution was prepared before each treatment and the mouth cavity was rinsed for 5 minutes. Food and beverage were not allowed for 2 hours post-treatment. The treatment was repeated twice daily and the patients were inspected once daily for plaque, saliva secretion, dryness, and adverse reactions. The patients were not allowed to brush their teeth during on-  
10 going study.

The treatment was terminated when all signs of plaque were gone but for no longer than 7 days.

2 hours after the first treatment all patients experienced a soft and smooth sense over the teeth and all patients believed the plaque was completely decompo-  
15 sed. Visual inspection showed remnants of plaque. 2 hours after the third treatment all signs of plaque were gone and treatments were terminated. No adverse reactions could be observed.

A suitable dose range for this indication is 0.1 to 100, preferably 1 to 35 mg per treatment.

## 20 Example 17 - Opportunistic Infections

These types of infections are developed in patients with totally suppressed immune system, caused by cancer, AIDS, immune suppressing drugs, irradiation, etc. Pathogenic microbial strains, and normally non-pathogenic strains may turn pathogenic, cause severe infections that finally lead to general sepsis which is the  
25 actual cause of death of patients suffering from these conditions.

Three patients, 2 patients in uterine cancer in stage IV and 1 patient with irradiation wound, with opportunistic infections in non-healing post-op. wounds were treated twice daily with drained dressings. After 12, 14 and 17 days the wounds had healed.

30 A suitable dose range for this indication is 0.01 to 100, preferably 1 to 25 mg per 100 cm<sup>2</sup>.

## Clinical Examples 18-19 - Eye Diseases

### Example 18 - Gray cataract on dog

The purpose of the study was to investigate the efficacy and usefulness of

Single-Protein and Multi-Protein preparations from Krill on gray cataract in dog. Lyophilized white powder without preservatives or anti-microbial additives. Single-Protein with both endo- and exopeptidase activities: 1 ampoule to be reconstituted in 5 ml of Water for Injection to a final concentration of 3 Casein-Units/ml. Multi-Protein with a mixture of endo- and exopeptidase activities: 1 ampoule to be reconstituted in 5 ml of Water for Injection to a final concentration of 5 Casein-Units/ml.

The right eye was treated with 2 drops, approx. 0.4 ml, of Multi-Protein solution. The procedure was repeated once daily and the dog was inspected for changes in opacity and adverse reactions.

The treatment was terminated when the eye appeared clear by visual inspection. The left eye was treated with Single-Protein solution according to an identical procedure as for Multi-Protein solution.

The treatment was terminated when the eye appeared clear by visual inspection.

After 5 days an obvious diminishing in the opacity could be noted in the right eye and after 10 days the eye looked very clear and the treatment was terminated.

Identical observations were made and treatment was terminated after 10 days also for the left eye. No adverse reactions were observed.

A suitable dose range for this indication is 0.01 to 50, preferably 0.1 to 5 mg per treatment.

#### Example 19 - Cataract of the eye

The purpose of the study was to investigate the efficacy and usefulness of Multi-Protein preparation from Krill on gray cataract.

Multi-Protein with a mixture of endo- and exopeptidase activities, 2.5 Casein-units/ml, was dropped into the right eye every 3 days.

An old lady in her 80's with day/night vision on one eye due to gray cataract was treated every three days with 0.4 ml, 1 Casein-Unit, of Multi-Protein preparation. After 5 treatments the study had to be terminated due to other medical reasons but an obvious reduction in opacity was observed and the lady reported improved vision on the affected eye. No irritation, pain or other discomfort could be observed during the treatment or 1 month post-treatment.

A suitable dose range for this indication is 0.01 to 50, preferably 0.1 to 5 mg per treatment.

Clinical Examples - Pain

Pain is initially caused by the mechanical rupture of tissues and the acute pain sensation is fading away shortly after the trauma. A certain tenderness remains throughout the early phases of the healing process. Infections and acute inflammations may cause severe pain due to swelling of tissues, chemical reactions, biochemical activities, forming of necrotic tissue, adhesions and scar formations. The pain may remain for a long time after terminated healing or even be permanent.

Pain is a very subjective parameter and it is extremely hard to interrupt clinically. By definition, pain is everything from light itching to severe disabling pain. Patients suffering from severe pain have a tendency of growing accustomed to the pain and their acceptance level is continuously elevated.

The onset of pain relief was the quickest and most obvious effect of the test preparations according to the invention. Pain relief was reported 20 minutes to 2 hours after the first application and in most cases the pain was reduced to a mild level or only a tenderness after 2 days. Independent of indication, acute or chronic pain, the patients reported an identical pattern of pain relief. Sense of feeling and touch did not disappear from the treated areas.

Patients that did not experience any pain before treatment, reported a smoothing and alleviating feeling after the first treatment, especially in treatments of the eye and mouth-cavity. (Cf. the Examples above, pain is a parameter in most of these studies.)

In urinary bladder infections and gum infections the pain sensations led to physico-social disturbances of the patients. With the quick on-set of pain relief from test preparation the patients regained their ability of concentration and were able to act as normal people within 2 days of treatment. (Compare Examples 3 and 10.)

The most objective scoring of pain sensation was performed in inflamed horse joints where the pain sensation was related to the time for supporting an affected leg. The results are comparable to the general results of studies in humans (compare Example 11).

A suitable dose range for this indication is 0.01 to 200, preferably 1 to 25 mg per treatment.



Clinical Examples 20-40 - Various indicationsExample 20 - Gastric ulcer

A man of 40 having recurring complaints characteristic of a mild form of gastric ulcer was treated with acid-resistant gelatin capsules containing 5 mg PHIM per capsule. He swallowed 1 capsule a day with a glass of water for 2 weeks. After about 4 days the stomach complaints disappeared and the stomach worked quite perfectly with natural faeces and no pain etc.

A 55 years old man having gastric ulcer complaints constantly recurring for 20 years was treated with the same dosage as above. Already after a few day's treatment the complaints had disappeared and his stomach worked normally.

Gastric ulcer is an inflammatory process probably starting due to a bacterial attack. First the intestinal mucosa is infected by the microbe and then the condition transforms to an inflammation which soon is converted to an ulcer. This means that there is a situation where the cells of the intestinal mucosa become divergent. The situation is quite analogous to that of skin infections and wounds; the difference between the skin and the intestinal mucosa is the presence in the intestinal mucosa of a cell system named Peyer's patch cell system consisting of highly active B-cells, T-cells, etc. This system is regarded to be the gateway to our autoimmune diseases. Owing to the fact that PHIM works in this cell system and has the ability to remove divergent cells from the sensitive mucosa layer, it should work, quite logically, also on autoimmune diseases like Crohn's disease, ulcerative colitis, rheumatoid arthritis, etc.

A suitable dose range for this indication is 0.5 to 300, preferably 1 to 50 mg per treatment.

Example 21 - Treatment of wrinkled skin

Wrinkled skin to a major part is caused by free radicals crosslinking the collagen. The formation of free radicals is caused by worned-out and dead cells being an excellent growth medium for bacteria speeding up in turn the formation of free radicals. By allowing PHIM to "eat" the dead cells and the bacteria, the cause of wrinkles is removed.

A 33 years old woman was treated each night for 60 days with a gauze bandage moistened with a PHIM 106 solution. The total amount of PHIM 106 used each night was about 0.15 mg. The bandage was allowed to be in close contact with the skin for 30 minutes.

By treating only the area below one of the eyes, the other side was used as

a control. Already after 15 day's treatment one could observe a difference in the elasticity of the skin and after totally 60 day's treatment there was a visually apparent difference as regards wrinkles. The treated skin area was very soft and elastic and the number and depth of the wrinkles had decreased considerably compared to the untreated skin area.

A suitable dose range for this indication is 0.01 to 100, preferably 1 to 25 mg per 100 cm<sup>2</sup>.

#### Example 22 - Polyps

A man of 62 having a polyp in his anus was treated. The man had suffered from the polyp for 3 years and had been treated by a physician. He had been treated with different kinds of medicines but no improvement was observed.

He was treated with a gauze bandage containing about 5 mg of PHIM dissolved in 5 ml of saline. The treatment was repeated totally 5 times. All trouble disappeared and at the next visit to the physician it was observed that the polyp had disappeared. 8 months after the treatment, the man is still free of complaints.

A suitable dose range for this indication is 0.5 to 250, preferably 1 to 50 mg per treatment.

#### Example 23 - Warts

A 35 years old man having a wart on his neck was treated for one week with a plaster ("Hansaplast") containing a solution of PHIM 106, about 0.1 mg/plaster. The treatment was repeated each day during a week. After 1 week's treatment the wart had completely disappeared.

A suitable dose range for this indication is 0.5 to 250, preferably 1 to 50 mg per treatment.

#### Example 24 - Common cold

5 patients in the age of from 30 to 63 years were treated with PHIM 106 only a few hours after the outbreak of the first cold symptoms. The treatment was carried out with nasal sprays every 4 hour and with mouth washes every 6 hour. The dose used in the nasal spray treatment was about 0.1 mg in each nostril at a time and in the mouth washing treatment about 1.5 mg/wash. When washing the mouth the solution was kept in the mouth for about 2-4 minutes whereupon the solution was swallowed. After 12 hours the common cold symptoms had

disappeared and the patients were free of complaints.

A suitable dose range for this indication is 0.1 to 100, preferably 1 to 25 mg per treatment.

Example 25 - Haemophilus influenza

5 A woman of 34 had recurring sinusitis by infection of Haemophilus influenza. A few hours after the appearance of the symptoms of pressure and pain in the nasal sinus, the mouth was washed for 3 minutes with a solution of 2 mg of PHIM 106 every two hours totally 4 times and about 0.1 mg of PHIM 106 was sprayed into each nostril. The spray treatment was repeated each three hours for  
10 a total of 3 days. The pressure caused by the nasal sinus infection disappeared already a few hours after the first treatment and the secretion from the nose strongly increased. After 3 day's total treatment the woman was free of complaints.

15 A suitable dose range for this indication is 0.1 to 100, preferably 1 to 25 mg per treatment.

Example 26 - Herpes Zoster

A 70 years old man having a very painful Herpes Zoster infection in his face since 10 months back was treated topically with a gauze bandage containing about 1-2 mg of PHIM, every three days.

20 Already after the first treatment the itch was reduced and also the pain, to disappear completely after 12 days. Owing to the infection, the man had had difficulties in chewing owing to pain in the palate, but after 12 days he was able to chew the food with no problems.

25 A suitable dose range for this indication is 0.01 to 100, preferably 1 to 25 mg per 100 cm<sup>2</sup>.

Example 27 - Herpes genitalis

A man of 62 having Herpes genitalis since 10 years back was treated. The complaints recurred regularly every 4 month and during the time of acute complaints the man abstained from sexual intercourse.

30 He was treated with a bandage soaked with a PHIM 106 solution, about 3 mg/bandage. The treatment was repeated twice a day for 2 days. His complaints disappeared already after the second treatment. Since the completion of the treatment, the man has had no complaints during the last 10 months.

A suitable dose range for this indication is 0.01 to 100, preferably 1 to 25 mg per treatment.

Example 28 - Hemorrhoids

Two persons were treated for hemorrhoids, one man of 55 years and one woman of 30 years. The woman had had complaints for about 3 years with pain and minor bleedings. She was treated with dry PHIM 106 powder wrapped in gauze bandage which was applied onto the area concerned. Each dose was about 5 mg. 5 treatments in total were needed before disappearance of the complaints. She has been totally free of complaints for one year now.

The man had been troubled off and on during the last years. Six months ago the complaints became acute with bleedings and very strong pain as a result thereof. The man was treated once with a gauze bandage soaked with about 4 mg of PHIM 106. The pain disappeared within about 20 minutes and after this single treatment all complaints disappeared and have not recurred since then.

A suitable dose range for this indication is 0.5 to 250, preferably 1 to 50 mg per treatment.

Example 29 - Tourist diarrhoea

A 41 years old man acutely developed food poisoning (probably from Staphylococcus) with diarrhoea and vomits. One hour after the man had fallen ill he was treated with 5 mg of PHIM 106 by keeping it in the mouth for about 3 minutes whereupon it was slowly swallowed. This procedure was repeated 3 times every second hour. After the fourth treatment the stomach pains had disappeared and the vomits and the severe diarrhoea totally ended.

A suitable dose range for this indication is 0.5 to 300, preferably 1 to 50 mg per treatment.

Example 30 - Thin-hairness

2 men were treated, 55 years old and 62 years old, respectively. They both had suffered from thin-hairness for the last 10 years. The treatment was carried out by soaking the entire scalp with a solution of PHIM 106, totally about 5 mg PHIM per treatment. In order to maintain the humidity in the scalp, it was covered with a shower cap for 30 minutes. The treatment was repeated once a week for about 3 months. After this time of treatment fresh hair began to grow out.

The reason for the good result seems to be that PHIM 106 effectively decomposes all dead and divergent cells being a good nutrient substrate for bacteria. Said bacteria produce toxins which locally trigger the cells of the skin layer to produce i.a. TNF, tumour necrosis factor, which in turn, when present in large amounts, affects the hair growth negatively. By removing said dead and divergent cells including bacteria also the microcirculation is affected in favour of a renewal of the hair.

A suitable dose range for this indication is 0.01 to 100, preferably 1 to 25 mg per 100 cm<sup>2</sup>.

10

#### Example 31 - Acne

2 women, age 29 and 30 years, were treated for acne in the face. The woman of 29 had severe complaints whereas the 30 years old woman had moderate complaints, mainly in the forehead.

They were treated with about 0.1 mg PHIM 106 several times a day for 4-6 days. The effect was quite remarkable already after the first treatment and after a few days of treatment the very infection had disappeared and the cure was almost total. One week after the treatment only pigment traces were evident.

A suitable dose range for this indication is 0.01 to 50, preferably 1 to 10 mg per treatment.

20

#### Example 32 - Bronchitis

A 55 years old man had relatively bad bronchitis complaints. The complaints manifested themselves in the form of respiration complaints, difficulty to walk longer distances than 100 meters without a break and severe tiredness as well as annoying hacking cough.

The cause of the bronchitis was considered by the physician to be a Mycoplasma infection which occurred 3 years earlier and which in spite of antibiotic treatment developed resistance. The infection also led to the formation of water in the pleura which was verified by X-ray examination.

The patient was treated with mouth washes, about 4 mg PHIM 106 each time. The PHIM solution was kept in the mouth for about 4 minutes and then it was slowly swallowed. This treatment was repeated during the first two weeks every second day. During this time also small amounts of PHIM 106 were inhaled.

During the first two weeks no improvement was observed but after two

weeks' treatment the lymph gland on the left side of the neck swelled resulting in pain. During this time the treatment was continued about 3 times. After about 1.5 weeks all problems regarding the lymph gland had disappeared and the bronchitis complaints of the patient began to subside. After further 3 weeks' treatment with mouth washes every fourth day the bronchitis complaint had completely disappeared.

After this total treatment extending over 6.5 weeks the patient had recovered completely and after a short time he could walk 5 kilometers with no problems.

A suitable dose range for this indication is 0.1 to 100, preferably 1 to 25 mg per treatment.

#### Example 33 - Prostatitis

A man of 52 years suffered from prostatitis complaints each winter since the age of 20. During the last 4 years said complaints became more acute resulting in extremely severe abdominal pain. In every acute phase he was treated with different kinds of antibiotics but as soon as the antibiotic treatment was completed, the complaints recurred within some week. At such a recurring prostatitis problem of mild type, the man received acid-resistant capsules containing PHIM 106; about 5 mg/capsule. He took 2 capsules/day for one week totally. All symptoms disappeared and the man has had no single recurrence during the last 12 months.

A suitable dose range for this indication is 0.5 to 300, preferably 1 to 50 mg per treatment.

#### Example 34 - Resistant Strain of Mycoplasma Infection

A 55 years old man having a resistant strain of Mycoplasma was treated. The man fell ill acutely 3 years ago and was treated with different kinds of antibiotics, but owing to underdosing a resistant form developed. Some weeks after the infection the man contracted high fever with a very severe cough as a result and in X-ray examination water in the pleura was observed.

The complaints of the man manifested themselves in the form of respiration complaints, difficulty to walk longer distances than 100 meter without a break and severe tiredness as well as annoying hacking cough.

The patient was treated with mouth washes, about 4 mg PHIM 106 each time. The PHIM solution was kept in the mouth for about 4 minutes and then it

was slowly swallowed. This treatment was repeated during the first two weeks every second day. During this time also small amounts of PHIM 106 were inhaled.

5 During the first two weeks no improvement was observed but after two weeks' treatment the lymph gland on the left side of the neck swelled resulting in pain. During this time the treatment was continued about 3 times. After about 1.5 weeks all problems regarding the lymph nodes had disappeared and the bronchitis complaints of the patient began to subside. After further 3 weeks' treatment with mouth washes every fourth day the bronchitis complaint had  
10 completely disappeared.

After this total treatment extending over 6.5 weeks the patient had recovered completely and after a short time he could walk 5 kilometers with no problems.

15 A suitable dose range for this indication is 0.1 to 100, preferably 1 to 25 mg per treatment.

#### Example 35 - Mastitis in human

A woman, 28 years old, got very severe galactostasis complaints already 3 days after delivery manifesting themselves in lactiferous glands hard as stone and an intense pain. These complaints set in already half an hour after breast-feeding.  
20 She was treated at the Academic Hospital in Uppsala, Sweden, with various methods available, but nothing helped.

A solution of about 0.1 mg PHIM 106 was dropped onto the nipple of the woman when the intense pain began. All pains disappeared within about 15 minutes and after about 45 minutes the hard lactiferous glands had become soft.

25 This treatment was repeated after each breast-feeding for more than 3 months. In order to check whether the treatment was needed all the time, the woman sometimes refrained from treatment directly after breast-feeding before onset of the pain. At each occasion this check was made the intense pains and the hard lactiferous glands recurred.

30 A suitable dose range for this indication is 0.01 to 25, preferably 0.1 to 5 mg per treatment.

#### Example 36 - Allergic Itch

A woman, age 28, got allergic problems in the form of intense itch with nettle rashis above one of the knees and also on and below the chin. The rash

looked like white, somewhat spread elevations on the knee whereas the chin was totally spotted with small rash of the same colour as the skin.

5 A gauze bandage was wetted with PHIM 106 solution, about 2 mg. The gauze was attached above the rash on the area above the knee. After 10 minutes the gauze bandage was removed. 45 minutes later the itch began to fade out and had completely disappeared after 1.5 hours. The white elevations had also disappeared and the nettle rash had faded.

10 24 hours later the area under and on the chin was treated. This area now itched intensively and was more irritated than before owing to the woman's scratching.

Directly upon application of the gauze bandage with the PHIM solution, the itch increased and the gauze bandage was removed after 7 minutes owing to a very intense itch. During a period of 1.5 hours the itch declined and completely disappeared 1.45 hours later.

15 No problems whatsoever were observed neither on the area at the knee nor in the face after 48 and 24 hours, respectively.

A suitable dose range for this indication is 0.01 to 100, preferably 1-25 mg per 100 cm<sup>2</sup>.

#### Example 37 - Anti-adhesion of tendon to sheath

20 The purpose of the study was to investigate the anti-adhesion properties of Multi-Protein from Krill in healing of ruptured Achilles tendon in rabbits. The left Achilles tendon of two rabbits was ruptured and immediately sutured in a split/overlapping technique enabling a non-immobilized left leg post-op.

25 On Day 5 post-op. there was an evident adhesion between the tendon and the sheath and 1 mg (0.25 ml) of the Multi-Protein was injected interstitially in the sheath on Day 5 and repeated on Day 7 and 9 post-op. 24 hours after the first injection there was no evident adhesion between tendon and sheath and again the tendon glided freely in the sheath. Six weeks post-op. the adhesion had not recurred.

30 Eight months post-op. the animals were sacrificed and the tendons were macroscopically inspected for adhesions, surplus of fibrin and collagen. The tendons and sheaths had healed separately and no signs of adhesions could be observed. The tensile strength of the operated left leg tendons were compared to the unoperated right leg tendons and no difference in tensile strength could be  
35 detected.



Multi-Protein specifically decomposes the surplus of fibrin without affecting the fibrin need for a proper healing of tendon and sheath, respectively.

A suitable dose range for this indication is 0.1 to 100, preferably 1 to 10 mg per treatment.

5

Example 38 - Detachment of adhered wrist

The purpose of the study was to investigate the efficacy of Multi-Protein in the decomposition of fibrinous tissue in wrists with reduced mobility.

10 A woman in her 40's suffered from a stiff wrist due to a long immobilisation of the joint with hard plaster after a complicated fracture of the arm, 25% of normal mobility.

Despite a training programme the mobility of the affected joint improved poorly and the diagnosis was fixation due to fibrin coating inside the joint.

15 Multi-Protein was injected, 2 mg (0.5 ml), intraarticularly for totally 4 times, 3 days apart. The mobility improved successively over 14 days to 50-60% mobility. This woman recovered a mobility to 70-80% after 4 months on training.

No adverse reactions were observed.

A suitable dose range for this indication is 0.1 to 100, preferably 1 to 10 mg per treatment.

Example 39 - Anti-thrombolytic/anti-embolic properties of Single-Protein

20 The purpose of the study was to investigate the efficacy of Single-Protein from Krill in the treatment of thrombi and emboli.

The thrombi were caused by an artificial stasis of the main ear vein till a proper thrombus had developed. Single-Protein was injected, 0.5 mg (0.2 ml), into vein in the direction towards the thrombus, 2 cm from the ischemic area. Within 25 30 minutes the thrombus was completely dissolved and the blood had free passage. Small necroses developed in the area but these were resorbed within 7 days.

In the control animals the ischemic area turned totally necrotic within 4-5 days.

30 A suitable dose range for this indication is 0.1 to 200, preferably 1 to 10 mg per treatment.

Example 40 - Treatment of Glaucoma

The purpose of the study was to investigate the efficacy of Multi-Protein in

the treatment of increased intraocular pressure.

A man, age 74, experienced a slight pain/discomfort in the right eye and it was found that he suffered from an increased intraocular pressure. At check-ups it was established that the increase of pressure was permanent and not caused  
5 by acute reasons.

Every four day 0.1 mg of Multi-Protein was dropped into the affected eye for totally three times. Two weeks post-treatment the intraocular pressure was normal and still 4 months post-treatment the pressure was normal.

The man experienced an immediate pain relief, within 20 minuts, at the  
10 first treatment.

No adverse reactions were observed.

A suitable dose range for this indication is 0.01 to 50, preferably 0.1 to  
5 mg per treatment.

Example 41 - Anti-viral effect on HIV-contaminated cell lines, in vitro

15 This study was carried out at the Swedish National Bacterological Laboratory (SBL). Multi-Protein was compared to AZT and Foscarnet. All preparations were tested at dilutions from undiluted to  $10^{-5}$  (highest concentration for Multi-Protein was 5 mg/ml). The preparations were added to the cell linjes, HIV-I infected to 40-60%, under identical and standardized conditions.

20 At low dilutions of AZT and Foscarnet, all cells in the cultures were attacked and killed. Only dead and collapsed cells were detected in these cultures.

Multi-Protein, at low dilutions, shows inhibiting effect on the virus. In the cultures 40-60%, identical to the initial values in resp. culture, of the cells were attacked and they were detached from surface. These attacked cells showed  
25 morphological changes and the virus was unable to proliferate. The uninfected cell in the Multi-Protein group were not attacked, neither by the Multi-Protein nor by liberated viruses from attacked cells; they stuck to the surface and showed no signs of morphological changes.

Thus, it is shown that Multi-Protein from Krill may distinguish between  
30 healthy and divergent cells, such as viral host cells, and may specifically recognize, entrap and destroy only the divergent matters without causing harm to the healthy cells.

A suitable dose range for this indication is 1 to 500, preferably 10 to  
300 mg per treatment.

**Inhibiting efficacy - Trial 1**

	<u>Virus (IC50)</u>	<u>Cell viability (tox.)</u>
	(HIV-1, strain HTLV IIIB moi 0.4)	
	Multi-Protein	200
5	AZT	100
	Foscarnet	200
		100 (deformed cells)
		100
		100

Control: 50% infected cells. Cell toxicity and percentage of infected cells measured by immunofluorescence.

**Inhibiting efficacy - Trial 2**

	<u>Virus (IC50)</u>	<u>Cell viability (tox.)</u>
10	(HIV-1, strain HTLV IIIB moi 0.2)	
	Multi-Protein	200-400
	AZT	100
	Foscarnet	100
		100-200 (deformed cells)
		100
		100

15 Control: 50% infected cells. Cell toxicity and percentage of infected cells measured by immunofluorescence.

**Example 42 - Athlet's foot (Epidermophytosis)**

The purpose was to study the effectiveness and usefulness of Multi-Protein in epidermophytosis of the foot.

20 41 patients with fungus infections were included in this study, treated once a day with a Multi-Protein foot bath, 5 cu/ml, for 30 minutes for 3 days and with Hydrogel, 5 cu/ml, overnight, for maximum 7 days.

The pain relief was instant in many patients and totally gone within 2 days for others. Plaques over open surfaces, in cracks and under nails were easily removed and all signs of plaque, smell and infections were gone after three days.

25 A suitable dose range for this indication is 0.01 to 100, preferably 1 to 25 mg per 100 cm<sup>2</sup>.

**Example 43 - Eczema infections**

30 The purpose was to study the effectiveness and usefulness of Multi-Protein in eczematous seborrheic and psoriasis infections.

Fourty patients were treated once to twice daily with Multi-Protein

Hydrogel, 2.5 cu/ml.

Patients with dry eczema/plaque showed no signs of inflammation or infection after 2-4 treatments, 1-2 days. The fatty type of seborrheic plaques disappeared after 6-9 days, though the inflammations/infections had vanished within the initial 2-4 days.

Patients with psoriasis plaque experienced an improved efficacy from their normal steroid creams, probably due to the effective removal of the plaque by Multi-Protein which resulted in better access of the steroids into the skin.

A suitable dose range for this indication is 0.01 to 100, preferably 1 to 25 mg per 100 cm<sup>2</sup>.

#### Example 44 - Prepuce infection

The purpose was to study the effectiveness and usefulness of Multi-protein in prepuce infections in infants.

Two infants, 4 resp. 6 weeks old, were treated twice daily with 1 cu/ml, Multi-Protein solution. Approx. 10 ml of the solution was flushed under the prepuce morning and evening, using a standard syringe with a soft catheter. After 3 days both the infants were free from symptoms and the infections did not recur within a 2 months' follow-up.

A suitable dose range for this indication is 0.01 to 100, preferably to 1 to 25 mg per treatment.

#### Example 45 - Prepuce infections in dogs

The purpose was to study the effectiveness and usefulness of Multi-Protein in prepuce infections in dogs.

Six dogs were flushed under the prepuce once daily with the Multi-protein solution, 1 cu/ml. 10 ml of the Multi-Protein solution were sucked into a standard disposable syringe. A soft silicone catheter was attached to the syringe and the catheter was inserted under the prepuce and the area was slowly flushed. Approx. 1 ml of the solution was kept under the prepuce for minimum 2 minutes and the dogs were kept from licking the area for 30 minutes.

The purulent exudation stopped within 2 days in all the cases and all signs of infection and inflammation were gone within 4 days.

A suitable dose range for this indication is 0.1 to 100, preferably 1 to 25 mg per treatment.

Example 46 - General purpose eye drops

The purpose was to study the effectiveness and usefulness of Multi-Protein in "tired and irritated" eyes but without any signs of clinical inflammation or infection.

5 Twelve patients with no record of eye diseases, allergic reactions to air pollutants or eye infections/inflammation were treated ad hoc for "tired and irritated eyes". 2 drops of Multi-protein solution, 0.1 cu/ml, were dropped into the eyes whenever needed.

10 All patients experienced an immediate alleviation of tension/weak pain, within 30 minutes. No one reported any change in light sensitivity, focusing or any dilatation of the pupils. Sometimes a transitory dryness was experienced.

No irritation, increase in lacrimal secretion or other adverse reaction was observed.

15 A suitable dose range for this indication is 0.01 to 50, preferably 0.1 to 5 mg per treatment.

Example 47 - Abscesses in calves

The purpose was to study the effectiveness and usefulness of Multi-protein in abscesses in calves, using Multi-Protein solution, 5 cu/ml.

20 Two calves with abscesses, approx. size of 25 to 40 ml, on the neck, formed after injection with Calcium solution, were treated once daily. 10 ml of the Multi-Protein solution were instilled through a drainage tube and kept in place for min. 4 hours. Then the tube was openend and left so till the next treatment.

25 After the third treatment the drainage fluid was clear and after the sixth treatment the tubes were removed. The "pockets" healed completely after 9 resp. 12 days.

A suitable dose range for this indication is 0.1 to 200, preferably 1 to 20 mg per treatment.

Example 48 - Boils in dogs

30 The purpose was to study the effectiveness and usefulness of Multi-Protein in infected boils on the paws of dogs.

Three boxers with painful, infected and excudating/bleeding boils between the toes were treated twice daily with Multi-Protein solutions, 5 cu/ml.

A gauze was drained with 2 ml of the solution and then applied over the boil. The paw was bandaged to keep the gauze fixed and a rubber boot was used

for protection.

An obvious pain relief could be observed after 1 day and the purulent exudation/bleeding stopped within 2 days. After 5-7 days' treatment only slight signs of inflammation could be observed and after 11-15 days all signs of the boils were gone and the dogs could move around freely.

A suitable dose range for this indication is 0.1 to 100, preferably 1 to 25 mg per treatment.

Doses for various indications

**Figure 13** shows the Dose-Response curve for one specific indication, namely burns, and shows the percentage efficacy, expressed as antimicrobial activity, as a function of the amount of PHIM in mg per 100 cm<sup>2</sup> of wound area. An almost 100% efficacy is reached at a dose of about 2 mg of PHIM per 100 cm<sup>2</sup> wound area. The Dose-Response curve shown would be representative also for other applications.

**Figure 14** shows Dose-Range intervals for PHIM, i.e. used doses for reaching 100% efficacy, defined as cured patients, for various indications. The efficacy is plotted against the amount of PHIM in mg per 100 cm<sup>2</sup> of afflicted area. The approximate dose ranges are (mg PHIM/100 cm<sup>2</sup> afflicted area):

- eye infections 0.5-0.8
- inflammations 0.1-15
- viral infections 0.1-1
- fungous infections 1-15
- bacterial infections 0.5-25
- pain relief 0.1-25

**Figure 15** shows the maximal accumulated amount per kg body weight of PHIM to reach a cure, i.e. the clinical end-point, for various indications. The approximate maximal amounts for various indications are (mg PHIM/kg body weight):

- eye infections 1
- topical wound infections 5
- urethra infections 9
- fungus infections 5
- Herpes simplex infections 5
- fatty skin plaques 18
- full thickness burns 20

- opportunistic infections 28

**Figure 16** shows the minimal accumulated amount per kg body weight of PHIM to reach a cure for various indications. The approximate minimal amounts for various indications are (mg PHIM/kg body weight):

- |    |                             |    |
|----|-----------------------------|----|
| 5  | - eye infections            | <1 |
|    | - topical wound infections  | 3  |
|    | - urethra infections        | 7  |
|    | - fungus infections         | 3  |
|    | - Herpes simplex infections | 4  |
| 10 | - fatty skin plaques        | 13 |
|    | - full thickness burns      | 13 |
|    | - opportunistic infections  | 15 |

#### Conclusions of the Clinical Examples 1 to 51

Single-Protein and Multi-Protein preparations according to the invention present a total range of actions that seem to resemble the mode of action of phagocytizing cells.

No clinical limitations or drawbacks could be established from the investigated indications. On the contrary, the preparations exhibit good efficacy in clinical situations where the natural immune defence was not responding, e.g. wounds in stasis, and where the immune defence was completely suppressed, e.g. opportunistic infections.

#### Adverse Reactions

No adverse reactions were observed in any of the many patients included in the above reported studies. Patients suffering from poly-allergies, seafood allergies, sensitive skin, dry eyes and patients with known suppressed resp. hyperactive immune system have been included in studies or tested separately without exhibiting any signs of adverse reactions.

It has been shown that the claimed Multi-Protein and Single-Protein preparations are atoxic.

Based on these full and preliminary clinical investigations, it can also reasonably be concluded that the inventive substances and compositions would be effective as a cure of a very great number of other diseases and conditions, where the immune system is responding, such as glaucoma; trachoma; cancer;

AIDS/HIV; autoimmune disease such as Rheumatoid arthritis, Crohn's disease, multiple sclerosis, ulcerative colitis; diseases such as cholera, leprocy, malaria, hepatitis, typhoid fever; sepsis; transplantation of organs and grafts (prophylaxis). techniques; cosmetics.

5

#### Clinical Example 49 - Cancer

This study was carried out by Prof. Takashi Makita, Yamaguchi University, Japan.

#### Background

Cancer diseases are very complex and consist of many different diseases. 10 The complexity is increasing when the tumours are growing and the primary tumour is spreading metastasis to other organs as well as into the lymphnodes. Additional to the increasing burden of the tumours are the opportunistic infections, which occur partly as a result of a depressed immune defence system, caused by the tumour itself, but also as a result of the conventional treatment 15 with chemotherapy, which is the most common treatment used today for treatment of cancer.

Many different problems are connected with the use of traditional chemotherapy. The major problem is that anticancer drugs do not have the properties to distinguish between healthy tissue cells vs cancer cells. This is the most 20 serious problem, because the white blood cells needed for the immune defence are destroyed by the chemotherapy treatment. Consequently, it is not possible to treat cancer patients in an optimal way.

The depressed immune defence results in increased tumour burden as well as uncontrollable opportunistic infections. The combination of limited possibilities 25 for optical treatment and opportunistic infections, decrease the quality of life of the patients who are suffering from cancer diseases. There are very few well controlled studies in humans and in general the efficacy is normally around 20-25%, depending on the type of cancer.

In a well controlled phase II study performed in Japan in patients suffering 30 from primary and secondary liver cancer; the response rate (CR and PR) was 9.5% for Adriamycin and 20% for Mitomycin C. See T. Taguchi et al, Regional Cancer Treatment (1992) 4:161-165.

In animal studies the efficacy is normally higher depending on the fact that higher doses of anticancer drugs are given compared with treatment of human 35 patients, because adverse reactions are very difficult to study in animal models,



with the exception of objective parameters. It is also very difficult to compare historical data.

5 However, Cisplatin has been used in rats with implanted Yoshida Sarcoma and tumour cells have been removed from the tumour and cultured with the purpose to study surviving cells, the result being that 53% of the cells are not killed by Cisplatin. See K.R. Harp et al, Antitumor, Toxic and Biochemical Properties of Cisplatin.

10 Similar experiments have been performed with Mitomycin C in doses up to 0.5 mg/kg. In that case the efficacy for non-resistant Yoshida Sarcoma was almost 100%, calculated as 30 days of survival of the rats. The dose of 0.5 mg/kg used in rats is impossible to use in human because of severe adverse reaction such as bone marrow depression, which is lethal for the patients. Yoshida Sarcoma easily becomes resistant to Mitomycin C and in that case no effects could be detected despite the high dose of 0.5 mg/kg or even higher doses.

15 The side effect profile with the mentioned dose level as well as lower doses includes loss of body weight, hair loss, decreased leucocytes and chronic diarrhoea. See Mitomycin C, Kyowo Hakko Ltd., Tokyo, Japan. Anticancer agents as Adriamycin, Cisplatin, Mitomycin C etc., are very toxic and can be used only for intra-venous and intra-arterial administration.

20 Furthermore, the tumour cells very often develop resistance to the anti-cancer agents in a similar way as bacteria do develop resistance to antibiotics. The development of resistance is a severe drawback for curable treatment.

#### Summary of test procedure and results

25 The purpose of the study was to investigate the efficacy and usefulness of PHIM 106 on treatment of Yoshida Sarcoma in rats.

PHIM 106 was injected in three different routes, intraperitoneally (i.p.), intratumorally (i.t.) and subcutaneously (s.c.) to white Wistar rats with implanted Yoshida Sarcoma. PHIM 106 was used as a single injection of 5 mg/kg i.p., i.t. and s.c. and as repeated doses of 1.25 mg/kg s.c. twice a day during 7 days, 5 mg/kg s.c. every second day for a total of 4 injections, and 12.5 mg/kg s.c. every second day for a total of 4 injections.

The treatment was started when the size of the implanted tumour was 10 mm x 10 mm.

The rats were sacrificed 7 days after finished injection. The size of the

tumours was measured and compared with the untreated control rats.

The reduction of the size of the tumour was 46% in rats treated i.t. with a single dose, 56% in rats treated s.c. with a single dose and 49% in rats treated i.p.

5 In the group treated with repeated doses of 1.25 mg/kg twice a day during 7 days s.c. the efficacy was 72%.

In the groups receiving 5 mg/kg and 12.5 mg/kg s.c. every second day for a total of 4 injections, the tumour responses were 53% and 69% respectively.

10 One rat in the group receiving 12.5 mg/kg had negative tumour growth. The degree of metastasis in the treatment groups was very small compared to the control rats.

The treated rats showed normal behavior regarding drinking and eating, in contrast to the control rats. No adverse reactions could be observed during this trial.

#### Description of PHIM 106

15 As explained above, PHIM 106 is an abbreviation for proteins having enzymatic properties and originating from marine sources, in the below tests from antarctic krill. According to the invention fundamental new properties have been discovered of these proteins. The hypothesis is that the proteins first recognize sick and divergent cells as well as microbes and then destroy the target cells by  
20 the enzymatic properties. Nothing happens with the healthy tissue cells.

The mechanism behind the sharp selectivity is under investigation, but the working hypothesis is that the proteins are capable of reacting on the same signals as our own immune defence system, and attack all foreign invaders as well as divergent cells.

25 Cancer cells are divergent in the sense that they express fragments of tumour proteins on the cell surface and they will be recognized as divergent by the immune defence system compared with healthy tissue cells.

PHIM 106 has been used in open human studies in more than 400 patients without any kind of side effects.

30 In animal no toxicity can be detected. Up to 5 g of PHIM 106/kg body weight of rats has been injected i.v. without any sign of toxicity.

As PHIM 106 consists of proteins with a size of 24-34,000 Daltons and origin from marine sources formation of antibodies would be expected, but no formation of antibodies could be detected when rabbits and guinea pigs were  
35 immunized.

## Materials and methods

### Aim of study

To investigate in small comparative studies the routes of administration, the sequence between the injections and a dose response curve and an overall  
5 usefulness of PHIM 106 using white Wistar rats with implanted Yoshida Sarcoma.

A second objective was also to study the targeting properties of PHIM 106 by using it for treatment of the tumour from the veins as well as from the lymphatic vessels.

10

### Design of the study

Comparative study with injection of PHIM 106 as a single injection i.p., i.t., s.c., repeated doses every two day and a total of 4 injections s.c. The control groups was untreated. The treatment was started when the implanted tumour cells had a size of about 10 mm x 10 mm.

15

The rats were sacrificed 7 days after the treatment was finished and the size of the tumour were measured. Histopathological examination was performed.

### Formulation of PHIM 106

Lyophilized white powder without preservatives or antimicrobial additives.

The white powder was reconstituted in Saline for injection to a final  
20 concentration of 5 mg/ml solution.

### Procedure

$1 \times 10^4$  Yoshida Sarcoma cells were implanted subcutaneously on the back of white Wistar rats. The treatment of the rats started when the size of the tumours was 10 mm x 10 mm.

25

PHIM 106 was injected in three different routes, intraperitoneal (i.p.), intratumoral (i.t.) and subcutaneously (s.c.) about 3-5 cm from the tumour in the healthy part of the skin.

The animals were divided into the following 7 groups.

Group 1. The control group of 11 rats without treatment.

30

Group 2. 5 rats treated with a single injection of 5 mg PHIM 106/kg directly into the center of the tumour (i.t.).

Group 3. Treated with a single injection of 5 mg PHIM 106/kg subcutaneously (s.c.).

- Group 4. 1 rat treated intraperitoneally (i.p.) with a single injection of 5 mg PHIM 106/kg.
- Group 5. 3 rats treated subcutaneously (s.c.) with 1.25 mg PHIM 106/kg twice a day during 7 days.
- 5 Group 6. 5 rats treated subcutaneously (s.c.) with 5 mg PHIM 106/kg every second day for a total of 4 injections.
- Group 7. 5 rats treated subcutaneously (s.c.) with 12.5 mg PHIM 106/kg every second day for a total of 4 injections.

Seven days after the treatment was finished, the rats were sacrificed and the volume of the tumors was measured. The rats in the control group were sacrificed at the same day as in the treatment groups.

Histopathology was also performed of the tumour in all the groups.

Blood was collected and stored for later examination.

### Results

15 In group 2, treated with a single injection i.t. of 5 mg PHIM 106/kg, the reduction of the tumour compared with the control was 46%.

In group 3, also treated with single injection s.c. of 5 mg PHIM 106/kg, the reduction of the tumour was 56%, and in group 4, treated as 2 and 3 but i.p. the reduction of the tumour was 49%.

20 In groups 6 and 7, treated s.c. with repeated doses of 5 mg PHIM 106/kg and 12.5 mg PHIM 106/kg, the reduction of the tumour was 53% and 69%.

The best efficacy was seen in group 5 treated with repeated doses during 7 days. The reduction of the size compared with the control was 72%. See Figs. 17, 18 and 19.

25 In all the groups which received treatment more than 50% of the size of the tumours is very necrotic compared to the tumours in the control group. See Pict. 1 and 2.

Within 24 hours after the injection of PHIM 106 the tumours seems to be necrotic.

30 No adverse reaction could be recognized during or after the treatment.

Within 24 hours from the injection of PHIM, the tumours seem to be necrotic. The size of the necrotic part of the tumours increased and the tumours are smaller and more distinct compared to the control rats. See Pict. 3 and 4.

Differences of body weight could be detected between the control group vs the rats which received treatments. The rats in the control group increased

35

more than the rats in the treatment groups.

No adverse reaction could be observed during or after the treatment.

A suitable dose range for this indication is 0.1 to 500, preferably 1 to 300 mg per treatment.

5

### Discussion

The number of rats was limited and therefore no statistical calculation could be performed. However, the objective with the study was to investigate the tumor efficacy as such related to the number of doses, the amount of PHIM 106 calculated per kg body weight and to get an indication if PHIM 106 is attacking  
10 the tumour when used in different routes of administration.

Overall impression of usefulness was naturally also a very important objective for the study.

Cancer cells are divergent from the immunological points of view and PHIM 106 should therefore, according to the above, hypothesis about the recognizing and  
15 targeting properties of divergent cells, attack and destroy the tumour cells, irrespective of the mode of administration. The results indicate that the tumour efficacy is strong and that the degree of efficacy is similar when it is injected i.p., i.t. or s.c.

Repeated doses of PHIM 106 are better than a single dose, as could be  
20 expected because the Yoshida Sarcoma tumour is very fast growing.

The reduction of the tumours is greater in the groups which received 12.5 mg PHIM 106/kg than in the groups which got 5 mg PHIM 106/kg.

On the other hand, the rats which were treated every day for 7 days with a total amount of 17.5 mg PHIM 106/kg had little better efficacy than the rats  
25 which were treated every second day with a total of 4 injections and a total of 50 mg PHIM 106/kg.

Yoshida Sarcoma is very malignant and fast growing. Therefore, it could be expected that treatment every day should give better results. All the rats in the treatment groups are in good condition and they had together an increase in  
30 body weight of about 10 gr compared with rats in the control group which increased the body weight with about 24 gr. The only explanation for that should be the very large tumour burden. The tumours in the treatment groups are very distinct and solid compared to the tumors in the control group which are spread out into the stomach etc. This also means that there have been problems in  
35 measuring the whole size of the tumour in the control group, because the tumours

cover a large surface. It is interesting to notice, that one rat in the group treated with 12.5 mg PHIM 106/kg had no tumour growth at al. The tumour had decreased by about 15% compared with the size at the staging day.

5 Histopathological examination of the tumour in the control group and in the test groups clearly shows that the treated rats with PHIM 106 were very necrotic compared of the untreated rats.

10 The fact that PHIM 106 was active when administered in three different routes, shows that PHIM 106 is targeting the tumour both from the vein and artery. The subcutaneous administration is of special interest, because PHIM 106 must have been taken up by the lymphatic vessels and will partly reach the tumour via the lymphatic route. The lymphatic uptake of PHIM 106 is also very important for destroying metastasis which partly are spread out that way. The evidence for decreased metastasis could also been seen in the treatment groups compared with the control group. In the control group lungs, intestine, liver large amount of metastasis could be recognized. In the treatment groups over 95% of the rats were free from detectable metastasis. The remaining 5% of the rats had only a few small metastasis in the intestine area.

15 Even if the number of animal was rather small in the different groups, it should be emphasized that every rat responded to the treatment. The possibility of using a drug for treatment of cancer without any restriction of the methods of administration will, in combination with lack of observable side effects, place PHIM 106 in a new category of anticancer drugs, presumably depending on the natural targeting properties thereof.

20 The antimicrobial effects of PHIM 106 observed in open pilot studies, will also be of additional importance for the treatment of cancer patients suffering from opportunistic infections. Yoshida Sarcoma is much more malignant than the known tumours in man.

#### Example 50 - Navel treatment

30 A 4 days old boy was treated with PHIM 106 in order to remove necrotic tissue and to avoid upcoming infection.

For the treatment a gauze was used, which had been saturated with a solution of PHIM 106, about 2 mg/piece of gauze. The gauze was wound around the very navel-string so that it covered both healthy navel-string and the somewhat infected as well as the necrotic part of the navel-string. The bandage was changed 4 times per 12 hours. After about 12 hours PHIM 106 has removed the

35

necrotic and the infected part, whereas the healthy part of the navel-string was completely uneffected. No degradation of the healthy skin on the navel-string could be observed, neither could any infection or any skin irritation or inflammation be observed. The healthy navel was treated 4 more times.

5 Day 6 after the birth the baby was checked at the hospital and it was found that the baby had a very fine navel without any infection, much to the surprise of the doctor and in contrast to the majority of the babies who were examined on the same occasion.

10 A suitable dose range for this indication is 0.01 to 100, preferably 1 to 25 mg per treatment.

#### Example 51 - Infected wound

15 A 3 months old boy who had surgery for hydro cele och scrotal hernia showed 10 days after surgery a serious infection in the surgery wound in the form of puss formation. Parts of the surgery wound was about to crack after the stitches have been removed.

The boy was treated for 3 days with dressings which had been soaked in PHIM 106, 4 mg per treatment. After 3 days of treatment the entire infection was gone and the wound had healed.

The entire operation wound had a length about 15 cm.

20 A suitable dose range for this indication is 0.01 to 100, preferably 1 to 25 mg per treatment.

#### Toxicity on mice

25 It has not been possible to demonstrate any toxicity of PHIM on humans or animals, despite administration of extreme overdoses, up to about 100 times the corresponding effective dose. The toxicity of PHIM has also been tested on mice with s.c. implanted P388 murine leukemia (a chemically induced cancer) and compared with doxorubicin, a well known anti-cancer drug, abbreviation DOX. The results are summarized in the following Table. It can be seen that no mouse in the PHIM group or the control group died or lost weight, whereas all mice in the doxorubicin group, except for the lowest dosage, lost weight and died. It may be worth mentioning that the highest dose of PHIM (20 mg/kg) is far higher than any of the curing doses used in any of the clinical examples which have been reported earlier in this description.

30

**Toxicity of PHIM and DOX administered i.p. daily during  
9 consecutive days to mice with P388 murine leukemia**

5	Drug	Dose (mg/kg)	Toxic death	Body weight change (g)
	Control	0	0/6	+ 2.3
	PHIM	20	0/6	+ 3.3
10		10	0/6	+ 3.3
		5	0/6	+ 3.3
	DOX	5	6/6	- 2.3
		2.5	6/6	- 0.6
		1.25	0/6	+ 0.5
15	<hr/>			

Dosage - general

As noted in connection with the above reported toxicity tests, no toxic effects have been observed despite very heavy overdosage. This is not only true in the case with murine leukemia, but also in all of the clinical examples. Not  
20 either has any reduction of the therapeutical effect due to overdosage been observed in any of the clinical examples. In other words, the upper dosage limit is so much higher than the effective dose, so virtually any (reasonable) dosage can safely be used.

The smallest effective dose varies somewhat depending on the condition to  
25 be treated, and the presently preferred dosages for the various indications are as follows.

Administration routes and formulations

The substances of the invention can be safely used in human and animal therapy by virtue of their negligible toxicity.

30 The therapeutic regimen for the different clinical indications must be adapted to the type of pathology taking into account, as usual, also the route of



administration, the form in which the compound is administered and the age, weight and conditions of the subject involved.

The substances of the invention can be applied or administered in the form of solutions. The solutions can be administered e.g. topically (superficial wounds, intact skin); by instillation (urinary tract, fistules); in the form of eye-drops; as a rinsing solution; by inhalation; by injection (intraarticularly, intraarterially, intravenously, intraperitoneally, subcutaneously, intramuscularly); and nasally.

The substances of the invention can also be administered in the form of gels, e.g. topically and by instillation (fistules, decubitus wounds).

When in dry powder form, the substances can be administered e.g. topically, intestinally in acid-resistant capsules and by inhalation.

Dry powder of the substances of the invention is contained in ampoules, each containing either 15 cu of Single-Protein or 25 cu of Multi-Protein. In order to prepare a ready-to-use solution the contents of one ampoule are reconstituted with sterile sodium chloride solution or sterile water to form solutions containing from 0.10 to 25 cu of Multi-Protein/Single-Protein.

When using the substances of the invention in the form of a gel, powdered Multi-Protein or Single-Protein ex tempore is formulated with a hydrogel to the desired concentration to form a ready-to-use hydrogel. The hydrogel as such consists of low molecular weight hydrolyzed starch containing >90% of water.

From our studies it can be concluded that, by using the above administration routes, the substances of the invention find their way through the blood system, arterielly and venously, and through the lymphatic system. In the topical administration route there is a direct contact between the enzymes and its substrate.

## PHARMACUETICAL FORMULATIONS

### Powder-Ampoules

15 cu of Single-Protein or 25 cu of Multi-Protein are filled into a conventional ampoule using known technique.

### Ready-to-use solution

The contents of an ampoule (cf. above) are reconstituted with sterile sodium chloride solution (physiological saline) or sterile water to a concentration of Multi- or Single-Protein of from 0.10 to 25 cu/ml.

Hydrogel

A hydrogel consisting of low molecular weight hydrolyzed starch containing >90% of water is prepared in a way known per se. Upon preparation of the gel it is packed in portions and the packages are sterilized (autoclaving).

5

Ready-to-use Hydrogel

Powdered Multi-Protein/Single-Protein is formulated ex tempore with the Hydrogel (cf. above) to the desired concentration, e.g. 2.5 or 5 cu/ml.

Further explanation of the drawings

**Figure 1:** Average Exudation ratio over 5 days' treatment with Single-enzyme (—■—) and Multi-enzyme (.....□.....) preparations from Krill.

5 Single-enzyme: 20 patients were included from start till day 2. 18 patients from day 2 till 3.5 and 9 patients from day 3.5 till end of study.

Multi-enzyme: 20 patients, 21 wounds, from start till day 2.5. 18 patients, 19 wounds, from day 2.5 till 4 and 12 patients, 12 wounds, from day 4 till end of study.

10 For all patients the termination criterion of "No signs of clinical infection" was reached latest on day 5.

**Figure 2:** Average Erythema scoring over 5 days' treatment with Single-enzyme (—■—) and Multi-enzyme (.....□.....) preparations from Krill.

The intensified redness of the erythema was probably due to reduced swelling and oedema of the surrounding tissue.

15 **Figure 3:** Average Swelling/Oedema scoring over 5 days' treatment with Single-enzyme (—■—) and Multi-enzyme (.....□.....) preparations from Krill.

**Figure 4:** Average Pain scoring over 5 days' treatment with Single-enzyme (—■—) and Multi-enzyme (.....□.....) preparations from Krill. Pain  
20 sensations were reported by the patients themselves on an analogous scale from 0-5, No Pain - Unbearable Pain.

**Figure 5:** Average Pain Relief scoring over 7 days' treatment with Multi-enzyme (.....□.....) preparations from Krill.

25 **Figure 6:** Average Inflammation scoring over 7 days' treatment with Multi-enzyme (.....□.....) preparations from Krill.

**Figure 7:** Erythema/swelling as a function of infection scored over 9 days' treatment with Multi-enzyme (.....□.....) preparation from Krill.

**Figure 8:** Pain sensation scored over 7 days' treatment with Multi-enzyme (.....□.....) preparation from Krill.

30 **Figure 9:** Average Time between Urinations scoring over 4 days' treatment with Multi-enzyme (.....□.....) preparations from Krill.

**Figure 10:** Average Pain Relief scoring over 4 days' treatment with Multi-enzyme (.....□.....) preparations from Krill.

35 **Figure 11:** Average Pain Relief scoring over 7 days' treatment with Multi-enzyme (.....□.....) preparations from Krill.

Definitions: Severe Pain: Horse is not supporting itself on painful leg.

**SUBSTITUTE SHEET**

Moderate Pain: Horse is from time to time supporting itself on painful leg, more than 30 seconds each time. Mild Pain: Horse is continuously supporting itself on painful leg, more than 2 minutes each time.

**Figure 12:** Decomposing efficacy of Single-enzyme preparation from Krill on necroses, fibrin, pus and blood clots over 7 days treatment.

—B—: Black necrotic tissue; - -Y- -: Yellow fibrinous and purulent tissues; ...R...: Red granulation tissue and epithelium.

**Figure 13:** Dose-Response Curve - Efficacy expressed as antimicrobial activity of PHIM in burns.

**Figure 14:** Dose-Range Intervals for PHIM - used doses for reaching 100% efficacy, i.e. defined as cured patients.

A = eye infections; B = inflammations; C = viral infections; D = fungous infections; E = bacterial infections and F = pain relief.

**Figure 15:** Accumulated doses of PHIM applied on patients - maximal amount per kg bodyweight of PHIM to reach a cure.

A = eye infections; G = topical wound infections; H = urethra infections; I = fungous infections; J = Herpes simplex infections; K = fatty skin plaques; L = full thickness burns and M = opportunistic infections.

**Figure 16:** Accumulated doses of PHIM applied on patients - minimal amount per kg bodyweight of PHIM to reach a cure.

A = eye infections; G = topical wound infections; H = urethra infections; I = fungous infections; J = Herpes simplex infections; K = fatty skin plaques; L = full thickness burns and M = opportunistic infections.

**Figure 17:** Tumor efficacy of single injection of PHIM 106 compared with control.

**Figure 18:** Tumor efficacy of repeated injection of PHIM 106 vs control.

Bar (n=4): S.C. 1.25 mg twice a day/kg. Q1D 1-7; Bar: (n=5) S.C. 5 mg/kg. Q4D. D 1, 3, 5, 7; Bar (n=5): S.C. 12.5 mg/kg. Q4D. D 1, 3, 5, 7.

**Figure 19:** Volume of the tumors in the control vs treatment groups.

**Figure 20:** Control (low power).

**Figure 21:** Control (high magnification).

**Figure 22:** Subcutaneous (low power).

**Figure 23:** Subcutaneous (high magnification).

**Figure 24:** Control, no treatment.

**Figure 25:** Control, no treatment.

**SUBSTITUTE SHEET**

**Figure 26:** Subcutaneous single injection.

**Figure 27:** Subcutaneous single injection.

**Figure 28:** Temperature stability of PHIM. pH 7.0; 30°C for 20 hours.

5 **Figure 29:** Temperature optimum of PHIM. Total proteolytic activity expressed as digested area of bovine casein (Bio Rad Protease Substrate Tablets); pH 7.0; 30°C for 24 hours.

10 **Figure 30:** pH stability of PHIM. Reconstituted PHIM kept at room temperature for 2 to 18 hours. Total proteolytic activity expressed as digested area of bovine casein (Bio Rad Protease Substrate Tablets), 30°C for 20 hours.

**Figure 31:** pH optimum of PHIM. Total proteolytic activity expressed as digested area of bovine casein (Bio Rad Protease Substrate Tablets); 30°C for 16 hours. pH 5.0, 6.0, 7.0, 8.0, 9.0 and 9.5.

15 **Figure 32:** Dose-activity curve of PHIM. Protein concentration according to Bradford (Bradford, M. Anal. Biochem., 72, 248, 1976). Total proteolytic activity expressed as digested area of bovine casein (Bio Rad Protease Substrate Gel Tablets), pH 7.0, temp. 30°C for 24 hours. Doses: 0.1, 0.3, 0.5, 0.9, 1.5, 2.5, 5.0 and 15 mg.

**SUBSTITUTE SHEET**

CLAIMS

1. Use of a non-immunogenic enzyme composition which has been isolated from antarctic krill and exhibits both endo- and exo-peptidase activity for the manufacture of a medicament for the treatment of infections.
- 5 2. Use of a non-immunogenic enzyme composition which has been isolated from antarctic krill and exhibits both endo- and exo-peptidase activity for the manufacture of a medicament for the treatment of inflammations.
3. Use of a non-immunogenic enzyme composition which has been isolated from antarctic krill and exhibits both endo- and exo-peptidase activity for the  
10 manufacture of a medicament for the treatment of cancers.
4. Use of a non-immunogenic enzyme composition which has been isolated from antarctic krill and exhibits both endo- and exo-peptidase activity for the manufacture of a medicament for the treatment of HIV/AIDS.
5. Use of a non-immunogenic enzyme composition which has been isolated  
15 from antarctic krill and exhibits both endo- and exo-peptidase activity for the manufacture of a medicament for the treatment of pain.
6. Use of a non-immunogenic enzyme composition which has been isolated from antarctic krill and exhibits both endo- and exo-peptidase activity for the  
20 manufacture of a medicament for the treatment of polyps, warts, hemorrhoids, plaque, wrinkles, thin hair, allergic itch, anti-adhesion.
7. Use of a non-immunogenic enzyme composition which has been isolated from antarctic krill and exhibits both endo- and exo-peptidase activity for the manufacture of a medicament for the treatment of eye diseases such as cataract, glaucom, etc.
- 25 8. Use according to claim 1, **characterized in** that the infection is selected from the group consisting of viral, bacterial, fungus and mycoplasmatic infections.
9. Use according to claim 2, **characterized in** that the inflammations are

selected from the group consisting of acute and chronic inflammations.

10. Use according to claim 9, **characterized in** that the inflammations are selected from the group consisting of gingivitis, arthritis, mastitis, sinusitis, bronchitis, prostatitis and gastric ulcer.

5 11. Use according to any one of the preceding claims, **characterized in** that said non-immunogenic enzyme composition comprises a single enzyme having both endo- and exo-peptidase activity and a molecular weight from about 26,000 to about 32,000.

10 12. Use according to any one of claims 1 to 10, **characterized in** that said non-immunogenic enzyme composition comprises a mixture of enzymes having endo-peptidase activity with enzymes having exo-peptidase activity.

FIG. 1

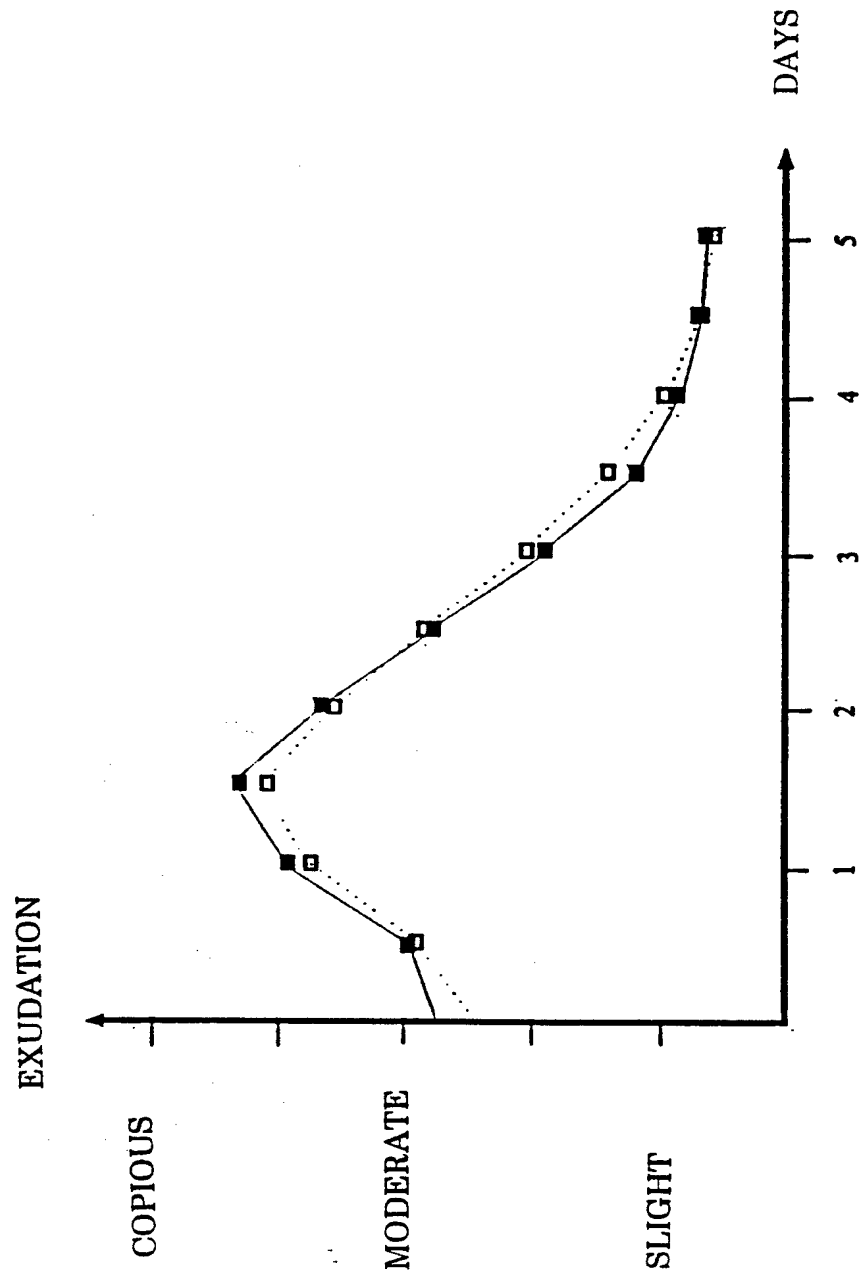
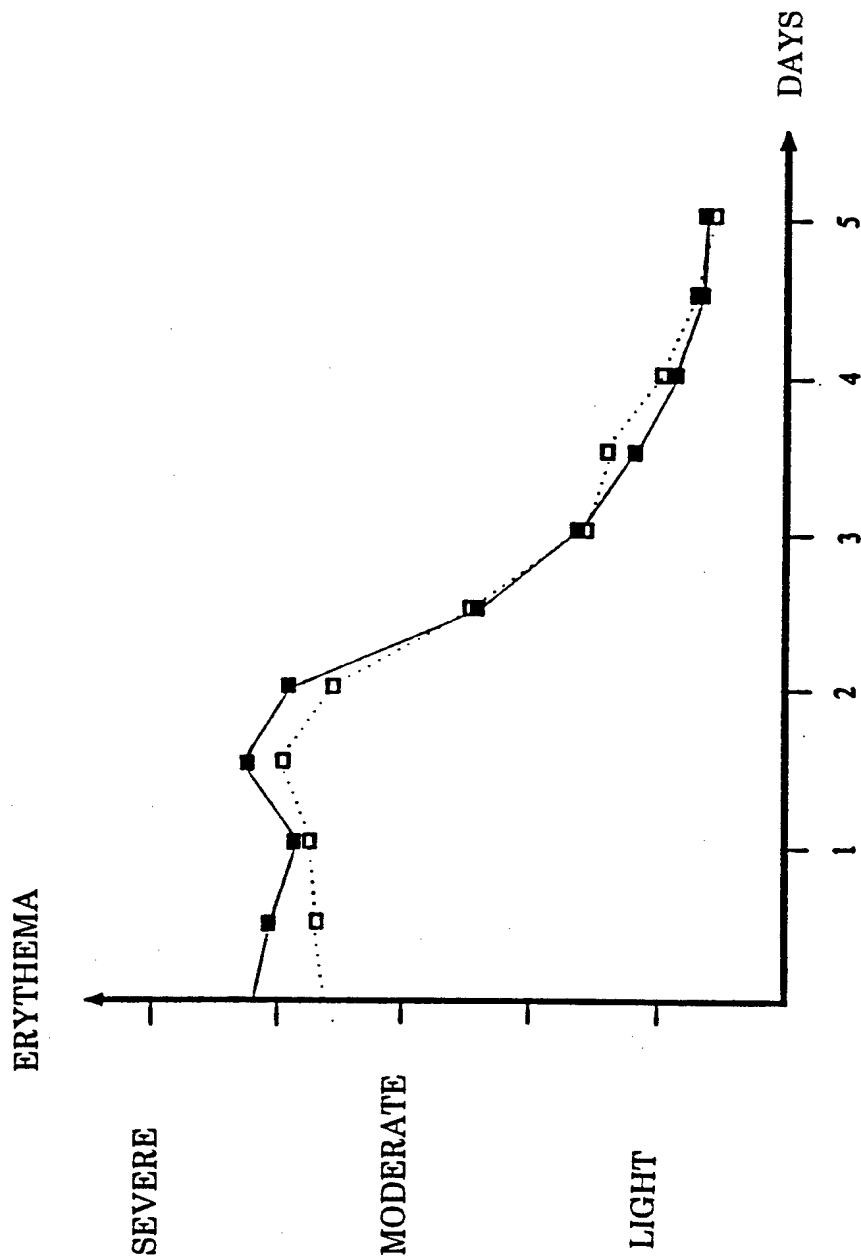


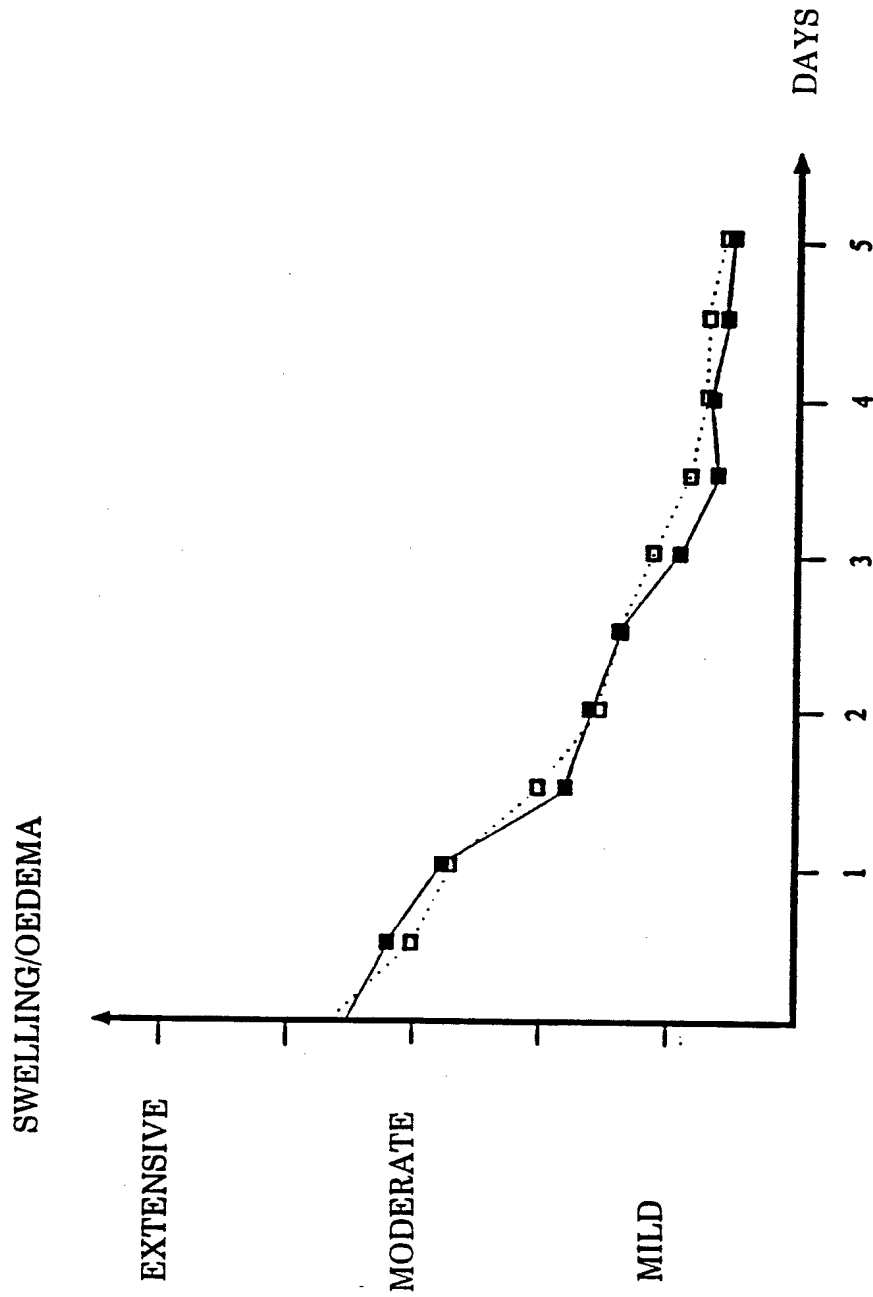


FIG. 2



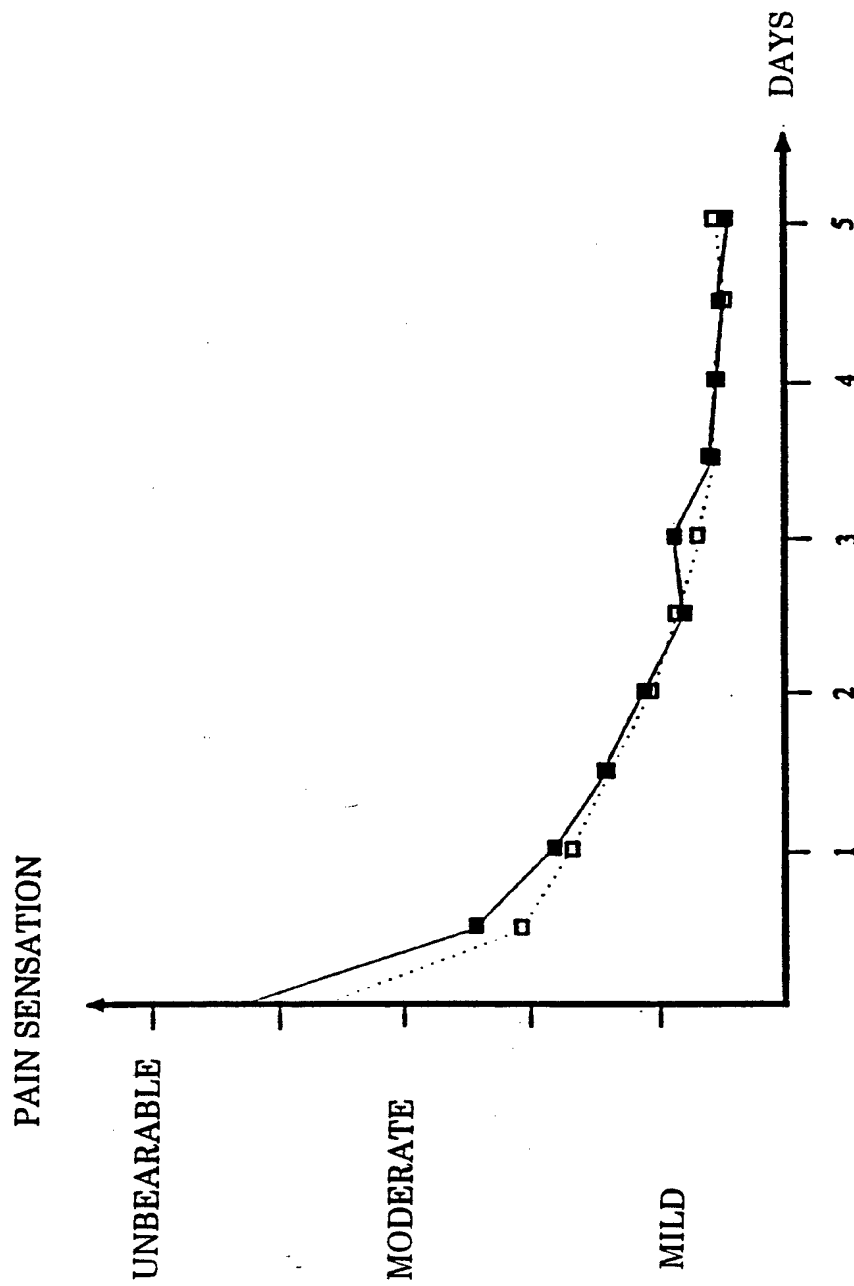
3/25

**FIG. 3**

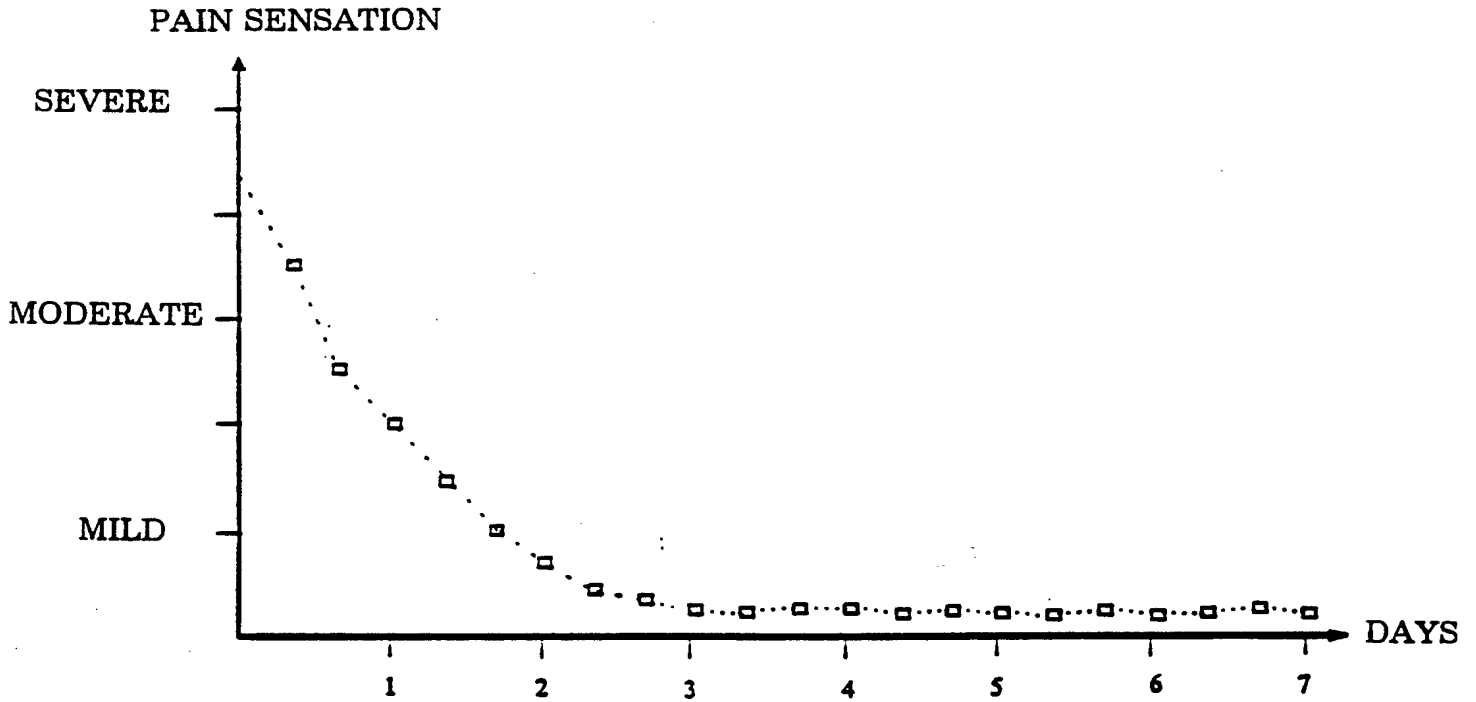


4/25

FIG. 4



**FIG. 5**



**FIG. 6**

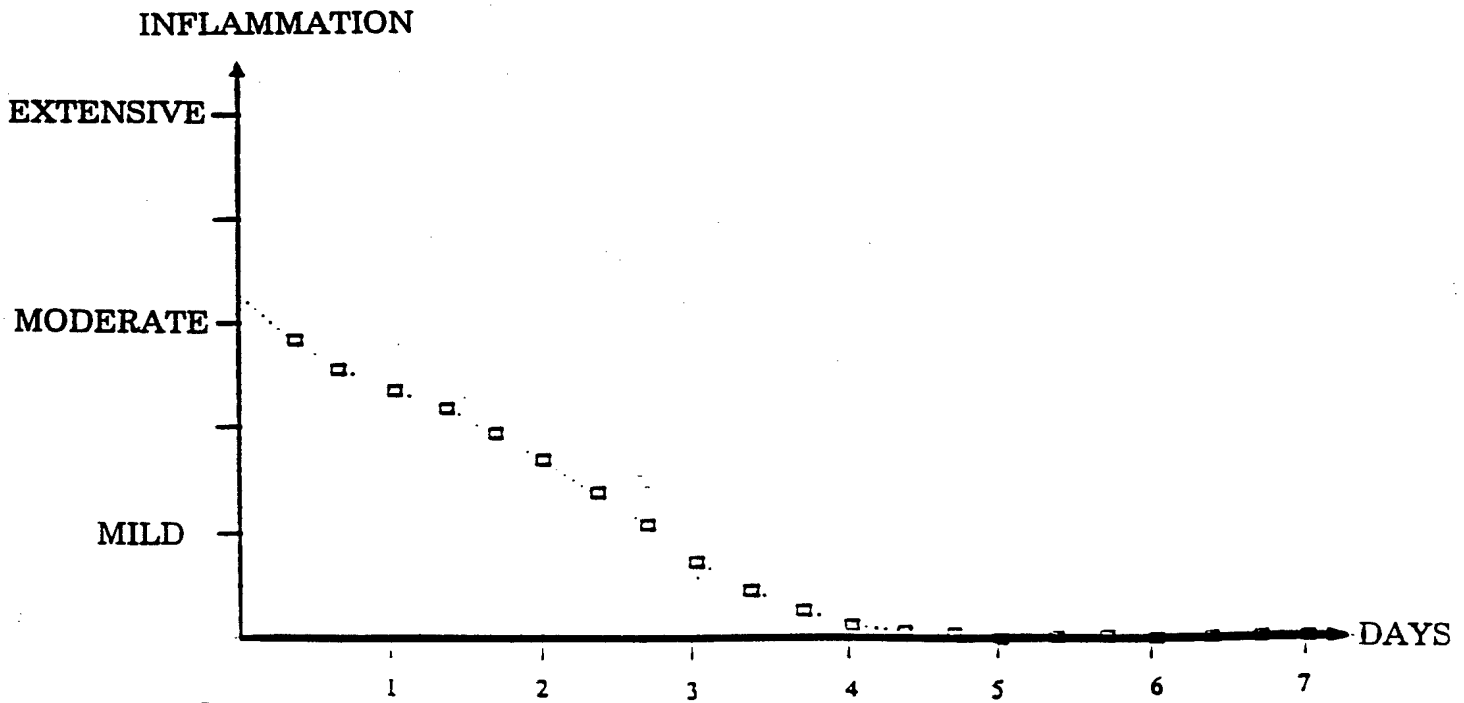


FIG. 7

6/25

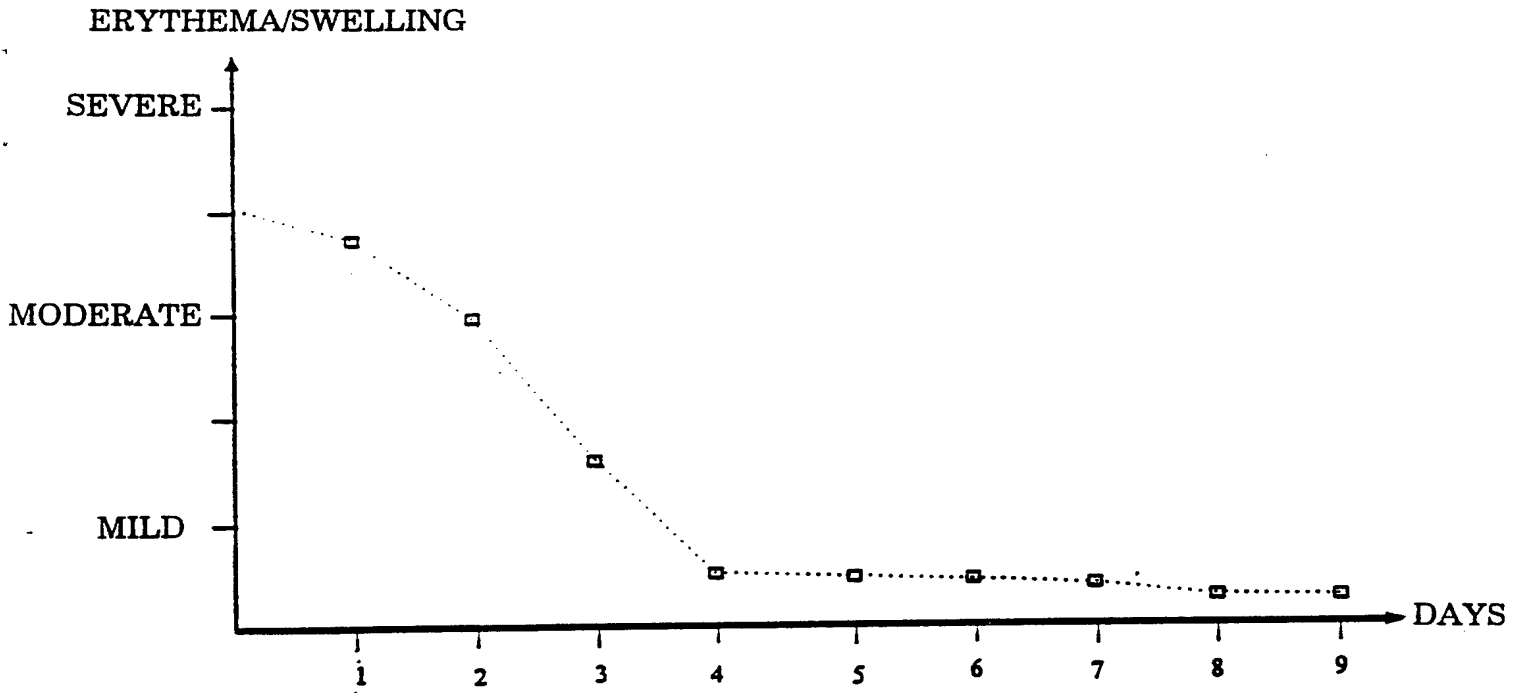


FIG. 8

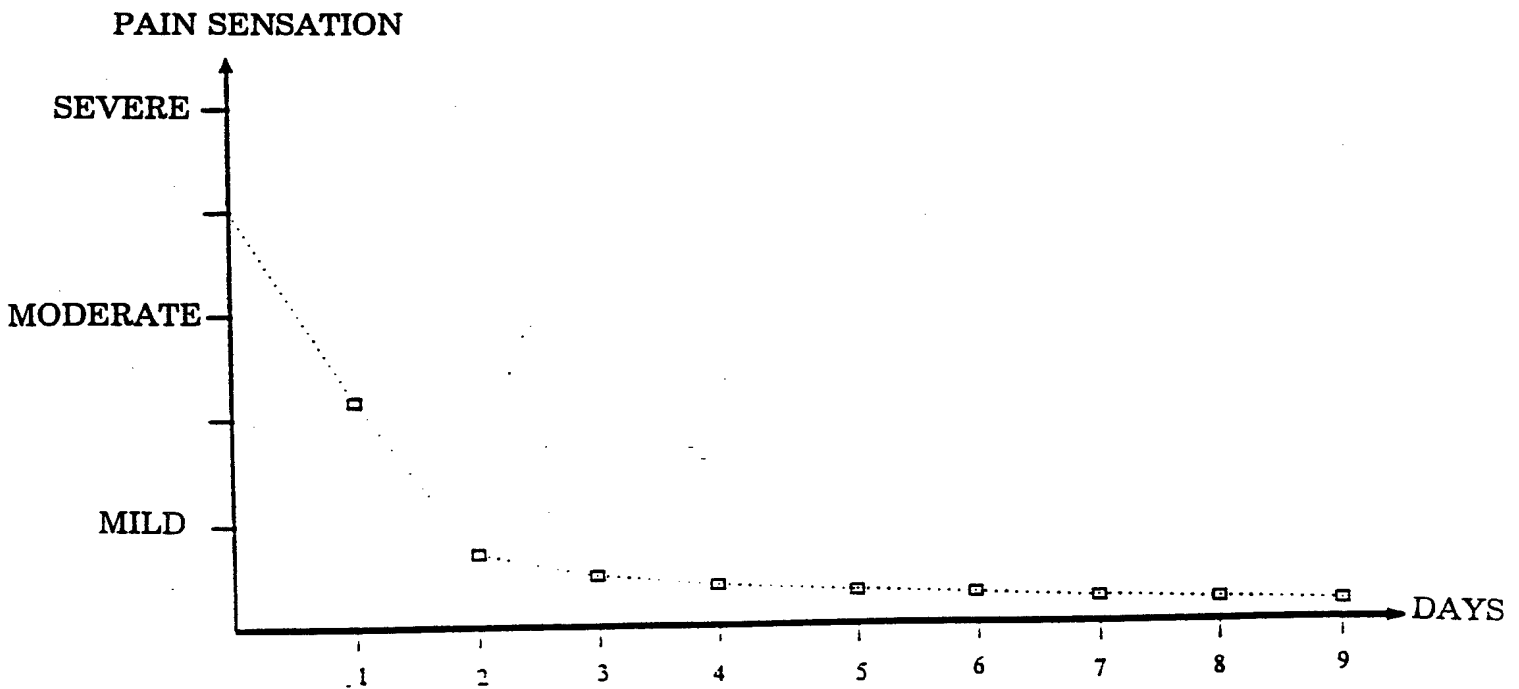


FIG. 9

7/25

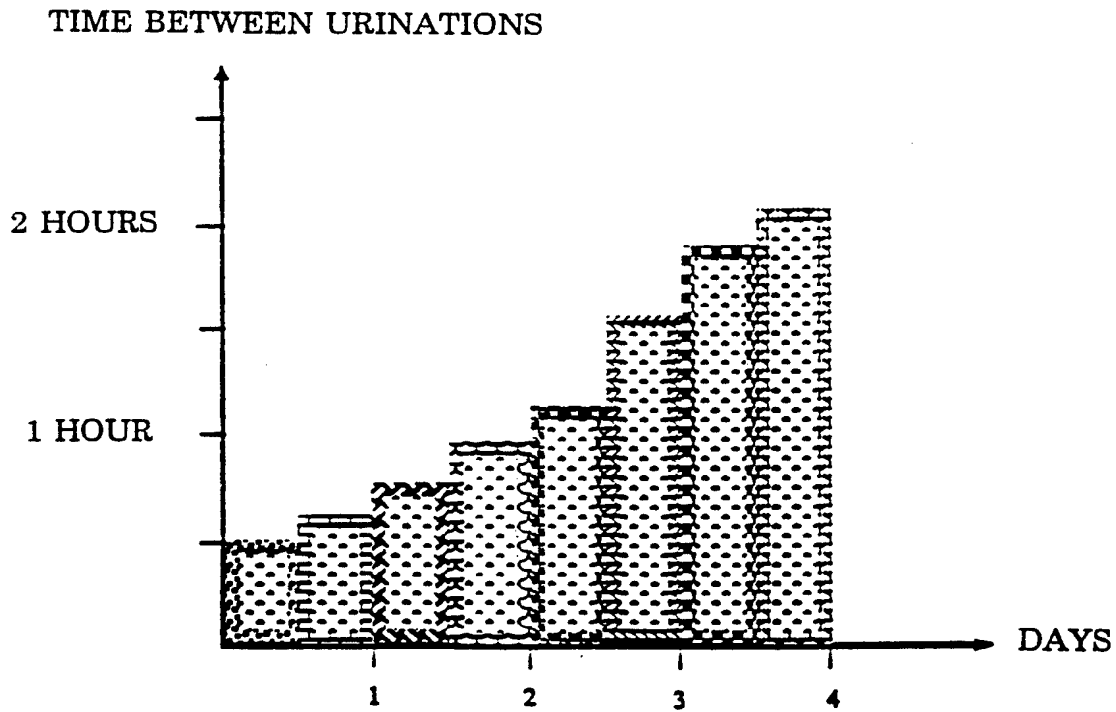


FIG. 10

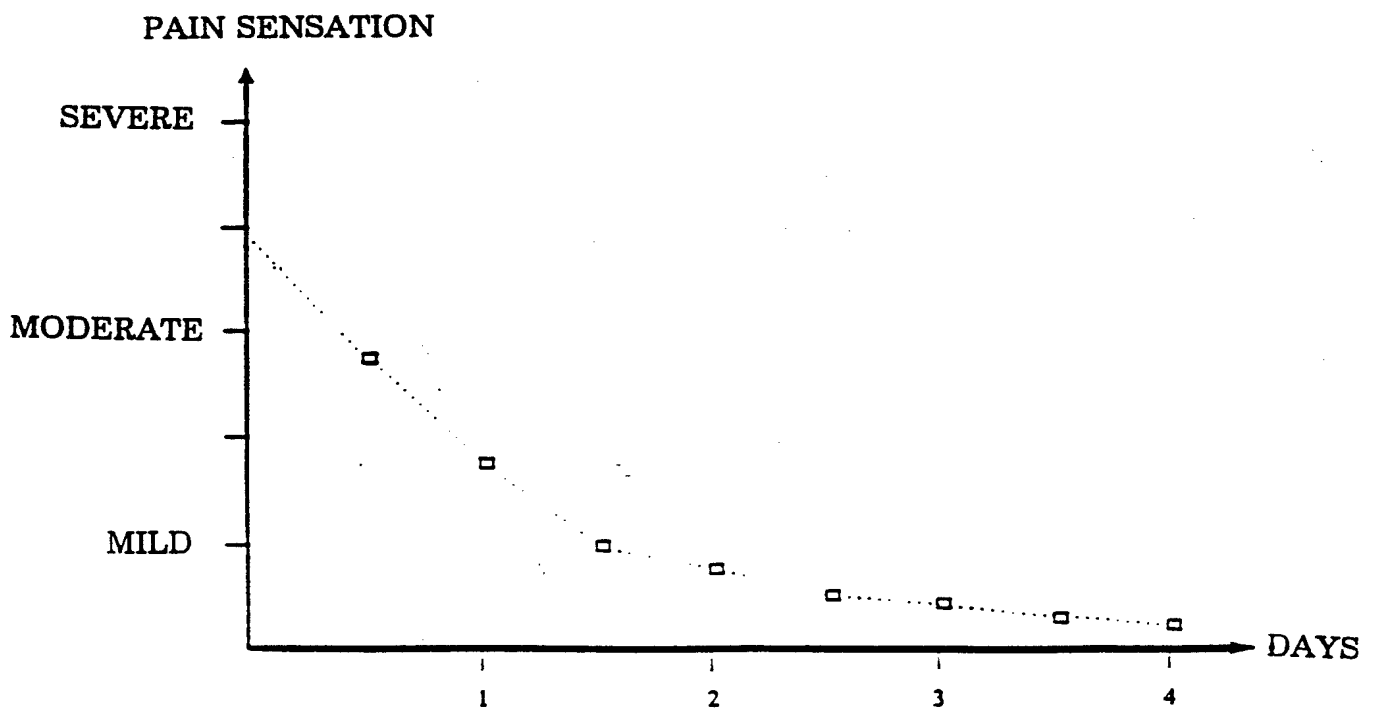
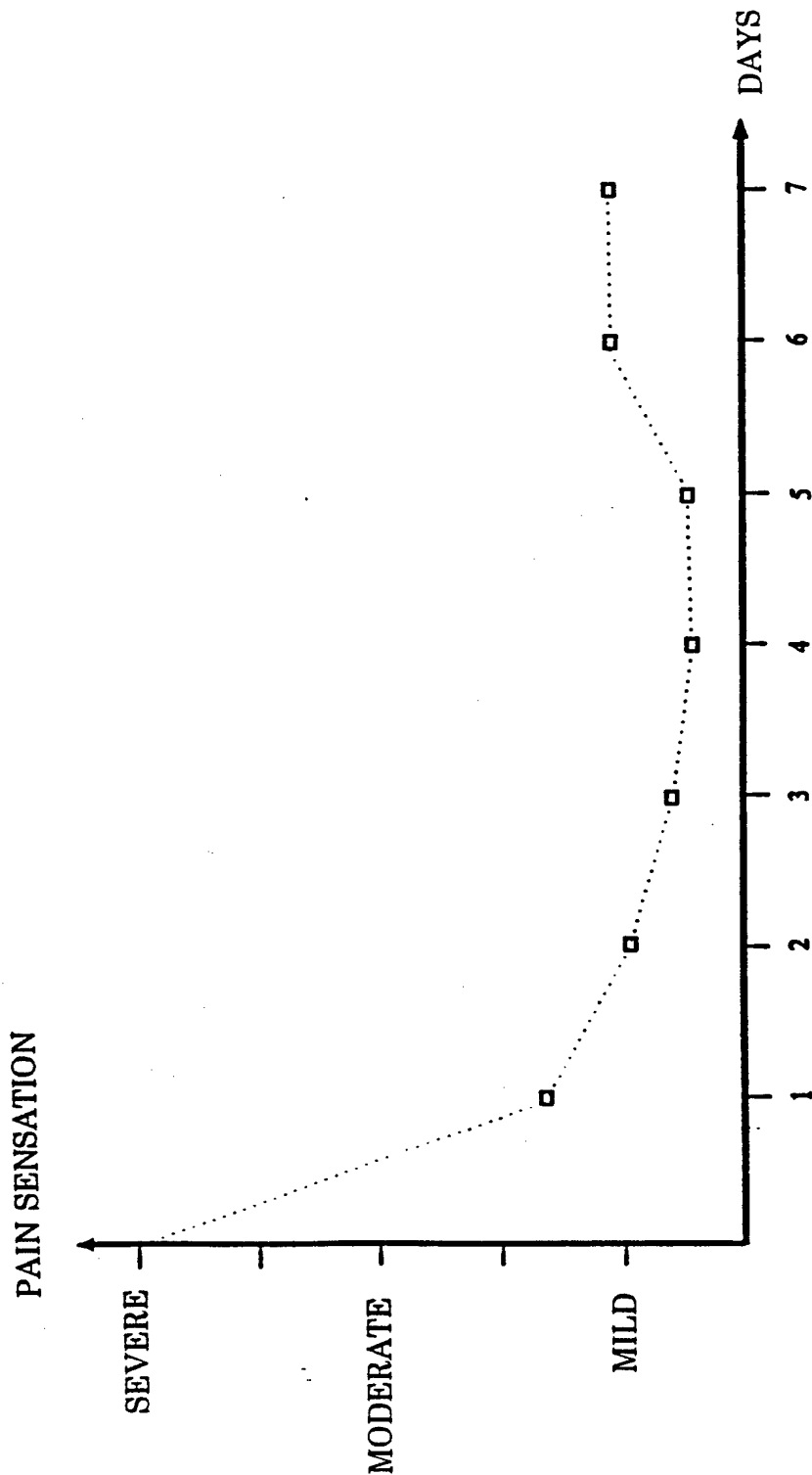
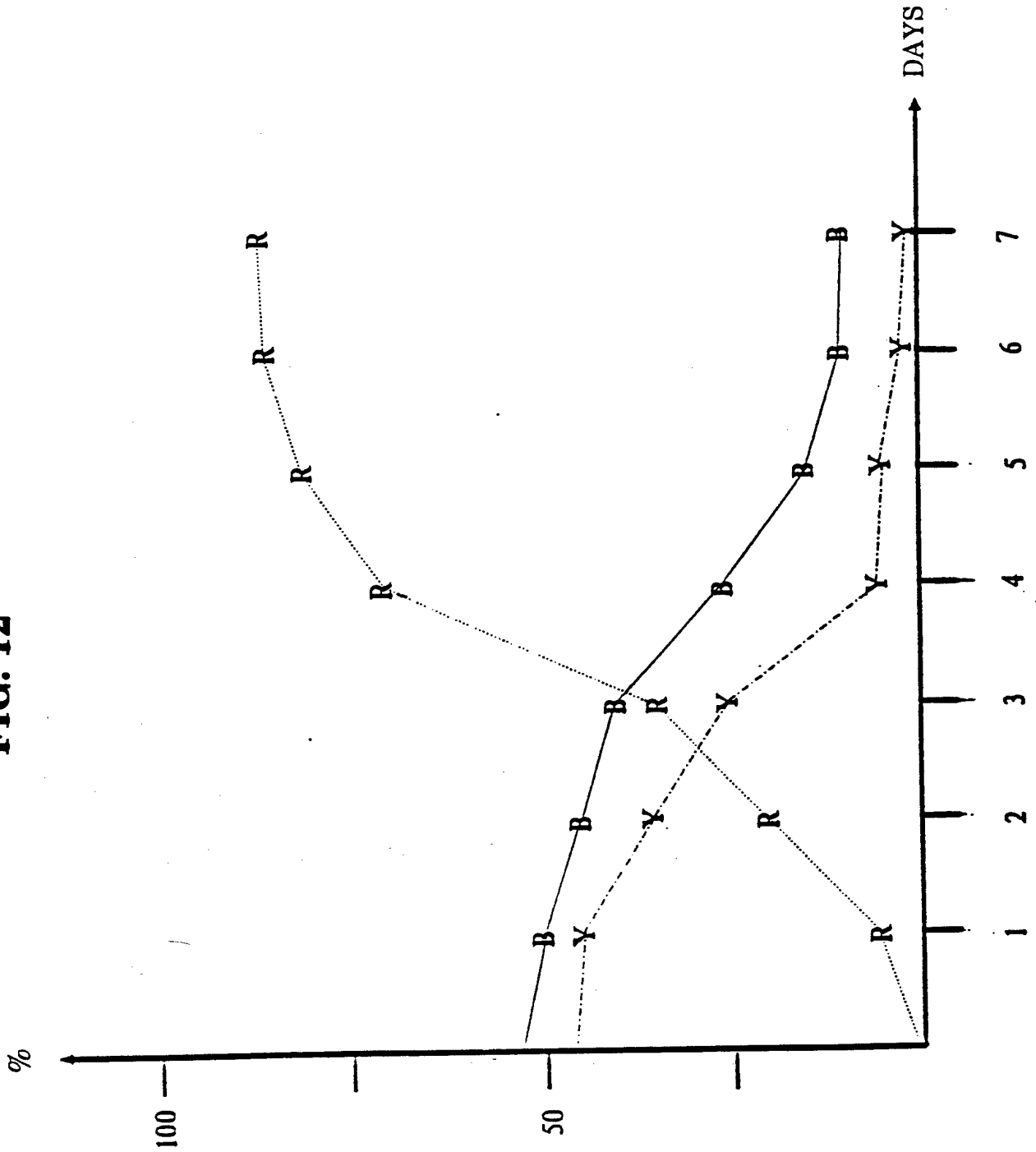


FIG. 11



9/25

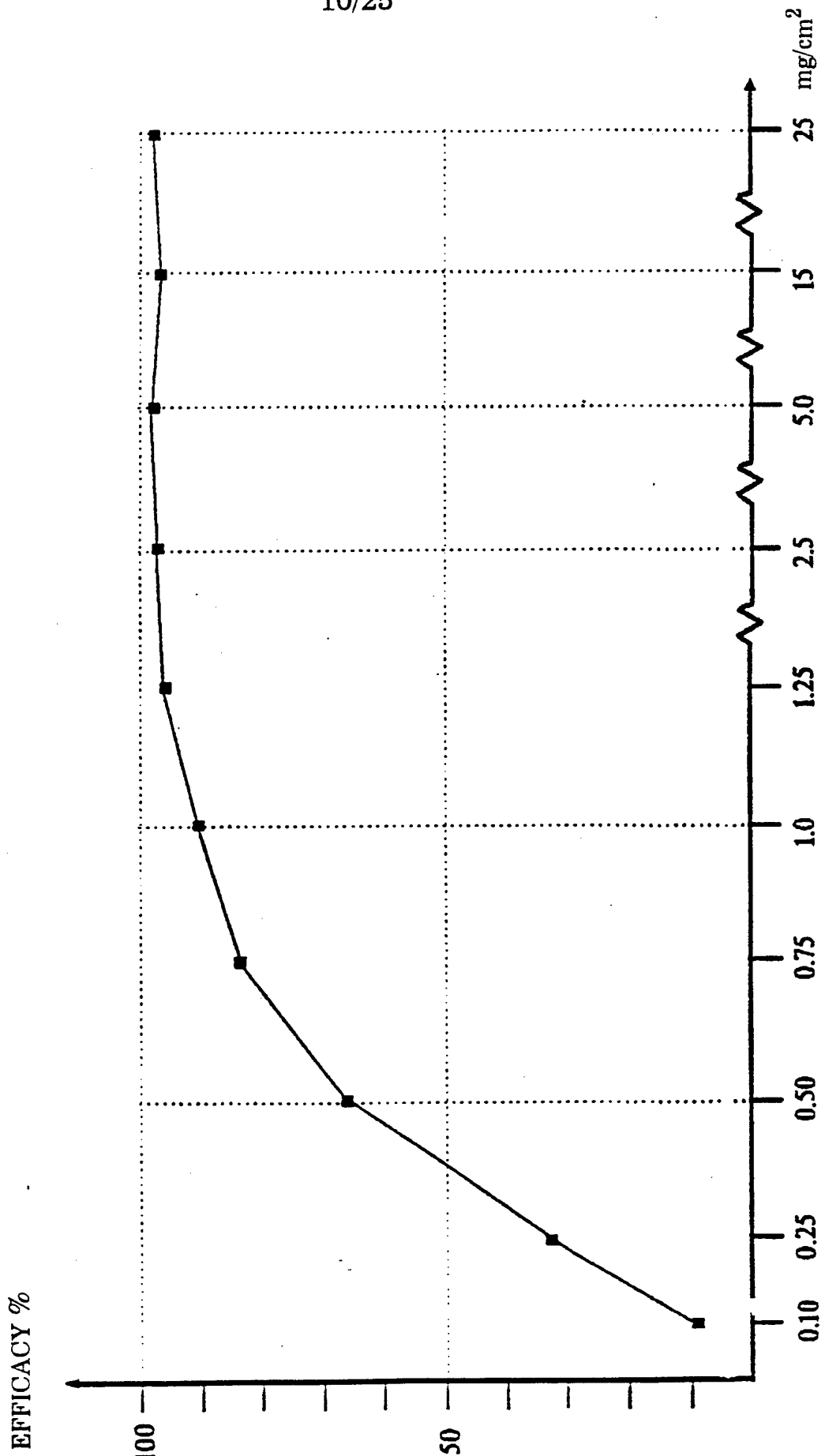
FIG. 12





10/25

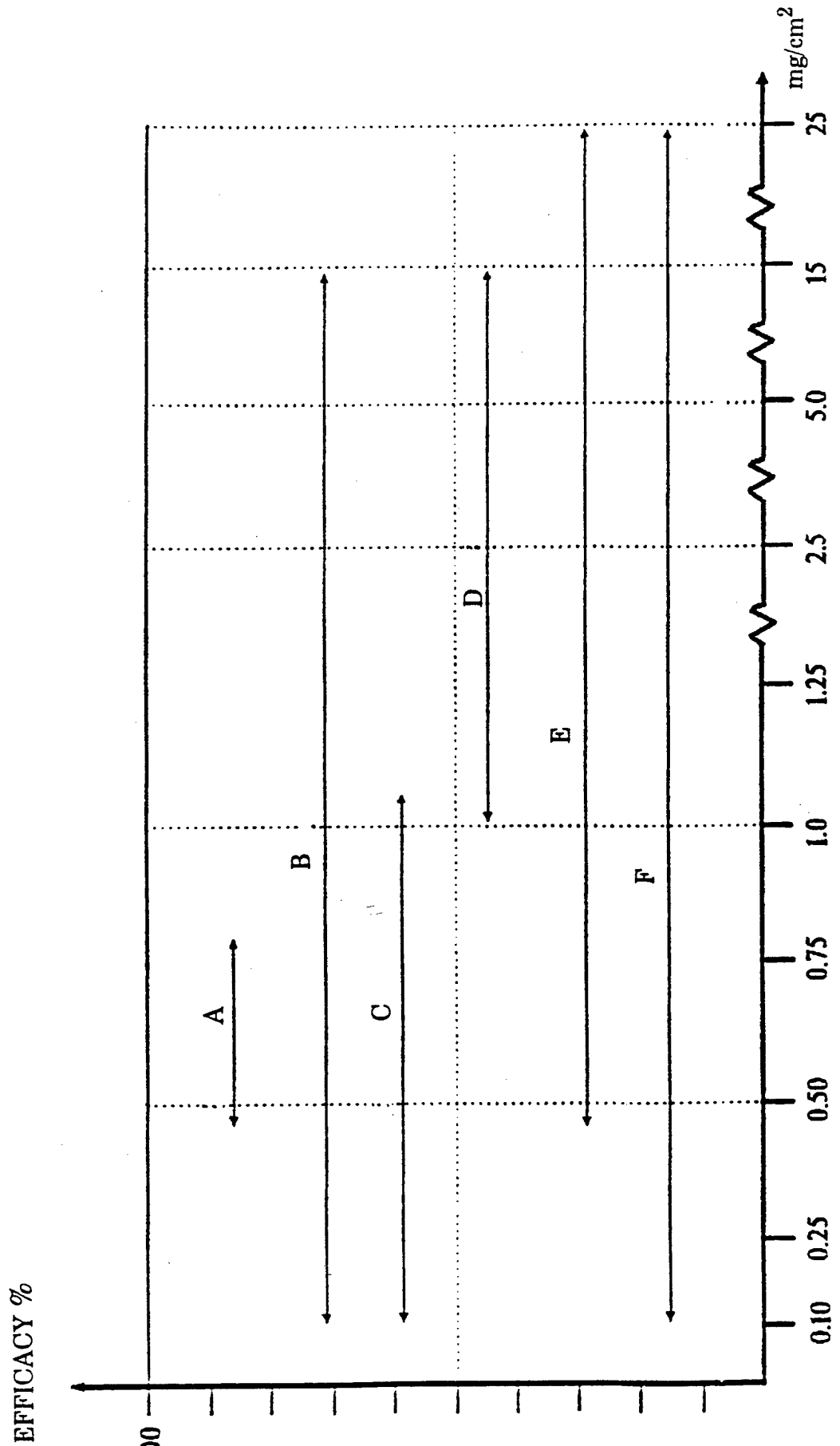
FIG. 13



SUBSTITUTE SHEET

11/25

FIG. 14



12/25

FIG. 15

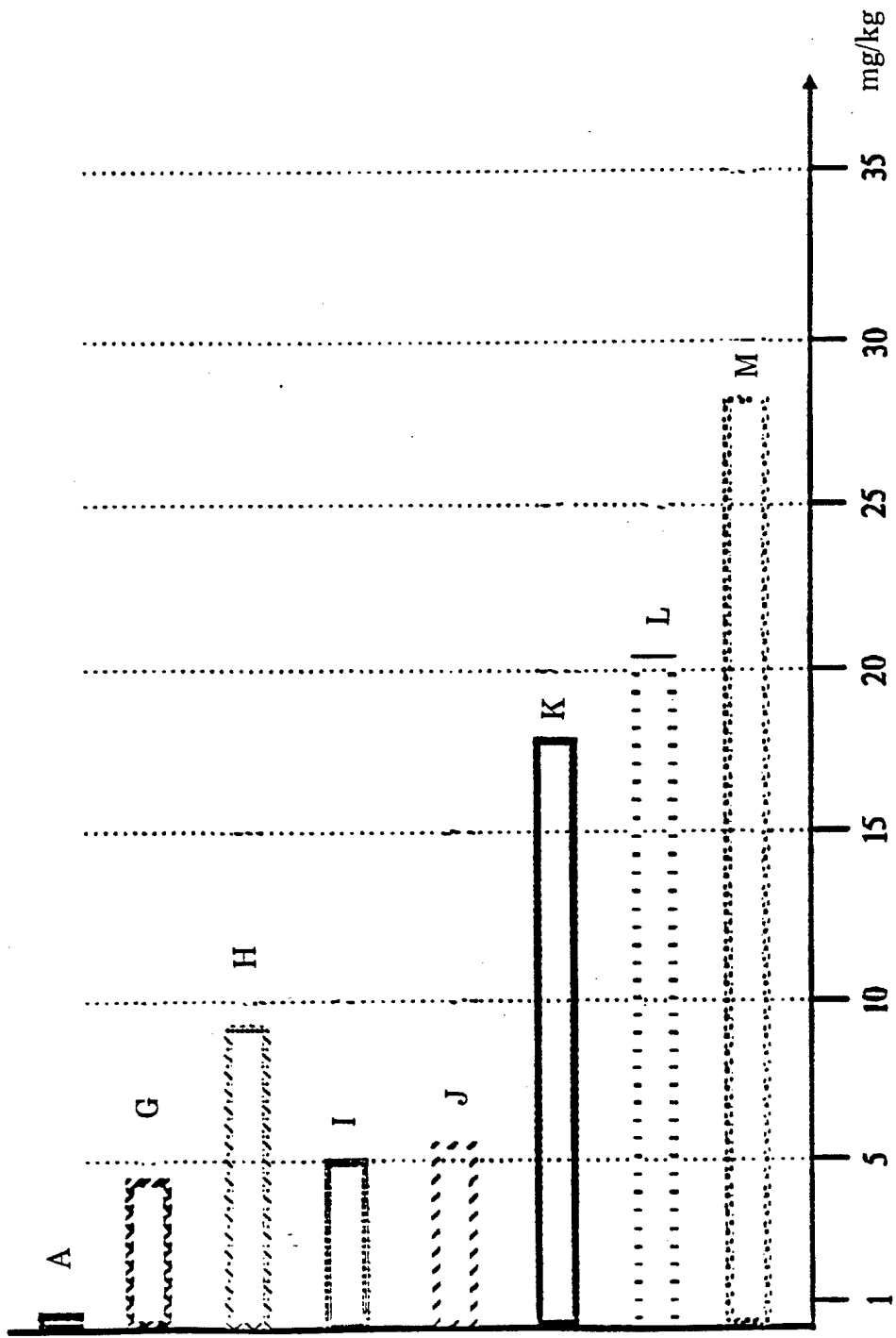
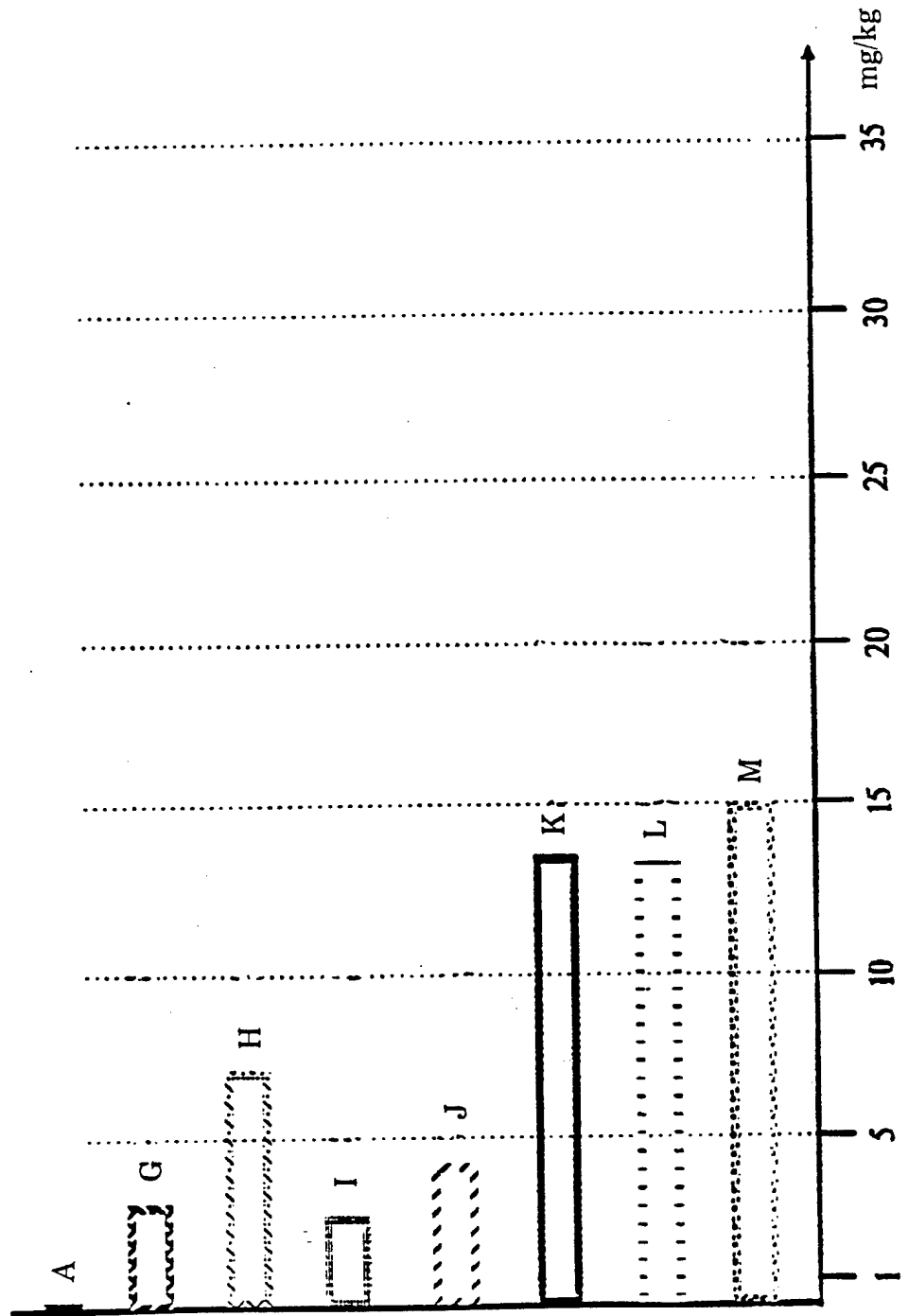


FIG. 16



**FIG. 17**

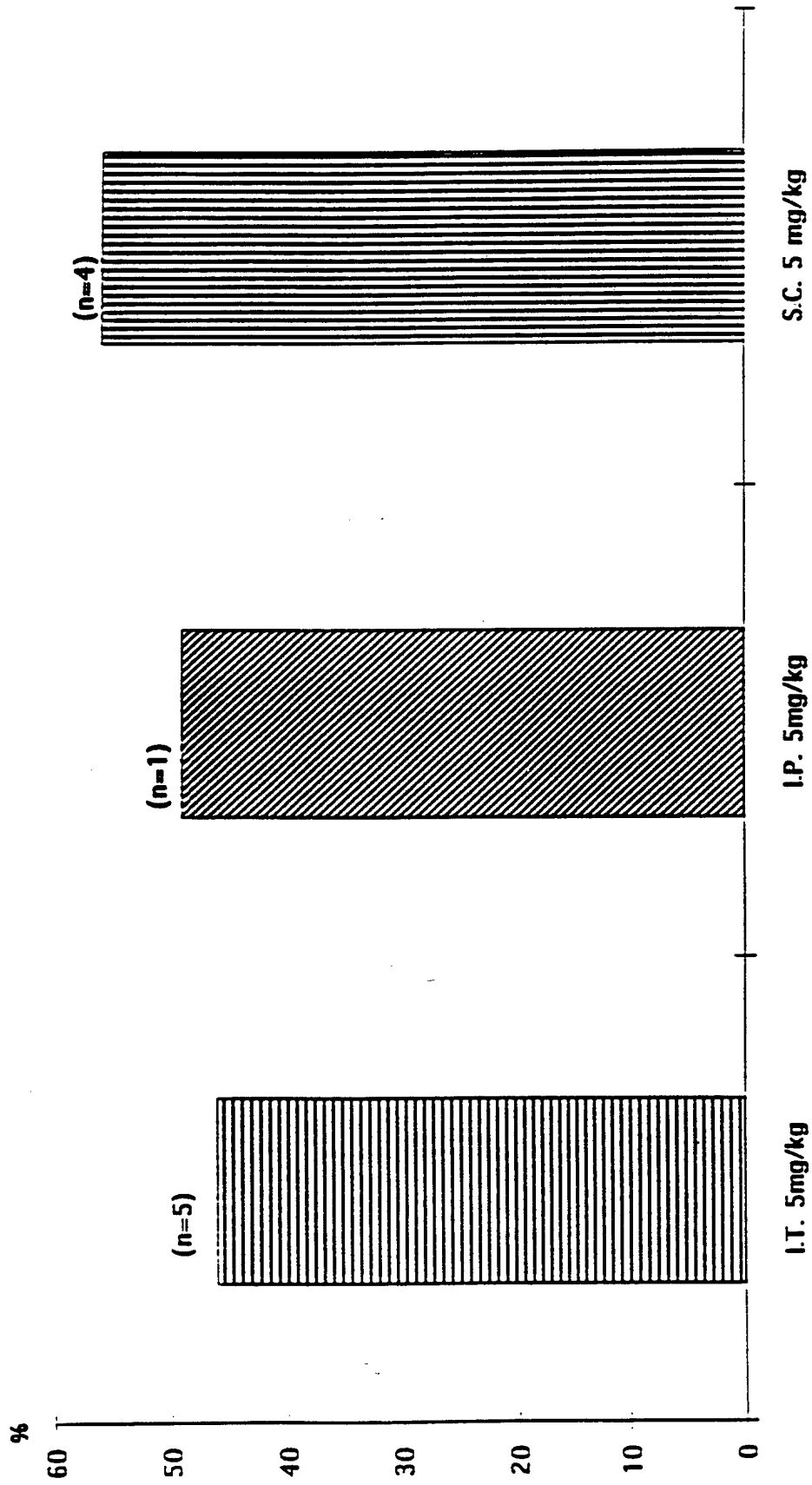


FIG. 18

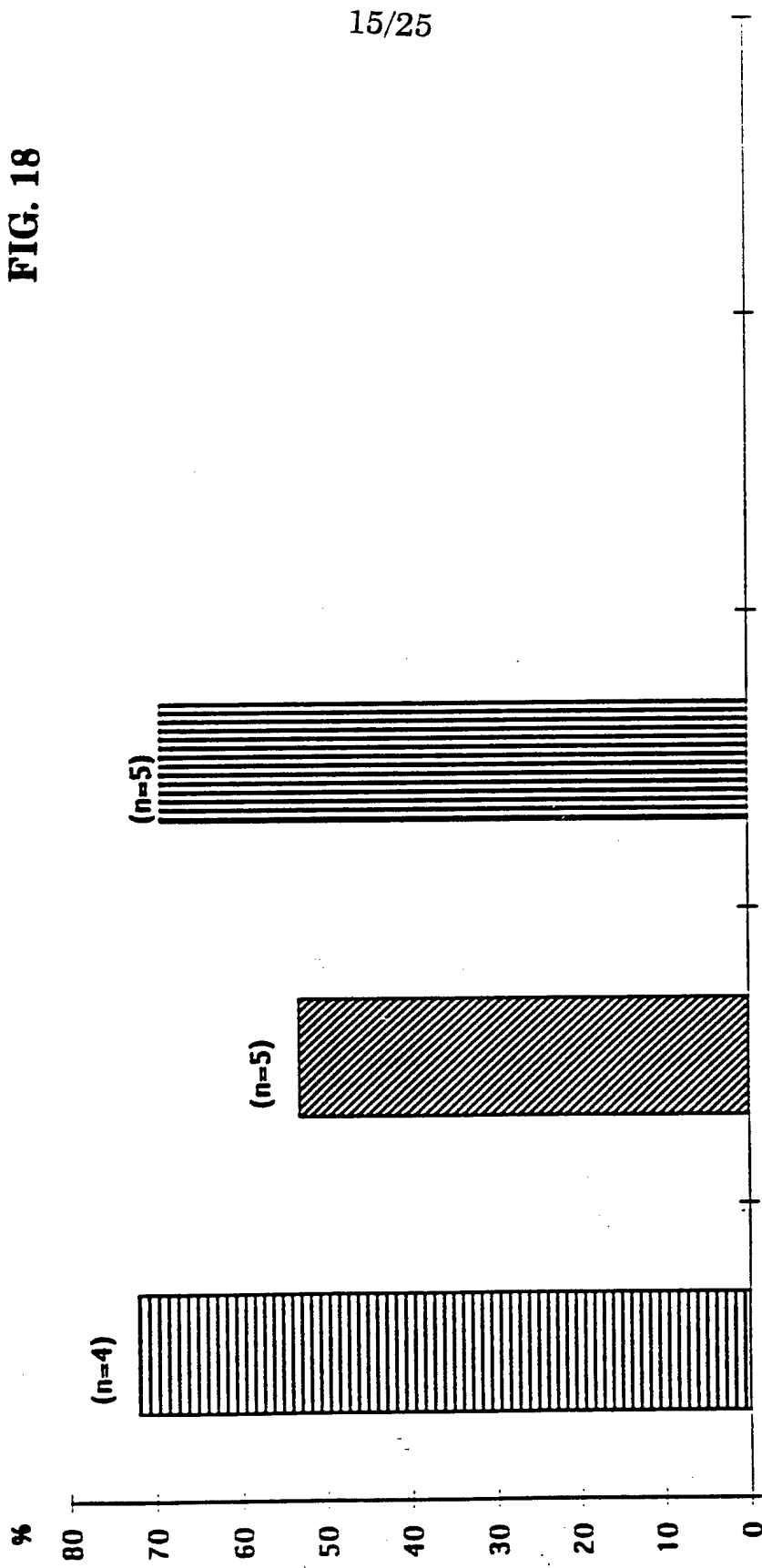
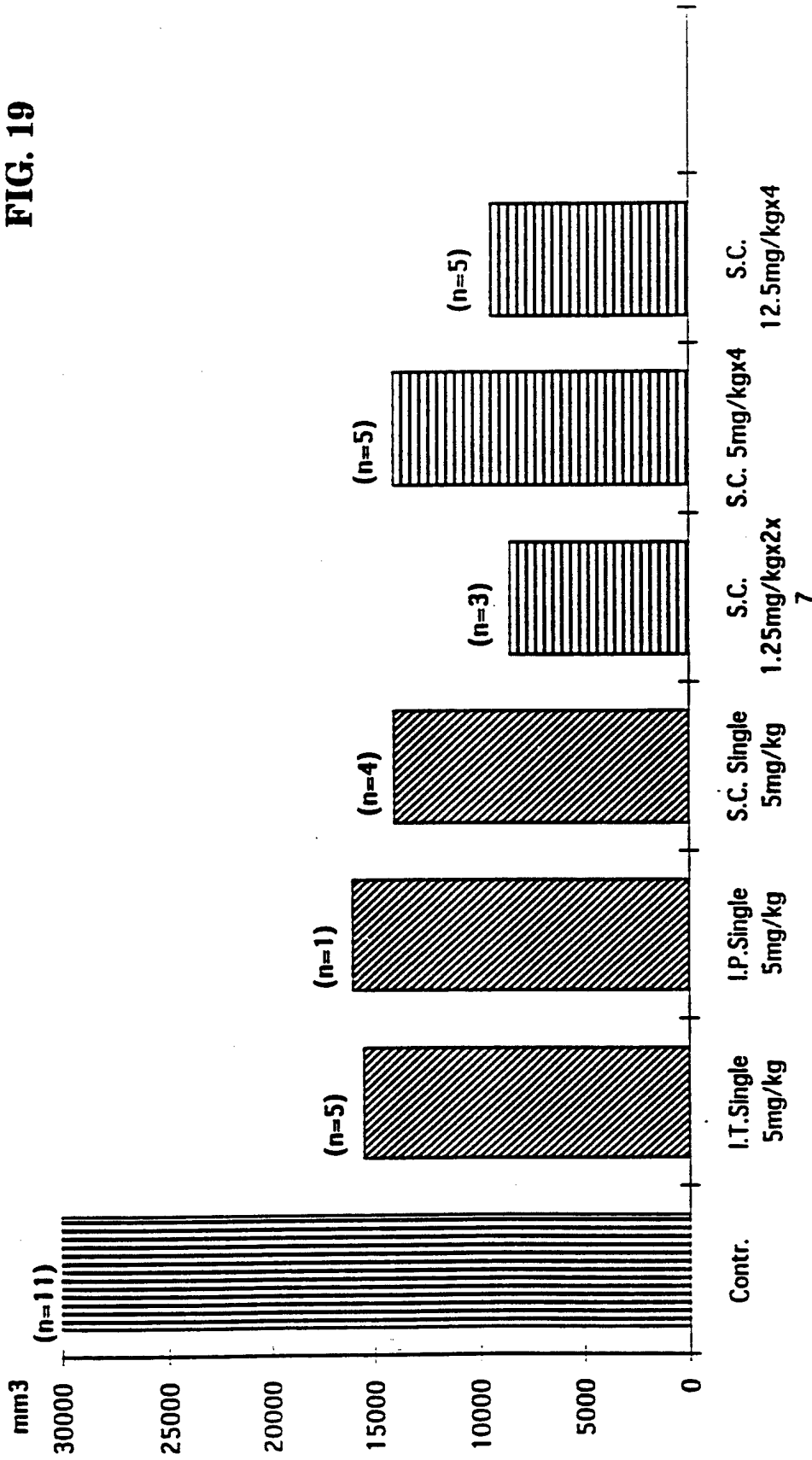
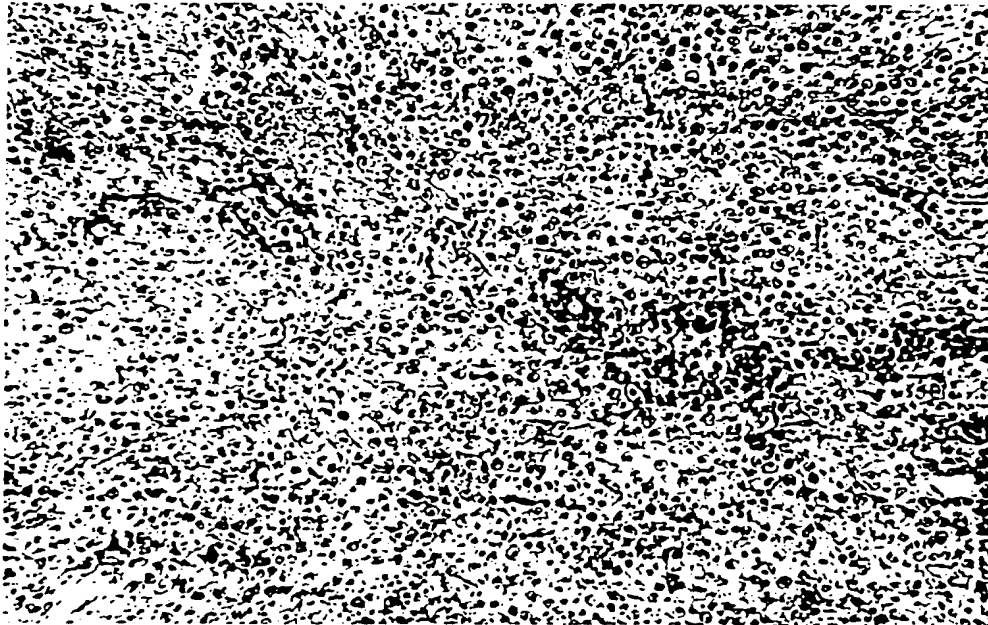
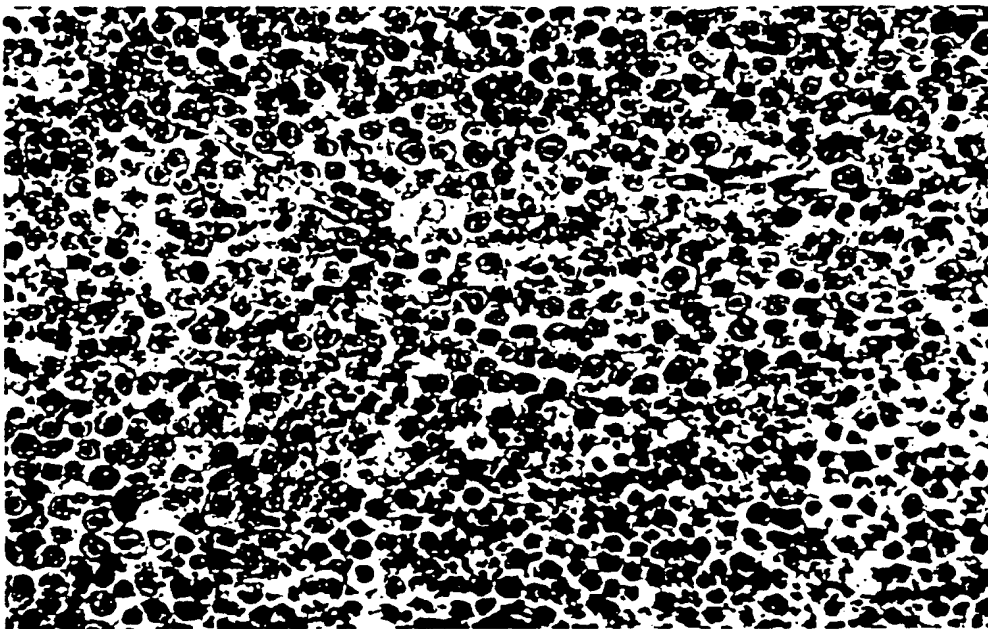


FIG. 19





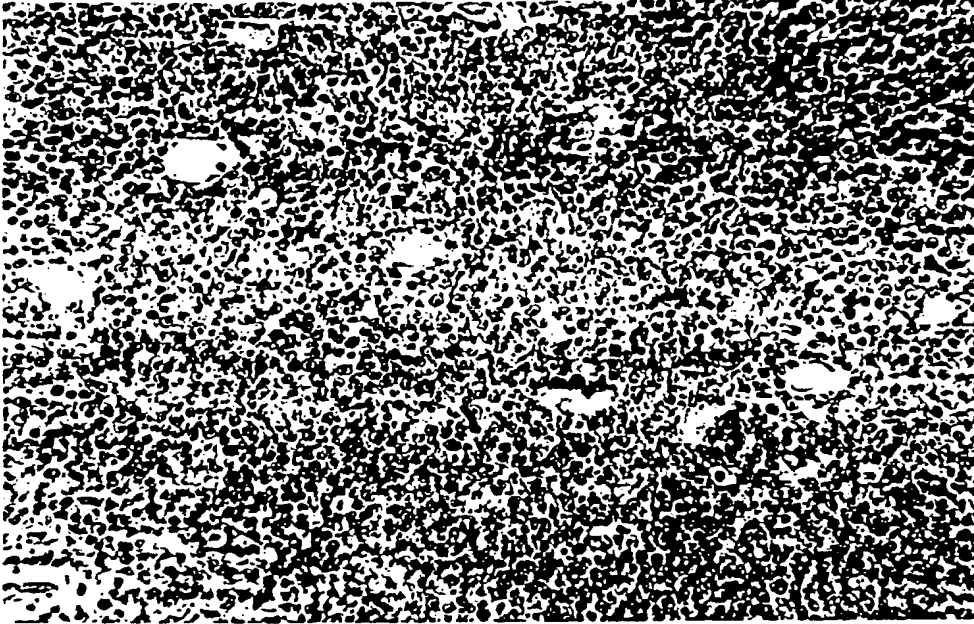
**FIG. 20**



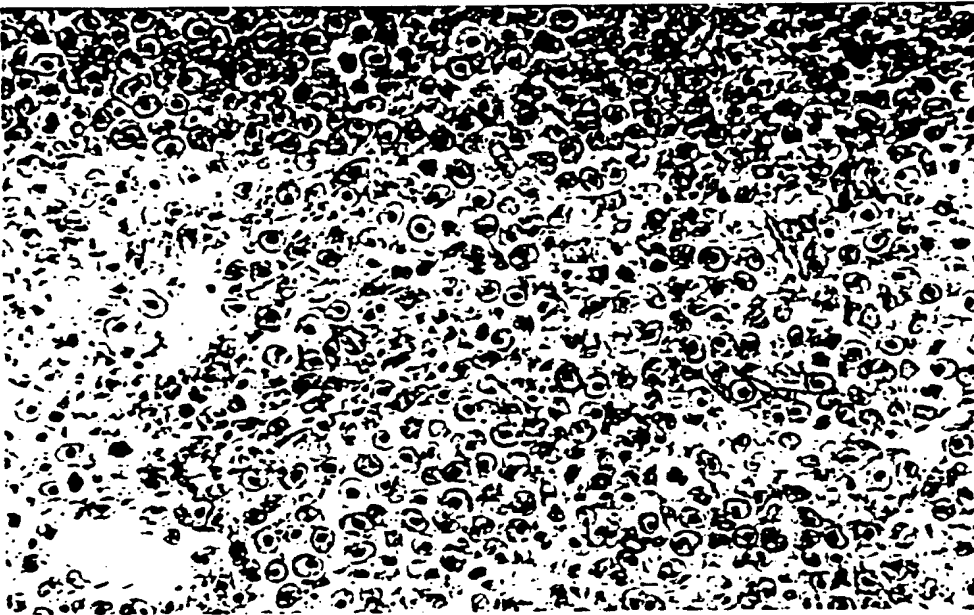
**FIG. 21**



**FIG. 22**

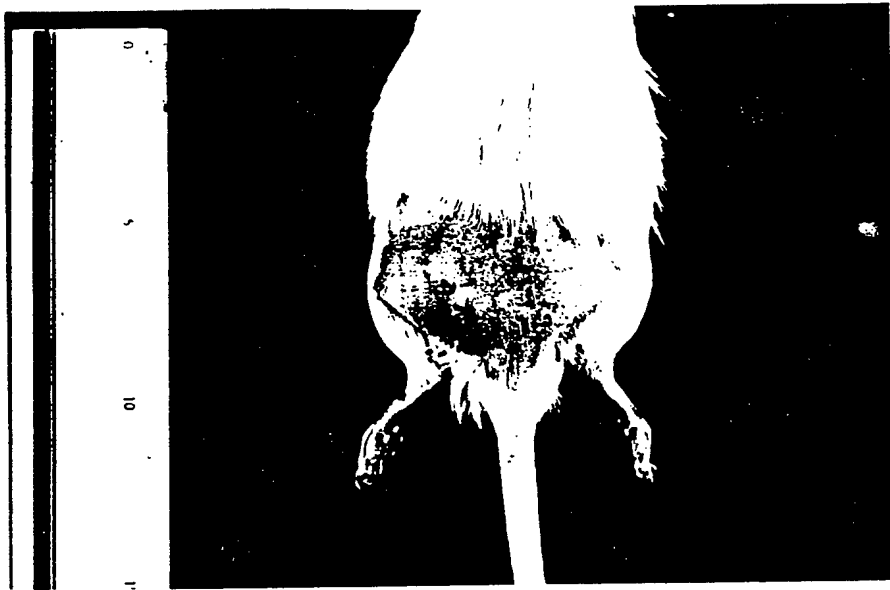


**FIG. 23**



19/25

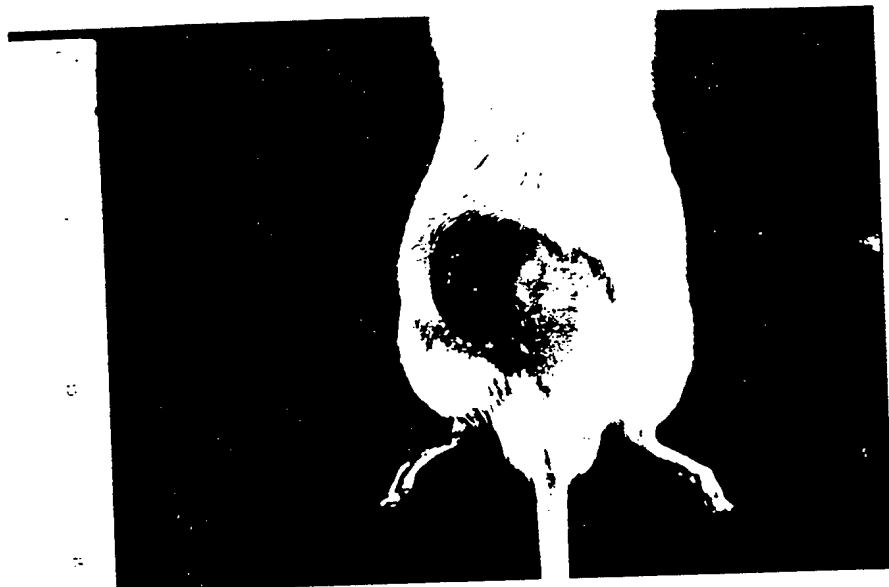
**FIG. 24**



**FIG. 25**



20/25

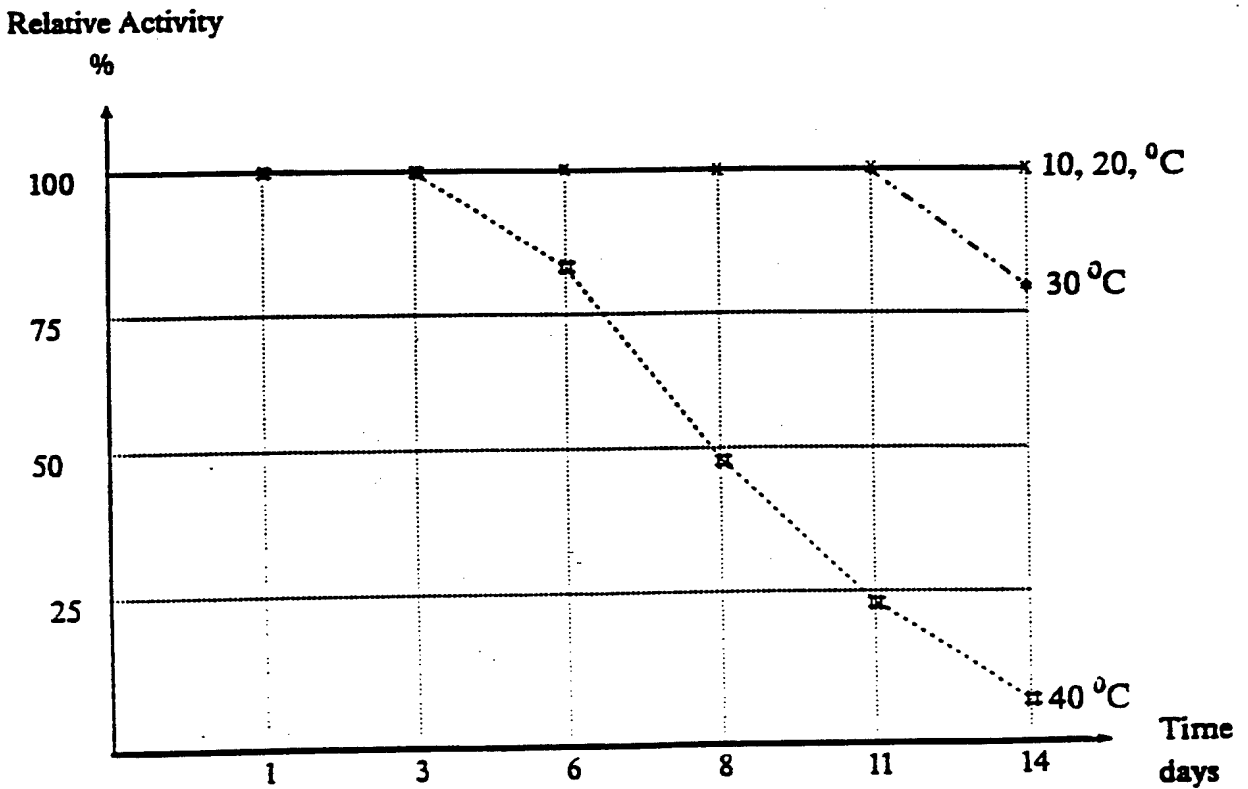
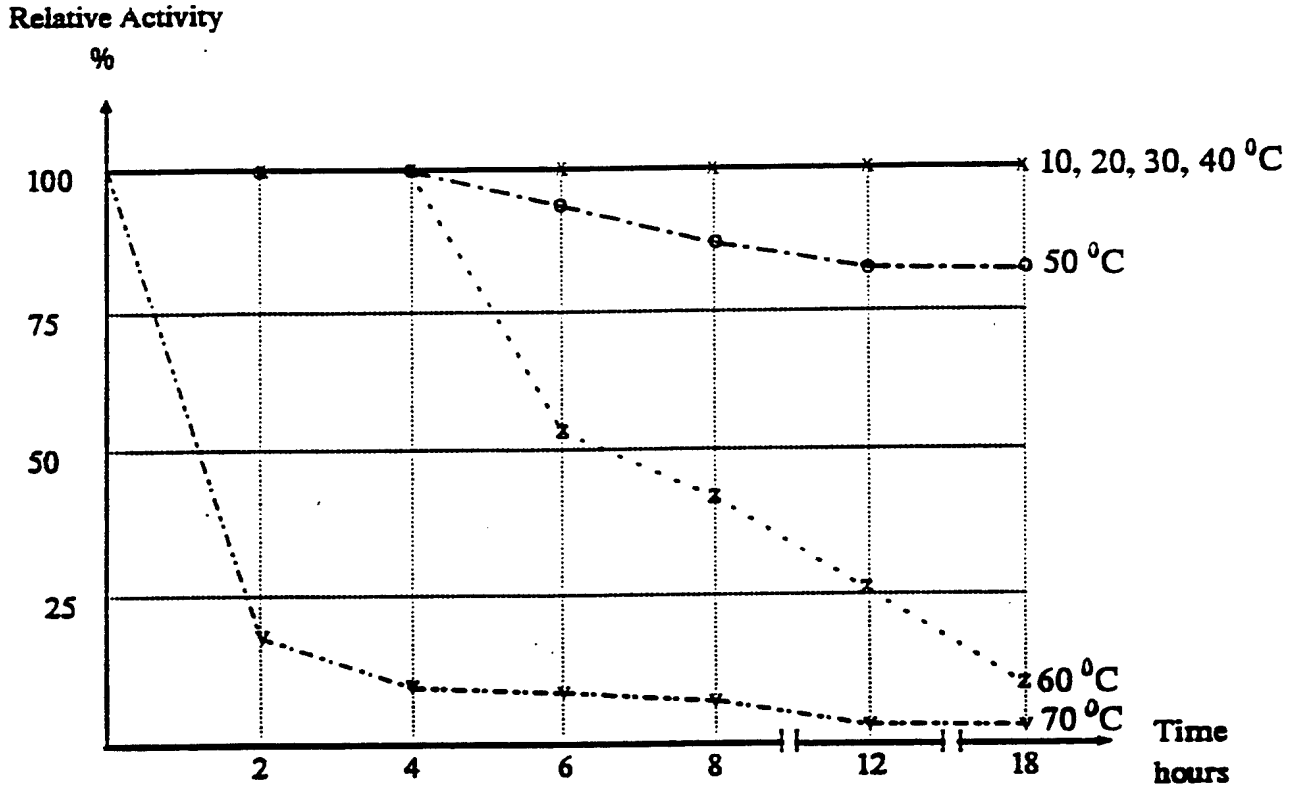


**FIG. 26**



**FIG. 27**

FIG. 28



22/25

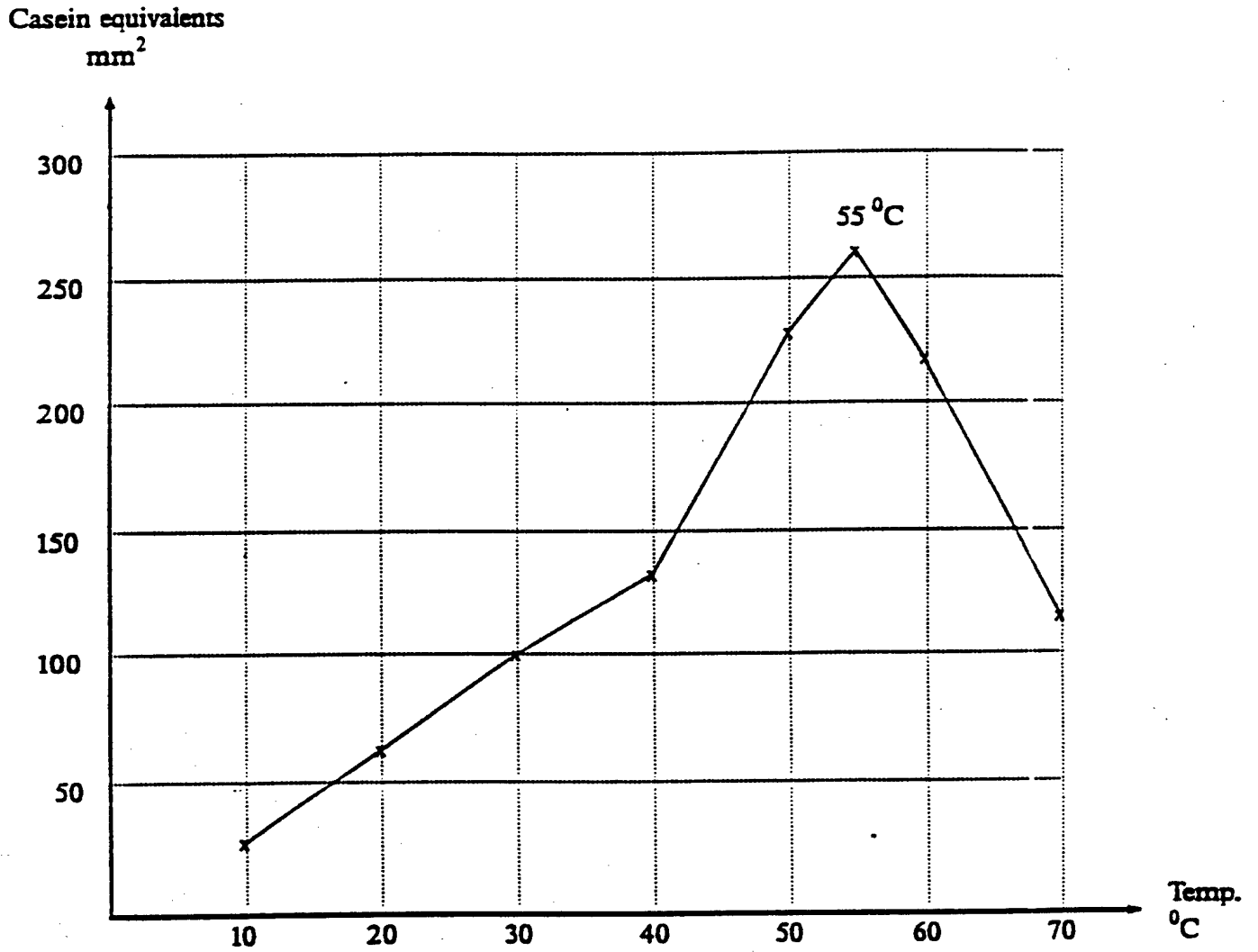


FIG. 30

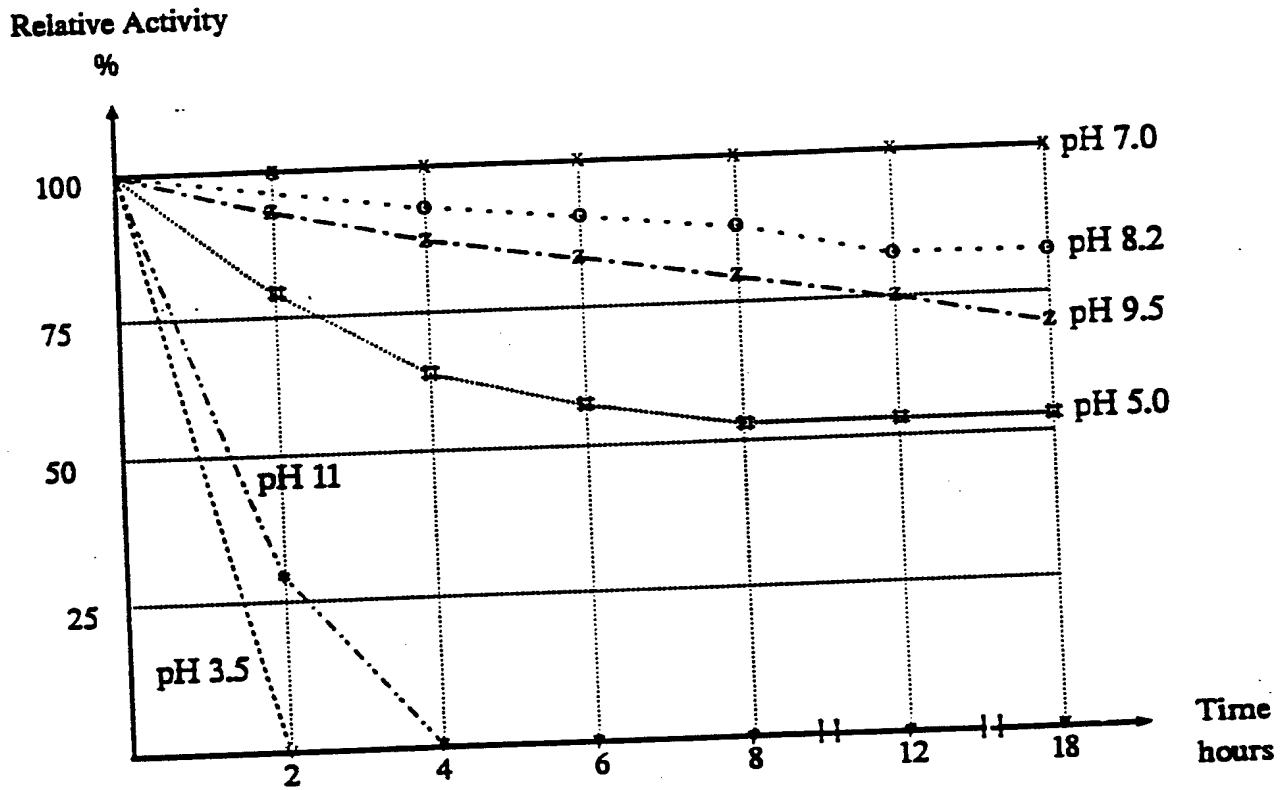
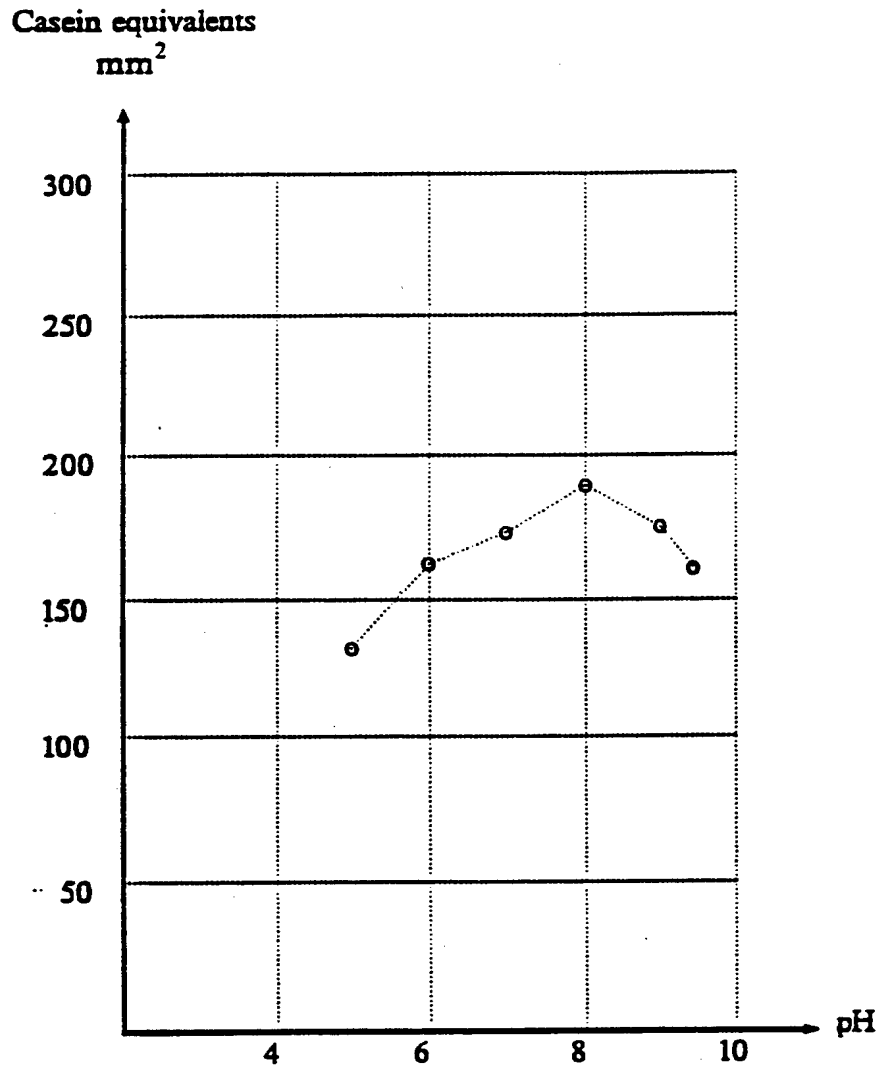
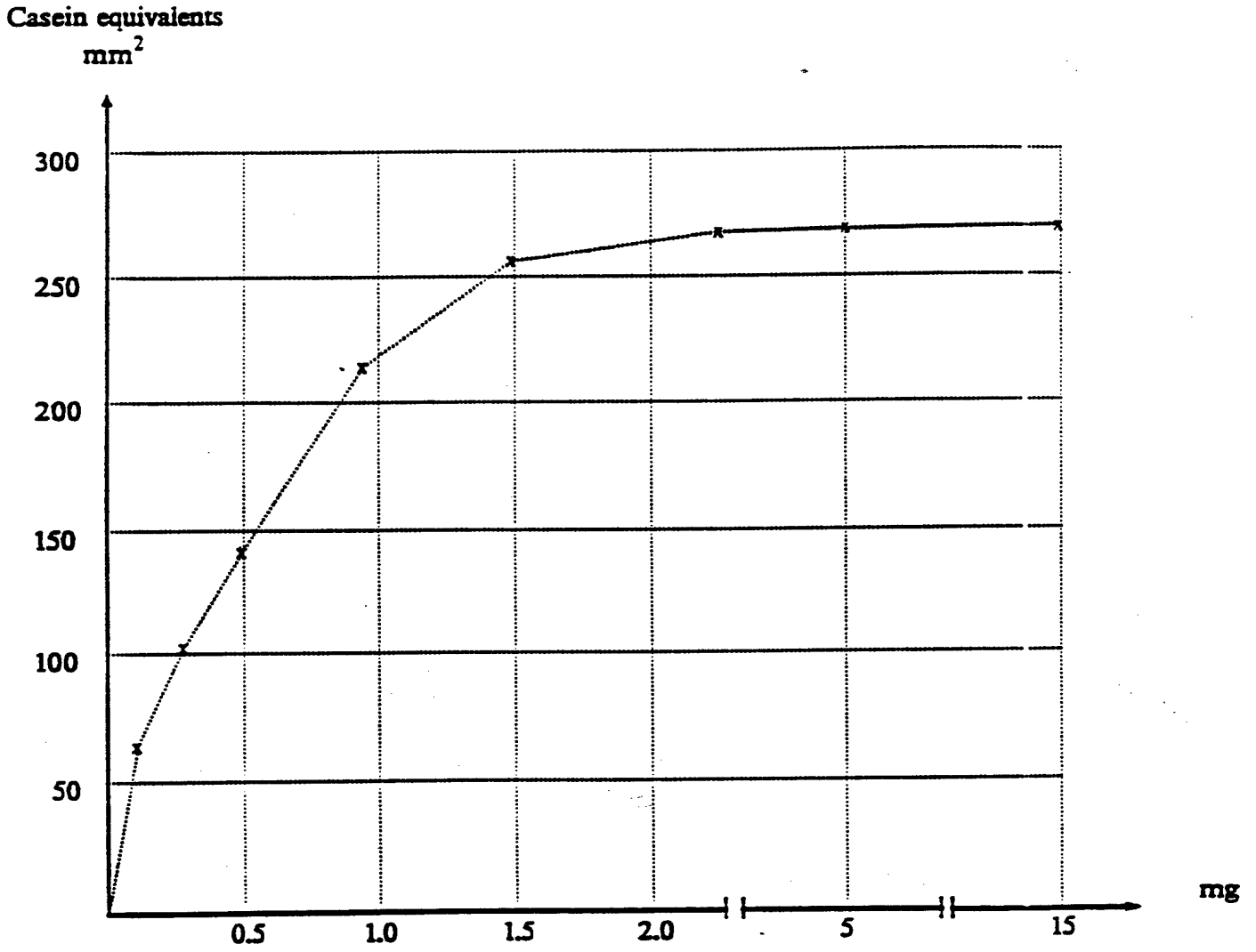


FIG. 31



**FIG. 32**





## INTERNATIONAL SEARCH REPORT

International application No.

PCT/SE 93/00455

## A. CLASSIFICATION OF SUBJECT MATTER

IPC5: A61K 37/54, C12N 9/50

According to International Patent Classification (IPC) or to both national classification and IPC

## B. FIELDS SEARCHED

Minimum documentation searched (classification system followed by classification symbols)

IPC5: A61K

Documentation searched other than minimum documentation to the extent that such documents are included in the fields searched

SE,DK,FI,NO classes as above

Electronic data base consulted during the international search (name of data base and, where practicable, search terms used)

MEDLINE, BIOSIS, EMBASE, CA, WPI, CLAIMS

## C. DOCUMENTS CONSIDERED TO BE RELEVANT

Category*	Citation of document, with indication, where appropriate, of the relevant passages	Relevant to claim No.
X	Dialog Information Services, file 347, Japio, Dialog accession no. 01854319, Hara Kenji et al: "Anti-inflammatory agent", Section: C, Section No. 366, Vol. 10, No. 235, Pg. 85, August 14, 1986, (19860814).	1-12
	--	
A	EP, A1, 0170115 (KAO CORPORATION), 5 February 1986 (05.02.86)	1-12
	-- -----	

 Further documents are listed in the continuation of Box C. See patent family annex.

## \* Special categories of cited documents:

- "A" document defining the general state of the art which is not considered to be of particular relevance
- "E" earlier document but published on or after the international filing date
- "L" document which may throw doubts on priority claim(s) or which is cited to establish the publication date of another citation or other special reason (as specified)
- "O" document referring to an oral disclosure, use, exhibition or other means
- "P" document published prior to the international filing date but later than the priority date claimed

"T" later document published after the international filing date or priority date and not in conflict with the application but cited to understand the principle or theory underlying the invention

"X" document of particular relevance: the claimed invention cannot be considered novel or cannot be considered to involve an inventive step when the document is taken alone

"Y" document of particular relevance: the claimed invention cannot be considered to involve an inventive step when the document is combined with one or more other such documents, such combination being obvious to a person skilled in the art

"&" document member of the same patent family

Date of the actual completion of the international search

2 Sept 1993

Date of mailing of the international search report

06 -09- 1993

Name and mailing address of the ISA/  
Swedish Patent Office  
Box 5055, S-102 42 STOCKHOLM  
Facsimile No. +46 8 666 02 86

Authorized officer

Jonny Brun  
Telephone No. +46 8 782 25 00







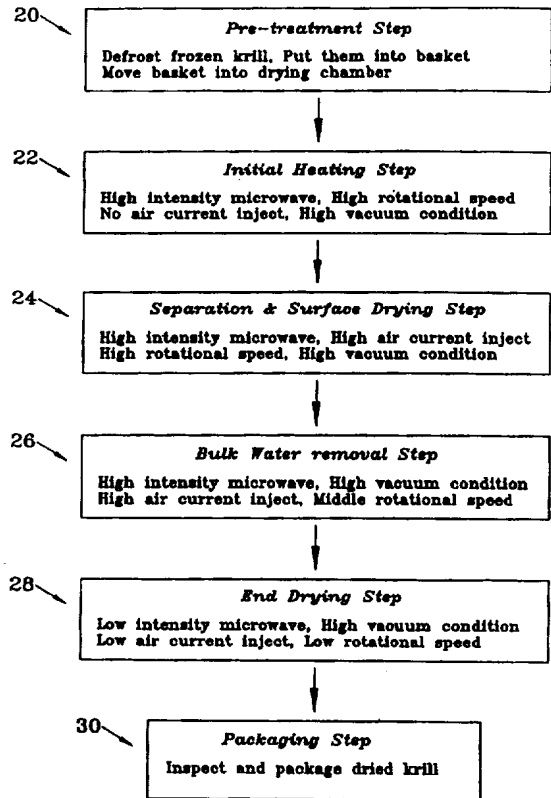
INTERNATIONAL APPLICATION PUBLISHED UNDER THE PATENT COOPERATION TREATY (PCT)

<p>(51) International Patent Classification <sup>6</sup> : <b>A23B 4/03</b></p>	<p><b>A1</b></p>	<p>(11) International Publication Number: <b>WO 97/38585</b> (43) International Publication Date: 23 October 1997 (23.10.97)</p>
<p>(21) International Application Number: PCT/CA97/00238 (22) International Filing Date: 9 April 1997 (09.04.97) (30) Priority Data: 08/632,832 16 April 1996 (16.04.96) US (71) Applicant: THE UNIVERSITY OF BRITISH COLUMBIA [CA/CA]; 2075 Wesbrook Mall, Vancouver, British Columbia V6T 1Z1 (CA). (72) Inventors: DURANCE, Timothy, Douglas; 3656 Point Grey Road, Vancouver, British Columbia V6R 1A9 (CA). LIU, Fang; 109 - 2730 Acadia Road, Vancouver, British Columbia V6T 1R9 (CA). (74) Agent: ROWLEY, C., A.; MacMillan Bloedel Research, Patents &amp; Licensing, 4225 Kincaid Street, Burnaby, British Columbia V5G 4P5 (CA).</p>		<p>(81) Designated States: AL, AM, AT, AU, AZ, BA, BB, BG, BR, BY, CA, CH, CN, CU, CZ, DE, DK, EE, ES, FI, GB, GE, HU, IL, IS, JP, KE, KG, KP, KR, KZ, LC, LK, LR, LS, LT, LU, LV, MD, MG, MK, MN, MW, MX, NO, NZ, PL, PT, RO, RU, SD, SE, SG, SI, SK, TJ, TM, TR, TT, UA, UG, UZ, VN, ARIPO patent (GH, KE, LS, MW, SD, SZ, UG), Eurasian patent (AM, AZ, BY, KG, KZ, MD, RU, TJ, TM), European patent (AT, BE, CH, DE, DK, ES, FI, FR, GB, GR, IE, IT, LU, MC, NL, PT, SE), OAPI patent (BF, BJ, CF, CG, CI, CM, GA, GN, ML, MR, NE, SN, TD, TG).</p> <p><b>Published</b> <i>With international search report. Before the expiration of the time limit for amending the claims and to be republished in the event of the receipt of amendments.</i></p>

(54) Title: DEHYDRATED KRILL AND METHOD OF PRODUCING SAME

(57) Abstract

A new form of dried krill is provided by a plurality of substantially separate whole dried krill carcasses substantially all of which have a natural red color and sufficient strength and integrity to withstand normal handling without crumbling into small pieces and retain a strong wholesome fish aroma and flavor. The krill are dried by a method wherein a sequence of energy applications are applied at pressures below atmospheric and the surface of the product simultaneously swept by air to remove moisture. During the process the krill are subjected to a tumbling action. The energy applications are preferably microwave energy applications.



**FOR THE PURPOSES OF INFORMATION ONLY**

Codes used to identify States party to the PCT on the front pages of pamphlets publishing international applications under the PCT.

AL	Albania	ES	Spain	LS	Lesotho	SI	Slovenia
AM	Armenia	FI	Finland	LT	Lithuania	SK	Slovakia
AT	Austria	FR	France	LU	Luxembourg	SN	Senegal
AU	Australia	GA	Gabon	LV	Latvia	SZ	Swaziland
AZ	Azerbaijan	GB	United Kingdom	MC	Monaco	TD	Chad
BA	Bosnia and Herzegovina	GE	Georgia	MD	Republic of Moldova	TG	Togo
BB	Barbados	GH	Ghana	MG	Madagascar	TJ	Tajikistan
BE	Belgium	GN	Guinea	MK	The former Yugoslav Republic of Macedonia	TM	Turkmenistan
BF	Burkina Faso	GR	Greece	ML	Mali	TR	Turkey
BG	Bulgaria	HU	Hungary	MM	Mongolia	TT	Trinidad and Tobago
BJ	Benin	IE	Ireland	MN	Mongolia	UA	Ukraine
BR	Brazil	IL	Israel	MR	Mauritania	UG	Uganda
BY	Belarus	IS	Iceland	MW	Malawi	US	United States of America
CA	Canada	IT	Italy	MX	Mexico	UZ	Uzbekistan
CF	Central African Republic	JP	Japan	NE	Niger	VN	Viet Nam
CG	Congo	KE	Kenya	NL	Netherlands	YU	Yugoslavia
CH	Switzerland	KG	Kyrgyzstan	NO	Norway	ZW	Zimbabwe
CI	Côte d'Ivoire	KP	Democratic People's Republic of Korea	NZ	New Zealand		
CM	Cameroon	KR	Republic of Korea	PL	Poland		
CN	China	KZ	Kazakstan	PT	Portugal		
CU	Cuba	LC	Saint Lucia	RO	Romania		
CZ	Czech Republic	LI	Liechtenstein	RU	Russian Federation		
DE	Germany	LK	Sri Lanka	SD	Sudan		
DK	Denmark	LR	Liberia	SE	Sweden		
EE	Estonia			SG	Singapore		

## Dehydrated Krill and Method of Producing Same

### Field of Invention

The present invention relates to a new form of dried krill and to a process and apparatus for producing such substantially dry krill.

### 5 Background

Krill are small marine crustaceans belong to the family Euphasiacea. They are closely related, but distinct from the shrimp family, Decapoda. More than 80 species of Euphasiacea are known but only about six species are commercially important, particularly *Euphasia pacifica*, *E. superba*, *Thysanoessa spinifera*, *T. inspinata*, *T.*  
10 *longipes* and *T. rashii*. Frozen and dried krill and krill products are consumed as human food. Substantial quantities of krill are also caught and processed for animal feeds, especially fish feed.

The main current market for dried krill product is for fish food with another important market being human food where it is used as a flavorant. The texture, color,  
15 flavor and aroma are important characteristics of the dried krill and generally reflect the quality of the product.

Currently there are two known methods of drying krill to produce the product for the market. Both processes produce a dried krill with poor coloring and generally of small particle size i.e. broken pieces or ,more likely in powder form.

20 Freeze drying of krill is one of the process use to produce dried krill. In this process the krill are frozen shortly after they are caught and then freeze dried at a convenient time. The dried product is usually in block form. The krill are brittle and easily broken and are in many cases crushed into a powder. Freeze dried krill have a very low moisture content due to the nature of the drying process, exhibit a pale red  
25 color, initially has a mild aroma, but oxidizes quickly to take on a fishy odor and has a flat or oxidized flavor. Protein retention of freeze dried krill is excellent.

Another method of drying krill is air drying wherein the fresh krill is immediately blanched and then dried in trays or ground and spray dried. Obviously with this technique the krill is treated immediately. The resultant product has a high  
30 moisture content (greater than about 12%), may be in whole or broken form if tray dried or in powder form if spray dried, has a yellow to pale red color, very mild weak aroma and little flavor. Blanching and air drying of krill significantly reduces its protein content.

It will be apparent that the dried product formed by either of the two methods is not high quality in that the color aroma and flavor, which are some of the most important characteristics of the product have been significantly deteriorated.

### **Brief description of the Invention**

5 It is the main object of the invention to provide a new dried krill product that has a natural red color, is largely unbroken, has a strong, desirable characteristic odor and good taste and to provide a method and apparatus for producing same.

Broadly the present invention relates to a dried krill product comprising a plurality of substantially separate whole dried krill carcasses substantially all of which  
10 have a natural red color and sufficient strength and integrity to withstand normal handling without crumbling into small pieces and retain a strong wholesome fish aroma and flavor.

The present invention also relates to a method and apparatus for producing dried krill products in the form of whole but separate carcasses comprising arranging  
15 raw krill in an at least partially separated arrangement in a microwave transparent carrier, partially drying said raw krill to provide a partially dried product substantially free of surface moisture but containing a first amount of unbound moisture within its structure, heating said partially dried product by means of electromagnetic radiation, subjecting said partially dried predate to a reduced pressure below atmospheric  
20 pressure during at least a portion of a period of time in which said product is subjected to electromagnetic radiation coordinated to provide a heated dried product containing unbound within its structure a second amount of moisture sufficient to generate flexibility and strength in the product, such that the form of whole krill is maintained during the drying process and subjecting said krill to a tumbling action during said  
25 partially drying and said heating by means of electromagnetic energy.

Preferably said partially drying includes defrosting said raw krill prior to said heating said partially dried product by means of electromagnetic radiation,

Preferably said subjecting to reduce pressure below atmospheric pressure includes sweeping surfaces of said product with moisture unsaturated air.

30 Preferably said below atmospheric pressure will be less than 120 Torr preferably less than 100 Torr and said pressure will be attained in less than 2 minutes preferably less than 1.7 minutes.

Preferably said second amount of moisture comprises between 10 and 40 % by weight of the separate dried product.

Preferably said dried product will be at a temperature of between 40 and 90 °C

Preferably said electromagnetic radiation comprise microwaves

### **Brief Description of the Drawing**

Further features, objects and advantages will be apparent from the detailed  
5 description of the preferred embodiments of the present invention taken in conjunction  
with the accompanying drawing in which;

Fig. 1 is a flow chart of the method of the present invention.

Fig. 2 is a diagram of one embodiment of the apparatus of the present  
invention.

10 Figure 3 is an illustration of a typical whole dried krill carcass as produced  
using the present invention.

### **Description of the preferred Embodiment**

The method of the present invention is suitable for the preparation of dried krill  
and other sea foods for either fresh krill or frozen krill which may be defrosted and  
15 pressed to remove some of the free water. In this description, the term wet product  
shall mean fresh or frozen krill or other sea foods to which the invention may be  
applied for example shrimp, algae, small fish, etc.

The following description will deal primarily with krill, but it is intended that  
the term krill to read where reasonable as any of other similar materials that may be  
20 treated or processed to advantage using the present invention. It will be apparent that  
when a different material is to be dried to provide the dried product the conditions will  
have to be tuned to obtain the desired natural color and high quality in the dried  
product.

As shown Figure 1, initial preparation of fresh or frozen krills as designated by  
25 the box 20 includes the steps of defrosting, if required, and weighting the fresh krill  
and arranging them in or on a microwave transparent carrier such as a basket or the  
like for transport. Preferably the fresh krill will also be treated to drain excess surface  
moisture by a pressing or centrifugation method.

In carrying out the method of the invention as part of the preparation stage 20  
30 of Figure 1 fresh krill are preferably placed in a suitable transport system such as the  
plastic basket drum and, if desired treated with suitable seasoning. If krill was frozen  
before drying, it will preferably be defrosted before drying, although defrosting can be  
achieved in the vacuum microwave chamber during a heating stage, if desired. It is



believed that predrying of previously frozen and defrosted krill enhances the drying rate because some water is removed as drip loss and need not be evaporated.

After such treatment, the treated product is subjected to an initial heating step as indicated at 22 which at least partially dries the krills preferably by application of microwave energy under partial vacuum conditions with reduced oxygen concentration. During this initial heating step 22 water releases from the krill, drips from the baskets 64 (see Figure 2) and is removed from the vacuum chamber 60 (Figure 2) as liquid, through the vacuum pump 88 or through an optional draining system (not shown). The time to complete step 22 depends on the weight of fresh krill in the chamber and microwave power density and is set so that at the end of the initial heating step 22, the moisture content of the krill is about 70 % to 78 % by weight.

The initial heating step 22 is followed by a moisture separation and surface drying step 24, wherein a high intensity microwave field (more than about 0.6 kW/kg of krill) is applied. The intensity of the field in step 24 is preferably selected to raise the temperature of the krill to about 60 °C in about 10 minutes, thereby to rapidly convert a major portion of the moisture within the krills into a heated vapor. While typically raw krill have a moisture content of approximately 80 % by weight and it is slightly reduced to about 70 to 78 % in step 22, the expose of the krills to the high intensity microwave field in the moisture separation and drying at 24 applies sufficient heat to heat the krill the required temperature to substantially prevent enzyme reaction and also to reduce the moisture content, yet not so high as to damage the krill. The separation and surface drying step 24 is carried out preferably at a pressure of about 80 to 120 Torr and a temperature of about 47 °C to 55 °C. The drying step 24 may take up to about 15 minutes.

In the preferred embodiment of the present invention, total moisture content of the krill leaving the stage 24 is about 60 % to 75 % by weight of the krills with desired optimum of about 73 %.

The separation and surface drying step 24 serves to vaporize a substantial portion of the tissue moisture and flush the water vapor out of the chamber. It also serves to dry the shell surface of the krill, thereby allowing the subsequent bulk water drying step 26 of the present invention.

If the krill are insufficiently dried in the separation and surface drying step 24, the shell of the krill will be sticky and the krill will tend to form a ball if placed together in a revolving basket.

Air flow rates for these air currents in step 24 are preferably between about  
5  $2.8 \times 10^{-5}$  and  $5.6 \times 10^{-5}$  m<sup>3</sup>/kg.s fresh krill. Because a larger amount of moisture escapes from the krill during expose to the high intensity microwave field, the air injection method preferably is used to minimize condensation within the chamber. Such condensation would decrease the amount of microwave energy available for heating and drying krill because the condense again absorbs microwave energy in the chamber,  
10 is vaporized and may again condense on the chamber wall. This is called the "heat pump effect" and it greatly reduces microwave energy usage efficiency and increases the processing time if not minimized or prevented.

Next the partially dried krill are subjected to a bulk water drying step as indicated at 26 wherein further moisture is preferably removed by evaporation under  
15 below atmospheric pressure conditions and the use of air jets which spray dry air over the partially dried krill product i.e. the product is swept by air currents which pick up moisture from the surface of the product while it is simultaneously subjected to the application of high intensity microwave energy under below atmospheric pressure conditions.

20 In the bulk water removal step 26 the at least partially dried krill are exposed to a middle intensity microwave field for a period of time to raise their temperature to at least 50 °C within about 10 minutes and under a pressure of about 100 Torr to reduce the moisture content of krill to about 65 % to 30 % by weight. The temperature of krill is higher because in part of the increased mass flow resistance of the krill surface  
25 increases the vapor pressure inside the krill body thereby effecting the vapor temperature by thermodynamic relationship between vapor pressure and temperature

The intensity of the microwave field and the duration of exposure is coordinated with the weight of fresh krill to achieve the desired dehydration and heating rates.

30 Preferably heat is being applied in the stage 22 and the separation and surface drying and bulk water removing steps 24 and 26 are carried out in the same closed vessel.

Obviously any step requiring pressure and/or a controlled atmosphere other than atmospheric must be carried out in some form of closed container which in some stages must also contain microwave energy when used. Where such conditions are not applied the krill need not to be so contained.

5           After a bulk removal step 26, the substantially dehydrated krill are finish dried in end drying step 28 to the desired moisture content by applying a low microwave intensity (about 0.4 kW/kg krill), high vacuum (less than 80 Torr) and a low air injection flow rate e.g.  $2.8 \times 10^{-5}$  m<sup>3</sup>/kg.s. If desired, this end drying step 28 may alternatively be achieve using hot air drying at elevated temperature about 45 °C and at  
10 atmosphere air pressure, but finish drying in a conventional air dryer or oven is slower. With either option after end drying in step 28 the resultant product is a dried krill composed of substantially whole carcasses with natural red color, a moisture content of about 10 % to 15 % by weight and retaining its wholesome seafood aroma and flavor.

15           The krill is subjected to a tumbling action applied thereto by rotation of the basket or the like in which it is contained during the stages or steps 22, 24, 26 and 28 to facilitate the escape of moisture from the load of krill, permit more uniform drying and to impede the individual krill from sticking together.

          The dried krill product so produced is shown in Figure 3 and will consist  
20 mainly of whole krill 40 and a significant portion of krill pieces similar to those shown at 42, and will not contain a substantial amount of powdered krill.

          Turning to Figure 2, equipment for carrying the process of the present invention is illustrated schematically. The equipment includes a microwave and vacuum chamber 60 having an inlet door 62. The krill product in suitable, substantially  
25 cylindrical shaped (for rotation within the chamber 60 as will be described below) containers (baskets) 64 of is delivered to the chamber 60. The baskets 64 are substantially right cylindircal containing the product are introduced into the chamber 60 at the appropriate point in the process (depending on where microwave power is to be first applied, for example to defrost frozen krill) and are sealed within the chamber  
30 60 for the application of energy, reduced pressure and sweeping of surfaces with dry air as described above.

The microwave energy is provided in the illustrated system by three magnetrons 70, 72 and 74 which inject the microwaves into the chamber 60 through sealing windows 76, 78 and 80 and hence into the basket(s) 64 within the chamber 60.

5 The baskets 64 are shown supported within the chamber on a rolling system 86 formed by a plurality of horizontal rollers 85 (only one shown) that in turn is preferably supported by a suitable platform 87 on side of which is supported by a load cell 82 which measures the weight in the chamber 60 and delivers this information to the control computer 84. The rolling of the basket 64 during the process applies a tumbling action to the krill.

10 Suitable temperature and pressure gauges schematically indicated at 90 measure the temperature and pressure in the chamber 60 and provide this information to the control computer 84.

Below atmospheric pressure is applied by vacuum pump 88 controlled by computer 84 to reduce ambient pressure within the chamber to the appropriate level, at 15 the appropriate time in the process and air is bled into the chamber 60 at the appropriate times under control of the flow meter 92 which in turn regulates the air flow based on the commands from the computer 84.

After completion of the operation to be carried out in the chamber 60 the baskets 64 are removed through the door 62.

20 Destructive enzyme reactions take place within a few hours at temperatures above freezing, especially when oxygen content is high around the krill and these reactions change the natural red color of fresh krill to black, and also cause a loss of protein content due to enzyme catalyzed hydrolysis during drying. The vacuum condition, the elevated temperature during the initial heating step 22 and the rapid 25 drying rate during steps 24, 26, 28 and 30 substantially prevent these reactions.

**Example 1:**

The frozen krill (*Euphausia pacifica*) are defrosted first and drained of free water. 5.0 kilograms of krill with initial moisture content of 80 % by weight are placed into plastic rolling (cylindrical) basket (Fig. 1) then moved into the microwave vacuum 30 dehydration system 60. High intensity microwave power (above defined), high rate of rotation of the basket on a horizontal axis (4 RPM) and 120 Torr of ambient pressure are used in step 22. There is no air injection flow during the step 22. The temperature of the krill is about 60°C in the initial heating step 22. The chamber

pressure in the step 22 is 100 Torr and the time is 10 minutes. At end of step 22, the moisture content of krill is 78 % by weight.

After the initial heating step 22, the krill are next subjected to a separation and surface drying step 24 wherein high intensity microwave energy is applied. The air injection flow rate is  $5.6 \times 10^{-5}$  m<sup>3</sup>/kg.s with air temperature 20 °C. The chamber pressure in step 24 is 120 Torr. The separation and surface drying step 24 is 15 minutes long. High air flow rate quickly sweeps water vapor out of the chamber and the surface of krill dry without sticking to each other. The moisture content of krill at end of the separation and surface drying step 24 is 74.6 % by weight.

In the bulk water removal step 26 following step 24 the ambient pressure is 100 Torr and air injection flow rate is  $2.8 \times 10^{-5}$  m<sup>3</sup>/kg.s. The rotational speed of basket is 2 RPM. and the temperature of krill is 65 °C. High intensity of microwave is used in this step. At end of step 26, the krill weigh 2.2 kilograms with moisture content of 63 % by weight. End drying step drying step 28 was finished by air dryer in this example.

The final krill product after above treatment has a natural red color which was measured by LabScan Color Meter (Hunter Associate Laboratory, Inc.), L = 30.92, a = 12.94, and b = 6.81. The protein content of dried krills is about 54 % by weight. The final moisture content is 12% by weight.

### **Example 2:**

Following the flow chart in Fig. 1, the six kilograms of fresh krill with initial moisture content of 77 % by weight are placed into plastic cylindrical basket then moved in microwave vacuum dehydration system in the pre-treatment step 20. The initial heating step 22 following step 20 applies high intensity microwave energy (0.6 kW/kg krill), high rotation rate (4 RPM) and 15.95 kPa (120 Torr) of ambient pressure. No air injection is used in the step 22. The temperature of krill is 60 °C in the initial heating step 22 and heating time is 10 minutes long. At end of the step 22, the krill weigh is reduced to 4.38 kilograms and the moisture content is 70 % by weight.

High intensity microwave energy (0.65 kW/kg.krill), high rotation speed (4 RPM), high air injection flow rate,  $5.6 \times 10^{-5}$  m<sup>3</sup>/kg.s, and 15.95 kPa absolute (120 Torr) ambient pressure are applied in surface drying step 24 after the step 22. The surface of krill is dried quickly. At end of separation drying step 24, the krill are separated from each other and krill surfaces are more dry than inside the body. The

drying time during the separation and drying step 24 is ten minutes. The weight of krill at end of the step 24 is 3.5 kg with 62 percent of moisture content by weight.

In the bulk water removal step 26 following the step 24 the ambient pressure is 13.28 kPa and air injection flow rate is  $2.8 \times 10^{-5}$  m<sup>3</sup>/kg.s. The rotational speed of the plastic basket is 2 RPM. The moisture content of krill at end of bulk water removal step 26 is 35 % by weight and the total weight of krill is reduced to 2.04 kilograms. Time is 45 minutes from the beginning of drying.

After the bulk water removal step 26, krill are finish dried in low intensity, high vacuum and low air current injection rate, in the finish drying step 28, i.e. 0.4 kW per kilogram of krill, 10.63 kPa ambient pressure,  $2.8 \times 10^{-5}$  m<sup>3</sup>/kg.s of air injection flow rate (air temperature is 20°C) and the basket is revolving at one RPM. The duration of the finish drying step 28 is 20 minutes. The dehydrated krill leaving the step 28 has a weight of 1.48 kilograms with a moisture content of 11.5 % by weight. The color of the dried krill product was measured by LabScan Color Meter (Hunter Association Laboratory, Inc.). The results of measure are L = 33.16, a = 16.36 and b = 6.81. The protein content was about the same as the last example.

Having described the invention modifications will be evident to those skilled in the art without departing from the invention as defined in the appended claims.

We claim

1. A dried krill product comprising a plurality of substantially separate whole dried krill carcasses substantially all of which have a natural red color and sufficient strength and integrity to withstand normal handling without crumbling into small pieces and retain a strong wholesome fish aroma and flavor.  
5
2. A method for producing dried krill products in the form of whole but separate carcasses comprising arranging raw krill in an at least partially separated arrangement in a microwave transparent carrier, partially drying said raw krill to provide a partially dried product substantially free of surface moisture but containing a first amount of unbound moisture within its structure, heating said partially dried product by means of  
10 electromagnetic radiation, subjecting said partially dried product to a reduced pressure below atmospheric pressure during at least the portion of a period of time in which said product is subjected to electromagnetic radiation to provide a heated dried product containing unbound within its structure a second amount of moisture sufficient  
15 to generate flexibility and strength in the product, such that the form of whole krill is maintained during the drying process, and subjecting said krill to a tumbling action during said partial drying and said heating by electromagnetic radiation.
3. A method as defined in claim 2 wherein said partially drying includes defrosting said raw krill prior to heating said partially dried product by means of electromagnetic  
20 radiation.
4. A method as defined in claim 2 wherein said subjecting said partially dried product to reduce pressure below atmospheric pressure includes sweeping surfaces of said product with moisture unsaturated air.
5. A method as defined in claim 2, 3 or 4 wherein said second amount of moisture  
25 comprises between 10 and 40 % by weight of the dried product.
6. A method as defined in claim 2, 3 or 4 wherein said pressure below atmospheric pressure is less than 120 Torr and said pressure is attained in less than 2 minutes.
7. A method as defined in claim 2, 3 or 4 wherein said pressure below  
30 atmospheric pressure is less than 100 Torr and said pressure is attained in less than 1.7 minutes.
8. A method as defined in claim 2, 3 or 4 wherein said dried product is heated to a temperature of between 40 and 90 °C.

9. A method as defined in claim 2, 3 or 4 wherein said electromagnetic radiation comprise microwaves.



1/3

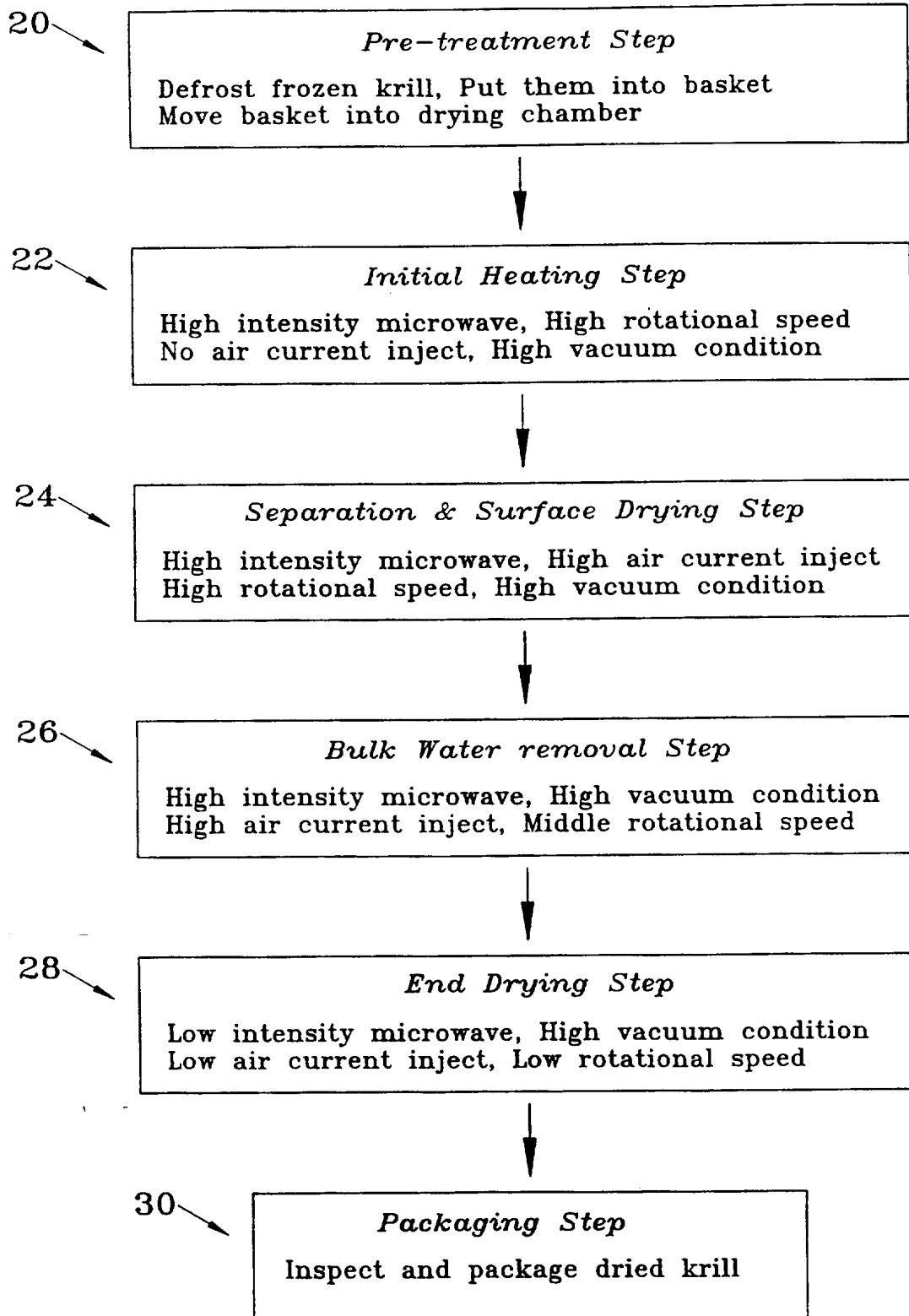


Figure 1

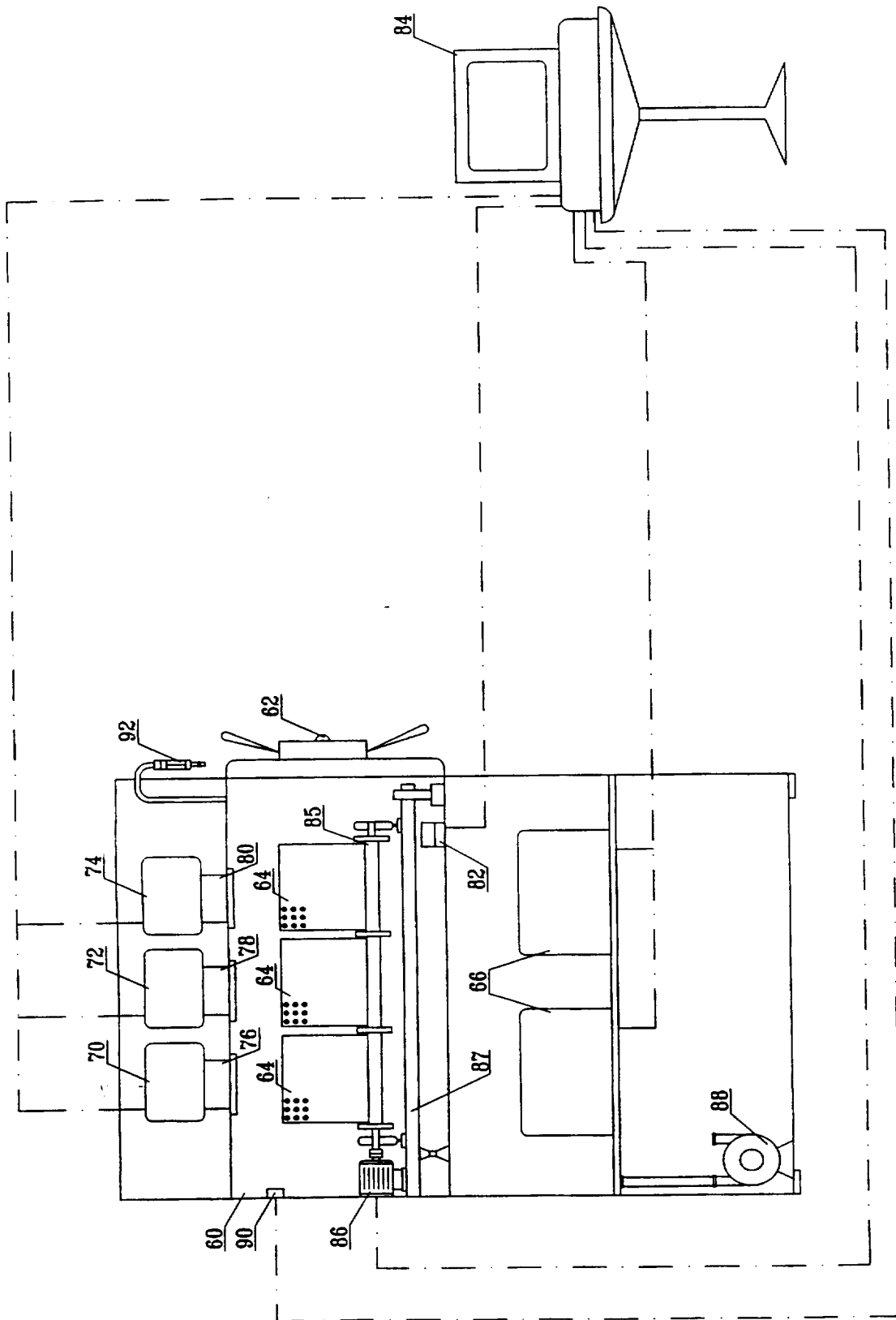


Figure 2

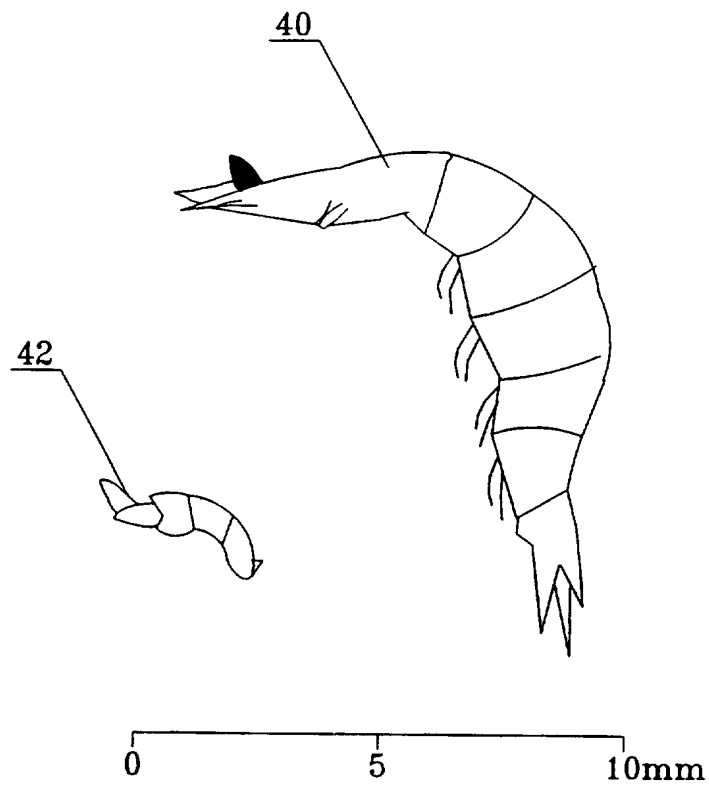


Figure 3

SUBSTITUTE SHEET (RULE 26)

# INTERNATIONAL SEARCH REPORT

International Application No  
PCT/CA 97/00238

A. CLASSIFICATION OF SUBJECT MATTER  
IPC 6 A23B4/03

According to International Patent Classification (IPC) or to both national classification and IPC

B. FIELDS SEARCHED

Minimum documentation searched (classification system followed by classification symbols)  
IPC 6 A23B

Documentation searched other than minimum documentation to the extent that such documents are included in the fields searched

Electronic data base consulted during the international search (name of data base and, where practical, search terms used)

C. DOCUMENTS CONSIDERED TO BE RELEVANT

Category *	Citation of document, with indication, where appropriate, of the relevant passages	Relevant to claim No.
X	GB 1 112 438 A (D. J. GODSON) 8 May 1968  see claims 1-8; example 2 ---	1,2,4,5, 8,9
A	US 5 467 694 A (MEIJI SEIKA) 21 November 1995 see column 1, line 13 - line 16; figures see column 2, line 11 - line 16 ---	1
A	CA 2 118 159 A (PRAWNTO SHRIMP MACHINE) 7 December 1995 see the whole document ---	1
A	PATENT ABSTRACTS OF JAPAN vol. 11, no. 63 (C-406), 26 February 1987 & JP 61 224966 A (AKABOSHI RYOICHI ET AL.), 6 October 1986, see abstract ---	1
-/--		

Further documents are listed in the continuation of box C.

Patent family members are listed in annex.

\* Special categories of cited documents :

- \*A\* document defining the general state of the art which is not considered to be of particular relevance
- \*E\* earlier document but published on or after the international filing date
- \*L\* document which may throw doubts on priority claim(s) or which is cited to establish the publication date of another citation or other special reason (as specified)
- \*O\* document referring to an oral disclosure, use, exhibition or other means
- \*P\* document published prior to the international filing date but later than the priority date claimed

- \*T\* later document published after the international filing date or priority date and not in conflict with the application but cited to understand the principle or theory underlying the invention
- \*X\* document of particular relevance; the claimed invention cannot be considered novel or cannot be considered to involve an inventive step when the document is taken alone
- \*Y\* document of particular relevance; the claimed invention cannot be considered to involve an inventive step when the document is combined with one or more other such documents, such combination being obvious to a person skilled in the art.
- \*&\* document member of the same patent family

Date of the actual completion of the international search

12 August 1997

Date of mailing of the international search report

10.09.97

Name and mailing address of the ISA

European Patent Office, P.B. 5818 Patentlaan 2  
NL - 2280 HV Rijswijk  
Tel. (+31-70) 340-2040, Tx. 31 651 epo nl,  
Fax (+31-70) 340-3016

Authorized officer

Guyon, R

# INTERNATIONAL SEARCH REPORT

International Application No  
PCT/CA 97/00238

C.(Continuation) DOCUMENTS CONSIDERED TO BE RELEVANT

Category *	Citation of document, with indication, where appropriate, of the relevant passages	Relevant to claim No.
A	PATENT ABSTRACTS OF JAPAN vol. 13, no. 211 (C-597), 17 May 1989 & JP 01 030562 A (TAGUCHI YUKITOSHI), 1 February 1989, see abstract  ---	1
A	 GB 1 025 959 A (UNILEVER) 14 April 1966 see claims 1-4,9  -----	1

1

# INTERNATIONAL SEARCH REPORT

Information on patent family members

International Application No <b>PCT/CA 97/00238</b>
--

Patent document cited in search report	Publication date	Patent family member(s)	Publication date
GB 1112438 A		NONE	
US 5467694 A	21-11-95	JP 7274922 A GB 2288718 A,B	24-10-95 01-11-95
CA 2118159 A	07-12-95	NONE	
GB 1025959 A		NONE	



INTERNATIONAL APPLICATION PUBLISHED UNDER THE PATENT COOPERATION TREATY (PCT)

<p>(51) International Patent Classification <sup>6</sup> : <b>A61K 33/14, 31/66, 31/20</b></p>	<p><b>A2</b></p>	<p>(11) International Publication Number: <b>WO 97/39759</b> (43) International Publication Date: 30 October 1997 (30.10.97)</p>
<p>(21) International Application Number: PCT/US97/06712 (22) International Filing Date: 23 April 1997 (23.04.97) (30) Priority Data: 60/016,140 24 April 1996 (24.04.96) US (71) Applicant (for all designated States except US): BRIGHAM AND WOMEN'S HOSPITAL [US/US]; 75 Francis Street, Boston, MA 02115 (US). (72) Inventors; and (75) Inventors/Applicants (for US only): STOLL, Andrew, L. [US/US]; 35 Old Winter Street, Lincoln, MA 01773 (US). SEVERUS, Wolfram, E. [DE/DE]; Badensche Strasse 7, D-10825 Berlin (DE). (74) Agent: SANZO, Michael, A.; Vinson &amp; Elkins, 1455 Pennsylvania Avenue, N.W., Washington, DC 20004 (US).</p>		<p>(81) Designated States: AU, CA, JP, US, European patent (AT, BE, CH, DE, DK, ES, FI, FR, GB, GR, IE, IT, LU, MC, NL, PT, SE).  <b>Published</b> <i>Without international search report and to be republished upon receipt of that report.</i></p>
<p>(54) Title: OMEGA-3 FATTY ACIDS AND OMEGA-3 PHOSPHATIDYLCHOLINE IN THE TREATMENT OF BIPOLAR DISORDER</p>		
<p>(57) Abstract</p> <p>The present invention is directed to a method of treating patients with bipolar disorder by administering omega-3 fatty acids. These may be administered in a substantially purified form, as part of a pharmaceutical composition, or as part of a larger molecule, e.g. a triacylglycerol, which releases free fatty acid after ingestion by a patient. The present invention is also directed to triacylglycerols which are esterified at the gamma carbon of glycerol to phosphocholine and at either the alpha or beta carbon of glycerol to an omega-3 fatty acid. These "omega-3 phosphatidylcholines" are also used in the treatment of patients with bipolar disorder.</p>		

**FOR THE PURPOSES OF INFORMATION ONLY**

Codes used to identify States party to the PCT on the front pages of pamphlets publishing international applications under the PCT.

AL	Albania	ES	Spain	LS	Lesotho	SI	Slovenia
AM	Armenia	FI	Finland	LT	Lithuania	SK	Slovakia
AT	Austria	FR	France	LU	Luxembourg	SN	Senegal
AU	Australia	GA	Gabon	LV	Latvia	SZ	Swaziland
AZ	Azerbaijan	GB	United Kingdom	MC	Monaco	TD	Chad
BA	Bosnia and Herzegovina	GE	Georgia	MD	Republic of Moldova	TG	Togo
BB	Barbados	GH	Ghana	MG	Madagascar	TJ	Tajikistan
BE	Belgium	GN	Guinea	MK	The former Yugoslav Republic of Macedonia	TM	Turkmenistan
BF	Burkina Faso	GR	Greece			TR	Turkey
BG	Bulgaria	HU	Hungary	ML	Mali	TT	Trinidad and Tobago
BJ	Benin	IE	Ireland	MN	Mongolia	UA	Ukraine
BR	Brazil	IL	Israel	MR	Mauritania	UG	Uganda
BY	Belarus	IS	Iceland	MW	Malawi	US	United States of America
CA	Canada	IT	Italy	MX	Mexico	UZ	Uzbekistan
CF	Central African Republic	JP	Japan	NE	Niger	VN	Viet Nam
CG	Congo	KE	Kenya	NL	Netherlands	YU	Yugoslavia
CH	Switzerland	KG	Kyrgyzstan	NO	Norway	ZW	Zimbabwe
CI	Côte d'Ivoire	KP	Democratic People's Republic of Korea	NZ	New Zealand		
CM	Cameroon			PL	Poland		
CN	China	KR	Republic of Korea	PT	Portugal		
CU	Cuba	KZ	Kazakstan	RO	Romania		
CZ	Czech Republic	LC	Saint Lucia	RU	Russian Federation		
DE	Germany	LI	Liechtenstein	SD	Sudan		
DK	Denmark	LK	Sri Lanka	SE	Sweden		
EE	Estonia	LR	Liberia	SG	Singapore		



## **Omega-3 Fatty Acids and Omega-3 Phosphatidylcholine in the Treatment of Bipolar Disorder**

---

### *Field of the Invention*

The present invention relates to medical treatments for psychiatric disorders. More specifically, it is concerned with novel methods and compositions for treating patients with bipolar disorder.

### *Background of the Invention*

Patients with bipolar disorder suffer recurrent, alternating cycles of mania and depression. In a controlled clinical study performed more than a decade ago, it was reported that lecithin (phosphatidylcholine) has anti-manic properties when administered to such patients (Cohen *et al.*, *Am. J. Psychiatry* 139:1162-1164 (1982); see also Cohen *et al.*, *Am. J. Psychiatry* 137:242-243 (1980); Schreier, *Am. J. Psychiatry* 139:108-110 (1982)). More recent reports, have suggested that the beneficial effects observed for lecithin are due primarily to the metabolic release of free choline (Stoll *et al.*, *Biol. Psychiatry* 37:170-174 (1995)).

Although effective in reducing mania, lecithin is not widely used in treating bipolar patients. One of the main reasons for this is that 15-30 grams of lecithin per day must typically be given to a patient in order to obtain a beneficial effect and the intake of such a large quantity of lipid would, over time, tend to promote cardiovascular disease. An ideal solution to this problem would be to administer a therapeutic agent that has the same beneficial effect as lecithin in controlling mania but which does not have the same adverse effect with respect to cardiovascular disease.

The present invention is directed to phosphatidylcholines in which the  $\alpha$  or  $\beta$  carbon of glycerol is esterified to an omega-3 fatty acid. These fatty acids are unique among dietary fats in that they inhibit thrombosis and platelet aggregation and can lower blood pressure (see Dimmitt, *Clin. Exp. Pharmacol. Physiol.* 22:204-208 (1995)). Thus, the "omega-3 phosphatidylcholines" disclosed herein produce the same effects as lecithin in bipolar patients due to the release of free choline but reduce, rather than increase, the risk that a patient will suffer a stroke or coronary thrombosis.

In addition, the present invention is directed to a method of treating bipolar disorder using omega-3 fatty acids themselves, *i.e.* apart from phosphatidylcholine. These may be administered in a purified state, as part of a composition containing other therapeutic agents or

-2-

as part of another compound, e.g. a triacylglycerol, which is metabolized to release free fatty acid *in vivo*.

### *Summary of the Invention*

An evaluation of mood stabilizing agents indicates that all such agents presently used to treat bipolar patients have an inhibitory effect on neuronal signal transduction systems. The present invention is based, in part, upon this discovery and the upon the recognition that omega-3 fatty acids are useful in treating pathological conditions involving excessive cell signal transduction (see e.g., Sperling, *Rheum. Dis. Clinics* 17 (1991); Sperling, *et al.*, *J. Clin. Invest.* 91:651-660 (1993)).

Thus, a method has been developed for treating a human patient for bipolar disorder by administering omega-3 fatty acids at a dosage sufficient to reduce or eliminate the symptoms associated with the disorder, i.e. at a dosage sufficient to reduce the frequency of mood fluctuations or lessen the severity of the mania or depression experienced by such patients. The omega-3 fatty acids should be administered at a dosage of between about 1 and about 30 grams per day. The two most preferred omega-3 fatty acids are eicosapentanoic acid and docosahexanoic acid and these should typically be administered at daily dosages of 2-10 grams and 1-5 grams respectively. The fatty acids may be administered as the sole therapeutic agent or in conjunction with other agents known to be useful in the treatment of bipolar patients. In particular, the fatty acids may be administered either with a source of lithium or choline. In addition, omega-3 fatty acids may be taken by patients as a component of another molecule, e.g. a triacylglycerol, and be metabolically released after ingestion.

The present invention is also directed to an omega-3 phosphatidylcholine useful in the treatment of bipolar disorder, consisting of glycerol esterified at both its  $\alpha$  and  $\beta$  carbons to fatty acids. At least one, and preferably both, of these fatty acids is an omega-3 fatty acid and the  $\gamma$  position of the glycerol must be esterified to phosphocholine. It is preferred that at least one of the esterified fatty acids be either eicosapentanoic acid or docosahexanoic acid. Omega-3 phosphatidylcholines with eicosapentanoic acid esterified to the  $\alpha$  carbon and docosahexanoic acid esterified to the  $\beta$  carbon and vice versa are the most preferred. In all cases, the  $\gamma$  position of the triacylglycerol is esterified to phosphocholine.

-3-

In another aspect, the present invention is directed to a pharmaceutical composition comprising one or more of the omega-3 phosphatidylcholines discussed above. The composition should contain sufficient triacylglycerol so that one or more unit doses provides enough agent to reduce or eliminate the symptoms associated with bipolar disorder. In some instances, lithium may be also incorporated into the composition in order to improve therapeutic effects.

5 The present invention is also directed to a method for treating bipolar disorder in a human patient by administering an omega-3 phosphatidylcholine. It is expected that this phosphatidylcholine will typically be administered at a dosage sufficient to provide between 1 and 30 (preferably between 2 and 8) grams of free omega-3 fatty acid to the patient. Again, administration may be carried out concurrently with the administration of other therapeutic agents such as lithium.

### *Detailed Description of the Invention*

In the following description, reference will be made to various methodologies well-known to those skilled in the art of medicine and pharmacology. Such methodologies are described in standard reference works setting forth the general principals of these disciplines. Included among the relevant references are: Goodwin, F.K. and Jamison, K.R., Manic Depressive Illness, Oxford University Press (1990); and Bloom, F. and Kupfer, D., Psychopharmacology. The Fourth Generation of Progress, Raven Press (1994).

#### **A. Definitions**

20 Bipolar disorder: Bipolar disorder refers to a form of psychosis characterized by abnormally severe mood swings. The patient alternates between episodes of mania and episodes of depression.

Omega-3 fatty acids: Fatty acids are long chain aliphatic molecules beginning with a methyl group and ending with a carboxyl group. Omega-3 fatty acids contain a double bond in the third position from the methyl group. Two common, long chain omega-3 fatty acids are eicosapentanoic acid (20 carbons in length) and docosahexanoic acid (22 carbons in length). These are both found in fish oils

-4-

**Triacylglycerol:** Compounds in which the carboxyl groups of fatty acids are esterified to the hydroxyls of all three carbons found in glycerol are referred to as triacylglycerols or triglycerides. Triacylglycerols in which the terminal carbon of glycerol (the " $\gamma$  carbon") is esterified to phosphocholine are called phosphatidylcholines. The next carbon in the glycerol is referred to herein as the " $\beta$  carbon" and the following carbon is referred to as the " $\alpha$  carbon."

**Omega-3 phosphatidylcholine:** As used herein the term "omega-3 phosphatidylcholine" refers to a triacylglycerol in which the  $\gamma$  carbon of glycerol is esterified to phosphocholine and at least one of the other carbons of glycerol is esterified to an omega-3 fatty acid.

**Choline:** Choline (hydroxyethyl trimethyl ammonium hydroxide) is considered to be a vitamin of the B complex and is derivable from many foods. Unless otherwise indicated, the term "choline" as used herein, refers not only to the isolated choline molecule (*i.e.* free choline) but also to any biologically compatible salt of choline (*e.g.*, choline bitartrate).

**Lithium:** Unless otherwise indicated, the term "lithium" refers to any salt containing lithium as the cationic component.

## **B. Method of Treating Patients For Bipolar Disorder Using Omega-3 Fatty Acids**

The present invention is directed to a method for treating human patients for bipolar disorder by administering omega-3 fatty acids. Although the method is not restricted to any one particular type of omega-3 fatty acid, it is preferred that eicosapentanoic acid (EPA) or docosahexanoic acid (DHA) be used. Both EPA and DHA are found in a variety of fish oils and are commercially available in an essentially pure form.

### *Dosage*

The total daily dosage of omega-3 fatty acid administered to a human patient should be at least the amount required to reduce or eliminate the symptoms associated with bipolar disorder. Specifically, the dosage should be high enough to either reduce the severity of the manic and depressive episodes experienced by patients or decrease the frequency at which such episodes occur. Physicians may begin by administering relatively small doses of omega-3 fatty acid (*e.g.* 1 gram per day) and then adjust the dosage upward as it becomes clear that the patient can tolerate the treatment. The final daily dosage should be between 1 and 30 grams of fatty acid

-5-

per day with typical doses ranging between 2 and 10 grams per day. Dosages may be provided in either a single or multiple dosage regiment.

These are simply guidelines since the actual dose must be carefully selected and titrated by the attending physician based upon clinical factors unique to each patient. The optimal daily dose will be determined by methods known in the art and will be influenced by factors such as the age of the patient and other clinically relevant factors. In many cases, a patient will already be taking medications for the treatment of bipolar disorder at the time that treatment with omega-3 fatty acid is initiated. In addition, patients may be taking medications for other diseases or conditions. The other medications may be continued during the time that omega-3 fatty acid is given to the patient but it is particularly advisable in such cases to begin with low doses to determine if adverse side effects are experienced.

#### *Dosage Forms and Route of Administration*

The present invention is not limited to any particular dosage form or route of administration. Oral administration will generally be most convenient, however, the invention is compatible with parenteral, transdermal, sublingual, buccal or implantable routes of administration as well.

Omega-3 fatty acids may be given in a substantially purified form or as part of a pharmaceutical composition containing one or more excipients or flavoring agents. Compositions may also include other active ingredients for the treatment of bipolar disorder, e.g. lithium. Preparations may be solid or liquid and take any of the pharmaceutical forms presently used in human medicine, e.g. tablets, gel capsules, granules, suppositories, transdermal compositions or injectable preparations.

The active ingredient or ingredients may be incorporated into dosage forms in conjunction with any of the vehicles which are commonly employed in pharmaceutical preparations, e.g. talc, gum arabic, lactose, starch, magnesium searate, cocoa butter, aqueous or non-aqueous solvents, oils, paraffin derivatives or glycols. Emulsions such as those described in U.S. 5,434,183, may also be used in which vegetable oil (e.g., soybean oil or safflower oil), emulsifying agent (e.g., egg yolk phospholipid) and water are combined with glycerol. Fatty acids may be incorporated into preparations either in the form of the free acid or as a pharmaceutically acceptable salt. Methods for preparing appropriate formulations are

-6-

well known in the art (*see e.g.*, Remington's Pharmaceutical Sciences, 16th Ed., A. Oslo Ed., Easton, PA (1980)).

#### *Manner of Treatment*

In order to determine the effect of administered omega-3 fatty acid on mood alteration, patients should be evaluated on a regular basis over an extended period of time, *e.g.* 1 to 4 weeks. One good manner of carrying out evaluations is for patients to keep a daily diary in which they chart their moods. For example, patients may keep a daily record in which they rate their best and worst moods as either normal, mildly, moderately or severely depressed; and mildly, moderately, or severely manic. These records should help the patient and their physician determine if moods fluctuate less frequently or become less extreme in intensity. Ideally, such a diary should be kept both before and after the administration of omega-3 fatty acid is begun. The evaluation of mood alterations by the patient should also be supplemented with periodic clinical evaluations carried out by a physician.

In some cases, the evaluation discussed above may indicate that mood fluctuations have become so stabilized in a patient as the result of administering omega-3 fatty acid at the initial concentration that no further adjustment in dosage is necessary. In other cases, the dosage of omega-3 fatty acid may be increased in order to obtain a more efficacious result. In general, dosage should not be increased beyond the point at which further stabilization of mood alteration is observed. If adverse side effects are experienced by patients, then dosages may be adjusted in a downward direction accordingly.

The process of adjusting dosage in an upward or downward direction and evaluating the effect of the adjustment on mood changes should be continued until an optimum dosage is discovered, *i.e.* the dosage at which the patient experiences the best balance between therapeutic effectiveness and discomfort due to side effects. In cases where adverse side effects are not experienced, the optimal dosage is the lowest dose resulting in maximum stabilization of mood fluctuation.

Omega-3 fatty acids may be used in combination with other agents effective at treating bipolar disorder, *e.g.* lithium or choline. These other agents may either be given together with omega-3 fatty acid in a single dosage form or they may be administered separately. Choline should be administered at an initial dose of about 50 mg of free choline per kg of body weight

-7-

supplied either as a single unit dose or, preferably, divided into multiple doses during the day. The choline may be administered either as a free base or in the form of a pharmaceutically acceptable salt. The final dosage of choline should typically be between about 2 and about 8 grams of free choline per day.

5 Patients taking lithium should continue taking the drug during the time at which choline and/or omega-3 fatty acid treatment is begun. Optimal dosages for each of the drugs may then be determined sequentially. For example, choline administration may be initiated and then optimized followed by the initiation and optimization of omega-3 fatty acid treatment. The problem of adjusting the dosages of multiple therapeutic agents is one that is routinely  
10 encountered by physicians and can be solved using well-established procedures similar to those discussed herein.

#### *Kits*

Individual preparations containing omega-3 fatty acid and other therapeutic agents for bipolar disorder, such as choline or lithium, may be provided in the form of a kit, comprising  
15 a carrier (*e.g.* a box or bag) compartmentalized to receive one or more components (bottles, vials, packets, etc.) in close confinement. Such a kit will be carried by patients with bipolar disorder and will typically contain written instructions concerning the way in which the enclosed drugs should be taken, potential side effects, etc. The kit should be portable, and be generally convenient for use by patients.

#### 20 C. Omega-3 Phosphatidylcholines

The present invention is also directed to omega-3 phosphatidylcholines in which glycerol is esterified at its  $\gamma$  carbon to phosphocholine and at least one of the fatty acids esterified to either the  $\alpha$  or  $\beta$  carbons is an omega-3 fatty acid. It is preferred that *both* the  $\alpha$  carbon and  $\beta$  carbon of glycerol be esterified to an omega-3 fatty acid, with the preferred fatty acids being  
25 EPA and DHA. The most preferred phosphatidylcholines contain both DHA and EPA, one esterified at the  $\alpha$  carbon of glycerol and the other at the  $\beta$  carbon.

The phosphatidylcholines of the present invention may be synthesized using standard techniques well known in the art, see *e.g.* U.S. No. 4,701,468. One suitable method is to synthesize the "omega-3 phosphatidylcholines" from commercially available precursor lyso-

-8-

phosphatidylcholines. Specifically, a lyso-phosphatidylcholine is acylated by combining the desired omega-3 fatty acid anhydride (*e.g.* from EPA or DHA) and 4-pyrrolidinopyridine as a catalyst (1.2 equivalents) in alcohol-free chloroform. Depending on the reaction conditions and the relative proportions of fatty acid, several different omega-3 phosphatidylcholine species will be generated. Using EPA and DHA, four major species will occur: dieicosapentanoylphosphatidylcholine, didocosahexanoylphosphatidylcholine, 1-eicosapentanoyl, 2-docosahexanoylphosphatidylcholine, and 1-docosahexanoyl, 2-eicosapentanoylphosphatidylcholine. The specific phosphatidylcholines of interest may then be isolated by well-established chromatographic methods.

#### 10           **D.    Method of Treating Bipolar Disorder Using Omega-3 Phosphatidylcholines**

The omega-3 phosphatidylcholines described above may be used for treating humans with bipolar disorder in the same manner and following the same procedures as those discussed in connection with omega-3 fatty acids. The phosphatidylcholines may be given in a substantially purified form or as part of a pharmaceutical composition, It is expected that optimized dosages will have sufficient omega-3 phosphatidylcholine to deliver between about one and about 30 grams of free omega-3 fatty acid per day, with the preferred daily dose being between 1 and 10 grams. Patients should keep diaries of daily mood fluctuations and be evaluated by a physician on a regular basis to determine the effect of treatment. Based upon such evaluations dosages may be increased or decreased as needed.

As with omega-3 fatty acids, the omega-3 phosphatidylcholines may be delivered by any route and are compatible with any dosage form. Oral dosage forms such as tablets, capsules, powder packets and liquid solutions will generally be preferred. Therapeutically inert agents may be added to improve the palatability of preparations and additional therapeutic agents may be included. It will be appreciated that one particularly attractive composition would include both a source of lithium as well as omega-3 phosphatidylcholine.

In cases where parenteral administration is elected as the route of administration, preparations containing omega-3 phosphatidylcholine may be provided to patients in combination with pharmaceutically acceptable sterile aqueous or non-aqueous solvents, suspensions or



-9-

emulsions. Examples of non-aqueous solvents are propylene glycol, polyethylene glycol, vegetable oil, fish oil, and injectable organic esters. Aqueous carriers include water, water-alcohol solutions, emulsions or suspensions, including saline and buffered medical parenteral vehicles including sodium chloride solution, Ringer's dextrose solution, dextrose plus sodium chloride solution, Ringer's solution containing lactose, or fixed oils. Intravenous vehicles may include fluid and nutrient replenishers, electrolyte replenishers, such as those based upon Ringer's dextrose, and the like.

Omega-3 phosphatidylcholine and other agents useful in treating bipolar patients, preferably lithium or choline, may be provided as separate components in the form of a kit designed to be carried and used by bipolar patients. The kit would contain written instructions concerning the way in which the enclosed agents should be taken and other pertinent information.

---

All references cited herein are fully incorporated by reference. Having now fully described the invention, it will be understood by those of skill in the art that the invention may be performed within a wide and equivalent range of conditions, parameters and the like, without affecting the spirit or scope of the invention or any embodiment thereof.

-10-

***What is Claimed is:***

1. A method of treating a human patient for bipolar disorder, comprising administering an omega-3 fatty acid to said patient at a dosage sufficient to reduce or eliminate the symptoms of said disorder.
2. The method of claim 1, wherein said omega-3 fatty acid is administered at a dose of between about 1 and about 30 grams per day.
3. The method of claim 1, wherein said omega-3 fatty acid is in a substantially pure form.
4. The method of claim 1, wherein said omega-3 fatty acid is eicosapentanoic acid.
5. The method of claim 4, wherein said eicosapentanoic acid is administered at a dose of between about 2 and about 10 grams per day.
6. The method of claim 1, wherein said omega-3 fatty acid is docosahexanoic acid.
7. The method of claim 6, wherein said docosahexanoic acid is administered at a dose of between about 1 and about 5 grams per day.
8. The method of claim 1, further comprising administering a source of lithium to said patient at a dose sufficient to reduce or eliminate the symptoms of said disorder.
9. The method of claim 1, further comprising administering a source of choline to said patient at a dose effective at reducing or eliminating the symptoms of said disorder.
10. An omega-3 phosphatidylcholine useful in the treatment of bipolar disorder consisting of glycerol, wherein:

-11-

- a) the  $\alpha$  and  $\beta$  carbons of said glycerol are both esterified to a fatty acid, at least one of which is an omega-3 fatty acid; and
- b) the  $\gamma$  carbon of said glycerol is esterified to phosphocholine.

11. The omega-3 phosphatidylcholine of claim 10, wherein both the  $\alpha$  and  $\beta$  carbons of said glycerol are esterified to an omega-3 fatty acid.

12. The omega-3 phosphatidylcholines of either claim 10 or 11, wherein eicosapentanoic acid is esterified to either the  $\alpha$  or  $\beta$  carbon of said glycerol.

13. The omega-3 phosphatidylcholine of either claim 10 or 11, wherein docosahexanoic acid is esterified to either the  $\alpha$  or  $\beta$  carbon of said glycerol.

14. The omega-3 phosphatidylcholine of claim 10, wherein eicosapentanoic acid is esterified to the  $\alpha$  carbon of said glycerol and docosahexanoic acid is esterified to the  $\beta$  carbon of said glycerol.

15. The omega-3 phosphatidylcholine of claim 10, wherein docosahexanoic acid is esterified to the  $\alpha$  carbon of said glycerol and eicosapentanoic acid is esterified to the  $\beta$  carbon of said omega-3 phosphatidylcholines.

16. A pharmaceutical composition comprising the omega-3 phosphatidylcholine of claim 10, wherein one or more unit doses of said composition provides an amount of said omega-3 phosphatidylcholine sufficient to reduce or eliminate the symptoms of said bipolar disorder.

17. The pharmaceutical composition of claim 16, further comprising a source of lithium.

18. A method of treating bipolar disorder in a human patient, comprising administering the omega-3 phosphatidylcholine of claim 10 to said patient at a dose sufficient to reduce or eliminate the symptoms of said disorder.

-12-

19. The method of claim 18, further comprising administering a source of lithium to said patient at a dosage sufficient to reduce or eliminate the symptoms of said disorder.
20. A kit comprising a carrier containing enclosed confinement therein one or more components, wherein:
- a) a first component contains an omega-3 fatty acid; and
  - b) a second component contains a therapeutic agent useful in the treatment of bipolar disorder.
21. The kit of claim 20 wherein:
- a) said first component contains an omega-3 fatty acid selected from the group consisting of eicosapentanoic acid and docosahexanoic acid; and
  - b) said second component is selected from the group consisting of a source of choline and a source of lithium.
22. A kit comprising a carrier containing in close confinement therein, none or more components wherein:
- a) a first component contains an omega-3 phosphatidyl-choline; and
  - b) a second component contains a therapeutic agent useful in the treatment of bipolar disorder.
23. The kit of claim 22, wherein the  $\alpha$  carbon of said glycerol is esterified to eicosapentanoic acid and the  $\beta$  carbon of said glycerol is a esterified to docosa-hexanoic acid.
24. The kit of claim 22, wherein the  $\alpha$  carbon of said glycerol is esterified to docosahexanoic acid and the  $\beta$  carbon of said glycerol is a esterified to eicosapentanoic acid
24. The kit of any one of claims 22-24, wherein said second component is selected from the group consisting of a source of choline and a source of lithium.



INTERNATIONAL APPLICATION PUBLISHED UNDER THE PATENT COOPERATION TREATY (PCT)

<p>(51) International Patent Classification <sup>6</sup> : A23K 1/10, 1/16, 1/18, A23N 17/00, C12N 9/00, A23J 1/04</p>	<p>A1</p>	<p>(11) International Publication Number: <b>WO 98/34498</b>  (43) International Publication Date: 13 August 1998 (13.08.98)</p>
<p>(21) International Application Number: PCT/CA98/00082 (22) International Filing Date: 9 February 1998 (09.02.98)  (30) Priority Data: 2,197,137 7 February 1997 (07.02.97) CA  (71) Applicant (for all designated States except US): BIOZYME SYSTEMS INC. [CA/CA]; 4160 Marine Drive, West Vancouver, British Columbia V7V 1A7 (CA).  (72) Inventors; and (75) Inventors/Applicants (for US only): SAXBY, David, J. [CA/CA]; 4727 South Piccadily, West Vancouver, British Columbia V6Z 2R1 (CA). SPENCE, John, A. [CA/CA]; 2025 Gisby Street, West Vancouver, British Columbia V7V 4N2 (CA). SAXBY, Gregor [CA/CA]; 4727 South Piccadily, West Vancouver, British Columbia V6Z 2R1 (CA). ALOISE, Pedro [CA/CA]; 202-1725 Osoyoos Crescent, Vancouver, British Columbia V6T 1X7 (CA).  (74) Agent: UREN, John, Russell; #202-1590 Bellevue Avenue, West Vancouver, British Columbia V7V 1A7 (CA).</p>		<p>(81) Designated States: AL, AM, AT, AU, AZ, BA, BB, BG, BR, BY, CA, CH, CN, CU, CZ, DE, DK, EE, ES, FI, GB, GE, GH, GM, GW, HU, ID, IL, IS, JP, KE, KG, KP, KR, KZ, LC, LK, LR, LS, LT, LU, LV, MD, MG, MK, MN, MW, MX, NO, NZ, PL, PT, RO, RU, SD, SE, SG, SI, SK, SL, TJ, TM, TR, TT, UA, UG, US, UZ, VN, YU, ZW, ARIPO patent (GH, GM, KE, LS, MW, SD, SZ, UG, ZW), Eurasian patent (AM, AZ, BY, KG, KZ, MD, RU, TJ, TM), European patent (AT, BE, CH, DE, DK, ES, FI, FR, GB, GR, IE, IT, LU, MC, NL, PT, SE), OAPI patent (BF, BJ, CF, CG, CI, CM, GA, GN, ML, MR, NE, SN, TD, TG).</p> <p><b>Published</b> <i>With international search report. Before the expiration of the time limit for amending the claims and to be republished in the event of the receipt of amendments.</i></p>

(54) Title: METHOD AND APPARATUS FOR PROCESSING KRILL HYDROLYSATES

(57) Abstract

Method and apparatus used in producing a feed product or premix and the products made by the method. A predetermined quantity of krill hydrolysate is added to a predetermined quantity of dry carrier with or without a predetermined quantity of liquid marine protein. The mixture is subject to evaporation and drying steps in which relatively heavier particles are separated from relatively lighter particles. The mixture may be blended, ground and subject to chemical reaction in a balance tank prior to entering a dryer. The dryer utilises a warm air source, a tower and a cyclone to dry the mixture following its entry into the dryer. Temperature sensitive enzymes or other bioactive products may be added to the product produced from the dryer. A method for obtaining enzymes from a fresh krill extract or an autolysed krill preparation and the product are also disclosed. A method for separating the bound protein and pigments from crustacean waste using krill enzymes and a product produced by the method are also described.

**FOR THE PURPOSES OF INFORMATION ONLY**

Codes used to identify States party to the PCT on the front pages of pamphlets publishing international applications under the PCT.

<b>AL</b>	Albania	<b>ES</b>	Spain	<b>LS</b>	Lesotho	<b>SI</b>	Slovenia
<b>AM</b>	Armenia	<b>FI</b>	Finland	<b>LT</b>	Lithuania	<b>SK</b>	Slovakia
<b>AT</b>	Austria	<b>FR</b>	France	<b>LU</b>	Luxembourg	<b>SN</b>	Senegal
<b>AU</b>	Australia	<b>GA</b>	Gabon	<b>LV</b>	Latvia	<b>SZ</b>	Swaziland
<b>AZ</b>	Azerbaijan	<b>GB</b>	United Kingdom	<b>MC</b>	Monaco	<b>TD</b>	Chad
<b>BA</b>	Bosnia and Herzegovina	<b>GE</b>	Georgia	<b>MD</b>	Republic of Moldova	<b>TG</b>	Togo
<b>BB</b>	Barbados	<b>GH</b>	Ghana	<b>MG</b>	Madagascar	<b>TJ</b>	Tajikistan
<b>BE</b>	Belgium	<b>GN</b>	Guinea	<b>MK</b>	The former Yugoslav Republic of Macedonia	<b>TM</b>	Turkmenistan
<b>BF</b>	Burkina Faso	<b>GR</b>	Greece			<b>TR</b>	Turkey
<b>BG</b>	Bulgaria	<b>HU</b>	Hungary	<b>ML</b>	Mali	<b>TT</b>	Trinidad and Tobago
<b>BJ</b>	Benin	<b>IE</b>	Ireland	<b>MN</b>	Mongolia	<b>UA</b>	Ukraine
<b>BR</b>	Brazil	<b>IL</b>	Israel	<b>MR</b>	Mauritania	<b>UG</b>	Uganda
<b>BY</b>	Belarus	<b>IS</b>	Iceland	<b>MW</b>	Malawi	<b>US</b>	United States of America
<b>CA</b>	Canada	<b>IT</b>	Italy	<b>MX</b>	Mexico	<b>UZ</b>	Uzbekistan
<b>CF</b>	Central African Republic	<b>JP</b>	Japan	<b>NE</b>	Niger	<b>VN</b>	Viet Nam
<b>CG</b>	Congo	<b>KE</b>	Kenya	<b>NL</b>	Netherlands	<b>YU</b>	Yugoslavia
<b>CH</b>	Switzerland	<b>KG</b>	Kyrgyzstan	<b>NO</b>	Norway	<b>ZW</b>	Zimbabwe
<b>CI</b>	Côte d'Ivoire	<b>KP</b>	Democratic People's Republic of Korea	<b>NZ</b>	New Zealand		
<b>CM</b>	Cameroon			<b>PL</b>	Poland		
<b>CN</b>	China	<b>KR</b>	Republic of Korea	<b>PT</b>	Portugal		
<b>CU</b>	Cuba	<b>KZ</b>	Kazakstan	<b>RO</b>	Romania		
<b>CZ</b>	Czech Republic	<b>LC</b>	Saint Lucia	<b>RU</b>	Russian Federation		
<b>DE</b>	Germany	<b>LI</b>	Liechtenstein	<b>SD</b>	Sudan		
<b>DK</b>	Denmark	<b>LK</b>	Sri Lanka	<b>SE</b>	Sweden		
<b>EE</b>	Estonia	<b>LR</b>	Liberia	<b>SG</b>	Singapore		

5

10

TITLE OF THE INVENTION

15

METHOD AND APPARATUS FOR PROCESSING KRILL HYDROLYSATES

INTRODUCTION

20

This invention relates to a method and apparatus used in producing a feed product or premix and the product made by the method and, more particularly, to a process using co-drying to dry a mixture of krill hydrolysate and dry carrier or a mixture of krill hydrolysate, fish

25

hydrolysate and dry carrier. The invention further relates to recovering enzymes from krill and, more particularly, to recovering enzymes from both freshly harvested and hydrolyzed krill. The invention further relates to

30

utilising krill enzymes for removing protein from marine and biological wastes and, more particularly, for removing

- 2 -

protein, chitin and other constituents from crustacean and other marine wastes.

#### BACKGROUND OF THE INVENTION

5

With the advent of increasing activity in aquaculture or fish farming in the early to mid-1980s, research has been ongoing into increasing productivity or growth rate and reducing the mortality rate of fish raised in aquaculture conditions since survival of such fish is important. One such factor relates to enhancing the nutritional value and palatability of feed used in raising such fish. In addition to the nutritional value, it is desirable to reduce the cost of feed to such fish since, typically, the feed totals approximately 40 to 50% of the cost of raising the fish. Such feed should be a high quality feed to meet the objectives of having high nutritional value to maximize growth and to reduce fish mortality.

20

The requirement for feed products in aquaculture is projected to grow substantially and, as a result, there is and will be pressure to obtain the necessary ingredients for fish food. The possibility of using zooplankton and, in particular, euphausiids, as a fish feed, appetizer or food product has been investigated and has been found to be possible and desirable, particularly as a feed product.

25

In addition, blends of krill hydrolysates and fish hydrolysates or any one of these with a dry carrier, can

30



- 3 -

provide alternatives to fish meals in aquaculture and other animal feed diets. Euphausiids are a natural feed harvested directly from coastal waters and have a high nutritional value but, previously, the cost of harvesting and processing such zooplankton for a feed product has been prohibitively expensive.

As well, the questions of the availability of the biomass of such zooplankton and its harvesting, handling, storage and processing are parameters that must be investigated in order to determine whether the product would be appropriate as a feed product.

Through papers written by Fulton and other authors, the use of zooplankton as a food or feed product has been contemplated for some time. In particular, antarctic krill (Euphausia superba) for human consumption have been investigated, although relatively little work has been investigated related to aquaculture. The use of Euphausia pacifica in the coastal waters of British Columbia, Canada has been considered in relation to its use in aquaculture and other animal feeds.

It appears, from those investigations, that the necessary biomass is available in coastal waters. Previously, euphausiids have been used as a pet food ingredient and some aquaculture operators have used euphausiids as a feed product. The euphausiids were used for such purposes in a frozen form after being harvested and

- 4 -

in some cases, the euphausiids were freeze dried following harvesting. This is an expensive procedure.

5 In processing feed products, it has typically been the case that the ingredients used in such feed products are heated to a high temperature around 100°C when the product is processed and dried. By heating the product to such a high temperature, it is believed that the enzymes and other proteins in the product are denatured. If, however, it is  
10 intended to utilize the product for early stage or juvenile aquaculture, which young fish have relatively undeveloped digestive systems, it is desirable that in some application, the euphausiid products maintain a certain proportion of enzymes which will assist the digestive process in juvenile  
15 and other life stages. If the theory that enzymes are advantageous in nutrition is correct, such destruction of the enzymes during the aforementioned drying process is disadvantageous.

20 It is also desirable to have a natural product, where the proteins are not denatured, available for early stage juvenile or larvae feed. In some previous products, exogenous enzymes have been added to the zooplankton mix. However, the addition of such enzymes is difficult to  
25 control and can result in a complete hydrolysis of the proteins to amino acids. The presence of free amino acids in the feed needs to be controlled since they can create an inferior product of substantially reduced value as a feed product.

30

- 5 -

It has been shown, surprisingly, that the degree of enzyme activity which results in determining the digestibility of a product, reaches a relatively constant value after a certain period of time in a natural product.

5 Recent investigations conducted by the applicant have confirmed this characteristic for Euphausia pacifica. This characteristic was first discovered in relation to Euphausia  
superba by Kubota and Sakai in a report entitled "Autolysis of Antarctic Krill Protein and Its Inactivation by Combined  
10 Effects of Temperature and pH", Transactions of the Tokyo University of Fisheries, number 2, page 53-63, March 1978. However, the antarctic krill study done by Messrs. Kubota and Sakai had the objective of limiting enzyme activity which was deleterious to obtaining a food as opposed to a  
15 feed product. Messrs. Kubota and Sakai wished to inhibit the enzymatic activity by certain processing techniques which they considered desirable when the product was intended as a food product.

20 An appropriate degree of hydrolysis is obtained during the digestion of the euphausiids. The approximate degree of hydrolysis will vary depending on the final application and it can be monitored by measuring the apparent viscosity in the final product. Further processing  
25 may then take place in order to make a useful product for commercial feed. Such processes may include adding acid to obtain an acid stabilized product concentrating fractionating or drying the product. A variety of drying techniques such as freeze drying, spray drying, or vacuum  
30 and air drying. Spray drying, as well as some other drying

- 6 -

processes, however, are done at temperatures that will permanently inactivate the enzymes in the euphausiids which, as earlier mentioned, may be undesirable for aquaculture purposes although it is acceptable for purposes where the product is intended to be used as a carotenoid biopigment for coloring purposes in both feed and food products or as a source of protein, fatty acids, minerals or other nutrients.

#### SUMMARY OF THE INVENTION

10

According to one aspect of the invention, there is provided a method of producing a feed product comprising the steps of adding a predetermined quantity of krill hydrolysate to a quantity of dry carrier to produce a mixture and co-drying said mixture to obtain an end product. The dry carrier may conveniently be a plant protein, dry krill, fish meal, byproduct meal or other dry ingredient suitable for inclusion in a diet.

20

According to a further aspect of the invention, there is provided a product produced by adding a predetermined quantity of krill hydrolysate to a quantity of liquid marine protein and a quantity of dry carrier to produce a mixture and co-drying said mixture.

25

According to a further aspect of the invention, there is provided a co-drying apparatus for drying a mixture of krill hydrolysate with or without an evaporator and liquid marine product and a dry carrier comprising a dryer

- 7 -

for concentrating, mixing, agitating, heating and separating particles of said mixture.

According to still a further aspect of the invention, there is provided a method of obtaining an enzyme extract from a liquid krill hydrolysate comprising the steps of subjecting said hydrolysate to decanting and then to centrifugation to obtain a clarified liquid and further subjecting said clarified liquid to ultrafiltration using a membrane with a capacity to retain said enzymes having a molecular weight greater than 10,000 daltons and the product produced by the method.

According to still a further aspect of the invention, there is provided a method of obtaining an enzyme extract from fresh krill comprising the steps of squeezing said krill to obtain an aqueous extract and subjecting said aqueous extract to ultrafiltration with a membrane adapted to retain enzymes having molecular weights above 10,000 daltons and the product produced by the method.

According to still yet a further aspect of the invention, there is provided a method for removal of protein from non-stabilized or fresh crustacean shell wastes comprising grinding said crustacean wastes and water, transferring said product to a digester, adding a predetermined quantity of krill enzymes to said digester, subjecting said mixture to digestion for a predetermined time period at a predetermined temperature, dewatering said digested product to obtain a first portion being relatively

- 8 -

enzymatically active and relatively high in protein and a second portion of shell material relatively high in chitin and low in protein.

5                   According to still yet a further aspect of the invention, there is provided a method for removal of protein from acid stabilized shell wastes comprising grinding said crustacean wastes, transferring said small particulate size shell wastes to a digester, adding a predetermined quantity  
10 of krill enzymes to said digester, subjecting said mixture to digestion for a predetermined time period at a predetermined temperature, dewatering said digested product to obtain a first portion being relatively enzymatically active and relatively high in protein and a second portion  
15 of shell material relatively high in chitin and low in protein.

BRIEF DESCRIPTION OF THE SEVERAL VIEWS OF THE DRAWINGS

20                   Specific embodiments of the invention will now be described, by way of example only, with the use of drawings in which:

                  Figure 1A is a diagrammatic isometric view of a  
25 fishing vessel with an attached net which utilizes the euphausiid harvesting technique according to the invention;

                  Figure 1B is a diagrammatic front view of a net in  
an alternative harvesting technique according to the  
30 invention;

- 9 -

Figure 2A is a diagrammatic side view of a cage which is used to maintain the cod end of the fishing net illustrated in Figure 1 in an open position and which is further used to transport the harvested euphausiids to the harvesting vessel;

5

Figures 2B and 2C are side and rear views, respectively, of the dewatering trough used to remove water from the harvested euphausiids;

10

Figure 3 is a diagrammatic process chart illustrating the processing of the euphausiids subsequent to the dewatering steps illustrated in Figure 2 and prior to the drying step;

15

Figures 4A and 4B are end and side sectional views of the heat exchanger used to raise the temperature of the harvested euphausiids prior to the digester process;

20

Figure 5 is a diagrammatic side sectional view of the digester used to create the desired enzyme activity within the euphausiids;

25

Figure 6 is a diagrammatic side sectional view of a ball drier used to dry the euphausiids following removal of the euphausiids from the surge tank located downstream from the digester;

30

Figure 7 is a flow chart illustrating the process of co-drying the product according to the invention;

- 10 -

Figure 8 is a diagrammatic view of the dehydrator used in the co-drying process according to the invention;

Figure 9 is a diagrammatic view of the codrying process according to a further aspect of the present invention;

Figure 10 is a diagrammatic flow chart illustrating the enzyme extraction process utilising hydrolysed krill;

Figure 11 is a diagrammatic flow chart illustrating the enzyme extraction process utilising fresh krill; and

Figure 12 is a diagrammatic flow chart illustrating the removal of protein and other constituents from crustacean wastes using krill enzymes according to a further aspect of the present invention.

#### DESCRIPTION OF SPECIFIC EMBODIMENT

Referring now to the drawings, a towing vessel 10 is illustrated in Figure 1. A plurality of towing ropes 11, 12, 13 are connected to the towing vessel 10 in order to tow a barge 14 and a net 20. A plurality of ropes 21 (only one of which is shown) are connected to the net 20 and extend downwardly from the barge 14. Weights 22 are connected to the bottom of the open forward facing portion of the net 20 in order to maintain the net 20 at a desired and



- 11 -

predetermined depth where the concentration of zooplankton is satisfactory.

5 The cod or rearward end 23 of the net 20 is maintained in an open condition by the use of a cage generally illustrated at 24 in Figure 2. Cage 24 is of cylindrical configuration and is positioned within the cod end of net 20. It is made from aluminum and is preferably corrosion resistant. A fitting 30 is welded to the  
10 downstream end of the cage 24 and one end of a swivel connection 31 is joined to the fitting 30 to prevent fouling the net in the event components become unstable under adverse harvesting conditions. A hose 32 is connected to the other end of the connection 31.

15

Referring again to Figure 1, hose 32 extends upwardly from the cod end of the net 20 to the barge 14. A pump of a variety of configurations but, conveniently, a diaphragm sump pump 33, is located at the other end of the  
20 hose 32 on barge 14. A dewatering trough is generally shown at 34 and is illustrated in Figures 2B and 2C. Dewatering trough 34 has a lengthwise generally rectangular configuration and is also located on barge 14. Dewatering trough conveniently takes the configuration of a "lazy I".  
25 A set of screens 40 positioned at obtuse angles are utilised to allow water to drain from the pumped euphausiids and exit the trough 34 through drain pipes 41 while the euphausiids accumulate within the dewatering trough 34.

- 12 -

A blast freezer 42 was also located on the barge 14 to stabilize the harvested euphausiids. The blast freezer 42 subjects the euphausiids to a temperature of approximately +9° to -17°C and is used to freeze the dewatered euphausiids and stabilize the product for further processing. The euphausiids accumulate within the dewatering trough 34 and which are periodically removed from the trough 34 from time to time for freezing. Thereafter, the frozen euphausiids are transported to a processing location and processed as described hereafter. Alternatively, the euphausiids may conveniently be processed aboard a vessel.

In prototype demonstrations, the net 20 utilised for the harvesting operation was a specially designed 13 ft. by 21 ft. plankton net suspended from a 46 ft. aluminum barge. The pumping action was by a three inch diaphragm pump located on the barge 14 and the freezing action occurred within a minus seventeen (-17°C) degree centigrade blast freezer 42.

As earlier described, the frozen euphausiids are transported to a processing location in order to transform the euphausiids into the desired feed product. Reference is now made to the flow chart of Figure 3.

A pump 43 is connected to a hopper 44 which receives the euphausiids which are now in a thawed condition. Pump 43 is connected to a heat exchanger generally illustrated at 50 and diagrammatically illustrated

- 13 -

in Figure 3. The heat exchanger 50 is intended to raise the temperature of the euphausiids to a temperature of approximately 40°C to 60°C which will more closely approximate the temperature maintained in the digester which is generally lower than 70°C and which digester is generally illustrated at 51. Digester 51 is located downstream of the heat exchanger 50 in the process illustrated in Figure 3.

Although several different types of heat exchangers may be used, heat exchanger 50 conveniently comprises a plurality of pipes 52 (Figure 4A) in which the euphausiids are conveyed through the heat exchanger. Heated water enters the inlet 54 of the heat exchanger 50 and is circulated through the heat exchanger 50 generally following the flow path seen in Figure 4B which utilizes a plurality of baffles 53. The heated water exits the heat exchanger at outlet 61. Following the increase of temperature created in the euphausiids by the heat exchanger 50, the euphausiids pass to the digester 51.

20

Digester 51 is seen in greater detail in Figure 5. It comprises a product inlet 61 and a product outlet 62. A water inlet 63 and a water outlet 64 are provided. A water jacket 70 through which the heated water circulates surrounds the cylindrical cavity area 71 of the digester 51 which contains the euphausiids. A plurality of stirring discs 72 are located vertically within the cavity area 71 of the digester 51 and are used to stir the euphausiids when they are positioned within the digester 51. A valve 73 is used to close the product outlet 62 so as to maintain the

30

- 14 -

euphausiids within the digester 51 until the proper temperature and time for the desired enzyme action within the euphausiids has taken place. The time period has conveniently extended between thirty (30) minutes and two  
5 (2) hours.

It is thought that a degree of hydrolysis will enhance digestibility of the feed product particularly for early stage larvae or juveniles but also for virtually all  
10 fish. This degree of hydrolysis is determined by the applications and will be monitored by measuring the apparent viscosity in the final product. In utilising the digester 51 illustrated in Figure 5, a batch process is currently being used with a volume of euphausiids of 250 lb./hr being  
15 used.

The valve 62 is then opened and the quantity of euphausiids within the digester 51 pass through the valve 62 and are transported through valve 74 to the surge tank or  
20 heated batch storage vessel 80 where they await treatment in the dryer, conveniently a ball dryer generally illustrated at 81 (Figure 6) where relatively low and controlled temperatures can be applied to the euphausiids such that any enzymes existing within the euphausiids are not inactivated  
25 as would otherwise be the case in a normal drying process.

The euphausiids pass from the storage vessel 80 to the ball dryer 81 through product inlet 83 and, thence, about the periphery of the dryer 81 initially through the  
30 application zones 91 where the balls initially contact the

- 15 -

euphausiids and begin the drying process. The ball dryer 81 performs a "soft" drying process which reduces damage to the euphausiids because of its gentle action by way of controlled temperature. The ball drying process utilises a continuous feed into the ball dryer 81 and a product flow of 15 lb./hr. is available.

As the balls and euphausiids move downwardly through the drying zones 92, they meet a counter-current flow of controlled-temperature drying air at less than 50°C which air enters the ball dryer 81 through air inlet 82. Air flow, temperature and dwell time are precisely controlled and monitored within this zone. All of these are variable factors which depend upon whether the product is wet or dried and what period of time the product is intended to stay in the dryer 81.

In the separation zone 93 at the bottom of the dryer 81, the ball and euphausiids meet a co-current flow of controlled temperature air for final drying and separation. The dried euphausiids leave the ball dryer 81 through the product outlet 84 and pass to the packaging step. The drying balls are elevated by rotating helix 94 and recycled to the application zone 91 and the process continues.

One of many commercial and known dryers may be used for the air drying of the euphausiids.

It is contemplated that although the processing of the euphausiids has been described as taking place at a land

- 16 -

location, such processing steps may take place at the harvesting location on board either the harvesting vessel or another vessel conveniently located nearby. This results in advantages in that the euphausiids need not be frozen following harvesting and need not be transported to a land based processing plant thereby resulting in considerable cost savings and quality improvement. In addition, the euphausiids may be introduced directly to a low temperature dryer on board a vessel following harvesting or to an evaporator. The dried or concentrated euphausiids, after being subjected to the digester and/or the drying processes, may then be stored on the vessel until a substantial quantity of krill hydrolysate concentrate has been obtained at which time they may be transferred to another vessel for transport to the processing vessel itself which, when full, will transport the euphausiids to the shore.

Likewise and while it is desirable for the digester and drying steps to take place concurrently and sequentially in the event the euphausiids are intended to be used as a feed product for juvenile and early stage larvae.

A further harvesting technique is contemplated in Figure 1B. In this technique, weights 101 are connected to the mouth end of the net generally illustrated at 114 at the ends of the lower horizontal beam 103. Floats 100 are connected to the top horizontal beam 102 of the mouth end of the net 114. Depending on the size of the net 114, lines are connected on one end to attachment points 104, in the first instance or, alternatively, to points 110, 111, 112,

- 17 -

113 and, on the other end, to the towing vessel. The net  
114 is pulled through the water gathering the zooplankton  
which enter the net 114 through the mouth.

5           Many applications for the hydrolysed krill and  
hydrolysed krill concentrate products are also contemplated  
because of the desirable characteristics of the of the krill  
hydrolysate in which the proteins and nutritional value is  
retained and improved through the partial digestions of the  
10 proteins. For example, fish under stress, which is common  
with cultivated species raised with aquacultural techniques,  
are reluctant to eat and, accordingly, therapeutic drug  
delivery and special diets used for such marine species are  
difficult to use because the fish do not find such products  
15 palatable. The hydrolysed krill products and other  
zooplankton products according to the invention may be used  
with such special diets and drug delivery by creating an  
enhanced flavour and enhanced assimilation when the  
medicinal product such as a pellet is coated or mixed with  
20 the hydrolysed zooplankton product in a liquid or paste  
form. Likewise, while other such products may include  
specially added amino acids and other compounds to enhance  
the flavour of the product, the hydrolysed krill according  
to the present invention preserves, enhances and optimises  
25 the level of certain free amino acids and other flavourants  
thereby allowing flavour enhancement with a natural product  
and without the addition of amino acids or other  
flavourants. Likewise, the krill hydrolysates retain the  
protein and nutrient quality including the original  
30 pigments, fatty acids, other nutrients and mineral elements.

- 18 -

The activity of the enzymes, which are contained in the krill, is also retained in the hydrolysed natural product according to the invention. Such enzymes allow for enhanced digestion of feed by certain cultivated marine species by increasing the availability of peptides and free amino acids without creating additional harmful stress on such species.

Yet a further application contemplated by the present invention is the use of hydrolysed krill that is blended and codried in association with plant or vegetable protein and other dry carriers such as soymeal, corn gluten meal and canola meal in fish feed mixtures. The range of co-drying carriers used in the blending process include a wide range of dry animal or vegetable protein and feed ingredients including soy conola and other soil seed meals, coarse ground cereal gains and flours, oil seed concentrates and isolates, corn and cereal glutens, pea and pulse meals, oil seed and cereal processing by products and brans, dried yeasts, algae and other single cell organisms, milk powders, blood meal and other body fluid products, namial and poultry by products, fish and shellfish meals, and vitaminised mineral premixes. Such applications would increase the palatability, amino acid balance and other nutrient levels in the dry blended meal so that it can be used to replace fish meal in aquaculture feeds and other applications. Further enzymes in the hydrolysed krill products according to the invention are preserved following he hydrolysis and can be allowed to act on the plant proteins. The enhanced digestibility of a product combination of plant protein and hydrolysed krill is also contemplated to improve the



- 19 -

efficiency of the feed and decrease the fecal load in the environment by fish fed with diets containing such combination. This can be an important feature with the rearing of cultivated marine and freshwater species.

5 Likewise, the palatability of such non-fish meal proteins, in particular, plant proteins such as canola, corn gluten or soy meal is enhanced.

Experiments conducted to date utilize the enzymes  
10 in krill to carry out a limited hydrolysis of soy, canola and other plant proteins. For example, one part of dry canola or soy meal which has added ten percent (10%) wheat bran is blended with five (5) parts of hydrolysed krill. The hydrolysate is pumped from the digester to the feed  
15 stock hopper and the dry blend is added. The mixture is brought to the desired temperature while agitated in the digester for approximately one (1) hour. Measurements of phytic acid and the levels of the amino acids and ammonia are then taken. For example, 250 lbs. of krill is  
20 hydrolysed by bringing the krill to approximately 45° Celsius. The temperature is held for one (1) hour and is then blended with 5 lbs. of wheat bran with 45 lbs. of canola concentrate. The use of wheat bran is necessary to provide phytase, an enzyme which is absent in canola meal  
25 and krill. The phytic acid is dephosphorylated by phytase from the wheat bran. The phytic acid is acted on by the phytase enzyme. It is noted that the blend may be retained in the digester for an extended period, up to a period of four (4) hours or even longer.

30

- 20 -

In yet a further embodiment of the invention, it is contemplated that the wet krill hydrolysate product is evaporated and then mixed with and co-dried with other wet and dry products. Various predetermined ratios of wet krill hydrolysate and liquid marine products may be concentrated and then mixed with dry carrier conveniently in the form of dried krill products, dried vegetable protein and/or dried fish product, used in combination or singly. The resulting moist blend is subject to concentration, processing and co-drying in a dehydrator such as a dryer. A dehydrator system with the following characteristics has been found to work well, namely a type of flash and fluidized drier or combination thereof with an agitator and vertical or tangential flow of heated air. Although the temperature of the inflowing air may be high at impact (the impact temperature), the temperature of the product is not significantly increased in the dryer. This is an important element in the drying system. Following hot air impact and agitation, the water evaporates rapidly and the duration of the drying process is greatly reduced as set out in greater detail hereafter.

Co-drying the mixture of the krill hydrolysate, liquid marine product and the dry carrier product mixture has been found to be relatively economical at relatively low temperatures. Under such conditions, the krill proteins, pigments and other constituents are substantially preserved. Thus produced, the product has unique benefits for dietary uses in aquaculture and animal feeds. These blended and agglomerated dry products are uniquely different

- 21 -

from other product mixes. The unique sequences and control of the process provides intimate agglomeration and adsorption of the krill hydrolysate with the dry carrier. It also preserves the unique nutrient quality of the krill hydrolysate in the blend without significant losses due to excess heat or oxidation during the drying process. Further, cost savings and economic advantages in the manufacture of the product are improved.

10                    Depending on the moisture content of the dry carrier, liquid marine protein, and the krill hydrolysate, and the proportion of each in the mixture to be co-dried, the removal of moisture can be accomplished by a drying process at relatively low temperatures thereby to preserve the temperature and oxidation sensitive constituents including the krill constituents and the krill pigments. Particles of the dry carrier are coated with, adsorbed and absorbed with the wet hydrolysate thereby facilitating the drying process by exposing a greater surface area of wet hydrolysate and/or liquid fish product for heated air to act upon. The mixture may then be fractured into smaller particles which further increases the available surface area to expedite the drying process. At the outset, the mixture may be placed in a reactor cell balance tank to permit chemical interactions between components of the mixture, such reactions including enzymatic activity of a wide range of enzymes including proteolytic, lipolytic and carbohydrate splitting enzyme prior to drying. A well-mixed, homogeneous mixture is prepared to reduce and to eliminate high moisture pockets. Water is then removed from this mixture by an

- 22 -

evaporator and a subsequent dehydrator such as is described above and the endproduct is a dried krill premix or feedstuff blended with the aforementioned carrier.

Temperature sensitive enzymes, flavorants or other bioactive products may be added to the cooled endproduct after the drying step. Alternatively, the krill hydrolysate may be combined with wet fish products and other carriers such as dry fish meal, corn meal, canola meal, oil seed meal, or other vegetable meals, used in combination or taken singly.

10

Referring now to the drawings, Figure 7 illustrates the steps of the co-drying process in its entirety according to the present invention. A predetermined quantity of wet krill hydrolysate product 210 is mixed with a predetermined quantity of liquid marine protein 212 and a predetermined amount of dry carrier 211, conveniently dried krill product, dried fish product and/or dried vegetable protein used in combination or taken singly. The resulting mixture is placed in a mixing blender 215, where the various ratios of hydrolysate, marine protein and dry carrier are thoroughly blended. The blending required will vary with the constitution of the mixture. The blended mixture is then ground within a grinder 217 where the mixture is reduced to particles of substantially uniform size. The ground mixture is then transferred to reactor cell balance tank 216 where the continuously stirred blended mixture is allowed to chemically react and/or undergo enzymatic action prior to the drying process. After the intended reaction has taken place in the tank 216, the mixture is conveyed to the dehydrator 220 for drying.

25

30

- 23 -

The dehydrator 220 is illustrated in greater detail in Figure 8 and with reference thereto, the mixture enters the agitator bowl 224 of the dehydrator 220 through inlet 219 where the mixture is agitated into smaller particles which is intended to prevent clumping of the mixture. A continuous feed of mixture into the dehydrator 220 is intended through inlet 219.

Directly heated air from the burner 221 or indirectly heated air is directed to the agitator bowl 224 of the dehydrator 220 by way of fans (not illustrated) where the air mixes with particles of the mixture in the bowl 224. The particles are carried up the drying tower 230 by the column of hot air. The classifier 231 sorts the particles at the top of tower 230. Drier mixture consists of lighter, individual particles which proceed along the column of hot air into a cyclone 232. The classifier 231 redirects larger and heavier masses of more damp mixture back to the agitator bowl 224 for further agitation and drying.

The particles are drawn downwards along a spiralling column of heated air in cyclone 232 and centrifugal action removes further moisture from the particles. At the bottom of the cyclone 232, the particles are isolated from the air column by airlock 233 and are sorted by a rotary screen 234. Smaller, lighter particles of dried product pass through the rotary screen 234 and exit the dehydrator 220 at outlet 240 for further processing. Larger, heavier particles of damp mixture are redirected to

- 24 -

the agitator bowl 224 from outlet 241 for further agitation and drying within several seconds.

5 With reference again to Figure 7, heated product 241 exiting the dehydrator 220 from outlet 240. The average transit time through the dryer is between 60 and 90 seconds and the end moisture content below 10% moisture may then be permitted to cool. Some of this dried product 245 may be further used in the co-drying process as a quantity of the dry carrier 211 so as to increase the fluid content of  
10 marine constituents. Temperature sensitive enzyme active products 242 or other bioactive products, which might be denatured by the drying process, may be introduced to the dried product 241 after the product has passed through the  
15 dehydrator 220 as illustrated. The dried product 241 then undergoes further mixing and blending at mixing step 250 to ensure the homogenous addition of the temperature sensitive enzyme active products 242. The final product 243 may then proceed to a packaging step such as a bagger 244 or to a  
20 storage bin 245 prior to further use in aquaculture or animal feeds.

Concentration and Co-Drying of Krill with Vegetable proteins Trials

25

The objectives were the concentration of liquid krill hydrolysate to 42%DM in a rising film plate evaporator. (Alfa Vap). The drying of a krill concentrate blend with soya meal and corn gluten meal in a flash dryer (drier with  
30 performance characteristics as defined), to determine the

- 25 -

maximum amount of krill concentrate that can be added to the dry vegetable protein meal.

Raw material hydrolysed krill with 18-20% DM including  
5 approximately 0.3% oil.

Evaporator. The hydrolysed krill was concentrated in an Alfa Vap evaporator from 18-20% DM to 42% DM. The 42% level was not obtained with any difficulty.

10

#### Mixing

The mixing was done in 100 kg batches using a cylindrical container with a vertical shaft paddle. This was  
15 accomplished without unusual difficulties.

#### Drying

Drying and mixing was carried out in two steps: Step 1 was  
20 mixing the krill concentrate and carrier (vegetable and protein) and drying to about 90% DM. Step 2 was mixing the dried product from step 1 with more krill concentrate and drying a second time.

#### 25 Flash Drying

The mixtures were dried in a flash dryer. This was done by feeding the mixture into a chamber containing a fast rotating agitator. Through intake air ducts hot air was led  
30 through the chamber and agitator.

- 26 -

Impact Temperature was 165-175 deg. C.

Drying Temperature (set point) is 110 deg. C to 125 deg C.

5 Capacity

The flow to the dryer for all three test vegetable protein products was 600-700 kg/hr. This gave an evaporation rate of approximately 500 kg/hr. in the dryer.

10

Results

The temperature of the product is not increased in the dryer by any significant amount. The evaporation of the water on the product keeps the temperature low. The rapid transit of the product through the dryer also minimizes the temperature and time effects that can reduce the value of the product as a feed.

20 A third or fourth step is also contemplated and considered possible with this type of dryer.

Other driers besides those of ball dryer 81 (Figure 6) are contemplated. For example, dryers such as direct heated flash driers or fluidized bed driers that cause rapid drying of the particles within a few seconds are well known. With reference to Figure 9, a built in air scrubber generally illustrated at 500 is used for odour control. A burner or indirect heating system 501 heats the air to the required level with impact temperatures not

30



- 27 -

exceeding 450 deg. C before the air enters agitator 502. the product is augered tangentially into the agitator chamber 503 where most of the water in the product is evaporated. Agitator 502 rotates with a high tangential  
5 speed of the agitator blades concurrent with the tangential air flow. The motion of the agitator 502 causes mechanical fluidization of the particles and comminutes the particles, thus accelerating evaporation. The acceleration of the drying velocity reduces the adverse effect of heat or the  
10 heat burden on the product during the drying process.

In yet a further embodiment of the invention, it is contemplated that a process for obtaining enzymes from the Euphausia superba species of krill and other krill  
15 species is of interest. Euphasia superba ("E.s.") is a small crustacean from the Antarctic that contains numerous enzymes that are principally but not exclusively represented by proteases, amylases, chitinases, carboxymethy cellulases, lipases, etc. This enzymatic cocktail as a whole or in a  
20 partial purified form can be used for a number of industrial applications such as aquaculture and other general feed manufacturing and the further process of marine and other proteins. The inclusion rate of enzymes in the feed would vary depending on the target species and the composition of  
25 the diet. For example, these krill enzyme cocktails can be added to aquaculture diets containing large quantities of vegetable proteins which would otherwise be difficult to process by the animals and which could also be part of specialty diets for larval stages of shrimp and starter  
30 diets for salmonids where higher survival rates are

- 28 -

required. Krill enzymes may also conveniently be used to produce protein hydrolysates from other proteins to incorporate into diets or to improve the functional properties of these diets. Other potential applications would include the production of flavors, protein and peptide extraction from marine by products, protein and pigment recovery from shrimp and crab shell offal, the production of free amino acids and other benefits relating to the actions of these krill enzymes on biological materials.

10

Using the processes previously disclosed, it was desired to obtain enzymes from the previously autolysed krill preparations.

15

With reference to Figures 9 and 10, ultrafiltration membrane 303 was used with the krill hydrolysate 301 and with fresh krill 310. Since most of the krill-derived enzymes have molecular weights above 20,000 daltons, experiments were conducted to determine the most appropriate molecular weight cut-off ultrafiltration membrane to attempt a concentration of the aqueous phase enzyme-rich E.s. and E.p. extracts. It was revealed during experiments that total protease activity begins to become apparent in the filtrates at the 50,000 molecular weight cut off and up. On the other hand, trypsin-like activity is present in filtrates at 30,000 molecular weight cut off. It is therefore desirable to use a 10,000 dalton cut off membrane for filtration purposes.

20

25

- 29 -

In order to handle larger volumes of krill hydrolysate and to concentrate the enzyme extracts, a tangential flow filtration ("TFF") cartridge 302 was used using a 10,000 dalton molecular weight cut-off. One such cartridge commercially available is a Millipore Preparative Scale Tangential Flow Filtration cartridge. Such cartridges are intended to handle volumes from 100 ml to 100 liters, although it is readily possible to scale up such techniques to handle larger volumes, if desired. Before subjecting the krill extracts to TFF, they were centrifuged at 4000-10000 x G for twenty(20) minutes in a Beckman centrifuge 300 to clarify from solids and eliminate part of the fat. Rather than centrifugation, this clarification step can be replaced by prefiltration 303 with a larger pore filter. After centrifugation, the aqueous phase 305 containing the enzymes of interest was recover and stored at 4 deg. C. The autolysed krill extracts were run through a one square foot TFF cartridge 302 using a Hoechst displacement pump 304. The initial extract volume was about two(2) liters and was brought down to approximately 250-300 ml after four(4) to five(5) hours of operation (below 20 psi of pressure). It was revealed that enzymatic activity recovery differed significantly between the two samples (i.e., autolysed and freshly squeezed extracts).

25

By measuring the trypsin-like activity ("TLA"), it was found that the recovery of krill enzymes from the fresh frozen krill 310 was relatively smaller than the recovery from hydrolysed krill 301. However, the total units recovered after ultrafiltration were higher for fresh frozen

30

- 30 -

extracts. Accordingly, TLA could be recovered from either freshly squeezed or autolysed krill preparations. Since there was little or no enzymatic activity associated with the filtrate, it is apparent the proteins of interest were not leaching out through the membrane filter.

The resultant enzyme cocktail obtained by the ultrafiltration technique from both the hydrolysed and fresh krill 301, 310, respectively, could then be coupled with freeze drying 313 which would reduce the amount of water associated with the enzymes significantly which would reduce transportation costs. Subsequent processing could then be performed on the enzyme cocktails to further increase the purity and quality of the enzymes present.

Yet a further aspect of the invention relates to a method for removal of protein from crustacean wastes using the aforementioned krill enzyme extracts. With reference to Figure 12, a quantity of crustacean wastes 400, 401 is ground to dried particulate size by grinders 402, 403, respectively, with a portion of water added to facilitate this grinding. Various of a plurality of grinders which will accomplish this include a piranha pump, a macerator or cerator, all of which are known. Acid stabilized shell waste 400 is then de-watered through a de-watering system 404, many of which are readily known to be available, such as the Vincent screw press, wine presses or centrifuges. Non acid stabilized shell waste 401 has no need to be de-watered prior to the addition of enzymes. Water is conveniently added to the de-watered acid stabilized shell

- 31 -

waste 410 to facilitate enzymatic reaction. The shell waste 410 is transferred to a digesting tank 411 where an amount of krill enzyme cocktail 412 is added. The enzyme cocktail can be in either a concentrated or non-concentrated form consistent with squeezed extractions from the whole animal as has been described. The squeezed fractions are in the range of 25-75% of the whole animal depending on the amount of enzyme desired and the need to keep the enzyme with the krill to facilitate autolysis. The shell enzyme mixture is subjected to digestion in the digester 411 for a time period in the range of one(1) to forty-eight(48) hrs at a temperature in the range of 0 to 70 Celsius with an optimum temperature being approximately 45 deg. Celsius. Following the digestive process, the mixture is subjected to water removal 413 as has been described. Two fractions will result, a protein rich enzymatically active portion 414 and a shell material portion 415 high in chitin and low in protein. The liquid high protein portion 414 is low temperature dried or co-dried as earlier described or acid stablized. The shell portion 415 can then be further processed by the addition of more enzyme cocktail to facilitate further protein removal in further steps or can be subjected to traditional deproteinization or demineralization techniques as illustrated generally at 420. The extent of de-mineralization necessary can be greatly reduced by the storing of the shell waste for long periods of time while stabilized with acids, preferably formic.

In experiments which have been conducted to date, 70kg of water was added to 210 kg of mechanically peeled

- 32 -

shrimp shell wastes. The slurry was subjected to grinding with a piranha pump to a suitable particle size. 60kg of this slurry was combined with 15 kg of Euphasia superba juice obtained by squeezing whole krill through a screw press 315 (Figure 11) to obtain 50% by weight of the animal in a liquid form. The shell juice mixture was subjected to digestion for six(6) hours at 45 deg. C. The mixture was dewatered by pressing through a Vincent screw press to obtain the protein rich enzymatically active portion and the shell ash portion 415, as described. The shell portion was approximately 7.5% by weight and the liquid portion made up the remainder. The liquid portion was acid stabilized with 3% by weight formic acid. The shell portion was washed and dried.

In a second trial conducted to establish the efficacy of using krill enzymes for the removal of protein from shrimp shell wastes and the benefit of reincorporating the superba squeezed solids, 26 kg of squeezed superba juice, obtained through the procedures described, was incubated with 10 kg water and 70 kg of ground shrimp shell for six(6) hours at 45 deg C. Samples were taken every hour and squeezed through a screw press. After six(6) hours, 14 kg of squeezed superba solids comprising the remainder of the whole animal after enzyme liquid removal were added into the mixture and hydrolyzed for an additional one and one-half (1.5) hours. The remaining slurry was squeezed and the separate fractions were frozen.

- 33 -

While specific embodiments of the invention have been described, such descriptions should be taken as illustrative of the invention only and not as limiting its scope as defined in accordance with the accompanying claims.

5

- 34 -

## WE CLAIM:

1. Method of producing a feed product comprising the steps of adding a predetermined quantity of krill hydrolysate to a quantity of liquid marine protein and a quantity of dry carrier to produce a mixture and co-drying said mixture to obtain an end product.

2. Method as in claim 1 wherein said mixture is mixed prior to co-drying said mixture.

3. Method as in claim 2 wherein said mixture is subjected to chemical and/or enzymatic reaction for a predetermined time period prior to co-drying said mixture.

4. Method as in claim 3 wherein said mixture is co-dried in a dryer or other dehydrator.

5. Method as in claim 4 wherein said mixture is ground prior to being subject to said chemical reaction.

6. Method as in claim 5 wherein said mixture is cooled following drying of said mixture in said dryer.

7. Method as in claim 6 wherein said dry carrier may be one or a combination of dry marine protein



- 35 -

meals, dried krill products, dried vegetable and dried fish product.

5           8.           Method as in claim 7 wherein said liquid marine protein may be liquid fish product.

10           9.           Method as in claim 8 wherein temperature sensitive enzyme active or other bioactive dry products are added or readded to said mixture following said drying of said mixture.

15           10.           Method as in claim 9 and further comprising mixing said temperature sensitive enzyme active products with said mixture.

          11.           Method as in claim 1 wherein said mixture is co-dried in a dryer or other dehydrator.

20           12.           Method as in claim 11 wherein said dryer includes an agitator to agitate said mixture entering said dryer.

25           13.           Method as in claim 12 wherein said dryer further includes a drying tower downstream from said agitator and a heat source to provide heat to said tower.

          14.           Method as in claim 13 and further comprising a classifier downstream of said tower for separating said mixture, said mixture comprising relatively

- 36 -

lighter and relatively heavier particles, said classifier separating said lighter from said heavier particles.

5           15.           Method as in claim 14 wherein said relatively heavier particles are returned to said agitator.

          16.           Method as in claim 14 and further comprising a cyclone downstream from said classifier.

10           17.           Method as in claim 16 wherein said cyclone removes further moisture from said relatively lighter particles.

15           18.           Method as in claim 17 wherein said relatively lighter particles are separated into relatively smaller and relatively larger particles.

          19.           Method as in claim 18 wherein said relatively larger particles are returned to said agitator.

20           20.           A feed product or additive produced by the method as in any one of claims 1 to 19.

25           21.           Co-drying apparatus for drying a mixture of krill hydrolysate, liquid marine product and a dry carrier comprising a dryer for agitating, heating and separating particles of said mixture.

- 37 -

22. Co-drying apparatus as in claim 21 and further comprising a mixer for blending said mixture prior to said mixture entering said dryer.

5 23. Co-drying apparatus as in claim 22 and further comprising a reactor cell for treating said mixture prior to said mixture entering said dryer.

10 24. Co-drying apparatus as in claim 23 and further comprising a grinder for grinding said mixture prior to said mixture entering said reactor cell.

15 25. Co-drying apparatus as in claim 24 wherein said dryer produces a product.

26. Co-drying apparatus as in claim 25 and further comprising a mixer for mixing said product following said product exiting said dryer.

20 27. Co-drying apparatus as in claim 21 wherein said dryer comprises a source of warm air, an agitator for agitating said mixture following entry of said mixture into said dryer, a tower to expose said mixture to said warm air, a first classifier to separate the relatively  
5 lighter particles of said mixture from the relatively heavier particles of said mixture, a cyclone for drying said relatively lighter particles separated from said relatively heavier particles, and a second classifier to separate relatively lighter particles and relatively heavier

- 38 -

particles constituting said relatively lighter particles in said cyclone.

5                   28.           Co-dryer as in claim 27 and further comprising a fan to move said warm air within said dryer.

10                   29.           Method of obtaining an enzyme extract from a liquid krill hydrolysate comprising the steps of subjecting said hydrolysate to centrifugation to obtain a clarified liquid and further subjecting said clarified liquid to ultrafiltration using a membrane with a capacity to retain said enzymes having a molecular weight greater than 10,000 daltons.

15                   30.           Method of obtaining an enzyme extract from a liquid krill hydrolysate as in claim 29 and further comprising the step of storing said clarified liquid at a reduced temperature for a predetermined time period.

20                   31.           Method of obtaining an enzyme extract from a liquid krill hydrolysate as in claim 30 wherein said ultrafiltration is achieved using a tangential flow filtration system.

25                   32.           Method of obtaining an enzyme extract from a liquid krill hydrolysate as in claim 31 wherein said enzyme extract obtained from said ultrafiltration is freeze dried.

- 39 -

33. Method of obtaining an enzyme extract from a liquid krill hydrolysate as in claim 32 wherein said krill is *Euphausia superba*.

5 34. Method of obtaining an enzyme extract from a liquid krill hydrolysate as in claim 32 wherein said krill is *Euphausia pacifica*.

10 35. Method of obtaining an enzyme extract from fresh krill comprising the steps of squeezing said krill to obtain an aqueous extract and subjecting said aqueous extract to ultrafiltration with a membrane adapted to retain enzymes having molecular weights above 10,000 daltons.

15 36. Method of obtaining an enzyme extract from fresh krill as in claim 35 wherein said ultrafiltration is achieved using a tangential flow filtration system allowing enzymes to retain which have molecular weights  
20 above 10,000 daltons.

37. Method of obtaining an enzyme extract from fresh krill as in claim 36 and further including the step of centrifuging said aqueous extract prior to  
25 subjecting said extract to ultrafiltration.

38. Method of obtaining an enzyme extract from fresh krill as in claim 37 and further comprising the step of storing said aqueous extract at a reduced  
0 temperature following said centrifuging.

- 40 -

39. Method of obtaining an enzyme extract from fresh krill as in claim 38 wherein said reduced temperature is approximately 4 degrees Celsius.

5 40. Method of obtaining an enzyme extract from fresh krill as in claim 39 and further comprising subjecting said enzyme extract obtained from said ultrafiltration to low temperature drying.

10 41. Product produced by the method as in any one of claims 29 to 39.

15 42. Method for removal of protein from non-stabilized crustacean shell wastes, comprising grinding said crustacean wastes and water to a relatively small particulate size, transferring said small particulate size product to a digester, adding a predetermined quantity of krill enzymes to said digester, subjecting said mixture to digestion for a predetermined time period at a predetermined  
20 temperature, dewatering said digested product to obtain a first portion being relatively enzymatically active and relatively high in protein and a second portion of shell material relatively high in chitin and low in protein.

25 43. Method for removal of protein from acid stabilized shell wastes comprising grinding said crustacean wastes to a described small particulate size, transferring desired size shell wastes to a digester, adding a predetermined quantity of krill enzymes to said digester,  
0 subjecting said mixture to digestion for a predetermined

- 41 -

time period at a predetermined temperature, dewatering said digested product to obtain a first portion being relatively enzymatically active and relatively high in protein and a second portion of shell ash relatively high in chitin and low in protein.

44. Method as in claim 42 and further comprising drying said liquid portion by means of low temperature drying to preserve the enzymatic activity.

45. Method as in claim 44 wherein said drying is by way of a flash drier.

46. Method as in claim 45 wherein said drying is by way of a fluidized bed drier.

47. Method as in claim 42 and further comprising adding krill enzyme material to said shell material portion.

48. Method as in claim 43 and further comprising adding krill enzyme material to said shell material portion.

49. Method as in claim 42 wherein said product is subject to digestion between approximately 0-70 degrees Celsius and for times between 30 minutes and several hours.

- 42 -

50. Method as in claim 43 wherein said product is subject to digestion between approximately 0-70 degrees Celsius.

5 51. Method of producing a concentrated krill hydrolysate comprising the steps of harvesting, digesting and evaporating the krill hydrolysate to provide a partial hydrolysis for a predetermined time and temperature so as to enhance the nutrient characteristics of said krill.

10 52. Method of producing a dry krill premix or feedstuff comprising the steps of producing a predetermined amount of concentrated krill hydrolysate, producing a predetermined amount of dry matter and mixing  
15 said concentrated krill hydrolysate and said dry carrier matter and co-drying said mixture.

20 54. Method as in claim 52 wherein the dry matter is selected from the group of vegetable and/or vegetable and/or animal protein meals and by products.



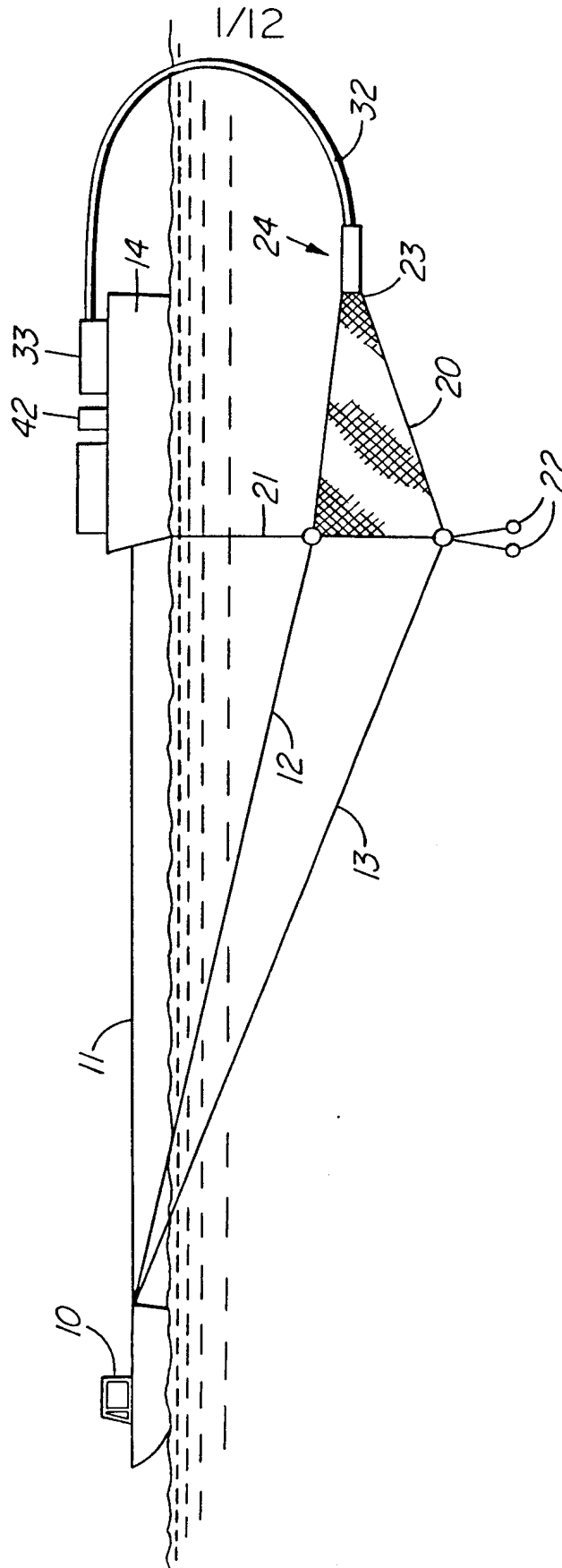


FIG. 1A

SUBSTITUTE SHEET (RULE 26)

2/12

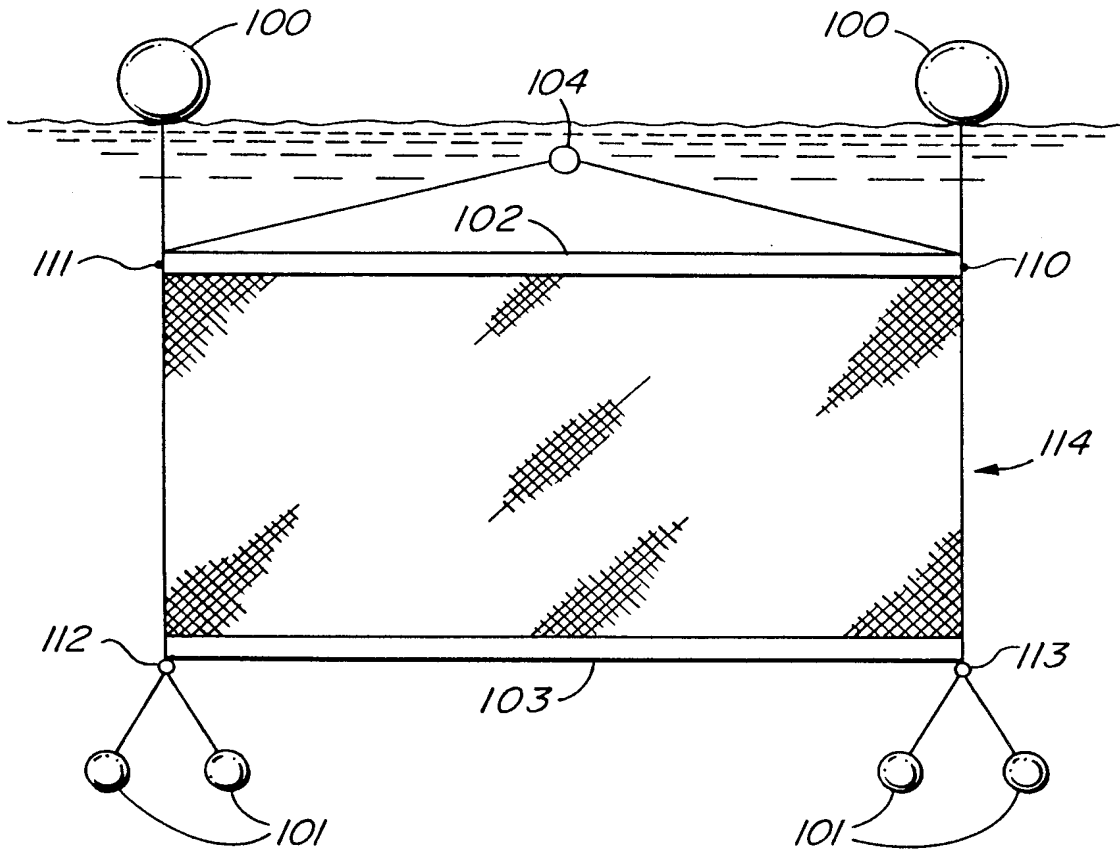


FIG. 1B

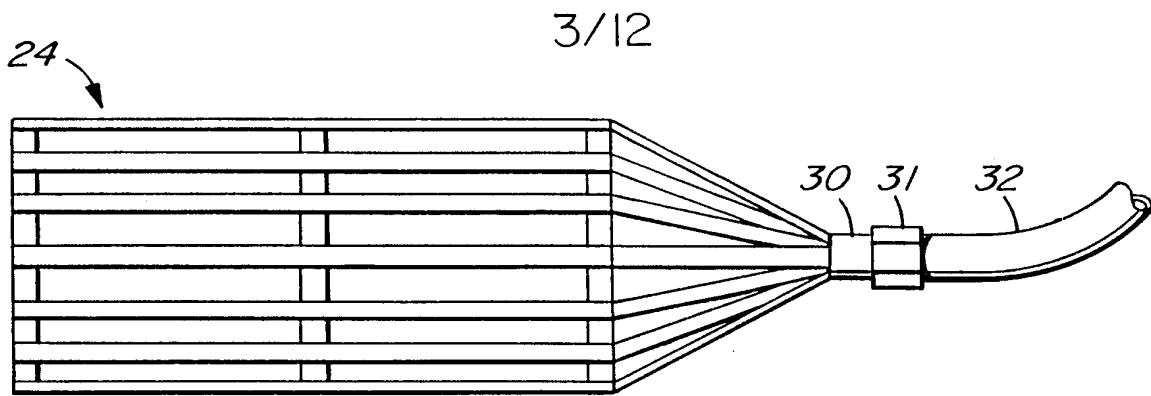


FIG. 2A

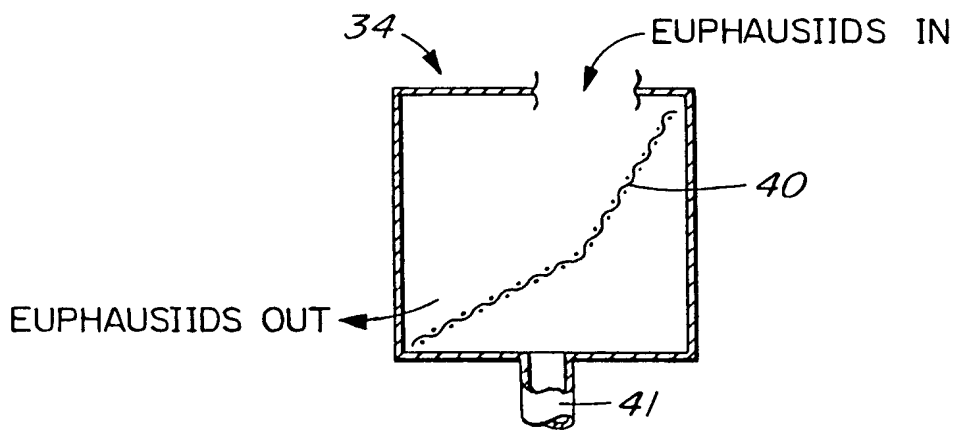


FIG. 2B

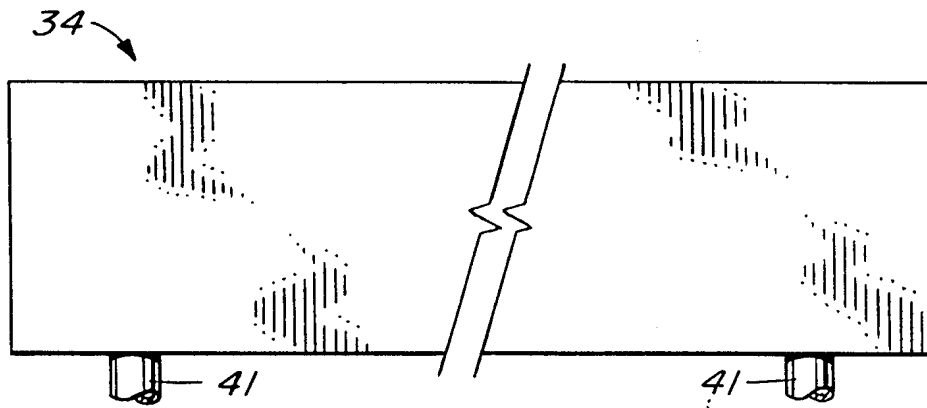
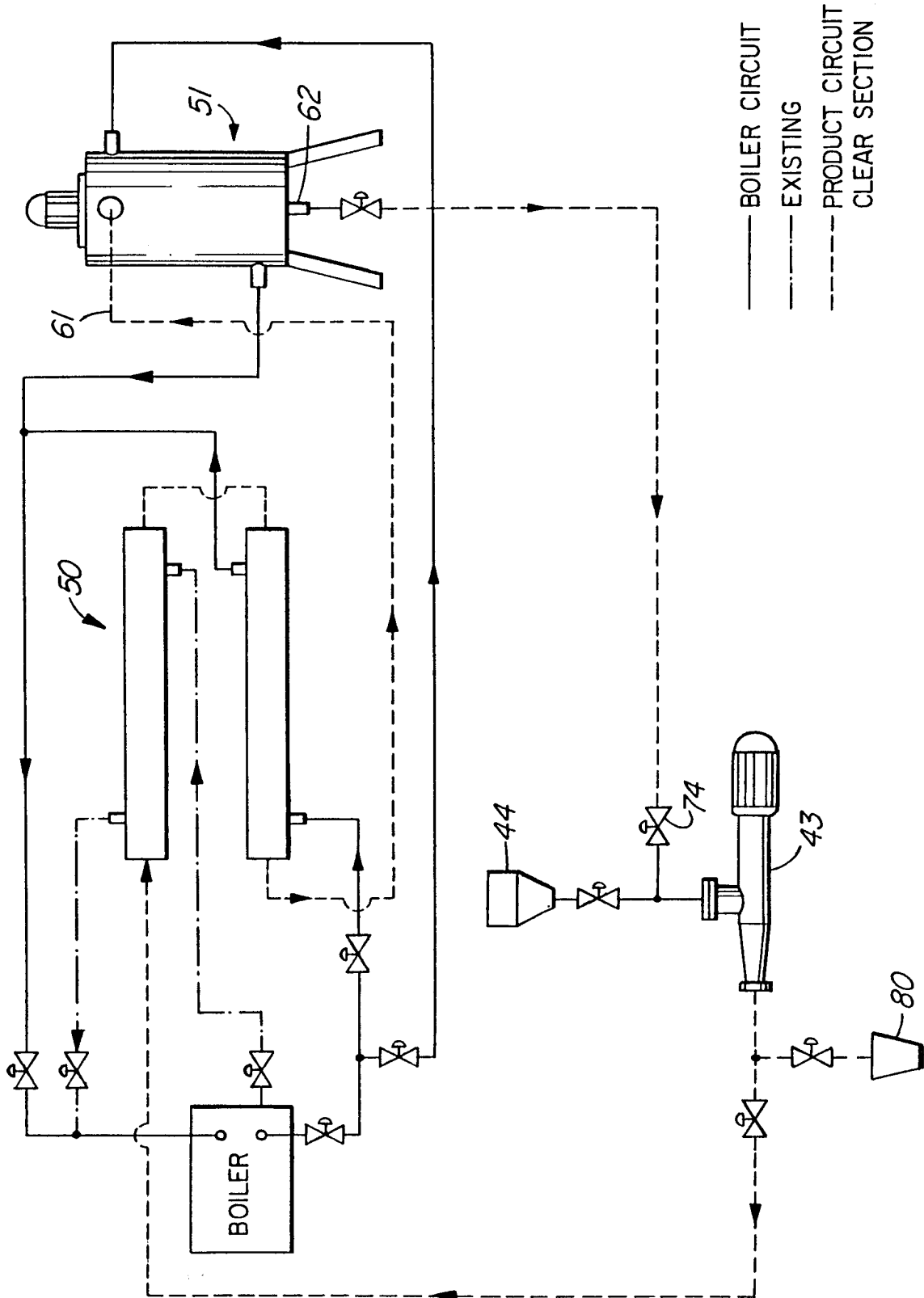


FIG. 2C

4/12



— BOILER CIRCUIT  
- - - EXISTING  
- · - · - PRODUCT CIRCUIT  
CLEAR SECTION

FIG. 3

SUBSTITUTE SHEET (RULE 26)

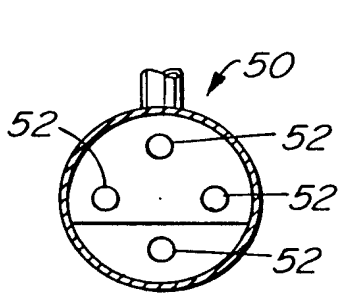


FIG. 4A

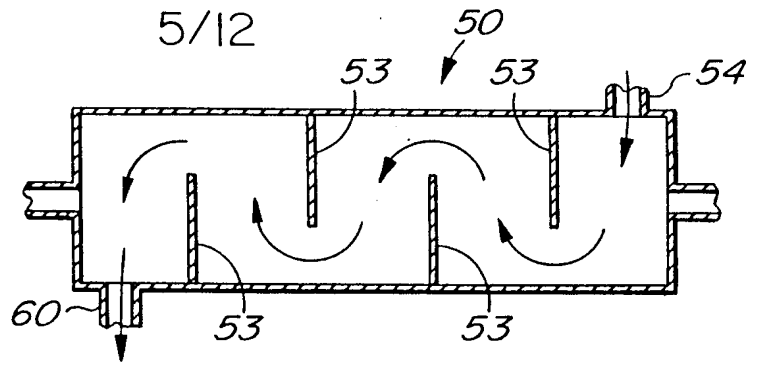


FIG. 4B

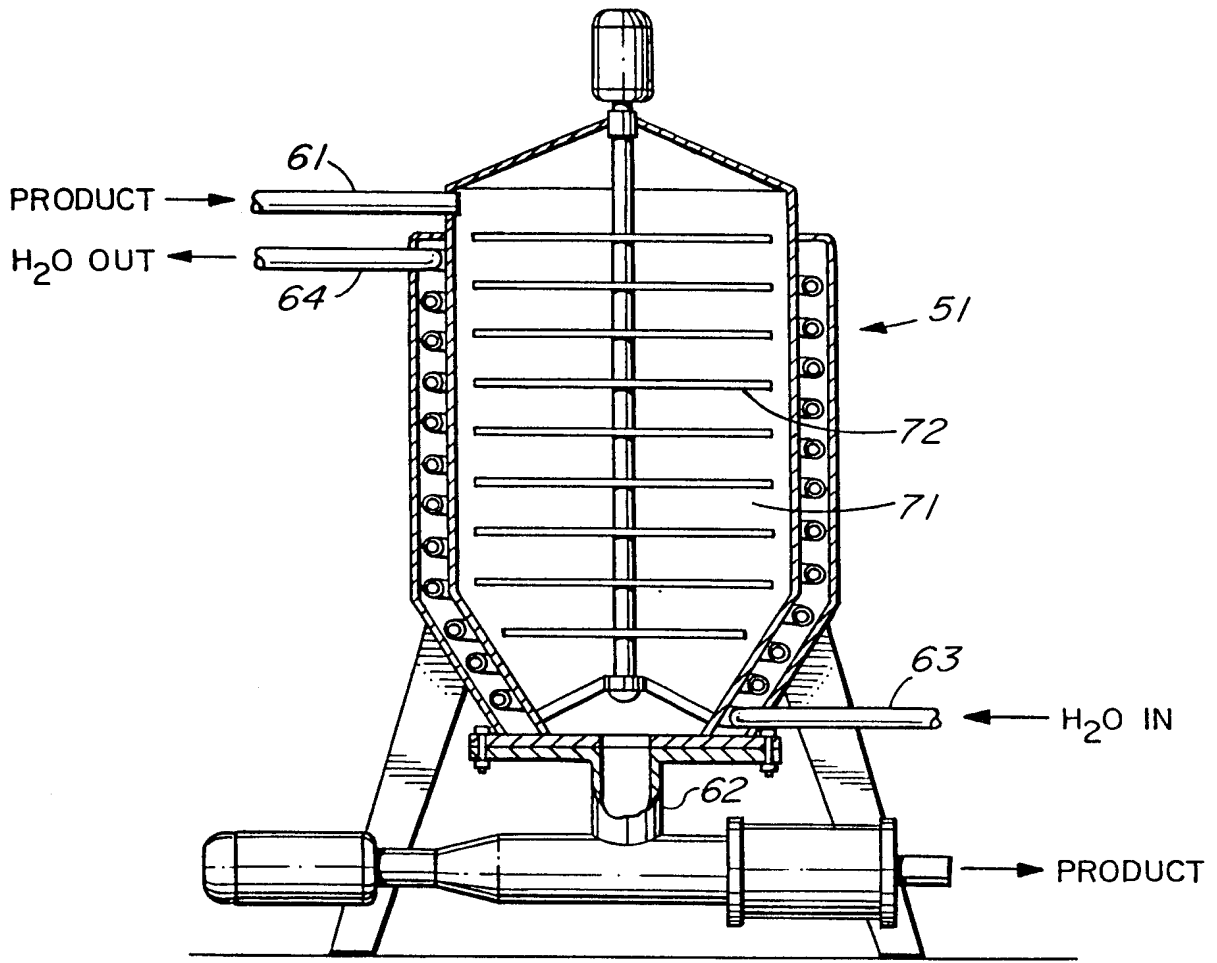


FIG. 5

SUBSTITUTE SHEET (RULE 26)

6/12

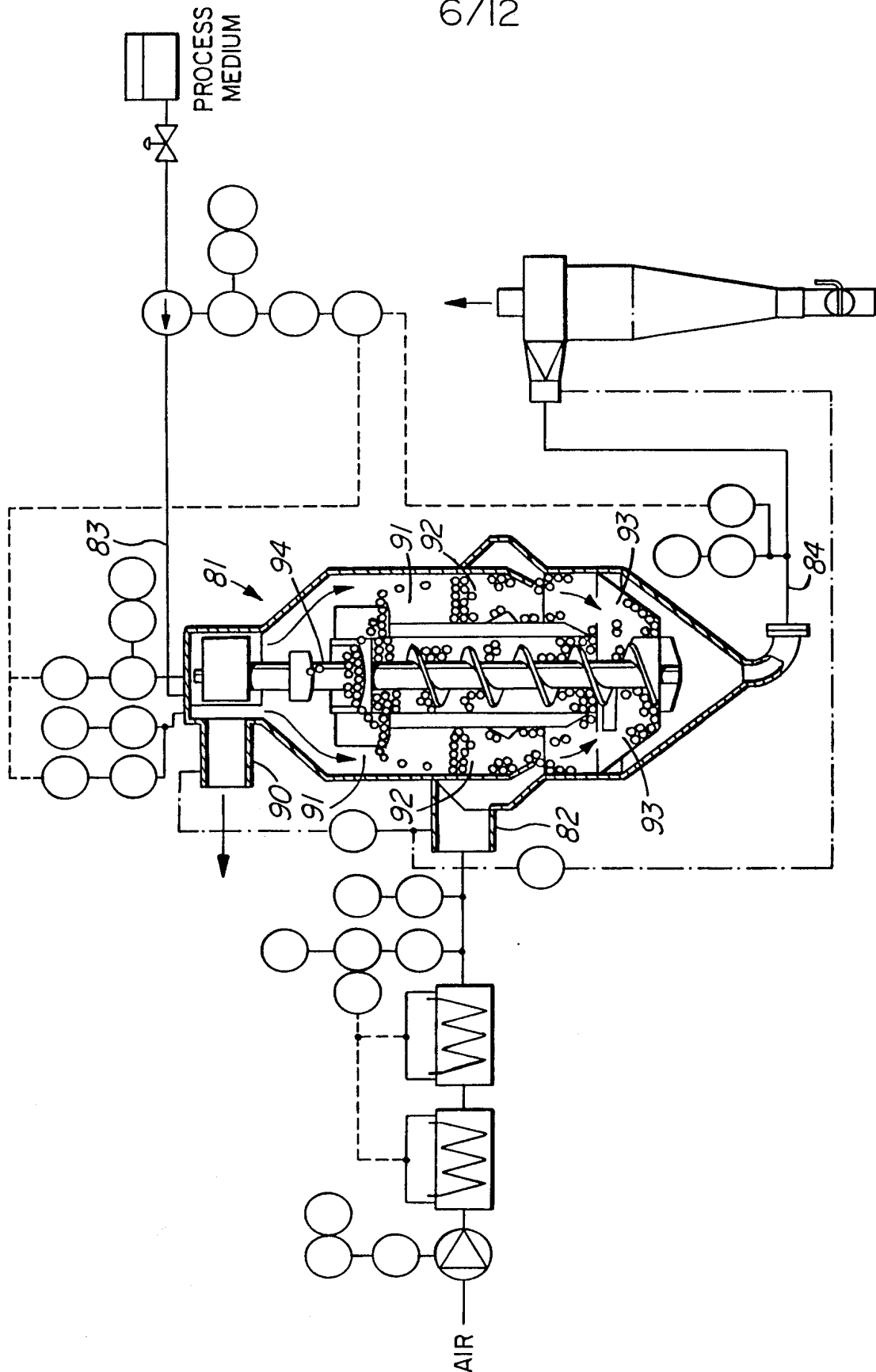


FIG. 6

7/12

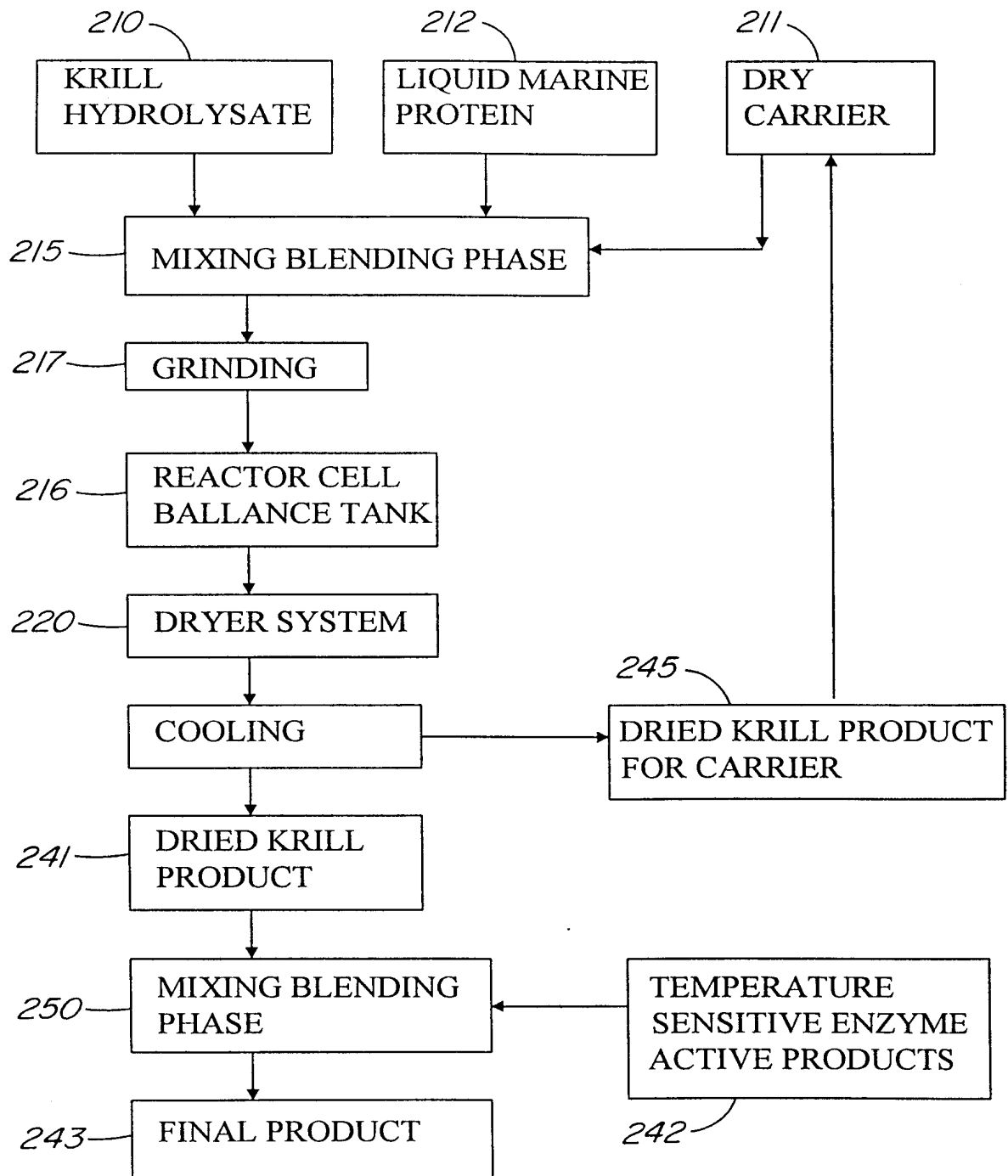


FIG. 7

SUBSTITUTE SHEET (RULE 26)

8/12

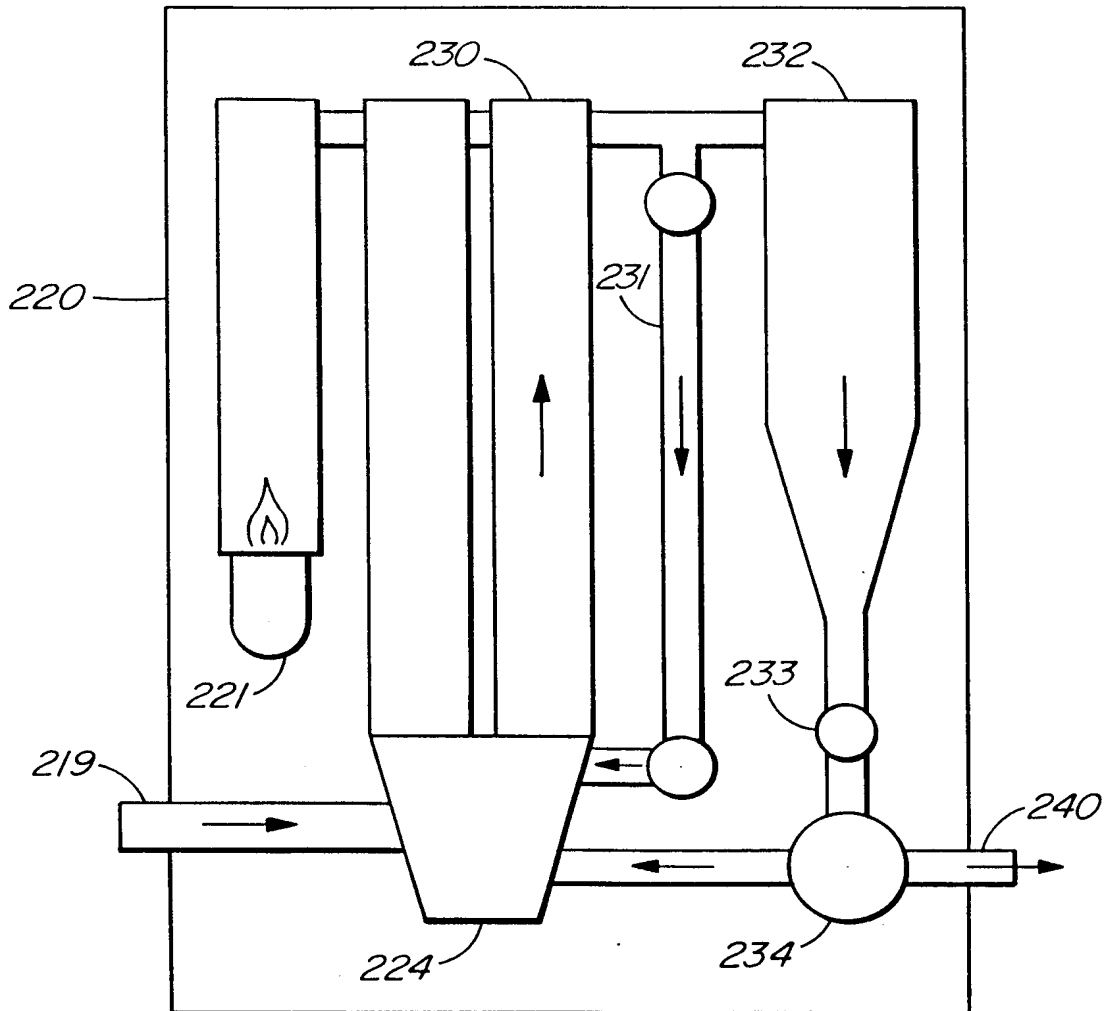


FIG. 8



9/12

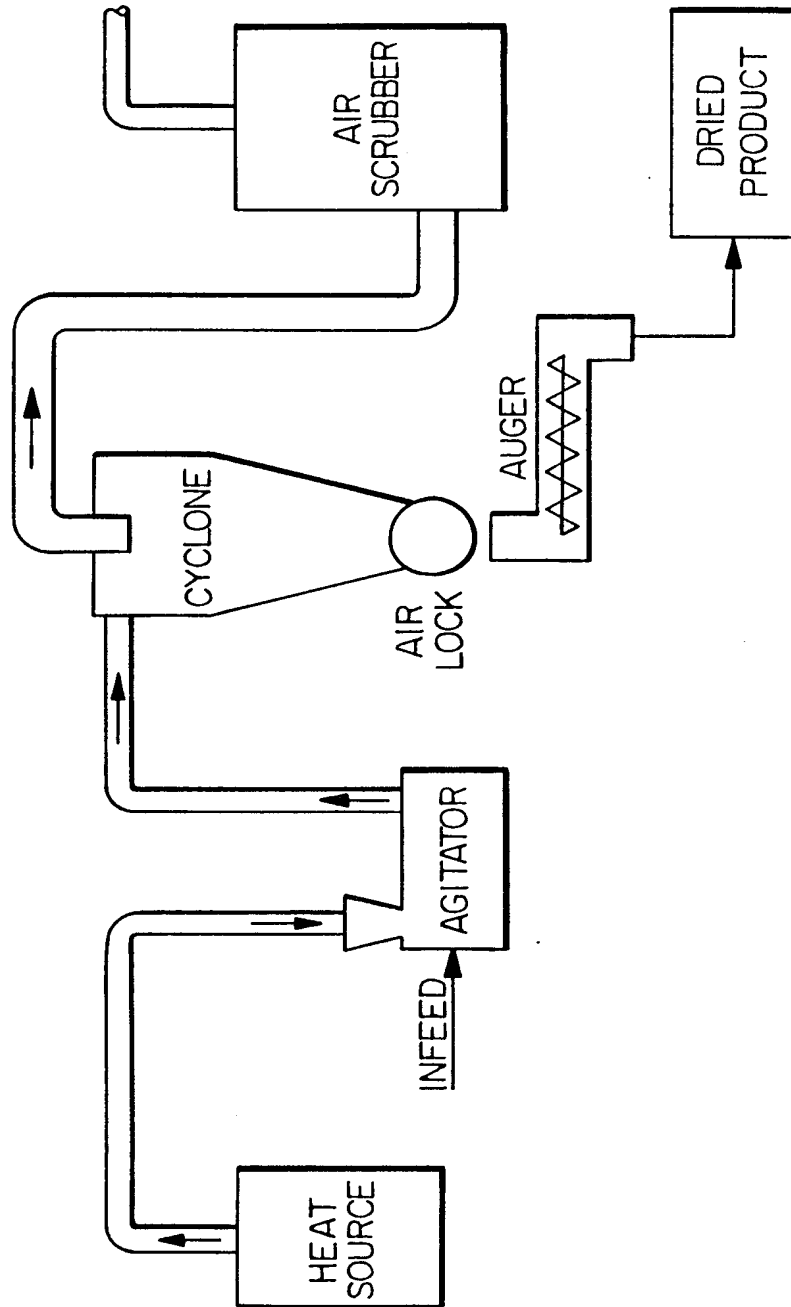


FIG. 9

10/12

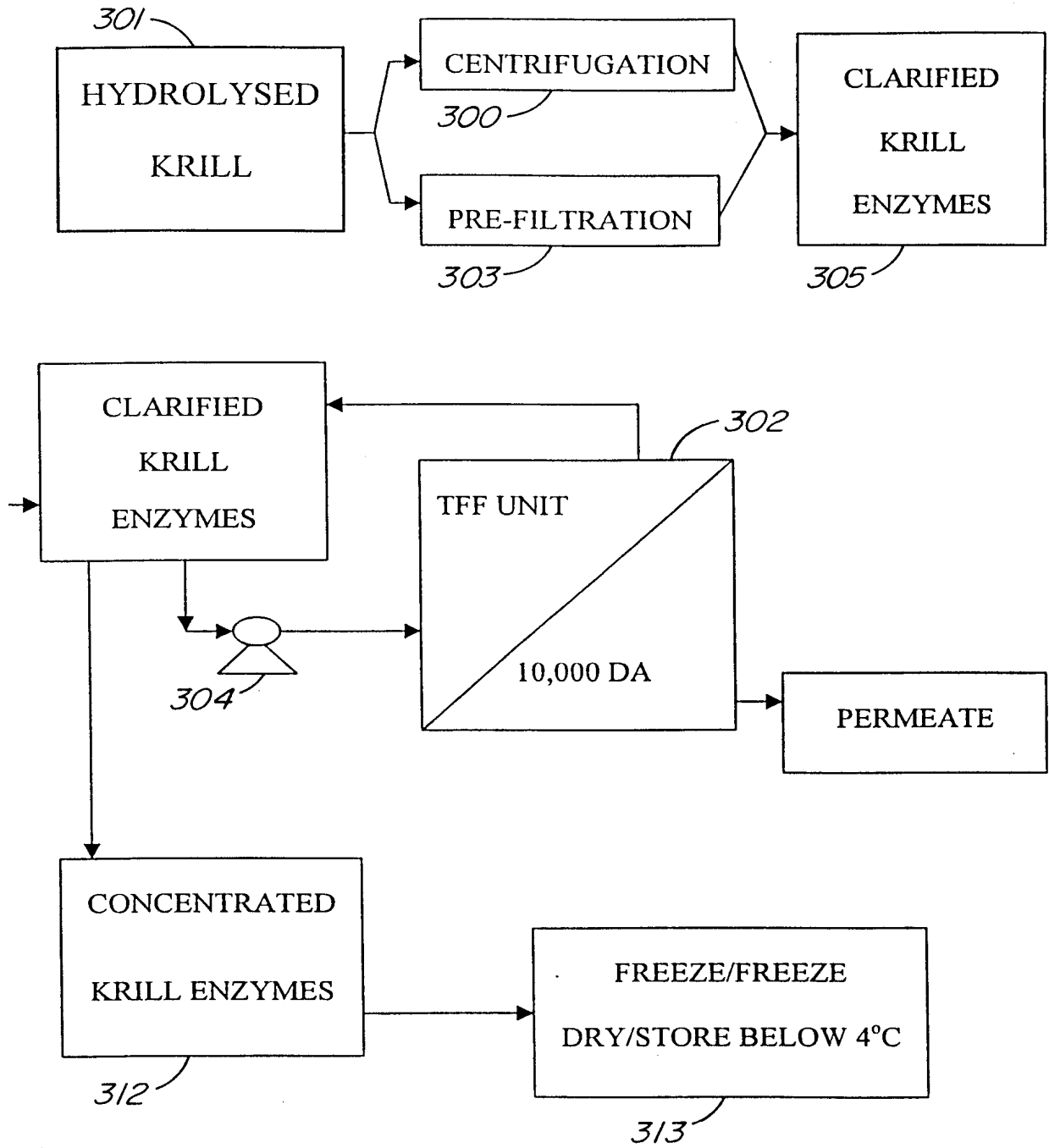


FIG. 10

11/12

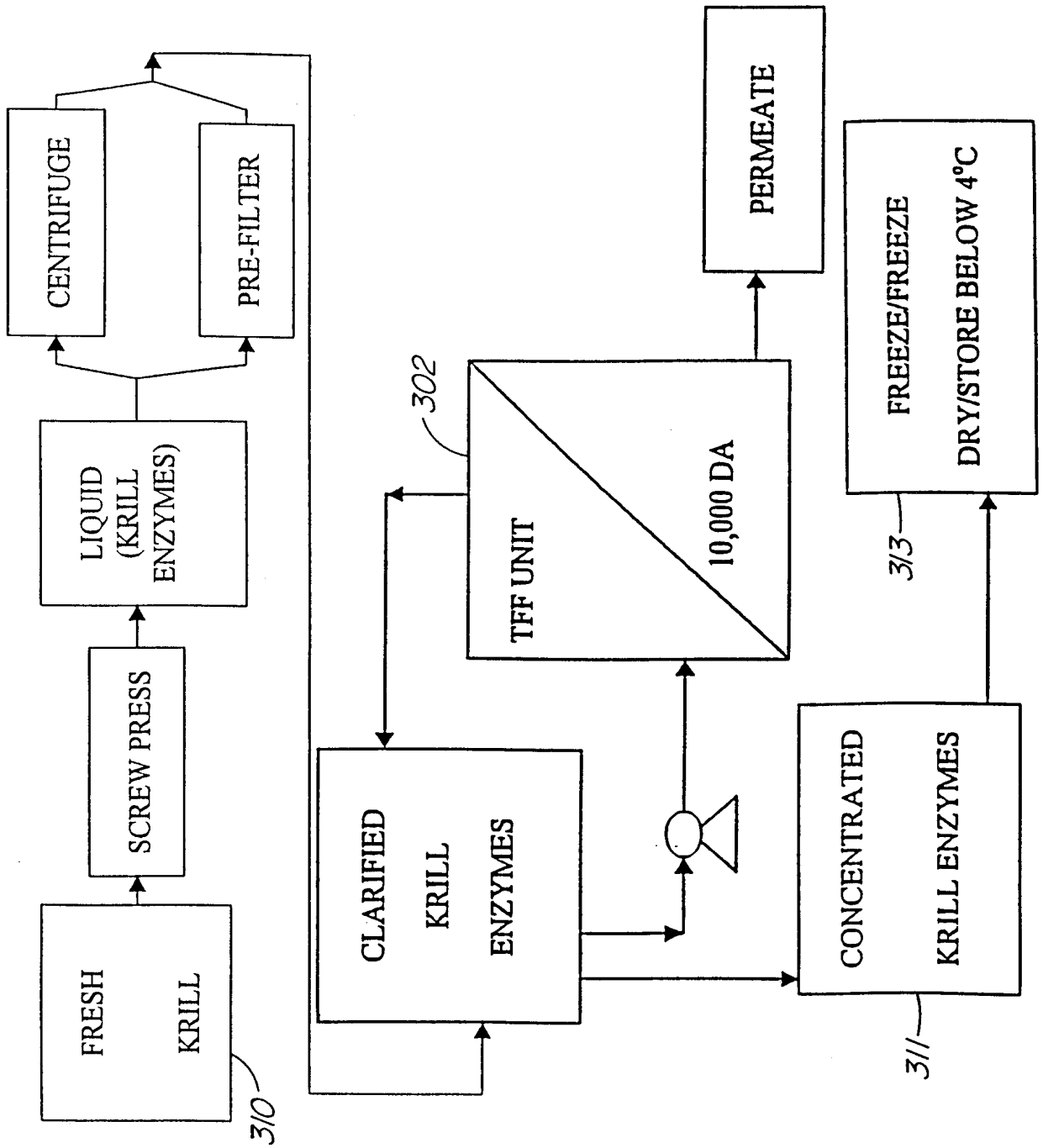


FIG. 11

12/12

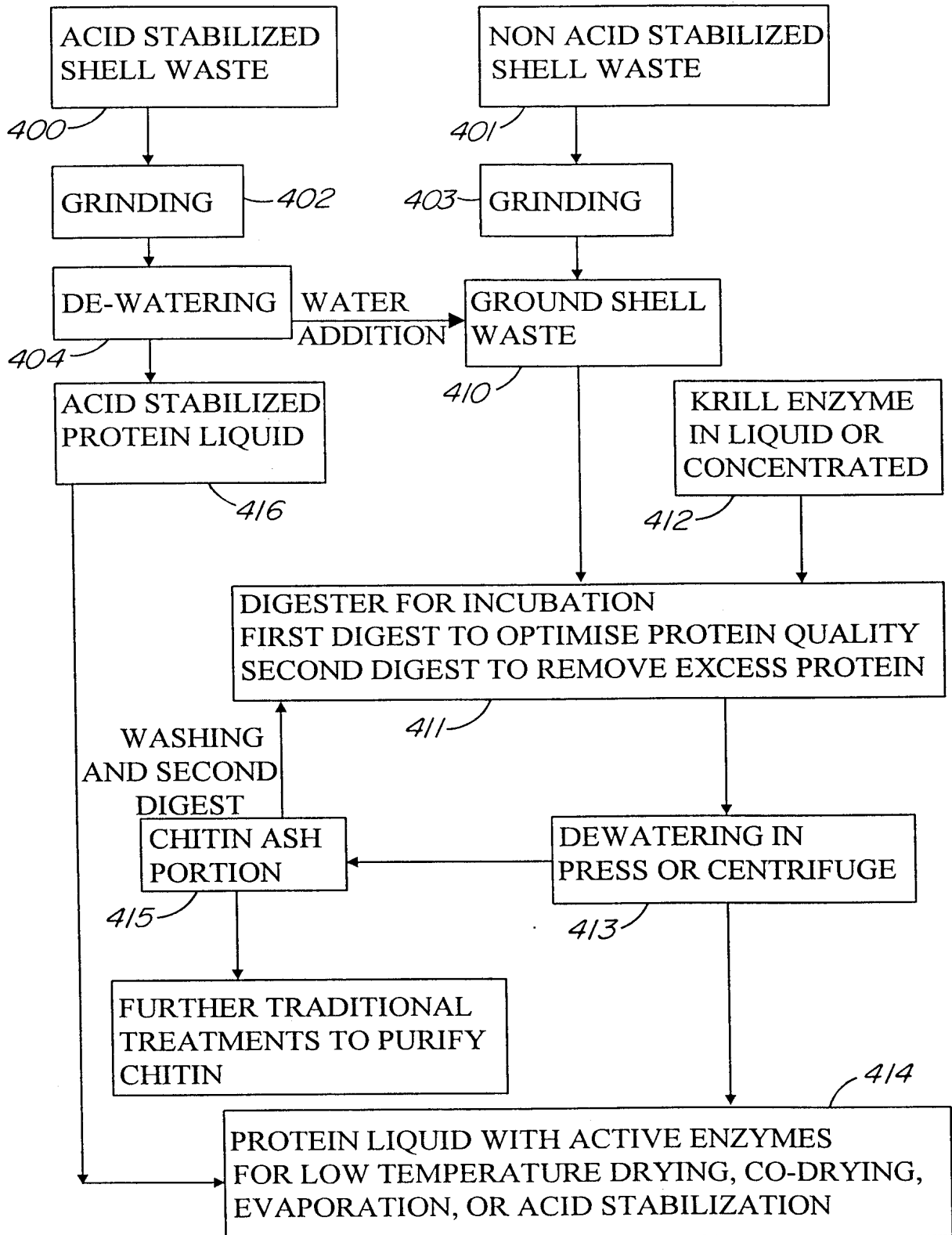


FIG. 12

# INTERNATIONAL SEARCH REPORT

International Application No  
PCT/CA 98/00082

**A. CLASSIFICATION OF SUBJECT MATTER**  
 IPC 6 A23K1/10 A23K1/16 A23K1/18 A23N17/00 C12N9/00  
 A23J1/04

According to International Patent Classification (IPC) or to both national classification and IPC

**B. FIELDS SEARCHED**

Minimum documentation searched (classification system followed by classification symbols)  
 IPC 6 A23K C12N A23J A23N

Documentation searched other than minimum documentation to the extent that such documents are included in the fields searched

Electronic data base consulted during the international search (name of data base and, where practical, search terms used)

**C. DOCUMENTS CONSIDERED TO BE RELEVANT**

Category *	Citation of document, with indication, where appropriate, of the relevant passages	Relevant to claim No.
X	DATABASE WPI Section Ch, Week 8447 Derwent Publications Ltd., London, GB; Class C03, AN 84-293719 XP002070859 & SU 1 084 005 A (N BASSIN FISHING IND) see abstract	1, 20, 52
X	WO 95 22893 A (SPECIALTY MARINE FEEDS INC) 31 August 1995 see page 15, line 19 - page 17, line 19 see claims 11-28, 30-46 -/--	51

Further documents are listed in the continuation of box C.       Patent family members are listed in annex.

\* Special categories of cited documents :

<p>"A" document defining the general state of the art which is not considered to be of particular relevance</p> <p>"E" earlier document but published on or after the international filing date</p> <p>"L" document which may throw doubts on priority claim(s) or which is cited to establish the publication date of another citation or other special reason (as specified)</p> <p>"O" document referring to an oral disclosure, use, exhibition or other means</p> <p>"P" document published prior to the international filing date but later than the priority date claimed</p>	<p>"T" later document published after the international filing date or priority date and not in conflict with the application but cited to understand the principle or theory underlying the invention</p> <p>"X" document of particular relevance; the claimed invention cannot be considered novel or cannot be considered to involve an inventive step when the document is taken alone</p> <p>"Y" document of particular relevance; the claimed invention cannot be considered to involve an inventive step when the document is combined with one or more other such documents, such combination being obvious to a person skilled in the art.</p> <p>"&amp;" document member of the same patent family</p>
--	--

Date of the actual completion of the international search  <b>8 July 1998</b>	Date of mailing of the international search report  <b>21/07/1998</b>
---	---

Name and mailing address of the ISA European Patent Office, P.B. 5818 Patentlaan 2 NL - 2280 HV Rijswijk Tel. (+31-70) 340-2040, Tx. 31 651 epo nl, Fax: (+31-70) 340-3016	Authorized officer  <b>Dekeirel, M</b>
--	--

1

INTERNATIONAL SEARCH REPORT

International Application No  
PCT/CA 98/00082

C.(Continuation) DOCUMENTS CONSIDERED TO BE RELEVANT		
Category	Citation of document, with indication, where appropriate, of the relevant passages	Relevant to claim No.
X	WO 89 01031 A (PHARMACIA AB) 9 February 1989 see page 5, paragraph 2 see page 7, paragraph 1 see examples 1-3 see claim 1	29-34, 41
A	---	35-40
X	WO 89 10960 A (PHARMACIA AB) 16 November 1989 see page 8, last paragraph see page 11, paragraph 3 - paragraph 5 see page 14, paragraph 3 see page 27, paragraph 4 see claims 1,7,17	42,43
X	WO 90 05026 A (AKT CONSULTANTS) 17 May 1990 see figure 1	21,27
A	---	
A	PATENT ABSTRACTS OF JAPAN vol. 017, no. 315 (C-1071), 16 June 1993 & JP 05 030923 A (RIKEN VITAMIN CO LTD), 9 February 1993, see abstract	1,20,52
A	---	
A	DATABASE WPI Section Ch, Week 9602 Derwent Publications Ltd., London, GB; Class D13, AN 96-018544 XP002070860 & RU 2 034 492 C (TROITSKII B N) see abstract	1,20,52
	-----	

# INTERNATIONAL SEARCH REPORT

Information on patent family members

International Application No PCT/CA 98/00082
---

Patent document cited in search report	Publication date	Patent family member(s)	Publication date
WO 9522893    A	31-08-1995	CA 2134515 A	28-04-1996
		AU 1802695 A	11-09-1995
		CN 1146709 A	02-04-1997
		EP 0758842 A	26-02-1997
		FI 963343 A	27-08-1996
		JP 10500004 T	06-01-1998
WO 8901031    A	09-02-1989	AT 124085 T	15-07-1995
		AU 2259788 A	01-03-1989
		DE 3854050 D	27-07-1995
		EP 0393035 A	24-10-1990
		JP 2504465 T	20-12-1990
WO 8910960    A	16-11-1989	NONE	
WO 9005026    A	17-05-1990	AU 4518389 A	28-05-1990
		CA 2002193 A	03-05-1990
		DK 158990 A	22-08-1990
		EP 0403608 A	27-12-1990
		GR 89100729 A	31-12-1990
		PT 92192 A, B	31-05-1990
		US 5105560 A	21-04-1992



## INTERNATIONAL APPLICATION PUBLISHED UNDER THE PATENT COOPERATION TREATY (PCT)

<b>(51) International Patent Classification <sup>6</sup> :</b> <b>A23K 1/10, 1/16, 1/18, A23J 1/04, A23N 17/00, C12N 9/00</b>	<b>A1</b>	<b>(11) International Publication Number:</b> <b>WO 99/39589</b> <b>(43) International Publication Date:</b> 12 August 1999 (12.08.99)
<b>(21) International Application Number:</b> PCT/CA99/00075 <b>(22) International Filing Date:</b> 9 February 1999 (09.02.99) <b>(30) Priority Data:</b> 09/020,695                      9 February 1998 (09.02.98)                      US <b>(71) Applicant (for all designated States except US):</b> BIOZYME SYSTEMS INC. [CA/CA]; 4160 Marine Drive, West Vancouver, British Columbia V7V 1N6 (CA). <b>(71)(72) Applicants and Inventors:</b> SAXBY, David, J. [CA/CA]; 4727 South Piccadily, West Vancouver, British Columbia V7W 1J8 (CA). SPENCE, John, A. [CA/CA]; 2025 Gisby Street, West Vancouver, British Columbia V7V 4N2 (CA). SAXBY, Gregar [CA/CA]; 4727 South Piccadily, West Vancouver, British Columbia V7W 1J8 (CA). ALOISE, Pedro [CA/CA]; 202-1725 Osoyoos Crescent, Vancouver, British Columbia V6T 1X7 (CA). <b>(74) Agent:</b> UREN, John, Russell; Suite 202, 1590 Bellevue Avenue, West Vancouver, British Columbia V7V 1A7 (CA).		<b>(81) Designated States:</b> AL, AM, AT, AU, AZ, BA, BB, BG, BR, BY, CA, CH, CN, CU, CZ, DE, DK, EE, ES, FI, GB, GE, GH, GM, HU, ID, IL, IS, JP, KE, KG, KP, KR, KZ, LC, LK, LR, LS, LT, LU, LV, MD, MG, MK, MN, MW, MX, NO, NZ, PL, PT, RO, RU, SD, SE, SG, SI, SK, SL, TJ, TM, TR, TT, UA, UG, US, UZ, VN, YU, ZW, ARIPO patent (GH, GM, KE, LS, MW, SD, SZ, UG, ZW), Eurasian patent (AM, AZ, BY, KG, KZ, MD, RU, TJ, TM), European patent (AT, BE, CH, CY, DE, DK, ES, FI, FR, GB, GR, IE, IT, LU, MC, NL, PT, SE), OAPI patent (BF, BJ, CF, CG, CI, CM, GA, GN, GW, ML, MR, NE, SN, TD, TG).  <b>Published</b> <i>With international search report.</i> <i>Before the expiration of the time limit for amending the claims and to be republished in the event of the receipt of amendments.</i>
<b>(54) Title:</b> METHOD AND APPARATUS FOR PROCESSING KRILL HYDROLYSATES		
<b>(57) Abstract</b>  Method and apparatus used in producing a feed product or premix and the products made by the method. A predetermined quantity of krill hydrolysate is added to a predetermined quantity of dry carrier with or without a predetermined quantity of liquid marine protein. The mixture is subject to evaporation and drying steps in which relatively heavier particles are separated from relatively lighter particles. The mixture may be blended, ground and subject to chemical reaction in a balance tank prior to entering a dryer. The dryer utilises a warm air source, a tower and a cyclone to dry the mixture following its entry into the dryer. Temperature sensitive enzymes or other bioactive products may be added to the product produced from the dryer. A method for obtaining enzymes from a fresh krill extract or an autolysed krill preparation and the product are also disclosed. A method for separating the bound protein and pigments from crustacean waste using krill enzymes and a product produced by the method are also described.		



**FOR THE PURPOSES OF INFORMATION ONLY**

Codes used to identify States party to the PCT on the front pages of pamphlets publishing international applications under the PCT.

<b>AL</b>	Albania	<b>ES</b>	Spain	<b>LS</b>	Lesotho	<b>SI</b>	Slovenia
<b>AM</b>	Armenia	<b>FI</b>	Finland	<b>LT</b>	Lithuania	<b>SK</b>	Slovakia
<b>AT</b>	Austria	<b>FR</b>	France	<b>LU</b>	Luxembourg	<b>SN</b>	Senegal
<b>AU</b>	Australia	<b>GA</b>	Gabon	<b>LV</b>	Latvia	<b>SZ</b>	Swaziland
<b>AZ</b>	Azerbaijan	<b>GB</b>	United Kingdom	<b>MC</b>	Monaco	<b>TD</b>	Chad
<b>BA</b>	Bosnia and Herzegovina	<b>GE</b>	Georgia	<b>MD</b>	Republic of Moldova	<b>TG</b>	Togo
<b>BB</b>	Barbados	<b>GH</b>	Ghana	<b>MG</b>	Madagascar	<b>TJ</b>	Tajikistan
<b>BE</b>	Belgium	<b>GN</b>	Guinea	<b>MK</b>	The former Yugoslav Republic of Macedonia	<b>TM</b>	Turkmenistan
<b>BF</b>	Burkina Faso	<b>GR</b>	Greece			<b>TR</b>	Turkey
<b>BG</b>	Bulgaria	<b>HU</b>	Hungary	<b>ML</b>	Mali	<b>TT</b>	Trinidad and Tobago
<b>BJ</b>	Benin	<b>IE</b>	Ireland	<b>MN</b>	Mongolia	<b>UA</b>	Ukraine
<b>BR</b>	Brazil	<b>IL</b>	Israel	<b>MR</b>	Mauritania	<b>UG</b>	Uganda
<b>BY</b>	Belarus	<b>IS</b>	Iceland	<b>MW</b>	Malawi	<b>US</b>	United States of America
<b>CA</b>	Canada	<b>IT</b>	Italy	<b>MX</b>	Mexico	<b>UZ</b>	Uzbekistan
<b>CF</b>	Central African Republic	<b>JP</b>	Japan	<b>NE</b>	Niger	<b>VN</b>	Viet Nam
<b>CG</b>	Congo	<b>KE</b>	Kenya	<b>NL</b>	Netherlands	<b>YU</b>	Yugoslavia
<b>CH</b>	Switzerland	<b>KG</b>	Kyrgyzstan	<b>NO</b>	Norway	<b>ZW</b>	Zimbabwe
<b>CI</b>	Côte d'Ivoire	<b>KP</b>	Democratic People's Republic of Korea	<b>NZ</b>	New Zealand		
<b>CM</b>	Cameroon		Republic of Korea	<b>PL</b>	Poland		
<b>CN</b>	China	<b>KR</b>	Republic of Korea	<b>PT</b>	Portugal		
<b>CU</b>	Cuba	<b>KZ</b>	Kazakstan	<b>RO</b>	Romania		
<b>CZ</b>	Czech Republic	<b>LC</b>	Saint Lucia	<b>RU</b>	Russian Federation		
<b>DE</b>	Germany	<b>LI</b>	Liechtenstein	<b>SD</b>	Sudan		
<b>DK</b>	Denmark	<b>LK</b>	Sri Lanka	<b>SE</b>	Sweden		
<b>EE</b>	Estonia	<b>LR</b>	Libertia	<b>SG</b>	Singapore		

5

10

TITLE OF THE INVENTION

METHOD AND APPARATUS FOR PROCESSING KRILL HYDROLYSATES

15

INTRODUCTION

20

This invention relates to a method and apparatus used in producing a feed product or premix and the product made by the method and, more particularly, to a process using co-drying to dry a mixture of krill hydrolysate and dry carrier or a mixture of krill hydrolysate, fish hydrolysate and dry carrier. The invention further relates to recovering enzymes from krill and, more particularly, to recovering enzymes from both freshly harvested and hydrolyzed krill. The invention further relates to utilising krill enzymes for removing protein from marine and biological wastes and, more particularly, for removing

25

30

protein, chitin and other constituents from crustacean and other marine wastes.

#### BACKGROUND OF THE INVENTION

5

With the advent of increasing activity in aquaculture or fish farming in the early to mid-1980s, research has been ongoing into increasing productivity or growth rate and reducing the mortality rate of fish raised in aquaculture conditions since survival of such fish is important. One such factor relates to enhancing the nutritional value and palatability of feed used in raising such fish. In addition to the nutritional value, it is desirable to reduce the cost of feed to such fish since, typically, the feed totals approximately 40 to 50% of the cost of raising the fish. Such feed should be a high quality feed to meet the objectives of having high nutritional value to maximize growth and to reduce fish mortality.

20

The requirement for feed products in aquaculture is projected to grow substantially and, as a result, there is and will be pressure to obtain the necessary ingredients for fish food. The possibility of using zooplankton and, in particular, euphausiids, as a fish feed, appetizer or food product has been investigated and has been found to be possible and desirable, particularly as a feed product.

In addition, blends of krill hydrolysates and fish hydrolysates or any one of these with a dry carrier, can

30

- 3 -

provide alternatives to fish meals in aquaculture and other animal feed diets. Euphausiids are a natural feed harvested directly from coastal waters and have a high nutritional value but, previously, the cost of harvesting and processing such zooplankton for a feed product has been prohibitively expensive.

As well, the questions of the availability of the biomass of such zooplankton and its harvesting, handling, storage and processing are parameters that must be investigated in order to determine whether the product would be appropriate as a feed product.

Through papers written by Fulton and other authors, the use of zooplankton as a food or feed product has been contemplated for some time. In particular, antarctic krill (Euphausia superba) for human consumption have been investigated, although relatively little work has been investigated related to aquaculture. The use of Euphausia pacifica in the coastal waters of British Columbia, Canada has been considered in relation to its use in aquaculture and other animal feeds.

It appears, from those investigations, that the necessary biomass is available in coastal waters. Previously, euphausiids have been used as a pet food ingredient and some aquaculture operators have used euphausiids as a feed product. The euphausiids were used for such purposes in a frozen form after being harvested and

- 4 -

in some cases, the euphausiids were freeze dried following harvesting. This is an expensive procedure.

5 In processing feed products, it has typically been the case that the ingredients used in such feed products are heated to a high temperature around 100°C when the product is processed and dried. By heating the product to such a high temperature, it is believed that the enzymes and other proteins in the product are denatured. If, however, it is  
10 intended to utilize the product for early stage or juvenile aquaculture, which young fish have relatively undeveloped digestive systems, it is desirable that in some application, the euphausiid products maintain a certain proportion of enzymes which will assist the digestive process in juvenile  
15 and other life stages. If the theory that enzymes are advantageous in nutrition is correct, such destruction of the enzymes during the aforementioned drying process is disadvantageous.

20 It is also desirable to have a natural product, where the proteins are not denatured, available for early stage juvenile or larvae feed. In some previous products, exogenous enzymes have been added to the zooplankton mix. However, the addition of such enzymes is difficult to  
25 control and can result in a complete hydrolysis of the proteins to amino acids. The presence of free amino acids in the feed needs to be controlled since they can create an inferior product of substantially reduced value as a feed product.

30

- 5 -

It has been shown, surprisingly, that the degree of enzyme activity which results in determining the digestibility of a product, reaches a relatively constant value after a certain period of time in a natural product.

5 Recent investigations conducted by the applicant have confirmed this characteristic for Euphausia pacifica. This characteristic was first discovered in relation to Euphausia  
superba by Kubota and Sakai in a report entitled "Autolysis of Antarctic Krill Protein and Its Inactivation by Combined  
10 Effects of Temperature and pH", Transactions of the Tokyo University of Fisheries, number 2, page 53-63, March 1978. However, the antarctic krill study done by Messrs. Kubota and Sakai had the objective of limiting enzyme activity which was deleterious to obtaining a food as opposed to a  
15 feed product. Messrs. Kubota and Sakai wished to inhibit the enzymatic activity by certain processing techniques which they considered desirable when the product was intended as a food product.

20 An appropriate degree of hydrolysis is obtained during the digestion of the euphausiids. The approximate degree of hydrolysis will vary depending on the final application and it can be monitored by measuring the apparent viscosity in the final product. Further processing  
25 may then take place in order to make a useful product for commercial feed. Such processes may include adding acid to obtain an acid stabilized product concentrating fractionating or drying the product. A variety of drying techniques such as freeze drying, spray drying, or vacuum  
30 and air drying. Spray drying, as well as some other drying

processes, however, are done at temperatures that will permanently inactivate the enzymes in the euphausiids which, as earlier mentioned, may be undesirable for aquaculture purposes although it is acceptable for purposes where the product is intended to be used as a carotenoid biopigment for coloring purposes in both feed and food products or as a source of protein, fatty acids, minerals or other nutrients.

#### SUMMARY OF THE INVENTION

10

According to one aspect of the invention, there is provided a method of producing a feed product comprising the steps of adding a predetermined quantity of krill hydrolysate to a quantity of dry carrier to produce a mixture and co-drying said mixture to obtain an end product. The dry carrier may conveniently be a plant protein, dry krill, fish meal, byproduct meal or other dry ingredient suitable for inclusion in a diet.

20

According to a further aspect of the invention, there is provided a product produced by adding a predetermined quantity of krill hydrolysate to a quantity of liquid marine protein and a quantity of dry carrier to produce a mixture and co-drying said mixture.

25

According to a further aspect of the invention, there is provided a co-drying apparatus for drying a mixture of krill hydrolysate with or without an evaporator and liquid marine product and a dry carrier comprising a dryer

for concentrating, mixing, agitating, heating and separating particles of said mixture.

According to still a further aspect of the  
5 invention, there is provided a method of obtaining an enzyme  
extract from a liquid krill hydrolysate comprising the steps  
of subjecting said hydrolysate to decanting and then to  
centrifugation to obtain a clarified liquid and further  
subjecting said clarified liquid to ultrafiltration using a  
10 membrane with a capacity to retain said enzymes having a  
molecular weight greater than 10,000 daltons and the product  
produced by the method.

According to still a further aspect of the  
15 invention, there is provided a method of obtaining an enzyme  
extract from fresh krill comprising the steps of squeezing  
said krill to obtain an aqueous extract and subjecting said  
aqueous extract to ultrafiltration with a membrane adapted  
to retain enzymes having molecular weights above 10,000  
20 daltons and the product produced by the method.

According to still yet a further aspect of the  
invention, there is provided a method for removal of protein  
from non-stabilized or fresh crustacean shell wastes  
25 comprising grinding said crustacean wastes and water,  
transferring said product to a digester, adding a  
predetermined quantity of krill enzymes to said digester,  
subjecting said mixture to digestion for a predetermined  
time period at a predetermined temperature, dewatering said  
30 digested product to obtain a first portion being relatively



enzymatically active and relatively high in protein and a second portion of shell material relatively high in chitin and low in protein.

5                   According to still yet a further aspect of the invention, there is provided a method for removal of protein from acid stabilized shell wastes comprising grinding said crustacean wastes, transferring said small particulate size shell wastes to a digester, adding a predetermined quantity  
10 of krill enzymes to said digester, subjecting said mixture to digestion for a predetermined time period at a predetermined temperature, dewatering said digested product to obtain a first portion being relatively enzymatically active and relatively high in protein and a second portion  
15 of shell material relatively high in chitin and low in protein.

BRIEF DESCRIPTION OF THE SEVERAL VIEWS OF THE DRAWINGS

20                   Specific embodiments of the invention will now be described, by way of example only, with the use of drawings in which:

25                   Figure 1A is a diagrammatic isometric view of a fishing vessel with an attached net which utilizes the euphausiid harvesting technique according to the invention;

30                   Figure 1B is a diagrammatic front view of a net in an alternative harvesting technique according to the invention;

Figure 2A is a diagrammatic side view of a cage which is used to maintain the cod end of the fishing net illustrated in Figure 1 in an open position and which is further used to transport the harvested euphausiids to the harvesting vessel;

Figures 2B and 2C are side and rear views, respectively, of the dewatering trough used to remove water from the harvested euphausiids;

10

Figure 3 is a diagrammatic process chart illustrating the processing of the euphausiids subsequent to the dewatering steps illustrated in Figure 2 and prior to the drying step;

15

Figures 4A and 4B are end and side sectional views of the heat exchanger used to raise the temperature of the harvested euphausiids prior to the digester process;

20

Figure 5 is a diagrammatic side sectional view of the digester used to create the desired enzyme activity within the euphausiids;

Figure 6 is a diagrammatic side sectional view of a ball drier used to dry the euphausiids following removal of the euphausiids from the surge tank located downstream from the digester;

25

Figure 7 is a flow chart illustrating the process of co-drying the product according to the invention;

30

- 10 -

Figure 8 is a diagrammatic view of the dehydrator used in the co-drying process according to the invention;

5 Figure 9 is a diagrammatic view of the codrying process according to a further aspect of the present invention;

10 Figure 10 is a diagrammatic flow chart illustrating the enzyme extraction process utilising hydrolysed krill;

15 Figure 11 is a diagrammatic flow chart illustrating the enzyme extraction process utilising fresh krill; and

20 Figure 12 is a diagrammatic flow chart illustrating the removal of protein and other constituents from crustacean wastes using krill enzymes according to a further aspect of the present invention.

#### DESCRIPTION OF SPECIFIC EMBODIMENT

Referring now to the drawings, a towing vessel 10 is illustrated in Figure 1. A plurality of towing ropes 11, 12, 13 are connected to the towing vessel 10 in order to tow a barge 14 and a net 20. A plurality of ropes 21 (only one of which is shown) are connected to the net 20 and extend downwardly from the barge 14. Weights 22 are connected to the bottom of the open forward facing portion of the net 20 in order to maintain the net 20 at a desired and

- 11 -

predetermined depth where the concentration of zooplankton is satisfactory.

5 The cod or rearward end 23 of the net 20 is maintained in an open condition by the use of a cage generally illustrated at 24 in Figure 2. Cage 24 is of cylindrical configuration and is positioned within the cod end of net 20. It is made from aluminum and is preferably corrosion resistant. A fitting 30 is welded to the  
10 downstream end of the cage 24 and one end of a swivel connection 31 is joined to the fitting 30 to prevent fouling the net in the event components become unstable under adverse harvesting conditions. A hose 32 is connected to the other end of the connection 31.

15

Referring again to Figure 1, hose 32 extends upwardly from the cod end of the net 20 to the barge 14. A pump of a variety of configurations but, conveniently, a diaphragm sump pump 33, is located at the other end of the  
20 hose 32 on barge 14. A dewatering trough is generally shown at 34 and is illustrated in Figures 2B and 2C. Dewatering trough 34 has a lengthwise generally rectangular configuration and is also located on barge 14. Dewatering trough conveniently takes the configuration of a "lazy L".  
25 A set of screens 40 positioned at obtuse angles are utilised to allow water to drain from the pumped euphausiids and exit the trough 34 through drain pipes 41 while the euphausiids accumulate within the dewatering trough 34.

- 12 -

A blast freezer 42 was also located on the barge 14 to stabilize the harvested euphausiids. The blast freezer 42 subjects the euphausiids to a temperature of approximately +9° to -17°C and is used to freeze the dewatered euphausiids and stabilize the product for further processing. The euphausiids accumulate within the dewatering trough 34 and which are periodically removed from the trough 34 from time to time for freezing. Thereafter, the frozen euphausiids are transported to a processing location and processed as described hereafter. Alternatively, the euphausiids may conveniently be processed aboard a vessel.

In prototype demonstrations, the net 20 utilised for the harvesting operation was a specially designed 13 ft. by 21 ft. plankton net suspended from a 46 ft. aluminum barge. The pumping action was by a three inch diaphragm pump located on the barge 14 and the freezing action occurred within a minus seventeen (-17°C) degree centigrade blast freezer 42.

As earlier described, the frozen euphausiids are transported to a processing location in order to transform the euphausiids into the desired feed product. Reference is now made to the flow chart of Figure 3.

A pump 43 is connected to a hopper 44 which receives the euphausiids which are now in a thawed condition. Pump 43 is connected to a heat exchanger generally illustrated at 50 and diagrammatically illustrated

- 13 -

in Figure 3. The heat exchanger 50 is intended to raise the temperature of the euphausiids to a temperature of approximately 40°C to 60°C which will more closely approximate the temperature maintained in the digester which is generally lower than 70°C and which digester is generally illustrated at 51. Digester 51 is located downstream of the heat exchanger 50 in the process illustrated in Figure 3.

Although several different types of heat exchangers may be used, heat exchanger 50 conveniently comprises a plurality of pipes 52 (Figure 4A) in which the euphausiids are conveyed through the heat exchanger. Heated water enters the inlet 54 of the heat exchanger 50 and is circulated through the heat exchanger 50 generally following the flow path seen in Figure 4B which utilizes a plurality of baffles 53. The heated water exits the heat exchanger at outlet 61. Following the increase of temperature created in the euphausiids by the heat exchanger 50, the euphausiids pass to the digester 51.

20

Digester 51 is seen in greater detail in Figure 5. It comprises a product inlet 61 and a product outlet 62. A water inlet 63 and a water outlet 64 are provided. A water jacket 70 through which the heated water circulates surrounds the cylindrical cavity area 71 of the digester 51 which contains the euphausiids. A plurality of stirring discs 72 are located vertically within the cavity area 71 of the digester 51 and are used to stir the euphausiids when they are positioned within the digester 51. A valve 73 is used to close the product outlet 62 so as to maintain the

30

- 14 -

euphausiids within the digester 51 until the proper temperature and time for the desired enzyme action within the euphausiids has taken place. The time period has conveniently extended between thirty (30) minutes and two  
5 (2) hours.

It is thought that a degree of hydrolysis will enhance digestibility of the feed product particularly for early stage larvae or juveniles but also for virtually all  
10 fish. This degree of hydrolysis is determined by the applications and will be monitored by measuring the apparent viscosity in the final product. In utilising the digester 51 illustrated in Figure 5, a batch process is currently  
15 being used with a volume of euphausiids of 250 lb./hr being used.

The valve 62 is then opened and the quantity of euphausiids within the digester 51 pass through the valve 62 and are transported through valve 74 to the surge tank or  
20 heated batch storage vessel 80 where they await treatment in the dryer, conveniently a ball dryer generally illustrated at 81 (Figure 6) where relatively low and controlled temperatures can be applied to the euphausiids such that any enzymes existing within the euphausiids are not inactivated  
25 as would otherwise be the case in a normal drying process.

The euphausiids pass from the storage vessel 80 to the ball dryer 81 through product inlet 83 and, thence, about the periphery of the dryer 81 initially through the  
30 application zones 91 where the balls initially contact the

- 15 -

euphausiids and begin the drying process. The ball dryer 81 performs a "soft" drying process which reduces damage to the euphausiids because of its gentle action by way of controlled temperature. The ball drying process utilises a continuous feed into the ball dryer 81 and a product flow of 15 lb./hr. is available.

As the balls and euphausiids move downwardly through the drying zones 92, they meet a counter-current flow of controlled-temperature drying air at less than 50°C which air enters the ball dryer 81 through air inlet 82. Air flow, temperature and dwell time are precisely controlled and monitored within this zone. All of these are variable factors which depend upon whether the product is wet or dried and what period of time the product is intended to stay in the dryer 81.

In the separation zone 93 at the bottom of the dryer 81, the ball and euphausiids meet a co-current flow of controlled temperature air for final drying and separation. The dried euphausiids leave the ball dryer 81 through the product outlet 84 and pass to the packaging step. The drying balls are elevated by rotating helix 94 and recycled to the application zone 91 and the process continues.

One of many commercial and known dryers may be used for the air drying of the euphausiids.

It is contemplated that although the processing of the euphausiids has been described as taking place at a land



- 16 -

location, such processing steps may take place at the harvesting location on board either the harvesting vessel or another vessel conveniently located nearby. This results in advantages in that the euphausiids need not be frozen following harvesting and need not be transported to a land based processing plant thereby resulting in considerable cost savings and quality improvement. In addition, the euphausiids may be introduced directly to a low temperature dryer on board a vessel following harvesting or to an evaporator. The dried or concentrated euphausiids, after being subjected to the digester and/or the drying processes, may then be stored on the vessel until a substantial quantity of krill hydrolysate concentrate has been obtained at which time they may be transferred to another vessel for transport to the processing vessel itself which, when full, will transport the euphausiids to the shore.

Likewise and while it is desirable for the digester and drying steps to take place concurrently and sequentially in the event the euphausiids are intended to be used as a feed product for juvenile and early stage larvae.

A further harvesting technique is contemplated in Figure 1B. In this technique, weights 101 are connected to the mouth end of the net generally illustrated at 114 at the ends of the lower horizontal beam 103. Floats 100 are connected to the top horizontal beam 102 of the mouth end of the net 114. Depending on the size of the net 114, lines are connected on one end to attachment points 104, in the first instance or, alternatively, to points 110, 111, 112,

- 17 -

113 and, on the other end, to the towing vessel. The net 114 is pulled through the water gathering the zooplankton which enter the net 114 through the mouth.

5                   Many applications for the hydrolysed krill and hydrolysed krill concentrate products are also contemplated because of the desirable characteristics of the of the krill hydrolysate in which the proteins and nutritional value is retained and improved through the partial digestions of the  
10 proteins. For example, fish under stress, which is common with cultivated species raised with aquacultural techniques, are reluctant to eat and, accordingly, therapeutic drug delivery and special diets used for such marine species are difficult to use because the fish do not find such products  
15 palatable. The hydrolysed krill products and other zooplankton products according to the invention may be used with such special diets and drug delivery by creating an enhanced flavour and enhanced assimilation when the medicinal product such as a pellet is coated or mixed with  
20 the hydrolysed zooplankton product in a liquid or paste form. Likewise, while other such products may include specially added amino acids and other compounds to enhance the flavour of the product, the hydrolysed krill according to the present invention preserves, enhances and optimises  
25 the level of certain free amino acids and other flavourants thereby allowing flavour enhancement with a natural product and without the addition of amino acids or other flavourants. Likewise, the krill hydrolysates retain the protein and nutrient quality including the original  
30 pigments, fatty acids, other nutrients and mineral elements.

The activity of the enzymes, which are contained in the krill, is also retained in the hydrolysed natural product according to the invention. Such enzymes allow for enhanced digestion of feed by certain cultivated marine species by  
5 increasing the availability of peptides and free amino acids without creating additional harmful stress on such species.

Yet a further application contemplated by the present invention is the use of hydrolysed krill that is  
10 blended and codried in association with plant or vegetable protein and other dry carriers such as soymeal, corn gluten meal and canola meal in fish feed mixtures. The range of co-drying carriers used in the blending process include a wide range of dry animal or vegetable protein and feed  
15 ingredients including soy conola and other soil seed meals, coarse ground cereal gains and flours, oil seed concentrates and isolates, corn and cereal glutens, pea and pulse meals, oil seed and cereal processing by products and brans, dried yeasts, algae and other single cell organisms, milk powders,  
20 blood meal and other body fluid products, namial and poultry by products, fish and shellfish meals, and vitaminised mineral premixes. Such applications would increase the palatability, amino acid balance and other nutrient levels in the dry blended meal so that it can be used to replace  
25 fish meal in aquaculture feeds and other applications. Further enzymes in the hydrolysed krill products according to the invention are preserved following he hydrolysis and can be allowed to act on the plant proteins. The enhanced digestibility of a product combination of plant protein and  
30 hydrolysed krill is also contemplated to improve the

- 19 -

efficiency of the feed and decrease the fecal load in the environment by fish fed with diets containing such combination. This can be an important feature with the rearing of cultivated marine and freshwater species.

5 Likewise, the palatability of such non-fish meal proteins, in particular, plant proteins such as canola, corn gluten or soy meal is enhanced.

Experiments conducted to date utilize the enzymes  
10 in krill to carry out a limited hydrolysis of soy, canola and other plant proteins. For example, one part of dry canola or soy meal which has added ten percent (10%) wheat bran is blended with five (5) parts of hydrolysed krill. The hydrolysate is pumped from the digester to the feed  
15 stock hopper and the dry blend is added. The mixture is brought to the desired temperature while agitated in the digester for approximately one (1) hour. Measurements of phytic acid and the levels of the amino acids and ammonia are then taken. For example, 250 lbs. of krill is  
20 hydrolysed by bringing the krill to approximately 45° Celsius. The temperature is held for one (1) hour and is then blended with 5 lbs. of wheat bran with 45 lbs. of canola concentrate. The use of wheat bran is necessary to provide phytase, an enzyme which is absent in canola meal  
25 and krill. The phytic acid is dephosphorylated by phytase from the wheat bran. The phytic acid is acted on by the phytase enzyme. It is noted that the blend may be retained in the digester for an extended period, up to a period of four (4) hours or even longer.

30

In yet a further embodiment of the invention, it is contemplated that the wet krill hydrolysate product is evaporated and then mixed with and co-dried with other wet and dry products. Various predetermined ratios of wet krill hydrolysate and liquid marine products may be concentrated and then mixed with dry carrier conveniently in the form of dried krill products, dried vegetable protein and/or dried fish product, used in combination or singly. The resulting moist blend is subject to concentration, processing and co-drying in a dehydrator such as a dryer. A dehydrator system with the following characteristics has been found to work well, namely a type of flash and fluidized drier or combination thereof with an agitator and vertical or tangential flow of heated air. Although the temperature of the inflowing air may be high at impact (the impact temperature), the temperature of the product is not significantly increased in the dryer. This is an important element in the drying system. Following hot air impact and agitation, the water evaporates rapidly and the duration of the drying process is greatly reduced as set out in greater detail hereafter.

Co-drying the mixture of the krill hydrolysate, liquid marine product and the dry carrier product mixture has been found to be relatively economical at relatively low temperatures. Under such conditions, the krill proteins, pigments and other constituents are substantially preserved. Thus produced, the product has unique benefits for dietary uses in aquaculture and animal feeds. These blended and agglomerated dry products are uniquely different

- 21 -

from other product mixes. The unique sequences and control of the process provides intimate agglomeration and adsorption of the krill hydrolysate with the dry carrier. It also preserves the unique nutrient quality of the krill hydrolysate in the blend without significant losses due to excess heat or oxidation during the drying process. Further, cost savings and economic advantages in the manufacture of the product are improved.

10                    Depending on the moisture content of the dry carrier, liquid marine protein, and the krill hydrolysate, and the proportion of each in the mixture to be co-dried, the removal of moisture can be accomplished by a drying process at relatively low temperatures thereby to preserve the temperature and oxidation sensitive constituents including the krill constituents and the krill pigments. Particles of the dry carrier are coated with, adsorbed and absorbed with the wet hydrolysate thereby facilitating the drying process by exposing a greater surface area of wet hydrolysate and/or liquid fish product for heated air to act upon. The mixture may then be fractured into smaller particles which further increases the available surface area to expedite the drying process. At the outset, the mixture may be placed in a reactor cell balance tank to permit chemical interactions between components of the mixture, such reactions including enzymatic activity of a wide range of enzymes including proteolytic, lipolytic and carbohydrate splitting enzyme prior to drying. A well-mixed, homogeneous mixture is prepared to reduce and to eliminate high moisture pockets. Water is then removed from this mixture by an

evaporator and a subsequent dehydrator such as is described above and the endproduct is a dried krill premix or feedstuff blended with the aforementioned carrier.

Temperature sensitive enzymes, flavorants or other bioactive products may be added to the cooled endproduct after the drying step. Alternatively, the krill hydrolysate may be combined with wet fish products and other carriers such as dry fish meal, corn meal, canola meal, oil seed meal, or other vegetable meals, used in combination or taken singly.

10

Referring now to the drawings, Figure 7 illustrates the steps of the co-drying process in its entirety according to the present invention. A predetermined quantity of wet krill hydrolysate product 210 is mixed with a predetermined quantity of liquid marine protein 212 and a predetermined amount of dry carrier 211, conveniently dried krill product, dried fish product and/or dried vegetable protein used in combination or taken singly. The resulting mixture is placed in a mixing blender 215, where the various ratios of hydrolysate, marine protein and dry carrier are thoroughly blended. The blending required will vary with the constitution of the mixture. The blended mixture is then ground within a grinder 217 where the mixture is reduced to particles of substantially uniform size. The ground mixture is then transferred to reactor cell balance tank 216 where the continuously stirred blended mixture is allowed to chemically react and/or undergo enzymatic action prior to the drying process. After the intended reaction has taken place in the tank 216, the mixture is conveyed to the dehydrator 220 for drying.

25

20

15

The dehydrator 220 is illustrated in greater detail in Figure 8 and with reference thereto, the mixture enters the agitator bowl 224 of the dehydrator 220 through inlet 219 where the mixture is agitated into smaller particles which is intended to prevent clumping of the mixture. A continuous feed of mixture into the dehydrator 220 is intended through inlet 219.

Directly heated air from the burner 221 or indirectly heated air is directed to the agitator bowl 224 of the dehydrator 220 by way of fans (not illustrated) where the air mixes with particles of the mixture in the bowl 224. The particles are carried up the drying tower 230 by the column of hot air. The classifier 231 sorts the particles at the top of tower 230. Drier mixture consists of lighter, individual particles which proceed along the column of hot air into a cyclone 232. The classifier 231 redirects larger and heavier masses of more damp mixture back to the agitator bowl 224 for further agitation and drying.

The particles are drawn downwards along a spiralling column of heated air in cyclone 232 and centrifugal action removes further moisture from the particles. At the bottom of the cyclone 232, the particles are isolated from the air column by airlock 233 and are sorted by a rotary screen 234. Smaller, lighter particles of dried product pass through the rotary screen 234 and exit the dehydrator 220 at outlet 240 for further processing. Larger, heavier particles of damp mixture are redirected to



the agitator bowl 224 from outlet 241 for further agitation and drying within several seconds.

5 With reference again to Figure 7, heated product 241 exiting the dehydrator 220 from outlet 240. The average transit time through the dryer is between 60 and 90 seconds and the end moisture content below 10% moisture may then be permitted to cool. Some of this dried product 245 may be further used in the co-drying process as a quantity of the  
10 dry carrier 211 so as to increase the fluid content of marine constituents. Temperature sensitive enzyme active products 242 or other bioactive products, which might be denatured by the drying process, may be introduced to the dried product 241 after the product has passed through the  
15 dehydrator 220 as illustrated. The dried product 241 then undergoes further mixing and blending at mixing step 250 to ensure the homogenous addition of the temperature sensitive enzyme active products 242. The final product 243 may then proceed to a packaging step such as a bagger 244 or to a  
20 storage bin 245 prior to further use in aquaculture or animal feeds.

Concentration and Co-Drying of Krill with Vegetable proteins Trials

25

The objectives were the concentration of liquid krill hydrolysate to 42%DM in a rising film plate evaporator. (Alfa Vap). The drying of a krill concentrate blend with soya meal and corn gluten meal in a flash dryer (drier with  
30 performance characteristics as defined), to determine the

maximum amount of krill concentrate that can be added to the dry vegetable protein meal.

5 Raw material hydrolysed krill with 18-20% DM including approximately 0.3% oil.

10 Evaporator. The hydrolysed krill was concentrated in an Alfa Vap evaporator from 18-20% DM to 42% DM. The 42% level was not obtained with any difficulty.

#### Mixing

15 The mixing was done in 100 kg batches using a cylindrical container with a vertical shaft paddle. This was accomplished without unusual difficulties.

#### Drying

20 Drying and mixing was carried out in two steps: Step 1 was mixing the krill concentrate and carrier (vegetable and protein) and drying to about 90% DM. Step 2 was mixing the dried product from step 1 with more krill concentrate and drying a second time.

#### 25 Flash Drying

30 The mixtures were dried in a flash dryer. This was done by feeding the mixture into a chamber containing a fast rotating agitator. Through intake air ducts hot air was led through the chamber and agitator.

- 26 -

Impact Temperature was 165-175 deg. C.

Drying Temperature (set point) is 110 deg. C to 125 deg C.

5 Capacity

The flow to the dryer for all three test vegetable protein products was 600-700 kg/hr. This gave an evaporation rate of approximately 500 kg/hr. in the dryer.

10

Results

The temperature of the product is not increased in the dryer by any significant amount. The evaporation of the water on the product keeps the temperature low. The rapid transit of the product through the dryer also minimizes the temperature and time effects that can reduce the value of the product as a feed.

20 A third or fourth step is also contemplated and considered possible with this type of dryer.

Other driers besides those of ball dryer 81 (Figure 6) are contemplated. For example, dryers such as direct heated flash driers or fluidized bed driers that cause rapid drying of the particles within a few seconds are well known. With reference to Figure 9, a built in air scrubber generally illustrated at 500 is used for odour control. A burner or indirect heating system 501 heats the air to the required level with impact temperatures not

30

exceeding 450 deg. C before the air enters agitator 502. the product is augered tangentially into the agitator chamber 503 where most of the water in the product is evaporated. Agitator 502 rotates with a high tangential  
5 speed of the agitator blades concurrent with the tangential air flow. The motion of the agitator 502 causes mechanical fluidization of the particles and comminutes the particles, thus accelerating evaporation. The acceleration of the drying velocity reduces the adverse effect of heat or the  
10 heat burden on the product during the drying process.

In yet a further embodiment of the invention, it is contemplated that a process for obtaining enzymes from the Euphausia superba species of krill and other krill  
15 species is of interest. Euphausia superba ("E.s.") is a small crustacean from the Antarctic that contains numerous enzymes that are principally but not exclusively represented by proteases, amylases, chitinases, carboxymethyl cellulases, lipases, etc. This enzymatic cocktail as a whole or in a  
20 partial purified form can be used for a number of industrial applications such as aquaculture and other general feed manufacturing and the further process of marine and other proteins. The inclusion rate of enzymes in the feed would vary depending on the target species and the composition of  
25 the diet. For example, these krill enzyme cocktails can be added to aquaculture diets containing large quantities of vegetable proteins which would otherwise be difficult to process by the animals and which could also be part of specialty diets for larval stages of shrimp and starter  
30 diets for salmonids where higher survival rates are

required. Krill enzymes may also conveniently be used to produce protein hydrolysates from other proteins to incorporate into diets or to improve the functional properties of these diets. Other potential applications would include the production of flavors, protein and peptide extraction from marine by products, protein and pigment recovery from shrimp and crab shell offal, the production of free amino acids and other benefits relating to the actions of these krill enzymes on biological materials.

10

Using the processes previously disclosed, it was desired to obtain enzymes from the previously autolysed krill preparations.

15

With reference to Figures 9 and 10, ultrafiltration membrane 303 was used with the krill hydrolysate 301 and with fresh krill 310. Since most of the krill-derived enzymes have molecular weights above 20,000 daltons, experiments were conducted to determine the most appropriate molecular weight cut-off ultrafiltration membrane to attempt a concentration of the aqueous phase enzyme-rich E.s. and E.p. extracts. It was revealed during experiments that total protease activity begins to become apparent in the filtrates at the 50,000 molecular weight cut off and up. On the other hand, trypsin-like activity is present in filtrates at 30,000 molecular weight cut off. It is therefore desirable to use a 10,000 dalton cut off membrane for filtration purposes.

20

25

In order to handle larger volumes of krill hydrolysate and to concentrate the enzyme extracts, a tangential flow filtration ("TFF") cartridge 302 was used using a 10,000 dalton molecular weight cut-off. One such  
5 cartridge commercially available is a Millipore Preparative Scale Tangential Flow Filtration cartridge. Such cartridges are intended to handle volumes from 100 ml to 100 liters, although it is readily possible to scale up such techniques to handle larger volumes, if desired. Before subjecting the  
10 krill extracts to TFF, they were centrifuged at 4000-10000 x G for twenty(20) minutes in a Beckman centrifuge 300 to clarify from solids and eliminate part of the fat. Rather than centrifugation, this clarification step can be replaced by prefiltration 303 with a larger pore filter. After  
15 centrifugation, the aqueous phase 305 containing the enzymes of interest was recover and stored at 4 deg. C. The autolysed krill extracts were run through a one square foot TFF cartridge 302 using a Hoechst displacement pump 304. The initial extract volume was about two(2) liters and was  
20 brought down to approximately 250-300 ml after four(4) to five(5) hours of operation (below 20 psi of pressure). It was revealed that enzymatic activity recovery differed significantly between the two samples (i.e., autolysed and freshly squeezed extracts).

25  
By measuring the trypsin-like activity ("TLA"), it was found that the recovery of krill enzymes from the fresh frozen krill 310 was relatively smaller than the recovery from hydrolysed krill 301. However, the total units  
30 recovered after ultrafiltration were higher for fresh frozen

- 30 -

extracts. Accordingly, TLA could be recovered from either freshly squeezed or autolysed krill preparations. Since there was little or no enzymatic activity associated with the filtrate, it is apparent the proteins of interest were not leaching out through the membrane filter.

The resultant enzyme cocktail obtained by the ultrafiltration technique from both the hydrolysed and fresh krill 301, 310, respectively, could then be coupled with freeze drying 313 which would reduce the amount of water associated with the enzymes significantly which would reduce transportation costs. Subsequent processing could then be performed on the enzyme cocktails to further increase the purity and quality of the enzymes present.

15

Yet a further aspect of the invention relates to a method for removal of protein from crustacean wastes using the aforementioned krill enzyme extracts. With reference to Figure 12, a quantity of crustacean wastes 400, 401 is ground to dried particulate size by grinders 402, 403, respectively, with a portion of water added to facilitate this grinding. Various of a plurality of grinders which will accomplish this include a piranha pump, a macerator or cerator, all of which are known. Acid stabilized shell waste 400 is then de-watered through a de-watering system 404, many of which are readily known to be available, such as the Vincent screw press, wine presses or centrifuges. Non acid stabilized shell waste 401 has no need to be de-watered prior to the addition of enzymes. Water is conveniently added to the de-watered acid stabilized shell

30

- 31 -

waste 410 to facilitate enzymatic reaction. The shell waste 410 is transferred to a digesting tank 411 where an amount of krill enzyme cocktail 412 is added. The enzyme cocktail can be in either a concentrated or non-concentrated form

5 consistent with squeezed extractions from the whole animal as has been described. The squeezed fractions are in the range of 25-75% of the whole animal depending on the amount of enzyme desired and the need to keep the enzyme with the krill to facilitate autolysis. The shell enzyme mixture is

10 subjected to digestion in the digester 411 for a time period in the range of one(1) to forty-eight(48) hrs at a temperature in the range of 0 to 70 Celsius with an optimum temperature being approximately 45 deg. Celsius. Following the digestive process, the mixture is subjected to water

15 removal 413 as has been described. Two fractions will result, a protein rich enzymatically active portion 414 and a shell material portion 415 high in chitin and low in protein. The liquid high protein portion 414 is low temperature dried or co-dried as earlier described or acid

20 stablized. The shell portion 415 can then be further processed by the addition of more enzyme cocktail to facilitate further protein removal in further steps or can be subjected to traditional deproteinization or demineralization techniques as illustrated generally at 420.

25 The extent of de-mineralization necessary can be greatly reduced by the storing of the shell waste for long periods of time while stabilized with acids, preferably formic.

In experiments which have been conducted to date,

30 70kg of water was added to 210 kg of mechanically peeled



- 32 -

shrimp shell wastes. The slurry was subjected to grinding with a piranha pump to a suitable particle size. 60kg of this slurry was combined with 15 kg of Euphasia superba juice obtained by squeezing whole krill through a screw  
5 press 315 (Figure 11) to obtain 50% by weight of the animal in a liquid form. The shell juice mixture was subjected to digestion for six(6) hours at 45 deg. C. The mixture was dewatered by pressing through a Vincent screw press to obtain the protein rich enzymatically active portion and the  
10 shell ash portion 415, as described. The shell portion was approximately 7.5% by weight and the liquid portion made up the remainder. The liquid portion was acid stabilized with 3% by weight formic acid. The shell portion was washed and dried.

15

In a second trial conducted to establish the efficacy of using krill enzymes for the removal of protein from shrimp shell wastes and the benefit of reincorporating the superba squeezed solids, 26 kg of squeezed superba  
20 juice, obtained through the procedures described, was incubated with 10 kg water and 70 kg of ground shrimp shell for six(6) hours at 45 deg C. Samples were taken every hour and squeezed through a screw press. After six(6) hours, 14 kg of squeezed superba solids comprising the remainder of the  
25 whole animal after enzyme liquid removal were added into the mixture and hydrolyzed for an additional one and one-half (1.5) hours. The remaining slurry was squeezed and the separate fractions were frozen.

- 33 -

While specific embodiments of the invention have been described, such descriptions should be taken as illustrative of the invention only and not as limiting its scope as defined in accordance with the accompanying claims.

5

- 34 -

## WE CLAIM:

1. Method of producing a feed product comprising the steps of adding a predetermined quantity of  
5 krill hydrolysate to a quantity of liquid marine protein and a quantity of dry carrier to produce a mixture and co-drying said mixture to obtain an end product.
2. Method as in claim 1 wherein said  
10 mixture is mixed prior to co-drying said mixture.
3. Method as in claim 2 wherein said mixture is subjected to chemical and/or enzymatic reaction for a predetermined time period prior to co-drying said  
15 mixture.
4. Method as in claim 3 wherein said mixture is co-dried in a dryer or other dehydrator.
- 20 5. Method as in claim 4 wherein said mixture is ground prior to being subject to said chemical reaction.
6. Method as in claim 5 wherein said  
25 mixture is cooled following drying of said mixture in said dryer.
7. Method as in claim 6 wherein said dry carrier may be one or a combination of dry marine protein

- 35 -

meals, dried krill products, dried vegetable and dried fish product.

8. Method as in claim 7 wherein said liquid  
5 marine protein may be liquid fish product.

9. Method as in claim 8 wherein temperature  
sensitive enzyme active or other bioactive dry products are  
added or readded to said mixture following said drying of  
10 said mixture.

10. Method as in claim 9 and further  
comprising mixing said temperature sensitive enzyme active  
products with said mixture.

15 11. Method as in claim 1 wherein said  
mixture is co-dried in a dryer or other dehydrator.

20 12. Method as in claim 11 wherein said dryer  
includes an agitator to agitate said mixture entering said  
dryer.

25 13. Method as in claim 12 wherein said dryer  
further includes a drying tower downstream from said  
agitator and a heat source to provide heat to said tower.

14. Method as in claim 13 and further  
comprising a classifier downstream of said tower for  
separating said mixture, said mixture comprising relatively

- 36 -

lighter and relatively heavier particles, said classifier separating said lighter from said heavier particles.

15                   15.            Method as in claim 14 wherein said  
relatively heavier particles are returned to said agitator.

16.                Method as in claim 14 and further  
comprising a cyclone downstream from said classifier.

10                   17.            Method as in claim 16 wherein said  
cyclone removes further moisture from said relatively  
lighter particles.

15                   18.            Method as in claim 17 wherein said  
relatively lighter particles are separated into relatively  
smaller and relatively larger particles.

19.                Method as in claim 18 wherein said  
relatively larger particles are returned to said agitator.

20                   20.            A feed product or additive produced by  
the method as in any one of claims 1 to 19.

25                   21.            Co-drying apparatus for drying a mixture  
of krill hydrolysate, liquid marine product and a dry  
carrier comprising a dryer for agitating, heating and  
separating particles of said mixture.

- 37 -

22. Co-drying apparatus as in claim 21 and further comprising a mixer for blending said mixture prior to said mixture entering said dryer.

5 23. Co-drying apparatus as in claim 22 and further comprising a reactor cell for treating said mixture prior to said mixture entering said dryer.

10 24. Co-drying apparatus as in claim 23 and further comprising a grinder for grinding said mixture prior to said mixture entering said reactor cell.

15 25. Co-drying apparatus as in claim 24 wherein said dryer produces a product.

26. Co-drying apparatus as in claim 25 and further comprising a mixer for mixing said product following said product exiting said dryer.

20 27. Co-drying apparatus as in claim 21 wherein said dryer comprises a source of warm air, an agitator for agitating said mixture following entry of said mixture into said dryer, a tower to expose said mixture to said warm air, a first classifier to separate the relatively  
25 lighter particles of said mixture from the relatively heavier particles of said mixture, a cyclone for drying said relatively lighter particles separated from said relatively heavier particles, and a second classifier to separate relatively lighter particles and relatively heavier

- 38 -

particles constituting said relatively lighter particles in said cyclone.

28. Co-dryer as in claim 27 and further  
5 comprising a fan to move said warm air within said dryer.

29. Method of obtaining an enzyme extract  
from a liquid krill hydrolysate comprising the steps of  
subjecting said hydrolysate to centrifugation to obtain a  
10 clarified liquid and further subjecting said clarified  
liquid to ultrafiltration using a membrane with a capacity  
to retain said enzymes having a molecular weight greater  
than 10,000 daltons.

15 30. Method of obtaining an enzyme extract  
from a liquid krill hydrolysate as in claim 29 and further  
comprising the step of storing said clarified liquid at a  
reduced temperature for a predetermined time period.

20 31. Method of obtaining an enzyme extract  
from a liquid krill hydrolysate as in claim 30 wherein said  
ultrafiltration is achieved using a tangential flow  
filtration system.

25 32. Method of obtaining an enzyme extract  
from a liquid krill hydrolysate as in claim 31 wherein said  
enzyme extract obtained from said ultrafiltration is freeze  
dried.

- 39 -

33. Method of obtaining an enzyme extract from a liquid krill hydrolysate as in claim 32 wherein said krill is *Euphausia superba*.

5 34. Method of obtaining an enzyme extract from a liquid krill hydrolysate as in claim 32 wherein said krill is *Euphausia pacifica*.

10 35. Method of obtaining an enzyme extract from fresh krill comprising the steps of squeezing said krill to obtain an aqueous extract and subjecting said aqueous extract to ultrafiltration with a membrane adapted to retain enzymes having molecular weights above 10,000 daltons.

15

36. Method of obtaining an enzyme extract from fresh krill as in claim 35 wherein said ultrafiltration is achieved using a tangential flow filtration system allowing enzymes to retain which have molecular weights above 10,000 daltons.

20

37. Method of obtaining an enzyme extract from fresh krill as in claim 36 and further including the step of centrifuging said aqueous extract prior to subjecting said extract to ultrafiltration.

25

38. Method of obtaining an enzyme extract from fresh krill as in claim 37 and further comprising the step of storing said aqueous extract at a reduced temperature following said centrifuging.

30



- 40 -

39. Method of obtaining an enzyme extract from fresh krill as in claim 38 wherein said reduced temperature is approximately 4 degrees Celsius.

5 40. Method of obtaining an enzyme extract from fresh krill as in claim 39 and further comprising subjecting said enzyme extract obtained from said ultrafiltration to low temperature drying.

10 41. Product produced by the method as in any one of claims 29 to 39.

15 42. Method for removal of protein from non-stabilized crustacean shell wastes, comprising grinding said crustacean wastes and water to a relatively small particulate size, transferring said small particulate size product to a digester, adding a predetermined quantity of krill enzymes to said digester, subjecting said mixture to digestion for a predetermined time period at a predetermined temperature, dewatering said digested product to obtain a first portion being relatively enzymatically active and relatively high in protein and a second portion of shell material relatively high in chitin and low in protein.

25 43. Method for removal of protein from acid stabilized shell wastes comprising grinding said crustacean wastes to a described small particulate size, transferring desired size shell wastes to a digester, adding a predetemined quantity of krill enzymes to said digester, 30 subjecting said mixture to digestion for a predetermined

- 41 -

time period at a predetermined temperature, dewatering said digested product to obtain a first portion being relatively enzymatically active and relatively high in protein and a second portion of shell ash relatively high in chitin and low in protein.

44. Method as in claim 42 and further comprising drying said liquid portion by means of low temperature drying to preserve the enzymatic activity.

10

45. Method as in claim 44 wherein said drying is by way of a flash drier.

46. Method as in claim 45 wherein said drying is by way of a fluidized bed drier.

15

47. Method as in claim 42 and further comprising adding krill enzyme material to said shell material portion.

20

48. Method as in claim 43 and further comprising adding krill enzyme material to said shell material portion.

25

49. Method as in claim 42 wherein said product is subject to digestion between approximately 0-70 degrees Celsius and for times between 30 minutes and several hours.