



US005873065A

United States Patent [19]
Akagiri et al.

[11] Patent Number: 5,873,065
[45] Date of Patent: Feb. 16, 1999

[54] TWO-STAGE COMPRESSION AND EXPANSION OF COUPLING PROCESSED MULTI-CHANNEL SOUND SIGNALS FOR TRANSMISSION AND RECORDING

5,490,170 2/1996 Akagiri et al. 375/240
5,491,773 2/1996 Veldhuis et al. 395/2.38
5,535,300 7/1996 Hall, II et al. 395/2.36
5,539,829 7/1996 Lokhoff et al. 381/2
5,664,056 9/1997 Akagiri 704/229
5,687,157 11/1997 Imai et al. 369/124

[75] Inventors: Kenzo Akagiri, Tokyo, Japan; Mark Franklin Davis, Pacifica, Calif.; Craig Campbell Todd, Mill Valley, Calif.; Ray Milton Dolby, San Francisco, Calif.

Primary Examiner—David R. Hudspeth
Assistant Examiner—Tāivaldis Ivars Šmits
Attorney, Agent, or Firm—Limbach & Limbach LLP

[73] Assignee: Sony Corporation, Tokyo, Japan

[57] ABSTRACT

[21] Appl. No.: 446,689

[22] PCT Filed: Dec. 7, 1994

[86] PCT No.: PCT/US94/14267

§ 371 Date: Nov. 20, 1995

§ 102(e) Date: Nov. 20, 1995

A multi-channel signal compressor for compressing digital sound signals in the respective channels of a multi-channel sound system. The apparatus comprises a first-stage compression system and a second-stage compression system. In the first-stage compression system, a coupling circuit performs coupling between the digital sound signals of at least two of the channels to generate coupling-processed signals, one for each of the channels. A compressor circuit receives the coupling-processed signals from the coupling circuit and frequency divides each coupling-processed signal into frequency range signals in respective frequency ranges, and compresses the frequency range signals obtained by dividing each coupling-processed signal to generate a first-stage compressed signal. In the second-stage compression system, a determining circuit receives the first-stage compressed signal for each channel from the first-stage compression system and determines an energy for each channel from the first-stage compressed signal of the respective channel. A channel bit apportionment decision circuit operates in response to the determining circuit, and apportions a predetermined number of bits among the channels to apportion a number of bits to each channel. Finally, an additional compressor additionally compresses the first-stage compressed signal of each channel using, for each channel, the number of bits apportioned to the respective channel by the channel bit apportionment decision circuit.

[30] Foreign Application Priority Data

Dec. 7, 1993 [JP] Japan 5-306898

[51] Int. Cl.⁶ H04S 3/00; H04B 1/66; H04H 5/00

[52] U.S. Cl. 704/500; 381/2; 704/227; 704/229

[58] Field of Search 395/2.36, 2.38, 395/2.39; 381/2; 704/227, 229, 230, 500

[56] References Cited

U.S. PATENT DOCUMENTS

5,166,686 11/1992 Sugiyama 341/155
5,185,800 2/1993 Mahieux 704/500
5,241,603 8/1993 Akagiri et al. 704/205
5,285,498 2/1994 Johnston 381/2
5,341,457 8/1994 Hall, II et al. 704/226
5,471,558 11/1995 Tsutsui 704/219
5,481,614 1/1996 Johnston 381/2

16 Claims, 10 Drawing Sheets

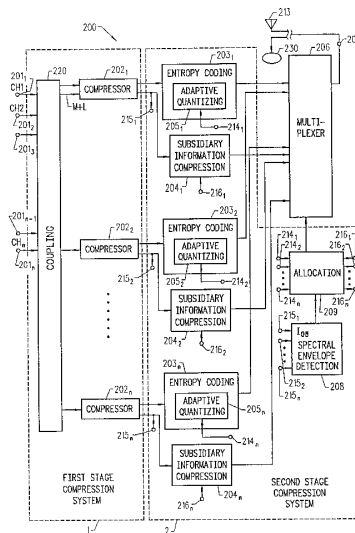

HULU LLC

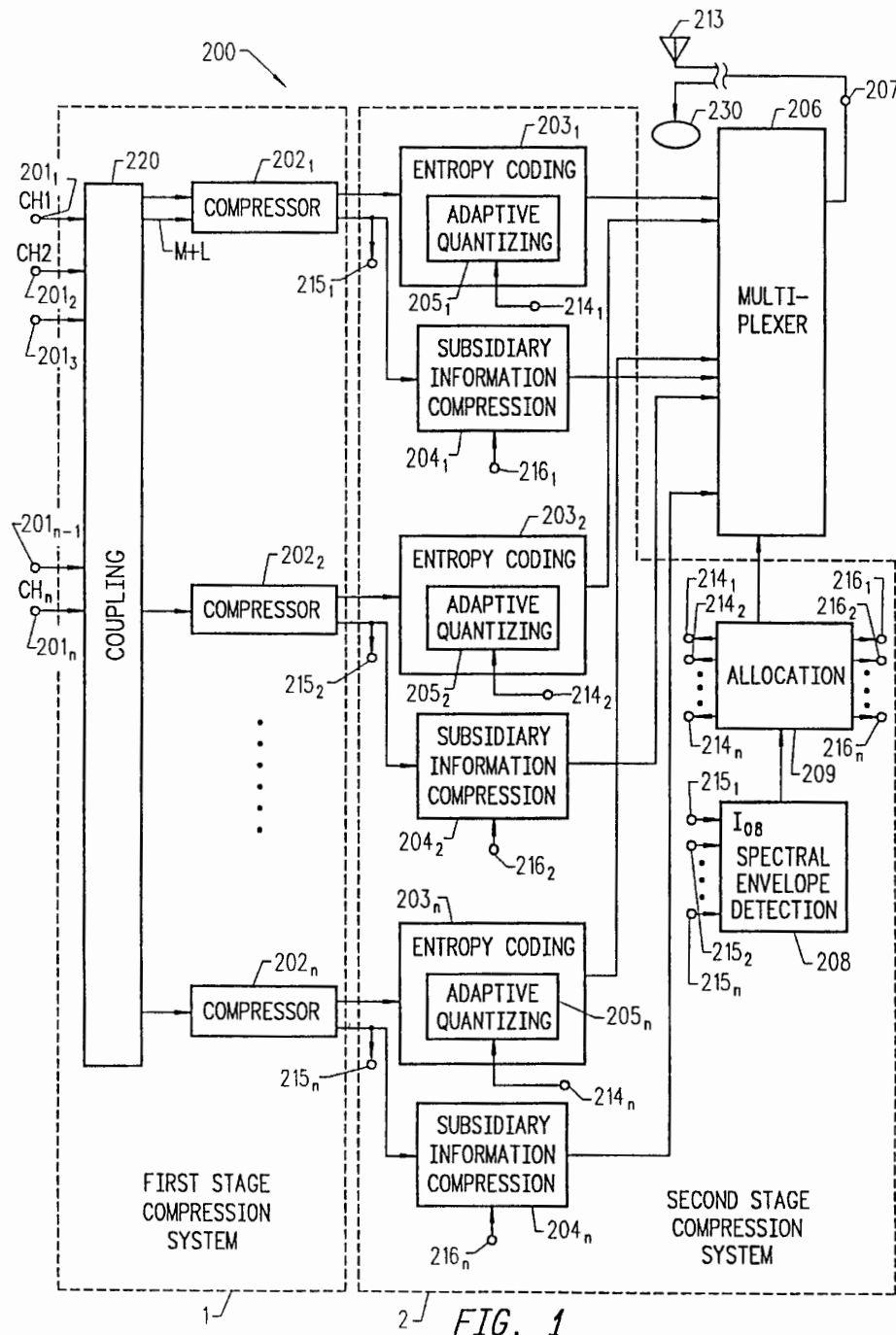

FIG. 1

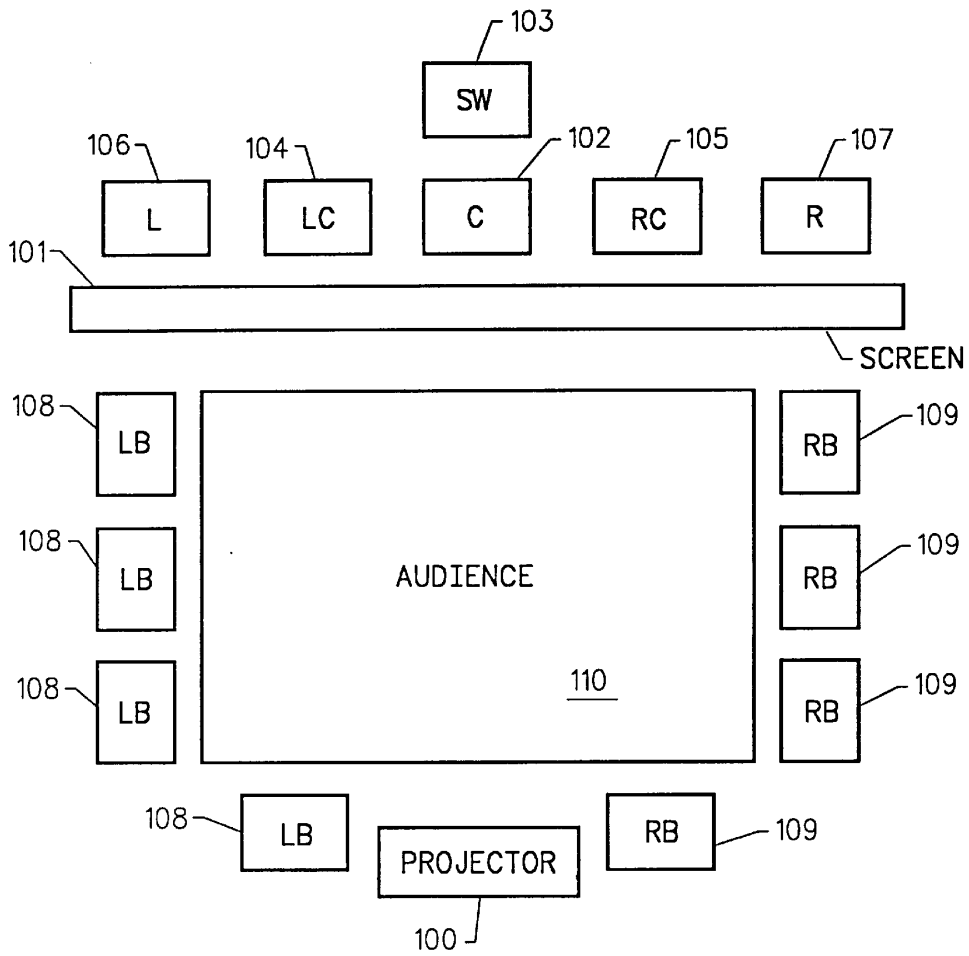

FIG. 2

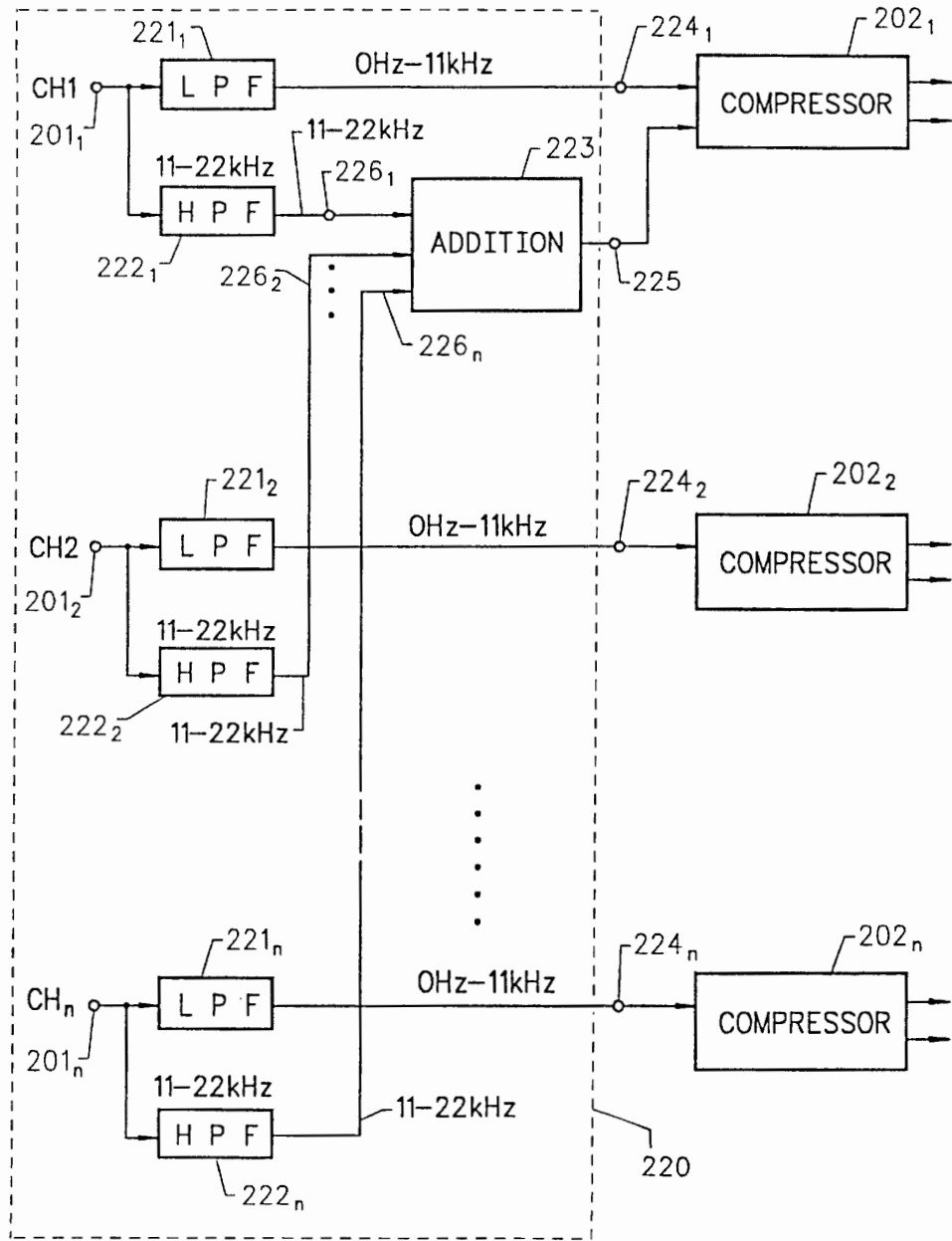
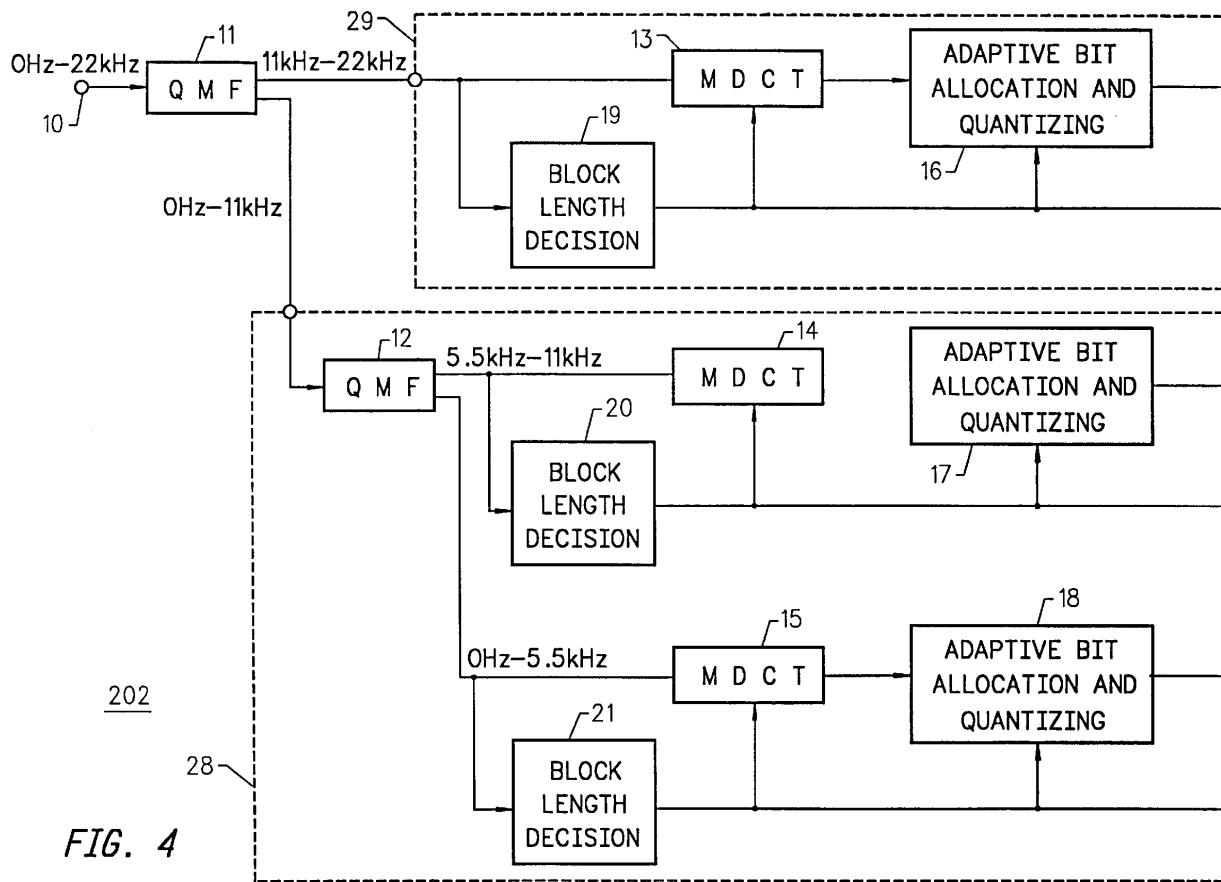

FIG. 3



Explore Litigation Insights

Docket Alarm provides insights to develop a more informed litigation strategy and the peace of mind of knowing you're on top of things.

Real-Time Litigation Alerts



Keep your litigation team up-to-date with **real-time alerts** and advanced team management tools built for the enterprise, all while greatly reducing PACER spend.

Our comprehensive service means we can handle Federal, State, and Administrative courts across the country.

Advanced Docket Research



With over 230 million records, Docket Alarm's cloud-native docket research platform finds what other services can't. Coverage includes Federal, State, plus PTAB, TTAB, ITC and NLRB decisions, all in one place.

Identify arguments that have been successful in the past with full text, pinpoint searching. Link to case law cited within any court document via Fastcase.

Analytics At Your Fingertips



Learn what happened the last time a particular judge, opposing counsel or company faced cases similar to yours.

Advanced out-of-the-box PTAB and TTAB analytics are always at your fingertips.

API

Docket Alarm offers a powerful API (application programming interface) to developers that want to integrate case filings into their apps.

LAW FIRMS

Build custom dashboards for your attorneys and clients with live data direct from the court.

Automate many repetitive legal tasks like conflict checks, document management, and marketing.

FINANCIAL INSTITUTIONS

Litigation and bankruptcy checks for companies and debtors.

E-DISCOVERY AND LEGAL VENDORS

Sync your system to PACER to automate legal marketing.