



- [54] **WAFER BONDING OF LIGHT EMITTING DIODE LAYERS**
- [75] Inventors: Fred A. Kish; Frank M. Steranka, both of San Jose; Dennis C. DeFevere, Palo Alto; Virginia M. Robbins, Los Gatos; John Uebbing, Palo Alto, all of Calif.
- [73] Assignee: Hewlett-Packard Company, Palo Alto, Calif.
- [21] Appl. No.: 36,532
- [22] Filed: Mar. 19, 1993
- [51] Int. Cl.⁵ H01L 21/20
- [52] U.S. Cl. 437/127; 437/129; 437/130; 437/117
- [58] Field of Search 437/127, 129, 130, 905, 437/974, 117, 229; 148/DIG. 135

[56] **References Cited**

U.S. PATENT DOCUMENTS

4,771,016	9/1988	Bajor et al.	148/DIG. 135
4,775,645	10/1988	Kurata et al.	437/905
4,846,931	7/1989	Gmitter et al.	156/633
4,864,369	9/1989	Snyder et al.	357/17
4,864,371	9/1989	Steranka	357/17
4,883,561	11/1989	Gmitter et al.	156/633
4,902,356	2/1990	Noguchi et al.	437/127
4,921,817	5/1990	Noguchi	437/127
4,971,925	11/1990	Alexander et al.	148/DIG. 135
4,992,837	2/1991	Sakai et al.	357/17
5,008,718	4/1991	Fletcher et al.	357/17
5,087,585	2/1992	Hayashi	437/974
5,110,748	5/1992	Sarma	437/974
5,135,877	8/1992	Albergo et al.	437/229
5,153,889	10/1992	Sugawara et al.	372/45
5,244,817	9/1993	Hawkins et al.	148/DIG. 135

OTHER PUBLICATIONS

- Dudley, J. J., et al., "144° C. operation of 1.3 μm In-GaAsP vertical cavity lasers on GaAs substrates", *Appl. Phys. Lett.*, 61 (26), Dec. 28, 1992, pp. 3095-3097.
- Ishiguro, Hisanori et al., "High efficient GaAlAs light-

-emitting diodes of 660 nm with a double heterostructure on a GaAlAs substrates", *Appl. Phys. Lett.*, 43 (11), Dec. 1, 1983, pp. 1034-1036.

Pollentier, I. et al., "Epitaxial Lift-off GaAs LEDs to Si for Fabrication of Opto-Electronic Integrated Circuits", *Electronics Letters*, vol. 36, No. 3, Feb. 1, 1990, pp. 193-194.

Schnitzer, I. et al., "Ultrahigh spontaneous emission quantum efficiency, 99.7% internally and 72% externally, from AlGaAs/GaAs/AlGaAs double heterostructures", *Appl. Phys. Lett.*, 63 (3), Jan. 11, 1993, pp. 131-133.

Sugawara, H. et al., "High-efficiency InGaAlP/GaAs visible light-emitting diodes", *Appl. Phys. Lett.*, 58 (10), Mar. 11, 1991, pp. 1010-1012.

Primary Examiner—Tom Thomas
Assistant Examiner—Kevin M. Picardat

[57] **ABSTRACT**

A method of forming a light emitting diode (LED) includes providing a temporary growth substrate that is selected for compatibility with fabricating LED layers having desired mechanical characteristics. For example, lattice matching is an important consideration. LED layers are then grown on the temporary growth substrate. High crystal quality is thereby achieved, whereafter the temporary growth substrate can be removed. A second substrate is bonded to the LED layers utilizing a wafer bonding technique. The second substrate is selected for optical properties, rather than mechanical properties. Preferably, the second substrate is optically transparent and electrically conductive and the wafer bonding technique is carried out to achieve a low resistance interface between the second substrate and the LED layers. Wafer bonding can also be carried out to provide passivation or light-reflection or to define current flow.

29 Claims, 13 Drawing Sheets

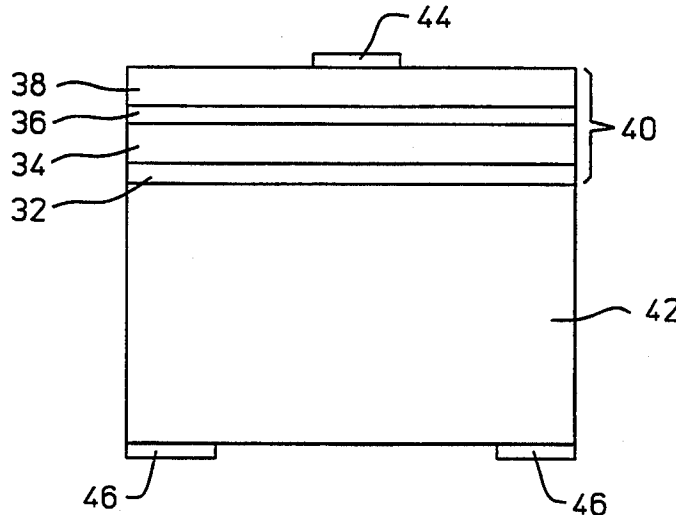

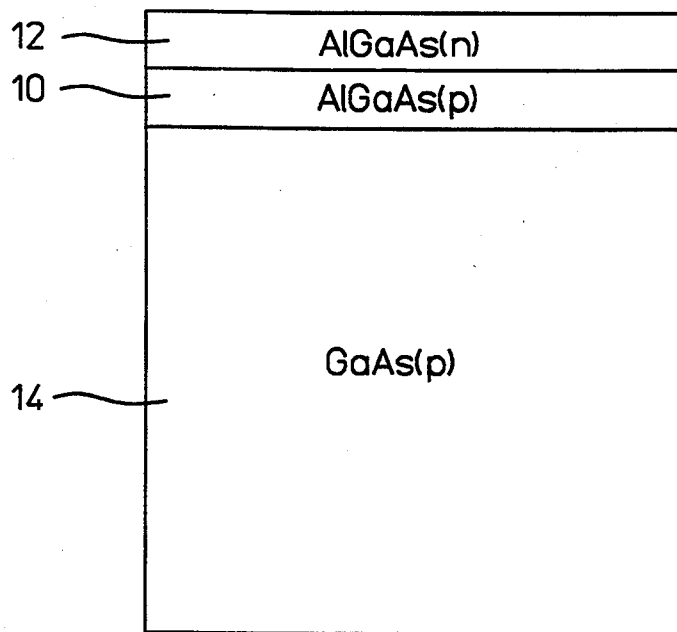

FIG. 1 (PRIOR ART)

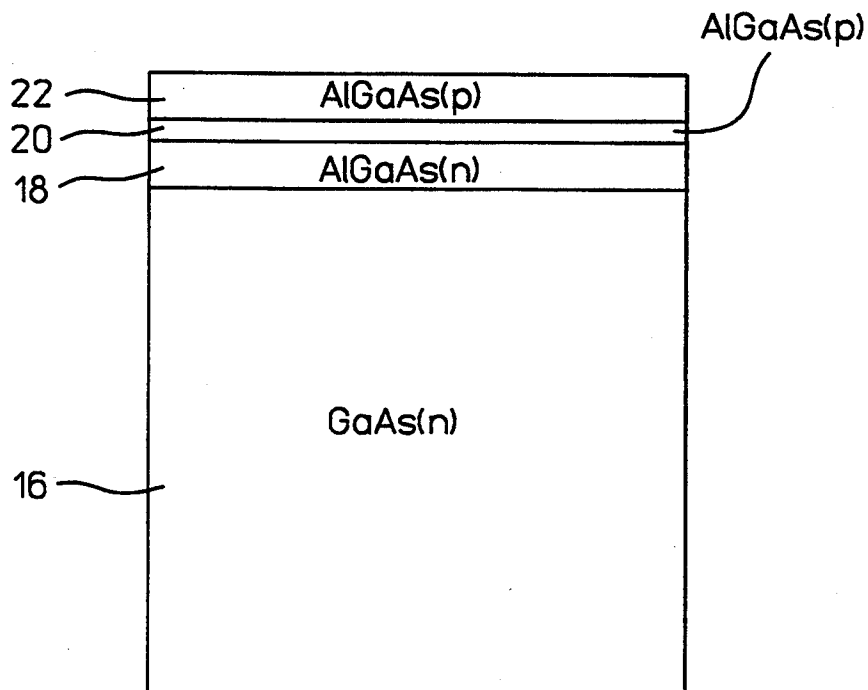

FIG. 2 (PRIOR ART)

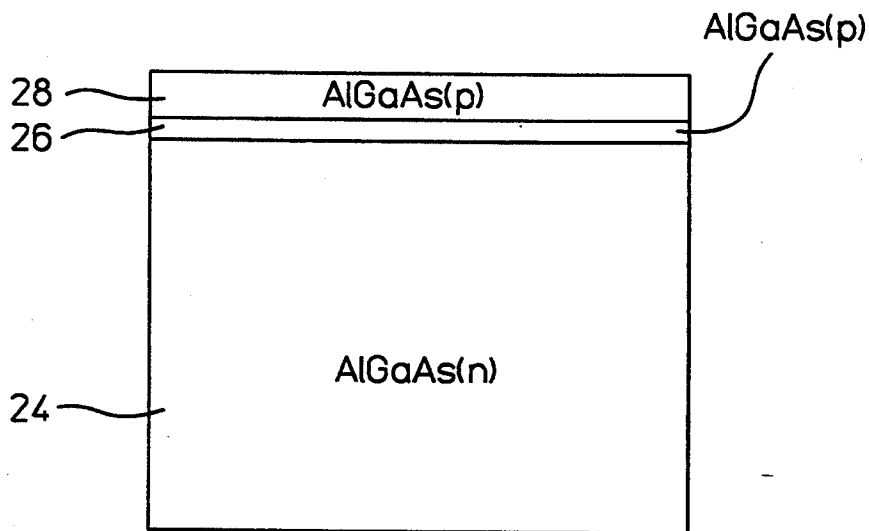

FIG. 3 (PRIOR ART)

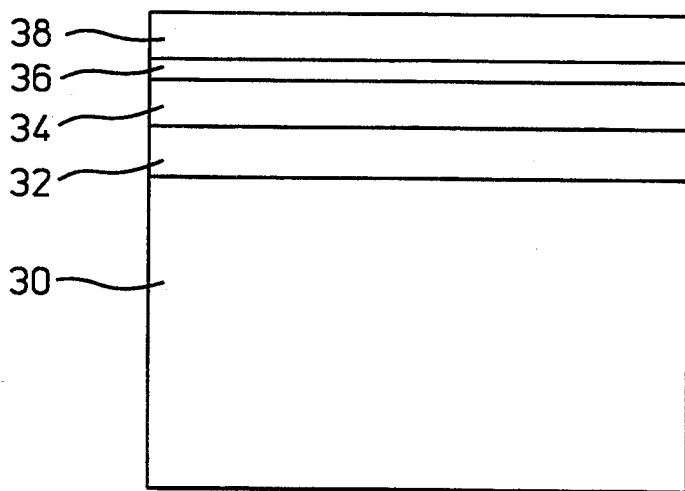

FIG. 4

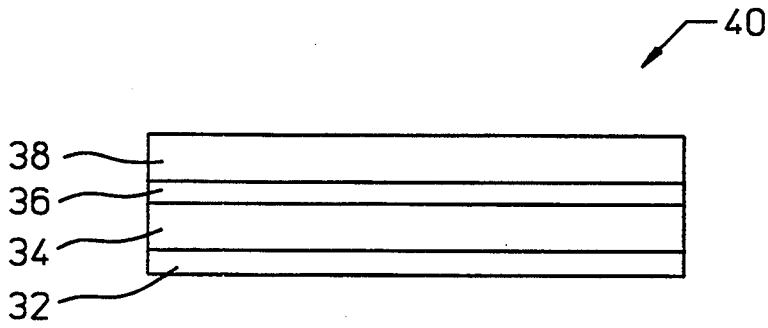

FIG. 5

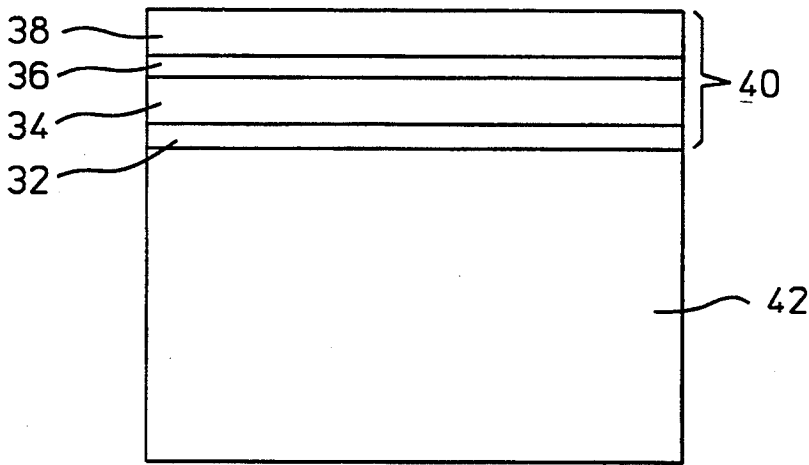

FIG. 6

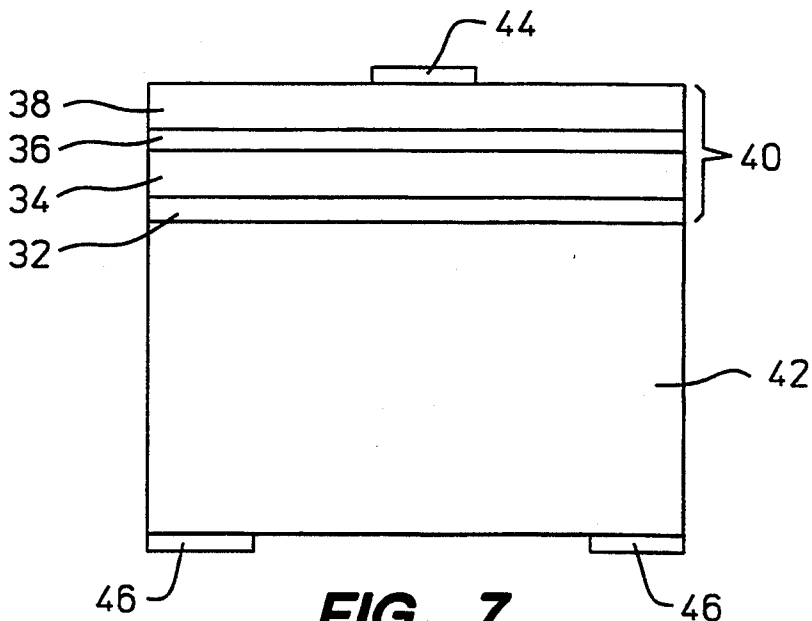

FIG. 7

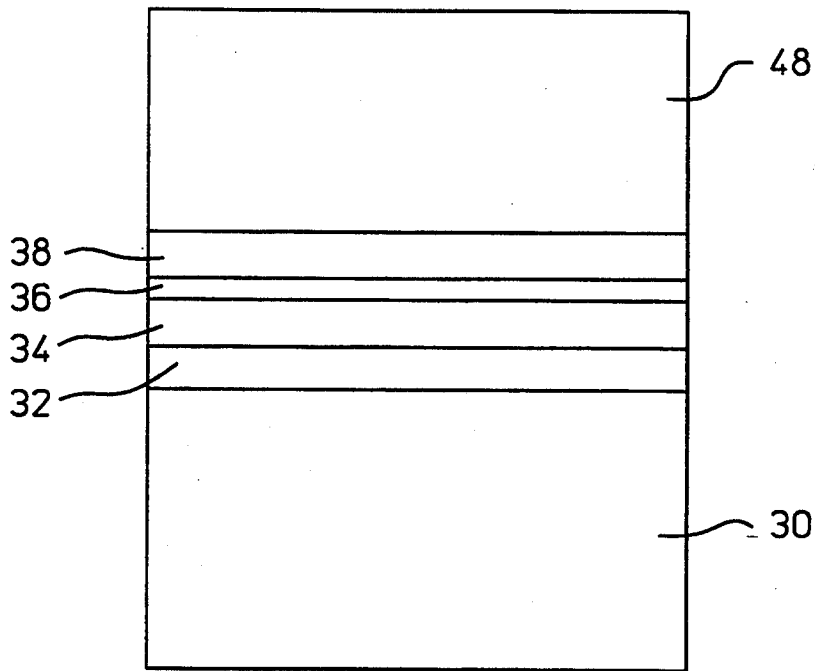

FIG. 8

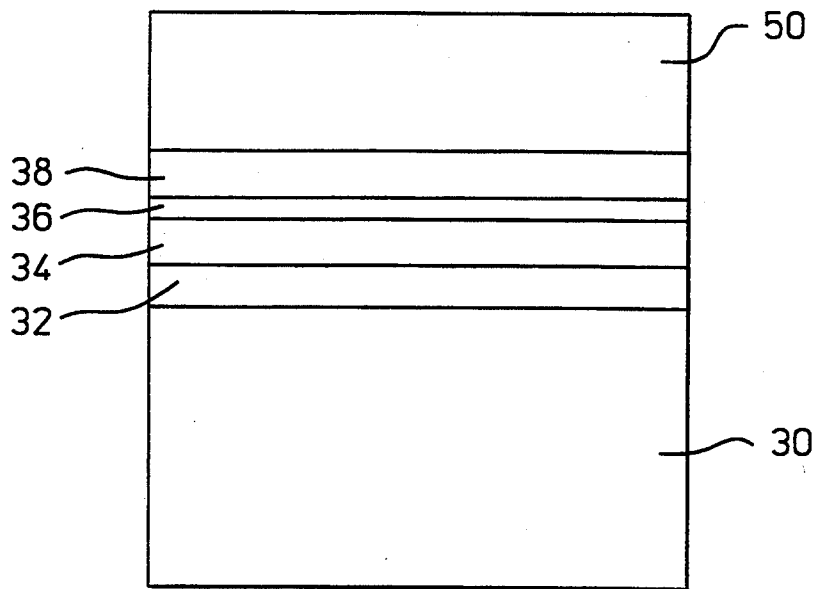

FIG. 9

Explore Litigation Insights

Docket Alarm provides insights to develop a more informed litigation strategy and the peace of mind of knowing you're on top of things.

Real-Time Litigation Alerts



Keep your litigation team up-to-date with **real-time alerts** and advanced team management tools built for the enterprise, all while greatly reducing PACER spend.

Our comprehensive service means we can handle Federal, State, and Administrative courts across the country.

Advanced Docket Research



With over 230 million records, Docket Alarm's cloud-native docket research platform finds what other services can't. Coverage includes Federal, State, plus PTAB, TTAB, ITC and NLRB decisions, all in one place.

Identify arguments that have been successful in the past with full text, pinpoint searching. Link to case law cited within any court document via Fastcase.

Analytics At Your Fingertips



Learn what happened the last time a particular judge, opposing counsel or company faced cases similar to yours.

Advanced out-of-the-box PTAB and TTAB analytics are always at your fingertips.

API

Docket Alarm offers a powerful API (application programming interface) to developers that want to integrate case filings into their apps.

LAW FIRMS

Build custom dashboards for your attorneys and clients with live data direct from the court.

Automate many repetitive legal tasks like conflict checks, document management, and marketing.

FINANCIAL INSTITUTIONS

Litigation and bankruptcy checks for companies and debtors.

E-DISCOVERY AND LEGAL VENDORS

Sync your system to PACER to automate legal marketing.