

UNITED STATES PATENT AND TRADEMARK OFFICE

BEFORE THE PATENT TRIAL AND APPEAL BOARD

NICHIA CORPORATION and CREE, INC.,
Petitioners,

v.

DOCUMENT SECURITY SYSTEMS, INC.,
Patent Owner.

IPR2018-01166¹
Patent 7,256,486 B2

Before SCOTT C. MOORE, AMBER L. HAGY, and
BRENT M. DOUGAL, *Administrative Patent Judges*.

HAGY, *Administrative Patent Judge*.

JUDGMENT
Final Written Decision
Determining Some Challenged Claims Unpatentable
35 U.S.C. § 318(a)

¹ Cree, Inc., who filed a Petition in IPR2019-00506, has been joined as a petitioner in this proceeding.

I. INTRODUCTION

Nichia Corporation² filed a Petition (Paper 2, “Pet.”) to institute an *inter partes* review of claims 1–6 (the “challenged claims”) of U.S. Patent 7,256,486 B2 (Ex. 1001, the “’486 patent”). Document Security Systems, Inc. (“Patent Owner”) filed a Preliminary Response (Paper 8, “Prelim. Resp.”). Pursuant to 35 U.S.C. § 314, we instituted an *inter partes* review of all challenged claims on all grounds presented in the Petition. Paper 9 (“Inst. Dec.”). Patent Owner filed a Patent Owner Response (Paper 13, “PO Resp.”), Petitioner filed a Reply (Paper 15, “Pet. Reply”), and Patent Owner filed a Sur-Reply (Paper 17, “PO Sur-Reply”).

Following institution, Cree, Inc., timely filed a motion for joinder in Case IPR2019-00506, in which it challenges the same claims of the ’486 patent on the same grounds on which we instituted review in this proceeding. *See* IPR2019-00506, Paper 1 (Petition), Paper 3 (Motion for Joinder). To administer the proceedings more efficiently, we granted the motion, joining Case IPR2019-00506 with the instant proceeding. Paper 14; IPR2019-00506, Paper 7. For purposes of this Decision, we refer to Nichia Corporation and Cree, Inc., jointly, as “Petitioner.”

On August 28, 2019, we conducted an oral hearing. A copy of the transcript (Paper 23, “Tr.”) is included in the record.

We have jurisdiction under 35 U.S.C. § 6(b). For the reasons that follow, we determine that Petitioner has shown by a preponderance of the evidence that claims 1–5 of the ’486 patent are unpatentable, but has not

² Petitioner, Nichia Corporation, identifies Nichia America Corporation as a real party-in-interest. Pet. 1.

shown by a preponderance of the evidence that claim 6 is unpatentable. This final written decision is issued pursuant to 35 U.S.C. § 318(a).

II. BACKGROUND

A. *Related Proceedings*

Petitioner states the '486 patent has been asserted by Patent Owner against Nichia Corporation and Nichia America Corporation in *Document Security Systems, Inc. v. Nichia America Corp., et al.*, No. 2:17-cv-08849, pending in the Central District of California. Pet. 1; *see also* Paper 5, 2.

Petitioner also states the '486 patent has been asserted by Patent Owner in several other court proceedings: *Document Security Systems, Inc. v. Everlight Americas Inc., et al.*, No. 2:17-cv-00310 (E.D. Tex.); *Document Security Systems, Inc. v. Everlight Americas Inc., et al.*, No. 2:17-cv-04273 (C.D. Cal.); *Document Security Systems, Inc. v. Cree, Inc.*, No. 2:17-cv-00309 (E.D. Tex.); *Document Security Systems, Inc. v. Cree, Inc.*, No. 2:17-cv-04263 (C.D. Cal.); *Document Security Systems, Inc. v. Seoul Semiconductor Co., Ltd., et al.*, No. 2:17-cv-00308 (E.D. Tex.); *Document Security Systems, Inc. v. Seoul Semiconductor Co., Ltd., et al.*, No. 8:17-cv-00981 (C.D. Cal.); *Document Security Systems, Inc. v. OSRAM GmbH, et al.*, No. 2:17-cv-05184 (C.D. Cal.); and *Document Security Systems, Inc. v. Lite-On Tech. Corp., et al.*, No. 2:17-cv-06050 (C.D. Cal.). *Id.* at 1–2. Patent Owner identifies the same proceedings. Paper 5, 2–3.

Petitioner also states the '486 patent is subject to the following petition for *inter partes* review: *Seoul Semiconductor Co., Ltd. v. Document Security Systems, Inc.*, No. IPR2018-00333 (“the '333 IPR”). Pet. 2; *see also* Paper 5, 3. In addition to the '333 IPR, Patent Owner identifies several

IPR2018-01166
Patent 7,256,486 B2

other *inter partes* review proceedings as ones that may also affect or be affected by a decision in this proceeding. Paper 5, 3–4. The ones involving the '486 patent are: IPR2018-01205 (U.S. Patent No. 7,256,486) (trial instituted, joined with IPR2018-00333, Paper 11); IPR2018-01220 (U.S. Patent No. 7,256,486) (institution denied, Paper 9); IPR2018-01225 (U.S. Patent No. 7,256,486) (trial instituted, joined with IPR2018-00333, Paper 14). *Id.*

On June 10, 2019, the Board issued its final written decision in the '333 IPR, in which the Board determined that all challenged claims (claims 1–3) of the '486 patent are unpatentable. IPR2018-00333, Paper 33 (“the '333 FWD”).

B. The '486 Patent

The '486 patent generally relates to a semiconductor packaging device. Ex. 1001, Abstract. The semiconductor packaging device can include a light emitting diode (LED). *Id.* at 5:20–22. A semiconductor device is illustrated in Figures 2A and 2B, reproduced below. *Id.* at 3:5–8.

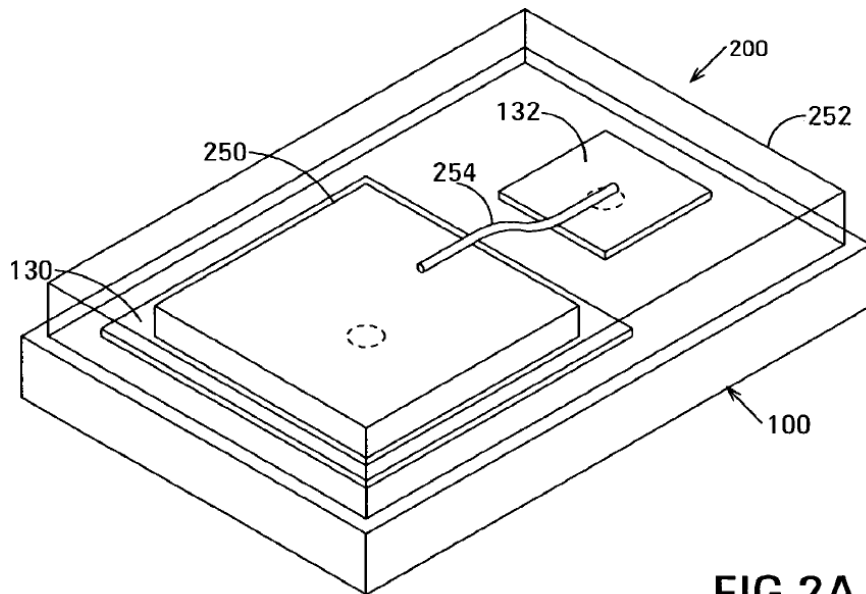

FIG. 2A

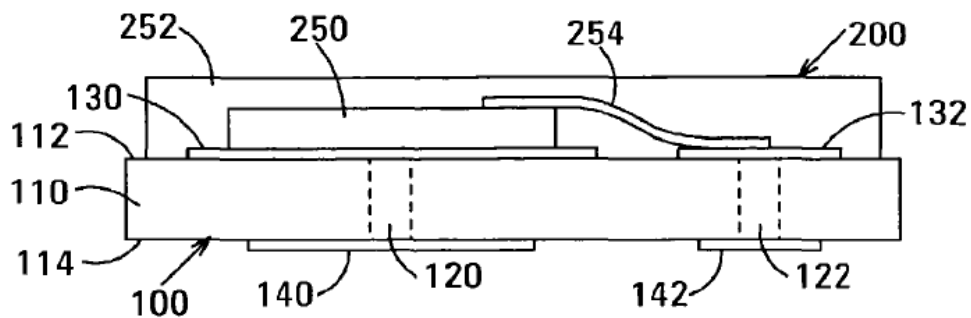

FIG. 2B

Figure 2A shows a perspective view of semiconductor device 200, including semiconductor die/LED 250. Ex. 1001, 3:5–8, 6:5–7. Figure 2B is a side view of semiconductor device 200. *Id.* at 3:5–8. Substrate 110, having major surfaces 112, 114, is shown having mounting pad 130 and bonding pad 132 on top major surface 112, and connecting pads 140, 142 on bottom major surface 114. *Id.* at 3:43–57, 4:64–66. Interconnecting elements 120, 122 pass through substrate 110 and connect mounting pad 130

Explore Litigation Insights

Docket Alarm provides insights to develop a more informed litigation strategy and the peace of mind of knowing you're on top of things.

Real-Time Litigation Alerts



Keep your litigation team up-to-date with **real-time alerts** and advanced team management tools built for the enterprise, all while greatly reducing PACER spend.

Our comprehensive service means we can handle Federal, State, and Administrative courts across the country.

Advanced Docket Research



With over 230 million records, Docket Alarm's cloud-native docket research platform finds what other services can't. Coverage includes Federal, State, plus PTAB, TTAB, ITC and NLRB decisions, all in one place.

Identify arguments that have been successful in the past with full text, pinpoint searching. Link to case law cited within any court document via Fastcase.

Analytics At Your Fingertips



Learn what happened the last time a particular judge, opposing counsel or company faced cases similar to yours.

Advanced out-of-the-box PTAB and TTAB analytics are always at your fingertips.

API

Docket Alarm offers a powerful API (application programming interface) to developers that want to integrate case filings into their apps.

LAW FIRMS

Build custom dashboards for your attorneys and clients with live data direct from the court.

Automate many repetitive legal tasks like conflict checks, document management, and marketing.

FINANCIAL INSTITUTIONS

Litigation and bankruptcy checks for companies and debtors.

E-DISCOVERY AND LEGAL VENDORS

Sync your system to PACER to automate legal marketing.