



US008698558B2

(12) **United States Patent**
Mathe et al.

(10) **Patent No.:** **US 8,698,558 B2**
(45) **Date of Patent:** **Apr. 15, 2014**

(54) **LOW-VOLTAGE POWER-EFFICIENT ENVELOPE TRACKER**

(75) Inventors: **Lennart K Mathe**, San Diego, CA (US);
Thomas Domenick Marra, San Diego, CA (US); **Todd R Sutton**, Del Mar, CA (US)

(73) Assignee: **QUALCOMM Incorporated**, San Diego, CA (US)

(*) Notice: Subject to any disclaimer, the term of this patent is extended or adjusted under 35 U.S.C. 154(b) by 38 days.

(21) Appl. No.: **13/167,659**

(22) Filed: **Jun. 23, 2011**

(65) **Prior Publication Data**

US 2012/0326783 A1 Dec. 27, 2012

(51) **Int. Cl.**
H03F 3/217 (2006.01)

(52) **U.S. Cl.**
USPC **330/251**; 330/136; 330/297

(58) **Field of Classification Search**
USPC 330/10, 136, 207 A, 251, 297
See application file for complete search history.

(56) **References Cited**

U.S. PATENT DOCUMENTS

5,905,407	A *	5/1999	Midya	330/10
6,300,826	B1	10/2001	Mathe et al.	
6,661,217	B2	12/2003	Kimball et al.	
6,792,252	B2	9/2004	Kimball et al.	
6,838,931	B2 *	1/2005	Midya et al.	330/10
7,061,313	B2	6/2006	Kimball et al.	
7,068,984	B2	6/2006	Mathe et al.	
7,368,985	B2	5/2008	Kusunoki	

7,679,433	B1	3/2010	Li	
7,755,431	B2 *	7/2010	Sun	330/297
7,932,780	B2 *	4/2011	Elia	330/136
8,030,995	B2 *	10/2011	Okubo et al.	330/297
8,237,499	B2 *	8/2012	Chen et al.	330/136
2005/0046474	A1	3/2005	Matsumoto et al.	
2005/0215209	A1	9/2005	Tanabe et al.	
2008/0278136	A1	11/2008	Murtojarvi	
2010/0001793	A1	1/2010	Van Zeijl et al.	
2011/0095827	A1	4/2011	Tanaka et al.	
2012/0293253	A1 *	11/2012	Khlat et al.	330/127

OTHER PUBLICATIONS

Choi, et al., "Envelope Tracking Power Amplifier Robust to Battery Depletion," 2010 IEEE.
MTT-S International Microwave SYmposium Digest (MTT), May 2010.

(Continued)

Primary Examiner — Khanh V Nguyen

(74) Attorney, Agent, or Firm — William M. Hooks

(57) **ABSTRACT**

Techniques for efficiently generating a power supply are described. In one design, an apparatus includes an envelope amplifier and a boost converter. The boost converter generates a boosted supply voltage having a higher voltage than a first supply voltage (e.g., a battery voltage). The envelope amplifier generates a second supply voltage based on an envelope signal and the boosted supply voltage (and also possibly the first supply voltage). A power amplifier operates based on the second supply voltage. In another design, an apparatus includes a switcher, an envelope amplifier, and a power amplifier. The switcher receives a first supply voltage and provides a first supply current. The envelope amplifier provides a second supply current based on an envelope signal. The power amplifier receives a total supply current including the first and second supply currents. In one design, the switcher detects the second supply current and adds an offset to generate a larger first supply current than without the offset.

20 Claims, 6 Drawing Sheets

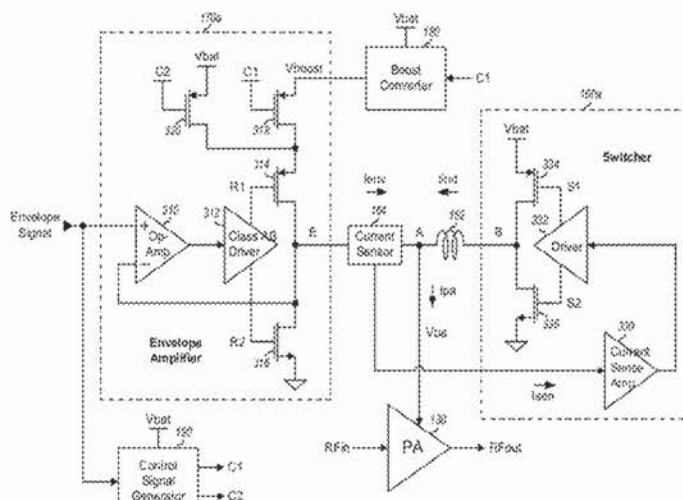

(56)

References Cited

OTHER PUBLICATIONS

Choi, J et al., "A Polar Transmitter With CMOS Programmable Hysteretic-Controlled Hybrid Switching Supply Modulator for Multi standard Applications", IEEE Transactions on Microwave Theory and Techniques, IEEE Service Center, Piscataway, NJ, US, vol. 57, No. 7, Jul. 1, 2009, pp. 1675-1686, XP011258456.

Ertl, H et al., "Basic Considerations and Topologies of Switched-Mode Assisted Linear Power Amplifiers", IEEE Transactions on Industrial Electronics, IEEE Service Center, Piscataway, NJ, USA, vol. 44, No. 1, Feb. 1, 1997, XP011023224.

International Search Report and Written Opinion—PCT/US2012/043915—ISA/EPO—Nov. 26, 2012.

Kang D., et al., "A Multimode/Multiband Power Amplifier With a Boosted Supply Modulator", IEEE Transactions on Microwave Theory and Techniques, IEEE Service Center, Piscataway, NJ, US, vol. 58, No. 10, Oct. 1, 2010, pp. 2598-2608, XP011317521, ISSN: 0018-9480.

Kang, D et al., "LTE Power Amplifier for envelope tracking polar transmitters", Microwave Conference (EUMC), 2010, European,

IEEE, Piscataway, NJ, USA, Sep. 28, 2010, pp. 628-631, XP031786114.

Kim D., et al., "High efficiency and wideband envelope tracking power amplifier with sweet spot tracking", Radio Frequency Integrated Circuits Symposium (RFIC) , 2010 IEEE, IEEE, Piscataway, NJ, USA, May 23, 2010, pp. 255-258, XP031684103, ISBN: 978-1-4244-6240-7.

Li, Y et al., "High Efficiency Wide Bandwidth Power Supplies for GSM and EDGE RF Power Amplifiers", Conference Proceedings/ IEEE International Symposium on Circuits and Systems (ISCAS): May 23-26, 2005, International Conference Center, Kobe, Japan, IEEE Service Center, Piscataway, NJ, May 23, 2005, pp. 1314-1317, XP010815779.

Partial International Search Report—PCT/US2012/043915—International Search Authority European Patent Office Oct. 4, 2012.

Stauth, J.T., et al., "Optimum Bias Calculation for Parallel Hybrid Switching-Linear Regulators", Applied Power Electronics Conference, APEC 2007—Twenty Second Annual IEEE, IEEE, PI, Feb. 1, 2007, pp. 569-574, XP031085267.

* cited by examiner

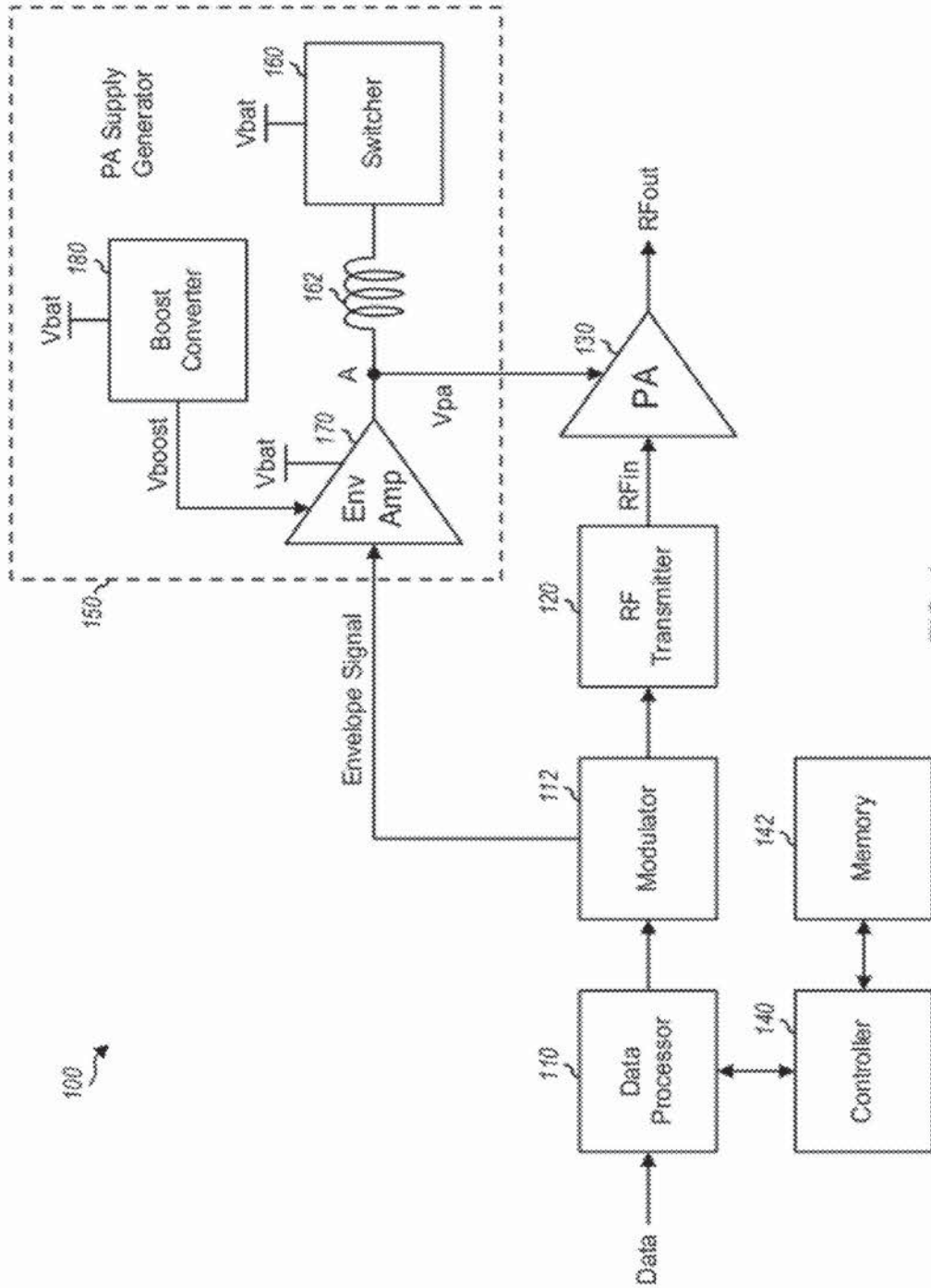

FIG. 1

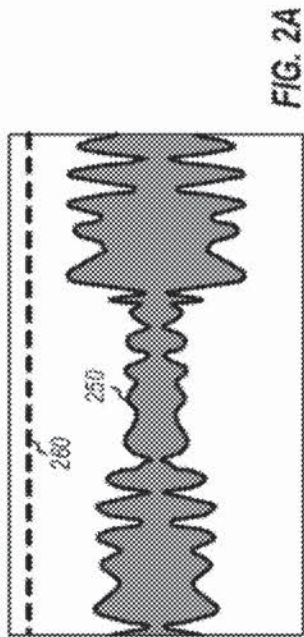

FIG. 2A

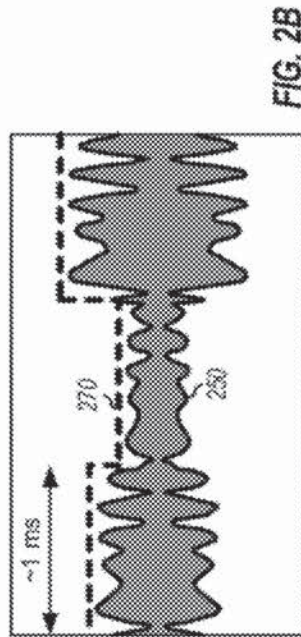

FIG. 2B

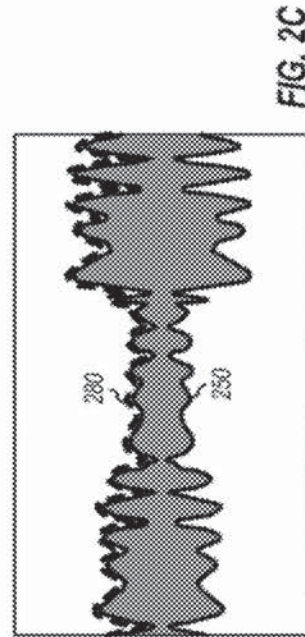
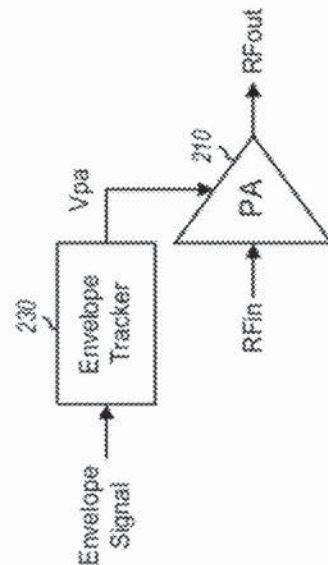
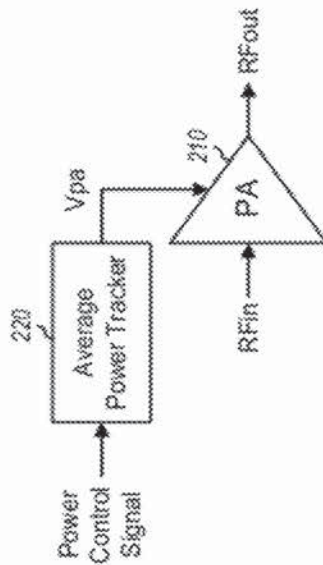
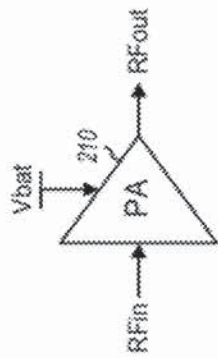

FIG. 2C



Explore Litigation Insights

Docket Alarm provides insights to develop a more informed litigation strategy and the peace of mind of knowing you're on top of things.

Real-Time Litigation Alerts



Keep your litigation team up-to-date with **real-time alerts** and advanced team management tools built for the enterprise, all while greatly reducing PACER spend.

Our comprehensive service means we can handle Federal, State, and Administrative courts across the country.

Advanced Docket Research



With over 230 million records, Docket Alarm's cloud-native docket research platform finds what other services can't. Coverage includes Federal, State, plus PTAB, TTAB, ITC and NLRB decisions, all in one place.

Identify arguments that have been successful in the past with full text, pinpoint searching. Link to case law cited within any court document via Fastcase.

Analytics At Your Fingertips



Learn what happened the last time a particular judge, opposing counsel or company faced cases similar to yours.

Advanced out-of-the-box PTAB and TTAB analytics are always at your fingertips.

API

Docket Alarm offers a powerful API (application programming interface) to developers that want to integrate case filings into their apps.

LAW FIRMS

Build custom dashboards for your attorneys and clients with live data direct from the court.

Automate many repetitive legal tasks like conflict checks, document management, and marketing.

FINANCIAL INSTITUTIONS

Litigation and bankruptcy checks for companies and debtors.

E-DISCOVERY AND LEGAL VENDORS

Sync your system to PACER to automate legal marketing.