



IEEE TRANSACTIONS

MICROWAVE THEORY AND TECHNIQUES

A PUBLICATION OF THE IEEE MICROWAVE THEORY AND TECHNIQUES SOCIETY



OCTOBER 2010

VOLUME 58

NUMBER 10

IETMAB

(ISSN 0018-9480)

PAPERS

Smart Antennas, Phased Arrays, and Radars

A Low-Power Shoe-Embedded Radar for Aiding Pedestrian Inertial Navigation *C. Zhou, J. Downey, D. Stancil, and T. Mukherjee* 2521

Active Circuits, Semiconductor Devices, and ICs

A 5.5-mW +9.4-dBm IIP3 1.8-dB NF CMOS LNA Employing Multiple Gated Transistors With Capacitance Desensitization *T. H. Jin and T. W. Kim* 2529

A Jitter-Optimized Differential 40-Gbit/s Transimpedance Amplifier in SiGe BiCMOS *C. Knochenhauer, S. Hauptmann, J. C. Scheytt, and F. Ellinger* 2538

2-D Electrical Interferometer: A Novel High-Speed Quantizer *Y. M. Tousei and E. Afshari* 2549

Optimized Design of a Highly Efficient Three-Stage Doherty PA Using Gate Adaptation *I. Kim, J. Moon, S. Jee, and B. Kim* 2562

A Compact 0.1–14-GHz Ultra-Wideband Low-Noise Amplifier in 0.13- μ m CMOS *P.-Y. Chang and S. S. H. Hsu* 2575

Optimization of a Photonically Controlled Microwave Switch and Attenuator *J. R. Flemish and R. L. Haupt* 2582

Wireless Communication Systems

Theoretical and Experimental Investigation of the Modulated Scattering Antenna Array for Mobile Terminal Applications *M. He, L. Wang, Q. Chen, Q. Yuan, and K. Sawaya* 2589

A Multimode/Multiband Power Amplifier With a Boosted Supply Modulator *D. Kang, D. Kim, J. Choi, J. Kim, Y. Cho, and B. Kim* 2598

Field Analysis and Guided Waves

Space-Charge Plane-Wave Interaction at Semiconductor Substrate Boundary *I. A. Elabyad, M. S. Eldessouki, and H. M. El-Hennawy* 2609

Full-Space Scanning Periodic Phase-Reversal Leaky-Wave Antenna *N. Yang, C. Caloz, and K. Wu* 2619

(Contents Continued on Back Cover)

*(Contents Continued from Front Cover)***CAD Algorithms and Numerical Techniques**

- Eliminating the Low-Frequency Breakdown Problem in 3-D Full-Wave Finite-Element-Based Analysis of Integrated Circuits *J. Zhu and D. Jiao* 2633
- A Unique Extraction of Metamaterial Parameters Based on Kramers–Kronig Relationship *Z. Szabó, G.-H. Park, R. Hedge, and E.-P. Li* 2646

Filters and Multiplexers

- A Substrate-Integrated Evanescent-Mode Waveguide Filter With Nonresonating Node in Low-Temperature Co-Fired Ceramic *L.-S. Wu, X.-L. Zhou, W.-Y. Yin, L. Zhou, and J.-F. Mao* 2654

Instrumentation and Measurement Techniques

- De-Embedding Method Using an Electromagnetic Simulator for Characterization of Transistors in the Millimeter-Wave Band *T. Hirano, H. Nakano, Y. Hirachi, J. Hirokawa, and M. Ando* 2663
- Temperature Dependence of Resonances in Metamaterials *V. V. Varadan and L. Ji* 2673
- Whispering Gallery Mode Hemisphere Dielectric Resonators With Impedance Plane *A. A. Barannik, S. A. Bunyaev, N. T. Cherpak, Y. V. Prokopenko, A. A. Kharchenko, and S. A. Vitusevich* 2682

MEMS and Acoustic Wave Components

- High-Reliability RF-MEMS Switched Capacitors With Digital and Analog Tuning Characteristics *A. Grichener and G. M. Rebeiz* 2692

Biological, Imaging, and Medical Applications

- Considerations for Developing an RF Exposure System: A Review for *in vitro* Biological Experiments *A. Paffi, F. Apollonio, G. A. Lovisolo, C. Marino, R. Pinto, M. Repacholi, and M. Liberti* 2702

- Information for Authors 2715

CALLS FOR PAPERS

- Special Issue on RF Nanoelectronics 2716

IEEE MICROWAVE THEORY AND TECHNIQUES SOCIETY

The Microwave Theory and Techniques Society is an organization, within the framework of the IEEE, of members with principal professional interests in the field of microwave theory and techniques. All members of the IEEE are eligible for membership in the Society upon payment of the annual Society membership fee of \$17.00, plus an annual subscription fee of \$23.00 per year for electronic media only or \$46.00 per year for electronic and print media. For information on joining, write to the IEEE at the address below. *Member copies of Transactions/Journals are for personal use only.*

ADMINISTRATIVE COMMITTEE

S. M. EL-GHAZALY, <i>President</i>		R. SNYDER, <i>President Elect</i>		M. MADHIAN, <i>Secretary</i>		N. KOLIAS, <i>Treasurer</i>	
L. BOGLIONE	J. HACKER	K. ITOH	T. LEE	A. MORTAZAWI	Y. NIKAWA	D. SCHREURS	R. SNYDER
W. CHAPPELL	M. HARRIS	S. KOUL	J. LIN	V. J. NAIR	G. PONCHAK	W. SHIROMA	B. SZENDRENYI
M. GUPTA	J. HAUSNER	J. LASKAR					R. WEIGEL
T. ITOH		K. TOMIYASU					
A. A. OLINER		L. YOUNG					
T. S. SAAD							
P. STAECKER							

Distinguished Lecturers

A. CANGELLARIS	S. GEVORGIAN	A. PHAM	K. WU
F. ELLINGER	F. GHANNOUCHI	P. TASKER	M. YU
A. FERRERO	S. LUCYSZYN	M. TENTZERIS	

Past Presidents

B. PERLMAN (2009)
J. MODELSKI (2008)
J. S. KENNEY (2007)

MTT-S Chapter Chairs

Albuquerque: H. J. WAGNON	Delhi/India: S. KOUL	Long Island/New York: J. COLOTTI	Portugal: C. PEIXEIRO	Springfield: P. R. SIQUEIRA
Atlanta: D. LEATHERWOOD	Denver: M. JANEZIC	Los Angeles/Coastal: W. DEAL	Princeton/Central Jersey: A. KATZ	Sweden: A. RYDBERG
Austria: A. SPRINGER	Eastern No. Carolina: T. NICHOLS	Los Angeles, Metro/San Fernando: F. MAIWALD	Queensland: A. RAKIC	Switzerland: M. MATTES
Baltimore: N. BUSHYAGER	Egypt: E. HASHISH	Malaysia: M. ESA	Rio de Janeiro: J. BERGMANN	Syracuse: E. ARVAS
Bangalore: T. SRINIVAS	Finland: A. LUUKKANEN	Malaysia, Penang: Y. CHOW	Rochester: S. CICCARELLI/J. VENKATARAMAN	Taegu: Y.-H. JEONG
Beijing: Z. FENG	Florida West Coast: K. A. O'CONNOR	Melbourne: K. LAMP	Romania: G. LOJEWSKI	Taipei: F.-T. TSAI
Belarus: A. GUSINSKY	Foothills: F. FREYNE	Mexico: R. M. RODRIGUES-DAGNINO	Russia, Moscow: V. A. KALOSHIN	Thailand: P. AKKARAEKTHALIN
Benelux: D. VANHOENACKER-JANVIER	France: P. EUDELIN	Milwaukee: S. G. JOSHI	Russia, Nizhny: Y. BELOV	Toronto: G. V. ELEFATHERIDES
Boston: J. MULDAVIN	Germany: K. SOLBACH	Mohawk Valley: E. P. RATAZZI	Russia, Novosibirsk: A. GRIDCHIN	Tucson: N. BURGESS
Brasilia: J. DA COSTA/A. KLAUTAU	Greece: R. MAKRI	Montreal: K. WU	Russia, Saint Petersburg: M. SITNIKOVA	Turkey: I. TEKIN
Buenaventura: M. QUDDUS	Harbin: Q. WU	Nanjing: W. X. ZHANG	Russia, Saratov: N. M. RYSKIN	Twin Cities: M. J. GAWRONSKI
Buffalo: J. WHALEN	Hawaii: R. MIYAMOTO	New Hampshire: D. SHERWOOD	Russia, Tomsk: R. V. MESCHERIAKOV	UK/RI: A. REZAZADEH
Bulgaria: K. ASPARUHOVA	Hong Kong: W. S. CHAN	New Jersey Coast: D. REYNOLDS	Saint Louis: D. MACKE	Ukraine, Kiev: Y. POPLAVKO
Cedar Rapids/Central Iowa: M. ROY	Houston: J. T. WILLIAMS	New South Wales: A. M. SANAGAVARAPU	San Diego: G. TWOMEY	Ukraine, East, Kharkov: O. V. SHRAMKOVA
Central & South Italy: G. D'INZEO	Houston, College Station: G. H. HUFF	New Zealand: A. WILLIAMSON	Santa Clara Valley/San Francisco: M. SAYED	Ukraine, East Student Branch Chapter, Kharkov: M. KRUSLOV
Central No. Carolina: N. S. DOGAN	Hungary: T. BERCELI	North Italy: G. VECCHI	Seattle: K. A. POULSON	Ukraine, Rep. of Georgia: D. KAKULIA
Chengdu: Z. NEI	Huntsville: H. G. SCHANTZ	North Jersey: H. DAYAL/K. DIXIT	Seoul: S. NAM	Ukraine, Vinnitsya: V. DUBOVOY
Chicago: H. LIU	Hyderabad: M. CHAKRAVARTI	Northern Australia: M. JACOB	Serbia and Montenegro: A. MARINCIC	Ukraine, West, Lviv: I. ISAYEV
Cleveland: M. SCARDELLETTI	India/Calcutta: D. GUHA	Northern Nevada: B. S. RAWAT	Shanghai: J. F. MAO	Venezuela: J. PEÑA
Columbus: F. TEYEIRA	India: D. BHATNAGER	Norway: Y. THODESEN	Singapore: A. ALPHONES	Victoria: K. GHORBANI
Connecticut: C. BLAIR	Indonesia: E. T. RAHARDO	Orange County: H. J. DE LOS SANTOS	South Africa: C. VAN NIEKIRK	Virginia Mountain: T. A. WINSLOW
Croatia: Z. SIPUS	Israel: S. AUSTER	Oregon: T. RUTTAN	South Australia: H. HANSON	Washington DC/Northern Virginia: J. QIU
Czech/Slovakia: P. HAZDRA	Japan: K. ARAKI	Orlando: X. GONG	South Brazil: R. GARCIA	Winnipeg: V. OKHMATOVSKI
Dallas: Q. ZHANG	Kansai: T. OHIRA	Ottawa: Q. YE	Southeastern Michigan: T. OZDEMIR	
Dayton: A. TERZUOLI	Kitchener-Waterloo: R. R. MANSOUR	Philadelphia: J. NACHAMKIN	Southern Alberta: E. FEAR	
	Lithuania: V. URBANAVICIUS	Phoenix: S. ROCKWELL	Spain: J. I. ALONSO	
		Poland: W. J. KRZYSZTOFIK		

Associate Editors

Editor-In-Chief GEORGE E. PONCHAK NASA Glenn Research Center Cleveland, OH USA	HERBERT ZIRATH Chalmers Univ. Technol. Goteborg, Sweden	KEVIN J. CHEN Hong Kong Univ. Sci. Technol. Hong Kong	N. SCOTT BARKER Univ. Virginia Charlottesville, VA USA
Editorial Assistant LINDA GAYDOSH OAI USA	WENDY VAN MOER Vrije Universiteit Brussel Brussels	MING YU COM DEV Cambridge, ON, Canada	COSTAS D. SARRIS Univ. Toronto, Toronto, ON, Canada
	JAE-SUNG RIEH Korea Univ. Seoul, Korea	CHIN-WEN TANG Nat. Chung Cheng Univ. Taiwan	CHRISTOPHE FUMEAUX The Univ. Adelaide Adelaide, South Australia, Australia
	QUAN XUE City Univ. Hong Kong Hong Kong	BART NAUWELAERS ESAT-TELEMIC Belgie, Belgium	DEUKHYOUN HEO Washington State Univ. Pullman, WA USA
	LEI ZHU Nanyang Technol. Univ. Singapore	JOHN PAPAPOLYMEROU Georgia Inst. Technol. Atlanta, GA USA	

K. REMLEY, *Editor-in-Chief, IEEE Microwave Magazine*

C. TZUANG, *Editor-in-Chief, IEEE Microwave and Wireless Component Letters*

T. LEE, *Web Master*

IEEE Officers

JON G. ROKNE, <i>Vice President, Publication Services and Products</i>
BARRY L. SHOOP, <i>Vice President, Member and Geographic Activities</i>
W. CHARLTON (CHUCK) ADAMS, <i>President, IEEE Standards Association</i>
ROGER D. POLLARD, <i>Vice President, Technical Activities</i>
EVELYN H. HIRT, <i>President, IEEE-USA</i>

IEEE Executive Staff

DR. E. JAMES PRENDERGAST, *Executive Director & Chief Operating Officer*

THOMAS SIEGERT, <i>Business Administration</i>	PATRICK MAHONEY, <i>Marketing</i>
MATTHEW LOEB, <i>Corporate Activities</i>	CECELIA JANKOWSKI, <i>Member and Geographic Activities</i>
DOUGLAS GORHAM, <i>Educational Activities</i>	ANTHONY DURNIAK, <i>Publications Activities</i>
BETSY DAVIS, <i>SPHR, Human Resources</i>	JUDITH GORMAN, <i>Standards Activities</i>
CHRIS BRANTLEY, <i>IEEE-USA</i>	MARY WARD-CALLAN, <i>Technical Activities</i>
ALEXANDER PASIK, <i>Information Technology</i>	

IEEE Periodicals Transactions/Journals Department

Staff Director: FRAN ZAPPULLA	Production Director: PETER M. TUOHY
Editorial Director: DAWN MELLEY	Senior Editor: CHRISTINA M. REZES
Managing Editor: MONA MITTRA	

IEEE TRANSACTIONS ON MICROWAVE THEORY AND TECHNIQUES (ISSN 0018-9480) is published monthly by the Institute of Electrical and Electronics Engineers, Inc. Responsibility for the contents rests upon the authors and not upon the IEEE, the Society/Council, or its members. **IEEE Corporate Office:** 3 Park Avenue, 17th Floor, New York, NY 10016-5997. **IEEE Operations Center:** 445 Hoes Lane, Piscataway, NJ 08854-4141. **NJ Telephone:** +1 732 981 0060. **Price/Publication Information:** Individual copies: IEEE Members \$20.00 (first copy only), nonmember \$125.00 per copy. (Note: Postage and handling charge not included.) Member and nonmember subscription prices available upon request. Available in microfiche and microfilm. **Copyright and Reprint Permissions:** Abstracting is permitted with credit to the source. Libraries are permitted to photocopy for private use of patrons, provided the per-copy fee indicated in the code at the bottom of the first page is paid through the Copyright Clearance Center, 222 Rosewood Drive, Danvers, MA 01923. For all other copying, reprint, or republication permission, write to Copyrights and Permissions Department, IEEE Publications Administration, 445 Hoes Lane, Piscataway, NJ 08854-4141. Copyright © 2010 by The Institute of Electrical and Electronics Engineers, Inc. **Postmaster:** Send address changes to IEEE TRANSACTIONS ON MICROWAVE THEORY AND TECHNIQUES, 445 Hoes Lane, Piscataway, NJ 08854-4141.



Find authenticated court documents without watermarks at docketalarm.com.

A Multimode/Multiband Power Amplifier With a Boosted Supply Modulator

Daehyun Kang, Dongsu Kim, Jinsung Choi, Jooseung Kim, Yunsung Cho, and Bumman Kim, *Fellow, IEEE*

This material may be protected by Copyright law (Title 17 U.S. Code)

Abstract—A multimode/multiband power amplifier (PA) with a boosted supply modulator is developed for handset applications. A linear broadband class-F amplifier is designed to have a constant fundamental impedance across 1.7–2 GHz and its second and third harmonic impedances are located at the high-efficiency area. To reduce the circuit size for handset application, the harmonic control circuits are merged into the broadband output matching circuit for the fundamental frequency. An envelope-tracking operation delivers high efficiency for the overall power. The linearity is improved by envelope tracking (ET) through intermodulation-distortion sweet-spot tracking at the maximum output power level. The efficiency and bandwidth (BW) are enhanced by a boosted supply modulator. Multimode operation is achieved by an ET technique with a programmable hysteresis control and automatic switching current adaptation of the hybrid supply modulator. For demonstration purpose, the PA and supply modulator are implemented using an InGaP/GaAs heterojunction bipolar transistor and a 65-nm CMOS process. For a long-term evolution signal, the envelope-tracking (ET) PA delivers a power-added efficiency (PAE) and an error vector magnitude of 33.3%–39% and 2.5%–3.5%, respectively, at an average power of 27.8 dBm across 1.7–2 GHz. For a wideband code-division multiple-access signal across 1.7–2 GHz, the ET PA performs a PAE, an ACLR1, and an ACLR2 of 40%–46.3%, from –39 to –42.5 dBc, and –51 to –58 dBc, respectively, at an average output power of 30.1 dBm. The ET PA with an EDGE signal delivers a PAE, an ACPRI, and an ACPRI2 of 37%–42%, from –56.5 to –59.3 dBc, and –63.5 to –69.5 dBc, respectively, at an average power of 28 dBm across the 300-MHz BW. These results show that the proposed design achieves highly efficient and linear power amplification for multimode/multiband wireless communication applications.

Index Terms—Efficient, enhanced data rates for GSM evolution (EDGE), envelope tracking (ET), handset, heterojunction bipolar transistors (HBT), linear, long-term evolution (LTE), monolithic microwave integrated circuit (MMIC), power amplifier (PA), supply modulator, wideband code division multiple access (WCDMA).

Manuscript received May 19, 2010; revised July 04, 2010; accepted July 04, 2010. Date of publication September 02, 2010; date of current version October 13, 2010. This work was supported by the World Class University (WCU) Program through the Korea Science and Engineering Foundation funded by the Ministry of Education, Science and Technology (Project R31-2008-000-10100-0), and by The Ministry of Knowledge Economy (MKE), Korea, under the Information Technology Research Center (ITRC) Support Program supervised by the National IT Industry Promotion Agency (NIPA) [NIPA-2010-(C1090-1011-0011)].

D. Kang, D. Kim, J. Kim, Y. Cho, and B. Kim are with the Department of Electrical Engineering, Pohang University of Science and Technology (POSTECH), Pohang, Gyeongbuk 790-784, Korea (e-mail: daehkang@postech.ac.kr; bmkim@postech.ac.kr).

I. INTRODUCTION

POWER amplifiers (PAs) for multifunctional smart mobile phones have become a very challenging area because the PA should handle voice, data, and broadcast with global roaming capability. Therefore, the PAs should have a multimode/multiband capability with high efficiency [1]. The input/output matching components of the transmitter are sensitive to frequency, thus preventing multiband operation. Low amplification efficiency leads to a short battery life and heat in mobile handsets. Moreover, as the information content increases, modulation systems need to have wider bandwidths (BWs) and a higher peak-to-average power ratio (PAPR), causing the PA to operate in a less efficient back-off region for linearity. To improve the low efficiency at the back-off power region, many efficiency enhancement techniques have undergone research for a long period of time.

The Doherty and the envelope elimination and restoration (EER) techniques have been investigated for high efficiency at the back-off power region. The efficiency at the back-off power region is important for handset applications because of frequent use of lower power levels and the high PAPR of the signals. The Doherty technique modulates the load according to the power level [2]–[5]. The load modulation is often achieved by a quarter-wavelength transformer, and linear operation is accomplished by third-order intermodulation (IM3) cancellation between the main and auxiliary amplifiers. Both of these are sensitive to the frequency of operation. Thus, the Doherty PAs have a limit for broadband operation.

The EER technique involves modulating the supply voltage according to the power level of a PA, and enhances efficiency at the back-off power region [6]–[16]. The EER structure comprises the supply modulator and the PA. Only the PA determines the RF operating frequency band. Thus, the EER technique is more advantageous for broadband operation than the Doherty technique.

The efficiency of the EER structure is determined by multiplication of the efficiencies of the supply modulator and the PA [12]. A highly efficient EER structure requires that both the supply modulator and PA be efficient. Thus, class-E, class-F, class-D, and class-J PAs can be candidates. The class-E PAs achieve high efficiency by turning on the transistor at the point when the drain-source (collector-emitter) capacitor does not have any charge. The class-F PA controls the voltage waveform to ensure it is square shaped, which increases the magnitude of

class-F PA, using a push–pull structure. The class-J PA utilizes the phase shift between the output current and voltage waveforms to render the second harmonic termination to a purely reactive regime [19].

The broadband approaches for class-E PAs and class-F PAs have been studied in [20] and [21]. However, these concepts are for base-station PAs, and use microstrip lines for matching. The microstrip lines are too bulky to be employed in PAs for handset applications. In [22], we have proposed broadband class-F PAs, which control the second and third harmonic impedances across a broad BW, but linearity is not considered as we intend to use a digital pre-distortion (DPD) technique. Broadband class-J PAs for base-station PAs have been also investigated [19]. The researchers have found the optimum efficiency contour for class-J operation across a broad BW, and matched the load impedance to the contour, thus, a 50% fractional BW with high efficiency is achieved. A gallium–nitride (GaN) device with a high supply voltage has a low Q for the output impedances due to the small output capacitance, and its gain drops 3 dB per octave frequency (normally it is 6 dB/octave because of its operation at the maximum stable gain (MSG) region). Despite the advantageous characteristics of the GaN device, it is too expensive at the moment to be utilized for handset devices and it requires too high bias voltage.

The ideal EER structure would deliver a 100% efficiency using a highly efficient supply modulator, but the limited BW of switching amplifiers and the low efficiency of wideband linear amplifiers for the modulators degrades the ideal efficiency. Some researchers have utilized the advantages of the wide-BW linear amplifier and the high-efficiency switching amplifier [10]–[15]. The switching amplifier does not follow most of the high slew-rate load current, and operates as a quasi-constant current source. The linear amplifier supplies and sinks the current to regulate the load according to the envelope of the signal. This structure is suitable for the envelope signal of modern wireless communication systems, which has the most power in the low-frequency region. In [15], we have proposed a hybrid switching amplifier (HSA) for multistandard applications. Automatic switching current adaption from an HSA and programmable hysteresis control can achieve multimode operation.

In this paper, we propose a multimode/multiband PA with a boosted supply modulator for handset applications. For this multiband PA design, the fundamental load is maintained at a consistent level across the BW. Harmonic impedances are searched for highly efficient class-F operation. The harmonic circuits are merged into the broadband matching circuit, thereby reducing their size and increasing the available BW. In contrast to our previous paper [22], the PA matching is modified for linear class-AB bias. An HSA with a boost converter driving the linear stage increases the RF BW due to reduced output capacitance of the RF device at the higher operating voltages provided by the boost converter. The HSA also improves the efficiency due to envelope tracking (ET). Finally the HSA improves linearity due to intermodulation-distortion (IMD) sweet-

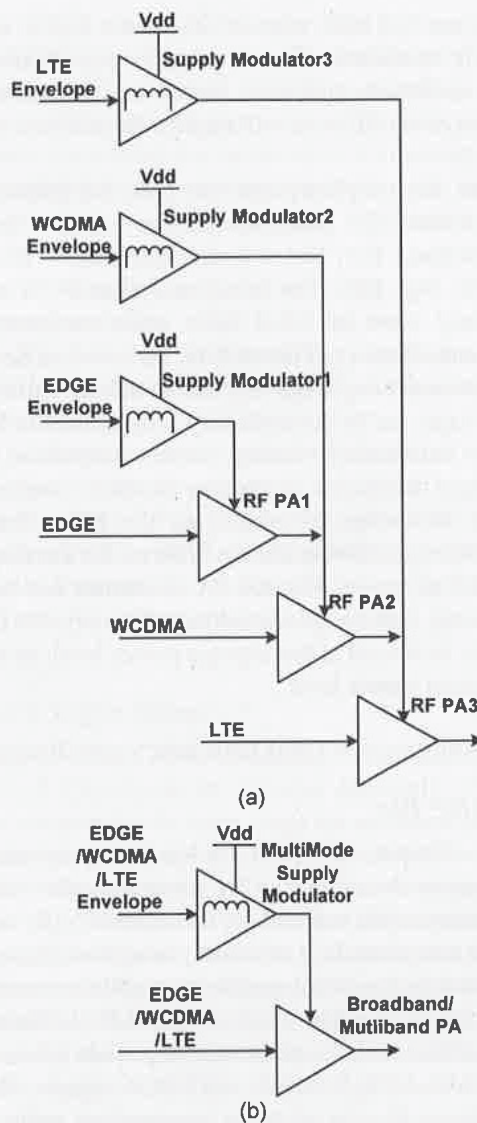

Fig. 1. (a) Conventional polar transmitter for multimode/multiband operation. (b) Proposed polar transmitter for multimode/multiband operation.

For demonstration purposes, the PA and supply modulator are implemented using an InGaP/GaAs HBT and a 65-nm CMOS processes, and are operated with signals of long-term evolution (LTE), wideband code division multiple access (WCDMA), and EDGE across frequencies of 1.7–2 GHz. The measured results prove that the proposed design achieves highly efficient and linear power amplification for multimode/multiband applications.

II. MULTIMODE/MULTIBAND POLAR TRANSMITTER

A conventional polar transmitter for multimode/multiband operation requires a PA and a supply modulator for each wireless communication standard, as shown in Fig. 1(a). For example, if we need transmitters operating for an LTE, a WCDMA, and an EDGE application across a 1.7–2.0-GHz frequency, supply modulators and PAs need to operate at different

Explore Litigation Insights

Docket Alarm provides insights to develop a more informed litigation strategy and the peace of mind of knowing you're on top of things.

Real-Time Litigation Alerts



Keep your litigation team up-to-date with **real-time alerts** and advanced team management tools built for the enterprise, all while greatly reducing PACER spend.

Our comprehensive service means we can handle Federal, State, and Administrative courts across the country.

Advanced Docket Research



With over 230 million records, Docket Alarm's cloud-native docket research platform finds what other services can't. Coverage includes Federal, State, plus PTAB, TTAB, ITC and NLRB decisions, all in one place.

Identify arguments that have been successful in the past with full text, pinpoint searching. Link to case law cited within any court document via Fastcase.

Analytics At Your Fingertips



Learn what happened the last time a particular judge, opposing counsel or company faced cases similar to yours.

Advanced out-of-the-box PTAB and TTAB analytics are always at your fingertips.

API

Docket Alarm offers a powerful API (application programming interface) to developers that want to integrate case filings into their apps.

LAW FIRMS

Build custom dashboards for your attorneys and clients with live data direct from the court.

Automate many repetitive legal tasks like conflict checks, document management, and marketing.

FINANCIAL INSTITUTIONS

Litigation and bankruptcy checks for companies and debtors.

E-DISCOVERY AND LEGAL VENDORS

Sync your system to PACER to automate legal marketing.