



INDUSTRIAL ELECTRONICS

A PUBLICATION OF THE IEEE INDUSTRIAL ELECTRONICS SOCIETY

FEBRUARY 1997

VOLUME 44

NUMBER 1

ITIED6

(ISSN 0278-0046)

SPECIAL SECTION ON ELECTRIC VEHICLE TECHNOLOGY

Guest Editorial	<i>C. C. Chan</i>	1
An Overview of Power Electronics in Electric Vehicles	<i>C. C. Chan and K. T. Chau</i>	3
Advanced Concepts in Electric Vehicle Design	<i>H. Shimizu, J. Harada, C. Bland, K. Kawakami, and L. Chan</i>	14
Propulsion System Design of Electric and Hybrid Vehicles	<i>M. Ehsani, K. M. Rahman, and H. A. Toliyat</i>	19
Novel Motors and Controllers for High-Performance Electric Vehicle with Four In-Wheel Motors	<i>M. Terashima, T. Ashikaga, T. Mizuno, K. Natori, N. Fujiwara, and M. Yada</i>	28
Axial Flux Machines Drives: A New Viable Solution for Electric Cars	<i>F. Profumo, Z. Zhang, and A. Tenconi</i>	39
A Permanent Magnet Hysteresis Hybrid Synchronous Motor for Electric Vehicles.....	<i>M. A. Rahman and R. Qin</i>	46
A Torque Controller Suitable for Electric Vehicles	<i>N. Mutoh, S. Kaneko, T. Miyazaki, R. Masaki, and S. Obara</i>	54
Analysis of Anti-Directional-Twin-Rotary Motor Drive Characteristics for Electric Vehicles	<i>A. Kawamura, N. Hoshi, T. W. Kim, T. Yokoyama, and T. Kume</i>	64
Resonant Snubber-Based Soft-Switching Inverters for Electric Propulsion Drives.....	<i>J.-S. Lai</i>	71
Design of Interface Circuits With Electrical Battery Models	<i>Y.-H. Kim and H.-D. Ha</i>	81

REGULAR PAPERS

Improved Modulation Techniques for PWM-VSI Drives	<i>F. Blaabjerg, J. K. Pedersen, and P. Thøgersen</i>	87
Optimal Control of Three-Level PWM Inverters.....	<i>S. Halász, A. A. M. Hassan, and B. T. Huu</i>	96
A New <i>N</i> -Level High Voltage Inversion System	<i>B.-S. Suh and D.-S. Hyun</i>	107
Basic Considerations and Topologies of Switched-Mode Assisted Linear Power Amplifiers.....	<i>H. Ertl, J. W. Kolar, and F. C. Zach</i>	116
Robust Temperature Control for Microwave Heating of Ceramics	<i>G. O. Beale</i>	124

LETTERS TO THE EDITOR

Automatic Color Grading of Ceramic Tiles Using Machine Vision	<i>C. Boukouvelas, J. Kittler, R. Marik, and M. Petrou</i>	132
Application of a PLL and ALL Noise Reduction Process in Optical Sensing Systems.....	<i>D. F. Clark and T. J. Moir</i>	136
Analysis of Unlocked and Acquisition Operation of a Phase-Locked Speed Control System	<i>C. A. Karybakas and T. L. Laopoulos</i>	138
A Programmable Cascaded Low-Pass Filter-Based Flux Synthesis for a Stator Flux-Oriented Vector-Controlled Induction Motor Drive	<i>B. K. Bose and N. R. Patel</i>	140



IEEE INDUSTRIAL ELECTRONICS SOCIETY

The Industrial Electronics Society is an organization, within the framework of the IEEE, of members with principal professional interest in electronics and electrical sciences as applied to control, treatment, and measurement of industrial processes. All members of the IEEE are eligible for membership in the Society and will receive this TRANSACTIONS upon payment of the annual membership fee of \$20.00. For information on joining, write to the IEEE at the address below. *Member copies of Transactions/Journals are for personal use only.*

IEEE TRANSACTIONS ON INDUSTRIAL ELECTRONICS

Editor-in-Chief

JOACHIM HOLTZ
Chair for Electrical Machines and Drives
University of Wuppertal
42097 Wuppertal, Germany
phone: 49 (202) 439 2936
fax: 49 (202) 428 424
e-mail: j.holtz@ieee.org

Associate Editors

B. W. BOMAR
Univ. of TN Space Inst.
G. BUJA
Univ. of Padova
M. Y. CHOW
North Carolina State Univ.
J. A. DE ABREU-GARCIA
Univ. of Akron
B. FRAZIER
Univ. of Utah
M. E. GREENE
Auburn Univ.
L. L. GRIGSBY
Auburn Univ.
D. HANSELMANN
Univ. of Maine

J. A. HEINEN
Marquette Univ.
K. HIROTA
Tohoku Univ.
J. HOLTZ
Wuppertal Univ.
J. Y. HUNG
Auburn Univ.
R. ISHII
Yokohama Nat. Univ.
L. C. JAIN
Univ. of South Australia
O. KAYNAK
Bogazici Univ.
M. P. KAZMIERKOWSKI
Warsaw Univ. of Tech.

E. J. KENNEDY
Univ. of Tennessee
M. S. KO
Seoul Nat. Univ.
K. KOSUGE
Tohoku Univ.
M. F. LAI
Chinese Culture Inst.
T. H. LEE
National Univ. of Singapore
T. S. LOW
National Univ. of Singapore
K. F. MAN
City Univ. of Hong Kong
R. M. NELMS
Auburn Univ.

K. OHNISHI
Keio Univ.
K. RAMU
Virginia Polytech.
F. A. STICH
Best Power Technology, Inc.
J. UCEDA
Univ. Politecnica de Madrid
A. C. WEAVER
Univ. of Virginia
C. H. WU
Auburn University
D. C. ZHANG
Hefei Univ. of Tech.
R. ZURAWSKI
Swinburne Univ. of Tech.

At Large

B. K. BOSE
Univ. of Tennessee

W. LEONHARD
Tech. Univ. of Braunschweig

Newsletter Editor

P. W. GOLD
NIST

THE INSTITUTE OF ELECTRICAL AND ELECTRONICS ENGINEERS, INC.

Officers

CHARLES K. ALEXANDER, *President*
JOSEPH BORDOGNA, *President-Elect*
PAUL Y. S. CHEUNG, *Secretary*
HOWARD L. WOLFMAN, *Treasurer*
JERRY R. YEARGAN, *Vice President, Educational Activities*

DANIEL R. BENIGNI, *Vice President, Professional Activities*
FRIEDOLF M. SMITS, *Vice President, Publication Activities*
RAYMOND D. FINDLAY, *Vice President, Regional Activities*
DONALD C. LOUGHRY, *Vice President, Standards Activities*
LLOYD A. MORLEY, *Vice President, Technical Activities*

MICHAEL MASTIN, *Director, Division X—Systems and Control*

Executive Staff

DANIEL J. SENESE, *Executive Director*

DONALD CURTIS, *Human Resources*
ANTHONY J. FERRARO, *Publications*
CECELIA JANKOWSKI, *Regional Activities*
PETER A LEWIS, *Educational Activities*

ANDREW G. SALEM, *Standards Activities*
RICHARD D. SCHWARTZ, *Business Administration*
W. THOMAS SUTTLE, *Professional Activities*
JOHN WITSKEN, *Information Technology*

IEEE Periodicals

Transactions/Journals Department

Staff Director: FRAN ZAPPULLA
Manager: GAIL S. FERENC
Editorial Manager: VALERIE CAMMARATA
Electronic Publishing Manager: TOM BONTRAGER
Managing Editor: MONA MITTRA
Associate Editor: KEITH H. EDICK

IEEE TRANSACTIONS ON INDUSTRIAL ELECTRONICS (ISSN 0278-0046) is published bimonthly by The Institute of Electrical and Electronics Engineers, Inc. Responsibility for the contents rests upon the authors and not upon the IEEE, the Society, or its members. **IEEE Corporate Office**, 345 East 47 Street, New York, NY 10017-2394. **IEEE Operations Center**, 445 Hoes Lane, P.O. Box 1331, Piscataway, NJ 08855-1331. **NJ Telephone:** 908-981-0060. **Price/Publication Information:** Individual copies: IEEE members \$10.00 (first copy only), nonmembers \$20.00 per copy. (Note: Add \$4.00 postage and handling charge to any order from \$1.00 to \$50.00, including prepaid orders.) Member and nonmember subscription prices available on request. Available in microfiche and microfilm. **Copyright and Reprint Permissions:** Abstracting is permitted with credit to the source. Libraries are permitted to photocopy for private use of patrons, provided the per-copy fee indicated in the code at the bottom of the first page is paid through the Copyright Clearance Center, 222 Rosewood Drive, Danvers, MA 01923. For all other use, permission should be sought from the Copyrights and Permissions Department, IEEE Publications Department, 4300 McGraw-Hill, New York, NY 10020.

Guest Editorial

Special Section on Electric Vehicle Technology

I AM VERY GLAD to be able to present a Special Section on Electric Vehicle Technology in this issue of our TRANSACTIONS. On the eve of going to press with this special section, I was confronted by the following data. As recently as 1950, there were only 53 million motor vehicles registered in the world, and their exhaust emissions could still be tolerated because of their relatively modest effects. In 1992, our planet had well over half a billion cars and trucks! By the year 2000, their number will exceed one billion! If they were all to be powered by gasoline and diesel oil, our world could not stand it. Therefore, one of the most pressing demands of our time is an alternative clean, efficient, intelligent, and environmentally friendly urban transportation system. Electric vehicles offer a solution for improving air quality, reducing reliance on fossil fuels, and they are energy efficient. Furthermore, electric vehicles will be more intelligent to improve traffic safety and road utilization. In this special section, there are ten papers authored by researchers in academia and industry. These papers address the state of the art as well as some of the key issues and key technology of electric vehicles. The first paper, by Chan and Chau, provides an overview of current electric vehicle technology and the challenges ahead. The second paper, by Shimizu, Harada, Bland, Kawakami, and Chan, describes a unique ECO Vehicle Project in Japan with an in-wheel motor drive system, a hollow load floor which accommodates the batteries, and a new battery management system. The third paper, by Ehsani, Rahman, and Toliyat, addresses the system design philosophies of electric and hybrid vehicle propulsion systems. The dynamics are studied in an attempt to find an optimal torque-speed profile for the

electric propulsion. The fourth paper, by Terashima, Ashikaga, Mizuno, Natori, Fujiwara, and Yada, describes unique in-wheel motors for a high-performance experimental electric vehicle. The fifth paper, by Profumo, Zhang, and Tenconi, describes alternative axial flux induction or synchronous in-wheel motors for electric vehicles. The sixth paper, by Rahman and Qin, presents the design, analysis, and PWM vector control of a hybrid permanent magnet hysteresis synchronous motor for electric vehicle application. The seventh paper, by Mutoh, Kaneko, Miyazaki, Masaki, and Obara, describes a torque controller which suits electric vehicle operating conditions. The eighth paper, by Kawamura, Hoshi, Kim, Yokoyama, and Kume, proposes an anti-directional-twin-rotary motor drive as a new power train for electric vehicles. The ninth paper, by Lai, presents resonant snubber-based soft-switching inverters for electric propulsion drives, which have superior performance in efficiency improvement, EMI reduction, and dv/dt reduction. The last paper, by Kim and Ha, deals with the design of interface circuits with electrical battery models. On the whole, the above ten papers address important technology for the next century. They deal with the key components in electric vehicle development, namely system design philosophy, various options of electric motor drives and energy management. These are challenges for our profession. The 21st century will be the environmental century, and electric vehicles will be the major means of urban transportation.

C. C. CHAN, *Guest Editor*
Dept. Electrical & Electronic Engineering
University of Hong Kong
Hong Kong

Publisher Item Identifier S 0278-0046(97)00066-X.

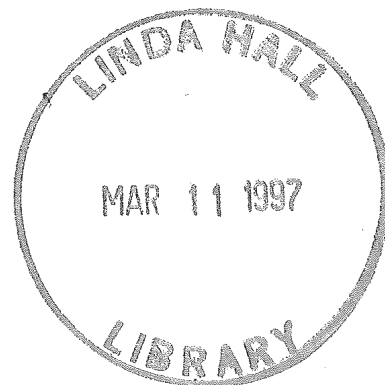

Basic Considerations and Topologies of Switched-Mode Assisted Linear Power Amplifiers

Hans Ertl, *Member, IEEE*, Johann W. Kolar, *Member, IEEE*, and Franz C. Zach, *Member, IEEE*

Abstract—This paper presents a combined power amplifier system consisting of a linear amplifier unit with a switched-mode (class D) current dumping stage arranged in parallel. With this topology, the fundamental drawback of conventional linear power amplifiers—the high loss—is avoided. Compared to a pure class D (switching) amplifier, the presented system needs no output filter to reduce the switching frequency harmonics. This filter (usually of multistage type) generally deteriorates the transient response of the system and impairs the feedback loop design. Furthermore, the low-frequency distortions of switching amplifiers caused by the interlock delay of their power transistors are avoided with the presented switched-mode assisted linear amplifier system. This can be considered as a master–slave system with a guiding linear amplifier and a supporting class D slave unit. The paper describes the operating principle of the system, analyzes the fundamental relationships for the circuit design, and presents simulation results. Finally, various further topologies of switched-mode assisted linear amplifiers are given.

Index Terms—Class D converters, dc–ac power conversion, power amplifiers, switching amplifiers.

I. INTRODUCTION

CONVENTIONAL linear power amplifiers (Fig. 1(a)) are replaced by switching (class D) amplifiers (Fig. 1(b)) in an increased quantity to overcome the essential drawback of linear amplifier systems, i.e., the high losses (especially in the case of nonresistive or nonlinear loads or if signals with high peak-to-rms ratio are amplified [1]). Nevertheless, if the output voltages have to be of very high quality (e.g., for high-end audio applications or for test and measuring equipment), switching amplifiers show significant limitations. The output voltage of a class D amplifier implies substantial switching-frequency components (high frequency distortions) which have to be reduced by a proper low-pass filter. However, this filter—which has to be in general of higher order type—reduces the dynamic response and increases the output impedance of the whole amplifier system. Also, the interlock delay time of the usually applied bridge topologies, and/or a ripple of the dc supply voltage $\pm U$ and/or the on-state voltages of the power semiconductor devices (transistors and freewheeling diodes), may result in low-frequency distortion [2] which hardly can be reduced by the described switching frequency output filter, but has to be lowered by using a special control loop design [3], [4]. A further problem of switching amplifiers is the possible occurrence of subharmonic frequency components which may

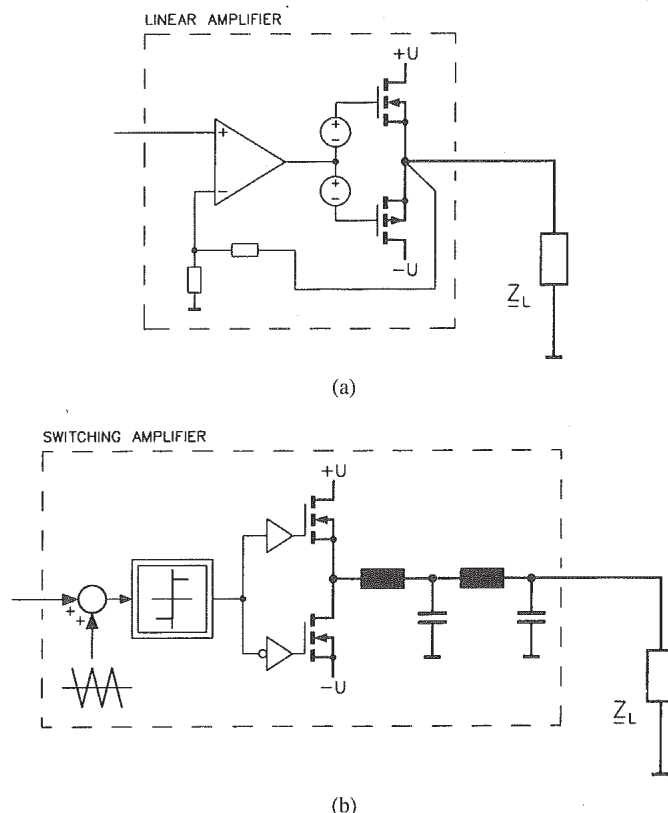

Fig. 1. Simplified circuit diagram of (a) a linear power amplifier and (b) a class D switching amplifier (the internal body diodes of the switching power MOSFET's are not shown).

result for a small signal-to-switching-frequency ratio, or if a pulse width modulation strategy with not constant switching frequency (e.g., hysteresis control or sigma–delta modulation) is applied. This subharmonic noise basically cannot be lowered by the output low-pass filter because the relevant frequency components lie within the power bandwidth of the amplifier.

To avoid the disadvantages described above, a concept originally proposed in [5] consisting of a parallel arrangement of a class D switching system and a conventional linear amplifier stage (Fig. 2) is analyzed. There, the output filter of the switching amplifier is reduced to a single coupling inductor determining the switching frequency ripple. Although the linear amplifier, therefore, can be considered as active filter which compensates the switching frequency ripple and the modulation noise, the basic idea of the proposed switched-mode assisted linear amplifier is that the linear amplifier acts as the guiding master system, whereas the task of the class D (slave) stage is to take over the current of the linear stage

Manuscript received February 13, 1996; revised July 13, 1996.

The authors are with the Power Electronics Section of the Technical University Vienna, A-1040 Vienna, Austria.

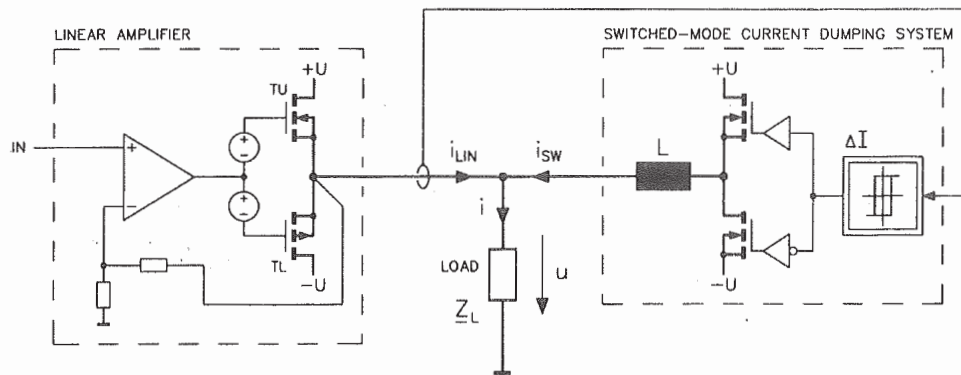

Fig. 2. Circuit diagram of a switched-mode assisted linear power amplifier.

(current dumping). In the ideal (stationary) case, the linear power amplifier only has to deliver the ripple of the class D stage which significantly reduces its power losses. Contrary to a (passive) output filter of a conventional switching amplifier, the linear amplifier of the proposed concept also reduces low-frequency distortions and subharmonic components. It has to be pointed out, however, that a very low output impedance of the linear system part is of paramount importance in order to get a high noise rejection. This circumstance has to be considered by an appropriate design of the linear amplifier circuitry and feedback system. Furthermore, the switched-mode assisted linear amplifier only allows a significant reduction but not a complete loss elimination as an idealized class D amplifier. Therefore, considering the losses, the proposed system can be seen as an intermediate solution between pure linear and pure class D power amplifiers. As an advantage of the proposed system, it has to be mentioned that the dynamic response of the whole system is determined by the linear stage and, therefore, not influenced by an output filter.

II. SYSTEM CONTROL—CALCULATION OF POWER LOSSES

The guidance of the class D part is realized by a current controller whose reference value is identical to the current through the load. Thus, only the control error and the ripple have to be delivered by the linear stage. Instead of an explicit subtraction of reference value (load current i) and actual value (class D stage output current i_{SW}), the calculation of the controlling quantity can be done in an implicit manner by direct measurement of the linear stage output current i_{LIN} . In the simplest case, the current controller can be a hysteresis controller (Fig. 2), which results in a nonconstant switching frequency within the fundamental period of the amplified signal. As an alternative, a pulse width modulator (PWM) with a superimposed linear current controller, or other types of current controllers being well-known from switched-mode power supplies (e.g., conductance control), can be applied. The usage of a PWM allows a switching frequency being constant which is, however, of not essential significance for this application, as stated before. An advantage of the hysteresis controller is its inherent overmodulation ability which yields a more efficient utilization of the dc supply

of the class D stage to a parallel arrangement being operated in an optimum phase-shifted manner, in order to reduce the total ripple current or increase the effective switching frequency, respectively. However, it should be mentioned that there exist solutions for two hysteresis-controlled converter branches (arranged in parallel) where a suboptimal phase shift can be achieved in a very simple way (Section V).

In the following, the losses of the linear amplifier stage shall be calculated for the case that a hysteresis current controller with a constant tolerance band ΔI is applied. It is assumed that the load current i and the output voltage u can be treated as constant within the switching interval T , or that there exists a sufficient signal-to-switching frequency ratio, respectively (Fig. 3). Furthermore, the power transistors are assumed to be ideal (neglect of delay times, on-state voltages, etc.). Also, dc supply voltage variations are neglected.

Switching Frequency: With the assumptions given above, the output voltage u (averaged within a pulse interval T) is determined by the duty cycle δ . If we apply the definition $m = u/U$ for normalizing the output voltage ($m = -1 \dots +1$), we get

$$\delta = \frac{1 + u/U}{2} = \frac{1 + m}{2}. \quad (1)$$

According to $u_L = L di_{SW}/dt$, the switching frequency $f_s = 1/T$ can be calculated

$$f_s = f_{S,\max} \cdot (1 - m^2) \quad \text{with} \quad f_{S,\max} = \frac{U}{2L \cdot \Delta I}. \quad (2)$$

Power Losses: The power losses of the linear stage depend on its operating mode, where one has to distinguish between class A (linear amplifier with quiescent current eliminating crossover distortions) and class B (without quiescent current) mode. The following table gives the local losses (i.e., the losses averaged within a switching period T) of the upper transistor TU and the lower transistor TL of the linear stage, where it is assumed that for class A mode the quiescent current is as small as possible ($I_Q = I_{Q,\min} = \Delta I/4$) (see Fig. 3(e)).

For $I_Q = \Delta I/4$, the class A mode losses are twice the losses of the class B mode. The total transistor losses p_T are not dependent on the modulation index m and, therefore, the local transistor losses p_T also represent the global losses

Explore Litigation Insights

Docket Alarm provides insights to develop a more informed litigation strategy and the peace of mind of knowing you're on top of things.

Real-Time Litigation Alerts



Keep your litigation team up-to-date with **real-time alerts** and advanced team management tools built for the enterprise, all while greatly reducing PACER spend.

Our comprehensive service means we can handle Federal, State, and Administrative courts across the country.

Advanced Docket Research



With over 230 million records, Docket Alarm's cloud-native docket research platform finds what other services can't. Coverage includes Federal, State, plus PTAB, TTAB, ITC and NLRB decisions, all in one place.

Identify arguments that have been successful in the past with full text, pinpoint searching. Link to case law cited within any court document via Fastcase.

Analytics At Your Fingertips



Learn what happened the last time a particular judge, opposing counsel or company faced cases similar to yours.

Advanced out-of-the-box PTAB and TTAB analytics are always at your fingertips.

API

Docket Alarm offers a powerful API (application programming interface) to developers that want to integrate case filings into their apps.

LAW FIRMS

Build custom dashboards for your attorneys and clients with live data direct from the court.

Automate many repetitive legal tasks like conflict checks, document management, and marketing.

FINANCIAL INSTITUTIONS

Litigation and bankruptcy checks for companies and debtors.

E-DISCOVERY AND LEGAL VENDORS

Sync your system to PACER to automate legal marketing.