

UNITED STATES PATENT AND TRADEMARK OFFICE

BEFORE THE PATENT TRIAL AND APPEAL BOARD

INTEL CORPORATION,
Petitioner,

v.

QUALCOMM, INC.,
Patent Owner.

Case IPR2018-01153
Patent 8,698,558 B2

Before TREVOR M. JEFFERSON, DANIEL N. FISHMAN, and
SCOTT B. HOWARD, *Administrative Patent Judges*.

JEFFERSON, *Administrative Patent Judge*.

DECISION
Institution of *Inter Partes* Review
37 C.F.R. § 42.108

I. INTRODUCTION

Intel Corporation (“Petitioner”) requests *inter partes* review of claims 1–9 of U.S. Patent No. 8,698,558 B2 (“the ’558 patent,” Ex. 1101) pursuant to 35 U.S.C. §§ 311 *et seq.* Paper 3 (“Petition” or “Pet.”). Qualcomm Incorporated (“Patent Owner”) filed a Preliminary Response. Paper 8 (“Prelim. Resp.”). We have jurisdiction under 35 U.S.C. § 314(a).

Institution of an *inter partes* review is authorized by statute when “the information presented in the petition . . . and any response . . . shows that there is a reasonable likelihood that the petitioner would prevail with respect to at least 1 of the claims challenged in the petition.” 35 U.S.C. § 314(a). Upon consideration of the Petition and Patent Owner’s Preliminary Response, we conclude the information presented shows there is a reasonable likelihood that Petitioner would prevail in establishing the unpatentability of claims 1–9 of the ’558 patent.

A. Related Proceedings

Apple Inc. is identified as an additional real party-in-interest. Pet. 2. The parties inform us that the ’558 patent is presently asserted against Petitioner in the litigation *Qualcomm Inc. v. Apple Inc.*, Case No. 3:17-cv-01375-DMS-MDD (S.D. Cal.) and against Apple in a proceeding before the International Trade Commission (“ITC”) captioned *In the Matter of Certain Mobile Elec. Devices and Radio Frequency Components Thereof*, Inv. No. 337-TA-1065. Pet. 2; Paper 6, 2. The parties also inform us that additional claims of the ’558 patent are at issue in related *inter partes* reviews, specifically claims 12–14 of the ’558 patent in IPR2018-01152, claims 15–

IPR2018-01153
Patent 8,698,558 B2

20 of the '558 patent in IPR2018-01554, and claims 10 and 11 in IPR2019-01240. Pet. 2; Paper 6, 2.

B. The '558 Patent

The '558 patent is titled, “Low-Voltage Power-Efficient Envelope Tracker” and discloses “[t]echniques for efficiently generating a power supply for a power amplifier” used in communication system transmitters.

Ex. 1101, 1:30–31, [54]. The '558 patent discloses that

transmitter typically includes a power amplifier (PA) to provide high transmit power for the output RF signal. The power amplifier should be able to provide high output power and have high power-added efficiency (PAE). Furthermore, the power amplifier may be required to have good performance and high PAE even with a low battery voltage.

Id. at 1:21–26. The '558 patent also discloses that the power amplifier apparatus may include: (1) in one embodiment an envelope amplifier and a boost converter; (2) in a second embodiment a switcher, an envelope amplifier, and a power amplifier; or (3) in a third embodiment a switcher that may sense an input current and generate a switching signal to charge and discharge an inductor providing a supply current. *Id.* at 1:31–34; 1:51–52; 1:66–2:2.

Figure 3, below, shows an exemplary switcher and envelope amplifier. *Id.* at 4:39–42.

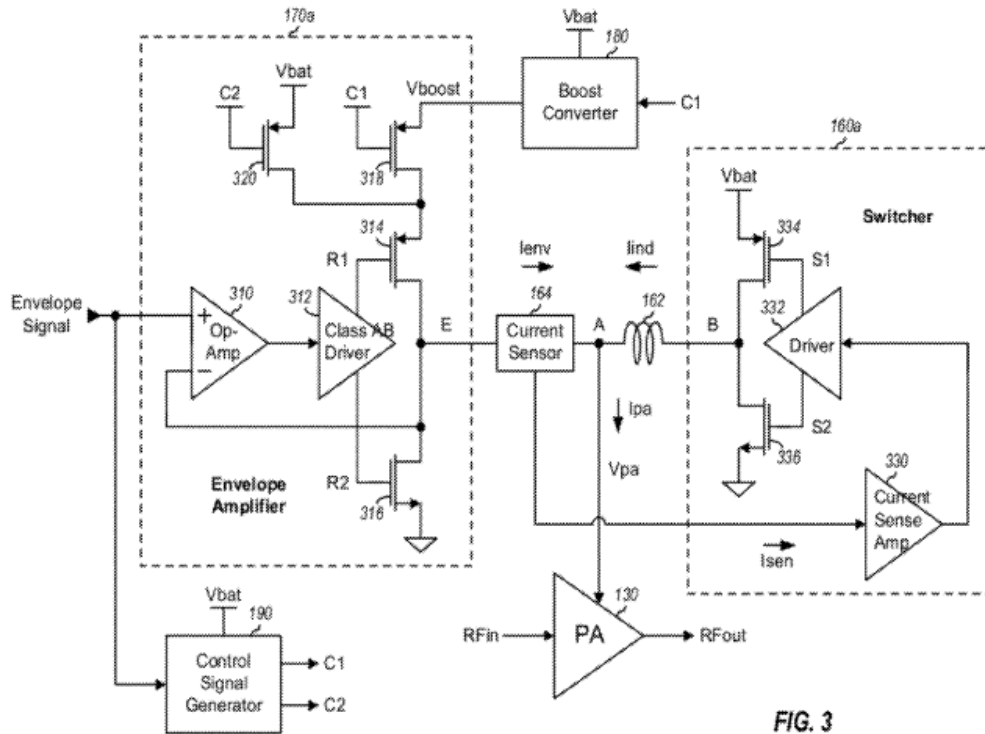

FIG. 3

Figure 3 shows switcher 160a and envelope amplifier 170a, which, in turn, includes operational amplifier (op-amp) 310 that receives the envelope signal. *Id.* at 4:41–63. Driver 312 has output (R1) coupled to the gate of P-channel metal oxide semiconductor (PMOS) transistor 314 and a second output (R2) coupled N-channel MOS (NMOS) transistor 316. *Id.* PMOS transistor 318 in envelope amplifier 170a is connected to receive C1 control signal via Vboost voltage from Boost Converter 180. *Id.* PMOS transistor 320 in envelope amplifier 170 receives a C2 control signal and Vbat voltage. *Id.*

Within switcher 160a, current sense amplifier 330 has its input coupled to current sensor 164 and its output coupled to an input of switcher driver 332. *Id.* at 4:64–66. Vbat voltage of switcher 160a provides current to power amplifier 130 via inductor 162 when the switcher is ON, and

inductor 120 provides stored energy to power amplifier 130 during the OFF state of the switcher circuit. In the ON state, the switcher is joined with the current from the envelope amplifier 170a (I_{env}) to provide a combined current (I_{pa}) to PA 130. *See Id.* at 3:21–27.

The '558 patent also discloses another embodiment for switcher circuit of Figure 3—specifically a switcher that uses offset current to lower the I_{sen} current from the current sensor, keeping the switcher in the ON state for a longer time and producing a larger I_{ind} current provided to power amplifier 130. *Id.* at 1:5–48, Figure 5.

C. Illustrative Claims

Claims 1, 6, and 8 are independent. Claim 1 is illustrative and reproduced below (Ex. 1101, 10:58–11:18).

1. An apparatus comprising:

a boost converter operative to receive a first supply voltage and generate a boosted supply voltage having a higher voltage than the first supply voltage; and

an envelope amplifier operative to receive an envelope signal and the boosted supply voltage and generate a second supply voltage based on the envelope signal and the boosted supply voltage, wherein the envelope amplifier is operative to further receive the first supply voltage and generate the second supply voltage based on the first supply voltage and generate the second supply voltage based on the first supply voltage or the boosted supply voltage, and further wherein the envelope amplifier comprises

an operational amplifier (op-amp) operative to receive the envelope signal and provide an amplified signal,

a driver operative to receive the amplified signal and provide a first control signal and a second control signal,

Explore Litigation Insights

Docket Alarm provides insights to develop a more informed litigation strategy and the peace of mind of knowing you're on top of things.

Real-Time Litigation Alerts



Keep your litigation team up-to-date with **real-time alerts** and advanced team management tools built for the enterprise, all while greatly reducing PACER spend.

Our comprehensive service means we can handle Federal, State, and Administrative courts across the country.

Advanced Docket Research



With over 230 million records, Docket Alarm's cloud-native docket research platform finds what other services can't. Coverage includes Federal, State, plus PTAB, TTAB, ITC and NLRB decisions, all in one place.

Identify arguments that have been successful in the past with full text, pinpoint searching. Link to case law cited within any court document via Fastcase.

Analytics At Your Fingertips



Learn what happened the last time a particular judge, opposing counsel or company faced cases similar to yours.

Advanced out-of-the-box PTAB and TTAB analytics are always at your fingertips.

API

Docket Alarm offers a powerful API (application programming interface) to developers that want to integrate case filings into their apps.

LAW FIRMS

Build custom dashboards for your attorneys and clients with live data direct from the court.

Automate many repetitive legal tasks like conflict checks, document management, and marketing.

FINANCIAL INSTITUTIONS

Litigation and bankruptcy checks for companies and debtors.

E-DISCOVERY AND LEGAL VENDORS

Sync your system to PACER to automate legal marketing.