

TO: Mail Stop 8 Director of the U.S. Patent and Trademark Office P.O. Box 1450 Alexandria, VA 22313-1450	REPORT ON THE FILING OR DETERMINATION OF AN ACTION REGARDING A PATENT OR TRADEMARK
---	--

In Compliance with 35 U.S.C. § 290 and/or 15 U.S.C. § 1116 you are hereby advised that a court action has been filed in the U.S. District Court for the Eastern District of Texas - Marshall Division on the following

Trademarks or Patents. (the patent action involves 35 U.S.C. § 292.);

DOCKET NO. 2:17-cv-424	DATE FILED May 12, 2017	U.S. DISTRICT COURT Eastern District of Texas - Marshall Division
PLAINTIFF BLITZSAFE TEXAS, LLC		DEFENDANT TATA MOTORS LTD., ET AL.
PATENT OR TRADEMARK NO.	DATE OF PATENT OR TRADEMARK	HOLDER OF PATENT OR TRADEMARK
1 7,489,786	February 10, 2009	Blitzsafe Texas, LLC
2 8,155,342	April 10, 2012	Blitzsafe Texas, LLC
3		
4		
5		

In the above—entitled case, the following patent(s)/ trademark(s) have been included:

DATE INCLUDED	INCLUDED BY	
	<input type="checkbox"/> Amendment <input type="checkbox"/> Answer <input type="checkbox"/> Cross Bill <input type="checkbox"/> Other Pleading	
PATENT OR TRADEMARK NO.	DATE OF PATENT OR TRADEMARK	HOLDER OF PATENT OR TRADEMARK
1		
2		
3		
4		
5		

In the above—entitled case, the following decision has been rendered or judgement issued:

DECISION/JUDGEMENT

CLERK	(BY) DEPUTY CLERK	DATE

Copy 1—Upon initiation of action, mail this copy to Director Copy 3—Upon termination of action, mail this copy to Director
 Copy 2—Upon filing document adding patent(s), mail this copy to Director Copy 4—Case file copy

AO 120 (Rev. 08/10)

TO: Mail Stop 8 Director of the U.S. Patent and Trademark Office P.O. Box 1450 Alexandria, VA 22313-1450	REPORT ON THE FILING OR DETERMINATION OF AN ACTION REGARDING A PATENT OR TRADEMARK
---	--

In Compliance with 35 U.S.C. § 290 and/or 15 U.S.C. § 1116 you are hereby advised that a court action has been filed in the U.S. District Court Northern District of Mississippi on the following
 Trademarks or Patents. (the patent action involves 35 U.S.C. § 292.)

DOCKET NO. 4:17-cv-00052-DMB-J	DATE FILED 4/27/2017	U.S. DISTRICT COURT Northern District of Mississippi	
PLAINTIFF Hawk Technology Systems, LLC		DEFENDANT Popeyes Louisiana Kitchen, Inc.	
PATENT OR TRADEMARK NO.	DATE OF PATENT OR TRADEMARK	HOLDER OF PATENT OR TRADEMARK	
1 RE43,462	6/12/2012	Hawk Technology Systems, LLC	
2			
3			
4			
5			

In the above—entitled case, the following patent(s)/ trademark(s) have been included:

DATE INCLUDED	INCLUDED BY <input type="checkbox"/> Amendment <input type="checkbox"/> Answer <input type="checkbox"/> Cross Bill <input type="checkbox"/> Other Pleading		
PATENT OR TRADEMARK NO.	DATE OF PATENT OR TRADEMARK	HOLDER OF PATENT OR TRADEMARK	
1			
2			
3			
4			
5			

In the above—entitled case, the following decision has been rendered or judgement issued:

DECISION/JUDGEMENT

CLERK David Crews,	(BY) DEPUTY CLERK <i>Jeffrey Manning</i>		DATE 5/5/2017
-----------------------	---	--	------------------

Copy 1—Upon initiation of action, mail this copy to Director Copy 3—Upon termination of action, mail this copy to Director
 Copy 2—Upon filing document adding patent(s), mail this copy to Director Copy 4—Case file copy

AO 120 (Rev. 08/10)

TO: Mail Stop 8 Director of the U.S. Patent and Trademark Office P.O. Box 1450 Alexandria, VA 22313-1450	REPORT ON THE FILING OR DETERMINATION OF AN ACTION REGARDING A PATENT OR TRADEMARK
---	---

In Compliance with 35 U.S.C. § 290 and/or 15 U.S.C. § 1116 you are hereby advised that a court action has been filed in the U.S. District Court for the Eastern District of Texas - Marshall Division on the following

Trademarks or Patents. (the patent action involves 35 U.S.C. § 292.);

DOCKET NO. 2:17-cv-423	DATE FILED May 12, 2017	U.S. DISTRICT COURT Eastern District of Texas - Marshall Division
PLAINTIFF BLITZSAFE TEXAS, LLC		DEFENDANT MAZDA MOTOR CORPORATION and MAZDA MOTOR OF AMERICA, INC., d/b/a MAZDA NORTH AMERICAN OPERATIONS, INC.
PATENT OR TRADEMARK NO.	DATE OF PATENT OR TRADEMARK	HOLDER OF PATENT OR TRADEMARK
1 7,489,786	February 10, 2009	Blitzsafe Texas, LLC
2 8,155,342	April 10, 2012	Blitzsafe Texas, LLC
3		
4		
5		

In the above—entitled case, the following patent(s)/ trademark(s) have been included:

DATE INCLUDED	INCLUDED BY	<input type="checkbox"/> Amendment <input type="checkbox"/> Answer <input type="checkbox"/> Cross Bill <input type="checkbox"/> Other Pleading
PATENT OR TRADEMARK NO.	DATE OF PATENT OR TRADEMARK	HOLDER OF PATENT OR TRADEMARK
1		
2		
3		
4		
5		

In the above—entitled case, the following decision has been rendered or judgement issued:

DECISION/JUDGEMENT

CLERK	(BY) DEPUTY CLERK	DATE
-------	-------------------	------

Copy 1—Upon initiation of action, mail this copy to Director Copy 3—Upon termination of action, mail this copy to Director
 Copy 2—Upon filing document adding patent(s), mail this copy to Director Copy 4—Case file copy

TO: Mail Stop 8 Director of the U.S. Patent and Trademark Office P.O. Box 1450 Alexandria, VA 22313-1450	REPORT ON THE FILING OR DETERMINATION OF AN ACTION REGARDING A PATENT OR TRADEMARK
---	---

In Compliance with 35 U.S.C. § 290 and/or 15 U.S.C. § 1116 you are hereby advised that a court action has been filed in the U.S. District Court for the Eastern District of Texas - Marshall Division on the following

Trademarks or Patents. (the patent action involves 35 U.S.C. § 292.);

DOCKET NO. 2:17-cv-430	DATE FILED 5/15/2017	U.S. DISTRICT COURT for the Eastern District of Texas - Marshall Division
PLAINTIFF BLITZSAFE TEXAS, LLC		DEFENDANT MITSUBISHI ELECTRIC CORPORATION, ET AL.
PATENT OR TRADEMARK NO.	DATE OF PATENT OR TRADEMARK	HOLDER OF PATENT OR TRADEMARK
1 7,489,786	2/10/2009	BLITZSAFE TEXAS, LLC
2 8,155,342	4/10/2012	BLITZSAFE TEXAS, LLC
3		
4		
5		

In the above—entitled case, the following patent(s)/ trademark(s) have been included:

DATE INCLUDED	INCLUDED BY <input type="checkbox"/> Amendment <input type="checkbox"/> Answer <input type="checkbox"/> Cross Bill <input type="checkbox"/> Other Pleading	
PATENT OR TRADEMARK NO.	DATE OF PATENT OR TRADEMARK	HOLDER OF PATENT OR TRADEMARK
1		
2		
3		
4		
5		

In the above—entitled case, the following decision has been rendered or judgement issued:

DECISION/JUDGEMENT

CLERK	(BY) DEPUTY CLERK	DATE
-------	-------------------	------

Copy 1—Upon initiation of action, mail this copy to Director Copy 3—Upon termination of action, mail this copy to Director
 Copy 2—Upon filing document adding patent(s), mail this copy to Director Copy 4—Case file copy

AO 120 (Rev. 08/10)

TO: Mail Stop 8 Director of the U.S. Patent and Trademark Office P.O. Box 1450 Alexandria, VA 22313-1450	REPORT ON THE FILING OR DETERMINATION OF AN ACTION REGARDING A PATENT OR TRADEMARK
---	---

In Compliance with 35 U.S.C. § 290 and/or 15 U.S.C. § 1116 you are hereby advised that a court action has been filed in the U.S. District Court for the Eastern District of Texas - Marshall Division on the following

Trademarks or Patents. (the patent action involves 35 U.S.C. § 292.);

DOCKET NO. 2:17-cv-422	DATE FILED May 12, 2017	U.S. DISTRICT COURT Eastern District of Texas - Marshall Division
PLAINTIFF BLITZSAFE TEXAS, LLC		DEFENDANT DAIMLER AG, ET AL.
PATENT OR TRADEMARK NO.	DATE OF PATENT OR TRADEMARK	HOLDER OF PATENT OR TRADEMARK
1 7,489,786	February 10, 2009	Blitzsafe Texas, LLC
2 8,155,342	April 10, 2012	Blitzsafe Texas, LLC
3		
4		
5		

In the above—entitled case, the following patent(s)/ trademark(s) have been included:

DATE INCLUDED	INCLUDED BY <input type="checkbox"/> Amendment <input type="checkbox"/> Answer <input type="checkbox"/> Cross Bill <input type="checkbox"/> Other Pleading	
PATENT OR TRADEMARK NO.	DATE OF PATENT OR TRADEMARK	HOLDER OF PATENT OR TRADEMARK
1		
2		
3		
4		
5		

In the above—entitled case, the following decision has been rendered or judgement issued:

DECISION/JUDGEMENT

CLERK	(BY) DEPUTY CLERK	DATE
-------	-------------------	------

Copy 1—Upon initiation of action, mail this copy to Director Copy 3—Upon termination of action, mail this copy to Director
 Copy 2—Upon filing document adding patent(s), mail this copy to Director Copy 4—Case file copy

AO 120 (Rev. 08/10)

TO: Mail Stop 8 Director of the U.S. Patent and Trademark Office P.O. Box 1450 Alexandria, VA 22313-1450	REPORT ON THE FILING OR DETERMINATION OF AN ACTION REGARDING A PATENT OR TRADEMARK
---	---

In Compliance with 35 U.S.C. § 290 and/or 15 U.S.C. § 1116 you are hereby advised that a court action has been filed in the U.S. District Court _____ for the Eastern District of Texas - Marshall Division _____ on the following

Trademarks or Patents. (the patent action involves 35 U.S.C. § 292.);

DOCKET NO. 2:17-cv-430	DATE FILED 5/15/2017	U.S. DISTRICT COURT for the Eastern District of Texas - Marshall Division
PLAINTIFF BLITZSAFE TEXAS, LLC		DEFENDANT MITSUBISHI ELECTRIC CORPORATION, ET AL.
PATENT OR TRADEMARK NO.	DATE OF PATENT OR TRADEMARK	HOLDER OF PATENT OR TRADEMARK
1 7,489,786	2/10/2009	BLITZSAFE TEXAS, LLC
2 8,155,342	4/10/2012	BLITZSAFE TEXAS, LLC
3		
4		
5		

In the above—entitled case, the following patent(s)/ trademark(s) have been included:

DATE INCLUDED	INCLUDED BY <input type="checkbox"/> Amendment <input type="checkbox"/> Answer <input type="checkbox"/> Cross Bill <input type="checkbox"/> Other Pleading	
PATENT OR TRADEMARK NO.	DATE OF PATENT OR TRADEMARK	HOLDER OF PATENT OR TRADEMARK
1		
2		
3		
4		
5		

In the above—entitled case, the following decision has been rendered or judgement issued:

DECISION/JUDGEMENT

CLERK	(BY) DEPUTY CLERK	DATE
-------	-------------------	------

Copy 1—Upon initiation of action, mail this copy to Director Copy 3—Upon termination of action, mail this copy to Director
 Copy 2—Upon filing document adding patent(s), mail this copy to Director Copy 4—Case file copy

AO 120 (Rev. 08/10)

TO: Mail Stop 8 Director of the U.S. Patent and Trademark Office P.O. Box 1450 Alexandria, VA 22313-1450	REPORT ON THE FILING OR DETERMINATION OF AN ACTION REGARDING A PATENT OR TRADEMARK
---	--

In Compliance with 35 U.S.C. § 290 and/or 15 U.S.C. § 1116 you are hereby advised that a court action has been filed in the U.S. District Court for the Eastern District of Texas - Marshall Division on the following

Trademarks or Patents. (the patent action involves 35 U.S.C. § 292.);

DOCKET NO. 2:17-cv-418	DATE FILED May 11, 2017	U.S. DISTRICT COURT Eastern District of Texas - Marshall Division
PLAINTIFF BLITZSAFE TEXAS, LLC		DEFENDANT BAYERISCHE MOTOREN WERKE AG, ET AL.
PATENT OR TRADEMARK NO.	DATE OF PATENT OR TRADEMARK	HOLDER OF PATENT OR TRADEMARK
1 7,489,786	February 10, 2009	Blitzsafe Texas, LLC
2 8,155,342	April 10, 2012	Blitzsafe Texas, LLC
3		
4		
5		

In the above—entitled case, the following patent(s)/ trademark(s) have been included:

DATE INCLUDED	INCLUDED BY <input type="checkbox"/> Amendment <input type="checkbox"/> Answer <input type="checkbox"/> Cross Bill <input type="checkbox"/> Other Pleading
PATENT OR TRADEMARK NO.	DATE OF PATENT OR TRADEMARK
1	
2	
3	
4	
5	

In the above—entitled case, the following decision has been rendered or judgement issued:

DECISION/JUDGEMENT

CLERK	(BY) DEPUTY CLERK	DATE
-------	-------------------	------

Copy 1—Upon initiation of action, mail this copy to Director Copy 3—Upon termination of action, mail this copy to Director
 Copy 2—Upon filing document adding patent(s), mail this copy to Director Copy 4—Case file copy

AO 120 (Rev. 08/10)

TO: Mail Stop 8 Director of the U.S. Patent and Trademark Office P.O. Box 1450 Alexandria, VA 22313-1450	REPORT ON THE FILING OR DETERMINATION OF AN ACTION REGARDING A PATENT OR TRADEMARK
---	---

In Compliance with 35 U.S.C. § 290 and/or 15 U.S.C. § 1116 you are hereby advised that a court action has been filed in the U.S. District Court for the Eastern District of Texas - Marshall Division on the following

Trademarks or Patents. (the patent action involves 35 U.S.C. § 292.);

DOCKET NO. 2:17-cv-420	DATE FILED May 11, 2017	U.S. DISTRICT COURT Eastern District of Texas - Marshall Division
PLAINTIFF BLITZSAFE TEXAS, LLC		DEFENDANT ZHEJIANG GEELY HOLDING GROUP CO., LTD., ET AL.
PATENT OR TRADEMARK NO.	DATE OF PATENT OR TRADEMARK	HOLDER OF PATENT OR TRADEMARK
1 7,489,786	February 10, 2009	Blitzsafe Texas, LLC
2 8,155,342	April 10, 2012	Blitzsafe Texas, LLC
3		
4		
5		

In the above—entitled case, the following patent(s)/ trademark(s) have been included:

DATE INCLUDED	INCLUDED BY <input type="checkbox"/> Amendment <input type="checkbox"/> Answer <input type="checkbox"/> Cross Bill <input type="checkbox"/> Other Pleading
PATENT OR TRADEMARK NO.	DATE OF PATENT OR TRADEMARK
1	
2	
3	
4	
5	

In the above—entitled case, the following decision has been rendered or judgement issued:

DECISION/JUDGEMENT

CLERK	(BY) DEPUTY CLERK	DATE

Copy 1—Upon initiation of action, mail this copy to Director Copy 3—Upon termination of action, mail this copy to Director
 Copy 2—Upon filing document adding patent(s), mail this copy to Director Copy 4—Case file copy

AO 120 (Rev. 08/10)

TO: Mail Stop 8 Director of the U.S. Patent and Trademark Office P.O. Box 1450 Alexandria, VA 22313-1450	REPORT ON THE FILING OR DETERMINATION OF AN ACTION REGARDING A PATENT OR TRADEMARK
---	---

In Compliance with 35 U.S.C. § 290 and/or 15 U.S.C. § 1116 you are hereby advised that a court action has been filed in the U.S. District Court for the Eastern District of Texas - Marshall Division on the following

Trademarks or Patents. (the patent action involves 35 U.S.C. § 292.);

DOCKET NO. 2:17-cv-421	DATE FILED May 11, 2017	U.S. DISTRICT COURT Eastern District of Texas - Marshall Division
PLAINTIFF BLITZSAFE TEXAS, LLC		DEFENDANT SUBARU CORPORATION, ET AL.
PATENT OR TRADEMARK NO.	DATE OF PATENT OR TRADEMARK	HOLDER OF PATENT OR TRADEMARK
1 7,489,786	February 10, 2009	Blitzsafe Texas, LLC
2 8,155,342	April 10, 2012	Blitzsafe Texas, LLC
3		
4		
5		

In the above—entitled case, the following patent(s)/ trademark(s) have been included:

DATE INCLUDED	INCLUDED BY	<input type="checkbox"/> Amendment <input type="checkbox"/> Answer <input type="checkbox"/> Cross Bill <input type="checkbox"/> Other Pleading
PATENT OR TRADEMARK NO.	DATE OF PATENT OR TRADEMARK	HOLDER OF PATENT OR TRADEMARK
1		
2		
3		
4		
5		

In the above—entitled case, the following decision has been rendered or judgement issued:

DECISION/JUDGEMENT

CLERK	(BY) DEPUTY CLERK	DATE
-------	-------------------	------

Copy 1—Upon initiation of action, mail this copy to Director Copy 3—Upon termination of action, mail this copy to Director
 Copy 2—Upon filing document adding patent(s), mail this copy to Director Copy 4—Case file copy

AO 120 (Rev. 08/10)

TO: Mail Stop 8 Director of the U.S. Patent and Trademark Office P.O. Box 1450 Alexandria, VA 22313-1450	REPORT ON THE FILING OR DETERMINATION OF AN ACTION REGARDING A PATENT OR TRADEMARK
---	---

In Compliance with 35 U.S.C. § 290 and/or 15 U.S.C. § 1116 you are hereby advised that a court action has been filed in the U.S. District Court for the Eastern District of Texas - Marshall Division on the following

Trademarks or Patents. (the patent action involves 35 U.S.C. § 292.);

DOCKET NO. 2:17-cv-424	DATE FILED May 12, 2017	U.S. DISTRICT COURT Eastern District of Texas - Marshall Division
PLAINTIFF BLITZSAFE TEXAS, LLC		DEFENDANT TATA MOTORS LTD., ET AL.
PATENT OR TRADEMARK NO.	DATE OF PATENT OR TRADEMARK	HOLDER OF PATENT OR TRADEMARK
1 7,489,786	February 10, 2009	Blitzsafe Texas, LLC
2 8,155,342	April 10, 2012	Blitzsafe Texas, LLC
3		
4		
5		

In the above—entitled case, the following patent(s)/ trademark(s) have been included:

DATE INCLUDED	INCLUDED BY	<input type="checkbox"/> Amendment <input type="checkbox"/> Answer <input type="checkbox"/> Cross Bill <input type="checkbox"/> Other Pleading
PATENT OR TRADEMARK NO.	DATE OF PATENT OR TRADEMARK	HOLDER OF PATENT OR TRADEMARK
1		
2		
3		
4		
5		

In the above—entitled case, the following decision has been rendered or judgement issued:

DECISION/JUDGEMENT

CLERK	(BY) DEPUTY CLERK	DATE
-------	-------------------	------

Copy 1—Upon initiation of action, mail this copy to Director Copy 3—Upon termination of action, mail this copy to Director
 Copy 2—Upon filing document adding patent(s), mail this copy to Director Copy 4—Case file copy

TO: Mail Stop 8 Director of the U.S. Patent and Trademark Office P.O. Box 1450 Alexandria, VA 22313-1450	REPORT ON THE FILING OR DETERMINATION OF AN ACTION REGARDING A PATENT OR TRADEMARK
---	---

In Compliance with 35 U.S.C. § 290 and/or 15 U.S.C. § 1116 you are hereby advised that a court action has been filed in the U.S. District Court for the Eastern District of Texas - Marshall Division on the following

Trademarks or Patents. (the patent action involves 35 U.S.C. § 292.);

DOCKET NO. 2:17-cv-422	DATE FILED May 12, 2017	U.S. DISTRICT COURT Eastern District of Texas - Marshall Division
PLAINTIFF BLITZSAFE TEXAS, LLC		DEFENDANT DAIMLER AG, ET AL.
PATENT OR TRADEMARK NO.	DATE OF PATENT OR TRADEMARK	HOLDER OF PATENT OR TRADEMARK
1 7,489,786	February 10, 2009	Blitzsafe Texas, LLC
2 8,155,342	April 10, 2012	Blitzsafe Texas, LLC
3		
4		
5		

In the above—entitled case, the following patent(s)/ trademark(s) have been included:

DATE INCLUDED	INCLUDED BY <input type="checkbox"/> Amendment <input type="checkbox"/> Answer <input type="checkbox"/> Cross Bill <input type="checkbox"/> Other Pleading	
PATENT OR TRADEMARK NO.	DATE OF PATENT OR TRADEMARK	HOLDER OF PATENT OR TRADEMARK
1		
2		
3		
4		
5		

In the above—entitled case, the following decision has been rendered or judgement issued:

DECISION/JUDGEMENT

CLERK	(BY) DEPUTY CLERK	DATE
-------	-------------------	------

Copy 1—Upon initiation of action, mail this copy to Director Copy 3—Upon termination of action, mail this copy to Director
 Copy 2—Upon filing document adding patent(s), mail this copy to Director Copy 4—Case file copy

TO: Mail Stop 8 Director of the U.S. Patent and Trademark Office P.O. Box 1450 Alexandria, VA 22313-1450	REPORT ON THE FILING OR DETERMINATION OF AN ACTION REGARDING A PATENT OR TRADEMARK
---	---

In Compliance with 35 U.S.C. § 290 and/or 15 U.S.C. § 1116 you are hereby advised that a court action has been filed in the U.S. District Court for the Eastern District of Texas - Marshall Division on the following

Trademarks or Patents. (the patent action involves 35 U.S.C. § 292.);

DOCKET NO. 2:17-cv-418	DATE FILED May 11, 2017	U.S. DISTRICT COURT Eastern District of Texas - Marshall Division
PLAINTIFF BLITZSAFE TEXAS, LLC		DEFENDANT BAYERISCHE MOTOREN WERKE AG, ET AL.
PATENT OR TRADEMARK NO.	DATE OF PATENT OR TRADEMARK	HOLDER OF PATENT OR TRADEMARK
1 7,489,786	February 10, 2009	Blitzsafe Texas, LLC
2 8,155,342	April 10, 2012	Blitzsafe Texas, LLC
3		
4		
5		

In the above—entitled case, the following patent(s)/ trademark(s) have been included:

DATE INCLUDED	INCLUDED BY <input type="checkbox"/> Amendment <input type="checkbox"/> Answer <input type="checkbox"/> Cross Bill <input type="checkbox"/> Other Pleading	
PATENT OR TRADEMARK NO.	DATE OF PATENT OR TRADEMARK	HOLDER OF PATENT OR TRADEMARK
1		
2		
3		
4		
5		

In the above—entitled case, the following decision has been rendered or judgement issued:

DECISION/JUDGEMENT

CLERK	(BY) DEPUTY CLERK	DATE
-------	-------------------	------

Copy 1—Upon initiation of action, mail this copy to Director Copy 3—Upon termination of action, mail this copy to Director
Copy 2—Upon filing document adding patent(s), mail this copy to Director Copy 4—Case file copy

TO: Mail Stop 8 Director of the U.S. Patent and Trademark Office P.O. Box 1450 Alexandria, VA 22313-1450	REPORT ON THE FILING OR DETERMINATION OF AN ACTION REGARDING A PATENT OR TRADEMARK
---	---

In Compliance with 35 U.S.C. § 290 and/or 15 U.S.C. § 1116 you are hereby advised that a court action has been filed in the U.S. District Court Eastern District of Texas - Marshall Division on the following

Trademarks or Patents. (the patent action involves 35 U.S.C. § 292.):

DOCKET NO. 2:17-CV-105	DATE FILED 2/3/2017	U.S. DISTRICT COURT Eastern District of Texas - Marshall Division
PLAINTIFF Blitzsafe Texas, LLC		DEFENDANT Robert Bosdh LLC and Robert Bosch GmbH
PATENT OR TRADEMARK NO.	DATE OF PATENT OR TRADEMARK	HOLDER OF PATENT OR TRADEMARK
1 7,489,786	2/10/2009	Blitzsafe Texas LLC
2 8,155,342 B2	4/10/2012	Blitzsafe Texas, LLC
3		
4		
5		

In the above—entitled case, the following patent(s)/ trademark(s) have been included:

DATE INCLUDED	INCLUDED BY <input type="checkbox"/> Amendment <input type="checkbox"/> Answer <input type="checkbox"/> Cross Bill <input type="checkbox"/> Other Pleading	
PATENT OR TRADEMARK NO.	DATE OF PATENT OR TRADEMARK	HOLDER OF PATENT OR TRADEMARK
1		
2		
3		
4		
5		

In the above—entitled case, the following decision has been rendered or judgement issued:

DECISION/JUDGEMENT

CLERK	(BY) DEPUTY CLERK	DATE
-------	-------------------	------

Copy 1—Upon initiation of action, mail this copy to Director Copy 3—Upon termination of action, mail this copy to Director
 Copy 2—Upon filing document adding patent(s), mail this copy to Director Copy 4—Case file copy

AO 120 (Rev. 08/10)

TO: Mail Stop 8 Director of the U.S. Patent and Trademark Office P.O. Box 1450 Alexandria, VA 22313-1450	REPORT ON THE FILING OR DETERMINATION OF AN ACTION REGARDING A PATENT OR TRADEMARK
---	---

In Compliance with 35 U.S.C. § 290 and/or 15 U.S.C. § 1116 you are hereby advised that a court action has been filed in the U.S. District Court Eastern District of Texas, Marshall Division on the following

Trademarks or Patents. (the patent action involves 35 U.S.C. § 292.):

DOCKET NO. 2:15-cv-01274-JRG	DATE FILED 7/16/2015	U.S. DISTRICT COURT Eastern District of Texas, Marshall Division
PLAINTIFF BLITZSAFE TEXAS, LLC		DEFENDANT HONDA MOTOR CO., LTD., et al.
PATENT OR TRADEMARK NO.	DATE OF PATENT OR TRADEMARK	HOLDER OF PATENT OR TRADEMARK
1 U.S. No. 7,489,786	2/10/2009	BLITZSAFE TEXAS, LLC
2 U.S. No. 8,155,342	4/10/2012	BLITZSAFE TEXAS, LLC
3		
4		
5		

In the above—entitled case, the following patent(s)/ trademark(s) have been included:

DATE INCLUDED	INCLUDED BY <input type="checkbox"/> Amendment <input type="checkbox"/> Answer <input type="checkbox"/> Cross Bill <input type="checkbox"/> Other Pleading	
PATENT OR TRADEMARK NO.	DATE OF PATENT OR TRADEMARK	HOLDER OF PATENT OR TRADEMARK
1		
2		
3		
4		
5		

In the above—entitled case, the following decision has been rendered or judgement issued:

DECISION/JUDGEMENT it is hereby ORDERED that all claims and causes of action asserted by Plaintiff Blitzsafe in this action against Defendants Honda Motor Co., Ltd. and the U.S. Honda Defendants, and all Counterclaims filed by the U.S. Honda Defendants against Plaintiff Blitzsafe, are hereby dismissed with prejudice
--

CLERK 	(BY) DEPUTY CLERK Nakisha Love	DATE 4/4/17
-----------	-----------------------------------	----------------

Copy 1—Upon initiation of action, mail this copy to Director Copy 3—Upon termination of action, mail this copy to Director
 Copy 2—Upon filing document adding patent(s), mail this copy to Director Copy 4—Case file copy

AO 120 (Rev. 08/10)

TO: Mail Stop 8 Director of the U.S. Patent and Trademark Office P.O. Box 1450 Alexandria, VA 22313-1450	REPORT ON THE FILING OR DETERMINATION OF AN ACTION REGARDING A PATENT OR TRADEMARK
---	---

In Compliance with 35 U.S.C. § 290 and/or 15 U.S.C. § 1116 you are hereby advised that a court action has been filed in the U.S. District Court Eastern District of Texas, Marshall Division on the following

Trademarks or Patents. (the patent action involves 35 U.S.C. § 292.):

DOCKET NO. 2:15-cv-01276-JRG	DATE FILED 7/16/2015	U.S. DISTRICT COURT Eastern District of Texas, Marshall Division
PLAINTIFF BLITZSAFE TEXAS, LLC		DEFENDANT NISSAN MOTOR CO., LTD. and NISSAN NORTH AMERICA, INC.
PATENT OR TRADEMARK NO.	DATE OF PATENT OR TRADEMARK	HOLDER OF PATENT OR TRADEMARK
1 U.S. No. 7,489,786	2/10/2009	BLITZSAFE TEXAS, LLC
2 U.S. No. 8,155,342	4/10/2012	BLITZSAFE TEXAS, LLC
3		
4		
5		

In the above—entitled case, the following patent(s)/ trademark(s) have been included:

DATE INCLUDED	INCLUDED BY <input type="checkbox"/> Amendment <input type="checkbox"/> Answer <input type="checkbox"/> Cross Bill <input type="checkbox"/> Other Pleading	
PATENT OR TRADEMARK NO.	DATE OF PATENT OR TRADEMARK	HOLDER OF PATENT OR TRADEMARK
1		
2		
3		
4		
5		

In the above—entitled case, the following decision has been rendered or judgement issued:

DECISION/JUDGEMENT ORDER OF DISMISSAL
--

CLERK <i>David A. O'Toole</i>	(BY) DEPUTY CLERK Nakisha Love	DATE 4/4/17
----------------------------------	-----------------------------------	----------------

Copy 1—Upon initiation of action, mail this copy to Director Copy 3—Upon termination of action, mail this copy to Director
 Copy 2—Upon filing document adding patent(s), mail this copy to Director Copy 4—Case file copy

AO 120 (Rev. 08/10)

TO: Mail Stop 8 Director of the U.S. Patent and Trademark Office P.O. Box 1450 Alexandria, VA 22313-1450	REPORT ON THE FILING OR DETERMINATION OF AN ACTION REGARDING A PATENT OR TRADEMARK
---	---

In Compliance with 35 U.S.C. § 290 and/or 15 U.S.C. § 1116 you are hereby advised that a court action has been filed in the U.S. District Court Eastern District of Texas, Marshall Division on the following

Trademarks or Patents. (the patent action involves 35 U.S.C. § 292.):

DOCKET NO. 2:15-cv-01277-JRG	DATE FILED 7/16/2015	U.S. DISTRICT COURT Eastern District of Texas, Marshall Division
PLAINTIFF BLITZSAFE TEXAS, LLC		DEFENDANT TOYOTA MOTOR CORPORATION, et al.
PATENT OR TRADEMARK NO.	DATE OF PATENT OR TRADEMARK	HOLDER OF PATENT OR TRADEMARK
1 U.S. No. 7,489,786	2/10/2009	BLITZSAFE TEXAS, LLC
2 U.S. No. 8,155,342	4/10/2012	BLITZSAFE TEXAS, LLC
3		
4		
5		

In the above—entitled case, the following patent(s)/ trademark(s) have been included:

DATE INCLUDED	INCLUDED BY <input type="checkbox"/> Amendment <input type="checkbox"/> Answer <input type="checkbox"/> Cross Bill <input type="checkbox"/> Other Pleading	
PATENT OR TRADEMARK NO.	DATE OF PATENT OR TRADEMARK	HOLDER OF PATENT OR TRADEMARK
1		
2		
3		
4		
5		

In the above—entitled case, the following decision has been rendered or judgement issued:

DECISION/JUDGEMENT ORDERED that all claims and causes of action asserted by Plaintiff Blitzsafe in this action against Defendants Toyota and all Counterclaims filed by Toyota against Plaintiff Blitzsafe are hereby dismissed with prejudice.
--

CLERK <i>David A. O'Poole</i>	(BY) DEPUTY CLERK Nakisha Love	DATE 2/21/17
----------------------------------	-----------------------------------	-----------------

Copy 1—Upon initiation of action, mail this copy to Director Copy 3—Upon termination of action, mail this copy to Director
 Copy 2—Upon filing document adding patent(s), mail this copy to Director Copy 4—Case file copy

UNITED STATES PATENT AND TRADEMARK OFFICE

BEFORE THE PATENT TRIAL AND APPEAL BOARD

TOYOTA MOTOR CORPORATION,
Petitioner,

v.

BLITZSAFE TEXAS, LLC,
Patent Owner.

Case IPR2016-00421
Patent 7,489,786 B2

Before JAMESON LEE, MIRIAM L. QUINN, and KERRY BEGLEY,
Administrative Patent Judges.

LEE, *Administrative Patent Judge.*

JUDGMENT
Joint Motion to Terminate
37 C.F.R. § 42.72

On February 17, 2017, the parties filed a joint motion to terminate this *inter partes* review with respect to both Petitioner and Patent Owner, on the basis that they have settled. Paper 26, 1. Also on February 17, 2017, the parties filed a copy of their written settlement agreement covering Patent

IPR2016-00421
Patent 7,489,786 B2

No. 7,489,786 B2 involved in this *inter partes* review (Ex. 2001), and a joint request to have their settlement agreement treated as business confidential information under 35 U.S.C. § 317(b) and 37 C.F.R. § 42.74(c) (Paper 27).

Under 35 U.S.C. § 317(a), “[a]n *inter partes* review instituted under this chapter shall be terminated with respect to any petitioner upon the joint request of the petitioner and patent owner, unless the Office has decided the merits of the proceeding before the request for termination is filed.” The requirement for terminating this proceeding with respect to Petitioner is met.

Under 35 U.S.C. § 317(a), “If no petitioner remains in the *inter partes* review, the Office may terminate the review or proceed to a final written decision under section 318(a).” Toyota Motor Corporation is the sole petitioner in this proceeding. The Board has discretion to terminate this proceeding with respect to Blitzsafe Texas, LLC as Patent Owner.

In this proceeding, all substantive papers have been filed by the parties, and we have ordered that no oral hearing will be held. Paper 25. A final written decision is expected by July 7, 2017, one year from institution of trial on July 7, 2016. In the joint motion, the parties indicate that they have settled their related district court action involving Patent No. 7,489,786 B2 and have moved before the district court for dismissal of the action. Paper 26, 1. They also indicate that they have agreed to seek termination of this *inter partes* review proceeding. *Id.*

In the circumstances of this case, particularly in light of the fact that a final written decision is not due until more than four months from now, we

IPR2016-00421
Patent 7,489,786 B2

determine that termination with respect to both Petitioner and Patent Owner is appropriate.

It is

ORDERED that the joint motion to terminate IPR2016-00421 both as to Petitioner and Patent Owner is *granted*, and that this *inter partes* review is hereby terminated as to all parties including Toyota Motor Corporation as Petitioner and Blitzsafe Texas, LLC as Patent Owner; and

FURTHER ORDERED that the parties' joint request (Paper 27) to have their settlement agreement (Exhibit 2001) treated as business confidential information under 35 U.S.C. § 317(b) and 37 C.F.R. § 42.74(c) is also *granted*.

PETITIONER:

William H. Mandir
John F. Rabena
Brian K. Shelton
Sughrue Mion PLLC
wmandir@sughrue.com
jrabena@sughrue.com
bshelton@sughrue.com

PATENT OWNER:

Peter Lambrianakos
Brown Rudnick LLP
plambrianakos@brownrudnick.com

UNITED STATES PATENT AND TRADEMARK OFFICE

BEFORE THE PATENT TRIAL AND APPEAL BOARD

AMERICAN HONDA MOTOR CO., INC.,
Petitioner,

v.

BLITZSAFE TEXAS, LLC,
Patent Owner.

Case IPR2016-01472
Patent 7,489,786 B2

Before JAMESON LEE, MIRIAM L. QUINN, and KERRY BEGLEY,
Administrative Patent Judges.

LEE, *Administrative Patent Judge.*

DECISION
Denying Institution of *Inter Partes* Review
37 C.F.R. § 42.108

I. INTRODUCTION

A. Background

On July 21, 2016, Petitioner filed a Petition (Paper 1, “Pet.”) to institute *inter partes* review of claims 1, 5–8, 10, 14, 57, 60–62, 64, and 65 of U.S. Patent No. 7,489,786 B2 (Ex. 1001, “the ’786 patent”). On November 15, 2016, Patent Owner filed a Preliminary Response (Paper 6, “Prelim. Resp.”).

To institute an *inter partes* review, we must determine that the information presented in the Petition shows “that there is a reasonable likelihood that the petitioner would prevail with respect to at least 1 of the claims challenged in the petition.” 35 U.S.C. § 314(a). Having considered both the Petition and the Preliminary Response, we determine that Petitioner has not demonstrated a reasonable likelihood that it would prevail in establishing the unpatentability of any of claims 1, 5–8, 10, 14, 57, 60–62, 64, and 65. We do not institute an *inter partes* review of any claim of the ’786 patent.

B. Related Matters

Petitioner indicates that the ’786 patent was asserted by Patent Owner against Petitioner in *Blitzsafe Texas, LLC v. Honda Motor Co., Ltd. et al.*, No. 2:15-cv-1274 (E.D. Tex.). Pet. 2. The parties indicate that the ’786 patent is the subject of four other actions in the Eastern District of Texas. Pet. 58–59; Paper 3, 1. The parties further indicate that the ’786 patent is the subject of two concluded matters in the District of New Jersey. Pet. 59; Paper 3, 2. The ’786 patent also is the subject patent in these *inter partes* review proceedings: IPR2016-00421, IPR2016-00422, IPR2016-01448, and IPR2016-01477. U.S. Patent No. 8,155,342 B2 is a

IPR2016-01472
Patent 7,489,786 B2

related patent, and that related patent is involved in IPR2016-00118, IPR2016-00418, IPR2016-00419, IPR2016-01445, IPR2016-01449, IPR2016-01473, IPR2016-01476, IPR2016-01533, IPR2016-01557, and IPR2016-01560.

C. The '786 Patent

The '786 patent is titled "Audio Device Integration System."

Ex. 1001, (54). The Abstract portion of the Specification explains:

[O]ne or more after-market audio devices, such as a CD player, CD changer, MP3 player, satellite receiver, DAB receiver, or the like, is integrated for use with an existing OEM or after-market car stereo system, wherein control commands can be issued at the car stereo and responsive data from the audio device can be displayed on the stereo.

Id. at Abstr.

In the Background of the Invention portion of the Specification, a problem with which the '786 patent is concerned is described as follows:

A particular problem with integrating after-market audio systems with existing car stereos is that signals generated by the car stereo is in a proprietary format, and is not capable of being processed by the after-market system. Additionally, signals generated by the after-market system are also in a proprietary format that is not recognizable by the car stereo. Thus, in order to integrate after-market systems with car stereos, it is necessary to convert signals between such systems.

Id. at 1:36–44. In the Summary of the Invention portion of the Specification, it is stated:

The commands generated at the control panel [of a car stereo] are received by the present invention and converted into a format recognizable by the after-market audio device. The formatted commands are executed by the audio device, and audio therefrom is channeled to the car stereo. Information from the audio device is received by the present invention, converted into a format

recognizable by the car stereo, and forwarded to the car stereo for display thereby.

Ex. 1001, 2:35–42.

The '786 patent describes:

Control commands generated at the car stereo are received, processed, converted into a format recognizable by the audio device, and dispatched to the audio device for execution. Information from the audio device, including track, disc, song, station, time, and other information, is received, processed, converted into a format recognizable by the car stereo, and dispatched to the car stereo for display thereon.

Id. Additional auxiliary sources also may be integrated together, and “a user can select between the [audio] device or the one or more auxiliary input sources by issuing selection commands through the car stereo.” *Id.*

Figures 2A–2C are reproduced below:

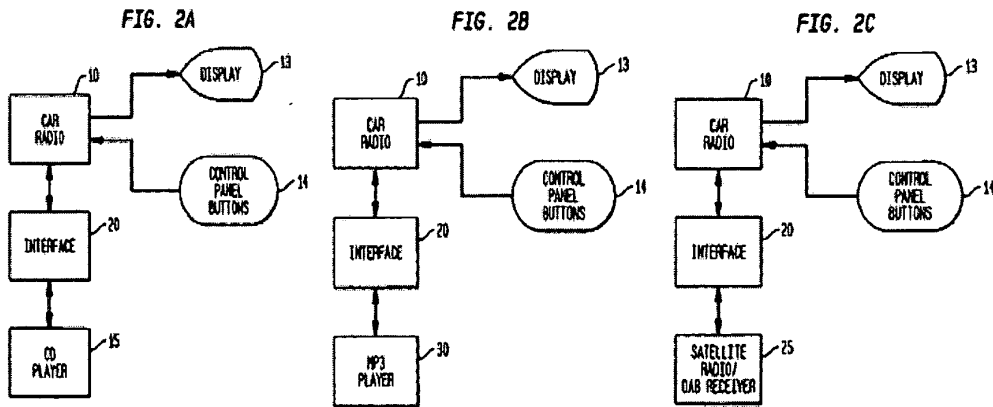

Figure 2A illustrates an embodiment integrating a CD player with the car stereo; Figure 2B illustrates an embodiment integrating a MP3 player with a car stereo; and Figure 2C illustrates an embodiment integrating a satellite or DAB receiver with a car stereo. *Id.* at 3:14–23. A more versatile embodiment is shown in Figure 1:

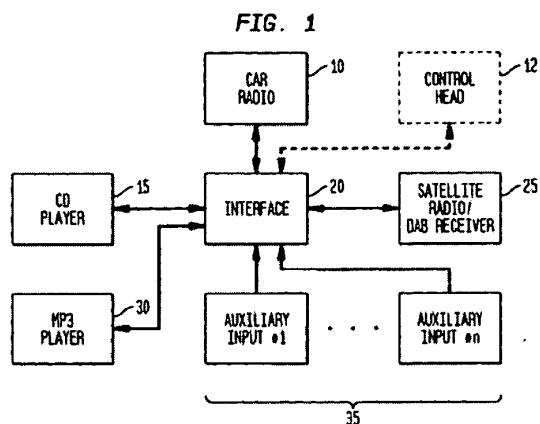

Figure 1 illustrates an embodiment integrating a CD player, a MP3 player, and a satellite radio or DAB receiver, and a number of auxiliary input sources with a car stereo. Ex. 1001, 3:12–13. As shown in the above figures, central to the '786 patent is an “interface” positioned between the car stereo and the audio device(s) and auxiliary input(s) being integrated.

With specific regard to Figure 2B, the '786 patent describes:

The interface 20 allows data and audio signals to be exchanged between the MP3 player 30 and the car radio 10, and processes and formats signals accordingly so that instructions and data from the radio 10 are processable by the MP3 player 30, and vice versa. Operational commands, such as track selection, pause, play, stop, fast forward, rewind, and other commands, are entered via the control panel buttons 14 of car radio 10, processed by the interface 20, and formatted for execution by the MP3 player 30. Data from the MP3 player, such as track, time, and song information, is received by the interface 20, processed thereby, and sent to the radio 10 for display on display 13. Audio from MP3 player 30 is selectively forwarded by the interface 20 to the radio 10 for playing.

Id. at 6:11–24. Similar description is provided with respect to Figures 2A and 2C. *Id.* at 5:49–55, 6:35–43.

Of all of the challenged claims, claims 1 and 57 are the only independent claims. Claim 1 is directed to a system that connects an after-market audio device as well as one or more auxiliary input sources to a car stereo. Claim 1 recites a first connector electrically connectable to a car stereo, a second connector electrically connectable to an after-market device, and a third connector electrically connectable to one or more auxiliary input sources. Ex. 1001, 21:33–38. Claim 1 also recites an interface connected between the first and second electrical connectors, and that the interface includes a microcontroller pre-programmed to execute:

- a first pre-programmed code portion for remotely controlling the after-market audio device using the car stereo by receiving a control command from the car stereo through said first connector in a format incompatible with the after-market audio device, processing the received control command into a formatted command compatible with the after-market audio device, and transmitting the formatted command to the after-market audio device through said second connector for execution by the after-market audio device;
- a second pre-programmed code portion for receiving data from the after-market audio device through said second connector in a format incompatible with the car stereo, processing the received data into formatted data compatible with the car stereo, and transmitting the formatted data to the car stereo through said first connector for display by the car stereo; and
- a third pre-programmed code portion for switching to one or more auxiliary input sources connected to said third electrical connector.

Id. at 21:44–64.

Claim 57 is directed to a system including an interface that connects a portable MP3 player to a car stereo. Unlike claim 1, claim 57 does not require the additional connection of the car stereo to one or more auxiliary

input sources. Claim 57 also does not require conversion of data from a format incompatible with the car stereo to a format compatible with the car stereo. But claim 57 requires the generation, within the interface, of a device presence signal that is transmitted to the car stereo to maintain the car stereo in an operational state. Claim 57 is reproduced below:

57. An audio device integration system comprising:
- a first electrical connector connectable to a car stereo;
 - a second electrical connector connectable to a portable MP3 player external to the car stereo
 - an interface connected between said first and second electrical connectors for transmitting audio from a portable MP3 player to a car stereo, said interface including a microcontroller in electrical communication with said first and second electrical connectors,
- said microcontroller pre-programmed to execute:
- a first pre-programmed code portion for generating a device presence signal and transmitting the signal to the car stereo to maintain the car stereo in an operational state; and
 - a second pre-programmed code portion for remotely controlling the MP3 player using the car stereo by receiving a control command from the car stereo through said first electrical connector in a format incompatible with the MP3 player, processing the control command into a formatted control command compatible with the MP3 player, and transmitting the formatted control command to the MP3 player through said second electrical connector for execution by the MP3 player.

Ex. 1001, 26:13–37.

D. Evidence Relied Upon

Petitioner relies on the following references:

Reference	Date	Exhibit
Bhogal	U.S. Patent No. 6,629,197 B1 Sept. 30, 2001, filed Nov. 3, 2000	Ex. 1004
Berry	U.S. Patent No. 6,559,773 B1 May 6, 2003, filed Dec. 21, 1999	Ex. 1005
Onishi	Japanese Patent Application Publication 2001-128280 ¹ May 11, 2001	Ex. 1006
Ohmura	U.S. Patent Application Publication 2001/0028717 A1 Oct. 11, 2001	Ex. 1008
Okagaki	EPO Patent Application Publication EP 0 953 486 A2 Nov. 3, 1999	Ex. 1009
Owens	U.S. Patent Application Publication 2002/0084910 A1 July 4, 2002	Ex. 1010
JP '954 ²	Japanese Utility Model Application Publication H7-6954 Jan. 31, 1995	Ex. 1011
Knobl	U.S. Patent Application Publication 2001/0025376 A1 Sept. 27, 2001	Ex. 1013

Petitioner also relies on the Declaration of James T. Geier. Ex. 1014.

¹ All citations to specific content of Onishi refers to its English translation (Ex. 1007).

² All citations to specific content of JP'954 refer to its English translation (Ex. 1012).

E. The Asserted Grounds

Petitioner asserts the following grounds of unpatentability:

Claim(s) Challenged	Basis	References
57, 60, 61, 64, and 65	§ 103(a)	Bhogal, Berry, and Onishi
62	§ 103(a)	Bhogal, Berry, Onishi, and Ohmura
64 and 65	§ 103(a)	Bhogal, Berry, Onishi, and Okagaki
1, 6, 7, 10, and 14	§ 103(a)	Bhogal, Onishi, and Owens
5	§ 103(a)	Bhogal, Onishi, Owens, and Berry
8	§ 103(a)	Bhogal, Onishi, Owens, and Ohmura
10	§ 103(a)	Bhogal, Onishi, Owens, and Knobl
1, 6, 7, 10, 14, 57, 60, and 61	§ 103(a)	JP '954, Onishi, and Owens
5	§ 103(a)	JP '954, Onishi, Owens, and Berry
8 and 62	§ 103(a)	JP '954, Onishi, Owens, and Ohmura
64 and 65	§ 103(a)	JP '954, Onishi, Owens, and Okagaki

II. ANALYSIS

The question of obviousness is resolved on the basis of underlying factual determinations including: (1) the scope and content of the prior art; (2) any differences between the claimed subject matter and the prior art; (3) the level of ordinary skill in the art; and (4) objective evidence of nonobviousness. *Graham v. John Deere Co.*, 383 U.S. 1, 17–18 (1966). One seeking to establish obviousness based on more than one reference also

must articulate sufficient reasoning with rational underpinning to combine teachings. *See KSR Int'l Co. v. Teleflex, Inc.*, 550 U.S. 398, 418 (2007).

With regard to the level of ordinary skill in the art, we determine that no express finding is necessary, on this record, and that the level of ordinary skill in the art is reflected by the prior art of record. *See Okajima v. Bourdeau*, 261 F.3d 1350, 1355 (Fed. Cir. 2001); *In re GPAC Inc.*, 57 F.3d 1573, 1579 (Fed. Cir. 1995); *In re Oelrich*, 579 F.2d 86, 91 (CCPA 1978).

A. Claim Construction

In an *inter partes* review, claim terms in an unexpired patent are interpreted according to their broadest reasonable construction in light of the specification of the patent in which they appear. 37 C.F.R. § 42.100(b); *Cuozzo Speed Techs., LLC v. Lee*, 136 S. Ct. 2131, 2142–46 (2016). Consistent with that standard, claim terms also are given their ordinary and customary meaning, as would be understood by one of ordinary skill in the art in the context of the entire disclosure. *See In re Translogic Tech., Inc.*, 504 F.3d 1249, 1257 (Fed. Cir. 2007). There are, however, two exceptions to that rule: “1) when a patentee sets out a definition and acts as his own lexicographer,” and “2) when the patentee disavows the full scope of a claim term either in the specification or during prosecution.” *Thorner v. Sony Computer Entm't Am. LLC*, 669 F.3d 1362, 1365 (Fed. Cir. 2012).

If an inventor acts as his or her own lexicographer, the definition must be set forth in the specification with reasonable clarity, deliberateness, and precision. *Renishaw PLC v. Marposs Societa' per Azioni*, 158 F.3d 1243, 1249 (Fed. Cir. 1998). It is improper to add into a claim an extraneous limitation, i.e., one that is added wholly apart from any need for the addition. *See, e.g., Hogan AB v. Dresser Indus., Inc.*, 9 F.3d 948, 950 (Fed. Cir.

1993); *E.I. du Pont de Nemours & Co. v. Phillips Petroleum Co.*, 849 F.2d 1430, 1433 (Fed. Cir. 1988). Although it is improper to read a limitation from the specification into the claims, *In re Van Geuns*, 988 F.2d 1181, 1184 (Fed. Cir. 1993), claims still must be read in view of the specification of which they are a part. *Microsoft Corp. v. Multi-Tech Sys., Inc.*, 357 F.3d 1340, 1347 (Fed. Cir. 2004).

Only terms which are in controversy need to be construed, and only to the extent necessary to resolve the controversy. *See Wellman, Inc. v. Eastman Chem. Co.*, 642 F.3d 1355, 1361 (Fed. Cir. 2011); *Vivid Techs., Inc. v. Am. Sci. & Eng'g, Inc.*, 200 F.3d 795, 803 (Fed. Cir. 1999).

1. “portable”

Independent claim 57 recites a portable MP3 player. It may be that the term requires no express construction, and simply would be understood by one with ordinary skill in the art. We note that even the '786 patent itself and Bhogal, both using the term “portable” in their written description, do not provide a definition therefor. Nevertheless, an express construction is helpful to this proceeding. We construe “portable,” in the context of the '786 patent, as meaning *capable of being carried by a user*.³

2. “interface”

Each of independent claims 1 and 57 recites an “interface.” Claims 1 and 57 each require the interface to be connected between a first electrical

³ This is the same construction provided by the Board in IPR2015-00421 when instituting trial in that proceeding. Both Petitioner and Patent Owner have urged that that construction be adopted in this proceeding. Pet. 9; Prelim. Resp. 3.

connector and a second electrical connector, where the first connector is connectable to a car stereo and the second connector is connectable to an after-market audio device (claim 1), or a portable MP3 player (claim 57).

Also, claim 57 recites that the interface is “for transmitting audio from a portable MP3 player to a car stereo”; and claim 1 recites that the interface is “for channeling audio signals to the car stereo from the after-market audio device.” With regard to an “interface,” the Specification states: “Thus, as can be readily appreciated, the interface 20 of the present invention allows for the integration of a multitude of devices and inputs with an OEM or after-market car radio or stereo.” Ex. 1001, 5:33–36. “As mentioned earlier, the interface 20 of the present invention allows for a plurality of disparate audio devices to be integrated with an existing car radio for use therewith.” *Id.* at 6:4–7.

Data from the MP3 player, such as track, time, and song information, is received by the interface 20, processed thereby, and sent to the radio 10 for displaying on display 13. Audio from the MP3 player 30 is selectively forwarded by the interface 20 to the radio 10 for playing.

Id. at 6:19–24. Thus, the Specification refers to the interface receiving information from an audio device and forwarding information to the car stereo, and to the interface allowing integration of a plurality of disparate audio devices with a car radio.

During prosecution, the Applicants of the '786 patent distinguished U.S. Patent 6,993,615 B2 (“Falcon”)⁴ in part by arguing that the reference

⁴ Falcon discloses a portable computing device connectable to a car stereo through an interface configurable within the portable computing device. Ex. 3001, Abstr.

failed to disclose an interface connected between a car stereo system and an external audio source. Ex. 1002, 267. Specifically, in distinguishing the invention from Falcon, Applicants stated: “[Falcon’s graphical user interface] is an entirely different concept than the interface of the present invention, which includes a physical interface device connected between a car stereo system and an external audio source (e.g., a plurality of auxiliary input sources).” *Id.*

Construing the term “interface” in light of the Specification, other language in the claims, as well as the prosecution history of the ’786 patent, we determine that—*interface is a physical unit that connects one device to another and that has a functional and structural identity separate from that of both connected devices.*⁵

In the specific context of claim 1, the connected devices are the car stereo and an after-market device. In the specific context of claim 57, the connected devices are the car stereo and a portable device. Each of claims 1 and 57 further requires the interface to include a microcontroller.

3. “device presence signal”

Claim 57 requires within the interface a microcontroller having a first pre-programmed code portion “for generating a *device presence signal* and transmitting the signal to the car stereo to maintain the car stereo in an operational state.” (Emphasis added). Claim 6 depends from claim 1 and further recites: “wherein said interface generates a device presence signal

⁵ This is the same construction provided by the Board in IPR2015-00421 when instituting trial in that proceeding. Both Petitioner and Patent Owner have urged that that construction be adopted in this proceeding. Pet. 9, Prelim. Resp. 3.

for maintaining the car stereo in a state responsive to processed data and audio signals.” A description of “device presence signal” is contained in the Specification in the discussion of an embodiment that is for connecting a CD player to the car stereo:

Beginning in step 110, a signal is generated by the present invention indicating that a CD player/changer is present, and the signal is continuously transmitted to the car stereo. Importantly, this signal prevents the car stereo from shutting off, entering a sleep mode, or otherwise being unresponsive to signals and/or data from an external source.

Ex. 1001, 12:29–35. All other disclosed embodiments, whether they are for connecting an MP3 player or an auxiliary device to the car stereo, refer back to the above-quoted description of the device presence signal. *Id.* at 13:15–18, 13:62–65, 14:48–51, 15:35–38, 16:12–15, 16:57–60.

We construe “device presence signal,” as *a signal indicating that an audio device, other than the car stereo, is connected to the interface.*⁶

B. Alleged Obviousness of Claims 1, 5–8, 10, 14, 57, 60–62, 64, and 65 over Prior Art Including Bhogal

Seven of Petitioner’s eleven alleged grounds of unpatentability rely in part on Bhogal. Because these seven grounds share a common deficiency with respect to Petitioner’s application of Bhogal to meet a limitation regarding the “interface” recited in independent claims 1 and 57,⁷ we group them for discussion purposes. We determine that Petitioner has not shown a

⁶ This is essentially the same construction as that provided by the Board in IPR2015-00421 when instituting trial in that proceeding. Both Petitioner and Patent Owner have urged that that construction be adopted in this proceeding. Pet. 9, Prelim. Resp. 3.

⁷ Claims 5–8, 10, and 14 depend, directly or indirectly, from claim 1, and claims 60–62, 64, and 65 depend, directly or indirectly, from claim 57.

reasonable likelihood that it would prevail in establishing unpatentability of any claim on the basis of any alleged ground of patentability relying in part on Bhogal.

1. Bhogal

Bhogal is titled “Method and System for Storing Digital Audio Data and Emulating Multiple CD-Changer Units.” Ex. 1004, (54). With regard to a problem that it addresses, Bhogal describes:

Typically, CD-changer units and car stereo units are designed so that they are compatible only if they are made by the same manufacturer. In other words, CD-changers and car stereos usually have a proprietary interface, and no industry standard currently exists for interfacing different makes of CD-changers and car stereos.

Id. at 4:57–62. To solve that problem, Bhogal provides a digital audio unit that is capable of emulating the operation of multiple CD-changers. *Id.* at 3:10–13. Regarding which one of many CD-changers to emulate, Bhogal describes:

In one case, the digital audio unit can detect a control signal [from a car stereo] for a CD-changer unit and then automatically select the type of CD-changer unit to be emulated based on the detected control signal. In a second case, the digital audio unit can receive a user selection for selecting a type of CD-changer unit to be emulated. *The softcopy digital audio files stored within the digital audio unit are thereby accessed through the controls and commands for a CD-changer unit.*

Ex. 1004, 3:13–20 (emphasis added). Bhogal describes that by emulating the operations of multiple types of CD-changer units, a single digital audio unit can be inserted in many different digital audio systems, “thereby extending the functionality of a digital audio system to include storage of

softcopy digital audio files that may be accessed through controls and commands for a CD-changer unit.” *Id.* at Abstr.

Figure 2 of Bhogal is reproduced below:

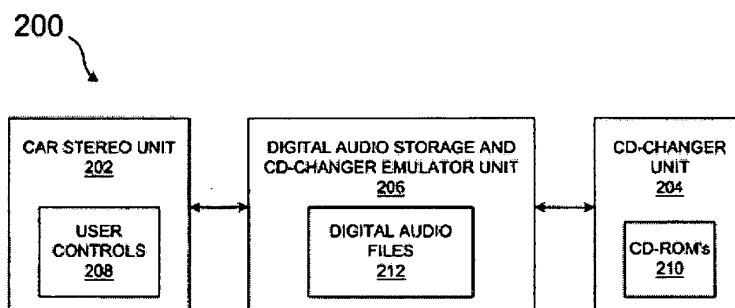

FIG. 2

Figure 2 illustrates an embodiment of Bhogal’s audio system. *Id.* at 3:31–33. Emulator 206 is connected between car stereo 202 and actual CD-changer 204. *Id.* at 5:11–16. Emulator 206 contains digital audio files 212, organized as virtual CD-ROMs, that may be accessed by a user through the car stereo. *Id.* at 5:39–42. Bhogal describes that, in one embodiment, “the emulator unit may be positioned in an independent *docking station* that accepts portable electronics, possibly in a standard manner such that the docking station also accepts other types of MP3 players.” *Id.* at 5:61–64 (emphasis added). When the emulator is not in the docking station, the car stereo and the actual CD-exchanger may operate together. *Id.* at 5:65–67.

Bhogal describes that, in a preferred embodiment, emulator 206 is a portable device. *Id.* at 6:18–21. Bhogal also describes that the emulator may connect to a personal computer in many different ways, including by use of “serial, Universal Serial Bus (USB), or parallel I/O connections, in a manner similar to that found on other types of commercially available

portable digital audio devices.” *Id.* at 6:32–40. Music files may be downloaded from any external source and stored within a digital audio file database within the emulator. *Id.* at 6:40–45. Bhogal thus provides access to softcopy digital audio files. In that regard, Bhogal states:

By recognizing the demand for softcopy digital audio files and the issue of backward compatibility, the present invention takes advantage of the interface between stereo units and CD-changer units to implement a methodology for providing access to softcopy digital files. The present invention emulates the CD-changer interface, which is usually a hardware interface for providing access to hardcopy digital audio files stored on CDs that are stored within the CD-changer, so that a stereo unit using the CD-changer interface can access softcopy digital audio files through its CD-changer interface.

Id. at 4:63–5:6. The softcopy digital audio files are organized as virtual CD-ROMs. *Id.* at 5:39–43. Additionally, the existing functionality of the actual CD-changer is not eliminated. In that connection, Bhogal states: “In addition, the present invention enables a CD-changer to ‘piggyback’ on a digital audio device containing the present invention so that the current jukebox functionality of storing and accessing CDs within a CD-changer is still available.” *Id.* at 5:6–10. In summary, Bhogal states:

By emulating the operations of multiple types of CD-changer units, the present invention enables a single digital audio device to be inserted in many different configurations of digital audio systems. The present invention thereby extends the functionality of a digital audio system to include storage of softcopy digital audio files that may be accessed through controls and commands for a CD-changer unit.

Id. at 9:65–10:5.

2. Independent Claims 1 and 57

For reasons discussed below, Petitioner has not shown a reasonable likelihood that it would prevail in establishing unpatentability of either claim 1 or claim 57 on any ground of obviousness relying in part on Bhogal.

- a) pre-programmed code portion for remotely controlling an audio device or MP3 player (claims 1 and 57)

Claim 1 requires a microcontroller within the interface to execute a pre-programmed code portion that is:

for remotely controlling the after-market audio device using the car stereo by receiving a control command from the car stereo through said first electrical connector in a format incompatible with the after-market audio device, processing the received control command into a formatted command compatible with the after-market device, and transmitting the formatted command to the after-market device through said second connector for execution by the after-market audio device.

Ex. 1001, 21:45–54. Claim 57 includes a similar limitation that differs from the above-quoted limitation of claim 1 by reciting a portable MP3 player instead of an after-market audio device. *Id.* at 22:28–37. Thus, claim 1 pertains to a car stereo remotely controlling an after-market audio device, and claim 57 pertains to a car stereo remotely controlling a portable MP3 player.

For this remote control aspect of claims 1 and 57, and aside from the specific requirement of a portable MP3 player of claim 57, Petitioner relies on Bhogal's disclosure. Bhogal pertains to an actual CD-changer and an emulator unit that emulates CD-changers, as discussed above.

According to Petitioner, Bhogal discloses the above-noted limitation for remotely controlling the audio device that is connected to the interface.

Pet. 19. Petitioner's argument is as follows:

Bhogal explains that typically, car stereos are designed to communicate only with CD-changers made by the same manufacturer. Ex. 1004, at 4:57–62. The emulator unit in Bhogal contains a “CD-changer unit specification database 312” which “contains operational information about various models of CD-changer units and the manner in which emulator unit 302 can interface with a particular type of CD-changer unit.” *Id.* at 7:1–4, FIG. 3. A signal/command interpreter unit 314 inside the emulator unit monitors for signals and commands from the car stereo intended for the selected type of CD-changer. *Id.* at 7:12–24. For example, when a user of the car stereo presses controls on the car stereo for changing CDs or for obtaining information about CDs, the emulator unit captures the commands and “performs appropriate processing.” *Id.* at 8:21–26. In doing so, the emulator unit “operates in a particular manner that is compatible with the CD-changer to which the emulator unit is connected.” *Id.* at 7:7–11. *See* Geier Decl., Ex. 1014, ¶¶ 53–55.

Id.

The argument is unpersuasive. None of the cited disclosure and explanations, as presented by Petitioner, pertains to remotely controlling an audio device that is connected to Bhogal's emulator unit. The operations identified by Petitioner support the emulator unit's role as an emulator, where the emulator interprets commands from the car stereo intended for an actual CD-changer, and uses the interpreted commands to access audio data files within the emulator itself that are organized as virtual CD-ROMs.

The claim limitation requires receiving a control command from the car stereo in a format incompatible with the connected audio device, processing it into a formatted control command that is compatible with the audio device, and transmitting the formatted command to the audio device. Petitioner has not identified any disclosure in Bhogal that describes

transmitting such a converted command to the connected audio device to control the audio device remotely.

There is an operation mode of the emulator called “pass-thru mode” in which the emulator passes commands from the car stereo to the audio device that is connected. Ex. 1004, 7:36–46. However, as described in Bhogal, the “pass-thru mode” does not involve any conversion of a command from a format that is incompatible with the connected audio device to a format that is compatible with the connected audio device. *Id.* In Bhogal, the car stereo and the actual CD-changer already communicate with each other compatibly, without the need for an intermediate interface to do any conversion of signals. As discussed above, Bhogal describes that when the emulator is not in the docking station, the car stereo and the actual CD-exchanger may operate together. *Id.* at 5:65–67.

In addition, there is an operation mode of the emulator called “end-unit” mode, in which the emulator replaces the CD-changer entirely and itself emulates the presence of the CD-changer. *Id.* at 7:47–49. Nothing in that mode of operation involves conversion of any command to be sent to the CD-changer to control the CD-changer remotely.

There also is an operation mode of the emulator called “combination mode,” in which the emulator also reads tracks and track information from the actual CD-changer unit connected to it, “to create virtual CDs with tracks from both sources.” *Id.* at 8:4–20. Petitioner identifies no disclosure in Bhogal that any conversion is performed on car stereo commands that are incompatible with the actual CD-changer to make them compatible with the CD-changer, much less transmitting such converted commands to the CD-changer to effect remote control of the CD-changer by the car stereo.

As noted above, the car stereo and the actual CD-changer already communicate with each other compatibly without need for an intermediate interface to do any conversion. Petitioner's reference to Bhogal's "processing" alone is insufficient to persuade us that Bhogal discloses the required conversion.

The foregoing reason alone constitutes sufficient basis to conclude that Petitioner has not shown reasonable likelihood that it would prevail in establishing unpatentability of any challenged claim on any ground based in part on Bhogal. We discuss below an additional deficiency with respect to claim 1 and claims dependent thereon, and an additional deficiency with respect to claim 57 and claims dependent thereon.

- b) receiving, processing, transmitting data, and converting data from incompatible format to compatible format (claim 1)

Claim 1 further requires the microcontroller within the interface to have a pre-programmed code portion that is:

for receiving data from the after-market audio device through said second connector in a format incompatible with the car stereo, processing the received data into formatted data compatible with the car stereo, and transmitting the formatted data to the car stereo through said first connector for display by the car stereo.

Ex. 1001, 21:55–61. According to Petitioner, Bhogal discloses format conversion of the display data from the CD-changer unit for display on the car stereo. Pet. 22, 32. Specifically, Petitioner argues: "Because the car stereo [of Bhogal] is designed to communicate using proprietary formats, *see* [Ex. 1004,] 4:57–62, the emulator unit generates data 'in the necessary format' to be sent to the car stereo." Pet. 22. Petitioner's argument is unpersuasive.

Petitioner cites no disclosure in Bhogal to the effect that data from the actual CD-changer is originally incompatible with the car stereo and requires a conversion in format to be compatible with and thus understood by the car stereo. Petitioner also cites no disclosure in Bhogal to the effect that any such data conversion is performed by the emulator unit of Bhogal. Although there is a necessary format for data from the audio device to be understood by the car stereo, Petitioner identifies no disclosure in Bhogal that indicates the car stereo and the audio device do not already share the same format without involvement of the emulator.

As discussed above, Bhogal describes that when the emulator is not in the docking station, the car stereo and the actual CD-exchanger may operate together. Ex. 1004, 5:65–67. Also, although the emulator has a “pass-thru mode,” operation in the pass-thru mode does not involve any conversion of data from a format that is incompatible with the car stereo to a format that is compatible with the car stereo. *Id.* at 7:36–46. As noted above, in the context of Bhogal, the car stereo and the audio device already communicate with each other compatibly without need for an interface to do any conversion of signals.

- c) generating and transmitting a device presence signal (claim 57)

Claim 57 further requires the microcontroller within the interface to have a pre-programmed code portion that is “for generating a device presence signal and transmitting the signal to the car stereo to maintain the car stereo in an operational state.” Ex. 1001, 26:22–26. According to Petitioner, neither Bhogal nor Berry discloses this limitation regarding the generation and transmission of a device presence signal, but Onishi does. Pet. 19–21. Specifically, Petitioner explains as follows:

Onishi discloses an on-vehicle audio device 50 (a car stereo) that includes a source selector 63. Ex. 1007, at [0060], [0063], FIG. 5. Source selector 63 accepts audio signals input from the on-vehicle device's tuner and CD player, as well as audio signals received by the on-vehicle device's AUX input terminal 55. *Id.* at [0064], FIG. 5. A system controller 60 in the on-vehicle device controls which of these audio signals is selected by the source selector and output through speakers. *Id.* at [0065]. Onishi describes at least two methods for the system controller 60 to detect that an AUX device is present. In one method, the system controller recognizes display information DD received from the AUX device through AUX input terminal 55. *Id.* at [0082]. In another method, the AUX input terminal 55 contains a voltage detector. *Id.* at [0083]. Based on the voltage detection, the system controller 60 determines if an AUX device is present. *Id.* When the AUX device has been detected, "*a control is performed*" (*i.e., a device presence signal is sent*) to the source selector 63 to select the AUX input as the audio source. *Id.* at [0084], FIG. 6 (S105). Consequently, analog audio signals from the MD player/recorder are output as sound from the vehicle speakers, *id.* at [0085], FIG. 6 (S106), and the car stereo is maintained in an operational state.

Id. at 19–20 (emphasis added).

Petitioner's explanation is misdirected and unpersuasive. The term "device presence signal" has been construed as *a signal indicating that an audio device, other than the car stereo, is connected to the interface*. The construction is the same as that urged by Petitioner. Pet. 9. Petitioner's above-quoted explanation does not support its assertion that Onishi discloses the generation of a device presence signal and transmitting that signal to the car stereo. Figure 5 of Onishi, as referenced by Petitioner, is reproduced below:

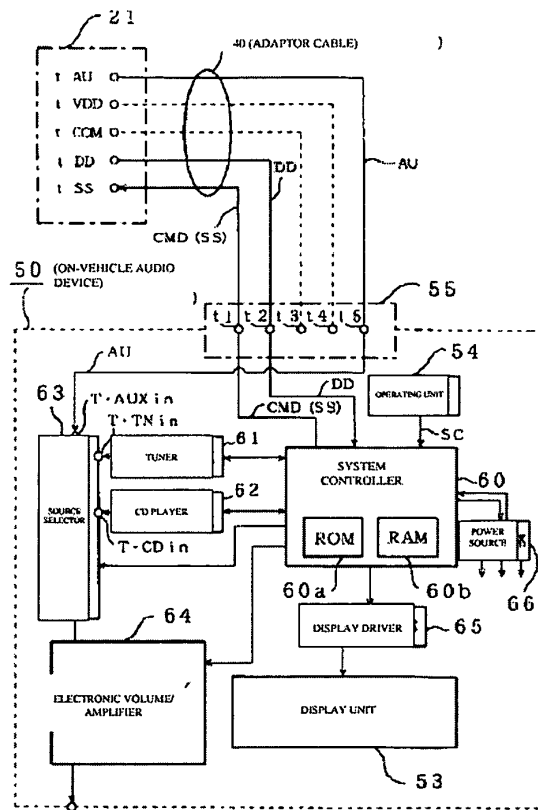

Figure 5 is a block diagram illustrating an internal configuration of an embodiment of the on-vehicle audio device of Onishi. Ex. 1007, 14.

As explained by Petitioner, the on-vehicle audio device, e.g., car stereo, detects the presence of an auxiliary device not by receiving a device presence signal, but by itself detecting the presence of an auxiliary device. Mere presence of data on an input line does not satisfy the requirements of a device presence signal as we have construed the term. For instance, the data could be received directly from an auxiliary device and not through an interface to which the auxiliary device is connected. According to claim 57, it is the microcontroller within the interface that has to generate the device presence signal and to transmit that device presence signal to the car stereo.

Also, what Petitioner identifies as a device presence signal actually is a control signal the on-vehicle audio device sends to an internal source selector, after it already has recognized that an auxiliary device is present, in order to select that auxiliary device as input. *Id.* ¶ 84.

Thus, Petitioner has not made a sufficient showing that Onishi discloses the generation of a device presence signal from outside of the car stereo and transmission of that signal to the car stereo. It follows, also, that Petitioner has not made a sufficient showing that Onishi's alleged teaching regarding the generation of a device presence signal and transmission of that signal to the car stereo, when applied to JP '954, results in satisfaction of claim 57's limitation directed to a device presence signal.

3. Dependent Claims 5–8, 10, 14, 60–62, 64, and 65

Each of claims 5–8, 10, 14, 60–62, 64, and 65 depends directly or indirectly from either claim 1 or 57. The deficiencies noted above with regard to claims 1 and 57 carry through to the claims depending therefrom. Accordingly, Petitioner has not shown a reasonable likelihood that it would prevail in establishing unpatentability of any of claims 5–8, 10, 14, 60–62, 64, and 65 on any alleged ground of obviousness relying in part on Bhogal.

C. Alleged Obviousness of Claims 1, 6, 7, 10, 14, 57, 60, and 61 as Obvious over JP '954, Onishi, and Owens

For reasons discussed below, we determine that Petitioner has not shown a reasonable likelihood that it would prevail in establishing unpatentability of any of claims 1, 6, 7, 10, 14, 57, 60, and 61 as obvious over JP'954, Onishi, and Owens.

1. JP '954

JP '954 is directed to solving the problem of equipment incompatibility, in the environment of automotive audio equipment, between a main unit made by one company and a CD changer made by another company. Ex. 1012, Abstr. Specifically, JP '954 describes the disadvantages associated with prior art systems as follows:

When installing an audio device in a vehicle on the occasion of a vehicle purchase, it is common for a so-called "basic" main unit to be installed. If one were to subsequently attempt to add a CD changer capable of automatically changing and playing a plurality of loaded CDs, prior to now it would have been necessary to purchase and install a model produced by the same manufacturer as the "basic" main unit, as the format of signals connecting the respective devices vary from manufacturer to manufacturer. Furthermore, if a user had installed both of these devices produced by the same manufacturer, and at a later point wished to upgrade the main unit to, for example, a model produced by company A, it would have been necessary for the same reason to also purchase a new CD changer made by company A.

Id. ¶ 2. JP '954 describes its objective as: "to make it possible to add a CD changer made by company B to a main unit made by company A, as well as to add a CD changer made by company A to a main unit made by company B." *Id.* ¶ 3. JP '954 achieves that objective by providing an interface unit as noted below:

(PROBLEM) Provide an interface unit for automotive audio equipment that renders possible the addition of a CD changer made by company B to a main unit made by company A as well as the addition of a CD changer made by company A to a main unit made by company B.

Ex. 1012, Abstr. JP '954 summarizes its interface unit as follows:

(MEANS FOR SOLVING) The [interface] unit is constituted by splitting signals into three systems, namely a control system, audio system and power system, and providing a conversion circuit for each of these systems.

Id. Figure 1 of JP '954 is reproduced below:

(Fig. 1)

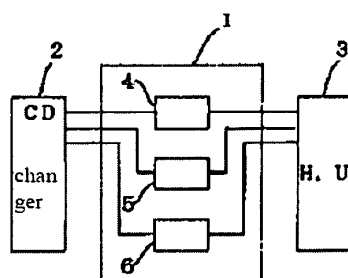

Figure 1 illustrates a block diagram of the structure of the audio system according to JP '954. *Id.* ¶ 6. Interface unit 1 “converts the format of the signal that links the CD changer 2 and the main unit 3, etc.” *Id.* Interface unit 1 links main unit 3 and CD changer 2, and is provided with control system conversion portion 4, audio system conversion portion 5, and power conversion portion 6. *Id.* at Abstr. Control conversion portion 4 is for the bus line, clock control signal, etc.; audio conversion portion 5 is for the audio signal; and power conversion portion 6 is for the power supply. *Id.* ¶ 6.

Figure 2 of JP '954 is reproduced below:

(Fig. 2)

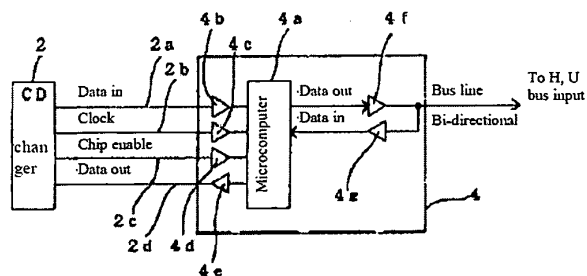

Figure 2 illustrates control system conversion portion 4. *Id.* ¶ 7.

Microcomputer 4a is provided to convert and unify different signal formats between the CD changer and the main unit. *Id.*

Figure 4 is reproduced below:

(Fig. 4)

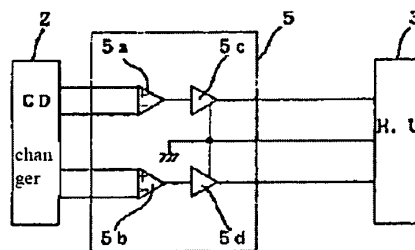

Figure 4 illustrates audio system conversion portion 5. *Id.* ¶ 11. It includes differential amplifiers 5a and 5b and amplifiers 5c and 5d. *Id.*

JP '954 states: “[a]lthough one embodiment example was described above, to expand the range of available inter-company format conversions, a switch can be provided on the microcomputer 4a to enable application to various models using a connection adapter between the CD changer and main unit. *Id.* ¶ 10.

2. Claims 57, 60, and 61

As noted above, claim 57 requires the microcontroller within the interface to have a pre-programmed code portion that is “for generating a device presence signal and transmitting the signal to the car stereo to maintain the car stereo in an operational state.” Ex. 1001, 26:22–26. According to Petitioner, Onishi discloses this limitation. Pet. 52–53. Specifically, Petitioner refers back to and incorporates its discussion of this limitation of claim 57 in the context of its assertion that claim 57 is unpatentable as obvious over Bhogal, Berry, and Onishi. *Id.* at 52.

For the same reasons discussed above, in the alleged obviousness of claim 57 over Bhogal, Berry, and Onishi, Petitioner has not made an adequate showing that Onishi discloses the generation of a device presence signal and transmitting that signal to the car stereo. The same deficiency carries through to claim 60 which depends from claim 57, and to claim 61 which depends from claim 60.

Accordingly, Petitioner has not shown a reasonable likelihood that it would prevail in establishing unpatentability of any of claims 57, 60, and 61 as obvious over JP '954, Onishi, and Owens.

3. Claim 1

For reasons discussed below, Petitioner has not shown a reasonable likelihood that it would prevail in establishing unpatentability of claim 1 as obvious over JP '954, Onishi, and Owens.

- a) receiving, processing, transmitting data, and converting data from incompatible format to compatible format

Claim 1 requires a microcontroller within the interface to execute a pre-programmed code portion that is:

for receiving data from the after-market audio device through said second connector in a format incompatible with the car stereo, processing the received data into formatted data compatible with the car stereo, and *transmitting the formatted data to the car stereo through said first connector for display by the car stereo.*

Ex. 1001, 21:55–61 (emphasis added). The same microcontroller also has to execute a pre-programmed code portion that is:

for remotely controlling the after-market audio device using the car stereo by receiving a control command from the car stereo through said first electrical connector in a format incompatible with the after-market audio device, processing the received control command into a formatted command compatible with the after-market device, and transmitting the formatted command to the after-market device through said second connector for execution by the after-market audio device.

Id. at 21:45–54.

Petitioner first accounts for the control command conversion or remote control limitation of claim 1, by referring to control system conversion 4 of JP '954. Pet. 44–45. In that regard, Figure 2 of JP '954 is again reproduced below:

(Fig. 2)

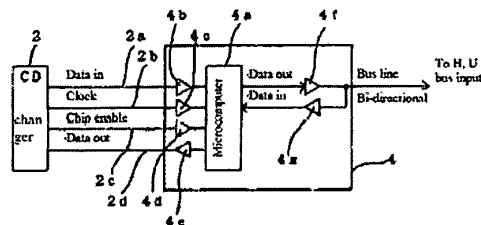

Figure 2 illustrates control system conversion portion 4. Ex. 1012 ¶ 7.

Petitioner explains:

The control signals converted by control conversion portion 4 include incoming signals from the main unit on “Data in” line

4g, which are converted and forwarded to the CD changer via “Data out” line 2c. *Id.* at FIG. 2; Geier Decl., Ex. 1004, at ¶¶ 133–34. The control conversion portion 4 also converts “operational status” data such as “PLAY, FWD, BWD, etc.” received from the CD changer via “Data in” line 2a and forward such data to the main unit via “Data out” line 4f. JP ’954, Ex. 1012, at (0008), (0009), FIG. 2. The ability of the interface unit to convert signal formats make it possible for a CD changer and a main unit made by different companies to communicate. *Id.* at (0005). *See also* Geier Decl., Ex. 1014, at ¶¶ 145–46.

Pet. 44–45.

Then, to satisfy the limitation about converting data and sending converted data for display in the car stereo, Petitioner cites to Onishi and interface unit 1 of JP ’954. Petitioner explains:

Onishi teaches that once the MD recorder/player is connected to the on-vehicle audio device, information from the MD recorder/player can be transmitted to and displayed by display unit 53 on the on-vehicle audio device (car stereo). Ex. 1007, at [0030], [0073]. This information reflects the track being played back, such as “track number,” “track name,” and “playback progress time.” *Id.* at [0086].

Pet. 45.

As shown by Onishi, it was a known technique to display on the car stereo information relating to an audio track being played, including information on the playback progress time, so that the user of the car stereo could be informed about status of playback. *See* Onishi, Ex. 1007, at [0030], [0073], [0086]; Geier Decl., Ex. 1014, ¶¶ 147–49. JP ’954 recognized the need to inform the car stereo of “operational status” data of the after-market device. *See* Ex. 1012, at (0009). It would have been obvious for a person of ordinary skill in the art at the time of the filing of the ’786 patent *to modify the interface unit of JP ’954 to include the feature of processing and forwarding operational data such as time and track information to the car stereo to display.* Geier Decl., Ex. 1014, ¶ 149. Such modification would have resulted in the

predictable improvement of allowing the interface unit to provide more information to the user. *Id.*

Id. at 45–46 (emphasis added).

Patent Owner responds and argues as follows:

Essentially Petitioner argues that because transmitting data from media players was known, it would have been obvious to implement it in JP '954. This argument is woefully short of a proper obviousness analysis. First, Petitioner does not address the analysis set forth by the Board [in IPR2016-00421 (Paper 13)], particularly that “conversion portion 4 in interface unit 1 is for communicating and converting control signals, not any data for display on a car stereo, such as song title and artist information.” Petitioner does not identify which microprocessor should include the pre-programmed code portion, particularly in light of the fact that conversion portion 4 is not meant for sending data, such as title and artist information, to the head unit.

PO Resp. 24–25.

We find the above-quoted arguments of Petitioner to be deficient and the above-quoted arguments of Patent Owner to be persuasive. Petitioner fails to make a sufficient distinction between interface unit 1 of JP '954 and control system conversion portion 4 within interface unit 1 of JP '954. Even assuming that, in light of Onishi, it would have been obvious to one with ordinary skill to send song and artist information back to the car stereo for display, Petitioner, in order to demonstrate that claim 1 would have been obvious, has to address *why* it would have been obvious to one with ordinary skill in the art to use control system conversion portion 4, and in particular microcomputer 4a within control system conversion portion 4, in JP '954 to perform that task. Interface unit 1 of JP '054 is not just control system conversion portion 4. Rather, it also includes audio

system conversion portion 5 and power conversion portion 6, as is shown in its Figure 1 reproduced below:

(Fig. 1)

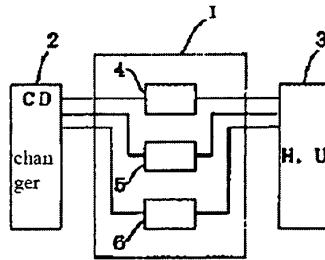

Figure 1 illustrates a block diagram of the structure of the audio system according to JP '954. Ex. 1012 ¶ 6.

Petitioner fails to account for why one with ordinary skill in the art would have modified control system conversion portion 4, specifically, and not something else, to add the functionality of sending song and artist information back to the car stereo for display. The omission is significant because we understand that control system conversion portion 4 of JP '954 relates to operational control and status of the CD-changer, and time and track information of songs do not reflect the operational status of the CD-changer but the content of the music being played or to be played. We recognize that microcomputer 4a sends back to the car stereo operational status of the CD-changer. But operational status data relate to operational control of the CD-changer, and are not information about songs and artists. Also, JP '954 does not describe that operational status data are for display at the car stereo. On this record, Petitioner has not provided reasoning with rational underpinning to support its conclusion that one with ordinary skill in the art would have selected microcomputer 4a in control system conversion

portion 4 of JP '954 to perform data conversion of song and artist information to send back to the car stereo for display.

- b) switching to one or more auxiliary input sources

Claim 1 further requires the microcontroller within the interface to execute a pre-programmed code portion that is “for switching to one or more auxiliary input source connected to said third electrical connector.”

Petitioner acknowledges that neither JP '954 nor Onishi discloses this limitation but asserts that Owens does. Pet. 46. Petitioner states:

Owens discloses an auxiliary input source such as VCR 44, tuner 46, or game station 48, which is connectable to A/V source selector 40. Ex. 1010, at [0025], [0026], [0009], FIG. 7. Owens also discloses a microprocessor that performs switching to one or more auxiliary input sources as required in claim 1. *Id.* at [0034]; Geier Decl., Ex. 1014, ¶¶ 151–152.

Id. at 47. Figure 7 of Owens is reproduced below:

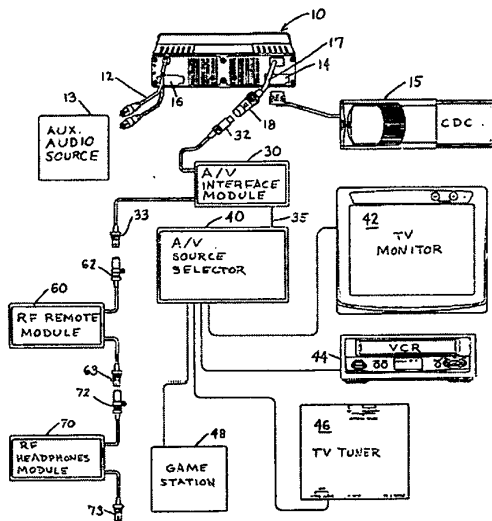

FIG. 1

Figure 7 of Owens illustrates a schematic diagram of an embodiment according to Owens. Ex. 1010, Fig. 7. Petitioner regards the A/V interface

module and A/V source selector in Owens as an interface between the car stereo and multiple audio or video devices. Pet. 48.

Petitioner argues:

As shown in Owens, it was well-known in the art to use devices like the A/V interface module and A/V source selector of Owens to provide an interface to serially connect **multiple** audio or video devices to a car stereo. Geier Decl., Ex. 1014, ¶¶ 154–57. Such a configuration would allow consumers to obtain a car stereo without a large initial investment and gradually buy and add additional modules to accommodate additional input sources. *See* Owens, Ex. 1009, at [0008]; Geier Decl., Ex. 1014, ¶ 157. As such, modifying the interface unit taught by JP '954, in view of Onishi, to permit one or more auxiliary audio or video sources, other than the after-market CD-changer unit, to be connected to a car stereo, and to configure the microprocessor inside JP '954's interface unit to be able to switch between (claim 1) and channel audio from (claim 14) those auxiliary sources, would have resulted in the predictable improvement of increasing the utility and versatility of the interface unit. *Id.* at ¶ 158.

Id. Petitioner's argument is unpersuasive.

It is not adequately explained by Petitioner why one with ordinary skill in the art would have chosen microcomputer 4a within control system conversion portion 4 of interface unit 1 within JP '954 to perform source switching. Petitioner's explanation is conclusory. The explanation also is without rational underpinning. For instance, microcomputer 4a in JP '954 does not itself perform all of the communication between the car stereo and the connected CD-changer. Some of the communication are conducted through audio system conversion portion 5. Ex. 1012, Abstr., Fig. 1. Also, in Owens, the processor that performs source selecting or switching is located within the car stereo. Ex. 1010 ¶¶ 33–34, Fig. 9. Petitioner does not explain why that location would have been moved to within control system

conversion portion 4 in JP '954, which is disposed in a link dedicated to a single audio or auxiliary device. For these reasons, Petitioner's stated rationale to combine teachings to arrive at the claim limitation pertaining to source switching is conclusory, illogical, and lacks a rational underpinning.

4. Claims 6, 7, 10, and 14

Claims 6, 7, 10, and 14 each depend, directly or indirectly, from claim 1, and thus incorporate all of the limitations of claim 1. The deficiencies discussed above in the context of claim 1 carry through to each of dependent claims 6, 7, 10, and 14. In addition, we note that claim 6 further recites: "wherein said interface generates a device presence signal for maintaining the car stereo in a state responsive to processed data and audio signals." Petitioner's arguments with regard to the limitation added by claim 6 are deficient for the same reasons discussed above, which explain why Petitioner's arguments are deficient with regard to the limitation in claim 57 that requires the microcontroller to execute a pre-programmed code portion "for generating a device presence signal and transmitting the signal to the car stereo to maintain the car stereo in an operational state."

Petitioner has not shown a reasonable likelihood that it would prevail in establishing unpatentability of any of claims 6, 7, 10, and 14 as obvious over JP '954, Onishi, and Owens.

D. Alleged Obviousness of Claim 5
over JP '954, Onishi, Owens, and Berry

Claim 5 depends from claim 1 and further recites: "wherein said interface further comprises a plug-and-play mode for automatically detecting device type of the after-market audio device connected to said second

electrical connector and integrating the after-market audio device based upon the device type.”

Petitioner’s addition of Berry does not cure the deficiencies discussed above in the context of the alleged ground of unpatentability of claim 1 over JP ’954, Onishi, and Owens. Accordingly, Petitioner has not shown a reasonable likelihood that it would prevail in establishing the unpatentability of claim 5 as obvious over JP ’954, Onishi, Owens, and Berry.

E. Alleged Obviousness of Claims 8 and 62
over JP ’954, Onishi, Owens, and Ohmura

Claim 8 depends directly from claim 1. Claim 62 depends indirectly from claim 57. Petitioner’s addition of Ohmura does not cure the deficiencies discussed above in the context of the alleged ground of unpatentability of claims 1 and 57 over JP ’954, Onishi, and Owens. Accordingly, Petitioner has not shown a reasonable likelihood that it would prevail in establishing the unpatentability of either claim 64 or claim 65 as obvious over JP ’954, Onishi, Owens, and Ohmura.

F. Alleged Obviousness of Claims 64 and 65
over JP ’954, Onishi, Owens, and Okagaki

Claim 64 depends from claim 57. Claim 65 depends from claim 64. Petitioner’s addition of Okagaki does not cure the deficiencies discussed above in the context of the alleged ground of unpatentability of claim 57 over JP ’954, Onishi, and Owens. Accordingly, Petitioner has not shown a reasonable likelihood that it would prevail in establishing the unpatentability of either claim 64 or claim 65 as obvious over JP ’954, Onishi, Owens, and Okagaki.

III. CONCLUSION

Petitioner has not demonstrated a reasonable likelihood that it would prevail in establishing the unpatentability of any of claims 57, 60, 61, 64, and 65 as obvious over Bhogal, Berry, and Onishi.

Petitioner has not demonstrated a reasonable likelihood that it would prevail in establishing the unpatentability of claim 62 as obvious over Bhogal, Berry, Onishi, and Ohmura.

Petitioner has not demonstrated a reasonable likelihood that it would prevail in establishing the unpatentability of either claim 64 or claim 65 as obvious over Bhogal, Berry, Onishi, and Okagaki.

Petitioner has not demonstrated a reasonable likelihood that it would prevail in establishing the unpatentability of any of claims 1, 6, 7, 10, and 14 as obvious over Bhogal, Onishi, and Owens.

Petitioner has not demonstrated a reasonable likelihood that it would prevail in establishing the unpatentability of claim 5 as obvious over Bhogal, Onishi, Owens, and Berry.

Petitioner has not demonstrated a reasonable likelihood that it would prevail in establishing the unpatentability of claim 8 as obvious over Bhogal, Onishi, Owens, and Ohmura.

Petitioner has not demonstrated a reasonable likelihood that it would prevail in establishing the unpatentability of claim 10 as obvious over Bhogal, Onishi, Owens, and Knobl.

Petitioner has not demonstrated a reasonable likelihood that it would prevail in establishing the unpatentability of claims 1, 6, 7, 10, 14, 57, 60, and 61 as obvious over JP '954, Onishi, and Owens.

IPR2016-01472
Patent 7,489,786 B2

Petitioner has not demonstrated a reasonable likelihood that it would prevail in establishing the unpatentability of claim 5 as obvious over JP '954, Onishi, Owens, and Berry.

Petitioner has not demonstrated a reasonable likelihood that it would prevail in establishing the unpatentability of claims 8 and 62 as obvious over JP '954, Onishi, Owens, and Ohmura.

Petitioner has not demonstrated a reasonable likelihood that it would prevail in establishing the unpatentability of claims 64 and 65 as obvious over JP '954, Onishi, Owens, and Okagaki.

IV. ORDER

It is

ORDERED that the Petition is *denied*, and no trial is instituted with respect to any claim of U.S. Patent No. 7,489,786 B2 on any alleged ground of unpatentability.

IPR2016-01472
Patent 7,489,786 B2

COUNSEL FOR PETITIONER:

Joseph Melnik
Joseph Beauchamp
H. Albert Liou
jmelnik@jonesday.com
jbeauchamp@jonesday.com
aliou@jonesday.com

COUNSEL FOR PATENT OWNER:

Peter Lambrianakos
Vincent Rubino
Shahar Harel
plambrianakos@brownrudnick.com
vrubino@brownrudnick.com
sharel@brownrudnick.com

UNITED STATES PATENT AND TRADEMARK OFFICE

BEFORE THE PATENT TRIAL AND APPEAL BOARD

AMERICAN HONDA MOTOR CO., INC.,
Petitioner,

v.

BLITZSAFE TEXAS, LLC,
Patent Owner.

Case IPR2016-01472
Patent 7,489,786 B2

Before JAMESON LEE, MIRIAM L. QUINN, and KERRY BEGLEY,
Administrative Patent Judges.

LEE, *Administrative Patent Judge.*

DECISION
Denying Institution of *Inter Partes* Review
37 C.F.R. § 42.108

I. INTRODUCTION

A. Background

On July 21, 2016, Petitioner filed a Petition (Paper 1, “Pet.”) to institute *inter partes* review of claims 1, 5–8, 10, 14, 57, 60–62, 64, and 65 of U.S. Patent No. 7,489,786 B2 (Ex. 1001, “the ’786 patent”). On November 15, 2016, Patent Owner filed a Preliminary Response (Paper 6, “Prelim. Resp.”).

To institute an *inter partes* review, we must determine that the information presented in the Petition shows “that there is a reasonable likelihood that the petitioner would prevail with respect to at least 1 of the claims challenged in the petition.” 35 U.S.C. § 314(a). Having considered both the Petition and the Preliminary Response, we determine that Petitioner has not demonstrated a reasonable likelihood that it would prevail in establishing the unpatentability of any of claims 1, 5–8, 10, 14, 57, 60–62, 64, and 65. We do not institute an *inter partes* review of any claim of the ’786 patent.

B. Related Matters

Petitioner indicates that the ’786 patent was asserted by Patent Owner against Petitioner in *Blitzsafe Texas, LLC v. Honda Motor Co., Ltd. et al.*, No. 2:15-cv-1274 (E.D. Tex.). Pet. 2. The parties indicate that the ’786 patent is the subject of four other actions in the Eastern District of Texas. Pet. 58–59; Paper 3, 1. The parties further indicate that the ’786 patent is the subject of two concluded matters in the District of New Jersey. Pet. 59; Paper 3, 2. The ’786 patent also is the subject patent in these *inter partes* review proceedings: IPR2016-00421, IPR2016-00422, IPR2016-01448, and IPR2016-01477. U.S. Patent No. 8,155,342 B2 is a

IPR2016-01472
Patent 7,489,786 B2

related patent, and that related patent is involved in IPR2016-00118, IPR2016-00418, IPR2016-00419, IPR2016-01445, IPR2016-01449, IPR2016-01473, IPR2016-01476, IPR2016-01533, IPR2016-01557, and IPR2016-01560.

C. The '786 Patent

The '786 patent is titled "Audio Device Integration System."

Ex. 1001, (54). The Abstract portion of the Specification explains:

[O]ne or more after-market audio devices, such as a CD player, CD changer, MP3 player, satellite receiver, DAB receiver, or the like, is integrated for use with an existing OEM or after-market car stereo system, wherein control commands can be issued at the car stereo and responsive data from the audio device can be displayed on the stereo.

Id. at Abstr.

In the Background of the Invention portion of the Specification, a problem with which the '786 patent is concerned is described as follows:

A particular problem with integrating after-market audio systems with existing car stereos is that signals generated by the car stereo is in a proprietary format, and is not capable of being processed by the after-market system. Additionally, signals generated by the after-market system are also in a proprietary format that is not recognizable by the car stereo. Thus, in order to integrate after-market systems with car stereos, it is necessary to convert signals between such systems.

Id. at 1:36–44. In the Summary of the Invention portion of the Specification, it is stated:

The commands generated at the control panel [of a car stereo] are received by the present invention and converted into a format recognizable by the after-market audio device. The formatted commands are executed by the audio device, and audio therefrom is channeled to the car stereo. Information from the audio device is received by the present invention, converted into a format

recognizable by the car stereo, and forwarded to the car stereo for display thereby.

Ex. 1001, 2:35–42.

The '786 patent describes:

Control commands generated at the car stereo are received, processed, converted into a format recognizable by the audio device, and dispatched to the audio device for execution. Information from the audio device, including track, disc, song, station, time, and other information, is received, processed, converted into a format recognizable by the car stereo, and dispatched to the car stereo for display thereon.

Id. Additional auxiliary sources also may be integrated together, and “a user can select between the [audio] device or the one or more auxiliary input sources by issuing selection commands through the car stereo.” *Id.*

Figures 2A–2C are reproduced below:

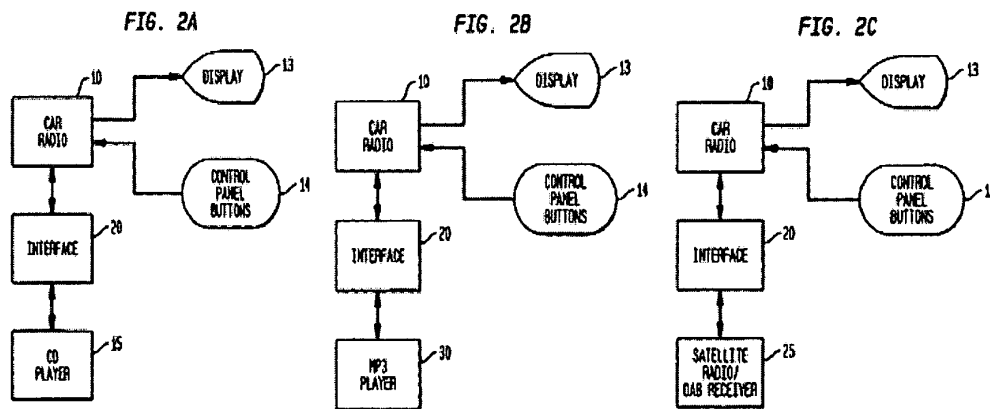

Figure 2A illustrates an embodiment integrating a CD player with the car stereo; Figure 2B illustrates an embodiment integrating a MP3 player with a car stereo; and Figure 2C illustrates an embodiment integrating a satellite or DAB receiver with a car stereo. *Id.* at 3:14–23. A more versatile embodiment is shown in Figure 1:

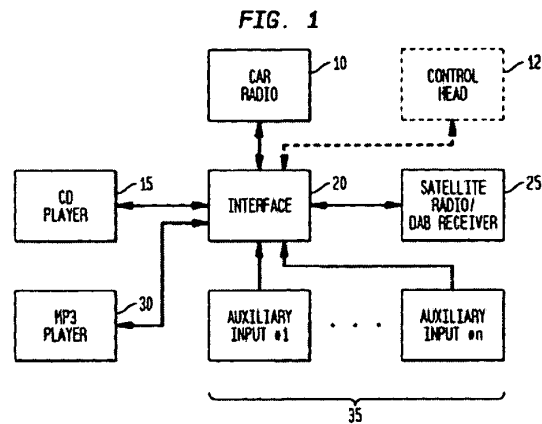

Figure 1 illustrates an embodiment integrating a CD player, a MP3 player, and a satellite radio or DAB receiver, and a number of auxiliary input sources with a car stereo. Ex. 1001, 3:12–13. As shown in the above figures, central to the '786 patent is an “interface” positioned between the car stereo and the audio device(s) and auxiliary input(s) being integrated.

With specific regard to Figure 2B, the '786 patent describes:

The interface 20 allows data and audio signals to be exchanged between the MP3 player 30 and the car radio 10, and processes and formats signals accordingly so that instructions and data from the radio 10 are processable by the MP3 player 30, and vice versa. Operational commands, such as track selection, pause, play, stop, fast forward, rewind, and other commands, are entered via the control panel buttons 14 of car radio 10, processed by the interface 20, and formatted for execution by the MP3 player 30. Data from the MP3 player, such as track, time, and song information, is received by the interface 20, processed thereby, and sent to the radio 10 for display on display 13. Audio from MP3 player 30 is selectively forwarded by the interface 20 to the radio 10 for playing.

Id. at 6:11–24. Similar description is provided with respect to Figures 2A and 2C. *Id.* at 5:49–55, 6:35–43.

Of all of the challenged claims, claims 1 and 57 are the only independent claims. Claim 1 is directed to a system that connects an after-market audio device as well as one or more auxiliary input sources to a car stereo. Claim 1 recites a first connector electrically connectable to a car stereo, a second connector electrically connectable to an after-market device, and a third connector electrically connectable to one or more auxiliary input sources. Ex. 1001, 21:33–38. Claim 1 also recites an interface connected between the first and second electrical connectors, and that the interface includes a microcontroller pre-programmed to execute:

- a first pre-programmed code portion for remotely controlling the after-market audio device using the car stereo by receiving a control command from the car stereo through said first connector in a format incompatible with the after-market audio device, processing the received control command into a formatted command compatible with the after-market audio device, and transmitting the formatted command to the after-market audio device through said second connector for execution by the after-market audio device;
- a second pre-programmed code portion for receiving data from the after-market audio device through said second connector in a format incompatible with the car stereo, processing the received data into formatted data compatible with the car stereo, and transmitting the formatted data to the car stereo through said first connector for display by the car stereo; and
- a third pre-programmed code portion for switching to one or more auxiliary input sources connected to said third electrical connector.

Id. at 21:44–64.

Claim 57 is directed to a system including an interface that connects a portable MP3 player to a car stereo. Unlike claim 1, claim 57 does not require the additional connection of the car stereo to one or more auxiliary

input sources. Claim 57 also does not require conversion of data from a format incompatible with the car stereo to a format compatible with the car stereo. But claim 57 requires the generation, within the interface, of a device presence signal that is transmitted to the car stereo to maintain the car stereo in an operational state. Claim 57 is reproduced below:

57. An audio device integration system comprising:
- a first electrical connector connectable to a car stereo;
 - a second electrical connector connectable to a portable MP3 player external to the car stereo
 - an interface connected between said first and second electrical connectors for transmitting audio from a portable MP3 player to a car stereo, said interface including a microcontroller in electrical communication with said first and second electrical connectors,
- said microcontroller pre-programmed to execute:
- a first pre-programmed code portion for generating a device presence signal and transmitting the signal to the car stereo to maintain the car stereo in an operational state; and
 - a second pre-programmed code portion for remotely controlling the MP3 player using the car stereo by receiving a control command from the car stereo through said first electrical connector in a format incompatible with the MP3 player, processing the control command into a formatted control command compatible with the MP3 player, and transmitting the formatted control command to the MP3 player through said second electrical connector for execution by the MP3 player.

Ex. 1001, 26:13–37.

D. Evidence Relied Upon

Petitioner relies on the following references:

Reference		Date	Exhibit
Bhogal	U.S. Patent No. 6,629,197 B1	Sept. 30, 2001, filed Nov. 3, 2000	Ex. 1004
Berry	U.S. Patent No. 6,559,773 B1	May 6, 2003, filed Dec. 21, 1999	Ex. 1005
Onishi	Japanese Patent Application Publication 2001-128280 ¹	May 11, 2001	Ex. 1006
Ohmura	U.S. Patent Application Publication 2001/0028717 A1	Oct. 11, 2001	Ex. 1008
Okagaki	EPO Patent Application Publication EP 0 953 486 A2	Nov. 3, 1999	Ex. 1009
Owens	U.S. Patent Application Publication 2002/0084910 A1	July 4, 2002	Ex. 1010
JP '954 ²	Japanese Utility Model Application Publication H7-6954	Jan. 31, 1995	Ex. 1011
Knobl	U.S. Patent Application Publication 2001/0025376 A1	Sept. 27, 2001	Ex. 1013

Petitioner also relies on the Declaration of James T. Geier. Ex. 1014.

¹ All citations to specific content of Onishi refers to its English translation (Ex. 1007).

² All citations to specific content of JP'954 refer to its English translation (Ex. 1012).

E. The Asserted Grounds

Petitioner asserts the following grounds of unpatentability:

Claim(s) Challenged	Basis	References
57, 60, 61, 64, and 65	§ 103(a)	Bhogal, Berry, and Onishi
62	§ 103(a)	Bhogal, Berry, Onishi, and Ohmura
64 and 65	§ 103(a)	Bhogal, Berry, Onishi, and Okagaki
1, 6, 7, 10, and 14	§ 103(a)	Bhogal, Onishi, and Owens
5	§ 103(a)	Bhogal, Onishi, Owens, and Berry
8	§ 103(a)	Bhogal, Onishi, Owens, and Ohmura
10	§ 103(a)	Bhogal, Onishi, Owens, and Knobl
1, 6, 7, 10, 14, 57, 60, and 61	§ 103(a)	JP '954, Onishi, and Owens
5	§ 103(a)	JP '954, Onishi, Owens, and Berry
8 and 62	§ 103(a)	JP '954, Onishi, Owens, and Ohmura
64 and 65	§ 103(a)	JP '954, Onishi, Owens, and Okagaki

II. ANALYSIS

The question of obviousness is resolved on the basis of underlying factual determinations including: (1) the scope and content of the prior art; (2) any differences between the claimed subject matter and the prior art; (3) the level of ordinary skill in the art; and (4) objective evidence of nonobviousness. *Graham v. John Deere Co.*, 383 U.S. 1, 17–18 (1966). One seeking to establish obviousness based on more than one reference also

must articulate sufficient reasoning with rational underpinning to combine teachings. *See KSR Int'l Co. v. Teleflex, Inc.*, 550 U.S. 398, 418 (2007).

With regard to the level of ordinary skill in the art, we determine that no express finding is necessary, on this record, and that the level of ordinary skill in the art is reflected by the prior art of record. *See Okajima v. Bourdeau*, 261 F.3d 1350, 1355 (Fed. Cir. 2001); *In re GPAC Inc.*, 57 F.3d 1573, 1579 (Fed. Cir. 1995); *In re Oelrich*, 579 F.2d 86, 91 (CCPA 1978).

A. Claim Construction

In an *inter partes* review, claim terms in an unexpired patent are interpreted according to their broadest reasonable construction in light of the specification of the patent in which they appear. 37 C.F.R. § 42.100(b); *Cuozzo Speed Techs., LLC v. Lee*, 136 S. Ct. 2131, 2142–46 (2016). Consistent with that standard, claim terms also are given their ordinary and customary meaning, as would be understood by one of ordinary skill in the art in the context of the entire disclosure. *See In re Translogic Tech., Inc.*, 504 F.3d 1249, 1257 (Fed. Cir. 2007). There are, however, two exceptions to that rule: “1) when a patentee sets out a definition and acts as his own lexicographer,” and “2) when the patentee disavows the full scope of a claim term either in the specification or during prosecution.” *Thorner v. Sony Computer Entm't Am. LLC*, 669 F.3d 1362, 1365 (Fed. Cir. 2012).

If an inventor acts as his or her own lexicographer, the definition must be set forth in the specification with reasonable clarity, deliberateness, and precision. *Renishaw PLC v. Marposs Societa' per Azioni*, 158 F.3d 1243, 1249 (Fed. Cir. 1998). It is improper to add into a claim an extraneous limitation, i.e., one that is added wholly apart from any need for the addition. *See, e.g., Hogan AB v. Dresser Indus., Inc.*, 9 F.3d 948, 950 (Fed. Cir.

1993); *E.I. du Pont de Nemours & Co. v. Phillips Petroleum Co.*, 849 F.2d 1430, 1433 (Fed. Cir. 1988). Although it is improper to read a limitation from the specification into the claims, *In re Van Geuns*, 988 F.2d 1181, 1184 (Fed. Cir. 1993), claims still must be read in view of the specification of which they are a part. *Microsoft Corp. v. Multi-Tech Sys., Inc.*, 357 F.3d 1340, 1347 (Fed. Cir. 2004).

Only terms which are in controversy need to be construed, and only to the extent necessary to resolve the controversy. *See Wellman, Inc. v. Eastman Chem. Co.*, 642 F.3d 1355, 1361 (Fed. Cir. 2011); *Vivid Techs., Inc. v. Am. Sci. & Eng'g, Inc.*, 200 F.3d 795, 803 (Fed. Cir. 1999).

1. “portable”

Independent claim 57 recites a portable MP3 player. It may be that the term requires no express construction, and simply would be understood by one with ordinary skill in the art. We note that even the '786 patent itself and Bhogal, both using the term “portable” in their written description, do not provide a definition-therefor. Nevertheless, an express construction is helpful to this proceeding. We construe “portable,” in the context of the '786 patent, as meaning *capable of being carried by a user*.³

2. “interface”

Each of independent claims 1 and 57 recites an “interface.” Claims 1 and 57 each require the interface to be connected between a first electrical

³ This is the same construction provided by the Board in IPR2015-00421 when instituting trial in that proceeding. Both Petitioner and Patent Owner have urged that that construction be adopted in this proceeding. Pet. 9; Prelim. Resp. 3.

connector and a second electrical connector, where the first connector is connectable to a car stereo and the second connector is connectable to an after-market audio device (claim 1), or a portable MP3 player (claim 57).

Also, claim 57 recites that the interface is “for transmitting audio from a portable MP3 player to a car stereo”; and claim 1 recites that the interface is “for channeling audio signals to the car stereo from the after-market audio device.” With regard to an “interface,” the Specification states: “Thus, as can be readily appreciated, the interface 20 of the present invention allows for the integration of a multitude of devices and inputs with an OEM or after-market car radio or stereo.” Ex. 1001, 5:33–36. “As mentioned earlier, the interface 20 of the present invention allows for a plurality of disparate audio devices to be integrated with an existing car radio for use therewith.” *Id.* at 6:4–7.

Data from the MP3 player, such as track, time, and song information, is received by the interface 20, processed thereby, and sent to the radio 10 for displaying on display 13. Audio from the MP3 player 30 is selectively forwarded by the interface 20 to the radio 10 for playing.

Id. at 6:19–24. Thus, the Specification refers to the interface receiving information from an audio device and forwarding information to the car stereo, and to the interface allowing integration of a plurality of disparate audio devices with a car radio.

During prosecution, the Applicants of the ’786 patent distinguished U.S. Patent 6,993,615 B2 (“Falcon”)⁴ in part by arguing that the reference

⁴ Falcon discloses a portable computing device connectable to a car stereo through an interface configurable within the portable computing device. Ex. 3001, Abstr.

failed to disclose an interface connected between a car stereo system and an external audio source. Ex. 1002, 267. Specifically, in distinguishing the invention from Falcon, Applicants stated: “[Falcon’s graphical user interface] is an entirely different concept than the interface of the present invention, which includes a physical interface device connected between a car stereo system and an external audio source (e.g., a plurality of auxiliary input sources).” *Id.*

Construing the term “interface” in light of the Specification, other language in the claims, as well as the prosecution history of the ’786 patent, we determine that—*interface is a physical unit that connects one device to another and that has a functional and structural identity separate from that of both connected devices.*⁵

In the specific context of claim 1, the connected devices are the car stereo and an after-market device. In the specific context of claim 57, the connected devices are the car stereo and a portable device. Each of claims 1 and 57 further requires the interface to include a microcontroller.

3. “device presence signal”

Claim 57 requires within the interface a microcontroller having a first pre-programmed code portion “for generating a *device presence signal* and transmitting the signal to the car stereo to maintain the car stereo in an operational state.” (Emphasis added). Claim 6 depends from claim 1 and further recites: “wherein said interface generates a device presence signal

⁵ This is the same construction provided by the Board in IPR2015-00421 when instituting trial in that proceeding. Both Petitioner and Patent Owner have urged that that construction be adopted in this proceeding. Pet. 9, Prelim. Resp. 3.

for maintaining the car stereo in a state responsive to processed data and audio signals.” A description of “device presence signal” is contained in the Specification in the discussion of an embodiment that is for connecting a CD player to the car stereo:

Beginning in step 110, a signal is generated by the present invention indicating that a CD player/changer is present, and the signal is continuously transmitted to the car stereo. Importantly, this signal prevents the car stereo from shutting off, entering a sleep mode, or otherwise being unresponsive to signals and/or data from an external source.

Ex. 1001, 12:29–35. All other disclosed embodiments, whether they are for connecting an MP3 player or an auxiliary device to the car stereo, refer back to the above-quoted description of the device presence signal. *Id.* at 13:15–18, 13:62–65, 14:48–51, 15:35–38, 16:12–15, 16:57–60.

We construe “device presence signal,” as *a signal indicating that an audio device, other than the car stereo, is connected to the interface.*⁶

B. Alleged Obviousness of Claims 1, 5–8, 10, 14, 57, 60–62, 64, and 65 over Prior Art Including Bhogal

Seven of Petitioner’s eleven alleged grounds of unpatentability rely in part on Bhogal. Because these seven grounds share a common deficiency with respect to Petitioner’s application of Bhogal to meet a limitation regarding the “interface” recited in independent claims 1 and 57,⁷ we group them for discussion purposes. We determine that Petitioner has not shown a

⁶ This is essentially the same construction as that provided by the Board in IPR2015-00421 when instituting trial in that proceeding. Both Petitioner and Patent Owner have urged that that construction be adopted in this proceeding. Pet. 9, Prelim. Resp. 3.

⁷ Claims 5–8, 10, and 14 depend, directly or indirectly, from claim 1, and claims 60–62, 64, and 65 depend, directly or indirectly, from claim 57.

reasonable likelihood that it would prevail in establishing unpatentability of any claim on the basis of any alleged ground of patentability relying in part on Bhogal.

1. Bhogal

Bhogal is titled “Method and System for Storing Digital Audio Data and Emulating Multiple CD-Changer Units.” Ex. 1004, (54). With regard to a problem that it addresses, Bhogal describes:

Typically, CD-changer units and car stereo units are designed so that they are compatible only if they are made by the same manufacturer. In other words, CD-changers and car stereos usually have a proprietary interface, and no industry standard currently exists for interfacing different makes of CD-changers and car stereos.

Id. at 4:57–62. To solve that problem, Bhogal provides a digital audio unit that is capable of emulating the operation of multiple CD-changers. *Id.* at 3:10–13. Regarding which one of many CD-changers to emulate, Bhogal describes:

In one case, the digital audio unit can detect a control signal [from a car stereo] for a CD-changer unit and then automatically select the type of CD-changer unit to be emulated based on the detected control signal. In a second case, the digital audio unit can receive a user selection for selecting a type of CD-changer unit to be emulated. *The softcopy digital audio files stored within the digital audio unit are thereby accessed through the controls and commands for a CD-changer unit.*

Ex. 1004, 3:13–20 (emphasis added). Bhogal describes that by emulating the operations of multiple types of CD-changer units, a single digital audio unit can be inserted in many different digital audio systems, “thereby extending the functionality of a digital audio system to include storage of

softcopy digital audio files that may be accessed through controls and commands for a CD-changer unit.” *Id.* at Abstr.

Figure 2 of Bhogal is reproduced below:

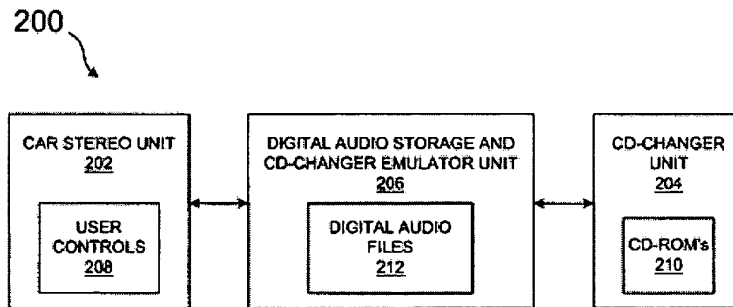

FIG. 2

Figure 2 illustrates an embodiment of Bhogal’s audio system. *Id.* at 3:31–33. Emulator 206 is connected between car stereo 202 and actual CD-changer 204. *Id.* at 5:11–16. Emulator 206 contains digital audio files 212, organized as virtual CD-ROMs, that may be accessed by a user through the car stereo. *Id.* at 5:39–42. Bhogal describes that, in one embodiment, “the emulator unit may be positioned in an independent *docking station* that accepts portable electronics, possibly in a standard manner such that the docking station also accepts other types of MP3 players.” *Id.* at 5:61–64 (emphasis added). When the emulator is not in the docking station, the car stereo and the actual CD-exchanger may operate together. *Id.* at 5:65–67.

Bhogal describes that, in a preferred embodiment, emulator 206 is a portable device. *Id.* at 6:18–21. Bhogal also describes that the emulator may connect to a personal computer in many different ways, including by use of “serial, Universal Serial Bus (USB), or parallel I/O connections, in a manner similar to that found on other types of commercially available

portable digital audio devices.” *Id.* at 6:32–40. Music files may be downloaded from any external source and stored within a digital audio file database within the emulator. *Id.* at 6:40–45. Bhogal thus provides access to softcopy digital audio files. In that regard, Bhogal states:

By recognizing the demand for softcopy digital audio files and the issue of backward compatibility, the present invention takes advantage of the interface between stereo units and CD-changer units to implement a methodology for providing access to softcopy digital files. The present invention emulates the CD-changer interface, which is usually a hardware interface for providing access to hardcopy digital audio files stored on CDs that are stored within the CD-changer, so that a stereo unit using the CD-changer interface can access softcopy digital audio files through its CD-changer interface.

Id. at 4:63–5:6. The softcopy digital audio files are organized as virtual CD-ROMs. *Id.* at 5:39–43. Additionally, the existing functionality of the actual CD-changer is not eliminated. In that connection, Bhogal states: “In addition, the present invention enables a CD-changer to ‘piggyback’ on a digital audio device containing the present invention so that the current jukebox functionality of storing and accessing CDs within a CD-changer is still available.” *Id.* at 5:6–10. In summary, Bhogal states:

By emulating the operations of multiple types of CD-changer units, the present invention enables a single digital audio device to be inserted in many different configurations of digital audio systems. The present invention thereby extends the functionality of a digital audio system to include storage of softcopy digital audio files that may be accessed through controls and commands for a CD-changer unit.

Id. at 9:65 10:5.

2. Independent Claims 1 and 57

For reasons discussed below, Petitioner has not shown a reasonable likelihood that it would prevail in establishing unpatentability of either claim 1 or claim 57 on any ground of obviousness relying in part on Bhogal.

- a) pre-programmed code portion for remotely controlling an audio device or MP3 player (claims 1 and 57)

Claim 1 requires a microcontroller within the interface to execute a pre-programmed code portion that is:

for remotely controlling the after-market audio device using the car stereo by receiving a control command from the car stereo through said first electrical connector in a format incompatible with the after-market audio device, processing the received control command into a formatted command compatible with the after-market device, and transmitting the formatted command to the after-market device through said second connector for execution by the after-market audio device.

Ex. 1001, 21:45–54. Claim 57 includes a similar limitation that differs from the above-quoted limitation of claim 1 by reciting a portable MP3 player instead of an after-market audio device. *Id.* at 22:28–37. Thus, claim 1 pertains to a car stereo remotely controlling an after-market audio device, and claim 57 pertains to a car stereo remotely controlling a portable MP3 player.

For this remote control aspect of claims 1 and 57, and aside from the specific requirement of a portable MP3 player of claim 57, Petitioner relies on Bhogal’s disclosure. Bhogal pertains to an actual CD-changer and an emulator unit that emulates CD-changers, as discussed above.

According to Petitioner, Bhogal discloses the above-noted limitation for remotely controlling the audio device that is connected to the interface.

Pet. 19. Petitioner's argument is as follows:

Bhogal explains that typically, car stereos are designed to communicate only with CD-changers made by the same manufacturer. Ex. 1004, at 4:57–62. The emulator unit in Bhogal contains a “CD-changer unit specification database 312” which “contains operational information about various models of CD-changer units and the manner in which emulator unit 302 can interface with a particular type of CD-changer unit.” *Id.* at 7:1–4, FIG. 3. A signal/command interpreter unit 314 inside the emulator unit monitors for signals and commands from the car stereo intended for the selected type of CD-changer. *Id.* at 7:12–24. For example, when a user of the car stereo presses controls on the car stereo for changing CDs or for obtaining information about CDs, the emulator unit captures the commands and “performs appropriate processing.” *Id.* at 8:21–26. In doing so, the emulator unit “operates in a particular manner that is compatible with the CD-changer to which the emulator unit is connected.” *Id.* at 7:7–11. *See* Geier Decl., Ex. 1014, ¶¶ 53–55.

Id.

The argument is unpersuasive. None of the cited disclosure and explanations, as presented by Petitioner, pertains to remotely controlling an audio device that is connected to Bhogal's emulator unit. The operations identified by Petitioner support the emulator unit's role as an emulator, where the emulator interprets commands from the car stereo intended for an actual CD-changer, and uses the interpreted commands to access audio data files within the emulator itself that are organized as virtual CD-ROMs.

The claim limitation requires receiving a control command from the car stereo in a format incompatible with the connected audio device, processing it into a formatted control command that is compatible with the audio device, and transmitting the formatted command to the audio device. Petitioner has not identified any disclosure in Bhogal that describes

transmitting such a converted command to the connected audio device to control the audio device remotely.

There is an operation mode of the emulator called “pass-thru mode” in which the emulator passes commands from the car stereo to the audio device that is connected. Ex. 1004, 7:36–46. However, as described in Bhogal, the “pass-thru mode” does not involve any conversion of a command from a format that is incompatible with the connected audio device to a format that is compatible with the connected audio device. *Id.* In Bhogal, the car stereo and the actual CD-changer already communicate with each other compatibly, without the need for an intermediate interface to do any conversion of signals. As discussed above, Bhogal describes that when the emulator is not in the docking station, the car stereo and the actual CD-exchanger may operate together. *Id.* at 5:65–67.

In addition, there is an operation mode of the emulator called “end-unit” mode, in which the emulator replaces the CD-changer entirely and itself emulates the presence of the CD-changer. *Id.* at 7:47–49. Nothing in that mode of operation involves conversion of any command to be sent to the CD-changer to control the CD-changer remotely.

There also is an operation mode of the emulator called “combination mode,” in which the emulator also reads tracks and track information from the actual CD-changer unit connected to it, “to create virtual CDs with tracks from both sources.” *Id.* at 8:4–20. Petitioner identifies no disclosure in Bhogal that any conversion is performed on car stereo commands that are incompatible with the actual CD-changer to make them compatible with the CD-changer, much less transmitting such converted commands to the CD-changer to effect remote control of the CD-changer by the car stereo.

As noted above, the car stereo and the actual CD-changer already communicate with each other compatibly without need for an intermediate interface to do any conversion. Petitioner's reference to Bhogal's "processing" alone is insufficient to persuade us that Bhogal discloses the required conversion.

The foregoing reason alone constitutes sufficient basis to conclude that Petitioner has not shown reasonable likelihood that it would prevail in establishing unpatentability of any challenged claim on any ground based in part on Bhogal. We discuss below an additional deficiency with respect to claim 1 and claims dependent thereon, and an additional deficiency with respect to claim 57 and claims dependent thereon.

- b) receiving, processing, transmitting data, and converting data from incompatible format to compatible format (claim 1)

Claim 1 further requires the microcontroller within the interface to have a pre-programmed code portion that is:

for receiving data from the after-market audio device through said second connector in a format incompatible with the car stereo, processing the received data into formatted data compatible with the car stereo, and transmitting the formatted data to the car stereo through said first connector for display by the car stereo.

Ex. 1001, 21:55–61. According to Petitioner, Bhogal discloses format conversion of the display data from the CD-changer unit for display on the car stereo. Pet. 22, 32. Specifically, Petitioner argues: "Because the car stereo [of Bhogal] is designed to communicate using proprietary formats, *see* [Ex. 1004,] 4:57–62, the emulator unit generates data 'in the necessary format' to be sent to the car stereo." Pet. 22. Petitioner's argument is unpersuasive.

Petitioner cites no disclosure in Bhogal to the effect that data from the actual CD-changer is originally incompatible with the car stereo and requires a conversion in format to be compatible with and thus understood by the car stereo. Petitioner also cites no disclosure in Bhogal to the effect that any such data conversion is performed by the emulator unit of Bhogal. Although there is a necessary format for data from the audio device to be understood by the car stereo, Petitioner identifies no disclosure in Bhogal that indicates the car stereo and the audio device do not already share the same format without involvement of the emulator.

As discussed above, Bhogal describes that when the emulator is not in the docking station, the car stereo and the actual CD-exchanger may operate together. Ex. 1004, 5:65–67. Also, although the emulator has a “pass-thru mode,” operation in the pass-thru mode does not involve any conversion of data from a format that is incompatible with the car stereo to a format that is compatible with the car stereo. *Id.* at 7:36–46. As noted above, in the context of Bhogal, the car stereo and the audio device already communicate with each other compatibly without need for an interface to do any conversion of signals.

- c) generating and transmitting a device presence signal (claim 57)

Claim 57 further requires the microcontroller within the interface to have a pre-programmed code portion that is “for generating a device presence signal and transmitting the signal to the car stereo to maintain the car stereo in an operational state.” Ex. 1001, 26:22–26. According to Petitioner, neither Bhogal nor Berry discloses this limitation regarding the generation and transmission of a device presence signal, but Onishi does. Pet. 19–21. Specifically, Petitioner explains as follows:

Onishi discloses an on-vehicle audio device 50 (a car stereo) that includes a source selector 63. Ex. 1007, at [0060], [0063], FIG. 5. Source selector 63 accepts audio signals input from the on-vehicle device's tuner and CD player, as well as audio signals received by the on-vehicle device's AUX input terminal 55. *Id.* at [0064], FIG. 5. A system controller 60 in the on-vehicle device controls which of these audio signals is selected by the source selector and output through speakers. *Id.* at [0065]. Onishi describes at least two methods for the system controller 60 to detect that an AUX device is present. In one method, the system controller recognizes display information DD received from the AUX device through AUX input terminal 55. *Id.* at [0082]. In another method, the AUX input terminal 55 contains a voltage detector. *Id.* at [0083]. Based on the voltage detection, the system controller 60 determines if an AUX device is present. *Id.* When the AUX device has been detected, "*a control is performed*" (*i.e., a device presence signal is sent*) to the source selector 63 to select the AUX input as the audio source. *Id.* at [0084], FIG. 6 (S105). Consequently, analog audio signals from the MD player/recorder are output as sound from the vehicle speakers, *id.* at [0085], FIG. 6 (S106), and the car stereo is maintained in an operational state.

Id. at 19–20 (emphasis added).

Petitioner's explanation is misdirected and unpersuasive. The term "device presence signal" has been construed as *a signal indicating that an audio device, other than the car stereo, is connected to the interface*. The construction is the same as that urged by Petitioner. Pet. 9. Petitioner's above-quoted explanation does not support its assertion that Onishi discloses the generation of a device presence signal and transmitting that signal to the car stereo. Figure 5 of Onishi, as referenced by Petitioner, is reproduced below:

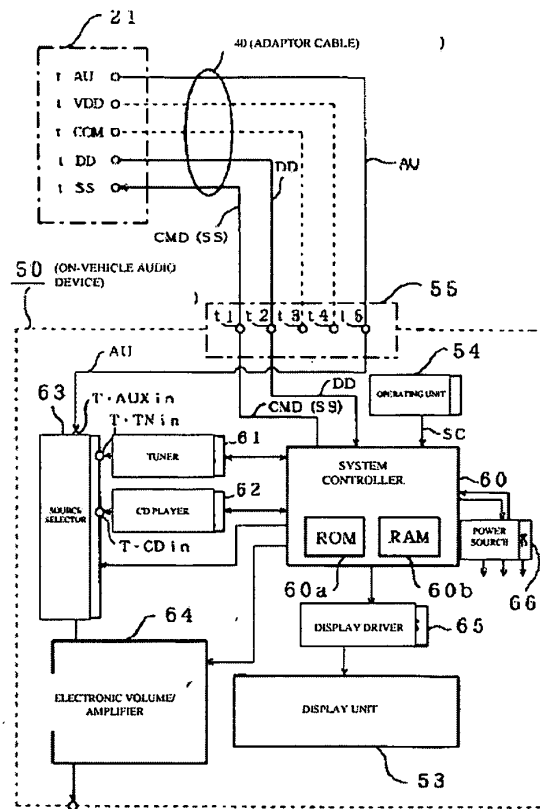

Figure 5 is a block diagram illustrating an internal configuration of an embodiment of the on-vehicle audio device of Onishi. Ex. 1007, 14.

As explained by Petitioner, the on-vehicle audio device, e.g., car stereo, detects the presence of an auxiliary device not by receiving a device presence signal, but by itself detecting the presence of an auxiliary device. Mere presence of data on an input line does not satisfy the requirements of a device presence signal as we have construed the term. For instance, the data could be received directly from an auxiliary device and not through an interface to which the auxiliary device is connected. According to claim 57, it is the microcontroller within the interface that has to generate the device presence signal and to transmit that device presence signal to the car stereo.

Also, what Petitioner identifies as a device presence signal actually is a control signal the on-vehicle audio device sends to an internal source selector, after it already has recognized that an auxiliary device is present, in order to select that auxiliary device as input. *Id.* ¶ 84.

Thus, Petitioner has not made a sufficient showing that Onishi discloses the generation of a device presence signal from outside of the car stereo and transmission of that signal to the car stereo. It follows, also, that Petitioner has not made a sufficient showing that Onishi's alleged teaching regarding the generation of a device presence signal and transmission of that signal to the car stereo, when applied to JP '954, results in satisfaction of claim 57's limitation directed to a device presence signal.

3. Dependent Claims 5–8, 10, 14, 60–62, 64, and 65

Each of claims 5–8, 10, 14, 60–62, 64, and 65 depends directly or indirectly from either claim 1 or 57. The deficiencies noted above with regard to claims 1 and 57 carry through to the claims depending therefrom. Accordingly, Petitioner has not shown a reasonable likelihood that it would prevail in establishing unpatentability of any of claims 5–8, 10, 14, 60–62, 64, and 65 on any alleged ground of obviousness relying in part on Bhogal.

C. Alleged Obviousness of Claims 1, 6, 7, 10, 14, 57, 60, and 61 as Obvious over JP '954, Onishi, and Owens

For reasons discussed below, we determine that Petitioner has not shown a reasonable likelihood that it would prevail in establishing unpatentability of any of claims 1, 6, 7, 10, 14, 57, 60, and 61 as obvious over JP'954, Onishi, and Owens.

1. JP '954

JP '954 is directed to solving the problem of equipment incompatibility, in the environment of automotive audio equipment, between a main unit made by one company and a CD changer made by another company. Ex. 1012, Abstr. Specifically, JP '954 describes the disadvantages associated with prior art systems as follows:

When installing an audio device in a vehicle on the occasion of a vehicle purchase, it is common for a so-called "basic" main unit to be installed. If one were to subsequently attempt to add a CD changer capable of automatically changing and playing a plurality of loaded CDs, prior to now it would have been necessary to purchase and install a model produced by the same manufacturer as the "basic" main unit, as the format of signals connecting the respective devices vary from manufacturer to manufacturer. Furthermore, if a user had installed both of these devices produced by the same manufacturer, and at a later point wished to upgrade the main unit to, for example, a model produced by company A, it would have been necessary for the same reason to also purchase a new CD changer made by company A.

Id. ¶ 2. JP '954 describes its objective as: "to make it possible to add a CD changer made by company B to a main unit made by company A, as well as to add a CD changer made by company A to a main unit made by company B." *Id.* ¶ 3. JP '954 achieves that objective by providing an interface unit as noted below:

(PROBLEM) Provide an interface unit for automotive audio equipment that renders possible the addition of a CD changer made by company B to a main unit made by company A as well as the addition of a CD changer made by company A to a main unit made by company B.

Ex. 1012, Abstr. JP '954 summarizes its interface unit as follows:

(MEANS FOR SOLVING) The [interface] unit is constituted by splitting signals into three systems, namely a control system, audio system and power system, and providing a conversion circuit for each of these systems.

Id. Figure 1 of JP '954 is reproduced below:

(Fig. 1)

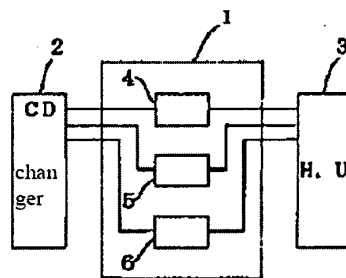

Figure 1 illustrates a block diagram of the structure of the audio system according to JP '954. *Id.* ¶ 6. Interface unit 1 “converts the format of the signal that links the CD changer 2 and the main unit 3, etc.” *Id.* Interface unit 1 links main unit 3 and CD changer 2, and is provided with control system conversion portion 4, audio system conversion portion 5, and power conversion portion 6. *Id.* at Abstr. Control conversion portion 4 is for the bus line, clock control signal, etc.; audio conversion portion 5 is for the audio signal; and power conversion portion 6 is for the power supply. *Id.* ¶ 6.

Figure 2 of JP '954 is reproduced below:

(Fig. 2)

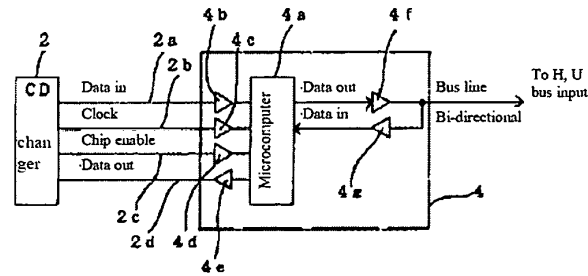

Figure 2 illustrates control system conversion portion 4. *Id.* ¶ 7.

Microcomputer 4a is provided to convert and unify different signal formats between the CD changer and the main unit. *Id.*

Figure 4 is reproduced below:

(Fig. 4)

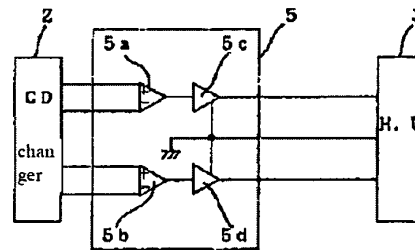

Figure 4 illustrates audio system conversion portion 5. *Id.* ¶ 11. It includes differential amplifiers 5a and 5b and amplifiers 5c and 5d. *Id.*

JP '954 states: “[a]lthough one embodiment example was described above, to expand the range of available inter-company format conversions, a switch can be provided on the microcomputer 4a to enable application to various models using a connection adapter between the CD changer and main unit. *Id.* ¶ 10.

2. Claims 57, 60, and 61

As noted above, claim 57 requires the microcontroller within the interface to have a pre-programmed code portion that is “for generating a device presence signal and transmitting the signal to the car stereo to maintain the car stereo in an operational state.” Ex. 1001, 26:22–26. According to Petitioner, Onishi discloses this limitation. Pet. 52–53. Specifically, Petitioner refers back to and incorporates its discussion of this limitation of claim 57 in the context of its assertion that claim 57 is unpatentable as obvious over Bhogal, Berry, and Onishi. *Id.* at 52.

For the same reasons discussed above, in the alleged obviousness of claim 57 over Bhogal, Berry, and Onishi, Petitioner has not made an adequate showing that Onishi discloses the generation of a device presence signal and transmitting that signal to the car stereo. The same deficiency carries through to claim 60 which depends from claim 57, and to claim 61 which depends from claim 60.

Accordingly, Petitioner has not shown a reasonable likelihood that it would prevail in establishing unpatentability of any of claims 57, 60, and 61 as obvious over JP '954, Onishi, and Owens.

3. Claim 1

For reasons discussed below, Petitioner has not shown a reasonable likelihood that it would prevail in establishing unpatentability of claim 1 as obvious over JP '954, Onishi, and Owens.

- a) receiving, processing, transmitting data, and converting data from incompatible format to compatible format

Claim 1 requires a microcontroller within the interface to execute a pre-programmed code portion that is:

for receiving data from the after-market audio device through said second connector in a format incompatible with the car stereo, processing the received data into formatted data compatible with the car stereo, and *transmitting the formatted data to the car stereo through said first connector for display by the car stereo.*

Ex. 1001, 21:55–61 (emphasis added). The same microcontroller also has to execute a pre-programmed code portion that is:

for remotely controlling the after-market audio device using the car stereo by receiving a control command from the car stereo through said first electrical connector in a format incompatible with the after-market audio device, processing the received control command into a formatted command compatible with the after-market device, and transmitting the formatted command to the after-market device through said second connector for execution by the after-market audio device.

Id. at 21:45–54.

Petitioner first accounts for the control command conversion or remote control limitation of claim 1, by referring to control system conversion 4 of JP '954. Pet. 44–45. In that regard, Figure 2 of JP '954 is again reproduced below:

(Fig. 2)

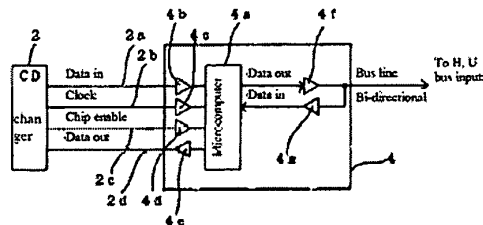

Figure 2 illustrates control system conversion portion 4. Ex. 1012 ¶ 7.

Petitioner explains:

The control signals converted by control conversion portion 4 include incoming signals from the main unit on “Data in” line

4g, which are converted and forwarded to the CD changer via “Data out” line 2c. *Id.* at FIG. 2; Geier Decl., Ex. 1004, at ¶¶ 133–34. The control conversion portion 4 also converts “operational status” data such as “PLAY, FWD, BWD, etc.” received from the CD changer via “Data in” line 2a and forward such data to the main unit via “Data out” line 4f. JP ’954, Ex. 1012, at (0008), (0009), FIG. 2. The ability of the interface unit to convert signal formats make it possible for a CD changer and a main unit made by different companies to communicate. *Id.* at (0005). *See also* Geier Decl., Ex. 1014, at ¶¶ 145–46.

Pet. 44–45.

Then, to satisfy the limitation about converting data and sending converted data for display in the car stereo, Petitioner cites to Onishi and interface unit 1 of JP ’954. Petitioner explains:

Onishi teaches that once the MD recorder/player is connected to the on-vehicle audio device, information from the MD recorder/player can be transmitted to and displayed by display unit 53 on the on-vehicle audio device (car stereo). Ex. 1007, at [0030], [0073]. This information reflects the track being played back, such as “track number,” “track name,” and “playback progress time.” *Id.* at [0086].

Pet. 45.

As shown by Onishi, it was a known technique to display on the car stereo information relating to an audio track being played, including information on the playback progress time, so that the user of the car stereo could be informed about status of playback. *See* Onishi, Ex. 1007, at [0030], [0073], [0086]; Geier Decl., Ex. 1014, ¶¶ 147–49. JP ’954 recognized the need to inform the car stereo of “operational status” data of the after-market device. *See* Ex. 1012, at (0009). It would have been obvious for a person of ordinary skill in the art at the time of the filing of the ’786 patent *to modify the interface unit of JP ’954 to include the feature of processing and forwarding operational data such as time and track information to the car stereo to display.* Geier Decl., Ex. 1014, ¶ 149. Such modification would have resulted in the

predictable improvement of allowing the interface unit to provide more information to the user. *Id.*

Id. at 45–46 (emphasis added).

Patent Owner responds and argues as follows:

Essentially Petitioner argues that because transmitting data from media players was known, it would have been obvious to implement it in JP '954. This argument is woefully short of a proper obviousness analysis. First, Petitioner does not address the analysis set forth by the Board [in IPR2016-00421 (Paper 13)], particularly that “conversion portion 4 in interface unit 1 is for communicating and converting control signals, not any data for display on a car stereo, such as song title and artist information.” Petitioner does not identify which microprocessor should include the pre-programmed code portion, particularly in light of the fact that conversion portion 4 is not meant for sending data, such as title and artist information, to the head unit.

PO Resp. 24–25.

We find the above-quoted arguments of Petitioner to be deficient and the above-quoted arguments of Patent Owner to be persuasive. Petitioner fails to make a sufficient distinction between interface unit 1 of JP '954 and control system conversion portion 4 within interface unit 1 of JP '954. Even assuming that, in light of Onishi, it would have been obvious to one with ordinary skill to send song and artist information back to the car stereo for display, Petitioner, in order to demonstrate that claim 1 would have been obvious, has to address *why* it would have been obvious to one with ordinary skill in the art to use control system conversion portion 4, and in particular microcomputer 4a within control system conversion portion 4, in JP '954 to perform that task. Interface unit 1 of JP '054 is not just control system conversion portion 4. Rather, it also includes audio

system conversion portion 5 and power conversion portion 6, as is shown in its Figure 1 reproduced below:

(Fig. 1)

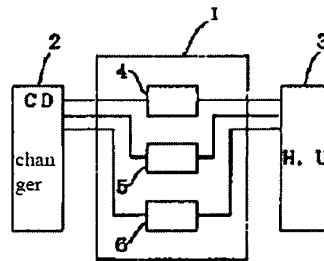

Figure 1 illustrates a block diagram of the structure of the audio system according to JP '954. Ex. 1012 ¶ 6.

Petitioner fails to account for why one with ordinary skill in the art would have modified control system conversion portion 4, specifically, and not something else, to add the functionality of sending song and artist information back to the car stereo for display. The omission is significant because we understand that control system conversion portion 4 of JP '954 relates to operational control and status of the CD-changer, and time and track information of songs do not reflect the operational status of the CD-changer but the content of the music being played or to be played. We recognize that microcomputer 4a sends back to the car stereo operational status of the CD-changer. But operational status data relate to operational control of the CD-changer, and are not information about songs and artists. Also, JP '954 does not describe that operational status data are for display at the car stereo. On this record, Petitioner has not provided reasoning with rational underpinning to support its conclusion that one with ordinary skill in the art would have selected microcomputer 4a in control system conversion

portion 4 of JP '954 to perform data conversion of song and artist information to send back to the car stereo for display.

b) switching to one or more auxiliary input sources

Claim 1 further requires the microcontroller within the interface to execute a pre-programmed code portion that is “for switching to one or more auxiliary input source connected to said third electrical connector.”

Petitioner acknowledges that neither JP '954 nor Onishi discloses this limitation but asserts that Owens does. Pet. 46. Petitioner states:

Owens discloses an auxiliary input source such as VCR 44, tuner 46, or game station 48, which is connectable to A/V source selector 40. Ex. 1010, at [0025], [0026], [0009], FIG. 7. Owens also discloses a microprocessor that performs switching to one or more auxiliary input sources as required in claim 1. *Id.* at [0034]; Geier Decl., Ex. 1014, ¶¶ 151–152.

Id. at 47. Figure 7 of Owens is reproduced below:

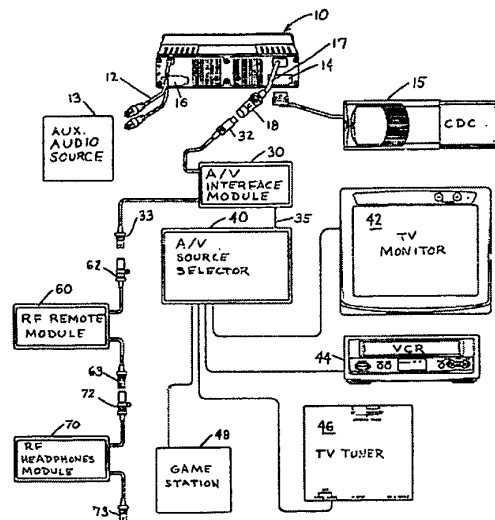

FIG. 1

Figure 7 of Owens illustrates a schematic diagram of an embodiment according to Owens. Ex. 1010, Fig. 7. Petitioner regards the A/V interface

module and A/V source selector in Owens as an interface between the car stereo and multiple audio or video devices. Pet. 48.

Petitioner argues:

As shown in Owens, it was well-known in the art to use devices like the A/V interface module and A/V source selector of Owens to provide an interface to serially connect **multiple** audio or video devices to a car stereo. Geier Decl., Ex. 1014, ¶¶ 154–57. Such a configuration would allow consumers to obtain a car stereo without a large initial investment and gradually buy and add additional modules to accommodate additional input sources. *See* Owens, Ex. 1009, at [0008]; Geier Decl., Ex. 1014, ¶ 157. As such, modifying the interface unit taught by JP '954, in view of Onishi, to permit one or more auxiliary audio or video sources, other than the after-market CD-changer unit, to be connected to a car stereo, and to configure the microprocessor inside JP '954's interface unit to be able to switch between (claim 1) and channel audio from (claim 14) those auxiliary sources, would have resulted in the predictable improvement of increasing the utility and versatility of the interface unit. *Id.* at ¶ 158.

Id. Petitioner's argument is unpersuasive.

It is not adequately explained by Petitioner why one with ordinary skill in the art would have chosen microcomputer 4a within control system conversion portion 4 of interface unit 1 within JP '954 to perform source switching. Petitioner's explanation is conclusory. The explanation also is without rational underpinning. For instance, microcomputer 4a in JP '954 does not itself perform all of the communication between the car stereo and the connected CD-changer. Some of the communication are conducted through audio system conversion portion 5. Ex. 1012, Abstr., Fig. 1. Also, in Owens, the processor that performs source selecting or switching is located within the car stereo. Ex. 1010 ¶¶ 33–34, Fig. 9. Petitioner does not explain why that location would have been moved to within control system

conversion portion 4 in JP '954, which is disposed in a link dedicated to a single audio or auxiliary device. For these reasons, Petitioner's stated rationale to combine teachings to arrive at the claim limitation pertaining to source switching is conclusory, illogical, and lacks a rational underpinning.

4. Claims 6, 7, 10, and 14

Claims 6, 7, 10, and 14 each depend, directly or indirectly, from claim 1, and thus incorporate all of the limitations of claim 1. The deficiencies discussed above in the context of claim 1 carry through to each of dependent claims 6, 7, 10, and 14. In addition, we note that claim 6 further recites: "wherein said interface generates a device presence signal for maintaining the car stereo in a state responsive to processed data and audio signals." Petitioner's arguments with regard to the limitation added by claim 6 are deficient for the same reasons discussed above, which explain why Petitioner's arguments are deficient with regard to the limitation in claim 57 that requires the microcontroller to execute a pre-programmed code portion "for generating a device presence signal and transmitting the signal to the car stereo to maintain the car stereo in an operational state."

Petitioner has not shown a reasonable likelihood that it would prevail in establishing unpatentability of any of claims 6, 7, 10, and 14 as obvious over JP '954, Onishi, and Owens.

D. Alleged Obviousness of Claim 5
over JP '954, Onishi, Owens, and Berry

Claim 5 depends from claim 1 and further recites: "wherein said interface further comprises a plug-and-play mode for automatically detecting device type of the after-market audio device connected to said second

electrical connector and integrating the after-market audio device based upon the device type.”

Petitioner’s addition of Berry does not cure the deficiencies discussed above in the context of the alleged ground of unpatentability of claim 1 over JP ’954, Onishi, and Owens. Accordingly, Petitioner has not shown a reasonable likelihood that it would prevail in establishing the unpatentability of claim 5 as obvious over JP ’954, Onishi, Owens, and Berry.

E. Alleged Obviousness of Claims 8 and 62
over JP ’954, Onishi, Owens, and Ohmura

Claim 8 depends directly from claim 1. Claim 62 depends indirectly from claim 57. Petitioner’s addition of Ohmura does not cure the deficiencies discussed above in the context of the alleged ground of unpatentability of claims 1 and 57 over JP ’954, Onishi, and Owens. Accordingly, Petitioner has not shown a reasonable likelihood that it would prevail in establishing the unpatentability of either claim 64 or claim 65 as obvious over JP ’954, Onishi, Owens, and Ohmura.

F. Alleged Obviousness of Claims 64 and 65
over JP ’954, Onishi, Owens, and Okagaki

Claim 64 depends from claim 57. Claim 65 depends from claim 64. Petitioner’s addition of Okagaki does not cure the deficiencies discussed above in the context of the alleged ground of unpatentability of claim 57 over JP ’954, Onishi, and Owens. Accordingly, Petitioner has not shown a reasonable likelihood that it would prevail in establishing the unpatentability of either claim 64 or claim 65 as obvious over JP ’954, Onishi, Owens, and Okagaki.

III. CONCLUSION

Petitioner has not demonstrated a reasonable likelihood that it would prevail in establishing the unpatentability of any of claims 57, 60, 61, 64, and 65 as obvious over Bhogal, Berry, and Onishi.

Petitioner has not demonstrated a reasonable likelihood that it would prevail in establishing the unpatentability of claim 62 as obvious over Bhogal, Berry, Onishi, and Ohmura.

Petitioner has not demonstrated a reasonable likelihood that it would prevail in establishing the unpatentability of either claim 64 or claim 65 as obvious over Bhogal, Berry, Onishi, and Okagaki.

Petitioner has not demonstrated a reasonable likelihood that it would prevail in establishing the unpatentability of any of claims 1, 6, 7, 10, and 14 as obvious over Bhogal, Onishi, and Owens.

Petitioner has not demonstrated a reasonable likelihood that it would prevail in establishing the unpatentability of claim 5 as obvious over Bhogal, Onishi, Owens, and Berry.

Petitioner has not demonstrated a reasonable likelihood that it would prevail in establishing the unpatentability of claim 8 as obvious over Bhogal, Onishi, Owens, and Ohmura.

Petitioner has not demonstrated a reasonable likelihood that it would prevail in establishing the unpatentability of claim 10 as obvious over Bhogal, Onishi, Owens, and Knobl.

Petitioner has not demonstrated a reasonable likelihood that it would prevail in establishing the unpatentability of claims 1, 6, 7, 10, 14, 57, 60, and 61 as obvious over JP '954, Onishi, and Owens.

IPR2016-01472
Patent 7,489,786 B2

Petitioner has not demonstrated a reasonable likelihood that it would prevail in establishing the unpatentability of claim 5 as obvious over JP '954, Onishi, Owens, and Berry.

Petitioner has not demonstrated a reasonable likelihood that it would prevail in establishing the unpatentability of claims 8 and 62 as obvious over JP '954, Onishi, Owens, and Ohmura.

Petitioner has not demonstrated a reasonable likelihood that it would prevail in establishing the unpatentability of claims 64 and 65 as obvious over JP '954, Onishi, Owens, and Okagaki.

IV. ORDER

It is

ORDERED that the Petition is *denied*, and no trial is instituted with respect to any claim of U.S. Patent No. 7,489,786 B2 on any alleged ground of unpatentability.

IPR2016-01472
Patent 7,489,786 B2

COUNSEL FOR PETITIONER:

Joseph Melnik
Joseph Beauchamp
H. Albert Liou
jmelnik@jonesday.com
jbeauchamp@jonesday.com
aliou@jonesday.com

COUNSEL FOR PATENT OWNER:

Peter Lambrianakos
Vincent Rubino
Shahar Harel
plambrianakos@brownrudnick.com
vrubino@brownrudnick.com
sharel@brownrudnick.com

UNITED STATES PATENT AND TRADEMARK OFFICE

BEFORE THE PATENT TRIAL AND APPEAL BOARD

HYUNDAI MOTOR COMPANY, HYUNDAI MOTOR AMERICA,
HYUNDAI MOTOR MANUFACTURING ALABAMA, LLC,
KIA MOTORS CORPORATION, KIA MOTORS AMERICA, INC., and
KIA MOTORS MANUFACTURING GEORGIA, INC.,
Petitioner,

v.

BLITZSAFE TEXAS, LLC,
Patent Owner.

Case IPR2016-01477
Patent 7,489,786 B2

Before JAMESON LEE, MIRIAM L. QUINN, and
KERRY BEGLEY, *Administrative Patent Judges*.

BEGLEY, *Administrative Patent Judge*.

DECISION

Denying Institution of *Inter Partes* Review
35 U.S.C. § 314(a), 37 C.F.R. § 42.108

Hyundai Motor Company, Hyundai Motor America, Hyundai Motor
Manufacturing Alabama, LLC, Kia Motors Corporation, Kia Motors
America, Inc., and Kia Motors Manufacturing Georgia, Inc. (collectively,

IPR2016-01477

Patent 7,489,786 B2

“Petitioner”) filed a Petition requesting *inter partes* review of claims 1, 5–8, 10, 14, 23, 24, 57, 60–62, 64, and 65 (“challenged claims”) of U.S. Patent No. 7,489,786 B2 (Ex. 1001, “the ’786 patent”). Paper 1 (“Pet.”). Blitzsafe Texas, LLC (“Patent Owner”) filed a Preliminary Response to the Petition. Paper 11 (“Prelim. Resp.”).

Pursuant to 35 U.S.C. § 314(a), an *inter partes* review may not be instituted unless “the information presented in the petition . . . and any response . . . shows that there is a reasonable likelihood that the petitioner would prevail with respect to at least 1 of the claims challenged in the petition.” Having considered the Petition and the Preliminary Response, we determine that the information presented does not show that there is a reasonable likelihood that Petitioner would prevail in establishing the unpatentability of any of the challenged claims of the ’786 patent. Accordingly, we deny institution of an *inter partes* review.

I. BACKGROUND

A. RELATED MATTERS

The parties represent that the ’786 patent is the subject of five ongoing infringement actions before the U.S. District Court for the Eastern District of Texas and was previously the subject of two infringement actions before the U.S. District Court for the District of New Jersey. Paper 8, 1–2; Pet. 2. In addition, the ’786 patent is or was previously the subject of several *inter partes* review proceedings before the Office, namely IPR2016-00421, IPR2016-00422, IPR2016-01448, and IPR2016-01472. Paper 8, 2; *see* Pet. 2. Related U.S. Patent No. 8,155,342 B2 is or was previously involved in IPR2016-00118, IPR2016-00418, IPR2016-00419, IPR2016-01445, IPR2016-01449, IPR2016-01473, IPR2016-01476, IPR2016-01533, IPR2016-01557, and IPR2016-01560. *See* Paper 8, 2.

B. THE '786 PATENT

The '786 patent explains that integrating an after-market audio system with an existing car stereo, such as a stereo from an original equipment manufacturer (“OEM”), presents a problem because signals generated by both systems are in a “proprietary format” and “are not capable of being processed” or recognized by the other system. Ex. 1001, 1:36–42; *see id.* at 2:26–29. Thus, “in order to integrate after-market systems with car stereos, it is necessary to convert signals between such systems.” *Id.* at 1:42–44.

The '786 patent is directed to an audio device integration system that allows after-market audio devices to be integrated for use with an existing car stereo system, such that control commands can be issued at the car stereo for execution by the audio device and data from the audio device can be displayed on the car stereo. *Id.* at [57], 2:12–42. More specifically, control commands generated at the car stereo are received, converted into a format recognizable by the after-market audio device, and dispatched to the device for execution. *Id.* at [57], 2:35–40. In addition, information from the audio device, such as track, channel, song, and artist information, is received, processed, converted into a format recognizable by the car stereo, and dispatched to the stereo for display. *Id.* at [57], 2:40–47. The audio device could, for example, comprise a “CD player, CD changer, MP3 player, satellite receiver, [or] digital audio broadcast (DAB) receiver.” *Id.* at 4:28–30; *see id.* at [57], 2:23–26. Figures 2A–2C are reproduced below:

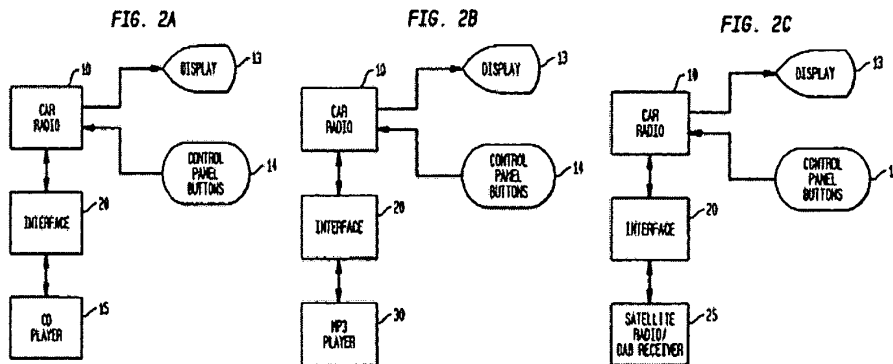

Figures 2A–C illustrate embodiments in which a car stereo is integrated with a CD player (Figure 2A), an MP3 player (Figure 2B), and a satellite radio or DAB receiver (Figure 2C). *Id.* at 3:14–23.

In addition, an audio device as well as auxiliary input sources may be integrated with a car stereo. *Id.* at [57], 2:53–56. A user then “can select between the external audio device and the auxiliary input using the controls of the car stereo.” *Id.* at 2:56–57. Figure 1 is reproduced below:

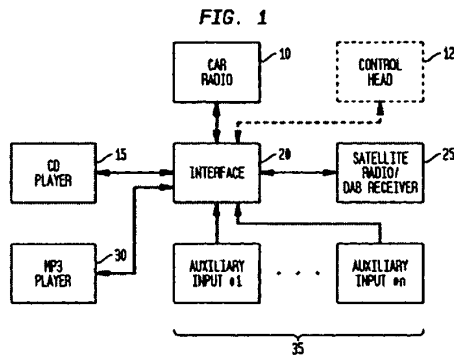

Figure 1 illustrates an embodiment integrating a car stereo with a CD player, a MP3 player, and a satellite radio or DAB receiver, as well as a number of auxiliary input sources. *Id.* at 3:12–13, 5:14–27.

As shown in the above figures, central to the ’786 patent is an “interface” positioned between the car stereo and the audio device(s) and auxiliary input(s). *See, e.g., id.* at Fig. 1, 2A–C, 5:33–36. The interface

allows for the integration of the audio devices and auxiliary inputs with the OEM or after-market car stereo. *Id.* at 5:33–36.

C. ILLUSTRATIVE CLAIM

Of the challenged claims, claims 1 and 57 of the '786 patent are independent. Claim 1, reproduced below, is illustrative:

1. An audio device integration system comprising:
 - a first connector electrically connectable to a car stereo;
 - a second connector electrically connectable to an after-market audio device external to the car stereo;
 - a third connector electrically connectable to one or more auxiliary input sources external to the car stereo and the after-market audio device;
 - an interface connected between said first and second electrical connectors for channeling audio signals to the car stereo from the after-market audio device, said interface including a microcontroller in electrical communication with said first and second electrical connectors, said microcontroller pre-programmed to execute:
 - a first pre-programmed code portion for remotely controlling the after-market audio device using the car stereo by receiving a control command from the car stereo through said first connector in a format incompatible with the after-market audio device, processing the received control command into a formatted command compatible with the after-market audio device, and transmitting the formatted command to the after-market audio device through said second connector for execution by the after-market audio device;
 - a second pre-programmed code portion for receiving data from the after-market audio device through said second connector in a format incompatible with the car stereo, processing the received data into formatted data compatible with the car stereo, and transmitting the formatted data to the car stereo through said first connector for display by the car stereo; and

IPR2016-01477
Patent 7,489,786 B2

a third pre-programmed code portion for switching to one or more auxiliary input sources connected to said third electrical connector.

Ex. 1001, 21:31–64.

D. ASSERTED PRIOR ART

The Petition relies upon the following asserted prior art references:

U.S. Patent No. 5,794,164 (issued Aug. 11, 1998) (Ex. 1007, “Beckert ’164”);

U.S. Patent No. 6,009,363 (issued Dec. 28, 1999) (Ex. 1008, “Beckert ’363”);

U.S. Patent No. 7,085,710 B1 (filed Jan. 7, 1998) (issued Aug. 1, 2006) (Ex. 1006, “Beckert ’710”);

Clarion AutoPC 310C Owner’s Manual (1998) (Ex. 1009, “AutoPC Manual”);

Universal Serial Bus Device Class Definition for Audio Data Formats (Release 1.0 1998) (Ex. 1011, “USB ADF”);

Sony Corporation, FM/MW/LW Cassette Car Stereo (1999) (Ex. 1012, “Sony XR-C5120R Manual”); and

Universal Serial Bus Specification (Rev. 2.0 2000) (Ex. 1010, “USB 2.0”).

In addition to these references, the Petition supports its contentions with the Declaration of Chris Kyriakakis, Ph.D. (Ex. 1003).

E. ASSERTED GROUNDS OF UNPATENTABILITY

Petitioner asserts the following grounds of unpatentability. Pet. 8–9.

Challenged Claim(s)	Basis	References
1, 10, 14, 23, and 24	§ 103 ¹	Beckert ’710 and Beckert ’164

¹ The Leahy-Smith America Invents Act (“AIA”), Pub. L. No. 112–29, 125 Stat. 284, 287–88 (2011), revised 35 U.S.C. § 103, effective March 16, 2013. Because the patent application resulting in the ’786 patent was filed before the effective date of the AIA, we refer to the pre-AIA version of § 103 throughout this Decision.

5	§ 103	Beckert '710, Beckert '164, AutoPC Manual, and USB 2.0
6	§ 103	Beckert '710, Beckert '164, and Beckert '363
7	§ 103	Beckert '710, Beckert '164, and AutoPC Manual
8	§ 103	Beckert '710, Beckert '164, and Sony XR-C5120R Manual
57, 60, 64, and 65	§ 103	Beckert '710, Beckert '164, and USB ADF
61	§ 103	Beckert '710, Beckert '164, USB ADF, and AutoPC Manual
62	§ 103	Beckert '710, Beckert '164, USB ADF, and Sony XR-C5120R Manual

II. ANALYSIS

A. LEVEL OF ORDINARY SKILL IN THE ART

We begin our analysis by addressing the level of ordinary skill in the art. We determine that in this case, no express articulation of the level of ordinary skill is necessary and that the level of ordinary skill in the art is reflected by the prior art of record. *See Okajima v. Bourdeau*, 261 F.3d 1350, 1355 (Fed. Cir. 2001); *In re GPAC Inc.*, 57 F.3d 1573, 1579 (Fed. Cir. 1995); *In re Oelrich*, 579 F.2d 86, 91 (CCPA 1978).

B. CLAIM CONSTRUCTION

The Board interprets claims terms of an unexpired patent using the “broadest reasonable construction in light of the specification of the patent.” 37 C.F.R. § 42.100(b); *Cuozzo Speed Techs., LLC v. Lee*, 136 S. Ct. 2131, 2144–46 (2016). Under this standard, we presume a claim term carries its “ordinary and customary meaning,” which “is the meaning that the term would have to a person of ordinary skill in the art” at the time of the invention. *In re Translogic Tech., Inc.*, 504 F.3d 1249, 1257 (Fed. Cir. 2007). A claim term will be interpreted more narrowly than its ordinary and

IPR2016-01477
Patent 7,489,786 B2

customary meaning only where: (1) the “patentee sets out a definition and acts as [its] own lexicographer,” or (2) the “patentee disavows the full scope of a claim term either in the specification or during prosecution.” *Aventis Pharma S.A. v. Hospira, Inc.*, 675 F.3d 1324, 1330 (Fed. Cir. 2012).

1. “*device presence signal*”

Independent claim 57 and dependent claim 6 each recite a “device presence signal.” Ex. 1001, 22:13–15, 26:23–27. Specifically, claim 57 requires that a microcontroller within an interface be pre-programmed to execute “a first pre-programmed code portion for generating a *device presence signal* and transmitting the signal to the car stereo to maintain the car stereo in an operational state.” *Id.* at 26:17–27 (emphasis added). Similarly, claim 6, which depends directly from independent claim 1, requires that the “interface generates a *device presence signal* for maintaining the car stereo in a state responsive to processed data and audio signals.” *Id.* at 22:13–15 (emphasis added).

Petitioner states that in a prior Institution Decision in IPR2016-00421, the Board construed the term “device presence signal” as: “a signal indicating that an audio device (claim 57) or video device (claim 86) or portable audio device (claim 92), other than the car stereo, is connected to the interface.” Pet. 17–18 (quoting *Toyota Motor Corp. v. Blitzsafe Texas, LLC*, Case IPR2016-00421, slip op. at 18 (PTAB July 7, 2016) (Paper 13) (“IPR2016-00421 Inst. Dec.”)) (emphasis omitted). Petitioner represents that it adopts and applies this construction in the Petition. *Id.* at 18. Patent Owner also adopts this construction of the term. Prelim. Resp. 3.

Having reconsidered the issue, we maintain our construction of the term “device presence signal” from the Institution Decision in

IPR2016-01477

Patent 7,489,786 B2

IPR2016-00421 for the reasons given in that decision. IPR2016-00421 Inst. Dec. 16–18. We repeat the relevant analysis below.

A description of a “device presence signal” is contained in the specification of the ’786 patent in the discussion of an embodiment that is for connecting a CD player to the car stereo:

Beginning in step 110, a signal is generated by the present invention indicating that a CD player/changer is present, and the signal is continuously transmitted to the car stereo. *Importantly, this signal prevents the car stereo from shutting off, entering a sleep mode, or otherwise being unresponsive to signals and/or data from an external source.*

Ex. 1001, 12:29–35 (emphasis added). All other disclosed embodiments, whether they are for connecting an MP3 player or an auxiliary device to the car stereo, refer back to this description of the device presence signal. *Id.* at 13:15–18, 13:62–65, 14:48–51, 15:35–38, 16:12–15, 16:57–60.

As we explained in IPR2016-00421, continuous transmission of a signal is not necessary to accord meaning to “device presence signal.” IPR2016-00421 Inst. Dec. 17. The manner of transmission simply reflects how the signal is transmitted and does not change what the signal was generated and intended to accomplish, and actually accomplishes. *Id.* The specification also does not put continuous transmission in the same category of importance as the requirements in the italicized portion of the above-quoted text. *Id.*

Moreover, in claims 6 and 57, the device presence signal is generated and transmitted by the interface that is connected between the first and second electrical connector, where the first electrical connector is connectable to a car stereo and the second electrical connector is connectable to an after-market audio device (claim 6) or portable MP3 player (claim 57).

IPR2016-01477

Patent 7,489,786 B2

See Ex. 1001, 21:30–44, 22:13–15, 26:13–27; IPR2016-00421 Inst.

Dec. 17–18. Claim 6, based on its dependency from claim 1, recites that the interface is for “channeling audio signals to the car stereo from the after-market audio device.” Ex. 1001, 21:38–44. Claim 57 recites that the interface is for “transmitting audio from a portable MP3 player to a car stereo.” *Id.* at 26:17–22. In the context of these claims, the device the presence of which is signaled by the interface is the device that connects to the interface to communicate with the car stereo.

Accordingly, for purposes of this Decision, we adopt our previous construction of “device presence signal” from IPR2016-00421 and adjust this construction to reflect the relevant challenged claims in this proceeding: *a signal indicating that an audio device (claim 6) or portable MP3 player (claim 57), other than the car stereo, is connected to the interface.*

2. Other Claim Terms

Based on our review of the record and the dispositive issues in our determination of whether to institute *inter partes* review on the asserted grounds of unpatentability, we need not address the construction of any other claim terms. See *Vivid Techs., Inc. v. Am. Sci. & Eng’g, Inc.*, 200 F.3d 795, 803 (Fed. Cir. 1999) (holding that only claim terms that “are in controversy” need to be construed and “only to the extent necessary to resolve the controversy”); Pet. 14–18; Prelim. Resp. 3–5.

C. ALLEGED OBVIOUSNESS OVER BECKERT ’710 AND BECKERT ’164

Petitioner argues claims 1, 10, 14, 23, and 24 of the ’786 patent are unpatentable as obvious over Beckert ’710 and Beckert ’164. Pet. 8, 18–45.

1. Beckert ’710

Beckert ’710 discloses a vehicle computer system, implementing an audio entertainment system, that is designed to support multiple audio

sources, such as radio, CD, and auxiliary inputs. Ex. 1006, [57], 1:5–9, 1:60–63, 12:57–61. The disclosed vehicle computer system 20 includes three modules: (1) faceplate module 80, (2) support module 82, and (3) computer module 84. *Id.* at 1:63–65, 5:34–37, Fig. 3. Beckert '710 explains that support module 82 and computer module 84 typically reside in a stationary base unit that is mounted in the dashboard of a vehicle, whereas faceplate module 80 resides on a faceplate to the base unit. *Id.* at 5:55–58, 6:48–49, 6:62–63, Fig. 1. Figure 3 is reproduced below.

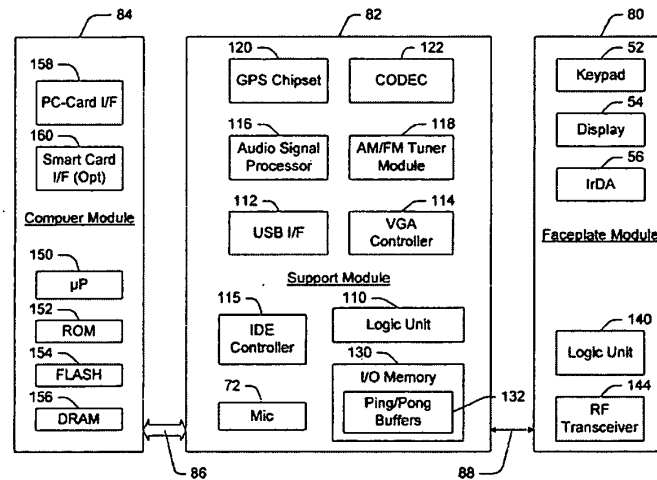

Fig. 3

Figure 3 depicts one implementation of the vehicle computer system disclosed in Beckert '710. *Id.* at 3:34–36.

Beckert '710 explains that support module 82 includes logic unit 110, which “performs many of the functions for the audio entertainment system.” *Id.* at 1:65–67, 5:55–58, 7:49–54. Logic unit 110 can be implemented as a “field programmable gate array (FPGA), application specific integrated circuit (ASIC), customized processor, or the like.” *Id.* at 1:67–2:3; *see id.* at 5:64–6:4. Support module 82 also features hardware interfaces, including universal serial bus (“USB”) interface 112, which connects support

IPR2016-01477

Patent 7,489,786 B2

module 82 to various USB peripheral devices, such as a CD-ROM changer and a TV tuner. *Id.* at 5:44–54, 6:5–11.

Beckert '710 discloses that computer module 84 features microprocessor 150, which runs an operating system. *Id.* at 2:6–9, 6:62–65. According to Beckert '710, “computer module 84 is operatively connected to the support module 82 via a multi-bit bus 86,” which is preferably a peripheral component interconnect (“PCI”) bus. *Id.* at 5:37–40; *see id.* at 2:9–11. In addition, faceplate module 88 is attached to support module 82 through a “detachable connector.” *Id.* at 6:48–53.

Beckert '710 explains that “[a] more detailed explanation of the three modules in the vehicle computer system is provided in” the patent application that resulted in Beckert '164 and “[a] detailed description of one implementation of the logic unit 110 is provided in” the patent application that resulted in Beckert '363. *Id.* at 7:19–25, 7:37–47; Ex. 1007, [21]; Ex. 1008, [21]. Beckert '710 “incorporate[s]” these applications “by reference.” Ex. 1006, 7:19–25, 7:37–47.

In addition, Beckert '710 discloses that “computer system 20 implements an audio manager API (application program interface) to enable applications running on the computer to control the various audio sources without knowing the hardware and implementation details of the underlying sound system.” *Id.* at 12:65–13:2; *see id.* at [54], 2:64–3:1. Figure 8 of Beckert '710 is reproduced below.

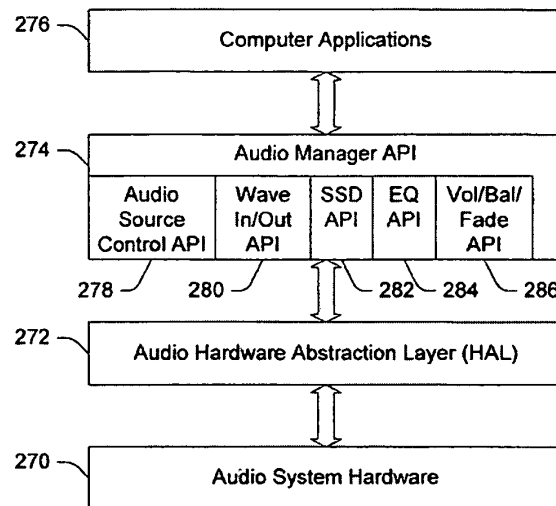

Figure 8 illustrates the “application-to-hardware architecture” discussed in Beckert ’710. *Id.* at 13:7; *see id.* at 3:44–45. Audio hardware 270 forms the lowest level of the architecture. *Id.* at 13:8–9. Audio hardware abstraction layer (“HAL”) 272, in turn, “defines a basic interface layer between the audio related drivers for the hardware 270 and the audio manager API layer 274.” *Id.* at 13:9–12. Next, audio manager API 274—which has five core components, audio source control API 278, wave-in and wave-out API 280, surround sound decoder API 282, equalization API 284, and volume/balance/fade API 286—“defines the APIs to access and control the underlying audio system.” *Id.* at 13:14–18. “[A]udio manager API 274 communicates with the audio device drivers for specific devices via the audio HAL interface 272” and “transfers calls made by the applications to the appropriate device driver(s).” *Id.* at [57], 3:4–6, 13:5–6, 14:38–40. Finally, “[a]top the audio manager API 274 are the applications 276.” *Id.* at 13:13–14.

Beckert ’710 further explains that “[d]ifferent APIs control different aspects of the audio system.” *Id.* at 13:19–20. For example, wave-out

IPR2016-01477

Patent 7,489,786 B2

API 280 controls foreground audio sources, whereas audio source control API 278 “control[s]” and “is used to select” background audio sources, including the “AM/FM tuner, CD player, auxiliary inputs, and other sources from the USB.” *Id.* at 13:22–32, 13:39–47.

2. *Beckert '164*

Similar to Beckert '710, Beckert '164 discloses a vehicle computer system with three modules, namely a computer module, support module, and faceplate module. Ex. 1007, [57], 1:4–5, 1:65, 2:22–42. Computer module 64 includes a processor that runs the operating system “to support the vehicle-related applications,” including “navigation, security, diagnostics, communications, and entertainment systems.” *Id.* at [57], 2:21–30, 3:14–17, 8:34–39.

3. *Discussion*

A patent claim is unpatentable as obvious under 35 U.S.C. § 103(a) if “the differences between” the claimed subject matter “and the prior art are such that the subject matter as a whole would have been obvious at the time the invention was made to a person having ordinary skill in the art to which said subject matter pertains.” 35 U.S.C. § 103(a). As the Supreme Court explained in *KSR International Co. v. Teleflex Inc.*, 550 U.S. 398 (2007), an invention “composed of several elements is not proved obvious merely by demonstrating that each of its elements was, independently, known in the prior art.” *Id.* at 418. Rather, “it can be important to identify a reason that would have prompted a person of ordinary skill in the relevant field to combine the elements in the way the claimed new invention does.” *Id.* In other words, “there must be some articulated reasoning with some rational underpinning to support the legal conclusion of obviousness.” *Id.* (quoting *In re Kahn*, 441 F.3d 977, 988 (Fed. Cir. 2006)). Accordingly, the U.S.

IPR2016-01477
Patent 7,489,786 B2

Court of Appeals for the Federal Circuit has made clear that a petitioner in an *inter partes* review proceeding cannot “satisfy its burden of proving obviousness” by “employ[ing] mere conclusory statements” and “must instead articulate specific reasoning, based on evidence of record” to support an obviousness determination. *In re Magnum Oil Tools Int’l, Ltd.*, 829 F.3d 1364, 1380–81 (Fed. Cir. 2016).

a. Independent Claim 1

Independent claim 1 of the ’786 patent recites that the “microcontroller,” included in the “interface,” is “pre-programmed to execute: a first pre-programmed code portion for:”

remotely controlling the after-market audio device using the car stereo by receiving a control command from the car stereo through said first connector in a format incompatible with the after-market audio device,
processing the received control command into a formatted command compatible with the after-market audio device,
and
transmitting the formatted command to the after-market audio device through said second connector for execution by the after-market audio device.

Ex. 1001, 21:38–54 (line breaks added). Accordingly, the claim requires that the recited microcontroller perform a format conversion of a control command received from the car stereo, specifically converting the command from a format incompatible with the after-market audio device to one compatible with the after-market audio device.

Relevant to this claim requirement, Petitioner identifies support module 82 of Beckert ’710 as the recited “interface,” a customized processor implementing logic unit 110 of Beckert ’710 as the recited “microcontroller,” and computer module 84 of Beckert ’710 and corresponding computer module 64 of Beckert ’164 as the recited “car

IPR2016-01477

Patent 7,489,786 B2

stereo.” *See* Pet. 22–24, 29–31. Specifically regarding the recited “first pre-programmed code portion for . . . processing the received control command into a formatted command compatible with the after-market audio device,” the Petition argues, and Dr. Kyriakakis opines, that audio manager API 274 and hardware abstraction layer 272 of Beckert ’710 perform the required format conversion. *Id.* at 32–35; Ex. 1003, 40–43; *see* Pet. 31–32; Ex. 1003, 39–40. The Petition and Dr. Kyriakakis’s declaration represent that in Beckert ’710, “commands issued by the car stereo (e.g., from the Computer Applications 276) . . . are converted through the Audio Manager API and the hardware abstraction layer to be able to communicate with a connected USB audio hardware device.” Pet. 35; Ex. 1003, 43. According to Petitioner, Beckert ’710 describes using the hardware abstraction layer “to process received commands from the car stereo into formatted commands for transfer to the audio system hardware.” Pet. 33; Ex. 1003, 41. Petitioner relies exclusively on these alleged teachings of Beckert ’710 and does not refer to Beckert ’164 for the “first pre-programmed code portion” limitation. *See* Pet. 31–35; Ex. 1003, 39–43.

Patent Owner contests Petitioner’s arguments that Beckert ’710 teaches the “first pre-programmed code portion” limitation, asserting that Petitioner merely “make[s] general allegations regarding an ‘API,’” but the API of Beckert ’710 “does not receive commands in an incompatible format, or translate commands.” Prelim. Resp. 12–13. Patent Owner argues that Beckert ’710 instead refers to “several other components involved in the command structure including device ‘drivers’ as well as the hardware itself.” *Id.* at 13. According to Patent Owner, Beckert ’710 expressly states only that the API “transfers calls made by the applications to the appropriate device drivers” and does not “describe the format that commands are

relayed from an API to a device driver and then subsequently to the devices.” *Id.* (quoting Ex. 1006, 2:64–3:6). Moreover, Patent Owner faults Petitioner for failing to “allege the location of the API with any further specificity” than Beckert ’710 itself, which states merely that the API is within the “vehicle computer system.” *Id.* Therefore, according to Patent Owner, Petitioner’s allegations are insufficient to demonstrate that Beckert ’710’s teaches the claim limitation because the vehicle computer system contains not only the component Petitioner identifies as the alleged “interface” but also the components Petitioner identifies as the alleged “car stereo” and “after-market audio device.” *Id.* Moreover, with regard to the hardware abstraction layer, Patent Owner asserts that Petitioner does “not map the hardware abstraction layer to the conversion limitations” and does “not explain where the . . . [l]ayer is located or how it represents ‘pre-programmed’ code.” *Id.*

We agree with Patent Owner that Petitioner has not sufficiently explained and supported its position that Beckert ’710 teaches or suggests claim 1’s requirement that a microcontroller “process[] the received control command into a formatted command compatible the after-market audio device.” *See id.* Nor has Petitioner adequately supported and explained its supporting assertion that this recitation is performed by audio manager API 274 and hardware abstraction layer 272, as opposed to, for example, the device drivers for specific audio devices. Moreover, even if this functionality is covered by audio manager API 274 and hardware abstraction layer 272, it is not explained adequately why or how either one maps to a “microcontroller” performing those functions.

With regard to hardware abstraction layer 272, Petitioner’s citation to Figure 8 and the accompanying general disclosure that “audio hardware

abstraction layer . . . 272 defines a basic interface layer between the audio related drivers for the hardware 270 and the audio manager API layer 274” fails to specify and show adequately that the hardware abstraction layer, rather than the device drivers of the audio devices, perform the format conversion of control commands required by claim 1. Ex. 1006, 13:9–12, Fig. 8; *see* Pet. 33–34 (citing Ex. 1006, 13:7–15, Fig. 8); Ex. 1003, 41–42 (citing Ex. 1006, 13:7–15, Fig. 8).

The relevant citations to Beckert ’710 regarding audio manager API 274 fare no better. Although Petitioner proffers citations to disclosures of Beckert ’710 that audio manager API 274 “enable[s] applications running on the computer to control the various audio sources without knowing the hardware and implementation details of the underlying sound system” and similarly, “defines the APIs to access and control the underlying audio system,” these general statements regarding “control” of audio sources do not show that audio manager API 274, in particular, converts a command into a format compatible with the relevant audio source device. Ex. 1006, [57], 2:64–3:1, 12:65–13:2, 13:14–15; *see* Pet. 32–34 (citing Ex. 1006, 2:64–3:6, 13:7–15); Ex. 1003, 40–42 (citing Ex. 1006, 2:64–3:6, 13:7–15). Moreover, the cited discussion in Beckert ’710 explaining that audio source control 278, a component of audio manager API 274, “control[s]” and “is used to select” background audio sources, such as “sources from the USB,” similarly lacks detail sufficient to demonstrate that audio manager API 274 performs the recited format conversion. Ex. 1006, 13:16–18, 13:28–31, 13:39–41, Fig. 9; *see* Pet. 32, 34–35 (citing Ex. 1006, 13:22–31, 13:37–42, Fig. 9); Ex. 1003, 40, 42–43 (citing Ex. 1006, 13:22–31, 13:37–42, Fig. 9).

In more particularly addressing the function of audio manager API 274, Beckert ’710 explains that its role is to “*communicate[] with the*

audio device drivers for specific devices via the audio HAL interface 272” and “*transfer[] calls* made by the applications *to the appropriate device driver(s)*.” Ex. 1006, [57], 3:2–6, 13:2–6, 14:37–40 (emphases added); *see* Pet. 32–34 (citing Ex. 1006, 2:64–3:6); Ex. 1003, 40–42 (citing Ex. 1006, 2:64–3:6). Petitioner has not explained or demonstrated sufficiently, with adequate record support, that a person of ordinary skill in the art would have understood the function of audio manager API 274, including transferring calls to device drivers for audio devices through the hardware abstraction layer, to involve the recited format conversion of control commands.

Petitioner also fails to address or provide explanation as to why it is not the device driver(s) for each specific audio device that perform such a conversion of a control command into a format compatible with the particular device. We find Petitioner’s failure in this regard particularly problematic given that device drivers were known in the art at the relevant time period to perform functionality consistent with the required format conversion. *See* Ex. 3001 (MICROSOFT COMPUTER DICTIONARY (5th ed. 2002)), 155 (explaining that a “device driver” is “[a] software component that permits a computer system to communicate with a device” and performs “data translation”); Ex. 1001, [22]. Moreover, it is unclear why the individual device drivers for particular audio devices in Beckert ’710 would be necessary, and what function they would perform, if audio manager API 274 or hardware abstraction layer 272 converts control commands into a format compatible with the relevant audio device before the drivers receive the command.

In addition, Petitioner has not addressed or shown that the device drivers in Beckert ’710 are part of the customized processor implementing logic unit 110 in support module 82, which Petitioner identifies as the

IPR2016-01477

Patent 7,489,786 B2

“microcontroller” of the “interface” recited in claim 1. *See* Pet. 29–35; Ex. 1003, 37–43; *see also, e.g.*, Ex. 1006, [57], 3:2–3, 13:2–3 (“Different audio devices and their drivers control different functionality of the audio system”); *id.* at 13:10–12 (“audio related drivers for the hardware 270”); *id.* at 14:37–41 (“audio device drivers for specific devices”). Therefore, we are not persuaded that there is adequate basis in the record to conclude that Beckert ’710 teaches, suggests, or otherwise would have conveyed a “microcontroller,” within an “interface,” “pre-programmed to execute: a first pre-programmed code portion for . . . processing the received control command into a formatted command compatible the after-market audio device,” as claim 1 requires.

With specific regard to Dr. Kyriakakis’s stated opinion in his declaration that one of ordinary skill in the art would have understood that in Beckert ’710, commands issued by computer applications are “converted through the Audio Manager API and the hardware abstraction layer to be able to communicate with” an “audio hardware device,” and that “command translation is at the core of HAL functionality,” these representations lack sufficient explanation and evidentiary support. Ex. 1003, 41, 43; *see* Prelim. Resp. 18 (arguing Dr. Kyriakakis’s declaration should be afforded no weight because it “fails to disclose the underlying facts [on] which it bases its obviousness conclusions . . . ; neglects to show how a person of ordinary skill in the art would understand . . . the references; and merely amounts to broad conclusory statements”). In particular, for the reasons explained above, Dr. Kyriakakis’s representations that hardware abstraction layer 272 and audio manager API 274 perform the recited format conversion of control commands are not supported adequately by the disclosures in the cited passages of Beckert ’710. Dr. Kyriakakis does not address or offer any

IPR2016-01477

Patent 7,489,786 B2

explanation as to why one of ordinary skill in the art would not have understood the device drivers in Beckert '710 to perform the format conversion of control commands. In addition, Dr. Kyriakakis's representations are particularly unconvincing and of minimal probative weight given that they generally repeat verbatim the precise statements in the claim chart of the Petition, with the mere addition of phrases like "it is my opinion that" and a single new sentence. *Compare* Pet. 32–35, with Ex. 1003, 40–43. Therefore, we are not persuaded by and do not credit these conclusory and unexplained representations as to what the cited disclosures of Beckert '710 would have conveyed to a person of ordinary skill. *See* 37 C.F.R. § 42.65(a); *In re Am. Acad. of Sci. Tech Ctr.*, 367 F.3d 1359, 1368 (Fed. Cir. 2004) (explaining that "the Board has broad discretion" to weigh declarations and "conclude that the lack of factual corroboration warrants discounting the opinions expressed"); *Rohm & Haas Co. v. Brotech Corp.*, 127 F.3d 1089, 1092 (Fed. Cir. 1997) ("Nothing in the [federal] rules [of evidence] or in our jurisprudence requires the fact finder to credit the unsupported assertions of an expert witness."); *Ashland Oil, Inc. v. Delta Resins & Refractories, Inc.*, 776 F.2d 281, 294 (Fed. Cir. 1985) ("Lack of factual support for expert opinion going to factual determinations . . . may render the testimony of little probative value . . .").

Accordingly, for the reasons given above, Petitioner has not supported sufficiently its argument that Beckert '710 teaches or suggests claim 1's requirement that a microcontroller "process[] the received control command into a formatted command compatible the after-market audio device," and Petitioner's supporting representation that this recitation is performed by audio manager API 274 and hardware abstraction layer 272, rather than the device drivers. In addition, even if we assume Petitioner had shown

IPR2016-01477

Patent 7,489,786 B2

sufficiently that audio manager API 274 and hardware abstraction layer 272 of Beckert '710 perform the recited format conversion of control commands, as it contends, Petitioner still would not have demonstrated adequately that Beckert '710 teaches or suggests that this functionality is performed by a “microcontroller,” within an “interface,” as claim 1 requires. In particular, we agree with Patent Owner that the Petition, as well as Dr. Kyriakakis’s supporting declaration, has not alleged or shown adequately *where* within the disclosed computer system any relevant code of audio manager API 274 and hardware abstraction layer 272 is executed, particularly whether any such code is executed by the processor within logic unit 110 of support module 82, which Petitioner identifies as the “microcontroller.” *See* Prelim. Resp. 13; Pet. 31–35; Ex. 1003, 39–43. The closest Petitioner comes to addressing this location is providing, without any supporting analysis or argument, a block quotation of Beckert '710’s statement that “logic unit 110 in support module 82 performs *many* of the functions for the audio entertainment system.” Ex. 1006, 7:50–52 (emphasis added); *see* Pet. 32–33 (quoting Ex. 1006, 7:49–54); Ex. 1003, 40–41 (quoting Ex. 1006, 7:49–54). Many functions, however, are not all. Petitioner has not provided sufficient argument or explanation to support that a person of ordinary skill in the art would have understood that customized processor of logic unit 110 performs the particular relevant functionality, specifically executing any code for format conversion of control commands for audio manager API 274 and hardware abstraction layer 272. For example, we note that computer module 84, which Petitioner identifies as the recited “car stereo,” also contains a processor, processor 150, which runs the computer system’s operating system and supports all vehicle applications. *See* Ex. 1006, 2:6–9,

7:1–5. Petitioner, however, fails to address why this other processor would not have executed any such code.

Nor do the cited disclosures of Beckert '710 specify the precise location of code for audio manager API 274 and hardware abstraction layer 272. Rather, as Patent Owner argues, Beckert '710, in addressing the location of the API, states only that “computer system 20 implements an audio manager API.” *Id.* at 12:65–66; *see id.* at [57], 2:64–65; Prelim. Resp. 13. Yet Beckert '710’s vehicle computer system 20 includes computer 22, featuring both computer module 84 (“car stereo”) and support module 82 (“interface”), as well as peripheral devices. *See Ex. 1006*, 1:60–64, 3:59–65, 5:34–37, Fig. 1; *Pet.* 22–23, 29–30. As to hardware abstraction layer 272, Beckert '710, as noted above, explains only that this layer “defines a basic interface layer between the audio related drivers for the hardware 270 and the audio manager API layer 274.” *Ex. 1006*, 13:9–12, Fig. 8; *see id.* at 14:37–40; *Pet.* 34 (quoting *Ex. 1006*, 13:7–15). Thus, Beckert '710 describes audio manager API 274 and hardware abstraction layer 272 as abstractions and does not limit their functionalities to a specific location within the disclosed computer system or more particularly, to logic unit 110 of support module 82. Accordingly, for the additional reason that Petitioner has not shown sufficiently that the processor within logic unit 110 (“microcontroller”) executes any relevant code of audio manager API 274 and hardware abstraction layer 272—which Petitioner contends performs the recited format conversion—Petitioner’s assertions and evidence are inadequate to show that Beckert '710 teaches or suggests claim 1’s requirement that a “microcontroller,” within an interface, is “pre-programmed to execute” a format conversion of a control command.

IPR2016-01477
Patent 7,489,786 B2

For the reasons given, Petitioner has not made a sufficient showing, with adequate record support, that Beckert '710 and Beckert '164 teach, suggest, or otherwise would have conveyed to one of ordinary skill "said microcontroller pre-programmed to execute: a first pre-programmed code portion for . . . processing the received control command into a formatted command compatible the after-market audio device," as recited in claim 1 of the '786 patent.

b. Dependent Claims 10, 14, 23, and 24

Claims 10, 14, 23, and 24 of the '786 patent depend, directly or indirectly, from independent claim 1. *See* Ex. 1001, 22:28–67. Accordingly, the deficiencies discussed above with respect to Petitioner's showing regarding the "first pre-programmed code portion" limitation of independent claim 1 carry through to these claims. Petitioner's specific arguments directed to the additional limitations of these dependent claims do not cure the deficiencies. *See* Pet. 39–45.

c. Conclusion

For the reasons given, we determine that the Petition does not show a reasonable likelihood that Petitioner would prevail in showing that Beckert '710 and Beckert '164 render obvious claims 1, 10, 14, 23, and 24 of the '786 patent.

**D. ALLEGED OBVIOUSNESS OVER BECKERT '710, BECKERT '164, AND
USB ADF**

Petitioner contends claims 57, 60, 64, and 65 of the '786 patent are unpatentable as obvious over Beckert '710, Beckert '164, and USB ADF. Pet. 9, 60–66.

1. *Independent Claim 57*

a. *“second pre-programmed code portion”*

Independent claim 57 includes a “second pre-programmed code portion” limitation that is very similar to the “first pre-programmed code portion” limitation of independent claim 1, with the main difference being that the “second pre-programmed code portion” limitation of claim 57 recites an “MP3 player” rather than the more general “after-market audio device” recited in claim 1. *See* Ex. 1001, 22:44–54, 26:27–38. In this asserted ground, the Petition’s analysis of the “second pre-programmed code portion” limitation of claim 57 consists only of an internal cross-reference to the claim charts for the corresponding limitations of claim 1 in the asserted ground of obviousness over Beckert ’710 and Beckert ’164. *See* Pet. 63–64; *see also id.* at 31–35. Accordingly, for substantially the same reasons given above in our analysis of the asserted ground challenging claim 1 as obvious over Beckert ’710 and Beckert ’164 that the Petition fails to show sufficiently that these references teach, suggest, or otherwise would have conveyed to a person of ordinary skill in the art the “first pre-programmed code portion” limitation of claim 1, we likewise are not persuaded that Petitioner has demonstrated adequately that these references teach, suggest, or otherwise would have conveyed to one of ordinary skill the “second pre-programmed code portion” limitation of claim 57.

b. *“first pre-programmed code portion”*

Claim 57 recites “a first pre-programmed code portion for generating a *device presence signal* and transmitting the signal to the car stereo to maintain the car stereo in an operational state.” Ex. 1001, 26:23–27 (emphasis added). The Petition’s analysis of this limitation features only an internal cross-reference to its discussion of a limitation of claim 1 in the

IPR2016-01477

Patent 7,489,786 B2

asserted ground of obviousness over Beckert '710 and Beckert '164. *See* Pet. 62–63 (“*See* discussion of claim limitation 1[f] in Ground 1.”); *id.* at 30–31 (analysis of limitation that the Petition refers to as limitation 1[f]).

Independent claim 1, however, does not recite a “device presence signal.” Ex. 1001, 21:31–64. Thus, the Petition’s analysis of claim 1, including the particular cross-referenced limitation, does not address or explain how Beckert '710 and Beckert '164 teach, suggest, or otherwise would have conveyed to one of ordinary skill in the art a “device presence signal”—i.e., a signal indicating that a portable MP3 player, other than the car stereo, is connected to the interface—and a code portion for generating and transmitting such a signal, as claim 57 requires. *See* Pet. 22–39. Moreover, based on our review of the portions of Beckert '710 and Beckert '164 cited in the Petition’s analysis of claim 1, they are insufficient to demonstrate that these references would have conveyed such a teaching or suggestion to a person of ordinary skill in the art.

Therefore, the Petition does not make a sufficient showing that Beckert '710, Beckert '164, and USB ADF would have rendered obvious a “a first pre-programmed code portion for generating a device presence signal and transmitting the signal to the car stereo to maintain the car stereo in an operational state,” as recited in claim 57.

2. *Dependent Claims 60, 64, and 65*

Claims 60, 64, and 65 of the '786 patent depend, directly or indirectly, from independent claim 57. *See* Ex. 1001, 26:43–63. Accordingly, the deficiencies discussed above with respect to Petitioner’s showing regarding the “first pre-programmed code portion” and “second pre-programmed code portion” limitations of independent claim 57 also apply to these claims.

IPR2016-01477

Patent 7,489,786 B2

Petitioner's specific arguments directed to the additional limitations of these dependent claims do not cure the deficiencies. *See* Pet. 64–66.

3. Conclusion

Based on our analysis above, we determine that the Petition does not demonstrate a reasonable likelihood that Petitioner would prevail in showing that claims 57, 60, 64, and 65 of the '786 patent would have been obvious over Beckert '710, Beckert '164, and USB ADF.

E. OTHER ASSERTED GROUNDS

In addition to the asserted grounds of obviousness relying on Beckert '710 and Beckert '164 as well as Beckert '710, Beckert '164, and USB ADF, addressed above, Petitioner asserts six other obviousness grounds challenging dependent claims 5–8, 61, and 62 of the '786 patent. *See* Pet. 8–9, 45–59, 66–69.

Dependent claims 5–8 each depend directly from independent claim 1. Ex. 1001, 22:8–23. As addressed above, Petitioner challenges independent claim 1 as obvious over Beckert '710 and Beckert '164. Petitioner argues that dependent claims 5–8 would have been obvious over these two references in addition to the AutoPC Manual and USB 2.0 for claim 5; Beckert '363 for claim 6; the AutoPC Manual for claim 7; and the Sony XR-C5120R Manual for claim 8. *See* Pet. 8–9, 45–59. The Petition's analysis of dependent claims 5–8 and specific arguments directed to the additional limitations of these claims do not cure the deficiencies outlined above in Petitioner's showing that Beckert '710 and Beckert '164 teach, suggest, or otherwise would have conveyed the “first pre-programmed code portion” limitation of independent claim 1, from which these claims depend. *See id.* at 45–49. The Petition does not rely on the additional asserted references—AutoPC Manual, USB 2.0, Beckert '363, and Sony XR-C5120R

Manual—to address this limitation. *See id.* Accordingly, for the reasons given above in our analysis of independent claim 1, we determine that the Petition does not show a reasonable likelihood that Petitioner would prevail in showing that dependent claims 5–8 of the ’786 patent are unpatentable.

In addition, dependent claims 61 and 62 each depend indirectly from independent claim 57. Ex. 1001, 26:44–55. Petitioner asserts that claim 57 would have been obvious over Beckert ’710, Beckert ’164, and USB ADF, as addressed in our analysis above. Petitioner argues that dependent claims 61 and 62 would have been obvious over these three references in addition to the AutoPC Manual for claim 61 and the Sony XR-C5120R Manual for claim 62. *See Pet. 9, 66–69.* The Petition does not rely on the additional asserted references, AutoPC Manual and Sony XR-C5120R Manual, to address the “first pre-programmed code portion” and “second pre-programmed code portion” limitations of independent claim 57, from which claims 61 and 62 depend. *See id.* at 66–69. Moreover, the specific arguments directed to the additional limitations of claims 61 and 62 do not cure the deficiencies outlined above in Petitioner’s showing that Beckert ’710, Beckert ’164, and USB ADF teach, suggest, or otherwise would have conveyed to one of ordinary skill in the art these limitations of independent claim 57. *See id.* Therefore, for the reasons given above in our analysis of independent claim 57, we determine that the Petition does not show a reasonable likelihood that Petitioner would prevail in showing that dependent claims 61 and 62 of the ’786 patent are unpatentable.

III. CONCLUSION

For the reasons given, we determine that the information presented in the Petition does not establish a reasonable likelihood that Petitioner would prevail in showing that any of the challenged claims of the ’786 patent,

IPR2016-01477

Patent 7,489,786 B2

claims 1, 5–8, 10, 14, 23, 24, 57, 60–62, 64, and 65, are unpatentable.

Therefore, we do not institute an *inter partes* review of any of the challenged claims on any of the asserted grounds.

IV. ORDER

For the reasons given, it is:

ORDERED that pursuant to 35 U.S.C. § 314(a), the Petition is *denied*, and no trial is instituted with respect to any claim of U.S. Patent No. 7,489,786 B2.

*

IPR2016-01477
Patent 7,489,786 B2

PETITIONER:

Paul R. Steadman
Matthew D. Satchwell
Gianni Minutoli
Nicholas Panno
DLA PIPER LLP
paul.steadman@dlapiper.com
matthew.satchwell@dlapiper.com
gianni.minutoli@dlapiper.com
nicholas.panno@dlapiper.com

PATENT OWNER:

Peter Lambrianakos
Sharhar Harel
Vincent J. Rubino, III
BROWN RUDNICK LLP
plambrianakos@brownrudnick.com
sharel@brownrudnick.com
vrubino@brownrudnick.com

PTO did not receive items marked with *

UNITED STATES PATENT AND TRADEMARK OFFICE

BEFORE THE PATENT TRIAL AND APPEAL BOARD

VOLKSWAGEN GROUP OF AMERICA, INC.,
Petitioner,

v.

BLITZSAFE TEXAS, LLC,
Patent Owner.

Case IPR2016-01448
Patent 7,489,786 B2

Before JAMESON LEE, MIRIAM L. QUINN, and KERRY BEGLEY,
Administrative Patent Judges.

LEE, *Administrative Patent Judge.*

DECISION
Denying Institution of *Inter Partes* Review
37 C.F.R. § 42.108(b)

I. INTRODUCTION

A. *Background*

On July 20, 2016, Petitioner filed a Petition (Paper 2, “Pet.”) to institute *inter partes* review of claims 1, 2, 4–8, 13, 14, 23, 24, 44, 47, 57, 58, 60–65, 86, 88–92, 94, 97, and 98 of U.S. Patent No. 7,489,786 B2 (Ex. 1001, “the ’786 patent”). On November 10, 2016, Patent Owner filed a Preliminary Response (Paper 6, “Prelim. Resp.”).

To institute an *inter partes* review, we must determine that the information presented in the petition shows “that there is a reasonable likelihood that the petitioner would prevail with respect to at least 1 of the claims challenged in the petition.” 35 U.S.C. § 314(a). Having considered both the Petition and the Preliminary Response, we determine that Petitioner has *not* demonstrated a reasonable likelihood that it would prevail in establishing the unpatentability of any challenged claim. Thus, we do not institute an *inter partes* review of any claim of the ’786 patent.

B. *Related Matters*

The parties indicate that the ’786 patent was asserted in five infringement actions before the United States District Court for the Eastern District of Texas and two infringement actions before the United States District Court for the District of New Jersey. Pet. 1; Paper 5, 1–2. The ’786 patent also is involved in IPR2016-00421, IPR2016-00422, IPR2016-01472, and IPR2016-01477. Paper 5, 2. Related U.S. Patent No. 8,155,342 B2 is involved in IPR2016-00118, IPR2016-00418, IPR2016-00419, IPR2016-01445, IPR2016-01449, IPR2016-01473, IPR2016-01476, IPR2016-01533, IPR2016-01557, and IPR2016-01560. Pet. 1; Paper 5, 1–2.

C. The '786 Patent

The '786 patent is titled "Audio Device Integration System."

Ex. 1001, at [54]. It states:

One or more after-market audio devices, such as a CD player, CD changer, MP3 player, satellite receiver, DAB receiver, or the like, is integrated for use with an existing OEM or after-market car stereo system, wherein control commands can be issued at the car stereo and responsive data from the audio device can be displayed on the stereo.

Id. at Abstr. The '786 patent also states:

Control commands generated at the car stereo are received, processed, converted into a format recognizable by the audio device, and dispatched to the audio device for execution. Information from the audio device, including track, disc, song, station, time, and other information, is received, processed, converted into a format recognizable by the car stereo, and dispatched to the car stereo for display thereon.

Id. Additional auxiliary sources also may be integrated together, and "a user can select between the [audio] device or the one or more auxiliary input sources by issuing selection commands through the car stereo." *Id.* A docking station is provided for docking a portable audio or video device for integration with the car stereo. *Id.* Figures 2A–2C are reproduced below:

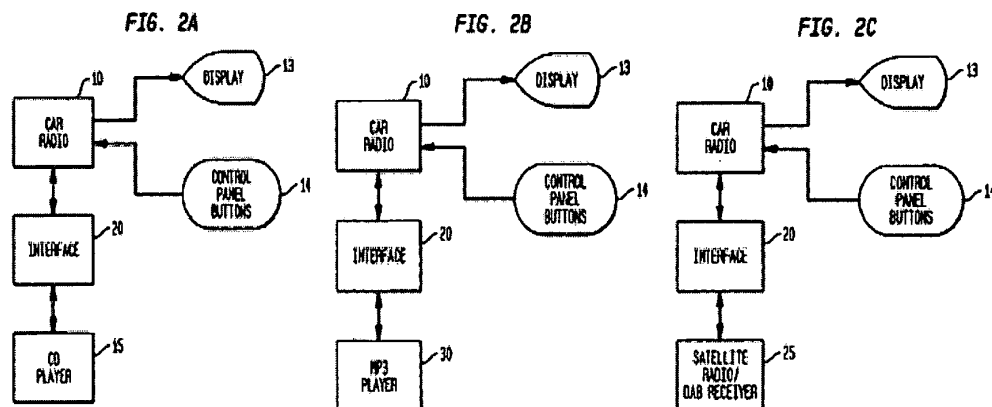

Figure 2A illustrates an embodiment integrating a CD player with the car stereo; Figure 2B illustrates an embodiment integrating a MP3 player with a car stereo; and Figure 2C illustrates an embodiment integrating a satellite or DAB receiver with a car stereo. *Id.* at 3:14–23. A more versatile embodiment is shown in Figure 1:

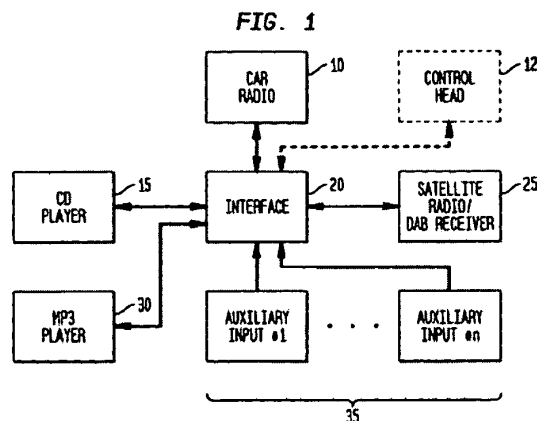

Figure 1 illustrates an embodiment integrating a CD player, a MP3 player, a satellite radio, or DAB receiver, and a number of auxiliary input sources with a car stereo. *Id.* at 3:12–13. As shown in the above Figures, central to the '786 patent is an “interface” positioned between the car stereo and the audio device(s) and auxiliary input(s) being integrated.

With regard to Figure 2B, the '786 patent describes:

The interface 20 allows data and audio signals to be exchanged between the MP3 player 30 and the car radio 10, and processes and formats signals accordingly so that instructions and data from the radio 10 are processable by the MP3 player 30, and vice versa. Operational commands, such as track selection, pause, play, stop, fast forward, rewind, and other commands, are entered via the control panel buttons 14 of car radio 10, processed by the interface 20, and formatted for execution by the MP3 player 30. Data from the MP3 player, such as track, time, and song information, is received by the interface 20, processed thereby, and sent to the radio 10 for display on display 13. Audio from

MP3 player 30 is selectively forwarded by the interface 20 to the radio 10 for playing.

Id. at 6:11–24. Similar description is provided with respect to Figures 2A and 2C. *Id.* at 5:49–55, 6:35–43.

Of the challenged claims, claims 1, 44, 57, 86, and 92 are independent. Claim 1 is directed to a system that connects an after-market audio device as well as one or more auxiliary input sources to a car stereo. In particular, claim 1 recites a first connector electrically connectable to a car stereo, a second connector electrically connectable to an after-market device, and a third connector electrically connectable to one or more auxiliary input sources. *Id.* at 21:33–38. Claim 1 also recites an interface that is connected between the first and second electrical connectors, and includes a “microcontroller pre-programmed to execute”:

- a first pre-programmed code portion for remotely controlling the after-market audio device using the car stereo by receiving a control command from the car stereo through said first connector in a format incompatible with the after-market audio device, processing the received control command into a formatted command compatible with the after-market audio device, and transmitting the formatted command to the after-market audio device through said second connector for execution by the after-market audio device;
- a second pre-programmed code portion for receiving data from the after-market audio device through said second connector in a format incompatible with the car stereo, processing the received data into formatted data compatible with the car stereo, and transmitting the formatted data to the car stereo through said first connector for display by the car stereo; and
- a third pre-programmed code portion for switching to one or more auxiliary input sources connected to said third electrical connector.

Id. at 21:44–64.

Claim 57 is directed to a system including an interface between a first electrical connector connectable to a car stereo and a second electrical connector connectable to a portable MP3 player. Claim 86 is directed to a system including an interface between a first electrical connector connectable to a car stereo and a second electrical connector connectable to an after-market video device. Claim 92 is directed to a system including an interface between a car stereo and a portable audio device. Claims 57, 86, and 92 each require the generation, within the interface, of a device presence signal that is transmitted to the car stereo to maintain the car stereo in an operational state. Claims 57, 86, and 92 are reproduced below:

57. An audio device integration system comprising:
- a first electrical connector connectable to a car stereo;
 - a second electrical connector connectable to a portable MP3 player external to the car stereo
 - an interface connected between said first and second electrical connectors for transmitting audio from a portable MP3 player to a car stereo, said interface including a microcontroller in electrical communication with said first and second electrical connectors,
- said microcontroller pre-programmed to execute:
- a first pre-programmed code portion for generating a device presence signal and transmitting the signal to the car stereo to maintain the car stereo in an operational state; and
 - a second pre-programmed code portion for remotely controlling the MP3 player using the car stereo by receiving a control command from the car stereo through said first electrical connector in a format incompatible with the MP3 player, processing the control command into a formatted control command compatible with the MP3 player, and transmitting the formatted control command to the MP3 player

through said second electrical connector for execution by the MP3 player.

Id. at 26:13–37.

86. A device for integrating video information for use with a car stereo, comprising:

- a first electrical connector connectable to a car stereo;
- a second electrical connector connectable to an after-market video device external to the car stereo;
- an interface connected between said first and second electrical connectors for transmitting video information from the after-market video device to the car stereo, the interface including a microcontroller in electrical communication with said first and second electrical connectors, said microcontroller pre-programmed to execute:
 - a first pre-programmed code portion for generating a device presence signal and transmitting the signal to the car stereo through said first electrical connector to maintain the car stereo in an operational state responsive to signals generated by the after-market video device.

Id. 28:40–56.

92. An audio device integration system comprising:

- a car stereo;
- a portable audio device external to the car stereo;
- an interface connected between the car stereo and the portable audio device, the interface including a microcontroller pre-programmed to execute:
 - first pre-programmed means for generating a device presence signal and transmitting the signal to the car stereo to maintain the car stereo in an operational state;
 - second pre-programmed means for remotely controlling the portable audio device using the car stereo by receiving a control command from the car stereo in a format incompatible with the portable audio device, processing

the control command into a formatted control command compatible with the portable audio device, and transmitting the formatted control command to the portable audio device for execution thereby; and

means for transmitting audio from the portable audio device to the car stereo.

Id. at 29:11–31.

Claim 44 is directed to an apparatus for docking a portable device for integration with a car stereo. It includes an interface connected between the data port and the car stereo, and is reproduced below:

44. An apparatus for docking a portable device for integration with a car stereo comprising:

a storage area remote from a car stereo for storing the portable device;

a docking portion within the storage area for communicating and physically mating with the portable device;

a data port in communication with the docking portion, the data port connectable with a device for integrating the portable device with the car stereo; and

an interface connected to said data port and to the car stereo, said interface channeling from the portable device to the car stereo said interface including a microcontroller in electrical communication with the portable device through said data port and the car stereo, said microcontroller pre-programmed to execute first program code for remotely controlling the portable device using the car stereo by processing control commands generated by the car stereo in a format incompatible with the portable device into formatted control commands compatible with the portable device, and dispatching formatted control commands to the portable device for execution thereby.

Id. at 25:1–22.

D. Evidence Relied Upon

Petitioner relies on the following references:

Reference		Pub. Date	Exhibit
Owens	U.S. Pub. No. 2002/0084910 A1	July 4, 2002	Ex. 1003
Beckert	U.S. Patent No. 6,175,789 B1	Jan. 16, 2001	Ex. 1004
Cooper	U.S. Patent No. 5,774,793	June 30, 1998	Ex. 1005
Ohmura	U.S. Pub. No. 2001/0028717 A1	Oct. 11, 2001	Ex. 1006
Berry	U.S. Patent No. 6,559,773 B1	May 6, 2003	Ex. 1007

Petitioner also relies on the Declaration of Scott Andrews. Ex. 1002.

E. The Asserted Grounds

Petitioner asserts the following grounds of unpatentability:

Claims Challenged	Basis	References
1, 2, 13, 14, 23, 24, 44, and 47	§ 103(a)	Owens, Beckert, and Cooper
7 and 8	§ 103(a)	Owens, Beckert, Cooper, and Ohmura
4, 5, 6, 57, 58, 60, 63, 64, 65, 86, 88, 89, 90, 91, 92, 94, 97, and 98	§ 103(a)	Owens, Beckert, Cooper, and Berry
61 and 62	§ 103(a)	Owens, Beckert, Cooper, Berry, and Ohmura

II. ANALYSIS

The question of obviousness is resolved on the basis of underlying factual determinations including: (1) the scope and content of the prior art; (2) any differences between the claimed subject matter and the prior art; (3) the level of ordinary skill in the art; and (4) objective evidence of

nonobviousness. *Graham v. John Deere Co.*, 383 U.S. 1, 17–18 (1966). One seeking to establish obviousness based on more than one reference also must articulate sufficient reasoning with rational underpinnings to combine teachings. *See KSR Int’l Co. v. Teleflex, Inc.*, 550 U.S. 398, 418 (2007).

Neither Petitioner nor Patent Owner proposes anything specific to reflect the level of ordinary skill in the art. We determine, however, that in this case no express articulation in that regard is necessary and that the level of ordinary skill in the art is reflected by the prior art of record. *See Okajima v. Bourdeau*, 261 F.3d 1350, 1355 (Fed. Cir. 2001); *In re GPAC Inc.*, 57 F.3d 1573, 1579 (Fed. Cir. 1995); *In re Oelrich*, 579 F.2d 86, 91 (CCPA 1978).

A. Claim Construction

In an *inter partes* review, claim terms in an unexpired patent are interpreted according to their broadest reasonable construction in light of the specification of the patent in which they appear. 37 C.F.R. § 42.100(b); *Cuozzo Speed Techs., LLC v. Lee*, 136 S. Ct. 2131, 2142–46 (2016). Consistent with that standard, claim terms also are given their ordinary and customary meaning, as would be understood by one of ordinary skill in the art in the context of the entire disclosure. *See In re Translogic Tech., Inc.*, 504 F.3d 1249, 1257 (Fed. Cir. 2007). There are, however, two exceptions to that rule: “1) when a patentee sets out a definition and acts as his own lexicographer,” and “2) when the patentee disavows the full scope of a claim term either in the specification or during prosecution.” *Thorner v. Sony Computer Entm’t Am. LLC*, 669 F.3d 1362, 1365 (Fed. Cir. 2012).

If an inventor acts as his or her own lexicographer, the definition must be set forth in the specification with reasonable clarity, deliberateness, and

precision. *Renishaw PLC v. Marposs Societa' per Azioni*, 158 F.3d 1243, 1249 (Fed. Cir. 1998). It is improper to add into a claim an extraneous limitation, i.e., one that is added wholly apart from any need for the addition. *See, e.g., Hognas AB v. Dresser Indus., Inc.*, 9 F.3d 948, 950 (Fed. Cir. 1993); *E.I. du Pont de Nemours & Co. v. Phillips Petroleum Co.*, 849 F.2d 1430, 1433 (Fed. Cir. 1988). Although it is improper to read a limitation from the specification into the claims, *In re Van Geuns*, 988 F.2d 1181, 1184 (Fed. Cir. 1993), claims still must be read in view of the specification of which they are a part. *Microsoft Corp. v. Multi-Tech Sys., Inc.*, 357 F.3d 1340, 1347 (Fed. Cir. 2004).

Only terms which are in controversy need to be construed, and only to the extent necessary to resolve the controversy. *See Wellman, Inc. v. Eastman Chem. Co.*, 642 F.3d 1355, 1361 (Fed. Cir. 2011); *Vivid Techs., Inc. v. Am. Sci. & Eng'g, Inc.*, 200 F.3d 795, 803 (Fed. Cir. 1999).

1. “interface”

Of all challenged claims, claims 1, 44, 57, 86, and 92 are independent, and each recites an “interface.”

Claims 1, 57, and 86 require the interface to be connected between a first electrical connector and a second electrical connector, where the first connector is connectable to a car stereo and the second connector is connectable to an after-market audio device (claim 1), a portable MP3 player (claim 57), or an after-market video device (claim 86). Claim 92 requires the interface to be connected between the car stereo and a portable audio device. Claim 44 recites a docking portion that mates with a portable device, and an interface that is connected to the car stereo as well as to a data port that communicates with the docking portion.

Also, claim 57 recites that the interface is “for transmitting audio from a portable MP3 player to a car stereo”; claim 86 recites that the interface is “for transmitting video information from the after-market video device to the car stereo”; claim 1 recites that the interface is “for channeling audio signals to the car stereo from the after-market audio device”; claim 44 recites an interface for “channeling audio from the portable device to the car stereo”; and claim 92 recites that the interface includes a microcontroller pre-programmed to execute “means for transmitting audio from the portable audio device to the car stereo.”

Neither party proposes a construction for the term “interface.” With regard to an “interface,” the Specification states:

Thus, as can be readily appreciated, the interface 20 of the present invention allows for the integration of a multitude of devices and inputs with an OEM or after-market car radio or stereo.

Ex. 1001, 5:33–36.

As mentioned earlier, the interface 20 of the present invention allows for a plurality of disparate audio devices to be integrated with an existing car radio for use therewith.

Id. at 6:4–7.

Data from the MP3 player, such as track, time, and song information, is received by the interface 20, processed thereby, and sent to the radio 10 for display on display 13. Audio from the MP3 player 30 is selectively forwarded by the interface 20 to the radio 10 for playing.

Id. at 6:19–24. Thus, the Specification refers to the interface receiving information from an audio device and forwarding information to the car stereo, and to the interface allowing integration of a plurality of disparate audio devices with a car radio.

In the decision instituting *inter partes* review in related IPR2016-00421, we noted that during prosecution, the applicants of the '786 patent distinguished U.S. Patent No. 6,993,615 B2 ("Falcon") in part by arguing that the reference failed to disclose an interface connected between a car stereo and an external audio source. Ex. 2003, 15. We further noted that in distinguishing the invention from Falcon, the applicants stated: "[Falcon's graphical user interface] is an entirely different concept than the interface of the present invention, which includes a physical interface device connected between a car stereo system and an external audio source (e.g., a plurality of auxiliary input sources)." *Id.* (citing Ex. 1102, 0267 (IPR2016-00421)).

Construing the term "interface" in light of the Specification, other language in the claims, as well as the prosecution history, we determine that—*interface is a physical unit that connects one device to another and that has a functional and structural identity separate from that of both connected devices.* This is the same construction as that we articulated in IPR2016-00421. *Id.*

In the specific context of claims 1 and 86, the connected devices are the car stereo and an after-market device. In the specific context of claims 44, 57, and 92, the connected devices are the car stereo and a portable device. Each of claims 1, 44, 57, 86, and 92 further requires the interface to include a microcontroller.

2. "integration" and "integrated"

Petitioner states:

The '786 patent states that "the term 'integration' or 'integrated' is intended to mean connecting one or more external devices or inputs to an existing car radio or stereo via an

interface, processing and handling signals and audio channels, allowing a user to control the devices via the car stereo, and displaying data from the devices on the radio. Ex. 1001 at 4:47–52.

Pet. 8. An express construction of either “integration” or “integrated” is unnecessary, beyond noting, as Petitioner has, what the Specification states about those terms, and that the statement explicitly requires an “interface,” which we have construed above.

B. Alleged Obviousness of Claims 1, 2, 13, 14, 23, 24, 44, and 47 over Owens, Beckert, and Cooper

We have reviewed the Petition and the Preliminary Response, and determine that Petitioner has not shown a reasonable likelihood that it would prevail in establishing the unpatentability of any of claims 1, 2, 13, 14, 23, 24, 44, and 47 as obvious over Owens, Beckert, and Cooper.

Petitioner has failed to articulate, with reasonable clarity (1) what element of which prior art reference is relied on to meet which element of each claim, and (2) what element from which reference is combined with what element of which other reference or references, and in what manner, to meet what element of each claim. Petitioner has not sufficiently identified differences between the claimed invention and the prior art, as well as the manner in which the prior art teachings are combined to account for such differences.

1. Claims 1, 2, 13, 14, 23, and 24

With regard to the recitation in claim 1 of “[a]n audio device integration system comprising a first connector electrically connectable to a car stereo,” Petitioner states:

Owens describes “an expandable system” for “serial additional of modules” such as A/V sources, and further

describes a “bus cable” connecting the head unit to the modules, including to an A/V interface module. Ex. 1003, Abstract, ¶¶ [0006], [0025]; Ex. 1002, ¶ 10. Beckert describes a vehicle computer system that is capable of integrating diverse and separate systems and can serve as, e.g., a multimedia entertainment system. Ex. 1004, 2:8–11, 5:36; Ex. 1002, ¶ 10. Cooper describes a system for connecting a plurality of cellular telephones to an automotive electronics and communication system; a cable (no. 44 in Fig. 2) connects the interface unit to a bus connector of the electronics and communications system. Ex. 1005, Abstract, 3:42–45, Figs. 1, 2; Ex. 1002, ¶ 10.

Pet. 14. The first sentence appears to identify the bus cable of Owens as the claimed first connector. If so, the significance of the cited disclosures from Beckert and Cooper is not explained. It is unclear whether Petitioner also asserts that each of Beckert and Cooper also discloses such a first connector connectable to a car stereo, and if so, which element of Beckert and Cooper constitutes such a first connector. For instance, the cited disclosure of Cooper refers to a cable, an interface unit, and a bus connector. It is further unclear whether Petitioner is combining multiple elements from the disclosures of Owens, Beckert, and Cooper to meet the recited first connector, and if so, then in what manner. We note that the cited disclosure of Cooper does not refer to any car stereo. With respect to this claim limitation pertaining to a first connector connectable to a car stereo, the claim chart provided by Petitioner on page 25 of the Petition does not provide further clarity. Indeed, the assertions are made even more unclear, because the claim chart no longer identifies any disclosure from Beckert for the “first connector” limitation.

With regard to the recitation in claim 1 of “a second connector electrically connectable to an after-market audio device external to the car stereo,” Petitioner states:

Owens describes that A/V devices (e.g., after-market audio devices), such as TV monitors, VCRs, tuners, game stations, etc., may be connected to a “source selector” which is connected to the A/V interface module. Ex. 1003, ¶ [0026]; Ex. 1002, ¶ 11. Beckert describes that the “support module” is connected to a USB hub, which provides connections to peripheral devices, such as CD-ROM changers, TV tuners, etc. Ex. 1004, 5:28–38; Ex. 1002, ¶ 11. Cooper describes a cable (no. 40 in Fig. 2) connecting the interface unit with a cellular phone. Ex. 1005, 3:29–41, Fig. 2; Ex. 1002, ¶ 11.

Pet. 15. The above-quoted text identifies two elements from Owens (source selector and A/V interface module), two elements from Beckert (support module and USB hub), and two elements from Cooper (cable and interface unit). It is unclear which one of those elements Petitioner relies on as the claimed second connector, and what is the significance of all the other identified elements in the mix. It is unclear whether Petitioner is relying on a combination of elements from multiple references to meet the claimed second connector, and if so, then in what manner. With respect to this claim limitation pertaining to a second connector connectable to a car stereo, the claim chart provided by Petitioner on page 26 of the Petition does not provide further clarity, and shares the same uncertainties.

With regard to the recitation in claim 1 of “a third connector electrically connectable to one or more auxiliary input sources external to the car stereo and the after-market audio device,” Petitioner states:

Owens describes “auxiliary plugs” (no. 12 in Fig. 1) for connection of an auxiliary audio source (no. 13 in Fig. 1), such as a cassette tape deck or an MP3 player, to the head unit. Ex. 1003, ¶ [0025], Fig. 1; Ex. 1002, ¶ 12. Beckert’s system is connectable to multiple external devices. For example, Beckert describes that “[t]he USB hub 70 provides connections to many peripheral devices (e.g., 128 devices).” Ex. 1004, 5:28–38; Ex. 1002, ¶ 12. Cooper describes that multiple cell phones may

be separately connected to the interface unit through multiple “cradle members.” Ex. 1005, claim 4, Fig. 1; Ex. 1002, ¶ 12.

Pet. 15. The first sentence appears to identify the auxiliary plugs of Owens as the claimed third connector. If so, the significance of the cited disclosure from Beckert and Cooper is not explained. It is unclear whether Petitioner also asserts that each of Beckert and Cooper also discloses such a third connector, and if so, which element of Beckert and Cooper constitutes such a third connector. For instance, the cited disclosure of Cooper refers to an interface unit and multiple cradle members. The cited disclosure of Beckert refers to a USB hub, but the USB hub already has been identified by Petitioner in connection with the second connector of claim 1. It is further unclear whether Petitioner is combining multiple elements from the disclosures of Owens, Beckert, and Cooper to meet the recited third connector, and if so, then in what manner. With respect to this claim limitation pertaining to a third connector connectable to one or more auxiliary input sources, the claim chart provided by Petitioner on page 26–27 of the Petition does not provide further clarity. Actually, Petitioner’s assertions are made even more unclear, because in the claim chart Petitioner identifies still a further element from Cooper, the docking station.

With regard to the recitation in claim 1 of “an interface connected between said first and second electrical connectors for channeling audio signals to the car stereo from the after-market audio device, said interface including a microcontroller in electrical communication with said first and second electrical connectors,” Petitioner states:

Owens describes an A/V interface module connected between the bus and the “source selector,” which in turn is connected to A/V sources; Owens further describes a “master microprocessor” that performs all of the system selection

functions (such as choosing between different A/V sources).
Ex. 1003, ¶¶ [0009]-[0010], [0034]; Ex. 1002, ¶ 13.

Beckert describes a support module (the interface) connected to a computer module (first electrical connection) and a USB hub (second electrical connection), for connection to peripheral devices such as a CD-ROM changer; the support module contains a logic unit that can be implemented as a microprocessor, and “is responsible for facilitation communication among the peripheral devices . . . and coordinating the functionality of the entertainment system.” Ex. 1004, 5:28–38, 5:40–55; Fig. 2; Ex. 1002, ¶ 13.

Cooper describes an interface unit (no. 36 in Fig. 2) connected via cables (nos. 40 and 44 in Fig. 2) to the audio and communications system of the vehicle and one or more cell phones; the system enables audio output of the connected cellular phones to be output on the audio/communication system of the vehicle. Ex. 1005, 3:29–45, 4:11–20, Figs. 1, 2; Ex. 1002, ¶ 13. The interface device includes a microcontroller that “contains, in its non-volatile memory, a data control program having a plurality of firmware drivers;” these drivers “have the operating circuitry and commands necessary for controlling the selected cellular telephone.” Ex. 1005, 3:12–22; 4:34–39; Ex. 1002, ¶ 13.

Pet. 16–17. The first sentence appears to identify the A/V interface module of Owens as the claimed interface. If so, the significance of the cited disclosures from Beckert and Cooper is not explained. It is unclear whether Petitioner is combining multiple elements from the disclosures of Owens, Beckert, and Cooper to meet the recited interface, and if so, then in what manner. We note also that none of the cited disclosures refers to channeling audio signals to the car stereo from the after-market audio device, which is a part of the limitation at issue. With respect to this claim limitation pertaining to an interface, the claim chart provided by Petitioner on page 27–29 of the Petition does not provide further clarity.

Additionally, assuming that Petitioner has relied on Owen's A/V interface module as the claimed interface, the limitation at issue still is not met. That is because the claim limitation requires a microprocessor in the interface. Petitioner has cited to the presence of a master microprocessor. But that master microprocessor is located within the car stereo and not in the A/V interface module. Ex. 1003 ¶¶ 33–34, Fig. 9.

On pages 23–24, the Petition includes a discussion of the reasoning to combine teachings from the various references. However, the reasoning provided is excessively generic and does not make a meaningful clarification of what specific elements of which reference are combined with what specific elements of what other reference or references, and in what manner.

For instance, Petitioner states: “It would have been mere routine adaptation to include the compatibility processing feature of Beckert in the integration system of Owens.” Pet. 23. In that regard, however, Petitioner (1) does not identify what elements are referred to as the “compatibility processing feature” of Beckert, (2) does not identify which elements of Owens and Beckert correspond to which claim elements, respectively, and (3) does not explain the particular manner of combining teachings on the level of the specific elements claimed. Also, Petitioner states:

pre-programming the system “for the communication of incompatible audio devices,” as described, for example, in Cooper, allows the user to “just plug the [device] into the interface system, and have the device work without the user having to manually change switch settings or load or unload software into the device for operation with the specific [device].”

Id. at 24 (citing Ex. 1005, 1:43–47). Petitioner does not explain which specific element of Cooper corresponds to what claim limitation and would be used in combination with what specific elements of either Owens or

Beckert, and in what manner. As presented by Petitioner, there is not a sufficiently specific blueprint on what elements of which reference are combined with what elements from other references, in an articulated manner, to satisfy each claim limitation.

Claims 2, 13, 14, 23, and 24 each depend, directly or indirectly, from claim 1. For the reasons discussed above, Petitioner has not shown a reasonable likelihood that it would prevail in establishing obviousness of claims 1, 2, 13, 14, 23, and 24 as obvious over Owens, Beckert, and Cooper.

2. Claims 44 and 47

Claim 44 is independent. The Petition's deficiencies with respect to claim 44 are similar to those discussed above with respect to claim 1. Petitioner has failed to articulate, with reasonable clarity (1) what element of which prior art reference is relied on to meet which element of claim 44, and (2) what element from which reference is combined with what element of which other reference or references, in what manner, to meet what element of claim 44. Petitioner has not sufficiently identified differences between the claimed invention and the prior art, as well as the manner in which the prior art is combined to account for the differences.

With regard to the recitation in claim 44 of "[a]n apparatus for docking a portable device for integration with a car stereo comprising: a storage area remote from a car stereo for storing the portable device," Petitioner states:

As discussed above, Owens and Beckert describe systems for integrating audio devices with a car stereo. *See* Section IV(A)(1)(i). One example of a connectable device in Owens is a game station (a portable device). Cooper describes a docking station that has a "cradle member," remote from the car's head unit, for storing cell phones; a cradle member may hold more

than one cell phone, and more than one cradle member may be provided. Ex. 1005, 3:5–11, Fig. 2; Ex. 1002, ¶ 22.

Pet. 21–22. The above-quoted statement does not identify anything specific in Owens or Beckert. Although it identifies in Cooper a docking station that includes one or more cradle members, and refers to a car’s “head unit,” i.e., a stereo, the cited text of Cooper does not support the reference to a car’s head unit. We find no reference to a car’s head unit in Cooper, at the location cited by Petitioner. And if Cooper discloses the limitation at hand, then the significance of Owens and Beckert is still unexplained. It is unclear whether Petitioner also asserts that each of Owen and Beckert also discloses the claimed storage area, and what is identified in Owens and Beckert as the claimed storage area. It is further unclear whether Petitioner is combining multiple elements from the disclosures of Owens, Beckert, and Cooper to meet the recited limitation, and if so, then in what manner. With respect to this claim limitation, the claim chart provided by Petitioner on page 39 of the Petition does not provide further clarity.

With regard to the recitation in claim 44 of “a docking portion within the storage area for communicating and physically mating with the portable device,” Petitioner states: “Cooper describes that the interface unit, which transfers data to the cell phone, may be either separate or incorporated into the cradle member. Ex. 1005, 3:5–15; Ex. 1002, ¶ 23.” Pet. 22. There no longer is any mention of Owens or Beckert, which means the significance of any teaching from Owens and Beckert with regard to the claimed storage area remains unclear. With regard to Cooper, there is no longer any mention of the docking station previously referenced in connection with the storage area. And if the cradle member is the storage area and the interface unit is the docking portion, that still does not change the fact that Cooper makes no

mention of a car stereo. With respect to this claim limitation, the claim chart provided by Petitioner on pages 39–40 of the Petition does not provide further clarity. Actually, Petitioner’s assertions are made even more unclear, because in the claim chart Petitioner identifies still a further element from Cooper into the mix, i.e., the docking station.

With regard to the recitation in claim 44 of “a data port in communication with the docking portion, the data port connectable with a device for integrating the portable device with the car stereo,” Petitioner states:

Cooper describes that external cables with compatible jacks (data ports) may attach the interface unit to the cellular phone for connecting the cellular phone to the car stereo. Ex. 1005, 4:52–59; Ex. 1002, ¶ 24. Further, Owens describes various “plugs” and an “adaptor harness” for connecting external devices to the car stereo (see nos. 18, 33, and 35 in Fig. 1). Ex. 1003, ¶¶ [0025], [0026], Figs. 1, 7; Ex. 1002, ¶ 24. Beckert describes a USB connection for connecting peripheral devices to the support module, and thus integrating the devices into a car’s automotive system. Ex. 1004, 5:28–38; Ex. 1002, ¶ 24.

Pet. 22. With respect to Owens, it is unclear what Petitioner identifies as the data port, the docking portion, and the “a device” that is recited in the limitation at issue. The same is true with respect to Beckert. As for Cooper, Petitioner does not specifically identify what constitutes the “a device” that is in the limitation at issue, and the cited portion of Cooper makes no mention of a car stereo. It is unclear whether Petitioner argues that each of Owens, Beckert, and Cooper by itself meets the limitation. And if not, it is unclear what element of each reference is combined with what element or elements of which other reference or references, and in what manner, to meet the limitation at hand. With respect to this limitation, the claim chart

provided by Petitioner on pages 40–41 of the Petition does not provide further clarity.

Claim 44 recites:

an interface connected to said data port and to the car stereo, said interface channeling audio from the portable device to the car stereo, said interface including a microcontroller in electrical communication with the portable device through said data port and the car stereo, said microcontroller pre-programmed to execute first program code for remotely controlling the portable device using the car stereo by processing control commands generated by the car stereo in a format incompatible with the portable device into formatted control commands compatible with the portable device, and dispatching formatted control commands to the portable device for execution thereby.

With regard to the above-quoted recitation of claim 44, Petitioner states:

“This limitation corresponds to the ‘interface’– and ‘first pre-programmed code portion’–[] limitations of claim 1 and is described by Owen[s], Beckert, and Cooper, as discussed in Sections IV(A)(1)(iv) and (v). *See* Ex. 1002, ¶¶ 13, 14, 25.” Pet. 23.

We have explained above the deficiency of Petitioner’s accounting of the claimed “interface” in the context of claim 1. In particular, Petitioner relies on the master microprocessor of Owens to meet the claimed microcontroller, but the master microprocessor of Owens is not a part of the “interface” as claim 1 and claim 44 require of the microcontroller. Also, the cited portions of Beckert do not describe remote controlling any portable device by use of control commands generated by a car stereo, and the cited portions of Cooper identify no car stereo. It is unclear whether Petitioner argues that each of Owens, Beckert, and Cooper by itself meets the limitation. And if not, it is unclear what element of each reference is combined with what element or elements of which other reference or

references, and in what manner, to meet the limitation at hand. With respect to this limitation, the claim chart provided by Petitioner on pages 41–42 of the Petition does not provide further clarity.

With regard to the reasoning provided on pages 23–24 of the Petition, with regard to combining teachings from prior art references, the deficiencies are already discussed above in the context of claims 1, 2, 13, 14, 23, and 24, and need not be reiterated here.

Claim 47 depends from claim 44. For the reasons discussed above with regard to claim 44, Petitioner has not shown a reasonable likelihood that it would prevail in establishing the unpatentability of claims 44 and 47 as obvious over Owens, Beckert, and Cooper.

C. Alleged Obviousness of Claims 7 and 8
over Owens, Beckert, Cooper, and Ohmura

Claims 7 and 8 each depends from claim 1. Petitioner relies on Ohmura to account for the limitations added by claims 7 and 8 relative to base claim 1. Pet. 42–43. For the reasons discussed above in connection with claim 1, Petitioner has not shown a reasonable likelihood that it would prevail in establishing the unpatentability of claim 7 or 8 as obvious over Owens, Beckert, Cooper, and Ohmura.

D. Alleged Obviousness of Claims 4–6, 57, 58, 60, 63–65, 86, 88–92, 94, 97, and 98 over Owens, Beckert, Cooper, and Berry

We have reviewed the Petition and the Preliminary Response, and determine that Petitioner has not shown a reasonable likelihood that it would prevail in establishing the unpatentability of any of claims 4–6, 57, 58, 60, 63–65, 86, 88–92, 94, 97, and 98 as obvious over Owens, Beckert, Cooper, and Berry.

Petitioner has failed to articulate, with reasonable clarity (1) what element of which prior art reference is relied on to meet which element of each claim, and (2) what element from which reference is combined with what element of which other reference or references, in what manner, to meet what element of each claim. Petitioner has not sufficiently identified differences between the claimed invention and the prior art, as well as the manner in which the prior art teachings are combined to account for such differences.

1. Claims 4–6

Each of claims 4–6 depends from claim 1. The deficiencies discussed above with respect to claim 1 are not cured by the additional citation of Berry in the combination of prior art. Furthermore, Petitioner’s specific discussion of the limitation additionally recited in each of claims 4–6, relative to base independent claim 1, compounds the confusion by relying on multiple references without clarification as to the role each reference plays in meeting the additional limitation. Pet. 46–47. For instance, for the limitation added by claim 4, Petitioner cites to the disclosure of Owens, Beckert, and Berry. *Id.* at 46. For the limitation added by claim 5, Petitioner cites to the disclosures of Owens, Cooper, and Berry. *Id.* at 46–47. For the limitation added by claim 6, Petitioner cites to the disclosures of Owens, Cooper, and Berry. *Id.* at 47. It is unclear how the claimed subject matter as a whole is met by the prior art. The claim chart provided by the Petitioner on pages 57–60 does not provide clarification. Regarding reasoning to combine as stated on pages 56–57 of the Petition, it is unclear for the same reasons explained above with respect to the combination of Owens, Beckert, and Cooper.

Accordingly, Petitioner has not shown a reasonable likelihood that it would prevail in establishing the unpatentability of claims 4–6.

2. Claims 57 and 86

Each of claims 57 and 86 recites: “a first electrical connector connectable to a car stereo.” Petitioner states: “These claim limitations mirror the first limitation of claim 1 and is described by Owens, Beckert and Cooper, as discussed in detail in Section IV(A)(1)(i).” Pet. 48. Thus, the deficiencies discussed above with respect to the first electrical connector limitation of claim 1 carry through to claims 57 and 86. Also, Petitioner’s accounting of this first connector limitation creates even more confusion by adding this statement: “Berry describes an audio/video integration system with an HMI that includes a plurality of shortcut buttons (first electrical connection) to create shortcuts to menu screens for device functionality, embedded in subsystems such as a CD player or AM/FM radio.” *Id.* It is unclear how the cited disclosures of Berry add to Petitioner’s accounting, already based on Owens, Beckert, and Cooper, with regard to this limitation of claims 57 and 86 regarding a first electrical connector. The significance of Berry’s disclosure in the mix is uncertain. Furthermore, it is unclear how a general “electrical connection” meets the limitation of an “electrical connector,” and what Petitioner regards as the first electrical connector in Berry. The claim chart on page 60 and 63 of the Petition provides no further clarification.

Claim 57 recites: “a second electrical connector connectable to a portable MP3 player external to the car stereo.” Claim 86 recites: “a second electrical connector connectable to an after-market video device external to

the car stereo.” With regard to these second connector limitations of claims 57 and 86, Petitioner asserts:

Owens describes that the auxiliary cable may connect to an MP3 player, and that the A/V interface module (which is connected to the head unit via a bus cable) may connect, through the source selector, to, e.g., a TV monitor, VCR, etc. Ex. 1003, at ¶¶ [0025], [0026]; Ex. 1002, ¶ 37. Beckert describes that a TV tuner may be connected to the support module. Ex. 1004, 5:28–38; Ex. 1002, ¶ 37. Further, Berry describes that electronic accessories, such as MP3 players, palm-sized PCs, or personal digital assistants (PDAs), may be connected to the system. Ex. 1007, 3:40–57; Ex. 1002, ¶ 37. *See further* Section IV(A)(1)(ii).

Pet. 48. The above-reproduced discussion is without reasonable clarity. It is unclear whether Petitioner asserts that each of Owens, Becket, and Berry discloses the second electrical connector of claims 57 and 86, or that some combination of Owens, Beckert, and Berry, in some manner, accounts for the second electrical connector limitation of claim 57 and/or 86. The significance of each prior art reference in the mix is unclear. On a separate level, it also is unclear which component within each of Owens, Beckert, and Berry Petitioner regards as the claimed second electrical connector. For instance, in Owens, it could be the auxiliary cable, bus cable, A/V interface module, or the source selector, because Petitioner’s use of “e.g.” and “etc.” in the above-quoted text indicates that a portable MP3 player may be connectable to the source selector. With regard to Beckert, Petitioner states merely that a TV tuner may be connected to the support module. With regard to Berry, Petitioner indicates only that electronic accessories such as MP3 players, PCs, and PDAs may be connected “to the system.” The claim chart on pages 60–61 and 63–64 of the Petition provides no further clarification.

Each of claims 57 and 86 recites: “an interface connected between said first and second electrical connectors.” Claim 57 further recites that the interface is for transmitting audio from a portable MP3 player to a car stereo. Claim 86 further recites that the interface is for transmitting video information from an after-market video device to the car stereo. Both claims 57 and 86 recite that the interface includes a microcontroller.

Petitioner states: “This [interface] limitation mirrors the ‘interface’– limitation of claim 1 and is described in Owens, Beckert, and Cooper, as discussed in detail in Section IV(A)(1)(iv).” Pet. 49. Thus, the deficiencies discussed above with respect to the interface limitation of claim 1 carry through to each of claims 57 and 86. Also, Petitioner’s accounting of the limitations of claims 57 and 86 creates even more confusion by adding this statement about Berry:

Berry describes a control panel/display subsystem which can be used as a device portal that “interfaces with devices on the dynamic local network;” the subsystem includes a controller that can “communicate with the various electronic accessory devices on dynamic local network.” Ex. 1007, 3:19–31; Ex. 1002, ¶ 38. As discussed above, MP3 players, palm-sized PCs, or PDAs may be connected as an electronic accessory to the system. Ex. 1002, ¶ 38. *See further* Section IV(A)(1)(iv).

Pet. 49. It is unclear what significance the above-quoted discussion of Berry has in the accounting Petitioner already provided for the claimed interface by reliance on Owens, Beckert, and Cooper. It is unclear what is supposedly missing from Owens, Beckert, and Cooper that Petitioner is relying on Berry to satisfy. With regard to the foregoing, the claim chart on page 61 and 64 of the Petition provides no clarification. Accordingly, Petitioner has not shown a reasonable likelihood that it would prevail in establishing the unpatentability of either claim 57 or claim 86 over Owens, Beckert, Cooper, and Berry.

3. Claims 58, 60, 63–65, and 88–91

Claims 58, 60, and 63–65 each depend directly or indirectly from claim 57. Claims 88–91 each depend directly from claim 86. The deficiencies of the Petition as discussed above with respect to claim 57 carry through to claims 58, 60, and 63–65, and the deficiencies of the Petition as discussed above with respect to claim 86 carry through to claims 88–91. Petitioner’s specific arguments directed to the limitations added by claims 58, 60, 63–65, and 88–91, relative to their base claims, do not cure the deficiencies of the arguments for independent claims 57 and 86. Thus, Petitioner has not shown a reasonable likelihood that it would prevail in establishing the unpatentability of any of claims 58, 60, 63–65, and 88–91 over Owens, Beckert, Cooper, and Berry.

4. Claims 92, 94, 97, and 98

Claim 92

Claim 92 recites: “an interface connected between the car stereo and the portable audio device, the interface including a microcontroller pre-programmed to execute.” In that regard, Petitioner states: “This claim limitation mirrors the ‘interface’-limitations of claim 1 and 57, and is described by Owens, Beckert, Cooper, and Berry, as discussed in detail in Section IV(A)(1)(iv) and IV(C)(1)(vi).” Pet. 54. The deficiencies of Petitioner’s accounting of the interface limitation of claims 1 and 57 have been discussed above in the context of claims 1 and 57. The same deficiencies apply to claim 92.

Claim 92 also recites three elements as follows:

first pre-programmed means for generating a device presence signal and transmitting the signal to the car stereo to maintain the car stereo in an operational state;

second pre-programmed means for remotely controlling the portable audio device using the car stereo by receiving a control command from the car stereo in a format incompatible with the portable audio device, processing the control command into a formatted control command compatible with the portable audio device, and transmitting the formatted control command to the portable audio device for execution thereby;

means for transmitting audio from the portable audio device to the car stereo.

Ex. 1001, 29:17–31. The sixth paragraph of 35 U.S.C. § 112 provides:¹

An element in a claim for a combination may be expressed as a means or step for performing a specified function without the recital of structure, material, or acts in support thereof, and such claim shall be construed to cover the corresponding structure, material, or acts described in the specification and equivalents thereof.

The above-quoted recitations of claim 92 presumptively set forth elements under 35 U.S.C. § 112 ¶ 6, and are construed to cover the corresponding structure, material, or acts described in the specification and equivalents thereof. See *Williamson v. Citrix Online, LLC*, 792 F.3d 1339, 1348 (Fed. Cir. 2015) (en banc); *In re Donaldson Co., Inc.*, 16 F.3d 1189, 1193 (Fed. Cir. 1994) (en banc).

Per 37 C.F.R. § 42.104(b)(3), the Petition must identify the structure, material, or acts described in the specification that correspond to each recited function. For a multitude of reasons discussed below, Petitioner has

¹ Paragraphs 1 through 6 of § 112 were renamed as paragraphs (a) through (f) when § 4(c) of the Leahy-Smith America Invents Act, Pub. L. No. 112–29, 125 Stat. 284, 329 (2011) (“AIA”) took effect on September 16, 2012. Because the patent application resulting in the ’786 patent was filed before the effective date of the AIA, we refer to the pre-AIA version of § 112.

not adequately identified corresponding structure in the Specification for these means-plus-function limitations of claim 92.

At the outset, and equally important, we determine that whatever Petitioner has identified as the corresponding structure, material, or acts for these means-plus-function limitations, Petitioner has failed to account for an expressly recited limitation pertaining to such elements. Specifically, claim 92 recites that the interface includes a microcontroller that is preprogrammed “to execute” each of the means-plus-function elements. Ex. 1001, 29:15–16. Petitioner has not explained, anywhere in the Petition, how a particular structure or its equivalent can be executed and how the applied prior art meets this “to execute” limitation. Petitioner has not addressed, or accounted for this requirement of the claim. This matter alone is sufficient to keep Petitioner from showing a reasonable likelihood that it would prevail in establishing the unpatentability of claim 92 over Owens, Beckert, Cooper, and Berry. Nonetheless, hereinafter, we discuss how Petitioner has not adequately identified corresponding structure, material, or acts in the Specification for these means-plus-function elements of claim 92.

First, Petitioner broke the “first pre-programmed means for generating a device presence signal and transmitting the signal to the car stereo to maintain the car stereo in an operational state” into two: (1) first pre-programmed means for generating a device presence signal; and (2) first pre-programmed means for transmitting the signal to the car stereo to maintain the car stereo in an operational state. Pet. 9. Petitioner has provided no justification for doing such division to create two separate means-plus-function elements and has essentially changed the claim.

Second, in identifying the corresponding disclosed structure for item (1), Petitioner identified “a microcontroller (U1) with hardware components such as resistors, diodes, capacitors, and oscillators.” *Id.* The identification, by using “such as” and without expressing how the components are connected, is insufficiently specific. No particular structural circuit arrangement is identified. Rather, Petitioner has identified common hardware components and noted that other hardware components are also covered. Petitioner further has not identified any disclosed algorithm for the microcontroller to perform the recited function. For a computer implemented means-plus-function element, the algorithm is a part of the corresponding structure. “In a means-plus-function claim in which the disclosed structure is a computer, or microprocessor, programmed to carry out an algorithm, the disclosed structure is not the general purpose computer, but rather the special purpose computer programmed to perform the disclosed algorithm.” *WMS Gaming, Inc. v. Int’l Game Tech.*, 184 F.3d 1339, 1349 (Fed. Cir. 1999). Although some exceptions may apply, *see In re Katz*, 639 F.3d 1303, 1316 (Fed. Cir. 2011), Petitioner has not explained the applicability of any exception.

Third, in identifying the corresponding disclosed structure for item (2), Petitioner identifies “the ‘resistors, diodes, capacitors, transistors, transformers, amplifiers, oscillator’ of FIG. 3B.” Pet. 9. Such identification is insufficiently specific. Petitioner has merely identified a bucket of common electrical components without indicating how these components are connected to each other to form a structure. Notably, Petitioner does not assert that the corresponding structure is the exact circuit shown in Figure 3B of the ’786 patent. In summary, a bucket of basic and common

electrical components does not adequately identify corresponding structure. Moreover, there is no Figure 3B in the '786 patent, only Figure 3B1 and Figure 3B2. Additionally, Petitioner has not identified any corresponding algorithm for implementing the recited function.

Fourth, Petitioner broke the “second pre-programmed means for remotely controlling the portable audio device using the car stereo by receiving a control command from the car stereo in a format incompatible with the portable audio device, processing the control command into a formatted control command compatible with the portable audio device, and transmitting the formatted control command to the portable audio device for execution thereby” into three: (3) means for remotely controlling the portable audio device using the car stereo, by receiving a control command from the car stereo in a format incompatible with the portable audio device; (4) means for remotely controlling the portable audio device using the car stereo by processing the control command into a formatted control command compatible with the portable audio device; and (5) means for remotely controlling the portable audio device using the car stereo by transmitting the formatted control command to the portable audio device for execution thereby. Pet. 9–10. Petitioner has provided no justification for doing such a division to create three separate means-plus-function elements, and has essentially changed the claim.

Fifth, in identifying the corresponding disclosed structure for item (3) noted above, Petitioner identifies a microcontroller “and a plurality of resistors (R1-R7), capacitors (C1-C2), and amplifier (A1).” *Id.* at 9. Petitioner does not indicate how many resistors, how many capacitors, or how the resistors, capacitors, and amplifier are connected to each other and

to the microcontroller to form a circuit structure capable of performing the recited function. No particular structural circuit arrangement is identified. Such a purported identification of corresponding structure is insufficiently specific. A multitude of different structures may be assembled from a plurality of resistors, capacitors, an amplifier, and a microcontroller. Additionally, Petitioner has not identified any corresponding disclosed algorithm for performing the recited function.

Sixth, in identifying the corresponding disclosed structure for item (4) above, Petitioner states: “the code or algorithm illustrated in Tables 1 and 2 of ‘786 Patent.” Pet. 10. Petitioner, however, has not identified any disclosed computer or processor that executes the identified code or algorithm. It is uncertain what Petitioner regards as such a computer or processor.

Seventh, in identifying the corresponding disclosed structure for item (5) above, Petitioner states:

circuit in Figure 3B ... having a plurality of resistors, diodes, capacitors, transistors, transformers, amplifiers, oscillator[s], among other structural components that provide the hardware framework, for the microcontroller to act as an interface in integrating an after-market device with a car stereo.

Id. We note that there is no Figure 3B in the '786 patent, only Figure 3B1 and Figure 3B2. It is also unclear what the “. . .” means in the above-quoted text. It is uncertain whether Petitioner has referred to the entirety of the schematics shown in Figure 3B1 and Figure 3B2, in combination. And if so, we are not sufficiently persuaded that the entirety of the circuit shown in Figure 3B1 and Figure 3B2 is the corresponding structure involved in transmitting formatted control command to the portable audio device.

With regard to means-plus-function limitations and what must be shown by Petitioner at trial, if trial is instituted, structure disclosed in the specification is corresponding structure only if the specification or prosecution history clearly links or associates that structure to the function recited in the claim. *Noah Sys., Inc. v. Intuit Inc.*, 675 F.3d 1302, 1311 (Fed. Cir. 2012); *Golight, Inc. v. Wal-Mart Stores, Inc.*, 355 F.3d 1327, 1334 (Fed. Cir. 2004); *Cardiac Pacemakers, Inc. v. St. Jude Med.*, 296 F.3d 1106, 1113 (Fed. Cir. 2002). Petitioner has not offered an explanation for the required linkage between the combined schematics of Figure 3B1 and Figure 3B2 and the recited function for the means-plus-function limitation at issue.

Eighth, claim 92 recites: “means for transmitting audio from the portable audio device to the car stereo.” With regard to identifying the corresponding structure for this means-plus-function limitation, Petitioner makes the same assertion as it presented for item (5) above. Pet. 10. The deficiencies of the assertion are the same as those discussed above with regard to item (5).

Claims 94, 97, and 98

Each of claims 94 and 97 depends from claim 92. Claim 98 depends from claim 97. The deficiencies of the Petition as discussed above with regard to claim 92 carry through to claims 94, 97, and 98 by way of their dependency on claim 92. Petitioner has not shown a reasonable likelihood that it would prevail in establishing the unpatentability of any of claims 94, 97, and 98 over Owens, Beckert, Cooper, and Berry.

E. Alleged Obviousness of Claims 61 and 62 over
Owens, Beckert, Cooper, Berry, and Ohmura

Claims 61 and 62 each depend from claim 60. The deficiencies of the Petition as discussed above with regard to claim 60 carry through to claims 61 and 62 by way of the dependency of claims 61 and 62 on claim 60. Petitioner has not shown a reasonable likelihood that it would prevail in establishing the unpatentability of either claim 61 or claim 62 over Owens, Beckert, Cooper, Berry, and Ohmura.

III. CONCLUSION

Petitioner has not demonstrated a reasonable likelihood that it would prevail in establishing the unpatentability of any of claims 1, 2, 4–8, 13, 14, 23, 24, 44, 47, 57, 58, 60–65, 86, 88–92, 94, 97, and 98 of the '786 patent.

IV. ORDER

It is

ORDERED that the Petition is *denied*, and no trial is instituted with respect to any claim of U.S. Patent No. 7,489,786 B2.

IPR2016-01448
Patent 7,489,786 B2

COUNSEL FOR PETITIONER:

Michael J. Lennon
Clifford A. Ulrich
mlennon@kenyon.com
culrich@kenyon.com

COUNSEL FOR PATENT OWNER:

Peter Lambrianakos
Vincent Rubino
Sharhar Harel
plambrianakos@brownrudnick.com
vrubino@brownrudnick.com
sharel@brownrudnick.com

UNITED STATES PATENT AND TRADEMARK OFFICE

BEFORE THE PATENT TRIAL AND APPEAL BOARD

TOYOTA MOTOR CORPORATION,
Petitioner,

v.

BLITZSAFE TEXAS, LLC,
Patent Owner.

Case IPR2015-00421
Patent 7,489,786 B2

Before JAMESON LEE, THOMAS L. GIANNETTI, and HUNG H. BUI,
Administrative Patent Judges.

LEE, *Administrative Patent Judge.*

DECISION
Institution of *Inter Partes* Review
37 C.F.R. § 42.108

I. INTRODUCTION

A. *Background*

On December 30, 2015, Petitioner filed a Corrected Petition (Paper 3, “Pet.”) to institute *inter partes* review of claims 1, 2, 4–8, 10, 13, 14, 23, 24, 44, 47, 57, 58, 60–65, 86, 88–92, 94, 97, and 98 of U.S. Patent No. 7,489,786 (Ex. 1101, “the ’786 patent”). On April 22, 2016, Patent Owner filed a Preliminary Response (Paper 10, “Prelim. Resp.”).

To institute an *inter partes* review, we must determine that the information presented in the Petition shows “that there is a reasonable likelihood that the petitioner would prevail with respect to at least 1 of the claims challenged in the petition.” 35 U.S.C. § 314(a). Having considered both the Petition and the Preliminary Response, we determine that Petitioner has demonstrated a reasonable likelihood that it would prevail in establishing the unpatentability of claims 44 and 47. Petitioner has not, however, shown a reasonable likelihood that it would prevail in establishing the unpatentability any other claim. We institute an *inter partes* review of claims 44 and 47 of the ’786 patent.

B. *Related Matters*

The parties indicate that the ’786 patent was asserted in five infringement actions before the United States District Court of the Eastern District of Texas and two infringement actions before the United States District Court for the District of New Jersey. Pet. 1–2, Paper 5, 1–2. The ’786 patent also is involved in IPR2016-00422. Related Patent 8,155,342 B2 is involved in IPR2016-00118, IPR2016-00418, and IPR2016-00419.

C. The '786 Patent

The '786 patent is titled "Audio Device Integration System." Ex. 1001 (54). "One or more after-market audio devices, such as a CD player, CD changer, MP3 player, satellite receiver, DAB receiver, or the like, is integrated for use with an existing OEM or after-market car stereo system, wherein control commands can be issued at the car stereo and responsive data from the audio device can be displayed on the stereo." *Id.* at Abstr. The '786 patent describes:

Control commands generated at the car stereo are received, processed, converted into a format recognizable by the audio device, and dispatched to the audio device for execution. Information from the audio device, including track, disc, song, station, time, and other information, is received, processed, converted into a format recognizable by the car stereo, and dispatched to the car stereo for display thereon.

Id. Additional auxiliary sources also may be integrated together, and "a user can select between the [audio] device or the one or more auxiliary input sources by issuing selection commands through the car stereo." *Id.* A docking station for docking a portable audio or video device for integration with the car stereo. *Id.* Figures 2A–2C are reproduced below:

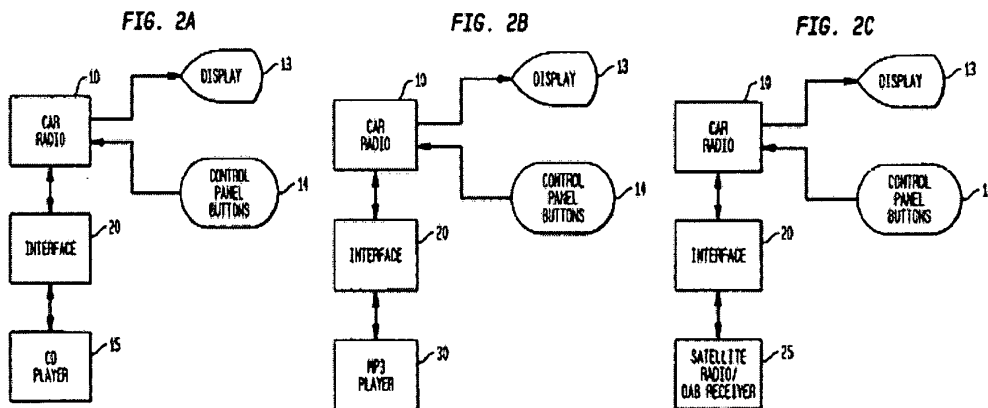

Figure 2A illustrates an embodiment integrating a CD player with the car stereo; Figure 2B illustrates an embodiment integrating a MP3 player with a car stereo; and Figure 2C illustrates an embodiment integrating a satellite or DAB receiver with a car stereo. *Id.* at 3:14–23. A more versatile embodiment is shown in Figure 1:

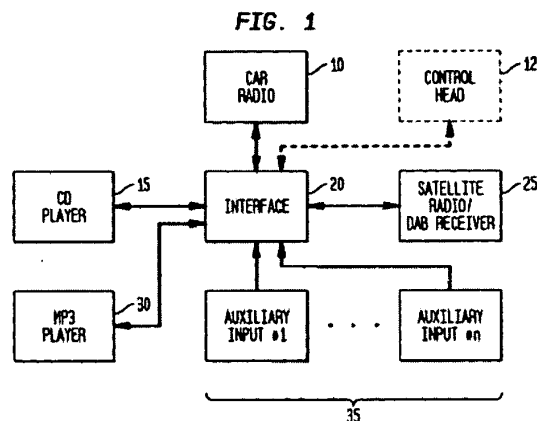

Figure 1 illustrates an embodiment integrating a CD player, a MP3 player, a satellite radio or DAB receiver, and a number of auxiliary input sources with a car stereo. *Id.* at 3:12–13. As shown in the above Figures, central to the '786 patent is an “interface” positioned between the car stereo and the audio device(s) and auxiliary input(s) being integrated.

With regard to Figure 2B, the '786 patent describes:

The interface 20 allows data and audio signals to be exchanged between the MP3 player 30 and the car radio 10, and processes and formats signals accordingly so that instructions and data from the radio 10 are processable by the MP3 player 30, and vice versa. Operational commands, such as track selection, pause, play, stop, fast forward, rewind, and other commands, are entered via the control panel buttons 14 of car radio 10, processed by the interface 20, and formatted for execution by the MP3 player 30. Data from the MP3 player, such as track, time, and song information, is received by the interface 20, processed thereby, and sent to the radio 10 for display on display 13. Audio from

MP3 player 30 is selectively forwarded by the interface 20 to the radio 10 for playing.

Id. at 6:11–24. Similar description is provided with respect to Figures 2A and 2C. *Id.* at 5:49–55, 6:35–43.

Claims 1, 44, 57, 86, and 92 are independent. Claim 1 is directed to a system that connects an after-market audio device as well as one or more auxiliary input sources to a car stereo. In particular, claim 1 recites a first connector electrically connectable to a car stereo, a second connector electrically connectable to an after-market device, and a third connector electrically connectable to one or more auxiliary input sources. *Id.* at 21:33–38. Claim 1 also recites an interface connected between the first and second electrical connectors, and that the interface includes a microcontroller pre-programmed to execute:

- a first pre-programmed code portion for remotely controlling the after-market audio device using the car stereo by receiving a control command from the car stereo through said first connector in a format incompatible with the after-market audio device, processing the received control command into a formatted command compatible with the after-market audio device, and transmitting the formatted command to the after-market audio device through said second connector for execution by the after-market audio device;
- a second pre-programmed code portion for receiving data from the after-market audio device through said second connector in a format incompatible with the car stereo, processing the received data into formatted data compatible with the car stereo, and transmitting the formatted data to the car stereo through said first connector for display by the car stereo; and
- a third pre-programmed code portion for switching to one or more auxiliary input sources connected to said third electrical connector.

Id. at 21:44–64.

Claim 57 is directed to a system including an interface that connects a portable MP3 player to a car stereo. Claim 86 is directed to a system including an interface that connects an after-market video device to a car stereo. Claim 92 is directed to a system including an interface that connects a portable audio device with a car stereo. Claims 57, 86, and 92 each require the generation, within an interface, of a device presence signal that is transmitted to the car stereo to maintain the car stereo in an operational state. Claims 57, 86, and 92 are reproduced below:

57. An audio device integration system comprising:
- a first electrical connector connectable to a car stereo;
 - a second electrical connector connectable to a portable MP3 player external to the car stereo
 - an interface connected between said first and second electrical connectors for transmitting audio from a portable MP3 player to a car stereo, said interface including a microcontroller in electrical communication with said first and second electrical connectors,
- said microcontroller pre-programmed to execute:
- a first pre-programmed code portion for generating a device presence signal and transmitting the signal to the car stereo to maintain the car stereo in an operational state; and
 - a second pre-programmed code portion for remotely controlling the MP3 player using the car stereo by receiving a control command from the car stereo through said first electrical connector in a format incompatible with the MP3 player, processing the control command into a formatted control command compatible with the MP3 player, and transmitting the formatted control command to the MP3 player through said second electrical connector for execution by the MP3 player.

Id. at 26:13–37.

86. A device for integrating video information for use with a car stereo, comprising:

- a first electrical connector connectable to a car stereo;
- a second electrical connector connectable to an after-market video device external to the car stereo;
- an interface connected between said first and second electrical connectors for transmitting video information from the after-market video device to the car stereo, the interface including a microcontroller in electrical communication with said first and second electrical connectors, said microcontroller pre-programmed to execute:
 - a first pre-programmed code portion for generating a device presence signal and transmitting the signal to the car stereo through said first electrical connector to maintain the car stereo in an operational state responsive to signals generated by the after-market video device.

Id. 28:40–56.

92. An audio device integration system comprising:

- a car stereo;
- a portable audio device external to the car stereo;
- an interface connected between the car stereo and the portable audio device, the interface including a microcontroller pre-programmed to execute:
 - first pre-programmed means for generating a device presence signal and transmitting the signal to the car stereo to maintain the car stereo in an operational state;
 - second pre-programmed means for remotely controlling the portable audio device using the car stereo by receiving a control command from the car stereo in a format incompatible with the portable audio device, processing the control command into a formatted control command compatible with the portable audio device, and

transmitting the formatted control command to the portable audio device for execution thereby; and means for transmitting audio from the portable audio device to the car stereo.

Id. at 29:11–31.

Claim 44 is directed to an apparatus for docking a portable device for integration with a car stereo. We reproduce claim 44 in the portion of our analysis below specifically discussing claim 44.

D. Evidence Relied Upon

Petitioner relies on the following references:¹

Reference		Date	Exhibit
Lau	International Pub. No. WO 01/67266 A1	Sept. 13, 2001	Ex. 1103
JP '954 ²	Jap. Pub. App. No. H7–6954	Jan. 31, 1995	Ex. 1106
XR-C5120	SONY® 3-865-814-11(1) Operating Instructions, Model No. XR-C5120 /1890	1999	Ex. 1108
XA-C30	SONY® 9-923-535-11 Source Selector Service Manual XA-C30	March, 1996	Ex. 1109
Bhogal	U.S. Patent No. 6,629,197 B1	Sept. 30, 2003	Ex. 1110

¹ For certain alleged grounds of unpatentability, Petitioner also relies on what it refers to as “known bus technology.” Hereinafter, we refer to that material as “KBT.” We understand Petitioner to have presented KBT as common knowledge and routine skill within the level of ordinary skill in the art that does not require citation of any particular reference.

² All citations to specific content of JP'954 refer to its English Translation (Ex. 1107).

Petitioner also relies on the Declaration of Thomas G. Matheson, Ph.D. Ex. 1115.

E. The Asserted Grounds

Petitioner asserts the following grounds of unpatentability:

Claim(s) Challenged	Basis	References
57, 58, 60, 64, 86, 88, 90, 91, 92, 94, and 97	§ 103(a)	JP '954 and Lau
61, 62, and 63	§ 103(a)	JP '954, Lau, and XR-C5120
65, 89, and 98	§ 103(a)	JP '954, Lau, and KBT
1, 2, 4, 7, 8, 13, 14, and 23	§ 103(a)	JP '954, XR-C5120, and XA-C30
5 and 24	§ 103(a)	JP '954, XR-C5120, XA-C30, and KBT
6 and 10	§ 103(a)	JP '954, XR-C5120, XA-C30, and Lau
44 and 47	§ 103(a)	JP '954, Lau, and Bhogal
57, 86, and 92	§ 103(a)	JP '954, Lau, and Bhogal ³

II. ANALYSIS

The question of obviousness is resolved on the basis of underlying factual determinations including: (1) the scope and content of the prior art;

³ Petitioner identifies this alleged ground of unpatentability simply as “obvious in view of Bhogal.” Pet. 57. However, a plain reading of Petitioner’s analysis on pages 57–59 of the Petition reveals that the alleged ground actually is that of obviousness over JP '954, Lau, and Bhogal. Also, although Petitioner labels this ground as directed to claims 57 and 86, a plain reading of the Petitioner’s analysis reveals that it is intended to apply to claims 57 and 92. We have restated the applicable claims as 57, 86, and 92.

(2) any differences between the claimed subject matter and the prior art; (3) the level of ordinary skill in the art; and (4) objective evidence of nonobviousness. *Graham v. John Deere Co.*, 383 U.S. 1, 17–18 (1966).

One seeking to establish obviousness based on more than one reference also must articulate sufficient reasoning with rational underpinnings to combine teachings. *See KSR Int'l Co. v. Teleflex, Inc.*, 550 U.S. 398, 418 (2007).

With regard to the level of ordinary skill in the art, we determine that no express finding is necessary, on this record, and that the level of ordinary skill in the art is reflected by the prior art of record. *See Okajima v. Bourdeau*, 261 F.3d 1350, 1355 (Fed. Cir. 2001); *In re GPAC Inc.*, 57 F.3d 1573, 1579 (Fed. Cir. 1995); *In re Oelrich*, 579 F.2d 86, 91 (CCPA 1978).

A. Claim Construction

In an *inter partes* review, claim terms in an unexpired patent are interpreted according to their broadest reasonable construction in light of the specification of the patent in which they appear. *See* 37 C.F.R. § 42.100(b); *Cuozzo Speed Techs., LLC v. Lee*, No. 15–446, 2016 WL 3369425, at *12 (U.S. June 20, 2016) (upholding the use of the broadest reasonable interpretation standard as the claim construction standard to be applied in an *inter partes* review proceeding). Consistent with the rule of broadest reasonable interpretation, claim terms also are given their ordinary and customary meaning, as would be understood by one of ordinary skill in the art in the context of the entire disclosure. *See In re Translogic Tech., Inc.*, 504 F.3d 1249, 1257 (Fed. Cir. 2007).

“Claims are not interpreted in a vacuum, but are part of and are read in light of the specification.” *Slimfold Mfg. Co. v. Kinkead Indus., Inc.*, 810 F.2d 1113, 1116 (Fed. Cir. 1987). Although it is improper to read a

IPR2016-00421
Patent 7,489,786 B2

limitation from the specification into the claims, *In re Van Geuns*, 988 F.2d 1181, 1184 (Fed. Cir. 1993), the claims still must be read in view of the specification of which they are a part. *Microsoft Corp. v. Multi-Tech Sys., Inc.*, 357 F.3d 1340, 1347 (Fed. Cir. 2004).

If a limitation of an embodiment described in the specification is not necessary to give meaning to a claim term, it would be “extraneous” and should not be read into the claim. *See Hoganas AB v. Dresser Indus., Inc.*, 9 F.3d 948, 950 (Fed. Cir. 1993); *E.I. du Pont de Nemours & Co. v. Phillips Petroleum Co.*, 849 F.2d 1430, 1433 (Fed. Cir. 1988). If the applicants for a patent desire to be their own lexicographer, the purported definition must be set forth in either the specification or prosecution history. *See CCS Fitness, Inc. v. Brunswick Corp.*, 288 F.3d 1359, 1366 (Fed. Cir. 2002). Such a definition must be set forth with reasonable clarity, deliberateness, and precision. *See Renishaw PLC v. Marposs Societa' per Azioni*, 158 F.3d 1243, 1249 (Fed. Cir. 1998); *In re Paulsen*, 30 F.3d 1475, 1480 (Fed. Cir. 1994). However, only terms which are in controversy need to be construed, and only to the extent necessary to resolve the controversy. *See Wellman, Inc. v. Eastman Chem. Co.*, 642 F.3d 1355, 1361 (Fed. Cir. 2011); *Vivid Techs., Inc. v. Am. Sci. & Eng'g, Inc.*, 200 F.3d 795, 803 (Fed. Cir. 1999).

I. “portable”

Independent claim 44 recites a portable device. Independent claim 57 recites a portable MP3 player. Independent claim 92 recites a portable audio device. Petitioner proposes that the term “portable” be construed the way it has been construed by the district court in related actions involving the '786 patent, i.e., “capable of being moved about.” Pet. 13–14 (citing Ex. 1112). Patent Owner argues that Petitioner’s proposed construction is unreasonably

broad because it “improperly broadens the plain meaning of the term to include anything which can be moved, no matter how large or unwieldy.” Prelim. Resp. 9. Patent Owner asserts that one with ordinary skill in the art could readily understand the plain meaning of the term “portable,” and that no further construction is necessary. *Id.*

We agree with Patent Owner that Petitioner’s proposed construction is unreasonably broad. In the Specification of the ’786 patent, the term “portable” is used to modify devices that can be integrated with a car stereo through an interface. In that context, not every device that is capable of being moved is reasonably deemed portable. Few items, if any, simply cannot be moved, given appropriate tools and persistent effort. Thus, the term must be read in context within its application environment. In that regard, we note that certain objects, although heavy and large, may be deemed portable, such as freight containers and emergency generators.

It may be that the term requires no express construction, and simply would be understood by one with ordinary skill in the art. We note that even the ’786 patent itself and Bhogal, both using the term “portable” in their written description, do not provide a definition therefor. Nevertheless, an express construction is helpful to this proceeding. We construe “portable,” in the context of the ’786 patent, as meaning *capable of being carried by a user*.

2. “interface”

Of all challenged claims, claims 1, 44, 57, 86, and 92 are independent, and each recites an “interface.”

Claims 1, 57, and 86 require the interface to be connected between a first electrical connector and a second electrical connector, where the first

connector is connectable to a car stereo and the second connector is connectable to an after-market audio device (claim 1), a portable MP3 player (claim 57), or an after-market video device (claim 86). Claim 92 requires the interface to be connected between the car stereo and a portable audio device. Claim 44 recites a docking portion that mates with a portable device, and an interface that is connected to the car stereo as well as to a data port that communicates with the docking portion.

Also, claim 57 recites that the interface is “for transmitting audio from a portable MP3 player to a car stereo”; claim 86 recites that the interface is “for transmitting video information from the after-market video device to the car stereo”; claim 1 recites that the interface is “for channeling audio signals to the car stereo from the after-market audio device”; claim 44 recites an interface for “channeling audio from the portable device to the car stereo”; and claim 92 recites that the interface includes a microcontroller pre-programmed to execute “means for transmitting audio from the portable audio device to the car stereo.”

Petitioner proposes the proper construction of “interface” is “a microcontroller that is functionally and structurally separate component from the car stereo, which integrates an after-market device with a car stereo,” and notes that that is the construction determined by the district court in related actions involving the ’786 patent. Pet. 12–14. For several reasons, the proposal is unpersuasive. First, as is noted by Patent Owner, even if the interface is deemed “functionally and structurally separate” from the car stereo, the proposed construction is incomplete in that it omits any requirement of separation or distinctness of the interface from the portable or after-market device connected thereto. Prelim. Resp. 8–9. Second, the

proposed construction is too narrow by specifying that the interface “integrates an after-market device with a car stereo.” We note that the Specification of the ’786 patent provides a special definition for “integration” or “integrated.” Ex. 1101, 4:47–52. We discern no reason to import limitations into a claim if they are unnecessary to accord meaning to the claim.

Third, the proposed construction is too narrow by requiring the interface to be a microcontroller. In the Specification of the ’786 patent, the term “interface” is described as including not only a microcontroller but also several discrete components, such as resistors, diodes, capacitors, transistors, oscillators, amplifiers, and multiplexers, shown in various embodiments of Figures 3A, 3B1–3B2, 3C1–3C2, and 3D. Ex. 1101, 9:8–20, 10:19–33, 11:4–18, 11:59–67. Thus, the term “interface” itself is not limited to a microcontroller. In that regard, we note that if the interface itself is construed as a microcontroller, as Petitioner proposes, then the additional claim language reciting that the interface includes a microcontroller would serve no meaningful purpose.

With regard to an “interface,” the Specification states:

Thus, as can be readily appreciated, the interface 20 of the present invention allows for the integration of a multitude of devices and inputs with an OEM or after-market car radio or stereo.

Ex. 1101, 5:33–36.

As mentioned earlier, the interface 20 of the present invention allows for a plurality of disparate audio devices to be integrated with an existing car radio for use therewith.

Id. at 6:4–7.

Data from the MP3 player, such as track, time, and song information, is received by the interface 20, processed thereby, and sent to the radio 10 for displaying on display 13. Audio from the MP3 player 30 is selectively forwarded by the interface 20 to the radio 10 for playing.

Id. at 6:19–24. Thus, the Specification refers to the interface receiving information from an audio device and forwarding information to the car stereo, and to the interface allowing integration of a plurality of disparate audio devices with a car radio.

During prosecution, the Applicants of the '786 patent distinguished U.S. Patent 6,993,615 B2 (“Falcon”),⁴ in part by arguing that the reference failed to disclose an interface connected between a car stereo and an external audio source. Ex. 1102, 0267. Specifically, in distinguishing the invention from Falcon, Applicants stated: “[Falcon’s graphical user interface] is an entirely different concept than the interface of the present invention, which includes a physical interface device connected between a car stereo system and an external audio source (e.g., a plurality of auxiliary input sources).”

Id.

Construing the term “interface” in light of the Specification, other language in the claims, as well as the prosecution history noted by Petitioner, we determine that—*interface is a physical unit that connects one device to another and that has a functional and structural identity separate from that of both connected devices.*

⁴ Falcon discloses a portable computing device connectable to a car stereo through an interface configurable within the portable computing device. Ex. 3001, Abstr.

In the specific context of claims 1 and 86, the connected devices are the car stereo and an after-market device. In the specific context of claims 44, 57, and 92, the connected devices are the car stereo and a portable device. Each of claims 1, 44, 57, 86, and 92 further requires the interface to include a microcontroller.

3. “*device presence signal*”

Each of claims 57 and 86 requires within the interface a microcontroller having a first pre-programmed code portion “for generating a *device presence signal* and transmitting the signal to the car stereo to maintain the car stereo in an operational state.” (Emphasis added). Claim 92 requires within the interface a microcontroller pre-programmed to execute “first pre-programmed means for generating a *device presence signal* and transmitting the signal to the car stereo to maintain the car stereo in an operational state.” (Emphasis added). A description of “device presence signal” is contained in the Specification in the discussion of an embodiment that is for connecting a CD player to the car stereo:

Beginning in step 110, a signal is generated by the present invention indicating that a CD player/changer is present, and the signal is continuously transmitted to the car stereo. Importantly, this signal prevents the car stereo from shutting off, entering a sleep mode, or otherwise being unresponsive to signals and/or data from an external source.

Ex. 1001, 12:29–35. All other disclosed embodiments, whether they are for connecting an MP3 player or an auxiliary device to the car stereo, refer back to the above-quoted description of the device presence signal. *Id.* at 13:15–18, 13:62–65, 14:48–51, 15:35–38, 16:12–15, 16:57–60.

Petitioner proposes that the term “device presence signal” be construed the way it has been construed by the district court in related

actions involving the '786 patent, i.e., “transmission of a continuous signal indicating an audio device is present.” Pet. 13 (citing Ex. 1112). Patent Owner has not proposed a construction. For two reasons, we do not adopt Petitioner’s proposed construction.

First, the proposed construction is too narrow because continuous transmission is not necessary to accord meaning to the term. The manner of transmission simply reflects how the signal is transmitted and does not change what the signal was generated and intended to accomplish and actually accomplishes. The Specification also does not put continuous transmission in the same category of importance as the requirements in the italicized portion of the above-quoted text.

Second, in claims 57 and 86, the device presence signal is generated and transmitted by the interface that is connected between the first and second electrical connector, where the first electrical connector is connectable to a car stereo and the second electrical connector is connectable to a portable MP3 player (claim 57) or an after-market video device (claim 86). Claim 57 recites that the interface is for transmitting audio from the portable MP3 player to the car stereo, and claim 86 recites that the interface is for transmitting video information from the after-market video device to the car stereo. In claim 92, the device presence signal is generated and transmitted by the interface that is connected between the car stereo and the portable audio device. Claim 92 further includes, within the interface, a means for transmitting audio from the portable audio device to the car stereo. In the context of these claims, the device the presence of which is signaled by the interface is that device which connects to the interface to

communicate with the car stereo. Petitioner's proposed construction does not make that clear.

On the record before us, we construe "device presence signal," as *a signal indicating that an audio device (claim 57) or video device (claim 86) or portable audio device (claim 92), other than the car stereo, is connected to the interface.*

B. Alleged Obviousness of Claims 57, 58, 60, 64, 86, 88, 90, 91, 92, 94, and 97 over JP '954 and Lau

We have reviewed the Petition and the Preliminary Response, and determine that Petitioner has not shown a reasonable likelihood that it would prevail in establishing unpatentability of claims 57, 58, 60, 64, 86, 88, 90, 91, 92, 94, and 97 as obvious over JP '954 and Lau.

1 .JP '954

JP '954 is directed to solving the problem of equipment incompatibility, in the environment of automotive audio equipment, between a main unit made by one company and a CD changer made by another company. Ex. 1101, Abstr. Specifically, JP '954 describes the disadvantages associated with prior art systems as follows:

When installing an audio device in a vehicle on the occasion of a vehicle purchase, it is common for a so-called "basic" main unit to be installed. If one were to subsequently attempt to add a CD changer capable of automatically changing and playing a plurality of loaded CDs, prior to now it would have been necessary to purchase and install a model produced by the same manufacturer as the "basic" main unit, as the format of signals connecting the respective devices vary from manufacturer to manufacturer. Furthermore, if a user had installed both of these devices produced by the same manufacturer, and at a later point wished to upgrade the main unit to, for example, a model produced by company A, it would have been necessary for the

same reason to also purchase a new CD changer made by company A.

Id. (0002). JP '954 describes its objective as: “to make it possible to add a CD changer made by company B to a main unit made by company A, as well as to add a CD changer made by company A to a main unit made by company B.” *Id.* (0003). JP '954 achieves that objective by providing an interface unit as noted below:

(PROBLEM) Provide an interface unit for automotive audio equipment that renders possible the addition of a CD changer made by company B to a main unit made by company A as well as the addition of a CD changer made by company A to a main unit made by company B.

Id. Abstr. JP '954 summarizes its interface unit as follows:

(MEANS FOR SOLVING) The [interface] unit is constituted by splitting signals into three systems, namely a control system, audio system and power system, and providing a conversion circuit for each of these systems.

Id. Figure 1 of JP '954 is reproduced below:

(Fig. 1)

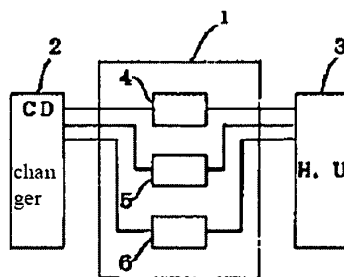

Figure 1 illustrates a block diagram of the structure of the audio system according to JP '954. *Id.* (0006). Interface unit 1 “converts the format of the signal that links the CD changer 2 and the main unit 3, etc.” *Id.*

Interface unit 1 links main unit 3 and CD changer 2, and is provided with control system conversion portion 4, audio system conversion portion 5, and power conversion portion 6. *Id.* at Abstr. Control conversion portion 4 is for the bus line, clock control signal, etc.; audio conversion portion 5 is for the audio signal; and power conversion portion 6 is for the power supply. *Id.* (0006).

Figure 2 of JP '954 is reproduced below:

(Fig. 2)

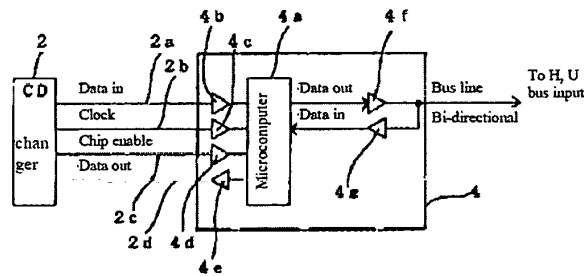

Figure 2 illustrates control system conversion portion 4. *Id.* (0007).

Microcomputer 4a is provided to convert and unify different signal formats between the CD changer and the main unit. *Id.*

Figure 4 is reproduced below:

(Fig. 4)

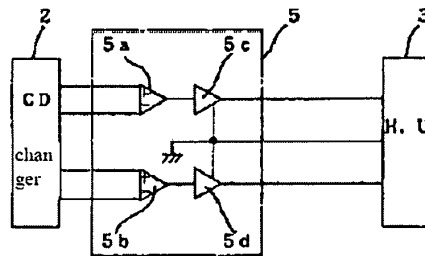

Figure 4 illustrates audio system conversion portion 5. *Id.* (0011). It includes differential amplifiers 5a and 5b and amplifiers 5c and 5d. *Id.*

JP '954 states: “[a]lthough one embodiment example was described above, to expand the range of available inter-company format conversions, a switch can be provided on the microcomputer 4a to enable application to various models using a connection adapter between the CD changer and main unit. *Id.* (0010).

2. *Lau*

Lau is titled “Vehicle Sound System,” and states that “there is a need for an improved automobile audio system that does not require cassettes or compact discs, can be used with reusable media and can play music downloaded from a computer or other device.” Ex. 1103 (54), 2:24–26. *Lau* indicates that pre-existing portable solid state music players that store music downloadable from a computer are unsatisfactory for use with an automobile stereo. *Id.* at 3:1–11. For instance, it is explained that all of the controls are on the portable player, and thus, a driver is unable to use the controls of the car stereo to control the music player. *Id.* at 3:12–16.

Figure 1 of *Lau* is reproduced below:

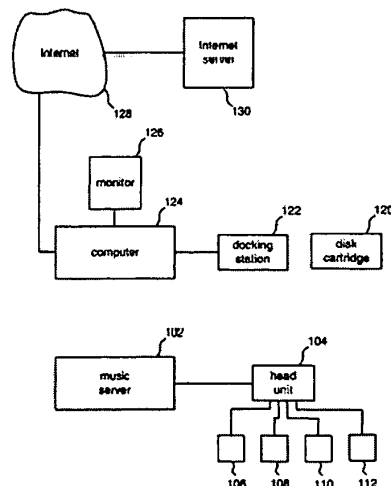

Fig. 1

Figure 1 illustrates an embodiment of Lau's vehicle sound system. *Id.* at 5:18. Head unit 104 is a standard automobile head unit and is connected to speakers 106, 108, 110, and 112. *Id.* at 7:17–20. Music server 102 is an audio/visual server and emulates a disc changer. *Id.* at 7:12–14. Lau explains that music server 102 is not an actual disc changer but only acts like a disc changer would act, based on communications to and from the unit. *Id.* at 7:14–17. Music server 102 communicates with head unit 102. *Id.* at 7:19. Lau describes that music server 102 may be mounted in the trunk of a car and head unit 104 is mounted in the dash board. *Id.* at 8:21–24.

Disk cartridge 120 can be inserted by a user either into music server 102 or docking station 122 connected to computer 124. *Id.* at 8:16–21. Computer 124 is a standard personal computer and is connected to Internet 128. *Id.* at 8:4–11. Internet server 130 is available through the Internet for downloading tracks and information about tracks, and in one embodiment, tracks are songs. *Id.* at 8:11–15. After a user downloads tracks onto disk cartridge 120, the cartridge is removed from docking station 122 and inserted into music server 102, and then the user can use head unit 104 to access and play tracks on the cartridge. *Id.* at 8:20–26.

3. *Claims 92, 94, and 97*

Claim 92, as reproduced above, includes several elements in the format of a “means”:

- first pre-programmed means for generating a device presence signal and transmitting the signal to the car stereo to maintain the car stereo in an operational state;
- second pre-programmed means for remotely controlling the portable audio device using the car stereo by receiving a control command from the car stereo in a format incompatible with the portable audio device, processing the control

command into a formatted control command compatible with the portable audio device, and transmitting the formatted control command to the portable audio device for execution thereby; and

means for transmitting audio from the portable audio device to the car stereo.

Claim 94 depends from claim 92 and claim 97 depends from claim 94.

Paragraph 6 of 35 U.S.C. § 112 states:⁵

An element in a claim for a combination may be expressed as a means or step for performing a specified function without the recital of structure, material, or acts in support thereof, and such claim shall be construed to cover the corresponding structure, material, or acts described in the specification and equivalents thereof.

The above-quoted recitations of claim 92 presumptively set forth elements under 35 U.S.C. § 112, ¶ 6, and are construed to cover the corresponding structure, material, or acts described in the specification and equivalents thereof. *Williamson v. Citrix Online, LLC*, 792 F.3d 1339, 1348 (Fed. Cir. 2015) (en banc).

The Board's trial rules require the Petition to identify the corresponding structure, material, or acts corresponding to each claimed function. Specifically, 37 C.F.R. § 42.104(b)(3) governs the content of a petition with respect to claim construction and provides: "[w]here the claim to be construed contains a means-plus-function or step-plus-function limitation as permitted under 35 U.S.C. § 112 [¶ 6], the construction of the

⁵ Paragraphs 1 through 6 of § 112 were renamed as paragraphs (a) through (f) when § 4(c) of the Leahy-Smith America Invents Act, Pub. L. No. 112-29, 125 Stat. 284, 329 (2011) ("AIA") took effect on September 16, 2012. Because the patent application resulting in the '786 patent was filed before the effective date of the AIA, we refer to the pre-AIA version of § 112.

claim must identify the specific portions of the specification that describe the structure, material, or acts corresponding to each claimed function.”⁶

37 C.F.R. § 42.104(b)(3).

The “construction” referred to by 37 C.F.R. § 42.104(b)(3) is the construction proposed by the Petitioner, one that Petitioner believes is the correct construction under applicable law and should apply in the involved proceeding. Here, Petitioner did not comply with 37 C.F.R. § 42.104(b)(3).

For each means-plus-function recitation in claim 92, Petitioner provided the construction of the United States District Court for the District of New Jersey. Pet. 15–19. However, Petitioner does not take ownership of the district court’s constructions by indicating, in some way, that it agrees with, proposes, or adopts the construction of this district court. Indeed, for two means-plus-function elements, i.e., (1) first pre-programmed means for generating a device presence signal (“generating means”), and (2) first pre-programmed means for . . . transmitting the [device presence] signal to the car stereo to maintain the car stereo in an operational state (“transmitting means”), Petitioner asserts that the district court’s constructions are incorrect. Pet. 16–17. For the transmitting means, Petitioner does offer its own construction as is required by 37 C.F.R. § 42.104(b)(3). Pet. 17. But for the generating means, Petitioner does not offer its construction by identifying corresponding structure, material, or acts in the Specification. Instead, for the transmitting means, Petitioner asserts that there is no

⁶ Structure disclosed in the specification is corresponding structure only if the specification or prosecution history clearly links or associates that structure to the function recited in the claim. *Golight, Inc. v. Wal-Mart Stores, Inc.*, 355 F.3d 1327, 1334 (Fed. Cir. 2004); *Cardiac Pacemakers, Inc. v. St. Jude Med.*, 296 F.3d 1106, 1113 (Fed. Cir. 2002).

corresponding structure, material, or acts in the Specification of the '786 patent, and characterizes the means-plus-function element as indefinite. Pet. 15.

Without expressly identifying a ground of unpatentability based on indefiniteness under 35 U.S.C. § 112, ¶ 2, Petitioner nonetheless has mounted, effectively, a challenge of claims 92, 94, and 97 as indefinite under 35 U.S.C. § 112, ¶ 2. We note that if there is no corresponding structure, material, or acts in the specification for a means-plus-function claim element, the claim is indefinite under 35 U.S.C. § 112, ¶ 2. *See In re Dossel*, 115 F.3d 942, 946 (Fed. Cir. 1997). Except for a narrow exception explained in *In re Katz*, 639 F.3d 1303, 1316 (Fed. Cir. 2011), concerning generic functions performed by a general purpose computer, such as “processing,” “receiving” and “storing,” a computer-implemented means-plus-function element is indefinite unless the specification discloses the specific algorithm used by the computer to perform the recited function. *Eon Corp. IP Holdings LLC v. AT&T Mobility LLC*, 785 F.3d 616, 621–23 (Fed. Cir. 2015); *Function Media, LLC v. Google, Inc.*, 708 F.3d 1310, 1318 (Fed. Cir. 2013); *Blackboard, Inc. v. Desire2Learn, Inc.*, 574 F.3d 1371, 1385 (Fed. Cir. 2009); *Net MoneyIN, Inc. v. Verisign, Inc.*, 545 F.3d 1359 (Fed. Cir. 2008); *Finisar Corp. v. DirectTV Group, Inc.*, 523 F.3d 1323, 1340 (Fed. Cir. 2008); *Aristocrat Technologies Australia Pty Ltd. v. Int'l Game Tech.*, 521 F.3d 1328 (Fed. Cir. 2008). Petitioner may not, however, in an *inter partes* review, assert a ground of unpatentability based on indefiniteness under 35 U.S.C. § 112, ¶ 2. *See* 35 U.S.C. § 311(b).

In any event, with regard to alleged obviousness of claims over prior art, because Petitioner has not identified structure, material, and acts in the

Specification of the '786 patent that correspond to the generating means of claim 92. Therefore, Petitioner has not accounted for how such unidentified structure, material, and acts would have been met by the prior art.

Accordingly, we determine that Petitioner has not shown a reasonable likelihood that it would prevail in establishing unpatentability of claims 92, 94, and 97 as obvious over JP '954 and Lau.

4. *Claims 57 and 86*

Each of claims 57 and 86 requires the microcontroller within the interface to execute a first pre-programmed code portion “for generating a device presence signal and transmitting the signal to the car stereo.” We have construed “device presence signal” as *a signal indicating that an audio device (claim 57) or video device (claim 86) or portable audio device (claim 92), other than the car stereo, is connected to the interface.*

Petitioner identifies head unit 3 in Figure 1 of JP '954 as the car stereo recited in claims 57 and 86, interface unit 1 in Figure 1 of JP '954 as the interface recited in claims 57 and 86, and microcomputer 4a in Figure 2 of JP '954 as the microcontroller recited in claims 57 and 86. Pet. 20, 26, 29. However, Petitioner does not contend that microcomputer 4a of JP '954 generates a device presence signal, much less transmit such a signal to the head unit. Instead, Petitioner identifies Lau as providing an interface including a microcontroller that generates a device presence signal and sends it to a car stereo, and asserts that in light of Lau's disclosure, it would have been obvious to one with ordinary skill in the art to do the same with the microcontroller of JP '954. Pet. 22–24. For reasons discussed below, we are not sufficiently persuaded that Lau discloses generation of a “device presence signal” within what Petitioner regards as the “interface” in Lau or

transmission of such a “device presence signal” to a car stereo.

Lau’s music server 102 is not the same kind of device as interface unit 1 of JP ’954. In Lau, what Petitioner regards as the portable MP3 device of claim 57 and the after-market video device of claim 86 is processor 302 (Pet. 26), and it is located in music server 102 and part and parcel with controller 320 which Petitioner regards as the interface (Pet. 26). Processor 302, as the purported portable or after-market device, is not just “connectable” to the interface through a connector as is recited in claims 57 and 86. Rather, it is always connected to controller 320. Ex. 1103, 21:18–22:4. This fixed configuration is illustrated in Lau’s Figure 6:

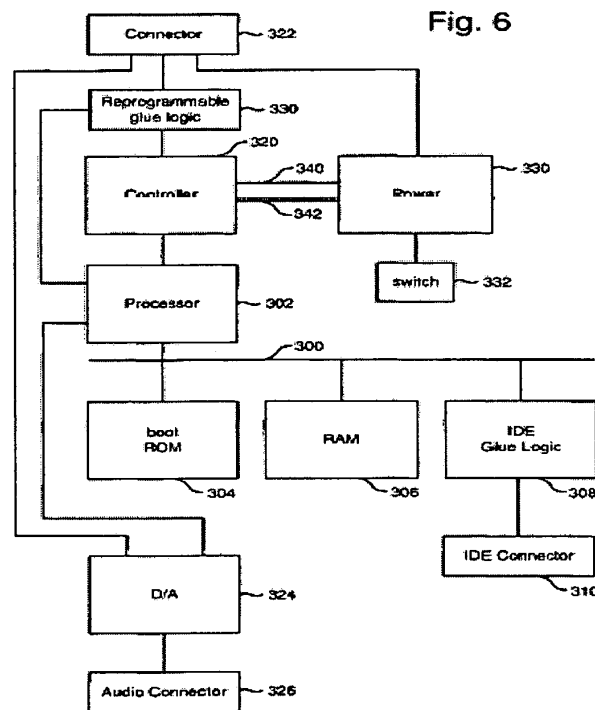

Figure 6 is a block diagram of one embodiment of the components within music server 102 shown in Figure 1. Ex. 1103, 5:23–24. Controller 320’s generating a signal to convey to a car stereo that processor 302 is connected

to it has little meaning, if any, and Petitioner has not sufficiently shown that that task is performed in Lau.

Petitioner explains that in Lau, it is disclosed that if music server 102 is connected to a car stereo that is Sony Model XR-C5120, then certain signals are required for normal operation, citing the testimony of Dr. Matheson (Ex. 1115 ¶¶ 89–90). Pet. 22–23. Petitioner further explains:

Lau teaches that controller 320 is programmed to perform a state machine in order to emulate a CD changer connected to a particular type of head unit (e.g., Sony Model XR-C 5120). In the “dormant state” when the music server is not in a “play state,” controller 320 is programmed to respond to packets sent by head unit 104 with corresponding response packets (*i.e.*, packet 7 in response to receiving packet 5, and packet 8 in response to receiving packet 6). *See* Lau at Fig. 11.

Pet. 23. Figure 11 of Lau is reproduced below:

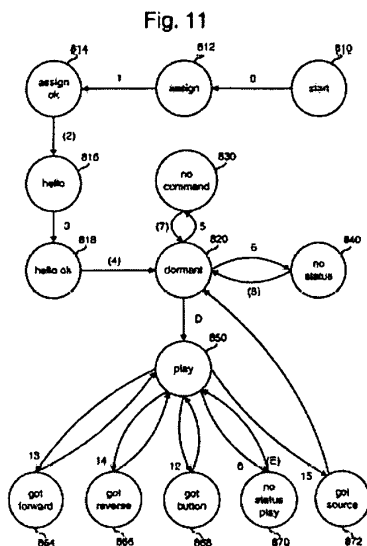

Figure 11 illustrates a state diagram for controller 320 within music server 102. Ex. 1103, 6:4.

Nothing in the above-noted explanations indicates that packet 7 or packet 8 sent by controller 320 conveys the message that a portable or after-market device is connected to controller 320. Petitioner asserts that the purpose of the response packets is to inform the car stereo of the presence of the CD changer while playback is not occurring, and that the response packets indicate an audio device is present. Pet. 24. Dr. Matheson's testimony is the same. Ex. 1115 ¶ 92. These assertions, however, are not accompanied by citation to the disclosure of Lau and are not adequately supported by the portions of Lau Petitioner does discuss, which we have addressed above.

Importantly, it is the connection of a separate portable or after-market device to the interface that must be conveyed by a device presence signal and not just the presence of any audio device such as the entirety of music server 102 itself or processor 302 which is fixedly configured with controller 320. As discussed above, processor 302 is not a portable or after-market device that is connected to controller 320 as the claimed interface. In that regard, Petitioner's explanations are deficient and the cited testimony of Dr. Matheson adds no meaningful explanation. Accordingly, Petitioner has not sufficiently shown that Lau discloses generating a device presence signal and transmitting it to the car stereo.

For the foregoing reasons, Petitioner has not shown a reasonable likelihood that it would prevail in establishing unpatentability of either claim 57 or claim 86 as obvious over JP '954 and Lau.

5. *Claims 58, 60, 64, 88, 90, and 91*

Each of claims 58, 60, 64, 88, 90, and 91 depends directly or indirectly from either claim 57 or 86. The deficiencies noted above with regard to claims 57 and 86 carry through to the claims depending therefrom. Accordingly, Petitioner has not shown a reasonable likelihood that it would prevail in establishing unpatentability of claims 58, 60, 64, 88, 90, and 91 as obvious over JP '954 and Lau.

C. *Alleged Obviousness of Claims 57, 86, and 92 over JP '954, Lau, and Bhogal*

This alleged ground of unpatentability adds Bhogal to the combined teachings of JP '954 and Lau which we have already discussed above. Bhogal is added to buttress the combined teachings of JP '954 and Lau with respect to the claim limitations requiring a “portable” device, and does not cure the deficiencies of the Petition, already addressed above, with regard to claims 57, 86, and 92. Accordingly, Petitioner has not shown a reasonable likelihood that it would prevail in establishing the unpatentability of any of claims 57, 86, and 92 as obvious over JP '954, Lau, and Bhogal.

D. *Alleged Obviousness of Claims 61–63 over JP '954, Lau, and XR-C5120*

Each of claims 61, 62, and 63 depends from claim 60. Claim 60 depends from claim 57. The deficiencies of Petitioner’s assertions with respect to claims 57 and 60, discussed above, are not cured by Petitioner’s application of the disclosure of XR-C5120 to the combined teachings of JP '954 and Lau. Accordingly, Petitioner has not shown a reasonable likelihood that it would prevail in establishing the unpatentability of any of claims 61, 62, and 63 as obvious over JP '954, Lau, and XR-C5120.

*E. Alleged Obviousness of Claims 65,
89, and 98 over JP '954, Lau, and KBT*

Claim 65 depends from claim 64 which depends from claim 57.

Claim 89 depends from claim 88 which depends from claim 86. Claim 98 depends from claim 97 which depends from claim 92. The deficiencies of Petitioner's assertions with respect to claims 57, 64, 86, 88, 92, and 97, discussed above, are not cured by Petitioner's application of KBT to the combined teachings of JP '954 and Lau. Petitioner has not shown a reasonable likelihood that it would prevail in establishing the unpatentability of any of claims 65, 89, and 98 as obvious over JP '954, Lau, KBT.

*F. Alleged Obviousness of Claims 1, 2, 4, 7, 8, 13,
14, and 23 over JP '954, XR-C5120 and XA-C30*

We have reviewed the Petition and the Preliminary Response, and determine that Petitioner has not shown a reasonable likelihood that it would prevail in establishing the unpatentability of any of claims 1, 2, 4, 7, 8, 13, 14, and 23 over JP '954, XR-C5120, and XA-C30.

1. Claim 1

As compared to claim 57, claim 1 (a) recites an after-market audio device rather than a portable MP3 player, (b) does not require the generation or transmission of a device presence signal, (c) adds a third connector that is electrically connectable to one or more auxiliary input sources external to the car stereo and the after-market audio device, (d) adds a code portion in the microcontroller within the interface, that is "for switching to one or more auxiliary input sources connected to the third electrical connector," and (f) adds a code portion in the microcontroller within the interface, that is "for receiving data from the after-market audio device through said second connector in a format incompatible with the car stereo, processing the

received data into formatted data compatible with the car stereo, and transmitting the formatted data to the car stereo through said first connector for display by the car stereo.”

For the addition of the third connector and the code portion for switching to one or more auxiliary input sources, Petitioner relies on XR-C5120 and XA-C30. Pet. 42–46. XR-C5120 is the Operating Instructions for Sony’s model XR-C5120 car stereo. Ex. 1108. It lists as optional equipment: “Source selector XA-C30.” *Id.* at 18. As noted above, for this decision we use the identification “XA-C30” to refer to the service manual of Sony’s Source Selector XA-C30 (Exhibit 1109). The service manual discloses how the source selector may be connected between a car stereo and multiple input sources. Ex. 1109, 2–3.

Petitioner illustrates its combination of Sony’s Source Selector XA-C30 with the car audio system of JP ’954 as follows:

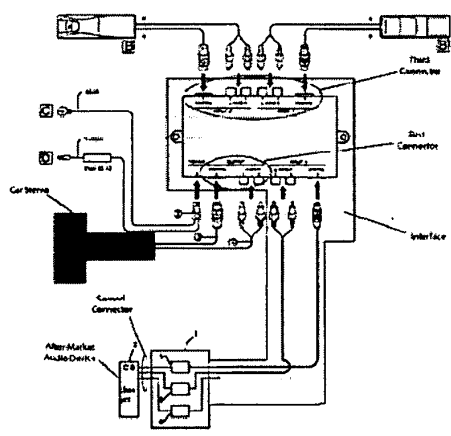

Composite of Sony XA-C30 and JP '954 Figure 1

Pet. 44. The Figure is a block diagram of the audio system of JP ’954 with the addition of the source selector disclosed in XR-C30. Each of first,

second, and third connectors as recited in claim 1 is illustrated in the above-reproduced Figure, together with the parts to which they are connected.

With respect to claim 1's requirement of a microcontroller having a code portion "for remotely controlling the after-market audio device," Petitioner points to microcomputer 4a within control conversion portion 4 of interface unit 1. Pet. 45. With respect to claim 1's requirement of a microcontroller having a code portion "for switching to one or more auxiliary input sources connected to said third electrical connector," Petitioner asserts: "The Sony XA-C30 Source Selector's microcontroller contains 4K Bytes of program ROM that inherently must be pre-programmed in order for the microcontroller to function." Pet. 45-46.

The analysis is incomplete because Petitioner has not shown that microcomputer 4a within control conversion portion 4 of interface unit 1 of JP '954 is the same microcontroller as the microcontroller within the Sony Source Selector XA-C30. Claim 1 requires the same microcontroller to include a code portion "for remotely controlling the after-market audio device," and another code portion "for switching to one or more auxiliary input sources connected to said third electrical connector." The Sony Source Selector XA-C30 is separate from and does not include interface unit 1 of JP '954. A block diagram of the Sony Source Selector XA-C30, as shown in XA-C30, is reproduced below:

Connections

Precautions

- Before making any connection, disconnect the ground terminal of the car battery to avoid short circuits.
- Connect the yellow power input leads only after all other leads have been connected.

- Be sure to connect the unit's ground wire securely to a metal point of the car. A loose disconnection may cause the unit to malfunction.
- If your car has an air-locked cassette or navigation system installed, disconnect it from the car battery's negative terminal *before* their installation. In such a case, make sure that all the car sections except the yellow power input cord are completely before disconnecting the yellow power input cord.

- This unit is compatible with the CDX-4500, CDX-7100 and XM-2500, but it is not compatible with the CDX-4501, CDX-6100 or CDX-7100-Moving mode.

Connection diagram

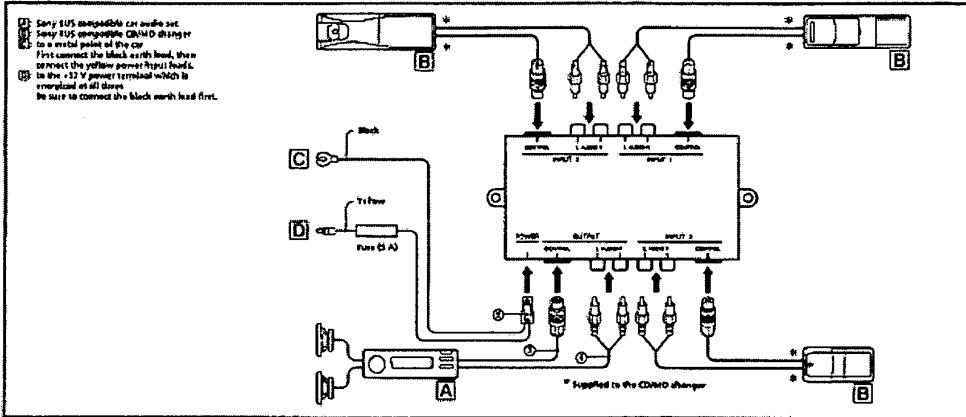

Ex. 1109, 2. The above Figure illustrates a connection diagram for Sony's Source Selector XA-C30.

With respect to claim 1's requirement of a microcontroller having a code portion "for receiving data from the after-market audio device through said second connector in a format incompatible with the car stereo, processing the received data into formatted data compatible with the car stereo, and transmitting the formatted data to the car stereo through said first connector for display by the car stereo," Petitioner points to microcomputer 4a within control conversion portion 4 of interface unit 1. Pet. 45. We are unpersuaded, because, as we discussed above, control conversion portion 4 in interface unit 1 is for communicating and converting control signals, not any data for display on a car stereo, such as song title and artist information.

2. Claims 2, 4, 7, 8, 13, 14, and 23

Each of claims 2, 4, 7, 8, 13, 14, and 23 depends directly from claim 1. The deficiencies discussed above with regard to claim 1 carry through to

these dependent claims. Petitioner has not shown a reasonable likelihood that it would prevail in establishing unpatentability of any of claims 2, 4, 7, 8, 13, 14, and 23 as obvious over JP '954, XR-C5120, and XA-C30.

*G. Alleged Obviousness of Claims 5 and 24
over JP '954, XR-C5120, XA-C30, and KBT*

Claim 5 depends from claim 1. Claim 24 depends from claim 23 which depends from claim 1. The deficiencies of Petitioner's assertions with respect to claims 1 and 23, discussed above, are not cured by Petitioner's application of KBT to the combined teachings of JP '954, XR-C5120, and XA-C30. Petitioner has not shown a reasonable likelihood that it would prevail in establishing the unpatentability of either claim 5 or claim 24 as obvious over JP '954, XR-C5120, XA-C30, and KBT.

*H. Alleged Obviousness of Claims 6 and 10
over JP '954, XR-C5120, XA-C30, and Lau*

Claims 6 and 10 each depends from claim 1. The deficiencies of Petitioner's assertions with respect to claim 1 are not cured by Petitioner's application of Lau to the combined teachings of JP '954, XR-C5120, and XA-C30. Thus, Petitioner has not shown a reasonable likelihood that it would prevail in establishing the unpatentability of either claim 6 or claim 10 as obvious over JP '954, XR-C5120, XA-C30, and Lau.

*I. Alleged Unpatentability of Claims 44
and 47 as Obvious over JP '954, Lau, and Bhogal*

1. Bhogal

Bhogal is titled "Method and System for Storing Digital Audio Data and Emulating Multiple CD-Changer Units." Ex. 1110 (54). It relates to a method and apparatus for enhancing storage and playback of digital audio

data. *Id.* at 1:9–11. With regard a problem that it addresses, Bhogal describes:

Typically, CD-changer units and car stereo units are designed so that they are compatible only if they are made by the same manufacturer. In other words, CD-changers and car stereos usually have a proprietary interface, and no industry standard currently exists for interfacing different makes of CD-changers and car stereos.

Id. at 4:57–62. To solve that problem, Bhogal provides a digital audio unit that can emulate the operation of multiple CD-changers. *Id.* at 3:10–13.

Regarding which one of many CD-changer to emulate, Bhogal describes:

In one case, the digital audio unit can detect a control signal for a CD-changer unit and then automatically select the type of CD-changer unit to be emulated based on the detected control signal. In a second case, the digital audio unit can receive a user selection for selecting a type of CD-changer unit to be emulated. The softcopy digital audio files stored within the digital audio unit are thereby accessed through the controls and commands for a CD-changer unit.

Id. at 3:13–20. Figure 2 of Bhogal is reproduced below:

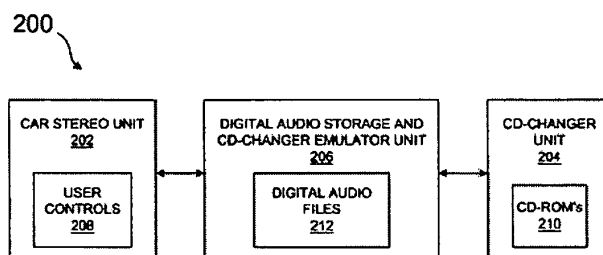

FIG. 2

Figure 2 illustrates an embodiment of Bhogal's audio system. *Id.* at 3:31–33. Emulator 206 is connected between car stereo 202 and actual CD-changer 204. *Id.* at 5:11–16. Emulator 206 contains digital audio files 212, organized as virtual CD-ROMs, that may be accessed by a user through the car stereo. *Id.* at 5:39–42. Bhogal describes that, in one embodiment, “the

emulator unit may be positioned in an independent *docking station* that accepts portable electronics, possibly in a standard manner such that the docking station also accepts other types of MP3 players.” *Id.* at 5:61–64 (emphasis added). When the emulator is not in the docking station, the car stereo and the actual CD-exchanger may operate together. *Id.* at 5:65–67.

Bhogal describes that, in a preferred embodiment, emulator 206 is a portable device. *Id.* at 6:18–21. Bhogal also describes that the emulator may connect to a personal computer in many different ways, including by use of “serial, Universal Serial Bus (USB), or parallel I/O connections, in a manner similar to that found on other types of commercially available portable digital audio devices.” *Id.* at 6:32–40.

2. *Claim 44*

Claim 44 is reproduced below:

44. An apparatus for docking a portable device for integration with a car stereo comprising:

- a storage area remote from a car stereo for storing the portable device;
- a docking portion within the storage area for communicating and physically mating with the portable device;
- a data port in communication with the docking portion, the data port connectable with a device for integrating the portable device with the car stereo; and
- an interface connected to said data port and to the car stereo, said interface channeling from the portable device to the car stereo said interface including a microcontroller in electrical communication with the portable device through said data port and the car stereo, said microcontroller pre-programmed to execute first program code for remotely controlling the portable device using the car stereo by processing control commands generated by the car stereo in a format

incompatible with the portable device into formatted control commands compatible with the portable device, and dispatching formatted control commands to the portable device for execution thereby.

Ex. 1101, 25:1–22.

Petitioner relies on Bhogal for its teaching about the use of a docking station that accepts portable electronics, with the rest of the claim elements being met by “JP ’954 (as combined with Lau)” or “JP ’954 in view of Lau.” Pet. 37, 39. Petitioner, however, does not explain within the section of the Petition discussing claim 44, how JP ’954 is modified in view of Lau or combined with Lau in the context of the obviousness assertion of claim 44. In that regard, Patent Owner asserts: “it is impossible to determine how Petitioner would modify the JP ’954 and Lau references to achieve the portable device and interface of the claim.” Prelim. Resp. 28.

We determine that because the discussion in the Petition of claim 44 immediately follows the discussion of the ground of unpatentability against other claims based on the combination of JP ’954 and Lau, Petitioner reasonably has conveyed, for claim 44, how JP ’954 would be modified in view of Lau, i.e., the same way JP ’954 and Lau are combined in the ground of unpatentability based on JP ’954 and Lau. Specifically, Petitioner asserts that in view of Lau it would have been obvious to one with ordinary skill in the art to substitute, in the system of JP ’954, a portable MP3 player for CD changer 2. Pet. 21.

In short, Petitioner proposes that it would have been obvious to one with ordinary skill in the art to substitute a portable MP3 player for CD changer 2 in JP ’954, and to connect that portable MP3 player to Interface Unit 1 of JP ’954 through a docking station. According to Petitioner, the

resulting combination meets the subject matter of claim 44. We are sufficiently persuaded by Petitioner's contentions.

Petitioner asserts that one with ordinary skill in the art would have used Bhogal's docking station in JP '954 because "the addition of a docking station would provide predictable ease of use in an automotive AV system." Pet. 39. That assertion is supported by the testimony of Dr. Matheson. Ex. 1115 ¶¶ 119, 123. We note that in the combined system of JP '954 and Lau, as noted above, a portable MP3 player has been substituted in for CD changer 2, and that Bhogal describes its emulator unit as a portable device (Ex. 1110, 6:18–21). Thus, the portable MP3 player in JP '954 would benefit from the convenience and ease of use provided by being removably placed in a docking station the same way Bhogal's emulator 206 would benefit from the convenience and ease of use provided by being removably placed in a docking station.

We also are sufficiently persuaded that one with ordinary skill in the art would have known to substitute a portable MP3 player for CD changer 2 of JP '954. Petitioner persuasively notes that Lau's music server 102 provides songs in MP3 format to head unit 104 (car stereo), and thus, is a MP3 player being emulated as a CD changer. Pet. 21 (citing Ex. 1103, 21:18–22:4). Specifically, Lau describes: "The music player is software for playing the particular music under consideration. For example, if the music is stored in MP3 format, the music player is a MP3 music player that can read, decode, and play MP3 files." *Id.* at 21:25–22:1. Thus, Lau discloses the desirability of connecting MP3 players to a car stereo, at least no less than that of connecting a CD changer to a car stereo. As for the portable aspect of an MP3 player, Petitioner accounts for that through the testimony

of Dr. Matheson, who testifies that “portable MP3 players were commonly available in the market.” Ex. 1115 ¶ 86.

We are sufficiently persuaded that the combined structure of JP '954, Lau, and Bhogal, as discussed above, satisfies all limitations of claim 44. For instance, the portable MP3 player would be the portable device recited in the claim; Bhogal's docking station would be the docking portion recited in the claim; and the MP3 player would be physically mating with the docking station as is required in the claim. Also, interface unit 1 of JP '954 would be the interface recited in the claim, and the docking station as the claimed docking portion would be electrically connected to interface unit 1 of JP '954 through a data port. We agree with Petitioner that “data port” is sufficiently broad to cover “electronic contact” through which data passes from one device to another. Pet. 38 (citing Ex. 1115 ¶ 120). The docking station necessarily would be in a storage area remote from the car stereo. As shown in Figure 1 of JP '954, interface unit 1 also would be connected to head unit 3 which is the car stereo.

According to claim 44, the interface must include a microcontroller that communicates with the portable device as well as the car stereo. That is the case with interface unit 1 of JP '954 in the system according to the combined teachings of JP '954, Lau, and Bhogal. As shown in Figure 2 of JP '954, microcontroller 4a within control system conversion portion 4 of if interface unit 1 of JP '954 is in electrical communication with CD changer 2 (now replaced by portable MP3 player), as well as with the head unit.

Claim 44 requires the microcontroller to be pre-programmed to execute first program code portion for remotely controlling the portable device using the car stereo by (1) processing control commands generated by

the car stereo in a format incompatible with the portable device into formatted control commands compatible with the portable device, and (2) dispatching formatted control commands to the portable device for execution thereby. Petitioner identifies microcomputer 4a in JP '954 as such a microcontroller. Pet. 39. Petitioner explains that microcomputer 4a is pre-programmed for remotely controlling CD changer 2 (replaced by portable MP3 player in the combined teachings of JP '954, Lau, and Bhogal) using the car stereo by converting control commands sent from head unit 3 into a format compatible with the portable MP3 player and transmitting them to the portable MP3 player for execution thereby. *Id.* The argument is supported by the testimony of Dr. Matheson. Ex. 1115 ¶ 124.

Figure 2 of JP '954 is reproduced below:

(Fig. 2)

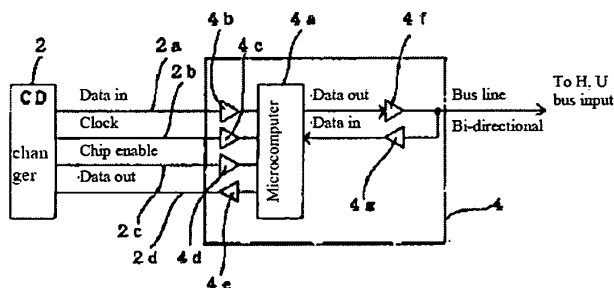

Figure 2 illustrates control system conversion portion 4 of interface unit 1 of JP '954. Ex. 1107 (0007). Microcomputer 4a is provided to convert and unify different signal formats between the CD changer and the main unit. *Id.* JP '954 summarizes its interface unit 1 as follows:

(MEANS FOR SOLVING) The [interface] unit is constituted by splitting signals into three systems, namely a control system, audio system and power system, and providing a conversion circuit for each of these systems.

Id. Abstr. JP '954 describes its objective as: “to make it possible to add a CD changer made by company B to a main unit made by company A, as well as to add a CD changer made by company A to a main unit made by company B.” *Id.* (0003).

Patent Owner asserts that Petitioner does not explain how control system conversion portion disclosed in JP '954 “could possibly convert data from an MP3 player or remotely control the MP3 player.” Prelim. Resp. 19. In that regard, Petitioner asserts: “to the extent that JP '954 discloses anything, that disclosure only relates to CD-changer technology.” *Id.* These arguments are unpersuasive. A patent disclosure need not expressly describe, specifically, what would have been known to one with ordinary skill in the art, insofar as the making and using of the claimed invention is concerned. *See Lindemann Maschinenfabrik GMBH v. American Hoist and Derrick Co.*, 730 F.2d 1452, 1463 (Fed. Cir. 1984). Moreover, on this record, the evidence does not establish that technology relating to control of CD changers is very much different from that relating to control of portable MP3 digital audio devices. Patent Owner may, after institution of trial, explore such issues by submitting evidence in that regard.

On this record, we determine that Petitioner has shown a reasonable likelihood that it would prevail in establishing the unpatentability of claim 44 as obvious over JP '954, Lau, and Bhogal.

3. *Claim 47*

Claim 47 depends from claim 44 and further recites: “wherein the data port comprises an RS-232 or Universal Serial Bus (USB) port.” Petitioner asserts that Bhogal describes its emulator unit as being coupled to the docking station in a “standard manner.” Pet. 55 (see Ex. 1110, 5:61–64).

Petitioner further asserts that Bhogal describes the emulator unit as being connectable to a personal computer, identifies various possibilities for the manner of connection, and refers to such manner as “similar to that found on other types of commercially available portable digital audio devices.” *Id.* (citing Ex. 1110, 6:32–37). In particular, Bhogal identifies such connections on commercially available portable digital audio devices as including “serial, universal Serial Bus (USB), or parallel I/O.” Ex. 1110, 6:34–37. It is also undisputed that “RS-232” refers to a serial bus. As such, we are sufficiently persuaded that one with ordinary skill in the art, in light of Bhogal, would have known to use a RS-232 or USB connection as a data port connecting to the docking station.

Petitioner has shown a reasonable likelihood that it would prevail in establishing the unpatentability of claim 47 as obvious over JP ’954, Lau, and Bhogal.

III. CONCLUSION

Petitioner has not demonstrated a reasonable likelihood that it would prevail in establishing the unpatentability of any of claims 1, 2, 4–8, 10, 13, 14, 23, 24, 57, 58, 60–65, 86, 88–92, 94, 97, and 98 of the ’786 patent. Petitioner has, however, demonstrated a reasonable likelihood that it would prevail in establishing the unpatentability of claims 44 and 47 as obvious over JP ’954, Lau, and Bhogal. We have not made a final determination with respect to the patentability of any claim or the construction of claim.

III. ORDER

It is

ORDERED that, pursuant to 35 U.S.C. § 314(a), an *inter partes* review is instituted as to claims 44 and 47 of the '786 patent on the ground of obviousness over JP '954, Lau, and Bhogal;

FURTHER ORDERED that no other ground of unpatentability, with respect to any claim, is instituted for trial; and

FURTHER ORDERED that pursuant to 35 U.S.C. § 314(c) and 37 C.F.R. § 42.4, notice is hereby given of the institution of a trial, which commences on the entry date of this decision.

COUNSEL FOR PETITIONER:

William Mandir
John Rabena
Brian Shelton
Sughrue Mion, PLLC

wmandir@sughrue.com
jrabena@sughrue.com
bshelton@sughrue.com

COUNSEL FOR PATENT OWNER:

Peter Lambrianakos
Brown Rudnick LLP

plambrianakos@brownrudnick.com

UNITED STATES PATENT AND TRADEMARK OFFICE

BEFORE THE PATENT TRIAL AND APPEAL BOARD

TOYOTA MOTOR CORPORATION,
Petitioner,

v.

BLITZSAFE TEXAS, LLC,
Patent Owner.

Case IPR2016-00422
Patent 7,489,786 B2

Before JAMESON LEE, THOMAS L. GIANNETTI, and HUNG H. BUI,
Administrative Patent Judges.

LEE, *Administrative Patent Judge.*

DECISION
Denying Institution of *Inter Partes* Review
37 C.F.R. § 42.108

I. INTRODUCTION

A. *Background*

On December 30, 2015, Petitioner filed a Petition (Paper 1, “Pet.”) to institute *inter partes* review of claims 1, 2, 4–8, 10, 13, 14, 23, 24, 44, 47, 57, 58, 60–65, 86, 88–92, 94, 97, and 98 of U.S. Patent No. 7,489,786 B2 (Ex. 1001, “the ’786 patent”). On April 11, 2016, Patent Owner filed a Preliminary Response (Paper 9, “Prelim. Resp.”).

To institute an *inter partes* review, we must determine that the information presented in the Petition shows “that there is a reasonable likelihood that the petitioner would prevail with respect to at least 1 of the claims challenged in the petition.” 35 U.S.C. § 314(a). Having considered both the Petition and the Preliminary Response, we determine that Petitioner has *not* demonstrated a reasonable likelihood that it would prevail in establishing the unpatentability of any claim. Thus, we do not institute an *inter partes* review of any claim of the ’786 patent.

B. *Related Matters*

The parties indicate that the ’786 patent was asserted in five infringement actions before the United States District Court of the Eastern District of Texas and two infringement actions before the United States District Court for the District of New Jersey. Pet. 1–2, Paper 5, 1–2. The ’786 patent also is involved in IPR2016-00421. Related Patent 8,155,342 B2 is involved in IPR2016-00118, IPR2016-00418, and IPR2016-00419.

C. *The ’786 Patent*

The ’786 patent is titled “AUDIO DEVICE INTEGRATION SYSTEM.” Ex. 1001 (54). “One or more after-market audio devices, such as a CD player, CD changer, MP3 player, satellite receiver, DAB receiver,

or the like, is integrated for use with an existing OEM or after-market car stereo system, wherein control commands can be issued at the car stereo and responsive data from the audio device can be displayed on the stereo.” *Id.* at Abstr. The ’786 patent describes:

Control commands generated at the car stereo are received, processed, converted into a format recognizable by the audio device, and dispatched to the audio device for execution. Information from the audio device, including track, disc, song, station, time, and other information, is received, processed, converted into a format recognizable by the car stereo, and dispatched to the car stereo for display thereon.

Id. Additional auxiliary sources also may be integrated together, and “a user can select between the [audio] device or the one or more auxiliary input sources by issuing selection commands through the car stereo.” *Id.* A docking station is provided for docking a portable audio or video device for integration with the car stereo. *Id.* Figures 2A–2C are reproduced below:

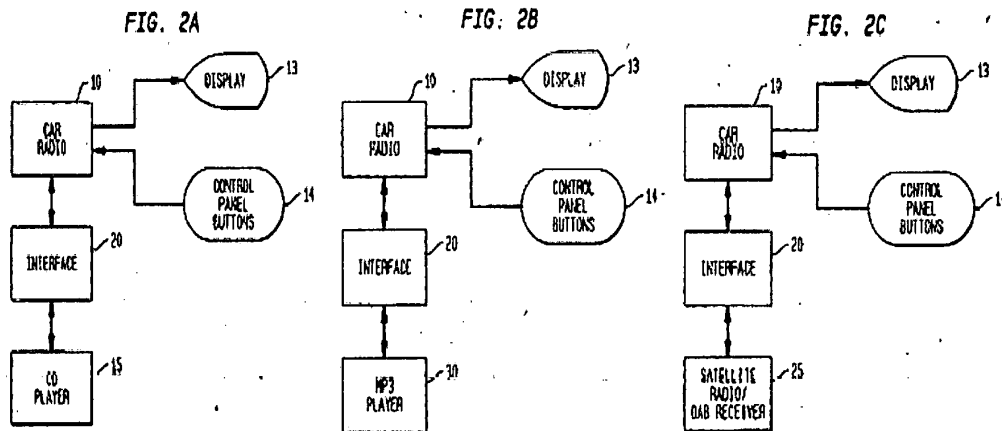

Figure 2A illustrates an embodiment integrating a CD player with the car stereo; Figure 2B illustrates an embodiment integrating a MP3 player with a car stereo; and Figure 2C illustrates an embodiment integrating a satellite or

DAB receiver with a car stereo. *Id.* at 3:14–23. A more versatile embodiment is shown in Figure 1:

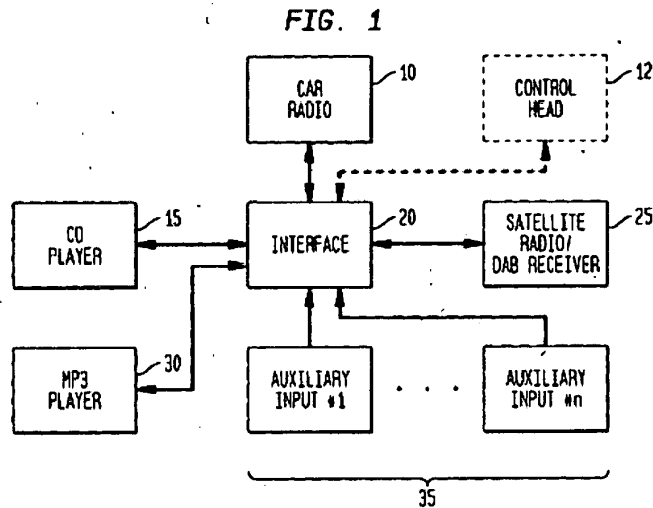

Figure 1 illustrates an embodiment integrating a CD player, a MP3 player, a satellite radio or DAB receiver, and a number of auxiliary input sources with a car stereo. *Id.* at 3:12–13. As shown in the above figures, central to the '786 patent is an “interface” positioned between the car stereo and the audio device(s) and auxiliary input(s) being integrated.

With regard to Figure 2B, the '786 patent describes:

The interface 20 allows data and audio signals to be exchanged between the MP3 player 30 and the car radio 10, and processes and formats signals accordingly so that instructions and data from the radio 10 are processable by the MP3 player 30, and vice versa. Operational commands, such as track selection, pause, play, stop, fast forward, rewind, and other commands, are entered via the control panel buttons 14 of car radio 10, processed by the interface 20, and formatted for execution by the MP3 player 30. Data from the MP3 player, such as track, time, and song information, is received by the interface 20, processed thereby, and sent to the radio 10 for display on display 13. Audio from MP3 player 30 is selectively forwarded by the interface 20 to the radio 10 for playing.

Id. at 6:11–24 (emphasis omitted). Similar description is provided with respect to Figures 2A and 2C. *Id.* at 5:49–55, 6:35–43.

Claims 1, 44, 57, 86, and 92 are independent. Claim 1 is directed to a system that connects an after-market audio device as well as one or more auxiliary input sources to a car stereo. In particular, it recites a first connector electrically connectable to a car stereo, a second connector electrically connectable to an after-market device, and a third connector electrically connectable to one or more auxiliary input sources. *Id.* at 21:33–38. Claim 1 also recites an interface connected between the first and second electrical connectors, and that the interface includes a microcontroller pre-programmed to execute:

- a first pre-programmed code portion for remotely controlling the after-market audio device using the car stereo by receiving a control command from the car stereo through said first connector in a format incompatible with the after-market audio device, processing the received control command into a formatted command compatible with the after-market audio device, and transmitting the formatted command to the after-market audio device through said second connector for execution by the after-market audio device;
- a second pre-programmed code portion for receiving data from the after-market audio device through said second connector in a format incompatible with the car stereo, processing the received data into formatted data compatible with the car stereo, and transmitting the formatted data to the car stereo through said first connector for display by the car stereo; and
- a third pre-programmed code portion for switching to one or more auxiliary input sources connected to said third electrical connector.

Id. at 21:44–64.

Claim 57 is directed to a system including an interface that connects a portable MP3 player to a car stereo. Claim 86 is directed to a system including an interface that connects an after-market video device to a car stereo. Claim 92 is directed to a system including an interface that connects a portable audio device with a car stereo. Claims 57, 86, and 92 are reproduced below:

57. An audio device integration system comprising:

a first electrical connector connectable to a car stereo;

a second electrical connector connectable to a portable MP3 player external to the car stereo

an interface connected between said first and second electrical connectors for transmitting audio from a portable MP3 player to a car stereo, said interface including a microcontroller in electrical communication with said first and second electrical connectors,

said microcontroller pre-programmed to execute:

a first pre-programmed code portion for generating a device presence signal and transmitting the signal to the car stereo to maintain the car stereo in an operational state; and

a second pre-programmed code portion for remotely controlling the MP3 player using the car stereo by receiving a control command from the car stereo through said first electrical connector in a format incompatible with the MP3 player, processing the control command into a formatted control command compatible with the MP3 player, and transmitting the formatted control command to the MP3 player through said second electrical connector for execution by the MP3 player.

Id. at 26:13–37.

86. A device for integrating video information for use with a car stereo, comprising:

- a first electrical connector connectable to a car stereo;
- a second electrical connector connectable to an after-market video device external to the car stereo;
- an interface connected between said first and second electrical connectors for transmitting video information from the after-market video device to the car stereo, the interface including a microcontroller in electrical communication with said first and second electrical connectors, said microcontroller pre-programmed to execute:
 - a first pre-programmed code portion for generating a device presence signal and transmitting the signal to the car stereo through said first electrical connector to maintain the car stereo in an operational state responsive to signals generated by the after-market video device.

Id. at 28:40–56.

92. An audio device integration system comprising:
- a car stereo;
 - a portable audio device external to the car stereo;
 - an interface connected between the car stereo and the portable audio device, the interface including a microcontroller pre-programmed to execute:
 - first pre-programmed means for generating a device presence signal and transmitting the signal to the car stereo to maintain the car stereo in an operational state;
 - second pre-programmed means for remotely controlling the portable audio device using the car stereo by receiving a control command from the car stereo in a format incompatible with the portable audio device, processing the control command into a formatted control command compatible with the portable audio device, and transmitting the formatted control command to the portable audio device for execution thereby; and
 - means for transmitting audio from the portable audio device to the car stereo.

Id. at 29:11–31.

Claim 44 is directed to an apparatus for docking a portable device for integration with a car stereo. *Id.* at 25:1–2. A docking portion is recited as physically mating with the portable device. *Id.* at 25:5–6. A data port is recited as being in communication with the docking portion. *Id.* at 25:7–8. An interface is recited as “connected to said data port and to the car stereo” and “channeling audio from the portable device to the car stereo.” *Id.* at 25:10–12. Claim 44 recites that the interface includes a microcontroller in electrical communication with the car stereo, and with the portable device through the data port. *Id.* at 5:12–14. Claim 44 further recites that the microcontroller is:

pre-programmed to execute first program code for remotely controlling the portable device using the car stereo by processing control commands generated by the car stereo in a format incompatible with the portable device into formatted control commands compatible with the portable device, and dispatching formatted control commands to the portable device for execution thereby.

Id. at 25:14–22.

D. Evidence Relied Upon

Petitioner relies on the following references:¹

¹ For certain alleged grounds of unpatentability, Petitioner also relies on what it refers to as “known bus technology.” Hereinafter, we refer to that material as “KBT.” We understand Petitioner to have presented KBT as common knowledge and routine skill within the level of ordinary skill in the art that does not require citation of any particular reference.

Reference		Date	Exhibit
Lau	International Pub. No. WO 01/67266 A1	Sept. 13, 2001	Ex. 1003
XR-C5120	SONY® 3-865-814-11(1) Operating Instructions, Model No. XR-C5120 /4890	1999	Ex. 1005
XA-C30	SONY® 9-923-535-11 Source Selector Service Manual XA-C30	March, 1996	Ex. 1006
Bhogal	U.S. Patent No. 6,629,197 B1	Sept. 30, 2003	Ex. 1008

Petitioner also relies on the Declaration of Thomas G. Matheson, Ph.D. Ex. 1015.

C. The Asserted Grounds

Petitioner asserts the following grounds of unpatentability:

Claim(s) Challenged	Basis	References
44, 57, 58, 60, 63, 64, 86, 88, 90, and 91	§ 102(b)	Lau
92, 94, and 97	§ 103(a)	Lau
1, 2, 4–8, 10, 13, 14, 23, 24, 61, and 62	§ 103(a)	Lau, XR-C5120, and XA-C30
47, 65, 89, and 98	§ 103(a)	Lau and KBT
24	§ 103(a)	Lau, XR-C5120, XA-C30, and KBT
44, 57, and 92	§ 103(a)	Lau and Bhogal

II. ANALYSIS

To establish anticipation, each and every element in a claim, arranged as recited in the claim, must be found in a single prior art reference.

Net MoneyIN, Inc. v. VeriSign, Inc., 545 F.3d 1359, 1369 (Fed. Cir. 2008); *Karsten Mfg. Corp. v. Cleveland Golf Co.*, 242 F.3d 1376, 1383 (Fed. Cir. 2001). The question of obviousness is resolved on the basis of underlying factual determinations including: (1) the scope and content of the prior art; (2) any differences between the claimed subject matter and the prior art; (3) the level of ordinary skill in the art; and (4) objective evidence of nonobviousness. *Graham v. John Deere Co.*, 383 U.S. 1, 17–18 (1966). One seeking to establish obviousness based on more than one reference also must articulate sufficient reasoning with rational underpinnings to combine teachings. *See KSR Int'l Co. v. Teleflex, Inc.*, 550 U.S. 398, 418 (2007).

With regard to the level of ordinary skill in the art, we determine that no express finding is necessary, on this record, and that the level of ordinary skill in the art is reflected by the prior art of record. *See Okajima v. Bourdeau*, 261 F.3d 1350, 1355 (Fed. Cir. 2001); *In re GPAC Inc.*, 57 F.3d 1573, 1579 (Fed. Cir. 1995); *In re Oelrich*, 579 F.2d 86, 91 (CCPA 1978).

A. Claim Construction

In an *inter partes* review, claim terms in an unexpired patent are interpreted according to their broadest reasonable construction in light of the specification of the patent in which they appear. *See* 37 C.F.R. § 42.100(b); *Cuozzo Speed Techs., LLC v. Lee*, No. 15–446, 2016 WL 3369425, at *12 (U.S. June 20, 2016) (upholding the use of the broadest reasonable interpretation standard as the claim construction standard to be applied in an *inter partes* review proceeding). Consistent with the rule of broadest

reasonable interpretation, claim terms also are given their ordinary and customary meaning, as would be understood by one of ordinary skill in the art in the context of the disclosure. *See In re Translogic Tech., Inc.*, 504 F.3d 1249, 1257 (Fed. Cir. 2007).

“Claims are not interpreted in a vacuum, but are part of and are read in light of the specification.” *Slimfold Mfg. Co. v. Kinkead Indus., Inc.*, 810 F.2d 1113, 1116 (Fed. Cir. 1987). Although it is improper to read a limitation from the specification into the claims, *In re Van Geuns*, 988 F.2d 1181, 1184 (Fed. Cir. 1993), the claims still must be read in view of the specification of which they are a part. *Microsoft Corp. v. Multi-Tech Sys., Inc.*, 357 F.3d 1340, 1347 (Fed. Cir. 2004).

If a limitation of an embodiment described in the specification is not necessary to give meaning to a claim term, it would be “extraneous” and should not be read into the claim. *See Hoganas AB v. Dresser Indus., Inc.*, 9 F.3d 948, 950 (Fed. Cir. 1993); *E.I. du Pont de Nemours & Co. v. Phillips Petroleum Co.*, 849 F.2d 1430, 1433 (Fed. Cir. 1988). If the applicants for a patent desire to be their own lexicographer, the purported definition must be set forth in either the specification or prosecution history. *See CCS Fitness, Inc. v. Brunswick Corp.*, 288 F.3d 1359, 1366 (Fed. Cir. 2002). Such a definition must be set forth with reasonable clarity, deliberateness, and precision. *See Renishaw PLC v. Marposs Società per Azioni*, 158 F.3d 1243, 1249 (Fed. Cir. 1998); *In re Paulsen*, 30 F.3d 1475, 1480 (Fed. Cir. 1994). However, only terms which are in controversy need to be construed, and only to the extent necessary to resolve the controversy. *See Wellman, Inc. v. Eastman Chem. Co.*, 642 F.3d 1355, 1361 (Fed. Cir. 2011); *Vivid Techs., Inc. v. Am. Sci. & Eng’g, Inc.*, 200 F.3d 795, 803 (Fed. Cir. 1999).

1. *“interface”*

Of all challenged claims, claims 1, 44, 57, 86, and 92 are independent, and each recites an “interface.”

Claims 1, 57, and 86 require the interface to be connected between a first electrical connector and a second electrical connector, where the first connector is connectable to a car stereo and the second connector is connectable to an after-market audio device (claim 1), a portable MP3 player (claim 57), or an after-market video device (claim 86). Claim 92 requires the interface to be connected between the car stereo and a portable audio device. Claim 44 recites a docking portion that mates with a portable device, and an interface that is connected to the car stereo as well as to a data port that communicates with the docking portion.

Also, claim 57 recites that the interface is “for transmitting audio from a portable MP3 player to a car stereo”; claim 86 recites that the interface is “for transmitting video information from the after-market video device to the car stereo”; claim 1 recites that the interface is “for channeling audio signals to the car stereo from the after-market audio device”; claim 44 recites an interface for “channeling audio from the portable device to the car stereo”; and claim 92 recites that the interface includes a microcontroller pre-programmed to execute “means for transmitting audio from the portable audio device to the car stereo.”

Petitioner proposes the proper construction of “interface” is “a microcontroller that is functionally and structurally separate component from the car stereo, which integrates an after-market device with a car stereo,” and notes that that is the construction determined by the district

court in related action involving the '786 patent. Pet. 12–13. For several reasons, the proposal is unpersuasive.

First, as is noted by Patent Owner, even if the interface is deemed “functionally and structurally separate” from the car stereo, the proposed construction is incomplete in that it omits any requirement of separation or distinctness of the interface from the portable or after-market device connected thereto. Prelim. Resp. 6–7. Second, the proposed construction is too narrow by specifying that the interface “integrates an after-market device with a car stereo.” We note that the Specification of the '786 patent provides a special definition for “integration” or “integrated.” Ex. 1001, 4:47–52. We discern no reason to import limitations into a claim if they are unnecessary to accord meaning to the claim.

Third, the proposed construction is too narrow by requiring the interface to be a microcontroller. In the Specification of the '786 patent, the term “interface” is described as including not only a microcontroller but also several discrete components, such as resistors, diodes, capacitors, transistors, oscillators, amplifiers, and multiplexers, shown in various embodiments of Figures 3A, 3B1–3B2, 3C1–3C2, and 3D. Ex. 1101, 9:8–20, 10:19–33, 11:4–18, 11:59–67. As such, the term “interface” itself is not limited to a microcontroller. In that regard, note that if the interface itself is construed as a microcontroller, as Petitioner proposes, then the additional claim language reciting that the interface includes a microcontroller would serve no meaningful purpose.

With regard to an “interface,” the Specification states:

Thus, as can be readily appreciated, the interface 20 of the present invention allows for the integration of a multitude of

devices and inputs with an OEM or after-market car radio or stereo.

Ex. 1001, 5:33–36 (emphasis omitted).

As mentioned earlier, the interface 20 of the present invention allows for a plurality of disparate audio devices to be integrated with an existing car radio for use therewith.

Id. at 6:4–7 (emphasis omitted).

Data from the MP3 player, such as track, time, and song information, is received by the interface 20, processed thereby, and sent to the radio 10 for displaying on display 13. Audio from the MP3 player 30 is selectively forwarded by the interface 20 to the radio 10 for playing.

Id. at 6:19–24 (emphasis omitted). Thus, the Specification refers to the interface receiving information from an audio device and forwarding information to the car stereo, and to the interface allowing integration of a plurality of disparate audio devices with a car radio.

During prosecution, the Applicants of the '786 patent distinguished U.S. Patent 6,993,615 B2 (“Falcon”),² in part by arguing that the reference failed to disclose an interface connected between a car stereo and an external audio source. Ex. 1002, 0267. Specifically, in distinguishing the invention from Falcon, Applicants stated: “[Falcon’s graphical user interface] is an entirely different concept than the interface of the present invention, which includes a physical interface device connected between a car stereo system and an external audio source (e.g., a plurality of auxiliary input sources).”

Id.

² Falcon discloses a portable computing device connectable to a car stereo through an interface configurable within the portable computing device. Ex. 3001, Abstr.

Construing the term “interface” in light of the Specification, other language in the claims, as well as the prosecution history noted by Petitioner, we determine that—*interface is a physical unit that connects one device to another and that has a functional and structural identity separate from that of both connected devices.*

In the specific context of claims 1 and 86, the connected devices are the car stereo and an after-market device. In the specific context of claims 44, 57, and 92, the connected devices are the car stereo and a portable device. Each of claims 1, 44, 57, 86, and 92 further requires the interface to include a microcontroller.

B. Alleged Anticipation of Claims 44, 57, 58, 60, 63, 64, 86, 88, 90, and 91 over Lau

We have reviewed the Petition and the Preliminary Response, and determine that Petitioner has not shown a reasonable likelihood that it would prevail in establishing that any of claims 44, 57, 58, 60, 63, 64, 86, 88, 90, and 91 is anticipated by Lau.

1. Lau

Lau is titled “VEHICLE SOUND SYSTEM,” and states that “there is a need for an improved automobile audio system that does not require cassettes or compact discs, can be used with reusable media and can play music downloaded from a computer or other device.” Ex. 1003 (54), 2:24–26. Lau indicates that pre-existing portable solid state music players that store music downloadable from a computer are unsatisfactory for use with an automobile audio system, i.e., a car stereo. *Id.* at 3:1–11. For instance, it is explained that all of the controls are on the portable player, and thus a driver is unable to use the controls of the car stereo to control the music player. *Id.* at 3:12–16.

Figure 1 of Lau is reproduced below:

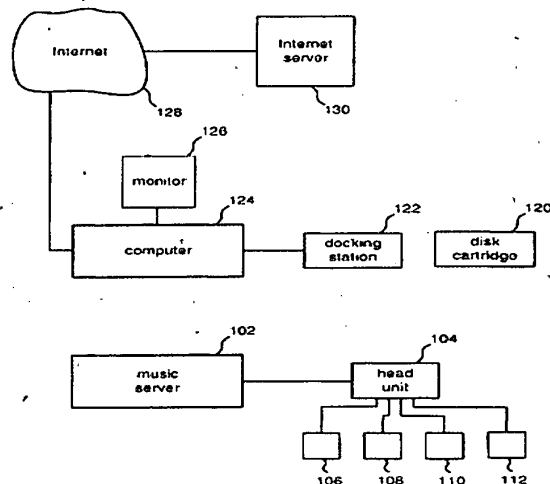

Fig. 1

Figure 1 illustrates an embodiment of Lau's vehicle sound system. *Id.* at 5:18. Head unit 104 is a standard automobile head unit and is connected to speakers 106, 108, 110, and 112. *Id.* at 7:17–20. Music server 102 is an audio/visual server and emulates a disc changer. *Id.* at 7:12–14. Lau explains that music server 102 is not an actual disc changer but only acts like a disc changer would act, based on communications to and from head unit 104. *Id.* at 7:14–17. Music server 102 communicates with head unit 104. *Id.* at 7:19. Lau describes that music server 102 may be mounted in the trunk of a car and head unit 104 is mounted in the dash board. *Id.* at 8:21–24.

Disk cartridge 120 can be inserted by a user either into music server 102 or docking station 122 connected to computer 124. *Id.* at 8:16–21. Computer 124 is a standard personal computer and is connected to Internet server 130, via Internet 128, for downloading tracks and information about tracks, and in one embodiment, tracks are songs. *Id.* at 8:4–15. After a user

downloads tracks onto disk cartridge 120, disk cartridge 120 is removed from docking station 122 and inserted into music server 102, and then the user can use head unit 104 to access and play tracks on disk cartridge 120. *Id.* at 8:20–26.

2. *Claims 57 and 86*

Determinative of our conclusion with respect to the alleged anticipation of claims 57 and 86 by Lau is our construction of the term “interface”—*interface is a physical unit that connects one device to another and that has a functional and structural identity separate from that of both connected devices.* In the context of claim 57, the two devices connected by the interface is the car stereo and a portable MP3 player. In the context of claim 86, the two devices connected by the interface is the car stereo and an after-market video device. Petitioner relies on different internal parts of Lau’s music server 102 to meet the interface of claims 57 and 86, the portable MP3 player of claim 57, and the after-market video device of claim 86. Figure 1 of Lau, as annotated by Petitioner, is reproduced below:

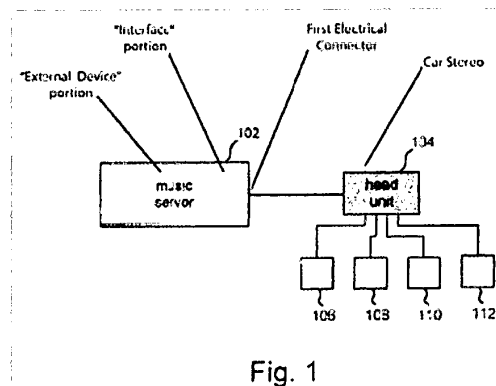

The annotated figure appears on page 22 of the Petition and illustrates the car stereo and interface of claims 57 and 86, the portable MP3 player of

claim 57, and the after-market video device of claim 86. Petitioner asserts: “Lau’s ‘head unit 104’ includes a car stereo. See, Lau, Abstract, 2:51-53; Ex. 1015 at ¶ 87. In Lau, the ‘interface’ (identified as microcontroller 320 and glue logic 330) is located within Lau’s music server 102.” Pet. 22. Petitioner further asserts: “This ‘interface’ is connected to circuitry dedicated to processing stored content for playback (processor 302 and associated components) that corresponds to the claimed external device (or ‘after-market device,’ as recited in claim 86).” *Id.*

Figure 6 of Lau, as annotated by Petitioner, illustrates the internal structure of Lau’s music server 102, and is reproduced below:

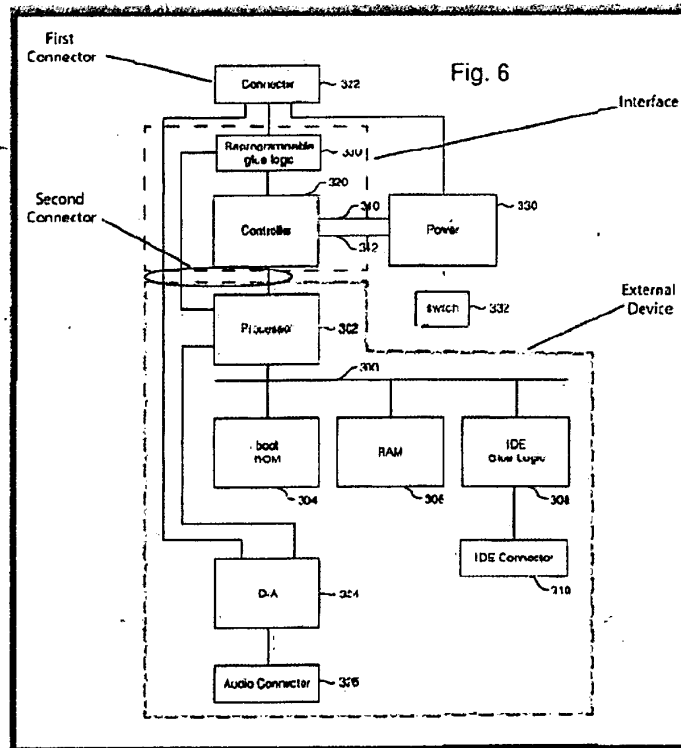

The annotated figure appears on page 22 of the Petition and illustrates the parts regarded by Petitioner as the “interface” in blue and surrounded by

dashed lines, and the parts regarded by Petitioner as the portable or after-market device in green and surrounded by dashed lines. We are unpersuaded by Petitioner's identification of the part colored blue in the above-reproduced illustration to meet the requirement of the interface in claims 57 and 86.

First, there is insufficient showing of *separate structural identity* between the alleged "interface" and the portion colored green by Petitioner in the same illustration and alleged as by Petitioner as the external device. Both blue and green portions are component parts within Lau's music server 102. It would be incorrect to regard them as having separate structural identities. Petitioner has not adequately explained what accords these portions separate structural identities, e.g., separate supporting frames, independent housing, etc. Also, Petitioner has not identified any description within Lau that refers to the combination of parts labeled in blue as collectively constituting a unit of any kind, or that refers to the combination of parts labeled in green as collectively constituting a unit of any kind. Thus, the separate structural identity requirement between the alleged interface and a portable MP3 player (claim 57) or an after-market video device (claim 86) is not met.

Second, there also is insufficient showing of *separate functional identity* between the alleged "interface" colored in blue and the portion colored green by Petitioner and alleged as the external device. Portions of Lau are reproduced below, which refute any assertion that controller 320 and glue logic 330 colored in blue, and processor 302 colored in green, have separate functional identities:

Glue logic 330 is reprogrammable. For example, glue logic 330 can be an FPGA or a PLD (as well as other suitable reprogrammable logic devices). Glue logic 330 is connected to and programmed by processor 302. Glue logic 330 provides latches, inverters and other glue logic that is specific for each head unit and used to make communication from controller 320 compatible with the particular head unit.

Ex. 1003, 13:5–9.

The flash memory internal to controller 320 stores firmware to program controller 320 to interface with the appropriate head unit. If music server 102 is initially set up to communicate with a first head unit and the user subsequently installs music server 102 into a different automobile with a different head unit, controller 320 can be reprogrammed to communicate with the new head unit by changing the firmware in the internal flash memory of controller 320.

Id. at 14:13–18.

As discussed above, a portion of the internal flash memory of controller [320] is used to store the firmware (interface program code) for programming controller 320 to communicate with head unit 104. In step 548, controller 320 requests that processor 302 access hard disk drive 178 and read the firmware version number stored in the /microcontroller config directory. In step 550, controller 320 receives the firmware version number from processor 302.

Id. at 15:13–18.

If in step 552 controller 320 determines that there is a firmware update on hard disk drive 178, then the method loops to step 554. In step 554, controller 320 sends a request to processor 302 to load new firmware. In step 556, the new firmware is received by controller 320.

Id. at 16:16–20.

If a firmware update is requested, the method of Figure 10 loops to step 740. In step 740, processor 302 accesses and reads new firmware from the /microcontroller config directory of hard disk drive 178. Step 740 also includes accessing and reading new

code to program glue logic 330. In step 742, the firmware is sent to controller 320. In step 744, processor 302 programs glue logic 330 according to the code read in step 740. The code used in step 744 may vary by head unit and/or firmware version.

Id. at 17:11–17.

It is evident from the above-quoted descriptions in Lau that processor 302 controls what firmware is used to program controller 320 and also programs the configuration of glue logic 330. Thus, the separate functional identity requirement between the alleged interface (colored in blue) and the portable or after-market device (colored in green) is not met.

3. *Claims 58, 60, 63, 64, 88, 90, and 91*

Each of claims 58, 60, 63, 64, 88, 90, and 91 depends directly or indirectly from either claim 57 or 86. The deficiency noted above with regard to claims 57 and 86 carries through to the claims depending therefrom. Accordingly, Petitioner has not shown a reasonable likelihood that it would prevail in establishing that any of claims 58, 60, 63, 64, 88, 90, and 91 is anticipated by Lau.

4. *Claim 44*

For claim 44, Petitioner draws anew the annotated borders it provided above in connection with its arguments directed to claims 57 and 86. Now, Petitioner regards most of the portions previously colored blue, green, and orange, together with the previously uncolored parts, but sans IDE Glue Logic 208 and IDE Connector 310, as the alleged interface, and regards disk cartridge 120, connectable to IDE Connector 310, as the portable device. Pet. 34–35. Lau’s Figure 6, re-annotated by Petitioner to provide different borders and different coloring for the same parts, is reproduced below:

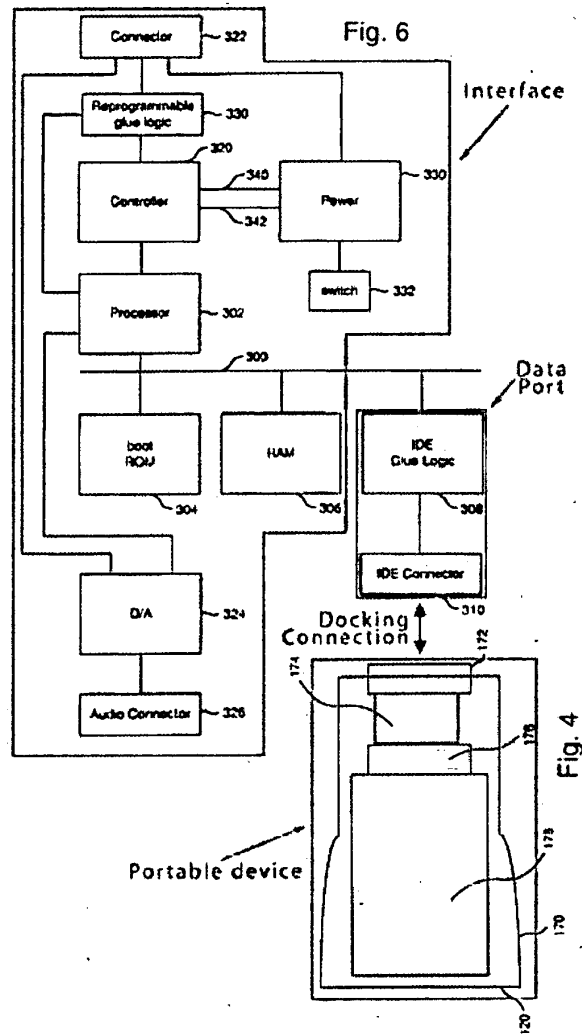

The annotated figure appears on page 34 of the Petition and illustrates the parts regarded by Petitioner as the “interface” colored in green, and the part regarded by Petitioner as the portable device colored in yellow. Pet. 34. Petitioner asserts that Lau’s disk cartridge 120 is the portable device colored in yellow. *Id.* For reasons discussed below, we are unpersuaded by Petitioner’s identification of the part colored in green above to satisfy the

requirement of the interface in claim 44, relative to Lau's disk cartridge 120 as the portable device.

As construed above, "interface" is a *physical unit that connects one device to another and that has a functional and structural identity separate from that of both connected devices*. Thus, what Petitioner identifies as the interface in Lau must have a functional and structural identity separate from those of what Petitioner identifies as the portable device.

With regard to separate structural identity, that indeed is the case, because Lau's disk cartridge 120 is removable from music server 102 and can be reinserted into music server 102 by a user. Ex. 1003, 8:16–21. The same, however, cannot be said as to separate functional identity relative to the alleged interface. In that regard, we note that disk cartridge 120 includes shell 170, connectors 172 and 176, and hard disk drive 178. *Id.* at 9:22–10:4. Hard disk drive 178 stores the firmware that processor 302 uses to reprogram controller 320 and the code that processor 302 uses to program glue logic 330 for communication with the car stereo. *Id.* at 16:16–20; 17:11–17. Furthermore, Lau describes that hard disk drive 178 stores the operating system for music server 102 as well as drivers including IDE driver, audio drivers, and a driver for the serial interface between processor 302 and controller 320. *Id.* at 11:17–21. Lau also describes that "music server 102 will not operate unless disk cartridge 120 is properly inserted in music server 102." *Id.* at 13:24–25. Based on all of these characteristics, disk cartridge 120 does not have separate functional identity relative to the alleged interface that includes processor 302 and controller 320. Rather, it is very much intertwined with and essential to the operation of the alleged interface.

Additionally, we determine that Lau's disk cartridge 120 is insufficient to constitute the portable device of claim 44. That is because disk cartridge 120, as described in Lau, includes only a shell casing, connectors, simple elements like capacitors and resistors for decoupling signals, and a hard disk drive. *Id.* at 9:22–10:4. As described in Lau, disk cartridge 120 is without any processing logic with which to execute control commands from the car stereo. Yet, such capability is implicit in claim 44, which recites that the microcontroller is pre-programmed to execute program code for remotely controlling the portable device “by processing control commands generated by the car stereo in a format incompatible with the portable device into formatted control commands compatible with the portable device, and *dispatching formatted control commands to the portable device for execution thereby.*” *Id.* at 25:17–22 (emphasis added). Accordingly, the portable device of claim 44 must include processing logic capable of executing control commands. Petitioner has not sufficiently shown that disk cartridge 120 includes such processing logic.

Accordingly, Petitioner has not shown a reasonable likelihood that it would prevail in establishing that claim 44 is anticipated by Lau.

C. *Alleged Obviousness of
Claims 92, 94, and 97 over Lau*

For reasons discussed below, we determine that Petitioner has not shown a reasonable likelihood that it would prevail in establishing unpatentability of claims 92, 94, and 97 as obvious over Lau.

Claim 92, as reproduced above, includes several elements in the format of a “means”:

first pre-programmed means for generating a device presence signal and transmitting the signal to the car stereo to maintain the car stereo in an operational state;

second pre-programmed means for remotely controlling the portable audio device using the car stereo by receiving a control command from the car stereo in a format incompatible with the portable audio device, processing the control command into a formatted control command compatible with the portable audio device, and transmitting the formatted control command to the portable audio device for execution thereby; and

means for transmitting audio from the portable audio device to the car stereo.

Claim 94 depends from claim 92 and claim 97 depends from claim 94.

Paragraph 6 of 35 U.S.C. § 112 states:³

An element in a claim for a combination may be expressed as a means or step for performing a specified function without the recital of structure, material, or acts in support thereof, and such claim shall be construed to cover the corresponding structure, material, or acts described in the specification and equivalents thereof.

The above-quoted recitations of claim 92 presumptively set forth elements under 35 U.S.C. § 112, ¶ 6, and are construed to cover the corresponding structure, material, or acts described in the specification and equivalents

³ Paragraphs 1 through 6 of § 112 were renamed as paragraphs (a) through (f) when § 4(c) of the Leahy-Smith America Invents Act, Pub. L. No. 112-29, 125 Stat. 284, 329 (2011) (“AIA”) took effect on September 16, 2012. Because the patent application resulting in the ’786 patent was filed before the effective date of the AIA, we refer to the pre-AIA version of § 112.

thereof. *Williamson v. Citrix Online, LLC*, 792 F.3d 1339, 1348 (Fed. Cir. 2015) (en banc).

For a means-plus-function element under 35 U.S.C. § 112, ¶ 6, the Board's trial rules require the Petition to identify the corresponding structure, material, or acts corresponding to each claimed function. Specifically, 37 C.F.R. § 42.104(b)(3) governs the content of a petition with respect to claim construction and provides: "[w]here the claim to be construed contains a means-plus-function or step-plus-function limitation as permitted under 35 U.S.C. § 112 [, ¶ 6], the construction of the claim must identify the specific portions of the specification that describe the structure, material, or acts corresponding to each claimed function."⁴ 37 C.F.R. § 42.104(b)(3).

The "construction" referred to by 37 C.F.R. § 42.104(b)(3) is the construction proposed by the Petitioner, one that Petitioner believes is the correct construction under applicable law and should apply in the involved proceeding. Here, Petitioner did not comply with 37 C.F.R. § 42.104(b)(3).

For each means-plus-function recitation in claim 92, Petitioner provided the construction of the United States District Court for the District of New Jersey. Pet. 16–20. However, Petitioner does not take ownership of the district court's constructions by indicating, in some way, that it agrees with, proposes, or adopts the construction of this district court. Indeed, for two means-plus-function elements, i.e., (1) first pre-programmed means for

⁴ Structure disclosed in the specification is corresponding structure only if the specification or prosecution history clearly links or associates that structure to the function recited in the claim. *Golight, Inc. v. Wal-Mart Stores, Inc.*, 355 F.3d 1327, 1334 (Fed. Cir. 2004); *Cardiac Pacemakers, Inc. v. St. Jude Med., Inc.*, 296 F.3d 1106, 1113 (Fed. Cir. 2002).

generating a device presence signal (“generating means”), and (2) first pre-programmed means for . . . transmitting the [device presence] signal to the car stereo to maintain the car stereo in an operational state (“transmitting means”), Petitioner asserts that the district court’s constructions are incorrect. Pet. 17–18. For the transmitting means, Petitioner does offer its own construction as is required by 37 C.F.R. § 42.104(b)(3). Pet. 18–19. But for the generating means, Petitioner does not offer its construction by identifying corresponding structure, material, or acts in the Specification. Instead, for the transmitting means, Petitioner asserts that there is no corresponding structure, material, or acts in the Specification of the ’786 patent, and characterizes the means-plus-function element as indefinite. Pet. 17.

Without expressly identifying a ground of unpatentability based on indefiniteness under 35 U.S.C. § 112, ¶ 2, Petitioner nonetheless has mounted, effectively, a challenge of claims 92, 94, and 97 as indefinite under 35 U.S.C. § 112, ¶ 2. We note that if there is no corresponding structure, material, or acts in the specification for a means-plus-function claim element, the claim is indefinite under 35 U.S.C. § 112, ¶ 2. *See In re Dossel*, 115 F.3d 942, 946 (Fed. Cir. 1997). Except for a narrow exception explained in *In re Katz*, 639 F.3d 1303, 1316 (Fed. Cir. 2011), concerning generic functions performed by a general purpose computer, such as “processing,” “receiving” and “storing,” a computer-implemented means-plus-function element is indefinite unless the specification discloses the specific algorithm used by the computer to perform the recited function. *Eon Corp. IP Holdings LLC v. AT&T Mobility LLC*, 785 F.3d 616, 621–23 (Fed. Cir. 2015); *Function Media, LLC v. Google, Inc.*, 708 F.3d 1310,

IPR2016-00422
Patent 7,489,786 B2

1318 (Fed. Cir. 2013); *Blackboard, Inc. v. Desire2Learn, Inc.*, 574 F.3d 1371, 1385 (Fed. Cir. 2009); *Net MoneyIN, Inc. v. VeriSign, Inc.*, 545 F.3d 1359, 1367 (Fed. Cir. 2008); *Finisar Corp. v. DirectTV Group, Inc.*, 523 F.3d 1323, 1340 (Fed. Cir. 2008); and *Aristocrat Technologies Australia Pty Ltd. v. Int'l Game Techs. Inc.*, 521 F.3d 1328, 1333 (Fed. Cir. 2008). Petitioner may not, however, in an *inter partes* review, assert a ground of unpatentability based on indefiniteness under 35 U.S.C. § 112, ¶ 2. *See* 35 U.S.C. § 311(b).

In any event, with regard to alleged obviousness of claims over prior art, Petitioner has not identified structure, material, and acts in the Specification of the '786 patent that correspond to the generating means of claim 92. Therefore, Petitioner has not accounted for how such unidentified structure, material, and acts would have been met by the prior art.

Furthermore, claim 92 requires an interface connected between a car stereo and a portable audio device. Petitioner relies on its arguments presented for claim 57 to explain how Lau discloses an interface connected between a car stereo and a portable audio device. Pet. 38, 43. We already rejected those arguments in the context of claim 57, as discussed above in Section II(B)(2). The arguments are no more persuasive for claim 92.

For the foregoing reasons, we determine that Petitioner has not shown a reasonable likelihood that it would prevail in establishing unpatentability of claims 92, 94, and 97 as obvious over Lau.

*D. Alleged Obviousness of Claims
44, 57, and 92 over Lau and Bhogal*

This alleged ground of unpatentability combines Bhogal's teachings with those of Lau. Specifically, Bhogal is added to buttress the teachings of Lau with respect to the claim limitations requiring a device that is "portable"

to be connected to the interface. Thus, as applied by Petitioner, Bhogal does not cure the deficiencies of the Petition, already addressed above, with regard to claims 44, 57, and 92. Accordingly, Petitioner has not shown a reasonable likelihood that it would prevail in establishing the unpatentability of any of claims 44, 57, and 92 as obvious over Lau and Bhogal.

E. Alleged Obviousness of Claims 47, 65, 89, and 98 over Lau and KBT

Claim 47 depends from claim 44. Claim 65 depends from claim 64 which depends from claim 57. Claim 89 depends from claim 88 which depends from claim 86. Claim 98 depends from claim 97 which depends from claim 92. The deficiencies of Petitioner's assertions with respect to claims 44, 57, and 86, as discussed above, are not cured by Petitioner's application of KBT. Accordingly, Petitioner has not shown a reasonable likelihood that it would prevail in establishing the unpatentability of any of claims 47, 65, 89, and 98, as obvious over Lau and KBT.

F. Alleged Obviousness of Claims 1, 2, 4-8, 10, 13, 14, 23, 24, 61, and 62 over Lau, XR-C5120, and XA-C30

We have reviewed the Petition and the Preliminary Response, and determine that Petitioner has not shown a reasonable likelihood that it would prevail in establishing the unpatentability of any of claims 1, 2, 4-8, 10, 13, 14, 23, 24, 61, and 62 as obvious over Lau, XR-C5120, and XA-C30.

1. Claim 1

Claim 1, like claim 57, recites an interface connected between the first and second electrical connectors and for channeling audio signals to the car stereo from another device, where the first connector is connectable to the car stereo and the second connector is connectable to an audio device. In

claim 57, that audio device is a portable MP3 player. In claim 1, that audio device is an after-market audio device.

Further as compared to claim 57, claim 1 (a) adds a third connector that is electrically connectable to one or more auxiliary input sources external to the car stereo and the after-market audio device, (b) adds a code portion in the microcontroller within the interface, that is “for switching to one or more auxiliary input sources connected to said third electrical connector,” and (c) adds a code portion in the microcontroller within the interface, that is “for receiving data from the after-market audio device through said second connector in a format incompatible with the car stereo, processing the received data into formatted data compatible with the car stereo, and transmitting the formatted data to the car stereo through said first connector for display by the car stereo.”

For the addition of the third connector and the code portion for switching to one or more auxiliary input sources, Petitioner relies on XR-C5120 and XA-C30. Pet. 45–48. XR-C5120 is the Operating Instructions for Sony’s model XR-C5120 car stereo. Ex. 1005. It lists as optional equipment: “Source selector XA-C30.” *Id.* at 18. As noted above, for this decision we use the identification “XA-C30” to refer to the service manual of Sony’s Source Selector XA-C30 (Exhibit 1006). The service manual discloses how the source selector may be connected between a car stereo and multiple input sources. Ex. 1006, 2–3.

A diagram of the Sony Source Selector XA-C30 is reproduced below:

Connections

Precautions

- Before making any connection, disconnect the ground terminal of the car battery to avoid short circuits.
- Connect the yellow power input leads only after all other leads have been connected.

• Be sure to connect the unit's ground wire securely to a metal point of the car. A loose connection may cause the unit to malfunction.
• If you use the car's horn or other systems installed downstream of the battery's negative terminal, disconnect the unit's power cable from the car's battery to prevent the yellow power input and an amplifier before connecting the yellow power input.

• This unit is compatible with the CD's: CDR, CDX 7102 and XA-3002. But it is not compatible with the CD's: CDX-7201, CD 15012 or CDX 7101. Refer to the manual for further details.

Connection diagram

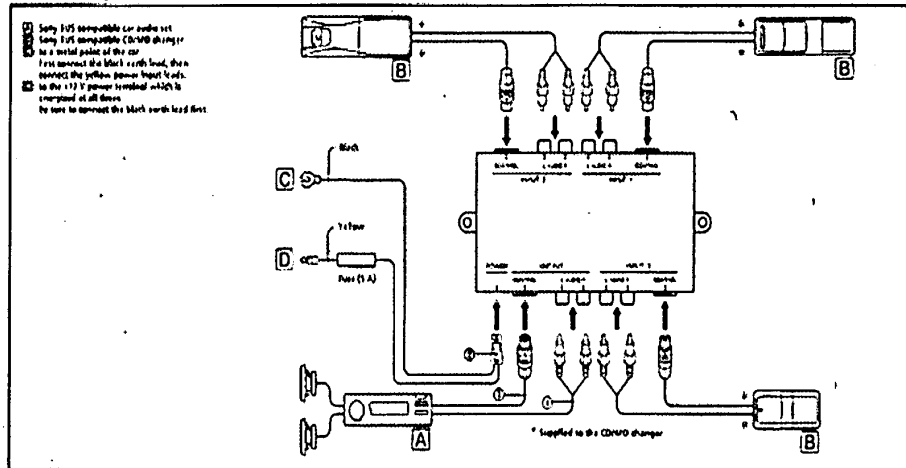

Ex. 1006, 2. The above figure illustrates a connection diagram for Sony's Source Selector XA-C30.

Petitioner illustrates its combination of Sony's Source Selector XA-C30 with the car audio system of Lau as follows:

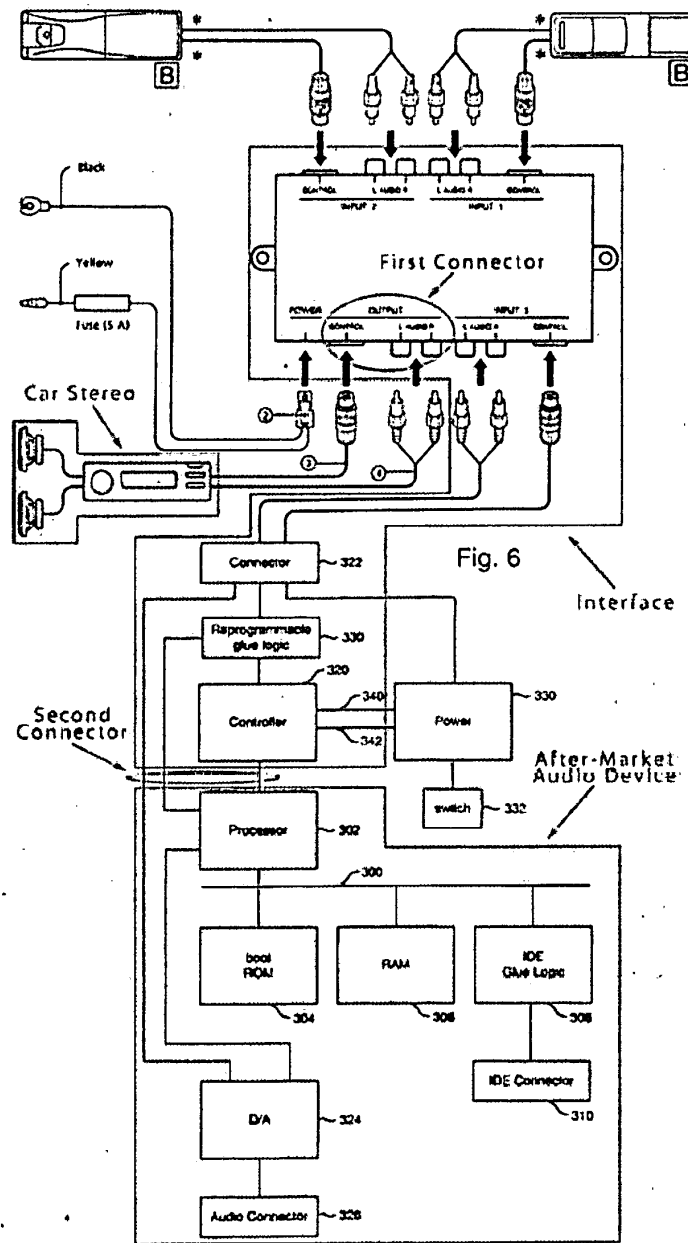

This annotated figure appears on page 46 of the Petition and illustrates the parts regarded by Petitioner as the “interface” in yellow, the part regarded by Petitioner as the after-market audio device in grey, and the car stereo colored in blue. Pet. 45–46. For reasons discussed below, we are unpersuaded that

Petitioner's combination of Lau, XR-C5120, and XA-C30, as illustrated above, meets all requirements of claim 1.

Based on our construction of "interface," the interface in claim 1 has to have separate functional and structural identity relative to the after-market audio device of claim 1, just as the interface in claim 57 has to have separate functional and structural identity relative to the portable MP3 player of claim 57. For the same reasons that the interface Petitioner identified in Lau for claim 57 does not have separate functional or structural identity with respect to what Petitioner identifies in Lau as the portable MP3 player of claim 57, the interface Petitioner identified in Lau for claim 1 does not have separate functional or structural identity with respect to what Petitioner identifies in Lau as the after-market audio device of claim 1.

With respect to claim 1's requirement of a microcontroller having a code portion "for remotely controlling the after-market audio device," Petitioner points to controller 320 as the microcontroller. Pet. 29, 33, 51. With respect to claim 1's requirement of a microcontroller having a code portion "for switching to one or more auxiliary input sources connected to said third electrical connector," Petitioner quotes this description in Lau: "The directory / microcontroller config [in disk cartridge 120] includes a series of files for configuring controller 320 (see Figure 6) to communicate with head unit 104. One file is a text file with a set of flags which indicate any of the following: disk cartridge change, *other devices connected*, head unit text on/off, time elapsed to be displayed up or down, etc." Pet. 52. (citing Ex. 1003, 10:25–11:2).

However, the fact that disk cartridge 120 contains a flag indicating "other devices connected" appears unrelated to the Sony Source Selector

XA-C30 (that part of the yellow portion above the car stereo in the above illustration) that connects the car stereo to controller 320 and a plurality of auxiliary input source as Petitioner has shown in the above illustration. Petitioner has not provided adequate explanation in that regard. There is insufficient basis to conclude that microcontroller 320 includes a code portion for switching to one or more auxiliary input sources connected to the third electrical connector, especially where, as here, the Sony Source Selector XA-C30 includes its own microprocessor controller IC1 (Ex. 1006, 8). Petitioner makes no explanation as to why it is not the controller within the Sony Source Selector XA-C30 that is “for switching to one or more auxiliary input sources connected to said third electrical connector.”

2. *Claims 2, 4–8, 10, 13, 14, 23, 24, 61, and 62*

Each of claims 2, 4–8, 10, 13, 14, and 23 depends from claim 1. Claim 24 depends from claim 23. Each of claims 61 and 62 depends from claim 60, which depends from claim 57. The deficiencies discussed above with regard to claim 1 carry through to claims 2, 4–8, 10, 13, 14, 23, and 24. Also, the deficiencies discussed above with regard to claim 57, in the context of alleged anticipation of claim 57 by Lau, carry through to claims 61 and 62 and are not cured by Petitioner’s application of XR-C5120 and XA-C30. Accordingly, Petitioner has not shown a reasonable likelihood that it would prevail in establishing unpatentability of any of claims 2, 4–8, 10, 13, 14, 23, 24, 61, and 62 as obvious over Lau, XR-C5120, and XA-C30.

G. *Alleged Obviousness of Claim 24 over Lau, XR-C5120, XA-C30, and KBT*

Claim 24 depends from claim 23, which depends from claim 1. The deficiencies of Petitioner’s assertions with respect to claim 1, as discussed above, are not cured by Petitioner’s application of KBT to the combined

IPR2016-00422
Patent 7,489,786 B2

teachings of Lau, XR-C5120, and XA-C30. Petitioner has not shown a reasonable likelihood that it would prevail in establishing the unpatentability of claim 24 as obvious over Lau, XR-C5120, XA-C30, and KBT.

III. CONCLUSION

Petitioner has *not* demonstrated a reasonable likelihood that it would prevail in establishing the unpatentability of any of claims 1, 2, 4–8, 10, 13, 14, 23, 24, 44, 47, 57, 58, 60–65, 86, 88–92, 94, 97, and 98 of the '786 patent.

III. ORDER

It is

ORDERED that the Petition is *denied* and no *inter partes* review is instituted for any claim on any alleged ground of unpatentability.

IPR2016-00422
Patent 7,489,786 B2

COUNSEL FOR PETITIONER:

William Mandir
John Rabena
Brian Shelton
SUGHRUE MION, PLLC
wmandir@sughrue.com
jrabena@sughrue.com
bshelton@sughrue.com

COUNSEL FOR PATENT OWNER:

Peter Lambrianakos
BROWN RUDNICK LLP
plambrianakos@brownrudnick.com

Under the Paperwork Reduction Act of 1995, no persons are required to respond to a collection of information unless it displays a valid OMB control number.

CHANGE OF CORRESPONDENCE ADDRESS <i>Patent</i> Address to: Mail Stop Post Issue Commissioner for Patents P.O. Box 1450 Alexandria, VA 22313-1450	Patent Number	7,489,786
	Issue Date	02/10/2009
	Application Number	10/316,961
	Filing Date	12/11/2002
	First Named Inventor	Ira Marlowe
	Attorney Docket Number	99878-00005

Please change the Correspondence Address for the above-identified patent to:

The address associated with Customer Number:

OR

Firm or Individual Name Ira Marlowe

BlitzSafe of America, Inc.
33 Honeck Street

Address

City Englewood	State NJ	ZIP 07631
-----------------------	-----------------	------------------

Country US

Telephone (973) 569-5000 **Email** i.marlowe@blitzsafe.com

This form cannot be used to change the data associated with a Customer Number. To change the data associated with an existing Customer Number use "Request for Customer Number Data Change" (PTO/SB/124).

This form will not affect any "fee address" provided for the above-identified patent. To change a "fee address" use the "Fee Address Indication Form" (PTO/SB/47).

I am the:

Patentee.

Assignee of record of the entire interest. See 37 CFR 3.71. Statement under 37 CFR 3.73(b) is enclosed. (Form PTO/SB/96).

Attorney or agent of record. Registration Number 48,319

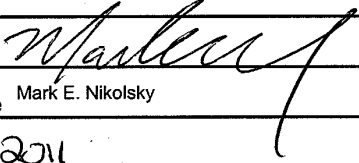
Signature 

Typed or Printed Name Mark E. Nikolsky

Date 8/8/2011 **Telephone** (973) 639-6987

NOTE: Signatures of all the inventors or assignees of record of the entire interest or their representative(s) are required. Submit multiple forms if more than one signature is required, see below".

*Total of 1 forms are submitted.

This collection of information is required by 37 CFR 1.33. The information is required to obtain or retain a benefit by the public which is to file (and by the USPTO to process) an application. Confidentiality is governed by 35 U.S.C. 122 and 37 CFR 1.11 and 1.14. This collection is estimated to take 3 minutes to complete, including gathering, preparing, and submitting the completed application form to the USPTO. Time will vary depending upon the individual case. Any comments on the amount of time you require to complete this form and/or suggestions for reducing this burden, should be sent to the Chief Information Officer, U.S. Patent and Trademark Office, U.S. Department of Commerce, P.O. Box 1450, Alexandria, VA 22313-1450. DO NOT SEND FEES OR COMPLETED FORMS TO THIS ADDRESS. **SEND TO: Mail Stop Post Issue, Commissioner for Patents, P.O. Box 1450, Alexandria, VA 22313-1450.**

If you need assistance in completing the form, call 1-800-PTO-9199 and select option 2.

Electronic Acknowledgement Receipt

EFS ID:	10684782
Application Number:	10316961
International Application Number:	
Confirmation Number:	4879
Title of Invention:	AUDIO DEVICE INTEGRATION SYSTEM
First Named Inventor/Applicant Name:	Ira Marlowe
Correspondence Address:	MICHAEL R FRISCIA MCCARTER & ENGLISH FOUR GATEWAY CENTER 100 MULBERRY STREET NEWARK NJ 07102 US 9735336599 -
Filer:	Mark E. Nikolsky/Janelle Fava
Filer Authorized By:	Mark E. Nikolsky
Attorney Docket Number:	9809/1
Receipt Date:	08-AUG-2011
Filing Date:	11-DEC-2002
Time Stamp:	13:03:23
Application Type:	Utility under 35 USC 111(a)

Payment information:

Submitted with Payment	no
------------------------	----

File Listing:

Document Number	Document Description	File Name	File Size(Bytes)/ Message Digest	Multi Part /.zip	Pages (if appl.)
1	Transmittal Letter	Transmittal.pdf	34654	no	1
			62b834564e3a39897b68e910851245fe7261ab5e		
Warnings:					
Information:					
2	Change of Address	ChangeofAddress.pdf	60170	no	1
			5471ce669d35089f9a3fc19e5c630ef7f192def		
Warnings:					
Information:					
Total Files Size (in bytes):			94824		
<p>This Acknowledgement Receipt evidences receipt on the noted date by the USPTO of the indicated documents, characterized by the applicant, and including page counts, where applicable. It serves as evidence of receipt similar to a Post Card, as described in MPEP 503.</p> <p><u>New Applications Under 35 U.S.C. 111</u> If a new application is being filed and the application includes the necessary components for a filing date (see 37 CFR 1.53(b)-(d) and MPEP 506), a Filing Receipt (37 CFR 1.54) will be issued in due course and the date shown on this Acknowledgement Receipt will establish the filing date of the application.</p> <p><u>National Stage of an International Application under 35 U.S.C. 371</u> If a timely submission to enter the national stage of an international application is compliant with the conditions of 35 U.S.C. 371 and other applicable requirements a Form PCT/DO/EO/903 indicating acceptance of the application as a national stage submission under 35 U.S.C. 371 will be issued in addition to the Filing Receipt, in due course.</p> <p><u>New International Application Filed with the USPTO as a Receiving Office</u> If a new international application is being filed and the international application includes the necessary components for an international filing date (see PCT Article 11 and MPEP 1810), a Notification of the International Application Number and of the International Filing Date (Form PCT/RO/105) will be issued in due course, subject to prescriptions concerning national security, and the date shown on this Acknowledgement Receipt will establish the international filing date of the application.</p>					

IN THE UNITED STATES PATENT AND TRADEMARK OFFICE

Customer No. 27614
Confirmation No. 4879

Commissioner for Patents
P.O. Box 1450
Alexandria, VA 22313-1450

Re: Our file: 99879-00005
Applicant: Ira Marlowe
Patent No.: 7,489,786
Issued: 02/10/2009
Serial No. 10/316,961
Filing Date: 12/11/2002
For: Audio Device Integration System

Sir:

Enclosed for filing in the United States Patent and Trademark Office is the following:

1. Change of Correspondence Address (1 page)
2. Transmittal Sheet (1 page)

CONDITIONAL PETITION

If any extension of time is required for the submission of the above-identified items, Applicant requests that this be considered a petition therefor. Please charge any additional charges or any other charges relating to this matter, or credit any overpayment, to the Deposit Account of the writer, **Account No. 503571**.

Respectfully submitted,

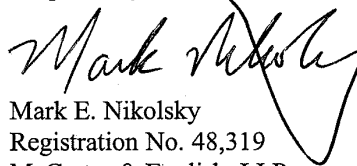

Mark E. Nikolsky
Registration No. 48,319
McCarter & English, LLP
Four Gateway Center
100 Mulberry Street
Newark, NJ 07102
Tel: (973) 639-6987
Fax: (973) 297-6624

8/8/2011
Date

CERTIFICATE OF ELECTRONIC FILING

I hereby certify that this correspondence is being electronically filed with the United States Patent and Trademark Office (via EFS-Web) on 8/8/2011.

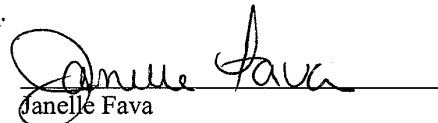

Janelle Fava

REQUEST FOR WITHDRAWAL AS ATTORNEY OR AGENT AND CHANGE OF CORRESPONDENCE ADDRESS	Application Number	10/316,961
	Filing Date	12/11/2002
	First Named Inventor	Ira M. Marlowe
	Art Unit	2614
	Examiner Name	Kurr, Jason R.
	Attorney Docket Number	99879-00005

**To: Commissioner for Patents
P.O. Box 1450
Alexandria, VA 22313-1450**

Please withdraw me as attorney or agent for the above identified patent application, and

all the practitioners of record;

the practitioners (with registration numbers) of record listed on the attached paper(s); or

the practitioners of record associated with Customer Number: 27614

NOTE: The immediately preceding box should only be marked when the practitioners were appointed using the listed Customer Number.

The reason(s) for this request are those described in 37 CFR :

<input type="checkbox"/> 10.40(b)(1)	<input type="checkbox"/> 10.40(b)(2)	<input type="checkbox"/> 10.40(b)(3)	<input type="checkbox"/> 10.40(b)(4)
<input type="checkbox"/> 10.40(c)(1)(i)	<input type="checkbox"/> 10.40(c)(1)(ii)	<input type="checkbox"/> 10.40(c)(1)(iii)	<input type="checkbox"/> 10.40(c)(1)(iv)
<input type="checkbox"/> 10.40(c)(1)(v)	<input checked="" type="checkbox"/> 10.40(c)(1)(vi)	<input type="checkbox"/> 10.40(c)(2)	<input type="checkbox"/> 10.40(c)(3)
<input type="checkbox"/> 10.40(c)(4)	<input type="checkbox"/> 10.40(c)(5)	<input type="checkbox"/> 10.40(c)(6) Please explain below:	

Certifications

Check each box below that is factually correct. WARNING: If a box is left unchecked, the request will likely not be approved.

1. I/We have given reasonable notice to the client, prior to the expiration of the response period, that the practitioner(s) intend to withdraw from employment.

2. I/We have delivered to the client or a duly authorized representative of the client all papers and property (including funds) to which the client is entitled.

3. I/We have notified the client of any responses that may be due and the time frame within which the client must respond.

Please provide an explanation, if necessary:

Under the Paperwork Reduction Act of 1995, no persons are required to respond to a collection of information unless it displays a valid OMB control number.

REQUEST FOR WITHDRAWAL AS ATTORNEY OR AGENT AND CHANGE OF CORRESPONDENCE ADDRESS

Complete the following section only when the correspondence address will change. Changes of address will only be accepted to an inventor or an assignee that has properly made itself of record pursuant to 37 CFR 3.71.

Change the correspondence address and direct all future correspondence to:

A. The address of the inventor or assignee associated with Customer Number: _____

OR

B. Inventor or Assignee name Ira M. Marlowe

Address BlitzSafe of America, Inc., 33 Honeck Street

City Englewood State NJ Zip 07631 Country US

Telephone (201) 569-5000 Email i.marlowe@blitzsafe.com

I am authorized to sign on behalf of myself and all withdrawing practitioners.

Signature

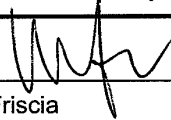

Name

Michael R. Friscia

Registration No. 33,884

Address McCarter & English, LLP, 100 Mulberry Street, Four Gateway Center

City Newark State NJ Zip 07102 Country US

Date

5/6/11

Telephone No. (973) 639-8493

NOTE: *Withdrawal is effective when approved rather than when received.*

[Page 2 of 2]

This collection of information is required by 37 CFR 1.36. The information is required to obtain or retain a benefit by the public which is to file (and by the USPTO to process) an application. Confidentiality is governed by 35 U.S.C. 122 and 37 CFR 1.11 and 1.14. This collection is estimated to take 12 minutes to complete, including gathering, preparing, and submitting the completed application form to the USPTO. Time will vary depending upon the individual case. Any comments on the amount of time you require to complete this form and/or suggestions for reducing this burden, should be sent to the Chief Information Officer, U.S. Patent and Trademark Office, U.S. Department of Commerce, P.O. Box 1450, Alexandria, VA 22313-1450. DO NOT SEND FEES OR COMPLETED FORMS TO THIS ADDRESS. SEND TO: Commissioner for Patents, P.O. Box 1450, Alexandria, VA 22313-1450.

If you need assistance in completing the form, call 1-800-PTO-9199 and select option 2.

Electronic Acknowledgement Receipt

EFS ID:	10037634
Application Number:	10316961
International Application Number:	
Confirmation Number:	4879
Title of Invention:	AUDIO DEVICE INTEGRATION SYSTEM
First Named Inventor/Applicant Name:	Ira Marlowe
Correspondence Address:	MICHAEL R FRISCIA MCCARTER & ENGLISH FOUR GATEWAY CENTER 100 MULBERRY STREET NEWARK NJ 07102 US 9735336599 -
Filer:	Michael R. Friscia/Janelle Fava
Filer Authorized By:	Michael R. Friscia
Attorney Docket Number:	9809/1
Receipt Date:	06-MAY-2011
Filing Date:	11-DEC-2002
Time Stamp:	14:33:20
Application Type:	Utility under 35 USC 111(a)

Payment information:

Submitted with Payment	no
------------------------	----

File Listing:

Document Number	Document Description	File Name	File Size(Bytes)/ Message Digest	Multi Part /.zip	Pages (if appl.)
1	Transmittal Letter	Transmittal.pdf	33946	no	1
			6e1818b4bbb1b07443c0b5971f1601617ff93240		
Warnings:					
Information:					
2	Petition to withdraw attorney or agent (SB83)	Withdrawal.pdf	111094	no	2
			5a49e16d05921888de20d71c41ee64a75bc86a84		
Warnings:					
Information:					
Total Files Size (in bytes):			145040		
<p>This Acknowledgement Receipt evidences receipt on the noted date by the USPTO of the indicated documents, characterized by the applicant, and including page counts, where applicable. It serves as evidence of receipt similar to a Post Card, as described in MPEP 503.</p> <p><u>New Applications Under 35 U.S.C. 111</u> If a new application is being filed and the application includes the necessary components for a filing date (see 37 CFR 1.53(b)-(d) and MPEP 506), a Filing Receipt (37 CFR 1.54) will be issued in due course and the date shown on this Acknowledgement Receipt will establish the filing date of the application.</p> <p><u>National Stage of an International Application under 35 U.S.C. 371</u> If a timely submission to enter the national stage of an international application is compliant with the conditions of 35 U.S.C. 371 and other applicable requirements a Form PCT/DO/EO/903 indicating acceptance of the application as a national stage submission under 35 U.S.C. 371 will be issued in addition to the Filing Receipt, in due course.</p> <p><u>New International Application Filed with the USPTO as a Receiving Office</u> If a new international application is being filed and the international application includes the necessary components for an international filing date (see PCT Article 11 and MPEP 1810), a Notification of the International Application Number and of the International Filing Date (Form PCT/RO/105) will be issued in due course, subject to prescriptions concerning national security, and the date shown on this Acknowledgement Receipt will establish the international filing date of the application.</p>					

IN THE UNITED STATES PATENT AND TRADEMARK OFFICE

Customer No. 27614
Confirmation No. 4879

Commissioner for Patents
P.O. Box 1450
Alexandria, VA 22313-1450

Examiner: Kurr, Jason R.
Art Unit: 2614

Re: Our file: 99879-00005
Applicant: Ira Marlowe
Serial No.: 10/316,961
Filed: 12/11/2002
Patent No.: 7,489,786
Issue Date: 02/10/2009
For: Audio Device Integration System

Sir:

Enclosed for filing in the United States Patent and Trademark Office is the following:

1. Request for Withdrawal as Attorney or Agent and Change of Correspondence Address
2. Transmittal Sheet

CONDITIONAL PETITION

If any extension of time is required for the submission of the above-identified items, Applicant requests that this be considered a petition therefor. Please charge any additional charges or any other charges relating to this matter, or credit any overpayment, to the Deposit Account of the writer, **Account No. 503571**.

5/6/11
Date

Respectfully submitted,

Michael R. Friscia
Registration No. 33,884
McCarter & English, LLP
Four Gateway Center
100 Mulberry Street
Newark, NJ 07102
Tel: (973) 639-8493
Fax: (973) 297-6627

CERTIFICATE OF ELECTRONIC FILING

I hereby certify that this correspondence is being electronically filed with the United States Patent and Trademark Office (via EFS-Web) on 5/6/2011.

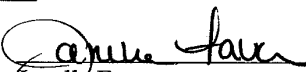
Janelle Fava

UNITED STATES PATENT AND TRADEMARK OFFICE
CERTIFICATE OF CORRECTION

PATENT NO. : 7,489,786 B2
APPLICATION NO. : 10/316961
DATED : February 10, 2009
INVENTOR(S) : Ira Marlowe

Page 1 of 2

It is certified that error appears in the above-identified patent and that said Letters Patent is hereby corrected as shown below:

On the Title Page Item (56), on Page 2 of the patent, the spelling of the Inventor's name of U.S. Patent No. 6,005,488 should read "Symanow, et al." instead of "Symanov, et al."

On the Title Page Item (56) in the References Cited Section, on Page 2 of the patent under Other Publications, the fourth reference listed, the website should read "www.venturatechnology.net" instead of "www.venturatechnoogy.net."

On the Title Page Item (56) in the References Cited Section, on Page 2 of the patent under Other Publications, please include the following reference: ""Automedia," magazine pages from Feb. 1999 issue (2 pages)."

On the Title Page Item (56) in the References Cited Section, on Page 2 of the patent under Other Publications, the nineteenth reference listed should read "3 pages" submitted instead of "2 pages."

Column 9, line 3, "USART" should be deleted and replaced with "UART."

Column 10, line 7, "USART" should be deleted and replaced with "UART."

Column 11, line 56, "USART" should be deleted and replaced with "UART."

Column 19, line 39, the second instance of the word "is" should be deleted and replaced with the word "if."

Column 23, line 54, "24" should be deleted and replaced with "25."

Column 27, line 25, "63" should be deleted and replaced with "66."

UNITED STATES PATENT AND TRADEMARK OFFICE
CERTIFICATE OF CORRECTION

PATENT NO. : 7,489,786 B2
APPLICATION NO. : 10/316961
DATED : February 10, 2009
INVENTOR(S) : Ira Marlowe

Page 2 of 2

It is certified that error appears in the above-identified patent and that said Letters Patent is hereby corrected as shown below:

Column 30, line 9, the word "comprises" and the word "comprising" should be deleted and replaced with "comprises."

Signed and Sealed this

Seventh Day of April, 2009

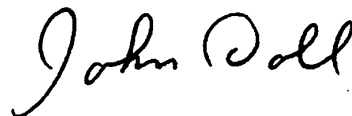

JOHN DOLL
Acting Director of the United States Patent and Trademark Office

IN THE UNITED STATES PATENT AND TRADEMARK OFFICE

Applicant(s): Ira Marlowe
Patent No: 7,489,786
Issued: 02/10/2009
For: Audio Device Integration System

COMMUNICATION

ATTN: CERTIFICATE OF CORRECTIONS BRANCH
Commissioner for Patents
P.O. Box 1450
Alexandria, VA 22313-1450

Sir:

Applicant respectfully submits a request for a Certificate of Correction for the above-referenced patent to correct typographical errors contained throughout the patent.

Additionally, Applicant notes that there should be two citations listed with the following title in the References Cited Section, on page 2 of the patent, under Other Publications:

“‘Automedia,’ magazine pages from Feb. 1999 issue (2 pages).”

This citation only appears once. However, two separate articles were submitted from the same issue of this magazine, and both were listed in an Information Disclosure Statement dated May 26, 2006. Accordingly, this citation should be listed twice on the issued patent. For reference, attached hereto at Exhibit A is a copy of the Information Disclosure Citation Form, dated May 26, 2006, which lists the aforementioned articles and is signed by the Examiner.

ME1 8212189v.1

Patent No. 7,489,786
March 12, 2009
Page 2

These changes are indicated on the enclosed Certificate of Correction.

The Commissioner is authorized to charge \$100.00 to Deposit Account No. **503571** to cover the government filing fee for filing the Request for Certificate of Correction under 37 C.F.R. § 1.323. If there are any additional fees due in connection with this matter, the Commissioner is authorized to charge them to Deposit Account No. **503571**.

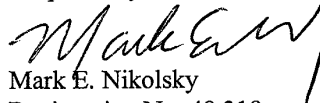

3/12/09
Date

Respectfully submitted,

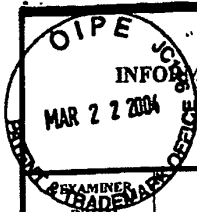

Mark E. Nikolsky
Registration No. 48,319
McCarter & English, LLP
Four Gateway Center
100 Mulberry Street
Newark, NJ 07102
Tel: (973) 639-6987
Fax: (973) 297-6624

EXHIBIT A

		Docket Number (Optional) 9809/1	Application Number 10/316,961
		Applicant(s) Ira Marlowe	
		Filing Date 12/11/02	Group Art Unit 2644
OTHER DOCUMENTS (Including Author, Title, Date, Pertinent Pages, Etc.)			
J/K	13	"Automedia," magazine pages from June/July 1996 issue (2 pages).	
	14	"Automedia," magazine pages from January 1998 issue (2 pages).	
	15	"Automedia," magazine pages from February 1998 issue (2 pages).	RECEIVED MAR 2 4 2004 Technology Center 2600
	16	"Automedia," magazine pages from July 1998 issue (2 pages).	
	17	"Automedia," magazine pages from September 1998 issue (2 pages).	
	18	"Automedia," magazine pages from November 1998 issue (12 pages).	
	19	"Automedia," magazine pages from February 1999 issue (2 pages).	
	20	"Automedia," magazine pages from February 1999 issue (2 pages).	
	21	"Car Stereo Review," magazine pages from June 1998 issue (5 pages).	
	22	"Car Stereo Review," magazine pages from January 1999 issue (2 pages).	
	23	"Car Stereo Review," magazine pages from April 1999 issue (3 pages).	
	24	"Car Audio and Electronics," magazine pages from December 1998 issue (2 pages).	
EXAMINER			DATE CONSIDERED 5/26/06
*EXAMINER: Initial if citation considered, whether or not citation is in conformance with MPEP Section 609; Draw line through citation if not in conformance and not considered. Include copy of this form with next communication to applicant.			

PO8B/REV04

SHEET 2 OF 5

**UNITED STATES PATENT AND TRADEMARK OFFICE
CERTIFICATE OF CORRECTION**

Page 1 of 1

PATENT NO. : 7,489,786
APPLICATION NO.: 10/316,961
ISSUE DATE : 02/10/2009
INVENTOR(S) : Ira Marlowe

It is certified that an error appears or errors appear in the above-identified patent and that said Letters Patent is hereby corrected as shown below:

In the References Cited Section, on Page 2 of the patent, in the first column, the spelling of the Inventor's name of U.S. Patent No. 6,005,488 should read "Symanow, et al." instead of "Symanov, et al."

In the References Cited Section, on Page 2 of the patent under Other Publications, in second column, the fourth reference listed, the website should read "www.venturatechnology.net" instead of "www.venturatechnoogy.net."

In the References Cited Section, on Page 2 of the patent under Other Publications, please include the following reference: "'Automedia," magazine pages from Feb. 1999 issue (2 pages)."

In the References Cited Section, on Page 2 of the patent under Other Publications, in second column, the nineteenth reference listed should read "3 pages" submitted instead of "2 pages."

Column 9, line 3, "USART" should be deleted and replaced with "UART."

Column 10, line 7, "USART" should be deleted and replaced with "UART."

Column 11, line 56, "USART" should be deleted and replaced with "UART."

Column 19, line 39, the second instance of the word "is" should be deleted and replaced with the word "if."

Column 23, line 54, "24" should be deleted and replaced with "25."

Column 27, line 25, "63" should be deleted and replaced with "66."

Column 30, line 9, the word "comprises" and the word "comprising" should be deleted and replaced with "comprises."

MAILING ADDRESS OF SENDER (Please do not use customer number below):

Mark E. Nikolsky, McCarter & English, LLP
Four Gateway Center
100 Mulberry Street
Newark, NJ 07102

This collection of information is required by 37 CFR 1.322, 1.323, and 1.324. The information is required to obtain or retain a benefit by the public which is to file (and by the USPTO to process) an application. Confidentiality is governed by 35 U.S.C. 122 and 37 CFR 1.14. This collection is estimated to take 1.0 hour to complete, including gathering, preparing, and submitting the completed application form to the USPTO. Time will vary depending upon the individual case. Any comments on the amount of time you require to complete this form and/or suggestions for reducing this burden, should be sent to the Chief Information Officer, U.S. Patent and Trademark Office, U.S. Department of Commerce, P.O. Box 1450, Alexandria, VA 22313-1450. DO NOT SEND FEES OR COMPLETED FORMS TO THIS ADDRESS. SEND TO: **Attention Certificate of Corrections Branch, Commissioner for Patents, P.O. Box 1450, Alexandria, VA 22313-1450.**

If you need assistance in completing the form, call 1-800-PTO-9199 and select option 2.

Electronic Patent Application Fee Transmittal

Application Number:	10316961				
Filing Date:	11-Dec-2002				
Title of Invention:	AUDIO DEVICE INTEGRATION SYSTEM				
First Named Inventor/Applicant Name:	Ira Marlowe				
Filer:	Mark E. Nikolsky/Janelle Fava				
Attorney Docket Number:	9809/1				
Filed as Small Entity					
Utility under 35 USC 111(a) Filing Fees					
Description	Fee Code	Quantity	Amount	Sub-Total in USD(\$)	
Basic Filing:					
Pages:					
Claims:					
Miscellaneous-Filing:					
Petition:					
Patent-Appeals-and-Interference:					
Post-Allowance-and-Post-Issuance:					
Certificate of correction	1811	1	100	100	
Extension-of-Time:					

Description	Fee Code	Quantity	Amount	Sub-Total in USD(\$)
Miscellaneous:				
Total in USD (\$)				100

Electronic Acknowledgement Receipt

EFS ID:	4955372
Application Number:	10316961
International Application Number:	
Confirmation Number:	4879
Title of Invention:	AUDIO DEVICE INTEGRATION SYSTEM
First Named Inventor/Applicant Name:	Ira Marlowe
Correspondence Address:	MICHAEL R FRISCIA MCCARTER & ENGLISH FOUR GATEWAY CENTER 100 MULBERRY STREET NEWARK NJ 07102 US 9735336599 -
Filer:	Mark E. Nikolsky/Janelle Fava
Filer Authorized By:	Mark E. Nikolsky
Attorney Docket Number:	9809/1
Receipt Date:	12-MAR-2009
Filing Date:	11-DEC-2002
Time Stamp:	15:03:41
Application Type:	Utility under 35 USC 111(a)

Payment information:

Submitted with Payment	yes
Payment Type	Deposit Account
Payment was successfully received in RAM	\$100

RAM confirmation Number	299
Deposit Account	503571
Authorized User	

The Director of the USPTO is hereby authorized to charge indicated fees and credit any overpayment as follows:

- Charge any Additional Fees required under 37 C.F.R. Section 1.16 (National application filing, search, and examination fees)
- Charge any Additional Fees required under 37 C.F.R. Section 1.17 (Patent application and reexamination processing fees)
- Charge any Additional Fees required under 37 C.F.R. Section 1.19 (Document supply fees)
- Charge any Additional Fees required under 37 C.F.R. Section 1.20 (Post Issuance fees)
- Charge any Additional Fees required under 37 C.F.R. Section 1.21 (Miscellaneous fees and charges)

File Listing:

Document Number	Document Description	File Name	File Size(Bytes)/ Message Digest	Multi Part /.zip	Pages (if appl.)
1	Miscellaneous Incoming Letter	transmittal.pdf	35421 d50210f3740e21a60d62eae5402b20f8e6cb457f	no	1

Warnings:

Information:

2	Request for Certificate of Correction	certificateofcorrection.pdf	167202 cae6ecdffffb27d671f81907f3e512d71615632b	no	5
---	---------------------------------------	-----------------------------	--	----	---

Warnings:

Information:

3	Fee Worksheet (PTO-06)	fee-info.pdf	29795 7f0d055a1f5dc3c3b4bb67495978b2e2bb7e108d	no	2
---	------------------------	--------------	---	----	---

Warnings:

Information:

Total Files Size (in bytes):	232418
-------------------------------------	--------

This Acknowledgement Receipt evidences receipt on the noted date by the USPTO of the indicated documents, characterized by the applicant, and including page counts, where applicable. It serves as evidence of receipt similar to a Post Card, as described in MPEP 503.

New Applications Under 35 U.S.C. 111

If a new application is being filed and the application includes the necessary components for a filing date (see 37 CFR 1.53(b)-(d) and MPEP 506), a Filing Receipt (37 CFR 1.54) will be issued in due course and the date shown on this Acknowledgement Receipt will establish the filing date of the application.

National Stage of an International Application under 35 U.S.C. 371

If a timely submission to enter the national stage of an international application is compliant with the conditions of 35 U.S.C. 371 and other applicable requirements a Form PCT/DO/EO/903 indicating acceptance of the application as a national stage submission under 35 U.S.C. 371 will be issued in addition to the Filing Receipt, in due course.

New International Application Filed with the USPTO as a Receiving Office

If a new international application is being filed and the international application includes the necessary components for an international filing date (see PCT Article 11 and MPEP 1810), a Notification of the International Application Number and of the International Filing Date (Form PCT/RO/105) will be issued in due course, subject to prescriptions concerning national security, and the date shown on this Acknowledgement Receipt will establish the international filing date of the application.

IN THE UNITED STATES PATENT AND TRADEMARK OFFICE

Attn: Certificate of Corrections Branch
Commissioner for Patents
P.O. Box 1450
Alexandria, VA 22313-1450

Customer No. 27614
Confirmation No. 4879

Re: Our file: 99879-00005
Applicant: Ira Marlowe
Patent No.: 7,489,786
Issued: 02/10/2009
Serial No. 10/316,961
Filing Date: 12/11/2002
For: Audio Device Integration System

Sir:

Enclosed for filing in the United States Patent and Trademark Office is the following:

1. Communication (4 pages)
2. Certificate of Correction (1 page)
3. Transmittal Sheet (1 page)

CONDITIONAL PETITION

If any extension of time is required for the submission of the above-identified items, Applicant requests that this be considered a petition therefor. Please charge any additional charges or any other charges relating to this matter, or credit any overpayment, to the Deposit Account of the writer, **Account No. 503571**.

Respectfully submitted,

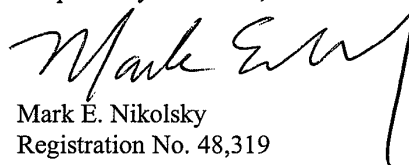

Mark E. Nikolsky
Registration No. 48,319
McCarter & English, LLP
Four Gateway Center
100 Mulberry Street
Newark, NJ 07102
Tel: (973) 639-6987
Fax: (973) 297-6624

3/12/09
Date

CERTIFICATE OF ELECTRONIC FILING

I hereby certify that this correspondence is being electronically filed with the United States Patent and Trademark Office (via EFS-Web) on 3/12/09

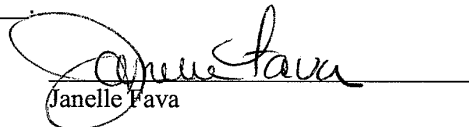

Janelle Fava



UNITED STATES PATENT AND TRADEMARK OFFICE

UNITED STATES DEPARTMENT OF COMMERCE
United States Patent and Trademark Office
Address: COMMISSIONER FOR PATENTS
P. O. Box 1450
Alexandria, Virginia 22313-1450
www.uspto.gov

APPLICATION NO.	ISSUE DATE	PATENT NO.	ATTORNEY DOCKET NO.	CONFIRMATION NO.
10/316,961	02/10/2009	7489786	9809/1	4879

7590 01/21/2009
MICHAEL R FRISCIA
MCCARTER & ENGLISH
FOUR GATEWAY CENTER
100 MULBERRY STREET
NEWARK, NJ 07102

ISSUE NOTIFICATION

The projected patent number and issue date are specified above.

Determination of Patent Term Adjustment under 35 U.S.C. 154 (b)
(application filed on or after May 29, 2000)

The Patent Term Adjustment is 820 day(s). Any patent to issue from the above-identified application will include an indication of the adjustment on the front page.

If a Continued Prosecution Application (CPA) was filed in the above-identified application, the filing date that determines Patent Term Adjustment is the filing date of the most recent CPA.

Applicant will be able to obtain more detailed information by accessing the Patent Application Information Retrieval (PAIR) WEB site (<http://pair.uspto.gov>).

Any questions regarding the Patent Term Extension or Adjustment determination should be directed to the Office of Patent Legal Administration at (571)-272-7702. Questions relating to issue and publication fee payments should be directed to the Customer Service Center of the Office of Patent Publication at (571)-272-4200.

APPLICANT(s) (Please see PAIR WEB site <http://pair.uspto.gov> for additional applicants):

Ira Marlowe, Fort Lee, NJ;

PART B - FEE(S) TRANSMITTAL

**Complete and send this form, together with applicable fee(s), to: Mail Mail Stop ISSUE FEE
 Commissioner for Patents
 P.O. Box 1450
 Alexandria, Virginia 22313-1450
 or Fax (571)-273-2885**

INSTRUCTIONS: This form should be used for transmitting the ISSUE FEE and PUBLICATION FEE (if required). Blocks 1 through 5 should be completed where appropriate. All further correspondence including the Patent, advance orders and notification of maintenance fees will be mailed to the current correspondence address as indicated unless corrected below or directed otherwise in Block 1, by (a) specifying a new correspondence address; and/or (b) indicating a separate "FEE ADDRESS" for maintenance fee notifications.

CURRENT CORRESPONDENCE ADDRESS (Note: Use Block 1 for any change of address)

7590 12/29/2008

MICHAEL R FRISCIA
 MCCARTER & ENGLISH
 FOUR GATEWAY CENTER
 100 MULBERRY STREET
 NEWARK, NJ 07102

Note: A certificate of mailing can only be used for domestic mailings of the Fee(s) Transmittal. This certificate cannot be used for any other accompanying papers. Each additional paper, such as an assignment or formal drawing, must have its own certificate of mailing or transmission.

Certificate of Mailing or Transmission

I hereby certify that this Fee(s) Transmittal is being deposited with the United States Postal Service with sufficient postage for first class mail in an envelope addressed to the Mail Stop ISSUE FEE address above, or being facsimile transmitted to the USPTO (571) 273-2885, on the date indicated below.

Diane M. Bodzioch	(Depositor's name)
	(Signature)
December 31, 2008	(Date)

APPLICATION NO.	FILING DATE	FIRST NAMED INVENTOR	ATTORNEY DOCKET NO.	CONFIRMATION NO.
10/316,961	12/11/2002	Ira Marlowe	9809/1	4879

TITLE OF INVENTION: AUDIO DEVICE INTEGRATION SYSTEM

APPLN. TYPE	SMALL ENTITY	ISSUE FEE DUE	PUBLICATION FEE DUE	PREV. PAID ISSUE FEE	TOTAL FEE(S) DUE	DATE DUE
nonprovisional	YES	\$755	\$0	\$720	\$755	03/30/2009

EXAMINER	ART UNIT	CLASS-SUBCLASS
KURR, JASON RICHARD	2614	381-086000

1. Change of correspondence address or indication of "Fee Address" (37 CFR 1.363).

Change of correspondence address (or Change of Correspondence Address form PTO/SB/122) attached.

"Fee Address" indication (or "Fee Address" Indication form PTO/SB/47; Rev 03-02 or more recent) attached. Use of a **Customer Number is required.**

2. For printing on the patent front page, list McCarter & English, LLP

(1) the names of up to 3 registered patent attorneys or agents OR, alternatively, 1 _____

(2) the name of a single firm (having as a member a registered attorney or agent) and the names of up to 2 registered patent attorneys or agents. If no name is listed, no name will be printed. 2 _____

3 _____

3. ASSIGNEE NAME AND RESIDENCE DATA TO BE PRINTED ON THE PATENT (print or type)

PLEASE NOTE: Unless an assignee is identified below, no assignee data will appear on the patent. If an assignee is identified below, the document has been filed for recordation as set forth in 37 CFR 3.11. Completion of this form is NOT a substitute for filing an assignment.

(A) NAME OF ASSIGNEE _____ (B) RESIDENCE: (CITY and STATE OR COUNTRY) _____

Please check the appropriate assignee category or categories (will not be printed on the patent): Individual Corporation or other private group entity Government

4a. The following fee(s) are submitted:

Issue Fee

Publication Fee (No small entity discount permitted)

Advance Order - # of Copies 5

4b. Payment of Fee(s): (Please first reapply any previously paid issue fee shown above)

A check is enclosed.

Payment by credit card. Form PTO-2038 is attached.

The Director is hereby authorized to charge the required fee(s), any deficiency, or credit any overpayment, to Deposit Account Number 503571 (enclose an extra copy of this form).

5. Change in Entity Status (from status indicated above)

a. Applicant claims SMALL ENTITY status. See 37 CFR 1.27. b. Applicant is no longer claiming SMALL ENTITY status. See 37 CFR 1.27(g)(2).

NOTE: The Issue Fee and Publication Fee (if required) will not be accepted from anyone other than the applicant; a registered attorney or agent; or the assignee or other party in interest as shown by the records of the United States Patent and Trademark Office.

Authorized Signature  Date December 31, 2008

Typed or printed name Michael R. Friscia Registration No. 33,884

This collection of information is required by 37 CFR 1.311. The information is required to obtain or retain a benefit by the public which is to file (and by the USPTO to process) an application. Confidentiality is governed by 35 U.S.C. 122 and 37 CFR 1.14. This collection is estimated to take 12 minutes to complete, including gathering, preparing, and submitting the completed application form to the USPTO. Time will vary depending upon the individual case. Any comments on the amount of time you require to complete this form and/or suggestions for reducing this burden, should be sent to the Chief Information Officer, U.S. Patent and Trademark Office, U.S. Department of Commerce, P.O. Box 1450, Alexandria, Virginia 22313-1450. DO NOT SEND FEES OR COMPLETED FORMS TO THIS ADDRESS. SEND TO: Commissioner for Patents, P.O. Box 1450, Alexandria, Virginia 22313-1450.

Under the Paperwork Reduction Act of 1995, no persons are required to respond to a collection of information unless it displays a valid OMB control number.

Electronic Patent Application Fee Transmittal

Application Number:	10316961				
Filing Date:	11-Dec-2002				
Title of Invention:	AUDIO DEVICE INTEGRATION SYSTEM				
First Named Inventor/Applicant Name:	Ira Marlowe				
Filer:	Michael R. Friscia/Diane Bodzioch				
Attorney Docket Number:	9809/1				
Filed as Small Entity					
Utility under 35 USC 111(a) Filing Fees					
Description	Fee Code	Quantity	Amount	Sub-Total in USD(\$)	
Basic Filing:					
Pages:					
Claims:					
Miscellaneous-Filing:					
Petition:					
Patent-Appeals-and-Interference:					
Post-Allowance-and-Post-Issuance:					
Utility Appl issue fee	2501	1	755	755	
Extension-of-Time:					

Description	Fee Code	Quantity	Amount	Sub-Total in USD(\$)
Miscellaneous:				
Printed copy of patent - no color	8001	5	3	15
Total in USD (\$)				770

Electronic Acknowledgement Receipt

EFS ID:	4543553
Application Number:	10316961
International Application Number:	
Confirmation Number:	4879
Title of Invention:	AUDIO DEVICE INTEGRATION SYSTEM
First Named Inventor/Applicant Name:	Ira Marlowe
Correspondence Address:	MICHAEL R FRISCIA MCCARTER & ENGLISH FOUR GATEWAY CENTER 100 MULBERRY STREET NEWARK NJ 07102 US 9735336599 -
Filer:	Michael R. Friscia/Diane Bodzioch
Filer Authorized By:	Michael R. Friscia
Attorney Docket Number:	9809/1
Receipt Date:	31-DEC-2008
Filing Date:	11-DEC-2002
Time Stamp:	13:50:18
Application Type:	Utility under 35 USC 111(a)

Payment information:

Submitted with Payment	no
------------------------	----

File Listing:

Document Number	Document Description	File Name	File Size(Bytes)/ Message Digest	Multi Part /.zip	Pages (if appl.)
1	Miscellaneous Incoming Letter	coverletter.pdf	25657 489b788f6930c4e7eaf3d7ec2d03fa49a89b1a1d	no	1
Warnings:					
Information:					
2	Miscellaneous Incoming Letter	Communication.pdf	20873 9028a455c81784f98baf14f826ffb023f379de9	no	1
Warnings:					
Information:					
3	Miscellaneous Incoming Letter	FeeTransmittal.pdf	34249 1d77f98c1cda1a570fdacbcd7756df58ce6bdb	no	1
Warnings:					
Information:					
4	Issue Fee Payment (PTO-85B)	PartB.pdf	63917 a5440b9be4c7f197e5374a85d873b145682bf3a5	no	1
Warnings:					
Information:					
5	Fee Worksheet (PTO-06)	fee-info.pdf	31878 1d468721515afa6c66e27bfaa2adfd6bb31524	no	2
Warnings:					
Information:					
Total Files Size (in bytes):			176574		
<p>This Acknowledgement Receipt evidences receipt on the noted date by the USPTO of the indicated documents, characterized by the applicant, and including page counts, where applicable. It serves as evidence of receipt similar to a Post Card, as described in MPEP 503.</p> <p><u>New Applications Under 35 U.S.C. 111</u> If a new application is being filed and the application includes the necessary components for a filing date (see 37 CFR 1.53(b)-(d) and MPEP 506), a Filing Receipt (37 CFR 1.54) will be issued in due course and the date shown on this Acknowledgement Receipt will establish the filing date of the application.</p> <p><u>National Stage of an International Application under 35 U.S.C. 371</u> If a timely submission to enter the national stage of an international application is compliant with the conditions of 35 U.S.C. 371 and other applicable requirements a Form PCT/DO/EO/903 indicating acceptance of the application as a national stage submission under 35 U.S.C. 371 will be issued in addition to the Filing Receipt, in due course.</p> <p><u>New International Application Filed with the USPTO as a Receiving Office</u> If a new international application is being filed and the international application includes the necessary components for an international filing date (see PCT Article 11 and MPEP 1810), a Notification of the International Application Number and of the International Filing Date (Form PCT/RO/105) will be issued in due course, subject to prescriptions concerning national security, and the date shown on this Acknowledgement Receipt will establish the international filing date of the application.</p>					

IN THE UNITED STATES PATENT AND TRADEMARK OFFICE

Applicant: Ira M. Marlowe
Serial No.: 10/316,961
Filed: 12/11/2002
Title: AUDIO DEVICE INTEGRATION SYSTEM

Examiner: Kurr, Jason R.

Art Unit: 2615

TRANSMITTAL OF PAYMENT OF ISSUE FEE (37 C.F.R. § 1.311)

Mail Stop Issue Fee
Commissioner for Patents
P.O. Box 1450
Alexandria, VA 22313-1450

Sir:

Enclosed for filing in the United States Patent and Trademark Office is the following:

1. Communication
2. Transmittal of Payment of Issue Fee(37 C.F.R. § 1.311)
3. Fee(s) Transmittal
4. Transmittal Sheet

CONDITIONAL PETITION

If any extension of time is required for the submission of the above-identified items, Applicant requests that this be considered a petition therefore. Please charge any additional charges or any other charges relating to this matter, or credit any overpayment, to the Deposit Account of the writer, **Account No. 503571.**

Respectfully submitted,

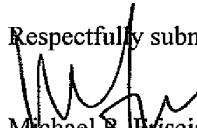
Michael R. Piviscia
Reg. No. 33,884
McCarter & English, LLP
Four Gateway Center
100 Mulberry Street
Newark, NJ 07102-4056
Tel: (973) 639-8493
Fax: (973) 297-6627

Dated: December 31, 2008

CERTIFICATE OF ELECTRONIC FILING

I hereby certify that this correspondence is being electronically filed with the United States Patent and Trademark Office (via EFS-Web) on December 31, 2008

Diane M. Bodzioch

IN THE UNITED STATES PATENT AND TRADEMARK OFFICE

Applicant: Ira M. Marlowe
Serial No.: 10/316,961
Filed: 12/11/2002
Title: AUDIO DEVICE INTEGRATION SYSTEM

Examiner: Kurr, Jason R.

Art Unit: 2615

COMMUNICATION

Mail Stop Issue Fee
Commissioner for Patents
P.O. Box 1450
Alexandria, VA 22313-1450

Sir:

Applicant previously paid an Issue Fee in the amount of \$720 on August 15, 2008, in connection with the present application. Applicant hereby requests that this payment be applied to the current Issue Fee of \$755, and herewith submits payment of the difference, i.e., \$35, due to an increase in issue fees. Applicant also submits herewith payment of \$15 for five (5) copies of the patent. Commissioner is hereby authorized to charge \$50, and any additional fees, to Deposit Account No. 503571.

Respectfully submitted,

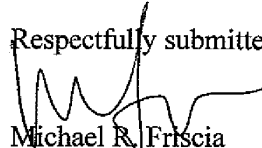
Michael R. Friscia
Reg. No. 33,884
McCarter & English, LLP
Four Gateway Center
100 Mulberry Street
Newark, NJ 07102-4056
Tel: (973) 639-8493
Fax: (973) 297-6627

Dated: December 31, 2008

TRANSMITTAL OF PAYMENT OF ISSUE FEE (Small Entity)
(37 C.F.R. 1.311)

Docket No.
9809/1

Applicant(s): Ira Marlowe

Application No.	Filing Date	Examiner	Customer No.	Group Art Unit	Confirmation No.
10/316,961	12/11/2002	Kurr, Jason Richard	27614	2615	4879

Invention: Audio Device Integration System

Mail Stop Issue Fee
COMMISSIONER FOR PATENTS
P.O. Box 1450
Alexandria, VA 22313-1450

Transmitted herewith are the following for the above-identified application.

- Issue Fee Transmittal Form PTOL-85
- Utility Fee: \$ 50.00 Design Fee: Plant Fee:
- Publication Fee:
- A check in the amount of is attached.
- The Director is hereby authorized to charge and credit Deposit Account No. as described below.
 - Charge the amount of \$50.00
 - Credit any overpayment.
 - Charge any additional fee required.
- Payment by credit card. Form PTO-2038 is attached.

WARNING: Information on this form may become public. Credit card information should not be included on this form. Provide credit card information and authorization on PTO-2038.

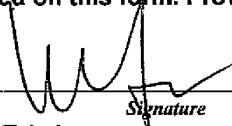

Dated: December 31, 2008

Michael R. Friscia
Registration No. 33,884
McCarter & English, LLP
Four Gateway Center
100 Mulberry Street
Newark, NJ 07102
Tel: (973) 639-8493
Fax: (973) 297-6627

CC:

Certificate of Transmission by Facsimile
This certificate may only be used if paying
by deposit account.

I certify that this document and authorization to charge account is being facsimile transmitted to the United States and Trademark Office (Fax _____) on _____ (Date) _____ Signature _____ _____ Typed or Printed Name of Person Signing Certificate

Certificate of Mailing by First Class Mail

I hereby certify that this correspondence is being deposited with the United States Postal Service with sufficient postage as first class mail in an envelope addressed to "Mail Stop Issue Fee, Commissioner for Patents, P.O. Box 1450, Alexandria, VA 22313-1450" [37 CFR 1.8(a)] on _____ (Date) _____ Signature of Person Mailing Correspondence _____ _____ Typed or Printed Name of Person Mailing Correspondence
--

P35SMALL/REV08

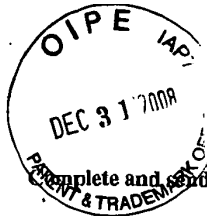

PART B - FEE(S) TRANSMITTAL

Complete and return this form, together with applicable fee(s), to: Mail Stop ISSUE FEE, Commissioner for Patents, P.O. Box 1450, Alexandria, Virginia 22313-1450 or Fax (571)-273-2885

INSTRUCTIONS: This form should be used for transmitting the ISSUE FEE and PUBLICATION FEE (if required). Blocks 1 through 5 should be completed where appropriate. All further correspondence including the Patent, advance orders and notification of maintenance fees will be mailed to the current correspondence address as indicated unless corrected below or directed otherwise in Block 1, by (a) specifying a new correspondence address; and/or (b) indicating a separate "FEE ADDRESS" for maintenance fee notifications.

CURRENT CORRESPONDENCE ADDRESS (Note: Use Block 1 for any change of address)

7590 12/29/2008

MICHAEL R FRISCIA
MCCARTER & ENGLISH
FOUR GATEWAY CENTER
100 MULBERRY STREET
NEWARK, NJ 07102

Note: A certificate of mailing can only be used for domestic mailings of the Fee(s) Transmittal. This certificate cannot be used for any other accompanying papers. Each additional paper, such as an assignment or formal drawing, must have its own certificate of mailing or transmission.

Certificate of Mailing or Transmission

I hereby certify that this Fee(s) Transmittal is being deposited with the United States Postal Service with sufficient postage for first class mail in an envelope addressed to the Mail Stop ISSUE FEE address above, or being facsimile transmitted to the USPTO (571) 273-2885, on the date indicated below.

Diane M. Bodzioch (Depositor's name)
(Diane M. Bodzioch) (Signature)
December 31, 2008 (Date)

Table with 5 columns: APPLICATION NO., FILING DATE, FIRST NAMED INVENTOR, ATTORNEY DOCKET NO., CONFIRMATION NO. Values: 10/316,961, 12/11/2002, Ira Marlowe, 9809/1, 4879

TITLE OF INVENTION: AUDIO DEVICE INTEGRATION SYSTEM
01/02/2009 SSANDAR1 00000008 503571 10316961
01 FC:2501 755.00 DA

Table with 7 columns: APPLN. TYPE, SMALL ENTITY, ISSUE FEE DUE, PUBLICATION FEE DUE, PREV. PAID ISSUE FEE, TOTAL FEE(S) DUE, DATE DUE. Values: nonprovisional, YES, \$755, \$0, \$720, \$755, 03/30/2009

Table with 3 columns: EXAMINER, ART UNIT, CLASS-SUBCLASS. Values: KURR, JASON RICHARD, 2614, 381-086000

- 1. Change of correspondence address or indication of "Fee Address" (37 CFR 1.363).
2. For printing on the patent front page, list McCarter & English, LLP
(1) the names of up to 3 registered patent attorneys or agents OR, alternatively,
(2) the name of a single firm (having as a member a registered attorney or agent) and the names of up to 2 registered patent attorneys or agents. If no name is listed, no name will be printed.

3. ASSIGNEE NAME AND RESIDENCE DATA TO BE PRINTED ON THE PATENT (print or type)

PLEASE NOTE: Unless an assignee is identified below, no assignee data will appear on the patent. If an assignee is identified below, the document has been filed for recordation as set forth in 37 CFR 3.11. Completion of this form is NOT a substitute for filing an assignment.

(A) NAME OF ASSIGNEE (B) RESIDENCE: (CITY and STATE OR COUNTRY)

Please check the appropriate assignee category or categories (will not be printed on the patent): Individual Corporation or other private group entity Government

4a. The following fee(s) are submitted:

- Issue Fee
Publication Fee (No small entity discount permitted)
Advance Order - # of Copies 5

4b. Payment of Fee(s): (Please first reapply any previously paid issue fee shown above)

- A check is enclosed.
Payment by credit card. Form PTO-2038 is attached.
The Director is hereby authorized to charge the required fee(s), any deficiency, or credit any overpayment, to Deposit Account Number 503571 (enclose an extra copy of this form).

5. Change in Entity Status (from status indicated above)

- a. Applicant claims SMALL ENTITY status. See 37 CFR 1.27.
b. Applicant is no longer claiming SMALL ENTITY status. See 37 CFR 1.27(g)(2).

NOTE: The Issue Fee and Publication Fee (if required) will not be accepted from anyone other than the applicant; a registered attorney or agent; or the assignee or other party in interest as shown by the records of the United States Patent and Trademark Office.

Authorized Signature Michael R. Friscia
Typed or printed name Michael R. Friscia

Date December 31, 2008
Registration No. 33,884

This collection of information is required by 37 CFR 1.311. The information is required to obtain or retain a benefit by the public which is to file (and by the USPTO to process) an application. Confidentiality is governed by 35 U.S.C. 122 and 37 CFR 1.14. This collection is estimated to take 12 minutes to complete, including gathering, preparing, and submitting the completed application form to the USPTO. Time will vary depending upon the individual case. Any comments on the amount of time you require to complete this form and/or suggestions for reducing this burden, should be sent to the Chief Information Officer, U.S. Patent and Trademark Office, U.S. Department of Commerce, P.O. Box 1450, Alexandria, Virginia 22313-1450. DO NOT SEND FEES OR COMPLETED FORMS TO THIS ADDRESS. SEND TO: Commissioner for Patents, P.O. Box 1450, Alexandria, Virginia 22313-1450.

Under the Paperwork Reduction Act of 1995, no persons are required to respond to a collection of information unless it displays a valid OMB control number.

Adjustment date: 01/02/2009 SSANDAR1
08/18/2008 INFO 00001768 503571 10316961
PTOL-85 (Rev. 08/07) Approved through 08/31/2008

OMB 0651-0033

U.S. Patent and Trademark Office; U.S. DEPARTMENT OF COMMERCE



UNITED STATES PATENT AND TRADEMARK OFFICE

UNITED STATES DEPARTMENT OF COMMERCE
United States Patent and Trademark Office
Address: COMMISSIONER FOR PATENTS
P.O. Box 1450
Alexandria, Virginia 22313-1450
www.uspto.gov

NOTICE OF ALLOWANCE AND FEE(S) DUE

7590 12/29/2008

MICHAEL R FRISCIA
MCCARTER & ENGLISH
FOUR GATEWAY CENTER
100 MULBERRY STREET
NEWARK, NJ 07102

EXAMINER

KURR, JASON RICHARD

ART UNIT PAPER NUMBER

2614

DATE MAILED: 12/29/2008

Table with 5 columns: APPLICATION NO., FILING DATE, FIRST NAMED INVENTOR, ATTORNEY DOCKET NO., CONFIRMATION NO.

10/316,961 12/11/2002 Ira Marlowe 9809/1 4879

TITLE OF INVENTION: AUDIO DEVICE INTEGRATION SYSTEM

Table with 7 columns: APPLN. TYPE, SMALL ENTITY, ISSUE FEE DUE, PUBLICATION FEE DUE, PREV. PAID ISSUE FEE, TOTAL FEE(S) DUE, DATE DUE

nonprovisional YES \$755 \$0 \$720 \$755 03/30/2009

THE APPLICATION IDENTIFIED ABOVE HAS BEEN EXAMINED AND IS ALLOWED FOR ISSUANCE AS A PATENT. PROSECUTION ON THE MERITS IS CLOSED. THIS NOTICE OF ALLOWANCE IS NOT A GRANT OF PATENT RIGHTS. THIS APPLICATION IS SUBJECT TO WITHDRAWAL FROM ISSUE AT THE INITIATIVE OF THE OFFICE OR UPON PETITION BY THE APPLICANT. SEE 37 CFR 1.313 AND MPEP 1308.

THE ISSUE FEE AND PUBLICATION FEE (IF REQUIRED) MUST BE PAID WITHIN THREE MONTHS FROM THE MAILING DATE OF THIS NOTICE OR THIS APPLICATION SHALL BE REGARDED AS ABANDONED. THIS STATUTORY PERIOD CANNOT BE EXTENDED. SEE 35 U.S.C. 151. THE ISSUE FEE DUE INDICATED ABOVE DOES NOT REFLECT A CREDIT FOR ANY PREVIOUSLY PAID ISSUE FEE IN THIS APPLICATION. IF AN ISSUE FEE HAS PREVIOUSLY BEEN PAID IN THIS APPLICATION (AS SHOWN ABOVE), THE RETURN OF PART B OF THIS FORM WILL BE CONSIDERED A REQUEST TO REAPPLY THE PREVIOUSLY PAID ISSUE FEE TOWARD THE ISSUE FEE NOW DUE.

HOW TO REPLY TO THIS NOTICE:

I. Review the SMALL ENTITY status shown above.

If the SMALL ENTITY is shown as YES, verify your current SMALL ENTITY status:

- A. If the status is the same, pay the TOTAL FEE(S) DUE shown above.
B. If the status above is to be removed, check box 5b on Part B - Fee(s) Transmittal and pay the PUBLICATION FEE (if required) and twice the amount of the ISSUE FEE shown above, or

If the SMALL ENTITY is shown as NO:

- A. Pay TOTAL FEE(S) DUE shown above, or
B. If applicant claimed SMALL ENTITY status before, or is now claiming SMALL ENTITY status, check box 5a on Part B - Fee(s) Transmittal and pay the PUBLICATION FEE (if required) and 1/2 the ISSUE FEE shown above.

II. PART B - FEE(S) TRANSMITTAL, or its equivalent, must be completed and returned to the United States Patent and Trademark Office (USPTO) with your ISSUE FEE and PUBLICATION FEE (if required). If you are charging the fee(s) to your deposit account, section "4b" of Part B - Fee(s) Transmittal should be completed and an extra copy of the form should be submitted. If an equivalent of Part B is filed, a request to reapply a previously paid issue fee must be clearly made, and delays in processing may occur due to the difficulty in recognizing the paper as an equivalent of Part B.

III. All communications regarding this application must give the application number. Please direct all communications prior to issuance to Mail Stop ISSUE FEE unless advised to the contrary.

IMPORTANT REMINDER: Utility patents issuing on applications filed on or after Dec. 12, 1980 may require payment of maintenance fees. It is patentee's responsibility to ensure timely payment of maintenance fees when due.

PART B - FEE(S) TRANSMITTAL

**Complete and send this form, together with applicable fee(s), to: Mail Mail Stop ISSUE FEE
 Commissioner for Patents
 P.O. Box 1450
 Alexandria, Virginia 22313-1450
 or Fax (571)-273-2885**

INSTRUCTIONS: This form should be used for transmitting the ISSUE FEE and PUBLICATION FEE (if required). Blocks 1 through 5 should be completed where appropriate. All further correspondence including the Patent, advance orders and notification of maintenance fees will be mailed to the current correspondence address as indicated unless corrected below or directed otherwise in Block 1, by (a) specifying a new correspondence address; and/or (b) indicating a separate "FEE ADDRESS" for maintenance fee notifications.

CURRENT CORRESPONDENCE ADDRESS (Note: Use Block 1 for any change of address)

Note: A certificate of mailing can only be used for domestic mailings of the Fee(s) Transmittal. This certificate cannot be used for any other accompanying papers. Each additional paper, such as an assignment or formal drawing, must have its own certificate of mailing or transmission.

7590 12/29/2008

MICHAEL R FRISCIA
 MCCARTER & ENGLISH
 FOUR GATEWAY CENTER
 100 MULBERRY STREET
 NEWARK, NJ 07102

Certificate of Mailing or Transmission

I hereby certify that this Fee(s) Transmittal is being deposited with the United States Postal Service with sufficient postage for first class mail in an envelope addressed to the Mail Stop ISSUE FEE address above, or being facsimile transmitted to the USPTO (571) 273-2885, on the date indicated below.

(Depositor's name)
(Signature)
(Date)

APPLICATION NO.	FILING DATE	FIRST NAMED INVENTOR	ATTORNEY DOCKET NO.	CONFIRMATION NO.
10/316,961	12/11/2002	Ira Marlowe	9809/1	4879

TITLE OF INVENTION: AUDIO DEVICE INTEGRATION SYSTEM

APPLN. TYPE	SMALL ENTITY	ISSUE FEE DUE	PUBLICATION FEE DUE	PREV. PAID ISSUE FEE	TOTAL FEE(S) DUE	DATE DUE
nonprovisional	YES	\$755	\$0	\$720	\$755	03/30/2009

EXAMINER	ART UNIT	CLASS-SUBCLASS
KURR, JASON RICHARD	2614	381-086000

<p>1. Change of correspondence address or indication of "Fee Address" (37 CFR 1.363).</p> <p><input type="checkbox"/> Change of correspondence address (or Change of Correspondence Address form PTO/SB/122) attached.</p> <p><input type="checkbox"/> "Fee Address" indication (or "Fee Address" Indication form PTO/SB/47; Rev 03-02 or more recent) attached. Use of a Customer Number is required.</p>	<p>2. For printing on the patent front page, list</p> <p>(1) the names of up to 3 registered patent attorneys or agents OR, alternatively, 1 _____</p> <p>(2) the name of a single firm (having as a member a registered attorney or agent) and the names of up to 2 registered patent attorneys or agents. If no name is listed, no name will be printed. 2 _____</p> <p>3 _____</p>
---	---

3. ASSIGNEE NAME AND RESIDENCE DATA TO BE PRINTED ON THE PATENT (print or type)

PLEASE NOTE: Unless an assignee is identified below, no assignee data will appear on the patent. If an assignee is identified below, the document has been filed for recordation as set forth in 37 CFR 3.11. Completion of this form is NOT a substitute for filing an assignment.

(A) NAME OF ASSIGNEE _____ (B) RESIDENCE: (CITY and STATE OR COUNTRY) _____

Please check the appropriate assignee category or categories (will not be printed on the patent): Individual Corporation or other private group entity Government

<p>4a. The following fee(s) are submitted:</p> <p><input type="checkbox"/> Issue Fee</p> <p><input type="checkbox"/> Publication Fee (No small entity discount permitted)</p> <p><input type="checkbox"/> Advance Order - # of Copies _____</p>	<p>4b. Payment of Fee(s): (Please first reapply any previously paid issue fee shown above)</p> <p><input type="checkbox"/> A check is enclosed.</p> <p><input type="checkbox"/> Payment by credit card. Form PTO-2038 is attached.</p> <p><input type="checkbox"/> The Director is hereby authorized to charge the required fee(s), any deficiency, or credit any overpayment, to Deposit Account Number _____ (enclose an extra copy of this form).</p>
---	--

5. Change in Entity Status (from status indicated above)

a. Applicant claims SMALL ENTITY status. See 37 CFR 1.27. b. Applicant is no longer claiming SMALL ENTITY status. See 37 CFR 1.27(g)(2).

NOTE: The Issue Fee and Publication Fee (if required) will not be accepted from anyone other than the applicant; a registered attorney or agent; or the assignee or other party in interest as shown by the records of the United States Patent and Trademark Office.

Authorized Signature _____ Date _____

Typed or printed name _____ Registration No. _____

This collection of information is required by 37 CFR 1.311. The information is required to obtain or retain a benefit by the public which is to file (and by the USPTO to process) an application. Confidentiality is governed by 35 U.S.C. 122 and 37 CFR 1.14. This collection is estimated to take 12 minutes to complete, including gathering, preparing, and submitting the completed application form to the USPTO. Time will vary depending upon the individual case. Any comments on the amount of time you require to complete this form and/or suggestions for reducing this burden, should be sent to the Chief Information Officer, U.S. Patent and Trademark Office, U.S. Department of Commerce, P.O. Box 1450, Alexandria, Virginia 22313-1450. DO NOT SEND FEES OR COMPLETED FORMS TO THIS ADDRESS. SEND TO: Commissioner for Patents, P.O. Box 1450, Alexandria, Virginia 22313-1450.

Under the Paperwork Reduction Act of 1995, no persons are required to respond to a collection of information unless it displays a valid OMB control number.



UNITED STATES PATENT AND TRADEMARK OFFICE

UNITED STATES DEPARTMENT OF COMMERCE
United States Patent and Trademark Office
Address: COMMISSIONER FOR PATENTS
P.O. Box 1450
Alexandria, Virginia 22313-1450
www.uspto.gov

Table with 5 columns: APPLICATION NO., FILING DATE, FIRST NAMED INVENTOR, ATTORNEY DOCKET NO., CONFIRMATION NO.
10/316,961 12/11/2002 Ira Marlowe 9809/1 4879

7590 12/29/2008

MICHAEL R FRISCIA
MCCARTER & ENGLISH
FOUR GATEWAY CENTER
100 MULBERRY STREET
NEWARK, NJ 07102

EXAMINER

KURR, JASON RICHARD

ART UNIT PAPER NUMBER

2614

DATE MAILED: 12/29/2008

Determination of Patent Term Adjustment under 35 U.S.C. 154 (b)
(application filed on or after May 29, 2000)

The Patent Term Adjustment to date is 820 day(s). If the issue fee is paid on the date that is three months after the mailing date of this notice and the patent issues on the Tuesday before the date that is 28 weeks (six and a half months) after the mailing date of this notice, the Patent Term Adjustment will be 820 day(s).

If a Continued Prosecution Application (CPA) was filed in the above-identified application, the filing date that determines Patent Term Adjustment is the filing date of the most recent CPA.

Applicant will be able to obtain more detailed information by accessing the Patent Application Information Retrieval (PAIR) WEB site (http://pair.uspto.gov).

Any questions regarding the Patent Term Extension or Adjustment determination should be directed to the Office of Patent Legal Administration at (571)-272-7702. Questions relating to issue and publication fee payments should be directed to the Customer Service Center of the Office of Patent Publication at 1-(888)-786-0101 or (571)-272-4200.

Notice of Allowability	Application No.	Applicant(s)	
	10/316,961	MARLOWE, IRA	
	Examiner	Art Unit	
	JASON R. KURR	2614	

-- The MAILING DATE of this communication appears on the cover sheet with the correspondence address--

All claims being allowable, PROSECUTION ON THE MERITS IS (OR REMAINS) CLOSED in this application. If not included herewith (or previously mailed), a Notice of Allowance (PTOL-85) or other appropriate communication will be mailed in due course. **THIS NOTICE OF ALLOWABILITY IS NOT A GRANT OF PATENT RIGHTS.** This application is subject to withdrawal from issue at the initiative of the Office or upon petition by the applicant. See 37 CFR 1.313 and MPEP 1308.

1. This communication is responsive to Applicant's Request for Continued Examination dated November 26, 2008.
2. The allowed claim(s) is/are 1-13,15-38,40-57,59-65,67-74 and 76-104.
3. Acknowledgment is made of a claim for foreign priority under 35 U.S.C. § 119(a)-(d) or (f).
 - a) All b) Some* c) None of the:
 1. Certified copies of the priority documents have been received.
 2. Certified copies of the priority documents have been received in Application No. _____ .
 3. Copies of the certified copies of the priority documents have been received in this national stage application from the International Bureau (PCT Rule 17.2(a)).

* Certified copies not received: _____.

Applicant has THREE MONTHS FROM THE "MAILING DATE" of this communication to file a reply complying with the requirements noted below. Failure to timely comply will result in ABANDONMENT of this application.
THIS THREE-MONTH PERIOD IS NOT EXTENDABLE.

4. A SUBSTITUTE OATH OR DECLARATION must be submitted. Note the attached EXAMINER'S AMENDMENT or NOTICE OF INFORMAL PATENT APPLICATION (PTO-152) which gives reason(s) why the oath or declaration is deficient.
5. CORRECTED DRAWINGS (as "replacement sheets") must be submitted.
 - (a) including changes required by the Notice of Draftsperson's Patent Drawing Review (PTO-948) attached
 - 1) hereto or 2) to Paper No./Mail Date _____.
 - (b) including changes required by the attached Examiner's Amendment / Comment or in the Office action of Paper No./Mail Date _____.

Identifying indicia such as the application number (see 37 CFR 1.84(c)) should be written on the drawings in the front (not the back) of each sheet. Replacement sheet(s) should be labeled as such in the header according to 37 CFR 1.121(d).
6. DEPOSIT OF and/or INFORMATION about the deposit of BIOLOGICAL MATERIAL must be submitted. Note the attached Examiner's comment regarding REQUIREMENT FOR THE DEPOSIT OF BIOLOGICAL MATERIAL.

Attachment(s)

- | | |
|--|--|
| <ol style="list-style-type: none"> 1. <input type="checkbox"/> Notice of References Cited (PTO-892) 2. <input type="checkbox"/> Notice of Draftsperson's Patent Drawing Review (PTO-948) 3. <input checked="" type="checkbox"/> Information Disclosure Statements (PTO/SB/08),
Paper No./Mail Date <u>11/26/08</u> 4. <input type="checkbox"/> Examiner's Comment Regarding Requirement for Deposit of Biological Material | <ol style="list-style-type: none"> 5. <input type="checkbox"/> Notice of Informal Patent Application 6. <input type="checkbox"/> Interview Summary (PTO-413),
Paper No./Mail Date _____ . 7. <input type="checkbox"/> Examiner's Amendment/Comment 8. <input type="checkbox"/> Examiner's Statement of Reasons for Allowance 9. <input type="checkbox"/> Other _____. |
|--|--|

/Xu Mei/
Primary Examiner, Art Unit 2614

Application Number 	Application/Control No. 10/316,961	Applicant(s)/Patent under Reexamination MARLOWE, IRA	
	Examiner JASON R. KURR	Art Unit 2614	

Under the Paperwork Reduction Act of 1995, no persons are required to respond to a collection of information unless it contains a valid OMB control number.

Substitute for form 1449/PTO		Complete if Known	
INFORMATION DISCLOSURE STATEMENT BY APPLICANT <i>(Use as many sheets as necessary)</i>		Application Number	10/316,961
		Filing Date	12/11/2002
		First Named Inventor	Ira M. Marlowe
		Art Unit	2615
		Examiner Name	Kurr, Jason R.
		Attorney Docket Number	99879-00005
Sheet	1	of	2

U. S. PATENT DOCUMENTS					
Examiner Initials*	Cite No. ¹	Document Number	Publication Date MM-DD-YYYY	Name of Patentee or Applicant of Cited Document	Pages, Columns, Lines, Where Relevant Passages or Relevant Figures Appear
		Number-Kind Code ² (if known)			
/JK/	1	US- 7,288,918	10/30/2007	DiStefano	
/JK/	2	US- 6,389,560	05/14/2002	Chew	
/JK/	3	US- 2005/0172001 A1	08/04/2005	Zaner, et al.	
/JK/	4	US- 2003/0156200 A1	08/21/2003	Romano, et al.	
/JK/	5	US- 5,808,373	09/15/1998	Hamanishi, et al.	
/JK/	6	US- 5,859,628	01/12/1999	Ross, et al.	
/JK/	7	US- 6,622,083	09/16/2003	Knockeart, et al.	
		US-			
		US-			
		US-			
		US-			
		US-			
		US-			
		US-			
		US-			
		US-			
		US-			
		US-			
		US-			

FOREIGN PATENT DOCUMENTS						
Examiner Initials*	Cite No. ¹	Foreign Patent Document	Publication Date MM-DD-YYYY	Name of Patentee or Applicant of Cited Document	Pages, Columns, Lines, Where Relevant Passages Or Relevant Figures Appear	T ⁵
		Country Code ³ -Number ⁴ -Kind Code ⁵ (if known)				
/JK/	8	JP 2000-286874 with English Translation	10/13/2000	Suzuki Motor Corp.		
/JK/	9	JP 11-273321 with English Translation	10/08/1999	Clarion Co. Ltd.		

Examiner Signature	/Jason Kurr/	Date Considered	12/03/2008
--------------------	--------------	-----------------	------------

*EXAMINER: Initial if reference considered, whether or not citation is in conformance with MPEP 609. Draw line through citation if not in conformance and not considered. Include copy of this form with next communication to applicant. ¹ Applicant's unique citation designation number (optional). ² See Kinds Codes of USPTO Patent Documents at www.uspto.gov or MPEP 901.04. ³ Enter Office that issued the document, by the two-letter code (WIPO Standard ST.3). ⁴ For Japanese patent documents, the indication of the year of the reign of the Emperor must precede the serial number of the patent document. ⁵ Kind of document by the appropriate symbols as indicated on the document under WIPO Standard ST.16 if possible. ⁶ Applicant is to place a check mark here if English language Translation is attached.

This collection of information is required by 37 CFR 1.97 and 1.98. The information is required to obtain or retain a benefit by the public which is to file (and by the USPTO to process) an application. Confidentiality is governed by 35 U.S.C. 122 and 37 CFR 1.14. This collection is estimated to take 2 hours to complete, including gathering, preparing, and submitting the completed application form to the USPTO. Time will vary depending upon the individual case. Any comments on the amount of time you require to complete this form and/or suggestions for reducing this burden, should be sent to the Chief Information Officer, U.S. Patent and Trademark Office, P.O. Box 1450, Alexandria, VA 22313-1450. DO NOT SEND FEES OR COMPLETED FORMS TO THIS ADDRESS. SEND TO: Commissioner for Patents, P.O. Box 1450, Alexandria, VA 22313-1450.

If you need assistance in completing the form, call 1-800-PTO-9199 (1-800-786-9199) and select option 2.

Under the Paperwork Reduction Act of 1995, no persons are required to respond to a collection of information unless it contains a valid OMB control number.

Substitute for form 1449/PTO INFORMATION DISCLOSURE STATEMENT BY APPLICANT (Use as many sheets as necessary)		Complete if Known	
		Application Number	10/316,961
		Filing Date	12/11/2002
		First Named Inventor	Ira Marlowe
		Art Unit	2615
		Examiner Name	Kurr, Jason R.
Sheet 2	of 2	Attorney Docket Number	99879-00005

NON PATENT LITERATURE DOCUMENTS			
Examiner Initials*	Cite No. ¹	Include name of the author (in CAPITAL LETTERS), title of the article (when appropriate), title of the item (book, magazine, journal, serial, symposium, catalog, etc.), date, page(s), volume-issue number(s), publisher, city and/or country where published.	T ²
/JK/	10	International Search Report of the International Searching Authority mailed September 25, 2008, issued in connection with International Patent Appln. No. PCT/US07/72182 (3 pages)	
/JK/	11	Written Opinion of the International Searching Authority mailed September 25, 2008, issued in connection with International Patent Appln. No. PCT/US07/72182 (7 pages)	
/JK/	12	Copy of Office Action dated July 9, 2008, from co-pending Application Serial No.: 10/732,909 (33 pages)	

Examiner Signature	/Jason Kurr/	Date Considered	12/03/2008
--------------------	--------------	-----------------	------------

*EXAMINER: Initial if reference considered, whether or not citation is in conformance with MPEP 609. Draw line through citation if not in conformance and not considered. Include copy of this form with next communication to applicant.
 1 Applicant's unique citation designation number (optional). 2 Applicant is to place a check mark here if English language Translation is attached.
 This collection of information is required by 37 CFR 1.98. The information is required to obtain or retain a benefit by the public which is to file (and by the USPTO to process) an application. Confidentiality is governed by 35 U.S.C. 122 and 37 CFR 1.14. This collection is estimated to take 2 hours to complete, including gathering, preparing, and submitting the completed application form to the USPTO. Time will vary depending upon the individual case. Any comments on the amount of time you require to complete this form and/or suggestions for reducing this burden, should be sent to the Chief Information Officer, U.S. Patent and Trademark Office, P.O. Box 1450, Alexandria, VA 22313-1450. DO NOT SEND FEES OR COMPLETED FORMS TO THIS ADDRESS. SEND TO: Commissioner for Patents, P.O. Box 1450, Alexandria, VA 22313-1450.

If you need assistance in completing the form, call 1-800-PTO-9199 (1-800-786-9199) and select option 2.

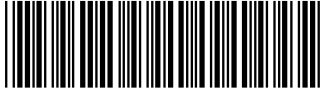
Issue Classification 	Application/Control No.	Applicant(s)/Patent under Reexamination	
	10/316,961	MARLOWE, IRA	
	Examiner	Art Unit	
	JASON R. KURR	2614	

ISSUE CLASSIFICATION											
ORIGINAL					CROSS REFERENCE(S)						
CLASS		SUBCLASS			CLASS	SUBCLASS (ONE SUBCLASS PER BLOCK)					
381		86			340	825.24					
INTERNATIONAL CLASSIFICATION					700	94					
H	0	4	B	1/00							
				/							
				/							
				/							
				/							
/Jason Kurr (12/18/08)/ (Assistant Examiner) (Date)					/Vivian Chin/ 12/19/08 (Primary Examiner) (Date)					Total Claims Allowed: 99	
(Legal Instruments Examiner) (Date)										O.G. Print Claim(s)	O.G. Print Fig.
										1	1

<input type="checkbox"/> Claims renumbered in the same order as presented by applicant		<input type="checkbox"/> CPA		<input type="checkbox"/> T.D.		<input type="checkbox"/> R.1.47							
Final	Original	Final	Original	Final	Original	Final	Original						
1	1	34	31	62	61	32	91		121		151		181
2	2	35	32	63	62	64	92		122		152		182
3	3	36	33	66	63	65	93		123		153		183
4	4	37	34	67	64	74	94		124		154		184
5	5	38	35	68	65	75	95		125		155		185
6	6	39	36		66	84	96		126		156		186
7	7	40	37	69	67	85	97		127		157		187
8	8	41	38	70	68	88	98		128		158		188
9	9		39	71	69	89	99		129		159		189
10	10	42	40	72	70	97	100		130		160		190
11	11	43	41	73	71	98	101		131		161		191
12	12	44	42	76	72	90	102		132		162		192
13	13	45	43	77	73	91	103		133		163		193
	14	47	44	78	74	99	104		134		164		194
14	15	48	45		75		105		135		165		195
15	16	46	46	79	76		106		136		166		196
16	17	49	47	80	77		107		137		167		197
17	18	50	48	81	78		108		138		168		198
18	19	51	49	82	79		109		139		169		199
19	20	52	50	83	80		110		140		170		200
20	21	53	51	86	81		111		141		171		201
21	22	54	52	87	82		112		142		172		202
22	23	55	53	92	83		113		143		173		203
25	24	56	54	93	84		114		144		174		204
26	25	57	55	94	85		115		145		175		205
27	26	58	56	95	86		116		146		176		206
28	27	59	57	96	87		117		147		177		207
29	28		58	23	88		118		148		178		208
30	29	60	59	24	89		119		149		179		209
33	30	61	60	31	90		120		150		180		210

Search Notes



Application/Control No.

10/316,961

Applicant(s)/Patent under Reexamination

MARLOWE, IRA

Examiner

JASON R. KURR

Art Unit

2614

SEARCHED

Class	Subclass	Date	Examiner
381	86	5/24/2006	JK
307	9.1,10.1	10/4/2006	JK
340	825.25	10/4/2006	JK
307	10.1	3/7/2007	JK
Update	Above	7/7/2007	JK
340	825.24	1/8/2008	JK
700	94	1/8/2008	JK
455	345,346	1/23/2008	JK
Updated	Above	5/22/2008	JK
701	36	5/22/2008	JK
710	303,304	7/6/2008	JK
Updated	Above	12/18/2008	JK

INTERFERENCE SEARCHED

Class	Subclass	Date	Examiner
See	Above	12/18/2008	JK

**SEARCH NOTES
(INCLUDING SEARCH STRATEGY)**

	DATE	EXMR
Searched, car stereo's and interfacing with auxiliary audio devices	5/24/2006	JK
Searched (digital audio broadcasting) DAB	5/29/2006	JK
Searched: mp3 players, interfacing, DAB digital audio broadcasts, satellite radio	11/7/2006	JK
Searched new IDS (2/16/07) and continuation applications	3/7/2007	JK
Searched (format conversions) w/ control and auxiliary units or after market units	1/23/2008	JK
Consulted: Dan Sellers + Andrew Flanders 700/94 Ping Lee , Xu Mei, suggested 455/3.06,345,346 and 710 docking stations	1/8/2008	JK
Updated class search Searched: online "internet", crutchfield mag., audiophile mag.	5/22/2008	JK
Inventor search: Ira Marlow Consulted: SPE Mark Reinhart class 710	7/6/2008	JK

EAST Search History

Ref #	Hits	Search Query	DBs	Default Operator	Plurals	Time Stamp
L1	811	381/86.ccls.	US-PGPUB; USPAT	OR	ON	2008/12/18 16:11
L2	502	340/825.25,825.24.ccls.	US-PGPUB; USPAT	OR	ON	2008/12/18 16:11
L3	3353	307/9.1,10.1.ccls.	US-PGPUB; USPAT	OR	ON	2008/12/18 16:12
L4	1690	700/94.ccls.	US-PGPUB; USPAT	OR	ON	2008/12/18 16:12
L5	763	455/345,346.ccls.	US-PGPUB; USPAT	OR	ON	2008/12/18 16:12
L6	1890	701/36.ccls.	US-PGPUB; USPAT	OR	ON	2008/12/18 16:12
L7	595	710/303,304.ccls.	US-PGPUB; USPAT	OR	ON	2008/12/18 16:12
L8	238	l1-l7	US-PGPUB; USPAT	OR	ON	2008/12/18 16:12
L9	43	l1-7	US-PGPUB; USPAT	OR	ON	2008/12/18 16:13
L10	9314	l1 l2 l3 l4 l5 l6 l7	US-PGPUB; USPAT	OR	ON	2008/12/18 16:13
L11	5771	l10 and ((@ad @rlad) <="20021211")	US-PGPUB; USPAT	OR	ON	2008/12/18 16:13
S212	7	("7288918" "6389560" "20050172001" "20030156200" "5808373" "5859628" "6622083"). pn.	US-PGPUB; USPAT	OR	OFF	2008/12/03 14:55

12/ 18/ 2008 4:16:02 PM

C:\Documents and Settings\jkurr\My Documents\EAST\Workspaces\10316961.wsp

Search Notes (continued)



Application/Control No.

10/316,961

Applicant(s)/Patent under Reexamination

MARLOWE, IRA

Examiner

JASON R. KURR

Art Unit

2614

SEARCHED

Class	Subclass	Date	Examiner

**SEARCH NOTES
(INCLUDING SEARCH STRATEGY)**

	DATE	EXMR
Reviewed IDS Documents	12/3/2008	JK
Updated Interference class searches	12/18/2008	JK

INTERFERENCE SEARCHED

Class	Subclass	Date	Examiner

PATENT WITHDRAWAL NOTICE

DATE WITHDRAWN

12/1/08

WITHDRAWAL NUMBER

16806

The following application has been **WITHDRAWN** from the

Tuesday, December 09, 2008 issue.

SERIAL NO.

10/316,961

PATENT NUMBER

7,463,741

DRAWINGS

000

CLASS

381/086

TITLE

AUDIO DEVICE INTEGRATION SYSTEM

NAME AND ADDRESS

IRA MARLOWE
FORT LEE, NJ

REASON FOR WITHDRAWAL

Office of Petitions granted applicant's request to withdraw patent from issue.

APPROVED

/Kimberly Terrell/, Manager
Patent Publication Branch
Office of Data Management



UNITED STATES PATENT AND TRADEMARK OFFICE

Commissioner for Patents
United States Patent and Trademark Office
P.O. Box 1450
Alexandria, VA 22313-1450
www.uspto.gov

Date : December 1, 2008
TO : Director, Office of Patent Publication
FROM : Office of Petitions
SUBJECT : Withdrawal from Issue of **Application No. 10/316,961**
Applicant(s) : Ira Marlowe
Application No. : 10/316,961
Filed : December 11, 2002

The above-identified application has been assigned Patent No.7,463,741 and an issue date of December 9, 2008.

It is hereby directed that this application be withdrawn from issue at the request of the applicant. Do not refund the issue fee.

The following erratum should be published in the Official Gazette if the above-identified application is published in the OG of December 9, 2008:

"All reference to Patent No. 7,463,741 to Ira Marlowe of New Jersey for AUDIO DEVICE INTEGRATION SYSTEM appearing in the Official Gazette of December 9, 2008 should be deleted since no patent was granted."

/Karen Creasy/
Karen Creasy
Petitions Examiner
Office of Petitions

cc: Paul Harrison
Deneise Boyd
Mary Louise McAskill
Niomi Farmer
Mary E. Johnson (Cookie)
Duane Davis (CDS)
Brad Harris
Kim Terrell
Lamont Fletcher



UNITED STATES PATENT AND TRADEMARK OFFICE

Commissioner for Patents
United States Patent and Trademark Office
P.O. Box 1450
Alexandria, VA 22313-1450
www.uspto.gov

**MICHAEL R. FRISCIA
MCCARTER & ENGLISH
FOUR GATEWAY CENTER
100 MULBERRY STREET
NEWARK NJ 07102**

COPY MAILED

DEC 01 2008

OFFICE OF PETITIONS

In re Application of :
Ira Marlowe :
Application No. 10/316,961 : DECISION GRANTING PETITION
Filed: December 11, 2002 : UNDER 37 CFR 1.313(c)(2)
Attorney Docket No. 9809/1 :

This is a decision on the petition under 37 CFR 1.313(c)(2), filed November 26, 2008, to withdraw the above-identified application from issue after payment of the issue fee.

The petition is **GRANTED**.

The above-identified application is withdrawn from issue for consideration of a submission under 37 CFR 1.114 (request for continued examination). See 37 CFR 1.313(c)(2).

Petitioner is advised that the issue fee paid on August 15, 2008 cannot be refunded. If, however, this application is again allowed, petitioner may request that it be applied towards the issue fee required by the new Notice of Allowance.¹

Telephone inquiries should be directed to the undersigned at (571) 272-3208.

This application is being referred to Technology Center AU 2615 for processing of the request for continued examination under 37 CFR 1.114 and for consideration of the concurrently filed IDS.

/Karen Creasy/
Karen Creasy
Petitions Examiner

¹ The request to apply the issue fee to the new Notice may be satisfied by completing and returning the new Part B – Fee(s) Transmittal Form (along with any balance due at the time of submission). *Petitioner is advised that the Issue Fee Transmittal Form must be completed and timely submitted to avoid abandonment of the application.*

IN THE UNITED STATES PATENT AND TRADEMARK OFFICE

Applicant: Ira M. Marlowe
Serial No.: 10/316,961
Filed: 12/11/2002
For: Audio Device Integration System

Examiner: Kurr, Jason R.

Art Unit: 2615

PETITION TO WITHDRAW FROM ISSUE UNDER 37 C.F.R. 1.313(c)

Mail Stop Petition

Commissioner for Patents
P.O. Box 1450
Alexandria, VA 22313-1450

Sir:

Applicant respectfully requests withdrawal from issuance of the above-identified patent application, which is scheduled to issue on **December 9, 2008**, in favor of the Request for Continued Examination (RCE) and Supplemental Information Disclosure Statement (IDS) submitted herewith.

The undersigned recently became aware of an International Search Report and Written Opinion and references contained therein, in connection with Applicant's co-pending PCT patent application. Additionally, an Office Action and cited references from Applicant's co-pending application Serial No. 10/732,909, as well as two Japanese references from a companion Japanese patent application, are being disclosed in the present IDS. None of the references being disclosed in the present IDS have been considered during prosecution of the present application. As such, it is respectfully requested that the present application be withdrawn from issuance so that the references

are made of record by way of the IDS submitted herewith and considered by the USPTO.

The USPTO is hereby authorized to charge Deposit Account No. 503571 for any and all charges due in connection with this submission, including, but not limited to, the petition fee under 37 C.F.R. § 1.17(h) for this Petition, as well as the required RCE fee. The Office is also authorized to charge any other required fees or underpayment and/or credit any underpayment to Deposit Account 503571.

Dated: 11/26/2008

Respectfully submitted,

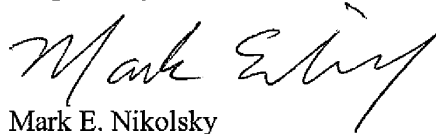

Mark E. Nikolsky
Reg. No. 48,319
McCarter & English, LLP
Four Gateway Center
100 Mulberry Street
Newark, NJ 07102
Tel.: (973) 639-6987
Fax: (973) 297-6624

**TRANSMITTAL OF INFORMATION DISCLOSURE STATEMENT
(Under 37 CFR 1.97(b) or 1.97(c))**

Docket No.
99879-00005

In Re Application Of: **Ira M. Marlowe**

Application No.	Filing Date	Examiner	Customer No.	Group Art Unit	Confirmation No.
10/316,961	12/11/2002	Kurr, Jason R.	27614	2615	4879

Title: **Audio Device Integration System**

Address to:

**Commissioner for Patents
P.O. Box 1450
Alexandria, VA 22313-1450**

37 CFR 1.97(b)

1. The Information Disclosure Statement submitted herewith is being filed within three months of the filing of a national application other than a continued prosecution application under 37 CFR 1.53(d); within three months of the date of entry of the national stage as set forth in 37 CFR 1.491 in an international application; before the mailing of a first Office Action on the merits, or before the mailing of a first Office Action after the filing of a request for continued examination under 37 CFR 1.114.

37 CFR 1.97(c)

2. The Information Disclosure Statement submitted herewith is being filed after the period specified in 37 CFR 1.97(b), provided that the Information Disclosure Statement is filed before the mailing date of a Final Action under 37 CFR 1.113, a Notice of Allowance under 37 CFR 1.311, or an Action that otherwise closes prosecution in the application, and is accompanied by one of:
- the statement specified in 37 CFR 1.97(e);
- OR**
- the fee set forth in 37 CFR 1.17(p).

P10A/REV06

TRANSMITTAL OF INFORMATION DISCLOSURE STATEMENT
(Under 37 CFR 1.97(b) or 1.97(c))

Docket No.
 99879-00005

In Re Application of: **Ira M. Marlowe**

Application No.	Filing Date	Examiner	Customer No.	Group Art Unit	Confirmation No.
10/316,961	12/11/2002	Kurr, Jason R.	27614	2615	4879

Title: **Audio Device Integration System**

Payment of Fee

(Only complete if Applicant elects to pay the fee set forth in 37 CFR 1.17(p))

- A check in the amount of _____ is attached.
- The Director is hereby authorized to charge and credit Deposit Account No. 503571 as described below.
 - Charge the amount of _____
 - Credit any overpayment.
 - Charge any additional fee required.
- Payment by credit card. Form PTO-2038 is attached.

WARNING: Information on this form may become public. Credit card information should not be included on this form. Provide credit card information and authorization on PTO-2038.

Certificate of Transmission by Facsimile*

I certify that this document and authorization to charge deposit account is being facsimile transmitted to the United States Patent and Trademark Office (Fa

 (Date)

 Signature

 Typed or Printed Name of Person Signing Certificate

Certificate of Mailing by First Class Mail

I hereby certify that this correspondence is being deposited with the United States Postal Service with sufficient postage as first class mail in an envelope addressed to "Commissioner for Patents, P.O. Box 1450, Alexandria, VA 22313-1450" [37 CFR 1.8(a)] on

 (Date)

 Signature of Person Mailing Correspondence

 Typed or Printed Name of Person Mailing Certificate

*This certificate may only be used if paying by deposit account.

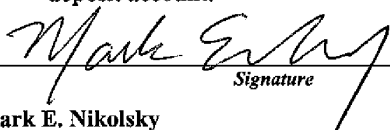
 Signature

Dated: 11/26/2008

Mark E. Nikolsky
 Registration No. 48,319
 McCarter & English, LLP
 Four Gateway Center
 100 Mulberry Street
 Newark, NJ 07102
 Tel: (973) 639-6987
 Fax: (973) 297-6624

cc:

P10A/REV06

Under the Paperwork Reduction Act of 1995, no persons are required to respond to a collection of information unless it contains a valid OMB control number.

Request for Continued Examination (RCE) Transmittal Address to: Mail Stop RCE Commissioner for Patents P.O. Box 1450 Alexandria, VA 22313-1450	Application Number	10/316,961
	Filing Date	12/11/2002
	First Named Inventor	Ira M. Marlowe
	Art Unit	2615
	Examiner Name	Kurr, Jason R.
	Attorney Docket Number	99879-00005

This is a Request for Continued Examination (RCE) under 37 CFR 1.114 of the above-identified application.
 Request for Continued Examination (RCE) practice under 37 CFR 1.114 does not apply to any utility or plant application filed prior to June 8, 1995, or to any design application. See Instruction Sheet for RCEs (not to be submitted to the USPTO) on page 2.

1. **Submission required under 37 CFR 1.114** Note: If the RCE is proper, any previously filed unentered amendments and amendments enclosed with the RCE will be entered in the order in which they were filed unless applicant instructs otherwise. If applicant does not wish to have any previously filed unentered amendment(s) entered, applicant must request non-entry of such amendment(s).

- a. Previously submitted. If a final Office action is outstanding, any amendments filed after the final Office action may be considered as a submission even if this box is not checked.
- i. Consider the arguments in the Appeal Brief or Reply Brief previously filed on _____
- ii. Other _____
- b. Enclosed
- i. Amendment/Reply
- ii. Affidavit(s)/ Declaration(s)
- iii. Information Disclosure Statement (IDS)
- iv. Other _____

2. **Miscellaneous**

- a. Suspension of action on the above-identified application is requested under 37 CFR 1.103(c) for a period of _____ months. (Period of suspension shall not exceed 3 months; Fee under 37 CFR 1.17(l) required)
- b. Other _____

3. **Fees**

- The RCE fee under 37 CFR 1.17(e) is required by 37 CFR 1.114 when the RCE is filed. The Director is hereby authorized to charge the following fees, any underpayment of fees, or credit any overpayments, to Deposit Account No. 503571. I have enclosed a duplicate copy of this sheet.
- a. RCE fee required under 37 CFR 1.17(e)
- ii. Extension of time fee (37 CFR 1.136 and 1.17)
- iii. Other _____
- b. Check in the amount of \$ _____ enclosed
- c. Payment by credit card (Form PTO-2038 enclosed)

WARNING: Information on this form may become public. Credit card information should not be included on this form. Provide credit card information and authorization on PTO-2038.

SIGNATURE OF APPLICANT, ATTORNEY, OR AGENT REQUIRED

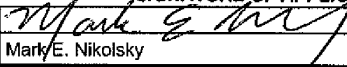
Signature		Date	11/26/2008
Name (Print/Type)	Mark E. Nikolsky	Registration No.	48,319

CERTIFICATE OF MAILING OR TRANSMISSION

I hereby certify that this correspondence is being deposited with the United States Postal Service with sufficient postage as first class mail in an envelope addressed to: Mail Stop RCE, Commissioner for Patents, P. O. Box 1450, Alexandria, VA 22313-1450 or facsimile transmitted to the U.S. Patent and Trademark Office on the date shown below.

Signature		Date	
Name (Print/Type)		Date	

This collection of information is required by 37 CFR 1.114. The information is required to obtain or retain a benefit by the public which is to file (and by the USPTO to process) an application. Confidentiality is governed by 35 U.S.C. 122 and 37 CFR 1.11 and 1.14. This collection is estimated to take 12 minutes to complete, including gathering, preparing, and submitting the completed application form to the USPTO. Time will vary depending upon the individual case. Any comments on the amount of time you require to complete this form and/or suggestions for reducing this burden, should be sent to the Chief Information Officer, U.S. Patent and Trademark Office, U.S. Department of Commerce, P.O. Box 1450, Alexandria, VA 22313-1450. **DO NOT SEND FEES OR COMPLETED FORMS TO THIS ADDRESS. SEND TO: Mail Stop RCE, Commissioner for Patents, P.O. Box 1450, Alexandria, VA 22313-1450.**
 If you need assistance in completing the form, call 1-800-PTO-9199 and select option 2.

Under the Paperwork Reduction Act of 1995, no persons are required to respond to a collection of information unless it contains a valid OMB control number.

Substitute for form 1449/PTO <h2 style="text-align: center;">INFORMATION DISCLOSURE STATEMENT BY APPLICANT</h2> <p style="text-align: center;"><i>(Use as many sheets as necessary)</i></p>	<h3 style="text-align: center;">Complete if Known</h3> <table border="1" style="width: 100%; border-collapse: collapse;"> <tr> <td>Application Number</td> <td>10/316,961</td> </tr> <tr> <td>Filing Date</td> <td>12/11/2002</td> </tr> <tr> <td>First Named Inventor</td> <td>Ira M. Marlowe</td> </tr> <tr> <td>Art Unit</td> <td>2615</td> </tr> <tr> <td>Examiner Name</td> <td>Kurr, Jason R.</td> </tr> <tr> <td>Attorney Docket Number</td> <td>99879-00005</td> </tr> </table>	Application Number	10/316,961	Filing Date	12/11/2002	First Named Inventor	Ira M. Marlowe	Art Unit	2615	Examiner Name	Kurr, Jason R.	Attorney Docket Number	99879-00005
Application Number	10/316,961												
Filing Date	12/11/2002												
First Named Inventor	Ira M. Marlowe												
Art Unit	2615												
Examiner Name	Kurr, Jason R.												
Attorney Docket Number	99879-00005												
Sheet <u>1</u> of <u>2</u>													

U. S. PATENT DOCUMENTS						
Examiner Initials*	Cite No. ¹	Document Number		Publication Date MM-DD-YYYY	Name of Patentee or Applicant of Cited Document	Pages, Columns, Lines, Where Relevant Passages or Relevant Figures Appear
		Number-Kind Code ² (if known)				
	1	US-	7,288,918	10/30/2007	DiStefano	
	2	US-	6,389,560	05/14/2002	Chew	
	3	US-	2005/0172001 A1	08/04/2005	Zaner, et al.	
	4	US-	2003/0156200 A1	08/21/2003	Romano, et al.	
	5	US-	5,808,373	09/15/1998	Hamanishi, et al.	
	6	US-	5,859,628	01/12/1999	Ross, et al.	
	7	US-	6,622,083	09/16/2003	Knockeart, et al.	
		US-				
		US-				
		US-				
		US-				
		US-				
		US-				
		US-				
		US-				
		US-				
		US-				
		US-				

FOREIGN PATENT DOCUMENTS								
Examiner Initials*	Cite No. ¹	Foreign Patent Document			Publication Date MM-DD-YYYY	Name of Patentee or Applicant of Cited Document	Pages, Columns, Lines, Where Relevant Passages Or Relevant Figures Appear	T ⁵
		Country Code ³	Number ⁴	Kind Code ⁵ (if known)				
	8	JP	2000-286874	with English Translation	10/13/2000	Suzuki Motor Corp.		
	9	JP	11-273321	with English Translation	10/08/1999	Clarion Co. Ltd.		

Examiner Signature	Date Considered
--------------------	-----------------

*EXAMINER: Initial if reference considered, whether or not citation is in conformance with MPEP 609. Draw line through citation if not in conformance and not considered. Include copy of this form with next communication to applicant. ¹ Applicant's unique citation designation number (optional). ² See Kinds Codes of USPTO Patent Documents at www.uspto.gov or MPEP 901.04. ³ Enter Office that issued the document, by the two-letter code (WIPO Standard ST.3). ⁴ For Japanese patent documents, the indication of the year of the reign of the Emperor must precede the serial number of the patent document. ⁵ Kind of document by the appropriate symbols as indicated on the document under WIPO Standard ST.16 if possible. ⁶ Applicant is to place a check mark here if English language Translation is attached.

This collection of information is required by 37 CFR 1.97 and 1.98. The information is required to obtain or retain a benefit by the public which is to file (and by the USPTO to process) an application. Confidentiality is governed by 35 U.S.C. 122 and 37 CFR 1.14. This collection is estimated to take 2 hours to complete, including gathering, preparing, and submitting the completed application form to the USPTO. Time will vary depending upon the individual case. Any comments on the amount of time you require to complete this form and/or suggestions for reducing this burden, should be sent to the Chief Information Officer, U.S. Patent and Trademark Office, P.O. Box 1450, Alexandria, VA 22313-1450. DO NOT SEND FEES OR COMPLETED FORMS TO THIS ADDRESS. SEND TO: Commissioner for Patents, P.O. Box 1450, Alexandria, VA 22313-1450.

If you need assistance in completing the form, call 1-800-PTO-9199 (1-800-786-9199) and select option 2.

Under the Paperwork Reduction Act of 1995, no persons are required to respond to a collection of information unless it contains a valid OMB control number.

Substitute for form 1449/PTO INFORMATION DISCLOSURE STATEMENT BY APPLICANT (Use as many sheets as necessary)		Complete if Known	
		Application Number	10/316,961
		Filing Date	12/11/2002
		First Named Inventor	Ira Marlowe
		Art Unit	2615
		Examiner Name	Kurr, Jason R.
Sheet 2	of 2	Attorney Docket Number	99879-00005

NON PATENT LITERATURE DOCUMENTS			
Examiner Initials*	Cite No. ¹	Include name of the author (in CAPITAL LETTERS), title of the article (when appropriate), title of the item (book, magazine, journal, serial, symposium, catalog, etc.), date, page(s), volume-issue number(s), publisher, city and/or country where published.	T ²
	10	International Search Report of the International Searching Authority mailed September 25, 2008, issued in connection with International Patent Appln. No. PCT/US07/72182 (3 pages)	
	11	Written Opinion of the International Searching Authority mailed September 25, 2008, issued in connection with International Patent Appln. No. PCT/US07/72182 (7 pages)	
	12	Copy of Office Action dated July 9, 2008, from co-pending Application Serial No.: 10/732,909 (33 pages)	

Examiner Signature	Date Considered
--------------------	-----------------

*EXAMINER: Initial if reference considered, whether or not citation is in conformance with MPEP 609. Draw line through citation if not in conformance and not considered. Include copy of this form with next communication to applicant.
 1 Applicant's unique citation designation number (optional). 2 Applicant is to place a check mark here if English language Translation is attached.
 This collection of information is required by 37 CFR 1.98. The information is required to obtain or retain a benefit by the public which is to file (and by the USPTO to process) an application. Confidentiality is governed by 35 U.S.C. 122 and 37 CFR 1.14. This collection is estimated to take 2 hours to complete, including gathering, preparing, and submitting the completed application form to the USPTO. Time will vary depending upon the individual case. Any comments on the amount of time you require to complete this form and/or suggestions for reducing this burden, should be sent to the Chief Information Officer, U.S. Patent and Trademark Office, P.O. Box 1450, Alexandria, VA 22313-1450. DO NOT SEND FEES OR COMPLETED FORMS TO THIS ADDRESS. SEND TO: Commissioner for Patents, P.O. Box 1450, Alexandria, VA 22313-1450.

If you need assistance in completing the form, call 1-800-PTO-9199 (1-800-786-9199) and select option 2.

(19) 日本国特許庁 (J P)

(12) 公開特許公報 (A)

(11) 特許出願公開番号

特開2000-286874

(P2000-286874A)

(43) 公開日 平成12年10月13日 (2000. 10. 13)

(51) Int.Cl. ⁷	識別記号	F I	ターレット* (参考)
H 0 4 L	12/40	H 0 4 L 11/00	3 2 0 3 D 0 2 0
B 6 0 R	11/02	B 6 0 R 11/02	B 5 K 0 3 2
H 0 4 L	12/28	H 0 4 L 11/00	3 1 0 Z 5 K 0 3 3

審査請求 未請求 請求項の数 6 O L (全 6 頁)

(21) 出願番号 特願平11-90570

(22) 出願日 平成11年3月31日 (1999. 3. 31)

(71) 出願人 000002082

スズキ株式会社

静岡県浜松市高塚町300番地

(72) 発明者 植村 宏

静岡県浜松市高塚町300番地 スズキ株式会社内

(74) 代理人 100079164

弁理士 高橋 勇

Fターム(参考) 3D02D BA02 BA05 BA09 BA10 BA13

BB01 BC03 BE03

5K032 BA06 BA08 DB03 DB04

5K033 BA06 BA08 DB03 DB04

(54) 【発明の名称】 車載用ヘッドユニット及び車載用外部機器

(57) 【要約】

【課題】 車載用オーディオの外部機器を低コストでかつ利用しやすいものとする。

【解決手段】 内部音楽ソース4からの音声信号を増幅するアンプ8と、外部機器を接続する外部機器コネクタ10と、この外部機器コネクタ10にケーブルを介して接続される外部機器から入力される音声信号と前記内部音楽ソースから入力される音声信号とを切替える切替スイッチ18と、前記内部音楽ソース4と前記外部機器30との切替えを制御する制御手段6とを備えている。しかも、外部機器コネクタ31が、バス接続用の複数のバス用ピン12を接続するバス用ピン接続端子と、このバス用ピンに併設されコントロール信号を送受する2つのコントロール用ピン接続端子と、前記外部機器と接続される前記バス用ピンおよび前記コントロールピンとを有する1本のケーブルに係合するコネクタ本体11とを備えた。

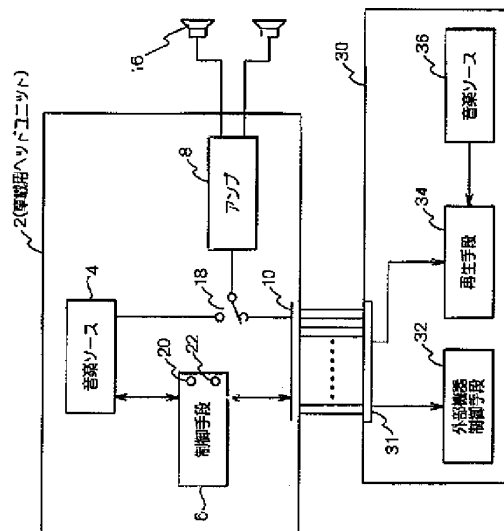

【特許請求の範囲】

【請求項1】 内部音楽ソースからの音声信号を増幅するアンプと、外部機器を接続する外部機器コネクタと、この外部機器コネクタにケーブルを介して接続される外部機器から入力される音声信号と前記内部音楽ソースから入力される音声信号とを切替える切替スイッチと、前記内部音楽ソースと前記外部機器との切替を制御する制御手段とを備えた車載用ヘッドユニットにおいて、前記外部機器コネクタが、バス接続用の複数のバス用ピン接続端子と、このバス用ピンに併設されコントロール信号を送受する2つのコントロール用ピン接続端子と、前記外部機器と接続される前記バス用ピンおよび前記コントロールピンとを有する1本のケーブルに係合するコネクタ本体とを備えたことを特徴とする車載用ヘッドユニット。

【請求項2】 前記制御手段が、前記始動時に前記バス用ピンと前記コントロールピンとに接続チェック信号それぞれ送信すると共に当該接続チェック信号に応答があった側のピン接続端子を有効と設定する第1の接続開始制御部を備えたことを特徴とする請求項1記載の車載用ヘッドユニット。

【請求項3】 前記制御手段が、前記始動時に前記2つのコントロール用ピン接続端子のうち一方を予め定められた一定期間中ハイにすると共に当該一定期間経過後は当該2つのコントロール用ピン接続端子への出力を前記始動時前の状態に戻す第2の接続開始制御部を備えたことを特徴とする請求項1記載の車載用ヘッドユニット。

【請求項4】 ヘッドユニットに対して外部機器となるTV、CD又はMD等の外部音楽ソースを再生する再生手段と、この再生手段によって再生される音声信号を前記ヘッドユニットへケーブルを介して伝達するためのヘッドユニット用コネクタと、このヘッドユニット用コネクタから入力される制御信号に応じて前記再生手段を制御する外部機器制御手段とを備えた車載用外部機器において、

前記ヘッドユニット用コネクタが、バス接続用の複数のバス用ピン接続端子と、このバス用ピンに併設されコントロール信号を送受する2つのコントロール用ピン接続端子と、前記外部機器と接続される前記バス用ピンおよび前記コントロールピンとを有する1本のケーブルに係合するコネクタ本体とを備えたと共に、前記再生手段に、前記ヘッドユニット用コネクタから入力される接続チェック信号に応じて前記コントロール用ピン接続端子又は前記バス用ピン接続端子の一方を選択する接続切替手段を備えたことを特徴とする車載用外部機器。

【請求項5】 ヘッドユニットに対して外部機器となるTV、CD又はMD等の外部音楽ソースを再生する再生手段と、前記ヘッドユニットから入力される制御信号に応じて前記再生手段を制御する外部機器制御手段とを備

えた車載用外部機器において、

前記外部機器制御手段に、前記ヘッドユニット又は他の外部機器と接続する2以上の拡張コネクタを併設し、前記拡張コネクタが、バス接続用の複数のバス用ピン接続端子と、このバス用ピンに併設されコントロール信号を送受する2つのコントロール用ピン接続端子と、前記外部機器と接続される前記バス用ピンおよび前記コントロールピンとを有する1本のケーブルに係合するコネクタ本体とを備え、

前記外部機器制御手段が、前記ヘッドユニットが接続されたコネクタに対して前記コントロール用ピン接続端子を有効と設定すると共に前記他の外部機器が接続されたコネクタに対して前記バス用ピン接続端子を有効に設定する複数接続制御部を備えたことを特徴とする車載用外部機器。

【発明の詳細な説明】

【0001】

【発明の属する技術分野】本発明は、車載用ヘッドユニット及び車載用外部機器に係り、特に、車載用ヘッドユニットに車載用外部機器を増設する際の接続方式に特徴のある車載用ヘッドユニット及び車載用外部機器に関する。

【0002】

【従来技術】従来、車載用オーディオのヘッドユニットと外部機器の接続方式は、デッキ接続とバス接続の2通がある。一般的には、ヘッドユニットは例えばFM/AMラジオ付きカセットであり、一方、外部機器はCDプレーヤ、MDプレーヤまたはTV等である。

【0003】

【発明が解決しようとする課題】しかしながら、上記従来例では、デッキ接続とバス接続の接続方式は互換性がないため、CDプレーヤはデッキ接続用とバス接続用の二種類を用意しなければならない、という不都合があった。このため、ユーザは、外部機器を選定する時に、自分のヘッドユニットがデッキ接続用であるのか、それともバス接続用であるのかを確認しなければならなかった。

【0004】

【発明の目的】本発明は、係る従来例の有する不都合を改善し、特に、車載用オーディオの外部機器を低コストでかつ利用しやすいものとするのできる車載用ヘッドユニット及び車載用外部機器を提供することを、その目的とする。

【0005】

【課題を解決するための手段】そこで、本発明による車載用ヘッドユニットでは、内部音楽ソースからの音声信号を増幅するアンプと、外部機器を接続する外部機器コネクタと、この外部機器コネクタにケーブルを介して接続される外部機器から入力される音声信号と前記内部音楽ソースから入力される音声信号とを切替える切替スイ

ッチと、前記内部音楽ソースと前記外部機器との切替えを制御する制御手段とを備えている。そして、外部機器コネクタが、バス接続用の複数のバス用ピン接続端子と、このバス用ピンに併設されコントロール信号を送受する2つのコントロール用ピン接続端子と、前記外部機器と接続される前記バス用ピンおよび前記コントロールピンとを有する1本のケーブルに係合するコネクタ本体とを備えた、という構成を採っている。これにより前述した目的を達成しようとするものである。

【0006】ここでは、外部機器コネクタが、バス接続用のバス用ピン接続端子と、デッキ接続用のコントロール用ピン接続端子とを備えたため、いずれの接続形式の外部機器であっても、同一のケーブルで接続される。このため、外部機器の購入に際して、ヘッドユニットのコネクタ形状に応じて外部機器を選択する必要がない。

【0007】

【発明の実施の形態】以下、本発明の実施の形態を図面を参照して説明する。図1は本発明による車載用ヘッドユニットと当該車載用ヘッドユニットに接続した車載用外部機器との構成を示すブロック図である。図1に示すように、車載用ヘッドユニット2は、内部音楽ソース4からの音声信号を増幅するアンプ8と、外部機器を接続する外部機器コネクタ10と、この外部機器コネクタ10にケーブルを介して接続される外部機器から入力される音声信号と前記内部音楽ソースから入力される音声信号とを切替える切替スイッチ18と、前記内部音楽ソース4と前記外部機器30との切替えを制御する制御手段6とを備えている。

【0008】しかも、図2に示すように、外部機器コネクタ31が、バス接続用の複数のバス用ピン12を接続するバス用ピン接続端子(図2のピン番号1, 2のBUS+と-)と、このバス用ピンに併設されコントロール信号を送受する2つのコントロール用ピン接続端子(図2のピン番号5, 13のCONT1及び2)と、前記外部機器と接続される前記バス用ピンおよび前記コントロールピンとを有する1本のケーブルに係合するコネクタ本体11とを備えている。

【0009】図2に示すように、本実施形態ではヘッドユニット2と外部機器30とを接続するコネクタ及び信号ラインをデッキ接続用とバス接続用の両方を含む形態としている。デッキ接続Dは、図3(A)に示すように、外部機器を1台のみ接続する方式である。その長所は低コストで製造できる点にあり、対処は、1台のみの接続であることと、CDチェンジャーなどをヘッドユニットの操作により制御することができない点にある。デッキ接続では、例えば、ヘッドユニットの内部音楽ソース(ラジオ、テープ)が動作中はCONT1を”Hi”とし、外部機器が動作中は、CONT2を”Hi”とする。外部機器が動作中にヘッドユニットが動作すると、CONT1を”Hi”とする。これに応じて外部機器は

再生を停止し、CONT2を”Lo”とする。

【0010】一方、バス接続は複数台の外部機器の接続が可能であり、また、CDチェンジャーなどの制御をヘッドユニットで行うことができる。バス接続では、各機器にアドレスを割り当ててバスにより接続し、動作、停止等の要求をやりとりすることで連携する。バス接続では、通信用ICが必要となり、マイコン処理が増えるため、コストが高くなってしまふ。一般的に、デッキ接続は廉価品に、バス接続は高級品に使用されている。

【0011】本実施形態では、図1に示すように、図2に示した方式の13ピンを用いることで、ヘッドユニットがバス接続であるのかまたはデッキ接続であるのかに関わらず、同一の外部機器を接続することができる。図1に示す例では、外部機器は、ヘッドユニットに対して外部機器となるTV, CD又はMD等の外部音楽ソースを再生する再生手段34と、この再生手段34によって再生される音声信号を前記ヘッドユニットへケーブルを介して伝達するためのヘッドユニット用コネクタ31と、このヘッドユニット用コネクタ31から入力される制御信号に応じて前記再生手段34を制御する外部機器制御手段32とを備えている。そして、ヘッドユニット用コネクタ31は、上述した外部機器コネクタと同一の形状、構造を採っている。そして、ヘッドユニット用コネクタから入力される接続チェック信号に応じて再生手段を前記コントロール用ピン接続端子又は前記バス用ピン接続端子の一方を選択する接続方式切替手段を備えている。この接続方式切替手段が、ヘッドユニットの採用する接続方式に応じて、バス接続またはデッキ接続を選択するため、ユーザがヘッドユニットの接続方式を確認する必要がなくなる。これは、ヘッドユニット側がデッキ接続またはバス接続のみに対応している場合に好適である。

【0012】また、ヘッドユニット側が両方の接続方式に対応している場合には、図1に示したヘッドユニット2の制御手段6が、始動時(ACC ON時)にバス用ピンと前記コントロールピンとに接続チェック信号それぞれ送信すると共に当該接続チェック信号に応答があった側のピン接続端子を有効と設定する第1の接続開始制御部20を備えるといふ。

【0013】さらに、ヘッドユニットがデッキ接続のみに対応している場合には、第1の接続開始制御部20に代えて、始動時に前記2つのコントロール用ピン接続端子のうち一方を予め定められた一定期間中ハイにすると共に当該一定期間経過後は当該2つのコントロール用ピン接続端子への出力を前記始動時前の状態に戻す第2の接続開始制御部を備えるといふ。この場合、デッキ接続にのみ対応した外部機器や、または両方の接続方式に対応した外部機器との間でデッキ接続を確立する。

【0014】図4は本実施形態による13ピンの接続方

式を使用して複数台の外部機器を接続した例を示すブロック図である。図4に示す例では、ヘッドユニットを低コストとするためにデッキ接続専用としつつ、図2に示すコネクタを採用する。そして、外部機器として操作パネルを有するTVを設け、このTVから2台の他の外部機器をバス接続する。そして、TVの操作パネルを操作することで、デッキ接続を介してヘッドユニットに送信する音楽ソースを選択する。図4に示す他の外部機器30、38は、図2に示すコネクタを有しつつ、さらにデッキ接続とバス接続の両方に対応したものとすると、当該他の外部機器を直接ヘッドユニット2に接続することもでき、接続の形態に応じて外部機器の接続方式及びコネクタを選択する必要がなくなる。

【0015】図4に示す外部機器40は、ヘッドユニット又は他の外部機器と接続する2以上の拡張コネクタ41を備えている。そして、当該拡張コネクタは、図1に示す外部機器コネクタと同様の形式、構造を採っている。そして、この外部機器40のコントローラとなる外部機器制御手段は、ヘッドユニット2が接続されたコネクタ41に対して前記コントロール用ピン接続端子を有効と設定することでデッキ接続を行い、さらに、他の外部機器が接続されたコネクタ41に対して前記バス用ピン接続端子を有効に設定することでバス接続する複数接続制御部を備えている。これにより、ヘッドユニット2を低コストとしつつ、複数台の外部機器を接続でき、そして、すべて同一のケーブルを利用して接続できるため、接続及び機器の選定が容易となる。

【0016】図5は本発明による車載用ヘッドユニットの実施例の構成を示すブロック図である。図5に示す車載用ヘッドユニットは、FM/AMラジオ付カセットである。図5に示すように、FM/AMラジオ付カセット(ヘッドユニット)は、車両アンテナで受信する電波に同調するチューナー回路52と、カセットテープを再生するテープヘッド54からの再生信号を増幅するテープイコライザアンプ53と、外部機器30から入力される音声信号を増幅するグラウンドアイソレーションアンプ55と、これらの音楽ソースからの音声信号を切替信号に応じて切り替える音声信号切替スイッチ18とを備えている。

【0017】FM/AMラジオ付カセット2はさらに、切替スイッチから入力される音声信号の増幅を調整するボリウム回路7と、このボリウム回路の出力を増幅するパワーアンプ8とを備えている。また、このパワーアンプ8は、スピーカー16に接続されている。そして、外部機器30とデッキ接続される制御手段としての制御用マイコン6を備えている。

【0018】図6に示すように、FM/AMラジオ付カセット2と外部機器との接続の確立は、AccON時の接続チェック信号の送受信により行う。図6(A)はデッキ接続を確立するための接続チェック信号の一例を示

す波形図であり、FM/AMラジオ付カセット2は、AccON時に500 [ms] CONT1を"Hi"とする。これにより、FM/AMラジオ付カセット2がデッキ接続を要求していることを外部機器に伝達する。また、FM/AMラジオ付カセット2がバス接続を外部機器に要求するには、図6(B)に示すように、AccON時直後に接続チェック信号となるパルス信号を各機器に送信し、返事を待つ。外部機器から当該接続チェック信号に応じた信号が入力されると、当該外部機器とバス接続を確立する。

【0019】図7に示すように、外部機器30は、AccON時に、バス信号とCONT1信号とをチェックして現在接続されているヘッドユニットがどちらの方式かを判断する。すなわち、AccONとなると、バス接続用の接続チェック信号が入力されたか否かを確認し(ステップS1)、図6(B)に示す信号が入力された場合にはバス接続を確立する(ステップS2)。一方、バス接続用の接続チェック信号が入力されない場合には、図6(A)に示すCONT1が"Hi"であるか否かを判定する(ステップS3)。そして、CONT1が"Hi"であれば、デッキ接続を確立する(ステップS4)。

【0020】また、AccONから2秒間バス信号、CONT1も入力されないときには、外部機器はヘッドユニットに対して接続要求のバス信号を送信する。

【0021】上述したように本実施形態によると、1つの接続コネクタの中にデッキ接続とバス接続の2つの方式の配線を入れ、そして、外部機器は、接続されたヘッドユニットがどちらの方式のものであるかを識別するため、外部機器は1機種で対応できるため、品種を少なくすることができ、そして、ユーザが外部機器を選定するときに自分のヘッドユニットがどちらの接続方式であるかを考慮する必要がなくなる。

【0022】

【発明の効果】本発明は以上のように構成され機能するので、これによると、外部機器コネクタが、バス接続用のバス用ピン接続端子と、デッキ接続用のコントロール用ピン接続端子とを備えたため、いずれの接続形式の外部機器であっても、同一のケーブルで接続することができ、従って、同一の機能の外部機器についてコネクタ形状別に外部機器の製造を行う必要がなく、また、ユーザは、外部機器の購入に際して、ヘッドユニットのコネクタ形状に応じて外部機器を選択する必要がなく、このため、外部機器の増設作業を簡単に行うことができる、という従来にない優れた車載用ヘッドユニット及び車載用外部機器を提供することができる。

【図面の簡単な説明】

【図1】本発明の一実施形態の構成を示すブロック図である。

【図2】図1に示した外部機器コネクタ等の形式及び構

造の一例を示す説明図である。

【図3】ヘッドユニットと外部機器の接続の例を示すブロック図であり、図3(A)はデッキ接続の一例を示し、図3(B)はバス接続の一例を示す図である。

【図4】デッキ接続形式のヘッドユニットに複数の外部機器を接続する例を示すブロック図である。

【図5】本発明の一実施例の構成を示すブロック図である。

【図6】接続チェック信号の一例を示す波形図であり、図6(A)はデッキ接続での接続チェック信号の一例を示す図で、図6(B)はバス接続での接続チェック信号の一例を示す図である。

【図7】図6に示す接続チェック信号を用いた外部機器

側の接続確立処理の一例を示すフローチャートである。

【符号の説明】

- 2 ヘッドユニット (例えば、FM/AMラジオ付カセット)
- 4 ヘッドユニットの音楽ソース (例えば、カセット)
- 6 制御手段 (制御用マイコン)
- 8 アンプ
- 10 外部機器用コネクタ
- 16 スピーカ
- 30 外部機器 (例えば、CDプレーヤ)
- 31 ヘッドユニット用コネクタ
- 32 外部機器接続制御手段 (制御用マイコン及び通信用IC)

【図1】

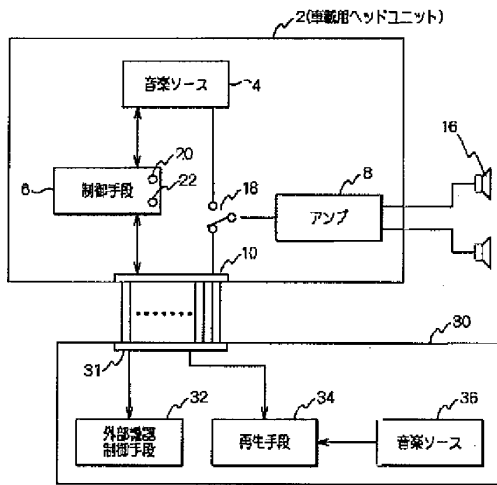

【図2】

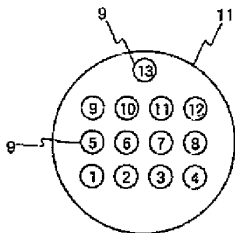

- | | |
|-------------|-------------------|
| 1. BUS- | 8. 音声 右 ch |
| 2. BUS+ | 9. バックアップ |
| 3. NC | 10. バックアップ |
| 4. イルミネーション | 11. ACC (アクセサリ電源) |
| 5. CONT 2 | 12. バスGND |
| 6. 音声信号GND | 13. CONT 1 |
| 7. 音声 左 ch | |

【図3】

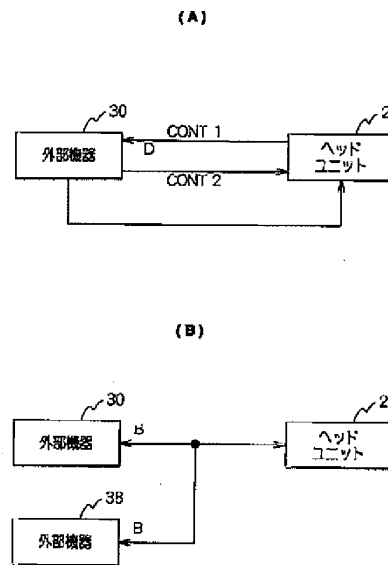

【図6】

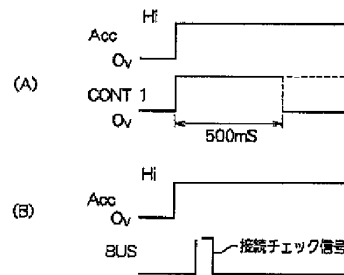

【図4】

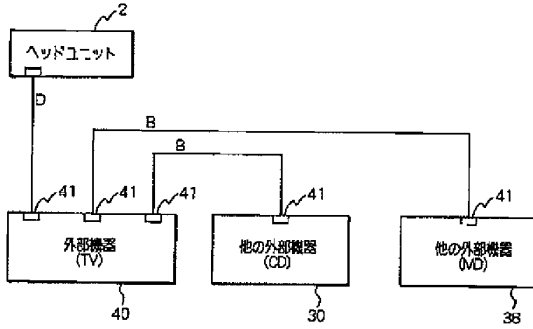

【図7】

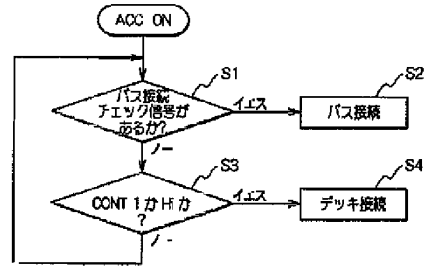

【図5】

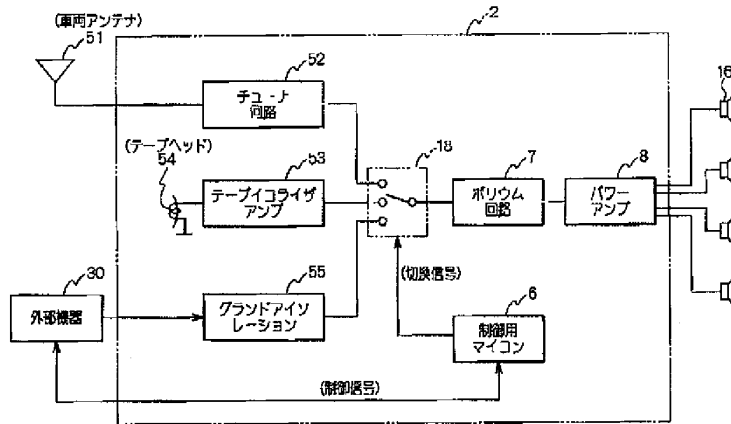

PATENT ABSTRACTS OF JAPAN

(11)Publication number : 2000-286874

(43)Date of publication of application : 13.10.2000

(51)Int.Cl. H04L 12/40
B60R 11/02
H04L 12/28

(21)Application number : 11-090570 (71)Applicant : SUZUKI MOTOR CORP

(22)Date of filing : 31.03.1999 (72)Inventor : UEMURA HIROSHI

(54) ON-VEHICLE HEAD UNIT AND ON-VEHICLE EXTERNAL DEVICE

(57)Abstract:

PROBLEM TO BE SOLVED: To provide an external device for an on-vehicle audio unit which device is inexpensive and easily used.

SOLUTION: An on-vehicle head unit 2 is provided with an amplifier 8 that amplifies an audio signal from an internal music source 4, an external unit connector 10 for connecting the head unit 2 to an external device, a changeover switch 18 that selects an audio signal received from the external device connected to the external unit connector 10 via a cable or the audio signal received from the internal music source, and a control means 6 that controls switching between the internal music source 4 and the external device 30. Furthermore, an external device connector 31 is provided with bus use pin connection terminals connected to a plurality of bus pins for bus connection, two control pin connection terminals provided along the bus pins to send/receive a control signal, and a connector main body engaging one cable connected to the external device and having the bus pins and the control pins.

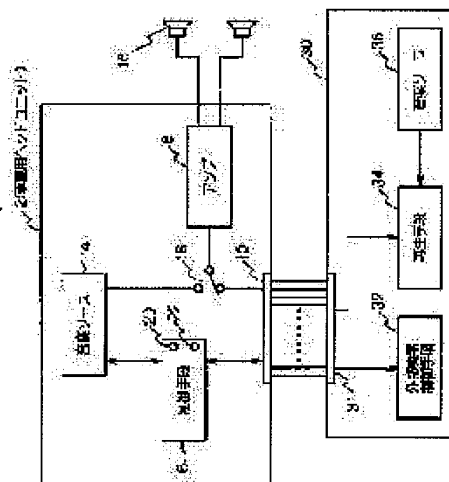

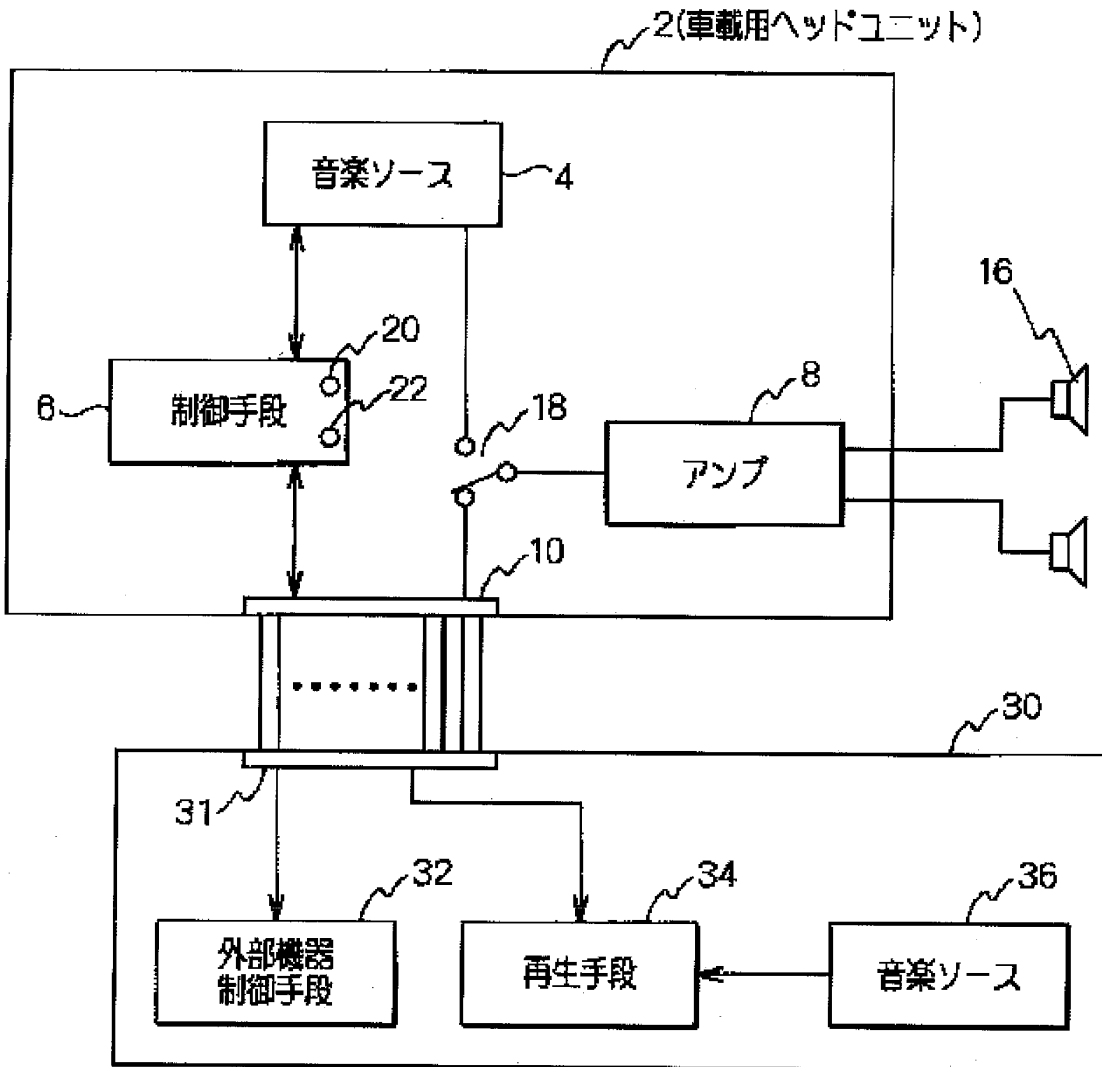

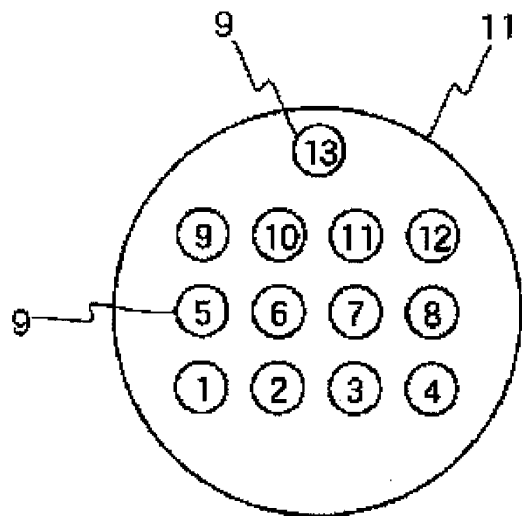

- | | |
|-------------|------------|
| 1. BUS- | 8. 音声 右 |
| 2. BUS+ | 9. バックア |
| 3. NC | 10. バックア |
| 4. イルミネーション | 11. ACC (ア |
| 5. CONT 2 | 12. バスGND |
| 6. 音声信号GND | 13. CONT 1 |
| 7. 音声 左 ch | |

(A)

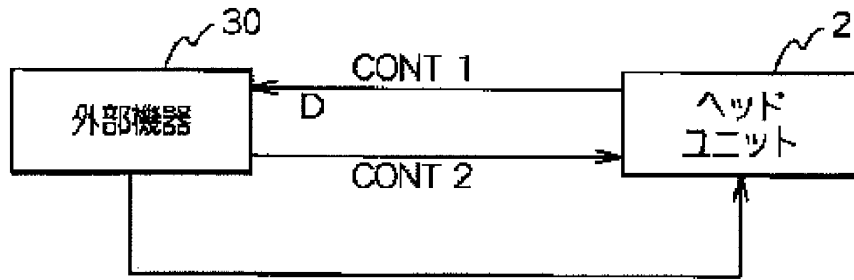

(B)

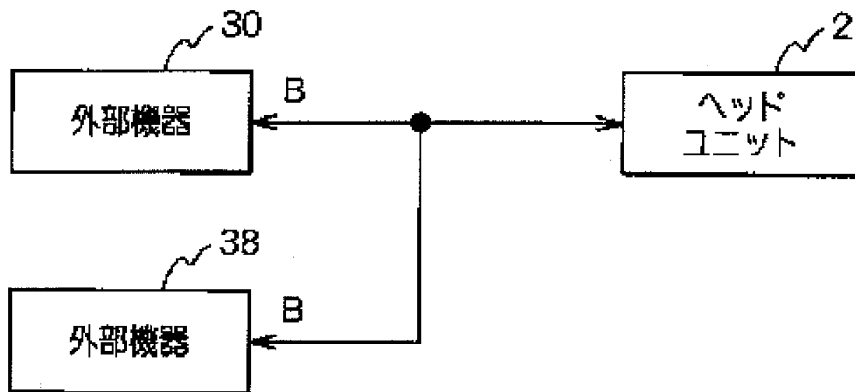

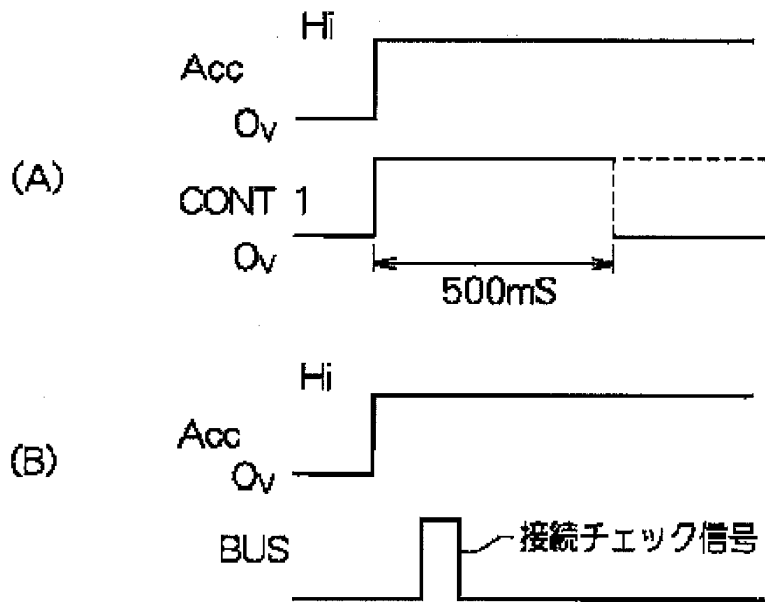

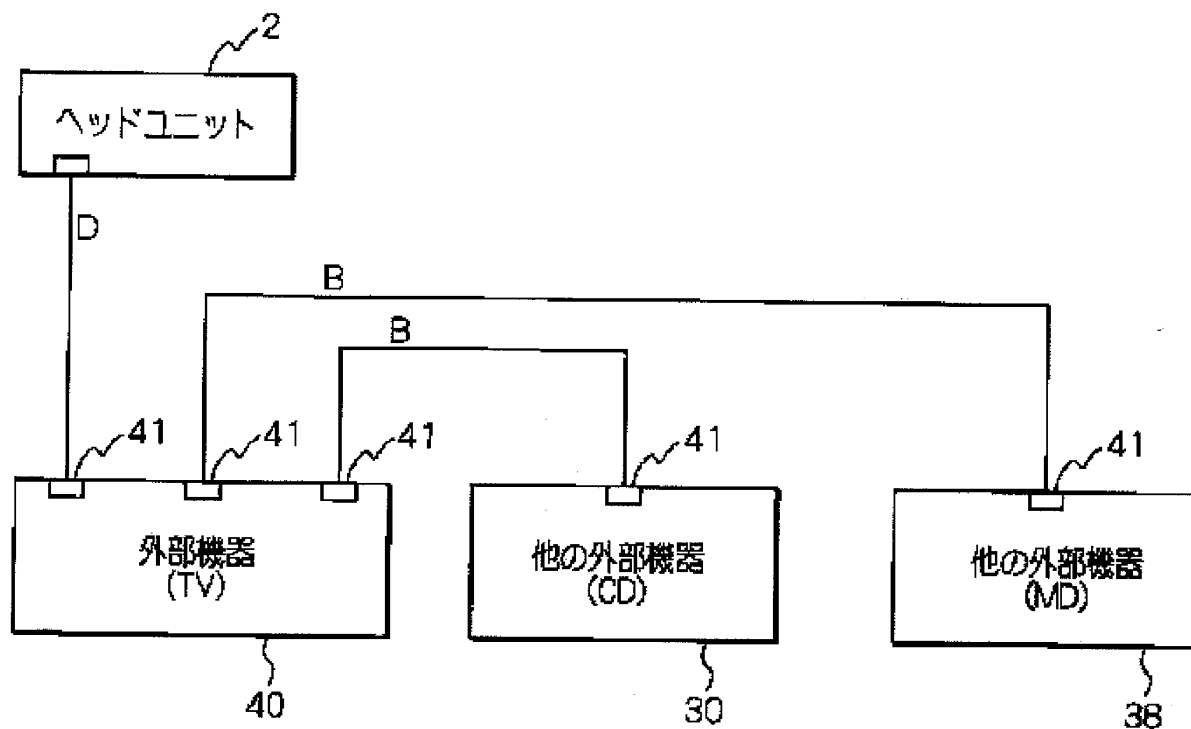

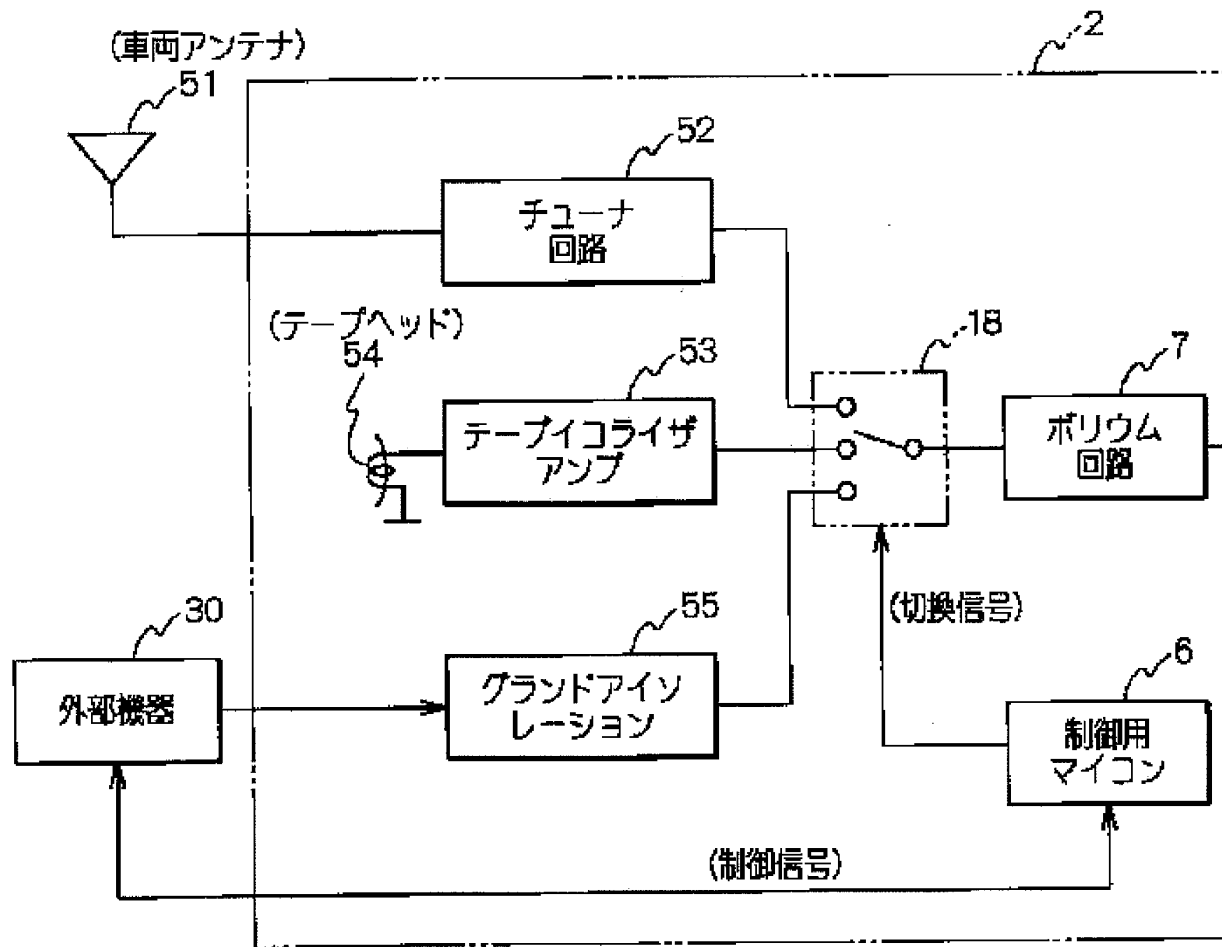

Drawing selection

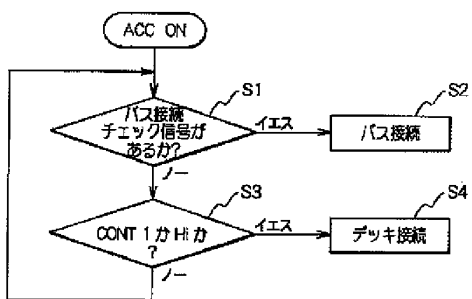

[Translation done.]

*** NOTICES ***

JPO and INPIT are not responsible for any damages caused by the use of this translation.

- 1.This document has been translated by computer. So the translation may not reflect the original precisely.
- 2.**** shows the word which can not be translated.
- 3.In the drawings, any words are not translated.

CLAIMS

[Claim(s)]

[Claim 1]Amplifier which amplifies an audio signal characterized by comprising the following from an internal music source, A changeover switch which changes an external device connector which connects an external instrument, and an audio signal inputted from an external instrument connected to this external device connector via a cable and an audio signal inputted from said internal music source, A head unit for mount provided with a control means which controls a change to said internal music source and said external instrument. A pin connection terminal for buses of plurality [external device connector / said] for bus connections.

Two pin connection terminals for control which are put side by side at this pin for buses, and send and receive a control signal.

Said pin for buses connected with said external instrument, and said control pin.

[Claim 2]Said control means, the time of said start up -- said pin for buses, and said control pin -- a connection check signal -- the head unit for mount according to claim 1 provided with the 1st starting connection control section that sets up a pin connection terminal of a side which it each transmitted and had a response in the connection check signal concerned as it is effective.

[Claim 3]Said control means, Make one side into a high in fixed time which was able to be defined beforehand between said two pin connection terminals for control at the time of said start up, and. The head unit for mount according to claim 1, wherein after the fixed time progress concerned is provided with the 2nd starting connection control section that returns an output to the two pin connection terminals for control concerned to a front state at the time of said start up.

*** NOTICES ***

JPO and INPIT are not responsible for any damages caused by the use of this translation.

- 1.This document has been translated by computer. So the translation may not reflect the original precisely.
- 2.*** shows the word which can not be translated.
- 3.In the drawings, any words are not translated.

DETAILED DESCRIPTION

[Detailed Description of the Invention]

[0001]

[Field of the Invention]This invention relates to the head unit for mount, and the external instrument for mount, and relates to the head unit for mount and the external instrument for mount which have the feature in the connection type at the time of extending the external instrument for mount to the head unit for mount especially.

[0002]

[Description of the Prior Art]Conventionally, the head unit of the audio for mount and the connection type of an external instrument have two copies, deck connection and a bus connection. Generally, a head unit is for example, a cassette with FM/AM radio, and, on the other hand, an external instrument is a CD player, an MD player, or TV.

[0003]

[Problem(s) to be Solved by the Invention]However, in the above-mentioned conventional example, since the connection type of deck connection and a bus connection was incompatible, there was inconvenience that the CD player had to prepare two kinds, the object for deck connection and the object for bus connections. for this reason, when a user selects an external instrument, its head unit is an object for deck connection -- or it had to be checked whether it was an object for bus connections.

[0004]

[Objects of the Invention]This invention improves the inconvenience which the starting conventional example has, and sets it as the purpose to provide the head unit for mount which shall be low cost and shall be especially easy to use the external instrument of the audio for mount, and the external instrument for mount.

[0005]

[Means for Solving the Problem]So, in a head unit for mount by this invention. Amplifier which

amplifies an audio signal from an internal music source, and an external device connector which connects an external instrument, It has a changeover switch which changes an audio signal inputted from an external instrument connected to this external device connector via a cable, and an audio signal inputted from said internal music source, and a control means which controls a change to said internal music source and said external instrument. And a pin connection terminal for buses of plurality [external device connector] for bus connections, Composition of having had a connector body engaged in one cable which has two pin connection terminals for control which are put side by side at this pin for buses, and send and receive a control signal, and said pins for buses connected with said external instrument and said control pins is taken. It is going to attain the purpose which this mentioned above.

[0006]Here, since an external device connector was provided with a pin connection terminal for buses for bus connections, and a pin connection terminal for control for deck connection, even if it is an external instrument of which connection form, it is connected by the same cable. For this reason, it is not necessary when purchasing an external instrument to choose an external instrument according to connector shape of a head unit.

[0007]

[Embodiment of the Invention]Hereafter, an embodiment of the invention is described with reference to drawings. Drawing 1 is a block diagram showing composition with the external instrument for mount linked to the head unit for mount by this invention, and the head unit for mount concerned. As shown in drawing 1, the head unit 2 for mount is provided with the following.

Amplifier 8 which amplifies the audio signal from the internal music source 4.

The external device connector 10 which connects an external instrument.

The changeover switch 18 which changes the audio signal inputted from the external instrument connected to this external device connector 10 via a cable, and the audio signal inputted from said internal music source.

The control means 6 which controls the change to said internal music source 4 and said external instrument 30.

[0008]And the pin connection terminal for buses (BUS+ and - of the pin numbers 1 and 2 of drawing 2) to which the external device connector 31 connects two or more pins 12 for buses for bus connections as shown in drawing 2, Two pin connection terminals for control (CONT1 of the pin numbers 5 and 13 of drawing 2, and 2) which are put side by side at this pin for buses, and send and receive a control signal, It has the connector body 11 engaged in one cable which has said pin for buses connected with said external instrument, and said control pin.

[0009]As shown in drawing 2, in this embodiment, the connector and signal line which connect

the head unit 2 and the external instrument 30 are made into the gestalt containing both the object for deck connection, and for bus connections. The deck connection D is a method which accepts one external instrument and connects, as shown in drawing 3 (A). The strong point is in the point which can be manufactured by low cost, and it being only one set of connection and the point which cannot control a CD changer etc. by operation of a head unit have management. In deck connection, while the internal music source (radio, tape) of a head unit operates, CONT1 is made into "Hi", and while the external instrument operates, CONT2 is made into "Hi", for example. An external instrument will make CONT1 "Hi", if the head unit operates working. According to this, an external instrument suspends reproduction and makes CONT2 "Lo".

[0010]On the other hand, connection of two or more sets of external instruments is possible for a bus connection, and it can control CD changer y- etc. by a head unit. At a bus connection, an address is assigned to each apparatus, and it connects by bus, and cooperates by exchanging the demand of operation, a stop, etc. In a bus connection, since IC for communication is needed and microcomputer processing increases, cost will become high. Generally, deck connection is used for low-priced goods, and the bus connection is used for quality articles.

[0011]a head unit is a bus connection in using 13 pins of the method shown in drawing 2 in this embodiment, as shown in drawing 1 – or although it is deck connection, it cannot be concerned, but the same external instrument can be connected. The reproduction means 34 which plays the alien-frequencies easy sauce in which an external instrument turns into an external instrument to a head unit, such as TV, CD, or MD, in the example shown in drawing 1, The connector 31 for head units for transmitting the audio signal reproduced by this reproduction means 34 to said head unit via a cable, It has the external instrument control means 32 which controls said reproduction means 34 according to the control signal inputted from this connector 31 for head units. And the connector 31 for head units has taken the same shape as the external device connector mentioned above, and structure. And it has the connection type switching means which chooses either said pin connection terminal for control, or said pin connection terminal for buses for a reproduction means according to the connection check signal inputted from the connector for head units. In order that this connection type switching means may choose a bus connection or deck connection according to the connection type which a head unit adopts, it becomes unnecessary for a user to check the connection type of a head unit. This is preferred when the head unit side supports only deck connection or a bus connection.

[0012]When the head unit side supports both connection types and the external instrument supports only one connection type, The control means 6 of the head unit 2 shown in drawing 1, the time of start up (at the time of ACC ON) -- the pin for buses, and said control pin -- a connection check signal -- it each transmits and it is good to have the 1st starting connection

control section 20 that sets up the pin connection terminal of the side which had a response in the connection check signal concerned as it is effective.

[0013]When the head unit supports only deck connection, It replaces with the 1st starting connection control section 20, One side is made into the high in fixed time which was able to be defined beforehand between said two pin connection terminals for control at the time of start up, and after the fixed time progress concerned is good to have the 2nd starting connection control section that returns the output to the two pin connection terminals for control concerned to a front state at the time of said start up. In this case, deck connection is established between the external instrument only corresponding to deck connection, or the external instrument corresponding to both connection types.

[0014]Drawing 4 is a block diagram showing the example which connected two or more sets of external instruments using the connection type of 13 pins by this embodiment. The connector shown in drawing 2 is adopted in the example shown in drawing 4, being only for deck connection, in order to make a head unit into low cost. And TV which has a navigational panel as an external instrument is formed, and the bus connection of two sets of other external instruments is carried out from this TV. And the music source which transmits to a head unit via deck connection by operating the navigational panel of TV is chosen. If other external instruments 30 and 38 shown in drawing 4 should correspond to both deck connection and a bus connection further, having a connector shown in drawing 2, being concerned -- others -- it becomes unnecessary to be also able to connect an external instrument to the head unit 2 directly, and to choose the connection type and connector of an external instrument according to the gestalt of connection

[0015]The external instrument 40 shown in drawing 4 is provided with the two or more expansion connectors 41 linked to a head unit or other external instruments. And the expansion connector concerned has taken the same form as the external device connector shown in drawing 1, and structure. And the external instrument control means used as the controller of this external instrument 40, Deck connection is made by setting up said pin connection terminal for control to the connector 41 to which the head unit 2 was connected, as it is effective, It has two or more connect control part which carries out a bus connection by setting up said pin connection terminal for buses effectively to the connector 41 to which other external instruments were connected. Thereby, making the head unit 2 into low cost, two or more sets of external instruments are connectable, and since it is altogether connectable using the same cable, connection and selection of apparatus become easy.

[0016]Drawing 5 is a block diagram showing the composition of the example of the head unit for mount by this invention. The head unit for mount shown in drawing 5 is a cassette with FM/AM radio. As shown in drawing 5, the cassette with FM/AM radio (head unit) is provided with the following.

The tuner circuit 52 which sides with the electric wave received with a vehicular antenna.
Tape equalizer amplifier 53 which amplifies the regenerative signal from the tape head 54 which plays a cassette tape.

Grand isolation amplifier 55 which amplifies the audio signal inputted from the external instrument 30.

The audio signal changeover switch 18 which changes the audio signal from these music sources according to a switching signal.

[0017]The cassette 2 with FM/AM radio is provided with the BORIUMU circuit 7 which adjusts further amplification of the audio signal inputted from a changeover switch, and the power amplification 8 which amplifies the output of this BORIUMU circuit. This power amplification 8 is connected to the speaker 16. And it has the control oriented microcomputer 6 as a control means by which deck connection is made with the external instrument 30.

[0018]As shown in drawing 6, transmission and reception of the connection check signal at the time of AccON perform establishment of connection between the cassette 2 with FM/AM radio, and an external instrument. Drawing 6 (A) is a wave form chart showing an example of the connection check signal for establishing deck connection, and the cassette 2 with FM/AM radio is 500 at the time of AccON. [ms] CONT1 is made into "Hi". This transmits to an external instrument that the cassette 2 with FM/AM radio is demanding deck connection. In order for the cassette 2 with FM/AM radio to require a bus connection of an external instrument, as shown in drawing 6 (B), he transmits the pulse signal which turns into a connection check signal immediately after at the time of AccON to each apparatus, and waits for the reply. If the signal according to the connection check signal concerned is inputted from an external instrument, the external instrument concerned and bus connection will be established.

[0019]As shown in drawing 7, the head unit which the external instrument 30 checks a bus signal and CONT1 signal at the time of AccON, and is connected now judges which method it is. That is, when it comes to AccON, it checks whether the connection check signal for bus connections has been inputted (Step S1), and a bus connection is established when the signal shown in drawing 6 (B) is inputted (Step S2). On the other hand, when the connection check signal for bus connections is not inputted, it is judged whether CONT1 shown in drawing 6 (A) is "Hi" (Step S3). And deck connection will be established if CONT1 is "Hi" (step S4).

[0020]When a bus signal and CONT1 are not inputted for 2 seconds from AccON, an external instrument transmits the bus signal of a connection request to a head unit.

[0021]According to this embodiment, as mentioned above, put wiring of two methods, deck connection and a bus connection, in one connection connector, and and an external instrument, Variety can be lessened, and when a user selects an external instrument, it becomes unnecessary for its head unit to take into consideration which connection type it is,

since the external instrument can respond by 1 model in order to identify of which method the connected head unit is a thing.

[0022]

[Effect of the Invention] Since this invention was constituted as mentioned above, and functioned and the external device connector was provided with the pin connection terminal for buses for bus connections, and the pin connection terminal for control for deck connection according to this, Even if it is an external instrument of which connection form, can connect by the same cable, therefore it is not necessary to manufacture an external instrument according to connector shape about the external instrument of the same function and, and a user faces the purchase of an external instrument, It is not necessary to choose an external instrument according to the connector shape of a head unit, and, for this reason, the outstanding head unit for mount and the external instrument for mount which are not in the former that the extension work of an external instrument can be done easily can be provided.

[Translation done.]

*** NOTICES ***

JPO and INPIT are not responsible for any damages caused by the use of this translation.

- 1.This document has been translated by computer. So the translation may not reflect the original precisely.
- 2.*** shows the word which can not be translated.
- 3.In the drawings, any words are not translated.

TECHNICAL FIELD

[Field of the Invention]This invention relates to the head unit for mount, and the external instrument for mount, and relates to the head unit for mount and the external instrument for mount which have the feature in the connection type at the time of extending the external instrument for mount to the head unit for mount especially.

[Translation done.]

* NOTICES *

JPO and INPIT are not responsible for any damages caused by the use of this translation.

- 1.This document has been translated by computer. So the translation may not reflect the original precisely.
- 2.**** shows the word which can not be translated.
- 3.In the drawings, any words are not translated.

PRIOR ART

[Description of the Prior Art]Conventionally, the head unit of the audio for mount and the connection type of an external instrument have two copies, deck connection and a bus connection. Generally, a head unit is for example, a cassette with FM/AM radio, and, on the other hand, an external instrument is a CD player, an MD player, or TV.

[Translation done.]

* NOTICES *

JPO and INPIT are not responsible for any damages caused by the use of this translation.

- 1.This document has been translated by computer. So the translation may not reflect the original precisely.
- 2.*** shows the word which can not be translated.
- 3.In the drawings, any words are not translated.

EFFECT OF THE INVENTION

[Effect of the Invention]Since this invention was constituted as mentioned above, and functioned and the external device connector was provided with the pin connection terminal for buses for bus connections, and the pin connection terminal for control for deck connection according to this, Even if it is an external instrument of which connection form, can connect by the same cable, therefore it is not necessary to manufacture an external instrument according to connector shape about the external instrument of the same function and, and a user faces the purchase of an external instrument, It is not necessary to choose an external instrument according to the connector shape of a head unit, and, for this reason, the outstanding head unit for mount and the external instrument for mount which are not in the former that the extension work of an external instrument can be done easily can be provided.

[Translation done.]

* NOTICES *

JPO and INPIT are not responsible for any damages caused by the use of this translation.

- 1.This document has been translated by computer. So the translation may not reflect the original precisely.
- 2.*** shows the word which can not be translated.
- 3.In the drawings, any words are not translated.

TECHNICAL PROBLEM

[Problem(s) to be Solved by the Invention]However, in the above-mentioned conventional example, since the connection type of deck connection and a bus connection was incompatible, there was inconvenience that the CD player had to prepare two kinds, the object for deck connection and the object for bus connections. for this reason, when a user selects an external instrument, its head unit is an object for deck connection -- or it had to be checked whether it was an object for bus connections.

[0004]

[Objects of the Invention]This invention improves the inconvenience which the starting conventional example has, and sets it as the purpose to provide the head unit for mount which shall be low cost and shall be especially easy to use the external instrument of the audio for mount, and the external instrument for mount.

[Translation done.]

* NOTICES *

JPO and INPIT are not responsible for any damages caused by the use of this translation.

- 1.This document has been translated by computer. So the translation may not reflect the original precisely.
- 2.**** shows the word which can not be translated.
- 3.In the drawings, any words are not translated.

MEANS

[Means for Solving the Problem]So, in a head unit for mount by this invention. Amplifier which amplifies an audio signal from an internal music source, and an external device connector which connects an external instrument, It has a changeover switch which changes an audio signal inputted from an external instrument connected to this external device connector via a cable, and an audio signal inputted from said internal music source, and a control means which controls a change to said internal music source and said external instrument. And a pin connection terminal for buses of plurality [external device connector] for bus connections, Composition of having had a connector body engaged in one cable which has two pin connection terminals for control which are put side by side at this pin for buses, and send and receive a control signal, and said pins for buses connected with said external instrument and said control pins is taken. It is going to attain the purpose which this mentioned above.

[0006]Here, since an external device connector was provided with a pin connection terminal for buses for bus connections, and a pin connection terminal for control for deck connection, even if it is an external instrument of which connection form, it is connected by the same cable. For this reason, it is not necessary when purchasing an external instrument to choose an external instrument according to connector shape of a head unit.

[0007]

[Embodiment of the Invention]Hereafter, an embodiment of the invention is described with reference to drawings. Drawing 1 is a block diagram showing composition with the external instrument for mount linked to the head unit for mount by this invention, and the head unit for mount concerned. As shown in drawing 1, the head unit 2 for mount is provided with the following.

Amplifier 8 which amplifies the audio signal from the internal music source 4.

The external device connector 10 which connects an external instrument.

The changeover switch 18 which changes the audio signal inputted from the external

instrument connected to this external device connector 10 via a cable, and the audio signal inputted from said internal music source.

The control means 6 which controls the change to said internal music source 4 and said external instrument 30.

[0008]And the pin connection terminal for buses (BUS+ and - of the pin numbers 1 and 2 of drawing 2) to which the external device connector 31 connects two or more pins 12 for buses for bus connections as shown in drawing 2, Two pin connection terminals for control (CONT1 of the pin numbers 5 and 13 of drawing 2, and 2) which are put side by side at this pin for buses, and send and receive a control signal, It has the connector body 11 engaged in one cable which has said pin for buses connected with said external instrument, and said control pin.

[0009]As shown in drawing 2, in this embodiment, the connector and signal line which connect the head unit 2 and the external instrument 30 are made into the gestalt containing both the object for deck connection, and for bus connections. The deck connection D is a method which accepts one external instrument and connects, as shown in drawing 3 (A). The strong point is in the point which can be manufactured by low cost, and it being only one set of connection and the point which cannot control a CD changer etc. by operation of a head unit have management. In deck connection, while the internal music source (radio, tape) of a head unit operates, CONT1 is made into "Hi", and while the external instrument operates, CONT2 is made into "Hi", for example. An external instrument will make CONT1 "Hi", if the head unit operates working. According to this, an external instrument suspends reproduction and makes CONT2 "Lo".

[0010]On the other hand, connection of two or more sets of external instruments is possible for a bus connection, and it can control CD changer y- etc. by a head unit. At a bus connection, an address is assigned to each apparatus, and it connects by bus, and cooperates by exchanging the demand of operation, a stop, etc. In a bus connection, since IC for communication is needed and microcomputer processing increases, cost will become high. Generally, deck connection is used for low-priced goods, and the bus connection is used for quality articles.

[0011]a head unit is a bus connection in using 13 pins of the method shown in drawing 2 in this embodiment, as shown in drawing 1 -- or although it is deck connection, it cannot be concerned, but the same external instrument can be connected. The reproduction means 34 which plays the alien-frequencies easy sauce in which an external instrument turns into an external instrument to a head unit, such as TV, CD, or MD, in the example shown in drawing 1, The connector 31 for head units for transmitting the audio signal reproduced by this reproduction means 34 to said head unit via a cable, It has the external instrument control means 32 which controls said reproduction means 34 according to the control signal inputted

from this connector 31 for head units. And the connector 31 for head units has taken the same shape as the external device connector mentioned above, and structure. And it has the connection type switching means which chooses either said pin connection terminal for control, or said pin connection terminal for buses for a reproduction means according to the connection check signal inputted from the connector for head units. In order that this connection type switching means may choose a bus connection or deck connection according to the connection type which a head unit adopts, it becomes unnecessary for a user to check the connection type of a head unit. This is preferred when the head unit side supports only deck connection or a bus connection.

[0012]When the head unit side supports both connection types and the external instrument supports only one connection type, The control means 6 of the head unit 2 shown in drawing 1, the time of start up (at the time of ACC ON) -- the pin for buses, and said control pin -- a connection check signal -- it each transmits and it is good to have the 1st starting connection control section 20 that sets up the pin connection terminal of the side which had a response in the connection check signal concerned as it is effective.

[0013]When the head unit supports only deck connection, It replaces with the 1st starting connection control section 20, One side is made into the high in fixed time which was able to be defined beforehand between said two pin connection terminals for control at the time of start up, and after the fixed time progress concerned is good to have the 2nd starting connection control section that returns the output to the two pin connection terminals for control concerned to a front state at the time of said start up. In this case, deck connection is established between the external instrument only corresponding to deck connection, or the external instrument corresponding to both connection types.

[0014]Drawing 4 is a block diagram showing the example which connected two or more sets of external instruments using the connection type of 13 pins by this embodiment. The connector shown in drawing 2 is adopted in the example shown in drawing 4, being only for deck connection, in order to make a head unit into low cost. And TV which has a navigational panel as an external instrument is formed, and the bus connection of two sets of other external instruments is carried out from this TV. And the music source which transmits to a head unit via deck connection by operating the navigational panel of TV is chosen. If other external instruments 30 and 38 shown in drawing 4 should correspond to both deck connection and a bus connection further, having a connector shown in drawing 2, being concerned -- others -- it becomes unnecessary to be also able to connect an external instrument to the head unit 2 directly, and to choose the connection type and connector of an external instrument according to the gestalt of connection

[0015]The external instrument 40 shown in drawing 4 is provided with the two or more expansion connectors 41 linked to a head unit or other external instruments. And the

expansion connector concerned has taken the same form as the external device connector shown in drawing 1, and structure. And the external instrument control means used as the controller of this external instrument 40, Deck connection is made by setting up said pin connection terminal for control to the connector 41 to which the head unit 2 was connected, as it is effective, it has two or more connect control part which carries out a bus connection by setting up said pin connection terminal for buses effectively to the connector 41 to which other external instruments were connected. Thereby, making the head unit 2 into low cost, two or more sets of external instruments are connectable, and since it is altogether connectable using the same cable, connection and selection of apparatus become easy.

[0016]Drawing 5 is a block diagram showing the composition of the example of the head unit for mount by this invention. The head unit for mount shown in drawing 5 is a cassette with FM/AM radio. As shown in drawing 5, the cassette with FM/AM radio (head unit) is provided with the following.

The tuner circuit 52 which sides with the electric wave received with a vehicular antenna.
Tape equalizer amplifier 53 which amplifies the regenerative signal from the tape head 54 which plays a cassette tape.

Grand isolation amplifier 55 which amplifies the audio signal inputted from the external instrument 30.

The audio signal changeover switch 18 which changes the audio signal from these music sources according to a switching signal.

[0017]The cassette 2 with FM/AM radio is provided with the BORIUMU circuit 7 which adjusts further amplification of the audio signal inputted from a changeover switch, and the power amplification 8 which amplifies the output of this BORIUMU circuit. This power amplification 8 is connected to the speaker 16. And it has the control oriented microcomputer 6 as a control means by which deck connection is made with the external instrument 30.

[0018]As shown in drawing 6, transmission and reception of the connection check signal at the time of AccON perform establishment of connection between the cassette 2 with FM/AM radio, and an external instrument. Drawing 6 (A) is a wave form chart showing an example of the connection check signal for establishing deck connection, and the cassette 2 with FM/AM radio is 500 at the time of AccON. [ms] CONT1 is made into "Hi". This transmits to an external instrument that the cassette 2 with FM/AM radio is demanding deck connection. In order for the cassette 2 with FM/AM radio to require a bus connection of an external instrument, as shown in drawing 6 (B), he transmits the pulse signal which turns into a connection check signal immediately after at the time of AccON to each apparatus, and waits for the reply. If the signal according to the connection check signal concerned is inputted from an external instrument, the external instrument concerned and bus connection will be established.

[0019]As shown in drawing 7, the head unit which the external instrument 30 checks a bus signal and CONT1 signal at the time of AccON, and is connected now judges which method it is. That is, when it comes to AccON, it checks whether the connection check signal for bus connections has been inputted (Step S1), and a bus connection is established when the signal shown in drawing 6 (B) is inputted (Step S2). On the other hand, when the connection check signal for bus connections is not inputted, it is judged whether CONT1 shown in drawing 6 (A) is "Hi" (Step S3). And deck connection will be established if CONT1 is "Hi" (step S4).

[0020]When a bus signal and CONT1 are not inputted for 2 seconds from AccON, an external instrument transmits the bus signal of a connection request to a head unit.

[0021]According to this embodiment, as mentioned above, put wiring of two methods, deck connection and a bus connection, in one connection connector, and an external instrument, Variety can be lessened, and when a user selects an external instrument, it becomes unnecessary for its head unit to take into consideration which connection type it is, since the external instrument can respond by 1 model in order to identify of which method the connected head unit is a thing.

[Translation done.]

(19) 日本国特許庁 (J P)

(12) 公開特許公報 (A)

(11) 特許出願公開番号

特開平11-273321

(43) 公開日 平成11年(1999)10月8日

(51) Int.Cl. ⁸	識別記号	F I	
G 1 1 B 31/00		G 1 1 B 31/00	N
B 6 0 R 11/02		B 6 0 R 11/02	B

審査請求 未請求 請求項の数12 OL (全 14 頁)

(21) 出願番号	特願平10-76115	(71) 出願人	000001487 クラリオン株式会社 東京都文京区白山5丁目35番2号
(22) 出願日	平成10年(1998)3月24日	(72) 発明者	井戸 和弘 東京都文京区白山5丁目35番2号 クラリオン株式会社内
		(72) 発明者	中鉢 善樹 東京都文京区白山5丁目35番2号 クラリオン株式会社内
		(72) 発明者	上原 永敏 東京都文京区白山5丁目35番2号 クラリオン株式会社内
		(74) 代理人	弁理士 木内 光春

最終頁に続く

(54) 【発明の名称】 カーオーディオシステム、車載用コンピュータ及びカーオーディオシステムの制御方法

(57) 【要約】

【課題】 汎用的なOSを持つ小形コンピュータとカーオーディオシステムとを組み合わせることで、互いの利点を活かす。

【解決手段】 コンピュータに含まれるCPU111の形式に対応したローカルバスB1と、カーオーディオシステムに含まれる機器15、21、22、3、16、7を接続するためのPCIバスB2と、それぞれのバスB1、B2の間でデータの形式を変換するPCIバスホストコントローラ114と、を備える。フラッシュROM113にはCPU111のためのOSを格納する。CPUはメモリ112などを効率よくアクセスすることで複雑な処理を高速に行う。コンピュータとカーオーディオシステムの両方の動作をスムーズに行う。音の信号を再生しながら別のバスで別の処理を行うといったマルチタスクが容易になる。CPUの形式を変える場合もCPUの形式に対応したバスだけを変えればよい。

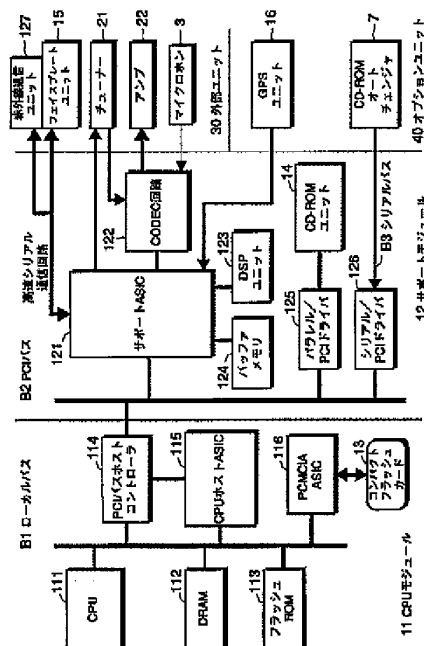

【特許請求の範囲】

【請求項1】 制御用のコンピュータを備えたカーオーディオシステムにおいて、

前記コンピュータはオペレーティングシステムを備え、このオペレーティングシステムは、

コンピュータ上の資源を管理する手段と、

ユーザインタフェースを含む入出力を制御する手段と、

予め決められた形式のプログラムを実行する手段と、

を備えたことを特徴とするカーオーディオシステム。

【請求項2】 制御用のコンピュータを備えたカーオーディオシステムにおいて、

前記コンピュータに含まれるCPUの形式に対応した第1のバスと、

前記カーオーディオシステムに含まれる機器を接続するための第2のバスと、

を備えたことを特徴とするカーオーディオシステム。

【請求項3】 制御用のコンピュータを備えたカーオーディオシステムにおいて、

前記コンピュータに含まれるCPUの形式に対応したローカルバスと、

前記カーオーディオシステムに含まれる機器を接続するためのPCIバスと、

を備えたことを特徴とするカーオーディオシステム。

【請求項4】 それぞれの前記バス間でデータの形式を変換する手段を備えたことを特徴とする請求項2又は3記載のカーオーディオシステム。

【請求項5】 前記カーオーディオシステムに含まれる複数の機器をデジチェーン形式で接続するための第3のバスを備えたことを特徴とする請求項1から4のいずれか1つに記載のカーオーディオシステム。

【請求項6】 予め決められた形式のプログラムを実行するために必要な環境を実現するオペレーティングシステムと、

カーオーディオシステムと、

前記カーオーディオシステムを制御する手段と、

を備えたことを特徴とする車載用コンピュータ。

【請求項7】 カーオーディオシステムを備えた車載用コンピュータにおいて、

前記コンピュータに含まれるCPUの形式に対応した第1のバスと、

前記カーオーディオシステムに含まれる機器を接続するための第2のバスと、

を備えたことを特徴とする車載用コンピュータ。

【請求項8】 カーオーディオシステムを備えた車載用コンピュータにおいて、

前記コンピュータに含まれるCPUの形式に対応したローカルバスと、

前記カーオーディオシステムに含まれる機器を接続するためのPCIバスと、

を備えたことを特徴とする車載用コンピュータ。

【請求項9】 それぞれの前記バス間でデータの形式を変換する手段を備えたことを特徴とする請求項7又は8記載の車載用コンピュータ。

【請求項10】 前記カーオーディオシステムに含まれる複数の機器をデジチェーン形式で接続するための第3のバスを備えたことを特徴とする請求項6から9のいずれか1つに記載の車載用コンピュータ。

【請求項11】 オペレーティングシステムを備えたコンピュータを使ってカーオーディオシステムを制御するカーオーディオシステムの制御方法において、前記オペレーティングシステムが、予め決められた形式のプログラムを実行するために必要な環境を実現するステップと、

前記プログラムが前記カーオーディオシステムを制御するステップと、

を含むことを特徴とするカーオーディオシステムの制御方法。

【請求項12】 コンピュータを使ってカーオーディオシステムを制御するカーオーディオシステムの制御方法において、

前記コンピュータに含まれるCPUが、このCPUの形式に対応した第1のバスを通してデータをやり取りするステップと、

前記カーオーディオシステムに含まれる機器が、機器を接続するための第2のバスを通してデータをやり取りするステップと、

を含むことを特徴とするカーオーディオシステムの制御方法。

【発明の詳細な説明】

【0001】

【発明の属する技術分野】本発明は、汎用的なOSを持つ小形コンピュータとカーオーディオシステムとを組み合わせることで、互いの利点を活かす技術に関するものである。

【0002】

【従来の技術】近年、半導体の技術がめざましい進歩をとげており、いろいろな分野の電子機器が、半導体を使うことによって小型化・高性能化している。このように半導体を使うことで小型化・高性能化している電子機器の1つに、パーソナルコンピュータ（以下「パソコン」という）がある。

【0003】特に最近では、ハンドヘルド（持ち運び型）やパームトップなどと呼ばれる小型のパソコン（以下「ハンドヘルドパソコン」と総称する）も増えている。このようなハンドヘルドパソコンに適した基本ソフトウェア、すなわちオペレーティングシステム（Operating System：以下「OS」という）として、例えばWindows（マイクロソフト株式会社の登録商標）CEなどが知られている。

【0004】このような汎用的なOSは、コンピュータ

の持っているCPUの処理能力やメモリなどをきめ細かく管理することで高度な処理能力を実現したり、プログラムに依存しない統一的で使いやすいユーザインタフェースを提供したり、予め決められた形式のプログラムであれば、自由に追加変更することでコンピュータの機能を追加変更できるという利点を持っている。

【0005】同じように、半導体を使うことで小型化・高性能化している別の電子機器としては、自動車に搭載するカーオーディオシステムやカーナビゲーションシステムが挙げられる。このうちカーオーディオシステムは、俗にカーステレオなどと呼ばれ、CDプレーヤやAMやFMのチューナーなどを、アンプやスピーカなどと組み合わせたものである。また、カーナビゲーションシステムは、方位磁石、走行距離計、GPSなどを使って車の現在位置を特定しながら、指定された目的地まで、地図を画面表示したり道案内をするシステムである。

【0006】なお、最近では、カーオーディオシステムに、カーナビゲーションシステム、ハンズフリーの携帯電話、盗難防止用の警報システムなどを組み合わせることも多いので、以下、これら車載用の電子機器を「カーオーディオシステム」と総称する。

【0007】

【発明が解決しようとする課題】上に述べたような、OSを備えたハンドヘルドパソコンと、カーオーディオシステムとは、従来では互いに全く別々のものであった。つまり、広い意味でのコンピュータを、制御用に備えたカーオーディオシステムは存在したが、この場合のコンピュータは特定の目的だけのために動く組み込みシステムと呼ばれるものである。

【0008】この組み込みシステムは、必要最小限の能力を持ったCPUを使い、スイッチ操作を受け付けたりディスク再生機構を動作させる、といったハードウェアに対する必要最小限の処理を、アセンブラなどを使った小さなプログラムで実現したものである。このため、パソコンのようにデータの加工や保存をしたり、プログラムを変更追加することで機能を変更追加するという使い方はできない。

【0009】一方、ハンドヘルドパソコンは、自ら音楽を鳴らしたり、カーオーディオシステムを制御する機能は持っていなかった。このため、ユーザは、ハンドヘルドパソコンを事実上車内に持ち込むことはあったが、カーオーディオシステムと関係付けて使うことはなかった。

【0010】ところで、最近のカーオーディオシステムは、ラジオのチューナー、カセットテープデッキやCDプレーヤといった従来の機器だけでなく、MDプレーヤ、CDやMDのオートチェンジャ、カーナビゲーションシステム、ユーザの命令を認識する音声認識装置、ハンズフリーの携帯電話、盗難防止用の警報システムという具合に、ますます多くの機器が組み込まれるようにな

ってきている。そして、このように複雑になってゆくカーオーディオシステムを、個々の装置に設けられたスイッチだけで使いこなすことは非常に難しい。

【0011】つまり、このようにカーオーディオシステムが複雑になると、操作キーやダイヤルといった多くのスイッチが車内のいろいろな場所にあることになる。このため、どれが何の操作キーなのかを覚えるのが大変である。

【0012】すなわち、複雑になってゆくカーオーディオシステムを使いこなすためには、複雑なシステムを制御する高度な処理能力、使いやすいユーザインタフェース、制御に関する機能を追加変更できるような柔軟性を持った小形コンピュータ、とりわけ汎用的なOSを備えたハンドヘルドパソコンと同等の情報処理装置を制御に使うことが望まれる。

【0013】また、ハンドヘルドパソコンの側から考えても、現代のように自動車を使うことが多く、渋滞も多い社会では、車内でも活用の幅を広げることが望まれる。特に、カーオーディオシステムと組み合わせることで、操作キーやメモリを兼用したり、ユーザが車内で知りたい情報をコンピュータを使った合成音声で読み上げさせ、その声をカーオーディオシステムのスピーカから聞いたり、カーオーディオシステムに組み込まれた携帯電話の回線で外部のコンピュータネットワークにアクセスしたり、といった使い方ができれば、今までよりも活用の幅を広げることができる。

【0014】なお、汎用的なOSを使うような高速なCPUと、カーオーディオシステムに含まれるような機器を組み合わせるときは、両者の動作速度の違いなどから、それぞれに合った別々のバスを備えることが望まれる。さらに、いくつもの機器を組み合わせたカーオーディオシステムでは、複数の機器を、単純なすっきりした配線で容易に接続できることが望まれる。

【0015】本発明は、上に述べたような従来技術の問題点を解決するために提案されたもので、その目的は、汎用的なOSを持つ小形コンピュータとカーオーディオシステムとを組み合わせることで、互いの利点を活かすことである。また、本発明の別の目的は、複数のバスを使うことで、高速なCPUとその他の機器の両方を、無駄なくスムーズに働かせることである。また、本発明の別の目的は、いろいろな機器をデジチェーン方式で芋づる式につなげるようにすることである。

【0016】

【課題を解決するための手段】上に述べた目的を達成するため、請求項1の発明は、制御用のコンピュータを備えたカーオーディオシステムにおいて、前記コンピュータはオペレーティングシステムを備え、このオペレーティングシステムは、コンピュータ上の資源を管理する手段と、ユーザインタフェースを含む入出力を制御する手段と、予め決められた形式のプログラムを実行する手段

と、を備えたことを特徴とする。請求項6の車載用コンピュータは、予め決められた形式のプログラムを実行するために必要な環境を実現するオペレーティングシステムと、カーオーディオシステムと、前記カーオーディオシステムを制御する手段と、を備えたことを特徴とする。請求項11の発明は、請求項1の発明を方法という見方からとらえたもので、オペレーティングシステムを備えたコンピュータを使ってカーオーディオシステムを制御するカーオーディオシステムの制御方法において、前記オペレーティングシステムが、予め決められた形式のプログラムを実行するために必要な環境を実現するステップと、前記プログラムが前記カーオーディオシステムを制御するステップと、を含むことを特徴とする。請求項1、6、11の発明では、カーオーディオシステムを制御するコンピュータが汎用的なOSを備えていて、この汎用的なOSは、CPUやメモリといった資源を管理することでコンピュータの能力を最大限発揮させ、また、プログラムに依存しない統一的で使いやすいユーザインタフェースを提供し、さらに、予め決められた形式のプログラムを追加したり変更することで機能の追加や変更を容易にする。このため、複雑なカーオーディオシステムの制御が容易になる。また、車内でもいろいろなプログラムを使ったり、カーオーディオシステムの機器を利用して情報処理をすることが可能になる。

【0017】請求項2の発明は、制御用のコンピュータを備えたカーオーディオシステムにおいて、前記コンピュータに含まれるCPUの形式に対応した第1のバスと、前記カーオーディオシステムに含まれる機器を接続するための第2のバスと、を備えたことを特徴とする。請求項7の発明は、カーオーディオシステムを備えた車載用コンピュータにおいて、前記コンピュータに含まれるCPUの形式に対応した第1のバスと、前記カーオーディオシステムに含まれる機器を接続するための第2のバスと、を備えたことを特徴とする。請求項12の発明は、請求項2の発明を方法という見方からとらえたもので、コンピュータを使ってカーオーディオシステムを制御するカーオーディオシステムの制御方法において、前記コンピュータに含まれるCPUが、このCPUの形式に対応した第1のバスを通してデータをやり取りするステップと、前記カーオーディオシステムに含まれる機器が、機器を接続するための第2のバスを通してデータをやり取りするステップと、を含むことを特徴とする。請求項3の発明は、制御用のコンピュータを備えたカーオーディオシステムにおいて、前記コンピュータに含まれるCPUの形式に対応したローカルバスと、前記カーオーディオシステムに含まれる機器を接続するためのPCIバスと、を備えたことを特徴とする。請求項8の発明は、カーオーディオシステムを備えた車載用コンピュータにおいて、前記コンピュータに含まれるCPUの形式に対応したローカルバスと、前記カーオーディオシステム

に含まれる機器を接続するためのPCIバスと、を備えたことを特徴とする。請求項4の発明は、請求項2又は3記載のカーオーディオシステムにおいて、それぞれの前記バス間でデータの形式を変換する手段を備えたことを特徴とする。請求項9の発明は、請求項7又は8記載の車載用コンピュータにおいて、それぞれの前記バス間でデータの形式を変換する手段を備えたことを特徴とする。請求項2、3、7、8、12の発明では、コンピュータのCPUと、カーオーディオシステムの機器とが、互いの形式に対応した違ったバスを使ってデータをやり取りし、データは、2つのバスの間では必要に応じて形式を変換して受け渡される(請求項4、9)。このため、各機器の動作よりCPUの動作が速くても、CPUは各機器の動作サイクルに合わせる必要がなく、メモリなどを効率よくアクセスすることで複雑な処理を高速に行うことができる。また、CPUがやり取りするデータと、機器がやり取りするデータとが、同じバスの伝達能力を奪い合うことがないので、コンピュータとカーオーディオシステムの両方の動作をスムーズに行うことができる。また、機器を接続するためのバスを使って音の信号を再生しながら、同時に、CPUの形式に対応したバスを使って別の処理を行うといったマルチタスクが容易になる。また、CPUを別の形式のものに変える場合も、各機器と、それら機器を接続するためのバスはそのまま、CPUの形式に対応したバスだけを新しいCPUの形式に合わせて変えればよいので、CPUの変更にも容易に対応することができる。

【0018】請求項5の発明は、請求項1から4のいずれか1つに記載のカーオーディオシステムにおいて、前記カーオーディオシステムに含まれる複数の機器をデジチェーン形式で接続するための第3のバスを備えたことを特徴とする。請求項10の発明は、請求項6から9のいずれか1つに記載の車載用コンピュータにおいて、前記カーオーディオシステムに含まれる複数の機器をデジチェーン形式で接続するための第3のバスを備えたことを特徴とする。請求項5、10の発明では、複数の機器を串ぶる式に次々と、デジチェーン形式でつないでゆくことができる。このため、機器の数が増えたり車内のあちこちに機器を分散設置するときも、スター方式のように長い配線が1箇所に集中することがなく、設置が容易になる。また、配線がすっきりわかりやすくなるので、構成を変えたり保守や修理をすることも容易になる。

【0019】

【発明の実施の形態】次に、本発明の実施の形態(以下「実施形態」という)について、図面を参照して具体的に説明する。この実施形態は、CDプレーヤなどのいろいろな機器を備えたカーオーディオシステムであるが、ハンドヘルドパソコンで使うような汎用的なOSを備えたコンピュータを備えていて、カーオーディオシステム

の制御もこのコンピュータで行うものである。なお、以下の説明で使うそれぞれの図について、それより前で説明した図と同じ部材や同じ種類の部材については同じ符号をつけ、説明は省略する。

【0020】〔1. 構成〕

〔1-1. 全体の構成〕まず、図1は、この実施形態の全体構成を示すブロック図である。この実施形態は、この図に示すように、メインユニット1の他に、カーオーディオシステムを構成する各機器として、チューナーアンプユニット2と、マイクロホン3と、GPSアンテナ4と、セキュリティコントロールユニット5と、電話ユニット6と、CD-ROMオートチェンジャ7と、電源バックアップ用の補助バッテリー9と、を備えている。

【0021】このうちメインユニット1は、制御用のコンピュータを内蔵して、このコンピュータによってシステム全体を制御する部分である。また、チューナーアンプユニット2は、AMとFMのアンテナ2aの他に、図示はしないが、ラジオチューナーと、スピーカを鳴らすためのアンプを備えた部分である。また、マイクロホン3は、音声認識による操作ができるように、ユーザの声を入力するためのものである。この音声認識の機能は、上に述べたコンピュータのプログラムによって実現される。

【0022】〔1-1-1. メインユニット〕また、メインユニット1は、コンパクトフラッシュカード13を差し込むためのソケット13Sと、付け外しできるフェイスプレートユニット15と、を備えている(図1)。コンパクトフラッシュカード13は、フラッシュメモリを使った記憶媒体で、メインユニット1に設けられたソケット13Sに差し込むことで、メインユニット1からデータを読み書きすることができる。このコンパクトフラッシュカード13は、データやプログラムなどを他のコンピュータとやり取りしたり、このカーオーディオシステムでのいろいろな設定データをバックアップしておくために使う。

【0023】また、付け外しできるフェイスプレートユニット15は、ユーザにいろいろな情報を表示する表示部と、ユーザがいろいろな操作をするための操作キーなどを設けた操作部と、を備えていて、DCP(Detachable Control Panel)とも呼ばれるものである。このフェイスプレートユニット15の表示部は、例えば横256ドット縦64ドットといった大型のカラーLCD(液晶表示装置)などである。

【0024】このフェイスプレートユニット15は、車を降りるときに取り外して持ち出せば、盗人がカーオーディオシステムを物色しても、肝心の表示部も操作部のないのを見て利用も販売もできないことをさとり、盗むことをあきらめるといって盗難防止効果がある。取り外したフェイスプレートユニット15は、ケース15aに入れて持ち歩けば、それ自体や周りのものを傷つける

ことがない。

【0025】また、このフェイスプレートユニット15は、図1には示さないが、ハンドヘルドパソコン8とIrDAなどの形式でデータをやり取りするための赤外線通信ユニットを備えている。

【0026】〔1-1-2. 他の機器〕また、GPSアンテナ4は、GPS衛星から電波を受け取るためのアンテナである。このGPSアンテナ4からの信号は、GPS受信機4aを経てメインユニット1内のGPSユニットに送られる。このGPSユニットは、図1には示さないが、受信機のある地球上の位置を電波から計算するものである。また、上に述べたコンピュータ上では、プログラムによってカーナビゲーションシステムの機能が実現され、計算結果はこのカーナビゲーションシステムの機能に渡される。

【0027】また、セキュリティコントロールユニット5は、振動や衝撃を検出するセンサ5aで、盗難やいたずらなどを検出すると、サイレン5bを鳴らすといった対応をする部分である。また、電話ユニット6は、自動車電話の機能を制御するユニットであり、電話アンテナ6aやハンドセット6bを使った通話を実現する部分である。また、CD-ROMオートチェンジャ7は、予めセットされた何枚かのCDを自動的に掛け替えることで、ユーザの選んだディスクや曲を再生するユニットである。

【0028】〔1-1-3. デイジーチェーン接続〕ここで、これらセキュリティコントロールユニット5、電話ユニット6及びCD-ROMオートチェンジャ7は、USB(Universal Serial Bus)によってメインユニット1に接続されている。このUSBは、複数の機器をデイジーチェーン形式で接続するためのシリアルバス(第3のバス)である。

【0029】この実施形態では、このようにUSBによって接続される機器は、外部とのデータのやり取りを、このUSBの形式で行うように構成されている。例えば、CD-ROMオートチェンジャ7は、アップストリーム用とダウンストリーム用のハブ(HUB)を備え、このCD-ROMオートチェンジャ7の内部では、音楽CDやCD-ROMからデジタルデータが一旦ATAPI形式(パラレル形式)で読み出されるが、読み出されたデータは、内蔵されているデータコンバータによって、シリアル形式であるUSB(Universal Serial Bus)形式に変換されたうえでUSBに送り出される。

【0030】この様な構成により、ユニット5、6、CD-ROMオートチェンジャ7の結線がシリアル結線となるので、それらユニット5、6、7をメインユニット1から離れた場所に設置する場合、その設置が容易となる。なお、図1ではユニット5、ユニット6、オートチェンジャ7の順で接続されているが、接続順は任意であり、また、必要なものみの接続としても良い。

【0031】〔1-2. メインユニットの内部構成〕次に、図2は、上に述べた各部分のうち主なものを示したブロック図であり、特に、メインユニット1内部の具体的な構成を中心に説明するものである。この図の全体は、破線で4つに区切ってあり、左寄りがCPUモジュール11、中央がサポートモジュール12、右上が外部ユニット30、右下がオプションユニット40になっている。このうち、CPUモジュール11とサポートモジュール12は、メインユニット1の内部に設けられている。

【0032】また、外部ユニット30とオプションユニット40は、メインユニット1に接続されているいくつかの機器をまとめて指しているものである。なお、図2では、説明の都合で、コンパクトフラッシュカード13はCPUモジュール11の下の方に、フェイスプレートユニット15は、外部ユニット30の上の方に示している。

【0033】このうちCPUモジュール11とサポートモジュール12は、カーオーディオシステム全体を制御する制御用コンピュータを構成している。このうちCPUモジュール11は、CPU111を中心とした論理的な演算処理をする部分であり、サポートモジュール12は、カーオーディオシステムに含まれる他の機器との入出力を行う部分である。

【0034】CPUモジュール11でデータの主な通り道になっているのは、CPU111を中心として形成されたローカルバスB1（第1のバス）である。一方、サポートモジュール12でデータの主な通り道になっているのは、各機器を接続するためのPCI（Peripheral Component Interconnect）バスB2（第2のバス）である。

【0035】〔1-2-1. CPUモジュールの構成〕CPUモジュール11のローカルバスB1は、CPU111の形式に合わせたもので、このローカルバスB1には、DRAM112と、フラッシュROM113と、PCIバスホストコントローラ114と、CPUホストASIC115と、PCMCIA・ASIC116が接続されている。このうちDRAM112は、CPU111がカーオーディオシステムの制御などの情報処理を行うときに、変数領域などのワークエリアを提供する部分である。

【0036】また、フラッシュROM113は、書き換え可能なROMで、ここでは、OS、BIOS、アプリケーションプログラムといった広い意味でのソフトウェアを格納している部分である。ここに格納されているOSの機能は、コンピュータ上の資源を管理すること、ユーザインタフェースを含む入出力を制御すること、予め決められた形式のプログラムを実行することなどであり、例えば、従来技術のところで述べたWindows CEをベースにしたものなどが考えられる。

【0037】また、PCIバスホストコントローラ114は、ローカルバスB1とPCIバスB2とを接続し、これら2つのバスの間でやり取りするデータの形式を変換する手段である。

【0038】また、CPUホストASIC115などの「ASIC」は、Application Specific Integrated Circuitの略で、ROMやRAM、CPUといった汎用的な集積回路に対して、特定の用途向けに作られたICやLSIを指す。具体的には、このCPUホストASIC115は、ローカルバスB1とPCIバスホストコントローラ114とのインタフェース用のASICである。つまり、このCPUホストASIC115は、PCIバスB2とCPUモジュール11との間でやり取りされるデータの窓口になる部分であり、具体的には、CPUモジュール11と外部との入出力をCPU111に代わって行うほか、PCIバスB2から送られてきたデータについて、CPU111に渡す種類のものかどうかを見分ける。

【0039】そして、CPUホストASIC115は、CPU111に渡すべきものはローカルバスB1を通じてCPU111に送るが、それ以外のもの、例えば送られてきたデータに対してCPU111が演算をするまでもなく、予め決められた反応を機械的に返せば足りるものについては、そのような反応を返す。

【0040】また、PCMCIA・ASIC116は、コンパクトフラッシュカード13が、いわゆるPCカードとしてPCMCIA（Personal Computer Memory Card International Association）の規格に基づいているのに対応したインタフェース用の部分であり、コンパクトフラッシュカード13に対するデータの読み書きを制御する部分である。

【0041】〔1-2-2. サポートモジュールにかかわる構成〕次に、サポートモジュール12のPCIバスB2は、カーオーディオシステムを構成するいろいろな機器との間でデータをやり取りするためのバスである。ここで、このPCIバスB2に接続される機器としては、外部ユニット30とオプションユニット40があり、これらはそれぞれ、いくつかの機器をまとめて指しているものである。

【0042】つまり、外部ユニット30は、図1に示したメインユニット1とは別のユニットになっているもので、この例では具体的には、メインユニット1から付け外しできるフェイスプレートユニット15、チューナーアンテナユニット2内に設けられたチューナー21とアンテナ22、マイクロホン3である。このうちフェイスプレートユニット15は、赤外線通信ユニット127を備えている。

【0043】また、オプションユニット40は、このカーオーディオシステムに組み込むかどうかをオプションとして選べるユニットであり、この例では具体的には、

GPSユニット16とCD-ROMオートチェンジャ7である。さらに、メインユニット1の内部にはCD-ROMユニット14があり、このCD-ROMユニット14もPCIバスB2に接続されている。このCD-ROMユニット14は、1枚のCDやCD-ROMからデジタルデータを読み出すためのプレーヤである。これらCD-ROMオートチェンジャ7とCD-ROMユニット14はどちらも、いわゆる音楽CDからデータを読み出す事もできるし、CD-ROMからデータを読み出す事もできるという互換性のある(コンパチブルな)ものである。

【0044】サポートモジュール12において、PCIバスB2がこれらの機器との間でデータをやり取りするためには、サポートASIC121、CODEC回路122、DSPユニット123、バッファメモリ124、パラレル/PCIDライバ125、シリアル/PCIDライバ126が使われる。

【0045】このうちサポートASIC121は、サポートモジュール12と各機器との間で、どこから来たデータをどこへ送るかというデータの交通整理をする部分である。また、CODEC回路122の「CODEC」とは「Coder/Decoder」つまりデータの符号化復号化技術の略語であり、このCODEC回路122は、例えば、与えられたデジタルデータをアナログ信号に変換するD/A変換をしたり、逆に、アナログ信号をデジタルデータに変換するA/D変換などを行う部分である。

【0046】また、DSPユニット123の「DSP」はデジタルサウンドプロセッサ、つまりデジタル形式の音の信号を専門に処理する回路を意味する略語で、このDSPユニット123は、音楽などを表わすデジタルデータを与えられると、システムに設定されている左右のバランス、ボリューム、フェイダー、サラウンド、イコライザといった項目が音の内容に反映されるように、デジタルデータを処理する部分である。

【0047】また、バッファメモリ124は、CD-ROMユニットなどの音響機器とPCIバスB2とではデータを読み書きするサイクルが違うことから、データを蓄えて少しずつ取り出すことでこの違いを埋めるためのバッファであり、SRAMなどで構成されている。

【0048】また、パラレル/PCIDライバ125は、CD-ROMユニット14から送られてくるパラレル形式のデジタルデータを、PCIバスB2のデータ形式に変換する部分である。また、シリアル/PCIDライバ126は、CD-ROMオートチェンジャ7から送られてくるシリアル形式のデジタルデータを、PCIバスB2のデータ形式に変換する部分である。

【0049】なお、赤外線通信ユニット127を含むフェイスプレートユニット15は、サポートASIC121に高速シリアル通信回路で接続され、GPSユニット16はサポートASIC121に、UART(Universal

Asynchronous Receiver-Transmitter)などの調歩同期シリアル通信回路で接続されている。また、CD-ROMユニット14はパラレル/PCIDライバ125に、ATAPI(AT Attachment Packet Interface)などのパラレル通信回路で接続されている。また、図示はしないが、赤外線通信ユニット127には、赤外線によるデータのやり取りを司るASICが設けられている。

【0050】〔2.作用〕上に述べたように構成されたこの実施形態は次のように働く。

〔2-1.全体的な作用〕

〔2-1-1.データの入力〕この実施形態では、各機器から入力されてくるデータのうち、デジタルデータは、サポートモジュール12のサポートASIC121に直接入力される。例えば、フェイスプレートユニット15からは、どのキーが押されたかというデータが送られてくる。また、GPSユニット16からは、GPS衛星からの電波を使って計算した緯度、経度といったデジタルデータが送られてくる。また、フェイスプレートユニット15に設けられた赤外線通信ユニット127からは、ハンドヘルドパソコン8から赤外線転送されたデジタルデータが送られてくる。

【0051】また、CD-ROMユニット14及びCD-ROMオートチェンジャ7からは、音楽CDから読み出した音のデータ、すなわちオーディオデータや、CD-ROMから読み出したデジタルデータ、すなわちCD-ROMデータが、パラレル/PCIDライバ125やシリアル/PCIDライバ126によってPCIバスB2のデータ形式に変換されたうえで、PCIバスB2経由でサポートASIC121に送られてくる。

【0052】さらに、図2には示さないが、図1に示したセキュリティコントロールユニット5からは異常の発生を知らせるデジタルデータが送られてくる。同様に、図1に示した電話ユニット6からは、通話の着信や発信元の電話番号などを知らせるデジタルデータ、すなわち文字データが送られてくるし、通話中には、相手の話し声を伝えるデジタルデータ、すなわち音声データがサポートASIC121に送られてくる。

【0053】なお、これらセキュリティコントロールユニット5や電話ユニット6は、シリアルバスB3にダイジーチェーン接続されているので、セキュリティコントロールユニット5や電話ユニット6から送られてくる情報は、CD-ROMオートチェンジャ7からのデジタルデータと同じように、シリアル/PCIDライバ126によってPCIバスB2のデータ形式に変換されたうえで、PCIバスB2経由で送られてくる。

【0054】一方、各機器から入力されてくるデータのうち、アナログ信号は、一旦CODEC回路122に入力され、このCODEC回路122によってデジタルデータに変換(A/D変換)されたうえで、サポートASIC121に渡される。例えば、マイクロホン3からは

ユーザの声がアナログ信号で入力され、チューナー21からは、チューニングの結果受信されたラジオの放送内容がアナログ信号で入力されてくる。

【0055】〔2-1-2. 入力されたデータの行き先〕このように集まってくる情報に対して、サポートASIC121はどの情報をどこに送るかという交通整理の役割を果たす。すなわち、サポートASIC121は、大まかには、音のデータはDSPユニット123で処理したうへCODEC回路122を通してアンプ22に送り、音以外のデータはCPUモジュール11に送る。但し、音のデータのなかでもマイクロホン3から入力されたデータは音声認識のためにCPUモジュール11に送る。

【0056】アンプ22に送られる音のデータとしては、例えば、チューナー21でチューニングされたラジオ放送の内容、CD-ROMユニット14やCD-ROMオートチェンジャ7で音楽CDから読み出された録音内容、電話ユニット6から送られてきた通話相手の話し声などが考えられる。

【0057】また、音以外のデータとしては、例えば、フェイスプレートユニット15でどの操作キーが押されたかのデータ、赤外線通信ユニット127から送られてきたファイルなどのデータ、GPSユニット16から送られてきた緯度、経度といったデジタルデータ、CD-ROMユニット14やCD-ROMオートチェンジャ7で、CD-ROMから読み出されたカーナビゲーションシステム用の地図の内容や地域ごとの情報の内容、セキュリティコントロールユニット5から送られてくる異常発生を知らせるデータ、電話ユニット6から送られてくる通話着信や発信元の電話番号などを知らせるデータなどが考えられる。

【0058】〔2-1-3. CPUモジュールでの情報処理〕CPUモジュール11では、サポートASIC121からデジタルデータが送られてくると、PCIバスホストコントローラ114が、送られてきたデータをローカルバスB1のデータ形式に変換したうへCPUホストASIC115に渡す。このCPUホストASIC115は、CPU111に代わって入出力を司り、データを渡されると、そのデータがCPU111に渡すべきものかそうでないかを、データの形式などから判断する。

【0059】つまり、CPUホストASIC115は、機械的に一定の反応を返せば足りるデータに対しては、予め決められた反応を、PCIバスホストコントローラ114を通してサポートモジュール12に返すが、それ以外のデータはCPU111に渡す。

【0060】CPU111は、フラッシュROM113に記録されているOSやプログラムのコードにしたがって、渡されたデータを処理し、この処理の際に必要なワークエリアなどの記憶領域としてはDRAM112を利

用する。例えば、マイクロホン3から入力されたユーザの声が送られてくると、CPU111は、予め用意している命令語の特徴を表わすパラメータや波形などと、受け取ったユーザの声とを比較し、一番似ている命令語をユーザが言ったものと推定し、その命令語にしたがって動作を行う。

【0061】また、コンパクトフラッシュカード13の読み書きは、CPUモジュール11において、CPU111からの依頼にしたがって、CPUホストASIC115がPCMCIA・ASIC116を制御することによって行われる。

【0062】そして、CPU111による情報処理の結果は、PCIバスホストコントローラ114によってPCIバスB2のデータ形式に変換されたうへで、サポートモジュール12に送られる。情報処理の結果としてサポートモジュール12に送られるデータとしては、サポートモジュール12の各部分や各機器に対する動作の指令などであり、サポートモジュール12では、このように送られてきたデータにしたがって入出力などの処理が行われる。

【0063】〔2-1-4. サポートモジュールでの入出力などの処理〕例えば、CDからのデータ読み出しやラジオのチューニングをさせる指令がCPUモジュール11から届くと、CD-ROMユニット14、CD-ROMオートチェンジャ7やチューナー21がそれにしたがった動作を行う。また、スピーカから出ている音の音源を現在とは別の機器に切り替える指令がCPUモジュール11から届くと、サポートASIC121はCODEC回路122に送り出すデジタルデータを、それまでの機器のものから、新しく指定された機器によるものに切り替える。

【0064】なお、デジタルデータをアンプ22に出力する場合、アンプ22はアナログ信号しか受け付けないので、CODEC回路122は、デジタルデータをアナログ信号に変換(D/A変換)したうへでアンプ22に出力する。

【0065】また、例えばユーザに対する表示データが、CPUモジュール11やその他の機器からサポートASIC121に送られてくると、サポートASIC121は、この表示データを高速シリアル通信回路を通してフェイスプレートユニット15に転送する。この場合、フェイスプレートユニット15では、転送されてきた表示データにしたがって、ユーザに対する情報が表示部に表示される。

【0066】続いて、上に述べたような各部分の動きによって、ユーザがこの実施形態のカーオーディオシステムをどのように使うことができるのかを具体的に説明する。

【0067】〔2-2. 操作と情報の表示〕この実施形態のカーオーディオシステムを操作するとき、ユーザ

は、フェイスプレートユニット15に設けられている操作キーを押してもよいし、操作の内用ごとに予め決められている語句を発話してもよい。例えば、ユーザがCDやFMチューナーを利用したいときは、CDに切り替える操作キーを押してもよいし、予め決められた語句として例えば「しーでいー」や「えふえむ」などとマイクロホン3に向かって発話すればよい。

【0068】ユーザが操作キーを押したときは、そのデータがサポートASIC121からCPUモジュール11に転送され、CPU111が新たな表示データをサポートASIC121に送り、フェイスプレートユニット15の表示部は、この表示データを使って、ラジオを操作するための画面表示やCDを操作するための画面表示などに切り替わる。

【0069】また、例えば、ユーザが「しーでいー」といった語句を発話すると、マイクロホン3からアナログ信号がCODEC回路122によってデジタルデータに変換され、このデジタルデータが、サポートASIC121からPCIBASホストコントローラとCPUホストASIC115を経てCPU111に送られ、CPU111は、このデジタルデータに基づいて、ユーザがどの言葉と言ったのかを認識し、認識結果に応じて、操作キーが押されたときと同じような対応をする。

【0070】なお、例えば、フェイスプレートユニット15の表示部をタッチパネルにしておき、コンピュータのグラフィカルユーザインタフェースとして、例えばその時点で使える機能をアイコンで表示部に表示し、ユーザが使いたい機能のアイコンを指で触るとその機能が働くようにすることもできる。さらに、例えば、そのようなアイコンによる表示と音声認識を合わせて使えば、一度にいくつかのアイコンが表示され、ユーザが「つぎ」と発話すれば画面が切り替わって次のいくつかのアイコンが表示され、ユーザが「もどる」と発話すれば画面が1つ前の状態に戻る、といった使い方も可能である。

【0071】〔2-3. ラジオを聞く場合〕上に述べたような操作で、例えばユーザが「えふえむ」と発話してラジオのFM放送を選び、CPU111がそれを認識すると、サポートASIC121はCPU111からの命令にしたがってチューナー21をFMの受信状態に切り替え、また、アンプ22に送り出すデータのソースをチューナー21からの音声のデータに切り替える。この場合、チューナー21は、前回選局した周波数を受信してもよいし、また、例えば、ユーザが「シークアップ」といった語句を発話することで、周波数を少しずつ変えながら受信状態のよい次の周波数を自動的に探す（自動掃引）ようにしてもよい。

【0072】このようにラジオを聞く場合は、チューナー21から送られてくる受信内容はアナログ信号なので、このアナログ信号はCODEC回路122に入力され、デジタルデータに変換されたうえでサポートAS I

C121に送られる。サポートASIC121は、CODEC回路122から受け取ったデジタルデータをDSPユニット123に渡し、DSPユニット123は、予めシステム上で設定されているバランスやボリュームといった設定項目にしたがってこのデジタルデータを処理し、サポートASIC121に送り返す。

【0073】そして、サポートASIC121は、このように返ってきたデジタルデータをCODEC回路122に再び送り返し、CODEC回路122はこのデジタルデータを再びアナログ信号に変換して戻したうえで、今度はアンプ22に送ってスピーカから流れるようにする。

【0074】〔2-4. CDの再生〕また、ユーザは、音楽CDを聞きたいときは、CD-ROMユニット14やCD-ROMオートチェンジャ7に聞きたい音楽CDをセットし、「すたーと」となどと音声などで再生を指示したり、次の曲へ飛ぶといった指示をすればよい。例えば、CD-ROMユニット14内の音楽CDを再生するときは、サポートASIC121からの指令によってCD-ROMユニット14が作動し、CD-ROMユニット14からはデジタルデータであるオーディオデータが送られてくる。

【0075】そして、パラレル/PCIDライバ125は、このオーディオデータをPCIBASB2のデータ形式に変換してサポートASIC121に送り、サポートASIC121は、PCIBASB2からオーディオデータを受け取ると、このオーディオデータを一旦DSPユニット123に渡して処理させ、処理されたオーディオデータを再びDSPユニット123から受け取ると、処理されたオーディオデータをデジタル入出力ポートからCODEC回路122に渡し、アナログ信号の形でアンプ22に出力させる。

【0076】音楽CDを再生するのがCD-ROMオートチェンジャ7のときは、シリアルバスB3から送られてくるシリアル形式のオーディオデータを、シリアル/PCIDライバ126がPCIBASB2のデータ形式に変換するが、それ以降の処理はCD-ROMユニット14の場合と同じように行われる。

【0077】なお、CD-ROMユニット14やCD-ROMオートチェンジャ7と、CODEC回路122やDSPユニット123とを相対的に比べると、前者は長い時間のサイクルでまとまった量のデータを送ってくるのに対して、後者は短い時間のサイクルでデータを少しずつ処理するため、両者の間にサイクルにずれがある。このため、サポートASIC121は、CD-ROMユニット14又はCD-ROMオートチェンジャ7がまとめて送ってきたデジタルデータをバッファメモリ124に格納し、一番古い部分から次々と取り出してはDSPユニット123に渡して処理させることで、上に述べたようなずれを埋めて再生が滑らかに行われるようにす

る。

【0078】〔2-5. CD-ROMとカーナビゲーションの利用〕また、ユーザが例えばカーナビゲーションシステムの機能を使いたいときは、例えばCD-ROMユニット14に、カーナビゲーションシステム用のデータ（アプリケーションソフト、地図等）が記録されたCD-ROMをセットしたうえで、カーナビゲーションシステムの機能を起動する。このようなカーナビゲーションシステムの機能は、例えばコンピュータのプログラムとしてCPUモジュール11のフラッシュROM113に記録しておき、CPU111にこのようなプログラムを実行させることによって実現することができる。

【0079】このようなカーナビゲーションシステムが、CD-ROMに記録された地図のデータや地域ごとのいろいろな情報などを読み出そうとするときは、例えばCD-ROMユニット14から読み出されたデジタルデータがパラレル/PCIドライバ125、PCIバスホストコントローラ114、CPUホストASIC115を経てCPU111に渡される。CPU111は、このように受け取った地図などのデータに基づいてフェイスプレートユニット15の表示部に表示するためのビットマップイメージをDRAM112上に作成したうえで、サポートモジュール12に送り出す。

【0080】また、このようにカーナビゲーションシステムを使うときは、図1に示したGPSアンテナ4でGPS衛星からの電波を受信し、図2のGPSユニット16がこの電波から緯度や経度などを計算し、このデータがCPU111に送られてくる。すると、CPU111は、これらの緯度や経度などのデータから、このカーオーディオシステムを積んだ車が現在どこを走っているのかを地図上で特定する事ができる。この結果、ユーザが入力しなくても出発地点として現在地を設定したり、現在の地点が中心となるような大まかな地図を表示したり、次の右折や左折を指示する図形を表示したりすることができる。

【0081】なお、ナビゲーション用のデータは、コンパクトフラッシュカード13（又はDRAM112）、又はフラッシュROM113に記憶しておいても良い。

【0082】また、すでに説明したような音声認識による操作の仕方は、このようにカーナビゲーションシステムの機能を使うときにも利用することができ、例えば、曲がり角ごとに右折や左折といった指示を出すカーナビゲーションシステムを使う場合、1つ前の指示や1つ先の指示をユーザが見たいときは、「つぎ」とか「もどる」といった語句を発話することで次々と表示を切り替えることもできる。

【0083】さらに、このような道案内はアンブ22を通して合成音声を出力することでユーザに知らせることもでき、このようにすれば、次にどこを曲がるか知るために表示部に視線を移す必要がなくなる。

【0084】〔2-6. 電話の利用〕また、ユーザは、電話ユニット6を使って通話するとき、次のようにコンピュータの利点とカーオーディオシステムの利点を活かすことができる。例えば、ユーザは、コンピュータのプログラムを使って、自分の知っている人の電話番号と名前をシステムの、例えばDRAM112、コンパクトフラッシュカード13に予め登録しておく。

【0085】電話が着信すると、図2には図示しないが、電話ユニット6からシリアルバスB3とシリアル/PCIドライバ126を通じて、電話が着信したことを知らせるデジタルデータと、発信元の電話番号を表わすデジタルデータがサポートASIC121に送られる。これらのデータはさらに、CPUモジュール11のCPU111に送られ、CPU111は、予め登録された電話番号の中に、今かかってきている発信元の電話番号が登録されているかどうかを検索する。

【0086】予め登録された電話番号の中に、今かかってきている発信元の電話番号があったときは、CPU111はその電話番号に対応する名前をサポートモジュール12に送り返すことで、フェイスプレートユニット15に電話をかけてきている人の名前を表示させたり、合成音声による「〇〇さんからです」といった案内を車載スピーカから流すことで、誰が電話をかけてきているかをユーザに知らせることができる。

【0087】このような表示や案内、また呼び出し音などで電話がかかってきていることを知ったユーザが、予め決められた語句を発話して電話をつなぐように指示すると、相手の声がスピーカから流れると同時に、マイクロホン3から入力されるユーザの声がCODEC回路122によってデジタルデータに変換され、サポートASIC121、シリアル/PCIドライバ126、シリアルバスB3を経て電話ユニット6に送られ、ユーザは手を使わずにいわゆるハンズフリーの状態に通話を行うことができる。

【0088】なお、呼び出し音が一定の回数だけ鳴ったところで、例えば電話ユニット6やCPUモジュール11に用意された留守番電話機能などが電話に応答する。

【0089】また、ユーザの側から発信しようとするときも、例えば、予め登録してある電話番号と名前を表示画面の上でつぎつぎに表示させ、電話を掛けたい相手が表示されたところで発信のアイコンなどを指でタッチすると、その電話番号がCPUモジュール11からデジタルデータとして電話ユニット6に転送されて自動的に電話がかかり、相手が出ればそのまま話することができる。

【0090】また、ユーザが登録した名前を発話し、CPUモジュール11がこれを認識することでその名前に対応する電話番号に自動的に発信したり、掛けたい電話番号を1桁ずつ発話して認識させたり、ユーザが「りだいやる」と発話したことを認識して電話を掛ける先を決めるようにすることもできる。

【0091】〔2-7. セキュリティコントロールユニットの利用〕また、セキュリティコントロールユニット5は、単独で使うこともできるし、上に述べた電話ユニット6と連動させて使うこともできる。例えば(図1)、ユーザは車を離れるときに、セキュリティコントロールユニット5を作動させ、送信機5cを持って降りる。車両のユーザと何ら関係のない第三者がドアノブに触れたり、鍵穴をいじったり、ドアやトランクをこじ開けようとしたり、車を無断で移動させようとする、それによる衝撃や振動をセンサ5aが感じ取り、センサ5aからの信号を受けたセキュリティコントロールユニット5は、例えばサイレン5bを大音量で鳴らす。これにより車外の環境に対し警報の効果がもたらされる。

【0092】ユーザ自身は、車に戻ってきたとき、持っている送信機5cを操作すれば、予め決められた暗号がセキュリティコントロールユニット5に送られ、セキュリティコントロールユニット5の機能は解除されるので、鍵を使ったり車を動かしてもサイレンが鳴ったりすることはない。

【0093】このようなセキュリティコントロールユニット5は、電話ユニット6と連動させて使えばさらに効果がある。つまり、センサ5aが異常を感知したとき、セキュリティコントロールユニット5は、サイレンを鳴らすだけでなく、割り込み信号を送ってCPUモジュール11及びサポートモジュール12を含むカーオーディオシステムを起動させる。このような起動を可能にするためには、カーオーディオシステムの電源と起動スイッチに接続した電子回路を用意し、割り込み信号が来ないかをこの電子回路に常に監視させておき、割り込み信号が来るとただちに電源と起動スイッチをオンにしてカーオーディオシステムを起動させればよい。

【0094】このように起動されたCPU11は、セキュリティコントロールユニット5から異常発生を知らせるデータを受け取ると、電話ユニット6に指令を送ることで電話を掛けさせる。このときに電話を掛ける先は、異常時の通報先として予め設定しておけばよく、例えば、警察、ユーザの持っている携帯電話、警備会社などとすればよい。そして、掛けた先に電話がつながると、合成音声や予め録音したアナウンスを相手に聞かせることで異常を知らせる。このようにすれば、知らせを受けた者が現場に急行できる。

【0095】〔2-8. ユーティリティプログラムの利用〕また、通常のハンドヘルドパソコンと同じように、OSやアプリケーションプログラムの機能として、アドレス帳、カレンダー、スケジュール管理、音声録音、時計、電卓、ゲームといった機能を利用すれば、車の中でもいろいろな情報処理を行うことが可能となる。さらに、これらの機能を実現するアプリケーションプログラムを削除したり、新しいものに入れ替えたり、追加することで、個々のユーザが自分にあった情報処理の環境を

整えることができる。

【0096】〔2-9. コンパクトフラッシュカードの利用〕また、この実施形態のカーオーディオシステムでは、コンパクトフラッシュカード13を使うことで、他のハンドヘルドパソコンや他のカーオーディオシステムなどとの間で情報をやり取りすることができる。

【0097】例えば、コンパクトフラッシュカード13から新しいアプリケーションプログラムやOSをフラッシュROM113に読み込ませることで、新しい機能を追加するしたりOSを更新することが容易になる。特に、汎用のOSを使うことによって、一般のソフトウェアメーカーがアプリケーションプログラムやOSの機能モジュールなどを作りやすくなるので、それを記録したコンパクトフラッシュカード13も出回って手に入れやすくなり、ユーザはこのカーオーディオシステムを、コンピュータとしても、より便利に使えるようになる。

【0098】また、他のパソコンやハンドヘルドパソコンで作ったアドレス帳のような個人的なデータを、コンパクトフラッシュカード13でこのカーオーディオシステムに持ち込めば、それまでの作業をこのカーオーディオシステム上で続けることができる。さらに、これとは逆に、このカーオーディオシステムで作ったデータをコンパクトフラッシュカード13で他のパソコンやハンドヘルドパソコンに移して作業を続けることもできる。

【0099】また、上に述べたようなユーティリティプログラムを使って自分が作ったデータを、コンパクトフラッシュカード13にバックアップコピーしておけば、カーオーディオシステムの不調や他人が使ったためにデータが消えたような場合でも、コンパクトフラッシュカード13からデータを再びメインユニット1に読み込ませて情報処理を続けることができる。

【0100】また、自分に合ったカーオーディオシステムのいろいろな設定をコンパクトフラッシュカード13にバックアップコピーしておけば、たとえ家族の他の誰かが設定を変えても、自分が車を使うときは自分の持っていたコンパクトフラッシュカード13をメインユニット1に差し込んで内容を読み込ませることで、自分にとって使い勝手のよい元通りの設定でカーオーディオシステムを使うことができる。

【0101】〔2-10. ハンドヘルドパソコンとの通信〕さらに、この実施形態では、赤外線通信ユニット127を使うことで、ハンドヘルドパソコン8との間で、コンパクトフラッシュカード13を抜き差ししたりケーブルなどで接続するといった手間をかけずに、容易にデータをやり取りすることができる。このため、ハンドヘルドパソコン8内に記録しておいたファイルなどを使ってOSやアプリケーションプログラムを更新したり、カーオーディオシステム上で作った個人的なデータをハンドヘルドパソコン8に直接移し替えたり、そのような個人的なデータのバックアップを、ハンドヘルドパソコン

8の持っている比較的大きな記憶領域に保存しておいたり、カーオーディオシステムの設定などをハンドヘルドパソコン8を通して他の車のカーオーディオシステムに移し替えたり、といったいろいろな使い方も可能になる。

【0102】〔3. 効果〕以上のように、この実施形態では、カーオーディオシステムを制御するコンピュータが汎用的なOSを備えていて、この汎用的なOSは、CPUやメモリといった資源を管理することでコンピュータの能力を最大限発揮させ、また、プログラムに依存しない統一的で使いやすいユーザインタフェースを提供し、さらに、予め決められた形式のプログラムを追加したり変更することで機能の追加や変更も容易にする。このため、複雑なカーオーディオシステムの制御が容易になる。

【0103】また、OSの規格にあったプログラムであれば、車内でもいろいろなプログラムを使うことが可能になり、カーオーディオシステムの表示部や操作キー、スピーカといった機器を利用して情報処理をすることも可能になる。もちろん、この場合でも、ハンドヘルドパソコン並の大きなメモリを使ってユーザが自分の個人的な情報を保存したり、パソコンのように情報を編集することができる。

【0104】また、この実施形態では、コンピュータのCPUと、カーオーディオシステムの機器とが、互いの形式に対応した違ったバスを使ってデータをやり取りし、データは、2つのバスの間では必要に応じて形式を変換して受け渡される。このため、各機器の動作よりCPUの動作が速くても、CPUは各機器の動作サイクルに合わせる必要がなく、メモリなどを効率よくアクセスすることで複雑な処理を高速に行うことができる。また、CPUがやり取りするデータと、機器がやり取りするデータとが、同じバスの伝達能力を奪い合うことがないので、コンピュータとカーオーディオシステムの両方がそれぞれの動作をスムーズに行うことができる。

【0105】また、機器を接続するためのバスを使って音の信号を再生しながら、同時に、CPUの形式に対応したバスを使って別の処理を行うといったマルチタスクが容易になる。また、CPUを別の形式のものに変える場合も、各機器と、それら機器を接続するためのバスはそのまま、CPUの形式に対応したバスだけを新しいCPUの形式に合わせて変えればよいので、CPUの変更にも容易に対応することができる。

【0106】特に、この実施形態では、複数の機器を手づる式に次々と、デジチェーン形式でつないでゆくことができる。このため、機器の数が増えたり車内のあちこちに機器を分散設置するときも、スター方式のように長い配線が1箇所に集中することがなく設置が容易になる。また、配線がすっきりわかりやすくなるので、カーオーディオシステムの構成を変えたり保守や修理をす

ることも容易になる。

【0107】加えて、この実施形態では、オーディオデータであるか文字データであるかといったデータの種類の関係なく、どのようなデータもUSBなどを通してデジタルデータとしてやり取りされ、処理されるので、環境変化やノイズの影響を受けにくく、オーディオ特性も安定する。

【0108】〔4. 他の実施の形態〕なお、本発明は上に述べた実施形態に限定されるものではなく、次に例示するような他の実施の形態も含むものである。例えば、上に述べた実施形態では、コンピュータのOSの具体例としてWindows CEを挙げたが、これは単なる例示に過ぎないので、他の種類の既にあるOSを使ったり、今後新しく登場するOSを使うことも本発明の範囲に含まれる。

【0109】また、上に述べた実施形態では車載用のカーオーディオシステムを制御する例を示したが、本発明は、家庭内で据え置き型ステレオなどの電気製品を制御するのに使うことも可能で、この場合も、新しいアプリケーションソフトウェアを使ったり、全体が小型で済むといった本発明の利点を活かすことができる。

【0110】また、上に述べた実施形態では、いろいろなバスや通信回路について具体的な規格を挙げたが、そのような規格は例示に過ぎず、同じような使い方ができるほかの規格に置き換えることもできる。また、例えば、第1のバスや第2のバスは、CPUモジュールとサポートモジュールをワンチップ化することで内部バスにすることもできる。

【0111】

【発明の効果】以上のように、本発明によれば、汎用的なOSを持つコンピュータとカーオーディオシステムを組み合わせることで互いの利点を活かし、複雑なカーオーディオシステムも容易に制御し、コンピュータの使い方も広げることができる。

【図面の簡単な説明】

【図1】この発明の実施形態の全体構成を示すブロック図。

【図2】この発明の実施形態について、メインユニットの内部構成を中心に示したブロック図。

【符号の説明】

- 1…メインユニット1
- 11…CPUモジュール
- 111…CPU
- 112…DRAM
- 113…フラッシュROM
- 114…PCIバスホストコントローラ
- 115…CPUホストASIC
- 116…PCMCIA・ASIC
- 12…サポートモジュール
- 121…サポートASIC

- | | |
|--------------------|----------------------|
| 122...CODEC回路 | 3...マイクロホン |
| 123...DSPユニット | 4...GPSアンテナ |
| 124...バッファメモリ | 4a...受信機 |
| 125...パラレル/PCIドライバ | 5...セキュリティコントロールユニット |
| 126...シリアル/PCIドライバ | 5a...センサ |
| 127...赤外線通信ユニット | 5b...サイレン |
| 13...コンパクトフラッシュカード | 5c...送信機 |
| 13S...ソケット | 6...電話ユニット |
| 14...CD-ROMユニット | 6a...アンテナ |
| 15...フェイスプレートユニット | 6b...ハンドセット |
| 15a...ケース | 7...CD-ROMオートチェンジャ |
| 16...GPSユニット | 8...ハンドヘルドパソコン |
| 2...チューナーアンプユニット | 9...補助バッテリー |
| 2a...アンテナ | 30...外部ユニット |
| 21...チューナー | 40...オプションユニット |
| 22...アンプ | |

【図1】

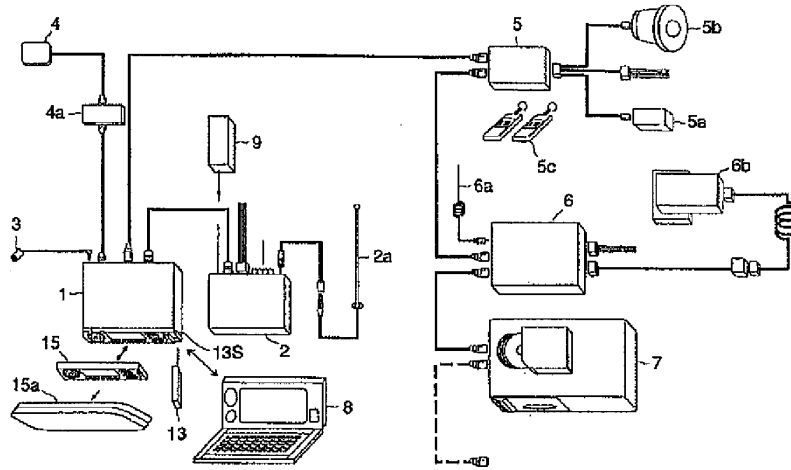

【図2】

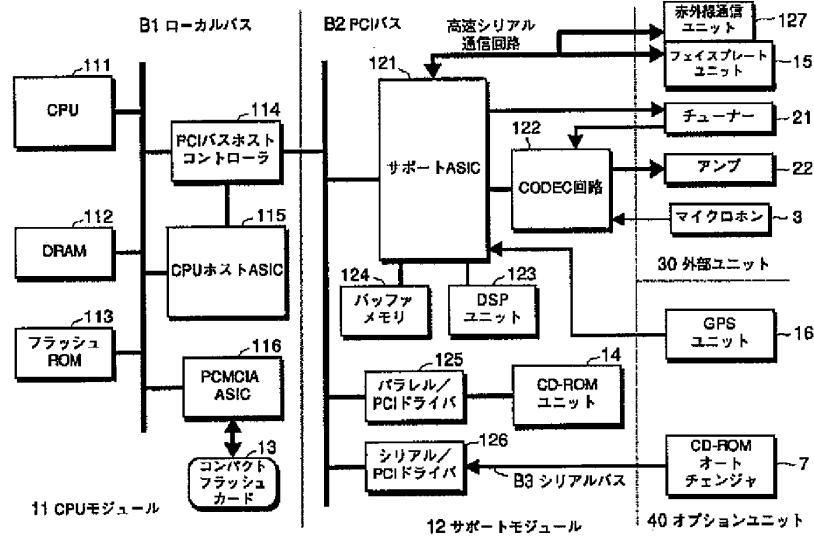

フロントページの続き

(72)発明者 浜島 貞文
 東京都文京区白山5丁目35番2号 クラリ
 オン株式会社内

PATENT ABSTRACTS OF JAPAN

(11)Publication number : 11-273321

(43)Date of publication of application : 08.10.1999

(51)Int.Cl.

G11B 31/00
B60R 11/02

(21)Application number : 10-076115

(71)Applicant : CLARION CO LTD

(22)Date of filing : 24.03.1998

(72)Inventor : IDO KAZUHIRO

NAKABACHI YOSHIKI

UEHARA NAGATOSHI

HAMASHIMA SADAFUMI

(54) CAR AUDIO SYSTEM, VEHICLE-MOUNTED COMPUTER, AND METHOD FOR CONTROLLING CAR AUDIO SYSTEM

(57)Abstract:

PROBLEM TO BE SOLVED: To utilize both advantages by combining a compact computer with a universal OS and a car audio system.

SOLUTION: A local bus B1 corresponding to the form of a CPU 11 included in a computer, a PCI bus B2 for connecting equipment 15, 21, 22, 3, 16, and 7 included in a car audio system, and a PCI bus host controller 114 for converting data form between the buses B1 and B2 are provided. An OS for the CPU 111 is stored in a flash ROM 113. The CPU 111 can speedily perform complex processing by efficiently accessing a memory 112 or the like. The computer and the car audio system can be operated smoothly. A multi-task can be facilitated, where another processing can be made with another path while an audio signal is being reproduced. Only the path corresponding to the form of the CPU 111 may be changed when the form of the CPU 111 is to be changed.

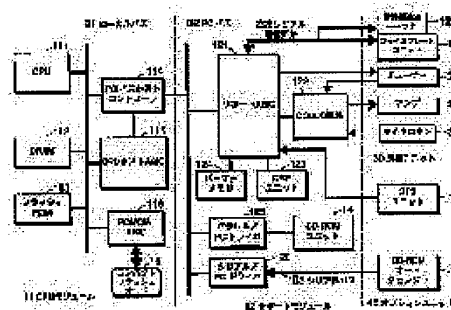

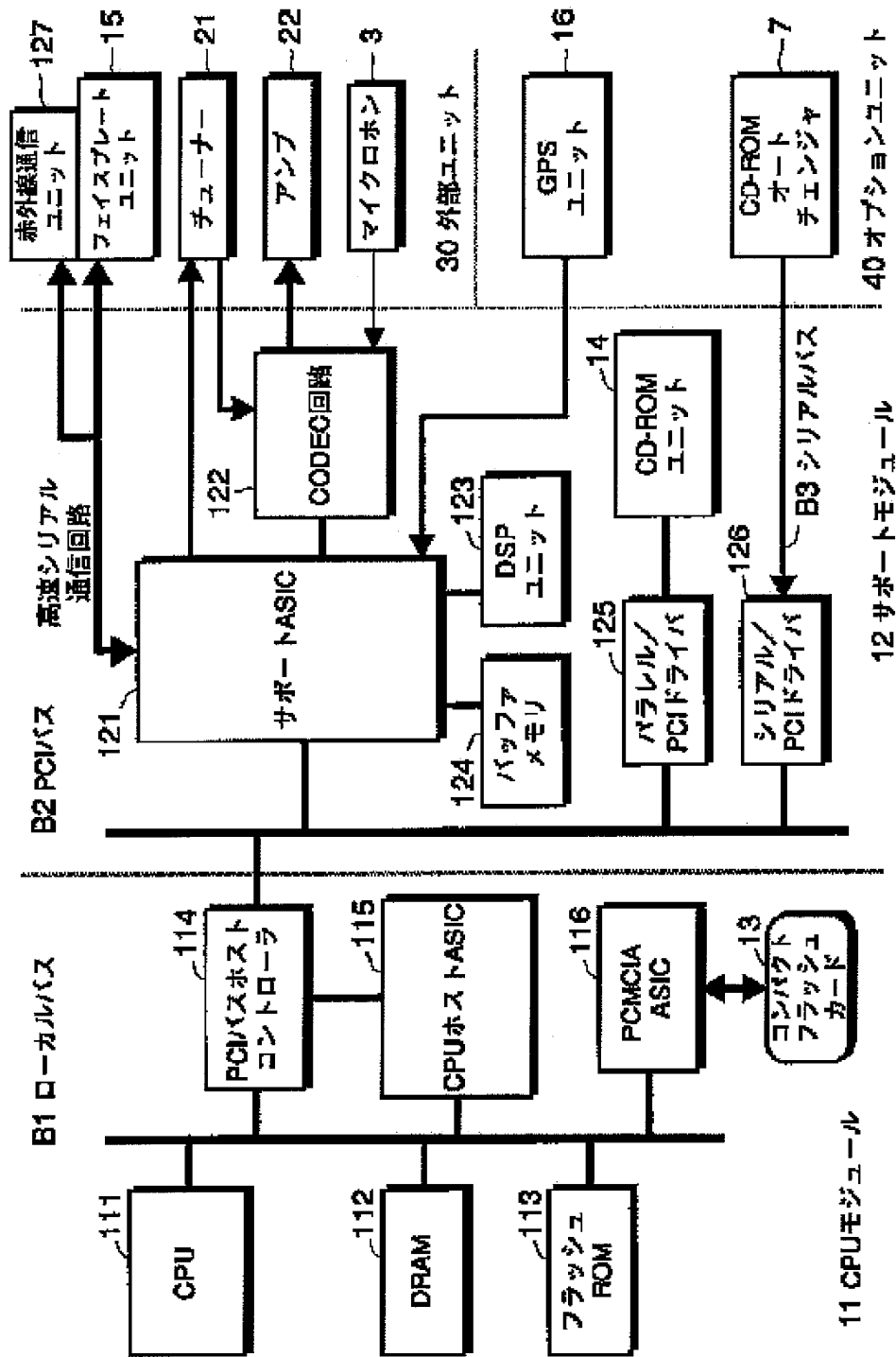

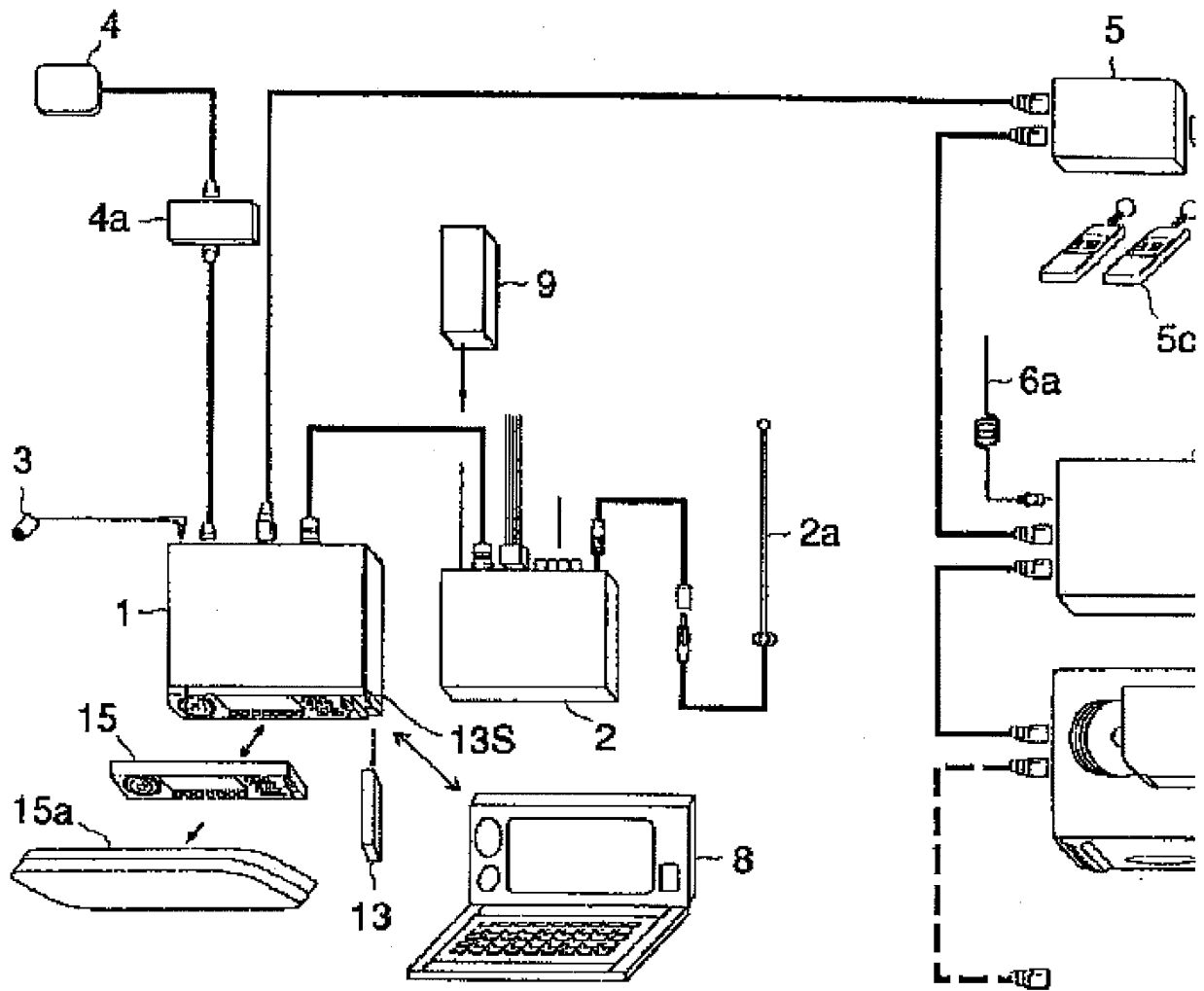

* NOTICES *

JPO and INPIT are not responsible for any damages caused by the use of this translation.

- 1.This document has been translated by computer. So the translation may not reflect the original precisely.
- 2.**** shows the word which can not be translated.
- 3.In the drawings, any words are not translated.

CLAIMS

[Claim(s)]

[Claim 1]A car audio system comprising provided with a computer for control:

A means by which said computer is provided with an operating system and this operating system manages resources on a computer.

A means to execute a program of form beforehand decided to be a means to control input and output containing a user interface.

[Claim 2]A car audio system comprising provided with a computer for control:

The 1st bus corresponding to form of CPU contained in said computer.

The 2nd bus for connecting apparatus contained in said car audio system.

[Claim 3]A car audio system comprising provided with a computer for control:

A local bus corresponding to form of CPU contained in said computer.

A PCI bus for connecting apparatus contained in said car audio system.

[Claim 4]The car audio system according to claim 2 or 3 provided with a means to change form of data between said each bus.

[Claim 5]A car audio system of any one statement of four from claim 1 provided with the 3rd bus for connecting two or more apparatus contained in said car audio system in daisy chain form.

[Claim 6]A computer for mount characterized by comprising the following.

An operating system which realizes environment required in order to execute a program of form decided beforehand.

A means to control a car audio system and said car audio system.

[Claim 7]A computer for mount provided with a car audio system characterized by comprising the following.

The 1st bus corresponding to form of CPU contained in said computer.

The 2nd bus for connecting apparatus contained in said car audio system.

[Claim 8]A computer for mount provided with a car audio system characterized by comprising the following.

A local bus corresponding to form of CPU contained in said computer.

A PCI bus for connecting apparatus contained in said car audio system.

[Claim 9]The computer for mount according to claim 7 or 8 provided with a means to change form of data between said each bus.

[Claim 10]A computer for mount of any one statement of nine from claim 6 provided with the 3rd bus for connecting two or more apparatus contained in said car audio system in daisy chain form.

[Claim 11]A control method of a car audio system which controls a car audio system using a computer provided with an operating system characterized by comprising the following.

A step which realizes environment which needs said operating system in order to execute a program of form decided beforehand.

A step by which said program controls said car audio system.

[Claim 12]A control method of a car audio system which controls a car audio system using a computer characterized by comprising the following.

A step with which CPU contained in said computer exchanges data through the 1st bus corresponding to form of this CPU.

A step which exchanges data through the 2nd bus for apparatus contained in said car audio system to connect apparatus.

[Translation done.]

*** NOTICES ***

JP0 and INPIT are not responsible for any damages caused by the use of this translation.

- 1.This document has been translated by computer. So the translation may not reflect the original precisely.
2. **** shows the word which can not be translated.
- 3.In the drawings, any words are not translated.

DETAILED DESCRIPTION

[Detailed Description of the Invention]

[0001]

[Field of the Invention]This invention is combining a small computer with general-purpose OS, and a car audio system, and relates to the art of harnessing a mutual advantage.

[0002]

[Description of the Prior Art]In recent years, progress with remarkable art of a semiconductor is accomplished and the electronic equipment of various fields has become a miniaturization and highly efficient by using a semiconductor. Thus, one of the electronic equipment made a miniaturization and highly efficient by using a semiconductor has a personal computer (henceforth a "personal computer").

[0003]The small personal computers (it names generically the following "hand-held PC") called [especially] a handheld computer (carried type), a palm top, etc. these days are also increasing in number. Windows(registered trademark of Microsoft Corp.) CE etc. are known, for example as base software (it is called below Operating System: "OS") suitable for such a hand-held PC, i.e., an operating system.

[0004]Such a general-purpose OS realizes advanced throughput by managing finely throughput, a memory, etc. of CPU which the computer has, or, If it is a program of the form which provided the user interface independent of a program which it is unific and is easy to use, or was decided beforehand, it has the advantage that the current update of the function of a computer can be carried out by carrying out a current update freely.

[0005]As another electronic equipment which similarly has been made a miniaturization and highly efficient by using a semiconductor, the car audio system and car-navigation system which are carried in a car are mentioned. Among these, a car audio system is commonly called a car stereo etc., and combines the tuner of a CD player, AM, or FM, etc. with amplifier, a loudspeaker, etc. A car-navigation system is a shown system to which a screen display of the

map is carried out to the specified destination, pinpointing the current position of a car using an azimuth magnet, an odometer, GPS, etc.

[0006]These days, since a car-navigation system, a handsfree cellular phone, an anti-theft alarm system, etc. are combined with a car audio system in many cases, the electronic equipment for these mount is hereafter named a "car audio system" generically.

[0007]

[Problem(s) to be Solved by the Invention]The hand-held PC provided with OS which was described above, and the car audio system were mutual completely separate in the former. That is, although the car audio system which prepared the computer in the large meaning for control existed, the computer in this case is called the embedded system which works only for the specific purpose.

[0008]CPU with necessary minimum capability is used for this embedded system, and it realizes necessary minimum processing to the hardware of receiving an operation switch or operating a disk reproduction mechanism, by the small program using an assembler etc. For this reason, usage of carrying out the change addition of the function by carrying out processing and preservation of data like a personal computer, or carrying out the change addition of the program cannot be done.

[0009]On the other hand, it did not have a function which a hand-held PC sounds music itself, or controls a car audio system. For this reason, although the user might carry the hand-held PC into in the car as a matter of fact, he did not use, having connected with the car audio system.

[0010]By the way, the latest car audio system, Not only in conventional apparatus called the tuner, cassette tape deck, and CD player of radio, Many apparatus is increasingly built into the condition of an MD player, CD, the autochanger of MD, a car-navigation system, the voice recognition equipment that recognizes a user's command, a handsfree cellular phone, and an anti-theft alarm system. And it is dramatically difficult to master the car audio system which becomes complicated in this way only with the switch in which it was provided by each device.

[0011]That is, when a car audio system becomes complicated in this way, many switches, such as an operation key and a dial, will be in various places in the car. For this reason, it is serious to memorize which is what operation key.

[0012]Namely, in order to master the car audio system which becomes complicated. To use for control an information processor equivalent to the hand-held PC provided with the small computer with the pliability which can carry out the current update of the function about the advanced throughput which controls a complicated system, the user interface, and control which are easy to use, and especially general-purpose OS is desired.

[0013]Even if it thinks from the hand-held PC side, a car is used like the present age in many cases, and in the car is wanted to expand the width of practical use in society also with much

traffic congestion. By combining with a car audio system especially, make an operation key and a memory serve a double purpose, or, The information which a user wants to know in the car is made to be read out by the synthesized speech using a computer, If usage of hearing the voice from the loudspeaker of a car audio system, or accessing an external computer network by the circuit of the cellular phone built into the car audio system can be done, the width of practical use can be expanded rather than former.

[0014]When combining high-speed CPU which uses general-purpose OS, and apparatus which is contained in a car audio system, to have a separate bus suitable for each from the difference in both working speed, etc. is desired. In the car audio system which combined a lot of apparatus, two or more apparatus is wanted to be easily connectable with simple refreshed wiring.

[0015]Proposed in order that this invention might solve the problem of conventional technology which was described above, it is combining a small computer with general-purpose OS, and a car audio system, and the purpose is to harness a mutual advantage. Another purpose of this invention is to use two or more buses, and is using both high-speed apparatus of CPU and others smoothly without futility. Another purpose of this invention is to connect various apparatus one after another with a daisy chain mode.

[0016]

[Means for Solving the Problem]In order to attain the purpose described above, an invention of claim 1 equips a car audio system provided with a computer for control with the following. A means by which said computer is provided with an operating system and this operating system manages resources on a computer.

A means to control input and output containing a user interface.

A means to execute a program of form decided beforehand.

A computer for mount of claim 6 is provided with the following.

An operating system which realizes environment required in order to execute a program of form decided beforehand.

Car audio system.

A means to control said car audio system.

An invention of claim 11 is what caught an invention of claim 1 from a view of a method, In a control method of a car audio system which controls a car audio system using a computer provided with an operating system, A step which realizes environment which needs said operating system in order to execute a program of form decided beforehand, and a step by which said program controls said car audio system are included. A computer which controls a car audio system by invention of claims 1, 6, and 11 is provided with general-purpose OS, and it this general-purpose OS, A user interface which carries out the maximum exertion of the capability of a computer by managing resources, such as CPU and a memory, and is not

dependent on a program and which it is unified and is easy to use is provided, and an addition and change of a function are made easy by adding a program of form decided further beforehand, or changing. For this reason, control of a complicated car audio system becomes easy. It becomes possible for in the car to use various programs, or to process information using apparatus of a car audio system.

[0017]An invention of claim 2 was provided with the 1st bus corresponding to form of CPU contained in said computer, and the 2nd bus for connecting apparatus contained in said car audio system in a car audio system provided with a computer for control. An invention of claim 7 was provided with the 1st bus corresponding to form of CPU contained in said computer, and the 2nd bus for connecting apparatus contained in said car audio system in a computer for mount provided with a car audio system. An invention of claim 12 is what caught an invention of claim 2 from a view of a method, In a control method of a car audio system which controls a car audio system using a computer, A step with which CPU contained in said computer exchanges data through the 1st bus corresponding to form of this CPU, Apparatus contained in said car audio system contains a step which exchanges data through the 2nd bus for connecting apparatus. An invention of claim 3 was provided with a PCI bus for connecting apparatus contained in said car audio system with a local bus corresponding to form of CPU contained in said computer in a car audio system provided with a computer for control. An invention of claim 8 was provided with a PCI bus for connecting apparatus contained in said car audio system with a local bus corresponding to form of CPU contained in said computer in a computer for mount provided with a car audio system. An invention of claim 4 was provided with a means to change form of data between said each bus, in the car audio system according to claim 2 or 3. An invention of claim 9 was provided with a means to change form of data between said each bus, in the computer for mount according to claim 7 or 8. In an invention of claims 2, 3, 7, 8, and 12, data is exchanged using a bus CPU of a computer and apparatus of a car audio system made the mistake in corresponding to a mutual form, and between two buses, if needed, data changes form, wins popularity and is passed (claims 4 and 9). For this reason, even if operation of CPU is quicker than operation of each apparatus, it is not necessary to double CPU with a motion cycle of each apparatus, and complicated processing can be performed at high speed by accessing a memory etc. efficiently. Since data which CPU exchanges, and data which apparatus exchanges do not scramble for communicative competence of the same bus, it can operate smoothly in both a computer and a car audio system. Multitasking of performing another processing using a bus corresponding to form of CPU becomes easy simultaneously, reproducing a signal of a sound using a bus for connecting apparatus. Also when changing CPU into a thing of another form, a bus for connecting these apparatus with each apparatus remains as it is, and since what is necessary is to change only a bus corresponding to form of CPU according to form of new CPU, it can

respond also to change of CPU easily.

[0018]An invention of claim 5 was provided with the 3rd bus for connecting two or more apparatus contained in said car audio system in a car audio system of any one statement of four from claim 1 in daisy chain form. An invention of claim 10 was provided with the 3rd bus for connecting two or more apparatus contained in said car audio system in a computer for mount of any one statement of nine from claim 6 in daisy chain form. In an invention of claims 5 and 10, two or more apparatus can be connected in daisy chain form one after another, and it can die. For this reason, also when the number of apparatus increases or distributed installation of the apparatus is carried out here and there [in the car], long wiring is not concentrated in one place like a star method, and installation becomes easy. Since wiring becomes intelligible shapely, it also becomes easy to change composition or to carry out maintenance and repair.

[0019]

[Embodiment of the Invention]Next, an embodiment of the invention (henceforth a "embodiment") is concretely described with reference to drawings. Although this embodiment is the car audio system provided with various apparatus, such as a CD player, it is provided with the computer provided with general-purpose OS which is used for a hand-held PC, and also performs control of a car audio system by this computer. The same numerals are attached about the member same about each figure used by the following explanation as the figure explained before it, or the same kind of member, and explanation is omitted.

[0020][1. composition]

[Composition of whole 1-1.] First, drawing 1 is a block diagram showing the entire configuration of this embodiment. As shown in this figure, this embodiment as each apparatus which constitutes a car audio system other than the main unit 1, It has the tuner amplifier unit 2, the microphone 3, the GPS antenna 4, the security control unit 5, the telephone unit 6, the CD-ROM autochanger 7, and the auxiliary battery 9 for power supply backup.

[0021]Among these, the main unit 1 is a portion which builds in the computer for control and controls the whole system by this computer. Although the tuner amplifier unit 2 does not carry out the graphic display other than the antenna 2a of AM and FM, it is the portion provided with a radio tuner and the amplifier for sounding a loudspeaker. The microphone 3 is for inputting a user's voice so that operation by speech recognition can be performed. The function of this speech recognition is realized by the program of the computer described above.

[0022][1-1-1. main unit] The main unit 1 is provided with the socket 13S for inserting CompactFlash card 13, and the face plate unit 15 removed [attach and] and made (drawing 1). CompactFlash card 13 is a storage using a flash memory, and data can be written from the main unit 1 by inserting in the socket 13S formed in the main unit 1. This CompactFlash card 13 is used in order to exchange data, a program, etc. with other computers or to back up

various information sets in this car audio system.

[0023]The face plate unit 15 attached, removed and made, It has the indicator which displays various information on a user, and the final controlling element which provided the operation key for a user to do various operations etc., and is referred to also as DCP (Detachable Control Panel). The indicator of this face plate unit 15 is large-sized color LCD (liquid crystal display) of 64 dots by 256 dots, etc., for example.

[0024]if it removes and carries out when getting off a car, even if a thief looks for a car audio system, neither use nor resale can do this face plate unit 15, also seeing an important indicator not have a final controlling element -- there are ** and a theft preventive effect of giving up stealing. If the removed face plate unit 15 is put into the case 15a and it carries around, it will damage neither itself nor a surrounding thing.

[0025]Although this face plate unit 15 is not shown in drawing 1, it is provided with the infrared-ray-communication unit for exchanging data in the form of the hand-held PC 8, IrDA, etc.

[0026][Apparatus] besides 1-1-2. The GPS antenna 4 is an antenna for receiving an electric wave from a GPS Satellite. The signal from this GPS antenna 4 is sent to the GPS unit in the main unit 1 through GPS receiver 4a. Although this GPS unit is not shown in drawing 1, it calculates the position on the earth with a receiver from an electric wave. On the computer described above, by a program, the function of a car-navigation system is realized and a calculation result is passed to the function of this car-navigation system.

[0027]The security control unit 5 is the sensor 5a which detects vibration and a shock, and when a theft, a mischief, etc. are detected, it is a portion which carries out correspondence of sounding the siren 5b. The telephone unit 6 is a unit which controls the function of a car telephone, and is a portion which realizes the telephone call using the telephone antenna 6a or the hand set 6b. The CD-ROM autochanger 7 is hanging automatically some CDs set beforehand again, and is a unit which plays the disk which the user chose, and music.

[0028][1-1-3. daisy chain connection] Here, these security control unit 5, the telephone unit 6, and the CD-ROM autochanger 7 are connected to the main unit 1 by USB (Universal Serial Bus). This USB is a serial bus (the 3rd bus) for connecting two or more apparatus in daisy chain form.

[0029]The apparatus connected by USB in this way comprises this embodiment so that data with the exterior may be exchanged in the form of this USB. For example, the CD-ROM autochanger 7, Although it has the hub (HUB) the object for upstreams, and for downstreams and digital data is once read from an audio CD or CD-ROM according to ATAPI form (parallel form) inside this CD-ROM autochanger 7, After the read data is changed into the USB (Universal Serial Bus) form which is serial form by the data converter built in, it is sent out to USB.

[0030]The installation becomes easy when installing these units 5, 6, and 7 in the place distant

from the main unit 1, since connection of the units 5 and 6 and the CD-ROM autochanger 7 turns into serial connection with such composition. Although connected in order of the unit 5, the unit 6, and the autochanger 7 in drawing 1, connection order is good also as connection of only arbitrary and required things.

[0031][The internal configuration of a 1-2. main unit] Next, drawing 2 is a block diagram showing the main things among each portion described above, and is especially explained focusing on the concrete composition of main unit 1 inside. This whole figure is divided into four with the dashed line, in the left, CPU module 11 and a center become the support module 12, the upper right becomes the external unit 30, and the lower right has become the option unit 40. Among these, CPU module 11 and the support module 12 are formed in the inside of the main unit 1.

[0032]The external unit 30 and the option unit 40 have pointed out collectively the apparatus of every some connected to the main unit 1. On account of explanation, CompactFlash card 13 is shown in the direction under CPU module 11, and drawing 2 shows the face plate unit 15 to the direction on the external unit 30.

[0033]Among these, CPU module 11 and the support module 12 constitute the computer for control which controls the whole car audio system. Among these, CPU module 11 is a portion which carries out logical data processing centering on CPU111, and the support module 12 is a portion which performs input and output with other apparatus contained in a car audio system.

[0034]The local bus B1 (the 1st bus) formed considering CPU111 as a center is a way with CPU module 11 as [main] data. PCI (Peripheral Component Interconnect) for that it is a way by the support module 12 as [main] data to connect each apparatus on the other hand It is bus B-2 (the 2nd bus).

[0035][Composition of a 1-2-1. CPU module] The local bus B1 of CPU module 11, It is what was doubled with the form of CPU111, and DRAM112, the flash ROM 113, the PCI bus host controller 114, CPU host ASIC115, and PCMCIA-ASIC116 are connected to this local bus B1. Among these, DRAM112 is a portion which provides work areas, such as a variable area, when CPU111 processes information in control of a car audio system, etc.

[0036]The flash ROM 113 is rewritable ROM and is a portion which stores the software in large meanings, such as OS, BIOS, and an application program, here. The function of OS stored here manages the resources on a computer, It is controlling the input and output containing a user interface, executing the program of the form decided beforehand, etc., for example, what used as the base Windows CE which conventional technology described by the way can be considered.

[0037]The PCI bus host controller 114 is a means to change the form of the data which connects the local bus B1 and PCI bus B-2, and is exchanged between these two buses.

[0038]"ASIC", such as CPU host ASIC115, is the abbreviation for Application Specific Integrated Circuit, and points out IC and LSI which were made for specific uses to general-purpose integrated circuits, such as ROM, RAM, and CPU. Specifically, this CPU host ASIC115 is ASIC for the interface of the local bus B1 and the PCI bus host controller 114. This CPU host ASIC115 [that is,], Between PCI bus B-2 and CPU module 11, are a portion which becomes a window of the data exchanged and specifically, Input and output with CPU module 11 and the exterior are performed instead of CPU111, and also it is recognized whether it is a thing of the kind passed to CPU111 about the data sent from PCI bus B-2.

[0039]And although what should pass CPU host ASIC115 to CPU111 is sent to CPU111 through the local bus B1, CPU111 does not need to calculate to the other thing, for example, the sent data, and such a reaction is returned about that for which it is sufficient if the reaction for which it opted beforehand is returned mechanically.

[0040]PCMCIA-ASIC116 CompactFlash card 13, It is a portion for an interface corresponding to being based on the standard of PCMCIA (Personal Computer Memory Card International Association) as what is called a PC card, It is a portion which controls the reading and writing of data to CompactFlash card 13.

[0041][Composition in connection with a 1-2-2. support module] Next, PCI bus B-2 of the support module 12 is a bus for exchanging data among various apparatus which constitutes a car audio system. Here, as apparatus connected to this PCI bus B-2, there are the external unit 30 and the option unit 40, and these have pointed out some apparatus collectively, respectively.

[0042]That is, the external unit 30 is unit with the another main unit 1 shown in drawing 1, and in this example specifically, It is the tuner 21, the amplifier 22, and the microphone 3 which were formed in the face plate unit 15 attached, removed and made from the main unit 1, and the tuner amplifier unit 2. Among these, the face plate unit 15 is provided with the infrared-ray-communication unit 127.

[0043]The option unit 40 is a unit from which it can choose whether to include in this car audio system as an option, and, specifically, are GPS unit 16 and the CD-ROM autochanger 7 in this example. There is the CD-ROM unit 14 in the inside of the main unit 1, and this CD-ROM unit 14 is also connected to PCI bus B-2. This CD-ROM unit 14 is a player for reading digital data from one CD or CD-ROM. These CD-ROM autochanger 7 and the CD-ROM unit 14 have the compatibility that data can also be read from what is called an audio CD, and both can also read data from CD-ROM (it is compatible).

[0044]In the support module 12, in order for PCI bus B-2 to exchange data among these apparatus, Support ASIC121, CODEC circuit 122, DSP unit 123, the buffer memory 124, the parallel / PCI driver 125, and the serial / PCI driver 126 are used.

[0045]Among these, support ASIC121 is a portion which controls traffic in the data where to

send the data which came from where between the support module 12 and each apparatus. "CODEC" of CODEC circuit 122 is an abbreviation of "Coder/Decoder", i.e., the coding decryption art of data, and this CODEC circuit 122, For example, it is a portion which performs the A/D conversion etc. which carry out D/A conversion which changes the given digital data into an analog signal, or change an analog signal into digital data conversely.

[0046]"DSP" of DSP unit 123 is an abbreviation to mean a digital sound processor, i.e., the circuit which processes the signal of the sound of digital format specially, and this DSP unit 123, When the digital data showing music etc. can be given, as items, such as balance of the right and left set as the system, volume, Feder, surround, and an equalizer, are reflected in the contents of the sound, it is a portion which processes digital data.

[0047]By audio equipment and PCI bus B-2s, such as a CD-ROM unit, since the buffer memory 124 differs in the cycle which write data, it is a buffer for this difference to be filled up with storing data and taking it out little by little, and comprises SRAM etc.

[0048]Parallel / PCI driver 125 is portions which change into the data format of PCI bus B-2 the digital data of parallel form sent from the CD-ROM unit 14. A serial / PCI driver 126 is portions which change into the data format of PCI bus B-2 the digital data of serial form sent from the CD-ROM autochanger 7.

[0049]The face plate unit 15 containing the infrared-ray-communication unit 127, It is connected to support ASIC121 in a high-speed serial communication circuit, and GPS unit 16 is connected to support ASIC121 in start-stop serial communication circuits, such as UART (UniversalAsynchronous Receiver-Transmitter). The CD-ROM unit 14 is connected to parallel / PCI driver 125 by parallel communication circuits, such as ATAPI (AT Attachment Packet Interface). Although a graphic display is not carried out, ASIC which manages an exchange of the data based on infrared rays is provided in the infrared-ray-communication unit 127.

[0050][2. operation] This embodiment constituted as stated above works as follows.

[2-1. -- overall operation]

[2-1-1. entry of data] According to this embodiment, the direct entry of the digital data is carried out to support ASIC121 of the support module 12 among the data inputted from each apparatus. For example, the data which key was pressed is sent from the face plate unit 15. From GPS unit 16, digital data called the latitude and longitude which were calculated using the electric wave from a GPS Satellite is sent. From the infrared-ray-communication unit 127 provided in the face plate unit 15, the digital data transmitted with infrared rays from the hand-held PC 8 is sent.

[0051]From the CD-ROM unit 14 and the CD-ROM autochanger 7. The data of the sound read from the audio CD, i.e., audio information, After the digital data read from CD-ROM, i.e., CD-ROM data, is changed into the data format of PCI bus B-2 by parallel / PCI driver 125, and the serial / PCI driver 126, it is sent to support ASIC121 via PCI bus B-2.

[0052]Although not shown in drawing 2, the digital data which tells generating of abnormalities is sent from the security control unit 5 shown in drawing 1. Similarly, from the telephone unit 6 shown in drawing 1, the digital data which tells the telephone number of the mail arrival and dispatch origin of a telephone call, etc., i.e., alphabetic data, is sent, and the digital data which tells a partner's voice, i.e., voice data, is sent during a telephone call support ASIC121.

[0053]These security control unit 5 and the telephone unit 6, Since daisy chain connection is carried out to the serial bus B3, the information sent from the security control unit 5 or the telephone unit 6, Like the digital data from the CD-ROM autochanger 7, after being changed into the data format of PCI bus B-2 by a serial / PCI driver 126, it is sent via PCI bus B-2.

[0054]On the other hand, among the data inputted from each apparatus, after the analog signal was once inputted into CODEC circuit 122 and is changed into digital data by this CODEC circuit 122 (A/D conversion), it is passed to support ASIC121. For example, from the microphone 3, a user's voice is inputted with an analog signal, and the contents of broadcast of the radio received as a result of tuning are inputted with an analog signal from the tuner 21.

[0055]Destination [of the data of which the [2-1-2. input was done]] The role of traffic control which information support ASIC121 sends where is played to the information for which it gathers in this way. That is, roughly, support ASIC121 was processed with DSP unit 123, and also it sends the data of a sound to the amplifier 22 through CODEC circuit 122, and data other than a sound is sent to CPU module 11. However, the data inputted from the microphone 3 also in the data of a sound is sent to CPU module 11 for speech recognition.

[0056]The contents of the radio broadcast tuned up by the tuner 21 as data of a sound sent to the amplifier 22, for example, The voice etc. of the contents of sound recording read from the audio CD with the CD-ROM unit 14 or the CD-ROM autochanger 7 and the call partner seen off from the telephone unit 6 can be considered.

[0057]The data of which operation key was pressed by the face plate unit 15 as data other than a sound, for example, With the digital data, the CD-ROM unit 14, and the CD-ROM autochanger 7 which are called the latitude and longitude which have been sent from the data of the file etc. which have been sent from the infrared-ray-communication unit 127, and GPS unit 16. The contents of the map for car-navigation systems and the contents of the information for every area which were read from CD-ROM, The data which tells the abnormal occurrence led from the security control unit 5, the data which tells the telephone number etc. of telephone call arrival [which is sent from the telephone unit 6] and dispatch origin, etc. can be considered.

[0058][Information processing with a 2-1-3. CPU module] In CPU module 11, if digital data is sent from support ASIC121, after the PCI bus host controller 114 changes the sent data into the data format of the local bus B1, CPU host ASIC115 will be passed. If this CPU host ASIC115 manages input and output instead of CPU111 and is passed data, it will judge [what

that data should pass to CPU111, or] from the form of data, etc. whether that is right.

[0059]That is, the other data is passed to CPU111 although the reaction for which it opted beforehand to the data for which it is sufficient if CPU host ASIC115 returns a fixed reaction mechanically is returned to the support module 12 through the PCI bus host controller 114.

[0060]CPU111 processes the passed data according to the code of OS and the program which are recorded on the flash ROM 113, and uses DRAM112 as storage areas, such as a work area required in the case of this processing. For example, when a user's voice inputted from the microphone 3 is sent, CPU111, The parameter showing the feature of the instruction word currently prepared beforehand, a waveform, etc. are compared with the voice of the user who received, a most alike instruction word is presumed to be what the user said, and it operates according to the instruction word.

[0061]In CPU module 11, according to the request from CPU111, reading and writing of CompactFlash card 13 are performed, when CPU host ASIC115 controls PCMCIA-ASIC116.

[0062]And the result of information processing by CPU111 is sent to the support module 12, after being changed into the data format of PCI bus B-2 by the PCI bus host controller 114. As data sent to the support module 12 as a result of information processing, it is instructions of the operation to each portion and each apparatus of the support module 12, etc., and processing of input and output etc. is performed in the support module 12 according to the data sent in this way.

[0063][Processing of input and output with a 2-1-4. support module etc.] For example, if the instructions which tuning of the data read from CD or radio is made arrive from CPU module 11, the CD-ROM unit 14, the CD-ROM autochanger 7, and the tuner 21 will perform operation according to it. If the instructions which change the sound source of the sound which has come out of the loudspeaker to apparatus different from the present arrive from CPU module 11, support ASIC121 will change the digital data sent out to CODEC circuit 122 from the thing of the apparatus till then to what is depended on the apparatus specified newly.

[0064]When outputting digital data to the amplifier 22, since the amplifier 22 receives only an analog signal, after CODEC circuit 122 changes digital data into an analog signal (D/A conversion), it outputs it to the amplifier 22.

[0065]If the indicative data to a user is sent to support ASIC121 from CPU module 11 or other apparatus, for example, support ASIC121 will transmit this indicative data to the face plate unit 15 through a high-speed serial communication circuit. In this case, in the face plate unit 15, the information to a user is displayed on an indicator according to the transmitted indicative data.

[0066]Then, work of each portion which was described above explains concretely how a user can use the car audio system of this embodiment.

[0067][Presenting of 2-2. operation and information] When operating the car audio system of this embodiment, a user may press the operation key provided in the face plate unit 15, and

may utter the words and phrases beforehand decided for every internal use of operation. as the words and phrases which may press the operation key changed to CD when a user wants to use CD and an FM tuner and which carried out and were decided beforehand -- for example, -- "-- carrying out - ****-" -- "-- what is necessary is to obtain, to increase and just to speak toward ***" etc. and the microphone 3

[0068]When a user presses the operation key, the data is transmitted to CPU module 11 from support ASIC121, CPU111 sends a new indicative data to support ASIC121, and the indicator of the face plate unit 15 changes to a screen display for operating a screen display and CD for operating radio using this indicative data, etc.

[0069]a user -- ", if it carries out and the words and phrases - ****-" are uttered, An analog signal is changed into digital data from the microphone 3 by CODEC circuit 122, From support ASIC121, through PCI bus host controller and CPU host ASIC115, it is sent to CPU111 by this digital data and CPU111, Based on this digital data, it recognizes which language the user said, and the same correspondence as the time of the operation key being pressed is carried out according to a recognition result.

[0070]For example, use the indicator of the face plate unit 15 as the touch panel, and as a graphical user interface of a computer, For example, the function which can be used at the time is displayed on an indicator by an icon, and if the icon of the function which a user wants to use is touched with a finger, the function can work. If they use, for example, a display and speech recognition in one voice by such an icon, The usage that a screen will return to the state in front of one if a screen will change, some following icons will be displayed if some icons are displayed at once and a user speaks with the "next", and a user speaks, saying "It returns" is also possible.

[0071][When 2-3. radio is listened to] it is the operation which was described above -- a user -- ", if obtain, and increase, it speaks with ***", FM broadcasting of radio is chosen and CPU111 recognizes it, Support ASIC121 changes the sauce of the data which changes the tuner 21 to the receive state of FM according to the command from CPU111, and is sent out to the amplifier 22 to the data of the sound from the tuner 21. in this case, the good next frequency of a receive state is looked for automatically, the tuner 21 being that carry out and a user utters the words and phrases "a seeking rise" which may receive the frequency tuned in last time, for example, and changing frequency little by little (automatic scanning) -- it may be made like.

[0072]Thus, since the receiving contents sent from the tuner 21 are analog signals when listening to radio, this analog signal is inputted into CODEC circuit 122, and after being changed into digital data, it is sent to support ASIC121. Support ASIC121 passes the digital data received from CODEC circuit 122 to DSP unit 123, and DSP unit 123, This digital data is processed according to the setting-out item of the balance and volume which are beforehand set up on the system, and it returns to support ASIC121.

[0073]And support ASIC121 returns again the digital data which has returned in this way to CODEC circuit 122, and after it changed this digital data into the analog signal again and CODEC circuit 122 returns it, it is sent to the amplifier 22 and it is made to flow through it from a loudspeaker shortly.

[0074][Playback of 2-4.CD] A user sets an audio CD to ask the CD-ROM unit 14 and the CD-ROM autochanger 7 and should just do directions of pointing to playback with "**** -", etc. a sound, etc., or flying to the following music to hear an audio CD. For example, when playing the audio CD in the CD-ROM unit 14, the CD-ROM unit 14 operates by the instructions from support ASIC121, and the audio information which is digital data is sent from the CD-ROM unit 14.

[0075]And parallel / PCI driver 125, Change this audio information into the data format of PCI bus B-2, send to support ASIC121 and support ASIC121, If the audio information which once passes this audio information to DSP unit 123, made process it, and was processed when audio information was received from PCI bus B-2 is again received from DSP unit 123, The processed audio information is passed to CODEC circuit 122 from a digital-input/output port, and it is made to output to the amplifier 22 in the form of an analog signal.

[0076]When the CD-ROM autochanger 7 reproduces an audio CD, a serial / PCI driver 126 changes into the data format of PCI bus B-2 the audio information of the serial form sent from the serial bus B3, but. Processing after it is performed like the case of the CD-ROM unit 14.

[0077]The CD-ROM unit 14 and the CD-ROM autochanger 7, If CODEC circuit 122 and DSP unit 123 are compared relatively, in order that the latter may process data little by little in the cycle of short time to the former sending the data of the quantity collected in the cycle of long time, a cycle has a gap among both. For this reason, support ASIC121 stores in the buffer memory 124 the digital data which the CD-ROM unit 14 or the CD-ROM autochanger 7 has sent collectively, A gap which was described above is filled up with passing DSP unit 123 and making it process, if it takes out from the oldest portion one after another, and reproduction is made to be performed smoothly.

[0078][Use of 2-5.CD-ROM and car navigation] A user for example, to use the function of a car-navigation system. For example, after setting to the CD-ROM unit 14 CD-ROM on which the data for car-navigation systems (application software, a map, etc.) was recorded, the function of a car-navigation system is started. The function of such a car-navigation system is realizable by recording on the flash ROM 113 of CPU module 11, for example as a program of a computer, and making CPU111 execute such a program.

[0079]When such a car-navigation system tries to read the data of the map recorded on CD-ROM, various information for every area, etc., For example, the digital data read from the CD-ROM unit 14 is passed to CPU111 through parallel / PCI driver 125, PCI bus host controller 114, and CPU host ASIC115. CPU111 created on DRAM112 the bitmapped image for

displaying on the indicator of the face plate unit 15 based on the data of the map etc. which were received in this way, and also it is sent out to the support module 12.

[0080]When using a car-navigation system in this way, the GPS antenna 4 shown in drawing 1 receives the electric wave from a GPS Satellite, GPS unit 16 of drawing 2 calculates latitude, longitude, etc. from this electric wave, and this data is sent to CPU111. Then, CPU111 can specify on a map where the car loading with this car audio system is running from the data of such latitude, longitude, etc. now. As a result, even if a user does not input, a its present location can be set up as a departure point, or the rough map that the present point takes the lead can be displayed, or the figure which directs next right-turn and left turn can be displayed.

[0081]The data for navigation may be memorized to CompactFlash card 13 (or DRAM112) or the flash ROM 113.

[0082]The method of operation by speech recognition which was already explained, Thus, also when using the function of a car-navigation system, it can use, For example, when using the car-navigation system which issues directions, such as right-turn and left turn, for every corner of a street and a user wants to see the directions before one, and directions of one beyond, one display after another can also be changed by uttering the "next" and the words and phrases of "returning."

[0083]In order to know where it will next turn, it becomes unnecessary to turn a look to an indicator, if a user can also be told about such guidance and it does in this way with outputting synthesized speech through the amplifier 22.

[0084][Use of a 2-6. telephone] The user can harness the advantage of a computer, and the advantage of a car audio system as follows, when talking over the telephone using the telephone unit 6. For example, the user registers into DRAM112 and CompactFlash card 13 of the system beforehand people's telephone number and name which he knows using the program of a computer.

[0085]If a telephone receives a message, it will not illustrate to drawing 2, but the digital data which tells that the telephone received a message from the telephone unit 6 through the serial bus B3, and the serial / PCI driver 126, and the digital data showing the telephone number of a sending agency are sent to support ASIC121. These data is further sent to CPU111 of CPU module 11, and CPU111 searches whether the telephone number of the dispatch origin which is hanging now into the telephone number registered beforehand is registered.

[0086]When there is a telephone number of the dispatch origin which is hanging now into the telephone number registered beforehand, CPU111 is returning the name corresponding to the telephone number to the support module 12, A user can be told about who is telephoning by displaying the name of those who are telephoning the face plate unit 15, or pouring the guidance by synthesized speech "it is from Mr. OO" from a mounted loudspeaker.

[0087]If the user who knew getting a telephone call in such a display, guidance, a calling

sound, etc. directs to utter the words and phrases decided beforehand and to connect a telephone, A user's voice inputted from the microphone 3 is changed into digital data by CODEC circuit 122 at the same time a partner's voice flows from a loudspeaker, It is sent to the telephone unit 6 through support ASIC121, the serial / PCI driver 126, and the serial bus B3, and the user can talk over the telephone in what is called the handsfree state, without using a hand.

[0088]The answering machine function etc. which were prepared for the telephone unit 6 or CPU module 11, for example answer a telephone in the place where only the number of times with a constant calling sound sounded.

[0089]If the icon of dispatch, etc. are touched with a finger in the place which displayed the telephone number and name which have been registered beforehand one after another on the display screen, for example and where the partner who wants to telephone was displayed also when it is going to send from the user side, The telephone number is transmitted to the telephone unit 6 as digital data from CPU module 11, and a telephone call is got automatically, and if a partner comes out, it can talk as it is.

[0090]Send to the telephone number corresponding to the name automatically because utter the name which the user registered and CPU module 11 recognizes this, or, a single figure speaks at a time, and a telephone number to hang is made to recognize, or a user is "person -- are and it does -- " -- the point which recognizes having spoken and telephones can be decided.

[0091][Use of a 2-7. security control unit] The security control unit 5 can also be used alone, and it can also be used for it, making it the telephone unit 6 described above interlocked with. For example, when leaving a car, (drawing 1) and a user operate the security control unit 5, and get down with the transmitter 5c. If the third party who is unrelated to the user of vehicles in any way is going to touch a doorknob, tamper with a keyhole, wrench a door and a suitcase open or is going to move a car without notice, The sensor 5a takes in the shock and vibration by it, and the security control unit 5 which received the signal from the sensor 5a sounds the siren 5b with Ryo Oto, for example. Thereby, the effect of an alarm is brought about to the environment outside a car.

[0092]Since the code decided beforehand will be sent to the security control unit 5 and the function of the security control unit 5 will be canceled if he operates the transmitter 5c which it has when the user itself has returned to the car, A key is not used, or even if it moves a car, a siren does not sound.

[0093]It is further effective if such a security control unit 5 uses making it the telephone unit 6 interlocked with. That is, when the sensor 5a has detected abnormalities, the security control unit 5 starts the car audio system which sends an interrupt signal and it not only sounds a siren, but contains CPU module 11 and the support module 12. In order to enable such

starting, the electronic circuit linked to the power supply and start switch of the car audio system is prepared, What is necessary is to make a power supply and a start switch one immediately, and just to start a car audio system, if this electronic circuit is made to always supervise whether the interrupt signal is coming and an interrupt signal comes it.

[0094]CPU111 started in this way makes it telephone by sending instructions to the telephone unit 6, when the data which tells an abnormal occurrence is received from the security control unit 5. The point which telephones at this time should just be taken as a cellular phone, a security company, etc. which what is necessary is just to set up beforehand as an information destination at the time of abnormalities, and the police and a user have. And abnormalities are told by the thing which hung and which will be told synthesized speech and against the announcement recorded beforehand if a telephone is connected previously. If it does in this way, those who received the notice can hasten at the spot.

[0095][Use of a 2-8. utility program] Like the usual hand-held PC, if functions, such as an address book, a calendar, schedule management, voice recording, a clock, a calculator, and a game, are used as a function of OS or an application program, it will become possible to perform information processing various also in a car. The environment of information processing which suited to itself can be improved by deleting the application program which realizes these functions, changing to a new thing, or adding.

[0096][Use of a 2-9. CompactFlash card] In the car audio system of this embodiment, information can be exchanged between other hand-held PCs, other car audio systems, etc. by using CompactFlash card 13.

[0097]For example, it becomes easy to add a new function, and it to be sufficient to make a new application program and OS read into the flash ROM 113 from CompactFlash card 13, and to update OS. Since it becomes easy for ordinary software makers to make an application program, the functional module of OS, etc. by using general-purpose OS especially, CompactFlash card 13 which recorded it also appears on the market, it becomes easy to get, and the user can use this car audio system now for convenience more also as a computer.

[0098]If individual data like the address book made with other personal computers and hand-held PCs is carried into this car audio system by CompactFlash card 13, the work till then can be continued on this car audio system. Contrary to this, the data made with this car audio system can be moved to other personal computers and hand-held PCs by CompactFlash card 13, and work can also be continued.

[0099]If the backup copy of the data which he made using a utility program which was described above is carried out to CompactFlash card 13, Since the bad condition and others of the car audio system used, even when data disappears, data can be made to be able to read into the main unit 1 from CompactFlash card 13 again, and information processing can be continued.

[0100]If the backup copy of various setting out of the car audio system suitable for itself is carried out to CompactFlash card 13, Even if someone of other families change setting out, inserting in the main unit 1 CompactFlash card 13 which he had, and making the contents read, when he uses a car can use a car audio system by user-friendly original setting out for itself.

[0101][Communication with a 2-10. hand-held PC] At this embodiment, data can be easily exchanged by using the infrared-ray-communication unit 127, without applying the time and effort of taking out and inserting CompactFlash card 13 or connecting by a cable etc., between the hand-held PCs 8. For this reason, update OS and an application program using the file etc. which were recorded in the hand-held PC 8, or. Move to the hand-held PC 8 directly the individual data made on the car audio system, or, Save backup of such individual data in the comparatively big storage area which the hand-held PC 8 has, or, Various usage of moving setting out of a car audio system, etc. to the car audio system of other cars through the hand-held PC 8 also becomes possible.

[0102][3. effect] As mentioned above, the computer which controls a car audio system by this embodiment is provided with general-purpose OS, and it this general-purpose OS, The user interface which carries out the maximum exertion of the capability of a computer by managing resources, such as CPU and a memory, and is not dependent on a program and which it is unific and is easy to use is provided, and an addition and change of a function are also made easy by adding the program of the form decided further beforehand, or changing. For this reason, control of a complicated car audio system becomes easy.

[0103]If it is the program which suited the standard of OS, it will become possible to use a program also with in the car [various], and it will also become possible to process information using apparatus, such as an indicator of a car audio system, an operation key, and a loudspeaker. Of course, a user can save his individual information even in this case using about the same big memory as a hand-held PC, or information can be edited like a personal computer.

[0104]In this embodiment, data is exchanged using the bus CPU of a computer and the apparatus of the car audio system made the mistake in corresponding to a mutual form, and between two buses, if needed, data changes form, wins popularity and is passed. For this reason, even if operation of CPU is quicker than operation of each apparatus, it is not necessary to double CPU with the motion cycle of each apparatus, and complicated processing can be performed at high speed by accessing a memory etc. efficiently. Since the data which CPU exchanges, and the data which apparatus exchanges do not scramble for the communicative competence of the same bus, both a computer and a car audio system can perform each operation smoothly.

[0105]Multitasking of performing another processing using the bus corresponding to the form

of CPU becomes easy simultaneously, reproducing the signal of a sound using the bus for connecting apparatus. Also when changing CPU into the thing of another form, the bus for connecting these apparatus with each apparatus remains as it is, and since what is necessary is to change only the bus corresponding to the form of CPU according to the form of new CPU, it can respond also to change of CPU easily.

[0106]In particular, in this embodiment, two or more apparatus can be connected in daisy chain form one after another, and it can die. For this reason, also when the number of apparatus increases or distributed installation of the apparatus is carried out here and there [in the car], long wiring is not concentrated in one place like a star method, and installation becomes easy. Since wiring becomes intelligible shapely, it also becomes easy to change the composition of a car audio system or to carry out maintenance and repair.

[0107]In addition, since any data is exchanged as digital data and processed through USB etc. in this embodiment regardless of the kind of data whether to be audio information or to be alphabetic data, It is hard to be influenced by the environmental variation or a noise, and an audio characteristic is also stabilized.

[0108][An embodiment] besides 4. This invention is not limited to the embodiment described above, and contains other embodiments which are illustrated next. For example, in the embodiment described above, although Windows CE was mentioned as an example of OS of a computer, since this is only mere illustration, using OS of other kinds which already uses a certain OS or will appear newly from now on is also included in the range of this invention.

[0109]Although the example which controls the car audio system for mount by the embodiment described above was shown, This invention can harness the advantage of this invention that it is also possible to use for controlling electric products, such as a non-portable stereo, new application software is used also in this case, or the whole is small and can be managed in a home.

[0110]Although the standard concrete about various buses and communication circuits was mentioned in the embodiment described above, such a standard is only illustration and can also be transposed to other standards which can do same usage. For example, the 1st bus and 2nd bus can also make a CPU module and a support module an internal bus by one-chip-izing.

[0111]

[Effect of the Invention]As mentioned above, according to this invention, taking advantage of a mutual advantage, a complicated car audio system and how to use a computer by controlling easily can be extended by combining a computer with general-purpose OS, and a car audio system.

[Translation done.]

* NOTICES *

JP0 and INPIT are not responsible for any damages caused by the use of this translation.

- 1.This document has been translated by computer. So the translation may not reflect the original precisely.
- 2.**** shows the word which can not be translated.
- 3.In the drawings, any words are not translated.

TECHNICAL FIELD

[Field of the Invention]This invention is combining a small computer with general-purpose OS, and a car audio system, and relates to the art of harnessing a mutual advantage.

[Translation done.]

*** NOTICES ***

JPO and INPIT are not responsible for any damages caused by the use of this translation.

1. This document has been translated by computer. So the translation may not reflect the original precisely.
2. **** shows the word which can not be translated.
3. In the drawings, any words are not translated.

PRIOR ART

[Description of the Prior Art] In recent years, progress with remarkable art of a semiconductor is accomplished and the electronic equipment of various fields has become a miniaturization and highly efficient by using a semiconductor. Thus, one of the electronic equipment made a miniaturization and highly efficient by using a semiconductor has a personal computer (henceforth a "personal computer").

[0003] The small personal computers (it names generically the following "hand-held PC") called [especially] a handheld computer (carried type), a palm top, etc. these days are also increasing in number. Windows (registered trademark of Microsoft Corp.) CE etc. are known, for example as base software (it is called below Operating System: "OS") suitable for such a hand-held PC, i.e., an operating system.

[0004] Such a general-purpose OS realizes advanced throughput by managing finely throughput, a memory, etc. of CPU which the computer has, or, If it is a program of the form which provided the user interface independent of a program which it is unific and is easy to use, or was decided beforehand, it has the advantage that the current update of the function of a computer can be carried out by carrying out a current update freely.

[0005] As another electronic equipment which similarly has been made a miniaturization and highly efficient by using a semiconductor, the car audio system and car-navigation system which are carried in a car are mentioned. Among these, a car audio system is commonly called a car stereo etc., and combines the tuner of a CD player, AM, or FM, etc. with amplifier, a loudspeaker, etc. A car-navigation system is a shown system to which a screen display of the map is carried out to the specified destination, pinpointing the current position of a car using an azimuth magnet, an odometer, GPS, etc.

[0006] These days, since a car-navigation system, a handsfree cellular phone, an anti-theft alarm system, etc. are combined with a car audio system in many cases, the electronic equipment for these mount is hereafter named a "car audio system" generically.

[Translation done.]

*** NOTICES ***

JPO and INPIT are not responsible for any damages caused by the use of this translation.

- 1.This document has been translated by computer. So the translation may not reflect the original precisely.
- 2.**** shows the word which can not be translated.
- 3.In the drawings, any words are not translated.

EFFECT OF THE INVENTION

[3. effect] As mentioned above, the computer which controls a car audio system by this embodiment is provided with general-purpose OS, and in this general-purpose OS, The user interface which carries out the maximum exertion of the capability of a computer by managing resources, such as CPU and a memory, and is not dependent on a program and which is unified and is easy to use is provided, and an addition and change of a function are also made easy by adding the program of the form decided further beforehand, or changing. For this reason, control of a complicated car audio system becomes easy.

[0103]If it is the program which suited the standard of OS, it will become possible to use a program also with in the car [various], and it will also become possible to process information using apparatus, such as an indicator of a car audio system, an operation key, and a loudspeaker. Of course, a user can save his individual information even in this case using about the same big memory as a hand-held PC, or information can be edited like a personal computer.

[0104]In this embodiment, data is exchanged using the bus CPU of a computer and the apparatus of the car audio system made the mistake in corresponding to a mutual form, and between two buses, if needed, data changes form, wins popularity and is passed. For this reason, even if operation of CPU is quicker than operation of each apparatus, it is not necessary to double CPU with the motion cycle of each apparatus, and complicated processing can be performed at high speed by accessing a memory etc. efficiently. Since the data which CPU exchanges, and the data which apparatus exchanges do not scramble for the communicative competence of the same bus, both a computer and a car audio system can perform each operation smoothly.

[0105]Multitasking of performing another processing using the bus corresponding to the form of CPU becomes easy simultaneously, reproducing the signal of a sound using the bus for connecting apparatus. Also when changing CPU into the thing of another form, the bus for

connecting these apparatus with each apparatus remains as it is, and since what is necessary is to change only the bus corresponding to the form of CPU according to the form of new CPU, it can respond also to change of CPU easily.

[0106]In particular, in this embodiment, two or more apparatus can be connected in daisy chain form one after another, and it can die. For this reason, also when the number of apparatus increases or distributed installation of the apparatus is carried out here and there [in the car], long wiring is not concentrated in one place like a star method, and installation becomes easy. Since wiring becomes intelligible shapely, it also becomes easy to change the composition of a car audio system or to carry out maintenance and repair.

[0107]In addition, since any data is exchanged as digital data and processed through USB etc. in this embodiment regardless of the kind of data whether to be audio information or to be alphabetic data, It is hard to be influenced by the environmental variation or a noise, and an audio characteristic is also stabilized.

[0108][An embodiment] besides 4. This invention is not limited to the embodiment described above, and contains other embodiments which are illustrated next. For example, in the embodiment described above, although Windows CE was mentioned as an example of OS of a computer, since this is only mere illustration, using OS of other kinds which already uses a certain OS or will appear newly from now on is also included in the range of this invention.

[0109]Although the example which controls the car audio system for mount by the embodiment described above was shown, This invention can harness the advantage of this invention that it is also possible to use for controlling electric products, such as a non-portable stereo, new application software is used also in this case, or the whole is small and can be managed in a home.

[0110]Although the standard concrete about various buses and communication circuits was mentioned in the embodiment described above, such a standard is only illustration and can also be transposed to other standards which can do same usage. For example, the 1st bus and 2nd bus can also make a CPU module and a support module an internal bus by one-chip-izing.

[Translation done.]

*** NOTICES ***

JPO and INPIT are not responsible for any damages caused by the use of this translation.

- 1.This document has been translated by computer. So the translation may not reflect the original precisely.
- 2.**** shows the word which can not be translated.
- 3.In the drawings, any words are not translated.

TECHNICAL PROBLEM

[Problem(s) to be Solved by the Invention]The hand-held PC provided with OS which was described above, and the car audio system were mutual completely separate in the former. That is, although the car audio system which prepared the computer in the large meaning for control existed, the computer in this case is called the embedded system which works only for the specific purpose.

[0008]CPU with necessary minimum capability is used for this embedded system, and it realizes necessary minimum processing to the hardware of receiving an operation switch or operating a disk reproduction mechanism, by the small program using an assembler etc. For this reason, usage of carrying out the change addition of the function by carrying out processing and preservation of data like a personal computer, or carrying out the change addition of the program cannot be done.

[0009]On the other hand, it did not have a function which a hand-held PC sounds music itself, or controls a car audio system. For this reason, although the user might carry the hand-held PC into in the car as a matter of fact, he did not use, having connected with the car audio system.

[0010]By the way, the latest car audio system, Not only in conventional apparatus called the tuner, cassette tape deck, and CD player of radio, Many apparatus is increasingly built into the condition of an MD player, CD, the autochanger of MD, a car-navigation system, the voice recognition equipment that recognizes a user's command, a handsfree cellular phone, and an anti-theft alarm system. And it is dramatically difficult to master the car audio system which becomes complicated in this way only with the switch in which it was provided by each device.

[0011]That is, when a car audio system becomes complicated in this way, many switches, such as an operation key and a dial, will be in various places in the car. For this reason, it is serious to memorize which is what operation key.

[0012]Namely, in order to master the car audio system which becomes complicated. To use for

control an information processor equivalent to the hand-held PC provided with the small computer with the pliability which can carry out the current update of the function about the advanced throughput which controls a complicated system, the user interface, and control which are easy to use, and especially general-purpose OS is desired.

[0013]Even if it thinks from the hand-held PC side, a car is used like the present age in many cases, and in the car is wanted to expand the width of practical use in society also with much traffic congestion. By combining with a car audio system especially, make an operation key and a memory serve a double purpose, or, The information which a user wants to know in the car is made to be read out by the synthesized speech using a computer, If usage of hearing the voice from the loudspeaker of a car audio system, or accessing an external computer network by the circuit of the cellular phone built into the car audio system can be done, the width of practical use can be expanded rather than former.

[0014]When combining high-speed CPU which uses general-purpose OS, and apparatus which is contained in a car audio system, to have a separate bus suitable for each from the difference in both working speed, etc. is desired. In the car audio system which combined a lot of apparatus, two or more apparatus is wanted to be easily connectable with simple refreshed wiring.

[0015]Proposed in order that this invention might solve the problem of conventional technology which was described above, it is combining a small computer with general-purpose OS, and a car audio system, and the purpose is to harness a mutual advantage. Another purpose of this invention is to use two or more buses, and is using both high-speed apparatus of CPU and others smoothly without futility. Another purpose of this invention is to connect various apparatus one after another with a daisy chain mode.

[Translation done.]

*** NOTICES ***

JPO and INPIT are not responsible for any damages caused by the use of this translation.

- 1.This document has been translated by computer. So the translation may not reflect the original precisely.
- 2.*** shows the word which can not be translated.
- 3.In the drawings, any words are not translated.

MEANS

[Means for Solving the Problem]In order to attain the purpose described above, an invention of claim 1 equips a car audio system provided with a computer for control with the following. A means by which said computer is provided with an operating system and this operating system manages resources on a computer.

A means to control input and output containing a user interface.

A means to execute a program of form decided beforehand.

A computer for mount of claim 6 is provided with the following.

An operating system which realizes environment required in order to execute a program of form decided beforehand.

Car audio system.

A means to control said car audio system.

An invention of claim 11 is what caught an invention of claim 1 from a view of a method, In a control method of a car audio system which controls a car audio system using a computer provided with an operating system, A step which realizes environment which needs said operating system in order to execute a program of form decided beforehand, and a step by which said program controls said car audio system are included. A computer which controls a car audio system by invention of claims 1, 6, and 11 is provided with general-purpose OS, and it this general-purpose OS, A user interface which carries out the maximum exertion of the capability of a computer by managing resources, such as CPU and a memory, and is not dependent on a program and which it is unific and is easy to use is provided, and an addition and change of a function are made easy by adding a program of form decided further beforehand, or changing. For this reason, control of a complicated car audio system becomes easy. It becomes possible for in the car to use various programs, or to process information using apparatus of a car audio system.

[0017]An invention of claim 2 was provided with the 1st bus corresponding to form of CPU

contained in said computer, and the 2nd bus for connecting apparatus contained in said car audio system in a car audio system provided with a computer for control. An invention of claim 7 was provided with the 1st bus corresponding to form of CPU contained in said computer, and the 2nd bus for connecting apparatus contained in said car audio system in a computer for mount provided with a car audio system. An invention of claim 12 is what caught an invention of claim 2 from a view of a method, In a control method of a car audio system which controls a car audio system using a computer, A step with which CPU contained in said computer exchanges data through the 1st bus corresponding to form of this CPU, Apparatus contained in said car audio system contains a step which exchanges data through the 2nd bus for connecting apparatus. An invention of claim 3 was provided with a PCI bus for connecting apparatus contained in said car audio system with a local bus corresponding to form of CPU contained in said computer in a car audio system provided with a computer for control. An invention of claim 8 was provided with a PCI bus for connecting apparatus contained in said car audio system with a local bus corresponding to form of CPU contained in said computer in a computer for mount provided with a car audio system. An invention of claim 4 was provided with a means to change form of data between said each bus, in the car audio system according to claim 2 or 3. An invention of claim 9 was provided with a means to change form of data between said each bus, in the computer for mount according to claim 7 or 8. In an invention of claims 2, 3, 7, 8, and 12, data is exchanged using a bus CPU of a computer and apparatus of a car audio system made the mistake in corresponding to a mutual form, and between two buses, if needed, data changes form, wins popularity and is passed (claims 4 and 9). For this reason, even if operation of CPU is quicker than operation of each apparatus, it is not necessary to double CPU with a motion cycle of each apparatus, and complicated processing can be performed at high speed by accessing a memory etc. efficiently. Since data which CPU exchanges, and data which apparatus exchanges do not scramble for communicative competence of the same bus, it can operate smoothly in both a computer and a car audio system. Multitasking of performing another processing using a bus corresponding to form of CPU becomes easy simultaneously, reproducing a signal of a sound using a bus for connecting apparatus. Also when changing CPU into a thing of another form, a bus for connecting these apparatus with each apparatus remains as it is, and since what is necessary is to change only a bus corresponding to form of CPU according to form of new CPU, it can respond also to change of CPU easily.

[0018]An invention of claim 5 was provided with the 3rd bus for connecting two or more apparatus contained in said car audio system in a car audio system of any one statement of four from claim 1 in daisy chain form. An invention of claim 10 was provided with the 3rd bus for connecting two or more apparatus contained in said car audio system in a computer for mount of any one statement of nine from claim 6 in daisy chain form. In an invention of claims

5 and 10, two or more apparatus can be connected in daisy chain form one after another, and it can die. For this reason, also when the number of apparatus increases or distributed installation of the apparatus is carried out here and there [in the car], long wiring is not concentrated in one place like a star method, and installation becomes easy. Since wiring becomes intelligible shapely, it also becomes easy to change composition or to carry out maintenance and repair.

[0019]

[Embodiment of the Invention]Next, an embodiment of the invention (henceforth a "embodiment") is concretely described with reference to drawings. Although this embodiment is the car audio system provided with various apparatus, such as a CD player, it is provided with the computer provided with general-purpose OS which is used for a hand-held PC, and also performs control of a car audio system by this computer. The same numerals are attached about the member same about each figure used by the following explanation as the figure explained before it, or the same kind of member, and explanation is omitted.

[0020][1. composition]

[Composition of whole 1-1.] First, drawing 1 is a block diagram showing the entire configuration of this embodiment. As shown in this figure, this embodiment as each apparatus which constitutes a car audio system other than the main unit 1, It has the tuner amplifier unit 2, the microphone 3, the GPS antenna 4, the security control unit 5, the telephone unit 6, the CD-ROM autochanger 7, and the auxiliary battery 9 for power supply backup.

[0021]Among these, the main unit 1 is a portion which builds in the computer for control and controls the whole system by this computer. Although the tuner amplifier unit 2 does not carry out the graphic display other than the antenna 2a of AM and FM, it is the portion provided with a radio tuner and the amplifier for sounding a loudspeaker. The microphone 3 is for inputting a user's voice so that operation by speech recognition can be performed. The function of this speech recognition is realized by the program of the computer described above.

[0022][1-1-1. main unit] The main unit 1 is provided with the socket 13S for inserting CompactFlash card 13, and the face plate unit 15 removed [attach and] and made (drawing 1). CompactFlash card 13 is a storage using a flash memory, and data can be written from the main unit 1 by inserting in the socket 13S formed in the main unit 1. This CompactFlash card 13 is used in order to exchange data, a program, etc. with other computers or to back up various information sets in this car audio system.

[0023]The face plate unit 15 attached, removed and made, It has the indicator which displays various information on a user, and the final controlling element which provided the operation key for a user to do various operations etc., and is referred to also as DCP (Detachable Control Panel). The indicator of this face plate unit 15 is large-sized color LCD (liquid crystal display) of 64 dots by 256 dots, etc., for example.

[0024]if it removes and carries out when getting off a car, even if a thief looks for a car audio system, neither use nor resale can do this face plate unit 15, also seeing an important indicator not have a final controlling element -- there are ** and a theft preventive effect of giving up stealing. If the removed face plate unit 15 is put into the case 15a and it carries around, it will damage neither itself nor a surrounding thing.

[0025]Although this face plate unit 15 is not shown in drawing 1, it is provided with the infrared-ray-communication unit for exchanging data in the form of the hand-held PC 8, IrDA, etc.

[0026][Apparatus] besides 1-1-2. The GPS antenna 4 is an antenna for receiving an electric wave from a GPS Satellite. The signal from this GPS antenna 4 is sent to the GPS unit in the main unit 1 through GPS receiver 4a. Although this GPS unit is not shown in drawing 1, it calculates the position on the earth with a receiver from an electric wave. On the computer described above, by a program, the function of a car-navigation system is realized and a calculation result is passed to the function of this car-navigation system.

[0027]The security control unit 5 is the sensor 5a which detects vibration and a shock, and when a theft, a mischief, etc. are detected, it is a portion which carries out correspondence of sounding the siren 5b. The telephone unit 6 is a unit which controls the function of a car telephone, and is a portion which realizes the telephone call using the telephone antenna 6a or the hand set 6b. The CD-ROM autochanger 7 is hanging automatically some CDs set beforehand again, and is a unit which plays the disk which the user chose, and music.

[0028][1-1-3. daisy chain connection] Here, these security control unit 5, the telephone unit 6, and the CD-ROM autochanger 7 are connected to the main unit 1 by USB (Universal Serial Bus). This USB is a serial bus (the 3rd bus) for connecting two or more apparatus in daisy chain form.

[0029]The apparatus connected by USB in this way comprises this embodiment so that data with the exterior may be exchanged in the form of this USB. For example, the CD-ROM autochanger 7, Although it has the hub (HUB) the object for upstreams, and for downstreams and digital data is once read from an audio CD or CD-ROM according to ATAPI form (parallel form) inside this CD-ROM autochanger 7, After the read data is changed into the USB (Universal Serial Bus) form which is serial form by the data converter built in, it is sent out to USB.

[0030]The installation becomes easy when installing these units 5, 6, and 7 in the place distant from the main unit 1, since connection of the units 5 and 6 and the CD-ROM autochanger 7 turns into serial connection with such composition. Although connected in order of the unit 5, the unit 6, and the autochanger 7 in drawing 1, connection order is good also as connection of only arbitrary and required things.

[0031][The internal configuration of a 1-2. main unit] Next, drawing 2 is a block diagram showing the main things among each portion described above, and is especially explained

focusing on the concrete composition of main unit 1 inside. This whole figure is divided into four with the dashed line, in the left, CPU module 11 and a center become the support module 12, the upper right becomes the external unit 30, and the lower right has become the option unit 40. Among these, CPU module 11 and the support module 12 are formed in the inside of the main unit 1.

[0032]The external unit 30 and the option unit 40 have pointed out collectively the apparatus of every some connected to the main unit 1. On account of explanation, CompactFlash card 13 is shown in the direction under CPU module 11, and drawing 2 shows the face plate unit 15 to the direction on the external unit 30.

[0033]Among these, CPU module 11 and the support module 12 constitute the computer for control which controls the whole car audio system. Among these, CPU module 11 is a portion which carries out logical data processing centering on CPU111, and the support module 12 is a portion which performs input and output with other apparatus contained in a car audio system.

[0034]The local bus B1 (the 1st bus) formed considering CPU111 as a center is a way with CPU module 11 as [main] data. PCI (Peripheral Component Interconnect) for that it is a way by the support module 12 as [main] data to connect each apparatus on the other hand It is bus B-2 (the 2nd bus).

[0035][Composition of a 1-2-1. CPU module] The local bus B1 of CPU module 11, It is what was doubled with the form of CPU111, and DRAM112, the flash ROM 113, the PCI bus host controller 114, CPU host ASIC115, and PCMCIA-ASIC116 are connected to this local bus B1. Among these, DRAM112 is a portion which provides work areas, such as a variable area, when CPU111 processes information in control of a car audio system, etc.

[0036]The flash ROM 113 is rewritable ROM and is a portion which stores the software in large meanings, such as OS, BIOS, and an application program, here. The function of OS stored here manages the resources on a computer, It is controlling the input and output containing a user interface, executing the program of the form decided beforehand, etc., for example, what used as the base Windows CE which conventional technology described by the way can be considered.

[0037]The PCI bus host controller 114 is a means to change the form of the data which connects the local bus B1 and PCI bus B-2, and is exchanged between these two buses.

[0038]"ASIC", such as CPU host ASIC115, is the abbreviation for Application Specific Integrated Circuit, and points out IC and LSI which were made for specific uses to general-purpose integrated circuits, such as ROM, RAM, and CPU. Specifically, this CPU host ASIC115 is ASIC for the interface of the local bus B1 and the PCI bus host controller 114. This CPU host ASIC115 [that is,], Between PCI bus B-2 and CPU module 11, are a portion which becomes a window of the data exchanged and specifically, Input and output with CPU module

11 and the exterior are performed instead of CPU111, and also it is recognized whether it is a thing of the kind passed to CPU111 about the data sent from PCI bus B-2.

[0039]And although what should pass CPU host ASIC115 to CPU111 is sent to CPU111 through the local bus B1, CPU111 does not need to calculate to the other thing, for example, the sent data, and such a reaction is returned about that for which it is sufficient if the reaction for which it opted beforehand is returned mechanically.

[0040]PCMCIA-ASIC116 CompactFlash card 13, It is a portion for an interface corresponding to being based on the standard of PCMCIA (Personal Computer Memory Card International Association) as what is called a PC card, It is a portion which controls the reading and writing of data to CompactFlash card 13.

[0041][Composition in connection with a 1-2-2. support module] Next, PCI bus B-2 of the support module 12 is a bus for exchanging data among various apparatus which constitutes a car audio system. Here, as apparatus connected to this PCI bus B-2, there are the external unit 30 and the option unit 40, and these have pointed out some apparatus collectively, respectively.

[0042]That is, the external unit 30 is unit with the another main unit 1 shown in drawing 1, and in this example specifically, It is the tuner 21, the amplifier 22, and the microphone 3 which were formed in the face plate unit 15 attached, removed and made from the main unit 1, and the tuner amplifier unit 2. Among these, the face plate unit 15 is provided with the infrared-ray-communication unit 127.

[0043]The option unit 40 is a unit from which it can choose whether to include in this car audio system as an option, and, specifically, are GPS unit 16 and the CD-ROM autochanger 7 in this example. There is the CD-ROM unit 14 in the inside of the main unit 1, and this CD-ROM unit 14 is also connected to PCI bus B-2. This CD-ROM unit 14 is a player for reading digital data from one CD or CD-ROM. These CD-ROM autochanger 7 and the CD-ROM unit 14 have the compatibility that data can also be read from what is called an audio CD, and both can also read data from CD-ROM (it is compatible).

[0044]In the support module 12, in order for PCI bus B-2 to exchange data among these apparatus, Support ASIC121, CODEC circuit 122, DSP unit 123, the buffer memory 124, the parallel / PCI driver 125, and the serial / PCI driver 126 are used.

[0045]Among these, support ASIC121 is a portion which controls traffic in the data where to send the data which came from where between the support module 12 and each apparatus. "CODEC" of CODEC circuit 122 is an abbreviation of "Coder/Decoder", i.e., the coding decryption art of data, and this CODEC circuit 122, For example, it is a portion which performs the A/D conversion etc. which carry out D/A conversion which changes the given digital data into an analog signal, or change an analog signal into digital data conversely.

[0046]"DSP" of DSP unit 123 is an abbreviation to mean a digital sound processor, i.e., the

circuit which processes the signal of the sound of digital format specially, and this DSP unit 123, When the digital data showing music etc. can be given, as items, such as balance of the right and left set as the system, volume, Feder, surround, and an equalizer, are reflected in the contents of the sound, it is a portion which processes digital data.

[0047]By audio equipment and PCI bus B-2s, such as a CD-ROM unit, since the buffer memory 124 differs in the cycle which write data, it is a buffer for this difference to be filled up with storing data and taking it out little by little, and comprises SRAM etc.

[0048]Parallel / PCI driver 125 is portions which change into the data format of PCI bus B-2 the digital data of parallel form sent from the CD-ROM unit 14. A serial / PCI driver 126 is portions which change into the data format of PCI bus B-2 the digital data of serial form sent from the CD-ROM autochanger 7.

[0049]The face plate unit 15 containing the infrared-ray-communication unit 127, It is connected to support ASIC121 in a high-speed serial communication circuit, and GPS unit 16 is connected to support ASIC121 in start-stop serial communication circuits, such as UART (UniversalAsynchronous Receiver-Transitter). The CD-ROM unit 14 is connected to parallel / PCI driver 125 by parallel communication circuits, such as ATAPI (AT Attachment Packet Interface). Although a graphic display is not carried out, ASIC which manages an exchange of the data based on infrared rays is provided in the infrared-ray-communication unit 127.

[Translation done.]

* NOTICES *

JP0 and INPIT are not responsible for any damages caused by the use of this translation.

- 1.This document has been translated by computer. So the translation may not reflect the original precisely.
- 2.**** shows the word which can not be translated.
- 3.In the drawings, any words are not translated.

OPERATION

[2. operation] This embodiment constituted as stated above works as follows.

[Translation done.]

*** NOTICES ***

JPO and INPIT are not responsible for any damages caused by the use of this translation.

- 1.This document has been translated by computer. So the translation may not reflect the original precisely.
- 2.**** shows the word which can not be translated.
- 3.In the drawings, any words are not translated.

DESCRIPTION OF DRAWINGS

[Brief Description of the Drawings]

[Drawing 1]The block diagram showing the entire configuration of the embodiment of this invention.

[Drawing 2]The block diagram shown focusing on the internal configuration of a main unit about the embodiment of this invention.

[Description of Notations]

- 1 -- Main unit 1
- 11 -- CPU module
- 111 -- CPU
- 112 -- DRAM
- 113 -- Flash ROM
- 114 -- PCI bus host controller
- 115 -- CPU host ASIC
- 116 -- PCMCIA-ASIC
- 12 -- Support module
- 121 -- Support ASIC
- 122 -- CODEC circuit
- 123 -- DSP unit
- 124 -- Buffer memory
- 125 -- Parallel / PCI driver
- 126 -- A serial / PCI driver
- 127 -- Infrared-ray-communication unit
- 13 -- CompactFlash card
- 13S -- Socket
- 14 -- CD-ROM unit

- 15 -- Face plate unit
- 15a -- Case
- 16 -- GPS unit
- 2 -- Tuner amplifier unit
- 2a -- Antenna
- 21 -- Tuner
- 22 -- Amplifier
- 3 -- Microphone
- 4 -- GPS antenna
- 4a -- Receiver
- 5 -- Security control unit
- 5a -- Sensor
- 5b -- Siren
- 5c -- Transmitter
- 6 -- Telephone unit
- 6a -- Antenna
- 6b -- Hand set
- 7 -- CD-ROM autochanger
- 8 -- Hand-held PC
- 9 -- Auxiliary battery
- 30 -- External unit
- 40 -- Option unit

[Translation done.]

Electronic Patent Application Fee Transmittal

Application Number:	10316961				
Filing Date:	11-Dec-2002				
Title of Invention:	AUDIO DEVICE INTEGRATION SYSTEM				
First Named Inventor/Applicant Name:	Ira Marlowe				
Filer:	Mark E. Nikolsky/Janelle Fava				
Attorney Docket Number:	9809/1				
Filed as Small Entity					
Utility under 35 USC 111(a) Filing Fees					
Description	Fee Code	Quantity	Amount	Sub-Total in USD(\$)	
Basic Filing:					
Pages:					
Claims:					
Miscellaneous-Filing:					
Petition:					
Petition fee- 37 CFR 1.17(h) (Group III)	1464	1	130	130	
Patent-Appeals-and-Interference:					
Post-Allowance-and-Post-Issuance:					
Extension-of-Time:					

Description	Fee Code	Quantity	Amount	Sub-Total in USD(\$)
Miscellaneous:				
Request for continued examination	2801	1	405	405
Total in USD (\$)				535

Electronic Acknowledgement Receipt

EFS ID:	4360396
Application Number:	10316961
International Application Number:	
Confirmation Number:	4879
Title of Invention:	AUDIO DEVICE INTEGRATION SYSTEM
First Named Inventor/Applicant Name:	Ira Marlowe
Correspondence Address:	MICHAEL R FRISCIA MCCARTER & ENGLISH FOUR GATEWAY CENTER 100 MULBERRY STREET NEWARK NJ 07102 US 9735336599 -
Filer:	Mark E. Nikolsky/Janelle Fava
Filer Authorized By:	Mark E. Nikolsky
Attorney Docket Number:	9809/1
Receipt Date:	26-NOV-2008
Filing Date:	11-DEC-2002
Time Stamp:	13:00:13
Application Type:	Utility under 35 USC 111(a)

Payment information:

Submitted with Payment	yes
Payment Type	Deposit Account
Payment was successfully received in RAM	\$535

RAM confirmation Number		9633			
Deposit Account		503571			
Authorized User					
<p>The Director of the USPTO is hereby authorized to charge indicated fees and credit any overpayment as follows:</p> <p>Charge any Additional Fees required under 37 C.F.R. Section 1.16 (National application filing, search, and examination fees)</p> <p>Charge any Additional Fees required under 37 C.F.R. Section 1.17 (Patent application and reexamination processing fees)</p> <p>Charge any Additional Fees required under 37 C.F.R. Section 1.19 (Document supply fees)</p> <p>Charge any Additional Fees required under 37 C.F.R. Section 1.20 (Post Issuance fees)</p> <p>Charge any Additional Fees required under 37 C.F.R. Section 1.21 (Miscellaneous fees and charges)</p>					
File Listing:					
Document Number	Document Description	File Name	File Size(Bytes)/ Message Digest	Multi Part /.zip	Pages (if appl.)
1	Miscellaneous Incoming Letter	Transmittal.pdf	26709 4f16f90b4384639300706ba1db5cbf62aad772a	no	1
Warnings:					
Information:					
2	Petition to Withdraw from Issue	Petition.pdf	43767 6662c75f4d4c01af772d04b0148ab9d1cd444625	no	2
Warnings:					
Information:					
3	Request for Continued Examination (RCE)	RCE.pdf	52429 c4c957ffa8152720bf95ed2f98cff5f42e362ce28	no	1
Warnings:					
This is not a USPTO supplied RCE SB30 form.					
Information:					
4	Information Disclosure Statement Letter	IDSLetter.pdf	57002 d0bceda5c5e80efbe003b6c0e04a42611fead17af	no	2
Warnings:					
Information:					
5	Information Disclosure Statement (IDS) Filed (SB/08)	IDS.pdf	86662 2749aee20520049a97b9db582a5f2896704e8df8	no	2
Warnings:					
Information:					
This is not an USPTO supplied IDS fillable form					
6	Foreign Reference	Ref8.pdf	1081189 eaf6f9e0a6b89651ea2e677da78f511c6aee14d	no	30
Warnings:					
Information:					

7	Foreign Reference	Ref9.pdf	2595147	no	55
			ab94437161f8cd657b2c30ffa215cad26d0c1e2c		
Warnings:					
Information:					
8	NPL Documents	Ref10.pdf	87753	no	3
			52c0b938d4224e7ae83cb85bd16382d632023671		
Warnings:					
Information:					
9	NPL Documents	Ref11.pdf	342401	no	7
			91060710303520de8819c75f509ad8220a8cc36b		
Warnings:					
Information:					
10	NPL Documents	Ref12.pdf	920635	no	33
			968fe53f73838fe7001611655c421127836b93d		
Warnings:					
Information:					
11	Fee Worksheet (PTO-06)	fee-info.pdf	32112	no	2
			bce6fe3b279049618589266d553f731f6b10781		
Warnings:					
Information:					
Total Files Size (in bytes):				5325806	
<p>This Acknowledgement Receipt evidences receipt on the noted date by the USPTO of the indicated documents, characterized by the applicant, and including page counts, where applicable. It serves as evidence of receipt similar to a Post Card, as described in MPEP 503.</p> <p><u>New Applications Under 35 U.S.C. 111</u> If a new application is being filed and the application includes the necessary components for a filing date (see 37 CFR 1.53(b)-(d) and MPEP 506), a Filing Receipt (37 CFR 1.54) will be issued in due course and the date shown on this Acknowledgement Receipt will establish the filing date of the application.</p> <p><u>National Stage of an International Application under 35 U.S.C. 371</u> If a timely submission to enter the national stage of an international application is compliant with the conditions of 35 U.S.C. 371 and other applicable requirements a Form PCT/DO/EO/903 indicating acceptance of the application as a national stage submission under 35 U.S.C. 371 will be issued in addition to the Filing Receipt, in due course.</p> <p><u>New International Application Filed with the USPTO as a Receiving Office</u> If a new international application is being filed and the international application includes the necessary components for an international filing date (see PCT Article 11 and MPEP 1810), a Notification of the International Application Number and of the International Filing Date (Form PCT/RO/105) will be issued in due course, subject to prescriptions concerning national security, and the date shown on this Acknowledgement Receipt will establish the international filing date of the application.</p>					

IN THE UNITED STATES PATENT AND TRADEMARK OFFICE

Customer No. 27614
Confirmation No. 4879

Mail Stop Petition
Commissioner for Patents
P.O. Box 1450
Alexandria, VA 22313-1450

Re: Our file: 99879-00005 Examiner: Kurr, Jason R.
Applicant: Ira M. Marlowe Art Unit: 2615
Serial No.: 10/316,961
Filing Date: 12/11/2002
Title: Audio Device Integration System

Sir:

Enclosed for filing in the United States Patent and Trademark Office is the following:

1. Petition to Withdraw from Issue Under 37 C.F.R. 1.313(c) (2 pages)
2. Request for Continued Examination (RCE) Transmittal (1 page)
3. Transmittal of Information Disclosure Statement (2 pages)
4. Form PTO/SB/08A (1 page)
5. Form PTO/SB/08B (2 page)
6. Copies of References 8-9 from Form PTO/SB/08A
7. Copies of References 10-12 from Form PTO/SB/08B
8. Transmittal Sheet (1 page)

CONDITIONAL PETITION

If any extension of time is required for the submission of the above-identified items, Applicant requests that this be considered a petition therefor. Please charge any additional charges or any other charges relating to this matter, or credit any overpayment, to the Deposit Account of the writer, Account No. 503571.

11/26/2008
Date

Respectfully submitted,

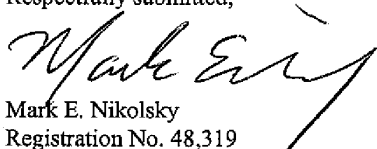
Mark E. Nikolsky
Registration No. 48,319
McCarter & English, LLP
Four Gateway Center
100 Mulberry Street
Newark, NJ 07102
Tel: (973) 639-6987
Fax: (973) 297-6624

CERTIFICATE OF ELECTRONIC FILING

I hereby certify that this correspondence is being electronically filed with the United States Patent and Trademark Office (via EFS-Web) on 11/26/2008.

Janelle Fava



UNITED STATES PATENT AND TRADEMARK OFFICE

UNITED STATES DEPARTMENT OF COMMERCE
United States Patent and Trademark Office
Address: COMMISSIONER FOR PATENTS
P. O. Box 1450
Alexandria, Virginia 22313-1450
www.uspto.gov

APPLICATION NO.	ISSUE DATE	PATENT NO.	ATTORNEY DOCKET NO.	CONFIRMATION NO.
10/316,961	12/09/2008	7463741	9809/1	4879

7590 11/19/2008
MICHAEL R FRISCIA
MCCARTER & ENGLISH
FOUR GATEWAY CENTER
100 MULBERRY STREET
NEWARK, NJ 07102

ISSUE NOTIFICATION

The projected patent number and issue date are specified above.

Determination of Patent Term Adjustment under 35 U.S.C. 154 (b)
(application filed on or after May 29, 2000)

The Patent Term Adjustment is 820 day(s). Any patent to issue from the above-identified application will include an indication of the adjustment on the front page.

If a Continued Prosecution Application (CPA) was filed in the above-identified application, the filing date that determines Patent Term Adjustment is the filing date of the most recent CPA.

Applicant will be able to obtain more detailed information by accessing the Patent Application Information Retrieval (PAIR) WEB site (<http://pair.uspto.gov>).

Any questions regarding the Patent Term Extension or Adjustment determination should be directed to the Office of Patent Legal Administration at (571)-272-7702. Questions relating to issue and publication fee payments should be directed to the Customer Service Center of the Office of Patent Publication at (571)-272-4200.

APPLICANT(s) (Please see PAIR WEB site <http://pair.uspto.gov> for additional applicants):

Ira Marlowe, Fort Lee, NJ;



UNITED STATES PATENT AND TRADEMARK OFFICE

Commissioner for Patents
United States Patent and Trademark Office
P.O. Box 1450
Alexandria, VA 22313-1450
www.uspto.gov

MICHAEL R FRISCIA
MCCARTER & ENGLISH
FOUR GATEWAY CENTER
100 MULBERRY STREET
NEWARK NJ 07102

COPY MAILED
NOV 07 2008
OFFICE OF PETITIONS

In Application of :
Ira Marlowe :
Application No. 10/316,961 : ON PETITION
Filed: December 11, 2002 :
Attorney Docket No.9809/1 :

This is a decision on the petition filed August 19, 2008, which is being treated as a request under 37 CFR 3.81(b)¹ to correct assignee data on the Fee(s) Transmittal form PTOL-85(b) so that the Letter of Patent will issue without an assignee name.

The request is **DISMISSED**.

Petitioner states that the assignee data was cited incorrectly on the Fee(s) Transmittal as "Blitzsafe of America". Accordingly, petitioner requests that the issued patent reflect no assignee on the front page of the Letters of Patent.

A review of the application file history and assignment records reveals that on June 18, 2003, an assignment was recorded from Ira M. Marlowe to Blitzsafe of America. On September 7, 2005, another assignment, was recorded from Blitzsafe of America to Ira Marlowe. On August 15, 2008, the issue fee was paid and Form PTOL-85B was filed noting that Blitzsafe of America should be listed as the assignee on the front page of the Letters of Patent. Petitioner now files the instant petition requesting that no assignee appear on the front page of the Letter of Patent.

37 CFR 3.81(b), effective June 25, 2004, reads:

After payment of the issue fee: Any request for issuance of an application in the name of the Assignee submitted after the date of payment of the issue fee, and any request for a patent to be corrected to state the name of the assignee, must state that the assignment was submitted for recordation as set forth in § 3.11 before issuance of the patent, and must include a request for a certificate of correction under § 1.323 of this chapter (accompanied by the fee set forth in § 1.20(a)) and the processing fee set forth in § 1.17(i) of this chapter.

¹ See MPEP 1309, subsection II and Official Gazette of June 22, 2004.

Accordingly, the Letters of Patent will issue with Blitzsafe of America as the assignee. After issuance of the Letter of Patent, petitioner may file a renewed request under 37 CFR 3.81(b) and Certificate of Correction requesting that Ira Marlowe be listed as the assignee for the patent.

Telephone inquiries concerning this decision may be directed to the undersigned at (571) 272-3222.

The application file is directed to the Office of Data Management for further processing.



Kenya A. McLaughlin
Petitions Attorney
Office of Petitions

UNITED STATES PATENT AND TRADEMARK OFFICE CERTIFICATE OF CORRECTION

PATENT NO. : To Be Determined (Serial No. 10/316,961)

DATED : To Be Determined

INVENTOR(S) : Ira M. Marlowe

It is certified that an error appears or errors appear in the above-identified patent and that said Letters Patent is hereby corrected as shown below:

On the Title Page of the patent, please delete the Assignee information.

MAILING ADDRESS OF SENDER (Please do not use customer number

Mark E. Nikolsky
McCarter & English, LLP
Four Gateway Center
100 Mulberry Street
Newark, NJ 07102

PATENT NO. _____

No. of additional copies



Under the Paperwork Reduction Act of 1995, no persons are required to respond to a collection of information unless it displays a valid OMB control number.

<p align="center">PROCESSING FEE Under 37 CFR 1.17(i) TRANSMITTAL</p> <p align="center">(Fees are subject to annual revision)</p> <p>Send completed form to: Commissioner for Patents P.O. Box 1450, Alexandria, VA 22313-1450</p>	Application Number	10/316,961
	Filing Date	12/11/2002
	First Named Inventor	Ira M. Marlowe
	Art Unit	2615
	Examiner Name	Kurr, Jason R.
	Attorney Docket Number	99879-00005

Enclosed is a paper filed under 37 CFR 3.81(b) that requires a processing fee (37 CFR 1.17(i)).
Payment of \$ 130.00 is enclosed.

This form should be included with the above-mentioned paper and faxed or mailed to the Office using the appropriate Mail Stop, if applicable. For transmittal of petition fees under 37 CFR 1.17(f), (g) or (h), see form PTO/SB/17p.

Payment of Fees (small entity amounts are NOT available for the processing fees)

The Commissioner is hereby authorized to charge the following fees to Deposit Account No. 503571:

processing fee under 37 CFR 1.17(i) any deficiency of fees and credit of any overpayments

Enclose a duplicative copy of this form for fee processing.

Check in the amount of \$ _____ is enclosed.

Payment by credit card (Form PTO-2038 or equivalent enclosed). Do not provide credit card information on this form.

**Processing Fees under 37 CFR 1.17(i): Fee \$130 Fee Code 1808 for all,
Except for § 1.221 papers (Fee Code 1803)**

For papers filed under:

- § 1.28(c)(3) - for processing a non-itemized fee deficiency based on an error in small entity status.
- § 1.41 - for supplying the name or names of the inventor or inventors after the filing date without an oath or declaration as prescribed by § 1.63, except in provisional applications.
- § 1.48 - for correcting inventorship, except in provisional applications.
- § 1.52(d) - for processing a nonprovisional application filed with a specification in a language other than English.
- § 1.53(b)(3) - to convert a provisional application filed under § 1.53(c) into a nonprovisional application under § 1.53(b).
- § 1.55 - for entry of late priority papers.
- § 1.71(g)(2) - to enter an amendment to the specification for purposes of 35 U.S.C. 103(c)(2) if not filed within the cited time periods
- § 1.99(e) - for processing a belated submission under § 1.99.
- § 1.103(b) - for requesting limited suspension of action, continued prosecution application (§ 1.53(d)).
- § 1.103(c) - for requesting limited suspension of action, request for continued examination (§ 1.114).
- § 1.103(d) - for requesting deferred examination of an application.
- § 1.217 - for processing a redacted copy of a paper submitted in the file of an application in which a redacted copy was submitted for the patent application publication.
- § 1.221 - for requesting voluntary publication or republication of an application. **Fee Code 1803**
- § 1.291(c)(5) - for processing a second or subsequent protest by the same real party in interest.
- § 1.497(d) - for filing an oath or declaration pursuant to 35 U.S.C. 371 (c)(4) naming an inventive entity different from the inventive entity set forth in the international stage.
- § 3.81 - for a patent to issue to assignee, assignment submitted after payment of the issue fee.



Signature
Mark E. Nikovsky

Typed or printed name

August 19, 2008

Date

48,319

Registration No., if applicable

This collection of information is required by 37 CFR 1.17. The information is required to obtain or retain a benefit by the public which is to file (and by the USPTO to process) an application. Confidentiality is governed by 35 U.S.C. 122 and 37 CFR 1.11 and 1.14. This collection is estimated to take 5 minutes to complete, including gathering, preparing, and submitting the completed application form to the USPTO. Time will vary depending upon the individual case. Any comments on the amount of time you require to complete this form and/or suggestions for reducing this burden, should be sent to the Chief Information Officer, U.S. Patent and Trademark Office, U. S. Department of Commerce, P.O. Box 1450, Alexandria, VA 22313-1450. DO NOT SEND FEES OR COMPLETED FORMS TO THIS ADDRESS. SEND TO: Commissioner of Patents, P.O. Box 1450, Alexandria, VA 22313-1450.

If you need assistance in completing the form, call 1-800-PTO-9199 and select option 2.

Electronic Patent Application Fee Transmittal

Application Number:	10316961			
Filing Date:	11-Dec-2002			
Title of Invention:	AUDIO DEVICE INTEGRATION SYSTEM			
First Named Inventor/Applicant Name:	Ira Marlowe			
Filer:	Mark E. Nikolsky/Diane Bodzioch			
Attorney Docket Number:	9809/1			
Filed as Small Entity				
Utility under 35 USC 111(a) Filing Fees				
Description	Fee Code	Quantity	Amount	Sub-Total in USD(\$)
Basic Filing:				
Pages:				
Claims:				
Miscellaneous-Filing:				
Petition:				
Patent-Appeals-and-Interference:				
Post-Allowance-and-Post-Issuance:				
Certificate of correction	1811	1	100	100
Extension-of-Time:				

Description	Fee Code	Quantity	Amount	Sub-Total in USD(\$)
Miscellaneous:				
Processing Fee, except for Provis. apps	1808	1	130	130
Total in USD (\$)				230

Electronic Acknowledgement Receipt

EFS ID:	3803104
Application Number:	10316961
International Application Number:	
Confirmation Number:	4879
Title of Invention:	AUDIO DEVICE INTEGRATION SYSTEM
First Named Inventor/Applicant Name:	Ira Marlowe
Correspondence Address:	MICHAEL R FRISCIA MCCARTER & ENGLISH FOUR GATEWAY CENTER 100 MULBERRY STREET NEWARK NJ 07102 US 9735336599 -
Filer:	Mark E. Nikolsky/Diane Bodzioch
Filer Authorized By:	Mark E. Nikolsky
Attorney Docket Number:	9809/1
Receipt Date:	19-AUG-2008
Filing Date:	11-DEC-2002
Time Stamp:	14:02:47
Application Type:	Utility under 35 USC 111(a)

Payment information:

Submitted with Payment	yes
Payment Type	Deposit Account
Payment was successfully received in RAM	\$230

RAM confirmation Number		8152			
Deposit Account		503571			
Authorized User					
<p>The Director of the USPTO is hereby authorized to charge indicated fees and credit any overpayment as follows:</p> <p>Charge any Additional Fees required under 37 C.F.R. Section 1.16 (National application filing, search, and examination fees)</p> <p>Charge any Additional Fees required under 37 C.F.R. Section 1.17 (Patent application and reexamination processing fees)</p> <p>Charge any Additional Fees required under 37 C.F.R. Section 1.19 (Document supply fees)</p> <p>Charge any Additional Fees required under 37 C.F.R. Section 1.20 (Post Issuance fees)</p> <p>Charge any Additional Fees required under 37 C.F.R. Section 1.21 (Miscellaneous fees and charges)</p>					
File Listing:					
Document Number	Document Description	File Name	File Size(Bytes)/ Message Digest	Multi Part /.zip	Pages (if appl.)
1	Miscellaneous Incoming Letter	coverletter_001.pdf	25549 de238b1b2d6c4120b72317b977949e0d39c3c730	no	1
Warnings:					
Information:					
2	Post Allowance Communication - Incoming	Request_001.pdf	39442 0ea7714ecee9f6329291bc2d02fd8ef80b94ff63c8	no	2
Warnings:					
Information:					
3	Request for Certificate of Correction	CertificateofCorrection_001.pdf	12653 8e11ffeab7069d8928d82a95170dd542405b5000	no	1
Warnings:					
Information:					
4	Miscellaneous Incoming Letter	Processingfeetransmittal_001.pdf	49857 8fe843208ae2755aabdf9001dbe94960771c735d6	no	1
Warnings:					
Information:					
5	Fee Worksheet (PTO-06)	fee-info.pdf	32078 c7f4a3d6e9007d3aa51590e9d0df900b940a73ea	no	2
Warnings:					
Information:					
Total Files Size (in bytes):			159579		

This Acknowledgement Receipt evidences receipt on the noted date by the USPTO of the indicated documents, characterized by the applicant, and including page counts, where applicable. It serves as evidence of receipt similar to a Post Card, as described in MPEP 503.

New Applications Under 35 U.S.C. 111

If a new application is being filed and the application includes the necessary components for a filing date (see 37 CFR 1.53(b)-(d) and MPEP 506), a Filing Receipt (37 CFR 1.54) will be issued in due course and the date shown on this Acknowledgement Receipt will establish the filing date of the application.

National Stage of an International Application under 35 U.S.C. 371

If a timely submission to enter the national stage of an international application is compliant with the conditions of 35 U.S.C. 371 and other applicable requirements a Form PCT/DO/EO/903 indicating acceptance of the application as a national stage submission under 35 U.S.C. 371 will be issued in addition to the Filing Receipt, in due course.

New International Application Filed with the USPTO as a Receiving Office

If a new international application is being filed and the international application includes the necessary components for an international filing date (see PCT Article 11 and MPEP 1810), a Notification of the International Application Number and of the International Filing Date (Form PCT/RO/105) will be issued in due course, subject to prescriptions concerning national security, and the date shown on this Acknowledgement Receipt will establish the international filing date of the application.

IN THE UNITED STATES PATENT AND TRADEMARK OFFICE

Applicant: Ira M. Marlowe
Serial No.: 10/316,961
Filed: 12/11/2002
Title: AUDIO DEVICE INTEGRATION SYSTEM

Examiner: Kurr, Jason R.

Art Unit: 2615

MAIL STOP PETITION

Commissioner for Patents
P.O. Box 1450
Alexandria, VA 22313-1450

Sir:

Enclosed for filing in the United States Patent and Trademark Office is the following:

1. Request Under 37 C.F.R. 3.81(b) for Correction of Assignee (2 pages)
2. Request for Certificate of Correction (1 page)
3. Processing Fee Under 37 C.F.R. 1.17(i) Transmittal (1 page)
4. Transmittal (1 page)

CONDITIONAL PETITION

If any extension of time is required for the submission of the above-identified items, Applicant requests that this be considered a petition therefore. Please charge any additional charges or any other charges relating to this matter, or credit any overpayment, to the Deposit Account of the writer, **Account No. 503571.**

Respectfully submitted,



Mark E. Nikolsky
Reg. No. 48,319
McCarter & English, LLP
Four Gateway Center
100 Mulberry Street
Newark, NJ 07102-4056
Tel: (973) 639-6987
Fax: (973) 297-6624

Dated: August 19, 2008

CERTIFICATE OF ELECTRONIC FILING

I hereby certify that this correspondence is being electronically filed with the United States Patent and Trademark Office (via EFS-Web) on August 19, 2008

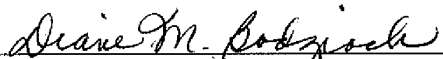

Diane M. Bodzioch

IN THE UNITED STATES PATENT AND TRADEMARK OFFICE

Applicant: Ira M. Marlowe
Serial No.: 10/316,961
Filed: 12/11/2002
Title: AUDIO DEVICE INTEGRATION SYSTEM

Examiner: Kurr, Jason R.

Art Unit: 2615

REQUEST UNDER 37 C.F.R. 3.81(b) FOR CORRECTION OF ASSIGNEE

MAIL STOP PETITION

Commissioner for Patents
P.O. Box 1450
Alexandria, VA 22313-1450

Sir:

Applicant submits this Petition under 37 C.F.R. 3.81(b) to correct the assignee information of the above-caption application.

The present application was initially assigned from the inventor Ira M. Marlowe to Blitzsafe of America, Inc., as indicated by the assignment recorded on June 18, 2003 (found on Reel 014184, Frame 0756). The application was then re-assigned back to the inventor, as indicated by the assignment recorded on September 7, 2005 (found on Reel 016502, Frame 0043). These assignments were submitted for recordation, and were recorded, well before issuance of a patent.

The Issue Fee for this application was paid on August 15, 2008. Unfortunately, the Name of Assignee section of Form PTOL-85B incorrectly listed Blitzsafe of America, Inc. as assignee. However, this section of the form should have been left blank, and no assignee should have been listed.

As required by 37 C.F.R. 3.81(b) and M.P.E.P. §307, Applicant herewith submits a request for a Certificate of Correction under 37 C.F.R. §1.323, as well as the fees required under 37 C.F.R. §§1.20(a) and 1.17(i). **Since this request is being submitted shortly after payment of the Issue Fee, Applicant believes that the United States Patent and Trademark Office should have sufficient time to correct the ribbon copy prior to issuance so that it does not recite assignee information. Accordingly, Applicant requests that the ribbon copy be printed without assignee information.**

Respectfully submitted,

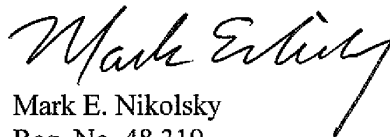

Mark E. Nikolsky
Reg. No. 48,319
McCarter & English, LLP
Four Gateway Center
100 Mulberry Street
Newark, NJ 07102-4056
Tel: (973) 639-6987
Fax: (973) 297-6624

Dated: August 19, 2008

PART B - FEE(S) TRANSMITTAL

Complete and send this form, together with applicable fee(s), to: **Mail** Mail Stop ISSUE FEE
Commissioner for Patents
P.O. Box 1450
Alexandria, Virginia 22313-1450
or Fax (571)-273-2885

INSTRUCTIONS: This form should be used for transmitting the ISSUE FEE and PUBLICATION FEE (if required). Blocks 1 through 5 should be completed where appropriate. All further correspondence including the Patent, advance orders and notification of maintenance fees will be mailed to the current correspondence address as indicated unless corrected below or directed otherwise in Block 1, by (a) specifying a new correspondence address; and/or (b) indicating a separate "FEE ADDRESS" for maintenance fee notifications.

CURRENT CORRESPONDENCE ADDRESS (Note: Use Block 1 for any change of address)

7590 07/31/2008

MICHAEL R FRISCIA
 MCCARTER & ENGLISH
 FOUR GATEWAY CENTER
 100 MULBERRY STREET
 NEWARK, NJ 07102

Note: A certificate of mailing can only be used for domestic mailings of the Fee(s) Transmittal. This certificate cannot be used for any other accompanying papers. Each additional paper, such as an assignment or formal drawing, must have its own certificate of mailing or transmission.

Certificate of Mailing or Transmission

I hereby certify that this Fee(s) Transmittal is being deposited with the United States Postal Service with sufficient postage for first class mail in an envelope addressed to the Mail Stop ISSUE FEE address above, or being facsimile transmitted to the USPTO (571) 273-2885, on the date indicated below.

Diane M. Bodzioch	(Depositor's name)
<i>Diane M. Bodzioch</i>	(Signature)
August 15, 2008	(Date)

APPLICATION NO.	FILING DATE	FIRST NAMED INVENTOR	ATTORNEY DOCKET NO.	CONFIRMATION NO.
10/316,961	12/11/2002	Ira Marlowe	9809/1	4879

TITLE OF INVENTION: AUDIO DEVICE INTEGRATION SYSTEM

APPLN. TYPE	SMALL ENTITY	ISSUE FEE DUE	PUBLICATION FEE DUE	PREV. PAID ISSUE FEE	TOTAL FEE(S) DUE	DATE DUE
nonprovisional	YES	\$720	\$0	\$0	\$720	10/31/2008

EXAMINER	ART UNIT	CLASS-SUBCLASS
KURR, JASON RICHARD	2615	381-086000

1. Change of correspondence address or indication of "Fee Address" (37 CFR 1.563).

- Change of correspondence address (or Change of Correspondence Address form PTO/SB/122) attached.
 "Fee Address" indication (or "Fee Address" Indication form PTO/SB/47; Rev 03-02 or more recent) attached. Use of a Customer Number is required.

2. For printing on the patent front page, list

- (1) the names of up to 3 registered patent attorneys or agents OR, alternatively,
 (2) the name of a single firm (having as a member a registered attorney or agent) and the names of up to 2 registered patent attorneys or agents. If no name is listed, no name will be printed.

McCarter & English, LLP

2 _____

3 _____

3. ASSIGNEE NAME AND RESIDENCE DATA TO BE PRINTED ON THE PATENT (print or type)

PLEASE NOTE: Unless an assignee is identified below, no assignee data will appear on the patent. If an assignee is identified below, the document has been filed for recordation as set forth in 37 CFR 3.11. Completion of this form is NOT a substitute for filing an assignment.

(A) NAME OF ASSIGNEE

Blitzsafe of America

(B) RESIDENCE: (CITY and STATE OR COUNTRY)

Englewood, NJ

Please check the appropriate assignee category or categories (will not be printed on the patent): Individual Corporation or other private group entity Government

4a. The following fee(s) are submitted:

- Issue Fee
 Publication Fee (No small entity discount permitted)
 Advance Order - # of Copies 5

4b. Payment of Fee(s): (Please first reapply any previously paid issue fee shown above)

- A check is enclosed.
 Payment by credit card. Form PTO-2038 is attached.
 The Director is hereby authorized to charge the required fee(s), any deficiency, or credit any overpayment, to Deposit Account Number 503571 (enclose an extra copy of this form).

5. Change in Entity Status (from status indicated above)

- a. Applicant claims SMALL ENTITY status. See 37 CFR 1.27. b. Applicant is no longer claiming SMALL ENTITY status. See 37 CFR 1.27(g)(2).

NOTE: The Issue Fee and Publication Fee (if required) will not be accepted from anyone other than the applicant; a registered attorney or agent; or the assignee or other party in interest as shown by the records of the United States Patent and Trademark Office.

Authorized Signature _____

Michael R. Friscia

Typed or printed name _____

Date August 15, 2008

Registration No. 33,884

This collection of information is required by 37 CFR 1.311. The information is required to obtain or retain a benefit by the public which is to file (and by the USPTO to process) an application. Confidentiality is governed by 35 U.S.C. 122 and 37 CFR 1.14. This collection is estimated to take 12 minutes to complete, including gathering, preparing, and submitting the completed application form to the USPTO. Time will vary depending upon the individual case. Any comments on the amount of time you require to complete this form and/or suggestions for reducing this burden, should be sent to the Chief Information Officer, U.S. Patent and Trademark Office, U.S. Department of Commerce, P.O. Box 1450, Alexandria, Virginia 22313-1450. DO NOT SEND FEES OR COMPLETED FORMS TO THIS ADDRESS. SEND TO: Commissioner for Patents, P.O. Box 1450, Alexandria, Virginia 22313-1450.

Under the Paperwork Reduction Act of 1995, no persons are required to respond to a collection of information unless it displays a valid OMB control number.

Electronic Patent Application Fee Transmittal

Application Number:	10316961			
Filing Date:	11-Dec-2002			
Title of Invention:	AUDIO DEVICE INTEGRATION SYSTEM			
First Named Inventor/Applicant Name:	Ira Marlowe			
Filer:	Michael R. Friscia/Diane Bodzioch			
Attorney Docket Number:	9809/1			
Filed as Small Entity				
Utility Filing Fees				
Description	Fee Code	Quantity	Amount	Sub-Total in USD(\$)
Basic Filing:				
Pages:				
Claims:				
Miscellaneous-Filing:				
Petition:				
Patent-Appeals-and-Interference:				
Post-Allowance-and-Post-Issuance:				
Utility Appl issue fee	2501	1	720	720
Extension-of-Time:				

Description	Fee Code	Quantity	Amount	Sub-Total in USD(\$)
Miscellaneous:				
Printed copy of patent - no color	8001	5	3	15
Total in USD (\$)				735

Electronic Acknowledgement Receipt

EFS ID:	3790713
Application Number:	10316961
International Application Number:	
Confirmation Number:	4879
Title of Invention:	AUDIO DEVICE INTEGRATION SYSTEM
First Named Inventor/Applicant Name:	Ira Marlowe
Correspondence Address:	MICHAEL R FRISCIA MCCARTER & ENGLISH FOUR GATEWAY CENTER 100 MULBERRY STREET NEWARK NJ 07102 US 9735336599 -
Filer:	Michael R. Friscia/Diane Bodzioch
Filer Authorized By:	Michael R. Friscia
Attorney Docket Number:	9809/1
Receipt Date:	15-AUG-2008
Filing Date:	11-DEC-2002
Time Stamp:	16:44:02
Application Type:	Utility under 35 USC 111(a)

Payment information:

Submitted with Payment	yes
Payment Type	Deposit Account
Payment was successfully received in RAM	\$ 735

RAM confirmation Number	1768				
Deposit Account	503571				
Authorized User					
<p>The Director of the USPTO is hereby authorized to charge indicated fees and credit any overpayment as follows:</p> <p>Charge any Additional Fees required under 37 C.F.R. Section 1.16 (National application filing, search, and examination fees)</p> <p>Charge any Additional Fees required under 37 C.F.R. Section 1.17 (Patent application and reexamination processing fees)</p> <p>Charge any Additional Fees required under 37 C.F.R. Section 1.19 (Document supply fees)</p> <p>Charge any Additional Fees required under 37 C.F.R. Section 1.20 (Post Issuance fees)</p> <p>Charge any Additional Fees required under 37 C.F.R. Section 1.21 (Miscellaneous fees and charges)</p>					
File Listing:					
Document Number	Document Description	File Name	File Size(Bytes) /Message Digest	Multi Part /.zip	Pages (if appl.)
1	Miscellaneous Incoming Letter	coverletter_001.pdf	25885	no	1
			3bb8edbe597b56d7f9db51c26f1c4b7fc3ded271		
Warnings:					
Information:					
2	Miscellaneous Incoming Letter	transmittal_001.pdf	34561	no	1
			9f470933d1c89c987983e887e3f8ac25d4030224		
Warnings:					
Information:					
3	Issue Fee Payment (PTO-85B)	PartB_001.pdf	66925	no	1
			4c57e42b5157124f537aaafe5d757b642fc5cdfa		
Warnings:					
Information:					
4	Fee Worksheet (PTO-06)	fee-info.pdf	8301	no	2
			05f01f5676fee616309fe71756708ca70ecc4a27		
Warnings:					
Information:					
Total Files Size (in bytes):			135672		

This Acknowledgement Receipt evidences receipt on the noted date by the USPTO of the indicated documents, characterized by the applicant, and including page counts, where applicable. It serves as evidence of receipt similar to a Post Card, as described in MPEP 503.

New Applications Under 35 U.S.C. 111

If a new application is being filed and the application includes the necessary components for a filing date (see 37 CFR 1.53(b)-(d) and MPEP 506), a Filing Receipt (37 CFR 1.54) will be issued in due course and the date shown on this Acknowledgement Receipt will establish the filing date of the application.

National Stage of an International Application under 35 U.S.C. 371

If a timely submission to enter the national stage of an international application is compliant with the conditions of 35 U.S.C. 371 and other applicable requirements a Form PCT/DO/EO/903 indicating acceptance of the application as a national stage submission under 35 U.S.C. 371 will be issued in addition to the Filing Receipt, in due course.

New International Application Filed with the USPTO as a Receiving Office

If a new international application is being filed and the international application includes the necessary components for an international filing date (see PCT Article 11 and MPEP 1810), a Notification of the International Application Number and of the International Filing Date (Form PCT/RO/105) will be issued in due course, subject to prescriptions concerning national security, and the date shown on this Acknowledgement Receipt will establish the international filing date of the application.

IN THE UNITED STATES PATENT AND TRADEMARK OFFICE

Applicant: Ira M. Marlowe
Serial No.: 10/316,961
Filed: 12/11/2002
Title: AUDIO DEVICE INTEGRATION SYSTEM

Examiner: Kurr, Jason R.

Art Unit: 2615

TRANSMITTAL OF PAYMENT OF ISSUE FEE (37 C.F.R. § 1.311)

Mail Stop Issue Fee
Commissioner for Patents
P.O. Box 1450
Alexandria, VA 22313-1450

Sir:

Enclosed for filing in the United States Patent and Trademark Office is the following:

1. Transmittal of Payment of Issue Fee (37 C.F.R. § 1.311)
2. Fee(s) Transmittal
3. Transmittal Sheet

CONDITIONAL PETITION

If any extension of time is required for the submission of the above-identified items, Applicant requests that this be considered a petition therefore. Please charge any additional charges or any other charges relating to this matter, or credit any overpayment, to the Deposit Account of the writer, **Account No. 503571**.

Respectfully submitted,

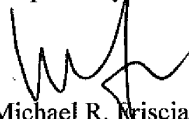

Michael R. Friscia
Reg. No. 33,884
McCarter & English, LLP
Four Gateway Center
100 Mulberry Street
Newark, NJ 07102-4056
Tel: (973) 639-8493
Fax: (973) 297-6627

Dated: August 15, 2008

CERTIFICATE OF ELECTRONIC FILING

I hereby certify that this correspondence is being electronically filed with the United States Patent and Trademark Office (via EFS-Web) on August 15, 2008.

Diane M. Bodzioch

TRANSMITTAL OF PAYMENT OF ISSUE FEE (Small Entity)
(37 C.F.R. 1.311)

Docket No.
9809/1

Applicant(s): Ira Marlowe

Application No.	Filing Date	Examiner	Customer No.	Group Art Unit	Confirmation No.
10/316,961	12/11/2002	Kurr, Jason Richard	27614	2615	4879

Invention: Audio Device Integration System

Mail Stop Issue Fee
COMMISSIONER FOR PATENTS
P.O. Box 1450
Alexandria, VA 22313-1450

Transmitted herewith are the following for the above-identified application.

- Issue Fee Transmittal Form PTOL-85
- Utility Fee: \$ 720.00 Design Fee: Plant Fee:
- Publication Fee:
- A check in the amount of is attached.
- The Director is hereby authorized to charge and credit Deposit Account No. as described below.
 - Charge the amount of \$735.00
 - Credit any overpayment.
 - Charge any additional fee required.
- Payment by credit card. Form PTO-2038 is attached.

WARNING: Information on this form may become public. Credit card information should not be included on this form. Provide credit card information and authorization on PTO-2038.

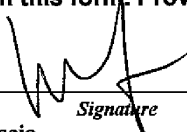

Dated: August 15, 2008

Michael R. Friscia
Registration No. 33,884
McCarter & English, LLP
Four Gateway Center
100 Mulberry Street
Newark, NJ 07102
Tel: (973) 639-8493
Fax: (973) 297-6627

CC:

Certificate of Transmission by Facsimile
This certificate may only be used if paying
by deposit account.

I certify that this document and authorization to charge account is being facsimile transmitted to the United States and Trademark Office (Fax) on _____ (Date)
_____ Signature
_____ Typed or Printed Name of Person Signing Certificate

Certificate of Mailing by First Class Mail

I hereby certify that this correspondence is being deposited with the United States Postal Service with sufficient postage as first class mail in an envelope addressed to "Mail Stop Issue Fee, Commissioner for Patents, P.O. Box 1450, Alexandria, VA 22313-1450" [37 CFR 1.8(a)] on _____ (Date)
_____ Signature of Person Mailing Correspondence
_____ Typed or Printed Name of Person Mailing Correspondence



UNITED STATES PATENT AND TRADEMARK OFFICE

UNITED STATES DEPARTMENT OF COMMERCE
United States Patent and Trademark Office
Address: COMMISSIONER FOR PATENTS
P.O. Box 1450
Alexandria, Virginia 22313-1450
www.uspto.gov

NOTICE OF ALLOWANCE AND FEE(S) DUE

7590 07/31/2008

MICHAEL R FRISCIA
MCCARTER & ENGLISH
FOUR GATEWAY CENTER
100 MULBERRY STREET
NEWARK, NJ 07102

EXAMINER

KURR, JASON RICHARD

ART UNIT PAPER NUMBER

2615

DATE MAILED: 07/31/2008

Table with 5 columns: APPLICATION NO., FILING DATE, FIRST NAMED INVENTOR, ATTORNEY DOCKET NO., CONFIRMATION NO.
10/316,961 12/11/2002 Ira Marlowe 9809/1 4879

TITLE OF INVENTION: AUDIO DEVICE INTEGRATION SYSTEM

Table with 7 columns: APPLN. TYPE, SMALL ENTITY, ISSUE FEE DUE, PUBLICATION FEE DUE, PREV. PAID ISSUE FEE, TOTAL FEE(S) DUE, DATE DUE
nonprovisional YES \$720 \$0 \$0 \$720 10/31/2008

THE APPLICATION IDENTIFIED ABOVE HAS BEEN EXAMINED AND IS ALLOWED FOR ISSUANCE AS A PATENT. PROSECUTION ON THE MERITS IS CLOSED. THIS NOTICE OF ALLOWANCE IS NOT A GRANT OF PATENT RIGHTS. THIS APPLICATION IS SUBJECT TO WITHDRAWAL FROM ISSUE AT THE INITIATIVE OF THE OFFICE OR UPON PETITION BY THE APPLICANT. SEE 37 CFR 1.313 AND MPEP 1308.

THE ISSUE FEE AND PUBLICATION FEE (IF REQUIRED) MUST BE PAID WITHIN THREE MONTHS FROM THE MAILING DATE OF THIS NOTICE OR THIS APPLICATION SHALL BE REGARDED AS ABANDONED. THIS STATUTORY PERIOD CANNOT BE EXTENDED. SEE 35 U.S.C. 151. THE ISSUE FEE DUE INDICATED ABOVE DOES NOT REFLECT A CREDIT FOR ANY PREVIOUSLY PAID ISSUE FEE IN THIS APPLICATION. IF AN ISSUE FEE HAS PREVIOUSLY BEEN PAID IN THIS APPLICATION (AS SHOWN ABOVE), THE RETURN OF PART B OF THIS FORM WILL BE CONSIDERED A REQUEST TO REAPPLY THE PREVIOUSLY PAID ISSUE FEE TOWARD THE ISSUE FEE NOW DUE.

HOW TO REPLY TO THIS NOTICE:

I. Review the SMALL ENTITY status shown above.

If the SMALL ENTITY is shown as YES, verify your current SMALL ENTITY status:

- A. If the status is the same, pay the TOTAL FEE(S) DUE shown above.
B. If the status above is to be removed, check box 5b on Part B - Fee(s) Transmittal and pay the PUBLICATION FEE (if required) and twice the amount of the ISSUE FEE shown above, or

If the SMALL ENTITY is shown as NO:

- A. Pay TOTAL FEE(S) DUE shown above, or
B. If applicant claimed SMALL ENTITY status before, or is now claiming SMALL ENTITY status, check box 5a on Part B - Fee(s) Transmittal and pay the PUBLICATION FEE (if required) and 1/2 the ISSUE FEE shown above.

II. PART B - FEE(S) TRANSMITTAL, or its equivalent, must be completed and returned to the United States Patent and Trademark Office (USPTO) with your ISSUE FEE and PUBLICATION FEE (if required). If you are charging the fee(s) to your deposit account, section "4b" of Part B - Fee(s) Transmittal should be completed and an extra copy of the form should be submitted. If an equivalent of Part B is filed, a request to reapply a previously paid issue fee must be clearly made, and delays in processing may occur due to the difficulty in recognizing the paper as an equivalent of Part B.

III. All communications regarding this application must give the application number. Please direct all communications prior to issuance to Mail Stop ISSUE FEE unless advised to the contrary.

IMPORTANT REMINDER: Utility patents issuing on applications filed on or after Dec. 12, 1980 may require payment of maintenance fees. It is patentee's responsibility to ensure timely payment of maintenance fees when due.

PART B - FEE(S) TRANSMITTAL

**Complete and send this form, together with applicable fee(s), to: Mail Mail Stop ISSUE FEE
 Commissioner for Patents
 P.O. Box 1450
 Alexandria, Virginia 22313-1450
 or Fax (571)-273-2885**

INSTRUCTIONS: This form should be used for transmitting the ISSUE FEE and PUBLICATION FEE (if required). Blocks 1 through 5 should be completed where appropriate. All further correspondence including the Patent, advance orders and notification of maintenance fees will be mailed to the current correspondence address as indicated unless corrected below or directed otherwise in Block 1, by (a) specifying a new correspondence address; and/or (b) indicating a separate "FEE ADDRESS" for maintenance fee notifications.

CURRENT CORRESPONDENCE ADDRESS (Note: Use Block 1 for any change of address)

Note: A certificate of mailing can only be used for domestic mailings of the Fee(s) Transmittal. This certificate cannot be used for any other accompanying papers. Each additional paper, such as an assignment or formal drawing, must have its own certificate of mailing or transmission.

7590 07/31/2008

MICHAEL R FRISCIA
 MCCARTER & ENGLISH
 FOUR GATEWAY CENTER
 100 MULBERRY STREET
 NEWARK, NJ 07102

Certificate of Mailing or Transmission

I hereby certify that this Fee(s) Transmittal is being deposited with the United States Postal Service with sufficient postage for first class mail in an envelope addressed to the Mail Stop ISSUE FEE address above, or being facsimile transmitted to the USPTO (571) 273-2885, on the date indicated below.

_____ (Depositor's name)
_____ (Signature)
_____ (Date)

APPLICATION NO.	FILING DATE	FIRST NAMED INVENTOR	ATTORNEY DOCKET NO.	CONFIRMATION NO.
10/316,961	12/11/2002	Ira Marlowe	9809/1	4879

TITLE OF INVENTION: AUDIO DEVICE INTEGRATION SYSTEM

APPLN. TYPE	SMALL ENTITY	ISSUE FEE DUE	PUBLICATION FEE DUE	PREV. PAID ISSUE FEE	TOTAL FEE(S) DUE	DATE DUE
nonprovisional	YES	\$720	\$0	\$0	\$720	10/31/2008

EXAMINER	ART UNIT	CLASS-SUBCLASS
KURR, JASON RICHARD	2615	381-086000

<p>1. Change of correspondence address or indication of "Fee Address" (37 CFR 1.363).</p> <p><input type="checkbox"/> Change of correspondence address (or Change of Correspondence Address form PTO/SB/122) attached.</p> <p><input type="checkbox"/> "Fee Address" indication (or "Fee Address" Indication form PTO/SB/47; Rev 03-02 or more recent) attached. Use of a Customer Number is required.</p>	<p>2. For printing on the patent front page, list</p> <p>(1) the names of up to 3 registered patent attorneys or agents OR, alternatively, 1 _____</p> <p>(2) the name of a single firm (having as a member a registered attorney or agent) and the names of up to 2 registered patent attorneys or agents. If no name is listed, no name will be printed. 2 _____</p> <p>3 _____</p>
---	---

3. ASSIGNEE NAME AND RESIDENCE DATA TO BE PRINTED ON THE PATENT (print or type)

PLEASE NOTE: Unless an assignee is identified below, no assignee data will appear on the patent. If an assignee is identified below, the document has been filed for recordation as set forth in 37 CFR 3.11. Completion of this form is NOT a substitute for filing an assignment.

(A) NAME OF ASSIGNEE _____ (B) RESIDENCE: (CITY and STATE OR COUNTRY) _____

Please check the appropriate assignee category or categories (will not be printed on the patent): Individual Corporation or other private group entity Government

<p>4a. The following fee(s) are submitted:</p> <p><input type="checkbox"/> Issue Fee</p> <p><input type="checkbox"/> Publication Fee (No small entity discount permitted)</p> <p><input type="checkbox"/> Advance Order - # of Copies _____</p>	<p>4b. Payment of Fee(s): (Please first reapply any previously paid issue fee shown above)</p> <p><input type="checkbox"/> A check is enclosed.</p> <p><input type="checkbox"/> Payment by credit card. Form PTO-2038 is attached.</p> <p><input type="checkbox"/> The Director is hereby authorized to charge the required fee(s), any deficiency, or credit any overpayment, to Deposit Account Number _____ (enclose an extra copy of this form).</p>
---	--

5. Change in Entity Status (from status indicated above)

a. Applicant claims SMALL ENTITY status. See 37 CFR 1.27. b. Applicant is no longer claiming SMALL ENTITY status. See 37 CFR 1.27(g)(2).

NOTE: The Issue Fee and Publication Fee (if required) will not be accepted from anyone other than the applicant; a registered attorney or agent; or the assignee or other party in interest as shown by the records of the United States Patent and Trademark Office.

Authorized Signature _____ Date _____

Typed or printed name _____ Registration No. _____

This collection of information is required by 37 CFR 1.311. The information is required to obtain or retain a benefit by the public which is to file (and by the USPTO to process) an application. Confidentiality is governed by 35 U.S.C. 122 and 37 CFR 1.14. This collection is estimated to take 12 minutes to complete, including gathering, preparing, and submitting the completed application form to the USPTO. Time will vary depending upon the individual case. Any comments on the amount of time you require to complete this form and/or suggestions for reducing this burden, should be sent to the Chief Information Officer, U.S. Patent and Trademark Office, U.S. Department of Commerce, P.O. Box 1450, Alexandria, Virginia 22313-1450. DO NOT SEND FEES OR COMPLETED FORMS TO THIS ADDRESS. SEND TO: Commissioner for Patents, P.O. Box 1450, Alexandria, Virginia 22313-1450.

Under the Paperwork Reduction Act of 1995, no persons are required to respond to a collection of information unless it displays a valid OMB control number.



UNITED STATES PATENT AND TRADEMARK OFFICE

UNITED STATES DEPARTMENT OF COMMERCE
United States Patent and Trademark Office
Address: COMMISSIONER FOR PATENTS
P.O. Box 1450
Alexandria, Virginia 22313-1450
www.uspto.gov

Table with 5 columns: APPLICATION NO., FILING DATE, FIRST NAMED INVENTOR, ATTORNEY DOCKET NO., CONFIRMATION NO.
Row 1: 10/316,961, 12/11/2002, Ira Marlowe, 9809/1, 4879
Row 2: 7590, 07/31/2008, [Empty], [Empty], [Empty]
Text: MICHAEL R FRISCIA, MCCARTER & ENGLISH, FOUR GATEWAY CENTER, 100 MULBERRY STREET, NEWARK, NJ 07102
Text: EXAMINER: KURR, JASON RICHARD
Text: ART UNIT: 2615, PAPER NUMBER: [Empty]
Text: DATE MAILED: 07/31/2008

Determination of Patent Term Adjustment under 35 U.S.C. 154 (b)
(application filed on or after May 29, 2000)

The Patent Term Adjustment to date is 820 day(s). If the issue fee is paid on the date that is three months after the mailing date of this notice and the patent issues on the Tuesday before the date that is 28 weeks (six and a half months) after the mailing date of this notice, the Patent Term Adjustment will be 820 day(s).

If a Continued Prosecution Application (CPA) was filed in the above-identified application, the filing date that determines Patent Term Adjustment is the filing date of the most recent CPA.

Applicant will be able to obtain more detailed information by accessing the Patent Application Information Retrieval (PAIR) WEB site (http://pair.uspto.gov).

Any questions regarding the Patent Term Extension or Adjustment determination should be directed to the Office of Patent Legal Administration at (571)-272-7702. Questions relating to issue and publication fee payments should be directed to the Customer Service Center of the Office of Patent Publication at 1-(888)-786-0101 or (571)-272-4200.

Notice of Allowability	Application No.	Applicant(s)	
	10/316,961	MARLOWE, IRA	
	Examiner	Art Unit	
	JASON R. KURR	2615	

-- The MAILING DATE of this communication appears on the cover sheet with the correspondence address--

All claims being allowable, PROSECUTION ON THE MERITS IS (OR REMAINS) CLOSED in this application. If not included herewith (or previously mailed), a Notice of Allowance (PTOL-85) or other appropriate communication will be mailed in due course. **THIS NOTICE OF ALLOWABILITY IS NOT A GRANT OF PATENT RIGHTS.** This application is subject to withdrawal from issue at the initiative of the Office or upon petition by the applicant. See 37 CFR 1.313 and MPEP 1308.

1. This communication is responsive to Applicant request for continued examination dated April 21, 2008.
2. The allowed claim(s) is/are 1-13,15-38,40-57,59-65,67-74 and 76-104.
3. Acknowledgment is made of a claim for foreign priority under 35 U.S.C. § 119(a)-(d) or (f).
 - a) All b) Some* c) None of the:
 1. Certified copies of the priority documents have been received.
 2. Certified copies of the priority documents have been received in Application No. _____ .
 3. Copies of the certified copies of the priority documents have been received in this national stage application from the International Bureau (PCT Rule 17.2(a)).

* Certified copies not received: _____.

Applicant has THREE MONTHS FROM THE "MAILING DATE" of this communication to file a reply complying with the requirements noted below. Failure to timely comply will result in ABANDONMENT of this application.
THIS THREE-MONTH PERIOD IS NOT EXTENDABLE.

4. A SUBSTITUTE OATH OR DECLARATION must be submitted. Note the attached EXAMINER'S AMENDMENT or NOTICE OF INFORMAL PATENT APPLICATION (PTO-152) which gives reason(s) why the oath or declaration is deficient.
5. CORRECTED DRAWINGS (as "replacement sheets") must be submitted.
 - (a) including changes required by the Notice of Draftsperson's Patent Drawing Review (PTO-948) attached
 - 1) hereto or 2) to Paper No./Mail Date _____.
 - (b) including changes required by the attached Examiner's Amendment / Comment or in the Office action of Paper No./Mail Date _____.

Identifying indicia such as the application number (see 37 CFR 1.84(c)) should be written on the drawings in the front (not the back) of each sheet. Replacement sheet(s) should be labeled as such in the header according to 37 CFR 1.121(d).
6. DEPOSIT OF and/or INFORMATION about the deposit of BIOLOGICAL MATERIAL must be submitted. Note the attached Examiner's comment regarding REQUIREMENT FOR THE DEPOSIT OF BIOLOGICAL MATERIAL.

Attachment(s)

- | | |
|--|---|
| <ol style="list-style-type: none"> 1. <input type="checkbox"/> Notice of References Cited (PTO-892) 2. <input type="checkbox"/> Notice of Draftsperson's Patent Drawing Review (PTO-948) 3. <input checked="" type="checkbox"/> Information Disclosure Statements (PTO/SB/08),
Paper No./Mail Date _____ 4. <input type="checkbox"/> Examiner's Comment Regarding Requirement for Deposit of Biological Material | <ol style="list-style-type: none"> 5. <input type="checkbox"/> Notice of Informal Patent Application 6. <input type="checkbox"/> Interview Summary (PTO-413),
Paper No./Mail Date _____ . 7. <input type="checkbox"/> Examiner's Amendment/Comment 8. <input checked="" type="checkbox"/> Examiner's Statement of Reasons for Allowance 9. <input type="checkbox"/> Other _____. |
|--|---|

Continued Examination Under 37 CFR 1.114

A request for continued examination under 37 CFR 1.114, including the fee set forth in 37 CFR 1.17(e), was filed in this application after final rejection. Since this application is eligible for continued examination under 37 CFR 1.114, and the fee set forth in 37 CFR 1.17(e) has been timely paid, the finality of the previous Office action has been withdrawn pursuant to 37 CFR 1.114. Applicant's submission filed on April 21, 2008 has been entered.

Allowable Subject Matter

Claims 1-13, 15-38, 40-57, 59-65, 67-74 and 76-104 are allowed. For the purposes of allowance, the original numbering of the claims has been changed.

The following is an examiner's statement of reasons for allowance:

The general concept of interfacing auxiliary after-market devices with a car stereo was known in the art at the time of the invention as evidenced by Owens et al (US 2002/0084910 A1) and Beckert et al (US 6,175,789 B1). However, the Examiner has not found prior art that teaches or suggests an interface unit containing a pre-programmed microcontroller that allows for the communication of incompatible audio devices as presented in the independent claims 1, 24, 30, 42, 55, 63 and 72. The Examiner has not found prior art that teaches or suggests an interface unit that includes a microcontroller pre-programmed to execute a code portion for generating and transmitting a device presence signal to a car stereo to maintain the stereo in an operational state responsive to signals from an after-market device as presented in the

independent claims 47, 81, 83, 104. Other prior art has been cited herein regarding the interfacing of audio devices with car stereos, however the other prior art of record also fails to teach or provide suggestion to arrive the combination of the elements and steps presented in the independent claims, again when said elements or steps are collectively considered in regards to each claim. For at least the reasons listed above, the dependent claims are also allowed in view of their respective dependencies upon the independent claims.

Any comments considered necessary by applicant must be submitted no later than the payment of the issue fee and, to avoid processing delays, should preferably accompany the issue fee. Such submissions should be clearly labeled "Comments on Statement of Reasons for Allowance."

Any inquiry concerning this communication or earlier communications from the examiner should be directed to JASON R. KURR whose telephone number is (571)272-0552. The examiner can normally be reached on M-F 10:00am to 6:30pm.

If attempts to reach the examiner by telephone are unsuccessful, the examiner's supervisor, Vivian Chin can be reached on (571) 273-7848. The fax phone number for the organization where this application or proceeding is assigned is 571-273-8300.

Information regarding the status of an application may be obtained from the Patent Application Information Retrieval (PAIR) system. Status information for published applications may be obtained from either Private PAIR or Public PAIR. Status information for unpublished applications is available through Private PAIR only. For more information about the PAIR system, see <http://pair-direct.uspto.gov>. Should you have questions on access to the Private PAIR system, contact the Electronic Business Center (EBC) at 866-217-9197 (toll-free). If you would like assistance from a USPTO Customer Service Representative or access to the automated information system, call 800-786-9199 (IN USA OR CANADA) or 571-272-1000.

/Jason R Kurr/
Examiner, Art Unit 2615

/Vivian Chin/
Supervisory Patent Examiner, Art Unit 2615

EAST Search History

Ref #	Hits	Search Query	DBs	Default Operator	Plurals	Time Stamp
L1	497	340/825.24-825.25.ccls.	US-PGPUB; USPAT	OR	OFF	2008/07/06 20:37
L2	312	l1 and ((@ad @rlad) <="20021211")	US-PGPUB; USPAT	OR	OFF	2008/07/06 20:37
L3	557	710/303,304.ccls.	US-PGPUB; USPAT	OR	OFF	2008/07/06 20:49
L4	372	l3 and ((@ad @rlad) <="20021211")	US-PGPUB; USPAT	OR	OFF	2008/07/06 20:49
L5	17	l4 and (car vehicle automobile) and (stereo radio)	US-PGPUB; USPAT	OR	OFF	2008/07/06 20:50
L6	14	("6608399").URPN.	USPAT	OR	OFF	2008/07/06 21:09
L7	14	("3756677" "4058357" "5154617" "5195183" "5339362" "5457629" "5581130" "5650929" "5978821" "5990573" "6086129" "6445082" "6469404" "6472770").PN.	US-PGPUB; USPAT; USOCR	OR	OFF	2008/07/06 21:10
L37	557	710/303,304.ccls.	US-PGPUB; USPAT	OR	OFF	2008/07/06 21:36
L38	3	l37 and (presence near signal)	US-PGPUB; USPAT	OR	OFF	2008/07/06 21:36
L39	16572	(hot dock\$3).ti.	US-PGPUB; USPAT	OR	OFF	2008/07/06 22:22
L40	15	(hot near dock\$3).ti.	US-PGPUB; USPAT	OR	OFF	2008/07/06 22:23
L41	895	(presence near signal) with (responsive operational)	US-PGPUB; USPAT	OR	ON	2008/07/06 22:32
L42	15	(presence near signal) with ((responsive operational) near state)	US-PGPUB; USPAT	OR	ON	2008/07/06 22:33
L43	118	OEM with (stereo radio)	US-PGPUB; USPAT	OR	ON	2008/07/06 22:41
L44	55	l43 and (auxiliary (after near market) aftermarket)	US-PGPUB; USPAT	OR	ON	2008/07/06 22:42
L45	391	marlowe.in.	US-PGPUB; USPAT	OR	ON	2008/07/06 22:42
L46	359	marlow.in.	US-PGPUB; USPAT	OR	ON	2008/07/06 22:43

L47	750	I45 I46	US-PGPUB; USPAT	OR	ON	2008/07/06 22:43
L48	48	I44 not I47	US-PGPUB; USPAT	OR	ON	2008/07/06 22:43
L49	19	I48 and ((@ad @rlad) <= "20021211")	US-PGPUB; USPAT	OR	OFF	2008/07/06 22:43
L50	202	((disc disk) near changer).ti.	US-PGPUB; USPAT	OR	OFF	2008/07/06 22:51
L51	35	I50 and (vehicle car automobile)	US-PGPUB; USPAT	OR	OFF	2008/07/06 22:51
L52	0	I51 and ((poll status presence) near signal)	US-PGPUB; USPAT	OR	OFF	2008/07/06 22:52
L53	4	I51 and (poll status presence)	US-PGPUB; USPAT	OR	OFF	2008/07/06 22:52
S146	760	381/86.ccls.	US-PGPUB; USPAT	OR	OFF	2008/05/22 14:36
S147	201	S146 and (interfac\$3 compatib\$5)	US-PGPUB; USPAT	OR	OFF	2008/05/22 14:37
S148	6	(ira near marlowe).in.	US-PGPUB; USPAT	OR	OFF	2008/05/22 14:38
S149	489	340/825.24,825.25.ccls.	US-PGPUB; USPAT	OR	OFF	2008/05/22 14:40
S150	22	("4068175" "4207511" "4365280" "4477764" "4481512" "4497038" "4868715" "4895326" "4911386" "5060229" "5104071" "5143343" "5198696" "5316868" "5424709" "5488283" "5569997" "5610376" "5641953" "5794164" "5859628" "6009363").PN.	US-PGPUB; USPAT; USOCR	OR	OFF	2008/05/22 14:44
S151	3484	307/9.1,10.1.ccls.	US-PGPUB; USPAT; USOCR	OR	OFF	2008/05/22 15:00
S152	2337	S151 and ((@ad @rlad) <= "20021211")	US-PGPUB; USPAT	OR	OFF	2008/05/22 15:00
S153	1447	700/94.ccls.	US-PGPUB; USPAT	OR	OFF	2008/05/22 15:33
S154	220	S153 and (car vehicle automobile)	US-PGPUB; USPAT	OR	OFF	2008/05/22 15:33
S155	130	S154 and ((@ad @rlad) <= "20021211")	US-PGPUB; USPAT	OR	OFF	2008/05/22 15:33
S156	1728	701/36.ccls.	US-PGPUB; USPAT	OR	OFF	2008/05/22 15:40
S157	742	455/345,346.ccls.	US-PGPUB; USPAT	OR	OFF	2008/05/22 16:03

S158	61128	audio and (car vehicle automobile)	US-PGPUB; USPAT	OR	ON	2008/05/22 16:04
S159	1057	S158 and (presence near signal)	US-PGPUB; USPAT	OR	ON	2008/05/22 16:04
S160	839	S159 and ((@ad @rlad) <= "20021211")	US-PGPUB; USPAT	OR	OFF	2008/05/22 16:04
S161	524	S160 and interfac\$3	US-PGPUB; USPAT	OR	OFF	2008/05/22 16:05
S162	82	S158 and ((presence near signal) with (respons\$4))	US-PGPUB; USPAT	OR	ON	2008/05/22 16:11
S163	72	S162 and ((@ad @rlad) <= "20021211")	US-PGPUB; USPAT	OR	OFF	2008/05/22 16:11

7/6/2008 11:21:58 PM

C:\Documents and Settings\jkurr\My Documents\EAST\Workspaces\10316961.wsp

Application Number 	Application/Control No. 10/316,961	Applicant(s)/Patent under Reexamination MARLOWE, IRA	
	Examiner JASON R. KURR	Art Unit 2615	

Search Notes



Application/Control No.

10/316,961

Applicant(s)/Patent under Reexamination

MARLOWE, IRA

Examiner

JASON R. KURR

Art Unit

2615

SEARCHED

Class	Subclass	Date	Examiner
381	86	5/24/2006	JK
307	9.1,10.1	10/4/2006	JK
340	825.25	10/4/2006	JK
307	10.1	3/7/2007	JK
Update	Above	7/7/2007	JK
340	825.24	1/8/2008	JK
700	94	1/8/2008	JK
455	345,346	1/23/2008	JK
Updated	Above	5/22/2008	JK
701	36	5/22/2008	JK
710	303,304	7/6/2008	JK

INTERFERENCE SEARCHED

Class	Subclass	Date	Examiner
See	Above	7/6/2008	JK

**SEARCH NOTES
(INCLUDING SEARCH STRATEGY)**

	DATE	EXMR
Searched, car stereo's and interfacing with auxiliary audio devices	5/24/2006	JK
Searched (digital audio broadcasting) DAB	5/29/2006	JK
Searched: mp3 players, interfacing, DAB digital audio broadcasts, satellite radio	11/7/2006	JK
Searched new IDS (2/16/07) and continuation applications	3/7/2007	JK
Searched (format conversions) w/ control and auxiliary units or after market units	1/23/2008	JK
Consulted: Dan Sellers + Andrew Flanders 700/94 Ping Lee , Xu Mei, suggested 455/3.06,345,346 and 710 docking stations	1/8/2008	JK
Updated class search Searched: online "internet", crutchfield mag., audiophile mag.	5/22/2008	JK
Inventor search: Ira Marlow Consulted: SPE Mark Reinhart class 710	7/6/2008	JK

Issue Classification 	Application/Control No.	Applicant(s)/Patent under Reexamination	
	10/316,961	MARLOWE, IRA	
	Examiner	Art Unit	
	JASON R. KURR	2615	

ISSUE CLASSIFICATION											
ORIGINAL					CROSS REFERENCE(S)						
CLASS		SUBCLASS			CLASS	SUBCLASS (ONE SUBCLASS PER BLOCK)					
381		86			340	825.24					
INTERNATIONAL CLASSIFICATION					700	94					
H	0	4	B	1/00							
				/							
				/							
				/							
				/							
/Jason Kurr (5/22/2008)/ (Assistant Examiner) (Date)					/Vivian Chin/ 7/07/08 (Primary Examiner) (Date)					Total Claims Allowed: 99	
(Legal Instruments Examiner) (Date)										O.G. Print Claim(s)	O.G. Print Fig.
										1	1

<input type="checkbox"/> Claims renumbered in the same order as presented by applicant		<input type="checkbox"/> CPA		<input type="checkbox"/> T.D.		<input type="checkbox"/> R.1.47							
Final	Original	Final	Original	Final	Original	Final	Original						
1	1	34	31	62	61	32	91		121		151		181
2	2	35	32	63	62	64	92		122		152		182
3	3	36	33	66	63	65	93		123		153		183
4	4	37	34	67	64	74	94		124		154		184
5	5	38	35	68	65	75	95		125		155		185
6	6	39	36		66	84	96		126		156		186
7	7	40	37	69	67	85	97		127		157		187
8	8	41	38	70	68	88	98		128		158		188
9	9		39	71	69	89	99		129		159		189
10	10	42	40	72	70	97	100		130		160		190
11	11	43	41	73	71	98	101		131		161		191
12	12	44	42	76	72	90	102		132		162		192
13	13	45	43	77	73	91	103		133		163		193
	14	47	44	78	74	99	104		134		164		194
14	15	48	45		75		105		135		165		195
15	16	46	46	79	76		106		136		166		196
16	17	49	47	80	77		107		137		167		197
17	18	50	48	81	78		108		138		168		198
18	19	51	49	82	79		109		139		169		199
19	20	52	50	83	80		110		140		170		200
20	21	53	51	86	81		111		141		171		201
21	22	54	52	87	82		112		142		172		202
22	23	55	53	92	83		113		143		173		203
25	24	56	54	93	84		114		144		174		204
26	25	57	55	94	85		115		145		175		205
27	26	58	56	95	86		116		146		176		206
28	27	59	57	96	87		117		147		177		207
29	28		58	23	88		118		148		178		208
30	29	60	59	24	89		119		149		179		209
33	30	61	60	31	90		120		150		180		210



UNITED STATES PATENT AND TRADEMARK OFFICE

UNITED STATES DEPARTMENT OF COMMERCE
 United States Patent and Trademark Office
 Address: COMMISSIONER FOR PATENTS
 P.O. Box 1450
 Alexandria, Virginia 22313-1450
 www.uspto.gov

BIB DATA SHEET

CONFIRMATION NO. 4879

SERIAL NUMBER 10/316,961	FILING or 371(c) DATE 12/11/2002 RULE	CLASS 381	GROUP ART UNIT 2615	ATTORNEY DOCKET NO. 9809/1		
APPLICANTS Ira Marlowe, Fort Lee, NJ;						
** CONTINUING DATA *****						
** FOREIGN APPLICATIONS *****						
** IF REQUIRED, FOREIGN FILING LICENSE GRANTED ** ** SMALL ENTITY ** 01/17/2003						
Foreign Priority claimed <input type="checkbox"/> Yes <input checked="" type="checkbox"/> No	35 USC 119(a-d) conditions met <input type="checkbox"/> Yes <input checked="" type="checkbox"/> No	<input type="checkbox"/> Met after Allowance	STATE OR COUNTRY NJ	SHEETS DRAWINGS 21	TOTAL CLAIMS 54	INDEPENDENT CLAIMS 5
Verified and Acknowledged	/JASON RICHARD KURR/ Examiner's Signature	Initials				
ADDRESS MICHAEL R FRISCIA MCCARTER & ENGLISH FOUR GATEWAY CENTER 100 MULBERRY STREET NEWARK, NJ 07102 UNITED STATES						
TITLE Audio device integration system						
FILING FEE RECEIVED 2805	FEES: Authority has been given in Paper No. _____ to charge/credit DEPOSIT ACCOUNT No. _____ for following:		<input type="checkbox"/> All Fees <input type="checkbox"/> 1.16 Fees (Filing) <input type="checkbox"/> 1.17 Fees (Processing Ext. of time) <input type="checkbox"/> 1.18 Fees (Issue) <input type="checkbox"/> Other _____ <input type="checkbox"/> Credit			

Under the Paperwork Reduction Act of 1995, no persons are required to respond to a collection of information unless it contains a valid OMB control number.

Substitute for form 1449/PTO		Complete if Known	
INFORMATION DISCLOSURE STATEMENT BY APPLICANT <i>(Use as many sheets as necessary)</i>		Application Number	10/316,961
		Filing Date	12/11/2002
		First Named Inventor	Ira Marlowe
		Art Unit	2615
		Examiner Name	Kurr, Jason R.
Sheet 1 of 3	Attorney Docket Number	99879-00005	

U. S. PATENT DOCUMENTS						
Examiner Initials*	Cite No. ¹	Document Number		Publication Date MM-DD-YYYY	Name of Patentee or Applicant of Cited Document	Pages, Columns, Lines, Where Relevant Passages or Relevant Figures Appear
		Number-Kind Code ² (if known)				
/JK/	1	US-	6,529,804	03/04/2003	Draggon, et al.	
/JK/	2	US-	6,058,319	05/02/2000	Sadler	
/JK/	3	US-	6,052,603	04/18/2000	Kinzalow, et al.	
/JK/	4	US-	5,794,164	08/11/1998	Beckert, et al.	
/JK/	5	US-	2004/0145457	07/29/2004	Schofield, et al.	
/JK/	6	US-	2004/0266336	12/30/2004	Patsiakos, et al.	
/JK/	7	US-	2002/0197954	12/26/2002	Schmitt, et al.	
/JK/	8	US-	2004/0151327	08/05/2004	Marlowe	
/JK/	9	US-	2005/0239434	10/27/2005	Marlowe	
/JK/	10	US-	2007/0015486	01/18/2007	Marlowe	
/JK/	11	US-	2007/0293183	12/20/2007	Marlowe	
		US-				
		US-				
		US-				
		US-				
		US-				
		US-				
		US-				
		US-				

FOREIGN PATENT DOCUMENTS							
Examiner Initials*	Cite No. ¹	Foreign Patent Document		Publication Date MM-DD-YYYY	Name of Patentee or Applicant of Cited Document	Pages, Columns, Lines, Where Relevant Passages Or Relevant Figures Appear	T ⁶
		Country Code ³ - Number ⁴ - Kind Code ⁵ (if known)					
/JK/	12	WO	2008/002954	01/03/2008	Ira Marlowe		
/JK/	13	WO	2006/094281	09/08/2006	Ira Marlowe		
/JK/	14	WO	2004/053722	06/24/2004	BlitzSafe of America, Inc		
/JK/	15	KR	1020010035788 English Abstract	05/07/2001	Gyu Jin Park		
/JK/	16	KR	1020010059192 English Abstract	07/06/2001	Hyundai Motor Company		

Examiner Signature	/Jason Kurr/	Date Considered	05/22/2008
--------------------	--------------	-----------------	------------

*EXAMINER: Initial if reference considered, whether or not citation is in conformance with MPEP 609. Draw line through citation if not in conformance and not considered. Include copy of this form with next communication to applicant. ¹ Applicant's unique citation designation number (optional). ² See Kinds Codes of USPTO Patent Documents at www.uspto.gov or MPEP 901.04. ³ Enter Office that issued the document, by the two-letter code (WIPO Standard ST.3). ⁴ For Japanese patent documents, the indication of the year of the reign of the Emperor must precede the serial number of the patent document. ⁵ Kind of document by the appropriate symbols as indicated on the document under WIPO Standard ST.16 if possible. ⁶ Applicant is to place a check mark here if English language translation is attached.

This collection of information is required by 37 CFR 1.97 and 1.98. The information is required to obtain or retain a benefit by the public which is to file (and by the USPTO to process) an application. Confidentiality is governed by 35 U.S.C. 122 and 37 CFR 1.14. This collection is estimated to take 2 hours to complete, including gathering, preparing, and submitting the completed application form to the USPTO. Time will vary depending upon the individual case. Any comments on the amount of time you require to complete this form and/or suggestions for reducing this burden, should be sent to the Chief Information Officer, U.S. Patent and Trademark Office, P.O. Box 1450, Alexandria, VA 22313-1450. DO NOT SEND FEES OR COMPLETED FORMS TO THIS ADDRESS. SEND TO: Commissioner for Patents, P.O. Box 1450, Alexandria, VA 22313-1450.

If you need assistance in completing the form, call 1-800-PTO-9199 (1-800-786-9199) and select option 2.

Under the Paperwork Reduction Act of 1995, no persons are required to respond to a collection of information unless it contains a valid OMB control number.

Substitute for form 1449/PTO INFORMATION DISCLOSURE STATEMENT BY APPLICANT (Use as many sheets as necessary)		<i>Complete if Known</i>			
		Application Number	10/316,961		
		Filing Date	12/11/2002		
		First Named Inventor	Ira Marlowe		
		Art Unit	2615		
		Examiner Name	Kurr, Jason R.		
Sheet	2	of	3	Attorney Docket Number	99879-00005

NON PATENT LITERATURE DOCUMENTS			
Examiner Initials*	Cite No. ¹	Include name of the author (in CAPITAL LETTERS), title of the article (when appropriate), title of the item (book, magazine, journal, serial, symposium, catalog, etc.), date, page(s), volume-issue number(s), publisher, city and/or country where published.	T ²
/JK/	17	Copy of Office Action dated August 8, 2006, from co-pending Application Serial No.: 10/732,909 (29 pages)	
/JK/	18	Copy of Interview Summary dated December 15, 2006, from co-pending Application Serial No.: 10/732,909 (3 pages)	
/JK/	19	Copy of Interview Summary dated January 3, 2007, from co-pending Application Serial No.: 10/732,909 (3 pages)	
/JK/	20	Copy of Office Action dated April 20, 2007, from co-pending Application Serial No.: 10/732,909 (20 pages)	
/JK/	21	Copy of Office Action dated October 3, 2007, from co-pending Application Serial No.: 10/732,909 (28 pages)	
/JK/	22	Copy of Interview Summary dated October 26, 2007, from co-pending Application Serial No.: 10/732,909 (3 pages)	
/JK/	23	International Search Report of the International Searching Authority mailed May 12, 2004, issued in connection with International Patent Appln. No. PCT/US03/39493 (4 pages)	
/JK/	24	International Search Report of the International Searching Authority mailed Sept. 24, 2007, issued in connection with International Patent Appln. No. PCT/US06/008043 (4 pages)	
/JK/	25	Written Opinion of the International Searching Authority mailed Sept. 24, 2007, issued in connection with International Patent Appln. No. PCT/US06/008043 (5 pages)	
/JK/	26	International Preliminary Report on Patentability issued Oct. 16, 2007, issued in connection with International Patent Appln. No. PCT/US06/008043 (1 page)	

Examiner Signature	/Jason Kurr/	Date Considered	07/29/2008
--------------------	--------------	-----------------	------------

*EXAMINER: Initial if reference considered, whether or not citation is in conformance with MPEP 609. Draw line through citation if not in conformance and not considered. Include copy of this form with next communication to applicant.
 1 Applicant's unique citation designation number (optional). 2 Applicant is to place a check mark here if English language Translation is attached.
 This collection of information is required by 37 CFR 1.98. The information is required to obtain or retain a benefit by the public which is to file (and by the USPTO to process) an application. Confidentiality is governed by 35 U.S.C. 122 and 37 CFR 1.14. This collection is estimated to take 2 hours to complete, including gathering, preparing, and submitting the completed application form to the USPTO. Time will vary depending upon the individual case. Any comments on the amount of time you require to complete this form and/or suggestions for reducing this burden, should be sent to the Chief Information Officer, U.S. Patent and Trademark Office, P.O. Box 1450, Alexandria, VA 22313-1450. DO NOT SEND FEES OR COMPLETED FORMS TO THIS ADDRESS. SEND TO: Commissioner for Patents, P.O. Box 1450, Alexandria, VA 22313-1450.

If you need assistance in completing the form, call 1-800-PTO-9199 (1-800-786-9199) and select option 2.

Under the Paperwork Reduction Act of 1995, no persons are required to respond to a collection of information unless it contains a valid OMB control number.

Substitute for form 1449/PTO INFORMATION DISCLOSURE STATEMENT BY APPLICANT (Use as many sheets as necessary)		Complete if Known	
		Application Number	10/316,961
		Filing Date	12/11/2002
		First Named Inventor	Ira Marlowe
		Art Unit	2615
		Examiner Name	Kurr, Jason R.
Sheet 3	of 3	Attorney Docket Number	99879-00005

NON PATENT LITERATURE DOCUMENTS			
Examiner Initials*	Cite No. ¹	Include name of the author (in CAPITAL LETTERS), title of the article (when appropriate), title of the item (book, magazine, journal, serial, symposium, catalog, etc.), date, page(s), volume-issue number(s), publisher, city and/or country where published.	T ²
/JK/	27	Russian Official Action with translation, issued by the Patent Office of the Russian Federation on Dec. 24, 2007, in connection with Russian App. No. 2006101060 (21 pages)	
/JK/	28	Written Opinion, mailed by the Australian Patent Office on Aug. 28, 2007, in connection with Singapore App. No. 200601303-1 (6 pages)	

Examiner Signature	/Jason Kurr/	Date Considered	07/29/2008
--------------------	--------------	-----------------	------------

*EXAMINER: Initial if reference considered, whether or not citation is in conformance with MPEP 609. Draw line through citation if not in conformance and not considered. Include copy of this form with next communication to applicant.
 1 Applicant's unique citation designation number (optional). 2 Applicant is to place a check mark here if English language Translation is attached.
 This collection of information is required by 37 CFR 1.98. The information is required to obtain or retain a benefit by the public which is to file (and by the USPTO to process) an application. Confidentiality is governed by 35 U.S.C. 122 and 37 CFR 1.14. This collection is estimated to take 2 hours to complete, including gathering, preparing, and submitting the completed application form to the USPTO. Time will vary depending upon the individual case. Any comments on the amount of time you require to complete this form and/or suggestions for reducing this burden, should be sent to the Chief Information Officer, U.S. Patent and Trademark Office, P.O. Box 1450, Alexandria, VA 22313-1450. DO NOT SEND FEES OR COMPLETED FORMS TO THIS ADDRESS. SEND TO: Commissioner for Patents, P.O. Box 1450, Alexandria, VA 22313-1450.

If you need assistance in completing the form, call 1-800-PTO-9199 (1-800-786-9199) and select option 2.



UNITED STATES PATENT AND TRADEMARK OFFICE

UNITED STATES DEPARTMENT OF COMMERCE
United States Patent and Trademark Office
Address: COMMISSIONER FOR PATENTS
P.O. Box 1450
Alexandria, Virginia 22313-1450
www.uspto.gov

APPLICATION NO.	FILING DATE	FIRST NAMED INVENTOR	ATTORNEY DOCKET NO.	CONFIRMATION NO.
10/316,961	12/11/2002	Ira Marlowe	9809/1	4879
7590 04/21/2008				
MICHAEL R FRISCIA MCCARTER & ENGLISH FOUR GATEWAY CENTER 100 MULBERRY STREET NEWARK, NJ 07102			EXAMINER KURR, JASON RICHARD	
			ART UNIT 2615	PAPER NUMBER
			MAIL DATE 04/21/2008	DELIVERY MODE PAPER

Please find below and/or attached an Office communication concerning this application or proceeding.

The time period for reply, if any, is set in the attached communication.

Interview Summary	Application No. 10/316,961	Applicant(s) MARLOWE, IRA	
	Examiner JASON R. KURR	Art Unit 2615	

All participants (applicant, applicant's representative, PTO personnel):

(1) JASON R. KURR. (3)_____.

(2) Mark E. Nikolsky. (4)_____.

Date of Interview: 02 April 2008.

Type: a) Telephonic b) Video Conference
c) Personal [copy given to: 1) applicant 2) applicant's representative]

Exhibit shown or demonstration conducted: d) Yes e) No.
If Yes, brief description: _____.

Claim(s) discussed: 1,24,30,42,47,55,63,72,81,83 and 104.

Identification of prior art discussed: Owens et al (US 2002/0084910 A1), Beckert et al (US 6,175,789 B1).

Agreement with respect to the claims f) was reached. g) was not reached. h) N/A.

Substance of Interview including description of the general nature of what was agreed to if an agreement was reached, or any other comments: Applicant discussed possible claim amendments and how they would overcome the above identified prior art.

(A fuller description, if necessary, and a copy of the amendments which the examiner agreed would render the claims allowable, if available, must be attached. Also, where no copy of the amendments that would render the claims allowable is available, a summary thereof must be attached.)

THE FORMAL WRITTEN REPLY TO THE LAST OFFICE ACTION MUST INCLUDE THE SUBSTANCE OF THE INTERVIEW. (See MPEP Section 713.04). If a reply to the last Office action has already been filed, APPLICANT IS GIVEN A NON-EXTENDABLE PERIOD OF THE LONGER OF ONE MONTH OR THIRTY DAYS FROM THIS INTERVIEW DATE, OR THE MAILING DATE OF THIS INTERVIEW SUMMARY FORM, WHICHEVER IS LATER, TO FILE A STATEMENT OF THE SUBSTANCE OF THE INTERVIEW. See Summary of Record of Interview requirements on reverse side or on attached sheet.

/Vivian Chin/
Supervisory Patent Examiner

Examiner Note: You must sign this form unless it is an Attachment to a signed Office action. Examiner's signature, if required

Summary of Record of Interview Requirements

Manual of Patent Examining Procedure (MPEP), Section 713.04, Substance of Interview Must be Made of Record

A complete written statement as to the substance of any face-to-face, video conference, or telephone interview with regard to an application must be made of record in the application whether or not an agreement with the examiner was reached at the interview.

Title 37 Code of Federal Regulations (CFR) § 1.133 Interviews Paragraph (b)

In every instance where reconsideration is requested in view of an interview with an examiner, a complete written statement of the reasons presented at the interview as warranting favorable action must be filed by the applicant. An interview does not remove the necessity for reply to Office action as specified in §§ 1.111, 1.135. (35 U.S.C. 132)

37 CFR §1.2 Business to be transacted in writing.

All business with the Patent or Trademark Office should be transacted in writing. The personal attendance of applicants or their attorneys or agents at the Patent and Trademark Office is unnecessary. The action of the Patent and Trademark Office will be based exclusively on the written record in the Office. No attention will be paid to any alleged oral promise, stipulation, or understanding in relation to which there is disagreement or doubt.

The action of the Patent and Trademark Office cannot be based exclusively on the written record in the Office if that record is itself incomplete through the failure to record the substance of interviews.

It is the responsibility of the applicant or the attorney or agent to make the substance of an interview of record in the application file, unless the examiner indicates he or she will do so. It is the examiner's responsibility to see that such a record is made and to correct material inaccuracies which bear directly on the question of patentability.

Examiners must complete an Interview Summary Form for each interview held where a matter of substance has been discussed during the interview by checking the appropriate boxes and filling in the blanks. Discussions regarding only procedural matters, directed solely to restriction requirements for which interview recordation is otherwise provided for in Section 812.01 of the Manual of Patent Examining Procedure, or pointing out typographical errors or unreadable script in Office actions or the like, are excluded from the interview recordation procedures below. Where the substance of an interview is completely recorded in an Examiners Amendment, no separate Interview Summary Record is required.

The Interview Summary Form shall be given an appropriate Paper No., placed in the right hand portion of the file, and listed on the "Contents" section of the file wrapper. In a personal interview, a duplicate of the Form is given to the applicant (or attorney or agent) at the conclusion of the interview. In the case of a telephone or video-conference interview, the copy is mailed to the applicant's correspondence address either with or prior to the next official communication. If additional correspondence from the examiner is not likely before an allowance or if other circumstances dictate, the Form should be mailed promptly after the interview rather than with the next official communication.

The Form provides for recordation of the following information:

- Application Number (Series Code and Serial Number)
- Name of applicant
- Name of examiner
- Date of interview
- Type of interview (telephonic, video-conference, or personal)
- Name of participant(s) (applicant, attorney or agent, examiner, other PTO personnel, etc.)
- An indication whether or not an exhibit was shown or a demonstration conducted
- An identification of the specific prior art discussed
- An indication whether an agreement was reached and if so, a description of the general nature of the agreement (may be by attachment of a copy of amendments or claims agreed as being allowable). Note: Agreement as to allowability is tentative and does not restrict further action by the examiner to the contrary.
- The signature of the examiner who conducted the interview (if Form is not an attachment to a signed Office action)

It is desirable that the examiner orally remind the applicant of his or her obligation to record the substance of the interview of each case. It should be noted, however, that the Interview Summary Form will not normally be considered a complete and proper recordation of the interview unless it includes, or is supplemented by the applicant or the examiner to include, all of the applicable items required below concerning the substance of the interview.

A complete and proper recordation of the substance of any interview should include at least the following applicable items:

- 1) A brief description of the nature of any exhibit shown or any demonstration conducted,
- 2) an identification of the claims discussed,
- 3) an identification of the specific prior art discussed,
- 4) an identification of the principal proposed amendments of a substantive nature discussed, unless these are already described on the Interview Summary Form completed by the Examiner,
- 5) a brief identification of the general thrust of the principal arguments presented to the examiner,
(The identification of arguments need not be lengthy or elaborate. A verbatim or highly detailed description of the arguments is not required. The identification of the arguments is sufficient if the general nature or thrust of the principal arguments made to the examiner can be understood in the context of the application file. Of course, the applicant may desire to emphasize and fully describe those arguments which he or she feels were or might be persuasive to the examiner.)
- 6) a general indication of any other pertinent matters discussed, and
- 7) if appropriate, the general results or outcome of the interview unless already described in the Interview Summary Form completed by the examiner.

Examiners are expected to carefully review the applicant's record of the substance of an interview. If the record is not complete and accurate, the examiner will give the applicant an extendable one month time period to correct the record.

Examiner to Check for Accuracy

If the claims are allowable for other reasons of record, the examiner should send a letter setting forth the examiner's version of the statement attributed to him or her. If the record is complete and accurate, the examiner should place the indication, "Interview Record OK" on the paper recording the substance of the interview along with the date and the examiner's initials.

Examiners' Note:

This is a corrected version of a previously mailed "Interview Summary" Paper No. 20080402. The Examiner has changed the date of the interview, the personal copy given to check box, and the substance of the interview at the request of the Applicant.

Application Number 	Application/Control No. 10/316,961	Applicant(s)/Patent under Reexamination MARLOWE, IRA	
	Examiner JASON R. KURR	Art Unit 2615	

Under the Paperwork Reduction Act of 1995, no persons are required to respond to a collection of information unless it displays a valid OMB control number.

Request For Continued Examination (RCE) Transmittal	Application Number	10/316,961
	Filing Date	12/11/2002
	First Named Inventor	Ira Marlowe
	Art Unit	2615
	Examiner Name	Kurr, Jason R.
	Attorney Docket Number	99879-00065

Address to:
Mail Stop RCE
Commissioner for Patents
P.O. Box 1450
Alexandria, VA 22313-1450

This is a Request for Continued Examination (RCE) under 37 CFR 1.114 of the above-identified application.
Request for Continued Examination (RCE) practice under 37 CFR 1.114 does not apply to any utility or plant application filed prior to June 8, 1995, or to any design application. See Instruction Sheet for RCEs (not to be submitted to the USPTO) on page 2.

1. **Submission required under 37 CFR 1.114** Note: If the RCE is proper, any previously filed unentered amendments and amendments enclosed with the RCE will be entered in the order in which they were filed unless applicant instructs otherwise. If applicant does not wish to have any previously filed unentered amendment(s) entered, applicant must request non-entry of such amendment(s).
- a. Previously submitted. If a final Office action is outstanding, any amendments filed after the final Office action may be considered as a submission even if this box is not checked.
- i. Consider the arguments in the Appeal Brief or Reply Brief previously filed on _____
- ii. Other _____
- b. Enclosed
- i. Amendment/Reply
- ii. Affidavit(s)/Declaration(s)
- iii. Information Disclosure Statement (IDS)
- iv. Other _____
2. **Miscellaneous**
- a. Suspension of action on the above-identified application is requested under 37 CFR 1.103(c) for a period of _____ months. (Period of suspension shall not exceed 3 months; Fee under 37 CFR 1.17(i) required)
- b. Other _____
3. **Fees** The RCE fee under 37 CFR 1.17(e) is required by 37 CFR 1.114 when the RCE is filed.
- a. The Director is hereby authorized to charge the following fees, any underpayment of fees, or credit any overpayments to Deposit Account No. 503571. I have enclosed a duplicate copy of this sheet.
- i. RCE fee required under 37 CFR 1.17(e)
- ii. Extension of time fee (37 CFR 1.136 and 1.17)
- iii. Other _____
- b. Check in the amount of \$ _____ enclosed
- c. Payment by credit card (Form PTO-2038 enclosed)

WARNING: Information on this form may become public. Credit card information should not be included on this form. Provide credit card information and authorization on PTO-2038.

SIGNATURE OF APPLICANT, ATTORNEY, OR AGENT REQUIRED

Signature	<i>Mark E. Nikolsky</i>	Date	4/24/2008
Name (Print / Type)	Mark E. Nikolsky	Registration No.	48,319

CERTIFICATE OF MAILING OR TRANSMISSION

I hereby certify that this correspondence is being deposited with the United States Postal Service with sufficient postage as first class mail in an envelope addressed to: Mail Stop RCE, Commissioner For Patents, P.O. Box 1450, Alexandria, VA 22313-1450 or facsimile transmitted to the U.S. Patent and Trademark Office on the date shown below.

Signature		Date	
Name (Print / Type)		Date	

This collection of information is required by 37 CFR 1.114. The information is required to obtain or retain a benefit by the public which is to file (and by the USPTO to process) an application. Confidentiality is governed by 35 U.S.C. 122 and 37 CFR 1.11 and 1.14. This collection is estimated to take 12 minutes to complete, including gathering, preparing, and submitting the completed application form to the USPTO. Time will vary depending upon the individual case. Any comments on the amount of time you require to complete this form and/or suggestions for reducing the burden, should be sent to the Chief Information Officer, U.S. Patent and Trademark Office, U.S. Department of Commerce, P.O. Box 1450, Alexandria, VA 22313-1450. DO NOT SEND FEES OR COMPLETED FORMS TO THIS ADDRESS. SEND TO: Mail Stop RCE, Commissioner for Patents, P.O. Box 1450, Alexandria, VA 22313-1450.

If you need assistance in completing the form, call 1-800-PTO-9199 and select option 2.

IN THE UNITED STATES PATENT AND TRADEMARK OFFICE

Applicant: Ira M. Marlowe
Serial No.: 10/316,961
Filed: 12/11/2002
Title: AUDIO DEVICE INTEGRATION SYSTEM

Examiner: Kurr, Jason R.

Art Unit: 2615

Mail Stop Amendment
Commissioner for Patents
P.O. Box 1450
Alexandria, VA 22313-1450

RESPONSE

Sir:

This is a response to the outstanding Office Action dated February 20, 2008. The Office Action was made final. The time period for response extends to and includes May 20, 2008.

Amendments to the Claims begin on page 2 of this response.

Remarks begin on page 29 of this response.

AMENDMENTS TO THE CLAIMS

1. (Currently Amended) An audio device integration system comprising:

a first connector electrically connectable to a car stereo;

a second connector electrically connectable to an after-market audio device external to a the car stereo;

a third connector electrically connectable to one or more auxiliary input sources external to a the car stereo and ~~an~~ the after-market audio device;

an interface connected between ~~the~~ said first and second electrical connectors for channeling audio signals to a the car stereo from ~~an~~ the after-market audio device, ~~the~~ said interface including a microcontroller in electrical communication with ~~the~~ said first and second electrical connectors, ~~the~~ said microcontroller ~~programmed~~ pre-programmed to execute:

a first pre-programmed code portion for remotely controlling ~~an~~ the after-market audio device using a the car stereo by receiving a control command from a the car stereo through ~~the~~ said first connector in a format incompatible with ~~an~~ the after-market audio device, processing a the received control command into a formatted command compatible with ~~an~~ the after-market audio device, and transmitting a the formatted command to ~~an~~ the after-market audio device through ~~the~~ said second connector for execution by ~~an~~ the after-market audio device;

a second pre-programmed code portion for receiving data from ~~an~~ the after-market audio device through ~~the~~ said second connector in a format incompatible with the car stereo, processing the received data into formatted data compatible with a the car stereo, and transmitting the formatted data to a the car stereo through ~~the~~ said first connector for display by a the car stereo; and

a third pre-programmed code portion for switching to one or more auxiliary input sources connected to ~~the~~ said third electrical connector.

2. (Currently Amended) The apparatus of claim 1, wherein the car stereo further ~~comprising~~ comprises an Original Equipment Manufacturer (OEM) car stereo connected to ~~the~~ said first electrical connector.

3. (Currently Amended) The apparatus of claim 1, wherein the car stereo further ~~comprising~~ comprises an after-market car stereo connected to ~~the~~ said first electrical connector.

4. (Currently Amended) The apparatus of claim 1, wherein the after-market audio device further ~~comprising~~ comprises a CD player, CD changer, MP3 player, Digital Audio Broadcast (DAB) receiver, or satellite receiver connected to ~~the~~ said second electrical connector.

5. (Currently Amended) The apparatus of claim 1, wherein ~~the~~ said interface further comprises a plug-and-play mode for automatically detecting a device type of ~~an~~ the after-market audio device connected to ~~the~~ said second electrical connector and integrating ~~an~~ the after-market audio device based upon the device type.

6. (Currently Amended) The apparatus of claim 1, wherein ~~the~~ said interface generates a device presence signal for maintaining a the car stereo in a state responsive to processed data and audio signals.

7. (Currently Amended) The apparatus of claim 1, wherein ~~the~~ said second pre-programmed code portion processes data generated by ~~an~~ the after-market audio device including track and time information.

8. (Currently Amended) The apparatus of claim 1, wherein ~~the~~ said second pre-programmed code portion processes data generated by ~~an~~ the after-market audio device including song title and artist information.

9. (Currently Amended) The apparatus of claim 1, wherein ~~the~~ said second pre-programmed code portion processes data generated by ~~an~~ the after-market audio device including channel number and channel name information.

10. (Currently Amended) The apparatus of claim 1, wherein ~~the~~ said interface processes video information generated by ~~an~~ the after-market audio device.

11. (Currently Amended) The apparatus of claim 1, wherein the formatted data is displayed as a menu on a display of a the car stereo.

12. (Previously Presented) The apparatus of claim 11, wherein the display comprises a graphic panel.

13. (Currently Amended) The apparatus of claim 1, wherein commands are input by a user using one or more control buttons or presets on a the car stereo.

14. (Cancelled)

15. (Currently Amended) The apparatus of claim 1, wherein audio signals from the one or more auxiliary input sources are selectively channeled to the car stereo by the said interface.

16. (Currently Amended) The apparatus of claim 1, wherein a user can select between the one or more auxiliary input sources by depressing keys on a the car stereo.

17. (Currently Amended) The apparatus of claim 1, wherein a user can select one of the auxiliary input sources by entering a disc number at a the car stereo.

18. (Currently Amended) The apparatus of claim 1, wherein a user can select one of the auxiliary input sources by entering a track number at a the car stereo.

19. (Currently Amended) The apparatus of claim 1, wherein a user can select one of the auxiliary input sources by entering both disc and track numbers at a the car stereo.

20. (Currently Amended) The apparatus of claim 1, wherein a user can select between an the audio device and the one or more auxiliary input sources by entering a sequence at a the car stereo.

21. (Original) The apparatus of claim 20, wherein the sequence comprises a track up selection followed by a track down selection.

22. (Currently Amended) The apparatus of claim 1, further comprising a second interface connected to ~~the first~~ said interface for providing a plurality of auxiliary input sources.

23. (Currently Amended) The apparatus of claim 22, wherein both ~~the first~~ said interface and ~~the~~ said second interface are controllable using a the car stereo.

24. (Currently Amended) An audio device integration system comprising:

a first electrical connector connectable to a car stereo;

a plurality of auxiliary electrical connectors connectable to a plurality of auxiliary input sources;

an interface connected between the said first electrical connector and the said plurality of auxiliary electrical connectors for channeling audio from at least one of a the plurality of auxiliary input sources to a the car stereo, the said interface including a microcontroller in electrical communication with the said first electrical connector and the said plurality of auxiliary electrical connectors, the said microcontroller ~~programmed~~ pre-programmed to execute:

a first pre-programmed code portion for remotely controlling at least one of a the plurality of auxiliary input sources using a the car stereo by receiving a control command from a the car stereo through the said first electrical connector in a format incompatible with at least one of a the plurality of auxiliary input sources, processing a received control command into a formatted control command compatible with at least one of a the plurality of auxiliary input sources, and transmitting a formatted control command to at least one of a the plurality of auxiliary input sources through at least one of the said plurality of auxiliary electrical connectors for execution by ~~the~~ at least one of a the plurality of auxiliary input sources;

a second pre-programmed code portion for receiving data from at least one of a the plurality of auxiliary input sources through at least one of the said plurality of auxiliary electrical connectors in a format incompatible with a the car stereo, processing the received data into formatted data compatible with a the car stereo, and transmitting the formatted data to a the car stereo through the said first electrical connector for display by a the car stereo; and

a third pre-programmed code portion for selecting one of a the plurality of auxiliary input sources from a the car stereo.

25. (Currently Amended) The apparatus of claim 24, wherein the third pre-programmed code portion for selecting one of a the plurality of auxiliary input sources processes a disc or track selection entered by a user using control buttons of a the car stereo to select one of a the plurality of auxiliary input sources.

26. (Currently Amended) The apparatus of claim 24, ~~further comprising wherein at least one of~~ the plurality of auxiliary input sources comprises a CD player, CD changer, MP3 player, satellite receiver, or a Digital Audio Broadcast (DAB) receiver connected to one of said plurality of auxiliary electrical connectors.

27. (Currently Amended) The apparatus of claim 24, wherein a device type of at least one of a the plurality of auxiliary input sources is automatically detected by the said interface and ~~the~~ at least one of a the plurality of auxiliary input sources is automatically integrated with a the car stereo based upon the device type.

28. (Currently Amended) The apparatus of claim 24, wherein the interface is switchable into an auxiliary input mode by issuing a control sequence at a the car stereo.

29. (Original) The apparatus of claim 28, wherein the control sequence comprises a track up command followed by a track down command.

30. (Currently Amended) A method for integrating an after-market device with a car stereo comprising:

providing an interface having a first electrical connector connectable to a car stereo, a second electrical connector connectable to an after-market device external to a the car stereo, a third electrical connector connectable to an auxiliary input source, and a pre-programmed microcontroller positioned within the said interface;

connecting the said first electrical connector to a the car stereo, the said second electrical connector to ~~an~~ the after-market device external to a the car stereo, and the said third electrical connector to ~~an~~ the auxiliary input source external to a the car stereo and ~~an~~ the after-market device;

remotely controlling the after-market device using the car stereo by:

receiving control commands from the car stereo at the interface through the said first electrical connector in a format incompatible with the after-market device; and

processing the control commands into formatted control commands compatible with the after-market device using a first pre-programmed code portion pre-programmed into and executed by ~~the~~ said microcontroller and dispatching the formatted control commands to the after-market device through ~~the~~ said second electrical connection;

receiving data in a format incompatible with the car stereo through ~~the~~ said second electrical connector and audio from the after-market device at the interface;

processing the data into formatted data compatible with the car stereo using a second pre-programmed code portion pre-programmed into and executed by the microcontroller and dispatching the audio and formatted data to the car stereo through ~~the~~ said first electrical connector;

displaying the formatted data on the car stereo and playing the audio through the car stereo; and

playing audio from the after-market device through the car stereo.

31. (Original) The method of claim 30, wherein the step of receiving data from the device comprises retrieving CD track and time information from the device.

32. (Original) The method of claim 30, wherein the step of receiving data from the device comprises retrieving MP3 song, title, track, and time information from the device.

33. (Original) The method of claim 30, wherein the step of receiving data from the device comprises retrieving channel number, channel name, artist, and song information from the device.

34. (Original) The method of claim 30, wherein the step of receiving data from the device comprises retrieving video information from the device.

35. (Previously Presented) The method of claim 30, wherein the step of displaying the formatted data comprises displaying the data in an LCD panel.

36. (Previously Presented) The method of claim 30, wherein the step of displaying the formatted data comprises displaying the data in a graphical user interface at the car stereo.

37. (Previously Presented) The method of claim 30, wherein the step of displaying formatted data comprises displaying video at the car stereo.

38. (Currently Amended) The method of claim 30, wherein the step of connecting the after-market device to ~~the~~ said second electrical connector comprises connecting a CD player, CD changer, MP3 player, satellite receiver, or a Digital Audio Broadcast (DAB) receiver to ~~the~~ said second electrical connector.

39. (Cancelled)

40. (Currently Amended) The method of claim 30, further comprising receiving a selection command from the car stereo and channeling data and audio from the auxiliary input source to the said interface in response to the selection command.

41. (Original) The method of claim 40, further comprising processing the data from the auxiliary input source for display on the car stereo.

42. (Currently Amended) An apparatus for docking a portable device for integration with a car stereo comprising:

a storage area remote from a car stereo for storing a the portable device;

a docking portion within the storage area for communicating and physically mating with a the portable device;

a data port in communication with the docking portion, the data port connectable with a device for integrating a the portable device with a the car stereo; and

an interface connected to ~~the~~ the said data port and to a the car stereo, ~~the said~~ the said interface channeling audio from a the portable device to a the car stereo, ~~the said~~ the said interface including a

microcontroller in electrical communication with a the portable device through ~~the~~ said data port and a the car stereo, ~~the~~ said microcontroller ~~executing pre-programmed to execute first program~~ code for remotely controlling a the portable device using a the car stereo by processing control commands generated by a the car stereo in a format incompatible with a the portable device into formatted control commands compatible with a the portable device, and dispatching formatted control commands to a the portable device for execution thereby.

43. (Currently Amended) The apparatus of claim 42, wherein ~~the~~ said storage area further comprises a top member, a bottom member, and a hinge interconnecting ~~the~~ said top member and ~~the~~ said bottom member at an edge thereof.

44. (Previously Presented) The apparatus of claim 42, wherein the data port comprises an RS-232 or Universal Serial Bus (USB) port.

45. (Currently Amended) The apparatus of claim 42, wherein the storage area further comprises a top portion and a bottom portion defining a sleeve for holding a the portable device.

46. (Currently Amended) The apparatus of claim 43, further comprising a clasp for retaining ~~the~~ said top and bottom members in a closed position.

47. (Currently Amended) A method of integrating an after-market device with an Original Equipment Manufacturer (OEM) or after-market car stereo comprising:

providing an interface having a first electrical connector, a second electrical connector, and a microcontroller positioned in ~~the~~ said interface and in electrical communication with ~~the~~ said first and second electrical connectors;

connecting the after-market device to ~~the~~ said first electrical connector;

connecting ~~the~~ said second electrical connector to a the car stereo;

determining whether the car stereo is an OEM car stereo or an after-market car stereo;

generating and transmitting a device presence signal to the car stereo using a first code portion pre-programmed into and executed by the microcontroller to maintain the car stereo in an operational state responsive to signals generated by the after-market device, the device presence signal based upon the car stereo; and

channeling audio signals from the after-market device to the car stereo using ~~the~~ said interface.

48. (Currently Amended) The method of claim 47, further comprising receiving control commands from the car stereo at ~~the~~ said interface in a format incompatible with the after-market device.

49. (Currently Amended) The method of claim 48, further comprising converting the control commands into a format recognizable by the after-market audio device using a second code portion pre-programmed into and executed by the microcontroller.

50. (Original) The method of claim 49, further comprising dispatching formatted commands to the after-market audio device for execution thereby.

51. (Currently Amended) The method of claim 47, further comprising converting data received at the interface from the after-market audio device in a format incompatible with the car stereo into a format compatible with the car stereo using a third code portion pre-programmed into and executed by the microcontroller.

52. (Original) The method of claim 51, further comprising displaying formatted data on the car stereo.

53. (Original) The method of claim 52, wherein the step of displaying formatted data comprises displaying channel numbers, channel names, titles, tracks, song names, or artist names on the car stereo.

54. (Original) The method of claim 52, wherein the step of displaying formatted data comprises displaying video on the car stereo.

55. (Currently Amended) An audio device integration system comprising:

a first electrical connector connectable to a car stereo;

a second electrical connector connectable to a portable MP3 player external to a the car stereo;

an interface connected between ~~the~~ said first and second electrical connectors for transmitting audio from a portable MP3 player to a car stereo, ~~the~~ said interface including a microcontroller in electrical communication with ~~the~~ said first and second electrical connectors, ~~the~~ said microcontroller ~~executing~~ pre-programmed to execute:

a first pre-programmed code portion for generating a device presence signal and transmitting the signal to a the car stereo to maintain a the car stereo in an operational state; and

a second pre-programmed code portion for remotely controlling ~~an~~ the MP3 player using a the car stereo by receiving a control command from a the car stereo through ~~the~~ said first electrical connector in a format incompatible with ~~an~~ the MP3 player, processing a the control command into a formatted control command compatible with ~~an~~ the MP3 player, and transmitting a the formatted control command to ~~an~~ the MP3 player through ~~the~~ said second electrical connector for execution by ~~an~~ the MP3 player.

56. (Currently Amended) The apparatus of claim 55, wherein the car stereo further comprising comprises an Original Equipment Manufacturer (OEM) car stereo; stereo connected to the first electrical connector.

57. (Currently Amended) The apparatus of claim 55, wherein the car stereo further comprising comprises an after-market car stereo connected to the first electrical connector.

58. (Cancelled)

59. (Currently Amended) The system of claim 55, wherein the said microcontroller executes is pre-programmed to execute a third code portion for receiving data from an the MP3 player in a format incompatible with a the car stereo, processing received data into formatted data compatible with a the car stereo, and transmitting formatted data to a the car stereo for display thereby.

60. (Currently Amended) The apparatus of claim 59, wherein the said third code portion processes data generated by an the MP3 player including track and time information.

61. (Currently Amended) The apparatus of claim 59, wherein the said third code portion processes data generated by an the MP3 player including song title and artist information.

62. (Currently Amended) The apparatus of claim 59, wherein commands are input by a user using one or more control buttons or presets on a the car stereo.

63. (Currently Amended) An audio device integration system comprising:

a first electrical connector connectable to a car stereo;

a second electrical connector connectable to a satellite radio receiver external to a the car stereo;

an interface connected between ~~the~~ said first and second electrical connectors for transmitting audio from a satellite radio receiver to a car stereo, the interface including a microcontroller in electrical communication with ~~the~~ said first and second electrical connectors, ~~the~~ said microcontroller ~~executing: pre-programmed to execute:~~

a first pre-programmed code portion for generating a device presence signal and transmitting the signal to a the car stereo to maintain a the car stereo in an operational state; and

a second pre-programmed code portion for remotely controlling a the satellite radio receiver using a the car stereo by receiving a control command from a the car stereo through the said first electrical connector in a format incompatible with a the satellite radio receiver, processing a received control command into a formatted control command compatible with a the satellite radio receiver, and transmitting a the formatted control command to the satellite radio receiver through the said second electrical connector for execution by a the satellite radio receiver.

64. (Currently Amended) The apparatus of claim 63, wherein the car stereo further comprising comprises an Original Equipment Manufacturer (OEM) car stereo connected to ~~the~~ said first electrical connector.

65. (Currently Amended) The apparatus of claim 63, wherein the car stereo further comprising comprises an after-market car stereo connected to ~~the~~ said first electrical connector.

66. (Cancelled)

67. (Currently Amended) The system of claim 63, wherein ~~the~~ said microcontroller ~~executes~~ is pre-programmed to execute a third code portion for receiving data from a the satellite radio receiver in a format incompatible with a the car stereo, processing received data into formatted data compatible with a the car stereo, and transmitting formatted data to a the car stereo for display thereby.

68. (Currently Amended) The apparatus of claim 67, wherein ~~the~~ said third code portion processes data generated by a the satellite radio receiver including track and time information.

69. (Currently Amended) The apparatus of claim 67, wherein ~~the~~ said third code portion processes data generated by a the satellite radio receiver including song title and artist information.

70. (Currently Amended) The apparatus of claim 67, wherein the said third code portion processes data generated by a the satellite radio receiver including a channel number and a channel name.

71. (Currently Amended) The apparatus of claim 67, wherein commands are input by a user using one or more control buttons or presets on a the car stereo.

72. (Currently Amended) An audio device integration system comprising:

a first electrical connector connectable to a car stereo;

a second electrical connector connectable to a digital audio broadcast receiver external to a the car stereo;

an interface connected between the said first and second electrical connectors for transmitting audio from a the digital audio broadcast receiver to a the car stereo, the said interface including a microcontroller in electrical communication with the said first and second electrical connectors, the said microcontroller ~~executing~~ pre-programmed to execute:

a first pre-programmed code portion for generating a device presence signal and transmitting the signal to a the car stereo to maintain a the car stereo in an operational state; and

a second pre-programmed code portion for remotely controlling a the digital audio broadcast receiver using a the car stereo by receiving a control command from a the car stereo through the said first electrical connector in a format incompatible with a the digital audio broadcast receiver, processing a received control command into a formatted control command compatible with a the digital audio broadcast receiver, and transmitting a the formatted control command to a the digital audio broadcast receiver through the said second electrical connector for execution by a the digital audio broadcast receiver.

73. (Currently Amended) The apparatus of claim 72, wherein the car stereo further ~~comprising~~ comprises an Original Equipment Manufacturer (OEM) car stereo connected to the said first electrical connector.

74. (Currently Amended) The apparatus of claim 72, wherein the car stereo further ~~comprising~~ comprises an after-market car stereo connected to the said first electrical connector.

75. (Cancelled)

76. (Currently Amended) The system of claim 72, wherein ~~the~~ the said microcontroller ~~executes~~ is pre-programmed to execute a third code portion for receiving data from a the digital audio broadcast receiver in a format incompatible with a the car stereo, processing incompatible

data into formatted data compatible with a the car stereo, and transmitting formatted data to a the car stereo for display thereby.

77. (Currently Amended) The apparatus of claim 76, wherein ~~the~~ said third code portion processes data generated by the digital audio broadcast receiver including track and time information.

78. (Currently Amended) The apparatus of claim 76, wherein ~~the~~ said third code portion processes data generated by the digital audio broadcast receiver including song title and artist information.

79. (Currently Amended) The apparatus of claim 76, wherein ~~the~~ said third code portion processes data generated by the digital audio broadcast receiver including a channel number and a channel name.

80. (Currently Amended) The apparatus of claim 76, wherein commands are input by a user using one or more control buttons or presets on a the car stereo.

81. (Currently Amended) A device for integrating video information for use with a car stereo, comprising:

a first electrical connector connectable to a car stereo;

a second electrical connector connectable to an after-market video device external to a the car stereo;

an interface connected between the said first and second electrical connectors for transmitting video information from ~~an~~ the after-market video device to a the car stereo, the interface including a microcontroller in electrical communication with the said first and second electrical connectors, ~~the said~~ microcontroller executing: pre-programmed to execute:

a first pre-programmed code portion for generating a device presence signal and transmitting the signal to a the car stereo through the said first electrical connector to maintain a the car stereo in an operational state responsive to signals generated by ~~an~~ the after-market video device.

82. (Currently Amended) The device of claim 81, further comprising means for converting video information into a format compatible with a the car stereo.

83. (Currently Amended) An audio device integration system comprising:

a car stereo;

a portable audio device external to the car stereo;

an interface connected between the car stereo and the portable audio device, the interface ~~including:~~ including a microcontroller pre-programmed to execute:

first pre-programmed means for generating a device presence signal and transmitting the signal to the car stereo to maintain the car stereo in an operational state;

second pre-programmed means for remotely controlling the portable audio device using the car stereo by receiving a control command from the car stereo in a format incompatible with the portable audio device, processing the control command into a formatted control command compatible with the portable audio device, and transmitting the formatted control command to the portable audio device for execution thereby; and

means for transmitting audio from the portable audio device to the car stereo.

84. (Previously Presented) The apparatus of claim 83, wherein the portable audio device comprises a portable CD player.

85. (Previously Presented) The apparatus of claim 83, wherein the portable audio device comprises a portable MP3 player.

86. (Previously Presented) The apparatus of claim 83, wherein the portable audio device comprises a portable satellite receiver.

87. (Previously Presented) The apparatus of claim 83, wherein the portable audio device comprises a portable Digital Audio Broadcast (DAB) receiver.

88. (Currently Amended) The apparatus of claim 1, ~~wherein the second electrical connector~~ ~~comprises~~ further comprising a bus connection established between ~~an~~ the after-market audio device and ~~the~~ said interface.

89. (Previously Presented) The apparatus of claim 88, wherein the bus connection comprises a Universal Serial Bus (USB) connection.

90. (Currently Amended) The apparatus of claim 24, wherein at least one of the plurality of auxiliary input connectors comprises a bus connection established between at least one of a the plurality of auxiliary input sources and ~~the~~ said interface.

91. (Previously Presented) The apparatus of claim 90, wherein the bus connection comprises a Universal Serial Bus (USB) connection.

92. (Currently Amended) The apparatus of claim 55, ~~wherein the second electrical connector~~ ~~comprises~~ further comprising a bus connection established between ~~an~~ the MP3 player and ~~the~~ said interface.

93. (Previously Presented) The apparatus of claim 92, wherein the bus connection comprises a Universal Serial Bus (USB) connection.

94. (Currently Amended) The apparatus of claim 63, ~~wherein the second electrical connector comprises~~ further comprising a bus connection established between a the satellite radio receiver and ~~the~~ said interface.

95. (Previously Presented) The apparatus of claim 94, wherein the bus connection comprises a Universal Serial Bus (USB) connection.

96. (Currently Amended) The apparatus of claim 72, ~~wherein the second electrical connector comprises~~ further comprising a bus connection established between a the digital audio broadcast receiver and ~~the~~ said interface.

97. (Previously Presented) The apparatus of claim 96, wherein the bus connection comprises a Universal Serial Bus (USB) connection.

98. (Currently Amended) The apparatus of claim 81, ~~wherein the second electrical connection comprises~~ further comprising a bus connection established between a the video device and ~~the~~ said interface.

99. (Previously Presented) The apparatus of claim 98, wherein the bus connection comprises a Universal Serial Bus (USB) connection.

100. (Currently Amended) The apparatus of claim 83, wherein the second electrical connector comprises further comprising a bus connection established between a the portable audio device and the said interface.

101. (Previously Presented) The apparatus of claim 100, wherein the bus connection comprises a Universal Serial Bus (USB) connection.

102. (Currently Amended) The apparatus of claim 81, wherein ~~the~~ said microcontroller ~~executes~~ is pre-programmed to execute a second code portion for receiving a control signal from a the car stereo in a format incompatible with a the video device, processing a received control signal into a formatted control signal compatible with a the video device, and transmitting a the formatted control signal to a the video device for execution thereby.

103. (Currently Amended) The apparatus of claim 102, wherein ~~the~~ said microcontroller ~~executes~~ is pre-programmed to execute a third code portion for receiving data from a the video device incompatible with a the car stereo, processing received data into formatted data compatible with a the car stereo, and transmitting formatted data to a the car stereo for display thereon.

104. (Currently Amended) An audio device integration system, comprising:

a first electrical connector electrically connectable to a car stereo;

a second electrical connector electrically connectable to an after-market, line-level audio source external to a the car stereo; and

an interface connected between ~~the~~ said first and second electrical connectors for transmitting audio from ~~an~~ the after-market, line level audio source to a the car stereo, ~~the~~ said interface including a microcontroller in electrical communication with ~~the~~ said first and second electrical connectors, ~~the~~ said microcontroller ~~executing:~~ pre-programmed to execute:

a first pre-programmed code portion for generating and transmitting a device presence signal to a the car stereo through ~~the~~ said first electrical connector to maintain a the car stereo in an operational state responsive to signals generated by the ~~an~~ after-market, line-level audio source.

REMARKS

Attorney for Applicant has carefully reviewed the outstanding final Office Action on the above-identified application. Applicant has amended the claims, as set forth herein, and respectfully submits that the application, as amended, is in condition for allowance. A Request for Continued Examination (RCE) is being filed herewith.

Attorney for Application would like to thank Examiner Jason Kurr for the courtesies extended in a personal interview conducted with the Examiner on April 2, 2008.

In the personal interview, the references cited in the Office Action were discussed, as well as amendments to the claims. In particular, amendments to the claims to differentiate over the new primary references Owens, et al. and Beckert, et al., were discussed.

Applicant notes that the Interview Summary dated April 9, 2008 incorrectly indicated the date of the personal interview as March 2, 2008. It also incorrectly indicated that a personal copy of the Interview Summary was given to the undersigned, and did not reflect in the Substance of the Interview Summary that claim amendments were discussed which would overcome the cited references. The undersigned contacted Examiner Kurr to indicate these discrepancies, and it was agreed that the Examiner would issue another Interview Summary correcting the foregoing. To this end, a new Interview Summary, dated April 21, 2008, was prepared, which reflects the foregoing corrections.

In the interview, it was agreed that independent Claim 1 and its associated dependent Claims 2-13 and 15-23 would overcome the references cited in the Office Action if amended to recite that the microcontroller of the interface of the present invention is “**pre-programmed to execute** a first **pre-programmed** code portion for remotely controlling an after-market audio device... ; a second **pre-programmed** code portion for receiving data from an after-market audio device...; and a third **pre-programmed** code portion for switching between one or more auxiliary input sources....” In particular, at the interview, it was discussed that neither of the primary references (i.e., Owens, et al. and Beckert, et al.), nor any of the remaining references, taken alone or in combination, teach or suggest providing an interface having a pre-programmed microcontroller which executes pre-programmed code portions for integrating an after-market device for use with a car stereo. As such, Applicant believes that Claims 1-13 and 15-23 are in condition for allowance.

Claims 1-11, 13, 15-20, and 22-23 were also amended to overcome the rejections in the Office Action under 35 U.S.C. § 112 with respect to usage of the words “a” and “the,” to provide antecedent basis, and to address matters of form. Applicant has also introduced the word “said” into the claims to refer to elements which are positively claimed, and used the word “the” to refer to elements which are not positively claimed.

Applicant has also amended independent Claim 24 in a manner similar to the foregoing amendments to independent Claim 1. Specifically, independent Claim 24 was amended to recite that the interface of the present invention includes a microcontroller which is **pre-programmed to execute** first, second, and third **pre-programmed** code portions. Claims 24-28 were also

amended to overcome the rejections in the Office Action under 35 U.S.C. § 112, to provide antecedent basis, and to address matters of form. Accordingly, Applicant submits that Claims 24-29 are in condition for allowance.

Applicant has amended independent Claims 30 and 83 in a manner similar to independent Claims 1 and 24, in that Claims 30 and 83 now recite that the microcontroller is **pre-programmed to execute** first and second **pre-programmed** code portions. Claims 30, 38, 40, 83, 88, 90, 92, 94, 96, 98, 100, and 102-103 were also amended to overcome the rejections in the Office Action under 35 U.S.C. § 112, to provide antecedent basis, and to address matters of form. Accordingly, Applicant submits that Claims 30-41 and 83-103 are in condition for allowance.

Applicant has amended independent Claims 42, 55, 63, and 72 in a similar fashion, so that they now recite that the microcontroller is **pre-programmed to execute** a ... **pre-programmed** code portion for remotely controlling a device external to a car stereo. Claims 42-43, 45-46, 55-57, 59-65, 67-74, and 76-80 were also amended to overcome the rejections in the Office Action under 35 U.S.C. § 112, to provide antecedent basis, and to address matters of form. As such, Applicant submits that Claims 42-46, 55-57, 59-65, 67-74, and 76-80 are in condition for allowance.

Applicant has amended independent Claims 47, 81, and 104 to recite that the microcontroller is **pre-programmed to execute** a first **pre-programmed** code portion for generating a device presence signal ... to maintain a car stereo in a responsive state. Claims 47-

49, 51, 81-82, and 104 were also amended to overcome the rejections in the Office Action under 35 U.S.C. § 112, to provide antecedent basis, and to address matters of form. Accordingly, Applicant submits that Claims 47-54, 81-82, and 104 are in condition for allowance.

All issues raised in the Office Action are believed to have been addressed. Claims 1-11, 13, 15-20, 22-28, 30, 38, 40, 42-43, 45-49, 51, 55-57, 59-65, 67-74, 76-83, 88, 90, 92, 94, 96, 98, 100, and 102-104 were amended. No new matter is believed to have been added. Claims 1-13, 15-38, 40-57, 59-65, 67-74, and 76-104 are pending and are in condition for allowance. Reexamination is requested and favorable action solicited.

Respectfully submitted,



Mark E. Nikolsky
Reg. No. 48,319
McCarter & English, LLP
Four Gateway Center
100 Mulberry Street
Newark, NJ 07102-4056
Tel.: 973-639-6987
Fax.: 973-297-6624

Date: 4/21/2008

**TRANSMITTAL OF INFORMATION DISCLOSURE STATEMENT
(Under 37 CFR 1.97(b) or 1.97(c))**

Docket No.
99879-00005

In Re Application Of: **Ira Marlowe**

Application No.	Filing Date	Examiner	Customer No.	Group Art Unit	Confirmation No.
10/316,961	12/11/2002	Kurr, Jason R.	27614	2615	4879

Title: **Audio Device Integration System**

Address to:
Commissioner for Patents
P.O. Box 1450
Alexandria, VA 22313-1450

37 CFR 1.97(b)

1. The Information Disclosure Statement submitted herewith is being filed within three months of the filing of a national application other than a continued prosecution application under 37 CFR 1.53(d); within three months of the date of entry of the national stage as set forth in 37 CFR 1.491 in an international application; before the mailing of a first Office Action on the merits, or before the mailing of a first Office Action after the filing of a request for continued examination under 37 CFR 1.114.

37 CFR 1.97(c)

2. The Information Disclosure Statement submitted herewith is being filed after the period specified in 37 CFR 1.97(b), provided that the Information Disclosure Statement is filed before the mailing date of a Final Action under 37 CFR 1.113, a Notice of Allowance under 37 CFR 1.311, or an Action that otherwise closes prosecution in the application, and is accompanied by one of:
- the statement specified in 37 CFR 1.97(e);
- OR**
- the fee set forth in 37 CFR 1.17(p).

P10A/REV05

TRANSMITTAL OF INFORMATION DISCLOSURE STATEMENT
(Under 37 CFR 1.97(b) or 1.97(c))

Docket No.
99879-00005

In Re Application of: **Ira Marlowe**

Application No.	Filing Date	Examiner	Customer No.	Group Art Unit	Confirmation No.
10/316,961	12/11/2002	Kurr, Jason R.	27614	2615	4879

Title: **Audio Device Integration System**

Payment of Fee

(Only complete if Applicant elects to pay the fee set forth in 37 CFR 1.17(p))

- A check in the amount of _____ is attached.
- The Director is hereby authorized to charge and credit Deposit Account No. 503571 as described below.
 - Charge the amount of _____
 - Credit any overpayment.
 - Charge any additional fee required.
- Payment by credit card. Form PTO-2038 is attached.

WARNING: Information on this form may become public. Credit card information should not be included on this form. Provide credit card information and authorization on PTO-2038.

Certificate of Transmission by Facsimile*

I certify that this document and authorization to charge deposit account is being facsimile transmitted to the United States Patent and Trademark Office (Fa

(Date)

Signature

Typed or Printed Name of Person Signing Certificate

Certificate of Mailing by First Class Mail

I hereby certify that this correspondence is being deposited with the United States Postal Service with sufficient postage as first class mail in an envelope addressed to "Commissioner for Patents, P.O. Box 1450, Alexandria, VA 22313-1450" [37 CFR 1.8(a)] on

(Date)

Signature of Person Mailing Correspondence

Typed or Printed Name of Person Mailing Certificate

*This certificate may only be used if paying by deposit account.

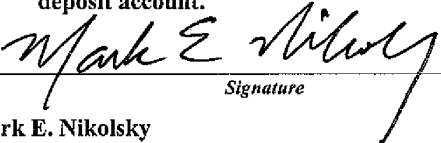

Signature

Dated: 4/21/2008

Mark E. Nikolsky
Registration No. 48,319
McCarter & English, LLP
Four Gateway Center
100 Mulberry Street
Newark, NJ 07102
Tel: (973) 639-6987
Fax: (973) 297-6624

cc:

P10A/REV06

Under the Paperwork Reduction Act of 1995, no persons are required to respond to a collection of information unless it contains a valid OMB control number.

Substitute for form 1449/PTO		Complete if Known	
INFORMATION DISCLOSURE STATEMENT BY APPLICANT <i>(Use as many sheets as necessary)</i>		Application Number	10/316,961
		Filing Date	12/11/2002
		First Named Inventor	Ira Marlowe
		Art Unit	2615
		Examiner Name	Kurr, Jason R.
Sheet 1 of 3	Attorney Docket Number	99879-00005	

U. S. PATENT DOCUMENTS					
Examiner Initials*	Cite No. ¹	Document Number	Publication Date MM-DD-YYYY	Name of Patentee or Applicant of Cited Document	Pages, Columns, Lines, Where Relevant Passages or Relevant Figures Appear
		Number-Kind Code ² (if known)			
	1	US- 6,529,804	03/04/2003	Draggon, et al.	
	2	US- 6,058,319	05/02/2000	Sadler	
	3	US- 6,052,603	04/18/2000	Kinzalow, et al.	
	4	US- 5,794,164	08/11/1998	Beckert, et al.	
	5	US- 2004/0145457	07/29/2004	Schofield, et al.	
	6	US- 2004/0266336	12/30/2004	Patsiokas, et al.	
	7	US- 2002/0197954	12/26/2002	Schmitt, et al.	
	8	US- 2004/0151327	08/05/2004	Marlowe	
	9	US- 2005/0239434	10/27/2005	Marlowe	
	10	US- 2007/0015486	01/18/2007	Marlowe	
	11	US- 2007/0293183	12/20/2007	Marlowe	
		US-			
		US-			
		US-			
		US-			
		US-			
		US-			
		US-			
		US-			

FOREIGN PATENT DOCUMENTS						
Examiner Initials*	Cite No. ¹	Foreign Patent Document	Publication Date MM-DD-YYYY	Name of Patentee or Applicant of Cited Document	Pages, Columns, Lines, Where Relevant Passages Or Relevant Figures Appear	T ⁶
		Country Code ³ - Number ⁴ - Kind Code ⁵ (if known)				
	12	WO 2008/002954	01/03/2008	Ira Marlowe		
	13	WO 2006/094281	09/08/2006	Ira Marlowe		
	14	WO 2004/053722	06/24/2004	BlitzSafe of America, Inc		
	15	KR 1020010035788 English Abstract	05/07/2001	Gyu Jin Park		
	16	KR 1020010059192 English Abstract	07/06/2001	Hyundai Motor Company		

Examiner Signature	Date Considered
--------------------	-----------------

*EXAMINER: Initial if reference considered, whether or not citation is in conformance with MPEP 609. Draw line through citation if not in conformance and not considered. Include copy of this form with next communication to applicant. ¹ Applicant's unique citation designation number (optional). ² See Kinds Codes of USPTO Patent Documents at www.uspto.gov or MPEP 901.04. ³ Enter Office that issued the document, by the two-letter code (WIPO Standard ST.3). ⁴ For Japanese patent documents, the indication of the year of the reign of the Emperor must precede the serial number of the patent document. ⁵ Kind of document by the appropriate symbols as indicated on the document under WIPO Standard ST.16 if possible. ⁶ Applicant is to place a check mark here if English language Translation is attached.

This collection of information is required by 37 CFR 1.97 and 1.98. The information is required to obtain or retain a benefit by the public which is to file (and by the USPTO to process) an application. Confidentiality is governed by 35 U.S.C. 122 and 37 CFR 1.14. This collection is estimated to take 2 hours to complete, including gathering, preparing, and submitting the completed application form to the USPTO. Time will vary depending upon the individual case. Any comments on the amount of time you require to complete this form and/or suggestions for reducing this burden, should be sent to the Chief Information Officer, U.S. Patent and Trademark Office, P.O. Box 1450, Alexandria, VA 22313-1450. DO NOT SEND FEES OR COMPLETED FORMS TO THIS ADDRESS. SEND TO: Commissioner for Patents, P.O. Box 1450, Alexandria, VA 22313-1450.

If you need assistance in completing the form, call 1-800-PTO-9199 (1-800-786-9199) and select option 2.

Under the Paperwork Reduction Act of 1995, no persons are required to respond to a collection of information unless it contains a valid OMB control number.

Substitute for form 1449/PTO		Complete if Known	
		Application Number	10/316,961
INFORMATION DISCLOSURE STATEMENT BY APPLICANT (Use as many sheets as necessary)		Filing Date	12/11/2002
		First Named Inventor	Ira Marlowe
		Art Unit	2615
		Examiner Name	Kurr, Jason R.
		Attorney Docket Number	99879-00005
Sheet	2	of	3

NON PATENT LITERATURE DOCUMENTS			
Examiner Initials*	Cite No. ¹	Include name of the author (in CAPITAL LETTERS), title of the article (when appropriate), title of the item (book, magazine, journal, serial, symposium, catalog, etc.), date, page(s), volume-issue number(s), publisher, city and/or country where published.	T ²
	17	Copy of Office Action dated August 8, 2006, from co-pending Application Serial No.: 10/732,909 (29 pages)	
	18	Copy of Interview Summary dated December 15, 2006, from co-pending Application Serial No.: 10/732,909 (3 pages)	
	19	Copy of Interview Summary dated January 3, 2007, from co-pending Application Serial No.: 10/732,909 (3 pages)	
	20	Copy of Office Action dated April 20, 2007, from co-pending Application Serial No.: 10/732,909 (20 pages)	
	21	Copy of Office Action dated October 3, 2007, from co-pending Application Serial No.: 10/732,909 (28 pages)	
	22	Copy of Interview Summary dated October 26, 2007, from co-pending Application Serial No.: 10/732,909 (3 pages)	
	23	International Search Report of the International Searching Authority mailed May 12, 2004, issued in connection with International Patent Appln. No. PCT/US03/39493 (4 pages)	
	24	International Search Report of the International Searching Authority mailed Sept. 24, 2007, issued in connection with International Patent Appln. No. PCT/US06/008043 (4 pages)	
	25	Written Opinion of the International Searching Authority mailed Sept. 24, 2007, issued in connection with International Patent Appln. No. PCT/US06/008043 (5 pages)	
	26	International Preliminary Report on Patentability issued Oct. 16, 2007, issued in connection with International Patent Appln. No. PCT/US06/008043 (1 page)	

Examiner Signature	Date Considered
---------------------------	------------------------

*EXAMINER: Initial if reference considered, whether or not citation is in conformance with MPEP 609. Draw line through citation if not in conformance and not considered. Include copy of this form with next communication to applicant.
 1 Applicant's unique citation designation number (optional). 2 Applicant is to place a check mark here if English language Translation is attached.
 This collection of information is required by 37 CFR 1.98. The information is required to obtain or retain a benefit by the public which is to file (and by the USPTO to process) an application. Confidentiality is governed by 35 U.S.C. 122 and 37 CFR 1.14. This collection is estimated to take 2 hours to complete, including gathering, preparing, and submitting the completed application form to the USPTO. Time will vary depending upon the individual case. Any comments on the amount of time you require to complete this form and/or suggestions for reducing this burden, should be sent to the Chief Information Officer, U.S. Patent and Trademark Office, P.O. Box 1450, Alexandria, VA 22313-1450. DO NOT SEND FEES OR COMPLETED FORMS TO THIS ADDRESS. SEND TO: Commissioner for Patents, P.O. Box 1450, Alexandria, VA 22313-1450.

If you need assistance in completing the form, call 1-800-PTO-9199 (1-800-786-9199) and select option 2.

Under the Paperwork Reduction Act of 1995, no persons are required to respond to a collection of information unless it contains a valid OMB control number.

Substitute for form 1449/PTO		Complete if Known	
		Application Number	10/316,961
INFORMATION DISCLOSURE STATEMENT BY APPLICANT (Use as many sheets as necessary)		Filing Date	12/11/2002
		First Named Inventor	Ira Marlowe
		Art Unit	2615
		Examiner Name	Kurr, Jason R.
		Attorney Docket Number	99879-00005
Sheet	3	of	3

NON PATENT LITERATURE DOCUMENTS			
Examiner Initials*	Cite No. ¹	Include name of the author (in CAPITAL LETTERS), title of the article (when appropriate), title of the item (book, magazine, journal, serial, symposium, catalog, etc.), date, page(s), volume-issue number(s), publisher, city and/or country where published.	T ²
	27	Russian Official Action with translation, issued by the Patent Office of the Russian Federation on Dec. 24, 2007, in connection with Russian App. No. 2006101060 (21 pages)	
	28	Written Opinion, mailed by the Australian Patent Office on Aug. 28, 2007, in connection with Singapore App. No. 200601303-1 (6 pages)	

Examiner Signature	Date Considered
-------------------------------	----------------------------

*EXAMINER: Initial if reference considered, whether or not citation is in conformance with MPEP 609. Draw line through citation if not in conformance and not considered. Include copy of this form with next communication to applicant.

¹ Applicant's unique citation designation number (optional). ² Applicant is to place a check mark here if English language Translation is attached. This collection of information is required by 37 CFR 1.98. The information is required to obtain or retain a benefit by the public which is to file (and by the USPTO to process) an application. Confidentiality is governed by 35 U.S.C. 122 and 37 CFR 1.14. This collection is estimated to take 2 hours to complete, including gathering, preparing, and submitting the completed application form to the USPTO. Time will vary depending upon the individual case. Any comments on the amount of time you require to complete this form and/or suggestions for reducing this burden, should be sent to the Chief Information Officer, U.S. Patent and Trademark Office, P.O. Box 1450, Alexandria, VA 22313-1450. DO NOT SEND FEES OR COMPLETED FORMS TO THIS ADDRESS. SEND TO: Commissioner for Patents, P.O. Box 1450, Alexandria, VA 22313-1450.

If you need assistance in completing the form, call 1-800-PTO-9199 (1-800-786-9199) and select option 2.

(19) World Intellectual Property Organization
International Bureau



(43) International Publication Date
3 January 2008 (03.01.2008)

PCT

(10) International Publication Number
WO 2008/002954 A2

- (51) **International Patent Classification:**
H05K 11/02 (2006.01) *H04B 1/06* (2006.01)
- (21) **International Application Number:**
PCT/US2007/072182
- (22) **International Filing Date:** 27 June 2007 (27.06.2007)
- (25) **Filing Language:** English
- (26) **Publication Language:** English
- (30) **Priority Data:**
11/475,847 27 June 2006 (27.06.2006) US
11/805,799 24 May 2007 (24.05.2007) US
- (71) **Applicant and**
- (72) **Inventor:** MARLOWE, Ira [US/US]; 6403 Hilltop Court, Fort Lee, NJ 07102 (US).

AT, AU, AZ, BA, BB, BG, BH, BR, BW, BY, BZ, CA, CH, CN, CO, CR, CU, CZ, DE, DK, DM, DO, DZ, EC, EE, EG, ES, FI, GB, GD, GE, GH, GM, GT, HN, HR, HU, ID, IL, IN, IS, JP, KE, KG, KM, KN, KP, KR, KZ, LA, LC, LK, LR, LS, LT, LU, LY, MA, MD, ME, MG, MK, MN, MW, MX, MY, MZ, NA, NG, NI, NO, NZ, OM, PG, PH, PL, PT, RO, RS, RU, SC, SD, SE, SG, SK, SL, SM, SV, SY, TJ, TM, TN, TR, TT, TZ, UA, UG, US, UZ, VC, VN, ZA, ZM, ZW.

(84) **Designated States** (*unless otherwise indicated, for every kind of regional protection available*): ARIPO (BW, GH, GM, KE, LS, MW, MZ, NA, SD, SL, SZ, TZ, UG, ZM, ZW), Eurasian (AM, AZ, BY, KG, KZ, MD, RU, TJ, TM), European (AT, BE, BG, CH, CY, CZ, DE, DK, EE, ES, FI, FR, GB, GR, HU, IE, IS, IT, LT, LU, LV, MC, MT, NL, PL, PT, RO, SE, SI, SK, TR), OAPI (BF, BJ, CF, CG, CI, CM, GA, GN, GQ, GW, ML, MR, NE, SN, TD, TG).

Published:

— *without international search report and to be republished upon receipt of that report*

For two-letter codes and other abbreviations, refer to the "Guidance Notes on Codes and Abbreviations" appearing at the beginning of each regular issue of the PCT Gazette.



WO 2008/002954 A2

(54) **Title:** MULTIMEDIA DEVICE INTEGRATION SYSTEM

(57) **Abstract:** A multimedia device integration system is provided. One or more after-market audio or video devices, such as a CD player, CD changer, digital media device, satellite receiver, DAB receiver, video device, digital camera, cellular telephone, portable navigation device, or any other device or combinations thereof, is integrated for use with an existing OEM or after-market car stereo or video system, wherein control commands can be issued at the car stereo or video system and data from the after-market device can be displayed on the car stereo or video system. Instructions generated at the car stereo or video system are received, processed, converted into a format recognizable by the after-market device, and dispatched to the after-market device for execution. Information from the after-market device is converted into a format recognizable by the car stereo or video system, and dispatched to the car stereo or video system for display thereon. The integration subsystem could be provided as an integrated circuit that can be installed in a car audiovisual system or a portable audiovisual device. A wireless or inductive battery charging circuit could be provided for wirelessly or inductively charging a battery of a portable after-market device.

MULTIMEDIA DEVICE INTEGRATION SYSTEM

SPECIFICATIONBACKGROUND OF THE INVENTIONFIELD OF THE INVENTION

The present invention relates to a multimedia device integration system. More specifically, the present invention relates to a multimedia device integration system for integrating after-market components such as satellite receivers, CD players, CD changers, digital media devices (*e.g.*, MP3 players, MP4 players, WMV players, Apple iPod devices, portable media centers, and other devices), Digital Audio Broadcast (DAB) receivers, auxiliary audio sources, video devices (*e.g.*, DVD players), cellular telephones, and other devices for use with factory-installed (OEM) or after-market car stereo and video systems.

RELATED ART

Automobile audio systems have continued to advance in complexity and the number of options available to automobile purchasers. Early audio systems offered a simple AM and/or FM tuner, and perhaps an analog tape deck for allowing cassettes, 8-tracks, and other types of tapes to be played while driving. Such early systems were closed, in that external devices could not be easily integrated therewith.

With advances in digital technology, CD players have been included with automobile audio systems. Original Equipment Manufacturers (OEMs) often produce car stereos having CD players and/or changers for allowing CDs to be played while driving. However, such systems often include proprietary buses and protocols that do not allow after-market audio systems, such as satellite receivers (*e.g.*, XM satellite tuners), digital audio broadcast (DAB) receivers, digital media players (*e.g.*, Apple iPod, MP3, MP4, WMV, etc.), CD changers, auxiliary input sources, video devices (*e.g.*, DVD players), cellular telephones, and the like, to be easily integrated therewith. Thus, automobile purchasers are frequently forced to either entirely replace the OEM audio system, or use same throughout the life of the vehicle or the duration of ownership. Even if the OEM radio is replaced with an after-market radio, the after-market radio also frequently is not operable with an external device.

A particular problem with integrating after-market audio and video systems with existing car stereo and video systems is that signals generated by both systems are in proprietary formats, and are not capable of being processed by the after-market system. Additionally, signals generated by the after-market system are also in a proprietary format that is not recognizable by the car stereo or video system. Thus, in order to integrate after-market systems with existing car stereo and video systems, it is necessary to convert signals between such systems.

It known in the art to provide one or more expansion modules for OEM and after-market car stereos for allowing external audio products to be integrated with the car stereo. However, such expansion modules only operate with and allow integration of external audio products manufactured by the same manufacturer as the OEM / after-market car stereo. For example, a satellite receiver manufactured by PIONEER, Inc., cannot be integrated with an OEM car radio manufactured by TOYOTA or an after-market car radio manufactured by CLARION, Inc. Thus, existing expansion modules only serve the limited purpose of integrating equipment by the same manufacturer as the car stereo. Thus, it would be desirable to provide an integration system that allows any audio device of any manufacture to be integrated with any OEM or after-market radio system. Further, radio-frequency (RF) transmitters and cassette tape adapters have been developed for allowing music from a device external to a car radio, such as a portable CD player, to be played through the car radio using the FM receiver or the cassette deck of the radio. However, such systems are often prone to interference, and do not provide high fidelity.

Moreover, it would be desirable to provide an integration system that not only achieves integration of various audio and video devices that are alien to a given OEM or after-market car stereo or video system, but also allows for information to be exchanged between the after-market device and the car stereo or video system. For example, it would be desirable to provide a system wherein station, track, time, and song information can be retrieved from the after-market device, formatted, and transmitted to the car stereo or video system for display thereby, such as at an LCD panel of the car stereo or on one or more display panels of a car video system. Such information could be transmitted and displayed on both hardwired car stereo and video systems (*e.g.*, radios installed in dashboards or at other locations within the car), or integrated for display on one or more software or graphically-driven radio systems operable with graphical display panels.

Additionally, it would be desirable to provide a multimedia device integration system that allows a user to control more than one device, such as a CD or satellite receiver and one or more auxiliary sources, and to quickly and conveniently switch between same using the existing controls of the car stereo or video system. Still further, it would be desirable to provide a multimedia device integration system that allows for wireless integration of portable devices for use with car audio and/or video systems, wherein full remote control of the portable device is provided at the controls of the car system.

Accordingly, the present invention addresses these needs by providing a multimedia device integration system that allows a plurality of after-market devices, such as CD players, CD changers, digital media devices (*e.g.*, MP3 players, MP4 players, Apple iPod, WMV players, portable media centers, and other devices), satellite receivers, DAB receivers, auxiliary input sources, video devices (*e.g.*, DVD players), cellular telephones, digital cameras, portable navigation devices, or any combination thereof, to be integrated into existing car stereo and video systems while allowing information to be displayed on, and control to be provided from, the car stereo or video system.

SUMMARY OF THE INVENTION

The present invention relates to a multimedia device integration system. One or more after-market audio devices, such as CD players, CD changers, digital media devices (*e.g.*, MP3 players, MP4 players, WMV players, Apple iPod devices, portable media centers), digital cameras, satellite receivers (*e.g.*, XM or Sirius receivers), digital audio broadcast (DAB) receivers, portable navigation devices, or auxiliary input sources, can be connected to and operate with an existing stereo system in an automobile, such as an OEM car stereo system or an after-market car stereo system installed in the automobile. The integration system connects to and interacts with the car stereo at any available port of the car stereo, such as a CD input port, a satellite input, or other known type of connection. If the car stereo system is an after-market car stereo system, the present invention generates a signal that is sent to the car stereo to keep same in an operational state and responsive to external data and signals. Commands generated at the control panel are received by the present invention and converted into a format recognizable by the after-market device. The formatted commands are executed by the after-market device, and audio therefrom is channeled to the car stereo. Information from the after-market device is received by the present invention, converted into a format recognizable by the car stereo, and forwarded to the car stereo for display thereby. The formatted information could include information relating to a CD or MP3 track being played, channel, song, and artist information from a satellite receiver or DAB receiver, or video information from one or more external devices connected to the present invention. The information can be presented as one or more menus, textual, or graphical prompts for display on an LCD display of the radio, allowing interaction with the user at the radio. A docking port may be provided for allowing portable external audio devices to be connected to the interface of the present invention.

In an embodiment of the present invention, a dual-input device is provided for integrating both an external audio device and an auxiliary input with an OEM or after-market car stereo. The user can select between the external audio device and the auxiliary input using the controls of the car stereo. The invention can automatically detect the type of device connected to the auxiliary input, and integrate same with the car stereo.

In another embodiment of the present invention, an interface is provided for integrating a plurality of auxiliary input sources with an existing car stereo system. A user can select between the auxiliary sources using the control panel of the car stereo. One or

more after-market audio devices can be integrated with the auxiliary input sources, and a user can switch between the audio device and the auxiliary input sources using the car stereo. Devices connected to the auxiliary input sources are inter-operable with the car stereo, and are capable of exchanging commands and data via the interface.

In another embodiment of the present invention, an interface is provided for integrating an external device for use with a car stereo or video system, wherein the interface is positioned within the car stereo or video system. The system comprises a car stereo or video system; an after-market device external to the car stereo or video system; an interface positioned within the car stereo or video system and connected between the car stereo or video system and the after-market device for exchanging data and audio or video signals between the car stereo or video system and the after-market device; means for processing and dispatching commands for controlling the after-market device from the car stereo or video system in a format compatible with the after-market device; and means for processing and displaying data from the after-market device on a display of the car stereo or video system in a format compatible with the car stereo or video system. The after-market device could comprise one or more of a CD changer, CD player, satellite receiver (*e.g.*, XM or Sirius), digital media device (*e.g.*, MP3, MP4, WMV, or Apple iPod device), video device (*e.g.*, DVD player), cellular telephone, or any combination thereof.

In another embodiment of the present invention, an interface is provided for integrating a cellular telephone for use with a car stereo or video system. The system comprises a car stereo or video system; a cellular telephone external to the car stereo or video system; an interface connected between the car stereo or video system and the cellular telephone for exchanging data and audio or video signals between the car stereo or video system and the cellular telephone; means for processing and dispatching commands for controlling the cellular telephone from the car stereo or video system in a format compatible with the cellular telephone; and means for processing and displaying data from the cellular telephone on a display of the car stereo or video system in a format compatible with the car stereo or video system.

In another embodiment of the present invention, an interface is provided for integrating an external video system for use with a car video system. The system comprises a car video system; an after-market video device external to the car video

system; an interface connected between the car video system and the after-market video device for exchanging data, audio, and video signals between the car video system and the after-market video device; means for processing and dispatching commands for controlling the after-market video device from the car video system in a format compatible with the after-market video device; and means for processing and displaying data from the after-market video device on a display of the car video system in a format compatible with the car video system.

The present invention also provides an interface for integrating a plurality of after-market devices for use with a car stereo or video system using a single interface. In one embodiment, the system comprises an interface in electrical communication with a car stereo or video system and an after-market device; a plurality of configuration jumpers in the interface for specifying a first device type corresponding to the car stereo or video system and a second device type corresponding to the after-market device; and a plurality of protocol conversion software blocks stored in memory in the interface for converting signals from the after-market device into a first format compatible with the car stereo or video system and for converting signals from the car stereo or video system into a second format compatible with the after-market device, wherein at least one of the protocol conversion software blocks are selected by the interface using settings of the plurality of configuration jumpers. In another embodiment, the system comprises an interface in electrical communication with a car stereo or video system and an after-market device; first and second wiring harnesses attached to the interface, wherein the first wiring harness includes a first electrical configuration corresponding to the car stereo or video system and the second wiring harness includes a second electrical configuration corresponding to the after-market device; and a plurality of protocol conversion software blocks stored in memory in the interface for converting signals from the after-market device into a first format compatible with the car stereo or video system and for converting signals from the car stereo or video system into a second format compatible with the after-market device, wherein at least one of the protocol conversion software blocks are selected by the interface using the first and second electrical configurations of the first and second wiring harnesses. A plurality of wiring harnesses can be provided for integrating a plurality of devices.

The present invention also provides a method for integrating an after-market device for use with a car stereo or video system, comprising the steps of interconnecting the car stereo or video system and the after-market device with an interface; determining a first device type corresponding to the car stereo or video system and a second device type corresponding to the after-market device; loading a protocol conversion software block from memory in the interface using the first and second device types; converting signals from the after-market device into a first format compatible with the car stereo or video system using the protocol conversion software block; and converting signals from the car stereo or video system into a second format compatible with the after-market device using the protocol conversion software block.

The present invention further provides a multimedia device integration system that allows for the wireless integration of a portable audio and/or video device with a car audio and/or video system. The portable device could comprise a CD changer, CD player, satellite receiver (*e.g.*, XM or Sirius), digital media device (*e.g.*, MP3, MP4, WMV, or Apple iPod device), video device (*e.g.*, DVD player), or a cellular telephone. The portable device includes a wireless interface and an integration subsystem positioned within the portable device. The wireless interface establishes a wireless communications channel between the portable device and the car system, and allows for the wireless exchange of control commands, data, video, and audio signals between the portable device and the car system. The integration module receives control commands issued at the car system and transmitted over the wireless channel, processes same into a format compatible with the portable device, and dispatches same to the portable device for execution thereby. The integration module also receives data from the portable device (including, but not limited to, track information, song information, artist information, time information, and other related information), processes the data into a format compatible with the car system, and transmits same over the wireless channel to the car system for display thereon. Optionally, the integration module could be positioned within the car system.

The integration module could also include a voice recognition subsystem for acquiring spoken commands from a user, converting same into control commands compatible with the portable device, and dispatching the processed control commands to the portable device for execution thereby. The voice commands could be received at the

car audio and/or video system (i.e., using a microphone connected to the car audio and/or video system or some other vehicle component), or at the portable device (i.e., using a microphone connected to or forming a part of the portable device). Additionally, the integration module could include a speech synthesizer for generating synthesized speech for conveying data generated by the portable device to a user. The synthesized speech could be channeled to the car audio and/or video system by the integration module to be played through the car audio and/or video system.

The present invention further provides a multimedia device integration system that allows for the integration of a portable audio and/or video device with a car audio and/or video system using a docking slot provided in the car system. The portable device includes an integration module positioned within the portable device and an external interface for allowing electrical communication with the car system via the docking slot. Optionally, the integration module could be positioned within the car audio or video system. The integration module could also include a voice recognition subsystem for acquiring spoken commands from a user, converting same into control commands compatible with the portable device, and dispatching the processed control commands to the portable device for execution thereby. Additionally, the integration module could include a speech synthesizer for generating synthesized speech for conveying data generated by the portable device to a user.

The present invention also provides a multimedia device integration system which allows a digital camera, such as a still digital camera or a digital video camera, to be integrated for use with an existing car audiovisual system. Data, video, and/or audio from the digital camera is received by the interface, processed into a format compatible with the car audiovisual system, and transmitted thereto for display on and/or playing through the car audiovisual system. Control commands for controlling the digital camera, which can be issued at the car audiovisual system, are received by the interface, processed into a format compatible with the digital camera, and transmitted thereto for execution by the digital camera.

The present invention also provides a multimedia device integration system which allows a portable navigation device, such as a portable GPS receiver, to be integrated for use with an existing car audiovisual system. Data, video, and/or audio from the portable navigation device is received by the interface, processed into a format compatible with the

car audiovisual system, and transmitted thereto for display on and/or playing through the car audiovisual system. Control commands for controlling the portable navigation device, which can be issued at the car audiovisual system, are received by the interface, processed into a format compatible with the portable navigation device, and transmitted thereto for execution by the portable navigation device.

The present invention also provides an interface integrated circuit that allows for the integration of an external portable audio and/or video device with a car audiovisual system, and which can be installed within the car audiovisual system. The interface integrated circuit could communicate with the portable audio and/or video device using one or more communications ports or a wireless transceiver. A manufacturer of a car audiovisual system could be provided with the interface integrated circuit and an electrical schematic for installing same. The interface integrated circuit could be provided with pre-installed firmware for converting data, audio, and/or video signals generated by the portable audio and/or video device into a format compatible with the car audiovisual system, and for converting control commands issued by the car audiovisual system into a format compatible with the portable audio and/or video device for execution thereby. The integrated circuit could also be installed in the portable audio and/or video device, or it could be embodied as a software product which is functionally equivalent to the integrated circuit and which is executed by an existing microprocessor of either the car audiovisual system or the portable audio and/or video device.

BRIEF DESCRIPTION OF THE DRAWINGS

These and other important features of the present invention will be apparent from the following Detailed Description of the Invention, taken in connection with the accompanying drawings, in which:

FIG. 1 is a block diagram showing the multimedia device integration system of the present invention.

FIG. 2A is a block diagram showing an alternate embodiment of the multimedia device integration system of the present invention, wherein a CD player is integrated with a car radio.

FIG. 2B is a block diagram showing an alternate embodiment of the multimedia device integration system of the present invention, wherein a MP3 player is integrated with a car radio.

FIG. 2C is a block diagram showing an alternate embodiment of the multimedia device integration system of the present invention, wherein a satellite or DAB receiver is integrated with a car radio.

FIG. 2D is a block diagram showing an alternate embodiment of the multimedia device integration system of the present invention, wherein a plurality of auxiliary input sources are integrated with a car radio.

FIG. 2E is a block diagram showing an alternate embodiment of the multimedia device integration system of the present invention, wherein a CD player and a plurality of auxiliary input sources are integrated with a car radio.

FIG. 2F is a block diagram showing an alternate embodiment of the present invention, wherein a satellite or DAB receiver and a plurality of auxiliary input source are integrated with a car radio.

FIG. 2G is a block diagram showing an alternate embodiment of the present invention, wherein a MP3 player and a plurality of auxiliary input sources are integrated with a car radio.

FIG. 2H is a block diagram showing an alternate embodiment of the present invention, wherein a plurality of auxiliary interfaces and an audio device are integrated with a car stereo.

FIG. 3A is a circuit diagram showing a device according to the present invention for integrating a CD player or an auxiliary input source with a car radio.

FIG. 3B is a circuit diagram showing a device according to the present invention for integrating both a CD player and an auxiliary input source with a car radio, wherein the CD player and the auxiliary input are switchable by a user.

FIG. 3C is a circuit diagram showing a device according to the present invention for integrating a plurality of auxiliary input sources with a car radio.

FIG. 3D is a circuit diagram showing a device according to the present invention for integrating a satellite or DAB receiver with a car radio.

FIG. 4A is a flowchart showing processing logic according to the present invention for integrating a CD player with a car radio.

FIG. 4B is a flowchart showing processing logic according to the present invention for integrating a MP3 player with a car radio.

FIG. 4C is a flowchart showing processing logic according to the present invention for integrating a satellite receiver with a car radio.

FIG. 4D is a flowchart showing processing logic according to the present invention for integrating a plurality of auxiliary input sources with a car radio.

FIG. 4E is a flowchart showing processing logic according to the present invention for integrating a CD player and one or more auxiliary input sources with a car radio.

FIG. 4F is a flowchart showing processing logic according to the present invention for integrating a satellite or DAB receiver and one or more auxiliary input sources with a car radio.

FIG. 4G is a flowchart showing processing logic according to the present invention for integrating a MP3 player and one or more auxiliary input sources with a car stereo.

FIG. 5 is a flowchart showing processing logic according to the present invention for allowing a user to switch between an after-market audio device and one or more auxiliary input sources.

FIG. 6 is a flowchart showing processing logic according to the present invention for determining and handling various device types connected to the auxiliary input ports of the invention.

FIG. 7A is a perspective view of a docking station according to the present invention for retaining an audio device within a car.

FIG. 7B is an end view of the docking station of **FIG. 7A**.

FIGS. 8A-8B are perspective views of another embodiment of the docking station of the present invention, which includes the multimedia device integration system of the present invention incorporated therewith.

FIG. 9 is a block diagram showing the components of the docking station of **FIGS. 8A-8B**.

FIG. 10 is a block diagram showing an alternate embodiment of the multimedia device integration system of the present invention, wherein the interface is incorporated within a car stereo or car video system.

FIG. 11A is a diagram showing an alternate embodiment of the multimedia device integration system of the present invention for integrating a cellular telephone for use with a car stereo or video system; **FIG. 11b** is a flowchart showing processing logic for integrating a cellular telephone for use with a car stereo or video system.

FIG. 12A is a diagram showing an alternate embodiment of the multimedia device integration system of the present invention for integrating an after-market video device for use with a car video system; **FIG. 12B** is a flowchart showing processing logic for integrating an after-market video device for use with a car video system.

FIG. 13A is a block diagram showing an alternate embodiment of the multimedia device integration system of the present invention, wherein configuration jumpers and protocol conversion software blocks are provided for integrating after-market devices of various types using a single interface.

FIG. 13B is a block diagram showing an alternate embodiment of the multimedia device integration system of the present invention, wherein wiring harnesses and protocol conversion software blocks are provided for integrating after-market devices of various types using a single interface.

FIG. 14 is a flowchart showing processing logic of the multimedia device integration system of the present invention for integrating after-market devices of various types using a single interface.

FIG. 15 is a flowchart showing processing logic of the multimedia device integration system of the present invention for allowing a user to specify one or more after-market device types for integration using a single interface.

FIG. 16 is a flowchart showing processing logic of the multimedia device integration system of the present invention for allowing a user to quickly navigate through

a list of songs on one or more after-market devices using the controls of a car stereo or video system.

FIG. 17 is a diagram showing another embodiment of the present invention, wherein a plurality of external devices are integrated using a single interface.

FIG. 18 is a diagram showing another embodiment of the present invention, wherein wireless integration is provided between a car audio and/or video system and a portable audio and/or video device using a wireless transceiver and an integration module positioned within the portable device.

FIG. 19 is a diagram showing another embodiment of the present invention, wherein wireless integration is provided between a car audio and/or video system and a portable audio and/or video device using a wireless transceiver and an integration module positioned within the car audio and/or video system.

FIG. 20 is a diagram showing another embodiment of the present invention, wherein a docking slot is provided in a car audio and/or video system for receiving a portable audio and/or video device, and an integration module is positioned within the portable device.

FIG. 21 is a diagram showing another embodiment of the present invention, wherein a docking slot is provided in a car audio and/or video system for receiving a portable audio and/or video device, and an integration module is positioned within the car audio and/or video system.

FIG. 22 is a diagram showing another embodiment of the present invention, wherein wireless integration is provided between a car audio and/or video system and a portable audio and/or video device, and the portable device includes an integration module having speech synthesis and recognition capabilities.

FIG. 23 is a diagram showing another embodiment of the present invention, wherein wireless integration is provided between a car audio and/or video system and a portable audio and/or video device, and the car audio and/or video system includes an integration module having speech synthesis and recognition capabilities.

FIG. 24 is a flowchart showing processing logic according to the present invention for wirelessly integrating a portable audio and/or video device for use with a car audio or video system.

FIG. 25A is a diagram showing another embodiment of the multimedia device integration system of the present invention for integrating a digital camera for use with a car audiovisual system; **FIG. 25B** is a flowchart showing processing logic for integrating the digital camera for use with the car audiovisual system.

FIG. 26A is a diagram showing another embodiment of the multimedia device integration system of the present invention for integrating a portable navigation device for use with a car audiovisual system; **FIG. 26B** is a flowchart showing processing logic for integrating the portable navigation device for use with the car audiovisual system.

FIG. 27 is a diagram showing another embodiment of the multimedia device integration system of the present invention, wherein the integration system is provided as an integrated circuit installed within a car audiovisual system.

DETAILED DESCRIPTION OF THE INVENTION

The present invention relates to a multimedia device integration system. One or more after-market devices, such as a CD player, CD changer, digital media player (*e.g.*, MP3 player, MP4 player, WMV player, Apple iPod, portable media center, or other device), satellite receiver, digital audio broadcast (DAB) receiver, video device (*e.g.*, DVD player), cellular telephone, or the like, can be integrated with an existing car radio or car video device, such as an OEM or after-market car stereo or video system. Control of the after-market device is enabled using the car stereo or car video system, and information from the after-market device, such as channel, artist, track, time, song, and other information, is retrieved from the after-market device, processed, and forwarded to the car stereo or car video system for display thereon. The information channeled to the car stereo or video system can include video from the external device, as well as graphical and menu-based information. A user can review and interact with information via the car stereo. Commands from the car stereo or video system are received, processed by the present invention into a format recognizable by the after-market device, and transmitted thereto for execution. One or more auxiliary input channels can be integrated by the present invention with the car stereo or video system. The user can switch between one or more after-market devices and one or more auxiliary input channels using the control panel buttons of the car stereo or video system.

As used herein, the term “integration” or “integrated” is intended to mean connecting one or more external devices or inputs to an existing car stereo or video system via an interface, processing and handling signals, audio, and/or video information, allowing a user to control the devices via the car stereo or video system, and displaying data from the devices on the car stereo or video system. Thus, for example, integration of a CD player with a car stereo system allows for the CD player to be remotely controlled via the control panel of the stereo system, and data from the CD player to be sent to the display of the stereo. Of course, control of after-market devices can be provided at locations other than the control panel of the car stereo or video system without departing from the spirit or scope of the present invention. Further, as used herein, the term “interoperable” is intended to mean allowing the external audio or video device to receive and process commands that have been formatted by the interface of the present invention, as well as allowing a car stereo or video system to display information that is generated by

the external audio or video device and processed by the present invention. Additionally, by the term “inter-operable,” it is meant allowing a device that is alien to the environment of an existing OEM or after-market car stereo or video system to be utilized thereby.

Also, as used herein, the terms “car stereo” and “car radio” are used interchangeably and are intended to include all presently existing car stereos, radios, video systems, such as physical devices that are present at any location within a vehicle, in addition to software and/or graphically- or display-driven receivers. An example of such a receiver is a software-driven receiver that operates on a universal LCD panel within a vehicle and is operable by a user via a graphical user interface displayed on the universal LCD panel. Further, any future receiver, whether a hardwired or a software/graphical receiver operable on one or more displays, is considered within the definition of the terms “car stereo” and “car radio,” as used herein, and is within the spirit and scope of the present invention. Moreover, the term “car” is not limited to any specific type of automobile, but rather, includes all automobiles. Additionally, by the term “after-market,” it is meant any device not installed by a manufacturer at the time of sale of the car.

FIG. 1 is a block diagram showing the multimedia device integration (or interface) system of the present invention, generally indicated at **20**. A plurality of devices and auxiliary inputs can be connected to the interface **20**, and integrated with an OEM or after-market car radio **10**. A CD player or changer **15** can be integrated with the radio **10** via interface **20**. A satellite radio or DAB receiver **25**, such as an XM or Sirius radio satellite receiver or DAB receiver known in the art, could be integrated with the radio **10**, via the interface **20**. Further, an MP3 player **30** could also be integrated with the radio **10** via interface **20**. The MP3 player **30** could be any known digital media device, such as an Apple iPod or any other digital media device. Moreover, a plurality of auxiliary input sources, illustratively indicated as auxiliary input sources **35** (comprising input sources 1 through n , n being any number), could also be integrated with the car radio **10** via interface **20**. Optionally, a control head **12**, such as that commonly used with after-market CD changers and other similar devices, could be integrated with the car radio **10** via interface **20**, for controlling any of the car radio **10**, CD player/changer **15**, satellite/DAB receiver **25**, MP3 player **30**, and auxiliary input sources **35**. Thus, as can be readily appreciated, the interface **20** of the present invention allows for the integration of a multitude of devices and inputs with an OEM or after-market car radio or stereo.

FIG. 2A is a block diagram of an alternate embodiment of the multimedia device interface system of the present invention, wherein a CD player/changer **15** is integrated with an OEM or after-market car radio **10**. The CD player **15** is electrically connected with the interface **20**, and exchanges data and audio signals therewith. The interface **20** is electrically connected with the car radio **10**, and exchanges data and audio signals therewith. In a preferred embodiment of the present invention, the car radio **10** includes a display **13** (such as an alphanumeric, electroluminescent display) for displaying information, and a plurality of control panel buttons **14** that normally operate to control the radio **10**. The interface **20** allows the CD player **15** to be controlled by the control buttons **14** of the radio **10**. Further, the interface **20** allows information from the CD player **15**, such as track, disc, time, and song information, to be retrieved therefrom, processed and formatted by the interface **20**, sent to the display **13** of the radio **10**.

Importantly, the interface **20** allows for the remote control of the CD player **15** from the radio **10** (e.g., the CD player **15** could be located in the trunk of a car, while the radio **10** is mounted on the dashboard of the car). Thus, for example, one or more discs stored within the CD player **15** can be remotely selected by a user from the radio **10**, and tracks on one or more of the discs can be selected therefrom. Moreover, standard CD operational commands, such as pause, play, stop, fast forward, rewind, track forward, and track reverse (among other commands) can be remotely entered at the control panel buttons **14** of the radio **10** for remotely controlling the CD player **15**.

FIG. 2B is a block diagram showing an alternate embodiment of the present invention, wherein an MP3 player **30** is integrated with an OEM or after-market car radio **10** via interface **20**. As mentioned earlier, the interface **20** of the present invention allows for a plurality of disparate audio devices to be integrated with an existing car radio for use therewith. Thus, as shown in **FIG. 2B**, remote control of the MP3 player **30** via radio **10** is provided for via interface **20**. The MP3 player **30** is electronically interconnected with the interface **20**, which itself is electrically interconnected with the car radio **10**. The interface **20** allows data and audio signals to be exchanged between the MP3 player **30** and the car radio **10**, and processes and formats signals accordingly so that instructions and data from the radio **10** are processable by the MP3 player **30**, and vice versa. Operational commands, such as track selection, pause, play, stop, fast forward, rewind, and other commands, are entered via the control panel buttons **14** of car radio **10**, processed by the

interface **20**, and formatted for execution by the MP3 player **30**. Data from the MP3 player, such as track, time, and song information, is received by the interface **20**, processed thereby, and sent to the radio **10** for display on display **13**. Audio from the MP3 player **30** is selectively forwarded by the interface **20** to the radio **10** for playing.

FIG. 2C is a block diagram showing an alternate embodiment of the present invention, wherein a satellite receiver or DAB receiver **25** is integrated with an OEM or after-market car radio **10** via the interface **20**. Satellite/DAB receiver **25** can be any satellite radio receiver known in the art, such as XM or Sirius, or any DAB receiver known in the art. The satellite/DAB receiver **25** is electrically interconnected with the interface **20**, which itself is electrically interconnected with the car radio **10**. The satellite/DAB receiver **25** is remotely operable by the control panel buttons **14** of the radio **10**. Commands from the radio **10** are received by the interface **20**, processed and formatted thereby, and dispatched to the satellite/DAB receiver **25** for execution thereby. Information from the satellite/DAB receiver **25**, including time, station, and song information, is received by the interface **20**, processed, and transmitted to the radio **10** for display on display **13**. Further, audio from the satellite/DAB receiver **25** is selectively forwarded by the interface **20** for playing by the radio **10**.

FIG. 2D is a block diagram showing an alternate embodiment of the present invention, wherein one or more auxiliary input sources **35** are integrated with an OEM or after-market car radio **10**. The auxiliary inputs **35** can be connected to analog sources, or can be digitally coupled with one or more audio devices, such as after-market CD players, CD changers, MP3 players, satellite receivers, DAB receivers, and the like, and integrated with an existing car stereo. Preferably, four auxiliary input sources are connectable with the interface **20**, but any number of auxiliary input sources could be included. Audio from the auxiliary input sources **35** is selectively forwarded to the radio **10** under command of the user. As will be discussed herein in greater detail, a user can select a desired input source from the auxiliary input sources **35** by depressing one or more of the control panel buttons **14** of the radio **10**. The interface **20** receives the command initiated from the control panel, processes same, and connects the corresponding input source from the auxiliary input sources **35** to allow audio therefrom to be forwarded to the radio **10** for playing. Further, the interface **20** determines the type of audio devices connected to the auxiliary input ports **35**, and integrates same with the car stereo **10**.