



US005227169A

United States Patent [19]

[11] Patent Number: **5,227,169**

Heiber et al.

[45] Date of Patent: **Jul. 13, 1993**

[54] **SORBITAN ESTERS AS SKIN PERMEATION ENHANCERS**

[56]

References Cited

U.S. PATENT DOCUMENTS

4,362,737	12/1982	Schäfer	514/399
4,690,683	9/1987	Chien et al.	424/449
4,710,191	12/1987	Kwiatek et al.	424/449
4,746,509	5/1988	Haggiage et al.	514/947
4,879,119	11/1989	Konno et al.	424/449
4,898,920	2/1990	Lee et al.	424/448

[75] Inventors: **Sonia Heiber, Salt Lake City; Dinesh Patel, Murray; Charles D. Ebert, Salt Lake City, all of Utah**

[73] Assignee: **Theratech, Inc., Salt Lake City, Utah**

[21] Appl. No.: **848,110**

Primary Examiner—Thurman K. Page

Assistant Examiner—Leon R. Horne

Attorney, Agent, or Firm—Morrison & Foerster

[22] Filed: **Mar. 9, 1992**

[57]

ABSTRACT

Related U.S. Application Data

[62] Division of Ser. No. 702,043, May 17, 1991, Pat. No. 5,122,383.

Skin permeation enhancer compositions are provided which increase the permeability of skin to transdermally administered pharmacologically active agents. The compositions contain a sorbitan ester in addition to the selected pharmacologically active agent, and may also contain a C₁-C₄ aliphatic alcohol. Methods and transdermal drug delivery systems for using the compositions are also provided.

[51] Int. Cl.⁵ **A61F 13/00**

[52] U.S. Cl. **424/449; 424/443; 424/447; 424/448**

[58] Field of Search **424/448, 449; 514/946, 514/947, 443**

27 Claims, 1 Drawing Sheet

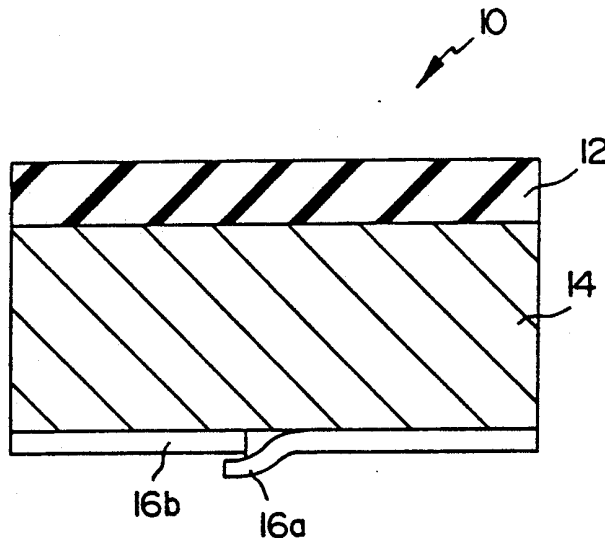

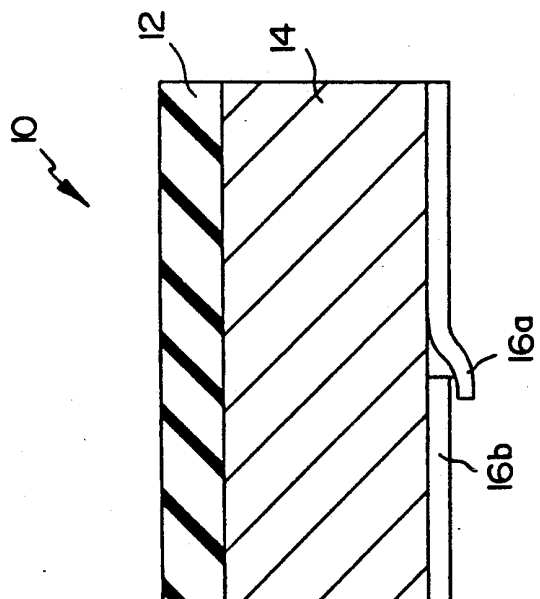

FIG. 1

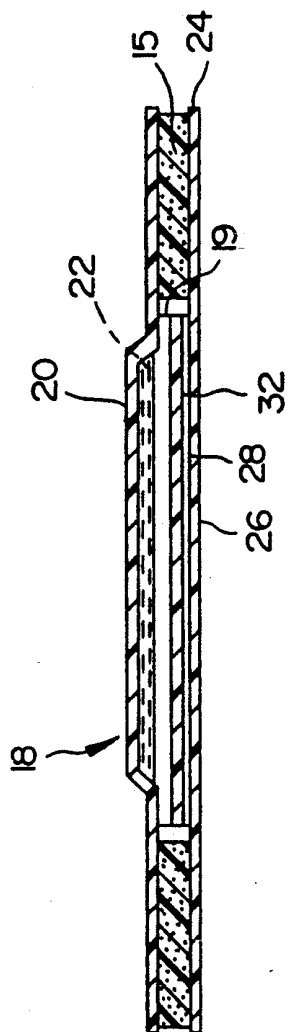

FIG. 2

SORBITAN ESTERS AS SKIN PERMEATION ENHANCERS

This application is a division of application Ser. No. 07/702,043 filed May 17, 1991, now U.S. Pat. No. 5,122,383 issued Jun. 16, 1992.

TECHNICAL FIELD

The present invention relates generally to the transdermal administration of pharmacologically active agents, and more particularly relates to methods and compositions for enhancing the permeability of the skin to such agents.

BACKGROUND

The delivery of drugs through the skin provides many advantages; primarily, such a means of delivery is a comfortable, convenient and noninvasive way of administering drugs. The variable rates of absorption and metabolism encountered in oral treatment are avoided, and other inherent inconveniences—e.g., gastrointestinal irritation and the like—are eliminated as well. Transdermal drug delivery also makes possible a high degree of control over blood concentrations of any particular drug.

Skin is a structurally complex, relatively thick membrane. Molecules moving from the environment into and through intact skin must first penetrate the stratum corneum and any material on its surface. They must then penetrate the viable epidermis, the papillary dermis, and the capillary walls into the blood stream or lymph channels. To be so absorbed, molecules must overcome a different resistance to penetration in each type of tissue. Transport across the skin membrane is thus a complex phenomenon. However, it is the cells of the stratum corneum which present the primary barrier to absorption of topical compositions or transdermally administered drugs. The stratum corneum is a thin layer of dense, highly keratinized cells approximately 10–15 microns thick over most of the body.

In order to increase skin permeability, and in particular to increase the permeability of the stratum corneum (i.e., so as to achieve enhanced penetration, through the skin, of the drug to be administered transdermally), the skin may be pretreated with a penetration enhancing agent (or "permeation enhancer", as sometimes referred to herein) prior to application of a drug. Alternatively, and preferably, a drug and a permeation enhancer are delivered concurrently.

The present invention is directed to a novel composition for enhancing the penetration of pharmacologically active agents through skin, the composition based on a sorbitan ester as will be described herein. The composition may or may not contain an aliphatic alcohol as an additional component. The sorbitan ester compositions of the invention have been found by the inventors herein to be particularly effective in enhancing the penetration of pharmaceutically active agents through skin.

While there are a number of patents and publications available which relate to the transdermal administration of drugs and to skin permeation enhancer compositions, applicants are unaware of any art which suggests that sorbitan esters are useful as permeation enhancers in the absence of additional permeation enhancing compounds or which describes the sorbitan ester/aliphatic alcohol compositions as described and claimed herein.

CITATION OF ART

The following references relate to one or more aspects of the present invention.

- Skin permeation enhancers, generally: Various compounds for enhancing the permeability of skin are known in the art. U.S. Pat. Nos. 4,006,218, 3,551,554 and 3,472,931, for example, respectively describe the use of dimethylsulfoxide (DMSO), dimethyl formamide (DMF) and N,N-dimethylacetamide (DMA) to enhance the absorption of pharmacologically active agents through the stratum corneum. Other compounds which have been used to enhance skin permeability include: decylmethylsulfoxide (C₁₀MSO); diethylene glycol monoethyl ether; polyethylene glycol monolaurate (PEGML; see, e.g., U.S. Pat. No. 4,568,343); glycerol monolaurate (U.S. Pat. No. 4,746,515); propylene glycol monolaurate; ethanol (e.g., as in U.S. Pat. No. 4,379,454); eucalyptol (U.S. Pat. No. 4,440,777; lecithin (U.S. Pat. No. 4,783,450); the 1-substituted azacycloheptan-2-ones, particularly 1-n-dodecylazacycloheptan-2-one (available under the trademark Azone® from Nelson Research & Development Co., Irvin, Cal.; see U.S. Pat. Nos. 3,989,816, 4,316,893, 4,405,616 and 4,557,934); propylene glycol in combination with a fatty acid such as linoleic acid (European Patent Publication No. 261429); "cell envelope disordering compounds" such as methyl laurate or oleic acid in combination with N-(hydroxyethyl) pyrrolidone (U.S. Pat. No. 4,537,776); C₃–C₄ diols (U.S. Pat. No. 4,552,872, European Patent Application Publication No. 043738); or a binary system of oleic acid, oleins or oleyl alcohol in combination with a lower alcohol (U.S. Pat. No. 4,863,970).
- Sorbitan analogs as permeation enhancers, specifically: T. Ogiso et al., *J. Pharmacobio-Dyn.*, 9:517–525 (1986), presents studies on percutaneous absorption in vivo and the penetration in vitro of indomethacin. Sorbitan monooleate, was tested as a permeation enhancer in combination with a dimethyl sulfoxide (DMSO) gel and was found to have no enhancing effect. T. Ogiso et al., *J. Pharm. Sci.*, 78(4):319–323 (1989), describes the combined use of laurocapram and sorbitan monooleate in a permeation enhancer composition also containing a DMSO gel, for the transdermal administration of indomethacin. W.-W. Shen et al., *J. Pharm. Sci.*, 65(12):1780–1783 (1986), describes the effect of various nonionic surfactants, including sorbitan monopalmitate and sorbitan trioleate, on the percutaneous absorption of salicylic acid. As with the latter two references, the sorbitan esters are used in conjunction with DMSO. U.S. Pat. No. 4,637,930 to Konno et al. describes a transdermal formulation for the administration of nicardipine hydrochloride which contains a mixed liquid composed of urea and an additional compound which may be a sorbitan "middle chain" (6–12 carbon atom) fatty acid ester.

SUMMARY OF THE INVENTION

Accordingly, it is a primary object of the invention to provide a method for enhancing the rate of penetration of a pharmacologically active agent through the skin.

It is another object of the invention to provide such a method which involves applying to a selected area of intact skin a therapeutically effective amount of the selected pharmacologically active agent in combination with a permeation enhancer composition containing a sorbitan ester.

It is still another object of the invention to provide such a method wherein the permeation enhancer composition consists essentially of: (1) a sorbitan ester; or (2) a sorbitan ester in combination with an aliphatic alcohol as will be described in detail herein.

It is a further object of the invention to provide a skin permeation enhancer composition comprising the pharmacologically active agent and a permeation enhancer composition which consists essentially of: (1) a sorbitan ester; or (2) a sorbitan ester in combination with an aliphatic alcohol.

It is still a further object of the invention to provide a transdermal system in the form of a laminated composite designed to adhere to the skin. The composite contains, in addition to the selected pharmacologically active agent to be administered, a permeation enhancer composition containing a sorbitan ester, and, optionally, an aliphatic alcohol.

Additional objects, advantages and novel features of the invention will be set forth in part in the description which follows, and in part will become apparent to those skilled in the art upon examination of the following, or may be learned by practice of the invention.

In one aspect, the invention is a method for administering a pharmacologically active agent transdermally so as to achieve relatively high transdermal fluxes, by administering, through a predetermined area of intact skin and for a predetermined period of time, (1) the agent, and (2) a permeation enhancer consisting essentially of a sorbitan ester, or a sorbitan ester in combination with a C₁-C₄ aliphatic alcohol. In a preferred embodiment, the skin permeation enhancer and the drug are administered in a single composition. As the clearance rate of many drugs from the body is quite high, it is generally preferred that administration be substantially continuous throughout the time period chosen for patch application.

In another aspect of the invention, a composition of matter is provided that is useful for the delivery of a pharmacologically active agent through the skin, comprising:

(a) a therapeutically effective amount of the pharmacologically active agent to be administered; and

(b) an amount of a permeation enhancer composition effective to enhance the penetration of the pharmacologically active agent through the skin, wherein the enhancer consists essentially of a sorbitan ester or a sorbitan ester combined with a C₁-C₄ aliphatic alcohol.

In still another aspect of the invention, a therapeutic system is provided for administering a drug transdermally, at relatively high fluxes as noted above, in the form of a skin patch. The skin patch is preferably in the form of a matrix-type laminated composite containing an upper backing layer that is substantially impermeable to the drug, and at least one drug/enhancer reservoir, one of which forms the basal surface of the device and is designed to adhere to the skin during use. The reservoir is a matrix which contains both the drug and a permeation enhancer as described above. Such a laminated composite preferably includes a strippable protective release liner laminated to the basal surface of the drug reservoir. The release liner is a disposable element designed to protect the exposed reservoir surface prior to use. In an alternative embodiment, a transdermal therapeutic system is provided in the form of a liquid reservoir-type laminated composite, e.g., as described in commonly assigned U.S. Pat. No. 4,849,224 to Chang et

al., the disclosure of which is incorporated by reference herein.

BRIEF DESCRIPTION OF THE DRAWING

FIG. 1 is a schematic sectional view through a laminated matrix-type transdermal system of the invention.

FIG. 2 is a schematic sectional view through a laminated liquid reservoir-type transdermal system of the invention.

DETAILED DESCRIPTION OF THE INVENTION

Before describing the present compositions, systems and methods of the invention in detail, it is to be understood that this invention is not limited to the particular drugs, sorbitan esters, aliphatic alcohols, or laminate materials described herein as such may, of course, vary. It is also to be understood that the terminology used herein is for the purpose of describing particular embodiments only, and is not intended to be limiting.

It must be noted that, as used in this specification and the appended claims, the singular forms "a," "an" and "the" include plural referents unless the content clearly dictates otherwise. Thus, for example, reference to a laminated structure containing "a drug" includes a mixture of two or more drugs, reference to "an adhesive" includes reference to one or more of such adhesives, and reference to "a sorbitan ester" includes reference to a mixture of two or more sorbitan esters.

In describing and claiming the present invention, the following terminology will be used in accordance with the definitions set out below.

"Penetration enhancement" or "permeation enhancement" as used herein relates to an increase in the permeability of skin to a pharmacologically active agent, i.e., so as to increase the rate at which the agent permeates into and through the skin. A "permeation enhancer" is a material which achieves such permeation enhancement, and a "penetration enhancing amount" of an enhancer as used herein means an amount effective to enhance skin penetration of a selected agent to a desired degree.

By "transdermal" drug delivery, applicant is using the term in its conventional sense, i.e., to indicate delivery of a drug by passage through the skin and into the blood stream. By "transmucosal" drug delivery, applicant intends delivery of a drug by passage of a drug through the mucosal tissue into the blood stream. "Topical" drug delivery is used to mean local administration of a topical drug as in, for example, the treatment of various skin disorders. These terms will sometimes be used interchangeably herein, i.e., aspects of the invention which are described in the context of "transdermal" drug delivery, unless otherwise specified, can apply to transmucosal or topical delivery as well. That is, the compositions, systems, and methods of the invention, unless explicitly stated otherwise, should be presumed to be equally applicable with any one of these three modes of drug delivery.

The term "drug" or "pharmacologically active agent" as used herein is intended to mean a compound or composition of matter which, when administered to an organism (human or animal) induces a desired pharmacologic and/or physiologic effect by local and/or systemic action. In general, the terms include the therapeutic or prophylactic agents in all major therapeutic/prophylactic areas of medicine. Examples of drugs useful in conjunction with the present invention include

anti-infectives such as antibiotics and antiviral agents; analgesics and analgesic combinations; anorexics; antihelminthics; antiarthritics; antiasthmatic agents; anticholinergic agents; anticonvulsants; antidepressants; antidiabetic agents; antidiarrheals; antihistamines; anti-inflammatory agents, antimigraine preparations; anti-motion sickness drugs; anti-nauseants; antineoplastics; antiparkinsonism drugs; antipruritics; antipsychotics; antipyretics; antispasmodics; anticholinergics; sympathomimetics; xanthine derivatives; cardiovascular preparations including calcium channel blockers and beta-blockers such as pindolol and antiarrhythmics; antihypertensives; diuretics; vasodilators including general coronary, peripheral and cerebral; central nervous system stimulants; cough and cold preparations, including decongestants; steroids; hypnotics; immunosuppressives; muscle relaxants; parasympatholytics; psychostimulants; sedatives; and tranquilizers. For purposes of the aforementioned definition, "drugs" as used herein also include locally administered topical medicaments such as antibacterial agents, antifungals, antimicrobials, cutaneous growth enhancers, antipsoriatics, anti-acne medicaments, and the like.

"Carriers" or "vehicles" as used herein refer to carrier materials without pharmacological activity which are suitable for administration in conjunction with the presently disclosed and claimed compositions, and include any such carrier or vehicle materials known in the art, e.g., any liquid, gel, solvent, liquid diluent, solubilizer, or the like. The carriers and vehicles suitable herein are "pharmaceutically acceptable" in that they are nontoxic, do not interfere with drug delivery, and are not for any other reasons biologically or otherwise undesirable. Examples of specific suitable carriers and vehicles for use herein include water, mineral oil, silicone, inorganic gels, aqueous emulsions, liquid sugars, waxes, petroleum jelly, and a variety of other oils and polymeric materials.

By a "therapeutically effective" amount of a drug or pharmacologically active agent is meant a nontoxic but sufficient amount of the drug or agent to provide the desired therapeutic effect.

The invention is thus in one embodiment a method for enhancing the rate of penetration of a pharmacologically active agent through the skin, wherein the method involves co-administration of the agent through a predetermined area of intact skin, and for a predetermined period of time, the selected agent and a permeation enhancer consisting essentially of a sorbitan ester or a sorbitan ester in combination with a C₁-C₄ aliphatic alcohol. The sorbitan esters which are useful in conjunction with the present invention have the structure

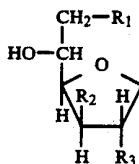

wherein the substituent R₁ has the structure —O(CO)R', where R' is selected from the group consisting of saturated, mono-unsaturated, di-unsaturated and tri-unsaturated aliphatic hydrocarbon substituents of 7 to 21 carbon atoms, preferably 11 to 21 carbon atoms, and may be substituted with 1 to 3 hydroxyl groups. The substituents R₂ and R₃ may be the same or different and are selected from the group consisting of hydroxyl and

—O(CO)R' as defined above. R₁, R₂ and R₃, may be, for example, lauryl, myristyl, palmityl, stearyl, palmitoleyl, oleyl, linoleyl, linolenyl, or ricinoleyl esters, or the like. Exemplary sorbitan esters are long-chain sorbitan monoesters, wherein R₁ is as defined above, R' is hydrocarbon of 11 to 21 carbon atoms, and R₂ and R₃ are both hydroxyl. Particularly preferred compounds within the class of sorbitan monoesters are sorbitan monooleate and sorbitan monolaurate.

In addition to a sorbitan ester, the permeation enhancer composition of the invention may also include a C₁-C₄ aliphatic alcohol component. Examples of suitable alcohols within this class include ethanol, D-propanol, isopropanol, t-butanol, and mixtures thereof.

The method of delivery of the present compositions may vary, but necessarily involves application of drug and enhancer to a selected intact surface of the skin or other tissue for a period of time sufficient to provide the desired blood level of drug. The method preferably involves administration of drug and enhancer simultaneously, in a single composition, i.e., as an ointment, gel, cream, or the like, or may involve use of a drug delivery device as taught, for example, in U.S. Pat. Nos. 4,849,224, 4,983,395, 4,568,343, 3,797,494 or 3,742,951.

When the drug to be administered and the permeation enhancer as described above are applied in the form of an ointment, gel, cream or the like, the amount of drug contained within the composition will depend on a variety of factors, including the desired rate of delivery, the desired dosage, the disease to be treated, the nature and activity of the drug, the desired effect, possible adverse reactions, the ability and speed of the drug selected to reach its intended target, and other factors within the particular knowledge of the patient and the physician. The amount of enhancer will typically be in the range of 0.1 wt. % to 40 wt. % relative to the total composition, more preferably on the order of about 2.5 wt. % to 15 wt. %. The composition may, in addition to drug and enhancer, include one or more selected carriers or excipients, and/or various agents and ingredients commonly employed in dermatological ointments and lotions. For example, fragrances, opacifiers, preservatives, antioxidants, gelling agents, perfumes, thickening agents, stabilizers, surfactants, emollients, coloring agents, and the like may be present so long as they are pharmaceutically acceptable and compatible with the drug and enhancer.

A transdermal delivery system for the administration of a drug can be constructed with the drug/enhancer composition described hereinabove. Preferred transdermal drug delivery systems for use herein are laminated composites which contain one or more drug/permeation enhancer reservoirs, a backing layer and, optionally, one or more additional layers (e.g., additional drug and/or enhancer reservoirs) as those skilled in the art of transdermal drug delivery will readily appreciate. FIG. 1 depicts an exemplary system, generally designated 10, that when applied to skin administers a selected pharmacologically active agent as outlined above. System 10 is a laminated composite in which the top layer 12 is a backing layer, its face forming the top surface of the composite. The drug reservoir, containing drug, enhancer as described herein, and optional carriers or vehicles, is shown at 14, immediately below and adjacent to the backing layer. Prior to use, the laminate also includes a strippable protective release liner. In a preferred embodiment, as described in co-

Explore Litigation Insights

Docket Alarm provides insights to develop a more informed litigation strategy and the peace of mind of knowing you're on top of things.

Real-Time Litigation Alerts



Keep your litigation team up-to-date with **real-time alerts** and advanced team management tools built for the enterprise, all while greatly reducing PACER spend.

Our comprehensive service means we can handle Federal, State, and Administrative courts across the country.

Advanced Docket Research



With over 230 million records, Docket Alarm's cloud-native docket research platform finds what other services can't. Coverage includes Federal, State, plus PTAB, TTAB, ITC and NLRB decisions, all in one place.

Identify arguments that have been successful in the past with full text, pinpoint searching. Link to case law cited within any court document via Fastcase.

Analytics At Your Fingertips



Learn what happened the last time a particular judge, opposing counsel or company faced cases similar to yours.

Advanced out-of-the-box PTAB and TTAB analytics are always at your fingertips.

API

Docket Alarm offers a powerful API (application programming interface) to developers that want to integrate case filings into their apps.

LAW FIRMS

Build custom dashboards for your attorneys and clients with live data direct from the court.

Automate many repetitive legal tasks like conflict checks, document management, and marketing.

FINANCIAL INSTITUTIONS

Litigation and bankruptcy checks for companies and debtors.

E-DISCOVERY AND LEGAL VENDORS

Sync your system to PACER to automate legal marketing.