

Art Unit: 3992

from a mixture of **inorganic** phosphors was discussed above in the rejection over Stevenson in view of APA, Wanmaker, and Nakamura which applies equally to claim 118.

Thus the only difference is that there is no indication that the phosphoric mixture of APA or Wanmaker is *dispersed in a polymer that is on or about* the GaN-based LED.

As noted above, Tabuchi teaches the phosphor **7** is coated on the wall of the transparent cover **6**:

A **phosphor layer 7** is provided by applying a **binding agent in which a phosphor** to convert the radiation from light emitting semiconductor device 4 to visible light is **dispersed on the inner surface of transparent cover 6**. Transparent cover 6 is made of a material such as **glass** or an **epoxy resin** is preferably fixed to stem 1 so that it can also function as a cap for hermetic sealing.

(Tabuchi translation, pp. 3-4; emphasis added)

Although Tabuchi does not indicate the identity of the binder, Martic teaches that it has long been known (since 1973) to use organic resins (i.e. polymers) as binding agents specifically for inorganic phosphors in the manufacture of luminescent screens:

5 In still another aspect, this invention relates to screens comprising **inorganic phosphors** wherein the **binding agent** for said phosphors comprises a **polyurethane elastomer** alone or in combination with an **alkyl methacrylate resin** in various ratio ranges.

(Martic, col. 1, lines 10-14; emphasis added)

It would have been obvious to one of ordinary skill in the art, at the time of the invention to disperse APA or Wanmaker's inorganic phosphors in the polymeric binding agent of Martic to make the phosphor layer **7** in Tabuchi, because Tabuchi is silent as to the binding agent for the phosphor, such that one of ordinary skill would use known binders specifically used for inorganic phosphors that must emit light.

This is all of the additional features of claims 118 and 129.

Proposed new **claims 134 and 144** read,

134. A light-emitting device, comprising:

at least one single-die **gallium nitride based semiconductor blue light-emitting diode (LED)** coupleable with a power supply to emit a primary radiation which is the same for each single-die LED present in the device, said primary radiation being a relatively shorter wavelength radiation; and

Art Unit: 3992

a down-converting luminophoric medium arranged in receiving relationship to said primary radiation, and which in exposure to said primary radiation, is excited to responsively emit a secondary, relatively longer wavelength, polychromatic radiation, with separate wavelengths of said polychromatic radiation mixing to produce a white light output,

wherein each of the at least one single-die gallium nitride based semiconductor blue light-emitting diode in interaction with luminophoric medium receiving its primary radiation produces white light output,

and wherein the luminophoric medium is **dispersed in a polymer that is on or about** the single-die gallium nitride based semiconductor blue light-emitting diode.

144. The light-emitting device of claim 134, wherein the luminophoric medium comprises **inorganic** luminophoric material.

Each of the additional features of these claims, highlighted in bold has been discussed above.

Proposed new **claims 162 and 167** read,

162. A light-emitting device, comprising:

at least one single-die **gallium nitride based** semiconductor **blue** light-emitting diode (LED) coupleable with a power supply to emit a primary radiation which is the same for each single-die LED present in the device, said primary radiation being a relatively shorter wavelength blue light radiation; and

a down-converting luminophoric medium arranged in receiving relationship to said primary radiation, and which in exposure to said primary radiation, is excited to responsively emit a secondary, relatively longer wavelength, polychromatic radiation, with separate wavelengths of said polychromatic radiation mixing to produce a white light output,

wherein each single-die gallium nitride based semiconductor blue light-emitting diode in interaction with luminophoric medium receiving its primary radiation produces white light output,

and wherein said at least one single-die gallium nitride based semiconductor blue light-emitting diode is **in a housing comprising a light-transmissive wall member in spaced relationship** to said at least one single-die gallium nitride based semiconductor blue light-emitting diode,

and wherein said luminophoric medium is **dispersed in or on said light-transmissive wall member.**

Art Unit: 3992

167. The light-emitting device of claim 162, wherein the luminophoric medium comprises **inorganic** luminophoric material.

Each of the additional features of these claims, highlighted in bold has been discussed above. Tabuchi's cover **6** is called a "transparent cover **6**" so it is necessarily a *housing comprising a light-transmissive wall member in spaced relationship* to the LED. The phosphor layer **7** is dispersed on transparent cover **6**.

Proposed new **claims 79, 80, 116, 117, 132, 133, 147, and 148** read,

79. The light-emitting device of claim 62, comprising a light-emitting diode lamp.

80. The light-emitting device of claim 79, wherein the light-emitting diode lamp comprises the at least one single-die gallium nitride based semiconductor blue light-emitting diode and **inorganic** luminophoric material within an **enclosure** comprising material that is light-transmissive of said white light output.

116. The light-emission device of claim 100, comprising a light-emitting diode lamp.

117. The light-emission device of claim 116, wherein the light-emitting diode lamp comprises the single-die gallium nitride based semiconductor blue light-emitting diode and **inorganic** luminophoric material within an **enclosure** comprising material that is light-transmissive of said white light.

132. The light-emission device of claim 118, comprising a light-emitting diode lamp.

133. The light-emission device of claim 132, wherein the light-emitting diode lamp comprises the single-die gallium nitride based semiconductor blue light-emitting diode and **inorganic** luminophoric material within an **enclosure** comprising material that is light-transmissive of said white light.

147. The light-emission device of claim 134, comprising a light-emitting diode lamp.

148. The light-emission device of claim 147, wherein the light-emitting diode lamp comprises the single-die gallium nitride based semiconductor blue light-emitting diode and **inorganic** luminophoric material within an **enclosure** comprising material that is light-transmissive of said white light output.

Regarding claims 79, 116, 132, and 147, the device of Stevenson as modified by the other references includes a single LED package which is therefore a lamp.

Art Unit: 3992

Regarding claims 80, 117, 133, and 147, as discussed above, Tabuchi teaches that the LED lamp includes an enclosure having a transparent cover **6** with the phosphor coating **7** on the interior surface thereof. Because the transparent cover **6** is transparent, it is *light-transmissive of said white light output*.

D. Tabuchi as a base reference

1. Claims 1, 5, 22, 26, 172, 173, 176, and 177 are rejected under 35 U.S.C. 102(b) as being anticipated by Tabuchi, as evidenced by the CRC Handbook.

Proposed amended claim 1 reads,

[1] 1. A light emitting device, comprising:

[2] at least one single-die semiconductor light-emitting diode (LED) coupleable with a power supply to emit a primary radiation **[3]** which is the same for each single-die semiconductor LED present in the device, **[4]** said primary radiation being a relatively shorter wavelength radiation outside the visible white light spectrum; and

[5] a down-converting luminophoric medium arranged in receiving relationship to said primary radiation, and which in exposure to said primary radiation responsively emits radiation at a multiplicity of wavelengths and in the visible white light spectrum, with said radiation of said multiplicity of wavelengths mixing to produce a white light output, **[6]** wherein each of the at least one single-die semiconductor light-emitting diode in interaction with luminophoric medium receiving its primary radiation produces white light output.

Feature **[1]**: 1. A light emitting device

Tabuchi's Fig. 1 (reproduced below) shows a LED **4**, which can be a GaN-based LED, in a housing including transparent cover **6** having a phosphor film **7** coated thereon to convert the primary radiation (UV or IR) from said LED **4** into visible light. Visible light includes white light. The LED includes two leads **3** for powering the LED.

Art Unit: 3992

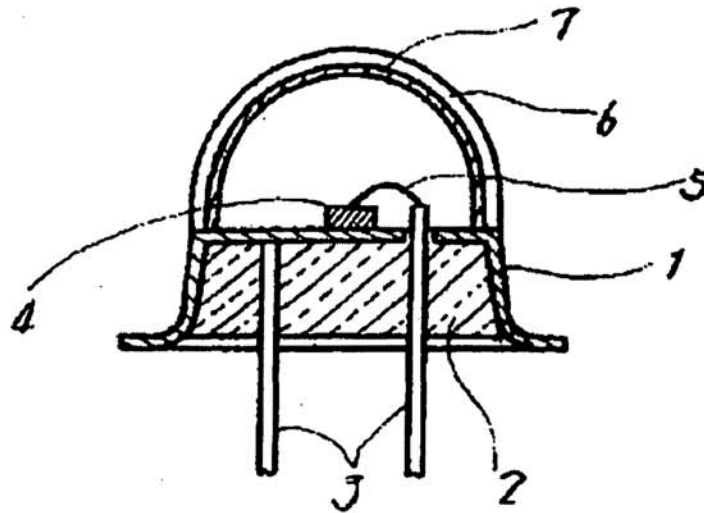

(Tabuchi, Fig. 1)

In regard to the embodiment shown in Fig. 1, Tabuchi states,

Figure 1 depicts a **light emitting semiconductor apparatus** of an example of the present utility model invention. In the example, the present utility model invention is applied to a light emitting semiconductor apparatus which employs a so-called TO-5 stem. Figure 1, glass 2 fixes leads 3 in a TO-5 metal stem 1. A **light emitting semiconductor device 4** is conductively connected to stem 1. A transparent cover 6 according to the present utility model invention is fixed on stem 1. **A phosphor layer 7 is provided by applying a binding agent in which a phosphor to convert the radiation from light emitting semiconductor device 4 to visible light is dispersed on the inner surface of transparent cover 6.** Transparent cover 6 is made of a material such as **glass** or an **epoxy resin** is preferably fixed to stem 1 so that it can also function as a cap for hermetic sealing.

In the light emitting apparatus of the present utility model invention, **phosphor layer 7 converts** infrared or **UV** emitted from **light emitting semiconductor device 4 to visible light** which is radiated in random directions. Therefore, the light emitting semiconductor apparatus can produce an emission with a uniform intensity over a large area. Further, the light emitting semiconductor apparatus utilizes a relatively small quantity of phosphor and hence, is inexpensive.

(Tabuchi translation, pp. 3-4; emphasis added)

A light emitting semiconductor apparatus of the present utility model invention is not limited to the structures and materials illustrated in the above examples. For example, it goes without saying that a **near UV light emitting devices with GaN** can be employed and that **an ordinary UV-visible light conversion phosphor** can be utilized.

(Tabuchi translation, p. 5; emphasis added)

Art Unit: 3992

Feature [2]: *at least one single-die semiconductor light-emitting diode (LED) coupleable with a power supply to emit a primary radiation*

Tabuchi's Fig. 1 above shows a *single-die semiconductor LED 4* where the semiconductor includes GaN when UV light is the primary light (*id.*). Fig. 1 also shows that leads **3** that couple the LED to a power supply (*id.*).

Feature [3]: *which is the same for each single-die semiconductor LED present in the device*

Only one LED is required by the claim. Therefore, the primary light is the same for each LED.

Feature [4]: *said primary radiation being a relatively shorter wavelength radiation outside the visible white light spectrum*

Ultraviolet (UV) light (i.e. below 400 nm wavelength) is necessarily outside the *visible white light spectrum*, as admitted in the '175 patent.

Feature [5]: *a down-converting luminophoric medium arranged in receiving relationship to said primary radiation, and which in exposure to said primary radiation responsively emits radiation at a multiplicity of wavelengths and in the visible white light spectrum, with said radiation of said multiplicity of wavelengths mixing to produce a white light output.*

Tabuchi discloses a down-converting luminophoric medium (phosphor film **7**, which can be "an **ordinary** UV-visible light conversion phosphor") for converting UV light from the GaN-based LED into visible light:

A light emitting semiconductor apparatus of the present utility model invention is not limited to the structures and materials illustrated in the above examples. For example, it goes without saying that a **near UV light emitting devices with GaN** can be employed and that an **ordinary UV-visible light conversion phosphor** can be utilized.

(Tabuchi translation, p. 5; emphasis added)

Visible light is 4000 Å to 7000 Å that inherently includes *a multiplicity of wavelengths*, again as evidenced by the CRC Handbook, above; therefore the "ordinary UV-visible light conversion phosphor" *responsively emits radiation at a multiplicity of wavelengths and in the visible white light spectrum.*

Feature [6]: wherein each of the at least one single-die semiconductor light-emitting diode in interaction with luminophoric medium receiving its primary radiation produces white light output.

Art Unit: 3992

It is implicit that each of Tabuchi's individual LEDs is capable of producing white light because one of ordinary skill would recognize that visible light made by "an **ordinary** UV-visible light conversion phosphor" includes white light.

This is all of the features of proposed amended claim 1.

Proposed amended **claim 5** reads,

5. A light-emitting device, comprising:

at least one single-die semiconductor light-emitting diode (LED) coupleable with a power supply to emit a primary radiation which is the same for each single-die LED present in the device, said primary radiation being a relatively shorter wavelength radiation; and

*a down-converting luminophoric medium arranged in receiving relationship to said primary radiation, and which in exposure to said primary radiation, **is excited to** responsively emit a secondary, **relatively longer wavelength, polychromatic** radiation, with **separate wavelengths** of said **polychromatic** radiation mixing to produce a white light output, each of the at least one single-die semiconductor light-emitting diode in interaction with luminophoric medium receiving its primary radiation produces white light output.*

Claim 5 is distinct from claim 1 in that (1) the primary radiation is not required to include radiation outside the visible white light spectrum; (2) the down-converting is required to yield longer wavelengths than that of the primary radiation; and (3) separate wavelengths are required to be produced.

With regard to **difference (1)**, claim 5 is broader in this respect; thus, Tabuchi discloses the claimed LED for the reasons indicated in conjunction with claim 1.

With regard to **differences (2) and (3)**, as discussed in rejecting claim 1 above, Tabuchi discloses that the light is down-converted (in terms of energy) to visible light by any "ordinary UV-visible light conversion phosphor". Visible light includes white light which is necessarily polychromatic, as evidenced by the CRC Handbook (i.e. visible light includes a combination of the wavelengths from 700 to 400 nm). Because Tabuchi discloses that any "ordinary UV-**visible** light conversion phosphor" can be used to produce the visible light, which includes white light, those of ordinary skill in the art would recognize that the phosphors to which Tabuchi refers include those producing white light.

This is all of the features of claim 5.

Claim 22 reads,

Art Unit: 3992

22. A light-emitting device according to claim 5, wherein each single-die semiconductor LED present in the device comprises a single-die two-lead semiconductor LED.

As noted above in rejecting claim 1, Tabuchi discloses a GaN-based LED having two leads **3** (Tabuchi translation, p. 5; Fig. 1).

Claim 26 reads,

26. A light-emission device, comprising

*a single-die, two-lead semiconductor light-emitting diode emitting radiation;
and*

a recipient down-converting luminophoric medium for down-converting the radiation emitted by the light-emitting diode, to a polychromatic white light.

This claim is significantly broader than claim 22 above. Tabuchi discloses each of the features of this claim for the reasons discussed in rejecting claims 1, 5, and 22 above.

Proposed new **claims 172 and 176** read,

172. The light-emitting device of claim 5, wherein the secondary, relatively longer wavelength, polychromatic radiation comprises a broad spectrum of frequencies.

176. The light-emission device of claim 26, wherein radiation down-converted by the recipient down-converting luminophoric medium comprises a broad spectrum of frequencies.

As noted above, visible light includes a broad spectrum of frequencies, as evidenced by the CRC Handbook. Therefore, Tabuchi's the secondary, down-converted radiation emitted from Tabuchi's light emitting device includes *a broad spectrum of frequencies*.

Proposed new **claims 173 and 177** read,

173. The light-emitting device of claim 5, wherein the single-die semiconductor light-emitting diode is on a support in an interior volume of a light-transmissive enclosure.

177. The light-emission device of claim 26, wherein the single-die, two-lead semiconductor light-emitting diode is on a support in an interior volume of a light-transmissive enclosure.

Art Unit: 3992

Tabuchi's Fig. 1, above shows that the *single-die, two-lead 3 semiconductor light-emitting diode 4 is on a support 1 in an interior volume of a light-transmissive enclosure 6.*

2. Claims 1, 5, 22, 26, 27-32, 41-46, 55-60, 172, 173, 176, and 177 are rejected under 35 U.S.C. 103(a) as being unpatentable over Tabuchi in view of Admitted Prior Art (APA).

The prior art of Tabuchi, as explained above, is believed to disclose each of the features of claims 1, 5, 22, 26, 172, 173, 176, and 177. If it is believed by Patentee, however, that Tabuchi does not include *white light*, then this may be a difference between Tabuchi and claims 1, 5, 22, 26, 172, 173, 176, and 177.

As noted above, Tabuchi discloses that any "**ordinary** UV-visible light conversion phosphor" can be used to produce the visible light (Tabuchi translation, p. 5; emphasis added).

APA teaches fluorescent light bulbs use ordinary UV-visible light conversion phosphors for producing white light and that such phosphors are inorganic:

It is well known that so-called **fluorescent lamps provide white light** illumination. In a fluorescent lamp, the Hg vapor in the vacuum tube is excited by an electrical discharge. The excited Hg atoms emit light, **primarily in the ultraviolet region** (e.g., 254 nm, 313 nm, 354 nm), which is absorbed by the **inorganic phosphors coating the inside walls of the tube**. The phosphors then emit light. These inorganic phosphors are designed as such to offer white light emission by "down-converting" (i.e., transforming a higher frequency, shorter wavelength form of energy to a lower frequency, longer wavelength form of energy) the ultraviolet emissions of the excited states of atomic Hg into a **broad spectrum** of emitted light which appears as **white** to the observer. **However, these light emitting devices are not solid-state, ...**

(the '175 patent, col. 3, lines 40-53; emphasis added)

It would have been obvious to one of ordinary skill in the art, at the time of the invention to use APA's inorganic phosphor in Tabuchi because Tabuchi explicitly suggests using any "**ordinary** UV-visible light conversion phosphor" and because APA teaches such an ordinary phosphor for producing white light from UV light.

Further regarding proposed new **claims 172 and 176** reads, as noted above, visible light includes a broad spectrum of frequencies, as evidenced by the CRC Handbook. Therefore, the secondary, down-converted radiation emitted from Tabuchi/APA's light emitting device includes *a broad spectrum of frequencies*, noting that APA teaches plural phosphors that necessarily emit plural wavelengths of light.

Art Unit: 3992

Proposed new **claims 27, 41, and 55** read,

27. The light emitting device of claim 1, wherein the luminophoric medium comprises an **inorganic** luminophor.

41. The light emitting device of claim 5, wherein the luminophoric medium comprises an **inorganic** luminophor.

55. The light emitting device of claim 26, wherein the luminophoric medium comprises an **inorganic** luminophor.

As just noted, APA teaches that the phosphor is inorganic.

Proposed new claims 28-30, 42-44, and 56-58 read,

28. The light emitting device of claim 27, wherein the inorganic luminophor is dispersed **on or in** a housing member.

29. The light emitting device of claim 27, wherein the inorganic luminophor is dispersed **in a film on a surface** of a housing member.

30. The light emitting device of claim 27, wherein the inorganic luminophor is **within** a housing member.

42. The light emitting device of claim 41, wherein the inorganic luminophor is dispersed **on or in** a housing member.

43. The light emitting device of claim 41, wherein the inorganic luminophor is dispersed **in a film on a surface** of a housing member.

44. The light emitting device of claim 41, wherein the inorganic luminophor is **within** a housing member.

56. The light emitting device of claim 55, wherein the inorganic luminophor is dispersed **on or in** a housing member.

57. The light emitting device of claim 55, wherein the inorganic luminophor is dispersed **in a film on a surface** of a housing member.

58. The light emitting device of claim 55, wherein the inorganic luminophor is **within** a housing member.

Tabuchi's Fig. 1, above, shows that the phosphor layer **7** is in a film on the inside surface of the transparent cover **6**:

A **phosphor layer 7** is provided by applying a **binding agent** in which a phosphor to convert the radiation from light emitting semiconductor device 4 to visible light is **dispersed on the inner surface of transparent cover 6**.

Art Unit: 3992

Transparent cover 6 is made of a material such as **glass** or an **epoxy resin** is preferably fixed to stem 1 so that it can also function as a cap for hermetic sealing.

(Tabuchi translation, p. 3, last full ¶; emphasis added)

Thus, Tabuchi discloses phosphor **7** is located *on, in, within, and in a film on a surface*, of a housing member **6**.

This is also entirely consistent with the APA phosphor which is a coating on the inside of the light bulb housing.

Proposed new **claims 31, 32, 45, 46, 59, and 60** read,

31. The light emitting device of claim 27, wherein each said LED comprises material selected from the group consisting of **gallium nitride and its alloys**.

32. The light emitting device of claim 27, wherein each said LED comprises **gallium nitride**.

45. The light-emitting device of claim 41, wherein each said LED comprises material selected from the group consisting of **gallium nitride and its alloys**.

46. The light-emitting device of claim 41, wherein each said LED comprises **gallium nitride**.

59. The light-emission device of claim 55, wherein the light-emitting diode comprises material selected from the group consisting of **gallium nitride and its alloys**.

60. The light-emission device of claim 55, wherein the light-emitting diode comprises **gallium nitride**.

As noted above, Tabuchi indicates that the LED is GaN when UV light is used as the primary radiation:

A light emitting semiconductor apparatus of the present utility model invention is not limited to the structures and materials illustrated in the above examples. For example, it goes without saying that a **near UV light emitting devices with GaN** can be employed and that **an ordinary UV-visible light conversion phosphor** can be utilized.

(Tabuchi translation, p. 5; emphasis added)

Art Unit: 3992

3. Claims 1, 5, 22, 26, 172, 173, 176, 177, and 187 are rejected under 35 U.S.C. 103(a) as being unpatentable over Tabuchi in view of Pinnow.

The prior art of Tabuchi, as explained above, is believed to disclose each of the features of claims 1, 5, 22, 26, 172, 173, 176, and 177. If it is believed by Patentee, however, that Tabuchi does not include *white light*, then this may be a difference between Tabuchi and claims 1, 5, 22, 26, 172, 173, 176, and 177.

As noted above, Tabuchi discloses that any "**ordinary** UV-visible light conversion phosphor" can be used to produce the visible light (Tabuchi translation, p. 5; emphasis added).

wherein each of the at least one single-die semiconductor light-emitting diode in interaction with luminophoric medium receiving its primary radiation produces white light output. (claim 1)

each of the at least one single-die semiconductor light-emitting diode in interaction with luminophoric medium receiving its primary radiation produces white light output. (claim 5)

a recipient down-converting luminophoric medium for down-converting the radiation emitted by the light-emitting diode, to a polychromatic white light. (claim 26)

Pinnow teaches a display wherein a laser (instead of an LED) is used to produce primary **visible or UV** light that is down-converted by a **mixture of phosphors** into visible, secondary light of longer wavelength light which explicitly includes white light:

A single color display is produced by projection using a scanning laser beam operating in the **visible** or **ultraviolet** and a photoluminescent screen which emits in the visible. **Combinations of phosphors** may be employed to simulate **white** or desired colors.

(Pinnow, abstract)

Pinnow's Fig. 3 shows the light emitting device (a display) including the laser **10** and one example of a phosphor screen **15**. The primary light from the laser **10** is down-converted by phosphor screen **15** to produce visible light. Importantly, Pinnow teaches that phosphors for each primary color can be mixed together in a **resin** to produce **white** light:

In this description, use will be made of the term "colorant" or "organic colorant." It is to be understood that this term includes photoluminescent organic dyes and pigments. **Pigments** are particularly useful and may be formed by **dissolving a dye in an organic resin solution which is subsequently condensed**. It is known that luminescent efficiency in certain cases may be enhanced if the dye is absorbed on a colloid which may take the form of gell [sic] fibers or particles of high molecular weight polymers.

Art Unit: 3992

(Pinnow, paragraph bridging cols. 1-3; emphasis added)

The invention is broadly premised on the use of such organic colorants. Monochromatic displays result from use of **homogeneous phosphor screens**. These may be present as **self-supporting members** or as **coatings**, and they may be made up on **one or any combination of colorants required to produce the desired balance**.

(Pinnow, col. 2, lines 15-20; emphasis added)

A black and **white** display can be achieved by scanning a monochromatic laser beam on a viewing screen that is **coated with an appropriate blend of phosphors** and direct scattering materials such as powdered MgO or talc. For example, a combination of scattered light from a **blue argon-ion laser beam (4,880 A.)** [i.e. **visible** light] and blue-to-red converted light from either of the Rhodamine dye phosphors can produce a **white** appearance since a straight line connecting these primaries on the chromaticity diagram passes very near to illuminant C.

A combination of **more than two primaries** can also be used to produce **white**. As an example, a **Cd-He laser** beam which illuminates a correctly proportioned mixture of MgO and dye phosphors 3,484 A. and 3,485 A. [i.e. **ultraviolet** light] can be used to achieve a white appearance. Alternately, MgO may be replaced by pyrene-containing materials or 7-diethyl amino, 4-methyl coumarin-containing materials (blue-to-blue and ultraviolet-to-blue converting phosphor, respectively, to completely eliminate speckle).

Regardless of how many phosphors are used, it is apparent from the chromaticity diagram that a necessary condition for achieving a true white is that the illuminating laser beam have a **wavelength of approximately 4,950 A. or shorter**. Otherwise, it is impossible to include illuminant C within a polygon whose primaries are the source and any combination of longer wavelengths that can be achieved by down-conversion of frequency. Fortunately, the argon-ion laser satisfies this necessary condition.

(Pinnow, col. 3, lines 24-55; emphasis added)

(It is noted that Pinnow uses "A." for "angstrom", which is properly, instead, Å.)

It is important to note in the final paragraph from Pinnow excerpted above, Pinnow tells those of ordinary skill that **any primary radiation can be used so long as its wavelength is 4950 Å (495 nm) or shorter**, providing examples of both **blue** and **UV** light sources for the primary light that is down-converted into visible light. Tabuchi's GaN-based LED meets this criteria, as discussed above. Tabuchi's GaN-based LED emits UV light. Therefore, those of ordinary skill using the phosphor mixtures taught by Pinnow have a certain expectation of success. Pinnow shows that the results of illuminating the phosphor mixture with UV light or blue light (i.e. shorter than 4950 Å) produces entirely predictable results in making white light of any shade desired.

Art Unit: 3992

It would have been obvious to one of ordinary skill in the art, at the time of the invention to use Pinnow's phosphor mixtures, made as coating or self-standing elements (Pinnow, col. 2, lines 15-20) as the phosphor mixture in Tabuchi, in order to produce a visible white light. Because Tabuchi is silent as to the specific "ordinary UV-visible light conversion phosphor" needed to produce visible light, one of ordinary skill would use known materials known to work for the intended purpose, such as that taught in Pinnow.

Thus, Tabuchi modified to ensure a mixture of phosphors is used, ensures that each of the at least one single-die semiconductor light-emitting diode in interaction with luminophoric medium [phosphor mixture] receiving its primary radiation produces white light output, as newly claimed in proposed amended claim 1, and as similarly claimed in claims 5 and 26.

Proposed new **claim 187** reads,

187. A light emitting device comprising a light-emitting diode operative to emit **blue or ultraviolet** radiation, **packaged with luminophoric medium in a polymeric matrix**, wherein the luminophoric medium absorbs blue or ultraviolet radiation from the light-emitting diode and down converts same to a broad spectrum of frequencies producing polychromatic white light, wherein the light-emitting diode is a single-die, two-lead semiconductor light-emitting diode.

Claim 187 is distinguished from claim 26 in (1) specifying the radiation emitted from the LED as being UV.

With regard to distinction (1), as discussed above, Tabuchi states that the GaN-based LED emits UV light and therefore reads on these claims.

With regard to distinction (2), as noted above, Tabuchi indicates that the phosphors are dispersed in a "binder":

Also as noted above, Pinnow teaches that the luminophoric medium is also homogeneously dispersed in a binder, i.e. an organic resin, from which coatings or self-supporting structures are made (Pinnow, paragraph bridging cols. 1-3; col. 2, lines 15-20). Thus, the phosphor coating of Pinnow including the mixture of phosphors that produce white light can be applied as the phosphor coating in Tabuchi. So done, Tabuchi's LED includes a light-emitting diode operative to emit ... **ultraviolet** radiation, **packaged with luminophoric medium in a polymeric matrix**, as required by claim 187.

4. Claims 2 and 23 are rejected under 35 U.S.C. 103(a) as being unpatentable over any of (1) Tabuchi in view of Stevenson and Imamura, (2) Tabuchi in view

Art Unit: 3992

of APA, Stevenson, and Imamura, and (3) Tabuchi in view of Pinnow, Stevenson, and Imamura.

Claims 2 and 23 read,

2. A light-emitting device according to claim 1, comprising a **two-lead array** of single-die semiconductor LEDs.

23. A light-emitting device according to claim 5, comprising a **two-lead array** of single-die semiconductor LEDs.

The prior art of any of (1) Tabuchi, (2) Tabuchi in view of APA, and (3) Tabuchi in view of Pinnow, as explained above, discloses each of the features of claim 1 and 5.

Tabuchi does not explicitly disclose a two-lead **array** of single-die LEDs.

As explained in detail above, Stevenson's and Tabuchi's light emitting devices produce light in the same way, wherein a GaN-based LED down-converts the primary radiation from said LED into secondary visible light, using phosphors. In addition, Stevenson teaches using an array of LEDs to produce a display (Stevenson, col. 4, lines 5-7).

It would have been obvious to one of ordinary skill in the art, at the time of the invention to use an array of Tabuchi's or Tabuchi/APA's, or Tabuchi/Pinnow's LED, as taught by Stevenson, in order to make a display, because Stevenson suggests using an array to make a display. In other words, Stevenson provides a reason to make an array of LED, specifically to make a display.

Then the only difference is that --even though Tabuchi and Stevenson both teach that each LED has two leads-- there is no teaching that the array has two leads.

Imamura's Figs. 4 and 5 (reproduced below) shows the top and side views of an light array **10** made from an array of single-die semiconductor LEDs **13** on a substrate **15** (Imamura, col. 3, lines 16-36).



(Imamura, Fig. 4)

Art Unit: 3992

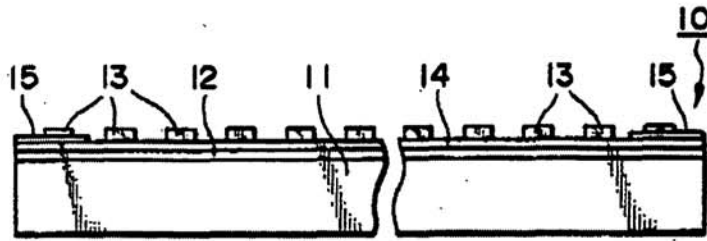

(Imamura, Fig. 5)

The array **10** can be used as a backlight for a liquid crystal display, such as shown in Fig. 8 (Imamura, col. 4, lines 59-61). Each LED die **13** has two leads that connect to the array's two leads, made from the gold-plated copper pattern **12** shown in the side view of right side of Fig. 5 and in the top view as the horizontal lines running across the top and bottom of the substrate **15** that connect the array of LEDs **13**. As also shown in Fig. 4, each of the array's two leads ends in a terminal. Thus, Imamura teaches a **two-lead array of single-die semiconductor LEDs**.

It would have been obvious to one of ordinary skill in the art, at the time of the invention to use Imamura's two-lead array configuration of plural identical LEDs of Tabuchi, or Tabuchi/APA, or Tabuchi/Pinnow --therefore *emitting identical radiation* - because Stevenson is silent as to how an array of LED would be wired for a display, such that one of ordinary skill would follow known ways of assembling an array such as taught by Imamura (Imamura, col. 3, lines 37-60).

5. Claims 3, 4, and 34-40 are rejected under 35 U.S.C. 103(a) as being unpatentable over Tabuchi in view of APA and Nakamura.

Claim 3 reads,

3. A light-emitting device, comprising:

*a semiconductor **laser** coupleable with a power supply to emit a primary radiation having a relatively shorter wavelength outside the **visible** light spectrum; and*

a down-converting luminophoric medium arranged in receiving relationship to said primary radiation, and which in exposure to said primary radiation responsively emits polychromatic radiation in the visible light spectrum, with different wavelengths of said polychromatic radiation mixing to produce a white light output.

Art Unit: 3992

Claim 3 is distinguished from claim 1 in that (1) a *semiconductor laser* is required versus a *single-die semiconductor LED*; (2) the primary radiation is required to be outside the **visible** light spectrum, as opposed to outside the visible **white** light spectrum; and (3) the wording associated with the luminophoric medium.

As discussed above in the rejection of claim 1 over Tabuchi in view of APA, Tabuchi in view of APA teaches all of the features of claim 3 except for the semiconductor laser. Instead, Tabuchi uses a GaN-based LED to produce the primary radiation.

With regard to **differences (1) and (2)** between claim 3 and claim 1, Tabuchi does not teach a semiconductor **laser** that produces primary radiation outside the visible spectrum. Tabuchi does, however, teach a GaN-based LED producing UV light which is outside the visible light spectrum:

A light emitting semiconductor apparatus of the present utility model invention is not limited to the structures and materials illustrated in the above examples. For example, it goes without saying that a **near UV light emitting devices with GaN** can be employed and that **an ordinary UV-visible light conversion phosphor** can be utilized.

(Tabuchi translation, p. 5; emphasis added)

Nakamura teaches GaN-based LEDs and laser diodes (LDs) that emit both blue and UV light. (In fact, one LED indicated as suitable in the '175 invention is a GaN LED from Nichia Chemicals, to which Nakamura is assigned. See the '175 patent, col. 9, lines 10-18. Thus, Patentee admits to using known GaN-based LED for the instant invention.)

Nakamura indicates that GaN-based LED emitting light *outside the visible white light spectrum* are known in the art:

Jpn. Pat. Appln. KOKAI Publication No. 4-68579 discloses a double-heterostructure having a p-type **GaInN** clad layer formed on an oxygen-doped, n-type **GaInN** light-emitting layer. ... The emission wavelength of the light-emitting device having this double-heterostructure is **365 to 406 nm**.

(Nakamura, col. 2, lines 7-14; emphasis added)

UV light is light less than 400 nm as evidenced by the CRC Handbook, *supra*.

In regard to its LEDs and lasers, Nakamura states the following:

The semiconductor device of the present invention includes a **light-emitting diode (LED)** and a **laser diode (LD)**.

(Nakamura, col. 4, lines 9-11)

It is still another object of the present invention to provide an **ultraviolet to red light-emitting device** having a wavelength in the region of **365 to 620 nm**.

Art Unit: 3992

(Nakamura, col. 2, lines 30-33; emphasis added)

FIG. 12 shows a structure of a **laser diode 40** having a double-heterostructure of the present invention.

The **laser diode 40** has a double-heterostructure constituted by an impurity-doped **In_xGa_{1-x}N active layer 18** described above in detail in association with the light-emitting diode, and two clad layers sandwiching the active layer **18**, i.e., an n-type gallium nitride-based compound semiconductor layer **16** and a p-type gallium nitride-based compound semiconductor layer **20**, as described above. A buffer layer **14** described above in detail is formed on a substrate **12** described above in detail. An n-type gallium nitride layer **42** is formed on the buffer layer **14**, providing a contact layer for an n-electrode described below.

(Nakamura, col. 11, line 61 to col. 12, line 6; emphasis added)

Nakamura shows that the wavelength of the LED or LD can be controlled by controlling the dopant:

In the light-emitting device of the present invention, when the value of x in In_xGa_{1-x}N of the light-emitting layer is close to 0, the device emits **ultraviolet** light. When the value of x increases, the emission falls in the longer-wavelength region. When the value of x is close to 1, the device emits red light. When the value of x is in the range of 0 < x < 0.5, the light-emitting device of the present invention emits **blue** to yellow light in the wavelength range of **450** to 550 nm.

(Nakamura, col. 4, lines 52-59; emphasis added)

It would have been obvious to one of ordinary skill in the art, at the time of the invention to substitute Tabuchi's UV-light-emitting GaN-based LED with Nakamura's UV-light-emitting GaN-based **LD**. This can be seen as simple substitution of one known element (Tabuchi's GaN-based LED) for another known element (Nakamura's GaN-based LD) to obtain predictable results and is one of the rationales identified by the Supreme Court in *KSR International Co. v. Teleflex Inc.*, 550 U.S. ___, ___, 82 USPQ2d 1385, 1395-97 (2007). (See MPEP 2143, Rationale B.)

The results are predictable because both Tabuchi's LED and Nakamura's LED and LD emit light in the same general region of the spectrum and are GaN-based, so the LED and LD materials are essentially the same. As will be discussed below, because the phosphor mixture disclosed in APA emits white light in response to UV radiation and Nakamura's LDs emits UV light, the results of using Nakamura's LD in place of Tabuchi's LED along with APA's phosphor mixtures yield predictable results, i.e. the production of white light.

Claim 4 and proposed new **claims 38-40** read,

Art Unit: 3992

4. A light-emitting device according to claim 3, wherein said semiconductor laser includes an active material selected from the group consisting of III-V alloys and II-VI alloys.

38. The light-emitting device of claim 34, wherein the semiconductor laser comprises material selected from the group consisting of **gallium nitride and its alloys**.

39. The light-emitting device of claim 34, wherein the semiconductor laser comprises **gallium nitride**.

40. The light-emitting device of claim 34, wherein the semiconductor laser comprises **gallium nitride alloy**.

Nakamura's LED and LD are made from GaN-based semiconductor material which is a *group III-V alloy*. In particular, when producing UV light, the value of x in $\text{In}_x\text{Ga}_{1-x}\text{N}$ approaches zero, the device emits ultraviolet light.

In the light-emitting device of the present invention, when the value of x in $\text{In}_x\text{Ga}_{1-x}\text{N}$ of the light-emitting layer is close to 0, the device emits **ultraviolet** light. When the value of x increases, the emission falls in the longer-wavelength region. When the value of x is close to 1, the device emits red light. When the value of x is in the range of $0 < x < 0.5$, the light-emitting device of the present invention emits **blue** to yellow light in the wavelength range of **450** to 550 nm.

(Nakamura, col. 4, lines 52-59; emphasis added)

Thus, Nakamura includes LDs wherein GaN and InGaN are used. Substitution of Tabuchi's GaN LED with Nakamura's LDs is the same as discussed above in conjunction with claim 3.

Proposed new **claims 34-37** read,

34. The light-emitting device of claim 3, wherein the luminophoric medium comprises an **inorganic** luminophor.

35. The light-emitting device of claim 34, wherein the inorganic luminophor is dispersed **on or in** a housing member.

36. The light-emitting device of claim 34, wherein the inorganic luminophor is dispersed **in a film on a surface** of a housing member.

37. The light-emitting device of claim 34, wherein the inorganic luminophor is **within** a housing member.

Art Unit: 3992

As discussed above in rejecting claims 27-30 over Tabuchi in view of APA inorganic phosphor mixture is obvious and the location of the phosphor **7** on, in, and within the housing member **6** in a film is disclosed in Tabuchi (Tabuchi, Fig. 1).

6. Claims 62, 63, 66-69, 74-80, 100, 101, 104-107, 110, 112-117, 162, and 164-171 are rejected under 35 U.S.C. 103(a) as being unpatentable over Tabuchi in view of APA, Wanmaker, and Nakamura.

Proposed new **claims 62 and 75** read,

62. A light-emitting device, comprising:

at least one single-die **gallium nitride based semiconductor blue light-emitting diode (LED)** coupleable with a power supply to emit a primary radiation which is the same for each single-die LED present in the device, said primary radiation being a relatively shorter wavelength blue light radiation; and

a down-converting luminophoric medium arranged in receiving relationship to said primary radiation, and which in exposure to said primary radiation, is excited to responsively emit a secondary, relatively longer wavelength, polychromatic radiation, with separate wavelengths of said polychromatic radiation mixing to produce a white light output, wherein each of the at least one single-die gallium nitride based semiconductor blue light-emitting diode in interaction with luminophoric medium receiving its primary radiation produces white light output,

and wherein the light-emitting device comprises one or more compatible characteristics selected from the group consisting of:

(i) the luminophoric medium being arranged **about** the single-die light-emitting diode;

(ii) the luminophoric medium being **contiguous to** the single-die light-emitting diode;

(iii) the single-die light-emitting diode comprising side surface and the luminophoric medium being in **laterally spaced relationship to said side surface**;

(iv) the luminophoric medium being dispersed **in polymer or glass**; and

(v) the luminophoric medium being **on polymer or glass**.

Art Unit: 3992

75. The light-emitting device of claim 62, wherein the luminophoric medium comprises **inorganic** luminophoric material.

Claim 62 is coextensive with claim 5, as indicated by Patentee (Remarks dated 3/26/2012, pp. 28-29). Claim 62 is distinguished from claim 5 in (1) the LED is required to be a blue-light-emitting GaN-based LED and (2) the one or more *compatible characteristics*. The substitution of Tabuchi's UV-light-emitting GaN-based LED with Nakamura's blue-light-emitting GaN-based LEDs was discussed above and is obvious for the same reasons. Tabuchi's Fig. 1 shows the luminophoric medium (phosphor 7) is (i) *about* the LED, (iii) laterally spaced from the side surface of the LED, and (v) on polymer or glass, as Tabuchi's transparent cover 6 is made from plastic or glass.

In addition, Tabuchi indicates that "an ordinary UV-visible light conversion phosphor" can be used to down convert the light from the LED to the visible light (Tabuchi translation, p. 4).

APA teaches that it is known in the art to use **inorganic** phosphor mixtures coated on a glass housing to convert primary radiation from electrically excited Hg (mercury) vapor, as in fluorescent bulbs:

It is well known that so-called **fluorescent lamps provide white light** illumination. In a fluorescent lamp, the Hg vapor in the vacuum tube is excited by an electrical discharge. The excited **Hg atoms emit light, primarily in the ultraviolet region** (e.g., 254 nm, 313 nm, 354 nm), which is absorbed by the **inorganic phosphors coating the inside walls of the tube**. The phosphors then emit light. These inorganic phosphors are designed as such to offer white light emission by "down-converting" (i.e., transforming a higher frequency, shorter wavelength form of energy to a lower frequency, longer wavelength form of energy) the **ultraviolet** emissions of the excited states of atomic Hg into a **broad spectrum** of emitted light which appears as **white** to the observer. **However, these light emitting devices are not solid-state, ...**

(the '175 patent, col. 3, lines 40-53; emphasis added)

The '175 patent is not entirely accurate as to the emission of Hg vapor that is converted to visible light. Rather, the '175 patent fails to acknowledge that, in fact, such high intensity **blue** light is emitted by the Hg vapor that the phosphor coatings include inorganic compounds that absorb and convert, not just the UV wavelengths, but also the **blue** wavelengths to longer wavelength visible light, so that the blue does not overwhelm the emitted light. In this regard, Wanmaker states,

To obtain a satisfactory rendition of the colours of articles irradiated by a fluorescent lamp it is necessary to **suppress the intensity of the blue mercury lines emitted by the mercury vapour discharge** at wave lengths of **405 and 436 nm**.

Art Unit: 3992

To what extent this suppression is to be effected is dependent on the desired quality of the colour rendition and on the desired colour temperature of the lamp. An **attenuation of the said blue mercury lines** can be obtained if the wall of the lamp is provided with a layer which includes a light yellow coloured **red luminescing material which absorbs at least a part of the blue mercury radiation**. The **emitted radiation of this luminescent material provides a desired contribution in the red part of the spectrum** of the radiation emitted by the lamp. This known step is described in United Kingdom patent specification 737,828. **Magnesium arsenate** activated by **quadrivalent manganese** is used in practice as a **blue absorbing red luminescing material**. Furthermore the lamp includes a second luminescent layer which is provided on the absorption layer and which comprises **one or more luminescent materials** with which it is possible to achieve the desired spectral distribution of the radiation emitted by the lamp.

(Wanmaker, col. 1, lines 18-22; emphasis added)

Wanmaker goes on to improve upon the prior art phosphors with other phosphors that also convert the mercury blue lines to longer wavelength visible light.

Wanmaker is important here because it shows that those of ordinary skill in the art knew in 1974 --20 years before the '175 patent-- how to choose **inorganic phosphor mixtures** that down-convert **blue** light to visible white light --such as that produced by Nakamura's GaN-based LEDs emitting light in the **blue** region of the spectrum. Thus, Wanmaker provides evidence of success and predictable results in using APA's or Wanmaker's mixture of **inorganic phosphors** along with Nakamura's GaN-based, blue-light emitting LED in place of Stevenson's GaN-based LED.

It would have been obvious to one of ordinary skill in the art, at the time of the invention to use APA's or Wanmaker's inorganic phosphor mixture to produce white light because Tabuchi indicates that any UV-visible light conversion phosphor can be used to make white light, and APA and Wanmaker teach known phosphors mixtures that produce white light from, *inter alia*, blue light, such that there is predictable results using said phosphor mixtures with Nakamura's GaN-based LED in place of Tabuchi's GaN LED.

This is all of the features of claims 62 and 75.

Proposed new **claims 63, 66-69, 74, and 80** read,

63. The light-emitting device of claim 62, comprising the luminophoric medium being arranged **about** the single-die light-emitting diode.

66. The light-emitting device of claim 62, comprising the single-die light-emitting diode comprising side die surface, and the luminophoric medium being in **laterally spaced relationship to said side die surface**.

Art Unit: 3992

67. The light-emitting device of claim 66, wherein the luminophoric medium is in **laterally spaced facing relationship to said side die surface.**

68. The light-emitting device of claim 62, comprising the single-die light-emitting diode being arranged to **directly impinge primary radiation on the luminophoric medium.**

69. The light-emitting device of claim 62, comprising the single-die light-emitting diode and luminophoric medium being arranged **without intermediate material therebetween.**

74. The light-emitting device of claim 62, comprising the luminophoric medium being **on polymer or glass.**

80. The light-emitting device of claim 79, wherein the light-emitting diode lamp comprises the at least one single-die gallium nitride based semiconductor blue light-emitting diode and **inorganic** luminophoric material **within an enclosure** comprising material that is light-transmissive of said white light output.

APA and Wanmaker teach that the phosphor can be homogeneously dispersed to make a coating, and Tabuchi discloses that the phosphor **7** is homogeneously dispersed in binder to make a coating on the transparent cover **6**, said cover being made from polymer or glass. The transparent cover forms an *enclosure* around the LED **4** and phosphor **7**.

It would have been obvious to one of ordinary skill in the art, at the time of the invention to use APA's or Wanmaker's phosphor mixture as Tabuchi's "ordinary UV-visible light conversion phosphor" layer **7** for the reasons indicated above. So placed, the orientation shown in Tabuchi's Fig. 1 discloses each of the features of claims 63, 66-69, 74, and 80.

Proposed new **claims 76-78** read,

76. The light-emitting device of claim 62, wherein the single-die light-emitting diode comprises gallium nitride and its alloys.

77. The light-emitting device of claim 62, wherein the single-die light-emitting diode comprises at least one of gallium nitride, indium gallium nitride, aluminum gallium nitride, and aluminum gallium indium nitride.

78. The light-emitting device of claim 62, wherein the at least one single-die gallium nitride based semiconductor blue light-emitting diode comprises only one single-die gallium nitride based semiconductor blue light-emitting diode.

Art Unit: 3992

As indicated above, Nakamura teaches GaN and its alloys make the blue-light-emitting LEDs; thus, modification of Tabuchi to use Nakamura's LEDs already includes the features of these claims.

Proposed new **claim 79** reads,

79. The light-emitting device of claim 62, comprising a light-emitting diode lamp.

Tabuchi alone or as modified according to Nakamura includes a single LED and therefore includes a lamp.

Proposed new **claims 100 and 113** read,

100. A light-emission device, comprising

a single-die, two-lead **gallium nitride based** semiconductor **blue light-emitting diode** emitting radiation; and

a recipient down-converting luminophoric medium for down-converting the radiation emitted by the light-emitting diode, to a polychromatic white light, wherein the light-emission device comprises one or more compatible characteristics selected from the group consisting of:

(i) the luminophoric medium being arranged **about** the single-die light-emitting diode;

(ii) the luminophoric medium being **contiguous to** the single-die light-emitting diode;

(iii) the single-die light-emitting diode comprising side surface and the luminophoric medium being in **laterally spaced relationship to said side surface**;

(iv) the luminophoric medium being dispersed **in polymer or glass**; and

(v) the luminophoric medium being **on polymer or glass**.

113. The light-emission device of claim 100, wherein the luminophoric medium comprises **inorganic** luminophoric material.

Claim 100 is coextensive with claim 26, as indicated by Patentee (Remarks dated 3/26/2012, pp. 40-41). Claim 100 differs from claim 26 in the same ways that claim 62 is distinguished from claim 5. Therefore claim 100 is obvious for the same additional reasons as indicated above in conjunction with claim 62.

This is all of the features of claims 100 and 113.

Art Unit: 3992

Proposed **new claims 101, 104-107, 110, 112, and 117** read,

101. The light-emission device of claim 100, comprising the luminophoric medium being arranged **about** the single-die light-emitting diode.

104. The light-emission device of claim 100, comprising the single-die light-emitting diode comprising side die surface, and the luminophoric medium being in **laterally spaced relationship to said side die surface**.

105. The light-emission device of claim 104, wherein the luminophoric medium is in **laterally spaced facing relationship to said side die surface**.

106. The light-emission device of claim 100, comprising the single-die light-emitting diode being arranged to **directly impinge** primary radiation on the luminophoric medium.

107. The light-emission device of claim 100, comprising the single-die light-emitting diode and luminophoric medium being arranged **without intermediate material** therebetween.

110. The light-emission device of claim 100, comprising the luminophoric medium being in a **homogeneous** composition.

112. The light-emission device of claim 100, comprising the luminophoric medium being **on** polymer or glass.

117. The light-emission device of claim 116, wherein the light-emitting diode lamp comprises the single-die gallium nitride based semiconductor blue light-emitting diode and **inorganic** luminophoric material **within an enclosure** comprising material that is light-transmissive of said white light.

Each of the above features was discussed above in conjunction with claims 63, 66-69, and 74 and applies here.

Proposed **new claims 114-116** read,

114. The light-emission device of claim 100, wherein the single-die light-emitting diode comprises gallium nitride and its alloys.

115. The light-emission device of claim 100, wherein the single-die light-emitting diode comprises at least one of gallium nitride, indium gallium nitride, aluminum gallium nitride, and aluminum gallium indium nitride.

116. The light-emission device of claim 100, comprising a light-emitting diode lamp.

Art Unit: 3992

Each of the above features was discussed above in conjunction with claims 76-79 and applies here.

Proposed new **claims 162 and 167** read,

162. A light-emitting device, comprising:

at least one single-die **gallium nitride based semiconductor blue light-emitting diode (LED)** coupleable with a power supply to emit a primary radiation which is the same for each single-die LED present in the device, said primary radiation being a relatively shorter wavelength blue light radiation; and

a down-converting luminophoric medium arranged in receiving relationship to said primary radiation, and which in exposure to said primary radiation, is excited to responsively emit a secondary, relatively longer wavelength, polychromatic radiation, with separate wavelengths of said polychromatic radiation mixing to produce a white light output,

wherein each single-die gallium nitride based semiconductor blue light-emitting diode in interaction with luminophoric medium receiving its primary radiation produces white light output,

and wherein said at least one single-die gallium nitride based semiconductor blue light-emitting diode is **in a housing comprising a light-transmissive wall member in spaced relationship** to said at least one single-die gallium nitride based semiconductor blue light-emitting diode,

and **wherein said luminophoric medium is dispersed in or on said light-transmissive wall member.**

167. The light-emitting device of claim 162, wherein the luminophoric medium comprises **inorganic luminophoric material.**

Claim 162 is coextensive with claim 26, as indicated by Patentee (Remarks dated 3/26/2012, pp. 58-59). Claim 162 differs from claim 5 in requiring the LED be a GaN-based blue-light-emitting LED and the orientation of the luminophoric medium in or on a light-transmissive wall member.

As noted above in this rejection, the substitution of Tabuchi's GaN-based LED with Nakamura's GaN-based LED is obvious. Also as noted above in conjunction with claims 63, 66-72, and 74, the light-transmissive wall member **6** having a phosphor coating **7** thereon in spaced relationship to the LED **4** is taught by Tabuchi. Thus, all of the additional features of claim 162 are obvious for the reasons already discussed above.

Proposed new **claims 164-166** read,

Art Unit: 3992

164. The light-emitting device of claim 162, wherein said luminophoric medium is **dispersed on** said light-transmissive wall member.

165. The light-emitting device of claim 162, wherein the light-transmissive wall member comprises **polymer**.

166. The light-emitting device of claim 162, wherein the light-transmissive wall member comprises **glass**.

Again, Tabuchi states that the housing member **6** onto which the phosphor **7** is dispersed can be made from glass or epoxy resin (i.e. polymer):

Transparent cover 6 is made of a material such as **glass** or an **epoxy resin**...

(Tabuchi translation, pp. 3-4; emphasis added)

Proposed new **claims 168 and 169** read,

168. The light-emitting device of claim 162, wherein the single-die light-emitting diode comprises **gallium nitride and its alloys**.

169. The light-emitting device of claim 162, wherein the single-die light-emitting diode comprises at least one of **gallium nitride, indium gallium nitride, aluminum gallium nitride, and aluminum gallium indium nitride**.

Again, Nakamura teaches GaN-based LED and the use of Nakamura's GaN-based, blue-light-emitting LED in place of Tabuchi's GaN-based LED is obvious for the reasons indicated above, which applies here.

Proposed new **claims 170 and 171** read,

170. The light-emitting device of claim 162, wherein the at least one single-die gallium nitride based semiconductor blue light-emitting diode comprises **only one** single-die gallium nitride based semiconductor blue light-emitting diode.

171. The light-emitting device of claim 162, comprising a light-emitting diode **lamp**.

Tabuchi teaches only one single LED which renders claims 170 and 171 obvious.

7. Claims 118, 121-126, 128-134, 137-142, and 144-148 are rejected under 35 U.S.C. 103(a) as being unpatentable over Tabuchi in view of APA, Wanmaker, Nakamura, and Martic.

Art Unit: 3992

Proposed new **claims 118 and 129** read,

118. A light-emission device, comprising

a single-die, two-lead **gallium nitride based semiconductor blue light-emitting diode emitting radiation; and**

a recipient down-converting luminophoric medium for down-converting the radiation emitted by the light-emitting diode, to a polychromatic white light, wherein the luminophoric medium is **dispersed in a polymer that is on or about the single-die, two-lead gallium nitride based semiconductor blue light-emitting diode.**

129. The light-emission device of claim 118, wherein the luminophoric medium comprises **inorganic luminophoric material.**

Claim 118 is coextensive with claim 26, as indicated by Patentee (Remarks dated 3/26/2012, p. 45). The **GaN-based blue LED** and the luminophoric medium made from a mixture of **inorganic** phosphors was discussed above in the rejection over Tabuchi in view of APA, Wanmaker, and Nakamura which applies equally to claim 118.

Thus the only difference is that there is no indication that the phosphoric mixture of APA or Wanmaker is *dispersed in a polymer that is on or about* the GaN-based LED.

As noted above, Tabuchi teaches the phosphor **7** is coated on the wall of the transparent cover **6**:

A **phosphor layer 7** is provided by applying a **binding agent in which a phosphor** to convert the radiation from light emitting semiconductor device 4 to visible light is **dispersed on the inner surface of transparent cover 6**. Transparent cover 6 is made of a material such as **glass** or an **epoxy resin** is preferably fixed to stem 1 so that it can also function as a cap for hermetic sealing.

(Tabuchi translation, pp. 3-4; emphasis added)

Although Tabuchi does not indicate the identity of the binder, Martic teaches that it has long been known (since 1973) to use organic resins (i.e. polymers) as binding agents specifically for inorganic phosphors in the manufacture of luminescent screens:

In still another aspect, this invention relates to screens comprising **inorganic phosphors** wherein the **binding agent** for said phosphors comprises a **polyurethane elastomer** alone or in combination with an **alkyl methacrylate resin** in various ratio ranges.

(Martic, col. 1, lines 10-14; emphasis added)

Art Unit: 3992

It would have been obvious to one of ordinary skill in the art, at the time of the invention to disperse APA or Wanmaker's inorganic phosphors in the polymeric binding agent of Martic to make the phosphor layer 7 in Tabuchi, because Tabuchi is silent as to the binding agent for the phosphor, such that one of ordinary skill would use known binders specifically used for inorganic phosphors that must emit light.

This is all of the additional features of claims 118 and 129.

Proposed new **claims 121-126, 128, 132, and 133** read,

121. The light-emission device of claim 118, comprising the luminophoric medium **dispersed in a polymer that is about** the single-die, two-lead gallium nitride based semiconductor blue light-emitting diode.

122. The light-emission device of claim 118, comprising the single-die, two-lead gallium nitride based semiconductor blue light-emitting diode comprising die side surface, and wherein the polymer is in **laterally spaced relationship to said side die surface.**

123. The light-emission device of claim 122, wherein the polymer is in **laterally spaced facing relationship to said side die surface.**

124. The light-emission device of claim 118, comprising the single-die, two-lead gallium nitride based semiconductor blue light-emitting diode being arranged to **directly impinge** radiation on the polymer.

125. The light-emission device of claim 118, comprising the single-die, two-lead gallium nitride based semiconductor blue light-emitting diode and polymer being arranged **without intermediate material therebetween.**

126. The light-emission device of claim 118, comprising the luminophoric medium being in a **homogeneous** composition.

128. The light-emission device of claim 118, comprising the luminophoric medium being **on** polymer or glass.

132. The light-emission device of claim 118, comprising a light-emitting diode lamp.

133. The light-emission device of claim 132, wherein the light-emitting diode lamp comprises the single-die gallium nitride based semiconductor blue light-emitting diode and **inorganic** luminophoric material **within an enclosure** comprising material that is **light-transmissive of said white light.**

Art Unit: 3992

Each of the above features was discussed above in conjunction with the rejection of claims 62, 63, 66-69, 74-80 over Tabuchi in view of APA, Wanmaker and Nakamura, above, and applies here.

Proposed new **claims 130-131** read,

130. The light-emission device of claim 118, wherein the single-die light-emitting diode comprises gallium nitride and its alloys.

131. The light-emission device of claim 118, wherein the single-die light-emitting diode comprises at least one of gallium nitride, indium gallium nitride, aluminum gallium nitride, and aluminum gallium indium nitride.

Each of the above features was discussed above in the rejection of claims 76-79 over Tabuchi in view of APA, Wanmaker and Nakamura, above, and applies here.

Proposed new **claims 134 and 144** read,

134. A light-emitting device, comprising:

at least one single-die **gallium nitride based semiconductor blue** light-emitting diode (LED) coupleable with a power supply to emit a primary radiation which is the same for each single-die LED present in the device, said primary radiation being a relatively shorter wavelength radiation; and

a down-converting luminophoric medium arranged in receiving relationship to said primary radiation, and which in exposure to said primary radiation, is excited to responsively emit a secondary, relatively longer wavelength, polychromatic radiation, with separate wavelengths of said polychromatic radiation mixing to produce a white light output,

wherein each of the at least one single-die gallium nitride based semiconductor blue light-emitting diode in interaction with luminophoric medium receiving its primary radiation produces white light output,

and wherein the luminophoric medium is **dispersed in a polymer that is on or about** the single-die gallium nitride based semiconductor blue light-emitting diode.

144. The light-emitting device of claim 134, wherein the luminophoric medium comprises **inorganic** luminophoric material.

Each of the features of this claim has been discussed in conjunction with claims 5 (Tabuchi in view of APA), 62 (Tabuchi in view of APA, Wanmaker and Nakamura), and 118 and 129, above and applies here.

Proposed new **claims 137-142, 147, and 148** read,

Art Unit: 3992

137. The light-emitting device of claim 134, comprising the luminophoric medium **dispersed in a polymer that is about** the single-die gallium nitride based semiconductor blue light-emitting diode.

138. The light-emitting device of claim 134, comprising the single-die gallium nitride based semiconductor blue light-emitting diode comprising die side surface, and wherein the polymer is in **laterally spaced relationship to said side die surface.**

139. The light-emitting device of claim 138, wherein the polymer is in **laterally spaced facing relationship to said side die surface.**

140. The light-emitting device of claim 134, comprising the single-die light-emitting diode being arranged to **directly impinge** radiation on the polymer.

141. The light-emitting device of claim 134, comprising the single-die light-emitting diode and polymer being arranged **without intermediate material therebetween.**

142. The light-emitting device of claim 134, comprising the luminophoric medium being in a **homogeneous** composition.

147. The light-emission device of claim 134, comprising a light-emitting diode lamp.

148. The light-emission device of claim 147, wherein the light-emitting diode lamp comprises the single-die gallium nitride based semiconductor blue light-emitting diode and **inorganic** luminophoric material within an **enclosure** comprising material that is **light-transmissive of said white light output.**

Each of the above features was discussed above in conjunction with the rejection of claims 63, 66-69, 74, 79, 80, and 162 over Tabuchi in view of APA, Wanmaker and Nakamura, above, and applies here.

Proposed new **claims 145 and 146** read,

145. The light-emitting device of claim 134, wherein the single-die light-emitting diode comprises gallium nitride and its alloys.

146. The light-emitting device of claim 134, wherein the single-die light-emitting diode comprises at least one of gallium nitride, indium gallium nitride, aluminum gallium nitride, and aluminum gallium indium nitride.

Each of the above features was discussed above in the rejection of claims 76-78 over Tabuchi in view of APA, Wanmaker and Nakamura, above, and applies here.

Art Unit: 3992

8. Claims 34, 35, 37-40 and 179 are rejected under 35 U.S.C. 103(a) as being unpatentable over Tabuchi in view of APA and Nakamura as applied to claims 3, 4, 34, and 38-40, above, and further in view of Tadatsu.

Again, proposed new claims 34, 35, 37, and 179 read,

34. The light-emitting device of claim 3, wherein the luminophoric medium comprises an **inorganic** luminophor.

35. The light-emitting device of claim 34, wherein the inorganic luminophor is dispersed **on or in** a housing member.

37. The light-emitting device of claim 34, wherein the inorganic luminophor is **within** a housing member.

179. The light-emitting device of claim 3, wherein the luminophoric medium is **contiguous to** said semiconductor laser.

The prior art of Tabuchi in view of APA and Nakamura, as explained above, discloses each of the features of claims 3, 4, 34, and 38-40.

Tadatsu teaches an alternative location for the phosphors. Tadatsu discloses a packaged LED **11** wherein a primary radiation is down-converted by a luminophor **5** to a longer wavelength, and is therefore in the same field of endeavor as is Tabuchi. Tadatsu also desires producing **white** light from a single LED. In this regard, Tadatsu states,

[Constitution] A light emitting diode having a light emitting device on a stem, the light emitting device being surrounded with a **resin mold**, wherein said **light emitting device is made of gallium nitride related compound semiconductors** which are expressed with a general formula of $Ga_xAl_{1-x}N$ (where $0 \leq x \leq 1$), and further wherein a **fluorescent dye or pigment**, which is **excited with emission light from said gallium nitride related compound semiconductors** and which **emits fluorescent light**, is **added to said resin mold**.

(Tadatsu translation, p. 1)

Tadatsu's Fig. 2 (reproduced below) shows the packaged LED have two leads **2, 3** and a housing member ("resin mold" **4**) within which the luminophor ("fluorescent dye" **5**) is dispersed. Tadatsu also indicates that the luminophor can be organic or inorganic:

[0003] Ordinarily, a resin with a large index of refraction and a high transparency is selected for the resin mold **4**, so that the emission light from the light emitting device is efficiently emitted to the air. In other cases, an **inorganic or organic pigment is mixed as a coloring agent in the resin mold 4** in order to convert or correct the emission color of the light emitting device. For instance, when a red pigment is added to a resin mold around a

Art Unit: 3992

green light emitting device having GaP semiconductor materials, its **emission color turns into white.**

(Tadatsu translation ¶ [0003]; emphasis added)

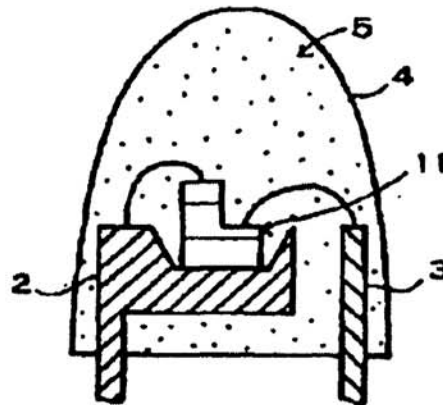

(Tadatsu, Fig. 2)

It would have been obvious to one of ordinary skill in the art, at the time of the invention to substitute the phosphor location used in Tabuchi with that location in Tadatsu because it is substitution of known equivalents to produce predictable results, as proven by Tadatsu. So modified, the luminophoric medium is in or within a housing member and is contiguous with the laser diode of Tabuchi/Nakamura.

Evidence of predictable results comes from Tadatsu. Tadatsu shows that dispersing the phosphor in a resin molded cap allows the primary radiation from the LED to be converted by the phosphor to secondary radiation and that the wavelengths mix are capable of mixing to produce white light. Thus, APA's inorganic phosphors in the resin housing member of Tadatsu would predictable produce white light when Tabuchi/Nakamura's GaN-based laser is packaged as in Tadatsu.

9. Claims 3-5, 12, 13, 21, 22, 26, 62, 63, 66-72, 74, 76-79, 100, 101, 104-110, 112, 114-116, 118, 121-126, 128, 130-132, 134, 137-142, 145-147, 162-166, 168-172, 178, 187, and 188 are rejected under 35 U.S.C. 103(a) as being unpatentable over Tabuchi in view of Pinnow and Nakamura.

The prior art of Tabuchi in view of Pinnow, as explained above, discloses each of the features of claim 5, 22, 26, 172, and 187.

Claim 3 reads,

3. A light-emitting device, comprising:

Art Unit: 3992

*a semiconductor **laser** coupleable with a power supply to emit a primary radiation having a relatively shorter wavelength outside the **visible** light spectrum; and*

a down-converting luminophoric medium arranged in receiving relationship to said primary radiation, and which in exposure to said primary radiation responsively emits polychromatic radiation in the visible light spectrum, with different wavelengths of said polychromatic radiation mixing to produce a white light output.

Claim 3 is distinguished from claim 1 in that (1) a *semiconductor **laser*** is required versus a *single-die semiconductor LED*; (2) the primary radiation is required to be outside the **visible** light spectrum, as opposed to outside the visible **white** light spectrum; and (3) the wording associated with the luminophoric medium.

With regard to **differences (1) and (2)**, Tabuchi does not teach a semiconductor **laser** that produces primary radiation outside the visible spectrum. Tabuchi does, however, teach a GaN-based LED producing UV light which is outside the visible light spectrum:

A light emitting semiconductor apparatus of the present utility model invention is not limited to the structures and materials illustrated in the above examples. For example, it goes without saying that a **near UV light emitting devices with GaN** can be employed and that **an ordinary UV-visible light conversion phosphor** can be utilized.

(Tabuchi translation, p. 5; emphasis added)

Nakamura teaches GaN-based LEDs and laser diodes (LDs) that emit both blue and UV light. (In fact, one LED indicated as suitable in the '175 invention is a GaN LED from Nichia Chemicals, to which Nakamura is assigned. See the '175 patent, col. 9, lines 10-18. Thus, Patentee admits to using known GaN-based LED for the instant invention.)

Nakamura indicates that GaN-based LED emitting light *outside the visible white light spectrum* are known in the art:

Jpn. Pat. Appln. KOKAI Publication No. 4-68579 discloses a double-heterostructure having a p-type **GaInN** clad layer formed on an oxygen-doped, n-type **GaInN** light-emitting layer. ... The emission wavelength of the light-emitting device having this double-heterostructure is **365 to 406 nm**.

(Nakamura, col. 2, lines 7-14; emphasis added)

UV light is light less than 400 nm as evidenced by the CRC Handbook, *supra*.

In regard to its LEDs and lasers, Nakamura states the following:

Art Unit: 3992

The semiconductor device of the present invention includes a **light-emitting diode (LED)** and a **laser diode (LD)**.

(Nakamura, col. 4, lines 9-11)

It is still another object of the present invention to provide an **ultraviolet to red light-emitting device** having a wavelength in the region of **365 to 620 nm**.

(Nakamura, col. 2, lines 30-33; emphasis added)

FIG. 12 shows a structure of a **laser diode 40** having a double-heterostructure of the present invention.

The **laser diode 40** has a double-heterostructure constituted by an impurity-doped **In_xGa_{1-x}N active layer 18** described above in detail in association with the light-emitting diode, and two clad layers sandwiching the active layer **18**, i.e., an n-type gallium nitride-based compound semiconductor layer **16** and a p-type gallium nitride-based compound semiconductor layer **20**, as described above. A buffer layer **14** described above in detail is formed on a substrate **12** described above in detail. An n-type gallium nitride layer **42** is formed on the buffer layer **14**, providing a contact layer for an n-electrode described below.

(Nakamura, col. 11, line 61 to col. 12, line 6; emphasis added)

Nakamura shows that the wavelength of the LED or LD can be controlled by controlling the dopant:

In the light-emitting device of the present invention, when the value of x in In_xGa_{1-x}N of the light-emitting layer is close to 0, the device emits **ultraviolet** light. When the value of x increases, the emission falls in the longer-wavelength region. When the value of x is close to 1, the device emits red light. When the value of x is in the range of 0 < x < 0.5, the light-emitting device of the present invention emits **blue** to yellow light in the wavelength range of **450** to 550 nm.

(Nakamura, col. 4, lines 52-59; emphasis added)

Nakamura provides numerous examples of LEDs emitting blue light (Examples 1-28 at cols. 13-20) including an emission **peak** value at, *inter alia*, 400 nm (Nakamura, col. 14, lines 64-65) at 405 nm (*id.*, claim 18, line 67), 430 nm (*id.*, col. 14, lines 51-52), and 480 nm (*id.*, col. 13, lines 40-42).

The peak emission wavelength at 400 nm and 405 nm show that the LEDs of these examples emit primarily **ultraviolet** light, as evidenced by the CRC Handbook. Similarly, those LEDs having peak emission at 430 nm and 480 nm emit primarily **blue** light.

It would have been obvious to one of ordinary skill in the art, at the time of the invention to substitute Tabuchi's GaN-based LED with either a UV-light-emitting GaN-based **LDs** (claim 3) or a blue- or UV-light-emitting GaN-based **LEDs** (claim 5)

Art Unit: 3992

disclosed in Nakamura. This can be seen as simple substitution of one known element (Tabuchi's GaN-based LED) for another known element (Nakamura's GaN-based LED or LD) to obtain predictable results and is one of the rationales identified by the Supreme Court in *KSR International Co. v. Teleflex Inc.*, 550 U.S. _____, 82 USPQ2d 1385, 1395-97 (2007). (See MPEP 2143, Rationale B.)

The results are predictable because both Tabuchi's and Nakamura's LED and LD emit light in the same general region of the spectrum and are GaN-based, so the LED and LD materials are essentially the same. In addition, Pinnow teaches that the wavelength of light need only be shorter than 495 nm (4950 Å) to be effective to be converted by the mixture of phosphors to white light. Moreover, Pinnow uses both blue and UV laser light, thereby indicating that it is the wavelength of light and not whether the primary radiation is coherent or incoherent that matters.

In regard to the predictability, as already noted above, Pinnow teaches that any wavelength of primary radiation can be down-converted by the mixture of phosphors to produce white light so long as the wavelength is less than 4950 Å (495 nm):

Regardless of how many phosphors are used, it is apparent from the chromaticity diagram that a necessary condition for achieving a true white is that the illuminating laser beam have a **wavelength of approximately 4,950 Å. or shorter**. Otherwise, it is impossible to include illuminant C within a polygon whose primaries are the source and any combination of longer wavelengths that can be achieved by down-conversion of frequency. Fortunately, the argon-ion laser satisfies this necessary condition.

(Pinnow, col. 3, lines 24-55; emphasis added)

(It is noted that Pinnow uses "A." for "angstrom", which is properly, instead, Å.)

Thus, Pinnow teaches those of ordinary skill that shifting the peak maximum of the LED in Tabuchi from UV to blue (slightly longer wavelength), by using one of Nakamura's GaN-based LD or LED (inventive or known) would yield entirely predictable results of white light emission with the down-converting phosphor mixture. The predictability results from using Nakamura's LEDs that emit light (UV or blue) having a wavelength of less than 4950 Å (495 nm).

Claim 4 reads,

4. A light-emitting device according to claim 3, wherein said semiconductor laser includes an active material selected from the group consisting of III-V alloys and II-VI alloys.

Nakamura's LED and LD are made from InGaN which is a *group III-V alloy*. Thus, substitution of Tabuchi's LED with Nakamura's LD, as discussed above, results in the laser including *group III-V alloy*.

Art Unit: 3992

Regarding **claim 5**, there is no requirement that the **primary** radiation is outside the visible white light spectrum, but substituting Tabuchi's GaN-based LED that emit either blue light or UV light with Nakamura's GaN-based LED still teaches all of the features of claim 5 because the **secondary** radiation emitted by the phosphor mixture of Tabuchi/Pinnow would be still white light, as evidenced by Pinnow.

Regarding **claims 12 and 13**, Nakamura, like Stevenson, fabricates the LED on sapphire substrates (Nakamura, col. 12, line 42) and the LEDs are multilayered (Nakamura's Figs. 1, 11, 12), so substitution of Tabuchi's GaN LED with the GaN-based LEDs in Nakamura, still reads on the features of claims 12 and 13.

Proposed amended **claim 21** reads,

21. A light-emitting device according to claim 5, wherein each single-die semiconductor LED present in the device comprises a single-die, two-lead gallium nitride based blue light semiconductor LED.

Both Tabuchi and Nakamura disclose that the LEDs have two leads. Substitution of Tabuchi's UV-light-emitting GaN LED with Nakamura's blue-light-emitting GaN-based LED is obvious for the reasons expressed above.

Regarding **claim 22**, both Tabuchi and Nakamura disclose that the LEDs have two leads. Thus again, substitution of Tabuchi's GaN LED with those in Nakamura, still teaches the features of claim 22.

Regarding **claim 26**, substitution of Tabuchi's GaN LED with those in Nakamura, still teaches the features of claim 26.

Regarding **claim 172**, substitution of Tabuchi's GaN LED with those in Nakamura, still results in the secondary, down-converted radiation having a broad spectrum of frequencies, because white light is produced, as evidenced by Pinnow.

Proposed new **claim 62** reads,

62. A light-emitting device, comprising:

at least one single-die gallium nitride based semiconductor blue light-emitting diode (LED) coupleable with a power supply to emit a primary radiation which is the same for each single-die LED present in the device, said primary radiation being a relatively shorter wavelength blue light radiation; and

a down-converting luminophoric medium arranged in receiving relationship to said primary radiation, and which in exposure to said primary radiation, is excited to responsively emit a secondary, relatively longer wavelength, polychromatic radiation, with separate wavelengths of said polychromatic radiation mixing to produce a white light output, wherein each of the at least

Art Unit: 3992

one single-die gallium nitride based semiconductor blue light-emitting diode in interaction with luminophoric medium receiving its primary radiation produces white light output,

and wherein the light-emitting device comprises one or more compatible characteristics selected from the group consisting of:

(i) the luminophoric medium being arranged **about** the single-die light-emitting diode;

(ii) the luminophoric medium being **contiguous to** the single-die light-emitting diode;

(iii) the single-die light-emitting diode comprising side surface and the luminophoric medium being in **laterally spaced relationship to said side surface**;

(iv) the luminophoric medium being dispersed **in polymer or glass**; and

(v) the luminophoric medium being **on polymer or glass**.

Claim 62 is coextensive with claim 5, as indicated by Patentee (Remarks dated 3/26/2012, pp. 28-29). Claim 62 is distinguished from claim 5 in (1) the LED is required to be a blue-light-emitting GaN-based LED and (2) the one or more *compatible characteristics*. The substitution of Tabuchi's UV-light-emitting GaN-based LED with Nakamura's blue-light-emitting GaN-based LEDs was discussed above and is obvious for the same reasons. Tabuchi's Fig. 1 shows the luminophoric medium (phosphor 7) is (i) *about* the LED, (iii) laterally spaced from the side surface of the LED, and (v) on polymer or glass, as Tabuchi's transparent cover 6 is made from plastic or glass.

In addition, Pinnow teaches that the phosphor mixture meets either of iv and v:

In this description, use will be made of the term "colorant" or "organic colorant." It is to be understood that this term includes photoluminescent organic dyes and pigments. **Pigments** are particularly useful and may be formed by **dissolving a dye in an organic resin solution [i.e. a polymer] which is subsequently condensed**. It is known that luminescent efficiency in certain cases may be enhanced if the dye is absorbed on a colloid which may take the form of gell [sic] fibers or particles of high molecular weight polymers.

(Pinnow, paragraph bridging cols. 1-3; emphasis added)

The invention is broadly premised on the use of such organic colorants. Monochromatic displays result from use of **homogeneous phosphor screens**. These may be present as **self-supporting members** or as

Art Unit: 3992

coatings, and they may be made up on **one or any combination of colorants required to produce the desired balance.**

(Pinnow, col. 2, lines 15-20; emphasis added)

Proposed new claims 63, 66-72, and 74 read,

63. The light-emitting device of claim 62, comprising the luminophoric medium being arranged **about** the single-die light-emitting diode.

66. The light-emitting device of claim 62, comprising the single-die light-emitting diode comprising side die surface, and the luminophoric medium being in **laterally spaced relationship to said side die surface.**

67. The light-emitting device of claim 66, wherein the luminophoric medium is in **laterally spaced facing relationship to said side die surface.**

68. The light-emitting device of claim 62, comprising the single-die light-emitting diode being arranged to **directly impinge primary radiation on the luminophoric medium.**

69. The light-emitting device of claim 62, comprising the single-die light-emitting diode and luminophoric medium being arranged **without intermediate material therebetween.**

70. The light-emitting device of claim 62, comprising the luminophoric medium being **dispersed in polymer or glass.**

71. The light-emitting device of claim 70, comprising the luminophoric medium being **dispersed in polymer about the single-die light-emitting diode.**

72. The light-emitting device of claim 70, comprising the luminophoric medium being in a **homogeneous** composition.

74. The light-emitting device of claim 62, comprising the luminophoric medium being **on polymer or glass.**

As discussed above, Pinnow teaches that the phosphor can be homogeneously dispersed in a resin (i.e. polymer) to make a coating or self-supporting member, and Tabuchi discloses that the phosphor **7** is a coating on the transparent cover **6** which can be made of polymer or glass.

It would have been obvious to one of ordinary skill in the art, at the time of the invention to use Pinnow's phosphor mixture as Tabuchi's any "ordinary UV-visible light conversion phosphor" layer **7** for the reasons indicated above. So places, the orientation shown in Tabuchi's Fig. 1 discloses each of the features of claims 63, 66-72, and 74.

Art Unit: 3992

Proposed new **claims 76-78** read,

76. The light-emitting device of claim 62, wherein the single-die light-emitting diode comprises gallium nitride and its alloys.

77. The light-emitting device of claim 62, wherein the single-die light-emitting diode comprises at least one of gallium nitride, indium gallium nitride, aluminum gallium nitride, and aluminum gallium indium nitride.

78. The light-emitting device of claim 62, wherein the at least one single-die gallium nitride based semiconductor blue light-emitting diode comprises only one single-die gallium nitride based semiconductor blue light-emitting diode.

As indicated above, Nakamura teaches GaN and its alloys make the blue-light-emitting LEDs; thus, modification of Tabuchi to use Nakamura's LEDs already includes the features of these claims.

Proposed new **claim 79** reads,

79. The light-emitting device of claim 62, comprising a light-emitting diode lamp.

Tabuchi alone or as modified according to Nakamura includes a single LED and therefore includes a lamp.

Proposed new **claim 100** reads,

100. A light-emission device, comprising

a single-die, two-lead **gallium nitride based** semiconductor **blue** light-emitting diode emitting radiation; and

a recipient down-converting luminophoric medium for down-converting the radiation emitted by the light-emitting diode, to a polychromatic white light, wherein the light-emission device comprises one or more compatible characteristics selected from the group consisting of:

(i) the luminophoric medium being arranged **about** the single-die light-emitting diode;

(ii) the luminophoric medium being **contiguous to** the single-die light-emitting diode;

(iii) the single-die light-emitting diode comprising side surface and the luminophoric medium being in **laterally spaced relationship to said side surface**;

Art Unit: 3992

(iv) the luminophoric medium being dispersed **in polymer or glass**; and

(v) the luminophoric medium being **on polymer or glass**.

Claim 100 is coextensive with claim 26, as indicated by Patentee (Remarks dated 3/26/2012, pp. 40-41). Claim 100 differs from claim 26 in the same ways that claim 62 is distinguished from claim 5. Therefore claim 100 is obvious for the same additional reasons as indicated above in conjunction with claim 62.

Proposed **new claims 101, 104-110, and 112** read,

101. The light-emission device of claim 100, comprising the luminophoric medium being arranged **about** the single-die light-emitting diode.

104. The light-emission device of claim 100, comprising the single-die light-emitting diode comprising side die surface, and the luminophoric medium being in **laterally spaced relationship to said side die surface**.

105. The light-emission device of claim 104, wherein the luminophoric medium is in **laterally spaced facing relationship to said side die surface**.

106. The light-emission device of claim 100, comprising the single-die light-emitting diode being arranged to **directly impinge** primary radiation on the luminophoric medium.

107. The light-emission device of claim 100, comprising the single-die light-emitting diode and luminophoric medium being arranged **without intermediate material** therebetween.

108. The light-emission device of claim 100, comprising the luminophoric medium being **dispersed in** polymer or glass.

109. The light-emission device of claim 108, comprising the luminophoric medium being **dispersed in polymer about** the single-die light-emitting diode.

110. The light-emission device of claim 100, comprising the luminophoric medium being in a **homogeneous** composition.

112. The light-emission device of claim 100, comprising the luminophoric medium being **on** polymer or glass.

Each of the above features was discussed above in conjunction with claims 63, 66-72, and 74 and applies here.

Proposed **new claims 114-116** read,

Art Unit: 3992

114. The light-emission device of claim 100, wherein the single-die light-emitting diode comprises gallium nitride and its alloys.

115. The light-emission device of claim 100, wherein the single-die light-emitting diode comprises at least one of gallium nitride, indium gallium nitride, aluminum gallium nitride, and aluminum gallium indium nitride.

116. The light-emission device of claim 100, comprising a light-emitting diode lamp.

Each of the above features was discussed above in conjunction with claims 76-79 and applies here.

Proposed new **claim 118** reads,

118. A light-emission device, comprising

a single-die, two-lead **gallium nitride based** semiconductor **blue** light-emitting diode emitting radiation; and

a recipient down-converting luminophoric medium for down-converting the radiation emitted by the light-emitting diode, to a polychromatic white light, wherein the luminophoric medium is **dispersed in a polymer that is on or about** the single-die, two-lead gallium nitride based semiconductor blue light-emitting diode.

Claim 118 is coextensive with claim 26, as indicated by Patentee (Remarks dated 3/26/2012, p. 45). Claim 118 differs from claim 26 in the same ways that claim 100 is distinguished from claim 26, except the *compatible characteristics* are as highlighted in bold. As noted above, Pinnow teaches these features and the combination remains obvious for the same reasons as indicated above.

Proposed new **claims 121-126 and 128** read,

121. The light-emission device of claim 118, comprising the luminophoric medium **dispersed in a polymer that is about** the single-die, two-lead gallium nitride based semiconductor blue light-emitting diode.

122. The light-emission device of claim 118, comprising the single-die, two-lead gallium nitride based semiconductor blue light-emitting diode comprising die side surface, and wherein the polymer is in **laterally spaced relationship to said side die surface.**

123. The light-emission device of claim 122, wherein the polymer is in **laterally spaced facing relationship to said side die surface.**

Art Unit: 3992

124. The light-emission device of claim 118, comprising the single-die, two-lead gallium nitride based semiconductor blue light-emitting diode being arranged to **directly impinge** radiation on the polymer.

125. The light-emission device of claim 118, comprising the single-die, two-lead gallium nitride based semiconductor blue light-emitting diode and polymer being arranged **without intermediate material therebetween**.

126. The light-emission device of claim 118, comprising the luminophoric medium being in a **homogeneous** composition.

128. The light-emission device of claim 118, comprising the luminophoric medium being **on** polymer or glass.

Each of the above features was discussed above in conjunction with claims 63, 66-72, and 74 and applies here.

Proposed new **claims 130-132** read,

130. The light-emission device of claim 118, wherein the single-die light-emitting diode comprises gallium nitride and its alloys.

131. The light-emission device of claim 118, wherein the single-die light-emitting diode comprises at least one of gallium nitride, indium gallium nitride, aluminum gallium nitride, and aluminum gallium indium nitride.

132. The light-emission device of claim 118, comprising a light-emitting diode lamp.

Each of the above features was discussed above in conjunction with claims 76-79 and applies here.

Proposed new **claim 134** reads,

134. A light-emitting device, comprising:

at least one single-die **gallium nitride based** semiconductor **blue** light-emitting diode (LED) coupleable with a power supply to emit a primary radiation which is the same for each single-die LED present in the device, said primary radiation being a relatively shorter wavelength radiation; and

a down-converting luminophoric medium arranged in receiving relationship to said primary radiation, and which in exposure to said primary radiation, is excited to responsively emit a secondary, relatively longer wavelength, polychromatic radiation, with separate wavelengths of said polychromatic radiation mixing to produce a white light output.

Art Unit: 3992

wherein each of the at least one single-die gallium nitride based semiconductor blue light-emitting diode in interaction with luminophoric medium receiving its primary radiation produces white light output,

and wherein the luminophoric medium is **dispersed in a polymer that is on or about** the single-die gallium nitride based semiconductor blue light-emitting diode.

Each of the features of this claim has been discussed in conjunction with claims 5, 62, and 118, above and applies here.

Proposed new **claims 137-142** read,

137. The light-emitting device of claim 134, comprising the luminophoric medium **dispersed in a polymer that is about** the single-die gallium nitride based semiconductor blue light-emitting diode.

138. The light-emitting device of claim 134, comprising the single-die gallium nitride based semiconductor blue light-emitting diode comprising die side surface, and wherein the polymer is in **laterally spaced relationship to said side die surface.**

139. The light-emitting device of claim 138, wherein the polymer is in **laterally spaced facing relationship to said side die surface.**

140. The light-emitting device of claim 134, comprising the single-die light-emitting diode being arranged to **directly impinge** radiation on the polymer.

141. The light-emitting device of claim 134, comprising the single-die light-emitting diode and polymer being arranged **without intermediate material therebetween.**

142. The light-emitting device of claim 134, comprising the luminophoric medium being in a **homogeneous** composition.

Each of the above features was discussed above in conjunction with claims 63, 66-72, and 74 and applies here.

Proposed new **claims 145-147** read,

145. The light-emitting device of claim 134, wherein the single-die light-emitting diode comprises gallium nitride and its alloys.

146. The light-emitting device of claim 134, wherein the single-die light-emitting diode comprises at least one of gallium nitride, indium gallium nitride, aluminum gallium nitride, and aluminum gallium indium nitride.

Art Unit: 3992

147. The light-emission device of claim 134, comprising a light-emitting diode lamp.

Each of the above features was discussed above in conjunction with claims 76-79 and applies here.

Proposed new **claim 162** reads,

162. A light-emitting device, comprising:

at least one single-die **gallium nitride based semiconductor blue light-emitting diode (LED)** coupleable with a power supply to emit a primary radiation which is the same for each single-die LED present in the device, said primary radiation being a relatively shorter wavelength blue light radiation; and

a down-converting luminophoric medium arranged in receiving relationship to said primary radiation, and which in exposure to said primary radiation, is excited to responsively emit a secondary, relatively longer wavelength, polychromatic radiation, with separate wavelengths of said polychromatic radiation mixing to produce a white light output,

wherein each single-die gallium nitride based semiconductor blue light-emitting diode in interaction with luminophoric medium receiving its primary radiation produces white light output,

and wherein said at least one single-die gallium nitride based semiconductor blue light-emitting diode is **in a housing comprising a light-transmissive wall member in spaced relationship** to said at least one single-die gallium nitride based semiconductor blue light-emitting diode,

and **wherein said luminophoric medium is dispersed in or on said light-transmissive wall member.**

Claim 162 is coextensive with claim 26, as indicated by Patentee (Remarks dated 3/26/2012, pp. 58-59). Claim 162 differs from claim 5 in requiring the LED be a GaN-based blue-light-emitting LED and the orientation of the luminophoric medium in or on a light-transmissive wall member.

As noted above in this rejection, the substitution of Tabuchi's GaN-based LED with Nakamura's GaN-based LED is obvious. Also as noted above in conjunction with claims 63, 66-72, and 74, the light-transmissive wall member **6** having a phosphor coating **7** thereon in spaced relationship to the LED **4** is taught by Tabuchi. Thus, all of the additional features of claim 162 are obvious for the reasons already discussed above.

Proposed new **claim 163** reads,

Art Unit: 3992

163. The light-emitting device of claim 162, wherein said luminophoric medium is **dispersed in said light-transmissive wall member.**

Although Tabuchi does not teach that the phosphor **7** can be *dispersed in* the wall member **6**, Pinnow teaches that a phosphor mixture dispersed in organic resin (i.e. polymer) can be used to make a self-supporting member. Again Pinnow states,

In this description, use will be made of the term "colorant" or "organic colorant." It is to be understood that this term includes photoluminescent organic dyes and pigments. **Pigments** are particularly useful and may be formed by **dissolving a dye in an organic resin solution [i.e. a polymer] which is subsequently condensed.** It is known that luminescent efficiency in certain cases may be enhanced if the dye is **absorbed on a colloid** which may take the form of gell [sic] fibers or particles of high molecular weight **polymers.**

(Pinnow, paragraph bridging cols. 1-3; emphasis added)

The invention is broadly premised on the use of such organic colorants. Monochromatic displays result from use of **homogeneous phosphor screens.** These may be present as **self-supporting members** or as **coatings**, and they may be made up on **one or any combination of colorants required to produce the desired balance.**

(Pinnow, col. 2, lines 15-20; emphasis added)

Thus, the phosphors may be dispersed in a polymer whether the polymer is coated made into a coating or formed into a "self-supporting member".

It would have been obvious to one of ordinary skill in the art, at the time of the invention to form Pinnow's phosphor mixture into a self-supporting member in the form of Tabuchi's wall member **6** because Pinnow teaches that the phosphor mixture functions for the same purpose whether it is in the form of a coating or a self-supporting member (*id.*). As such, Pinnow tells those of ordinary skill that it is a matter of design choice to form the phosphor mixture in resin as a self-supporting member or as a coating. Therefore, one of ordinary skill can see the Tabuchi's phosphor coating **7** on the wall member **6** can be consolidated into a self-supporting member having the phosphor dispersed therein.

This "design choice" is substantially rationale B: simple substitution of one known element for another (MPEP 2143). Pinnow proves the predictability because Pinnow teaches that both forms of the phosphor mixture in resin (coating or self-supporting member) function to down-convert blue or UV primary radiation into polychromatic secondary radiation that mixes to produce white light.

This is all of the features of claim 163.

Proposed new **claims 164-166** read,

Art Unit: 3992

164. The light-emitting device of claim 162, wherein said luminophoric medium is **dispersed on** said light-transmissive wall member.

165. The light-emitting device of claim 162, wherein the light-transmissive wall member comprises **polymer**.

166. The light-emitting device of claim 162, wherein the light-transmissive wall member comprises **glass**.

Again, Tabuchi states that the housing member **6** onto which the phosphor **7** is dispersed can be made from glass or epoxy resin (i.e. polymer):

Transparent cover 6 is made of a material such as **glass** or an **epoxy resin**...

(Tabuchi translation, pp. 3-4; emphasis added)

Proposed new **claims 168 and 169** read,

168. The light-emitting device of claim 162, wherein the single-die light-emitting diode comprises **gallium nitride and its alloys**.

169. The light-emitting device of claim 162, wherein the single-die light-emitting diode comprises at least one of **gallium nitride, indium gallium nitride, aluminum gallium nitride, and aluminum gallium indium nitride**.

Again, Nakamura teaches GaN-based LED and the use of Nakamura's GaN-based, blue-light-emitting LED in place of Tabuchi's GaN-based LED is obvious for the reasons indicated above, which applies here.

Proposed new **claims 170 and 171** read,

170. The light-emitting device of claim 162, wherein the at least one single-die gallium nitride based semiconductor blue light-emitting diode comprises **only one** single-die gallium nitride based semiconductor blue light-emitting diode.

171. The light-emitting device of claim 162, comprising a light-emitting diode **lamp**.

Tabuchi teaches only one single LED which renders claims 170 and 171 obvious.

Proposed new **claim 178** reads,

178. A light-emitting device, comprising:

a single-die gallium nitride based semiconductor blue light-emitting diode (LED) coupleable with a power supply to emit a primary radiation, said

Art Unit: 3992

primary radiation being a relatively shorter wavelength blue light radiation;
and

a down-converting luminophoric medium arranged in receiving relationship to
said primary radiation, and which in exposure to said primary radiation, is
excited to responsively emit a secondary, relatively longer wavelength,
polychromatic radiation, with separate wavelengths of said polychromatic
radiation mixing to produce a white light output.

Patentee indicates that claim 178 is claim 5 with the exception that the terminology "at least one" has been removed and that the LED is now limited to a GaN-based blue-light emitting diode (Patentee's Remarks dated 3/26/2012, p. 63). For the same reasons as indicated above, it would be obvious to use Nakamura's blue GaN-based LED in place of Tabuchi's UV GaN-based LED. This is all of the features of claim 178.

Regarding **claim 187**, substitution of Tabuchi's GaN LED with those in Nakamura, still results in the secondary, down-converted radiation having a broad spectrum of frequencies, because white light is produced, as evidenced by Pinnow.

Proposed new **claim 188** reads,

188. The light-emitting device of claim 187, wherein the light-emitting diode
is operative to emit **blue** light.

Nakamura discloses blue-light-emitting LED, so this claim is obvious for the same reasons as claims, 1, 5, 26, 178, and 187, as discussed above.

10. Claims 64, 65, 73, 102, 103, 111, 119, 120, 127, 135, 136, and 143 are
rejected under 35 U.S.C. 103(a) as being unpatentable over Tabuchi in view of
Pinnow and Nakamura as applied to claims 62, 72, 100, 110, 118, 126, 134, and
142, above, and further in view of Tadatsu.

Again, proposed new claims 64, 65, 73, 102, 103, 111, 119, 120, 127, 135, 136, and 143 read,

64. The light-emitting device of claim 62, comprising the luminophoric
medium being **contiguous to the single-die light-emitting diode.**

65. The light-emitting device of claim 64, comprising the single-die light-
emitting diode comprising side die surface, and the luminophoric medium
being **contiguous to the side die surface.**

73. The light-emitting device of claim 72, wherein the **homogeneous**
composition is **contiguous to the single die light-emitting diode.**

Art Unit: 3992

102. The light-emission device of claim 100, comprising the luminophoric medium being **contiguous to the single-die light-emitting diode.**

103. The light-emission device of claim 102, comprising the single-die light-emitting diode comprising side die surface, and the luminophoric medium being **contiguous to the side die surface.**

111. The light-emission device of claim 110, wherein the **homogeneous composition is contiguous to the single-die light-emitting diode.**

119. The light-emission device of claim 118, comprising the luminophoric medium **dispersed in a polymer that is on the single-die, two-lead gallium nitride based semiconductor blue light-emitting diode.**

120. The light-emission device of claim 119, comprising the single-die, two-lead gallium nitride based semiconductor blue light-emitting diode comprising die side surface, and wherein the **polymer is contiguous to the die side surface.**

127. The light-emission device of claim 126, wherein the **homogeneous composition is contiguous to the single-die light-emitting diode.**

135. The light-emitting device of claim 134, comprising the luminophoric medium **dispersed in a polymer that is on the single-die gallium nitride based semiconductor blue light-emitting diode.**

136. The light-emitting device of claim 135, comprising the single-die gallium nitride based semiconductor blue light-emitting diode comprising die side surface, and wherein the **polymer is contiguous to the die side surface.**

143. The light-emitting device of claim 142, wherein the homogeneous composition is **contiguous to the single-die light-emitting diode.**

The prior art of Tabuchi in view of Pinnow and Nakamura, as explained above, discloses each of the features of claims 62, 72, 100, 110, 118, 126, 134, and 142.

Tadatsu teaches an alternative location for the phosphors. Tadatsu discloses a packaged LED **11** wherein a primary radiation is down-converted by a luminophor **5** to a longer wavelength, and is therefore in the same field of endeavor as is Tabuchi. Tadatsu also desires producing **white** light from a single LED. In this regard, Tadatsu states,

[Constitution] A light emitting diode having a light emitting device on a stem, the light emitting device being surrounded with a **resin mold**, wherein said **light emitting device is made of gallium nitride related compound semiconductors** which are expressed with a general formula of $Ga_xAl_{1-x}N$ (where $0 \leq x \leq 1$), and further wherein a **fluorescent dye or pigment**, which

Art Unit: 3992

is **excited with emission light from said gallium nitride related compound semiconductors** and which **emits fluorescent light**, is **added to said resin mold**.

(Tadatsu translation, p. 1)

Tadatsu's Fig. 2 (reproduced below) shows the packaged LED have two leads **2, 3** and a housing member ("resin mold" **4**) within which the luminophor ("fluorescent dye" **5**) is dispersed. Tadatsu also indicates that the luminophor can be organic or inorganic:

[0003] Ordinarily, a resin with a large index of refraction and a high transparency is selected for the resin mold **4**, so that the emission light from the light emitting device is efficiently emitted to the air. In other cases, an **inorganic or organic pigment is mixed as a coloring agent in the resin mold 4** in order to convert or correct the emission color of the light emitting device. For instance, when a red pigment is added to a resin mold around a green light emitting device having GaP semiconductor materials, its **emission color turns into white**.

(Tadatsu translation ¶ [0003]; emphasis added)

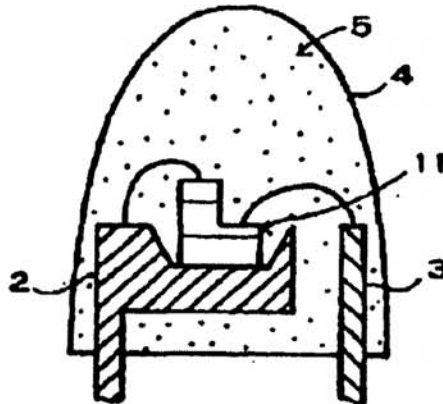

(Tadatsu, Fig. 2)

It would have been obvious to one of ordinary skill in the art, at the time of the invention to substitute the phosphor location used in Tabuchi with that location in Tadatsu because it is substitution of known equivalents to produce predictable results, as proven by Tadatsu. So modified, the luminophoric medium is in or within a housing member and is contiguous with the LED of Tabuchi/Nakamura.

Evidence of predictable results comes from Tadatsu. Tadatsu shows that dispersing the phosphor in a resin molded cap that is contiguous with all sides of the LED allows the primary radiation from the LED to be converted by the phosphor to secondary radiation and that the wavelengths mix are capable of mixing to produce white light. Thus, APA's inorganic phosphors in the resin housing member of

Art Unit: 3992

Tadatsu would predictable produce white light when Tabuchi/Nakamura's GaN-based laser is packaged as in Tadatsu.

11. Claims 5, 11-13, 22, 26, 172, 173, 187, and 188 are rejected under 35 U.S.C. 103(a) as being unpatentable over Tabuchi in view of Pinnow and Edmond.

The prior art of Tabuchi in view of Pinnow, as explained above, is believed to disclose each of the features of claim 5, 12, 13, 22, 26, 172, 173, and 187.

Tabuchi does not teach a LED made on a SiC substrate (claims 11 and 12) or from including specifically SiC LED structure layers (claim 12 and 13).

Edmond discloses LEDs made on a SiC substrate having a multilayered device structure, wherein the layers include SiC, said SiC-based LEDs have peak maximum at several ranges in the blue wavelength spectrum:

The present invention comprises a light emitting diode formed in silicon carbide and that emits **visible light** having a wavelength of between about **475-480 nanometers**, or between about **455-460 nanometers**, or between about **424-428 nanometers**. The diode comprises a **substrate of alpha silicon carbide** having a first conductivity type and a **first epitaxial layer of alpha silicon carbide** upon the substrate having the same conductivity type as the substrate. A **second epitaxial layer of alpha silicon carbide** is upon the first epitaxial layer, has the opposite conductivity type from the first layer, and **forms a p-n junction** with the first epitaxial layer.

(Edmond, abstract; emphasis added)

It would have been obvious to one of ordinary skill in the art, at the time of the invention to substitute Tabuchi's GaN-based LED with the SiC-based LED disclosed in Edmond. This can be seen as simple substitution of one known element (Tabuchi's GaN-based LED) for another known element (Edmond's SiC-based LED) to obtain predictable results (as evidenced by Pinnow) and is one of the rationales identified by the Supreme Court in *KSR International Co. v. Teleflex Inc.*, 550 U.S. ___, ___, 82 USPQ2d 1385, 1395-97 (2007). (See MPEP 2143, Rationale B.)

Both Tabuchi's and Edmond's LEDs emit light in the same general region of the spectrum (i.e. UV light), so even though the materials from which the LED are made are different, it is the wavelength of light emitted that counts, and Pinnow teaches that the wavelength of light need only be shorter than 495 nm (4950 Å) to be effective to be converted by the mixture of phosphors to white light.

In regard to the predictability, as already noted above, Pinnow teaches that any wavelength of primary radiation can be down-converted by the mixture of

Art Unit: 3992

phosphors to produce white light so long as the wavelength is less than 4950 Å (495 nm):

Regardless of how many phosphors are used, it is apparent from the chromaticity diagram that a necessary condition for achieving a true white is that the illuminating laser beam have a **wavelength of approximately 4,950 Å. or shorter**. Otherwise, it is impossible to include illuminant C within a polygon whose primaries are the source and any combination of longer wavelengths that can be achieved by down-conversion of frequency. Fortunately, the argon-ion laser satisfies this necessary condition.

(Pinnow, col. 3, lines 24-55; emphasis added)

(It is noted that Pinnow uses "A." for "angstrom", which is properly, instead, Å.)

Because Tabuchi's and Edmond's LED emit light in the same general region of the emission spectrum, blue-to-UV light, substituting a UV-light-emitting GaN-based LED with a blue-light-emitting SiC-based LED would yield predictable results in producing emission of white light with the down-converting phosphor mixture. The predictability results from using LEDs that emit light having a wavelength of less than 4950 Å (495 nm), as evidenced by Pinnow.

Tabuchi modified by Edmond to use Edmond's SiC LEDs therefore teaches each of the features of claims 5 and 11-13 as follows.

Regarding **claim 5**, there is no requirement that the light be outside the visible white light spectrum, but substituting Tabuchi's LED with those of Edmond would still read on claim 5 because the secondary radiation emitted by the phosphor mixture of Tabuchi/Pinnow would be white light.

Proposed amended **claims 11 and 12 and claim 13** read,

*11. A light-emitting device according to claim 5, wherein each single-die semiconductor LED present in the device is on a substrate in a multilayer device structure, and wherein said substrate comprises **silicon carbide**.*

*12. A light-emitting device according to claim 5, wherein each single-die semiconductor LED present in the device is on a substrate in a multilayer device structure, and wherein said substrate comprises a material selected from the group consisting of sapphire, **SiC**, and InGaAIN.*

*13. A light-emitting device according to claim 12, wherein said multilayer device structure includes layers selected from the group consisting of **silicon carbide**, aluminum nitride, gallium nitride, gallium phosphide, germanium carbide, indium nitride, and their mixtures and alloys.*

As shown in Edmond's abstract, above, and Edmond's Figs. 1-8, the substrate is SiC and the device layers include SiC.

Art Unit: 3992

The features of claims 22, 172, and 173 have been discussed above in conjunction with the rejection over Tabuchi in view of Pinnow and are not changed by the addition of Edmond.

Claims 26, 187, and 188 are obvious for the same reasons as discussed above in conjunction with claims 5 and 11-13 in that Edmond teaches a SiC **blue**-light-emitting LED, and the use of Edmond's LED in place of Tabuchi's is obvious.

E. Menda as a base reference

1. Claims 1, 3, 5, 22, and 26 are rejected under 35 U.S.C. 102(b) as being anticipated by Menda, as evidenced by any of Penguin, Fundamentals of Photonics, Morkoç, Abe, Tadatomo and LEDLASER.

Proposed amended claim 1 reads,

[1] 1. *A light emitting device, comprising:*

[2] *at least one single-die semiconductor light-emitting diode (LED) coupleable with a power supply to emit a primary radiation [3] which is the same for each single-die semiconductor LED present in the device, [4] said primary radiation being a relatively shorter wavelength radiation outside the visible white light spectrum; and*

[5] *a down-converting luminophoric medium arranged in receiving relationship to said primary radiation, and which in exposure to said primary radiation responsively emits radiation at a multiplicity of wavelengths and in the visible white light spectrum, with said radiation of said multiplicity of wavelengths mixing to produce a white light output, [6] wherein each of the at least one single-die semiconductor light-emitting diode in interaction with luminophoric medium receiving its primary radiation produces white light output.*

Feature [1]: 1. A light emitting device

Menda's Fig. 4 (reproduced below) shows a light emitting device, specifically a liquid crystal display (Menda translation, p. 7, ¶ [0021]).

[Fig 4]

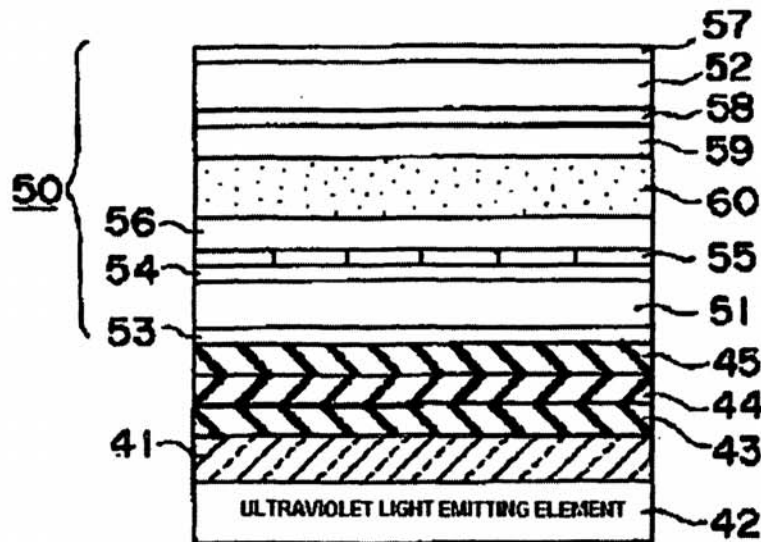

(Menda, Fig. 4)

Feature [2]: at least one single-die semiconductor light-emitting diode (LED) coupleable with a power supply to emit a primary radiation

Menda states,

In the above embodiment, an organic PL element has been realized using a ZnO ultraviolet light emitting element having a schottky junction structure. Likewise, the green light emitting organic PL element can also be realized by using a **solid ultraviolet light emitting element** having a structure of a **pn junction, MOS [Metal-Oxide-Semiconductor] junction** or the like. Further, light having colors other than green can also be emitted by changing the type of the organic coloring matter doped into the PL luminescent layer 22. Further, the amount of luminescence from the PL luminescent layer 22 can be regulated by regulating the amount of voltage or current applied to the ultraviolet light emitting element.

(Menda translation, ¶ [0018], p. 6, lines 1-11; emphasis added)

In addition, with regard to Fig. 4 (above), Menda states,

Menda states,

[0021] **Fig. 4** shows an example in which a PL [PhotoLuminescent] element according to the present invention has been applied to a backlight of a **liquid crystal display**. In the drawing, numeral **41** designates a glass substrate transparent to ultraviolet light. An **ultraviolet light emitting element 42**

Art Unit: 3992

as described in the first embodiment is provided on one side of the glass substrate **41**. Further, a **blue** PL luminescent layer **43**, a **green** PL luminescent layer **44**, and a **red** PL luminescent layer **45** as described in the second embodiment are stacked on the other side of the glass substrate **41**.

[0022] As shown in the drawing, a **liquid crystal display device 50** is stacked on the PL luminescent element having the above construction. ...

[0023] In the above embodiment, individual PL luminescent layers **43** to **45** of three primary colors are **excited by ultraviolet light emitted from the ultraviolet light emitting element 42** and emit respective lights, and these **three primary colors are mixed together** to provide a **white light**. The **white light** thus obtained is applied as a backlight of the liquid crystal display device **50** through the first glass substrate **51**. Also in this embodiment, a deterioration in the PL luminescent layers **43** to **45** can be avoided, and the service life of the PL luminescent layers **43** to **45** can be prolonged.

(Menda translation, p. 7; emphasis added)

The request fails to provide evidentiary support or sufficient explanation that a light-emitting pn junction **implicitly includes** a single-die semiconductor LED (light emitting diode). Accordingly, any of Penguin, Morkoç, Abe, and Tadatomo has been provided.

First, by definition, a "pn junction" is necessarily formed from semiconductor materials:

pn-junction The region at which two **semiconductors** of opposite polarity meet, i.e. at which p-type and n-type semiconductor meet. ...

(Penguin, p. 437; emphasis added)

Thus, Menda's pn junction is necessarily a *semiconductor*. Note also that the term "MOS" in Menda is an acronym for Metal-Oxide-**Semiconductor**, thereby placing one of ordinary skill squarely in the mindset of light-emitting **semiconductor** materials.

Because the pn junction produces UV light, it is necessarily a *semiconductor light-emitting* element, albeit not necessarily a *diode*. However, each of Penguin, Morkoç, Abe, and Tadatomo teaches that one of ordinary skill knows very well that a light-emitting **pn junction** implicitly includes a light-emitting **diode**, thereby providing evidence that Menda's "solid **ultraviolet light emitting element** having a **structure of a pn junction, MOS junction or the like**" (Menda, *id.*) implicitly includes the light-emitting **diode**.

Penguin's definition of "light emitting diode (LED)" includes the light-emitting, pn junction:

light-emitting diode (LED) A **p-n junction** diode that **emits light** as a result of direct radiative recombination of excess electron-hole pairs...

Art Unit: 3992

(Penguin, p. 315; 2nd emphasis added)

Given that the elements in Penguin's definition of "pn junction" and "light-emitting diode" are found in Menda's description of the UV light-emitting element, i.e. "solid ultraviolet **light emitting element** having a structure of a **pn junction**, MOS [Metal-Oxide-Semiconductor] junction or the like" (Menda, *id.*), Penguin teaches that those of ordinary skill in the art know that Menda's light-emitting pn junction **implicitly includes** the light-emitting **diode**.

Because the UV-light-emitting pn junction or UV LED, once produced, is of necessity finite, it is a **die** and therefore reads on *at least one single die*. Because power is required to produce light ("...the amount of luminescence from the PL luminescent layer 22, [43, 44, 45] can be regulated by regulating the **amount of voltage or current applied** to the ultraviolet light emitting element"; Menda, *id.*) the semiconductor light-emitting device is *coupleable with a power supply to emit a primary radiation*. In order to apply power across the pn junction to produce light, one electrode must be applied to the p-type semiconductor and one electrode must be applied to the n-type semiconductor; thus, Menda's pn junction is a *diode*.

Fundamentals of Photonics similarly indicates that those of ordinary skill knew before 1991 (the copyright date of the book) --that is two years before the foreign filing of Menda-- that light-emitting semiconductor **pn junctions** at least included light-emitting **diodes**. In this regard, the term "LED" is defined:

A **light-emitting diode (LED)** is a forward-biased **p-n junction** fabricated from a direct-gap **semiconductor** material that emits light via injection electroluminescence...

(Fundamentals of Photonics, p. 593; emphasis added)

Fundamentals of Photonics goes on to state that the both LEDs and semiconductor lasers are of "small size" and are used in displays:

Semiconductor photons sources, in the form of both **LEDs** and injection **lasers**, serve as highly efficient electronic-to-photon transducers. They are convenient because they are readily modulated by controlling the injected current. Their **small size**, high efficiency, high reliability, and compatibility with electronic systems are important factors in their successful use in many applications. These include lamp indicators; **display devices**; scanning, reading, and printing systems; fiber optic communication systems; and optical data storage systems such as compact-disc players.

(Fundamentals of Photonics, paragraph bridging pp. 593-594; emphasis added)

Thus, those of ordinary skill in the art also knew that **small**-sized LEDs and semiconductor lasers were used to make **display devices**, just as in Menda, i.e. the LCD. Therefore, **Fundamentals of Photonics** provides evidence that those of ordinary skill in the art knew before 1991, when the book was published (that is

Art Unit: 3992

two years before Menda) that the small-sized LEDs and semiconductor lasers were already known for use to make display devices.

With regard to semiconductor lasers, Fundamentals of Photonics states

16.2 SEMICONDUCTOR LASER AMPLIFIERS

The principle underlying the operation of a **semiconductor laser** amplifier is the same as that for other laser amplifiers: the creation of a population inversion that renders stimulated emission more prevalent than absorption. The population inversion is usually achieved by electric current injection in a **p-n junction diode**; a forward bias voltage causes carrier pairs to be injected into the junction region, where they recombine by means of stimulated emission.

(Fundamentals of Photonics, p. 609; emphasis added)

Thus, Fundamentals of Photonics shows that those of ordinary skill in the art know that semiconductor lasers are a form of pn junction and by extension that a light-emitting pn junction, such as Menda's, suggests semiconductor lasers as well as LEDs.

In addition, Fundamentals of Photonics states that the basic structure of the LED and semiconductor laser are the same:

Device Structures

LEDs may be constructed either in surface-emitting or edge-emitting configurations (fig. 16.1-10). The surface-emitting LED emits light from a face of the device that is parallel to the junction plane. Light emitted from the opposite face is absorbed by the substrate and lost or, preferably, reflected from a metallic contact (which is possible if a transparent substrate is used). The edge-emitting LED emits light from the edge of the junction region. The latter structure has usually been used for **diode lasers** as well, although surface-emitting **laser diodes** (SELDs) are being increasingly used. Surface emitting LEDs are generally more efficient than edge-emitting LEDs. Heterostructure LEDs, with configurations such as those described in Sec. 16.2C, provide superior performance.

(Fundamentals of Photonics, p. 606; emphasis added)

Furthermore, figures 16.1-11(a) and (b) (reproduced below) of Fundamentals of Photonics shows the LEDs are known to be implemented as *single dies*.

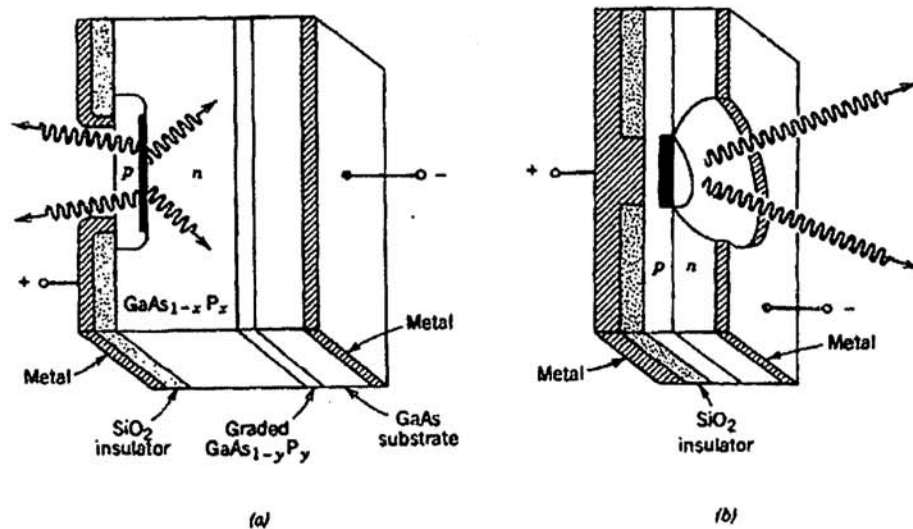

Figure 16.1-11 (a) A flat-diode-configuration $\text{GaAs}_{1-x}\text{P}_x$ LED. (b) A Burrus-type LED.

(Fundamentals of Photonics, p. 607; emphasis added)

Based on the foregoing, Fundamentals of Photonics provides evidence that those of ordinary skill in the art would appreciate that Menda's "solid ultraviolet **light emitting element** having a **structure of a pn junction, MOS junction or the like**" (Menda, *id.*) **implicitly includes** a *single-die semiconductor light-emitting diode* and a *single die semiconductor laser*.

Similarly, **Morkoç** provides evidence that light-emitting **pn junctions** include *single-die semiconductor light-emitting diodes (LEDs)*. In Morkoç's section entitled, "III. GaN-based III-V Nitride Semiconductors" Morkoç explicitly calls the light emitters, "**GaN p-n junction LEDs**" (emphasis added):

These advances in material quality and processing have allowed researchers to demonstrate and commercialize GaN **p-n junction LEDs** giving rise to optimism of a GaN-based **laser** soon to follow.

(Morkoç, p. 1379, right col. last full sentence; emphasis added)

The first GaN LED was reported over 20 years ago.¹⁴⁶ Due to the inability at the time to dope GaN p type, these devices were not **conventional p-n junction LEDs**, but rather metal-insulator-semiconductor (MIS) structures. Only recently, when Amano et al.¹⁰⁴ first obtained p-type GaN was the first **p-n junction GaN LED** realized. Soon after, some of these same workers introduced AlGaIn as a barrier material.¹⁴⁷

(Morkoç, p. 1387, right col., 1st full ¶; emphasis added)

The Amano et al. article is dated 1990 which is three years **before** the filing date of Menda. Morkoç also points out that the GaN-based LEDs produce UV light, i.e. light

Art Unit: 3992

of a wavelength less than 400 nm (Morkoç, p. 1388, Fig. 47 and associated text on p. 1389). Thus, Morkoç shows that those of ordinary skill knew **before** the time of Menda that a GaN-based, UV-light-emitting **diodes** were made from a semiconductor **pn junction before** the time of Menda.

See also Morkoç p. 1386, Fig. 41 and Fig. 43 captions, which also use the language "p-n junction LED" (emphasis added). See also Morkoç at p. 1387, which uses the language "p-n junction LEDs" and "p-n junction GaN LED".

Morkoç's Figs. 49, 52, 56, and 58 each show **single die** semiconductor lasers; thus those of ordinary skill in the art know that semiconductor light emitting devices, including LEDs and lasers are implemented as a **single die**, as claimed.

Thus, Morkoç teaches that those of ordinary skill in the art know that Menda's "solid ultraviolet light emitting element having a **structure of a pn junction**, MOS junction or the like" (Menda, *id.*) **implicitly includes at least one single-die semiconductor light-emitting diode (LED)**.

In addition to Penguin and Morkoç, **Abe** shows to those of ordinary skill in the art that a UV-light-emitting semiconductor pn junction includes both LEDs and lasers. In discussing the prior art, Abe states,

In addition, the light source described above includes a **light emitting diode** (which will be referred to as **LED** thereafter) as a display element used in OA (Office Automation) apparatuses and display units. The LED is adapted to **emit light** by applying current to **p-n junction** of a **semiconductor**.

(Abe, col. 1, lines 28-33; emphasis added)

Thus, Abe teaches that it was already known in the art at least by 1994 (the foreign priority date of Abe) that a light-emitting semiconductor pn junction includes light-emitting **diodes**, or LEDs.

Abe also shows that semiconductor lasers are implemented as a "single chip":

Either of AC and DC power sources may be used as a required power source. In case of using the AC power source, a rectifying device may be incorporated in a lighting circuit, or the **semiconductor laser element** and the lighting circuit may be integrated in a **single chip**.

(Abe, col. 2, lines 45-49; emphasis added)

Note that Abe includes the lighting circuit along with the semiconductor laser; thus, Abe also points out here that the lighting circuit and the semiconductor lasers are known to be implemented on separate semiconductor chips (i.e. die).

Abe's Figs. 1(a), 1(b), 4(a)-4(g), 5, 6, 8(a), 8(b), each shows the semiconductor laser element **1** implemented **single die**.

Art Unit: 3992

Based on the foregoing, Abe shows that those of ordinary skill in the art would understand that Menda's "solid ultraviolet light emitting element having a **structure of a pn junction, MOS junction or the like**" (Menda, *id.*) **implicitly includes at least one single-die semiconductor light-emitting diode (LED)**.

Finally, **Tadatomo** --a reference provided by Patentee in the IDS submitted 3/2/2011 -- shows that light-emitting **pn junctions** include both light-emitting **diodes** and **lasers**. In this regard, Tadatomo's Fig. 3 (reproduced below) shows a UV-light-emitting **diode** implemented as a **single die**.

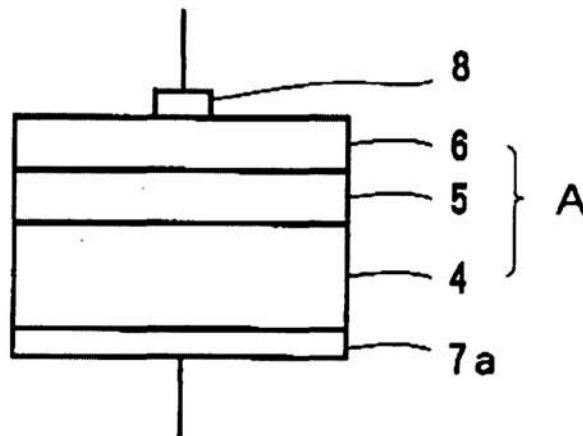
Fig. 3

(Tadatomo, Fig. 3)

In regard to Fig. 3, Tadatomo states,

FIG. 3 schematically shows the structure of **LED** of a typical semiconductor light emitting element. As shown in the Figure, the **LED** comprises a laminate A (**4, 5, 6**) including the GaN single crystal (n type) produced by the method of the present invention as a substrate **4**, and a **semiconductor layer 5 (n type)** and a **semiconductor layer 6 (p type)**, both being GaN group compound semiconductors, formed thereon, and **electrodes 8 and 7** set on the outermost layers **6** and **4** of the laminate A.

(Tadatomo, col. 8, lines 37-44; emphasis added)

In **FIG. 3**, the **light emitting part** has a simple two-layer **p-n junction**. The junction of the light emitting part may be **homo-junction** where the same materials are joined, or **hetero-junction** where different materials are joined. Furthermore, the junctional structure of the light emitting part is **not limited to two-layer junction** but may be **multi-layer junction** such as **double-hetero junction, single quantum well, multiple quantum well etc.**

Art Unit: 3992

With such junctional structure of the light emitting part, various **semiconductor light emitting elements** such as **LED** and **LD [Laser Diode]** are obtained.

(Tadatomo, col. 9, lines 8-19; emphasis added)

In addition, Tadatomo states,

The thick GaN single crystal of superior quality which is produced by the method of the present invention can be suitably used for **semiconductor light emitting elements** such as **light emitting diode (LED)**, **laser diode (LD)** and superluminescence diode, and electron devices. In the electron devices, the use of the GaN single crystal of the present invention as a substrate enables production of LED, LD etc. having the same electrode structure as in the conventional red LED etc. Those which emit blue lights are particularly important. In addition, the efficiency of the light emission of semiconductor light emitting elements by the use of the GaN single crystal of the present invention is advantageously high.

(Tadatomo, col. 8, lines 20-32; emphasis added)

Thus, Tadatomo teaches that those of ordinary skill in the art knew around 1993-1994 (the foreign priority dates of Tadatomo) that light-emitting **pn junctions** include **both** semiconductor light-emitting **diodes** and semiconductor **lasers** implemented as **single dies**. In addition, the electrodes **7, 8** shows that those of ordinary skill know that the light emitting element must have a power source in order to emit radiation (as claimed, "*coupleable with a power supply to emit a primary radiation*").

In summary, each of Penguin, Fundamentals of Photonics, Morkoç, Abe, and Tadatomo provides evidence that Menda's "solid ultraviolet light emitting element having a **structure of a pn junction**, MOS junction or the like" (Menda, *id.*) **implicitly includes** *at least one single-die semiconductor light-emitting diode (LED) coupleable with a power supply to emit a primary radiation*, as claimed.

Feature [3]: *which is the same for each single-die semiconductor LED present in the device*

As discussed above, Menda teaches at least one *single-die LED*, which is all that is required of the claim.

Feature [4]: *said primary radiation being a relatively shorter wavelength radiation outside the visible white light spectrum*

The LED emits ultraviolet (UV) light (i.e. below 400 nm wavelength) which is necessarily outside the *visible white light spectrum* (400 to about 700 nm wavelength).

Art Unit: 3992

Feature [5]: *a down-converting luminophoric medium arranged in receiving relationship to said primary radiation, and which in exposure to said primary radiation responsively emits radiation at a multiplicity of wavelengths and in the visible white light spectrum, with said radiation of said multiplicity of wavelengths mixing to produce a white light output*

As quoted above from Menda, in regard to the liquid crystal display shown in Fig. 4, Menda states,

[0021] **Fig. 4** shows an example in which a PL element according to the present invention has been applied to a backlight of a **liquid crystal display**. In the drawing, numeral **41** designates a glass substrate transparent to ultraviolet light. An **ultraviolet light emitting element 42** as described in the first embodiment is provided on one side of the glass substrate **41**. Further, a **blue** PL luminescent layer **43**, a **green** PL luminescent layer **44**, and a **red** PL luminescent layer **45** as described in the second embodiment are stacked on the other side of the glass substrate **41**.

[0022] As shown in the drawing, a **liquid crystal display device 50** is stacked on the PL luminescent element having the above construction. The liquid crystal display device 50 comprises a first glass substrate 51 and a second glass substrate 52. A polarizing plate 53 is stacked on one side of the glass substrate 51. A transparent electrode 54, a color filter 55, and an aligning film 56 are stacked in that order on the other side of the glass substrate 51. Further, a polarizing plate 57 is stacked on one side of the glass substrate 52, and a transparent electrode 58 and an aligning film 59 are stacked in that order on the other side of the glass substrate 52. A liquid crystal material 60 is filled into the two aligning films 56-59 to constitute a liquid crystal display cell.

[0023] In the above embodiment, individual PL luminescent layers **43** to **45** of **three primary colors are excited by ultraviolet light emitted from the ultraviolet light emitting element 42** and emit respective lights, and these **three primary colors are mixed together** to provide a **white light**. The **white light** thus obtained is applied as a backlight of the liquid crystal display device **50** through the first glass substrate **51**. Also in this embodiment, a deterioration in the PL luminescent layers **43** to **45** can be avoided, and the service life of the PL luminescent layers **43** to **45** can be prolonged.

(Menda translation, p. 7; emphasis added)

Fig. 4 shows that Menda's *luminophoric medium 43, 44, 45* is in *receiving relationship* to the UV light emitting element **42**.

Menda discloses that the UV light is down-converted (in terms of energy) to visible light. UV light has a wavelength of less than 400 nm and visible white light includes wavelengths between 400 to 700 nm. In particular, Menda's luminophoric medium yields light having separate wavelengths of blue **43**, green **44**, and red **45** that mix to produce white light when mixed (*Id.*).

Art Unit: 3992

Feature [6]: wherein each of the at least one single-die semiconductor light-emitting diode in interaction with luminophoric medium receiving its primary radiation produces white light output

Because the light source of Menda passes through all three PL layers 43, 44, and 45, each of the at least one single-die semiconductor light-emitting diode in interaction with luminophoric medium receiving its primary radiation produces white light output.

This is all of the features of claim 1.

Claim 3 reads,

3. A light-emitting device, comprising:

a semiconductor **laser** coupleable with a power supply to emit a primary radiation having a relatively shorter wavelength outside the **visible** light spectrum; and

a down-converting luminophoric medium arranged in receiving relationship to said primary radiation, and which in exposure to said primary radiation responsively emits polychromatic radiation in the visible light spectrum, with different wavelengths of said polychromatic radiation mixing to produce a white light output.

Claim 3 is distinguished from claim 1 in that (1) a semiconductor **laser** is required versus a *single-die semiconductor LED*; (2) the primary radiation is required to be outside the **visible** light spectrum, as opposed to outside the visible **white** light spectrum; and (3) the wording associated with the luminophoric medium.

With regard to **difference (1)**, claim 3 requires the LED be a *semiconductor laser*. Menda teaches that the UV-light emitting element can be a "pn junction", as just discussed. Thus, all pn junction, light-emitting devices are implicitly included. Penguin provides additional evidence that light-emitting pn junctions include semiconductor lasers. In this regard, Penguin states,

semiconductor laser *Syn.* diode laser A laser that uses a **p-n junction diode** made from a direct-gap **semiconductor material** such as gallium arsenide, GaAs. ...

(Penguin, p. 509; second emphasis added)

Similarly, as noted above, Morkoç states,

These advances in material quality and processing have allowed researchers to demonstrate and commercialize GaN **p-n junction LEDs** giving rise to optimism of a GaN-based **laser** soon to follow.

(Morkoç, p. 1379, right col. last full sentence; emphasis added)

Art Unit: 3992

Thus Menda's "pn junction" that produces UV light includes both LEDs and semiconductor **lasers** since both are within the scope of "pn junctions", as disclosed by Menda as the "UV light-emitting element" (Menda, ¶ [0018]).

As already indicated above, each of Fundamentals of Photonics, Abe, and Tadatomo teach those of ordinary skill that Menda's "solid ultraviolet light emitting element having a **structure of a pn junction**, MOS junction or the like" (Menda, ¶ [0018]) **implicitly includes** semiconductor **lasers**, as well as LEDs.

Finally, LEDLASER indicates that those of ordinary skill in the art know that a semiconductor laser is simply a specialized form of p-n junction diode:

Laser diodes (also called 'injection lasers') are in effect a specialised form of **LED**. Just like a **LED**, they're a form of **P-N junction diode** with a thin depletion layer where electrons and holes collide to create light photons, when the diode is forward biased. ...

In other words, they end up 'in sync' and forming continuous-wave **coherent radiation**.

(LEDLASER, p. 2, right col.; emphasis added)

Thus, LEDLASER shows that those of ordinary skill in the art know that Menda's "solid ultraviolet light emitting element having a **structure of a pn junction**, MOS junction or the like" (Menda, ¶ [0018]) **implicitly includes** semiconductor lasers, as well as LEDs because the laser is just the specialized form of the pn junction LED.

With regard to **difference (2)**, as noted above in discussing claim 1, UV light is outside the visible spectrum.

With regard to **difference (3)**, the difference is in wording only and is not distinct from claim 1. In other words, there is no difference between *polychromatic radiation* and *a multiplicity of wavelengths*, as it applies to mixing to produce white light.

Thus, Menda discloses all of the features of claim 3.

Claim 5 reads,

5. A light-emitting device, comprising:

at least one single-die semiconductor light-emitting diode (LED) coupleable with a power supply to emit a primary radiation which is the same for each single-die LED present in the device, said primary radiation being a relatively shorter wavelength radiation; and

Art Unit: 3992

*a down-converting luminophoric medium arranged in receiving relationship to said primary radiation, and which in exposure to said primary radiation, is **excited to** responsively emit a secondary, **relatively longer wavelength, polychromatic** radiation, with **separate wavelengths** of said **polychromatic** radiation mixing to produce a white light output, each of the at least one single-die semiconductor light-emitting diode in interaction with luminophoric medium receiving its primary radiation produces white light output.*

Claim 5 is distinct from claim 1 in that (1) the primary radiation is not required to be outside the visible white light spectrum; (2) the down-converting is required to yield longer wavelengths than that of the primary radiation; and (3) separate wavelengths are required to be produced.

With regard to **difference (1)**, claim 5 is broader in this respect; thus, Menda discloses the claimed LED for the reasons indicated in conjunction with claim 1.

With regard to **differences (2) and (3)**, as discussed in rejecting claim 1 above, Menda discloses that the UV light is down-converted (in terms of energy) to visible light. UV light has a wavelength of less than 400 nm and visible white light includes wavelengths between 400 to 700 nm. In particular, Menda's luminophoric medium yields light having separate wavelengths of blue **43**, green **44**, and red **45** that mix to produce white light when mixed (Menda translation, ¶¶ [0021]-[0023], *supra*).

This is all of the features of claim 5.

Claims 22 and 26 read,

*22. A light-emitting device according to claim 5, wherein each single-die semiconductor LED present in the device comprises a single-die **two-lead** semiconductor LED.*

26. A light-emission device, comprising

*a single-die, **two-lead** semiconductor light-emitting diode emitting radiation; and*

a recipient down-converting luminophoric medium for down-converting the radiation emitted by the light-emitting diode, to a polychromatic white light.

Independent claim 26 is broader than all of the other independent claims except for the feature that the LED has two leads. Thus, Menda, as discussed above, discloses each of the features of claim 26 and claims 21 and 22 except for explicitly indicating the number of leads of the UV light-emitting element **42**.

Art Unit: 3992

As noted above, the UV light-emitting element **42** can be a pn junction and thereby includes single-die semiconductor LED and semiconductor lasers, as evidenced by any of Penguin, Morkoç, Abe, and Tadamoto.

Tadamoto's Figs. 3, 4, 5, and 6 each show that those of ordinary skill know that a light-emitting pn junction implemented as a LED or LD has **two leads**, one attached to each electrode **7** and **8** for each of the p-type and n-type semiconductor of the pn junction.

Thus, Tadamoto provides evidence that Menda's "solid ultraviolet light emitting element having a **structure of a pn junction**, MOS [Metal-Oxide-Semiconductor] junction or the like" (Menda, ¶ [0018]) **implicitly includes two leads**, as required by each of claims 22 and 26.

2. Claims 2, 23, 24, 180, 181, and 186 are rejected under 35 U.S.C. 103(a) as being unpatentable over Menda, as evidenced by any of Penguin, Fundamentals of Photonics, Morkoç, Abe, and Tadamoto, and in view of Imamura.

Claims 2 and 23 read,

*2. A light-emitting device according to claim 1, comprising a **two-lead array** of single-die semiconductor LEDs.*

*23. A light-emitting device according to claim 5, comprising a **two-lead array** of single-die semiconductor LEDs.*

The prior art of Menda, as evidenced by any of Penguin, Fundamentals of Photonics, Morkoç, Abe, and Tadamoto, as explained above, discloses each of the claimed features of claims 1 and 5. Menda does not explicitly disclose a two-lead array of single-die LEDs.

Imamura's Figs. 4 and 5 (reproduced below) shows the top and side views of an light array **10** may from an array of single-die semiconductor LEDs **13** on a substrate **15** (Imamura, col. 3, lines 16-36).



(Imamura, Fig. 4)

Art Unit: 3992

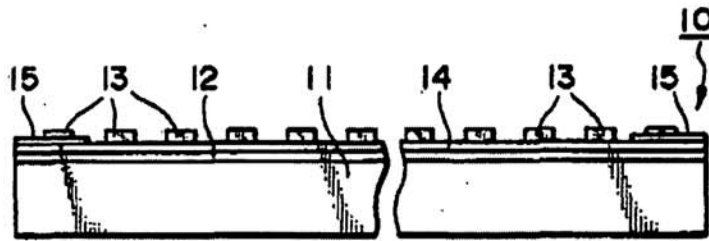

(Imamura, Fig. 5)

The array **10** can be used as a backlight for a liquid crystal display, such as shown in Fig. 8 (Imamura, col. 4, lines 59-61). Each LED die **13** has two leads that connect to the array's two leads, made from the gold-plated copper pattern **12** shown in the side view of right side of Fig. 5 and in the top view as the horizontal lines running across the top and bottom of the substrate **15** that connect the array of LEDs **13**. As also shown in Fig. 4, each of the array's two leads ends in a terminal. Thus, Imamura teaches a **two-lead array of single-die semiconductor LEDs**.

It would have been obvious to one of ordinary skill in the art, at the time of the invention to use Imamura's two-lead array configuration of plural identical UV LEDs --therefore *emitting identical UV radiation*-- for Menda's UV light emitting element **42**, in order to enable making a uniformly lit, larger, liquid crystal display than could be made from a single UV LED, as taught by Imamura (Imamura, col. 3, lines 37-60).

Proposed amended **claim 24** reads,

24. A liquid crystal display, including:

a backlight member including a **multiplicity of light-emitting devices**, each light-emitting device comprising:

at least one single-die semiconductor light-emitting diode (LED) coupleable with a power supply to emit a primary radiation which is the same for each single-die LED present in the device, said primary radiation being a relatively shorter wavelength radiation, and

a down-converting luminophoric medium arranged in receiving relationship to said primary radiation, and which in exposure to said primary radiation responsively emits a secondary, relatively longer wavelength, polychromatic radiation, with separate wavelengths of said polychromatic radiation mixing to produce a white light output, wherein each of the at least one single-die semiconductor light-emitting diode in interaction with luminophoric medium receiving its primary radiation produces white light output.

Art Unit: 3992

Claim 24 is distinct from claim 5 in that (1) a liquid crystal display is claimed as opposed to just a light emitting device, and (2) a multiplicity of light-emitting devices is required to make a backlight for the LCD.

Imamura is applied as above.

It would have been obvious to one of ordinary skill in the art, at the time of the invention to use Imamura's array configuration of plural **identical** UV LEDs --therefore *emitting identical UV radiation*-- for Menda's UV light emitting element **42**, in order to enable making a uniformly lit, larger, liquid crystal display than could be made from a single UV LED, as taught by Imamura (Imamura, col. 3, lines 37-60).

Further in this regard, the courts have held that mere duplication of parts has no patentable significance unless a new or unexpected result is produced. See *In re Harza*, 274 F.2d 669, 124 USPQ 378 (CCPA 1960). Thus, it would have been obvious to use more than one UV LED to increase the brightness or increase the size of the display.

Proposed new **claims 180 and 181** read,

180. The liquid crystal display of claim 24, wherein said multiplicity of light-emitting devices comprises an array of single-die semiconductor light-emitting diodes.

181. The liquid crystal display of claim 180, wherein said array comprises a regular pattern.

Imamura calls the LED array a "LED array substrate **10**" (Imamura, e.g. at col. 3, line 19) which is shown to be a rectangle, in Fig. 4. In addition, Imamura states,

A plurality of **LED array substrates 32** are mounted in the interior of a cover **33** to provide a **back-light 34** for illuminating a **liquid crystal display panel 30** and are supplied with a power through a connector **31**.

(Imamura, col. 4, lines 65-68; emphasis added)

Thus the array can be may whatever size is required for the LCD.

Proposed new **claim 186** reads,

186. The liquid crystal display of claim 24, comprising a **full-color liquid crystal display**.

Menda discloses a full-color LCD display. Menda's Fig. 4 shows the color filter **55** used to produce each of the different colors required for each pixel of the display (Menda translation, ¶ [0022]). In addition, Menda explicitly states that the LCDs are "full color" (Menda translation, ¶ [0019], 1st sentence).

Art Unit: 3992

3. Claims 1, 3, and 5 are rejected under 35 U.S.C. 103(a) as being unpatentable over Menda in view of any of Fundamentals of Photonics, Morkoç, Abe, and Tadatomo.

The prior art of Menda, as evidenced by any of Penguin, Fundamentals of Photonics, Morkoç, Abe, and Tadatomo, as explained above, is believed to disclose each of the features of claims 1, 3, and 5. If, however, it is believed by Patentee that any of Penguin, Fundamentals of Photonics, Morkoç, Abe, and Tadatomo does not provide sufficient evidence that Menda's UV-light emitting pn junction **implicitly includes a single-die semiconductor LED or a semiconductor laser**, then any of Morkoç, Fundamentals of Photonics, Abe, and Tadatomo at least renders this obvious.

As noted above, **Fundamentals of Photonics** indicates that those of ordinary skill knew before 1991 (the copyright date of the book) --that is two years before the foreign filing of Menda-- that light-emitting semiconductor **pn junctions** at least included light-emitting **diodes** and semiconductor **lasers**. In this regard, the term "LED" is defined:

A **light-emitting diode (LED)** is a forward-biased **p-n junction** fabricated from a direct-gap **semiconductor** material that emits light via injection electroluminescence...

(Fundamentals of Photonics, p. 593; emphasis added)

Fundamentals of Photonics goes on to state that the both LEDs and semiconductor lasers are of "small size" and are used in displays:

Semiconductor photon sources, in the form of both **LEDs** and injection **lasers**, serve as highly efficient electronic-to-photon transducers. They are convenient because they are readily modulated by controlling the injected current. Their **small size**, high efficiency, high reliability, and compatibility with electronic systems are important factors in their successful use in many applications. These include lamp indicators; **display devices**; scanning, reading, and printing systems; fiber optic communication systems; and optical data storage systems such as compact-disc players.

(Fundamentals of Photonics, paragraph bridging pp. 593-594; emphasis added)

Thus, those of ordinary skill in the art also knew that **small-sized** LEDs and semiconductor lasers were used to make **display devices**, just as in Menda, i.e. the LCD. Therefore, Fundamentals of Photonics provides evidence that those of ordinary skill in the art knew before 1991, when the book was published (that is two years before Menda) that the small-sized LEDs and semiconductor lasers were already known for use to make display devices.

With regard to semiconductor lasers, Fundamentals of Photonics states

Art Unit: 3992

16.2 SEMICONDUCTOR LASER AMPLIFIERS

The principle underlying the operation of a **semiconductor laser** amplifier is the same as that for other laser amplifiers: the creation of a population inversion that renders stimulated emission more prevalent than absorption. The population inversion is usually achieved by electric current injection in a **p-n junction diode**; a forward bias voltage causes carrier pairs to be injected into the junction region, where they recombine by means of stimulated emission.

(Fundamentals of Photonics, p. 609; emphasis added)

Thus, Fundamentals of Photonics shows that those of ordinary skill in the art know that semiconductor lasers are a form of pn junction and by extension that a light-emitting pn junction, such as Menda's, suggests semiconductor lasers as well as LEDs.

In addition, Fundamentals of Photonics states that the basic structure of the LED and semiconductor laser are the same:

Device Structures

LEDs may be constructed either in surface-emitting or edge-emitting configurations (fig. 16.1-10). The surface-emitting LED emits light from a face of the device that is parallel to the junction plane. Light emitted from the opposite face is absorbed by the substrate and lost or, preferably, reflected from a metallic contact (which is possible if a transparent substrate is used). The edge-emitting LED emits light from the edge of the junction region. The latter structure has usually been used for **diode lasers** as well, although surface-emitting **laser diodes** (SELDs) are being increasingly used. Surface emitting LEDs are generally more efficient than edge-emitting LEDs. Heterostructure LEDs, with configurations such as those described in Sec. 16.2C, provide superior performance.

(Fundamentals of Photonics, p. 606; emphasis added)

Furthermore, figures 16.1-11(a) and (b) (reproduced below) of Fundamentals of Photonics shows the LEDs are known to be implemented as *single dies*.

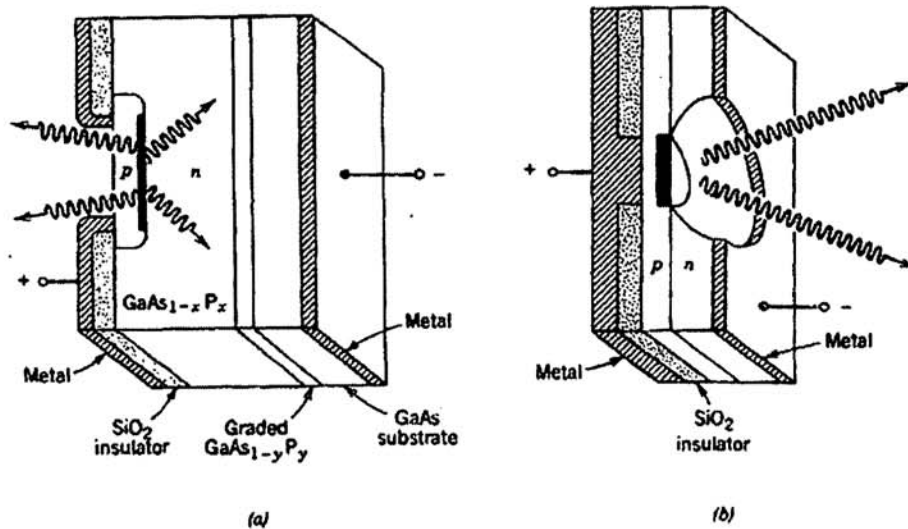

Figure 16.1-11 (a) A flat-diode-configuration $\text{GaAs}_{1-x}\text{P}_x$ LED. (b) A Burrus-type LED.

(Fundamentals of Photonics, p. 607; emphasis added)

Based on the foregoing, Fundamentals of Photonics provides evidence that those of ordinary skill in the art would appreciate that Menda's "solid ultraviolet **light emitting element** having a **structure of a pn junction**, MOS junction or the like" (Menda, *id.*) **implicitly includes** a *single-die semiconductor light-emitting diode* and a *single die semiconductor laser*.

Because Menda explicitly suggests making the UV light emitting element **42** of the liquid crystal **display** as a "solid ultraviolet light emitting element having a **structure of a pn junction**, MOS junction or the like" (Menda, ¶ [0018]), and because Fundamentals of Photonics states that the semiconductor LEDs and lasers are known to be used in "**display devices**", it would have been obvious to one of ordinary skill in the art, at the time of the invention to use known light-emitting pn junctions, such as those disclosed in Fundamentals of Photonics, which are *single-die semiconductor LEDs* and *semiconductor lasers*.

As noted above, **Morkoç** provides evidence that light-emitting **pn junctions** include *single-die semiconductor light-emitting diodes (LEDs)*. In Morkoç's section entitled, "III. GaN-based III-V Nitride Semiconductors" Morkoç explicitly calls the light emitters, "**GaN p-n junction LEDs**" (emphasis added):

These advances in material quality and processing have allowed researchers to demonstrate and commercialize GaN **p-n junction LEDs** giving rise to optimism of a GaN-based **laser** soon to follow.

(Morkoç, p. 1379, right col. last full sentence; emphasis added)

Art Unit: 3992

The first GaN LED was reported over 20 years ago.¹⁴⁶ Due to the inability at the time to dope GaN p type, these devices were not **conventional p-n junction LEDs**, but rather metal-insulator-semiconductor (MIS) structures. Only recently, when Amano et al.¹⁰⁴ first obtained p-type GaN was the first **p-n junction GaN LED** realized. Soon after, some of these same workers introduced AlGaIn as a barrier material.¹⁴⁷

(Morkoç, p. 1387, right col., 1st full ¶; emphasis added)

The Amano et al. article cited in Morkoç is dated 1990 which is three years **before** the filing date of Menda.

Morkoç also points out that the GaN-based LEDs produce UV light, i.e. light of a wavelength less than 400 nm (Morkoç, p. 1388, Fig. 47 and associated text on p. 1389). Thus, Morkoç shows that those of ordinary skill knew **before** the time of Menda that a GaN-based, UV-light-emitting **diodes** were made from a semiconductor pn junction **before** the time of Menda.

See also Morkoç p. 1386, Fig. 41 and Fig. 43 captions, which also use the language "p-n junction LED" (emphasis added). See also Morkoç at p. 1387, which uses the language "p-n junction LEDs" and "p-n junction GaN LED".

Morkoç's Figs. 49, 52, 56, and 58 each show **single die** semiconductor lasers; thus those of ordinary skill in the art know that semiconductor light emitting devices, including LEDs and lasers are implemented as a **single die**, as claimed.

Similarly, as noted above, Morkoç states,

These advances in material quality and processing have allowed researchers to demonstrate and commercialize **GaN p-n junction LEDs** giving rise to optimism of a **GaN-based laser** soon to follow.

(Morkoç, p. 1379, right col. last full sentence; emphasis added)

Thus, Morkoç teaches that those of ordinary skill in the art know that Menda's "solid ultraviolet light emitting element having a **structure of a pn junction**, MOS junction or the like" (Menda, ¶ [0018]) can be *at least one single-die semiconductor light-emitting diode (LED) or semiconductor lasers*.

Because Menda explicitly suggests making the UV light emitting element **42** as a "solid ultraviolet light emitting element having a **structure of a pn junction**, MOS junction or the like" (Menda, ¶ [0018]), it would have been obvious to one of ordinary skill in the art, at the time of the invention to use known UV-light-emitting pn junctions, such as those disclosed in Morkoç which include single-die semiconductor GaN-based LEDs and semiconductor lasers.

As also noted above, **Abe** shows to those of ordinary skill in the art that a UV-light-emitting semiconductor pn junction includes both LEDs and lasers. In discussing the prior art, Abe states,

Art Unit: 3992

In addition, the light source described above includes a **light emitting diode** (which will be referred to as **LED** thereafter) as a display element used in OA (Office Automation) apparatuses and display units. The LED is adapted to **emit light** by applying current to **p-n junction** of a **semiconductor**.

(Abe, col. 1, lines 28-33; emphasis added)

Thus, Abe teaches that it was already known in the art at least by 1994 (the foreign priority date of Abe) that a light-emitting semiconductor pn junction includes light-emitting **diodes**, or LEDs.

Abe also shows that semiconductor lasers are implemented as a "single chip":

Either of AC and DC power sources may be used as a required power source. In case of using the AC power source, a rectifying device may be incorporated in a lighting circuit, or the **semiconductor laser element** and the lighting circuit may be integrated in a **single chip**.

(Abe, col. 2, lines 45-49; emphasis added)

Note that Abe includes the lighting circuit along with the semiconductor laser; thus, Abe also points out here that the lighting circuit and the semiconductor lasers are known to be implemented on separate semiconductor chips (i.e. die).

Abe's Figs. 1(a), 1(b), 4(a)-4(g), 5, 6, 8(a), 8(b), each shows the UV-light emitting semiconductor laser element **1** implemented **single die**.

Based on the foregoing, Abe shows that those of ordinary skill in the art would understand that Menda's "solid ultraviolet light emitting element having a **structure of a pn junction, MOS junction or the like**" (Menda, ¶ [0018]) can be at *least one single-die semiconductor light-emitting diode (LED) or semiconductor laser*.

Because Menda explicitly suggests making the UV light emitting element **42** as a "solid ultraviolet light emitting element having a **structure of a pn junction, MOS junction or the like**" (Menda, *id.*), it would have been obvious to one of ordinary skill in the art, at the time of the invention to use known UV-light-emitting pn junctions, such as those disclosed in Abe which are single-die semiconductor LEDs and semiconductor lasers.

Finally, **Tadatomo** --a reference provided by Patentee in the IDS submitted 3/2/2011 -- shows that light-emitting **pn junctions** include both light-emitting **diodes** and **lasers**. In this regard, Tadatomo's Fig. 3 (reproduced below) shows a UV-light-emitting **diode** implemented as a **single die**.

Fig. 3

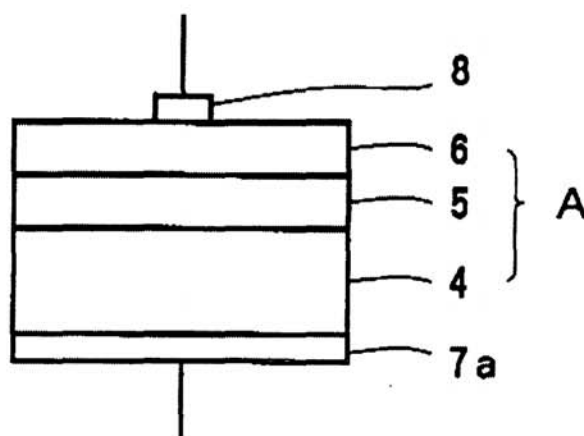

(Tadatomo, Fig. 3)

In regard to Fig. 3, Tadatomo states,

FIG. 3 schematically shows the structure of **LED** of a typical semiconductor light emitting element. As shown in the Figure, the **LED** comprises a laminate A (**4, 5, 6**) including the GaN single crystal (n type) produced by the method of the present invention as a substrate **4**, and a **semiconductor layer 5 (n type)** and a **semiconductor layer 6 (p type)**, both being GaN group compound semiconductors, formed thereon, and **electrodes 8 and 7** set on the outermost layers **6** and **4** of the laminate A.

(Tadatomo, col. 8, lines 37-44; emphasis added)

In **FIG. 3**, the **light emitting part** has a simple two-layer **p-n junction**. The junction of the light emitting part may be **homo-junction** where the same materials are joined, or **hetero-junction** where different materials are joined. Furthermore, the junctional structure of the light emitting part is **not limited to two-layer junction** but may be **multi-layer junction** such as **double-hetero junction, single quantum well, multiple quantum well etc.**

With such junctional structure of the light emitting part, various **semiconductor light emitting elements** such as **LED** and **LD [Laser Diode]** are obtained.

(Tadatomo, col. 9, lines 8-19; emphasis added)

In addition, Tadatomo states,

The thick **GaN** single crystal of superior quality which is produced by the method of the present invention can be suitably used for **semiconductor light emitting elements** such as **light emitting diode (LED), laser diode**

Art Unit: 3992

(LD) and superluminescence diode, and electron devices. In the electron devices, the use of the GaN single crystal of the present invention as a substrate enables production of LED, LD etc. having the same electrode structure as in the conventional red LED etc. Those which emit blue lights are particularly important. In addition, the efficiency of the light emission of semiconductor light emitting elements by the use of the GaN single crystal of the present invention is advantageously high.

(Tadamoto, col. 8, lines 20-32; emphasis added)

Thus, Tadamoto teaches that those of ordinary skill in the art knew around 1993-1994 (the foreign priority dates of Tadamoto) that light-emitting **pn junctions** include **both** semiconductor light-emitting **diodes** and semiconductor **lasers** implemented as **single dies**. In addition, the electrodes **7, 8** shows that those of ordinary skill know that the light emitting element must have a power source in order to emit radiation (as claimed, "*coupleable with a power supply to emit a primary radiation*").

Because Menda explicitly suggests making the UV light emitting element **42** as a "solid ultraviolet light emitting element having a **structure of a pn junction**, MOS junction or the like" (Menda, ¶ [0018]), it would have been obvious to one of ordinary skill in the art, at the time of the invention to use known UV-light-emitting pn junctions, such as those disclosed in Tadamoto, which are single-die semiconductor GaN-based LEDs and semiconductor lasers.

Based on the foregoing, even if Menda does not **implicitly include** the UV light-emitting pn junction is a *single-die semiconductor LED* or a *semiconductor laser*, then each of Morkoç, Abe, and Tadamoto at least makes this obvious, as indicated above. Again, given that Menda explicitly states the UV light emitting element **42** may be implemented as a "solid ultraviolet light emitting element having a **structure of a pn junction**, MOS junction or the like" (Menda translation, ¶ [0018]), it would have been obvious to those of ordinary skill in the art to use known pn junction, UV-light-emitting diodes and/or lasers disclosed in any of Morkoç, Abe, and Tadamoto, which are *single-die semiconductor LEDs* (claims 1 and 5) and/or *semiconductor lasers* (claim 3).

This is all of the features of claims 1, 3, and 5.

4. Claims 21, 22, and 26 are rejected under 35 U.S.C. 103(a) as being unpatentable over Menda in view of Tadamoto.

Proposed amended **claim 21** and **claim 22** reads,

21. A light-emitting device according to claim 5, wherein each single-die semiconductor LED present in the device comprises a single-die, two-lead gallium nitride based blue light semiconductor LED.

Art Unit: 3992

22. A light-emitting device according to claim 5, wherein each single-die semiconductor LED present in the device comprises a single-die two-lead semiconductor LED.

Menda does not teach that the LEDs have two leads.

As noted above in the previous rejection of claim 5, Menda in view of either of Tadatomo teaches that the GaN-based LEDs have two leads Tadatomo (Fig. 3); therefore, the modification of Menda by Tadatomo, as discussed above, results in a GaN-based LEDs having two leads.

Using Tadatomo's GaN-based LED as Menda's UV light source would have been obvious to one of ordinary skill in the art at the time of the invention for the same reasons as indicated in the previous rejection with regard to Tadatomo.

Claim 26 reads,

26. A light-emission device, comprising

*a single-die, two-lead semiconductor light-emitting diode emitting radiation;
and*

a recipient down-converting luminophoric medium for down-converting the radiation emitted by the light-emitting diode, to a polychromatic white light.

This claim is significantly broader than claim 22 above. Menda in view of either of Abe and Tadatomo teaches each of the features of this claim for the reasons discussed in rejecting claims 1, 5, and 22 above.

5. Claims 2, 23, 24, 180, 181, and 186 are rejected under 35 U.S.C. 103(a) as being unpatentable over Menda in view of any of Fundamentals of Photonics, Morkoç, Abe, and Tadatomo and further in view of Imamura.

Claims 2 and 23 read,

*2. A light-emitting device according to claim 1, comprising a **two-lead array** of single-die semiconductor LEDs.*

*23. A light-emitting device according to claim 5, comprising a **two-lead array** of single-die semiconductor LEDs.*

The prior art of Menda in view of any of Fundamentals of Photonics, Morkoç, Abe, and Tadatomo, as explained above, discloses each of the claimed features of claims 1 and 5. Menda does not explicitly disclose a two-lead **array** of single-die LEDs.

Art Unit: 3992

Imamura's Figs. 4 and 5 (reproduced below) shows the top and side views of an light array **10** may from an array of single-die semiconductor LEDs **13** on a substrate **15** (Imamura, col. 3, lines 16-36).

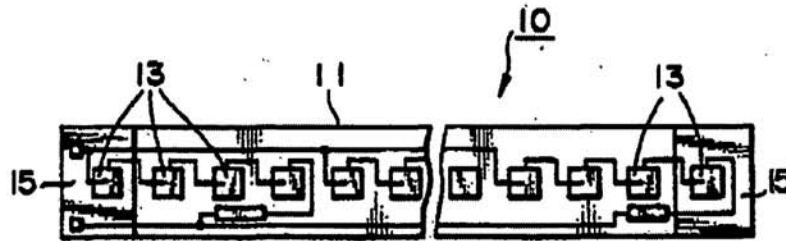

(Imamura, Fig. 4)

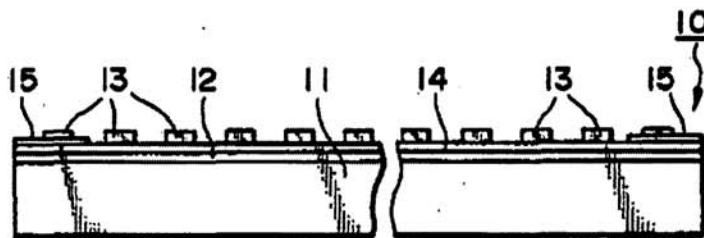

(Imamura, Fig. 5)

The array **10** can be used as a backlight for a liquid crystal display, such as shown in Fig. 8 (Imamura, col. 4, lines 59-61). Each LED die **13** has two leads that connect to the array's two leads, made from the gold-plated copper pattern **12** shown in the side view of right side of Fig. 5 and in the top view as the horizontal lines running across the top and bottom of the substrate **15** that connect the array of LEDs **13**. As also shown in Fig. 4, each of the array's two leads ends in a terminal. Thus, Imamura teaches a **two-lead array of single-die semiconductor LEDs**.

It would have been obvious to one of ordinary skill in the art, at the time of the invention to fashion Menda's UV backlight **42** of pn junction LED as Imamura's two-lead array configuration of plural identical UV LEDs --therefore *emitting identical UV radiation*-- in order to enable making a uniformly lit, larger, liquid crystal display than could be made from a single UV LED, as taught by Imamura (Imamura, col. 3, lines 37-60). Each LED would be that of Morkoç for the reasons indicated above.

Proposed amended **claim 24** reads,

24. A liquid crystal display, including:

a backlight member including a **multiplicity of light-emitting devices**, each light-emitting device comprising:

Art Unit: 3992

at least one single-die semiconductor light-emitting diode (LED) coupleable with a power supply to emit a primary radiation which is the same for each single-die LED present in the device, said primary radiation being a relatively shorter wavelength radiation, and

a down-converting luminophoric medium arranged in receiving relationship to said primary radiation, and which in exposure to said primary radiation responsively emits a secondary, relatively longer wavelength, polychromatic radiation, with separate wavelengths of said polychromatic radiation mixing to produce a white light output, wherein each of the at least one single-die semiconductor light-emitting diode in interaction with luminophoric medium receiving its primary radiation produces white light output.

Claim 24 is distinct from claim 5 in that (1) a liquid crystal display is claimed as opposed to just a light emitting device, and (2) a multiplicity of light-emitting devices is required to make a backlight for the LCD.

Imamura is applied as above.

It would have been obvious to one of ordinary skill in the art, at the time of the invention to fashion Menda's UV backlight **42** of pn junction LED as Imamura's two-lead array configuration of plural identical UV LEDs --therefore *emitting identical UV radiation*-- in order to enable making a uniformly lit, larger, liquid crystal display than could be made from a single UV LED, as taught by Imamura (Imamura, col. 3, lines 37-60). Each LED would be that of Morkoç for the reasons indicated above.

Further in this regard, the courts have held that mere duplication of parts has no patentable significance unless a new or unexpected result is produced. See *In re Harza*, 274 F.2d 669, 124 USPQ 378 (CCPA 1960). Thus, it would have been obvious to use more than one UV LED to increase the brightness or increase the size of the display.

Proposed new **claims 180 and 181** read,

180. The liquid crystal display of claim 24, wherein said multiplicity of light-emitting devices comprises an array of single-die semiconductor light-emitting diodes.

181. The liquid crystal display of claim 180, wherein said array comprises a regular pattern.

Imamura calls the LED array a "LED array substrate **10**" (Imamura, e.g. at col. 3, line 19) which is shown to be a rectangle, in Fig. 4. In addition, Imamura states,

Art Unit: 3992

A plurality of **LED array substrates 32** are mounted in the interior of a cover **33** to provide a **back-light 34** for illuminating a **liquid crystal display panel 30** and are supplied with a power through a connector **31**.

(Imamura, col. 4, lines 65-68; emphasis added)

Thus the array can be may whatever size is required for the LCD.

Proposed new **claim 186** reads,

186. The liquid crystal display of claim 24, comprising a **full-color liquid crystal display**.

Menda discloses a full-color LCD display. Menda's Fig. 4 shows the color filter **55** used to produce each of the different colors required for each pixel of the display (Menda translation, ¶ [0022]). In addition, Menda explicitly states that the LCDs are "full color" (Menda translation, ¶ [0019], 1st sentence).

6. Claims 4 and 11-13 are rejected under 35 U.S.C. 103(a) as being unpatentable over Menda in view of Morkoç.

Claims 4 and 13 and proposed amended claims 11 and 12 read,

4. *A light-emitting device according to claim 3, wherein said semiconductor laser includes an active material selected from the group consisting of III-V alloys and II-VI alloys.*

11. *A light-emitting device according to claim 5, wherein each single-die semiconductor LED present in the device is on a substrate in a multilayer device structure, and wherein said substrate comprises silicon carbide.*

12. *A light-emitting device according to claim 5, wherein each single-die semiconductor LED present in the device is on a substrate in a multilayer device structure, and wherein said substrate comprises a material selected from the group consisting of sapphire, SiC, and InGaAIN.*

13. *A light-emitting device according to claim 12, wherein said multilayer device structure includes layers selected from the group consisting of silicon carbide, aluminum nitride, gallium nitride, gallium phosphide, germanium carbide, indium nitride, and their mixtures and alloys.*

Menda does not indicate the materials from which the pn junction or substrate are made.

Morkoç teaches UV light-emitting LED and lasers made from III-V materials such as GaN, from II-VI materials such as ZnSe --as required by claim 4-- and from SiC:

Art Unit: 3992

For optical emitters and detectors, **ZnSe**, **SiC**, and **GaN** all have demonstrated operation in the green, blue, or **ultraviolet (UV) spectra**. Blue SiC light-emitting diodes (LEDs) have been on the market for several years, joined recently by **UV** and blue **GaN-based LEDs**. These products should find wide use in full color display and other technologies. ... In laser development, ZnSe leads the way with more sophisticated designs having further improved performance being rapidly demonstrated. If the low damage threshold of ZnSe continues to limit practical laser applications, **GaN** appears poised to become the semiconductor of choice for **short-wavelength lasers** in optical memory and other applications.

(Morkoç, abstract; emphasis added)

Morkoç indicates that GaN has been grown on silicon carbide (SiC) and sapphire (single crystal Al₂O₃) substrates --as required by **claims 11-13**. (See Morkoç, p. 1382, sections entitled, "C. Substrates for nitride epitaxy" and "D. Buffer layers for nitride heteroepitaxy on sapphire". Thus, GaN-based, UV LEDs and lasers can be fabricated on SiC and sapphire substrates --as required by claims 11-13.

LEDs and lasers require a pn junction, the p-type and n-type semiconductor being separate layers. In addition, the semiconductor material from which the pn junction, e.g. GaN, are made must be grown on a substrate, the substrate being an additional layer. This proves that LED and lasers are *multilayered device structures*, --as required by claims 11-13. Not the least of which lasers have quantum wells which are multilayer structures.

It would have been obvious to one of ordinary skill in the art, at the time of the invention to use Morkoç's materials for Menda's LED because Menda is silent to the details of the pn junction LED, such that one of ordinary skill would use known materials to make the LED, as taught in Morkoç. In this regard, it has been held that the selection of a known material based on its suitability for its intended use is *prima facie* obvious. See *Sinclair & Carroll Co., Inc. v. Interchemical Corp.*, 325 U.S. 327, 65 USPQ 297 (1945). See also *In re LESHIN*, 125 USPQ 416 (CCPA 1960). (See MPEP 2144.07.) In addition, given that Menda uses a UV-light LED and Morkoç teaches materials for UV-light LEDs, one of ordinary skill has a reasonable expectation of success.

7. Claims 48 and 52-54 are rejected under 35 U.S.C. 103(a) as being unpatentable over Menda in view of either of Morkoç and Tadatomo, as applied to claim 24 above, and further in view of Uehara or, in the alternative, over Menda in view of Imamura and either of Morkoç and Tadatomo, as applied to claim 24, above, and further in view of Uehara.

Proposed new claim 48 reads,