



US006088802A

United States Patent [19]
Bialick et al.

[11] Patent Number: 6,088,802
[45] Date of Patent: Jul. 11, 2000

[54] PERIPHERAL DEVICE WITH INTEGRATED SECURITY FUNCTIONALITY

5,828,832 10/1998 Holden et al. 395/187.01
5,878,142 3/1999 Caputo et al. 380/25

[75] Inventors: William P. Bialick, Clarksville, Md.;
Mark J. Sutherland, Milpitas, Calif.;
Janet L. Dolphin-Peterson, Belvedere,
Calif.; Thomas K. Rowland, Los
Gatos, Calif.; Kirk W. Skeba, Fremont,
Calif.; Russell D. Housley, Herndon,
Va.

FOREIGN PATENT DOCUMENTS

WO 82/03286 9/1982 WIPO .
WO 97/29416 8/1997 WIPO .

OTHER PUBLICATIONS

U.S. application No. 08/869,120, Bialick et al., filed Jun. 4, 1997, pending.

Primary Examiner—Ly V. Hua
Attorney, Agent, or Firm—David R. Graham

[73] Assignee: Spyrus, Inc., Santa Clara, Calif.

[57] ABSTRACT

[21] Appl. No.: 08/869,305

[22] Filed: Jun. 4, 1997

[51] Int. Cl.⁷ G06K 14/67

[52] U.S. Cl. 713/200; 713/201; 713/202

[58] Field of Search 395/188.01, 187.01,
395/186; 380/4, 25, 49; 713/200, 201, 202

The invention enables a peripheral device to communicate with a host computing device to enable one or more security operations to be performed by the peripheral device on data stored within the host computing device, data provided from the host computing device to the peripheral device (which can then be, for example, stored in the peripheral device or transmitted to yet another device), or data retrieved by the host computing device from the peripheral device (e.g., data that has been stored in the peripheral device, transmitted to the peripheral device from another device or input to the peripheral device by a person). In particular, the peripheral device can be adapted to enable, in a single integral peripheral device, performance of one or more security operations on data, and a defined interaction with a host computing device that has not previously been integrated with security operations in a single integral device. The defined interactions can provide a variety of types of functionality (e.g., data storage, data communication, data input and output, user identification). The peripheral device can also be implemented so that the security operations are performed in-line, i.e., the security operations are performed between the communication of data to or from the host computing device and the performance of the defined interaction. Moreover, the peripheral device can be implemented so that the security functionality of the peripheral device is transparent to the host computing device.

[56] References Cited

U.S. PATENT DOCUMENTS

4,709,136	11/1987	Watanabe	235/379
4,910,776	3/1990	Dyke	380/25
5,191,611	3/1993	Lang	380/25
5,282,247	1/1994	McLean et al.	380/4
5,297,206	3/1994	Orton	380/30
5,442,704	8/1995	Holtey	380/23
5,457,590	10/1995	Barrett et al.	360/133
5,473,692	12/1995	Davis	380/25
5,491,827	2/1996	Holtey	395/800
5,524,134	6/1996	Gustafson et al.	379/58
5,537,544	7/1996	Morisawa et al.	395/188.01
5,546,463	8/1996	Caputo et al.	380/25
5,548,721	8/1996	Denslow	395/187.01
5,610,981	3/1997	Mooney et al.	380/25
5,630,174	5/1997	Stone, III et al.	395/883
5,640,302	6/1997	Kikinis	361/687
5,694,335	12/1997	Hollenberg	364/514
5,742,683	4/1998	Lee et al.	380/23
5,770,849	6/1998	Novis et al.	235/492
5,790,674	8/1998	Houvenier et al.	380/23

39 Claims, 9 Drawing Sheets

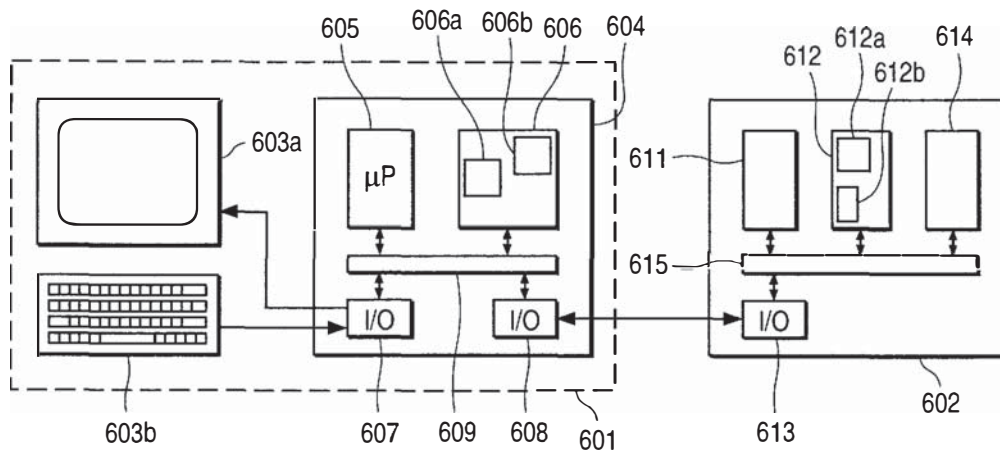

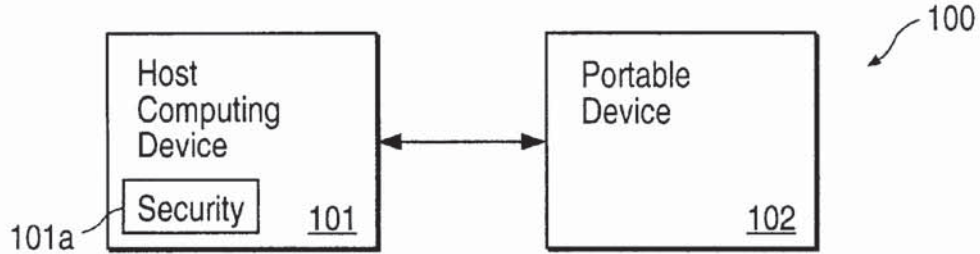

FIG. 1
(PRIOR ART)

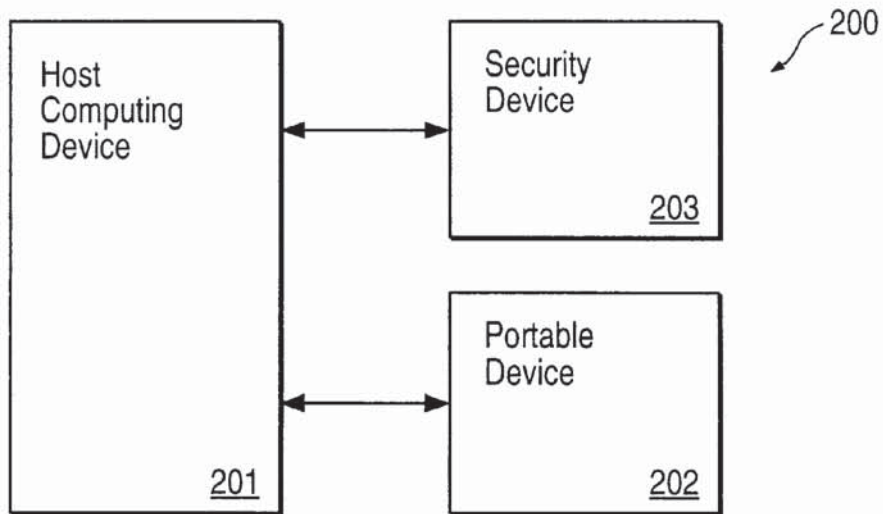

FIG. 2
(PRIOR ART)

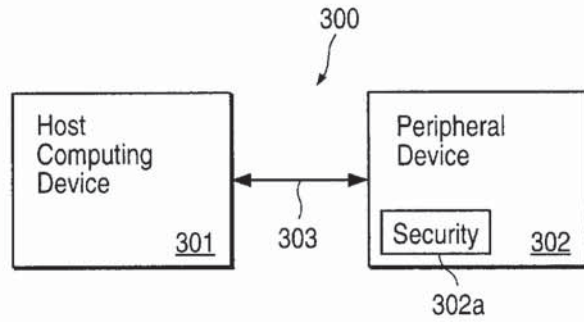

FIG. 3A

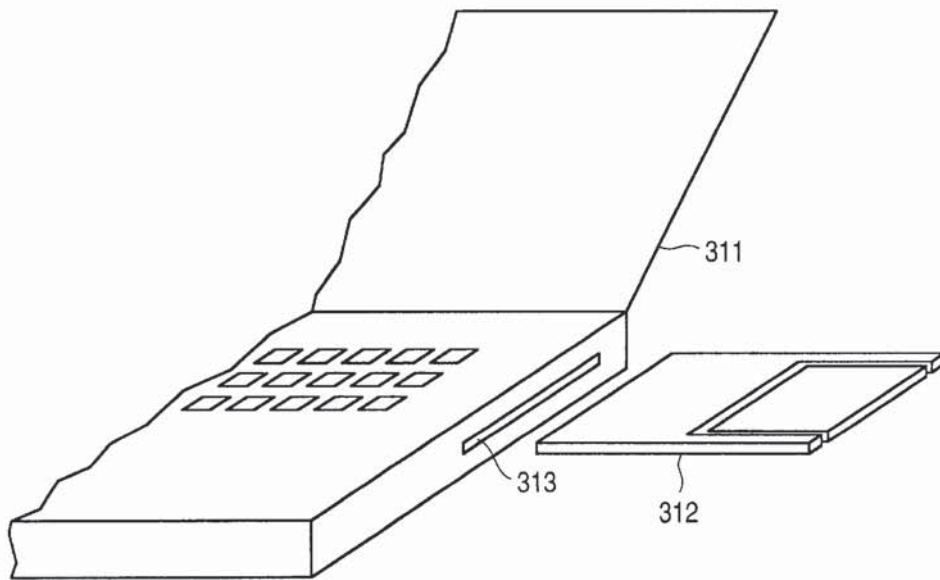

FIG. 3B

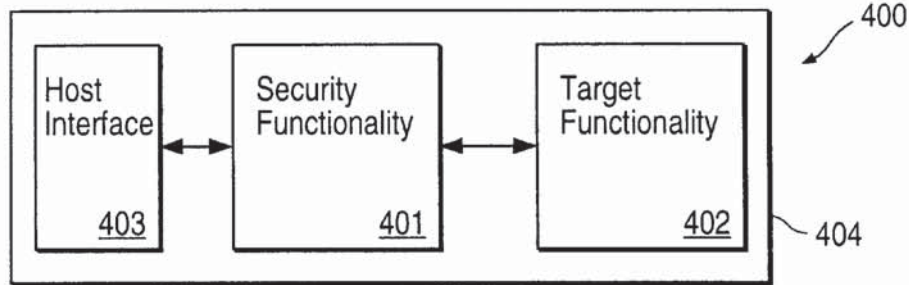

FIG. 4

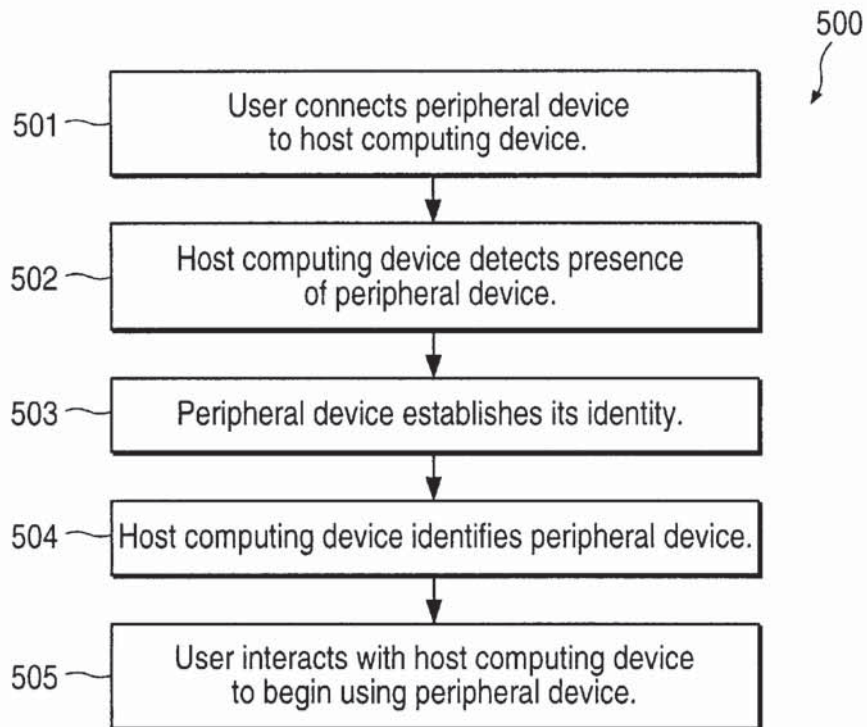

FIG. 5

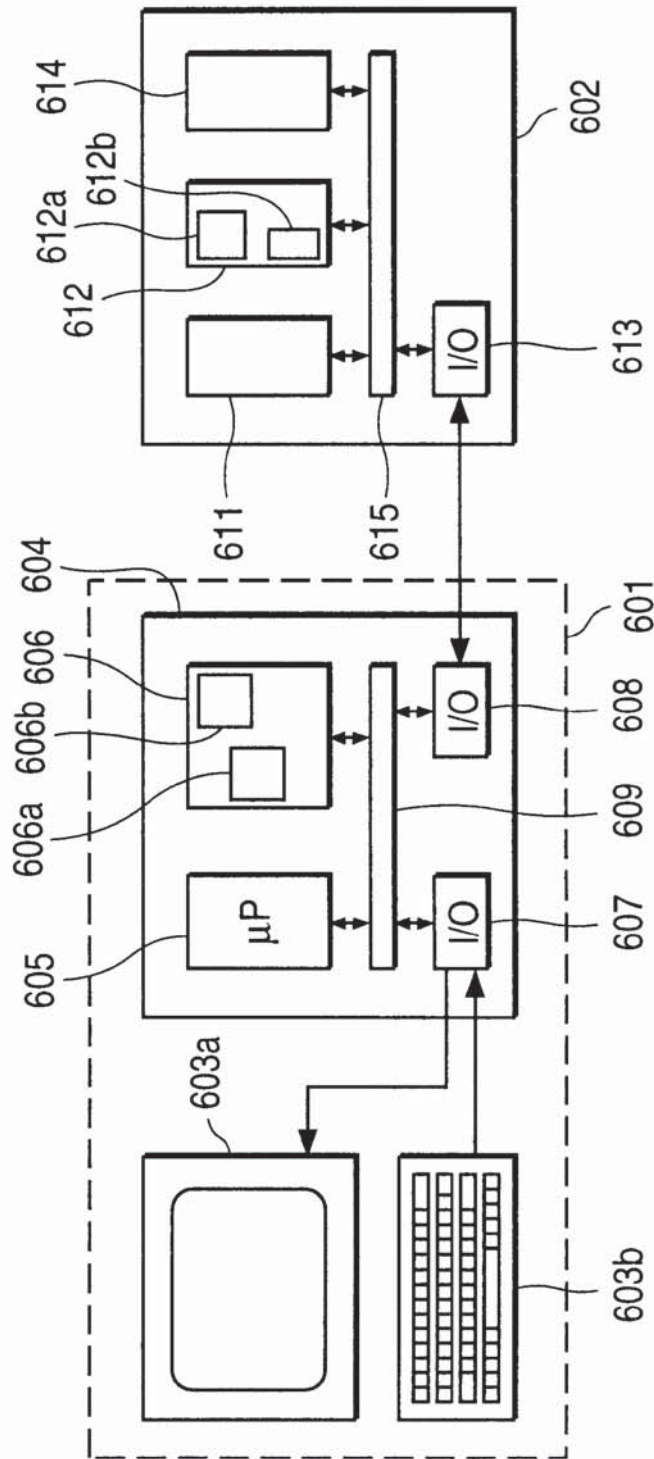

FIG. 6

Explore Litigation Insights

Docket Alarm provides insights to develop a more informed litigation strategy and the peace of mind of knowing you're on top of things.

Real-Time Litigation Alerts



Keep your litigation team up-to-date with **real-time alerts** and advanced team management tools built for the enterprise, all while greatly reducing PACER spend.

Our comprehensive service means we can handle Federal, State, and Administrative courts across the country.

Advanced Docket Research



With over 230 million records, Docket Alarm's cloud-native docket research platform finds what other services can't. Coverage includes Federal, State, plus PTAB, TTAB, ITC and NLRB decisions, all in one place.

Identify arguments that have been successful in the past with full text, pinpoint searching. Link to case law cited within any court document via Fastcase.

Analytics At Your Fingertips



Learn what happened the last time a particular judge, opposing counsel or company faced cases similar to yours.

Advanced out-of-the-box PTAB and TTAB analytics are always at your fingertips.

API

Docket Alarm offers a powerful API (application programming interface) to developers that want to integrate case filings into their apps.

LAW FIRMS

Build custom dashboards for your attorneys and clients with live data direct from the court.

Automate many repetitive legal tasks like conflict checks, document management, and marketing.

FINANCIAL INSTITUTIONS

Litigation and bankruptcy checks for companies and debtors.

E-DISCOVERY AND LEGAL VENDORS

Sync your system to PACER to automate legal marketing.