



US005943482A

# United States Patent [19] Culley et al.

[11] Patent Number: **5,943,482**  
[45] Date of Patent: **Aug. 24, 1999**

[54] **EXPANSION CARD INSERTION AND REMOVAL**

[75] Inventors: **Paul R. Culley**, Cypress; **Alan L. Goodrum**, Tomball; **Raymond Y.L. Chow**, Cypress; **Barry S. Basile**, Houston, all of Tex.

[73] Assignee: **Compaq Computer Corporation**, Houston, Tex.

[21] Appl. No.: **08/658,602**  
[22] Filed: **Jun. 5, 1996**

[51] **Int. Cl.<sup>6</sup>** ..... **G06F 13/00**  
[52] **U.S. Cl.** ..... **395/283; 395/750.01; 361/798**  
[58] **Field of Search** ..... **395/283, 750, 395/281, 282, 750.01, 750.02, 750.07; 439/73, 803, 832, 863, 864; 361/726, 732, 740, 759, 798**

### [56] **References Cited**

#### U.S. PATENT DOCUMENTS

3,767,974	10/1973	Donovan, Jr. et al. ....	317/101
3,853,379	12/1974	Goodman et al. ....	339/75
4,596,907	6/1986	LaGreco et al. ....	200/50
4,628,413	12/1986	Speraw ..... ..	361/415
4,835,737	5/1989	Herrig et al. ....	364/900
4,875,867	10/1989	Hoo ..... ..	439/157
4,999,787	3/1991	McNally et al. ....	364/514
5,003,431	3/1991	Imsdahl ..... ..	361/415
5,010,426	4/1991	Krenz ..... ..	360/97.01
5,191,970	3/1993	Brockway et al. ....	200/335
5,247,619	9/1993	Mutoh et al. ....	395/325
5,310,998	5/1994	Okuno ..... ..	235/380
5,317,482	5/1994	Bujtas ..... ..	361/798
5,317,483	5/1994	Swindler ..... ..	361/801
5,386,567	1/1995	Lien et al. ....	395/653
5,428,507	6/1995	Chatel et al. ....	361/798
5,454,080	9/1995	Fasig et al. ....	395/283
5,473,499	12/1995	Weir ..... ..	361/58
5,504,656	4/1996	Joist ..... ..	361/754
5,513,329	4/1996	Pecone ..... ..	395/281
5,530,302	6/1996	Hamre et al. ....	307/147

5,555,510	9/1996	Verseput et al. ....	395/282
5,581,712	12/1996	Herrman ..... ..	395/283
5,625,238	4/1997	Ady et al. ....	307/147
5,629,836	5/1997	Wright ..... ..	361/755

#### FOREIGN PATENT DOCUMENTS

0 241 905	10/1987	European Pat. Off. .
0 254 456	1/1988	European Pat. Off. .
28 50 440	5/1979	Germany .
34 09 021	9/1985	Germany .
WO 93/15459	8/1993	WIPO .

#### OTHER PUBLICATIONS

*IBM Technical Disclosure Bulletin*, vol. 34 No. 6, Nov. 1991, pp. 363-364, "Hot Plug Receptacle Actuated Mechanical Latch."  
Maintenance & Service Guide, COMPAQ Deskpro XL Series of Personal Computers; pp. 3-18, 5-34; COMPAQ Computer Corp., Houston, TX.; Dec. 15, 1995.  
Don Anderson, PCMCIA System Architecture, PC System Architecture Series, Second Edition, pp. 21-83, 113-141, 145-162, 229-309, 321-332, Copyright © 1995 by MindShare, Inc., Richardson, TX.  
Don Anderson/Tom Shanley, CardBus System Architecture, PC System Architecture Series, pp. 17-29, 39-58, 227-236, 321-361, Copyright © 1996 by MindShare, Inc., Richardson, TX.  
CompactPCI™ Specification, PCI Industrial Computers, Revision 10, Nov. 1, 1995, pp. 14, 36, and 50.

*Primary Examiner*—Glenn A. Auve  
*Attorney, Agent, or Firm*—Williams, Morgan & Amerson, P.C.

### [57] **ABSTRACT**

A computer system has a bus, a connector for a circuit card, and a clamp configured to selectively prevent removal of the circuit card from the connector when the clamp is engaged. The computer system has circuitry connected to monitor the engagement status of the clamp and to regulate delivery of power to the connector based on the engagement state of the clamp.

**26 Claims, 127 Drawing Sheets**

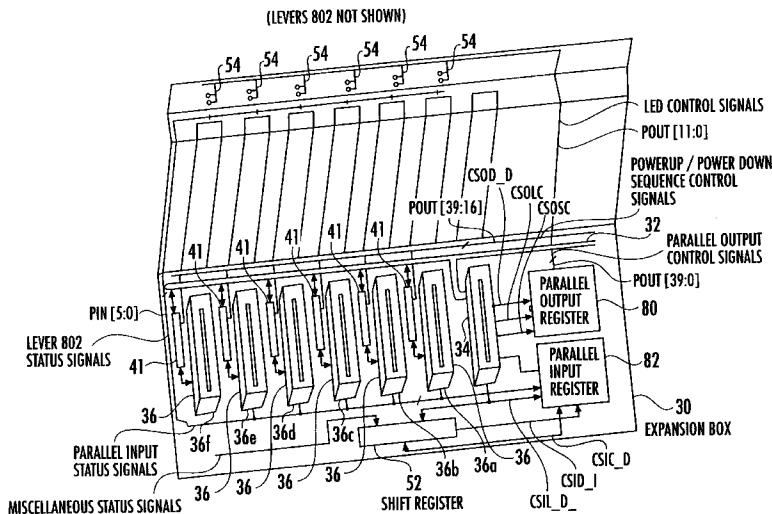

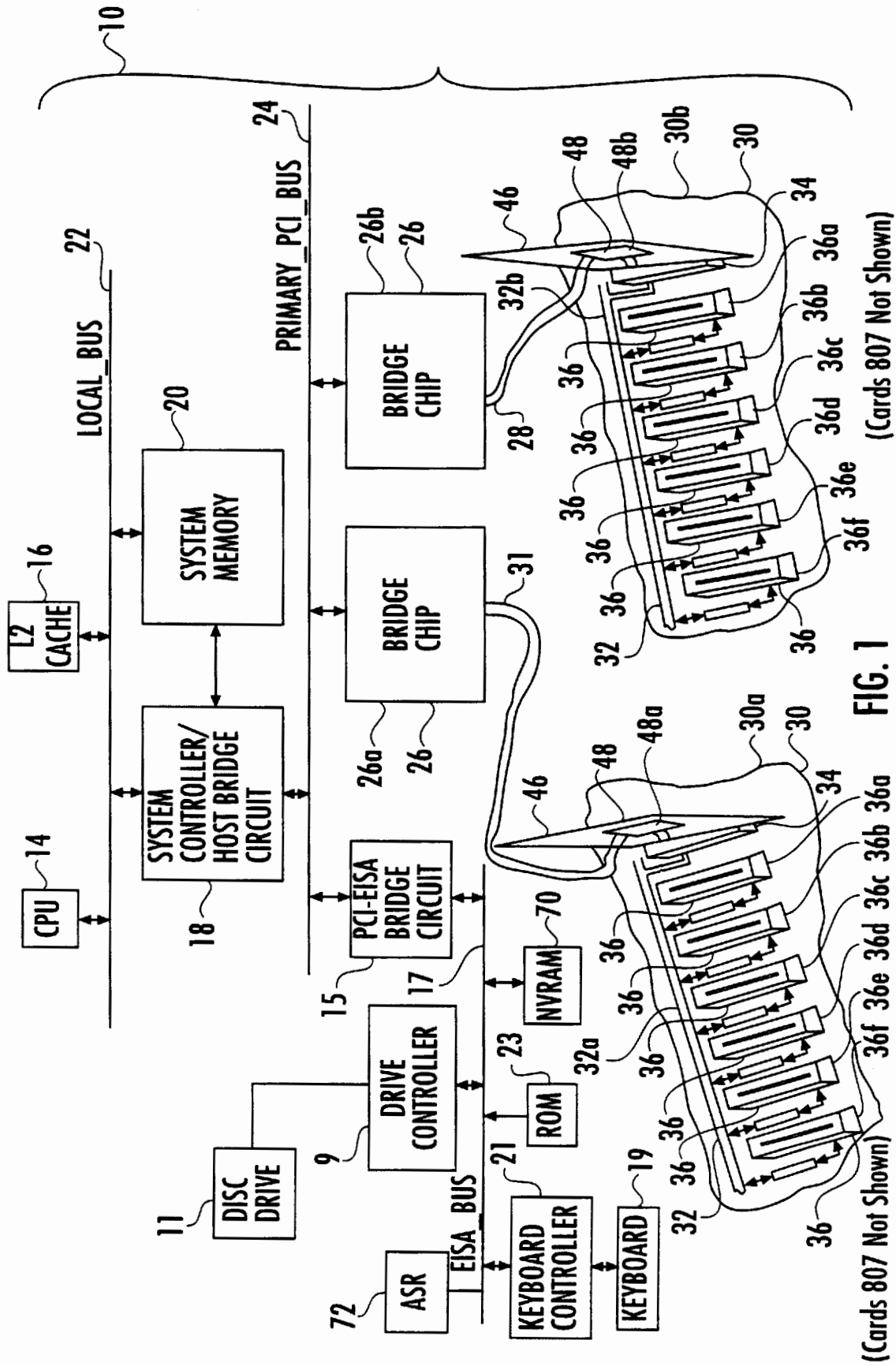



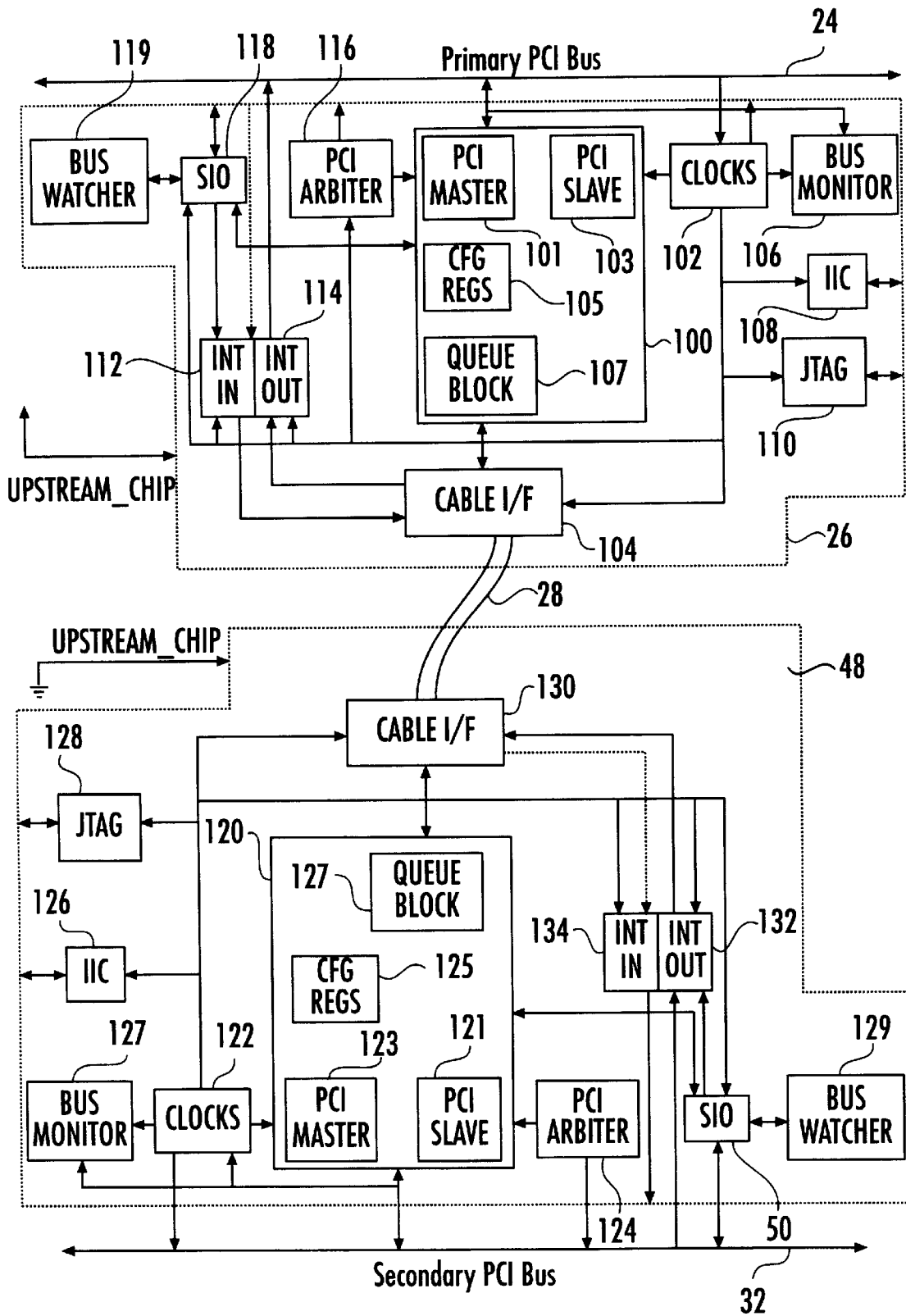

FIG. 3



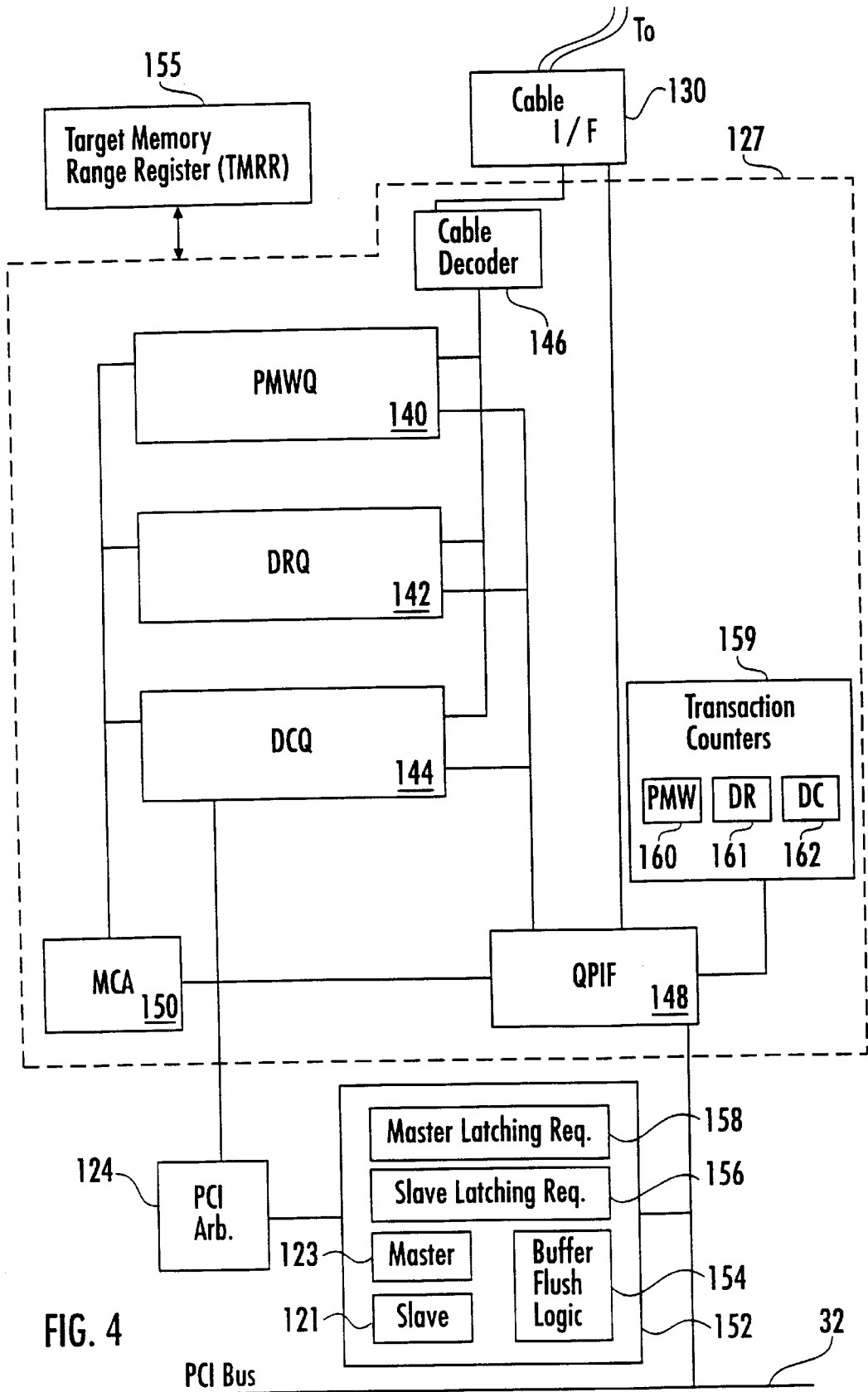

FIG. 4

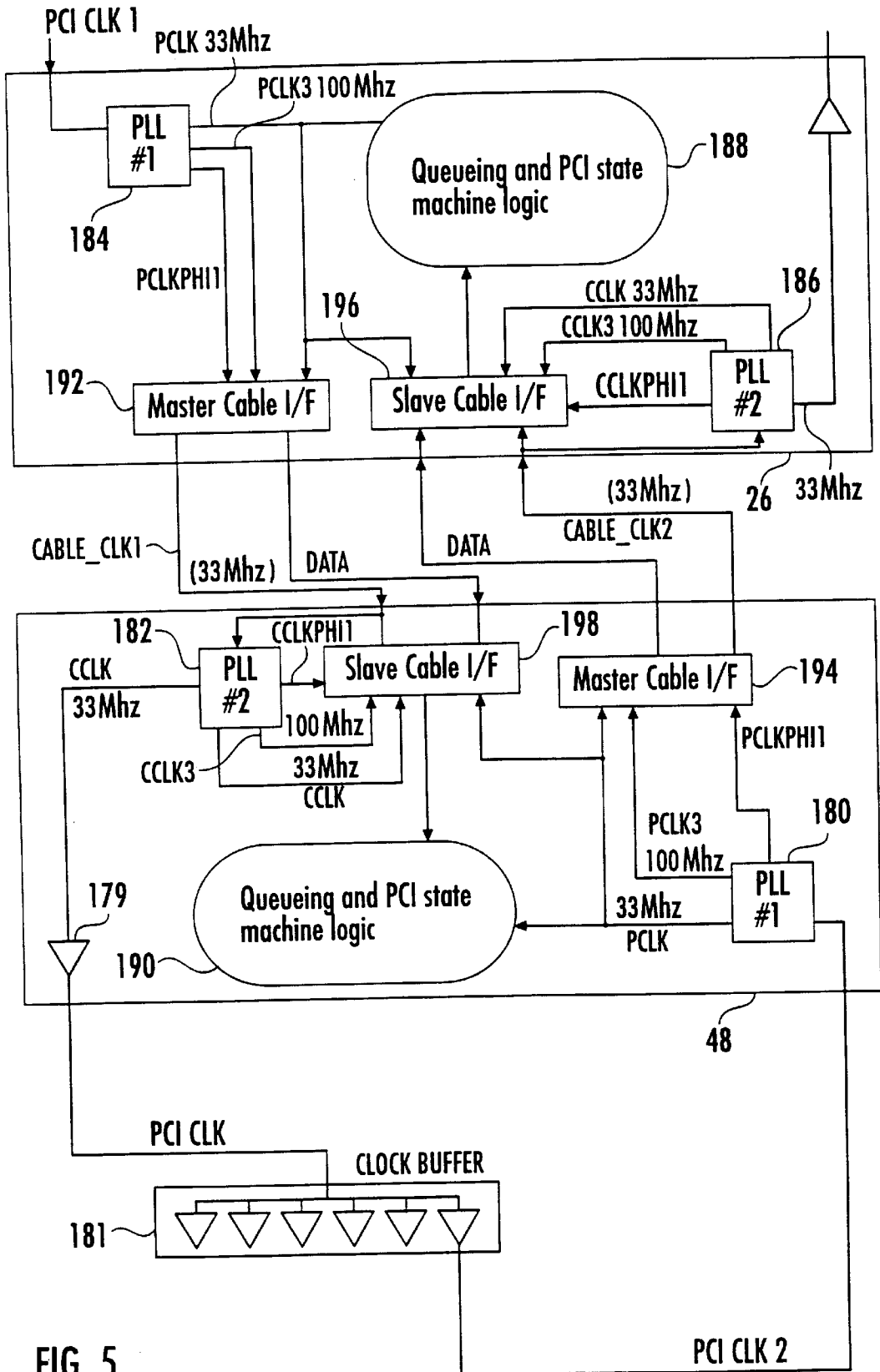

FIG. 5

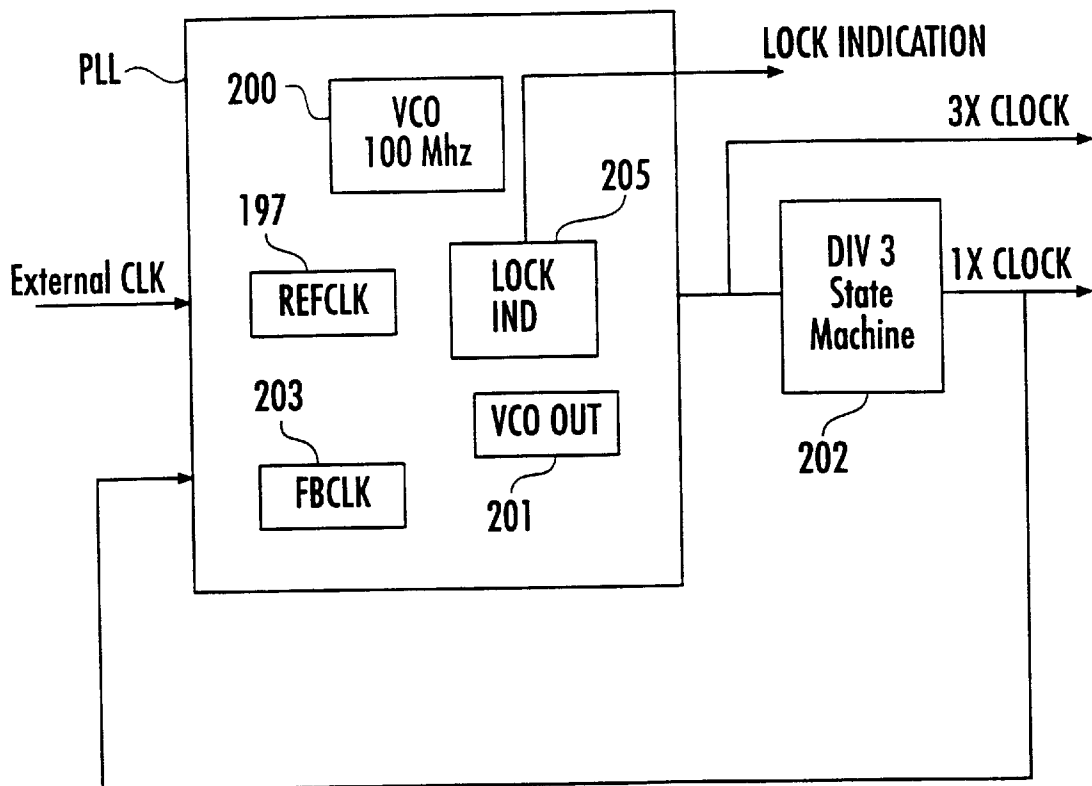

FIG. 6

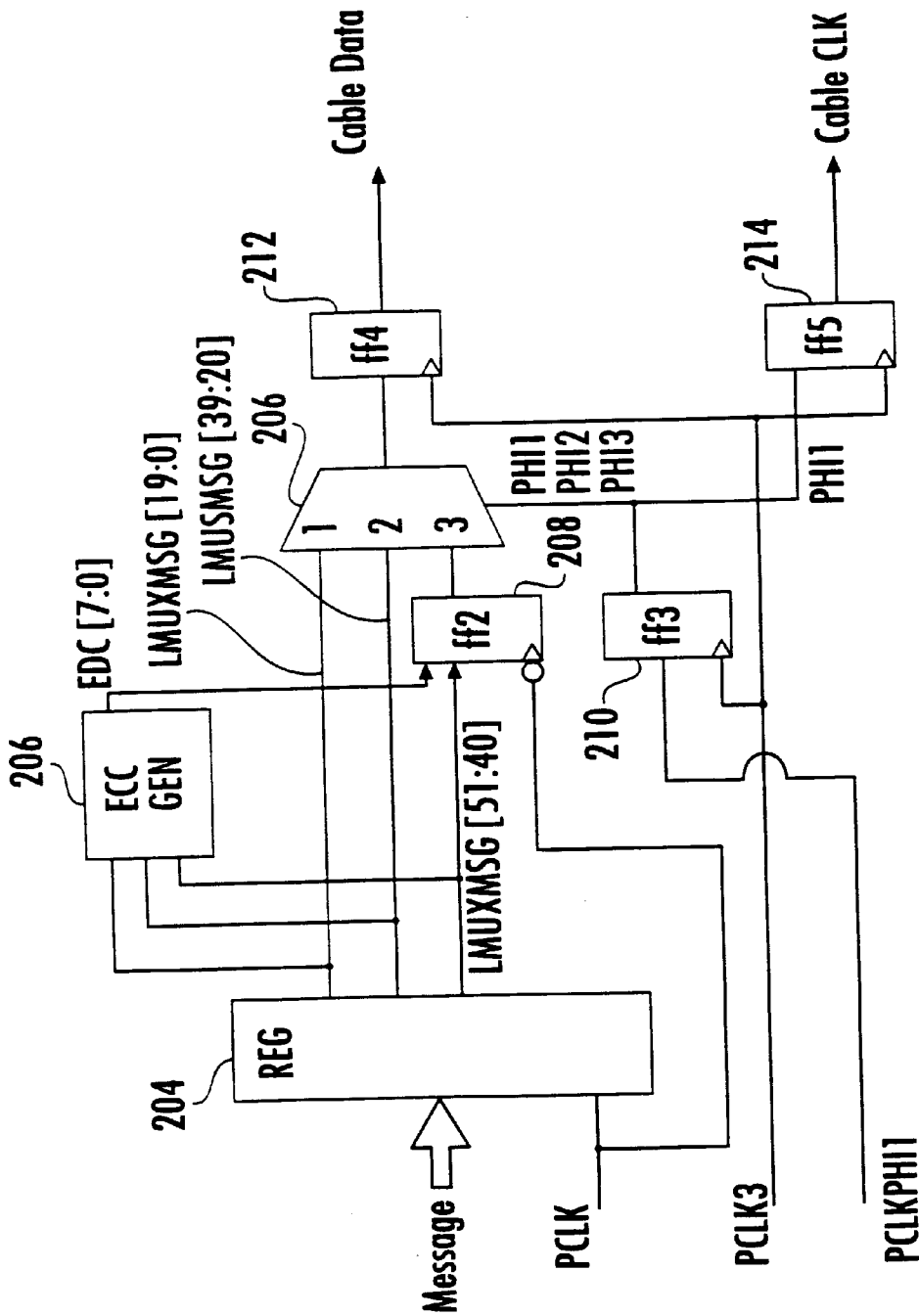

FIG. 7

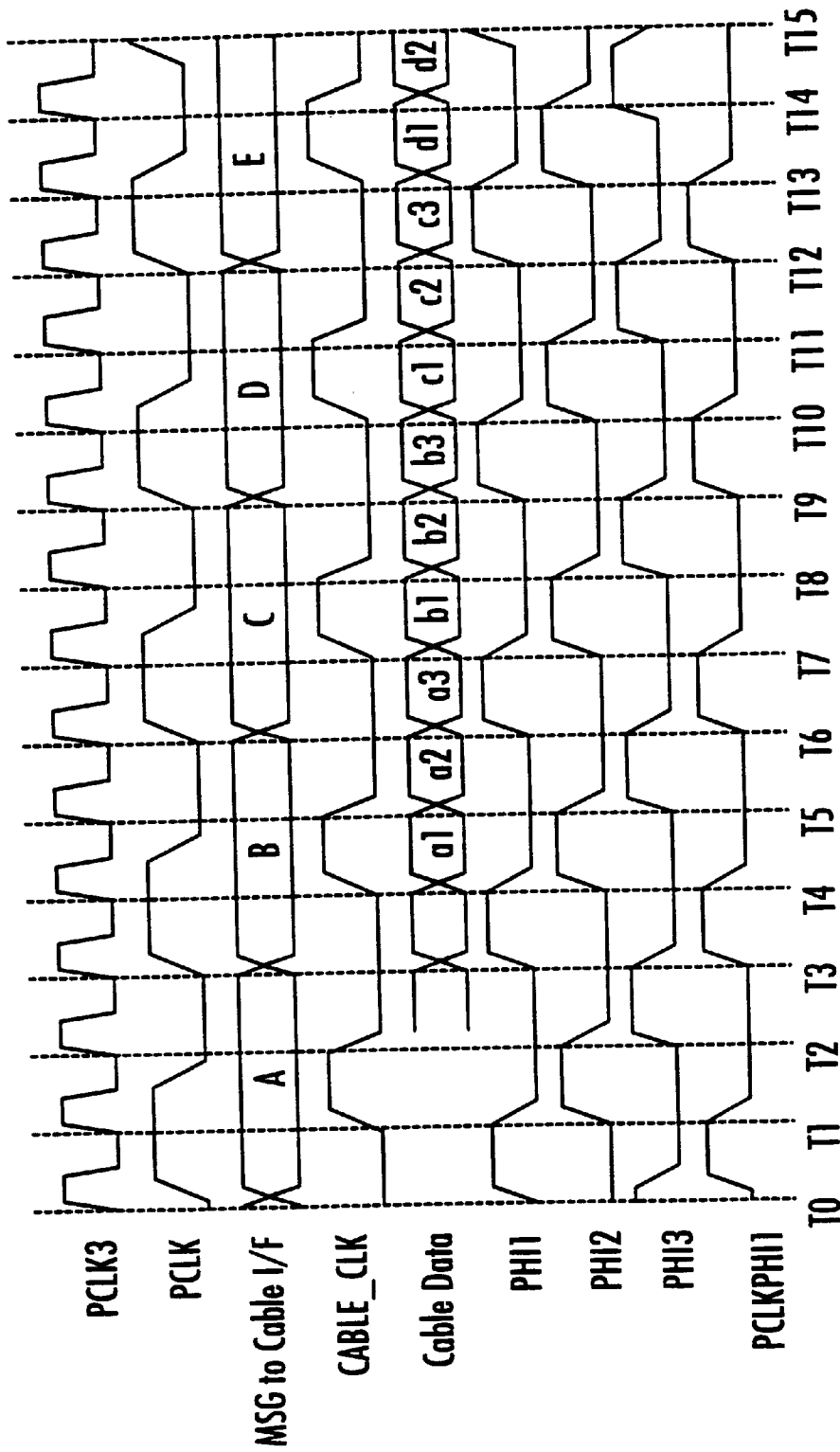

FIG. 8

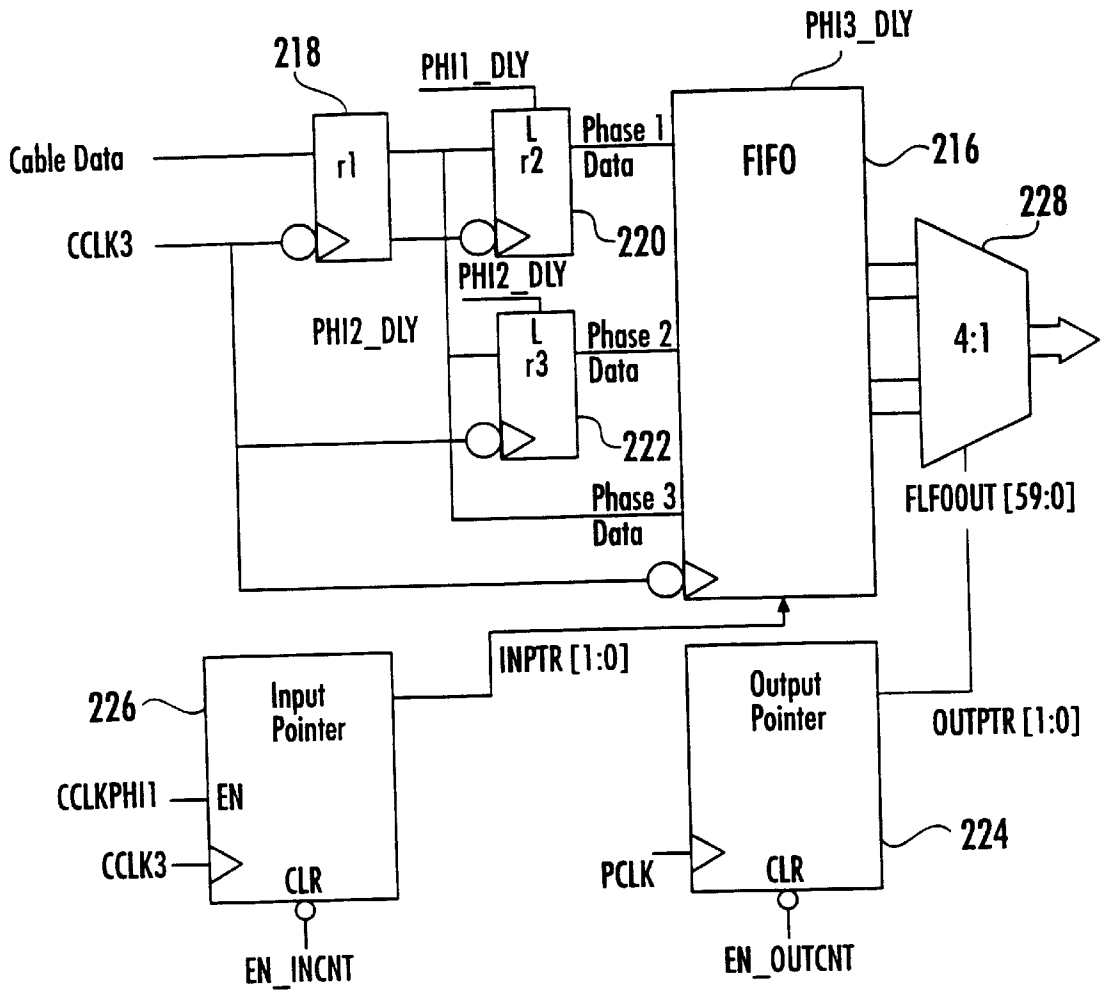

FIG. 9

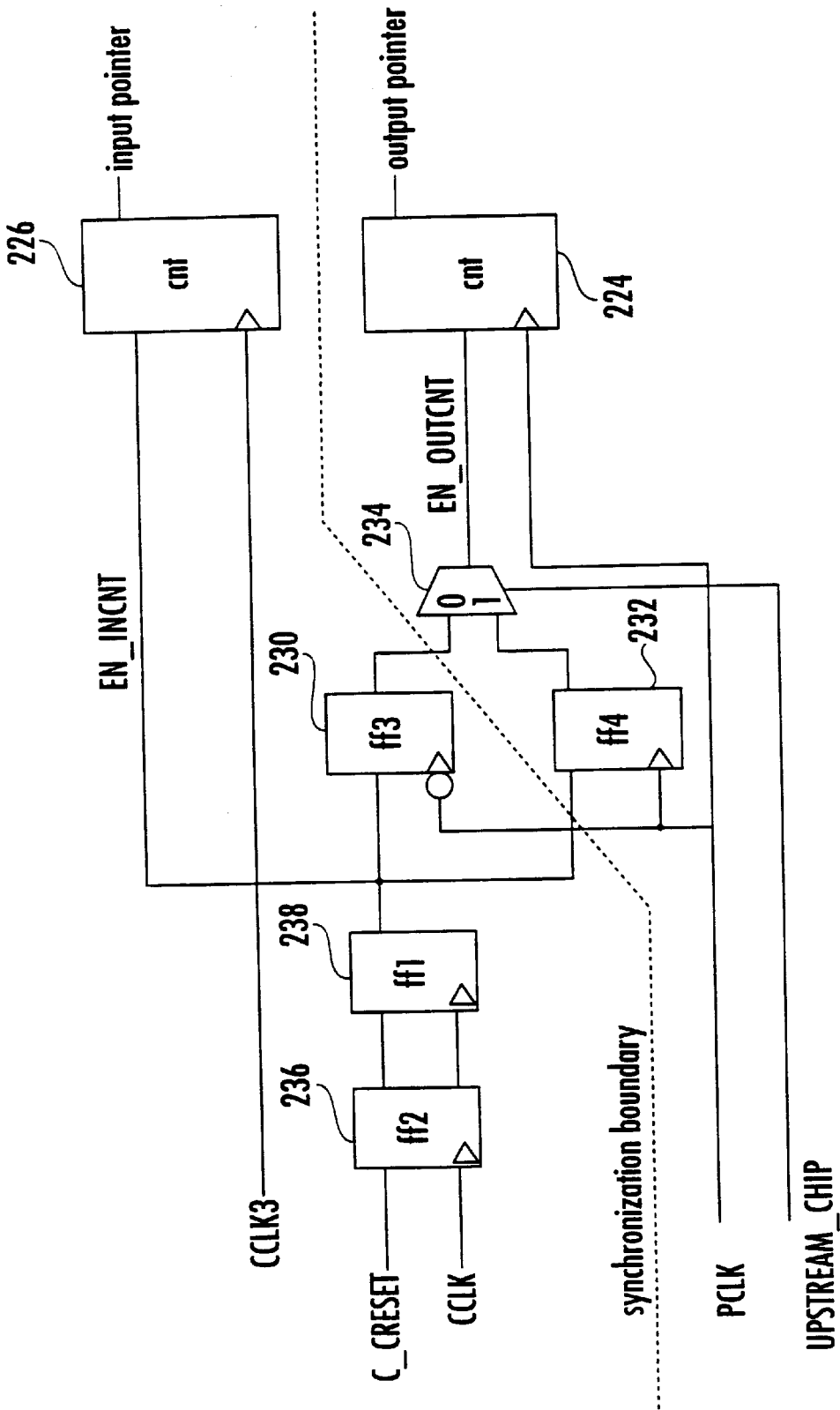

FIG. 10

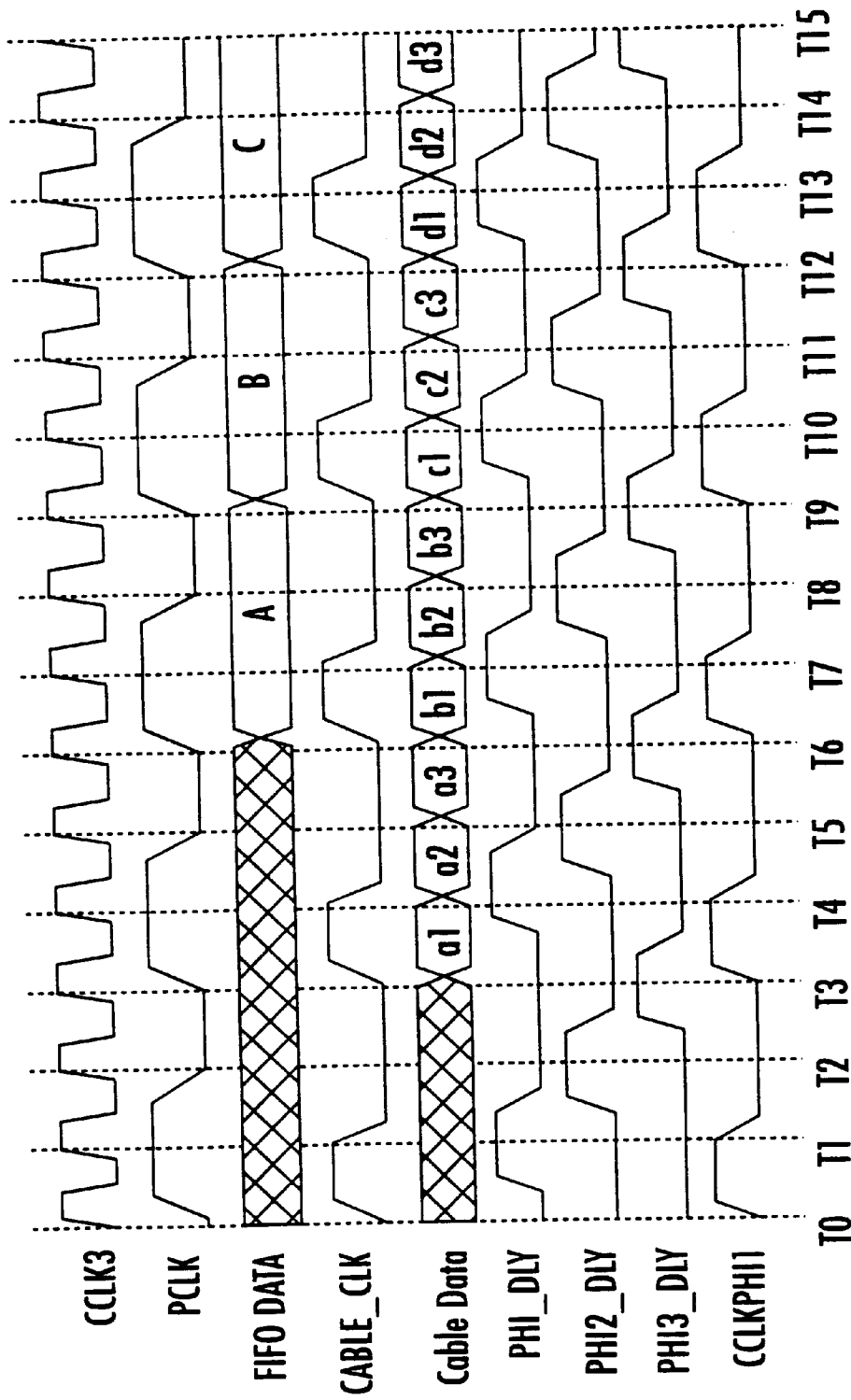

FIG. 11



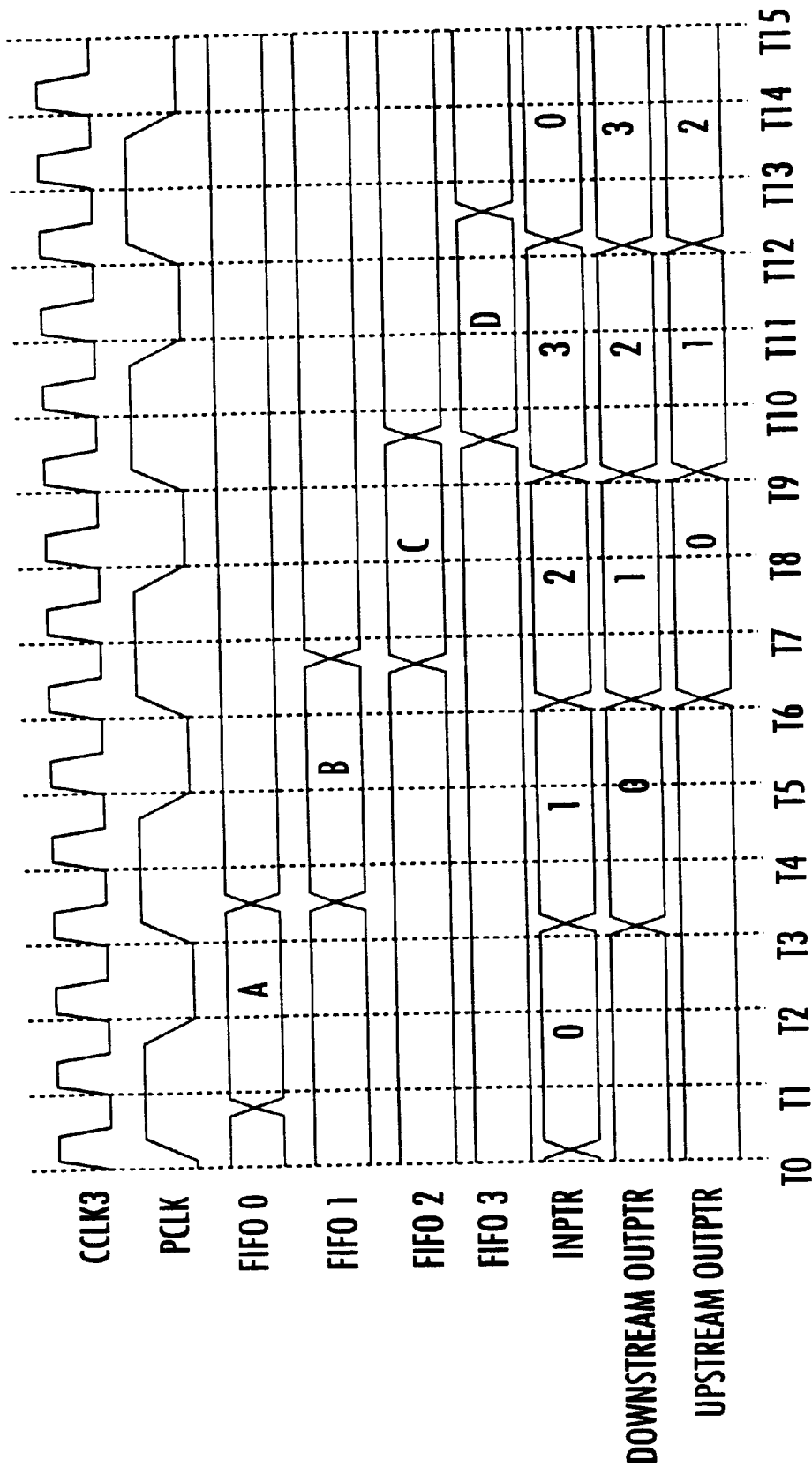

FIG. 12

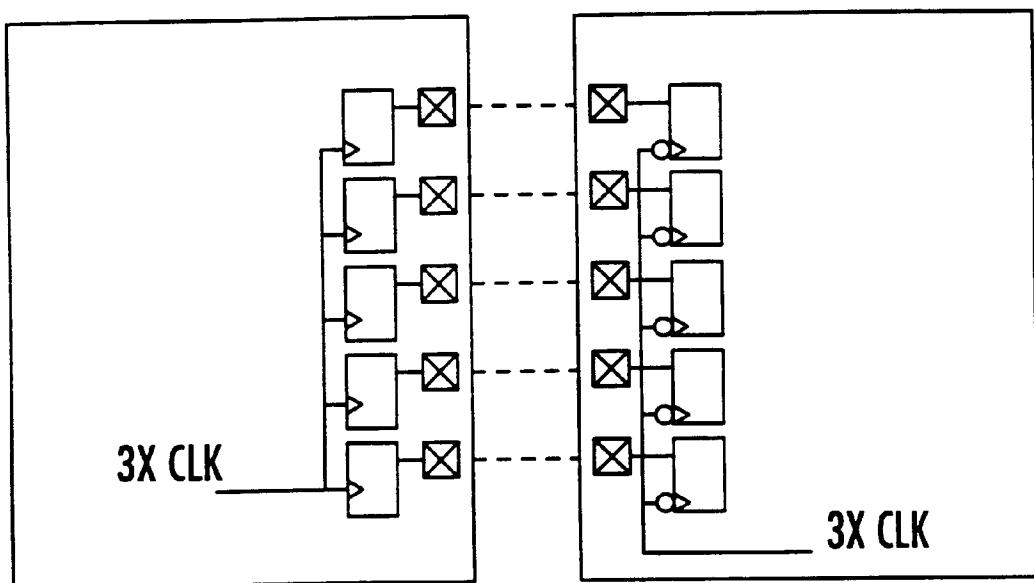

FIG. 13

Bit	Upstream-to-Downstream			Downstream-to-Upstream		
	Phase 1	Phase 2	Phase 3	Phase 1	Phase 2	Phase 3
20	CAD00	CAD20	CFRAME	CAD00	CAD20	CFRAME
19	CCBE3	CAD19	CAD31	CCBE3	CAD19	CAD31
18	CCBE2	CAD18	CAD30	CCBE2	CAD18	CAD30
17	CCBE1	CAD17	CAD29	CCBE1	CAD17	CAD29
16	CCBE0	CAD16	CAD28	CCBE0	CAD16	CAD28
15	CBUFF3	CAD15	CAD27	CBUFF3	CAD15	CAD27
14	CBUFF2	CAD14	CAD26	CBUFF2	CAD14	CAD26
13	CBUFF1	CAD13	CAD25	CBUFF1	CAD13	CAD25
12	CBUFF0	CAD12	CAD24	CBUFF0	CAD12	CAD24
11	PMW Ack	CAD11	CAD23	PMW Ack	CAD11	CAD23
10	Completion Removed	CAD10	CAD22	Completion Removed	CAD10	CAD22
9	LOCK	CAD09	CAD21	SERR	CAD09	CAD21
8	New Req	CAD08	EDC7	New Req	CAD08	EDC7
7	SPARE	CAD07	EDC6	SPARE	CAD07	EDC6
6	SPARE	CAD06	EDC5	SPARE	CAD06	EDC5
5	SPARE	CAD05	EDC4	SPARE	CAD05	EDC4
4	SPARE	CAD04	EDC3	SPARE	CAD04	EDC3
3	SPARE	CAD03	EDC2	SPARE	CAD03	EDC2
2	SPARE	CAD02	EDC1	SPARE	CAD02	EDC1
1	SPARE	CAD01	EDC0	SPARE	CAD01	EDC0

FIG. 14

Single Address Cycle		1st phase	2nd phase	subsequent phases
Delayed Read/Write Request	cbuf <3>	buff#	X	NA
	cbuf <2>	buff#	X	NA
	cbuf <1>	buff#	X	NA
	cbuf <0>	buff#	parity <sup>3</sup>	NA
	ccbe <3:0>	PCI cmd	BE<> <sup>1</sup>	NA
	cad<>	addr	data<> <sup>3</sup>	NA
Posted Memory Write	cbuf <3>	X	X	X
	cbuf <2>	X	data ready	data ready
	cbuf <1>	X	parity error	parity error
	cbuf <0>	X	parity	parity
	ccbe <3:0>	PCI cmd	BE<>	BE<>
	cad<>	addr	data	data
Delayed Read/Write Completion	cbuf <3>	buff#	end of completion	end of completion
	cbuf <2>	buff#	data ready	data ready
	cbuf <1>	buff#	parity error	parity error
	cbuf <0>	buff#	parity	parity
	ccbe <3:0>	DRC	status	status
	cad<>	X	data	data
Stream Connect	cbuf <3>	buff#	X	X
	cbuf <2>	buff#	data ready	data ready
	cbuf <1>	buff#	X	X
	cbuf <0>	buff#	X	X
	ccbe <3:0>	strm conn	X	X
	cad<>	X	X	X

FIG. 15A

Dual address cycle	1st phase (Class)	2nd phase	3rd phase	subsequent phases	
Delayed Read/Write Request	cbuff<3>	buff #	X	NA	
	cbuff<2>	buff #	X	NA	
	cbuff<1>	buff #	X	NA	
	cbuff<0>	buff #	parity	NA	
	cbuff<3:0>	DAC	PCI cmd	BE<>	NA
Posted Memory Write	cad<>	ms addr	data	NA	
	cbuff<3>	X	X	X	
	cbuff<2>	X	X	X	
	cbuff<1>	X	X	parity error	
	cbuff<0>	X	X	parity	
	ccbe<3:0>	DAC	PCI cmd	BE<>	BE<>
	cad<>	ms addr	addr	data	data

FIG. 15B

Parameter	Value
Impedance (Differential)	108 +/- 5 Ohms
Impedance (Single-ended)	67 +/- 5 Ohms
Propagation Delay	1.54 ns/ft min, 1.58 ns/ft max
Delay Skew	0.025 ns/ft max
Attenuation (Differential)	0.08 db/ft max @ 50 MHz
Length	12'
DC Resistance	0.070 Ohms/ft max

FIG. 16

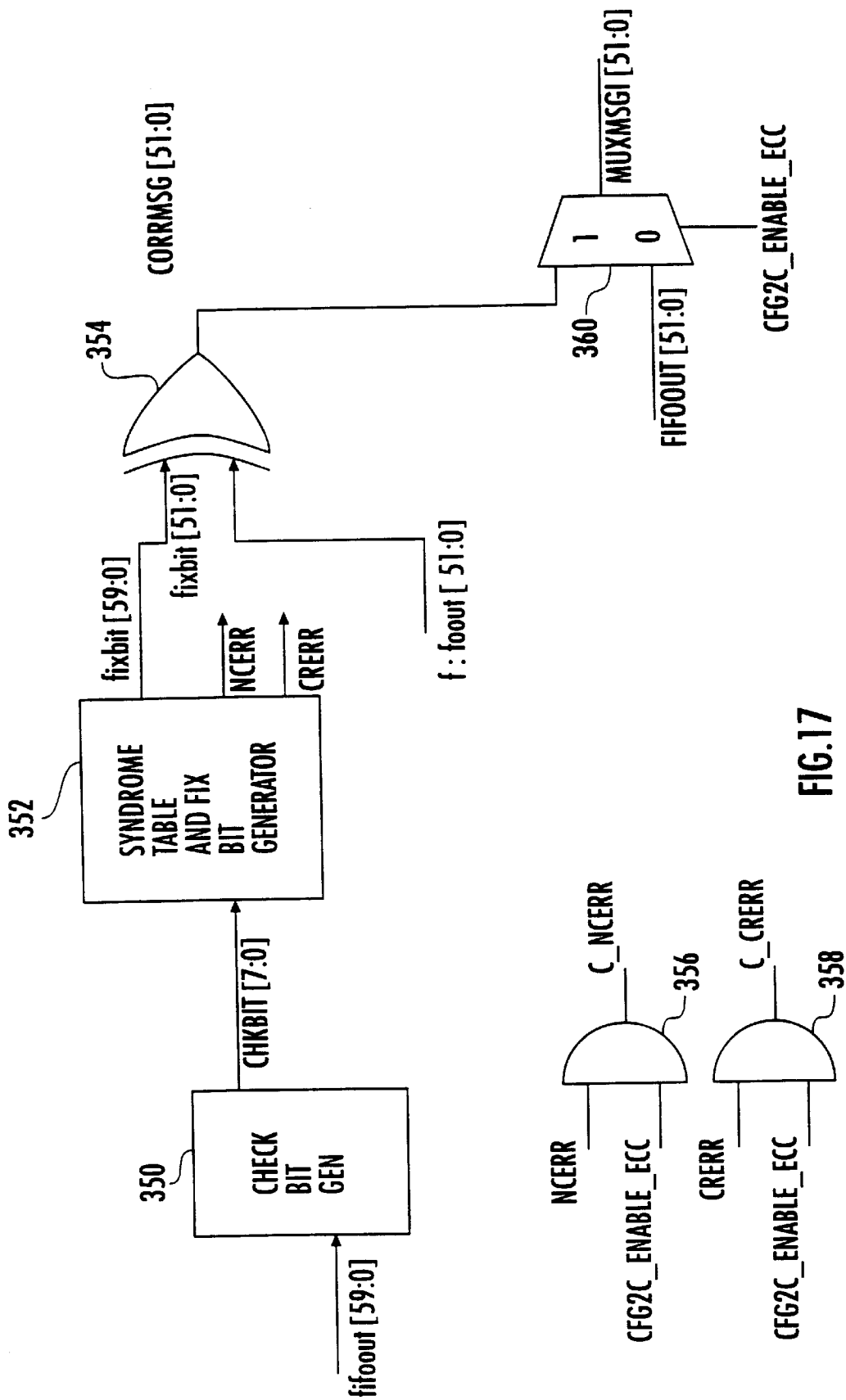

FIG. 17

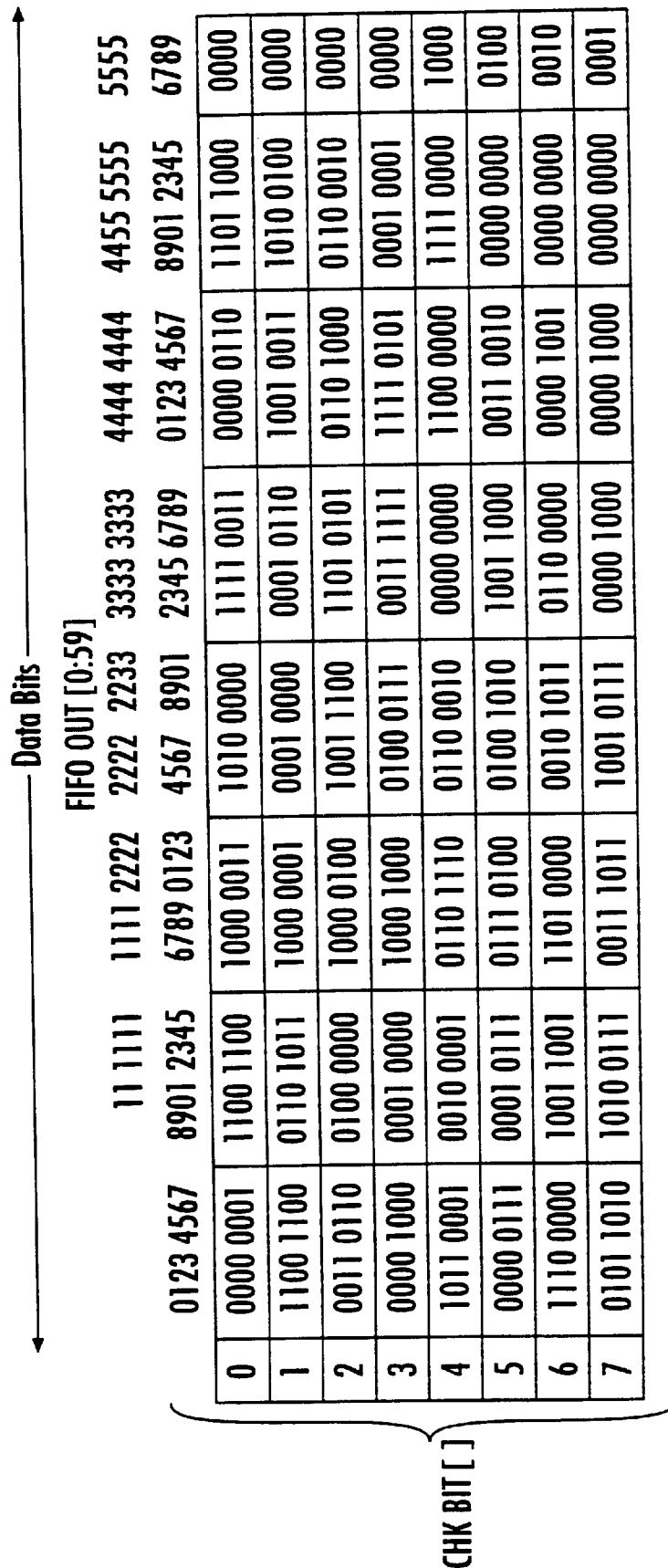
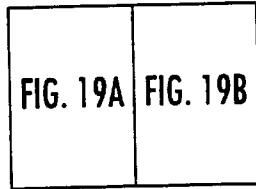

FIG. 18



FIG. 19



00 No Error	20 DB57	40 DB58
01 DB 52	21 UNCER	41 DB44,24
02 DB53	22 UNCER	42 DB52,12
03 UNCER	23 DB 46	43 DB12
04 DB54	24 DB 52,32	44 UNCER
05 UNCER	25 DB32	45 DB33
06 UNCER	26 DB05	46 UNCER
07 DB09	27 DB55,35	47 DB53,33
08 DB55	28 DB41,21	48 DB40,00
09 UNCER	29 UNCER	49 DB34
0A UNCER	2A DB43	4A DB47
0B DB38	2B UNCER	4B DB58,38
0C UNCER	2C DB42	4C UNCER
0D DB39	2D UNCER	4D DB54,34
0E DB37	2E DB57,37	4E DB44,04
0F DB24,04	2F DB35	4F DB16
10 DB56	30 UNCER	50 DB57,17
11 UNCER	31 DB07	51 DB26
12 DB49,09	32 UNCER	52 DB00
13 DB48	33 UNCER	53 UNCER
14 UNCER	34 DB21	54 DB02
15 DB49	35 UNCER	55 UNCER
16 DB50	36 UNCER	56 UNCER
17 DB23,03	37 UNCER	57 UNCER
18 UNCER	38 DB25	58 UNCER
19 DB51	39UNCER	59 UNCER
1A DB40	3A UNCER	5A UNCER
1B UNCER	3B UNCER	5B UNCER
1C DB41	3C UNCER	5C UNCER
1D UNCER	3D DB43,23,03	5D UNCER
1E DB25,05	3E UNCER	5E DB57,37,17
1F UNCER	3F UNCER	5F DB56,16

FIG. 19A

60 DB59,19	80 DB59	A0 DB 31,11	C0 UNCER	E0 DB19
61 UNCER	81 UNCER	A1 DB13	C1 DB08	E1 UNCER
62 UNCER	82 DB40,20	A2 DB14	C2 DB01	E2 UNCER
63 UNCER	83 DB23	A3 DB53,13	C3 UNCER	E3 UNCER
64 DB28	84 DB50,10	A4 DB06	C4 DB44	E4 DB33,13
65 UNCER	85 DB24	A5 DB28,08	C5 DB22,02	E5 UNCER
66 DB32,12	86 DB27	A6 DB54,14	C6 UNCER	E6 DB53,33,13
67 DB52,32,12	87 DB46,06	A7 UNCER	C7 UNCER	E7 DB36,16
68 DB11	88 UNCER	A8 DB36	C8 DB31	E8 UNCER
69 DB30,10	89 DB45	A9 DB43,23	C9 UNCER	E9 DB42,22,02
6A DB30,10	8A DB04	AA UNCER	CA DB20,00	EA DB41,21,0
6B UNCER	8B DB29,09	AB UNCER	CB DB44,24,04	EB DB34,14
6C UNCER	8C DB29	AC UNCER	CC DB47,27	EC UNCER
6D DB59,39,19	8D DB59,39	AD UNCER	CD UNCER	ED DB39,19
6E UNCER	8E UNCER	AE UNCER	CE UNCER	EE DB50,30
6F UNCER	8F UNCER	AF DB45,05	CF UNCER	EF DB54,34,14
70 DB17	90 UNCER	B0 DB18	D0 DB40,20,00	F0 DB 58,18
71 DB51,11	91 DB22	B1 DB45,25	D1 DB51,31	F1 UNCER
72 DB46,26	92 DB10	B2 UNCER	D2 48,08	F2 DB15
73 UNCER	93 UNCER	B3 UNCER	D3 UNCER	F3 UNCER
74 UNCER	94 DB03	B4 UNCER	D4 UNCER	F4 UNCER
75 UNCER	95 UNCER	B5 UNCER	D5 DB55,35,15	F5 DB26,06
76 UNCER	96 UNCER	B6 DB48,28,08	D6 DB46,26,06	F6 DB21,01
77 DB48,28	97 DB45,25,05	B7 DB27,07	D7 UNCER	F7 DB56,36,16
78 DB42,02	98 DB20	B8 DB56,36	D8 UNCER	F8 DB30
79 UNCER	99 DB49,29	B9 DB51,31,11	D9 UNCER	F9 UNCER
7A UNCER	9A UNCER	BA UNCER	DA UNCER	FA DB55,15
7B DB47,07	9B UNCER	BB DB38,18	DB UNCER	FB DB58,38,18
7C DB50,30,10	9C UNCER	BC UNCER	DC UNCER	FC UNCER
7D UNCER	9D UNCER	BD DB42,22	DD DB35,15	FD DB47,27,0
7E DB37,17	9E DB49,29,09	BE DB43,03	DE DB41,01	FE UNCER
7F UNCER	9F UNCER	BF UNCER	DF UNCER	FF UNCER

FIG. 19B

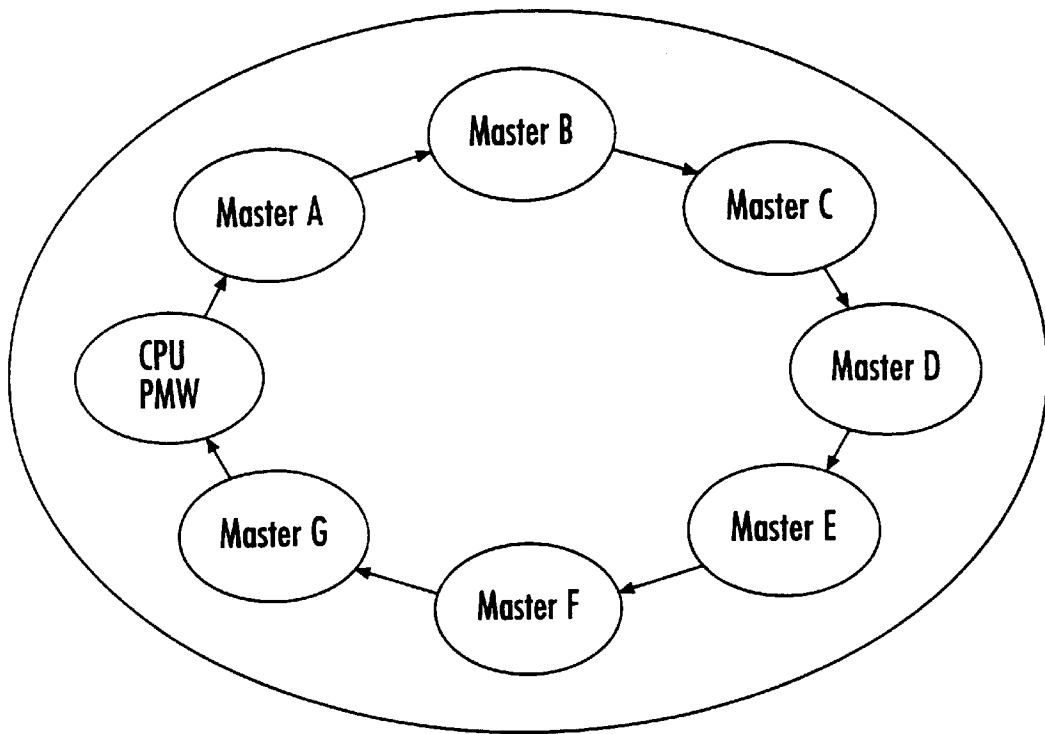

FIG. 20A

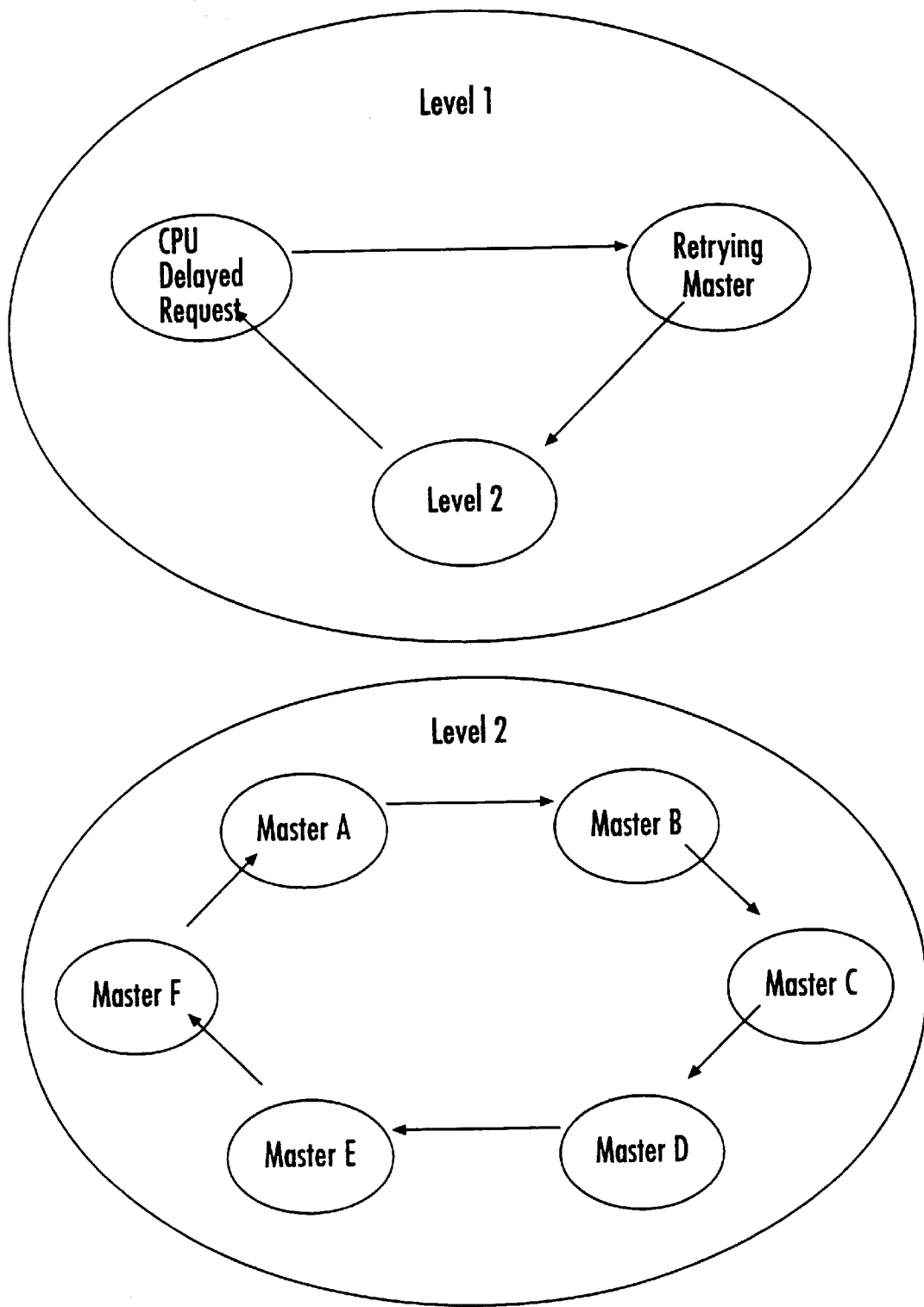

FIG 20B

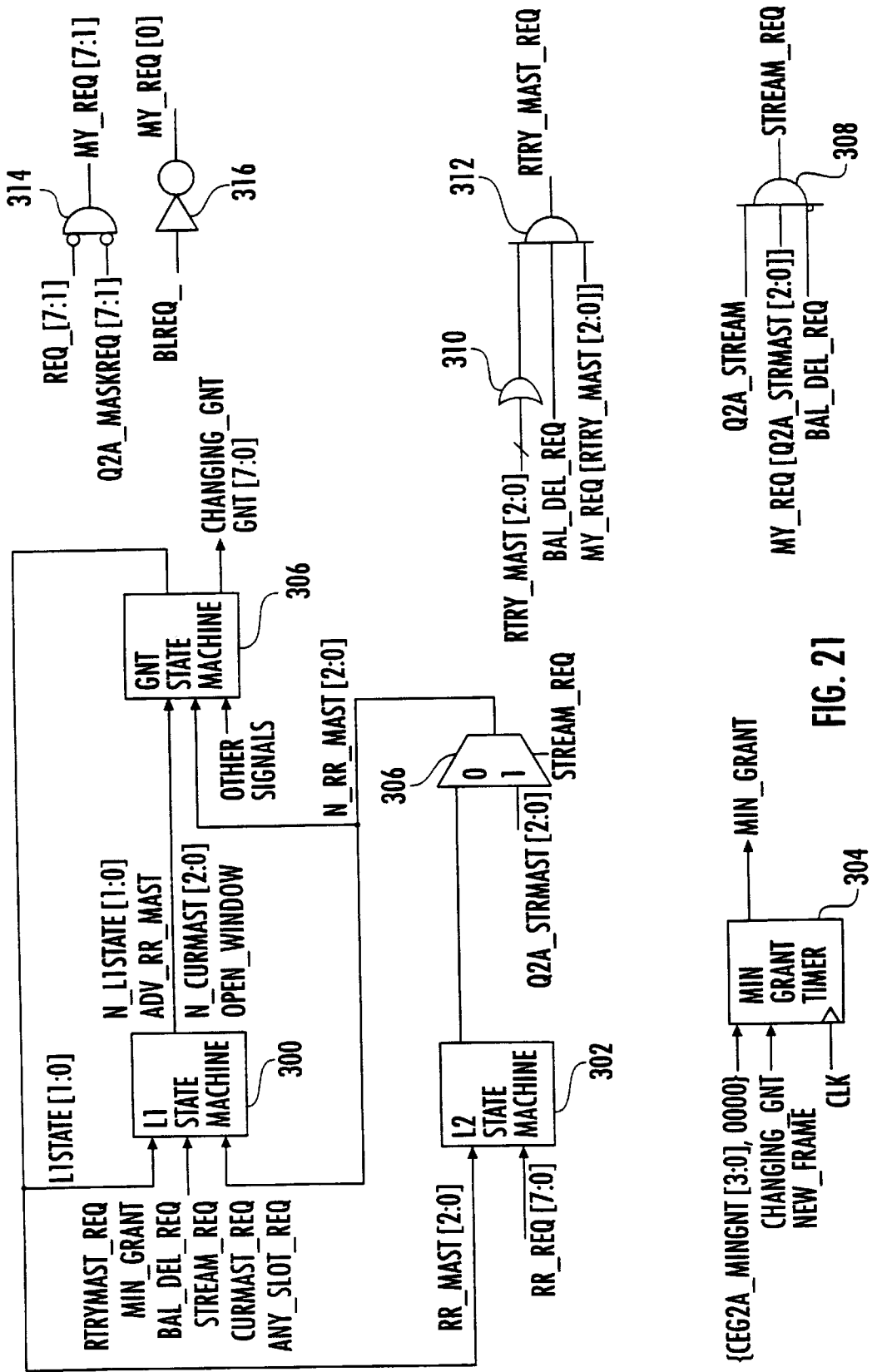

FIG. 21

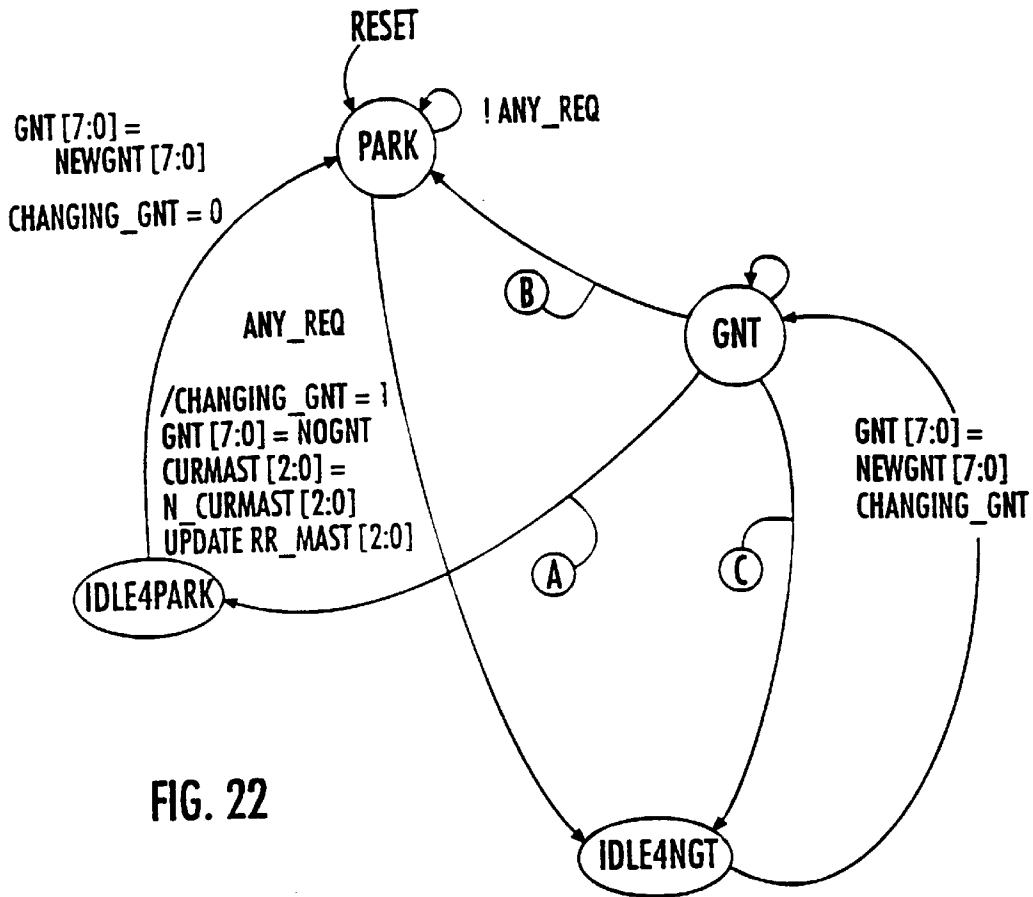
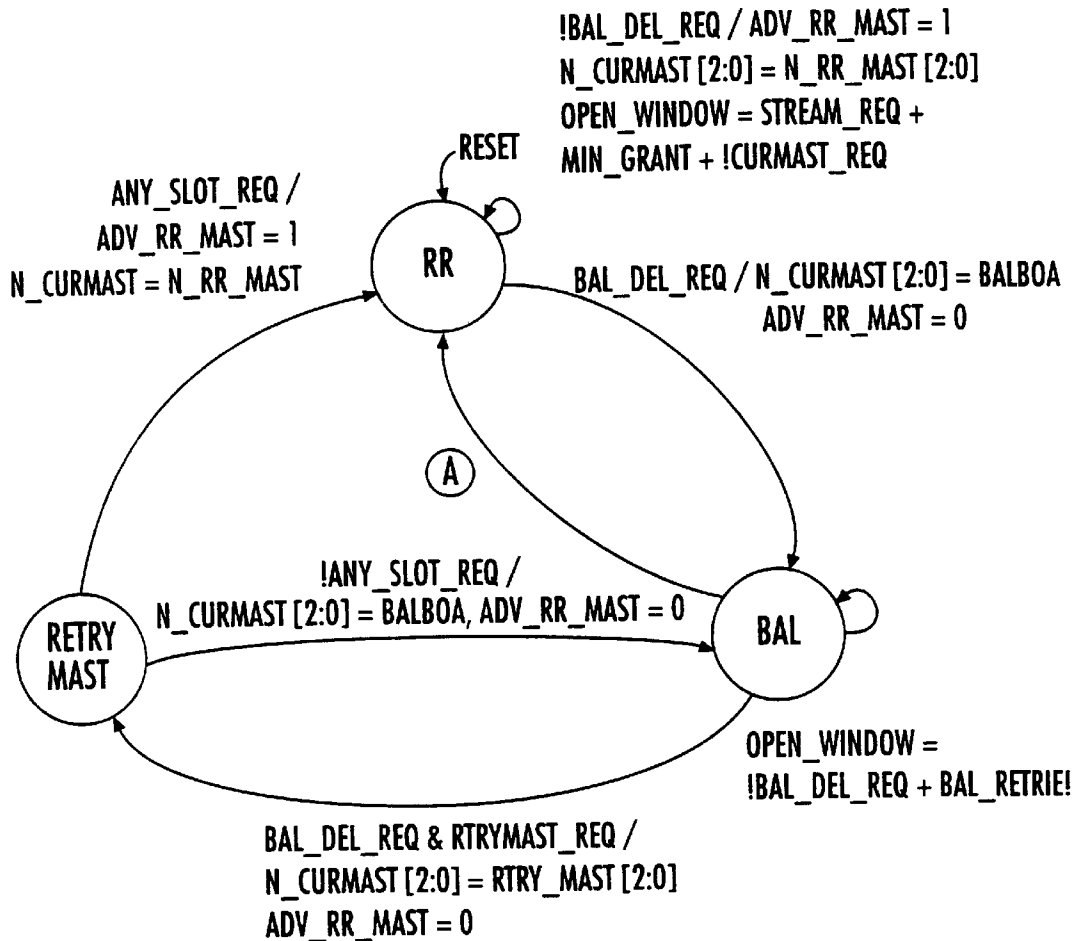

FIG. 22

- Ⓐ  $OPEN\_WINDOW \ \& \ !ANY\_REQ \ \& \ BUS\_IDLE \ \& \ (N\_CURMAST \neq CURMAST) \ / \ CHANGING\_GNT = 1$   
 $GNT[7:0] = NOGNT$   
 $CURMAST[2:0] = N\_CURMAST[2:0]$   
 $RR\_MAST[2:0] = N\_RR\_MAST[2:0]$   
 $L1STATE[1:0] = N\_L1STATE[1:0]$
- Ⓑ  $OPEN\_WINDOW \ \& \ !ANY\_REQ \ \& \ BUS\_IDLE \ \& \ (N\_CURMAST = CURMAST)$   
 $/L1STATE[1:0] = N\_L1STATE[1:0]$
- Ⓒ  $OPEN\_WINDOW \ \& \ (N\_CURMAST \neq CURMAST) \ / \ CHANGING\_GNT = 1$   
 $GNT[7:0] = NOGNT$   
 $CURMAST[2:0] = N\_CURMAST[2:0]$   
 $UPDATE \ RR\_MAST[2:0]$   
 $L1STATE[1:0] = N\_L1STATE[1:0]$



(A)  $!BAL\_DEL\_REQ +$   
 $BAL\_DEL\_REQ \& !RTRYMAST\_REQ$   
 $ANY\_SLOT\_REQ / ADV\_RR\_MAST = 1$   
 $N\_CURMAST[2:0] = N\_RR\_MAST[2:0]$

FIG. 23

CURMAST [2:0]	NEWGNT [7:0]
0	00000001
1	00000010
2	00000100
3	00001000
4	00010000
5	00100000
6	01000000
7	10000000

FIG. 24



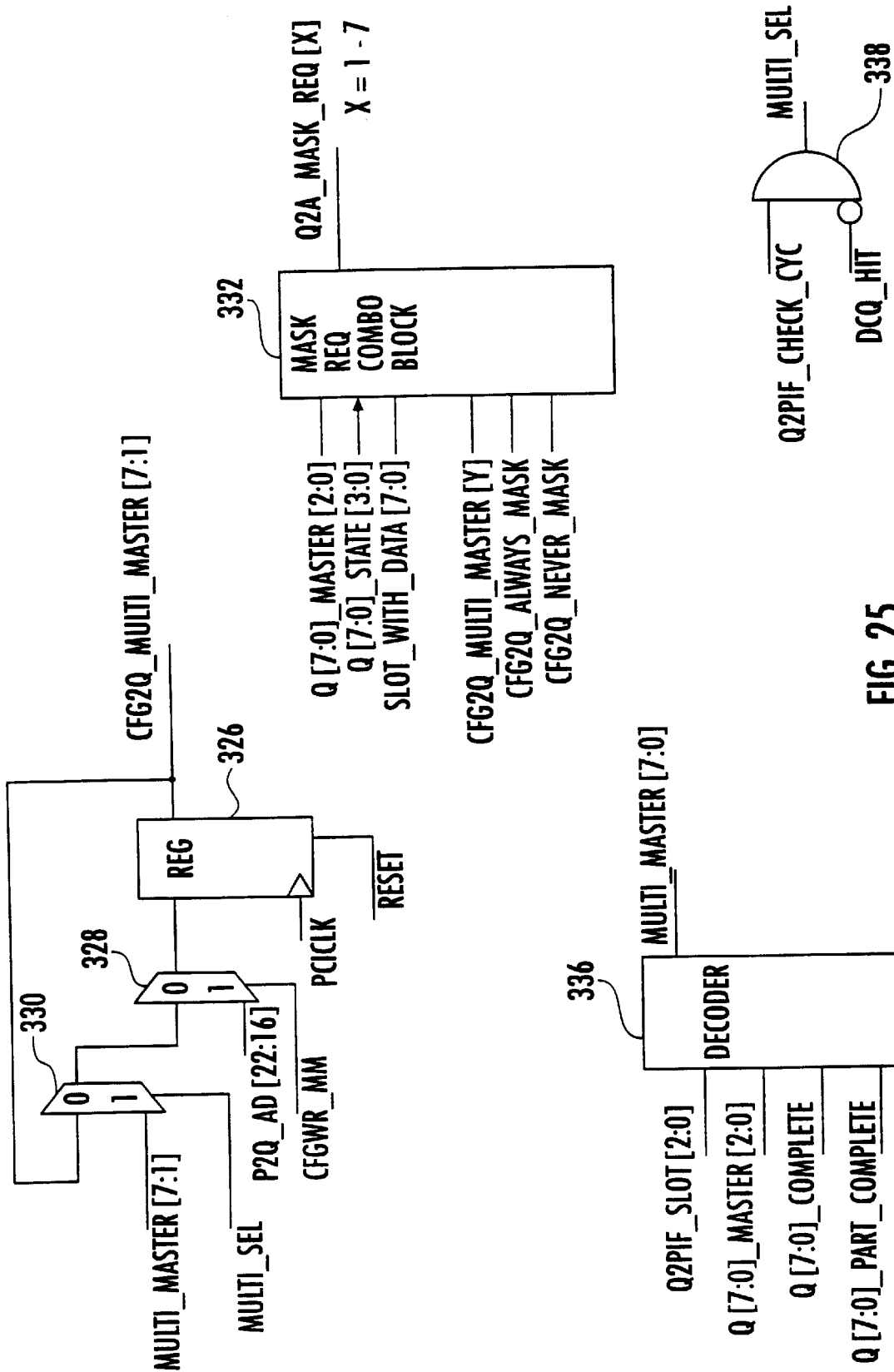

FIG. 25

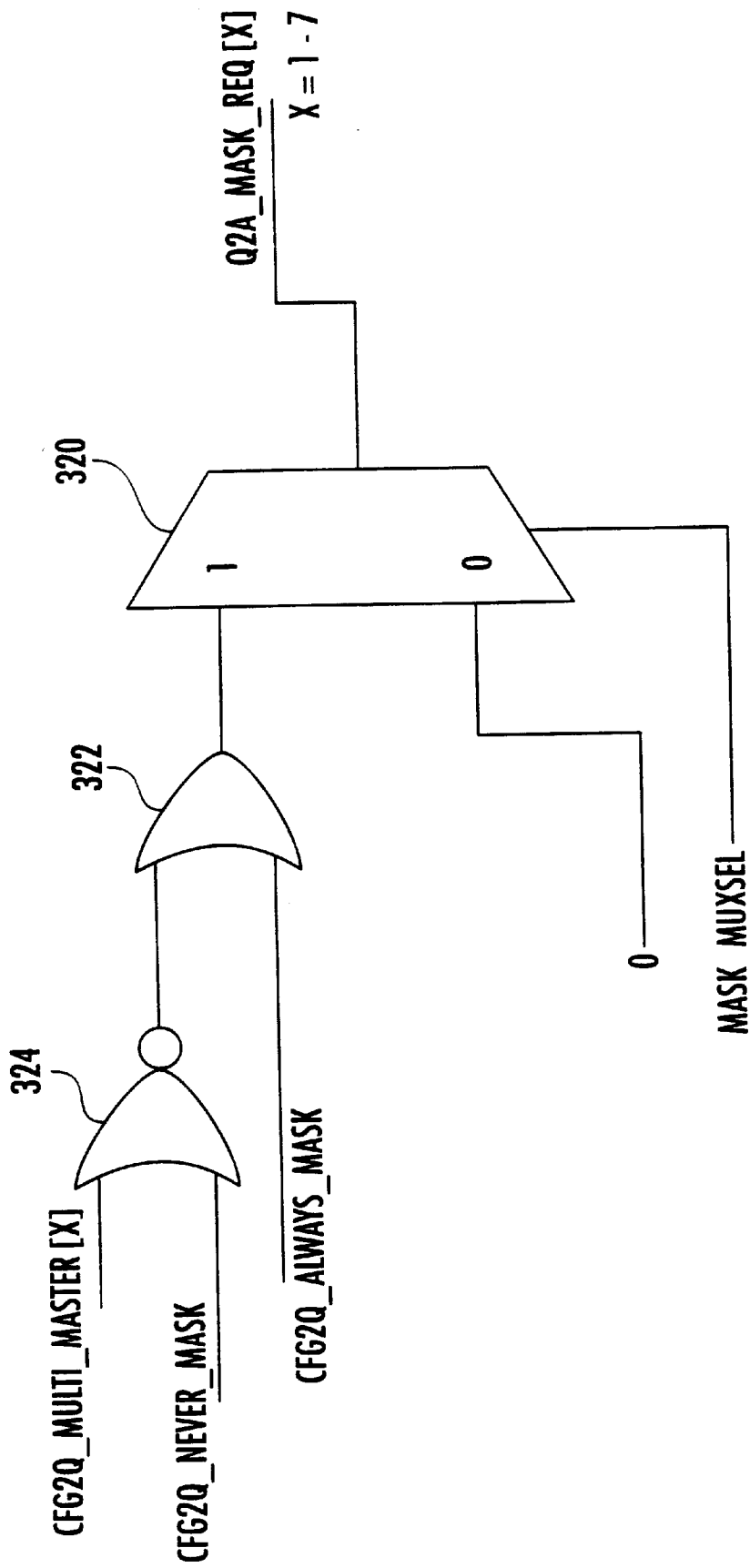

FIG. 26A

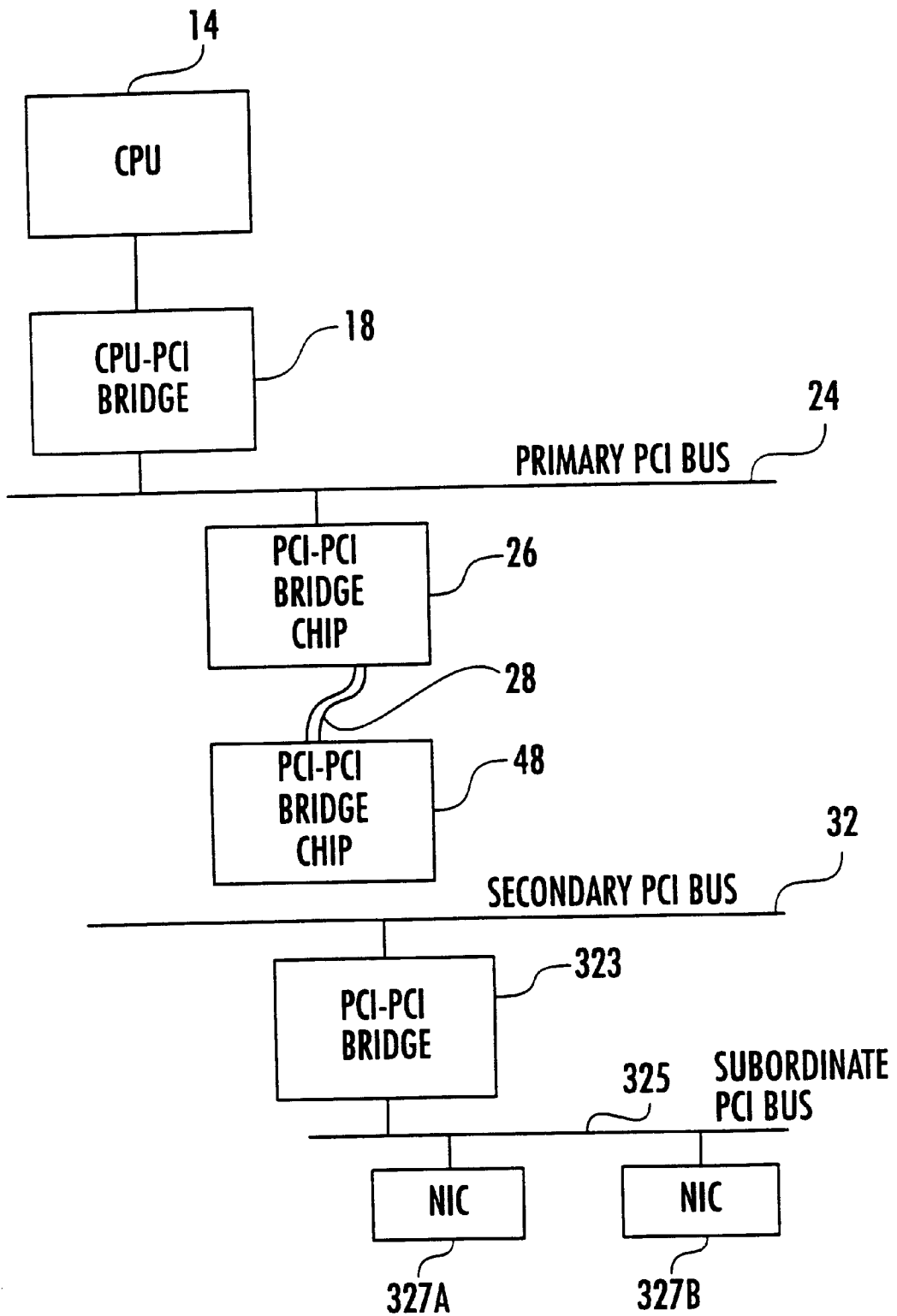
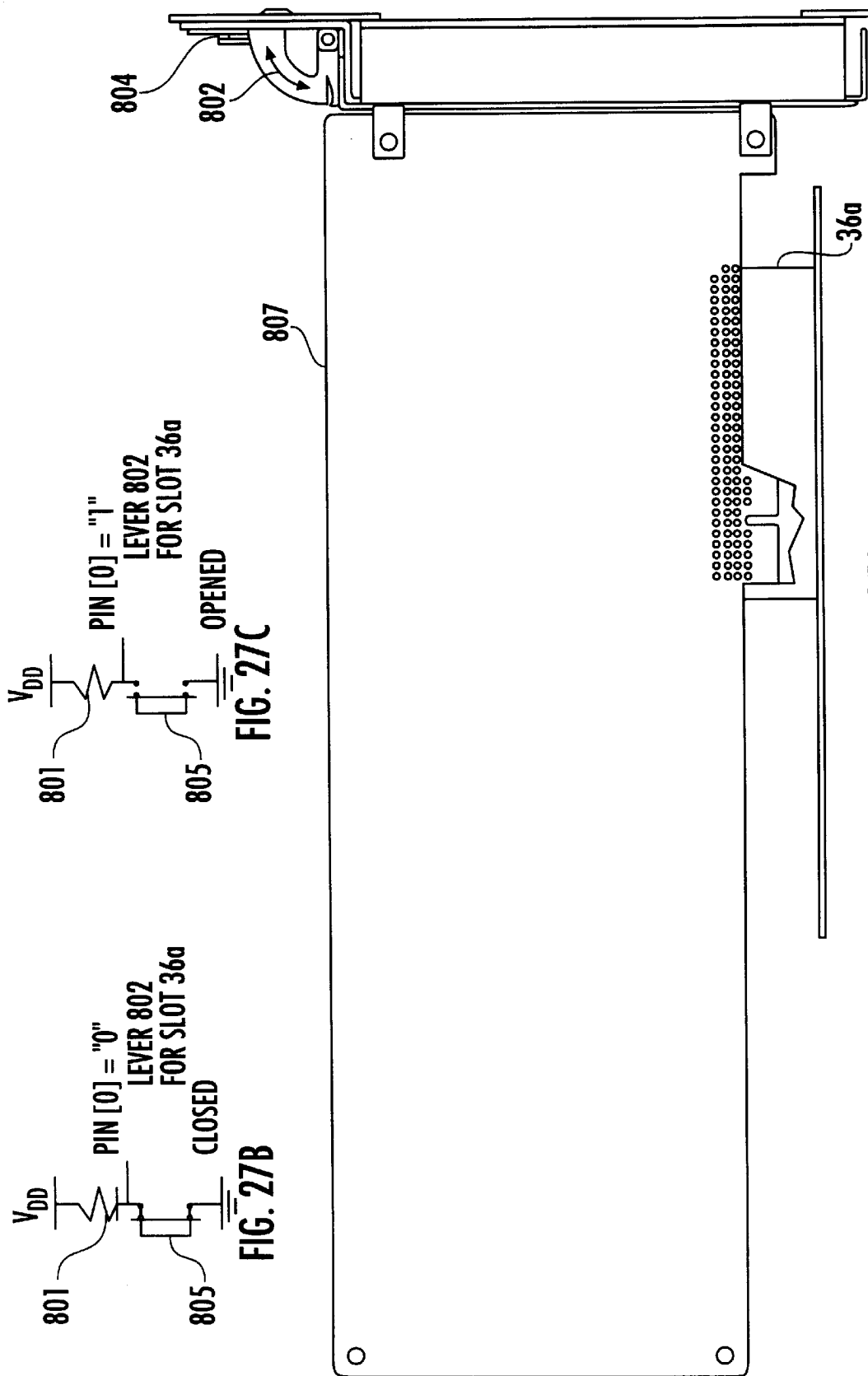

FIG. 26B



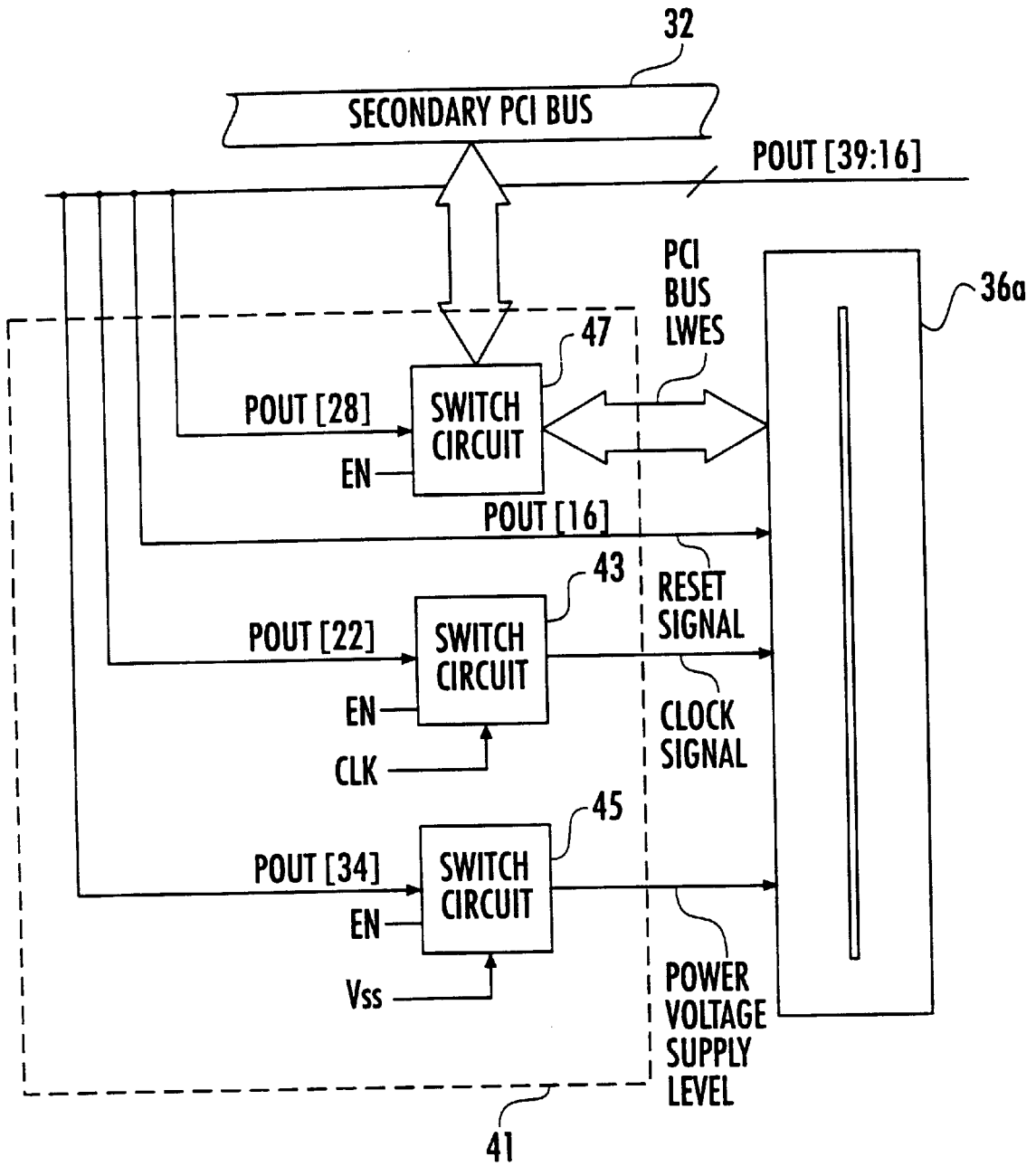

FIG. 28

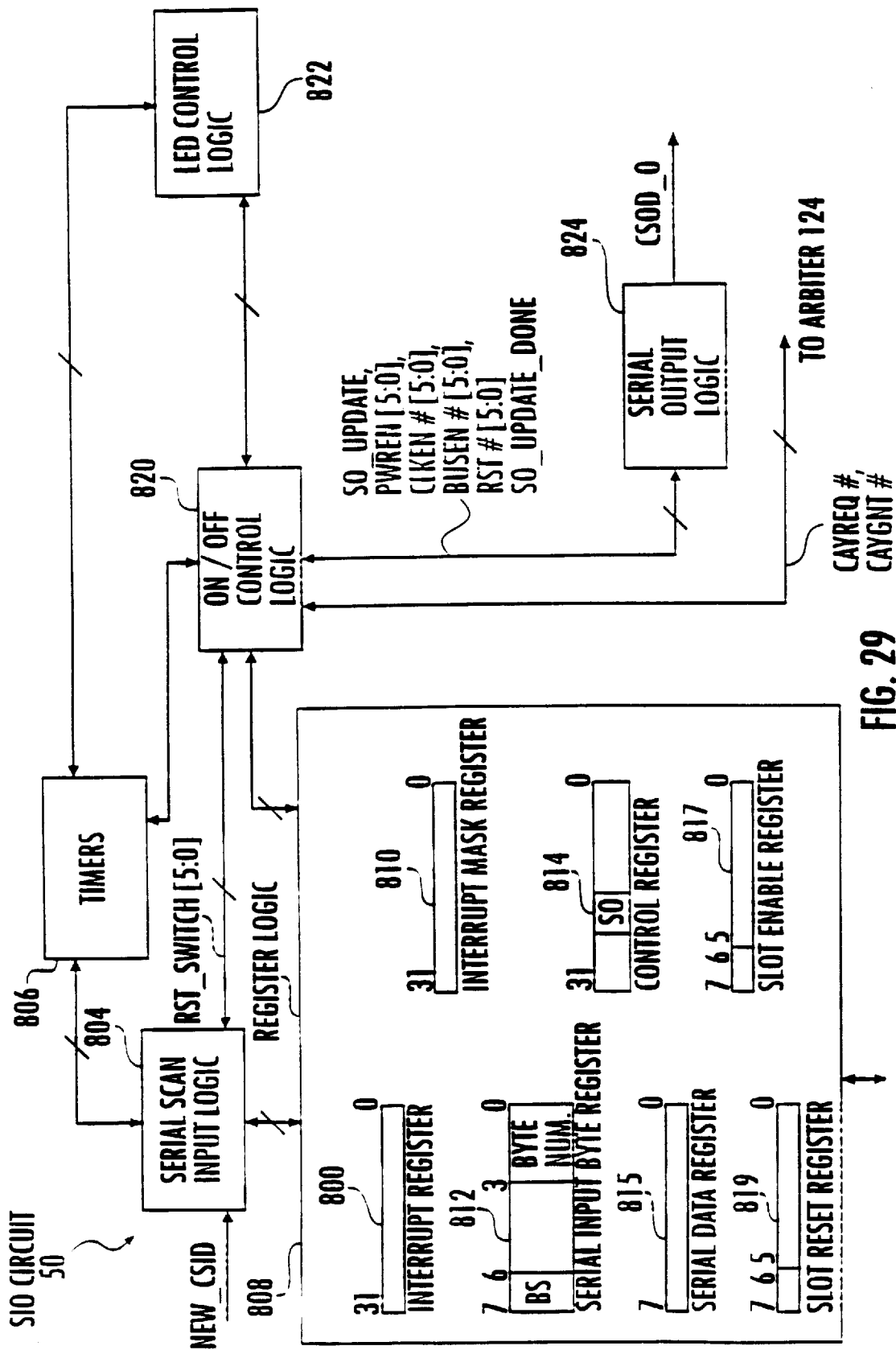

FIG. 29

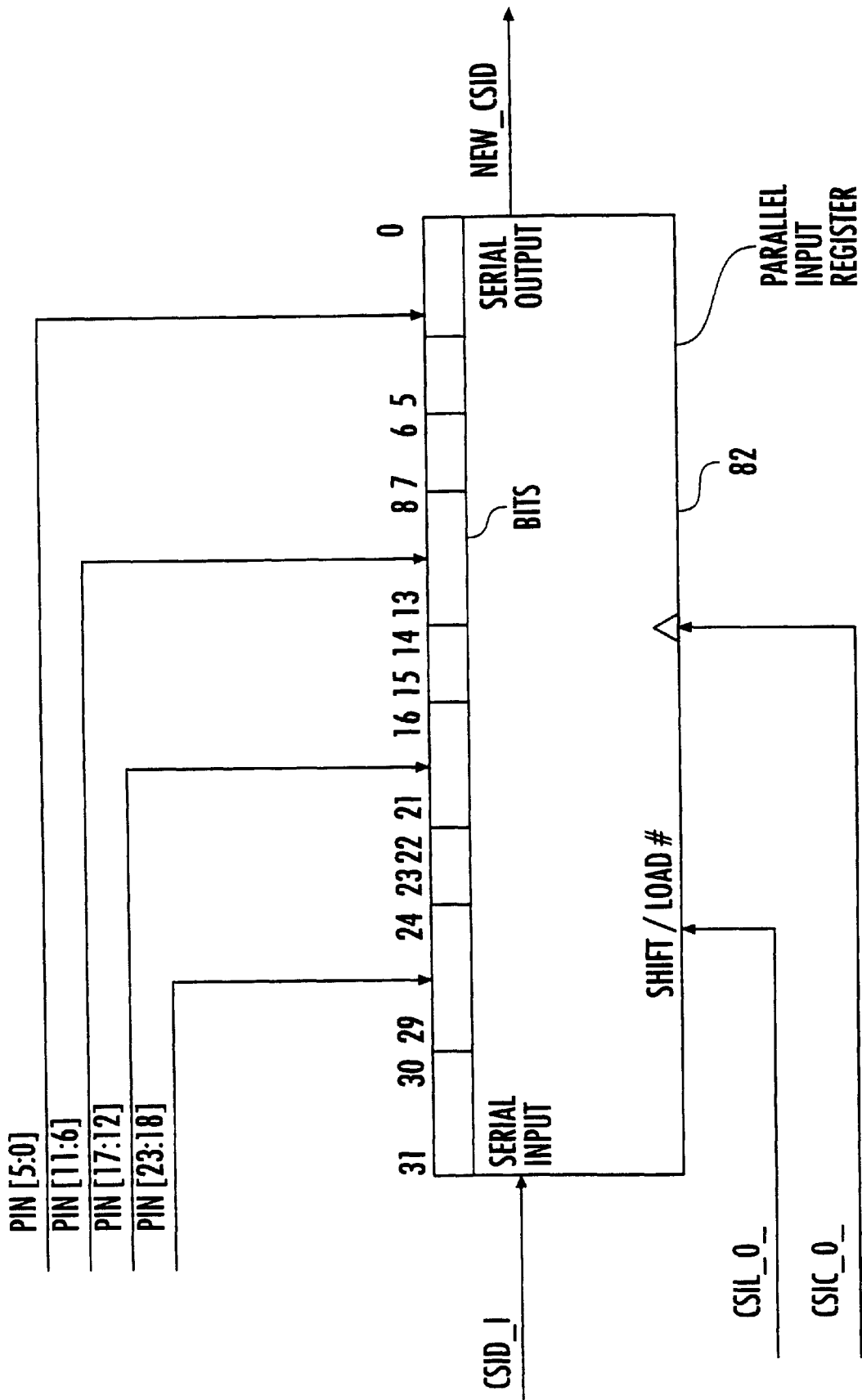

FIG. 30

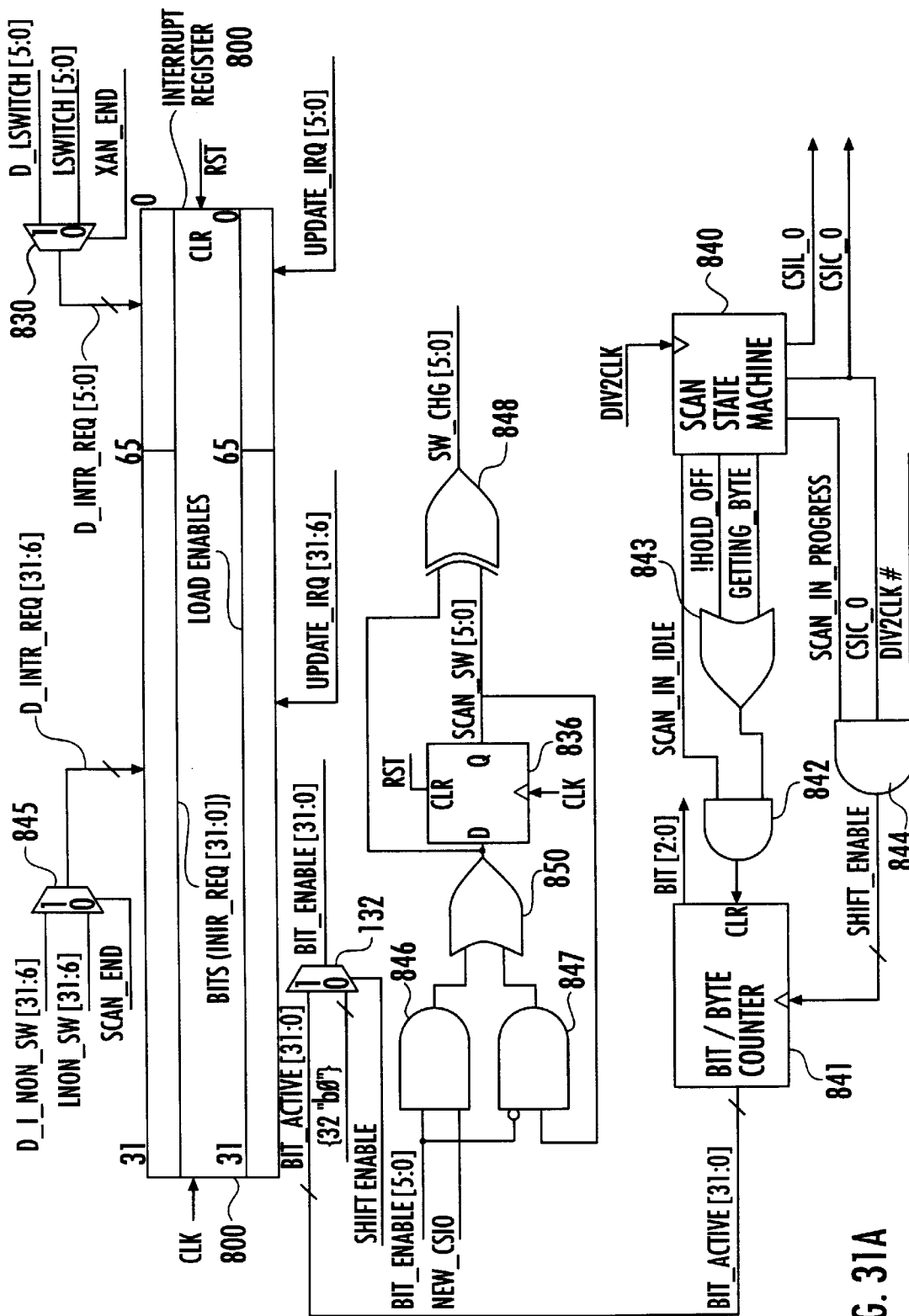

FIG. 31A





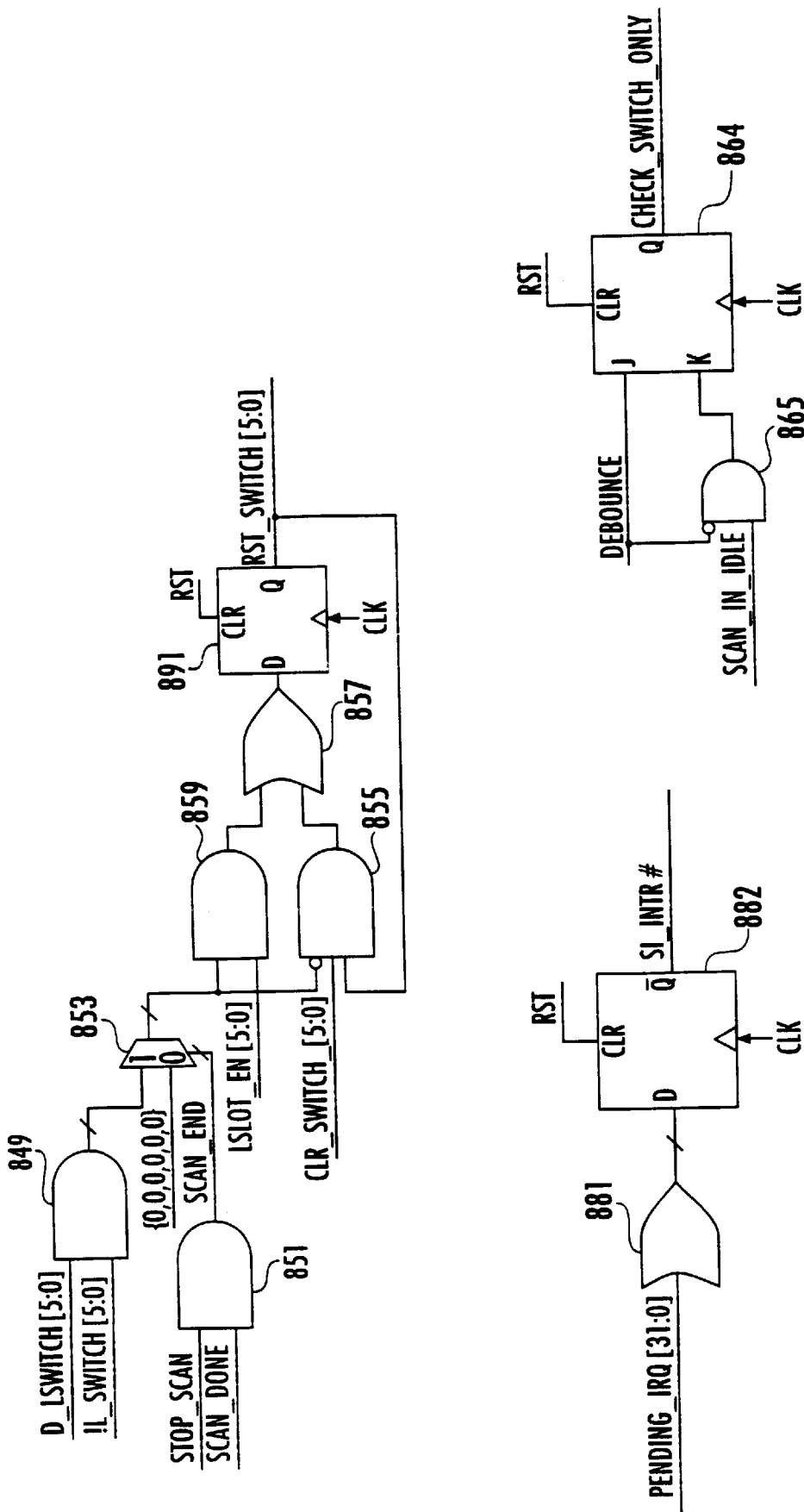

FIG. 31B2

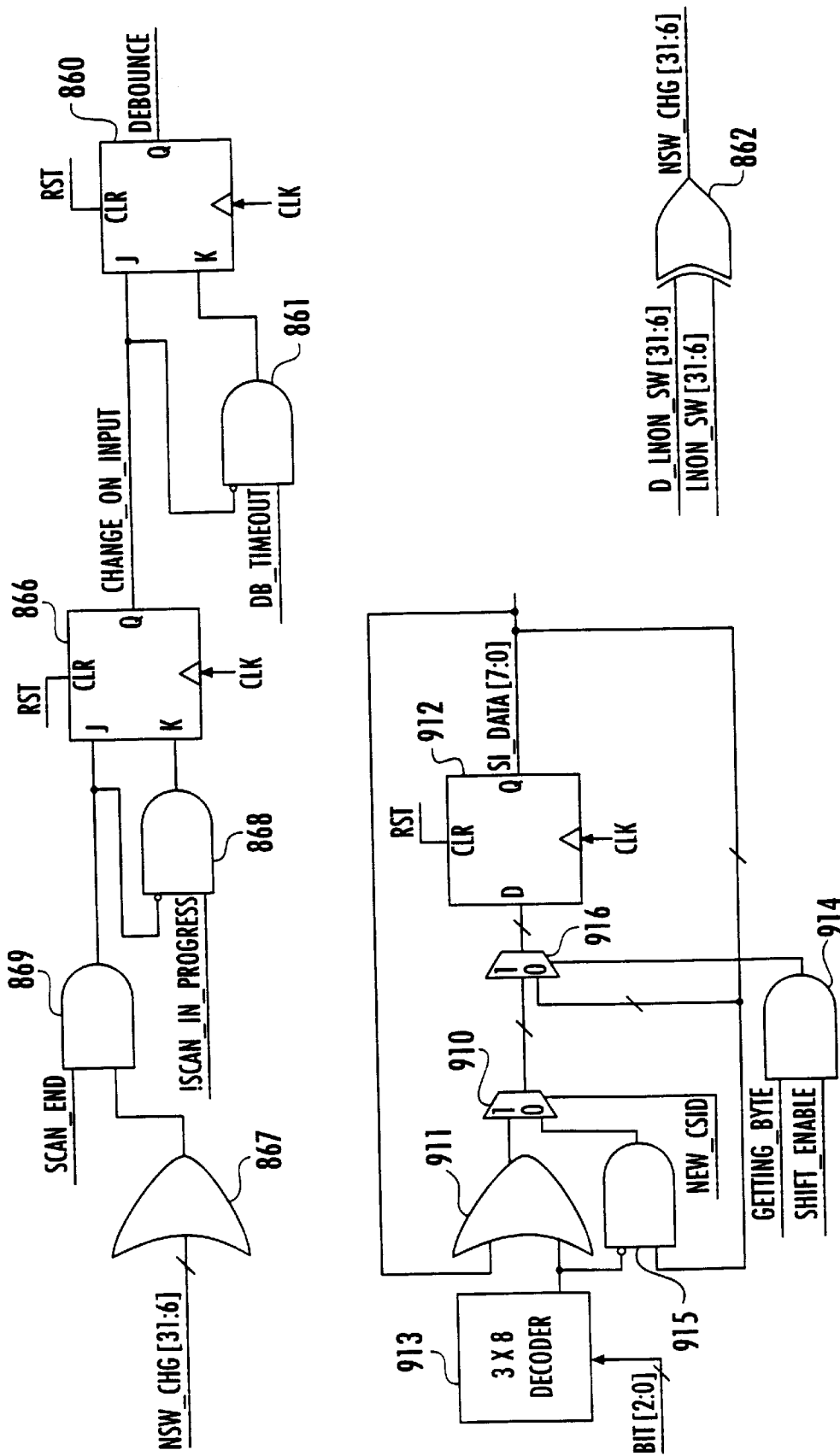

FIG. 31C

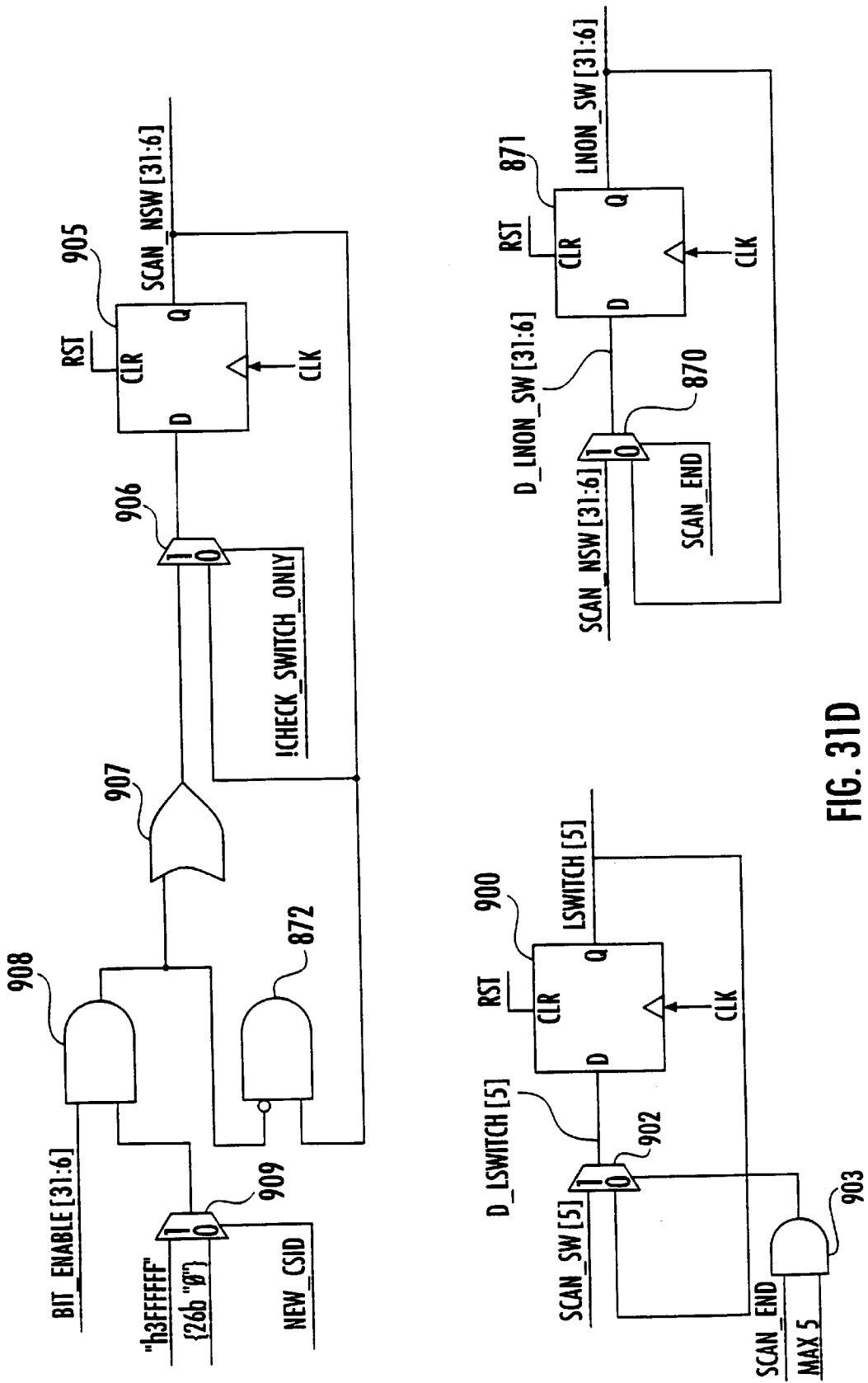

FIG. 31D

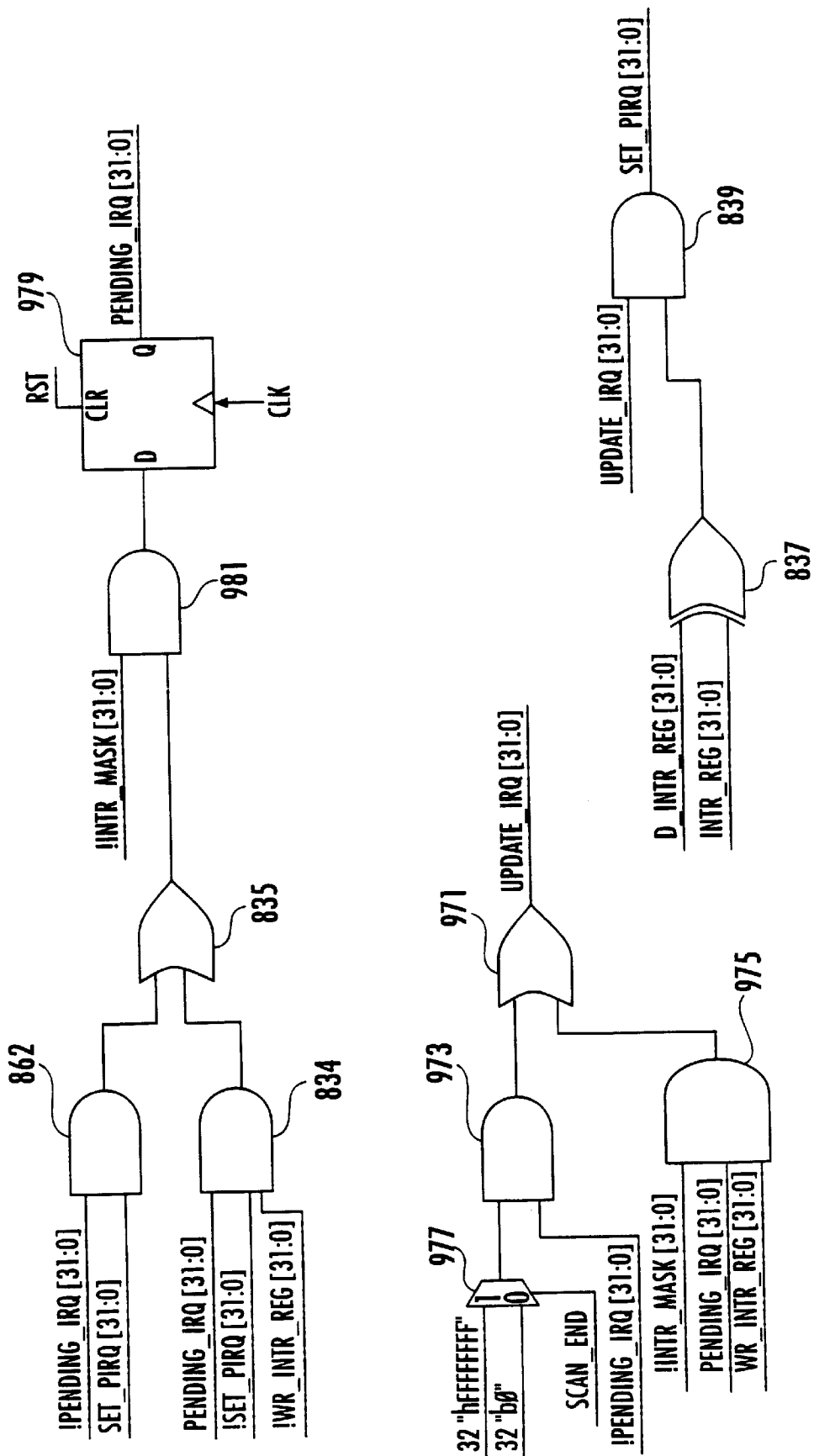
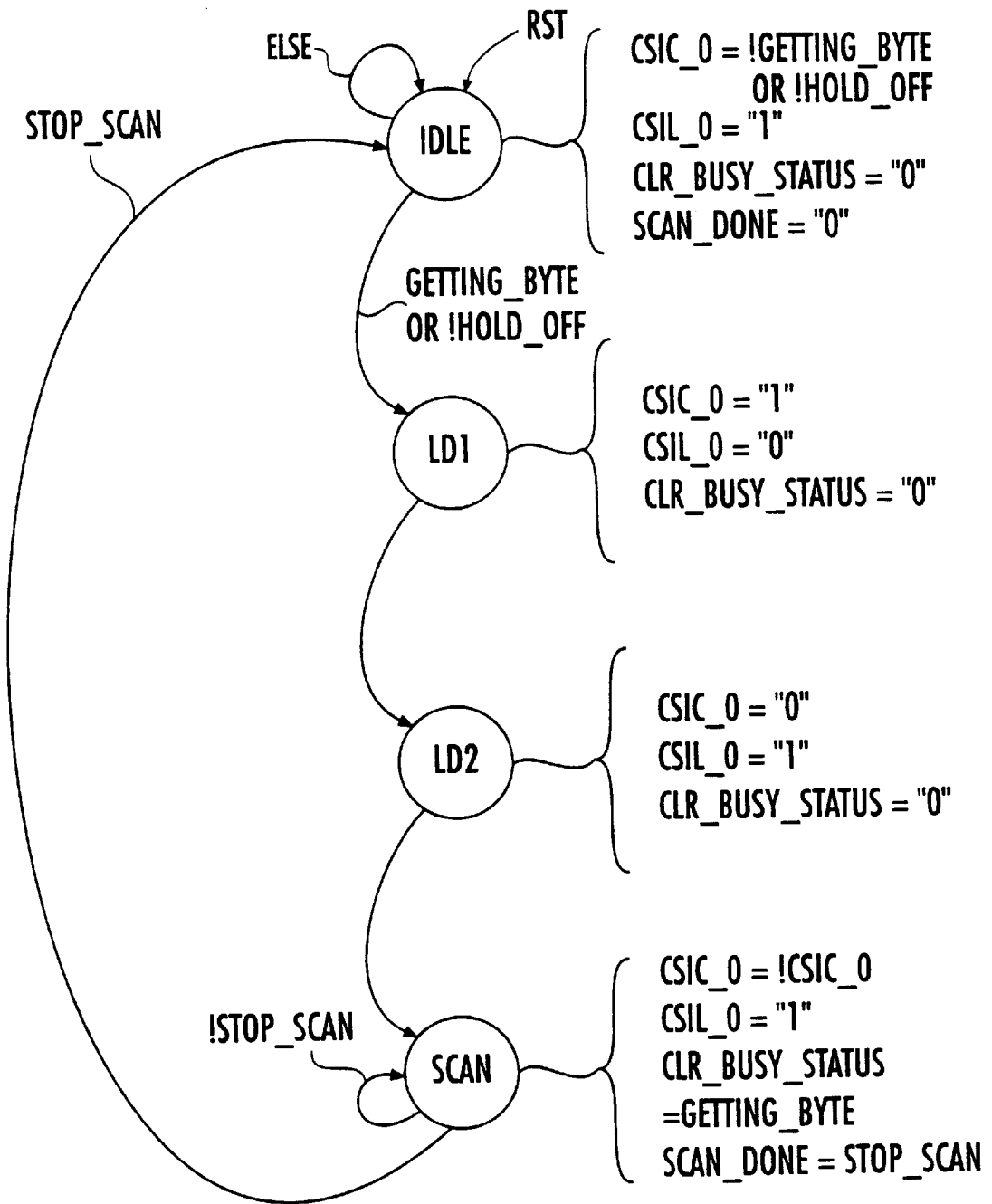

FIG. 31E



$$\begin{aligned}
 \text{STOP\_SCAN} = & (\text{BYTE\_PTR\_EQUAL\_CNT} \& \text{GETTING\_BYTE}) \text{ OR } ((\text{BYTE}[1] \& \\
 & \text{BIT}[0] \& \text{CHECK\_SWITCH\_ONLY}) \text{ OR } (\text{BYTE}[4] \& \text{BIT}[0] \\
 & \& \text{!CHECK\_SWITCH\_ONLY})) \& \text{!GETTING\_BYTE}
 \end{aligned}$$

FIG. 32A

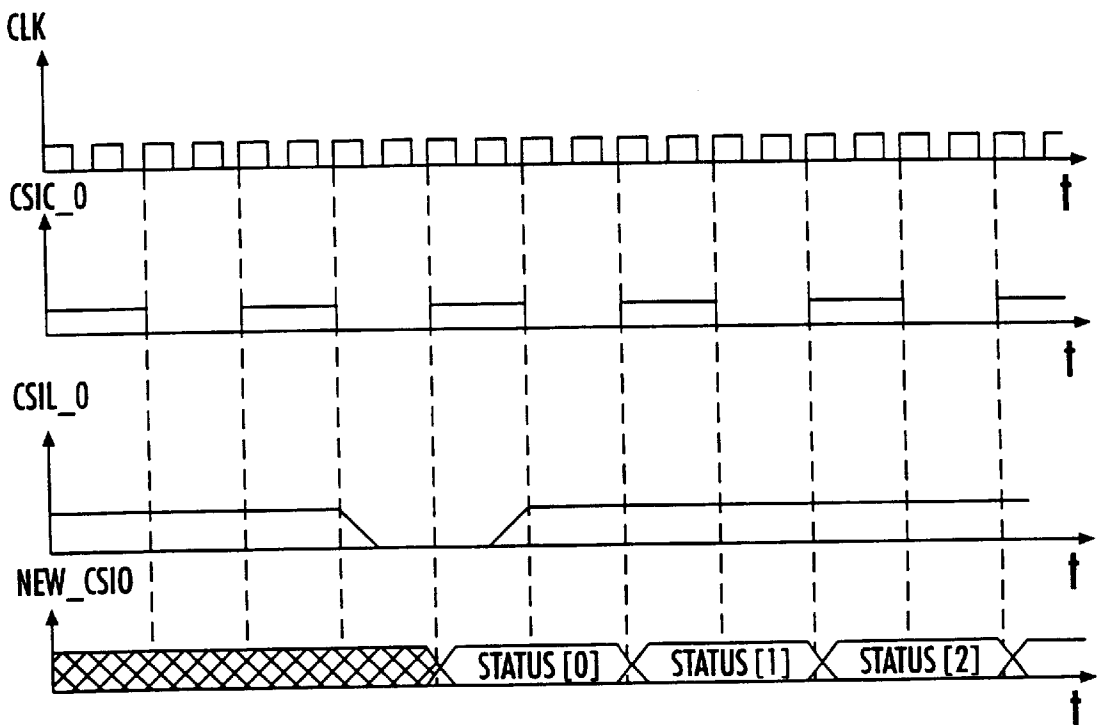

FIG. 32B

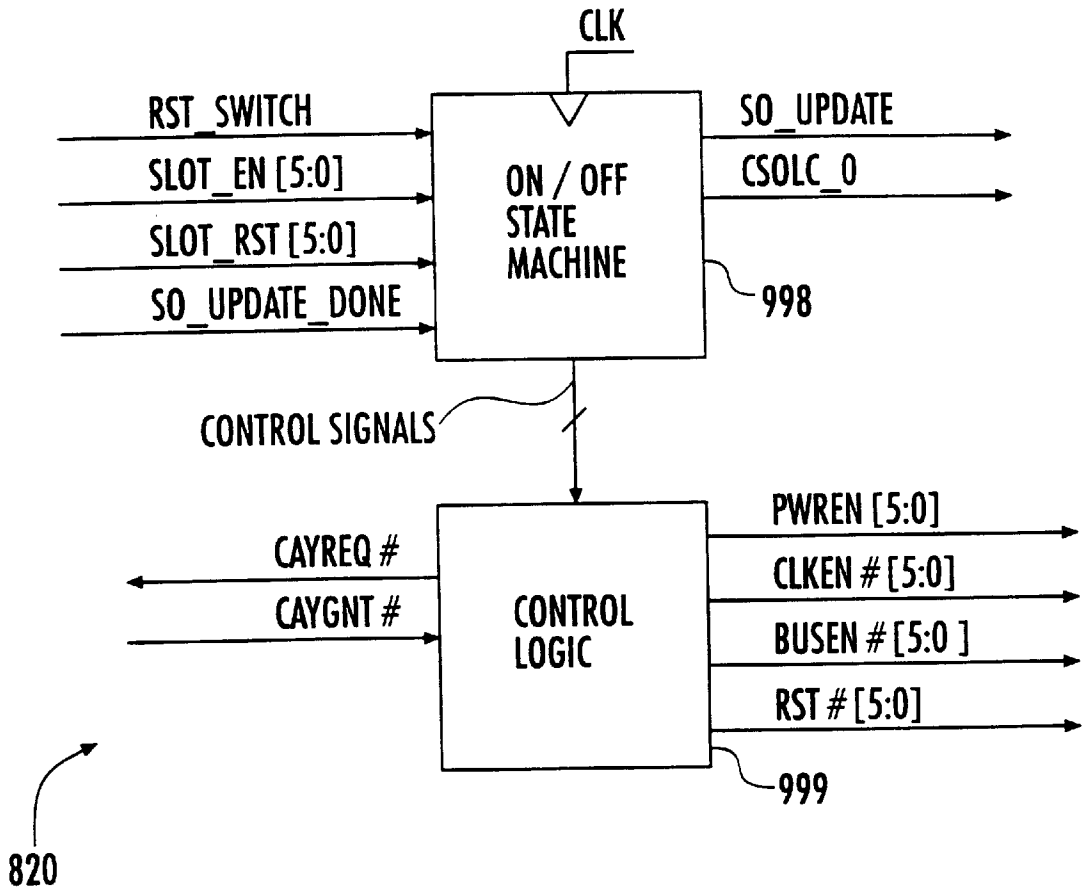

FIG. 33A



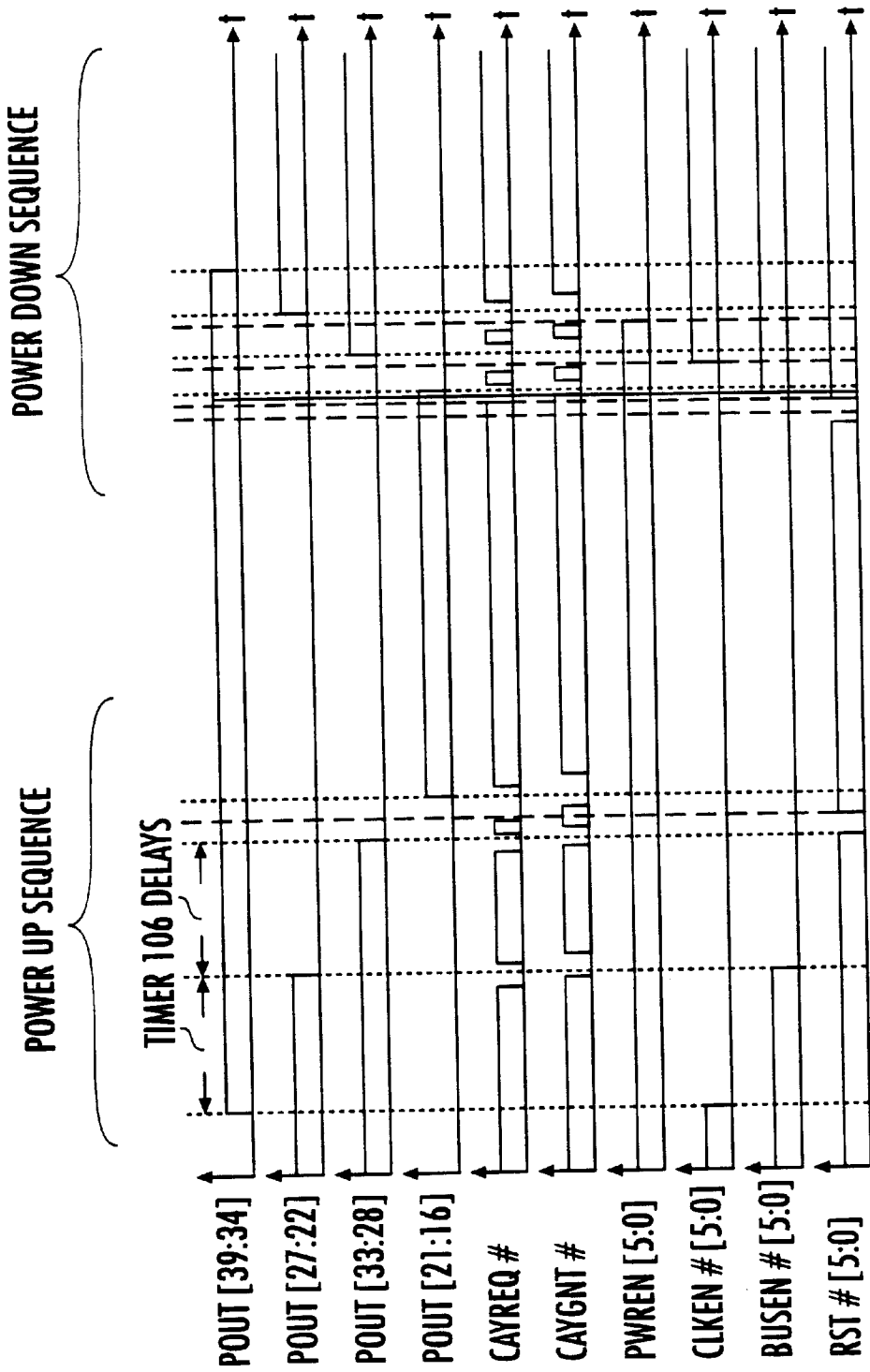

FIG. 33B

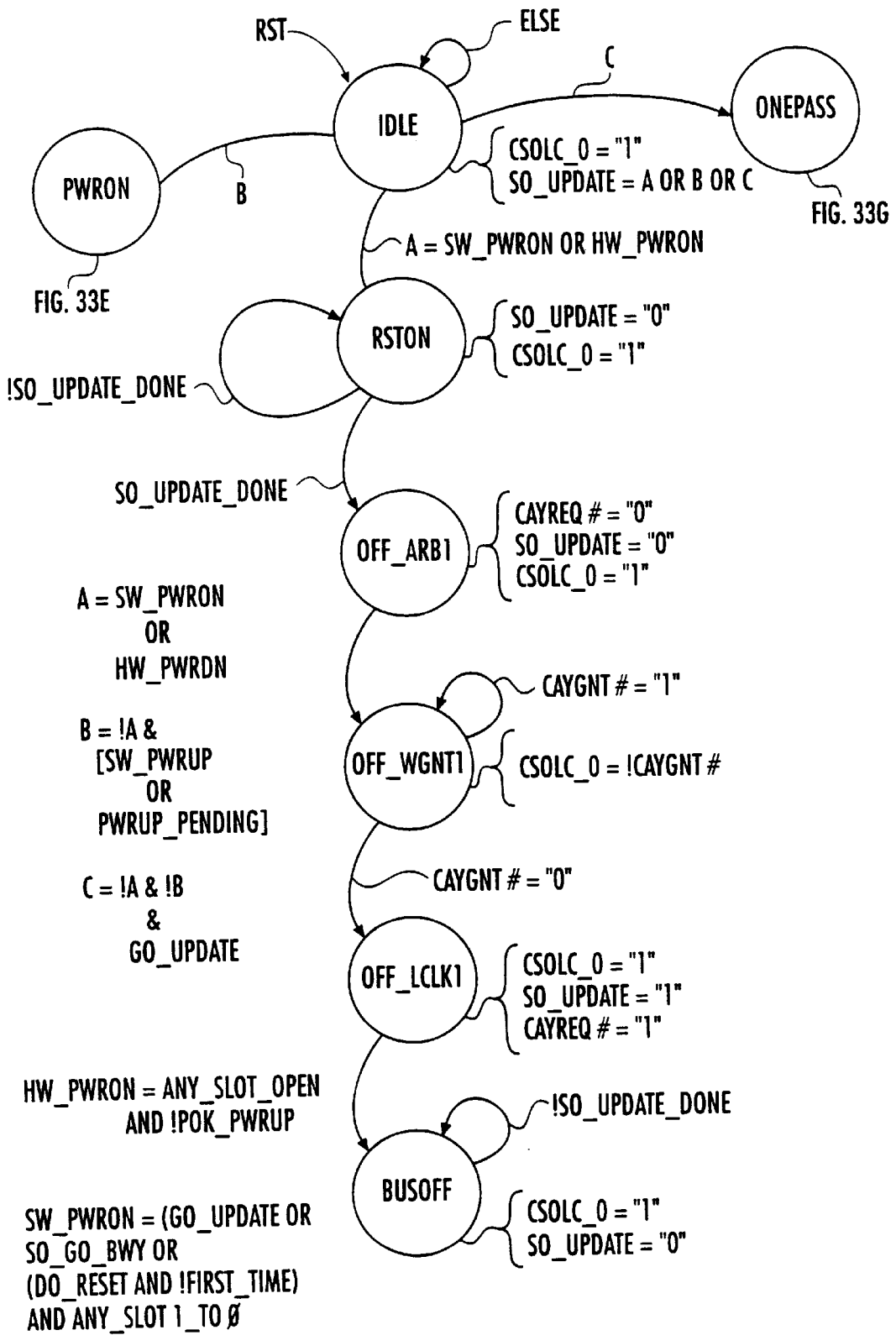

FIG. 33C

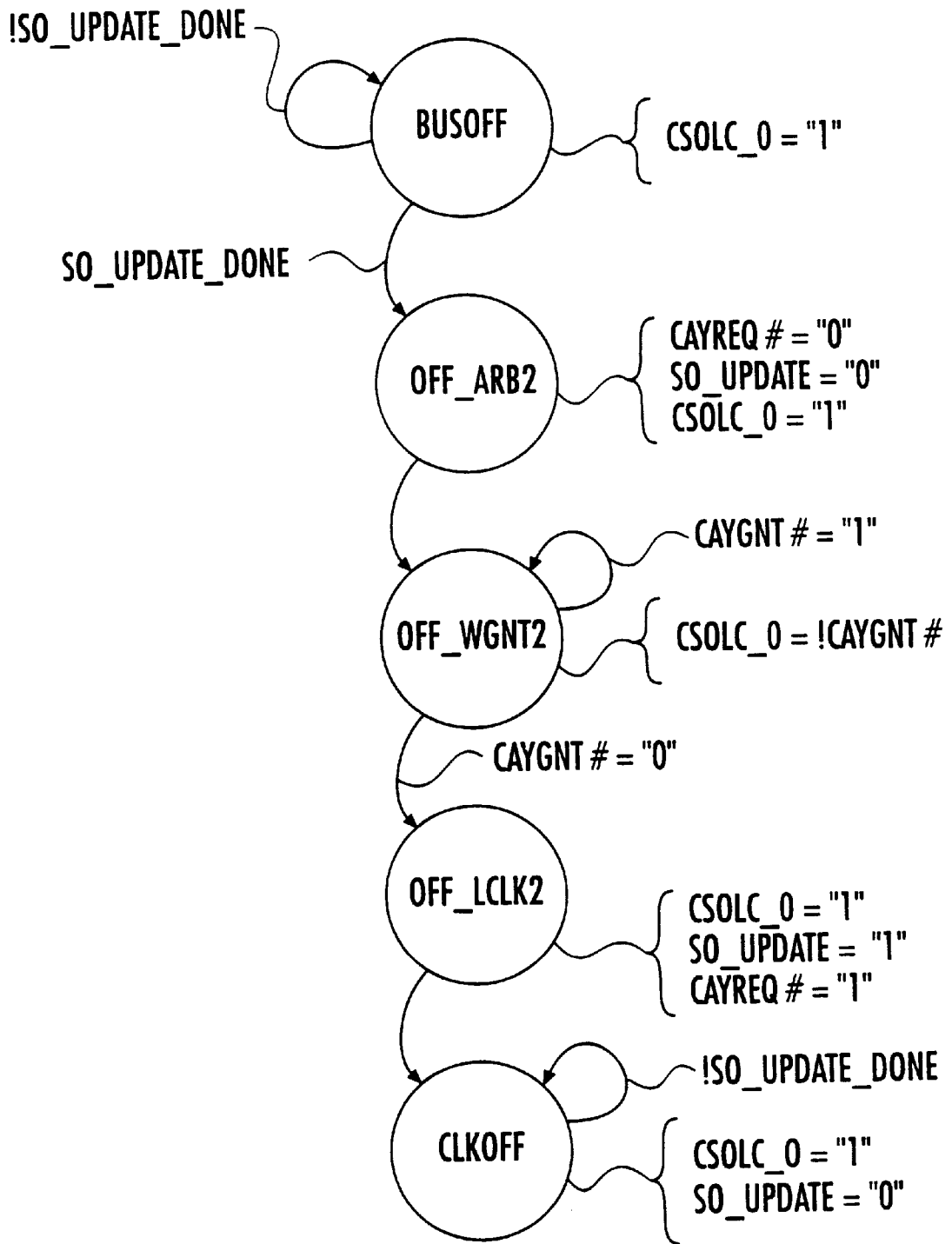

FIG. 33D

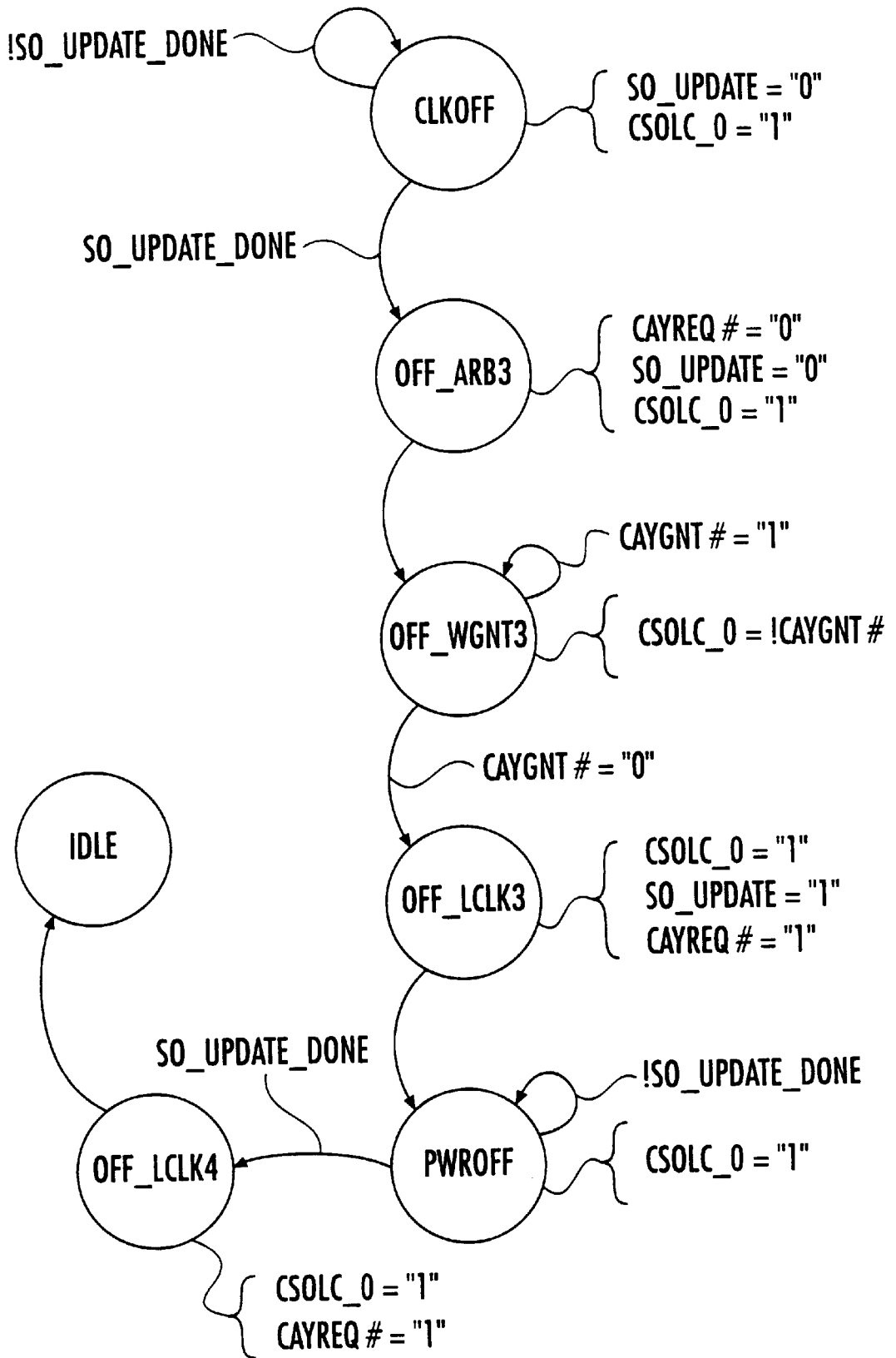

FIG. 33E

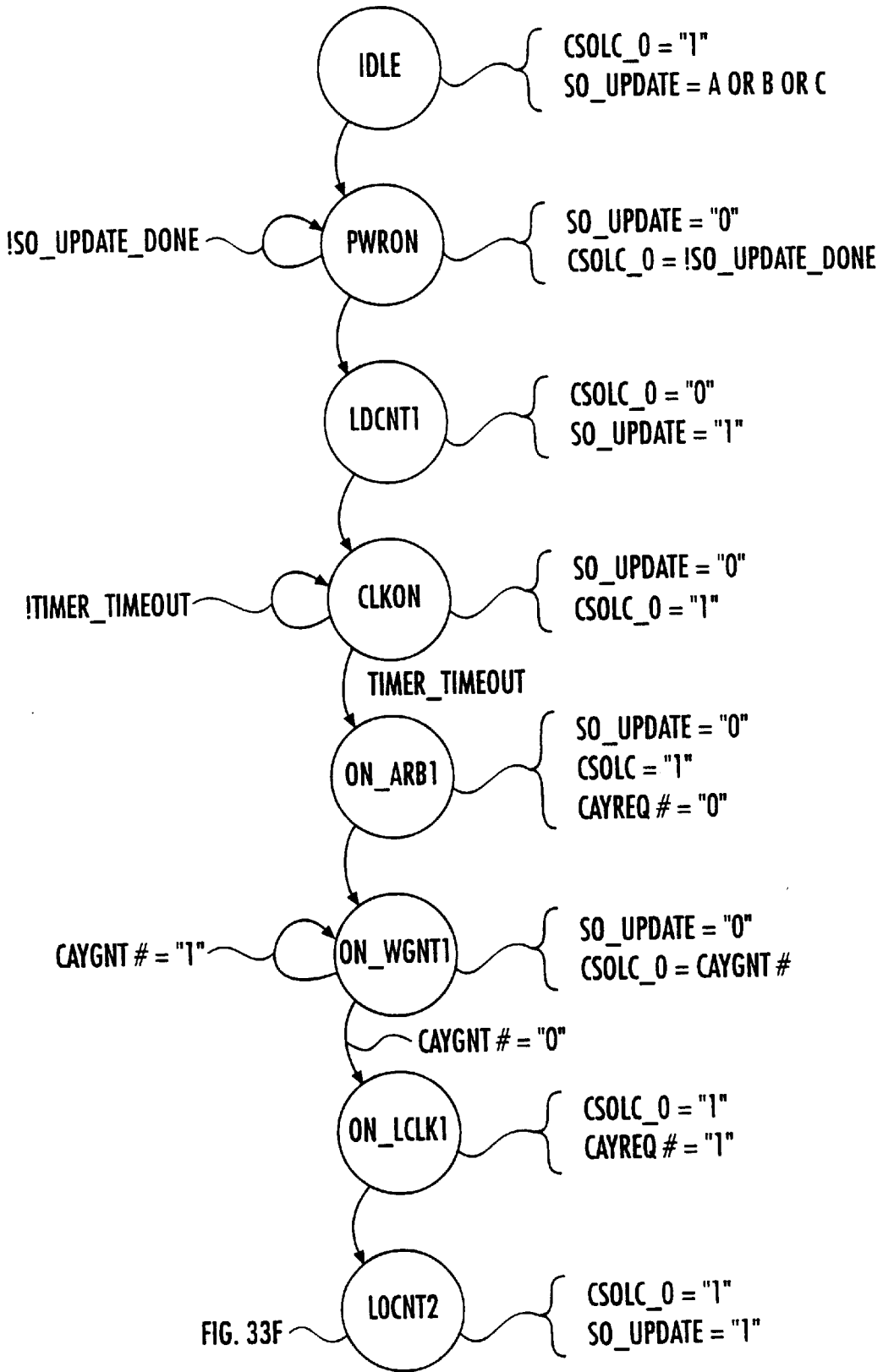

FIG. 33F

FIG. 33F

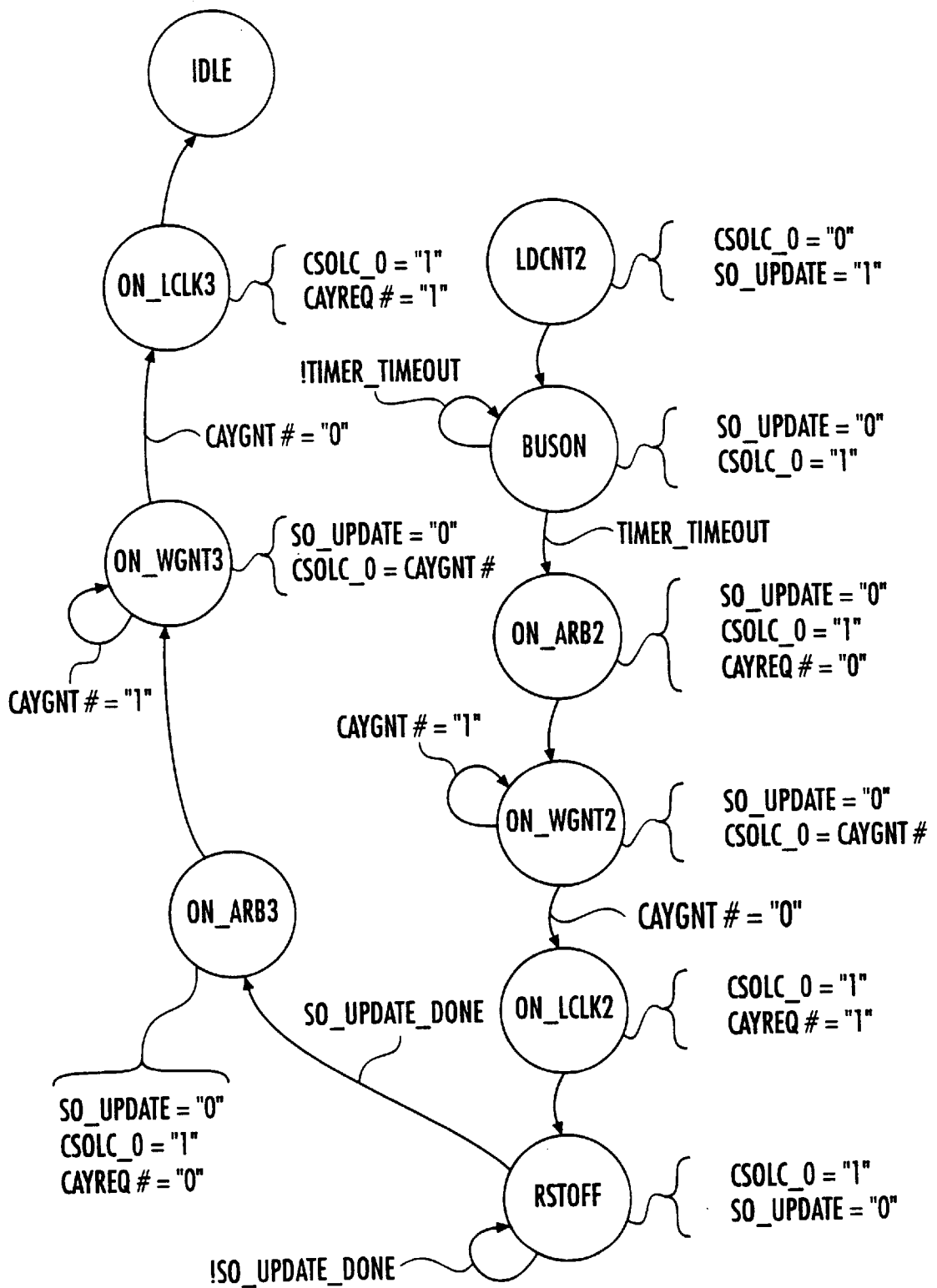

FIG. 33G

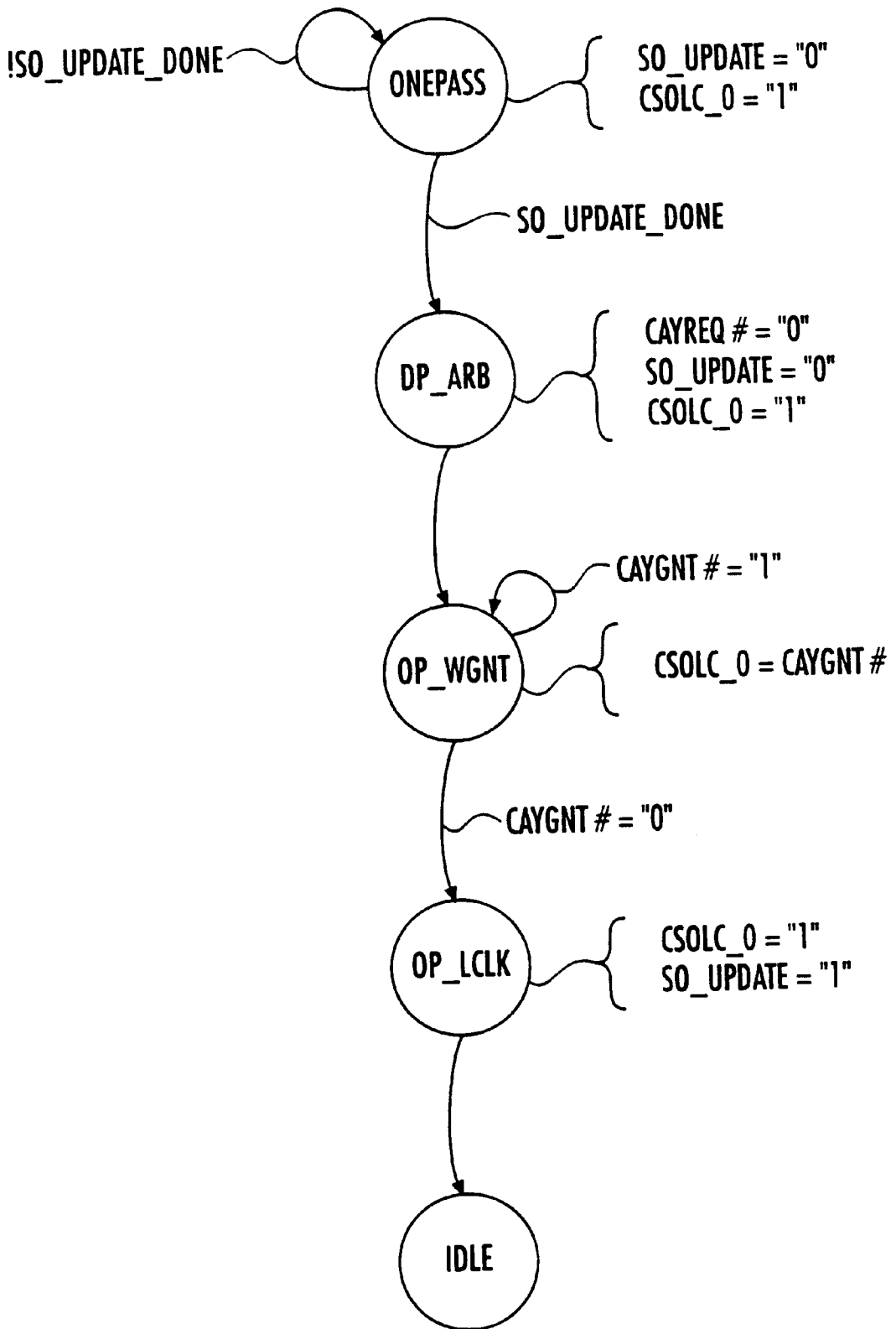

FIG. 33H

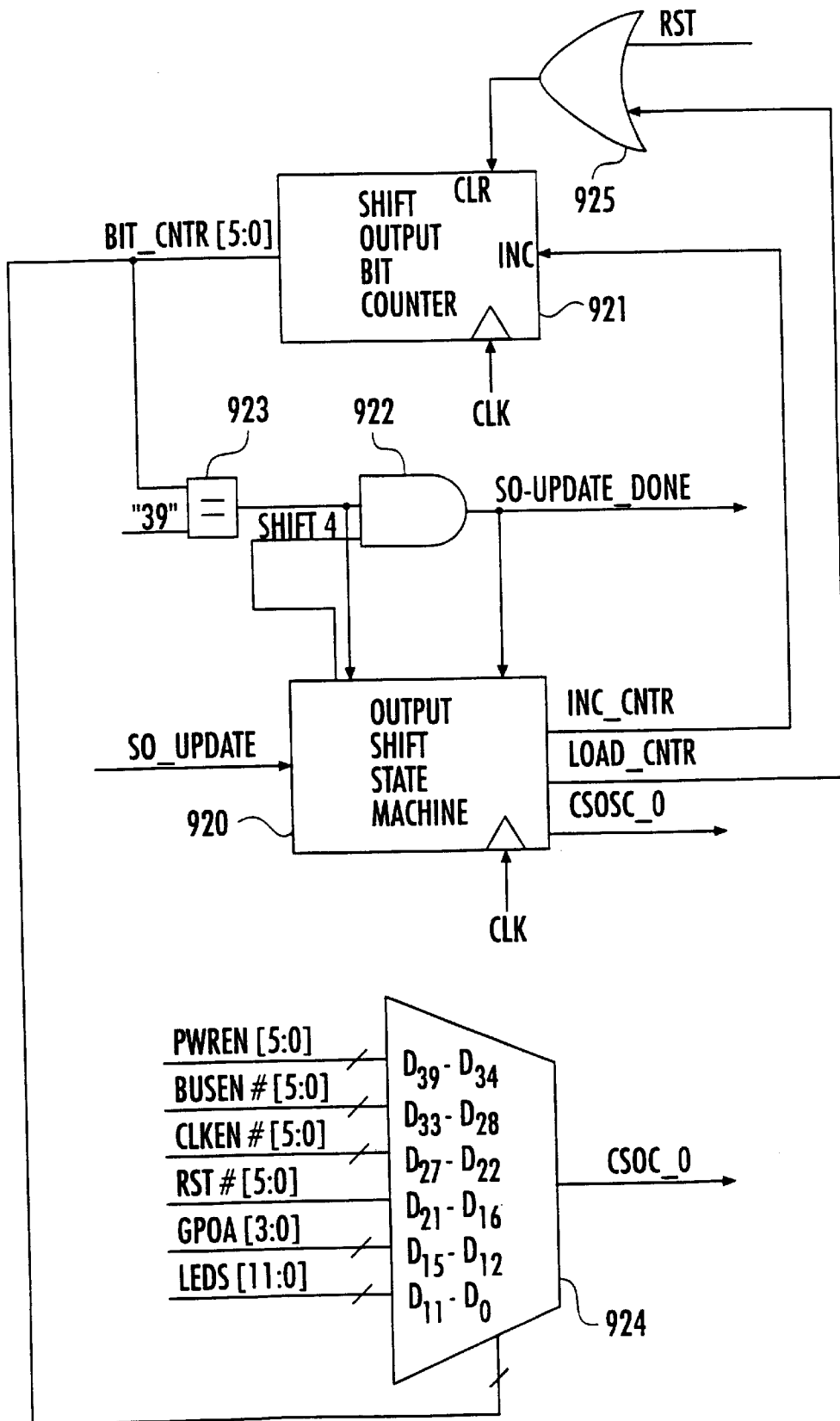

FIG. 34



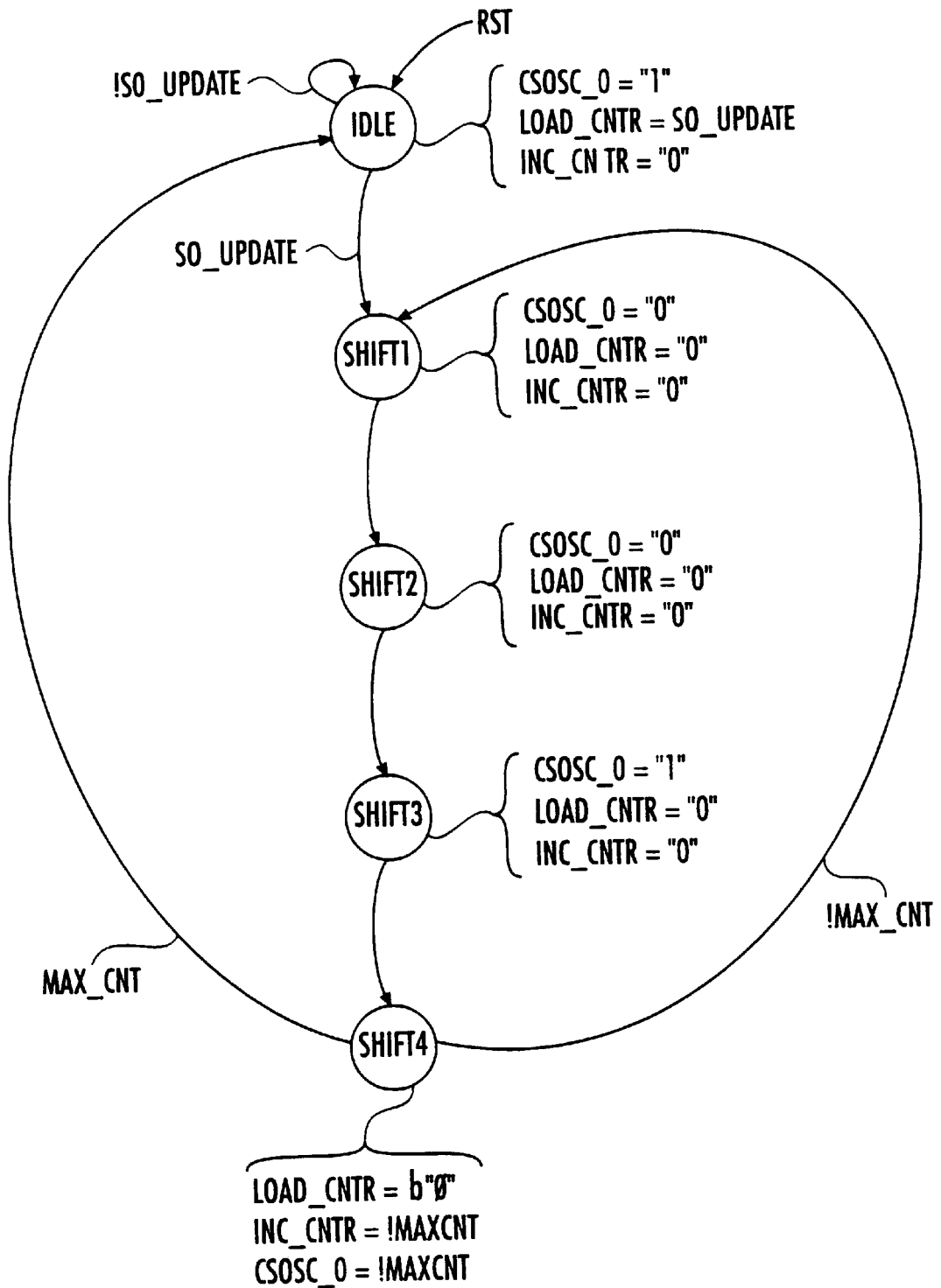

FIG. 35A

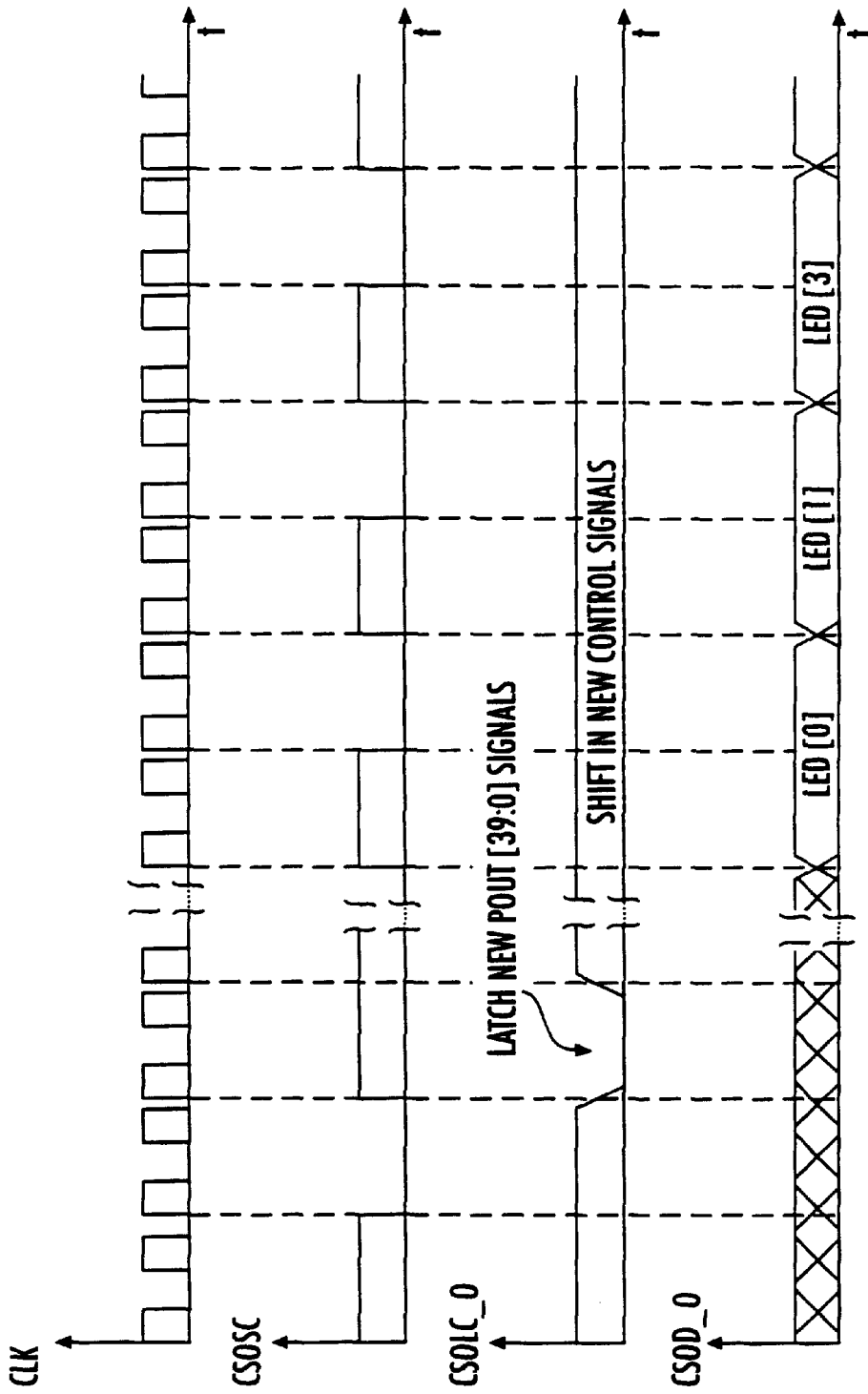

FIG. 35B

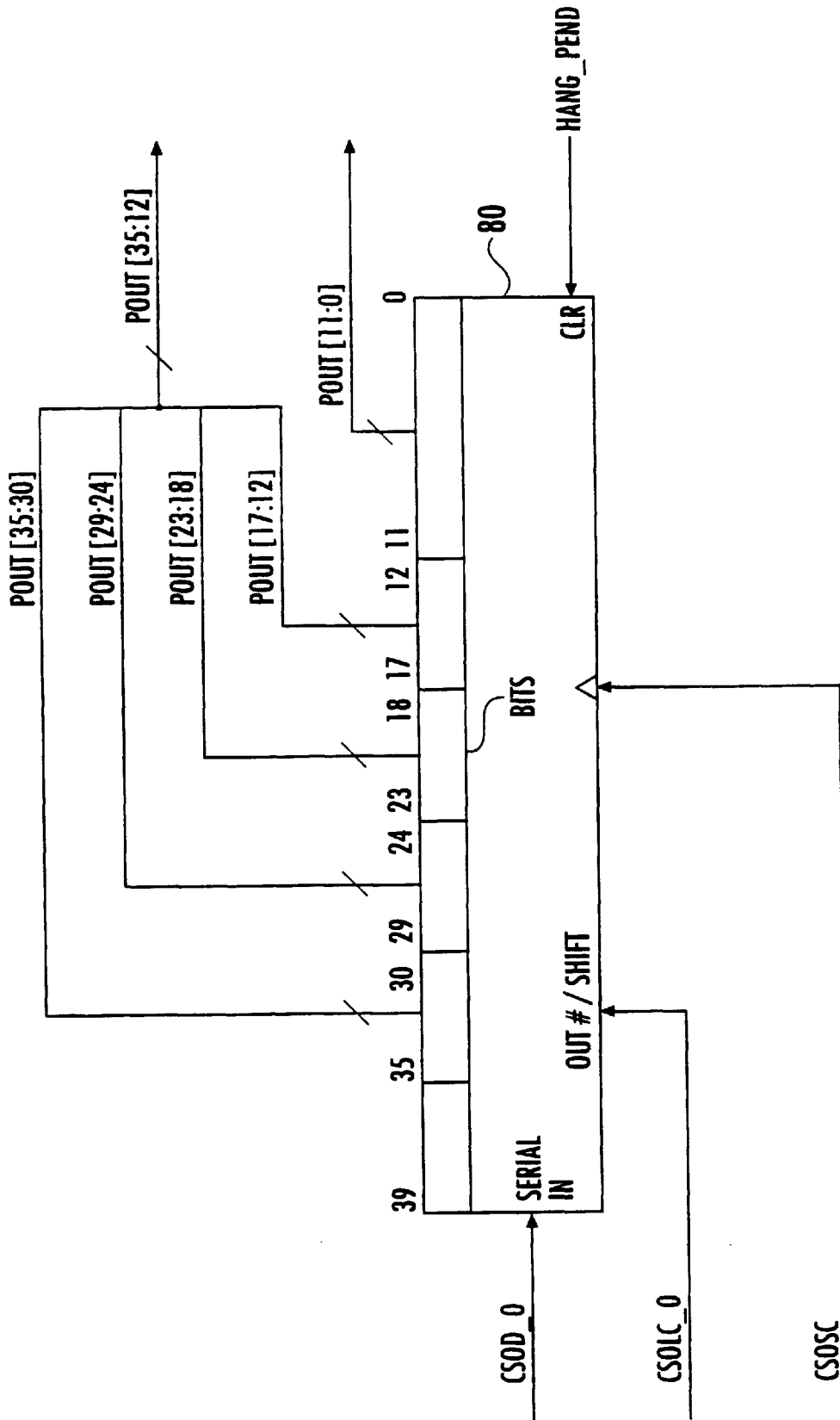

FIG. 36

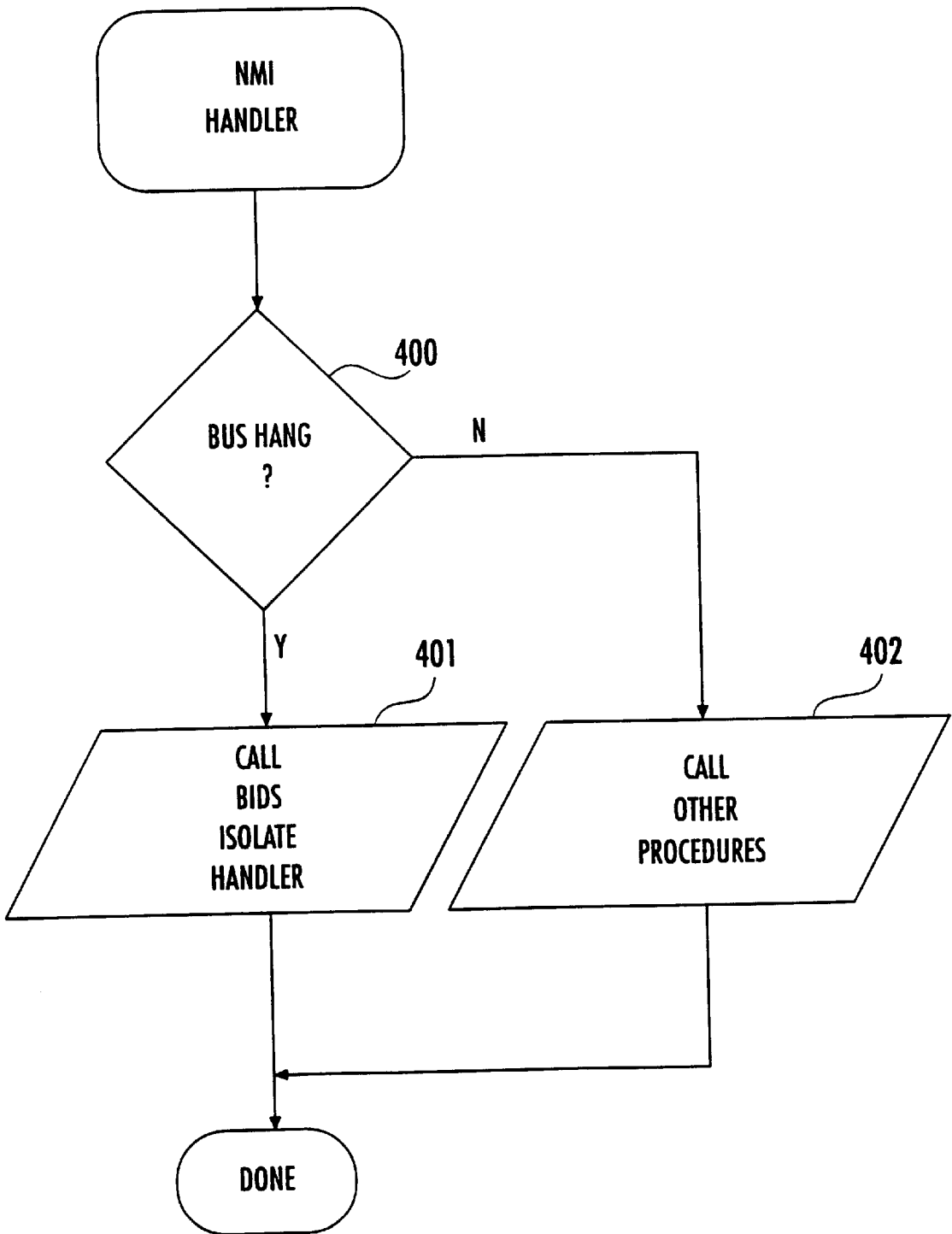

FIG. 37



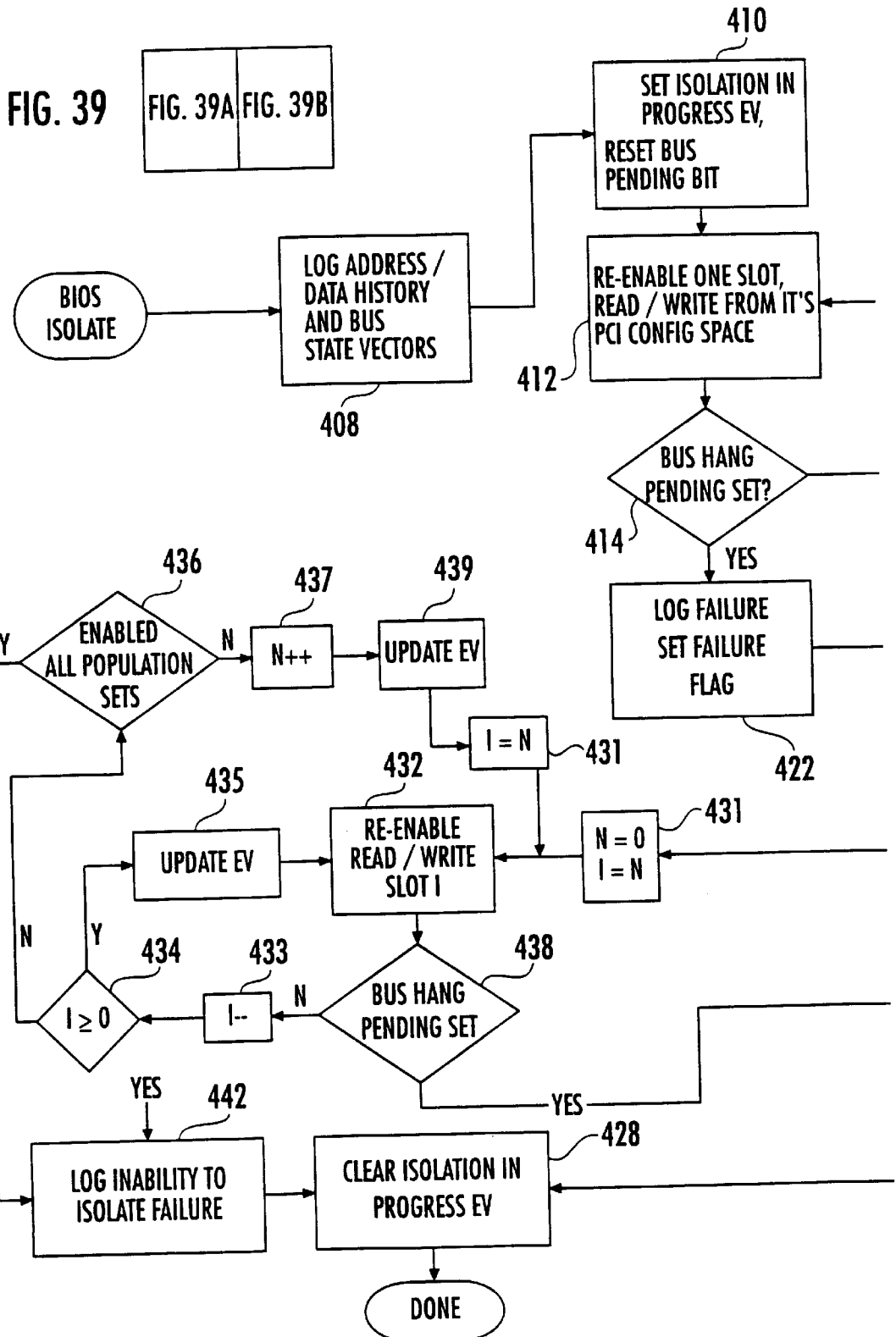

FIG. 39A

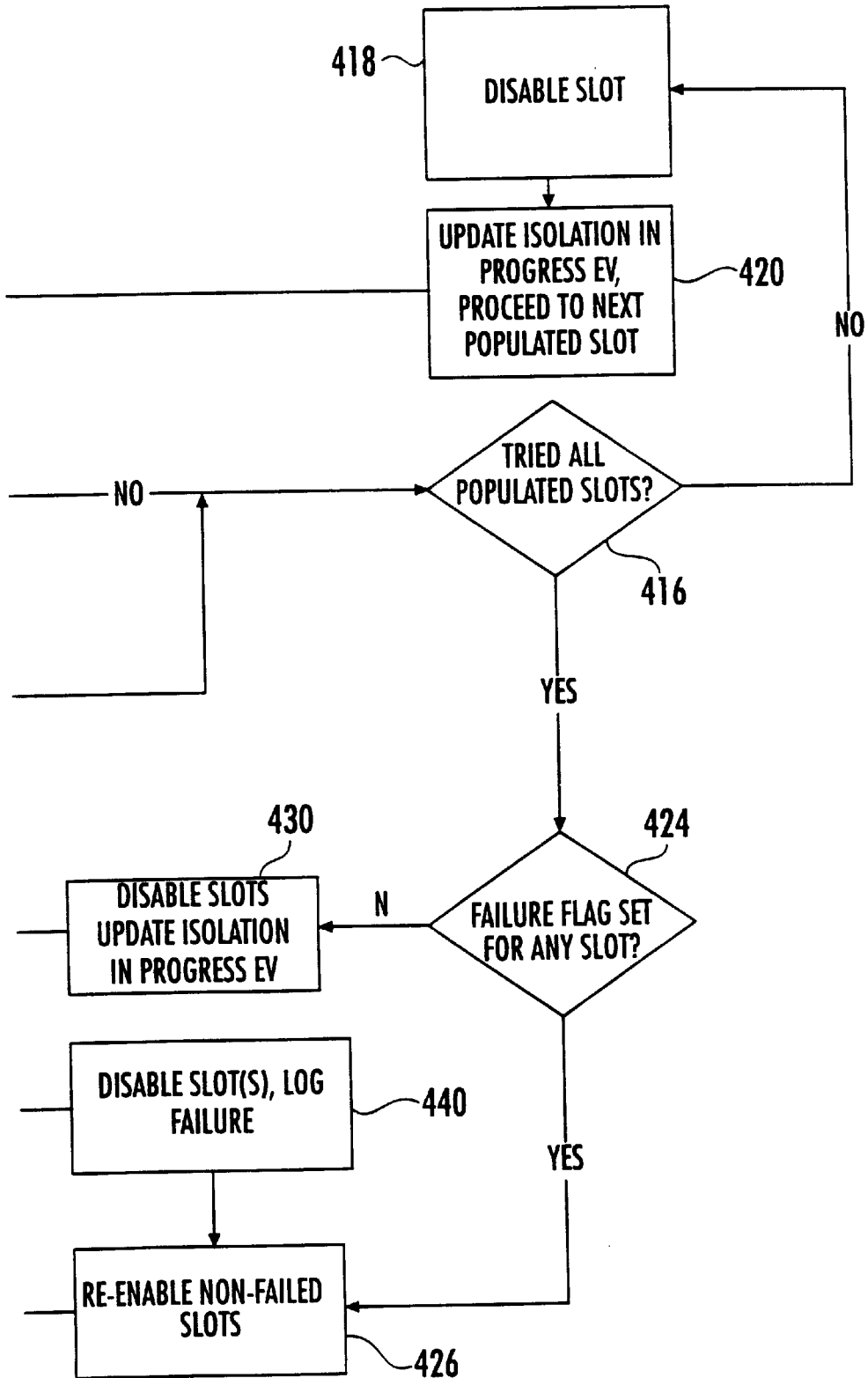

FIG. 39B

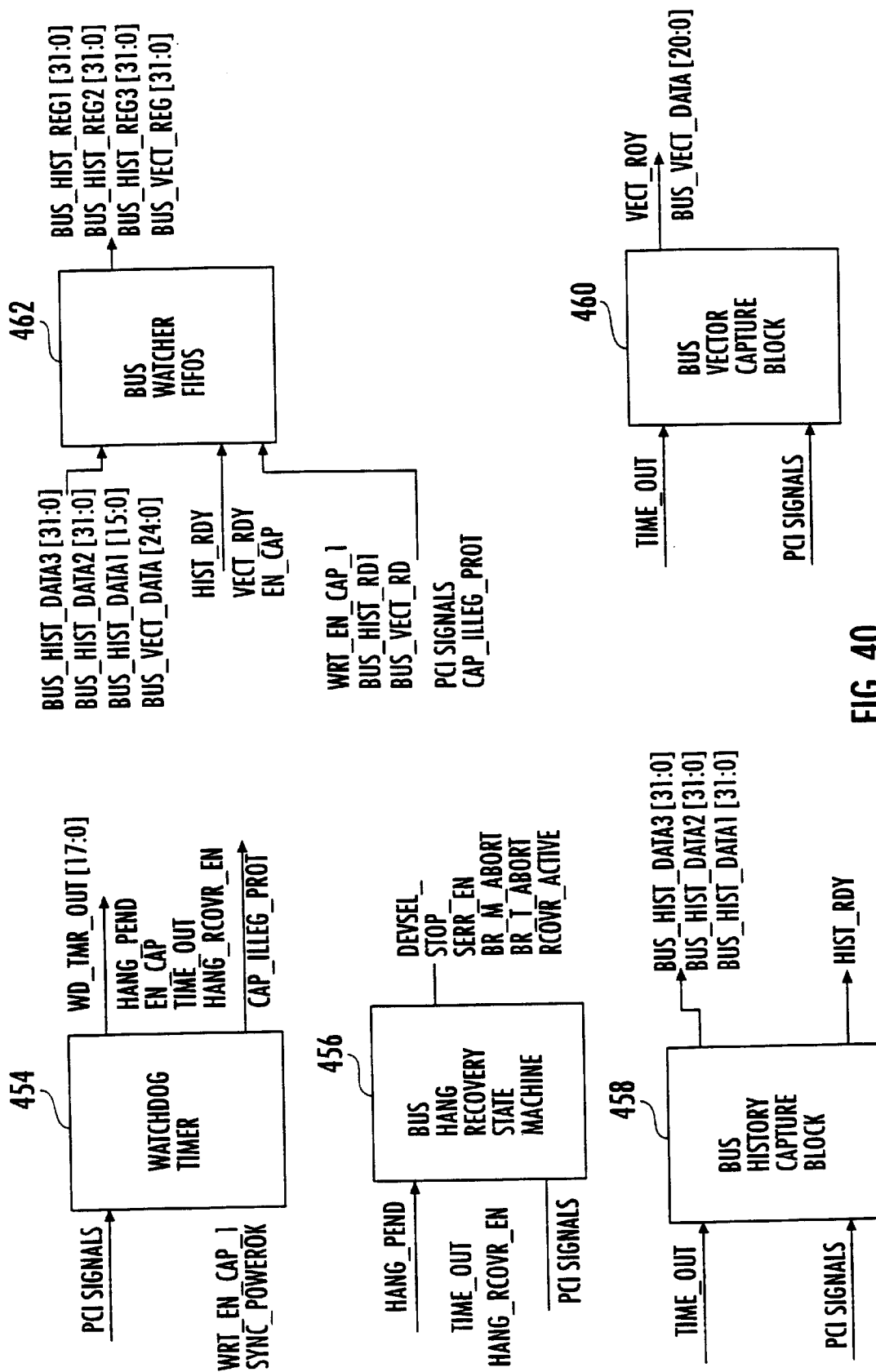

FIG. 40



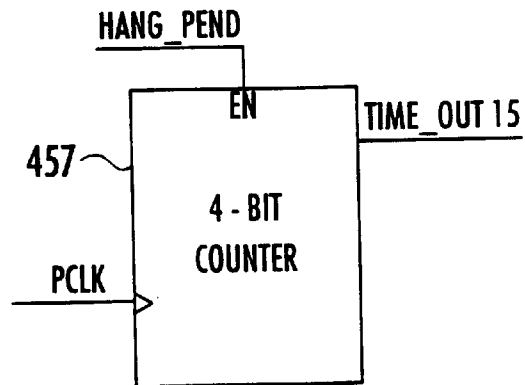
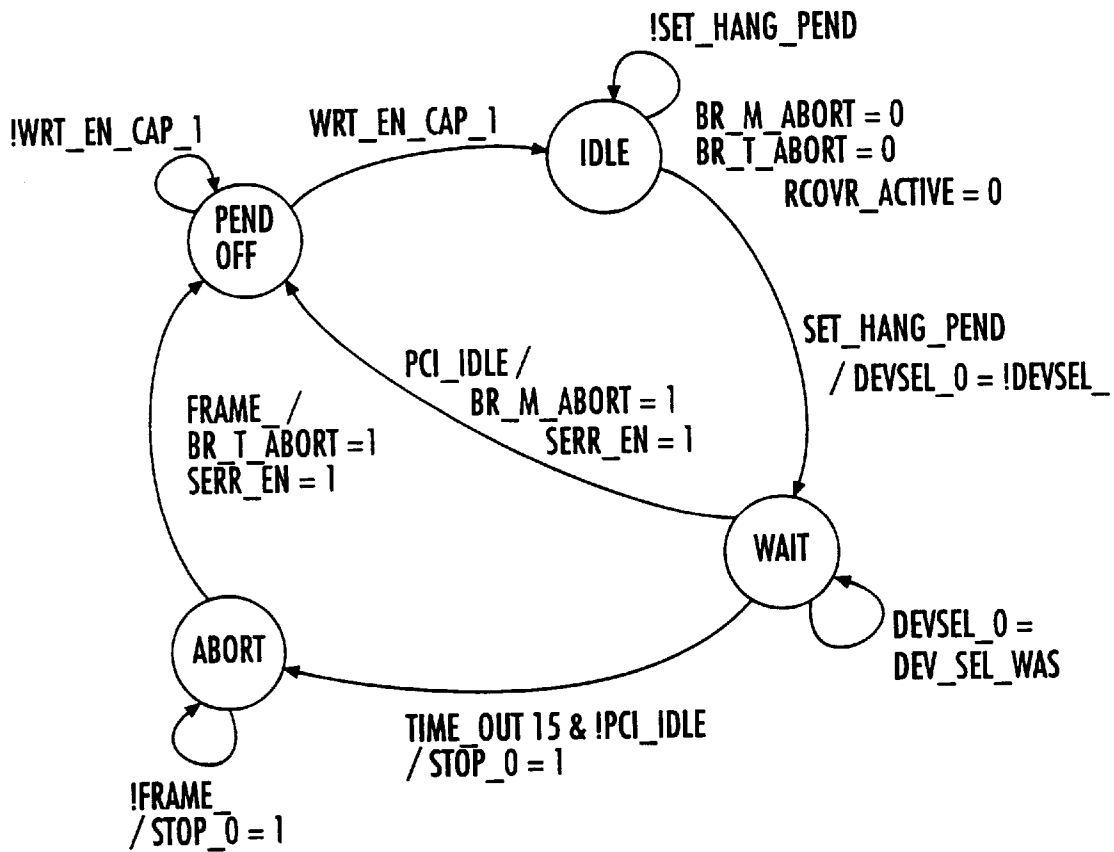

FIG. 41

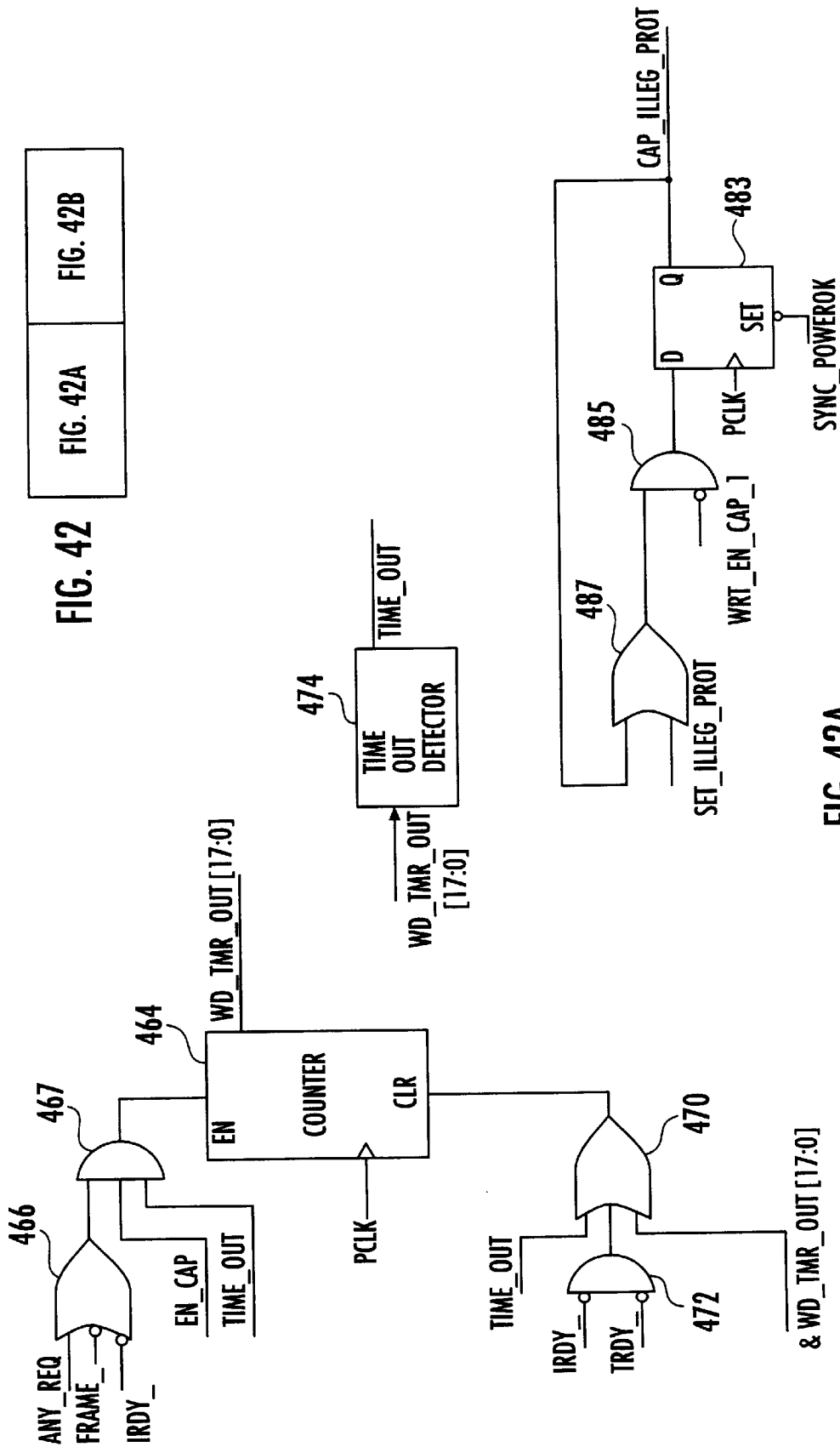

FIG. 42A

FIG. 42

FIG. 42A

FIG. 42B

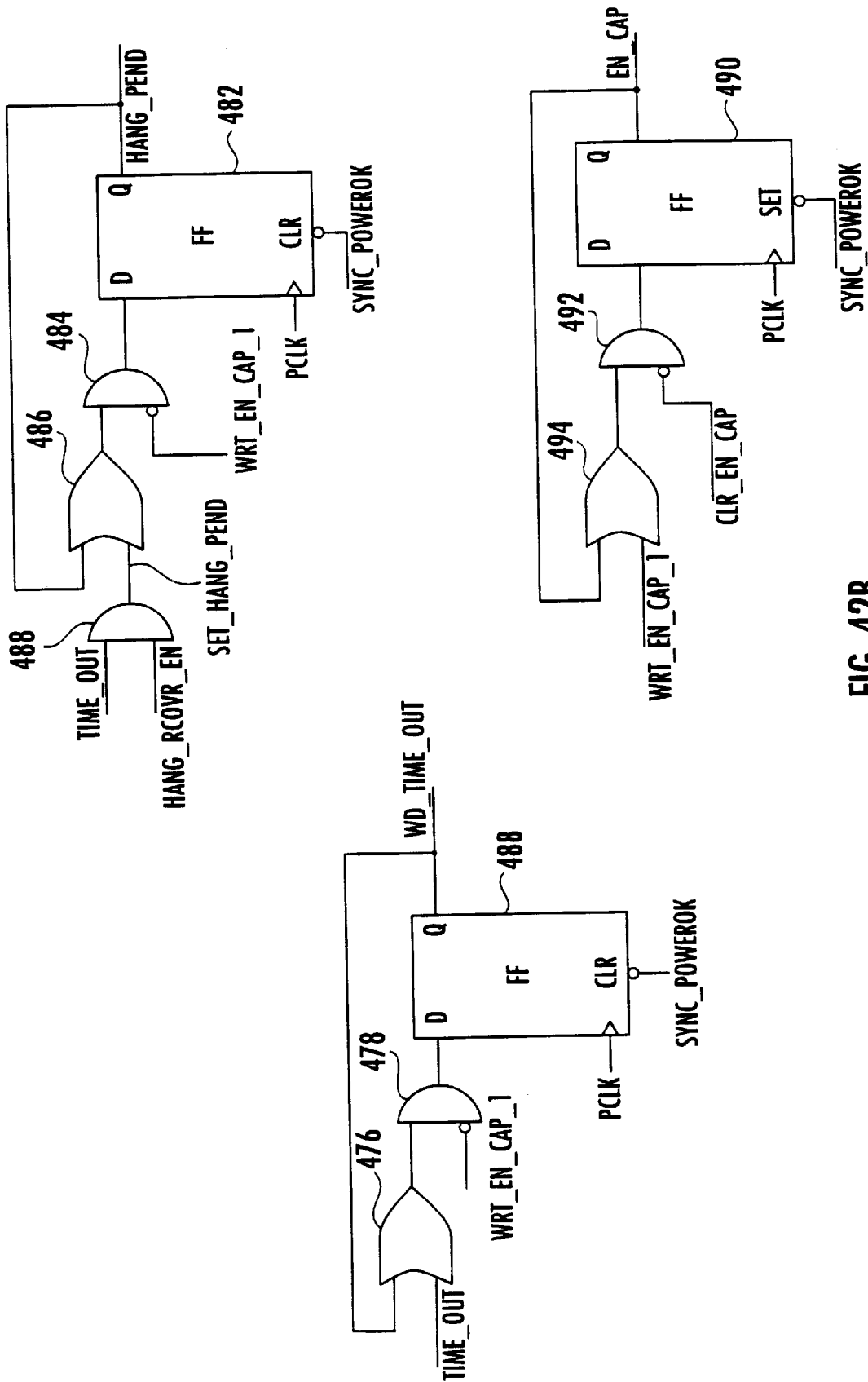

FIG. 42B

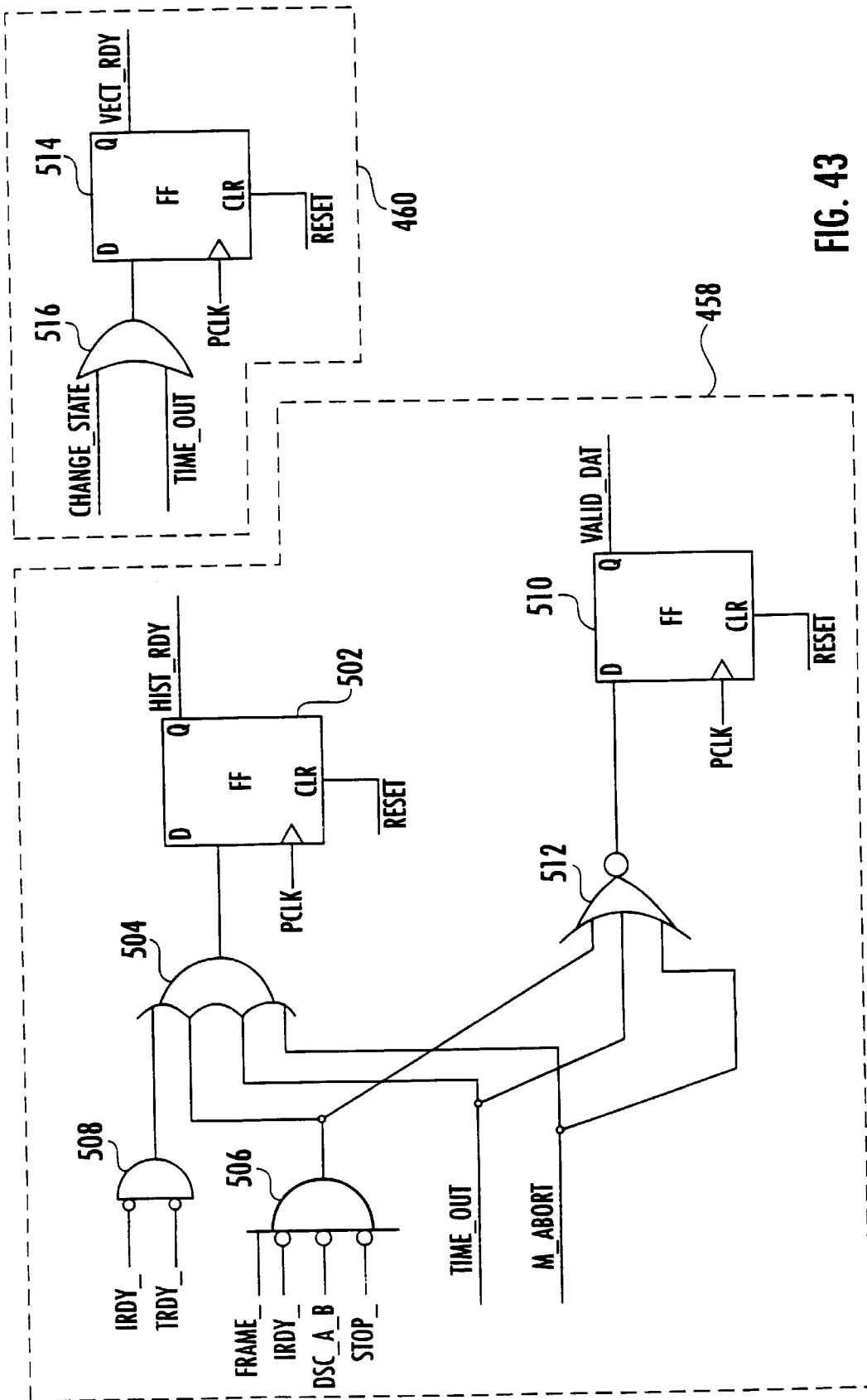

FIG. 43

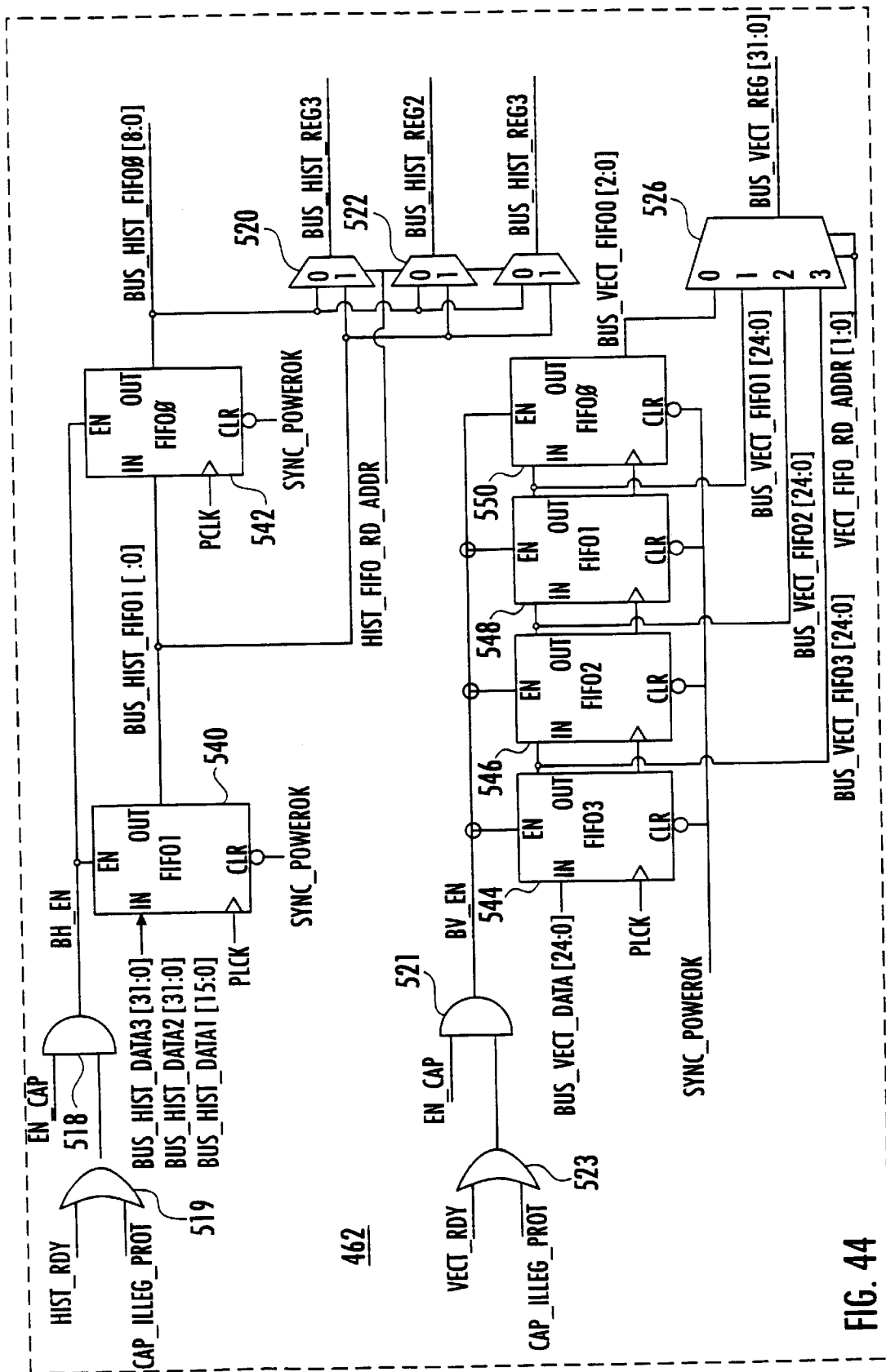

FIG. 44

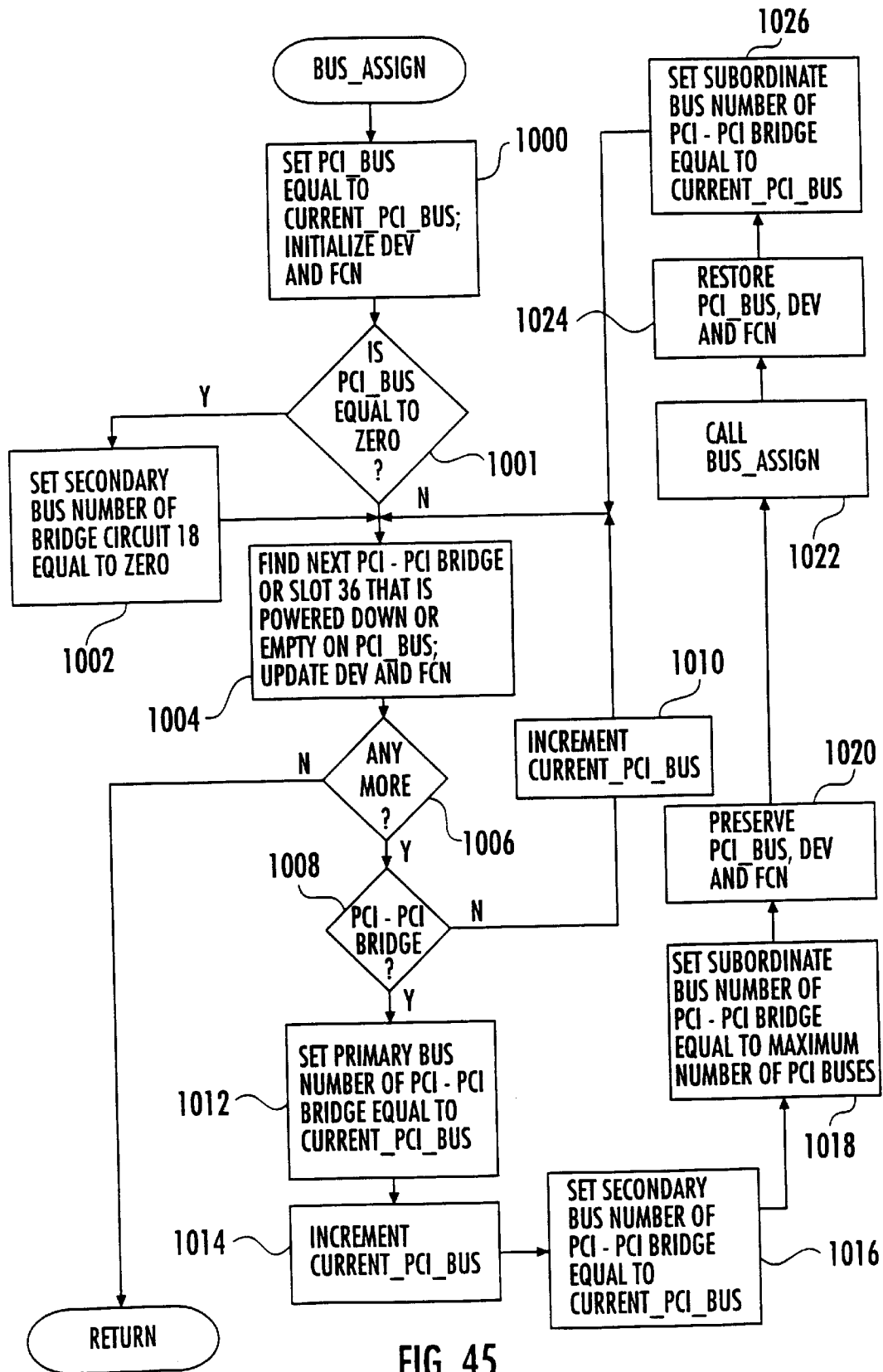

FIG. 45

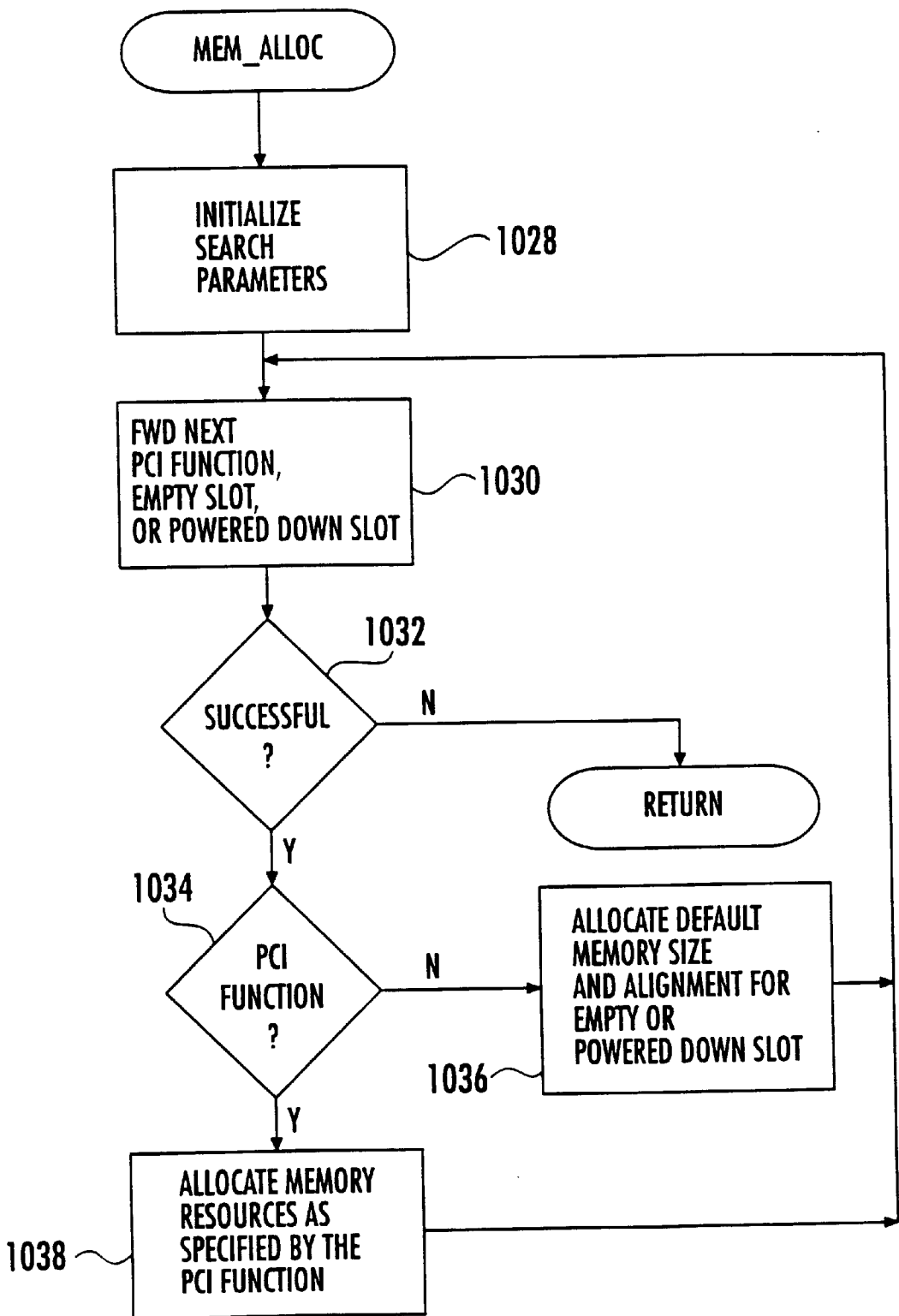

FIG. 46

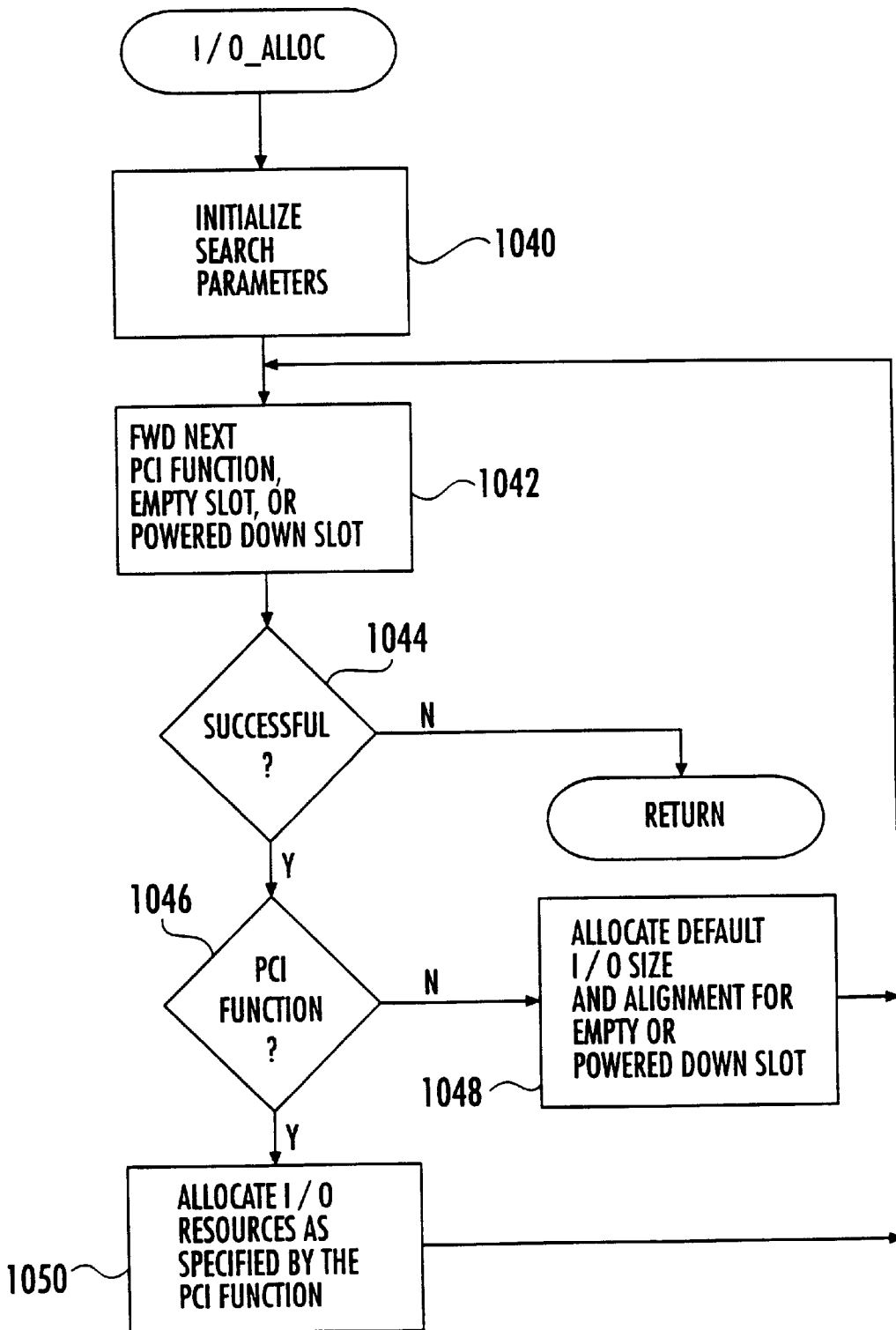

FIG. 47



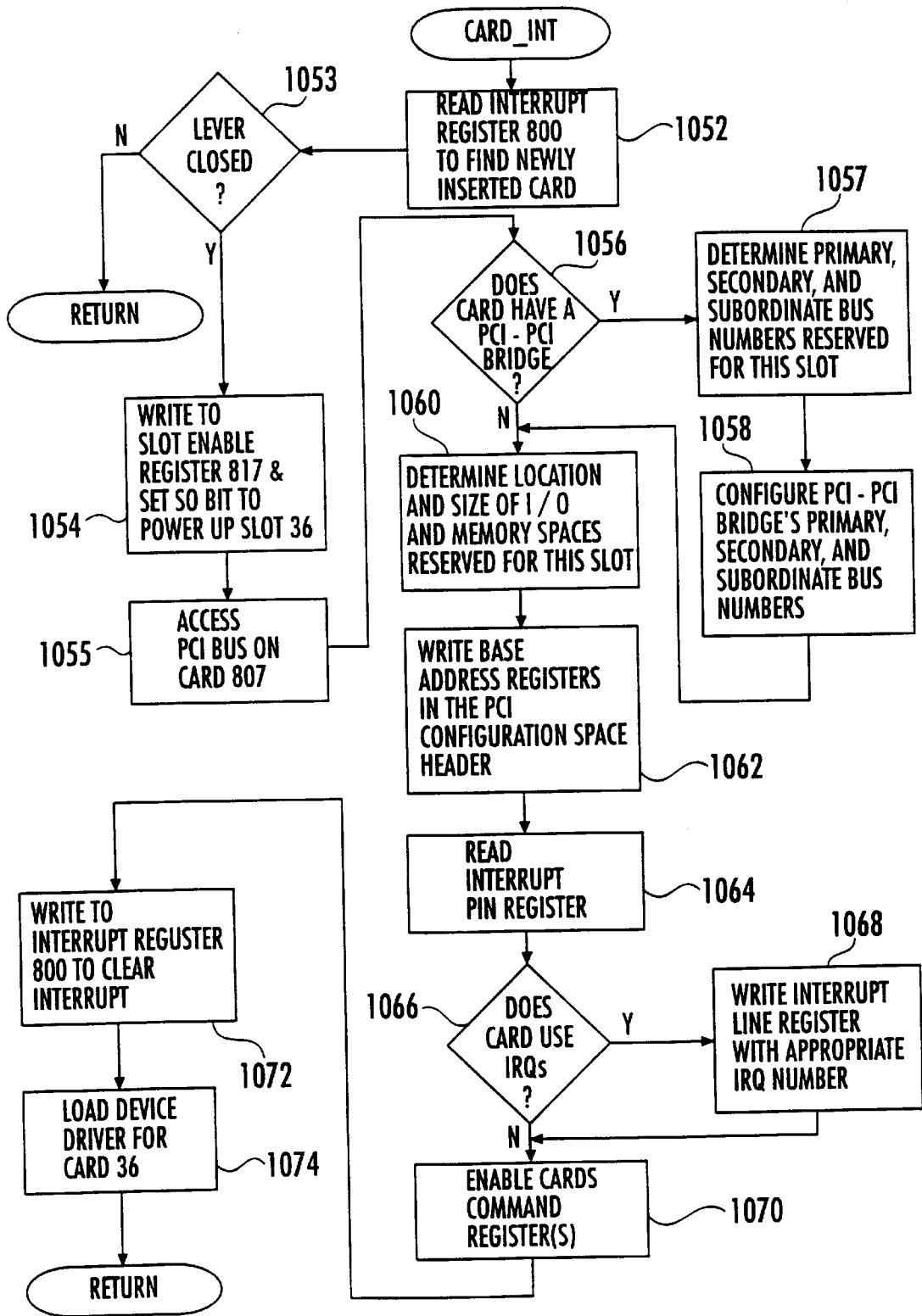

FIG. 48

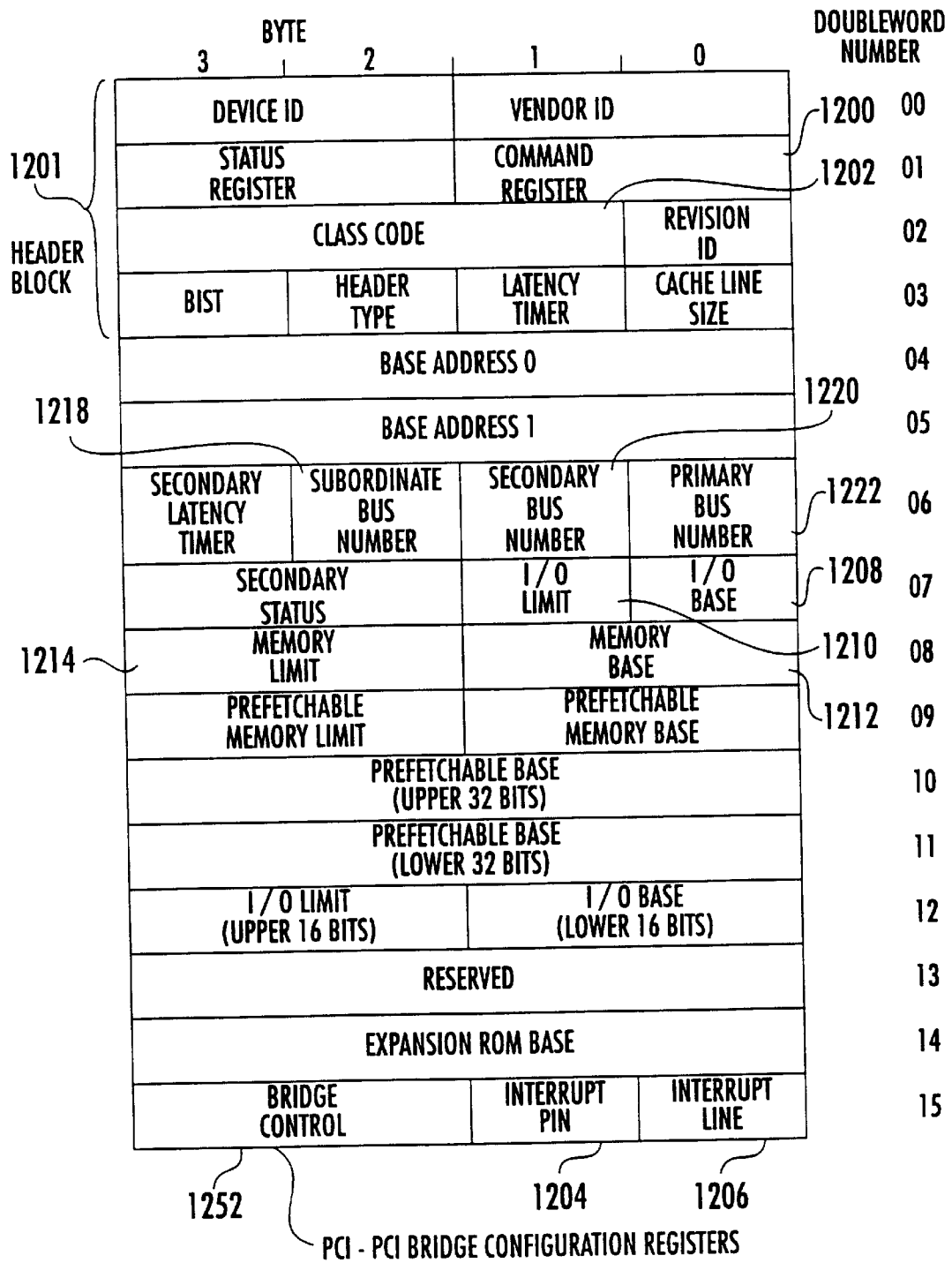

FIG. 49

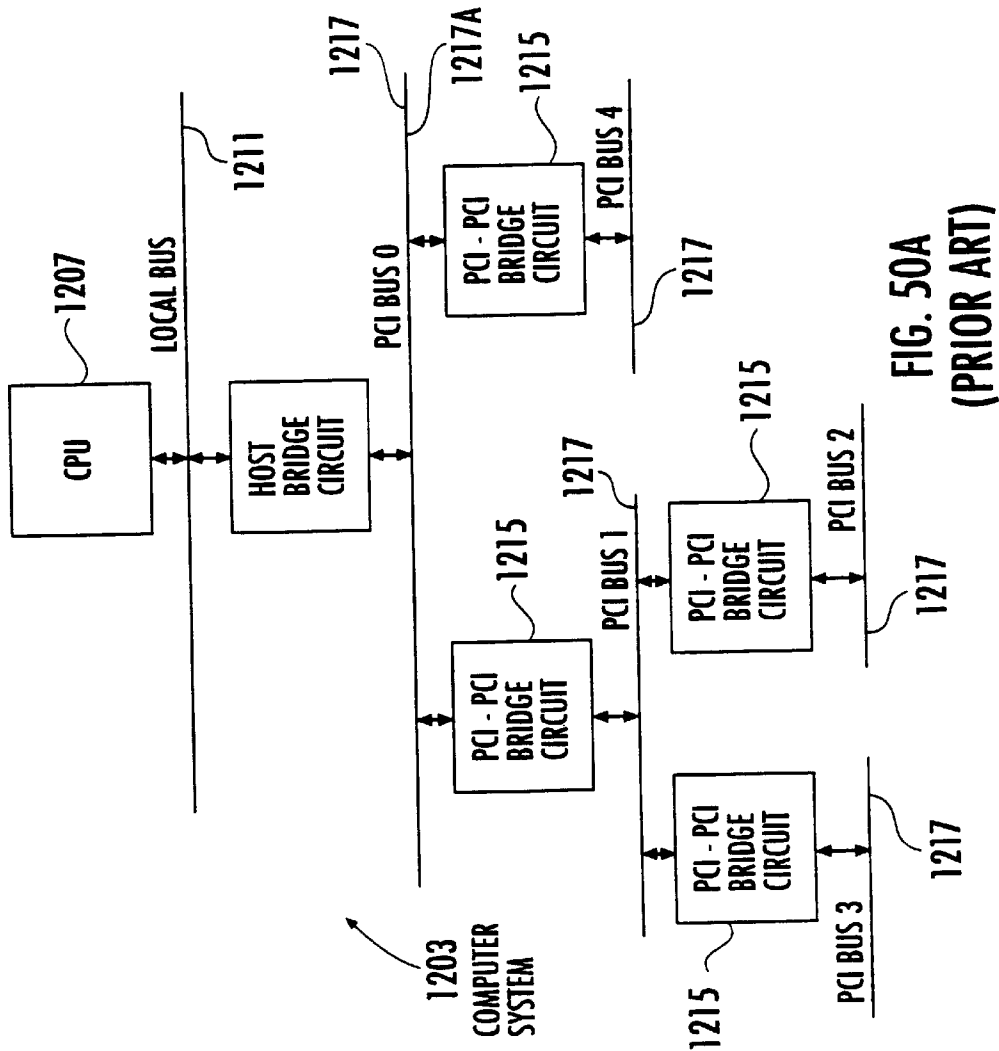

FIG. 50A  
(PRIOR ART)

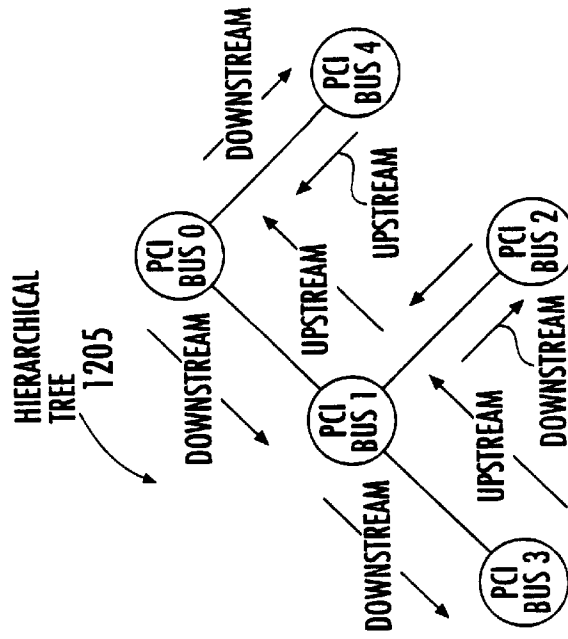

FIG. 50B  
(PRIOR ART)

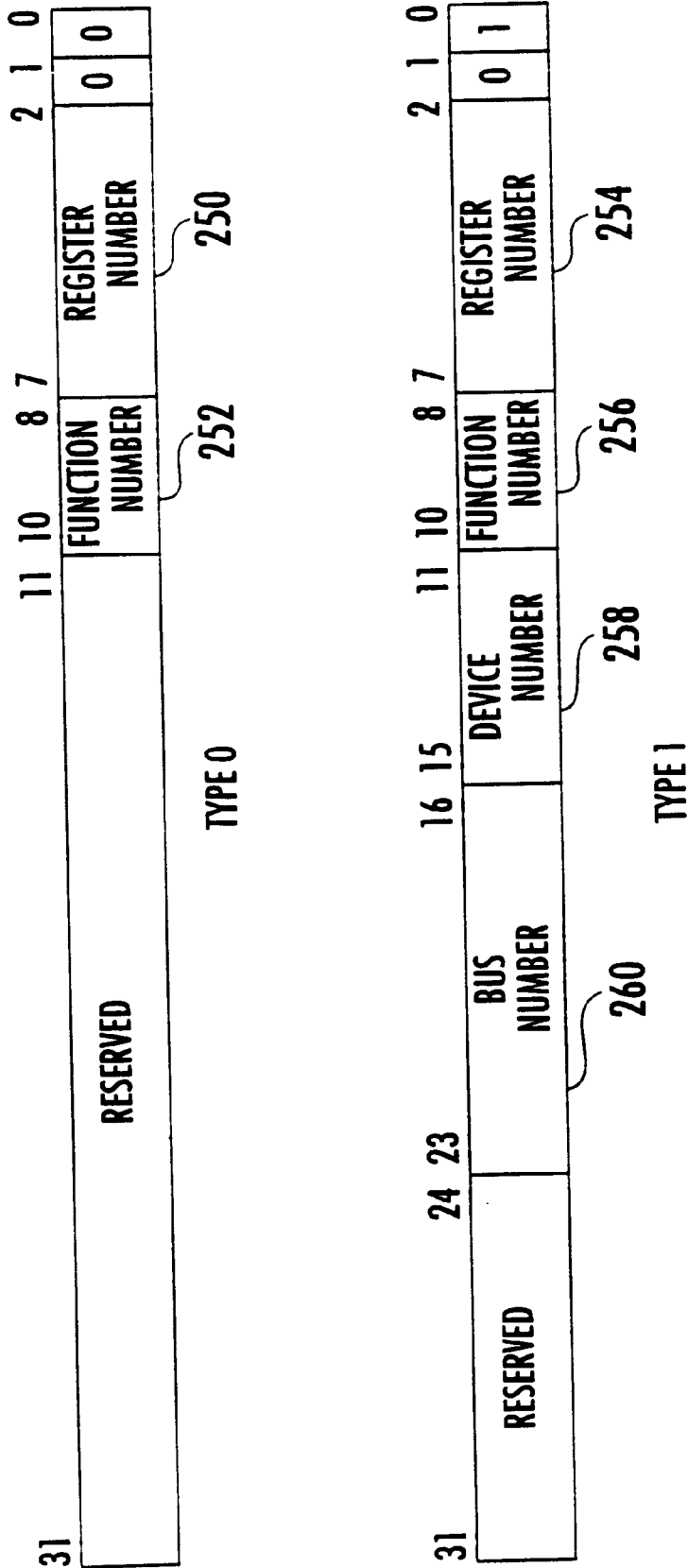

FIG. 51

PRIMARY ADDRESS AD [15::11]	SECONDARY ADDRESS BITS AD [31::16]
00000	0000 0000 0000 0001
00001	0000 0000 0000 0010
00010	0000 0000 0000 0100
00011	0000 0000 0000 1000
00100	0000 0000 0001 0000
00101	0000 0000 0010 0000
00110	0000 0000 0100 0000
00111	0000 0000 1000 0000
01000	0000 0001 0000 0000
01001	0000 0010 0000 0000
01010	0000 0100 0000 0000
01011	0000 1000 0000 0000
01100	0001 0000 0000 0000
01101	0010 0000 0000 0000
01110	0100 0000 0000 0000
01111	1000 0000 0000 0000
1XXXX	0000 0000 0000 0000

FIG. 52

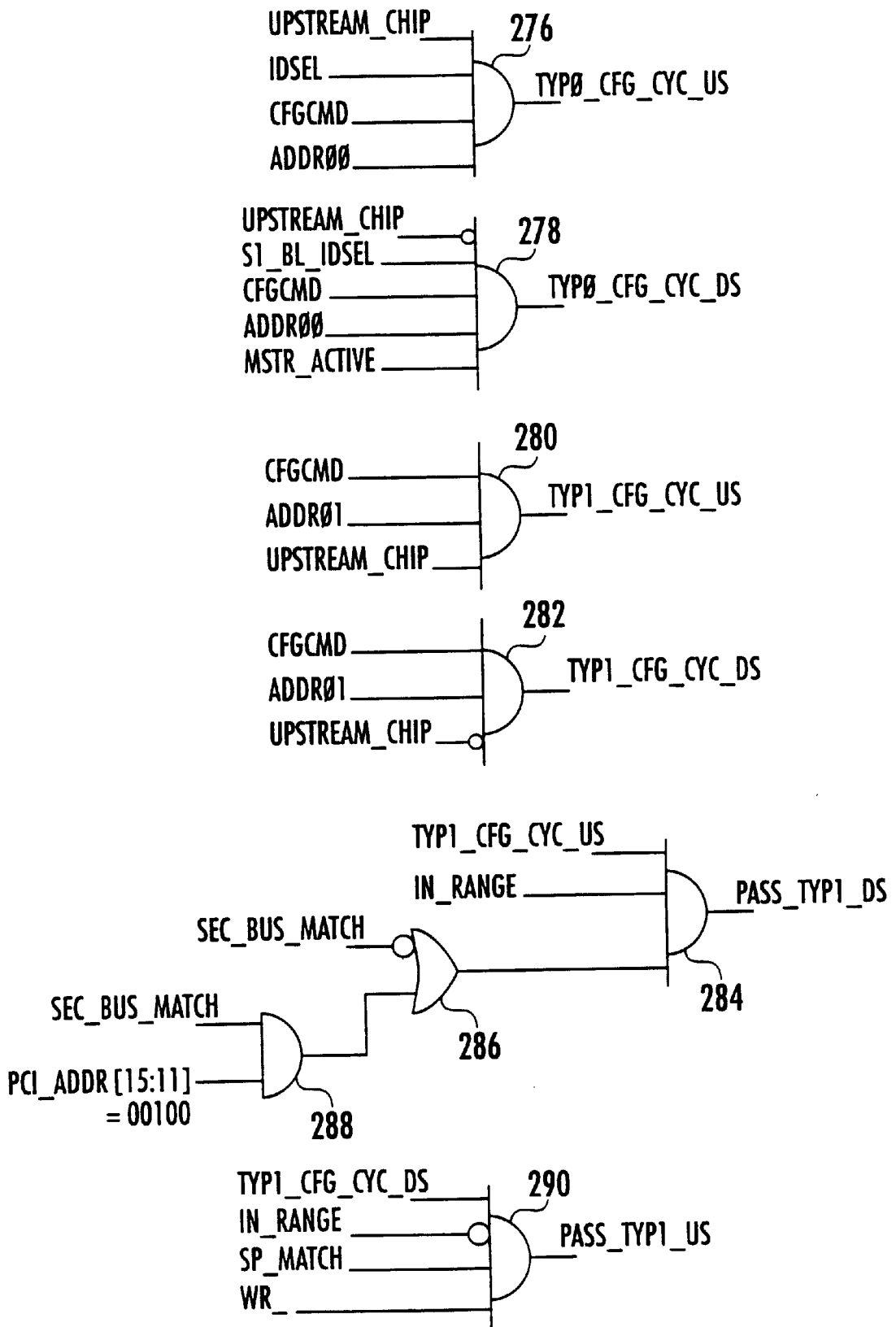

FIG. 53A

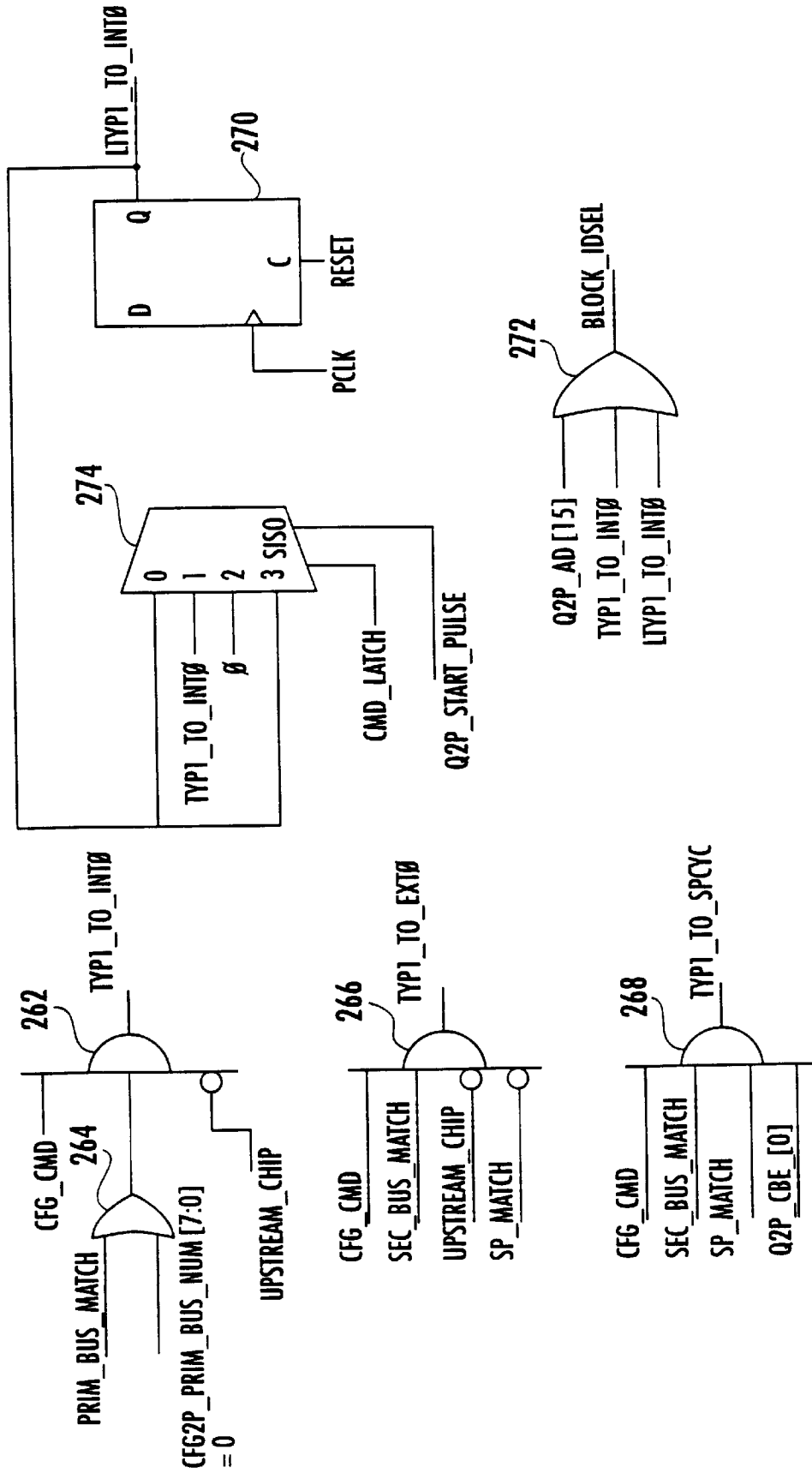

FIG. 53B

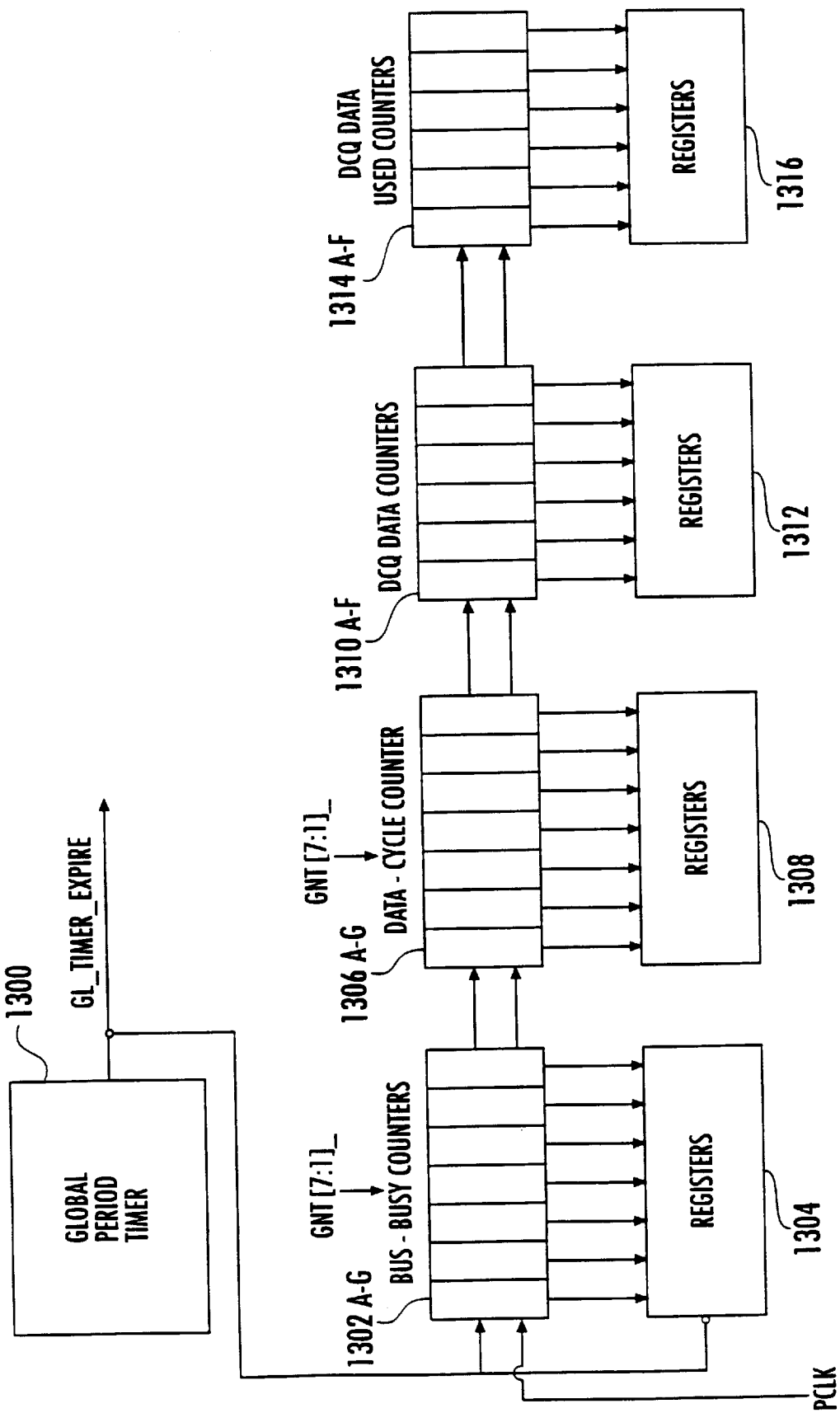

FIG. 54A



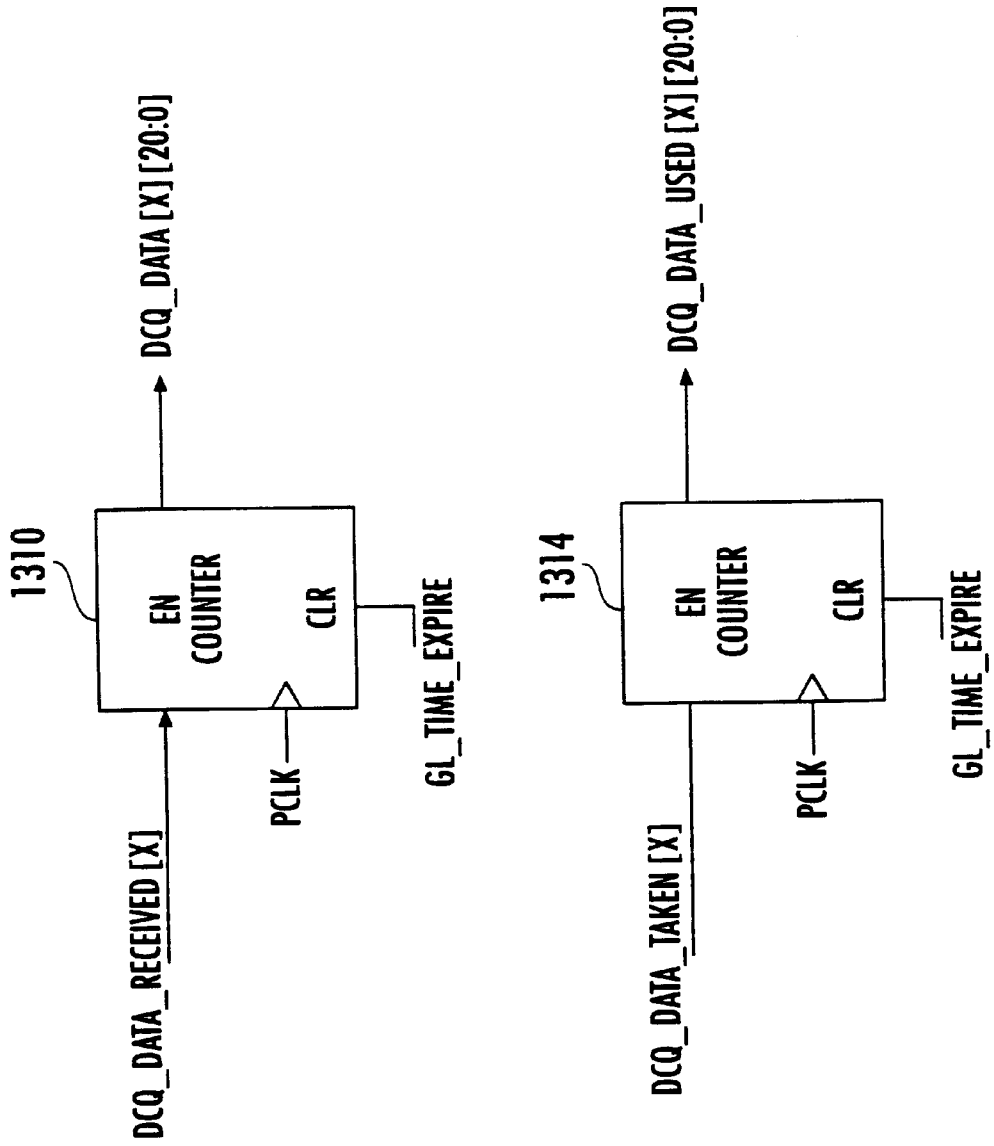

FIG. 54B

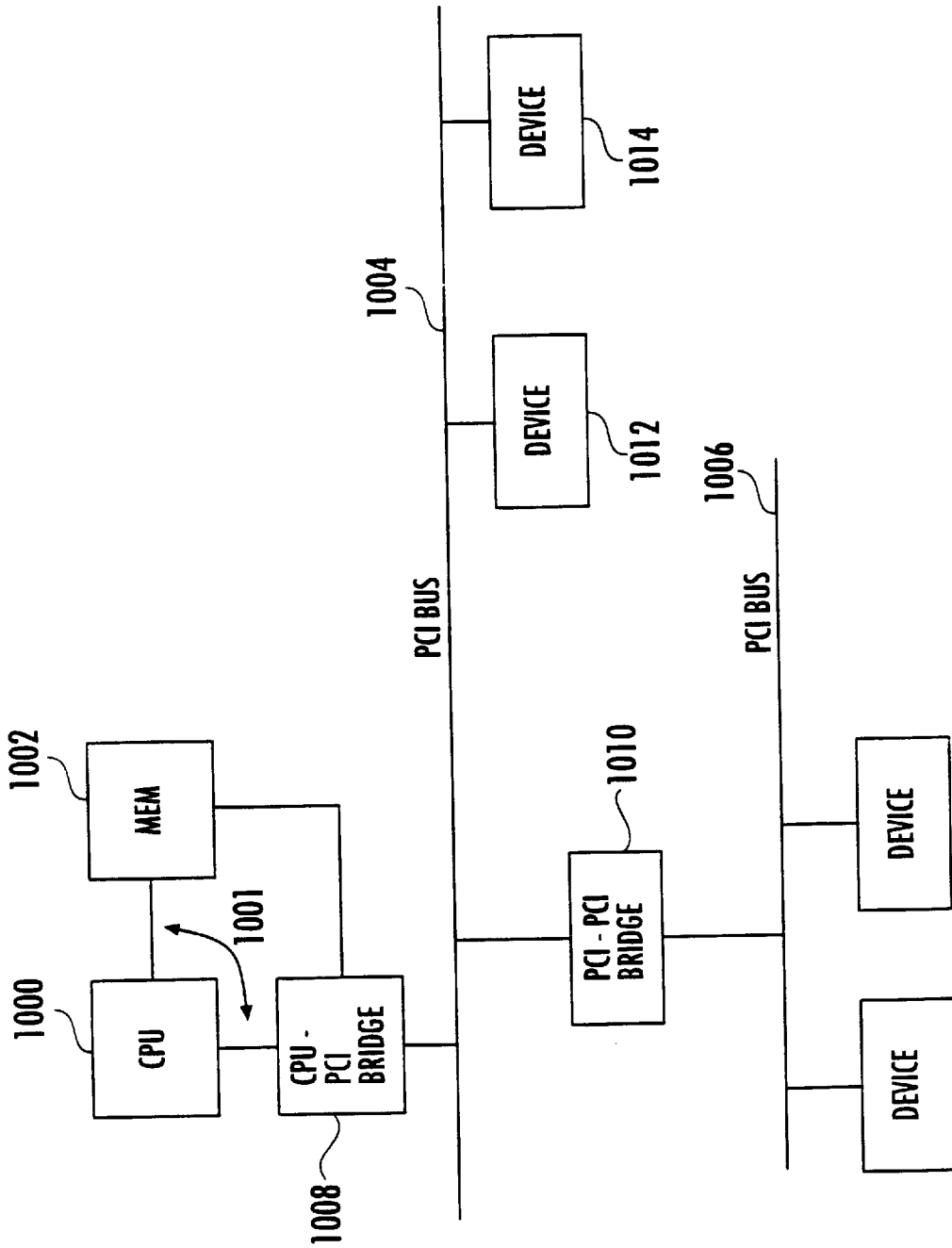

FIG. 55 (PRIOR ART)

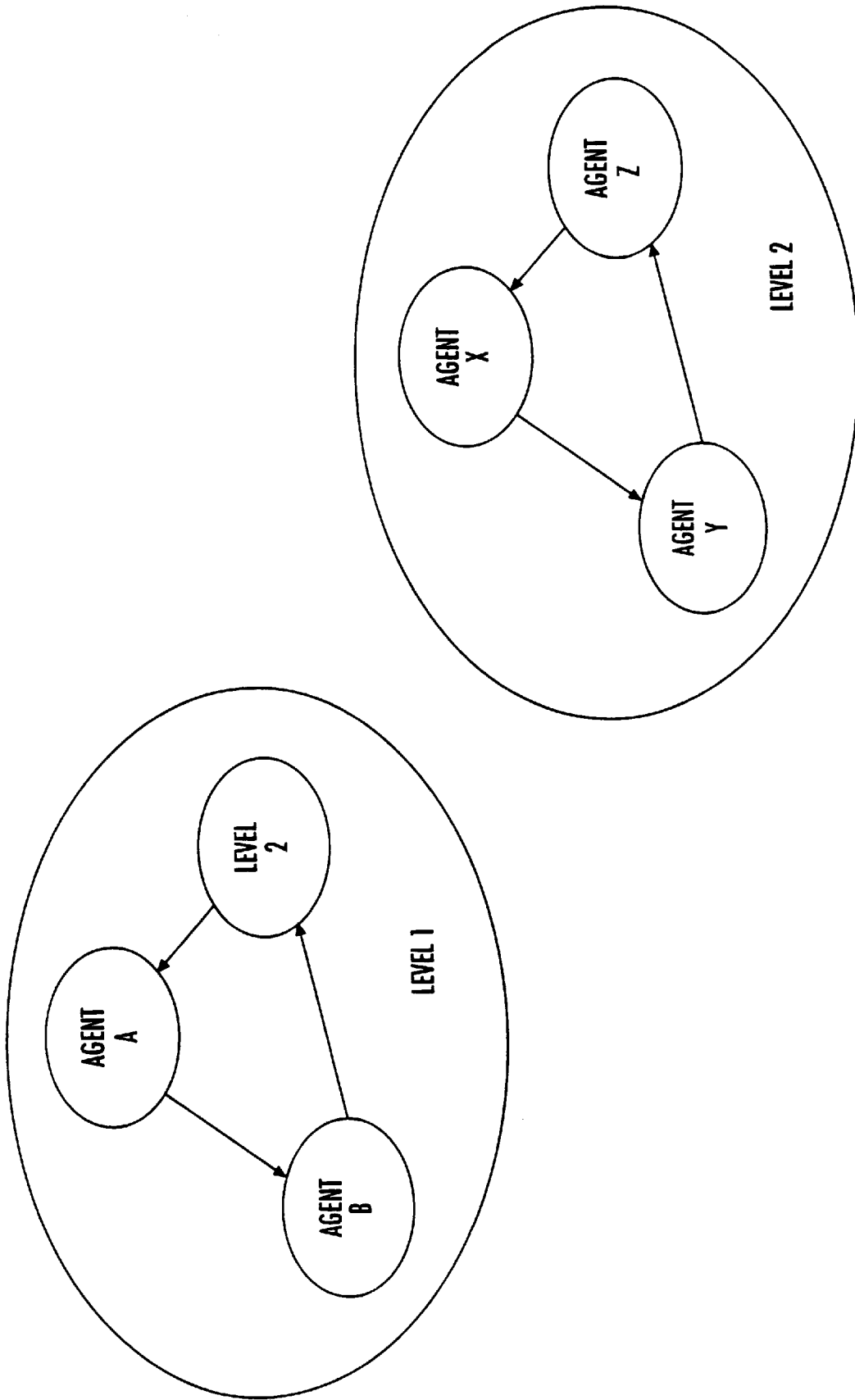

FIG. 56 (PRIOR ART)

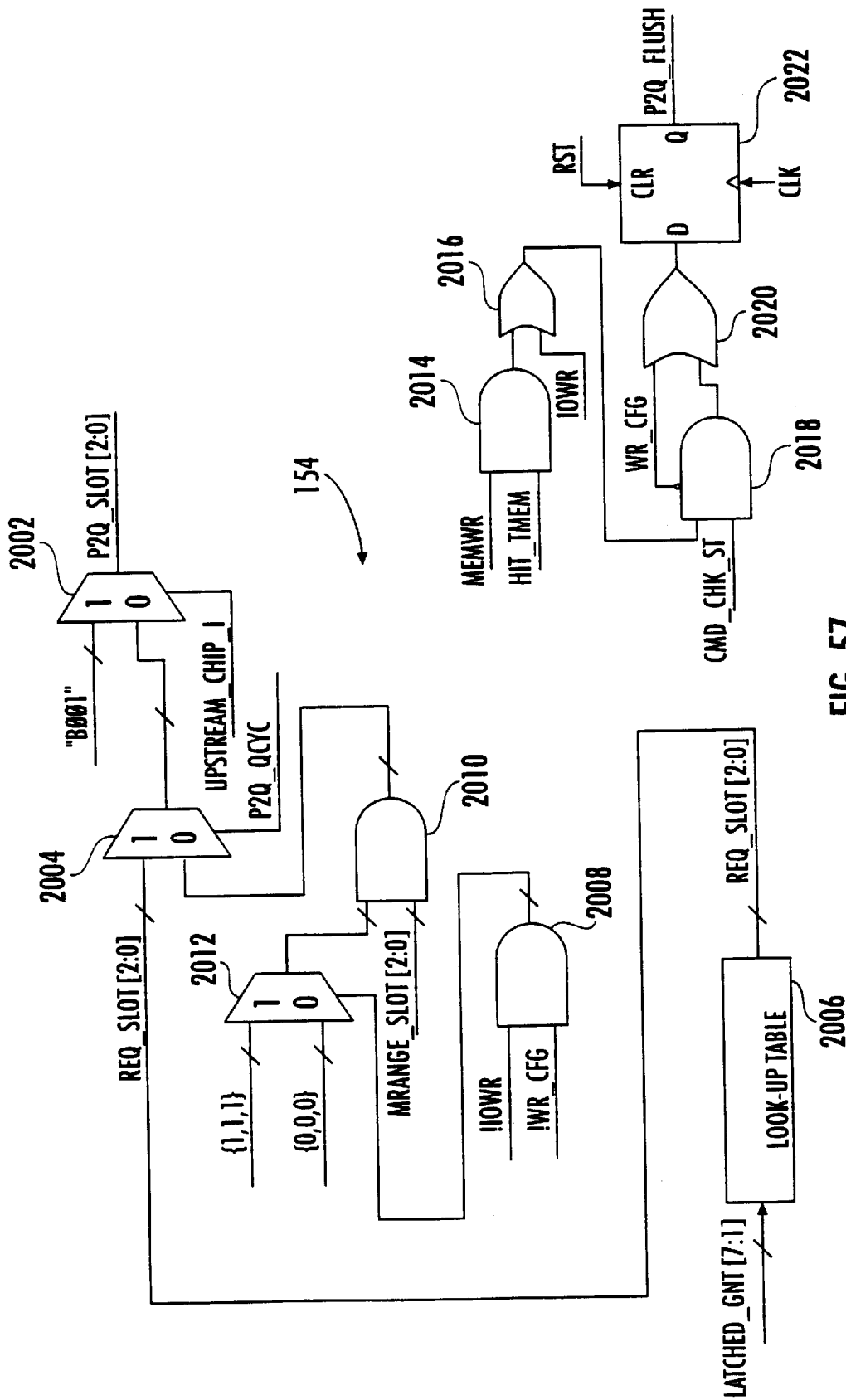

FIG. 57

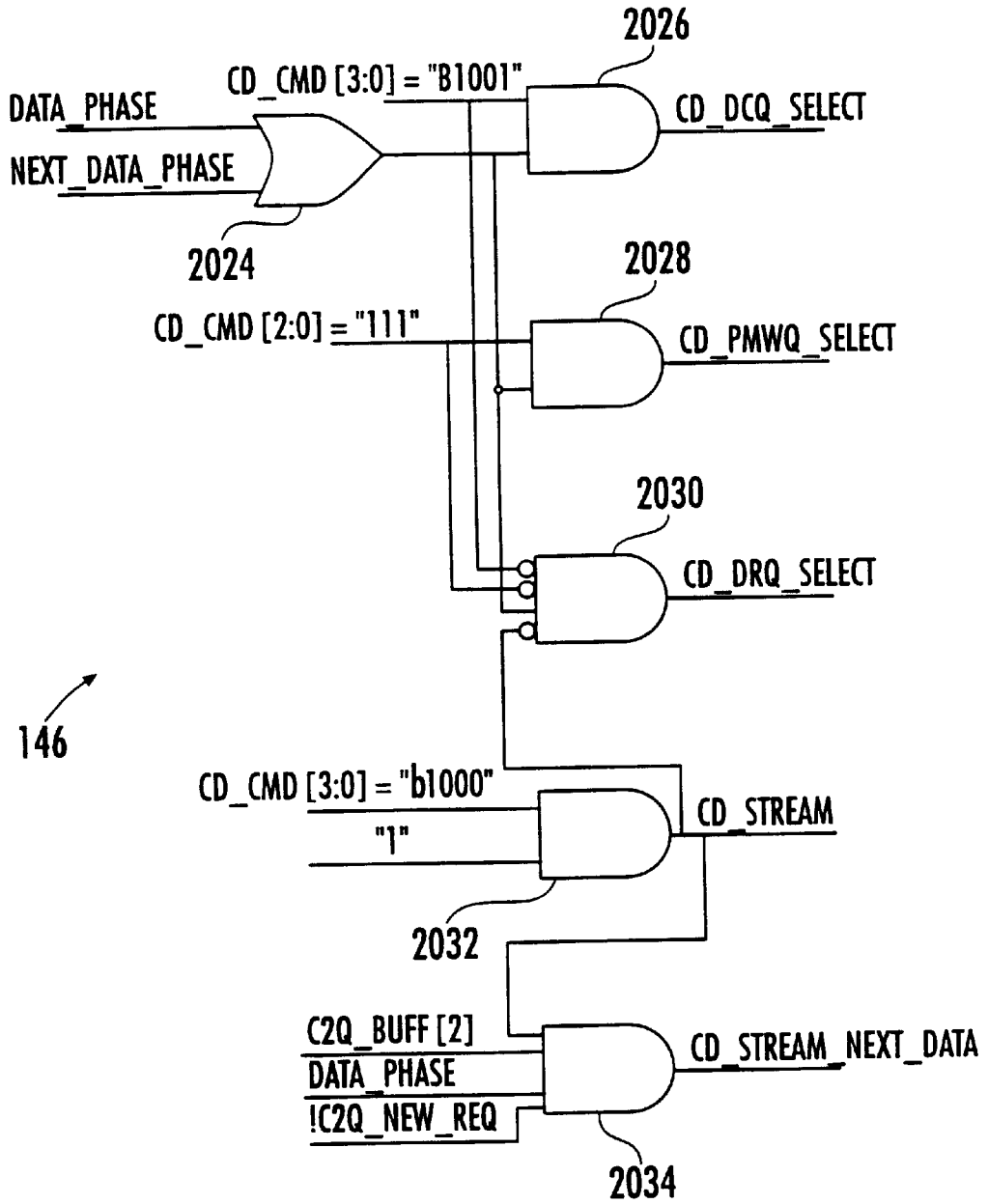

FIG. 58

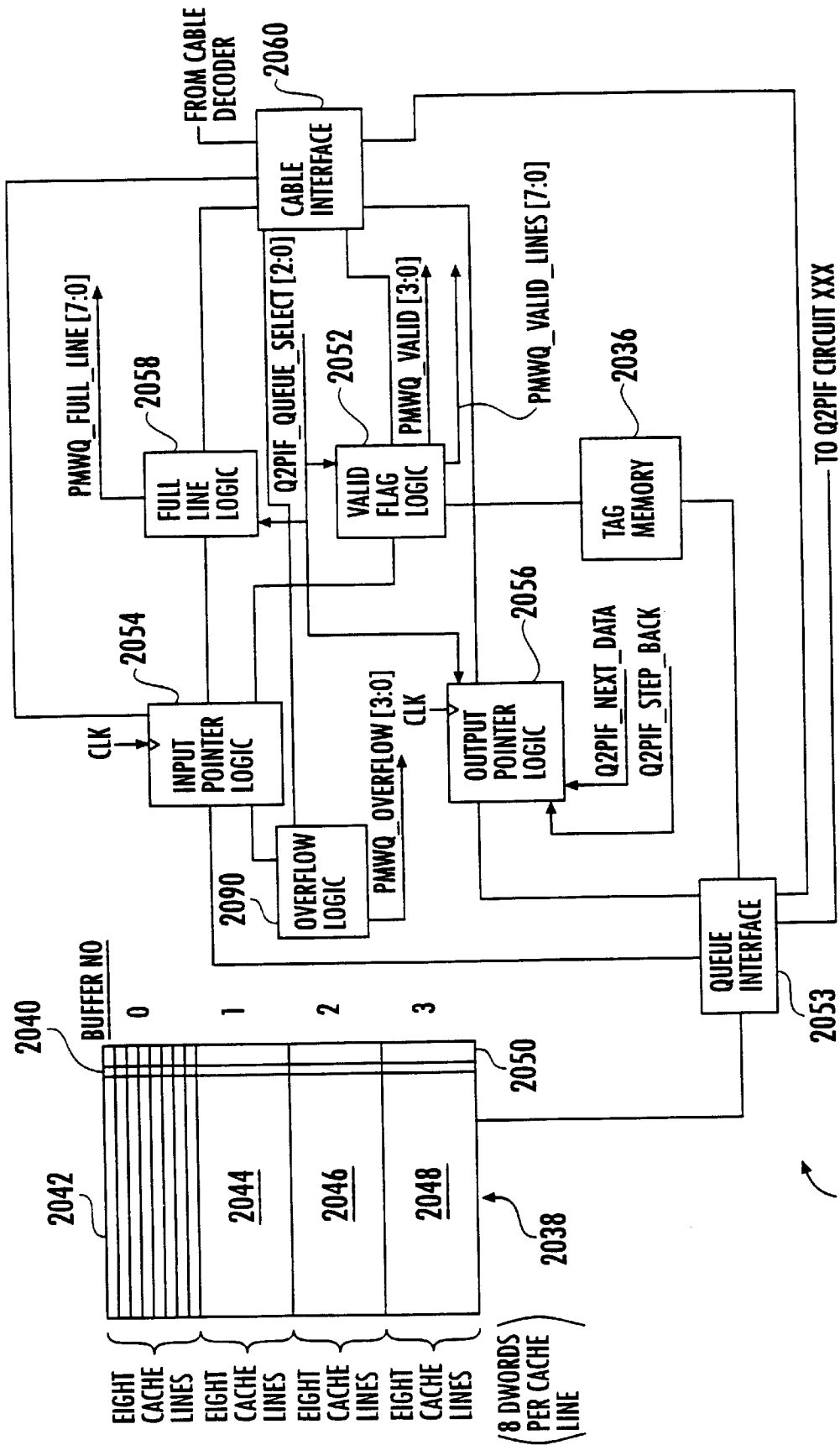

FIG. 59

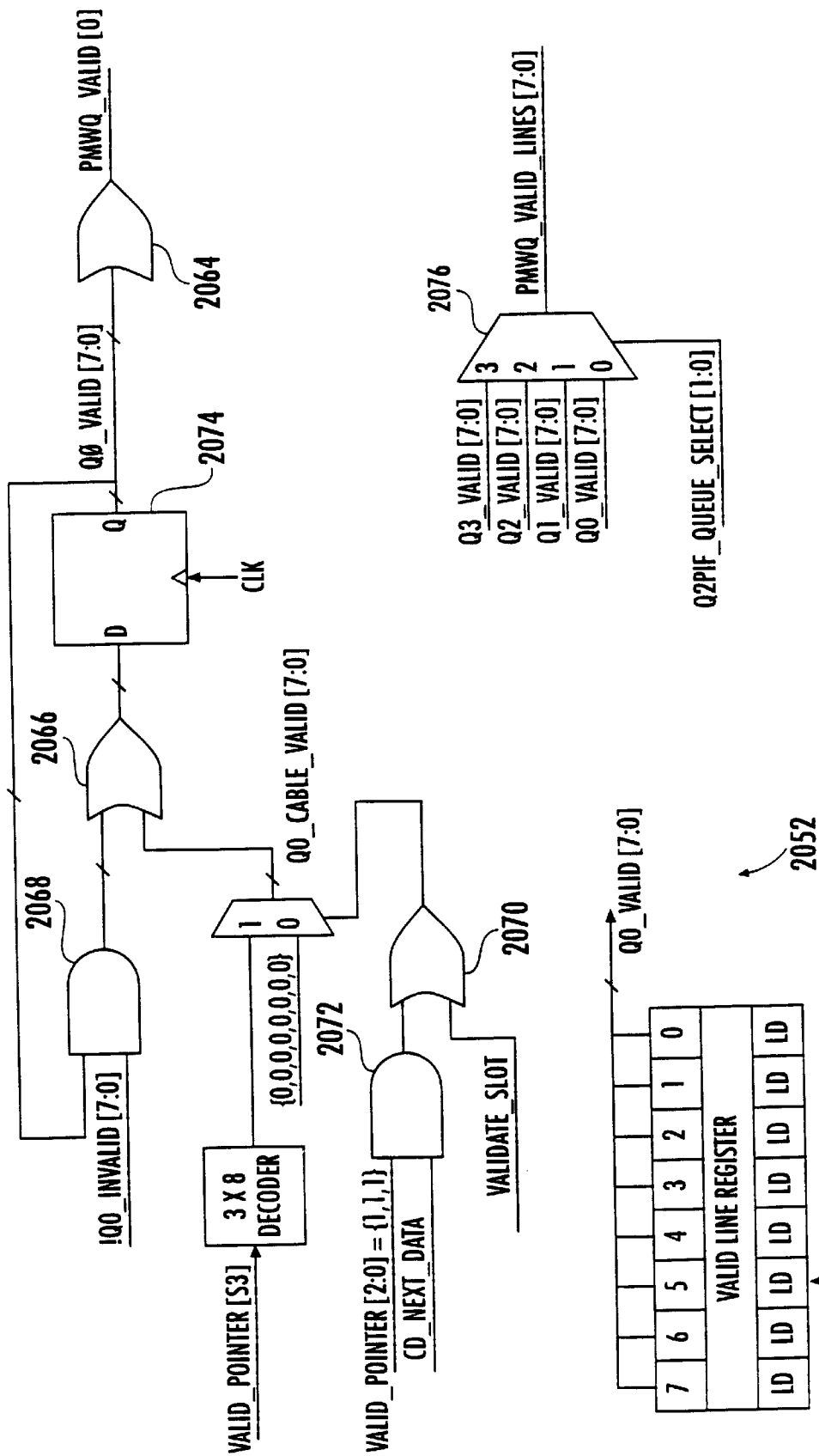

FIG. 60

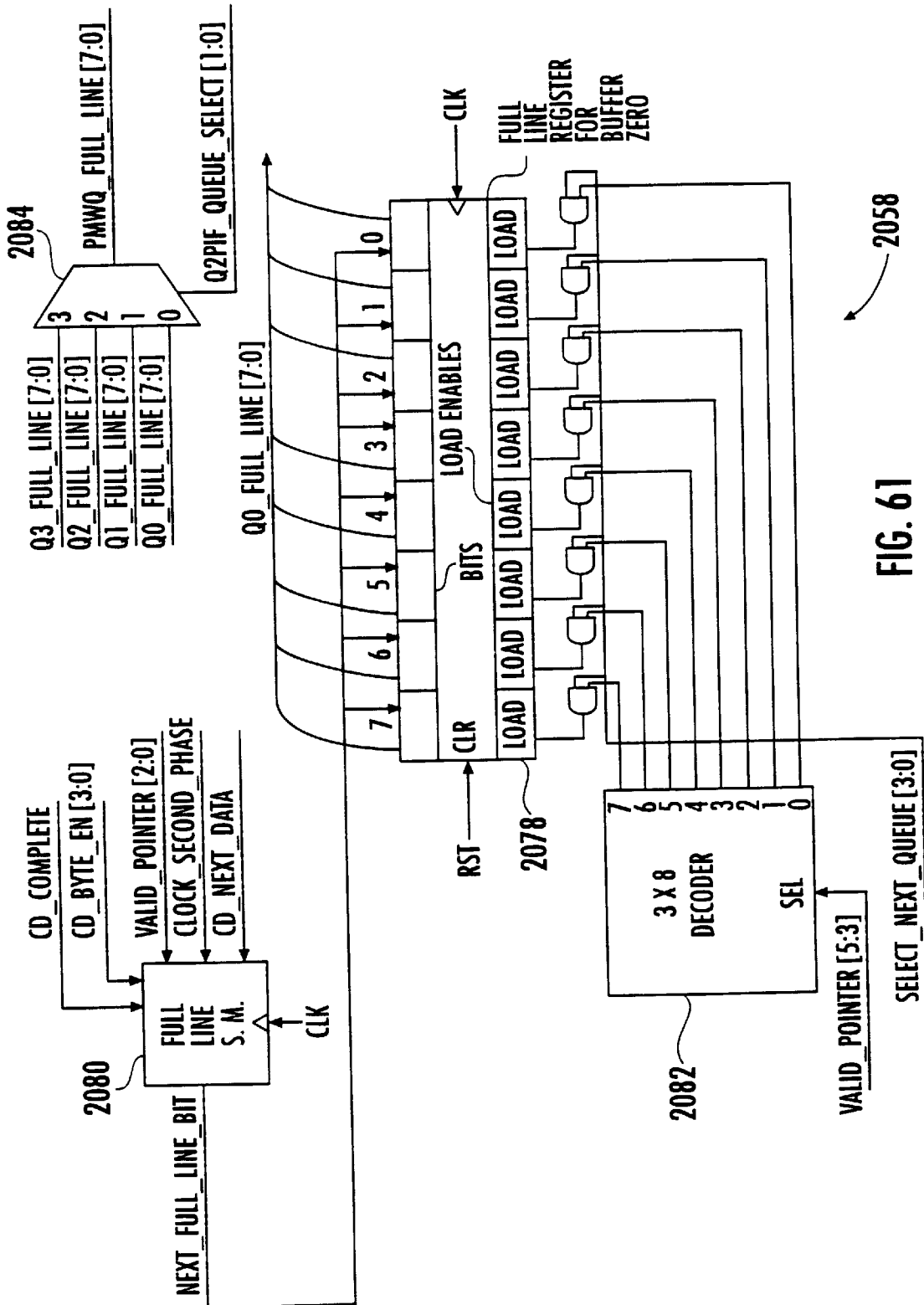
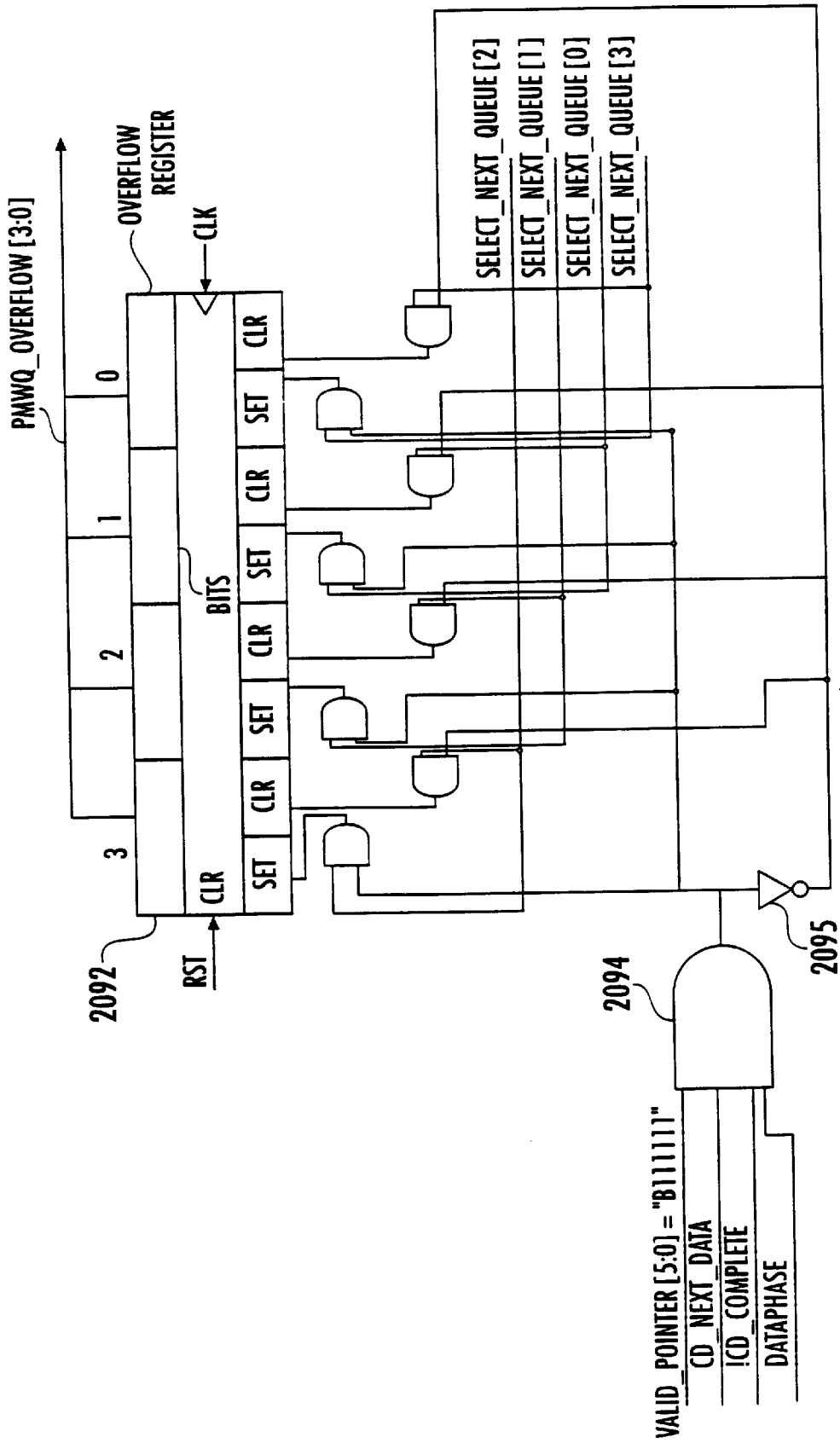

FIG. 61







2090 FIG. 63

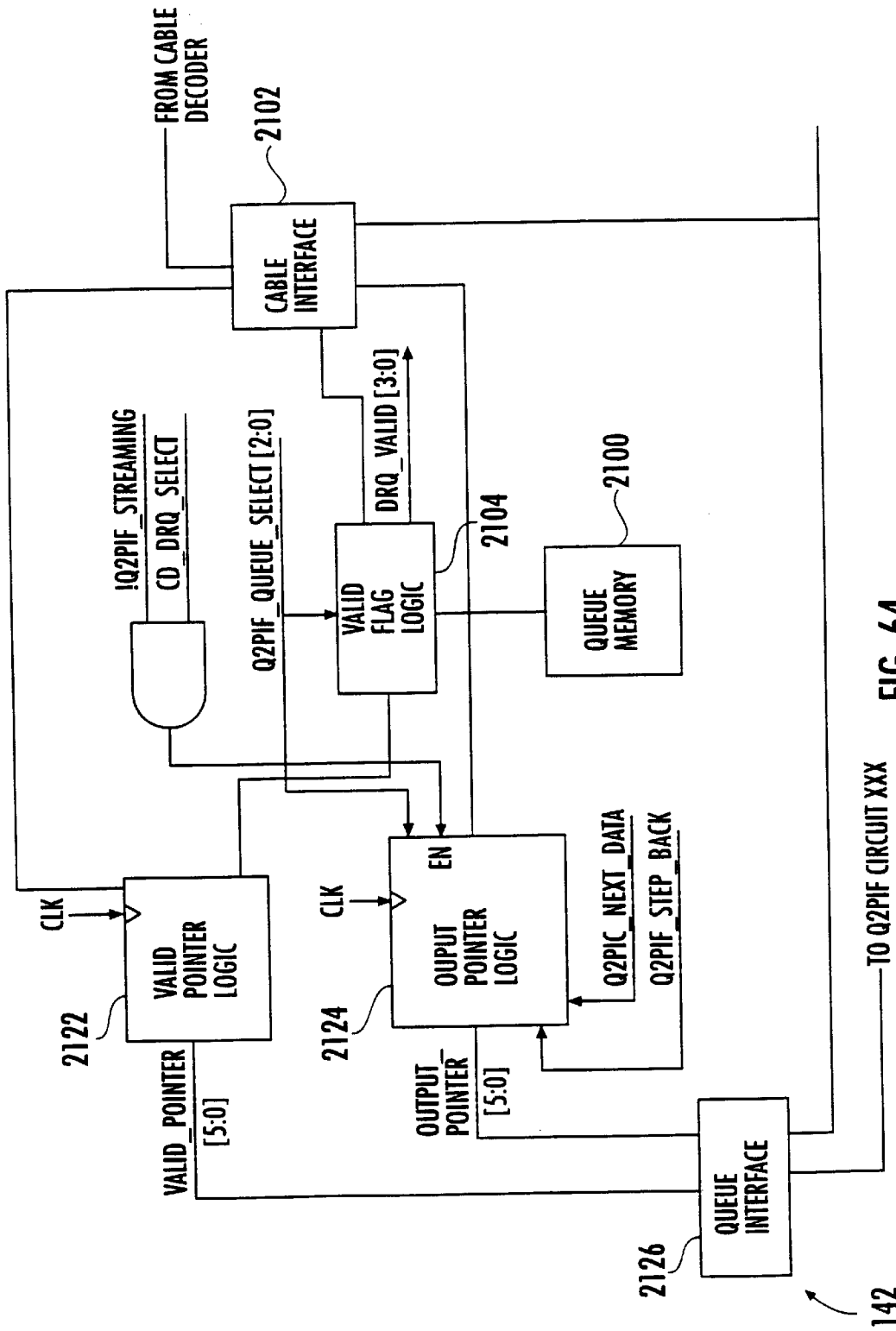

FIG. 64

TO Q2PIF CIRCUIT XXX

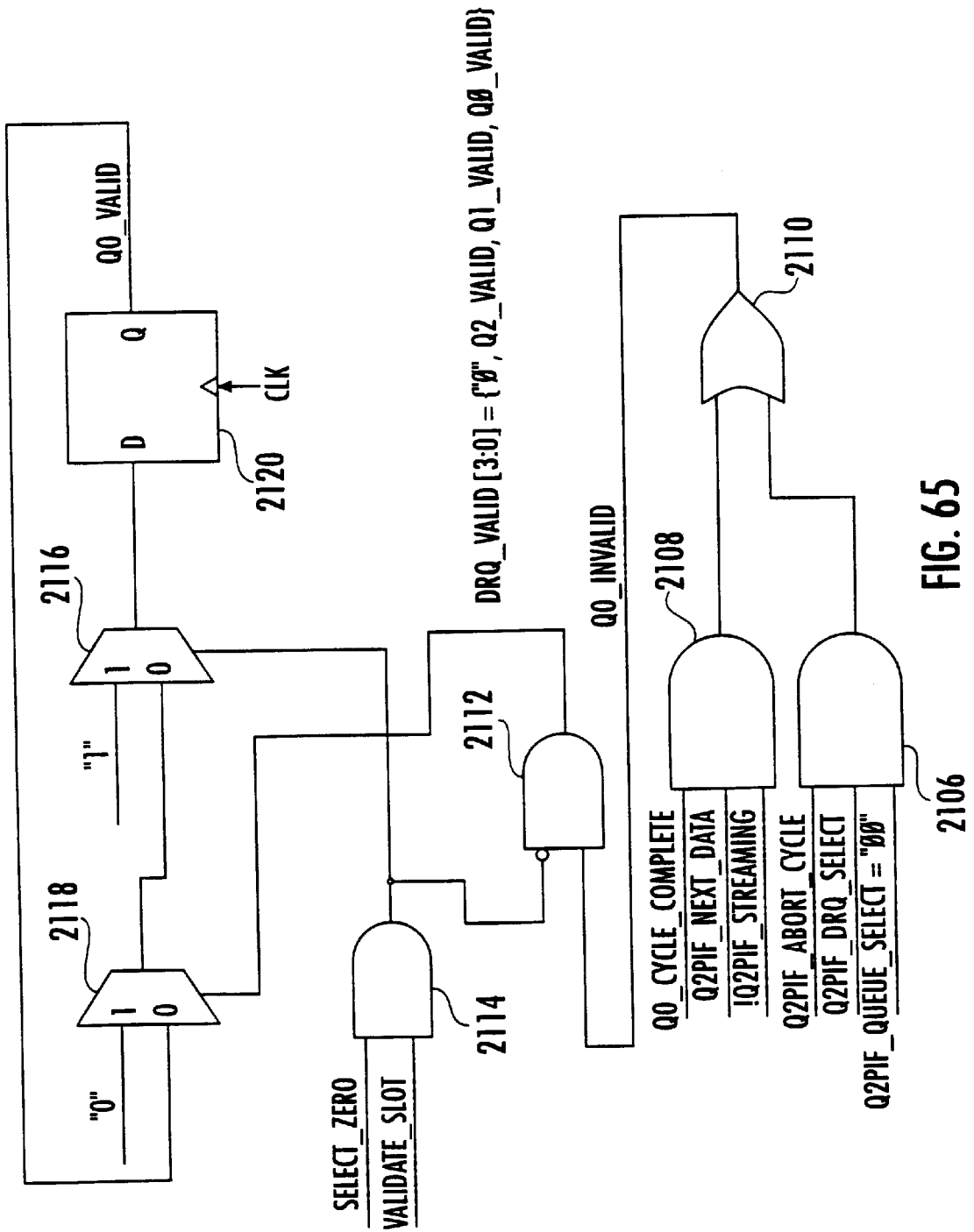

FIG. 65

2104

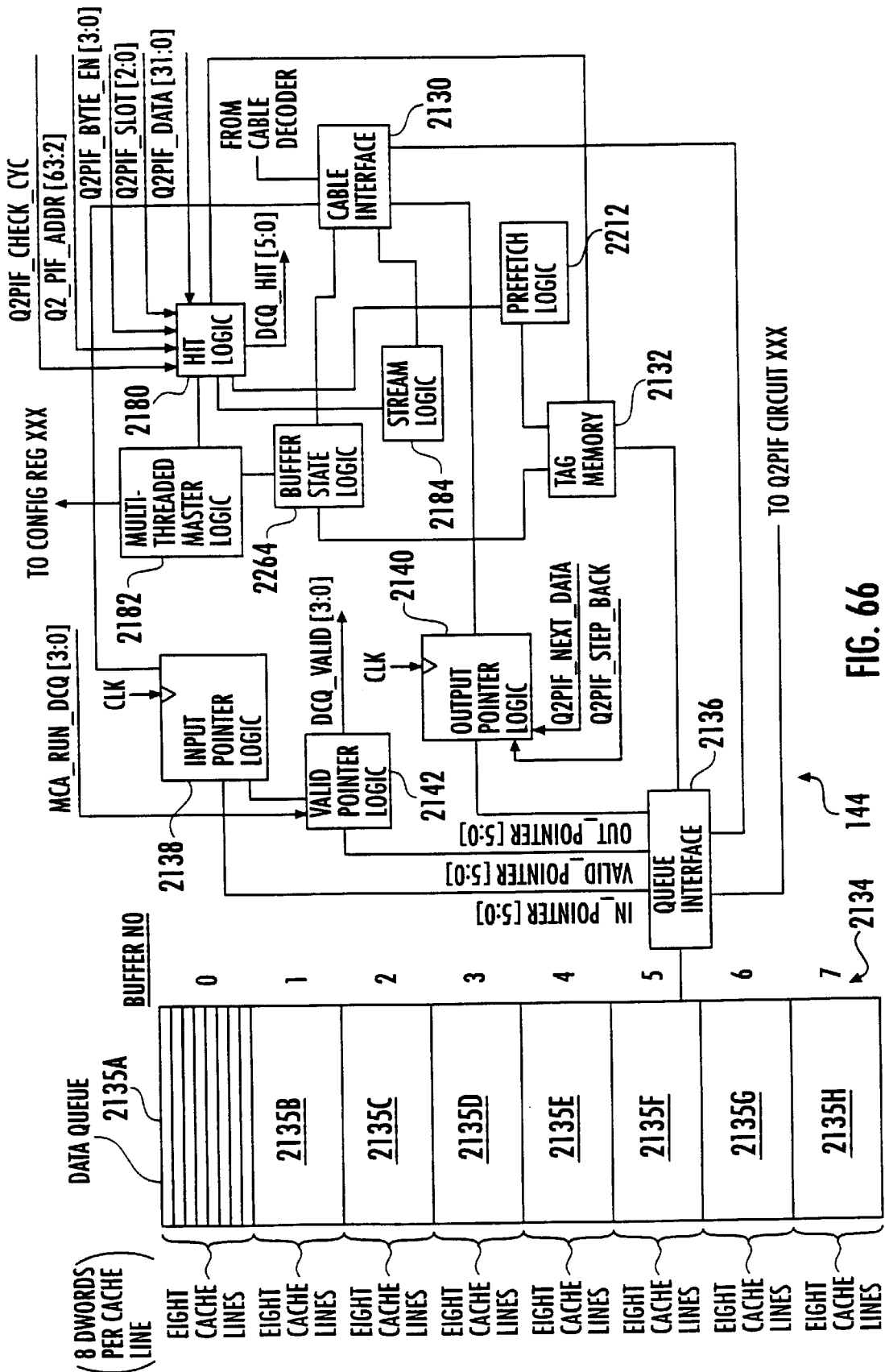

FIG. 66





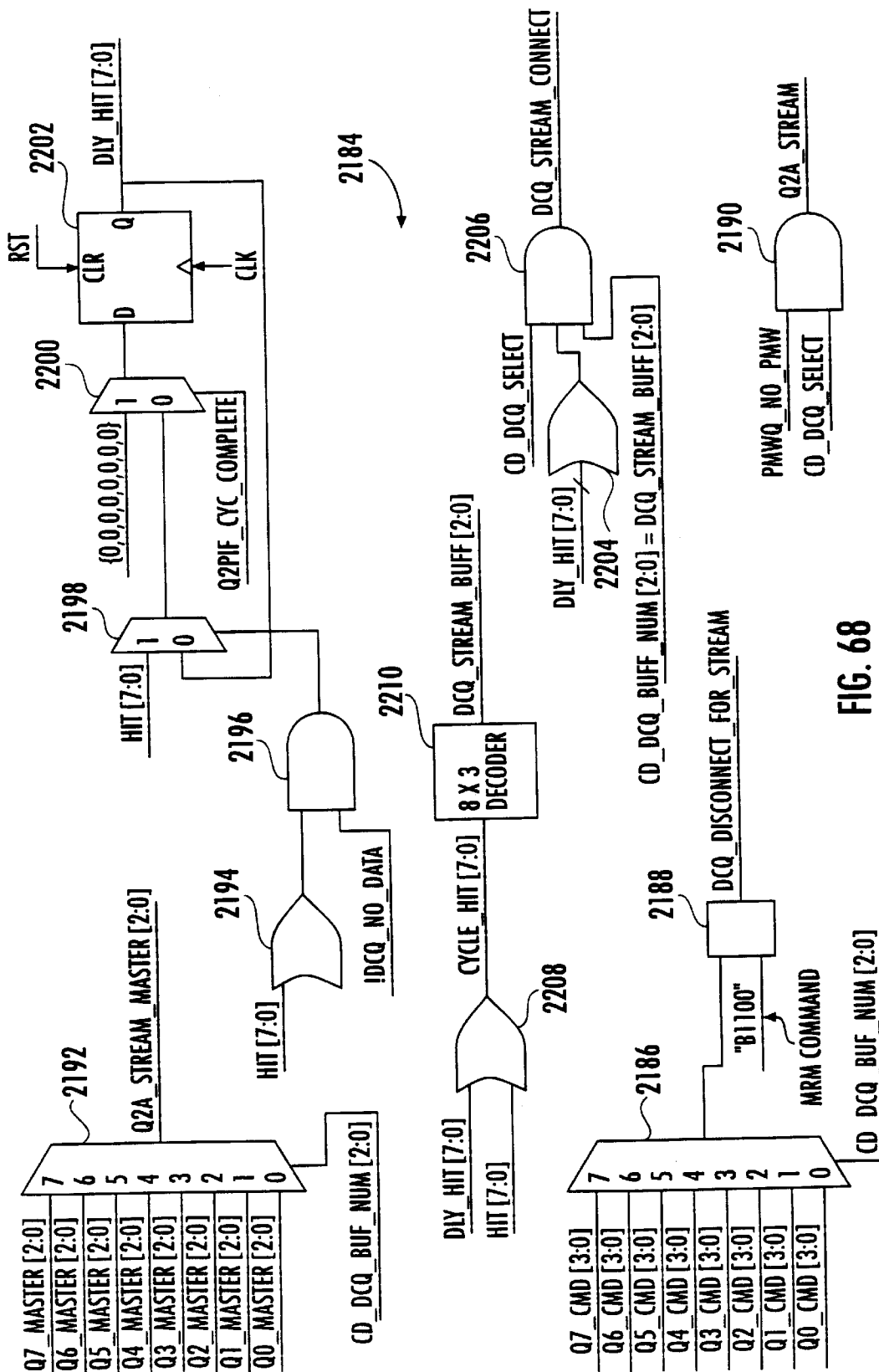

FIG. 68





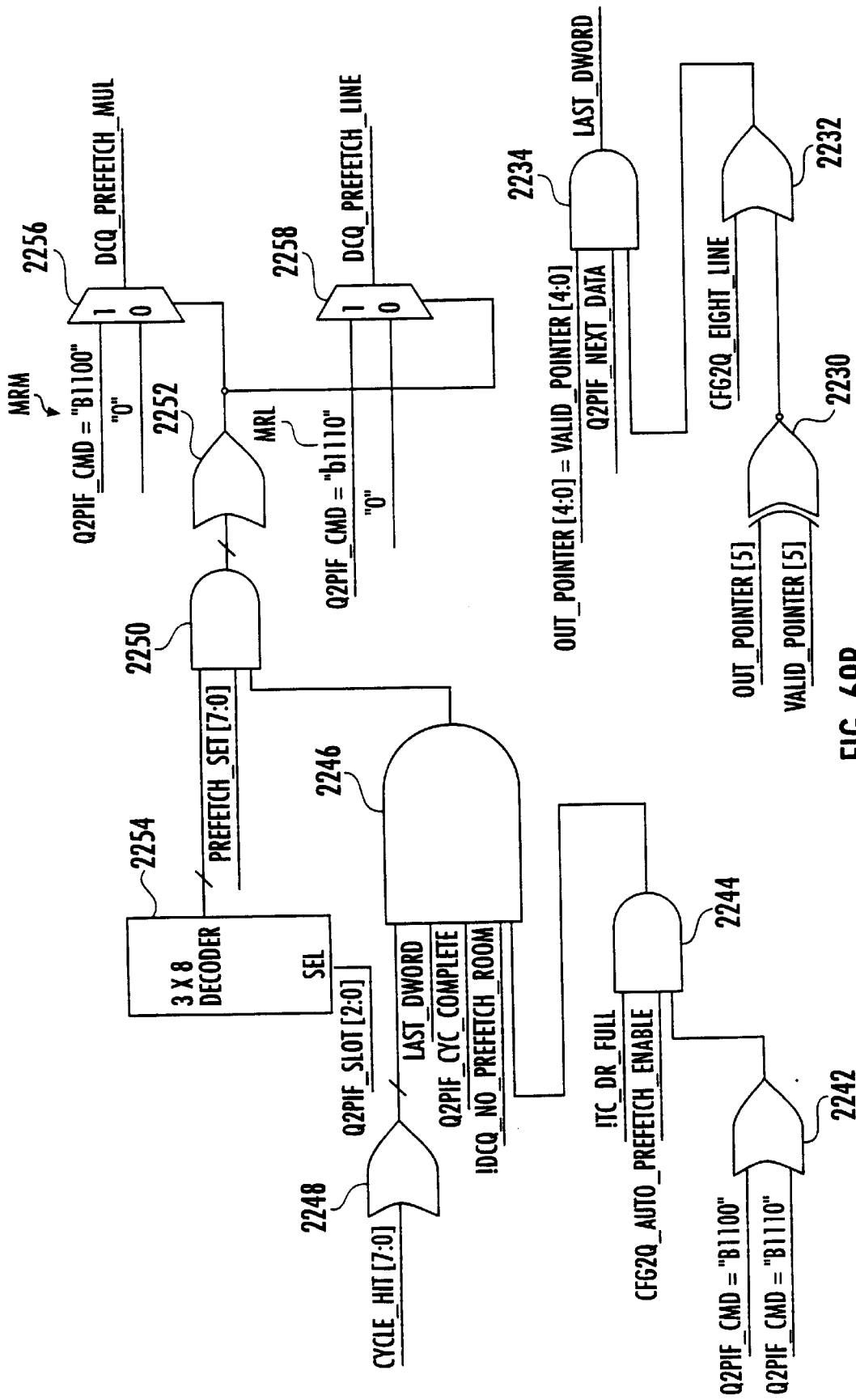

FIG. 69B

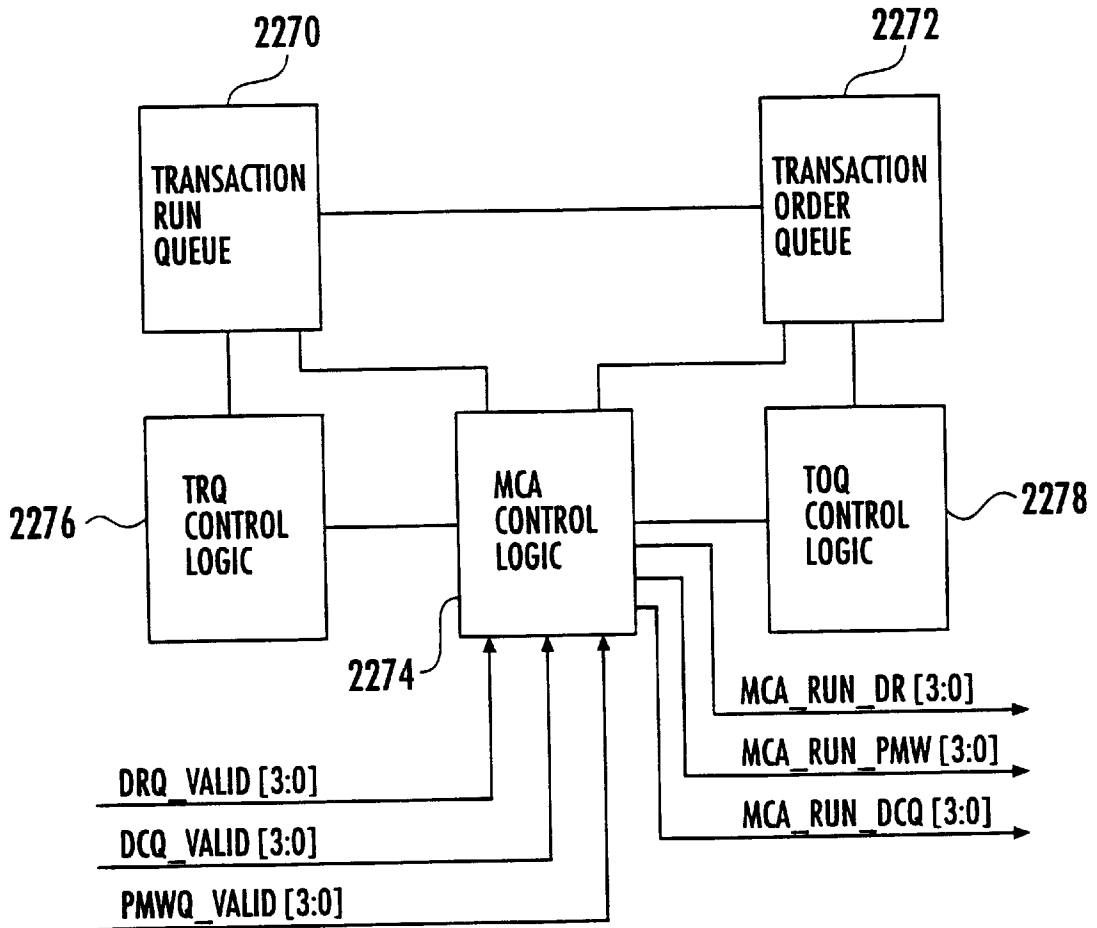
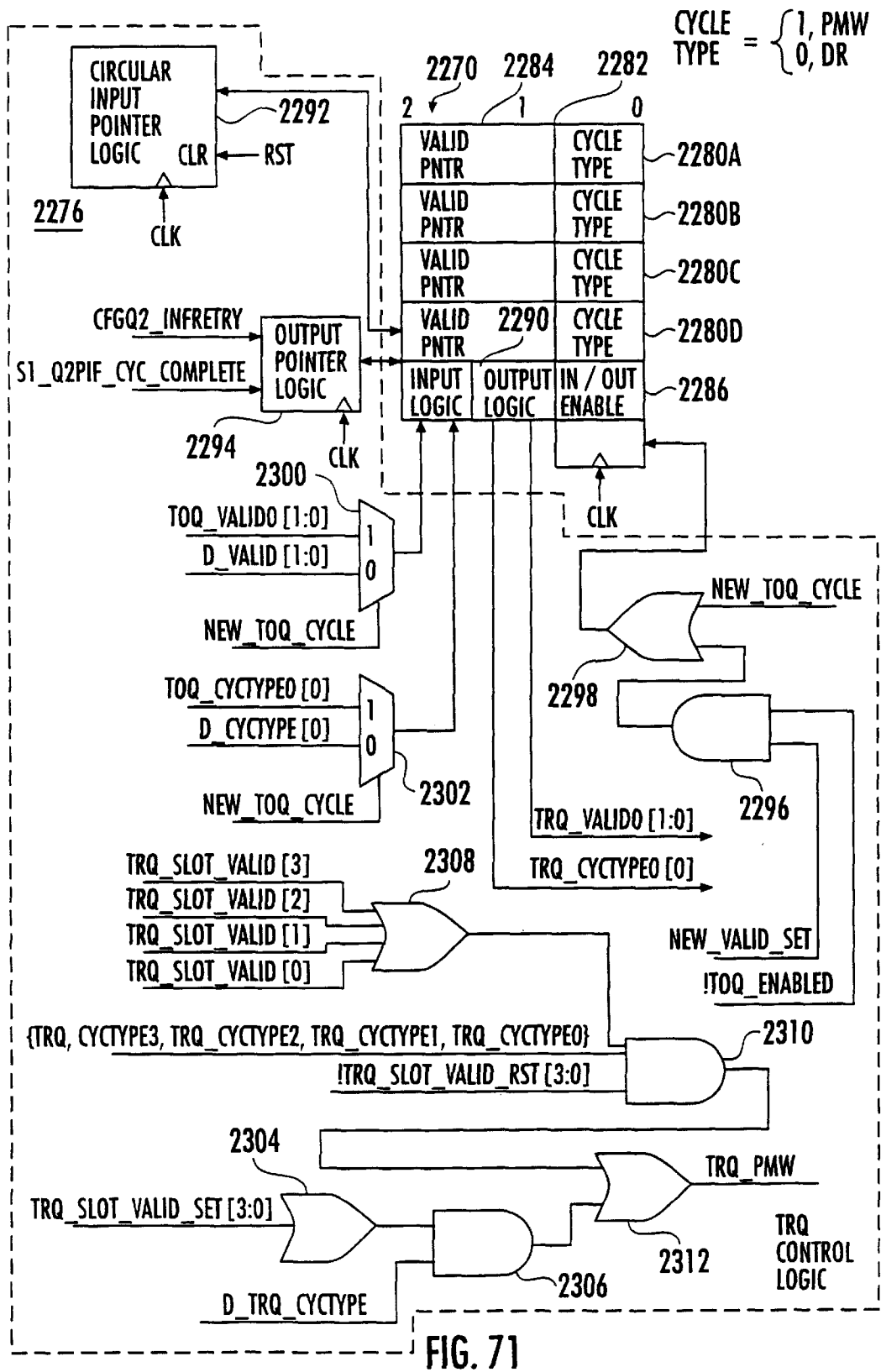

FIG. 70



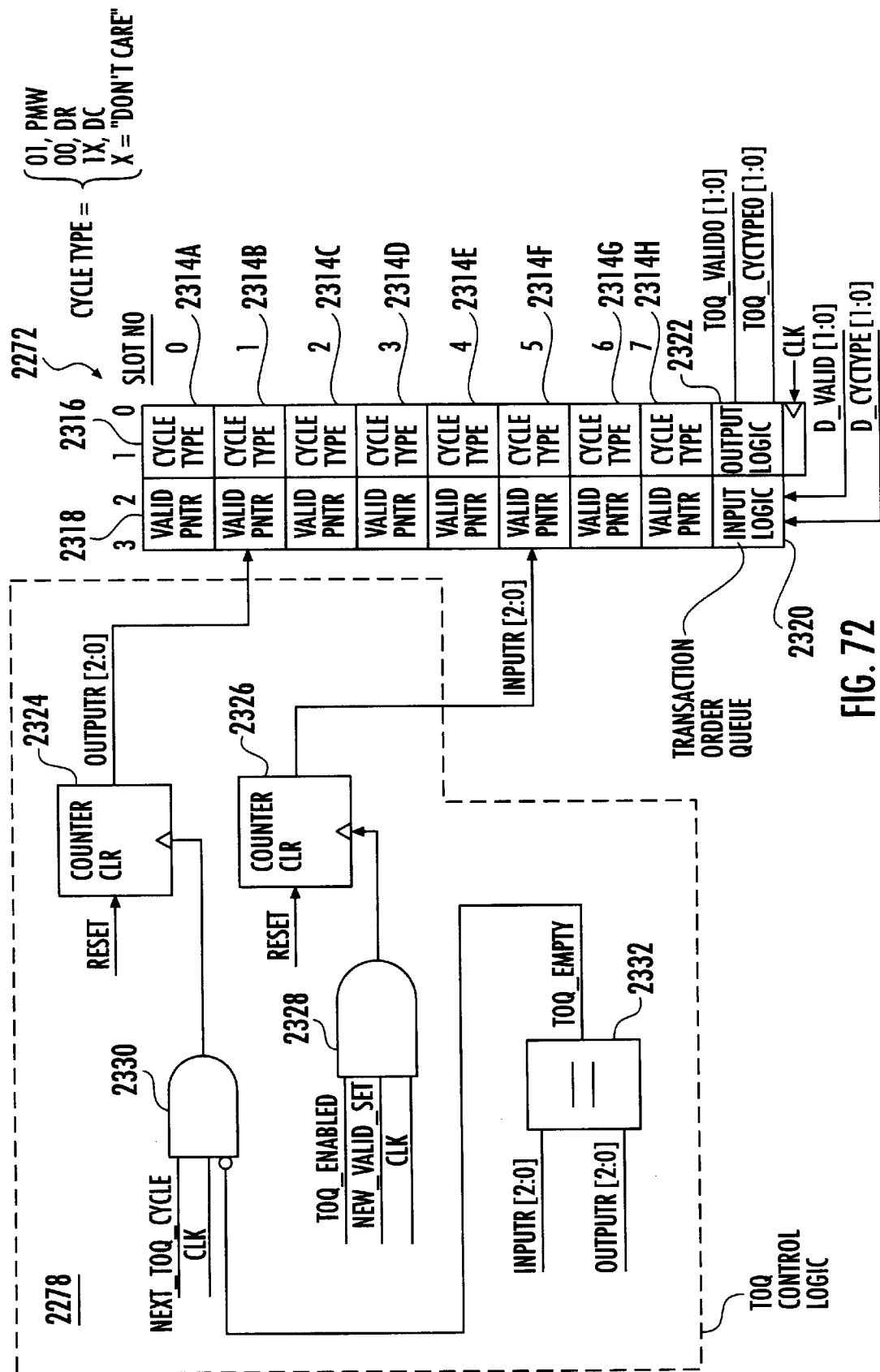

FIG. 72

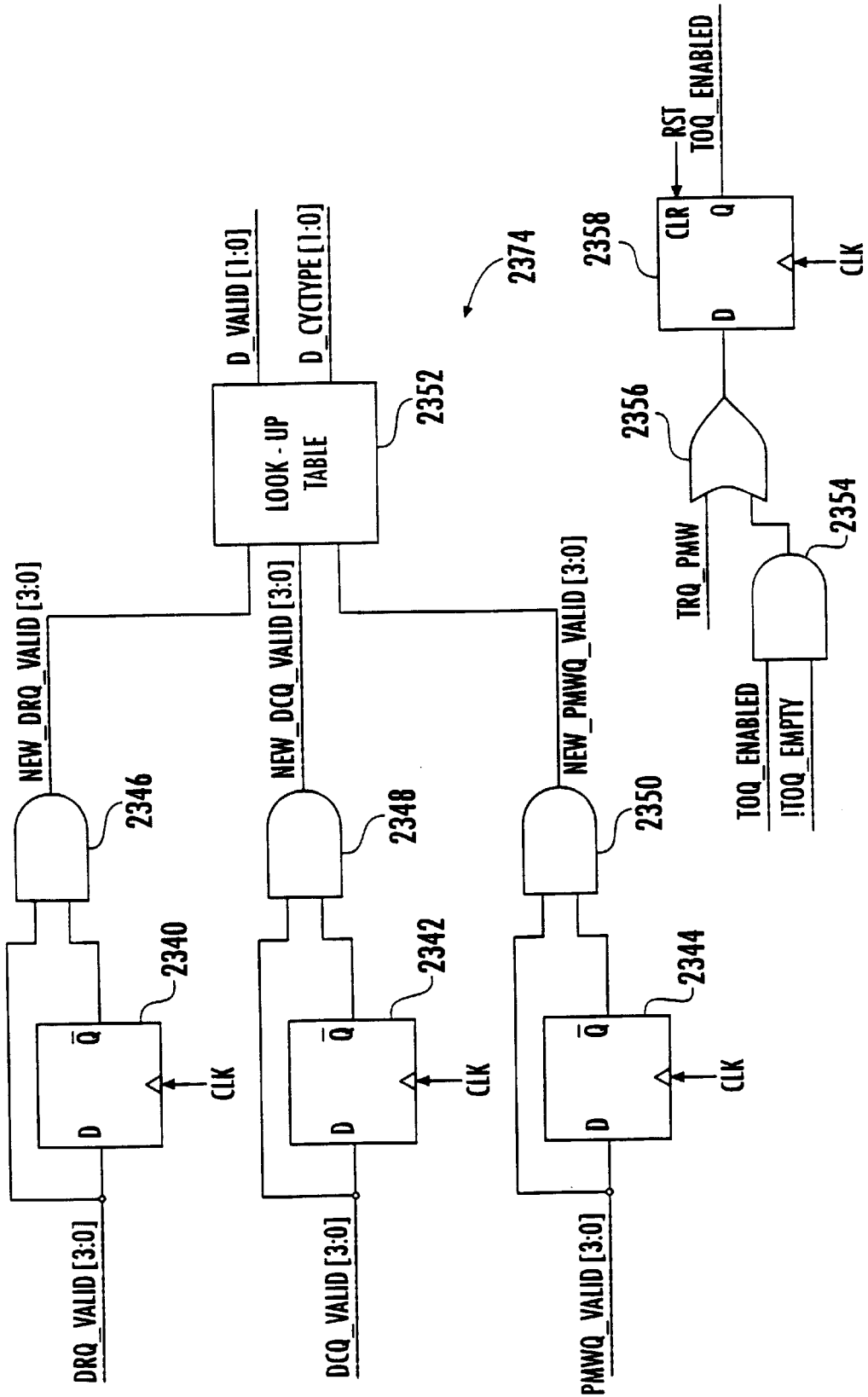

FIG. 73A

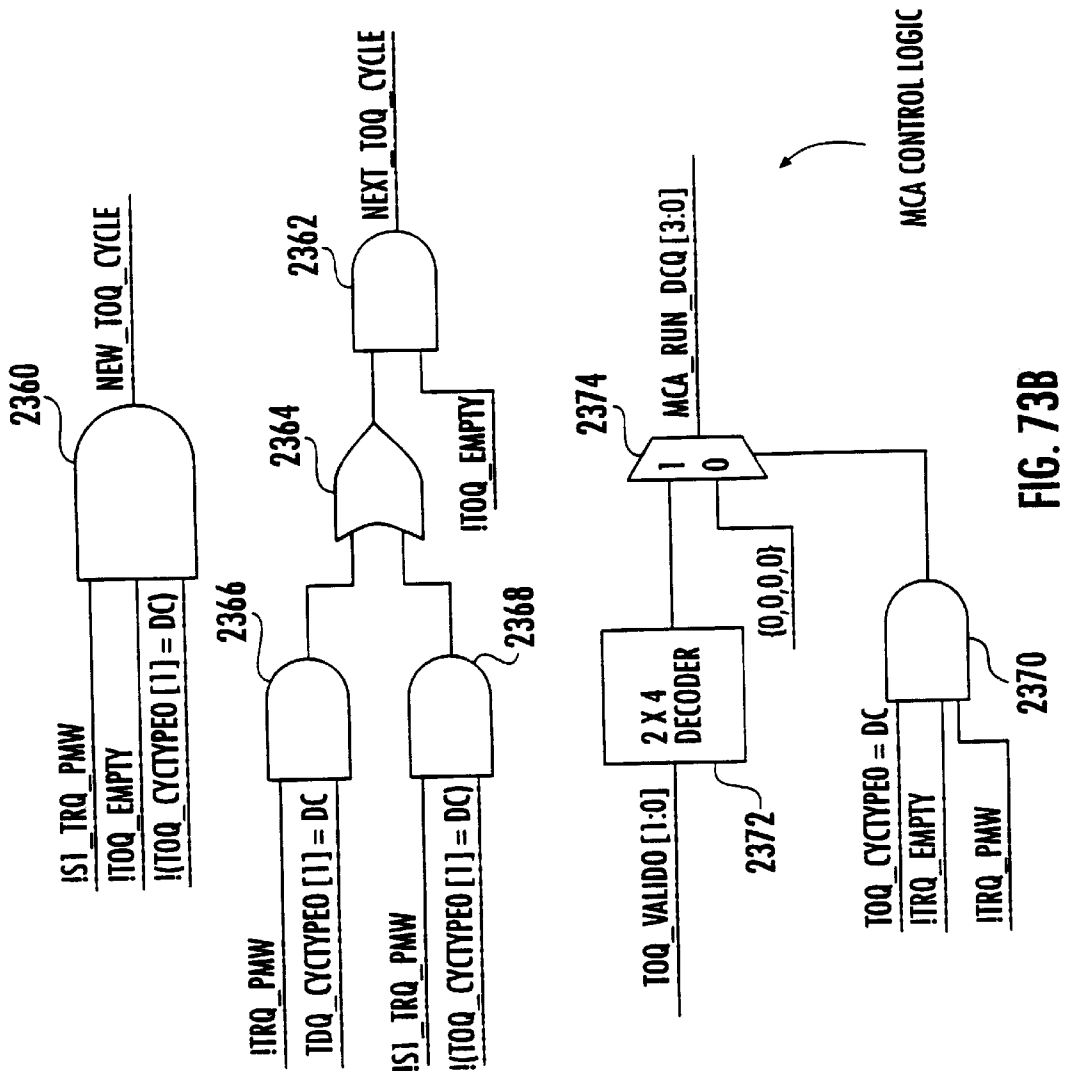

FIG. 73B

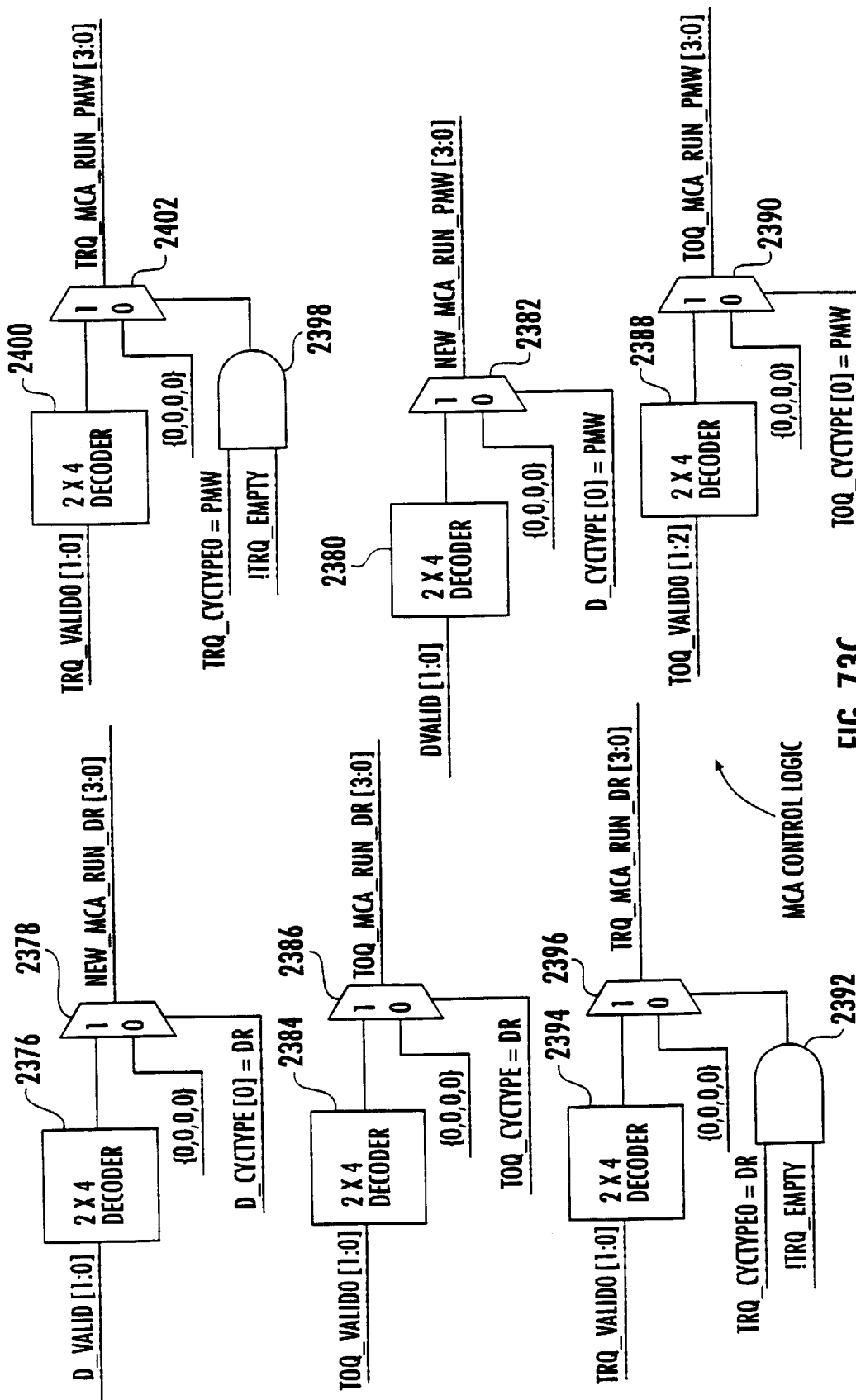

FIG. 73C



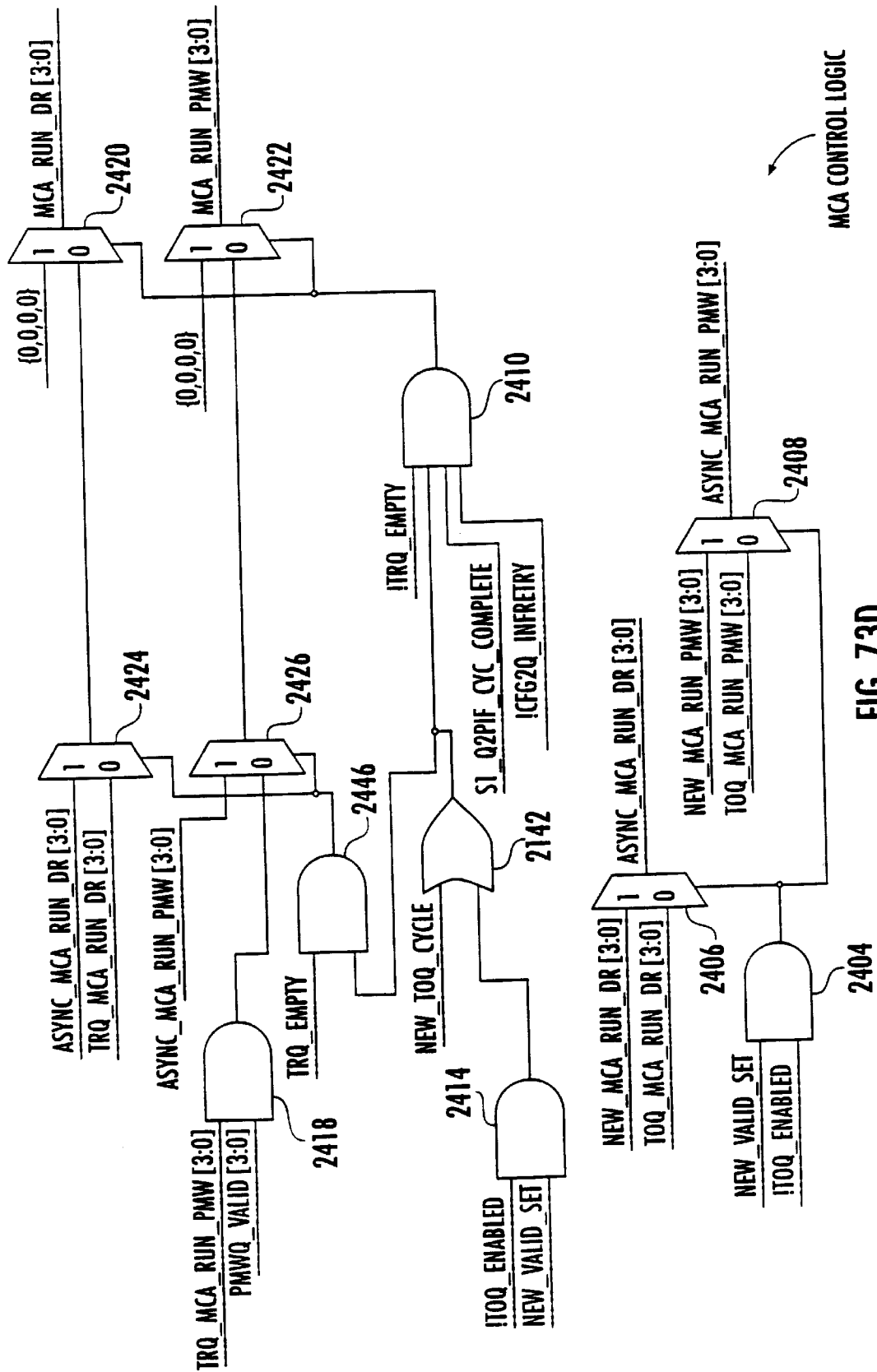

FIG. 73D

2352

{NEW_DRQ_VALID [3:0], NEW_DCQ_VALID [3:0], NEW_PMEW_VALID [3:0]}	D_VALID [1:0]	D_CYCTYPE [1:0]
0000 0000 0001	00	01
0000 0000 0010	01	01
0000 0000 0100	10	01
0000 0000 1000	11	01
0000 0001 0000	00	1X
0000 0010 0000	01	1X
0000 0100 0000	10	1X
0000 1000 0000	11	1X
0001 0000 0000	00	00
0010 0000 0000	01	00
0100 0000 0000	10	00
1000 0000 0000	11	00

FIG. 74

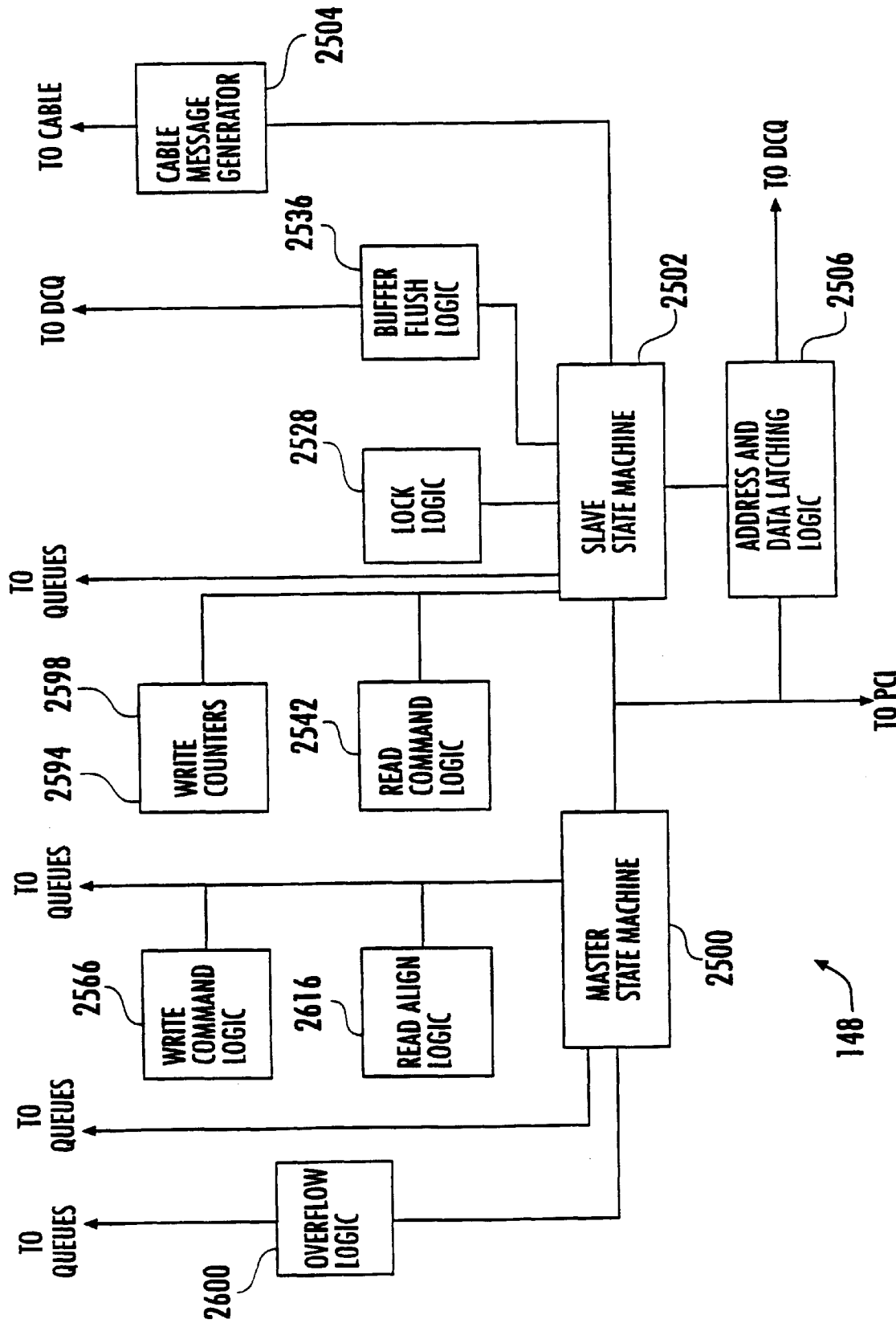

FIG. 75

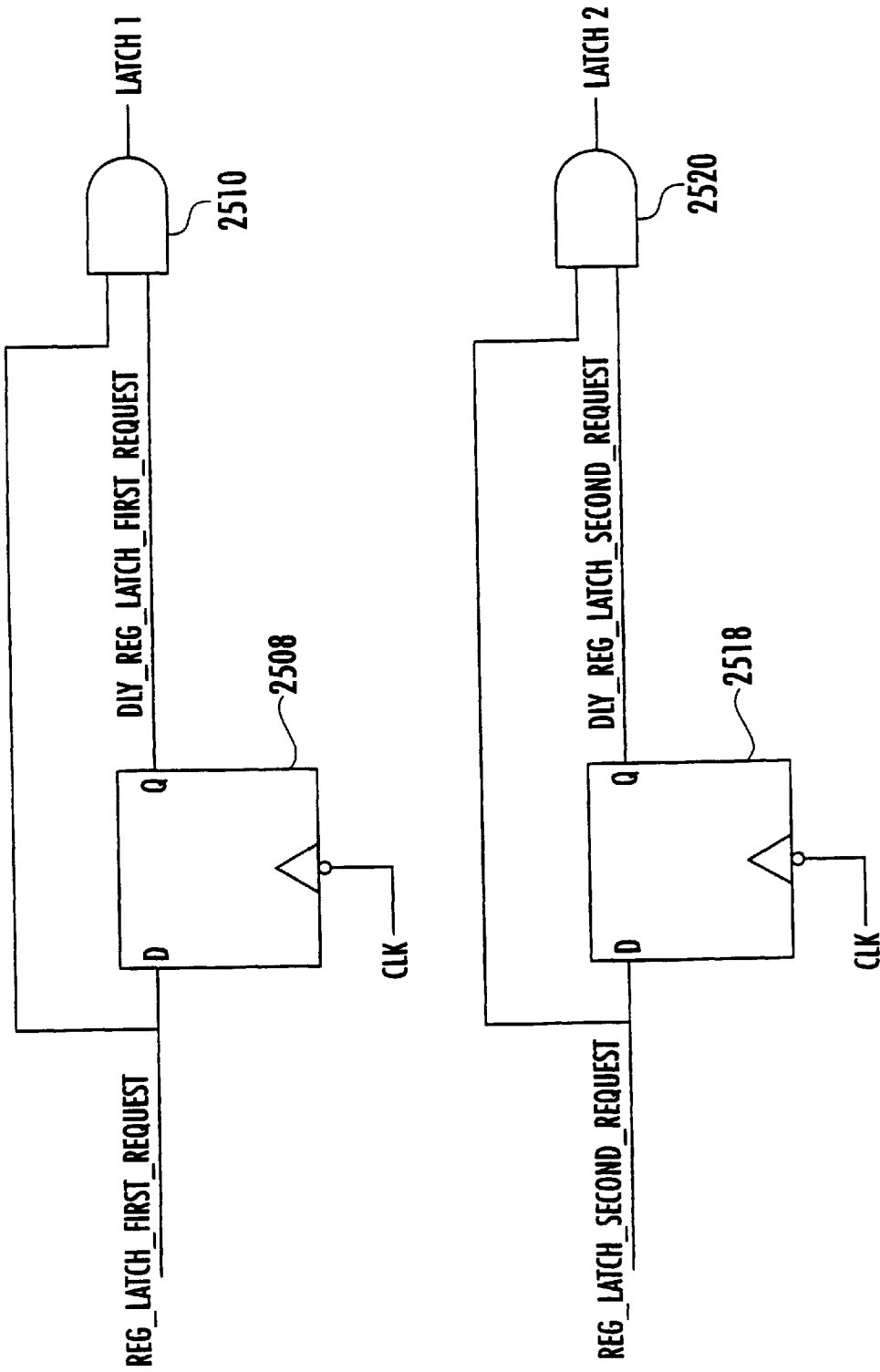

FIG. 76A

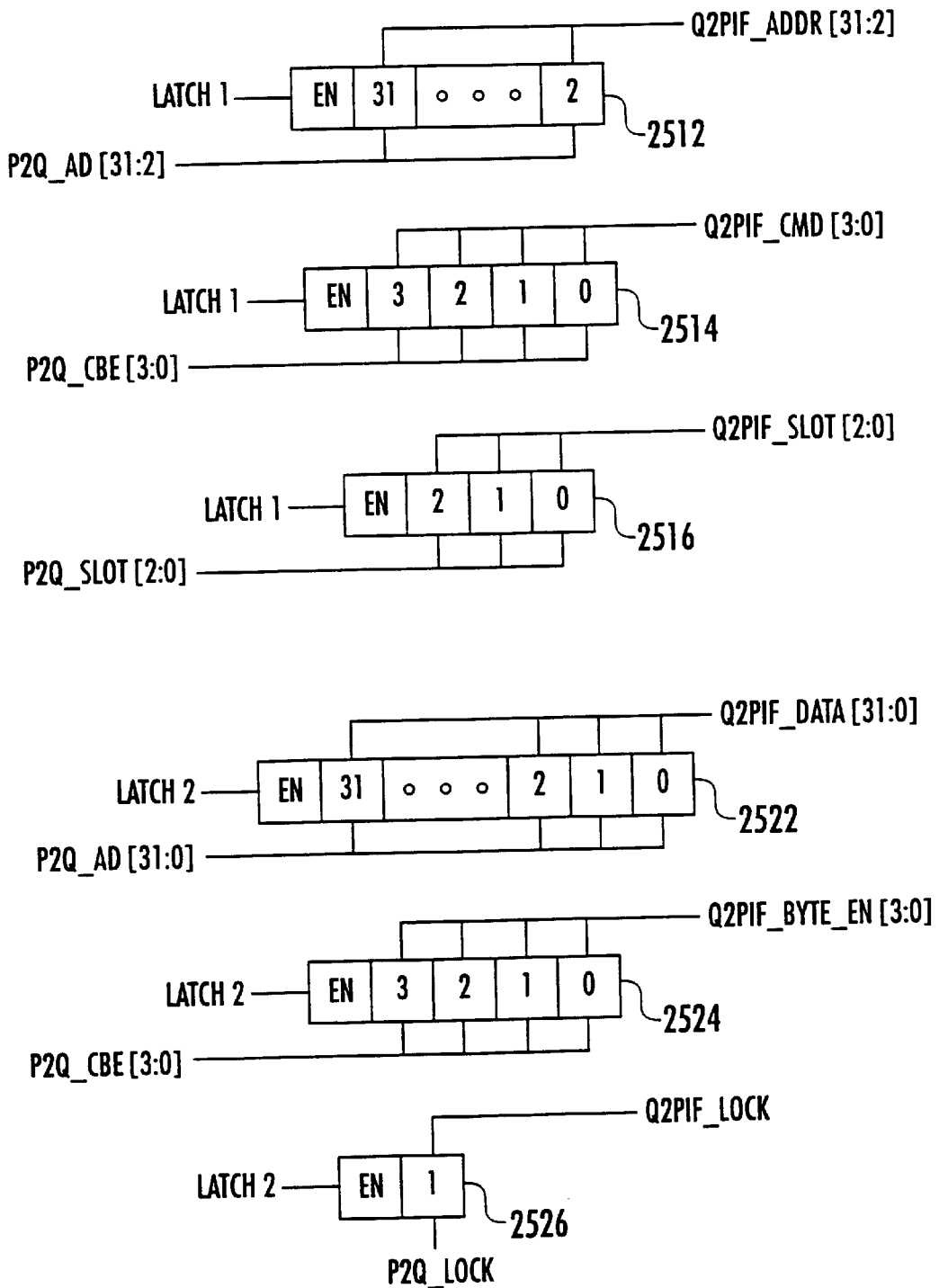

FIG. 76B

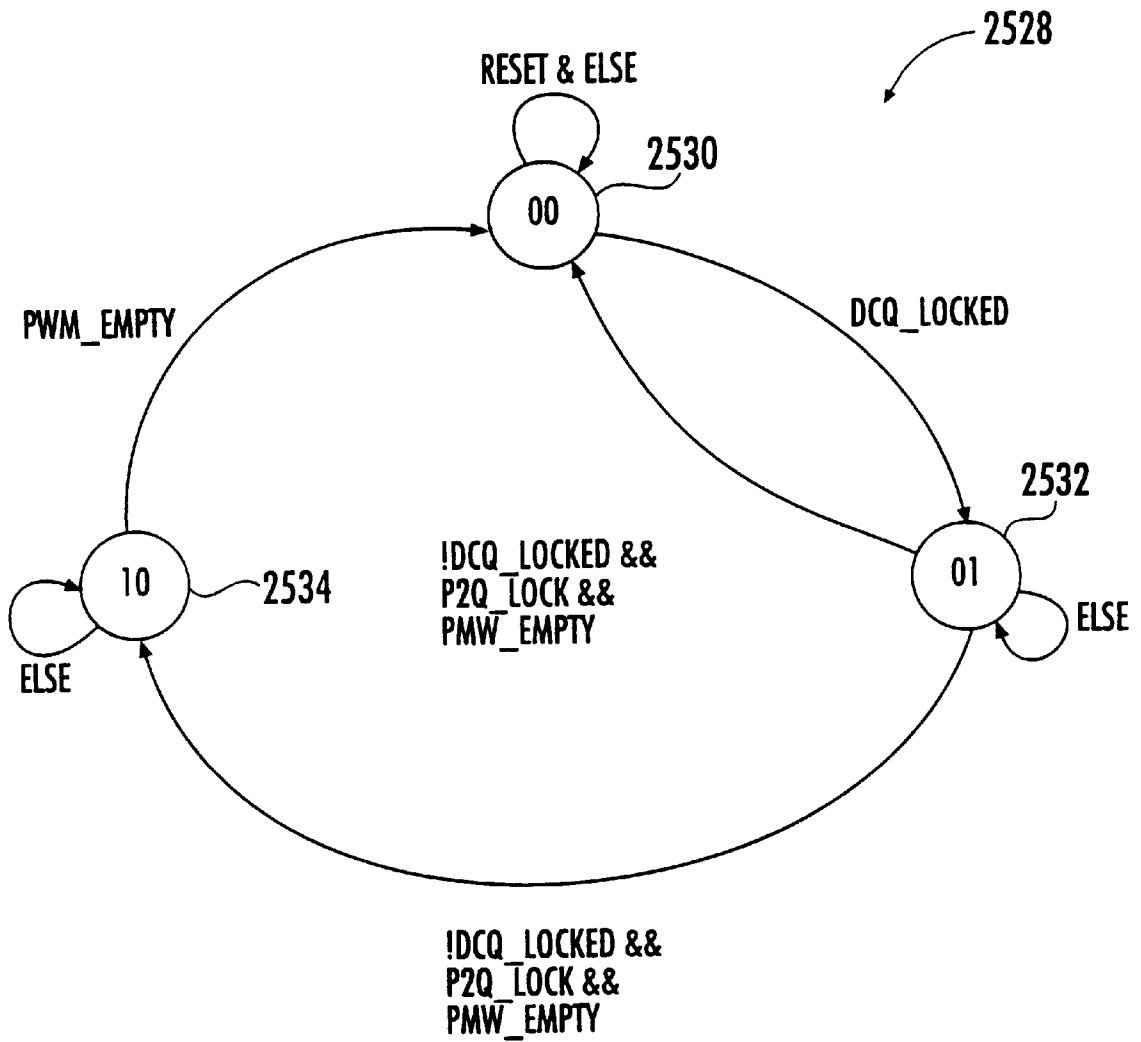

FIG. 77

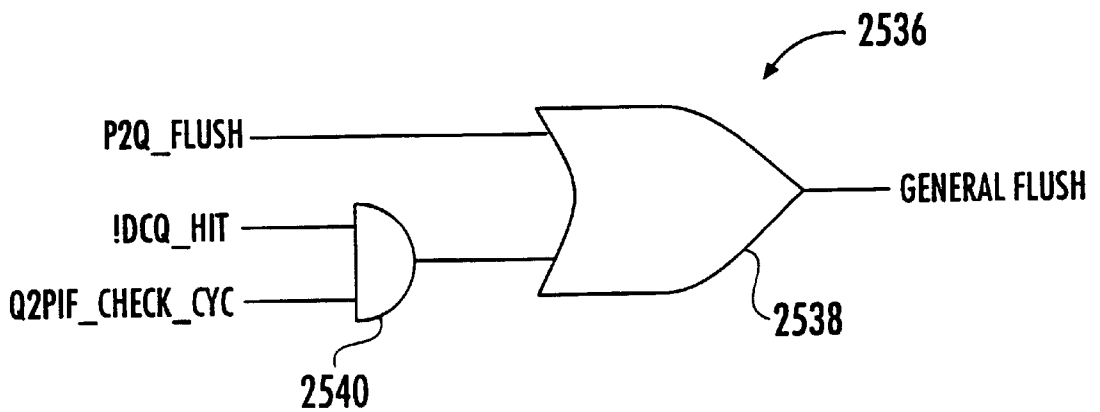

FIG. 78

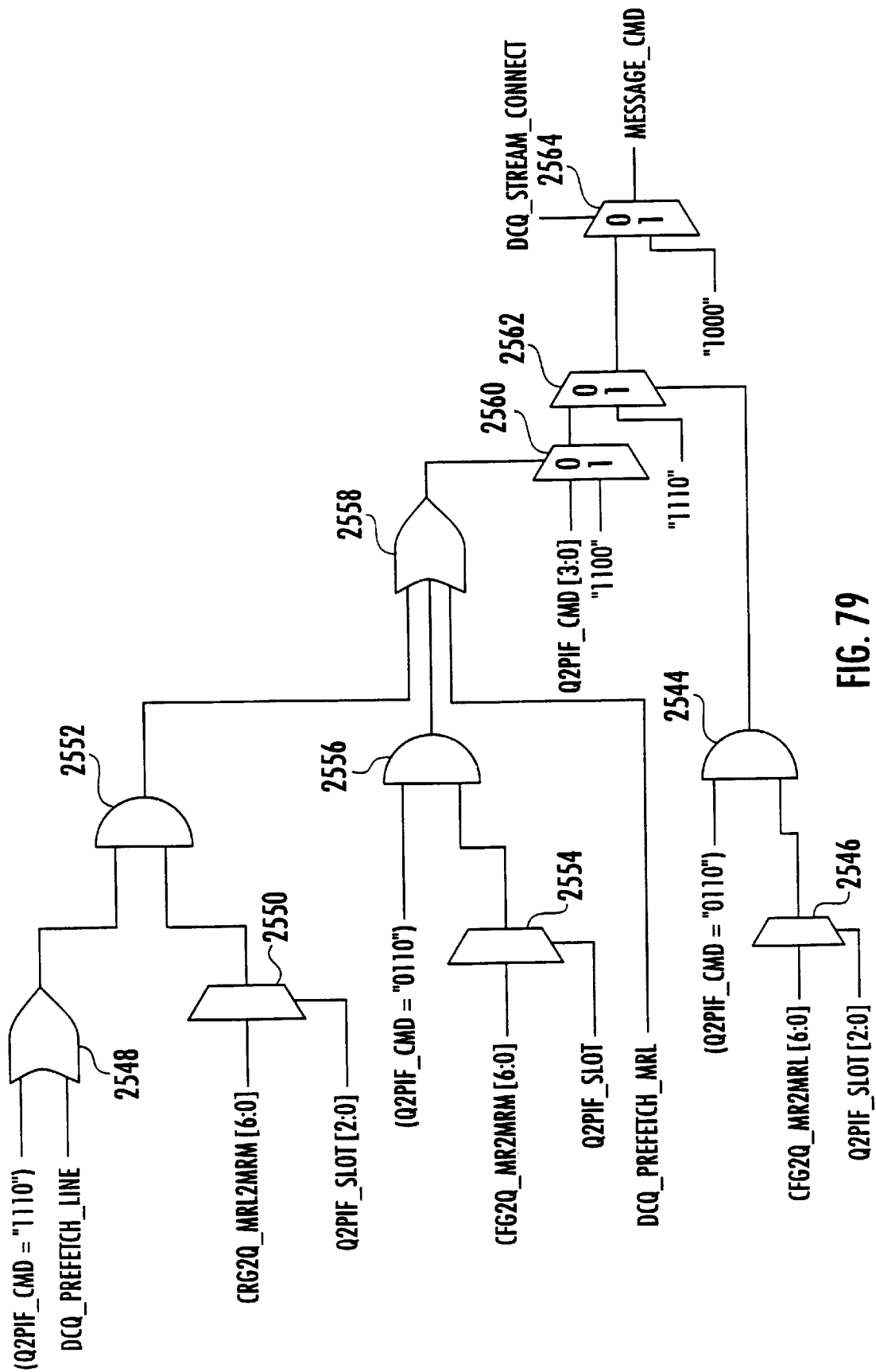

FIG. 79

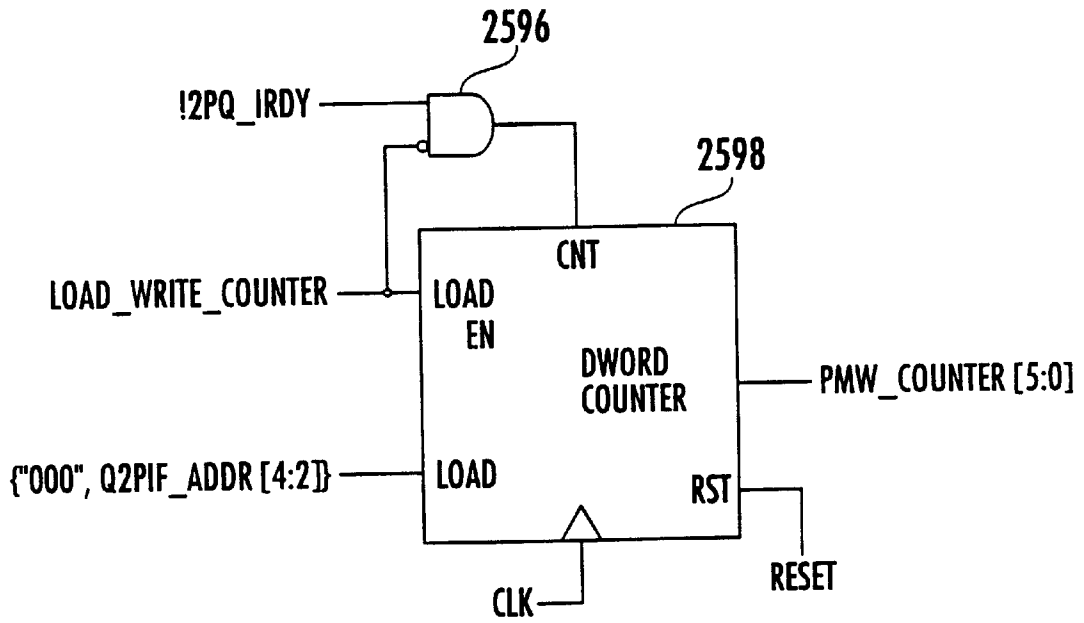
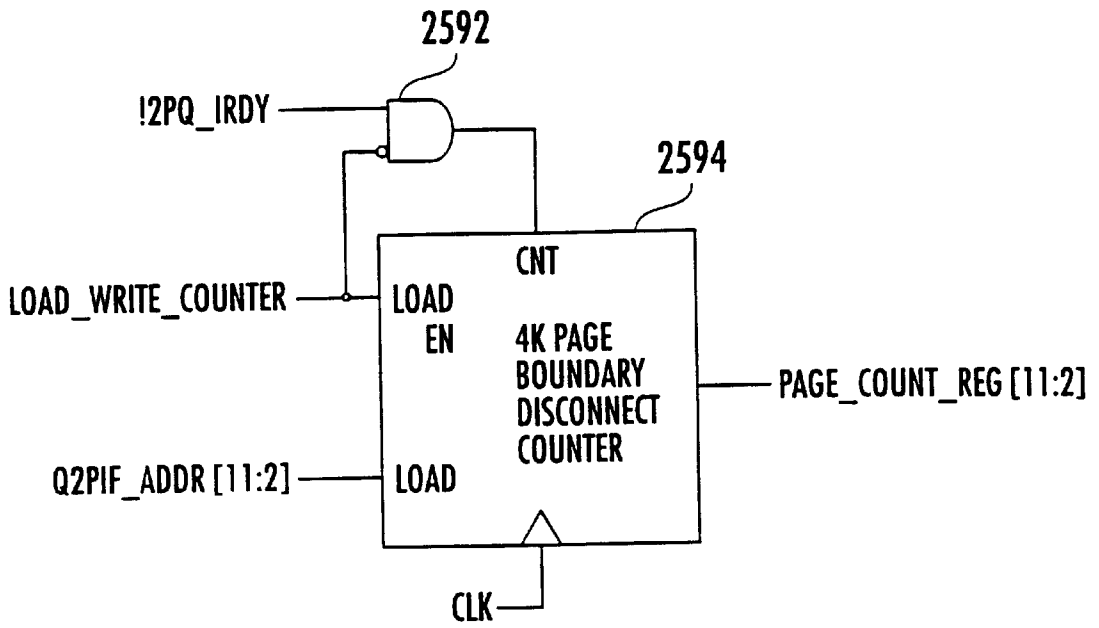

FIG. 80



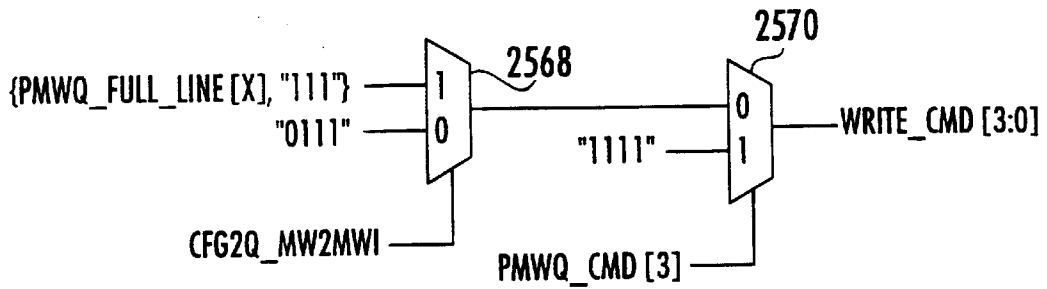

FIG. 81A

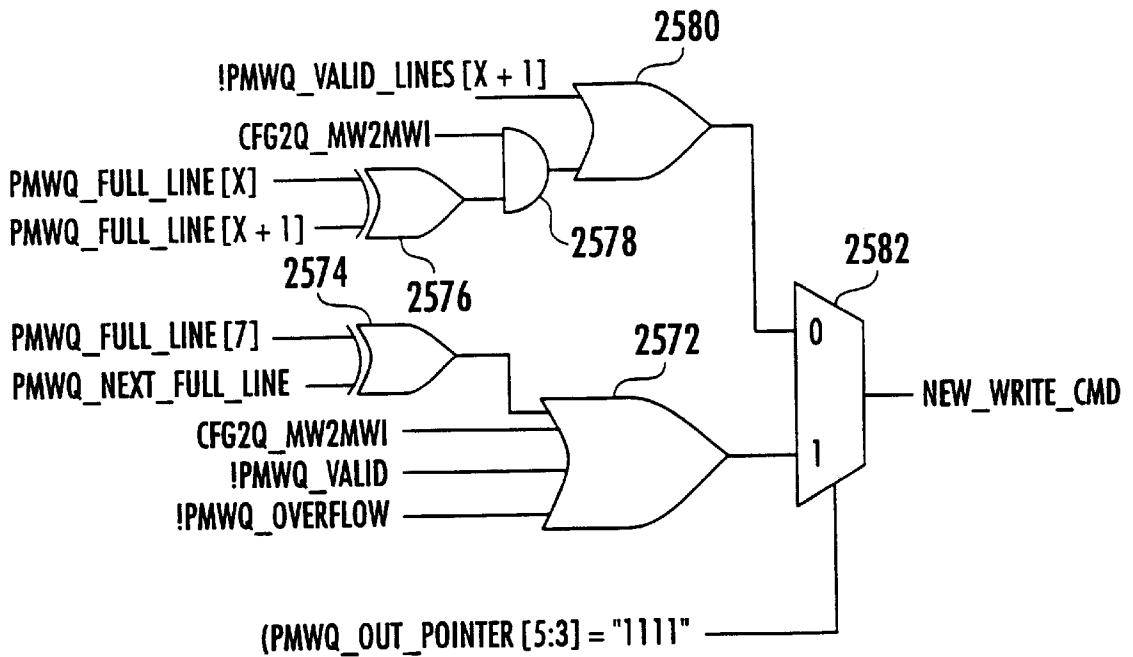

FIG. 81B

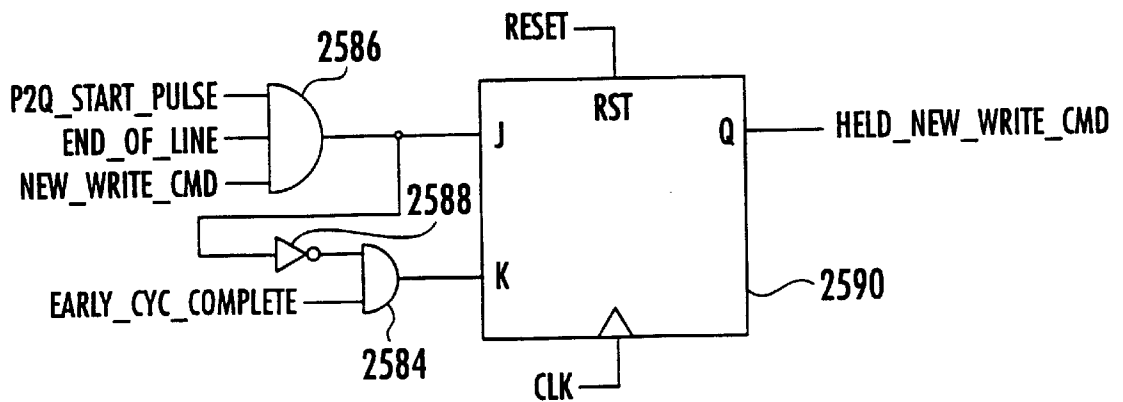

FIG. 81C

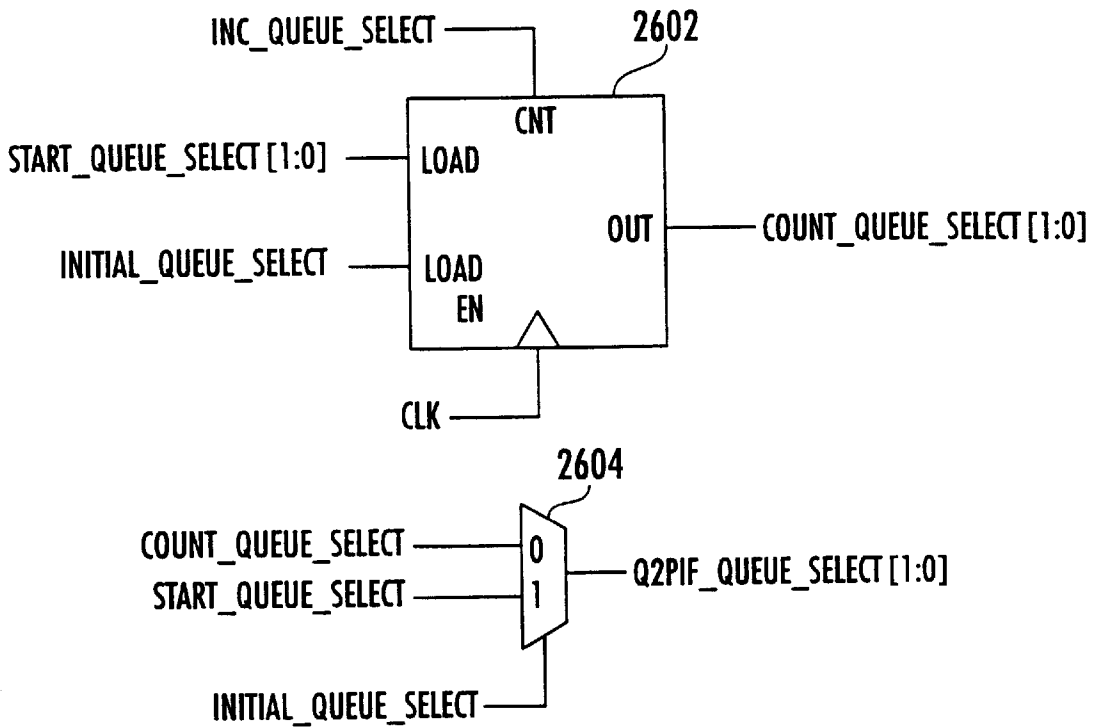

FIG. 82A

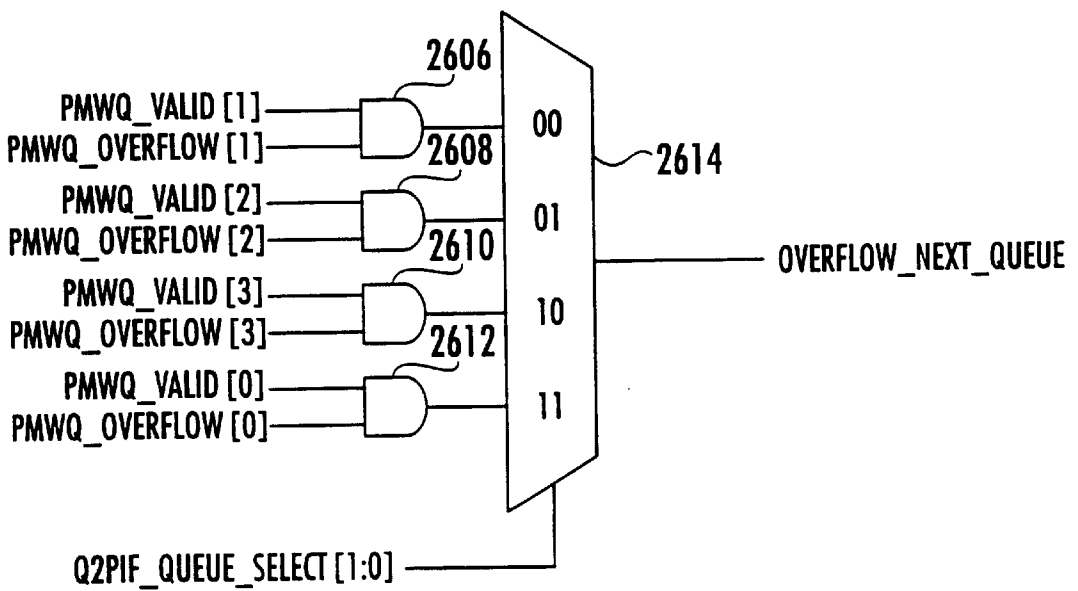
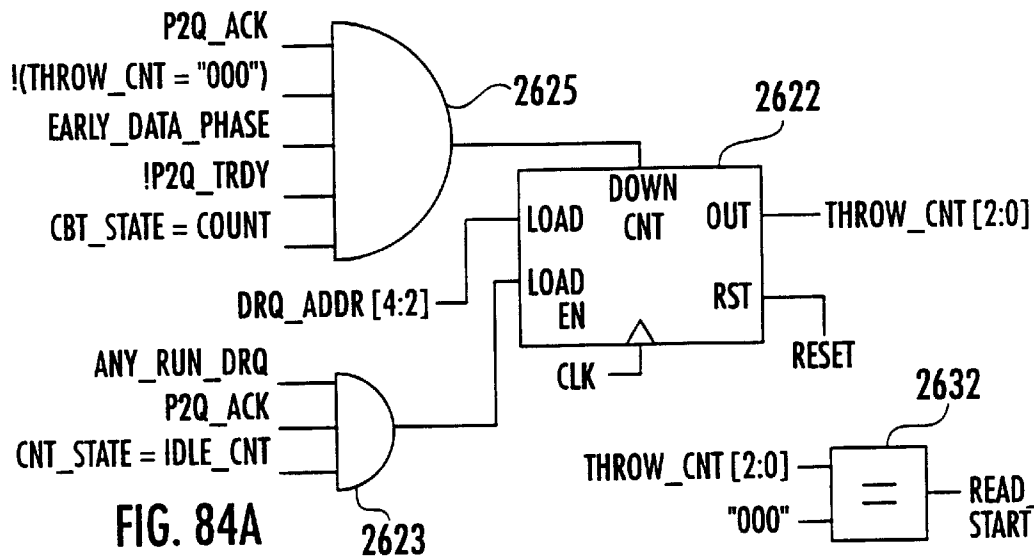
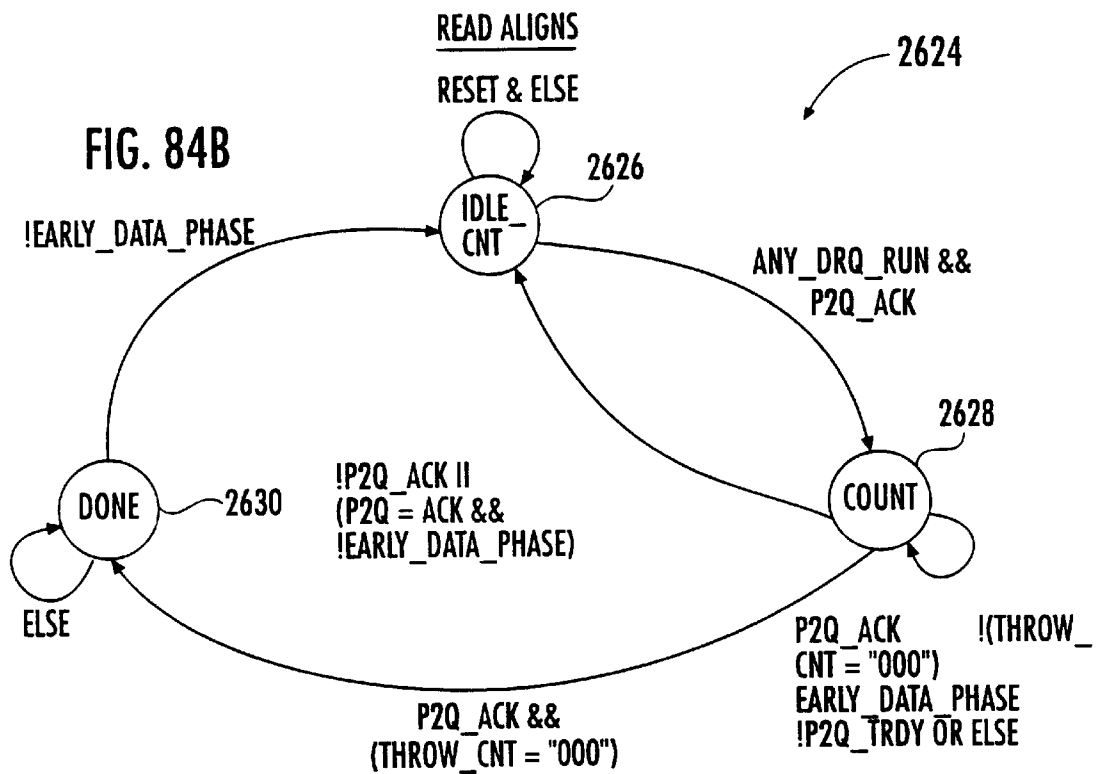
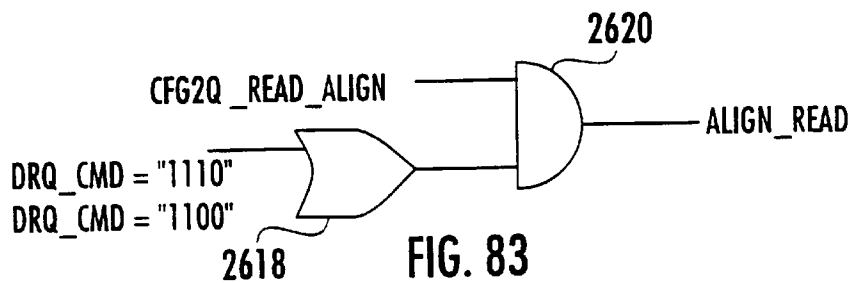

FIG. 82B



**FIG. 84C**



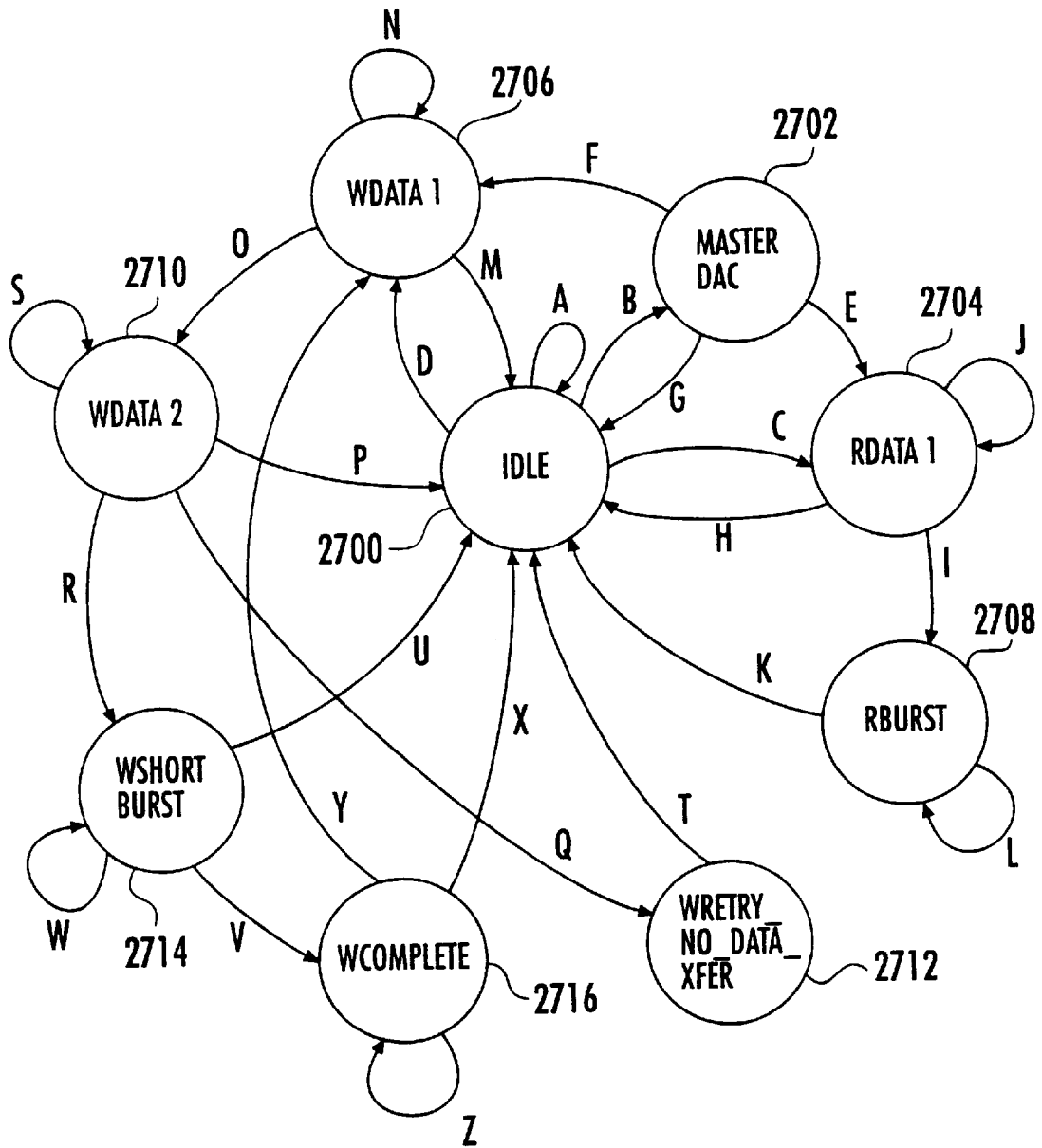

FIG. 85

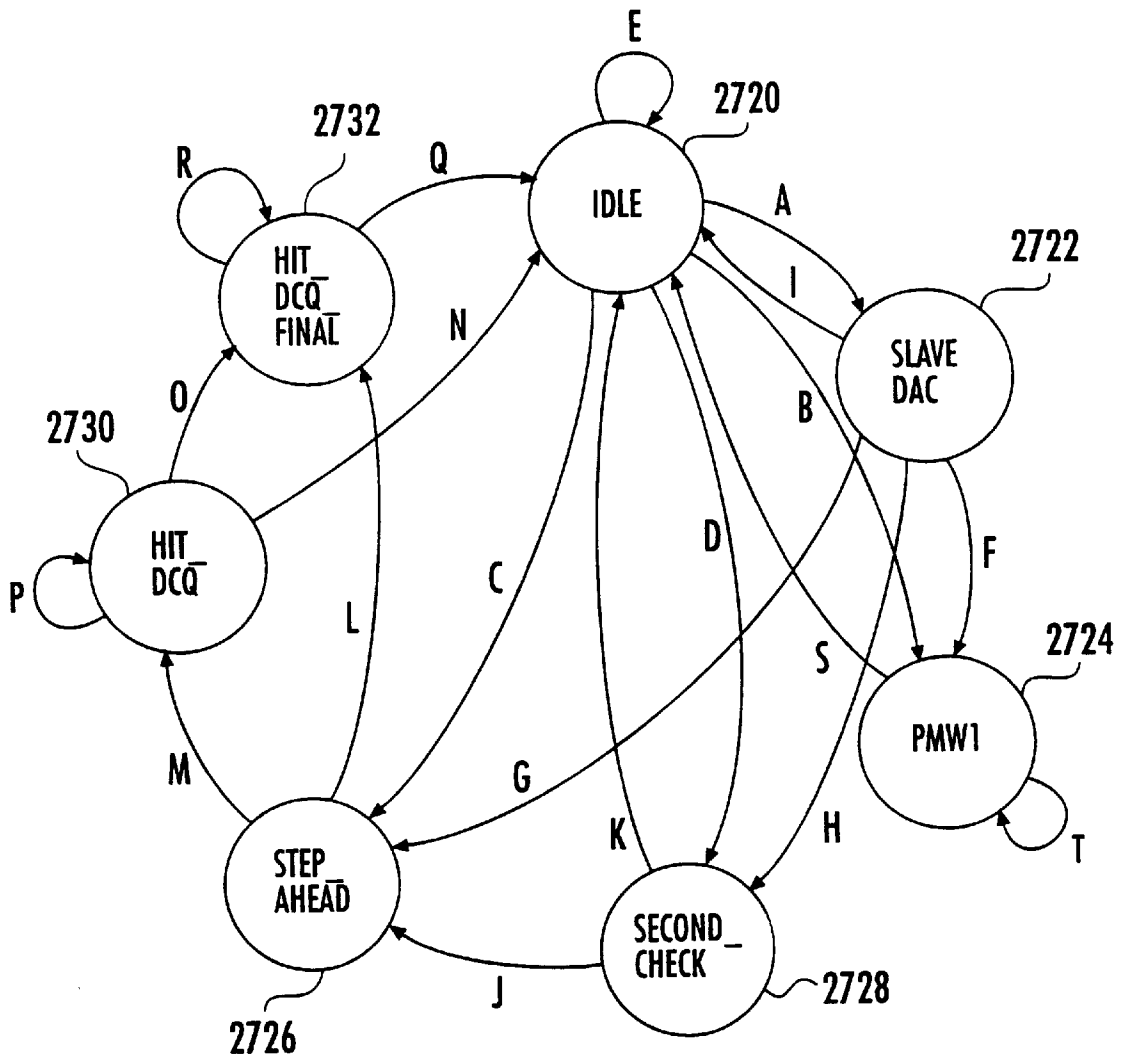

FIG. 86

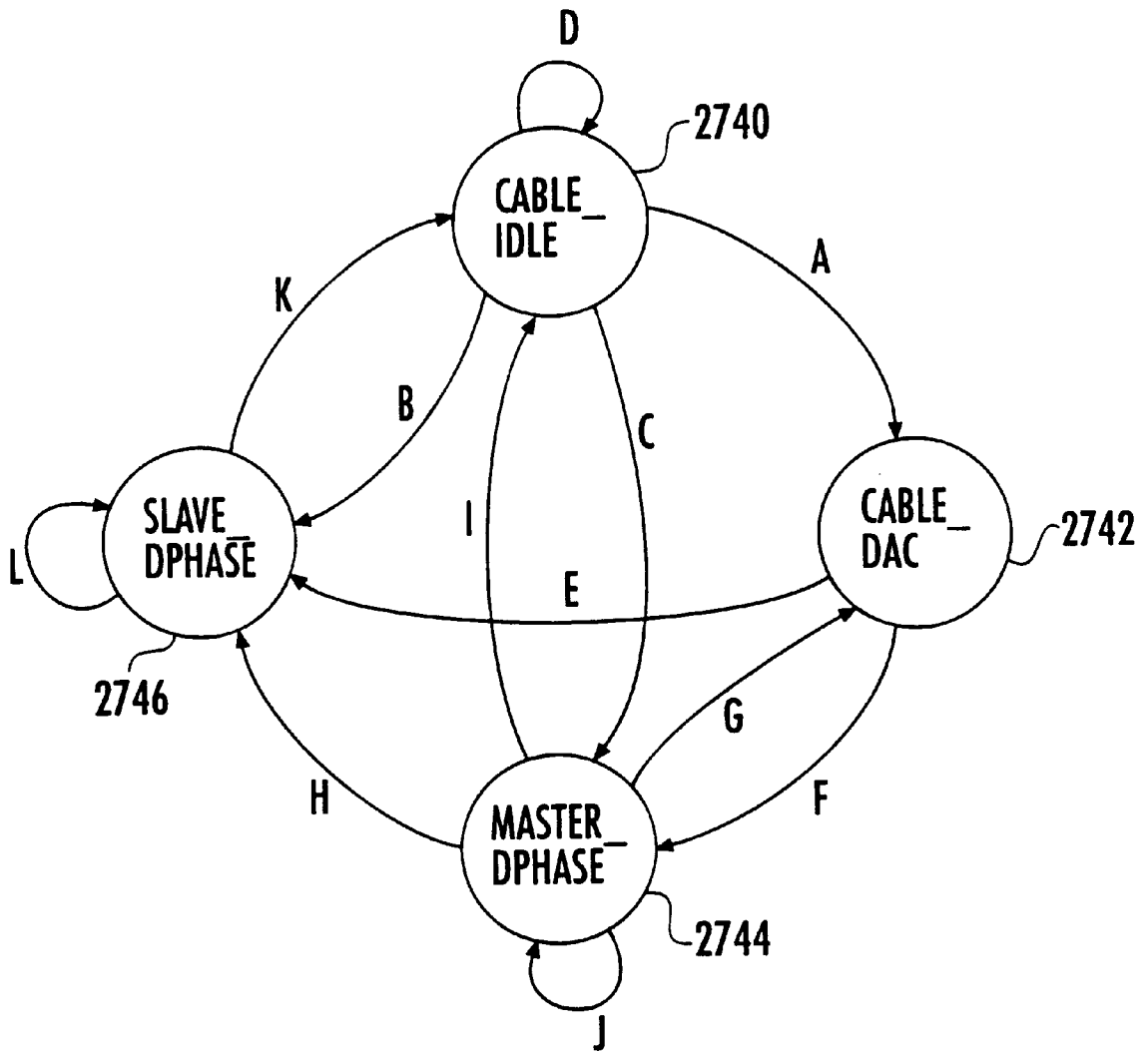

FIG. 87

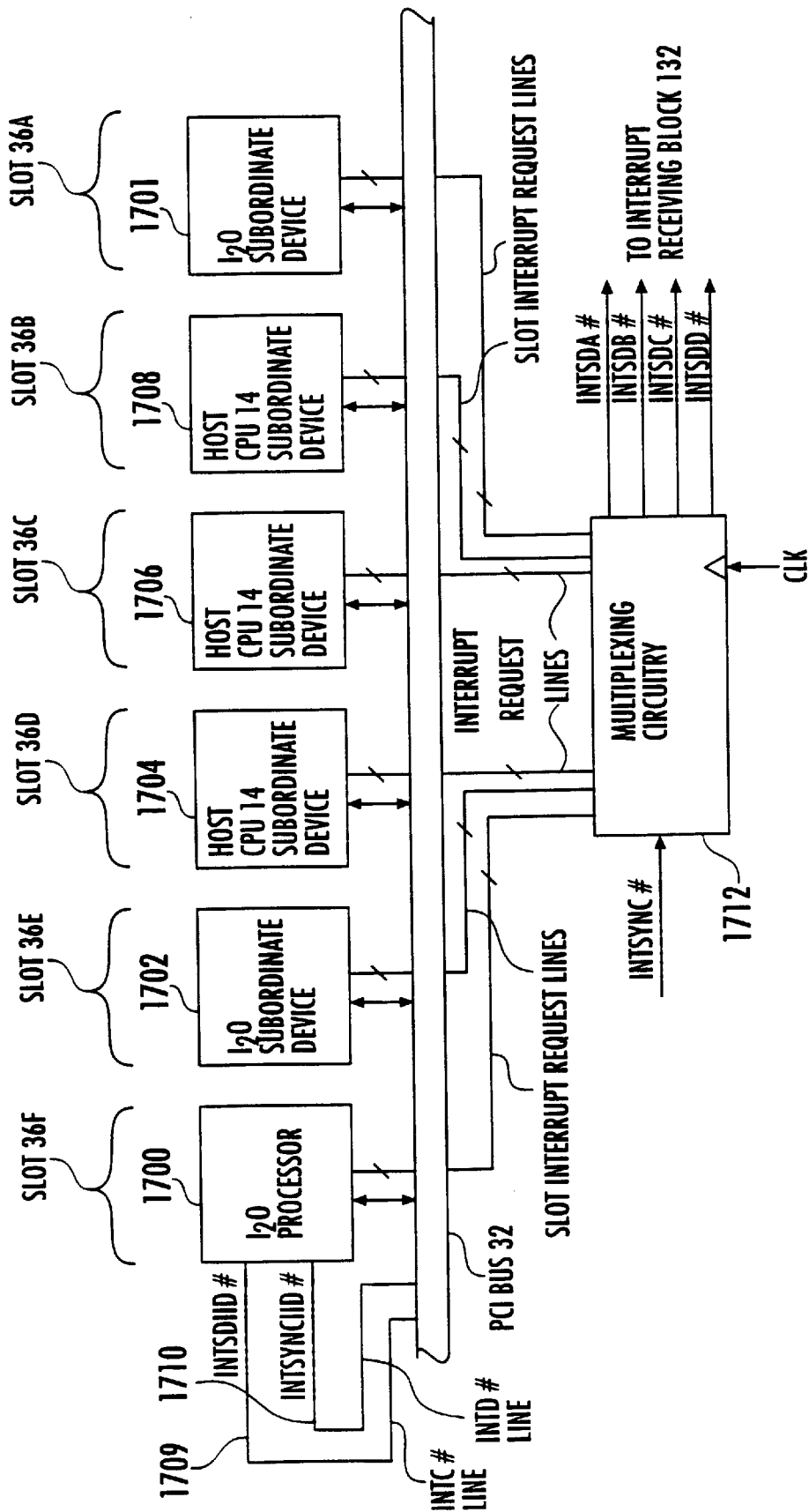

FIG. 88

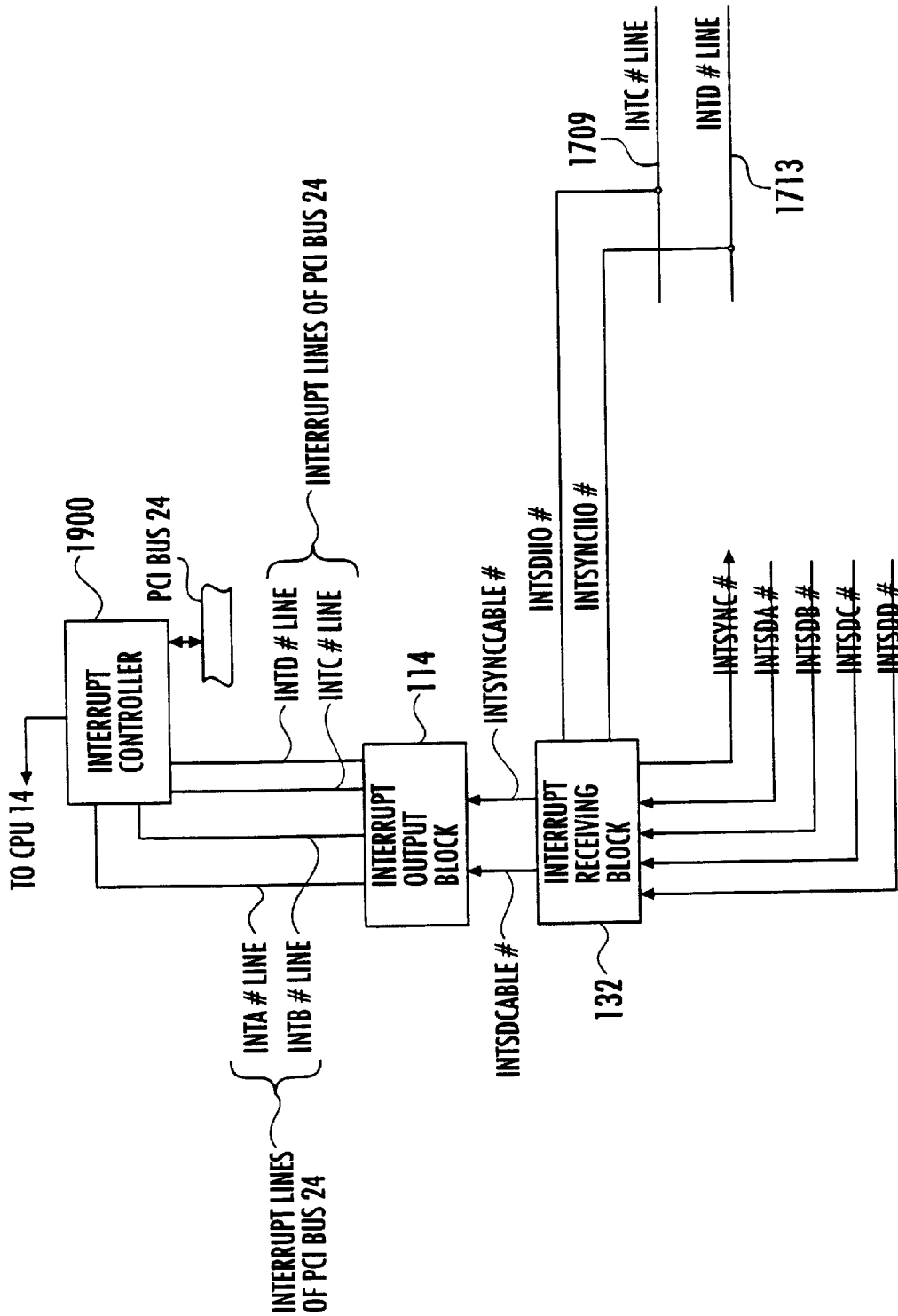

FIG. 89



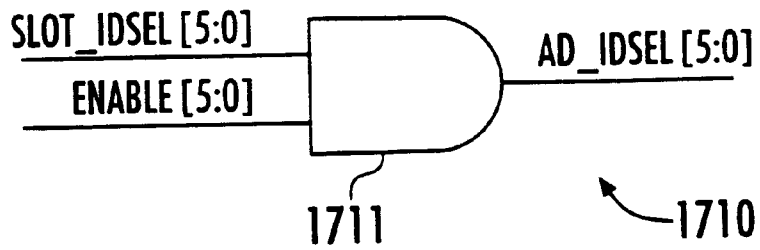

FIG. 90

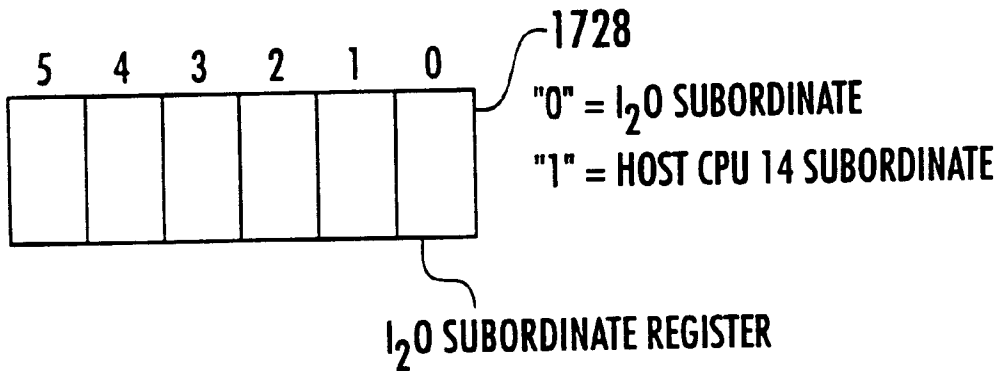

FIG. 91

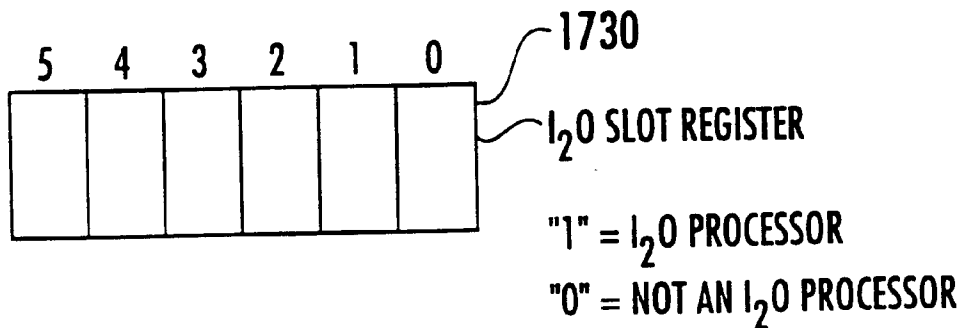

FIG. 92

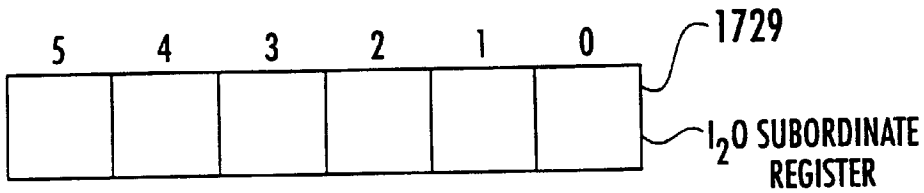

FIG. 93

"0" = I<sub>2</sub>O SUBORDINATE  
"1" = HOST CPU 14 SUBORDINATE



HOST CONFIGURATION  
ENABLE BIT

"1" = CPU 14 MAY CONFIGURE ON PCI BUS 32

"0" = I<sub>2</sub>O PROCESSOR 1700 IS CONFIGURING  
I<sub>2</sub>O SUBORDINATE DEVICES ON BUS 32

FIG. 94

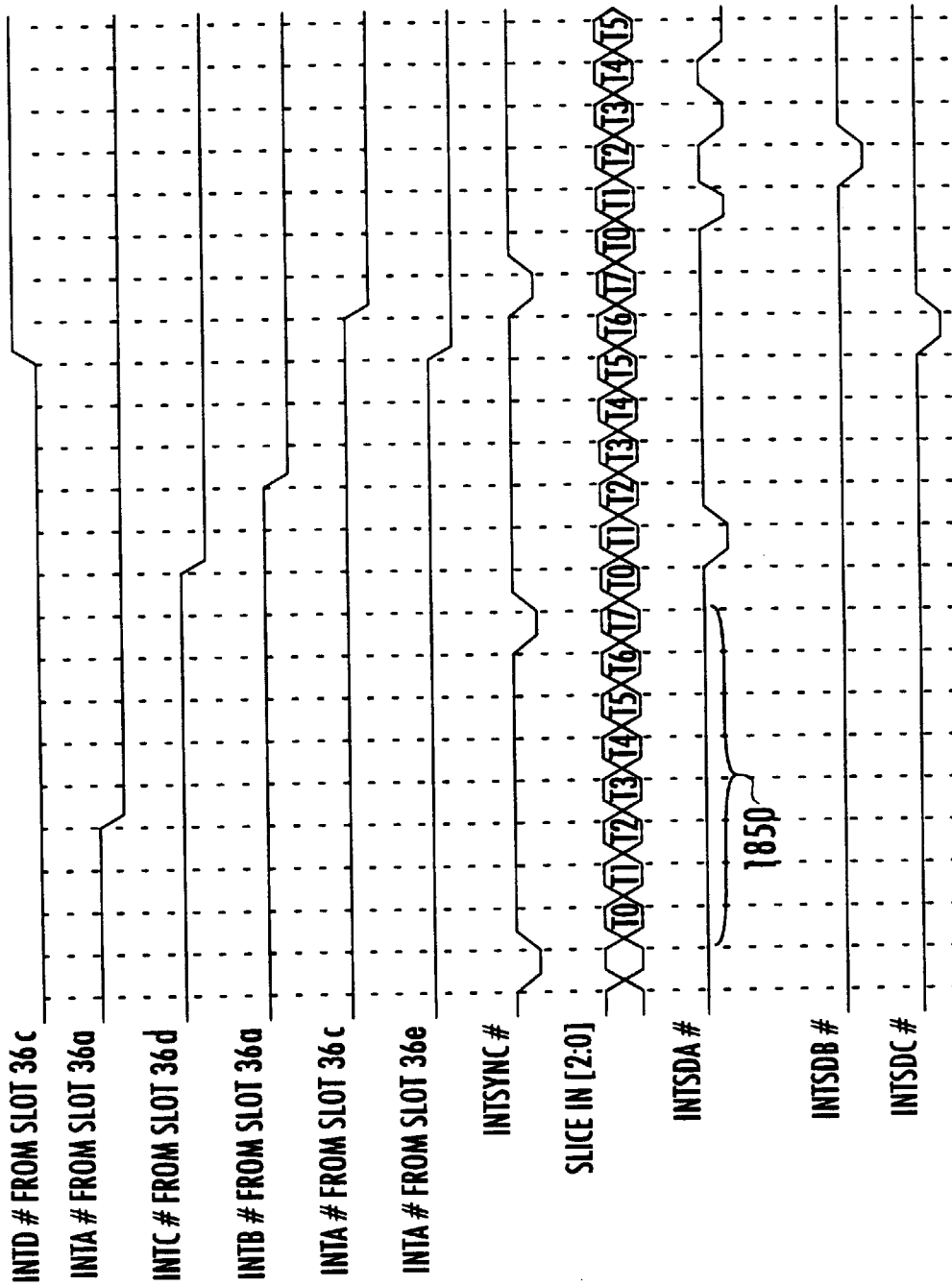

FIG. 95A
FIG. 95B

FIG. 95

FIG. 95A

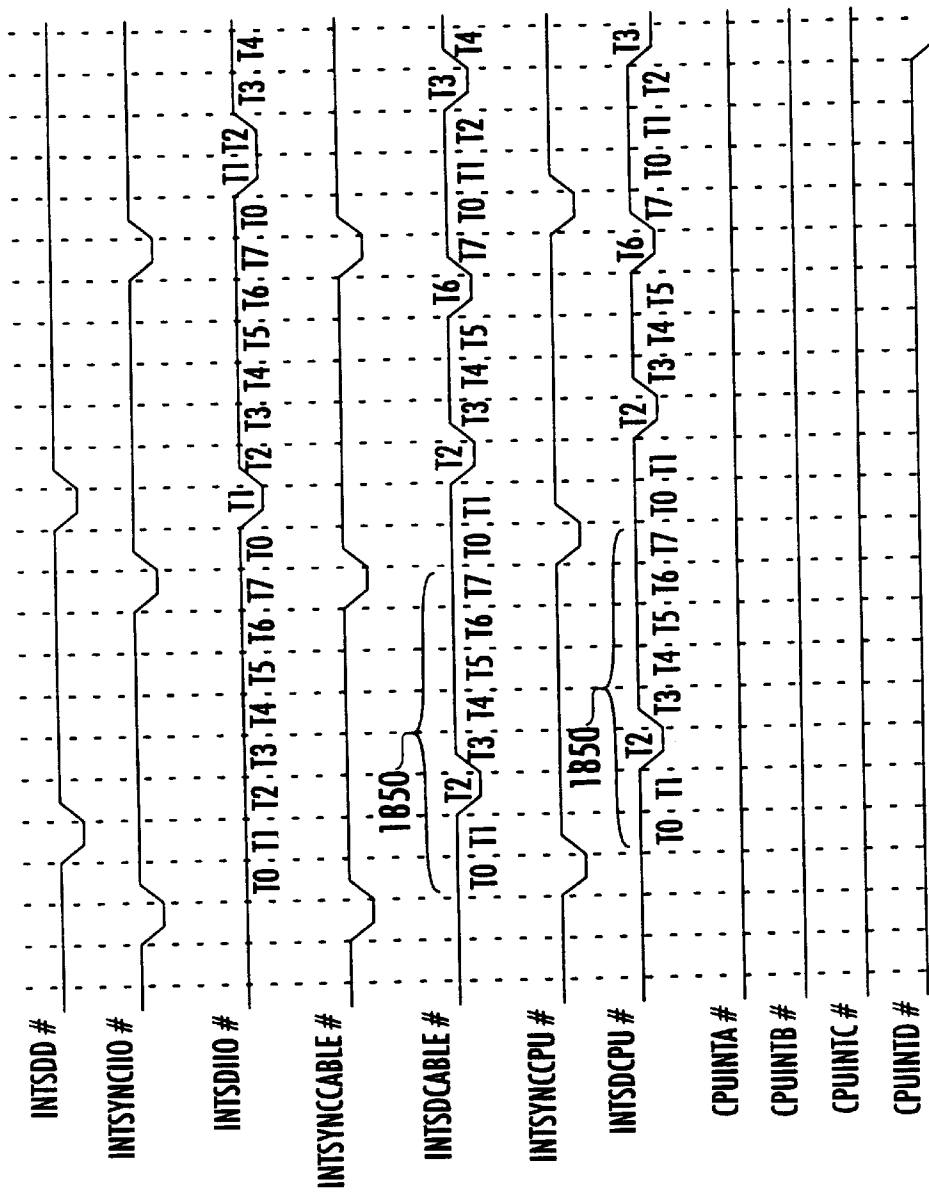

FIG. 95B

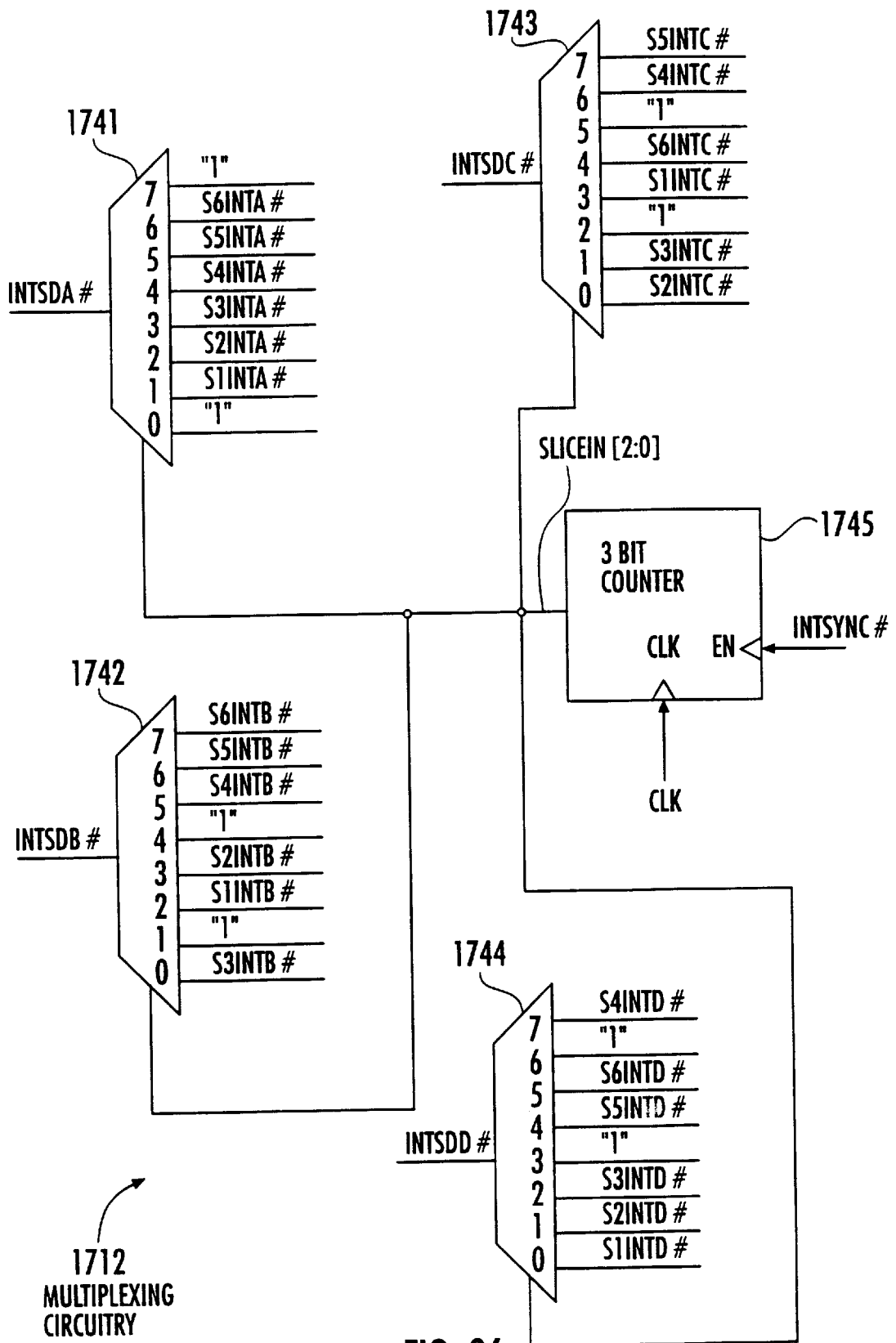

FIG. 96

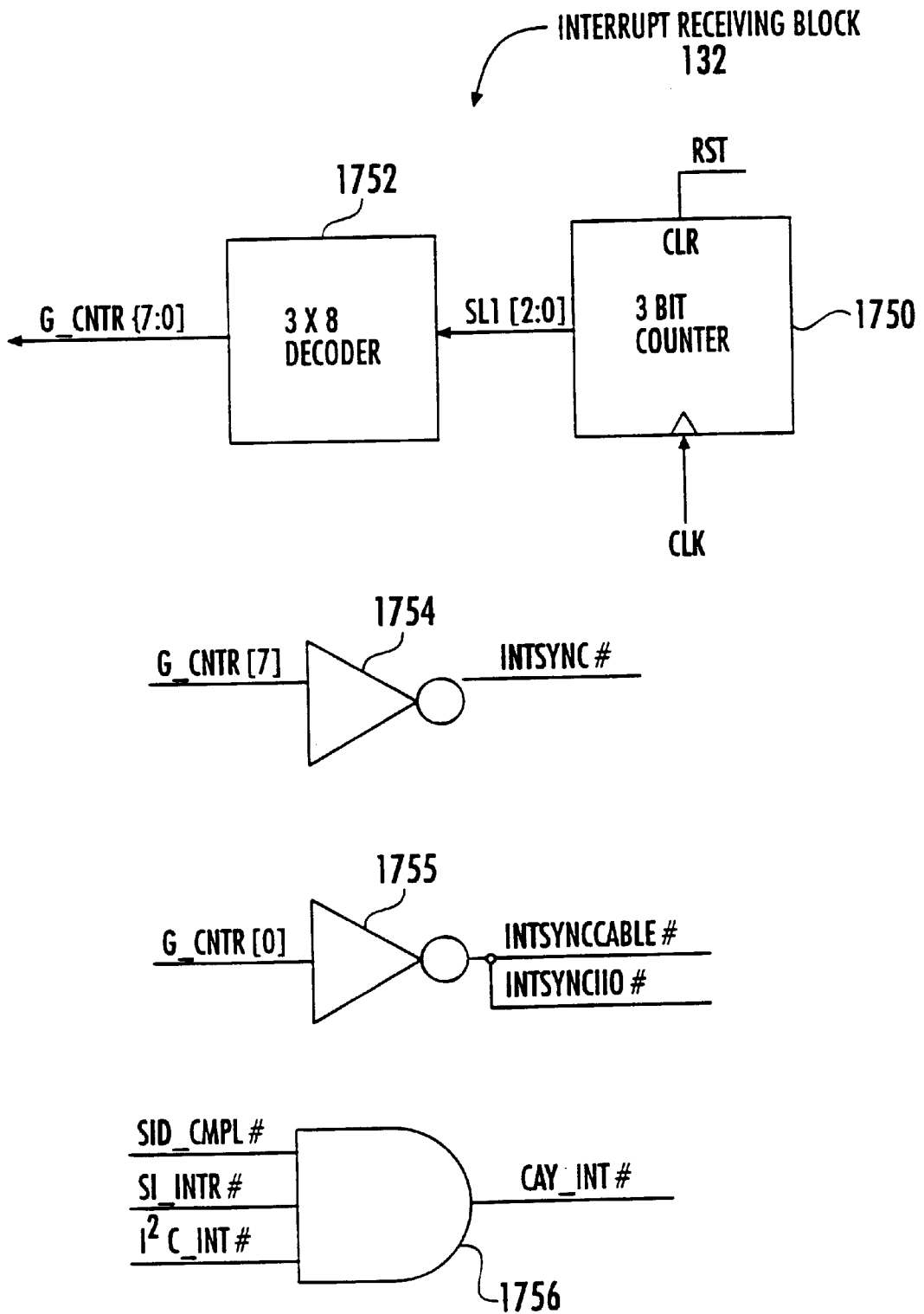

FIG. 97A

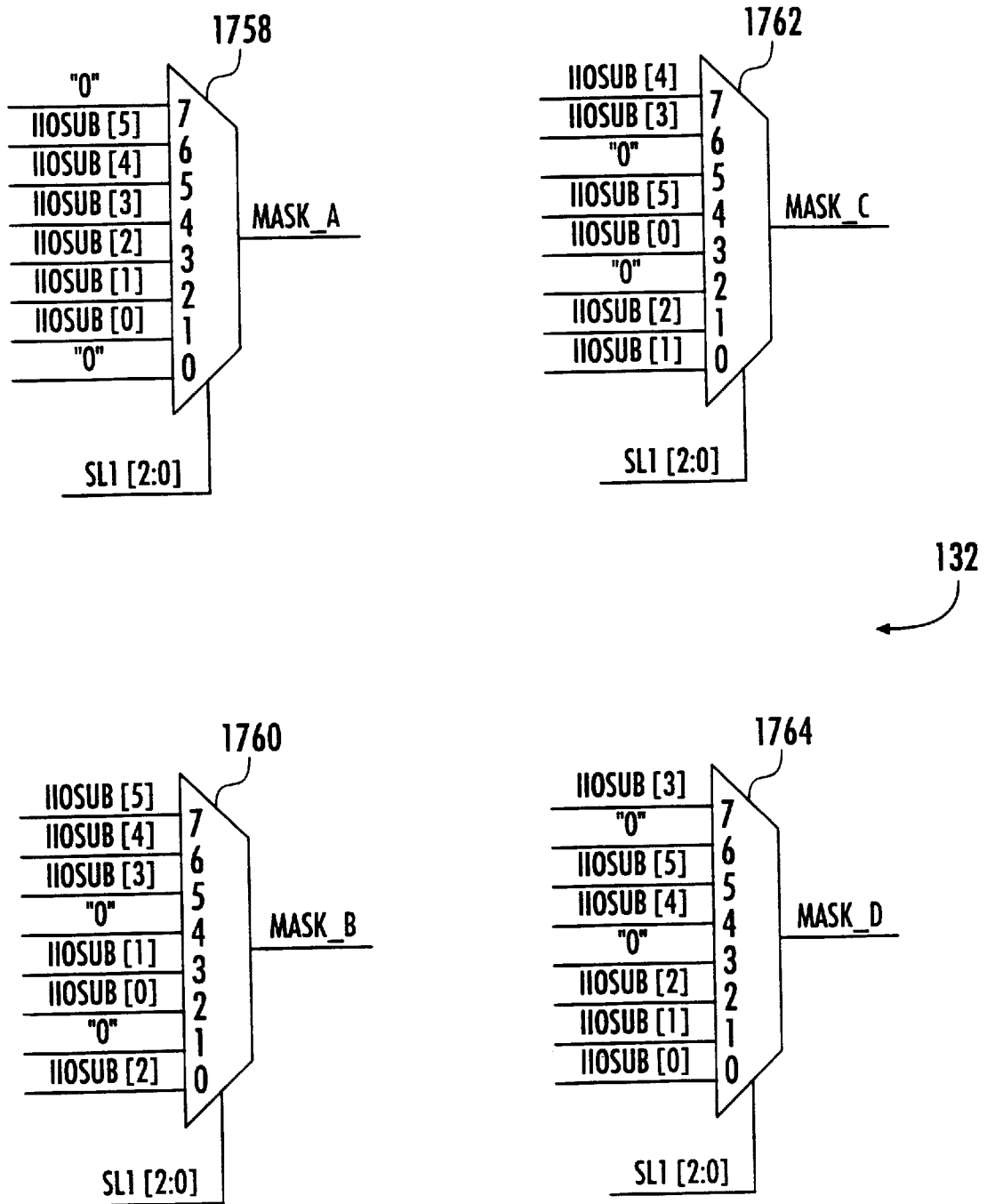

FIG. 97B

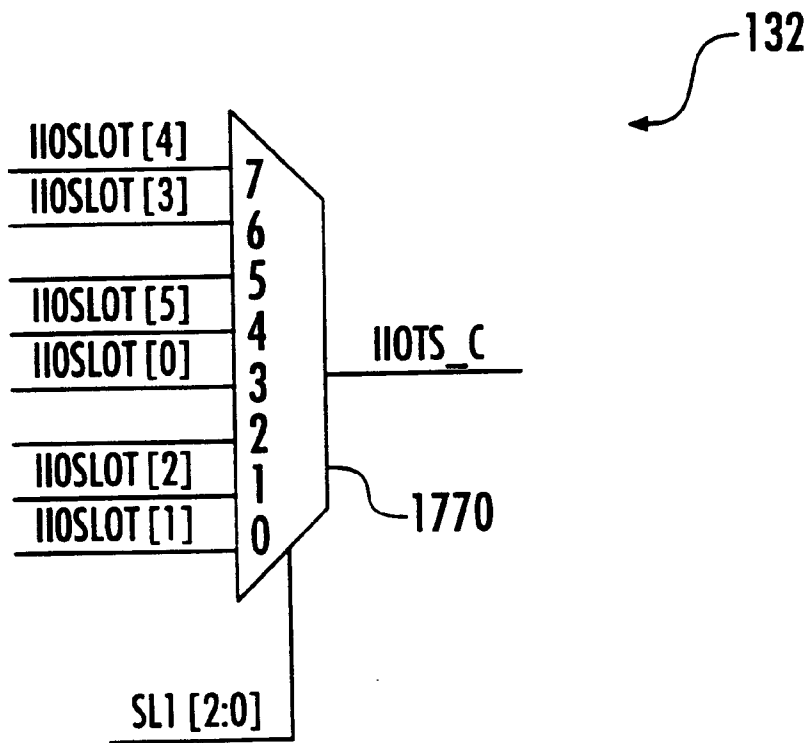
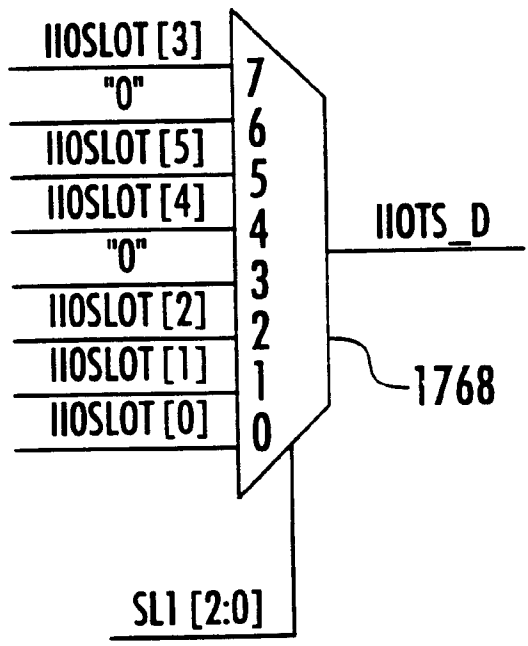

FIG. 97C



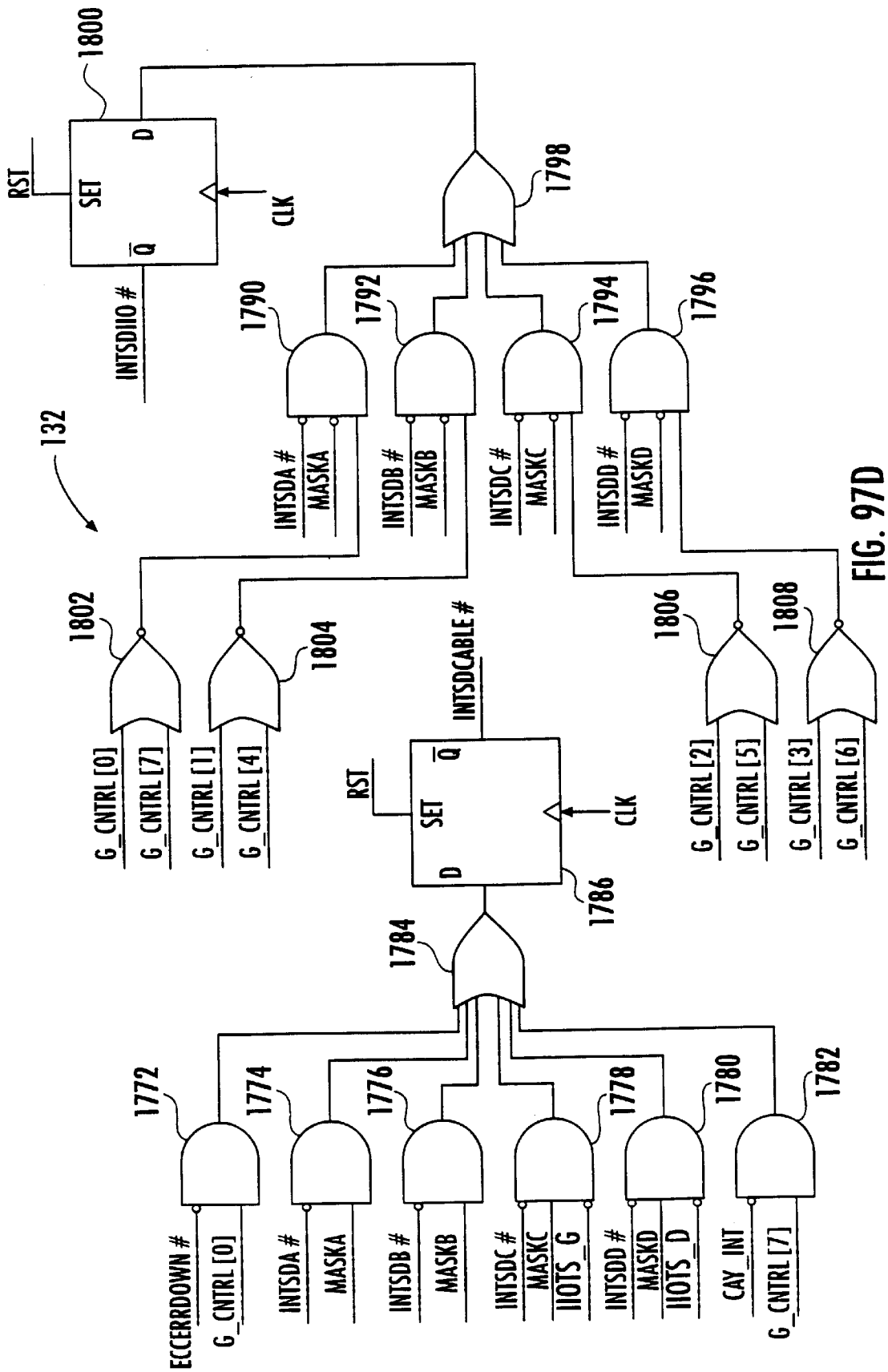

FIG. 97D

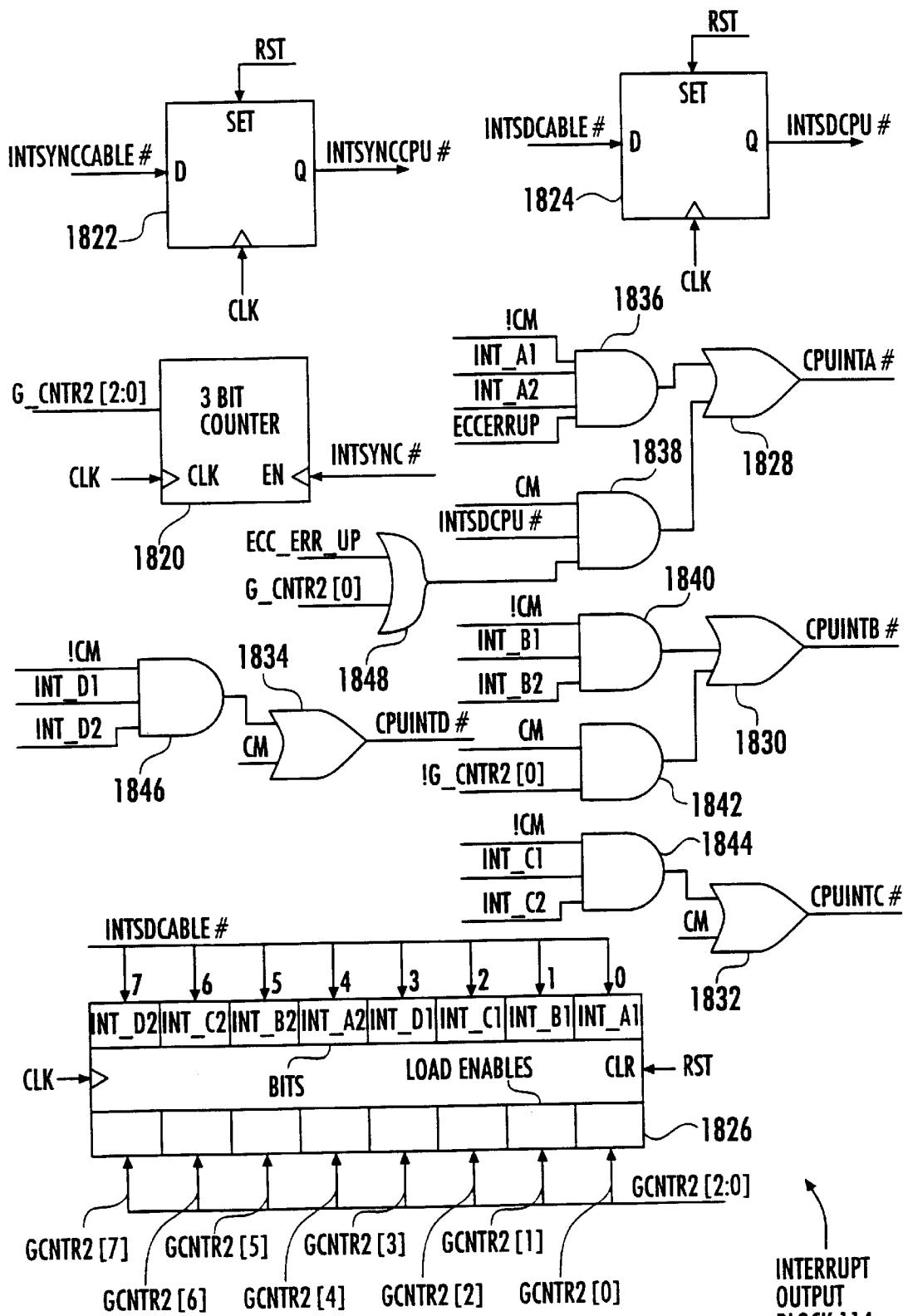

FIG. 98

INTERRUPT  
OUTPUT  
BLOCK 114

TIME SLICE	INTSDA #	INTSDD #	INTSDC #	INTSDB #
T0		SLOT 1. INTD #	SLOT 2. INTC #	SLOT 3. INTB #
T1	SLOT 1. INTA #	SLOT 2. INTD #	SLOT 3. INTC #	
T2	SLOT 2. INTA #	SLOT 3. INTD #		SLOT 1. INTB #
T3	SLOT 3. INTA #		SLOT 1. INTC #	SLOT 2. INTB #
T4	SLOT 4. INTA #	SLOT 5. INTD #	SLOT 6. INTC #	
T5	SLOT 5. INTA #	SLOT 6. INTD #		SLOT 4. INTB #
T6	SLOT 6. INTA #		SLOT 4. INTC #	SLOT 5. INTB #
T7		SLOT 4. INTD #	SLOT 5. INTC #	SLOT 6. INTB #

FIG. 99

SLOT 1 = SLOT 36A  
 SLOT 2 = SLOT 36B  
 SLOT 3 = SLOT 36C  
 SLOT 4 = SLOT 36D  
 SLOT 5 = SLOT 36E  
 SLOT 6 = SLOT 36F

INTERRUPT LINES ON PCI BUS 24	EXPANSION BUS 30 INTERRUPT SOURCES							
	BR_INTR #	SLOT 1. INTD #	SLOT 2. INTC #	SLOT 3. INTB #	SLOT 4. INTA #	SLOT 5. INTD #	SLOT 6. INTC #	"1"
INTA #								
INTB #	SLOT 1. INTA #	SLOT 2. INTD #	SLOT 3. INTC #	"1"	SLOT 5. INTA #	SLOT 6. INTD #	"1"	SLOT 4. INTB #
INTC #	SLOT 2. INTA #	SLOT 3. INTD #	"1"	SLOT 1. INTB #	SLOT 6. INTA #	"1"	SLOT 4. INTC #	SLOT 5. INTB #
INTD #	SLOT 3. INTA #	"1"	SLOT 1. INTC #	SLOT 2. INTB #	SI_INTR #	SLOT 4. INTD #	SLOT 5. INTC #	SLOT 6. INTB #

FIG. 100

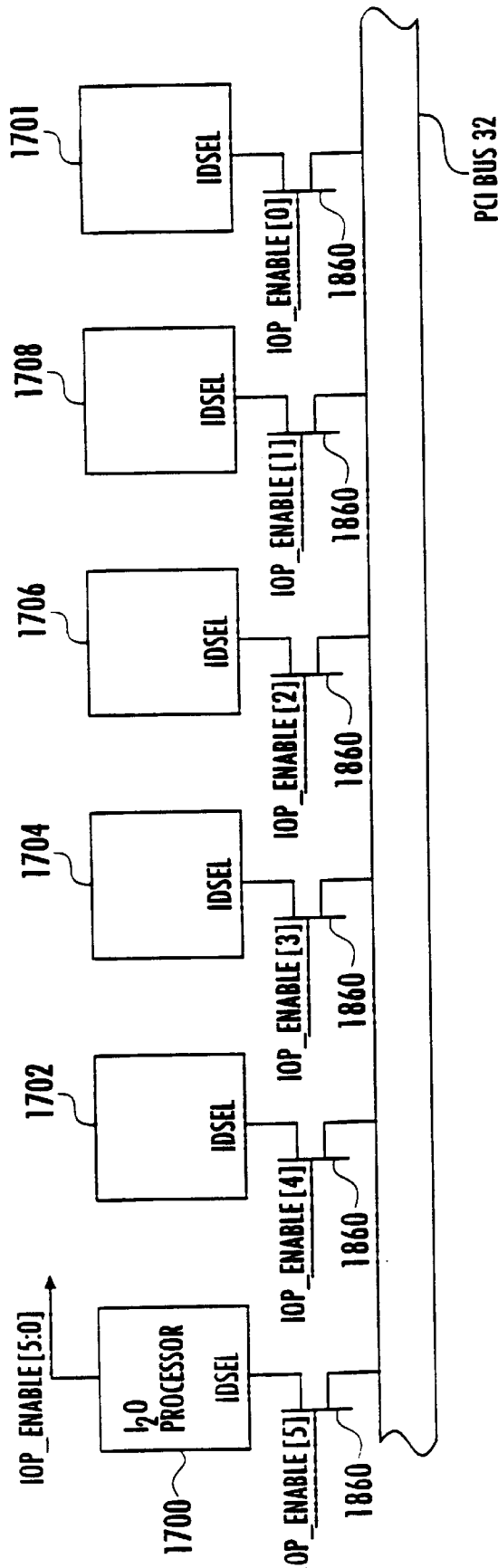

FIG. 101

## EXPANSION CARD INSERTION AND REMOVAL

### BACKGROUND

The invention relates to inserting and removing expansion cards.

Computer systems typically have expansion card slots for receiving and electrically coupling expansion cards to an expansion bus of the computer system. The expansion bus may be one of several types, such as an Industry Standard Architecture (ISA) bus, an Extended Industry Standard Architecture (EISA) bus or a Peripheral Component Interconnect (PCI) bus.

### SUMMARY

In general, in one aspect, the invention features a system having a connector for a circuit card and a clamp configured to selectively prevent removal of the circuit card from the connector when the clamp is engaged. The system has circuitry connected to monitor the engagement status of the clamp and to regulate delivery of power to the connector based on the engagement state of the clamp.

Implementations of the invention may include one or more of the following features. The system may include a communication link, and the circuitry may be further connected to regulate coupling of a communication link to the connector based on the engagement of the clamp. The circuit may include a switch actuated by the clamp furnishing an indication of the position of the switch and a circuit connected to update the engagement status when the indication indicates the same position for a predetermined duration.

In general, in another aspect, the invention features a method for use in a computer system having a central processing unit, a connector for a circuit card and a clamp configured to selectively prevent removal of the circuit card from the connector when the clamp is engaged. The method includes monitoring the engagement status of the clamp and providing an indication of the engagement status to the central processing unit.

Implementations of the invention may include one or more of the following. The invention may include providing an interrupt request to the central processing unit to indicate when the engagement status changes. The method may include storing the engagement status in a memory accessible by the central processing unit. The method may include monitoring a power status signal of the connector and providing an indication of the power status signal to the central processing unit. The method may include providing power to the connector when the clamp is engaged and removing power from the connector when the clamp is not engaged. The method may include determining if the central processing unit has enabled the connector to receive power and wherein the providing step only provides power if the central processing unit has enabled the connector to receive power. The method may include coupling a bus to the connector when the clamp is engaged and electrically isolating the bus from the connector when the clamp is not engaged. The isolating of the bus may include disconnecting a clock line and other lines of the bus, the other lines of the bus being disconnected before the clock line is disconnected and the power is removed. The electrically coupling may include connecting a clock line and other lines of the bus, the other lines of the bus being connected after the power is removed and the clock line is disconnected.

In general, in another aspect, the invention features a computer system having a central processing unit, a con-

connector for a circuit card, and a clamp configured to selectively prevent removal of the circuit card from the connector when the clamp is engaged. The computer system also has a circuit connected to monitor the engagement status of the lever and to provide an indication of the engagement status to the central processing unit.

Implementations of the invention may include one or more of the following. The circuit may be configured to provide an interrupt request to the central processing unit to indicate when the engagement status changes. The circuit may include a buffer, accessible by the central processing unit, connected to store the indication of the engagement status. The central processing unit may selectively enable the connector to receive power or a bus (e.g., a PCI bus) to receive power, and the computer system may further include a buffer connected to indicate if the central processing unit has enabled the connector or enabled the bus to receive power. The circuit connected to furnish power may only provide power if the central processing unit has enabled the connector to receive power and may only couple the bus if the central processing unit has enabled the connector to be coupled to the bus.

In general, in another aspect, the invention features a computer system having a bus, a connector for a circuit card coupled to the bus, and a clamp configured to selectively prevent removal of the circuit card from the connector when the clamp is engaged. The computer system has circuitry connected to monitor the engagement status of the clamp and to regulate delivery of power to the connector based on the engagement state of the clamp.

Among the advantages of the invention are one or more of the following. Expansion cards may be inserted and removed while the computer system remains powered up. The expansion card is powered down before the card can be removed from the slot. Software may selectively power up or power down expansion cards. If possible movement of the lever that secures the expansion card is detected, the movement of the lever is verified which minimizes unnecessary powering down of the expansion card. The control circuit has control of the expansion bus during critical phases of the power up and power down sequences, which promotes bus integrity.

Other advantages and features will become apparent from the following description and from the claims.

### DESCRIPTION

FIG. 1 is a block diagram of a computer system.

FIG. 2 is a block diagram of an expansion box of the computer system of FIG. 1.

FIG. 3 is a block diagram of the bridge chips in the computer system.

FIG. 4 is a block diagram of a queue block in each of the bridge chips.

FIG. 5 is a block diagram of the clock routing scheme in the bridge chips.

FIG. 6 is a block diagram of a clock generator in each of the bridge chips.

FIG. 7 is a block diagram of a master cable interface in each of the bridge chips for transmitting data over a cable connecting the bridge chips.

FIG. 8 is a timing diagram of signals in the master cable interface.

FIG. 9 is a block diagram of a slave cable interface in each of the bridge chips for receiving data transmitted over the cable.

FIG. 10 is a block diagram of logic generating input and output pointers for the receiving logic in the slave cable interface.

FIG. 11 is a timing diagram of signals in the slave cable interface.

FIG. 12 is a timing diagram of the input and output pointers and their relation to the received cable data.

FIG. 13 is a block diagram of the placement of flip flops and input and output pads in each of the bridge chips.

FIG. 14 is a table of the information carried by the cable.

FIG. 15A is a table showing the type of information carried by the cable signals associated with single address cycle transactions.

FIG. 15B is a table showing the type of information carried by the cable signals associated with dual-address cycle transactions.

FIG. 16 is a table of parameters associated with the cable.

FIG. 17 is a logic diagram of an error detection and correction circuit.

FIG. 18 is a parity-check matrix for generating check bits in the error detection and correction circuit.

FIG. 19 is a syndrome table for generating fix bits in the error detection and correction circuit.

FIG. 20A is a state diagram showing a round-robin arbitration scheme.

FIG. 20B is a state diagram showing a two-level arbitration scheme.

FIG. 21 is a logic diagram of an arbiter in each of the bridge chips.

FIG. 22 is a state diagram of a grant state machine in an arbiter.

FIG. 23 is a state diagram of a level one arbitration state machine in the arbiter.

FIG. 24 is a table showing generation of new grant signals based on the current master.

FIG. 25 is a block diagram of logic for generating mask bits and multi-threaded master indication bits.

FIG. 26A is a logic diagram of circuits for generating the masked bits.

FIG. 26B is a block diagram of a computer system with multiple layers of buses.

FIG. 27A is a side view of an expansion card inserted into a slot.

FIG. 27B–C are schematic diagrams of lever circuitry.

FIGS. 28–31 are schematic diagrams of circuitry of the expansion box.

FIG. 32A is a state diagram from the circuitry of the expansion box.

FIG. 32B are waveforms from the circuitry of the expansion box.

FIG. 33A is a schematic diagram of circuitry of the expansion box.

FIG. 33B are waveforms from the circuitry of the expansion box.

FIGS. 33C–H are a state diagram from the circuitry of the expansion box.

FIG. 34 is a schematic diagram of circuitry of the expansion box.

FIG. 35A is a state diagram from the circuitry of the expansion box.

FIG. 35B are waveforms from the circuitry of the expansion box.

FIG. 36 is a schematic diagram of circuitry of the expansion box.

FIG. 37 is a flow diagram of a non-maskable interrupt handler invoked in response to detection of a bus hang condition in the computer system.

FIG. 38 is a flow diagram of a BIOS routine that is invoked by a computer system lock-up event.

FIG. 39 is a flow diagram of a BIOS isolate routine invoked in response to a bus-hang condition or the computer lock-up event.

FIG. 40 is a block diagram of a bus watcher in each of the bridge chips.

FIG. 41 is a state diagram of logic in the bus watcher for returning the bus to an idle state.

FIG. 42 is a logic diagram of status signals in the bus watcher.

FIG. 43 is a logic diagram of bus history FIFOs and bus state vector FIFOs in the fault isolation circuit.

FIG. 44 is a logic diagram of circuitry for generating ready signals for indicating when the bus history and state vector information are available.

FIG. 45 is a flow diagram of a routine for assigning a bus number to a powered down or empty slot.

FIG. 46 is a flow diagram of a routine for allocating memory space for the computer system.

FIG. 47 is a flow diagram of a routine for allocating I/O space for the computer system.

FIG. 48 is a flow diagram of a routine for handling a recently powered up card.

FIG. 49 is a block diagram of configuration space for a PCI—PCI bridge circuit.

FIG. 50A is a block diagram of a computer system.

FIG. 50B is a bus number assignment tree.

FIG. 51 is a block diagram showing type 0 and type 1 configuration transactions.

FIG. 52 is a table showing mapping of address from a primary bus to a secondary bus.

FIGS. 53A and 53B are a logic diagram of circuitry for handling type 0 and type 1 configuration cycles.

FIG. 54A is a block diagram of circuitry for storing information to allow calculation of bus performance parameters.

FIG. 54B is a block diagram of pre fetch counters.

FIG. 55 is a block diagram of a computer system.

FIG. 56 is a block diagram of a PCI arbitration scheme.

FIG. 57 is a schematic diagram of a buffer flush logic block.

FIG. 58 is a schematic diagram of a cable decoder.

FIGS. 59–62 are schematic diagrams of a posted memory write queue, including control logic.

FIGS. 63–65 are schematic diagrams of a delayed request queue, including control logic.

FIGS. 66–69b are schematic diagrams of a delayed completion queue, including control logic.

FIGS. 70–74 are schematic diagrams and a table of a master cycle arbiter.

FIGS. 75–87 are schematic and state transition diagrams of a queue-block-to-PCI-bus interface.

FIG. 88 is a schematic block diagram showing bus devices connected to an expansion bus.

FIG. 89 is a schematic block diagram showing circuitry to route interrupt requests.

FIG. 90 is a schematic diagram of device select logic.  
 FIGS. 91–94 are schematic block diagrams of registers.  
 FIG. 95 is a graph showing waveforms for the computer system.  
 FIG. 96 is a schematic diagram of the multiplexing circuitry.  
 FIGS. 97A–D are schematic diagrams of the interrupt receiving block.  
 FIG. 98 is a schematic diagram of the interrupt output block.  
 FIG. 99 is a chart showing the time multiplexing of interrupt request signals.  
 FIG. 100 is a chart showing interrupt request mapping.  
 FIG. 101 is a schematic block diagram showing bus devices connected to an expansion bus.

### OVERVIEW

In the ensuing description, all signal mnemonics followed or preceded by a “#”, “\_”, or “!” signify inverted logic states.

As shown in FIG. 1, a computer system 10 includes a primary PCI bus 24 that is coupled to a bridge chip 26a and a bridge chip 26b, both of common design 26. The bridge chip 26a is coupled to a bridge chip 48a through a cable 31, and the bridge chip 26b is coupled to the bridge chip 48b through a cable 28. The bridge chips 48a and 48b are of common design 48, which is common to design 26 except that design 26 is in an upstream mode and design 48 is in a downstream mode.

The PCI bus 24 is interfaced to a local bus 22 through a system controller/host bridge circuit 18. The system controller/host bridge circuit 18 also controls access to a system memory 20 which is also coupled to the local bus 22 along with the CPU 14 and a level two (L2) cache 16.

A PCI-Extended Industry Standard Architecture (EISA) bridge 15 interfaces the PCI bus 24 to an EISA bus 17. Both a keyboard controller 21 and a Read Only Memory (ROM) 23 are coupled to the EISA bus 17. A non-volatile random access memory (NORM) 70 connected to the EISA bus 17 stores information which should survive the computer system shutting off. An automatic server recovery timer 72 monitors the computer system for inactivity. If the system locks up, the AIR timer 72 will expire after about 10 minutes. A keyboard 19 is monitored by the keyboard controller 21 for detection of depressed keys.

Referring to FIG. 2, the bridge chip 48a furnishes an interface to a PCI bus 32a, and the bridge chip 48b furnishes an interface to a PCI bus 32b. The PCI buses 32a and 32b are located on two expansion boxes 30a and 30b, of common design 30, and each expansion box 30 has six hot-plug slots 36 (36a–f) which are capable of receiving conventional expansion cards 807 (FIG. 27A). One slot 34 on the expansion box receives a card 46 which has the bridge chip 26. Each hot-plug slot 36 has associated switch circuitry 41 for connecting and disconnecting the slot 36 to and from the PCI bus 32. Six mechanical levers 802 are used to selectively secure (when closed or latched) the cards 807 to corresponding slots, as further described in U.S. Pat. application Ser. No. 08/658,385, entitled “Securing a Card in an Electronic Device,” filed on the same date as this application and incorporated by reference. Each expansion box 30 includes registers 52 and 82 for monitoring the levers 802 and status signals of the expansion box 30 and a register 80 for controlling connection and disconnection of slots 36 to the PCI bus 32.

Referring to FIG. 3, the bridge chip is designed to be used in pairs 26 and 48 to form a PCI–PCI bridge between the primary PCI bus 24 and the secondary PCI bus 32. The programming model is that of two hierarchical bridges. To the system software, the cable 28 appears as a PCI bus which contains exactly one device, the downstream bridge chip 48. This greatly simplifies the configuration of the 2-chip PCI–PCI bridge joining the primary and secondary buses. The bridge chip 26, which is closer to the CPU 14, joins the primary PCI bus 24 to the cable 28. The second PCI–PCI bridge 48 resides in the expansion box 30 and joins the cable 28 to the secondary PCI bus 32. A mode pin UPSTREAM\_CHIP determines whether the bridge chip operates in the upstream mode or the downstream mode. Some non-bridge functions such as a bus monitor 106 and hot plug logic in an SIO 50 are used only in the expansion box 30, and are non-functional in the upstream mode chip 26.

A clock generator 102 in the bridge chip 26 generates clocks based on the clock PCICLK1 on the primary PCI bus 24, with one of the generated clocks being provided through the cable 28 to a clock generator 122 in the downstream bridge chip 48. The clock generator 122 generates and drives the PCI clocks in the expansion box 30 at the same frequency of the primary PCI bus 24, which results in both bridge chips 26 and 48 being run at the same frequency. The downstream bridge chip 48 lags the upstream bridge chip 26 in phase by the delay of the cable 28. An asynchronous boundary in the upstream bridge chip 26 at the point where data is taken off of the cable 28 allows the phase delay to be any value (and therefore the cable to be of any length), with the only requirement only being that the frequency of the two bridge chips be the same.

The core logic of each bridge chip is the bridge logic block (100 or 120), which includes a PCI master (101 or 123) for acting as a master on the respective PCI bus, a PCI target or slave (103 or 121) for acting as a slave device on the respective PCI bus, configuration registers (105 or 125) which contain the configuration information of the corresponding bridge chip, and a queue block (107 or 127) containing several queues in which data associated with transactions between the primary PCI bus and the secondary PCI bus 32 are queued and managed. The data transferred between the upstream bridge chip 26 and the downstream bridge chip 48 are buffered by cable interfaces 104 and 130 in the bridge chips 26 and 48, respectively.

Interrupt routing logic is also included in each bridge chip. There are 8 interrupts, 6 from the secondary bus slots, 1 from an SIO circuit 50, and 1 from the downstream bridge chip 48. In the downstream chip 48, the interrupts are received by an interrupt receiving block 132 and sent up the cable 28 as a serial stream in sequential time slices. In the upstream bridge chip 26, the interrupts are received by an interrupt output block 114, which routes the interrupts to an interrupt controller.

The SIO circuit 50 furnishes control signals for lighting LEDs, for controlling reset, and for selectively connecting the slots 36 to the bus 32. It also includes logic for reading the engagement status of the levers 802, and the status of the cards 807 in each slot 36.

The bridge circuit 26 also includes support for interrupts in the expansion box 30, and, when installed in a slot in the host system with a proprietary interface to a multichannel interrupt controller, it sends the states of each interrupt in a serial stream. The bridge circuit 26 also can be configured to drive standard PCI INTA, INTB, INTC, and INTD signals if it is installed in a standard slot in the host system

Each bridge chip also includes a PCI arbiter (116 or 124) for controlling access to up to seven bus masters. As the upstream bridge 26 is installed in a slot, the PCI arbiter 116 in the upstream bridge chip 26 is disabled. Each bridge chip also includes an I<sup>2</sup>C controller (108 or 126) for communication with devices such as EEPROMs, temperature sensors, and so forth, a JTAG master (110 or 128) for performing test cycles, a bus monitor (106 or 127) for measuring bus utilization and efficiency and the efficiency of the bridge chip's prefetch algorithm, and a bus watcher (119 or 129) for storing bus history and state vector information and for notifying the CPU 14 of a bus hang condition. Certain blocks are disabled in each bridge chip as they are not used. In the upstream bridge chip 26, the bus watcher 119, the SIO 118, the PCI arbiter 116, and the bus monitor 106 are disabled. In addition, the interrupt receiving block 112 in the upstream chip 26 and the interrupt output block 134 in the downstream chip 48 are disabled.

#### Queue Block Overview

Referring to FIG. 4, the queue blocks 107 and 127 manage transactions flowing between the primary PCI bus 24 (in the upstream chip) or the secondary PCI bus 32 (in the downstream chip) and the cable interface 130. (From here on, the downstream bridge chip will be referred to with the assumption that upstream chip works identically, unless otherwise noted). The queue block 127 includes a cable decoder 146 that receives from the cable interface 130 transactions to be completed on the secondary PCI bus 32. After decoding a transaction, the decoder 146 places the transaction, along with all information included in the transaction, into one of three queues 140, 142, and 144. Each queue contains several transaction buffers, each of which stores a single transaction and therefore is able to handle several transactions simultaneously.

The first queue, a posted memory write queue (PMWQ) 140, stores posted memory write cycles issued by the CPU on the primary bus along with all information required to execute each cycle on the secondary bus 32. The PMWQ 140 has four transaction buffers, each of which holds one posted memory write transaction containing up to eight cache lines (256 bytes) of data. Under some circumstances, a posted memory write transaction having more than eight cache lines of data may overflow into one or more subsequent buffers, as described below.

The second queue, a delayed request queue (DRQ) 142, stores delayed request transactions (i.e., delayed read requests (DRR), such as memory read (MR), memory read line (MRL), and memory read multiple (MRM) requests; and, in the downstream chip, input/output (I/O) read/writes and configuration (config) read/writes) issued by the CPU on the primary bus along with all information required to execute each transaction on the secondary bus 32. The DRQ 142 has three transaction buffers, each of which is capable of holding one double-word, or "dword", of data for delayed writes.

The third queue, a delayed completion queue (DCQ) 144, stores delayed completion information provided by the upstream chip in response to delayed request transactions generated on the secondary bus 32. For a delayed read request, the corresponding completion information contains the read data requested by the initiating device and the read status (i.e., an indication of whether a parity error on target abort occurred). The delayed completion information returned for a delayed write transaction is the same as that returned for a delayed read request, except that no data is

returned for delayed writes. Since I/O and config read/writes occur only on the downstream bus, only the upstream DCQ will contain delayed completion information corresponding to one of these transactions. The DCQ 144 has eight completion buffers, each of which can hold up to eight cache lines of completion information for a single delayed request. In addition to the completion information, each completion buffer also contains a copy of the delayed request that generated the information. For delayed read transactions, a data "wstream" can be established between the primary bus 24 and the secondary bus 32 if the requesting device begins retrieving the requested data before the target device stops providing it to the DCQ 144. Under some circumstances, the DCQ 144 automatically will retrieve, or "prefetch," additional data when a requesting device retrieves all of the requested data from the corresponding buffer in the DCQ 144. Both streaming and automatic prefetching are discussed in more detail below.

A queue-to-PCI interface (QPIF) 148 manages transactions flowing from the queues 140, 142, and 144 to the PCI bus 32, and from the PCI bus 32 to the DCQ 144 and to the upstream chip through the cable interface 130. The QPIF 148 enters a "master" mode to run posted memory write and delayed request transactions from the PMWQ 140 and the DRQ 142 on the secondary bus. For both posted memory write and delayed read transactions, the QPIF 148 can "promote" a transaction that may involve less than a cache line of data (i.e., a memory write (MW) or a memory read (MR) transaction) to one that requires one or more cache lines (i.e., a memory write and invalidate (MWI) transaction or a memory read line (MRL) or memory read multiple (MRM) transaction) if certain conditions are met. The QPIF 148 also may convert a read transaction involving a single cache line of data (i.e., a MRL transaction) into one involving several cache lines of data (i.e., a MRM transaction). The QPIF 148 also may "correct" a MRL or MRM transaction that begins in the middle of a cache line by reading the entire cache line and then throwing away the unrequested portion of the data. Transaction promotion and read correction, both of which are described in more detail below, improve system efficiency by reducing the time required to retrieve data from a memory device.

The QPIF 148 enters a "slave" mode to provide data from the DCQ 144 to a requesting PCI device or to send transactions from the PCI bus 32 to the DCQ 144 and to the upstream chip through the cable. When the QPIF 148 receives a posted write transaction from the bus 32, it forwards the transaction to the upstream chip if a corresponding one of a group of transaction counters 159 indicate that the PMWQ in the other bridge chip is not full, as discussed below. When the QPIF 148 receives a delayed request, it first forwards the request to the DCQ 144 to determine whether the transaction already has been placed in the DCQ and, if so, whether the corresponding delayed completion information has been returned to the DCQ 144. If the delayed completion information is in the DCQ, the information is provided to the requesting device and the transaction is terminated. If the request already is enqueued but the delay completion information has not been returned, the requesting device is retried and the transaction is terminated on the PCI bus 32. If the transaction is not yet enqueued, the DCQ 144 reserves a completion buffer for the transaction and the QPIF 148 forwards the transaction to the upstream chip through the cable interface 130, as long as the corresponding transaction counter 159 indicates that the other bridge chip is not full.

If the DCQ 144 determines that one of its buffers contains data intended for a requesting device but different than the



data requested in the current transaction, the buffer may be flushed to prevent the requesting master from receiving stale data. The buffer is flushed when it contains prefetch data (i.e., data left in the buffer after the requesting device has retrieved some of the data, or data that was not specifically requested by the device), but is not flushed when it contains completion data (i.e., specifically requested by a device that has not yet returned to retrieve it). If the buffer contains completion data and the requesting device has issued a request that does not “hit” the buffer, the DCQ 144 tags the device as a “multi-threaded” device (i.e., one that is capable of maintaining more than one transaction at once) and allocates another completion buffer for the new request. The buffer flushing and multiple buffer allocation schemes are described in more detail below.

A master cycle arbiter (MCA) 150 in the queue block 127 maintains standard ordering constraints between posted memory write, delayed request, and delayed completion transactions, as set forth in the PCI Bridge Architecture Specification, Version 2.1. These constraints require that bus cycles maintain strong write ordering and that deadlocks do not occur. Therefore, the MCA 150 determines the order in which posted memory write transactions in the PMWQ 140 and delayed request transactions in the DRQ 142 are run on the PCI bus 32. The MCA 150 also controls the availability of delayed completion information stored in the DCQ 144. To ensure compliance with these rules, the downstream MCA 150 gives each posted memory write cycle an opportunity to bypass earlier-issued delayed request cycles, while both the downstream and the upstream MCAs 150 do not allow delayed request and delayed completion cycles to bypass earlier-issued posted memory write cycles. Transaction ordering by the MCA 150 is described in more detail below.

The transaction counters 159 in the downstream queue block 127 maintain a count of the number of transactions enqueued in the upstream bridge chip. A posted memory write (PMW) counter 160 indicates the number of PMW transactions held in the upstream posted memory write queue. The PMW counter 160 is incremented each time a PMW transaction is sent to the cable interface 130. The counter 160 is decremented each time the QPIF 148 receives a signal from the cable decoder 146 indicating that a PMW cycle has been completed on the upstream PCI bus 24. When the upstream PMWQ has enqueued the maximum number (four) of PMW transactions, the PMW counter 160 asserts a PMW full signal (tc\_pmw\_full) that tells the QPIF 148 to retry additional PMW cycles from the PCI bus 32. Likewise, a delayed request (DR) counter 161 counts the number of DR transactions held in the upstream delayed request queue. When the DRQ is holding the maximum number (three) of DR transactions, the DR counter 161 asserts a DR full signal (tc\_dr\_full) indicating that the QPIF 148 must retry all subsequent DR transactions from the PCI bus 32. A delayed completion (DC) counter 162 counts the number of delayed completions that are enqueued in the upstream master cycle arbiter. When the MCA is holding the maximum number (four) of delayed completions, the DC counter 162 asserts a DC full signal (tc\_dc\_full) that prevents the downstream QPIF 148 from running delayed request bus 32 on the secondary PCI bus 32. As soon as the full condition disappears, delayed completion information may be sent to downstream DCQ.

A PCI interface block 152 resides between the PCI bus 32 and the queue block 127. The PCI interface 152 includes a master block 123 and a slave (target) block 121. The slave block 121 allows PCI devices on the bus 32 to access the

bridge chip’s internal registers (e.g., target memory range registers 155 and configuration registers), to claim completion information stored in the DCQ 144, and to initiate transactions that are passed through the QPIF 148 and the cable interface 130 to the primary bus. The slave block 121 controls the availability of the PCI bus 32 to the PCI devices on the bus 32 by recognizing when each device asserts its REQ# line and forwarding the REQ# signals to the PCI arbiter 124. When the PCI arbiter 124 selects a requesting device to receive control of the bus, the slave block 121 grants the bus to the device by asserting the device’s GNT# line. As soon as the bus 32 is granted to the requesting device and the device asserts its FRAME# signal indicating the beginning of a transaction, the slave block 121 latches the transaction information (e.g., address, command, data, byte enables, parity, etc.) into a slave latching register 156. The queue block 127 then is able to retrieve the transaction information from the latching register 156 and provide it to the DCQ 144 and/or the cable interface 130.

Transactions supported by the PCI slave block 121 are shown in the following table.

PCI Interface Slave Transactions		
Transaction Type	Primary Interface	Secondary Interface
Interrupt Acknowledge	Not supported	Not supported
Special Cycle	Delayed	Delayed
I/O Read	Delayed	Delayed
I/O Write	Delayed	Delayed
Memory Read	Delayed	Delayed
Memory Write	Posted	Posted
Configuration Read (type 0)	Immediate	Not supported
Configuration Write (type 0)	Immediate	Not supported
Configuration Read (type 1)	Delayed	Not supported
Configuration Write (type 1)	Delayed	Not supported
Memory Read Multiple	Delayed (Streaming)	Delayed (Streaming)
Dual Address Cycle	Not Supported	Immediate
Memory Read Line	Delayed	Delayed
Memory Write and Invalidate	Posted	Posted

The master block 123 of the PCI interface 152 runs only cycles initiated by the queue block 127 (i.e., transactions held in the PMWQ 140 and DRQ 142). The queue block 127 requests the PCI bus by sending a request signal (q2p\_REQ) to the PCI master 123, which then determines whether to assert a corresponding request signal (blare\_) to the PCI arbiter 124. The master block 123 asserts blreq<sub>13</sub> if the queue block 127 is not running a locked cycle and the PCI bus 32 is not locked by another PCI device. When the PCI arbiter 124 selects the queue block 127, the master block 123 sends an acknowledge signal (p2q\_ack) to let the queue block 127 know it has control of the bus 32. If the PCI arbiter 124 has no outstanding requests from other devices on the bus 32, the master block 123 automatically sends the p2q\_ack grant signal to queue block 127, even if the queue block 127 has not asserted the q2p\_req signal. As soon as the queue block 127 wins arbitration (i.e., the arbiter 124 asserts the blunt\_ signal) and asserts its q2p\_frame signal to indicate the beginning of a transaction, the PCI master 123 latches outgoing transaction information (i.e., address, command, data, byte enables, parity, etc.) into a master latching register 158 in the PCI interface 152. The transaction information then is used to complete the transaction on the PCI bus 32.

Transactions supported by the master block 123 are shown in the following table.

PCI Interface Master Transactions		
Transaction Type	Primary Interface	Secondary Interface
Interrupt Acknowledge	Not supported	Not supported
Special Cycle	Supported	Supported
I/O Read	Supported	Supported
I/O Write	Supported	Supported
Memory Read	Supported	Supported
Memory Write	Supported	Supported
Configuration Read	Not Supported	Supported
Configuration write	Not Supported	Supported
Memory Read Multiple	Supported	Supported
Dual Address Cycle	Supported	Not Supported
Memory Read Line	Supported	Supported
Memory Write and Invalidate	Supported	Supported

In general, the master block 123 operates as a standard PCI master. However, unlike standard PCI bridges, the master block will not terminate a MRL, MRM, or MWI transaction until a cache line boundary is reached, even after the master latency timer (MLT) expires. Also, the master block 123 does not assert “initiator ready” (IRDY) wait states. The master block 123 runs a locked cycle on the PCI bus 32 if the queue block 127 asserts its “lock” signal (q2p\_lock) and releases its lock on the bus 32 when the queue block 127 asserts its “unlock” signal (q2p\_unlock).

Referring also to FIG. 57, the PCI interface 152 contains buffer flushing logic 154 that determines when one or all of the DCQ completion buffers should be flushed by the queue block 127. The PCI slave 121 generates two signals that are used by the queue block 127 to flush the completion buffers: a flush signal (p2q\_flush) that indicates when a buffer should be flushed, and a slot selection signal (p2q\_slot [2:0]) that indicates which PCI device (i.e., which slot on the PCI bus) should have data flushed. The following table shows the relationship between p2q\_slot [2:0] and the PCI slot number.

Creation of p2q_slot[2:0]	
p2q_slot[2:0]	slot number
000	all
001	1
010	2
011	3
100	4
101	5
110	6
111	7

When p2q\_flush is asserted, the queue block 127 will flush either all of the completion buffers in the DCQ 144 if p2q\_slot [2:0] is equal to “000” or the corresponding one of the eight completion buffers if p2q\_slot [2:0] has any other value. The queue block 127 keeps track of which completion buffers, if any, correspond to each PCI slot at any given time.

The p2q\_flush signal is asserted at the rising edge of the first PCI clock (CLK) cycle after a config write (wr\_cfg) cycle occurs or after an I/O write (iowr) cycle occurs or a memory write (memwr) cycle hits a downstream target (hit\_tmem) during a command check state (cmd\_chk\_st). Gates 2014, 2016, 2018, and 2020, and flip-flop 2022 are arranged to produce p2q\_flush in this way.

In the upstream bridge chip (i.e., when the upstream<sub>13</sub> chip\_i signal is asserted), p2q\_slot [2:0] always has a value of “001” since the CPU is the only master on the primary

PCI bus. In the downstream chip, the value of p2q\_slot depends upon whether the cycle leading to a flush condition is a cycle from the secondary bus 32 to the queue block 127 (i.e., if p2q\_qcyc is asserted). If the p2q\_qcyc signal is asserted, p2q\_slot [2:0] takes on the value of the req\_slot [2:0] signal produced by the PCI slave 121. The req\_slot [2:0] signal indicates which of the seven devices on the secondary PCI bus 32 has been granted control of the bus 32. The PCI slave 121 generates the req\_slot [2:0] signal by latching the value of the GNT# line for each of the seven slots on the bus 32 to form a seven bit latched grant signal (latched\_gnt\_[7:1]; the eighth grant line, which belongs to the queue block, is ignored) and encoding latched\_gnt [7:1] according to look-up table 2006, as follows.

Creation of req_slot[2:0]	
latched_gnt_[7:1]	req_slot[2:0]
1111111	000
1111110	001
1111101	010
1111011	011
1110111	100
1101111	101
1011111	110
0111111	111

If the cycle leading to the flush is not a secondary-PCI-to-queue-block cycle, it must be an I/O read or config read to the target memory range of one of the slots on the secondary bus 32. When the cycle is an I/O read or config read (i.e., !iowr AND !wr\_cfg), p2q\_slot [2:0] takes on the value of the PCI slot whose memory range has been hit (mrange\_slot [2:0]). Otherwise, the cycle is an I/O write or a config write, and p2q\_slot [2:0] is set equal to “000” so that all completion buffers are flushed. Gates 2008 and 2010 and multiplexers 2002 and 2004 are arranged to generate p2q\_flush [2:0] in this way.

Cable Decoder

Referring to FIG. 58, the cable decoder 146 receives transactions from the cable interface and selects the appropriate queue to receive each transaction. When the cable decoder is in the data phase (i.e., when data\_phase or next\_data phase, an asynchronous signal that sets the value of data\_phase at the next CLK cycle, is asserted), the cable decoder 146 looks at the command code (cd\_cmd [3:0]) sent across the cable to determine which queue should receive the transaction. As shown in the table below, when cd\_cmd [3:0] has a value of “1001”, the transaction is a delayed completion, so the cable decoder asserts a cd\_dcq\_select signal that tells the DCQ to claim the transaction. When the three LSB of the command code signal (cd\_cmd [2:0]) are “111”, the transaction is a posted memory write, so the cable decoder generates a cd<sub>13</sub>pmwq\_select signal to alert the PMWQ of the incoming transaction. When the transaction is neither a posted memory write nor a delayed completion and the command code does not represent a streaming signal, the cable decoder asserts a cd\_drq\_select signal that tells the DRQ to claim the transaction. Gates 2024, 2026, 2028, and 2030 are configured to generate the cd\_dcq\_select, cd\_pmwq\_select, and cd\_drq\_select signals in this way.

The following table shows the four bit command codes associated with each type of transaction.

Transaction Command Codes	
Transaction Type	Command Code
I/O Read	0010
I/O Write	0011
Config read	1010
Config write	1011
Memory read	0110
MRL	1110
MRM	1100
Memory write	0111
MWI	1111
Delayed completion	1001
Stream established	1000

When the downstream bridge chip has established a data stream between the primary bus and a secondary bus master, the upstream cable decoder receives a command code of “1000”. This code represents a streaming signal generated by the downstream chip to inform the upstream chip that a stream has been established. When the cable decoder receives this command code, it asserts a `cd_stream` signal that tells the QPIF in the upstream device to continue the transaction. The cable decoder also generates a `cd_stream_next_data` signal that instructs the upstream chip to provide another piece of data to the secondary bus. The `cd_stream_next_data` signal is asserted when `cd_stream` signal is asserted, the transaction is in the data phase (i.e., `data_phase` is asserted), and a `next13data` signal has been received from the downstream chip through the cable interface (the `next_data` signal appears on one of the lines of the `c2q_buff[3:0]` signal, which, when no stream is occurring, tells the queue block which downstream DCQ buffer is associated with the current transaction). The `cd_stream_next_data` signal is deasserted when either the `cd_stream` signal is deasserted or when a new request is received from the cable interface (i.e., `c2q_new13req` is asserted). Gates **2032** and **2034** are configured to generate the `cd_stream` and `cd_stream_next_data` signals in this way.

Posted Memory Write Queue

Referring to FIG. 59, the posted memory write queue (PMWQ) **140** is a storage element that contains all of the command information needed to execute posted write transactions on the target bus. The PMWQ includes a tag memory portion **2036** that holds information identifying each transaction, a data RAM **2038** that holds the write data associated with each transaction in the PMWQ, and various control blocks to manage the flow of transactions into and out of the PMWQ. For each transaction in the PMWQ, the tag memory **2036** maintains information such as the address to be written to, the PCI command code (MW or MWI), an address parity bit, and “locked cycle” and “dual address cycle” indication bits, as shown in the following table. The tag memory **2036** also stores a pointer to the data RAM location of the data corresponding to each of the transactions in the PMWQ.

Contents of PMWQ		
Field	Bits	Comments
Address	64	Upstream Transactions support Dual Address Cycles
PCI Command	1	Memory Write 0111

-continued

Contents of PMWQ		
Field	Bits	Comments
Byte Enables	0	Memory Write and Invalidate 1111 (only necessary to store <code>cbe[3]</code> )
		Store BEs on every valid transfer clock in the data RAM.
Parity	1/address	Must store PAR with each transfer along with 32-bit <code>addr/data</code> .
	0	Must store data parity bits on every valid data transfer in data RAM.
Data	0	Stored in data RAM up to 8 cache lines
Lock	1	
DAC Indication	1	Indicates whether address is 32 or 64 bits

Because the PCI Spec 2.1 requires posted memory write transactions to be executed in the order in which they are received, the tag memory **2036** is a circular FIFO device. The PMWQ, and therefore the tag memory **2036**, can handle up to four posted memory write transactions simultaneously.

The data RAM **2038** includes four data buffers **2042**, **2044**, **2046**, and **2048**, one for each transaction in the PMWQ. Each buffer can store up to eight cache lines, or 256 bytes, of data (eight words per cache line). For each cache line in a buffer, the buffer stores eight data parity bits **2040** (one per dword) and thirty-two enable bits **2050** (one per byte).

A cable interface block **2060** receives each transaction and the corresponding data from the cable decoder and places the transaction in the tag memory **2036**. A queue interface block **2053** receives the data from the cable interface block **2060** and places it in the appropriate location in the data RAM **2038**. The queue interface **2053** also retrieves data from the data RAM **2038** and provides it to the QPIF when the QPIF is running the corresponding transaction on the PCI bus. An input pointer logic block **2054** generates four input pointers, one for each buffer, that tell the queue interface **2053** where to place the next word of data. A valid (output) pointer block **2056** generates four output pointers, one for each buffer, that indicate the position of the next word to be taken.

Referring also to FIG. 60, a valid flag logic block **2052** maintains an eight bit valid line register **2062** for each of the four buffers in the data RAM **2038**. The valid line register **2062** indicates which of the eight cache lines in each buffer contain valid data. When the last word in a cache line has been filled with data (i.e., `valid_pointer[2:0]` equals “111” and `cd_next_data` is asserted, indicating that the word has been filled), the corresponding bit in an eight bit cable valid signal (i.e., `q0_cable_valid[7:0]`, `q1_cable_valid[7:0]`, etc.) is set. The bit to be set is determined by the three most significant bits of the valid pointer (`valid_pointer[5:3]`), which indicate the cache line being filled. The corresponding bit in the cable valid signal also is set when a slot validation signal (`validate_slot`) is received from the cable decoder at the end of a transaction. The cable valid signal is latched into the valid line register **2062** corresponding to the selected data buffer at the rising edge of the first PCI clock cycle (CLK) after the last word is filled or the `validate_slot` signal is received. Otherwise, the valid line register maintains its current value. The bits in the valid line registers **2062** are cleared when the corresponding bits of an eight bit invalidate signal (i.e., `q0_invalidate[7:0]`, `q1_invalidate[7:0]`, etc.) is asserted.

The valid flag logic block **2052** generates a `pmwq_valid[3:0]` signal that indicates which, if any, of the four data

## 15

buffers contains at least one valid line of data. The valid block **2052** also generates a `pmwq_valid_lines [7:0]` signal that indicates which of the eight cache lines of a selected data buffer are valid. A queue select signal from the QPIF (`q2pif_queue_select [1:0]`) is used to select which data buffer's valid line register **2062** is used to generate the `pmwq_valid_lines [7:0]` signal. When the queue block gains control of the bus to run a posted memory write cycle from a selected data buffer, the queue block transfers all data in each line whose corresponding bit is set in the `pmwq_valid_lines [7:0]` signal. Gates **2064**, **2066**, **2068**, **2070**, and **2072**, and flip-flop **2074** are arranged to set the values in the valid line register **2062** for the first data buffer (`q0_valid [7:0]`). Similar circuitry determines the contents of the valid registers for the other three data buffers. Multiplexer **2076** selects the value of the `pmwq_valid_lines [7:0]` signal.

Referring now to FIG. **61**, a full line logic block **2058** maintains an eight bit full line register **2078** for each of the four data buffers. The contents of each full line register **2078** indicate which of the eight cache lines in the corresponding data buffer are full. The bits in each full line register **2078** are set by an asynchronous `next_full13 line_bit` signal generated by full line state machine **2080**, described below. When a queue selection signal from the QPIF (`select_next_queue [3:0]`) selects one of the data buffers and the `next_full_line_bit` signal is asserted, the bit in the full line register **2078** corresponding to the cache line indicated by the three most significant bits of the valid pointer (`valid_pointer [5:3]`) is set. A 3x8 decoder **2082** converts the three bit valid pointer into an eight bit signal that determines which bit to set. An eight bit full line signal (`q0_full_line`) is generated for each data buffer from the contents of the corresponding full line register **2078**. The full line signal indicates which lines in the corresponding data buffer are full. The full line logic block **2058** also generates a `pmwq_full_line [7:0]` signal that indicates which cache lines of a selected data buffer are full. Multiplexer **2084** and the `q2pif_queue_select [1:0]` signal are used to generate the `pmwq_full_line [7:0]` signal.

Referring also to FIG. **62**, the full line state machine **2080** is placed in an IDLE state **2086** at reset. In the IDLE state **2086**, the `next_full_line_bit` is set to zero. When a transaction is placed in the PMWQ, the transaction occurs in two phases, an address phase and a data phase. When the data phase begins (i.e., a `clock_second_phase` signal is asserted) and the valid pointer points to the first word in a cache line (`valid_pointer [2:0] = "000"`), the state machine **2080** transitions to a DATA state **2088**. In the data state, the `next_full_line_bit` signal is asserted only if the valid pointer points to the last word in the cache line (`valid_pointer [2:0] = "111"`), the `cd_next_data` signal is asserted by the cable decoder (indicating that the last word was filled with data), and the byte enable signal from the cable decoder (`cd_byte_en [3:0]`) equals "0000". The state machine also transitions back to the IDLE state **2086** when these conditions occur. If these conditions do not occur before the transaction terminates (i.e., `cd_complete` is asserted), the `next_full_line_bit` signal remains deasserted and the state machine **2080** transitions back to the IDLE state **2086**. The state machine **2080** also transitions to the IDLE state **2086** without asserting the `next_full_line_bit` signal when the `cd_byte_en [3:0]` signal takes on a value other than "0000".

Referring again to FIG. **59** and also to FIG. **63**, the PMWQ normally must terminate a transaction from the cable decoder when the data buffer receiving the corresponding data is full. However, when the cable decoder continues to send data after the buffer is full, an overflow

## 16

logic block **2090** allows the data to overflow into the next empty buffer. The overflow logic block **2090** maintains an overflow register **2092** that indicates which, if any, of the four data buffers are being used as overflow buffers. The contents of the overflow register **2092** are used to produce a four bit overflow signal (`pmwq_overflow [3:0]`). When the transaction is in the data phase (i.e., `data_phase` is asserted), the valid pointer reaches the last word of a data buffer (i.e., `valid_pointer [5:0] = "111111"`), the cable decoder indicates that more data is coming (i.e., `cd_next_data` is asserted), and the cable decoder has not indicated that the transaction is complete (i.e., `cd_complete` is not asserted), the `select_next_queue [3:0]` signal, which points to the recently filled data buffer, is used to set the overflow register bit corresponding to the next data buffer. If the conditions are not met, the overflow bit is cleared. Gates **2094** and **2095** are used in conjunction with the `select_next_queue [3:0]` signal to set and clear the appropriate overflow register bits when these conditions are met.

A single transaction may continue to overflow into additional buffers until the last unused buffer is full. If more than one buffer is used as an overflow buffer, multiple overflow register bits will be set. Consecutive set bits in the overflow register indicate that a single transaction has overflowed into more than one buffer. The overflow bits are either set or cleared when the posted write transaction is placed into the PMWQ. Also, if the QPIF begins to run the PMW transaction on the target bus and empty the original buffer while the data is still entering the PMWQ, the original buffer may be reused to continue the overflow transaction. The overflow can continue until all of the available buffers are full.

## Delayed Request Queue

Referring to FIG. **64**, the DRQ **142** stores all of the information needed to complete delayed read request (DRR) and delayed write request (DWR) transactions on the target bus. The DRQ includes a queue memory **2100** that holds information such as the address to be read from or written to, the PCI command code, byte enables, address and data parity bits, "locked cycle" and "dual address cycle" indication bits, and the buffer number of the delayed completion buffer reserved in the initiating bridge chip for the completion information. The queue memory **2100** also holds up to thirty-two bits (one word) of data to be written to the target bus in a delayed write cycle. Because delayed write cycles never involve more than one word of data, no data RAM is needed in the DRQ. The DRQ, and therefore the queue memory **2100**, is capable of holding up request delayed request transactions at once. A cable interface block **2102** claims delayed request transactions from the cable decoder and places them into the queue memory **2100**. The following table shows the information maintained in the DRQ queue memory.

Contents of DRQ		
Field	Bits	Comments
Address	64	Upstream Transactions support Dual Address Cycles
PCI Command	4	I/O Read I/O Write Config Read Config Write Memory Read Memory Read Line Memory Read Multiple

-continued

Contents of DRQ		
Field	Bits	Comments
Byte Enables	4	Byte Enables not necessary on MRL, MRM
Parity	1/address 1/data transfer	Send data par with delayed write transactions
Data	32	Data queued on delayed write transactions.
Lock	1	
DAC Indication	1	Indicates whether address is 32 or 64 bits
Buff Num	3	Indicates DCQ buffer allocated for completion data

Referring also to FIG. 65, a valid flag logic block **2104** determines when the DRQ has received all of the information necessary to run the transactions in the queue memory **2100**. When one of the DRQ slots is selected by a corresponding slot select signal (i.e., `select_zero` for the first slot, `select_one` for the second slot, and `select_two` for the third slot) and the slot is validated by a `validate_slot` signal, indicating that the cable decoder has finished delivering the transaction to the DRQ, a valid signal corresponding to the slot (i.e., `q0_valid`, `q1_valid`, or `q2_valid`) is asserted at the rising edge of the next PCI clock (CLK) cycle. If a slot is not selected and validated by the `validate_slot` signal, the slot's valid signal is deasserted if the QPIF has selected the slot by asserting a DRQ select signal (`q2pif_drq_select`) and identifying the slot (`q2pif_queue_select=slot number`) but has aborted the transaction by asserting a cycle abort signal (`q2pif_abort_cycle`). The valid signal also is deasserted if the DRQ ends the transaction by asserting a cycle complete signal (e.g., `q0_cycle_complete`) while the QPIF is waiting for more data (i.e., `q2pif_next_data` is asserted). However, the cycle complete signal is ignored if the QPIF is currently streaming data to the other bridge chip (i.e., `q2pif_streaming` is asserted). Otherwise, if the slot's valid signal is not specifically asserted or deasserted on a clock cycle, it retains its current value. The valid flag logic block **2104** also generates a DRQ valid signal (`drq_valid [3:0]`) that indicates which, if any, of the three DRQ slots contains a valid transaction, by combining the valid signals for each individual slot (i.e., `drq_valid={0, q2_valid, q1_valid, q0_valid}`). Gates **2106**, **2108**, **2110**, **2112**, and **2114**, multiplexers **2116** and **2118**, and flip-flop **2120** are arranged to generate the slot valid signals and the DRQ valid signals in this manner.

The DRQ also includes pointer logic blocks that maintain pointers to the memory locations from which data is to be read during a delayed read request transactions. When the address at which the delayed read transaction will begin is loaded into the queue memory **2100**, a valid pointer logic block **2122** generates a six bit valid pointer that indicates where the transaction will end. If the transaction involves a single word (e.g., a memory read), the valid pointer logic **2122** sets the valid pointer equal to the address loaded into the queue memory **2100**. For a memory read line transaction, the valid pointer logic **2122** gives the valid pointer a value of "000111", which indicates that the last valid piece of data is eight dwords (i.e., one cache line) beyond the starting point. For a memory read multiple transaction, the valid pointer is set to "111111", which indicates that the last valid piece of data is sixty-four dwords (i.e., eight cache lines) beyond the starting point. The valid pointer logic **2122** maintains one valid pointer for each slot

in the DRQ (`valid_pointer_0 [5:0]`, `valid_pointer_1 [5:0]`, and `valid_pointer_2 [5:0]`). The location of the valid pointer is ignored by the DRQ when it receives a streaming signal from the QPIF (`q2pif_streaming`), as described in more detail below.

An output pointer logic block **2124** maintains three output pointers (`output_pointer_0 [5:0]`, `output_pointer_1 [5:0]`, and `output_pointer_2 [5:0]`), one for each slot in the DRQ, that indicate the next word of data to be read from memory and delivered to the other bridge chip. The pointer is incremented when the QPIF indicates that it is ready to read the next piece of data (i.e., it asserts the `q2pif_next_data` signal), once for every word read. Except in streaming situations, a transaction is terminated (completed) when the output pointer reaches the valid pointer. If a transaction terminates before all of the data is read (i.e., before the output pointer reaches the input pointer), the QPIF will pick up at the location indicated by the output pointer when the transaction resumes. If the output pointer is incremented but the output pointer logic **2124** receives a stepback signal (`q2pif_step_back`), indicating that the transaction was terminated on the PCI bus before the QPIF was able to read the last piece of data, the output pointer logic **2124** decrements the counter once so that the last unread piece of data can be read when the transaction resumes. A queue interface block **2126** provides transaction information and the valid and output pointers to the QPIF.

#### Delayed Completion Queue

Referring to FIG. 66, the DCQ **144** stores delayed completion messages containing the response of the target bus to each delayed request issued on the initiating bus. Delayed completion messages corresponding to delayed read requests include the requested data, while delayed completion messages corresponding to delayed write requests include no data. A cable interface block **2130** claims delayed completion messages from the cable decoder and provides the delayed completion information to a tag memory **2132**. The DCQ, and therefore the tag memory **2132**, is capable of storing up to eight delayed completion messages at once. The tag memory **2132** stores information such as the PCI command and the address contained in the original request leading to the delayed completion message, byte enable bits, address and data parity bits, and "locked cycle" and "dual address cycle" bits. For delayed write transactions, which always involve only in a single word of data, the tag memory **2132** stores a copy of the written data. Each of the eight slots in the tag memory **2132** includes an implied pointer to one of eight corresponding data buffers in a DCQ data RAM **2134**. For delayed read transactions, the returned data is stored in a corresponding data buffer **2135a-h** in the data RAM **2134**. The following table shows the information stored in the tag memory **2132** for each transaction held in the DCQ.

Contents of DCQ		
Field	Bits	Comments
Address	64	Upstream Transactions support Dual Address Cycles
PCI Command	4	I/O Read I/O Write Config Read Config Write Memory Read

-continued

Contents of DCQ		
Field	Bits	Comments
Byte Enables	4	Memory Read Line
		Memory Read Multiple
Parity	1/data transfer	Byte Enables not necessary on MRL, MRM
		Send data par with delayed write transactions
Data	32	Data queued on delayed write transactions.
Lock	1	
DAC Indication	1	Indicates whether address is 32 or 64 bits

Each of the eight data buffers in the DCQ data RAM **2134** may store up to eight cache lines (256 bytes) of delayed completion data. Therefore, the buffers are large enough to store all completion data for even the largest delayed request transactions (memory read multiple transactions). However, the capacity of each data buffer may be reduced to four cache lines by setting a configuration bit (`cfg2q_eight_line`) in the bridge chip's configuration registers. Each data buffer may be filled by data provided in a single delayed completion transaction, or if not all requested data is returned in a single delayed completion transaction, by multiple delayed completion transactions. However, each data buffer may contain data corresponding to only one original delayed request, regardless of how many delayed completion transactions it takes to provide the requested data.

A queue interface block **2136** controls the flow of completion data from the DCQ cable interface **2130** into the data RAM **2134** and out of the data RAM **2134** to the QPIF. Three logic blocks generate pointers that govern the input and output of data stored in the eight data buffers. The first block, an input pointer logic block **2138**, maintains a six bit input pointer for each of the eight data buffers (`in_pointer_0` [5:0], `in_pointer_1` [5:0], etc.). Each input pointer points to the location in the corresponding data buffer to place the next word of data. The second block, an output pointer logic block **2140**, maintains a six bit output pointer for each of the eight buffers (`out_pointer_0` [5:0], `out_pointer_1` [5:0], etc.). Each output pointer points to the location of the word of data immediately following the word last removed by the QPIF. The output pointer for a selected data buffer is incremented when the QPIF indicates that it is ready for the next piece of data (i.e., when `q2pif_next_data` is asserted). If the output pointer is incremented but the last piece of data does not reach the requesting device because the transaction was terminated by a device other than the QPIF, the QPIF asserts a stepback signal (`q2pif_step_back`) that causes the output pointer logic block **2140** to decrement the output pointer by one word.

The third pointer block, a valid pointer logic block **2142**, maintains for each of the eight data buffers a six bit valid pointer (`valid_pointer_0` [5:0], `valid_pointer_1` [5:0], etc.) that indicates the next word of data in the corresponding data buffer that is available to the QPIF. Because the PCI Spec 2.1 requires that read completion data not be returned before an earlier-initiated posted memory write transaction, delayed completion data placed into the DCQ while a posted memory write is pending in the PMWQ cannot be made available to the requesting device until the posted memory write is completed on the PCI bus and removed from the PMWQ. Therefore, as long as any earlier-enqueued posted memory write transactions remain in the PMWQ, the valid

pointer must remain at its current position. Then, when all earlier-enqueued posted memory writes have been removed from the PMWQ, the valid pointer may be moved to the same position as the in pointer. When the PMWQ is empty, all delayed completion data is valid (i.e., available to the requesting device) as soon as it is stored in the DCQ.

Referring also to FIGS. **67A** and **67B**, the valid pointer logic block **2142** must ask the master cycle arbiter (MCA) to validate all delayed completion transactions that enter the delayed completion queue while a posted memory write is pending in the PMWQ. But because the MCA can enqueue no more than four delayed completion transactions at once, as discussed below, the valid pointer logic block **2142** may request validation of no more than four delayed completion data buffers at once. The valid pointer logic block **2142** also must keep track of which four delayed completions transactions are enqueued in the MCA at any given time. To do so, the valid pointer logic block **2142** maintains two four-slot registers: a DCQ buffer number register **2144** and a validation request register **2146**. The buffer number register **2144** maintains the three-bit DCQ buffer number, as determined by the DCQ buffer number signal (`cd_dcq_buff_num` [2:0]) provided by the cable decoder, of each delayed completion transaction enqueued in the MCA. The validation request register **2146** maintains one transaction validation request bit for each of the DCQ buffers whose numbers are stored in the four slots **2148a-d** of the buffer number register **2144**. The request bit in each slot **2150a-d** of the validation request register **2146** is asserted if a corresponding delayed completion transaction is enqueued in the MCA. The values of the bits in the four validation request slots **2150a-d** are provided together to the MCA as a four bit validation request signal (`dcq_valid` [3:0]).

When a delayed completion transaction is to be enqueued in the MCA, its corresponding DCQ buffer number is loaded into one of the buffer number slots **2148a-d** by the `cd_dcq_buff_num` [2:0] signal. The slot **2148a-d** to be loaded is selected by a two bit selection signal (`next_valid_select` [1:0]). The value of the selection signal depends upon the value of the `dcq_valid` [3:0] signal generated by the validation request register **2146** and look-up table **2152**, the contents of which are shown in the table below. The slot is loaded when it is selected by `next_valid_select` [1:0], when the cable decoder has selected the DCQ and has completed the transaction (i.e., `cd_dcq_select` and `cd_complete` are asserted), and when at least one posted memory write transaction is pending in the PMWQ (i.e., `pmwq_no_pmw` is not asserted). Gates **2154**, **2156**, **2158**, **2160**, and **2162** and 2x4 decoder **2164** are arranged to load the buffer number register **2144** in this manner. Likewise, the corresponding bit in the validation request register **2146** is set by the output of gates **2154**, **2156**, **2158**, **2160**, and **2162** and 2x4 decoder **2164**.

Buffer number register slot selection		
<code>dcq_valid</code> [3:0]	<code>next_valid_select</code> [1:0]	slot #
xxx0	00	0
xx01	01	1
x011	10	2
0111	11	3

In response to the `dcq_valid` [3:0] signal, the MCA outputs a four bit DCQ run signal (`mca_run_dcq` [3:0]) that indicates which of the DCQ buffers pointed to by the buffer number register may have its valid pointer updated. The

mca\_run\_dcq [3:0] signal is provided to a valid pointer update logic block 2166, along with the pmwq\_no\_pmw signal and the in pointers for each of the eight data buffers. If a posted memory write transaction remains in the PMWQ after the MCA asserts one of the mca\_run\_dcq [3:0] bits (which will happen when a posted memory write transaction was enqueued after the delayed completion transaction was enqueued but before the MCA asserted the corresponding mca\_run\_dcq bit), the corresponding valid pointer is updated as long as no other delayed completion transactions corresponding to the same DCQ buffer are still enqueued in the MCA. If a delayed completion transaction for the same DCQ buffer is still enqueued in the MCA, the valid pointer may be updated only when the mca\_run\_dcq bit corresponding to this transaction is asserted. On the other hand, as soon as the pmwq\_no\_pmw signal is deasserted, all valid pointers are updated to match the corresponding in pointers regardless of whether delayed completions are still enqueued in the MCA. When a mca\_run\_dcq bit is asserted, the corresponding bit in the validation request register 2146 is cleared. Gates 2168, 2170, 2172, 2174, and 2176 are arranged to clear the validation request register bits in this manner.

Referring again to FIG. 66, a hit logic block 2180 determines when a delayed request transaction from a requesting device on the PCI bus has “hit” none of the delayed completion messages in the DCQ. According to the PCI Spec 2.1, the following attributes must be identical for a delayed completion to be matched with a request: address, PCI command, byte enables, address and data parity, data (if a write request), REQ64# (if a 64-bit data transaction), and LOCK# (if supported). When a request is latched by the PCI slave, the QPIF retrieves the request information, sends it to the DCQ, and asserts a check cycle signal (q2pif\_check\_cyc) that instructs the DCQ hit logic 2180 to compare the request information to the delayed completion messages stored in the DCQ tag memory 2132. The hit logic 2180 receives the sixty-four bit address signal (q2pif\_addr [63:2]), the four bit PCI command signal (q2pif\_cmd [3:0]), the four enable bits (q2pif\_byte\_en [3:0]), the dual address cycle bit (q2pif\_dac) (which corresponds to the PCI REQ64# signal), the lock bit (q2pif\_lock) from the QPIF, and, if the request is a write request, the data to be written (q2pif\_data [31:0]). Though not required by the PCI Spec 2.1, the QPIF also provides the slot number (q2pif\_slot [2:0]) of the requesting device to enhance the queue block’s buffer flushing routine, described below. The hit logic 2180 then compares each of these signals to the delayed completion information stored in the eight DCQ buffers. If all of the signals match the information of any of the delayed completion messages, the hit logic 2180 identifies the buffer containing the matching completion message by asserting a corresponding bit in an eight bit hit signal (dcq\_hit [7:0]). When a hit occurs, the QPIF retrieves the completion message and provides it to the requesting device and, if the request is a read request, begins removing the returned data from the corresponding data buffer in the data RAM 2134. If the request information does not match the completion information of any of the delayed completion messages in the DCQ, the request has “missed” the DCQ and is stored in the next available DCQ buffer and forwarded through the cable to the other bridge chip by the QPIF. A PCI device which initiates a request that misses the DCQ may have its REQ# line masked until its completion message is returned, as described in more detail below.

The hit logic 2180 also interfaces with a multi-threaded master detection block 2182 to detect which PCI slots, if

any, contain multi-threaded devices. Multi-threaded devices are capable of maintaining more than one delayed transaction at once and therefore must be treated specially. When a multi-threaded master is detected, a corresponding bit in the configuration registers is set to indicate that the device is able to sustain multiple outstanding delayed transactions and therefore that its REQ# line should not be masked. Multi-threaded master detection is discussed in more detail below.

Another function of the DCQ is to determine when an opportunity to create a stream of read data between the primary and secondary PCI buses exists. A streaming opportunity exists when delayed completion data is being placed into the DCQ by the cable decoder while it is still being placed onto the target bus by the target device. If the PCI device that initiated the transaction resubmits its request while the target device is still placing data on the PCI bus, a read stream is established. Because read streaming is an efficient way to transfer data between the primary and secondary PCI buses, the PCI bridge chip not only gives higher priority in the bus arbitration process to a device whose completion data is arriving, it also will attempt to terminate a non-streaming transaction to improve the possibility that a stream will be established. However, while in theory streaming can occur during any read cycle, in practice it is likely to occur only during transactions that involve a large amount of data (i.e., memory read multiple transactions). Therefore, the queue block will attempt to terminate transactions in favor of potential streaming opportunities only when the potential streaming transaction is a memory read multiple transaction.

Referring also to FIG. 68, a stream logic block 2184 in the DCQ determines whether a streaming opportunity exists and, if so, generates the signals required to support the stream. The stream logic block 2184 generates the signals required to disconnect a current transaction in favor of a potential stream. When the cable decoder is placing a delayed completion transaction in the DCQ, the stream logic 2184 uses the DCQ buffer number signal provided by the cable decoder (cd\_dcq\_buff\_num) to retrieve the PCI command code stored in the corresponding DCQ buffer (q0\_cmd [3:0], q1\_cmd [3:1], etc.). If the command code represents a memory read multiple request (i.e., “1100”), the stream logic 2184 asserts a disconnect-for-stream signal (dcq\_disconnect\_for\_stream) that instructs the QPIF and the PCI interface to terminate the current transaction due to a potential streaming opportunity. Multiplexer 2186 and comparator 2188 are arranged to generate the dcq\_disconnect\_for\_stream signal. Then, as long as the cable decoder continues to provide the completion data to the DCQ (i.e., the cd\_dcq\_select signal remains asserted) and no posted memory writes appear in the PMWQ (i.e., pmwq\_no\_pmw remains asserted), the stream logic 2184 provides a streaming request signal (q2a\_stream) directly to the PCI arbiter. The stream logic 2184 also provides the slot number of the potential streaming device (q2a\_stream\_master [2:0]) to the PCI arbiter by using the cd\_dcq\_buff\_num [2:0] signal to select the PCI slot number stored in the selected DCQ buffer (q0\_master [2:0] for DCQ buffer zero 2135a, q1\_master [2:0] for DCQ buffer one 2135b, etc.). The PCI arbiter then elevates the bus arbitration priority of the potential streaming device, as discussed in more detail below. If the potential streaming master is not granted the bus before the streaming opportunity disappears, its priority is returned to normal. Because the upstream bus has only one master device (the CPU), this feature is disabled in the upstream chip. Gate 2190 and multiplexer 2192 are arranged to generate the q2a\_stream and q2a\_stream\_master signals.

When a requesting device hits a delayed completion message stored in the DCQ, the corresponding bit of an eight bit hit signal (hit [7:0]) is asserted. The hit [7:0] signal indicates which of the eight DCQ buffers was hit by the current request. When this happens, if the corresponding DCQ buffer contains data (i.e., dcq\_no\_data is not asserted), the stream logic 2180 latches the value of the hit signal for the duration of the transaction (i.e., as long as q2pif\_cyc\_complete is asserted). The latched version of the hit signal forms a “delayed” hit signal (dly\_hit [7:0]). When either the hit signal or the delayed hit signal indicates that a DCQ buffer has been hit, a three bit DCQ stream buffer signal (dcq\_stream\_buff [2:0]) provides the buffer number of the hit DCQ buffer. Then, if the cable decoder places delayed completion data into the buffer while the cycle that hit the buffer is in progress (i.e., cd\_dcq\_select is asserted and cd\_dcq\_buff\_num [2:0] equals dcq\_stream\_buff [2:0]), the stream logic block 2180 asserts a stream connect signal (dcq\_stream\_connect) that tells the QPIF that a stream has been established. The QPIF then informs the bridge chip on the target bus that a stream has been established. If certain conditions are met, the target QPIF will continue to stream until it is told to stop by the initiating QPIF, as discussed in more detail below. Gates 2194 and 2196, multiplexers 2198 and 2200, and flip-flop 2202 are arranged to generate the delayed hit signal. Gates 2204, 2206, and 2208 and encoder 2210 are arranged as shown to generate the dcq\_stream\_connect and dcq\_stream\_buff [2:0] signals.

Referring again to FIG. 66, the DCQ will, under certain circumstances, automatically prefetch data from the target bus on behalf of a PCI master in anticipation that the master will come back and request the data. A prefetch logic block 2212 in the DCQ prefetches data when the reading master consumes all of the data in its DCQ buffer and the prefetch logic 2212 anticipates that the requesting device will return with a sequential read request (i.e., a request that picks up with data located at the next sequential location in memory). Because some devices, such as multi-threaded masters, routinely read all of the data requested in one transaction and then return with a different, non-sequential request, the prefetch logic 2212 includes prediction circuitry that disables the prefetch capabilities for each device on the PCI bus until the device has shown a tendency to issue sequential read requests. As soon as a device that has been receiving prefetched data returns with a non-sequential read request, the prediction circuitry will disable the prefetching function for that master.

Referring also to FIGS. 69A and 69B, the prefetch logic block 2212 includes a prefetch prediction register 2214, the output of which is an eight bit prefetch enable signal (prefetch\_set [7:0]) that governs whether the prefetch function is available for each of the devices on the PCI bus. All bits in the prefetch enable signal are cleared at reset (RST) and when the QPIF orders a general flush of all of the DCQ registers (i.e., general\_flush is asserted and q2pif\_slot [2:0] equals “000”). The general\_flush signal is discussed in more detail below. Gates 2216 and 2218 generate the signal that resets the prefetch\_set bits.

An individual bit in the prefetch enable signal is set when the corresponding PCI slot is selected by the q2pif\_slot signal and the following conditions occur: the requesting device hits a delayed completion buffer in the DCQ (i.e., one of the bits in the cycle\_hit [7:0] signal is asserted), the current transaction is a memory read line or memory read multiple cycle (i.e., q2pif\_cmd [3:0] equals “1100” or “11110”), the QPIF has indicated that the cycle is complete

(i.e., q2pif\_cyc\_complete is asserted), and the last word of data was taken from the DCQ buffer (i.e., last\_word is asserted). Gates 2220, 2222, 2224 and 2228a–h and decoder 2226 are arranged to set the prediction bits in this manner. The last\_word signal is asserted by the prefetch logic 2212 when the requesting device tries to read past the end of the DCQ buffer. This occurs when the out\_pointer and in\_pointer are equal, indicating that the end of the DCQ buffer has been reached (i.e., for a four cache line buffer, out\_pointer\_x [4:0] equals valid\_pointer\_x [4:0] or, for an eight cache line buffer, out\_pointer\_x [5:0] equals valid\_pointer\_x [5:0]) and when the requesting device tries to read another piece of data (i.e., q2pif\_next\_data is asserted). Gates 2230, 2232, and 2234 are arranged to generate the last\_word signal

An individual bit in the prefetch enable signal is cleared when the corresponding PCI slot is selected and either a PCI flush condition occurs (p2q\_flush is asserted), the QPIF tells the DCQ to step back the buffer’s valid pointer (q2p\_step\_back is asserted), or the requesting device initiates a transaction that misses all of the DCQ buffers (q2pif\_check\_cyc is asserted and dcq\_hit is deasserted). Gates 2236, 2238, and 2240a–h and decoder 2226 are arranged to clear the prediction enable bits in this manner.

When the prefetching function is enabled for a device on the PCI bus, the prefetch logic 212 can generate two types of prefetch signals for the device: a prefetch line signal (dcq\_prefetch\_line) and a prefetch multiple signal (dcq\_prefetch\_mul). The prefetch line signal is generated when the current PCI command from the requesting device is a memory read line signal, and the prefetch multiple signal is generated when the current PCI command is a memory read multiple signal. In either case, the corresponding prefetch signal is generated when the following conditions occur: the prefetch\_set bit for the requesting PCI slot is set; a corresponding prefetch enable bit in the configuration registers is set (cfg2q\_auto\_prefetch\_enable); the DRQ in the upstream chip is not full (!tc\_dc\_full); the DCQ buffer has room for the corresponding amount of prefetch data (!dcq\_no\_prefetch\_room); the current cycle hit the DCQ buffer; and the requesting master has tried to read past the end of the DCQ buffer (last\_word and q2pif\_cyc\_complete). Gates 2242, 2244, 2246, 2248, 2250, and 2252, decoder 2254, and multiplexers 2256 and 2258 are arranged to generate the prefetch signals in this manner.

When the prefetch logic 2212 generates a prefetch signal, it generates a corresponding prefetch address signal (dcq\_prefetch\_addr [63:2]) by concatenating the upper fifty-seven bits of the address stored in the corresponding DCQ buffer (q0\_addr [63:7] for buffer zero, q1\_addr [63:7] for buffer one, etc.) with the lower five bits of the buffer’s output pointer (out\_pointer\_0 [4:0], etc.). A dual address cycle signal (dcq\_prefetch\_dac) indicates whether the prefetch transaction is a dual or single address cycle. The dcq\_prefetch\_cycle signal takes on the value of the dual address bit stored in the DCQ buffer (q0\_dac, q1\_dac, etc.). For both the prefetch address and dual address cycle signals, the appropriate value is output from a multiplexer 2260 or 2262 and selected by the three bit DCQ buffer number signal indicating which DCQ buffer was hit by the current request.

Referring again to FIG. 66, each DCQ data buffer has several possible states, each of which is determined by a buffer state logic block 2264 in the DCQ. The following are the possible buffer states.

1. Empty. Available for allocation. A buffer is Empty after power up and after it is flushed.



2. Complete. The buffer contains completion information for a delayed completion from a real delayed request from a device on the PCI bus (i.e., not a prefetch request). The PCI device has not yet reconnected and taken data from the buffer. The delayed completion transaction is complete.
3. Prefetch. The buffer contains completion data for a prefetch request or requested data that was left in the buffer after the requesting master disconnected from the buffer. All of the completion data has arrived from the target.
4. PartComplete. The buffer is reserved for and may contain completion information for a real delayed request (i.e., not a prefetch request). The master has not yet reconnected and taken data from the buffer, and not all of the completion information has arrived from the target.
5. PartPrefetch. The buffer is reserved for or contains completion information for a prefetch request, or the buffer contains requested data that was left in the buffer after the requesting master disconnected from the buffer. Not all of the completion information has arrived from the target.
6. Discard. The buffer was flushed while in the Part-Prefetch state, but the last completion data has not yet arrived from the target. The buffer is placed in the Discard state to prevent it from being used until the transaction completes on the target bus and the last data arrives.

When the QPIF requests a DCQ buffer for a delayed request transaction, the buffer state logic 2264 allocates the buffers in the following order. If no buffer is in the Empty state or Prefetch state, the requesting master must be retried.

DCQ Buffer Allocation	
Buffer Number	Buffer State
Q0	Empty
Q1	Empty
Q2	Empty
Q3	Empty
Q4	Empty
Q5	Empty
Q6	Empty
Q7	Empty
Q0	Prefetch
Q1	Prefetch
Q2	Prefetch
Q3	Prefetch
Q4	Prefetch
Q5	Prefetch
Q6	Prefetch
Q7	Prefetch

When a device on the PCI bus initiates a delayed read request and a DCQ completion buffer is set aside, the buffer state logic 2264 changes the buffer's state to PartComplete. If the DCQ initiates a prefetch read, the buffer state is changed to PartPrefetch. When the last piece of completion data arrives, the buffer's state is changed from PartComplete or PartPrefetch to Complete or Prefetch, respectively. When the requesting device resubmits a retried read request and hits the buffer, any valid completion data is given to the master if the buffer is in the Complete, Prefetch, PartComplete, or PartPrefetch state. If the master does not take all of the data before disconnecting, the buffer's state is changed to Prefetch or PartPrefetch to indicate that the unclaimed data is considered to be prefetch data. If the

master takes the last piece of data when the buffer is in the Complete or Prefetch state, the buffer's state is changed to Empty.

If a flush signal is received while a buffer is in the Prefetch state, the prefetch data in the buffer is discarded and the buffer state is changed to Empty. If a flush event occurs while the buffer is in the PartPrefetch state and completion data is still arriving, the buffer is changed to the Discard state until all of the prefetch data arrives. When the transaction is complete, the prefetch data is discarded and the buffer state is changed to Empty. If the buffer is in the Complete or PartComplete state when a flush signal is received, the completion data is left in the buffer and the buffer state remains unchanged. If the flush signal occurs because the corresponding PCI device has issued a new request (i.e., a request that is not currently enqueued and that "misses" all of the completion buffers), as discussed below, the DCQ allocates a new buffer for the transaction, as discussed above. Therefore, a PCI device may have more than one completion buffer allocated. Multiple buffers may be allocated to a PCI device when the device has a buffer containing or awaiting completion data (i.e., the buffer is in the Complete or PartComplete state) and the device issues a new request. Because multi-threaded devices are the only devices that can maintain multiple transactions at once, only multi-threaded devices can have multiple completion buffers reserved simultaneously.

#### Master Cycle Arbiter

The Master Cycle Arbiter (MCA) determines the execution order of posted memory write and delayed request transactions while maintaining the ordering constraints between posted memory write, delayed request, and delayed completion cycles set forth in the PCI Spec 2.1. According to the PCI Spec 2.1, the MCA must guarantee that executed cycles maintain strong write ordering and that no deadlocks occur. To ensure that no deadlocks will occur, posted memory write cycles must be allowed to pass earlier enqueued delayed request cycles, and to maintain the required ordering constraints, delayed request cycles and delayed completion cycles must never be allowed to pass earlier-enqueued posted memory write cycles.

Referring to FIG. 70, the MCA uses two transaction queues, a transaction run queue (TRQ) (or transaction execution queue) 2270 and a transaction order queue (TOQ) 2272, to manage cycles enqueued in the PMWQ, DRQ, and DCQ. An MCA control block 2274 receives transactions from the PMWQ, DRQ, and DCQ in the form of four bit validation request signals (pmwq\_valid [3:0], drq\_valid [3:0], and dcq\_valid [3:0]) and outputs run commands in the form of four bit run signals (mca\_run\_pmwq [3:0], mca\_run\_drq [3:0], and mca\_run\_dcq [3:0]). The transactions are moved into and out of the TRQ 2270 and TOQ 2272 by a TRQ control block 2276 and a TOQ control block 2278, respectively.

Referring also to FIG. 71, the TRQ 2270 is the queue from which the MCA determines the transaction execution order. Transactions in the TRQ 2270 can be executed in any order without violating the transaction ordering rules, but once a posted memory write cycle is placed in the TRQ 2270, no other cycle can be placed in the TRQ 2270 until the posted memory write is removed. Transactions in the TRQ 2270 are tried in circular order and generally are completed in the order they were received. However, if a transaction in the TRQ 2270 is retried on the PCI bus, the MCA may select the next transaction in the TRQ 2270 to be tried on the PCI bus. Because delayed completion transactions are slave cycles

rather than master cycles, they are never placed in the TRQ 2270. Furthermore, because delayed completion information may be made available to the requesting device as soon as it enters the DCQ if no posted memory write cycles are pending in the PMWQ, delayed completion transactions are placed in the TOQ 2272 only when a posted memory write cycle is pending in the TRQ 2270, as discussed in more detail below.

The TRQ 2270 is a circular queue that holds up to four transactions at once. Because the MCA must always be able to run at least one posted memory write transaction to preserve the required ordering constraints, the TRQ 2270 can never hold more than three delayed request transactions at once. Furthermore the TRQ can hold only one posted write transaction at a time because posted writes cannot be passed by any later-initiated transaction, including other posted writes. Each slot 280a-d in the TRQ 2270 contains three bits of information: a one bit cycle type indicator 2282 (which equals "1" for posted memory write transactions and "0" for delayed request transactions), and a two bit valid pointer 2284, the four possible values of which identify which of the buffers in the PMWQ or the DRQ the enqueued transactions occupy. The TRQ 2270 also includes an input/output enable block 2286 that determines when a transaction may be moved into or out of the TRQ 2270, an input logic block 2288 that controls the placement of a transaction into the TRQ 2270, and an output logic block 2290 that controls removal of a transaction from the TRQ 2270. These logic blocks contain standard queue management circuitry.

A circular input pointer 2292 selects the next available slot for placement of an incoming transaction. The input pointer is circular to maintain, as much as possible, historical order of the incoming transactions.

A circular output pointer 2294 arbitrates between the transactions in the TRQ 2270 and determines their order of execution. The output pointer 2294 always begins with the top slot 2286a in the TRQ 2270 at startup and progresses circularly through the TRQ 2270. The output pointer 2294 may be configured to operate in either infinite retry or zero retry mode by setting or clearing, respectively, an infinite retry bit in the configuration registers (cfg2q\_infretry). In infinite retry mode, the output pointer 2294 remains on a transaction until the transaction is run successfully on the PCI bus. In zero retry mode, the output pointer 2294 is incremented each time a transaction is tried on the bus (i.e., q2pif\_cyc\_complete was asserted on the previous PCI clock cycle), regardless of whether the transaction completes successfully or is retried. Because the PCI Spec 2.1 mandates that posted memory write transactions be allowed to bypass delayed request transactions, the output pointer 2294 in at least one of the bridge chips must be configured to operate in zero retry mode. Here, the downstream chip always is configured to operate in zero retry mode. Alternatively, the output pointer may be configured to operate in finite retry mode, in which each transaction may be attempted on the PCI bus a predetermined number (e.g., three) of times before the output pointer increments. Both the upstream and downstream chips can be configured to operate in finite retry mode with violating the ordering constraints of the PCI Spec 2.1. In any case, the output pointer tries to maintain the historical order of transactions stored in the TRQ 2270, incrementing only when a transaction cannot be completed successfully on the target PCI bus.

When a posted memory write or delayed request cycle is popped out of the TOQ 2272 (new\_toq\_cycle is asserted), as discussed below, or when the TOQ 2272 is not enabled

(!toq\_enabled) and a new cycle is received by the MCA (new\_valid\_set), the cycle type bit and valid bits for the new cycle are loaded into the next empty slot in the TRQ. If the cycle is coming from the TOQ 2272, the valid bits and cycle type bit are provided by TOQ valid and cycle type signals (toq\_valid [1:0] and toq\_cyctype [0]), respectively. Otherwise, the new cycle information is provided by MCA valid and cycle type signals (d\_valido [1:0] and d\_cyctype [0]). Gates 2296 and 2298 and multiplexers 2300 and 2302 are arranged to control the selection of cycles to be loaded into the TRQ 2270. When a cycle is successfully run on the PCI bus, the cycle is removed from the transaction order queue and its cycle type bit and valid bits are provided to the MCA control block 2274 as TRQ cycle type and valid signals (trq\_cyctype [0] and trq\_valido [1:0]), respectively.

The TRQ control block 2276 generates a trq\_pmw signal that indicates when a posted memory write transaction is enqueued in the TRQ 2270. When this signal is asserted, subsequently issued delayed request and delayed completion transactions must be enqueued in the TOQ 2272, as discussed below. The trq\_pmw signal is asserted when the MCA control block 2274 has instructed the TRQ 2270 to enqueue a new posted memory write cycle (trq\_slot\_valid\_set does not equal "0000" and d\_trq\_cyctype equals "1"), or, alternatively, when any of the TRQ slots 2280a-d contains a cycle (trq\_slot\_valid [3:0] does not equal "0000"), at least one of the cycles is a posted memory write cycle (trq\_cyctype equals "1"), and the posted memory write cycle has not been cleared from the corresponding slot 2280a-d (!trq\_slot\_valid\_rst [3:0]). Gates 2304, 2306, 2308, 2310, and 2312 are arranged to generate the trq\_pmw signal in this manner.

Referring now to FIG. 72, the TOQ 2272 is a first-in-first-out (FIFO) queue that retains the historical order of transactions received by the bridge after a posted memory write transaction is placed in the TRQ 2270. Because all transactions must wait for earlier-issued posted memory writes to run, all transactions including posted memory write, delayed request, and delayed completion transactions, are placed in the TOQ 2270 when a posted memory write is enqueued in the TRQ 2270. Transactions in the TOQ 2272 must remain in the TOQ 2272 until the posted memory write transaction is removed from the TRQ 2270.

The TOQ 2270, which has eight slots 2314a-h, can hold up to three posted memory write transactions (the fourth will be stored in the TRQ 2270), three delayed request transactions, and four delayed completion transactions. Each of the slots 2314a-h in the TOQ 2272 contains two cycle type bits 2316 that identify the corresponding transaction ("01" is a posted memory write, "00" is a delayed request, and "1x" is a delayed completion) and two valid bits 2318 that identify which of the buffers in the PMWQ, DRQ, and DCQ the corresponding transaction occupies. The TOQ 2272 also includes standard input and output logic blocks 2320 and 2322, which control the movement of transactions into and out of the TOQ 2272.

The positions at which transactions are placed into and removed from the TOQ 2272 are determined by a three bit input counter 2326 (inputr [2:0]) and a three bit output counter 2324 (outputr [2:0]), respectively. Both counters begin at the first slot 2314a in the TOQ 2272 and increment through the queue as transactions are entered into and removed from the queue. The input counter 2326 increments on the rising edge of every PCI clock cycle at which the TOQ 2272 is enabled (toq\_enabled is asserted) and the MCA control block 2274 provides a new cycle to the TOQ 2272 (new\_valid\_set is asserted). The valid bits and cycle

type bits for each new cycle are provided by the MCA valid and cycle type signals (`d_valido [1:0]` and `d_cyctype [1:0]`). The output counter **2324** increments on the rising edge of each PCI clock cycle at which the MCA control block **2274** instructs the TOQ **2272** to move to the next cycle (`next_toq_cycle` is asserted) and the TOQ **2272** is not empty (i.e., `inputr [2:0]` does not equal `outputr [2:0]`). Cycles exiting the TOQ **2272** are represented by TOQ valid and cycletype signals (`toq_valido [1:0]` and `toq_cyctype [1:0]`). Gates **2328** and **2330** and comparator **2332** are arranged to properly clock the input pointer **2326** and output pointer **2324**.

When a delayed request transaction or posted memory write transaction is popped out of the TOQ **2272**, the transaction is placed in the TRQ **2270** to await arbitration. But because delayed completion transactions are target transactions and not master transactions, delayed completions are not placed in the TRQ **2270**. Instead, delayed completions are simply popped out of the TOQ **2272** and used to validate the corresponding data in the DCQ data buffers. However, as long as a posted memory write transaction is enqueued in the TRQ **2270**, all delayed completions must be placed in the TOQ **2272**, even when two or more delayed completions correspond to the same delayed request and therefore the same delayed completion buffer, as described above.

Referring to FIGS. **73A** through **73D**, the MCA control block **2274** controls the flow of transactions through the MCA. As discussed above, the PMWQ, DRQ, and DCQ request validation of transactions held in the queues by providing four bit validation signals `pmwq_valid [3:0]`, `drq_valid [3:0]`, and `dcq_valid [3:0]`, respectively, to the MCA. Among these signals, only one bit can change during each clock pulse since only a single new transaction can be placed into the queue block on each clock pulse. Therefore, the MCA control block identifies new validation requests by watching for the changing bits in the `pmwq_valid`, `drq_valid`, and `dcq_valid` signals. To do so, the MCA control block latches and inverts each signal at the rising edge of every PCI clock to create a delayed, inverted signal and compares the delayed, inverted signal to the current signal (i.e., the signal at the next clock pulse). Since only a newly changed bit will have the same value as its delayed and inverted counterpart, the MCA control block is able to detect which bit changed. Using flip-flops **2340**, **2342**, and **2344** and gates **2346**, **2348**, and **2350**, the MCA controller generates `new_pmwq_valid [3:0]`, `new_drq_valid [3:0]`, and `new_dcq_valid [3:0]` signals which, at each clock pulse, together identify whether the PMWQ, DRQ, or DCQ, if any, submitted a new transaction for validation and which buffer in the corresponding queue contains the new transaction. Referring also to FIG. **74**, the MCA control block uses a look-up table **2352** to convert the twelve bits of the `new_pmwq_valid`, `new_drq_valid`, and `new_dcq_valid` signals into the two bit `d_valid [1:0]` and `d_cyctype [1:0]` signals provided to the TRQ and TOQ, as discussed above.

The MCA controller enables the TOQ by latching the `toq_enabled` signal to a value of "1" when either the `trq_pmw` is asserted, indicating that a posted memory write cycle is enqueued in the TRQ, or when the `toq_enable` signal already is asserted and the TOQ is not empty (`!toq_empty`). Gates **2354** and **2356** and flip-flop **2358** are arranged to generate `toq_enabled` in this manner.

The MCA control block asserts the `new_toq_cycle` signal, which instructs the TRQ to enqueue the cycle being popped out of the TOQ, when there was not a posted memory write cycle in the TRQ during the previous clock

cycle (`!sl_trq_pmw`), when the TOQ is not empty (`!toq_empty`), and when the cycle being popped out of the TOQ is not a delayed completion transaction (`!(toq_cyctype [1]="DC")`). The MCA controller uses gate **2360** to generate the `new_toq_cycle` signal.

The `next_toq_cycle` signal, which is used to increment the TOQ output counter to the next cycle in the TOQ, is asserted when the TOQ is not empty (`!toq_empty`) and either when no posted memory write cycles currently are enqueued in the TRQ (`!trq_pmw`) and the next cycle in the TOQ is a delayed completion (`toq_cyctype [1]="DC"`) or when the next TOQ cycle is a posted memory write or delayed request transaction (`!(toq_cyctype [1]="DC")`) and there were no posted memory write transactions during the previous clock cycle (`!sl_trq_pmw`). The control block uses gates **2362**, **2364**, **2366**, and **2368** to generate the `next_toq_cycle` signal.

The MCA controller generates the `mca_run_dcq [3:0]` signal to indicate that a delayed completion transaction has been popped out of the TOQ. When the TRQ contains no posted memory write cycles (`!trq_pmw`), the TOQ is not empty (`!toq_empty`), and the TOQ cycle is a delayed completion (`toq_cyctype [1]="DC"`), the `mca_run_dcq [3:0]` signal takes on the value of the decoded `toq_valido [1:0]` signal, discussed above. Otherwise, the `mca_run_dcq [3:0]` signal equals "0000". Gate **2370**, decoder **2372**, and multiplexer **2374** are arranged to generate `mca_run_dcq [3:0]` in this manner.

The MCA control block generates `new_mca_run_dr [3:0]` and `new_mca_run_pmw [3:0]` signals to indicate that it has a new delayed request transaction and a posted memory write transaction, respectively, to be enqueued. The `new_mca_run_dr [3:0]` signal takes on the value of the 2x4 decoded `d_valido [1:0]` signal, discussed above, when the new cycle is a delayed request cycle (`d_cyctype [0]="DR"`). Otherwise, all bits of the `new_mca_run_dr [3:0]` signal are set to zero. Likewise, the `new_mca_run_pmw [3:0]` signal takes on the value of the 2x4 decoded `d_valido [1:0]` signal when the new cycle is a posted memory write transaction and is set to "0000" otherwise. Decoders **2376** and **2380** and multiplexers **2378** and **2382** are arranged to generate the `new_mca_run_dr` and `new_mca_run_pmw` signals in this manner.

The MCA controller generates `toq_mca_run_dr [3:0]` and `toq_mca_run_pmw [3:0]` signals to indicate when a new delayed request transaction or posted memory write transaction, respectively, has popped out of the TOQ. The `toq_mca_run_dr [3:0]` signal takes on the value of the 2x4 decoded `toq_valido [1:0]` signal when a delayed request cycle is popped out of the TOQ and a value of "0000" otherwise. Likewise, the `toq_mca_run_pmw [3:0]` signal takes on the value of the 2x4 decoded `toq_valido [1:0]` signal when a posted memory write cycle pops out of the TOQ and a value of "0000" otherwise. Decoders **2384** and **2388** and multiplexers **2386** and **2390** are used to generate the `toq_mca_run_dr` and `toq_mca_run_pmw` signals in this manner.

The MCA controller generates `trq_mca_run_dr [3:0]` and `trq_mca_run_pmw [3:0]` signals to indicate when a new delayed request transaction or posted memory write transaction, respectively, has won the arbitration in the TRQ and is ready to be run on the PCI bus. The `trq_mca_run_dr [3:0]` signal takes on the value of the 2x4 decoded `trq_valido [1:0]` signal when a delayed request cycle has won the arbitration and the TRQ is not empty. The `trq_mca_run_dr [3:0]` takes on a value of "0000" otherwise. Likewise, the

trq\_mca\_run\_pmw [3:0] signal takes on the value of the 2x4 decoded trq\_valido [1:0] signal when a posted memory write cycle has won the arbitration and the TRQ is not empty. The trq\_mca\_run\_pmw [3:0] signal is set to a value of "0000" otherwise. Gates 2392 and 2398, decoders 2394 and 2400, and multiplexers 2396 and 2402 are used to generate the trq\_mca\_run\_dr and trq\_mca\_run\_pmw signals in this manner.

When the TRQ is empty, the MCA may issue a request to run the next transaction in the TOQ while the transaction is being placed in the TRQ. When both the TRQ and the TOQ are empty, transactions may begin to run even before they have been enqueued into TRQ. Therefore, the MCA control block includes logic that determines when the new\_mca\_run or toq\_mca\_run signals may be used a synchronously to indicate that a transaction may be tried on the PCI bus. By converting the new\_mca\_run and toq\_mca\_run signals into asynchronous run signals, the MCA controller saves a PCI clock wait state. When the new\_valid\_set signal is asserted by the MCA control block and the TOQ is not enabled (!toq\_enabled), the async\_mca\_run\_dr [3:0] and async\_mca\_run\_pmw [3:0] signals take on the values of the new\_mca\_run\_dr [3:0] and new\_mca\_run\_pmw [3:0] signals, respectively. Otherwise, the asynchronous run signals take on the values of the toq\_mca\_run\_dr [3:0] and toq\_mca\_run\_pmw [3:0] signals. The MCA controller uses gate 2404 and multiplexers 2406 and 2408 to generate the asynchronous run signals.

When a PCI bus master has completed a transaction (s1\_q2pif\_cyc\_complete is asserted), the TRQ is not empty (!trq\_empty) and is configured for operation in the zero retry mode (!cfg2q\_infretry), and either a new transaction has popped out of the TOQ (new\_toq\_cycle) or the TOQ is not enabled (!toq\_enabled) and the MCA has received a new cycle to be validated (new\_valid\_set), the MCA cannot select a cycle to run on the PCI bus, so both the mca\_run\_dr [3:0] and mca\_run\_pmw [3:0] signals are set to "0000". Otherwise, if the TRQ is empty (trq\_empty) and either a new transaction has popped out of the TOQ (new\_toq\_cycle) or the TOQ is not enabled (!toq\_enabled) and the MCA has received a new cycle to be validated (new\_valid\_set), then the mca\_run\_dr [3:0] and mca\_run\_pmw [3:0] signals take on the value of the asynchronous run signals, async\_mca\_run\_dr [3:0] and async\_mca\_run\_pmw [3:0], respectively. Otherwise, the mca\_run\_dr [3:0] signal takes on the value of the trq\_mca\_run\_dr [3:0] signal and the mca\_run\_pmw [3:0] signal takes on the value of the trq\_run\_pmw [3:0] signal ANDed with validation request signal from the PMWQ (pmwq\_valid [3:0]). Gates 2410, 2412, 2414, 2416, and 2418 and multiplexers 2420, 2422, 2424, and 2426 are arranged to generate the MCA run signals in this manner.

#### The Queue-Block-to-PCI-Interface (QPIF)

Referring again to FIG. 4 and to FIG. 75, the QPIF 148 governs the flow of transactions between the queue block 127 and the PCI bus 32. The QPIF 148 also delivers transactions initiated on the PCI bus 32 to the cable interface 130. The QPIF 148 operates in two modes: master mode and slave mode. In the master mode, the QPIF 148 has control of the PCI bus and therefore executes transactions intended for target devices on the bus. A master state machine 2500 in the QPIF 148 retrieves transactions from the PMWQ and DRQ and executes them on the PCI bus when the QPIF is in the master mode. In the slave mode, the QPIF 148 receives transactions initiated by a device on the PCI bus and either provides the requested information to the initiating

device (if the information is available) or retries the initiating device (if the transaction is a delayed request) and forwards the transaction to the upstream chip. The transaction also is retried if the corresponding one of the transaction counters 159 indicates that the other bridge chip is full, as discussed above. A slave state machine 2502 receives an incoming transaction from the PCI bus and then checks the DCQ for a corresponding completion message and/or forwards the transaction to a cable message generator 2504, which in turn forwards the transaction through the cable to the upstream bridge chip.

Referring also to FIGS. 76A and 76B, the QPIF includes address and data latching logic 2506 that latches the incoming address phase and data phase information associated with each transaction initiated by a device on the PCI bus. The QPIF slave state machine 2502 controls operation of the address and data latching logic 2506. When a new transaction initiated on the PCI bus is intended for the QPIF, the slave state machine 2502 asserts an address phase latching signal (reg\_latch\_first\_request) indicating that the address phase information should be latched from the PCI bus. At the next falling edge of the PCI clock signal, the assertion of the reg\_latch\_first\_request signal causes a delayed address phase latching signal (dly\_reg\_latch\_first\_request) to be asserted. When both the original and the delayed address phase latching signals are asserted, the latching logic 2506 generates a first latching signal (latch1). Flip-flop 2508 and gate 2510 are arranged to generate the first latching signal in this manner.

The latching logic 2506 loads the address phase information from the PCI bus (via the PCI interface) into three address phase registers when the first latching signal is asserted. The first register is a thirty-bit address register 2512 that indicates the starting address of the current transaction. When the first latching signal is asserted, the address signal from the PCI interface (p2q\_ad [31:2]) is loaded into the address register 2512. The address register 2512 outputs the address signal used by the QPIF (q2pif\_addr [31:2]). The second register is a four bit command register 2514 that receives the PCI command code from the PCI bus (p2q\_cmd [3:0]) and outputs the QPIF command signal (q2pif\_cmd [3:0]). The third register is a three bit slot selection register 2516 that receives the p2q\_slot [2:0] signal indicating which PCI device is the current bus master and outputs the QPIF slot selection signal (q2pif\_slot [2:0]).

When the address phase of the PCI transaction ends, the slave state machine 2502 asserts a data phase latching signal (reg\_latch\_second\_request) indicating that the data phase information should be latched from the PCI bus. At the next falling edge of the PCI clock signal, the asserted reg\_latch\_first\_request signal causes a delayed data phase latching signal (dly\_reg\_latch\_second\_request) to be asserted. When both the original and the delayed data phase latching signals are asserted, the latching logic 2506 generates a second latching signal (latch2). Flip-flop 2518 and gate 2520 are arranged to generate the second latching signal in this manner.

The latching logic 2506 then loads the data phase information from the PCI bus (via the PCI interface) into three data phase registers when the second latching signal is asserted. The first data phase register is a thirty-two bit data register 2522 that receives the data associated with the current transaction on the PCI address/data lines (p2q\_ad [31:0]) and outputs the QPIF data signal (q2pif\_data [31:0]). The second data phase register is a four bit enable register 2524 that receives enable bits from the PCI bus (p2q\_cbe [3:0]) and outputs the QPIF byte enable signal

## 33

(q2pif byte\_en [3:0]). The third register is a three bit lock register **2526** that receives the PCI lock signal (p2q\_lock) indicating that the current transaction should be run as a locked transaction and outputs the QPIF lock signal (q2pif\_lock).

Referring again to FIG. 75 and also to FIG. 77, the QPIF includes a “lock” logic block **2528** that controls the “lock” state of the QPIF. The QPIF has three lock states: an unlocked state **2530** (lock\_state [1:0]=“00”) that indicates that no locked transactions are pending in the DCQ; a locked state **2532** (lock\_state [1:0]=“01”) indicating that a locked transaction has been received in the DCQ or is completing on the PCI bus; and an unlocked-but-retry state **2534** (lock\_state [1:0]=“10”) that indicates that the lock has been removed but that a posted memory write transaction pending in the other bridge chip must be run before the next transaction can be accepted.

At power-up and reset, the lock logic **2528** enters the unlocked state **2530** and waits for a locked transaction to enter the DCQ (indicated by the assertion of the dcq\_locked signal). At the first clock pulse after the dcq\_locked signal is asserted, the lock logic enters the locked state **2532**, which forces the QPIF slave state machine **2502** to retry all transaction requests from the PCI bus. The PCI interface also asserts a lock signal (p2q\_lock) that indicates it has locked the PCI bus for the transaction. After the locked transaction has completed and the requesting device has retrieved the locked completion data from the DCQ, the dcq\_locked signal is deasserted. At the first clock pulse after the dcq\_locked is deasserted, while the p2q\_lock signal is still asserted, if no posted memory writes are pending in the other bridge chip (i.e., the pmw\_empty signal is asserted by the cable decoder), the lock logic **2528** returns to the unlocked state **2530** and the slave state machine **2502** again is able to accept transaction requests. However, if the pmw\_empty signal is not asserted at the first clock pulse after the dcq\_lock signal is deasserted, the lock logic **2528** enters the unlocked-but-retry state **2534**, which forces the slave state machine **2502** to retry all transactions until the posted memory write cycle is completed on the other PCI bus. After the posted memory write cycle is complete, the pmw\_empty signal is asserted, and the lock logic **2528** returns to the unlocked state **2530**.

Referring again to FIG. 75 and also to FIG. 78, the QPIF includes buffer flush logic **2536** that determines when the DCQ should flush data from one or all of its data buffers. As discussed above, the PCI interface in the downstream chip generates a p2q\_flush signal when the upstream chip issues an I/O or config write or a memory write that hits the target memory range register (TMRR) of a downstream device. The QPIF buffer flush logic **2536** asserts a QPIF flush signal (general\_flush) that flushes the corresponding data buffer or all data buffers (depending upon the value of the p2q\_slot signal, as discussed above) when the p2q\_flush signal is received. Otherwise, the buffer flush logic **2536** asserts the general flush signal only when a device on the secondary bus issues a delayed request that misses all of the DCQ buffers when checked by the DCQ control logic (i.e., !dcq\_hit and q2pif\_check\_cyc are asserted). In either case, the general\_flush signal is used to flush only buffers that are in the “prefetch” state, as discussed above. Therefore, prefetch data is held in the DCQ until the PCI interface orders a flush or until the corresponding PCI device issues a non-sequential request (i.e., misses the DCQ). Gates **2538** and **2540** are arranged to generate the general\_flush signal in this manner.

When a multi-threaded device has more than one completion buffer allocated, at least one of which contains prefetch

## 34

data, the prefetch data remains in the corresponding buffer as long as the device does not issue a request that misses all of the DCQ buffers. As soon as the device issues a new request, all of its prefetch buffers are flushed. Alternatively, a prefetch buffer associated with a multi-threaded device could be flushed as soon as the device issues a request that hits another DCQ buffer.

Referring again to FIG. 75, the QPIF includes a read command logic block **2542** that receives read commands from the PCI interface and prefetch commands from the DCQ and provides an outgoing message command signal (message\_cmd) to the cable. In non-streaming situations, the outgoing message command may be same as the command received from the PCI bus or the DCQ, or the read command logic **2542** may convert the command into one involving a greater amount of data. Because transactions executed dword-by-dword take longer to complete on the host bus than transactions involving an entire cache line of data, and because single cache line transactions take longer to complete on the host bus than multiple cache line transactions, the read command logic often promotes “smaller” commands into “larger” ones to reduce the number of clock cycles consumed by the transaction (“read promotion”). For example, when a device on the secondary PCI bus issues a memory read command and then asks for every dword of data in a cache line, the read command logic **2542** is able to reduce the host latency by promoting the PCI command to a memory read line, which allows the upstream chip to read the entire cache line of data at once instead of reading each dword individually.

Referring also to FIG. 79, when the DCQ indicates that a read stream has been established (i.e., dcq\_stream\_connect is asserted), as discussed above, the read command logic **2542** generates a message command of “1000”, which informs the upstream chip that a stream is occurring. When no stream has been established, the read command logic **2542** must decide whether to send a memory read, memory read line, or memory read multiple command. If the command received from the PCI bus is a memory read (MR) command (q2p\_cmd [2:0] equals “0110”) and the corresponding memory-read-to-memory-read-line promotion bit (cfg2q\_mr2mrl) in the configuration registers is set, the read command logic **2542** generates a memory read line command (“1110”). On the other hand, if the PCI command is a memory read command and the corresponding memory-read-to-memory-read-multiple bit (cfg2q\_mr2mrm) is set, or if the command is a memory read line command (q2pif\_cmd [3:0] equals “1110”) from the PCI bus or a prefetch line command (dcq\_prefetch\_line is asserted) from the DCQ and the corresponding memory-read-line-to-memory-read-multiple bit (cfg2q\_mrl2mrm) is set, or if the command is a prefetch multiple command (dcq\_prefetch\_mul) from the DCQ, the read command logic **2542** generates a memory read multiple command (i.e., message\_cmd equals “1100”). If the command is a prefetch line command and the corresponding memory-read-line-to-memory-read-multiple bit is not set, the read command logic **2542** generates a MRL command (“1110”). Otherwise, the read command logic **2542** outputs the received PCI command (q2pif\_cmd [2:0]) as the message command signal. Gates **2544**, **2546**, **2548**, **2550**, **2552**, **2554**, **2556**, and **2558** and multiplexers **2560**, **2562**, and **2564** are arranged to generate the message\_cmd signal in this manner.

Referring again to FIG. 75, when the QPIF is operating in the master mode and has received control of the bus to run a transaction stored in the PMWQ, a write command logic block **2566** generates the command code that is executed on

the PCI bus. To reduce transaction time as discussed above, the write command logic can convert memory write (MW) commands, which involve data transfers one dword at a time into memory write and invalidate commands (MWI), which involve transfers of at least one entire cache line of data. The write command logic block **2566** can convert a command midstream when, e.g., the transaction begins as a memory write in the middle of a cache line and contains data crossing the next cache line boundary and including all eight dwords of data in the next cache line. In this situation, the write command logic **2566** terminates the memory write transaction when it reaches the first cache line boundary and initiates a memory write and invalidate transaction to transfer the next full cache line of data. The write command logic **2566** also may terminate a MWI transaction midstream in favor of a MW transaction if less than a cache line of data is to be written to the target bus after a cache line boundary is crossed.

Referring again to FIG. **75** and also to FIG. **80**, the slave state machine **2502** also maintains two counters that indicate when a posted write transaction initiated on the PCI bus should be terminated. A 4K page boundary counter **2594** generates a page count signal (page\_count\_reg [11:2]) that indicates when data transferred from the PCI bus reaches a 4K page boundary. Because a single memory access is not allowed to cross a 4K page boundary, the posted write transaction must be terminated on the initiating bus when a boundary is reached. The 4K page boundary counter **2594** is loaded with the third through twelfth bits of the transaction address (q2pif\_addr [11:2]) when the state machine asserts a load\_write\_counter signal (the circumstances surrounding assertion of this signal are discussed in more detail below). The counter **2594** then increments by one at the rising edge of each clock pulse after the load\_write\_counter signal is deasserted. The counter **2594** is not incremented on clock pulses during which the initiating device has inserted an initiator wait state (i.e., p2q\_irdy asserted). The output of gate **2592** determines when the counter is allowed to increment. When all bits in the page\_count\_reg [11:2] signal are high, a 4K page boundary has been reached and the slave state machine must terminate the posted write transaction and retry the initiating device.

A dword counter **2598** generates a pmw\_counter [5:0] signal that indicates the number of dwords written from the initiating bus during a posted write transaction. The pmw\_counter [5:0] signal then is used to indicate when an overflow has occurred or when the last line of the transaction has been reached, as discussed below. When the slave state machine **2503** asserts the load\_write\_counter signal, the third through fifth bits of the address signal (q2pif\_addr [4:2]) are loaded into the lower three bits of the counter **2598**, while the upper three bits are set to zero. This address offset indicates at which dword in a cache line the posted write transaction has started. The counter **2598** then increments by one at the rising edge of each clock pulse after the load\_write\_counter signal is deasserted. The counter **2598** is not incremented on clock pulses during which the initiating device has inserted an initiator wait state (i.e., p2q\_irdy asserted). The output of gate **2596** determines when the counter is allowed to increment. When all bits in the pmw\_counter [5:0] signal are high, the posted write has reached the end of the eighth cache line.

Referring to FIGS. **81A** through **81C**, the write command logic block **2566** generates a four bit write command signal (write\_cmd [3:0]) indicating the command code of the posted write transaction to be executed on the PCI bus. If the command code stored in the PMWQ represents a memory

write and invalidate command (pmwq\_cmd [3]="1"), the write command logic **2566** generates a write command code of "1111". If the PMWQ command code represents a memory write command, the write command logic **2566** looks at the memory-write-to-memory-write-and-invalidate configuration bit (cfg2q\_mw2mwi) corresponding to the target PCI slot. If the cfg2q\_mw2mwi bit is not set, the write command logic **2566** produces a memory write command ("0111"). If the configuration bit is set, the write command logic **2566** generates a MWI command if the next line in the PMWQ data buffer is full (pmwq\_full\_is asserted) and generates a MW command otherwise. Multiplexers **2568** and **2570** are arranged to generate the write\_cmd signal in this manner.

When the QPIF is executing a transaction on the PCI bus and has reached a cache line boundary, the write command logic **2566** may assert a new\_write\_cmd signal indicating that the current transaction must be terminated in favor of a new write command. If the transaction has reached the last cache line in the PMWQ data buffer (i.e., pmwq\_pointer [5:3] equals "111"), the new\_write command signal is asserted to indicate that the transaction should be terminated if the next PMWQ buffer is not an overflow buffer containing valid data, if the corresponding cfg2q\_mw2mwi bit is not set, or if the full\_line bits corresponding to the current cache line and the next cache line are different (i.e., pmwq\_full [7] does not equal pmwq\_next\_full\_line). If the transaction has not reached the end of the PMWQ buffer, the new\_write\_cmd signal is asserted either if the next line in the PMWQ buffer does not contain valid data (!pmwq\_valid\_lines [x+1]) or if the cfg2q\_mw2mwi bit is set and the full line bits for the current line and the next line are different (i.e., pmwq\_full [x] does not equal pmwq\_full [x+1]). Gates **2572**, **2574**, **2576**, **2578**, and **2580** and multiplexer **2582** are arranged to generate the new\_write\_cmd signal in this manner.

After the new\_write\_cmd signal is asserted, the transaction is not terminated until the write command logic block **2566** asserts a synchronous new write command signal (held\_new\_write\_cmd). The held\_new\_write\_cmd signal is asserted at the first clock pulse after the new\_write\_cmd signal is asserted and the end\_of\_line signal is asserted indicating that the end of the cache line has been reached, as long as the PCI interface has not terminated the transaction (i.e., p2q\_start\_pulse is asserted). The held\_new\_write\_cmd signal is deasserted at reset and at the first clock pulse after the new\_write\_cmd, end\_of\_line, and p2q\_start\_pulse signals are deasserted and the QPIF terminates the transaction (i.e., the asynchronous early\_cyc\_complete signal is asserted). Otherwise, the held\_new\_write\_cmd signal retains its current value. Gates **2584** and **2586**, inverter **2588**, and flip-flop **2590** are arranged to generate the held\_new\_write\_cmd signal in this manner.

Referring again to FIG. **75** and also to FIG. **82A**, the QPIF includes an overflow logic block **2600** that allows the master state machine **2500** to manage overflow data, if any, when executing a posted write transaction on the target bus. When the QPIF receives a transaction run signal (mca\_run\_pmw or mca\_run\_dr, discussed above) from the MCA, the overflow logic **2600** generates a two bit initial queue selection signal (start\_queue\_select [2:0]) indicating which of the buffers in the PMWQ or DRQ should be selected to run the current transaction. The following table shows how the start\_queue\_select signal is generated.

Creation of start_queue_select signal		
MCA Run Code {mca_run_pmw, mca_run_dr}	start_queue_select	
00000001	00	
00000010	01	
00000100	10	
00001000	11	
00010000	00	
00100000	01	
01000000	10	
10000000	11	

When the QPIF is executing a posted write transaction on the target bus, a two bit QPIF queue selection signal (q2pif\_queue\_select [1:0]) is used to select the appropriate buffer in the PMWQ. When the transaction is initiated, the master state machine 2500 asserts a queue selection signal (initial\_queue\_select) that causes the q2pif\_queue\_select signal to take on the value of the initial queue selection signal (start\_queue\_select). At the same time, a queue selection counter 2602 is loaded with the value of the start\_queue\_select signal. After the initial\_queue\_select signal is deasserted, the q2pif\_queue\_select signal takes on the value of the count\_queue\_select signal generated by the counter 2602. When the posted memory write transaction overflows into the next PMWQ buffer, the master state machine 2500 asserts an increment queue selection signal (inc\_queue\_select) that causes the counter 2602 to increment by one. As a result, the q2pif\_select\_signal is incremented and the next buffer in the PMWQ is selected to continue the transaction. Multiplexer 2604 determines the value of the q2pif\_queue\_select signal.

Referring also to FIG. 82B, the overflow logic 2600 asserts an overflow\_next\_queue signal when the master state machine 2500 should continue pulling information from the next PMWQ buffer during a posted memory write transaction. Using the q2pif\_queue\_select [1:0] signal to determine which PMWQ is currently selected, the overflow logic 2600 asserts the overflow\_next\_queue signal when the valid bit (pmwq\_valid) and the overflow bit (pmwq\_overflow) corresponding to the next PMWQ buffer are set. The pmwq\_valid and pmwq\_overflow flags are discussed above. Gates 2606, 2608, 2610, and 2612 and multiplexer 2614 are arranged to generate the overflow\_next\_queue signal in this manner.

Referring again to FIG. 75, the QPIF includes a read align logic block 2616 that allows the QPIF to correct misaligned memory read line and memory read multiple transactions. Read line correction occurs when the QPIF, while operating in the master mode, receives a MRL or MRM transaction that begins in the middle of a cache line. To reduce transaction time, the QPIF begins the read transaction on the cache line boundary and ignores the unrequested dwords instead of individually reading only the requested dwords of data.

Referring also to FIG. 83, the read align logic 2616 activates the read alignment feature by asserting an align\_

read signal. This signal is asserted when the command stored in the corresponding DRQ buffer is a memory read line or memory read multiple command (i.e., drq\_cmd [3:0] equals “1110” or “1100”, respectively), and when the read alignment configuration bit (cfg2q\_read\_align) corresponding to the target PCI device is set. Gates 2618 and 2620 are arranged to produce the align\_read signal in this manner.

Referring also to FIGS. 84A through 84C, the read align logic 2616 includes a read alignment down counter 2622 that counts the dwords from the cache line boundary and indicates when the master state machine 2500 reaches the first requested dword. The counter 2622 includes a state machine 2624 that controls the operation of the counter 2622.

At reset, the counter 2622 enters an IDLE\_CNT state 2626 in which no counting occurs. When the MCA instructs the QPIF to run a delayed request transaction on the PCI bus (i.e., when any bits in the mca\_run\_dr [3:0] are asserted), the QPIF asserts a delayed request run signal (any\_drq\_run) indicating that it is attempting to run a delayed request transaction. While the counter is in the IDLE\_CNT state 2622, its three bit output signal (throw\_cnt [2:0]) is loaded with the dword offset of the transaction address (drq\_addr [4:2]) when the any\_run\_drq signal is asserted and the QPIF gains control of the PCI bus (i.e., p2q\_ack is asserted). Gate 2623 generates the load enable signal. Then, at the rising edge of the next PCI clock cycle, the counter 2622 enters the COUNT state 2628. If the transaction begins at a cache line boundary, the dword offset equals “000” and no count is needed. When read alignment is activated, the master state machine 2500 begins each MRL and MRM transaction at the cache line boundary, regardless of the actual starting address.

While in the COUNT state 2628, the counter 2622 decrements by one on every clock pulse as long as the p2q\_ack signal is asserted, throw\_cnt has not reached zero, the transaction is in the data phase (i.e., the asynchronous signal early\_data\_is asserted), and the target device has not issued a target ready wait state (!p2q\_trdy). Gate 2625 determines when the counter is decremented. If the PCI interface takes the bus away from the QPIF (p2q\_ack is deasserted) or if the data phase ends (early\_data\_is deasserted), the counter 2622 stops decrementing and reenters the IDLE\_CNT state 2626. If the throw\_cnt signal reaches “000” while the p2q\_ack signal is still asserted, the counter 2622 stops counting and enters the DONE state 2630. Otherwise, the counter remains in the COUNT state 2628.

When the counter reaches “000”, the read align logic 2616 asserts a read\_data\_start signal that instructs the master state machine 2500 to begin reading data from the target device. Comparator 2632 generates the read\_data\_start signal. After the read\_data\_start signal is asserted, the counter 2622 remains in the DONE state 2630 until the data phase ends (early\_data\_phase is deasserted).

Referring to FIG. 85, the master state machine controls the operation of the QPIF when the QPIF is operating in the master mode. In the master mode, the QPIF executes posted write transactions and delayed request transactions on the PCI bus. The following table shows the events causing state transitions in the master state machine.

MASTER STATE MACHINE		
Current State	Event	Next State
IDLE	A=(any_run&&!cable_busy&&!p2q_master_dphase)    (any_run_drg && tc_dc_full)	IDLE

MASTER STATE MACHINE		
Current State	Event	Next State
IDLE	B: p2q_ack && q2p_dac_flag	MASTER_DAC
IDLE	C: p2q_ack && any_drg_run	RDATA1
IDLE	D: p2q_ack && !(q2p_dac_flag    any_drg_run)	WDATA1
MASTER_DAC	E: p2q_ack && any_drg_run && p2q_start_pulse	RDATA1
	F: p2q_ack && p2q_start_pulse && !any_drg_run	WDATA1
	G: !p2q_ack	IDLE
RDATA1	H: !p2q_ack	IDLE
	I: p2q_ack && p2q_start_pulse	RBURST
	J: p2q_ack && !p2q_start_pulse	RDATA1
RBURST	K: !p2q_ack    p2q_retry    p2q_target_abort    (queue_cyc_complete && !(p2q_last_dphase && p2q_master_dphase && cd_stream && stream_match && !cfg2q_stream_disable) && !p2q_trdy)    (read_page_disconnect && !p2q_trdy)	IDLE
	L: p2q_ack && !p2q_retry && !p2q_target_abort && ((read_page_disconnect && p2q_trdy)    (queue_cyc_ complete && ((p2q_last_dphase && p2q_master_dphase && cd_stream && stream_match && !cfs2q_stream_disable) && p2q_trdy))    !p2q_trdy    otherwise)	RBURST
WDATA1	M: !p2q_ack    p2q_retry    p2q_target_abort    ((queue_cyc_complete    held_new_write_cmd    end_of_line && new_write_cmd    p2q_last_dphase    a1_p2q_last_dphase) && !p2q_trdy)	IDLE
	N: p2q_ack && !p2q_retry && !p2q_target_abort && (queue_cyc_complete    held_new_write_cmd    end_of_line && new_write_cmd    p2q_last_dphase    s1_p2q_last_dphase) && p2q_trdy	WDATA1
	O: otherwise	WDATA2
WDATA2	P: !p2q_qck    (p2q_retry && !p2q_trdy)    p2q_target_abort	IDLE
	Q: p2q_ack && p2q_retry && p2q_trdy	WRETRY
	R: p2q_ack && !p2q_retry && !p2q_target_abort && (queue_cyc_complete    end_of_line && new_write_ cmd) && (!p2q_trdy    p2q_start_pulse)	WSHORT_BURST
	S: otherwise	WDATA2
WRETRY	T: Always	IDLE
WSHORT_BURST	U: !p2q_ack    p2q_retry    p2q_target_abort	IDLE
	V: p2q_ack && !p2q_retry && !p2q_target_abort && (overflow_next_queue && !new_write_cmd && !p2q_trdy)    !p2q_trdy)	WCOMPLETE
	W: otherwise	WSHORT_BURST
WCOMPLETE	X: p2q_retry    p2q_target_abort    (!(overflow_next_ queue && !new_write_cmd && !p2q_last_dphase) && !p2q_trdy)	IDLE
	Y: !p2q_retru && !p2q_target_abort && ((overflow_ next_queue && !new_write_cmd && !p2q_last_dphase) && !p2q_trdy)	WDATA1
	Z: otherwise	WCOMPLETE

Mster state transitions

At reset, the master state machine enters an IDLE state **2700** in which the QPIF awaits instructions to run a transaction on the PCI bus. When the QPIF receives a run signal from the MCA (any\_run is asserted when any bit in the mca\_run\_pmw signal or mca\_run\_dr signal is asserted), the cable is not busy delivering a message (!cable\_busy), and the PCI interface is not trying to finish the previous transaction (!p2q\_master\_dphase), the master state machine attempts to run the transaction on the PCI bus. If the transaction is a delayed request transaction (any\_run\_drg is asserted) and the other chip does not have room for a delayed completion (tc\_dc\_full is asserted) the master state machine is not able to run the request and steps the MCA to the next transaction. Otherwise, if the PCI interface has given the QPIF control of the bus (p2q\_ack is asserted), the master state machine begins to execute the transaction on the PCI bus. In the IDLE state **2700**, the master provides the address phase information, discussed above, to the PCI bus. If the transaction to be run is a dual address cycle (q2pif\_dac\_flag is asserted), the master state machine enters a MASTER\_DAC state **2702** in which the second half of the

address information is provided. If the transaction is not a dual address cycle and is a delayed request transaction (any\_run\_drg is asserted), the master state machine then enters an RDATA1 read state **2704**, in which the master state machine begins the data phase of the delayed request transaction. If the transaction is not a dual address cycle and is not a delayed request, it is a posted memory write transaction, so the master state machine enters a WDATA1 write state **2706**, in which the master state machine enters the data phase of the posted memory write transaction.

In the MASTER\_DAC state **2704=2**, the master state machine provides the second half of the address phase information. Then, if the p2q\_ack signal is still asserted and the transaction is a delayed request, the master state machine enters the RDATA1 state **2704** when it receives the start signal (p2q\_start\_pulse) from the PCI interface. If the transaction is not a delayed request, the master state machine enters the WDATA1 state **2706** when it receives the PCI start pulse. The master state machine also initiates a delayed completion message on the cable when the PCI start pulse is received by asserting an asynchronous completion message



signal (early\_master\_send\_message). If the p2q\_ack signal has been deasserted by the PCI interface, the master state machine returns to the IDLE state 2700 and waits to retry the transaction.

The RDATA1 state 2704 is the initial state for delayed read and delayed write requests. In this state, the master state machine waits for the PCI start pulse before entering an RBURST burst data phase 2708. When the state machine first enters the RDATA1 state 2704, it initiates a completion message on the cable (if not already done in the MASTER\_DAC state 2702). Then, if the p2q\_ack is deasserted by the PCI interface, the master state machine terminates the transaction, steps the MCA to the next transaction, and reenters the IDLE state 2700. Otherwise, when the PCI start pulse appears, the master state machine prepares to enter the RBURST state 2708. If the QPIF indicates the end of the transaction (queue\_cyc\_complete) or if the transaction has reached a 4K page boundary (read\_page\_disconnect is asserted because all bits in the drq\_addr [11:2] signal are high), the master state machine deasserts the QPIF's frame\_signal and indicates that the next piece of data is the last piece (asynchronous signal early\_last\_master\_data is asserted) before entering the RBURST state 2708. The master state machine also asserts an asynchronous early\_master\_lastline signal, indicating that the last line of data has been reached, if the read\_Page\_disconnect\_lastline signal is asserted or if the DRQ last line signal (drq\_lastline) is asserted and the QPIF has not received a streaming signal from the other bridge chip (cd\_stream or stream\_match are not asserted or cfq2q\_stream\_disable is not set). If the PCI start pulse is not asserted, the master state machine remains in the RDATA1 state 2704 until the QPIF terminates the transaction or a 4K page boundary is reached, which will return the state machine to the IDLE state 2700, or until the PCI start pulse appears, which forces the state machine to enter the RBURST state 2708

In the RBURST state 2708, the master state machine bursts data to the PCI bus. If a completion message has not yet been initiated, the master state machine initiates a completion message upon entering the RBURST state 2708. Then, if the p2q\_ack signal is deasserted, or if the QPIF transaction is retried by the PCI interface (p2q\_retry is asserted), or if the PCI interface aborts the transaction (p2q\_target\_abort is asserted), the master state machine terminates the transaction on the PCI bus, aborts the completion message on the cable, and returns to the IDLE state. When the p2q\_ack signal is taken away, the master cycle arbiter continues to select the current transaction. But when the transaction is retried or aborted, the master state machine steps the MCA to the next transaction.

While the p2q\_ack signal is still asserted and the QPIF transaction is not retried or aborted, the master state machine nevertheless terminates the transaction and returns to the IDLE state 2700 if a 4K page boundary is reached and the PCI interface indicates that the target device has stopped taking data (p2q\_trdy is no longer asserted). If the target device took the last piece of data, the master state machine remains in the RBURST state 2708.

If the QPIF asserts the queue\_cyc\_complete signal indicating that the transaction has completed, the master in general will terminate the transaction and return to the IDLE state 2700 if the p2q\_trdy signal is deasserted or remain in the RBURST state 2708 until the last dword of data is transferred if the p2q\_trdy signal remains asserted. However, if the transaction is in the data phase and is not in the last data phase (p2q\_master\_dphase and !p2q\_last\_dphase) and a stream has been established with the other

bridge chip (cd\_stream and stream\_match and !cfg2q\_stream\_disable), the master state machine will remain in the RBURST phase indefinitely. When the QPIF is streaming, the master state machine asserts a streaming signal (q2pif\_streaming) that forces the QPIF to continue to provide data to the requesting device on the other PCI bus until that device terminates the transaction.

If the p2q\_ack signal remains asserted and neither the p2q\_retry, p2q\_target\_abort, or queue\_cyc\_complete signals are asserted, the master state machine looks at the p2q\_trdy signal. If the signal is not asserted, indicating that the target device has taken or provided the last piece of data, the master state machine asserts its next data signal (early\_next\_data), which indicates that the QPIF is ready to transfer another piece of data. The next data signal is asserted only if the transaction is not a corrected read (align\_read is not asserted) or if the transaction is a corrected read and the read\_data\_start signal has been asserted. If the p2q\_trdy signal is asserted, indicating that the target has not performed the last data transfer, the state machine remains in the RBURST state 2708.

In the WDATA1 state 2706, the master state machine begins the data phase of a posted memory write transaction. If the p2q\_ack signal is deasserted or the p2q\_retry or p2q\_target\_abort signals are asserted while the master state machine is in this state, the transaction is terminated on the PCI bus and the state machine returns to the IDLE state 2700. When the p2q\_ack signal is deasserted, the MCA remains on the current cycle; otherwise, the master state machine steps the MCA to the next transaction.

If the p2q\_ack signal remains asserted and the transaction is neither retried nor aborted, the master state machine must determine whether the write involves a single dword or more than one dword. If in the WDATA1 state the queue\_cyc\_complete signal is asserted, the held new write command signal is asserted, the end\_of\_line and new\_write\_cmd signals are asserted, or the transaction has reached the last dword of data, the transaction involves a single dword. In this situation, the transaction terminates and the state machine returns to the IDLE state 2700 only when the target took the last piece of data (!p2q\_trdy). Otherwise, the state machine remains in the WDATA2 state 2710. If the transaction involves more than one dword of data, the master state machine enters a WDATA2 burst data phase state 2710. Just before entering the WDATA2 state, the master state machine inserts a q2p\_irdy wait state if the overflow\_next\_queue signal has been asserted.

In the WDATA2 state 2710, the master state machine bursts data to the PCI bus. If the p2q\_ack signal is deasserted or the transaction is aborted by the PCI interface, the transaction is terminated in the QPIF and the master state machine reenters the IDLE state 2710. If the transaction is retried by the PCI interface but the PCI interface took the data provided (!p2q\_trdy), the master state machine reenters the IDLE state 2700. Otherwise, the state machine enters a WRETRY stepback state 2712 that steps the PMWQ out pointer back to the previous piece of data by generating the stepback signal discussed above. From the WRETRY state 2712, the state machine always reenters the IDLE state 2700.

If the p2q\_ack signal remains asserted and the transaction is neither retried nor aborted, the master state machine determines whether the transaction is complete. If the QPIF indicates the end of the transaction (queue\_cyc\_complete is asserted) or the end of a cache line is reached and a new write command is needed (end\_of\_line and new\_write\_

command are asserted), the state machine enters a WSHORT\_BURST state **2714** when either the last piece of data was taken (!p2q\_trdy) or the PCI start pulse is received. In either case, only two dwords of data must be written to the PCI bus. Otherwise, the state machine remains in the WDATA2 state **2710**. When the state machine enters the WSHORT\_BURST state **2714**, the QPIF frame\_signal remains asserted if the transaction can overflow into the next queue and a new write command is not needed.

In the WSHORT\_BURST state **2714**, the master state machine prepares to write the final two dwords of data to the PCI bus. If the p2q\_ack signal is deasserted or the cycle is retried or aborted by the PCI interface, the state machine terminates the transaction and returns to the IDLE state **2700**. When the PCI acknowledge signal disappears or the cycle is aborted, the master state machine asserts the step-back signal to indicate that the PMWQ out pointer should be stepped back to the previous dword. When the transaction is retried by the PCI interface, the out pointer is stepped back only if the target device did not take the last piece of data (p2q\_trdy is asserted). When the transaction is not terminated and it can overflow into the next PMWQ buffer (overflow\_next\_queue is asserted) and a new write command is not needed, the master state machine keeps the QPIF frame signal asserted and then enters a WCOMPLETE state **2716** if the target device has taken the last piece of data or stays in the WSHORT\_BURST state **2714** otherwise. If the transaction cannot overflow into the next queue or a new write command is needed, the state machine deasserts the frame signal to indicate the end of the QPIF transaction and then enters the WCOMPLETE state **2716** if the last piece of data was taken by the target device or remains in the WSHORT\_BURST state **2714** otherwise.

In the WCOMPLETE state **2716**, the master state machine terminates the posted memory write transaction.

The state machine enters the IDLE state **2700** if the transaction is retried or aborted by the PCI interface. If the transaction is retried, the PMWQ out pointer is incremented only if the target device took the last piece of data. If the transaction can overflow into the next queue, a new write command is not needed, and the transaction is not in the last data phase, the master state machine increments the queue selection counter and returns to the WDATA1 state **2706** to continue the transaction from the overflow queue, as long as the target device took the last piece of data. If the target device did not take the last piece of data, the master state machine remains in the WCOMPLETE state **2716**.

If the transaction will not overflow into the next PMWQ buffer, the master state machine terminates the transaction and returns to the IDLE state **2700** if the target took the last piece of data. Otherwise, the state machine remains in the WCOMPLETE state **2716** until one of the terminating events discussed above occurs.

Referring to FIG. **86**, the slave state machine controls the operation of the QPIF when the QPIF is operating in the slave mode. In the slave mode, the QPIF receives posted write transactions and delayed request transactions from devices on the PCI bus and forwards the transactions to the target bus through the cable. The following table shows the events causing state transitions in the slave state machine.

SLAVE STATE MACHINE		
CURRENT STATE	EVENT	NEXT STATE
SLAVE_IDLE	A: p2q_qcyc && p2q_dac_flag && !p2q_perr B: p2q_qcyc && !p2q_dac_flag && pmw_request && !p2q_perr && !(tc_pmw_full && !dcq_locked && !lock_state[1]) C: p2q_qcyc && !p2q_dac_flag && !pmw_request && !p2q_perr && (mem_read_line    mem_read_mul) && (dcq_hit && !dcq_no_data && !lock_state[1]) D: p2q_qcyc && !p2q_dac_flag && !pmw_request && !p2q_perr && !(mem_read_line    mem_read_mul) E: [p2q_qcyc && !p2q_dac_flag && pmw_request && !p2q_perr && !(tc_pmw_full && !dcq_locked && !lock_state[1])]    [p2q_qcyc && !p2q_dac_flag && !pmw_request && !p2q_perr && !(tc_pmw_full && !dcq_locked && !lock_state[1])]    [p2q_qcyc && !p2q_dac_flag && !pmw_request && !p2q_perr && (mem_read_line    mem_read_mul) && !dcq_hit && !dcq_no_data && !lock_state[1]]    otherwise	SLAVE_DAC PMW1 STEP_AHEAD SECOND_CHECK SLAVE_IDLE
SLAVE_DAC	F: p2q_qcyc && pmw_request && !p2q_perr && !(tc_pmw_full && !dcq_locked && !lock_state[1]) G: p2q_qcyc && !pmw_request && !p2q_perr && (mem_read_line    mem_read_mul) && (dcq_hit && !dcq_no_data && !lock_state[1]) H: p2q_qcyc && !pmw_request && !p2q_perr && !(mem_read_line    mem_read_mul) I: otherwise	PMW1 STEP_AHEAD SECOND_CHECK SLAVE_IDLE
SECOND_CHECK	J: !io_write && !config_write && !p2q_perr && (dcq_hit && !dcq_no_data && !lock_state[1] && dwr_check_ok) K: otherwise	STEP_AHEAD SLAVE_IDLE
STEP_AHEAD	L: dcq_no_data M: otherwise	SLAVE_IDLE HIT_DCQ_FINAL
HIT_DCQ	N: !p2q_qcyc O: p2q_qcyc && (dcq_no_data && !p2q_irdy    (pmw_counter[2] && pmw_counter[1] && pmw_counter[0] && read_disconnect_for_stream) P: otherwise	HIT_DCQ SLAVE_IDLE HIT_DCQ_FINAL

-continued

## SLAVE STATE MACHINE

CURRENT STATE	EVENT	NEXT STATE
HIT_DCQ_FINAL	Q: !p2q_qcyc    !p2q_irdy R: otherwise	HIT_DCQ SLAVE_IDLE
PMW1	S: !p2q_qcyc T: otherwise	HIT_DCQ_FINAL SLAVE_IDLE PMW1

Slave state transitions

At reset, the slave state machine enters an IDLE state 2720, in which the QPIF waits for a transaction to be initiated by a device on the PCI bus. If a transaction initiated on the bus does not target the QPIF (q2p\_qcyc is not asserted), the slave state machine continues in the IDLE state 2720. When a transaction on the PCI bus does target the QPIF, the slave state machine enters a SLAVE\_DAC dual address cycle state 2722 if the p2q\_dac flag is asserted and an address parity error has not occurred (p2q\_perr\_is low). If the transaction is not a dual address cycle and is a posted memory write request, and if a parity error has not occurred in the address phase, the slave state machine loads the write counters (i.e., asserts load\_write\_counter) and determines whether it can accept the transaction. If the PMWQ in the other bridge chip is full (tc\_dc\_full is asserted by the DC transaction counter) or the DCQ is locked (dcq\_locked is asserted) or the QPIF lock logic is in the unlocked-but-retry state (lock\_state [1] equals "1"), the slave state machine terminates the transaction by asserting an asynchronous retry signal (early\_retry) that is passed to PCI interface as q2pif\_retry and remains in the IDLE state 2720. If the QPIF can accept the transaction, the slave state machine initiates the posted memory write message on the cable and enters a PMW1 state 2724, in which the transaction is forwarded up the cable.

If the transaction is not a dual address cycle or a posted memory write request, the slave state machine loads the dword counter (asserts load\_write\_counter) and, if no parity error has occurred, analyzes the delayed request transaction. If the transaction is a MRL or a MRM transaction and the QPIF lock logic is not in the unlocked-but-retry state, the slave state machine asserts the QPIF check cycle signal (q2pif\_check\_cyc), which instructs the DCQ to compare the latched request to the delayed completion messages in the DCQ buffers. If the request hits a DCQ buffer that is not empty (dcq\_hit and !dcq\_no\_data), the slave state machine enters a STEP\_AHEAD state 2726 in which the QPIF begins delivering the requested information to the PCI bus. If the MRL or MRM request misses all of the DCQ data buffers (!dcq\_hit), the DCQ is not full (!dcq\_full), the delayed request queue in the other bridge chip is not full (!tc\_dr\_full), and the DCQ and QPIF are not locked (!dcq\_locked and !lock\_state [1]), the slave state machine asserts the q2pif\_retry signal, forwards the request down the cable, and remains in the IDLE state 2720. If the request misses the DCQ and the request cannot be sent down the cable, the QPIF simply retries the requesting device and remains in the IDLE state 2720.

If the delayed request is not a MRL or MRM transaction, a second clock cycle is needed to check the request because the data or byte enables must be compared to the contents of the DCQ buffers, so the slave state machine enters a SECOND\_CHECK state 2728. If a parity error occurs or if the lock logic is in the unlocked-but-retry state, the state

machine retries the requesting device and remains in the IDLE state 2720.

In the SLAVE\_DAC state 2722, the slave state machine receives the second half of the address phase information. If the requesting device has not targeted the QPIF, the slave state machine ignores the transaction and remains in the IDLE state 2720. When the QPIF is the target device, the state transition events are the same as those in the IDLE state 2720. Specifically, if the transaction is a posted memory write request and a parity error has not occurred, the slave state machine loads the write counters and determines whether it can accept the transaction. If the PMWQ in the other bridge chip is full (tc\_pmw\_full is asserted), the DCQ is locked, or the QPIF lock logic is in the unlocked-but-retry state, the slave state machine retries the requesting device and returns to the IDLE state 2720. If the QPIF can accept the transaction, the slave state machine initiates the posted memory write message on the cable and enters the PMWL state 2724.

If the transaction is not a posted memory write request, the slave state machine loads the dword counter and, if no parity error has occurred, analyzes the delayed request transaction. If the transaction is a MRL or a MRM transaction and the QPIF lock logic is not in the unlocked-but-retry state, the slave state machine asserts the QPIF check cycle signal. If the request hits a DCQ buffer that is not empty, the slave state machine enters the STEP\_AHEAD state 2726. If the MRL or MRM request misses all of the DCQ data buffers, the DCQ is not full, the delayed request queue in the other bridge chip is not full (tc\_dr\_full is not asserted), and the DCQ and QPIF are not locked, the slave state machine asserts the q2pif\_retry signal, forwards the request down the cable, and returns to the IDLE state 2720. If the request misses the DCQ and the request cannot be sent down the cable, the QPIF simply retries the requesting device and returns to the IDLE state 2720.

If the delayed request is not a MRL or MRM transaction, a second clock cycle is needed to check the request because the data or byte enables must be compared to the contents of the DCQ buffers, so the slave state machine enters the SECOND\_CHECK state 2728. If a parity error occurs or if the lock logic is in the unlocked-but-retry state, the state machine retries the requesting device and returns to the IDLE state 2720.

In the PMW1 state 2724, the slave state machine forwards a posted memory write transaction through the cable to the target device. When the state machine first enters the PMW1 state 2724, it deasserts the load\_write\_counter signal. If the dword counter indicates that the posted memory write transaction is in the last cache line (pmw\_counter [5:3] equals "111") and the PMWQ in the other bridge is full (tc\_mw\_full) and the write overflow feature is disabled (!cfg2q\_write\_overflow), or if the write\_Page\_disconnect signal is asserted because the transaction has reached a 4K

page boundary, or if the DCQ has asserted the `dcq_disconnect_for_stream` signal and the write disconnect feature is not disabled (`!cfg2q_wrdiscnt` disable), the slave state machine asserts the `slave_lastline` signal indicating that the current cache line will be the last to be transferred. The slave state machine then remains in the PMW1 state 2724 until the `p2q_qcyc` signal is deasserted, indicating that the transaction has completed on the PCI bus. After leaving the PMW1 state 2724, the slave state machine reenters the IDLE state 2720.

In the SECOND\_CHECK state 2728, the slave state machine has the DCQ compare the second phase of request information to the delayed completion information in the DCQ buffers. If the transaction is not a delayed write request (`!io_write` and `!config_write`) or there is no parity error (`!p2q_perr`), and if the DCQ is not locked and the `dwr_check_ok` signal is asserted, the slave state machine asserts the `q2pif_check_cyc`. The `dwr_check_ok` signal is asserted either when the transaction is not a delayed write request or when it is a delayed write request and a `p2q_irdy` wait state has not been inserted. If the request hits one of the DCQ buffers and the buffer is not empty, the slave state machine enters the STEP\_AHEAD state 2726. If the request misses all of the DCQ buffers but the QPIF can send the message down the cable, the slave state machine retries the requesting device, forwards the transaction down the cable, and reenters the IDLE state 2720. Otherwise, if the request missed all of the DCQ buffers and the QPIF could not send the transaction down the cable, or if a parity error occurred on a delayed write request, the state machine will retry the requesting device and reenter the IDLE state 2720.

In the STEP\_AHEAD state 2726, the slave state machine increments the DCQ output pointer to the next dword. This state is necessary immediately after a DCQ buffer is hit because the PCI interface latches the first dword of data without asserting the `!p2q_trdy` signal. From the STEP\_AHEAD state 2726, the state machine enters a HIT\_DCQ state 2730, in which data is provided from the appropriate DCQ buffer to the requesting device, if the last dword of data has not been taken. Otherwise, the state machine enters a HIT\_DCQ\_FINAL state 2732, in which the requesting device is retried because the DCQ buffer contains no more data.

From the HIT\_DCQ state 2730, when the delayed request transaction terminates on the PCI bus before it terminates in the QPIF (i.e., `p2q_qcyc` is deasserted), the state machine terminates the transaction in the QPIF and asserts the stepback signal, which indicates that the DCQ output pointer should be decremented because the last piece of data was not taken by the requesting device. The state machine then reenters the IDLE state 2720. If the DCQ buffer runs out of data while the requesting device continues to request it (`dcq_no_data` and `!p2q_irdy`), or if the `pmw_counter` indicates that the last dword has been reached and the `read_disconnect_for_stream` signal has been asserted, the slave state machine retries the requesting device and enters the HIT\_DCQ\_FINAL state 2732. If the transaction terminates to establish a stream, the step back signal is asserted and the output pointer of the appropriate DCQ buffer is decremented. In any other situation, the slave state machine continues to provide data in the HIT\_DCQ state 2730.

In the HIT\_DCQ\_FINAL state 2732, the slave state machine has one dword of data left to transfer. If the PCI bus terminates the transaction before the requesting device takes the last piece of data (i.e., `p2q_qcyc` is deasserted), the slave state machine asserts the stepback signal and returns to the IDLE state 2720. If the `p2q_qcyc` signal remains asserted and the requesting device has not asserted an initiator wait state (`!p2q_irdy`), the requesting device is retried because the last piece of data has been taken. The state machine then reenters the IDLE state 2720. Otherwise, the slave state machine remains in the HIT\_DCQ\_FINAL state 2732.

Referring to FIG. 87, the cable message generator is a state machine that creates cable messages from transaction information obtained from the master and slave state machines. In addition to an IDLE state 2740, the cable message generator also includes a dual address cycle (CABLE\_DAC) state 2742, a master data phase (MASTER\_DPHASE) state 2744, and a slave data phase (SLAVE\_DPHASE) state 2746. The following table shows the events causing state transitions in the cable message generator.

CABLE MESSAGE GENERATOR

CURRENT STATE	EVENT	NEXT STATE
CABLE_IDLE	A: ( <code>send_message</code> && <code>q2pif_dac</code> )    (( <code>dcq_prefetch_mul</code>    <code>dcq_prefetch_line</code> )&& <code>dcq_prefetch_dac</code> )	CABLE_DAC
	B: ( <code>send_message</code> && <code>!q2pif_dac</code> )    (( <code>dcq_prefetch_mul</code>    <code>dcq_prefetch_line</code> )&& <code>!dcq_prefetch_dac</code> )    ( <code>dcq_stream_connect</code> && <code>!(drq_valid[3:0])</code> ) && ( <code>dcq_stream_connect</code>    <code>!p2q_ack</code>    <code>dcq_prefetch_line</code>    <code>dcq_prefetch_mul</code> )	SLAVE_DPHASE
	C: ( <code>send_message</code> && <code>!q2pif_dac</code> )    (( <code>dcq_prefetch_mul</code>    <code>dcq_prefetch_line</code> ) && <code>!dcq_prefetch_dac</code> )    ( <code>dcq_stream_connect</code> && <code>!(drq_valid[3:0])</code> ) && <code>!dcq_stream_connect</code> && <code>!(p2q_ack    dcq_prefetch_mul    dcq_prefetch_line)</code> )	MASTER_DPHASE
	D: otherwise	CABLE_IDLE
CABLE_DAC	E: <code>!p2q_ack</code>    <code>dcq_prefetch_mul</code>    <code>dcq_prefetch_line</code>	SLAVE_DPHASE
	F: otherwise	MASTER_DPHASE
MASTER_DPHASE	G: <code>send_message</code> && <code>q2pif_dac</code>	CABLE_DAC
	H: <code>send_message</code> && <code>!q2pif_dac</code>	SLAVE_DPHASE
	I: <code>!send_message</code> && ( <code>early_last_master_data</code> && <code>!p2q_trdy</code>    <code>master_abort_cable</code> )	CABLE_IDLE
	J: otherwise	MASTER_DPHASE
SLAVE_DPHASE	K: ( <code>!(drq_stream_connect</code> && <code>!drq_valid[3:0])</code> && <code>p2q_qcyc</code> ) && ( <code>dly_read_request</code>    <code>dly_single_write_request</code> )	CABLE_IDLE

-continued

CABLE MESSAGE GENERATOR

CURRENT STATE	EVENT	NEXT STATE
	dcq_prefetch_mul    dcq_prefetch_line)    L: early_last_slave_data    dcq_stream_connect && !(drq_valid[3:0]) && p2q_qcyc and otherwise	SLAVE_DPHASE

Cable Message Generator State Transitions

At reset, the cable message generator enters the IDLE state 2740, in which it waits for transaction information to arrive from the master or slave state machines. From the IDLE state 2740, if the cable message generator receives a prefetch multiple signal (dcq\_prefetch\_mul) or a prefetch line signal (dcq\_prefetch\_line), the cable address signal (early\_cad [31:2]) equals the prefetch address signal (dcq\_prefetch\_addr [31:2]). Otherwise the early\_cad [31:2] signal takes on the value of the QPIF address signal (q2pif\_addr [31:2]). When the cable message is initiated by the master state machine, the message is a delayed completion message, so the command code (early\_ccbe [3:0]) equals “1001”. When the cable message is initiated by the slave state machine, the command code takes on the value of the message\_cmd [3:0] signal, discussed above.

If the send\_message signal is asserted, indicating that either the master state machine or the slave state machine has initiated a message, and the corresponding transaction is not a dual address cycle, or if the cable message generator receives a prefetch request that is not a dual address cycle, or if the cable message generator receives a stream connect signal and no delayed requests from the CPU are pending in the downstream DRQ, the cable message generator asserts a sent\_pmw signal that indicates that a posted memory write request from the PCI bus will be sent down the cable. The sent\_pmw signal is not asserted if a stream has been established by the DCQ. The cable message generator asserts a sent\_dr signal when a read request or delayed write request is received from the slave state machine or a prefetch signal is received and when a stream has not been established by the DCQ.

If the DCQ has established a stream (dcq\_stream\_connect is asserted), the buffer number for the cable signal (early\_cbuff [2:0]) takes on the value of the DCQ stream buffer (dcq\_stream\_buff [2:0]), the cable command code (early\_ccbe [3:0]) is set equal to “1000”, and the cable message generator enters the SLAVE\_DPHASE state 2746. Otherwise, if the QPIF is in the slave mode and the cable message generator receives either a prefetch multiple or a prefetch line signal, the cable buffer signal takes on the value of the DCQ buffer number (dcq\_buff [2:0]) and the cable message generator enters the SLAVE\_DPHASE state 2746. Otherwise, the QPIF is operating in the master mode and the cable message generator enters the MASTER\_DPHASE state 2744.

When the cable message generator receives the send\_message signal and a transaction that is a dual address cycle, or when it receives a prefetch request that is a dual address cycle, the message generator enters the CABLE\_DAC state 2742. For a prefetch signal, the cable address signal is set equal to the upper thirty two bits of the dcq\_prefetch\_addr [63:0] signal; otherwise, the cable address equals the upper thirty-two bits of the q2pif\_addr [63:0] signal. Also, if the cable message generator receives the transaction from the slave state machine, the cable buffer number equals the DCQ

buffer number; otherwise, the cable buffer number equals the DRQ buffer number (no completion messages are generated for posted memory write transactions) In the CABLE\_DAC state 2742, the cable message decoder generates the second half of the address phase information. As in the IDLE state 2740, the cable address signal takes on the value of the prefetch address when the received transaction is a prefetch line or prefetch multiple request and takes on the value of the q2pif\_addr [31:2] otherwise. The sent\_pmw signal is asserted when the message generator receives a posted memory write transaction from the slave state machine, and the sent\_dr signal is asserted when it receives a prefetch request or a delayed request from the slave state machine. If a prefetch request or a request from the slave state machine is received, the cable message generator enters the SLAVE\_DPHASE state 2746. Otherwise, the message generator enters the MASTER\_DPHASE state 2744.

In the MASTER\_DPHASE state 2744, the cable message generator attempts to send a delayed completion message down the cable. However, if the PCI interface grants the bus to a device on the PCI bus before the QPIF gets control of the bus, the cable message generator must leave the MASTER\_DPHASE state 2744 to send the newly received message. Therefore, if the send\_message signal is asserted while the message generator is in the MASTER\_DPHASE state 2744, the q2c\_new\_req signal is asserted to indicate the start of a new message. If the q2pif\_dac\_flag is asserted, the new transaction is a dual address cycle and the cable message generator enters the CABLE\_DAC state 2742. Otherwise, message generator enters the SLAVE\_DPHASE state 2746.

If the send\_message signal is not asserted, then the cable message generator is sending a delayed completion message from the master state machine. When the master state machine has completed the last data transfer with the PCI bus and the target device has acknowledged the transfer (!p2q\_trdy), or when the master has aborted the transaction on the cable, the cable message generator asserts a sent\_dc signal indicating that the delayed completion message was sent down the cable and reenters the IDLE state 2740. Otherwise, the message generator remains in the MASTER\_DPHASE state 2744 and continues generating the delayed completion message.

From the SLAVE\_DPHASE state 2746, as long as a stream is established with the upstream chip, no delayed requests from the CPU are pending in the downstream DRQ, and the requesting device continues to send data to the QPIF (q2p\_qcyc is asserted), the cable message generator remains in the SLAVE\_DPHASE state 2746 and continues to forward the transaction from the requesting device. Otherwise, if the cable message generator receives a delayed request or a prefetch request, the cable message generator forwards the request and, in the case of a delayed write request, the one dword of data to the upstream device and then enters the IDLE state 2740. Otherwise, the cable

message generator has received a posted memory write request. In this situation, the cable message generator stays in the SLAVE\_DPHASE state 2746 and continues to forward the posted memory write information down the cable until the early\_last\_slave\_data signal is asserted, indicating the last piece of data has been sent by the slave state machine. The message generator then terminates the cable transaction and reenters the IDLE state 2740.

#### Cable Interface

To ensure the valid transfer of data between the two bridge chips, data sent through the cable 28 must be synchronized properly to the clocks from the clock generators 102 and 122. The downstream clock generator 122 bases its clocks on an upstream clock (which in turn is based on the PCI bus clock PCICLK1) transmitted down the cable 28 with the data. As a result, upstream data transmitted downstream is synchronized to the clocks generated in the downstream bridge chip 48. However, the phase delay associated with the cable 28 between the main clocks generated in the upstream chip 26 and the data transferred back upstream from the downstream chip 48 is unknown. The length of the cable 28 range from 10 to as large as 100 feet (if appropriate interface technology is used). The receiving logic in the upstream cable interface 104 is effectively an asynchronous boundary with respect to the upstream clock. Consequently, the receiving logic needs to re-synchronize the downstream-to-upstream data to the clock from the upstream clock generator 102.

Referring to FIG. 5, the clock distribution scheme in the 2-chip PCI-PCI bridge is shown. Transactions which are forwarded between the bridge chips 26 and 48 are encoded into multiple time-multiplexed messages. The format of the messages is similar to the PCI transaction format (except for time multiplexing) and includes an address and one or more data phases and modified handshake signals in addition to signals which are added to indicate buffer number and special bridge function commands. Each cable interface 104 or 130 includes a master cable interface (192 or 194) and a slave cable interface (196 or 198). The master cable interface 192 or 194 transmits messages out onto the cable 28, and the slave cable interface 3075 196 or 198 receives messages from the cable 28.

The clock generator 102 or 122 in each bridge chip includes two on-chip PLLs for clock generation. A PLL 184 in the upstream bridge chip 26 locks on the primary PCI bus input clock PCICLK1. In the downstream bridge chip 48, the PLL 180 locks to an incoming clock PCICLK2 from a clock buffer 181.

In the ensuing description, a "1× clock" refers to a clock having the same frequency as the clock PCICLK1, while a "3× clock" refers to a clock having three times the frequency of the clock PCICLK1. A 1× clock PCLK generated by the PLL 184 or 180 (in the bridge chip 26 or 48, respectively) is used for the corresponding bridge chip's PCI bus interface logic 188 or 190, and the 3× clock PCLK3 is used to run the cable message generation logic in the master cable interface 192 or 194. The other PLL 186 or 182 is used to lock to a cable input clock CABLE\_CLK1 (from upstream) or CABLE\_CLK2 (from downstream) and to generate a 1× clock CCLK and a 3× clock CCLK3 to capture incoming cable data. The clock outputs of the PLL 186 or 182 are routed to the slave cable interface 196 or 198, respectively

The PLLs are arranged in the layout to balance the 1× and 3× clocks as closely as possible to minimize the skew between them.

The PLL 184 or 180 generates a phase indicator signal PCLKPHI1, which indicates to the master cable interface 192 or 194 when the first phase of data should be presented to the cable 28. On the upstream side, the signal PCLKPHI1 is based on the PCI clock PCICLK1; on the downstream side, the signal PCLKPHI1 is based on the PCI clock PCICLK2. The PLL 186 or 182 generates a phase indicator signal CCLKPHI1, based on the cable clock CABLE\_CLK1 or CABLE\_CLK2, to indicate to the slave cable interface 196 or 198 when the first phase of data has come down the cable 28.

The PCI clock PCICLK2 for the secondary PCI bus 32 is generated off a 1× clock BUFCLK of the PLL 182 in the downstream bridge chip 48. The clock BUFCLK drives the clock buffer 181 through a driver 179. The buffer 181 outputs a separate clock signal for each of the six slots on the secondary PCI bus 32 as well as the clock PCICLK2, which is routed back as the bus input clock to the downstream bridge chip 48. By basing the clock PCLK on the clock PCICLK2 from the clock buffer 181, the clock schemes of the upstream and downstream chips are made to appear more similar since both are based on an external bus clock.

The cable clock CABLE\_CLK1 is a 33% duty cycle clock. The PLL 182 first converts the 33% duty cycle clock to a 50% duty cycle clock for output as BUFCLK.

The PCI Specification, Version 2.1, requires that the PCI bus clock must meet the following requirements: clock cycle time greater than or equal to 30 ns; clock high time greater than 11 ns; clock low time greater than or equal to 11 ns; and clock slew rate between 1 and 4 ns.

When the computer system is powered up, the upstream chip 26 is powered on last, the upstream PLL 184 sends the clock CABLE\_CLK1 (through the master interface 192) down the cable 28, which is then locked to by the downstream PLL 182 and PLL 180. The downstream PLL 180 then sends the clock CABLE\_CLK2 back upstream to be locked to by the PLL 186.

The system is not completely operational until all four PLLs have acquired lock.

If the upstream bridge chip 26 powers up and the downstream bridge chip 48 is not yet turned on, the upstream bridge chip 26 behaves as a PCI-PCI bridge with nothing connected to its downstream bus (the cable 28). As a result, the upstream bridge chip 26 does not accept any cycles until the downstream bridge chip 48 is powered on and the upstream PLL 186 has acquired "lock" from the cable clock CABLE\_CLK2.

The upstream bridge chip 26 floats all of its PCI output buffers and state machines a synchronously with assertion of the PCI reset signal PCIRST1\_ on the primary bus 24. During reset, the PLL 184 may be attempting to acquire lock on the PCI bus clock PCICLK1. Since the PCI Specification guarantees that the signal PCIRST1\_ will remain active for at least 100 μs after the PCI bus clock becomes stable, the PLL 184 has about 100 μs to acquire a lock.

The downstream bridge chip 48 resets all internal state machines upon detection of the primary bus PCIRST1\_ signal. In response, the downstream bridge chip 48 also asserts a slot-specific reset to each slot on the secondary PCI bus 32, as well as a secondary PCI bus reset signal PCIRST2\_.

Referring to FIG. 6, each PLL includes a voltage-controlled oscillator (VCO) 200 generating an output 201 (the 3× clock) between 75 Mhz (for a 25-Mhz PCI bus) and 100 Mhz (for a 33-Mhz PCI bus). The VCO 200 receives a reference clock 197, which is the PCI bus clock. Each PLL

has a lock detection circuit **205** which indicates by a lock indication bit that the PLL phase is locked to its reference accurately enough to perform its intended function.

The lock indication bits are written to a status register in the configuration space **105** or **125** of each bridge chip. On the downstream side, a power-good/lock status bit is transmitted to the upstream bridge chip **26** to indicate the main elements of the downstream bridge chip **48** are stable (power is stable) and the downstream PLLs are locked (lock indication bits of the two PLLs are active). The lock indication bit is also gated with the EDC status bits such that EDC errors are not reported as such until the PLLs are locked. Thus, the bridge chip pair can come up to an error-free communication state without software intervention. The lock indication bit also provides some diagnostic information which can distinguish between a PLL lock failure and other data errors. The clock generation circuitry includes a four-state machine **202** to generate a divide-by-3 clock (1× clock) of the VCO output **201**. The 1× clock is fed back to the PLL at input **203**.

Data is moved down the cable **28** at a 3× clock (PCLK3) rate in three time-multiplexed phases to produce a 1× clock message transfer rate. Referring to FIG. 7, the circuitry in the master cable interface **192** or **194** for disassembling and transmitting the cable message includes a register **204**, which samples the out-going message at the local PCLK boundary. The flip-flop **208** provides extra margin for hold time on the third phase of the transmitted message by holding this phase for an extra half of a PCLK. Since the output register **212** is clocked with the 3× clock PCLK3, this reduces the need for tight control on the skew between the 1× and 3× clocks. From the phase indication signal PCLKPHI1, a set of three flip-flops **210** generates successive PHI1, PHI2, and PHI3 signals, representing phases 1, 2 and 3, respectively, which in turn control a 60:20 multiplexer **206**. The three phases of data (LMUXMSG [19:0] LMUXMSG [39:20], {LMUXMSG [51:40], EDC [7:0]}) are successively multiplexed into the register **212** and driven through the cable **28**. The third phase of data includes error correction bits EDC [7:0] generated by an ECC generator **206** (FIG. 17) from the register **204** output bits LMUXMSG [51:0]. The flip-flop **214**, clocked by PCLK3, receives the PHI1 signal and clocks it out as the cable clock CABLE\_CLK1 or CABLE\_CLK2.

Since the master cable interface **192** or **94** is a 1×-to-3× communication interface, a one 3×-clock latency is incurred, resulting in a single 3× clock phase shift of the transmitted cable message from the PCI bus clock as shown in FIG. 8. In period T0, message A is presented to the input of the register **204** and the first phase clock indicator PCLKPHI1 is asserted high. The signal PHIL is asserted high from a previous cycle. In period T1, the cable clock CABLE\_CLK1 or CABLE\_CLK2 is driven high in response to the signal PHI1 being high. The PCLKPHI1 pulse causes the signal PHI2 to be pulsed high in period T1. Next, in period T2, the signal PHI3 is pulsed in response to the signal PHI2. In period T3, the signal PHI1 is pulsed high in response to the signal PHI3 being high. Message A is also loaded into the register **204** on the rising edge of the clock PCLK in period T3. Next, in period T4, the signal PHI1 causes the multiplexer **206** to select the first phase data A1 for loading into the register **212**. Next, in period T5, the second phase data A2 is selected and loaded into the register **212**. Then, in period T6, the third phase data A3 is loaded into the register **212**. This process is repeated for messages B, C, D and E in the subsequent clock periods.

As shown in FIG. 8, the cable clock CABLE\_CLK has a 33% duty cycle. Alternatively, the cable clock CABLE\_

CLK can be designed to have an average duty cycle of 50%, which can be accomplished, for example, by sending out the cable clock as 33% high-66% low-66% high-33% low. Having an average 50% duty cycle could result in better pass characteristics in the cable **28**.

Referring to FIG. 9, a slave cable interface first-in-first-out buffer (FIFO) **216** assembles incoming data from the cable **28** and transmits the assembled data to the queues and PCI state machines in the receiving bridge chip. The FIFO **216** is 4 entries deep, with each entry capable of holding one complete cable message. The depth of the FIFO **216** allows for the cable data to be synchronized to the local bridge chip clock without losing any effective bandwidth in the cable interface. In addition, on the upstream side, the FIFO **216** is an asynchronous boundary for the cable data coming from the downstream bridge chip **48**. The FIFO **216** ensures that the cable data is properly synchronized with respect to PCLK before it is outputted to the rest of the chip.

The entries of the FIFO **216** are selected by an input pointer INPTR [1:0] from an input pointer counter **226**, which is clocked by the signal CCLK3, cleared when a signal EN\_INCNT is low, and enabled by the phase indicator CCLKPHI1. The negative edge of the 3× clock CCLK3 from the PLL **186** or **182** is used to latch incoming data from the cable **28**, first into a 20-bit register **218**, and then into a register **220** if a phase one indication signal PHI1\_DLY is asserted, or into a register **222** if a phase two indication signal PHI2\_DLY is asserted. The phase 1 data, phase 2 data and phase 3 data from the registers **220**, **222** and **218**, respectively, are loaded into the selected entry of the FIFO **216** on the negative edge of CCLK3 when the phase 3 indication signal PHI3\_DLY is asserted. The four sets of outputs from the FIFO **216** are received by a 240:60 multiplexer **228**, which is selected by an output pointer OUTPTR [1:0] from an output pointer counter **224** clocked by PCLK and cleared when a signal EN\_OUTCNT is low.

Referring to FIG. 10, the input pointer and output pointer counters **226** and **224** continuously traverse through the FIFO **216** filling and emptying data. The counters **226** and **224** are offset in such a way as to guarantee valid data in a location before it is read out. The initialization of the pointers is different for an upstream bridge chip **26** than for a downstream bridge chip **48** due to synchronization uncertainties.

Flip-flops **236** and **238** synchronize the reset signal C\_CRESET, which is asynchronous to the clocks in the bridge chip, to the CCLK clock boundary. The signal EN\_INCNT is generated by the flip-flop **238**. The input pointer is incremented on the rising edge of the clock CCLK3 if the first phase indication signal CCLKPHI1 and the signal EN\_INCNT. The output pointer is then started at a later local PCLK clock boundary PCLK when it can be guaranteed that the data will be valid in the FIFO **216**. The upstream and downstream bridge chips must handle the starting of the output pointer differently since the phase relationship of the cable clock to the local clock is not known for the upstream bridge chip **26** but is known for the downstream bridge chip **48**.

In the downstream bridge chip **48**, the phase relationship between the incoming cable clock CABLE\_CLK1 and the secondary PCI bus clock PCICLK2 is known since the PCI clock PCICLK2 is generated from the cable clock. As a result, no synchronization penalty exists for the output pointer OUTPTR [1:0] in the downstream bridge chip **48**, and the output pointer can track the input pointer INPTR [1:0] as closely as possible. A flip-flop **230**, which is clocked

on the negative edge of the clock PCLK, is used to avoid any clock skew problems between the clock CCLK generated by the PLL 182 and the clock PCLK generated by the PLL 180. Though these two clocks have identical frequencies and should be in phase with each other, there is an unknown skew between the two clocks since they are generated from two different PLLs. On the downstream side, the signal EN\_OUTCNT is the signal EN\_INCNT latched on the negative edge of the signal PCLK by the flip-flop 230. A multiplexer 234 selects the output of the flip-flop 230 since the signal UPSTREAM\_CHIP is low.

In the upstream bridge chip 26, the cable interface is treated as completely asynchronous. The phase uncertainty is due to the unknown phase shift of the cable 28 itself. Designing for this uncertainty gives complete freedom on the length of cable 28. What is known is that the clocks in the upstream and downstream bridge chips have the same frequency, since they both have their origin in the upstream PCI bus clock PCICLK1. In the upstream bridge chip 26, the signal EN\_OUTCNT is the signal EN\_INCNT latched on the positive edge of the clock PCLK by a flip-flop 232. The multiplexer 234 selects the output of the flip-flop 232 since the signal UPSTREAM\_CHIP is high. The flip-flop 232 guarantees that even for the worst-case lineup of the cable clock CABLE\_CLK2 and the local PCI clock PCLK (one complete PCLK period phase shift), there is valid data in the FIFO 216 before the data is transmitted to the rest of the chip.

Referring to FIG. 11, the cable data is received by the slave cable interface 196 or 198 as three phase time-multiplexed signals A1, A2 and A3; B1, B2 and B3; C1, C2 C3; and so forth. A previous transaction is completed in periods T0, T1 and T2. Beginning in period T3, the first phase data A1 is presented to the register 218 and the first phase indicator CCLKPHI1 is pulsed high. On the falling edge of CCLK3 in period T3, the data A1 is loaded into the register 218, and the local phase 1 indication signal PHI\_DLY is pulsed high. In period T4, on the falling edge of clock, the phase 1 data A1 is loaded into the register 220, the phase 2 data A2 is loaded into the register 218, and the phase 2 indication signal PHI2\_DLY is pulsed high. In period T5, on the falling edge of CCLK3, the phase 2 data is loaded into the register 222, the phase 3 data A3 is loaded into the register 218, and the phase 3 indication signal PHI3\_DLY is pulsed high. In period T6, the contents of the registers 220, 222, and 218 are loaded into the selected entry of the FIFO 216 on the following edge of CCLK3. Also in period T6, the data B1 is presented to the register 218 along with the indication signal CCLKPHI1. Messages B and C are loaded into the FIFO 216 in the same manner as message A in subsequent periods.

Referring to FIG. 12, the input pointer INPTR [1:0] starts at the value 0 in period T0 on the rising edge of the clock CCLK3. Also in period T0, message A is loaded into FIFO 0 on the falling edge of the clock CCLK3. In the downstream bridge chip 48, the output pointer OUTPTR [1:0] is incremented to the value 0 on the next rising edge of the clock PCLK in period T3. Also in period T3, the input pointer INPTR [1:0] is incremented to the value 1 on the rising edge of the clock CCLK3, and message B is loaded into FIFO 1 on the falling edge of CCLK3. Cable data is thus loaded into FIFO0, FIFO1, FIFO2, and FIFO3 in a circular fashion.

On the upstream side, if the input pointer INPTR [1:0] is 0 in period T0, the output pointer OUTPTR [1:0] is incremented to the value 0 in period T6, two PCLK periods after the input pointer INPTR [1:0]. The two PCLK period lag in the upstream bridge chip 26 allows the phase delay in the

cable 28 to be of any value, which has the advantage that the cable length need not be of a specific fixed value.

Referring to FIG. 13, the input and output flip flops on the cable interface are custom-placed by the manufacturer of the chips to minimize the skew between the cable data and the clock passed with it. The amount of wire between each flip-flop and the I/O are maintained as consistent as possible between all cable interface signals.

#### Cable Message

Sixty bits of cable data constitute one message. The 60 bits are multiplexed onto 20 cable lines and are transmitted each 10 ns over the cable 28. The table in FIG. 14 shows the bits and the phase each bit is assigned to. The first three columns show the upstream-to-downstream data transfer format, and the last three columns show the downstream-to-upstream data transfer format. The following is a description of the signals.

EDC [7:0]: The signals are the eight syndrome bits used to detect and correct errors encountered in transmitting data over the cable 28.

CAD [31:0]: The signals are the 32 address or data bits.

CFRAME\_: The signal is used to signal the start and end of a cable transaction, similar to the PCI FRAME\_signal.

CCBE [3:0]: The four bits form byte enables in some PCI clock phases and either a PCI command or a message code in other PCI clock phases.

CBUFF [3:0]: In the address phase, the signals indicate a buffer number for initializing the bridge chip delayed completion queue (DCQ) 148 to tie upstream and downstream delayed read completion (DRC) and delayed read request (DRR) transactions. After the address phase, the signals contain the parity bit, parity error indication and the data ready signal.

COMPLETION REMOVED: The bit is used to signal that a delayed completion has been removed from the transaction ordering queue (TOQ) on the other side of the cable 28.

PMW ACKNOWLEDGE: The bit is used to signal that a posted memory write (PMW) has been completed on the other side and has been removed from the transaction run queue (TRQ).

LOCK\_: The bit is transmitted downstream (but not upstream) to identify locked cycles.

SERR\_: The bit is used to transmit an SERR\_indication upstream, but is not transmitted downstream.

INTSYNC and INTDATA: The bits carry the eight interrupts from downstream to upstream in a serially multiplexed format. The signal INTSYNC is the synchronization signal indicating the start of the interrupt sequence and the signal INTDATA is the serial data bit. The signals INTSYNC and INTDATA are routed on separate lines over the cable 28.

RESET SECONDARY BUS: The bit is asserted when the CPU 14 writes to the secondary reset bit in a bridge control register in the upstream bridge chip 26. It causes the downstream bridge chip 48 to reset to a power up state. The reset signals for the slots are also asserted. The signal RESET secondary bus is routed on a separate line over the cable 28.

Because the address and data in each PCI transaction is multiplexed over the same lines, each PCI transaction includes an address phase and at least one data phase (more than one for burst transactions). The PCI specification also supports single address transactions (32-bit addressing) and dual-address transactions (64-bit addressing).



Referring to FIG. 15A, a table shows what information appears on each portion of the bus during address and data phases of the single-address transactions. For a single address transaction, the first phase is the address phase and the second and subsequent phases are data phases. In the address phase of a delayed read/write request transaction, the signals CBUFF [3:0] indicate the DCQ buffer number for initializing the bridge chip DCQ 148 to tie upstream and downstream DRC and DRR transactions. After the address phase, the signal CBUFF [0] contains the parity bit. The signals CCBE [3:0] contain the PCI command in the address phase and the byte enable bits in the data phases.

For posted memory write transactions, the signals CBUFF [3:0] are “don’t care” in the address phase and contain the data-ready indication, parity error indication, and parity bit in the data phases.

In a delayed read/write completion transaction, the signals CBUFF [3:0] contain the DCQ buffer numbers in the address phase and the end-of-completion indication, data-ready indication, parity error indication, and parity bit in the data phases. The signals CCBE [3:0] contain a code representing a DRC transaction in the address phase and the status bits of the DRC transaction in the data phases. Delayed completion transactions return the status of the destination bus for each data phase. The data parity bit is transmitted on CCBE [3]\_. Other status conditions are encoded on the CCBE [2:0]\_ bus, with a binary value 000 indicating normal completion and a binary value 001 indicating a target abort condition. The address/data bits CAD [31:0] are “don’t care” in the address phase and contain data during the data phases.

In a stream connect transaction, the signals CBUFF [3:0] contain a buffer number in the address phase and the signal CBUFF [2] contains the data-ready indication in the data phases. The signals CCBE [3:0] contain a code representing a stream connect transaction in the address phase and are “don’t care” in the data phases. The address/data bits CAD [31:0] are not used during a stream connect transaction.

The table in FIG. 15B shows the encoding of the signals for dual-address transactions. In delayed read/write request transactions, the signals CBUFF [3:0] contain a buffer number in the first and second address phases and the signal CBUFF [0] contains the parity bit in the data phase. The signals CCBE [3:0] contain a code representing a dual-address cycle in the first address phase, the PCI command in the second address phase, and the byte enable bits in the data phase. The signals CAD [31:0] contain the most significant address bits in the first address phase, the least significant address bits in the second address phase, and the data bits in the data phase. In a dual-address posted memory write transaction, the signals CBUFF [3:0] are “don’t care” in the first two address phases, but the signals CBUFF [1:0] contain the parity error indication bit and the parity bit in the data phases. The signals CCBE [3:0] contain a code representing a dual-address cycle in the first address phase, the PCI command bits in the second address phase, and the byte enable bits in the data phases. The signals CAD [31:0] contain the most significant address bits in the first address phase, the remaining address bits in the second address phase, and the data bits in the data phases.

There are three possible states for the data transfer: not-last, last-of-cable-transfer, and last-of-request. The not-last state is indicated by asserting the bit CBUFF [2] while FRAME<sub>is</sub> is active, which indicates that another word of data is being presented. The last-of-cable-transfer state is indicated by asserting the bit CBUFF [2] while the signal CFRAME<sub>is</sub> is inactive. The last-of-request state is indicated

by asserting the bits CBUFF [3] and CBUFF [2] while the signal CFRAME<sub>is</sub> is inactive.

The following four IEEE 1149.1 Boundary-Scan (JTAG) signals are included in the cable 28 to effect a JTAG test chain: TCK (the test clock), TDI (test data input), TDO (test data output) and TMS (test mode select). The optional TRST<sub>is</sub> is not transmitted down the cable, but TRST<sub>is</sub> can be generated from power-good.

The JTAG signals are routed from the system PCI connector through the upstream bridge chip 26, including JTAG master 110, down the cable 28 to the downstream bridge chip 48 to the JTAG master 128, which distributes the JTAG signals to each of the six PCI slots on the secondary PCI bus 32. The return path is from the JTAG master 128, up the cable 28 back to the upstream bridge chip 26 and then to the PCI slot on the primary PCI bus 24. The signals TDO, TCK, and TMS are downstream bound signals. The signal TDI is an upstream bound signal.

One type of cable 28 that can be used is a cylindrical 50-pair shielded cable designed to support the High Performance Parallel Interface (HIPPI) standard. A second type of cable is a shielded 50-pair ribbon cable. The advantages of the first are standardization, ruggedness and reliable uniform manufacture. The advantages of the second are greater mechanical flexibility, automatic termination to the connector in assembly and possibly lower cost.

The table of FIG. 16 shows some of the HIPPI cable specifications. The ground shield consists of a braid over aluminum tape and carries only minimum DC currents due to the differential nature of the buffers to be used. The method of signaling is true differential which provides several advantages, with differential buffers used to send and receive signals over the cable 28. First the true differential method is less expensive than fiber optics for this short distance and less complex to interface than other serial methods. Differential signaling provides significant common mode noise immunity and common mode operating range, is available in ASICs and is faster than TTL. When using twisted pair and shielding, it minimizes electromagnetic radiation. When using low voltage swings, it minimizes power dissipation.

The signaling levels chosen as a target are described in the IEEE Draft Standard for Low-Voltage Differential Signals (LVDS) for Scalable Coherent Interface (SCI), Draft 1.10 (May 5, 1995).

The cable connector is an AMP metallic shell 100-pin connector with two rows of pins. The rows are 100 mils apart and the pins are on 50-mil centers. The metal shell provides EMI shielding and the connection of the ground path from the cable shield to the board connector. The mating right angle board connector just fits a PCI bracket. The connector is to have a bar running between the rows of pins to divert electrostatic discharges from the signal pins when the connector is disconnected. A pair of thumb screws attached to the cable connector will secure the mated connectors.

#### Error Detection and Correction

An error detection and correction (EDC) method is implemented on each bridge chip to protect communication over the cable 28. Since the data is time-multiplexed into three 20-bit groups to be sent over 20 pairs of wires, each triplet of “adjacent” bits (i.e., bits associated with the same wire in the cable 28) is arranged so as to be transmitted on a single wire pair. The EDC method can correct single-bit failures and multi-bit failures occurring in the same bit position in

each of the three time-multiplexed phases. The multi-bit failures are typically associated with a hardware failure, e.g., a broken or defective wire or a faulty pin on bridge chips **26**, **48**.

Twenty wire pairs of the cable **28** are used for downstream communication and **20** more for upstream communication. For the remaining ten pairs in the **50**-pair HIPPI cable **28** (which pass such information as the clock signals `CABLE_CLK1` and `CABLE_CLK2`, reset signals, and the power good/PLL-lock signal), error detection and correction is not implemented.

The following are the underlying assumptions for the EDC algorithm. Most errors are single bit errors. The probability of having random multiple-bit errors in the same transaction is extremely remote because the cable **28** is not susceptible to interference from internal or external sources. Errors caused by a defective wire may affect a single bit or a group of bits transmitted on that wire. When a hardware failure occurs, the logic state of the corresponding differential buffer is in a single valid logic state.

Referring to FIG. 17, the output signals `FIFOOUT [59:0]` from the multiplexer **228** in the slave cable interface **196** or **198** are provided to the input of a check bit generator **350**, which produces check bits `CHKBIT [7:0]`. The check bits are generated according to the parity-check matrix shown in FIG. 18, in which the first row corresponds to `CHKBIT [0]`, the second row corresponds to `CHKBIT [1]`, and so forth. The bits across a row correspond to data bits `FIFOOUT [0:59]`.

The check bits are generated by an exclusive-OR of all the data bits `FIFOOUT [X]` ( $X$  is equal to 0–59), which have a “1” value in the parity-check matrix. Thus, the check bit `CHKBIT [0]` is an exclusive-OR of data bits `FIFOOUT [7]`, `FIFOOUT [8]`, `FIFOOUT [9]`, `FIFOOUT [12]`, `FIFOOUT [13]`, `FIFOOUT [16]`, `FIFOOUT [22]`, `FIFOOUT [23]`, `FIFOOUT [8 24]`, `FIFOOUT [26]`, `FIFOOUT [32]`, `FIFOOUT [33]`, `FIFOOUT [34]`, `FIFOOUT [35]`, `FIFOOUT [38]`, `FIFOOUT [39]`, `FIFOOUT [45]`, `FIFOOUT [46]`, `FIFOOUT [48]`, `FIFOOUT [49]`, `FIFOOUT [51]`, and `FIFOOUT [52]`. Similarly, the check bit `CHKBIT [1]` is an exclusive-OR of bits **0**, **1**, **4**, **5**, **9**, **10**, **12**, **14**, **15**, **16**, **23**, **27**, **35**, **37**, **38**, **40**, **43**, **46**, **47**, **48**, **50**, and **53**. Check bits `CHKBIT [2:7]` are generated in similar fashion according to the parity-check matrix of FIG. 18. The parity check matrix is based upon the **20** sub-channels or wires per time-multiplexed phase and a probability that multiple errors in the accumulated data are attributable to a faulty sub-channel or wire that affects the same data position in each time-multiplexed phase.

In the master cable interface **192** or **194**, the check bits `CHKBIT [7:0]` are provided as error detection and correction bits `EDC [7:0]` along with other cable data to allow error correction logic in the slave cable interface **196** or **198** to detect and correct data errors.

The check bits `CHKBIT [7:0]` are provided to a fix bit generator **352**, which generates fix bits `FIXBIT [59:0]` according to the syndrome table shown in FIG. 19. The check bits `CHKBIT [7:0]` have 256 ( $2^8$ ) possible values. The syndrome table in FIG. 19 contains 256 possible positions. Each of the 256 positions in the syndrome table contains 2 entries, the first entry being the hexadecimal value of the check bits `CHKBIT [7:0]`, and the second entry indicating the cable data status associated with that position. Thus, for example, a hexadecimal value 00 indicates a no-error condition, a hexadecimal value 01 indicates an error in data bit **52**, a hexadecimal value 02 indicates an error in data bit

**53**, a hexadecimal value 03 indicates an uncorrectable error (UNCER), and so forth.

The EDC logic is capable of detecting up to 3 erroneous bits, as long as those data bits are adjacent, i.e., associated with the same wire. Thus, for example, if the check bits `CHKBIT [7:0]` contain a hexadecimal value 3D, then data bits **3**, **23**, and **43** are erroneous. The cable **28** carries cable data `CABLE_DATA [19:0]`. Thus, data bits `FIFOOUT [3]`, `FIFOOUT [23]`, and `FIFOOUT [43]` are associated with the fourth position of the cable data, i.e., `CABLE_DATA [3]`. The EDC method can also correct two-bit errors associated with the same cable wire. Thus, for example, a hexadecimal check bit value of 0F indicates errors in data bits `FIFOOUT [4]` and `FIFOOUT [24]`, both associated with `CABLE_DATA [4]`.

The fix bit generator **352** also produces signals `NCERR` (uncorrectable error) and `CRERR` (correctable error). If no error is indicated by the check bits, then the signals `CRERR` (correctable error) and `NCERR` (non-correctable error) are both deasserted low. In those positions in the syndrome table containing the uncorrectable state UNCER, the signal `NCERR` is asserted high and the signal `CRERR` is deasserted low. Otherwise, where a correctable data error is indicated, the signal `NCERR` is deasserted low and the signals `CRERR` is asserted high.

The lower 52 bits of the fix bits `FIXBIT [51:0]` are provided to one input of 52 exclusive-OR gates **354**, whose other input receives one of each the lower 52 bits of the FIFO data `FIFOOUT [51:0]`. The upper 8 FIFO bits `FIFOOUT [59:52]`, allocated to the error detection and correction bits `EDC [7:0]`, are used to generate the check bits and the syndrome bits, but are not subject to error correction. The exclusive-OR gates **354** perform a bit-wise exclusive-OR operation of the fix bits `FIXBIT [51:0]` and the data bits `FIFOOUT [51:0]`. If the data signals `FIFOOUT [51:0]` contain correctable, erroneous data bits, those data bits are flipped by the exclusive-OR operation. The exclusive-OR gates **354** provide the corrected data `CORRMSG [51:0]` to the 1 input of a multiplexer **360**. The 0 input of the multiplexer **360** receives the data bits `FIFOOUT [51:0]`, and the multiplexer **360** is selected by a configuration signal `CFG2_C_ENABLE_ECC`. The output of the multiplexer **360** produces signals `MUXMSGI [51:0]`. If the system software enables error detection and correction by setting the signal `CFG2C_ENABLE_ECC` high, then the multiplexer **360** selects the corrected data `CORRMSG [51:0]` for output. Otherwise, if error detection and correction is disabled, the data bits `FIFOOUT [51:0]` are used.

The non-correctable and correctable error indicators `NCERR` and `CRERR` are provided to inputs of AND gates **356** and **358**, respectively. The AND gates **356** and **358** are enabled by the signal `CFG2C_ENABLE_ECC`. The outputs of the AND gates **356** and **358** produce signals `C_NLERR` and `C_CRERR`, respectively. The signals `C_NLERR` and `C_CRERR` can be asserted only if error detection and correction is enabled. When an error is detected, the fix bits are latched and used for diagnostic purposes.

If a correctable error is indicated (the signal `C_CRERR` is high), then an interrupt is generated to the interrupt receiving block **132**, forwarded up to the interrupt output block **114**, and then transmitted to the system interrupt controller and then to the CPU **14** to invoke an interrupt handler. Non-correctable errors indicated by the signal `C_NCERR` will cause the system error `SERR` to be asserted, which in turn causes the system interrupt controller

(not shown) to assert the non-maskable interrupt (NMI) to the CPU 14. In the downstream bridge chip 48, non-correctable errors will also cause the power-good/PLL lock indication bit sent up the cable 28 to be negated so that the upstream bridge chip 26 does not send cycles downstream.

To prevent spurious interrupts during and just after power-up, error detection and correction on both the upstream and downstream bridge chips is disabled during power-up until the upstream PLL 186 and downstream PLL 182 have locked to the clock CABLE\_CLK1 or CABLE\_CLK2.

System management software responding to the correctable-error interrupt determines the cause by reading the latched fix bits. If a hardware failure is determined (e.g., multiple data error bits associated with the same cable wire), then the system management software can notify the user of the condition to fix the hardware failure. The system management software responds to SERR\_ caused by an uncorrectable error by shutting down the system or performing other functions programmed by the user.

#### Secondary Bus Arbiter

Referring to FIG. 3, each bridge chip includes a PCI arbiter 116 or 124. Since the upstream bridge chip 26 is normally installed in a slot, the PCI arbiter 116 is disabled. The PCI arbiter 124 supports 8 masters: 7 generic PCI masters (REQ [7:1]\_, GNT [7:1]\_) including the six PCI slots and the hot plug controller in the SIO 50, and the bridge chip itself (BLREQ\_, BLGNT\_). The signals BLREQ\_ and BLGNT\_ are routed from and to the PCI master block 123. The bridge chip asserts the signal BLREQ\_ if a transaction from the CPU 14 targeted for the secondary PCI bus 32 is received by the upstream and downstream bridge chips 26 and 48. The request and grant lines REQ [1]\_ and GNT [1]\_ for the SIO 50 are routed internally in the downstream bridge chip 48. The PCI arbiter 124 inserts a PCICLK2 delay between negation of a GNT\_ signal for one master and the assertion of a GNT\_ signal for another master.

In the downstream bridge chip 48, the PCI arbiter 124 is enabled or disabled based on the sampled value of REQ [7]\_ at the rising edge of the signal PCIRST2\_. If the bridge chip 48 samples REQ [7]\_ low on PCIRST2\_, it will disable the PCI arbiter 124. If the PCI arbiter 124 is disabled, then an external arbiter (not shown) is used and the hot plug request is driven out on the REQ [1]\_ pin and hot plug grant is input on the GNT [1]\_ pin. The bridge PCI bus request is driven out on the REQ [2]\_ pin and its grant is input on the GNT [2]\_ pin. If the bridge chip 48 samples REQ [7]\_ high on PCIRST2\_, it will enable the PCI arbiter 124.

The PCI arbiter 124 negates a master's GNT\_ signal either to service a higher priority initiator, or in response to the master's REQ\_ signal being negated. Once its GNT\_ signal is negated, the current bus master maintains ownership of the bus until the bus returns to idle.

If no PCI agents are currently using or requesting the bus, the PCI arbiter 124 does one of two things depending on the value of a PARKMSTRSEL configuration register in the configuration space 125. If the register contains the value 0, the PCI arbiter 124 uses the last active master to park on the bus 32; if it contains the value 1, then the bus is parked at the bridge chip 48.

The PCI arbiter 124 includes a PCI minimum grant timer 304 (FIG. 21) which controls the minimum active time of all the GNT\_ signals. The default value for the timer 304 is the hexadecimal value 0000 which indicates that there is no minimum grant time requirement. The timer 304 can be programmed with a value from 1 to 255, to indicate the

number of PCICLK2 clock periods the GNT\_ line is active. Alternatively, an individual minimum grant timer can be assigned to each PCI master on the secondary bus 32 to provide more flexibility. The minimum grant time is applicable only when the current master is asserting its REQ\_ signal. Once the REQ\_ signal is deasserted, the GNT\_ signal can be removed regardless of the minimum grant time value.

Referring to FIG. 20A, in normal operation, the PCI arbiter 124 implements a round-robin priority scheme (second level arbitration scheme). The eight masters in the round-robin scheme include devices connected to the six slots of the expansion box 30, the SIO 50, and a posted memory write (PMW) request from the upstream bridge chip 26. All masters on the PCI bus 32 in this scheme have the same priority as the bridge chip 48. After a master has been granted the secondary PCI bus 32 and the master has asserted the FRAME\_ signal, the bus is re-arbitrated and the current master is put on the bottom of the round-robin stack. If the master negates its request or the minimum grant timer 304 expires, the PCI bus 32 is granted to the next highest priority master. Locked cycles are not treated any differently by the PCI arbiter 124.

In response to certain events, the arbitration scheme is modified to optimize system performance. The events include: 1) an upstream-to-downstream delayed read or delayed write request is pending, 2) a downstream-to-upstream delayed read request is pending with no read completion indication provided, and 3) a streaming possibility exists while the bridge chip 26 is the current master on the upstream bus 24.

When a delayed request is detected, the bridge chip 48 becomes the next master to be granted the secondary PCI bus 32. Once the bridge chip 48 is granted the bus 32, it maintains ownership of the bus 32 until it completes all outstanding delayed requests or one of its cycles is retried. If the bridge chip 48 is retried, then a two-level arbitration scheme is implemented by the arbiter 124. One primary cause of the bridge chip read cycle being retried is that the target device is a bridge with a posted write buffer that needs to be flushed. In this case, the optimum operation is to grant the bus 32 to the retrying target to allow it to empty its posted write buffer so it can accept the bridge chip read request.

Referring to FIG. 20B, the two-level arbitration protocol includes a first level arbitration scheme which is a round-robin scheme among three possible masters: the delayed request from the CPU 14, a request from the retrying master, and a master selected by the second-level arbitration scheme. Each of the three masters in the first-level arbitration scheme is guaranteed every third arbitration slot. For memory cycles, the slot associated with the retrying target can be determined from target memory range configuration registers in the configuration space 125 of the bridge chip 48, which store the memory range associated with each PCI device. If the retrying master cannot be determined (as in the case of an I/O read), or if the retrying master is not requesting the secondary bus 32, then the first level arbitration scheme would be between the bridge chip 48 and a level-two master.

The retrying master is not masked from the level-two arbitration. Thus, it is possible for it to have two back-to-back arbitration wins if it is the next master in the level-two arbitration scheme.

For example, if an upstream-to-downstream read is retried and Master C (the retrying master) is requesting the bus 32

as well as Master B and Master E, the order of the bus grants would be as follows in descending order: the bridge chip 48, the retrying master (Master C), Master C, the bridge chip 48, the retrying master C, Master E, the bridge chip 48, and so forth, until the bridge chip 48 is able to complete its transaction and the PCI arbiter 124 reverts back to its level-two arbitration scheme for normal operation.

If, as another example, the bridge chip read is retried and the only other requesting masters are Master A and Master D (i.e., the retrying master is not requesting the bus or it could not be identified because it is accessing I/O space), the order of the bus grants is as follows: the bridge chip 48, Master A, the bridge chip 48, Master D, and so forth.

The two-level arbitration scheme gives delayed requests from the CPU 14 the highest priority. Although this arbitration method favors heavily the CPU 14, every requesting device on the bus 32 is eventually granted the PCI bus 32. By so doing, there is less chance that the other secondary bus masters would be starved when a PCI bridge chip request is retried.

Referring to FIG. 21, the PCI arbiter 124 includes an L2 state machine 302 to implement the level-two round-robin arbitration scheme. The L2 state machine 302 receives signals RR\_MAST [2:0], which indicate the current round-robin master. The L2 state machine 302 also receives request signals RR\_REQ [7:0], corresponding to the 8 possible masters of the secondary PCI bus 32. Based on the current master and the state of the request signals, the L2 state machine 302 generates a value representing the next round-robin master. The output of the L2 state machine 302 is provided to the 0 input of a 6:3 multiplexer 306, whose 1 input receives signals Q2A\_STRMAST [2:0]. The select input of the multiplexer 306 receives a signal STREAM\_REQ, which is asserted high by an AND gate 308 when a streaming opportunity exists (Q2A\_STREAM is high), the streaming master on the secondary PCI bus 32 is asserting its request line (MY\_REQ [Q2A\_STRMAST [2:0]] is high), and a delayed request is not pending (BAL\_DEL\_REQ is low).

The output of the multiplexer 306 drives signals N\_RR\_MAST [2:0] which represent the next round-robin master in the level-two arbitration scheme. The signals N\_RR\_MAST [2:0] are received by an L1 state machine 300, which also receives the following signals: a signal RTRYMAST\_REQ (which represents the request of the retrying bus master); a signal MIN\_GRANT (which is asserted when the minimum grant timer 304 times out); the delayed request signal BAL\_DEL\_REQ; the stream request signal STREAM\_REQ; a signal CURMAST\_REQ (indicating that the current master is maintaining assertion of its request signal); a signal ANY\_SLOT\_REQ (which is asserted high if any of the request signals REQ [7:1] is asserted, but not including the bridge chip request BLREQ, which is asserted); and signals L1STATE [1:0] (which represent the current state of the L1 state machine 300). The L1 state machine 300 selects one of the three possible L1 masters, including the retrying master (RTRYMAST\_REQ), the delayed request from the bridge chip 48 (BAL\_DEL\_REQ), and the level-two master (ANY\_SLOT\_REQ).

The retrying master request signal RTRYMAST\_REQ is generated by an AND gate 312, which receives the signal BAL\_DEL\_REQ, the signal MY\_REQ [RTRY\_MAST [2:0]] (which indicates if the retrying master is asserting its request), and the output of an OR gate 310. The inputs of the OR gate 310 receive the signals RTRY\_MAST [2:0]. Thus, if a retrying master has been identified (RTRY\_MAST [2:0]

is non-zero), a delayed request is present (BAL\_DEL\_REQ is high), and the retrying master has asserted its request, then the signal RTRYMAST\_REQ is asserted.

The L1 state machine 300 generates signals N\_L1STATE [1:0] (representing the next state of the L1 state machine 300), as well as signals N\_CURMAST [2:0] (representing the next master according to the level-two arbitration scheme). The L1 state machine 300 also generates a signal OPEN\_WINDOW, which indicates when a re-arbitration window exists for a grant state machine 306 to change masters on the secondary PCI bus 32. A signal ADV\_RR\_MAST provided by the L1 state machine 300 indicates to the grant state machine 306 when to load the value of the signals N\_RR\_MAST [2:0] into the signals RR\_MAST [2:0] to advance the next level-two round-robin master.

The grant state machine 306 outputs grant signals GNT [7:0] as well as a signal CHANGING\_GNT to indicate that ownership of the bus 32 is changing. The grant signals GNT [7:1] are inverted from the GNT [7:1] signals, and the grant signal BLGNT is inverted from the GNT [0] signal. The grant state machine 306 also generates signals L1STATE [1:0] and signals RR\_MAST [2:0].

The minimum grant timer 304 is clocked by the signal PCLK and generates the signal MIN\_GRANT. The minimum grant timer 304 also receives the signal CHANGING\_GNT and NEW\_FRAME (indicating a new FRAME signal has been asserted). The initial value of the minimum grant timer 304 is loaded as a value {CFG2A\_MINGNT [3:0], 0000}, with the signals CFG2A\_MINGNT [3:0] being stored configuration bits in the configuration space 125 which define the initial value of the minimum grant timer 304. The minimum grant timer 304 is re-loaded after it has counted down to zero and the signal CHANGING\_GNT is asserted high. After the minimum grant timer 304 is loaded with a new value, it begins decrementing when the signal NEW\_FRAME is asserted high and the signal CHANGING\_GNT is deasserted low by the grant state machine 306, which indicates that a new transaction has started on the PCI bus 32.

Signals MY\_REQ [7:1] are generated by a NOR gate 314, whose inputs receive the request signals REQ [7:1] and mask signals Q2AMASKREQ [7:1]. Assertion of the mask bit Q2AMASKREQ [X], X=1-7, masks the request REQ [X] of the corresponding master, which prevents the PCI arbiter 124 from responding to the request signal. A signal MY\_REQ [0] is driven by an inverter 316, which receives the bridge request BLREQ.

Referring to FIG. 22 the grant state machine 306 includes four states: PARK, GNT, IDLE4GNT, and IDLE4PARK. On assertion of a reset signal RESET (generated from the PCI reset signal PCIRST2), the grant state machine 306 enters state PARK, where it remains while a signal ANY\_REQ is deasserted. The signal ANY\_REQ is asserted high if any of the request lines to the PCI arbiter 124 is asserted. In the PARK state, the PCI-PCI bridge 48 is parked as the owner of the PCI bus 32 when another request is not present.

If the signal ANY\_REQ is asserted, the grant state machine 306 transitions from state PARK to state IDLE4GNT, and the signal CHANGING\_GNT is asserted high to indicate that the PCI arbiter 124 is changing masters. The grant signals GNT [7:0] are cleared to all zeros, and the signals CURMAST [2:0] are updated with the value of the next master N\_CURMAST [2:0]. In addition, the round-robin master signals RR\_MAST [2:0] are updated with the next round-robin master value N\_RR\_MAST [2:0] if the signal ADV\_RR\_MAST is asserted by the L1 300. The

signal `ADV_RR_MAST` when high indicates that the next L1 master is one of the L2 masters.

From state `IDLE4GNT`, the grant state machine **306** next transitions to the `GNT` state, and the signals `GNT [7:0]` are set to the state of new grant signals `NEWGNT [7:0]` and the signal `CHANGING_GNT` is negated low. The signals `NEWGNT [7:0]` are based on the state of the current master signals `CURMAST [2:0]`, as shown in FIG. 24.

From state `GNT`, three transitions are possible. The grant state machine **306** returns to the `PARK` state if an arbitration window is open (`OPEN_WINDOW` is high), no request is pending (`ANY_REQ` is low), the PCI bus **32** is idle (`BUS_IDLE` is high), and the next master is the current master (i.e., the current master is the parking master). In the transition back from the `GNT` state to the `PARK` state, the signals `L1STATE [1:0]` are updated with the signals `N_L1STATE [1:0]`. However, if no requests are pending and the bus is idle, but the current master is not the parking master (i.e., the signals `N_CURMAST [2:0]` are not equal to the value of the signals `CURMAST [2:0]`), an idle state is needed and the grant state machine **306** transitions from the `GNT` state to the `IDLE4PARK` state. The L1 state values `L1STATE [1:0]` are updated. From the `IDLE4PARK` state, the grant state machine **306** transitions to the `PARK` state, setting the grant signals `GNT [7:0]` equal to the new grant signals `NEWGNT [7:0]` to grant the PCI bus **32** to the new master. The signal `CHANGING_GNT` is also negated low.

If the arbitration window opens up (`OPEN_WINDOW` is high), and the next master is not the current master (the signals `N_CURMAST [2:0]` are not equal to the signals `CURMAST [2:0]`), then the grant state machine **306** transitions to the idle state `IDLE4GNT` to change bus master grants. In the transition, the signal `CHANGING_GNT` is asserted high, the signals `GNT [7:0]` are cleared to all zeros, the signals `CURMAST [2:0]` are updated with the next master value `N_CURMAST [2:0]`, and the L1 state signals `L1STATE [1:0]` are updated with the next state value `N_L1STATE [1:0]`. In addition, the round-robin master signals `RR_MAST [2:0]` are updated with the next round-robin master `N_RR_MAST [2:0]` if the signal `ADV_RR_MAST` is asserted high. The grant signals `GNT [7:0]` are then assigned to the value `NEWGNT [7:0]` in the transition from the `IDLE4GNT` state to the `GNT` state.

Referring to FIG. 23, the L1 state machine **300** (FIG. 21) starts in state `RR` upon assertion of the `RESET` signal, where the state machine **300** remains while a delayed request signal `BAL_DEL_REQ` is negated low (indicating there is no delayed request pending). While in the `RR` state, the signal `ADV_RR_MAST` is asserted high to allow the grant state machine **306** to update the round-robin master (i.e., setting signals `RR_MAST [2:0]` equal to the value `N_RR_MAST [2:0]`). The `RR` state is the round-robin state in which the level-two arbitration scheme is used. While in the `RR` state, the next master signals `N_CURMAST [2:0]` are set equal to the next round-robin master `N_RR_MAST [2:0]`, and the signal `OPEN_WINDOW` is set high if a stream request opportunity exists (`STREAM_REQ` is high), or the minimum grant timer **304** has expired (`MIN_GRANT` is high), or the current master has negated its request (`CURMAST_REQ` goes low). When asserted high, the signal `OPEN_WINDOW` allows a new arbitration to take place.

If a delayed request is detected (`BAL_DEL_REQ` goes high), the L1 state machine **300** transitions from the `RR` state to the `BAL` state, setting the next master state `N_CURMAST [2:0]` as the bridge chip **48** and deasserting the signal `ADV_RR_MAST` to disable the level-two

round-robin arbitration. In the `BAL` state, the signal `OPEN_WINDOW` is asserted high if the delayed request is deasserted (`BAL_DEL_REQ` goes low) or the delayed request has been retried (`BAL_RETRIED` goes high). If the signal `BAL_DEL_REQ` is negated low, or if the delayed request `BAL_DEL_REQ` is asserted high but the retrying master request is negated low (`RTRYMAST_REQ` is low) and the slot request `ANY_SLOT_REQ` is asserted high, then the L1 state machine **300** transitions back to the `RR` state. In the transition, the signal `ADV_RR_MAST` is asserted high and the next master signals `N_CURMAST [2:0]` are set equal to the next round-robin master `N_RR_MAST [2:0]`. If the signal `BAL_DEL_REQ` is deasserted, that indicates that the arbiter **124** should revert back to the level-two round-robin scheme. If the delayed request signal is asserted but the retrying master request is negated, then the level-one arbitration scheme is between the slots on the PCI bus **32** and the bridge chip **48**.

If both the delayed request `BAL_DEL_REQ` and the retrying master request `RTRYMAST_REQ` are asserted, then the L1 state machine **300** transitions from state `BAL` to state `RETRY_MAST`, and the retrying master is set as the next master (`N_CURMAST [2:0]` is set equal to `RTRYMAST [2:0]`). The signal `ADV_RR_MAST` is maintained low. In the `RETRY_MAST` state, if none of the PCI slot masters are asserting a request (`ANY_SLOT_REQ` is low), then the level-one arbitration scheme is between the retrying master and the bridge chip **48**, and the L1 state machine **300** transitions back to the `BAL` state. The bridge chip **48** is set as the next master (`N_CURMAST [2:01]` is equal to the state `BALBOA`), and the signal `ADV_RR_MAST` is maintained low. However, the L1 state machine **300** transitions from the `RETRY_MAST` state to the `RR` state if any one of the slot masters is asserting a request (`ANY_SLOT_REQ` is high). In the transition, the signal `ADV_RR_MAST` is asserted high, and the next round robin master is set as the next master (`N_CURMAST [2:0]` is set equal to `N_RR_MAST [2:0]`).

To take advantage of the streaming capabilities of the bridge chip, when data for a DRC starts arriving from the cable **28**, the master associated with that DRC becomes the highest priority device (assuming its `REQ_` is asserted). This allows the master to receive the data stream coming down the cable **28** while the window of opportunity is there for streaming. If the bridge chip **48** cannot connect the master before the DRC queue fills up, then the upstream bridge chip **24** will disconnect and only a portion of the data would be passed to the requesting master, necessitating the master to issue another read request on the upstream bus **24**. The streaming master retains the highest priority as long as DRC data continues to arrive from the cable **28**. If the master repeats a different cycle/address, it will be retried, but it will maintain ownership of the secondary PCI bus **32** until its request goes away or the opportunity for streaming passes.

#### Retrying Requests and Multi-Threaded Masters

Since each bridge chip is a delayed transaction device, if a device on the downstream bus **32** issues a read request destined for an upstream target, the downstream bridge chip **48** will issue a retry transaction (described in the PCI specification) on the secondary bus **32** and forward the request up the cable **28**. The retry transaction causes the requesting master to give up control of the PCI bus **32** and negate its `REQ_` line. After negating its `REQ_` line, the retried master will re-assert a request for the same cycle at a later time, which may result in its `GNT_` being asserted (if its `REQ_` line is not masked) and the bus master being

retried again until the read completion indication is asserted in the downstream bridge chip 48.

Referring to FIG. 25, to avoid the unnecessary servicing of retry requests, the REQ\_ line of a secondary bus master which issues a retried delayed read or write request is masked by asserting the appropriate one of signals Q2A\_MASK\_REQ [7:1] (requests from the bridge chip 48 which are retried are not masked) until the delayed completion returns. In this fashion, other requesting masters are given priority to get their requests in. As soon as the first information associated with the delayed completion is returned, the REQ\_ line of the corresponding master is unmasked and the retried master is able to enter arbitration again.

However, a special case exists for multi-threaded (or multi-headed) masters on the downstream bus 32 (FIG. 26B), which are able to assert a first request, get retried, and come back with a different request. One such multi-threaded bus device is a PCI-PCI bridge 323 connecting the secondary PCI bus 32 and a subordinate PCI bus 325. The bus 325 is connected to network interface cards (NICs) 327A and 327B which are connected to two different networks. Thus, if the request from the NIC 327A for the primary PCI bus 32 is retried by the bridge chip 48, the NIC 327B can generate a different request. In this case, the REQ\_ lines of the multi-threaded masters are not masked, as indicated by the signal CFG2Q\_MULTI\_MASTER [X] being set high.

A status register 326 determines if a slot is single- or multi-threaded. On reset, the register 326 is cleared to assume that each secondary bus device is single-threaded. Each slot is then monitored to determine if it requests a different cycle while another cycle from the same master is pending. If multi-threaded behavior is observed in a master, then that master is marked as such by setting the corresponding bit CFG2Q\_MULTI\_MASTER [X] high.

The input of the status register 326 is connected to the output of a 14:7 multiplexer 328, whose 0 input is connected to the output of a 14:7 multiplexer 330 and whose 1 input is connected to address bits P2Q\_AD [22:16]. A select signal CFGWR\_MM selects the 0 and 1 inputs of the multiplexer 328. When asserted high, the signal CFGWR\_MM causes a configuration write of the status register 326 from the data bits P2Q\_AD [22:16], allowing software control of the bits in the register 326. The 1 input of the multiplexer 330 receives multi-master signals MULTI\_MASTER [7:1], the 0 input receives the output of the register 326, and the multiplexer 330 is selected by a signal MULTI\_SEL. The signal MULTI\_SEL is generated by an AND gate 338, whose first input receives a signal Q2PIF\_CHECK\_CYC (asserted high to indicate that the current transaction information should be checked with information stored in the queue block 127 for a match, such as during a delayed memory read or write request from a bus device on the secondary PCI bus 32), and the other input receives the inverted state of a signal DCQ\_HIT (indicating that the current address information does not match the address information associated with a pending request of the requesting master in the DCQ 148). Thus, if a failed comparison occurred, the value of signals CFG2Q\_MULTI\_MASTER [7:1] is updated.

A bit MULTI\_MASTER [X] is asserted high if master X has a pending request that has been retried, and master X subsequently comes back with a different request. This is checked by comparing the transaction information (e.g., address, byte enables, data for a write) of the pending request with the address of the new request. A failed comparison indicates that the master is multi-threaded. Once

a multi-master configuration bit CFG2Q\_MULTI\_MASTER [X] (X=1-7) is set high, the bit is maintained high.

The signals MULTI\_MASTER [7:1] are generated by a decoder 336. The decoder 336 receives signals Q2PIF\_SLOT [2:0] (slot number for the current delayed request from a master), Q [7:0]\_MASTER [2:0] (the master associated with each of the eight buffers in the DCQ 148), Q [7:0]\_COMPLETE (the completion status of each of the eight queues), and Q [7:0]\_PART\_COMPLETE (the partial completion status of each of the buffers in the delayed completion queue). For example, if the signal QO\_MASTER [2:0] contains the value 4, then that indicates DCQ buffer 0 stores the transaction information of a delayed request from the bus device in slot 4. The signal QY\_COMPLETE, Y=0-7, if asserted high indicates if DCQ buffer Y has received all the data associated with delayed request transaction. The signal QY\_PART\_COMPLETE, Y=0-7, if asserted high indicates that DCQ buffer Y has been allocated as the DCQ buffer for a delayed transaction of one of the masters but all the data associated with the delayed transaction has not been received.

If the current slot number Q2PIF\_SLOT [2:0] is equal to the value of any one of the eight queue master indication signals Q [7:0]\_MASTER [2:0], and the corresponding DCQ buffer is in the complete or part complete state, then the corresponding one of the bits MULTI\_MASTER [7:1] is set high if the signal DCQ\_HIT is low and the signal Q2PIF\_CHECK\_CYC is high. Thus, for example, if the signal Q2PIF\_SLOT [2:0] contains the value 2, indicating that the device in slot 2 is the current master of the delayed request, and DCQ buffer 5 is storing a pending request for the slot 2 master (Q5\_MASTER [2:0] =5), and either of signals Q5\_COMPLETE or Q5\_PART\_COMPLETE is high, and if the signal Q2PIF\_CHECK\_CYC is high and the signal DCQ\_HIT is low, then the bit MULTI\_MASTER [2] is set high to indicate that the slot 2 device is a multi-threaded master.

A mask request generation block 332 produces signals Q2A\_MASK\_REQ [X] (X=1-7) in response to signals Q [7:0]\_MASTER [2:0], Q [7:0]\_STATE [3:0]) (which indicates the state of delayed completion queues 0-7), SLOT\_WITH\_DATA [7:0] (which indicate if delayed completion Qs 0-7 contain valid data), CFG2Q\_MULTI\_MASTER [X] (X=1-7), CFG2Q\_ALWAYS\_MASK, and CFG2Q\_NEVER\_MASK.

Referring to FIG. 26A, the mask request generation block 332 includes a 2:1 multiplexer 320 for producing the signal Q2A\_MASK\_REQ [X] (X=1-7). The 1 input of the multiplexer 320 is connected to the output of an OR gate 322 and the 0 input is tied low. The select input of the multiplexer 320 is driven by a signal MASK\_MUXSEL. One input of the OR gate 322 is connected to the output of a NOR gate 324, which receives a signal CFG2Q\_MULTI\_MASTER [X] (indicating a multi-threaded master), and the other input receives a signal CFG2Q\_NEVER\_MASK (a configuration bit indicating that the request line should not be masked if a multi-threaded master is detected). The other input of the OR gate 322 receives a signal CFG2Q\_ALWAYS\_MASK, which is a configuration bit indicating that the corresponding mask bit Q2A\_MASK\_REQ [X] should always be masked if the signal MUXSEL is asserted high. The signal MASK\_MUXSEL is asserted high if the request from the secondary bus master is not to data already existing in the queue block 127, i.e., the request must be transmitted to the primary PCI bus 24. Thus each time a request is transmitted from a device on the secondary PCI bus 32 upstream to the primary PCI

bus 24, a check is performed on bits CFG2Q\_MULTI\_MASTER [7:1] to determine if a multi-threaded master has been detected.

The masking of requests can be overridden by setting the appropriate bits in the configuration registers 125. The available modes include: 1) normal mode in which request masking is enabled except if multi-threaded master (CFG2Q\_NEVER\_MASK=0, CFG2Q\_ALWAYS\_MASK=0), 2) always mask mode in which requests from retried masters are masked even if multi-threaded (CFG2Q\_ALWAYS\_MASK=1), and 3) never mask mode in which the requests are never masked (CFG2Q\_NEVER\_MASK=1, CFG2Q\_ALWAYS\_MASKED =0).

Expansion Card Insertion and Removal Connecting Expansion Cards

As shown in FIGS. 1 and 27A, the two expansion boxes 30a and 30b, of common design 30, each have the six hot-plug slots 36 (36a-f) in which the conventional expansion cards 807 can be inserted and removed (hot-plugged) while the computer system 10 remains powered up. The six mechanical levers 802 are used to selectively secure (when closed, or latched) the expansion cards 807 that are inserted into corresponding hot-plug slots 36. For purposes of removing or inserting the expansion card 807 into one of the slots 36, the corresponding lever 802 must be opened, or unlatched, and as long as the lever 802 is opened, the corresponding slot 36 remains powered down.

When the lever 802 that secures the expansion card 807 to its slot 36 is opened, the computer system 10 senses this occurrence and powers down the card 807 (and corresponding slot 36) before the card 807 can be removed from its slot 36. Slots 36 that are powered down, like other slots 36 not holding cards 807, remain powered down until software of the computer system 10 selectively powers up the slots 36.

The card 46 inserted into the card slot 34 has the bridge chip 48 that monitors the securement status (open or closed) of the levers 802 and powers down any card 807 (and corresponding slot 36) that is not secured by its lever 802. Software of the computer system 10 can also selectively power down any one of the slots 36.

The cards 807 are powered up through a power up sequence and powered down through a power down sequence. In the power up sequence, power is first supplied to the card 807 being powered up, and thereafter, a PCI clock

signal (from the PCI bus 32) is furnished to the card 807 being powered up. Remaining PCI bus signal lines of the card 807 are then coupled to corresponding lines of the PCI bus 32. Lastly, the reset signal for the card 807 being powered up is negated which brings the card 807 out of reset.

The power up sequence allows the circuitry of the card 807 being powered up to become fully functional with the PCI clock signal before the remaining PCI bus signals are provided. When the clock signal and remaining PCI bus signals are connected to the card 807 and before the card 807 is reset, the bridge chip 48 has control of the PCI bus 32. Because the bridge chip 48 has control of the PCI bus 32 during these times, potential glitches on the PCI bus 32 from the power up sequence do not disturb operations of the cards 807 that are powered up.

In the power down sequence, the card 807 being powered down is first reset. Next, the PCI bus signals, excluding the PCI clock signal, are removed from the card 807. The bridge chip 48 subsequently disconnects the PCI clock signal from the card 807 before power from the card 807 is removed. The power down sequence minimizes the propagation of false signals from the card 807 being powered down to the bus 32 because circuitry on the card 807 remains fully functional until the PCI bus signal lines are removed.

When the PCI clock signal and remaining PCI bus signals are disconnected, and when the card 807 is reset, the bridge chip 48 has control of the PCI bus 32. Because the bridge chip 48 has control of the PCI bus 32 during these times, potential glitches on the PCI bus 32 from the power down sequence do not disturb operations of the cards 807 that are powered up.

The bridge chip 48 includes the Serial Input/Output (SIO) circuit 50 which controls the power up and power down sequences of the slots 36 through twenty-four control signals POUT [39:16]. The control signals POUT [39:16] are a subset of forty output control signals POUT [39:0] generated by the SIO circuit 50. The control signals POUT [39:16] are latched versions of slot bus enable signals BUSEN#[5:0], slot power enable signals PWREN [5:0], slot clock enable signals CLKEN#[5:0] and slot reset signals RST#[5:0], all internal signals of the SIO circuit 50, further described below. The control signals POUT [39:0] and their relationship to the signals BUSEN#[5:0], PWREN [5:0], CLKEN#[5:0] and RST#[5:0] are described in the following table:

PARALLEL OUTPUT CONTROL SIGNALS (POUT[39:0])

SIGNAL POSITION	DESCRIPTION	ASSOCIATED CONTROL SIGNALS	WHEN SIGNAL IS ACTIVE
0-11	Control signals for LEDs 54		
12-15	General purpose output signals	GPOA[3:0]	
16	Reset signal for slot 36a	(RST#[0])	Low
17	Reset signal for slot 36b	(RST#[1])	Low
18	Reset signal for slot 36c	(RST#[2])	Low
19	Reset signal for slot 36d	(RST#[3])	Low
20	Reset signal for slot 36e	(RST#[4])	Low
21	Reset signal for slot 36f	(RST#[5])	Low
22	Clock enable signal for slot 36a	(CLKEN#[0])	Low
23	Clock enable signal for slot 36b	(CLKEN#[1])	Low
24	Clock enable signal for slot 36c	(CLKEN#[2])	Low
25	Clock enable signal for slot 36d	(CLKEN#[3])	Low
26	Clock enable signal for slot 36e	(CLKEN#[4])	Low
27	Clock enable signal for slot 36f	(CLKEN#[5])	Low
28	Bus enable signal for slot 36a	(BUSEN#[0])	Low

## PARALLEL OUTPUT CONTROL SIGNALS (POUT[39:0])

SIGNAL POSITION	DESCRIPTION	ASSOCIATED CONTROL SIGNALS	WHEN SIGNAL IS ACTIVE
29	Bus enable signal for slot 36b	(BUSEN#[1])	Low
30	Bus enable signal for slot 36c	(BUSEN#[2])	Low
31	Bus enable signal for slot 36d	(BUSEN#[3])	Low
32	Bus enable signal for slot 36e	(BUSEN#[4])	Low
33	Bus enable signal for slot 36f	(BUSEN#[5])	Low
34	Power enable signal for slot 36a	(PWREN[0])	High
35	Power enable signal for slot 36b	(PWREN[1])	High
36	Power enable signal for slot 36c	(PWREN[2])	High
37	Power enable signal for slot 36d	(PWREN[3])	High
38	Power enable signal for slot 36e	(PWREN[4])	High
39	Power enable signal for slot 36f	(PWREN[5])	High

As shown in FIGS. 2 and 28, each hot-plug slot 36 has the associated switch circuitry 41 for connecting and disconnecting the slot 36 to and from the PCI bus 32. The switch circuitry 41 for each slot 36 receives four of the control signals POUT [39:16]. As an example, for the slot 36a, when the control signal POUT [28] is asserted, or low, the slot 36a is connected to the bus signal lines of the PCI bus 32 by a switch circuit 47. When the control signal POUT [28] is deasserted, or high, the slot 36a is disconnected from the bus signal lines of the PCI bus 32.

When the control signal POUT [22] is asserted, or low, the slot 36a is connected to a PCI clock signal CLK through a switch circuit 43. When the control signal POUT [22] is deasserted, or high, the slot 36a is disconnected from the clock signal CLK.

When the control signal POUT [34] is asserted, or high, the slot 36a is connected to a card voltage supply level  $V_{SS}$  through a switch circuit 45. When the control signal POUT [34] is deasserted, or low, the slot 36a is disconnected from the card voltage supply level  $V_{SS}$ .

When the control signal POUT [16] is asserted, or low, the slot 36a is reset and when the control signal POUT [16] is deasserted, or high, the slot 36a comes out of the reset state.

As seen in FIG. 2, the SIO circuit 50 may selectively monitor up to one hundred twenty-eight (sixteen bytes) of latched status signals STATUS [127:0] furnished by the expansion box 30. The status signals STATUS [127:0] form a "snapshot" of selected conditions of the expansion box 30. The status signals STATUS [127:0] include six status signals STATUS [127:0] which indicate the securement status (opened or closed) of each of the levers 802. The SIO circuit 50 monitors the status signals STATUS [31:0] for changes in their logical voltage levels. The SIO circuit 50 serially shifts the status signals STATUS [127:32] into the SIO circuit 50 when instructed to do so by the CPU 14.

The SIO circuit 50 serially receives the status signals STATUS [127:0], least significant signal first, via a serial data signal NEW\_CSID. The data signal NEW\_CSID is furnished by the serial output of the thirty-two bit, parallel input shift register 82 located on board the expansion box 30 along with the slots 36.

The register 82, through its parallel inputs, receives twenty-four parallel status signals PIN [23:0], four associated with each of the hot-plug slots 36, that are included in the thirty-two least significant status signals STATUS [31:0]. When the status indicated by one or more of the status signals STATUS [31:0] changes (the logical voltage level changes), the bridge chip 48 generates an interrupt request

to the CPU 14 by asserting, or driving low, a serial interrupt request signal SI\_INTR# which is received by the interrupt receiving block 132. The status signals PIN [23:0] include two PCI card presence signals (PRSNT1# and PRSNT2#) associated with each slot 36.

Six status signals PIN [5:0], corresponding to their latched versions, status signals STATUS [5:0], indicate the securement, or engagement, status (open or closed) of each the levers 802. Six sliding switches 805 (FIGS. 27A–27C) are actuated by the movement of their corresponding levers 802 and are used to electrically indicate the securement status of the corresponding lever 802. Each switch 805 has a first terminal coupled to ground and a second terminal furnishing the corresponding one of the status signals PIN [5:0]. The second terminal is coupled to a supply voltage level VDD through one of six resistors 801.

If one of the levers 802 opens and the card 807 secured by the lever 802 becomes unsecured, the corresponding one of the status signals PIN [5:0] is asserted, or driven high. As an example, for the slot 36a, the status signal PIN [0] is deasserted, or driven low, when the corresponding lever 802 is closed. When the lever 802 for the slot 36a is opened, the status signal PIN [0] is asserted, or driven high.

The register 82 also receives a serial stream of latched status signals STATUS [127:32] that do not cause interrupts when the logical voltage level of one of the signals STATUS [127:32] changes. The status signals STATUS [127:32] are formed by the sixteen bit shift register 52 located on board the expansion box 30 with the slots 36. The shift register 52 receives status signals at its parallel inputs and latches the status signals STATUS [127:32] when instructed to do so by the SIO circuit 50. The shift register 52 serializes the status signals STATUS [127:32] and furnishes the signals STATUS [127:32] to the serial input of the register 82 via a serial data signal CSID\_I.

When instructed by the SIO circuit 50, the register 82 latches status signals PIN [23:0], forms the status signals STATUS [31:0], furnishes the status signals STATUS [31:0] and furnishes a byte or more of the status signals STATUS [127:32] (when requested by the CPU 14), in a least significant signal first fashion, to the SIO circuit 50 via the serial data signal NEW\_CSID. The status signals STATUS [127:0] are described by the following table:



STATUS [127:0]	
BIT	DESCRIPTION
0	Lever 802 status signal for slot 36a (PIN[0])
1	Lever 802 status signal for slot 36b (PIN[1])
2	Lever 802 status signal for slot 36c (PIN[2])
3	Lever 802 status signal for slot 36d (PIN[3])
4	Lever 802 status signal for slot 36e (PIN[4])
5	Lever 802 status signal for slot 36f (PIN[5])
6	Reserved for lever 802 status signal for additional hot-plug slot
7	Reserved for lever 802 status signal for additional hot-plug slot
8	PRSNT2# signal for slot 36a (PIN[6])
9	PRSNT2# signal for slot 36b (PIN[7])
10	PRSNT2# signal for slot 36c (PIN[8])
11	PRSNT2# signal for slot 36d (PIN[9])
12	PRSNT2# signal for slot 36e (PIN[10])
13	PRSNT2# signal for slot 36f (PIN[11])
14	Reserved for PRSNT#2 signal for additional hot-plug slot 36
15	Reserved for PRSNT#2 signal for additional hot-plug slot 36
16	PRSNT1# signal for slot 36a (PIN[12])
17	PRSNT1# signal for slot 36b (PIN[13])
18	PRSNT1# signal for slot 36c (PIN[14])
19	PRSNT1# signal for slot 36d (PIN[15])
20	PRSNT1# signal for slot 36e (PIN[16])
21	PRSNT1# signal for slot 36f (PIN[17])
22	Reserved for PRSNT1# signal for additional hot-plug slot 36
23	Reserved for PRSNT1# signal for additional hot-plug slot 36
24	Power fault status for slot 36a (PIN[18])
25	Power fault status for slot 36b (PIN[19])
26	Power fault status for slot 36c (PIN[20])
27	Power fault status for slot 36d (PIN[21])
28	Power fault status for slot 36e (PIN[22])
29	Power fault status for slot 36f (PIN[23])
30	Reserved for power fault status for additional hot-plug slot 36
31	Reserved for power fault status for additional hot-plug slot 36
32-127	Status signals that do not cause interrupt requests when their status changes

As shown in FIGS. 2 and 30, when the SIO circuit 50 asserts, or drives low, a register load signal CSIL\_O<sub>0</sub>, the shift register 52 latches the status signals STATUS [127:32] and the shift register 82 latches the status signals STATUS [31:0]. When the SIO circuit 50 negates, or drives high, the signal CSIL\_O<sub>0</sub>, both the registers 52 and 82 serially shift their data to the SIO circuit 50 on the positive edge of a clock signal CSIC\_O furnished by the SIO circuit 50. The clock signal CSIC\_O is synchronized to and one fourth the frequency of the PCI clock signal CLK.

As shown in FIG. 29, for purposes of monitoring, or scanning, the status signals STATUS [31:0], the SIO circuit 50 uses a thirty-two bit interrupt register 800 whose bit positions correspond to the signals STATUS [31:0]. The SIO circuit 50 updates the bits of the interrupt register 800 to equal the corresponding status signals STATUS [31:0] that have been debounced, as further described below. Two status signals STATUS [7:6] are reserved for additional hot-plug slots 36, and the seventh and eighth most significant bits of the interrupt register 800 are also reserved for the additional slots 36. The interrupt register 800 is part of a register logic block 808 of the SIO circuit 50 which is coupled to the PCI bus 32.

Serial scan input logic 804 of the SIO circuit 50 sequentially scans, or monitors, the status signals STATUS [31:0], least significant signal first, for changes, as indicated by transitions in their logical voltage levels. If the status of one or more of the status signals STATUS [5:0] associated with the levers 802 changes, the serial scan input logic 804 enters a slow scan mode such that the status signals STATUS [5:0]

are scanned thirty-two times within a predetermined debounce time interval. If one or more of the status signals STATUS [5:0] changes, the serial scan input logic 804 updates the interrupt register 800 (and asserts the serial interrupt signal SI\_INTR#) if the changed status signal STATUS [5:0] remains at the same logical voltage level for at least a predetermined debounce time interval. The serial scan input logic 804 is coupled to programmable timers 806 which generate and indicate the end of the debounce delay interval initiated by the serial scan logic 804. Requiring the status to remain stable for the debounce time interval minimizes the inadvertent powering down of one of the hot-plug slots 36 due to a false value (i.e., a "glitch") indicated by one of the status signals STATUS [5:0]. When all of the status signals STATUS [5:0] remain at the same logical voltage level for at least the debounce time interval, the serial scan input logic 804 then proceeds to once again scan all thirty-two status signals STATUS [31:0] in the faster scan mode.

If the serial scan input logic 804 detects a change in one of the status signals STATUS [31:6], the serial scan input logic 804 instructs the timers 806 to measure another debounce delay interval, subsequently asserts the serial interrupt signal SI\_INTR#, updates the interrupt register 800 with the signals STATUS [31:6] that have changed, and ignores further changes in the status signals STATUS [31:6] until the debounce time interval expires. After expiration of the debounce time interval, the serial scan input logic 804 proceeds to recognize changes in the thirty-two status signals STATUS [31:0].

When the serial interrupt signal SI\_INTR# is asserted, the CPU 14 subsequently reads the interrupt register 800, determines which (may be more than one) status signals STATUS [31:0] caused the interrupt, and deasserts the serial interrupt signal SI\_INTR# by writing a "1" to the bit or bits of the interrupt register 800 that have changed.

The CPU 14 may selectively mask interrupt requests caused by the status signals STATUS [31:0] by writing a "1" to a corresponding bit of a thirty-two bit interrupt mask register 810. The CPU 14 can also selectively read any byte of the status signals STATUS [47:0] by writing a byte number of the selected byte to a serial input byte register 812. The SIO circuit 50 then transfers the desired byte into a serial data register 815.

For example, to read the third byte (byte number two) of the status signals STATUS [23:16], the CPU 14 writes a "2" to the serial input byte register 812. The serial scan input logic 804 then serially shifts byte two of the status signals STATUS [23:16] into the serial data register 815. A busy status bit BS of the serial input byte register 812 is equal to "1" when the CPU 14 initially writes the desired byte number to the serial input byte register 812. The bit BS is cleared by the SIO circuit 50 after the requested byte has been shifted into the serial data register 815.

The CPU 14 can power up one of the slots 36 by writing a "1" to a corresponding bit of a slot enable register 817 and disable the slot 36 by writing a "0" to this bit. Furthermore, the CPU 14 can reset one of the slots 36 by writing a "1" to a corresponding bit of a slot reset register 819. The contents of the slot enable 817 and slot reset 819 registers are represented by signals SLOT\_EN [5:01] and SLOT\_RST [5:0], respectively.

To initiate the request indicated by the slot enable 817 and reset 819 registers, the CPU 14 writes a "1" to an SO bit of control register 814. After the SO bit is asserted (which asserts, or drives high, a GO\_UPDATE signal), the SIO

circuit **50** initiates and controls the required power down and/or power up sequences.

The serial scan input logic **804** is coupled to ON/OFF control logic **820** which controls the power up and power down sequences. The ON/OFF control logic **820** furnishes the signals **BUSEN#[5:0]**, **CLKEN#[5:0]**, **RST#[5:0]** and **PWREN [5:0]** to serial output logic **824**.

Each power up or power down sequence involves four shift phases during which another step of the power down or power up sequence is performed. During each shift phase, the ON/OFF control logic **820** instructs the serial output logic **824** to combine the control signals **BUSEN#[5:0]**, **CLKEN#[5:0]**, **RST#[5:0]** and **PWREN [5:0]**; latch these signals; and serially furnish these signals (via a serial data signal **CSOD\_O**) to the serial input of an output shift register **80**. At end of each shift phase, the ON/OFF control logic **820** instructs the shift register **80** to update the control signals **POUT [35:12]**.

The ON/OFF control logic **820** is also interfaced to the register logic **808** and Light Emitting Diode (LED) control logic **822**. The LED control logic **122** controls the on/off status of the six LEDs **54**, which visually indicate whether the corresponding levers **802** are latched or unlatched. The LEDs **54** can be programmed to blink when turned on through LED control registers (not shown) of the register logic **808**.

As shown in FIG. **31A**, the serial scan input logic **804** includes a scan state machine **840** which controls the scanning of the status signals **STATUS [31:0]** for changes and controls the shifting of a selected byte of the status signals **STATUS [47:0]** into the serial input byte register **815**.

The scan state machine **840** is clocked on the negative edge of a clock signal **DIV2CLK**, which is synchronized to a PCI clock signal **CLK** and one half of the frequency of the PCI clock signal **CLK**. The load and clock signals, **CSIL\_o\_** and **CSIC\_O**, respectively, are furnished by the scan state machine **840**. The clock signal, when enabled, is synchronized to the clock signal **CSIC\_O**.

A bit/byte counter **841**, through a thirty-two bit signal **BIT\_ACTIVE [31:0]**, indicates which bit of the status signals **STATUS [31:0]** is currently represented by the serial data signal **NEW\_CSID**. The asserted bit of the signal **BIT\_ACTIVE [31:0]** has the same bit position as the status signal **STATUS [31:0]** represented by the data signal **NEW\_CSID**.

The counter **841** also furnishes a three bit signal **BIT [2:0]** which represents which bit of the current byte of the status signals **STATUS [31:0]** is currently being scanned by the scan state machine **840**. The counter **841** is clocked on the negative edge of a signal **SHIFT\_ENABLE**. The outputs of the counter **841** are reset, or cleared, when the output of an AND gate **842**, connected to the clear input of the counter **841**, is negated.

The scan state machine **840** furnishes a signal **SCAN\_IN\_IDLE** which when asserted, or high, indicates that the scan state machine **840** is in an IDLE state and not currently scanning any of the status signals **STATUS [127:0]**. The signal **SCAN\_IN\_IDLE** is deasserted otherwise.

The signal **SCAN\_IN\_IDLE** is furnished to one input of the AND gate **842**. The other input of the AND gate **842** is connected to the output of an OR gate **843**. One input of the OR gate **843** receives an inverted **HOLD\_OFF** signal, and the other input of the OR gate **843** receives a signal **GETTING\_BYTE**.

The signal **HOLD\_OFF**, when asserted, or driven high, indicates that a change in one of the status signals **STATUS**

**[5:0]** has been detected, and the serial scan logic **804** has entered the slow scan mode. In the slow scan mode, the serial scan input logic **804** waits for a predetermined slow scan interval before traversing the status signals **STATUS [31:0]** again. The serial scan input logic **804** counts the number of times the serial scan signals **STATUS [5:0]** are scanned during the slow scan mode and uses this count to determine when one of the status signal **STATUS [5:0]** has remain unchanged for the debounce delay interval, as further described below.

Therefore, when the scan state machine **840** is in the IDLE state and the either the **HOLD\_OFF** signal is deasserted or the scan state machine **840** is reading in a selected byte (selected by the CPU **14**) of the status signals **STATUS [47:0]**, all outputs of the counter **841** are cleared, or set equal to zero.

The signal **SHIFT\_ENABLE** is furnished by the output of an AND gate **844**. One input of the AND gate **844** receives the clock signal **CSIC\_O**. Another input of the AND gate **844** receives a signal **DIV2CLK#**. The signal **DIV2CLK#** is asserted, or driven low, on the negative edge of the signal **CLKDIV4**. The third input of the AND gate **844** receives a signal **SCAN\_IN\_PROGRESS**, which when asserted, or driven high, indicates that the scan state machine **840** is currently scanning the status signals **STATUS [127:0]**, and the signal **SCAN\_IN\_PROGRESS** is deasserted otherwise.

Therefore, when the scan state machine **840** is not shifting in the status signals **STATUS [127:0]**, the counter **841** is disabled. Furthermore, when enabled, the counter **841** is clocked on the negative edge of the clock signal **DIV2CLK**.

The interrupt register **800** receives input signals **D\_INTR\_REG [31:0]** at its corresponding thirty-two inputs. The load enable inputs of the interrupt register **800** receive corresponding load enable signals **UPDATE\_IRQ [31:0]**. The interrupt register **800** is clocked on the positive edge of the PCI clock signal **CLK**.

For purposes of keeping track of the status signals **STATUS [5:0]** after each scan, a multi-bit, D-type flip-flop **836** furnishes status signals **SCAN\_SW [5:0]**. The clear input of the flip-flop **836** receives the reset signal **RST**, and the flip-flop **836** is clocked on the positive edge of the clock signal **CLK**. The input of the flip-flop **836** is connected to the output of a multi-bit OR gate **850** which has one input connected to the output of a multi-bit AND gate **846** and one input connected to the output of a multi-bit AND gate **847**. One input of the AND gate **846** receives six bit enable signals **BIT\_ENABLE [5:0]** (described below) and the other input of the AND gate **846** receives the serial data signal **NEW\_CSID**. One input of the AND gate **847** receives inverted bit enable signals **BIT\_ENABLE [5:0]**, and the other input of the AND gate **847** receives the signals **SCAN\_SW [5:0]**.

Only one of the bit enable signals **BIT\_ENABLE [5:0]** is asserted at one time (when the scan state machine **840** is scanning), and the asserted bit indicates which one of the corresponding status signals **STATUS [31:0]** is represented by the signal **NEW\_CSID**. Thus, when the scan state machine **840** is scanning, on every positive edge of the clock signal **CLK**, the signals **SCAN\_SW [5:0]** are updated.

The bit enable signals **BIT\_ENABLE [31:0]** are furnished by the output of a multi-bit multiplexer **832** that receives the bits **BIT\_ACTIVE [31:0]** at its one input. The zero input of the multiplexer **832** receives a thirty-two bit signal indicative of logic zero. The select input of the multiplexer **832** receives the signal **SHIFT\_ENABLE**.

For purposes of detecting a change in the status signals STATUS [5:0], a multi-bit, Exclusive Or (XOR) gate 848 furnishes switch change signals SW\_CHG [5:0]. When one of the signals SW\_CHG [5:0] is asserted, or high, the logical voltage of the corresponding status signal STATUS [5:0] changed during successive scans. One input of the XOR gate 848 is connected to the input of the flip-flop 836, and the other input of the XOR gate 848 receives the signals SCAN\_SW [5:0].

As shown in FIG. 31D, for purposes of indicating when the logical voltage level of a selected status signal STATUS [5:0] has remained at the logical voltage level for at least the duration of the debounce delay interval, the scan input logic 804 has six signals LSWITCH [5:0]. The non-inverting input of a D-type flip-flop 900 furnishes the signal LSWITCH [5] at its non-inverting output. The signal LSWITCH [5] is asserted, or driven high, to indicate the above-described condition and deasserted otherwise. The flip-flop 900 is clocked on the positive edge of the clock signal CLK, and the clear input of the flip-flop 900 receives the RST signal.

The input of the flip-flop 900 is connected to the output of a multiplexer 902 which furnishes a D\_LSWITCH [5] signal. The select input of the multiplexer 902 is connected to the output of an AND gate 903 that receives a MAX5 signal and a SCAN\_END signal. The SCAN\_END signal, when asserted, indicates the scan state machine 840 has completed the current scan. Five signals (MAX5, MAX4, MAX3, MAX2, MAX1 AND MAX0) indicate whether the corresponding status signal STATUS [5], STATUS [4], STATUS [3], STATUS [2], STATUS [1], or STATUS [0], respectively, has remained at the same logical voltage level for at least the duration of the debounce time interval. The zero input of the multiplexer 902 receives the signal LSWITCH [5], and the one input of the multiplexer 902 receives the signal SCAN\_SW [5]. The signal SCAN\_END is furnished by the output of an AND gate 851 (FIG. 31B). The AND gate 851 receives a signal STOP\_SCAN and a signal SCAN\_DONE. The signal STOP\_SCAN is asserted, or driven high, when conditions for ending the scanning by the scan state machine 840 are present, as further described below. The signal SCAN\_END is a pulsed (for one cycle of the CLK signal) version of the STOP\_SCAN signal. The signals LSWITCH [4]-LSWITCH [0] and D\_LSWITCH [4]-D\_LSWITCH [0] are generated in a similar fashion from the respective SCAN\_SW [4]-SCAN\_SW [0] signals and the respective signals MAX4-MAX0.

For purposes of updating the logical voltage level of the status signals STATUS [31:6] as these signals are scanned in, a multi-bit D-type flip-flop 905 (FIG. 31D) furnishes twenty-six signals SCAN\_NSW [31:6]. One of the signals SCAN\_NSW [31:6] is asserted, or driven high, to indicate this condition and deasserted otherwise. The flip-flop 905 is clocked on the positive edge of the clock signal CLK, and the clear input of the flip-flop 905 receives the RST signal.

The input of the flip-flop 905 is connected to the output of a multi-bit multiplexer 906. The select input of the multiplexer 906 receives an inverted CHECK\_SWITCH\_ONLY signal. The CHECK\_SWITCH\_ONLY signal is asserted, or driven high, when the scan state machine 840 is only scanning the status signals STATUS [5:0] or status signals STATUS [127:32] (i.e., ignoring changes in the signals STATUS [31:6]) and deasserted otherwise. The zero input of the multiplexer 906 receives the signals SCAN\_NSW [31:6], and the one input of the multiplexer 906 is connected to the output of a multi-bit OR gate 907. One input of the OR

gate 907 is connected to the output of a multi-bit AND gate 908, and the other input of the OR gate 907 is connected to the output of a multi-bit AND gate 872.

One input of the AND gate 908 receives the signals BIT\_ENABLE [31:6]. The other input of the AND gate 908 is connected to the output of a multi-bit multiplexer 909. If the NEW\_CSID signal is asserted, or high, the multiplexer 909 furnishes a twenty-six bit signal equal to "h3FFFFFF." Otherwise, the multiplexer furnishes a twenty-six bit signal equal to "0." One input of the AND gate 872 is connected to the inverted output of the AND gate 908, and the other input of the AND gate 872 receives the signals SCAN\_NSW [31:6].

For purposes of storing the logical voltage level of the status signals STATUS [31:6] after every scan, a multi-bit, D-type flip-flop 871 furnishes twenty-six signals LNON\_SW [31:6]. One of the signals LNON\_SW [31:6] is asserted, or driven high, to indicate this condition and deasserted otherwise. The flip-flop 871 is clocked on the positive edge of the clock signal CLK, and the clear input of the flip-flop 871 receives the RST signal.

The input of the flip-flop 871 is connected to the output of a multi-bit multiplexer 870 which furnishes the signals D\_LNON\_SW [31:6]. The select input of the multiplexer 870 receives the signal SCAN\_END. The zero input of the multiplexer 870 receives the signals LNON\_SW [31:6], and the one input of the multiplexer 807 receives the signals SCAN\_NSW [31:6].

As shown in FIG. 31B, for purposes of generating the MAX0, MAX1, MAX2, MAX3, MAX4, and MAX5 signals, the serial input logic 804 includes six counters 831a-f, respectively, of common design 831. Each counter 831 is initialized (to a predetermined count value) when an AND gate 892 asserts, or drives high, its output. For the counter 831a, the AND gate 892 receives the signal BIT\_ENABLE [0], the signal SW\_CHG [0] and an inverted signal QUICK\_FILTER. The signal QUICK\_FILTER, when asserted, or high, can be used to circumvent the debounce time interval. The QUICK\_FILTER signal is normally deasserted, or low. The clock input of the counter 831 is connected to the output of an AND gate 893. For the counter 831a, the AND gate 893 receives the BIT\_ENABLE [0] signal, the inverted SW\_CHG [0] signal, the inverted GETTING\_BYTE signal, and the inverted MAX0 signal. Therefore, for the counter 831a, once the logical voltage of the status signal STATUS [0] changes, each time the serial scan logic 804 scans the status signal STATUS [0], the counter 831a is incremented. When the counter 831a reaches its maximum value, the signal MAX0 is asserted which indicates the debounce time interval has elapsed. If the logical voltage of the status signal STATUS [0] changes during the count, the counter 831a is reinitialized and the count begins again. The other counters 831b-f function in a similar fashion for their corresponding status signals STATUS [5:1].

The HOLD\_OFF signal, when asserted, instructs one of the timers 806 to measure a predetermined slow scan interval which puts the serial scan state machine 840 in the slow scan mode. When the timer 806 completes measuring this delay interval, the timer 806 asserts, or drives high, a FTR\_TIMEOUT signal which is otherwise deasserted, or negated. The product of this slow scan interval and the number of counts for the counter 831 to reach its maximum value is equal to the debounce time interval (8 ms).

The HOLD\_OFF signal is furnished by the output of a JK flip-flop 885. The flip-flop 885 is clocked on the positive

edge of the CLK signal, and the clear input of the flip-flop **885** receives the RST signal. The J input is connected to the output of an AND gate **883**, and the K input is connected to the output of an AND gate **884**. One input of the AND gate **884** is connected to the output of a JK-type flip-flop **896**, and the other input of the AND gate **883** receives the SCAN\_END signal. One input of the AND gate **884** is connected to the inverted output of the AND gate **883**, one input of the AND gate **884** receives the FTR\_TIMEOUT signal, and another input of the AND gate **884** receives a SCAN\_IN\_IDLE signal, which is asserted when the scan state machine **840** is in its IDLE state, as further described below.

The flip-flop **895** is clocked on the positive edge of the CLK signal, and the clear input of the flip-flop **895** receives the RST signal. The J input is connected to the output of a NAND gate **894** which receives the MAX0, MAX1, MAX2, MAX3, MAX4 and MAX5 signals. The K input is connected to the output of an AND gate **826** which is connected to the inverted J input of the flip-flop **895** and receives an inverted SCAN\_IN\_PROGRESS signal which is asserted when the scan state machine **840** is scanning the status signals STATUS [31:0].

For purposes of generating the CHECK\_SWITCH\_ONLY signal, the serial scan input logic **804** includes a JK-type flip-flop **864** which furnishes the CHECK\_SWITCH\_ONLY signal at its non-inverting output and is clocked on the positive edge of the CLK signal. The clear input of the flip-flop **864** receives the RST signal, and the J input of the flip-flop **864** receives a DEBOUNCE signal, which when asserted, or driven high, indicates that one of the logical voltage level of one or more of the status signals STATUS [31:6] has changed. The K input of the flip-flop **864** is connected to the output of an AND gate **865**. One input of the AND gate **865** receives the inverted DEBOUNCE signal, and one input of the AND gate **865** receives the SCAN\_IN\_IDLE signal.

As shown in FIG. 31C, the debounce signal DEBOUNCE is furnished by the non-inverting output of a JK-type flip-flop **860**. The flip-flop **860** is clocked by the positive edge of the clock signal CLK, and the clear input of the flip-flop **860** receives the reset signal RST. The J input of the flip-flop **860** receives a signal CHANGE\_ON\_INPUT signal. The CHANGE\_ON\_INPUT signal is asserted, or driven high, when a change in one of the status signals STATUS [31:6] is detected at the end of a scan by the serial input logic **804** and deasserted otherwise. The K input is connected to the output of an AND gate **861** which receives a DB\_TIMEOUT signal at one of its inputs. The other input of the AND gate **861** receives the inverted CHANGE\_ON\_INPUT signal. The DB\_TIMEOUT signal is asserted by the timers **106** for one cycle of the CLK signal when the debounce time delay (initiated by the assertion of the DEBOUNCE signal) has expired. The assertion of the DB\_TIMEOUT signal negates the DEBOUNCE signal on the next positive edge of the CLK signal.

The CHANGE\_ON\_INPUT signal is furnished by the non-inverting output of a JK-type flip-flop **866** which is clocked on the positive edge of the CLK signal. The clear input of the flip-flop receives the RST signal. The J input of the flip-flop **866** is connected to the output of an AND gate **869** which receives the SCAN\_END signal, and another input of the AND gate **869** is connected to the output of an OR gate **867**. The OR gate **867** logically ORs all of a set of NSW\_CHG [31:6] signals. The bit positions of the signals NSW\_CHG [31:6] correspond to the bit positions of the status signals STATUS [31:6] and indicate, by their assertion, whether the corresponding status signal STATUS

[31:6] has changed after the last scan. The AND gate **869** further receives the SCAN\_END signal. The K input of the flip-flop **866** is connected to the output of an AND gate **868** which receives the inverted SCAN\_IN\_PROGRESS signal and the inverted output of the AND gate **869**. The signals NSW\_CHG [31:6] are furnished by the output of a multi-bit, XOR gate **862** which receives the signals D\_LNON\_SW [31:6] and LNON\_SW [31:6].

The non-inverting output of a multi-bit D-type flip-flop **912** furnishes bits SI\_DATA [7:0] for the serial data register **815**. The clear input of the flip-flop **912** receives the signal RST, and the flip-flop **912** is clocked on the positive edge of the CLK signal. The signal input of the flip-flop **912** is connected to the output of a multi-bit multiplexer **916**. The select input of the multiplexer **916** is connected to the output of an AND gate **914**, and the zero input of the multiplexer **916** receives the bits SI\_DATA [7:0]. The AND gate **914** receives the signals GETTING\_BYTE and SHIFT\_ENABLE. Thus, when the serial scan logic **804** is not shifting in a requested byte of the status signals STATUS [47:0], the values of the bits SI\_DATA [7:0] are preserved.

The one input of the multiplexer **916** is connected to the output of a multi-bit multiplexer **910**. The one input of the multiplexer **910** is connected to the output of a multi-bit OR gate **911**, and the zero input of the multiplexer is connected to the output of a multi-bit AND gate **915**. The select input of the multiplexer **910** receives the signal NEW\_CSID.

One input of the AND gate **915** receives the bits SI\_DATA [7:0], and an inverting input of the AND gate **915** is connected to the output of a 3x8 decoder **913**. The decoder **913** receives the signal BIT [2:0]. One input of the OR gate **911** receives the bits SI\_DATA [7:0], and the other input of the OR gate **911** receives the output of the decoder **913**.

The serial input logic **804** furnishes five signals RST\_SWITCH [5:0] (corresponding to the bit positions of the status signals STATUS [5:0] to the ON/OFF control logic **820** which indicate, by their assertion, whether the corresponding slot **36a-f** should be powered down. The ON/OFF control logic **820** indicates when the slot **36** (indicated by the RST\_SWITCH [5:0] signals) has subsequently been powered down by the subsequent assertion of one of five signals CLR\_SWITCH [5:0] signals whose bit positions correspond to the signals RST\_SWITCH [5:0]. After receiving the indication that the slot **36** has been powered down, the serial logic **804** then deasserts the corresponding RST\_SWITCH [5:0] signal.

The signals RST\_SWITCH [5:0] are furnished by the non-inverting output of a multi-bit, D-type flip-flop **891** (FIG. 31B). The clear input of the flip-flop **891** receives the reset signal RST, and the flip-flop **891** is clocked on the positive edge of the clock signal CLK. The input of the flip-flop **891** is connected to the output of a multi-bit OR gate **857** which has one input connected to the output of a multi-bit AND gate **859** and one input connected to the output of a multi-bit AND gate **855**. One input of the AND gate **859** is connected to the output of a multiplexer **853**, and the other input of the AND gate **859** receives latched slot enable signals L SLOT\_EN [5:0] which indicate, by their assertion, whether the corresponding slot **36a-f** is powered up. One input of the AND gate **855** receives the signals CLR\_SWITCH [5:0] signals. Another input of the AND gate **855** receives the signals RST\_SWITCH [5:0]. Another input of the AND gate **855** is connected to the inverted output of the multiplexer **853**.

The zero input of the multiplexer **853** receives a six bit signal indicative of zero. The one input of the multiplexer

## 81

**853** is connected to the output of a multi-bit AND gate **849**. One input of the AND gate **849** receives the signals `D_LSWITCH [5:0]`, and the other input of the AND gate **849** receives the inverted signals `L_SWITC`<sub>H</sub> `[5:0]`. The select input of the multiplexer **853** receives the `SCAN_END` signal.

For purposes of generating the `SI_INTR#` signal, the serial scan logic **804** includes a D-type flip-flop **882** which furnishes the serial interrupt signal `SI_INTR#` at its inverting output. The flip-flop **882** is clocked on the positive edge of the `CLK` signal, and the clear input of the flip-flop **882** receives the `RST` signal. The input of the flip-flop **882** is connected to the output of an OR gate **881** which receives thirty two pending interrupt signals `PENDING_IRQ [31:0]`, which indicate, by their assertion, or driving high, whether an interrupt is pending for the corresponding one of the status signals `STATUS [31:0]`. The signals `PENDING_IRQ [31:0]` are otherwise deasserted.

As shown in FIG. 31E, a multi-bit, D-type flip-flop **979** furnishes the signals `PENDING_IRQ [31:0]` at its non-inverting output. The flip-flop **979** is clocked on the positive edge of the signal `CLK` signal and receives the signal `RST` at its clear input. The input of the flip-flop **979** is connected to the output of a multi-bit AND gate **981** which receives inverted interrupt mask signals `INTR_MASK [31:0]` at one input. The signals `INTR_MASK [31:0]` are indicative of corresponding bit of the interrupt mask register **810**. The other input of the AND gate **981** is connected to the output of a multi-bit OR gate **835**. One input of the OR gate **835** is connected to the output of a multi-bit AND gate **862**, and the other input of the OR gate **835** is connected to the output of a multi-bit AND gate **834**.

The AND gate **862** receives inverted `PENDING_IRQ [31:0]` signals and signals `SET_PIRQ [31:0]`. The signals `SET_PIRQ [31:0]` are asserted to indicate an interrupt request should be generated for the corresponding one of the status signals `STATUS [31:0]`. Therefore, the signals `PENDING_IRQ [31:0]` are updated with the signals `SET_PIRQ [31:0]` if not masked by the signals `INTR_MASK [31:0]`.

The AND gate **834** receives the signals `PENDING_IRQ [31:0]`, inverted signals `SET_PIRQ [31:0]` and inverted `WR_INTR_REG [31:0]` signals. The signals `WR_INTR_REG [31:0]` indicate the write data furnished by the CPU **14** to the interrupt register **800**. The CPU clears an interrupt by writing a "1" to the corresponding bit of the interrupt register **800**. Therefore, if this occurs, and no new interrupt requests are indicated for the corresponding one of the status signals `STATUS [31:0]`, the corresponding one of the signals `PENDING_IRQ [31:0]` is cleared.

The signals `SET_PIRQ [31:0]` are furnished by the output of a multi-bit AND gate **839**. One input of the AND gate **839** receives the signals `UPDATE_IRQ [31:0]`. The other input of the AND gate **839** is connected to the output of a multi-bit XOR gate **837**. One input of the XOR gate **837** receives the signals `D_INTR_REG [31:0]`, the other input of the XOR gate **837** receives the signals `INTR_REG [31:0]`. Therefore, when the bits of the interrupt register **800** transition from one logical state to another, an interrupt request is generated.

For purposes of updating the bits of the interrupt register **800**, the signals `UPDATE_IRQ [31:0]` are furnished to the corresponding load inputs of the register **800**. When one of the signals `UPDATE_IRQ [31:0]` is asserted, or driven high, the corresponding bit is loaded with the corresponding one of the signals `D_INTR_REG [31:0]`.

The signals `UPDATE_IRQ [31:0]` are furnished by the output of a multi-bit OR gate **971**. One input of the OR gate

## 82

**971** is connected to the output of a multi-bit AND gate **973**. One input of the AND gate **973** is connected to the output of a multi-bit multiplexer **977**, and the other input of the AND gate **973** receives inverted `PENDING_IRQ [31:0]` signals.

The select input of the multiplexer **977** receives the signal `SCAN_END`, the one input of the multiplexer **977** receives a thirty-two bit signal indicative of "hFFFFFFF," and the zero input of the multiplexer **977** receives a thirty-two bit signal indicative of "0." Therefore, at the end of a scan, the signals `UPDATE_IRQ [31:0]` allow the bits of the interrupt register **800** to be updated that correspond to the asserted `PENDING_IRQ [31:0]` signals.

Another input of the OR gate **971** is connected to the output of a multi-bit AND gate **975**. One input of the AND gate **975** receives the inverted `INTR_MASK [31:0]` signals, another input of the AND gate **975** receives the signals `PENDING_IRQ [31:0]`, and another input of the AND gate **975** receives the signals `WR_INTR_REG [31:0]`. Therefore, the CPU **14** can selectively clear bits of the signals `PENDING_IRQ [31:0]`.

The signals `D_INTR_REG [5:0]` are furnished by the output of a multi-bit multiplexer **830**. When the `SCAN_END` signal is asserted, the signals `D_INTR_REG [5:0]` are equal to the signals `D_LSWITCH [5:0]`. When the `SCAN_END` signal is deasserted, the signals `D_INTR_REG [5:0]` are equal to the signals `LSWITCH [5:0]`.

The signals `D_INTR_REG [31:6]` are furnished by the output of a multi-bit multiplexer **845**. When the `SCAN_END` signal is asserted, the signals `D_INTR_REG [31:6]` are equal to the signals `D_LNON_SW [31:6]`. When the `SCAN_END` signal is deasserted, the signals `D_INTR_REG [5:0]` are equal to the signals `LNON_SW [31:6]`. The interrupt register **800** takes on new values only when the signal `SCAN_END` is asserted.

As shown in FIGS. 32A–B, the scan state machine **840** enters an IDLE state after the assertion of the reset signal `RST`. When not in the IDLE state, the scan state machine **840** toggles the states of the serial input clock signal `CSIC_0` in order to clock the shift register **82**. Furthermore, when not in a first load state `LD1`, the scan state machine **840** asserts, or drives high, the load signal `CSIL_0` in order to enable the registers **82** and **52** to serially shift the status signals `STATUS [127:0]` to the SIO circuit **50**. In the IDLE state, the scan state machine **840** sets the signal `SCAN_DONE` equal to zero.

The scan state machine **840** transitions from the IDLE state to the state `LD1` when either the signal `GETTING_BYTE` is asserted or the signal `HOLD_OFF` is deasserted. Otherwise, the scan state machine **840** remains in the IDLE state. In the `LD1` state, the scan state machine **840** asserts, or drives low, the load signal `CSIL_0` which enables the registers **82** and **52** to latch and start receiving the status signals `STATUS [127:0]`.

The scan state machine **840** transitions from the `LD1` state, to a load two state `LD2`. In the `LD2` state, the load signal `CSIL_0` is kept asserted which enables the registers **82** and **52** to serially shift the status signals `STATUS [127:0]`.

The scan state machine **840** subsequently transitions to a scan state `SCAN`. In the `SCAN` state, the serial scan input logic **804** scans in one of the status signals `STATUS [127:0]` on each negative edge of the clock signal `DIV2CLK`. When the signal `STOP_SCAN` is asserted, the scan state machine **840** transitions back to the IDLE state. The `STOP_SCAN` signal is asserted when either the desired byte of the status signals `STATUS [127:0]` has been shifted into the serial data register **815**; the lever status signals `STATUS [5:0]` have

been scanned in and the serial interrupt signal `SI_INTR#` has been asserted; or all of the status signals `STATUS [31:0]` have been shifted in. In the `SCAN` state, the `SCAN_DONE` signal is set equal to the `STOP_SCAN` signal

As shown in FIG. 33A, the ON/OFF control logic **820** includes an ON/OFF state machine **998** which receives the signals `RST_SWITCH [5:0]`, `SLOT_EN [5:0]` and `SLOT_RST_ [5:0]`. Based on the conditions indicated by these signals, the ON/OFF state machine **998** indicates and controls the appropriate power up or power down sequences. The ON/OFF state machine **998** furnishes control signals to control logic **999**.

The ON/OFF state machine **998** furnishes a serial output update signal `SO_UPDATE` to the serial output logic **824**. When the signal `SO_UPDATE` is asserted, or driven high, the serial output logic **824** begins the shifting phase and serially shifts control data, via the signal `CSOD_0`, to the register **80**. The serial output logic **824** indicates completion of the shifting phase by asserting a signal `SO_UPDATE_DONE` which is received by the ON/OFF state machine **998**. The ON/OFF state machine **998** subsequently updates the control signals `POUT [39:0]` by negating, or clocking, the latch signal `CSOLC_O` which is received by the register **80**.

The control logic **999** furnishes the signals `PWREN [5:0]`, `CLKEN#[5:0]`, `BUSEN#[5:0]` and `RST#[5:0]` to the serial output logic **824**. The control logic **999** also furnishes a PCI bus request signal `CAYREQ#` to and receives a PCI bus grant signal `CAYGNT#` from the arbiter **124**. The ON/OFF control logic **820** asserts, or drives low, the signal `CAYREQ#` to request the PCI bus **32**, and when the arbiter **124** asserts, or drives low, the signal `CAYGNT#`, the arbiter **124** has granted control of the PCI bus **32** to the ON/OFF control logic **820**.

As shown in FIGS. 33B–G, the ON/OFF state machine **998** enters an idle state `IDLE` upon assertion of the reset signal `RST`. If not idle, the ON/OFF state machine **998** controls one of three sequences: the power down sequence, the power on sequence, or the one pass sequence used to update the control signals `POUT [39:0]` as indicated by the slot enable **817** and LED control (not shown) registers. The ON/OFF state machine **998** asserts, or drives high, the load signal `CSOLC_O` for one cycle of the clock signal `CLK` of the register **80** until the ON/OFF state machine **998** determines the control signals `POUT [39:0]` are to be updated. When the control signals `POUT [39:0]` are updated, the ON/OFF state machine **998** negates the signal `CSOLC_O` which updates the control signals `POUT [39:0]`.

The ON/OFF state machine **998** begins the power down sequence when either the software requests a power down of at least one of the slots **36**, as indicated by the deassertion of the signals `SLOT_EN [5:0]`; or the serial scan input logic **804** determines at least one of the slots **36a–f** should undergo the power down sequence, as indicated by the assertion of the signals `RST_SWITCH [5:0]`. To begin the power down sequence, the ON/OFF state machine **998** asserts the `SO_UPDATE` signal to begin a shifting phase and transitions from the `IDLE` state to a `RSTON` state.

During the `RSTON` state, the control logic **999** negates the reset signals `RST#[5:0]` for the slots **36** that are to be powered down, and the serial output logic **824** serially shifts the reset signals `RST#[5:0]` to the output register **80**. The ON/OFF state machine **998** also negates the signal `SO_UPDATE`. Once all forty-control signals are shifted by the serial output logic **824** to the register **80**, as indicated by the assertion of the signal `SO_UPDATE_DONE`, the ON/OFF state machine **998** transitions from the `RSTON` state to an `OFF_ARB1` state.

In the `OFF_ARB1` state, the ON/OFF state machine **998** requests control of the secondary PCI bus **32** by asserting the request signal `CAYREQ#`. The ON/OFF state machine **998** then transitions to an `OFF_WGNT1` state where it waits for the grant of the secondary PCI bus **32**. When the arbiter **124** grants control of the bus **32**, as indicated by the assertion of the `CAYGNT#` signal, the ON/OFF state machine **998** negates the signal `CSOLC_O` for one cycle of the signal `CLK` to update the control signals `POUT [39:0]` and transitions to an `OFF_LCLK1` state.

In the `OFF_LCLK1` state, the ON/OFF state machine **998** asserts the signal `SO_UPDATE` to begin another shift phase. The ON/OFF state machine **998** transitions from the `OFF_LCLK1` state to a bus off state `BUSOFF`. During the `BUSOFF` state, the control logic **999** deasserts, or drives high, the bus enable signals `BUSEN#[5:0]` for the slots **36** that are to be powered down, and the serial output logic **824** serially shifts the bus enable signals `BUSEN#[5:0]` to the output register **80**. The ON/OFF state machine **998** also negates the signal `SO_UPDATE`. Once all forty-control signals are shifted by the serial output logic **824**, as indicated by the assertion of the signal `SO_UPDATE_DONE`, the ON/OFF state machine **998** transitions from the `BUSOFF` state to an `OFF_ARB2` state where the state machine **998** once again requests control of the secondary PCI bus **32**. The state machine **998** then transitions to an `OFF_WGNT2` state where it waits for the grant of the PCI bus **32**. Once the grant is received, the state machine **998** transitions to an `OFF_LCLK2` state where the control signals `POUT [39:0]` are updated by negating the signal `CSOLC_O` for one cycle of the signal `CLK`. The state machine **998** then transitions to a clock off state `CLKOFF`.

During the `CLKOFF` state, the control logic **999** deasserts, or drives high, the clock enable signals `CLKEN#[5:0]` for the slots **36** that are to be powered down. The bus enable signals `BUSEN#[5:0]` do not change, and the serial output logic **824** serially shifts the clock enable signals `CLKEN#[5:0]` to the output register **80**. The ON/OFF state machine **998** also negates the signal `SO_UPDATE`. Once all forty control signals are shifted by the serial output logic **824**, as indicated by the assertion of the signal `SO_UPDATE_DONE`, the ON/OFF state machine **998** transitions from the `CLKOFF` state to an `OFF_ARB3` state, where the state machine **998** once again requests control of the PCI bus **32**. The state machine **998** then transitions to an `OFF_WGNT3` state where it waits for the grant of the PCI bus **32**. Once the grant is received, the state machine **998** transitions to an `OFF_LCLK3` state where the control signals `POUT [39:0]` are updated by negating the signal `CSOLC_O` for one cycle of the signal `CLK`. The state machine **998** then transitions to a power off state `PWROFF`.

During the `PWROFF` state, the control logic **999** deasserts, or drives low, the power enable signals `PWREN [5:0]` for the slots **36** that are to be powered down. The signals `RST#[5:0]`, `BUSEN#[5:0]`, and `CLKEN#[5:0]` do not change, and the serial output logic **824** serially shifts the power enable signals `PWREN [5:0]` to the output register **80**. The ON/OFF state machine **998** also negates the signal `SO_UPDATE`. Once all forty control signals are shifted by the serial output logic **824**, as indicated by the assertion of the signal `SO_UPDATE_DONE`, the ON/OFF state machine **998** transitions from the `PWROFF` state to an `OFF_LCLK4` state where the signals `POUT [39:0]` are updated by negating the signal `CSOLC_O` for one cycle of the signal `CLK`. The state machine **998** then transitions to the `IDLE` state which completes the power down sequence.

If a power down sequence is not required, the ON/OFF state machine **998** then determines if the power up sequence

is required. If either the software has requested at least one of the slots **36** to powered up or a power up of the expansion box **30** is pending, then the ON/OFF state machine **998** transitions from the IDLE state to a power on PWRON state to begin the power on sequence. To begin the power on sequence, the ON/OFF state machine **998** asserts the SO\_UPDATE signal to begin a shift phase and transitions from the IDLE state to a power on state PWRON.

During the PWRON state, the control logic **999** asserts the power enable signals PWREN [5:0] for the slots **36** that are to be powered up, and the serial output logic **824** serially shifts the power enable signals PWREN [5:0] to the output register **80**. The ON/OFF state machine **998** also negates the signal SO\_UPDATE. Once all forty control signals are shifted by the serial output logic **824**, as indicated by the assertion of the signal SO\_UPDATE\_DONE, the ON/OFF state machine **998** transitions from the PWRON state to a timer **806** initialization state LDCNT1 and negates the load signal CSOLC\_O to update the control signals POUT [39:0].

In the LDCNT1 state, the ON/OFF state machine **998** initializes the timers **806** so that the timers **806** provide an indication when a predetermined stabilization delay interval has expired. The stabilization delay interval allows sufficient time for the card **807** that is being powered up to stabilize once the voltage level  $V_{SS}$  is furnished to the card **807**. In the LDCNT1 state, the ON/OFF state machine **998** also asserts the signal CSOLC\_O. The ON/OFF state machine **820** transitions from the LDCNT1 state to a CLKON state.

During the CLKON state, the control logic **999** asserts, or drives low, the clock enable signals CLKEN#[5:0] for the slots **36** that are to be powered up. The PWREN [5:0] signals remain unchanged, and the serial output logic **824** serially shifts the clock enable signals CLKEN#[5:0] to the output register **80**. The ON/OFF state machine **998** also negates the signal SO\_UPDATE. Once the stabilization delay interval has expired, the ON/OFF state machine **998** transitions from the CLKOFF state to an ON\_ARB1 state.

In the ON\_ARB1 state, the ON/OFF state machine **998** requests control of the secondary PCI bus **32** by asserting the request signal CAYREQ#. The ON/OFF state machine **998** then transitions to an ON\_WGNT1 state where it waits for the grant of the secondary PCI bus **32**. Once control of the bus **32** is granted, as indicated by the assertion of the CAYGNT# signal, the ON/OFF state machine **998** negates the signal CSOLC\_O to update the control signals POUT [39:0] and transitions to an ON\_LCLK1 state where the signals POUT [39:0] are updated.

The ON/OFF state machine **998** transitions from the ON\_LCLK1 state to a LDCNT2 state where the timers **806** are initialized so that the timers **806** provide an indication when another predetermined stabilization delay interval has expired. This delay interval is used to allow the clock signal on the card **807** being powered up to stabilize before the power up sequence continues. The ON/OFF state machine **998** transitions from the LDCNT2 state to a bus on state BUSON.

During the BUSON state, the control logic **999** asserts, or drives low, the bus enable signals BUSEN#[5:0] for the slots **36** that are to be powered down. The signals CLKEN#[5:0] and PWREN [5:0] remain unchanged, and the serial output logic **824** serially shifts the bus enable signals BUSEN#[5:0] to the output register **80**. The ON/OFF state machine **998** also negates the signal SO\_UPDATE. Once the stabilization delay interval has expired, the ON/OFF state machine **998** transitions from the BUSON state to an ON\_ARB2 state

where the state machine **998** once again requests control of the PCI bus **32**. The state machine **998** then transitions to an ON\_WGNT2 state where it waits for the grant of the bus **32**. Once the grant is received, the state machine **998** transitions to an ON\_LCLK2 state where the signals POUT [39:0] are updated by negating the signal CSOLC\_O for one cycle of the signal CLK. The state machine **998** then transitions to a reset off state RSTOFF.

During the RSTOFF state, the control logic **999** asserts, or negates, the reset signals RST#[5:0] for the slots **36** that are to be powered up, depending on their respective SLOT\_RST [5:0] signals. The signals CLKEN#[5:0], PWREN [5:0] and BUSEN#[5:0] remain unchanged, and the serial output logic **824** serially shifts the reset signals RST#[5:0] to the output register **80**. The ON/OFF state machine **998** also negates the signal SO\_UPDATE. Once all forty control signals are shifted by the serial output logic **824**, as indicated by the assertion of the signal SO\_UPDATE\_DONE, the ON/OFF state machine **998** transitions from the RSTON state to an ON\_ARB3 state where the state machine **998** once again requests control of the bus **32**. The state machine **998** then transitions to an ON\_WGNT3 state where it waits for the grant of the bus **32**. Once the grant is received, the state machine **998** transitions to an ON\_LCLK3 state where the signals POUT [39:0] are updated by negating the signal CSOLC\_O for one cycle of the signal CLK. The state machine **998** then transitions back to the IDLE state.

If neither the power up sequence nor the power down sequence is required, the ON/OFF state machine **998** then determines if a one pass sequence is needed to update selected ones of the signals POUT [39:0]. If the GO\_UPDATE signal is asserted, and if any bits of the slot enable register **817** or slot reset register **819** changes, then the ON/OFF state machine **998** transitions to a ONEPASS state and asserts the SO\_UPDATE signal. The ON/OFF state machine **998** remains in the ONEPASS state until the forty control signals have been shifted to the register **80**. The ON/OFF state machine **998** then transitions to an OP\_ARB state where the state machine **998** requests control of the PCI bus **32** by asserting the signal CAYREQ#. The state machine **998** then transitions to an OP\_WGNT state where it waits for the grant of the bus **32**. Once the grant is received, the state machine **998** transitions to an OP\_LCLK state where the signals POUT [39:0] are updated by negating the signal CSOLC\_O for one cycle of the signal CLK. The state machine **998** then transitions back to the IDLE state.

As shown in FIG. **34**, the serial output logic **824** includes a shift output bit counter **921** that provides a six bit counter output signal BIT\_CNTR [5:0] which tracks the control signal shifted out of the serial output logic **824** via the signal CSOD\_O. When the signal BIT\_CNTR [5:0] is equal to a six digit number equivalent to "39" then a signal MAX\_CNT is asserted. The signal MAX\_CNT is provided to the input of an AND gate **922**. The AND gate **922** further receives a signal SHIFT4 which is asserted when the output shift state machine **920** enters its SHIFT4 state, further described below. The output of the AND gate **922** provides the signal SO\_UPDATE\_DONE.

The output shift state machine **920** furnishes an increment counter signal INC\_CNTR to the bit counter **921**. When the INC\_CNTR signal is asserted, the bit counter **921** increments the value represented by the signal BIT\_CNTR [5:0]. When a load counter signal LOAD\_CNTR is asserted or when the RST signal is asserted, then the output of an OR gate **925**, connected to a clear input of the bit counter **921**, clears the signal BIT\_CNTR [5:0].

The signal BIT\_CNTR [5:0] is furnished to the select input of a multi-bit multiplexer **924** that furnishes the signal



CSOD\_0. The zero through eleven inputs of the multiplexer 924 receive the LED control signals LEDS [11:0]. The twelve through fifteen inputs of the multiplexer 924 receive general purpose output signals GPOA [3:0]. The sixteen through twenty-one inputs receive the reset signals RST# [5:0]. The twenty-two through twenty-seven inputs receive the clock enable signals CLKEN#[5:0]. The twenty-eight through thirty-three inputs receive the bus enable signals BUSEN#[5:0]. The thirty-four through thirty-nine inputs receive the power enable signals PWREN [5:0].

As shown in FIGS. 35A–B, the output shift state machine 920 enters an IDLE state when the signal RST is asserted. If the signal SO\_UPDATE is asserted, then the output shift state machine 920 transitions from the IDLE state to a SHIFT1 state.

Because the output shift state machine 920 is clocked on the positive edge of the PCI clock signal CLK, the output shift state machine 920 transitions through a SHIFT1 state, a SHIFT2 state, a SHIFT3 state and a SHIFT4 state to generate the clock signal CSOSC\_O that is one fourth of the frequency of the clock signal CLK. During the SHIFT1 and SHIFT2 states the clock signal CSOSC\_O is negated, or low, and during the SHIFT3 and SHIFT4 states, the clock signal CSOSC\_O is asserted, or high. When the current shift phase is completed, as indicated by the assertion of the signal MAXCNT, the shift state machine 920 returns to the IDLE state and the clock signal CSOSC\_O is asserted until the beginning of the next shifting phase.

As shown in FIG. 36, a HANG\_PEND signal is received by the clear input of the register 80. The assertion, or driving high, or the HANG\_PEND signal asynchronously clears the appropriate output control signals POUT [39:0] to power down all slots 36 when the PCI bus 32 is in a locked up condition, as further described below.

#### Fault Isolation

The bus watcher 129 can detect for a hang condition on the secondary PCI bus 32. If a hang condition is detected, the bus watcher 129 sets a bus hang pending bit, which causes the SIO 50 to power down the slots on the secondary PCI bus 32 and a non-maskable interrupt (NMI) to be transmitted to the CPU 14. The CPU 14 responds to the NMI by invoking an NMI routine to isolate the slot(s) causing the hang condition. Once identified, the defective slot(s) are disabled or powered off.

For software diagnostic purposes, the bus watcher 129 in the downstream bridge chip 48 includes a bus history FIFO and a bus vector FIFO. When the secondary PCI bus 32 is functioning properly, the bus history information, which includes an address group (including the PCI address, PCI command signals, PCI master number, and the address parity bit) and a data group (including the PCI data, byte enable signals C/BE [3:0]\_, parity error signal PERR\_, the data parity bit, a burst cycle indication bit, and a data valid flag), are recorded by the bus watcher 129 in each transaction. When the PCI signal FRAME\_ is asserted on the secondary PCI bus 32 to start a bus transaction, the address group and each subsequent data group are stored in the bus history FIFO. If the transaction is a burst transaction, then the burst cycle indication bit is set active on the second data phase. After the first data phase, the address field in the address group associated with the subsequent data groups in the burst transaction is incremented by 4 and the new address group and data group are stored in the next location of the bus history FIFO. If data is not transferred because of a retry condition or a disconnect-without-data condition, the valid data indication bit is set low.

Both the address group and the data group flow through a 2-stage pipeline to allow time for the data group to collect the data parity bit and data parity error bit, and stop the recording process when a data parity error occurs before the next address group is stored. If the bus hangs in the middle of a write data phase, the data is stored, and a bus-hang status bit is set in a bus-hang indication register 482 (FIG. 42) accessible via configuration space. If the bus hangs in the middle of a read data phase, the data is marked as not valid, and the bus-hang bit is set.

Bus state vectors are assembled and stored in the bus vector FIFO, including the following PCI control signals: slot request signals REQ [7:0]\_; slot grant signals GNT [7:0]\_; the FRAME\_ signal; the PCI device select signal DEVSEL\_; the PCI initiator ready signal IRDY\_; the PCI target ready signal TRDY\_; the STOP\_ signal; the PCI parity error signal PERR\_; the PCI system error signal SERR\_; and the LOCK\_ signal. On each PCI clock in which the bus state vector changes, i.e., any one of the listed signals changes state, the new vector is stored into the bus vector FIFO.

The bus watcher 129 includes a watch-dog timer 454 (FIG. 40) to determine whether the secondary bus 32 has locked up. If the watch-dog timer 454 expires, then the bus 32 has hung. The following are examples of bus-hang conditions that can be detected by the watch-dog timer 454: The FRAME\_ signal is stuck high or low; the signal TRDY\_ is not asserted in response to IRDY\_; the PCI arbiter 124 does not grant the bus to any master; and a master requesting the bus 32 keeps getting retried.

When the watch-dog timer 454 expires, the bus hang pending bit is set active in the bus-hang indication register 482. When set active, the bus hang pending bit disables the bus watcher 129. Next, the slot enable bits in the SIO 50 are cleared, causing the slots to be powered off. The SIO 50 then asserts the system error signal SERR\_.

To isolate the cause of a bus-hang condition, the system error signal SERR\_ causes the interrupt logic in the system to issue the NMI to the CPU 14. Referring to FIG. 37, the NMI handler first determines 400 if the bus hang pending bit is set by reading the bus hang indication register 482. If so, the NMI handler calls 401 a BIOS isolation handler for isolating the defective slot or slots. Otherwise, other NMI procedures are called 402.

As a fail-safe mechanism, the computer system also includes the automatic server recovery (ASR) timer 72 which is cleared when certain software routines are executed by the operating system. If the ASR timer expires (e.g., after 10 minutes), that indicates that the operating system has locked up. The secondary PCI bus 32 hanging may be the cause of the system lock up, in which case the NMI may never get to the CPU 14. If the ASR timer expires, then an ASR-generated reboot occurs. The ASR timer also ensures that if the BIOS isolation handler is in the middle of isolating a faulty slot on the PCI bus 32, and the computer system hangs to cause the ASR reboot, the isolate routine can pick up where it left off just before the ASR time-out event.

Referring to FIG. 38, a BIOS ASR handler is invoked in response to an ASR reboot condition. The ASR handler first checks 444 to determine if an isolation-in-progress event variable (EV) contains active information indicating that the isolation process was in progress prior to the ASR time-out event. The isolation-in-progress EV is stored in non-volatile memory (NVRAM) 70 and includes header information which is set active to indicate that the isolation process has started. The isolation-in-progress EV is also updated with the



current state of the isolation process, including the slots which have been checked, the slots which are defective, and the slots which have been enabled.

If the isolation process was in progress, the BIOS ASR handler re-enables **448** all slots except the ones that were enabled immediately prior to the ASR event, which is determined from the isolation-in-progress EV. The enabled slots prior to the ASR reboot were probably the cause of the ASR lock-up. As a result, those slots are disabled (i.e., powered off). Next, the disabled slot numbers are logged **450** as fail status information stored in the NVRAM, and the isolation-in-progress EV is cleared. The BIOS ASR handler then checks **452** to determine if the bus-hang pending bit is set. If so, the bus-hang pending bit is cleared (by performing an I/O cycle on the secondary PCI bus **32**) to re-enable the bus watcher **129**.

If the isolation-in-progress EV is not set **444** to the active state, indicating that the isolation process was not running when the ASR event occurred, the routine checks **446** to determine if the bus-hang pending bit is set. If not, then the BIOS ASR handler is done. If the bus-hang pending bit is set **446**, indicating that a bus-hang condition occurred before the ASR event, the BIOS ASR handler calls the BIOS isolation handler to isolate the faulty slot or slots.

Referring to FIG. **39**, the BIOS isolation handler first logs **408** to the fail status information portion of the NVRAM the bus history and bus state vector information stored in the history and vector FIFOs in the bus monitor **127**. The bus history and bus state vector FIFOs are read and their contents transferred to the NVRAM. Next, the header information of the isolation-in-progress event variable is set **410** to indicate that the isolation process is in progress. The bus-hang pending bit is cleared (by writing to a predetermined configuration address) to re-enable the bus watcher **129**. Next, the isolation routine re-enables **412** (i.e., powers up) the first populated slot (i.e., slot with a PCI device connected), and reads and writes from the PCI configuration space of the device. A slot is re-enabled by writing to the slot enable register **817** (FIG. **29**). Next, the routine determines **414** if the bus-hang pending bit is set active, indicating that the device connected to the slot caused the bus to hang while reading from it. If not, the routine determines **416** if all populated slots have been checked. If not, the first populated slot is disabled **418** and the isolation-in-progress EV is updated **420** to indicate that the first populated slot has been tried by the BIOS isolation handler. If the routine determines **414** that the bus-hang pending bit is set active, the slot is indicated as being failed (e.g., by setting active a fail flag for that slot) in the fail status information portion of the NVRAM. Next, the loop consisting of steps **412**, **414**, **416**, **418** and **420** is performed until all populated slots have been checked.

If all populated slots have been checked **416**, the routine checks **424** to determine if any slot is indicated as failed in the fail status information portion of the NVRAM. If so, the routine **398** re-enables **426** only the non-failing slots. Then, the isolation-in-progress EV is cleared **428**, and the BIOS isolation routine is complete.

If none of the slots are indicated **424** as failed, then that indicates that the bus-hang condition is not caused by a single slot, but may be caused by more than one device being active at the same time. To confirm that, the BIOS isolation handler first disables (i.e., powers down) **430** all the slots, and updates the isolation-in-progress EV with this information. Next, the BIOS isolation handler clears **431** a count variable N to zero and sets a count variable I to the value of N. The count variable N represents the count of the populated slots.

The BIOS isolation handler re-enables (i.e., powers up) **432** the populated slot I (which is initially slot N) and reads and writes to its PCI configuration space. The handler then checks **438** to determine if the bus-hang pending bit is set. If not, the handler decrements **433** the variable I and checks **434** if the variable I is greater than or equal to zero. If so, the handler updates **435** the isolation-in-progress EV and re-enables **432** and reads and writes the next populated slot I. The handler then checks **438** if the bus hang pending bit is set for this next slot. In this manner, for each slot N that is to be enabled, the previously enabled slots are also powered on one at a time to determine if a combination of slots is causing the failure if the variable I is determined **434** to be less than zero, then the handler checks **436** to determine if all populated slots have been enabled. If not, the variable N is incremented **437**, the isolation-in-progress EV is updated **439**, and the variable I is again set **441** equal to the value of N.

If the bus hang pending bit is set **438** active, then potentially two slots are disabled **440**: slot N (which is the slot currently being enabled) and slot I (which is the slot currently being read from and written to). If the value of I and N are the same, then only slot N is disabled.

If the handler determines **436** that all populated slots have been enabled (and a failure could not be identified), then the handler logs **442** in the NVRAM its inability to isolate the failure. Next, the handler clears **428** the isolation-in-progress EV.

Referring to FIG. **40**, the watch-dog timer **454**, provides output signals WD\_TMR\_OUT[17:0] (timer count value), HANG\_PEND (bus hang condition present), EN\_CAP (the software has enable capture of the bus and vector history information), TIME\_OUT (the watch-dog timer **454** has timed out), a signal HANG\_RCOVR\_EN (set high by software to enable the hang recovery logic in the bus watcher **129** and in the SIO **50**) and a signal CAP\_ILLEG\_PROT (to indicate an illegal cycle on the PCI bus **32**).

The signal HANG\_PEND is provided to the SIO **50** to shut down the secondary bus slots. The input signals to the watch-dog timer **454** include some of the PCI bus signals, a signal WRT\_EN\_CAP\_1 (pulsed high by software to re-enable the capture of the bus history and bus vector information by the fault isolation block **129**), and a power-good indicator signal SYNC\_POWEROK (indicating that power in the computer system is stable).

A bus hang recovery state machine **456** receives the signals HANG\_PEND, TIME\_OUT, and HANG\_RCOVR\_EN from the watch-dog timer **454**. The recovery state machine **456** also receives some of the PCI signals. The output signals from the bus hang recovery state machine **456** includes a device select signal DEVSEL\_O for driving the PCI signal DEVSEL\_, a signal STOP\_O for driving the PCI signal STOP\_, a signal SERR\_EN which enables assertion of the system error signal SERR\_, a signal BR\_M\_ABORT (indicating that the bus watcher **129** has recovered with a master abort), a signal BR\_T\_ABORT (indicating that the bus watcher **129** has recovered with a target abort), and a signal RCOVR\_ACTIVE (for indicating when the bus hang recovery state machine **456** is active). The bus hang recovery state machine **456** ensures that the secondary PCI bus **32** is brought back to the idle state to allow the software to isolate the faulty slot. When the hang condition is detected, the SIO **50** powers down the secondary bus slots, which would automatically place the bus **32** into the idle state if one of the slot devices was the bus master when the hang condition occurred. However, if one

of the slot devices was the target (and the bridge chip **48** was the master) when the bus hang occurred, then the bridge chip **48** would remain on the bus. To take the bridge chip off the bus, the recovery state machine **456** forces a retry cycle on the PCI bus **32** by asserting the signal `STOP_`.

A bus history capture block **458** monitors the PCI bus **32** for transactions, and presents the bus history information (including the address and data) on to output signals `BUS_HIST_DATA3 [31:0]` (the bus history address), `BUS_HIST_DATA2 [31:0]` (the bus history data), and `BUS_HIST_DATA1 [15:0]` (parity error signal `!PERR_`, parity bit `PAR`, valid data bit `VALID_DAT`, address parity bit `ADDRPAR`, burst indicator `BURST`, master number `MASTER [2:0]`, byte enable bits `CBE [3:0]`, and command bits `CMD [3:0]`). The bus history capture block **458** asserts a signal `HIST_RDY` when data is available on the `BUS_HIST_DATA` signals, which is true at the end of each data phase in a normal transaction, or if the transaction is terminated with a master abort, a retry, while the assertion of the time out signal `TIME_OUT`.

A bus vector capture block **460** captures the states of certain PCI control signals when any of those control signals changes state. The vector is captured and output as signals `BUS_VECT_DATA [20:0]`, which contain the request signals `!REQ [7:0]`, grant signals `!GNT [7:0]`, time out signal `TIME_OUT`, lock signal `LOCK_`, system error signal `SERR_`, parity error signal `PERR_`, stop signal `STOP_`, target ready signal `TRDY_`, initiator ready signal `IRDY_`, device select signal `DEVSEL_`, and frame signal `FRAME_`. The bus vector capture block **460** asserts a signal `VECT_RDY` if any of the bus vector `BUS_VECT_DATA [24:0]` has changed or the watch-dog timer **454** has expired (`TIME_OUT` is high).

The bus history and bus vector signals are presented to the inputs of bus watcher FIFOs, which includes a 2-deep bus history FIFO and a 4-deep vector history FIFO. The outputs of the bus history FIFOs are presented as signals `BUS_HIST_REG1 [31:0]`, `BUS_HIST_REG2 [31:0]`, and `BUS_HIST_REG3 [31:0]`. The outputs of the vector history FIFO are presented as signals `BUS_VECT_REG [31:0]`. The system software reads the outputs of the bus history FIFO by generating an I/O read cycle which causes a signal `BUS_HIST_RD1` to be asserted, and reads the outputs of the vector FIFO by generating an I/O read cycle which causes a signal `BUS_VECT_RD` to be asserted.

Referring to FIG. **41**, the recovery state machine **456** begins in state `IDLE` when the signal `SYNC_POWEROK` is negated low, indicating that power is not yet stable. The state machine remains in state `IDLE` while the signal `HANG_PEND` is low. In state `IDLE`, signals `BR_M_ABORT`, `BR_T_ABORT` and `RCOVR_ACTIVE` are negated low. The signal `RCOVR_ACTIVE` is active high in the other states `WAIT`, `ABORT`, and `PEND_OFF`. If the signal `SET_HANG_PEND` is asserted high, the state machine transitions to state `WAIT`. In the transition, the signal `DEVSEL_O` is set equal to the inverted state of the device select signal `DEVSEL_`. This insures that if the device select signal `DEVSEL_` is asserted by a target before the bus hang condition, the recovery state machine **456** maintains the signal `DEVSEL_` asserted. In state `WAIT`, the signal `DEVSEL_O` is set equal to the state of the signal `DEVSEL_WAS`, which is set high if the signal `DEVSEL_` is asserted by a target before the state machine transition to the `WAIT` state.

From state `WAIT`, the bus hang recovery state machine **456** transitions to the `PEND_OFF` state if a signal `PCI_`

`IDLE` is asserted, indicating that the PCI bus **32** has gone idle (i.e., signals `FRAME_` and `IRDY_` are both negated high). In the transition, the signal `BR_M_ABORT` is set high to indicate that one of the slot devices was the master before the hang condition and powering down the slot device caused the PCI bus to go idle. A signal `SERR_EN` is also set high to enable assertion of the system error signal `SERR_` or if `INTA_` is enabled.

If a slot device was a target before the bus hang condition, then the bus master will remain on the PCI bus **32**. To force the bus master off the PCI bus **32**, the bus hang recovery state machine **456** issues a retry on the PCI bus **32**. A counter **457** counts a predetermined number of `PCLK` periods (e.g., 15 `PCLK` period) after the signal `HANG_PEND` is asserted high. The 15 `PCLK` periods insure sufficient rise time on `FRAME_` and `IRDY_` to give the signals time to go back to their idle states. When 15 `PCLK` periods have elapsed, the counter **457** asserts the signal `TIME_OUT15`. If the signal `TIME_OUT15` is asserted high, and the signal `PCI_IDLE` remains low, then the state machine transitions from state `WAIT` to state `ABORT`. In the transition, the signal `STOP_O` is asserted high to drive the `PCI_STOP_` signal active to retry the bus master. The state machine remains in state `ABORT` while the bus master maintains the signal `FRAME` asserted low. In state `ABORT`, the signal `STOP_O` is maintained high. Once the bus master deasserts the `FRAME_` signal in response to the retry condition, the state machine transitions from state `ABORT` to state `PEND_OFF`. In the transition, the signal `BR_T_ABORT` is asserted high to indicate that the target abort was necessary after the bus hang condition to place the bus **32** in the idle state. The signal `SERR_EN` is also asserted high to enable assertion of the signal `SERR_` or if `INTA_` is enabled. The state machine remains in state `PEND_OFF` until the signal `WRT_EN_CAP_1` has been asserted high at which time it transitions back to state `IDLE`.

System software can read the value of the `BR_M_ABORT` and `BR_T_ABORT` signals to determine if the slot device involved in the bus hang was a master or a slave.

Referring to FIG. **42**, the watch-dog timer **454** includes an 18-bit `LSFR` counter **464** which is clocked by the signal `PCLK`. The counter **464** is enabled when the output of an `AND` gate **467** is asserted high, which occurs when a new master issues a request (`ANY_REQ` is high), the bus cycle has started (signals `FRAME_` and `IRDY_` are both asserted), the enable capture signal `EN_CAP` is asserted, and the signal `TIME_OUT` is low. An `OR` gate **466** receives the signal `ANY_REQ` and the inverted states of signals `FRAME_` and `IRDY_`. The `AND` gate **467** receives the output of the `OR` gate **466**, signal `EN_CAP`, and the inverted state of the signal `TIME_OUT`. The output of the counter drives signals `WD_TMR_OUT [17:0]` and is cleared when a time out condition is detected (`TIME_OUT` is high), a data transfer has taken place (both signals `IRDY_` and `TRDY_` are asserted low), or all output bits of the counter **464** are high (which is an illegal condition). The clear condition is indicated by an `OR` gate **470**, which receives the signal `TIME_OUT`, the bit-wise `AND` of the signals `WD_TMR_OUT [17:0]`, and the output of an `AND` gate **472**. The inputs of the `AND` gate **472** receive the inverted state of the signal `IRDY_` and the inverted state of the signal `TRDY_`.

The signal `TIME_OUT` is asserted high by a time out detector **474** when the timer signals `WD_TMR_OUT [17:0]` count to the binary value 1000000000000000. The signal `TIME_OUT` is provided to one input of an `OR` gate **476**, whose output is connected to the input of an `AND` gate

478. The other input of the AND gate 478 receives the inverted state of a signal `WRT_EN_CAP_1` (controlled by software to re-enable the bus history and bus vector capture), and its output is connected to the D input of a D-type flip-flop 488. The flip-flop 488 is clocked by the signal `PCLK` and drives an output signal `WD_TIME_OUT`, which is fed back to the other input of the OR gate 476. The flip-flop 488 is cleared when the power-good signal `SYNC_POWEROK` is negated. Thus, an ASR reset does not clear the signal `WD_TIME_OUT`.

The `HANG_PEND` signal is asserted high by a D-type flip-flop 482, whose D input is connected to the output of an AND gate 484 and which is clocked by the signal `PCLK`. One input of the AND gate 484 is connected to the output of an OR gate 486, and its other input receives the inverted state of the signal `WRT_EN_CAP_1`. One input of the OR gate 486 is connected to the signal `HANG_PEND`, and the other input is connected to the output of an AND gate 488. The inputs of the AND gate 488 receive the signal `TIME_OUT` and the enable signal `HANG_RCOVR_EN`. Thus, if system software enables bus hang recovery (`HANG_RCOVR_EN` is high), then a time-out condition will cause the signal `HANG_PEND` to be set high. The signal `HANG_PEND` is cleared when the system software causes the signal `WRT_EN_CAP_1` to be asserted (by performing an I/O cycle on the bus 32) or when the signal `SYNC_POWEROK` is negated. The bit `HANG_PEND` is not negated by an ASR reboot.

The enable capture signal `EN_CAP` is generated by a D-type flip-flop 490, whose D input receives the output of an AND gate 492. One input of the AND gate 492 is connected to the output of an OR gate 494, and its other input is connected to the inverted state of a signal `CLR_EN_CAP`. One input of the OR gate 494 is routed back to the signal `EN_CAP` and the other input receives the signal `WRT_EN_CAP_1`. The flip-flop 490 is clocked by the signal `PCLK` and set high when the signal `SYNC_POWEROK` is negated low. Once the signal `EN_CAP` is set high by the software via the signal `WRT_EN_CAP_1`, it is maintained high. The signal `CLR_EN_CAP` is asserted to clear the signal `EN_CAP` (disable capture of information), which occurs when a time-out has occurred (`TIME_OUT` is high), a system error has occurred (`SERR` is low), a parity error has occurred (`PERR` is low), or an illegal bus protocol has been detected (`CAP_ILLEG_PROT` is high).

The signal `CAP_ILLEG_PROT` is generated by a D-type flip-flop 483, whose D input receives the output of an AND gate 485. One input of the AND gate receives the inverted state of the signal `WRT_EN_CAP_1`, and the other input receives the output of an OR gate 487. The OR gate 487 receives the signals `CAP_ILLEG_PROT` and `SET_ILLEG_PROT`. The signal `SET_ILLEG_PROT` is asserted when capture is enabled (`EN_CAP` is high), the state machine 456 is not active (`RCOVR_ACTIVE` is low), the bus is idle, and any of signals `DEVSEL`, `TRDY`, or `IRDY` is asserted low. This condition is an illegal condition, which triggers capture of the bus history and bus vector information.

Referring to FIG. 43, the bus history ready signal `HIST_RDY` is generated by a D-type flip-flop 502, which is clocked by the signal `PCLK` and cleared by the signal `RESET`. The D input of the flip-flop 502 is connected to the output of an OR gate 504, whose inputs receive the signal `TIME_OUT`, a signal `M_ABORT` (master abort signal delayed by one `PCLK`), the output of an AND gate 506, and the output of an AND gate 508. The AND gate 506 asserts its output if a retry, disconnect C or target abort cycle is

present on the secondary bus 32 (the signal `FRAME`, the inverted state of the signal `IRDY`, the inverted state of the signal `STOP`, and the inverted state of the signal `DSC_A_B` are all true). The AND gate 508 asserts its output when a completed data transfer has occurred (the signals `IRDY` and `TRDY` are both low). Thus, the bus history information is loaded into the bus history FIFOs when the watch-dog timer 454 times out, a retry, disconnect C, or target abort condition is present, the master has aborted the cycle, or a cycle has successfully completed.

The valid data indication signal `VALID_DAT` is generated by a D-type flip-flop 510, which is clocked by the signal `PCLK` and cleared by the signal `RESET`. The D input of the flip-flop 510 is connected to the output of a NOR gate 512, which receives the signal `TIME_OUT`, master abort signal `M_ABORT`, and the output of the AND gate 506. Thus, data is valid unless a time out is detected, a master abort cycle is issued, or a retry, disconnect C, or target abort cycle is present.

The signal `VECT_RDY` is generated by a D type flip-flop 514, which is clocked by the signal `PCLK` and cleared by the signal `RESET`. The D input of the flip-flop 514 is connected to the output of an OR gate 516, which receives the time out signal `TIME_OUT` and a signal `CHANGE_STATE` indicating that one of the PCI control signals in the bus vector has changed state. Thus, the state vector information is loaded into the vector FIFOs whenever control signals on the PCI bus 32 change state or when a time-out occurred.

Referring to FIG. 44, the bus history data {`BUS_HIST_DATA3 [31:0]`, `BUS_HIST_DATA2 [31:0]`, `BUS_HIST_DATA1 [15:0]`} is provided to the input of bus history register 540, which is the first stage of the bus history FIFO. The bus history 501 provides output signals `BUS_HIST_FIFO1 [79:0]`, to the register 542 (the second state of the pipeline), which provides output signals `BUS_HIST_FIFO0 [79:0]`. Both bus history registers 540 and 542 are clocked by the signal `PCLK` and cleared when the power-good signal `SYNC_POWEROK` is low.

The bus history registers 540 and 542 are loaded when the output of an AND gate 518 is driven high. The AND gate 518 receives the enable capture bit `EN_CAP` and the OR of the bus history ready signal `HIST_RDY` and the `CAP_ILLEG_PROT` signal (OR gate 519). The output signals `BUS_HIST_FIFO0 [79:0]` and `BUS_HIST_FIFO1 [79:0]` are provided to the 0 and 1 inputs, respectively, of multiplexers 520, 522, and 524. Each of the multiplexers 520, 522, and 524 is selected by a read address signal `HIST_FIFO_RD_ADDR` (which starts out low to select the output of the bus register 502 and is toggled on each subsequent read). The multiplexers 520, 522, and 524 drive output signals `BUS_HIST_REG3 [31:0]`, `BUS_HIST_REG2 [31:0]`, and `BUS_HIST_REG1 [15:0]`, respectively.

The bus vector data signals `BUS_VECT_DATA [24:0]` are provided to the inputs of a bus vector register 544, whose output is routed to the input of a bus vector register 546. The output of the bus vector register 546 is routed to the input of a bus vector register 548, whose output is in turn routed to the input of a bus vector register 550. Each of the bus vector registers 0-3 are clocked by the signal `PCLK` and cleared when the signals `SYNC_POWEROK` is low. The bus vector registers are loaded when the output of the AND gate 521 is asserted high. The AND gate 521 receives the signal `EN_CAP` and the OR of signals `VECT_RDY` and `CAP_ILLEG_PROT` (OR gate 523). The bus vector registers 550, 548, 546 and 544 produce output signals `BUS_VECT_FIFO0 [24:0]`, `BUS_VECT_FIFO1 [24:0]`, `BUS_VECT`

FIFO2[24:0], and BUS\_VECT\_FIFO3[24:0], respectively, which are in turn provided to the 0, 1, 2, and 3 inputs of a multiplexer 526, respectively. The output of the multiplexer 526 provides signals BUS\_VECT\_REG [31:0], with the multiplexer 526 selecting one of its inputs based on the state of address signals VECT\_FIFO\_RD\_ADDR [1:0] (which begin with a binary value 00 and is incremented on each successive read).

Thus, the bus history and bus state vector information is captured in response to assertion of signals HIST\_RDY or VECT\_RDY, respectively, or in response to assertion of the signal CAP\_ILLEG\_PROT if an illegal bus protocol condition is detected.

#### Expansion Card Space Reservation

Unlike conventional computer systems, in the initial configuration of the computer system 10 at power up, the CPU 14 reserves memory space and PCI bus numbers for the slots 36 that are empty (no card 807 inserted) or powered down.

As is typically done, the CPU 14 assigns bus numbers for PCI buses (e.g., PCI buses 24, 32a–b and PCI bus(es) of the cards 807 that are inserted into slots 36 and powered up) that are present when the computer system 10 is first powered up.

Each PCI—PCI bridge circuit (e.g., PCI—PCI bridge 26, 48), in its configuration register space 1252 (FIG. 49), has a subordinate bus number register 1218 and a secondary bus number register 1220. The subordinate bus number register 1218 contains a subordinate bus number which is the highest PCI bus number downstream of the PCI—PCI bridge circuit, and the secondary bus number register 1220 contains a secondary bus number which is the PCI bus number of the PCI bus immediately downstream of the PCI—PCI bridge circuit. Thus, the values stored in the subordinate 1218 and secondary 1220 bus number registers define the range of PCI bus numbers that are downstream of the PCI—PCI bridge circuit.

The configuration register space 1252 also has a primary bus number register 1222. The primary bus number register 1222 contains the number of the PCI bus located immediately upstream of the PCI—PCI bridge circuit.

The system controller/host bridge circuit 18 also has the subordinate 1218 and secondary 1220 bus number registers. After configuration, the subordinate bus number register 1218 of the circuit 18 contains the maximum PCI bus number present in the computer system. The secondary bus number register 1220 of the circuit 18 contains bus number zero, as the PCI bus immediately downstream of the circuit 18 (PCI bus 24) always is assigned bus number zero.

Unlike the known system, the CPU 14 recognizes that one of the slots 36 that is initially powered down or empty may introduce one or more additional PCI buses (present on the card 807 inserted into the slot 36 initially powered down) into the computer system 10 after the computer system 10 is already powered up and configured. Accordingly, during initial configuration, the CPU 14 reserves memory space, I/O space and a predetermined number (e.g., one or three) of PCI bus numbers for any slot 36 that is powered down or empty.

Thus, PCI—PCI bridge circuits of the computer system 10 do not have to be reconfigured to accommodate the card 807 that has recently been powered up. Only the PCI—PCI bridge circuit of the card 807 that was recently powered up needs to be configured. The remainder of the computer system 10 remains unchanged.

As part of the resource reservation process, a Basic Input/Output System (BIOS) stored in the ROM 23 and

shadowed (and write-protected) in the memory 20, builds a table specifying resource ranges being reserved for the slots 36. This table includes bus number, memory, and I/O resource ranges for use in configuring a PCI device that has been newly added to the system 10. The operating system uses this table to determine what resources have been reserved and what resources are available for configuring the newly added PCI devices.

As shown in FIG. 45, in a recursive PCI configuration routine called BUS\_ASSIGN, the CPU 14 assigns PCI bus numbers and programs configuration registers 1252 of the PCI—PCI bridge circuits accordingly. The CPU 14 accomplishes this by scanning one PCI bus at a time for PCI devices. The BUS\_ASSIGN routine is part of the BIOS stored in the ROM 23 and is used to initially configure the computer system 10 after power up.

The CPU 14 first sets 1000 the value of a search parameter PCI\_BUS equal to the value of another search parameter CURRENT\_PCI\_BUS and initializes 1000 search parameters FCN and DEV. The parameter PCI\_BUS indicates the bus number of the PCI bus currently being scanned by the CPU 14, and when the BUS\_ASSIGN routine is first executed by the CPU 14, the parameter PCI\_BUS indicates bus number zero.

The parameter CURRENT\_PCI\_BUS indicates the next PCI bus number available for assignment by the CPU, and when the routine BUS\_ASSIGN is first executed by the CPU 14, the parameter CURRENT\_PCI\_BUS indicates bus number zero. The parameters FCN and DEV indicate the current PCI function and PCI device, respectively, currently being scanned by the CPU 14.

The CPU 14 determines 1001 whether the parameter PCI\_BUS indicates bus number zero, and if so, the CPU 14 sets 1002 the secondary bus number register 1220 of the system controller/host bridge circuit 18 equal to zero. The CPU 14 then finds 1004 the next PCI—PCI bridge circuit or the slot 36 that is powered down or empty on the PCI bus indicated by the parameter PCI\_BUS.

For purposes of determining if the next found PCI device is a PCI—PCI bridge circuit or does not exist (a powered down or empty slot) the CPU 14 attempts to read from a value from a one word vendor ID register located in the configuration space of every PCI device. A value of “hFFFF” (where the prefix “h” denotes hexadecimal representation) is reserved and not used by any vendor. If the attempted read from the vendor ID register returns a value of “HFFFF,” then this indicates no PCI device is present.

If the CPU 14 determines 1006 there are no more unfound PCI—PCI bridge circuits or slots 36 that are powered down or empty on the PCI bus indicated by the parameter PCI\_BUS, a return is made from the last call made to the BUS\_ASSIGN routine. Otherwise, the CPU 14 determines 1008 whether another PCI—PCI bridge circuit was found, and if not, the CPU 14 increments 1010 the parameter CURRENT\_PCI\_BUS, as a slot 36 that is powered down or empty was found, and finds 1004 the next PCI—PCI bridge circuit or slot 36 that is powered down or empty. Thus, by incrementing 1010 the parameter CURRENT\_PCI\_BUS, the CPU 14 effectively reserves a bus number for the slot 36 that is powered down or empty. Alternatively, the CPU 14 may reserve more than one bus number for the slot 36 that is powered down or empty.

If the CPU 14 found a PCI—PCI bridge circuit, the CPU 14 then sets 1012 the primary bus number of the PCI—PCI bridge circuit equal to the parameter CURRENT\_PCI\_BUS. The CPU 14 then increments 1014 the parameter

CURRENT\_PCI\_BUS and sets **1016** the secondary bus number of the PCI—PCI bridge equal to the new bus number indicated by the parameter CURRENT\_PCI\_BUS.

The CPU **14** then sets **1018** the subordinate bus number of the found PCI—PCI bridge circuit equal to the maximum possible number of PCI buses by writing to the subordinate bus number register **1218**. This value for the subordinate bus number register **1218** is temporary and allows the CPU **14** to find and program additional downstream PCI—PCI bridge circuits or slots **36** that are powered down or empty.

The CPU **14** finds additional downstream PCI—PCI bridge circuits or slots **36** that are powered down or empty by preserving **1022** the parameters PCI\_BUS, DEV and FCN and recursively calling **1022** the BUS\_ASSIGN routine. The CPU **14** then restores **1024** the values for the parameters PCI\_BUS, DEV and FCN, and returns the latest call of the BUS\_ASSIGN routine to update the parameter CURRENT\_PCI\_BUS with the next PCI bus number to be assigned by the CPU **14**.

The CPU **14** then updates **1026** the subordinate bus number of the found PCI—PCI bridge by setting **1026** the subordinate bus number equal to the parameter CURRENT\_PCI\_BUS. Thus, this completes the assignment of the PCI bus number to the found PCI—PCI bridge circuit and additional downstream PCI—PCI bridge circuits and slots **36** that are powered down or empty. The CPU **14** then finds **1004** the next PCI—PCI bridge circuit or slot **36** that is powered down or empty on the PCI bus indicated by the parameter PCI\_BUS.

As shown in FIG. **46**, after the PCI bus numbers are assigned, the CPU **14** executes a memory space allocation routine called MEM\_ALLOC to allocate memory space for PCI functions and slots **36** that are powered down or empty. The CPU **14** first initializes **1028** search parameters used in aiding the CPU **14** in finding the located PCI functions and slots **36** that are powered down or empty.

The CPU **14** then finds **1030** the next PCI function or slot **36** that is powered down or empty. If the CPU **14** determines **1032** that all PCI functions and all slots **36** that are powered down or empty have been allocated memory space, the CPU **14** returns from the routine MEM\_ALLOC. Otherwise, the CPU **14** determines **1032** whether a PCI function was found.

If so, the CPU **14** allocates **1038** memory resources as specified by the PCI function. Otherwise, one of the slots **36** that is powered down or empty is found, and the CPU **14** allocates **1036** a default memory size and memory alignment for the slot **36**. The default memory size can either be a predetermined size determined before power up of the computer system **10** or a size determined after a determination of the memory resources required by the computer system **10**.

When allocating memory space, the CPU **14** programs memory base **1212** and memory limit **1214** registers of the PCI—PCI bridge circuits that are upstream of the found PCI function. The CPU **14** also programs base address registers of the corresponding PCI devices appropriately. The CPU **14** then finds **1030** the next PCI function or slot **36** that is powered down or empty.

As shown in FIG. **47**, after the PCI bus numbers are assigned, the CPU **14** executes an I/O space allocation routine called I/O\_ALLOC to allocate I/O space for PCI functions and slots **36** that are empty. The CPU **14** first initializes **1040** search parameters used in aiding the CPU **14** in finding the located PCI functions and slots **36** that are powered down or empty.

The CPU **14** finds **1042** the next PCI function or slot **36** that is powered down or empty. If the CPU **14** determines

**1044** that all PCI functions and slots **36** that are powered down or empty have been allocated I/O space, the CPU **14** returns from the I/O\_ALLOC routine. Otherwise, the CPU **14** determines **1044** whether a PCI function was found. If so, the CPU **14** allocates **1050** I/O resources as specified by the PCI function. Otherwise, a slot **36** that is powered down or empty was found, and the CPU **14** allocates **1048** a default I/O size and I/O alignment for the slot **36**. The default I/O size can either be a predetermined size determined before power up of the computer system **10** or a size determined after a determination of the I/O resources required by the computer system **10**.

When allocating I/O space, the CPU **14** programs the I/O base **1208** and limit **1210** registers of the PCI—PCI bridge circuits upstream of the PCI function or slot **36**. The CPU **14** also programs base address registers of the corresponding PCI devices appropriately. The CPU **14** then finds **1042** the next PCI function or slot **36** that is powered down or empty.

As shown in FIG. **48**, after initial configuration, when an interrupt is generated that indicates one of the levers **802** has opened or closed, the CPU **14** executes an interrupt service routine called CARD\_INT. The CPU **14** reads **1052** the contents of the interrupt register **800** to determine **1053** whether the lever **802** has been opened or closed. If the CPU **14** determines **1053** that the lever **802** causing the interrupt was opened, the CPU **14** returns from the routine CARD\_INT.

Otherwise, the CPU **14** writes **1054** to the slot enable register **817** and sets **1054** the SO bit to initiate the power up of the slot **36** and the card **807** inserted into the slot **36**. The CPU **14** then waits (not shown) for the card **807** to power up. The CPU **14** then accesses **1055** the PCI bus on the card, if any. The CPU **14** then determines **1056** whether the card **807** that was just powered up has a PCI bus (and PCI—PCI bridge circuit). If so, the CPU **14** determines **1057** the primary, secondary and subordinate bus numbers reserved for the slot **36** in which the card **807** was powered up. The CPU **14** subsequently configures **1058** the PCI—PCI bridge circuit on the card **807** that was powered up.

The CPU **14** then determines **1060** the location and size of I/O and memory spaces reserved for the slot **36**. The CPU **14** subsequently writes **1062** to base address registers in the PCI configuration header space of the card **807** that was powered up. The CPU **14** then reads **1064** an interrupt pin register in the configuration space of the card **807** to determine **1066** whether the card **807** uses interrupt requests. If so, the CPU **14** writes **1068** an interrupt line register in the configuration space of the card **807** with an assigned IRQ number.

The CPU then enables **1070** command registers of the card **870** which are located in the configuration space of the card **807** and allow the card **807** to respond to memory and I/O accesses on the PCI bus **32**. The CPU **14** subsequently writes **1072** to the interrupt register **800** to clear the interrupt request and loads **1074** a software device driver for the card **807**. The CPU **14** then returns from the routine CARD\_INT.

#### Bridge Configuration

Functionally, bridge chips between **48** form a PCI—PCI bridge between PCI buses **24** and **32**. However, each bridge chip includes configuration space which must be independently configured. One solution is to treat the two bridges as independent devices forming one bridge, but that would require modification of the BIOS configuration routine. The other solution is to define the cable **28** as a bus so that the configuration routine can configure the upstream

bridge chip **26** as a PCI—PCI bridge between the PCI bus **24** and the cable **28**, and the downstream bridge chip **48** as a PCI—PCI bridge between the cable **28** and the PCI bus **32**. One advantage of this second solution is that standard PCI configuration cycles can be run to configure the bridge chips **26** and **48** as if they were two PCI—PCI bridges, when in fact the two bridge chips actually form one PCI—PCI bridge.

There are two types of configuration transactions on a PCI bus: type 0 and type 1. A type 0 configuration cycle is intended for devices on the PCI bus on which the configuration cycle is generated while a type 1 configuration cycle is targeted for devices on a secondary PCI bus accessed via a bridge. FIG. 51 illustrates the address format of the type 0 and type 1 configuration cycles. A type 0 configuration command is specified by setting PCI address bits AD [1:0] to 00 during a configuration cycle. A type 0 configuration cycle is not forwarded across a PCI—PCI bridge, but stays local on the bus on which the type 0 configuration transaction was generated.

A type 1 configuration command is specified by setting address bits AD [1:0] to binary value 01. Type 1 configuration commands can be forwarded by a PCI—PCI bridge to any level in the PCI bus hierarchy. Ultimately, a PCI—PCI bridge converts a type 1 command to a type 0 command to configure devices connected to the secondary interface of the PCI—PCI bridge.

Configuration parameters stored in the configuration registers **105** or **125** of the bridge identify the bus numbers for its primary PCI interface (primary bus number) and secondary PCI interface (secondary bus number) and a subordinate bus number that indicates the highest numbered PCI bus subordinate to the bridge. The bus numbers are set by the PCI configuration routine BUS\_ASSIGN (FIG. 45). For example, in the upstream bridge chip **26**, the primary bus number is the bus number of the bus **24**, the secondary bus number is the number of the cable **28**, and the subordinate bus number is the number of the secondary PCI bus **32** or the number of a deeper PCI bus if one exists. In the downstream bridge chip **48**, the primary bus number is the number of the cable bus **28**, the secondary bus number is the number of the PCI bus **32**, and the subordinate bus number is the number of a PCI bus located deeper in the PCI bus hierarchy, if one exists.

Referring to FIG. 53A, detection of configuration cycles are handled by logic in the PCI target block **103** or **121** in the upstream bridge chip **26** or downstream bridge chip **48**, respectively. A type 0 configuration cycle detected on the upstream bus **24** is indicated by asserting a signal TYPO\_CFG\_CYC\_US generated by an AND gate **276**. The AND gate **276** receives signals UPSTREAM\_CHIP, IDSEL (chip select during configuration transactions), CFGCMD (configuration command cycle detected) and ADDR00 (bits **1** and **0** are both zeros). A type 0 configuration cycle detected by the downstream bridge chip **48** is indicated by a signal TYPO\_CFG\_CYC\_DS generated by an AND gate **278**, which receives a signal S1\_BL\_IDSEL (IDSEL signal for the downstream bridge chip **48**), the signal CFGCMD, the signal ADDR00, a signal MSTR\_ACTIVE (indicating that the bridge chip **48** is the master on a secondary PCI bus **32**), and the inverted state of a signal UPSTREAM\_CHIP.

Detection of a type 1 configuration cycle by the PCI target **103** in the upstream bridge chip **26** is indicated by asserting a signal TYP1\_CFG\_CYC\_US from an AND gate **280**, which receives signals CFGCMD, ADDR01 (bits **1** and **0** are

low and high, respectively) and UPSTREAM\_CHIP. Detection of a type 1 configuration cycle on the downstream bus **32** is indicated by asserting a signal TYP1\_CFG\_CYC\_DS from an AND gate **282**, which receives the signals CFGCMD, ADDR01, and the inverted state of the signal UPSTREAM\_CHIP.

The bridge chip receiving the type 0 transaction uses the register number field **250** in the configuration transaction address to access the appropriate configuration register. The function number field **252** specifies one of eight functions to be performed in a multi-functional device during the configuration transaction. A PCI device can be multi-functional and have such functions as a hard disk drive controller, a memory controller, a bridge, and so forth.

When the bridge chip **26** sees a type 1 configuration transaction on its upstream bus **26**, it can forward the transaction either downstream, translate the transaction to a type 0 transaction, convert the transaction to a special cycle, or ignore the transaction (based on the bus number parameters stored in the configuration registers **105** or **125**). If a transaction is forwarded, it is up to the PCI master of the destination bridge chip to convert the type 1 transaction to the corresponding appropriate transaction. If a bridge chip handles the transaction itself, then it responds by asserting the signal DEVSEL\_ on the PCI bus and handles the transaction as a normal delayed transaction.

In a type 1 configuration transaction, the bus number field **260** selects a unique PCI bus in the PCI hierarchy. PCI target block **103** passes a type 1 configuration cycle from the upstream chip **26** down to the downstream bridge chip **48** if a signal PASS\_TYP1\_DS is asserted by an AND gate **284**. The AND gate **284** receives the signal TYP1\_CFG\_CYC\_US and a signal IN\_RANGE (the bus number field **260** is greater than or equal to the stored secondary bus number and less than or equal to the stored subordinate bus number). The other input of the AND gate **284** is connected to the output of an OR gate **286**, which has one input connected to the output of an AND gate **288** and the other input receiving the inverted state of a signal SEC\_BUS\_MATCH. Thus, if a type 1 cycle is detected, the signal IN\_RANGE is asserted and the bus number field **260** does not match the stored secondary bus number, the signal PASS\_TYP1\_DS is asserted. If the bus field **260** does not match the stored secondary bus number, then bus devices on or below the downstream bus **32** are addressed. The AND gate **288** asserts its output high if the signal SEC\_BUS\_MATCH is asserted high and the device number field **258** indicates that the target of the type 1 configuration cycle is the configuration space of the downstream bridge chip **48**. If this is true, the type 1 configuration transaction is forwarded down the cable **28** to the downstream bridge chip **48** for translation to a type 0 configuration transaction. The PCI target **121** in the downstream bridge chip **48** responds to the transaction and reads and writes the downstream bridge configuration registers **125** according to the type 0 transaction. The control pins of the downstream chip are driven and read and write data appear on the downstream PCI bus **32** as if a type 0 transaction is running on the downstream bus (for debug purposes), although each IDSEL on the downstream bus **32** is blocked so that no device actually responds to the type 0 transaction.

If the PCI target block **103** in the upstream bridge chip **26** detects a type 1 configuration transaction on its upstream bus **24**, having a bus number field equal to the stored secondary bus number (the cable bus **28**) but not addressing device **0** (searching for other devices on the cable bus **28**), then the target block **103** ignores the transaction on the primary bus **26**.

## 101

If the PCI target **121** detects a type 1 configuration write transaction (WR\_high) on the secondary PCI bus **32**, which has a bus number field **260** outside the range of the secondary bus number and subordinate bus number (IN\_RANGE low), and if the device number **258**, the function number **256**, and the register number **254** indicate a special cycle (SP\_MATCH high), then a signal PASS\_TYPI\_US is asserted by an AND gate **290**. The AND gate **290** receives the signal TYPI\_CFG\_CYC\_DS, the signal SP\_MATCH, the write/read strobe WR\_, and the inverted state of the signal IN\_RANGE. When the PCI master **101** in the upstream bridge chip **26** receives such a cycle, it runs a special cycle on the primary PCI bus **24**.

Configuration transactions are ignored by a bridge chip under certain conditions. If the target block **103** in the upstream bridge chip **26** detects a type 1 configuration transaction on the PCI bus **24** (its upstream bus), and the bus number field **260** is less than the secondary bus number or greater than the subordinate bus number stored in the bridge chip's configuration space, then the target block **103** ignores the transaction.

If the target block **121** in the downstream bridge chip **48** detects a type 1 configuration transaction on the secondary PCI bus **32** (its downstream bus), and the bus number field **260** is greater than or equal to the secondary bus number and less than or equal to the subordinate bus number stored in the bridge chip's configuration space, then the target block **121** ignores the transaction. In addition, type 1 configuration commands going upstream are ignored if the type 1 command does not specify a conversion to a special cycle transaction regardless of the bus number specified in the type 1 command.

Referring to FIG. 53B, the PCI master **101** or **123** watches for a configuration cycle transferred over the cable **28**. If the PCI master **123** in the downstream bridge chip **48** detects a type 1 configuration transaction from the upstream bridge chip **26**, it compares the bus number field **260** with the primary bus number and secondary bus number stored in the configuration space of the bridge chip **48**. If the bus number field **260** matches either the stored primary bus number (i.e., cable **28**) or the stored secondary bus number (addressing a device directly connected to the downstream bus **32**), the downstream bridge chip **48** translates the transaction to a type 0 transaction (by setting AD [1:0] = 00) as it passes the configuration transaction onto the bus. The type 0 transaction is performed on the PCI bus **32** by the PCI master block **123**.

The following are translations performed of fields in the type 1 configuration transaction. The device number field **258** in the type 1 configuration transaction is decoded by the PCI master **123** to generate a unique address in the translated type 0 transaction on the secondary bus **32**, as defined in table of FIG. 52. The secondary address bits AD [31:16] decoded from the device number field **258** are used by the PCI master **123** to generate the appropriate chip select signals IDSEL for the devices on the secondary PCI bus **32**. When the address bit AD [15] is equal to 1, then the bridge chip **48** maintains all of address bits AD [31:16] deasserted low (no IDSEL asserted). The register number field **254** and the function number field **256** of the type 1 configuration command are passed unmodified to the type 0 configuration command. The function number field **256** selects one of eight functions, and the register number field **254** selects a double word in the configuration register space of the selected function.

For a type 1 configuration transaction targeted to the downstream bridge chip **48**, the bridge chip **48** converts the

## 102

type 1 transaction to a type 0 transaction as if it were addressing a device on the downstream bus **32**, but the AD [31:16] pins are set to zeros so that no secondary PCI bus device receives an IDSEL. The PCI master logic **123** detects this by asserting a signal TYPI\_TO\_INT0 driven by an AND gate **262**. The AND gate **262** receives a signal CFG\_CMD (indicating a configuration command cycle), the output of an OR gate **264**, and the inverted state of the signal UPSTREAM\_CHIP (type-1-to-type-0 translation is disabled in the upstream bridge chip **26**). The OR gate **264** asserts its output high if a signal PRIM\_BUS\_MATCH is asserted (the bus number field **260** matches the stored primary bus number), or if the stored primary bus number CFG2P\_PRIM\_BUS\_NUM [7:0] is equal to zero (indicating that the primary bus number in the configuration space of the bridge chip **48** has not been configured by the system BIOS yet and the current type 1 configuration cycle is going to the internal configuration space to program the primary bus number of the bridge chip **48**).

A signal TYPL\_TO\_EXT0 is asserted by an AND gate **266** and responds to a match to the stored secondary bus number. The inputs of the AND gate **266** receive the signal CFG\_CMD, the signal SEC\_BUS\_MATCH, the inverted state of the signal UPSTREAM\_CHIP, and the inverted state of a signal SP\_MATCH (not a special cycle). The signal TYPL\_TO\_EXT0 indicates that the converted type 0 configuration transaction is targeted to a device on the secondary PCI bus **32**.

The signal TYPI\_TO\_INT0 is provided to the 1 input of a 4:1 multiplexer **274**. The 2 input is tied low and the 0 and 3 inputs of the multiplexer **274** receive a signal LTYPI\_TO\_INT0 from a D type flip-flop **270**. The select input S1 of the multiplexer **274** receives a signal CMD\_LATCH (FRAME\_ asserted for a new cycle on the PCI bus **32**), and the select input S0 receives a signal P2Q\_START\_PULSE (which indicates when high that an address has been sent to the PCI bus **32**). The output of the multiplexer **274** is connected to the D input of a flip-flop **270**, which is clocked by the signal PCLK and cleared by the signal RESET. The IDSEL signals to the secondary bus devices are blocked by asserting a signal BLOCK\_IDSEL from an OR gate **272**, which receives at its inputs signals Q2P\_AD [15] (no conversion needed according to Table 1 of the FIG. 6), TYPI\_TO\_INT0 and LTYPI\_TO\_INT0. The signal LTYPI\_TO\_INT0 extends the assertion of the signal BLOCK\_IDSEL.

If the PCI master **123** in the downstream bridge chip **48** receives a type 1 configuration transaction from the upstream bridge chip **26** in which the bus number field **260** is greater than the stored secondary bus number and less than or equal to the stored subordinate bus number, then the PCI master block **123** forwards the type 1 transaction to the secondary PCI bus **32** unchanged. Some other device on the secondary PCI bus **32**, e.g., another bridge device **323** (FIG. 26B), will receive the type 1 configuration transaction and forward to its secondary bus (PCI bus **325**).

A type 1 configuration transaction to special cycle translation is performed if the PCI master **123** detects a type 1 configuration write transaction from the upstream bridge chip **26** and the bus number field **260** matches the stored secondary bus number and if the device number field **258**, the function number field **256**, and the register number field **254** indicates a special cycle (SP\_MATCH is high). This is indicated by an AND gate **268** asserting a signal TYPE1\_TO\_SPCYC high. The AND gate **268** receives SP\_MATCH, and Q2P\_CBE [0] (command bit for special cycle). The data from the type 1 configuration transaction



becomes the data for the special cycle on the destination bus. The address during a special cycle is ignored.

#### Bus Performance Monitor

The bus monitor **127** (FIG. 3) includes circuitry for storing information to calculate certain bus performance parameters. The parameters include bus utilization, bus efficiency, and read data efficiency. Bus utilization is the ratio of the time that the bus is busy performing a transaction to a predetermined global period of time. Bus efficiency is the ratio of the number of PCI clock periods actually used for data transfer to the total number of clock periods during the bus busy period. Read data efficiency is the ratio of the number of the read data bytes accessed by a device on the secondary PCI bus **32** from the delayed completion queue (DCQ) **144** (FIG. 4) to the total number of data bytes fetched for that master by the bridge chip **48**. The information stored in the bus monitor **127** is retrieved by system software to calculate the desired parameters.

Referring to FIG. 54A, a global period timer **1300** (which can be 32 bits wide) counts a total period of time during which the various parameters are to be calculated. The timer **1300** is programmed to the hexadecimal value FFFFFFFF. If the PCI clock PCICLK2 is running at 33 MHz, then the timer period is approximately 2 minutes. When the timer **1300** decrements to 0, it asserts a signal GL\_TIME\_EXPIRE.

The bus monitor **127** includes 7 slot-specific bus-busy counters **1302A–G**, six of the counters corresponding, respectively, to the 6 slots on the secondary PCI bus **32** and one to the SIO **50**. The bus-busy counters **1302A–G** are cleared when the signal GL\_TIME\_EXPIRE is asserted. Depending on which bus device has control of the secondary bus **32**, the bus-busy counter **1302** increments on every PCI clock in which the secondary PCI bus FRAME\_ or IRDY\_ signal is asserted. The appropriate one of the seven counters is selected by one of the grant signals GNT[7:1]\_. Thus, for example, the bus-busy counter **1302A** is selected when the signal GNT[1]\_ is asserted low, indicating that the SIO is the current master on the secondary PCI bus **32**.

Seven data-cycle counters **1306A–G**, corresponding, respectively, to the 6 slots on the secondary PCI bus **32** and the SIO **50**, keep track of the time during which a data transfer is actually occurring between a master and a target during a transaction on the PCI bus **32**. The selected data-cycle counter **1306** is incremented on every PCI clock in which the secondary bus IRDY\_ and TRDY\_ signals are both asserted low. The data-cycle counters **1306A–G** are cleared when the signal GL\_TIME\_EXPIRE is asserted.

Six DCQ data counters **1310A–F** are included in the bus monitor **127** for keeping track of the amount of data loaded into the DCQ buffers. The six DCQ data counters **1310A–F** correspond to the 6 slots on the secondary PCI bus **32**. The selected DCQ data counter **1310** increments on every PCI clock in which delayed read completion (DRC) data is received from the cable **28** and loaded into the prefetch buffers.

Another set of counters, DCQ-data-used counters **1314A–F**, are used to keep track of the amount of data loaded into the DCQ **144** actually used by the 6 slots on the secondary PCI bus **32**. The selected DCQ-data-used counter **1314** increments on every PCI clock in which the secondary bus master reads data from the corresponding DCQ buffer. Both the DCQ-data counters **1310A–F** and DCQ-data-used counters **1314A–F** increment on each data cycle regardless of the number of bytes actually transferred. In most cases, the number of bytes transferred in each data cycle is 4.

When the global period timer **1300** times out and asserts the signal GL\_TIME\_EXPIRE, several events occur. First, the global period timer **1300** reloads its original count value, which is the hexadecimal value FFFFFFFF. The contents of all the other counters, including the bus-busy counters **1302A–G**, data-cycle counters **1306A–G**, DCQ data counters **1310A–F**, and DCQ-data-used counters **1314A–F**, are loaded into registers **1304**, **1308**, **1312**, and **1316**, respectively. The counters **1302**, **1306**, **1310**, and **1314** are then cleared to 0. The global period timer **1300** then begins to count again after it is reloaded with its original value.

The signal GL\_TIME\_EXPIRE is provided to the interrupt receiving block **132**, which forwards the interrupt over the cable **28** to the interrupt output block **114**, which in turn generates an interrupt to the CPU **14**. The CPU **14** responds to the interrupt by invoking an interrupt handler to perform the bus performance analysis. The interrupt handler accesses the contents of the registers **1304**, **1308**, **1312**, and **1316**, and calculates the several parameters, including the bus utilization, bus efficiency, and prefetch efficiency parameters associated with the 6 secondary bus slots and the SIO **50**.

The bus utilization parameter is the value of the bus-busy counter **1302** divided by the initial value of the global period timer **1300**, which is the hexadecimal value FFFFFFFF. Thus, bus utilization is the percentage of the total global time during which a bus master is performing a bus transaction.

A PCI transaction includes an address phase and at least one data transfer phase. A bus master asserts the signal FRAME\_ to indicate the beginning and duration of an active bus transaction. When the signal FRAME\_ is deasserted, that indicates the transaction is in the final data phase or the transaction has been completed. The signal IRDY\_ indicates that the bus master is able to complete the current data phase of the bus transaction. During a write, the signal IRDY\_ indicates that valid data is present on the bus. During a read, the signal IRDY\_ indicates the master is prepared to accept read data. The addressed PCI target responds to the bus transaction by asserting the signal TRDY\_ to indicate that the target is able to complete the current data phase of the transaction. During a read, the signal TRDY\_ indicates that valid data is present on the bus; during a write, the signal TRDY\_ indicates the target is prepared to accept data. Wait states can be inserted between the address and data phases and between consecutive data phases of the bus transaction.

During the address phase or the wait states, no data transfer is actually occurring.

Actual data transfer is occurring only when both signals IRDY\_ and TRDY\_ are asserted low. To determine the data transfer bus efficiency, the interrupt handler divides the value of the data-cycle counter **1306** by the value of the bus-busy counter **1302**. The bus efficiency represents the amount of time during which a data transfer actually occurs during a bus transaction. By calculating this value, the computer system can be made aware of target devices which require many wait states and therefore are inefficient.

The bridge chip **48** can fetch data from the primary PCI bus **26** and store the data in the DCQ **144**. The DCQ **144** has each eight buffers, each being assignable to a secondary bus master. For example, a memory read multiple transaction generated by a secondary bus master targeted at the primary bus will cause bridge **26**, **48** to fetch **8** cache lines from the memory **20** and load into the DCQ **144**. A memory read line transaction will cause the PCI–PCI bridge **26**, **48** to fetch one line of data from the memory **20**. In addition, as



described in conjunction with FIGS. 75 and 79, the PCI—PCI bridge 26, 48 can perform read promotion, which converts a read request from a secondary bus master to a read request for a larger block of data. In these instances, there exists a possibility that not all of the fetched data will be used by the bus master. In that case, the unread data is discarded, which reduces the read data efficiency. Measuring the read data efficiency allows system designers to understand how a bus master is utilizing read data fetched by the bridge chip 26, 48 from the primary bus 24.

Referring to FIG. 54B, the counter 1310 increments on the rising edge of the clock PCLK if the signal DCQ\_DATA\_RECEIVED [X], X=2-7, is asserted, indicating that four bytes of data are being received by a DCQ buffer associated with master X from the cable 28. The counter 1310 outputs count value DCQ\_DATA [X] [20:0], X=2-7, which is cleared to zero when the signal GL\_TIME\_EXPIRE is asserted.

The counter 1314 increments on the rising edge of the clock PCLK if a signal DCQ\_DATA\_TAKEN [X], X=2-7, is asserted, indicating that four bytes of data are read from a DCQ buffer associated with master X. The counter 1314 is cleared when the signal GL\_TIME\_EXPIRE is high.

To determine the amount of the DCQ data that is actually used by the devices on the secondary PCI bus 32, the prefetch efficiency is calculated by the interrupt handler. This is determined by taking the ratio of the value in the DCQ-data-used counter 1314 to the value in the DCQ data counter 1310. Even though not all data transferred into or out of the prefetch buffers are 4 bytes wide, that ratio is closely approximated by assuming that every data phase transfers the same number of bytes.

In response to the calculated parameters, a user or the computer manufacturer can better understand computer system performance. For example, if bus efficiency is low, then the PCI device involved could be replaced with a different part by the computer manufacturer. Knowing the DCQ read data efficiency allows the computer manufacturer to change its DCQ fetch algorithm to better improve efficiency.

#### Using Subordinate Bus Devices

As shown in FIG. 88, six expansion cards inserted into the six expansion cards slots 36a-f introduce bus devices 1704-1708 that are subordinate to the CPU 14 and bus devices 1701-1702 that are subordinate to an I<sub>2</sub>O processor 1700. Although all of the subordinate bus devices 1701-1708 are connected to the common PCI bus 32, the I<sub>2</sub>O subordinate devices 1701-1702 appear to the CPU 14 to only be addressable through the I<sub>2</sub>O processor 1700 and not directly addressable via the PCI bus 32. Therefore, the PCI bus 32 serves as both an I<sub>2</sub>O subordinate device bus and a CPU 14 subordinate device bus.

For purposes of preventing the CPU 14 from recognizing the I<sub>2</sub>O subordinate devices 1701-1702 as PCI bus 32 devices, the bridge chip 48 includes logic 1710 (FIG. 90) for preventing the I<sub>2</sub>O subordinate devices 1701-1702 from responding to configuration cycles run by the CPU 14. The expansion box 30 also includes multiplexing circuitry 1712 which cooperates with the interrupt receiving block 132 of the bridge chip 48 to mask interrupt requests originating with the I<sub>2</sub>O subordinate devices 1701-1702 from propagating to the CPU 14. Interrupt requests originating with I<sub>2</sub>O subordinate bus devices 1701-1702 are redirected by the interrupt receiving block 132 to the I<sub>2</sub>O processor 1700. The I<sub>2</sub>O processor 700 configures the I<sub>2</sub>O subordinate devices 1701-1702; receives and processes interrupt requests origi-

nating from the I<sub>2</sub>O subordinate devices 1701-1702; and controls operation of the I<sub>2</sub>O subordinate devices as directed by the CPU 14.

After power up of the computer system 10 and when a card 807 is powered up (i.e., a new bus device is introduced on the PCI bus 32), the I<sub>2</sub>O processor 1700 scans the PCI bus 32 to identify I<sub>2</sub>O subordinate bus devices. For purposes of identifying the type of bus device (I<sub>2</sub>O subordinate bus device or CPU 14 subordinate device), the I<sub>2</sub>O processor 1700 runs configuration cycles on the PCI bus 32 to read the device identification word (Device ID) of each bus device. The Device ID is located in the configuration header space of all PCI devices. The I<sub>2</sub>O processor 1700 stores the results of this scan in a six bit I<sub>2</sub>O subordinate register 1729 (FIG. 93) inside the I<sub>2</sub>O processor 1700 which is accessible by the CPU 14. Bits zero through five of the register 1729 are associated with slots 36a-f, respectively. A value of "1" for a bit indicates the associated slot 36 has a bus device subordinate to the CPU 14 and a value of "0" for a bit indicates the associated slot 36 has a bus device subordinate to the I<sub>2</sub>O processor 1700.

The I<sub>2</sub>O processor 1700 can be inserted into any of the slots 36a-f. For purposes of identifying which slot 36, if any, contains an I<sub>2</sub>O processor, the CPU 14 scans the PCI bus 32 and reads the Device ID of the bus devices connected to the bus 32. The CPU 14 does not attempt to configure any devices 1704-1708 on the bus 32 until a host configuration enable bit 1726 (FIG. 94) inside the I<sub>2</sub>O processor 1700 indicates to the CPU 14 that the I<sub>2</sub>O processor 1700 has completed its identification of I<sub>2</sub>O subordinate devices 1701-1702 on the bus 32. The host configuration enable bit 1726 has a value of "0" (value at power up) to disable configuration of the devices on the bus 32 by the CPU 14 and a value of "1" to enable configuration of the CPU 14 subordinate devices 1704-1708 on the bus 32. When the CPU 14 does configure bus devices on the bus 32, the CPU 14 does not "see" the I<sub>2</sub>O subordinate device 1701-1702 because of the masking by the logic 1710, as described below.

After the host enable configuration bit 1726 is set, the CPU 14 reads the contents of the I<sub>2</sub>O subordinate register 1729 and transfers the read contents to a six bit I<sub>2</sub>O subordinate register 1728 (FIG. 91) of the bridge chip 48. The register 1728 indicates the subordinate status (I<sub>2</sub>O processor 1700 subordinate or CPU 14 subordinate) of the bus devices in the same manner as the register 1729. Before the CPU 14 writes to the register 1728, the register 1728 contains all ones (value at power up) which allows the CPU 14 to scan the bus 32 for the I<sub>2</sub>O processor 1700. The interrupt receiving block 132 uses the register 1728 to identify which interrupt requests received by the block 132 should be routed to the CPU 14 and which interrupt requests received by the block 132 should be routed to the I<sub>2</sub>O processor 1700 for processing. Furthermore, the logic 1710 uses the contents of the register 1728 to block recognition by the CPU 14 of the I<sub>2</sub>O subordinate devices 1701-1702 from the CPU 14.

For purposes of indicating to the interrupt receiving block 132, which bus device, if any, is an I<sub>2</sub>O processor, the CPU 14 sets one bit of an I<sub>2</sub>O slot register 730 (FIG. 92) whose bits 0-5 correspond to the slots 36a-f, respectively. For this register 1730, located inside the bridge chip 48, a value of "0" for a bit indicates the associated slot 36 does not have an I<sub>2</sub>O processor and a value of "1" for the bit indicates the associated slot 36 has an I<sub>2</sub>O processor.

As shown in FIG. 90, the logic 1710 includes a multi-bit AND gate 1711 which furnishes signals AD\_IDSEL [5:0] to

address/data lines of the bus 32 to select devices on the bus 32 during configuration cycles. The AND gate 1711 receives a six bit signal ENABLE [5:0] having bits indicative of and corresponding to bits of the I<sub>2</sub>O subordinate register 1728. The AND gate 1711 also receives the typical identification select signals SLOT\_IDSEL [5:0] furnished by the bridge chip 48 for selecting devices on the bus 32 during configuration cycles. Therefore, the signals ENABLE [5:0] are used to selectively mask the signals SLOT\_IDSEL [5:0] from the PCI bus 32 when configuration cycles are run by the CPU 14.

For purposes of controlling the destination of interrupt requests from the slots 36a-d, the four standard PCI interrupt request signals (INTA#, INTB#, INTC# and INTD#) provided by each slot 36 are furnished to multiplexing circuitry 1712 (FIG. 88). The multiplexing circuitry 1712 serializes the PCI interrupt request signals received from the slots 36 and furnishes the signals to the interrupt receiving block 132 via four time multiplexed serial interrupt request signals: INTSDA#, INTDSB#, INTSDC#, and INTSDD#.

As shown in FIG. 89, the interrupt receiving block 132 furnishes interrupt request signals for the CPU 14 to the interrupt output block 114 via a time multiplexed serial interrupt request signal INTSDCABLE#. The interrupt receiving block 132 furnishes interrupt request signals for the I<sub>2</sub>O processor 700 via a time multiplexed serial interrupt request signal INTSDIIO# furnished via a PCI INTC# line 1709 of the bus 32 to the I<sub>2</sub>O processor 1700. The interrupt output block 114 furnishes the interrupt requests destined for the CPU 14 to one or more of the standard PCI interrupt request lines (INTA#, INTB#, INTC#, and INTD#) of the PCI bus 24. An interrupt controller 1900, external to the bridge chip 26, receives the interrupt requests from the PCI interrupt request lines of the PCI bus 24. The interrupt controller 1900 prioritizes the interrupt requests (which may include interrupt requests from other devices on the PCI bus 24) and furnishes them to the CPU 14. The interrupt output block 114 may either asynchronously (when in an asynchronous mode) furnish the interrupt request signals to the interrupt request lines of the PCI bus 24 or serially (when in a serial mode) furnish the interrupt request signals to the INTA# line of the PCI bus 24, as further described below.

As shown in FIG. 95, all of the time multiplexed serial data signals represent their data via an interrupt cycle 1850 which comprises eight successive time slices (T0-T7). The duration of each time slice is one cycle of the PCI clock signal CLK. Each time slice represents a "snapshot" of the status of one or more interrupt request signals. As shown in FIG. 99, the signal INTSDA# represents the sampled INTA# interrupt request signals from the slots 36a-f. The signal INTSDB# represents the sampled INTB# interrupt request signals from the slots 36a-f. The signal INTSDC# represents the sampled INTC# interrupt request signals from the slots 36a-f. The signal INTSDD# represents the sampled INTD# interrupt request signals from the slots 36a-f.

For purposes of combining the interrupt signals INTSDA#-D# into the signal INTSDIIO#, the interrupt receiving block 132 logically ANDs the signals INTSDA#-D# together while simultaneously masking interrupt request signals destined for the CPU 14. Similarly, for purposes of combining the interrupt signals INTSDA#-D# into the signal INTSDCABLE#, the interrupt receiving block 132 logically ANDs the signals INTSDA#-D# together while simultaneously masking interrupt request signals destined for the CPU 14.

For the purpose of instructing the interrupt output block 114 when another interrupt cycle 1850 is beginning, the

interrupt receiving block 132 furnishes a synchronization signal INTSYNCCABLE# to the interrupt output block 114. The falling, or negative, edge of the signal INTSYNCCABLE# indicates that time slice T0 of the interrupt cycle 1850 transmitted via the signal INTSDCABLE# is beginning on the next positive edge of the CLK signal. A signal INTSYNCIIO# is used in an analogous fashion to indicate an upcoming time slice T0 of the interrupt cycle 1850 transmitted via the signal INTSDIIO#. The signal INTSYNCIIO# is furnished by the interrupt receiving block 132 to the I<sub>2</sub>O processor 1700 via a PCI INTD# line 1713 of the bus 32. For the purpose of instructing the multiplexing circuitry 1712 when to transmit another interrupt cycle 1850 via the interrupt signals INTSDA#-D#, the interrupt receiving block 132 furnishes a synchronization signal INTSYNC# to the multiplexing circuitry 1712. The falling, or negative, edge of the signal INTSYNC# indicates the multiplexing circuitry 1712 should be transmitting time slice T0 of the signals INTSDA#-D# on the next positive edge of the CLK signal.

As shown in FIG. 96, the multiplexing circuitry 1712 includes four multiplexers 1741-1744 which furnish the signals INTSDA#, INTSDB#, INTSDC# and INTSDD#, respectively. The select inputs of the multiplexers 1741-1744 receive a time slice signal SLICEIN [2:0] which is used to indicate the time slices T0-T7 of the signals INTSDA#-D#. The INTA#-D# interrupt request signals from the slots 36 are furnished to the inputs of the multiplexers 1741-744, respectively.

The signal SLICEIN [2:0] is furnished by the output of a three bit counter 1745 that is clocked on the positive edge of the PCI clock signal CLK. The interrupt synchronization signal INTSYNC# is received by a clocked enable input of the counter 1745. On the negative edge of the signal INTSYNC#, the counter 1745 resets to zero (SLICEIN [2:0] equals zero). The counter 1745 increments the value indicated by the SLICEIN [2:0] signal until the SLICEIN [2:0] signal is equal to "7" where it remains until the counter 1745 is once again reset by the INTSYNC# signal.

As shown in FIG. 97A, for purposes of tracking the time slices T0-T7, the interrupt receiving block 132 includes a three bit counter 1750 that is clocked on the positive edge of the CLK signal. The counter 1750 furnishes an output signal SL1 [2:0] which is received by the select input of a 3x8 decoder 1752. The decoder 1752 furnishes an eight bit signal G\_CNTR [7:0] with the asserted bit of the signal G\_CNTR [7:0] indicating the time slice of the signals INTSDIIO# and INTSDCABLE#.

The INTSYNC# signal is furnished by the output of an inverter 1754 that receives the most significant bit of the G\_CNTR [7:0] signal, G\_CNTR [7]. Although the INTSYNC# signal is pulsed low during the time slice T7, the interrupt receiving block 132 could alternatively wait several cycles of the CLK signal after ending an interrupt cycle 1850 before pulsing the INTSYNC# signal low. The signals INTSYNCCABLE# and INTSYNCIIO# are both provided by the output of an inverter 1755 which receives the bit G\_CNTR [0].

An additional interrupt request signal CAY\_INT# for the CPU 14 is provided by the SIO circuit 50. The CAY\_INT# signal is logically ANDed with the INTSDA#-D# signals during time slice T0. The CAY\_INT# signal is furnished by the output of an AND gate 1756 which receives a SIO\_CMPL# signal, the SI\_INTR# signal, and an I<sup>2</sup>C\_INT# signal. The SIO\_CMPL# signal is asserted, or driven low, when the SIO circuit 50 has completed a serial output

process. The I<sup>2</sup>C\_INT# signal is asserted, or driven low, to indicate completion of a transaction over an I<sup>2</sup>C bus (not shown) connected to the bridge chip 48. The I<sub>2</sub>C\_INT# signal is deasserted, or driven high, otherwise.

For purposes of masking interrupt requests, the interrupt receiving block 132 generates four masking signals: MASKA, MASKB, MASKC and MASKD. When the MASKA signal is asserted, or driven high, during a particular time slice (T0–T7) of the signal INTSDA#, an interrupt request indicated by the serial interrupt signal INTSDA# during that particular time slice is masked from the CPU 14. If the MASKA signal is deasserted, or driven low, during the particular time slice, the interrupt request indicated by the serial interrupt signal INTSDA# is masked from the I<sub>2</sub>O processor 1700. The MASKB-D signals function similarly to mask interrupt requests furnished by the signals INTSDB#-D#.

As shown in FIG. 97B, a multiplexer 1758 furnishes the MASKA signal. The select input of the multiplexer 1758 receives the SL1 [2:0] signal. The eight inputs of the multiplexer 1758 receive inverted IIO\_SUB [5:0] signals which are indicative of corresponding bits of the I<sub>2</sub>O subordinate register 1728. The signals IIO\_SUB [5:0] are connected to the appropriate inputs of the multiplexer 1758 so that when the INTSDA# signal indicates the interrupt status for a particular slot 36, the MASKA signal concurrently indicates the associated bit of the register 1728 for that slot 36. Three other multiplexers 1760, 1762, and 1764 furnish the signals MASKB, MASKC and MASKD, respectively. Similar to the generation of the MASKA signal, the signals IIO\_SUB [5:0] are connected to the appropriate inputs of multiplexers 1760, 1762, and 1764 so that the MASKB, MASKC and MASKD signals indicate the bit of the register 1728 associated with the slot represented by the signals INTSDB#, INTSDC#, and INTSDD#. The multiplexers 1760–1764 receive the signal SL1 [2:0] at their select inputs.

As shown in FIG. 97C, the interrupt receiving block 132 also includes two multiplexers 1768 and 1770 which furnish two masking signals, IIOTS\_D and IIOTS\_C, used to mask the INTD# and INTC# signals furnished by the slot interrupt lines of the I<sub>2</sub>O processor 1700 because the lines 1709 and 1713 are used to furnish the signals INTSDIIO# and INTSYNCIIO#, respectively, to the I<sub>2</sub>O processor 1700. The select inputs of both multiplexers 1768 and 1770 receive the signal SL1 [2:0], and the signal inputs of the multiplexers 1768 and 1770 receive signals IIOSLOT [5:0] which are indicative of the corresponding bits of the I<sub>2</sub>O slot register 1730. The signals IIOSLOT [5:0] are connected to the appropriate inputs of multiplexers 1768 and 1770 so that when the INTSDC#-D# signals indicate the interrupt status for a particular slot 36, the IIOSLOT [5:0] signal selected by the multiplexers 1768 and 1770 concurrently indicate the associated bit of the register 1730 for that slot 36.

As shown in FIG. 97D, six AND gates 1772–1782 are used to combine the signals INTSDA#-INTSDD# and mask selected interrupt request signals from the CPU 14. The AND gate 1772 receives an inverted ECC\_ERR\_DOWN# signal (asserted to indicate an error detected by the chip 48b in cable transmissions) and the bit G\_CNTRL[0]. The AND gate 1774 receives an inverted INTSDA# signal and the MASKA signal. The AND gate 1776 receives an inverted INTSDB# signal and the MASKB signal. The AND gate 1778 receives an inverted INTSDC# signal, the MASKC signal and the IIOTS\_C signal. The AND gate 1780 receives an inverted INTSDC# signal, the MASKD signal, and the IIOTS\_D signal. The AND gate 1782 receives an inverted CAY\_INT signal and the G\_CNTRL signal.

The outputs of the AND gates 1772–1782 are connected as inputs to an OR gate 1784 which has its output connected to the signal input of a D-type flip-flop 1786. The flip-flop 1786 is clocked on the positive edge of the CLK signal, and the set input of the flip-flop 1786 receives the RST signal. The inverting output of the flip-flop 1786 furnishes the INTSDCABLE# signal.

Four AND gates 1790–1796 are used to combine the INTSDA#-D# signals and mask selected interrupt request signals from the I<sub>2</sub>O processor 1700. The AND gate 1790 receives an inverted INTSDA# signal and an inverted MASKA signal. Another input of the AND gate 1790 is connected to the output of a NOR gate 1802 which masks the INTSDA# signal during the time slices T0 and T7 because no card interrupt requests are include in these time slices. The NOR gate 1802 receives the bits G\_CNTRL [0] and G\_CNTRL [7]. The AND gate 1792 receives an inverted INTSDB# signal and an inverted MASKB signal. Another input of the AND gate 1792 is connected to the output of a NOR gate 1804 which masks the INTSDB# signal during the time slices T1 and T4 because no card interrupt requests are include in these time slices. The NOR gate 1802 receives the bits G\_CNTRL [1] and G\_CNTRL [4].

The AND gate 1794 receives an inverted INTSDC# signal and an inverted MASKC signal. Another input of the AND gate 1794 is connected to the output of a NOR gate 1806 which masks the INTSDC# signal during the time slices T2 and T5 because no card interrupt requests are include in these time slices. The NOR gate 1806 receives the bits G\_CNTRL [2] and G\_CNTRL [5]. The AND gate 1796 receives an inverted INTSDD# signal and an inverted MASKD signal. Another input of the AND gate 1796 is connected to the output of a NOR gate 1808 which masks the INTSDD# signal during the time slices T3 and T6 because no card interrupt requests are include in these time slices. The NOR gate 1808 receives the bits G\_CNTRL [3] and G\_CNTRL [6].

The outputs of the AND gates 1790–1796 are connected as inputs to an OR gate 1798 which has its output connected to the signal input of a D-type flip-flop 1800. The flip-flop 1800 is clocked on the positive edge of the CLK signal, and the set input of the flip-flop 1800 receives the RST signal. The inverting output of the flip-flop 1800 furnishes the INTSDIIO# signal.

As shown in FIG. 98, the interrupt output block 114 includes a three bit counter 1820 of common design with the counter 1745. The counter 1820 is clocked on the positive edge of the signal CLK, furnishes an output signal G\_CNTRL2 [2:0], and begins counting from zero to seven after being reset by the INTSYNC# signal.

For purposes of furnishing the INTSYNCCPU# signal, the interrupt output block 114 includes a D-type flip-flop 1822 that is clocked on the positive edge of the CLK signal. The set input of the flip-flop 1822 receives the RST signal, and the signal input of the flip-flop 1822 receives the INTSYNCCABLE# signal. The non-inverting output of the flip-flop 1822 furnishes the INTSYNCCPU# signal.

For purposes of furnishing the INTSDCPU# signal, the interrupt output block 114 includes a D-type flip-flop 1824 that is clocked on the positive edge of the CLK signal. The set input of the flip-flop 1824 receives the RST signal, and the signal input of the flip-flop 1824 receives the INTSD-CABLE# signal. The non-inverting output of the flip-flop 1824 furnishes the INTSDCPU# signal.

The interrupt requests received by the interrupt receiving block 114 are furnished to the interrupt controller 1900

either asynchronously or serially. In the asynchronous mode, the interrupt requests are mapped to the four PCI interrupt lines (commonly referred to as a “barber poling”) on the PCI bus **24** as shown in FIG. **100**.

For purposes of holding the interrupt information provided by the INTSDCABLE# signal, the interrupt output block **114** includes an eight bit register **1826**. All signal inputs receive the INTSDCABLE# signal. The load enable inputs of bits **0–7** receive the bits G\_CNTR [0]–G\_CNTR [7], respectively. Therefore, for example, during time slice **T4**, bit **3** is loaded with the value represented by the INTSDCABLE# signal. Bits **0** (represented by a INT\_A1 signal) and **4** (represented by a INT\_A2 signal) are mapped into a CPUINTA# signal. Bits **1** (represented by a INT\_B1 signal) and **5** (represented by a INT\_B2 signal) are mapped into a CPUINTB# signal. Bits **2** (represented by a INT\_C1 signal) and **6** (represented by a INT\_C2 signal) are mapped into a CPUINTC# signal. Bits **3** (represented by a INT\_D1 signal) and **7** (represented by a INT\_D2 signal) are mapped into a CPUINTD# signal.

Four OR gates **1828–1834** furnish the signals CPUINTA#, CPUINTB#, CPUINTC#, and CPUINTD#, which are provided to the PCI interrupt lines INTA#, INTB#, INTC# and INTD#, respectively, of the PCI bus **24**. The OR gate **1828** has one input connected to the output of an AND gate **1836**. The AND gate receives an inverted CM signal. The signal CM is furnished by a bit of a configuration register of the bridge chip **26** and is asserted, or driven high, to indicate the asynchronous mode and deasserted, or driven low, to indicate the synchronous mode. The AND gate **1836** also receives the signal INT\_A1, the signal INT\_A2, and a signal ECC\_ERR\_UP (used to indicate an error in cable transmissions).

The OR gate **1828** has an input connected to the output of an AND gate **1838**. The AND gate **1838** receives the CM signal and the INTSDCPU# signal. Another input of the AND gate **1838** is connected to the output of an OR gate **1848**. The OR gate **1848** receives the ECC\_ERR\_UP signal and the bit G\_CNTR2 [0].

The OR gate **1830** has one input connected to the output of an AND gate **1840** and one input connected to the output of an AND gate **1842**. The AND gate **1840** receives an inverted CM signal, the signal INT\_B1, and the signal INT\_B2. The AND gate **1842** receives the signal CM and an inverted bit G\_CNTR2 [0] (used to provide the “sync”, signal to the interrupt controller **1900** during the serial mode).

The OR gate **1832** has one input connected to the output of an AND gate **1844** and one input receiving the CM signal. The AND gate **1844** receives an inverted CM signal, the INT\_C1 signal, and the INT\_C2 signal. The OR gate **1834** has one input connected to the output of an AND gate **1846** and one input receiving the CM signal. The AND gate **1846** receives an inverted CM signal, the INT\_DL signal, and the INT\_D2 signal.

Other embodiments are within the scope of the following claims.

What is claimed is:

**1.** A system comprising:

a connector for receiving a circuit card, the connector having a plurality of external connections;

a clamp configured to selectively prevent removal of the circuit card from the connector when the clamp is engaged;

circuitry connected to monitor the engagement status of the clamp, and to regulate delivery of power to the connector based on the engagement state of the clamp; and

circuitry connected to regulate electrical coupling of the circuit card to the external connections based on the engagement status of the clamp.

**2.** The system of claim **1** further comprising:

a communication link coupled to the plurality of external connections of the connector.

**3.** The system of claim **1** wherein the circuitry includes: a switch actuated by the clamp furnishing an indication of the position of the switch; and

a circuit connected to update the engagement status when the indication indicates the same position for a predetermined duration.

**4.** A method for use in a computer system having a central processing unit, the method comprising:

using a clamp to selectively prevent removal of a circuit card from a connector, the connector configured to receive the circuit card and electrically couple the circuit card to the central processing unit;

monitoring the engagement status of the clamp;

providing an indication of the engagement status to the central processing unit;

electrically coupling the central processing unit to the connector when the clamp is engaged; and

electrically isolating the central processing unit from the connector when the clamp is not engaged.

**5.** The method of claim **4** further comprising:

monitoring a power status signal of the connector; and providing an indication of the power status signal to the central processing unit.

**6.** The method of claim **4** further comprising:

providing power to the connector when the clamp is engaged; and

removing power from the connector when the clamp is not engaged.

**7.** The method of claim **4**, wherein

coupling the central processing unit includes electrically coupling a bus to the connector when the clamp is engaged; and

electrically isolating the central processing unit includes electrically isolating the bus from the connector when the clamp is not engaged.

**8.** The method of claim **7**, wherein isolating the bus includes:

disconnecting a clock line and other lines of the bus, the other lines of the bus being disconnected before the clock line is disconnected and the power is removed.

**9.** The method of claim **7** wherein the electrically coupling includes

connecting a clock line and other lines of the bus, the other lines of the bus being connected after the power is provided and the clock line is connected.

**10.** The method of claim **4** wherein the computer system has a switch actuated by the clamp furnishing an indication of the position of the switch, the method further comprising:

updating the engagement status when the indication indicates the same position for a predetermined duration.

**11.** A method for use in a computer system having a central processing unit, the method comprising:

using a clamp to selectively prevent removal of a circuit card from a connector, the connector configured to receive the circuit card and electrically couple the circuit card to the central processing unit;

monitoring the engagement status of the clamp; providing an indication of the engagement status to the central processing unit; and

## 113

- providing an interrupt request to the central processing unit to indicate when the engagement status changes.
- 12.** A method for use in a computer system having a central processing unit, the method comprising:
- 5 using a clamp to selectively prevent removal of a circuit card from a connector, the connector configured to receive the circuit card and electrically couple the circuit card to the central processing unit;
  - 10 monitoring the engagement status of the clamp; providing an indication of the engagement status to the central processing unit; and
  - 15 storing the engagement status in a memory accessible by the central processing unit.
- 13.** A method for use in a computer system having a central processing unit, the method comprising:
- 20 using a clamp to selectively prevent removal of a circuit card from a connector, the connector configured to receive the circuit card and electrically couple the circuit card to the central processing unit;
  - 25 monitoring the engagement status of the clamp; providing an indication of the engagement status to the central processing unit;
  - 30 providing power to the connector when the clamp is engaged; and
  - 35 removing power from the connector when the clamp is not engaged; and
  - 40 determining if the central processing unit has enabled the connector to receive power and wherein the step of providing power only provides power if the central processing unit has enabled the connector to receive power.
- 14.** A computer system comprising:
- 45 a central processing unit;
  - 50 a connector for receiving a circuit card and coupling the circuit card to the central processing unit;
  - 55 a clamp configured to selectively prevent removal of the circuit card from the connector when the clamp is engaged;
  - 60 a first circuit connected to monitor the engagement status of the clamp and to provide an indication of the engagement status to the central processing unit; and
  - 65 a second circuit connected to regulate electrical coupling of the circuit card to the central processing unit based on the indication of the engagement status of the clamp.
- 15.** The computer system of claim **14** wherein the first circuit monitors a power status signal of the connector and provides an indication of the power status signal to the central processing unit.
- 16.** The computer system of claim **14** further comprising:
- 70 a third circuit connected to furnish power to the connector when the clamp is engaged and to remove power from the computer when the clamp is not engaged based on the indication of the engagement status.
- 17.** The computer system of claim **16** further comprising:
- 75 a bus coupled between the central processing unit and the connector, wherein the second circuit is adapted to couple the bus to the connector when the clamp is engaged and electrically isolate the bus from the connector when the clamp is not engaged.
- 18.** The computer system of claim **17** wherein the central processing unit selectively enables the bus to be coupled to the connector, the computer system further comprising:

## 114

- 80 a buffer connected to indicate if the central processing unit has enabled the bus to be connected to the connector, and
  - 85 wherein the second circuit only couples the bus to the connector if the central processing unit has enabled the connector to be coupled to the bus.
- 19.** The computer system of claim **17** wherein the isolating the bus includes:
- 90 disconnecting a clock line and other lines of the bus, the other lines of the bus being disconnected before the clock line is disconnected and the power is removed.
- 20.** The computer system of claim **17** wherein the electrically coupling includes
- 95 connecting a clock line and other lines of the bus, the other lines of the bus being connected after the power is provided and the clock line is connected.
- 21.** The computer system of claim **17** wherein the bus comprises a PCI bus.
- 22.** The computer system of claim **14** wherein the circuit includes:
- 100 a switch actuated by the clamp furnishing an indication of the position of the switch; and
  - 105 a third circuit connected to update the engagement status when the indication indicates the same position for a predetermined duration.
- 23.** A computer system comprising:
- 110 a central processing unit;
  - 115 a connector for receiving a circuit card and coupling the circuit card to the central processing unit;
  - 120 a clamp configured to selectively prevent removal of the circuit card from the connector when the clamp is engaged; and
  - 125 a circuit connected to monitor the engagement status of the clamp and to provide an indication of the engagement status to the central processing unit, wherein the first circuit is configured to provide an interrupt request to the central processing unit to indicate when the engagement status changes.
- 24.** A computer system comprising:
- 130 a central processing unit,
  - 135 a connector for receiving a circuit card and coupling the circuit card to the central processing unit;
  - 140 a clamp configured to selectively prevent removal of the circuit card from the connector when the clamp is engaged; and
  - 145 a circuit connected to monitor the engagement status of the clamp and to provide an indication of the engagement status to the central processing unit, wherein the circuit includes a buffer, accessible by the central processing unit, connected to store the indication of the engagement status.
- 25.** A computer system comprising:
- 150 a central processing unit;
  - 155 a connector for receiving a circuit card and coupling the circuit card to the central processing unit, wherein the central processing unit selectively enables the connector to receive power;
  - 160 a clamp configured to selectively prevent removal of the circuit card from the connector when the clamp is engaged;
  - 165 a first circuit connected to monitor the engagement status of the clamp and to provide an indication of the engagement status to the central processing unit;
  - 170 a second circuit connected to furnish power to the connector when the clamp is engaged and to remove power

**115**

from the computer when the clamp is not engaged based on the indication of the engagement status; and  
a buffer connected to indicate if the central processing unit has enabled the connector to receive power, and wherein the second circuit connected to furnish power only provides power if the central processing unit has enabled the connector to receive power.

26. A computer system comprising:

- a bus;
- a connector for receiving a circuit card, the connector coupled to the bus;

**116**

a clamp configured to selectively prevent removal of the circuit card from the connector when the clamp is engaged;  
circuitry connected to monitor the engagement status of the clamp and to regulate delivery of power to the connector based on the engagement state of the clamp; and  
circuitry connected to regulate electrical coupling of the circuit card to the bus based on the engagement status of the clamp.

\* \* \* \* \*