

[54] **TELECOMMUNICATIONS ADAPTER PROVIDING NON-REPUDIABLE COMMUNICATIONS LOG AND SUPPLEMENTAL POWER FOR A PORTABLE PROGRAMMABLE DEVICE**

[75] Inventors: **Frederick W. Whitridge**, Greenwich; **Brendan F. Hemingway**, New Haven, both of Conn.

[73] Assignee: **PDA Peripherals Inc.**, Greenwich, Conn.

[21] Appl. No.: **09/143,188**

[22] Filed: **Aug. 28, 1998**

[51] Int. Cl.<sup>7</sup> ..... **G06F 13/14**; G06F 3/00; H04M 1/00

[52] U.S. Cl. .... **710/72**; 455/556; 455/557; 455/572; 235/380; 235/472.01; 320/114; 375/222

[58] Field of Search ..... 320/114; 235/380, 235/472.01; 375/222; 455/556, 557, 572; 709/302; 710/72

[56] **References Cited**

**U.S. PATENT DOCUMENTS**

4,697,281	9/1987	O'Sullivan	455/557
5,468,948	11/1995	Koenck et al.	235/472
5,524,134	6/1996	Gustafson et al.	455/410
5,606,594	2/1997	Register et al.	455/550
5,625,673	4/1997	Grewe et al.	455/556
5,754,655	5/1998	Hughes et al.	380/24
5,907,815	5/1999	Grimm et al.	455/557
5,920,177	7/1999	Davis	320/114
5,983,073	11/1999	Ditzik	455/11.1
6,035,214	3/2000	Henderson	455/556

*Primary Examiner*—Thomas C. Lee  
*Assistant Examiner*—Albert Wang  
*Attorney, Agent, or Firm*—Brown Raysman Millstein Felder & Steiner LLP

[57] **ABSTRACT**

A portable adapter that provides non-repudiable telecommunications services to bar-code reading hand-held computers and palm-top or tablet-type mobile computers is disclosed. The adapter provides supplemental power supply and processing capacity that supports API communications functions, such as interactive voice recognition, conference calling, data encryption, VoIP packetization and other signal-format conversions that are not implemented on mobile computers. In particular, the device automatically logs IP packet identifiers and DOV dialing and status signals, without the user having access to edit this information, thereby providing a "non-repudiation" record of all communications. The adapter also supports intensive use of the host computer's serial port by supplementing the power available from the host computer's battery, or replacing that battery with a connector. For plant inspection and inventory auditing, ground-based cellular communications are implemented for supporting on-site work, including conference calling to discuss apparent pilferage or imminent safety hazards, and removable WORM recording media for documenting these discussions. For repair shop use, a standard phone jack or 10-base-T connector allows the device to upload engine test-data, with reports or estimates dictated by the mechanic to the repair shop's LAN server. For hospital use, the device includes removable WORM media for logging patient test results and examination reports. The hospital device also uses a dedicated local-area RF or IR transmitter, with location-specific encryption, to protect the privacy of lab reports received by the device, and to limit use of these devices to hospital's own premises.

**4 Claims, 3 Drawing Sheets**

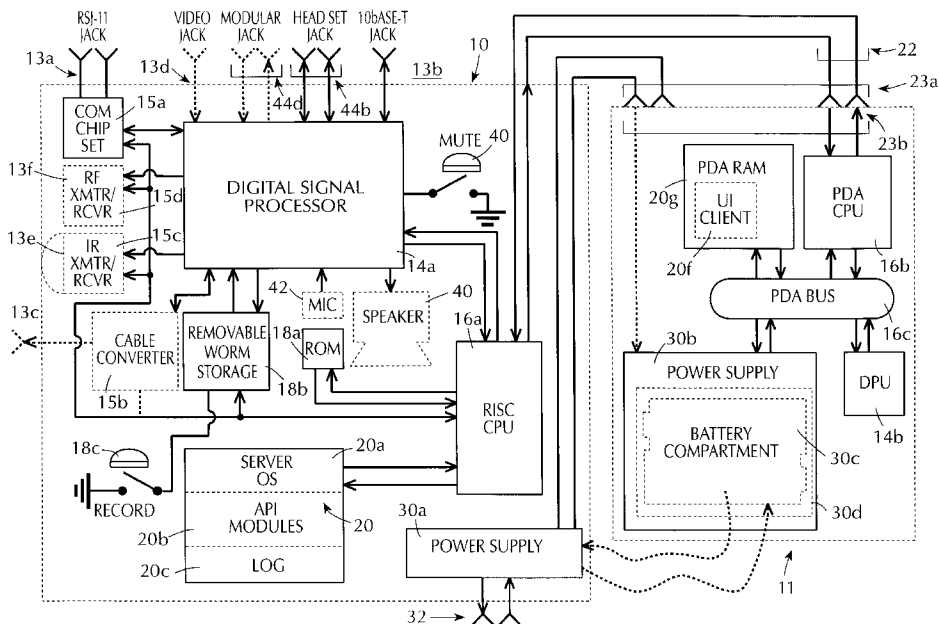

FIG. 1a

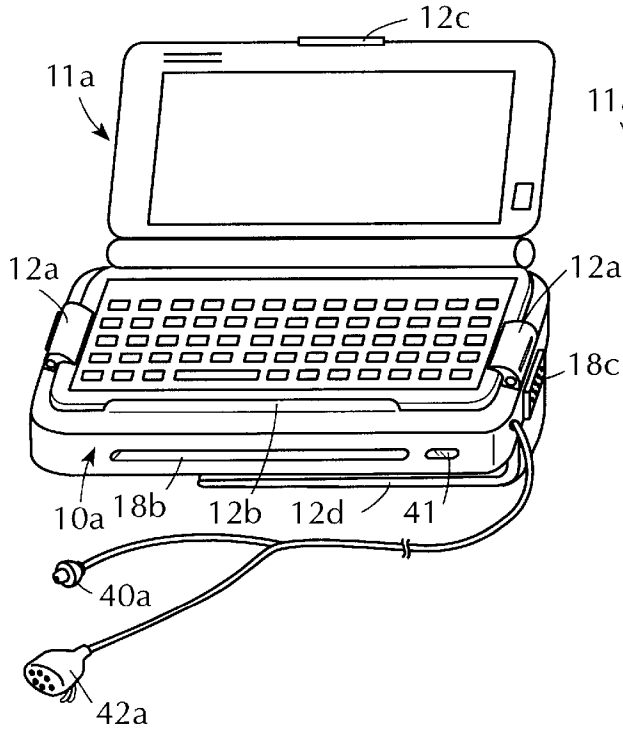

FIG. 1b

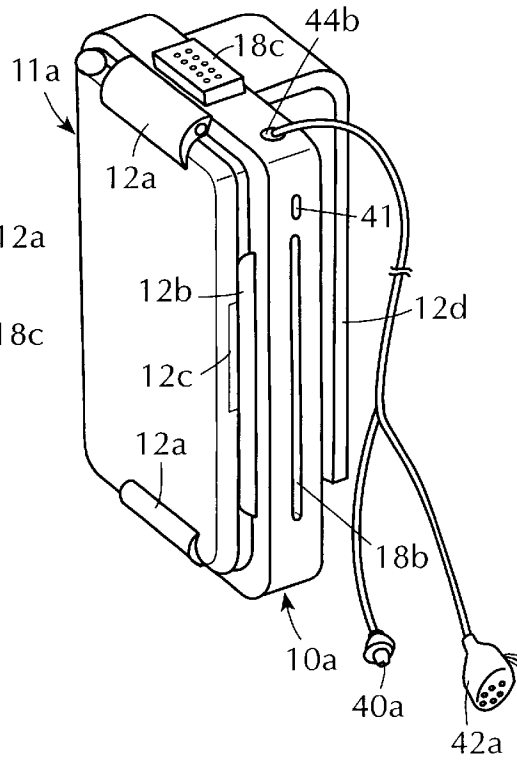

FIG. 2

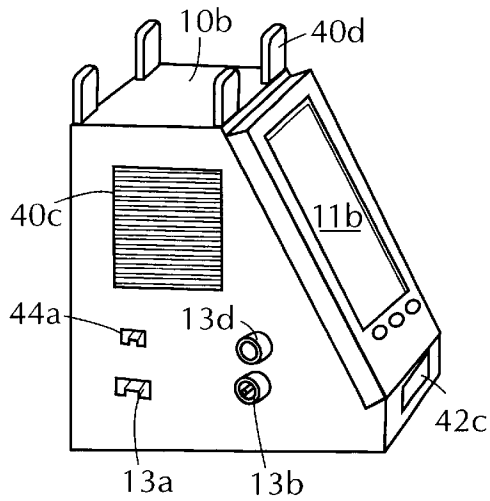
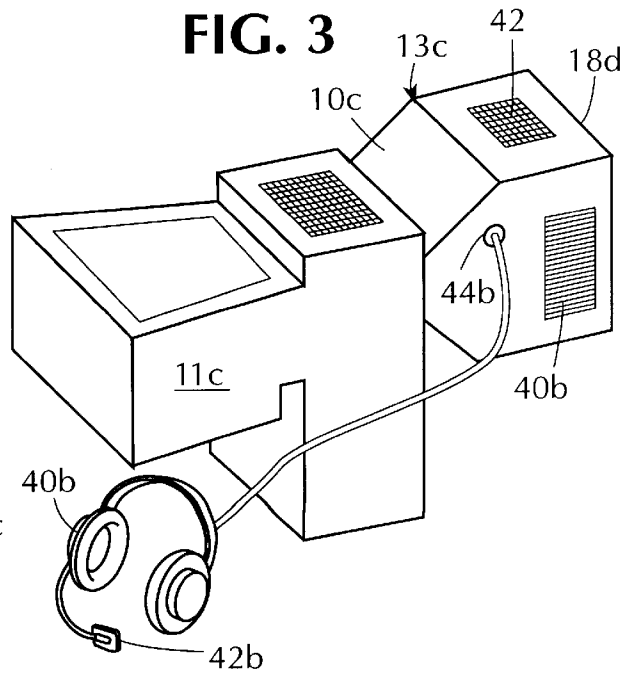

FIG. 3





### FIG. 5a

(PRIOR ART)

IP Version (4)	Header Length (4)
Total of Service (8)	
Total Length (16)	
Identifier (16)	
Flags (3)	PDU Fragment Offset (13)
Time to Live (8)	
Protocol (8)	
Header Checksum (16)	
Source Address (32)	
Destination Address (32)	
Options and Padding (Variable)	
Data (Variable)	

### FIG. 5b

(PRIOR ART)

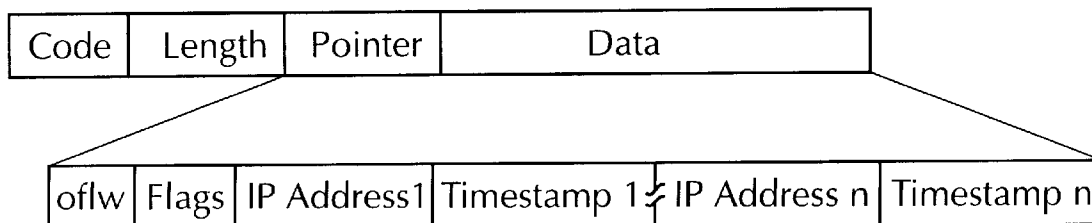

**TELECOMMUNICATIONS ADAPTER  
PROVIDING NON-REPUDIABLE  
COMMUNICATIONS LOG AND  
SUPPLEMENTAL POWER FOR A PORTABLE  
PROGRAMMABLE DEVICE**

BACKGROUND OF THE INVENTION

1. Field of the Invention

The present invention pertains to hand-held computers, such as personal data assistants (PDAs). More particularly, the present invention is directed to providing automated telecommunications for mobile computers.

2. Discussion of Related Art

Desktop computers are designed to be used at a desk. Portable or "laptop" computers are designed to be carried from place to place, but are used in essentially the same way as desktop computers, with the computer device resting on some fixed surface. In contrast, hand-held or "mobile" computers are computers designed to be used on the move. There are three common configurations of these mobile computers: pistol-grip computers, such as those made by Telxon™; keyboard-based palmtop computers such as the Psion Organizer™; and tablet computers, such as Apple's Newton™ or 3Com's Palm Pilot™ that provide an iconic "GUI" interface and accept handwritten information. The latter two, particularly the tablet computers, are also referred to as "PDAs".

Hand-held computers are widely used for inventory control, in the publishing and retail grocery businesses, for example, and often share a pistol-shaped housing with devices that read and store bar-code information. Palmtop computers are essentially desktop computers including the conventional features of the desktop computer: display, keyboard, etc., but greatly reduced in size and usually housed in an open-faced case, rather than the "clamshell" folding case used for the larger, "laptop" computers. Tablet computers are similar to the palmtop computers in size, but they are computerized, paper-less note pads: the user 'writes' on the tablet with a stylus, and the tablet interprets the movement of the user's stylus as commands and data. The tablet computers are often GUI driven, so that the stylus can be used to actuate GUI "button" icons, even operate a GUI keyboard.

All mobile computers are designed to be as lightweight as possible. This is particularly problematic for power supply design, and output devices, generally, require substantial power supply capacity. Having very little power to spare, these mobile computers have spawned a flood of peripheral and accessory devices that offer various functions expanding the built-in input and output (I/O) capabilities of mobile computers as local area network (LAN) and wide-area network (WAN) telecommunications terminals, as well as, printer terminals. For example, U.S. Pat. Nos. 5,606,594 and 5,625,673 disclose communications accessories that provide an enclosure for and add functions to a PDA unit. However "accessories", unlike peripheral devices, do not have the computing power to provide an application program interface (API) for the mobile host computer.

With the rise of the Internet and the advent of Voice-over-IP (VoIP) telephony, providing computer-based telecommunications now demands more processing capacity than ever before. In addition to the basic serial data-over-voice (DOV) connectivity work done by conventional modems that are available as accessories, digital call-control features such as conference calling require API support. Also, conversions turning audio and other signals into bit streams, bit streams

into bytes and bytes into IP packets, as well as the reverse process turning received IP packets back into sound, text or images, require API support. Mobile computers simply do not have the computing power to provide the API support nor the power needed to support the data speeds and bandwidths required for initiating and maintaining the communications services required for many current IP applications. Audio and video, in general, and VoIP audio in particular, have stringent real-time performance standards and require API support for their specialized high-speed control and data conversion functions.

SUMMARY OF THE INVENTION

In accordance with the present invention, non-repudiable telecommunications services are provided for mobile computers by a communications adapter having telecommunications server operating system and applications interface software. Telecommunications services are provided to the user by the adapter through a user interface (UI) client installed on the mobile host computer.

The UI client installed on the mobile computer cooperates with a server operating system in the adapter to execute and support API communications functions. In particular embodiments these functions include voice mail, voice recognition, dictation, call logging and conferencing, as well as encryption, IVR and data-format conversions. In particular embodiments, the adapter provides the computers the power supply and processing capacity needed for interactive voice recognition, conference calling, data encryption and VoIP packetization, capacity that the computers themselves lack, as well as the connections and interfaces for communication links that are not implemented in standard mobile computers.

To use the adapter for telecommunications, a mobile computer having the interface software installed thereon is connected to the adapter. A communications link is connected to the adapter, if necessary. In particular embodiments the communications link is a PSTN line or a LAN connection, a cellular or wireless telephone set, or a telephone line. The adapter is then activated, which activates the UI on the mobile host computer, waking up the host computer. The user selects the interface module for use with a link connected to the adapter and directs the UI to send an appropriate control message or messages to the adapter's call-processing software. In particular embodiments the interfaces support PSTN, PPP, VoIP, DTMF or video communications, respectively.

In one particular embodiment, the mobile computer is connected to the power supply of the adapter by replacing a battery in the mobile computer with a connector shaped like the battery. In another embodiment the adapter connects to the power supply of the mobile computer through a connector provided by the computer.

In a particular embodiment, the adapter stores data received and transmitted by the adapter as part of a non-repudiable communications log. Preferably, the mobile computer is provided read-only access to communications payload data stored in the log file through the UI installed on the mobile computer. In a further particular embodiment, the adapter includes a record button that selects a dictation interface module which logs the dictation event and converts the spoken information to a data format.

The conventional computer peripheral devices designed for desktop and laptop computers are simpler and have less computing power than their host computer. The present invention, instead is more specialized and has more com-

# Explore Litigation Insights

Docket Alarm provides insights to develop a more informed litigation strategy and the peace of mind of knowing you're on top of things.

## Real-Time Litigation Alerts



Keep your litigation team up-to-date with **real-time alerts** and advanced team management tools built for the enterprise, all while greatly reducing PACER spend.

Our comprehensive service means we can handle Federal, State, and Administrative courts across the country.

## Advanced Docket Research



With over 230 million records, Docket Alarm's cloud-native docket research platform finds what other services can't. Coverage includes Federal, State, plus PTAB, TTAB, ITC and NLRB decisions, all in one place.

Identify arguments that have been successful in the past with full text, pinpoint searching. Link to case law cited within any court document via Fastcase.

## Analytics At Your Fingertips



Learn what happened the last time a particular judge, opposing counsel or company faced cases similar to yours.

Advanced out-of-the-box PTAB and TTAB analytics are always at your fingertips.

## API

Docket Alarm offers a powerful API (application programming interface) to developers that want to integrate case filings into their apps.

## LAW FIRMS

Build custom dashboards for your attorneys and clients with live data direct from the court.

Automate many repetitive legal tasks like conflict checks, document management, and marketing.

## FINANCIAL INSTITUTIONS

Litigation and bankruptcy checks for companies and debtors.

## E-DISCOVERY AND LEGAL VENDORS

Sync your system to PACER to automate legal marketing.