



US008752749B2

(12) **United States Patent**
Moore et al.

(10) **Patent No.:** **US 8,752,749 B2**
(45) **Date of Patent:** ***Jun. 17, 2014**

(54) **ROBOTICALLY-CONTROLLED DISPOSABLE MOTOR-DRIVEN LOADING UNIT**

(75) Inventors: **Kyle P. Moore**, Mason, OH (US); **Frederick E. Shelton, IV**, Hillsboro, OH (US); **William B. Weisenburgh, II**, Maineville, OH (US); **Jerome R. Morgan**, Cincinnati, OH (US); **Mark H. Ransick**, West Chester, OH (US); **Eugene L. Timperman**, Cincinnati, OH (US)

(73) Assignee: **Ethicon Endo-Surgery, Inc.**, Cincinnati, OH (US)

(*) Notice: Subject to any disclaimer, the term of this patent is extended or adjusted under 35 U.S.C. 154(b) by 418 days.

This patent is subject to a terminal disclaimer.

(21) Appl. No.: **13/118,210**

(22) Filed: **May 27, 2011**

(65) **Prior Publication Data**

US 2011/0290855 A1 Dec. 1, 2011

Related U.S. Application Data

(63) Continuation-in-part of application No. 12/856,099, filed on Aug. 13, 2010, now Pat. No. 8,196,795, which is a continuation of application No. 12/031,628, filed on Feb. 14, 2008, now Pat. No. 7,793,812.

(51) **Int. Cl.**
A61B 17/068 (2006.01)

(52) **U.S. Cl.**
USPC **227/176.1**; 227/19; 227/180.1

(58) **Field of Classification Search**
USPC 227/19, 175.1, 176.1, 175.2, 178.1, 227/180.1; 606/139, 219

See application file for complete search history.

(56) **References Cited**

U.S. PATENT DOCUMENTS

66,052 A	6/1867	Smith
662,587 A	11/1900	Blake
670,748 A	3/1901	Weddeler
951,393 A	3/1910	Hahn
1,306,107 A	6/1919	Elliott
1,314,601 A	9/1919	McCaskey

(Continued)

FOREIGN PATENT DOCUMENTS

AU	2012200178 B2	7/2013
CA	2458946 A1	3/2003

(Continued)

OTHER PUBLICATIONS

European Search Report, Application No. 09250367.1, dated Apr. 14, 2009 (7 pages).

(Continued)

Primary Examiner — Scott A. Smith

(57) **ABSTRACT**

A self contained motor-powered disposable loading unit for use with a robotic system configured to generate control systems therefor. The disposable loading unit may contain a battery that is retained in a disconnected position when the disposable loading unit is not in use and is moved to a connected position when the disposable loading unit is coupled to the robotic system to permit the motor to be selectively powered thereby. Indicators may be supported on the disposable loading unit to indicate when the axial drive assembly thereof is in a starting position and an ending position. Another indicator may be provided to indicate when the anvil assembly is in a closed position.

17 Claims, 95 Drawing Sheets

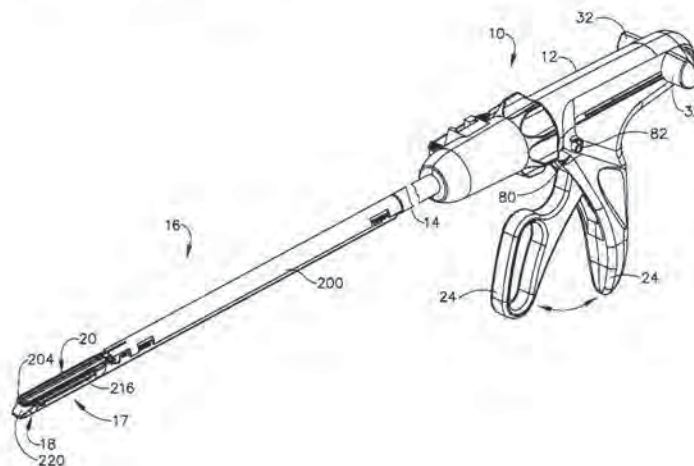

(56)

References Cited

U.S. PATENT DOCUMENTS

1,677,337	A	7/1928	Grove	4,473,077	A	9/1984	Noiles et al.
2,037,727	A	4/1936	La Chapelle	4,475,679	A	10/1984	Fleury, Jr.
2,132,295	A	10/1938	Hawkins	4,485,816	A	12/1984	Krumme
2,161,632	A	6/1939	Nattenheimer	4,486,928	A	12/1984	Tucker et al.
2,211,117	A	8/1940	Hess	4,488,523	A	12/1984	Shichman
2,214,870	A	9/1940	West	4,489,875	A	12/1984	Crawford et al.
2,441,096	A	5/1948	Happe	4,500,024	A	2/1985	DiGiovanni et al.
2,526,902	A	10/1950	Rublee	4,505,272	A	3/1985	Utyamyshev et al.
2,674,149	A	4/1954	Benson	4,505,273	A	3/1985	Braun et al.
2,804,848	A	9/1957	O'Farrell et al.	4,505,414	A	3/1985	Filipi
2,808,482	A	10/1957	Zanichkowsky et al.	4,506,671	A	3/1985	Green
2,853,074	A	9/1958	Olson	4,520,817	A	6/1985	Green
3,032,769	A	5/1962	Palmer	4,522,327	A	6/1985	Korthoff et al.
3,075,062	A	1/1963	Iaccarino	4,526,174	A	7/1985	Froehlich
3,078,465	A	2/1963	Bobrov	4,527,724	A	7/1985	Chow et al.
3,166,072	A	1/1965	Sullivan, Jr.	4,530,453	A	7/1985	Green
3,266,494	A	8/1966	Brownrigg et al.	4,531,522	A	7/1985	Bedi et al.
3,269,630	A	8/1966	Fleischer	4,532,927	A	8/1985	Miksza, Jr.
3,357,296	A	12/1967	Lefever	4,548,202	A	10/1985	Duncan
3,490,675	A	1/1970	Green et al.	4,565,189	A	1/1986	Mabuchi
3,494,533	A	2/1970	Green et al.	4,566,620	A	1/1986	Green et al.
3,551,987	A	1/1971	Wilkinson	4,571,213	A	2/1986	Ishimoto
3,572,159	A	3/1971	Tschanz	4,573,468	A	3/1986	Conta et al.
3,598,943	A	8/1971	Barrett	4,573,469	A	3/1986	Golden et al.
3,643,851	A	2/1972	Green et al.	4,573,622	A	3/1986	Green et al.
3,662,939	A	5/1972	Bryan	4,576,167	A	3/1986	Noiles et al.
3,717,294	A	2/1973	Green	4,580,712	A	4/1986	Green
3,734,207	A	5/1973	Fishbein	4,589,416	A	5/1986	Green
3,740,994	A	6/1973	DeCarlo, Jr.	4,591,085	A	5/1986	Di Giovanni
3,744,495	A	7/1973	Johnson	4,604,786	A	8/1986	Howie, Jr.
3,746,002	A	7/1973	Haller	4,605,001	A	8/1986	Rothfuss et al.
3,751,902	A	8/1973	Kingsbury et al.	4,605,004	A	8/1986	Di Giovanni et al.
3,819,100	A	6/1974	Noiles et al.	4,606,343	A	8/1986	Conta et al.
3,821,919	A	7/1974	Knohl	4,607,638	A	8/1986	Crainich
3,841,474	A	10/1974	Maier	4,608,981	A	9/1986	Rothfuss et al.
3,851,196	A	11/1974	Hinds	4,610,250	A	9/1986	Green
3,885,491	A	5/1975	Curtis	4,610,383	A	9/1986	Rothfuss et al.
3,892,228	A	7/1975	Mitsui	4,619,262	A	10/1986	Taylor
3,894,174	A	7/1975	Cartun	4,629,107	A	12/1986	Fedotov et al.
3,940,844	A	3/1976	Colby et al.	4,632,290	A	12/1986	Green et al.
RE28,932	E	8/1976	Noiles et al.	4,633,874	A	1/1987	Chow et al.
4,060,089	A	11/1977	Noiles	4,641,076	A	2/1987	Linden
4,129,059	A	12/1978	Van Eck	4,646,722	A	3/1987	Silverstein et al.
4,169,990	A	10/1979	Lerdman	4,655,222	A	4/1987	Florez et al.
4,198,982	A	4/1980	Förtner et al.	4,663,874	A	5/1987	Sano et al.
4,207,898	A	6/1980	Becht	4,664,305	A	5/1987	Blake, III et al.
4,213,562	A	7/1980	Garrett et al.	4,665,916	A	5/1987	Green
4,250,436	A	2/1981	Weissman	4,667,674	A	5/1987	Korthoff et al.
4,261,244	A	4/1981	Becht et al.	4,671,445	A	6/1987	Barker et al.
4,272,662	A	6/1981	Simpson	4,676,245	A	6/1987	Fukuda
4,275,813	A	6/1981	Noiles	4,693,248	A	9/1987	Failla
4,289,133	A	9/1981	Rothfuss	4,708,141	A	11/1987	Inoue et al.
4,305,539	A	12/1981	Korolkov et al.	4,709,120	A	11/1987	Pearson
4,317,451	A	3/1982	Cerwin et al.	4,715,520	A	12/1987	Roehr, Jr. et al.
4,321,002	A	3/1982	Froehlich	4,719,917	A	1/1988	Barrows et al.
4,331,277	A	5/1982	Green	4,728,020	A	3/1988	Green et al.
4,340,331	A	7/1982	Savino	4,728,876	A	3/1988	Mongeon et al.
4,347,450	A	8/1982	Colligan	4,729,260	A	3/1988	Dudden
4,349,028	A	9/1982	Green	4,730,726	A	3/1988	Holzwarth
4,353,371	A	10/1982	Cosman	4,741,336	A	5/1988	Failla et al.
4,379,457	A	4/1983	Gravener et al.	4,743,214	A	5/1988	Tai-Cheng
4,380,312	A	4/1983	Landrus	4,752,024	A	6/1988	Green et al.
4,383,634	A	5/1983	Green	4,754,909	A	7/1988	Barker et al.
4,393,728	A	7/1983	Larson et al.	4,767,044	A	8/1988	Green
4,396,139	A	8/1983	Hall et al.	4,773,420	A	9/1988	Green
4,402,445	A	9/1983	Green	4,777,780	A	10/1988	Holzwarth
4,408,692	A	10/1983	Siegel et al.	4,787,387	A	11/1988	Burbank, III et al.
4,415,112	A	11/1983	Green	4,790,225	A	12/1988	Moody et al.
4,428,376	A	1/1984	Mericle	4,805,617	A	2/1989	Bedi et al.
4,429,695	A	2/1984	Green	4,805,823	A	2/1989	Rothfuss
4,434,796	A	3/1984	Karapetian et al.	4,809,695	A	3/1989	Gwathmey et al.
4,442,964	A	4/1984	Becht	4,817,847	A	4/1989	Redtenbacher et al.
4,451,743	A	5/1984	Suzuki et al.	4,819,853	A	4/1989	Green
4,454,887	A	6/1984	Krüger	4,821,939	A	4/1989	Green
4,467,805	A	8/1984	Fukuda	4,827,911	A	5/1989	Broadwin et al.
				4,834,720	A	5/1989	Blinkhorn
				4,844,068	A	7/1989	Arata et al.
				4,848,637	A	7/1989	Pruitt
				4,869,414	A	9/1989	Green et al.

(56)

References Cited

U.S. PATENT DOCUMENTS

4,869,415	A	9/1989	Fox	5,223,675	A	6/1993	Taft
4,880,015	A	11/1989	Nierman	5,234,447	A	8/1993	Kaster et al.
4,890,613	A	1/1990	Golden et al.	5,236,440	A	8/1993	Hlavacek
4,892,244	A	1/1990	Fox et al.	5,239,981	A	8/1993	Anapliotis
4,893,622	A	1/1990	Green et al.	5,240,163	A	8/1993	Stein et al.
4,903,697	A	2/1990	Resnick et al.	5,242,457	A	9/1993	Akopov et al.
4,915,100	A	4/1990	Green	5,244,462	A	9/1993	Delahuerga et al.
4,930,503	A	6/1990	Pruitt	5,246,156	A	9/1993	Rothfuss et al.
4,930,674	A	6/1990	Barak	5,246,443	A	9/1993	Mai
4,932,960	A	6/1990	Green et al.	5,253,793	A	10/1993	Green et al.
4,938,408	A	7/1990	Bedi et al.	5,258,009	A	11/1993	Connors
4,941,623	A	7/1990	Pruitt	5,258,012	A	11/1993	Luscombe et al.
4,944,443	A	7/1990	Odds et al.	5,259,366	A	11/1993	Reydel et al.
4,955,959	A	9/1990	Tompkins et al.	5,260,637	A	11/1993	Pizzi
4,978,049	A	12/1990	Green	5,263,629	A	11/1993	Trumbull et al.
4,986,808	A	1/1991	Broadwin et al.	5,263,973	A	11/1993	Cook
4,988,334	A	1/1991	Hornlein et al.	5,268,622	A	12/1993	Philipp
5,002,553	A	3/1991	Shiber	5,271,543	A	12/1993	Grant et al.
5,009,661	A	4/1991	Michelson	5,271,544	A	12/1993	Fox et al.
5,014,899	A	5/1991	Presty et al.	RE34,519	E	1/1994	Fox et al.
5,015,227	A	5/1991	Broadwin et al.	5,275,323	A	1/1994	Schulze et al.
5,027,834	A	7/1991	Pruitt	5,275,608	A	1/1994	Forman et al.
5,031,814	A	7/1991	Tompkins et al.	5,281,216	A	1/1994	Klicek
5,040,715	A	8/1991	Green et al.	5,282,806	A	2/1994	Hauber et al.
5,042,707	A	8/1991	Taheri	5,282,829	A	2/1994	Hermes
5,061,269	A	10/1991	Muller	5,285,945	A	2/1994	Brinkerhoff et al.
5,062,563	A	11/1991	Green et al.	5,289,963	A	3/1994	McGarry et al.
5,065,929	A	11/1991	Schulze et al.	5,297,714	A	3/1994	Kramer
5,071,052	A	12/1991	Rodak et al.	5,304,204	A	4/1994	Bregen
5,071,430	A	12/1991	de Salis et al.	5,307,976	A	5/1994	Olson et al.
5,074,454	A	12/1991	Peters	5,309,927	A	5/1994	Welch
5,080,556	A	1/1992	Carreno	5,312,023	A	5/1994	Green et al.
5,083,695	A	1/1992	Foslien et al.	5,312,024	A	5/1994	Grant et al.
5,084,057	A	1/1992	Green et al.	5,312,329	A	5/1994	Beaty et al.
5,088,979	A	2/1992	Filipi et al.	5,314,424	A	5/1994	Nicholas
5,088,997	A	2/1992	Delahuerga et al.	5,318,221	A	6/1994	Green et al.
5,094,247	A	3/1992	Hernandez et al.	5,330,487	A	7/1994	Thornton et al.
5,100,420	A	3/1992	Green et al.	5,330,502	A	7/1994	Hassler et al.
5,104,025	A	4/1992	Main et al.	5,332,142	A	7/1994	Robinson et al.
5,106,008	A	4/1992	Tompkins et al.	5,333,422	A	8/1994	Warren et al.
5,111,987	A	5/1992	Moeinzadeh et al.	5,333,772	A	8/1994	Rothfuss et al.
5,116,349	A	5/1992	Aranyi	5,334,183	A	8/1994	Wuchinich
5,122,156	A	6/1992	Granger et al.	5,336,232	A	8/1994	Green et al.
5,129,570	A	7/1992	Schulze et al.	5,339,799	A	8/1994	Kami et al.
5,137,198	A	8/1992	Nobis et al.	5,341,724	A	8/1994	Vatel
5,139,513	A	8/1992	Segato	5,341,810	A	8/1994	Dardel
5,141,144	A	8/1992	Foslien et al.	5,342,395	A	8/1994	Jarrett et al.
5,142,932	A	9/1992	Moya et al.	5,342,396	A	8/1994	Cook
5,156,315	A	10/1992	Green et al.	5,344,060	A	9/1994	Gravener et al.
5,156,609	A	10/1992	Nakao et al.	5,348,259	A	9/1994	Blanco et al.
5,156,614	A	10/1992	Green et al.	5,350,391	A	9/1994	Iacovelli
5,158,567	A	10/1992	Green	5,350,400	A	9/1994	Esposito et al.
D330,699	S	11/1992	Gill	5,352,229	A	10/1994	Goble et al.
5,163,598	A	11/1992	Peters et al.	5,352,235	A	10/1994	Koros et al.
5,171,247	A	12/1992	Hughett et al.	5,352,238	A	10/1994	Green et al.
5,171,249	A	12/1992	Stefanchik et al.	5,354,303	A	10/1994	Spaeth et al.
5,171,253	A	12/1992	Klieman et al.	5,356,006	A	10/1994	Alpern et al.
5,188,111	A	2/1993	Yates et al.	5,358,510	A	10/1994	Luscombe et al.
5,190,517	A	3/1993	Zieve et al.	5,359,231	A	10/1994	Flowers et al.
5,192,288	A	3/1993	Thompson et al.	D352,780	S	11/1994	Glaeser et al.
5,195,968	A	3/1993	Lundquist et al.	5,360,428	A	11/1994	Hutchinson, Jr.
5,197,648	A	3/1993	Gingold	5,364,003	A	11/1994	Williamson, IV
5,200,280	A	4/1993	Karasa	5,366,134	A	11/1994	Green et al.
5,205,459	A	4/1993	Brinkerhoff et al.	5,366,479	A	11/1994	McGarry et al.
5,207,697	A	5/1993	Carusillo et al.	5,368,015	A	11/1994	Wilk
5,209,747	A	5/1993	Knoepfler	5,370,645	A	12/1994	Klicek et al.
5,211,649	A	5/1993	Kohler et al.	5,372,596	A	12/1994	Klicek et al.
5,217,457	A	6/1993	Delahuerga et al.	5,372,602	A	12/1994	Burke
5,217,478	A	6/1993	Rexroth	5,374,277	A	12/1994	Hassler
5,219,111	A	6/1993	Bilotti et al.	5,376,095	A	12/1994	Ortiz
5,221,036	A	6/1993	Takase	5,379,933	A	1/1995	Green et al.
5,221,281	A	6/1993	Klicek	5,381,782	A	1/1995	DeLaRama et al.
5,222,963	A	6/1993	Brinkerhoff et al.	5,382,247	A	1/1995	Cimino et al.
5,222,975	A	6/1993	Crainich	5,383,880	A	1/1995	Hooven
5,222,976	A	6/1993	Yoon	5,383,881	A	1/1995	Green et al.
				5,383,888	A	1/1995	Zvenyatsky et al.
				5,383,895	A	1/1995	Holmes et al.
				5,389,098	A	2/1995	Tsuruta et al.
				5,391,180	A	2/1995	Tovey et al.

(56)

References Cited

U.S. PATENT DOCUMENTS

5,392,979	A	2/1995	Green et al.	5,485,952	A	1/1996	Fontayne
5,395,030	A	3/1995	Kuramoto et al.	5,487,499	A	1/1996	Sorrentino et al.
5,395,033	A	3/1995	Byrne et al.	5,487,500	A	1/1996	Knodel et al.
5,395,312	A	3/1995	Desai	5,489,058	A	2/1996	Plyley et al.
5,397,046	A	3/1995	Savage et al.	5,489,256	A	2/1996	Adair
5,397,324	A	3/1995	Carroll et al.	5,496,312	A	3/1996	Klicek
5,403,312	A	4/1995	Yates et al.	5,496,317	A	3/1996	Goble et al.
5,405,072	A	4/1995	Zlock et al.	5,497,933	A	3/1996	DeFonzo et al.
5,405,073	A	4/1995	Porter	5,503,320	A	4/1996	Webster et al.
5,405,344	A	4/1995	Williamson et al.	5,503,635	A	4/1996	Sauer et al.
5,407,293	A	4/1995	Crainich	5,503,638	A	4/1996	Cooper et al.
5,409,498	A	4/1995	Braddock et al.	5,505,363	A	4/1996	Green et al.
5,411,508	A	5/1995	Bessler et al.	5,507,426	A	4/1996	Young et al.
5,413,267	A	5/1995	Solyntjes et al.	5,509,596	A	4/1996	Green et al.
5,413,268	A	5/1995	Green et al.	5,509,916	A	4/1996	Taylor
5,413,272	A	5/1995	Green et al.	5,511,564	A	4/1996	Wilk
5,415,334	A	5/1995	Williamson, IV et al.	5,514,129	A	5/1996	Smith
5,415,335	A	5/1995	Knodel, Jr.	5,514,157	A	5/1996	Nicholas et al.
5,417,361	A	5/1995	Williamson, IV	5,518,163	A	5/1996	Hooven
5,421,829	A	6/1995	Olichney et al.	5,518,164	A	5/1996	Hooven
5,422,567	A	6/1995	Matsunaga	5,520,678	A	5/1996	Heckele et al.
5,423,809	A	6/1995	Klicek	5,520,700	A	5/1996	Beyar et al.
5,425,745	A	6/1995	Green et al.	5,522,817	A	6/1996	Sander et al.
5,431,322	A	7/1995	Green et al.	5,527,320	A	6/1996	Carruthers et al.
5,431,668	A	7/1995	Burbank, III et al.	5,529,235	A	6/1996	Boiarski et al.
5,433,721	A	7/1995	Hooven et al.	D372,086	S	7/1996	Grasso et al.
5,438,302	A	8/1995	Goble	5,531,744	A	7/1996	Nardella et al.
5,439,155	A	8/1995	Viola	5,533,521	A	7/1996	Granger
5,439,156	A	8/1995	Grant et al.	5,533,581	A	7/1996	Barth et al.
5,439,479	A	8/1995	Schichman et al.	5,533,661	A	7/1996	Main et al.
5,441,191	A	8/1995	Linden	5,535,934	A	7/1996	Boiarski et al.
5,441,193	A	8/1995	Gravener	5,535,935	A	7/1996	Vidal et al.
5,441,494	A	8/1995	Ortiz	5,535,937	A	7/1996	Boiarski et al.
5,445,304	A	8/1995	Plyley et al.	5,540,375	A	7/1996	Bolanos et al.
5,445,644	A	8/1995	Pietrafitta et al.	5,541,376	A	7/1996	Ladtkow et al.
5,447,417	A	9/1995	Kuhl et al.	5,542,594	A	8/1996	McKean et al.
5,447,513	A	9/1995	Davison et al.	5,542,949	A	8/1996	Yoon
5,449,355	A	9/1995	Rhum et al.	5,543,119	A	8/1996	Sutter et al.
5,449,365	A	9/1995	Green et al.	5,547,117	A	8/1996	Hamblin et al.
5,449,370	A	9/1995	Vaitekunas	5,549,621	A	8/1996	Bessler et al.
5,452,836	A	9/1995	Huitema et al.	5,549,628	A	8/1996	Cooper et al.
5,452,837	A	9/1995	Williamson, IV et al.	5,549,637	A	8/1996	Crainich
5,454,378	A	10/1995	Palmer et al.	5,551,622	A	9/1996	Yoon
5,454,827	A	10/1995	Aust et al.	5,553,675	A	9/1996	Pitzen et al.
5,456,401	A	10/1995	Green et al.	5,553,765	A	9/1996	Knodel et al.
5,458,579	A	10/1995	Chodorow et al.	5,554,169	A	9/1996	Green et al.
5,462,215	A	10/1995	Viola et al.	5,556,416	A	9/1996	Clark et al.
5,464,013	A	11/1995	Lemelson	5,558,665	A	9/1996	Kieturakis
5,464,144	A	11/1995	Guy et al.	5,558,671	A	9/1996	Yates
5,464,300	A	11/1995	Crainich	5,560,530	A	10/1996	Bolanos et al.
5,465,894	A	11/1995	Clark et al.	5,560,532	A	10/1996	DeFonzo et al.
5,465,895	A	11/1995	Knodel et al.	5,562,239	A	10/1996	Boiarski et al.
5,465,896	A	11/1995	Allen et al.	5,562,241	A	10/1996	Knodel et al.
5,466,020	A	11/1995	Page et al.	5,562,682	A	10/1996	Oberlin et al.
5,467,911	A	11/1995	Tsuruta et al.	5,562,690	A	10/1996	Green et al.
5,468,253	A	11/1995	Bezwada et al.	5,562,701	A	10/1996	Huitema et al.
5,470,006	A	11/1995	Rodak	5,562,702	A	10/1996	Huitema et al.
5,470,007	A	11/1995	Plyley et al.	5,564,615	A	10/1996	Bishop et al.
5,470,009	A	11/1995	Rodak	5,569,161	A	10/1996	Ebling et al.
5,472,132	A	12/1995	Savage et al.	5,569,270	A	10/1996	Weng
5,472,442	A	12/1995	Klicek	5,569,284	A	10/1996	Young et al.
5,473,204	A	12/1995	Temple	5,571,090	A	11/1996	Sherts
5,474,057	A	12/1995	Makower et al.	5,571,100	A	11/1996	Goble et al.
5,474,566	A	12/1995	Alesi et al.	5,571,116	A	11/1996	Bolanos et al.
5,476,206	A	12/1995	Green et al.	5,571,285	A	11/1996	Chow et al.
5,476,479	A	12/1995	Green et al.	5,573,543	A	11/1996	Akopov et al.
5,478,003	A	12/1995	Green et al.	5,574,431	A	11/1996	McKeown et al.
5,478,354	A	12/1995	Tovey et al.	5,575,789	A	11/1996	Bell et al.
5,480,089	A	1/1996	Blewett	5,575,799	A	11/1996	Bolanos et al.
5,480,409	A	1/1996	Riza	5,575,803	A	11/1996	Cooper et al.
5,482,197	A	1/1996	Green et al.	5,575,805	A	11/1996	Li
5,484,095	A	1/1996	Green et al.	5,577,654	A	11/1996	Bishop
5,484,398	A	1/1996	Stoddard	5,579,978	A	12/1996	Green et al.
5,484,451	A	1/1996	Akopov et al.	5,580,067	A	12/1996	Hamblin et al.
5,485,947	A	1/1996	Olson et al.	5,582,611	A	12/1996	Tsuruta et al.
				5,582,617	A	12/1996	Klieman et al.
				5,584,425	A	12/1996	Savage et al.
				5,586,711	A	12/1996	Plyley et al.
				5,588,579	A	12/1996	Schnut et al.

(56)

References Cited

U.S. PATENT DOCUMENTS

5,588,580	A	12/1996	Paul et al.	5,692,668	A	12/1997	Schulze et al.
5,588,581	A	12/1996	Conlon et al.	5,693,042	A	12/1997	Boiarski et al.
5,591,170	A	1/1997	Spievack et al.	5,693,051	A	12/1997	Schulze et al.
5,591,187	A	1/1997	Dekel	5,695,494	A	12/1997	Becker
5,597,107	A	1/1997	Knodel et al.	5,695,504	A	12/1997	Gifford, III et al.
5,599,151	A	2/1997	Daum et al.	5,695,524	A	12/1997	Kelley et al.
5,599,344	A	2/1997	Paterson	5,697,543	A	12/1997	Burdorff
5,599,350	A	2/1997	Schulze et al.	5,697,943	A	12/1997	Sauer et al.
5,601,224	A	2/1997	Bishop et al.	5,700,270	A	12/1997	Peysner et al.
5,603,443	A	2/1997	Clark et al.	5,702,387	A	12/1997	Arts et al.
5,605,272	A	2/1997	Witt et al.	5,702,408	A	12/1997	Wales et al.
5,605,273	A	2/1997	Hamblin et al.	5,702,409	A	12/1997	Rayburn et al.
5,607,094	A	3/1997	Clark et al.	5,704,087	A	1/1998	Strub
5,607,095	A	3/1997	Smith et al.	5,704,534	A	1/1998	Huitema et al.
5,607,433	A	3/1997	Polla et al.	5,706,997	A	1/1998	Green et al.
5,607,450	A	3/1997	Zvenyatsky et al.	5,706,998	A	1/1998	Plyley et al.
5,609,285	A	3/1997	Grant et al.	5,707,392	A	1/1998	Kortenbach
5,609,601	A	3/1997	Kolesa et al.	5,709,334	A	1/1998	Sorrentino et al.
5,611,709	A	3/1997	McAnulty	5,709,680	A	1/1998	Yates et al.
5,613,966	A	3/1997	Makower et al.	5,711,472	A	1/1998	Bryan
5,615,820	A	4/1997	Viola	5,713,128	A	2/1998	Schrenk et al.
5,618,294	A	4/1997	Aust et al.	5,713,505	A	2/1998	Huitema
5,618,303	A	4/1997	Marlow et al.	5,713,895	A	2/1998	Lontine et al.
5,618,307	A	4/1997	Donlon et al.	5,713,896	A	2/1998	Nardella
5,620,289	A	4/1997	Curry	5,715,987	A	2/1998	Kelley et al.
5,620,452	A	4/1997	Yoon	5,715,988	A	2/1998	Palmer
5,624,452	A	4/1997	Yates	5,716,366	A	2/1998	Yates
5,626,587	A	5/1997	Bishop et al.	5,718,359	A	2/1998	Palmer et al.
5,626,595	A	5/1997	Sklar et al.	5,718,360	A	2/1998	Green et al.
5,628,446	A	5/1997	Geiste et al.	5,718,548	A	2/1998	Costellessa
5,628,743	A	5/1997	Cimino	5,720,744	A	2/1998	Eggleston et al.
5,630,539	A	5/1997	Plyley et al.	D393,067	S	3/1998	Geary et al.
5,630,540	A	5/1997	Blewett	5,725,536	A	3/1998	Oberlin et al.
5,630,782	A	5/1997	Adair	5,725,554	A	3/1998	Simon et al.
5,632,432	A	5/1997	Schulze et al.	5,728,121	A	3/1998	Bimbo et al.
5,632,433	A	5/1997	Grant et al.	5,730,758	A	3/1998	Allgeyer
5,634,584	A	6/1997	Okorochoa et al.	5,732,871	A	3/1998	Clark et al.
5,636,779	A	6/1997	Palmer	5,732,872	A	3/1998	Bolduc et al.
5,636,780	A	6/1997	Green et al.	5,733,308	A	3/1998	Daugherty et al.
5,639,008	A	6/1997	Gallagher et al.	5,735,445	A	4/1998	Vidal et al.
5,643,291	A	7/1997	Pier et al.	5,735,848	A	4/1998	Yates et al.
5,645,209	A	7/1997	Green et al.	5,735,874	A	4/1998	Measamer et al.
5,647,526	A	7/1997	Green et al.	5,738,474	A	4/1998	Blewett
5,647,869	A	7/1997	Goble et al.	5,738,648	A	4/1998	Lands et al.
5,649,937	A	7/1997	Bito et al.	5,743,456	A	4/1998	Jones et al.
5,651,491	A	7/1997	Heaton et al.	5,747,953	A	5/1998	Philipp
5,653,373	A	8/1997	Green et al.	5,749,889	A	5/1998	Bacich et al.
5,653,374	A	8/1997	Young et al.	5,749,893	A	5/1998	Vidal et al.
5,653,677	A	8/1997	Okada et al.	5,752,644	A	5/1998	Bolanos et al.
5,653,721	A	8/1997	Knodel et al.	5,752,965	A	5/1998	Francis et al.
5,655,698	A	8/1997	Yoon	5,755,717	A	5/1998	Yates et al.
5,657,921	A	8/1997	Young et al.	5,758,814	A	6/1998	Gallagher et al.
5,658,281	A	8/1997	Heard	5,762,255	A	6/1998	Chrisman et al.
5,658,300	A	8/1997	Bito et al.	5,762,256	A	6/1998	Mastri et al.
5,662,258	A	9/1997	Knodel et al.	5,766,188	A	6/1998	Igaki
5,662,260	A	9/1997	Yoon	5,766,205	A	6/1998	Zvenyatsky et al.
5,662,662	A	9/1997	Bishop et al.	5,769,892	A	6/1998	Kingwell
5,665,085	A	9/1997	Nardella	5,772,379	A	6/1998	Evensen
5,667,517	A	9/1997	Hooven	5,772,578	A	6/1998	Heimberger et al.
5,667,527	A	9/1997	Cook	5,772,659	A	6/1998	Becker et al.
5,669,544	A	9/1997	Schulze et al.	5,776,130	A	7/1998	Byusse et al.
5,669,904	A	9/1997	Platt, Jr. et al.	5,779,130	A	7/1998	Alesi et al.
5,669,907	A	9/1997	Platt, Jr. et al.	5,779,131	A	7/1998	Knodel et al.
5,669,918	A	9/1997	Balazs et al.	5,779,132	A	7/1998	Knodel et al.
5,673,840	A	10/1997	Schulze et al.	5,782,396	A	7/1998	Mastri et al.
5,673,841	A	10/1997	Schulze et al.	5,782,397	A	7/1998	Koukline
5,673,842	A	10/1997	Bittner et al.	5,782,749	A	7/1998	Riza
5,678,748	A	10/1997	Plyley et al.	5,782,859	A	7/1998	Nicholas et al.
5,680,981	A	10/1997	Mililli et al.	5,784,934	A	7/1998	Izumisawa
5,680,982	A	10/1997	Schulze et al.	5,785,232	A	7/1998	Vidal et al.
5,680,983	A	10/1997	Plyley et al.	5,785,647	A	7/1998	Tompkins et al.
5,683,349	A	11/1997	Makower et al.	5,787,897	A	8/1998	Kieturakis
5,685,474	A	11/1997	Seeber	5,792,135	A	8/1998	Madhani et al.
5,688,270	A	11/1997	Yates et al.	5,792,165	A	8/1998	Klieman et al.
5,690,269	A	11/1997	Bolanos et al.	5,794,834	A	8/1998	Hamblin et al.
				5,796,188	A	8/1998	Bays
				5,797,536	A	8/1998	Smith et al.
				5,797,537	A	8/1998	Oberlin et al.
				5,797,538	A	8/1998	Heaton et al.

(56)

References Cited

U.S. PATENT DOCUMENTS

5,797,906	A	8/1998	Rhum et al.	5,971,916	A	10/1999	Koren
5,797,959	A	8/1998	Castro et al.	5,988,479	A	11/1999	Palmer
5,799,857	A	9/1998	Robertson et al.	5,997,528	A	12/1999	Bisch et al.
5,806,676	A	9/1998	Wasgien	6,003,517	A	12/1999	Sheffield et al.
5,807,376	A	9/1998	Viola et al.	6,004,319	A	12/1999	Goble et al.
5,807,378	A	9/1998	Jensen et al.	6,010,054	A	1/2000	Johnson et al.
5,807,393	A	9/1998	Williamson, IV et al.	6,012,494	A	1/2000	Balazs
5,809,441	A	9/1998	McKee	6,013,076	A	1/2000	Goble et al.
5,810,721	A	9/1998	Mueller et al.	6,015,406	A	1/2000	Goble et al.
5,810,811	A	9/1998	Yates et al.	6,017,322	A	1/2000	Snoke et al.
5,810,855	A	9/1998	Rayburn et al.	6,017,356	A	1/2000	Frederick et al.
5,813,813	A	9/1998	Daum et al.	6,022,352	A	2/2000	Vandewalle
5,814,057	A	9/1998	Oi et al.	6,024,741	A	2/2000	Williamson, IV et al.
5,817,084	A	10/1998	Jensen	6,024,748	A	2/2000	Manzo et al.
5,817,091	A	10/1998	Nardella et al.	6,027,501	A	2/2000	Goble et al.
5,817,093	A	10/1998	Williamson, IV et al.	6,032,849	A	3/2000	Mastri et al.
5,817,109	A	10/1998	McGarry et al.	6,033,378	A	3/2000	Lundquist et al.
5,817,119	A	10/1998	Klieman et al.	6,033,399	A	3/2000	Gines
5,820,009	A	10/1998	Melling et al.	6,033,427	A	3/2000	Lee
5,823,066	A	10/1998	Huitema et al.	6,039,733	A	3/2000	Buysse et al.
5,826,776	A	10/1998	Schulze et al.	6,039,734	A	3/2000	Goble
5,827,271	A	10/1998	Buysse et al.	6,042,601	A	3/2000	Smith
5,827,298	A	10/1998	Hart et al.	6,045,560	A	4/2000	McKean et al.
5,829,662	A	11/1998	Allen et al.	6,050,472	A	4/2000	Shibata
5,833,690	A	11/1998	Yates et al.	6,050,990	A	4/2000	Tankovich et al.
5,833,695	A	11/1998	Yoon	6,053,390	A	4/2000	Green et al.
5,833,696	A	11/1998	Whitfield et al.	6,053,922	A	4/2000	Krause et al.
5,836,503	A	11/1998	Ehrenfels et al.	RE36,720	E	5/2000	Green et al.
5,836,960	A	11/1998	Kolesa et al.	6,056,735	A	5/2000	Okada et al.
5,839,639	A	11/1998	Sauer et al.	6,056,746	A	5/2000	Goble et al.
5,843,096	A	12/1998	Igaki et al.	6,063,097	A	5/2000	Oi et al.
5,843,132	A	12/1998	Ilvento	6,063,098	A	5/2000	Houser et al.
5,846,254	A	12/1998	Schulze et al.	6,066,132	A	5/2000	Chen et al.
5,849,011	A	12/1998	Jones et al.	6,068,627	A	5/2000	Orszulak et al.
5,855,311	A	1/1999	Hamblin et al.	6,071,233	A	6/2000	Ishikawa et al.
5,855,583	A	1/1999	Wang et al.	6,074,386	A	6/2000	Goble et al.
5,860,581	A	1/1999	Robertson et al.	6,077,286	A	6/2000	Cuschieri et al.
5,860,975	A	1/1999	Goble et al.	6,079,606	A	6/2000	Milliman et al.
5,865,361	A	2/1999	Milliman et al.	6,082,577	A	7/2000	Coates et al.
5,868,760	A	2/1999	McGuckin, Jr.	6,083,234	A	7/2000	Nicholas et al.
5,871,135	A	2/1999	Williamson, IV et al.	6,083,242	A	7/2000	Cook
5,873,885	A	2/1999	Weidenbenner	6,086,600	A	7/2000	Kortenbach
5,876,401	A	3/1999	Schulze et al.	6,090,106	A	7/2000	Goble et al.
5,878,193	A	3/1999	Wang et al.	6,093,186	A	7/2000	Goble
5,878,937	A	3/1999	Green et al.	6,099,537	A	8/2000	Sugai et al.
5,878,938	A	3/1999	Bittner et al.	6,099,551	A	8/2000	Gabbay
5,891,160	A	4/1999	Williamson, IV et al.	6,102,271	A	8/2000	Longo et al.
5,893,506	A	4/1999	Powell	6,109,500	A	8/2000	Alli et al.
5,893,835	A	4/1999	Witt et al.	6,117,148	A	9/2000	Ravo et al.
5,894,979	A	4/1999	Powell	6,117,158	A	9/2000	Measamer et al.
5,897,562	A	4/1999	Bolanos et al.	6,119,913	A	9/2000	Adams et al.
5,899,914	A	5/1999	Zirps et al.	6,120,433	A	9/2000	Mizuno et al.
5,901,895	A	5/1999	Heaton et al.	6,123,241	A	9/2000	Walter et al.
5,902,312	A	5/1999	Frater et al.	H1904	H	10/2000	Yates et al.
5,904,693	A	5/1999	Dicesare et al.	6,126,058	A	10/2000	Adams et al.
5,906,625	A	5/1999	Bito et al.	6,126,670	A	10/2000	Walker et al.
5,908,402	A	6/1999	Blythe	6,131,789	A	10/2000	Schulze et al.
5,908,427	A	6/1999	McKean et al.	6,132,368	A	10/2000	Cooper
5,911,353	A	6/1999	Bolanos et al.	6,139,546	A	10/2000	Koenig et al.
5,915,616	A	6/1999	Viola et al.	6,155,473	A	12/2000	Tompkins et al.
5,918,791	A	7/1999	Sorrentino et al.	6,156,056	A	12/2000	Kearns et al.
5,919,198	A	7/1999	Graves, Jr. et al.	6,159,146	A	12/2000	El Gazayerli
5,928,256	A	7/1999	Riza	6,159,200	A	12/2000	Verdura et al.
5,931,847	A	8/1999	Bittner et al.	6,162,208	A	12/2000	Hipps
5,931,853	A	8/1999	McEwen et al.	6,165,175	A	12/2000	Wampler et al.
5,937,951	A	8/1999	Izuchukwu et al.	6,165,184	A	12/2000	Verdura et al.
5,938,667	A	8/1999	Peysers et al.	6,165,188	A	12/2000	Saadat et al.
5,941,442	A	8/1999	Geiste et al.	6,168,605	B1	1/2001	Measamer et al.
5,944,172	A	8/1999	Hannula	6,171,316	B1	1/2001	Kovac et al.
5,944,715	A	8/1999	Goble et al.	6,171,330	B1	1/2001	Benchetrit
5,948,030	A	9/1999	Miller et al.	6,174,308	B1	1/2001	Goble et al.
5,951,552	A	9/1999	Long et al.	6,174,309	B1	1/2001	Wrublewski et al.
5,951,574	A	9/1999	Stefanchik et al.	6,179,776	B1	1/2001	Adams et al.
5,954,259	A	9/1999	Viola et al.	6,181,105	B1	1/2001	Cutolo et al.
5,964,774	A	10/1999	McKean et al.	6,182,673	B1	2/2001	Kindermann et al.
				6,193,129	B1	2/2001	Bittner et al.
				6,197,042	B1	3/2001	Ginn et al.
				6,202,914	B1	3/2001	Geiste et al.
				6,214,028	B1	4/2001	Yoon et al.

(56)

References Cited

U.S. PATENT DOCUMENTS

6,220,368	B1	4/2001	Ark et al.	6,491,701	B2	12/2002	Tierney et al.
6,223,835	B1	5/2001	Habedank et al.	6,492,785	B1	12/2002	Kasten et al.
6,228,081	B1	5/2001	Goble	6,494,896	B1	12/2002	D'Alessio et al.
6,228,084	B1	5/2001	Kirwan, Jr.	6,500,194	B2	12/2002	Benderev et al.
6,231,565	B1	5/2001	Tovey et al.	6,503,257	B2	1/2003	Grant et al.
6,234,178	B1	5/2001	Goble et al.	6,503,259	B2	1/2003	Huxel et al.
6,241,139	B1	6/2001	Milliman et al.	6,505,768	B2	1/2003	Whitman
6,241,723	B1	6/2001	Heim et al.	6,510,854	B2	1/2003	Goble
6,248,117	B1	6/2001	Blatter	6,511,468	B1	1/2003	Cragg et al.
6,249,076	B1	6/2001	Madden et al.	6,517,535	B2	2/2003	Edwards
6,250,532	B1	6/2001	Green et al.	6,517,565	B1	2/2003	Whitman et al.
6,258,107	B1	7/2001	Balázs et al.	6,517,566	B1	2/2003	Hovland et al.
6,261,286	B1	7/2001	Goble et al.	6,522,101	B2	2/2003	Malackowski
6,264,086	B1	7/2001	McGuckin, Jr.	6,543,456	B1	4/2003	Freeman
6,264,087	B1	7/2001	Whitman	6,547,786	B1	4/2003	Goble
6,270,508	B1	8/2001	Klieman et al.	6,550,546	B2	4/2003	Thürler et al.
6,273,897	B1	8/2001	Dalessandro et al.	6,551,333	B2	4/2003	Kuhns et al.
6,277,114	B1	8/2001	Bullivant et al.	6,554,861	B2	4/2003	Knox et al.
6,293,942	B1	9/2001	Goble et al.	6,558,379	B1	5/2003	Batchelor et al.
6,296,640	B1	10/2001	Wampler et al.	6,565,560	B1	5/2003	Goble et al.
6,302,311	B1	10/2001	Adams et al.	6,569,085	B2	5/2003	Kortenbach et al.
6,305,891	B1	10/2001	Burlingame	6,569,171	B2	5/2003	DeGuillebon et al.
6,306,134	B1	10/2001	Goble et al.	6,578,751	B2	6/2003	Hartwick
6,309,403	B1	10/2001	Minor et al.	6,582,427	B1	6/2003	Goble et al.
6,315,184	B1	11/2001	Whitman	6,588,643	B2	7/2003	Bolduc et al.
6,320,123	B1	11/2001	Reimers	6,589,164	B1	7/2003	Flaherty
6,324,339	B1	11/2001	Hudson et al.	6,592,538	B1	7/2003	Hotchkiss et al.
6,325,799	B1	12/2001	Goble	6,592,597	B2	7/2003	Grant et al.
6,325,810	B1	12/2001	Hamilton et al.	6,596,432	B2	7/2003	Kawakami et al.
6,330,965	B1	12/2001	Milliman et al.	D478,665	S	8/2003	Isaacs et al.
6,331,181	B1	12/2001	Tierney et al.	D478,986	S	8/2003	Johnston et al.
6,331,761	B1	12/2001	Kumar et al.	6,601,749	B2	8/2003	Sullivan et al.
6,334,860	B1	1/2002	Dorn	6,602,252	B2	8/2003	Mollenauer
6,336,926	B1	1/2002	Goble	6,605,078	B2	8/2003	Adams
6,338,737	B1	1/2002	Toledano	6,605,669	B2	8/2003	Awokola et al.
6,346,077	B1	2/2002	Taylor et al.	6,616,686	B2	9/2003	Coleman et al.
6,352,503	B1	3/2002	Matsui et al.	6,619,529	B2	9/2003	Green et al.
6,352,532	B1	3/2002	Kramer et al.	6,620,166	B1	9/2003	Wenstrom, Jr. et al.
6,358,224	B1	3/2002	Tims et al.	6,626,834	B2	9/2003	Dunne et al.
6,364,877	B1	4/2002	Goble et al.	6,629,630	B2	10/2003	Adams
6,364,888	B1	4/2002	Niemeyer et al.	6,629,974	B2	10/2003	Penny et al.
6,370,981	B2	4/2002	Watarai	6,629,988	B2	10/2003	Weadock
6,373,152	B1	4/2002	Wang et al.	6,636,412	B2	10/2003	Smith
6,387,113	B1	5/2002	Hawkins et al.	6,638,108	B2	10/2003	Tachi
6,387,114	B2	5/2002	Adams	6,638,285	B2	10/2003	Gabbay
6,391,038	B2	5/2002	Vargas et al.	6,638,297	B1	10/2003	Huitema
6,398,781	B1	6/2002	Goble et al.	RE38,335	E	11/2003	Aust et al.
6,398,797	B2	6/2002	Bombard et al.	6,641,528	B2	11/2003	Torii
6,402,766	B2	6/2002	Bowman et al.	6,644,532	B2	11/2003	Green et al.
6,406,440	B1	6/2002	Stefanchik	6,645,201	B1	11/2003	Utley et al.
6,409,724	B1	6/2002	Penny et al.	6,646,307	B1	11/2003	Yu et al.
H2037	H	7/2002	Yates et al.	6,648,816	B2	11/2003	Irion et al.
6,416,486	B1	7/2002	Wampler	D484,243	S	12/2003	Ryan et al.
6,416,509	B1	7/2002	Goble et al.	D484,595	S	12/2003	Ryan et al.
6,419,695	B1	7/2002	Gabbay	D484,596	S	12/2003	Ryan et al.
RE37,814	E	8/2002	Allgeyer	6,656,193	B2	12/2003	Grant et al.
6,428,070	B1	8/2002	Takanashi et al.	6,666,875	B1	12/2003	Sakurai et al.
6,429,611	B1	8/2002	Li	6,669,073	B2	12/2003	Milliman et al.
6,436,097	B1	8/2002	Nardella	6,671,185	B2	12/2003	Duval
6,436,107	B1	8/2002	Wang et al.	D484,977	S	1/2004	Ryan et al.
6,436,110	B2	8/2002	Bowman et al.	6,676,660	B2	1/2004	Wampler et al.
6,436,122	B1	8/2002	Frank et al.	6,679,410	B2	1/2004	Würsch et al.
6,439,446	B1	8/2002	Perry et al.	6,681,978	B2	1/2004	Geiste et al.
6,440,146	B2	8/2002	Nicholas et al.	6,681,979	B2	1/2004	Whitman
6,443,973	B1	9/2002	Whitman	6,682,527	B2	1/2004	Strul
6,450,391	B1	9/2002	Kayan et al.	6,682,528	B2	1/2004	Frazier et al.
6,454,781	B1	9/2002	Witt et al.	6,685,727	B2	2/2004	Fisher et al.
6,468,275	B1	10/2002	Wampler et al.	6,692,507	B2	2/2004	Pugsley et al.
6,471,106	B1	10/2002	Reining	6,695,199	B2	2/2004	Whitman
6,482,200	B2	11/2002	Shippert	6,698,643	B2	3/2004	Whitman
6,485,490	B2	11/2002	Wampler et al.	6,699,235	B2	3/2004	Wallace et al.
6,488,196	B1	12/2002	Fenton, Jr.	6,704,210	B1	3/2004	Myers
6,488,197	B1	12/2002	Whitman	6,705,503	B1	3/2004	Pedicini et al.
6,491,201	B1	12/2002	Whitman	6,712,773	B1	3/2004	Viola
6,491,690	B1	12/2002	Goble et al.	6,716,223	B2	4/2004	Leopold et al.
				6,716,232	B1	4/2004	Vidal et al.
				6,716,233	B1	4/2004	Whitman
				6,722,552	B2	4/2004	Fenton, Jr.
				6,723,087	B2	4/2004	O'Neill et al.

(56)

References Cited

U.S. PATENT DOCUMENTS

- | | | | | | | | |
|-----------|----|---------|----------------------|-----------|----|---------|----------------------|
| 6,723,091 | B2 | 4/2004 | Goble et al. | 6,953,138 | B1 | 10/2005 | Dworak et al. |
| 6,726,697 | B2 | 4/2004 | Nicholas et al. | 6,953,139 | B2 | 10/2005 | Milliman et al. |
| 6,729,119 | B2 | 5/2004 | Schnipke et al. | 6,959,851 | B2 | 11/2005 | Heinrich |
| 6,736,825 | B2 | 5/2004 | Blatter et al. | 6,959,852 | B2 | 11/2005 | Shelton, IV et al. |
| 6,736,854 | B2 | 5/2004 | Vadurro et al. | 6,960,163 | B2 | 11/2005 | Ewers et al. |
| 6,740,030 | B2 | 5/2004 | Martone et al. | 6,960,220 | B2 | 11/2005 | Marino et al. |
| 6,747,121 | B2 | 6/2004 | Gogolewski | 6,964,363 | B2 | 11/2005 | Wales et al. |
| 6,749,560 | B1 | 6/2004 | Konstorum et al. | 6,966,907 | B2 | 11/2005 | Goble |
| 6,752,768 | B2 | 6/2004 | Burdorff et al. | 6,966,909 | B2 | 11/2005 | Marshall et al. |
| 6,752,816 | B2 | 6/2004 | Culp et al. | 6,972,199 | B2 | 12/2005 | Lebouitz et al. |
| 6,755,195 | B1 | 6/2004 | Lemke et al. | 6,974,462 | B2 | 12/2005 | Sater |
| 6,755,338 | B2 | 6/2004 | Hahnen et al. | 6,978,921 | B2 | 12/2005 | Shelton, IV et al. |
| 6,758,846 | B2 | 7/2004 | Goble et al. | 6,978,922 | B2 | 12/2005 | Bilotti et al. |
| 6,761,685 | B2 | 7/2004 | Adams et al. | 6,981,628 | B2 | 1/2006 | Wales |
| 6,767,352 | B2 | 7/2004 | Field et al. | 6,981,941 | B2 | 1/2006 | Whitman et al. |
| 6,767,356 | B2 | 7/2004 | Kanner et al. | 6,981,978 | B2 | 1/2006 | Gannoe |
| 6,769,590 | B2 | 8/2004 | Vresh et al. | 6,984,203 | B2 | 1/2006 | Tartaglia et al. |
| 6,769,594 | B2 | 8/2004 | Orban, III | 6,984,231 | B2 | 1/2006 | Goble et al. |
| 6,773,409 | B2 | 8/2004 | Truckai et al. | 6,986,451 | B1 | 1/2006 | Mastri et al. |
| 6,773,438 | B1 | 8/2004 | Knodel et al. | 6,988,649 | B2 | 1/2006 | Shelton, IV et al. |
| 6,777,838 | B2 | 8/2004 | Miekka et al. | 6,988,650 | B2 | 1/2006 | Schwemberger et al. |
| 6,780,151 | B2 | 8/2004 | Grabover et al. | 6,990,796 | B2 | 1/2006 | Schnipke et al. |
| 6,780,180 | B1 | 8/2004 | Goble et al. | 6,994,708 | B2 | 2/2006 | Manzo |
| 6,783,524 | B2 | 8/2004 | Anderson et al. | 6,997,931 | B2 | 2/2006 | Sauer et al. |
| 6,786,382 | B1 | 9/2004 | Hoffman | 7,000,818 | B2 | 2/2006 | Shelton, IV et al. |
| 6,786,864 | B2 | 9/2004 | Matsuura et al. | 7,000,819 | B2 | 2/2006 | Swayze et al. |
| 6,786,896 | B1 | 9/2004 | Madani et al. | 7,001,380 | B2 | 2/2006 | Goble |
| 6,790,173 | B2 | 9/2004 | Saadat et al. | 7,001,408 | B2 | 2/2006 | Knodel et al. |
| 6,793,652 | B1 | 9/2004 | Whitman et al. | 7,008,435 | B2 | 3/2006 | Cummins |
| 6,805,273 | B2 | 10/2004 | Bilotti et al. | 7,018,390 | B2 | 3/2006 | Turovskiy et al. |
| 6,806,808 | B1 | 10/2004 | Watters et al. | 7,025,743 | B2 | 4/2006 | Mann et al. |
| 6,808,525 | B2 | 10/2004 | Latterell et al. | 7,029,435 | B2 | 4/2006 | Nakao |
| 6,814,741 | B2 | 11/2004 | Bowman et al. | 7,032,798 | B2 | 4/2006 | Whitman et al. |
| 6,817,508 | B1 | 11/2004 | Racenet et al. | 7,032,799 | B2 | 4/2006 | Viola et al. |
| 6,817,509 | B2 | 11/2004 | Geiste et al. | 7,033,356 | B2 | 4/2006 | Latterell et al. |
| 6,817,974 | B2 | 11/2004 | Cooper et al. | 7,036,680 | B1 | 5/2006 | Flannery |
| 6,821,273 | B2 | 11/2004 | Mollenauer | 7,037,344 | B2 | 5/2006 | Kagan et al. |
| 6,821,284 | B2 | 11/2004 | Sturtz et al. | 7,041,868 | B2 | 5/2006 | Greene et al. |
| 6,827,712 | B2 | 12/2004 | Tovey et al. | 7,044,352 | B2 | 5/2006 | Shelton, IV et al. |
| 6,827,725 | B2 | 12/2004 | Batchelor et al. | 7,044,353 | B2 | 5/2006 | Mastri et al. |
| 6,828,902 | B2 | 12/2004 | Casden | 7,048,687 | B1 | 5/2006 | Reuss et al. |
| 6,830,174 | B2 | 12/2004 | Hillstead et al. | 7,052,494 | B2 | 5/2006 | Goble et al. |
| 6,832,998 | B2 | 12/2004 | Goble | 7,055,730 | B2 | 6/2006 | Ehrenfels et al. |
| 6,834,001 | B2 | 12/2004 | Myono | 7,055,731 | B2 | 6/2006 | Shelton, IV et al. |
| 6,835,199 | B2 | 12/2004 | McGuckin, Jr. et al. | 7,056,284 | B2 | 6/2006 | Martone et al. |
| 6,835,336 | B2 | 12/2004 | Watt | 7,056,330 | B2 | 6/2006 | Gayton |
| 6,837,846 | B2 | 1/2005 | Jaffe et al. | 7,059,331 | B2 | 6/2006 | Adams et al. |
| 6,843,403 | B2 | 1/2005 | Whitman | 7,059,508 | B2 | 6/2006 | Shelton, IV et al. |
| 6,843,789 | B2 | 1/2005 | Goble | 7,063,712 | B2 | 6/2006 | Vargas et al. |
| 6,846,307 | B2 | 1/2005 | Whitman et al. | 7,066,879 | B2 | 6/2006 | Fowler et al. |
| 6,846,308 | B2 | 1/2005 | Whitman et al. | 7,066,944 | B2 | 6/2006 | Laufer et al. |
| 6,846,309 | B2 | 1/2005 | Whitman et al. | 7,070,083 | B2 | 7/2006 | Jankowski |
| 6,849,071 | B2 | 2/2005 | Whitman et al. | 7,070,559 | B2 | 7/2006 | Adams et al. |
| RE38,708 | E | 3/2005 | Bolanos et al. | 7,071,287 | B2 | 7/2006 | Rhine et al. |
| 6,863,694 | B1 | 3/2005 | Boyce et al. | 7,075,770 | B1 | 7/2006 | Smith |
| 6,866,178 | B2 | 3/2005 | Adams et al. | 7,077,856 | B2 | 7/2006 | Whitman |
| 6,866,671 | B2 | 3/2005 | Tierney et al. | 7,077,856 | B2 | 7/2006 | Whitman |
| 6,872,214 | B2 | 3/2005 | Sonnenschein et al. | 7,080,769 | B2 | 7/2006 | Vresh et al. |
| 6,874,669 | B2 | 4/2005 | Adams et al. | 7,081,114 | B2 | 7/2006 | Rashidi |
| 6,877,647 | B2 | 4/2005 | Green et al. | 7,083,073 | B2 | 8/2006 | Yoshie et al. |
| 6,878,106 | B1 | 4/2005 | Herrmann | 7,083,075 | B2 | 8/2006 | Swayze et al. |
| 6,889,116 | B2 | 5/2005 | Jinno | 7,083,571 | B2 | 8/2006 | Wang et al. |
| 6,893,435 | B2 | 5/2005 | Goble | 7,083,615 | B2 | 8/2006 | Peterson et al. |
| 6,905,057 | B2 | 6/2005 | Swayze et al. | 7,083,620 | B2 | 8/2006 | Jahns et al. |
| 6,905,497 | B2 | 6/2005 | Truckai et al. | 7,087,071 | B2 | 8/2006 | Nicholas et al. |
| 6,913,608 | B2 | 7/2005 | Liddicoat et al. | 7,090,637 | B2 | 8/2006 | Danitz et al. |
| 6,913,613 | B2 | 7/2005 | Schwarz et al. | 7,090,673 | B2 | 8/2006 | Dycus et al. |
| 6,923,803 | B2 | 8/2005 | Goble | 7,090,683 | B2 | 8/2006 | Brock et al. |
| 6,929,641 | B2 | 8/2005 | Goble et al. | 7,090,684 | B2 | 8/2006 | McGuckin, Jr. et al. |
| 6,931,830 | B2 | 8/2005 | Liao | 7,094,202 | B2 | 8/2006 | Nobis et al. |
| 6,932,218 | B2 | 8/2005 | Kosann et al. | 7,094,247 | B2 | 8/2006 | Monassevitch et al. |
| 6,936,042 | B2 | 8/2005 | Wallace et al. | 7,097,089 | B2 | 8/2006 | Marczyk |
| 6,939,358 | B2 | 9/2005 | Palacios et al. | 7,098,794 | B2 | 8/2006 | Lindsay et al. |
| 6,942,662 | B2 | 9/2005 | Goble et al. | 7,104,741 | B2 | 9/2006 | Krohn |
| 6,945,444 | B2 | 9/2005 | Gresham et al. | 7,108,695 | B2 | 9/2006 | Witt et al. |
| | | | | 7,108,701 | B2 | 9/2006 | Evens et al. |
| | | | | 7,108,709 | B2 | 9/2006 | Cummins |
| | | | | 7,111,769 | B2 | 9/2006 | Wales et al. |
| | | | | 7,112,214 | B2 | 9/2006 | Peterson et al. |
| | | | | RE39,358 | E | 10/2006 | Goble |

(56)

References Cited

U.S. PATENT DOCUMENTS

7,114,642	B2	10/2006	Whitman	7,300,450	B2	11/2007	Vleugels et al.
7,118,582	B1	10/2006	Wang et al.	7,303,106	B2	12/2007	Milliman et al.
7,121,446	B2	10/2006	Arad et al.	7,303,107	B2	12/2007	Milliman et al.
7,122,028	B2	10/2006	Looper et al.	7,303,108	B2	12/2007	Shelton, IV
7,128,253	B2	10/2006	Mastri et al.	7,303,556	B2	12/2007	Metzger
7,128,254	B2	10/2006	Shelton, IV et al.	7,308,998	B2	12/2007	Mastri et al.
7,128,748	B2	10/2006	Mooradian et al.	7,322,975	B2	1/2008	Goble et al.
7,131,445	B2	11/2006	Amoah	7,324,572	B2	1/2008	Chang
7,133,601	B2	11/2006	Phillips et al.	7,328,828	B2	2/2008	Ortiz et al.
7,134,587	B2	11/2006	Schwemberger et al.	7,328,829	B2	2/2008	Arad et al.
7,140,527	B2	11/2006	Ehrenfels et al.	7,330,004	B2	2/2008	DeJonge et al.
7,140,528	B2	11/2006	Shelton, IV	7,334,717	B2	2/2008	Rethy et al.
7,143,923	B2	12/2006	Shelton, IV et al.	7,334,718	B2	2/2008	McAlister et al.
7,143,924	B2	12/2006	Scirica et al.	7,336,048	B2	2/2008	Lohr
7,143,925	B2	12/2006	Shelton, IV et al.	7,336,184	B2	2/2008	Smith et al.
7,143,926	B2	12/2006	Shelton, IV et al.	7,338,513	B2	3/2008	Lee et al.
7,147,138	B2	12/2006	Shelton, IV	7,341,591	B2	3/2008	Grinberg
7,147,139	B2	12/2006	Schwemberger et al.	7,343,920	B2	3/2008	Toby et al.
7,147,140	B2	12/2006	Wukusick et al.	7,348,763	B1	3/2008	Reinhart et al.
7,147,637	B2	12/2006	Goble	RE40,237	E	4/2008	Bilotti et al.
7,147,650	B2	12/2006	Lee	7,351,258	B2	4/2008	Ricotta et al.
7,150,748	B2	12/2006	Ebbutt et al.	7,354,447	B2	4/2008	Shelton, IV et al.
7,153,300	B2	12/2006	Goble	7,357,287	B2	4/2008	Shelton, IV et al.
7,156,863	B2	1/2007	Sonnenschein et al.	7,364,060	B2	4/2008	Milliman
7,159,750	B2	1/2007	Racenet et al.	7,364,061	B2	4/2008	Swayze et al.
7,160,299	B2	1/2007	Baily	7,377,928	B2	5/2008	Zubik et al.
7,161,036	B2	1/2007	Oikawa et al.	7,380,695	B2	6/2008	Doll et al.
7,168,604	B2	1/2007	Milliman et al.	7,380,696	B2	6/2008	Shelton, IV et al.
7,172,104	B2	2/2007	Scirica et al.	7,386,730	B2	6/2008	Uchikubo
7,179,223	B2	2/2007	Motoki et al.	7,388,217	B2	6/2008	Buschbeck et al.
7,179,267	B2	2/2007	Nolan et al.	7,396,356	B2	7/2008	Mollnauer
7,182,239	B1	2/2007	Myers	7,397,364	B2	7/2008	Govari
7,182,763	B2	2/2007	Nardella	7,398,907	B2	7/2008	Racenet et al.
7,188,758	B2	3/2007	Viola et al.	7,398,908	B2	7/2008	Holsten et al.
7,189,207	B2	3/2007	Viola	7,401,721	B2	7/2008	Holsten et al.
7,195,627	B2	3/2007	Amoah et al.	7,404,508	B2	7/2008	Smith et al.
7,204,835	B2	4/2007	Latterell et al.	7,404,509	B2	7/2008	Ortiz et al.
7,207,233	B2	4/2007	Wadge	7,407,075	B2	8/2008	Holsten et al.
7,207,471	B2	4/2007	Heinrich et al.	7,407,076	B2	8/2008	Racenet et al.
7,207,472	B2	4/2007	Wukusick et al.	7,407,078	B2	8/2008	Shelton, IV et al.
7,207,556	B2	4/2007	Saitoh et al.	7,410,086	B2	8/2008	Ortiz et al.
7,208,005	B2	4/2007	Frecker et al.	7,416,101	B2	8/2008	Shelton, IV et al.
7,210,609	B2	5/2007	Leiboff et al.	7,418,078	B2	8/2008	Blanz et al.
7,211,081	B2	5/2007	Goble	RE40,514	E	9/2008	Mastri et al.
7,211,084	B2	5/2007	Goble et al.	7,419,080	B2	9/2008	Smith et al.
7,213,736	B2	5/2007	Wales et al.	7,422,136	B1	9/2008	Marczyk
7,214,224	B2	5/2007	Goble	7,422,139	B2	9/2008	Shelton, IV et al.
7,217,285	B2	5/2007	Vargas et al.	7,424,965	B2	9/2008	Racenet et al.
7,220,260	B2	5/2007	Fleming et al.	7,431,188	B1	10/2008	Marczyk
7,220,272	B2	5/2007	Weadock	7,431,189	B2	10/2008	Shelton, IV et al.
7,225,963	B2	6/2007	Scirica	7,431,694	B2	10/2008	Stefanchik et al.
7,225,964	B2	6/2007	Mastri et al.	7,431,730	B2	10/2008	Viola
7,234,624	B2	6/2007	Gresham et al.	7,434,715	B2	10/2008	Shelton, IV et al.
7,235,089	B1	6/2007	McGuckin, Jr.	7,434,717	B2	10/2008	Shelton, IV et al.
7,235,302	B2	6/2007	Jing et al.	7,438,209	B1	10/2008	Hess et al.
7,237,708	B1	7/2007	Guy et al.	7,439,354	B2	10/2008	Lenges et al.
7,238,195	B2	7/2007	Viola	7,441,684	B2	10/2008	Shelton, IV et al.
7,241,288	B2	7/2007	Braun	7,441,685	B1	10/2008	Boudreaux
7,246,734	B2	7/2007	Shelton, IV	7,442,201	B2	10/2008	Pugsley et al.
7,247,161	B2	7/2007	Johnston et al.	7,448,525	B2	11/2008	Shelton, IV et al.
7,252,660	B2	8/2007	Kunz	7,455,208	B2	11/2008	Wales et al.
7,255,696	B2	8/2007	Goble et al.	7,455,676	B2	11/2008	Holsten et al.
7,256,695	B2	8/2007	Hamel et al.	7,455,682	B2	11/2008	Viola
7,258,262	B2	8/2007	Mastri et al.	7,461,767	B2	12/2008	Viola et al.
7,260,431	B2	8/2007	Libbus et al.	7,464,846	B2	12/2008	Shelton, IV et al.
7,265,374	B2	9/2007	Lee et al.	7,464,847	B2	12/2008	Viola et al.
7,267,679	B2	9/2007	McGuckin, Jr. et al.	7,464,849	B2	12/2008	Shelton, IV et al.
7,273,483	B2	9/2007	Wiener et al.	7,467,740	B2	12/2008	Shelton, IV et al.
7,278,562	B2	10/2007	Mastri et al.	7,467,849	B2	12/2008	Silverbrook et al.
7,278,563	B1	10/2007	Green	7,472,814	B2	1/2009	Mastri et al.
7,278,994	B2	10/2007	Goble	7,472,815	B2	1/2009	Shelton, IV et al.
7,282,048	B2	10/2007	Goble et al.	7,473,253	B2	1/2009	Dycus et al.
7,295,907	B2	11/2007	Lu et al.	7,479,608	B2	1/2009	Smith
7,296,724	B2	11/2007	Green et al.	7,481,347	B2	1/2009	Roy
7,297,149	B2	11/2007	Vitali et al.	7,481,349	B2	1/2009	Holsten et al.
				7,481,824	B2	1/2009	Boudreaux et al.
				7,485,133	B2	2/2009	Cannon et al.
				7,490,749	B2	2/2009	Schall et al.
				7,494,039	B2	2/2009	Racenet et al.

(56)

References Cited

U.S. PATENT DOCUMENTS

7,494,499	B2	2/2009	Nagase et al.	7,718,556	B2	5/2010	Matsuda et al.
7,500,979	B2	3/2009	Hueil et al.	7,721,930	B2	5/2010	McKenna et al.
7,501,198	B2	3/2009	Barlev et al.	7,721,931	B2	5/2010	Shelton, IV et al.
7,506,790	B2	3/2009	Shelton, IV	7,721,934	B2	5/2010	Shelton, IV et al.
7,506,791	B2	3/2009	Omaits et al.	7,721,936	B2	5/2010	Shelton, IV et al.
7,510,107	B2	3/2009	Timun et al.	7,722,610	B2	5/2010	Viola et al.
7,517,356	B2	4/2009	Heinrich	7,726,537	B2	6/2010	Olson et al.
7,524,320	B2	4/2009	Tierney et al.	7,726,538	B2	6/2010	Holsten et al.
7,530,985	B2	5/2009	Takemoto et al.	7,731,072	B2	6/2010	Timm et al.
7,546,940	B2	6/2009	Milliman et al.	7,735,703	B2	6/2010	Morgan et al.
7,547,312	B2	6/2009	Bauman et al.	7,738,971	B2	6/2010	Swayze et al.
7,549,563	B2	6/2009	Mather et al.	7,740,159	B2	6/2010	Shelton, IV et al.
7,549,564	B2	6/2009	Boudreaux	7,743,960	B2	6/2010	Whitman et al.
7,549,998	B2	6/2009	Braun	7,744,627	B2	6/2010	Orban, III et al.
7,552,854	B2	6/2009	Wixey et al.	7,748,587	B2	7/2010	Haramiishi et al.
7,556,185	B2	7/2009	Viola	7,753,245	B2	7/2010	Boudreaux et al.
7,556,186	B2	7/2009	Milliman	7,753,904	B2	7/2010	Shelton, IV et al.
7,559,450	B2	7/2009	Wales et al.	7,766,209	B2	8/2010	Baxter, III et al.
7,559,452	B2	7/2009	Wales et al.	7,766,210	B2	8/2010	Shelton, IV et al.
7,563,862	B2	7/2009	Sieg et al.	7,766,821	B2	8/2010	Brunnen et al.
7,566,300	B2	7/2009	Devierre et al.	7,766,894	B2	8/2010	Weitzner et al.
7,568,603	B2	8/2009	Shelton, IV et al.	7,770,774	B2	8/2010	Mastri et al.
7,568,604	B2	8/2009	Ehrenfels et al.	7,770,775	B2	8/2010	Shelton, IV et al.
7,568,619	B2	8/2009	Todd et al.	7,771,396	B2	8/2010	Stefanchik et al.
7,575,144	B2	8/2009	Ortiz et al.	7,772,720	B2	8/2010	McGee et al.
7,588,174	B2	9/2009	Holsten et al.	7,776,060	B2	8/2010	Mooradian et al.
7,588,175	B2	9/2009	Timm et al.	7,780,054	B2	8/2010	Wales
7,588,176	B2	9/2009	Timun et al.	7,780,055	B2	8/2010	Scirica et al.
7,588,177	B2	9/2009	Racenet	7,780,663	B2	8/2010	Yates et al.
7,591,783	B2	9/2009	Boulais et al.	7,780,685	B2	8/2010	Hunt et al.
7,597,229	B2	10/2009	Boudreaux et al.	7,784,662	B2	8/2010	Wales et al.
7,600,663	B2	10/2009	Green	7,789,889	B2	9/2010	Zubik et al.
7,604,150	B2	10/2009	Boudreaux	7,793,812	B2	9/2010	Moore et al.
7,604,151	B2	10/2009	Hess et al.	7,794,475	B2	9/2010	Hess et al.
7,607,557	B2	10/2009	Shelton, IV et al.	7,798,386	B2	9/2010	Schall et al.
7,611,038	B2	11/2009	Racenet et al.	7,799,039	B2	9/2010	Shelton, IV et al.
7,615,003	B2	11/2009	Stefanchik et al.	7,803,151	B2	9/2010	Whitman
7,624,902	B2	12/2009	Marczyk et al.	7,806,891	B2	10/2010	Nowlin et al.
7,631,793	B2	12/2009	Rethy et al.	7,810,692	B2	10/2010	Hall et al.
7,635,074	B2	12/2009	Olson et al.	7,810,693	B2	10/2010	Broehl et al.
7,637,409	B2	12/2009	Marczyk	7,815,092	B2	10/2010	Whitman et al.
7,641,092	B2	1/2010	Kruszynski et al.	7,815,565	B2	10/2010	Stefanchik et al.
7,641,093	B2	1/2010	Doll et al.	7,819,296	B2	10/2010	Hueil et al.
7,641,095	B2	1/2010	Viola	7,819,297	B2	10/2010	Doll et al.
7,644,848	B2	1/2010	Swayze et al.	7,819,298	B2	10/2010	Hall et al.
7,648,519	B2	1/2010	Lee et al.	7,819,299	B2	10/2010	Shelton, IV et al.
7,651,017	B2	1/2010	Ortiz et al.	7,823,592	B2	11/2010	Bettuchi et al.
7,651,498	B2	1/2010	Shifrin et al.	7,824,401	B2	11/2010	Manzo et al.
7,656,131	B2	2/2010	Embrey et al.	7,828,189	B2	11/2010	Holsten et al.
7,658,311	B2	2/2010	Boudreaux	7,828,794	B2	11/2010	Sartor
7,658,312	B2	2/2010	Vidal et al.	7,828,808	B2	11/2010	Hinman et al.
7,665,646	B2	2/2010	Prommersberger	7,832,408	B2	11/2010	Shelton, IV et al.
7,665,647	B2	2/2010	Shelton, IV et al.	7,832,611	B2	11/2010	Boyden et al.
7,669,746	B2	3/2010	Shelton, IV	7,832,612	B2	11/2010	Baxter, III et al.
7,669,747	B2	3/2010	Weisenburgh, II et al.	7,836,400	B2	11/2010	May et al.
7,670,334	B2	3/2010	Hueil et al.	7,837,079	B2	11/2010	Holsten et al.
7,673,780	B2	3/2010	Shelton, IV et al.	7,837,080	B2	11/2010	Schwemberger
7,673,781	B2	3/2010	Swayze et al.	7,837,081	B2	11/2010	Holsten et al.
7,673,782	B2	3/2010	Hess et al.	7,845,533	B2	12/2010	Marczyk et al.
7,673,783	B2	3/2010	Morgan et al.	7,845,534	B2	12/2010	Viola et al.
7,674,255	B2	3/2010	Braun	7,845,536	B2	12/2010	Viola et al.
7,682,307	B2	3/2010	Danitz et al.	7,845,537	B2	12/2010	Shelton, IV et al.
7,686,201	B2	3/2010	Csiky	7,846,149	B2	12/2010	Jankowski
7,686,826	B2	3/2010	Lee et al.	7,850,642	B2	12/2010	Moll et al.
7,688,028	B2	3/2010	Phillips et al.	7,857,185	B2	12/2010	Swayze et al.
7,691,098	B2	4/2010	Wallace et al.	7,857,186	B2	12/2010	Baxter, III et al.
7,699,204	B2	4/2010	Viola	7,861,906	B2	1/2011	Doll et al.
7,699,844	B2	4/2010	Utley et al.	7,866,527	B2	1/2011	Hall et al.
7,699,859	B2	4/2010	Bombard et al.	7,870,989	B2	1/2011	Viola et al.
7,703,653	B2	4/2010	Shah et al.	7,871,418	B2	1/2011	Thompson et al.
7,708,180	B2	5/2010	Murray et al.	7,887,530	B2	2/2011	Zemlok et al.
7,708,758	B2	5/2010	Lee et al.	7,891,531	B1	2/2011	Ward
7,714,239	B2	5/2010	Smith	7,891,532	B2	2/2011	Mastri et al.
7,717,312	B2	5/2010	Beetel	7,900,805	B2	3/2011	Shelton, IV et al.
7,718,180	B2	5/2010	Karp	7,905,380	B2	3/2011	Shelton, IV et al.
				7,905,381	B2	3/2011	Baxter, III et al.
				7,909,191	B2	3/2011	Baker et al.
				7,909,220	B2	3/2011	Viola
				7,909,221	B2	3/2011	Viola et al.

(56)

References Cited

U.S. PATENT DOCUMENTS

- | | | | | | | | |
|-----------|----|---------|-----------------------|-----------|----|---------|---------------------|
| 7,913,891 | B2 | 3/2011 | Doll et al. | 8,162,197 | B2 | 4/2012 | Mastri et al. |
| 7,913,893 | B2 | 3/2011 | Mastri et al. | 8,167,185 | B2 | 5/2012 | Shelton, IV et al. |
| 7,914,543 | B2 | 3/2011 | Roth et al. | 8,167,895 | B2 | 5/2012 | D'Agostino et al. |
| 7,918,376 | B1 | 4/2011 | Knodel et al. | 8,172,122 | B2 | 5/2012 | Kasvikis et al. |
| 7,918,377 | B2 | 4/2011 | Measamer et al. | 8,172,124 | B2 | 5/2012 | Shelton, IV et al. |
| 7,918,848 | B2 | 4/2011 | Lau et al. | 8,186,555 | B2 | 5/2012 | Shelton, IV et al. |
| 7,922,061 | B2 | 4/2011 | Shelton, IV et al. | 8,186,560 | B2 | 5/2012 | Hess et al. |
| 7,922,063 | B2 | 4/2011 | Zemlok et al. | 8,192,460 | B2 | 6/2012 | Orban, III et al. |
| 7,934,630 | B2 | 5/2011 | Shelton, IV et al. | 8,196,795 | B2 | 6/2012 | Moore et al. |
| 7,934,631 | B2 | 5/2011 | Balbierz et al. | 8,196,796 | B2 | 6/2012 | Shelton, IV et al. |
| 7,938,307 | B2 | 5/2011 | Bettuchi | 8,201,721 | B2 | 6/2012 | Zemlok et al. |
| 7,941,865 | B2 | 5/2011 | Seman, Jr. et al. | 8,205,781 | B2 | 6/2012 | Baxter, III et al. |
| 7,942,303 | B2 | 5/2011 | Shah | 8,210,411 | B2 | 7/2012 | Yates et al. |
| 7,942,890 | B2 | 5/2011 | D'Agostino et al. | 8,210,414 | B2 | 7/2012 | Bettuchi et al. |
| 7,944,175 | B2 | 5/2011 | Mori et al. | 8,210,415 | B2 | 7/2012 | Ward |
| 7,950,560 | B2 | 5/2011 | Zemlok et al. | 8,211,125 | B2 | 7/2012 | Spivey |
| 7,951,166 | B2 | 5/2011 | Orban et al. | 8,215,531 | B2 | 7/2012 | Shelton, IV et al. |
| 7,954,682 | B2 | 6/2011 | Giordano et al. | 8,220,468 | B2 | 7/2012 | Cooper et al. |
| 7,954,684 | B2 | 6/2011 | Boudreaux | 8,220,688 | B2 | 7/2012 | Laurent et al. |
| 7,954,686 | B2 | 6/2011 | Baxter, III et al. | 8,220,690 | B2 | 7/2012 | Hess et al. |
| 7,954,687 | B2 | 6/2011 | Zemlok et al. | 8,225,799 | B2 | 7/2012 | Bettuchi |
| 7,955,257 | B2 | 6/2011 | Frasier et al. | 8,231,040 | B2 | 7/2012 | Zemlok et al. |
| 7,959,050 | B2 | 6/2011 | Smith et al. | 8,231,041 | B2 | 7/2012 | Marczyk et al. |
| 7,959,051 | B2 | 6/2011 | Smith et al. | 8,231,043 | B2 | 7/2012 | Tarinelli et al. |
| 7,963,963 | B2 | 6/2011 | Francischelli et al. | 8,241,271 | B2 | 8/2012 | Millman et al. |
| 7,966,799 | B2 | 6/2011 | Morgan et al. | 8,245,898 | B2 | 8/2012 | Smith et al. |
| 7,967,180 | B2 | 6/2011 | Scirica | 8,245,901 | B2 | 8/2012 | Stopek |
| 7,972,298 | B2 | 7/2011 | Wallace et al. | 8,256,654 | B2 | 9/2012 | Bettuchi et al. |
| 7,980,443 | B2 | 7/2011 | Scheib et al. | 8,257,391 | B2 | 9/2012 | Orban, III et al. |
| 7,988,026 | B2 | 8/2011 | Knodel et al. | 8,267,300 | B2 | 9/2012 | Boudreaux |
| 7,988,027 | B2 | 8/2011 | Olson et al. | 8,272,553 | B2 | 9/2012 | Mastri et al. |
| 7,992,757 | B2 | 8/2011 | Wheeler et al. | 8,276,801 | B2 | 10/2012 | Zemlok et al. |
| 7,997,469 | B2 | 8/2011 | Olson et al. | 8,276,802 | B2 | 10/2012 | Kostrzewski |
| 8,002,696 | B2 | 8/2011 | Suzuki | 8,292,155 | B2 | 10/2012 | Shelton, IV et al. |
| 8,002,795 | B2 | 8/2011 | Beetel | 8,298,677 | B2 | 10/2012 | Wiesner et al. |
| 8,006,365 | B2 | 8/2011 | Levin et al. | 8,308,040 | B2 | 11/2012 | Huang et al. |
| 8,006,885 | B2 | 8/2011 | Marczyk | 8,308,042 | B2 | 11/2012 | Aranyi |
| 8,006,889 | B2 | 8/2011 | Adams et al. | 8,308,046 | B2 | 11/2012 | Prommersberger |
| 8,011,550 | B2 | 9/2011 | Aranyi et al. | 8,317,070 | B2 | 11/2012 | Hueil et al. |
| 8,011,551 | B2 | 9/2011 | Marczyk et al. | 8,322,455 | B2 | 12/2012 | Shelton, IV et al. |
| 8,011,553 | B2 | 9/2011 | Mastri et al. | 8,322,589 | B2 | 12/2012 | Boudreaux |
| 8,011,555 | B2 | 9/2011 | Tarinelli et al. | 8,328,062 | B2 | 12/2012 | Viola |
| 8,016,176 | B2 | 9/2011 | Kasvikis et al. | 8,328,064 | B2 | 12/2012 | Racenet et al. |
| 8,016,177 | B2 | 9/2011 | Bettuchi et al. | 8,328,802 | B2 | 12/2012 | Deville et al. |
| 8,020,742 | B2 | 9/2011 | Marczyk | 8,333,313 | B2 | 12/2012 | Boudreaux et al. |
| 8,020,743 | B2 | 9/2011 | Shelton, IV | 8,348,127 | B2 | 1/2013 | Marczyk |
| 8,025,199 | B2 | 9/2011 | Whitman et al. | 8,348,129 | B2 | 1/2013 | Bedi et al. |
| 8,028,883 | B2 | 10/2011 | Stopek | 8,348,131 | B2 | 1/2013 | Omaitis et al. |
| 8,034,077 | B2 | 10/2011 | Smith et al. | 8,348,972 | B2 | 1/2013 | Soltz et al. |
| 8,038,045 | B2 | 10/2011 | Bettuchi et al. | 8,353,437 | B2 | 1/2013 | Boudreaux |
| 8,038,046 | B2 | 10/2011 | Smith et al. | 8,353,438 | B2 | 1/2013 | Baxter, III et al. |
| 8,056,787 | B2 | 11/2011 | Boudreaux et al. | 8,353,439 | B2 | 1/2013 | Baxter, III et al. |
| 8,056,788 | B2 | 11/2011 | Mastri et al. | 8,360,296 | B2 | 1/2013 | Zingman |
| 8,062,330 | B2 | 11/2011 | Prommersberger et al. | 8,360,297 | B2 | 1/2013 | Shelton, IV et al. |
| 8,066,167 | B2 | 11/2011 | Measamer et al. | 8,365,973 | B1 | 2/2013 | White et al. |
| D650,074 | S | 12/2011 | Hunt et al. | 8,365,976 | B2 | 2/2013 | Hess et al. |
| 8,083,119 | B2 | 12/2011 | Prommersberger | 8,366,559 | B2 | 2/2013 | Papenfuss et al. |
| 8,083,120 | B2 | 12/2011 | Shelton, IV et al. | 8,371,491 | B2 | 2/2013 | Huitema et al. |
| 8,084,001 | B2 | 12/2011 | Burns et al. | 8,372,094 | B2 | 2/2013 | Bettuchi et al. |
| 8,091,756 | B2 | 1/2012 | Viola | 8,393,513 | B2 | 3/2013 | Jankowski |
| 8,097,017 | B2 | 1/2012 | Viola | 8,393,514 | B2 | 3/2013 | Shelton, IV et al. |
| 8,100,310 | B2 | 1/2012 | Zemlok | 8,397,971 | B2 | 3/2013 | Yates et al. |
| 8,108,072 | B2 | 1/2012 | Zhao et al. | 8,403,198 | B2 | 3/2013 | Sorrentino et al. |
| 8,113,410 | B2 | 2/2012 | Hall et al. | 8,408,439 | B2 | 4/2013 | Huang et al. |
| 8,123,103 | B2 | 2/2012 | Millman | 8,409,079 | B2 | 4/2013 | Oakamoto et al. |
| 8,123,767 | B2 | 2/2012 | Bauman et al. | 8,414,577 | B2 | 4/2013 | Boudreaux et al. |
| 8,128,645 | B2 | 3/2012 | Sonnenschein et al. | 8,424,740 | B2 | 4/2013 | Shelton, IV et al. |
| 8,136,712 | B2 | 3/2012 | Zingman | 8,444,036 | B2 | 5/2013 | Shelton, IV |
| 8,141,762 | B2 | 3/2012 | Bedi et al. | 8,453,904 | B2 | 6/2013 | Eskaros et al. |
| 8,152,041 | B2 | 4/2012 | Kostrzewski | 8,453,907 | B2 | 6/2013 | Laurent et al. |
| 8,157,145 | B2 | 4/2012 | Shelton, IV et al. | 8,453,908 | B2 | 6/2013 | Bedi et al. |
| 8,157,152 | B2 | 4/2012 | Holsten et al. | 8,453,912 | B2 | 6/2013 | Mastri et al. |
| 8,157,153 | B2 | 4/2012 | Shelton, IV et al. | 8,453,914 | B2 | 6/2013 | Laurent et al. |
| 8,161,977 | B2 | 4/2012 | Shelton, IV et al. | 8,459,520 | B2 | 6/2013 | Giordano et al. |
| 8,162,138 | B2 | 4/2012 | Bettenhausen et al. | 8,459,525 | B2 | 6/2013 | Yates et al. |
| | | | | 8,464,922 | B2 | 6/2013 | Marczyk |
| | | | | 8,464,923 | B2 | 6/2013 | Shelton, IV |
| | | | | 8,464,925 | B2 | 6/2013 | Hull et al. |
| | | | | 8,474,677 | B2 | 7/2013 | Woodard, Jr. et al. |

(56)

References Cited

U.S. PATENT DOCUMENTS

8,479,969	B2	7/2013	Shelton, IV	2005/0054946	A1	3/2005	Krzyzanowski
8,485,412	B2	7/2013	Shelton, IV et al.	2005/0059997	A1	3/2005	Bauman et al.
8,485,413	B2	7/2013	Scheib et al.	2005/0070929	A1	3/2005	Dalessandro et al.
8,499,993	B2	8/2013	Shelton, IV et al.	2005/0075561	A1	4/2005	Golden
8,517,239	B2	8/2013	Scheib et al.	2005/0080454	A1	4/2005	Drews et al.
8,517,243	B2	8/2013	Giordano et al.	2005/0085693	A1	4/2005	Belson et al.
8,517,244	B2	8/2013	Shelton, IV et al.	2005/0090817	A1	4/2005	Phan
8,529,600	B2	9/2013	Woodard, Jr. et al.	2005/0096683	A1	5/2005	Ellins et al.
8,540,128	B2	9/2013	Shelton, IV et al.	2005/0103819	A1	5/2005	Racenet et al.
8,540,129	B2	9/2013	Baxter, III et al.	2005/0107814	A1	5/2005	Johnston et al.
8,540,131	B2	9/2013	Swayze	2005/0107824	A1	5/2005	Hillstead et al.
8,540,133	B2	9/2013	Bedi et al.	2005/0113820	A1	5/2005	Goble et al.
8,561,870	B2	10/2013	Baxter, III et al.	2005/0119525	A1	6/2005	Takemoto
8,567,656	B2	10/2013	Shelton, IV et al.	2005/0119669	A1	6/2005	Demmy
8,573,461	B2	11/2013	Shelton, IV et al.	2005/0124855	A1	6/2005	Jaffe et al.
2001/0025183	A1	9/2001	Shahidi	2005/0125009	A1	6/2005	Perry et al.
2002/0022836	A1	2/2002	Goble et al.	2005/0131173	A1	6/2005	McDaniel et al.
2002/0029036	A1	3/2002	Goble et al.	2005/0131211	A1	6/2005	Bayley et al.
2002/0095175	A1	7/2002	Brock et al.	2005/0131390	A1	6/2005	Heinrich et al.
2002/0117534	A1	8/2002	Green et al.	2005/0131436	A1	6/2005	Johnston et al.
2002/0134811	A1	9/2002	Napier et al.	2005/0131437	A1	6/2005	Johnston et al.
2002/0165541	A1	11/2002	Whitman	2005/0131457	A1	6/2005	Douglas et al.
2003/0023316	A1	1/2003	Brown et al.	2005/0137454	A1	6/2005	Saadat et al.
2003/0093103	A1	5/2003	Malackowski et al.	2005/0137455	A1	6/2005	Ewers et al.
2003/0096158	A1	5/2003	Takano et al.	2005/0143759	A1	6/2005	Kelly
2003/0105478	A1	6/2003	Whitman et al.	2005/0145675	A1	7/2005	Hartwick et al.
2003/0130677	A1	7/2003	Whitman et al.	2005/0154258	A1	7/2005	Tartaglia et al.
2003/0139741	A1	7/2003	Goble et al.	2005/0165419	A1	7/2005	Sauer et al.
2003/0153908	A1	8/2003	Goble et al.	2005/0165435	A1	7/2005	Johnston et al.
2003/0195387	A1	10/2003	Kortenbach et al.	2005/0169974	A1	8/2005	Tenerz et al.
2003/0205029	A1	11/2003	Chapolini et al.	2005/0171522	A1	8/2005	Christopherson
2003/0216732	A1	11/2003	Truckai et al.	2005/0177181	A1	8/2005	Kagan et al.
2003/0220660	A1	11/2003	Kortenbach et al.	2005/0182298	A1	8/2005	Ikeda et al.
2004/0002726	A1	1/2004	Nunez et al.	2005/0187545	A1	8/2005	Hooven et al.
2004/0006335	A1	1/2004	Garrison	2005/0187572	A1	8/2005	Johnston et al.
2004/0006340	A1	1/2004	Latterell et al.	2005/0187576	A1	8/2005	Whitman et al.
2004/0006372	A1	1/2004	Racenet et al.	2005/0189397	A1	9/2005	Jankowski
2004/0030333	A1	2/2004	Goble	2005/0192609	A1	9/2005	Whitman et al.
2004/0034357	A1	2/2004	Beane et al.	2005/0192628	A1	9/2005	Viola
2004/0034369	A1	2/2004	Sauer et al.	2005/0203550	A1	9/2005	Laufer et al.
2004/0044364	A1	3/2004	DeVries et al.	2005/0216055	A1	9/2005	Scirica et al.
2004/0068161	A1	4/2004	Couvillon, Jr.	2005/0228224	A1	10/2005	Okada et al.
2004/0068307	A1	4/2004	Goble	2005/0240222	A1	10/2005	Shipp
2004/0070369	A1	4/2004	Sakahibara	2005/0245965	A1	11/2005	Orban, III et al.
2004/0078037	A1	4/2004	Batchelor et al.	2005/0251128	A1	11/2005	Amoah
2004/0093024	A1	5/2004	Lousararian et al.	2005/0256452	A1	11/2005	DeMarchi et al.
2004/0094597	A1	5/2004	Whitman et al.	2005/0256522	A1	11/2005	Francischelli et al.
2004/0097987	A1	5/2004	Pugsley et al.	2005/0261676	A1	11/2005	Hall et al.
2004/0098040	A1	5/2004	Taniguchi et al.	2005/0261677	A1	11/2005	Hall et al.
2004/0101822	A1	5/2004	Weisner et al.	2005/0263563	A1	12/2005	Racenet et al.
2004/0108357	A1	6/2004	Milliman et al.	2005/0267455	A1	12/2005	Eggers et al.
2004/0111081	A1	6/2004	Whitman et al.	2005/0274768	A1	12/2005	Cummins et al.
2004/0115022	A1	6/2004	Albertson et al.	2006/0004407	A1	1/2006	Hiles et al.
2004/0116952	A1	6/2004	Sakurai et al.	2006/0008787	A1	1/2006	Hayman et al.
2004/0147909	A1	7/2004	Johnston et al.	2006/0011699	A1	1/2006	Olson et al.
2004/0164123	A1	8/2004	Racenet et al.	2006/0015009	A1	1/2006	Jaffe et al.
2004/0167572	A1	8/2004	Roth et al.	2006/0020247	A1	1/2006	Kagan et al.
2004/0173659	A1	9/2004	Green et al.	2006/0020258	A1	1/2006	Strauss et al.
2004/0181219	A1	9/2004	Goble et al.	2006/0020336	A1	1/2006	Liddicoat
2004/0186470	A1	9/2004	Goble et al.	2006/0025811	A1	2/2006	Shelton, IV
2004/0193189	A1	9/2004	Kortenbach et al.	2006/0025812	A1	2/2006	Shelton, IV
2004/0222268	A1	11/2004	Bilotti et al.	2006/0025813	A1	2/2006	Shelton et al.
2004/0230214	A1	11/2004	Donofrio et al.	2006/0041188	A1	2/2006	Dirusso et al.
2004/0232201	A1	11/2004	Wenchell et al.	2006/0047275	A1	3/2006	Goble
2004/0236352	A1	11/2004	Wang et al.	2006/0047303	A1	3/2006	Ortiz et al.
2004/0243147	A1	12/2004	Lipow	2006/0047307	A1	3/2006	Ortiz et al.
2004/0243151	A1	12/2004	Demmy et al.	2006/0049229	A1	3/2006	Milliman et al.
2004/0243163	A1	12/2004	Casiano et al.	2006/0052825	A1	3/2006	Ransick et al.
2004/0243176	A1	12/2004	Hahnen et al.	2006/0060630	A1	3/2006	Shelton, IV et al.
2004/0254566	A1	12/2004	Plicchi et al.	2006/0064086	A1	3/2006	Odom
2004/0254608	A1	12/2004	Huitema et al.	2006/0079735	A1	4/2006	Martone et al.
2004/0260315	A1	12/2004	Dell et al.	2006/0085031	A1	4/2006	Bettuchi
2004/0267310	A1	12/2004	Racenet et al.	2006/0085033	A1	4/2006	Criscuolo et al.
2005/0032511	A1	2/2005	Malone et al.	2006/0086032	A1	4/2006	Valencic et al.
2005/0033357	A1	2/2005	Braun	2006/0087746	A1	4/2006	Lipow
				2006/0100643	A1	5/2006	Laufer et al.
				2006/0108393	A1	5/2006	Heinrich et al.
				2006/0111711	A1	5/2006	Goble
				2006/0111723	A1	5/2006	Chapolini et al.

(56)

References Cited

U.S. PATENT DOCUMENTS

2006/0122636	A1	6/2006	Bailly et al.	2007/0299427	A1	12/2007	Yeung et al.
2006/0142772	A1	6/2006	Ralph et al.	2008/0015598	A1	1/2008	Prommersberger
2006/0149163	A1	7/2006	Hibner et al.	2008/0029570	A1	2/2008	Shelton et al.
2006/0161185	A1	7/2006	Saadat et al.	2008/0029573	A1	2/2008	Shelton et al.
2006/0173470	A1	8/2006	Oray et al.	2008/0029574	A1	2/2008	Shelton et al.
2006/0180634	A1	8/2006	Shelton, IV et al.	2008/0029575	A1	2/2008	Shelton et al.
2006/0200123	A1	9/2006	Ryan	2008/0030170	A1	2/2008	Dacquay et al.
2006/0201989	A1	9/2006	Ojeda	2008/0035701	A1	2/2008	Racenet et al.
2006/0212069	A1	9/2006	Shelton, IV	2008/0041916	A1	2/2008	Milliman et al.
2006/0217729	A1	9/2006	Eskridge et al.	2008/0041917	A1	2/2008	Racenet et al.
2006/0226196	A1	10/2006	Hueil et al.	2008/0078800	A1	4/2008	Hess et al.
2006/0235469	A1	10/2006	Viola	2008/0078802	A1	4/2008	Hess et al.
2006/0241655	A1	10/2006	Viola	2008/0082114	A1	4/2008	McKenna et al.
2006/0241692	A1	10/2006	McGuckin, Jr. et al.	2008/0082125	A1	4/2008	Murray et al.
2006/0244460	A1	11/2006	Weaver	2008/0082126	A1	4/2008	Murray et al.
2006/0252993	A1	11/2006	Freed et al.	2008/0083813	A1	4/2008	Zemlok et al.
2006/0253069	A1	11/2006	Li et al.	2008/0114385	A1	5/2008	Byrum et al.
2006/0258904	A1	11/2006	Stefanchik et al.	2008/0128469	A1	6/2008	Dalessandro et al.
2006/0259073	A1	11/2006	Miyamoto et al.	2008/0129253	A1	6/2008	Shiue et al.
2006/0264927	A1	11/2006	Ryan	2008/0140115	A1	6/2008	Stopek
2006/0264929	A1	11/2006	Goble et al.	2008/0154299	A1	6/2008	Linveh
2006/0271042	A1	11/2006	Latterell et al.	2008/0167522	A1	7/2008	Giordano et al.
2006/0271102	A1	11/2006	Bosshard et al.	2008/0169328	A1	7/2008	Shelton
2006/0278680	A1	12/2006	Viola et al.	2008/0169329	A1	7/2008	Shelton et al.
2006/0278681	A1	12/2006	Viola et al.	2008/0169331	A1	7/2008	Shelton et al.
2006/0284730	A1	12/2006	Schmid et al.	2008/0169332	A1	7/2008	Shelton et al.
2006/0289602	A1	12/2006	Wales et al.	2008/0169333	A1	7/2008	Shelton et al.
2006/0291981	A1	12/2006	Viola et al.	2008/0172087	A1	7/2008	Fuchs et al.
2007/0023476	A1	2/2007	Whitman et al.	2008/0172088	A1	7/2008	Smith et al.
2007/0023477	A1	2/2007	Whitman et al.	2008/0183193	A1	7/2008	Omori et al.
2007/0027468	A1	2/2007	Wales et al.	2008/0185419	A1	8/2008	Smith et al.
2007/0027469	A1	2/2007	Smith et al.	2008/0197167	A1	8/2008	Viola et al.
2007/0027472	A1	2/2007	Hiles et al.	2008/0200835	A1	8/2008	Monson et al.
2007/0027551	A1	2/2007	Farnsworth et al.	2008/0200949	A1	8/2008	Hiles et al.
2007/0034668	A1	2/2007	Holsten et al.	2008/0228029	A1	9/2008	Mikkaichi et al.
2007/0055219	A1	3/2007	Whitman et al.	2008/0245841	A1	10/2008	Smith et al.
2007/0070574	A1	3/2007	Nerheim et al.	2008/0251568	A1	10/2008	Zemlok et al.
2007/0073341	A1	3/2007	Smith	2008/0251569	A1	10/2008	Smith et al.
2007/0078484	A1	4/2007	Talarico et al.	2008/0255413	A1	10/2008	Zemlok et al.
2007/0083193	A1	4/2007	Werneth et al.	2008/0262654	A1	10/2008	Omori et al.
2007/0084897	A1	4/2007	Shelton, IV et al.	2008/0283570	A1	11/2008	Boyden et al.
2007/0102472	A1	5/2007	Shelton, IV	2008/0287944	A1	11/2008	Pearson et al.
2007/0106113	A1	5/2007	Ravo	2008/0290134	A1	11/2008	Bettuchi et al.
2007/0106317	A1	5/2007	Shelton, IV et al.	2008/0296346	A1	12/2008	Shelton, IV et al.
2007/0114261	A1	5/2007	Ortiz et al.	2008/0297287	A1	12/2008	Shachar et al.
2007/0118175	A1	5/2007	Butler et al.	2008/0308602	A1	12/2008	Timm et al.
2007/0129605	A1	6/2007	Schaaf	2008/0308603	A1	12/2008	Shelton, IV et al.
2007/0135803	A1	6/2007	Belson	2008/0308608	A1	12/2008	Prommersberger
2007/0158358	A1	7/2007	Mason, II et al.	2008/0314960	A1	12/2008	Marczyk et al.
2007/0170225	A1	7/2007	Shelton, IV et al.	2009/0001121	A1	1/2009	Hess et al.
2007/0173806	A1	7/2007	Orszulak et al.	2009/0001122	A1	1/2009	Prommersberger et al.
2007/0173813	A1	7/2007	Odom	2009/0001124	A1	1/2009	Hess et al.
2007/0175949	A1	8/2007	Shelton, IV et al.	2009/0001130	A1	1/2009	Hess et al.
2007/0175950	A1	8/2007	Shelton, IV et al.	2009/0005807	A1	1/2009	Hess et al.
2007/0175951	A1	8/2007	Shelton, IV et al.	2009/0005808	A1	1/2009	Hess et al.
2007/0175955	A1	8/2007	Shelton, IV et al.	2009/0005809	A1	1/2009	Hess et al.
2007/0181632	A1	8/2007	Milliman	2009/0012534	A1	1/2009	Madhani et al.
2007/0194079	A1	8/2007	Hueil et al.	2009/0012556	A1	1/2009	Boudreaux et al.
2007/0194082	A1	8/2007	Morgan et al.	2009/0020958	A1	1/2009	Soul
2007/0203510	A1	8/2007	Bettuchi	2009/0048589	A1	2/2009	Takashino et al.
2007/0213750	A1	9/2007	Weadock	2009/0054908	A1	2/2009	Zand et al.
2007/0219571	A1	9/2007	Balbierz et al.	2009/0078736	A1	3/2009	Van Lue
2007/0221700	A1	9/2007	Ortiz et al.	2009/0088774	A1	4/2009	Swarup et al.
2007/0221701	A1	9/2007	Ortiz et al.	2009/0090763	A1	4/2009	Zemlok et al.
2007/0225562	A1	9/2007	Spivey et al.	2009/0093728	A1	4/2009	Hyde et al.
2007/0239028	A1	10/2007	Houser et al.	2009/0108048	A1	4/2009	Zemlok et al.
2007/0243227	A1	10/2007	Gertner	2009/0112229	A1	4/2009	Omori et al.
2007/0244471	A1	10/2007	Malackowski	2009/0114701	A1	5/2009	Zemlok et al.
2007/0246505	A1	10/2007	Pace-Florida et al.	2009/0143805	A1	6/2009	Palmer et al.
2007/0249999	A1	10/2007	Sklar et al.	2009/0149871	A9	6/2009	Kagan et al.
2007/0260278	A1	11/2007	Wheeler et al.	2009/0157067	A1	6/2009	Kane et al.
2007/0270784	A1	11/2007	Smith et al.	2009/0198272	A1	8/2009	Kerver et al.
2007/0270884	A1	11/2007	Smith et al.	2009/0206125	A1	8/2009	Huitema et al.
2007/0286892	A1	12/2007	Herzberg et al.	2009/0206126	A1	8/2009	Huitema et al.
2007/0288044	A1	12/2007	Jinno et al.	2009/0206131	A1	8/2009	Weisenburgh, II et al.
				2009/0206132	A1	8/2009	Hueil et al.
				2009/0206133	A1	8/2009	Morgan et al.
				2009/0206137	A1	8/2009	Hall et al.
				2009/0206139	A1	8/2009	Hall et al.

(56)

References Cited

U.S. PATENT DOCUMENTS

2009/0206141	A1	8/2009	Huitema et al.	2011/0118761	A1	5/2011	Baxter, III et al.
2009/0206142	A1	8/2009	Huitema et al.	2011/0125176	A1	5/2011	Yates et al.
2009/0209946	A1	8/2009	Swayze et al.	2011/0125177	A1	5/2011	Yates et al.
2009/0209979	A1	8/2009	Yates et al.	2011/0132964	A1	6/2011	Weisenburgh, II et al.
2009/0209990	A1	8/2009	Yates et al.	2011/0132965	A1	6/2011	Moore et al.
2009/0213685	A1	8/2009	Mak et al.	2011/0144430	A1	6/2011	Spivey et al.
2009/0218384	A1	9/2009	Aranyi	2011/0144640	A1	6/2011	Heinrich et al.
2009/0242610	A1	10/2009	Shelton, IV et al.	2011/0147433	A1	6/2011	Shelton, IV et al.
2009/0255974	A1	10/2009	Viola	2011/0147434	A1	6/2011	Hueil et al.
2009/0255975	A1	10/2009	Zemlok et al.	2011/0155781	A1	6/2011	Swensgard et al.
2009/0255976	A1	10/2009	Marczyk et al.	2011/0155784	A1	6/2011	Shelton, IV et al.
2009/0255977	A1	10/2009	Zemlok	2011/0155786	A1	6/2011	Shelton, IV
2009/0255978	A1	10/2009	Viola et al.	2011/0155787	A1	6/2011	Baxter, III et al.
2009/0292283	A1	11/2009	Odom	2011/0163146	A1	7/2011	Ortiz et al.
2009/0308907	A1	12/2009	Nalagatla et al.	2011/0163147	A1	7/2011	Laurent et al.
2010/0012704	A1	1/2010	Tarinelli Racenet et al.	2011/0174861	A1	7/2011	Shelton, IV et al.
2010/0023024	A1	1/2010	Zeiner et al.	2011/0174862	A1	7/2011	Shelton, IV et al.
2010/0049084	A1	2/2010	Nock et al.	2011/0178536	A1	7/2011	Kostrzewski
2010/0057087	A1	3/2010	Cha	2011/0192882	A1	8/2011	Hess et al.
2010/0069942	A1	3/2010	Shelton, IV	2011/0210156	A1	9/2011	Smith et al.
2010/0072254	A1	3/2010	Aranyi et al.	2011/0253765	A1	10/2011	Nicholas et al.
2010/0076475	A1	3/2010	Yates et al.	2011/0275901	A1	11/2011	Shelton, IV
2010/0087840	A1	4/2010	Ebersole et al.	2011/0276083	A1	11/2011	Shelton, IV et al.
2010/0089970	A1	4/2010	Smith et al.	2011/0278343	A1	11/2011	Knodel et al.
2010/0094289	A1	4/2010	Taylor et al.	2011/0282446	A1	11/2011	Schulte et al.
2010/0096431	A1	4/2010	Smith et al.	2011/0288573	A1	11/2011	Yates et al.
2010/0108740	A1	5/2010	Pastorelli et al.	2011/0290851	A1	12/2011	Shelton, IV
2010/0108741	A1	5/2010	Hessler et al.	2011/0290853	A1	12/2011	Shelton, IV et al.
2010/0133317	A1	6/2010	Shelton, IV et al.	2011/0290854	A1	12/2011	Timm et al.
2010/0145146	A1	6/2010	Melder	2011/0290856	A1	12/2011	Shelton, IV et al.
2010/0147922	A1	6/2010	Olson	2011/0295242	A1	12/2011	Spivey et al.
2010/0163598	A1	7/2010	Belzer	2011/0295269	A1	12/2011	Swensgard et al.
2010/0179382	A1	7/2010	Shelton, IV et al.	2011/0295270	A1	12/2011	Giordano et al.
2010/0179540	A1	7/2010	Marczyk et al.	2011/0295295	A1	12/2011	Shelton, IV et al.
2010/0186219	A1	7/2010	Smith	2012/0022523	A1	1/2012	Smith et al.
2010/0193566	A1	8/2010	Schieb et al.	2012/0024934	A1	2/2012	Shelton, IV et al.
2010/0200637	A1	8/2010	Beetel	2012/0024935	A1	2/2012	Shelton, IV et al.
2010/0222901	A1	9/2010	Swayze et al.	2012/0024936	A1	2/2012	Baxter, III et al.
2010/0224669	A1	9/2010	Shelton, IV et al.	2012/0029272	A1	2/2012	Shelton, IV et al.
2010/0230465	A1	9/2010	Smith et al.	2012/0029544	A1	2/2012	Shelton, IV et al.
2010/0243707	A1	9/2010	Olson et al.	2012/0029547	A1	2/2012	Shelton, IV et al.
2010/0243708	A1	9/2010	Aranyi et al.	2012/0046692	A1	2/2012	Smith et al.
2010/0243709	A1	9/2010	Hess et al.	2012/0071711	A1	3/2012	Shelton, IV et al.
2010/0258611	A1	10/2010	Smith et al.	2012/0071866	A1	3/2012	Kerr et al.
2010/0268030	A1	10/2010	Viola et al.	2012/0074196	A1	3/2012	Shelton, IV et al.
2010/0276471	A1	11/2010	Whitman	2012/0074198	A1	3/2012	Huitema et al.
2010/0292540	A1	11/2010	Hess et al.	2012/0074200	A1	3/2012	Schmid et al.
2010/0294827	A1	11/2010	Boyden et al.	2012/0074201	A1	3/2012	Baxter, III et al.
2010/0294829	A1	11/2010	Giordano et al.	2012/0080332	A1	4/2012	Shelton, IV et al.
2010/0301095	A1	12/2010	Shelton, IV et al.	2012/0080335	A1	4/2012	Shelton, IV et al.
2010/0305552	A1	12/2010	Shelton, IV et al.	2012/0080336	A1	4/2012	Shelton, IV et al.
2010/0312261	A1	12/2010	Suzuki et al.	2012/0080337	A1	4/2012	Shelton, IV et al.
2010/0331880	A1	12/2010	Stopek	2012/0080338	A1	4/2012	Shelton, IV et al.
2011/0003528	A1	1/2011	Lam	2012/0080339	A1	4/2012	Shelton, IV et al.
2011/0006099	A1	1/2011	Hall et al.	2012/0080340	A1	4/2012	Shelton, IV et al.
2011/0006101	A1	1/2011	Hall et al.	2012/0080344	A1	4/2012	Shelton, IV
2011/0011916	A1	1/2011	Levine	2012/0080345	A1	4/2012	Morgan et al.
2011/0017799	A1	1/2011	Whitman et al.	2012/0080475	A1	4/2012	Smith et al.
2011/0017801	A1	1/2011	Zemlok et al.	2012/0080477	A1	4/2012	Leimbach et al.
2011/0022032	A1	1/2011	Zemlok et al.	2012/0080478	A1	4/2012	Morgan et al.
2011/0024477	A1	2/2011	Hall et al.	2012/0080479	A1	4/2012	Shelton, IV
2011/0024478	A1	2/2011	Shelton, IV	2012/0080480	A1	4/2012	Woodard, Jr. et al.
2011/0024479	A1	2/2011	Swensgard et al.	2012/0080481	A1	4/2012	Widenhouse et al.
2011/0036887	A1	2/2011	Zemlok et al.	2012/0080482	A1	4/2012	Schall et al.
2011/0036890	A1	2/2011	Ma	2012/0080483	A1	4/2012	Riestenberg et al.
2011/0060363	A1	3/2011	Hess et al.	2012/0080484	A1	4/2012	Morgan et al.
2011/0068148	A1	3/2011	Hall et al.	2012/0080485	A1	4/2012	Woodard, Jr. et al.
2011/0084112	A1	4/2011	Kostrzewski	2012/0080486	A1	4/2012	Woodard, Jr. et al.
2011/0087276	A1	4/2011	Bedi et al.	2012/0080488	A1	4/2012	Shelton, IV et al.
2011/0087279	A1	4/2011	Shah et al.	2012/0080489	A1	4/2012	Shelton, IV et al.
2011/0095068	A1	4/2011	Patel	2012/0080490	A1	4/2012	Shelton, IV et al.
2011/0101065	A1	5/2011	Milliman	2012/0080491	A1	4/2012	Shelton, IV et al.
2011/0114697	A1	5/2011	Baxter, III et al.	2012/0080493	A1	4/2012	Shelton, IV et al.
2011/0114700	A1	5/2011	Baxter, III et al.	2012/0080496	A1	4/2012	Schall et al.
2011/0118754	A1	5/2011	Dachs, II et al.	2012/0080498	A1	4/2012	Shelton, IV et al.
				2012/0080499	A1	4/2012	Schall et al.
				2012/0080500	A1	4/2012	Morgan et al.
				2012/0080501	A1	4/2012	Morgan et al.
				2012/0080502	A1	4/2012	Morgan et al.

(56)

References Cited

U.S. PATENT DOCUMENTS

2012/0080503	A1	4/2012	Woodard, Jr. et al.
2012/0083833	A1	4/2012	Shelton, IV et al.
2012/0083834	A1	4/2012	Shelton, IV et al.
2012/0083835	A1	4/2012	Shelton, IV et al.
2012/0083836	A1	4/2012	Shelton, IV et al.
2012/0132450	A1	5/2012	Timm et al.
2012/0138658	A1	6/2012	Ullrich et al.
2012/0138660	A1	6/2012	Shelton, IV
2012/0150192	A1	6/2012	Dachs, II et al.
2012/0160721	A1	6/2012	Shelton, IV et al.
2012/0175399	A1	7/2012	Shelton et al.
2012/0187179	A1	7/2012	Gleiman
2012/0199630	A1	8/2012	Shelton, IV et al.
2012/0199631	A1	8/2012	Shelton, IV et al.
2012/0199632	A1	8/2012	Spivey et al.
2012/0203247	A1	8/2012	Shelton, IV et al.
2012/0205421	A1	8/2012	Shelton, IV
2012/0234890	A1	9/2012	Aronhalt et al.
2012/0234891	A1	9/2012	Aronhalt et al.
2012/0234892	A1	9/2012	Aronhalt et al.
2012/0234893	A1	9/2012	Schuckmann et al.
2012/0234895	A1	9/2012	O'Connor et al.
2012/0234896	A1	9/2012	Ellerhorst et al.
2012/0234897	A1	9/2012	Shelton, IV et al.
2012/0234898	A1	9/2012	Shelton, IV et al.
2012/0234899	A1	9/2012	Scheib et al.
2012/0238823	A1	9/2012	Hagerty et al.
2012/0238824	A1	9/2012	Widenhouse et al.
2012/0238826	A1	9/2012	Yoo et al.
2012/0238829	A1	9/2012	Shelton, IV et al.
2012/0239009	A1	9/2012	Mollere et al.
2012/0239010	A1	9/2012	Shelton, IV et al.
2012/0239075	A1	9/2012	Widenhouse et al.
2012/0239082	A1	9/2012	Shelton, IV et al.
2012/0241491	A1	9/2012	Aldridge et al.
2012/0241492	A1	9/2012	Shelton, IV et al.
2012/0241493	A1	9/2012	Baxter, III et al.
2012/0241496	A1	9/2012	Mandakolathur Vasudevan et al.
2012/0241497	A1	9/2012	Mandakolathur Vasudevan et al.
2012/0241498	A1	9/2012	Gonzalez et al.
2012/0241499	A1	9/2012	Baxter, III et al.
2012/0241500	A1	9/2012	Timmer et al.
2012/0241501	A1	9/2012	Swayze et al.
2012/0241502	A1	9/2012	Aldridge et al.
2012/0241503	A1	9/2012	Baxter, III et al.
2012/0241505	A1	9/2012	Alexander, III et al.
2012/0248169	A1	10/2012	Widenhouse et al.
2012/0253298	A1	10/2012	Henderson et al.
2012/0265230	A1	10/2012	Yates et al.
2012/0283707	A1	11/2012	Giordano et al.
2012/0283748	A1	11/2012	Ortiz et al.
2012/0286019	A1	11/2012	Hueil et al.
2012/0292367	A1	11/2012	Morgan et al.
2012/0292370	A1	11/2012	Hess et al.
2012/0298719	A1	11/2012	Shelton, IV et al.
2012/0298722	A1	11/2012	Hess et al.
2012/0312860	A1	12/2012	Ming et al.
2012/0318842	A1	12/2012	Anim et al.
2012/0318843	A1	12/2012	Henderson et al.
2012/0318844	A1	12/2012	Shelton, IV et al.
2012/0325892	A1	12/2012	Kostrzewski
2013/0012931	A1	1/2013	Spivey et al.
2013/0012957	A1	1/2013	Shelton, IV et al.
2013/0018361	A1	1/2013	Bryant
2013/0020375	A1	1/2013	Shelton, IV et al.
2013/0020376	A1	1/2013	Shelton, IV et al.
2013/0023861	A1	1/2013	Shelton, IV et al.
2013/0026208	A1	1/2013	Shelton, IV et al.
2013/0026210	A1	1/2013	Shelton, IV et al.
2013/0037596	A1	2/2013	Bear et al.
2013/0048697	A1	2/2013	Shelton, IV et al.
2013/0056518	A1	3/2013	Swensgard
2013/0056520	A1	3/2013	Swensgard
2013/0056521	A1	3/2013	Swensgard
2013/0056522	A1	3/2013	Swensgard
2013/0075443	A1	3/2013	Giordano et al.
2013/0075448	A1	3/2013	Schmid et al.
2013/0075449	A1	3/2013	Schmid et al.
2013/0075450	A1	3/2013	Schmid et al.
2013/0079814	A1	3/2013	Hess et al.
2013/0087597	A1	4/2013	Shelton, IV et al.
2013/0103024	A1	4/2013	Monson et al.
2013/0105551	A1	5/2013	Zingman
2013/0116668	A1	5/2013	Shelton, IV et al.
2013/0116669	A1	5/2013	Shelton, IV et al.
2013/0126581	A1	5/2013	Yates et al.
2013/0126582	A1	5/2013	Shelton, IV et al.
2013/0126583	A1	5/2013	Hueil et al.
2013/0146641	A1	6/2013	Shelton, IV et al.
2013/0146642	A1	6/2013	Shelton, IV et al.
2013/0146643	A1	6/2013	Schmid et al.
2013/0153636	A1	6/2013	Shelton, IV et al.
2013/0153641	A1	6/2013	Shelton, IV et al.
2013/0168435	A1	7/2013	Huang et al.
2013/0172929	A1	7/2013	Hess et al.
2013/0175317	A1	7/2013	Yates et al.
2013/0175321	A1	7/2013	Shelton, IV et al.
2013/0175322	A1	7/2013	Yates et al.
2013/0181030	A1	7/2013	Hess et al.
2013/0181033	A1	7/2013	Shelton, IV et al.
2013/0181034	A1	7/2013	Shelton, IV et al.
2013/0184718	A1	7/2013	Smith et al.
2013/0184719	A1	7/2013	Shelton, IV et al.
2013/0186932	A1	7/2013	Shelton, IV et al.
2013/0186933	A1	7/2013	Shelton, IV et al.
2013/0186934	A1	7/2013	Shelton, IV et al.
2013/0186936	A1	7/2013	Shelton, IV
2013/0190733	A1	7/2013	Giordano et al.
2013/0190757	A1	7/2013	Yates et al.
2013/0193188	A1	8/2013	Shelton, IV et al.
2013/0193189	A1	8/2013	Swensgard et al.
2013/0197556	A1	8/2013	Shelton, IV et al.
2013/0200132	A1	8/2013	Moore et al.
2013/0206814	A1	8/2013	Morgan et al.
2013/0214030	A1	8/2013	Aronhalt et al.
2013/0221063	A1	8/2013	Aronhalt et al.
2013/0221064	A1	8/2013	Aronhalt et al.
2013/0221065	A1	8/2013	Aronhalt et al.
2013/0233906	A1	9/2013	Hess et al.
2013/0248576	A1	9/2013	Laurent et al.
2013/0248577	A1	9/2013	Leimbach et al.
2013/0256365	A1	10/2013	Shelton, IV et al.
2013/0256366	A1	10/2013	Shelton, IV et al.
2013/0256367	A1	10/2013	Scheib et al.
2013/0256368	A1	10/2013	Timm et al.
2013/0256369	A1	10/2013	Schmid et al.
2013/0256371	A1	10/2013	Shelton, IV et al.
2013/0256372	A1	10/2013	Baxter, III et al.
2013/0256373	A1	10/2013	Schmid et al.
2013/0256374	A1	10/2013	Shelton, IV et al.
2013/0256375	A1	10/2013	Shelton, IV et al.
2013/0256376	A1	10/2013	Barton et al.
2013/0256377	A1	10/2013	Schmid et al.
2013/0256378	A1	10/2013	Schmid et al.
2013/0256379	A1	10/2013	Schmid et al.
2013/0256380	A1	10/2013	Schmid et al.
2013/0256382	A1	10/2013	Swayze et al.
2013/0256383	A1	10/2013	Aronhalt et al.
2013/0261648	A1	10/2013	Laurent et al.
2013/0270322	A1	10/2013	Scheib et al.

FOREIGN PATENT DOCUMENTS

CA	2512960	A1	1/2006
CA	2514274	A1	1/2006
CN	2488482	Y	5/2002
CN	1523725	A	8/2004
CN	1634601	A	7/2005
CN	1868411	A	11/2006
CN	1915180	A	2/2007
CN	101011286	A	8/2007
CN	101095621	A	1/2008
CN	101023879	B	3/2013
DE	273689	C	5/1914

(56)

References Cited

FOREIGN PATENT DOCUMENTS

DE	1775926	A	1/1972	EP	0603472	B1	11/1998
DE	3036217	A1	4/1982	EP	0605351	B1	11/1998
DE	3212828	A1	11/1982	EP	0878169	A1	11/1998
DE	3210466	A1	9/1983	EP	0879742	A1	11/1998
DE	3709067	A1	9/1988	EP	0695144	B1	12/1998
DE	9412228	U	9/1994	EP	0722296	B1	12/1998
DE	19509116	A1	9/1996	EP	0760230	B1	2/1999
DE	19851291	A1	1/2000	EP	0623316	B1	3/1999
DE	19924311	A1	11/2000	EP	0650701	B1	3/1999
DE	69328576	T2	1/2001	EP	0537572	B1	6/1999
DE	20016423	U1	2/2001	EP	0923907	A1	6/1999
DE	10052679	A1	5/2001	EP	0843906	B1	3/2000
DE	20112837	U1	10/2001	EP	0552050	B1	5/2000
DE	20121753	U1	4/2003	EP	0833592	B1	5/2000
DE	10314072	A1	10/2004	EP	0830094	B1	9/2000
DE	202007003114	U1	6/2007	EP	1034747	A1	9/2000
EP	0122046	A1	10/1984	EP	1034748	A1	9/2000
EP	0070230	B1	10/1985	EP	0694290	B1	11/2000
EP	0156774	A2	10/1985	EP	1050278	A1	11/2000
EP	0387980	B1	10/1985	EP	1053719	A1	11/2000
EP	0033548	B1	5/1986	EP	1053720	A1	11/2000
EP	0129442	B1	11/1987	EP	1055399	A1	11/2000
EP	0276104	A2	7/1988	EP	1055400	A1	11/2000
EP	0178940	B1	1/1991	EP	1080694	A1	3/2001
EP	0178941	B1	1/1991	EP	1090592	A1	4/2001
EP	0248844	B1	1/1993	EP	1095627	A1	5/2001
EP	0545029	A1	6/1993	EP	1256318	B1	5/2001
EP	0277959	B1	10/1993	EP	0806914	B1	9/2001
EP	0233940	B1	11/1993	EP	0768840	B1	12/2001
EP	0261230	B1	11/1993	EP	0908152	B1	1/2002
EP	0639349	A2	2/1994	EP	0872213	B1	5/2002
EP	0324636	B1	3/1994	EP	0862386	B1	6/2002
EP	0593920	A1	4/1994	EP	0949886	B1	9/2002
EP	0594148	A1	4/1994	EP	1238634	A2	9/2002
EP	0427949	B1	6/1994	EP	0858295	B1	12/2002
EP	0523174	B1	6/1994	EP	0656188	B1	1/2003
EP	0600182	A2	6/1994	EP	0717960	B1	2/2003
EP	0310431	B1	11/1994	EP	1284120	A1	2/2003
EP	0375302	B1	11/1994	EP	1287788	A1	3/2003
EP	0376562	B1	11/1994	EP	0717966	B1	4/2003
EP	0630612	A1	12/1994	EP	0869742	B1	5/2003
EP	0634144	A1	1/1995	EP	0829235	B1	6/2003
EP	0646356	A2	4/1995	EP	0887046	B1	7/2003
EP	0646357	A1	4/1995	EP	0852480	B1	8/2003
EP	0653189	A2	5/1995	EP	0891154	B1	9/2003
EP	0669104	A1	8/1995	EP	0813843	B1	10/2003
EP	0511470	B1	10/1995	EP	0873089	B1	10/2003
EP	0674876	A2	10/1995	EP	0856326	B1	11/2003
EP	0679367	A2	11/1995	EP	1374788	A1	1/2004
EP	0392547	B1	12/1995	EP	0741996	B1	2/2004
EP	0685204	A1	12/1995	EP	0814712	B1	2/2004
EP	0364216	B1	1/1996	EP	1402837	A1	3/2004
EP	0699418	A1	3/1996	EP	0705570	B1	4/2004
EP	0702937	A1	3/1996	EP	0959784	B1	4/2004
EP	0705571	A1	4/1996	EP	1407719	A2	4/2004
EP	0711611	A2	5/1996	EP	1086713	B1	5/2004
EP	0484677	B2	6/1996	EP	0996378	B1	6/2004
EP	0541987	B1	7/1996	EP	1426012	A1	6/2004
EP	0667119	B1	7/1996	EP	0833593	B2	7/2004
EP	0708618	B1	3/1997	EP	1442694	A1	8/2004
EP	0770355	A1	5/1997	EP	0888749	B1	9/2004
EP	0503662	B1	6/1997	EP	0959786	B1	9/2004
EP	0447121	B1	7/1997	EP	1459695	A1	9/2004
EP	0625077	B1	7/1997	EP	1254636	B1	10/2004
EP	0633749	B1	8/1997	EP	1473819	A1	11/2004
EP	0710090	B1	8/1997	EP	1477119	A1	11/2004
EP	0578425	B1	9/1997	EP	1479345	A1	11/2004
EP	0625335	B1	11/1997	EP	1479347	A1	11/2004
EP	0552423	B1	1/1998	EP	1479348	A1	11/2004
EP	0592244	B1	1/1998	EP	0754437	B2	12/2004
EP	0648476	B1	1/1998	EP	1025807	B1	12/2004
EP	0649290	B1	3/1998	EP	1001710	B1	1/2005
EP	0598618	B1	9/1998	EP	1520521	A1	4/2005
EP	0676173	B1	9/1998	EP	1520522	A1	4/2005
EP	0678007	B1	9/1998	EP	1520523	A1	4/2005
				EP	1520525	A1	4/2005
				EP	1522264	A1	4/2005
				EP	1523942	A2	4/2005
				EP	1550408	A1	7/2005

(56)

References Cited

FOREIGN PATENT DOCUMENTS

EP	1557129	A1	7/2005	EP	1943955	A2	7/2008
EP	1064883	B1	8/2005	EP	1943957	A2	7/2008
EP	1067876	B1	8/2005	EP	1943964	A1	7/2008
EP	0870473	B1	9/2005	EP	1943976	A2	7/2008
EP	1157666	B1	9/2005	EP	1593337	B1	8/2008
EP	0880338	B1	10/2005	EP	1970014	A1	9/2008
EP	1158917	B1	11/2005	EP	1980213	A2	10/2008
EP	1344498	B1	11/2005	EP	1759645	B1	11/2008
EP	0906764	B1	12/2005	EP	1990014	A2	11/2008
EP	1330989	B1	12/2005	EP	1552795	B1	12/2008
EP	0771176	B2	1/2006	EP	1693008	B1	12/2008
EP	1621138	A2	2/2006	EP	1759640	B1	12/2008
EP	1621139	A2	2/2006	EP	1997439	A2	12/2008
EP	1621141	A2	2/2006	EP	2000102	A2	12/2008
EP	1621145	A2	2/2006	EP	2005894	A2	12/2008
EP	1621151	A2	2/2006	EP	2005901	A1	12/2008
EP	1034746	B1	3/2006	EP	2008595	A2	12/2008
EP	1201196	B1	3/2006	EP	1736104	B1	3/2009
EP	1632191	A2	3/2006	EP	1749486	B1	3/2009
EP	1647231	A1	4/2006	EP	1782743	B1	3/2009
EP	1065981	B1	5/2006	EP	2039302	A2	3/2009
EP	1082944	B1	5/2006	EP	2039316	A2	3/2009
EP	1652481	A2	5/2006	EP	1721576	B1	4/2009
EP	1382303	B1	6/2006	EP	1733686	B1	4/2009
EP	1253866	B1	7/2006	EP	2044890	A1	4/2009
EP	1032318	B1	8/2006	EP	1550409	B1	6/2009
EP	1045672	B1	8/2006	EP	1550413	B1	6/2009
EP	1617768	B1	8/2006	EP	1719461	B1	6/2009
EP	1693015	A2	8/2006	EP	1745748	B1	8/2009
EP	1400214	B1	9/2006	EP	2090237	A1	8/2009
EP	1702567	A2	9/2006	EP	2090241	A1	8/2009
EP	1129665	B1	11/2006	EP	2090244	A2	8/2009
EP	1400206	B1	11/2006	EP	2090245	A1	8/2009
EP	1721568	A1	11/2006	EP	2090256	A2	8/2009
EP	1256317	B1	12/2006	EP	2095777	A2	9/2009
EP	1285633	B1	12/2006	EP	2098170	A2	9/2009
EP	1728473	A1	12/2006	EP	2110082	A1	10/2009
EP	1728475	A2	12/2006	EP	2111803	A2	10/2009
EP	1479346	B1	1/2007	EP	1813208	B1	11/2009
EP	1484024	B1	1/2007	EP	1908426	B1	11/2009
EP	1754445	A2	2/2007	EP	2116195	A1	11/2009
EP	1759812	A1	3/2007	EP	1607050	B1	12/2009
EP	1767163	A1	3/2007	EP	1815804	B1	12/2009
EP	1769756	A1	4/2007	EP	1875870	B1	12/2009
EP	1769758	A1	4/2007	EP	2151204	A1	2/2010
EP	1581128	B1	5/2007	EP	2165660	A2	3/2010
EP	1780825	A1	5/2007	EP	1566150	B1	4/2010
EP	1785097	A2	5/2007	EP	1813206	B1	4/2010
EP	1790293	A2	5/2007	EP	1769754	B1	6/2010
EP	1790294	A1	5/2007	EP	1854416	B1	6/2010
EP	1800610	A1	6/2007	EP	2198787	A1	6/2010
EP	1300117	B1	8/2007	EP	1647286	B1	9/2010
EP	1813199	A1	8/2007	EP	1535565	B1	10/2010
EP	1813200	A2	8/2007	EP	1702570	B1	10/2010
EP	1813201	A1	8/2007	EP	1785098	B1	10/2010
EP	1813202	A1	8/2007	EP	2005896	B1	10/2010
EP	1813203	A2	8/2007	EP	2030578	B1	11/2010
EP	1813207	A1	8/2007	EP	1627605	B1	12/2010
EP	1813209	A1	8/2007	EP	1994890	B1	1/2011
EP	1837041	A1	9/2007	EP	2286738	A2	2/2011
EP	0922435	B1	10/2007	EP	1690502	B1	3/2011
EP	1487359	B1	10/2007	EP	2292153	A1	3/2011
EP	1599146	B1	10/2007	EP	1769755	B1	4/2011
EP	1839596	A1	10/2007	EP	2090240	B1	4/2011
EP	2110083	A2	10/2007	EP	2305135	A1	4/2011
EP	1857057	A2	11/2007	EP	1813205	B1	6/2011
EP	1402821	B1	12/2007	EP	2090243	B1	6/2011
EP	1872727	A1	1/2008	EP	2329773	A1	6/2011
EP	1550410	B1	2/2008	EP	1908414	B1	11/2011
EP	1671593	B1	2/2008	EP	2153781	B1	11/2011
EP	1897502	A1	3/2008	EP	1847225	B1	12/2011
EP	1611856	B1	4/2008	EP	1785102	B1	1/2012
EP	1908417	A2	4/2008	EP	2090253	B1	3/2012
EP	1330201	B1	6/2008	EP	1813204	B1	7/2012
EP	1702568	B1	7/2008	EP	2005895	B1	8/2012
				EP	2090248	B1	8/2012
				EP	2090252	B1	10/2012
				EP	2517637	A1	10/2012
				EP	2517645	A2	10/2012

(56)

References Cited

FOREIGN PATENT DOCUMENTS

EP	2517649	A2	10/2012	JP	2005131163	A	5/2005
EP	2517651	A2	10/2012	JP	2005131164	A	5/2005
EP	1884206	B1	3/2013	JP	2005131173	A	5/2005
FR	459743	A	11/1913	JP	2005131211	A	5/2005
FR	999646	A	2/1952	JP	2005131212	A	5/2005
FR	1112936	A	3/1956	JP	2005-144183	A	6/2005
FR	2598905	A1	11/1987	JP	2005-516714	A	6/2005
FR	2765794	A	1/1999	JP	2005137423	A	6/2005
GB	939929	A	10/1963	JP	2005152416	A	6/2005
GB	1210522	A	10/1970	JP	2005-523105	A	8/2005
GB	1217159	A	12/1970	JP	2005524474	A	8/2005
GB	1339394	A	12/1973	JP	2005-335432	A	12/2005
GB	2109241	A	6/1983	JP	2006-034975	A	2/2006
GB	2272159	A	5/1994	JP	2006-34977	A	2/2006
GB	2284242	A	5/1995	JP	2006-034980	A	2/2006
GB	2336214	A	10/1999	JP	2006-506106	A	2/2006
GB	2425903	A	11/2006	JP	2006-187649	A	7/2006
GR	930100110	A	11/1993	JP	2006-218297	A	8/2006
JP	50-33988	U	4/1975	JP	2006-281405	A	10/2006
JP	S 58500053	A	1/1983	JP	2006-346445	A	12/2006
JP	61-98249	A	5/1986	JP	2007-61628	A	3/2007
JP	S 61502036	A	9/1986	JP	2007-098130	A	4/2007
JP	S 63-59764	A	3/1988	JP	3906843	B2	4/2007
JP	S 63-147449	A	6/1988	JP	2007-117725	A	5/2007
JP	63-203149	A	8/1988	JP	2007-222615	A	6/2007
JP	H 02-279149	A	11/1990	JP	2007-203051	A	8/2007
JP	3-12126	A	1/1991	JP	2007-203057	A	8/2007
JP	H 05-084252	A	4/1993	JP	2007-524435	A	8/2007
JP	5-212039	A	8/1993	JP	2007-229448	A	9/2007
JP	6007357	A	1/1994	JP	2007-325922	A	12/2007
JP	H 6-30945	A	2/1994	JP	2008-68073	A	3/2008
JP	H 06-26812	U	4/1994	JP	2008-283459	A	11/2008
JP	H 6-121798	A	5/1994	JP	2009-506799	A	2/2009
JP	7051273	A	2/1995	JP	2009-106752	A	5/2009
JP	7-124166	A	5/1995	JP	2009-539420	A	11/2009
JP	07-171163	A	7/1995	JP	2010-098844	A	4/2010
JP	7-255735	A	10/1995	RU	1814161	A1	5/1993
JP	8-33642	A	2/1996	RU	2008830	C1	3/1994
JP	8033641	A	2/1996	RU	2141279	C1	11/1999
JP	8-164141	A	6/1996	RU	2187249	C2	8/2002
JP	H 08-182684	A	7/1996	RU	2189091	C2	9/2002
JP	H 08-507708	A	8/1996	RU	32984	U1	10/2003
JP	8229050	A	9/1996	RU	2225170	C2	3/2004
JP	H 09-501081	A	2/1997	RU	42750	U1	12/2004
JP	H 09-501577	A	2/1997	RU	61114	U1	2/2007
JP	10-512469	A	12/1998	SU	189517	A	1/1967
JP	2000-14632	A	1/2000	SU	328636	A	9/1972
JP	2000033071	A	2/2000	SU	674747	A1	7/1979
JP	2000-112002	A	4/2000	SU	886900	A1	12/1981
JP	2000171730	A	6/2000	SU	1009439	A	4/1983
JP	2000287987	A	10/2000	SU	1022703	A1	6/1983
JP	2000325303	A	11/2000	SU	1333319	A2	8/1987
JP	2001-514541	A	9/2001	SU	1377053	A1	2/1988
JP	2001-517473	A	10/2001	SU	1509051	A1	9/1989
JP	2001286477	A	10/2001	SU	1561964	A1	5/1990
JP	2002143078	A	5/2002	SU	1708312	A1	1/1992
JP	2002369820	A	12/2002	SU	1722476	A1	3/1992
JP	2003-500153	A	1/2003	SU	1752361	A1	8/1992
JP	2003-164066	A	6/2003	WO	WO 82/02824	A1	9/1982
JP	2003-521301	A	7/2003	WO	WO 86/02254	A1	4/1986
JP	2004-162035	A	6/2004	WO	WO 91/15157	A1	10/1991
JP	2004-229976	A	8/2004	WO	WO 92/20295	A1	11/1992
JP	2004-531280	A	10/2004	WO	WO 92/21300	A1	12/1992
JP	2004-532084	A	10/2004	WO	WO 93/08755	A1	5/1993
JP	2004-329624	A	11/2004	WO	WO 93/13718	A1	7/1993
JP	2004-344663	A	12/2004	WO	WO 93/14690	A1	8/1993
JP	2005-028147	A	2/2005	WO	WO 93/15648	A1	8/1993
JP	2005-28148	A	2/2005	WO	WO 93/15850	A1	8/1993
JP	2005-028149	A	2/2005	WO	WO 93/19681	A1	10/1993
JP	2005-505309	A	2/2005	WO	WO 94/00060	A1	1/1994
JP	2005505322	T	2/2005	WO	WO 94/11057	A1	5/1994
JP	2005-103280	A	4/2005	WO	WO 94/12108	A1	6/1994
JP	2005-103281	A	4/2005	WO	WO 94/18893	A1	9/1994
JP	2005-511131	A	4/2005	WO	WO 94/20030	A1	9/1994
JP	2005103293	A	4/2005	WO	WO 94/22378	A1	10/1994
				WO	WO 94/23659	A1	10/1994
				WO	WO 94/24943	A1	11/1994
				WO	WO 94/24947	A1	11/1994
				WO	WO 95/02369	A1	1/1995

(56)

References Cited

FOREIGN PATENT DOCUMENTS

WO	WO 95/03743	A1	2/1995	WO	WO 00/72762	A1	12/2000
WO	WO 95/06817	A1	3/1995	WO	WO 00/72765	A1	12/2000
WO	WO 95/09576	A1	4/1995	WO	WO 01/03587	A1	1/2001
WO	WO 95/09577	A1	4/1995	WO	WO 01/05702	A1	1/2001
WO	WO 95/14436	A1	6/1995	WO	WO 01/10482	A1	2/2001
WO	WO 95/17855	A1	7/1995	WO	WO 01/35845	A1	5/2001
WO	WO 95/18383	A1	7/1995	WO	WO 01/54594	A1	8/2001
WO	WO 95/18572	A1	7/1995	WO	WO 01/58371	A1	8/2001
WO	WO 95/19739	A1	7/1995	WO	WO 01/62158	A2	8/2001
WO	WO 95/20360	A1	8/1995	WO	WO 01/62161	A1	8/2001
WO	WO 95/23557	A1	9/1995	WO	WO 01/62162	A1	8/2001
WO	WO 95/24865	A1	9/1995	WO	WO 01/62164	A2	8/2001
WO	WO 95/25471	A3	9/1995	WO	WO 01/62169	A2	8/2001
WO	WO 95/26562	A1	10/1995	WO	WO 01/78605	A2	10/2001
WO	WO 95/29639	A1	11/1995	WO	WO 01/80757	A2	11/2001
WO	WO 96/04858	A1	2/1996	WO	WO 01/91646	A1	12/2001
WO	WO 96/18344	A2	6/1996	WO	WO 02/00121	A1	1/2002
WO	WO 96/19151	A1	6/1996	WO	WO 02/07608	A2	1/2002
WO	WO 96/19152	A1	6/1996	WO	WO 02/07618	A1	1/2002
WO	WO 96/20652	A1	7/1996	WO	WO 02/17799	A1	3/2002
WO	WO 96/21119	A1	7/1996	WO	WO 02/19920	A1	3/2002
WO	WO 96/22055	A1	7/1996	WO	WO 02/19932	A1	3/2002
WO	WO 96/23448	A1	8/1996	WO	WO 02/30297	A2	4/2002
WO	WO 96/24301	A1	8/1996	WO	WO 02/32322	A2	4/2002
WO	WO 96/27337	A1	9/1996	WO	WO 02/36028	A1	5/2002
WO	WO 96/31155	A1	10/1996	WO	WO 02/43571	A2	6/2002
WO	WO 96/35464	A1	11/1996	WO	WO 02/58568	A1	8/2002
WO	WO 96/39085	A1	12/1996	WO	WO 02/060328	A1	8/2002
WO	WO 96/39086	A1	12/1996	WO	WO 02/067785	A2	9/2002
WO	WO 96/39087	A1	12/1996	WO	WO 02/098302	A1	12/2002
WO	WO 96/39088	A1	12/1996	WO	WO 03/000138	A2	1/2003
WO	WO 96/39089	A1	12/1996	WO	WO 03/001329	A2	1/2003
WO	WO 97/00646	A1	1/1997	WO	WO 03/013363	A1	2/2003
WO	WO 97/00647	A1	1/1997	WO	WO 03/013372	A2	2/2003
WO	WO 97/01989	A1	1/1997	WO	WO 03/015604	A2	2/2003
WO	WO 97/06582	A1	2/1997	WO	WO 03/020106	A2	3/2003
WO	WO 97/10763	A1	3/1997	WO	WO 03/020139	A2	3/2003
WO	WO 97/10764	A1	3/1997	WO	WO 03/024339	A1	3/2003
WO	WO 97/11648	A2	4/1997	WO	WO 03/079909	A3	3/2003
WO	WO 97/11649	A1	4/1997	WO	WO 03/030743	A2	4/2003
WO	WO 97/15237	A1	5/1997	WO	WO 03/037193	A1	5/2003
WO	WO 97/24073	A1	7/1997	WO	WO 03/047436	A3	6/2003
WO	WO 97/24993	A1	7/1997	WO	WO 03/055402	A1	7/2003
WO	WO 97/30644	A1	8/1997	WO	WO 03/057048	A1	7/2003
WO	WO 97/34533	A1	9/1997	WO	WO 03/057058	A1	7/2003
WO	WO 97/37598	A1	10/1997	WO	WO 03/063694	A1	8/2003
WO	WO 97/39688	A2	10/1997	WO	WO 03/077769	A1	9/2003
WO	WO 98/17180	A1	4/1998	WO	WO 03/079911	A1	10/2003
WO	WO 98/27880	A1	7/1998	WO	WO 03/082126	A1	10/2003
WO	WO 98/30153	A1	7/1998	WO	WO 03/086206	A1	10/2003
WO	WO 98/47436	A1	10/1998	WO	WO 03/088845	A2	10/2003
WO	WO 99/03407	A1	1/1999	WO	WO 03/090630	A2	11/2003
WO	WO 99/03408	A1	1/1999	WO	WO 03/094743	A1	11/2003
WO	WO 99/03409	A1	1/1999	WO	WO 03/094745	A1	11/2003
WO	WO 99/12483	A1	3/1999	WO	WO 03/094746	A1	11/2003
WO	WO 99/12487	A1	3/1999	WO	WO 03/094747	A1	11/2003
WO	WO 99/12488	A1	3/1999	WO	WO 03/101313	A1	12/2003
WO	WO 99/15086	A1	4/1999	WO	WO 03/105698	A2	12/2003
WO	WO 99/15091	A1	4/1999	WO	WO 03/105702	A2	12/2003
WO	WO 99/23933	A2	5/1999	WO	WO 2004/006980	A2	1/2004
WO	WO 99/23959	A1	5/1999	WO	WO 2004/011037	A2	2/2004
WO	WO 99/25261	A1	5/1999	WO	WO 2004/019769	A1	3/2004
WO	WO 99/29244	A1	6/1999	WO	WO 2004/019803	A1	3/2004
WO	WO 99/34744	A1	7/1999	WO	WO 2004/021868	A2	3/2004
WO	WO 99/45849	A1	9/1999	WO	WO 2004/028585	A2	4/2004
WO	WO 99/48430	A1	9/1999	WO	WO 2004/032754	A2	4/2004
WO	WO 99/51158	A1	10/1999	WO	WO 2004/032760	A2	4/2004
WO	WO 00/24322	A1	5/2000	WO	WO 2004/032762	A1	4/2004
WO	WO 00/24330	A1	5/2000	WO	WO 2004/032763	A2	4/2004
WO	WO 00/41638	A1	7/2000	WO	WO 2004/034875	A2	4/2004
WO	WO 00/48506	A1	8/2000	WO	WO 2004/047626	A1	6/2004
WO	WO 00/53112	A2	9/2000	WO	WO 2004/047653	A2	6/2004
WO	WO 00/54653	A1	9/2000	WO	WO 2004/049956	A2	6/2004
WO	WO 00/57796	A1	10/2000	WO	WO 2004/052426	A2	6/2004
WO	WO 00/64365	A1	11/2000	WO	WO 2004/056276	A1	7/2004
				WO	WO 2004/056277	A1	7/2004
				WO	WO 2004/062516	A1	7/2004
				WO	WO 2004/078050	A2	9/2004
				WO	WO 2004/078051	A2	9/2004

(56)

References Cited

FOREIGN PATENT DOCUMENTS

WO	WO 2004/078236	A2	9/2004
WO	WO 2004/086987	A1	10/2004
WO	WO 2004/096015	A2	11/2004
WO	WO 2004/096057	A2	11/2004
WO	WO 2004/103157	A2	12/2004
WO	WO 2004/105593	A1	12/2004
WO	WO 2004/105621	A1	12/2004
WO	WO 2004/112618	A2	12/2004
WO	WO 2004/112652	A2	12/2004
WO	WO 2005/027983	A2	3/2005
WO	WO 2005/037329	A2	4/2005
WO	WO 2005/044078	A2	5/2005
WO	WO 2005/055846	A1	6/2005
WO	WO 2005/072634	A2	8/2005
WO	WO 2005/078892	A1	8/2005
WO	WO 2005/079675	A2	9/2005
WO	WO 2005/096954	A2	10/2005
WO	WO 2005/112806	A2	12/2005
WO	WO 2005/112808	A1	12/2005
WO	WO 2005/115251	A1	12/2005
WO	WO 2005/115253	A2	12/2005
WO	WO 2005/117735	A1	12/2005
WO	WO 2005/122936	A1	12/2005
WO	WO 2006/023486	A1	3/2006
WO	WO 2006/023578	A2	3/2006
WO	WO 2006/027014	A1	3/2006
WO	WO 2006/028314	A1	3/2006
WO	WO 2006/044490	A2	4/2006
WO	WO 2006/044581	A2	4/2006
WO	WO 2006/044810	A2	4/2006
WO	WO 2006/051252	A1	5/2006
WO	WO 2006/059067	A1	6/2006
WO	WO 2006/083748	A1	8/2006
WO	WO 2006/092563	A1	9/2006
WO	WO 2006/092565	A1	9/2006
WO	WO 2006/115958	A1	11/2006
WO	WO 2006/125940	A1	11/2006
WO	WO 2006/132992	A1	12/2006
WO	WO 2007/002180	A2	1/2007
WO	WO 2007/016290	A2	2/2007
WO	WO 2007/018898	A2	2/2007
WO	WO 2007/089603	A2	8/2007
WO	WO 2007/098220	A2	8/2007
WO	WO 2007/121579	A1	11/2007
WO	WO 2007/131110	A2	11/2007
WO	WO 2007/137304	A2	11/2007
WO	WO 2007/139734	A2	12/2007
WO	WO 2007/142625	A2	12/2007
WO	WO 2007/147439	A1	12/2007
WO	WO 2008/021969	A2	2/2008
WO	WO 2008/039249	A1	4/2008
WO	WO 2008/039270	A1	4/2008
WO	WO 2008/045383	A2	4/2008
WO	WO 2008/057281	A2	5/2008
WO	WO 2008/070763	A1	6/2008
WO	WO 2008/089404	A2	7/2008
WO	WO 2008/101080	A1	8/2008
WO	WO 2008/109125	A1	9/2008
WO	WO 2008/124748	A1	10/2008
WO	WO 2009/023851	A1	2/2009
WO	WO 2009/046394	A1	4/2009
WO	WO 2009/137761	A2	11/2009
WO	WO 2009/143092	A1	11/2009
WO	WO 2009/143331	A1	11/2009
WO	WO 2010/028332	A2	3/2010
WO	WO 2010/030434	A1	3/2010
WO	WO 2010/054404	A1	5/2010
WO	WO 2010/063795	A1	6/2010
WO	WO 2010/098871	A2	9/2010
WO	WO 2012/021671	A1	2/2012
WO	WO 2012/044551	A1	4/2012
WO	WO 2012/044820	A1	4/2012
WO	WO 2012/044844	A2	4/2012

OTHER PUBLICATIONS

- European Examination Report, Application No. 09250367.1, dated Mar. 4, 2010 (8 pages).
- International Search Report for PCT/US2012/039302, dated Sep. 4, 2012 (5 pages).
- Disclosed Anonymously, "Motor-Driven Surgical Stapler Improvements," Research Disclosure Database No. 526041, Published: Feb. 2008.
- C.C. Thompson et al., "Peroral Endoscopic Reduction of Dilated Gastrojejunal Anastomosis After Roux-en-Y Gastric Bypass: A Possible New Option for Patients with Weight Regain," *Surg Endosc* (2006) vol. 20, pp. 1744-1748.
- B.R. Coolman, DVM, MS et al., "Comparison of Skin Staples With Sutures for Anastomosis of the Small Intestine in Dogs," Abstract; <http://www.blackwell-synergy.com/doi/abs/10.1053/jvet.2000.7539?cookieSet=1&journalCode=vsu> which redirects to <http://www3.interscience.wiley.com/journal/119040681/abstract?CRETRY=1&SRETRY=0>; [online] accessed: Sep. 22, 2008 (2 pages).
- The Sodem Aseptic Battery Transfer Kit, Sodem Systems, (2000), 3 pages.
- "Biomedical Coatings," Fort Wayne Metals, Research Products Corporation, obtained online at www.fwmetals.com on Jun. 21, 2010 (1 page).
- Van Meer et al., "A Disposable Plastic Compact Wrist for Smart Minimally Invasive Surgical Tools," *LAAS/CNRS* (Aug. 2005).
- Breedveld et al., "A New, Easily Miniaturized Sterrable Endoscope," *IEEE Engineering in Medicine and Biology Magazine* (Nov./Dec. 2005).
- D. Tuite, Ed., "Get The Lowdown On Ultracapacitors," Nov. 15, 2007; [online] URL: <http://electronicdesign.com/Articles/Print.cfm?ArticleID=17465>, accessed Jan. 15, 2008 (5 pages).
- Datasheet for Panasonic TK Relays Ultra Low Profile 2 A Polarized Relay, Copyright Matsushita Electric Works, Ltd. (Known of at least as early as Aug. 17, 2010), 5 pages.
- ASTM procedure D2240-00, "Standard Test Method for Rubber Property-Durometer Hardness," (Published Aug. 2000).
- ASTM procedure D2240-05, "Standard Test Method for Rubber Property-Durometer Hardness," (Published Apr. 2010).
- Covidien Brochure, "Endo GIA™ Reloads with Tri-Staple™ Technology," (2010), 1 page.
- Covidien Brochure, "Endo GIA™ Reloads with Tri-Staple™ Technology and Endo GIA™ Ultra Universal Staplers," (2010), 2 pages.
- Covidien Brochure, "Endo GIA™ Black Reload with Tri-Staple™ Technology," (2012), 2 pages.
- Covidien Brochure, "Endo GIA™ Curved Tip Reload with Tri-Staple™ Technology," (2012), 2 pages.
- Covidien Brochure, "Endo GIA™ Reloads with Tri-Staple™ Technology," (2010), 2 pages.
- Covidien Brochure, "Endo GIA™ Ultra Universal Stapler," (2010), 2 pages.
- Miyata et al., "Biomolecule-Sensitive Hydrogels," *Advanced Drug Delivery Reviews*, 54 (2002) pp. 79-98.
- Jeong et al., "Thermosensitive Sol-Gel Reversible Hydrogels," *Advanced Drug Delivery Reviews*, 54 (2002) pp. 37-51.
- Byrne et al., "Molecular Imprinting Within Hydrogels," *Advanced Drug Delivery Reviews*, 54 (2002) pp. 149-161.
- Qiu et al., "Environment-Sensitive Hydrogels for Drug Delivery," *Advanced Drug Delivery Reviews*, 53 (2001) pp. 321-339.
- Hoffman, "Hydrogels for Biomedical Applications," *Advanced Drug Delivery Reviews*, 43 (2002) pp. 3-12.
- Hoffman, "Hydrogels for Biomedical Applications," *Advanced Drug Delivery Reviews*, 54 (2002) pp. 3-12.
- Peppas, "Physiologically Responsive Hydrogels," *Journal of Bioactive and Compatible Polymers*, vol. 6 (Jul. 1991) pp. 241-246.
- Ebara, "Carbohydrate-Derived Hydrogels and Microgels," *Engineered Carbohydrate-Based Materials for Biomedical Applications: Polymers, Surfaces, Dendrimers, Nanoparticles, and Hydrogels*, Edited by Ravin Narain, 2011, pp. 337-345.
- Peppas, Editor "Hydrogels in Medicine and Pharmacy," vol. I, *Fundamentals*. CRC Press, 1986.
- U.S. Appl. No. 12/031,542, filed Feb. 14, 2008.
- U.S. Appl. No. 12/031,556, filed Feb. 14, 2008.

(56)

References Cited

OTHER PUBLICATIONS

U.S. Appl. No. 12/031,573, filed Feb. 14, 2008.
U.S. Appl. No. 13/369,629, filed Feb. 9, 2012.
U.S. Appl. No. 12/032,024, filed Feb. 15, 2008.
U.S. Appl. No. 13/958,922, filed Aug. 5, 2013.
U.S. Appl. No. 13/958,932, filed Aug. 5, 2013.
U.S. Appl. No. 13/965,877, filed Aug. 13, 2013.
U.S. Appl. No. 13/967,388, filed Aug. 15, 2013.
U.S. Appl. No. 13/967,449, filed Aug. 15, 2013.
U.S. Appl. No. 13/967,716, filed Aug. 15, 2013.
U.S. Appl. No. 13/970,971, filed Aug. 20, 2013.
U.S. Appl. No. 13/971,006, filed Aug. 20, 2013.
U.S. Appl. No. 13/971,012, filed Aug. 20, 2013.
U.S. Appl. No. 13/971,022, filed Aug. 20, 2013.
U.S. Appl. No. 13/536,271, filed Jun. 28, 2012.
U.S. Appl. No. 13/536,288, filed Jun. 28, 2012.
U.S. Appl. No. 13/536,277, filed Jun. 28, 2012.
U.S. Appl. No. 13/536,295, filed Jun. 28, 2012.
U.S. Appl. No. 13/536,326, filed Jun. 28, 2012.
U.S. Appl. No. 13/536,303, filed Jun. 28, 2012.
U.S. Appl. No. 13/536,393, filed Jun. 28, 2012.

U.S. Appl. No. 13/536,362, filed Jun. 28, 2012.
U.S. Appl. No. 13/536,284, filed Jun. 28, 2012.
U.S. Appl. No. 13/536,374, filed Jun. 28, 2012.
U.S. Appl. No. 13/536,292, filed Jun. 28, 2012.
U.S. Appl. No. 13/536,301, filed Jun. 28, 2012.
U.S. Appl. No. 13/536,313, filed Jun. 28, 2012.
U.S. Appl. No. 13/536,323, filed Jun. 28, 2012.
U.S. Appl. No. 13/536,379, filed Jun. 28, 2012.
U.S. Appl. No. 13/536,386, filed Jun. 28, 2012.
U.S. Appl. No. 13/536,360, filed Jun. 28, 2012.
U.S. Appl. No. 13/536,335, filed Jun. 28, 2012.
U.S. Appl. No. 13/536,417, filed Jun. 28, 2012.
U.S. Appl. No. 13/763,035, filed Feb. 8, 2013.
U.S. Appl. No. 13/763,042, filed Feb. 8, 2013.
U.S. Appl. No. 13/763,048, filed Feb. 8, 2013.
U.S. Appl. No. 13/763,054, filed Feb. 8, 2013.
U.S. Appl. No. 13/763,065, filed Feb. 8, 2013.
U.S. Appl. No. 14/012,831, filed Aug. 28, 2013.
U.S. Appl. No. 14/013,755, filed Aug. 29, 2013.
U.S. Appl. No. 14/014,800, filed Aug. 30, 2013.
U.S. Appl. No. 14/015,200, filed Aug. 30, 2013.
U.S. Appl. No. 14/015,435, filed Aug. 30, 2013.
U.S. Appl. No. 14/015,509, filed Aug. 30, 2013.
U.S. Appl. No. 14/064,940, filed Oct. 28, 2013.

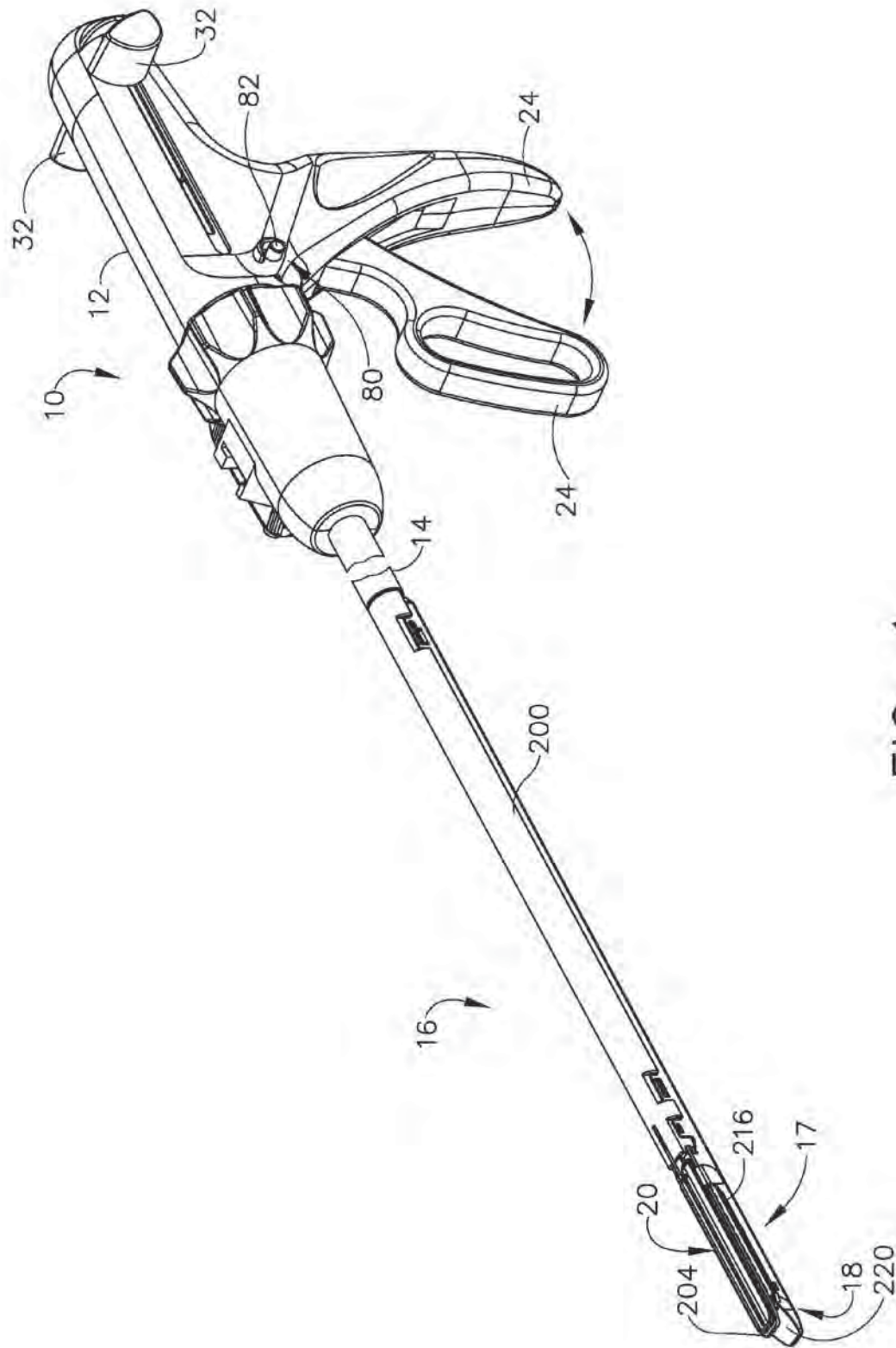

FIG. 1

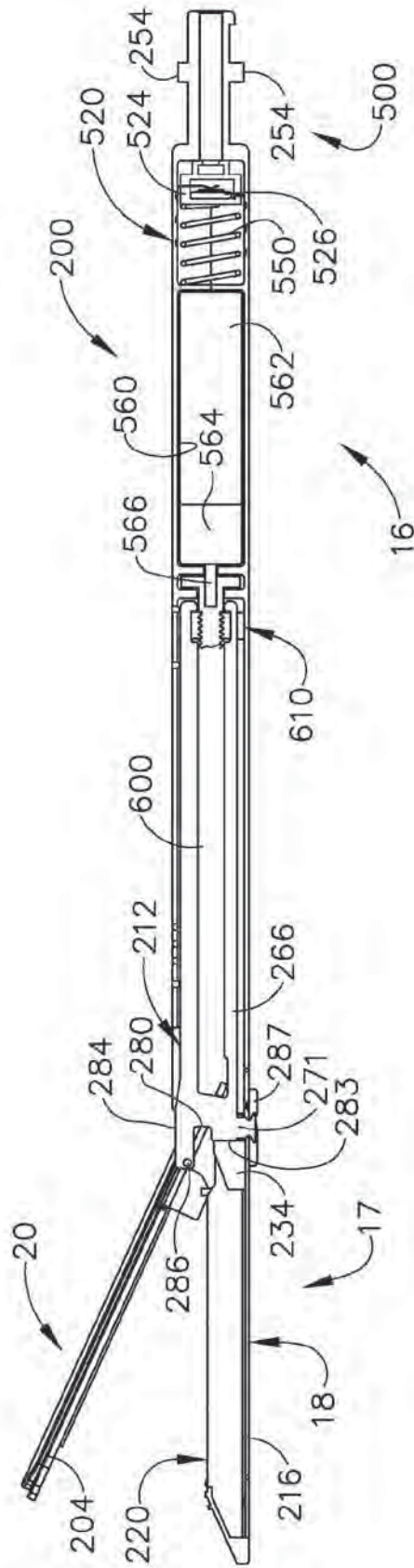

FIG. 2

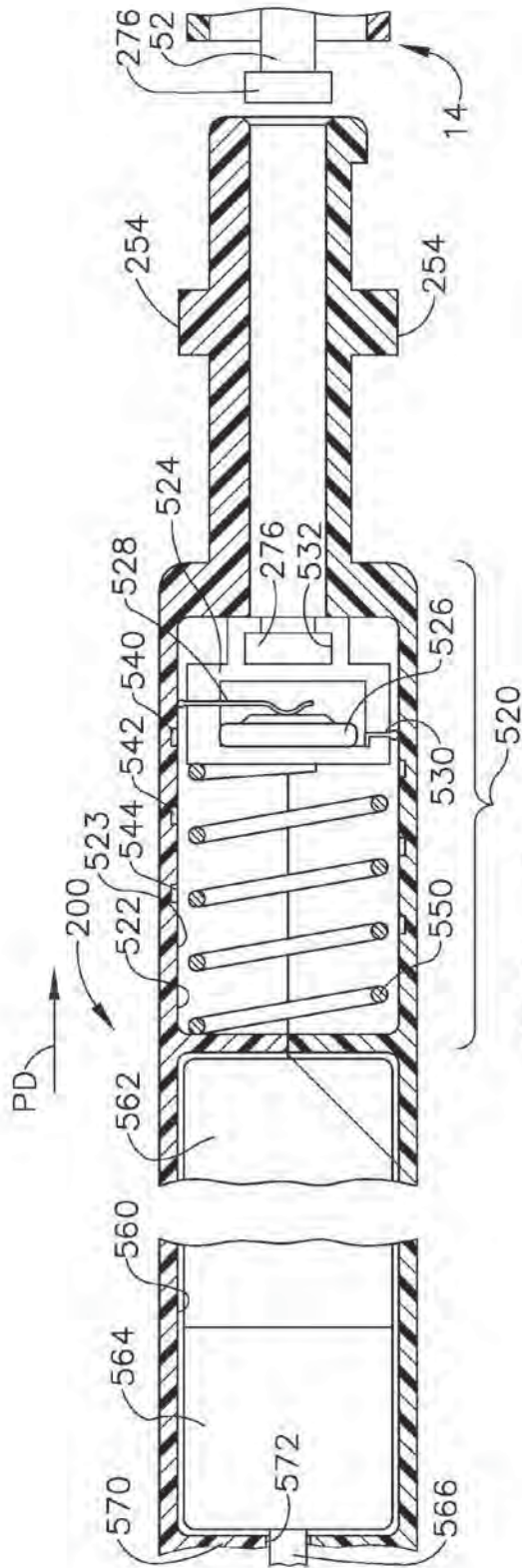

FIG. 3

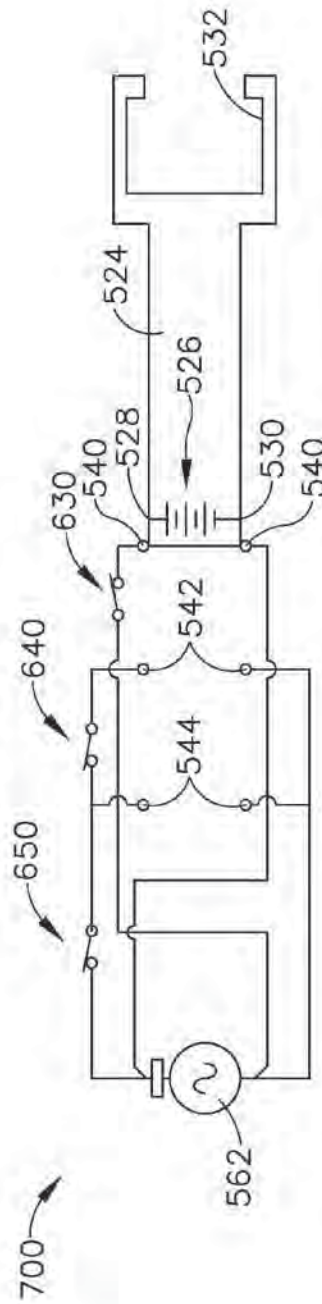

FIG. 4

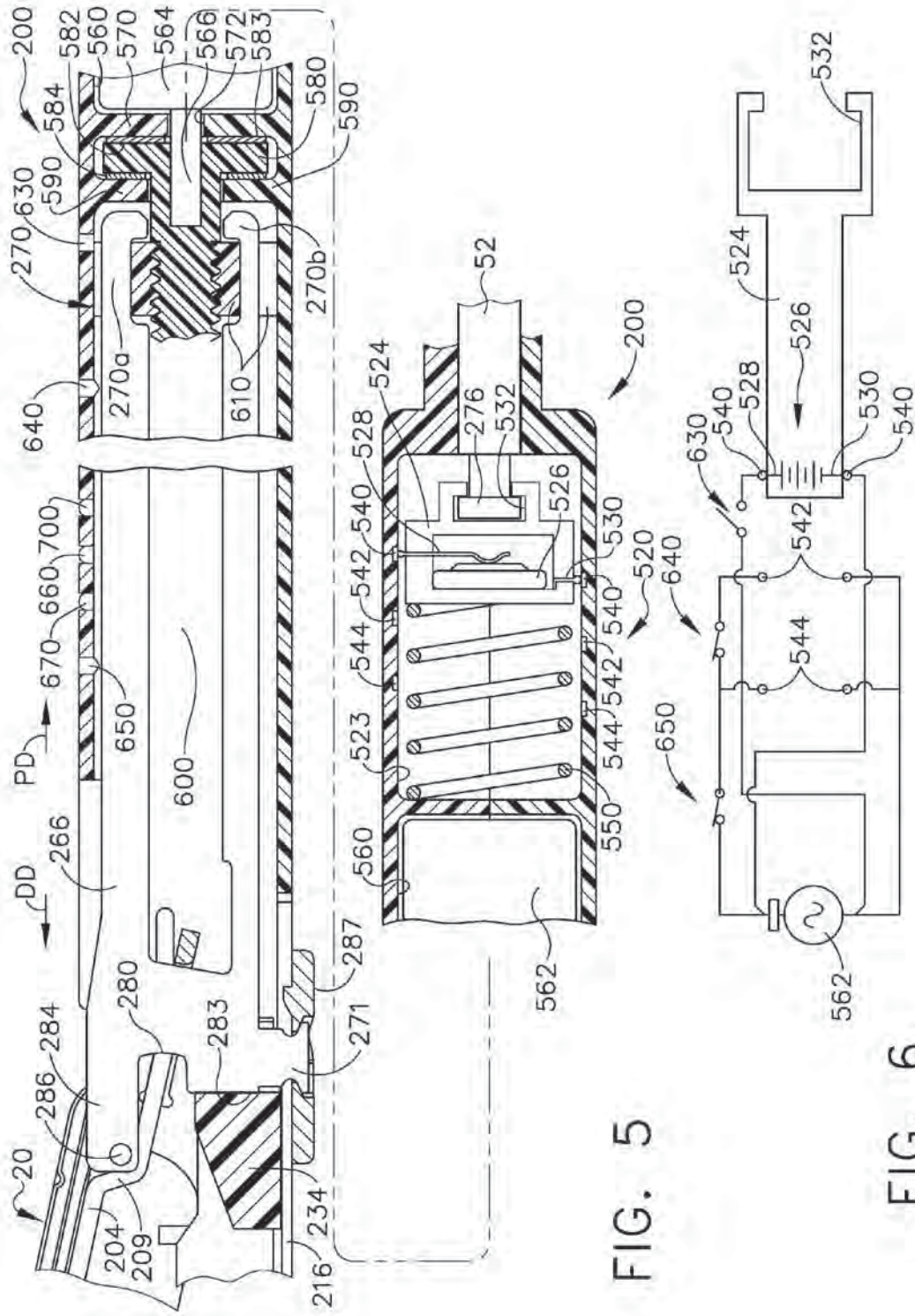

FIG. 5

FIG. 6

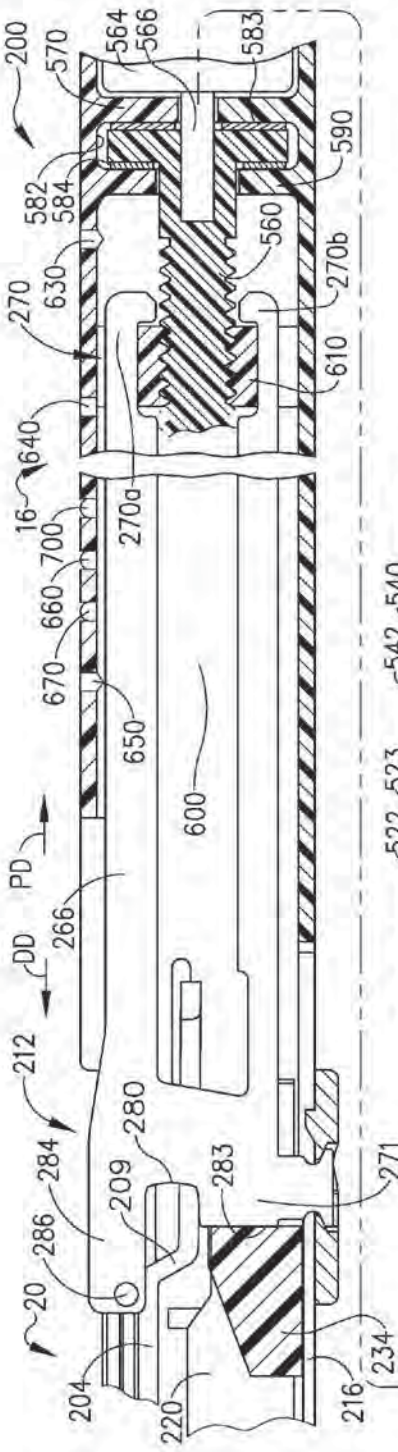

FIG. 7

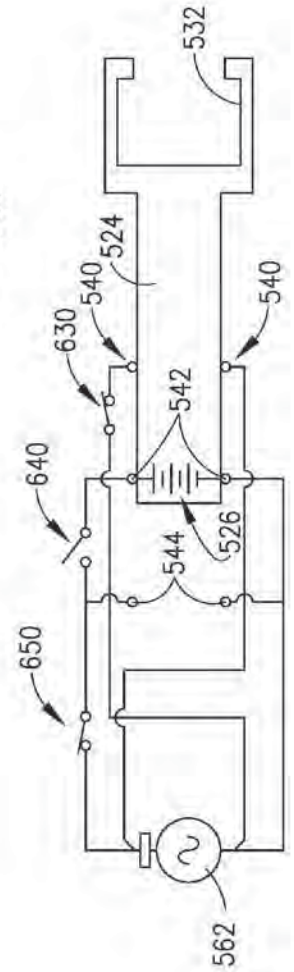
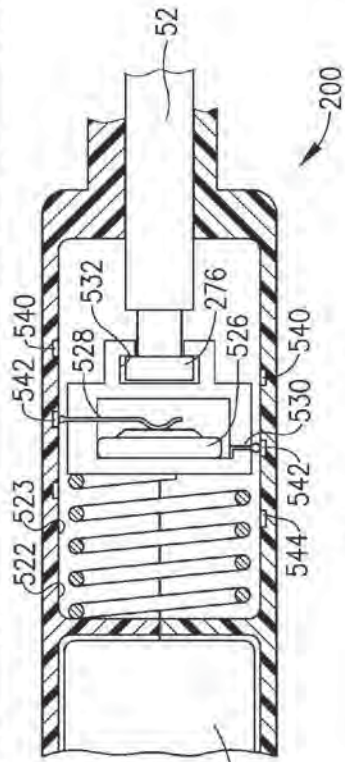

FIG. 8

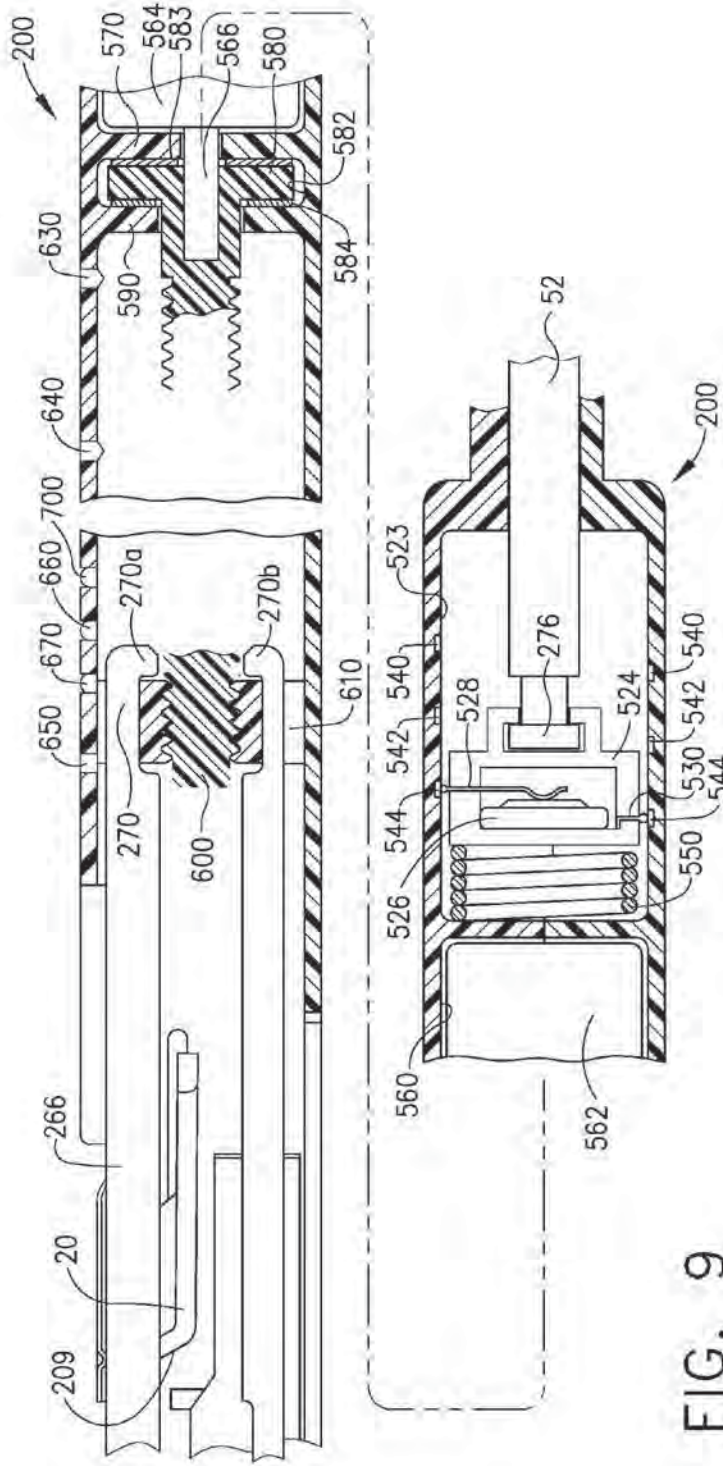

FIG. 9

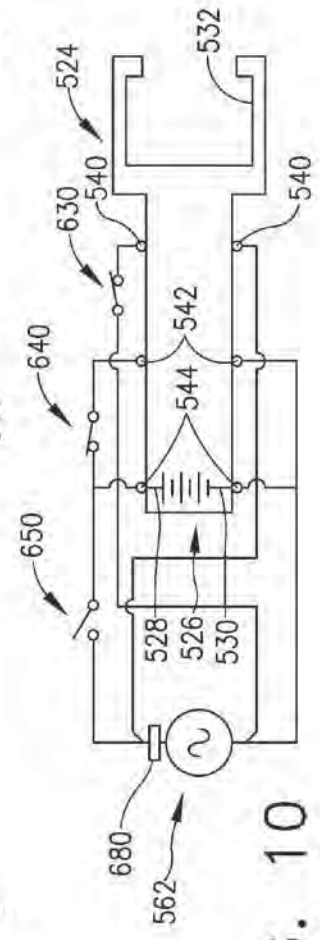

FIG. 10

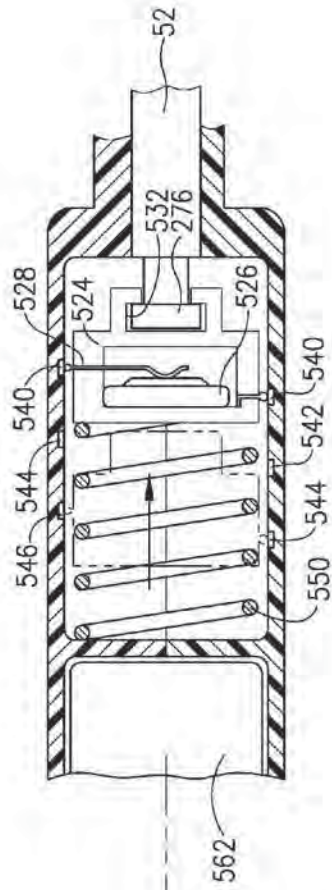
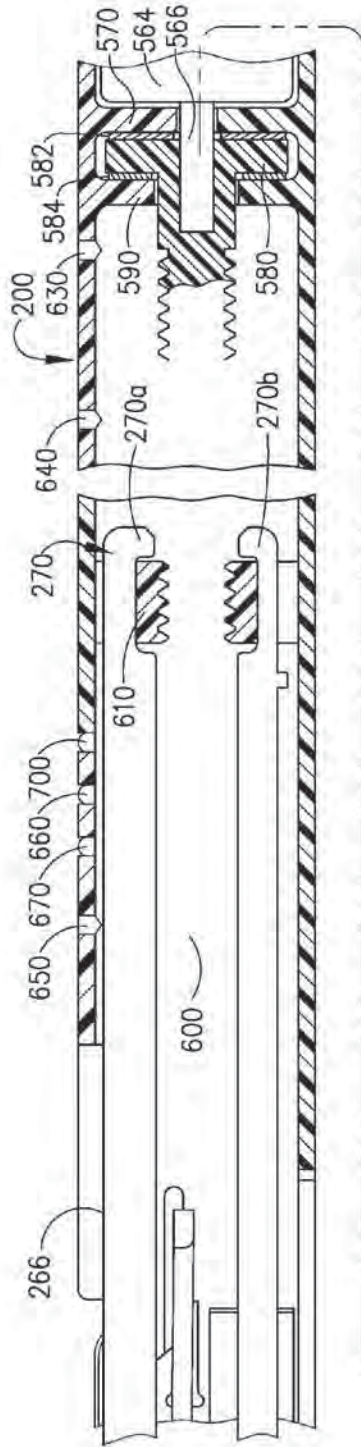

FIG. 11

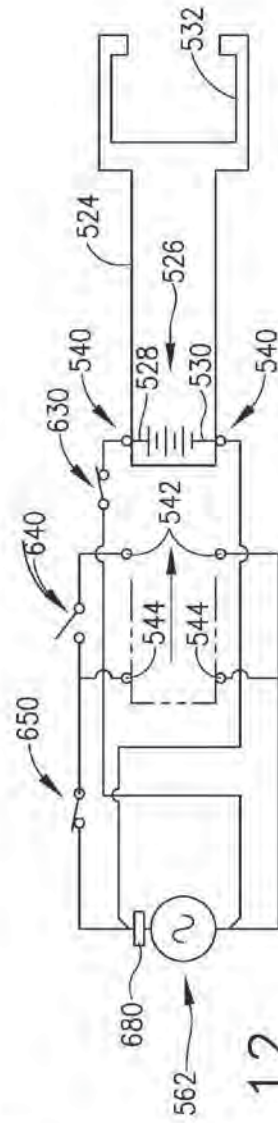

FIG. 12

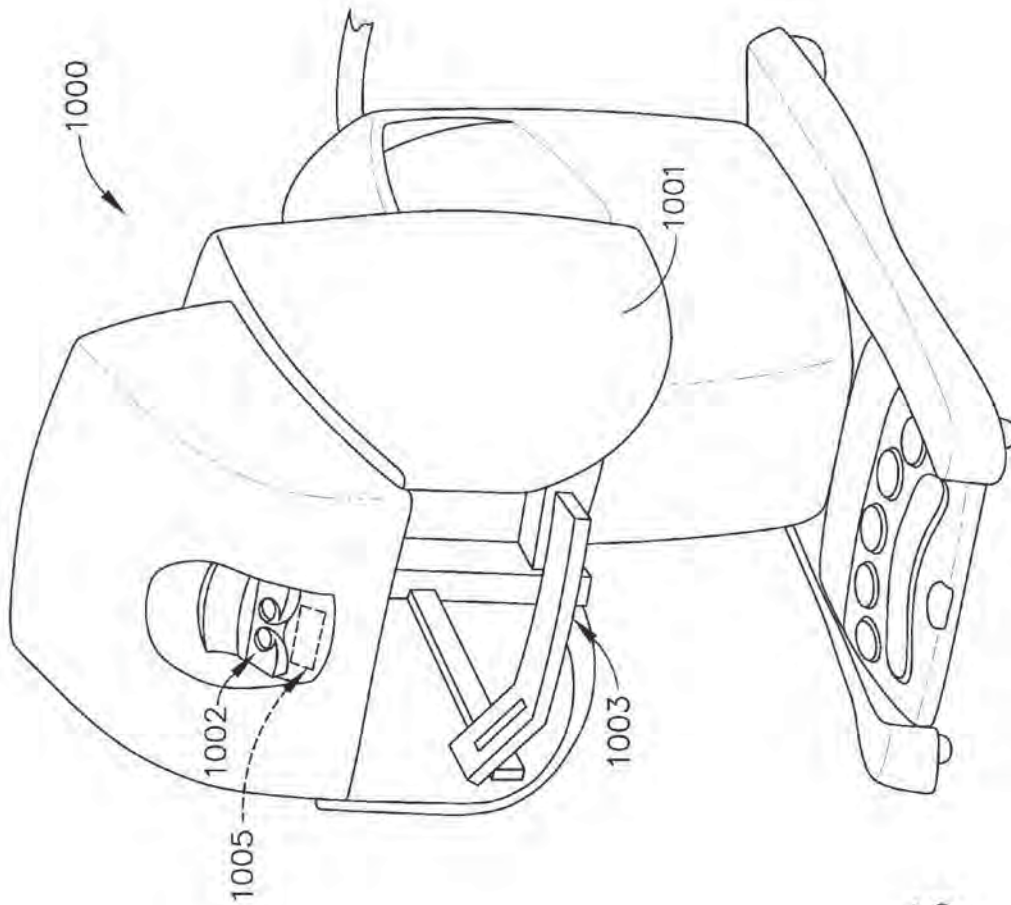

FIG. 13

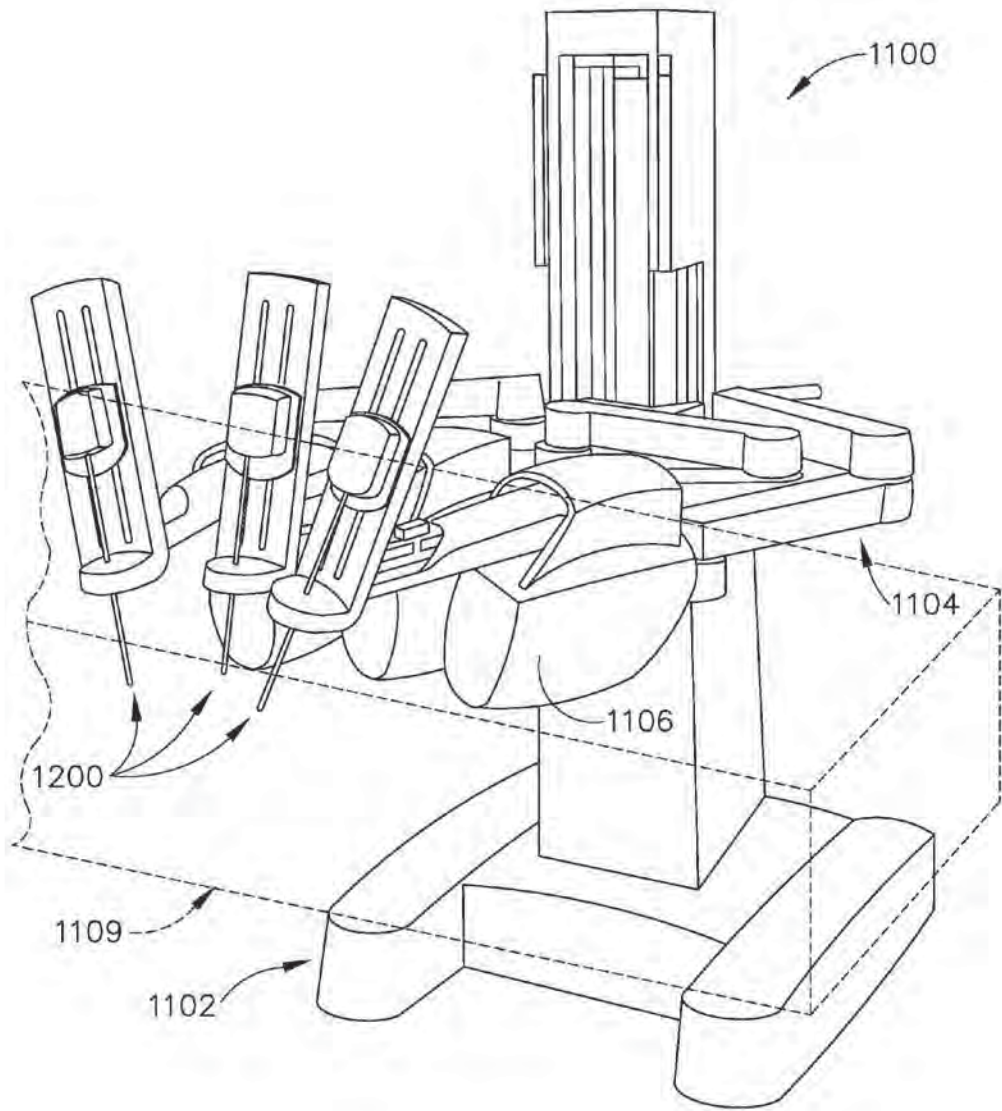

FIG. 14

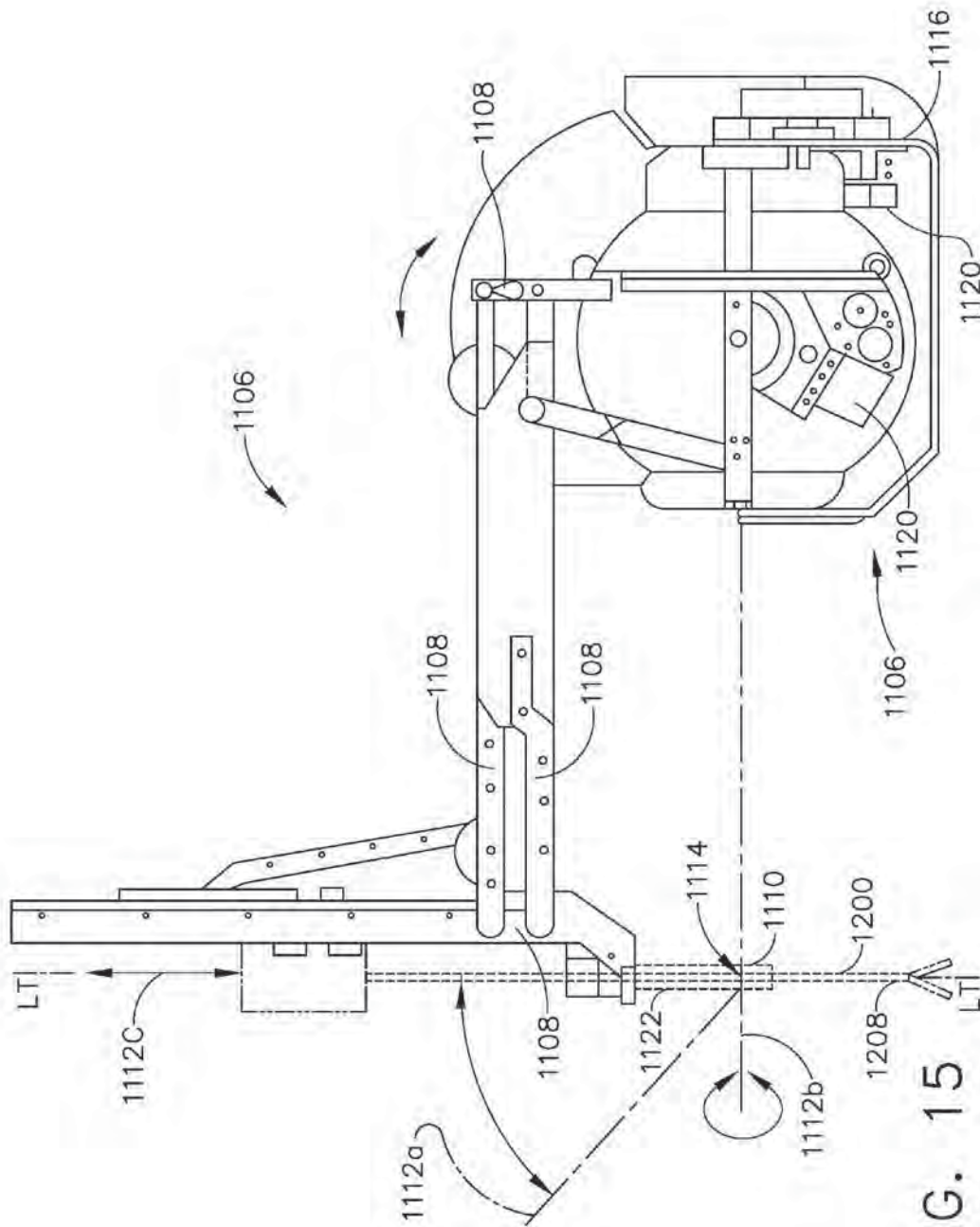

FIG. 15

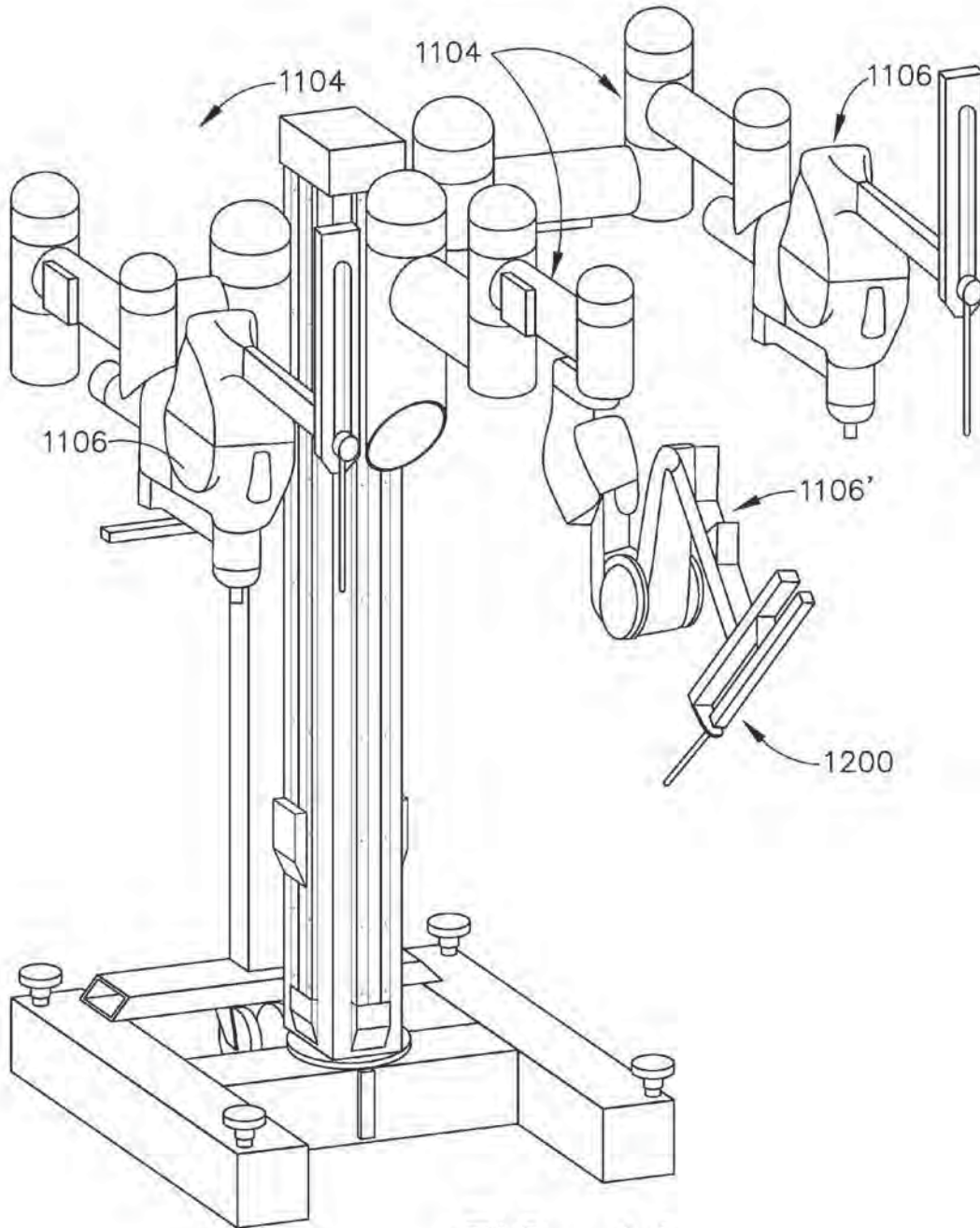

FIG. 16

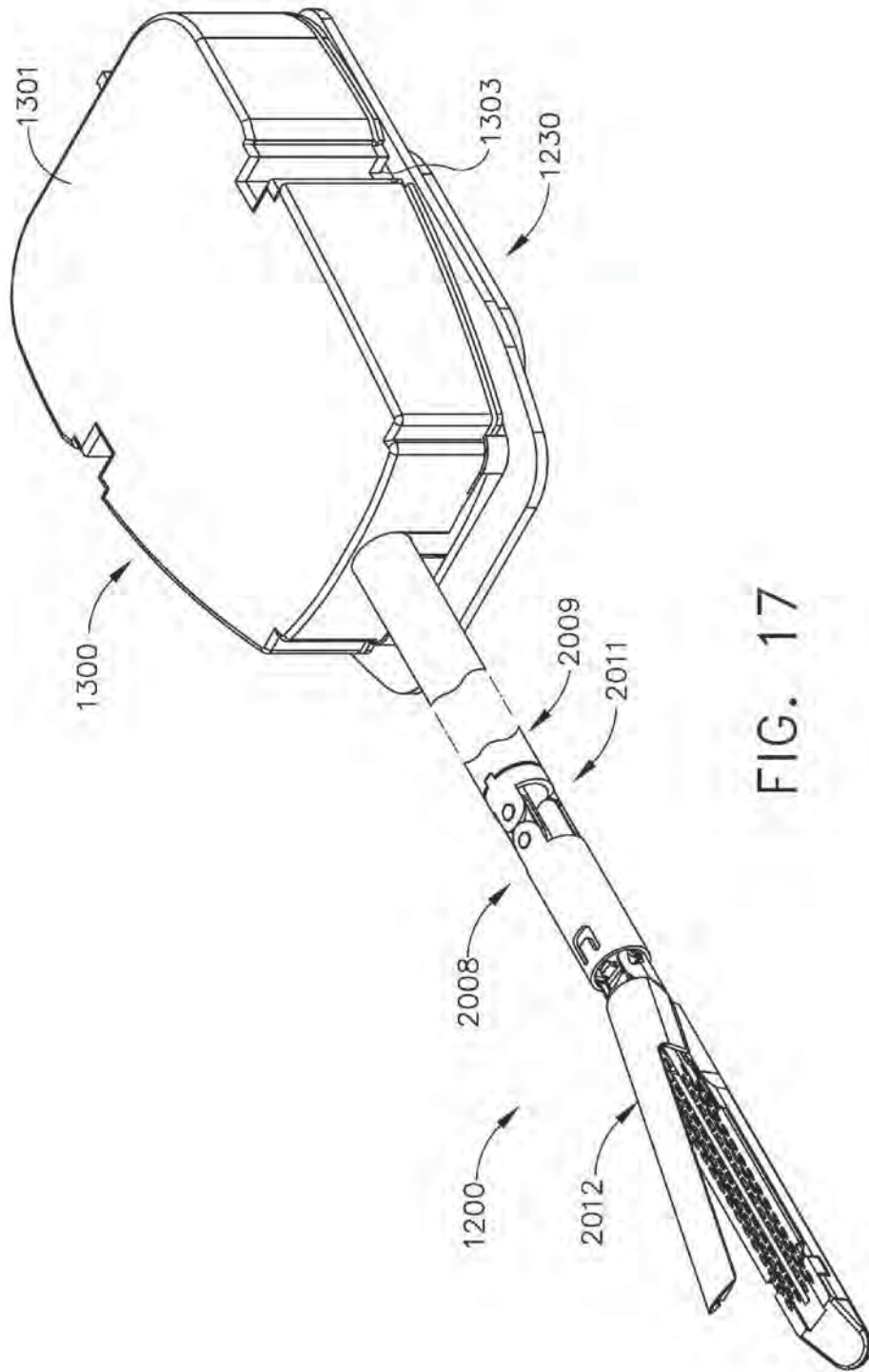

FIG. 17

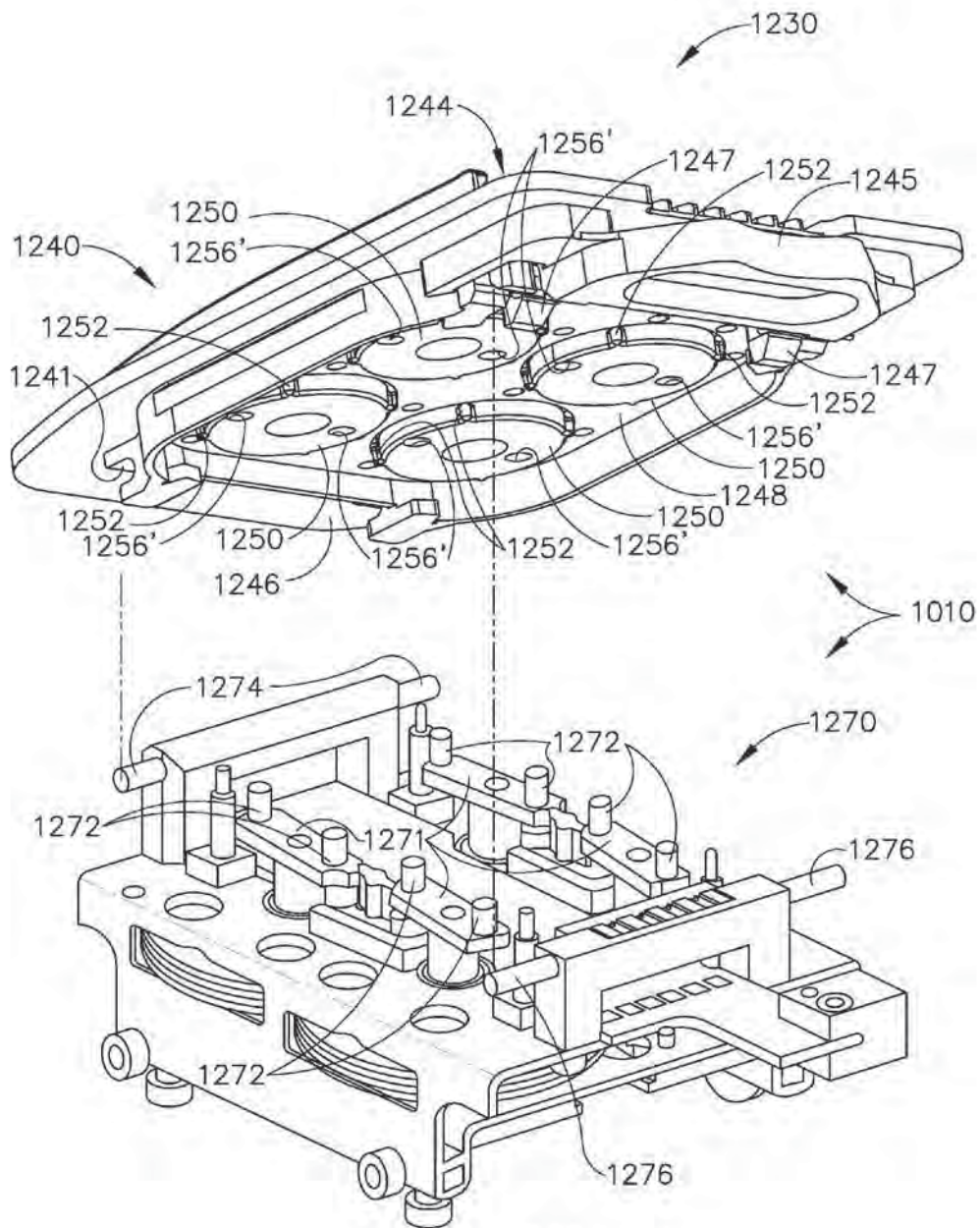

FIG. 18

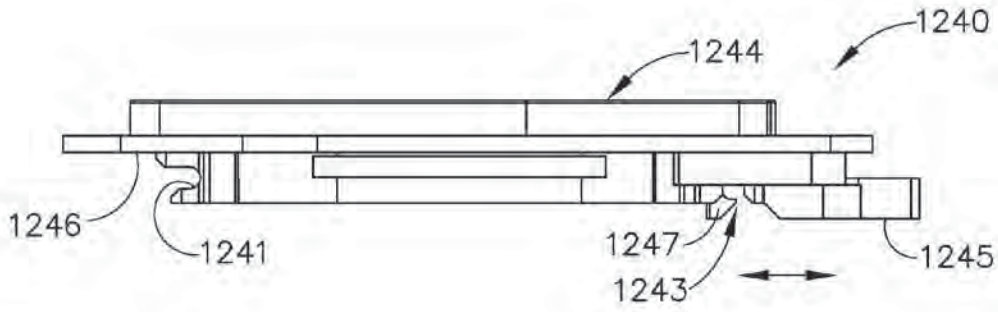

FIG. 19

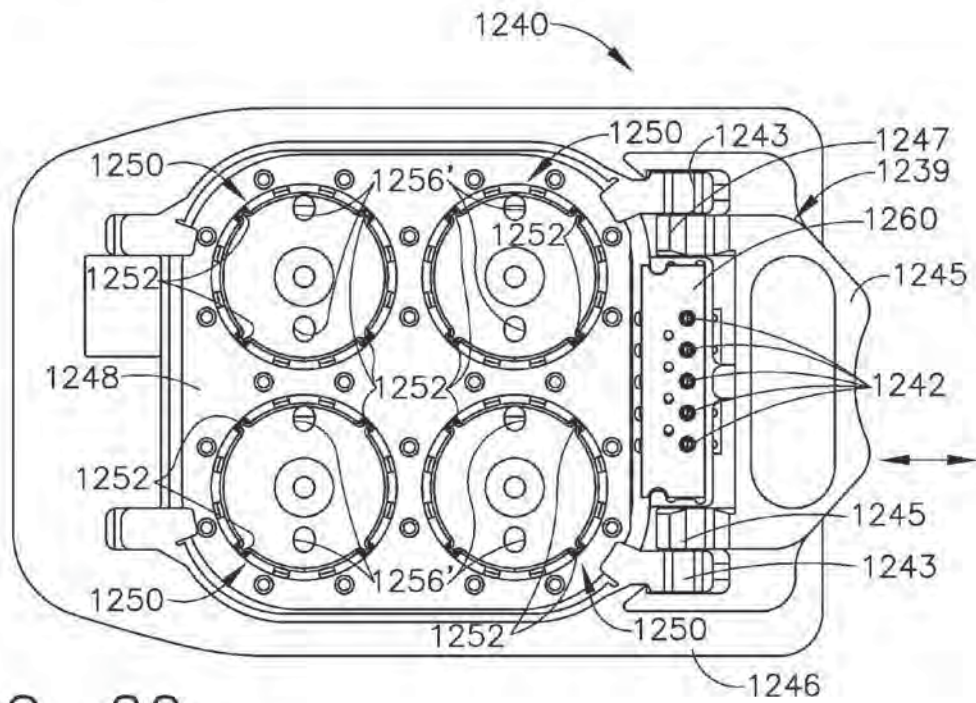

FIG. 20

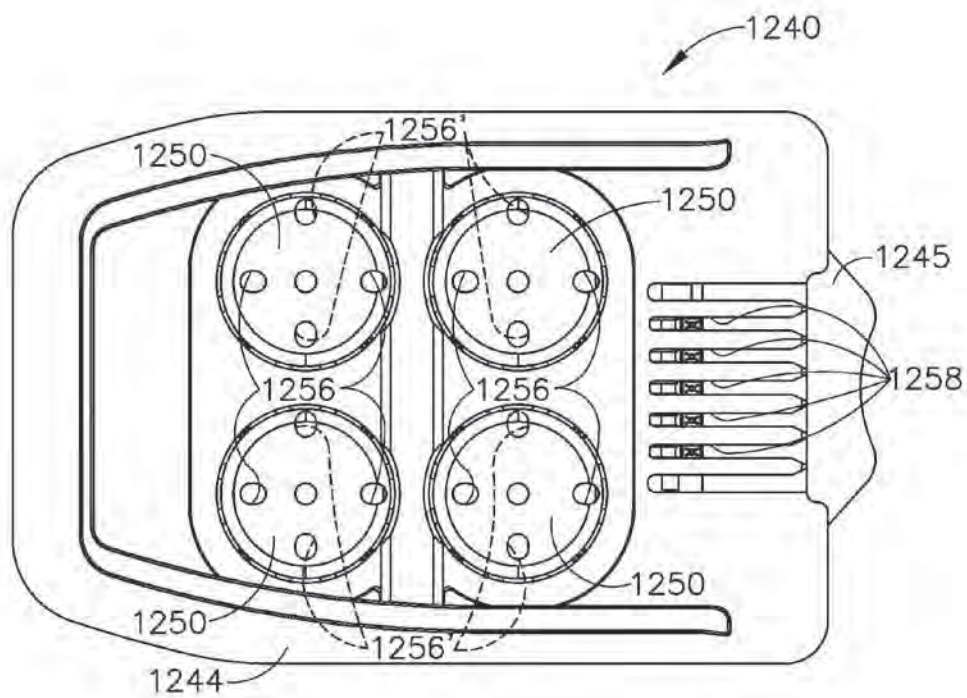

FIG. 21

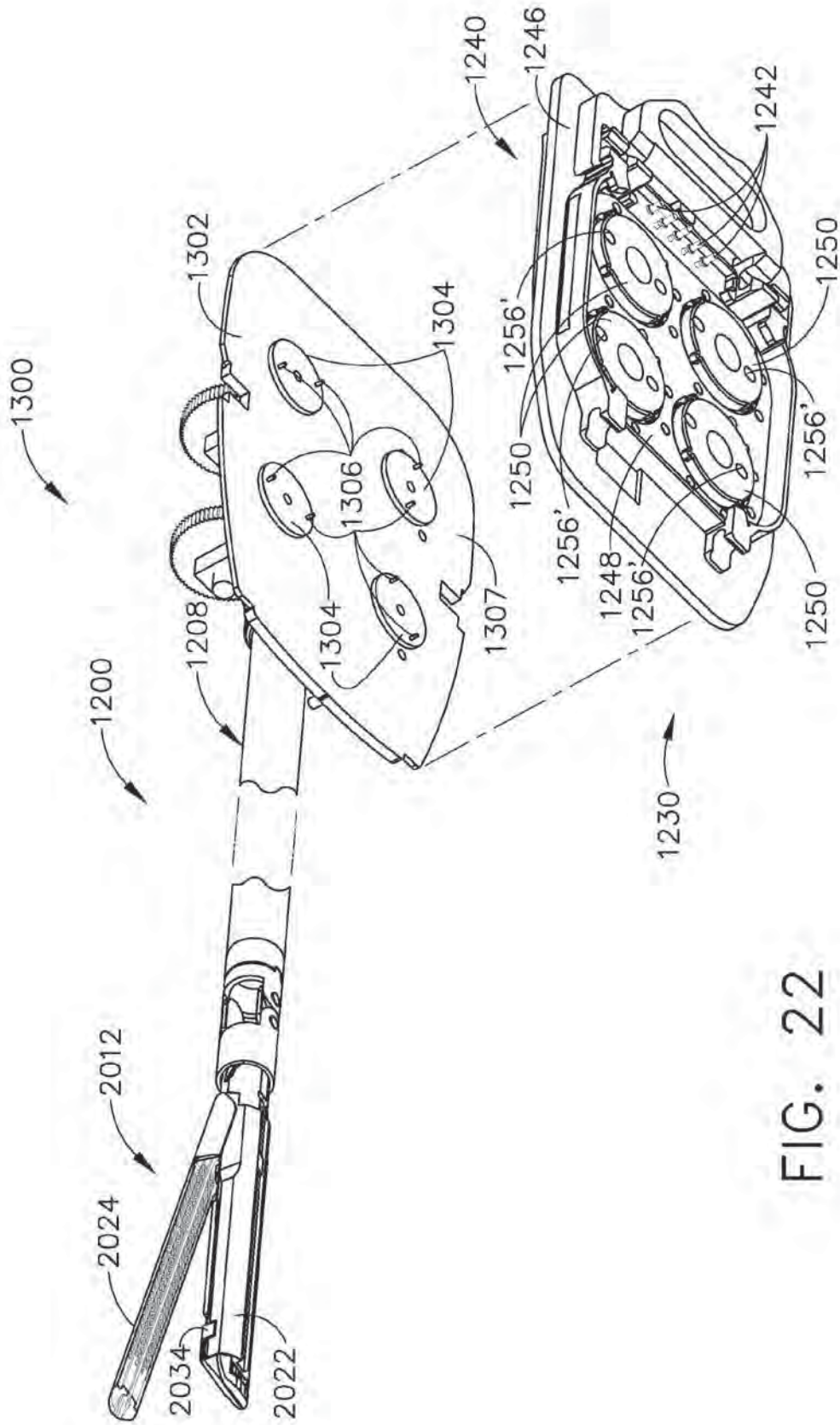

FIG. 22

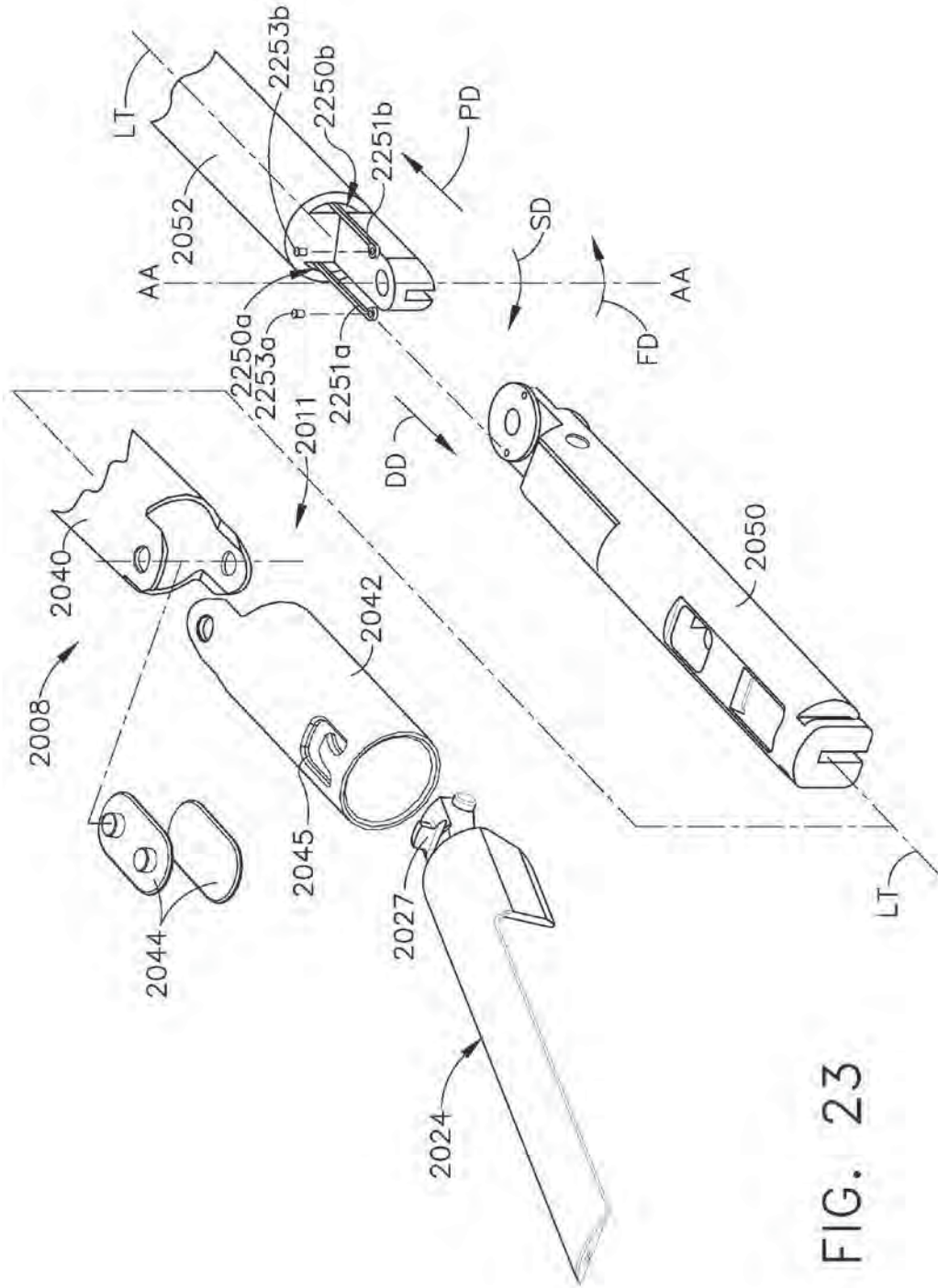

FIG. 23

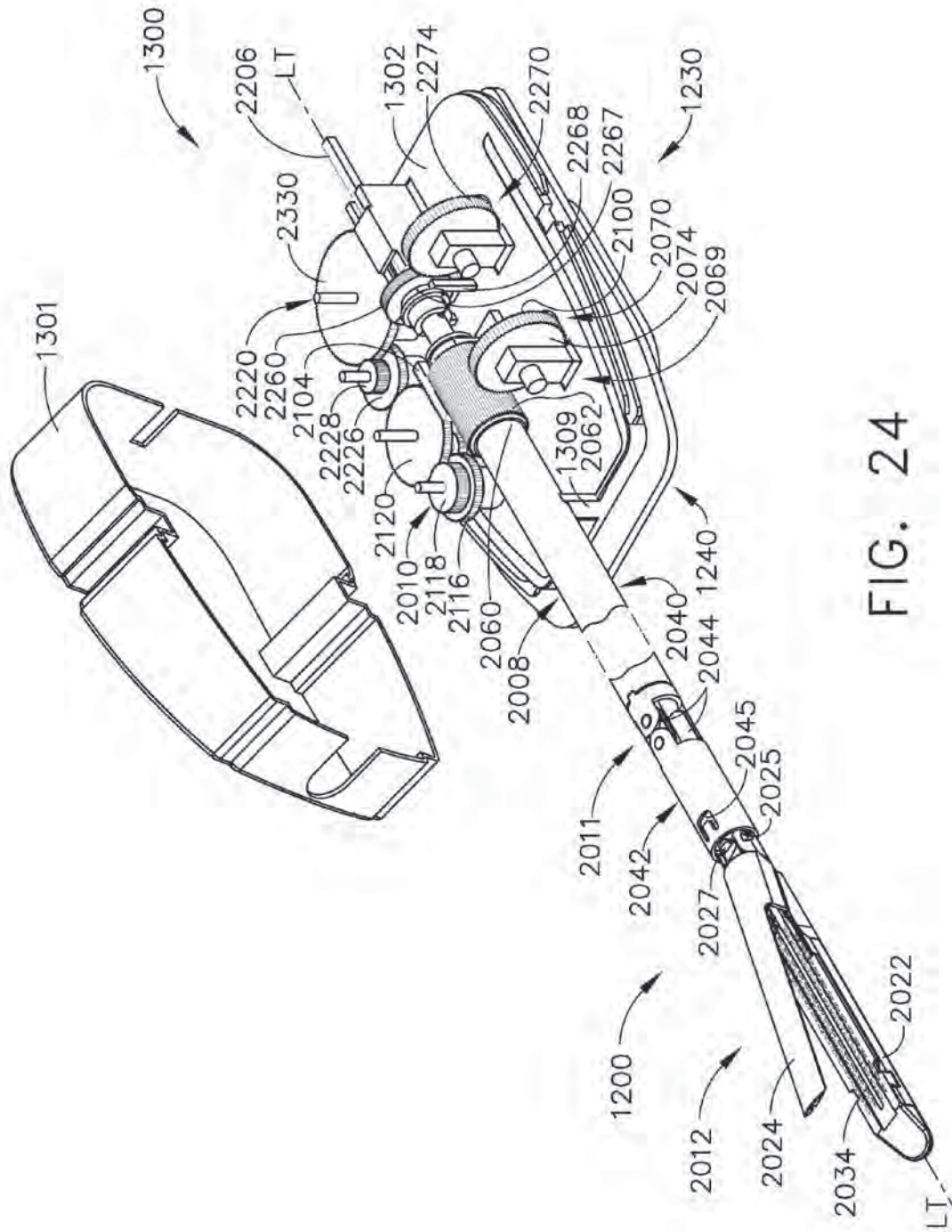

FIG. 24

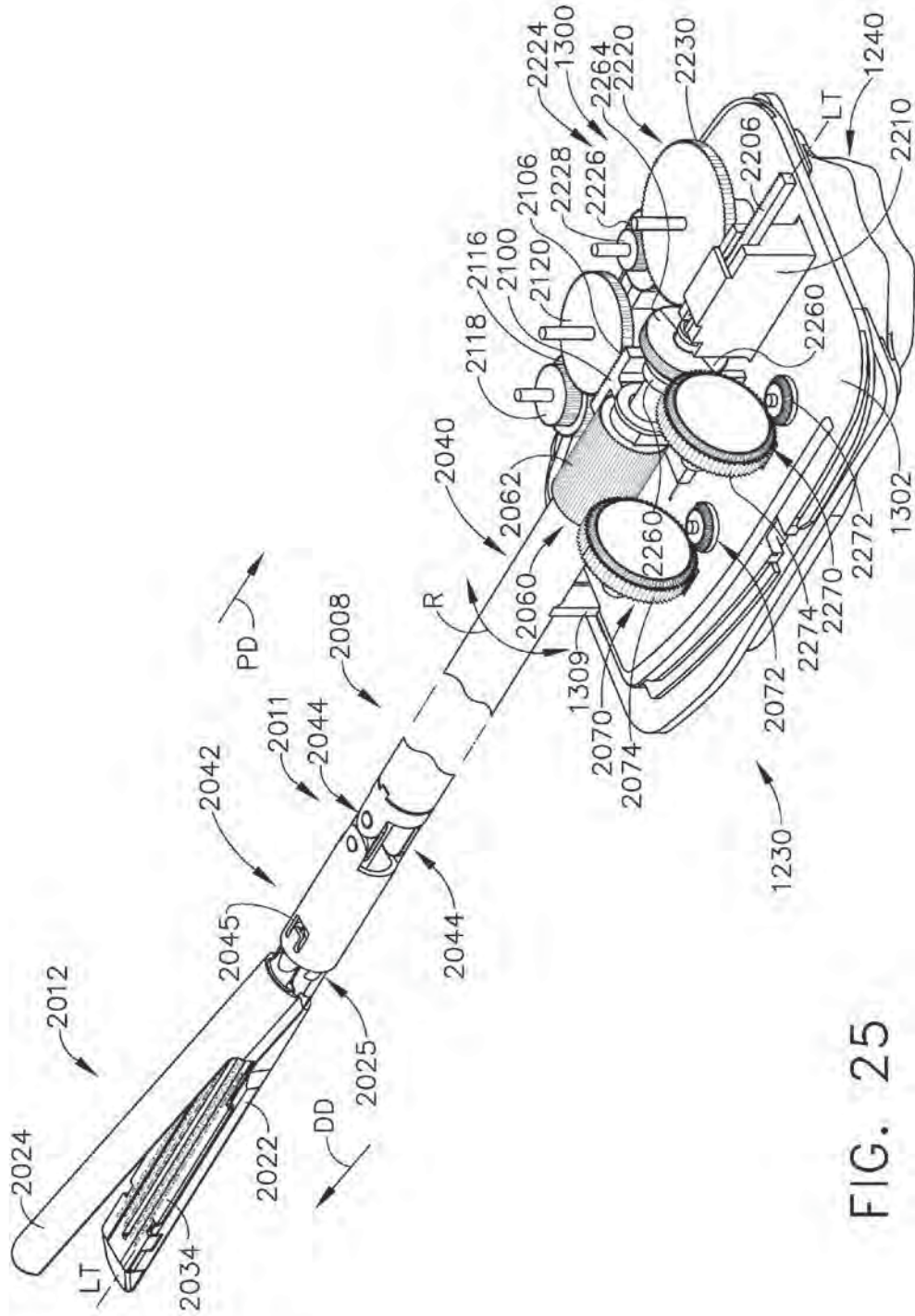

FIG. 25

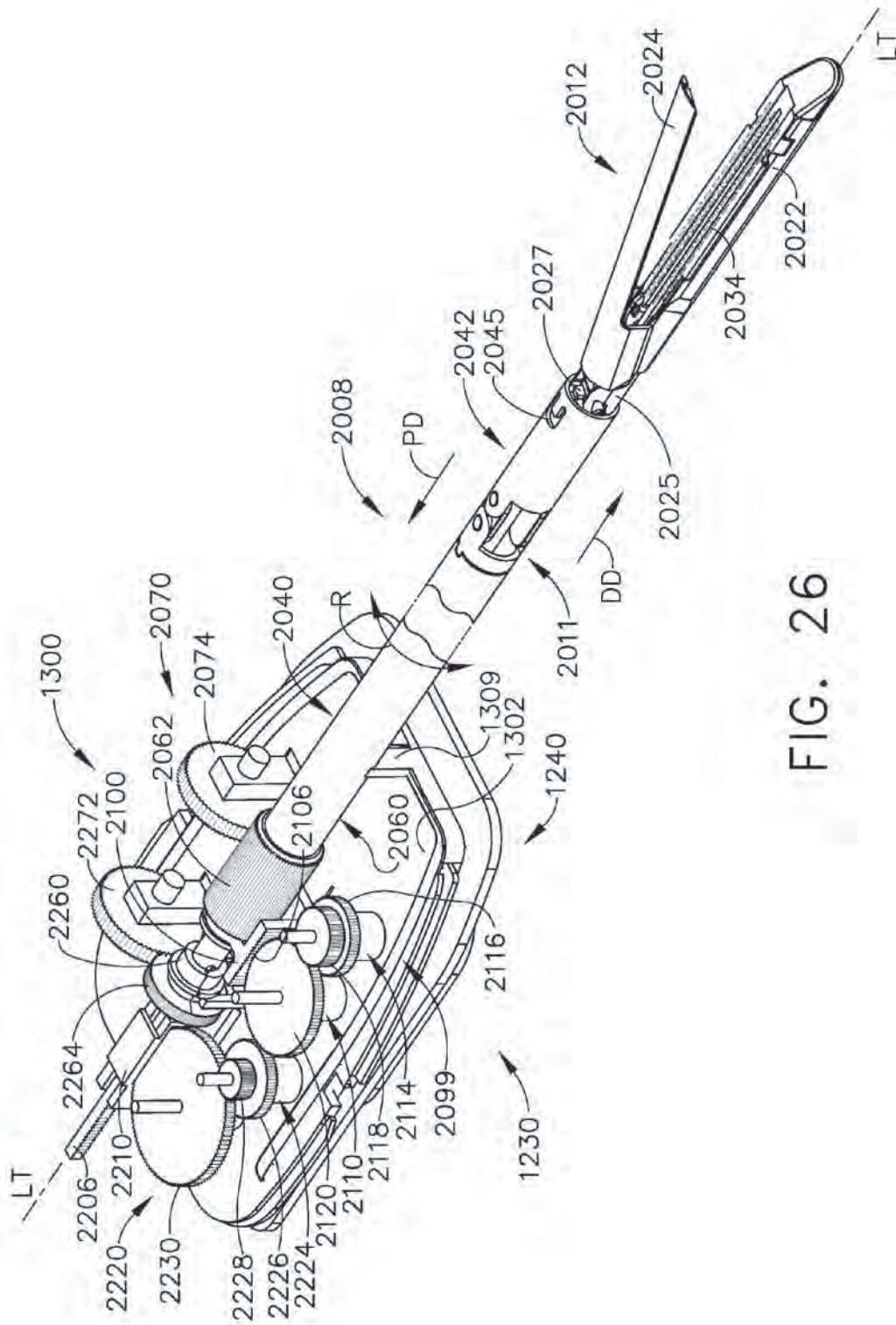

FIG. 26

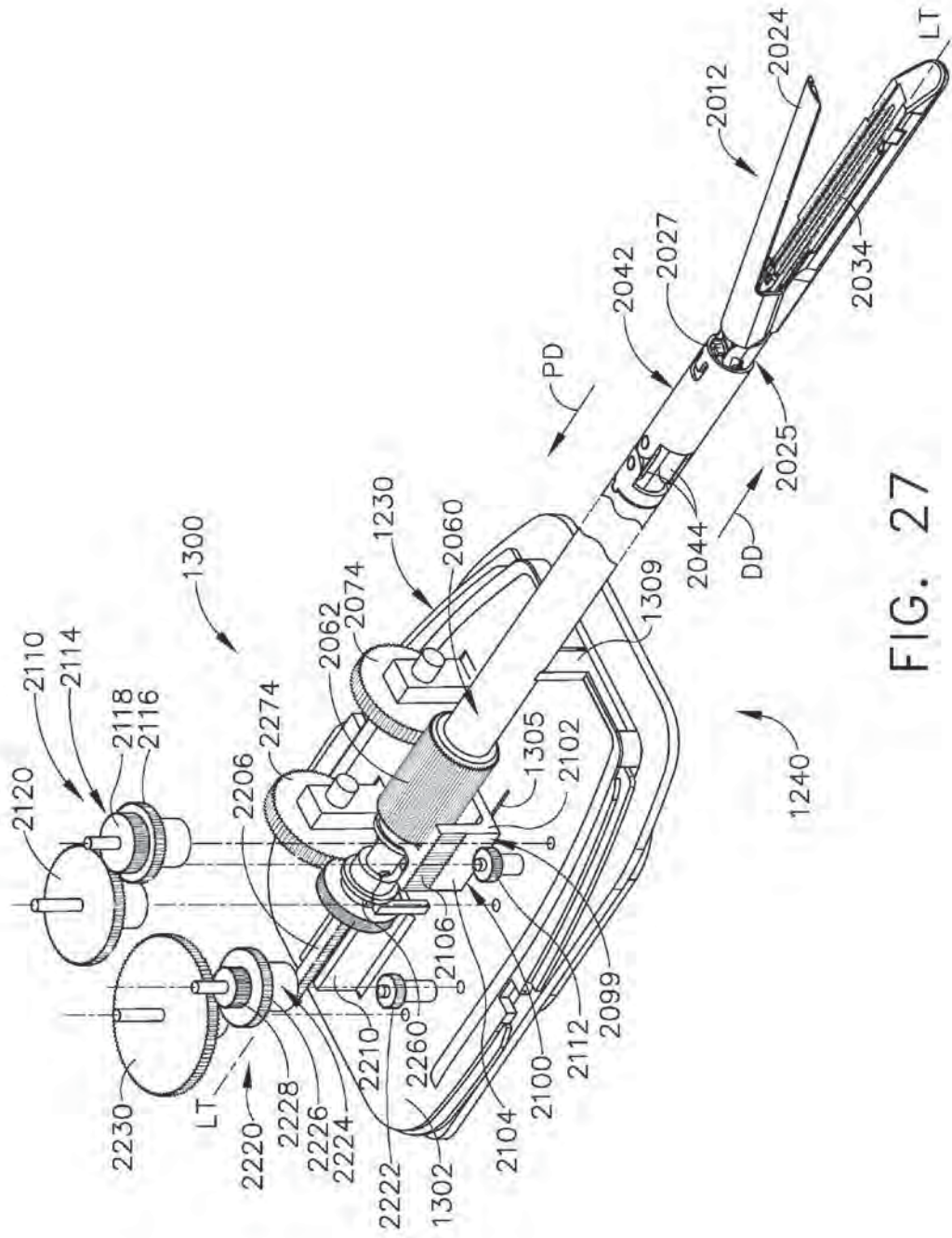

FIG. 27

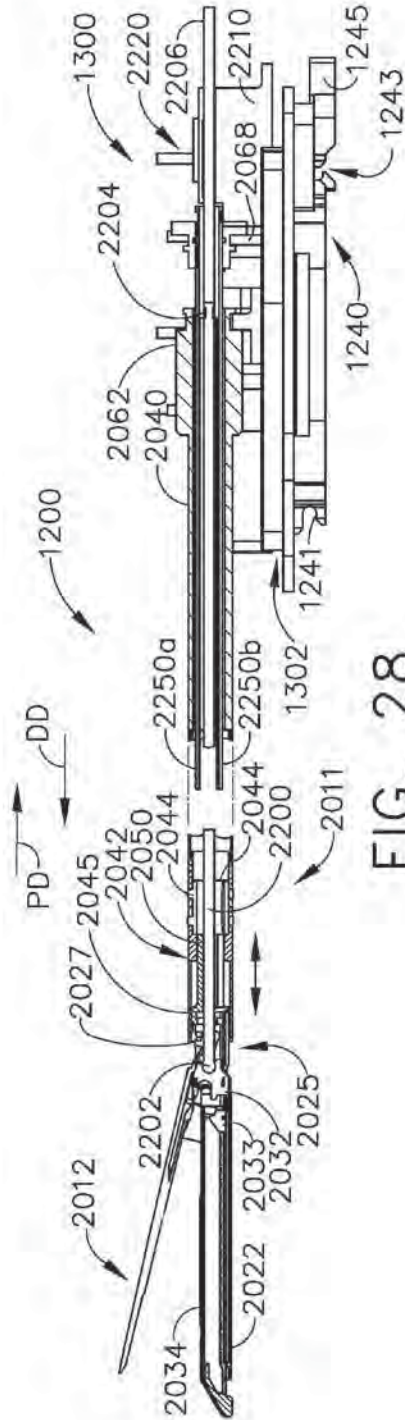

FIG. 28

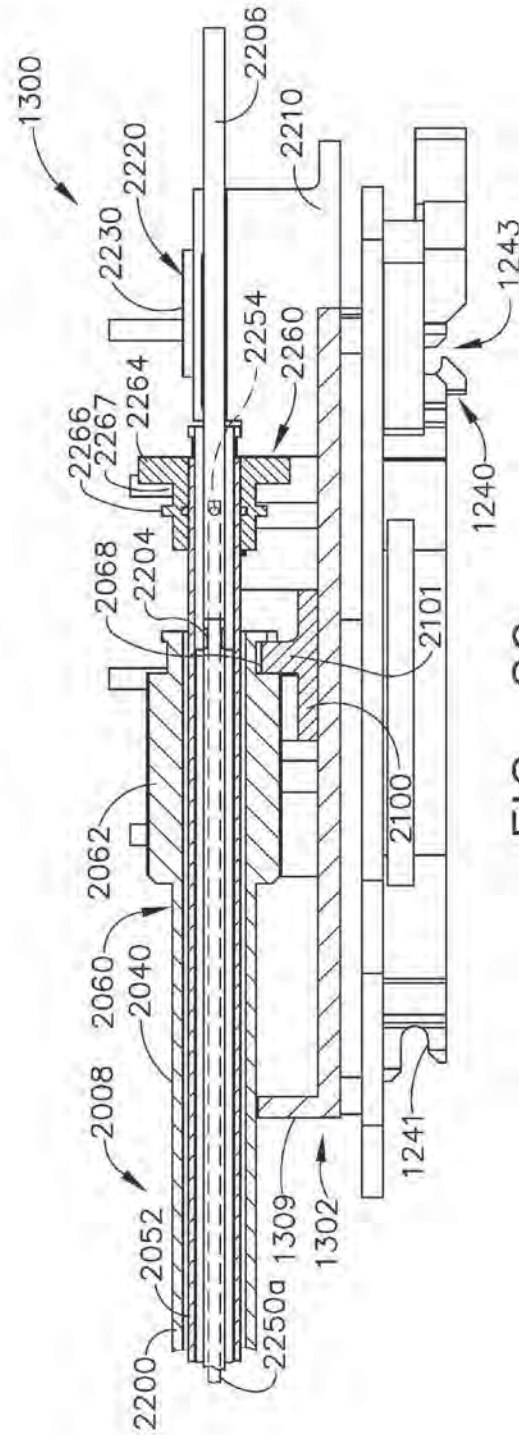

FIG. 29

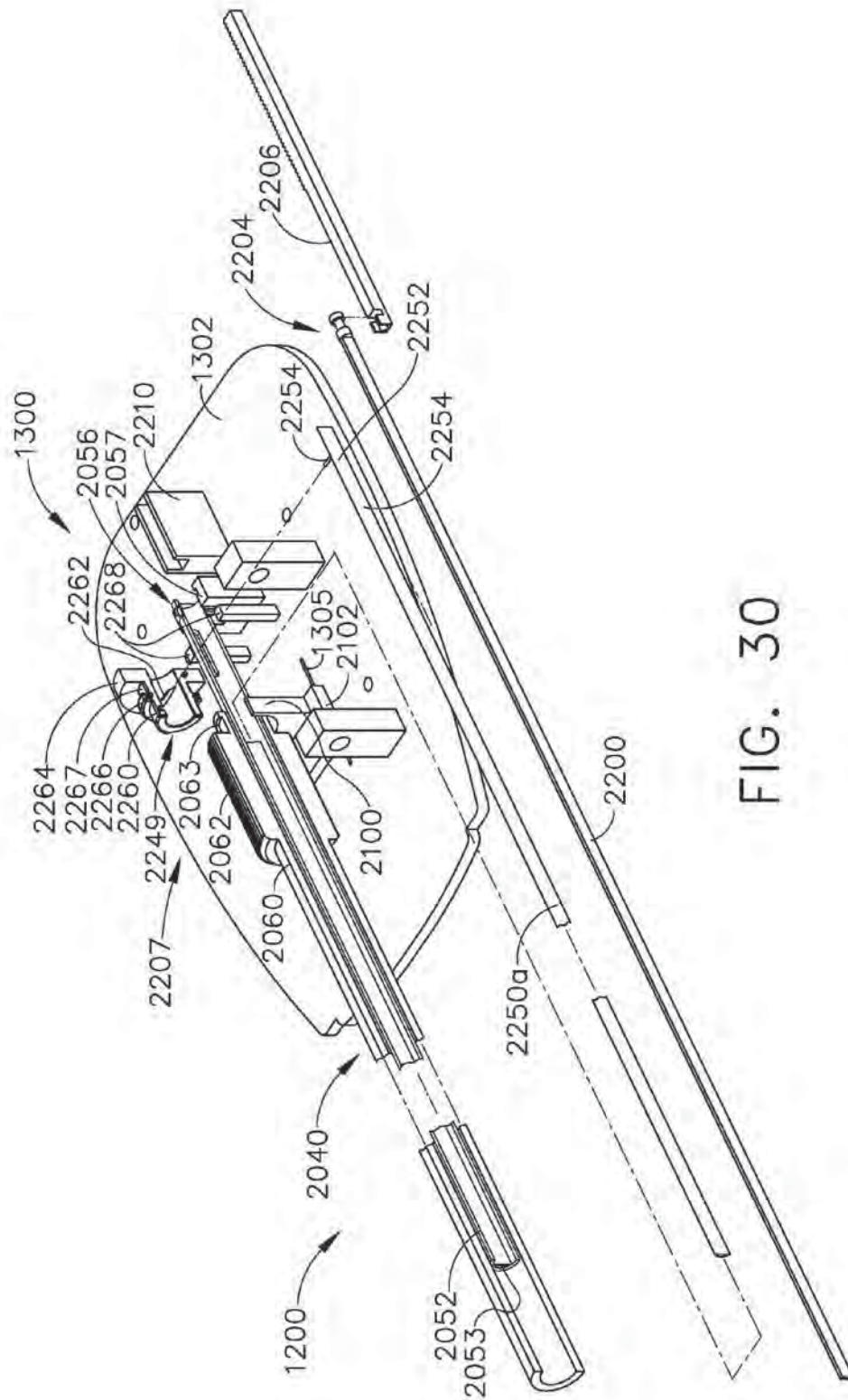

FIG. 30

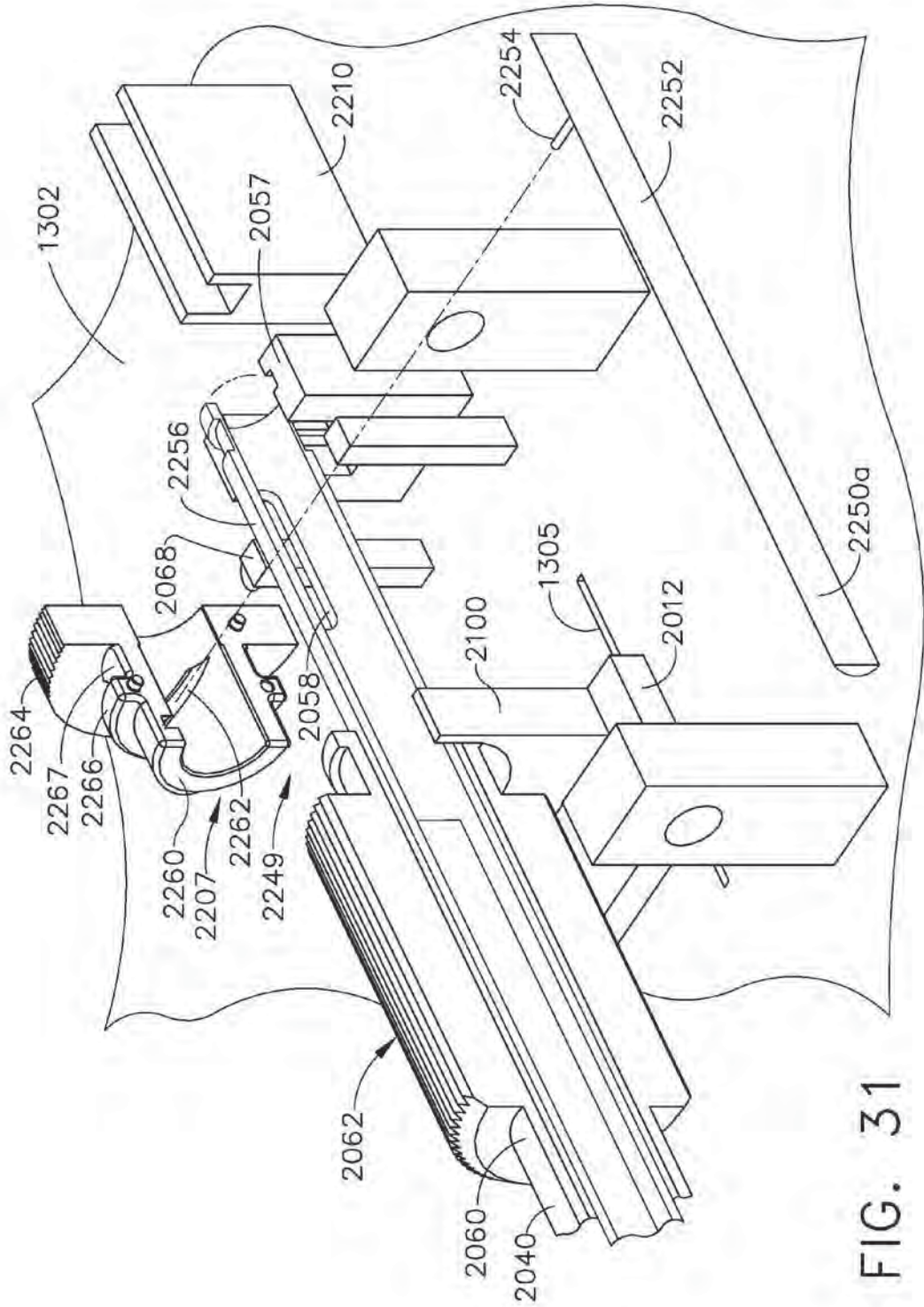

FIG. 31

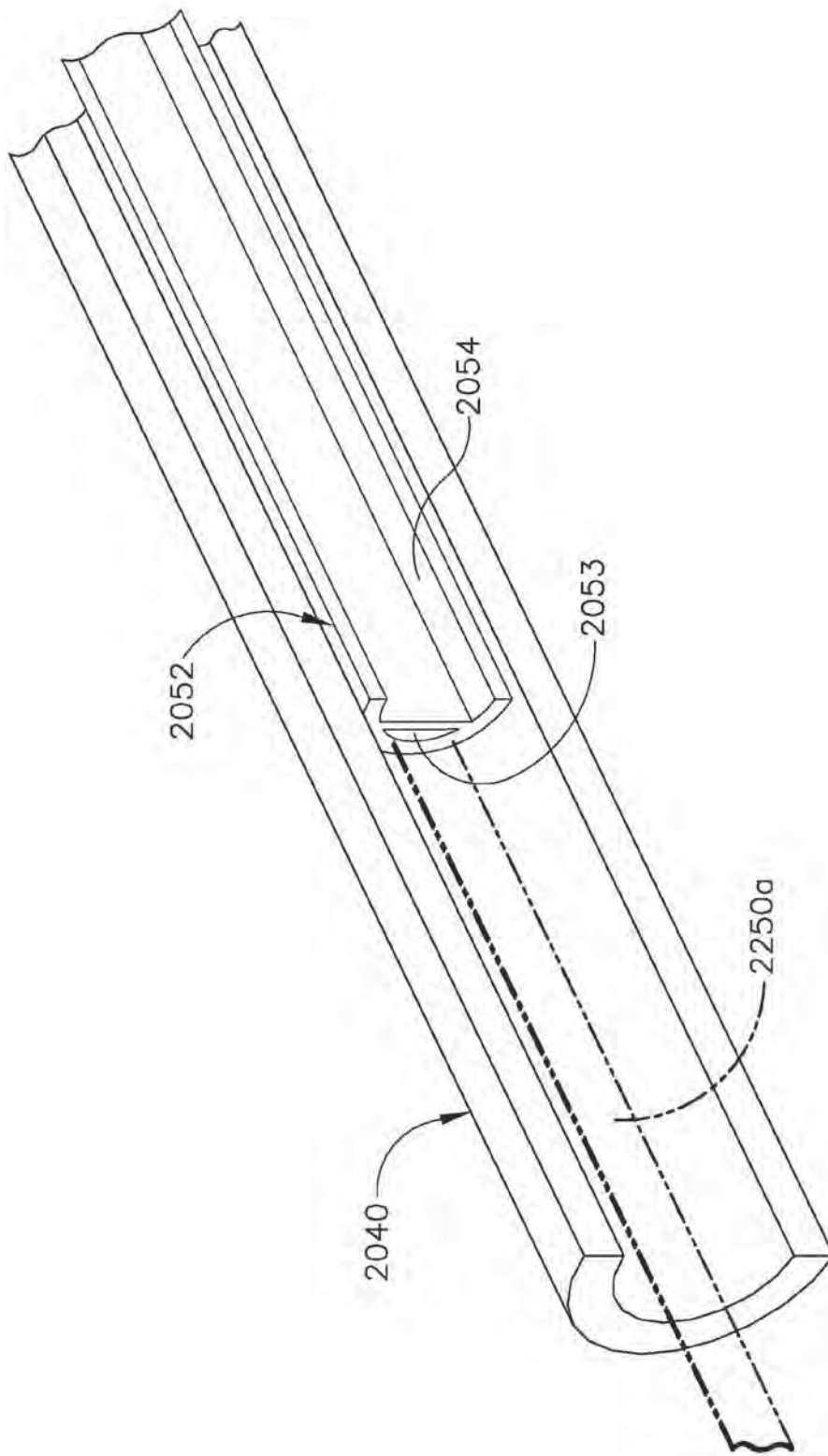

FIG. 32

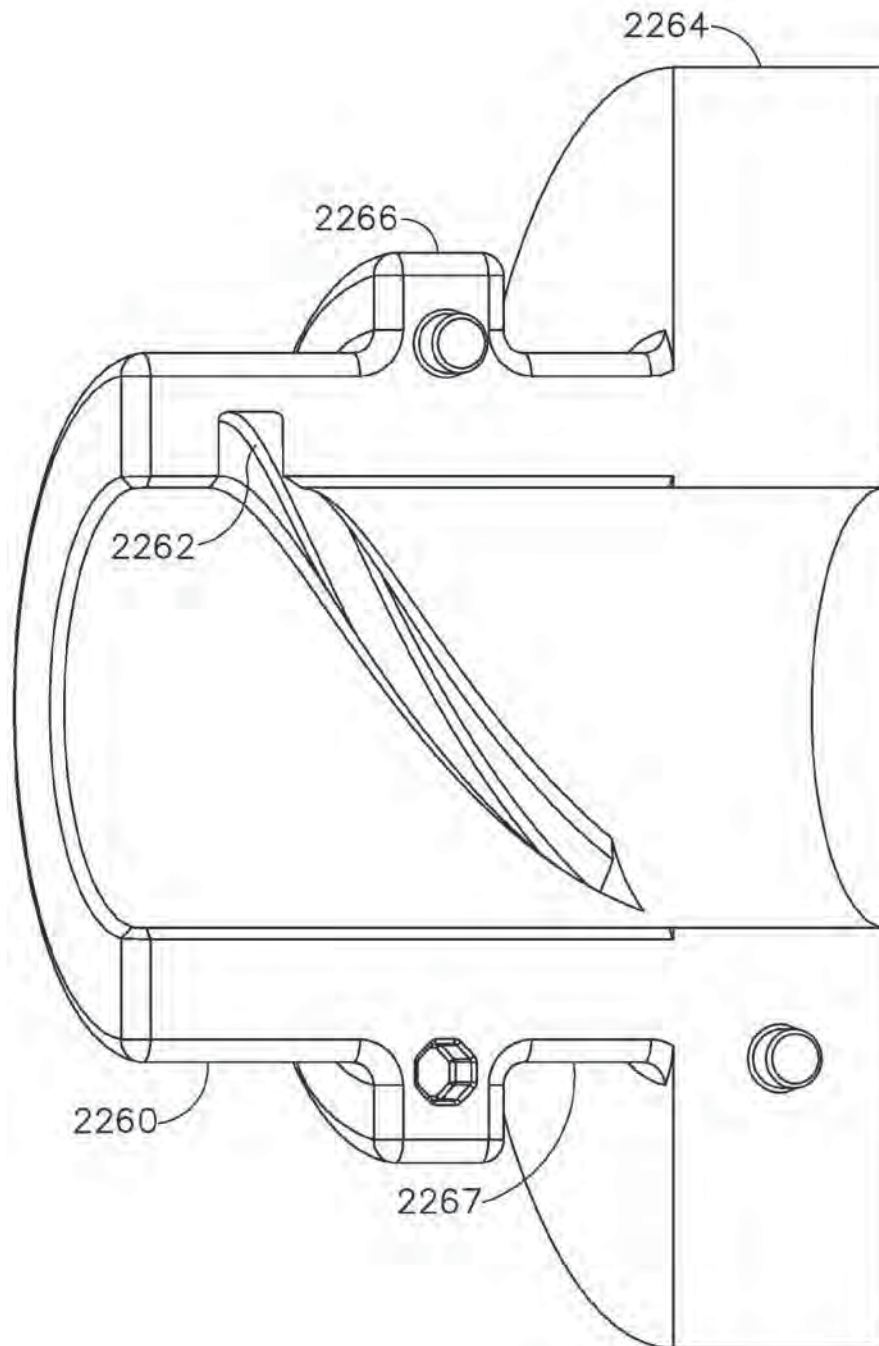

FIG. 33

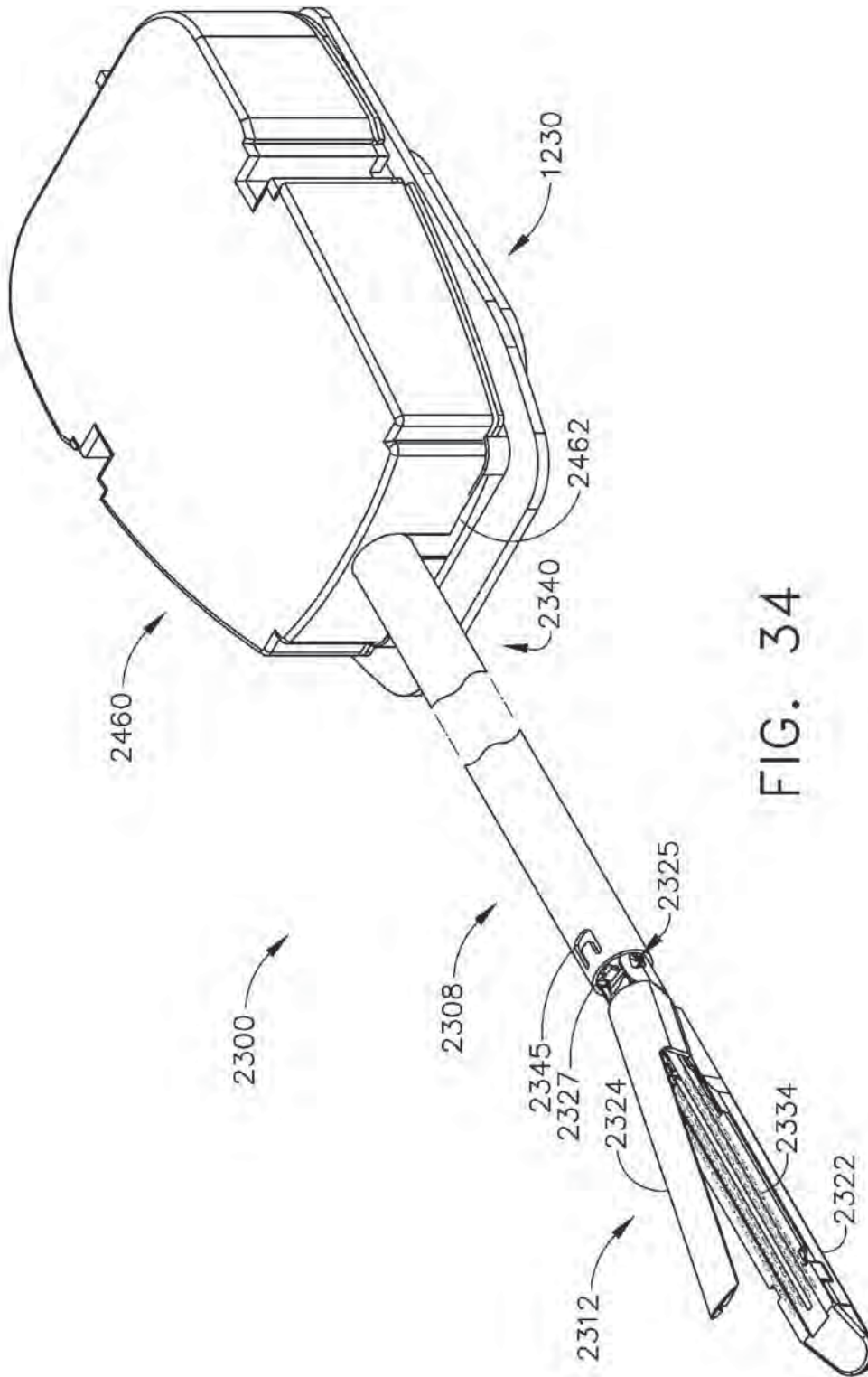

FIG. 34

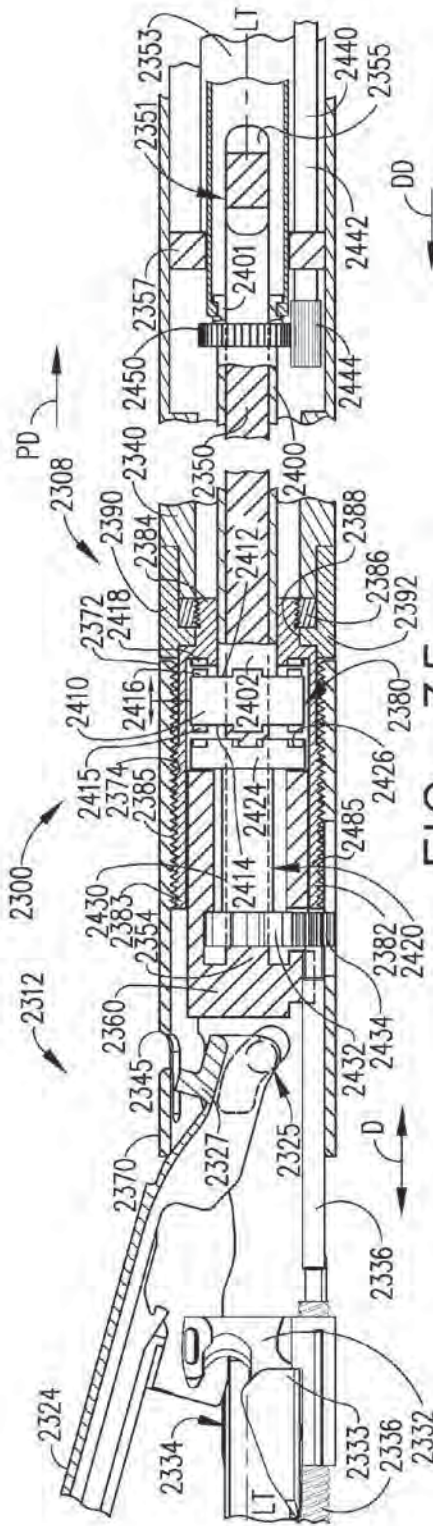

FIG. 35

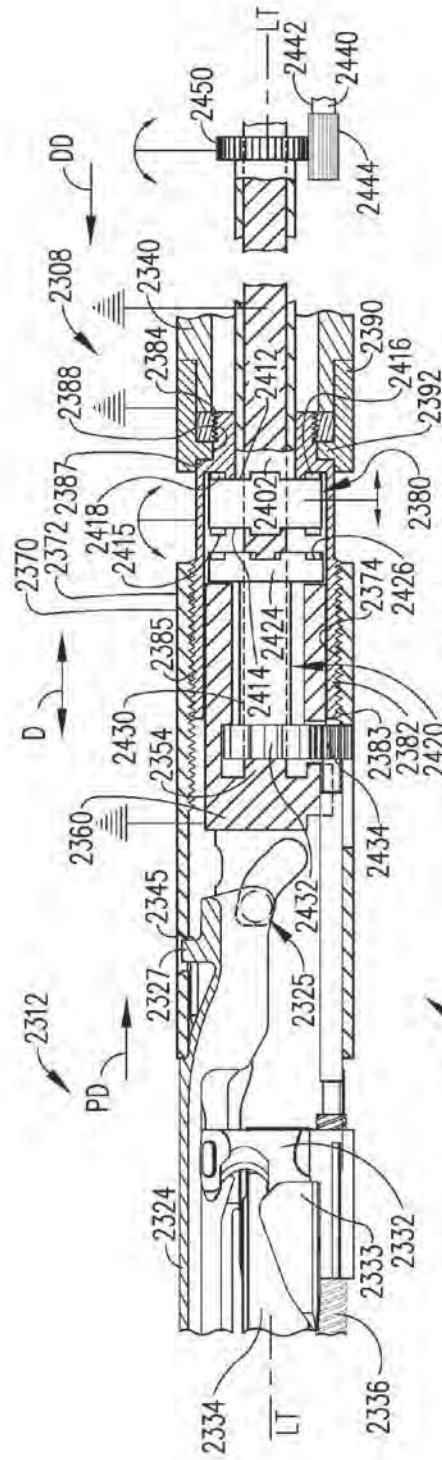

FIG. 36

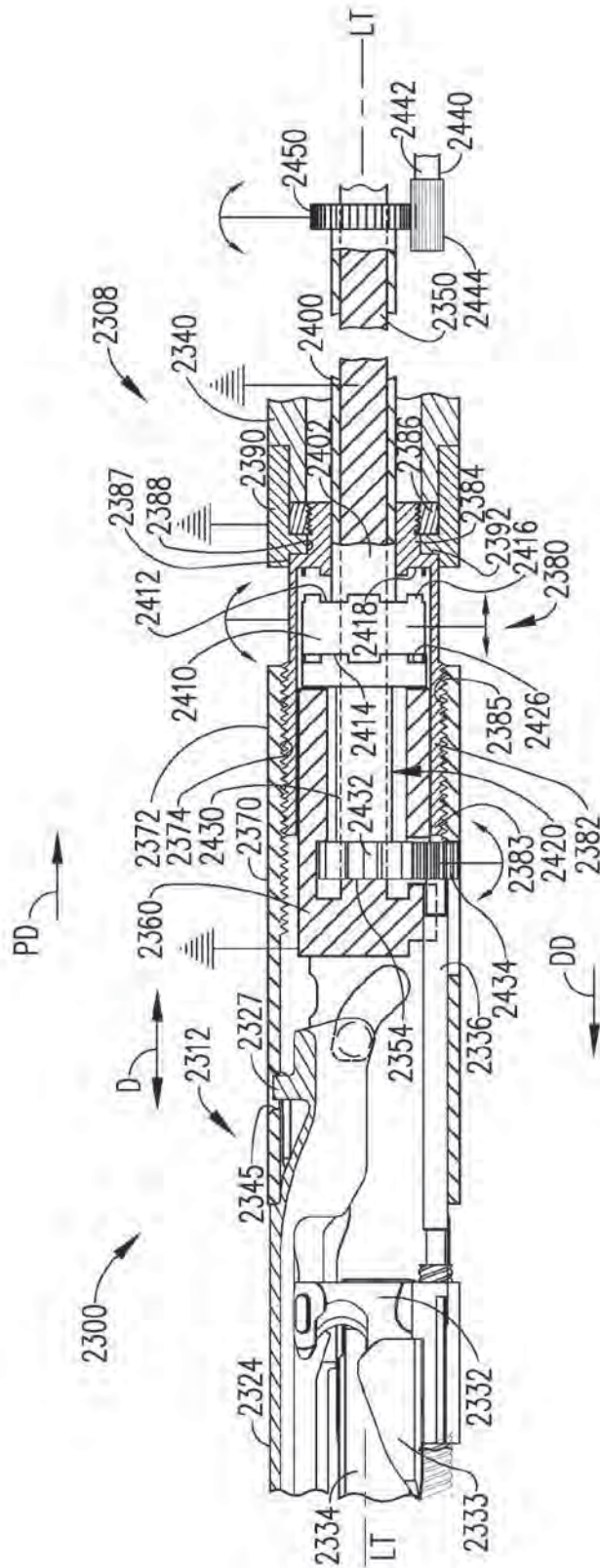

FIG. 37

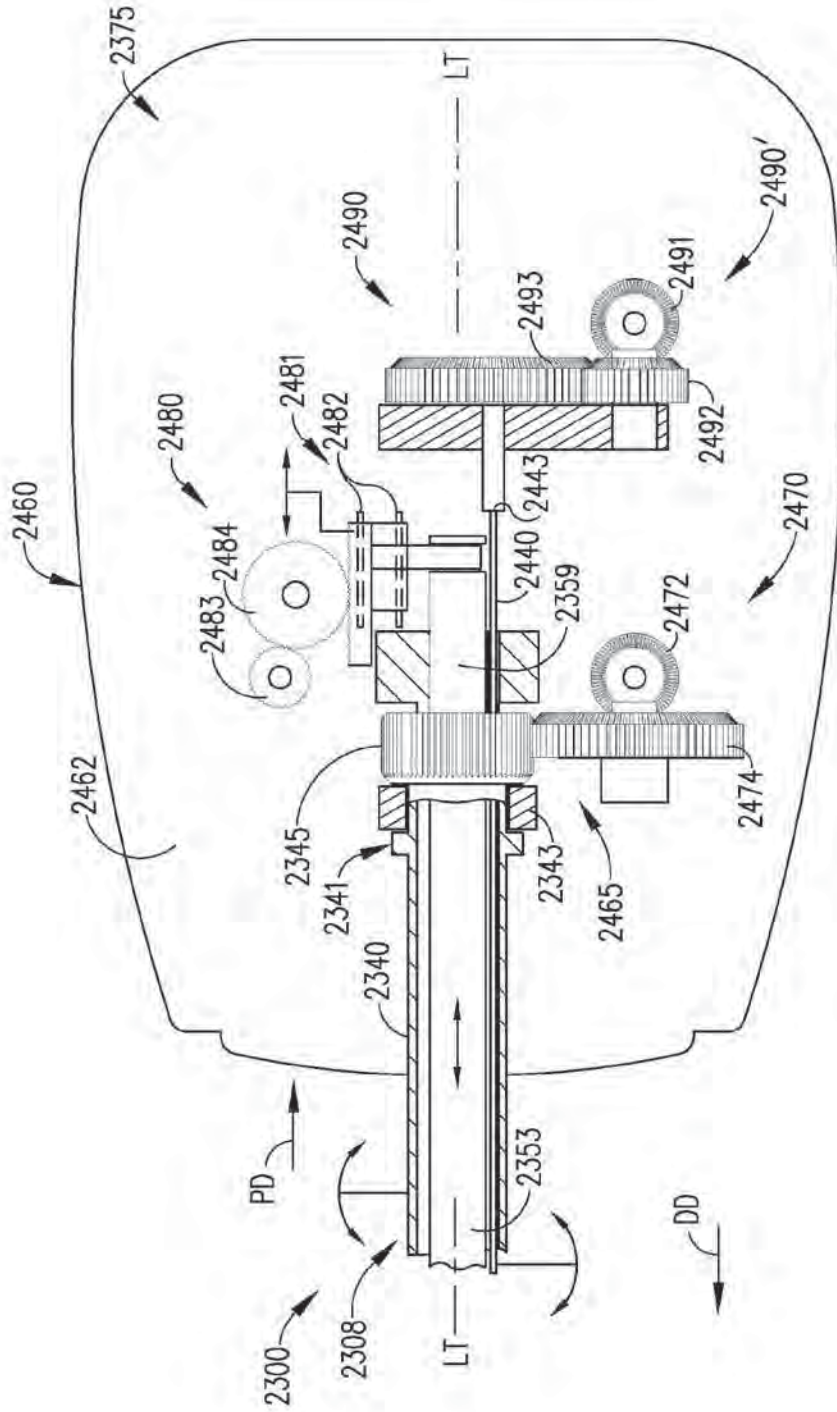

FIG. 38

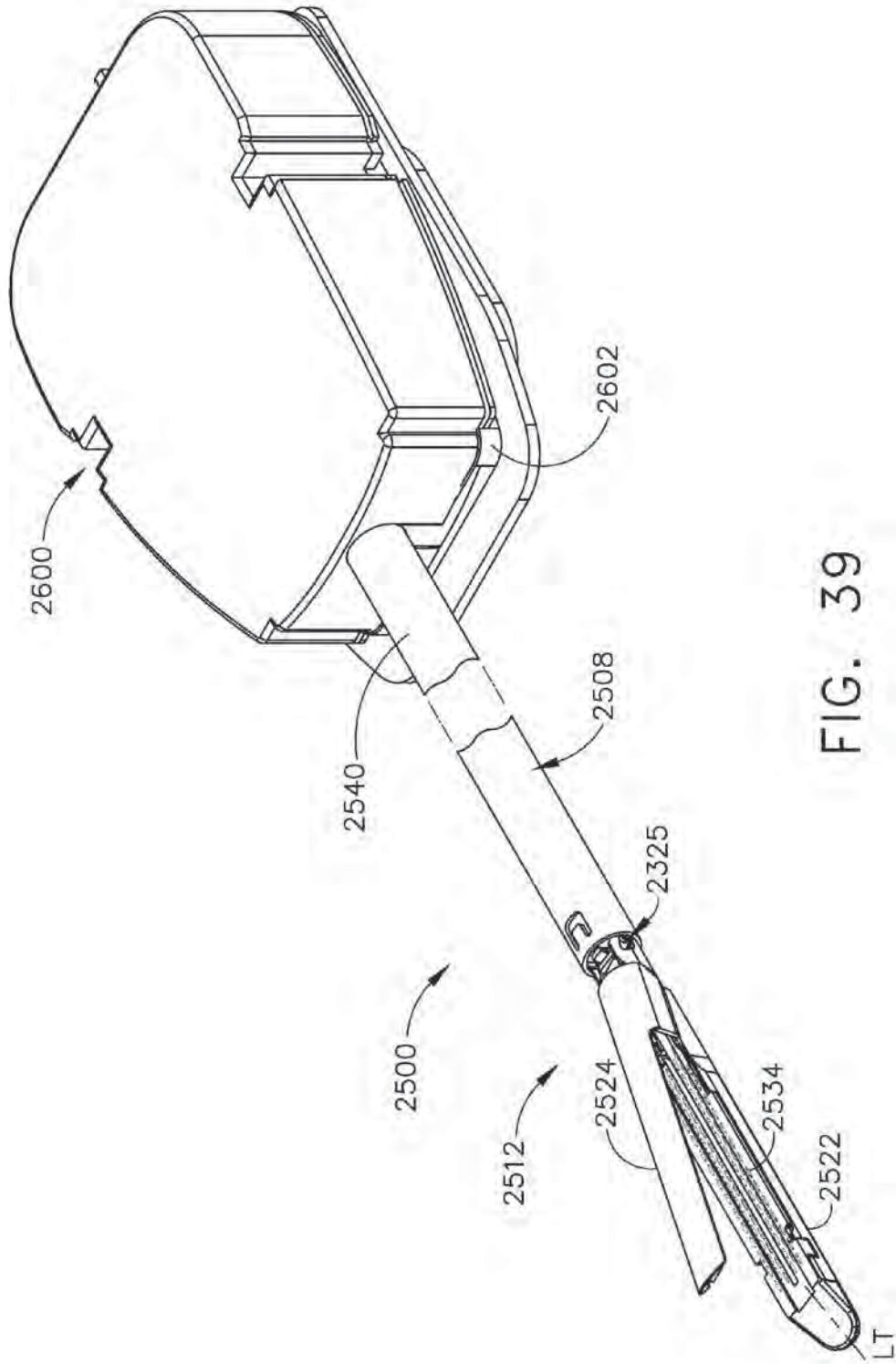

FIG. 39

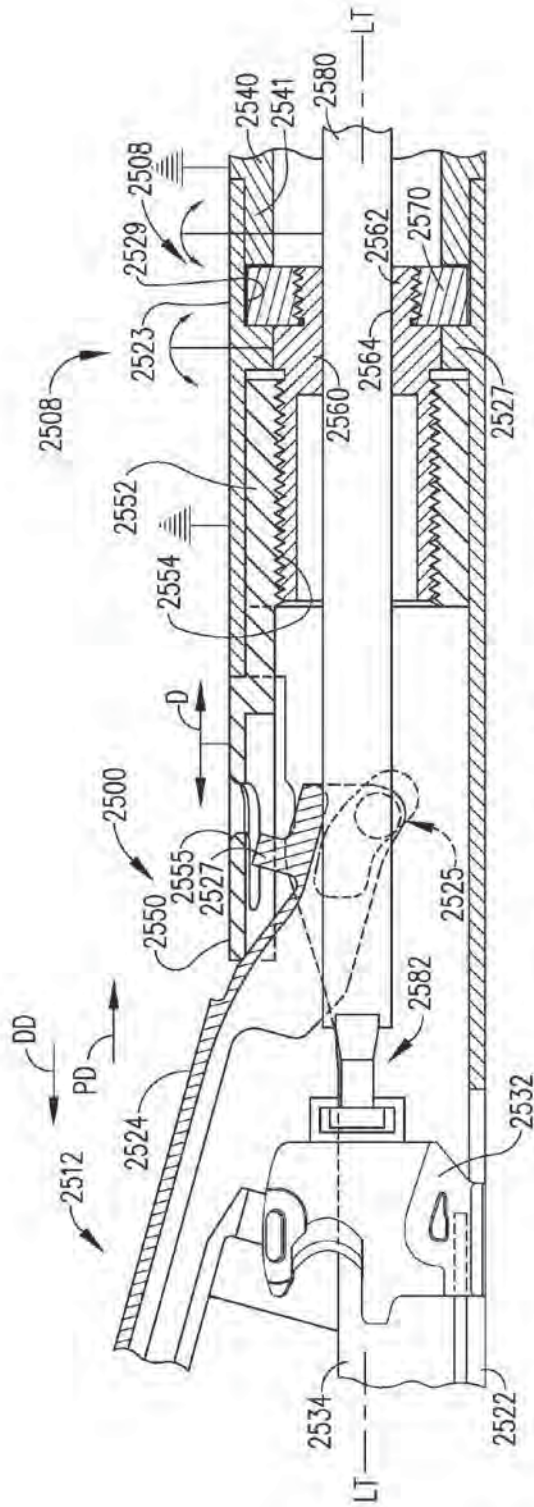

FIG. 40

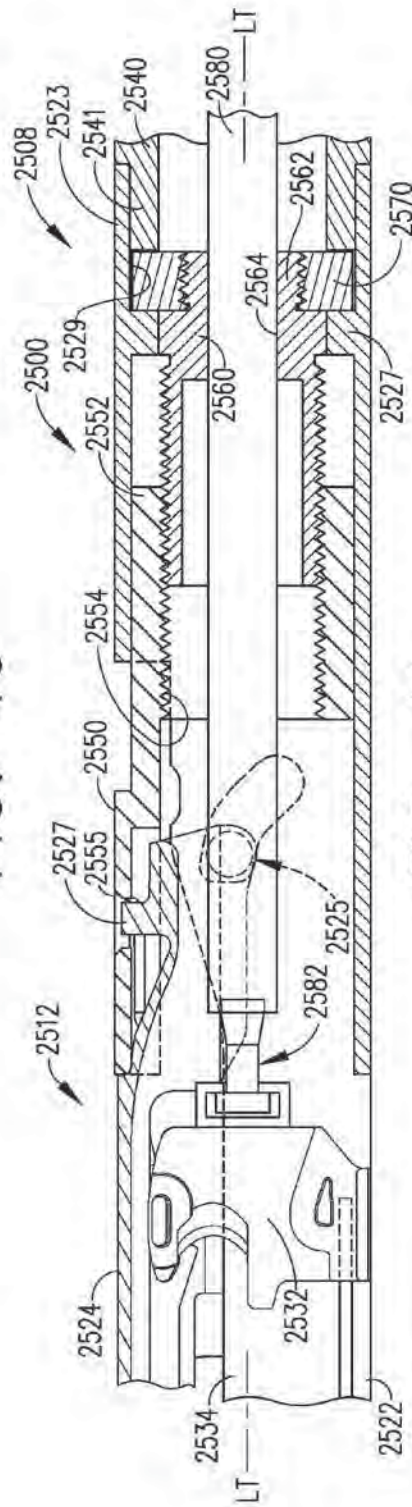

FIG. 41

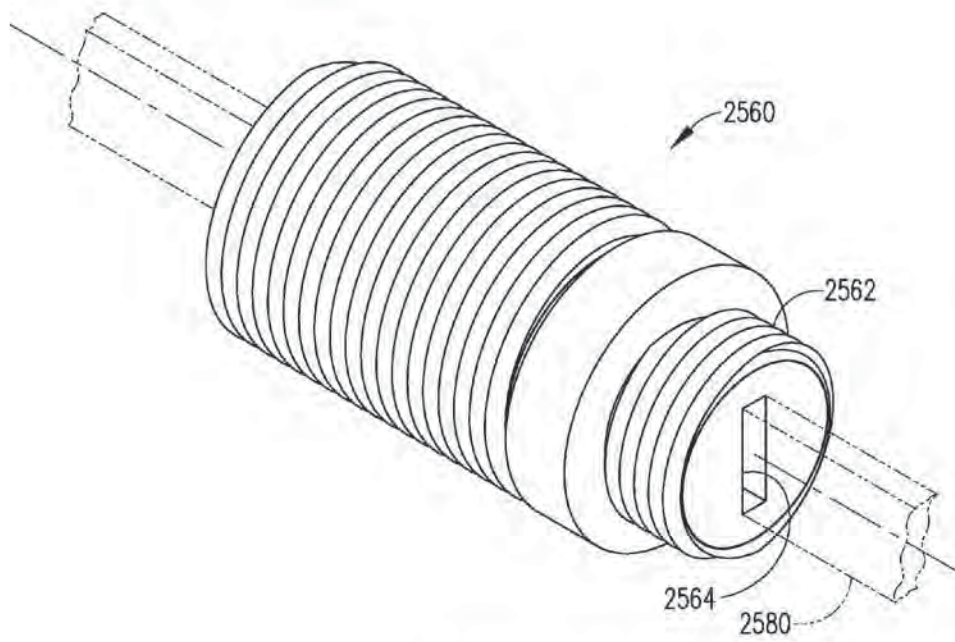

FIG. 42

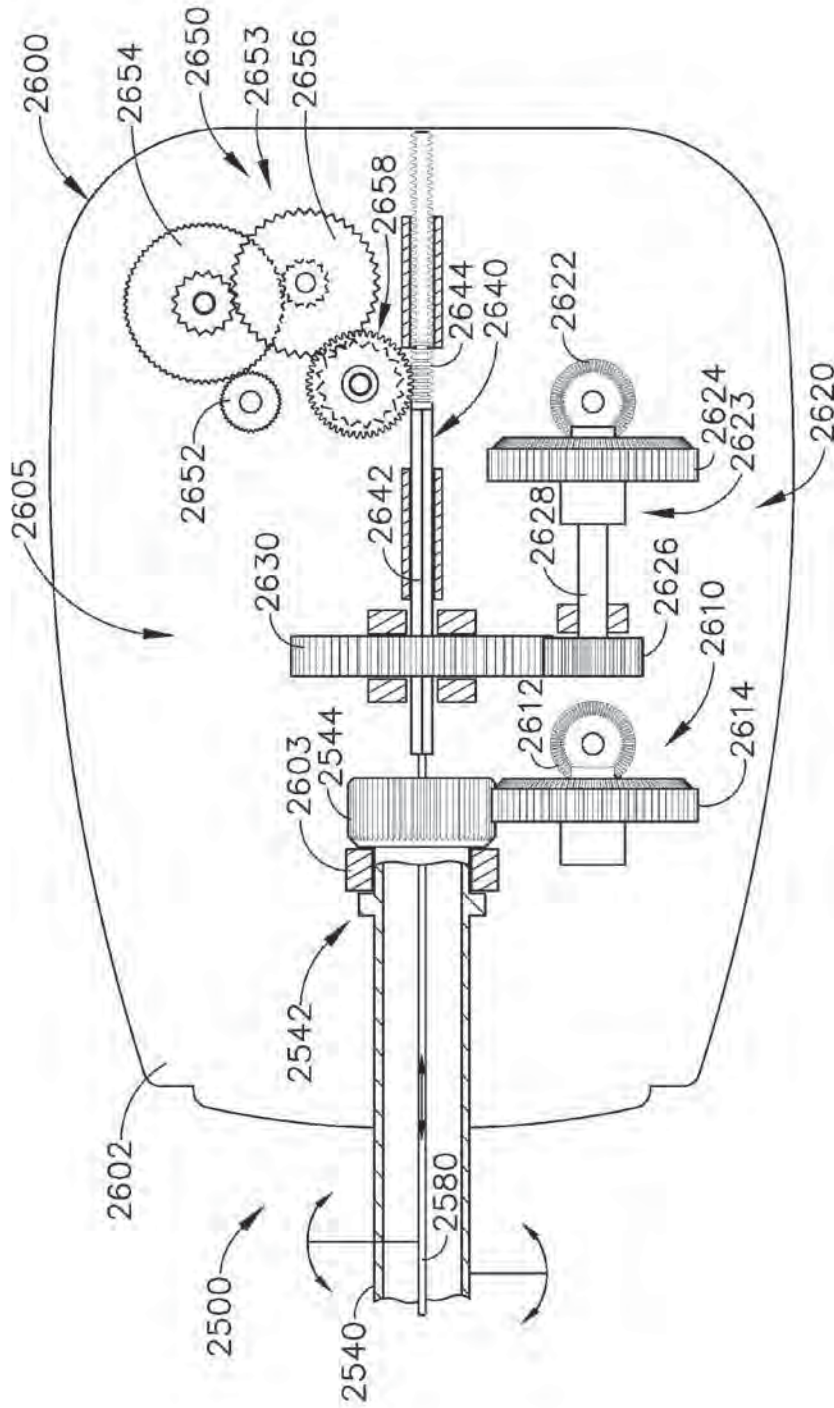

FIG. 43

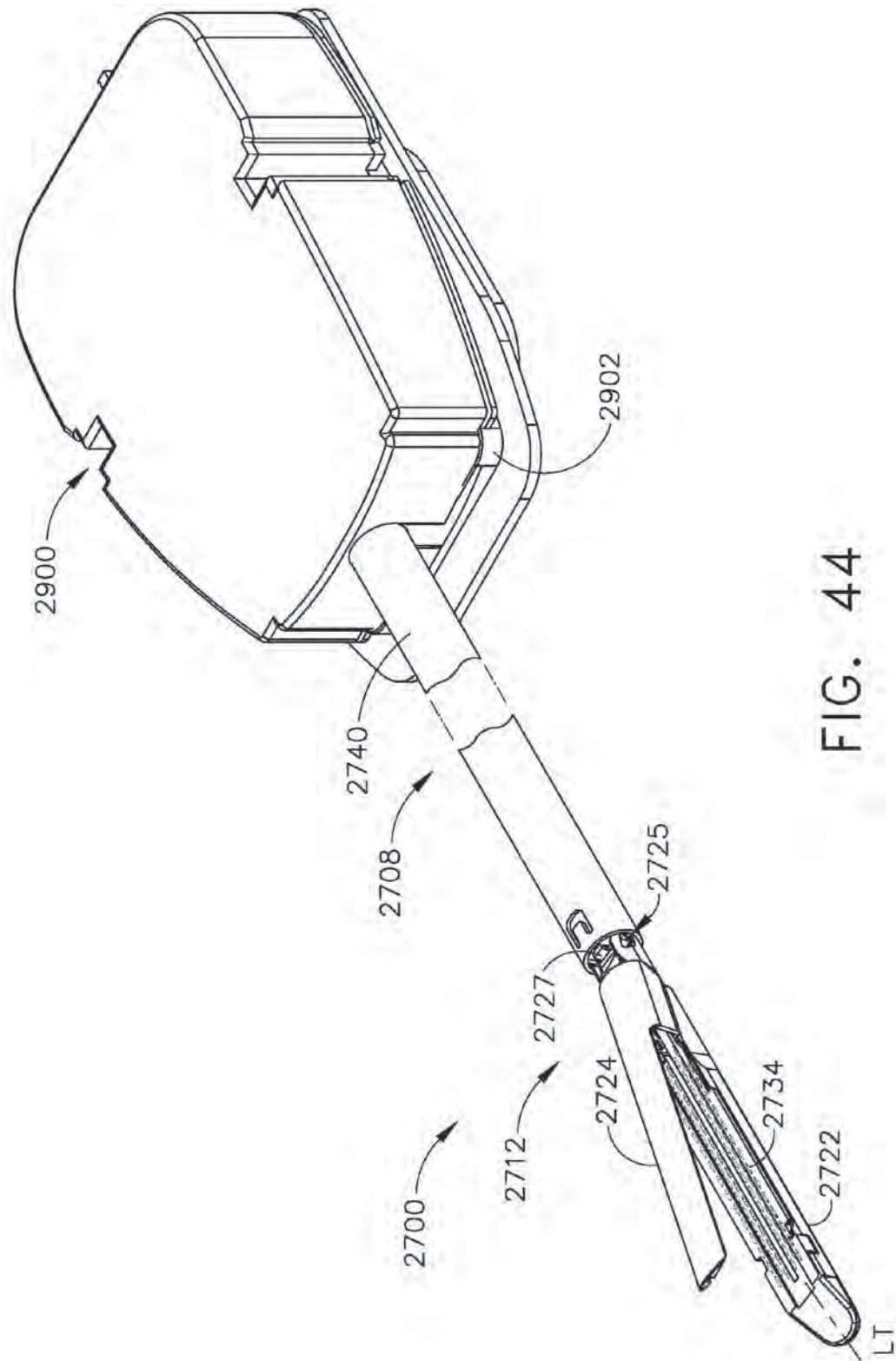

FIG. 44

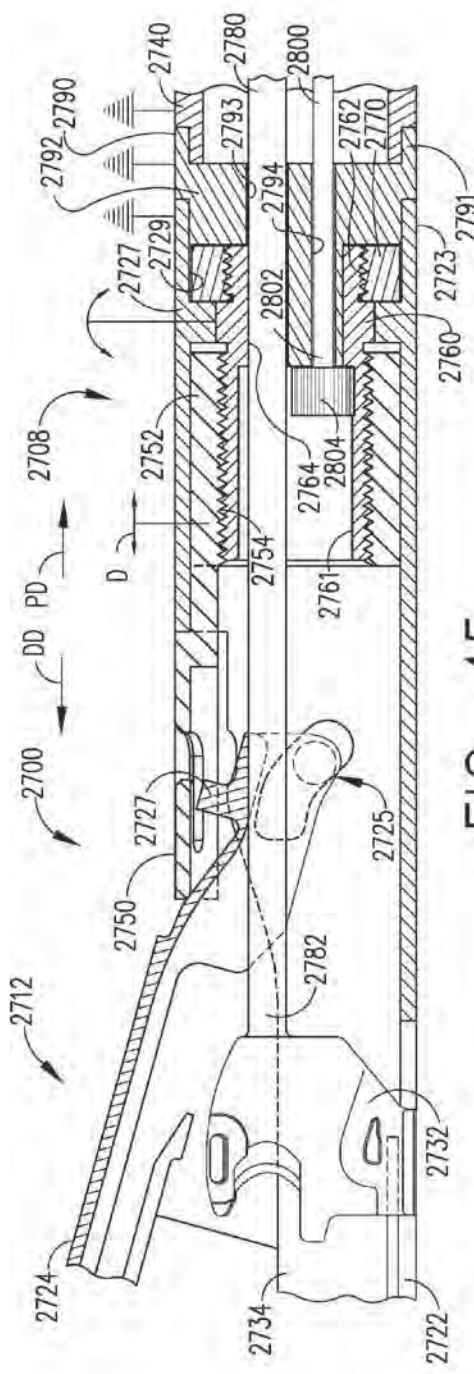

FIG. 45

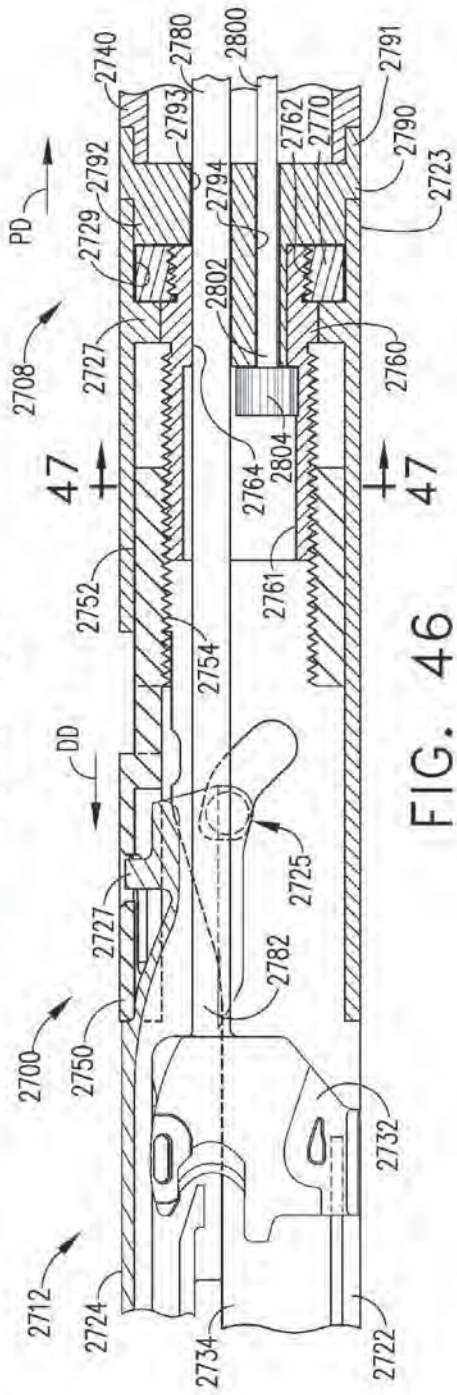

FIG. 46

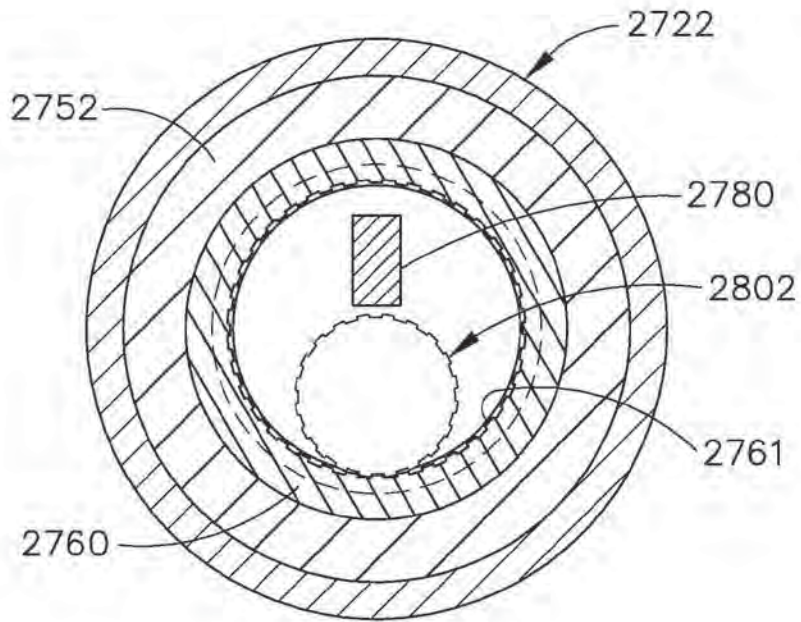

FIG. 47

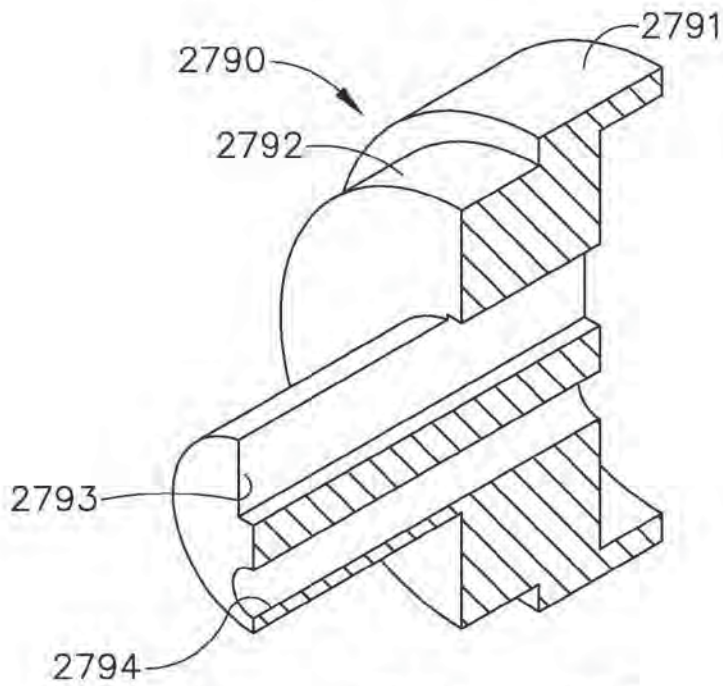

FIG. 48

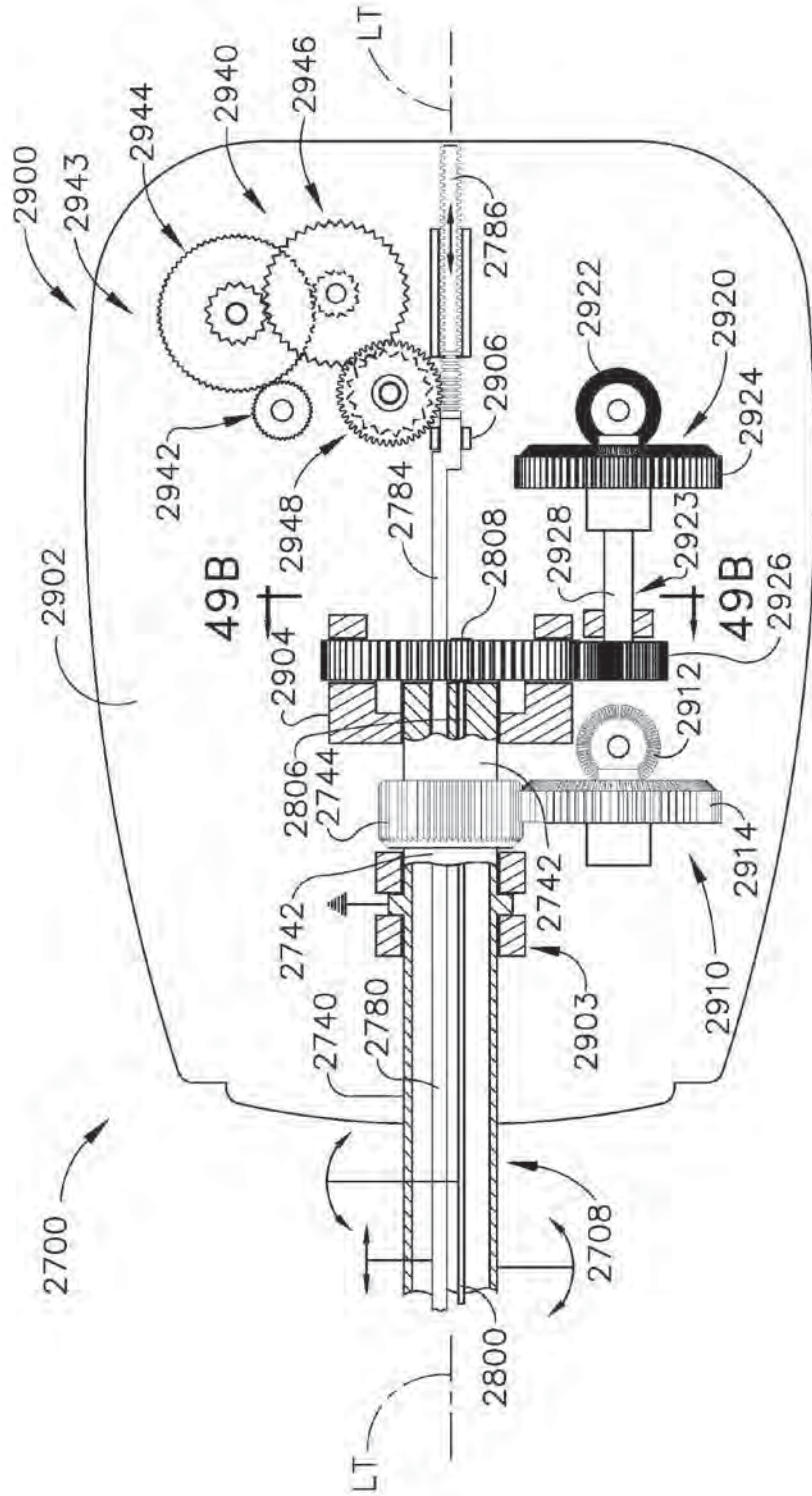

FIG. 49

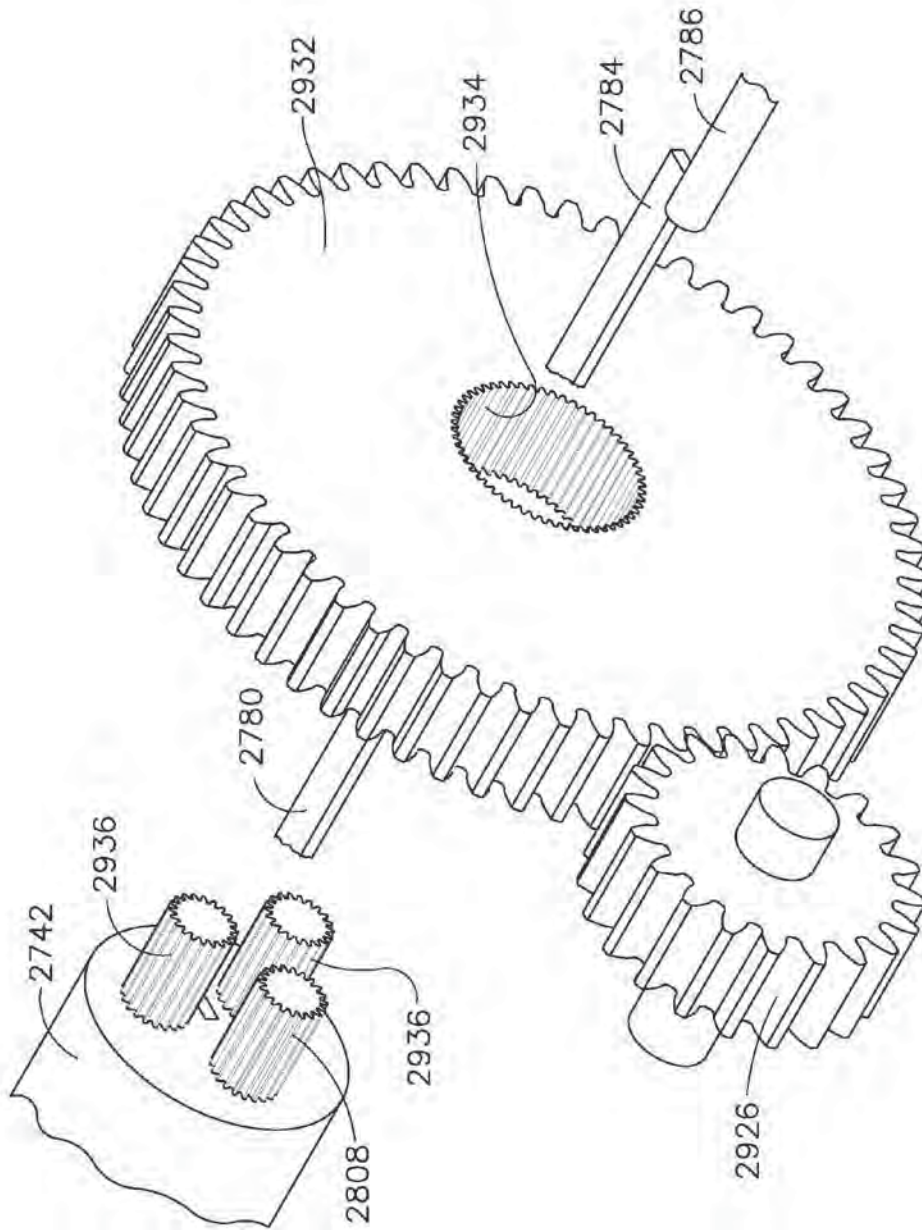

FIG. 49A

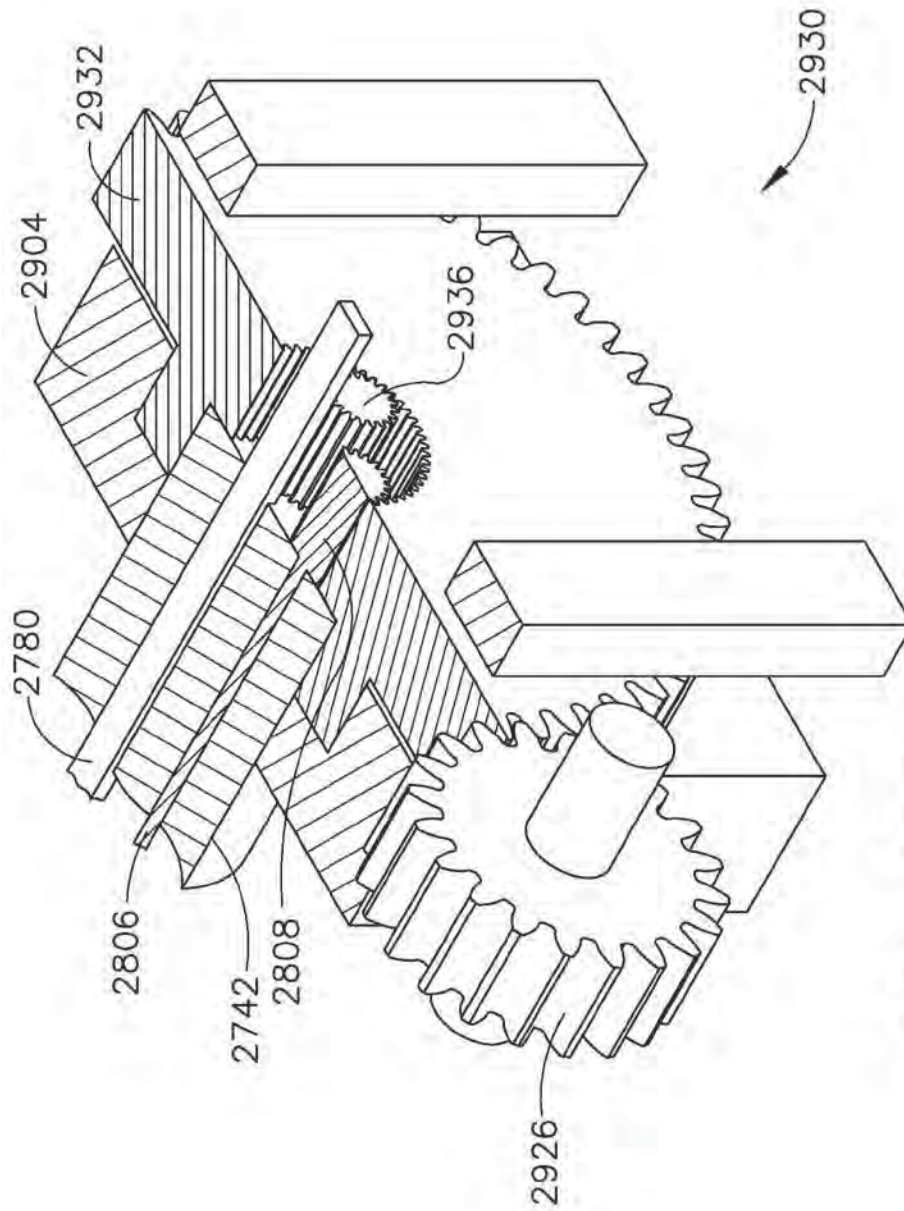

FIG. 49B

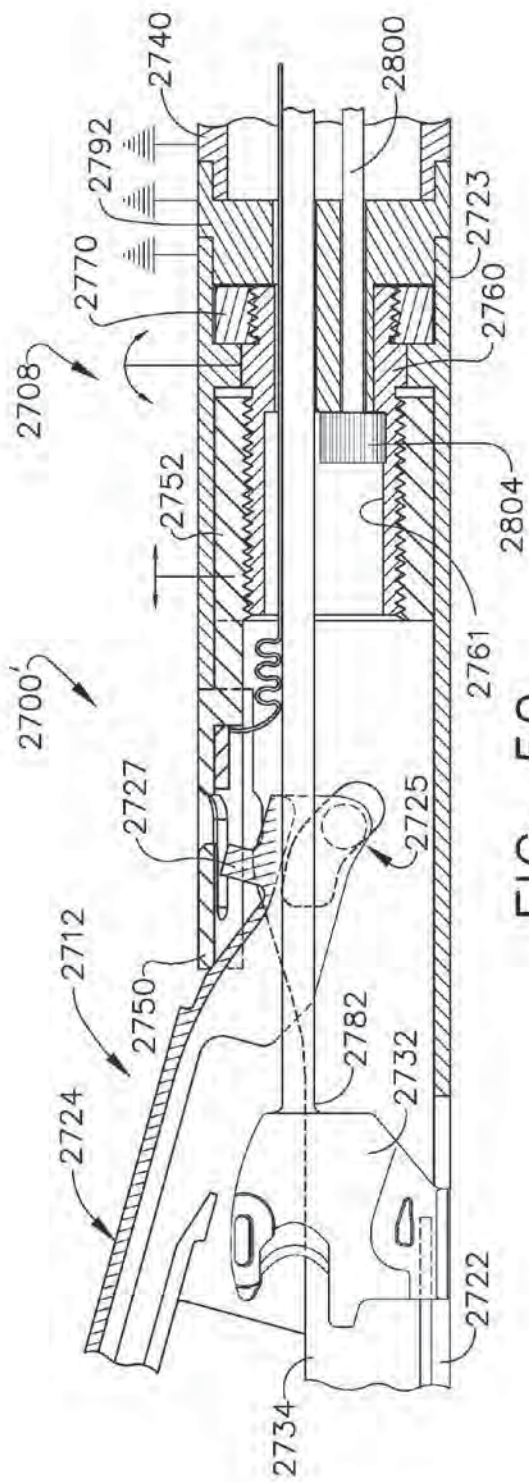

FIG. 50

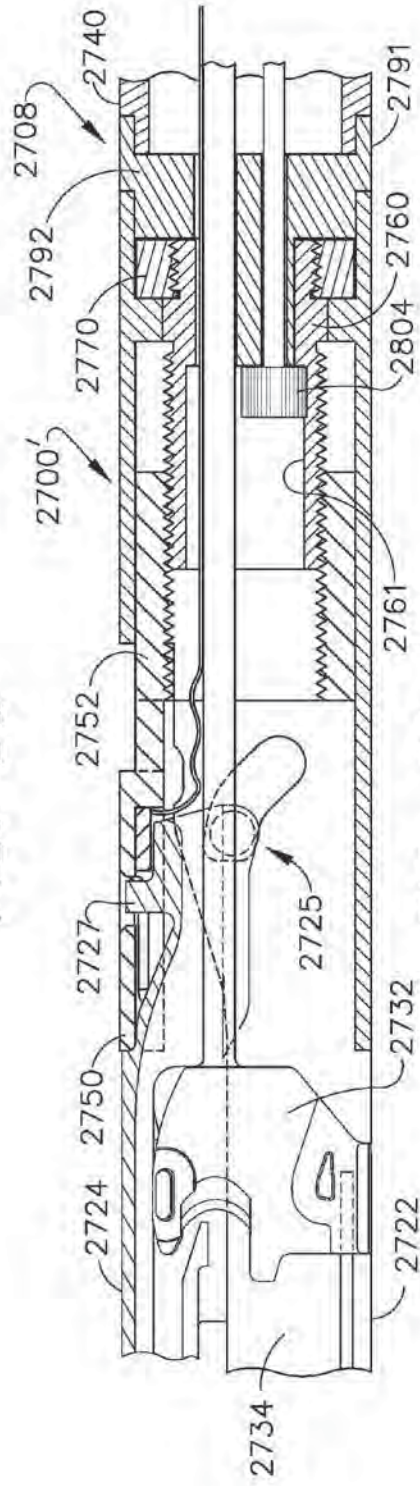

FIG. 51

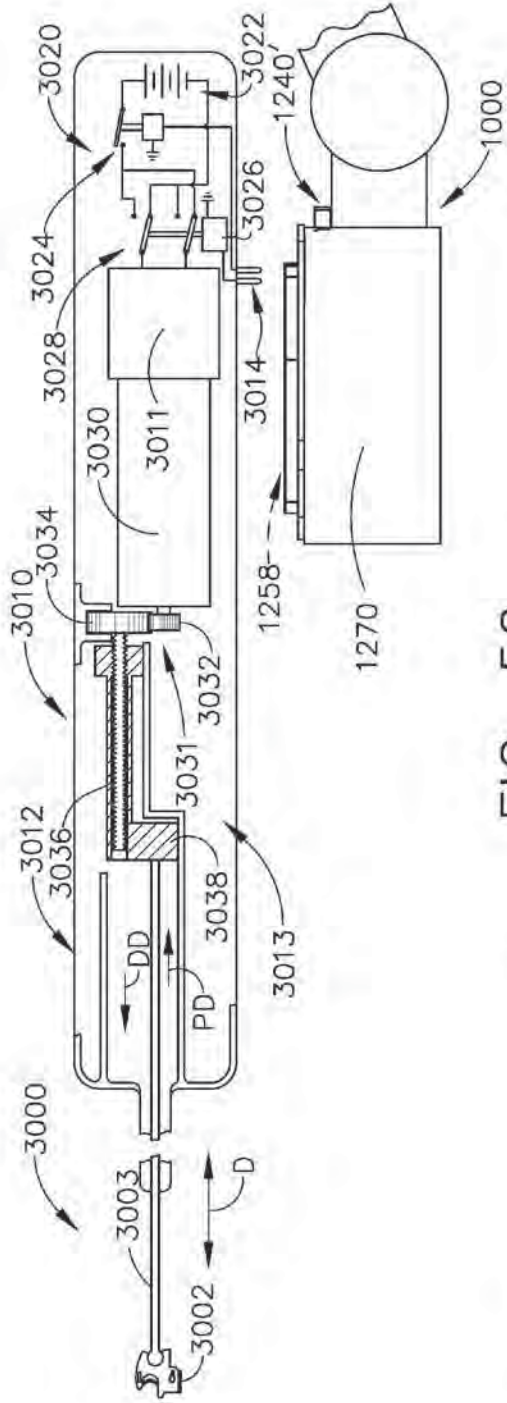

FIG. 52

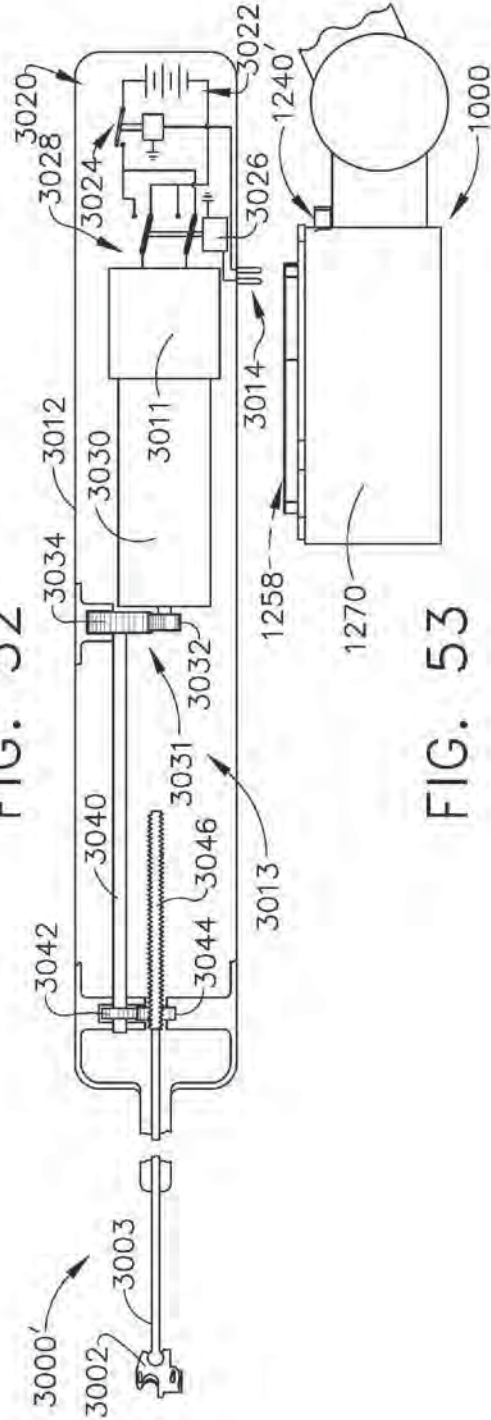

FIG. 53

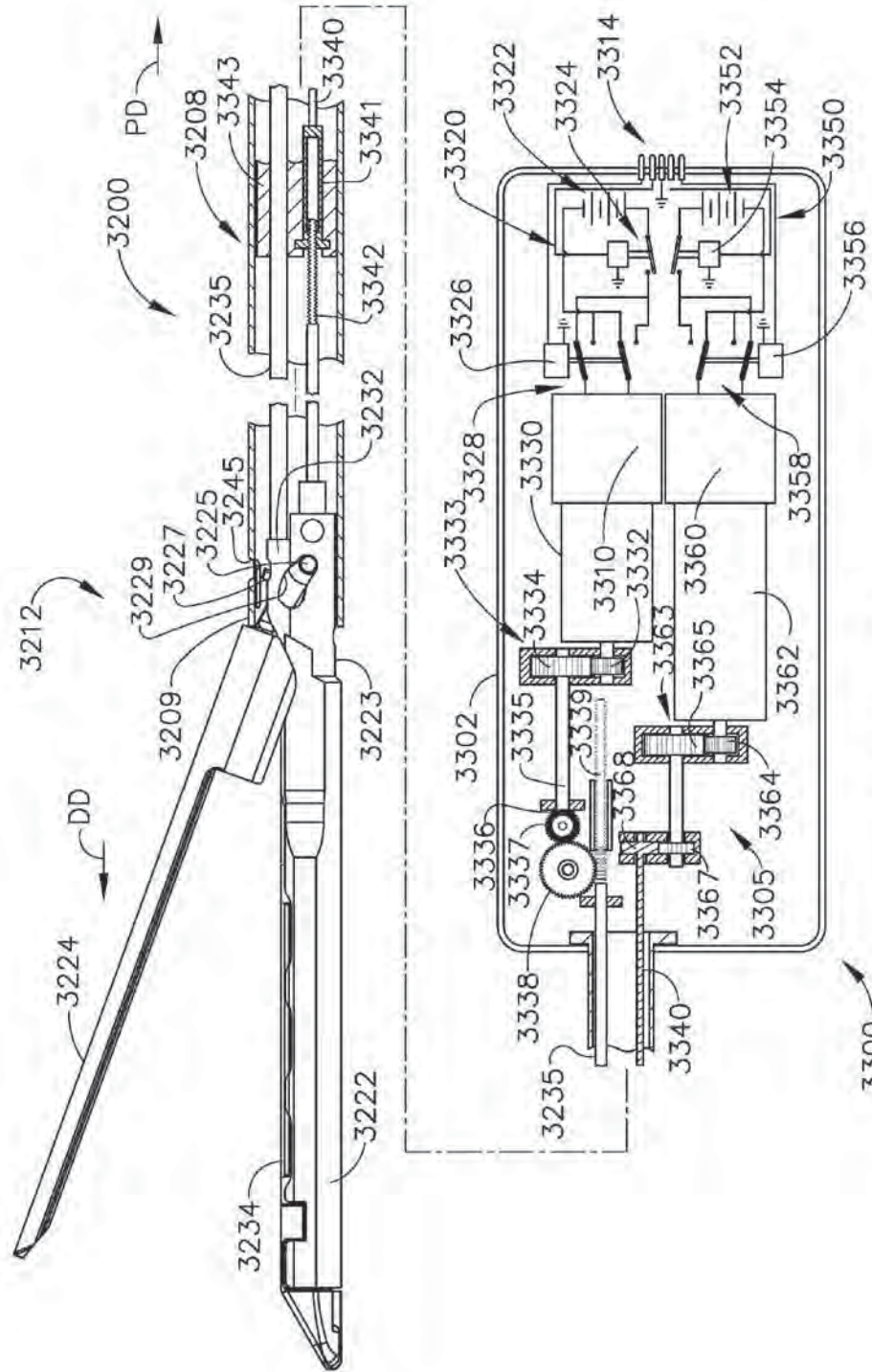

FIG. 54

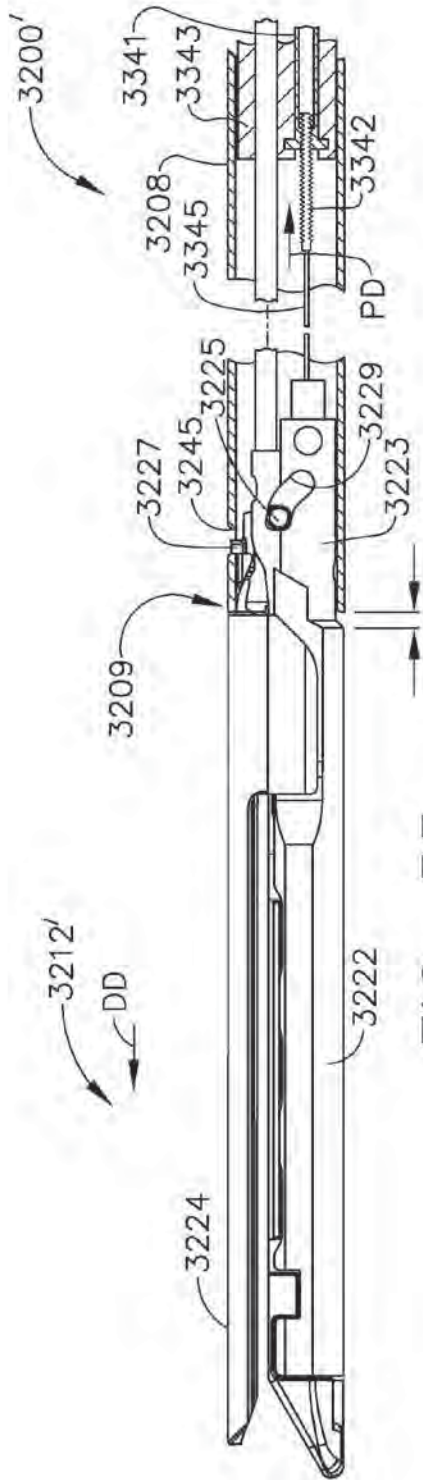

FIG. 55

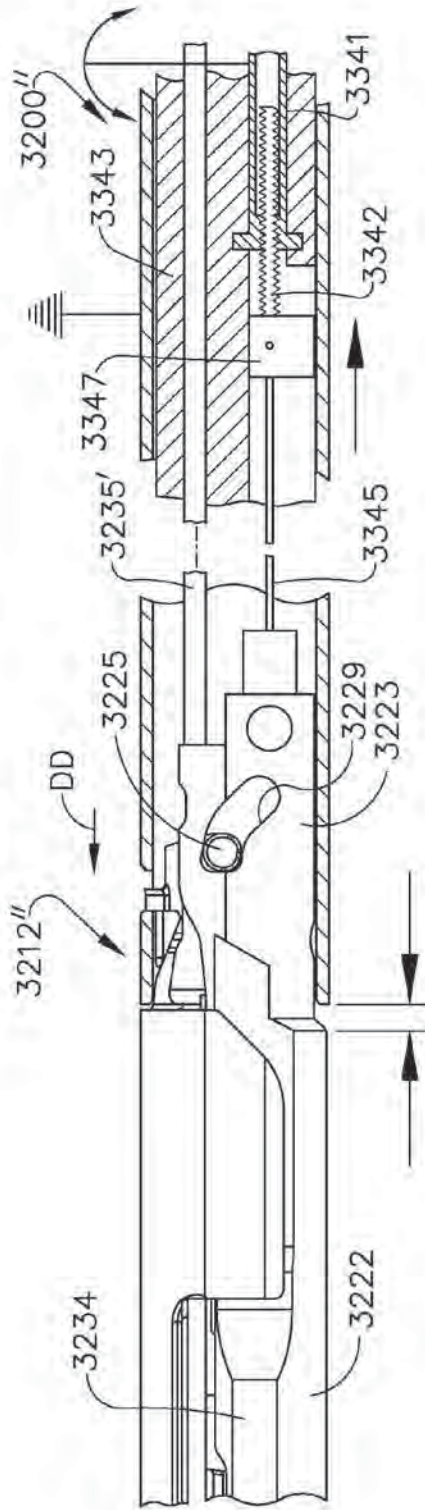

FIG. 56

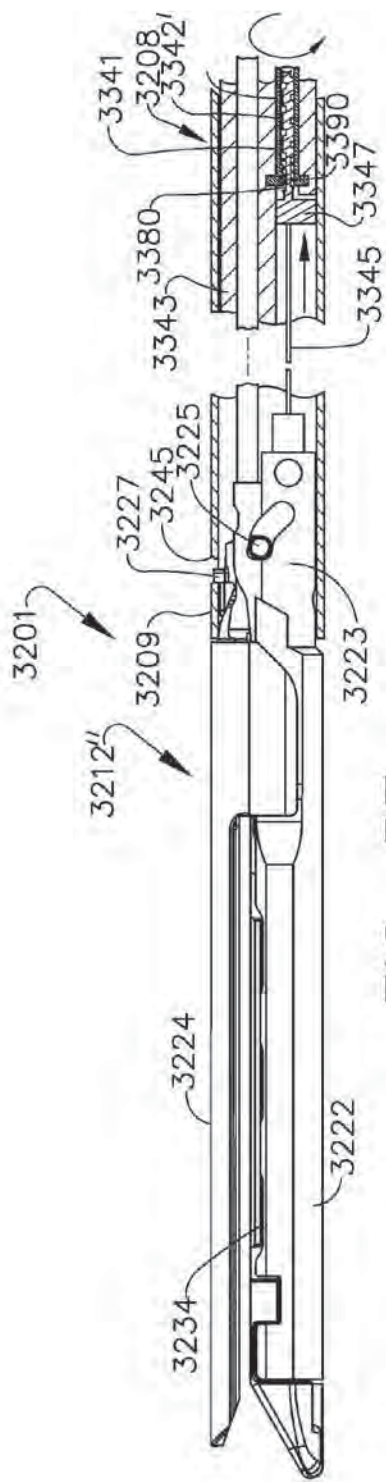

FIG. 57

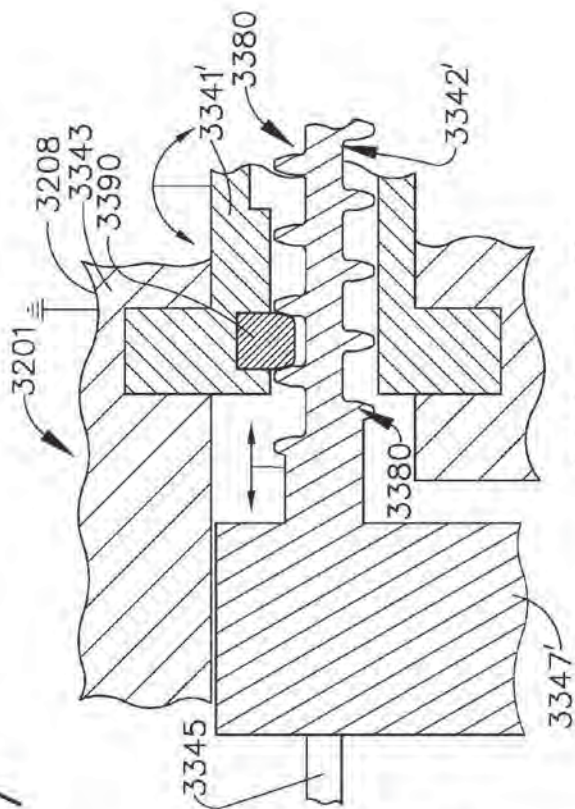

FIG. 59

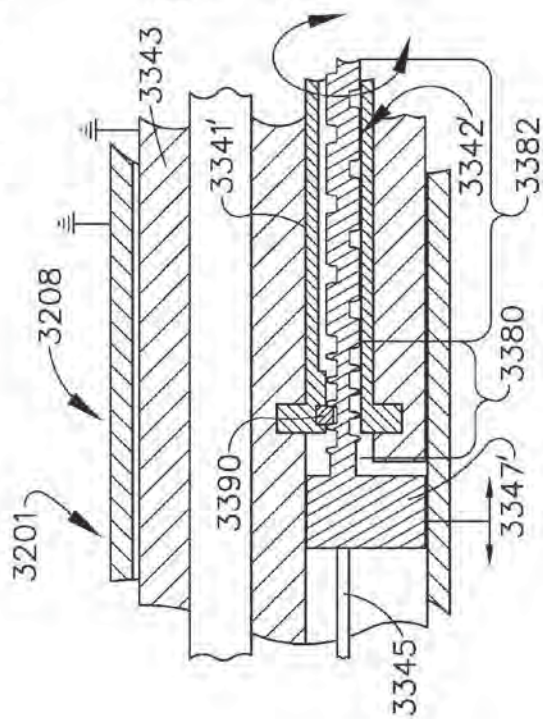

FIG. 58

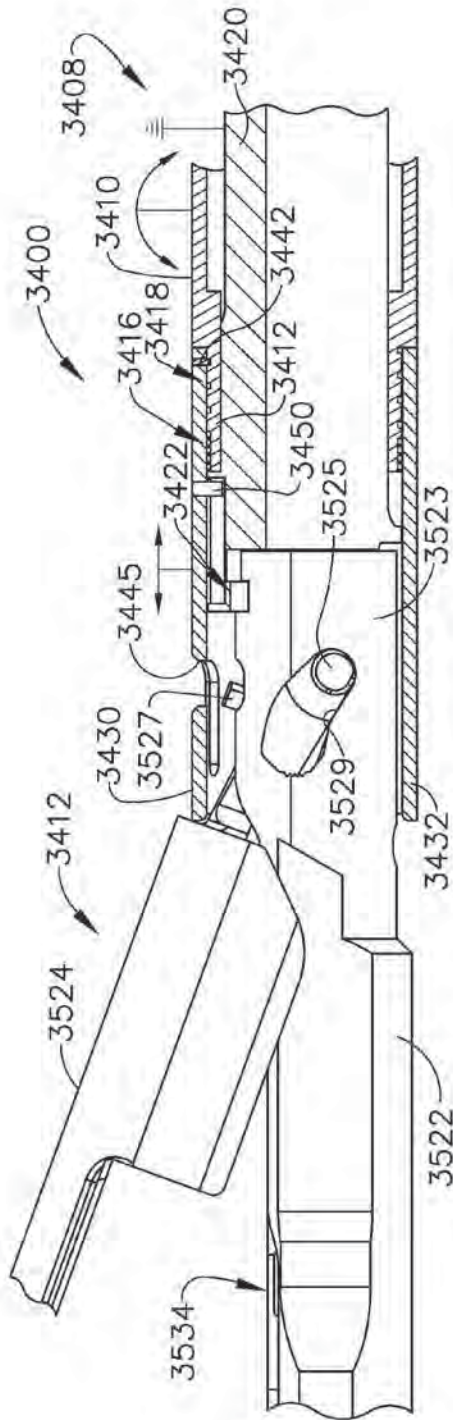

FIG. 60

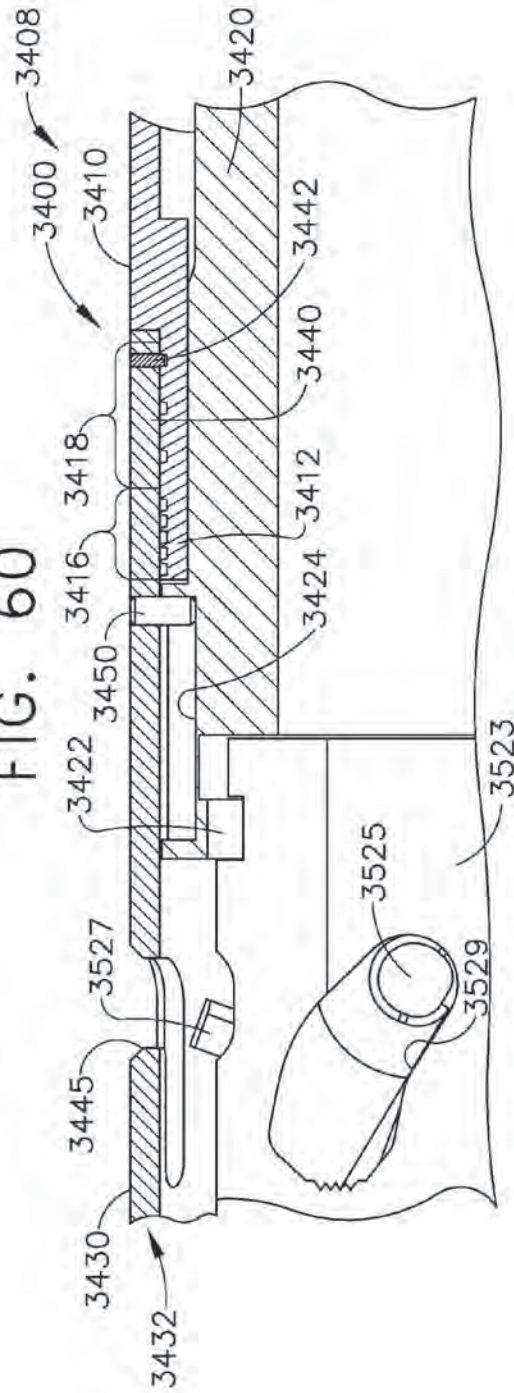

FIG. 61

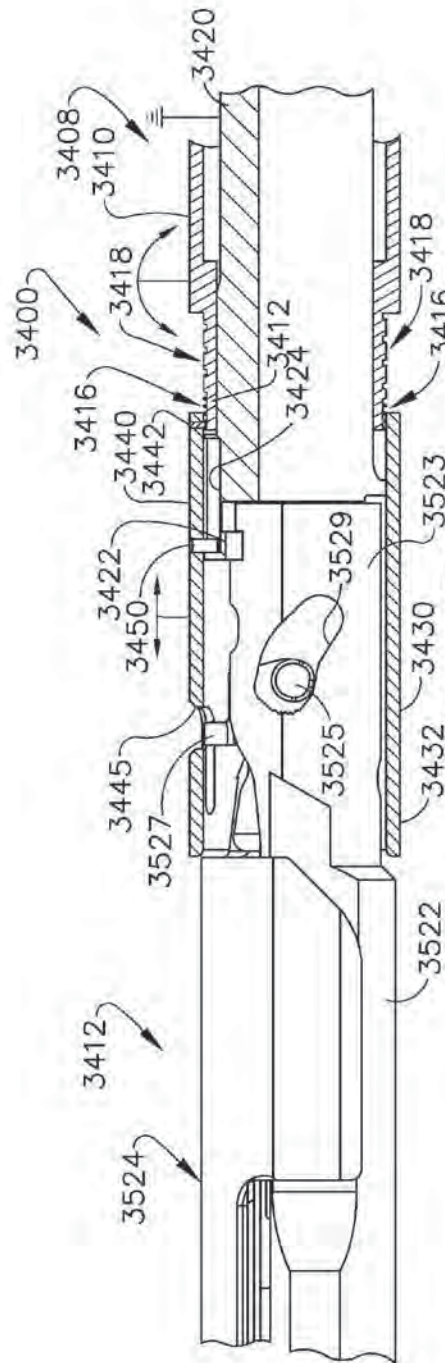

FIG. 62

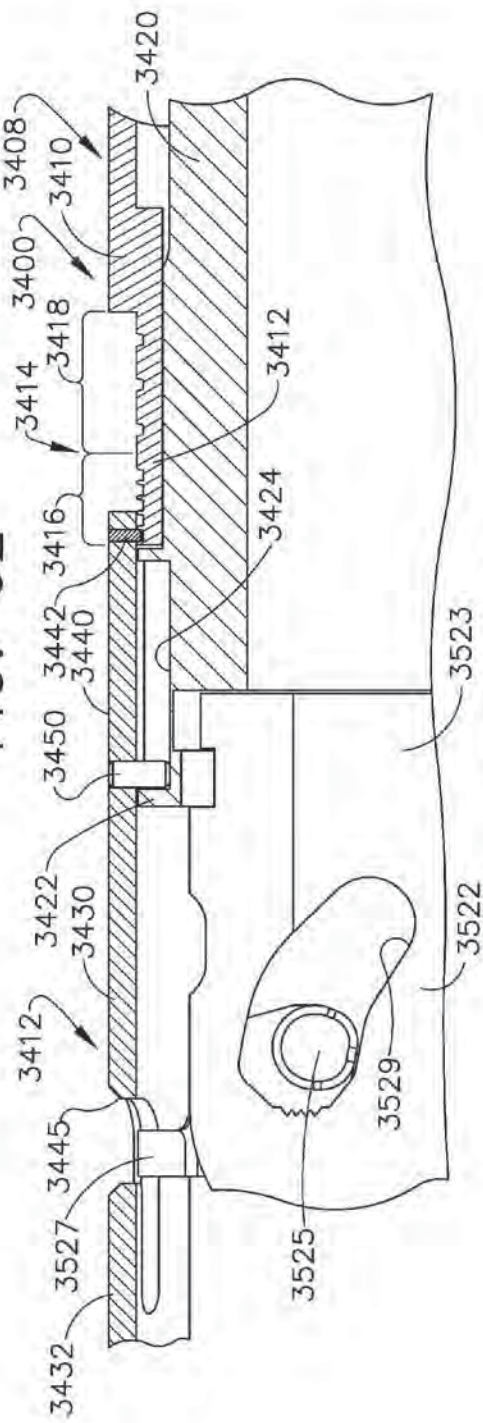

FIG. 63

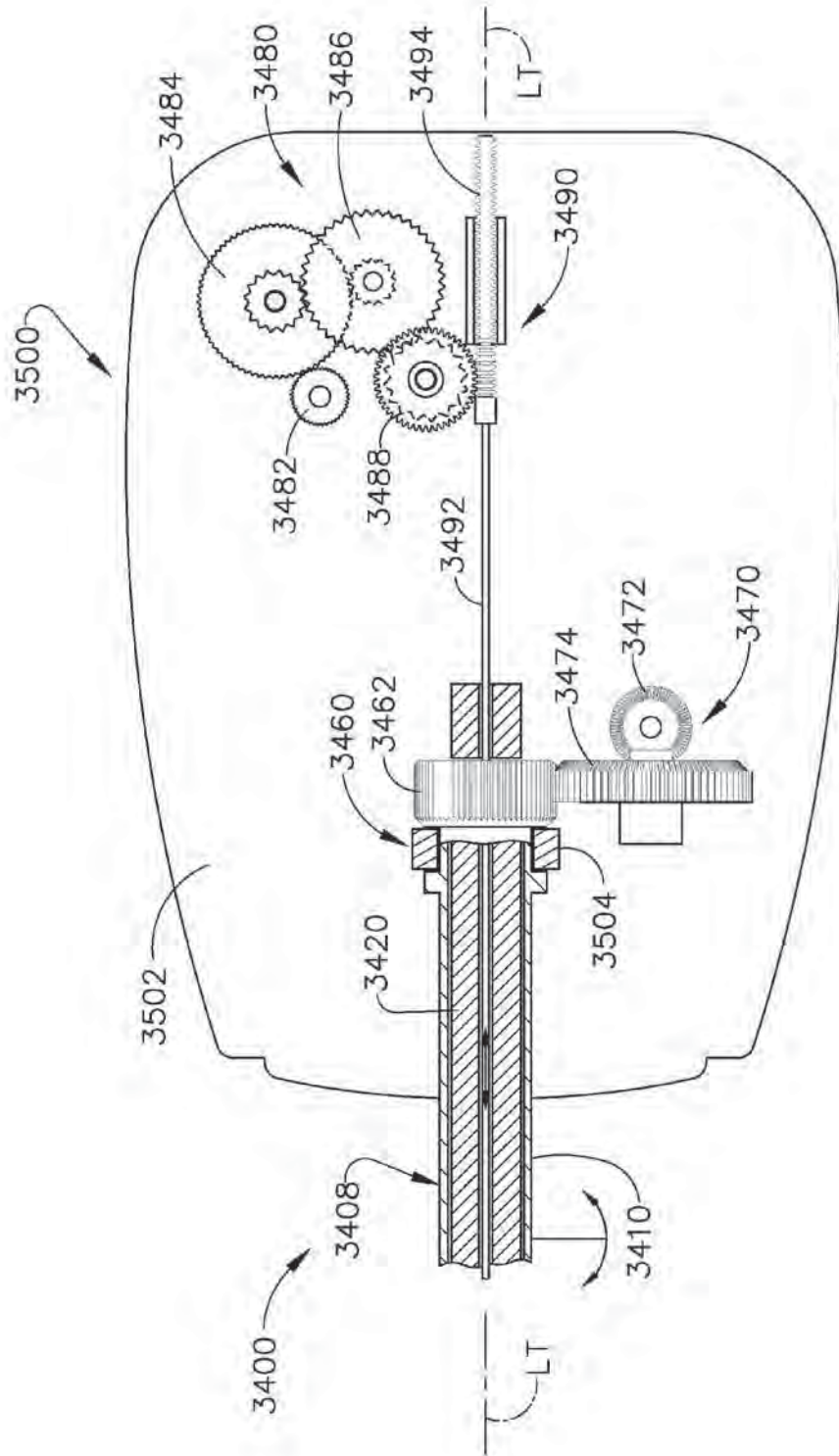

FIG. 64

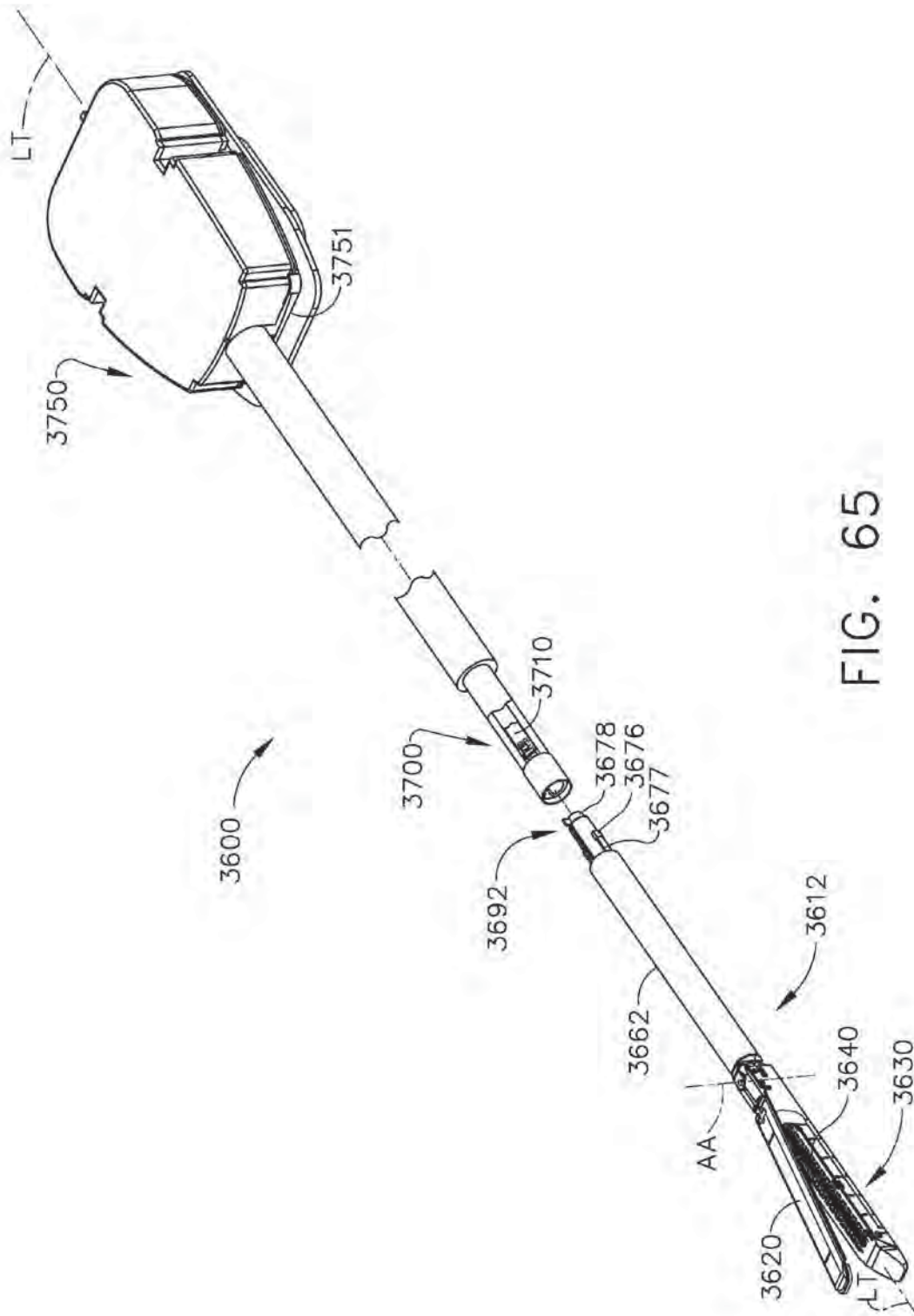

FIG. 65

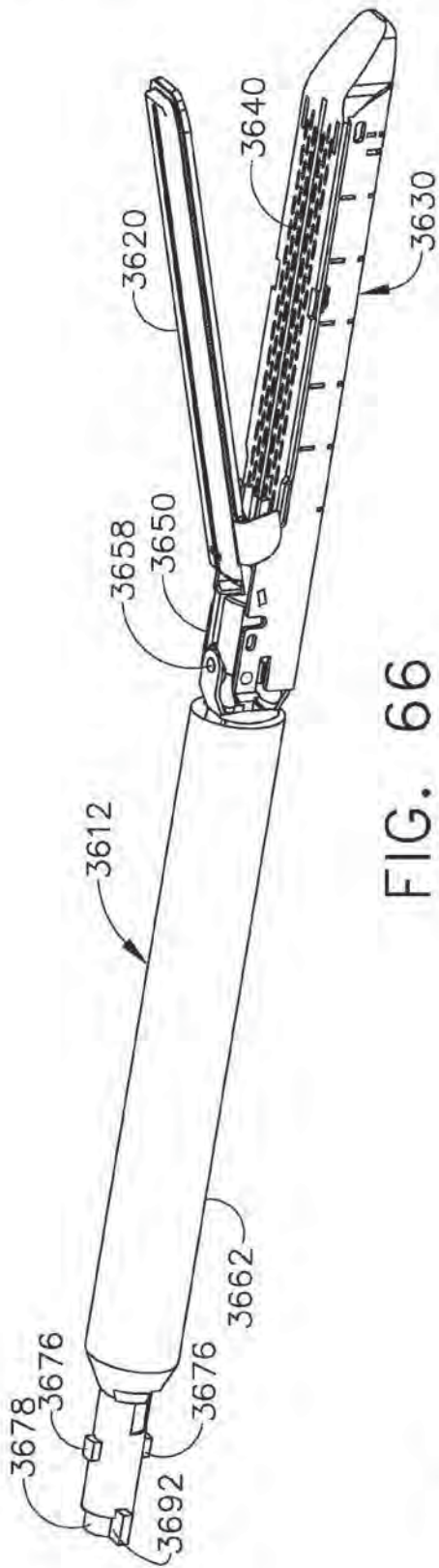

FIG. 66

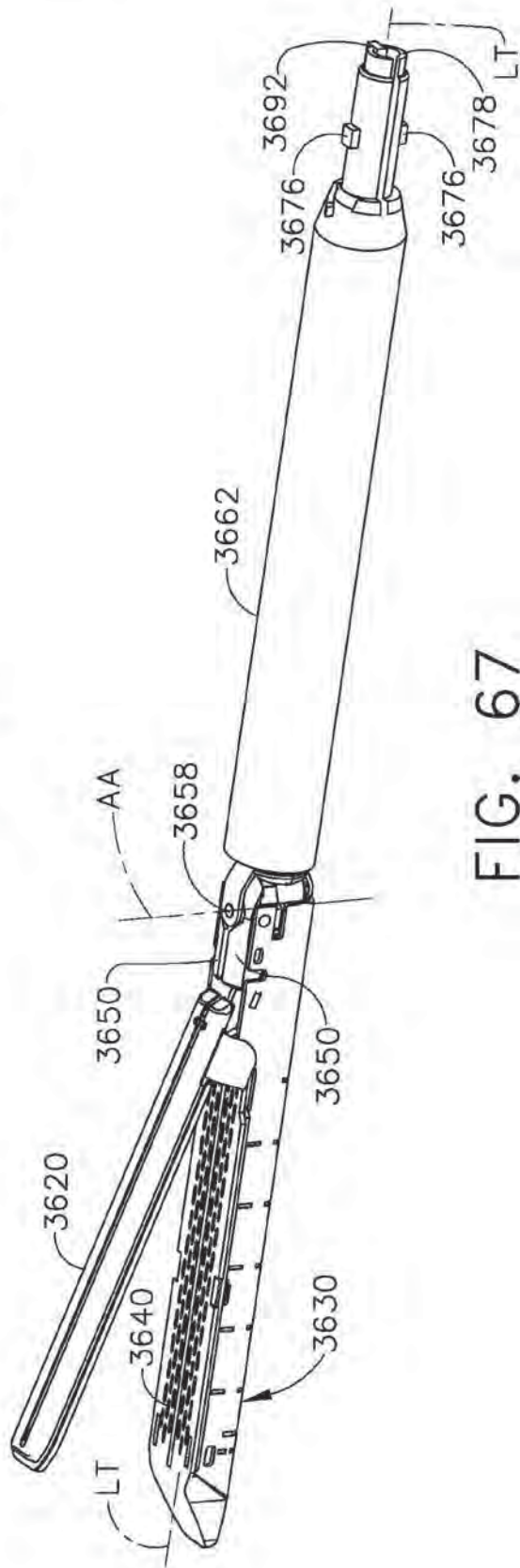

FIG. 67

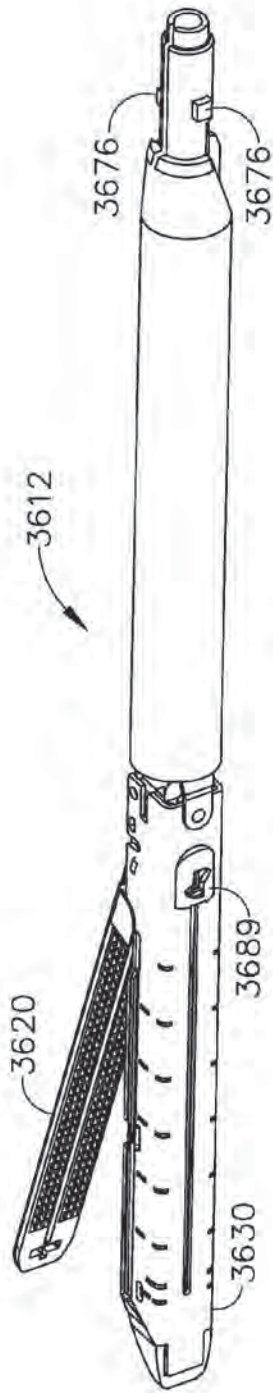

FIG. 68

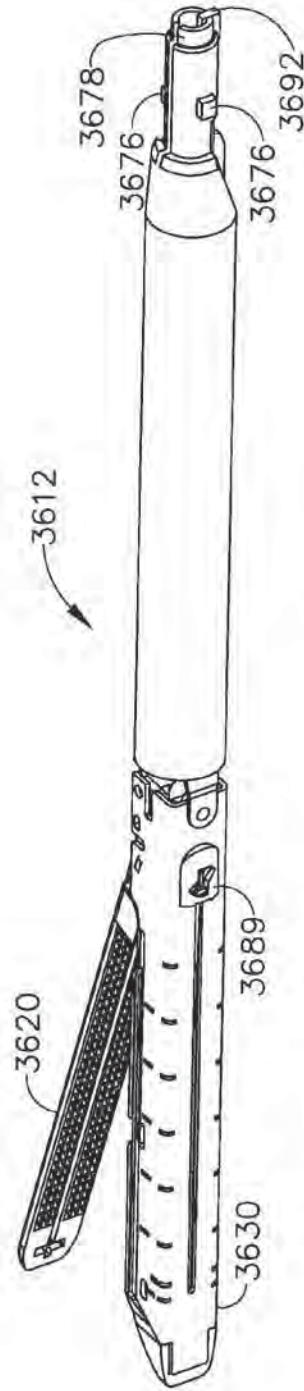

FIG. 69

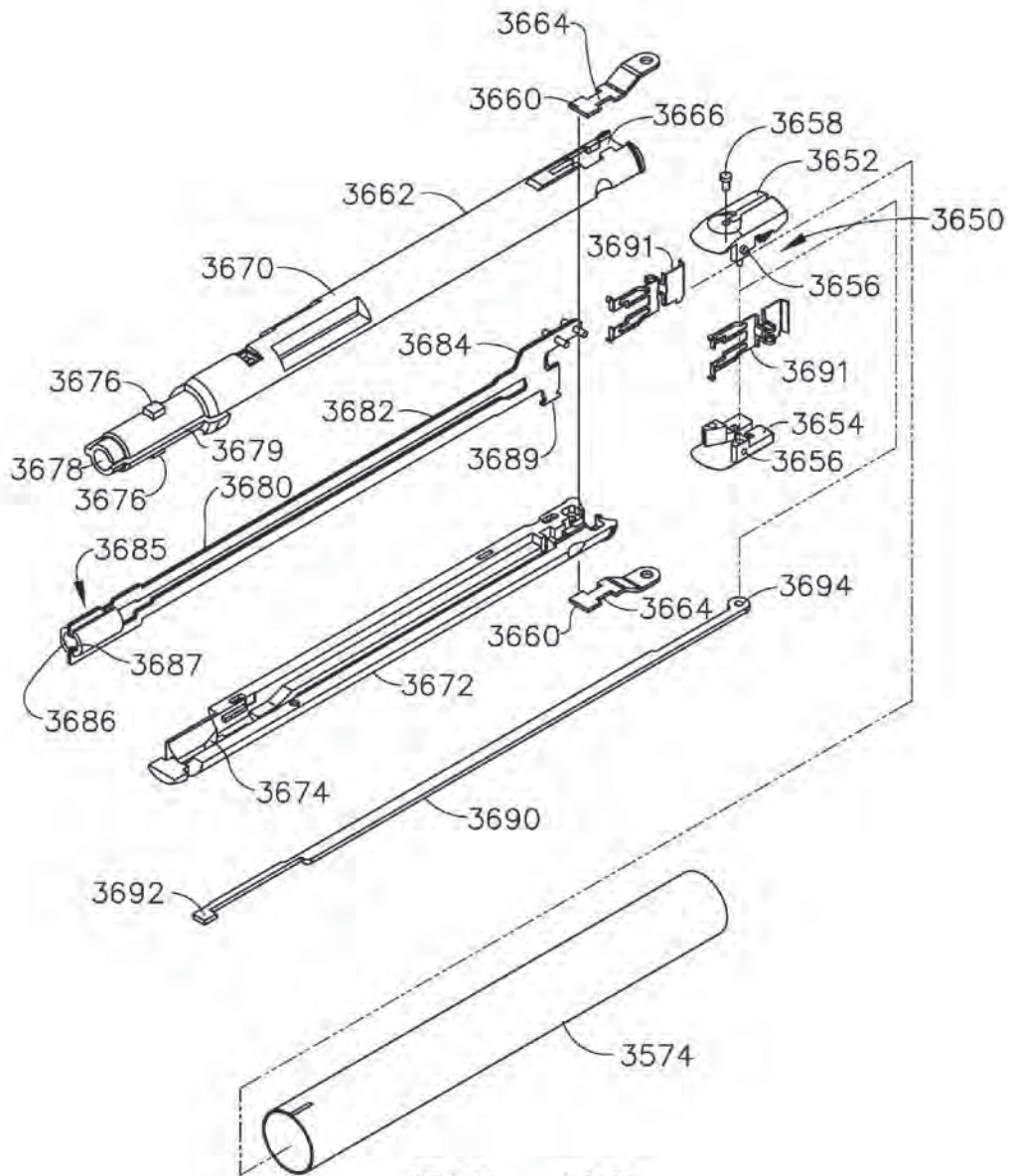
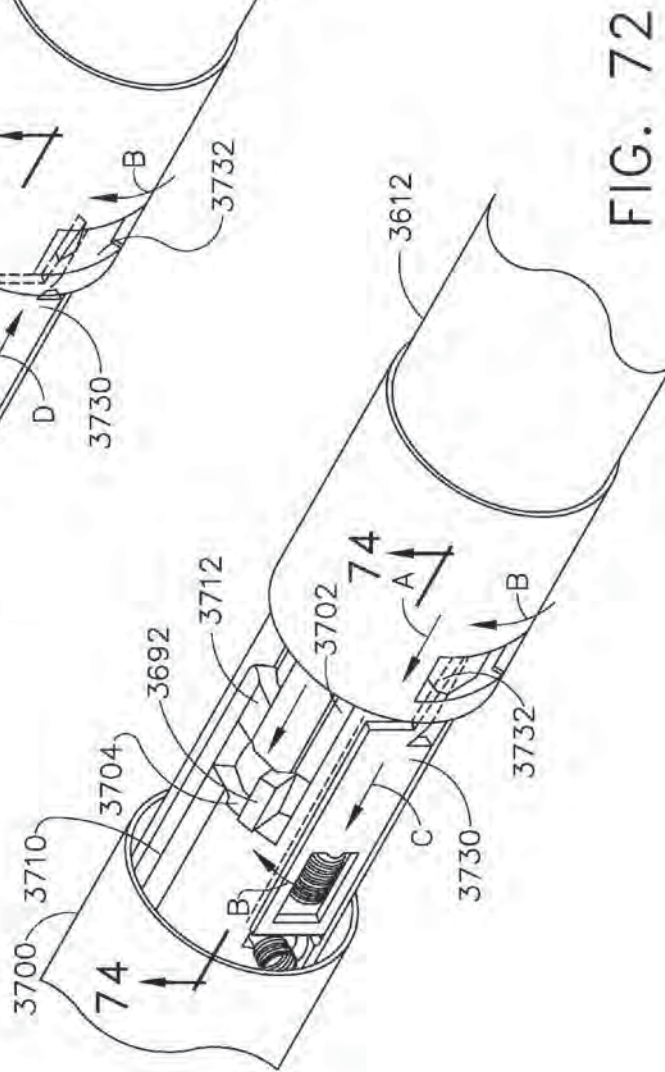
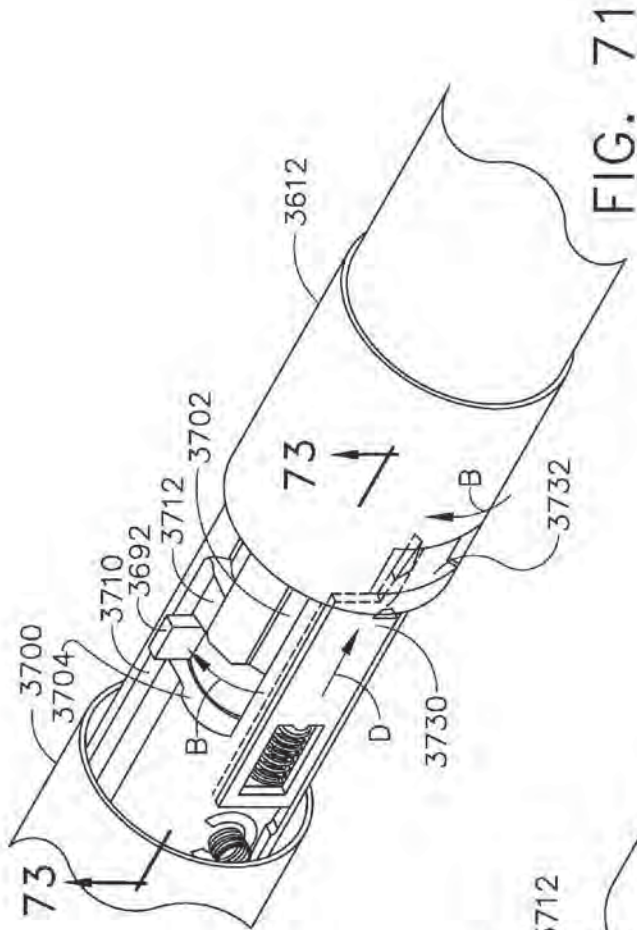

FIG. 70



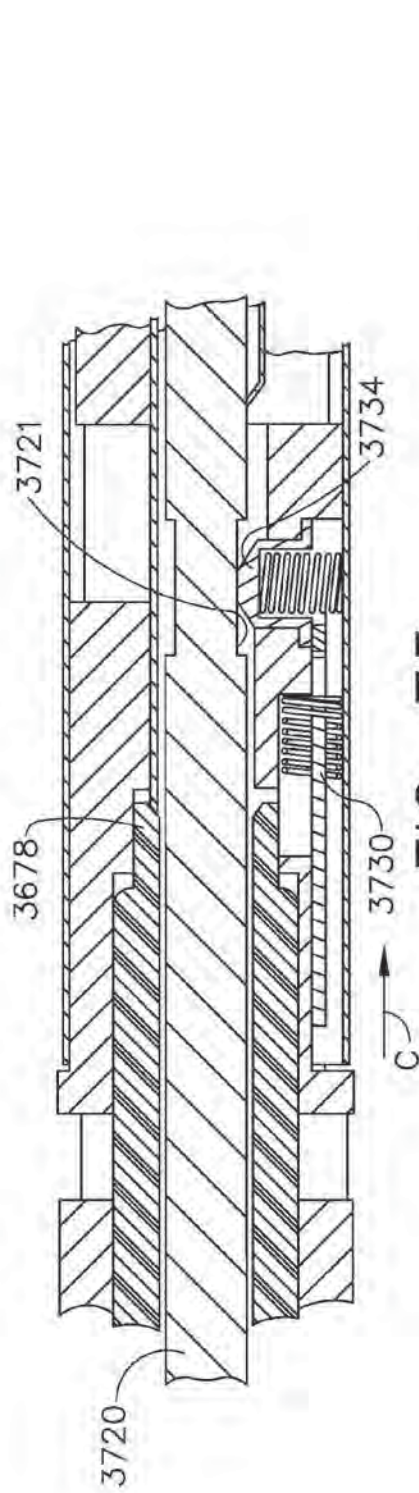

FIG. 73

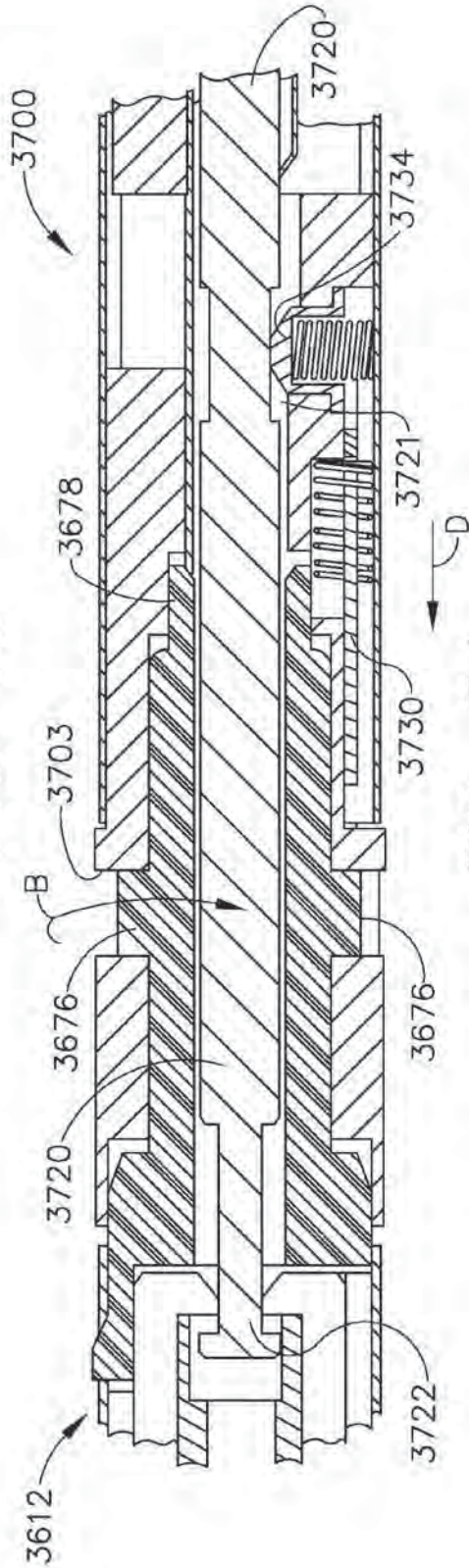

FIG. 74

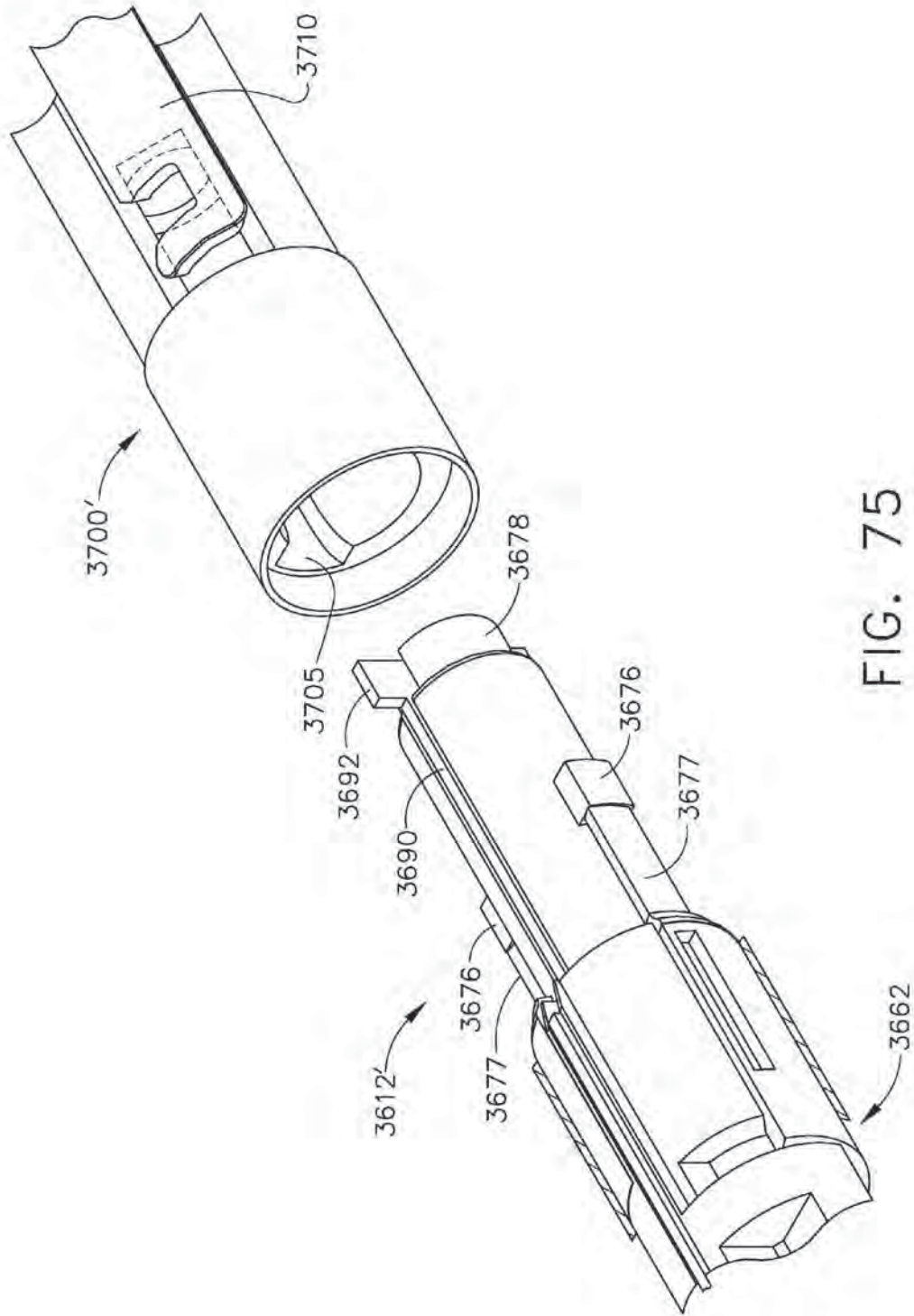

FIG. 75

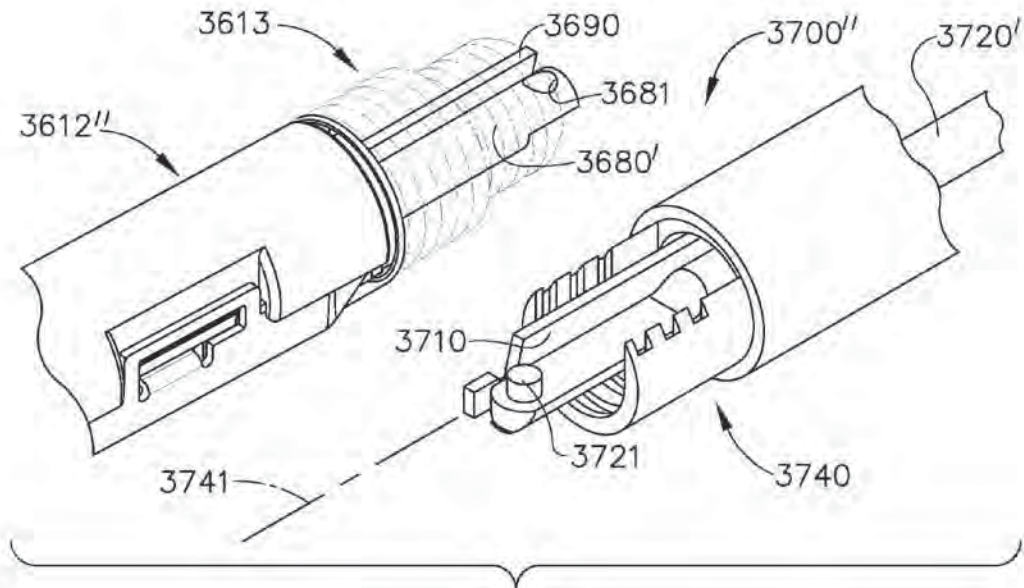

FIG. 76

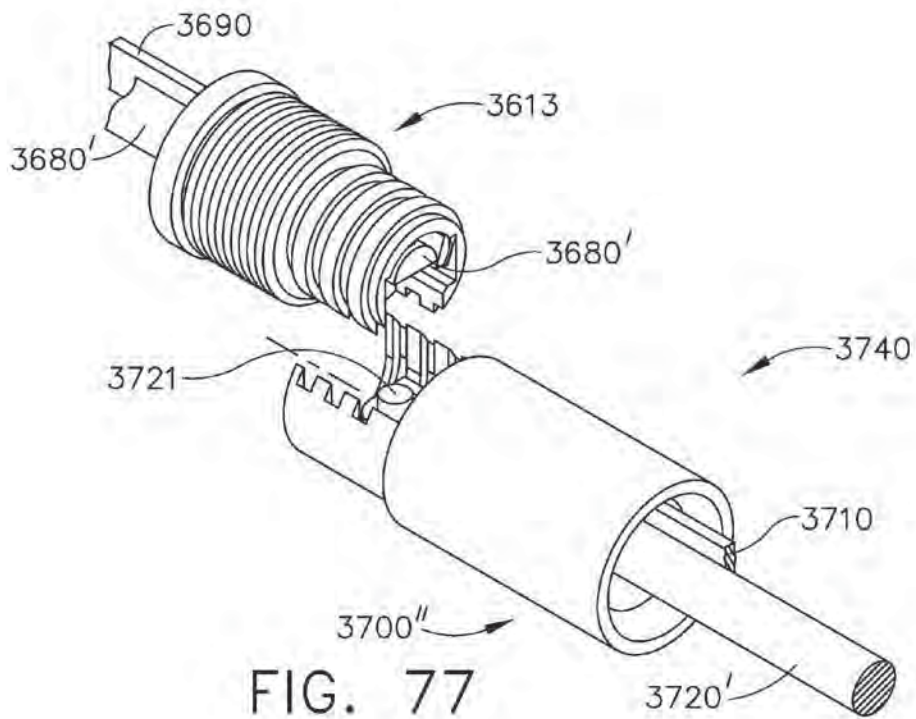

FIG. 77

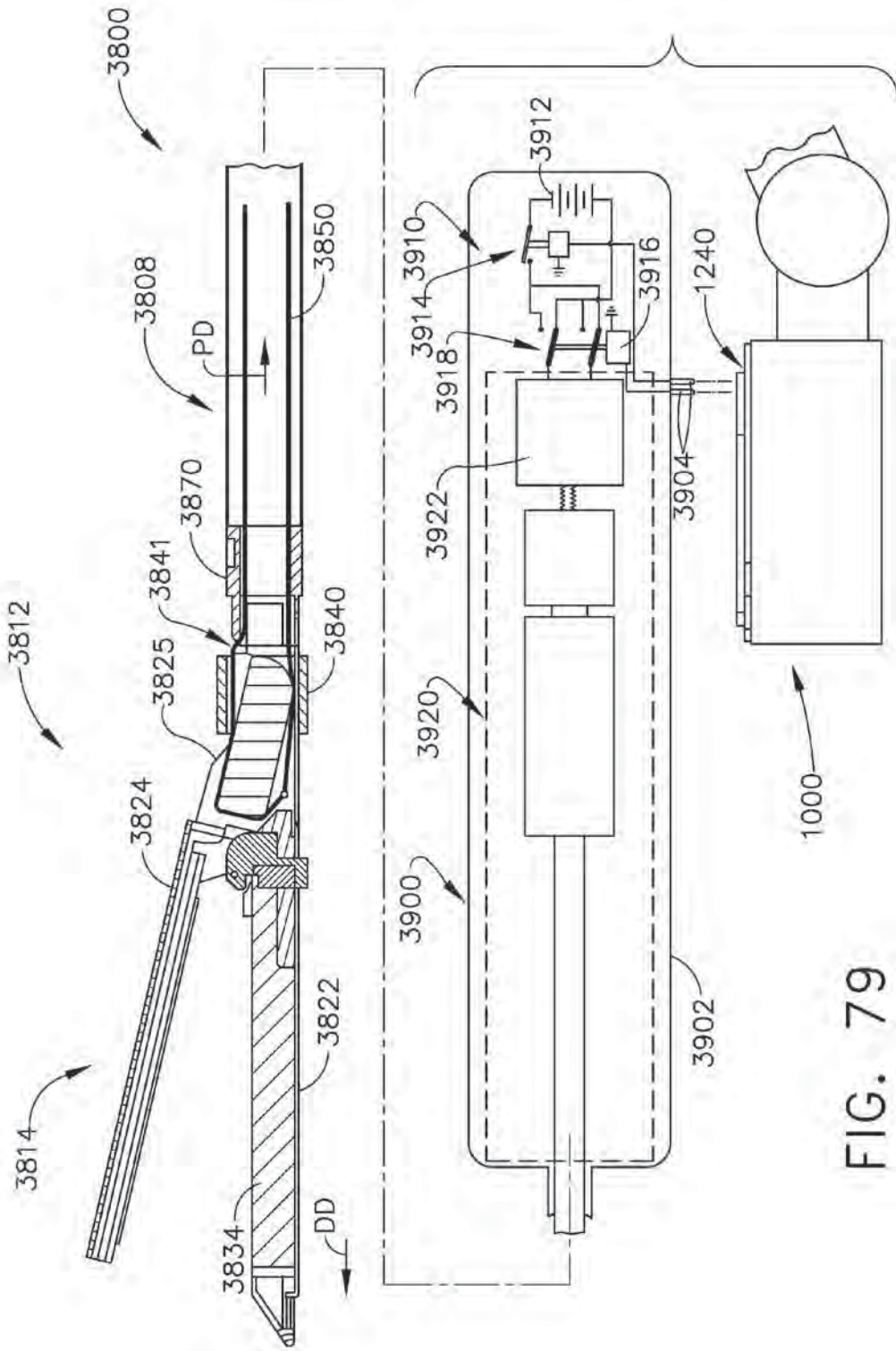

FIG. 79

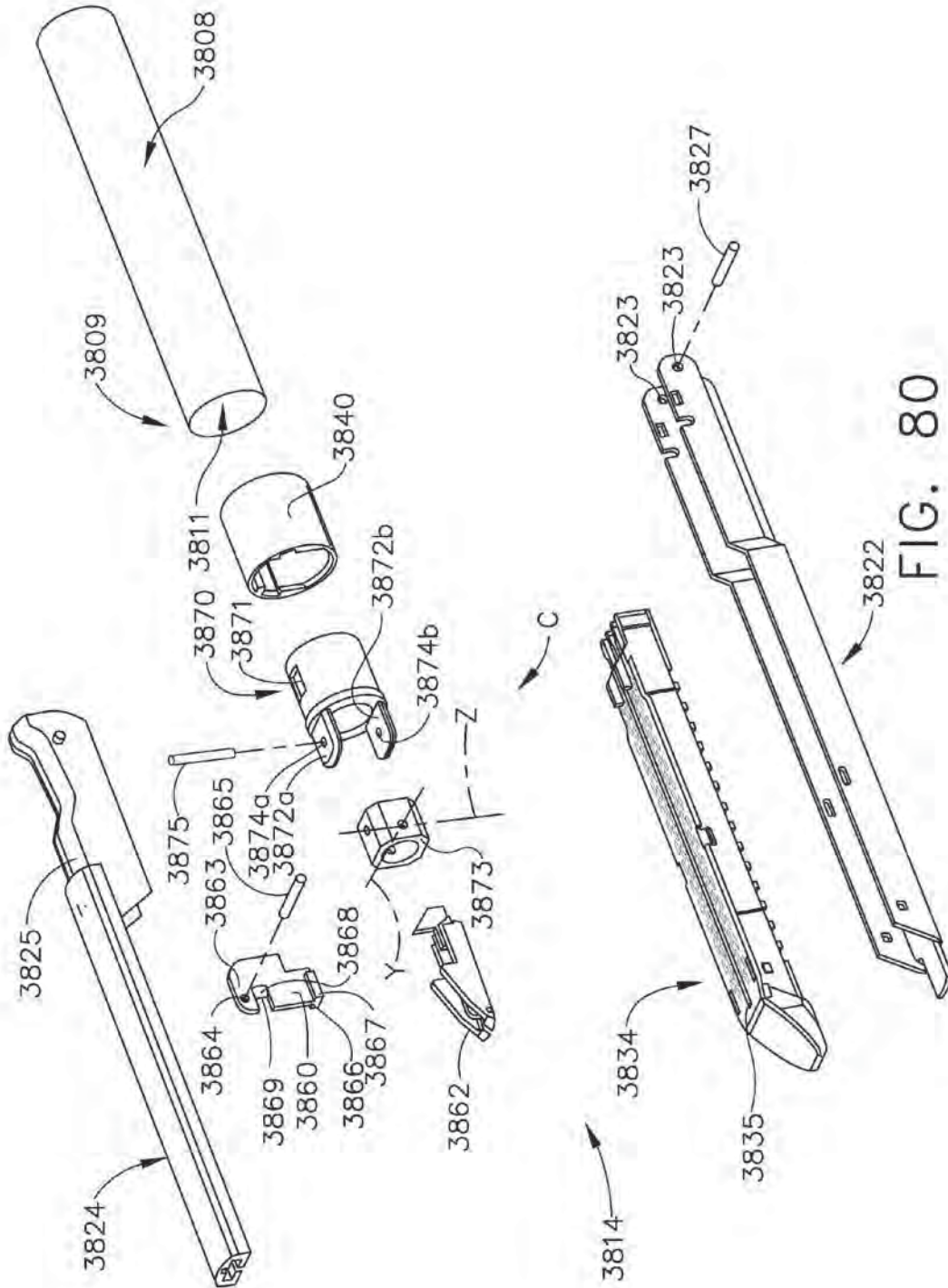
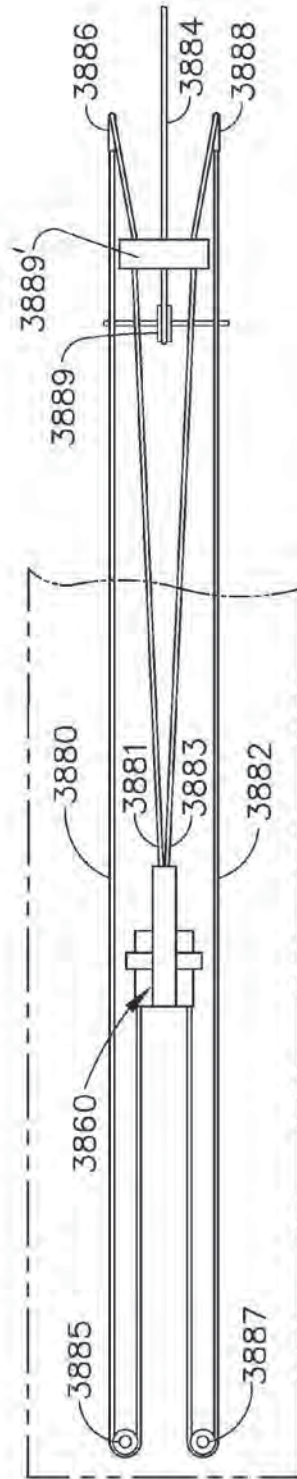
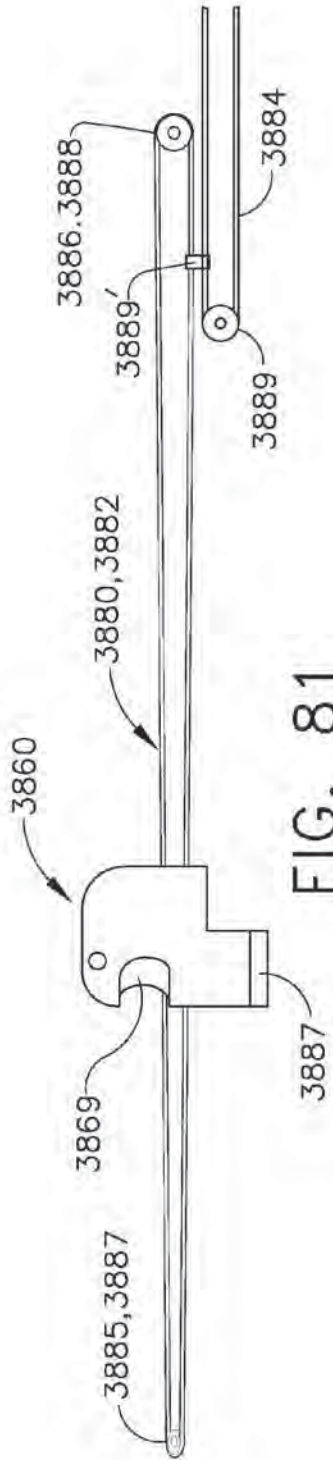

FIG. 80



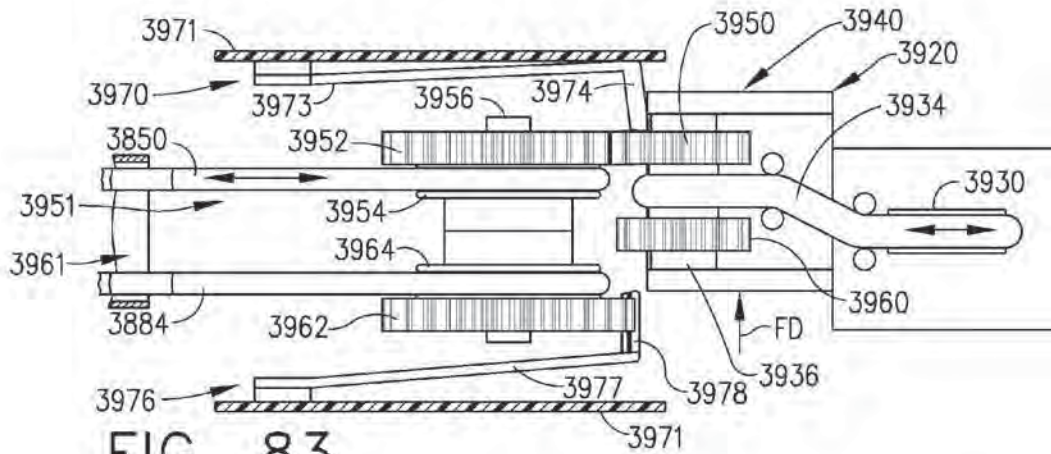

FIG. 83

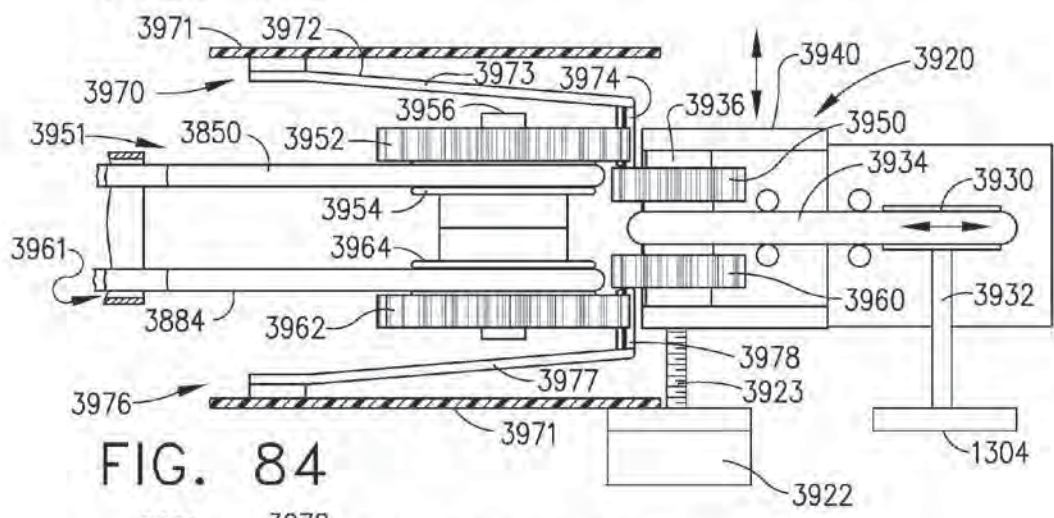

FIG. 84

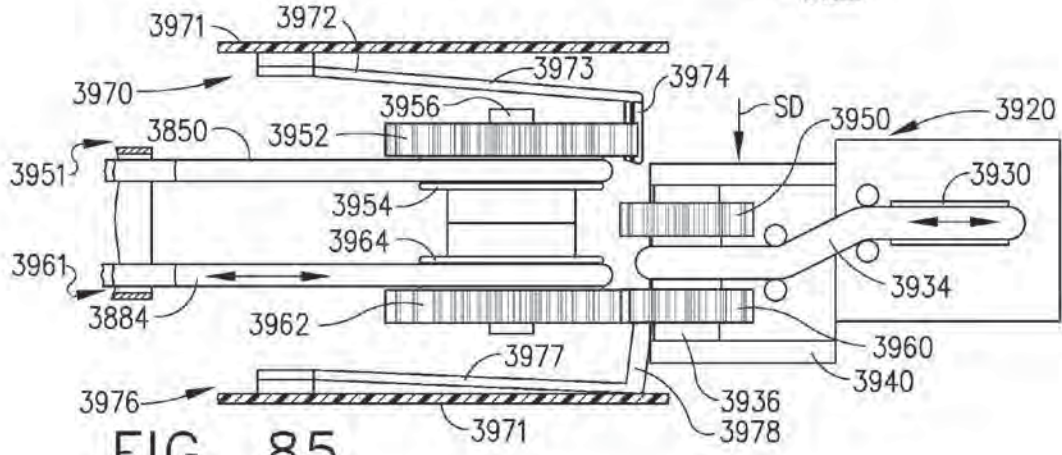

FIG. 85

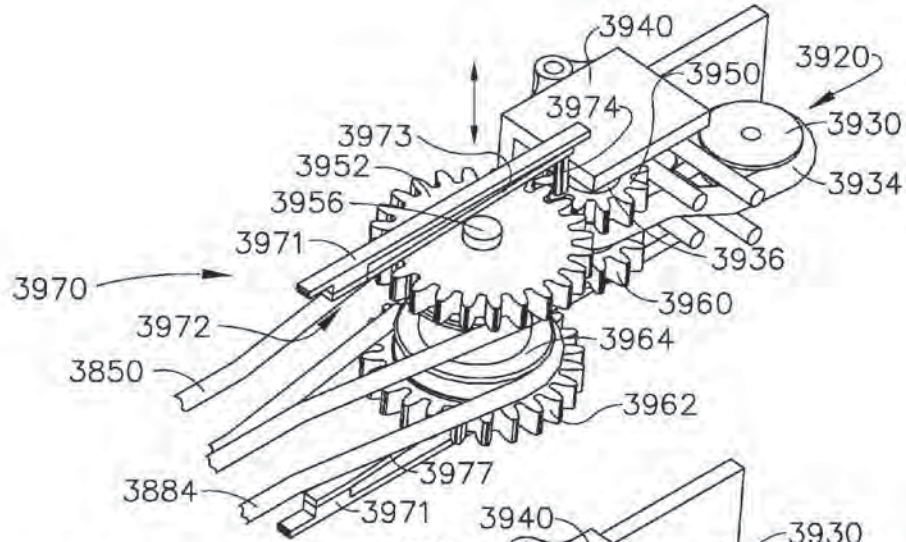

FIG. 86

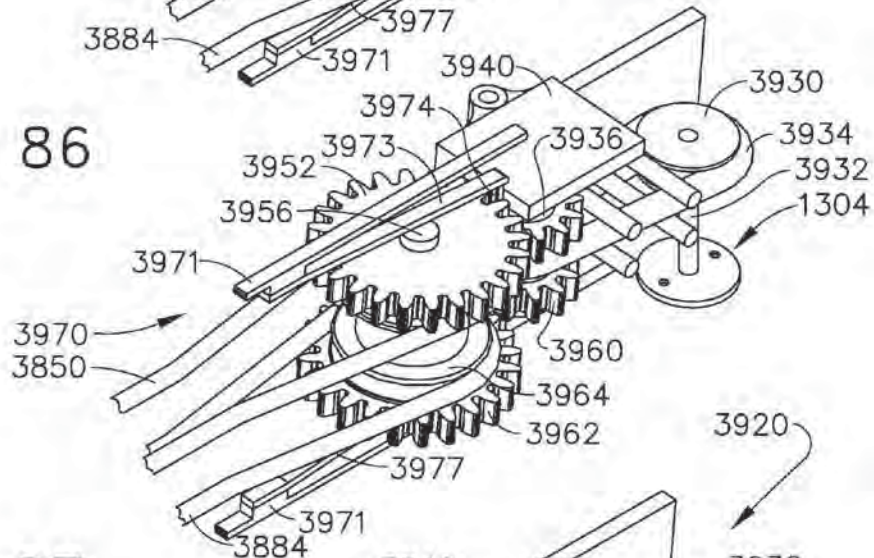

FIG. 87

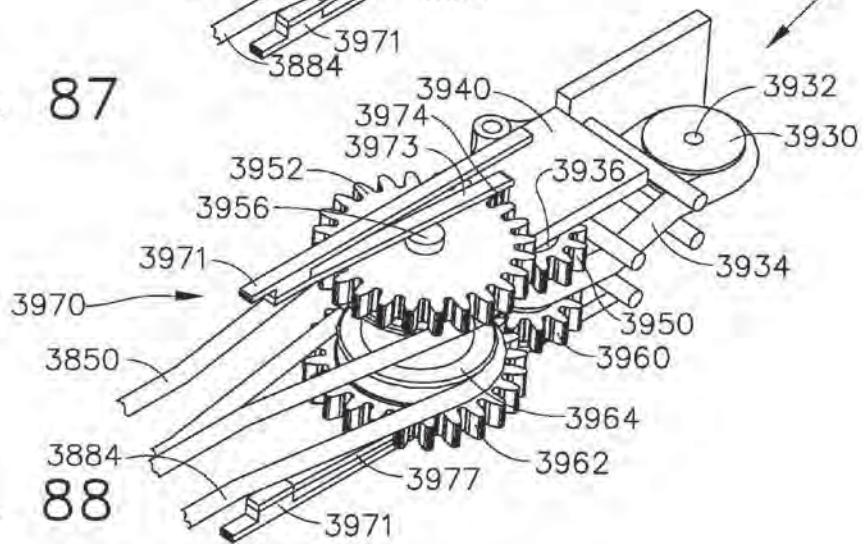

FIG. 88

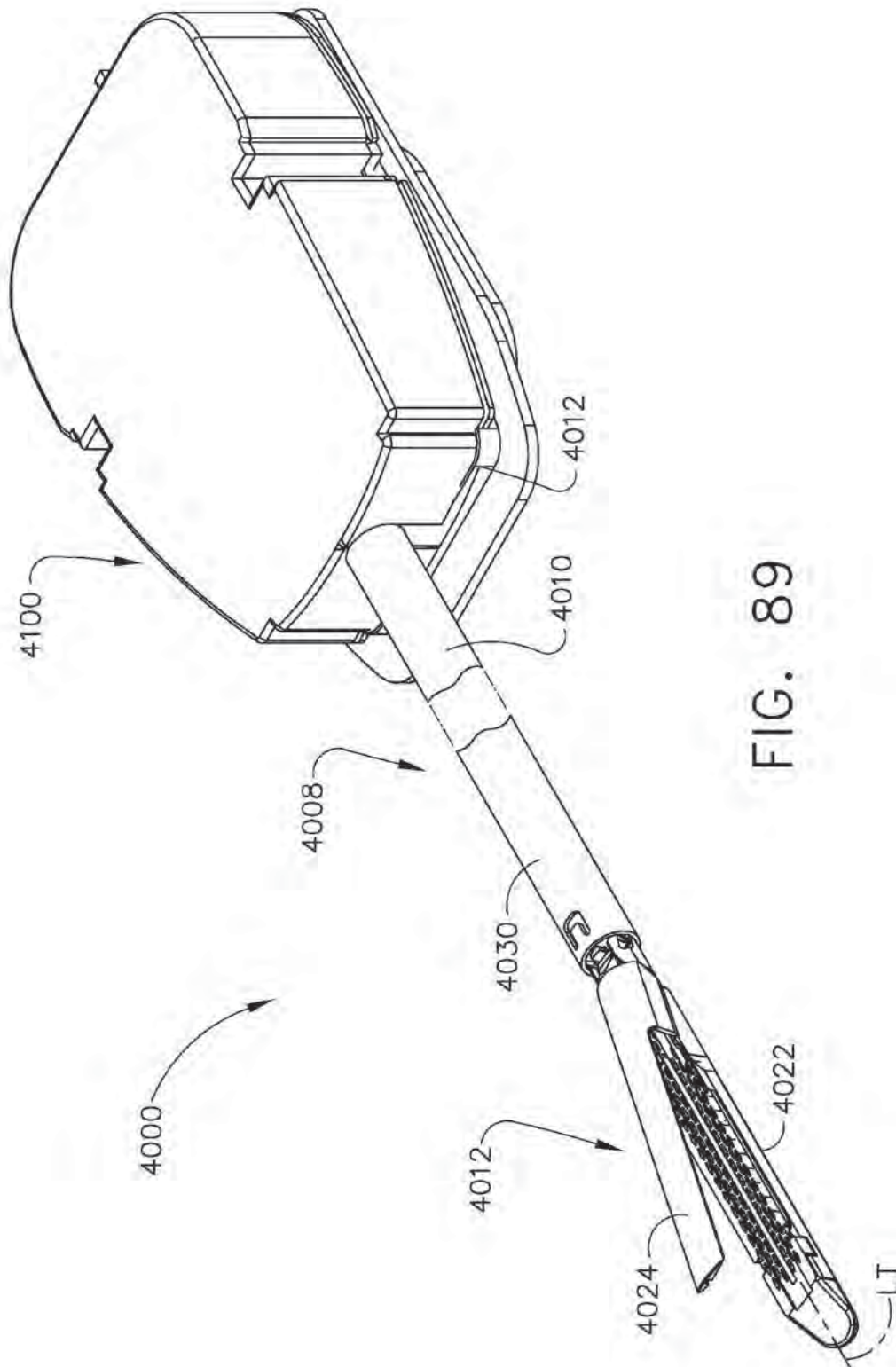

FIG. 89

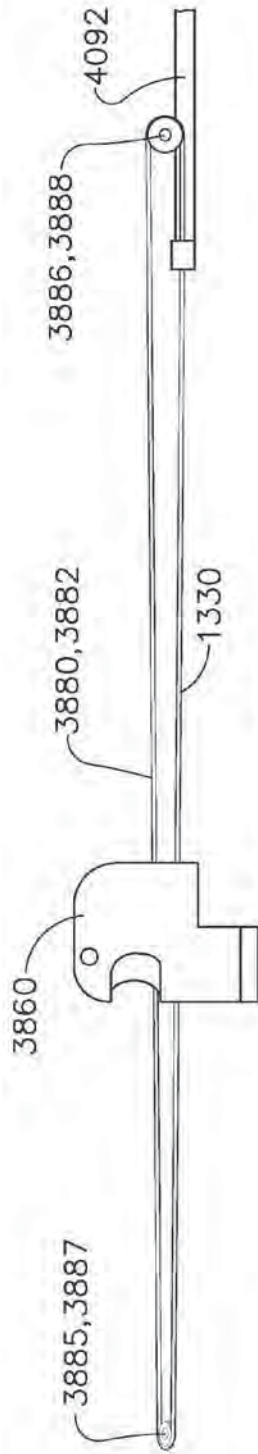

FIG. 90

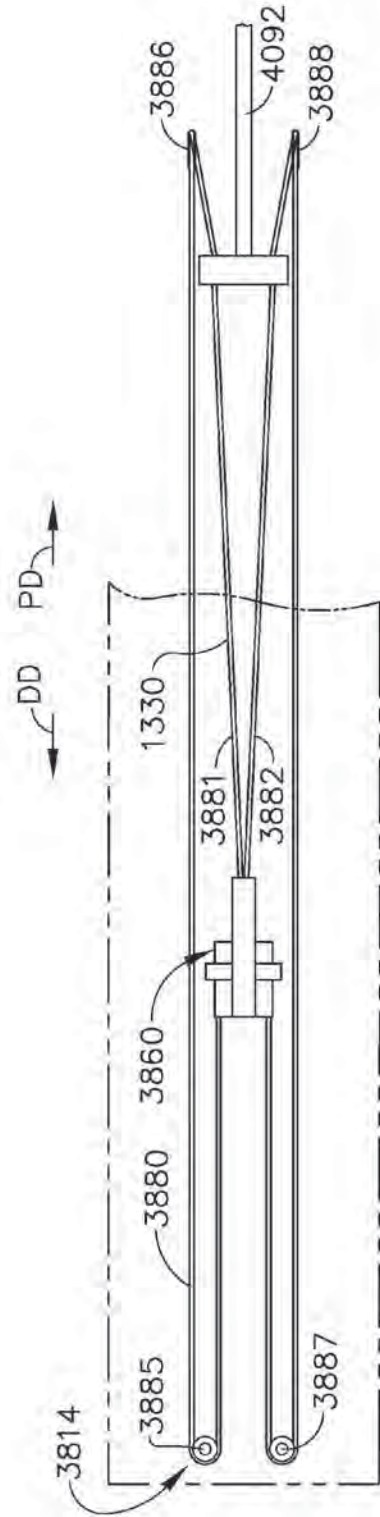

FIG. 91

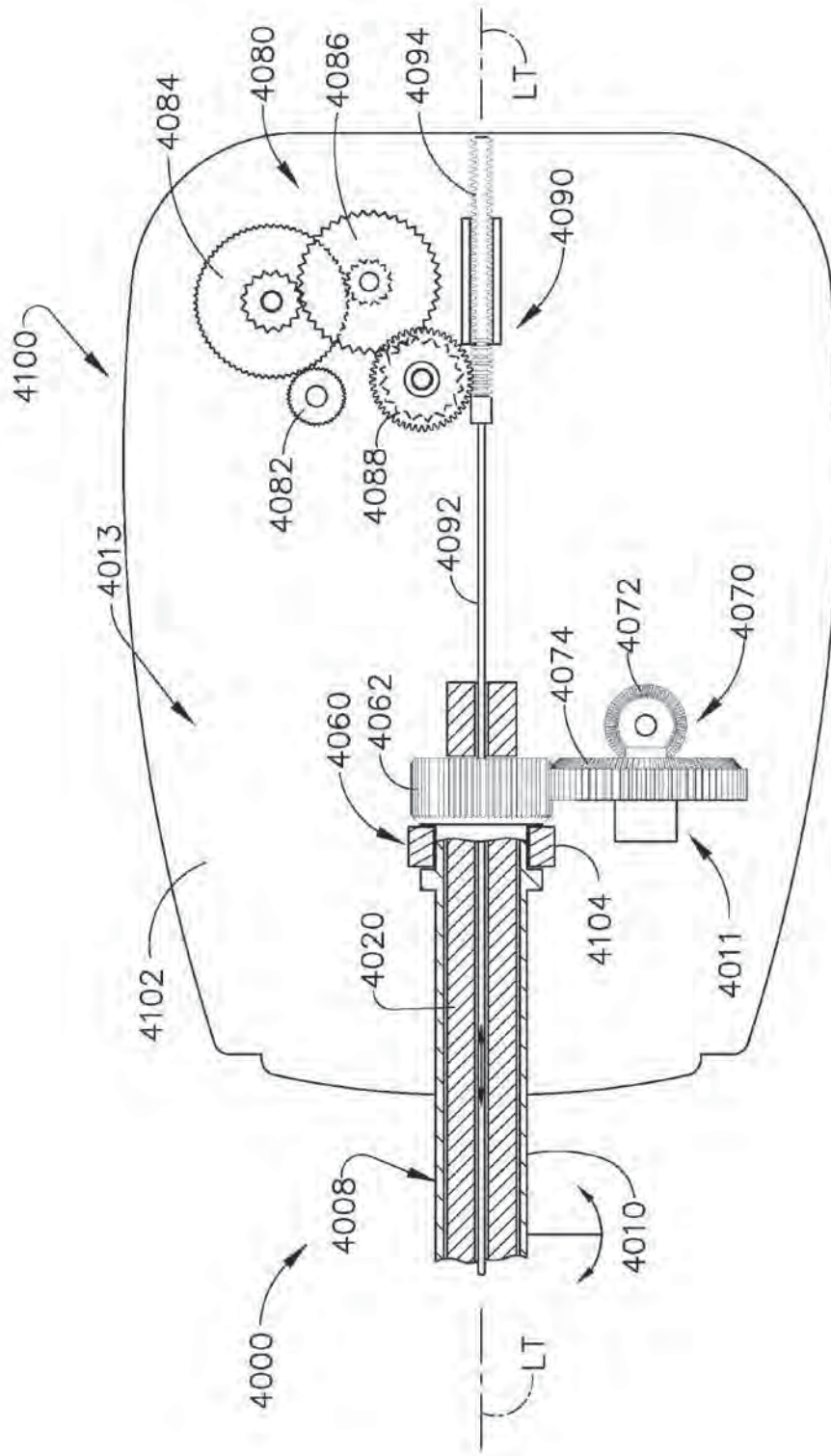

FIG. 92

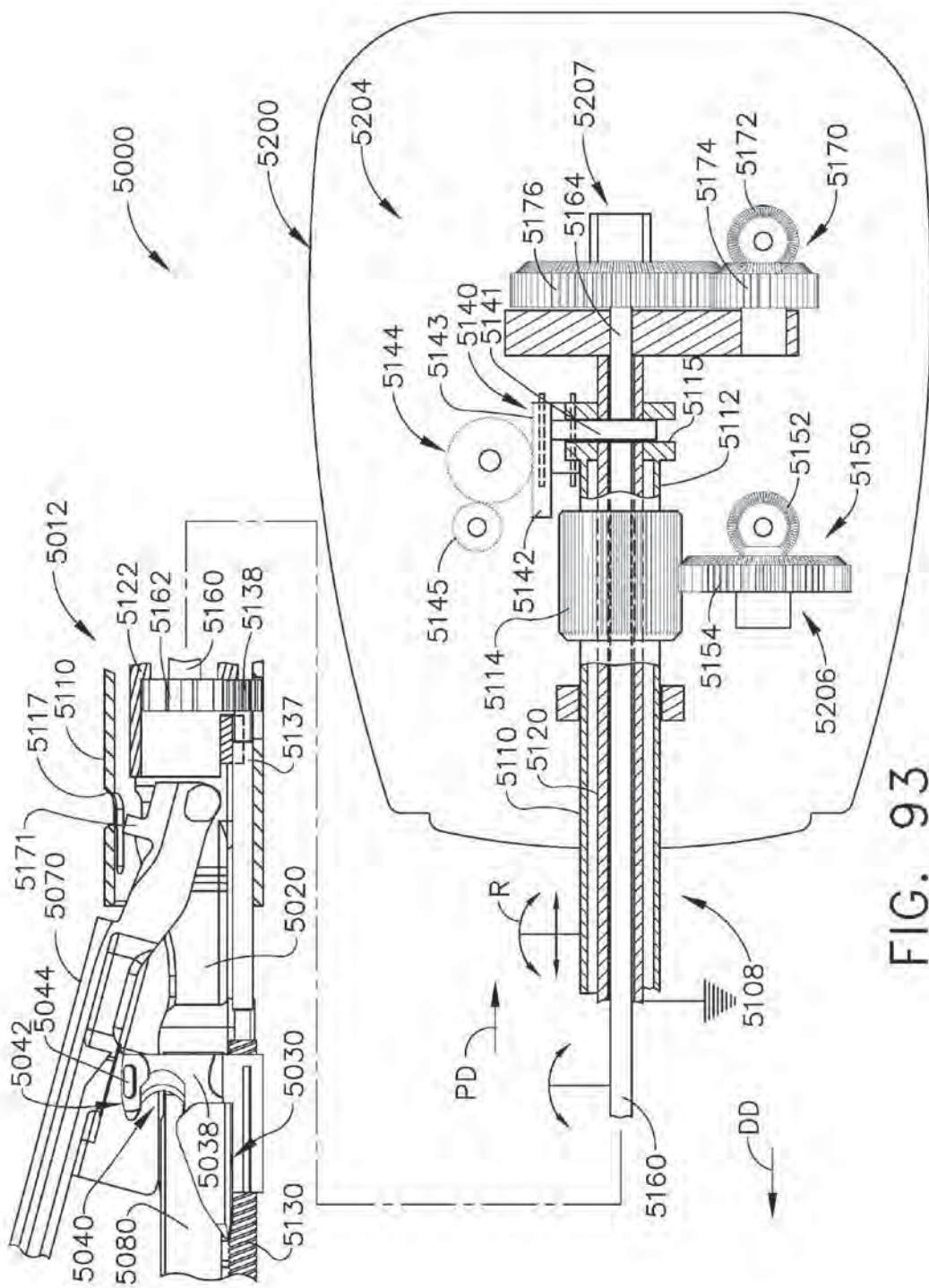
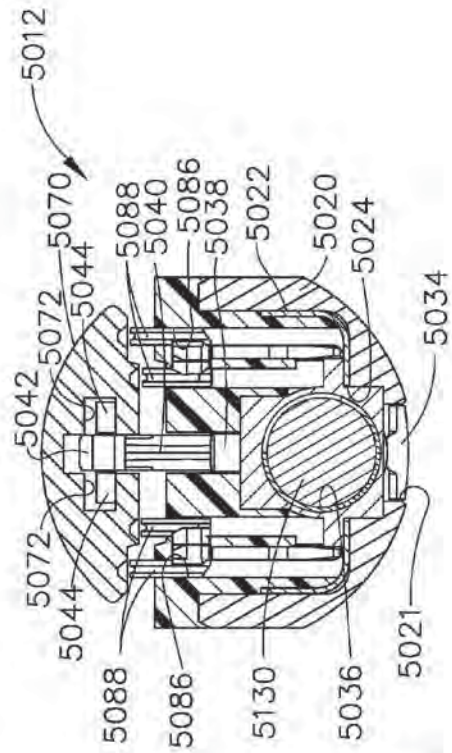
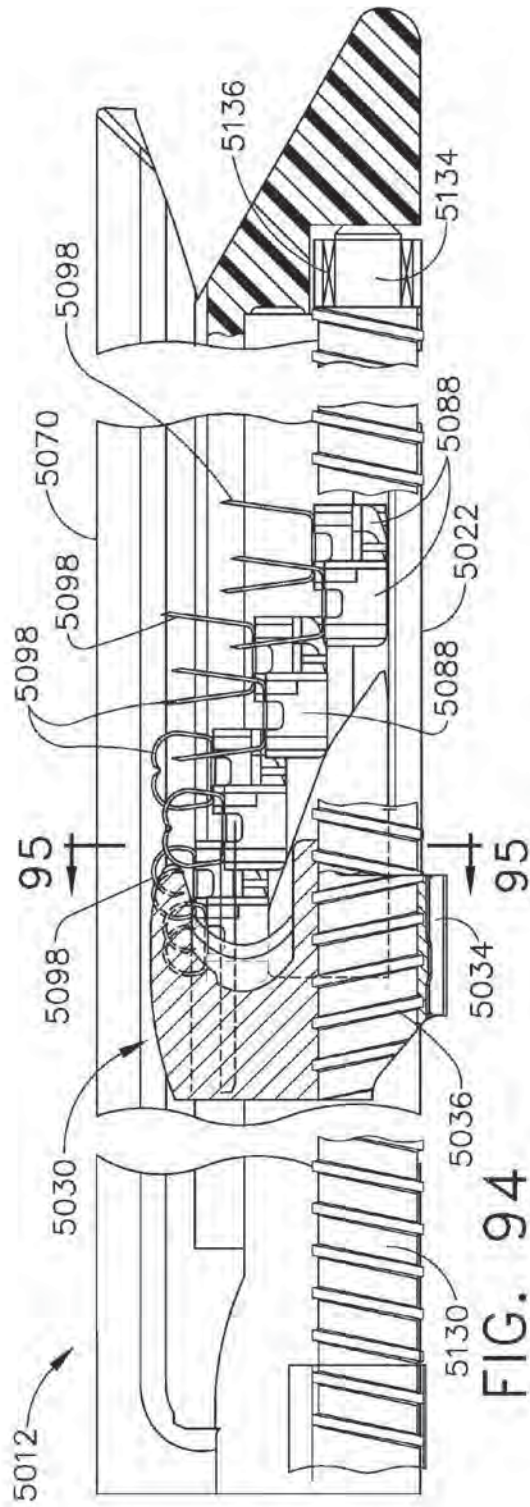

FIG. 93



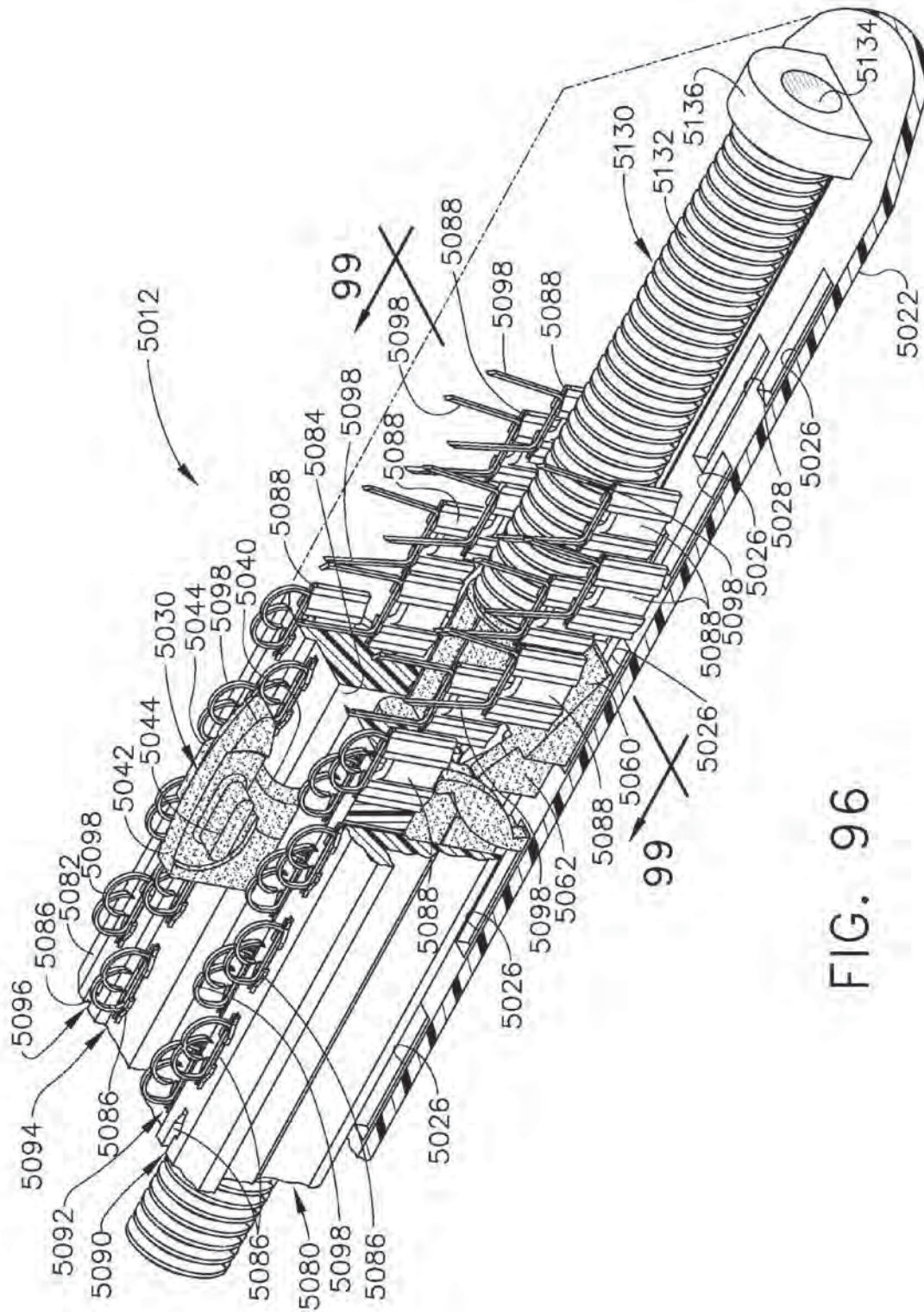

FIG. 96

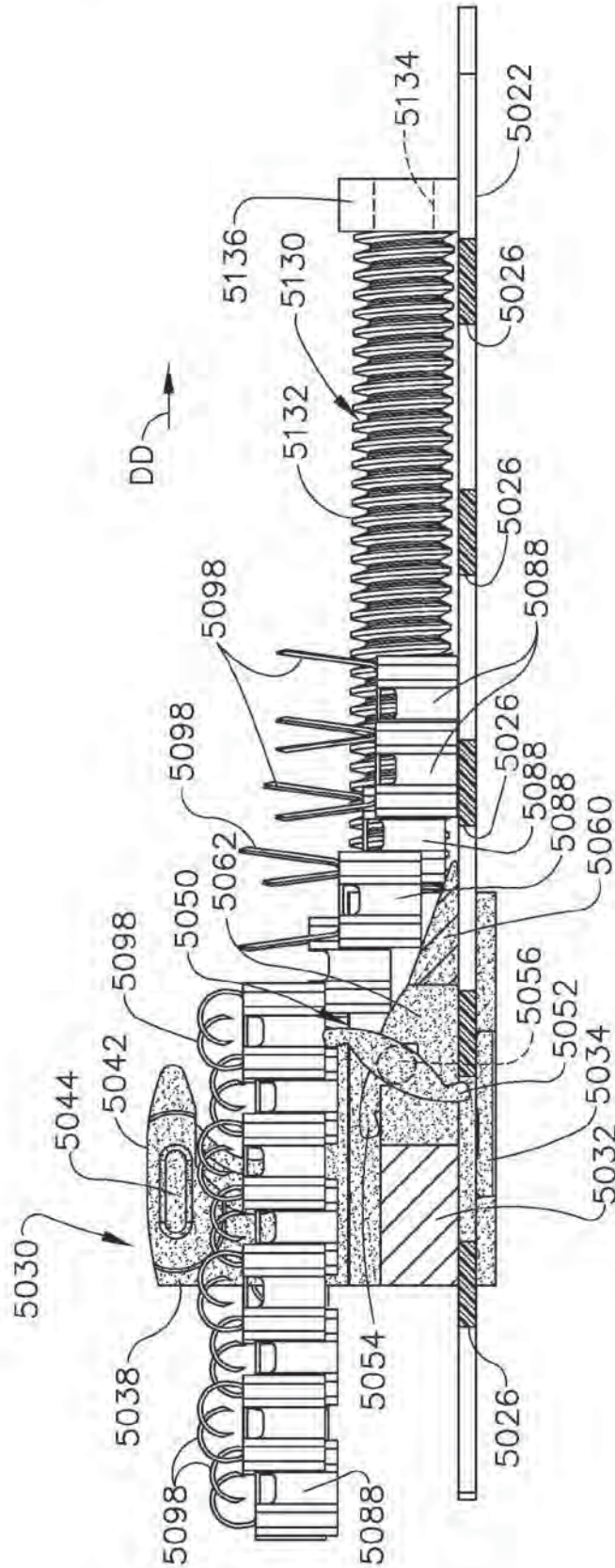

FIG. 97

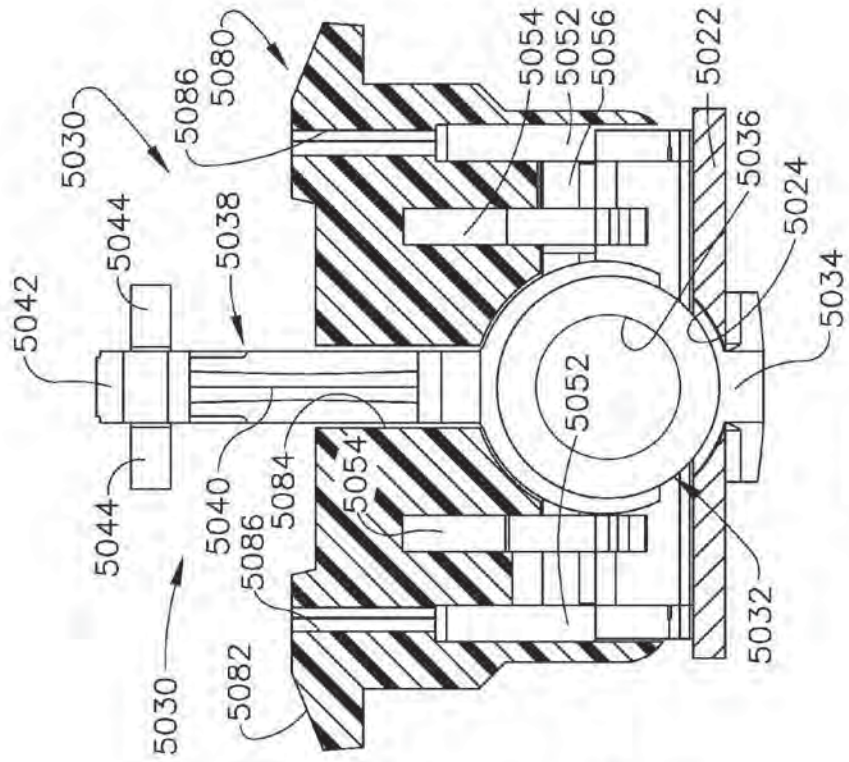

FIG. 99

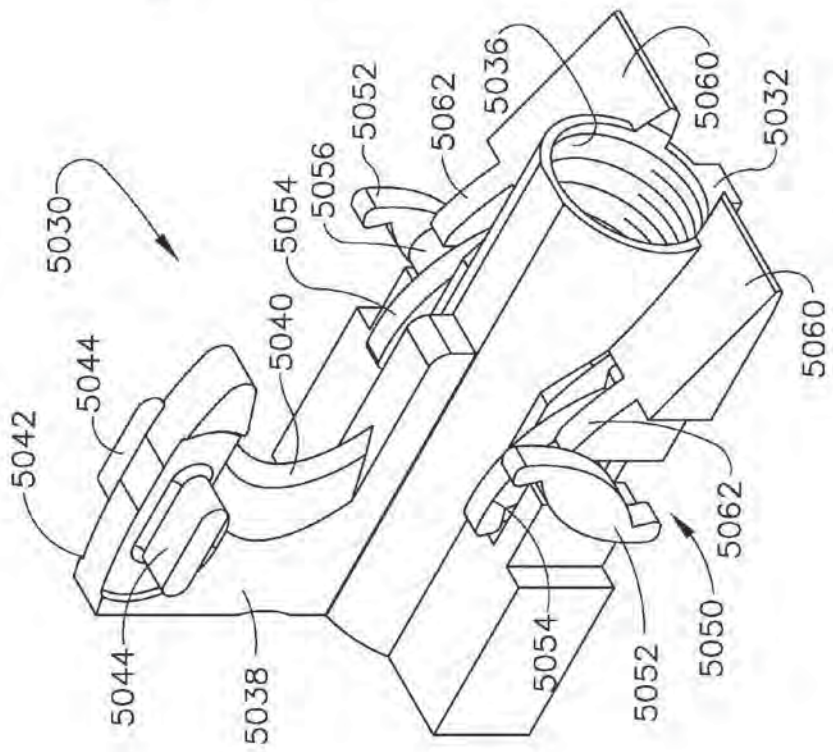

FIG. 98

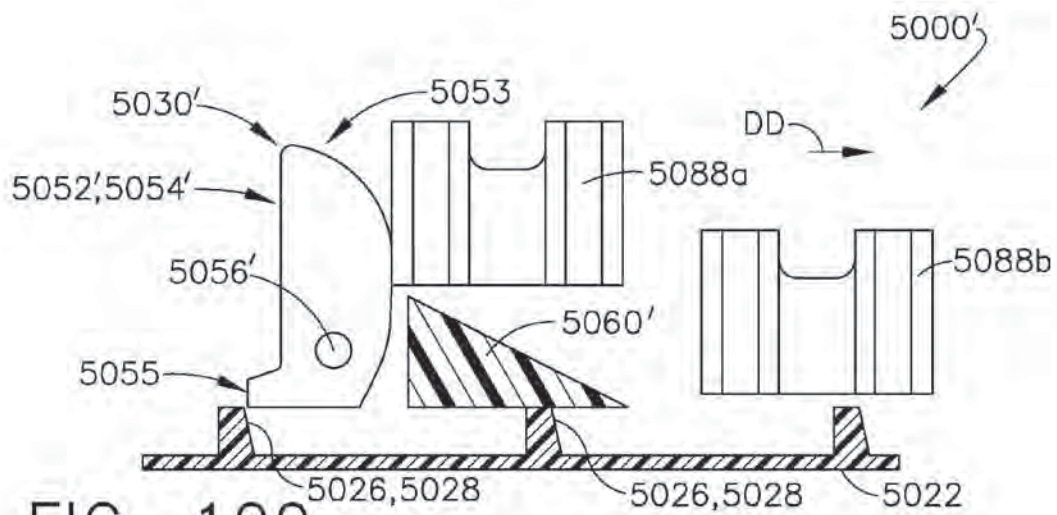

FIG. 100

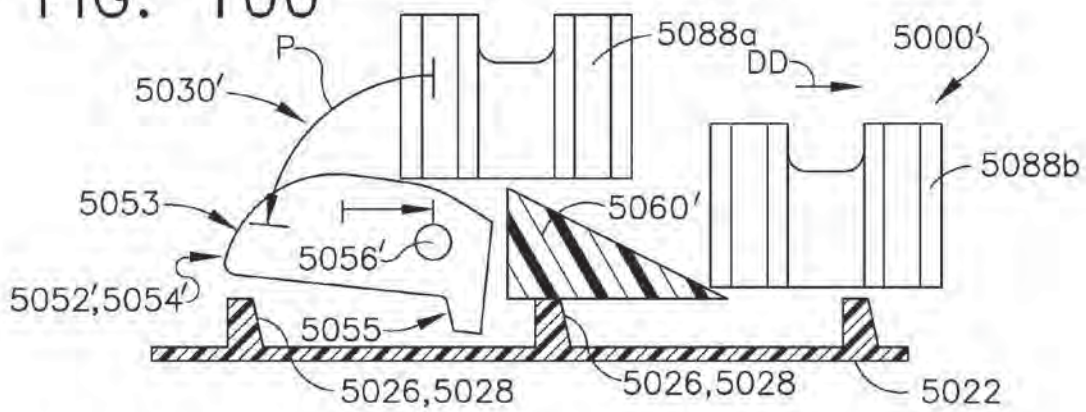

FIG. 101

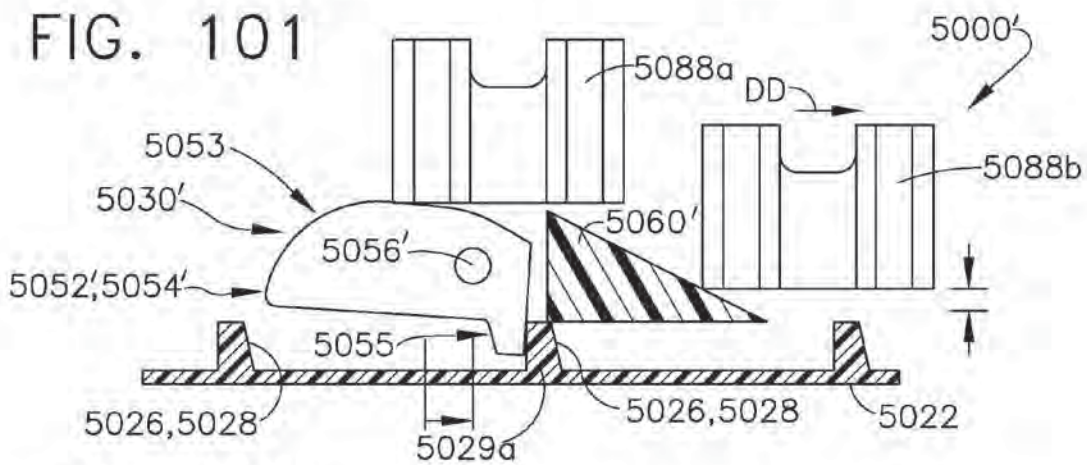

FIG. 102

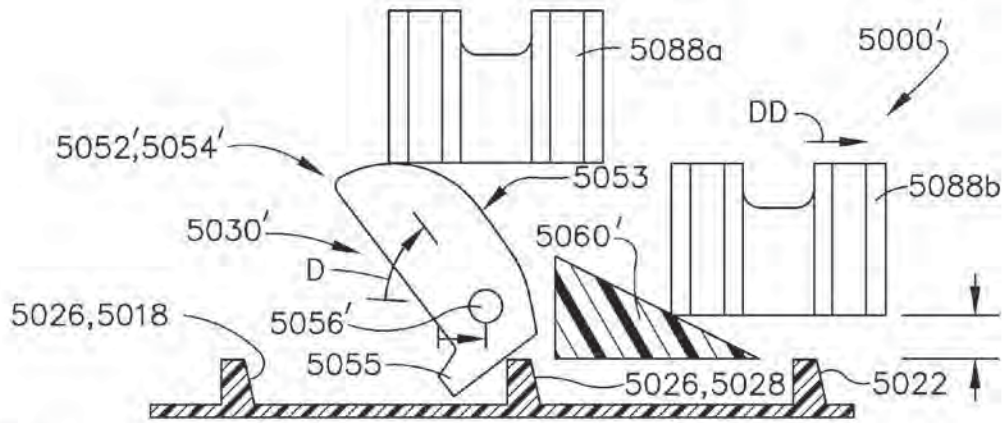

FIG. 103

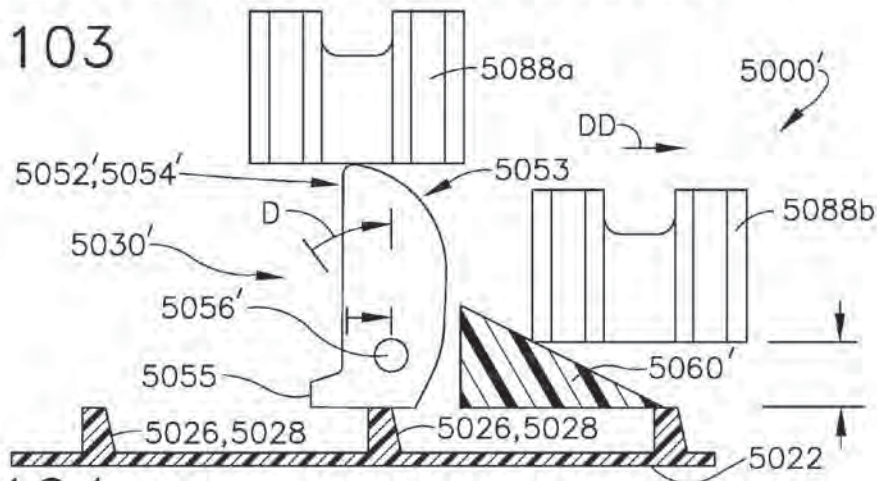

FIG. 104

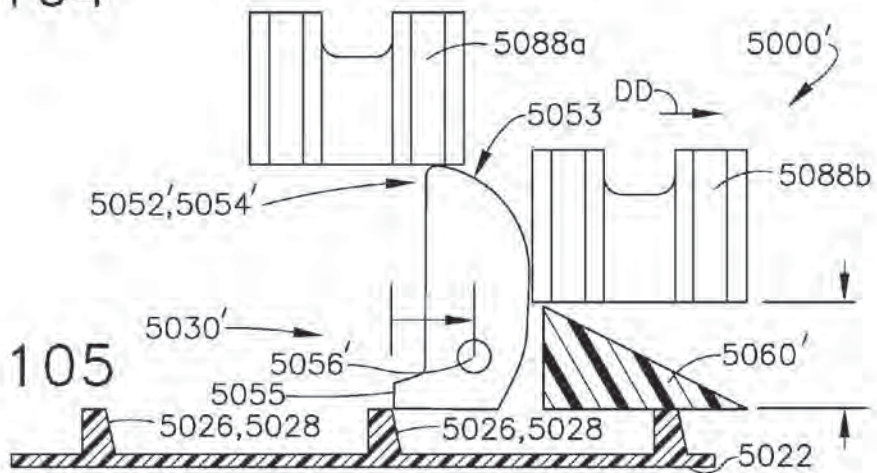

FIG. 105

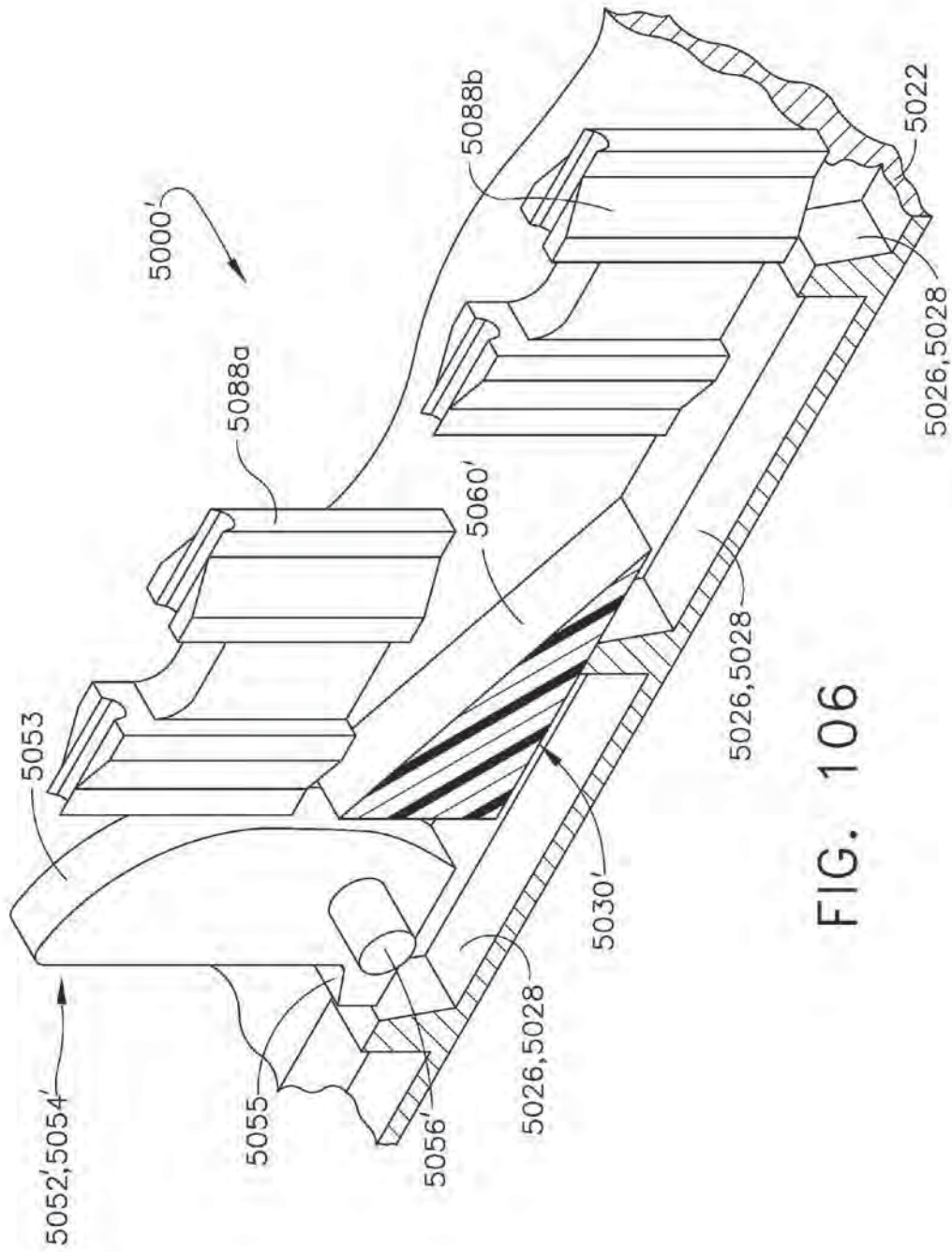

FIG. 106

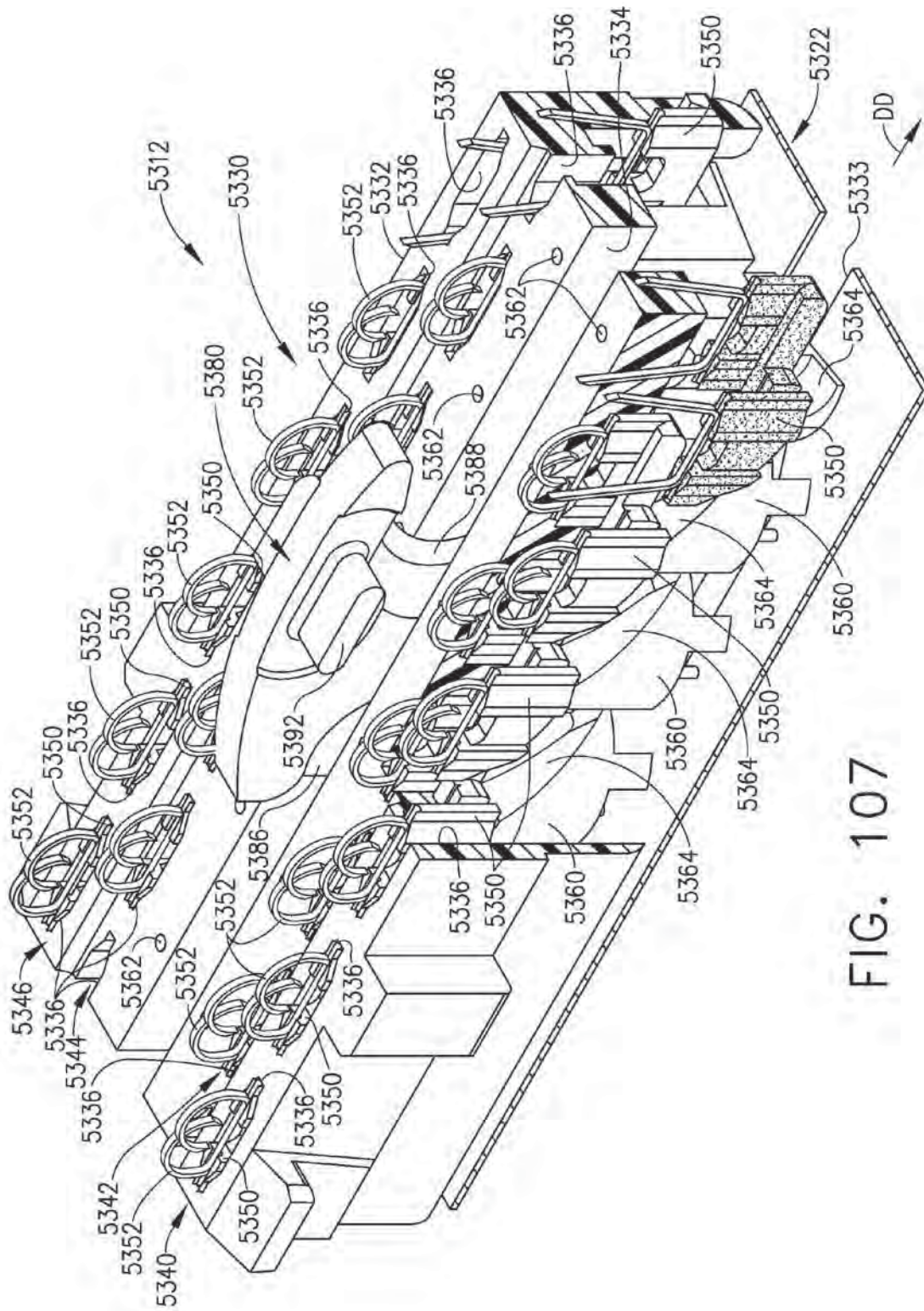

FIG. 107

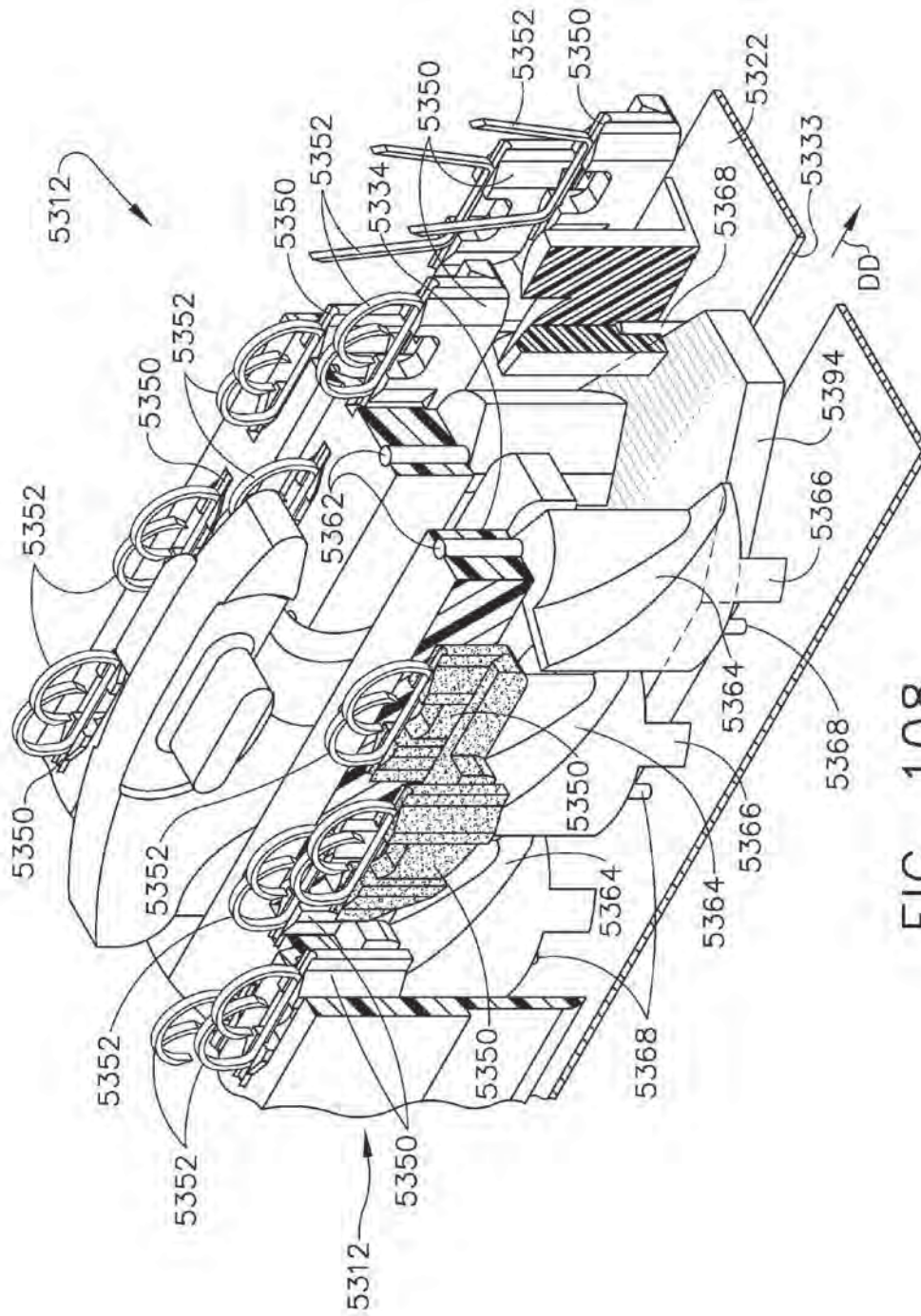

FIG. 108

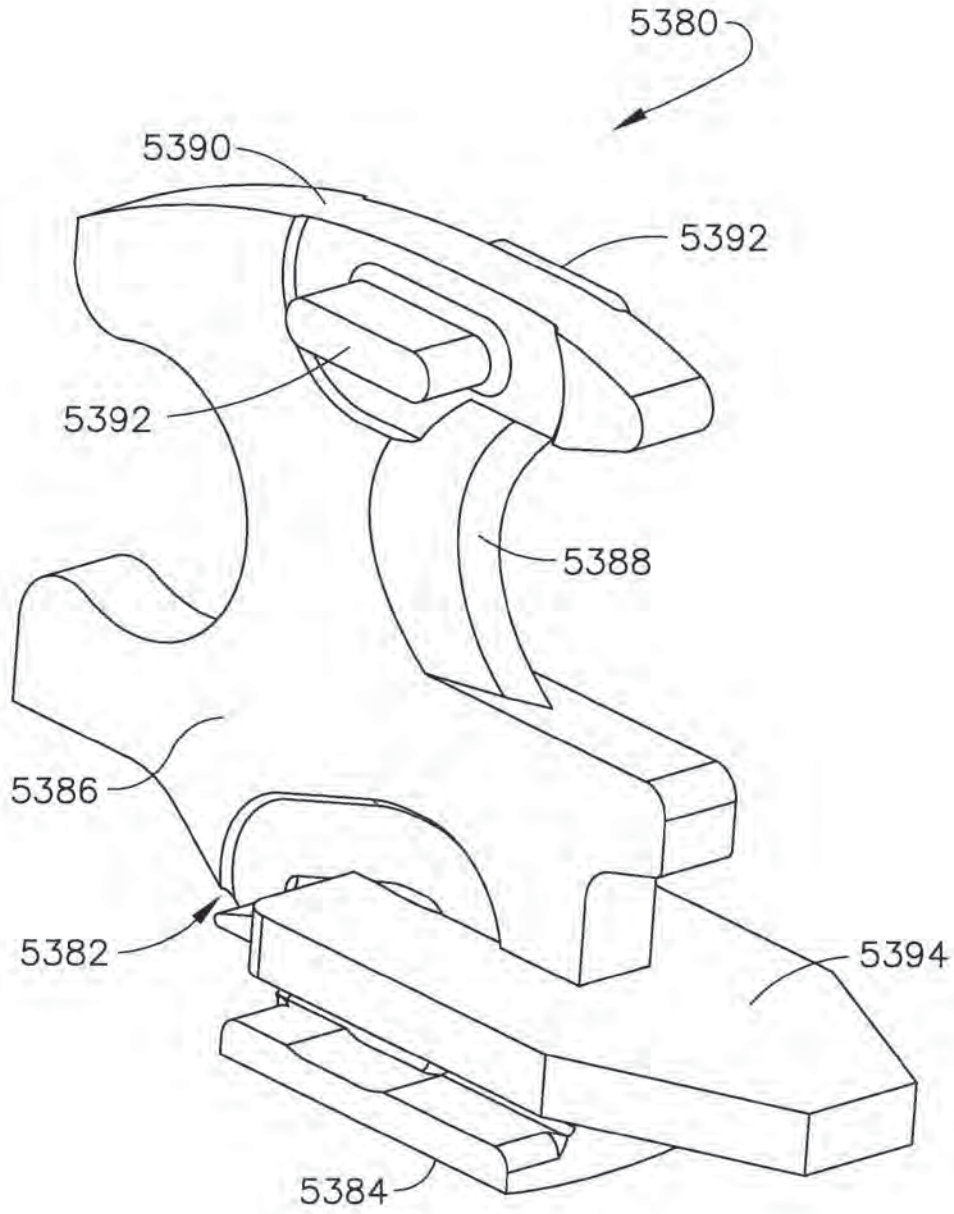

FIG. 109

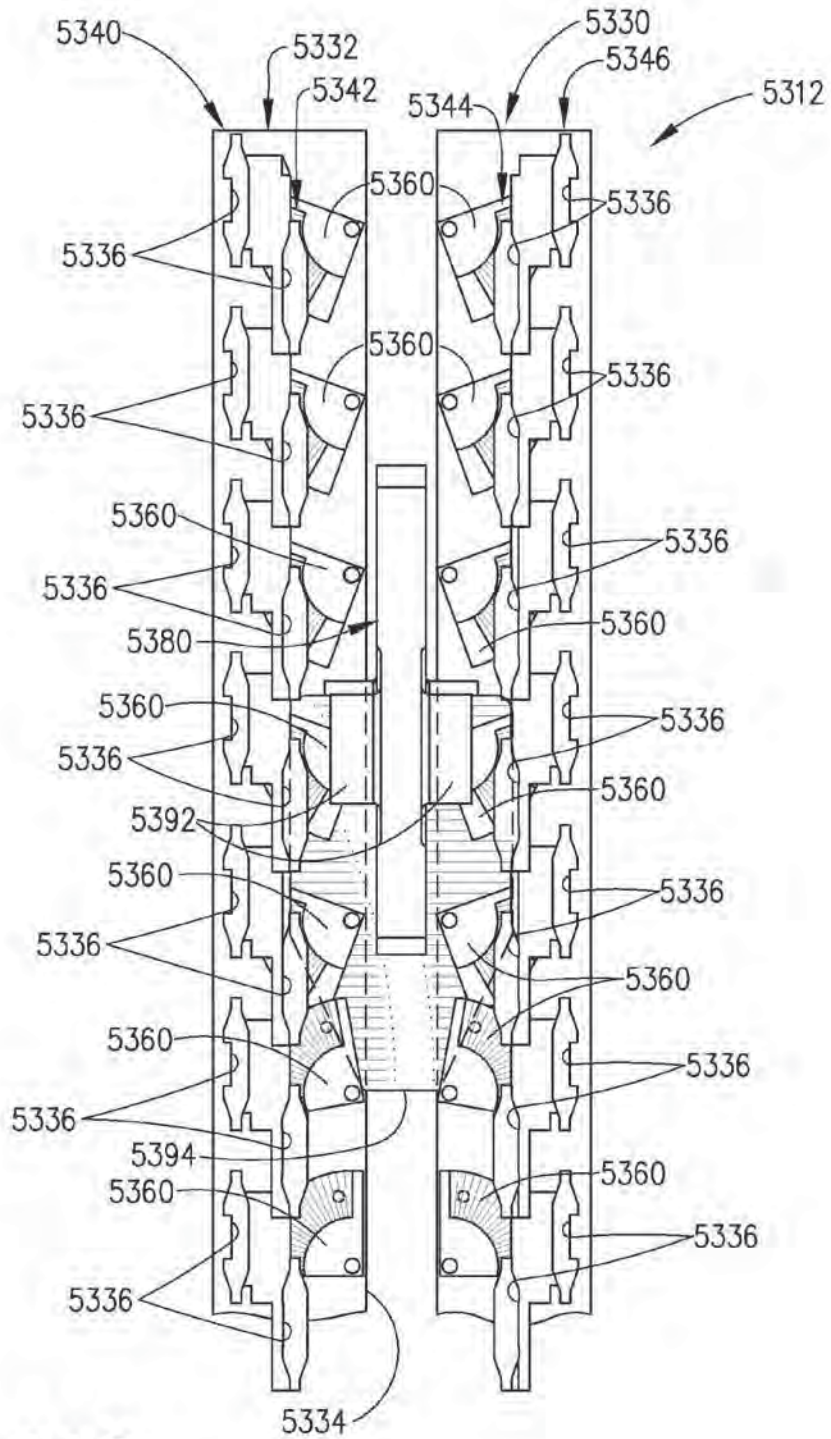

FIG. 110

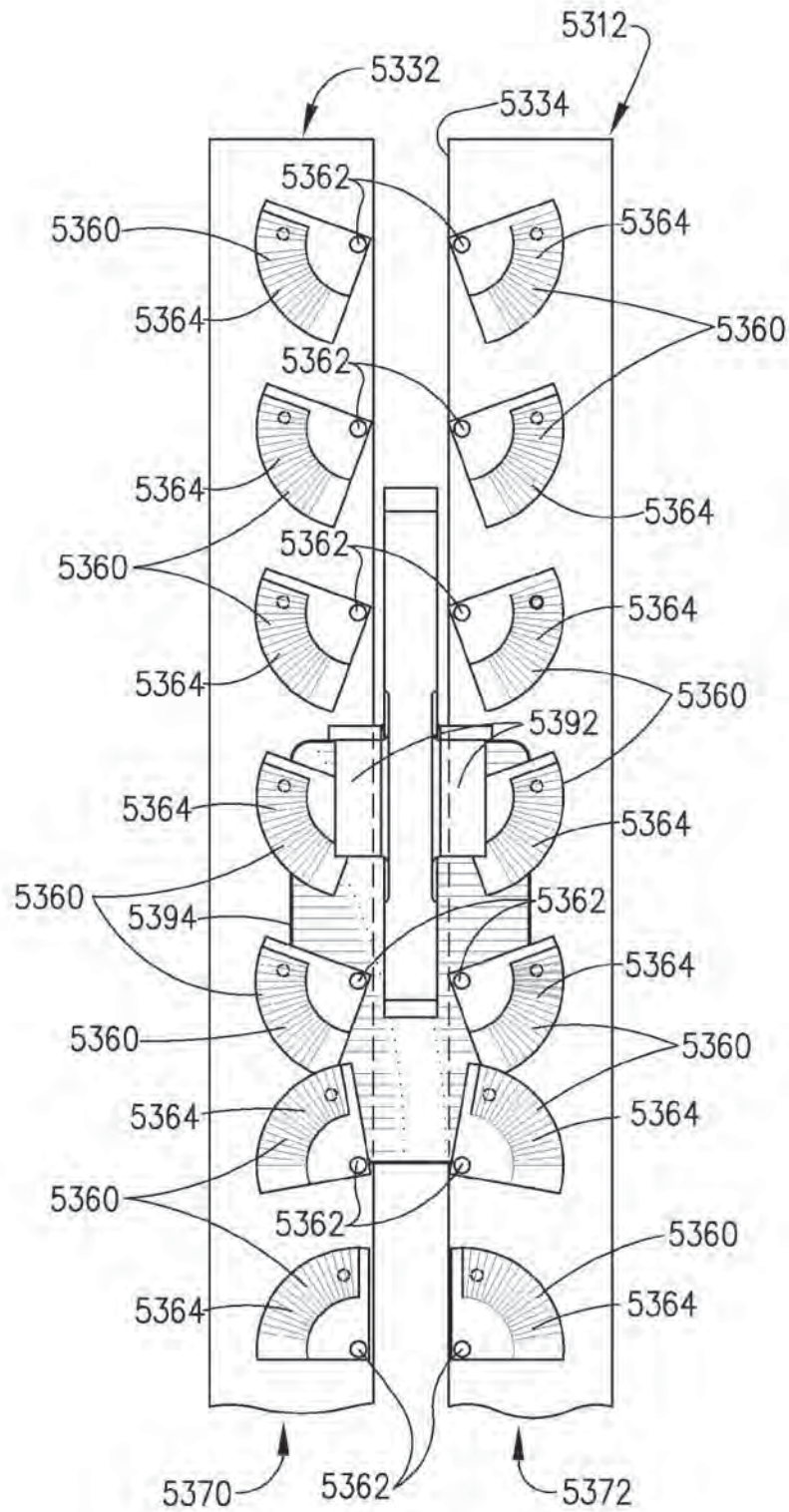

FIG. 111

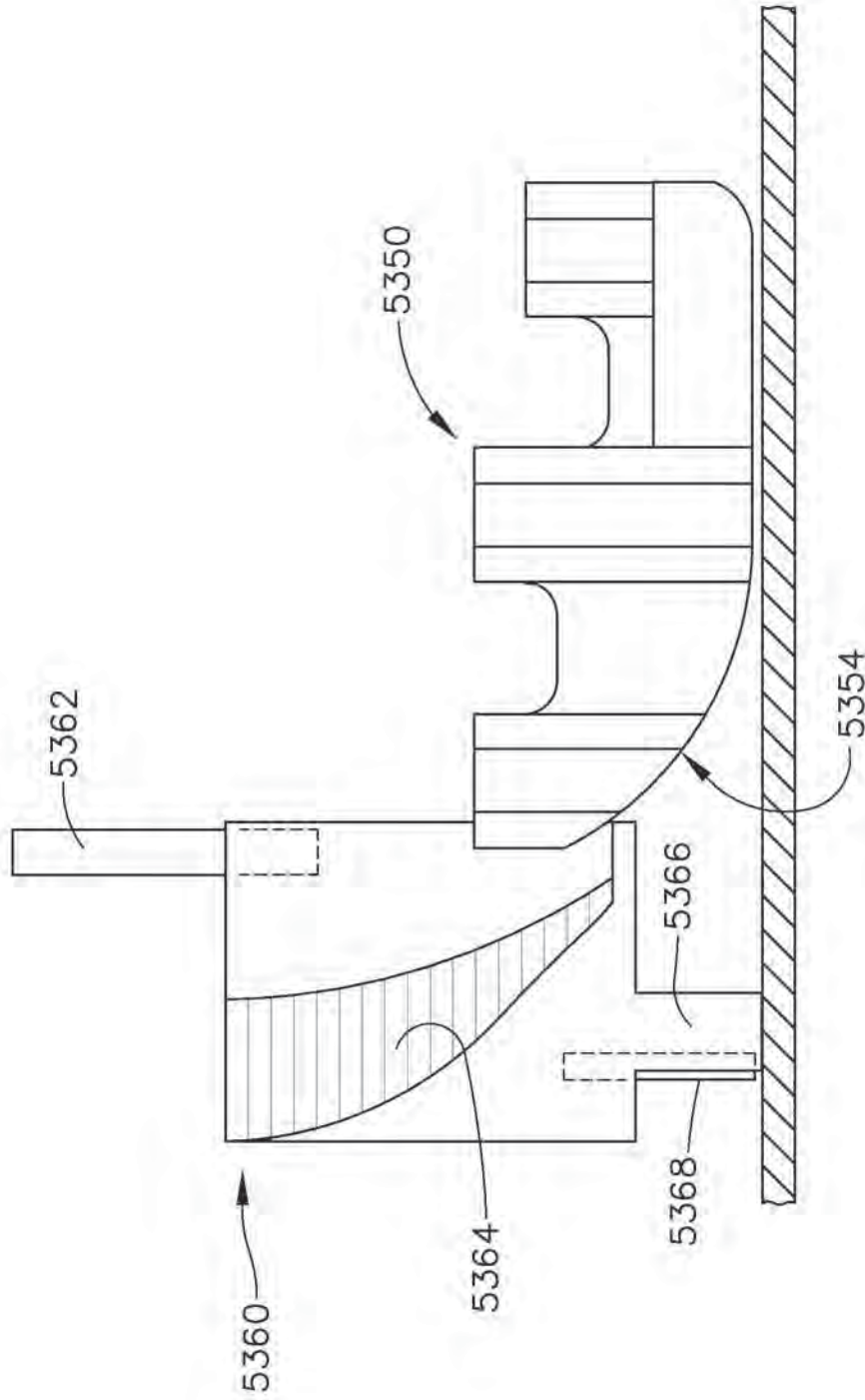

FIG. 112

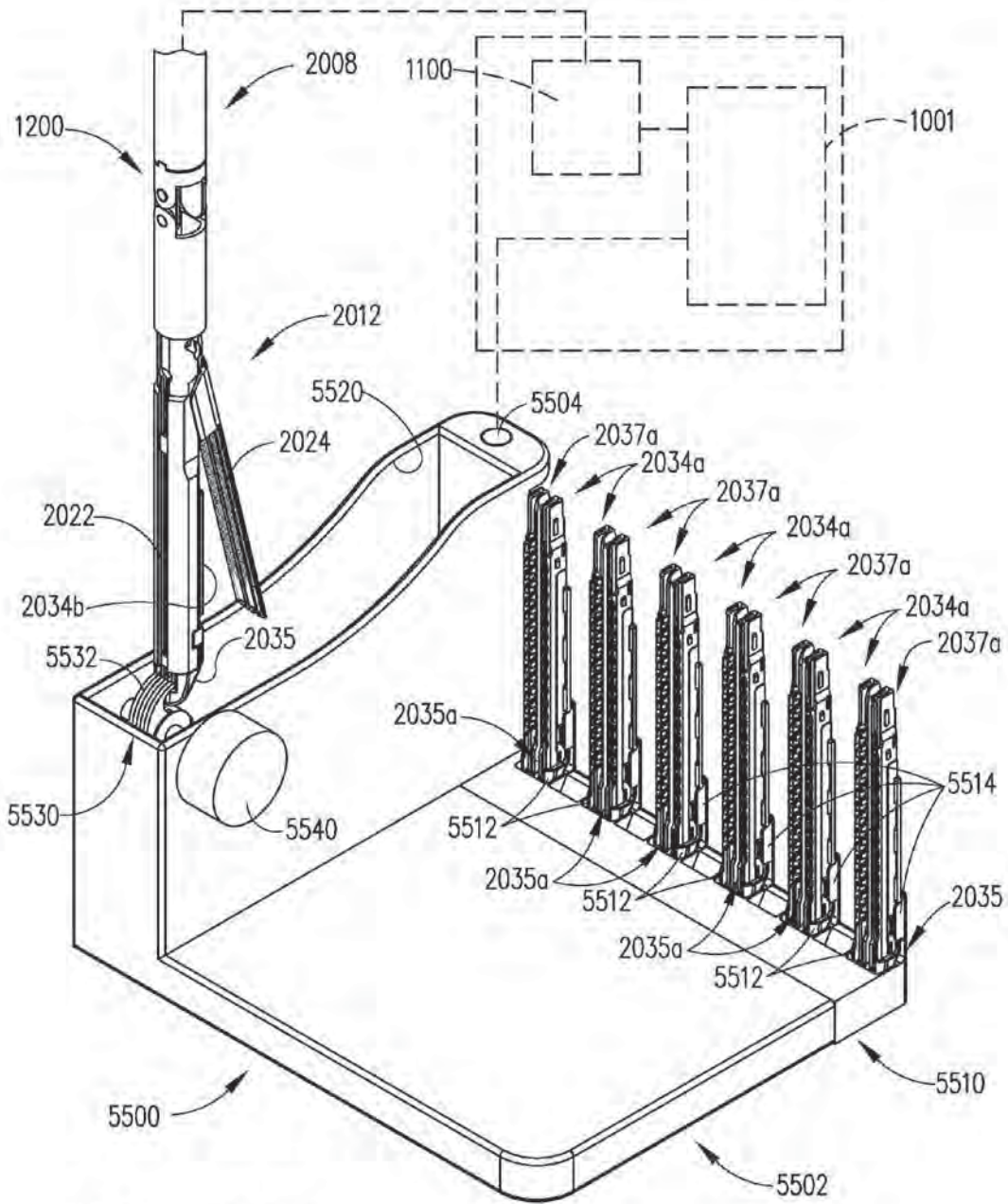

FIG. 113

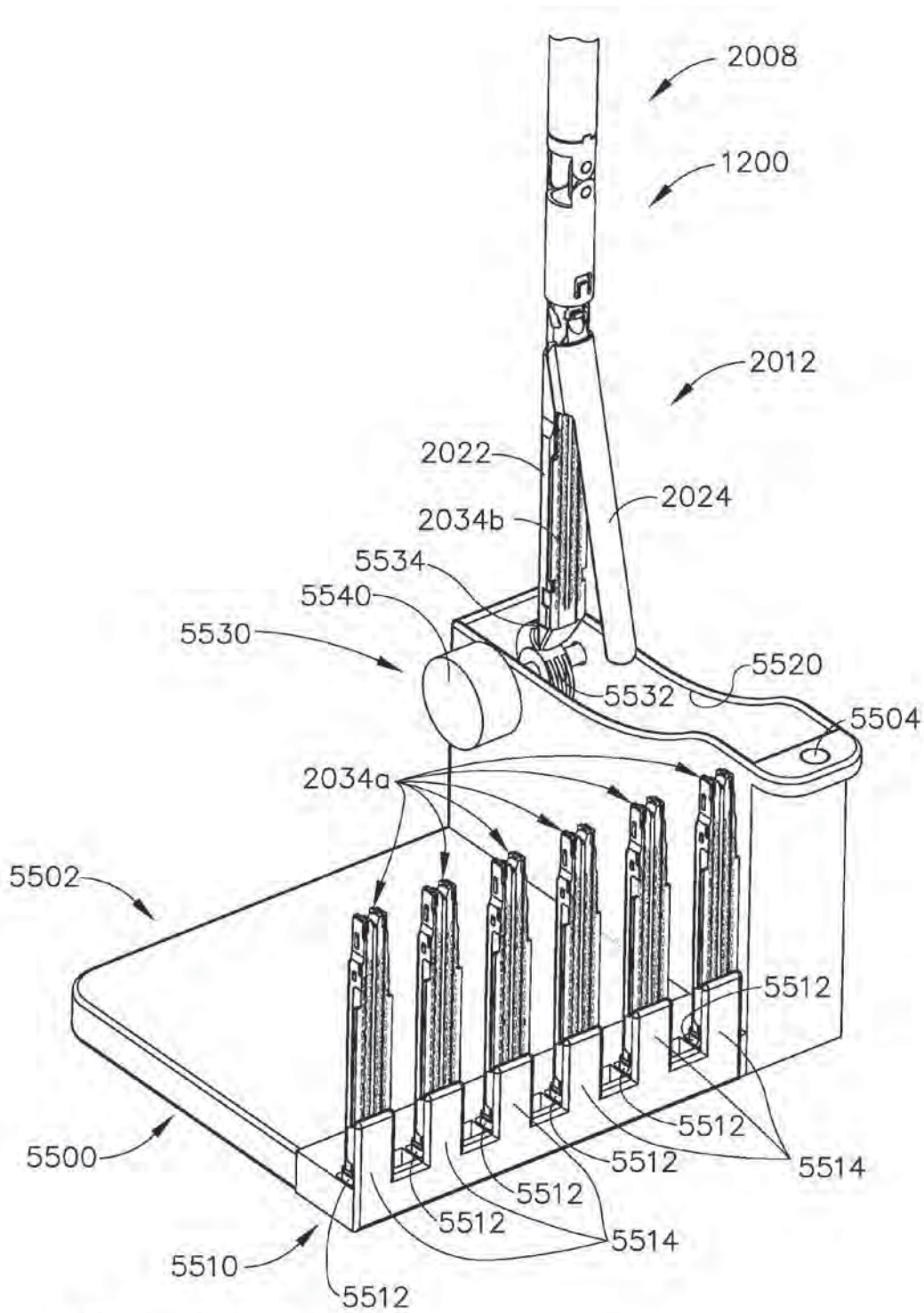
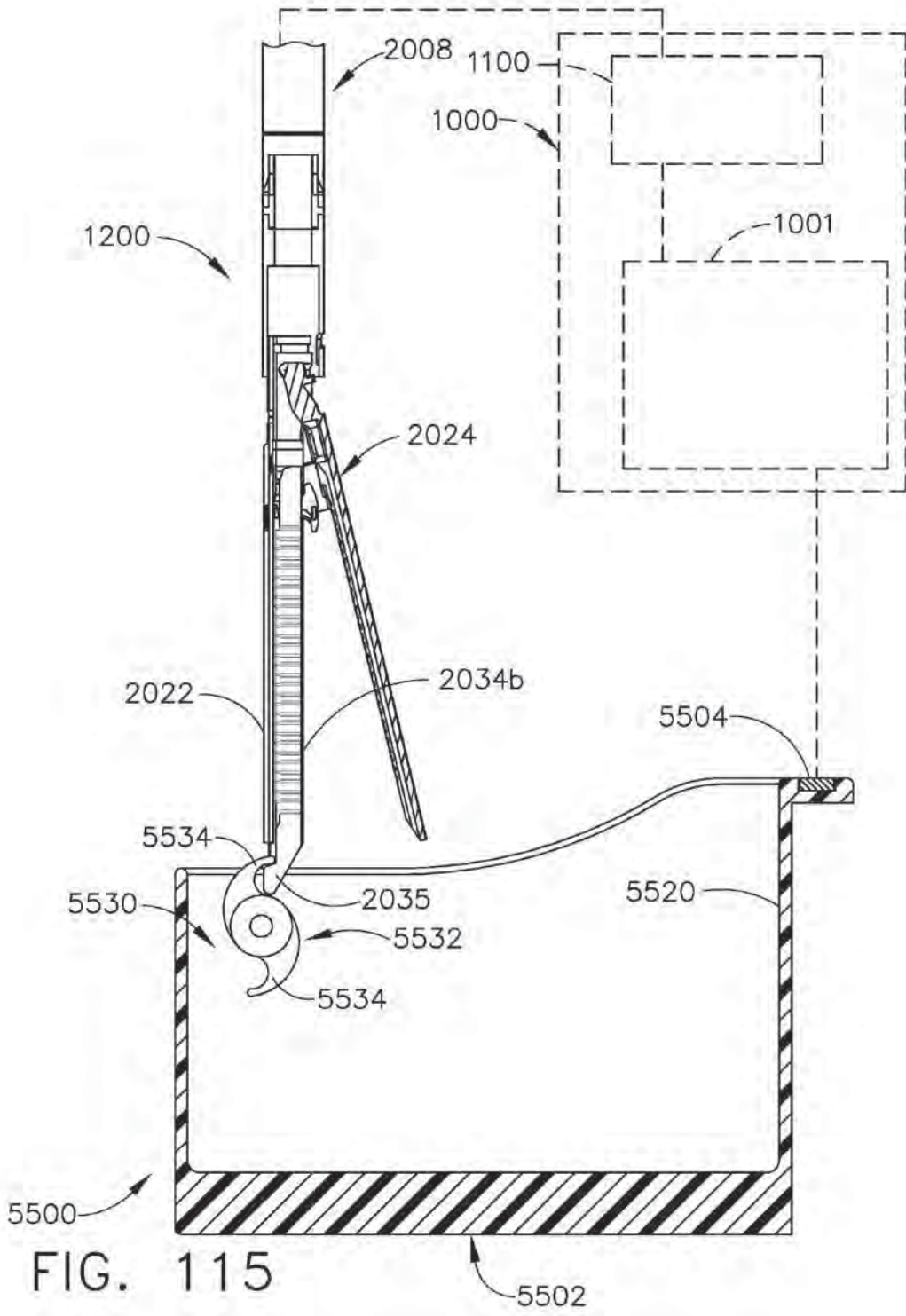

FIG. 114



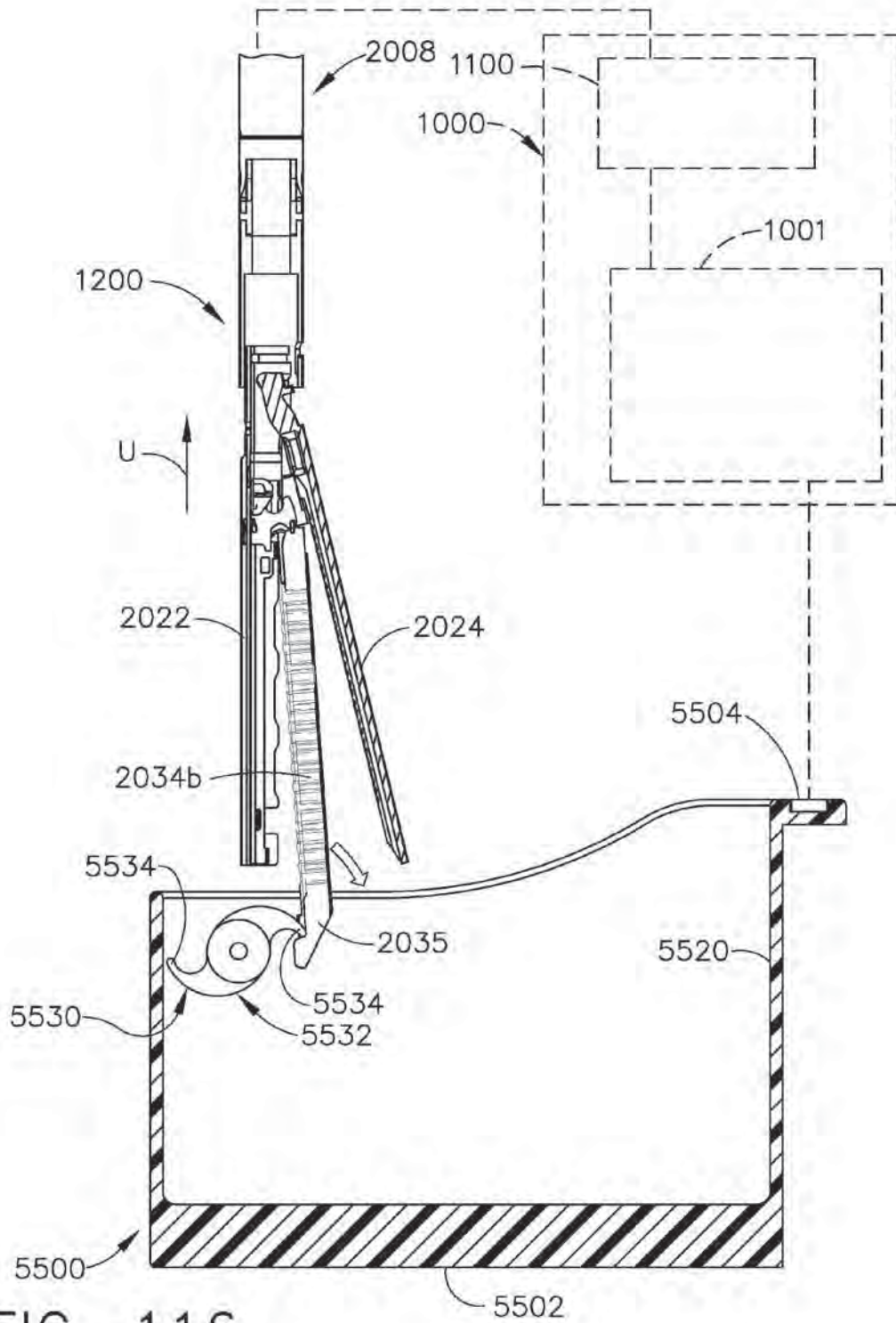
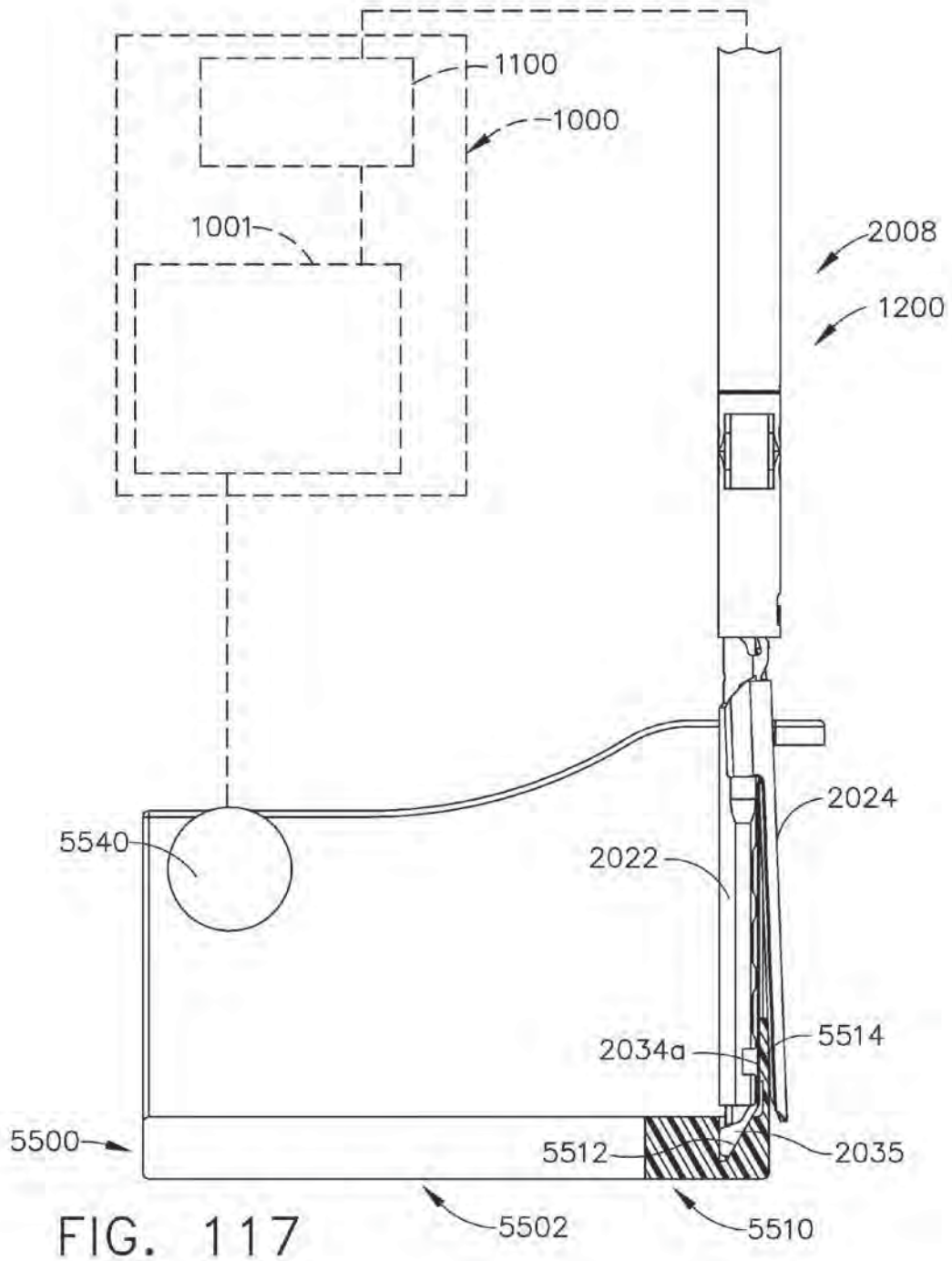

FIG. 116



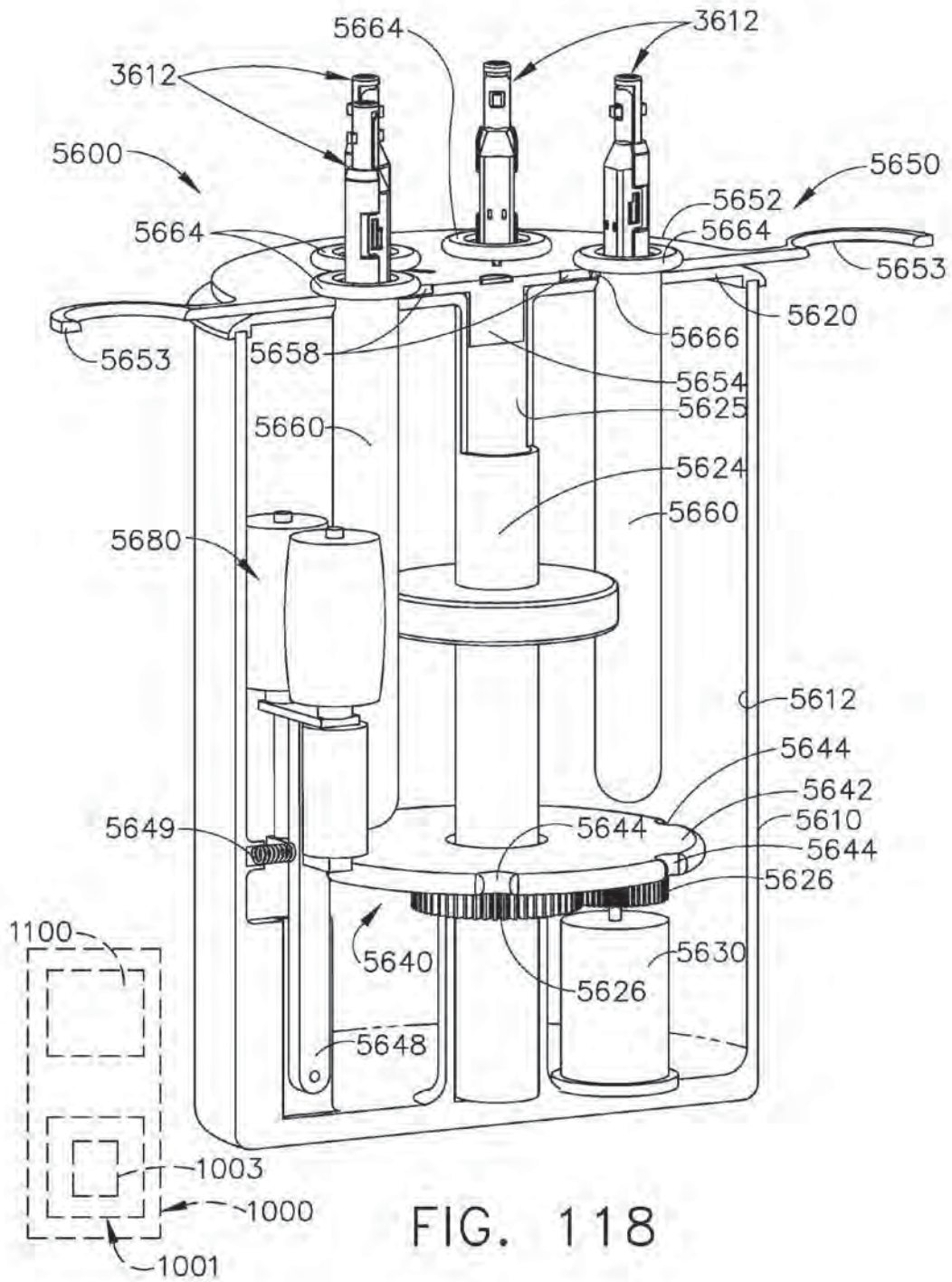

FIG. 118

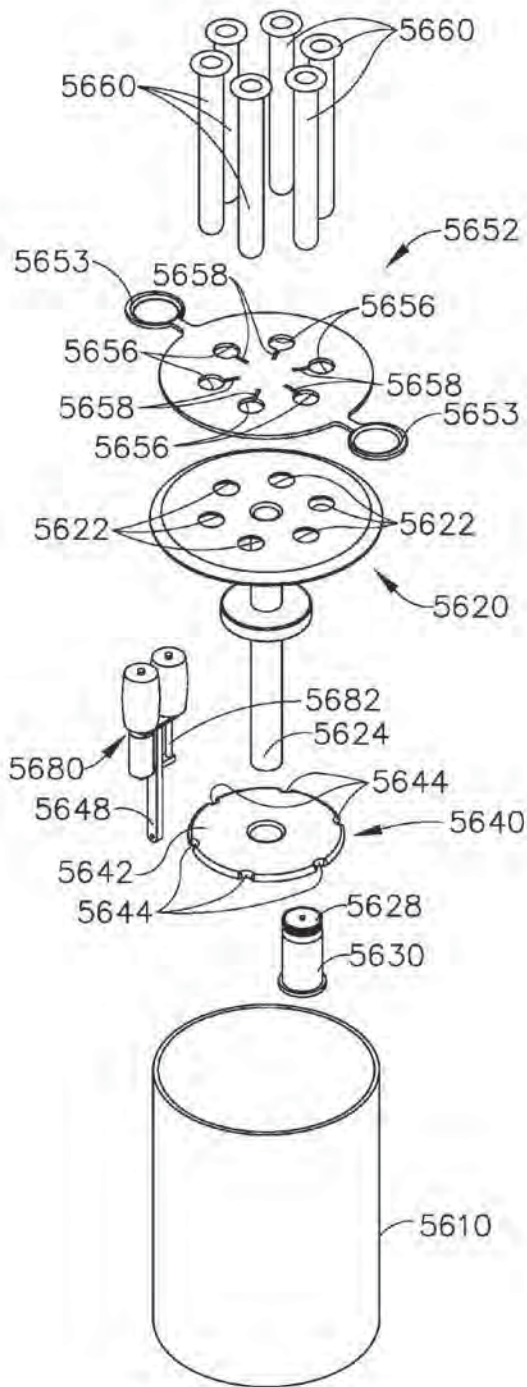

FIG. 119

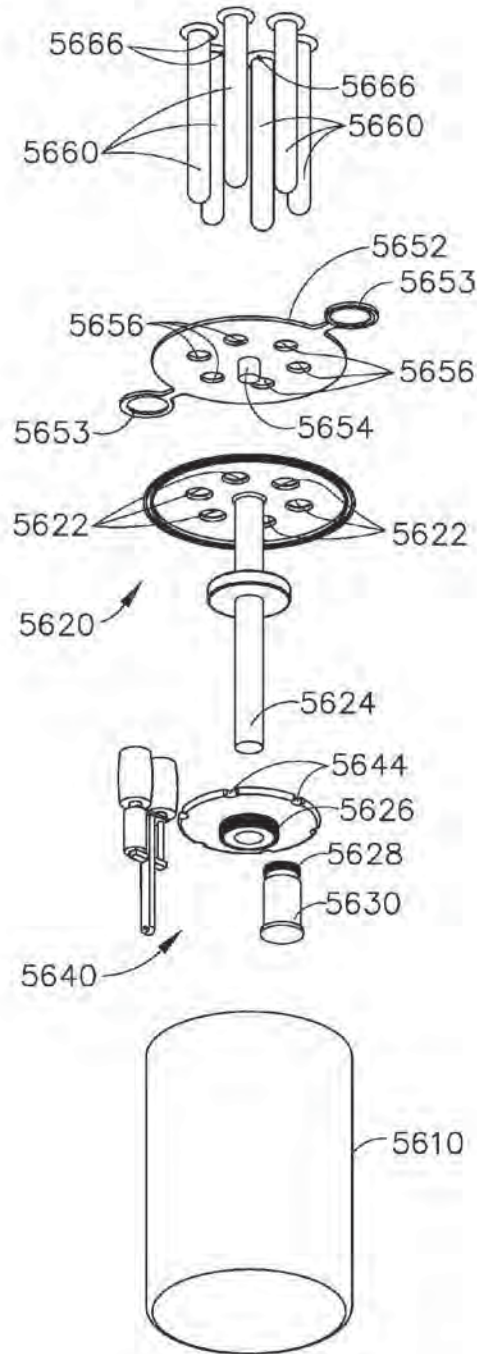

FIG. 120

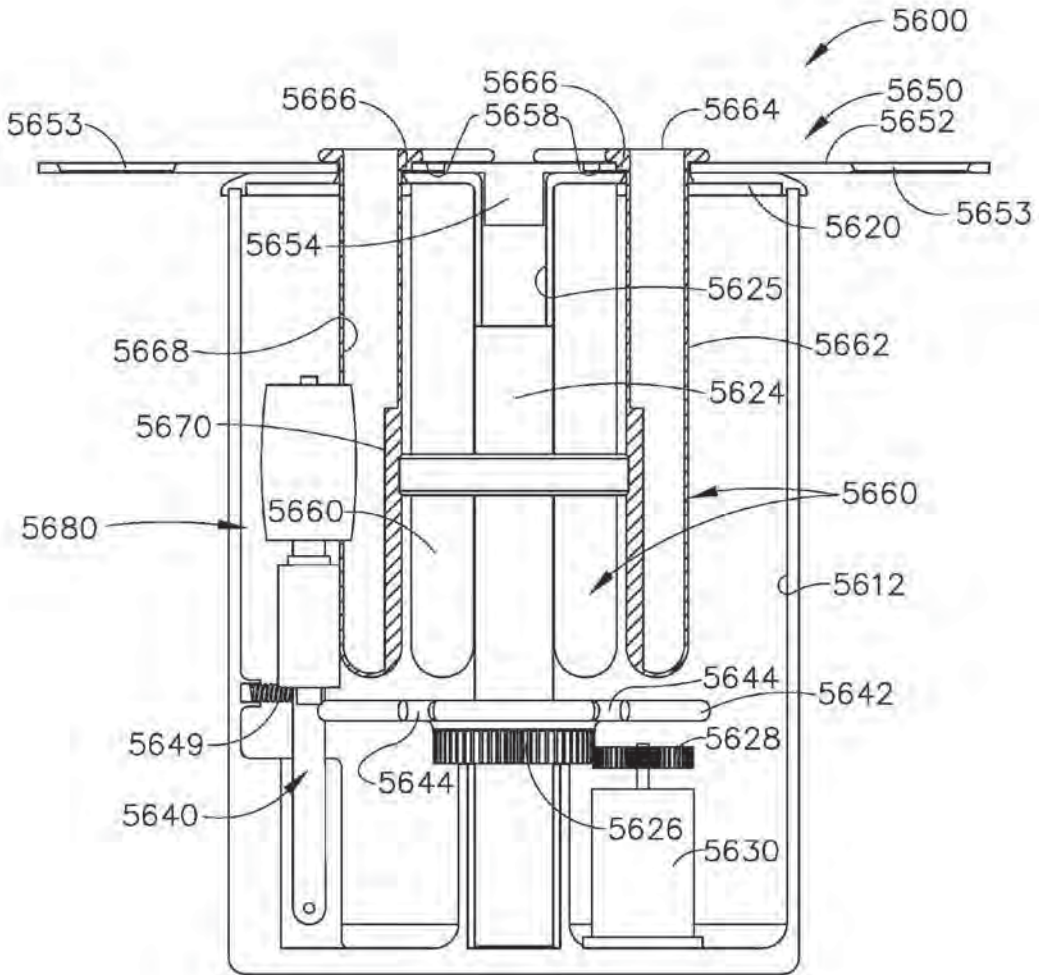

FIG. 121

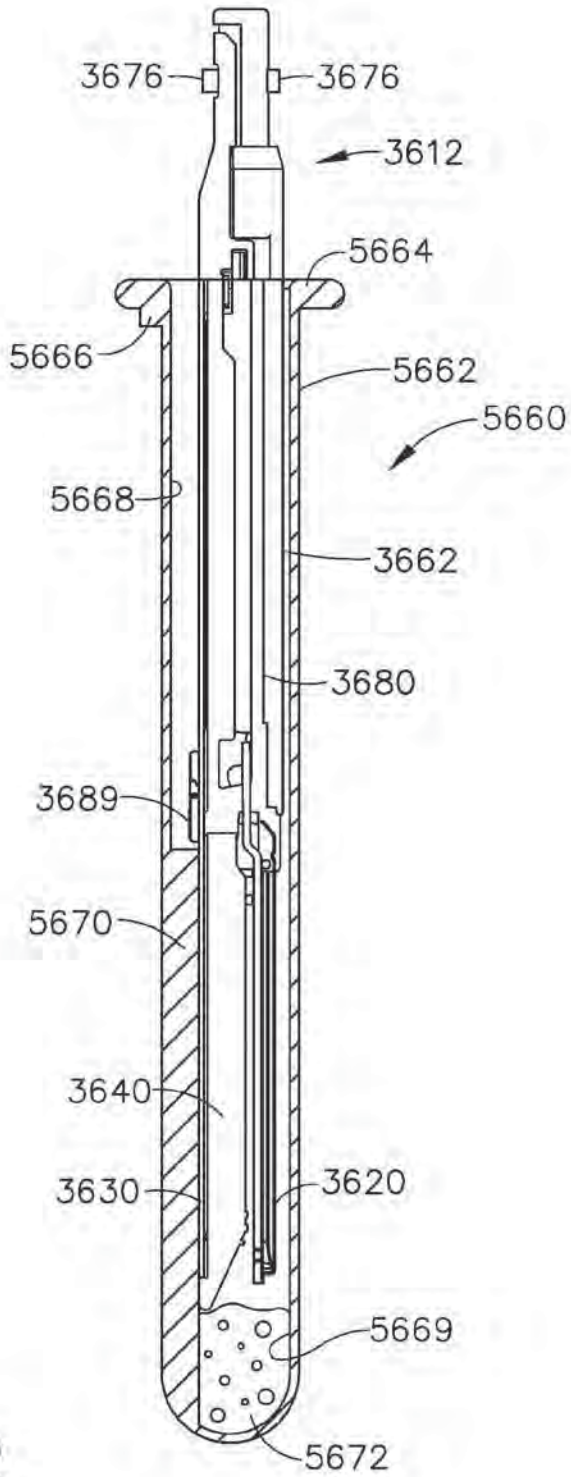
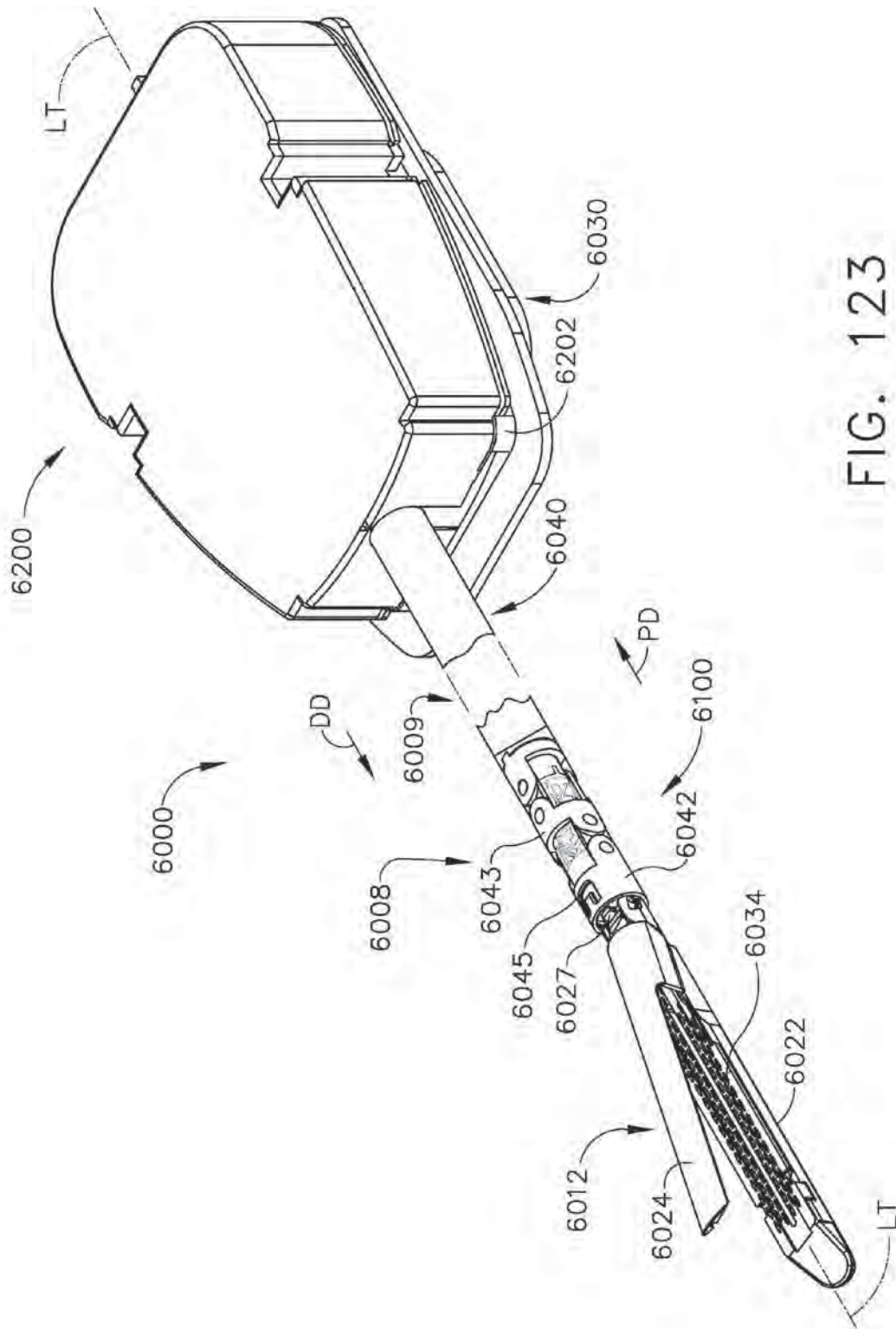

FIG. 122



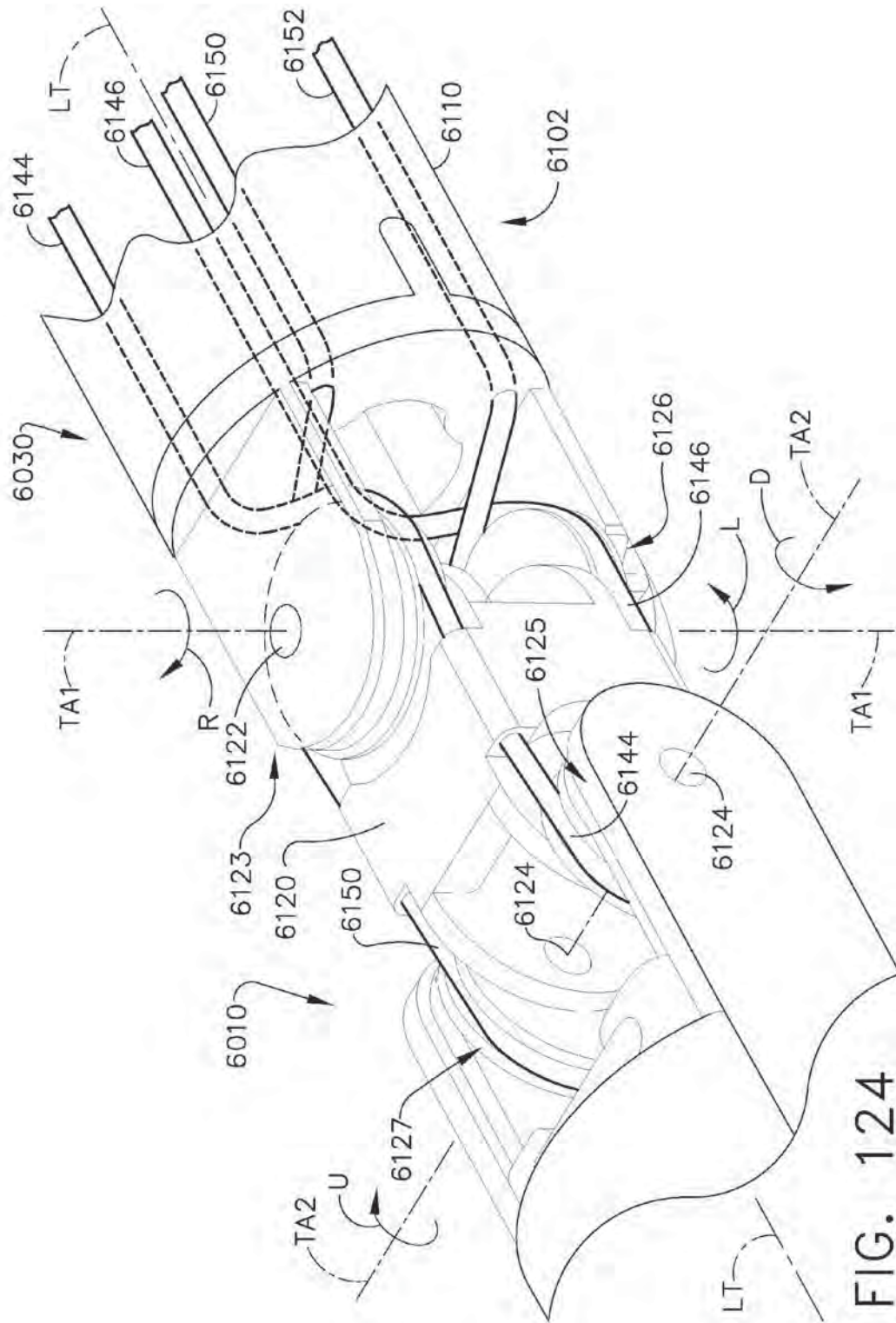

FIG. 124

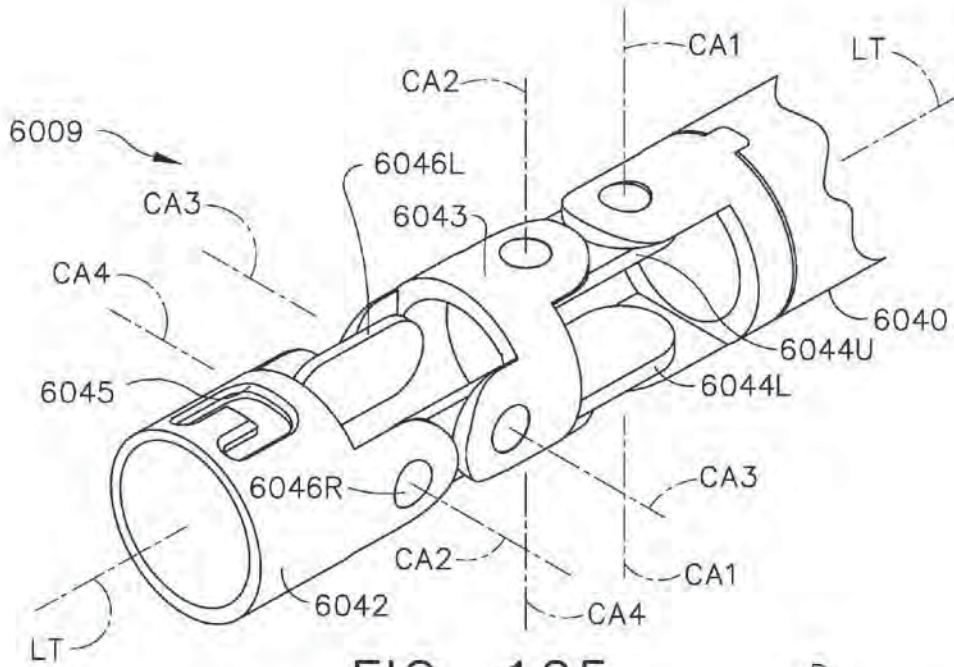

FIG. 125

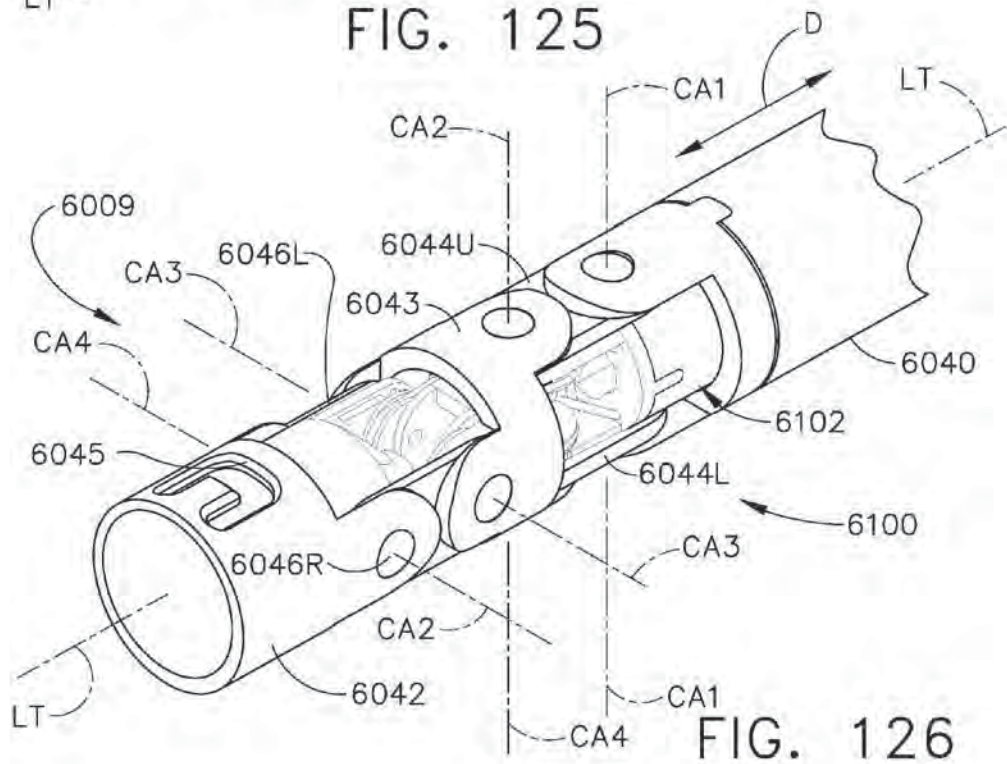

FIG. 126

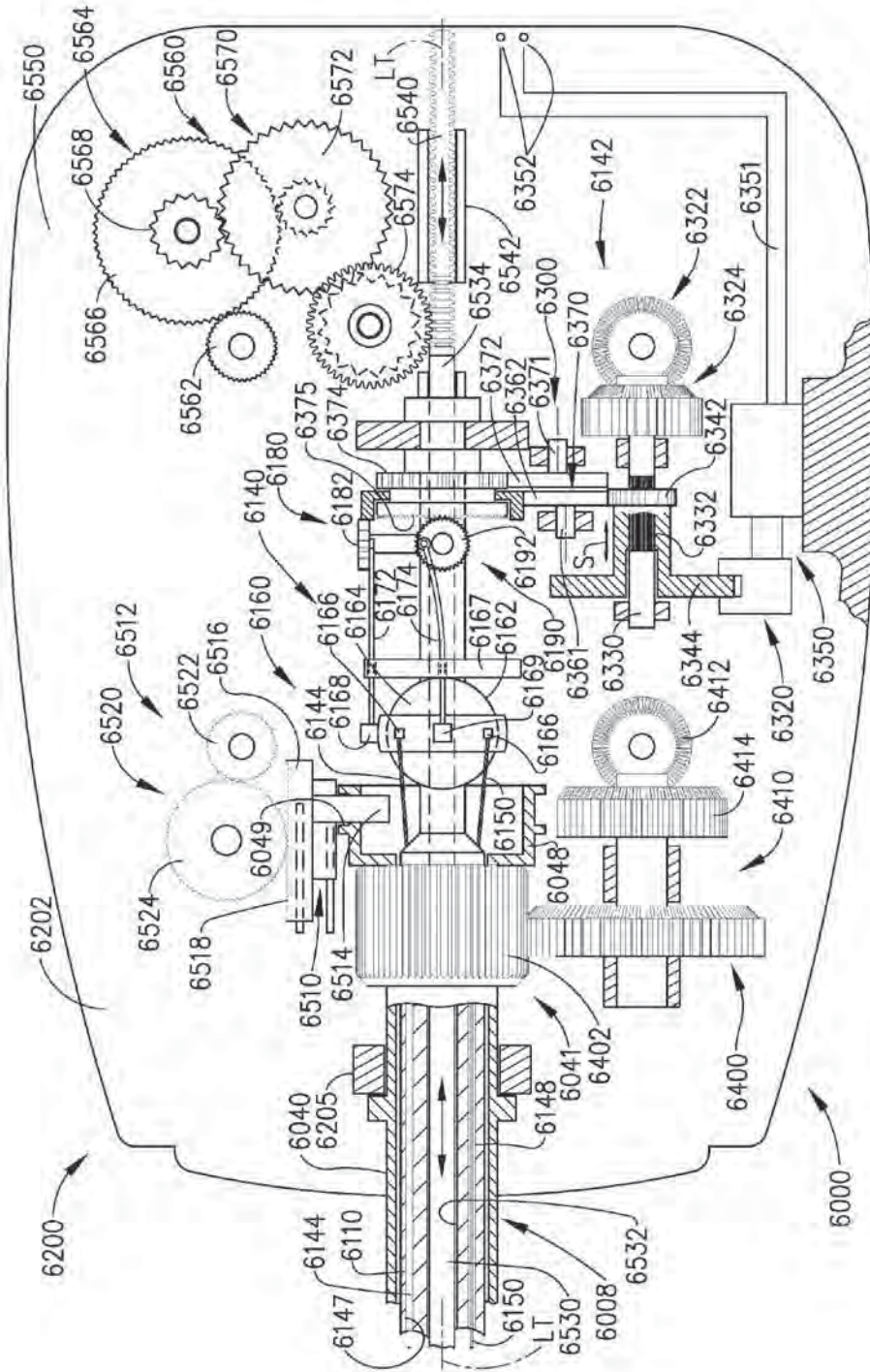

FIG. 127

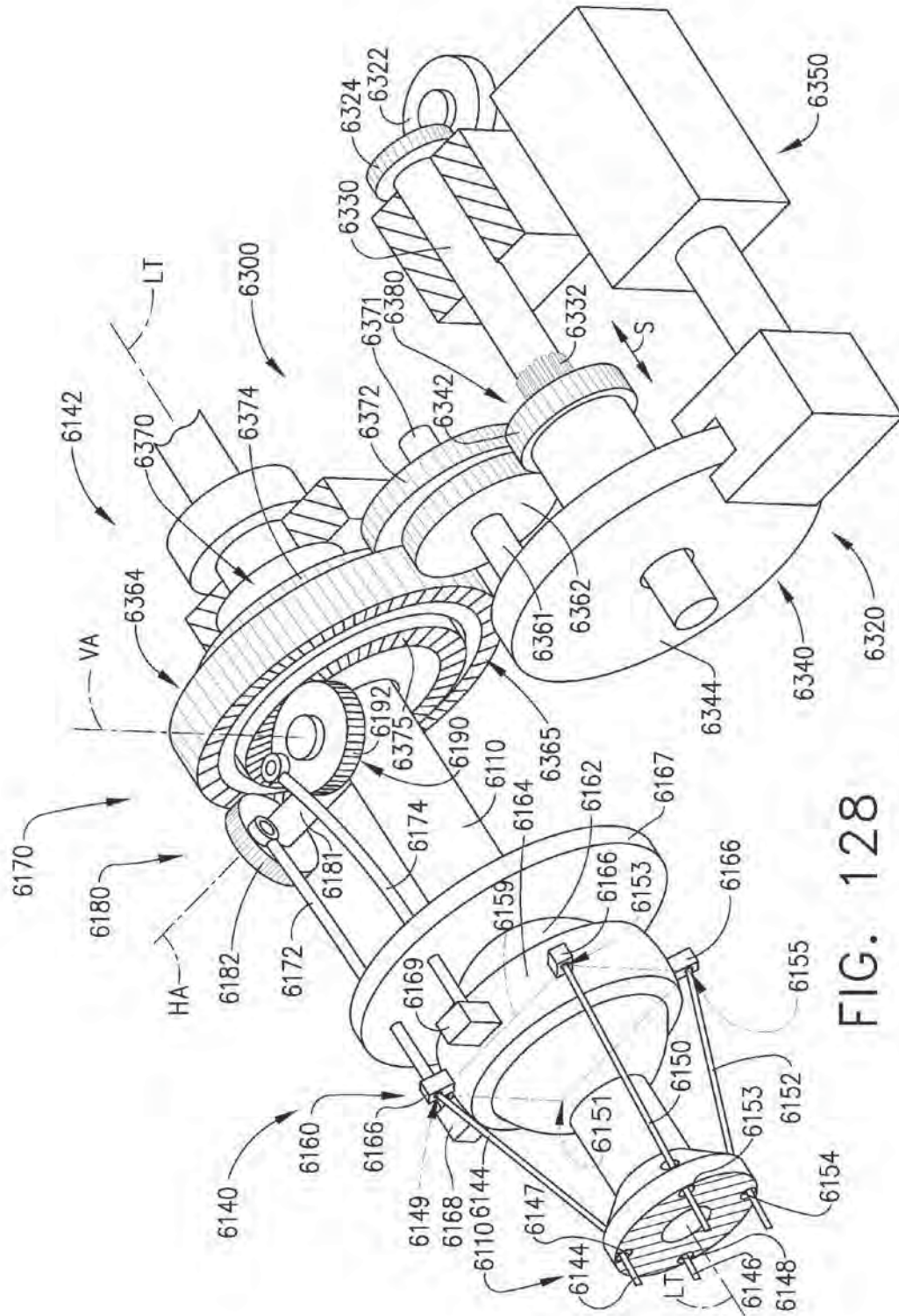

FIG. 128

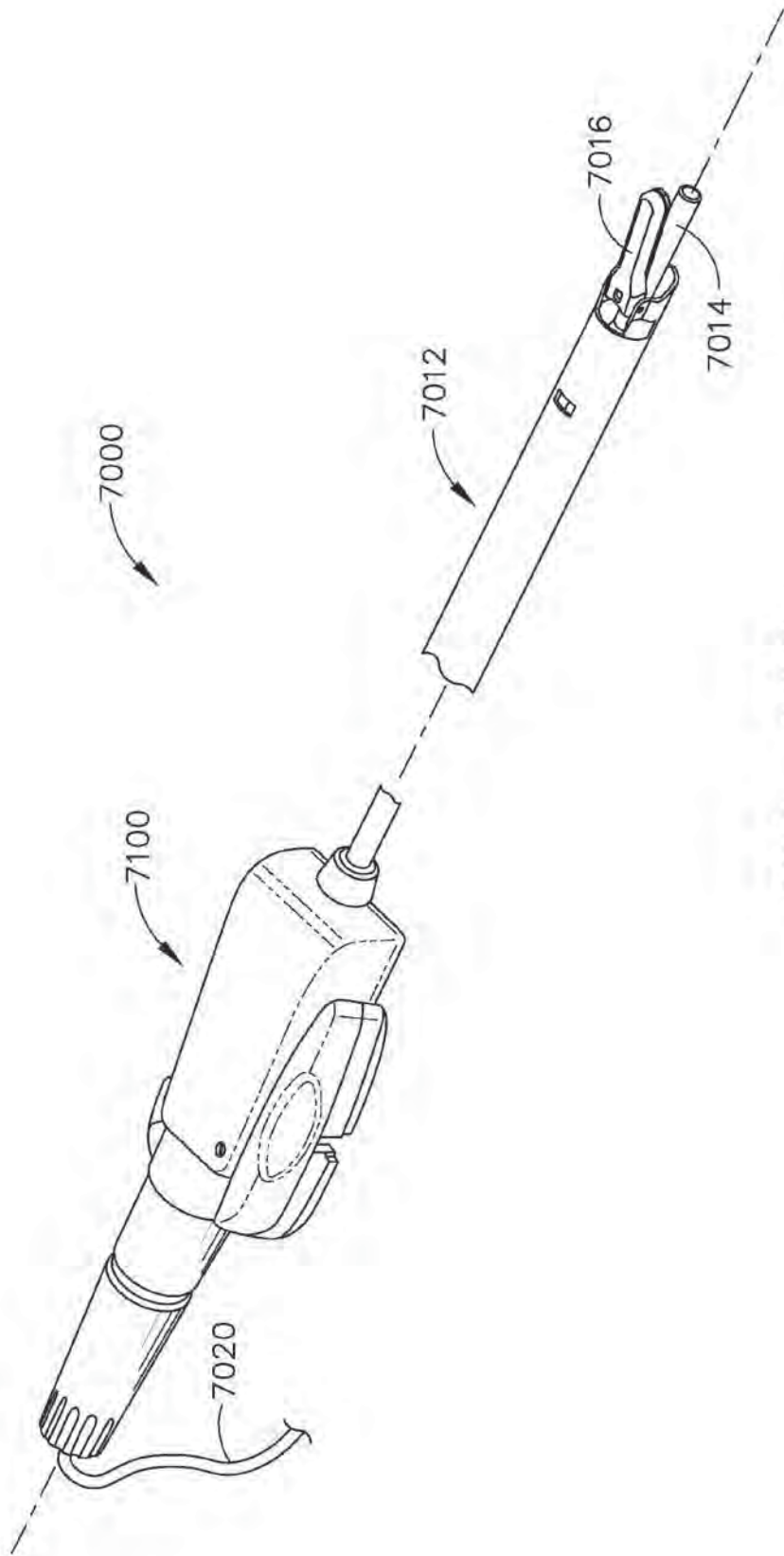

FIG. 129

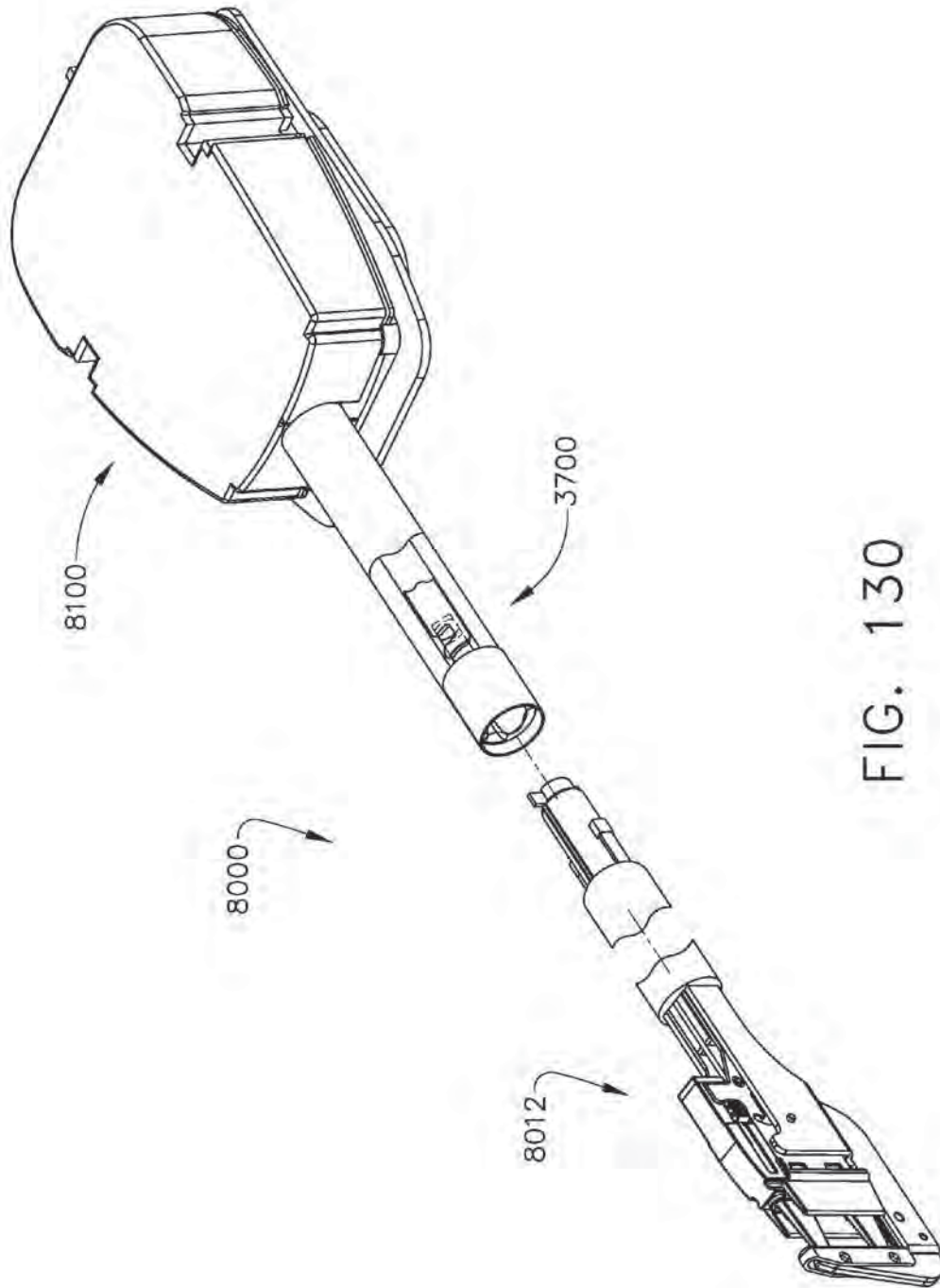

FIG. 130

1

**ROBOTICALLY-CONTROLLED DISPOSABLE
MOTOR-DRIVEN LOADING UNIT****CROSS-REFERENCE TO RELATED
APPLICATIONS**

This non-provisional application for patent is a continuation-in-part patent application of U.S. patent application Ser. No. 12/856,099, filed Aug. 13, 2010, U.S. Patent Publication No. US 2010/0301096 A1, now U.S. Pat. No. 8,196,795 which is a continuation patent application of U.S. patent application Ser. No. 12/031,628, filed Feb. 14, 2008, now U.S. Pat. No. 7,793,812, the disclosures of which are herein incorporated by reference in their respective entireties.

FIELD OF THE INVENTION

The present invention relates in general to endoscopic surgical instruments including, but not limited to, surgical cutting and stapling apparatuses that have disposable loading units that are capable of applying lines of staples to tissue while cutting the tissue between those staple lines and, more particularly, to improvements relating to such disposable loading units.

BACKGROUND

Endoscopic surgical instruments are often preferred over traditional open surgical devices since a smaller incision tends to reduce the post-operative recovery time and complications. Consequently, significant development has gone into a range of endoscopic surgical instruments that are suitable for precise placement of a distal end effector at a desired surgical site through a cannula of a trocar. These distal end effectors engage the tissue in a number of ways to achieve a diagnostic or therapeutic effect (e.g., endocutter, grasper, cutter, staplers, clip applier, access device, drug/gene therapy delivery device, and energy device using ultrasound, RF, laser, etc.).

Known surgical staplers include an end effector that simultaneously makes a longitudinal incision in tissue and applies lines of staples on opposing sides of the incision. The end effector includes a pair of cooperating jaw members that, if the instrument is intended for endoscopic or laparoscopic applications, are capable of passing through a cannula passageway. One of the jaw members supports a staple cartridge that has at least two laterally spaced rows of staples. The other jaw member defines an anvil having staple-forming pockets aligned with the rows of staples in the cartridge. The instrument commonly includes a plurality of reciprocating wedges which, when driven distally, pass through openings in the staple cartridge and engage drivers supporting the staples to effect the firing of the staples toward the anvil.

One type of surgical stapling apparatus is configured to operate with disposable loading units (DLU's) that are constructed to support a staple cartridge and knife assembly therein. Once the procedure is completed, the entire DLU is discarded. Such instruments that are designed to accommodate DLU's purport to offer the advantage of a "fresh" knife blade for each firing of the instrument. Examples of such surgical stapling apparatuses and DLU's are disclosed in U.S. Pat. No. 5,865,361 to Milliman et al., the disclosure of which is herein incorporated by reference in its entirety.

Such prior disposable loading units, however, require the clinician to continuously ratchet the handle to fire the staples and cut the tissue. There is a need for a surgical stapling

2

apparatus configured for use with a disposable loading unit that is driven by a motor contained in the disposable loading unit.

SUMMARY

In one general aspect of various embodiments of the present invention, there is provided a disposable loading unit for attachment to a surgical cutting and stapling apparatus. In various embodiments, the disposable loading unit may comprise a carrier that supports a staple cartridge therein. An anvil assembly may be movably coupled to the carrier for selective movable travel between open and closed positions relative to the staple cartridge. An axial drive assembly may be supported within the carrier such that it can move in a distal direction from a start position to an end position through the carrier and the staple cartridge. The axial drive assembly may also be retracted in a proximal direction from the end position back to the start position. A motor may be supported within the carrier and constructed to drive the axial drive assembly in the distal and proximal directions. A battery may be supported within the carrier and be coupled to the motor for supplying power thereto.

In still another general aspect of various embodiments of the present invention, there is provided a disposable loading unit for attachment to a surgical cutting and stapling apparatus. In various embodiments, the disposable loading unit includes a carrier that supports a staple cartridge therein. An anvil assembly may be movably coupled to the carrier for selective movable travel between open and closed positions relative to the staple cartridge. A housing may be coupled to the carrier and be configured for removable operable attachment to the surgical stapling apparatus. An axial drive assembly may be supported within the carrier and the housing to move in a distal direction from a start position to an end position through the carrier and the staple cartridge. The axial drive assembly may also be retracted in a proximal direction from the end position to the start position. A motor may be supported within the carrier and configured to interface with the axial drive assembly to drive the axial drive assembly in the distal and proximal directions. A battery may be supported within the carrier and be coupled to the motor for supplying power thereto. The battery may be selectively movable between a disconnected position and connected positions in response to motions applied thereto by a portion of the surgical stapling apparatus.

In another general aspect of various embodiments of the present invention, there is provided a surgical cutting and stapling apparatus. Various embodiments of the instrument may include a handle assembly that operably supports a drive assembly therein that is constructed to impart drive motions and a retraction motion. A movable handle portion may be operably supported on the handle assembly and configured to interface with the drive system such that manipulation of the movable handle causes the drive system to impart the drive motions. An elongated body may protrude from the handle assembly and have a distal end that is coupleable to a disposable loading unit. In various embodiments, the disposable loading unit may comprise a carrier that has a staple cartridge supported therein. An anvil assembly may be movably coupled to the carrier for selective movable travel between open and closed positions relative to the staple cartridge. An axial drive assembly may be supported within the carrier such that the axial drive assembly may move in a distal direction from a start position to an end position through the carrier and the staple cartridge and also in a proximal direction from the end position to the start position. A motor may be supported

3

within the carrier and configured to interface with the axial drive assembly to drive the axial drive assembly in the distal and proximal directions. A battery may be supported within the carrier and be coupled to the motor for supplying power thereto. The battery may be configured to interface with a portion of the elongated body to receive the drive motions therefrom upon manipulation of the moveable handle.

In accordance with other general aspects of various embodiments of the present invention, there is provided a disposable loading unit for use with a remotely controllable system. In various embodiments, the disposable loading unit comprises a cartridge assembly that has an elongated housing coupled thereto that is configured for operable attachment to an elongated shaft assembly for transmitting control motions from a control portion of the remotely controllable system. The disposable loading unit further comprises an axial drive assembly that is supported for selective axial travel through the cartridge assembly from a start position to an end position upon application of a rotary control motion thereto from the elongated shaft assembly. A motor is supported within the housing and operably interfaces with the axial drive assembly to selectively apply the rotary motion thereto. A power source is axially movable within the housing from a disconnected position wherein the power source is disconnected from the motor to at least one connected position wherein the power source provides power to said motor.

In accordance with yet other general aspects of various embodiments of the present invention, there is provided a surgical instrument that includes a tool drive portion that is configured for operable attachment to a portion of a robotic system for receiving control motions therefrom. An elongated shaft is coupled to the tool drive portion. An axially movable control member is operably supported within the elongated shaft and is axially movable in response to actuation motions applied thereto from the robotic system. The surgical instrument further includes a disposable loading unit that has a housing that is coupled to the elongated shaft. A staple cartridge is supported by the housing assembly and an axial drive assembly is supported for selective axial travel through the cartridge assembly from a start position to an end position upon application of a rotary motion thereto. A motor is supported within the housing and operably interfaces with the axial drive assembly to selectively apply the rotary motion thereto. A power source is axially movable within the housing from a disconnected position wherein the power source is disconnected from the motor to a first connected position wherein the power source provides power to the motor upon attachment to the control member.

In accordance with still other general aspects of various embodiments of the present invention, there is provided a surgical instrument that includes a tool drive portion that is configured for operable attachment to a portion of a robotic system for receiving control motions therefrom. An elongated shaft is coupled to the tool drive portion. An axially movable control member is operably supported within the elongated shaft and is axially movable in response to actuation motions applied thereto from the robotic system. The surgical instrument further includes a disposable loading unit that has a housing that is coupled to the elongated shaft. A staple cartridge is supported by the housing assembly and an axial drive assembly is supported for selective axial travel through the cartridge assembly from a start position to an end position upon application of a rotary motion thereto. A motor is supported within the housing and operably interfaces with the axial drive assembly to selectively apply the rotary motion thereto. A movable battery holder is coupleable to the control member and is axially movable within the housing in

4

response to motions applied thereto by a control rod. A battery is supported within the battery housing and is configured for selective axial communication with a series of axially spaced contact arrangements in the housing for controlling supply of power from the battery to the motor.

These and other objects and advantages of the present invention shall be made apparent from the accompanying drawings and the description thereof.

BRIEF DESCRIPTION OF THE FIGURES

The accompanying drawings, which are incorporated in and constitute a part of this specification, illustrate embodiments of the invention, and, together with the general description of various embodiments of the invention given above, and the detailed description of the embodiments given below, serve to explain various principles of the present invention.

FIG. 1 is a perspective view of a disposable loading unit embodiment of the present invention coupled to a conventional surgical cutting and stapling apparatus;

FIG. 2 is a cross-sectional view of the disposable loading unit of FIG. 1 with several components shown in full view for clarity;

FIG. 3 is a cross-sectional view of a proximal end of the disposable loading unit embodiment of FIGS. 1 and 2 with various components shown in full view for clarity;

FIG. 4 is a schematic of a circuit embodiment of the disposable loading unit of FIGS. 1-3;

FIG. 5 is a cross-sectional view of the disposable loading unit of FIGS. 1-3 when the disposable loading unit has been attached to the elongated body of the surgical instrument;

FIG. 6 is a schematic view of the circuit illustrating the position of various components of the disposable loading unit after it has been attached to the surgical instrument;

FIG. 7 is a cross-sectional view of the disposable loading unit of FIGS. 1-6 when the drive beam has been moved to the anvil closed position;

FIG. 8 is a schematic view of the circuit illustrating the position of various components of the disposable loading unit after the drive beam has been moved to the anvil closed position;

FIG. 9 is a cross-sectional view of the disposable loading unit of FIGS. 1-8 when the drive beam has been moved to its distal-most fired position;

FIG. 10 is a schematic view of the circuit illustrating the position of various components of the disposable loading unit after the drive beam has been moved to its distal-most fired position;

FIG. 11 is a cross-sectional view of the disposable loading unit of FIGS. 1-10 as the drive beam is being returned to a starting position;

FIG. 12 is a schematic view of the circuit illustrating the position of various components of the disposable loading unit as the drive beam is being returned to a start position;

FIG. 13 is a perspective view of one robotic controller embodiment;

FIG. 14 is a perspective view of one robotic surgical arm cart/manipulator of a robotic system operably supporting a plurality of surgical tool embodiments of the present invention;

FIG. 15 is a side view of the robotic surgical arm cart/manipulator depicted in FIG. 14;

FIG. 16 is a perspective view of an exemplary cart structure with positioning linkages for operably supporting robotic manipulators that may be used with various surgical tool embodiments of the present invention;

5

FIG. 17 is a perspective view of a surgical tool embodiment of the present invention;

FIG. 18 is an exploded assembly view of an adapter and tool holder arrangement for attaching various surgical tool embodiments to a robotic system;

FIG. 19 is a side view of the adapter shown in FIG. 18;

FIG. 20 is a bottom view of the adapter shown in FIG. 18;

FIG. 21 is a top view of the adapter of FIGS. 18 and 19;

FIG. 22 is a partial bottom perspective view of the surgical tool embodiment of FIG. 17;

FIG. 23 is a partial exploded view of a portion of an articulatable surgical end effector embodiment of the present invention;

FIG. 24 is a perspective view of the surgical tool embodiment of FIG. 22 with the tool mounting housing removed;

FIG. 25 is a rear perspective view of the surgical tool embodiment of FIG. 22 with the tool mounting housing removed;

FIG. 26 is a front perspective view of the surgical tool embodiment of FIG. 22 with the tool mounting housing removed;

FIG. 27 is a partial exploded perspective view of the surgical tool embodiment of FIG. 26;

FIG. 28 is a partial cross-sectional side view of the surgical tool embodiment of FIG. 22;

FIG. 29 is an enlarged cross-sectional view of a portion of the surgical tool depicted in FIG. 28;

FIG. 30 is an exploded perspective view of a portion of the tool mounting portion of the surgical tool embodiment depicted in FIG. 22;

FIG. 31 is an enlarged exploded perspective view of a portion of the tool mounting portion of FIG. 30;

FIG. 32 is a partial cross-sectional view of a portion of the elongated shaft assembly of the surgical tool of FIG. 22;

FIG. 33 is a side view of a half portion of a closure nut embodiment of a surgical tool embodiment of the present invention;

FIG. 34 is a perspective view of another surgical tool embodiment of the present invention;

FIG. 35 is a cross-sectional side view of a portion of the surgical end effector and elongated shaft assembly of the surgical tool embodiment of FIG. 34 with the anvil in the open position and the closure clutch assembly in a neutral position;

FIG. 36 is another cross-sectional side view of the surgical end effector and elongated shaft assembly shown in FIG. 35 with the clutch assembly engaged in a closure position;

FIG. 37 is another cross-sectional side view of the surgical end effector and elongated shaft assembly shown in FIG. 35 with the clutch assembly engaged in a firing position;

FIG. 38 is a top view of a portion of a tool mounting portion embodiment of the present invention;

FIG. 39 is a perspective view of another surgical tool embodiment of the present invention;

FIG. 40 is a cross-sectional side view of a portion of the surgical end effector and elongated shaft assembly of the surgical tool embodiment of FIG. 39 with the anvil in the open position;

FIG. 41 is another cross-sectional side view of a portion of the surgical end effector and elongated shaft assembly of the surgical tool embodiment of FIG. 39 with the anvil in the closed position;

FIG. 42 is a perspective view of a closure drive nut and portion of a knife bar embodiment of the present invention;

FIG. 43 is a top view of another tool mounting portion embodiment of the present invention;

FIG. 44 is a perspective view of another surgical tool embodiment of the present invention;

6

FIG. 45 is a cross-sectional side view of a portion of the surgical end effector and elongated shaft assembly of the surgical tool embodiment of FIG. 44 with the anvil in the open position;

FIG. 46 is another cross-sectional side view of a portion of the surgical end effector and elongated shaft assembly of the surgical tool embodiment of FIG. 45 with the anvil in the closed position;

FIG. 47 is a cross-sectional view of a mounting collar embodiment of a surgical tool embodiment of the present invention showing the knife bar and distal end portion of the closure drive shaft;

FIG. 48 is a cross-sectional view of the mounting collar embodiment of FIG. 47;

FIG. 49 is a top view of another tool mounting portion embodiment of another surgical tool embodiment of the present invention;

FIG. 49A is an exploded perspective view of a portion of a gear arrangement of another surgical tool embodiment of the present invention;

FIG. 49B is a cross-sectional perspective view of the gear arrangement shown in FIG. 49A;

FIG. 50 is a cross-sectional side view of a portion of a surgical end effector and elongated shaft assembly of another surgical tool embodiment of the present invention employing a pressure sensor arrangement with the anvil in the open position;

FIG. 51 is another cross-sectional side view of a portion of the surgical end effector and elongated shaft assembly of the surgical tool embodiment of FIG. 50 with the anvil in the closed position;

FIG. 52 is a side view of a portion of another surgical tool embodiment of the present invention in relation to a tool holder portion of a robotic system with some of the components thereof shown in cross-section;

FIG. 53 is a side view of a portion of another surgical tool embodiment of the present invention in relation to a tool holder portion of a robotic system with some of the components thereof shown in cross-section;

FIG. 54 is a side view of a portion of another surgical tool embodiment of the present invention with some of the components thereof shown in cross-section;

FIG. 55 is a side view of a portion of another surgical end effector embodiment of a portion of a surgical tool embodiment of the present invention with some components thereof shown in cross-section;

FIG. 56 is a side view of a portion of another surgical end effector embodiment of a portion of a surgical tool embodiment of the present invention with some components thereof shown in cross-section;

FIG. 57 is a side view of a portion of another surgical end effector embodiment of a portion of a surgical tool embodiment of the present invention with some components thereof shown in cross-section;

FIG. 58 is an enlarged cross-sectional view of a portion of the end effector of FIG. 57;

FIG. 59 is another cross-sectional view of a portion of the end effector of FIGS. 57 and 58;

FIG. 60 is a cross-sectional side view of a portion of a surgical end effector and elongated shaft assembly of another surgical tool embodiment of the present invention with the anvil in the open position;

FIG. 61 is an enlarged cross-sectional side view of a portion of the surgical end effector and elongated shaft assembly of the surgical tool embodiment of FIG. 60;

7

FIG. 62 is another cross-sectional side view of a portion of the surgical end effector and elongated shaft assembly of FIGS. 60 and 61 with the anvil thereof in the closed position;

FIG. 63 is an enlarged cross-sectional side view of a portion of the surgical end effector and elongated shaft assembly of the surgical tool embodiment of FIGS. 60-62;

FIG. 64 is a top view of a tool mounting portion embodiment of a surgical tool embodiment of the present invention;

FIG. 65 is a perspective assembly view of another surgical tool embodiment of the present invention;

FIG. 66 is a front perspective view of a disposable loading unit arrangement that may be employed with various surgical tool embodiments of the present invention;

FIG. 67 is a rear perspective view of the disposable loading unit of FIG. 66;

FIG. 68 is a bottom perspective view of the disposable loading unit of FIGS. 66 and 67;

FIG. 69 is a bottom perspective view of another disposable loading unit embodiment that may be employed with various surgical tool embodiments of the present invention;

FIG. 70 is an exploded perspective view of a mounting portion of a disposable loading unit depicted in FIGS. 66-68;

FIG. 71 is a perspective view of a portion of a disposable loading unit and an elongated shaft assembly embodiment of a surgical tool embodiment of the present invention with the disposable loading unit in a first position;

FIG. 72 is another perspective view of a portion of the disposable loading unit and elongated shaft assembly of FIG. 71 with the disposable loading unit in a second position;

FIG. 73 is a cross-sectional view of a portion of the disposable loading unit and elongated shaft assembly embodiment depicted in FIGS. 71 and 72;

FIG. 74 is another cross-sectional view of the disposable loading unit and elongated shaft assembly embodiment depicted in FIGS. 71-73;

FIG. 75 is a partial exploded perspective view of a portion of another disposable loading unit embodiment and an elongated shaft assembly embodiment of a surgical tool embodiment of the present invention;

FIG. 76 is a partial exploded perspective view of a portion of another disposable loading unit embodiment and an elongated shaft assembly embodiment of a surgical tool embodiment of the present invention;

FIG. 77 is another partial exploded perspective view of the disposable loading unit embodiment and an elongated shaft assembly embodiment of FIG. 76;

FIG. 78 is a top view of another tool mounting portion embodiment of a surgical tool embodiment of the present invention;

FIG. 79 is a side view of another surgical tool embodiment of the present invention with some of the components thereof shown in cross-section and in relation to a robotic tool holder of a robotic system;

FIG. 80 is an exploded assembly view of a surgical end effector embodiment that may be used in connection with various surgical tool embodiments of the present invention;

FIG. 81 is a side view of a portion of a cable-driven system for driving a cutting instrument employed in various surgical end effector embodiments of the present invention;

FIG. 82 is a top view of the cable-driven system and cutting instrument of FIG. 81;

FIG. 83 is a top view of a cable drive transmission embodiment of the present invention in a closure position;

FIG. 84 is another top view of the cable drive transmission embodiment of FIG. 83 in a neutral position;

FIG. 85 is another top view of the cable drive transmission embodiment of FIGS. 83 and 84 in a firing position;

8

FIG. 86 is a perspective view of the cable drive transmission embodiment in the position depicted in FIG. 83;

FIG. 87 is a perspective view of the cable drive transmission embodiment in the position depicted in FIG. 84;

FIG. 88 is a perspective view of the cable drive transmission embodiment in the position depicted in FIG. 85;

FIG. 89 is a perspective view of another surgical tool embodiment of the present invention;

FIG. 90 is a side view of a portion of another cable-driven system embodiment for driving a cutting instrument employed in various surgical end effector embodiments of the present invention;

FIG. 91 is a top view of the cable-driven system embodiment of FIG. 90;

FIG. 92 is a top view of a tool mounting portion embodiment of another surgical tool embodiment of the present invention;

FIG. 93 is a top cross-sectional view of another surgical tool embodiment of the present invention;

FIG. 94 is a cross-sectional view of a portion of a surgical end effector embodiment of a surgical tool embodiment of the present invention;

FIG. 95 is a cross-sectional end view of the surgical end effector of FIG. 103 taken along line 95-95 in FIG. 94;

FIG. 96 is a perspective view of the surgical end effector of FIGS. 94 and 95 with portions thereof shown in cross-section;

FIG. 97 is a side view of a portion of the surgical end effector of FIGS. 94-96;

FIG. 98 is a perspective view of a sled assembly embodiment of various surgical tool embodiments of the present invention;

FIG. 99 is a cross-sectional view of the sled assembly embodiment of FIG. 98 and a portion of the elongated channel of FIG. 97;

FIGS. 100-105 diagrammatically depict the sequential firing of staples in a surgical tool embodiment of the present invention;

FIG. 106 is a partial perspective view of a portion of a surgical end effector embodiment of the present invention;

FIG. 107 is a partial cross-sectional perspective view of a portion of a surgical end effector embodiment of a surgical tool embodiment of the present invention;

FIG. 108 is another partial cross-sectional perspective view of the surgical end effector embodiment of FIG. 107 with a sled assembly axially advancing therethrough;

FIG. 109 is a perspective view of another sled assembly embodiment of another surgical tool embodiment of the present invention;

FIG. 110 is a partial top view of a portion of the surgical end effector embodiment depicted in FIGS. 107 and 108 with the sled assembly axially advancing therethrough;

FIG. 111 is another partial top view of the surgical end effector embodiment of FIG. 110 with the top surface of the surgical staple cartridge omitted for clarity;

FIG. 112 is a partial cross-sectional side view of a rotary driver embodiment and staple pusher embodiment of the surgical end effector depicted in FIGS. 107 and 108;

FIG. 113 is a perspective view of an automated reloading system embodiment of the present invention with a surgical end effector in extractive engagement with the extraction system thereof;

FIG. 114 is another perspective view of the automated reloading system embodiment depicted in FIG. 113;

FIG. 115 is a cross-sectional elevational view of the automated reloading system embodiment depicted in FIGS. 113 and 114;

FIG. 116 is another cross-sectional elevational view of the automated reloading system embodiment depicted in FIGS. 113-115 with the extraction system thereof removing a spent surgical staple cartridge from the surgical end effector;

FIG. 117 is another cross-sectional elevational view of the automated reloading system embodiment depicted in FIGS. 113-116 illustrating the loading of a new surgical staple cartridge into a surgical end effector;

FIG. 118 is a perspective view of another automated reloading system embodiment of the present invention with some components shown in cross-section;

FIG. 119 is an exploded perspective view of a portion of the automated reloading system embodiment of FIG. 118;

FIG. 120 is another exploded perspective view of the portion of the automated reloading system embodiment depicted in FIG. 119;

FIG. 121 is a cross-sectional elevational view of the automated reloading system embodiment of FIGS. 118-120;

FIG. 122 is a cross-sectional view of an orientation tube embodiment supporting a disposable loading unit therein;

FIG. 123 is a perspective view of another surgical tool embodiment of the present invention;

FIG. 124 is a partial perspective view of an articulation joint embodiment of a surgical tool embodiment of the present invention;

FIG. 125 is a perspective view of a closure tube embodiment of a surgical tool embodiment of the present invention;

FIG. 126 is a perspective view of the closure tube embodiment of FIG. 125 assembled on the articulation joint embodiment of FIG. 124;

FIG. 127 is a top view of a portion of a tool mounting portion embodiment of a surgical tool embodiment of the present invention;

FIG. 128 is a perspective view of an articulation drive assembly embodiment employed in the tool mounting portion embodiment of FIG. 127;

FIG. 129 is a perspective view of another surgical tool embodiment of the present invention; and

FIG. 130 is a perspective view of another surgical tool embodiment of the present invention.

DETAILED DESCRIPTION

Applicant of the present application also owns the following patent applications that have been filed on even date herewith and which are each herein incorporated by reference in their respective entireties:

U.S. patent application Ser. No. 13/118,259, entitled "Surgical Instrument With Wireless Communication Between a Control Unit of a Robotic System and Remote Sensor", U.S. Patent Application Publication No. US 2011-0295270 A1;

U.S. patent application Ser. No. 13/118,194, entitled "Robotically-Controlled Endoscopic Accessory Channel", U.S. Patent Application Publication No. US 2011-0295242 A1;

U.S. patent application Ser. No. 13/118,253, entitled "Robotically-Controlled Motorized Surgical Instrument", U.S. Patent Application Publication No. US 2011-0295269 A1;

U.S. patent application Ser. No. 13/118,278, entitled "Robotically-Controlled Surgical Stapling Devices That Produce Formed Staples Having Different Lengths", U.S. Patent Application Publication No. US 2011-0290851 A1;

U.S. patent application Ser. No. 13/118,190, entitled "Robotically-Controlled Motorized Cutting and Fastening Instrument", U.S. Patent Application Publication No. US 2011-0288573 A1;

U.S. patent application Ser. No. 13/118,223, entitled "Robotically-Controlled Shaft Based Rotary Drive Systems For Surgical Instruments", U.S. Patent Application Publication No. US 2011-0290854 A1;

U.S. patent application Ser. No. 13/118,263, entitled "Robotically-Controlled Surgical Instrument Having Recording Capabilities", U.S. Patent Application Publication No. US 2011-0295295 A1;

U.S. patent application Ser. No. 13/118,272, entitled "Robotically-Controlled Surgical Instrument With Force Feedback Capabilities", U.S. Patent Application Publication No. US 2011-0290856 A1;

U.S. patent application Ser. No. 13/118,246, entitled "Robotically-Driven Surgical Instrument With E-Beam Driver", U.S. Patent Application Publication No. US 2011-0290853 A1;

U.S. patent application Ser. No. 13/118,241, entitled "Surgical Stapling Instruments With Rotatable Staple Deployment Arrangements", U.S. Patent Application Publication No. US 2012-0298719 A1.

Certain exemplary embodiments will now be described to provide an overall understanding of the principles of the structure, function, manufacture, and use of the devices and methods disclosed herein. One or more examples of these embodiments are illustrated in the accompanying drawings. Those of ordinary skill in the art will understand that the devices and methods specifically described herein and illustrated in the accompanying drawings are non-limiting exemplary embodiments and that the scope of the various embodiments of the present invention is defined solely by the claims. The features illustrated or described in connection with one exemplary embodiment may be combined with the features of other embodiments. Such modifications and variations are intended to be included within the scope of the present invention.

Uses of the phrases "in various embodiments," "in some embodiments," "in one embodiment", or "in an embodiment", or the like, throughout the specification are not necessarily all referring to the same embodiment. Furthermore, the particular features, structures, or characteristics of one or more embodiments may be combined in any suitable manner in one or more other embodiments. Such modifications and variations are intended to be included within the scope of the present invention.

Turning to the Drawings, wherein like numerals denote like components throughout the several views, FIG. 1 depicts a disposable loading unit 16 of the present invention that is coupled to a conventional surgical cutting and stapling apparatus 10. The construction and general operation of a cutting and stapling apparatus 10 is described in U.S. Pat. No. 5,865,361, the disclosure of which has been herein incorporated by reference. Thus, the present Detailed Description will not discuss the various components of the apparatus 10 and their operation herein beyond what is necessary to describe the operation of the disposable loading unit 16 of the present invention.

As the present Detailed Description proceeds, it will be appreciated that the terms "proximal" and "distal" are used herein with reference to a clinician gripping a handle assembly 12 of the surgical stapling apparatus 10 to which the disposable loading unit 16 is attached. Thus, the disposable loading unit 16 is distal with respect to the more proximal handle assembly 12. It will be further appreciated that, for convenience and clarity, spatial terms such as "vertical", "horizontal", "up", "down", "right", and "left" are used herein with respect to the drawings. However, surgical instru-

11

ments are used in many orientations and positions, and these terms are not intended to be limiting and absolute.

As can be seen in FIG. 1, the disposable loading unit 16 may generally comprise a tool assembly 17 for performing surgical procedures such as cutting tissue and applying staples on each side of the cut. The tool assembly 17 may include a cartridge assembly 18 that includes a staple cartridge 220 that is supported in a carrier 216. An anvil assembly 20 may be pivotally coupled to the carrier 216 in a known manner for selective pivotal travel between open and closed positions. The anvil assembly 20 includes an anvil portion 204 that has a plurality of staple deforming concavities (not shown) formed in the undersurface thereof. The staple cartridge 220 houses a plurality of pushers or drivers (not shown) that each have a staple or staples (not shown) supported thereon. An actuation sled 234 is supported within the tool assembly 17 and is configured to drive the pushers and staples in the staple cartridge 220 in a direction toward the anvil assembly 20 as the actuation sled 234 is driven from the proximal end of the tool assembly 17 to the distal end 220. See FIG. 2.

The disposable loading unit 16 may further include an axial drive assembly 212 that comprises a drive beam 266 that may be constructed from a single sheet of material or, preferably, from multiple stacked sheets. However, the drive beam 266 may be constructed from other suitable material configurations. The distal end of drive beam 266 may include a vertical support strut 271 which supports a knife blade 280 and an abutment surface 283 which engages the central portion of actuation sled 234 during a stapling procedure. Knife blade 280 may be generally positioned to translate slightly behind actuation sled 234 through a central longitudinal slot in staple cartridge 220 to form an incision between rows of stapled body tissue. A retention flange 284 may project distally from vertical strut 271 and support a camming pin or pins 286 at its distal end. Camming pin 286 may be dimensioned and configured to engage camming surface 209 on anvil portion 204 to clamp anvil portion 204 against body tissue. See FIGS. 5 and 7. In addition, a leaf spring (not shown) may be provided between the proximal end of the anvil portion 204 and the distal end portion of the housing 200 to bias the anvil assembly 20 to a normally open position. The carrier 216 may also have an elongated bottom slot therethrough through which a portion of the vertical support strut 271 extends to have a support member 287 attached thereto.

As can also be seen in FIG. 1, the disposable loading unit 16 may also have a housing portion 200 that is adapted to snap onto or otherwise be attached to the carrier 216. The proximal end 500 of housing 200 may include engagement nubs 254 for releasably engaging elongated body 14 of a surgical stapling apparatus. Nubs 254 form a bayonet type coupling with the distal end of the elongated body portion 14 of the surgical stapling apparatus as described in U.S. Pat. No. 5,865,361.

The housing 200 may further include a switch portion 520 that movably houses a battery 526 therein. More specifically and with reference to FIG. 3, the switch portion 520 of the housing 200 defines a battery cavity 522 that movably supports a battery holder 524 that houses a battery 526 therein. As can be seen in FIG. 3, a first battery contact 528 is supported in electrical contact with the battery 526 and protrudes out through the battery holder 524 for sliding engagement with the inside wall 523 of the battery cavity 522. Similarly, a second battery contact 530 is mounted in electrical contact with the battery 526 and also protrudes out of the battery holder 524 to slide along the inside wall 523 of the battery cavity 522. The battery holder 524 has a control rod socket 532 therein configured to receive the distal end 276 of control

12

rod 52 when the proximal end of disposable loading unit 16 is coupled to the elongated body 14 of surgical stapling apparatus 10. As can also be seen in FIG. 3, a series of contacts 540, 542, 544 may be oriented within the wall 523 for contact with the battery contacts 530. The purpose of the contacts 540, 542, and 544 will be discussed in further detail below. As can also be seen in FIG. 3, a biasing member or switch spring 550 is positioned within the battery cavity 522 to bias the battery holder 524 in the proximal direction "PD" such that when the disposable reload 16 is not attached to the elongated body 14, the battery holder 524 is biased to its proximal-most position shown in FIG. 3. When retained in that "pre-use" or "disconnected" position by spring 550, the battery contacts 528 and 530 do not contact any of the contacts 540, 542, 544 within the battery cavity 522 to prevent the battery 526 from being drained during non-use.

As can also be seen in FIG. 3, the housing 200 may further have a motor cavity 560 therein that houses a motor 562 and a gear box 564. The gear box 564 has an output shaft 566 that protrudes through a hole 572 in a proximal bulkhead 570 formed in the housing 200. See FIG. 5. The output shaft 566 is keyed onto or otherwise non-rotatably coupled to a thrust disc 580. As can be seen in FIG. 5, the thrust disc 580 is rotatably supported within a thrust disc cavity 582 formed between the proximal bulkhead 570 and a distal bulkhead 590 formed in the housing 200. In addition, the thrust disc 580 is rotatably supported between a proximal thrust bearing 583 and a distal thrust bearing 584 as shown. As can also be seen in FIG. 5, the thrust disc 580 may be formed on a proximal end of a drive screw 600 that threadedly engages a drive nut 610 that is supported within an engagement section 270 formed on the distal end of the drive beam 266. In various embodiments, the engagement section 270 may include a pair of engagement fingers 270a and 270b that are dimensioned and configured to be received within a slot in the drive nut 610 to non-rotatably affix the drive nut 610 to the drive beam 266. Thus, rotation of the drive screw 600 within the drive nut 610 will drive the drive beam 266 in the distal direction "DD" or in the proximal direction "PD" depending upon the direction of rotation of the drive screw 600.

The disposable loading unit 16 may further include a return switch 630 that is mounted in the housing 200 and is adapted to be actuated by the knife nut 610. As can also be seen in FIG. 5, a switch 640 is mounted in the housing 200 and is also oriented to be actuated by the knife nut 610 to indicate when the anvil assembly 20 has been closed. A switch 650 is mounted in the housing 200 and is also adapted to be actuated by the knife nut 610 to indicate that the axial drive assembly 212 has moved to its finished position. The specific operations of switches 630, 640, 650 will be discussed in further detail below.

FIG. 4 illustrates a circuit embodiment 700 of the present invention that illustrates the positions of various components of the disposable loading unit 16 of the present invention when in a "pre-use" condition. For example, the various components of the disposable loading unit 16 may be in this pre-use orientation when the unit 16 is being stored or shipped. As can be seen in that Figure, when in this orientation, the battery contacts 528 and 530 do not contact any of the contacts 540, 542, 544 in the housing 200 which prevents the battery 526 from being drained during non-use.

FIGS. 5 and 6 illustrate the positions of various components of the disposable loading unit 16 after it has been coupled to the elongated body 14 of the surgical cutting and stapling instrument 10. In particular, as can be seen in FIG. 5, the distal end 276 of the control rod 52 has been coupled to the battery holder 524. When the control rod 52 is attached to the

13

battery holder 524, the battery holder 524 is moved in the distal direction "DD" against the spring 550 such that the battery contacts 528, 530 are brought into contact with the return contacts 540 in the housing 200. Also, when in that position, the knife nut 610 actuates the return switch 630 into an open orientation. It will be appreciated that the return switch 630 is a normally closed switch that is actuated to the open position by the knife nut 610. As shown in FIG. 6, when the return switch 630 is open, the motor 562 is not powered.

FIGS. 7 and 8 illustrate the positions of various components of the disposable loading unit 16 after the clinician has actuated the movable handle 24 (shown in FIG. 1) of the surgical cutting and stapling instrument 10. As discussed in U.S. Pat. No. 5,865,361, when the movable handle 24 is initially moved toward the stationary handle member 22, the control rod 52 is caused to move in the distal direction "DD". As can be seen in FIG. 7, as the control rod 52 is initially moved in the distal direction during the anvil close stroke, the battery holder 524 moves the battery 526 to a position wherein the battery contacts 528, 530 contact the anvil close contacts 542. Power is now permitted to flow from the battery 526 to the motor 562 which rotates the drive screw 600 and causes the drive beam 266 to move distally. As the drive beam 266 moves distally in the "DD" direction, the camming pin 286 engages cam portion 209 of anvil portion 204 and causes the anvil assembly 20 to pivot to a closed position as illustrated in FIG. 7. As the drive beam 266 moves distally to the anvil closed position, the knife nut 610 moves out of contact with the return switch 630 which permits the return switch to resume its normally open position. The knife nut 610 then actuates the anvil closed switch 640 and moves it to an open position. See FIG. 8. In various embodiments one or more anvil closed lights 660 may be mounted in the housing 200 for providing a visual indication to the clinician that the anvil assembly 20 has been moved to the closed position.

When the clinician desires to fire the instrument 10 (i.e., actuate the instrument 10 to cause it to cut and staple tissue), the clinician first depresses the plunger 82 of the firing lock-out assembly 80 (FIG. 1) as discussed in U.S. Pat. No. 5,865,361. Thereafter, movable handle 24 may be actuated. As the movable handle 24 is depressed, the control rod 52 moves the battery holder 524 and battery 526 to the position illustrated in FIGS. 9 and 10. As can be seen in those Figures, when the battery 526 is moved into that position, the battery contacts 528, 530 are brought into contact with the fire contacts 544. The switch 650 is normally closed until it is actuated by the knife nut 610. Thus, when the battery contacts 528, 530 contact the firing contacts 544, power flows from the battery 526 to the motor 562 which drives the drive screw 600. As the drive screw 600 is rotated, the drive beam 266 and knife nut 610 are driven in the distal direction "DD" to advance actuation sled 234 through staple cartridge 220 to effect ejection of staples and cutting of tissue. Once the drive beam 266 reaches the end of the firing stroke (i.e., all of the staples in the staple cartridge 220 have been fired), knife nut 610 is positioned to actuate the normally closed switch 650 and move it to an open position (illustrated in FIG. 10) which stops the flow of power from the battery 526 to the motor 562. In various embodiments, a distal indication light or lights 670 may be mounted on the housing 200 to provide an indication to the clinician that the drive beam 266 has reached its distal-most fired position.

To retract the drive beam 266, the clinician grasps the retract knobs 32 (shown in FIG. 1) on the handle assembly 12 and pulls them in the proximal direction "PD". The operation and construction of the retract knobs 32 is discussed in U.S. Pat. No. 5,865,361. Once the clinician moves the drive beam

14

266 a sufficient distance in the proximal direction "PD" so as to move the battery to contacts 540 (FIG. 11), power will be supplied through switch 630 to reverse the motor 562. Knife nut then releases switch 650. The motor 562 then drives the drive beam 266 distal to switch 630, which opens. The return switch 630 is also in its normally closed position thereby permitting power to flow to the motor 562 and rotate the drive screw 610 in an opposite direction to drive the drive beam 266 in the proximal direction "PD". Once the knife nut 610 actuates the knife return switch 630, the knife return switch 630 is moved to an open position thereby stopping flow of power from the battery 526 to the motor 562. In various embodiments, a starting light 700 may be mounted in the housing 200 to provide an indication that the drive beam 266 is in the starting position.

FIGS. 11 and 12 illustrate the positions of various components of the disposable loading unit 16 of the present invention when the distal end of the drive beam 266 and blade 280 inadvertently becomes jammed during the firing stroke (i.e., when the blade 280 is being distally advanced through the tissue clamped in the tool assembly 17). To address such occurrence, a current limiter 680 may be provided as shown in FIG. 12. The current limiter 680 serves to turn off the motor 562 when the amount of current that it is drawing exceeds a predetermined threshold. It will be understood that the amount of current that the motor 562 draws during a jam would increase over the amount of current drawn during normal firing operations. Once the current limiter 680 shuts down the motor 562, the clinician can retract the drive beam 266 by grasping the retract knobs 32 (shown in FIG. 1) on the handle assembly 12 and pulling them in the proximal direction "PD" and the motor 562 will drive the drive screw 600 in reverse in the manner described above. Thus, the current limiter 680 serves to stop the motor 562 when the axial drive assembly 212 encounters resistance that exceeds a predetermined amount of resistance which is associated with the predetermined maximum amount of current that the motor 562 should draw under normal operating circumstances. This feature also saves the battery power so the drive beam 266 can be retracted.

Thus, the disposable loading unit 16 of the present invention comprises a self-contained motor driven disposable loading unit that may be used in connection with conventional surgical cutting and stapling instruments that traditionally required the clinician to manually advance and retract the drive assembly and cutting blade of a disposable loading unit coupled thereto. Various embodiments of the disposable loading unit 16 may be constructed to facilitate the automatic retraction of the axial drive assembly should the blade encounter a predetermined amount of resistance.

While several embodiments of the invention have been described, it should be apparent, however, that various modifications, alterations and adaptations to those embodiments may occur to persons skilled in the art with the attainment of some or all of the advantages of the invention. For example, according to various embodiments, a single component may be replaced by multiple components, and multiple components may be replaced by a single component, to perform a given function or functions. This application is therefore intended to cover all such modifications, alterations and adaptations without departing from the scope and spirit of the disclosed invention as defined by the appended claims.

Any patent, publication, or other disclosure material, in whole or in part, that is said to be incorporated by reference herein is incorporated herein only to the extent that the incorporated materials does not conflict with existing definitions, statements, or other disclosure material set forth in this dis-

15

closure. As such, and to the extent necessary, the disclosure as explicitly set forth herein supersedes any conflicting material incorporated herein by reference. Any material, or portion thereof, that is said to be incorporated by reference herein, but which conflicts with existing definitions, statements, or other disclosure material set forth herein will only be incorporated to the extent that no conflict arises between that incorporated material and the existing disclosure material.

The invention which is intended to be protected is not to be construed as limited to the particular embodiments disclosed. The embodiments are therefore to be regarded as illustrative rather than restrictive. Variations and changes may be made by others without departing from the spirit of the present invention. Accordingly, it is expressly intended that all such equivalents, variations and changes which fall within the spirit and scope of the present invention as defined in the claims be embraced thereby.

Over the years a variety of minimally invasive robotic (or "telesurgical") systems have been developed to increase surgical dexterity as well as to permit a surgeon to operate on a patient in an intuitive manner. Many of such systems are disclosed in the following U.S. patents which are each herein incorporated by reference in their respective entirety: U.S. Pat. No. 5,792,135, entitled "Articulated Surgical Instrument For Performing Minimally Invasive Surgery With Enhanced Dexterity and Sensitivity", U.S. Pat. No. 6,231,565, entitled "Robotic Arm DLUS For Performing Surgical Tasks", U.S. Pat. No. 6,783,524, entitled "Robotic Surgical Tool With Ultrasound Cauterizing and Cutting Instrument", U.S. Pat. No. 6,364,888, entitled "Alignment of Master and Slave In a Minimally Invasive Surgical Apparatus", U.S. Pat. No. 7,524,320, entitled "Mechanical Actuator Interface System For Robotic Surgical Tools", U.S. Pat. No. 7,691,098, entitled "Platform Link Wrist Mechanism", U.S. Pat. No. 7,806,891, entitled "Repositioning and Reorientation of Master/Slave Relationship in Minimally Invasive Telesurgery", and U.S. Pat. No. 7,824,401, entitled "Surgical Tool With Wristed Monopolar Electrosurgical End Effectors". Many of such systems, however, have in the past been unable to generate the magnitude of forces required to effectively cut and fasten tissue.

FIG. 13 depicts one version of a master controller 1001 that may be used in connection with a robotic arm slave cart 1100 of the type depicted in FIG. 14. Master controller 1001 and robotic arm slave cart 1100, as well as their respective components and control systems are collectively referred to herein as a robotic system 1000. Examples of such systems and devices are disclosed in U.S. Pat. No. 7,524,320 which has been herein incorporated by reference. Thus, various details of such devices will not be described in detail herein beyond that which may be necessary to understand various embodiments and forms of the present invention. As is known, the master controller 1001 generally includes master controllers (generally represented as 1003 in FIG. 13) which are grasped by the surgeon and manipulated in space while the surgeon views the procedure via a stereo display 1002. The master controllers 1001 generally comprise manual input devices which preferably move with multiple degrees of freedom, and which often further have an actuatable handle for actuating tools (for example, for closing grasping saws, applying an electrical potential to an electrode, or the like).

As can be seen in FIG. 14, in one form, the robotic arm cart 1100 is configured to actuate a plurality of surgical tools, generally designated as 1200. Various robotic surgery systems and methods employing master controller and robotic arm cart arrangements are disclosed in U.S. Pat. No. 6,132,368, entitled "Multi-Component Telepresence System and

16

Method", the full disclosure of which is incorporated herein by reference. In various forms, the robotic arm cart 1100 includes a base 1002 from which, in the illustrated embodiment, three surgical tools 1200 are supported. In various forms, the surgical tools 1200 are each supported by a series of manually articulatable linkages, generally referred to as set-up joints 1104, and a robotic manipulator 1106. These structures are herein illustrated with protective covers extending over much of the robotic linkage. These protective covers may be optional, and may be limited in size or entirely eliminated in some embodiments to minimize the inertia that is encountered by the servo mechanisms used to manipulate such devices, to limit the volume of moving components so as to avoid collisions, and to limit the overall weight of the cart 1100. Cart 1100 will generally have dimensions suitable for transporting the cart 1100 between operating rooms. The cart 1100 may be configured to typically fit through standard operating room doors and onto standard hospital elevators. In various forms, the cart 1100 would preferably have a weight and include a wheel (or other transportation) system that allows the cart 1100 to be positioned adjacent an operating table by a single attendant.

Referring now to FIG. 15, in at least one form, robotic manipulators 1106 may include a linkage 1108 that constrains movement of the surgical tool 1200. In various embodiments, linkage 1108 includes rigid links coupled together by rotational joints in a parallelogram arrangement so that the surgical tool 1200 rotates around a point in space 1110, as more fully described in issued U.S. Pat. No. 5,817,084, the full disclosure of which is herein incorporated by reference. The parallelogram arrangement constrains rotation to pivoting about an axis 1112a, sometimes called the pitch axis. The links supporting the parallelogram linkage are pivotally mounted to set-up joints 1104 (FIG. 14) so that the surgical tool 1200 further rotates about an axis 1112b, sometimes called the yaw axis. The pitch and yaw axes 1112a, 1112b intersect at the remote center 1114, which is aligned along a shaft 1208 of the surgical tool 1200. The surgical tool 1200 may have further degrees of driven freedom as supported by manipulator 1106, including sliding motion of the surgical tool 1200 along the longitudinal tool axis "LT-LT". As the surgical tool 1200 slides along the tool axis LT-LT relative to manipulator 1106 (arrow 1112c), remote center 1114 remains fixed relative to base 1116 of manipulator 1106. Hence, the entire manipulator is generally moved to re-position remote center 1114. Linkage 1108 of manipulator 1106 is driven by a series of motors 1120. These motors actively move linkage 1108 in response to commands from a processor of a control system. As will be discussed in further detail below, motors 1120 are also employed to manipulate the surgical tool 1200.

An alternative set-up joint structure is illustrated in FIG. 16. In this embodiment, a surgical tool 1200 is supported by an alternative manipulator structure 1106' between two tissue manipulation tools. Those of ordinary skill in the art will appreciate that various embodiments of the present invention may incorporate a wide variety of alternative robotic structures, including those described in U.S. Pat. No. 5,878,193, entitled "Automated Endoscope System For Optimal Positioning", the full disclosure of which is incorporated herein by reference. Additionally, while the data communication between a robotic component and the processor of the robotic surgical system is primarily described herein with reference to communication between the surgical tool 1200 and the master controller 1001, it should be understood that similar communication may take place between circuitry of a manipulator, a set-up joint, an endoscope or other image

capture device, or the like, and the processor of the robotic surgical system for component compatibility verification, component-type identification, component calibration (such as off-set or the like) communication, confirmation of coupling of the component to the robotic surgical system, or the like.

An exemplary non-limiting surgical tool 1200 that is well-adapted for use with a robotic system 1000 that has a tool drive assembly 1010 (FIG. 18) that is operatively coupled to a master controller 1001 that is operable by inputs from an operator (i.e., a surgeon) is depicted in FIG. 17. As can be seen in that Figure, the surgical tool 1200 includes a surgical end effector 2012 that comprises an endocutter. In at least one form, the surgical tool 1200 generally includes an elongated shaft assembly 2008 that has a proximal closure tube 2040 and a distal closure tube 2042 that are coupled together by an articulation joint 2011. The surgical tool 1200 is operably coupled to the manipulator by a tool mounting portion, generally designated as 1300. The surgical tool 1200 further includes an interface 1230 which mechanically and electrically couples the tool mounting portion 1300 to the manipulator. One form of interface 1230 is illustrated in FIGS. 16-22. In various embodiments, the tool mounting portion 1300 includes a tool mounting plate 1302 that operably supports a plurality of (four are shown in FIG. 22) rotatable body portions, driven discs or elements 1304, that each include a pair of pins 1306 that extend from a surface of the driven element 1304. One pin 1306 is closer to an axis of rotation of each driven element 1304 than the other pin 1306 on the same driven element 1304, which helps to ensure positive angular alignment of the driven element 1304. Interface 1230 includes an adaptor portion 1240 that is configured to mountingly engage the mounting plate 1302 as will be further discussed below. The adaptor portion 1240 may include an array of electrical connecting pins 1242 (FIG. 20) which may be coupled to a memory structure by a circuit board within the tool mounting portion 1300. While interface 1230 is described herein with reference to mechanical, electrical, and magnetic coupling elements, it should be understood that a wide variety of telemetry modalities might be used, including infrared, inductive coupling, or the like.

As can be seen in FIGS. 18-21, the adapter portion 1240 generally includes a tool side 1244 and a holder side 1246. In various forms, a plurality of rotatable bodies 1250 are mounted to a floating plate 1248 which has a limited range of movement relative to the surrounding adaptor structure normal to the major surfaces of the adaptor 1240. Axial movement of the floating plate 1248 helps decouple the rotatable bodies 1250 from the tool mounting portion 1300 when the levers 1303 along the sides of the tool mounting portion housing 1301 are actuated (See FIG. 17). Other mechanisms/arrangements may be employed for releasably coupling the tool mounting portion 1300 to the adaptor 1240. In at least one form, rotatable bodies 1250 are resiliently mounted to floating plate 1248 by resilient radial members which extend into a circumferential indentation about the rotatable bodies 1250. The rotatable bodies 1250 can move axially relative to plate 1248 by deflection of these resilient structures. When disposed in a first axial position (toward tool side 1244) the rotatable bodies 1250 are free to rotate without angular limitation. However, as the rotatable bodies 1250 move axially toward tool side 1244, tabs 1252 (extending radially from the rotatable bodies 1250) laterally engage detents on the floating plates so as to limit angular rotation of the rotatable bodies 1250 about their axes. This limited rotation can be used to help drivingly engage the rotatable bodies 1250 with drive pins 1272 of a corresponding tool holder portion 1270 of the

robotic system 1000, as the drive pins 1272 will push the rotatable bodies 1250 into the limited rotation position until the pins 1234 are aligned with (and slide into) openings 1256'. Openings 1256 on the tool side 1244 and openings 1256' on the holder side 1246 of rotatable bodies 1250 are configured to accurately align the driven elements 1304 (FIG. 22) of the tool mounting portion 1300 with the drive elements 1271 of the tool holder 1270. As described above regarding inner and outer pins 1306 of driven elements 1304, the openings 1256, 1256' are at differing distances from the axis of rotation on their respective rotatable bodies 1250 so as to ensure that the alignment is not 180 degrees from its intended position. Additionally, each of the openings 1256 is slightly radially elongated so as to fittingly receive the pins 1306 in the circumferential orientation. This allows the pins 1306 to slide radially within the openings 1256, 1256' and accommodate some axial misalignment between the tool 1200 and tool holder 1270, while minimizing any angular misalignment and backlash between the drive and driven elements. Openings 1256 on the tool side 1244 are offset by about 90 degrees from the openings 1256' (shown in broken lines) on the holder side 1246, as can be seen most clearly in FIG. 21.

Various embodiments may further include an array of electrical connector pins 1242 located on holder side 1246 of adaptor 1240, and the tool side 1244 of the adaptor 1240 may include slots 1258 (FIG. 21) for receiving a pin array (not shown) from the tool mounting portion 1300. In addition to transmitting electrical signals between the surgical tool 1200 and the tool holder 1270, at least some of these electrical connections may be coupled to an adaptor memory device 1260 (FIG. 20) by a circuit board of the adaptor 1240.

A detachable latch arrangement 1239 may be employed to releasably affix the adaptor 1240 to the tool holder 1270. As used herein, the term "tool drive assembly" when used in the context of the robotic system 1000, at least encompasses various embodiments of the adapter 1240 and tool holder 1270 and which has been generally designated as 1010 in FIG. 18. For example, as can be seen in FIG. 18, the tool holder 1270 may include a first latch pin arrangement 1274 that is sized to be received in corresponding clevis slots 1241 provided in the adaptor 1240. In addition, the tool holder 1270 may further have second latch pins 1276 that are sized to be retained in corresponding latch devices 1243 in the adaptor 1240. See FIG. 20. In at least one form, a latch assembly 1245 is movably supported on the adapter 1240 and is biasable between a first latched position wherein the latch pins 1276 are retained within their respective latch clevis 1243 and an unlatched position wherein the second latch pins 1276 may be into or removed from the latch devices 1243. A spring or springs (not shown) are employed to bias the latch assembly into the latched position. A lip on the tool side 1244 of adaptor 1240 may slidably receive laterally extending tabs of tool mounting housing 1301.

Turning next to FIGS. 22-29, in at least one embodiment, the surgical tool 1200 includes a surgical end effector 2012 that comprises in this example, among other things, at least one component 2024 that is selectively movable between first and second positions relative to at least one other component 2022 in response to various control motions applied thereto as will be discussed in further detail below. In various embodiments, component 2022 comprises an elongated channel 2022 configured to operably support a surgical staple cartridge 2034 therein and component 2024 comprises a pivotally translatable clamping member, such as an anvil 2024. Various embodiments of the surgical end effector 2012 are configured to maintain the anvil 2024 and elongated channel 2022 at a spacing that assures effective stapling and severing

of tissue clamped in the surgical end effector **2012**. As can be seen in FIG. 28, the surgical end effector **2012** further includes a cutting instrument **2032** and a sled **2033**. The cutting instrument **2032** may be, for example, a knife. The surgical staple cartridge **2034** operably houses a plurality of surgical staples (not show) therein that are supported on movable staple drivers (not shown). As the cutting instrument **2032** is driven distally through a centrally-disposed slot (not shown) in the surgical staple cartridge **2034**, it forces the sled **2033** distally as well. As the sled **2033** is driven distally, its "wedge-shaped" configuration contacts the movable staple drivers and drives them vertically toward the closed anvil **2024**. The surgical staples are formed as they are driven into the forming surface located on the underside of the anvil **2024**. The sled **2033** may be part of the surgical staple cartridge **2034**, such that when the cutting instrument **2032** is retracted following the cutting operation, the sled **2033** does not retract. The anvil **2024** may be pivotably opened and closed at a pivot point **2025** located at the proximal end of the elongated channel **2022**. The anvil **2024** may also include a tab **2027** at its proximal end that interacts with a component of the mechanical closure system (described further below) to facilitate the opening of the anvil **2024**. The elongated channel **2022** and the anvil **2024** may be made of an electrically conductive material (such as metal) so that they may serve as part of an antenna that communicates with sensor(s) in the end effector, as described above. The surgical staple cartridge **2034** could be made of a nonconductive material (such as plastic) and the sensor may be connected to or disposed in the surgical staple cartridge **2034**, as was also described above.

As can be seen in FIGS. 22-29, the surgical end effector **2012** is attached to the tool mounting portion **1300** by an elongated shaft assembly **2008** according to various embodiments. As shown in the illustrated embodiment, the shaft assembly **2008** includes an articulation joint generally indicated as **2011** that enables the surgical end effector **2012** to be selectively articulated about an articulation axis AA-AA that is substantially transverse to a longitudinal tool axis LT-LT. See FIG. 23. In other embodiments, the articulation joint is omitted. In various embodiments, the shaft assembly **2008** may include a closure tube assembly **2009** that comprises a proximal closure tube **2040** and a distal closure tube **2042** that are pivotably linked by a pivot links **2044** and operably supported on a spine assembly generally depicted as **2049**. In the illustrated embodiment, the spine assembly **2049** comprises a distal spine portion **2050** that is attached to the elongated channel **2022** and is pivotally coupled to the proximal spine portion **2052**. The closure tube assembly **2009** is configured to axially slide on the spine assembly **2049** in response to actuation motions applied thereto. The distal closure tube **2042** includes an opening **2045** into which the tab **2027** on the anvil **2024** is inserted in order to facilitate opening of the anvil **2024** as the distal closure tube **2042** is moved axially in the proximal direction "PD". The closure tubes **2040**, **2042** may be made of electrically conductive material (such as metal) so that they may serve as part of the antenna, as described above. Components of the main drive shaft assembly (e.g., the drive shafts **2048**, **2050**) may be made of a nonconductive material (such as plastic).

In use, it may be desirable to rotate the surgical end effector **2012** about the longitudinal tool axis LT-LT. In at least one embodiment, the tool mounting portion **1300** includes a rotational transmission assembly **2069** that is configured to receive a corresponding rotary output motion from the tool drive assembly **1010** of the robotic system **1000** and convert that rotary output motion to a rotary control motion for rotating the elongated shaft assembly **2008** (and surgical end

effector **2012**) about the longitudinal tool axis LT-LT. In various embodiments, for example, the proximal end **2060** of the proximal closure tube **2040** is rotatably supported on the tool mounting plate **1302** of the tool mounting portion **1300** by a forward support cradle **1309** and a closure sled **2100** that is also movably supported on the tool mounting plate **1302**. In at least one form, the rotational transmission assembly **2069** includes a tube gear segment **2062** that is formed on (or attached to) the proximal end **2060** of the proximal closure tube **2040** for operable engagement by a rotational gear assembly **2070** that is operably supported on the tool mounting plate **1302**. As can be seen in FIG. 25, the rotational gear assembly **2070**, in at least one embodiment, comprises a rotation drive gear **2072** that is coupled to a corresponding first one of the driven discs or elements **1304** on the adapter side **1307** of the tool mounting plate **1302** when the tool mounting portion **1300** is coupled to the tool drive assembly **1010**. See FIG. 22. The rotational gear assembly **2070** further comprises a rotary driven gear **2074** that is rotatably supported on the tool mounting plate **1302** in meshing engagement with the tube gear segment **2062** and the rotation drive gear **2072**. Application of a first rotary output motion from the tool drive assembly **1010** of the robotic system **1000** to the corresponding driven element **1304** will thereby cause rotation of the rotation drive gear **2072**. Rotation of the rotation drive gear **2072** ultimately results in the rotation of the elongated shaft assembly **2008** (and the surgical end effector **2012**) about the longitudinal tool axis LT-LT (represented by arrow "R" in FIG. 25). It will be appreciated that the application of a rotary output motion from the tool drive assembly **1010** in one direction will result in the rotation of the elongated shaft assembly **2008** and surgical end effector **2012** about the longitudinal tool axis LT-LT in a first direction and an application of the rotary output motion in an opposite direction will result in the rotation of the elongated shaft assembly **2008** and surgical end effector **2012** in a second direction that is opposite to the first direction.

In at least one embodiment, the closure of the anvil **2024** relative to the staple cartridge **2034** is accomplished by axially moving the closure tube assembly **2009** in the distal direction "DD" on the spine assembly **2049**. As indicated above, in various embodiments, the proximal end **2060** of the proximal closure tube **2040** is supported by the closure sled **2100** which comprises a portion of a closure transmission, generally depicted as **2099**. In at least one form, the closure sled **2100** is configured to support the closure tube **2009** on the tool mounting plate **1320** such that the proximal closure tube **2040** can rotate relative to the closure sled **2100**, yet travel axially with the closure sled **2100**. In particular, as can be seen in FIG. 30, the closure sled **2100** has an upstanding tab **2101** that extends into a radial groove **2063** in the proximal end portion of the proximal closure tube **2040**. In addition, as can be seen in FIGS. 27 and 30, the closure sled **2100** has a tab portion **2102** that extends through a slot **1305** in the tool mounting plate **1302**. The tab portion **2102** is configured to retain the closure sled **2100** in sliding engagement with the tool mounting plate **1302**. In various embodiments, the closure sled **2100** has an upstanding portion **2104** that has a closure rack gear **2106** formed thereon. The closure rack gear **2106** is configured for driving engagement with a closure gear assembly **2110**. See FIG. 27.

In various forms, the closure gear assembly **2110** includes a closure spur gear **2112** that is coupled to a corresponding second one of the driven discs or elements **1304** on the adapter side **1307** of the tool mounting plate **1302**. See FIG. 22. Thus, application of a second rotary output motion from the tool drive assembly **1010** of the robotic system **1000** to the corre-

21

sponding second driven element 1304 will cause rotation of the closure spur gear 2112 when the tool mounting portion 1300 is coupled to the tool drive assembly 1010. The closure gear assembly 2110 further includes a closure reduction gear set 2114 that is supported in meshing engagement with the closure spur gear 2112. As can be seen in FIGS. 26 and 27, the closure reduction gear set 2114 includes a driven gear 2116 that is rotatably supported in meshing engagement with the closure spur gear 2112. The closure reduction gear set 2114 further includes a first closure drive gear 2118 that is in meshing engagement with a second closure drive gear 2120 that is rotatably supported on the tool mounting plate 1302 in meshing engagement with the closure rack gear 2106. Thus, application of a second rotary output motion from the tool drive assembly 1010 of the robotic system 1000 to the corresponding second driven element 1304 will cause rotation of the closure spur gear 2112 and the closure transmission 2110 and ultimately drive the closure sled 2100 and closure tube assembly 2009 axially. The axial direction in which the closure tube assembly 2009 moves ultimately depends upon the direction in which the second driven element 1304 is rotated. For example, in response to one rotary output motion received from the tool drive assembly 1010 of the robotic system 1000, the closure sled 2100 will be driven in the distal direction "DD" and ultimately drive the closure tube assembly 1009 in the distal direction. As the distal closure tube 2042 is driven distally, the end of the closure tube segment 2042 will engage a portion of the anvil 2024 and cause the anvil 2024 to pivot to a closed position. Upon application of an "opening" output motion from the tool drive assembly 1010 of the robotic system 1000, the closure sled 2100 and shaft assembly 2008 will be driven in the proximal direction "PD". As the distal closure tube 2042 is driven in the proximal direction, the opening 2045 therein interacts with the tab 2027 on the anvil 2024 to facilitate the opening thereof. In various embodiments, a spring (not shown) may be employed to bias the anvil to the open position when the distal closure tube 2042 has been moved to its starting position. In various embodiments, the various gears of the closure gear assembly 2110 are sized to generate the necessary closure forces needed to satisfactorily close the anvil 2024 onto the tissue to be cut and stapled by the surgical end effector 2012. For example, the gears of the closure transmission 2110 may be sized to generate approximately 70-120 pounds.

In various embodiments, the cutting instrument 2032 is driven through the surgical end effector 2012 by a knife bar 2200. See FIGS. 28 and 30. In at least one form, the knife bar 2200 may be fabricated from, for example, stainless steel or other similar material and has a substantially rectangular cross-sectional shape. Such knife bar configuration is sufficiently rigid to push the cutting instrument 2032 through tissue clamped in the surgical end effector 2012, while still being flexible enough to enable the surgical end effector 2012 to articulate relative to the proximal closure tube 2040 and the proximal spine portion 2052 about the articulation axis AA-AA as will be discussed in further detail below. As can be seen in FIGS. 31 and 32, the proximal spine portion 2052 has a rectangular-shaped passage 2054 extending therethrough to provide support to the knife bar 2200 as it is axially pushed therethrough. The proximal spine portion 2052 has a proximal end 2056 that is rotatably mounted to a spine mounting bracket 2057 attached to the tool mounting plate 1032. See FIG. 30. Such arrangement permits the proximal spine portion 2052 to rotate, but not move axially, within the proximal closure tube 2040.

As shown in FIG. 28, the distal end 2202 of the knife bar 2200 is attached to the cutting instrument 2032. The proximal

22

end 2204 of the knife bar 2200 is rotatably affixed to a knife rack gear 2206 such that the knife bar 2200 is free to rotate relative to the knife rack gear 2206. See FIG. 39. As can be seen in FIGS. 24-29, the knife rack gear 2206 is slidably supported within a rack housing 2210 that is attached to the tool mounting plate 1302 such that the knife rack gear 2206 is retained in meshing engagement with a knife gear assembly 2220. More specifically and with reference to FIG. 27, in at least one embodiment, the knife gear assembly 2220 includes a knife spur gear 2222 that is coupled to a corresponding third one of the driven discs or elements 1304 on the adapter side 1307 of the tool mounting plate 1302. See FIG. 22. Thus, application of another rotary output motion from the robotic system 1000 through the tool drive assembly 1010 to the corresponding third driven element 1304 will cause rotation of the knife spur gear 2222. The knife gear assembly 2220 further includes a knife gear reduction set 2224 that includes a first knife driven gear 2226 and a second knife drive gear 2228. The knife gear reduction set 2224 is rotatably mounted to the tool mounting plate 1302 such that the first knife driven gear 2226 is in meshing engagement with the knife spur gear 2222. Likewise, the second knife drive gear 2228 is in meshing engagement with a third knife drive gear 2230 that is rotatably supported on the tool mounting plate 1302 in meshing engagement with the knife rack gear 2206. In various embodiments, the gears of the knife gear assembly 2220 are sized to generate the forces needed to drive the cutting element 2032 through the tissue clamped in the surgical end effector 2012 and actuate the staples therein. For example, the gears of the knife drive assembly 2230 may be sized to generate approximately 40 to 100 pounds. It will be appreciated that the application of a rotary output motion from the tool drive assembly 1010 in one direction will result in the axial movement of the cutting instrument 2032 in a distal direction and application of the rotary output motion in an opposite direction will result in the axial travel of the cutting instrument 2032 in a proximal direction.

In various embodiments, the surgical tool 1200 employs and articulation system 2007 that includes an articulation joint 2011 that enables the surgical end effector 2012 to be articulated about an articulation axis AA-AA that is substantially transverse to the longitudinal tool axis LT-LT. In at least one embodiment, the surgical tool 1200 includes first and second articulation bars 2250a, 2250b that are slidably supported within corresponding passages 2053 provided through the proximal spine portion 2052. See FIGS. 30 and 32. In at least one form, the first and second articulation bars 2250a, 2250b are actuated by an articulation transmission generally designated as 2249 that is operably supported on the tool mounting plate 1032. Each of the articulation bars 2250a, 2250b has a proximal end 2252 that has a guide rod protruding therefrom which extend laterally through a corresponding slot in the proximal end portion of the proximal spine portion 2052 and into a corresponding arcuate slot in an articulation nut 2260 which comprises a portion of the articulation transmission. FIG. 40 illustrates articulation bar 2250a. It will be understood that articulation bar 2250b is similarly constructed. As can be seen in FIG. 31, for example, the articulation bar 2250a has a guide rod 2254 which extends laterally through a corresponding slot 2058 in the proximal end portion 2056 of the distal spine portion 2050 and into a corresponding arcuate slot 2262 in the articulation nut 2260. In addition, the articulation bar 2250a has a distal end 2251a that is pivotally coupled to the distal spine portion 2050 by, for example, a pin 2253a and articulation bar 2250b has a distal end 2251b that is pivotally coupled to the distal spine portion 2050 by, for example, a pin 2253b. In particular, the articu-

23

lation bar **2250a** is laterally offset in a first lateral direction from the longitudinal tool axis LT-LT and the articulation bar **2250b** is laterally offset in a second lateral direction from the longitudinal tool axis LT-LT. Thus, axial movement of the articulation bars **2250a** and **2250b** in opposing directions will result in the articulation of the distal spine portion **2050** as well as the surgical end effector **2012** attached thereto about the articulation axis AA-AA as will be discussed in further detail below.

Articulation of the surgical end effector **2012** is controlled by rotating the articulation nut **2260** about the longitudinal tool axis LT-LT. The articulation nut **2260** is rotatably journaled on the proximal end portion **2056** of the distal spine portion **2050** and is rotatably driven thereon by an articulation gear assembly **2270**. More specifically and with reference to FIG. 25, in at least one embodiment, the articulation gear assembly **2270** includes an articulation spur gear **2272** that is coupled to a corresponding fourth one of the driven discs or elements **1304** on the adapter side **1307** of the tool mounting plate **1302**. See FIG. 22. Thus, application of another rotary input motion from the robotic system **1000** through the tool drive assembly **1010** to the corresponding fourth driven element **1304** will cause rotation of the articulation spur gear **2272** when the interface **1230** is coupled to the tool holder **1270**. An articulation drive gear **2274** is rotatably supported on the tool mounting plate **1302** in meshing engagement with the articulation spur gear **2272** and a gear portion **2264** of the articulation nut **2260** as shown. As can be seen in FIGS. 30 and 31, the articulation nut **2260** has a shoulder **2266** formed thereon that defines an annular groove **2267** for receiving retaining posts **2268** therein. Retaining posts **2268** are attached to the tool mounting plate **1302** and serve to prevent the articulation nut **2260** from moving axially on the proximal spine portion **2052** while maintaining the ability to be rotated relative thereto. Thus, rotation of the articulation nut **2260** in a first direction, will result in the axial movement of the articulation bar **2250a** in a distal direction "DD" and the axial movement of the articulation bar **2250b** in a proximal direction "PD" because of the interaction of the guide rods **2254** with the spiral slots **2262** in the articulation gear **2260**. Similarly, rotation of the articulation nut **2260** in a second direction that is opposite to the first direction will result in the axial movement of the articulation bar **2250a** in the proximal direction "PD" as well as cause articulation bar **2250b** to axially move in the distal direction "DD". Thus, the surgical end effector **2012** may be selectively articulated about articulation axis "AA-AA" in a first direction "FD" by simultaneously moving the articulation bar **2250a** in the distal direction "DD" and the articulation bar **2250b** in the proximal direction "PD". Likewise, the surgical end effector **2012** may be selectively articulated about the articulation axis "AA-AA" in a second direction "SD" by simultaneously moving the articulation bar **2250a** in the proximal direction "PD" and the articulation bar **2250b** in the distal direction "DD." See FIG. 23.

The tool embodiment described above employs an interface arrangement that is particularly well-suited for mounting the robotically controllable medical tool onto at least one form of robotic arm arrangement that generates at least four different rotary control motions. Those of ordinary skill in the art will appreciate that such rotary output motions may be selectively controlled through the programmable control systems employed by the robotic system/controller. For example, the tool arrangement described above may be well-suited for use with those robotic systems manufactured by Intuitive Surgical, Inc. of Sunnyvale, Calif., U.S.A., many of which may be described in detail in various patents incorpo-

24

rated herein by reference. The unique and novel aspects of various embodiments of the present invention serve to utilize the rotary output motions supplied by the robotic system to generate specific control motions having sufficient magnitudes that enable end effectors to cut and staple tissue. Thus, the unique arrangements and principles of various embodiments of the present invention may enable a variety of different forms of the tool systems disclosed and claimed herein to be effectively employed in connection with other types and forms of robotic systems that supply programmed rotary or other output motions. In addition, as will become further apparent as the present Detailed Description proceeds, various end effector embodiments of the present invention that require other forms of actuation motions may also be effectively actuated utilizing one or more of the control motions generated by the robotic system.

FIGS. 34-38 illustrate yet another surgical tool **2300** that may be effectively employed in connection with the robotic system **1000** that has a tool drive assembly that is operably coupled to a controller of the robotic system that is operable by inputs from an operator and which is configured to provide at least one rotary output motion to at least one rotatable body portion supported on the tool drive assembly. In various forms, the surgical tool **2300** includes a surgical end effector **2312** that includes an elongated channel **2322** and a pivotally translatable clamping member, such as an anvil **2324**, which are maintained at a spacing that assures effective stapling and severing of tissue clamped in the surgical end effector **2312**. As shown in the illustrated embodiment, the surgical end effector **2312** may include, in addition to the previously-mentioned elongated channel **2322** and anvil **2324**, a cutting instrument **2332** that has a sled portion **2333** formed thereon, a surgical staple cartridge **2334** that is seated in the elongated channel **2322**, and a rotary end effector drive shaft **2336** that has a helical screw thread formed thereon. The cutting instrument **2332** may be, for example, a knife. As will be discussed in further detail below, rotation of the end effector drive shaft **2336** will cause the cutting instrument **2332** and sled portion **2333** to axially travel through the surgical staple cartridge **2334** to move between a starting position and an ending position. The direction of axial travel of the cutting instrument **2332** depends upon the direction in which the end effector drive shaft **2336** is rotated. The anvil **2324** may be pivotally opened and closed at a pivot point **2325** connected to the proximate end of the elongated channel **2322**. The anvil **2324** may also include a tab **2327** at its proximate end that operably interfaces with a component of the mechanical closure system (described further below) to open and close the anvil **2324**. When the end effector drive shaft **2336** is rotated, the cutting instrument **2332** and sled **2333** will travel longitudinally through the surgical staple cartridge **2334** from the starting position to the ending position, thereby cutting tissue clamped within the surgical end effector **2312**. The movement of the sled **2333** through the surgical staple cartridge **2334** causes the staples therein to be driven through the severed tissue and against the closed anvil **2324**, which turns the staples to fasten the severed tissue. In one form, the elongated channel **2322** and the anvil **2324** may be made of an electrically conductive material (such as metal) so that they may serve as part of the antenna that communicates with sensor(s) in the end effector, as described above. The surgical staple cartridge **2334** could be made of a nonconductive material (such as plastic) and the sensor may be connected to or disposed in the surgical staple cartridge **2334**, as described above.

It should be noted that although the embodiments of the surgical tool **2300** described herein employ a surgical end

25

effector **2312** that staples the severed tissue, in other embodiments different techniques for fastening or sealing the severed tissue may be used. For example, end effectors that use RF energy or adhesives to fasten the severed tissue may also be used. U.S. Pat. No. 5,709,680, entitled "Electrosurgical Hemostatic Device" to Yates et al., and U.S. Pat. No. 5,688, 270, entitled "Electrosurgical Hemostatic Device With Recessed And/Or Offset Electrodes" to Yates et al., which are incorporated herein by reference, discloses cutting instruments that use RF energy to fasten the severed tissue. U.S. patent application Ser. No. 11/267,811 to Morgan et al., now U.S. Pat. No. 7,673,783 and U.S. patent application Ser. No. 11/267,383 to Shelton et al., now U.S. Pat. No. 7,607,557, which are also incorporated herein by reference, disclose cutting instruments that use adhesives to fasten the severed tissue. Accordingly, although the description herein refers to cutting/stapling operations and the like, it should be recognized that this is an exemplary embodiment and is not meant to be limiting. Other tissue-fastening techniques may also be used.

In the illustrated embodiment, the surgical end effector **2312** is coupled to an elongated shaft assembly **2308** that is coupled to a tool mounting portion **2460** and defines a longitudinal tool axis LT-LT. In this embodiment, the elongated shaft assembly **2308** does not include an articulation joint. Those of ordinary skill in the art will understand that other embodiments may have an articulation joint therein. In at least one embodiment, the elongated shaft assembly **2308** comprises a hollow outer tube **2340** that is rotatably supported on a tool mounting plate **2462** of a tool mounting portion **2460** as will be discussed in further detail below. In various embodiments, the elongated shaft assembly **2308** further includes a distal spine shaft **2350**. Distal spine shaft **2350** has a distal end portion **2354** that is coupled to, or otherwise integrally formed with, a distal stationary base portion **2360** that is non-movably coupled to the channel **2322**. See FIGS. 35-37.

As shown in FIG. 35, the distal spine shaft **2350** has a proximal end portion **2351** that is slidably received within a slot **2355** in a proximal spine shaft **2353** that is non-movably supported within the hollow outer tube **2340** by at least one support collar **2357**. As can be further seen in FIGS. 35 and 36, the surgical tool **2300** includes a closure tube **2370** that is constrained to only move axially relative to the distal stationary base portion **2360**. The closure tube **2370** has a proximal end **2372** that has an internal thread **2374** formed therein that is in threaded engagement with a transmission arrangement, generally depicted as **2375** that is operably supported on the tool mounting plate **2462**. In various forms, the transmission arrangement **2375** includes a rotary drive shaft assembly, generally designated as **2381**. When rotated, the rotary drive shaft assembly **2381** will cause the closure tube **2370** to move axially as will be describe in further detail below. In at least one form, the rotary drive shaft assembly **2381** includes a closure drive nut **2382** of a closure clutch assembly generally designated as **2380**. More specifically, the closure drive nut **2382** has a proximal end portion **2384** that is rotatably supported relative to the outer tube **2340** and is in threaded engagement with the closure tube **2370**. For assembly purposes, the proximal end portion **2384** may be threadably attached to a retention ring **2386**. Retention ring **2386**, in cooperation with an end **2387** of the closure drive nut **2382**, defines an annular slot **2388** into which a shoulder **2392** of a locking collar **2390** extends. The locking collar **2390** is non-movably attached (e.g., welded, glued, etc.) to the end of the outer tube **2340**. Such arrangement serves to affix the closure drive nut **2382** to the outer tube **2340** while enabling the

26

closure drive nut **2382** to rotate relative to the outer tube **2340**. The closure drive nut **2382** further has a distal end **2383** that has a threaded portion **2385** that threadably engages the internal thread **2374** of the closure tube **2370**. Thus, rotation of the closure drive nut **2382** will cause the closure tube **2370** to move axially as represented by arrow "D" in FIG. 36.

Closure of the anvil **2324** and actuation of the cutting instrument **2332** are accomplished by control motions that are transmitted by a hollow drive sleeve **2400**. As can be seen in FIGS. 35 and 36, the hollow drive sleeve **2400** is rotatably and slidably received on the distal spine shaft **2350**. The drive sleeve **2400** has a proximal end portion **2401** that is rotatably mounted to the proximal spine shaft **2353** that protrudes from the tool mounting portion **2460** such that the drive sleeve **2400** may rotate relative thereto. See FIG. 35. As can also be seen in FIGS. 35-37, the drive sleeve **2400** is rotated about the longitudinal tool axis "LT-LT" by a drive shaft **2440**. The drive shaft **2440** has a drive gear **2444** that is attached to its distal end **2442** and is in meshing engagement with a driven gear **2450** that is attached to the drive sleeve **2400**.

The drive sleeve **2400** further has a distal end portion **2402** that is coupled to a closure clutch **2410** portion of the closure clutch assembly **2380** that has a proximal face **2412** and a distal face **2414**. The proximal face **2412** has a series of proximal teeth **2416** formed thereon that are adapted for selective engagement with corresponding proximal teeth cavities **2418** formed in the proximal end portion **2384** of the closure drive nut **2382**. Thus, when the proximal teeth **2416** are in meshing engagement with the proximal teeth cavities **2418** in the closure drive nut **2382**, rotation of the drive sleeve **2400** will result in rotation of the closure drive nut **2382** and ultimately cause the closure tube **2370** to move axially as will be discussed in further detail below.

As can be most particularly seen in FIGS. 35 and 36, the distal face **2414** of the drive clutch portion **2410** has a series of distal teeth **2415** formed thereon that are adapted for selective engagement with corresponding distal teeth cavities **2426** formed in a face plate portion **2424** of a knife drive shaft assembly **2420**. In various embodiments, the knife drive shaft assembly **2420** comprises a hollow knife shaft segment **2430** that is rotatably received on a corresponding portion of the distal spine shaft **2350** that is attached to or protrudes from the stationary base **2360**. When the distal teeth **2415** of the closure clutch portion **2410** are in meshing engagement with the distal teeth cavities **2426** in the face plate portion **2424**, rotation of the drive sleeve **2400** will result in rotation of the drive shaft segment **2430** about the stationary shaft **2350**. As can be seen in FIGS. 35-37, a knife drive gear **2432** is attached to the drive shaft segment **2430** and is meshing engagement with a drive knife gear **2434** that is attached to the end effector drive shaft **2336**. Thus, rotation of the drive shaft segment **2430** will result in the rotation of the end effector drive shaft **2336** to drive the cutting instrument **2332** and sled **2333** distally through the surgical staple cartridge **2334** to cut and staple tissue clamped within the surgical end effector **2312**. The sled **2333** may be made of, for example, plastic, and may have a sloped distal surface. As the sled **2333** traverses the elongated channel **2322**, the sloped forward surface of the sled **2333** pushes up or "drive" the staples in the surgical staple cartridge **2334** through the clamped tissue and against the anvil **2324**. The anvil **2324** turns or "forms" the staples, thereby stapling the severed tissue. As used herein, the term "fire" refers to the initiation of actions required to drive the cutting instrument and sled portion in a distal direction through the surgical staple cartridge to cut the tissue clamped in the surgical end effector and drive the staples through the severed tissue.

In use, it may be desirable to rotate the surgical end effector 2312 about the longitudinal tool axis LT-LT. In at least one embodiment, the transmission arrangement 2375 includes a rotational transmission assembly 2465 that is configured to receive a corresponding rotary output motion from the tool drive assembly 1010 of the robotic system 1000 and convert that rotary output motion to a rotary control motion for rotating the elongated shaft assembly 2308 (and surgical end effector 2312) about the longitudinal tool axis LT-LT. As can be seen in FIG. 38, a proximal end 2341 of the outer tube 2340 is rotatably supported within a cradle arrangement 2343 attached to the tool mounting plate 2462 of the tool mounting portion 2460. A rotation gear 2345 is formed on or attached to the proximal end 2341 of the outer tube 2340 of the elongated shaft assembly 2308 for meshing engagement with a rotation gear assembly 2470 operably supported on the tool mounting plate 2462. In at least one embodiment, a rotation drive gear 2472 is coupled to a corresponding first one of the driven discs or elements 1304 on the adapter side of the tool mounting plate 2462 when the tool mounting portion 2460 is coupled to the tool drive assembly 1010. See FIGS. 22 and 38. The rotation drive assembly 2470 further comprises a rotary driven gear 2474 that is rotatably supported on the tool mounting plate 2462 in meshing engagement with the rotation gear 2345 and the rotation drive gear 2472. Application of a first rotary output motion from the robotic system 1000 through the tool drive assembly 1010 to the corresponding driven element 1304 will thereby cause rotation of the rotation drive gear 2472 by virtue of being operably coupled thereto. Rotation of the rotation drive gear 2472 ultimately results in the rotation of the elongated shaft assembly 2308 (and the end effector 2312) about the longitudinal tool axis LT-LT (primary rotary motion).

Closure of the anvil 2324 relative to the staple cartridge 2034 is accomplished by axially moving the closure tube 2370 in the distal direction "DD". Axial movement of the closure tube 2370 in the distal direction "DD" is accomplished by applying a rotary control motion to the closure drive nut 2382. To apply the rotary control motion to the closure drive nut 2382, the closure clutch 2410 must first be brought into meshing engagement with the proximal end portion 2384 of the closure drive nut 2382. In various embodiments, the transmission arrangement 2375 further includes a shifter drive assembly 2480 that is operably supported on the tool mounting plate 2462. More specifically and with reference to FIG. 38, it can be seen that a proximal end portion 2359 of the proximal spine portion 2353 extends through the rotation gear 2345 and is rotatably coupled to a shifter gear rack 2481 that is slidably affixed to the tool mounting plate 2462 through slots 2482. The shifter drive assembly 2480 further comprises a shifter drive gear 2483 that is coupled to a corresponding second one of the driven discs or elements 1304 on the adapter side of the tool mounting plate 2462 when the tool mounting portion 2460 is coupled to the tool holder 1270. See FIGS. 22 and 38. The shifter drive assembly 2480 further comprises a shifter driven gear 2478 that is rotatably supported on the tool mounting plate 2462 in meshing engagement with the shifter drive gear 2483 and the shifter rack gear 2482. Application of a second rotary output motion from the robotic system 1000 through the tool drive assembly 1010 to the corresponding driven element 1304 will thereby cause rotation of the shifter drive gear 2483 by virtue of being operably coupled thereto. Rotation of the shifter drive gear 2483 ultimately results in the axial movement of the shifter gear rack 2482 and the proximal spine portion 2353 as well as the drive sleeve 2400 and the closure clutch 2410 attached thereto. The direction of axial travel of the closure clutch

2410 depends upon the direction in which the shifter drive gear 2483 is rotated by the robotic system 1000. Thus, rotation of the shifter drive gear 2483 in a first rotary direction will result in the axial movement of the closure clutch 2410 in the proximal direction "PD" to bring the proximal teeth 2416 into meshing engagement with the proximal teeth cavities 2418 in the closure drive nut 2382. Conversely, rotation of the shifter drive gear 2483 in a second rotary direction (opposite to the first rotary direction) will result in the axial movement of the closure clutch 2410 in the distal direction "DD" to bring the distal teeth 2415 into meshing engagement with corresponding distal teeth cavities 2426 formed in the face plate portion 2424 of the knife drive shaft assembly 2420.

Once the closure clutch 2410 has been brought into meshing engagement with the closure drive nut 2382, the closure drive nut 2382 is rotated by rotating the closure clutch 2410. Rotation of the closure clutch 2410 is controlled by applying rotary output motions to a rotary drive transmission portion 2490 of transmission arrangement 2375 that is operably supported on the tool mounting plate 2462 as shown in FIG. 38. In at least one embodiment, the rotary drive transmission 2490 includes a rotary drive assembly 2490' that includes a gear 2491 that is coupled to a corresponding third one of the driven discs or elements 1304 on the adapter side of the tool mounting plate 2462 when the tool mounting portion 2460 is coupled to the tool holder 1270. See FIGS. 22 and 38. The rotary drive transmission 2490 further comprises a first rotary driven gear 2492 that is rotatably supported on the tool mounting plate 2462 in meshing engagement with a second rotary driven gear 2493 and the rotary drive gear 2491. The second rotary driven gear 2493 is coupled to a proximal end portion 2443 of the drive shaft 2440.

Rotation of the rotary drive gear 2491 in a first rotary direction will result in the rotation of the drive shaft 2440 in a first direction. Conversely, rotation of the rotary drive gear 2491 in a second rotary direction (opposite to the first rotary direction) will cause the drive shaft 2440 to rotate in a second direction. As indicated above, the drive shaft 2440 has a drive gear 2444 that is attached to its distal end 2442 and is in meshing engagement with a driven gear 2450 that is attached to the drive sleeve 2400. Thus, rotation of the drive shaft 2440 results in rotation of the drive sleeve 2400.

A method of operating the surgical tool 2300 will now be described. Once the tool mounting portion 2462 has been operably coupled to the tool holder 1270 of the robotic system 1000 and oriented into position adjacent the target tissue to be cut and stapled, if the anvil 2334 is not already in the open position (FIG. 35), the robotic system 1000 may apply the first rotary output motion to the shifter drive gear 2483 which results in the axial movement of the closure clutch 2410 into meshing engagement with the closure drive nut 2382 (if it is not already in meshing engagement therewith). See FIG. 36. Once the controller 1001 of the robotic system 1000 has confirmed that the closure clutch 2410 is meshing engagement with the closure drive nut 2382 (e.g., by means of sensor(s) in the surgical end effector 2312 that are in communication with the robotic control system), the robotic controller 1001 may then apply a second rotary output motion to the rotary drive gear 2492 which, as was described above, ultimately results in the rotation of the rotary drive nut 2382 in the first direction which results in the axial travel of the closure tube 2370 in the distal direction "DD". As the closure tube 2370 moved in the distal direction, it contacts a portion of the anvil 2323 and causes the anvil 2324 to pivot to the closed position to clamp the target tissue between the anvil 2324 and the surgical staple cartridge 2334. Once the robotic controller 1001 determines that the anvil 2334 has been piv-

oted to the closed position by corresponding sensor(s) in the surgical end effector 2312 in communication therewith, the robotic system 1000 discontinues the application of the second rotary output motion to the rotary drive gear 2491. The robotic controller 1001 may also provide the surgeon with an indication that the anvil 2334 has been fully closed. The surgeon may then initiate the firing procedure. In alternative embodiments, the firing procedure may be automatically initiated by the robotic controller 1001. The robotic controller 1001 then applies the primary rotary control motion 2483 to the shifter drive gear 2483 which results in the axial movement of the closure clutch 2410 into meshing engagement with the face plate portion 2424 of the knife drive shaft assembly 2420. See FIG. 46. Once the controller 1001 of the robotic system 1000 has confirmed that the closure clutch 2410 is meshing engagement with the face plate portion 2424 (by means of sensor(s)) in the end effector 2312 that are in communication with the robotic controller 1001), the robotic controller 1001 may then apply the second rotary output motion to the rotary drive gear 2492 which, as was described above, ultimately results in the axial movement of the cutting instrument 2332 and sled portion 2333 in the distal direction "DD" through the surgical staple cartridge 2334. As the cutting instrument 2332 moves distally through the surgical staple cartridge 2334, the tissue clamped therein is severed. As the sled portion 2333 is driven distally, it causes the staples within the surgical staple cartridge to be driven through the severed tissue into forming contact with the anvil 2324. Once the robotic controller 1001 has determined that the cutting instrument 2324 has reached the end position within the surgical staple cartridge 2334 (by means of sensor(s)) in the end effector 2312 that are in communication with the robotic controller 1001), the robotic controller 1001 discontinues the application of the second rotary output motion to the rotary drive gear 2491. Thereafter, the robotic controller 1001 applies the secondary rotary output motion to the rotary drive gear 2491 which ultimately results in the axial travel of the cutting instrument 2332 and sled portion 2333 in the proximal direction "PD" to the starting position. Once the robotic controller 1001 has determined that the cutting instrument 2324 has reached the starting position by means of sensor(s) in the surgical end effector 2312 that are in communication with the robotic controller 1001, the robotic controller 1001 discontinues the application of the secondary rotary output motion to the rotary drive gear 2491. Thereafter, the robotic controller 1001 applies the primary rotary output motion to the shifter drive gear 2483 to cause the closure clutch 2410 to move into engagement with the rotary drive nut 2382. Once the closure clutch 2410 has been moved into meshing engagement with the rotary drive nut 2382, the robotic controller 1001 then applies the secondary output motion to the rotary drive gear 2491 which ultimately results in the rotation of the rotary drive nut 2382 in the second direction to cause the closure tube 2370 to move in the proximal direction "PD". As can be seen in FIGS. 35-37, the closure tube 2370 has an opening 2345 therein that engages the tab 2327 on the anvil 2324 to cause the anvil 2324 to pivot to the open position. In alternative embodiments, a spring may also be employed to pivot the anvil 2324 to the open position when the closure tube 2370 has been returned to the starting position (FIG. 35).

FIGS. 39-43 illustrate yet another surgical tool 2500 that may be effectively employed in connection with the robotic system 1000. In various forms, the surgical tool 2500 includes a surgical end effector 2512 that includes a "first portion" in the form of an elongated channel 2522 and a "second movable portion" in the form of a pivotally translatable clamping member, such as an anvil 2524, which are maintained at a

spacing that assures effective stapling and severing of tissue clamped in the surgical end effector 2512. As shown in the illustrated embodiment, the surgical end effector 2512 may include, in addition to the previously-mentioned elongated channel 2522 and anvil 2524, a "third movable portion" in the form of a cutting instrument 2532, a sled (not shown), and a surgical staple cartridge 2534 that is removably seated in the elongated channel 2522. The cutting instrument 2532 may be, for example, a knife. The anvil 2524 may be pivotably opened and closed at a pivot point 2525 connected to the proximate end of the elongated channel 2522. The anvil 2524 may also include a tab 2527 at its proximate end that is configured to operably interface with a component of the mechanical closure system (described further below) to open and close the anvil 2524. When actuated, the knife 2532 and sled travel longitudinally along the elongated channel 2522, thereby cutting tissue clamped within the surgical end effector 2512. The movement of the sled along the elongated channel 2522 causes the staples of the surgical staple cartridge 2534 to be driven through the severed tissue and against the closed anvil 2524, which turns the staples to fasten the severed tissue. In one form, the elongated channel 2522 and the anvil 2524 may be made of an electrically conductive material (such as metal) so that they may serve as part of the antenna that communicates with sensor(s) in the surgical end effector, as described above. The surgical staple cartridge 2534 could be made of a nonconductive material (such as plastic) and the sensor may be connected to or disposed in the surgical staple cartridge 2534, as described above.

It should be noted that although the embodiments of the surgical tool 2500 described herein employ a surgical end effector 2512 that staples the severed tissue, in other embodiments different techniques for fastening or sealing the severed tissue may be used. For example, end effectors that use RF energy or adhesives to fasten the severed tissue may also be used. U.S. Pat. No. 5,709,680, entitled "Electrosurgical Hemostatic Device" to Yates et al., and U.S. Pat. No. 5,688,270, entitled "Electrosurgical Hemostatic Device With Recessed And/Or Offset Electrodes" to Yates et al., which are incorporated herein by reference, discloses cutting instruments that use RF energy to fasten the severed tissue. U.S. patent application Ser. No. 11/267,811 to Morgan et al., now U.S. Pat. No. 7,673,783 and U.S. patent application Ser. No. 11/267,383 to Shelton et al., now U.S. Pat. No. 7,607,557, which are also incorporated herein by reference, disclose cutting instruments that use adhesives to fasten the severed tissue. Accordingly, although the description herein refers to cutting/stapling operations and the like, it should be recognized that this is an exemplary embodiment and is not meant to be limiting. Other tissue-fastening techniques may also be used.

In the illustrated embodiment, the elongated channel 2522 of the surgical end effector 2512 is coupled to an elongated shaft assembly 2508 that is coupled to a tool mounting portion 2600. In at least one embodiment, the elongated shaft assembly 2508 comprises a hollow spine tube 2540 that is non-movably coupled to a tool mounting plate 2602 of the tool mounting portion 2600. As can be seen in FIGS. 40 and 41, the proximal end 2523 of the elongated channel 2522 comprises a hollow tubular structure configured to be attached to the distal end 2541 of the spine tube 2540. In one embodiment, for example, the proximal end 2523 of the elongated channel 2522 is welded or glued to the distal end of the spine tube 2540.

As can be further seen in FIGS. 40 and 41, in at least one non-limiting embodiment, the surgical tool 2500 further includes an axially movable actuation member in the form of

31

a closure tube 2550 that is constrained to move axially relative to the elongated channel 2522 and the spine tube 1540. The closure tube 2550 has a proximal end 2552 that has an internal thread 2554 formed therein that is in threaded engagement with a rotatably movable portion in the form of a closure drive nut 2560. More specifically, the closure drive nut 2560 has a proximal end portion 2562 that is rotatably supported relative to the elongated channel 2522 and the spine tube 2540. For assembly purposes, the proximal end portion 2562 is threadably attached to a retention ring 2570. The retention ring 2570 is received in a groove 2529 formed between a shoulder 2527 on the proximal end 2523 of the elongated channel 2522 and the distal end 2541 of the spine tube 1540. Such arrangement serves to rotatably support the closure drive nut 2560 within the elongated channel 2522. Rotation of the closure drive nut 2560 will cause the closure tube 2550 to move axially as represented by arrow "D" in FIG. 40.

Extending through the spine tube 2540 and the closure drive nut 2560 is a drive member which, in at least one embodiment, comprises a knife bar 2580 that has a distal end portion 2582 that is rotatably coupled to the cutting instrument 2532 such that the knife bar 2580 may rotate relative to the cutting instrument 2582. As can be seen in FIG. 40-42, the closure drive nut 2560 has a slot 2564 therein through which the knife bar 2580 can slidably extend. Such arrangement permits the knife bar 2580 to move axially relative to the closure drive nut 2560. However, rotation of the knife bar 2580 about the longitudinal tool axis LT-LT will also result in the rotation of the closure drive nut 2560. The axial direction in which the closure tube 2550 moves ultimately depends upon the direction in which the knife bar 2580 and the closure drive nut 2560 are rotated. As the closure tube 2550 is driven distally, the distal end thereof will contact the anvil 2524 and cause the anvil 2524 to pivot to a closed position. Upon application of an opening rotary output motion from the robotic system 1000, the closure tube 2550 will be driven in the proximal direction "PD" and pivot the anvil 2524 to the open position by virtue of the engagement of the tab 2527 with the opening 2555 in the closure tube 2550.

In use, it may be desirable to rotate the surgical end effector 2512 about the longitudinal tool axis LT-LT. In at least one embodiment, the tool mounting portion 2600 is configured to receive a corresponding first rotary output motion from the robotic system 1000 and convert that first rotary output motion to a rotary control motion for rotating the elongated shaft assembly 2508 about the longitudinal tool axis LT-LT. As can be seen in FIG. 38, a proximal end 2542 of the hollow spine tube 2540 is rotatably supported within a cradle arrangement 2603 attached to a tool mounting plate 2602 of the tool mounting portion 2600. Various embodiments of the surgical tool 2500 further include a transmission arrangement, generally depicted as 2605, that is operably supported on the tool mounting plate 2602. In various forms the transmission arrangement 2605 include a rotation gear 2544 that is formed on or attached to the proximal end 2542 of the spine tube 2540 for meshing engagement with a rotation drive assembly 2610 that is operably supported on the tool mounting plate 2602. In at least one embodiment, a rotation drive gear 2612 is coupled to a corresponding first one of the rotational bodies, driven discs or elements 1304 on the adapter side of the tool mounting plate 2602 when the tool mounting portion 2600 is coupled to the tool holder 1270. See FIGS. 22 and 43. The rotation drive assembly 2610 further comprises a rotary driven gear 2614 that is rotatably supported on the tool mounting plate 2602 in meshing engagement with the rotation gear 2544 and the rotation drive gear 2612. Application of a first rotary output motion from the

32

robotic system 1000 through the tool drive assembly 1010 to the corresponding driven rotational body 1304 will thereby cause rotation of the rotation drive gear 2612 by virtue of being operably coupled thereto. Rotation of the rotation drive gear 2612 ultimately results in the rotation of the elongated shaft assembly 2508 (and the end effector 2512) about the longitudinal tool axis LT-LT.

Closure of the anvil 2524 relative to the surgical staple cartridge 2534 is accomplished by axially moving the closure tube 2550 in the distal direction "DD". Axial movement of the closure tube 2550 in the distal direction "DD" is accomplished by applying a rotary control motion to the closure drive nut 2382. In various embodiments, the closure drive nut 2560 is rotated by applying a rotary output motion to the knife bar 2580. Rotation of the knife bar 2580 is controlled by applying rotary output motions to a rotary closure system 2620 that is operably supported on the tool mounting plate 2602 as shown in FIG. 43. In at least one embodiment, the rotary closure system 2620 includes a closure drive gear 2622 that is coupled to a corresponding second one of the driven rotatable body portions discs or elements 1304 on the adapter side of the tool mounting plate 2462 when the tool mounting portion 2600 is coupled to the tool holder 1270. See FIGS. 22 and 43. The closure drive gear 2622, in at least one embodiment, is in meshing driving engagement with a closure gear train, generally depicted as 2623. The closure gear drive train 2623 comprises a first driven closure gear 2624 that is rotatably supported on the tool mounting plate 2602. The first closure driven gear 2624 is attached to a second closure driven gear 2626 by a drive shaft 2628. The second closure driven gear 2626 is in meshing engagement with a third closure driven gear 2630 that is rotatably supported on the tool mounting plate 2602. Rotation of the closure drive gear 2622 in a second rotary direction will result in the rotation of the third closure driven gear 2630 in a second direction. Conversely, rotation of the closure drive gear 2483 in a secondary rotary direction (opposite to the second rotary direction) will cause the third closure driven gear 2630 to rotate in a secondary direction.

As can be seen in FIG. 43, a drive shaft assembly 2640 is coupled to a proximal end of the knife bar 2580. In various embodiments, the drive shaft assembly 2640 includes a proximal portion 2642 that has a square cross-sectional shape. The proximal portion 2642 is configured to slideably engage a correspondingly shaped aperture in the third driven gear 2630. Such arrangement results in the rotation of the drive shaft assembly 2640 (and knife bar 2580) when the third driven gear 2630 is rotated. The drive shaft assembly 2640 is axially advanced in the distal and proximal directions by a knife drive assembly 2650. One form of the knife drive assembly 2650 comprises a rotary drive gear 2652 that is coupled to a corresponding third one of the driven rotatable body portions, discs or elements 1304 on the adapter side of the tool mounting plate 2462 when the tool mounting portion 2600 is coupled to the tool holder 1270. See FIGS. 22 and 43. The rotary driven gear 2652 is in meshing driving engagement with a gear train, generally depicted as 2653. In at least one form, the gear train 2653 further comprises a first rotary driven gear assembly 2654 that is rotatably supported on the tool mounting plate 2602. The first rotary driven gear assembly 2654 is in meshing engagement with a third rotary driven gear assembly 2656 that is rotatably supported on the tool mounting plate 2602 and which is in meshing engagement with a fourth rotary driven gear assembly 2658 that is in meshing engagement with a threaded portion 2644 of the drive shaft assembly 2640. Rotation of the rotary drive gear 2652 in a third rotary direction will result in the axial

advancement of the drive shaft assembly 2640 and knife bar 2580 in the distal direction "DD". Conversely, rotation of the rotary drive gear 2652 in a tertiary rotary direction (opposite to the third rotary direction) will cause the drive shaft assembly 2640 and the knife bar 2580 to move in the proximal direction.

A method of operating the surgical tool 2500 will now be described. Once the tool mounting portion 2600 has been operably coupled to the tool holder 1270 of the robotic system 1000, the robotic system 1000 can orient the surgical end effector 2512 in position adjacent the target tissue to be cut and stapled. If the anvil 2524 is not already in the open position (FIG. 49), the robotic system 1000 may apply the second rotary output motion to the closure drive gear 2622 which results in the rotation of the knife bar 2580 in a second direction. Rotation of the knife bar 2580 in the second direction results in the rotation of the closure drive nut 2560 in a second direction. As the closure drive nut 2560 rotates in the second direction, the closure tube 2550 moves in the proximal direction "PD". As the closure tube 2550 moves in the proximal direction "PD", the tab 2527 on the anvil 2524 interfaces with the opening 2555 in the closure tube 2550 and causes the anvil 2524 to pivot to the open position. In addition or in alternative embodiments, a spring (not shown) may be employed to pivot the anvil 2354 to the open position when the closure tube 2550 has been returned to the starting position (FIG. 40). The opened surgical end effector 2512 may then be manipulated by the robotic system 1000 to position the target tissue between the open anvil 2524 and the surgical staple cartridge 2534. Thereafter, the surgeon may initiate the closure process by activating the robotic control system 1000 to apply the second rotary output motion to the closure drive gear 2622 which, as was described above, ultimately results in the rotation of the closure drive nut 2382 in the second direction which results in the axial travel of the closure tube 2250 in the distal direction "DD". As the closure tube 2550 moves in the distal direction, it contacts a portion of the anvil 2524 and causes the anvil 2524 to pivot to the closed position to clamp the target tissue between the anvil 2524 and the staple cartridge 2534. Once the robotic controller 1001 determines that the anvil 2524 has been pivoted to the closed position by corresponding sensor(s) in the end effector 2512 that are in communication therewith, the robotic controller 1001 discontinues the application of the second rotary output motion to the closure drive gear 2622. The robotic controller 1001 may also provide the surgeon with an indication that the anvil 2524 has been fully closed. The surgeon may then initiate the firing procedure. In alternative embodiments, the firing procedure may be automatically initiated by the robotic controller 1001.

After the robotic controller 1001 has determined that the anvil 2524 is in the closed position, the robotic controller 1001 then applies the third rotary output motion to the rotary drive gear 2652 which results in the axial movement of the drive shaft assembly 2640 and knife bar 2580 in the distal direction "DD". As the cutting instrument 2532 moves distally through the surgical staple cartridge 2534, the tissue clamped therein is severed. As the sled portion (not shown) is driven distally, it causes the staples within the surgical staple cartridge 2534 to be driven through the severed tissue into forming contact with the anvil 2524. Once the robotic controller 1001 has determined that the cutting instrument 2532 has reached the end position within the surgical staple cartridge 2534 by means of sensor(s) in the surgical end effector 2512 that are in communication with the robotic controller 1001, the robotic controller 1001 discontinues the application of the second rotary output motion to the rotary drive gear

2652. Thereafter, the robotic controller 1001 applies the secondary rotary control motion to the rotary drive gear 2652 which ultimately results in the axial travel of the cutting instrument 2532 and sled portion in the proximal direction "PD" to the starting position. Once the robotic controller 1001 has determined that the cutting instrument 2524 has reached the starting position by means of sensor(s) in the end effector 2512 that are in communication with the robotic controller 1001, the robotic controller 1001 discontinues the application of the secondary rotary output motion to the rotary drive gear 2652. Thereafter, the robotic controller 1001 may apply the secondary rotary output motion to the closure drive gear 2622 which results in the rotation of the knife bar 2580 in a secondary direction. Rotation of the knife bar 2580 in the secondary direction results in the rotation of the closure drive nut 2560 in a secondary direction. As the closure drive nut 2560 rotates in the secondary direction, the closure tube 2550 moves in the proximal direction "PD" to the open position.

FIGS. 44-49B illustrate yet another surgical tool 2700 that may be effectively employed in connection with the robotic system 1000. In various forms, the surgical tool 2700 includes a surgical end effector 2712 that includes a "first portion" in the form of an elongated channel 2722 and a "second movable portion" in one form comprising a pivotally translatable clamping member, such as an anvil 2724, which are maintained at a spacing that assures effective stapling and severing of tissue clamped in the surgical end effector 2712. As shown in the illustrated embodiment, the surgical end effector 2712 may include, in addition to the previously-mentioned channel 2722 and anvil 2724, a "third movable portion" in the form of a cutting instrument 2732, a sled (not shown), and a surgical staple cartridge 2734 that is removably seated in the elongated channel 2722. The cutting instrument 2732 may be, for example, a knife. The anvil 2724 may be pivotably opened and closed at a pivot point 2725 connected to the proximal end of the elongated channel 2722. The anvil 2724 may also include a tab 2727 at its proximal end that interfaces with a component of the mechanical closure system (described further below) to open and close the anvil 2724. When actuated, the knife 2732 and sled to travel longitudinally along the elongated channel 2722, thereby cutting tissue clamped within the surgical end effector 2712. The movement of the sled along the elongated channel 2722 causes the staples of the surgical staple cartridge 2734 to be driven through the severed tissue and against the closed anvil 2724, which turns the staples to fasten the severed tissue. In one form, the elongated channel 2722 and the anvil 2724 may be made of an electrically conductive material (such as metal) so that they may serve as part of the antenna that communicates with sensor(s) in the surgical end effector, as described above. The surgical staple cartridge 2734 could be made of a nonconductive material (such as plastic) and the sensor may be connected to or disposed in the surgical staple cartridge 2734, as described above.

It should be noted that although the embodiments of the surgical tool 2500 described herein employ a surgical end effector 2712 that staples the severed tissue, in other embodiments different techniques for fastening or sealing the severed tissue may be used. For example, end effectors that use RF energy or adhesives to fasten the severed tissue may also be used. U.S. Pat. No. 5,709,680, entitled "Electrosurgical Hemostatic Device" to Yates et al., and U.S. Pat. No. 5,688,270, entitled "Electrosurgical Hemostatic Device With Recessed And/Or Offset Electrodes" to Yates et al., which are incorporated herein by reference, discloses cutting instruments that use RF energy to fasten the severed tissue. U.S.

patent application Ser. No. 11/267,811, now U.S. Pat. No. 7,673,783 to Morgan et al. and U.S. patent application Ser. No. 11/267,383 to Shelton et al., now U.S. Pat. No. 7,607,557, which are also incorporated herein by reference, disclose cutting instruments that use adhesives to fasten the severed tissue. Accordingly, although the description herein refers to cutting/stapling operations and the like, it should be recognized that this is an exemplary embodiment and is not meant to be limiting. Other tissue-fastening techniques may also be used.

In the illustrated embodiment, the elongated channel 2722 of the surgical end effector 2712 is coupled to an elongated shaft assembly 2708 that is coupled to a tool mounting portion 2900. Although not shown, the elongated shaft assembly 2708 may include an articulation joint to permit the surgical end effector 2712 to be selectively articulated about an axis that is substantially transverse to the tool axis LT-LT. In at least one embodiment, the elongated shaft assembly 2708 comprises a hollow spine tube 2740 that is non-movably coupled to a tool mounting plate 2902 of the tool mounting portion 2900. As can be seen in FIGS. 45 and 46, the proximal end 2723 of the elongated channel 2722 comprises a hollow tubular structure that is attached to the spine tube 2740 by means of a mounting collar 2790. A cross-sectional view of the mounting collar 2790 is shown in FIG. 47. In various embodiments, the mounting collar 2790 has a proximal flanged end 2791 that is configured for attachment to the distal end of the spine tube 2740. In at least one embodiment, for example, the proximal flanged end 2791 of the mounting collar 2790 is welded or glued to the distal end of the spine tube 2740. As can be further seen in FIGS. 45 and 46, the mounting collar 2790 further has a mounting hub portion 2792 that is sized to receive the proximal end 2723 of the elongated channel 2722 thereon. The proximal end 2723 of the elongated channel 2722 is non-movably attached to the mounting hub portion 2792 by, for example, welding, adhesive, etc.

As can be further seen in FIGS. 45 and 46, the surgical tool 2700 further includes an axially movable actuation member in the form of a closure tube 2750 that is constrained to move axially relative to the elongated channel 2722. The closure tube 2750 has a proximal end 2752 that has an internal thread 2754 formed therein that is in threaded engagement with a rotatably movable portion in the form of a closure drive nut 2760. More specifically, the closure drive nut 2760 has a proximal end portion 2762 that is rotatably supported relative to the elongated channel 2722 and the spine tube 2740. For assembly purposes, the proximal end portion 2762 is threadably attached to a retention ring 2770. The retention ring 2770 is received in a groove 2729 formed between a shoulder 2727 on the proximal end 2723 of the channel 2722 and the mounting hub 2729 of the mounting collar 2790. Such arrangement serves to rotatably support the closure drive nut 2760 within the channel 2722. Rotation of the closure drive nut 2760 will cause the closure tube 2750 to move axially as represented by arrow "D" in FIG. 45.

Extending through the spine tube 2740, the mounting collar 2790, and the closure drive nut 2760 is a drive member, which in at least one embodiment, comprises a knife bar 2780 that has a distal end portion 2782 that is coupled to the cutting instrument 2732. As can be seen in FIGS. 45 and 46, the mounting collar 2790 has a passage 2793 therethrough for permitting the knife bar 2780 to slidably pass therethrough. Similarly, the closure drive nut 2760 has a slot 2764 therein through which the knife bar 2780 can slidably extend. Such arrangement permits the knife bar 2780 to move axially relative to the closure drive nut 2760.

Actuation of the anvil 2724 is controlled by a rotary driven closure shaft 2800. As can be seen in FIGS. 45 and 46, a distal end portion 2802 of the closure drive shaft 2800 extends through a passage 2794 in the mounting collar 2790 and a closure gear 2804 is attached thereto. The closure gear 2804 is configured for driving engagement with the inner surface 2761 of the closure drive nut 2760. Thus, rotation of the closure shaft 2800 will also result in the rotation of the closure drive nut 2760. The axial direction in which the closure tube 2750 moves ultimately depends upon the direction in which the closure shaft 2800 and the closure drive nut 2760 are rotated. For example, in response to one rotary closure motion received from the robotic system 1000, the closure tube 2750 will be driven in the distal direction "DD". As the closure tube 2750 is driven distally, the opening 2745 will engage the tab 2727 on the anvil 2724 and cause the anvil 2724 to pivot to a closed position. Upon application of an opening rotary motion from the robotic system 1000, the closure tube 2750 will be driven in the proximal direction "PD" and pivot the anvil 2724 to the open position. In various embodiments, a spring (not shown) may be employed to bias the anvil 2724 to the open position (FIG. 45).

In use, it may be desirable to rotate the surgical end effector 2712 about the longitudinal tool axis LT-LT. In at least one embodiment, the tool mounting portion 2900 is configured to receive a corresponding first rotary output motion from the robotic system 1000 for rotating the elongated shaft assembly 2708 about the tool axis LT-LT. As can be seen in FIG. 49, a proximal end 2742 of the hollow spine tube 2740 is rotatably supported within a cradle arrangement 2903 and a bearing assembly 2904 that are attached to a tool mounting plate 2902 of the tool mounting portion 2900. A rotation gear 2744 is formed on or attached to the proximal end 2742 of the spine tube 2740 for meshing engagement with a rotation drive assembly 2910 that is operably supported on the tool mounting plate 2902. In at least one embodiment, a rotation drive gear 2912 is coupled to a corresponding first one of the driven discs or elements 1304 on the adapter side of the tool mounting plate 2602 when the tool mounting portion 2600 is coupled to the tool holder 1270. See FIGS. 22 and 49. The rotation drive assembly 2910 further comprises a rotary driven gear 2914 that is rotatably supported on the tool mounting plate 2902 in meshing engagement with the rotation gear 2744 and the rotation drive gear 2912. Application of a first rotary control motion from the robotic system 1000 through the tool holder 1270 and the adapter 1240 to the corresponding driven element 1304 will thereby cause rotation of the rotation drive gear 2912 by virtue of being operably coupled thereto. Rotation of the rotation drive gear 2912 ultimately results in the rotation of the elongated shaft assembly 2708 (and the end effector 2712) about the longitudinal tool axis LT-LT (primary rotary motion).

Closure of the anvil 2724 relative to the staple cartridge 2734 is accomplished by axially moving the closure tube 2750 in the distal direction "DD". Axial movement of the closure tube 2750 in the distal direction "DD" is accomplished by applying a rotary control motion to the closure drive nut 2760. In various embodiments, the closure drive nut 2760 is rotated by applying a rotary output motion to the closure drive shaft 2800. As can be seen in FIG. 49, a proximal end portion 2806 of the closure drive shaft 2800 has a driven gear 2808 thereon that is in meshing engagement with a closure drive assembly 2920. In various embodiments, the closure drive system 2920 includes a closure drive gear 2922 that is coupled to a corresponding second one of the driven rotational bodies or elements 1304 on the adapter side of the tool mounting plate 2462 when the tool mounting portion

2900 is coupled to the tool holder 1270. See FIGS. 22 and 49. The closure drive gear 2922 is supported in meshing engagement with a closure gear train, generally depicted as 2923. In at least one form, the closure gear train 2923 comprises a first driven closure gear 2924 that is rotatably supported on the tool mounting plate 2902. The first closure driven gear 2924 is attached to a second closure driven gear 2926 by a drive shaft 2928. The second closure driven gear 2926 is in meshing engagement with a planetary gear assembly 2930. In various embodiments, the planetary gear assembly 2930 includes a driven planetary closure gear 2932 that is rotatably supported within the bearing assembly 2904 that is mounted on tool mounting plate 2902. As can be seen in FIGS. 49 and 49B, the proximal end portion 2806 of the closure drive shaft 2800 is rotatably supported within the proximal end portion 2742 of the spine tube 2740 such that the driven gear 2808 is in meshing engagement with central gear teeth 2934 formed on the planetary gear 2932. As can also be seen in FIG. 49A, two additional support gears 2936 are attached to or rotatably supported relative to the proximal end portion 2742 of the spine tube 2740 to provide bearing support thereto. Such arrangement with the planetary gear assembly 2930 serves to accommodate rotation of the spine shaft 2740 by the rotation drive assembly 2910 while permitting the closure driven gear 2808 to remain in meshing engagement with the closure drive system 2920. In addition, rotation of the closure drive gear 2922 in a first direction will ultimately result in the rotation of the closure drive shaft 2800 and closure drive nut 2760 which will ultimately result in the closure of the anvil 2724 as described above. Conversely, rotation of the closure drive gear 2922 in a second opposite direction will ultimately result in the rotation of the closure drive nut 2760 in an opposite direction which results in the opening of the anvil 2724.

As can be seen in FIG. 49, the proximal end 2784 of the knife bar 2780 has a threaded shaft portion 2786 attached thereto which is in driving engagement with a knife drive assembly 2940. In various embodiments, the threaded shaft portion 2786 is rotatably supported by a bearing 2906 attached to the tool mounting plate 2902. Such arrangement permits the threaded shaft portion 2786 to rotate and move axially relative to the tool mounting plate 2902. The knife bar 2780 is axially advanced in the distal and proximal directions by the knife drive assembly 2940. One form of the knife drive assembly 2940 comprises a rotary drive gear 2942 that is coupled to a corresponding third one of the rotatable bodies, driven discs or elements 1304 on the adapter side of the tool mounting plate 2902 when the tool mounting portion 2900 is coupled to the tool holder 1270. See FIGS. 22 and 49. The rotary drive gear 2942 is in meshing engagement with a knife gear train, generally depicted as 2943. In various embodiments, the knife gear train 2943 comprises a first rotary driven gear assembly 2944 that is rotatably supported on the tool mounting plate 2902. The first rotary driven gear assembly 2944 is in meshing engagement with a third rotary driven gear assembly 2946 that is rotatably supported on the tool mounting plate 2902 and which is in meshing engagement with a fourth rotary driven gear assembly 2948 that is in meshing engagement with the threaded portion 2786 of the knife bar 2780. Rotation of the rotary drive gear 2942 in one direction will result in the axial advancement of the knife bar 2780 in the distal direction "DD". Conversely, rotation of the rotary drive gear 2942 in an opposite direction will cause the knife bar 2780 to move in the proximal direction. Tool 2700 may otherwise be used as described above.

FIGS. 50 and 51 illustrate a surgical tool embodiment 2700' that is substantially identical to tool 2700 that was described in detail above. However tool 2700' includes a

pressure sensor 2950 that is configured to provide feedback to the robotic controller 1001 concerning the amount of clamping pressure experienced by the anvil 2724. In various embodiments, for example, the pressure sensor may comprise a spring biased contact switch. For a continuous signal, it would use either a cantilever beam with a strain gage on it or a dome button top with a strain gage on the inside. Another version may comprise an off switch that contacts only at a known desired load. Such arrangement would include a dome on the base wherein the dome is one electrical pole and the base is the other electrical pole. Such arrangement permits the robotic controller 1001 to adjust the amount of clamping pressure being applied to the tissue within the surgical end effector 2712 by adjusting the amount of closing pressure applied to the anvil 2724. Those of ordinary skill in the art will understand that such pressure sensor arrangement may be effectively employed with several of the surgical tool embodiments described herein as well as their equivalent structures.

FIG. 52 illustrates a portion of another surgical tool 3000 that may be effectively used in connection with a robotic system 1000. The surgical tool 3000 employs on-board motor(s) for powering various components of a surgical end effector cutting instrument. In at least one non-limiting embodiment for example, the surgical tool 3000 includes a surgical end effector in the form of an endocutter (not shown) that has an anvil (not shown) and surgical staple cartridge arrangement (not shown) of the types and constructions described above. The surgical tool 3000 also includes an elongated shaft (not shown) and anvil closure arrangement (not shown) of the types described above. Thus, this portion of the Detailed Description will not repeat the description of those components beyond that which is necessary to appreciate the unique and novel attributes of the various embodiments of surgical tool 3000.

In the depicted embodiment, the end effector includes a cutting instrument 3002 that is coupled to a knife bar 3003. As can be seen in FIG. 52, the surgical tool 3000 includes a tool mounting portion 3010 that includes a tool mounting plate 3012 that is configured to mountingly interface with the adaptor portion 1240' which is coupled to the robotic system 1000 in the various manners described above. The tool mounting portion 3010 is configured to operably support a transmission arrangement 3013 thereon. In at least one embodiment, the adaptor portion 1240' may be identical to the adaptor portion 1240 described in detail above without the powered rotation bodies and disc members employed by adapter 1240. In other embodiments, the adaptor portion 1240' may be identical to adaptor portion 1240. Still other modifications which are considered to be within the spirit and scope of the various forms of the present invention may employ one or more of the mechanical motions (i.e., rotary motion(s)) from the tool holder portion 1270 (as described hereinabove) to power/actuate the transmission arrangement 3013 while also employing one or more motors within the tool mounting portion 3010 to power one or more other components of the surgical end effector. In addition, while the end effector of the depicted embodiment comprises an endocutter, those of ordinary skill in the art will understand that the unique and novel attributes of the depicted embodiment may be effectively employed in connection with other types of surgical end effectors without departing from the spirit and scope of various forms of the present invention.

In various embodiments, the tool mounting plate 3012 is configured to at least house a first firing motor 3011 for supplying firing and retraction motions to the knife bar 3003 which is coupled to or otherwise operably interfaces with the

39

cutting instrument 3002. The tool mounting plate 3012 has an array of electrical connecting pins 3014 which are configured to interface with the slots 1258 (FIG. 21) in the adapter 1240'. Such arrangement permits the controller 1001 of the robotic system 1000 to provide control signals to the electronic control circuit 3020 of the surgical tool 3000. While the interface is described herein with reference to mechanical, electrical, and magnetic coupling elements, it should be understood that a wide variety of telemetry modalities might be used, including infrared, inductive coupling, or the like.

Control circuit 3020 is shown in schematic form in FIG. 52. In one form or embodiment, the control circuit 3020 includes a power supply in the form of a battery 3022 that is coupled to an on-off solenoid powered switch 3024. Control circuit 3020 further includes an on/off firing solenoid 3026 that is coupled to a double pole switch 3028 for controlling the rotational direction of the motor 3011. Thus, when the controller 1001 of the robotic system 1000 supplies an appropriate control signal, switch 3024 will permit battery 3022 to supply power to the double pole switch 3028. The controller 1001 of the robotic system 1000 will also supply an appropriate signal to the double pole switch 3028 to supply power to the motor 3011. When it is desired to fire the surgical end effector (i.e., drive the cutting instrument 3002 distally through tissue clamped in the surgical end effector, the double pole switch 3028 will be in a first position. When it is desired to retract the cutting instrument 3002 to the starting position, the double pole switch 3028 will be moved to the second position by the controller 1001.

Various embodiments of the surgical tool 3000 also employ a gear box 3030 that is sized, in cooperation with a firing gear train 3031 that, in at least one non-limiting embodiment, comprises a firing drive gear 3032 that is in meshing engagement with a firing driven gear 3034 for generating a desired amount of driving force necessary to drive the cutting instrument 3002 through tissue and to drive and form staples in the various manners described herein. In the embodiment depicted in FIG. 52, the driven gear 3034 is coupled to a screw shaft 3036 that is in threaded engagement with a screw nut arrangement 3038 that is constrained to move axially (represented by arrow "D"). The screw nut arrangement 3038 is attached to the firing bar 3003. Thus, by rotating the screw shaft 3036 in a first direction, the cutting instrument 3002 is driven in the distal direction "DD" and rotating the screw shaft in an opposite second direction, the cutting instrument 3002 may be retracted in the proximal direction "PD".

FIG. 53 illustrates a portion of another surgical tool 3000' that is substantially identical to tool 3000 described above, except that the driven gear 3034 is attached to a drive shaft 3040. The drive shaft 3040 is attached to a second driver gear 3042 that is in meshing engagement with a third driven gear 3044 that is in meshing engagement with a screw 3046 coupled to the firing bar 3003.

FIG. 54 illustrates another surgical tool 3200 that may be effectively used in connection with a robotic system 1000. In this embodiment, the surgical tool 3200 includes a surgical end effector 3212 that in one non-limiting form, comprises a component portion that is selectively movable between first and second positions relative to at least one other end effector component portion. As will be discussed in further detail below, the surgical tool 3200 employs on-board motors for powering various components of a transmission arrangement 3305. The surgical end effector 3212 includes an elongated channel 3222 that operably supports a surgical staple cartridge 3234. The elongated channel 3222 has a proximal end 3223 that slidably extends into a hollow elongated shaft assembly 3208 that is coupled to a tool mounting portion

40

3300. In addition, the surgical end effector 3212 includes an anvil 3224 that is pivotally coupled to the elongated channel 3222 by a pair of trunnions 3225 that are received within corresponding openings 3229 in the elongated channel 3222. A distal end portion 3209 of the shaft assembly 3208 includes an opening 3245 into which a tab 3227 on the anvil 3224 is inserted in order to open the anvil 3224 as the elongated channel 3222 is moved axially in the proximal direction "PD" relative to the distal end portion 3209 of the shaft assembly 3208. In various embodiments, a spring (not shown) may be employed to bias the anvil 3224 to the open position.

As indicated above, the surgical tool 3200 includes a tool mounting portion 3300 that includes a tool mounting plate 3302 that is configured to operably support the transmission arrangement 3305 and to mountingly interface with the adaptor portion 1240' which is coupled to the robotic system 1000 in the various manners described above. In at least one embodiment, the adaptor portion 1240' may be identical to the adaptor portion 1240 described in detail above without the powered disc members employed by adapter 1240. In other embodiments, the adaptor portion 1240' may be identical to adaptor portion 1240. However, in such embodiments, because the various components of the surgical end effector 3212 are all powered by motor(s) in the tool mounting portion 3300, the surgical tool 3200 will not employ or require any of the mechanical (i.e., non-electrical) actuation motions from the tool holder portion 1270 to power the surgical end effector 3200 components. Still other modifications which are considered to be within the spirit and scope of the various forms of the present invention may employ one or more of the mechanical motions from the tool holder portion 1270 (as described hereinabove) to power/actuate one or more of the surgical end effector components while also employing one or more motors within the tool mounting portion to power one or more other components of the surgical end effector.

In various embodiments, the tool mounting plate 3302 is configured to support a first firing motor 3310 for supplying firing and retraction motions to the transmission arrangement 3305 to drive a knife bar 3335 that is coupled to a cutting instrument 3332 of the type described above. As can be seen in FIG. 54, the tool mounting plate 3212 has an array of electrical connecting pins 3014 which are configured to interface with the slots 1258 (FIG. 21) in the adapter 1240'. Such arrangement permits the controller 1001 of the robotic system 1000 to provide control signals to the electronic control circuits 3320, 3340 of the surgical tool 3200. While the interface is described herein with reference to mechanical, electrical, and magnetic coupling elements, it should be understood that a wide variety of telemetry modalities might be used, including infrared, inductive coupling, or the like.

In one form or embodiment, the first control circuit 3320 includes a first power supply in the form of a first battery 3322 that is coupled to a first on-off solenoid powered switch 3324. The first firing control circuit 3320 further includes a first on/off firing solenoid 3326 that is coupled to a first double pole switch 3328 for controlling the rotational direction of the first firing motor 3310. Thus, when the robotic controller 1001 supplies an appropriate control signal, the first switch 3324 will permit the first battery 3322 to supply power to the first double pole switch 3328. The robotic controller 1001 will also supply an appropriate signal to the first double pole switch 3328 to supply power to the first firing motor 3310. When it is desired to fire the surgical end effector (i.e., drive the cutting instrument 3232 distally through tissue clamped in the surgical end effector 3212, the first switch 3328 will be positioned in a first position by the robotic controller 1001. When it is desired to retract the cutting instrument 3232 to the

starting position, the robotic controller 1001 will send the appropriate control signal to move the first switch 3328 to the second position.

Various embodiments of the surgical tool 3200 also employ a first gear box 3330 that is sized, in cooperation with a firing drive gear 3332 coupled thereto that operably interfaces with a firing gear train 3333. In at least one non-limiting embodiment, the firing gear train 3333 comprises a firing driven gear 3334 that is in meshing engagement with drive gear 3332, for generating a desired amount of driving force necessary to drive the cutting instrument 3232 through tissue and to drive and form staples in the various manners described herein. In the embodiment depicted in FIG. 54, the driven gear 3334 is coupled to a drive shaft 3335 that has a second driven gear 3336 coupled thereto. The second driven gear 3336 is supported in meshing engagement with a third driven gear 3337 that is in meshing engagement with a fourth driven gear 3338. The fourth driven gear 3338 is in meshing engagement with a threaded proximal portion 3339 of the knife bar 3235 that is constrained to move axially. Thus, by rotating the drive shaft 3335 in a first direction, the cutting instrument 3232 is driven in the distal direction "DD" and rotating the drive shaft 3335 in an opposite second direction, the cutting instrument 3232 may be retracted in the proximal direction "PD".

As indicated above, the opening and closing of the anvil 3224 is controlled by axially moving the elongated channel 3222 relative to the elongated shaft assembly 3208. The axial movement of the elongated channel 3222 is controlled by a closure control system 3339. In various embodiments, the closure control system 3339 includes a closure shaft 3340 which has a hollow threaded end portion 3341 that threadably engages a threaded closure rod 3342. The threaded end portion 3341 is rotatably supported in a spine shaft 3343 that operably interfaces with the tool mounting portion 3300 and extends through a portion of the shaft assembly 3208 as shown. The closure system 3339 further comprises a closure control circuit 3350 that includes a second power supply in the form of a second battery 3352 that is coupled to a second on-off solenoid powered switch 3354. Closure control circuit 3350 further includes a second on/off firing solenoid 3356 that is coupled to a second double pole switch 3358 for controlling the rotation of a second closure motor 3360. Thus, when the robotic controller 1001 supplies an appropriate control signal, the second switch 3354 will permit the second battery 3352 to supply power to the second double pole switch 3354. The robotic controller 1001 will also supply an appropriate signal to the second double pole switch 3358 to supply power to the second motor 3360. When it is desired to close the anvil 3224, the second switch 3348 will be in a first position. When it is desired to open the anvil 3224, the second switch 3348 will be moved to a second position.

Various embodiments of tool mounting portion 3300 also employ a second gear box 3362 that is coupled to a closure drive gear 3364. The closure drive gear 3364 is in meshing engagement with a closure gear train 3363. In various non-limiting forms, the closure gear train 3363 includes a closure driven gear 3365 that is attached to a closure drive shaft 3366. Also attached to the closure drive shaft 3366 is a closure drive gear 3367 that is in meshing engagement with a closure shaft gear 3360 attached to the closure shaft 3340. FIG. 54 depicts the end effector 3212 in the open position. As indicated above, when the threaded closure rod 3342 is in the position depicted in FIG. 54, a spring (not shown) biases the anvil 3224 to the open position. When it is desired to close the anvil 3224, the robotic controller 1001 will activate the second motor 3360 to rotate the closure shaft 3340 to draw the threaded closure rod 3342 and the channel 3222 in the proximal direction "PD". As

the anvil 3224 contacts the distal end portion 3209 of the shaft 3208, the anvil 3224 is pivoted to the closed position.

A method of operating the surgical tool 3200 will now be described. Once the tool mounting portion 3302 has been operably coupled to the tool holder 1270 of the robotic system 1000, the robotic system 1000 can orient the end effector 3212 in position adjacent the target tissue to be cut and stapled. If the anvil 3224 is not already in the open position, the robotic controller 1001 may activate the second closure motor 3360 to drive the channel 3222 in the distal direction to the position depicted in FIG. 54. Once the robotic controller 1001 determines that the surgical end effector 3212 is in the open position by sensor(s) in the end effector and/or the tool mounting portion 3300, the robotic controller 1001 may provide the surgeon with a signal to inform the surgeon that the anvil 3224 may then be closed. Once the target tissue is positioned between the open anvil 3224 and the surgical staple cartridge 3234, the surgeon may then commence the closure process by activating the robotic controller 1001 to apply a closure control signal to the second closure motor 3360. The second closure motor 3360 applies a rotary motion to the closure shaft 3340 to draw the channel 3222 in the proximal direction "PD" until the anvil 3224 has been pivoted to the closed position. Once the robotic controller 1001 determines that the anvil 3224 has been moved to the closed position by sensor(s) in the surgical end effector 3212 and/or in the tool mounting portion 3300 that are in communication with the robotic control system, the motor 3360 may be deactivated. Thereafter, the firing process may be commenced either manually by the surgeon activating a trigger, button, etc. on the controller 1001 or the controller 1001 may automatically commence the firing process.

To commence the firing process, the robotic controller 1001 activates the firing motor 3310 to drive the firing bar 3235 and the cutting instrument 3232 in the distal direction "DD". Once robotic controller 1001 has determined that the cutting instrument 3232 has moved to the ending position within the surgical staple cartridge 3234 by means of sensors in the surgical end effector 3212 and/or the motor drive portion 3300, the robotic controller 1001 may provide the surgeon with an indication signal. Thereafter the surgeon may manually activate the first motor 3310 to retract the cutting instrument 3232 to the starting position or the robotic controller 1001 may automatically activate the first motor 3310 to retract the cutting element 3232.

The embodiment depicted in FIG. 54 does not include an articulation joint. FIGS. 55 and 56 illustrate surgical tools 3200' and 3200'' that have end effectors 3212', 3212'', respectively that may be employed with an elongated shaft embodiment that has an articulation joint of the various types disclosed herein. For example, as can be seen in FIG. 55, a threaded closure shaft 3342 is coupled to the proximal end 3223 of the elongated channel 3222 by a flexible cable or other flexible member 3345. The location of an articulation joint (not shown) within the elongated shaft assembly 3208 will coincide with the flexible member 3345 to enable the flexible member 3345 to accommodate such articulation. In addition, in the above-described embodiment, the flexible member 3345 is rotatably affixed to the proximal end portion 3223 of the elongated channel 3222 to enable the flexible member 3345 to rotate relative thereto to prevent the flexible member 3229 from "winding up" relative to the channel 3222. Although not shown, the cutting element may be driven in one of the above described manners by a knife bar that can also accommodate articulation of the elongated shaft assembly. FIG. 56 depicts a surgical end effector 3212'' that is substantially identical to the surgical end effector 3212

43

described above, except that the threaded closure rod 3342 is attached to a closure nut 3347 that is constrained to only move axially within the elongated shaft assembly 3208. The flexible member 3345 is attached to the closure nut 3347. Such arrangement also prevents the threaded closure rod 3342 from winding-up the flexible member 3345. A flexible knife bar 3235' may be employed to facilitate articulation of the surgical end effector 3212'.

The surgical tools 3200, 3200', and 3200" described above may also employ anyone of the cutting instrument embodiments described herein. As described above, the anvil of each of the end effectors of these tools is closed by drawing the elongated channel into contact with the distal end of the elongated shaft assembly. Thus, once the target tissue has been located between the staple cartridge 3234 and the anvil 3224, the robotic controller 1001 can start to draw the channel 3222 inward into the shaft assembly 3208. In various embodiments, however, to prevent the end effector 3212, 3212', 3212" from moving the target tissue with the end effector during this closing process, the controller 1001 may simultaneously move the tool holder and ultimately the tool such to compensate for the movement of the elongated channel 3222 so that, in effect, the target tissue is clamped between the anvil and the elongated channel without being otherwise moved.

FIGS. 57-59 depict another surgical tool embodiment 3201 that is substantially identical to surgical tool 3200" described above, except for the differences discussed below. In this embodiment, the threaded closure rod 3342' has variable pitched grooves. More specifically, as can be seen in FIG. 58, the closure rod 3342' has a distal groove section 3380 and a proximal groove section 3382. The distal and proximal groove sections 3380, 3382 are configured for engagement with a lug 3390 supported within the hollow threaded end portion 3341'. As can be seen in FIG. 58, the distal groove section 3380 has a finer pitch than the groove section 3382. Thus, such variable pitch arrangement permits the elongated channel 3222 to be drawn into the shaft 3208 at a first speed or rate by virtue of the engagement between the lug 3390 and the proximal groove segment 3382. When the lug 3390 engages the distal groove segment, the channel 3222 will be drawn into the shaft 3208 at a second speed or rate. Because the proximal groove segment 3382 is coarser than the distal groove segment 3380, the first speed will be greater than the second speed. Such arrangement serves to speed up the initial closing of the end effector for tissue manipulation and then after the tissue has been properly positioned therein, generate the amount of closure forces to properly clamp the tissue for cutting and sealing. Thus, the anvil 3234 initially closes fast with a lower force and then applies a higher closing force as the anvil closes more slowly.

The surgical end effector opening and closing motions are employed to enable the user to use the end effector to grasp and manipulate tissue prior to fully clamping it in the desired location for cutting and sealing. The user may, for example, open and close the surgical end effector numerous times during this process to orient the end effector in a proper position which enables the tissue to be held in a desired location. Thus, in at least some embodiments, to produce the high loading for firing, the fine thread may require as many as 5-10 full rotations to generate the necessary load. In some cases, for example, this action could take as long as 2-5 seconds. If it also took an equally long time to open and close the end effector each time during the positioning/tissue manipulation process, just positioning the end effector may take an undesirably long time. If that happens, it is possible that a user may abandon such use of the end effector for use of

44

a conventional grasper device. Use of graspers, etc. may undesirably increase the costs associated with completing the surgical procedure.

The above-described embodiments employ a battery or batteries to power the motors used to drive the end effector components. Activation of the motors is controlled by the robotic system 1000. In alternative embodiments, the power supply may comprise alternating current "AC" that is supplied to the motors by the robotic system 1000. That is, the AC power would be supplied from the system powering the robotic system 1000 through the tool holder and adapter. In still other embodiments, a power cord or tether may be attached to the tool mounting portion 3300 to supply the requisite power from a separate source of alternating or direct current.

In use, the controller 1001 may apply an initial rotary motion to the closure shaft 3340 (FIG. 54) to draw the elongated channel 3222 axially inwardly into the elongated shaft assembly 3208 and move the anvil from a first position to an intermediate position at a first rate that corresponds with the point wherein the distal groove section 3380 transitions to the proximal groove section 3382. Further application of rotary motion to the closure shaft 3340 will cause the anvil to move from the intermediate position to the closed position relative to the surgical staple cartridge. When in the closed position, the tissue to be cut and stapled is properly clamped between the anvil and the surgical staple cartridge.

FIGS. 60-64 illustrate another surgical tool embodiment 3400 of the present invention. This embodiment includes an elongated shaft assembly 3408 that extends from a tool mounting portion 3500. The elongated shaft assembly 3408 includes a rotatable proximal closure tube segment 3410 that is rotatably journaled on a proximal spine member 3420 that is rigidly coupled to a tool mounting plate 3502 of the tool mounting portion 3500. The proximal spine member 3420 has a distal end 3422 that is coupled to an elongated channel portion 3522 of a surgical end effector 3412. For example, in at least one embodiment, the elongated channel portion 3522 has a distal end portion 3523 that "hookingly engages" the distal end 3422 of the spine member 3420. The elongated channel 3522 is configured to support a surgical staple cartridge 3534 therein. This embodiment may employ one of the various cutting instrument embodiments disclosed herein to sever tissue that is clamped in the surgical end effector 3412 and fire the staples in the staple cartridge 3534 into the severed tissue.

Surgical end effector 3412 has an anvil 3524 that is pivotally coupled to the elongated channel 3522 by a pair of trunnions 3525 that are received in corresponding openings 3529 in the elongated channel 3522. The anvil 3524 is moved between the open (FIG. 60) and closed positions (FIGS. 61-63) by a distal closure tube segment 3430. A distal end portion 3432 of the distal closure tube segment 3430 includes an opening 3445 into which a tab 3527 on the anvil 3524 is inserted in order to open and close the anvil 3524 as the distal closure tube segment 3430 moves axially relative thereto. In various embodiments, the opening 3445 is shaped such that as the closure tube segment 3430 is moved in the proximal direction, the closure tube segment 3430 causes the anvil 3524 to pivot to an open position. In addition or in the alternative, a spring (not shown) may be employed to bias the anvil 3524 to the open position.

As can be seen in FIGS. 60-63, the distal closure tube segment 3430 includes a lug 3442 that extends from its distal end 3440 into threaded engagement with a variable pitch groove/thread 3414 formed in the distal end 3412 of the rotatable proximal closure tube segment 3410. The variable

pitch groove/thread 3414 has a distal section 3416 and a proximal section 3418. The pitch of the distal groove/thread section 3416 is finer than the pitch of the proximal groove/thread section 3418. As can also be seen in FIGS. 60-63, the distal closure tube segment 3430 is constrained for axial movement relative to the spine member 3420 by an axial retainer pin 3450 that is received in an axial slot 3424 in the distal end of the spine member 3420.

As indicated above, the anvil 2524 is open and closed by rotating the proximal closure tube segment 3410. The variable pitch thread arrangement permits the distal closure tube segment 3430 to be driven in the distal direction "DD" at a first speed or rate by virtue of the engagement between the lug 3442 and the proximal groove/thread section 3418. When the lug 3442 engages the distal groove/thread section 3416, the distal closure tube segment 3430 will be driven in the distal direction at a second speed or rate. Because the proximal groove/thread section 3418 is coarser than the distal groove/thread segment 3416, the first speed will be greater than the second speed.

In at least one embodiment, the tool mounting portion 3500 is configured to receive a corresponding first rotary motion from the robotic controller 1001 and convert that first rotary motion to a primary rotary motion for rotating the rotatable proximal closure tube segment 3410 about a longitudinal tool axis LT-LT. As can be seen in FIG. 64, a proximal end 3460 of the proximal closure tube segment 3410 is rotatably supported within a cradle arrangement 3504 attached to a tool mounting plate 3502 of the tool mounting portion 3500. A rotation gear 3462 is formed on or attached to the proximal end 3460 of the closure tube segment 3410 for meshing engagement with a rotation drive assembly 3470 that is operably supported on the tool mounting plate 3502. In at least one embodiment, a rotation drive gear 3472 is coupled to a corresponding first one of the driven discs or elements 1304 on the adapter side of the tool mounting plate 3502 when the tool mounting portion 3500 is coupled to the tool holder 1270. See FIGS. 22 and 64. The rotation drive assembly 3470 further comprises a rotary driven gear 3474 that is rotatably supported on the tool mounting plate 3502 in meshing engagement with the rotation gear 3462 and the rotation drive gear 3472. Application of a first rotary control motion from the robotic controller 1001 through the tool holder 1270 and the adapter 1240 to the corresponding driven element 1304 will thereby cause rotation of the rotation drive gear 3472 by virtue of being operably coupled thereto. Rotation of the rotation drive gear 3472 ultimately results in the rotation of the closure tube segment 3410 to open and close the anvil 3524 as described above.

As indicated above, the surgical end effector 3412 employs a cutting instrument of the type and constructions described above. FIG. 64 illustrates one form of knife drive assembly 3480 for axially advancing a knife bar 3492 that is attached to such cutting instrument. One form of the knife drive assembly 3480 comprises a rotary drive gear 3482 that is coupled to a corresponding third one of the driven discs or elements 1304 on the adapter side of the tool mounting plate 3502 when the tool drive portion 3500 is coupled to the tool holder 1270. See FIGS. 22 and 64. The knife drive assembly 3480 further comprises a first rotary driven gear assembly 3484 that is rotatably supported on the tool mounting plate 5200. The first rotary driven gear assembly 3484 is in meshing engagement with a third rotary driven gear assembly 3486 that is rotatably supported on the tool mounting plate 3502 and which is in meshing engagement with a fourth rotary driven gear assembly 3488 that is in meshing engagement with a threaded portion 3494 of drive shaft assembly 3490 that is coupled to

the knife bar 3492. Rotation of the rotary drive gear 3482 in a second rotary direction will result in the axial advancement of the drive shaft assembly 3490 and knife bar 3492 in the distal direction "DD". Conversely, rotation of the rotary drive gear 3482 in a secondary rotary direction (opposite to the second rotary direction) will cause the drive shaft assembly 3490 and the knife bar 3492 to move in the proximal direction.

FIGS. 65-74 illustrate another surgical tool 3600 embodiment of the present invention that may be employed in connection with a robotic system 1000. As can be seen in FIG. 65, the tool 3600 includes an end effector in the form of a disposable loading unit 3612. Various forms of disposable loading units that may be employed in connection with tool 3600 are disclosed, for example, in U.S. Patent Application Publication No. US 2009/0206131 A1, entitled "End Effector Arrangements For a Surgical Cutting and Stapling Instrument", the disclosure of which is herein incorporated by reference in its entirety.

In at least one form, the disposable loading unit 3612 includes an anvil assembly 3620 that is supported for pivotal travel relative to a carrier 3630 that operably supports a staple cartridge 3640 therein. A mounting assembly 3650 is pivotally coupled to the cartridge carrier 3630 to enable the carrier 3630 to pivot about an articulation axis AA-AA relative to a longitudinal tool axis LT-LT. Referring to FIG. 70, mounting assembly 3650 includes upper and lower mounting portions 3652 and 3654. Each mounting portion includes a threaded bore 3656 on each side thereof dimensioned to receive threaded bolts (not shown) for securing the proximal end of carrier 3630 thereto. A pair of centrally located pivot members 3658 extends between upper and lower mounting portions via a pair of coupling members 3660 which engage a distal end of a housing portion 3662. Coupling members 3660 each include an interlocking proximal portion 3664 configured to be received in grooves 3666 formed in the proximal end of housing portion 3662 to retain mounting assembly 3650 and housing portion 3662 in a longitudinally fixed position in relation thereto.

In various forms, housing portion 3662 of disposable loading unit 3614 includes an upper housing half 3670 and a lower housing half 3672 contained within an outer casing 3674. The proximal end of housing half 3670 includes engagement nubs 3676 for releasably engaging an elongated shaft 3700 and an insertion tip 3678. Nubs 3676 form a bayonet-type coupling with the distal end of the elongated shaft 3700 which will be discussed in further detail below. Housing halves 3670, 3672 define a channel 3674 for slidably receiving axial drive assembly 3680. A second articulation link 3690 is dimensioned to be slidably positioned within a slot 3679 formed between housing halves 3670, 3672. A pair of blow out plates 3691 are positioned adjacent the distal end of housing portion 3662 adjacent the distal end of axial drive assembly 3680 to prevent outward bulging of drive assembly 3680 during articulation of carrier 3630.

In various embodiments, the second articulation link 3690 includes at least one elongated metallic plate. Preferably, two or more metallic plates are stacked to form link 3690. The proximal end of articulation link 3690 includes a hook portion 3692 configured to engage first articulation link 3710 extending through the elongated shaft 3700. The distal end of the second articulation link 3690 includes a loop 3694 dimensioned to engage a projection formed on mounting assembly 3650. The projection is laterally offset from pivot pin 3658 such that linear movement of second articulation link 3690 causes mounting assembly 3650 to pivot about pivot pins 3658 to articulate the carrier 3630.

In various forms, axial drive assembly 3680 includes an elongated drive beam 3682 including a distal working head 3684 and a proximal engagement section 3685. Drive beam 3682 may be constructed from a single sheet of material or, preferably, multiple stacked sheets. Engagement section 3685 includes a pair of engagement fingers which are dimensioned and configured to mountingly engage a pair of corresponding retention slots formed in drive member 3686. Drive member 3686 includes a proximal porthole 3687 configured to receive the distal end 3722 of control rod 2720 (See FIG. 74) when the proximal end of disposable loading unit 3614 is engaged with elongated shaft 3700 of surgical tool 3600.

Referring to FIGS. 65 and 72-74, to use the surgical tool 3600, a disposable loading unit 3612 is first secured to the distal end of elongated shaft 3700. It will be appreciated that the surgical tool 3600 may include an articulating or a non-articulating disposable loading unit. To secure the disposable loading unit 3612 to the elongated shaft 3700, the distal end 3722 of control rod 3720 is inserted into insertion tip 3678 of disposable loading unit 3612, and insertion tip 3678 is slid longitudinally into the distal end of the elongated shaft 3700 in the direction indicated by arrow "A" in FIG. 72 such that hook portion 3692 of second articulation link 3690 slides within a channel 3702 in the elongated shaft 3700. Nubs 3676 will each be aligned in a respective channel (not shown) in elongated shaft 3700. When hook portion 3692 engages the proximal wall 3704 of channel 3702, disposable loading unit 3612 is rotated in the direction indicated by arrow "B" in FIGS. 71 and 74 to move hook portion 3692 of second articulation link 3690 into engagement with finger 3712 of first articulation link 3710. Nubs 3676 also form a "bayonet-type" coupling within annular channel 3703 in the elongated shaft 3700. During rotation of loading unit 3612, nubs 3676 engage cam surface 3732 (FIG. 72) of block plate 3730 to initially move plate 3730 in the direction indicated by arrow "C" in FIG. 72 to lock engagement member 3734 in recess 3721 of control rod 3720 to prevent longitudinal movement of control rod 3720 during attachment of disposable loading unit 3612. During the final degree of rotation, nubs 3676 disengage from cam surface 3732 to allow blocking plate 3730 to move in the direction indicated by arrow "D" in FIGS. 71 and 74 from behind engagement member 3734 to once again permit longitudinal movement of control rod 3720. While the above-described attachment method reflects that the disposable loading unit 3612 is manipulated relative to the elongated shaft 3700, the person of ordinary skill in the art will appreciate that the disposable loading unit 3612 may be supported in a stationary position and the robotic system 1000 may manipulate the elongated shaft portion 3700 relative to the disposable loading unit 3612 to accomplish the above-described coupling procedure.

FIG. 75 illustrates another disposable loading unit 3612' that is attachable in a bayonet-type arrangement with the elongated shaft 3700' that is substantially identical to shaft 3700 except for the differences discussed below. As can be seen in FIG. 75, the elongated shaft 3700' has slots 3705 that extend for at least a portion thereof and which are configured to receive nubs 3676 therein. In various embodiments, the disposable loading unit 3612' includes arms 3677 extending therefrom which, prior to the rotation of disposable loading unit 3612', can be aligned, or at least substantially aligned, with nubs 3676 extending from housing portion 3662. In at least one embodiment, arms 3677 and nubs 3676 can be inserted into slots 3705 in elongated shaft 3700', for example, when disposable loading unit 3612' is inserted into elongated shaft 3700'. When disposable loading unit 3612' is rotated, arms 3677 can be sufficiently confined within slots 3705 such

that slots 3705 can hold them in position, whereas nubs 3676 can be positioned such that they are not confined within slots 3705 and can be rotated relative to arms 3677. When rotated, the hook portion 3692 of the articulation link 3690 is engaged with the first articulation link 3710 extending through the elongated shaft 3700'.

Other methods of coupling the disposable loading units to the end of the elongated shaft may be employed. For example, as shown in FIGS. 76 and 77, disposable loading unit 3612" can include connector portion 3613 which can be configured to be engaged with connector portion 3740 of the elongated shaft 3700". In at least one embodiment, connector portion 3613 can include at least one projection and/or groove which can be mated with at least one projection and/or groove of connector portion 3740. In at least one such embodiment, the connector portions can include co-operating dovetail portions. In various embodiments, the connector portions can be configured to interlock with one another and prevent, or at least inhibit, distal and/or proximal movement of disposable loading unit 3612" along axis 3741. In at least one embodiment, the distal end of the axial drive assembly 3680" can include aperture 3681 which can be configured to receive projection 3721 extending from control rod 3720'. In various embodiments, such an arrangement can allow disposable loading unit 3612" to be assembled to elongated shaft 3700 in a direction which is not collinear with or parallel to axis 3741. Although not illustrated, axial drive assembly 3680' and control rod 3720 can include any other suitable arrangement of projections and apertures to operably connect them to each other. Also in this embodiment, the first articulation link 3710 which can be operably engaged with second articulation link 3690.

As can be seen in FIGS. 65 and 78, the surgical tool 3600 includes a tool mounting portion 3750. The tool mounting portion 3750 includes a tool mounting plate 3751 that is configured for attachment to the tool drive assembly 1010. The tool mounting portion operably supported a transmission arrangement 3752 thereon. In use, it may be desirable to rotate the disposable loading unit 3612 about the longitudinal tool axis defined by the elongated shaft 3700. In at least one embodiment, the transmission arrangement 3752 includes a rotational transmission assembly 3753 that is configured to receive a corresponding rotary output motion from the tool drive assembly 1010 of the robotic system 1000 and convert that rotary output motion to a rotary control motion for rotating the elongated shaft 3700 (and the disposable loading unit 3612) about the longitudinal tool axis LT-LT. As can be seen in FIG. 78, a proximal end 3701 of the elongated shaft 3700 is rotatably supported within a cradle arrangement 3754 that is attached to the tool mounting plate 3751 of the tool mounting portion 3750. A rotation gear 3755 is formed on or attached to the proximal end 3701 of the elongated shaft 3700 for meshing engagement with a rotation gear assembly 3756 operably supported on the tool mounting plate 3751. In at least one embodiment, a rotation drive gear 3757 drivingly coupled to a corresponding first one of the driven discs or elements 1304 on the adapter side of the tool mounting plate 3751 when the tool mounting portion 3750 is coupled to the tool drive assembly 1010. The rotation transmission assembly 3753 further comprises a rotary driven gear 3758 that is rotatably supported on the tool mounting plate 3751 in meshing engagement with the rotation gear 3755 and the rotation drive gear 3757. Application of a first rotary output motion from the robotic system 1000 through the tool drive assembly 1010 to the corresponding driven element 1304 will thereby cause rotation of the rotation drive gear 3757 by virtue of being operably coupled thereto. Rotation of the rotation drive

gear 3757 ultimately results in the rotation of the elongated shaft 3700 (and the disposable loading unit 3612) about the longitudinal tool axis LT-LT (primary rotary motion).

As can be seen in FIG. 78, a drive shaft assembly 3760 is coupled to a proximal end of the control rod 2720. In various embodiments, the control rod 2720 is axially advanced in the distal and proximal directions by a knife/closure drive transmission 3762. One form of the knife/closure drive assembly 3762 comprises a rotary drive gear 3763 that is coupled to a corresponding second one of the driven rotatable body portions, discs or elements 1304 on the adapter side of the tool mounting plate 3751 when the tool mounting portion 3750 is coupled to the tool holder 1270. The rotary driven gear 3763 is in meshing driving engagement with a gear train, generally depicted as 3764. In at least one form, the gear train 3764 further comprises a first rotary driven gear assembly 3765 that is rotatably supported on the tool mounting plate 3751. The first rotary driven gear assembly 3765 is in meshing engagement with a second rotary driven gear assembly 3766 that is rotatably supported on the tool mounting plate 3751 and which is in meshing engagement with a third rotary driven gear assembly 3767 that is in meshing engagement with a threaded portion 3768 of the drive shaft assembly 3760. Rotation of the rotary drive gear 3763 in a second rotary direction will result in the axial advancement of the drive shaft assembly 3760 and control rod 2720 in the distal direction "DD". Conversely, rotation of the rotary drive gear 3763 in a secondary rotary direction which is opposite to the second rotary direction will cause the drive shaft assembly 3760 and the control rod 2720 to move in the proximal direction. When the control rod 2720 moves in the distal direction, it drives the drive beam 3682 and the working head 3684 thereof distally through the surgical staple cartridge 3640. As the working head 3684 is driven distally, it operably engages the anvil 3620 to pivot it to a closed position.

The cartridge carrier 3630 may be selectively articulated about articulation axis AA-AA by applying axial articulation control motions to the first and second articulation links 3710 and 3690. In various embodiments, the transmission arrangement 3752 further includes an articulation drive 3770 that is operably supported on the tool mounting plate 3751. More specifically and with reference to FIG. 78, it can be seen that a proximal end portion 3772 of an articulation drive shaft 3771 configured to operably engage with the first articulation link 3710 extends through the rotation gear 3755 and is rotatably coupled to a shifter rack gear 3774 that is slidably affixed to the tool mounting plate 3751 through slots 3775. The articulation drive 3770 further comprises a shifter drive gear 3776 that is coupled to a corresponding third one of the driven discs or elements 1304 on the adapter side of the tool mounting plate 3751 when the tool mounting portion 3750 is coupled to the tool holder 1270. The articulation drive assembly 3770 further comprises a shifter driven gear 3778 that is rotatably supported on the tool mounting plate 3751 in meshing engagement with the shifter drive gear 3776 and the shifter rack gear 3774. Application of a third rotary output motion from the robotic system 1000 through the tool drive assembly 1010 to the corresponding driven element 1304 will thereby cause rotation of the shifter drive gear 3776 by virtue of being operably coupled thereto. Rotation of the shifter drive gear 3776 ultimately results in the axial movement of the shifter gear rack 3774 and the articulation drive shaft 3771. The direction of axial travel of the articulation drive shaft 3771 depends upon the direction in which the shifter drive gear 3776 is rotated by the robotic system 1000. Thus, rotation of the shifter drive gear 3776 in a first rotary direction will result in the axial movement of the articulation drive shaft

3771 in the proximal direction "PD" and cause the cartridge carrier 3630 to pivot in a first direction about articulation axis AA-AA. Conversely, rotation of the shifter drive gear 3776 in a second rotary direction (opposite to the first rotary direction) will result in the axial movement of the articulation drive shaft 3771 in the distal direction "DD" to thereby cause the cartridge carrier 3630 to pivot about articulation axis AA-AA in an opposite direction.

FIG. 79 illustrates yet another surgical tool 3800 embodiment of the present invention that may be employed with a robotic system 1000. As can be seen in FIG. 79, the surgical tool 3800 includes a surgical end effector 3812 in the form of an endocutter 3814 that employs various cable-driven components. Various forms of cable driven endocutters are disclosed, for example, in U.S. Pat. No. 7,726,537, entitled "Surgical Stapler With Universal Articulation and Tissue Pre-Clamp" and U.S. Patent Application Publication No. US 2008/0308603A1, entitled "Cable Driven Surgical Stapling and Cutting Instrument With Improved Cable Attachment Arrangements", the disclosures of each are herein incorporated by reference in their respective entireties. Such endocutters 3814 may be referred to as a "disposable loading unit" because they are designed to be disposed of after a single use. However, the various unique and novel arrangements of various embodiments of the present invention may also be employed in connection with cable driven end effectors that are reusable.

As can be seen in FIG. 79, in at least one form, the endocutter 3814 includes an elongated channel 3822 that operably supports a surgical staple cartridge 3834 therein. An anvil 3824 is pivotally supported for movement relative to the surgical staple cartridge 3834. The anvil 3824 has a cam surface 3825 that is configured for interaction with a pre-clamping collar 3840 that is supported for axial movement relative thereto. The end effector 3814 is coupled to an elongated shaft assembly 3808 that is attached to a tool mounting portion 3900. In various embodiments, a closure cable 3850 is employed to move pre-clamping collar 3840 distally onto and over cam surface 3825 to close the anvil 3824 relative to the surgical staple cartridge 3834 and compress the tissue therebetween. Preferably, closure cable 3850 attaches to the pre-clamping collar 3840 at or near point 3841 and is fed through a passageway in anvil 3824 (or under a proximal portion of anvil 3824) and fed proximally through shaft 3808. Actuation of closure cable 3850 in the proximal direction "PD" forces pre-clamping collar 3840 distally against cam surface 3825 to close anvil 3824 relative to staple cartridge assembly 3834. A return mechanism, e.g., a spring, cable system or the like, may be employed to return pre-clamping collar 3840 to a pre-clamping orientation which re-opens the anvil 3824.

The elongated shaft assembly 3808 may be cylindrical in shape and define a channel 3811 which may be dimensioned to receive a tube adapter 3870. See FIG. 80. In various embodiments, the tube adapter 3870 may be slidingly received in friction-fit engagement with the internal channel of elongated shaft 3808. The outer surface of the tube adapter 3870 may further include at least one mechanical interface, e.g., a cutout or notch 3871, oriented to mate with a corresponding mechanical interface, e.g., a radially inwardly extending protrusion or detent (not shown), disposed on the inner periphery of internal channel 3811 to lock the tube adapter 3870 to the elongated shaft 3808. In various embodiments, the distal end of tube adapter 3870 may include a pair of opposing flanges 3872a and 3872b which define a cavity for pivotably receiving a pivot block 3873 therein. Each flange 3872a and 3872b may include an aperture 3874a and 3874b that is oriented to receive a pivot pin 3875 that extends

through an aperture in pivot block 3873 to allow pivotable movement of pivot block 3873 about an axis that is perpendicular to longitudinal tool axis "LT-LT". The channel 3822 may be formed with two upwardly extending flanges 3823a, 3823b that have apertures therein, which are dimensioned to receive a pivot pin 3827. In turn, pivot pin 3875 mounts through apertures in pivot block 3873 to permit rotation of the surgical end effector 3814 about the "Y" axis as needed during a given surgical procedure. Rotation of pivot block 3873 about pin 3875 along "Z" axis rotates the surgical end effector 3814 about the "Z" axis. See FIG. 80. Other methods of fastening the elongated channel 3822 to the pivot block 3873 may be effectively employed without departing from the spirit and scope of the present invention.

The surgical staple cartridge 3834 can be assembled and mounted within the elongated channel 3822 during the manufacturing or assembly process and sold as part of the surgical end effector 3812, or the surgical staple cartridge 3834 may be designed for selective mounting within the elongated channel 3822 as needed and sold separately, e.g., as a single use replacement, replaceable or disposable staple cartridge assembly. It is within the scope of this disclosure that the surgical end effector 3812 may be pivotally, operatively, or integrally attached, for example, to distal end 3809 of the elongated shaft assembly 3808 of a disposable surgical stapler. As is known, a used or spent disposable loading unit 3814 can be removed from the elongated shaft assembly 3808 and replaced with an unused disposable unit. The endocutter 3814 may also preferably include an actuator, preferably a dynamic clamping member 3860, a sled 3862, as well as staple pushers (not shown) and staples (not shown) once an unspent or unused cartridge 3834 is mounted in the elongated channel 3822. See FIG. 80.

In various embodiments, the dynamic clamping member 3860 is associated with, e.g., mounted on and rides on, or with or is connected to or integral with and/or rides behind sled 3862. It is envisioned that dynamic clamping member 3860 can have cam wedges or cam surfaces attached or integrally formed or be pushed by a leading distal surface thereof. In various embodiments, dynamic clamping member 3860 may include an upper portion 3863 having a transverse aperture 3864 with a pin 3865 mountable or mounted therein, a central support or upward extension 3866 and substantially T-shaped bottom flange 3867 which cooperate to slidingly retain dynamic clamping member 3860 along an ideal cutting path during longitudinal, distal movement of sled 3862. The leading cutting edge 3868, here, knife blade 3869, is dimensioned to ride within slot 3835 of staple cartridge assembly 3834 and separate tissue once stapled. As used herein, the term "knife assembly" may include the aforementioned dynamic clamping member 3860, knife 3869, and sled 3862 or other knife/beam/sled drive arrangements and cutting instrument arrangements. In addition, the various embodiments of the present invention may be employed with knife assembly/cutting instrument arrangements that may be entirely supported in the staple cartridge 3834 or partially supported in the staple cartridge 3834 and elongated channel 3822 or entirely supported within the elongated channel 3822.

In various embodiments, the dynamic clamping member 3860 may be driven in the proximal and distal directions by a cable drive assembly 3870. In one non-limiting form, the cable drive assembly comprises a pair of advance cables 3880, 3882 and a firing cable 3884. FIGS. 81 and 82 illustrate the cables 3880, 3882, 3884 in diagrammatic form. As can be seen in those Figures, a first advance cable 3880 is operably supported on a first distal cable transition support 3885 which may comprise, for example, a pulley, rod, capstan, etc. that is

attached to the distal end of the elongated channel 3822 and a first proximal cable transition support 3886 which may comprise, for example, a pulley, rod, capstan, etc. that is operably supported by the elongated channel 3822. A distal end 3881 of the first advance cable 3880 is affixed to the dynamic clamping assembly 3860. The second advance cable 3882 is operably supported on a second distal cable transition support 3887 which may, for example, comprise a pulley, rod, capstan etc. that is mounted to the distal end of the elongated channel 3822 and a second proximal cable transition support 3888 which may, for example, comprise a pulley, rod, capstan, etc. mounted to the proximal end of the elongated channel 3822. The proximal end 3883 of the second advance cable 3882 may be attached to the dynamic clamping assembly 3860. Also in these embodiments, an endless firing cable 3884 is employed and journaled on a support 3889 that may comprise a pulley, rod, capstan, etc. mounted within the elongated shaft 3808. In one embodiment, the retract cable 3884 may be formed in a loop and coupled to a connector 3889' that is fixedly attached to the first and second advance cables 3880, 3882.

Various non-limiting embodiments of the present invention include a cable drive transmission 3920 that is operably supported on a tool mounting plate 3902 of the tool mounting portion 3900. The tool mounting portion 3900 has an array of electrical connecting pins 3904 which are configured to interface with the slots 1258 (FIG. 21) in the adapter 1240'. Such arrangement permits the robotic system 1000 to provide control signals to a control circuit 3910 of the tool 3800. While the interface is described herein with reference to mechanical, electrical, and magnetic coupling elements, it should be understood that a wide variety of telemetry modalities might be used, including infrared, inductive coupling, or the like.

Control circuit 3910 is shown in schematic form in FIG. 79. In one form or embodiment, the control circuit 3910 includes a power supply in the form of a battery 3912 that is coupled to an on-off solenoid powered switch 3914. In other embodiments, however, the power supply may comprise a source of alternating current. Control circuit 3910 further includes an on/off solenoid 3916 that is coupled to a double pole switch 3918 for controlling motor rotation direction. Thus, when the robotic system 1000 supplies an appropriate control signal, switch 3914 will permit battery 3912 to supply power to the double pole switch 3918. The robotic system 1000 will also supply an appropriate signal to the double pole switch 3918 to supply power to a shifter motor 3922.

Turning to FIGS. 83-88, at least one embodiment of the cable drive transmission 3920 comprises a drive pulley 3930 that is operably mounted to a drive shaft 3932 that is attached to a driven element 1304 of the type and construction described above that is designed to interface with a corresponding drive element 1250 of the adapter 1240. See FIGS. 18 and 84. Thus, when the tool mounting portion 3900 is operably coupled to the tool holder 1270, the robot system 1000 can apply rotary motion to the drive pulley 3930 in a desired direction. A first drive member or belt 3934 drivingly engages the drive pulley 3930 and a second drive shaft 3936 that is rotatably supported on a shifter yoke 3940. The shifter yoke 3940 is operably coupled to the shifter motor 3922 such that rotation of the shaft 3923 of the shifter motor 3922 in a first direction will shift the shifter yoke in a first direction "FD" and rotation of the shifter motor shaft 3923 in a second direction will shift the shifter yoke 3940 in a second direction "SD". Other embodiments of the present invention may employ a shifter solenoid arrangement for shifting the shifter yoke in said first and second directions.

53

As can be seen in FIGS. 83-86, a closure drive gear 3950 mounted to a second drive shaft 3936 and is configured to selectively mesh with a closure drive assembly, generally designated as 3951. Likewise a firing drive gear 3960 is also mounted to the second drive shaft 3936 and is configured to selectively mesh with a firing drive assembly generally designated as 3961. Rotation of the second drive shaft 3936 causes the closure drive gear 3950 and the firing drive gear 3960 to rotate. In one non-limiting embodiment, the closure drive assembly 3951 comprises a closure driven gear 3952 that is coupled to a first closure pulley 3954 that is rotatably supported on a third drive shaft 3956. The closure cable 3850 is drivingly received on the first closure pulley 3954 such that rotation of the closure driven gear 3952 will drive the closure cable 3850. Likewise, the firing drive assembly 3961 comprises a firing driven gear 3962 that is coupled to a first firing pulley 3964 that is rotatably supported on the third drive shaft 3956. The first and second driving pulleys 3954 and 3964 are independently rotatable on the third drive shaft 3956. The firing cable 3884 is drivingly received on the first firing pulley 3964 such that rotation of the firing driven gear 3962 will drive the firing cable 3884.

Also in various embodiments, the cable drive transmission 3920 further includes a braking assembly 3970. In at least one embodiment, for example, the braking assembly 3970 includes a closure brake 3972 that comprises a spring arm 3973 that is attached to a portion of the transmission housing 3971. The closure brake 3972 has a gear lug 3974 that is sized to engage the teeth of the closure driven gear 3952 as will be discussed in further detail below. The braking assembly 3970 further includes a firing brake 3976 that comprises a spring arm 3977 that is attached to another portion of the transmission housing 3971. The firing brake 3976 has a gear lug 3978 that is sized to engage the teeth of the firing driven gear 3962.

At least one embodiment of the surgical tool 3800 may be used as follows. The tool mounting portion 3900 is operably coupled to the interface 1240 of the robotic system 1000. The controller or control unit of the robotic system is operated to locate the tissue to be cut and stapled between the open anvil 3824 and the staple cartridge 3834. When in that initial position, the braking assembly 3970 has locked the closure driven gear 3952 and the firing driven gear 3962 such that they cannot rotate. That is, as shown in FIG. 84, the gear lug 3974 is in locking engagement with the closure driven gear 3952 and the gear lug 3978 is in locking engagement with the firing driven gear 3962. Once the surgical end effector 3814 has been properly located, the controller 1001 of the robotic system 1000 will provide a control signal to the shifter motor 3922 (or shifter solenoid) to move the shifter yoke 3940 in the first direction. As the shifter yoke 3940 is moved in the first direction, the closure drive gear 3950 moves the gear lug 3974 out of engagement with the closure driven gear 3952 as it moves into meshing engagement with the closure driven gear 3952. As can be seen in FIG. 83, when in that position, the gear lug 3978 remains in locking engagement with the firing driven gear 3962 to prevent actuation of the firing system. Thereafter, the robotic controller 1001 provides a first rotary actuation motion to the drive pulley 3930 through the interface between the driven element 1304 and the corresponding components of the tool holder 1240. As the drive pulley 3930 is rotated in the first direction, the closure cable 3850 is rotated to drive the preclamping collar 3840 into closing engagement with the cam surface 3825 of the anvil 3824 to move it to the closed position thereby clamping the target tissue between the anvil 3824 and the staple cartridge 3834. See FIG. 79. Once the anvil 3824 has been moved to the closed position, the robotic controller 1001 stops the appli-

54

cation of the first rotary motion to the drive pulley 3930. Thereafter, the robotic controller 1001 may commence the firing process by sending another control signal to the shifter motor 3922 (or shifter solenoid) to cause the shifter yoke to move in the second direction "SD" as shown in FIG. 94. As the shifter yoke 3940 is moved in the second direction, the firing drive gear 3960 moves the gear lug 3978 out of engagement with the firing driven gear 3962 as it moves into meshing engagement with the firing driven gear 3962. As can be seen in FIG. 85, when in that position, the gear lug 3974 remains in locking engagement with the closure driven gear 3952 to prevent actuation of the closure system. Thereafter, the robotic controller 1001 is activated to provide the first rotary actuation motion to the drive pulley 3930 through the interface between the driven element 1304 and the corresponding components of the tool holder 1240. As the drive pulley 3930 is rotated in the first direction, the firing cable 3884 is rotated to drive the dynamic clamping member 3860 in the distal direction "DD" thereby firing the staples and cutting the tissue clamped in the end effector 3814. Once the robotic system 1000 determines that the dynamic clamping member 3860 has reached its distal most position—either through sensors or through monitoring the amount of rotary input applied to the drive pulley 3930, the controller 1001 may then apply a second rotary motion to the drive pulley 3930 to rotate the closure cable 3850 in an opposite direction to cause the dynamic clamping member 3860 to be retracted in the proximal direction "PD". Once the dynamic clamping member has been retracted to the starting position, the application of the second rotary motion to the drive pulley 3930 is discontinued. Thereafter, the shifter motor 3922 (or shifter solenoid) is powered to move the shifter yoke 3940 to the closure position (FIG. 83). Once the closure drive gear 3950 is in meshing engagement with the closure driven gear 3952, the robotic controller 1001 may once again apply the second rotary motion to the drive pulley 3930. Rotation of the drive pulley 3930 in the second direction causes the closure cable 3850 to retract the preclamping collar 3840 out of engagement with the cam surface 3825 of the anvil 3824 to permit the anvil 3824 to move to an open position (by a spring or other means) to release the stapled tissue from the surgical end effector 3814.

FIG. 89 illustrates a surgical tool 4000 that employs a gear driven firing bar 4092 as shown in FIGS. 90-92. This embodiment includes an elongated shaft assembly 4008 that extends from a tool mounting portion 4100. The tool mounting portion 4100 includes a tool mounting plate 4102 that operable supports a transmission arrangement 4103 thereon. The elongated shaft assembly 4008 includes a rotatable proximal closure tube 4010 that is rotatably journaled on a proximal spine member 4020 that is rigidly coupled to the tool mounting plate 4102. The proximal spine member 4020 has a distal end that is coupled to an elongated channel portion 4022 of a surgical end effector 4012. The surgical effector 4012 may be substantially similar to surgical end effector 3412 described above. In addition, the anvil 4024 of the surgical end effector 4012 may be opened and closed by a distal closure tube 4030 that operably interfaces with the proximal closure tube 4010. Distal closure tube 4030 is identical to distal closure tube 3430 described above. Similarly, proximal closure tube 4010 is identical to proximal closure tube segment 3410 described above.

Anvil 4024 is opened and closed by rotating the proximal closure tube 4010 in manner described above with respect to distal closure tube 3410. In at least one embodiment, the transmission arrangement comprises a closure transmission, generally designated as 4011. As will be further discussed

55

below, the closure transmission 4011 is configured to receive a corresponding first rotary motion from the robotic system 1000 and convert that first rotary motion to a primary rotary motion for rotating the rotatable proximal closure tube 4010 about the longitudinal tool axis L-T-LT. As can be seen in FIG. 92, a proximal end 4060 of the proximal closure tube 4010 is rotatably supported within a cradle arrangement 4104 that is attached to a tool mounting plate 4102 of the tool mounting portion 4100. A rotation gear 4062 is formed on or attached to the proximal end 4060 of the closure tube segment 4010 for meshing engagement with a rotation drive assembly 4070 that is operably supported on the tool mounting plate 4102. In at least one embodiment, a rotation drive gear 4072 is coupled to a corresponding first one of the driven discs or elements 1304 on the adapter side of the tool mounting plate 4102 when the tool mounting portion 4100 is coupled to the tool holder 1270. See FIGS. 22 and 92. The rotation drive assembly 4070 further comprises a rotary driven gear 4074 that is rotatably supported on the tool mounting plate 4102 in meshing engagement with the rotation gear 4062 and the rotation drive gear 4072. Application of a first rotary control motion from the robotic system 1000 through the tool holder 1270 and the adapter 1240 to the corresponding driven element 1304 will thereby cause rotation of the rotation drive gear 4072 by virtue of being operably coupled thereto. Rotation of the rotation drive gear 4072 ultimately results in the rotation of the closure tube segment 4010 to open and close the anvil 4024 as described above.

As indicated above, the end effector 4012 employs a cutting element 3860 as shown in FIGS. 90 and 91. In at least one non-limiting embodiment, the transmission arrangement 4103 further comprises a knife drive transmission that includes a knife drive assembly 4080. FIG. 92 illustrates one form of knife drive assembly 4080 for axially advancing the knife bar 4092 that is attached to such cutting element using cables as described above with respect to surgical tool 3800. In particular, the knife bar 4092 replaces the firing cable 3884 employed in an embodiment of surgical tool 3800. One form of the knife drive assembly 4080 comprises a rotary drive gear 4082 that is coupled to a corresponding second one of the driven discs or elements 1304 on the adapter side of the tool mounting plate 4102 when the tool mounting portion 4100 is coupled to the tool holder 1270. See FIGS. 22 and 92. The knife drive assembly 4080 further comprises a first rotary driven gear assembly 4084 that is rotatably supported on the tool mounting plate 4102. The first rotary driven gear assembly 4084 is in meshing engagement with a third rotary driven gear assembly 4086 that is rotatably supported on the tool mounting plate 4102 and which is in meshing engagement with a fourth rotary driven gear assembly 4088 that is in meshing engagement with a threaded portion 4094 of drive shaft assembly 4090 that is coupled to the knife bar 4092. Rotation of the rotary drive gear 4082 in a second rotary direction will result in the axial advancement of the drive shaft assembly 4090 and knife bar 4092 in the distal direction "DD". Conversely, rotation of the rotary drive gear 4082 in a secondary rotary direction (opposite to the second rotary direction) will cause the drive shaft assembly 4090 and the knife bar 4092 to move in the proximal direction. Movement of the firing bar 4092 in the proximal direction "PD" will drive the cutting element 3860 in the distal direction "DD". Conversely, movement of the firing bar 4092 in the distal direction "DD" will result in the movement of the cutting element 3860 in the proximal direction "PD".

FIGS. 93-99 illustrate yet another surgical tool 5000 that may be effectively employed in connection with a robotic system 1000. In various forms, the surgical tool 5000 includes

56

a surgical end effector 5012 in the form of a surgical stapling instrument that includes an elongated channel 5020 and a pivotally translatable clamping member, such as an anvil 5070, which are maintained at a spacing that assures effective stapling and severing of tissue clamped in the surgical end effector 5012. As can be seen in FIG. 95, the elongated channel 5020 may be substantially U-shaped in cross-section and be fabricated from, for example, titanium, 203 stainless steel, 304 stainless steel, 416 stainless steel, 17-4 stainless steel, 17-7 stainless steel, 6061 or 7075 aluminum, chromium steel, ceramic, etc. A substantially U-shaped metal channel pan 5022 may be supported in the bottom of the elongated channel 5020 as shown.

Various embodiments include an actuation member in the form of a sled assembly 5030 that is operably supported within the surgical end effector 5012 and axially movable therein between a starting position and an ending position in response to control motions applied thereto. In some forms, the metal channel pan 5022 has a centrally-disposed slot 5024 therein to movably accommodate a base portion 5032 of the sled assembly 5030. The base portion 5032 includes a foot portion 5034 that is sized to be slidably received in a slot 5021 in the elongated channel 5020. See FIG. 95. As can be seen in FIGS. 94, 95, 98, and 99, the base portion 5032 of sled assembly 5030 includes an axially extending threaded bore 5036 that is configured to be threadedly received on a threaded drive shaft 5130 as will be discussed in further detail below. In addition, the sled assembly 5030 includes an upstanding support portion 5038 that supports a tissue cutting blade or tissue cutting instrument 5040. The upstanding support portion 5038 terminates in a top portion 5042 that has a pair of laterally extending retaining fins 5044 protruding therefrom. As shown in FIG. 95, the fins 5044 are positioned to be received within corresponding slots 5072 in anvil 5070. The fins 5044 and the foot 5034 serve to retain the anvil 5070 in a desired spaced closed position as the sled assembly 5030 is driven distally through the tissue clamped within the surgical end effector 5014. As can also be seen in FIGS. 97 and 99, the sled assembly 5030 further includes a reciprocating or sequentially activatable drive assembly 5050 for driving staple pushers toward the closed anvil 5070.

More specifically and with reference to FIGS. 95 and 96, the elongated channel 5020 is configured to operably support a surgical staple cartridge 5080 therein. In at least one form, the surgical staple cartridge 5080 comprises a body portion 5082 that may be fabricated from, for example, Vectra, Nylon (6/6 or 6/12) and include a centrally disposed slot 5084 for accommodating the upstanding support portion 5038 of the sled assembly 5030. See FIG. 95. These materials could also be filled with glass, carbon, or mineral fill of 10%-40%. The surgical staple cartridge 5080 further includes a plurality of cavities 5086 for movably supporting lines or rows of staple-supporting pushers 5088 therein. The cavities 5086 may be arranged in spaced longitudinally extending lines or rows 5090, 5092, 5094, 5096. For example, the rows 5090 may be referred to herein as first outboard rows. The rows 5092 may be referred to herein as first inboard rows. The rows 5094 may be referred to as second inboard rows and the rows 5096 may be referred to as second outboard rows. The first inboard row 5090 and the first outboard row 5092 are located on a first lateral side of the longitudinal slot 5084 and the second inboard row 5094 and the second outboard row 5096 are located on a second lateral side of the longitudinal slot 5084. The first staple pushers 5088 in the first inboard row 5092 are staggered in relationship to the first staple pushers 5088 in the first outboard row 5090. Similarly, the second staple pushers 5088 in the second outboard row 5096 are staggered in rela-

57

tionship to the second pushers **5088** in the second inboard row **5094**. Each pusher **5088** operably supports a surgical staple **5098** thereon.

In various embodiments, the sequentially-activatable or reciprocatably—activatable drive assembly **5050** includes a pair of outboard drivers **5052** and a pair of inboard drivers **5054** that are each attached to a common shaft **5056** that is rotatably mounted within the base **5032** of the sled assembly **5030**. The outboard drivers **5052** are oriented to sequentially or reciprocatingly engage a corresponding plurality of outboard activation cavities **5026** provided in the channel pan **5022**. Likewise, the inboard drivers **5054** are oriented to sequentially or reciprocatingly engage a corresponding plurality of inboard activation cavities **5028** provided in the channel pan **5022**. The inboard activation cavities **5028** are arranged in a staggered relationship relative to the adjacent outboard activation cavities **5026**. See FIG. **96**. As can also be seen in FIGS. **96** and **98**, in at least one embodiment, the sled assembly **5030** further includes distal wedge segments **5060** and intermediate wedge segments **5062** located on each side of the bore **5036** to engage the pushers **5088** as the sled assembly **5030** is driven distally in the distal direction “DD”. As indicated above, the sled assembly **5030** is threadedly received on a threaded portion **5132** of a drive shaft **5130** that is rotatably supported within the end effector **5012**. In various embodiments, for example, the drive shaft **5130** has a distal end **5134** that is supported in a distal bearing **5136** mounted in the surgical end effector **5012**. See FIGS. **95** and **96**.

In various embodiments, the surgical end effector **5012** is coupled to a tool mounting portion **5200** by an elongated shaft assembly **5108**. In at least one embodiment, the tool mounting portion **5200** operably supports a transmission arrangement generally designated as **5204** that is configured to receive rotary output motions from the robotic system. The elongated shaft assembly **5108** includes an outer closure tube **5110** that is rotatable and axially movable on a spine member **5120** that is rigidly coupled to a tool mounting plate **5201** of the tool mounting portion **5200**. The spine member **5120** also has a distal end **5122** that is coupled to the elongated channel portion **5020** of the surgical end effector **5012**.

In use, it may be desirable to rotate the surgical end effector **5012** about a longitudinal tool axis LT-LT defined by the elongated shaft assembly **5008**. In various embodiments, the outer closure tube **5110** has a proximal end **5112** that is rotatably supported on the tool mounting plate **5201** of the tool drive portion **5200** by a forward support cradle **5203**. The proximal end **5112** of the outer closure tube **5110** is configured to operably interface with a rotation transmission portion **5206** of the transmission arrangement **5204**. In various embodiments, the proximal end **5112** of the outer closure tube **5110** is also supported on a closure sled **5140** that is also movably supported on the tool mounting plate **5201**. A closure tube gear segment **5114** is formed on the proximal end **5112** of the outer closure tube **5110** for meshing engagement with a rotation drive assembly **5150** of the rotation transmission **5206**. As can be seen in FIG. **93**, the rotation drive assembly **5150**, in at least one embodiment, comprises a rotation drive gear **5152** that is coupled to a corresponding first one of the driven discs or elements **1304** on the adapter side **1307** of the tool mounting plate **5201** when the tool drive portion **5200** is coupled to the tool holder **1270**. The rotation drive assembly **5150** further comprises a rotary driven gear **5154** that is rotatably supported on the tool mounting plate **5201** in meshing engagement with the closure tube gear segment **5114** and the rotation drive gear **5152**. Application of a first rotary control motion from the robotic system **1000** through the tool holder **1270** and the adapter **1240** to the

58

corresponding driven element **1304** will thereby cause rotation of the rotation drive gear **5152**. Rotation of the rotation drive gear **5152** ultimately results in the rotation of the elongated shaft assembly **5108** (and the end effector **5012**) about the longitudinal tool axis LT-LT (represented by arrow “R” in FIG. **93**).

Closure of the anvil **5070** relative to the surgical staple cartridge **5080** is accomplished by axially moving the outer closure tube **5110** in the distal direction “DD”. Such axial movement of the outer closure tube **5110** may be accomplished by a closure transmission portion **5144** of the transmission arrangement **5204**. As indicated above, in various embodiments, the proximal end **5112** of the outer closure tube **5110** is supported by the closure sled **5140** which enables the proximal end **5112** to rotate relative thereto, yet travel axially with the closure sled **5140**. In particular, as can be seen in FIG. **93**, the closure sled **5140** has an upstanding tab **5141** that extends into a radial groove **5115** in the proximal end portion **5112** of the outer closure tube **5110**. In addition, as was described above, the closure sled **5140** is slidably mounted to the tool mounting plate **5201**. In various embodiments, the closure sled **5140** has an upstanding portion **5142** that has a closure rack gear **5143** formed thereon. The closure rack gear **5143** is configured for driving engagement with the closure transmission **5144**.

In various forms, the closure transmission **5144** includes a closure spur gear **5145** that is coupled to a corresponding second one of the driven discs or elements **1304** on the adapter side **1307** of the tool mounting plate **5201**. Thus, application of a second rotary control motion from the robotic system **1000** through the tool holder **1270** and the adapter **1240** to the corresponding second driven element **1304** will cause rotation of the closure spur gear **5145** when the interface **1230** is coupled to the tool mounting portion **5200**. The closure transmission **5144** further includes a driven closure gear set **5146** that is supported in meshing engagement with the closure spur gear **5145** and the closure rack gear **5143**. Thus, application of a second rotary control motion from the robotic system **1000** through the tool holder **1270** and the adapter **1240** to the corresponding second driven element **1304** will cause rotation of the closure spur gear **5145** and ultimately drive the closure sled **5140** and the outer closure tube **5110** axially. The axial direction in which the closure tube **5110** moves ultimately depends upon the direction in which the second driven element **1304** is rotated. For example, in response to one rotary closure motion received from the robotic system **1000**, the closure sled **5140** will be driven in the distal direction “DD” and ultimately the outer closure tube **5110** will be driven in the distal direction as well. The outer closure tube **5110** has an opening **5117** in the distal end **5116** that is configured for engagement with a tab **5071** on the anvil **5070** in the manners described above. As the outer closure tube **5110** is driven distally, the proximal end **5116** of the closure tube **5110** will contact the anvil **5070** and pivot it closed. Upon application of an “opening” rotary motion from the robotic system **1000**, the closure sled **5140** and outer closure tube **5110** will be driven in the proximal direction “PD” and pivot the anvil **5070** to the open position in the manners described above.

In at least one embodiment, the drive shaft **5130** has a proximal end **5137** that has a proximal shaft gear **5138** attached thereto. The proximal shaft gear **5138** is supported in meshing engagement with a distal drive gear **5162** attached to a rotary drive bar **5160** that is rotatably supported with spine member **5120**. Rotation of the rotary drive bar **5160** and ultimately rotary drive shaft **5130** is controlled by a rotary knife transmission **5207** which comprises a portion of the

59

transmission arrangement 5204 supported on the tool mounting plate 5210. In various embodiments, the rotary knife transmission 5207 comprises a rotary knife drive system 5170 that is operably supported on the tool mounting plate 5201. In various embodiments, the knife drive system 5170 includes a rotary drive gear 5172 that is coupled to a corresponding third one of the driven discs or elements 1304 on the adapter side of the tool mounting plate 5201 when the tool drive portion 5200 is coupled to the tool holder 1270. The knife drive system 5170 further comprises a first rotary driven gear 5174 that is rotatably supported on the tool mounting plate 5201 in meshing engagement with a second rotary driven gear 5176 and the rotary drive gear 5172. The second rotary driven gear 5176 is coupled to a proximal end portion 5164 of the rotary drive bar 5160.

Rotation of the rotary drive gear 5172 in a first rotary direction will result in the rotation of the rotary drive bar 5160 and rotary drive shaft 5130 in a first direction. Conversely, rotation of the rotary drive gear 5172 in a second rotary direction (opposite to the first rotary direction) will cause the rotary drive bar 5160 and rotary drive shaft 5130 to rotate in a second direction 2400. Thus, rotation of the drive shaft 2440 results in rotation of the drive sleeve 2400.

One method of operating the surgical tool 5000 will now be described. The tool drive 5200 is operably coupled to the interface 1240 of the robotic system 1000. The controller 1001 of the robotic system 1000 is operated to locate the tissue to be cut and stapled between the open anvil 5070 and the surgical staple cartridge 5080. Once the surgical end effector 5012 has been positioned by the robot system 1000 such that the target tissue is located between the anvil 5070 and the surgical staple cartridge 5080, the controller 1001 of the robotic system 1000 may be activated to apply the second rotary output motion to the second driven element 1304 coupled to the closure spur gear 5145 to drive the closure sled 5140 and the outer closure tube 5110 axially in the distal direction to pivot the anvil 5070 closed in the manner described above. Once the robotic controller 1001 determines that the anvil 5070 has been closed by, for example, sensors in the surgical end effector 5012 and/or the tool drive portion 5200, the robotic controller 1001 system may provide the surgeon with an indication that signifies the closure of the anvil. Such indication may be, for example, in the form of a light and/or audible sound, tactile feedback on the control members, etc. Then the surgeon may initiate the firing process. In alternative embodiments, however, the robotic controller 1001 may automatically commence the firing process.

To commence the firing process, the robotic controller applies a third rotary output motion to the third driven disc or element 1304 coupled to the rotary drive gear 5172. Rotation of the rotary drive gear 5172 results in the rotation of the rotary drive bar 5160 and rotary drive shaft 5130 in the manner described above. Firing and formation of the surgical staples 5098 can be best understood from reference to FIGS. 94, 96, and 97. As the sled assembly 5030 is driven in the distal direction "DD" through the surgical staple cartridge 5080, the distal wedge segments 5060 first contact the staple pushers 5088 and start to move them toward the closed anvil 5070. As the sled assembly 5030 continues to move distally, the outboard drivers 5052 will drop into the corresponding activation cavity 5026 in the channel pan 5022. The opposite end of each outboard driver 5052 will then contact the corresponding outboard pusher 5088 that has moved up the distal and intermediate wedge segments 5060, 5062. Further distal movement of the sled assembly 5030 causes the outboard drivers 5052 to rotate and drive the corresponding pushers 5088 toward the anvil 5070 to cause the staples 5098 sup-

60

ported thereon to be formed as they are driven into the anvil 5070. It will be understood that as the sled assembly 5030 moves distally, the knife blade 5040 cuts through the tissue that is clamped between the anvil and the staple cartridge. Because the inboard drivers 5054 and outboard drivers 5052 are attached to the same shaft 5056 and the inboard drivers 5054 are radially offset from the outboard drivers 5052 on the shaft 5056, as the outboard drivers 5052 are driving their corresponding pushers 5088 toward the anvil 5070, the inboard drivers 5054 drop into their next corresponding activation cavity 5028 to cause them to rotatably or reciprocatingly drive the corresponding inboard pushers 5088 towards the closed anvil 5070 in the same manner. Thus, the laterally corresponding outboard staples 5098 on each side of the centrally disposed slot 5084 are simultaneously formed together and the laterally corresponding inboard staples 5098 on each side of the slot 5084 are simultaneously formed together as the sled assembly 5030 is driven distally. Once the robotic controller 1001 determines that the sled assembly 5030 has reached its distal most position—either through sensors or through monitoring the amount of rotary input applied to the drive shaft 5130 and/or the rotary drive bar 5160, the controller 1001 may then apply a third rotary output motion to the drive shaft 5130 to rotate the drive shaft 5130 in an opposite direction to retract the sled assembly 5030 back to its starting position. Once the sled assembly 5030 has been retracted to the starting position (as signaled by sensors in the end effector 5012 and/or the tool drive portion 5200), the application of the second rotary motion to the drive shaft 5130 is discontinued. Thereafter, the surgeon may manually activate the anvil opening process or it may be automatically commenced by the robotic controller 1001. To open the anvil 5070, the second rotary output motion is applied to the closure spur gear 5145 to drive the closure sled 5140 and the outer closure tube 5110 axially in the proximal direction. As the closure tube 5110 moves proximally, the opening 5117 in the distal end 5116 of the closure tube 5110 contacts the tab 5071 on the anvil 5070 to pivot the anvil 5070 to the open position. A spring may also be employed to bias the anvil 5070 to the open position when the closure tube 5116 has been returned to the starting position. Again, sensors in the surgical end effector 5012 and/or the tool mounting portion 5200 may provide the robotic controller 1001 with a signal indicating that the anvil 5070 is now open. Thereafter, the surgical end effector 5012 may be withdrawn from the surgical site.

FIGS. 100-105 diagrammatically depict the sequential firing of staples in a surgical tool assembly 5000' that is substantially similar to the surgical tool assembly 5000 described above. In this embodiment, the inboard and outboard drivers 5052', 5054' have a cam-like shape with a cam surface 5053 and an actuator protrusion 5055 as shown in FIGS. 100-106. The drivers 5052', 5054' are journaled on the same shaft 5056' that is rotatably supported by the sled assembly 5030'. In this embodiment, the sled assembly 5030' has distal wedge segments 5060' for engaging the pushers 5088. FIG. 100 illustrates an initial position of two inboard or outboard drivers 5052', 5054' as the sled assembly 5030' is driven in the distal direction "DD". As can be seen in that Figure, the pusher 5088a has advanced up the wedge segment 5060' and has contacted the driver 5052', 5054'. Further travel of the sled assembly 5030' in the distal direction causes the driver 5052', 5054' to pivot in the "P" direction (FIG. 101) until the actuator portion 5055 contacts the end wall 5029a of the activation cavity 5026, 5028 as shown in FIG. 102. Continued advancement of the sled assembly 5030' in the distal direction "DD" causes the driver 5052', 5054' to rotate in the "D" direction as

61

shown in FIG. 103. As the driver 5052', 5054' rotates, the pusher 5088a rides up the cam surface 5053 to the final vertical position shown in FIG. 104. When the pusher 5088a reaches the final vertical position shown in FIGS. 104 and 105, the staple (not shown) supported thereon has been driven into the staple forming surface of the anvil to form the staple.

FIGS. 107-112 illustrate a surgical end effector 5312 that may be employed for example, in connection with the tool mounting portion 1300 and shaft 2008 described in detail above. In various forms, the surgical end effector 5312 includes an elongated channel 5322 that is constructed as described above for supporting a surgical staple cartridge 5330 therein. The surgical staple cartridge 5330 comprises a body portion 5332 that includes a centrally disposed slot 5334 for accommodating an upstanding support portion 5386 of a sled assembly 5380. See FIGS. 107-109. The surgical staple cartridge body portion 5332 further includes a plurality of cavities 5336 for movably supporting staple-supporting pushers 5350 therein. The cavities 5336 may be arranged in spaced longitudinally extending rows 5340, 5342, 5344, 5346. The rows 5340, 5342 are located on one lateral side of the longitudinal slot 5334 and the rows 5344, 5346 are located on the other side of longitudinal slot 5334. In at least one embodiment, the pushers 5350 are configured to support two surgical staples 5352 thereon. In particular, each pusher 5350 located on one side of the elongated slot 5334 supports one staple 5352 in row 5340 and one staple 5352 in row 5342 in a staggered orientation. Likewise, each pusher 5350 located on the other side of the elongated slot 5334 supports one surgical staple 5352 in row 5344 and another surgical staple 5352 in row 5346 in a staggered orientation. Thus, every pusher 5350 supports two surgical staples 5352.

As can be further seen in FIGS. 107, 108, the surgical staple cartridge 5330 includes a plurality of rotary drivers 5360. More particularly, the rotary drivers 5360 on one side of the elongated slot 5334 are arranged in a single line 5370 and correspond to the pushers 5350 in lines 5340, 5342. In addition, the rotary drivers 5360 on the other side of the elongated slot 5334 are arranged in a single line 5372 and correspond to the pushers 5350 in lines 5344, 5346. As can be seen in FIG. 107, each rotary driver 5360 is rotatably supported within the staple cartridge body 5332. More particularly, each rotary driver 5360 is rotatably received on a corresponding driver shaft 5362. Each driver 5360 has an arcuate ramp portion 5364 formed thereon that is configured to engage an arcuate lower surface 5354 formed on each pusher 5350. See FIG. 112. In addition, each driver 5360 has a lower support portion 5366 extend therefrom to slidably support the pusher 5360 on the channel 5322. Each driver 5360 has a downwardly extending actuation rod 5368 that is configured for engagement with a sled assembly 5380.

As can be seen in FIG. 109, in at least one embodiment, the sled assembly 5380 includes a base portion 5382 that has a foot portion 5384 that is sized to be slidably received in a slot 5333 in the channel 5322. See FIG. 107. The sled assembly 5380 includes an upstanding support portion 5386 that supports a tissue cutting blade or tissue cutting instrument 5388. The upstanding support portion 5386 terminates in a top portion 5390 that has a pair of laterally extending retaining fins 5392 protruding therefrom. The fins 5392 are positioned to be received within corresponding slots (not shown) in the anvil (not shown). As with the above-described embodiments, the fins 5392 and the foot portion 5384 serve to retain the anvil (not shown) in a desired spaced closed position as the sled assembly 5380 is driven distally through the tissue clamped within the surgical end effector 5312. The upstanding support portion 5386 is configured for attachment to a

62

knife bar 2200 (FIG. 28). The sled assembly 5380 further has a horizontally-extending actuator plate 5394 that is shaped for actuating engagement with each of the actuation rods 5368 on the pushers 5360.

Operation of the surgical end effector 5312 will now be explained with reference to FIGS. 107 and 108. As the sled assembly 5380 is driven in the distal direction "DD" through the staple cartridge 5330, the actuator plate 5394 sequentially contacts the actuation rods 5368 on the pushers 5360. As the sled assembly 5380 continues to move distally, the actuator plate 5394 sequentially contacts the actuator rods 5368 of the drivers 5360 on each side of the elongated slot 5334. Such action causes the drivers 5360 to rotate from a first unactuated position to an actuated portion wherein the pushers 5350 are driven towards the closed anvil. As the pushers 5350 are driven toward the anvil, the surgical staples 5352 thereon are driven into forming contact with the underside of the anvil. Once the robotic system 1000 determines that the sled assembly 5080 has reached its distal most position through sensors or other means, the control system of the robotic system 1000 may then retract the knife bar and sled assembly 5380 back to the starting position. Thereafter, the robotic control system may then activate the procedure for returning the anvil to the open position to release the stapled tissue.

FIGS. 113-117 depict one form of an automated reloading system embodiment of the present invention, generally designated as 5500. In one form, the automated reloading system 5500 is configured to replace a "spent" surgical end effector component in a manipulatable surgical tool portion of a robotic surgical system with a "new" surgical end effector component. As used herein, the term "surgical end effector component" may comprise, for example, a surgical staple cartridge, a disposable loading unit or other end effector components that, when used, are spent and must be replaced with a new component. Furthermore, the term "spent" means that the end effector component has been activated and is no longer useable for its intended purpose in its present state. For example, in the context of a surgical staple cartridge or disposable loading unit, the term "spent" means that at least some of the unformed staples that were previously supported therein have been "fired" therefrom. As used herein, the term "new" surgical end effector component refers to an end effector component that is in condition for its intended use. In the context of a surgical staple cartridge or disposable loading unit, for example, the term "new" refers to such a component that has unformed staples therein and which is otherwise ready for use.

In various embodiments, the automated reloading system 5500 includes a base portion 5502 that may be strategically located within a work envelope 1109 of a robotic arm cart 1100 (FIG. 14) of a robotic system 1000. As used herein, the term "manipulatable surgical tool portion" collectively refers to a surgical tool of the various types disclosed herein and other forms of surgical robotically-actuated tools that are operably attached to, for example, a robotic arm cart 1100 or similar device that is configured to automatically manipulate and actuate the surgical tool. The term "work envelope" as used herein refers to the range of movement of the manipulatable surgical tool portion of the robotic system. FIG. 14 generally depicts an area that may comprise a work envelope of the robotic arm cart 1100. Those of ordinary skill in the art will understand that the shape and size of the work envelope depicted therein is merely illustrative. The ultimate size, shape and location of a work envelope will ultimately depend upon the construction, range of travel limitations, and location of the manipulatable surgical tool portion. Thus, the term "work envelope" as used herein is intended to cover a variety

of different sizes and shapes of work envelopes and should not be limited to the specific size and shape of the sample work envelope depicted in FIG. 14.

As can be seen in FIG. 113, the base portion 5502 includes a new component support section or arrangement 5510 that is configured to operably support at least one new surgical end effector component in a "loading orientation". As used herein, the term "loading orientation" means that the new end effector component is supported in such away so as to permit the corresponding component support portion of the manipulatable surgical tool portion to be brought into loading engagement with (i.e., operably seated or operably attached to) the new end effector component (or the new end effector component to be brought into loading engagement with the corresponding component support portion of the manipulatable surgical tool portion) without human intervention beyond that which may be necessary to actuate the robotic system. As will be further appreciated as the present Detailed Description proceeds, in at least one embodiment, the preparation nurse will load the new component support section before the surgery with the appropriate length and color cartridges (some surgical staple cartridges may support certain sizes of staples the size of which may be indicated by the color of the cartridge body) required for completing the surgical procedure. However, no direct human interaction is necessary during the surgery to reload the robotic endocutter. In one form, the surgical end effector component comprises a staple cartridge 2034 that is configured to be operably seated within a component support portion (elongated channel) of any of the various other end effector arrangements described above. For explanation purposes, new (unused) cartridges will be designated as "2034a" and spent cartridges will be designated as "2034b". The Figures depict cartridges 2034a, 2034b designed for use with a surgical end effector 2012 that includes a channel 2022 and an anvil 2024, the construction and operation of which were discussed in detail above. Cartridges 2034a, 2034b are identical to cartridges 2034 described above. In various embodiments, the cartridges 2034a, 2034b are configured to be snappingly retained (i.e., loading engagement) within the channel 2022 of a surgical end effector 2012. As the present Detailed Description proceeds, however, those of ordinary skill in the art will appreciate that the unique and novel features of the automated cartridge reloading system 5500 may be effectively employed in connection with the automated removal and installation of other cartridge arrangements without departing from the spirit and scope of the present invention.

In the depicted embodiment, the term "loading orientation" means that the distal tip portion 2035a of the a new surgical staple cartridge 2034a is inserted into a corresponding support cavity 5512 in the new cartridge support section 5510 such that the proximal end portion 2037a of the new surgical staple cartridge 2034a is located in a convenient orientation for enabling the arm cart 1100 to manipulate the surgical end effector 2012 into a position wherein the new cartridge 2034a may be automatically loaded into the channel 2022 of the surgical end effector 2012. In various embodiments, the base 5502 includes at least one sensor 5504 which communicates with the control system 1003 of the robotic controller 1001 to provide the control system 1003 with the location of the base 5502 and/or the reload length and color of each staged or new cartridge 2034a.

As can also be seen in the Figures, the base 5502 further includes a collection receptacle 5520 that is configured to collect spent cartridges 2034b that have been removed or disengaged from the surgical end effector 2012 that is operably attached to the robotic system 1000. In addition, in one

form, the automated reloading system 5500 includes an extraction system 5530 for automatically removing the spent end effector component from the corresponding support portion of the end effector or manipulatable surgical tool portion without specific human intervention beyond that which may be necessary to activate the robotic system. In various embodiments, the extraction system 5530 includes an extraction hook member 5532. In one form, for example, the extraction hook member 5532 is rigidly supported on the base portion 5502. In one embodiment, the extraction hook member has at least one hook 5534 formed thereon that is configured to hookingly engage the distal end 2035 of a spent cartridge 2034b when it is supported in the elongated channel 2022 of the surgical end effector 2012. In various forms, the extraction hook member 5532 is conveniently located within a portion of the collection receptacle 5520 such that when the spent end effector component (cartridge 2034b) is brought into extractive engagement with the extraction hook member 5532, the spent end effector component (cartridge 2034b) is dislodged from the corresponding component support portion (elongated channel 2022), and falls into the collection receptacle 5020. Thus, to use this embodiment, the manipulatable surgical tool portion manipulates the end effector attached thereto to bring the distal end 2035 of the spent cartridge 2034b therein into hooking engagement with the hook 5534 and then moves the end effector in such a way to dislodge the spent cartridge 2034b from the elongated channel 2022.

In other arrangements, the extraction hook member 5532 comprises a rotatable wheel configuration that has a pair of diametrically-opposed hooks 5334 protruding therefrom. See FIGS. 113 and 116. The extraction hook member 5532 is rotatably supported within the collection receptacle 5520 and is coupled to an extraction motor 5540 that is controlled by the controller 1001 of the robotic system. This form of the automated reloading system 5500 may be used as follows. FIG. 115 illustrates the introduction of the surgical end effector 2012 that is operably attached to the manipulatable surgical tool portion 1200. As can be seen in that Figure, the arm cart 1100 of the robotic system 1000 locates the surgical end effector 2012 in the shown position wherein the hook end 5534 of the extraction member 5532 hookingly engages the distal end 2035 of the spent cartridge 2034b in the surgical end effector 2012. The anvil 2024 of the surgical end effector 2012 is in the open position. After the distal end 2035 of the spent cartridge 2034b is engaged with the hook end 5532, the extraction motor 5540 is actuated to rotate the extraction wheel 5532 to disengage the spent cartridge 2034b from the channel 2022. To assist with the disengagement of the spent cartridge 2034b from the channel 2022 (or if the extraction member 5530 is stationary), the robotic system 1000 may move the surgical end effector 2012 in an upward direction (arrow "U" in FIG. 116). As the spent cartridge 2034b is dislodged from the channel 2022, the spent cartridge 2034b falls into the collection receptacle 5520. Once the spent cartridge 2034b has been removed from the surgical end effector 2012, the robotic system 1000 moves the surgical end effector 2012 to the position shown in FIG. 117.

In various embodiments, a sensor arrangement 5533 is located adjacent to the extraction member 5532 that is in communication with the controller 1001 of the robotic system 1000. The sensor arrangement 5533 may comprise a sensor that is configured to sense the presence of the surgical end effector 2012 and, more particularly the tip 2035b of the spent surgical staple cartridge 2034b thereof as the distal tip portion 2035b is brought into engagement with the extraction member 5532. In some embodiments, the sensor arrangement

65

5533 may comprise, for example, a light curtain arrangement. However, other forms of proximity sensors may be employed. In such arrangement, when the surgical end effector 2012 with the spent surgical staple cartridge 2034b is brought into extractive engagement with the extraction member 5532, the sensor senses the distal tip 2035b of the surgical staple cartridge 2034b (e.g., the light curtain is broken). When the extraction member 5532 spins and pops the surgical staple cartridge 2034b loose and it falls into the collection receptacle 5520, the light curtain is again unbroken. Because the surgical end effector 2012 was not moved during this procedure, the robotic controller 1001 is assured that the spent surgical staple cartridge 2034b has been removed therefrom. Other sensor arrangements may also be successfully employed to provide the robotic controller 1001 with an indication that the spent surgical staple cartridge 2034b has been removed from the surgical end effector 2012.

As can be seen in FIG. 117, the surgical end effector 2012 is positioned to grasp a new surgical staple cartridge 2034a between the channel 2022 and the anvil 2024. More specifically, as shown in FIGS. 114 and 117, each cavity 5512 has a corresponding upstanding pressure pad 5514 associated with it. The surgical end effector 2012 is located such that the pressure pad 5514 is located between the new cartridge 2034a and the anvil 2024. Once in that position, the robotic system 1000 closes the anvil 2024 onto the pressure pad 5514 which serves to push the new cartridge 2034a into snapping engagement with the channel 2022 of the surgical end effector 2012. Once the new cartridge 2034a has been snapped into position within the elongated channel 2022, the robotic system 1000 then withdraws the surgical end effector 2012 from the automated cartridge reloading system 5500 for use in connection with performing another surgical procedure.

FIGS. 118-122 depict another automated reloading system 5600 that may be used to remove a spent disposable loading unit 3612 from a manipulatable surgical tool arrangement 3600 (FIGS. 65-78) that is operably attached to an arm cart 1100 or other portion of a robotic system 1000 and reload a new disposable loading unit 3612 therein. As can be seen in FIGS. 118 and 119, one form of the automated reloading system 5600 includes a housing 5610 that has a movable support assembly in the form of a rotary carousel top plate 5620 supported thereon which cooperates with the housing 5610 to form a hollow enclosed area 5612. The automated reloading system 5600 is configured to be operably supported within the work envelop of the manipulatable surgical tool portion of a robotic system as was described above. In various embodiments, the rotary carousel plate 5620 has a plurality of holes 5622 for supporting a plurality of orientation tubes 5660 therein. As can be seen in FIGS. 119 and 120, the rotary carousel plate 5620 is affixed to a spindle shaft 5624. The spindle shaft 5624 is centrally disposed within the enclosed area 5612 and has a spindle gear 5626 attached thereto. The spindle gear 5626 is in meshing engagement with a carousel drive gear 5628 that is coupled to a carousel drive motor 5630 that is in operative communication with the robotic controller 1001 of the robotic system 1000.

Various embodiments of the automated reloading system 5600 may also include a carousel locking assembly, generally designated as 5640. In various forms, the carousel locking assembly 5640 includes a cam disc 5642 that is affixed to the spindle shaft 5624. The spindle gear 5626 may be attached to the underside of the cam disc 5642 and the cam disc 5642 may be keyed onto the spindle shaft 5624. In alternative arrangements, the spindle gear 5626 and the cam disc 5642 may be independently non-rotatably affixed to the spindle shaft 5624. As can be seen in FIGS. 119 and 120, a plurality

66

of notches 5644 are spaced around the perimeter of the cam disc 5642. A locking arm 5648 is pivotally mounted within the housing 5610 and is biased into engagement with the perimeter of the cam disc 5642 by a locking spring 5649. As can be seen in FIG. 118, the outer perimeter of the cam disc 5642 is rounded to facilitate rotation of the cam disc 5642 relative to the locking arm 5648. The edges of each notch 5644 are also rounded such that when the cam disc 5642 is rotated, the locking arm 5648 is cammed out of engagement with the notches 5644 by the perimeter of the cam disc 5642.

Various forms of the automated reloading system 5600 are configured to support a portable/replaceable tray assembly 5650 that is configured to support a plurality of disposable loading units 3612 in individual orientation tubes 5660. More specifically and with reference to FIGS. 119 and 120, the replaceable tray assembly 5650 comprises a tray 5652 that has a centrally-disposed locator spindle 5654 protruding from the underside thereof. The locator spindle 5654 is sized to be received within a hollow end 5625 of spindle shaft 5624. The tray 5652 has a plurality of holes 5656 therein that are configured to support an orientation tube 5660 therein. Each orientation tube 5660 is oriented within a corresponding hole 5656 in the replaceable tray assembly 5650 in a desired orientation by a locating fin 5666 on the orientation tube 5660 that is designed to be received within a corresponding locating slot 5658 in the tray assembly 5650. In at least one embodiment, the locating fin 5666 has a substantially V-shaped cross-sectional shape that is sized to fit within a V-shaped locating slot 5658. Such arrangement serves to orient the orientation tube 5660 in a desired starting position while enabling it to rotate within the hole 5656 when a rotary motion is applied thereto. That is, when a rotary motion is applied to the orientation tube 5660 the V-shaped locating fin 5666 will pop out of its corresponding locating slot enabling the tube 5660 to rotate relative to the tray 5652 as will be discussed in further detail below. As can also be seen in FIGS. 118-120, the replaceable tray 5652 may be provided with one or more handle portions 5653 to facilitate transport of the tray assembly 5652 when loaded with orientation tubes 5660.

As can be seen in FIG. 122, each orientation tube 5660 comprises a body portion 5662 that has a flanged open end 5664. The body portion 5662 defines a cavity 5668 that is sized to receive a portion of a disposable loading unit 3612 therein. To properly orient the disposable loading unit 3612 within the orientation tube 5660, the cavity 5668 has a flat locating surface 5670 formed therein. As can be seen in FIG. 122, the flat locating surface 5670 is configured to facilitate the insertion of the disposable loading unit into the cavity 5668 in a desired or predetermined non-rotatable orientation. In addition, the end 5669 of the cavity 5668 may include a foam or cushion material 5672 that is designed to cushion the distal end of the disposable loading unit 3612 within the cavity 5668. Also, the length of the locating surface may cooperate with a sliding support member 3689 of the axial drive assembly 3680 of the disposable loading unit 3612 to further locate the disposable loading unit 3612 at a desired position within the orientation tube 5660.

The orientation tubes 5660 may be fabricated from Nylon, polycarbonate, polyethylene, liquid crystal polymer, 6061 or 7075 aluminum, titanium, 300 or 400 series stainless steel, coated or painted steel, plated steel, etc. and, when loaded in the replaceable tray 5662 and the locator spindle 5654 is inserted into the hollow end 5625 of spindle shaft 5624, the orientation tubes 5660 extend through corresponding holes 5662 in the carousel top plate 5620. Each replaceable tray 5662 is equipped with a location sensor 5663 that communicates with the control system 1003 of the controller 1001 of

67

the robotic system 1000. The sensor 5663 serves to identify the location of the reload system, and the number, length, color and fired status of each reload housed in the tray. In addition, an optical sensor or sensors 5665 that communicate with the robotic controller 1001 may be employed to sense the type/size/length of disposable loading units that are loaded within the tray 5662.

Various embodiments of the automated reloading system 5600 further include a drive assembly 5680 for applying a rotary motion to the orientation tube 5660 holding the disposable loading unit 3612 to be attached to the shaft 3700 of the surgical tool 3600 (collectively the "manipulatable surgical tool portion") that is operably coupled to the robotic system. The drive assembly 5680 includes a support yoke 5682 that is attached to the locking arm 5648. Thus, the support yoke 5682 pivots with the locking arm 5648. The support yoke 5682 rotatably supports a tube idler wheel 5684 and a tube drive wheel 5686 that is driven by a tube motor 5688 attached thereto. Tube motor 5688 communicates with the control system 1003 and is controlled thereby. The tube idler wheel 5684 and tube drive wheel 5686 are fabricated from, for example, natural rubber, sanoprene, isoplast, etc. such that the outer surfaces thereof create sufficient amount of friction to result in the rotation of an orientation tube 5660 in contact therewith upon activation of the tube motor 5688. The idler wheel 5684 and tube drive wheel 5686 are oriented relative to each other to create a cradle area 5687 therebetween for receiving an orientation tube 5060 in driving engagement therein.

In use, one or more of the orientation tubes 5660 loaded in the automated reloading system 5600 are left empty, while the other orientation tubes 5660 may operably support a corresponding new disposable loading unit 3612 therein. As will be discussed in further detail below, the empty orientation tubes 5660 are employed to receive a spent disposable loading unit 3612 therein.

The automated reloading system 5600 may be employed as follows after the system 5600 is located within the work envelope of the manipulatable surgical tool portion of a robotic system. If the manipulatable surgical tool portion has a spent disposable loading unit 3612 operably coupled thereto, one of the orientation tubes 5660 that are supported on the replaceable tray 5662 is left empty to receive the spent disposable loading unit 3612 therein. If, however, the manipulatable surgical tool portion does not have a disposable loading unit 3612 operably coupled thereto, each of the orientation tubes 5660 may be provided with a properly oriented new disposable loading unit 3612.

As described hereinabove, the disposable loading unit 3612 employs a rotary "bayonet-type" coupling arrangement for operably coupling the disposable loading unit 3612 to a corresponding portion of the manipulatable surgical tool portion. That is, to attach a disposable loading unit 3612 to the corresponding portion of the manipulatable surgical tool portion (3700—see FIG. 71, 72), a rotary installation motion must be applied to the disposable loading unit 3612 and/or the corresponding portion of the manipulatable surgical tool portion when those components have been moved into loading engagement with each other. Such installation motions are collectively referred to herein as "loading motions". Likewise, to decouple a spent disposable loading unit 3612 from the corresponding portion of the manipulatable surgical tool, a rotary decoupling motion must be applied to the spent disposable loading unit 3612 and/or the corresponding portion of the manipulatable surgical tool

68

away from each other. Such decoupling motions are collectively referred to herein as "extraction motions".

To commence the loading process, the robotic system 1000 is activated to manipulate the manipulatable surgical tool portion and/or the automated reloading system 5600 to bring the manipulatable surgical tool portion into loading engagement with the new disposable loading unit 3612 that is supported in the orientation tube 5660 that is in driving engagement with the drive assembly 5680. Once the robotic controller 1001 (FIG. 13) of the robotic control system 1000 has located the manipulatable surgical tool portion in loading engagement with the new disposable loading unit 3612, the robotic controller 1001 activates the drive assembly 5680 to apply a rotary loading motion to the orientation tube 5660 in which the new disposable loading unit 3612 is supported and/or applies another rotary loading motion to the corresponding portion of the manipulatable surgical tool portion. Upon application of such rotary loading motions(s), the robotic controller 1001 also causes the corresponding portion of the manipulatable surgical tool portion to be moved towards the new disposable loading unit 3612 into loading engagement therewith. Once the disposable loading unit 3612 is in loading engagement with the corresponding portion of the manipulatable tool portion, the loading motions are discontinued and the manipulatable surgical tool portion may be moved away from the automated reloading system 5600 carrying with it the new disposable loading unit 3612 that has been operably coupled thereto.

To decouple a spent disposable loading unit 3612 from a corresponding manipulatable surgical tool portion, the robotic controller 1001 of the robotic system manipulates the manipulatable surgical tool portion so as to insert the distal end of the spent disposable loading unit 3612 into the empty orientation tube 5660 that remains in driving engagement with the drive assembly 5680. Thereafter, the robotic controller 1001 activates the drive assembly 5680 to apply a rotary extraction motion to the orientation tube 5660 in which the spent disposable loading unit 3612 is supported and/or applies a rotary extraction motion to the corresponding portion of the manipulatable surgical tool portion. The robotic controller 1001 also causes the manipulatable surgical tool portion to withdraw away from the spent rotary disposable loading unit 3612. Thereafter the rotary extraction motion(s) are discontinued.

After the spent disposable loading unit 3612 has been removed from the manipulatable surgical tool portion, the robotic controller 1001 may activate the carousel drive motor 5630 to index the carousel top plate 5620 to bring another orientation tube 5660 that supports a new disposable loading unit 3612 therein into driving engagement with the drive assembly 5680. Thereafter, the loading process may be repeated to attach the new disposable loading unit 3612 therein to the portion of the manipulatable surgical tool portion. The robotic controller 1001 may record the number of disposable loading units that have been used from a particular replaceable tray 5652. Once the controller 1001 determines that all of the new disposable loading units 3612 have been used from that tray, the controller 1001 may provide the surgeon with a signal (visual and/or audible) indicating that the tray 5652 supporting all of the spent disposable loading units 3612 must be replaced with a new tray 5652 containing new disposable loading units 3612.

FIGS. 123-128 depict another non-limiting embodiment of a surgical tool 6000 of the present invention that is well-adapted for use with a robotic system 1000 that has a tool drive assembly 1010 (FIG. 18) that is operatively coupled to a master controller 1001 that is operable by inputs from an

operator (i.e., a surgeon). As can be seen in FIG. 123, the surgical tool 6000 includes a surgical end effector 6012 that comprises an endocutter. In at least one form, the surgical tool 6000 generally includes an elongated shaft assembly 6008 that has a proximal closure tube 6040 and a distal closure tube 6042 that are coupled together by an articulation joint 6100. The surgical tool 6000 is operably coupled to the manipulator by a tool mounting portion, generally designated as 6200. The surgical tool 6000 further includes an interface 6030 which may mechanically and electrically couple the tool mounting portion 6200 to the manipulator in the various manners described in detail above.

In at least one embodiment, the surgical tool 6000 includes a surgical end effector 6012 that comprises, among other things, at least one component 6024 that is selectively movable between first and second positions relative to at least one other component 6022 in response to various control motions applied to component 6024 as will be discussed in further detail below to perform a surgical procedure. In various embodiments, component 6022 comprises an elongated channel 6022 configured to operably support a surgical staple cartridge 6034 therein and component 6024 comprises a pivotally translatable clamping member, such as an anvil 6024. Various embodiments of the surgical end effector 6012 are configured to maintain the anvil 6024 and elongated channel 6022 at a spacing that assures effective stapling and severing of tissue clamped in the surgical end effector 6012. Unless otherwise stated, the end effector 6012 is similar to the surgical end effector 2012 described above and includes a cutting instrument (not shown) and a sled (not shown). The anvil 6024 may include a tab 6027 at its proximal end that interacts with a component of the mechanical closure system (described further below) to facilitate the opening of the anvil 6024. The elongated channel 6022 and the anvil 6024 may be made of an electrically conductive material (such as metal) so that they may serve as part of an antenna that communicates with sensor(s) in the end effector, as described above. The surgical staple cartridge 6034 could be made of a nonconductive material (such as plastic) and the sensor may be connected to or disposed in the surgical staple cartridge 6034, as was also described above.

As can be seen in FIG. 123, the surgical end effector 6012 is attached to the tool mounting portion 6200 by the elongated shaft assembly 6008 according to various embodiments. As shown in the illustrated embodiment, the elongated shaft assembly 6008 includes an articulation joint generally designated as 6100 that enables the surgical end effector 6012 to be selectively articulated about a first tool articulation axis AA1-AA1 that is substantially transverse to a longitudinal tool axis LT-LT and a second tool articulation axis AA2-AA2 that is substantially transverse to the longitudinal tool axis LT-LT as well as the first articulation axis AA1-AA1. See FIG. 124. In various embodiments, the elongated shaft assembly 6008 includes a closure tube assembly 6009 that comprises a proximal closure tube 6040 and a distal closure tube 6042 that are pivotally linked by a pivot links 6044 and 6046. The closure tube assembly 6009 is movably supported on a spine assembly generally designated as 6102.

As can be seen in FIG. 125, the proximal closure tube 6040 is pivotally linked to an intermediate closure tube joint 6043 by an upper pivot link 6044U and a lower pivot link 6044L such that the intermediate closure tube joint 6043 is pivotable relative to the proximal closure tube 6040 about a first closure axis CA1-CA1 and a second closure axis CA2-CA2. In various embodiments, the first closure axis CA1-CA1 is substantially parallel to the second closure axis CA2-CA2 and both closure axes CA1-CA1, CA2-CA2 are substantially trans-

verse to the longitudinal tool axis LT-LT. As can be further seen in FIG. 134, the intermediate closure tube joint 6043 is pivotally linked to the distal closure tube 6042 by a left pivot link 6046L and a right pivot link 6046R such that the intermediate closure tube joint 6043 is pivotable relative to the distal closure tube 6042 about a third closure axis CA3-CA3 and a fourth closure axis CA4-CA4. In various embodiments, the third closure axis CA3-CA3 is substantially parallel to the fourth closure axis CA4-CA4 and both closure axes CA3-CA3, CA4-CA4 are substantially transverse to the first and second closure axes CA1-CA1, CA2-CA2 as well as to longitudinal tool axis LT-LT.

The closure tube assembly 6009 is configured to axially slide on the spine assembly 6102 in response to actuation motions applied thereto. The distal closure tube 6042 includes an opening 6045 which interfaces with the tab 6027 on the anvil 6024 to facilitate opening of the anvil 6024 as the distal closure tube 6042 is moved axially in the proximal direction "PD". The closure tubes 6040, 6042 may be made of electrically conductive material (such as metal) so that they may serve as part of the antenna, as described above. Components of the spine assembly 6102 may be made of a non-conductive material (such as plastic).

As indicated above, the surgical tool 6000 includes a tool mounting portion 6200 that is configured for operable attachment to the tool mounting assembly 1010 of the robotic system 1000 in the various manners described in detail above. As can be seen in FIG. 127, the tool mounting portion 6200 comprises a tool mounting plate 6202 that operably supports a transmission arrangement 6204 thereon. In various embodiments, the transmission arrangement 6204 includes an articulation transmission 6142 that comprises a portion of an articulation system 6140 for articulating the surgical end effector 6012 about a first tool articulation axis TA1-TA1 and a second tool articulation axis TA2-TA2. The first tool articulation axis TA1-TA1 is substantially transverse to the second tool articulation axis TA2-TA2 and both of the first and second tool articulation axes are substantially transverse to the longitudinal tool axis LT-LT. See FIG. 124.

To facilitate selective articulation of the surgical end effector 6012 about the first and second tool articulation axes TA1-TA1, TA2-TA2, the spine assembly 6102 comprises a proximal spine portion 6110 that is pivotally coupled to a distal spine portion 6120 by pivot pins 6122 for selective pivotal travel about TA1-TA1. Similarly, the distal spine portion 6120 is pivotally attached to the elongated channel 6022 of the surgical end effector 6012 by pivot pins 6124 to enable the surgical end effector 6012 to selectively pivot about the second tool axis TA2-TA2 relative to the distal spine portion 6120.

In various embodiments, the articulation system 6140 further includes a plurality of articulation elements that operably interface with the surgical end effector 6012 and an articulation control arrangement 6160 that is operably supported in the tool mounting member 6200 as will be described in further detail below. In at least one embodiment, the articulation elements comprise a first pair of first articulation cables 6144 and 6146. The first articulation cables are located on a first or right side of the longitudinal tool axis. Thus, the first articulation cables are referred to herein as a right upper cable 6144 and a right lower cable 6146. The right upper cable 6144 and the right lower cable 6146 extend through corresponding passages 6147, 6148, respectively along the right side of the proximal spine portion 6110. See FIG. 128. The articulation system 6140 further includes a second pair of second articulation cables 6150, 6152. The second articulation cables are located on a second or left side of the longitudinal tool axis.

71

Thus, the second articulation cables are referred to herein as a left upper articulation cable 6150 and a left articulation cable 6152. The left upper articulation cable 6150 and the left lower articulation cable 6152 extend through passages 6153, 6154, respectively in the proximal spine portion 6110.

As can be seen in FIG. 124, the right upper cable 6144 extends around an upper pivot joint 6123 and is attached to a left upper side of the elongated channel 6022 at a left pivot joint 6125. The right lower cable 6146 extends around a lower pivot joint 6126 and is attached to a left lower side of the elongated channel 6022 at left pivot joint 6125. The left upper cable 6150 extends around the upper pivot joint 6123 and is attached to a right upper side of the elongated channel 6022 at a right pivot joint 6127. The left lower cable 6152 extends around the lower pivot joint 6126 and is attached to a right lower side of the elongated channel 6022 at right pivot joint 6127. Thus, to pivot the surgical end effector 6012 about the first tool articulation axis TA1-TA1 to the left (arrow "L"), the right upper cable 6144 and the right lower cable 6146 must be pulled in the proximal direction "PD". To articulate the surgical end effector 6012 to the right (arrow "R") about the first tool articulation axis TA1-TA1, the left upper cable 6150 and the left lower cable 6152 must be pulled in the proximal direction "PD". To articulate the surgical end effector 6012 about the second tool articulation axis TA2-TA2, in an upward direction (arrow "U"), the right upper cable 6144 and the left upper cable 6150 must be pulled in the proximal direction "PD". To articulate the surgical end effector 6012 in the downward direction (arrow "DW") about the second tool articulation axis TA2-TA2, the right lower cable 6146 and the left lower cable 6152 must be pulled in the proximal direction "PD".

The proximal ends of the articulation cables 6144, 6146, 6150, 6152 are coupled to the articulation control arrangement 6160 which comprises a ball joint assembly that is a part of the articulation transmission 6142. More specifically and with reference to FIG. 128, the ball joint assembly 6160 includes a ball-shaped member 6162 that is formed on a proximal portion of the proximal spine 6110. Movably supported on the ball-shaped member 6162 is an articulation control ring 6164. As can be further seen in FIG. 128, the proximal ends of the articulation cables 6144, 6146, 6150, 6152 are coupled to the articulation control ring 6164 by corresponding ball joint arrangements 6166. The articulation control ring 6164 is controlled by an articulation drive assembly 6170. As can be most particularly seen in FIG. 128, the proximal ends of the first articulation cables 6144, 6146 are attached to the articulation control ring 6164 at corresponding spaced first points 6149, 6151 that are located on plane 6159. Likewise, the proximal ends of the second articulation cables 6150, 6152 are attached to the articulation control ring 6164 at corresponding spaced second points 6153, 6155 that are also located along plane 6159. As the present Detailed Description proceeds, those of ordinary skill in the art will appreciate that such cable attachment configuration on the articulation control ring 6164 facilitates the desired range of articulation motions as the articulation control ring 6164 is manipulated by the articulation drive assembly 6170.

In various forms, the articulation drive assembly 6170 comprises a horizontal articulation assembly generally designated as 6171. In at least one form, the horizontal articulation assembly 6171 comprises a horizontal push cable 6172 that is attached to a horizontal gear arrangement 6180. The articulation drive assembly 6170 further comprises a vertically articulation assembly generally designated as 6173. In at least one form, the vertical articulation assembly 6173 comprises a vertical push cable 6174 that is attached to a

72

vertical gear arrangement 6190. As can be seen in FIGS. 127 and 128, the horizontal push cable 6172 extends through a support plate 6167 that is attached to the proximal spine portion 6110. The distal end of the horizontal push cable 6174 is attached to the articulation control ring 6164 by a corresponding ball/pivot joint 6168. The vertical push cable 6174 extends through the support plate 6167 and the distal end thereof is attached to the articulation control ring 6164 by a corresponding ball/pivot joint 6169.

The horizontal gear arrangement 6180 includes a horizontal driven gear 6182 that is pivotally mounted on a horizontal shaft 6181 that is attached to a proximal portion of the proximal spine portion 6110. The proximal end of the horizontal push cable 6172 is pivotally attached to the horizontal driven gear 6182 such that, as the horizontal driven gear 6172 is rotated about horizontal pivot axis HA, the horizontal push cable 6172 applies a first pivot motion to the articulation control ring 6164. Likewise, the vertical gear arrangement 6190 includes a vertical driven gear 6192 that is pivotally supported on a vertical shaft 6191 attached to the proximal portion of the proximal spine portion 6110 for pivotal travel about a vertical pivot axis VA. The proximal end of the vertical push cable 6174 is pivotally attached to the vertical driven gear 6192 such that as the vertical driven gear 6192 is rotated about vertical pivot axis VA, the vertical push cable 6174 applies a second pivot motion to the articulation control ring 6164.

The horizontal driven gear 6182 and the vertical driven gear 6192 are driven by an articulation gear train 6300 that operably interfaces with an articulation shifter assembly 6320. In at least one form, the articulation shifter assembly comprises an articulation drive gear 6322 that is coupled to a corresponding one of the driven discs or elements 1304 on the adapter side 1307 of the tool mounting plate 6202. See FIG. 22. Thus, application of a rotary input motion from the robotic system 1000 through the tool drive assembly 1010 to the corresponding driven element 1304 will cause rotation of the articulation drive gear 6322 when the interface 1230 is coupled to the tool holder 1270. An articulation driven gear 6324 is attached to a splined shifter shaft 6330 that is rotatably supported on the tool mounting plate 6202. The articulation driven gear 6324 is in meshing engagement with the articulation drive gear 6322 as shown. Thus, rotation of the articulation drive gear 6322 will result in the rotation of the shaft 6330. In various forms, a shifter driven gear assembly 6340 is movably supported on the splined portion 6332 of the shifter shaft 6330.

In various embodiments, the shifter driven gear assembly 6340 includes a driven shifter gear 6342 that is attached to a shifter plate 6344. The shifter plate 6344 operably interfaces with a shifter solenoid assembly 6350. The shifter solenoid assembly 6350 is coupled to corresponding pins 6352 by conductors 6352. See FIG. 127. Pins 6352 are oriented to electrically communicate with slots 1258 (FIG. 21) on the tool side 1244 of the adaptor 1240. Such arrangement serves to electrically couple the shifter solenoid assembly 6350 to the robotic controller 1001. Thus, activation of the shifter solenoid 6350 will shift the shifter driven gear assembly 6340 on the splined portion 6332 of the shifter shaft 6330 as represented by arrow "S" in FIGS. 136 and 137. Various embodiments of the articulation gear train 6300 further include a horizontal gear assembly 6360 that includes a first horizontal drive gear 6362 that is mounted on a shaft 6361 that is rotatably attached to the tool mounting plate 6202. The first horizontal drive gear 6362 is supported in meshing engagement with a second horizontal drive gear 6364. As can be seen in

FIG. 128, the horizontal driven gear 6182 is in meshing engagement with the distal face portion 6365 of the second horizontal driven gear 6364.

Various embodiments of the articulation gear train 6300 further include a vertical gear assembly 6370 that includes a first vertical drive gear 6372 that is mounted on a shaft 6371 that is rotatably supported on the tool mounting plate 6202. The first vertical drive gear 6372 is supported in meshing engagement with a second vertical drive gear 6374 that is concentrically supported with the second horizontal drive gear 6364. The second vertical drive gear 6374 is rotatably supported on the proximal spine portion 6110 for travel there-around. The second horizontal drive gear 6364 is rotatably supported on a portion of said second vertical drive gear 6374 for independent rotatable travel thereon. As can be seen in FIG. 128, the vertical driven gear 6192 is in meshing engagement with the distal face portion 6375 of the second vertical driven gear 6374.

In various forms, the first horizontal drive gear 6362 has a first diameter and the first vertical drive gear 6372 has a second diameter. As can be seen in FIGS. 127 and 128, the shaft 6361 is not on a common axis with shaft 6371. That is, the first horizontal driven gear 6362 and the first vertical driven gear 6372 do not rotate about a common axis. Thus, when the shifter gear 6342 is positioned in a center "locking" position such that the shifter gear 6342 is in meshing engagement with both the first horizontal driven gear 6362 and the first vertical drive gear 6372, the components of the articulation system 6140 are locked in position. Thus, the shiftable shifter gear 6342 and the arrangement of first horizontal and vertical drive gears 6362, 6372 as well as the articulation shifter assembly 6320 collectively may be referred to as an articulation locking system, generally designated as 6380.

In use, the robotic controller 1001 of the robotic system 1000 may control the articulation system 6140 as follows. To articulate the end effector 6012 to the left about the first tool articulation axis TA1-TA1, the robotic controller 1001 activates the shifter solenoid assembly 6350 to bring the shifter gear 6342 into meshing engagement with the first horizontal drive gear 6362. Thereafter, the controller 1001 causes a first rotary output motion to be applied to the articulation drive gear 6322 to drive the shifter gear in a first direction to ultimately drive the horizontal driven gear 6182 in another first direction. The horizontal driven gear 6182 is driven to pivot the articulation ring 6164 on the ball-shaped portion 6162 to thereby pull right upper cable 6144 and the right lower cable 6146 in the proximal direction "PD". To articulate the end effector 6012 to the right about the first tool articulation axis TA1-TA1, the robotic controller 1001 activates the shifter solenoid assembly 6350 to bring the shifter gear 6342 into meshing engagement with the first horizontal drive gear 6362. Thereafter, the controller 1001 causes the first rotary output motion in an opposite direction to be applied to the articulation drive gear 6322 to drive the shifter gear 6342 in a second direction to ultimately drive the horizontal driven gear 6182 in another second direction. Such actions result in the articulation control ring 6164 moving in such a manner as to pull the left upper cable 6150 and the left lower cable 6152 in the proximal direction "PD". In various embodiments the gear ratios and frictional forces generated between the gears of the vertical gear assembly 6370 serve to prevent rotation of the vertical driven gear 6192 as the horizontal gear assembly 6360 is actuated.

To articulate the end effector 6012 in the upper direction about the second tool articulation axis TA2-TA2, the robotic controller 1001 activates the shifter solenoid assembly 6350 to bring the shifter gear 6342 into meshing engagement with

the first vertical drive gear 6372. Thereafter, the controller 1001 causes the first rotary output motion to be applied to the articulation drive gear 6322 to drive the shifter gear 6342 in a first direction to ultimately drive the vertical driven gear 6192 in another first direction. The vertical driven gear 6192 is driven to pivot the articulation ring 6164 on the ball-shaped portion 6162 of the proximal spine portion 6110 to thereby pull right upper cable 6144 and the left upper cable 6150 in the proximal direction "PD". To articulate the end effector 6012 in the downward direction about the second tool articulation axis TA2-TA2, the robotic controller 1001 activates the shifter solenoid assembly 6350 to bring the shifter gear 6342 into meshing engagement with the first vertical drive gear 6372. Thereafter, the controller 1001 causes the first rotary output motion to be applied in an opposite direction to the articulation drive gear 6322 to drive the shifter gear 6342 in a second direction to ultimately drive the vertical driven gear 6192 in another second direction. Such actions thereby cause the articulation control ring 6164 to pull the right lower cable 6146 and the left lower cable 6152 in the proximal direction "PD". In various embodiments, the gear ratios and frictional forces generated between the gears of the horizontal gear assembly 6360 serve to prevent rotation of the horizontal driven gear 6182 as the vertical gear assembly 6370 is actuated.

In various embodiments, a variety of sensors may communicate with the robotic controller 1001 to determine the articulated position of the end effector 6012. Such sensors may interface with, for example, the articulation joint 6100 or be located within the tool mounting portion 6200. For example, sensors may be employed to detect the position of the articulation control ring 6164 on the ball-shaped portion 6162 of the proximal spine portion 6110. Such feedback from the sensors to the controller 1001 permits the controller 1001 to adjust the amount of rotation and the direction of the rotary output to the articulation drive gear 6322. Further, as indicated above, when the shifter drive gear 6342 is centrally positioned in meshing engagement with the first horizontal drive gear 6362 and the first vertical drive gear 6372, the end effector 6012 is locked in the articulated position. Thus, after the desired amount of articulation has been attained, the controller 1001 may activate the shifter solenoid assembly 6350 to bring the shifter gear 6342 into meshing engagement with the first horizontal drive gear 6362 and the first vertical drive gear 6372. In alternative embodiments, the shifter solenoid assembly 6350 may be spring activated to the central locked position.

In use, it may be desirable to rotate the surgical end effector 6012 about the longitudinal tool axis LT-LT. In at least one embodiment, the transmission arrangement 6204 on the tool mounting portion includes a rotational transmission assembly 6400 that is configured to receive a corresponding rotary output motion from the tool drive assembly 1010 of the robotic system 1000 and convert that rotary output motion to a rotary control motion for rotating the elongated shaft assembly 6008 (and surgical end effector 6012) about the longitudinal tool axis LT-LT. In various embodiments, for example, a proximal end portion 6041 of the proximal closure tube 6040 is rotatably supported on the tool mounting plate 6202 of the tool mounting portion 6200 by a forward support cradle 6205 and a closure sled 6510 that is also movably supported on the tool mounting plate 6202. In at least one form, the rotational transmission assembly 6400 includes a tube gear segment 6402 that is formed on (or attached to) the proximal end 6041 of the proximal closure tube 6040 for operable engagement by a rotational gear assembly 6410 that is operably supported on the tool mounting plate 6202. As can be

seen in FIG. 136, the rotational gear assembly 6410, in at least one embodiment, comprises a rotation drive gear 6412 that is coupled to a corresponding second one of the driven discs or elements 1304 on the adapter side 1307 of the tool mounting plate 6202 when the tool mounting portion 6200 is coupled to the tool drive assembly 1010. See FIG. 22. The rotational gear assembly 6410 further comprises a first rotary driven gear 6414 that is rotatably supported on the tool mounting plate 6202 in meshing engagement with the rotation drive gear 6412. The first rotary driven gear 6414 is attached to a drive shaft 6416 that is rotatably supported on the tool mounting plate 6202. A second rotary driven gear 6418 is attached to the drive shaft 6416 and is in meshing engagement with tube gear segment 6402 on the proximal closure tube 6040. Application of a second rotary output motion from the tool drive assembly 1010 of the robotic system 1000 to the corresponding driven element 1304 will thereby cause rotation of the rotation drive gear 6412. Rotation of the rotation drive gear 6412 ultimately results in the rotation of the elongated shaft assembly 6008 (and the surgical end effector 6012) about the longitudinal tool axis LT-LT. It will be appreciated that the application of a rotary output motion from the tool drive assembly 1010 in one direction will result in the rotation of the elongated shaft assembly 6008 and surgical end effector 6012 about the longitudinal tool axis LT-LT in a first direction and an application of the rotary output motion in an opposite direction will result in the rotation of the elongated shaft assembly 6008 and surgical end effector 6012 in a second direction that is opposite to the first direction.

In at least one embodiment, the closure of the anvil 2024 relative to the staple cartridge 2034 is accomplished by axially moving a closure portion of the elongated shaft assembly 2008 in the distal direction "DD" on the spine assembly 2049. As indicated above, in various embodiments, the proximal end portion 6041 of the proximal closure tube 6040 is supported by the closure sled 6510 which comprises a portion of a closure transmission, generally depicted as 6512. As can be seen in FIG. 127, the proximal end portion 6041 of the proximal closure tube portion 6040 has a collar 6048 formed thereon. The closure sled 6510 is coupled to the collar 6048 by a yoke 6514 that engages an annular groove 6049 in the collar 6048. Such arrangement serves to enable the collar 6048 to rotate about the longitudinal tool axis LT-LT while still being coupled to the closure transmission 6512. In various embodiments, the closure sled 6510 has an upstanding portion 6516 that has a closure rack gear 6518 formed thereon. The closure rack gear 6518 is configured for driving engagement with a closure gear assembly 6520. See FIG. 127.

In various forms, the closure gear assembly 6520 includes a closure spur gear 6522 that is coupled to a corresponding second one of the driven discs or elements 1304 on the adapter side 1307 of the tool mounting plate 6202. See FIG. 22. Thus, application of a third rotary output motion from the tool drive assembly 1010 of the robotic system 1000 to the corresponding second driven element 1304 will cause rotation of the closure spur gear 6522 when the tool mounting portion 6202 is coupled to the tool drive assembly 1010. The closure gear assembly 6520 further includes a closure reduction gear set 6524 that is supported in meshing engagement with the closure spur gear 6522 and the closure rack gear 2106. Thus, application of a third rotary output motion from the tool drive assembly 1010 of the robotic system 1000 to the corresponding second driven element 1304 will cause rotation of the closure spur gear 6522 and the closure transmission 6512 and ultimately drive the closure sled 6510 and the proximal closure tube 6040 axially on the proximal spine portion 6110.

The axial direction in which the proximal closure tube 6040 moves ultimately depends upon the direction in which the third driven element 1304 is rotated. For example, in response to one rotary output motion received from the tool drive assembly 1010 of the robotic system 1000, the closure sled 6510 will be driven in the distal direction "DD" and ultimately drive the proximal closure tube 6040 in the distal direction "DD". As the proximal closure tube 6040 is driven distally, the distal closure tube 6042 is also driven distally by virtue of its connection with the proximal closure tube 6040. As the distal closure tube 6042 is driven distally, the end of the closure tube 6042 will engage a portion of the anvil 6024 and cause the anvil 6024 to pivot to a closed position. Upon application of an "opening" output motion from the tool drive assembly 1010 of the robotic system 1000, the closure sled 6510 and the proximal closure tube 6040 will be driven in the proximal direction "PD" on the proximal spine portion 6110. As the proximal closure tube 6040 is driven in the proximal direction "PD", the distal closure tube 6042 will also be driven in the proximal direction "PD". As the distal closure tube 6042 is driven in the proximal direction "PD", the opening 6045 therein interacts with the tab 6027 on the anvil 6024 to facilitate the opening thereof. In various embodiments, a spring (not shown) may be employed to bias the anvil 6024 to the open position when the distal closure tube 6042 has been moved to its starting position. In various embodiments, the various gears of the closure gear assembly 6520 are sized to generate the necessary closure forces needed to satisfactorily close the anvil 6024 onto the tissue to be cut and stapled by the surgical end effector 6012. For example, the gears of the closure transmission 6520 may be sized to generate approximately 70-120 pounds of closure forces.

In various embodiments, the cutting instrument is driven through the surgical end effector 6012 by a knife bar 6530. See FIG. 127. In at least one form, the knife bar 6530 is fabricated with a joint arrangement (not shown) and/or is fabricated from material that can accommodate the articulation of the surgical end effector 6102 about the first and second tool articulation axes while remaining sufficiently rigid so as to push the cutting instrument through tissue clamped in the surgical end effector 6012. The knife bar 6530 extends through a hollow passage 6532 in the proximal spine portion 6110.

In various embodiments, a proximal end 6534 of the knife bar 6530 is rotatably affixed to a knife rack gear 6540 such that the knife bar 6530 is free to rotate relative to the knife rack gear 6540. The distal end of the knife bar 6530 is attached to the cutting instrument in the various manners described above. As can be seen in FIG. 127, the knife rack gear 6540 is slidably supported within a rack housing 6542 that is attached to the tool mounting plate 6202 such that the knife rack gear 6540 is retained in meshing engagement with a knife drive transmission portion 6550 of the transmission arrangement 6204. In various embodiments, the knife drive transmission portion 6550 comprises a knife gear assembly 6560. More specifically and with reference to FIG. 127, in at least one embodiment, the knife gear assembly 6560 includes a knife spur gear 6562 that is coupled to a corresponding fourth one of the driven discs or elements 1304 on the adapter side 1307 of the tool mounting plate 6202. See FIG. 22. Thus, application of another rotary output motion from the robotic system 1000 through the tool drive assembly 1010 to the corresponding fourth driven element 1304 will cause rotation of the knife spur gear 6562. The knife gear assembly 6560 further includes a knife gear reduction set 6564 that includes a first knife driven gear 6566 and a second knife drive gear 6568. The knife gear reduction set 6564 is rotatably mounted

77

to the tool mounting plate **6202** such that the first knife driven gear **6566** is in meshing engagement with the knife spur gear **6562**. Likewise, the second knife drive gear **6568** is in meshing engagement with a third knife drive gear assembly **6570**. As shown in FIG. **127**, the second knife driven gear **6568** is in meshing engagement with a fourth knife driven gear **6572** of the third knife drive gear assembly **6570**. The fourth knife driven gear **6572** is in meshing engagement with a fifth knife driven gear assembly **6574** that is in meshing engagement with the knife rack gear **6540**. In various embodiments, the gears of the knife gear assembly **6560** are sized to generate the forces needed to drive the cutting instrument through the tissue clamped in the surgical end effector **6012** and actuate the staples therein. For example, the gears of the knife gear assembly **6560** may be sized to generate approximately 40 to 100 pounds of driving force. It will be appreciated that the application of a rotary output motion from the tool drive assembly **1010** in one direction will result in the axial movement of the cutting instrument in a distal direction and application of the rotary output motion in an opposite direction will result in the axial travel of the cutting instrument in a proximal direction.

As can be appreciated from the foregoing description, the surgical tool **6000** represents a vast improvement over prior robotic tool arrangements. The unique and novel transmission arrangement employed by the surgical tool **6000** enables the tool to be operably coupled to a tool holder portion **1010** of a robotic system that only has four rotary output bodies, yet obtain the rotary output motions therefrom to: (i) articulate the end effector about two different articulation axes that are substantially transverse to each other as well as the longitudinal tool axis; (ii) rotate the end effector **6012** about the longitudinal tool axis; (iii) close the anvil **6024** relative to the surgical staple cartridge **6034** to varying degrees to enable the end effector **6012** to be used to manipulate tissue and then clamp it into position for cutting and stapling; and (iv) firing the cutting instrument to cut through the tissue clamped within the end effector **6012**. The unique and novel shifter arrangements of various embodiments of the present invention described above enable two different articulation actions to be powered from a single rotatable body portion of the robotic system.

The various embodiments of the present invention have been described above in connection with cutting-type surgical instruments. It should be noted, however, that in other embodiments, the inventive surgical instrument disclosed herein need not be a cutting-type surgical instrument, but rather could be used in any type of surgical instrument including remote sensor transponders. For example, it could be a non-cutting endoscopic instrument, a grasper, a stapler, a clip applier, an access device, a drug/gene therapy delivery device, an energy device using ultrasound, RF, laser, etc. In addition, the present invention may be in laparoscopic instruments, for example. The present invention also has application in conventional endoscopic and open surgical instrumentation as well as robotic-assisted surgery.

FIG. **129** depicts use of various aspects of certain embodiments of the present invention in connection with a surgical tool **7000** that has an ultrasonically powered end effector **7012**. The end effector **7012** is operably attached to a tool mounting portion **7100** by an elongated shaft assembly **7008**. The tool mounting portion **7100** may be substantially similar to the various tool mounting portions described hereinabove. In one embodiment, the end effector **7012** includes an ultrasonically powered jaw portion **7014** that is powered by alternating current or direct current in a known manner. Such ultrasonically-powered devices are disclosed, for example, in

78

U.S. Pat. No. 6,783,524, entitled "Robotic Surgical Tool With Ultrasound Cauterizing and Cutting Instrument", the entire disclosure of which is herein incorporated by reference. In the illustrated embodiment, a separate power cord **7020** is shown. It will be understood, however, that the power may be supplied thereto from the robotic controller **1001** through the tool mounting portion **7100**. The surgical end effector **7012** further includes a movable jaw **7016** that may be used to clamp tissue onto the ultrasonic jaw portion **7014**. The movable jaw portion **7016** may be selectively actuated by the robotic controller **1001** through the tool mounting portion **7100** in any one of the various manners herein described.

FIG. **130** illustrates use of various aspects of certain embodiments of the present invention in connection with a surgical tool **8000** that has an end effector **8012** that comprises a linear stapling device. The end effector **8012** is operably attached to a tool mounting portion **8100** by an elongated shaft assembly **3700** of the type and construction describe above. However, the end effector **8012** may be attached to the tool mounting portion **8100** by a variety of other elongated shaft assemblies described herein. In one embodiment, the tool mounting portion **8100** may be substantially similar to tool mounting portion **3750**. However, various other tool mounting portions and their respective transmission arrangements describe in detail herein may also be employed. Such linear stapling head portions are also disclosed, for example, in U.S. Pat. No. 7,673,781, entitled "Surgical Stapling Device With Staple Driver That Supports Multiple Wire Diameter Staples", the entire disclosure of which is herein incorporated by reference.

Various sensor embodiments described in U.S. Patent Publication No. 2011/0062212 A1 to Shelton, IV et al., the disclosure of which is herein incorporated by reference in its entirety, may be employed with many of the surgical tool embodiments disclosed herein. As was indicated above, the master controller **1001** generally includes master controllers (generally represented by **1003**) which are grasped by the surgeon and manipulated in space while the surgeon views the procedure via a stereo display **1002**. See FIG. **13**. The master controllers **1001** are manual input devices which preferably move with multiple degrees of freedom, and which often further have an actuatable handle for actuating the surgical tools. Some of the surgical tool embodiments disclosed herein employ a motor or motors in their tool drive portion to supply various control motions to the tool's end effector. Such embodiments may also obtain additional control motion(s) from the motor arrangement employed in the robotic system components. Other embodiments disclosed herein obtain all of the control motions from motor arrangements within the robotic system.

Such motor powered arrangements may employ various sensor arrangements that are disclosed in the published US patent application cited above to provide the surgeon with a variety of forms of feedback without departing from the spirit and scope of the present invention. For example, those master controller arrangements **1003** that employ a manually actuatable firing trigger can employ run motor sensor(s) to provide the surgeon with feedback relating to the amount of force applied to or being experienced by the cutting member. The run motor sensor(s) may be configured for communication with the firing trigger portion to detect when the firing trigger portion has been actuated to commence the cutting/stapling operation by the end effector. The run motor sensor may be a proportional sensor such as, for example, a rheostat or variable resistor. When the firing trigger is drawn in, the sensor detects the movement, and sends an electrical signal indicative of the voltage (or power) to be supplied to the correspond-

ing motor. When the sensor is a variable resistor or the like, the rotation of the motor may be generally proportional to the amount of movement of the firing trigger. That is, if the operator only draws or closes the firing trigger in a small amount, the rotation of the motor is relatively low. When the firing trigger is fully drawn in (or in the fully closed position), the rotation of the motor is at its maximum. In other words, the harder the surgeon pulls on the firing trigger, the more voltage is applied to the motor causing greater rates of rotation. Other arrangements may provide the surgeon with a feed back meter **1005** that may be viewed through the display **1002** and provide the surgeon with a visual indication of the amount of force being applied to the cutting instrument or dynamic clamping member. Other sensor arrangements may be employed to provide the master controller **1001** with an indication as to whether a staple cartridge has been loaded into the end effector, whether the anvil has been moved to a closed position prior to firing, etc.

In alternative embodiments, a motor-controlled interface may be employed in connection with the controller **1001** that limit the maximum trigger pull based on the amount of loading (e.g., clamping force, cutting force, etc.) experienced by the surgical end effector. For example, the harder it is to drive the cutting instrument through the tissue clamped within the end effector, the harder it would be to pull/actuate the activation trigger. In still other embodiments, the trigger on the controller **1001** is arranged such that the trigger pull location is proportionate to the end effector-location/condition. For example, the trigger is only fully depressed when the end effector is fully fired.

The devices disclosed herein can be designed to be disposed of after a single use, or they can be designed to be used multiple times. In either case, however, the device can be reconditioned for reuse after at least one use. Reconditioning can include any combination of the steps of disassembly of the device, followed by cleaning or replacement of particular pieces, and subsequent reassembly. In particular, the device can be disassembled, and any number of the particular pieces or parts of the device can be selectively replaced or removed in any combination. Upon cleaning and/or replacement of particular parts, the device can be reassembled for subsequent use either at a reconditioning facility, or by a surgical team immediately prior to a surgical procedure. Those skilled in the art will appreciate that reconditioning of a device can utilize a variety of techniques for disassembly, cleaning/replacement, and reassembly. Use of such techniques, and the resulting reconditioned device, are all within the scope of the present application.

Although the present invention has been described herein in connection with certain disclosed embodiments, many modifications and variations to those embodiments may be implemented. For example, different types of end effectors may be employed. Also, where materials are disclosed for certain components, other materials may be used. The foregoing description and following claims are intended to cover all such modification and variations.

Any patent, publication, or other disclosure material, in whole or in part, that is said to be incorporated by reference herein is incorporated herein only to the extent that the incorporated materials does not conflict with existing definitions, statements, or other disclosure material set forth in this disclosure. As such, and to the extent necessary, the disclosure as explicitly set forth herein supersedes any conflicting material incorporated herein by reference. Any material, or portion thereof, that is said to be incorporated by reference herein, but which conflicts with existing definitions, statements, or other disclosure material set forth herein will only be incorporated

to the extent that no conflict arises between that incorporated material and the existing disclosure material.

What is claimed is:

1. A disposable loading unit for use with a remotely controllable system, said disposable loading unit comprising:
 - a cartridge assembly;
 - an elongated housing coupled to said cartridge assembly and configured for operable attachment to an elongated shaft assembly for transmitting control motions from a control portion of the remotely controllable system;
 - an axial drive assembly supported for selective axial travel through said cartridge assembly from a start position to an end position upon application of a rotary control motion thereto from said elongated shaft assembly;
 - a motor supported within said housing and operably interfacing with said axial drive assembly to selectively apply said rotary control motion thereto; and
 - a power source axially movable within said housing from a disconnected position wherein said power source is disconnected from said motor to at least one connected position wherein said power source provides power to said motor, said axially movable power source being configured for attachment to an axially movable control member of the remotely controllable system such that said power source is axially moved from said disconnected position to one of said at least one connected positions upon attachment to the control member.
2. The disposable loading unit of claim 1 wherein said cartridge assembly further comprises an anvil assembly selectively movable between an open position and a closed position upon application of a closing motion thereto from said axial drive assembly.
3. The disposable loading unit of claim 2 wherein said disposable loading unit further comprises:
 - a first contact arrangement in said housing, said first contact arrangement communicating with said motor and configured for contact with said power source when said power source is in a first one of said at least one connected positions; and
 - a second contact arrangement in said housing, said second contact arrangement communicating with said motor and configured for contact with said power source when said power source is in a second one of said at least one connected positions.
4. The disposable loading unit of claim 3 wherein when said power source is in said first connected position, said power source is axially movable to said second connected position upon application of an actuation motion to said axially movable control member.
5. The disposable loading unit of claim 4 wherein when said power source is in said second connected position, said motor powers said axial drive assembly to apply said closing motion to said anvil assembly.
6. The disposable loading unit of claim 5 further comprising a third contact arrangement in said housing, said third contact arrangement communicating with said motor and configured for contact with said power source when said power source is in a third one of said at least one connected positions.
7. The disposable loading unit of claim 6 wherein when said power source is in said third connected position, said motor drives said axial drive assembly distally to said end position within said cartridge assembly.
8. The disposable loading unit of claim 7 wherein said axial drive assembly comprises:
 - a drive beam operably coupled to said motor; and
 - a tissue cutting edge on said drive beam.

81

9. The disposable loading unit of claim 7 further comprising means for stopping said motor from driving said axial drive assembly in said distal direction when said axial drive assembly encounters resistance that exceeds a predetermined amount of resistance.

- 10. A surgical instrument comprising:
 - a tool drive portion configured for operable attachment to a portion of a robotic system for receiving control motions therefrom;
 - an elongated shaft coupled to said tool drive portion;
 - an axially movable control member operably supported within said elongated shaft and being axially movable in response to actuation motions applied thereto from said robotic system; and
 - a disposable loading unit comprising:
 - a housing assembly coupled to said elongated shaft;
 - a cartridge assembly supported by said housing assembly;
 - an axial drive assembly supported for selective axial travel through said cartridge assembly from a start position to an end position upon application of a rotary motion thereto;
 - a motor supported within said housing assembly and operably interfacing with said axial drive assembly to selectively apply said rotary motion thereto; and
 - a power source axially movable within said housing assembly from a disconnected position wherein said power source is disconnected from said motor to a first connected position wherein said power source provides power to said motor upon attachment to the control member.

11. The surgical instrument of claim 10 wherein said cartridge assembly further comprises an anvil assembly that is selectively movable between an open position and a closed position upon application of a closing motion thereto from said axial drive assembly.

12. The surgical instrument of claim 11 wherein said disposable loading unit further comprises:

- a first contact arrangement in said housing assembly, said first contact arrangement communicating with said motor and configured for contact with said power source when said power source is said first connected position; and
- a second contact arrangement in said housing assembly, said second contact arrangement communicating with said motor and configured for contact with said power source when said power source is in a second connected position such that said motor powers said axial drive assembly to apply said closing motion to said anvil assembly.

13. The surgical instrument of claim 12 further comprising a third contact arrangement in said housing assembly com-

82

municating with said motor and configured for contact with said power source when said power source is in a third connected position.

14. The surgical instrument of claim 13 wherein when said power source is in said third connected position, said motor drives said axial drive assembly distally to said end position within said cartridge assembly.

15. The surgical instrument of claim 10 wherein said disposable loading unit further comprises:

- a first contact arrangement in said housing assembly, said first contact arrangement communicating with said motor and configured for contact with said power source when said power source is said first connected position; and
- a second contact arrangement in said housing assembly, said second contact arrangement communicating with said motor and configured for contact with said power source when said power source is in a second connected position.

16. The surgical instrument of claim 15 wherein when said power source is in said first connected position, said power source is axially movable to said second connected position upon application of an actuation motion to said axially movable control member.

- 17. A surgical instrument comprising:
 - a tool drive portion configured for operable attachment to a portion of a robotic system for receiving control motions therefrom;
 - an elongated shaft coupled to said tool drive portion;
 - an axially movable control member operably supported within said elongated shaft and being axially movable in response to actuation motions applied thereto from said robotic system; and
 - a disposable loading unit comprising:
 - a housing assembly coupled to said elongated shaft;
 - a cartridge assembly supported by said housing assembly;
 - an axial drive assembly supported for selective axial travel through said cartridge assembly from a start position to an end position upon application of a rotary motion thereto;
 - a motor supported within said housing assembly and operably interfacing with said axial drive assembly to selectively apply said rotary motion thereto;
 - a movable battery holder coupleable to said control member and being axially movable within said housing assembly in response to motions applied thereto by a control rod; and
 - a battery supported within said battery holder and configured for selective axial communication with a series of axially spaced contact arrangements in said housing assembly for controlling supply of power from said battery to said motor.

* * * * *