



[54] AUTONOMOUS LAWN MOWER

[75] Inventors: Thomas H. Noonan, Havertown; John Fisher, Avondale, both of Pa.; Barry Bryant, New Baltimore, Mich.

[73] Assignee: Mobot, Inc., Havertown, Pa.

[21] Appl. No.: 611,679

[22] Filed: Nov. 13, 1990

[51] Int. Cl.<sup>5</sup> ..... G06F 15/50; B62D 1/28

[52] U.S. Cl. .... 364/424.02; 180/168

[58] Field of Search ..... 364/424.01, 424.02; 180/167-170

[56] References Cited

U.S. PATENT DOCUMENTS

3,095,939	4/1960	Hine	180/167
3,482,644	12/1969	Krieger et al.	180/79.1
3,550,714	10/1964	Bellinger	180/79.1
3,563,327	11/1968	Mier	18/79.1
3,734,229	5/1973	Comer	180/98
3,800,902	4/1974	Keller	180/79.1
4,028,454	12/1986	Ito	364/424.02
4,119,900	10/1978	Kremnitz	318/587
4,137,984	2/1979	Jennings et al.	180/98
4,306,329	12/1981	Yokoi	180/167
4,530,056	7/1985	Mackinnon et al.	364/424.02
4,626,993	12/1986	Okuyama et al.	364/424.02
4,679,152	7/1987	Perdue	364/424.02
4,694,639	9/1987	Chen et al.	56/10.2
4,730,690	3/1988	McNutt et al.	180/274
4,742,283	5/1988	Bolger et al.	318/587
4,800,978	1/1989	Wasa et al.	180/168
4,847,774	7/1989	Tomikawa et al.	364/449
4,990,841	5/1991	Elder	318/587
4,993,507	2/1991	Ohkura	364/426.01

OTHER PUBLICATIONS

The Lawn Ranger Rescues the Weekend, "Electronic House", Sep./Oct. 1990, p. 32.

Primary Examiner—Thomas G. Black  
Attorney, Agent, or Firm—Sixbey, Friedman, Leedom & Ferguson

[57] ABSTRACT

Disclosed is an automatic, self propelled lawn mower that references its position within a cutting area using electronically stored path and terrain information as a primary navigation system, senses a non magnetic, non-current carrying metallic guide path as a secondary navigation system, senses underground metallic references for use as position reference points as a further navigation system, incorporates an ultrasonic obstacle detection system to stop the vehicle if unexpected obstacles are encountered. The vehicle further includes a cow-catcher front bumper arrangement to divert small objects away from the cutting blades, contains bumper switches to shut off the vehicle upon contact with large objects, contains an inclinometer sensor to halt the vehicle during unexpected tilting, incorporates a radio communications link to notify an off-board monitoring system of problems, contains an on-board power generation system using an internal combustion engine, generator, and a battery arrangement. The lawn mower also provides a navigation controller and servo motor positioning system that plans path motion, using sensory data and stored map data and to turn the drive wheels to propel the vehicle in the desired manner.

28 Claims, 7 Drawing Sheets

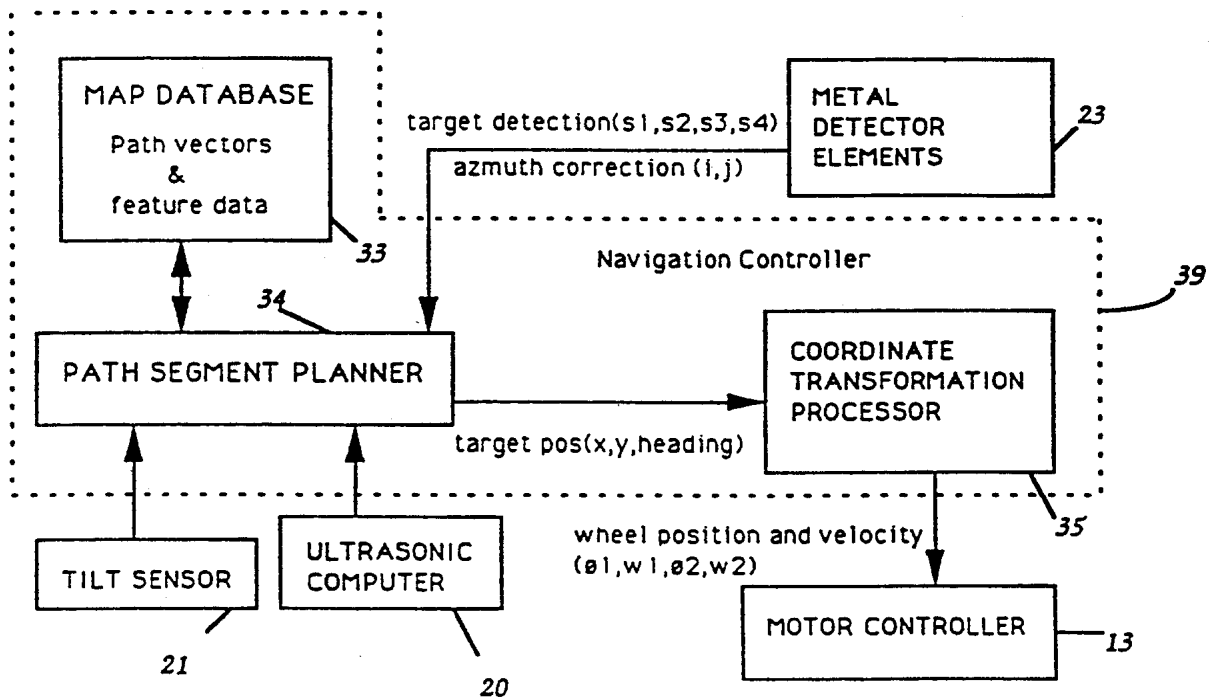



FIG. 2A

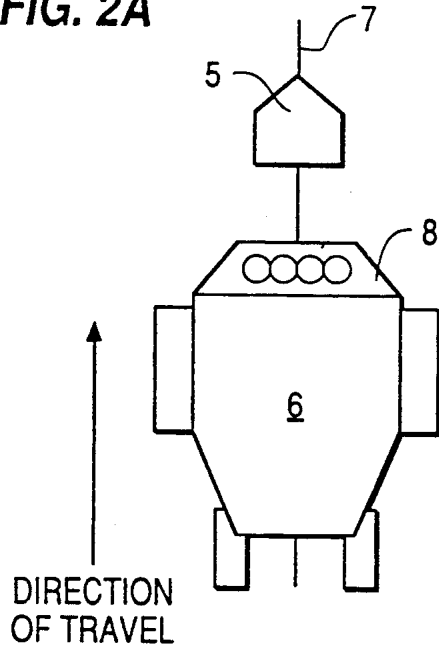

FIG. 2B

SENSOR NUMBER

	s1	s2	s3	s4
d1	0	0	0	0
d2	0	1	0	0
d3	0	1	1	0
d4	1	1	1	0
d5	1	1	1	1
d6	1	1	1	1
d7	0	0	0	0

SENSOR VALUES

FIG. 3

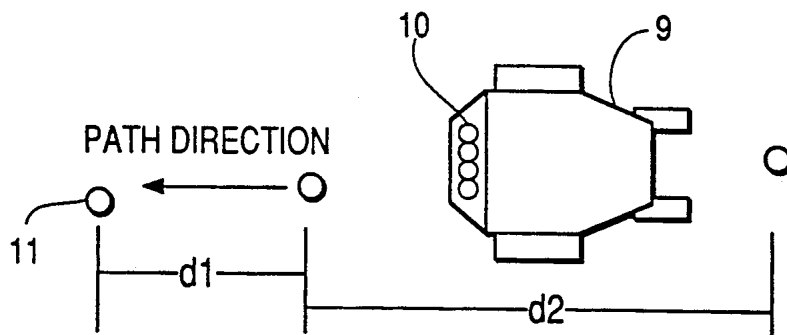

FIG. 4

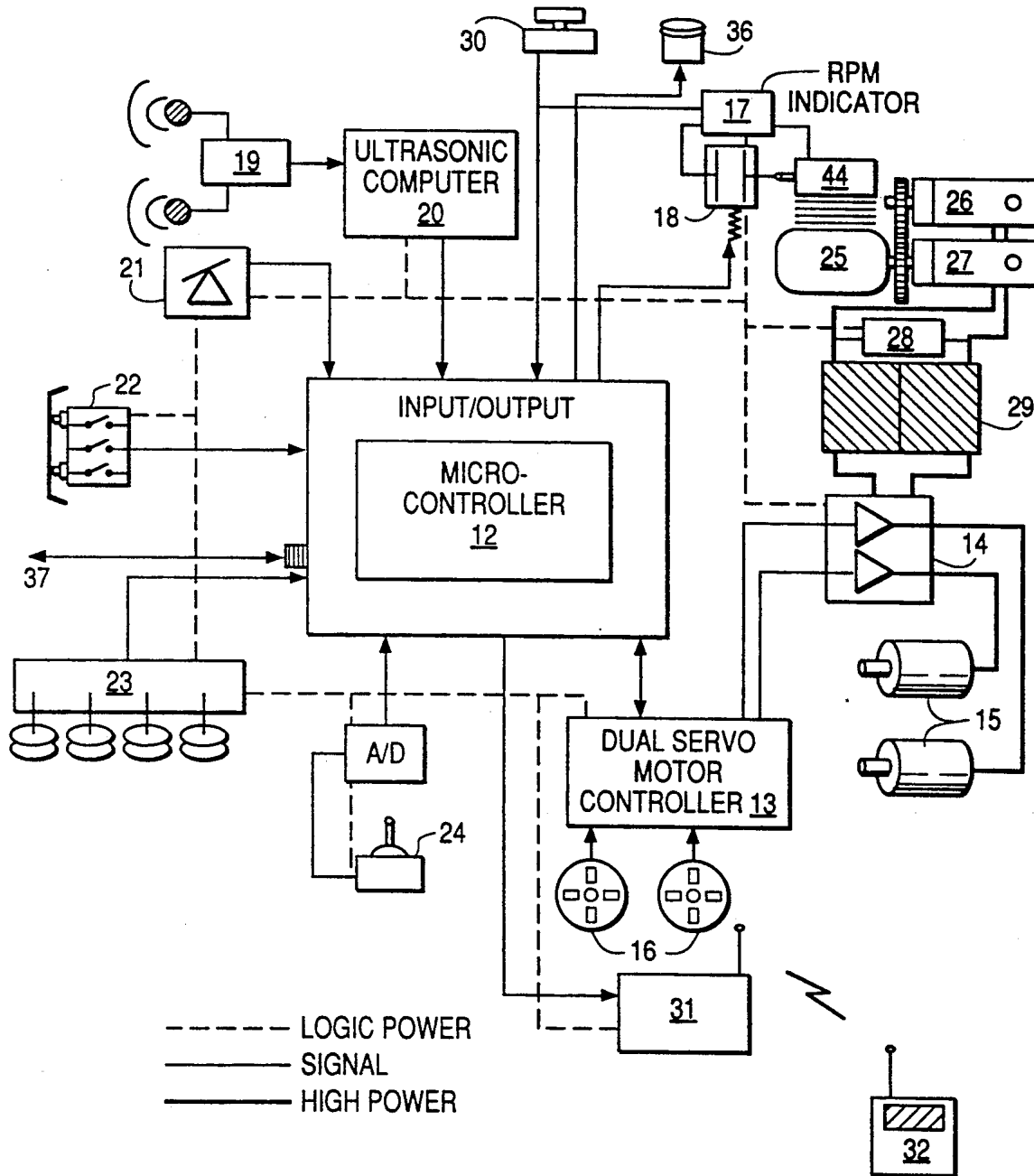
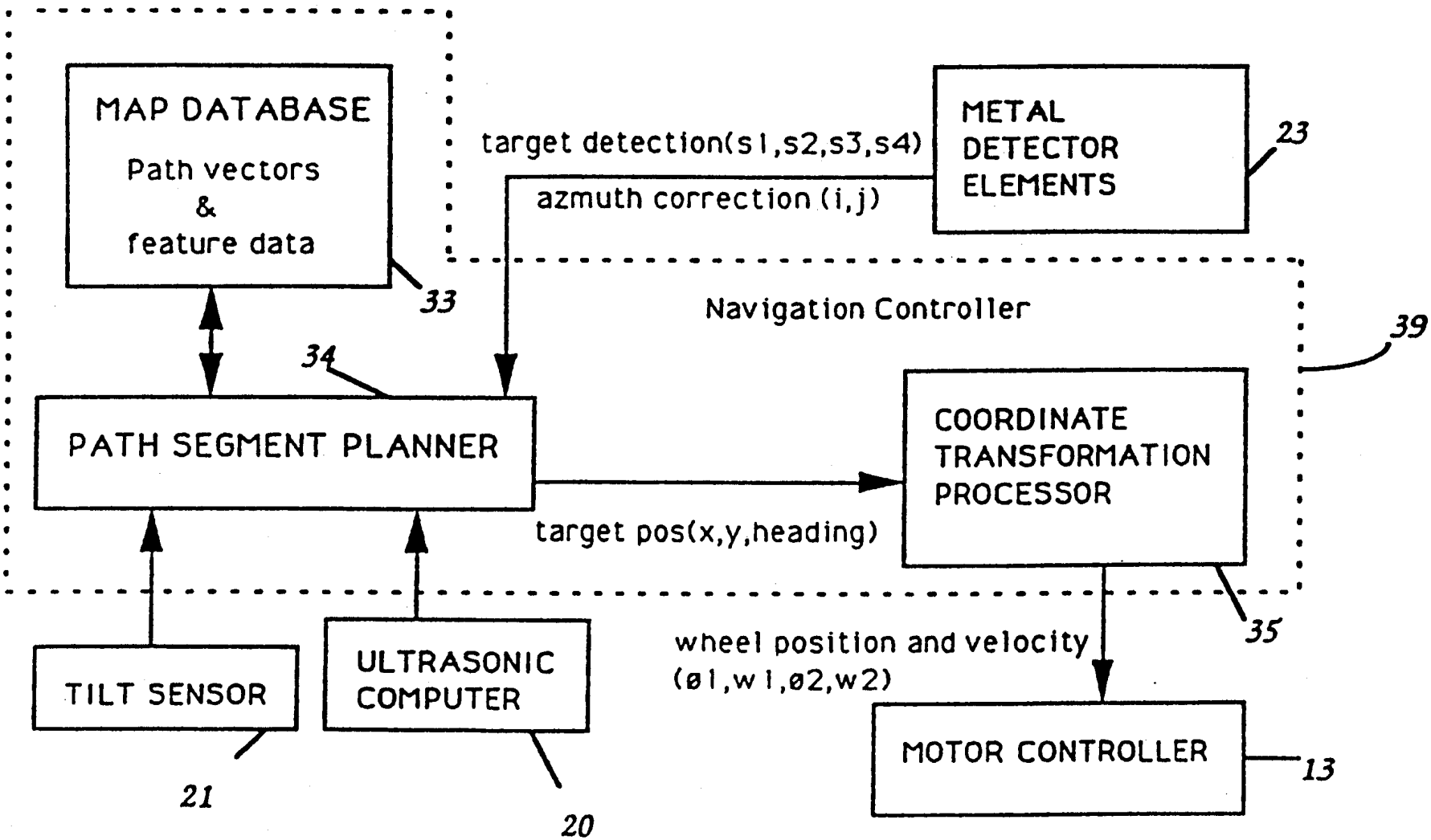

FIG. 5



# Explore Litigation Insights

Docket Alarm provides insights to develop a more informed litigation strategy and the peace of mind of knowing you're on top of things.

## Real-Time Litigation Alerts



Keep your litigation team up-to-date with **real-time alerts** and advanced team management tools built for the enterprise, all while greatly reducing PACER spend.

Our comprehensive service means we can handle Federal, State, and Administrative courts across the country.

## Advanced Docket Research



With over 230 million records, Docket Alarm's cloud-native docket research platform finds what other services can't. Coverage includes Federal, State, plus PTAB, TTAB, ITC and NLRB decisions, all in one place.

Identify arguments that have been successful in the past with full text, pinpoint searching. Link to case law cited within any court document via Fastcase.

## Analytics At Your Fingertips



Learn what happened the last time a particular judge, opposing counsel or company faced cases similar to yours.

Advanced out-of-the-box PTAB and TTAB analytics are always at your fingertips.

## API

Docket Alarm offers a powerful API (application programming interface) to developers that want to integrate case filings into their apps.

## LAW FIRMS

Build custom dashboards for your attorneys and clients with live data direct from the court.

Automate many repetitive legal tasks like conflict checks, document management, and marketing.

## FINANCIAL INSTITUTIONS

Litigation and bankruptcy checks for companies and debtors.

## E-DISCOVERY AND LEGAL VENDORS

Sync your system to PACER to automate legal marketing.