

(12) **United States Patent**
Kawagoe et al.

(10) **Patent No.:** **US 6,574,536 B1**
(45) **Date of Patent:** **Jun. 3, 2003**

- (54) **MOVING APPARATUS FOR EFFICIENTLY MOVING ON FLOOR WITH OBSTACLE**
- (75) Inventors: **Nobukazu Kawagoe**, Toyonaka (JP); **Yuichi Kawakami**, Itami (JP); **Kyoko Nakamura**, Toyonaka (JP); **Yasuhisa Kinto**, Amagasaki (JP)
- (73) Assignee: **Minolta Co., Ltd.**, Osaka (JP)
- (*) Notice: Subject to any disclaimer, the term of this patent is extended or adjusted under 35 U.S.C. 154(b) by 799 days.

5,280,431 A	1/1994	Summerville et al.	701/23
5,283,739 A	2/1994	Summerville et al.	701/23
5,305,217 A	4/1994	Nakamura et al.	701/25
5,353,224 A	10/1994	Lee et al.	701/25
5,402,051 A	3/1995	Fujiwara et al.	318/587
5,434,490 A	7/1995	Ishida et al.	318/587
5,488,277 A	1/1996	Nishikawa et al.	318/587
5,548,511 A	8/1996	Bancroft	701/23
5,568,589 A	10/1996	Hwang	706/52
5,613,261 A *	3/1997	Kawakami et al.	15/98
5,636,402 A *	6/1997	Kubo et al.	15/98
5,652,489 A *	7/1997	Kawakami	318/587
5,696,675 A *	12/1997	Nakamura et al.	701/25
5,717,484 A *	2/1998	Hamaguchi et al.	356/3.12
5,720,077 A *	2/1998	Nakamura et al.	15/340.1
5,735,959 A *	4/1998	Kubo et al.	15/98

(21) Appl. No.: **08/789,127**
(22) Filed: **Jan. 27, 1997**

(30) **Foreign Application Priority Data**

Jan. 29, 1996 (JP)	8-013134
Jan. 29, 1996 (JP)	8-013225
Mar. 29, 1996 (JP)	8-076953

(51) **Int. Cl.**⁷ **G01C 22/00; G05D 1/00**
(52) **U.S. Cl.** **701/23; 701/24; 15/53.3; 15/98; 15/319; 318/568.1; 318/568.12; 318/568.13; 901/1; 901/5**

(58) **Field of Search** **701/23, 24, 25, 701/26, 27, 117, 118, 301, 302; 318/587, 568.12, 580; 15/340.1, 319, 325, 49.1, 53.3, 98; 901/1, 2, 3; 180/167, 168, 279, 169**

(56) **References Cited**

U.S. PATENT DOCUMENTS

4,473,787 A	9/1984	Schick	318/587
4,700,427 A	10/1987	Knepper	15/319
4,780,817 A	10/1988	Lofgren	701/23
4,802,096 A	1/1989	Hainsworth et al.	364/461
4,920,520 A	4/1990	Göbel et al.	367/99
4,962,453 A	10/1990	Pong et al.	701/25
4,982,329 A	1/1991	Tabata et al.	701/25
5,032,775 A	7/1991	Mizuno et al.	318/587
5,036,935 A	8/1991	Kohara	180/168
5,179,329 A	1/1993	Nishikawa et al.	318/587
5,220,263 A	6/1993	Onishi et al.	318/587

FOREIGN PATENT DOCUMENTS

JP	61-245215	10/1986
JP	62-154008	7/1987
JP	2-127378	5/1990
JP	3-184105	8/1991
JP	5-165517	7/1993
JP	5-257533	10/1993
JP	6-119035	4/1994
JP	7-47045	2/1995
JP	7-16204	3/1995

* cited by examiner

Primary Examiner—Jacques H. Louis-Jacques
(74) *Attorney, Agent, or Firm*—McDermott, Will & Emery

(57) **ABSTRACT**

A moving robot first moves straight in a first forward path. When encountering an obstacle such as shelf, the robot makes a U-turn to move straight in a backward path located with a prescribed distance away from the first forward path. When encountering another obstacle, the robot again makes a U-turn to move straight in a second forward path extending in the same direction as that of the first forward path but located with a distance away from the backward path. When the robot exceeding the point of the U-turn in the first forward path is detected during running in the second forward path, presence of a region where the robot has not run yet is recognized, and running in that region is carried out thereafter.

27 Claims, 22 Drawing Sheets

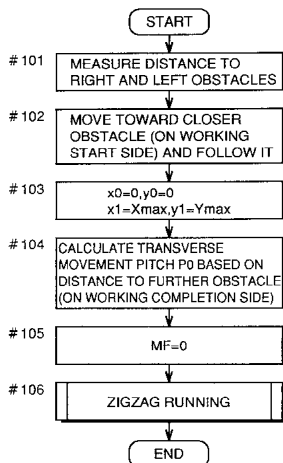

FIG. 1

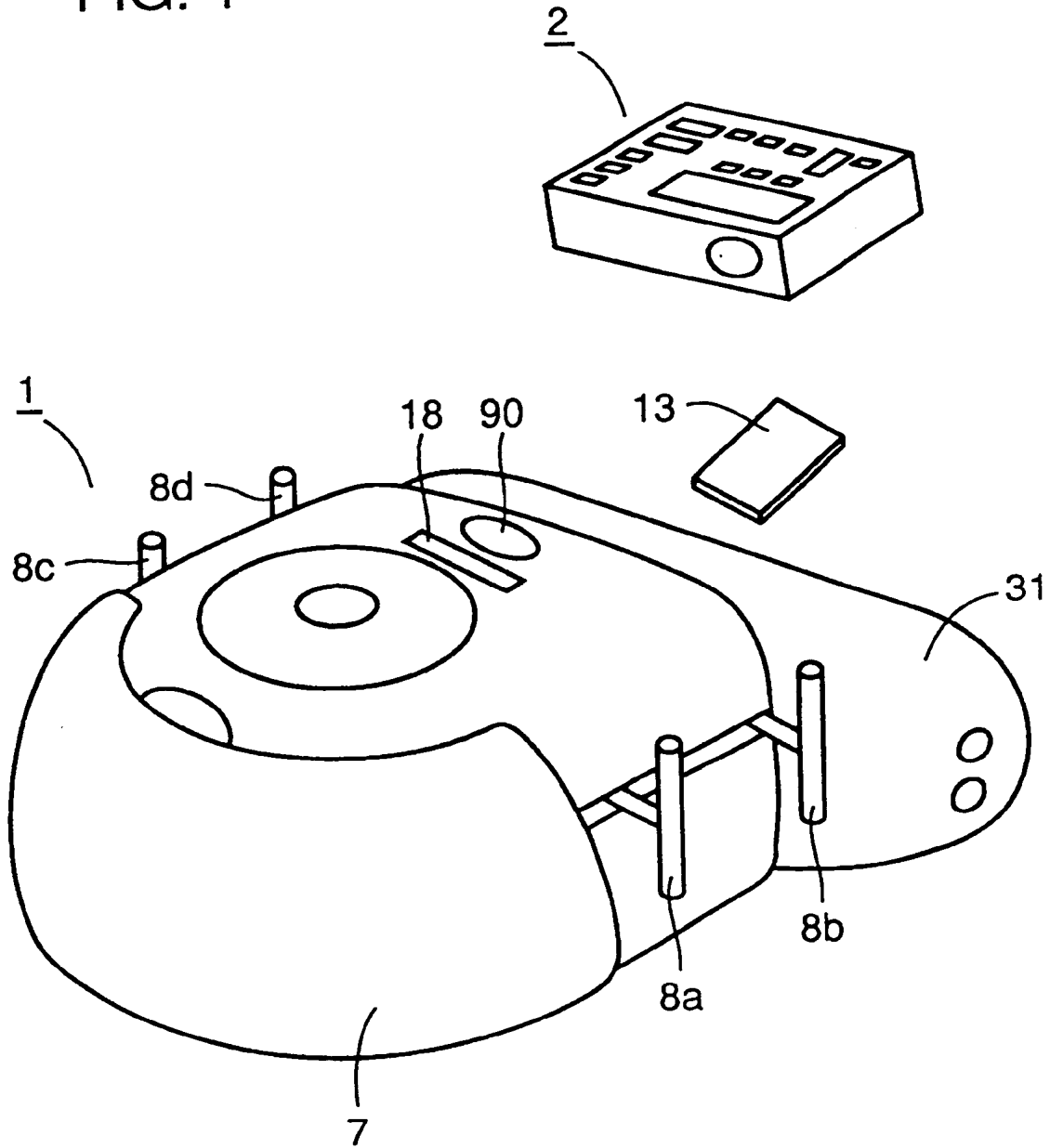

FIG. 2

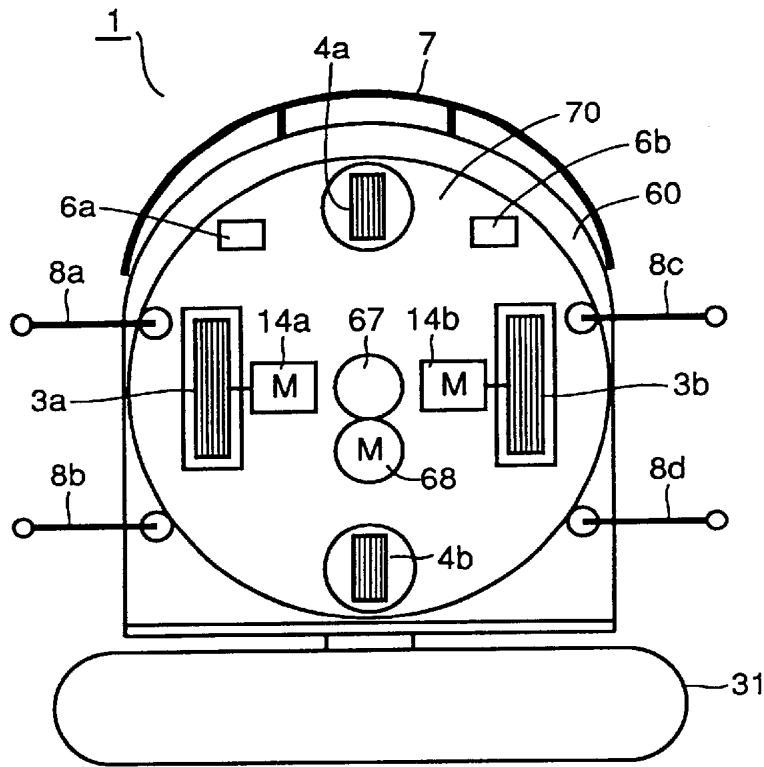

FIG. 3

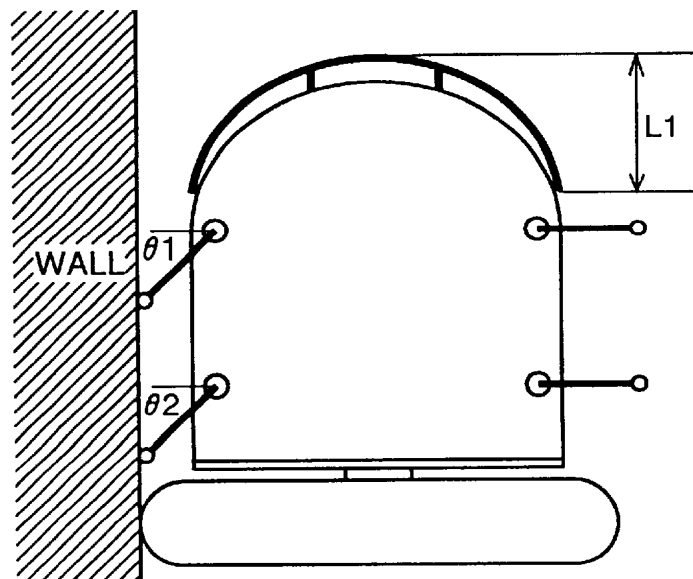

FIG. 4

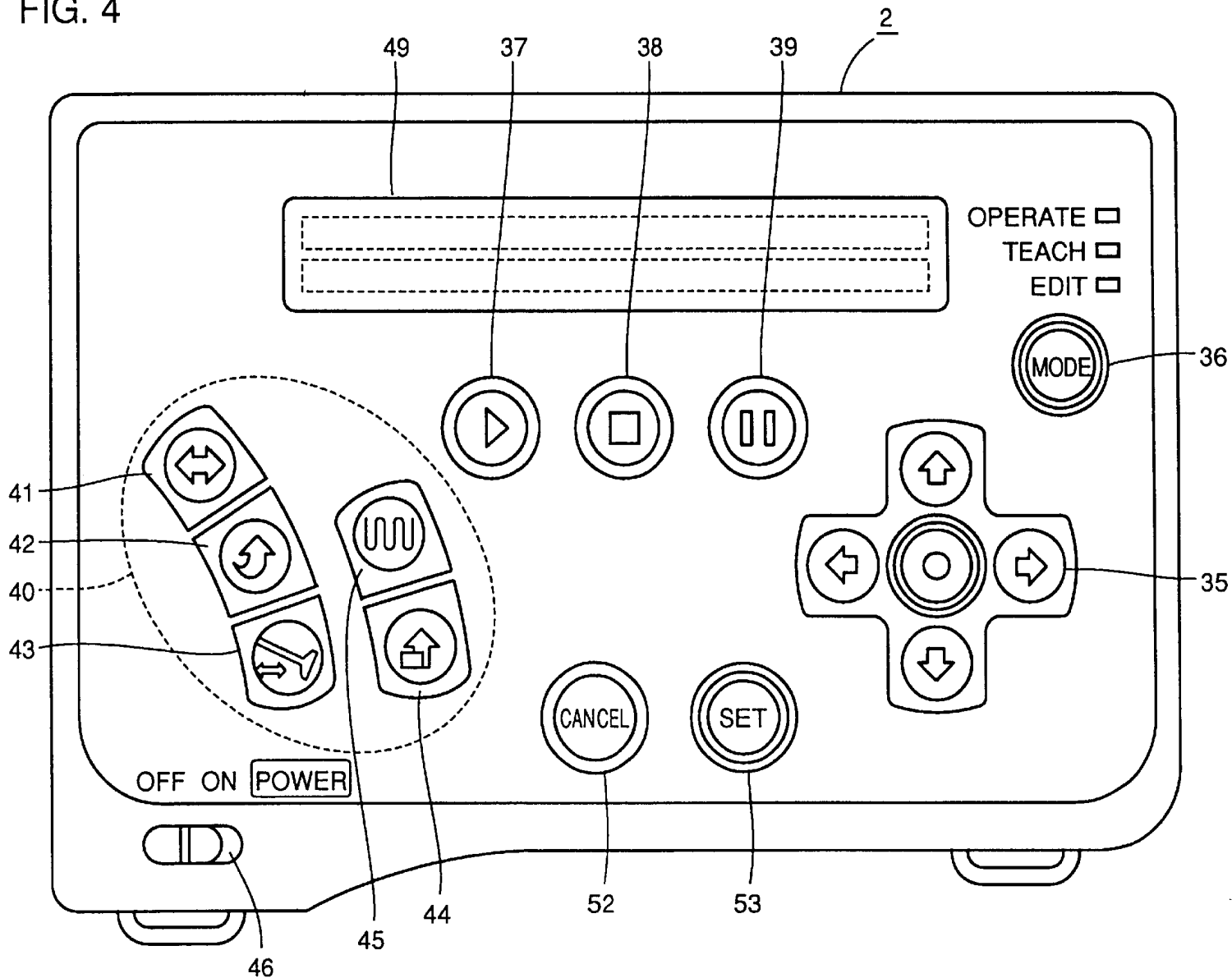
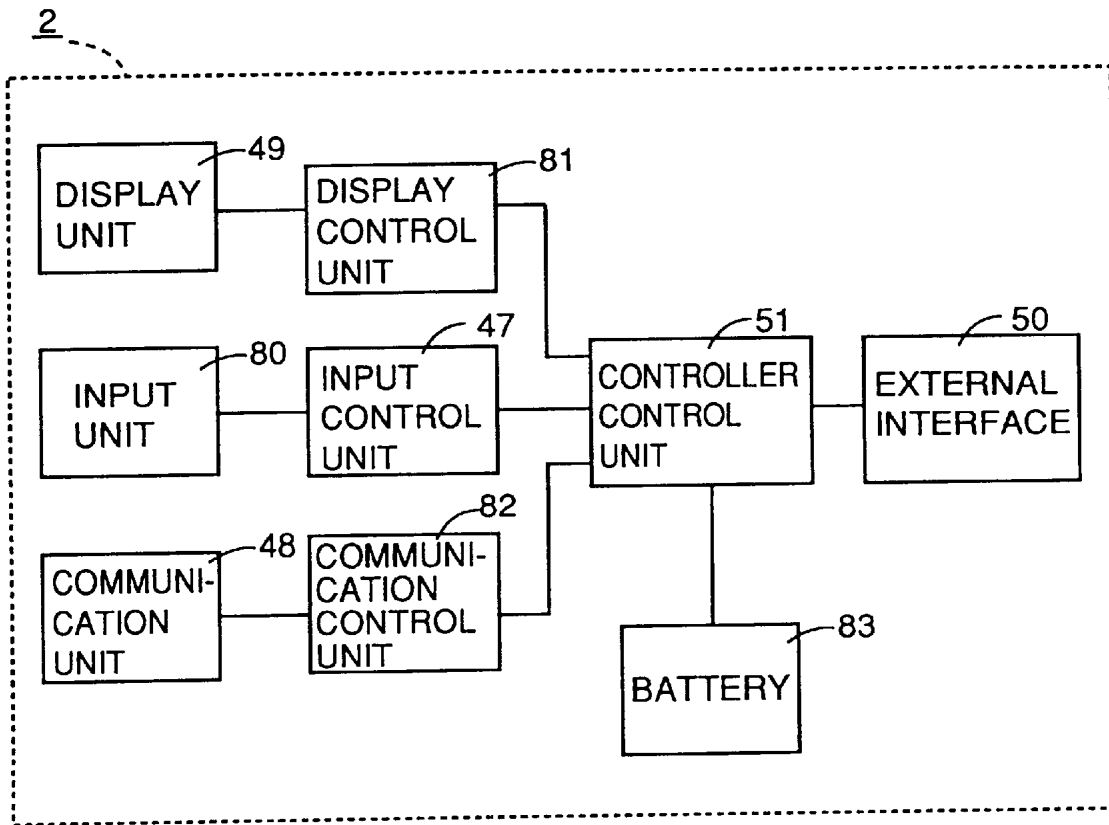

FIG. 5

START RUNNING BY SETTING "ZIGZAG"
LONGITUDINAL 300 cm TRANSVERSE **300** cm END ↓

FIG. 7



Explore Litigation Insights

Docket Alarm provides insights to develop a more informed litigation strategy and the peace of mind of knowing you're on top of things.

Real-Time Litigation Alerts



Keep your litigation team up-to-date with **real-time alerts** and advanced team management tools built for the enterprise, all while greatly reducing PACER spend.

Our comprehensive service means we can handle Federal, State, and Administrative courts across the country.

Advanced Docket Research



With over 230 million records, Docket Alarm's cloud-native docket research platform finds what other services can't. Coverage includes Federal, State, plus PTAB, TTAB, ITC and NLRB decisions, all in one place.

Identify arguments that have been successful in the past with full text, pinpoint searching. Link to case law cited within any court document via Fastcase.

Analytics At Your Fingertips



Learn what happened the last time a particular judge, opposing counsel or company faced cases similar to yours.

Advanced out-of-the-box PTAB and TTAB analytics are always at your fingertips.

API

Docket Alarm offers a powerful API (application programming interface) to developers that want to integrate case filings into their apps.

LAW FIRMS

Build custom dashboards for your attorneys and clients with live data direct from the court.

Automate many repetitive legal tasks like conflict checks, document management, and marketing.

FINANCIAL INSTITUTIONS

Litigation and bankruptcy checks for companies and debtors.

E-DISCOVERY AND LEGAL VENDORS

Sync your system to PACER to automate legal marketing.