

**CLAIMS**

1. A method of navigating an autonomous surface treatment apparatus over a predetermined field of operation, comprising the steps of:

- dividing said predetermined field of operation into cells, each of which being adapted to be indicated as treated, untreated or occupied by an obstacle;
- 5 - determining, for a current cell in which the autonomous apparatus is located, a navigation route to an obstacle-free and untreated cell that requires the smallest amount of energy for moving the autonomous surface treatment apparatus thereto according to a predetermined energy cost function; and
- navigating the autonomous surface treatment apparatus from the current cell  
10 to the obstacle-free and untreated cell according to the determined navigation route and updating the indication of that cell as treated,

**characterized** by the steps of:

- defining a search algorithm based on the question whether there is an untreated cell with cost N, where N starts at 1 and counts upwards to create  
15 a number of cost levels based on specific movements of the autonomous surface treatment apparatus required for it to arrive at said untreated cell;
- building three lists around the current cell each list containing the coordinates of cells with the lowest cost and of the coordinates of cells of the two consecutive higher cost levels, but limited to cells adjacent to the current  
20 cell;
- processing the lists, one by one in cost-order, starting with the list having the lowest cost, wherein as a list is processed the cells are examined one by one to identify cells indicated as untreated;
- during processing of a list, adding cells to the two consecutive lists of higher  
25 cost by considering, for each cell under process, adjacent cells in the directions forward, left and right;
- after processing of a list and updating the two consecutive lists of higher cost, discarding the list under process and processing the list next to follow;

- repeating the search process until an untreated and unoccupied cell has been found;
2. The method according to claim 1,  
**characterized** in that said energy cost function depends both on the distance from the current cell to an obstacle-free and untreated cell as well as the total change of direction required for moving thereto, a larger change of direction and a larger distance being given a larger cost.
3. The method according to claim 1 or 2,  
**characterized** by restricting said autonomous apparatus to move from cell to cell in a limited number of directions.
4. The method according to claim 3,  
**characterized** in that the cost for a route that requires more than one cell-to-cell movement is determined by accumulating the cost for each change of direction along the route and taking the total distance into account.
5. The method according to any of the preceding claims,  
**characterized** in that the step of determining a navigation route that requires the smallest amount of energy according to a predetermined energy cost function includes the steps of:
- allocating to each of a number of cells in the surroundings of the current cell a cost based on the distance to that cell as well as the total change of direction required for moving thereto;
  - checking, in cost-order starting from the cell having the lowest cost, whether any of the cost-allocated cells is indicated as untreated until an untreated cell is found; and
  - extracting the route to the found cell as a lowest-cost route that is used as the navigation route.
6. The method according to claim 5,  
**characterized** by allocating costs to cells in the surroundings of the current cell that fall within a given cost interval and checking the cost-allocated cells for an untreated cell in cost-order, and if no such untreated cell is found among these cells, gradually

increasing the cost interval within which cells are allocated costs and continuing to check cells in cost-order until an untreated cell is found.

7. The method according to claim 5 or 6,  
**characterized** by assigning to each cost-allocated cell a direction indicator to enable  
5 extraction of the lowest-cost route by means of back tracing.
8. The method according to any of the preceding claims,  
**characterized** in that the size of the cells is approximately equal to or smaller than the  
size of the autonomous apparatus.
9. The method according to any of the preceding claims,  
10 **characterized** in that said determining step and said navigating step are repeated until  
the entire field of operation has been treated.
10. The method according to any of the preceding claims,  
**characterized** in that cells are being indicated as occupied by an obstacle based on  
information from an obstacle detection system of the autonomous apparatus.
- 15 11. An autonomous surface treatment apparatus having power operated means for  
moving the apparatus, a sensing system for detection of obstacles and a navigation  
system for navigating the apparatus over a predetermined field of operation,  
said navigation system comprising:
- means for logically dividing said predetermined field of operation into cells,  
20 each of which is being adapted to be indicated as treated, untreated or  
occupied by an obstacle;
  - means for determining, for a current cell in which the autonomous apparatus  
is located, a navigation route to an obstacle-free and untreated cell that  
requires the smallest amount of energy for moving the autonomous surface  
25 treatment apparatus thereto according to a predetermined energy cost  
function; and
  - means for navigating the autonomous surface treatment apparatus from the  
current cell to the obstacle-free and untreated cell according to the determined  
navigation route and updating the indication of that cell as treated,
- 30 **characterized** by computing means adapted to perform the following operations:

- defining a search algorithm based on the question whether there is an untreated cell with cost  $N$ , where  $N$  starts at 1 and counts upwards, to create a number of cost levels based on specific movements of the autonomous surface treatment apparatus required for it to arrive at said untreated cell;
- 5 – building three lists around the current cell each list containing the coordinates of cells with the lowest cost and of the coordinates of cells of the two consecutive higher cost levels, but limited to cells adjacent to the current cell;
- processing the lists, one by one in cost-order, starting with the list having the lowest cost, wherein as a list is processed the cells are examined one by one
- 10 to identify cells indicated as untreated;
- during processing of a list, adding cells to the two consecutive lists of higher cost by considering, for each cell under process, adjacent cells in the directions forward, left and right;
- after processing of a list and updating the two consecutive lists of higher cost,
- 15 discarding the list under process until an untreated and unoccupied cell has been found.

12. The apparatus according to claim 11,  
**characterized** in that said energy cost function depends both on the distance from the current cell to an obstacle-free and untreated cell as well as the total change of  
20 direction required for moving thereto, a larger change of direction and a larger distance being given a larger cost.

13. The apparatus according to claim 11 or 12,  
**characterized** in that said autonomous apparatus is restricted to move from cell to cell in a limited number of directions.

25 14. The apparatus according to claim 13,  
**characterized** in that the cost for a route that requires more than one cell-to-cell movement is determined by accumulating the cost for each change of direction along the route and taking the total distance into account.

15. The apparatus according to any of the claims 11-14,  
30 **characterized** in that said means for determining a navigation route that requires the

smallest amount of energy according to a predetermined energy cost function includes:

- means for allocating to each of a number of cells in the surroundings of the current cell a cost based on the distance to that cell as well as the total change of direction required for moving thereto;
- 5 – means for checking, in cost-order starting from the cell having the lowest cost, whether any of the cost-allocated cells is indicated as untreated until such an untreated cell is found; and
- means for extracting the route to the found cell as a lowest-cost navigation route to an untreated cell.

10 16. The apparatus according to claim 15,  
**characterized** in that said allocating means and said checking means interwork in such a manner that costs are allocated to cells in the surroundings of the current cell that fall within a given cost interval and that these cost-allocated cells are checked in cost-order to find an untreated cell, and that if no such untreated cell is found among these cells  
15 the cost interval within which cells are allocated costs is gradually increased and the checking of cells is continued in cost-order until an untreated cell is found.

17. The apparatus according to claim 15 or 16,  
**characterized** in that said navigation system further comprises means for assigning to each cost-allocated cell a direction indicator to enable extraction of the lowest-cost  
20 route by means of back tracking.

18. The apparatus according to any of the claims 11-17,  
**characterized** in that the size of the cells is approximately equal to or smaller than the size of the autonomous apparatus.

19. The apparatus according to any of the claims 11-18,  
25 **characterized** in that determining means is configured for determining a sequence of navigation routes according to which the navigation means operates until the entire field of operation has been treated.

20. The apparatus according to any of the claims 11-19,  
**characterized** in that said autonomous surface treatment apparatus is operable for  
30 performing floor treatment such as vacuum cleaning, sweeping, brushing or polishing

within said field of operation.

21. A computer program for navigating an autonomous surface treatment apparatus over

a predetermined field of operation, when the program is executed by a computer  
5 arranged in connection with said autonomous apparatus,

said computer program comprising:

- program means for logically dividing said predetermined field of operation into cells, each of which adapted to be indicated as treated, untreated or occupied by an obstacle;
- 10 – program means for performing, for a current cell in which the autonomous apparatus is located, a structured search for an obstacle-free and untreated cell, wherein said program means for performing a structured search comprises:
  - program means for allocating to each of a number of cells in the  
15 surroundings of the current cell a cost based on the distance to that cell as well as the total change of direction required for moving thereto;
  - program means for checking, in cost-order starting from the cell having the lowest cost, whether any of the cost-allocated cells is indicated as untreated until such an untreated cell is found; and
  - 20 – program means for extracting the route to a found cell as a lowest-cost navigation route to an untreated cell; and
  - program means for navigating the autonomous surface treatment apparatus from the current cell to an obstacle-free and untreated cell according to the extracted lowest-cost navigation route and updating the indication of that  
25 cell as treated,

**characterized** in that said program means for performing a structured search further comprises:

- program means for building three lists around the current cell, a first list containing the coordinates of cells with the lowest cost and the two  
30 additional lists containing the coordinates for cells of the two following

cost levels, respectively;

- program means for processing the lists, one by one in cost-order, starting with the list having the lowest cost, wherein as a list is processed the cells are examined one by one to identify cells indicated as untreated;
- 5 – said program means for processing the lists in doing so adding cells to the two consecutive lists of higher cost by considering, for each cell under process, adjacent cells in the direction forward, left and right;
- said program means for processing the lists, after completion of a list and updating the two consecutive lists of higher cost, discarding the list thus  
10 completed and processing the list next to follow;

22. The computer program according to claim 21,  
**characterized** in that said allocating program means and said checking program means interwork in such a manner that costs are allocated to cells in the surroundings of the current cell that fall within a given cost interval and that these cost-allocated cells are  
15 checked in cost-order to find an untreated cell and that if no such untreated cell is found among these cells the cost interval within which cells are allocated costs is gradually increased and the checking of cells is continued in cost-order until an untreated cell is found.

23. The computer program according to claim 21 or 22,  
20 **characterized** by program means for assigning to each cost-allocated cell a direction indicator to enable extraction of the lowest-cost route by means of back tracing.

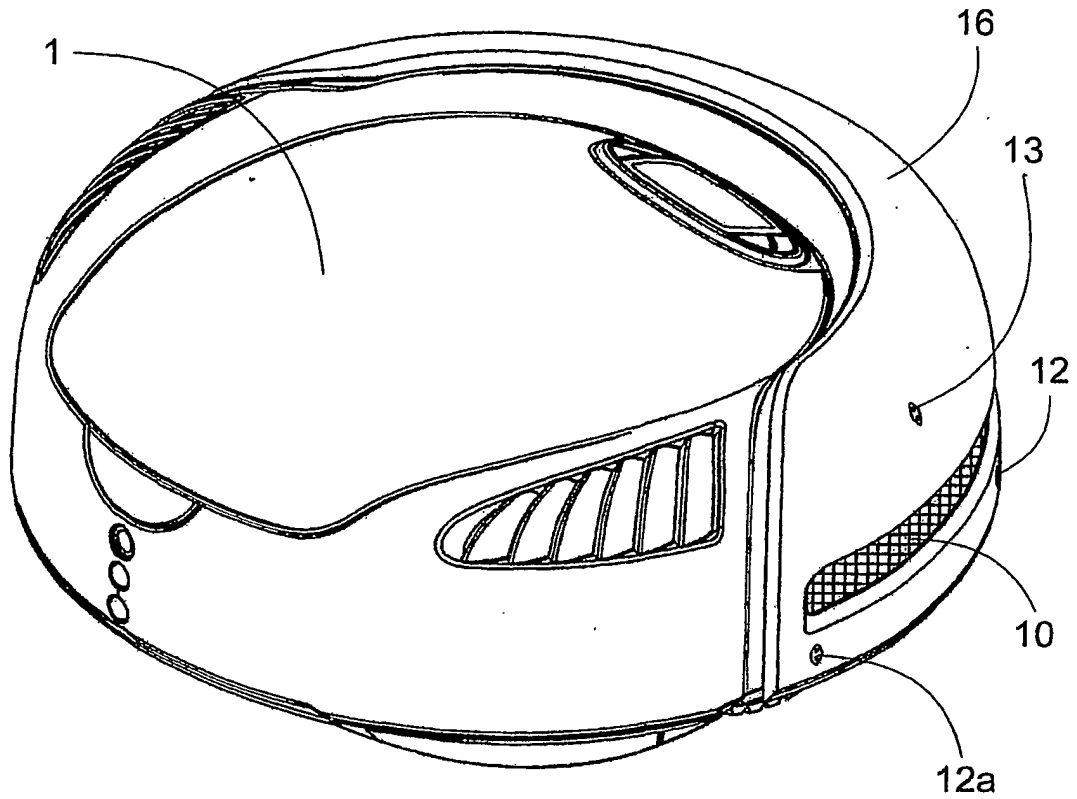


Fig. 1

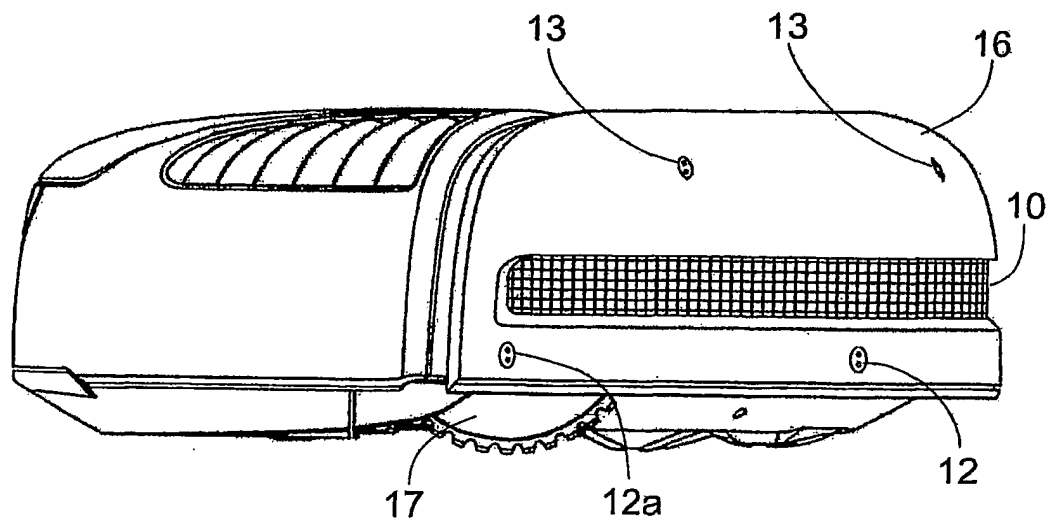


Fig. 2



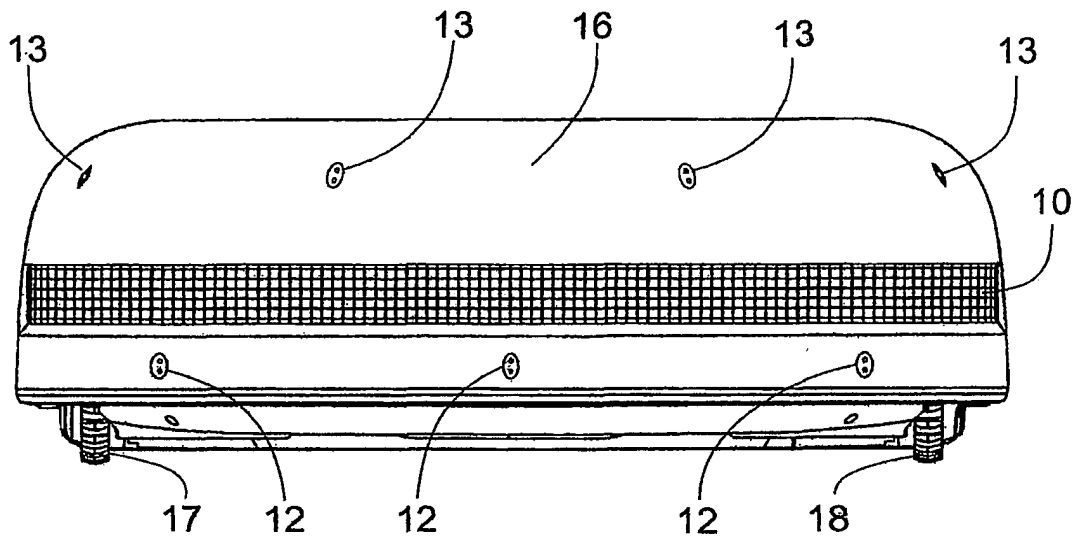


Fig. 3

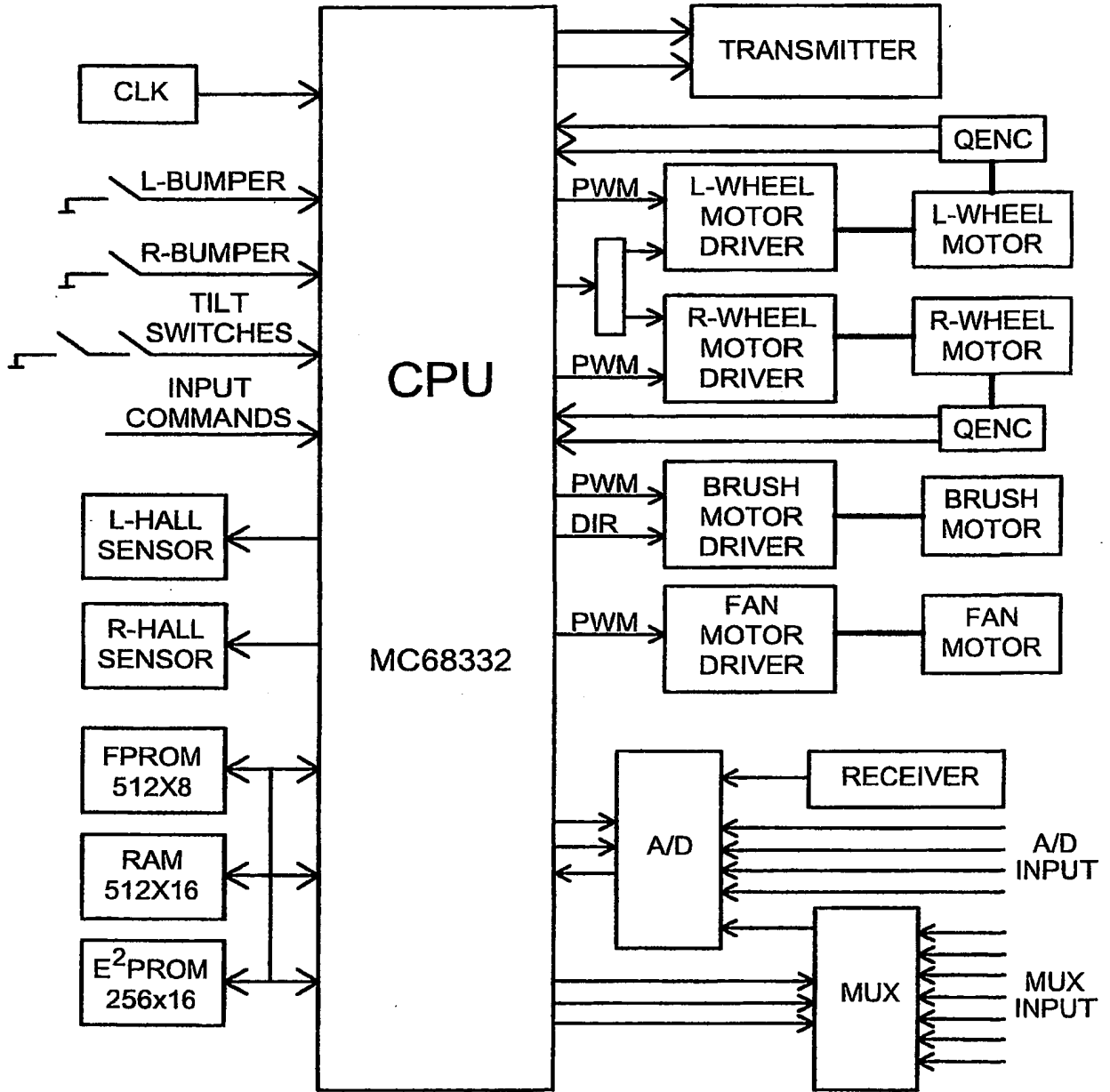


Fig. 4

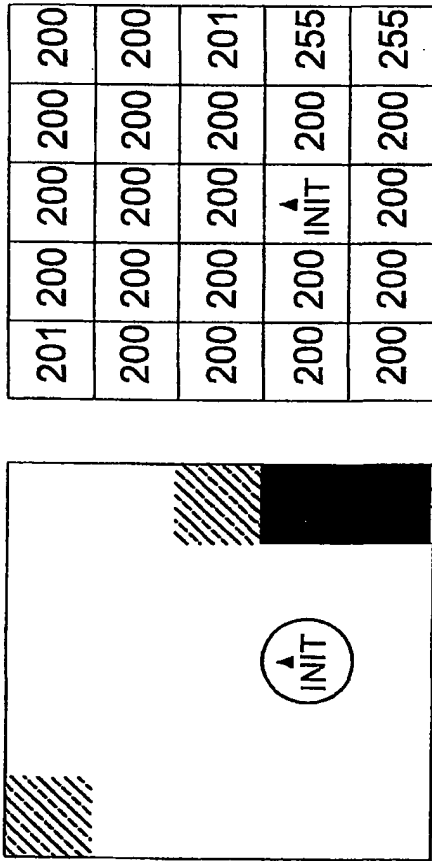


Fig. 5

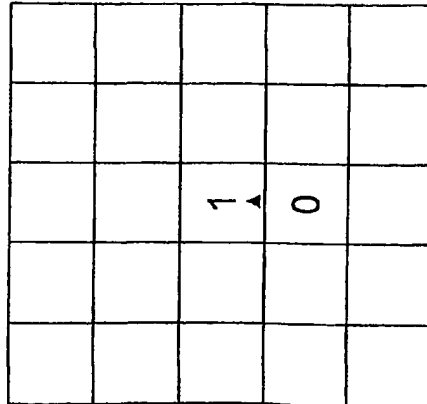


Fig. 6A

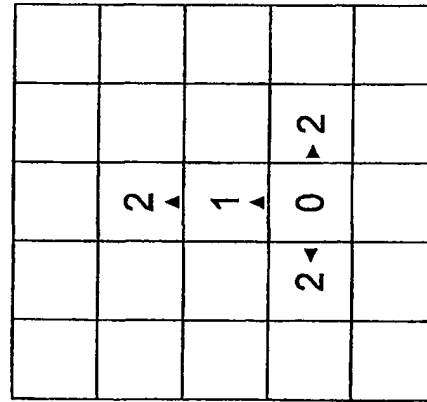


Fig. 6B

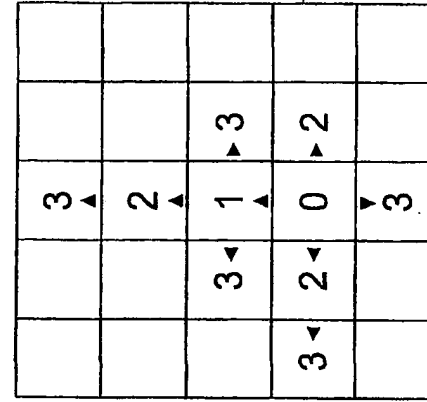


Fig. 6C

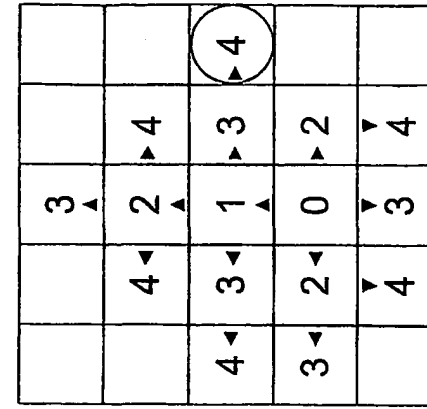


Fig. 6D

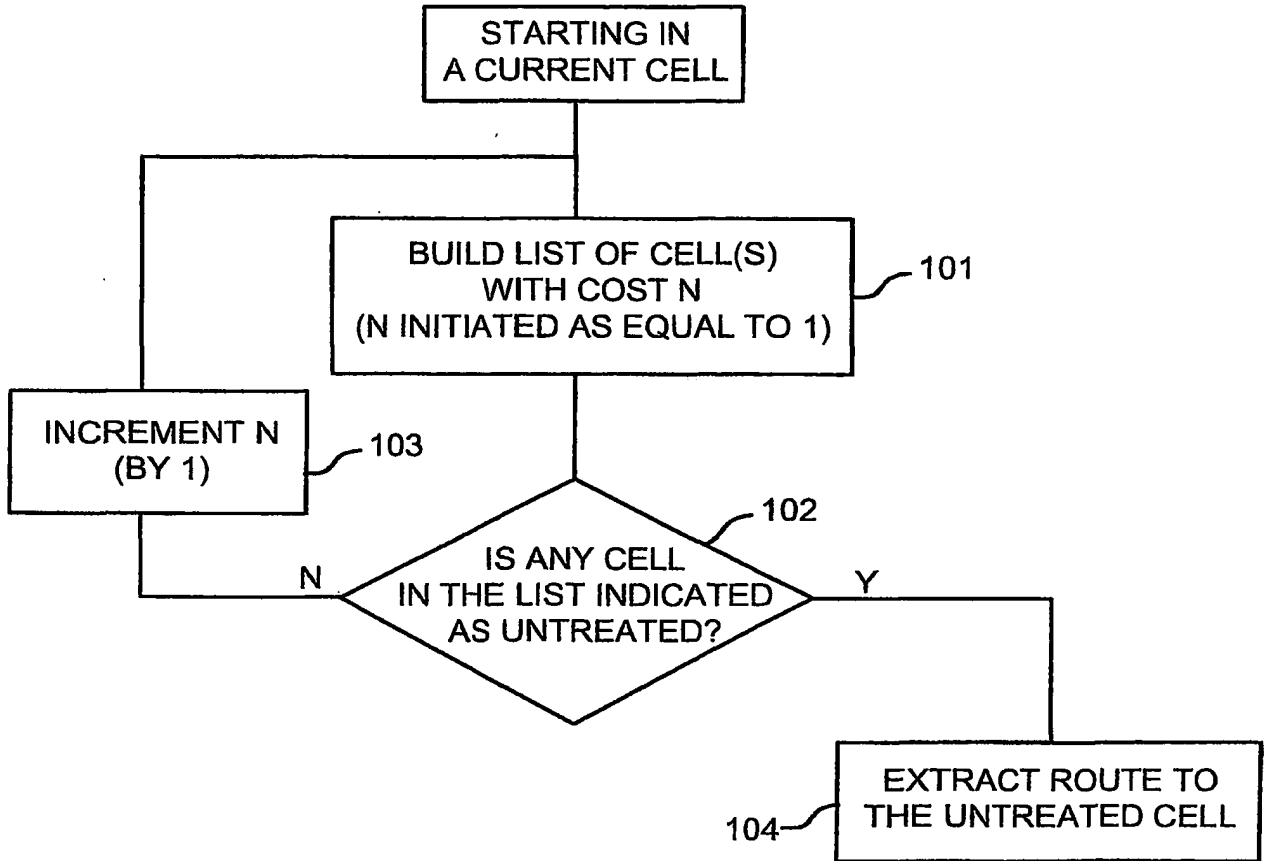
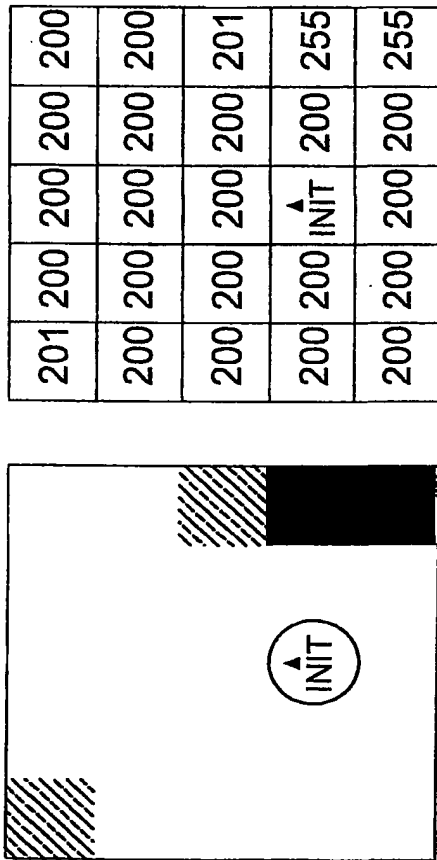


Fig. 7



201	200	200	200	200
200	200	200	200	200
200	200	200	200	201
200	200	INIT	200	255
200	200	200	200	255

Fig. 8

6/13

		1		
	2	0	2	
			3	

Fig. 9A

		2		
	3	1	3	
	2	0	2	
			3	

Fig. 9B

	4	2	4	
	3	1	3	
3	2	0	2	
	4	3	4	

Fig. 9C

5	3	5		
4	2	4		
4	3	1	3	4
3	2	0	2	
5	4	3	4	

Fig. 9D

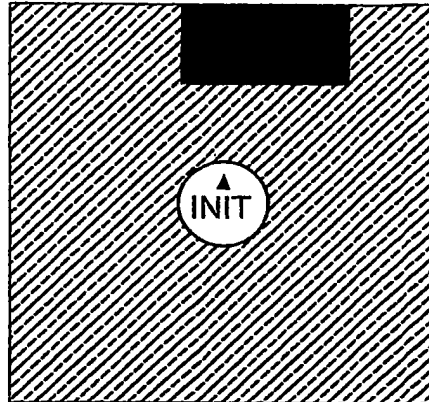


Fig. 10

		1		
		0		

201	201	255	255	201
201	201	201	201	201
201	201	↑ INIT	201	201
201	201	201	201	201
201	201	201	201	201

Fig. 11A

	2	0	2	

201	201	255	255	201
201	201	↑	201	201
201	201		201	201
201	201	201	201	201
201	201	201	201	201

Fig. 11B

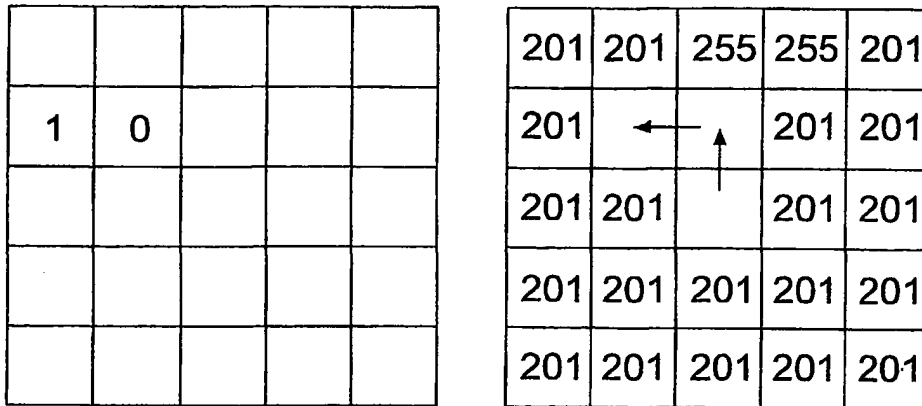


Fig. 11C

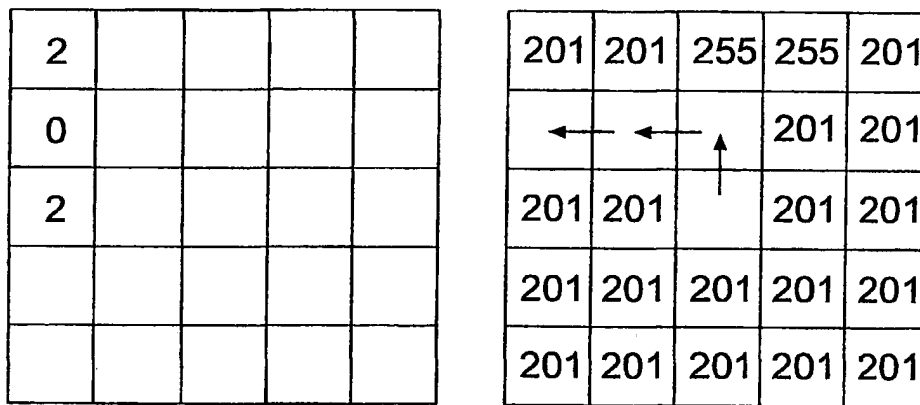


Fig. 11D

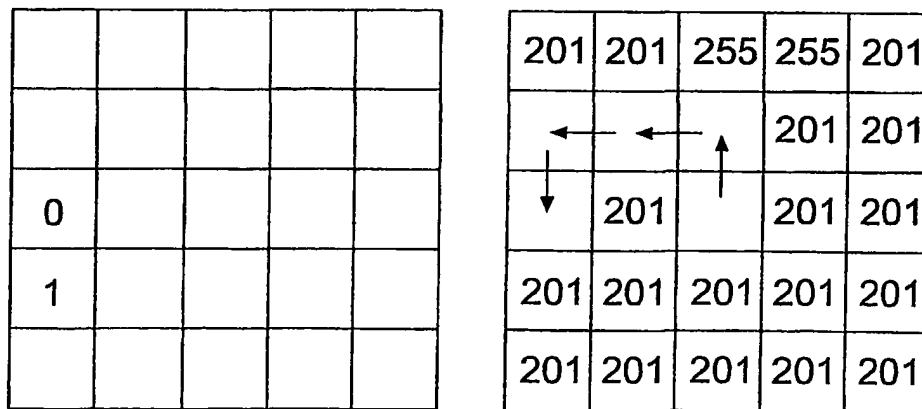


Fig. 11E

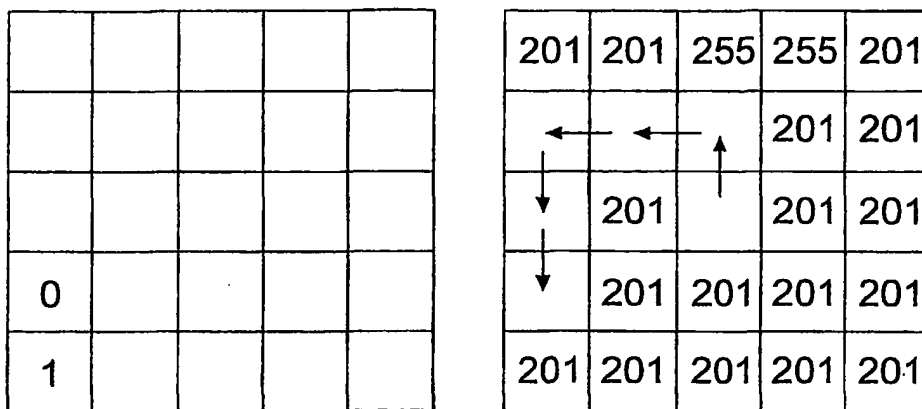


Fig. 11F

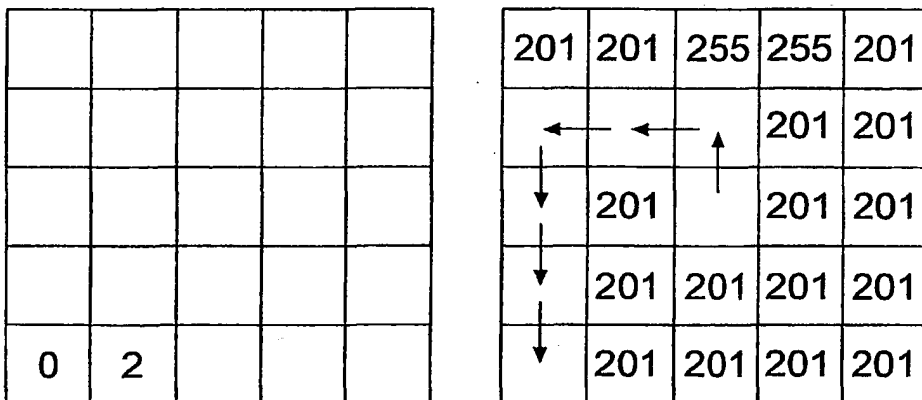


Fig. 11G

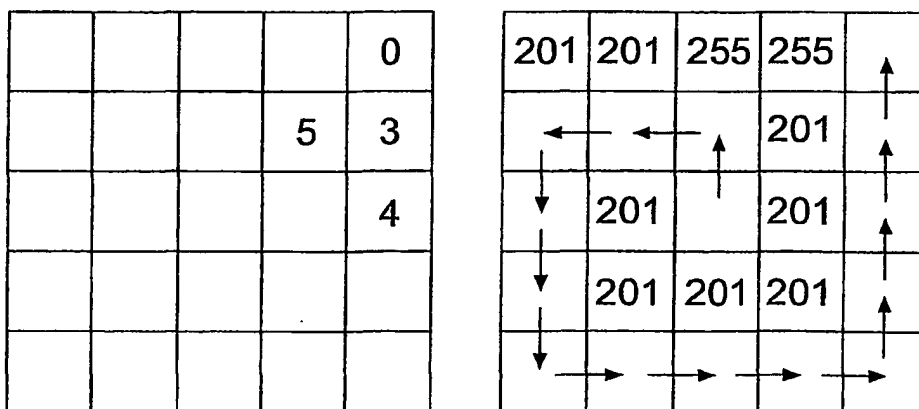


Fig. 11H



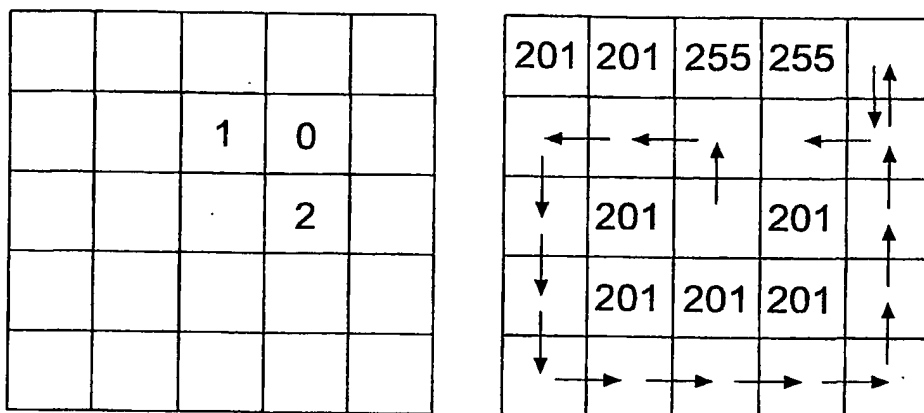


Fig. 11I

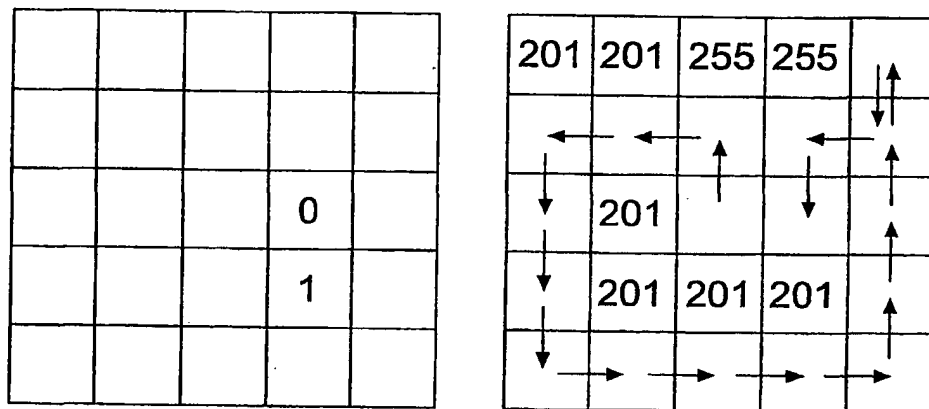


Fig. 11J

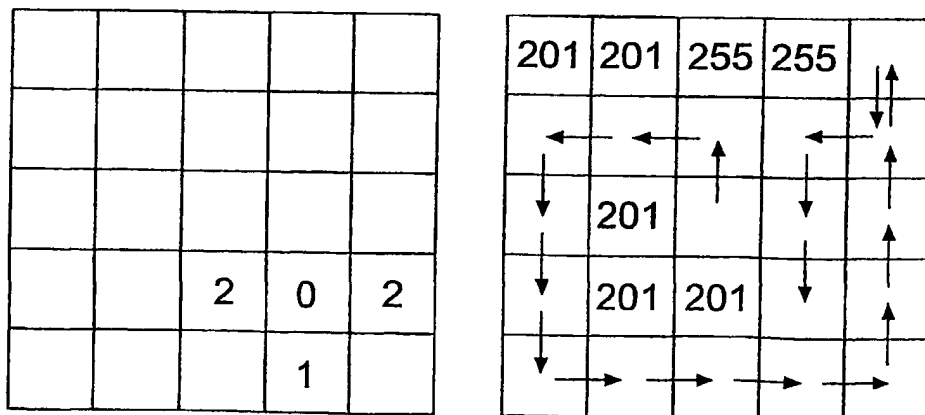


Fig. 11K

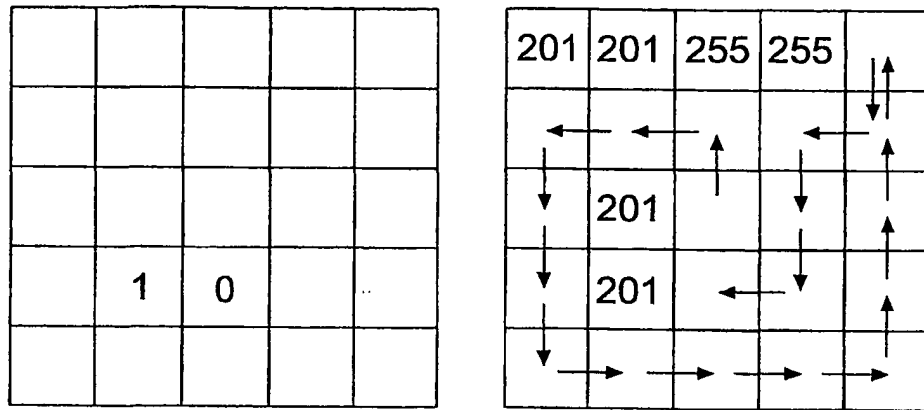


Fig. 11L

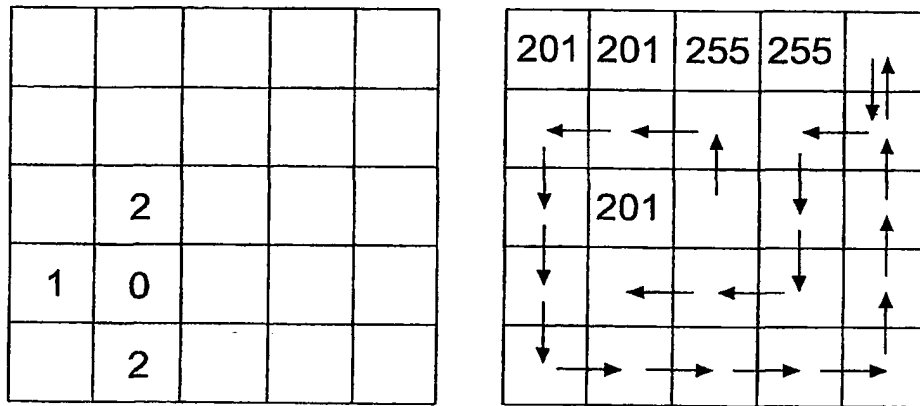


Fig. 11M

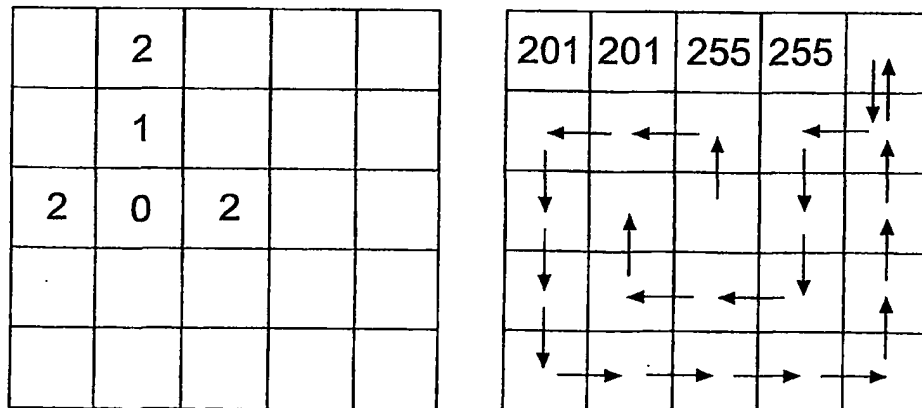


Fig. 11N





International application No.

PCT/SE 02/00471

## A. CLASSIFICATION OF SUBJECT MATTER

IPC7: G05D 1/02

According to International Patent Classification (IPC) or to both national classification and IPC

## B. FIELDS SEARCHED

Minimum documentation searched (classification system followed by classification symbols)

IPC7: B25J, G05D

Documentation searched other than minimum documentation to the extent that such documents are included in the fields searched

SE,DK,FI,NO classes as above

Electronic data base consulted during the international search (name of data base and, where practicable, search terms used)

EPO-INTERNAL, WPI, PAJ

## C. DOCUMENTS CONSIDERED TO BE RELEVANT

Category*	Citation of document, with indication, where appropriate, of the relevant passages	Relevant to claim No.
A	WO 9940496 A (SIEMENS AKTIENGESELLSCHAFT), 12 August 1999 (12.08.99), page 2, line 29 - line 36, abstract --	1-23
A	US 4674048 A (K.OKUMURA), 16 June 1987 (16.06.87), column 3, line 33 - column 6, line 17, figures 3-6, cited in the application --	1-23
A	US 5353224 A (J.W.LEE ET AL), 4 October 1994 (04.10.94), column 3, line 41 - column 5, line 4, abstract --	1-23

 Further documents are listed in the continuation of Box C.
  See patent family annex.

* Special categories of cited documents:	"T" later document published after the international filing date or priority date and not in conflict with the application but cited to understand the principle or theory underlying the invention
"A" document defining the general state of the art which is not considered to be of particular relevance	"X" document of particular relevance: the claimed invention cannot be considered novel or cannot be considered to involve an inventive step when the document is taken alone
"E" earlier application or patent but published on or after the international filing date	"Y" document of particular relevance: the claimed invention cannot be considered to involve an inventive step when the document is combined with one or more other such documents, such combination being obvious to a person skilled in the art
"L" document which may throw doubts on priority claim(s) or which is cited to establish the publication date of another citation or other special reason (as specified)	"&" document member of the same patent family
"O" document referring to an oral disclosure, use, exhibition or other means	
"P" document published prior to the international filing date but later than the priority date claimed	

Date of the actual completion of the international search  6 June 2002	Date of mailing of the international search report  02-07- 2002
Name and mailing address of the ISA/ Swedish Patent Office Box 5055, S-102 42 STOCKHOLM Facsimile No. +46 8 666 02 86	Authorized officer  Göran Magnusson /itw Telephone No. +46 8 782 25 00

INTERNATIONAL SEARCH REPORT

International application No.

PCT/SE 02/00471

C (Continuation). DOCUMENTS CONSIDERED TO BE RELEVANT

Category*	Citation of document, with indication, where appropriate, of the relevant passages	Relevant to claim No.
A	US 5321614 A (G.T.D.ASHWORTH), 14 June 1994 (14.06.94), column 1, line 56 - column 4, line 28, figure 4, abstract --	1-23
A	US 5659779 A (R.T.LAIRD ET AL), 19 August 1997 (19.08.97), column 3, line 17 - line 37 -- -----	1-23

## INTERNATIONAL SEARCH REPORT

International application No.

PCT/SE 02/00471

Patent document cited in search report			Publication date	Patent family member(s)		Publication date
WO	9940496	A	12/08/99	DE	19804195 A	05/08/99
				DE	59900221 D	00/00/00
				EP	1053516 A,B	22/11/00
				SE	1053516 T3	
				JP	2002502997 T	29/01/02
				US	6240342 B	29/05/01
-----						
US	4674048	A	16/06/87	AT	44322 T	15/07/89
				CA	1217836 A	07/02/87
				DE	3478824 D	00/00/00
				EP	0142594 A,B	29/05/85
				SE	0142594 T3	
				JP	60093522 A	25/05/85
				JP	1708982 C	11/11/92
				JP	3079723 B	19/12/91
JP	60093524 A	25/05/85				
-----						
US	5353224	A	04/10/94	DE	69124587 D,T	11/09/97
				EP	0490736 A,B	17/06/92
				JP	4333902 A	20/11/92
				KR	9300081 B	08/01/93
KR	9605628 Y	10/07/96				
-----						
US	5321614	A	14/06/94	NONE		
-----						
US	5659779	A	19/08/97	NONE		
-----						

(19) World Intellectual Property Organization  
International Bureau



(43) International Publication Date  
15 May 2003 (15.05.2003)

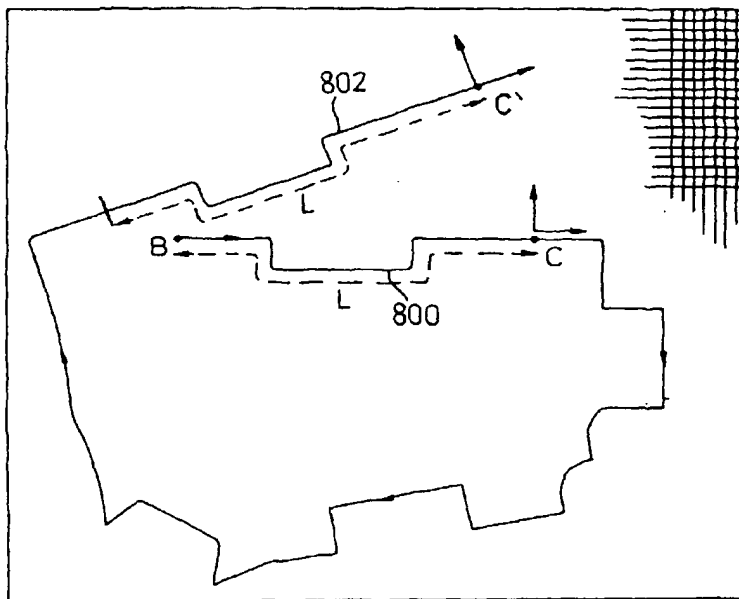
PCT

(10) International Publication Number  
WO 03/040845 A1

- (51) International Patent Classification<sup>7</sup>: G05D 1/02
  - (21) International Application Number: PCT/GB02/04919
  - (22) International Filing Date: 31 October 2002 (31.10.2002)
  - (25) Filing Language: English
  - (26) Publication Language: English
  - (30) Priority Data:  
0126497.7 3 November 2001 (03.11.2001) GB
  - (71) Applicant (for all designated States except US): DYSON LTD [GB/GB]; Tethbury Hill, Malmesbury, Wiltshire SN16 0RP (GB).
  - (72) Inventors; and
  - (75) Inventors/Applicants (for US only): ALDRED, Michael, David [GB/GB]; 16 Sutherland Crescent, Cepen Park North, Chippenham, Wiltshire SN14 6RS (GB). SHARDLOW, Andrew, Michael [GB/GB]; 4 Castlewood Cottages, Highwalls Road, Dinas Powys, South Glamorgan CF64 4AN (GB).
  - (74) Agents: CAGE, John, D. et al.; Intellectual Property Department, Dyson Limited, Tetbury Hill, Malmesbury, Wiltshire SN16 0RP (GB).
  - (81) Designated States (national): AE, AG, AL, AM, AT, AU, AZ, BA, BB, BG, BR, BY, BZ, CA, CH, CN, CO, CR, CU, CZ, DE, DK, DM, DZ, EC, EE, ES, FI, GB, GD, GE, GH, GM, HR, HU, ID, IL, IN, IS, JP, KE, KG, KP, KR, KZ, LC, LK, LR, LS, LT, LU, LV, MA, MD, MG, MK, MN, MW, MX, MZ, NO, NZ, OM, PH, PL, PT, RO, RU, SD, SE, SG, SI, SK, SL, TJ, TM, TN, TR, TT, TZ, UA, UG, US, UZ, VC, VN, YU, ZA, ZM, ZW.
  - (84) Designated States (regional): ARIPO patent (GH, GM, KE, LS, MW, MZ, SD, SL, SZ, TZ, UG, ZM, ZW), Eurasian patent (AM, AZ, BY, KG, KZ, MD, RU, TJ, TM), European patent (AT, BE, BG, CH, CY, CZ, DE, DK, EE, ES, FI, FR, GB, GR, IE, IT, LU, MC, NL, PT, SE, SK, TR), OAPI patent (BF, BJ, CF, CG, CI, CM, GA, GN, GQ, GW, ML, MR, NE, SN, TD, TG).
- Published:  
— with international search report

[Continued on next page]

(54) Title: AN AUTONOMOUS MACHINE



(57) Abstract: An autonomous machine explores the area in which it is located, constructing a map of the area based on information collected by the machine as the machine explores the area. The machine determines when it has returned to a previously visited position within the area. The map is corrected when the machine returns to the previously visited position, based on the knowledge that the current position and the previously visited position are the same.

WO 03/040845 A1





---

*For two-letter codes and other abbreviations, refer to the "Guidance Notes on Codes and Abbreviations" appearing at the beginning of each regular issue of the PCT Gazette.*

### An Autonomous Machine

This invention relates to an autonomous machine, such as an autonomous machine for cleaning a floor area.

5

There have been various proposals to provide autonomous or robotic machines for performing duties such as cleaning or polishing a floor area or for mowing grass. In their simplest form, an autonomous machine requires a training phase during which the machine is manually led around the area in which it is to work. Following this training phase, the autonomous machine will then perform the required work as it follows the path which it stored in its memory during the training phase. Other machines may simply follow a predetermined route which is marked by means such as a cable which is buried beneath the working area.

10

15 Other autonomous machines are supplied with a map of the environment in which they are to be used. The machine then uses this map to plan a route around the environment.

There have also been proposals for autonomous machines which are capable of exploring the environment in which they are placed without human supervision, and without advance knowledge of the layout of the environment. The machine may explore the environment during a learning phase and will subsequently use this information during a working phase. An autonomous machine shown in WO 00/38025 initially travels around the perimeter of an area, recognises when it has completed a single lap of the area, and then steps inwardly after that and subsequent laps of the room so as to cover the area in a spiral-like pattern.

20

25 Autonomous machines are known to build a map of the working area using the information they acquire during the learning phase. Autonomous machines of this last type are particularly attractive to users as they can be left to work with minimal human supervision.

25

30 Autonomous machines usually have some form of odometry system for measuring the distance and direction travelled by the machine. Distance and direction information can be derived from sensors which monitor movement of each of the wheels. The machine uses

30

the odometry information to deduce how far it has travelled since a starting position in the working area, and thus where it currently is located within the area. Unfortunately, relying on odometry information alone is unreliable as errors can quickly accumulate, and this can eventually lead to a complete disorientation of the machine. For example, if  
5 one of the drive wheels of the machine slips on the floor surface the odometry system will record a movement, since the wheel has turned, whereas, due to the wheel slippage, the machine does not actually move across the surface. Poor odometry information results in a difference between the calculated position of the machine and the actual position of the machine. In a floor cleaning machine this could result in the machine not travelling across  
10 some areas of the floor surface, which would remain dirty, or the machine becoming lost.

Odometry information can be supplemented, or replaced entirely, by other information. A paper entitled "Gyrodometry: A New Method for Combining Data from Gyros and Odometry in Mobile Robots" presented at the 1996 IEEE International Conference on  
15 Robotics and Automation, Minneapolis, Apr 22-28, 1996, pp. 423-428, describes a proposal for reducing the problems of odometry-based robots in which the odometry data is substituted by gyro data during the short periods when odometry data is unreliable. Some systems position navigation beacons around an area such that the machine can calculate its position by a process of triangulating information received from a number of  
20 beacons. However, this has the obvious disadvantage of requiring beacons to be positioned around each area where the machine will work, and the associated cost of these beacons. US 6,255,793 describes a system of this type where the boundary of the working area is defined by markers. One of the ways in which the calculated location of the autonomous machine can be corrected is by detecting the presence of markers which each  
25 have a unique identity.

The present invention seeks to provide an improved autonomous machine.

A first aspect of the present invention provides an autonomous machine comprising:

- driving means for moving the machine along a surface, and

5 - a navigation system, including a memory means, for navigating the cleaning machine around an area,

the navigation system comprising:

means for causing the machine to explore the area in which it is located, constructing a map of the area based on information collected by the machine as the machine explores the  
10 area,

means for determining when the machine has returned to a previously visited position within the area,

means for correcting the map when the machine returns to the previously visited position, based on the knowledge that the current position and the previously visited position are the  
15 same.

This allows the machine to create a map which is an accurate representation of the area, even where the machine may suffer from errors in gathering information to construct the map, such as the errors which accumulate when relying on odometry information.  
20

Preferably, the exploring means is arranged to cause the machine to follow a boundary of the area, storing path information on the path travelled by the machine as the machine follows the boundary; and the determining means is arranged to determine when the machine has returned to a previously visited position in the area by comparing the latest  
25 section of the path travelled by the machine with information representing a section of the path previously stored in the memory, and for deciding when the new path information and previously stored path information are substantially the same.

The boundary can take many forms. In a room of a building, the boundary will be the  
30 walls of the room and the boundaries of objects placed within the room such as items of furniture. In an outdoor area, the boundary may be a pre-existing barrier such as a fence

or wall or it may be any form of barrier which is positioned especially for use with the autonomous machine.

As an alternative to using path data to recognise when the machine has returned to a  
5 previously visited position, the machine can use feature-based information which is collected by sensors on the machine. The feature-based information can be light-based information such as the amplitude, direction and/or colour of light at positions within the room, magnetic measurements or distance measurements. Alternatively, the machine could recognise some kind of marker at a position in the area.

10

The navigation system can be implemented entirely in hardware, in software running on a processor, or a combination of these. Accordingly, a further aspect of the present invention provides software for operating the cleaning machine in the manner described herein. The software is conveniently stored on a machine-readable medium such as a  
15 memory device.

The autonomous machine can take many forms: it can be a robotic vacuum cleaner, floor polisher, lawn mower or a robotic machine which performs some other function. Alternatively, it could be a general purpose robotic vehicle which is capable of carrying or  
20 towing a work implement chosen by a user.

Embodiments of the present invention will now be described, by way of example only, with reference to the accompanying drawings, in which:-

25 Figure 1 shows an embodiment of an autonomous machine according to the invention;

Figure 2 shows the electrical systems in the machine of Figure 1;

Figure 3 shows the overall set of machine behaviours;

Figure 4 shows the method for navigating the machine around the boundary of a  
30 working area;

Figures 5 and 6 show the machine operating in an example room scenario;

Figure 7 shows the process for matching path sections;

Figure 8 shows the machine-generated map of the working area following an initial traverse of the boundary of the working area;

Figure 9 shows the map correction process;

Figure 10 shows the coordinate system used in the map correction process;

5 Figure 11 shows the method for scanning the working area;

Figure 12 shows a reciprocating scanning movement;

Figure 13 shows the map of a room and free space areas;

Figure 14 shows one of the selected free space areas of the room;

Figure 15 shows types of free space areas which may exist within the room;

10 Figure 16 shows a way of reaching scanning start points;

Figure 17 shows a way of coping with centrally positioned objects; and,

Figures 18-20 show scanning behaviours.

Figure 1 of the drawings shows a robotic, or autonomous, floor cleaning machine in the  
15 form of a robotic vacuum cleaner 100.

The cleaner comprises a main body or supporting chassis 102, two driven wheels 104, a brushbar housing 120, batteries 110, a dust separating and collecting apparatus 130, a user interface 140 and various sensors 150, 152, 154. The supporting chassis 102 is  
20 generally circular in shape and is supported on the two driven wheels 104 and a castor wheel (not shown). The driven wheels 104 are arranged at either end of a diameter of the chassis 102, the diameter lying perpendicular to the longitudinal axis of the cleaner 100. The driven wheels 104 are mounted independently of one another via support bearings (not shown) and each driven wheel 104 is connected directly to a traction  
25 motor which is capable of driving the respective wheel 104 in either a forward direction or a reverse direction. A full range of manoeuvres are possible by independently controlling each of the traction motors.

Mounted on the underside of the chassis 102 is a cleaner head 120 which includes a  
30 suction opening facing the surface on which the cleaner 100 is supported. A brush bar 122 (not shown) is rotatably mounted in the suction opening and a motor is mounted on the cleaner head 120 for driving the brush bar.

The chassis 102 carries a plurality of sensors 150, 152, 154 which are positioned on the chassis such that the navigation system of the cleaner can detect obstacles in the path of the cleaner 100 and the proximity of the cleaner to a wall or other boundary such as a piece of furniture. The sensors shown here comprise several ultrasonic sensors 150 which are capable of detecting walls and objects and several passive infra red (PIR) sensors which can detect the presence of humans, animals and heat sources such as a fire. However, the array of sensors can take many different forms. Position Sensitive Devices (PSDs) may be used instead of, or in addition to, the ultrasonic sensors. In an alternative embodiment the cleaner may navigate by mechanically sensing the boundary of the working area and boundaries of obstacles placed within the area. Each side of the vehicle carries an odometry wheel. This is a non-driven wheel which rotates as the machine moves along the surface. Each wheel has an optical encoder associated with it for monitoring the rotation of the odometry wheel. By examining the information received from each odometry wheel, the navigation system can determine both the distance travelled by the machine and the change in angular direction of the machine. It is preferred that the odometry wheel is a non-driven wheel as this increases the accuracy of the information obtained from the wheel. However, a simpler embodiment of the machine can derive odometry information directly from one of the driven wheels.

20

The vacuum cleaner 100 also includes a motor and fan unit supported on the chassis 102 for drawing dirty air into the vacuum cleaner 100 via the suction opening in the cleaner head 120.

25

Figure 2 shows, in schematic form, the electrical systems for the cleaner of Figure 1. The navigation system comprises a microprocessor 200 which operates according to control software which is stored on a non-volatile memory 210, such as a ROM or FLASH ROM. Another memory 220 is used during normal operation of the machine to store data, such as the path data and a map of the working area, and other operating parameters. The navigation system receives inputs about the environment surrounding the machine from sensor array 150, 152, 154 and inputs about movement of the machine from odometry wheel movement sensors 160, 162. The navigation system also receives

30

inputs from switches 142 on the user interface, such as start, pause, stop or a selection of operating speed or standard of required cleanliness. The navigation system provides a plurality of output control signals: signals for driving the traction motors 105 of the wheels 104, a signal for operating the suction motor 132 which drives the suction fan 130 and a signal for operating the motor 122 which drives the brush bar 125. It also provides outputs from illuminating indicator lamps 144 on the user interface 140. Power is supplied by rechargeable battery packs 110.

### Navigation method

The operation of the machine will now begin to be described with reference to Figures 3-7. Figure 3 is a flow chart of the overall set of behaviours followed by the machine. Figure 4 is a flow chart of the process for navigating around a boundary of the working area. Figures 5 and 6 show an example of a working area in a room of a house, the room having a boundary which is defined by walls 405, a doorway 410, a fire place 415 and articles of furniture 420 – 426 (e.g. sofa, chair) placed against the walls of the room. These figures also show an example path 430 taken by the machine. Figure 6 illustrates the path matching process.

When the machine is first started it has no knowledge of the area in which it is positioned. Thus, the machine must first explore the area in which it is to work to acquire a knowledge of the area.

### Boundary Scanning

The machine is left in the room by a user. Ideally the user is required to place the machine pointing towards an outer boundary of the room or with its left side against the boundary. The user can start the machine at any point on the boundary. In Figure 4 the machine is shown starting at point A. The first action of the machine is to detect the closest wall 405 (step 305) and move towards it. The machine then aligns to the wall (point B) and starts the suction motor 132 and brush bar motor 122. It waits until the motors reach operating speed and then moves off. The machine then begins to navigate around the boundary of the room, continuously detecting the presence of the wall and maintaining the machine at a predetermined distance from the wall. The machine navigates around the obstacles 420-



426 in the same manner as for the walls 405, maintaining the machine at a predetermined distance from the obstacles. The machine continuously records information about the path that it takes in following the boundary of the room. The machine derives information on the distance and direction of travel from the odometry wheel sensors 160, 162.

5

As the machine follows the boundary of an area, the navigation system samples, at regular distance intervals, the angular change in direction of the machine (compared with the direction at the previous sample). It is important to note that this information represents the path (or trajectory) of the machine rather than information about objects that it senses around it. The distance between samples will depend, inter alia, on the environment where the machine is used, the processing power available, memory size, the matching criteria. At each sample period, the navigation system determines the angular change in the direction of the machine compared with the previous sample. The angular change is stored in the memory 220 as part of a vector of all sampled values. Figure 5 shows part of the path 430 followed by the machine. At each sampling point 500 the corresponding arrow and angular value indicates the change compared with the previous sampling point 500.

10  
15

In addition to recording the angular direction changes at regular, fairly widely spaced apart intervals, the navigation system also plots, in detail, the path followed by the machine in order to construct a map of the working area. Figure 8 shows an example of the map of the room shown in Figure 4. Each point of the machine's path around the boundary is defined by a coordinate on the map. Also, as will be described later, the machine uses sensors on the left and right hand sides of the machine to detect the distance to the nearest obstacles on each side of the machine. This 'distance to obstacle' information is recorded on the map for points along the machine's path.

20  
25

As soon as the machine has travelled a distance  $L$ , it begins to compare the last  $L$  metres worth of the angular path data with previous  $L$  metre blocks of path data to find a match and hence to establish whether the machine has returned to a previously visited position along the boundary. Once the machine has made one complete clock-wise trip around the boundary of the room, and arrived again at point B, the matching process should not yet have found a suitable path match, so the machine continues to follow the boundary.

30

At point C' (i.e. point C on the second lap of the room) the machine recognises that it has returned to a previously visited position on the boundary of the room. This is because the matching process will have found a suitable match between the most recent L metres worth of path data and the initial L metres worth of path data stored by the machine. This completion point will always result in a L metre overlap of the boundary that is double covered. Once the start point has been detected the machine stops and shuts down the suction and brush bar motors.

The matching process works by comparing a block ('window') of the stored direction data with a previously stored block of direction data. This technique is often called a sliding window technique.

The angular change of direction data is processed by a sub-sampling process to derive three other sets of data, which are also stored in the path data vector. (Note, for simplicity only two sub-sampled sets of data are shown in Figure 7.) Each sub-sampled set of data represents a coarser interpretation of the actual path travelled by the machine. Since even a good machine is likely to vary in the first and second attempts that it takes to traverse the same portion of boundary, these sub-sampled data sets provide useful information on the underlying direction changes which are likely to form a good match in the matching process.

For each level of sub-sampling, the most recent window of data is compared with earlier, equally sized, windows of data in the overall data vector. For each comparison, each element in the new and tested windows of data are compared. The overall difference between the two windows of data, at each sub-sampling level, is converted to a metric representative of the 'quality of match'. We favour using a percentage value, but other techniques can equally be used. The matching process has a threshold value for the 'quality of match' metric which indicates, from experience, a positive match between two sets of path data. For example, we have found a match of >98% is indicative of a positive match between two sets of path data which represent the same position in a room. A skilled person will appreciate that there are many refinements

which can be made to this basic scheme and many other ways in which the path data can be compared.

5 The matching process allows the machine to establish when it has returned to a start position on the boundary. This is something that a machine must discover when it is set to work in an area of which it has no advance knowledge of the size, shape, layout etc.

10 While the machine is moving around the boundary it stores sections of path data from the boundary path as "markers". The use of markers will be described more fully below. They are a way of allowing the machine to quickly determine its position on the boundary. The number of markers that are stored around the boundary depends on the amount of processing power available in the matching engine of the machine – more markers requires more comparisons. If the machine can only store a limited number of markers, the navigation system can automatically expand the distance between the markers as the length  
15 of the perimeter increases.

The path length  $L$  required for matching, the distance between sampling points and the quality metric threshold indicative of a strong match are all dependent on the working area and conditions where the machine will be used. These can be readily determined  
20 by trial. In a domestic environment we have found that a distance  $L$  of 3.6m, a distance between sampling points of 7.5 cm and markers positioned every 2m around the boundary provides good results.

### **Boundary Map Correction**

25 As described above, the initial exploration process involves the machine following the boundary for just over one full circuit, and storing the path that the machine follows. The machine determines that it has returned to the starting point on the boundary after an overlap distance. As shown in Figure 8, the boundary map produced in this way is usually not closed, which means that the common start 800 and finish 802 path sections (which in  
30 the real world are the same, as identified by the path matching process) have different locations and orientations due to accumulated odometry errors. It is necessary to represent all path points on a single Cartesian co-ordinate system (frame), though the choice of

frame is arbitrary. If we choose the frame to be that of the finish point of the robot, then the error in the path increases as we move backwards from the finish section, along the travelled path, towards the start point.

- 5 The map closure (correction) process progressively deforms the map as we travel from the end (no deformation) to the start (maximum deformation) such that the start segment maps onto the finish segment. This ensures that we have zeroed the error at the start point and have generally reduced the error elsewhere.
- 10 Figure 9 shows the steps of the map correction process. The initial steps of the process 355, 360 are the boundary following method. We can set up two local Cartesian coordinate systems (local frames or *views*)  $V_1$  and  $V_2$  such that their origins and x-axes are positioned and oriented relative to corresponding locations in the start and finish boundary map segments, respectively, which were identified by the path
- 15 matching process.

As shown in Figure 10, a view is defined by three vectors, a position vector  $r$  for the origin, and unit vectors for the local x and y axes,  $e_x$  and  $e_y$ .

- 20 The position of any point  $p$  in a view is given in vector notation by:

$$p'_x = (p - r) \bullet e_x \quad p'_y = (p - r) \bullet e_y$$

or equivalently in matrix notation:

$$p' = M(p - r) \text{ where } M = \begin{bmatrix} \langle e_x \rangle \\ \langle e_y \rangle \end{bmatrix}$$

- 25 In view  $V_1$ , the start of the boundary is at the origin and a tangent to the boundary at the start points along the x-axis. Similarly, in view  $V_2$ , the start of the overlapping segment is at the origin, and the tangent to the path at this point is along the x-axis. By “looking” at the start with  $V_1$  and the finish with  $V_2$ , the projection of start and finish segments have the same position and orientation. For points P between the start and finish, we must use some intermediate view between  $V_1$  and  $V_2$ . As a view is a linear
- 30 operator, and as error accumulates as the robot travels on its path, a simple scheme is to

linearly interpolate between the two as a function of the proportion of the total boundary length travelled.

$$V_i(\rho) = (1 - \rho)V_1 + \rho V_2$$

and the position of any intermediate path point is given by:

5 
$$p_\rho = V_i(\rho)p_\rho$$

The view which projects each point into the new map changes smoothly from the start view to the end view as we travel along the boundary path from start to finish.

10 Finally, to make the finish segment correspond to the segment in the robot co-ordinate system, a post-projection rotation and translation is applied (step 380).

An alternative way of considering the map correction is as follows. When the machine has completed a circuit of the area and the path matching process has determined that the machine has returned to a known position, it is possible to calculate the difference in distance and angle between the two points on the navigation system's map of the area which are known to be the same position. This total accumulated error can then be divided among the coordinates which have been recorded for that initial traverse of the area. In its simplest form, the error can be equally divided among all of the points in a linear manner (small portion of the error for the points near the start, larger portion for the pints near the finish.) Once the machine has updated the map coordinates, it uses the updated map for the subsequent navigation of the area.

15

20

Once the machine has established a good map of the working area the machine then begins the task of cleaning the entire floor area, which is described in the flow chart of Figure 11.

25

The basic technique that the machine uses to cover a floor area is a reciprocating scanning movement, as shown in Figure 12. That is, from a start point 450, the machine follows a set of parallel straight line paths 451, each path 451 being followed by a step across movement 455 that positions the machine pointing back in the direction from which it has just come but translated one brush bar width across in the direction of the scan. The straight line path is maintained by monitoring the orientation of the machine and correcting the speeds of the left and right traction motors so as to maintain a straight line. The step

30

across action can take place in multiple segments, as shown by action 460. This allows the machine to match the profile of the object that has impeded the straight trajectory. There are a number of movement sequences that are used to maximise the depth of the scan and these are detailed after this general description. Eventually the machine will no longer be able to continue scanning in the direction it has chosen. This will occur when there is no more space to move into or when there have been a number of short traverses.

For a simple room, the machine may be able to completely traverse the floor area with one reciprocating scanning movement. However, for most room layouts the combination of unusual room shape and objects placed within the room (particularly objects positioned away from the walls) will require two or more separate scanning movements.

Once the boundary map has been corrected the machine examines the shape of the room and looks for the most appropriate point to start the cleaning scan from. There are various ways of doing this.

### **Room scanning**

A preferred way of scanning the room will now be described. Initially the machine looks for uncleaned regions that are adjacent to the boundary. As the machine travelled around the boundary of the area it also used the sensor or sensors on the sides of the machine to measure the distance to the nearest obstacles located to the sides of the machine and recorded that information on the map. Once the machine completes a lap of the boundary of the area it then processes the 'distance to obstacle' data to derive a free space vector. The free space vector (605, Figure 13) represents the amount of uncleaned space in a direction from that point on the map. The free space will be the distance to an obstacle minus any distance that the machine has already covered during its path. The free space vectors are plotted on the map at regular points around the boundary path. Since the machine has not travelled through the centre of the area, and lacks any advance knowledge of the layout of the area, this is the best information that the machine has of the layout of the area within the boundary. When deciding where to begin scanning, the navigation system looks at where, on the map, the free space vectors are located (step 505, Figure 11). The system looks for the longest length of boundary with free space vectors. An

alternative criterion is for the system to choose the closest boundary section to the machine's current position which has free space located adjacent to it. Boundary sections with free space adjacent to them are located at 610, 612, 614. Having found the longest boundary with free space (section 610), the navigation system attempts to find the dominant edge orientation of this part of the area (step 520). In performing a reciprocating pattern, the machine is particularly prone to accumulating odometry errors at the places where it turns through 180 degrees. Thus, it is preferred to traverse an area in a manner which minimises the number of turns. We have found that the dominant edge orientation of an area has been found to be the best direction to traverse an area.

10

There are various ways in which the dominant edge orientation can be found. One way is to plot the direction (as an absolute angle) of each segment of the selected path section 610 on a histogram. One axis of the chart represents the absolute angle of the paths and the other axis represents the accumulated length of path segments at a particular angle. For a complicated path this could result in a lot of computation. The computation can be simplified by only recording a segment of the path as a different angle when its angular direction differs from an earlier part of the path by more than a particular angular range, e.g. ten degrees. If this simplification is followed, the plot at each angular value can be represented by a distribution curve. Segments which are separated by 180 degrees can be plotted at the same angular value on the bar chart since they are parallel to one another. This bar chart can be readily processed to derive the dominant direction of the area.

15

20

Having identified the dominant direction, the navigation system isolates the area of the map in which the selected boundary path section lies, as shown in Figure 14. The navigation system rotates the isolated part of the area until it is aligned in the dominant direction and then finds the extremities of this part of the area. The navigation system then selects one of the extremities as a start point for the scan.

25

A further analysis is made of the selected part of the room area. This determines whether the free space is located inside or outside the boundary. Figure 15 shows two types of area which can be encountered. An internal free space area is enclosed by the boundary section whereas an external area free space area surrounds the boundary section. The navigation

30

system can determine the type of free space area by summing the angular change between each segment of the boundary section. An angular change sum of 360 degrees indicates an internal area whereas an angular sum of -360 degrees represents an external area.

5 There are some heuristics in selecting the start point. If the end points 620, 630 of a scan area are spaced apart from one another on the map by more than a predetermined distance then they are considered to represent an open area. If the free space area is an internal area, the navigation system will try not to choose one of these end points as a start point as this will tend to cause the machine to scan towards the boundary in a direction which is

10 possibly away from other free space that could be cleaned. The navigation system attempts to select a start point located elsewhere on the boundary, i.e. bounded on both sides by other path segments of the selected path section. A start point of this type has been found to cause the machine to scan inwards into the area rather than outwards. When the machine scans inwards it can often clean other free space areas after the isolated area

15 has been cleaned, which can reduce the overall number of separate scanning operations that are required to cover the room area. Also, if there is a choice of start point, the nearer start point to the current position of the machine is chosen, providing the machine is able to localise (reset odometry errors) before reaching the start point.

20 As shown in Figure 16, once a start point on the map has been selected, an L meter section of the boundary path data preceding the desired scan start point is extracted from the memory (step 530). If necessary, the machine then selects a point further back along the boundary from the start of the extracted section and marks this as a target point. The machine then attempts to find a path across the room to this target point from its current

25 location. It does this by searching the room map for places that it has previously visited it then plots a path over these spaces to the target point on the boundary. It then moves to the target point and follows the boundary until it matches the trajectory section for the start of the next cleaning scan. Matching of this segment of the boundary path data is carried out in the same way as that of matching to find the start position.

30

If it fails to find a route to the target point (step 545), either because the route was too risky or because it encountered an object on the way, then it moves onto the boundary. It moves



round the boundary until it reaches one of the better free space points and starts a scan from there.

5 Once the machine reaches the scan start point it orients to the chosen scan direction (the dominant direction identified earlier) and proceeds to scan in a reciprocating manner into the uncleaned space (step 550). While the machine is moving in a straight line it is constantly checking to see if it has already visited the space it is on. Once it sees that it has run over a previously visited space by its own length then it stops and carries out a step across. Since this step across is in open space it is a single segment step across. This  
10 cleaning scan continues until either it is blocked or there have been a small number of short traverses or the whole of the previous traverse was on space that had been visited previously. During the scanning process, the navigation system records the travelled path on the map, such that the machine knows which positions of the map have been cleaned, and also continues to record the distance to the nearest obstacle seen by the machine's  
15 sensors on the map. After each scanning operation the machine processes the distance information recorded on the map, taking account of the areas already cleaned by the machine, to calculate a free space vector. The free space vectors are plotted on the map and can then be used by the navigation system to decide the next area where scanning should occur.

20

A period of reciprocating scanning will induce odometry errors. Therefore, between each period of scanning, the machine looks for the boundary of the area and follows the boundary of the area (step 560). As the machine travels around the boundary of the area it stores the path travelled by the machine. The machine travels for a distance of at least the  
25 minimum distance necessary for finding a match, i.e. L metres. The matching process attempts to match the new block of boundary path data with the boundary path data that was originally stored in the memory. If a block of path data matches positively then the machine knows it has returned to a known position on the map and can thus rest the odometry error to zero. If the matching process fails to find a good match then the  
30 machine will continue on the boundary until it should have reached one of the marker positions. If this also fails then it assumes that it is on a central object.

If the machine correctly recognised a position on the boundary then it realigns the just completed traverse scan and the boundary section onto the free space map, based on the measured error between the machine's perceived position on the map and the actual position on the map. The navigation system then finds the next largest uncleaned part of the area (step 505).

The machine then repeats the search for freespace and the moves to them until all the space that can be identified on the map has been completed (steps 510, 515).

10 During the matching process, in addition to looking for a strong match between blocks of data, the matching process also makes a number of safety checks. It makes sure that the orientation of the matching section is roughly the same as the extracted section and that they both roughly lie in the same part of the internal map. The odometry error gradually increases with distance travelled. The matching process sets an event horizon, 15 i.e. a boundary for possible positions on the map where, due to odometry error, a match may occur. Any matches which correspond to positions in the room which are not, due to the size of the odometry error, possible positions for the machine are discounted.

### Central Objects

20 A complex area is likely to include obstacles which are located away from the boundary of the area, such as a coffee table. Figure 17 shows a strategy for coping with central objects. The machine performs a scanning operation 750 and eventually reaches a point at 760 where it can no longer continue the scanning movement. The machine then proceeds to follow the edge of the object 785, cleaning around the edge of the object. After travelling 25 a distance of L metres around the object 785 the machine will attempt to match the last L metre path section with the path recorded around the boundary of the room. This should fail to give a suitable match. Thus, the machine recognises that it is following the edge of an object. The machine jumps off of the object at position 780, on the remote side of the object in the direction of the scan, and follows the boundary of the room 790 until it can 30 match the travelled path with the previously stored boundary path data. At this point the navigation system can reset any odometry error and accurately place the position of the

object 785. Note, in following the edge of a central object, the machine may travel around the object several times until it has travelled a distance of L metres.

### Scanning behaviours

5 Figures 18-20 show some of the ways in which the machine operates during a scanning operation. As previously described with reference to Figure 12, the scanning operation comprises a series of parallel straight line paths which are offset from one another by a distance W, which will usually be equal to the width of the cleaning head of the machine. However, irregular boundary shapes do not always permit the machine to  
10 follow a regular scanning pattern. Figure 18 shows a segmented step across where the machine follows the boundary 800 of the room in segments 804, 806 until it has travelled the total required step across distance W. At each step the machine rotates until it sees a clear path ahead and travels forward until it needs to turn. The step across distance W can be determined from trigonometry of the travelled paths 804, 806. A  
15 complex step across movement may comprise more segments than are shown here. This movement allows the machine to properly cover the floor surface and to continue the scanning movement at the regular width W.

Figures 19 and 20 show other situations where the boundary prevents the machine from  
20 performing a regular step across movement. In Figure 19 the machine reaches the end of movement 810 and follows the wall along path 812 until it can step across at 813 to the proper scan separation distance W. Figure 20 shows a similar scenario where the machine must travel back on itself along path 822 until it can travel across along path 823 and continue the scanning movement at the regular width W. In these movements  
25 the machine monitors, during path 810, 820 the distance on its right hand side to the wall/obstacles to determine whether the machine will be able to step across to continue its scanning movement.

### Markers

30 Markers are L metre sections of path data which can be used at various times by the navigation system to quickly determine the current position on the boundary. They are particularly useful in allowing the machine to cope with the kinds of errors that can

occur when the machine is forced to follow a different path around the boundary, e.g. because something has been moved. If the machine is travelling around the boundary looking for a particular L metre section of the path but fails to find it, it will usually find the marker positioned after that particular section of required boundary and thus allow  
5 the machine to quickly recognise the error. Markers are also useful when the machine attempts to travel across a room area to reach a start point for a scan but misses it for some reason. This may occur if the machine does not properly reach the target point before the L metre section of boundary preceding the start point (see Figure 16). Should the machine not find the start point, it follows the boundary of the area and should find  
10 the next marker on the boundary. Upon finding the marker the machine can recognise its error and try again.

### Alternatives

The described method of recognising a previously visited position in an area by  
15 matching travelled path sections is dependent on several factors. Firstly, the navigation system should be able to cause the machine to travel in a closely similar manner when negotiating the same boundary on different occasions. The value of the 'quality of match' threshold and the process of sub-sampling path data so that the matching process considers the underlying path rather than the detailed path does allow for some variation  
20 between travelled paths while still allowing a successful match. Secondly, the matching process is dependent on the L metre path that is used during the matching process being unique to a position in the room. In rooms that possess one or more lines of symmetry, it is possible for the L metre path to be common to two or more positions within the room. Obviously, a truly rectangular room with no other obstacles on the boundary  
25 would cause a problem. The system can be made more robust in several ways.

Firstly, the length of the path used in the matching process can be increased until it does represent a unique position in the room. This can be performed automatically as part of the navigation method. Should the machine travel for more than a predetermined time  
30 period without finding a match, the navigation system can automatically increase the length of the matching window.

Secondly, the path data can be supplemented by other information gathered by the machine during a traverse of the area. This additional information can be absolute direction information obtained from an on-board compass, information about the direction, intensity and/or colour of the light field around the machine obtained from on-board light detectors or information about the distance of near or far objects from the machine detected by on-board distance sensors. In each case, this additional information is recorded against positions on the travelled path.

The map correction process described above applies a linear correction to the travelled path. In an alternative embodiment, the accumulated error can be divided among the set of coordinates in a more complex manner. For example, if the machine is aware that wheel slippage occurred half way around the traverse of the room boundary, it can distribute more (or all) of the accumulated error to the last half of the path coordinates.

The above method describes the machine following a clockwise path around an area. The machine may equally take an anti-clockwise path around the area during its initial lap of the boundary of the area. Also, in following the boundary to reach a start position for area scanning, the machine may follow the boundary in a clockwise or anti-clockwise direction.

In performing the cleaning method, it is preferred that the cleaning machine steps across by substantially the width of the cleaner head on the cleaner so that the cleaning machine covers all of the floor surface in the minimum amount of time. However, the distance by which the cleaning machine steps inwardly or outwardly can have other values. For example, by stepping by only a fraction of the width of the cleaner head, such as one half of the width, the cleaning machine overlaps with a previous traverse of the room which is desirable if a user requires a particularly thorough cleaning of the floor. The step distance can be chosen by the user. There are various ways in which the user can choose the step distance: the user can be presented with a plurality of buttons or a control that specifies the step distances, or controls having symbols or descriptions indicative of the effect of the cleaner operating at the step distances, such as "normal cleaning", "thorough cleaning". The buttons can be incorporated in the user panel (140, Fig. 1), a remote control or both of these.

Claims

1. An autonomous machine comprising:
  - driving means for moving the machine along a surface, and
  - 5 - a navigation system, including a memory means, for navigating the cleaning machine around an area,  
the navigation system comprising:  
means for causing the machine to explore the area in which it is located, constructing a map of the area based on information collected by the machine as the machine explores the  
10 area,  
means for determining when the machine has returned to a previously visited position within the area,  
means for correcting the map when the machine returns to the previously visited position, based on the knowledge that the current position and the previously visited position are the  
15 same.
2. An autonomous machine according to claim 1 wherein the correcting means distributes any error among the points on the map which has been constructed.
- 20 3. An autonomous machine according to claim 1 or 2 wherein the exploring means is arranged to cause the machine to follow a boundary of the area, storing path information on the path travelled by the machine as the machine follows the boundary; and the determining means is arranged to determine when the machine has returned to a previously  
25 visited position in the area by comparing the latest section of the path travelled by the machine with information representing a section of the path previously stored in the memory, and for deciding when the new path information and previously stored path information are substantially the same.
4. An autonomous machine according to claim 3 wherein the path information is  
30 stored at regular intervals.
5. An autonomous machine according to claim 4 wherein the path information is

stored at intervals which are spaced by an equal distance from one another.

6. An autonomous machine according to any one of claims 3-5 wherein the path information is representative of the change in direction of the machine as the machine follows the boundary of the area.

7. An autonomous machine according to claim 6 wherein the path information is the relative change in direction of the machine compared to a previous point at which path information was stored.

10

8. An autonomous machine according to any one of claims 3-7 wherein the navigation system is arranged to derive, from the stored path information, a second set of path information which is a less detailed representation of the travelled path.

9. An autonomous machine according to claim 8 wherein the comparison means is arranged to use the second set of path information in deciding whether the new path information and previously stored path information are substantially the same.

10. An autonomous machine according to any one of claims 3-9 wherein the navigation system also comprises means for sensing another parameter and for storing this other parameter in the memory along with the path information as the machine follows the boundary of the area.

11. An autonomous machine according to claim 10 wherein the comparison means also uses, on at least some occasions, the other parameter to determine when the machine has returned to a previously visited position in the area.

12. An autonomous machine according to claim 10 or 11 wherein the other parameter is the absolute direction of the machine.

30

13. A method of controlling an autonomous machine comprising:  
- causing the machine to explore the area in which it is located, constructing a map

of the area based on information collected by the machine as the machine explores the area,

- determining when the machine has returned to a previously visited position within the area,

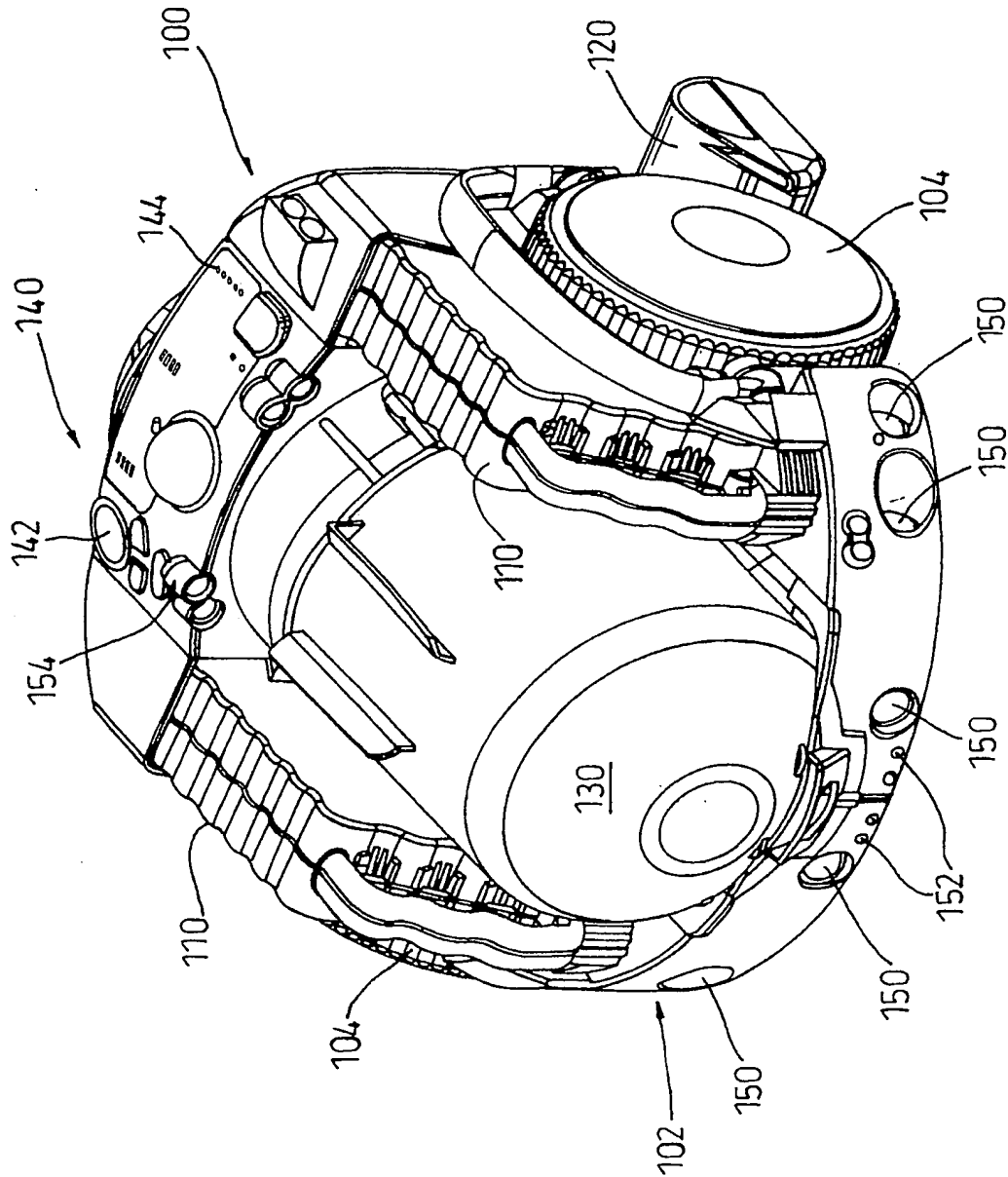
5 - correcting the map when the machine returns to the previously visited position, based on the knowledge that the current position and the previously visited position are the same.

14 Software for controlling an autonomous machine to perform the method according  
10 to claim 13.

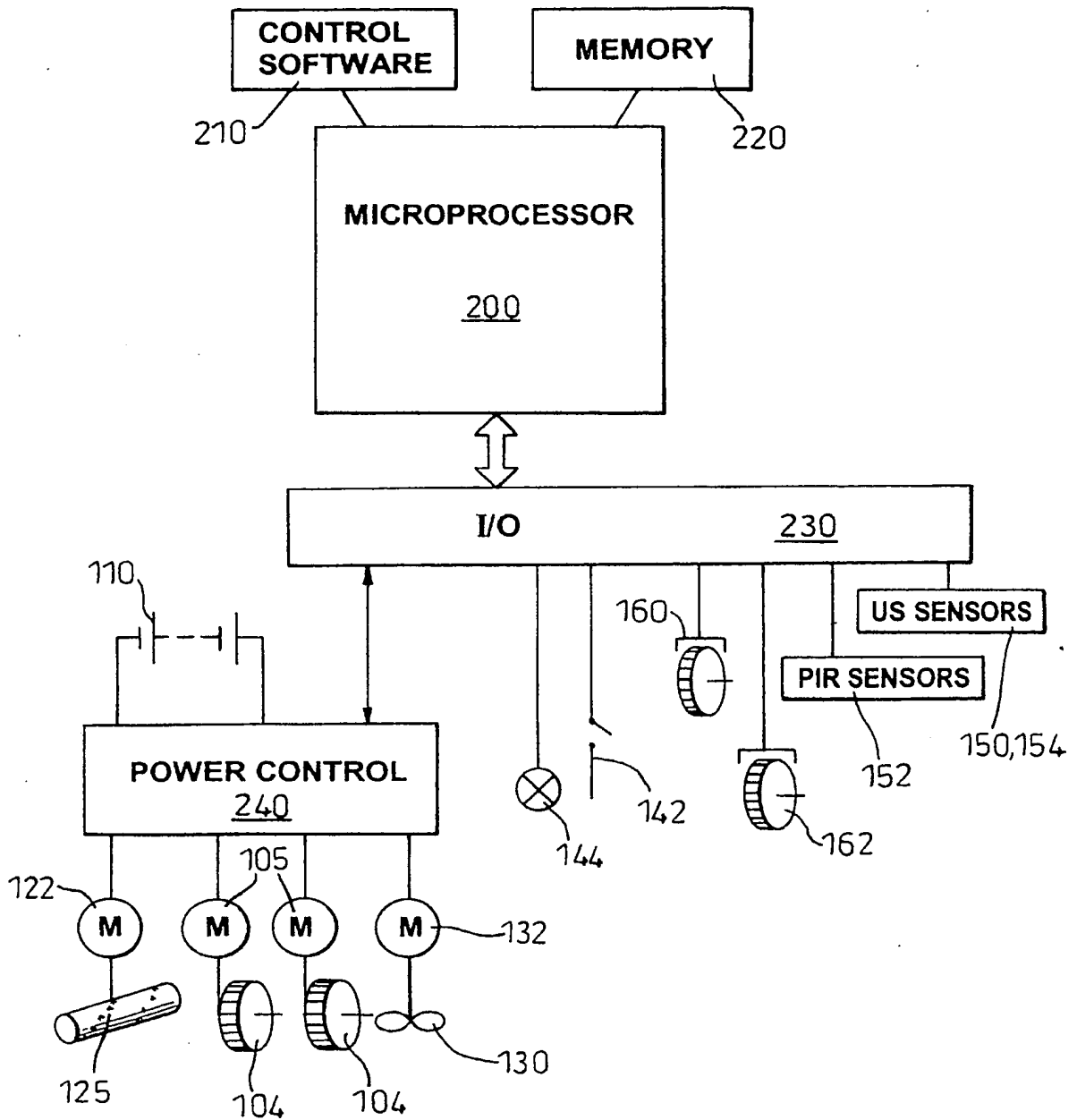
15. An autonomous machine, a method of controlling an autonomous machine or software method for controlling an autonomous machine substantially as described herein with reference to the accompanying drawings.

15

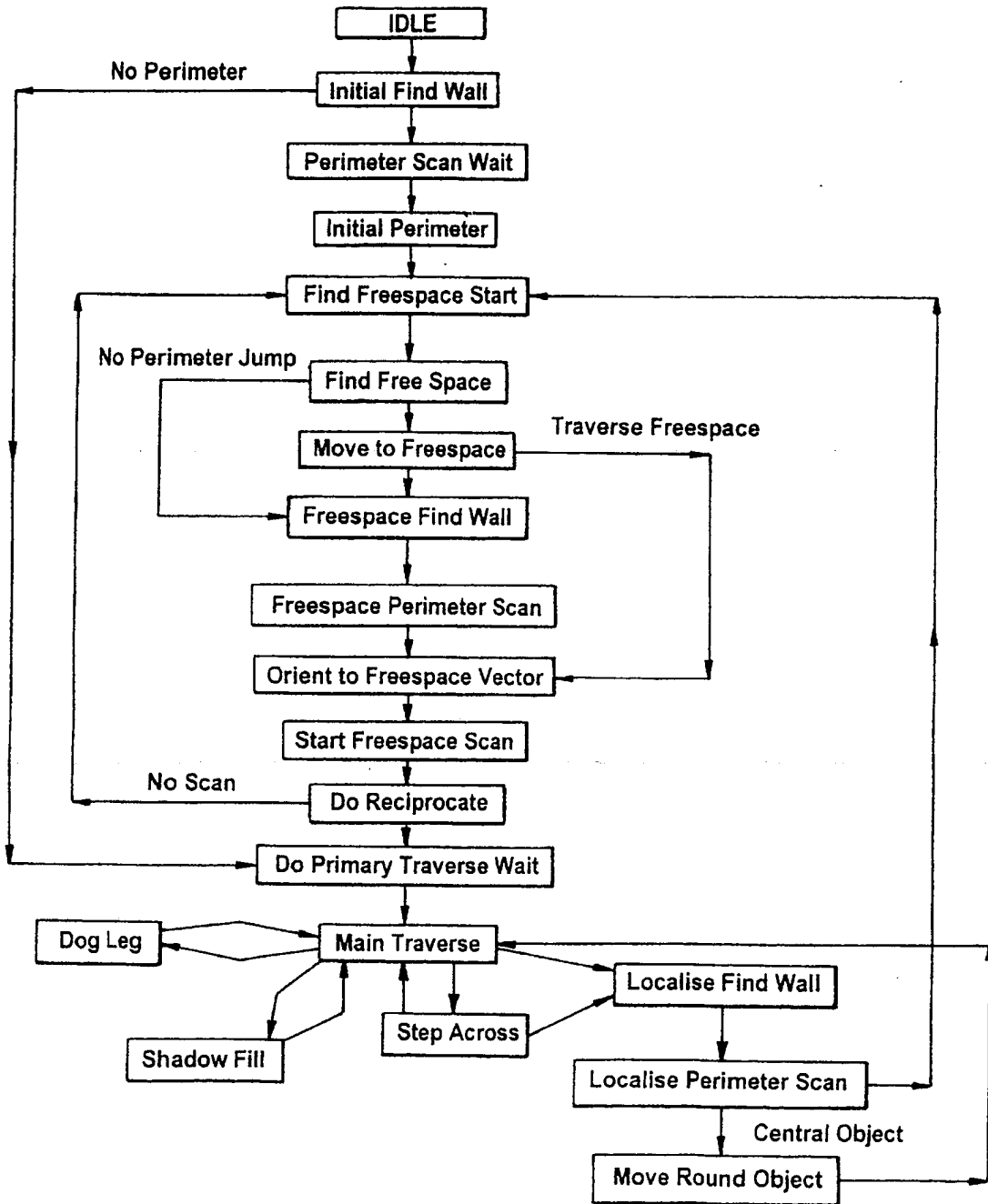




**Fig. 1**

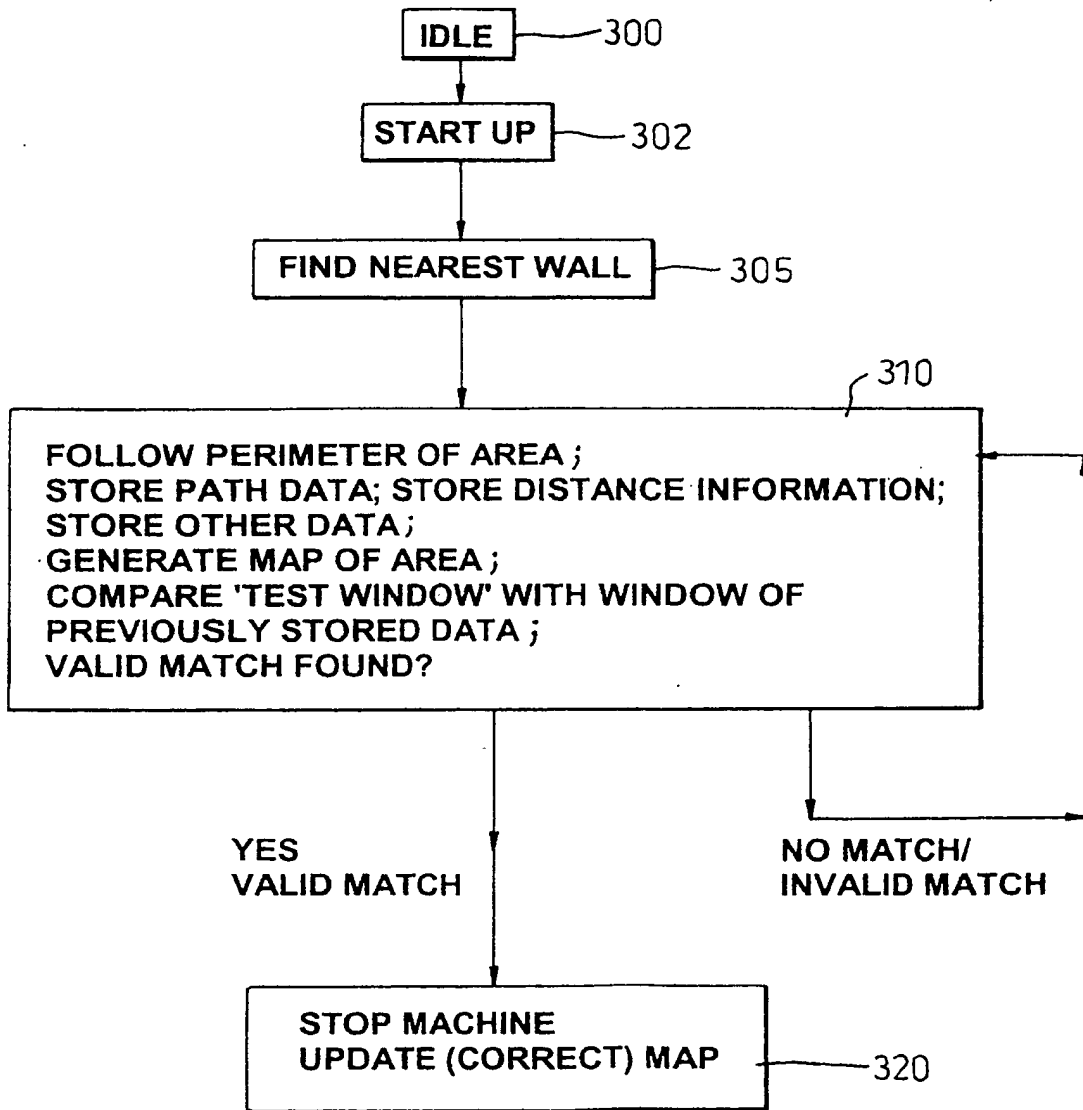


*Fig. 2*

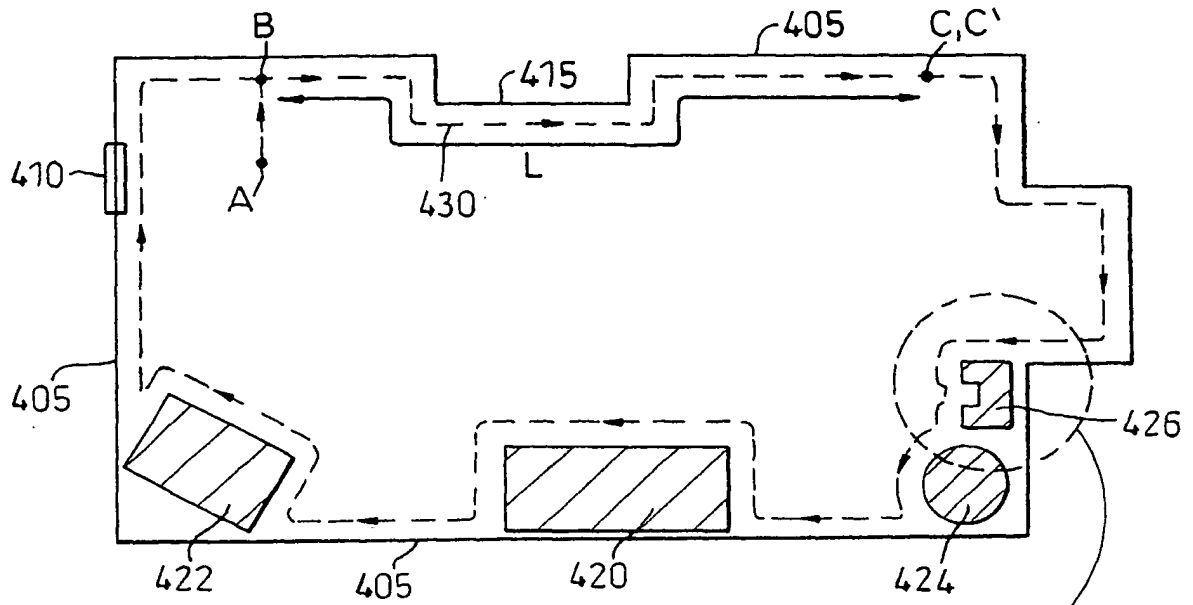


*Fig. 3*

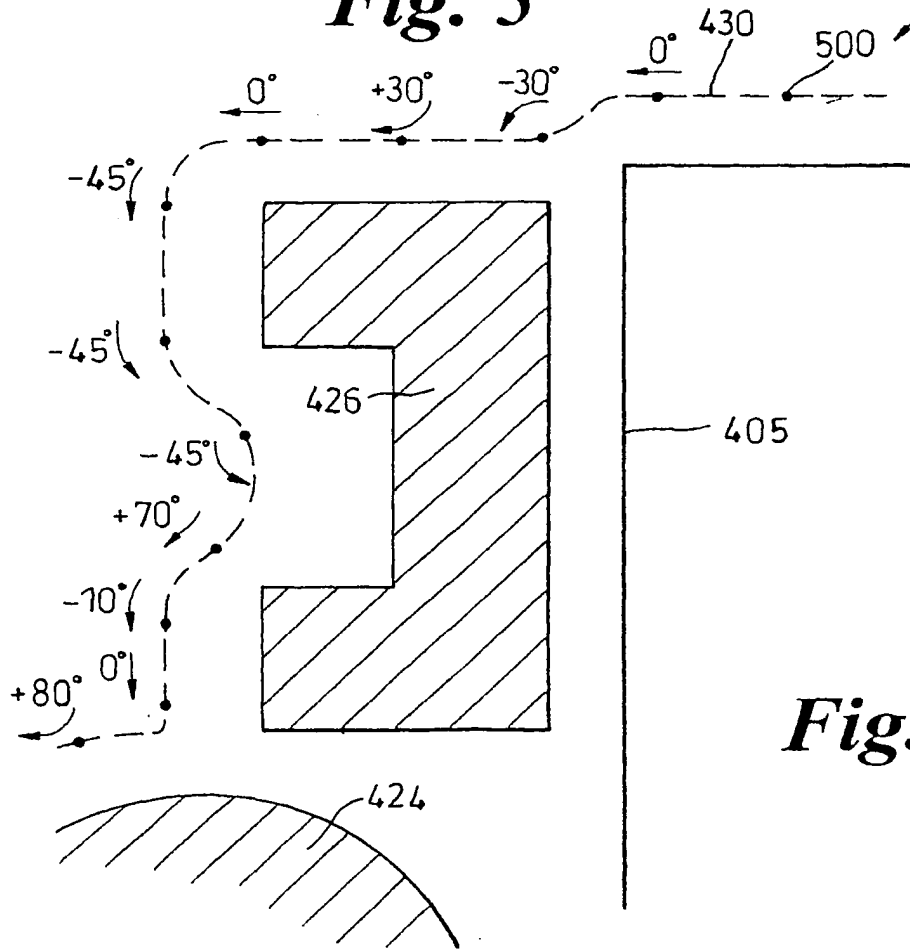
4/13



*Fig. 4*



**Fig. 5**



**Fig. 6**

	0	4	0	5	0	-10	-20	-5	0	0	0	10	10	10	0	0	5	15	0	-10	-10	0	0
PATH DATA VECTOR																							
	20	8	-5	-15	-3	0	10	5	3	8	-10	0											
SUB-SAMPLED SET (1)																							
	14		-10		-2	8			6														
SUB-SAMPLED SET (2)																							

TESTED BLOCK (indicated by a dashed box around the first 10 columns)

TEST WINDOW (indicated by a dashed box around the last 10 columns)

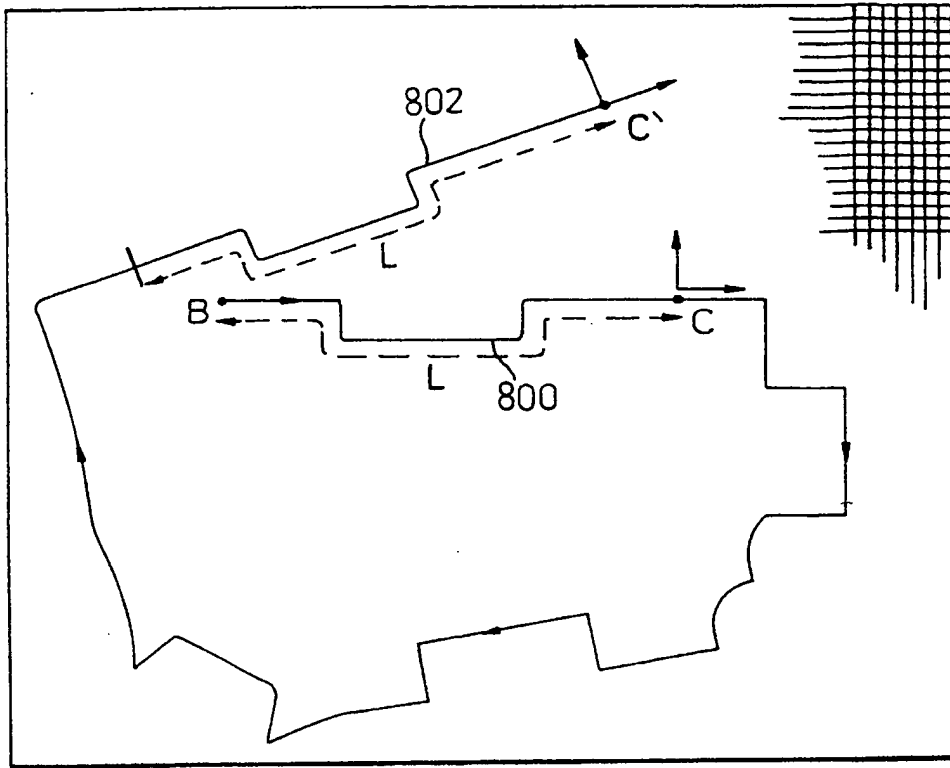
TABLE OF DIFFERENCES

PATH DATA	0	15	25	20	5	10	0	0
SUB-SAMPLED SET (1)	8	23	7	0				
SUB-SAMPLED SET (2)	16			3				

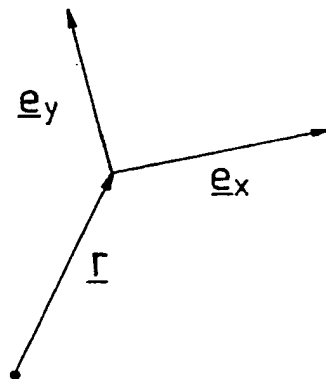
% MATCH (indicated by an arrow pointing to the right)

*Fig. 7*

7/13

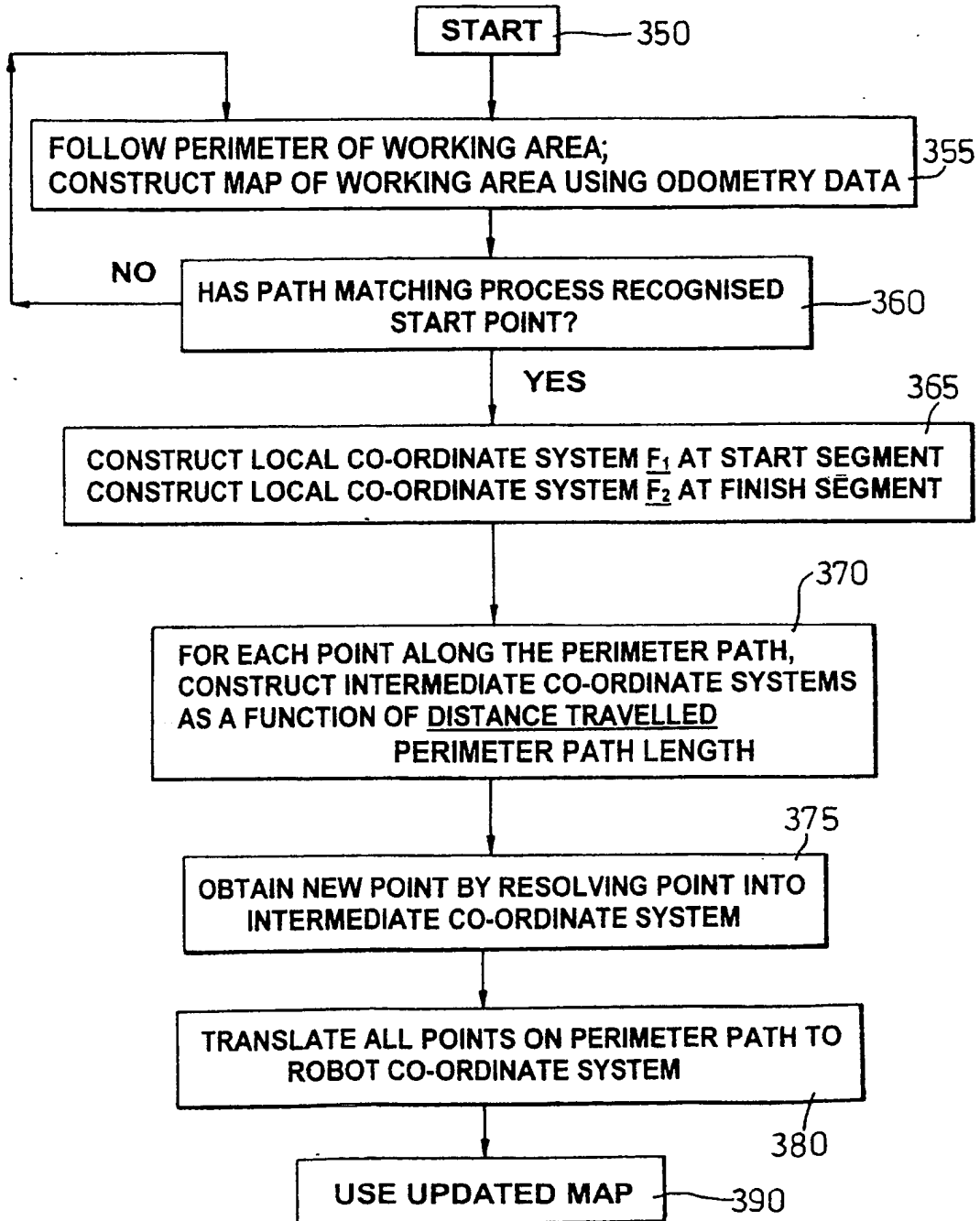


**Fig. 8**



**Fig. 10**

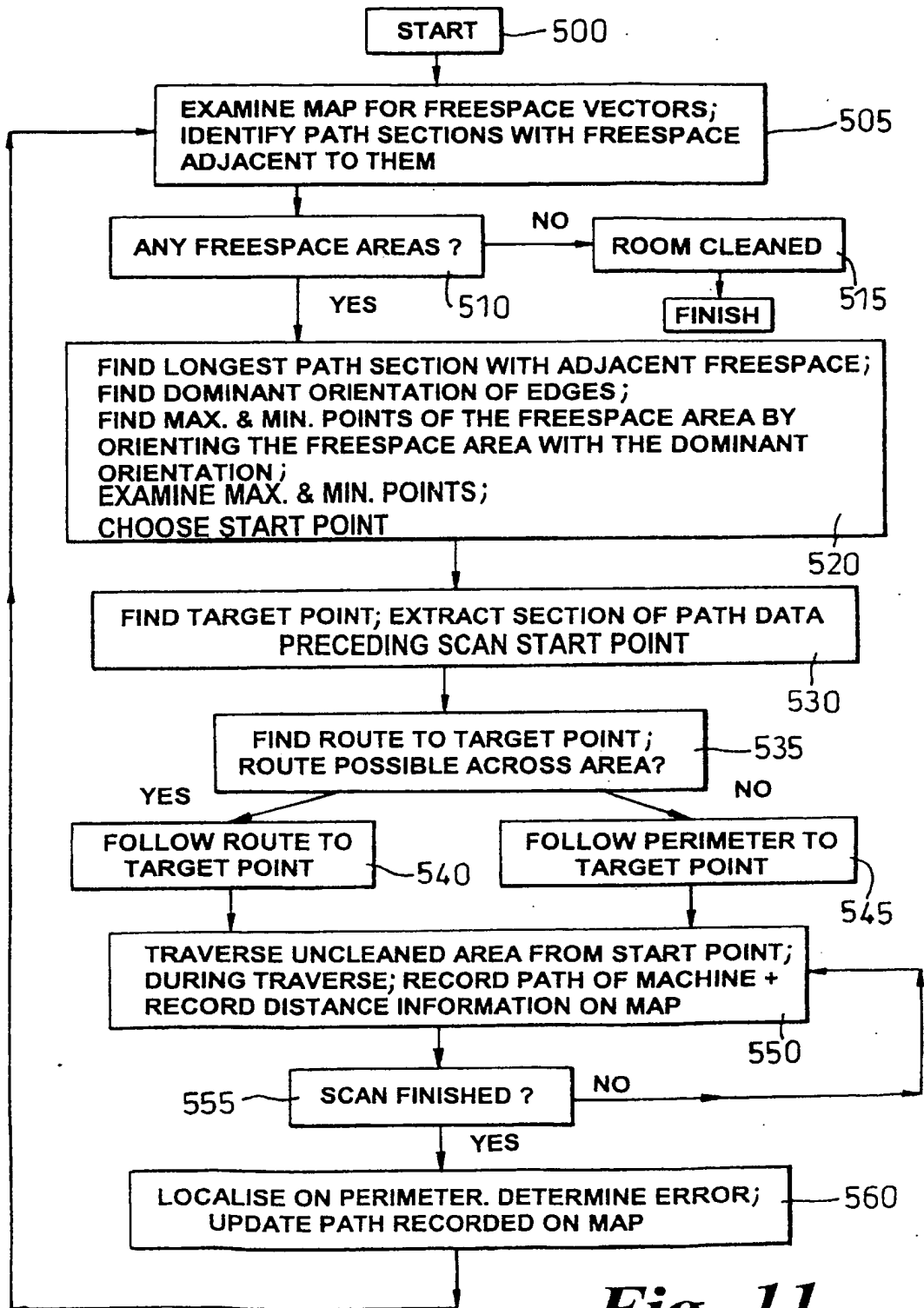
8/13



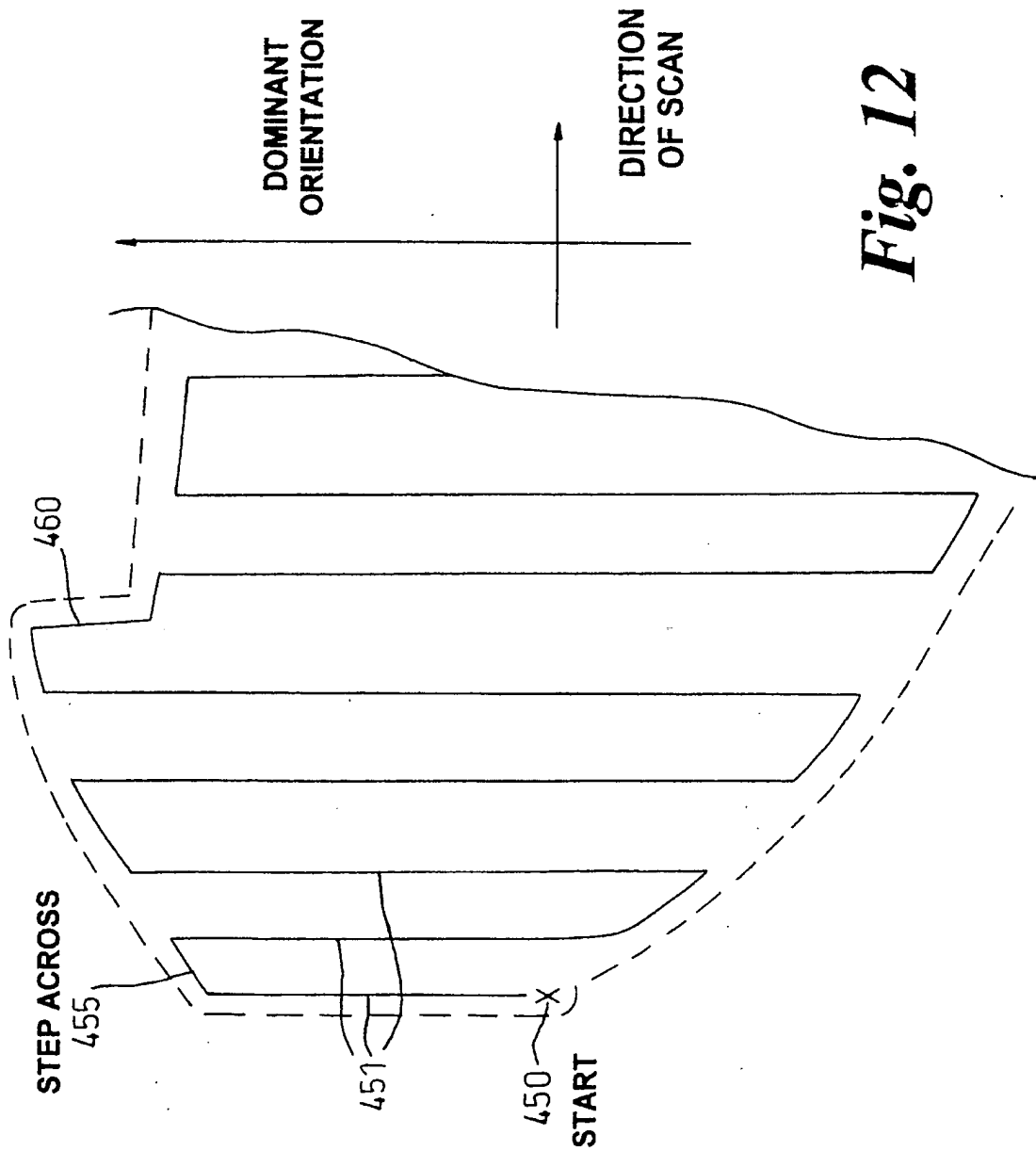
*Fig. 9*



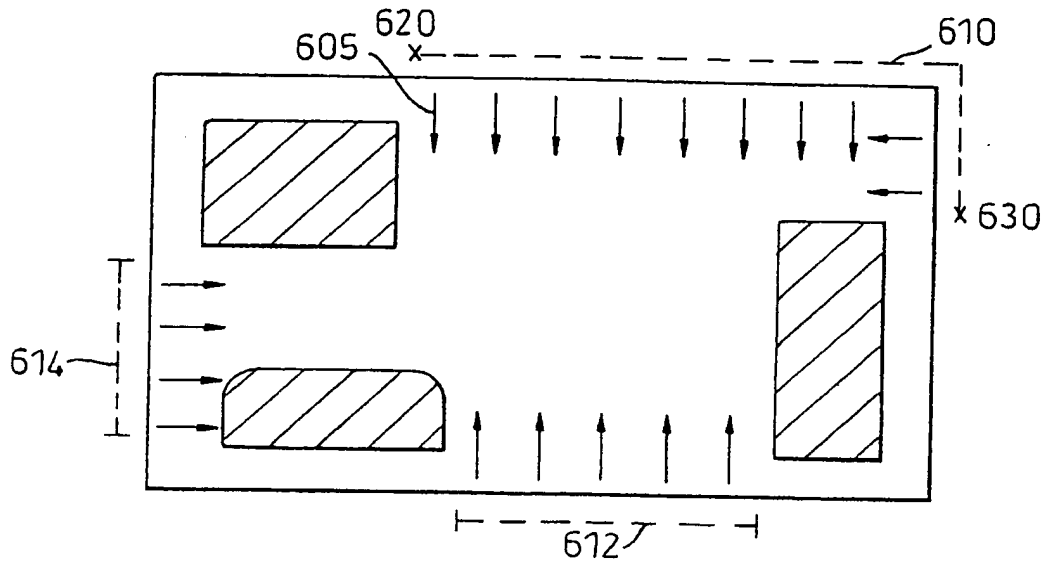
9/13



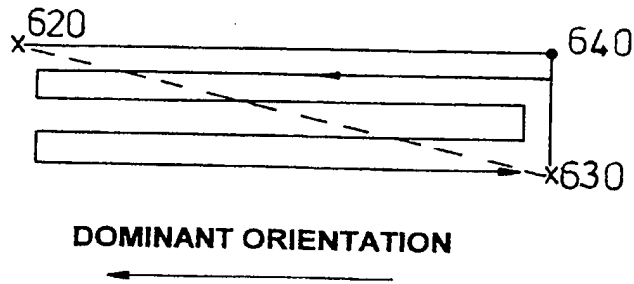
*Fig. 11*



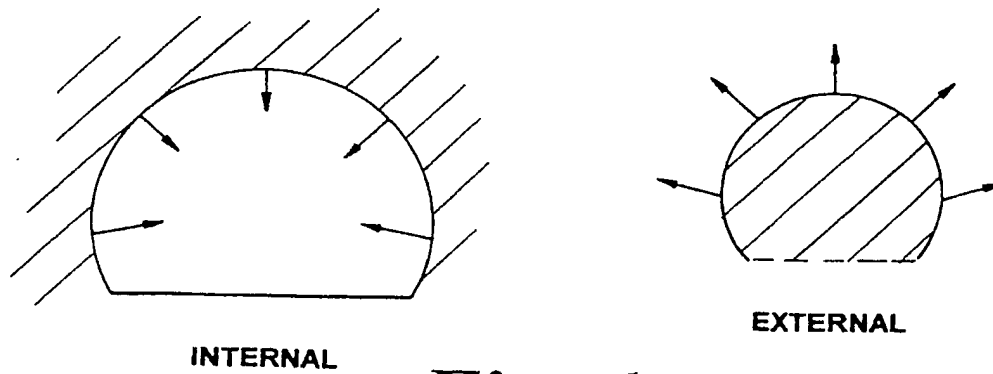
11/13



**Fig. 13**

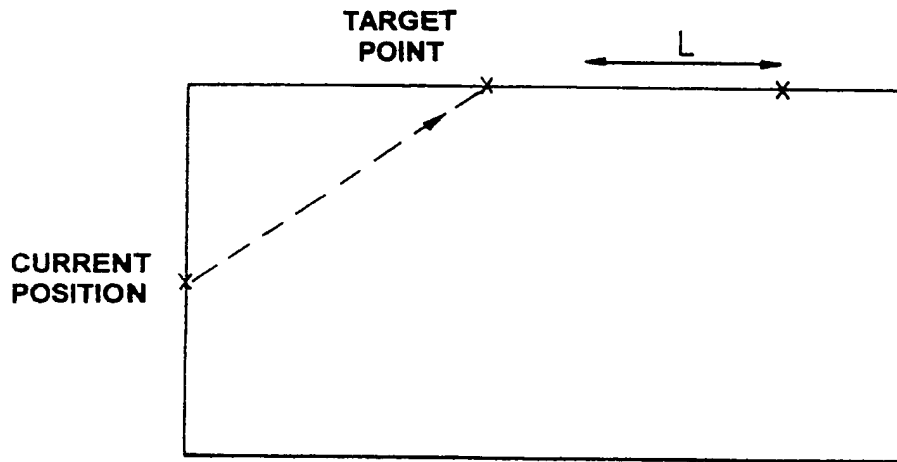


**Fig. 14**

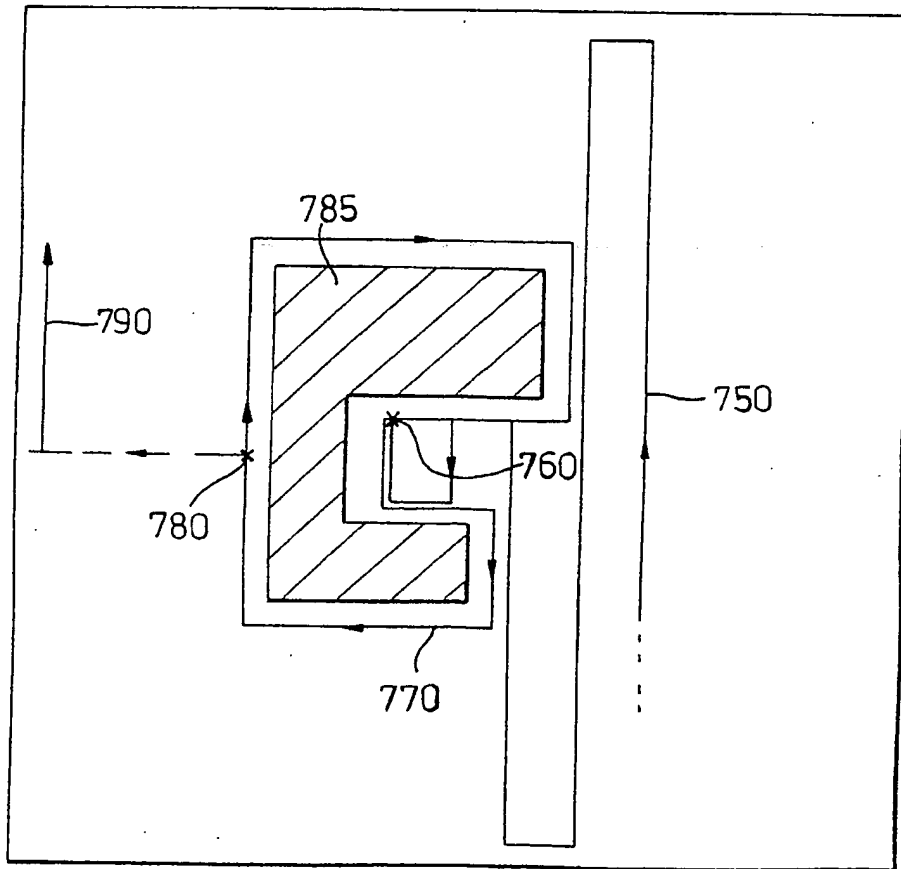


**Fig. 15**

12/13

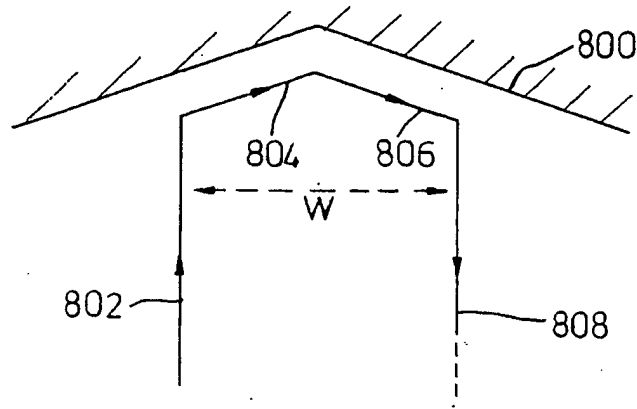


*Fig. 16*

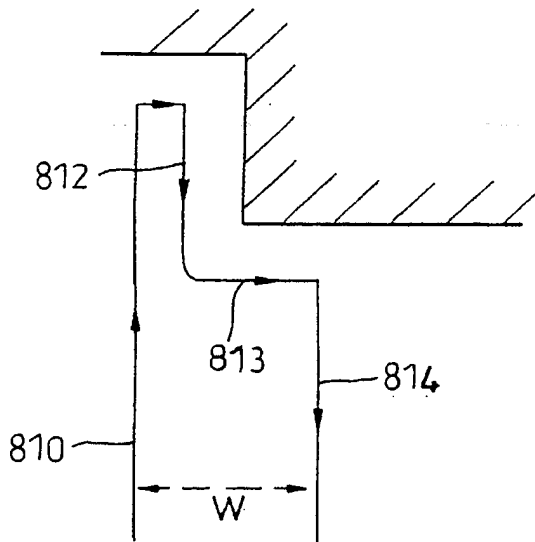


*Fig. 17*

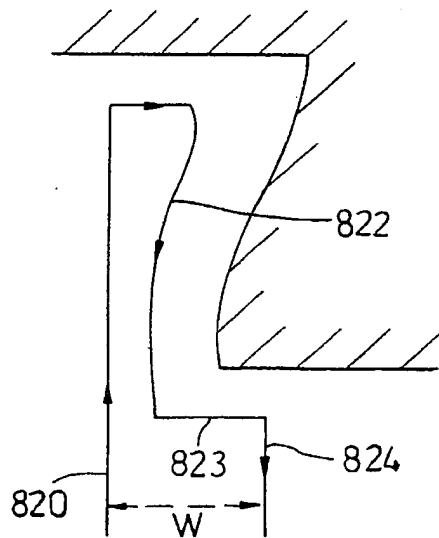
13/13



**Fig. 18**



**Fig. 19**



**Fig. 20**

# INTERNATIONAL SEARCH REPORT

International Application No <b>PCT/GB 02/04919</b>
--

<b>A. CLASSIFICATION OF SUBJECT MATTER</b> IPC 7 G05D1/02		
According to International Patent Classification (IPC) or to both national classification and IPC		
<b>B. FIELDS SEARCHED</b>		
Minimum documentation searched (classification system followed by classification symbols) IPC 7 G05D A47L A01D		
Documentation searched other than minimum documentation to the extent that such documents are included in the fields searched		
Electronic data base consulted during the international search (name of data base and, where practical, search terms used) EPO-Internal, WPI Data, PAJ		
<b>C. DOCUMENTS CONSIDERED TO BE RELEVANT</b>		
Category *	Citation of document, with indication, where appropriate, of the relevant passages	Relevant to claim No.
A	WO 00 38025 A (NOTETRY LTD ;ALDRED MICHAEL DAVID (GB); BISSET DAVID LINDSEY (GB)) 29 June 2000 (2000-06-29) cited in the application the whole document	1-14
A	LANG S Y T ET AL: "Coordination of behaviours for mobile robot floor cleaning" INTELLIGENT ROBOTS AND SYSTEMS, 1998. PROCEEDINGS., 1998 IEEE/RSJ INTERNATIONAL CONFERENCE ON VICTORIA, BC, CANADA 13-17 OCT. 1998, NEW YORK, NY, USA, IEEE, US, 13 October 1998 (1998-10-13), pages 1236-1241, XP010311567 ISBN: 0-7803-4465-0 Paragraph 4. Environment Exploration and Motion Planning	1-14
-/--		
<input checked="" type="checkbox"/> Further documents are listed in the continuation of box C. <span style="margin-left: 200px;"><input checked="" type="checkbox"/> Patent family members are listed in annex.</span>		
* Special categories of cited documents : *A* document defining the general state of the art which is not considered to be of particular relevance *E* earlier document but published on or after the international filing date *L* document which may throw doubts on priority claim(s) or which is cited to establish the publication date of another citation or other special reason (as specified) *O* document referring to an oral disclosure, use, exhibition or other means *P* document published prior to the international filing date but later than the priority date claimed *T* later document published after the international filing date or priority date and not in conflict with the application but cited to understand the principle or theory underlying the invention *X* document of particular relevance; the claimed invention cannot be considered novel or cannot be considered to involve an inventive step when the document is taken alone *Y* document of particular relevance; the claimed invention cannot be considered to involve an inventive step when the document is combined with one or more other such documents, such combination being obvious to a person skilled in the art. *&* document member of the same patent family		
Date of the actual completion of the international search  <b>14 January 2003</b>	Date of mailing of the international search report  <b>27/01/2003</b>	
Name and mailing address of the ISA European Patent Office, P.B. 5818 Patentlaan 2 NL - 2280 HV Rijswijk Tel. (+31-70) 340-2040, Tx. 31 651 epo nl, Fax: (+31-70) 340-3016	Authorized officer  <b>Gardella, S</b>	

INTERNATIONAL SEARCH REPORT

International Application No  
PCT/GB 02/04919

C.(Continuation) DOCUMENTS CONSIDERED TO BE RELEVANT		
Category *	Citation of document, with indication, where appropriate, of the relevant passages	Relevant to claim No.
A	WO 95 26512 A (ELECTROLUX AB ; EDLUND LEIF (SE)) 5 October 1995 (1995-10-05) page 9, line 5 -page 11, line 35 -----	1-14
A	US 5 001 635 A (YASUTOMI FUMIO ET AL) 19 March 1991 (1991-03-19) the whole document -----	1-14

FURTHER INFORMATION CONTINUED FROM PCT/ISA/ 210

Continuation of Box I.2

Claims Nos.: 15

Claim 15 does not include any technical feature but merely refers to the description and to the drawings.

The applicant's attention is drawn to the fact that claims, or parts of claims, relating to inventions in respect of which no international search report has been established need not be the subject of an international preliminary examination (Rule 66.1(e) PCT). The applicant is advised that the EPO policy when acting as an International Preliminary Examining Authority is normally not to carry out a preliminary examination on matter which has not been searched. This is the case irrespective of whether or not the claims are amended following receipt of the search report or during any Chapter II procedure.



INTERNATIONAL SEARCH REPORT

International application No.  
PCT/GB 02/04919

Box I Observations where certain claims were found unsearchable (Continuation of item 1 of first sheet)

This International Search Report has not been established in respect of certain claims under Article 17(2)(a) for the following reasons:

- 1.  Claims Nos.:  
because they relate to subject matter not required to be searched by this Authority, namely:
  
- 2.  Claims Nos.: 15  
because they relate to parts of the International Application that do not comply with the prescribed requirements to such an extent that no meaningful International Search can be carried out, specifically:  
see FURTHER INFORMATION sheet PCT/ISA/210
  
- 3.  Claims Nos.:  
because they are dependent claims and are not drafted in accordance with the second and third sentences of Rule 6.4(a).

Box II Observations where unity of invention is lacking (Continuation of item 2 of first sheet)

This International Searching Authority found multiple inventions in this international application, as follows:

- 1.  As all required additional search fees were timely paid by the applicant, this International Search Report covers all searchable claims.
  
- 2.  As all searchable claims could be searched without effort justifying an additional fee, this Authority did not invite payment of any additional fee.
  
- 3.  As only some of the required additional search fees were timely paid by the applicant, this International Search Report covers only those claims for which fees were paid, specifically claims Nos.:
  
- 4.  No required additional search fees were timely paid by the applicant. Consequently, this International Search Report is restricted to the invention first mentioned in the claims; it is covered by claims Nos.:

Remark on Protest

- The additional search fees were accompanied by the applicant's protest.
- No protest accompanied the payment of additional search fees.

**INTERNATIONAL SEARCH REPORT**

Information on patent family members

International Application No
PCT/GB 02/04919

Patent document cited in search report		Publication date	Patent family member(s)	Publication date
WO 0038025	A	29-06-2000	GB 2344900 A	21-06-2000
			AU 1575300 A	12-07-2000
			GB 2361553 A	24-10-2001
			WO 0038025 A1	29-06-2000
WO 9526512	A	05-10-1995	SE 502834 C2	29-01-1996
			AU 689571 B2	02-04-1998
			AU 2155495 A	17-10-1995
			CA 2186223 A1	05-10-1995
			DE 69520736 D1	23-05-2001
			DE 69520736 T2	22-11-2001
			EP 0753160 A1	15-01-1997
			ES 2156940 T3	01-08-2001
			JP 9511060 T	04-11-1997
			SE 9401061 A	30-09-1995
			WO 9526512 A1	05-10-1995
			US 5867800 A	02-02-1999
US 5001635	A	19-03-1991	JP 1180010 A	18-07-1989
			KR 9200946 B1	31-01-1992



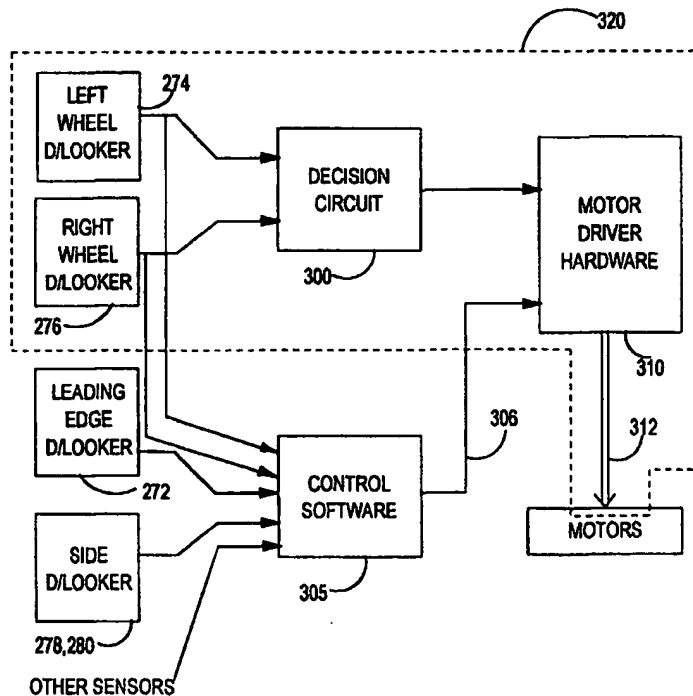
INTERNATIONAL APPLICATION PUBLISHED UNDER THE PATENT COOPERATION TREATY (PCT)

<p>(51) International Patent Classification 7 : <b>G05D 1/02</b></p>	<p>A1</p>	<p>(11) International Publication Number: <b>WO 00/38026</b> (43) International Publication Date: 29 June 2000 (29.06.00)</p>
<p>(21) International Application Number: PCT/GB99/04090 (22) International Filing Date: 6 December 1999 (06.12.99) (30) Priority Data: 9827758.5 18 December 1998 (18.12.98) GB (71) Applicant (for all designated States except US): NOTETRY LIMITED [GB/GB]; Kingsmead Mill, Little Somerford, Wiltshire SN15 5JN (GB). (72) Inventors; and (75) Inventors/Applicants (for US only): BISSET, David, Lindsey [GB/GB]; 4 Chandler Way, Chippenham, Wiltshire SN15 3YG (GB). CLARK, Alan, Gerard [GB/GB]; 3 Grange Cottages, Grange Lane, Malmesbury, Wiltshire SN16 0EP (GB). (74) Agents: SMITH, Gillian, Ruth et al.; Dyson Research Limited, P.O. Box 2080, Malmesbury, Wiltshire SN16 0SW (GB).</p>		<p>(81) Designated States: AE, AL, AM, AT, AU, AZ, BA, BB, BG, BR, BY, CA, CH, CN, CR, CU, CZ, DE, DK, DM, EE, ES, FI, GB, GD, GE, GH, GM, HR, HU, ID, IL, IN, IS, JP, KE, KG, KP, KR, KZ, LC, LK, LR, LS, LT, LU, LV, MA, MD, MG, MK, MN, MW, MX, NO, NZ, PL, PT, RO, RU, SD, SE, SG, SI, SK, SL, TJ, TM, TR, TT, TZ, UA, UG, US, UZ, VN, YU, ZA, ZW, ARIPO patent (GH, GM, KE, LS, MW, SD, SL, SZ, TZ, UG, ZW), Eurasian patent (AM, AZ, BY, KG, KZ, MD, RU, TJ, TM), European patent (AT, BE, CH, CY, DE, DK, ES, FI, FR, GB, GR, IE, IT, LU, MC, NL, PT, SE), OAPI patent (BF, BJ, CF, CG, CI, CM, GA, GN, GW, ML, MR, NE, SN, TD, TG).  Published With international search report.</p>

(54) Title: SENSORS ARRANGEMENT

(57) Abstract

An autonomous vehicle (100), such as a robotic cleaning device, comprises wheels (104) for supporting the vehicle and for allowing the vehicle to traverse a surface. Downward looking wheel sensors (274, 276) are provided for sensing the presence of a surface in front of the wheels and a further sensor (272) is provided at or near a leading edge of the vehicle for sensing the presence of a surface beneath the leading edge of the vehicle. The vehicle is arranged so that movement of the vehicle is possible if the leading edge sensor (272) detects the absence of a surface beneath the leading edge of the vehicle providing the wheel sensors (274, 276) indicate the presence of a surface adjacent the wheel. When the leading edge sensor (272) detects the absence of a surface beneath the leading edge of the vehicle, the vehicle performs an edge following routine.



**FOR THE PURPOSES OF INFORMATION ONLY**

Codes used to identify States party to the PCT on the front pages of pamphlets publishing international applications under the PCT.

AL	Albania	ES	Spain	LS	Lesotho	SI	Slovenia
AM	Armenia	FI	Finland	LT	Lithuania	SK	Slovakia
AT	Austria	FR	France	LU	Luxembourg	SN	Senegal
AU	Australia	GA	Gabon	LV	Latvia	SZ	Swaziland
AZ	Azerbaijan	GB	United Kingdom	MC	Monaco	TD	Chad
BA	Bosnia and Herzegovina	GE	Georgia	MD	Republic of Moldova	TG	Togo
BB	Barbados	GH	Ghana	MG	Madagascar	TJ	Tajikistan
BE	Belgium	GN	Guinea	MK	The former Yugoslav Republic of Macedonia	TM	Turkmenistan
BF	Burkina Faso	GR	Greece	ML	Mali	TR	Turkey
BG	Bulgaria	HU	Hungary	MN	Mongolia	TT	Trinidad and Tobago
BJ	Benin	IE	Ireland	MR	Mauritania	UA	Ukraine
BR	Brazil	IL	Israel	MW	Malawi	UG	Uganda
BY	Belarus	IS	Iceland	MX	Mexico	US	United States of America
CA	Canada	IT	Italy	NE	Niger	UZ	Uzbekistan
CF	Central African Republic	JP	Japan	NL	Netherlands	VN	Viet Nam
CG	Congo	KE	Kenya	NO	Norway	YU	Yugoslavia
CH	Switzerland	KG	Kyrgyzstan	NZ	New Zealand	ZW	Zimbabwe
CI	Côte d'Ivoire	KP	Democratic People's Republic of Korea	PL	Poland		
CM	Cameroon	KR	Republic of Korea	PT	Portugal		
CN	China	KZ	Kazakstan	RO	Romania		
CU	Cuba	LC	Saint Lucia	RU	Russian Federation		
CZ	Czech Republic	LI	Liechtenstein	SD	Sudan		
DE	Germany	LK	Sri Lanka	SE	Sweden		
DK	Denmark	LR	Liberia	SG	Singapore		
EE	Estonia						

### Sensors Arrangement

The invention relates to an arrangement of sensors for an autonomous vehicle, particularly but not exclusively for an autonomous vacuum cleaner.

5

An autonomous vehicle generally has a plurality of sensors for detecting obstacles in the path of the vehicle to prevent collision or accidents. While some autonomous vehicles can cope with undulating surfaces, they usually need to avoid any areas where there is a significant change in height, such as stairs where there is a danger that the machine can become stuck or fall, causing damage to the vehicle and to others. It is known to provide an autonomous vehicle with sensors that monitor the presence of a surface; these are often called "downlooking" or "drop-off" sensors.

A robotic cleaning device described in Patent Application WO 93/03399 has drop-off sensors at a forward edge of the cleaning device and is arranged to stop the drive motors when one of the drop-off sensors senses the absence of a surface beneath the cleaning device.

Safety regulations require that downlooking sensors should cause the vehicle to stop whenever the sensors detect the absence of a surface. This places severe constraints on flexibility of controlling the vehicle near to any places where there is a significant change in height. The present invention seeks to provide more flexibility in operating an autonomous vehicle under these conditions.

According to a first aspect of the invention, there is provided an autonomous vehicle comprising wheels for supporting the vehicle and for allowing the vehicle to traverse a surface, wherein downward looking wheel sensors are provided for sensing the presence of a surface in front of the wheels and a further sensor is provided at or near a leading edge of the vehicle for sensing the presence of a surface beneath the leading edge of the vehicle.

30

Preferably the vehicle is arranged so that movement of the vehicle is permitted when the leading edge sensor detects the absence of a surface beneath the leading edge of the vehicle providing the wheel sensors indicate the presence of a surface adjacent the wheel. This allows more flexibility in controlling movement of the cleaning device.

5

Preferably, the vehicle is arranged to operate so that when the leading edge sensor detects the absence of a surface beneath the leading edge of the vehicle, the vehicle performs an edge following routine. The edge following routine can be a zig-zag movement along the edge, or it can use a further downlooking sensor which senses the presence of a surface adjacent a side edge of the vehicle.

10

Further aspects of the invention provide a method of operating an autonomous vehicle, software for performing a method of controlling operation of an autonomous vehicle and a control apparatus for controlling operation of an autonomous vehicle.

15

An embodiment of the present invention will now be described, by way of example only, with reference to the accompanying drawings, wherein:

Figure 1 is a perspective view of an autonomous vehicle, specifically a vacuum cleaner, according to an embodiment of the invention;

20

Figure 2 is a front view of the autonomous vehicle of Figure 1;

Figure 3 is a rear view of the autonomous vehicle of Figure 1;

Figures 4a and 4b are side views, taken from the right and left sides respectively, of the autonomous vehicle of Figure 1;

Figures 5a and 5b are underneath and plan views respectively of the autonomous vehicle of Figure 1;

25

Figure 6 is a schematic view illustrating the positioning of infra-red sensors on the autonomous vehicle of Figure 1;

Figure 7 is a schematic view illustrating the grouping of infra-red sensors on the autonomous vehicle of Figure 1;

30

- Figure 8 is a schematic view illustrating the positioning of ultra-sonic sensors on the autonomous vehicle of Figure 1; and
- Figure 9 is a schematic view illustrating the positioning of further infra-red sensors on the autonomous vehicle of Figure 1;
- 5 Figure 10 shows the form of a downlooking sensor;
- Figure 11 schematically shows how the downlooking sensors are used by the control system for the vehicle;
- Figure 12 shows a control system for the cleaner;
- Figure 13 shows one example of a sideways downlooking sensor;
- 10 Figures 14 and 15 show two ways in which the cleaner can operate when the cleaner reaches an edge of a surface that it is cleaning; and
- Figure 16 is a flow diagram of a method for operating the cleaner.

- 15 The embodiment illustrated takes the form of an autonomous vacuum cleaner. The vacuum cleaner 100 shown in the said drawings has a supporting chassis 102 which is generally circular in shape and is supported on two driven wheels 104 and a castor wheel 106. The chassis 102 is preferably manufactured from high-strength moulded plastics material, such as ABS, but can equally be made from metal such as aluminium
- 20 or steel. The chassis 102 provides support for the components of the cleaner 100 which will be described below. The driven wheels 104 are arranged at either end of a diameter of the chassis 102, the diameter lying perpendicular to the longitudinal axis of the cleaner 100. Each driven wheel 104 is moulded from a high-strength plastics material and carries a comparatively soft, ridged band around its circumference to enhance the
- 25 grip of the wheel 104 when the cleaner 100 is traversing a smooth floor. The soft, ridged band also enhances the ability of the wheels 104 to mount and climb over small obstacles. The driven wheels 104 are mounted independently of one another via support bearings (not shown) and each driven wheel 104 is connected directly to a motor 105
- 30 which is capable of driving the respective wheel 104 in either a forward direction or a reverse direction. By driving both wheels 104 forward at the same speed, the cleaner 100 can be driven in a forward direction. By driving both wheels 104 in a reverse

direction at the same speed, the cleaner 100 can be driven in a backward direction. By driving the wheels 104 in opposite directions, the cleaner 100 can be made to rotate about its own central axis so as to effect a turning manoeuvre. The aforementioned method of driving a vehicle is well known and will not therefore be described any  
5 further here.

The castor wheel 106 is significantly smaller in diameter than the driven wheels 104 as can be seen from, for example, Figures 4a and 4b. The castor wheel 106 is not driven and merely serves to support the chassis 102 at the rear of the cleaner 100. The location  
10 of the castor wheel 106 at the trailing edge of the chassis 102, and the fact that the castor wheel 106 is swivellingly mounted on the chassis by means of a swivel joint 110, allows the castor wheel 106 to trail behind the cleaner 100 in a manner which does not hinder the manoeuvrability of the cleaner 100 whilst it is being driven by way of the driven wheels 104. The castor wheel 106 can be made from a moulded plastics material  
15 or can be formed from another synthetic material such as Nylon.

Mounted on the underside of the chassis 102 is a cleaner head 122 which includes a suction opening 124 facing the surface on which the cleaner 100 is supported. The suction opening 124 is essentially rectangular and extends across the majority of the  
20 width of the cleaner head 122. A brush bar 125 is rotatably mounted in the suction opening 124 and a motor (not shown) is mounted on the upper surface of the cleaner head 122 for driving the brush bar 125 by way of a drive belt (not shown) extending between a shaft of the motor and the brush bar 125. The cleaner head 122 is mounted on the chassis 102 in such a way that the cleaner head 122 is able to float on the surface  
25 to be cleaned. This is achieved in this embodiment in that the cleaner head 122 is pivotally connected to an arm (not shown) which in turn is pivotally connected to the underside of the chassis 102. The double articulation of the connection between the cleaner head 122 and the chassis 102 allows the cleaner head to move freely in a vertical direction with respect to the chassis 102. This enables the cleaner head to climb over  
30 small obstacles such as books, magazines, rug edges, etc. Obstacles of up to approximately 25mm in height can be traversed in this way. A flexible or telescopic



conduit is located between a rear portion of the cleaner head 122 and an inlet port located in the chassis 102.

As can be seen from Figures 5a and 5b, the cleaner head 122 is asymmetrically mounted on the chassis 102 so that one side of the cleaner head 122 protrudes beyond the general circumference of the chassis 102. This allows the cleaner 100 to clean up to the edge of a room on the side of the cleaner 100 on which the cleaner head 122 protrudes.

The chassis 102 carries a plurality of sensors which are designed and arranged to detect obstacles in the path of the cleaner 100 and its proximity to, for example, a wall or other boundary such as a piece of furniture. The sensors comprise several ultra-sonic sensors and several infra-red sensors. The array of sensors will be described in more detail below. Control software, comprising navigation controls and steering devices for navigating and manoeuvring the cleaner 100 around a defined area in order to clean the carpet or other surface within the area, is housed within a housing 142 located beneath a control panel 144 or elsewhere within the cleaner 100. The specific design of the control software does not form part of the present invention. In the manner of known autonomous vehicles, the control software is able to receive the outputs of the sensors and to drive the motors 105 so that obstacles are avoided whilst following a path specified by algorithms appropriate to the nature of the vehicle. Any appropriate software can be used in this way to navigate the cleaner 100 around a room to be cleaned.

The vacuum cleaner 100 also includes a motor and fan unit 150 supported on the chassis 102 for drawing dirty air into the vacuum cleaner 100 via the suction opening 124 in the cleaner head 122. The chassis 102 also carries a cyclonic separator 152 for separating dirt and dust from the air drawn into the cleaner 100. The inlet port which communicates with the rear portion of the cleaner head 122 via the conduit mentioned above forms the inlet to the cyclonic separator 152. The cyclonic separator, which

preferably comprises two cyclones in series, need not be described any further here, being known technology and described adequately elsewhere.

5 The cyclonic separator 152 is releasable from the chassis 102 in order to allow emptying of the cyclonic separator 152. A hooked catch (not shown) is provided by means of which the cyclonic separator 152 is held in position when the cleaner 100 is in use. When the hooked catch is released (by manual pressing of a button 134 located in the control panel 144), the cyclonic separator 152 can be lifted away from the chassis 102 by means of gripper portions 170. The cyclonic separator 152 can then be emptied.

10

Two battery packs 160 are located on the chassis 102 on either side of the cyclonic separator 152. The battery packs 160 are identical and are spaced from the central axis of the vacuum cleaner 100 by a significant distance, say between 50 and 150 mm.

15 The vacuum cleaner 100 described above operates in the following manner. In order for the cleaner 100 to traverse the area to be cleaned, the wheels 104 are driven by the motors 105 which, in turn, are powered by the batteries 160. The direction of movement of the cleaner 100 is determined by the control software which communicates with the sensors which are designed to detect any obstacles in the path of  
20 the cleaner 100 so as to navigate the cleaner 100 around the area to be cleaned. The normal forward direction of the cleaner 100 is such that the cleaner head 122 trails behind the driven wheels 104. The battery packs 160 also power the motor and fan unit 150 which draws air into the cleaner 100 via the cleaner head 122 and passes it to the cyclonic separator 152 where the dirt and dust is separated from the airflow. The  
25 battery packs 160 are also used to power the motor which drives the brush bar 125 which, in turn assists with pick-up, particularly on carpets. The air which exits the cyclonic separator 152 is passed across the motor and fan unit 150 by appropriate ducting, as is common in many appliances, including vacuum cleaners.

30 The sensor array forming part of the vacuum cleaner 100 will now be described in more detail. The array comprises a plurality of ultra-sonic sensors and a plurality of infra-red

sensors. The majority of the sensors are located in a forward surface 180 of the vacuum cleaner 100. The forward surface 180 is substantially semi-circular in plan view, as can be seen from Figures 5a and 5b. However, further sensors are located at the uppermost extremity of the cleaner 100, at the rear of the cleaner 100, immediately over the brush bar 122, and on the underside of the cleaner 100. Details are given below.

Three ultra-sonic sensors 202, 204 and 206, each consisting of an ultra-sonic emitter and an ultra-sonic receiver, are positioned in the forward surface 180. A first of the said ultra-sonic sensors 202, comprising an emitter 202a and a receiver 202b, is directed in a forward direction so that the emitted signals are transmitted in the normal forward direction of travel of the cleaner 100. A second ultra-sonic sensor 204, comprising an emitter 204a and a receiver 204b, is directed such that the emitted signals are transmitted outwardly to the left of the cleaner 100 in a direction which is perpendicular to the direction of transmission by the ultra-sonic sensor 202. A third ultra-sonic sensor 206, comprising an emitter 206a and a receiver 206b, is directed such that the emitted signals are transmitted outwardly to the right of the cleaner 100 in a direction which is perpendicular to the direction of transmission by the ultra-sonic sensor 202 and opposite to the direction of transmission by the ultra-sonic sensor 204. A fourth ultra-sonic sensor 208, comprising an emitter 208a and a receiver 208b, is located in the rear of the cleaner 100 (see Figure 3) and is directed rearwardly so that the emitted signals are transmitted parallel to the normal forward direction of travel of the cleaner 100 but in the opposite direction. These four sensors 202, 204, 206, 208 detect the presence of walls and obstacles to the front, left, right and rear of the cleaner 100.

A fifth ultra-sonic sensor 210 is located in the forward surface 180. The fifth ultra-sonic sensor 210 comprises an emitter 210a and a receiver 210b. The fifth ultra-sonic sensor 210 is positioned so that the emitter 210a transmits at an angle which is substantially midway between the directions in which the forward- and left-looking sensors 202, 204 transmit. In the embodiment, the sensor 210 transmits in a direction of 45° to the normal forward direction of travel of the vacuum cleaner 100. As can be seen from

Figure 1, the sensor 210 transmits to the side of the cleaner 100 on which the cleaner head 122 protrudes.

Figure 8 shows schematically the arrangement of ultra-sonic sensors 202, 204, 206, 208  
5 and 210 on the vacuum cleaner 100 if the normal direction of forward travel is along the arrow F. In the arrangement shown, the angle  $\alpha$  is  $45^\circ$ , although variations to this arrangement are possible.

The inclusion of the sensor 210 provides the vehicle 100 with greater angular control as  
10 it moves along a wall or other obstacle with the cleaner head 122 close to the wall. The sensor 210 is able to detect the presence of a wall or similar large obstacle and, if the wall or other obstacle alongside which the vehicle is moving disappears (for example, when a corner is encountered), then the vehicle 100 is made aware of the change earlier than it would have been if the sensor 210 had not been present. This allows the vehicle  
15 to take account of corners and other changes in its environment with greater accuracy and manoeuvrability.

A plurality of infra-red sensors are also included in the forward surface 180. The infra-red sensors comprise emitters 220 and receivers 230. Most of the emitters 220 are  
20 arranged in four groups of three which are spaced substantially evenly around the forward surface 180. A first emitter group 220a comprises a central emitter 222a and two side emitters 224a. A second emitter group 220b comprises a central emitter 222b and two side emitters 224b. A third emitter group 220c comprises a central emitter 222c and two side emitters 224c and a fourth emitter group 220d comprises a central  
25 emitter 222d and two side emitters 224d. One of the emitter groups 220b is illustrated in Figure 7. Each side emitter 224b is arranged at an angle  $\beta$  of approximately  $60^\circ$  to the central emitter 222b. Each emitter 222b, 224b has a beam angle  $\gamma$  of approximately  $50^\circ$ . This arrangement creates a field of relatively even emitted signals covering an angle of substantially  $170^\circ$  to  $180^\circ$ . It will be appreciated that a similar field can be  
30 created by providing a larger number of emitters, each having a smaller beam angle than the arrangement illustrated in Figure 7.

Figure 6 illustrates the arrangement of the emitter groups 220a, 220b, 220c, 220d on the cleaner 100. As will be seen from the figure, the first emitter group 220a is located at the end of a radial line extending at an angle  $d$  of  $30^\circ$  to the transverse axis 190 of the cleaner 100 on the left side thereof. The fourth emitter group 220d is located at the end of a radial line also extending at an angle  $d$  of  $30^\circ$  to the transverse axis 190 but on the right side of the cleaner 100. The second and third emitter groups 220b, 220c are located at the ends of radial lines extending at an angle  $e$  of  $60^\circ$  to the transverse axis 190 on the left and right sides of the cleaner 100 respectively. The third emitter group 220c is identical to the second emitter group 220b as illustrated in Figure 7. However, the first and fourth emitter groups 220a, 220d each have one side emitter 224a', 224d' which is specifically directioned so that the signal emitted is parallel to the transverse axis 190. This is achieved, in this specific case, by varying the angle  $b$  between the relevant central emitter 222a, 222d and the respective side emitter 224a', 224d' from  $60^\circ$  to  $30^\circ$ . It will be appreciated that, if either of the angles  $b$  and  $d$  differ from the values given above, then the extent of the variation in angle  $b$  between the relevant central emitter 222a, 222d and the respective side emitter 224a, 224d will need to be adjusted so that the side emitter 224a', 224d' remains directed outwardly in a direction parallel to the transverse axis 190. Two additional emitters 226 are positioned close to the central axis of the cleaner 100 and are directioned so that they emit signals in a substantially forward direction with respect to the normal direction of travel.

The first and fourth emitter groups 220a, 220d are located in a horizontal plane which is vertically spaced from the horizontal plane in which the second and third emitter groups 220b, 220c are located. The first and fourth emitter groups 220a, 220d are located at a higher level than the second and third emitter groups 220b, 220c. The additional emitters 226 are also spaced vertically from the two aforementioned horizontal planes. The arrangement is symmetrical about the longitudinal axis of the cleaner 100. The whole of the array of emitters is designed so that at least two of the emitters will send signals directly to any point in the path of the cleaner (in the forward direction). (This will not apply, of course, to points which are extremely close to the cleaner itself.)

The receivers 230 are spaced substantially evenly around the forward surface 180. A first receiver 230a is located adjacent each of the emitters 224a, 224d which are directioned parallel to the transverse axis 190 so as to receive signals therefrom. These receivers 230a are specifically paired with the emitters 224a, 224d. The remaining  
5 receivers 230b are spaced substantially evenly around the forward surface 180 and are not paired with any of the emitters at all. The receivers 230 are all located in a single horizontal plane with the exception of two central receivers 230b which are located adjacent the forward-looking emitters 226. The lack of pairing of the receivers with the emitters gives the cleaner 100 an enhanced ability to detect its position within an  
10 environment and with respect to objects and obstacles.

Two passive infra-red detectors 240 are located in the forward surface 180 for the purpose of detecting heat sources such as humans, animals and fires. The passive infra-red detector 240 is directioned so that it looks in a forward direction to detect heat  
15 sources in its path.

Two forward-looking ultra-sonic sensors 250, each comprising an emitter 250a and a receiver 250b, are positioned at an uppermost extremity of the cleaner 100 so that they are able to sense obstacles immediately in front of the cleaner and at or near an  
20 uppermost extremity thereof. In this case, the sensors 250 are positioned in the casing of the fan and motor unit 150 so that they both look along the uppermost edge of the cyclonic separator 152. The direction of each sensor 250 is parallel to the direction of the other sensor 250. The sensors 250 are able to detect any obstacles which are at a sufficiently high level not to be detected by the sensors arranged in the forward surface  
25 180 but which would constitute an obstruction to the forward movement of the cleaner 100. Rearward-looking sensors could also be provided at a high level if required, but none is shown in the embodiment illustrated in the drawings. It will be appreciated that a similar effect can be achieved using sensors (preferably ultra-sonic sensors) positioned lower on the cleaner than the uppermost extremity but directioned so as to look towards  
30 the appropriate area adjacent the uppermost extremity in front of the cleaner 100.

Further infra-red sensors 260, 262 are positioned on the chassis 102 immediately above the protruding end of the cleaner head 122. Each sensor 260, 262 comprises an emitter 260a, 262a and a receiver 260b, 262b. The first of these sensors 260 is directioned so that the emitter 260a emits a signal in a direction parallel to the longitudinal axis of the cleaner head 122 or of the brush bar 125. The direction of the signal from the sensor 260 is therefore perpendicular to the forward direction of travel and parallel to the direction of the signal emitted by emitter 224a'. The sensor 260 is thus able to detect the distance of a wall or other obstacle along which the cleaner 100 is intended to travel. In combination with the emitter 224a' and the receiver 230a, the sensor 260 is also able to maintain the direction of travel of the cleaner 100 parallel with the wall or other obstacle along which the cleaner 100 is intended to travel. This is achieved by way of the parallel signals being maintained essentially identical. Any variation between the two signals can be easily recognised and the path of the cleaner 100 can then be adjusted to compensate for the discrepancy. The arrangement is illustrated in Figure 9. As will be seen from the figure, the distance between the directions of the two signals is approximately one half of the length of the cleaner 100, although this can be varied to a considerable extent. Preferably, the distance will not be less than a quarter of the length of the vehicle nor more than three quarters thereof.

The second of the further infra-red sensors 262 is directioned so that the emitter 262a sends a signal rearwardly in a direction parallel to the direction of travel of the cleaner 100. The sensor 262 is able to detect the presence of an obstacle on which the cleaner head 122 may become lodged if the cleaner 100 were traveling in a rearward direction or turning or rotating about a vertical axis.

Infra-red sensors 272, 274, 276 are provided on the underside of the cleaner 100. Each sensor 272, 274, 276 is directioned so that it looks downwardly towards the surface across which the cleaner 100 travels and which the cleaner 100 is intended to clean. Two downward-looking sensors 274, 276 are provided in the chassis 102 immediately in front of each of the driven wheels 104. A further downward-looking sensor 272 is provided at the front edge of the chassis 102 and on or close to the longitudinal axis of

the cleaner 100. Each sensor 272, 274, 276 comprises an emitter and a receiver. In the embodiment illustrated, the outermost component of each sensor 274, 276 is a receiver and the innermost component is an emitter. Each of the sensors 272, 274, 276 is capable of detecting the presence or absence of the surface across which the cleaner 100 travels. A signal is sent to the control software to bring the cleaner 100 to a halt, or to turn, immediately one of the sensors 274, 276 detects that the surface is absent. This is likely to be due to the presence of a stairway or other edge of the surface. The cleaner 100 is thus prevented from falling from a height in the event that a stairway or other edge is encountered. For safety reasons, each of the sensors located in front of each wheel is connected to the control software via different circuits so that, should one circuit fail, the other sensor will still be functional in order to avoid an accident occurring. Further downlooking sensors 278, 280 are provided on the underside of the cleaner 100 adjacent the periphery of the cleaner. Side downlooking sensors 278, 280 are arranged to detect the presence of a surface adjacent a side edge of the vehicle outside of the path of the wheel and forward of the wheel, in the normal direction of movement of the vehicle. The normal, forward, direction of movement of the vehicle is shown as arrow 290. These downlooking sensors 278, 280 look diagonally downwards, so that the sensors can be mounted on the underside of the cleaner where they are protected from damage.

20

Figure 10 shows the form of a downlooking sensor, mounted in the underside 415 of the vehicle for detecting the presence of surface 410 in proximity to the vehicle. A transmit part of the sensor comprises a source 400, typically an LED, a lens 402 for forming an output of source 400 into a collimated beam directed downwards towards surface 410. A receive part comprises a lens 406 for gathering light reflected by surface 410 and a sensor 408 which generates an output 412 for feeding to control circuitry. Sensor 408 is a position sensitive device (PSD) which provides an output that varies according to the position of received light on the sensor. As surface 410 moves nearer or further from the receiver, the position of received light reflected from surface 410 moves across the target of sensor 408 as shown by the double-headed arrows. The PSD is typically a light-sensitive semiconductor device. For safety reasons it is preferred that a second

30



light receiving part is provided 416, 418. This second receiving part 416, 418 is located on the opposite side of the transmit part to the first receive part and generates an output for feeding to control circuitry. Should either or both of the output signals 412, 420 indicate the absence of a surface beneath the cleaning device, the control circuitry stops  
5 the cleaning device.

Figure 11 schematically shows how the downlooking sensors are used by the control system for the vehicle. Outputs from the left and right wheel downlooking detectors 274, 276 are fed to a decision circuit 300. This examines the output signals and decides  
10 whether the surface is close enough to the vehicle. This can be achieved by a comparison of voltage levels: a first voltage provided by the downlooking sensor being compared with a threshold voltage representing an acceptable surface distance. Other decision techniques can be used. An output from the decision circuit 300 is fed to motor driver hardware 310, which provides output signals 312 to operate the motors for  
15 driving the wheels 104 of the vehicle. Motor driver hardware is responsive to both the signal from the decision circuit 300 and to an output from control software 305. For safety reasons, the wheel downlooking sensors 274, 276 directly control the motors in hardware. All of the elements in the control path, shown by dashed box 320, are hardware. This is to prevent any delay in braking the wheels in the event that the  
20 vehicle reaches an edge of a surface. The wheel downlooking sensors 274, 276 as well as the leading edge downlooker 272, side downlookers 278, 280 and other sensors feed their respective outputs, via suitable interface circuitry, to control software 305 which controls movement of the vehicle. Control software 305 provides outputs 306 to the motor driver hardware 310. The control software is able to use the sensor outputs to  
25 guide the vehicle in a manner that is more flexible than just relying on the wheel downlooking sensors.

Figure 12 shows a control system for the cleaner. It comprises two rechargeable batteries 161, 162, a battery and motor management system 41, a motor 50 for driving a  
30 suction fan, traction motors 43 for driving the left and right hand wheels 104 of the vacuum cleaner, a motor 28 for driving the brush bar of the vacuum cleaner and

processing circuitry 23, which includes a microprocessor and field programmable gate arrays (FPGA). A user interface board 29 provides a plurality of user switches 75 by which a user can control the cleaning device and a plurality of indicator lamps 76 by which the cleaning device can indicate to the user. The user interface board also  
5 couples to the light detector 17, as the upper face of the cleaning device provides the light detector with an unobstructed view of the environment. The microprocessor and FPGA share tasks, with the FPGA mainly being used to process data from the ultrasonic sensors, extracting the important information from the signals received by the ultrasonic receivers. A communications bus 70 couples the processing circuitry 23 to the battery  
10 and motor management system 512 and the user interface board 29.

A non-volatile memory 96, such as a ROM or FLASH ROM, stores the control software, another memory 97 is used during normal operation of the device. The movement control sensors described above are coupled to the processing circuitry 23.

15

Figure 13 shows one example of a side downlooking sensor 278 for following an edge of a floor surface. It is preferred to provide a side downlooking sensor looks sideways, from a mounting position on the cleaning device which lies within the envelope of the cleaning device. The sideways downlooking sensor comprises a transmit part TX and a  
20 receive part RX. Both the TX and RX parts are angled downward and outward from the underside of the cleaner to sense the presence of an edge of a surface 500 outside the path of the wheel 104 of the cleaner. Mounting the sensor within the envelope of the vehicle has the advantage that the vehicle's exterior is not cluttered by sensors, which could become caught on obstacles or become damaged. The sideways looking sensor  
25 operates in the same manner as the sensor shown in Figure 10. As an alternative to the sideways diagonally downlooking sensor shown here, a downlooking sensor could be provided which looks directly downwards and which is mounted on an arm which extends sufficiently outwardly from the side of the cleaning device that the sensor has a clear line-of-sight to the floor surface.

30

Figures 14 and 15 show two ways in which the cleaner can operate when the cleaner reaches an edge of a surface that it is cleaning. In Figure 14 the cleaner does not have a side downlooking sensor. Numeral 510 represents a descending staircase extending from corner 512 of a room. In use, the cleaner follows wall 505, along path 506. It reaches corner 512 and attempts to follow the wall 514 extending from the corner. However, the cleaner senses edge 516 at the top of the staircase using its leading edge sensor. The cleaner then enters an edge following routine in which reverses at a fairly and then moves forward at a shallow angle to the edge, until its leading edge sensor 272 again senses the absence of a surface beneath the leading edge of the cleaning device. It repeats this manoeuvre in a zig-zag fashion until it reaches wall 518.

In Figure 15 the cleaner is provided with a sideways downlooking sensor. As before, it approaches along path 506 until it reaches corner 512 and attempts to follow the wall. Leading edge sensor senses the edge 516 of the staircase and using the sideways downlooking sensor 278, the cleaner follows edge 516 until it reaches wall 518.

Figure 16 is a flow diagram illustrating one way in which control software (305, Figure 11) can operate the cleaner. The cleaner usually operates in "wall follow" mode to follow the perimeters of a room either adjacent the wall, or a multiple of cleaner widths from the wall, at step 550. At step 552 the cleaner detects the absence of a surface using its leading edge sensor. It then enters an edge following mode which can take several forms. Steps 554, 556, 560 represent the zig-zag mode previously described, whereas step 558, 560 represent the side downlooking sensor mode. When the presence of a wall is sensed, the cleaner re-enters wall following mode.

The invention is not limited to the precise details of the embodiment illustrated and described above. Although the vehicle described is a vacuum cleaner, it will be appreciated that the sensor arrangement can be applied to any other type of autonomous vehicle which is required to propel itself across a surface without human intervention and without colliding with obstacles or objects in its path. Domestic appliances are becoming increasingly sophisticated and it is envisaged that domestic appliances other

than vacuum cleaners will become autonomous over the years. The sensor arrangement described above will be equally applicable thereto.

**Claims**

1. An autonomous vehicle comprising wheels for supporting the vehicle and for  
5 allowing the vehicle to traverse a surface, wherein downward looking wheel sensors are provided for sensing the presence of a surface in front of the wheels and a further sensor is provided at or near a leading edge of the vehicle for sensing the presence of a surface beneath the leading edge of the vehicle.
- 10 2. A vehicle according to claim 1 comprising a control apparatus for controlling movement of the vehicle, the control apparatus being arranged to permit movement of the vehicle when the leading edge sensor detects the absence of a surface beneath the leading edge of the vehicle, providing the wheel sensors indicate the presence of a surface adjacent the wheel.
- 15 3. A vehicle according to claim 1 or 2 arranged so that, when the leading edge sensor detects the absence of a surface beneath the leading edge of the vehicle, the vehicle performs an edge following routine.
- 20 4. A vehicle according to claim 3 arranged so that the edge following routine is a repeating movement that causes the vehicle to reverse and then move forwards at an angle to the edge until the leading edge sensor again senses the absence of a surface beneath the leading edge.
- 25 5. A vehicle according to claim 3 provided with a further downward looking sensor for detecting the presence of a surface adjacent a side edge of the vehicle outside of the path of the wheel, and wherein the edge following routine uses an output from the side edge sensor to follow the edge of a surface.
- 30 6. A vehicle according to claim 5 wherein the side edge sensor is mounted on the vehicle within the path of the wheel and is angled diagonally downward and outwardly

to detect the presence of a surface adjacent a side edge of the vehicle outside of the path of the wheel.

7. A vehicle according to claim 5 or 6 wherein the side edge sensor detects the presence of a surface adjacent a side edge of the vehicle outside of the path of the wheel and forward of the wheel, in the normal direction of movement of the vehicle.

8. A vehicle according to any one of claims 5 to 7 wherein the further sensor is mounted on an underside of the vehicle.

10

9. A vehicle according to any one of the preceding claims wherein control of the vehicle by the wheel downward looking sensors is performed entirely in hardware and control of the vehicle by a combination of the wheel and leading edge downward looking sensors is performed using control software.

15

10. A vehicle according to any one of the preceding claims in the form of an autonomous cleaning device.

11. A vehicle according to any one of the preceding claims in the form of an autonomous vacuum cleaner.

20

12. A method of operating an autonomous vehicle comprising wheels for supporting the vehicle and for allowing the vehicle to traverse a surface and a control apparatus for controlling movement of the vehicle; the method comprising receiving information from downward looking wheel sensors provided immediately forward of the wheels indicative of the presence of a surface in front of the wheel and a further sensor provided at or near an unsupported leading edge of the vehicle indicative of the presence of a surface beneath the leading edge of the vehicle, and controlling movement of the vehicle so as to permit movement of the vehicle when the leading edge sensor detects the absence of a surface beneath the leading edge of the vehicle, providing the wheel sensors indicate the presence of a surface adjacent the wheel.

30

13. Software for performing a method of controlling operation of an autonomous vehicle comprising wheels for supporting the vehicle and for allowing the vehicle to traverse a surface, and a control apparatus for controlling movement of the vehicle, the software causing the control apparatus to:

5 - receive information from downward looking wheel sensors located immediately forward of the wheels indicative of the presence of a surface in front of the wheel and from a further sensor provided at or near an unsupported leading edge of the vehicle indicative of the presence of a surface beneath the leading edge of the vehicle;

10 and,

- control movement of the vehicle so as to permit movement of the vehicle when the leading edge sensor detects the absence of a surface beneath the leading edge of the vehicle, providing the wheel sensors indicate the presence of a surface adjacent the wheel.

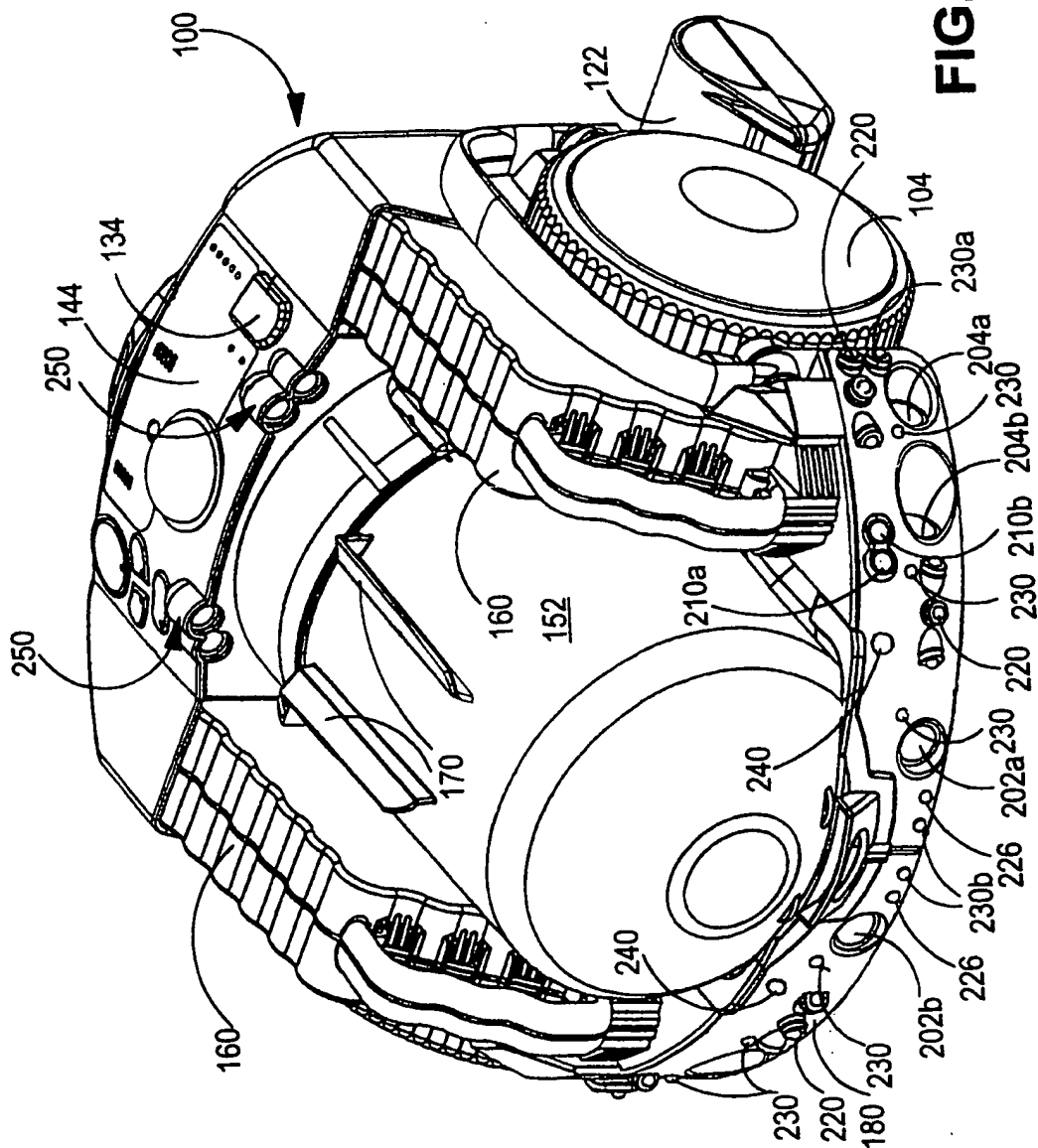
15

14. Control apparatus for controlling operation of an autonomous vehicle comprising wheels for supporting the vehicle and for allowing the vehicle to traverse a surface, the control apparatus being arranged to:

20 - receive information from downward looking wheel sensors located immediately forward of the wheels indicative of the presence of a surface in front of the wheel and from a further sensor provided at or near an unsupported leading edge of the vehicle indicative of the presence of a surface beneath the leading edge of the vehicle;

and,

25 - control movement of the vehicle so as to permit movement of the vehicle when the leading edge sensor detects the absence of a surface beneath the leading edge of the vehicle, providing the wheel sensors indicate the presence of a surface adjacent the wheel.



**FIG.1.**



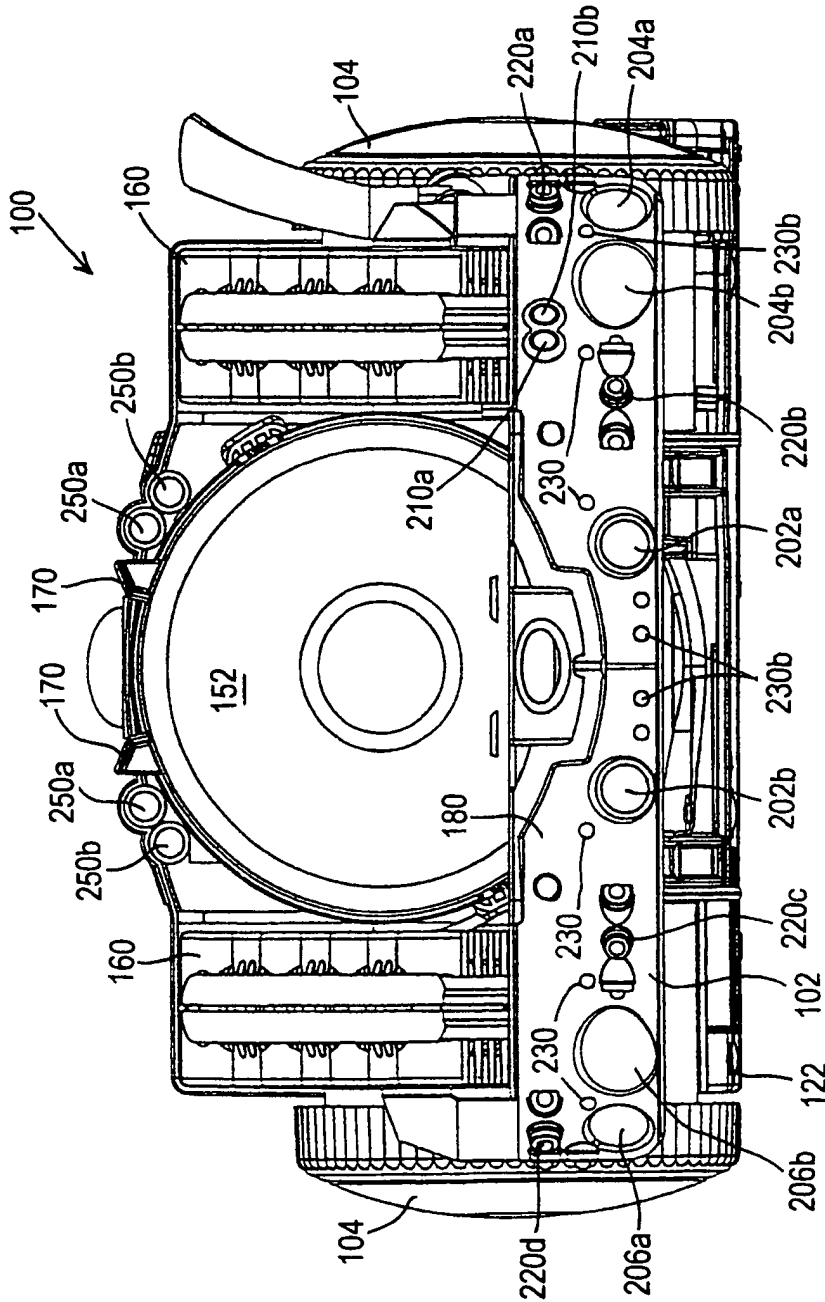


FIG.2.

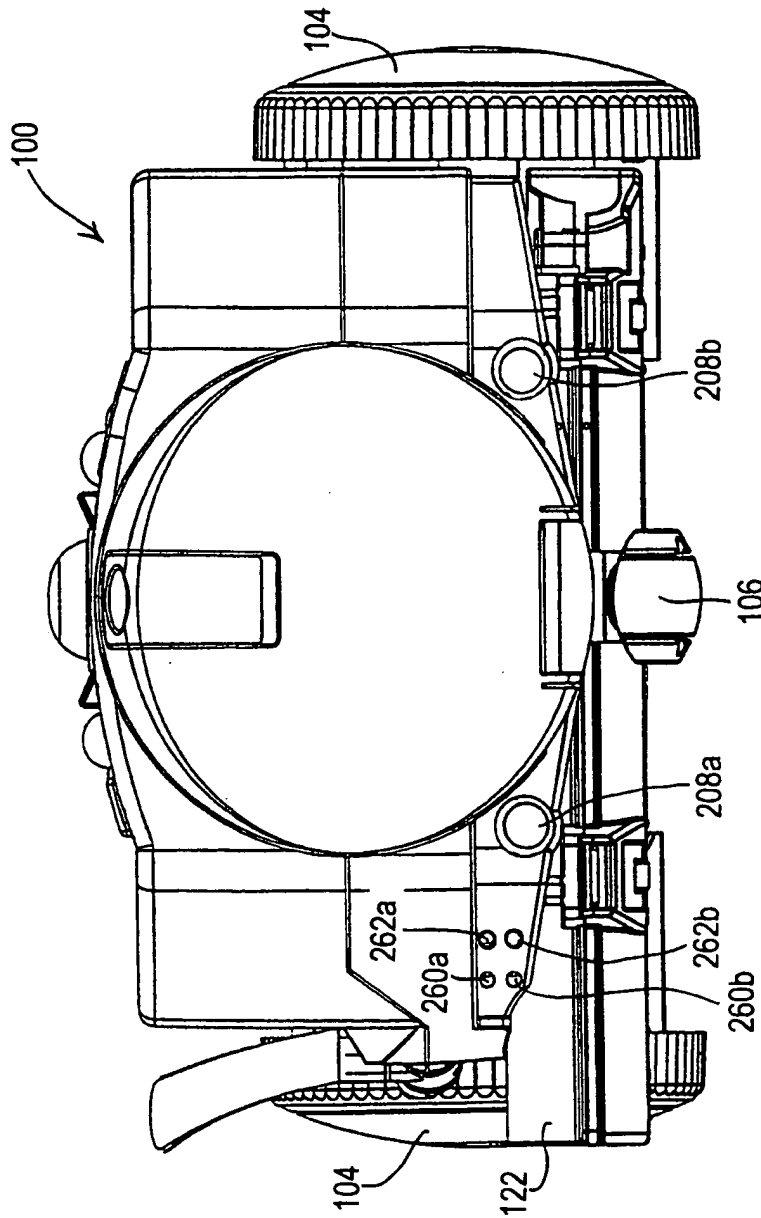


FIG.3.

4/11

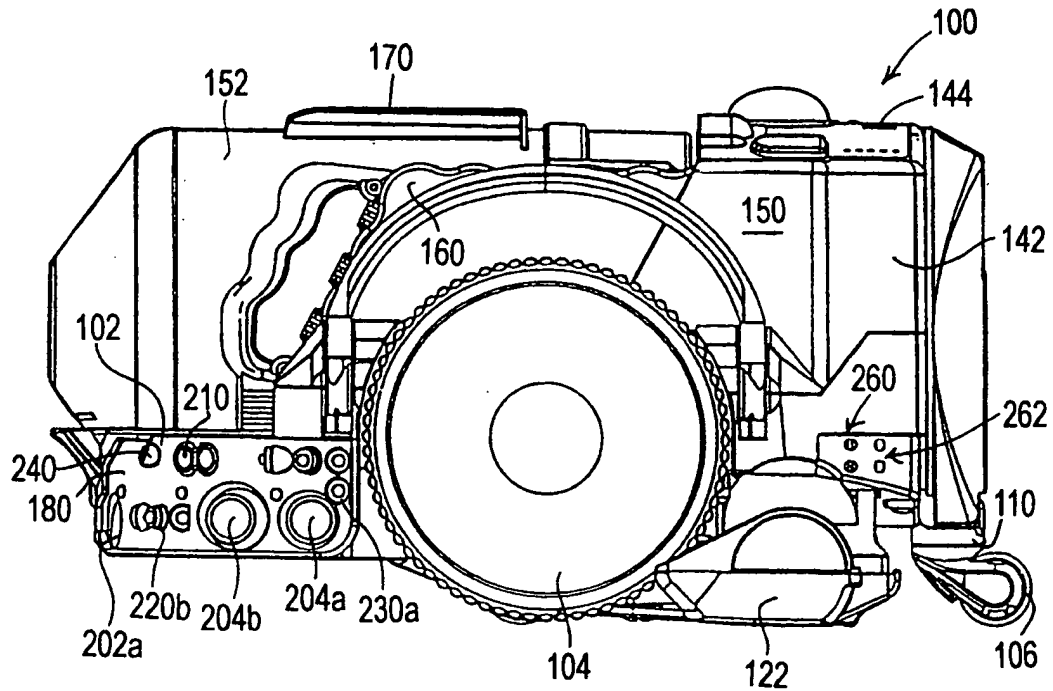


FIG. 4a.

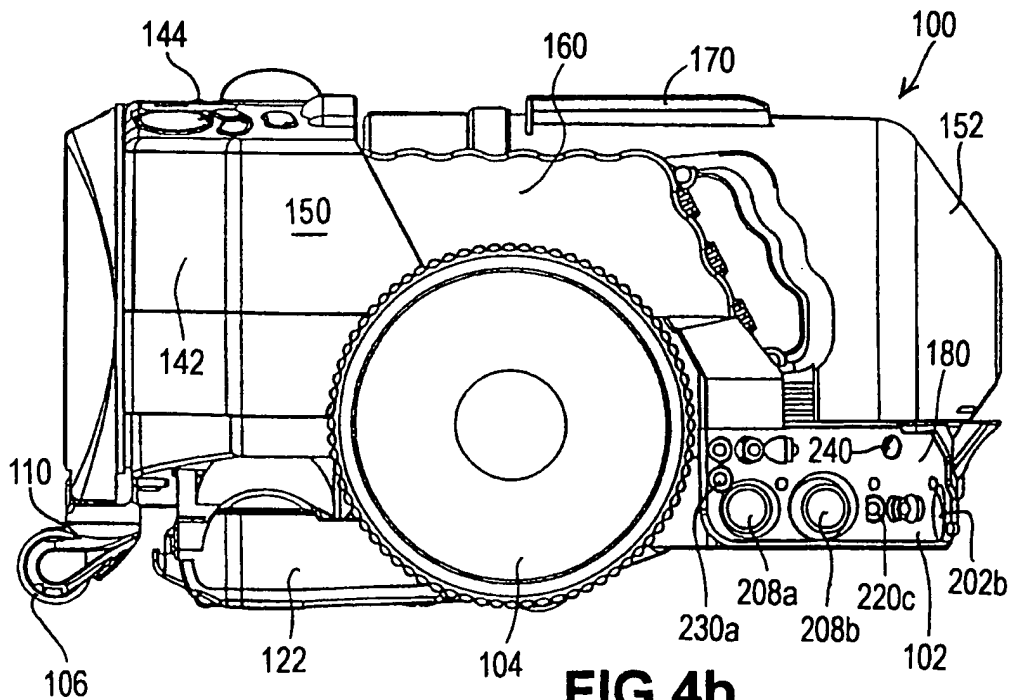


FIG. 4b.

5/11

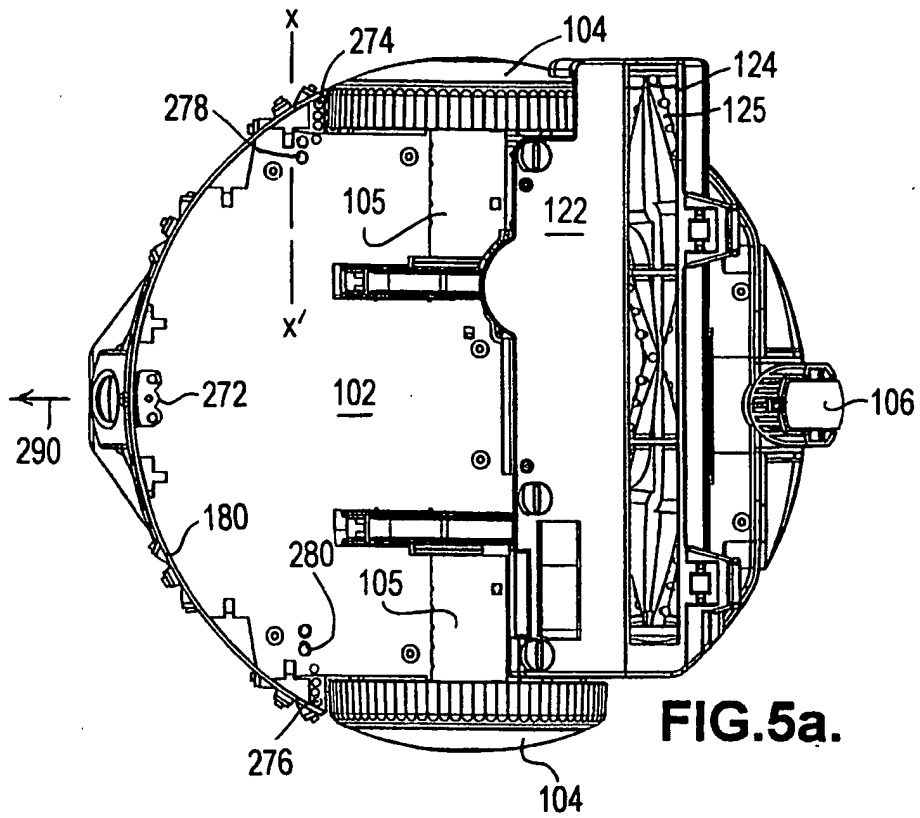


FIG. 5a.

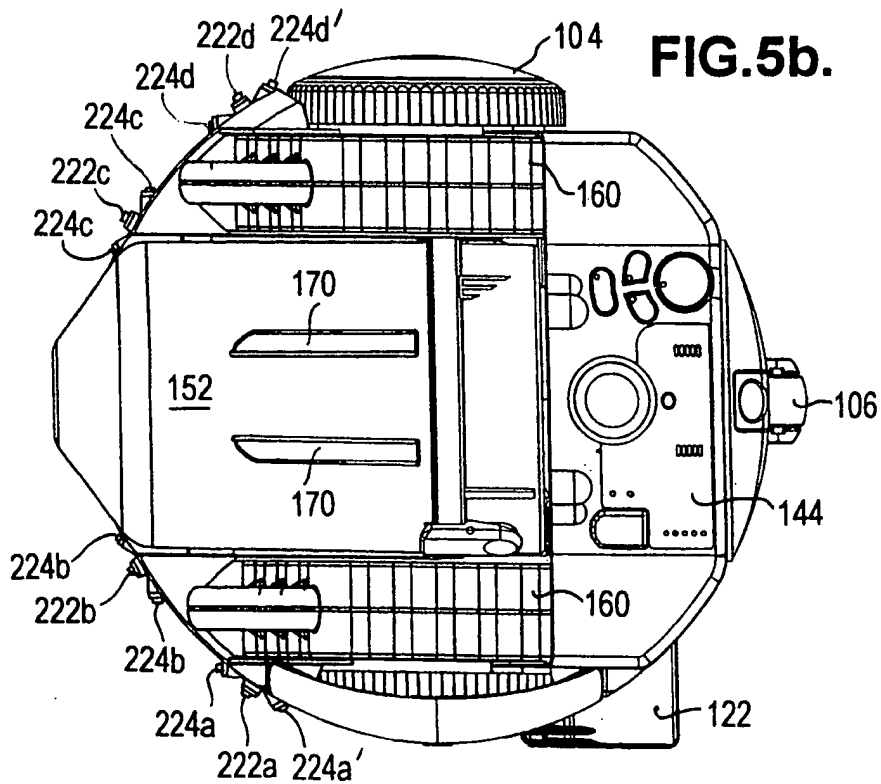
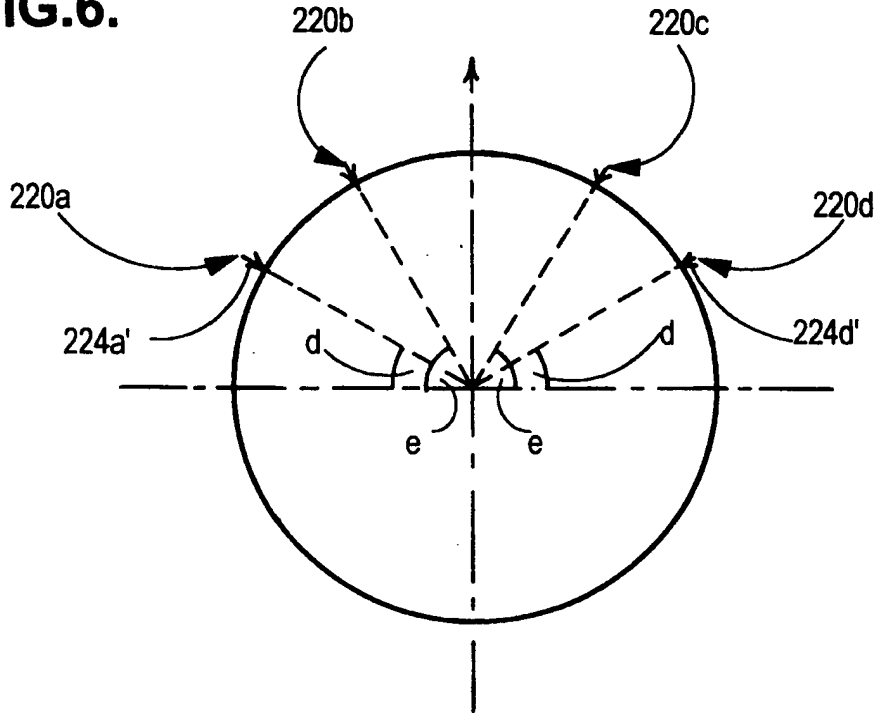
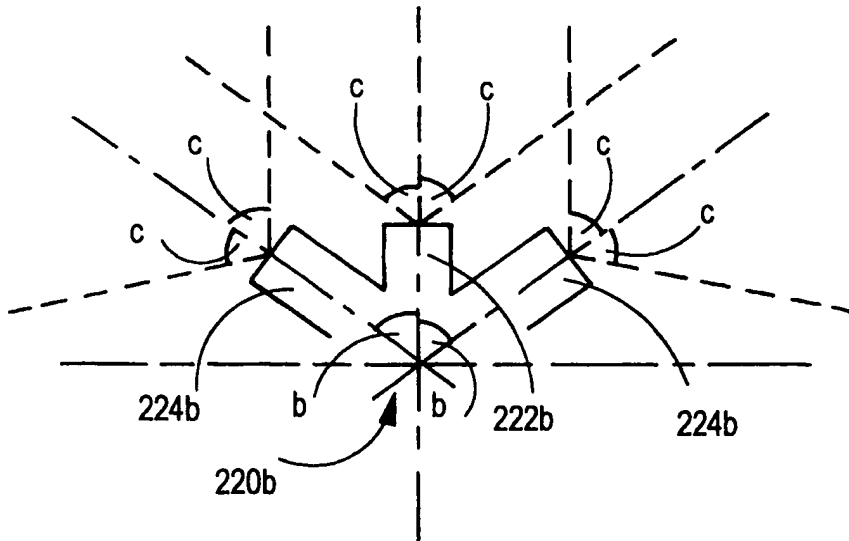


FIG. 5b.

**FIG.6.**



**FIG.7.**



7/11

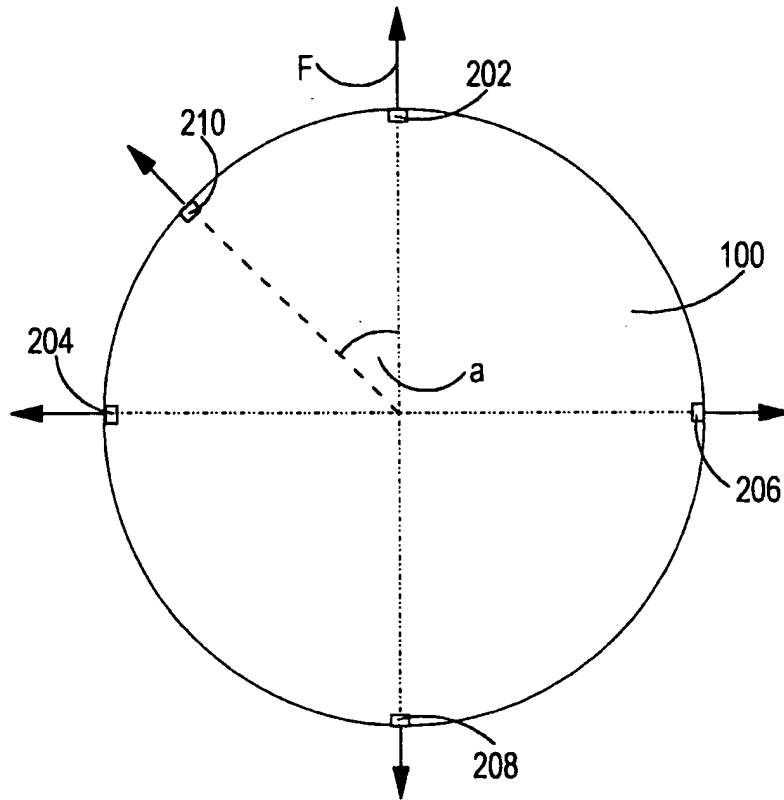


FIG. 8.

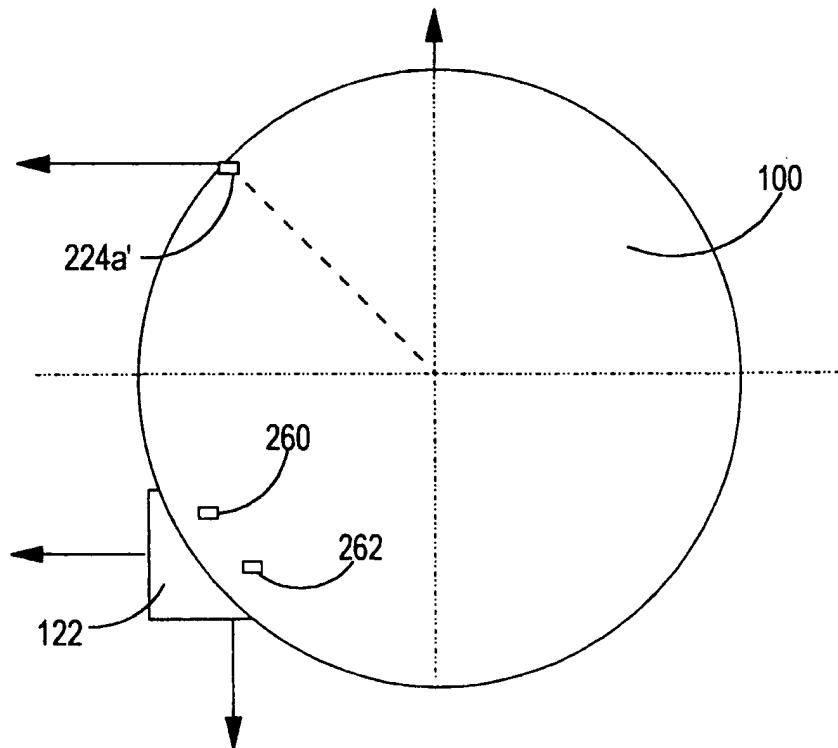


FIG. 9.

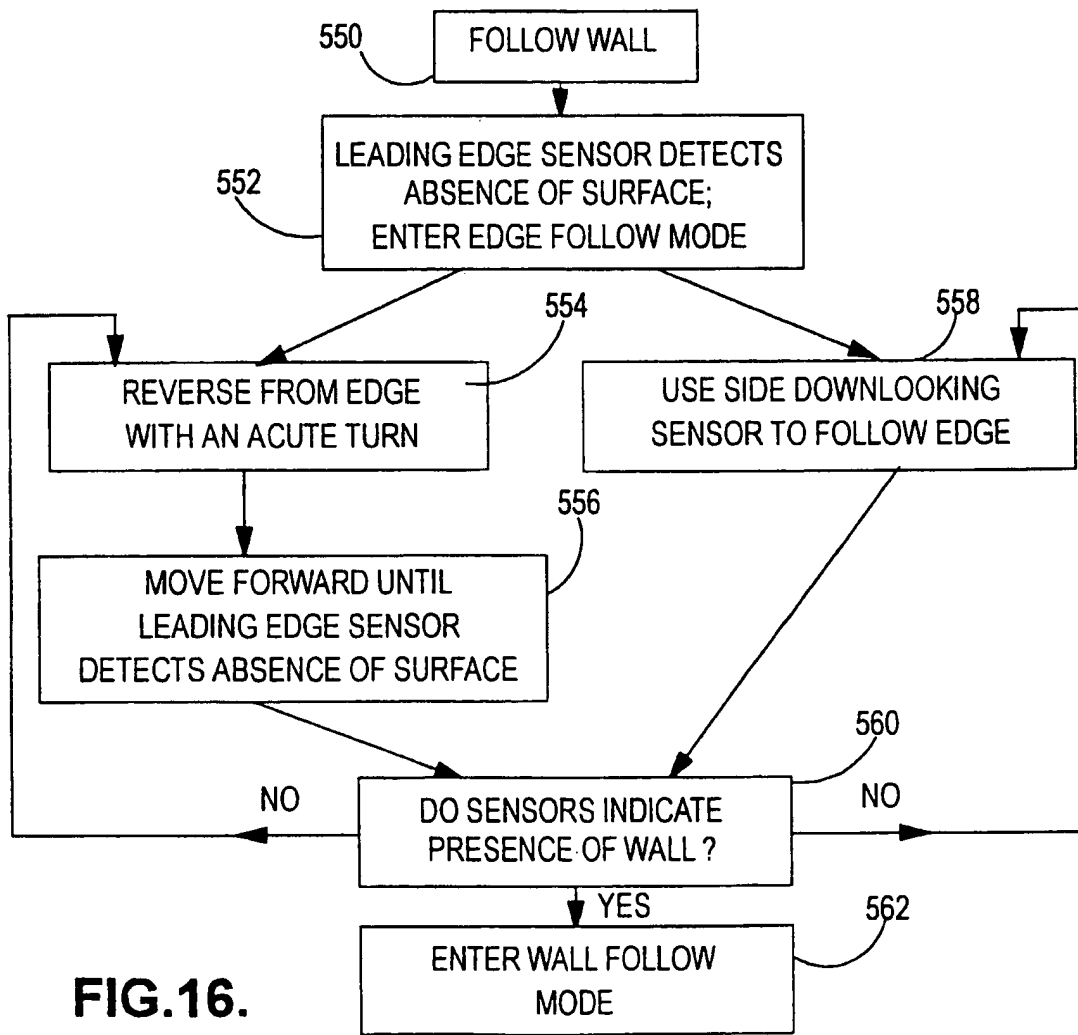
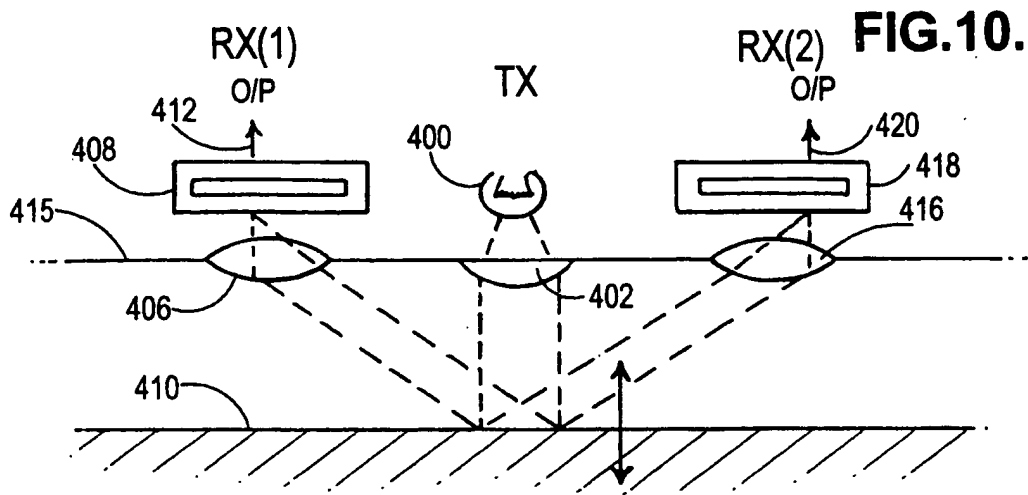


FIG. 16.

9/11

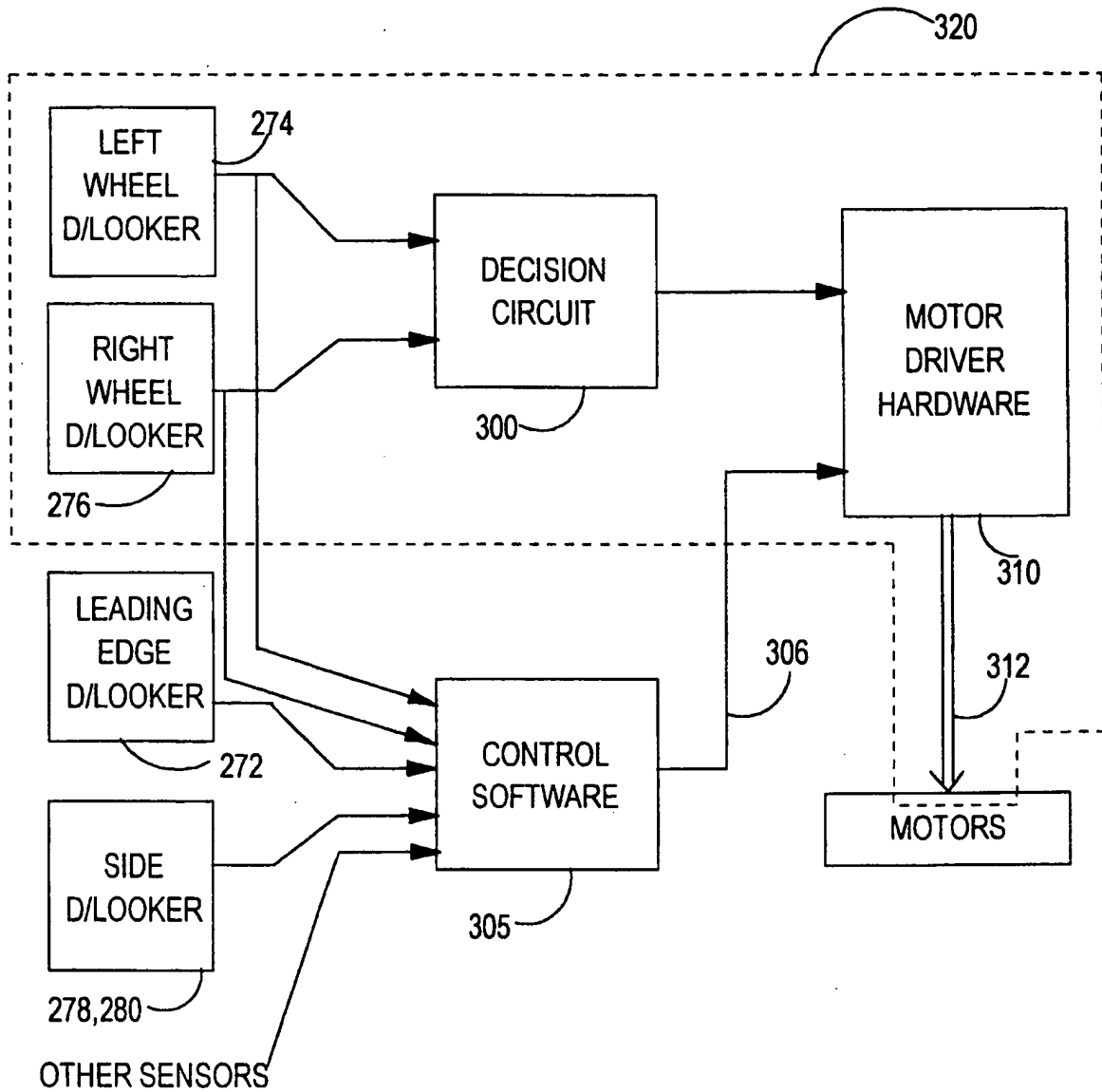


FIG.11.



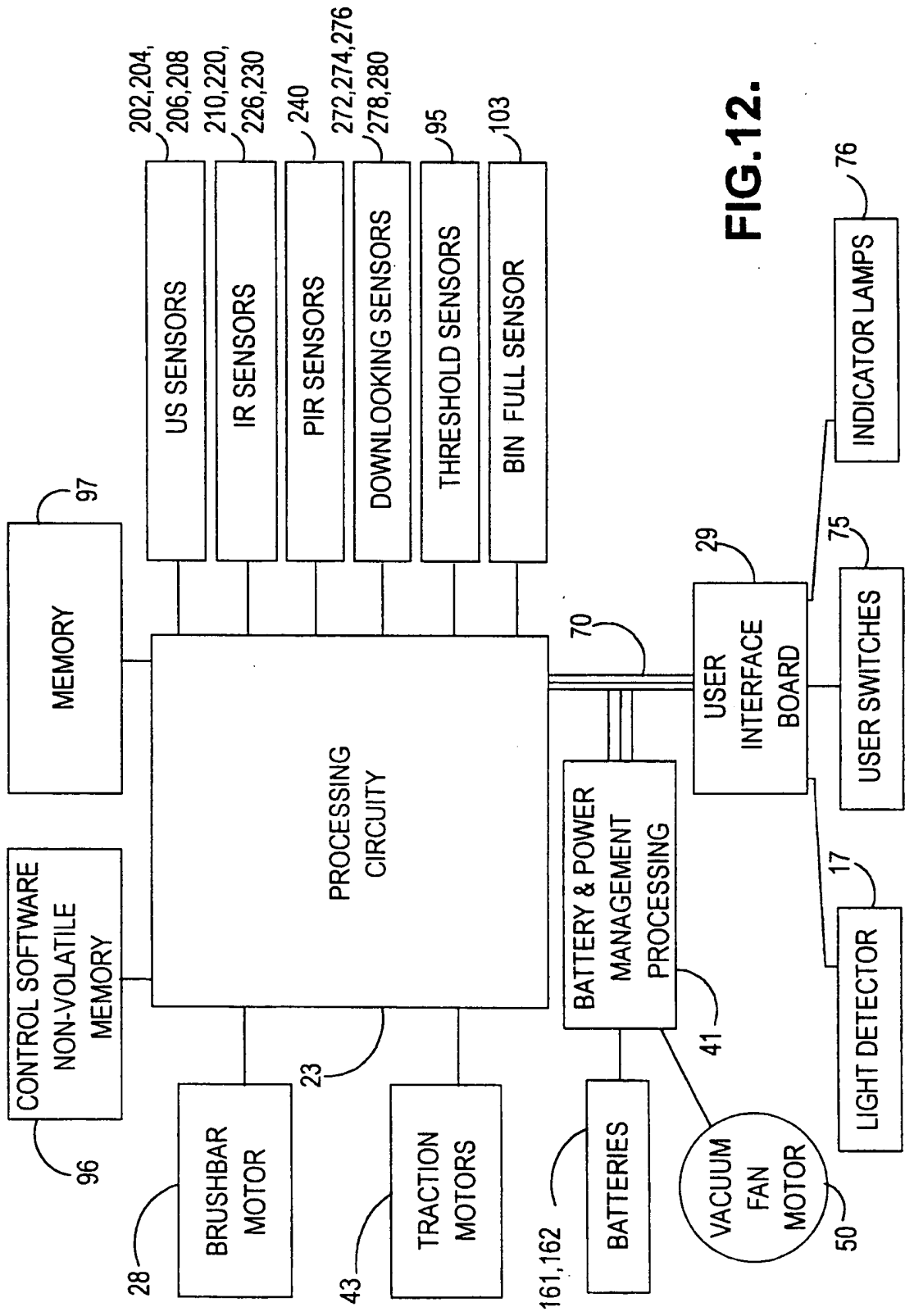
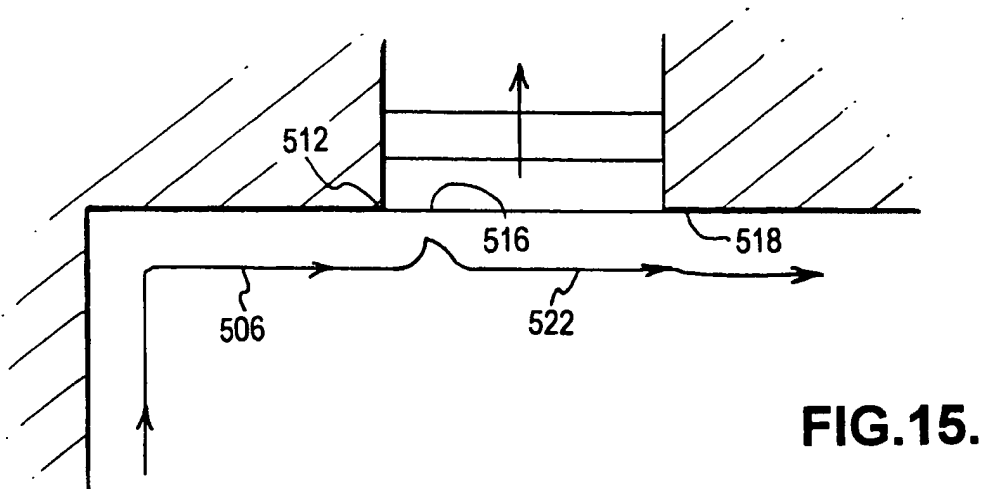
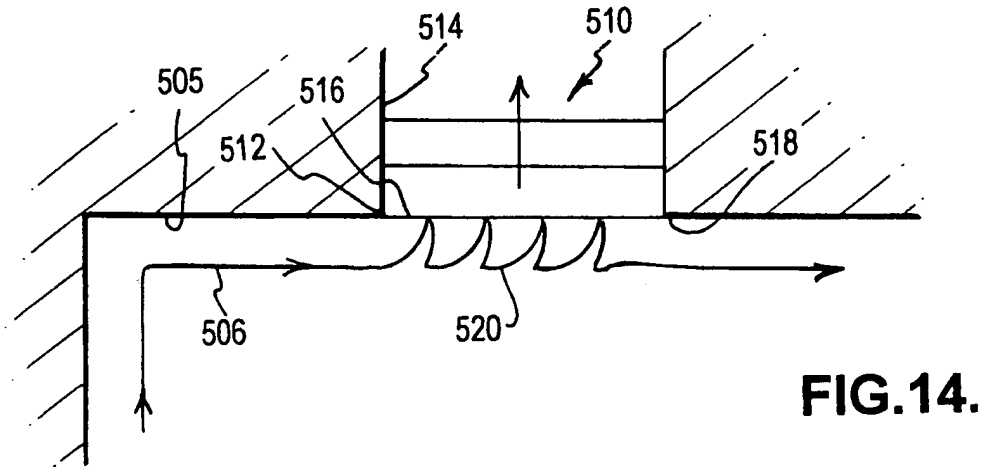
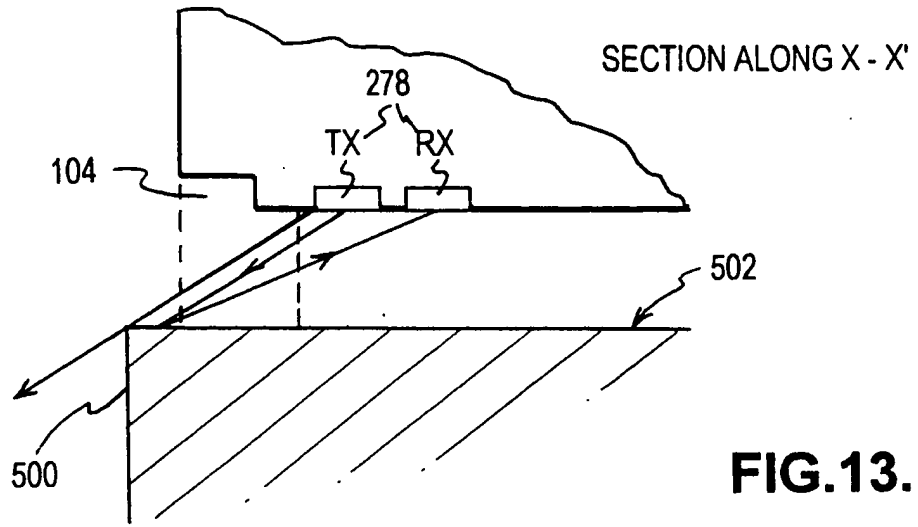


FIG.12.

11/11



# INTERNATIONAL SEARCH REPORT

International Application No

PCT/GB 99/04090

**A. CLASSIFICATION OF SUBJECT MATTER**  
 IPC 7 G05D1/02

According to International Patent Classification (IPC) or to both national classification and IPC

**B. FIELDS SEARCHED**

Minimum documentation searched (classification system followed by classification symbols)

IPC 7 G05D

Documentation searched other than minimum documentation to the extent that such documents are included in the fields searched

Electronic data base consulted during the international search (name of data base and, where practical, search terms used)

**C. DOCUMENTS CONSIDERED TO BE RELEVANT**

Category *	Citation of document, with indication, where appropriate, of the relevant passages	Relevant to claim No.
X	US 5 377 106 A (G. DRUNK ET AL.) 27 December 1994 (1994-12-27)	1
A	column 11, line 47 - line 65; figures 1-7	12-14
A	US 5 321 614 A (G.T.D. ASHWORTH) 14 June 1994 (1994-06-14)	1
A	column 5, line 48 - column 6, line 3; figures 1-4	
A	WO 93 03399 A (AKTIEBOLAGET ELECTROLUX) 18 February 1993 (1993-02-18) cited in the application page 7, line 6 - line 15; figure 4	1
A	WO 97 41451 A (AKTIEBOLAGET ELECTROLUX) 6 November 1997 (1997-11-06) page 6, line 8 - line 14; figures 1-3	1
	-/-	

Further documents are listed in the continuation of box C.

Patent family members are listed in annex.

\* Special categories of cited documents:

- "A" document defining the general state of the art which is not considered to be of particular relevance
- "E" earlier document but published on or after the international filing date
- "L" document which may throw doubts on priority claim(s) or which is cited to establish the publication date of another citation or other special reason (as specified)
- "O" document referring to an oral disclosure, use, exhibition or other means
- "P" document published prior to the international filing date but later than the priority date claimed

- "T" later document published after the international filing date or priority date and not in conflict with the application but cited to understand the principle or theory underlying the invention
- "X" document of particular relevance; the claimed invention cannot be considered novel or cannot be considered to involve an inventive step when the document is taken alone
- "Y" document of particular relevance; the claimed invention cannot be considered to involve an inventive step when the document is combined with one or more other such documents, such combination being obvious to a person skilled in the art.
- "&" document member of the same patent family

Date of the actual completion of the international search

14 March 2000

Date of mailing of the international search report

20/03/2000

Name and mailing address of the ISA

European Patent Office, P.B. 5818 Patentlaan 2  
 NL - 2280 HV Rijswijk  
 Tel. (+31-70) 340-2040, Tx. 31 651 epo nl,  
 Fax (+31-70) 340-3016

Authorized officer

Goetz, P

# INTERNATIONAL SEARCH REPORT

Intern. Appl. No.

PCT/GB 99/04090

C. (Continuation) DOCUMENTS CONSIDERED TO BE RELEVANT		
Category *	Citation of document, with indication, where appropriate, of the relevant passages	Relevant to claim No.
A	FR 2 695 342 A (ONET SA) 11 March 1994 (1994-03-11) page 6, line 31 - line 36; figure 1	1

1

# INTERNATIONAL SEARCH REPORT

Information on patent family members

International Application No

PCT/GB 99/04090

Patent document cited in search report	Publication date	Patent family member(s)	Publication date	
US 5377106    A	27-12-1994	DE 3709627 A	13-10-1988	
		AT 129821 T	15-11-1995	
		DE 3854649 D	07-12-1995	
		WO 8807711 A	06-10-1988	
		EP 0378528 A	25-07-1990	
		JP 3500098 T	10-01-1991	
		-----		
US 5321614    A	14-06-1994	NONE		
-----				
WO 9303399    A	18-02-1993	NONE		
-----				
WO 9741451    A	06-11-1997	SE 506907 C	02-03-1998	
		AU 713488 B	02-12-1999	
		AU 2795597 A	19-11-1997	
		CA 2225420 A	06-11-1997	
		EP 0835459 A	15-04-1998	
		JP 11510935 T	21-09-1999	
		SE 9601664 A	31-10-1997	
		US 5935179 A	10-08-1999	
		-----		
		FR 2695342    A	11-03-1994	FR 2648071 A
AT 104838 T	15-05-1994			
AU 5839490 A	07-01-1991			
CA 2058929 A	08-12-1990			
DE 69008530 D	01-06-1994			
EP 0476023 A	25-03-1992			
EP 0584888 A	02-03-1994			
WO 9014788 A	13-12-1990			
JP 5502743 T	13-05-1993			
MC 2184 A	16-09-1992			
US 5341540 A	30-08-1994			
-----				

(12) INTERNATIONAL APPLICATION PUBLISHED UNDER THE PATENT COOPERATION TREATY (PCT)

(19) World Intellectual Property Organization  
International Bureau



(43) International Publication Date  
15 May 2003 (15.05.2003)

PCT

(10) International Publication Number  
WO 03/040846 A1

(51) International Patent Classification<sup>7</sup>: G05D 1/02

(81) Designated States (*national*): AE, AG, AL, AM, AT, AU, AZ, BA, BB, BG, BR, BY, BZ, CA, CH, CN, CO, CR, CU, CZ, DE, DK, DM, DZ, EC, EE, ES, FI, GB, GD, GE, GH, GM, HR, HU, ID, IL, IN, IS, JP, KE, KG, KP, KR, KZ, LC, LK, LR, LS, LT, LU, LV, MA, MD, MG, MK, MN, MW, MX, MZ, NO, NZ, OM, PI, PL, PT, RO, RU, SD, SE, SG, SI, SK, SL, TJ, TM, TN, TR, TT, TZ, UA, UG, US, UZ, VC, VN, YU, ZA, ZM, ZW.

(21) International Application Number: PCT/GB02/04955

(22) International Filing Date:  
1 November 2002 (01.11.2002)

(25) Filing Language: English

(26) Publication Language: English

(30) Priority Data:  
0126492.8 3 November 2001 (03.11.2001) GB

(84) Designated States (*regional*): ARIPO patent (GH, GM, KE, LS, MW, MZ, SD, SL, SZ, TZ, UG, ZM, ZW), Eurasian patent (AM, AZ, BY, KG, KZ, MD, RU, TJ, TM), European patent (AT, BE, BG, CH, CY, CZ, DE, DK, EE, ES, FI, FR, GB, GR, IE, IT, LU, MC, NL, PT, SE, SK, TR), OAPI patent (BF, BJ, CF, CG, CI, CM, GA, GN, GQ, GW, ML, MR, NE, SN, TD, TG).

(71) Applicant (*for all designated States except US*): DYSON LTD [GB/GB]; Tetbury Hill, Malmesbury, Wiltshire SN16 0RP (GB).

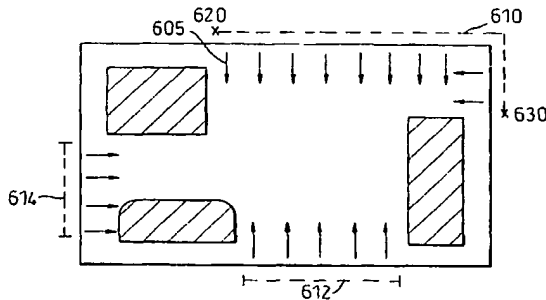
Published:  
— with international search report

(72) Inventor; and  
(75) Inventor/Applicant (*for US only*): ALDRED, Michael, David [GB/GB]; 16 Sutherland Crescent, Cepen Park North, Chippenham, Wiltshire SN14 6RS (GB).

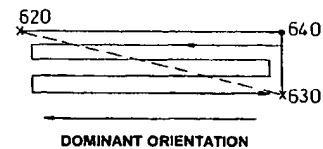
*For two-letter codes and other abbreviations, refer to the "Guidance Notes on Codes and Abbreviations" appearing at the beginning of each regular issue of the PCT Gazette.*

(74) Agents: CAGE, John, D. et al.; Intellectual Property Department, Dyson Limited, Tetbury Hill, Malmesbury, Wiltshire SN16 0RP (GB).

(54) Title: AN AUTONOMOUS MACHINE



13



14

(57) Abstract: An autonomous machine navigates around an area, storing information about the area and determines, from the stored information, an optimum direction for the machine to traverse the area. The machine can maximise the length between turning points of the scanning pattern. The machine acquires information about the area (such as the amount of free space to a side of the machine) as the machine follows a boundary of the area.



WO 03/040846 A1

### An Autonomous Machine

This invention relates to an autonomous machine, such as an autonomous machine for cleaning a floor area.

5

There have been various proposals to provide autonomous or robotic machines for performing duties such as cleaning or polishing a floor area or for mowing grass. In their simplest form, an autonomous machine requires a training phase during which the machine is manually led around the area in which it is to work. Following this training phase, the autonomous machine will then perform the required work as it follows the path which it stored in its memory during the training phase. Other machines may simply follow a predetermined route which is marked by means such as a cable which is buried beneath the working area.

10

Other autonomous machines are supplied with a map of the environment in which they are to be used. The machine then uses this map to plan a route around the environment.

15

There have also been proposals for autonomous machines which are capable of exploring the environment in which they are placed without human supervision, and without advance knowledge of the layout of the environment. The machine may explore the environment during a learning phase and will subsequently use this information during a working phase. An autonomous machine shown in WO 00/38025 initially travels around the perimeter of an area, recognises when it has completed a single lap of the area, and then steps inwardly after that and subsequent laps of the room so as to cover the area in a spiral-like pattern. Autonomous machines are known to build a map of the working area using the information they acquire during the learning phase. Autonomous machines of this last type are particularly attractive to users as they can be left to work with minimal human supervision.

20

25

Many autonomous machines are used to perform tasks such as floor cleaning where they need to cover the entire working area. Many machines use some form of reciprocating

30

scanning pattern to cover the area. However, while this pattern works well in regularly shaped areas realistic working environments, such as a room of a house, can cause problems.

5 The present invention seeks to provide an improved autonomous machine.

A first aspect of the present invention provides an autonomous machine for traversing an area comprising:

- power operated means for moving the machine along a surface of an area, and
- 10 - a navigation system, including sensors and a memory means, for navigating the machine around the area,

the navigation system being arranged, in use, to store information about the area and to traverse the area by a scanning pattern, wherein the navigation system is also arranged to determine, from the stored information, an optimum direction for the machine to traverse  
15 the area.

Preferably the navigation system is arranged to determine, from the stored information, a direction for the machine to traverse the area which maximises the length between turning points of the scanning pattern. By selecting an optimum direction for the scanning pattern,  
20 the machine reduces the number of turning points and hence reduces the errors which can accumulate in the navigation system. This is particularly important where the navigation system relies on odometry information.

Preferably, the navigation system is arranged to cause the machine to follow a boundary of  
25 the area to acquire the information about the area. This information can include information about the amount of free space to one or both sides of the machine.

In selecting an area for scanning, the navigation system can find the longest length of boundary having free space alongside it, or it can find the nearest part of the boundary, to  
30 the current position of the machine, having free space alongside it.



Preferably the navigation system is arranged to update the stored information about the amount of free space as the machine traverses the area to account for the places where the machine has visited.

- 5 In selecting an area for scanning, the navigation system can be arranged to determine a dominant orientation of the edges of an area and to use the dominant orientation as the direction of each path of the scanning pattern. This should minimise the number of turning points as the machine performs the scanning operation. Preferably, the navigation system is also arranged to determine, for the area selected for scanning, a starting point to begin  
10 the scanning pattern which will cause the machine to move outwardly from the edges of the area.

Alternatively, in selecting an area for scanning, the navigation system is arranged to determine the direction of a line which connects the end points of the boundary of the  
15 selected area and to use the determined direction as the direction of each path of the scanning pattern.

The navigation system can be implemented entirely in hardware, in software running on a processor, or a combination of these. Accordingly, a further aspect of the present  
20 invention provides software for operating the cleaning machine in the manner described herein. The software is conveniently stored on a machine-readable medium such as a memory device.

The autonomous machine can take many forms: it can be a robotic vacuum cleaner, floor  
25 polisher, lawn mower or a robotic machine which performs some other function. Alternatively, it could be a general purpose robotic vehicle which is capable of carrying or towing a work implement chosen by a user.

Embodiments of the present invention will now be described, by way of example only,  
30 with reference to the accompanying drawings, in which:-

Figure 1 shows an embodiment of an autonomous machine according to the invention;

Figure 2 shows the electrical systems in the machine of Figure 1;

Figure 3 shows the overall set of machine behaviours;

5 Figure 4 shows the method for navigating the machine around the boundary of a working area;

Figures 5 and 6 show the machine operating in an example room scenario;

Figure 7 shows the process for matching path sections;

10 Figure 8 shows the machine-generated map of the working area following an initial traverse of the boundary of the working area;

Figure 9 shows the map correction process;

Figure 10 shows the coordinate system used in the map correction process;

Figure 11 shows the method for scanning the working area;

Figure 12 shows a reciprocating scanning movement;

15 Figure 13 shows the map of a room and free space areas;

Figures 14 and 14A show two schemes for scanning one of the selected free space areas of the room;

Figures 15 and 16 show the room of Figure 13 as the machine performs a scanning pattern across the room;

20 Figure 17 shows types of free space areas which may exist within the room;

Figure 18 shows a way of reaching scanning start points;

Figure 19 shows a way of coping with centrally positioned objects; and,

Figures 20-22 show scanning behaviours.

25 Figure 1 of the drawings shows a robotic, or autonomous, floor cleaning machine in the form of a robotic vacuum cleaner 100.

The cleaner comprises a main body or supporting chassis 102, two driven wheels 104, a brushbar housing 120, batteries 110, a dust separating and collecting apparatus 130, a  
30 user interface 140 and various sensors 150, 152, 154. The supporting chassis 102 is generally circular in shape and is supported on the two driven wheels 104 and a castor

wheel (not shown). The driven wheels 104 are arranged at either end of a diameter of the chassis 102, the diameter lying perpendicular to the longitudinal axis of the cleaner 100. The driven wheels 104 are mounted independently of one another via support bearings (not shown) and each driven wheel 104 is connected directly to a traction motor which is capable of driving the respective wheel 104 in either a forward direction or a reverse direction. A full range of manoeuvres are possible by independently controlling each of the traction motors.

Mounted on the underside of the chassis 102 is a cleaner head 120 which includes a suction opening facing the surface on which the cleaner 100 is supported. A brush bar 122 (not shown) is rotatably mounted in the suction opening and a motor is mounted on the cleaner head 120 for driving the brush bar.

The chassis 102 carries a plurality of sensors 150, 152, 154 which are positioned on the chassis such that the navigation system of the cleaner can detect obstacles in the path of the cleaner 100 and the proximity of the cleaner to a wall or other boundary such as a piece of furniture. The sensors shown here comprise several ultrasonic sensors 150 which are capable of detecting walls and objects and several passive infra red (PIR) sensors which can detect the presence of humans, animals and heat sources such as a fire. However, the array of sensors can take many different forms. Position Sensitive Devices (PSDs) may be used instead of, or in addition to, the ultrasonic sensors. In an alternative embodiment the cleaner may navigate by mechanically sensing the boundary of the working area and boundaries of obstacles placed within the area. Each side of the vehicle carries an odometry wheel. This is a non-driven wheel which rotates as the machine moves along the surface. Each wheel has an optical encoder associated with it for monitoring the rotation of the odometry wheel. By examining the information received from each odometry wheel, the navigation system can determine both the distance travelled by the machine and the change in angular direction of the machine. It is preferred that the odometry wheel is a non-driven wheel as this increases the accuracy of the information obtained from the wheel. However, a simpler embodiment of the machine can derive odometry information directly from one of the driven wheels.

The vacuum cleaner 100 also includes a motor and fan unit supported on the chassis 102 for drawing dirty air into the vacuum cleaner 100 via the suction opening in the cleaner head 120.

5

Figure 2 shows, in schematic form, the electrical systems for the cleaner of Figure 1. The navigation system comprises a microprocessor 200 which operates according to control software which is stored on a non-volatile memory 210, such as a ROM or FLASH ROM. Another memory 220 is used during normal operation of the machine to  
10 store data, such as the path data and a map of the working area, and other operating parameters. The navigation system receives inputs about the environment surrounding the machine from sensor array 150, 152, 154 and inputs about movement of the machine from odometry wheel movement sensors 160, 162. The navigation system also receives inputs from switches 142 on the user interface, such as start, pause, stop or a selection  
15 of operating speed or standard of required cleanliness. The navigation system provides a plurality of output control signals: signals for driving the traction motors 105 of the wheels 104, a signal for operating the suction motor 132 which drives the suction fan 130 and a signal for operating the motor 122 which drives the brush bar 125. It also provides outputs from illuminating indicator lamps 144 on the user interface 140.

20 Power is supplied by rechargeable battery packs 110.

### **Navigation method**

The operation of the machine will now begin to be described with reference to Figures 3-7. Figure 3 is a flow chart of the overall set of behaviours followed by the machine.

25 Figure 4 is a flow chart of the process for navigating around a boundary of the working area. Figures 5 and 6 show an example of a working area in a room of a house, the room having a boundary which is defined by walls 405, a doorway 410, a fire place 415 and articles of furniture 420 – 426 (e.g. sofa, chair) placed against the walls of the room. These figures also show an example path 430 taken by the machine. Figure 6 illustrates  
30 the path matching process.

When the machine is first started it has no knowledge of the area in which it is positioned. Thus, the machine must first explore the area in which it is to work to acquire a knowledge of the area.

## 5 **Boundary Scanning**

The machine is left in the room by a user. Ideally the user is required to place the machine pointing towards an outer boundary of the room or with its left side against the boundary. The user can start the machine at any point on the boundary. In Figure 4 the machine is shown starting at point A. The first action of the machine is to detect the closest wall 405  
10 (step 305) and move towards it. The machine then aligns to the wall (point B) and starts the suction motor 132 and brush bar motor 122. It waits until the motors reach operating speed and then moves off. The machine then begins to navigate around the boundary of the room, continuously detecting the presence of the wall and maintaining the machine at a predetermined distance from the wall. The machine navigates around the obstacles 420-  
15 426 in the same manner as for the walls 405, maintaining the machine at a predetermined distance from the obstacles. The machine continuously records information about the path that it takes in following the boundary of the room. The machine derives information on the distance and direction of travel from the odometry wheel sensors 160, 162.

20 As the machine follows the boundary of an area, the navigation system samples, at regular distance intervals, the angular change in direction of the machine (compared with the direction at the previous sample). It is important to note that this information represents the path (or trajectory) of the machine rather than information about objects that it senses around it. The distance between samples will depend, inter alia, on the environment where  
25 the machine is used, the processing power available, memory size, the matching criteria. At each sample period, the navigation system determines the angular change in the direction of the machine compared with the previous sample. The angular change is stored in the memory 220 as part of a vector of all sampled values. Figure 5 shows part of the path 430 followed by the machine. At each sampling point 500 the corresponding arrow  
30 and angular value indicates the change compared with the previous sampling point 500.

In addition to recording the angular direction changes at regular, fairly widely spaced apart intervals, the navigation system also plots, in detail, the path followed by the machine in order to construct a map of the working area. Figure 8 shows an example of the map of the room shown in Figure 4. Each point of the machine's path around the boundary is defined  
5 by a coordinate on the map. Also, as will be described later, the machine uses sensors on the left and right hand sides of the machine to detect the distance to the nearest obstacles on each side of the machine. This 'distance to obstacle' information is recorded on the map for points along the machine's path.

10 As soon as the machine has travelled a distance  $L$ , it begins to compare the last  $L$  metres worth of the angular path data with previous  $L$  metre blocks of path data to find a match and hence to establish whether the machine has returned to a previously visited position along the boundary. Once the machine has made one complete clock-wise trip around the boundary of the room, and arrived again at point B, the matching process should not  
15 yet have found a suitable path match, so the machine continues to follow the boundary. At point C' (i.e. point C on the second lap of the room) the machine recognises that it has returned to a previously visited position on the boundary of the room. This is because the matching process will have found a suitable match between the most recent  $L$  metres worth of path data and the initial  $L$  metres worth of path data stored by the  
20 machine. This completion point will always result in a  $L$  metre overlap of the boundary that is double covered. Once the start point has been detected the machine stops and shuts down the suction and brush bar motors.

The matching process works by comparing a block ('window') of the stored direction  
25 data with a previously stored block of direction data. This technique is often called a sliding window technique.

The angular change of direction data is processed by a sub-sampling process to derive three other sets of data, which are also stored in the path data vector. (Note, for  
30 simplicity only two sub-sampled sets of data are shown in Figure 7.) Each sub-sampled set of data represents a coarser interpretation of the actual path travelled by the machine.

Since even a good machine is likely to vary in the first and second attempts that it takes to traverse the same portion of boundary, these sub-sampled data sets provide useful information on the underlying direction changes which are likely to form a good match in the matching process.

5

For each level of sub-sampling, the most recent window of data is compared with earlier, equally sized, windows of data in the overall data vector. For each comparison, each element in the new and tested windows of data are compared. The overall difference between the two windows of data, at each sub-sampling level, is converted to a metric representative of the 'quality of match'. We favour using a percentage value, but other techniques can equally be used. The matching process has a threshold value for the 'quality of match' metric which indicates, from experience, a positive match between two sets of path data. For example, we have found a match of >98% is indicative of a positive match between two sets of path data which represent the same position in a room. A skilled person will appreciate that there are many refinements which can be made to this basic scheme and many other ways in which the path data can be compared.

The matching process allows the machine to establish when it has returned to a start position on the boundary. This is something that a machine must discover when it is set to work in an area of which it has no advance knowledge of the size, shape, layout etc.

While the machine is moving around the boundary it stores sections of path data from the boundary path as "markers". The use of markers will be described more fully below. They are a way of allowing the machine to quickly determine its position on the boundary. The number of markers that are stored around the boundary depends on the amount of processing power available in the matching engine of the machine – more markers requires more comparisons. If the machine can only store a limited number of markers, the navigation system can automatically expand the distance between the markers as the length of the perimeter increases.

The path length  $L$  required for matching, the distance between sampling points and the quality metric threshold indicative of a strong match are all dependent on the working area and conditions where the machine will be used. These can be readily determined by trial. In a domestic environment we have found that a distance  $L$  of 3.6m, a distance  
5 between sampling points of 7.5 cm and markers positioned every 2m around the boundary provides good results.

### Boundary Map Correction

As described above, the initial exploration process involves the machine following the  
10 boundary for just over one full circuit, and storing the path that the machine follows. The machine determines that it has returned to the starting point on the boundary after an overlap distance. As shown in Figure 8, the boundary map produced in this way is usually not closed, which means that the common start 800 and finish 802 path sections (which in the real world are the same, as identified by the path matching process) have different  
15 locations and orientations due to accumulated odometry errors. It is necessary to represent all path points on a single Cartesian co-ordinate system (frame), though the choice of frame is arbitrary. If we choose the frame to be that of the finish point of the robot, then the error in the path increases as we move backwards from the finish section, along the travelled path, towards the start point.

20

The map closure (correction) process progressively deforms the map as we travel from the end (no deformation) to the start (maximum deformation) such that the start segment maps onto the finish segment. This ensures that we have zeroed the error at the start point and have generally reduced the error elsewhere.

25

Figure 9 shows the steps of the map correction process. The initial steps of the process  
355, 360 are the boundary following method. We can set up two local Cartesian coordinate systems (local frames or *views*)  $V_1$  and  $V_2$  such that their origins and x-axes are positioned and oriented relative to corresponding locations in the start and  
30 finish boundary map segments, respectively, which were identified by the path matching process.



As shown in Figure 10, a view is defined by three vectors, a position vector  $\mathbf{r}$  for the origin, and unit vectors for the local x and y axes,  $\mathbf{e}_x$  and  $\mathbf{e}_y$ .

5 The position of any point  $\mathbf{p}$  in a view is given in vector notation by:

$$p'_x = (\mathbf{p} - \mathbf{r}) \bullet \mathbf{e}_x \quad p'_y = (\mathbf{p} - \mathbf{r}) \bullet \mathbf{e}_y$$

or equivalently in matrix notation:

$$\mathbf{p}' = \mathbf{M}(\mathbf{p} - \mathbf{r}) \quad \text{where } \mathbf{M} = \begin{bmatrix} \langle \mathbf{e}_x \rangle \\ \langle \mathbf{e}_y \rangle \end{bmatrix}$$

10 In view  $\mathbf{V}_1$ , the start of the boundary is at the origin and a tangent to the boundary at the start points along the x-axis. Similarly, in view  $\mathbf{V}_2$ , the start of the overlapping segment is at the origin, and the tangent to the path at this point is along the x-axis. By “looking” at the start with  $\mathbf{V}_1$  and the finish with  $\mathbf{V}_2$ , the projection of start and finish segments have the same position and orientation. For points P between the start and finish, we must use some intermediate view between  $\mathbf{V}_1$  and  $\mathbf{V}_2$ . As a view is a linear operator, and as error accumulates as the robot travels on its path, a simple scheme is to linearly interpolate between the two as a function of the proportion of the total boundary length travelled.

$$\mathbf{V}_i(\rho) = (1 - \rho)\mathbf{V}_1 + \rho\mathbf{V}_2$$

and the position of any intermediate path point is given by:

20 
$$\mathbf{p}_\rho = \mathbf{V}_i(\rho)\mathbf{p}_\rho$$

The view which projects each point into the new map changes smoothly from the start view to the end view as we travel along the boundary path from start to finish.

25 Finally, to make the finish segment correspond to the segment in the robot co-ordinate system, a post-projection rotation and translation is applied (step 380).

An alternative way of considering the map correction is as follows. When the machine has completed a circuit of the area and the path matching process has determined that the machine has returned to a known position, it is possible to calculate the difference in

distance and angle between the two points on the navigation system's map of the area which are known to be the same position. This total accumulated error can then be divided among the coordinates which have been recorded for that initial traverse of the area. In its simplest form, the error can be equally divided among all of the points in a linear manner (small portion of the error for the points near the start, larger portion for the points near the finish.) Once the machine has updated the map coordinates, it uses the updated map for the subsequent navigation of the area.

Once the machine has established a good map of the working area the machine then begins the task of cleaning the entire floor area, which is described in the flow chart of Figure 11.

The basic technique that the machine uses to cover a floor area is a reciprocating scanning movement, as shown in Figure 12. That is, from a start point 450, the machine follows a set of parallel straight line paths 451, each path 451 being followed by a step across movement 455 that positions the machine pointing back in the direction from which it has just come but translated one brush bar width across in the direction of the scan. The straight line path is maintained by monitoring the orientation of the machine and correcting the speeds of the left and right traction motors so as to maintain a straight line. The step across action can take place in multiple segments, as shown by action 460. This allows the machine to match the profile of the object that has impeded the straight trajectory. There are a number of movement sequences that are used to maximise the depth of the scan and these are detailed after this general description. Eventually the machine will no longer be able to continue scanning in the direction it has chosen. This will occur when there is no more space to move into or when there have been a number of short traverses.

For a simple room, the machine may be able to completely traverse the floor area with one reciprocating scanning movement. However, for most room layouts the combination of unusual room shape and objects placed within the room (particularly objects positioned away from the walls) will require two or more separate scanning movements.

Once the boundary map has been corrected the machine examines the shape of the room and looks for the most appropriate point to start the cleaning scan from. There are various ways of doing this.

## 5 **Room scanning**

A preferred way of scanning the room will now be described. Initially the machine looks for uncleaned regions that are adjacent to the boundary. As the machine travelled around the boundary of the area it also used the sensor or sensors on the sides of the machine to measure the distance to the nearest obstacles located to the sides of the machine and recorded that information on the map. Once the machine completes a lap of the boundary of the area it then processes the 'distance to obstacle' data to derive a free space vector. The free space vector (605, Figure 13) represents the amount of uncleaned space in a direction from that point on the map. The free space will be the distance to an obstacle minus any distance that the machine has already covered during its path. The free space vectors are plotted on the map at regular points around the boundary path. Since the machine has not travelled through the centre of the area, and lacks any advance knowledge of the layout of the area, this is the best information that the machine has of the layout of the area within the boundary. When deciding where to begin scanning, the navigation system looks at where, on the map, the free space vectors are located (step 505, Figure 11). The system looks for the longest length of boundary with free space vectors. An alternative criterion is for the system to choose the closest boundary section to the machine's current position which has free space located adjacent to it. Boundary sections with free space adjacent to them are located at 610, 612, 614. Having found the longest boundary with free space (section 610), the navigation system attempts to find the dominant edge orientation of this part of the area (step 520). In performing a reciprocating pattern, the machine is particularly prone to accumulating odometry errors at the places where it turns through 180 degrees. Thus, it is preferred to traverse an area in a manner which minimises the number of turns. We have found that the dominant edge orientation of an area has been found to be the best direction to traverse an area.

30

There are various ways in which the dominant edge orientation can be found. One way is to plot the direction (as an absolute angle) of each segment of the selected path section 610 on a histogram. One axis of the chart represents the absolute angle of the paths and the other axis represents the accumulated length of path segments at a particular angle. For a  
5 complicated path this could result in a lot of computation. The computation can be simplified by only recording a segment of the path as a different angle when its angular direction differs from an earlier part of the path by more than a particular angular range, e.g. ten degrees. If this simplification is followed, the plot at each angular value can be represented by a distribution curve. Segments which are separated by 180 degrees can be  
10 plotted at the same angular value on the bar chart since they are parallel to one another. This bar chart can be readily processed to derive the dominant direction of the area.

Having identified the dominant direction, the navigation system isolates the area of the map in which the selected boundary path section lies, as shown in Figure 14. The  
15 navigation system rotates the isolated part of the area until it is aligned in the dominant direction and then finds the extremities of this part of the area. The navigation system then selects one of the extremities as a start point for the scan.

A further analysis is made of the selected part of the room area. This determines whether  
20 the free space is located inside or outside the boundary. Figure 15 shows two types of area which can be encountered. An internal free space area is enclosed by the boundary section whereas an external area free space area surrounds the boundary section. The navigation system can determine the type of free space area by summing the angular change between each segment of the boundary section. An angular change sum of 360 degrees indicates an  
25 internal area whereas an angular sum of -360 degrees represents an external area.

There are some heuristics in selecting the start point. If the end points 620, 630 of a scan area are spaced apart from one another on the map by more than a predetermined distance then they are considered to represent an open area. If the free space area is an internal  
30 area, the navigation system will try not to choose one of these end points as a start point as this will tend to cause the machine to scan towards the boundary in a direction which is

possibly away from other free space that could be cleaned. The navigation system attempts to select a start point located elsewhere on the boundary, i.e. bounded on both sides by other path segments of the selected path section. A start point of this type has been found to cause the machine to scan inwards into the area rather than outwards. When  
5 the machine scans inwards it can often clean other free space areas after the isolated area has been cleaned, which can reduce the overall number of separate scanning operations that are required to cover the room area. Also, if there is a choice of start point, the nearer start point to the current position of the machine is chosen, providing the machine is able to localise (reset odometry errors) before reaching the start point.

10

As shown in Figure 16, once a start point on the map has been selected, an L meter section of the boundary path data preceding the desired scan start point is extracted from the memory (step 530). If necessary, the machine then selects a point further back along the boundary from the start of the extracted section and marks this as a target point. The  
15 machine then attempts to find a path across the room to this target point from its current location. It does this by searching the room map for places that it has previously visited it then plots a path over these spaces to the target point on the boundary. It then moves to the target point and follows the boundary until it matches the trajectory section for the start of the next cleaning scan. Matching of this segment of the boundary path data is carried out  
20 in the same way as that of matching to find the start position.

If it fails to find a route to the target point (step 545), either because the route was too risky or because it encountered an object on the way, then it moves onto the boundary. It moves round the boundary until it reaches one of the better free space points and starts a scan  
25 from there.

Once the machine reaches the scan start point it orients to the chosen scan direction (the dominant direction identified earlier) and proceeds to scan in a reciprocating manner into the uncleaned space (step 550). While the machine is moving in a straight line it is  
30 constantly checking to see if it has already visited the space it is on. Once it sees that it has run over a previously visited space by its own length then it stops and carries out a step

across. Since this step across is in open space it is a single segment step across. This cleaning scan continues until either it is blocked or there have been a small number of short traverses or the whole of the previous traverse was on space that had been visited previously. During the scanning process, the navigation system records the travelled path  
5 on the map, such that the machine knows which positions of the map have been cleaned, and also continues to record the distance to the nearest obstacle seen by the machine's sensors on the map. After each scanning operation the machine processes the distance information recorded on the map, taking account of the areas already cleaned by the machine, to calculate a free space vector. The free space vectors are plotted on the map  
10 and can then be used by the navigation system to decide the next area where scanning should occur.

A period of reciprocating scanning will induce odometry errors. Therefore, between each period of scanning, the machine looks for the boundary of the area and follows the  
15 boundary of the area (step 560). As the machine travels around the boundary of the area it stores the path travelled by the machine. The machine travels for a distance of at least the minimum distance necessary for finding a match, i.e. L metres. The matching process attempts to match the new block of boundary path data with the boundary path data that was originally stored in the memory. If a block of path data matches positively then the  
20 machine knows it has returned to a known position on the map and can thus rest the odometry error to zero. If the matching process fails to find a good match then the machine will continue on the boundary until it should have reached one of the marker positions. If this also fails then it assumes that it is on a central object.

25 If the machine correctly recognised a position on the boundary then it realigns the just completed traverse scan and the boundary section onto the free space map, based on the measured error between the machine's perceived position on the map and the actual position on the map. The navigation system then finds the next largest uncleaned part of the area (step 505).

30

The machine then repeats the search for freespace and the moves to them until all the space that can be identified on the map has been completed (steps 510, 515).

5 During the matching process, in addition to looking for a strong match between blocks of data, the matching process also makes a number of safety checks. It makes sure that the orientation of the matching section is roughly the same as the extracted section and that they both roughly lie in the same part of the internal map. The odometry error gradually increases with distance travelled. The matching process sets an event horizon, i.e. a boundary for possible positions on the map where, due to odometry error, a match  
10 may occur. Any matches which correspond to positions in the room which are not, due to the size of the odometry error, possible positions for the machine are discounted.

An alternative technique for determining the direction in which to travel across a selected area of free space will now be described with reference to Figure 14A. As described  
15 above, when deciding where to begin scanning, the navigation system looks at where, on the map, the free space vectors are located (step 505, Figure 11). The system looks for the longest length of boundary with free space vectors or for the closest boundary section to the machine's current position which has free space located adjacent to it. However, rather than finding the dominant edge orientation of this part of the area (step 520), the navigation  
20 system simply joins the two ends 620, 630 of the selected boundary section and takes the connecting line 615 as the direction to be used during the scanning operation. The navigation system selects a start point 640 for the scan which is opposite the connecting line 615, i.e. so that the machine will travel across the selected area towards the perceived edge of the free space area. The start point 640 is the furthest point on the boundary from  
25 the connecting line 615. As shown in Figure 14A, this is the point on the boundary which lies at a furthest distance from the connecting line 615 when a line is drawn perpendicular to the connecting line 615. The machine locates the start point using the same techniques as previously described. Once the machine has arrived at the start point it begins the reciprocating scanning pattern, with a direction which is parallel to the connecting line  
30 615. The progression of the scan, i.e. the direction in which the machine moves after each line of the scan, is generally perpendicular to the connecting line 615. The machine stops

when it cannot continue the scanning pattern any further. For an initial area, the reason for stopping the scanning pattern will be that the machine has reached an object or the boundary. For subsequent areas, the machine may stop, or restrict the width of the scanned pattern if the map of visited places indicates that the position has previously been  
5 traversed. This alternative scheme has several benefits. Firstly, it reduces the amount of computation required to find the initial direction of the scan compared to the technique for finding the dominant direction, as described above. Secondly, it has been found that this technique is successful in allowing the machine to traverse most or all of the selected area before proceeding to other free space areas.

10

Figures 15 and 16 show the same room as Figure 13, and illustrate the scanning patterns performed by the machine. In these examples, the direction of the scan patterns follows the scheme just described. Having identified a part of the boundary 610 which has free space located adjacent to it, the machine determines the connecting line 615 and selects the  
15 start point 640. The machine finds the start point and then begins to perform the scan 650, with each path of the scan being aligned parallel with the connecting line 615. The scan continues beyond the area that was initially identified (see Figure 14A) and the machine stops the scanning pattern when it reaches the boundary on the far side of the area at point 652. The machine updates the map of visited places and then examines the updated map to  
20 select the next part of the boundary which has free space located alongside it. In this example, it is part 614 of the boundary. As part 614 of the boundary is a straight line, the connecting line between the boundary points is a straight line too, and thus the direction of each path of this next scan pattern is parallel with part 614 of the boundary. As shown in Figure 16, the machine begins a second scanning pattern, away from the boundary, into the  
25 uncleaned area. The navigation system will determine when the machine arrives at a position which has previously been visited, and will stop. In this simple example there are no other areas remaining to be cleaned. However, for a more complex area, the navigation system of the machine will continue to select parts of the boundary which have uncleaned (unvisited) free space alongside them and will select a direction for the scanning pattern  
30 based on the shape of those parts of the boundary. Should any parts of the area remain uncleaned (unvisited) after the machine has performed scanning patterns from the



boundary, the machine then selects those areas which are adjacent to objects placed within the area. The procedure for dealing with central objects is described more fully below. If, after this, there are still uncleaned (unvisited) areas, the machine will select a part of the boundary, or an object, near to the uncleaned area and will begin a scanning pattern from  
5 this starting point, with the scanning pattern progressing into the uncleaned area. The use of a part of the boundary or an object as a starting point allows the machine to have a good reference for the scanning pattern.

### Central Objects

10 A complex area is likely to include obstacles which are located away from the boundary of the area, such as a coffee table. Figure 19 shows a strategy for coping with central objects. The machine performs a scanning operation 750 and eventually reaches a point at 760 where it can no longer continue the scanning movement. The machine then proceeds to follow the edge of the object 785, cleaning around the edge of the object. After travelling  
15 a distance of L metres around the object 785 the machine will attempt to match the last L metre path section with the path recorded around the boundary of the room. This should fail to give a suitable match. Thus, the machine recognises that it is following the edge of an object. The machine jumps off of the object at position 780, on the remote side of the object in the direction of the scan, and follows the boundary of the room 790 until it can  
20 match the travelled path with the previously stored boundary path data. At this point the navigation system can reset any odometry error and accurately place the position of the object 785. Note, in following the edge of a central object, the machine may travel around the object several times until it has travelled a distance of L metres.

### 25 Scanning behaviours

Figures 20-22 show some of the ways in which the machine operates during a scanning operation. As previously described with reference to Figure 12, the scanning operation comprises a series of parallel straight line paths which are offset from one another by a distance W, which will usually be equal to the width of the cleaning head of the  
30 machine. However, irregular boundary shapes do not always permit the machine to follow a regular scanning pattern. Figure 20 shows a segmented step across where the

machine follows the boundary 800 of the room in segments 804, 806 until it has travelled the total required step across distance  $W$ . At each step the machine rotates until it sees a clear path ahead and travels forward until it needs to turn. The step across distance  $W$  can be determined from trigonometry of the travelled paths 804, 806. A  
5 complex step across movement may comprise more segments than are shown here. This movement allows the machine to properly cover the floor surface and to continue the scanning movement at the regular width  $W$ .

Figures 21 and 22 show other situations where the boundary prevents the machine from  
10 performing a regular step across movement. In Figure 21 the machine reaches the end of movement 810 and follows the wall along path 812 until it can step across at 813 to the proper scan separation distance  $W$ . Figure 22 shows a similar scenario where the machine must travel back on itself along path 822 until it can travel across along path 823 and continue the scanning movement at the regular width  $W$ . In these movements  
15 the machine monitors, during path 810, 820 the distance on its right hand side to the wall/obstacles to determine whether the machine will be able to step across to continue its scanning movement.

### Markers

20 Markers are  $L$  metre sections of path data which can be used at various times by the navigation system to quickly determine the current position on the boundary. They are particularly useful in allowing the machine to cope with the kinds of errors that can occur when the machine is forced to follow a different path around the boundary, e.g. because something has been moved. If the machine is travelling around the boundary  
25 looking for a particular  $L$  metre section of the path but fails to find it, it will usually find the marker positioned after that particular section of required boundary and thus allow the machine to quickly recognise the error. Markers are also useful when the machine attempts to travel across a room area to reach a start point for a scan but misses it for some reason. This may occur if the machine does not properly reach the target point  
30 before the  $L$  metre section of boundary preceding the start point (see Figure 18). Should the machine not find the start point, it follows the boundary of the area and should find

the next marker on the boundary. Upon finding the marker the machine can recognise its error and try again.

### Alternatives

5 The described method of recognising a previously visited position in an area by matching travelled path sections is dependent on several factors. Firstly, the navigation system should be able to cause the machine to travel in a closely similar manner when negotiating the same boundary on different occasions. The value of the 'quality of match' threshold and the process of sub-sampling path data so that the matching process  
10 considers the underlying path rather than the detailed path does allow for some variation between travelled paths while still allowing a successful match. Secondly, the matching process is dependent on the L metre path that is used during the matching process being unique to a position in the room. In rooms that possess one or more lines of symmetry, it is possible for the L metre path to be common to two or more positions within the  
15 room. Obviously, a truly rectangular room with no other obstacles on the boundary would cause a problem. The system can be made more robust in several ways.

Firstly, the length of the path used in the matching process can be increased until it does represent a unique position in the room. This can be performed automatically as part of  
20 the navigation method. Should the machine travel for more than a predetermined time period without finding a match, the navigation system can automatically increase the length of the matching window.

Secondly, the path data can be supplemented by other information gathered by the  
25 machine during a traverse of the area. This additional information can be absolute direction information obtained from an on-board compass, information about the direction, intensity and/or colour of the light field around the machine obtained from on-board light detectors or information about the distance of near or far objects from the machine detected by on-board distance sensors. In each case, this additional  
30 information is recorded against positions on the travelled path.

The map correction process described above applies a linear correction to the travelled path. In an alternative embodiment, the accumulated error can be divided among the set of coordinates in a more complex manner. For example, if the machine is aware that wheel slippage occurred half way around the traverse of the room boundary, it can  
5 distribute more (or all) of the accumulated error to the last half of the path coordinates.

The above method describes the machine following a clockwise path around an area. The machine may equally take an anti-clockwise path around the area during its initial lap of the boundary of the area. Also, in following the boundary to reach a start position for area  
10 scanning, the machine may follow the boundary in a clockwise or anti-clockwise direction.

In performing the cleaning method, it is preferred that the cleaning machine steps across by substantially the width of the cleaner head on the cleaner so that the cleaning machine covers all of the floor surface in the minimum amount of time. However, the distance by  
15 which the cleaning machine steps inwardly or outwardly can have other values. For example, by stepping by only a fraction of the width of the cleaner head, such as one half of the width, the cleaning machine overlaps with a previous traverse of the room which is desirable if a user requires a particularly thorough cleaning of the floor. The step distance can be chosen by the user. There are various ways in which the user can choose the step  
20 distance: the user can be presented with a plurality of buttons or a control that specifies the step distances, or controls having symbols or descriptions indicative of the effect of the cleaner operating at the step distances, such as "normal cleaning", "thorough cleaning". The buttons can be incorporated in the user panel (140, Fig. 1), a remote control or both of these.

25

Claims

1. An autonomous machine for traversing an area comprising:
  - power operated means for moving the machine along a surface of an area, and
  - 5 - a navigation system, including sensors and a memory means, for navigating the machine around the area,  
the navigation system being arranged, in use, to store information about the area and to traverse the area by a scanning pattern, wherein the navigation system is also arranged to determine, from the stored information, an optimum direction for the machine to traverse  
10 the area.
2. An autonomous machine according to claim 1 wherein the navigation system is arranged to determine, from the stored information, a direction for the machine to traverse the area which maximises the length between turning points of the scanning pattern.  
15
3. An autonomous machine according to claim 1 or 2 wherein the navigation system is arranged to cause the machine to follow a boundary of the area to acquire the information about the area.
- 20 4. An autonomous machine according to claim 3 wherein the information about the area is information about the amount of free space to a side of the machine which is acquired as the machine travels around the boundary of the area.
5. An autonomous machine according to claim 4 wherein the navigation system is  
25 arranged to select an area for scanning on the basis of the longest length of boundary having free space alongside it.
6. An autonomous machine according to claim 4 wherein the navigation system is  
30 arranged to select an area for scanning on the basis of the nearest part of the boundary, to the current position of the machine, having free space alongside it.

7. An autonomous machine according to any one of claims 4 to 6 wherein the navigation system is arranged to update the stored information about the amount of free space as the machine traverses the area to account for the places where the machine has visited.

5

8. An autonomous machine according to any one of the preceding claims wherein the navigation system is arranged to select an area to traverse by the scanning pattern, to determine a dominant orientation of the edges of the selected area, and to use the dominant orientation as the direction of each path of the scanning pattern.

10

9. An autonomous machine according to any one of the preceding claims wherein the navigation system is arranged to select an area to traverse by the scanning pattern and to determine, for the selected area, a starting point to begin the scanning pattern which will cause the machine to move outwardly from the boundary of the area.

15

10. An autonomous machine according to any one of the preceding claims wherein the navigation system is arranged to select, from the stored information, an area to traverse by the scanning pattern and to determine the direction of a line which connects the end points of the boundary of the selected area, wherein the determined direction is used as the direction of each path of the scanning pattern.

20

11. An autonomous machine according to claim 10 wherein the navigation system is arranged to select a starting point for the scanning pattern which is opposite the line which connects the end points of the selected area.

25

12. An autonomous machine according to claim 11 wherein the navigation system is arranged to select a starting point for the scanning pattern which is furthest from the line which connects the end points of the selected area.

30

13. An autonomous machine according to any one of the preceding claims wherein the scanning pattern is a reciprocating pattern.

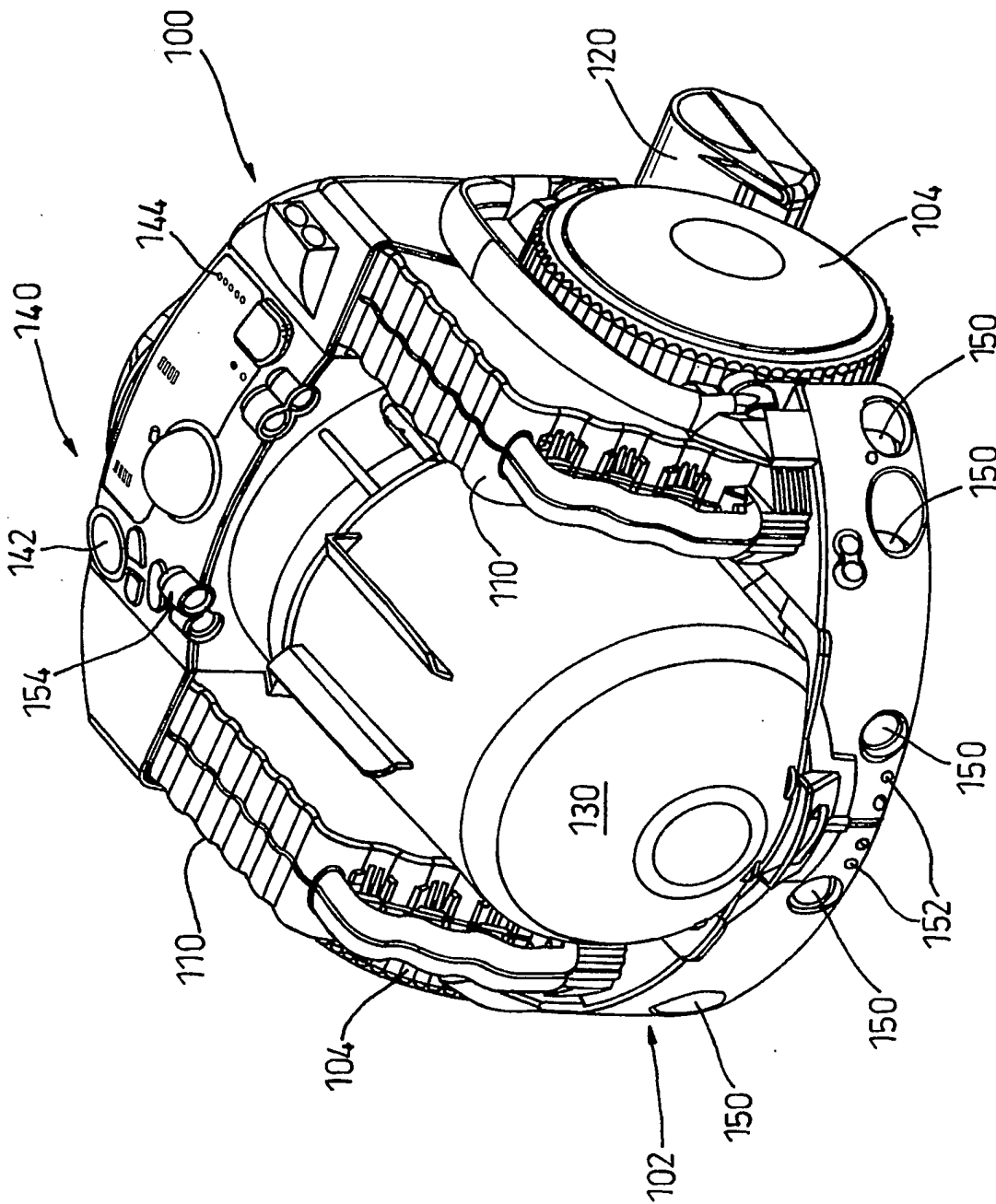
14. A method of controlling an autonomous machine comprising navigating the machine around an area, storing information about the area and determining, from the stored information, an optimum direction for the machine to traverse the area.

5

15. A method according to claim 14 wherein the step of determining an optimum direction for the machine to traverse the area comprises maximising the length between turning points of the scanning pattern

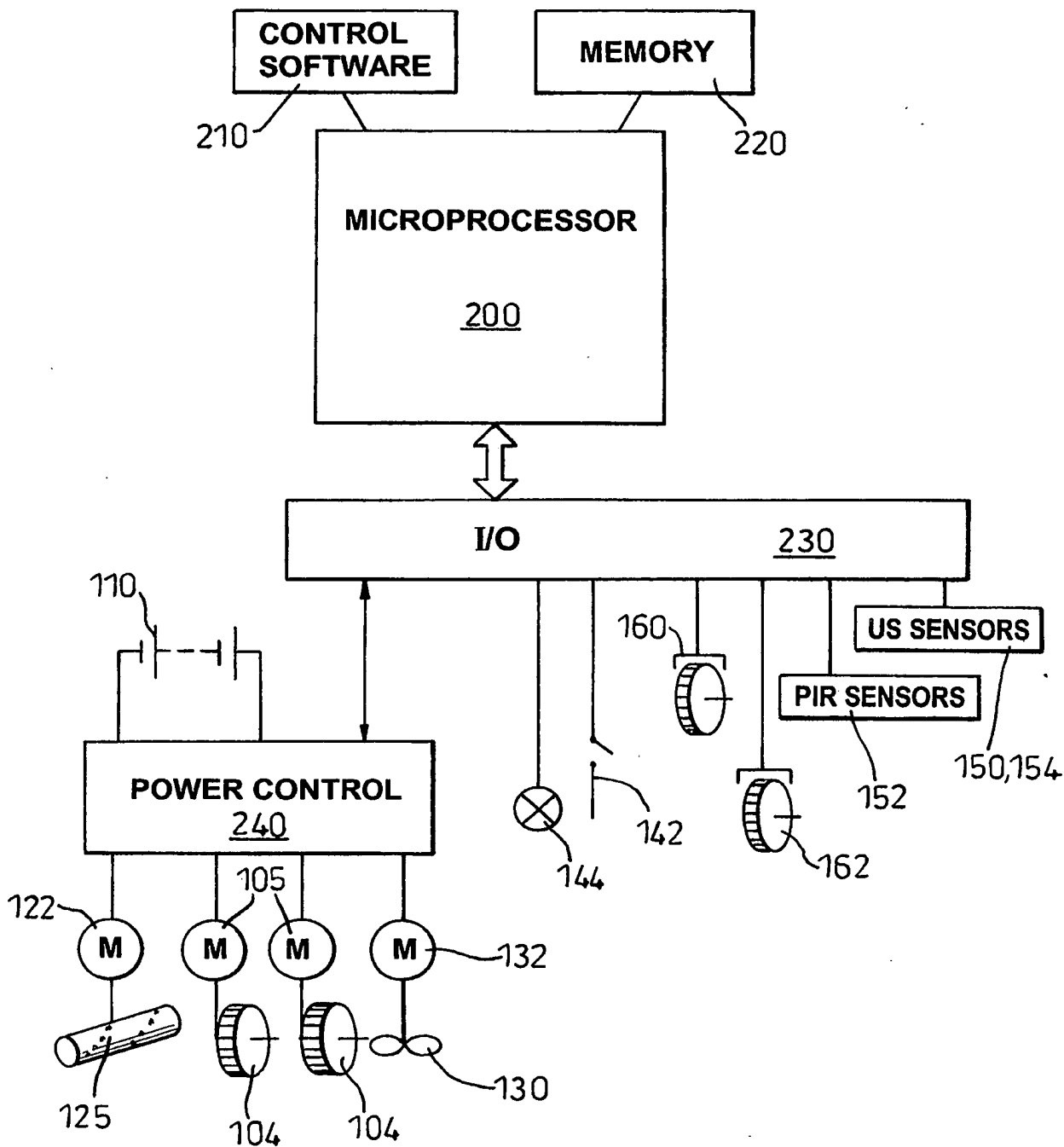
10 16. Software for controlling an autonomous machine to perform the method according to claim 14 or 15.

15 17. An autonomous machine, a method of controlling an autonomous machine or software method for controlling an autonomous machine substantially as described herein with reference to the accompanying drawings.

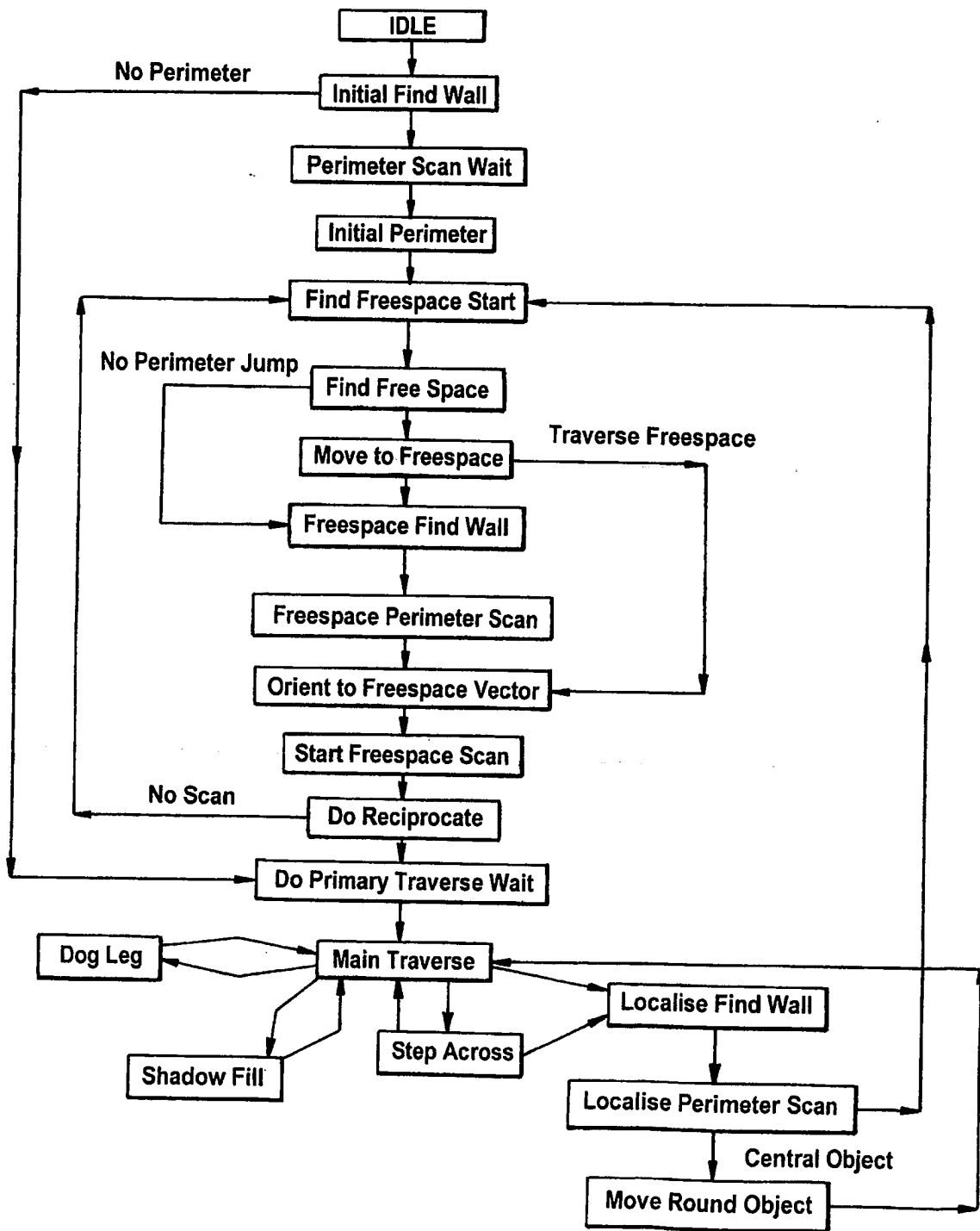


**Fig. 1**



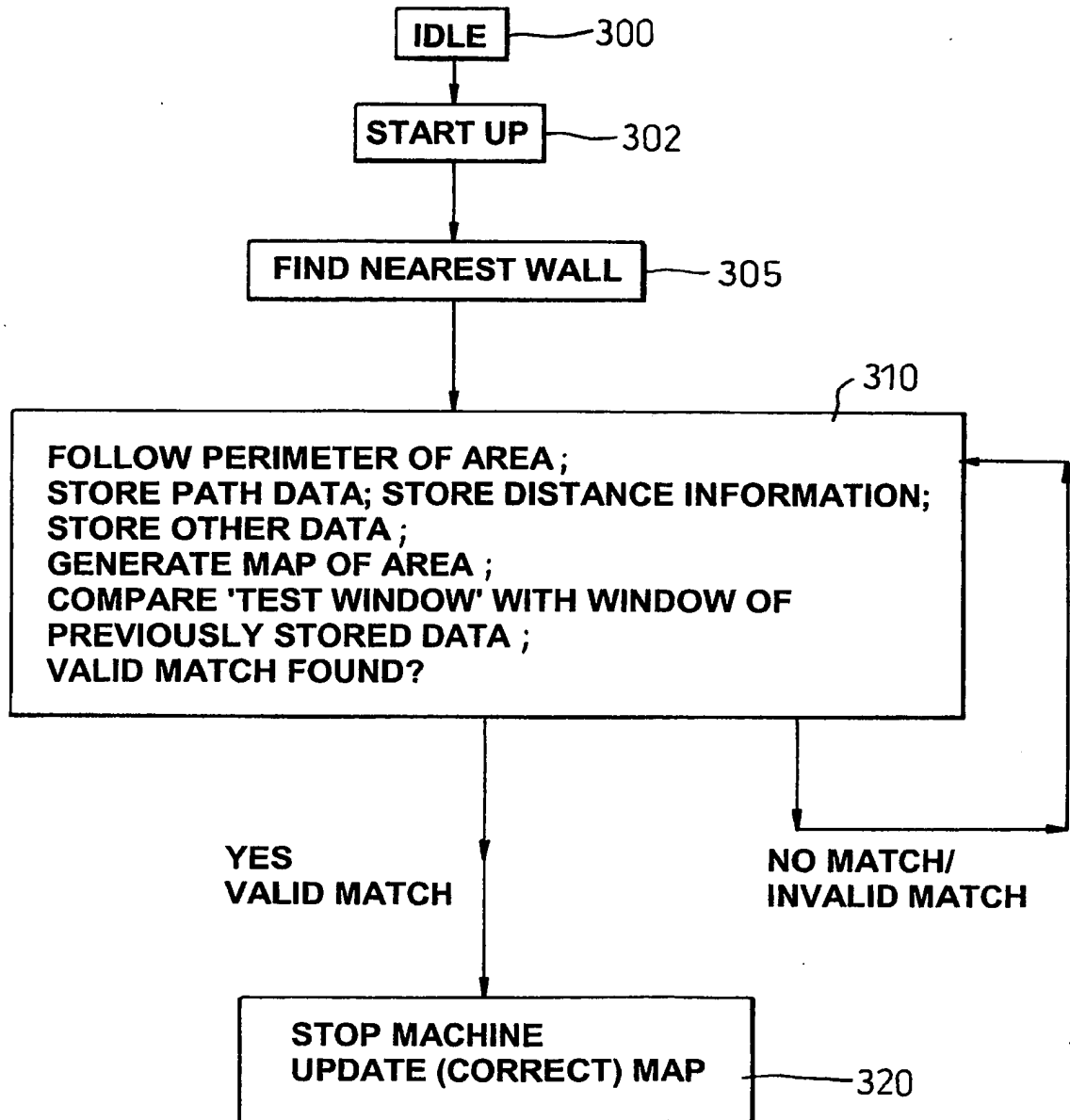


**Fig. 2**

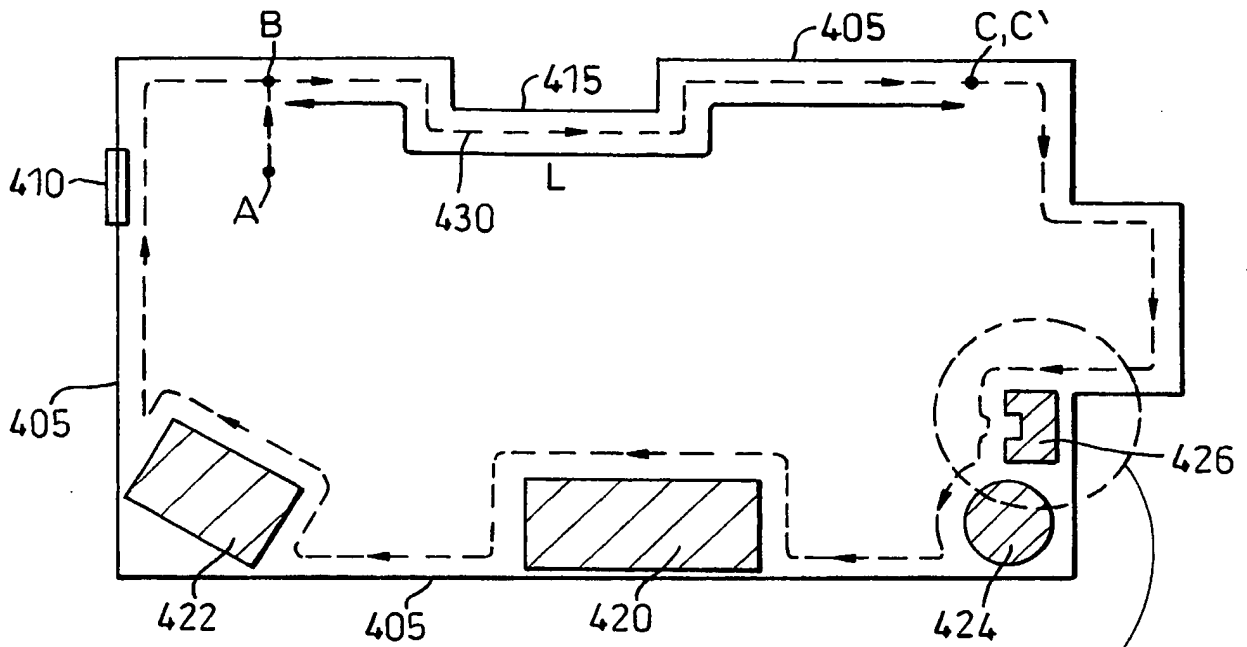


*Fig. 3*

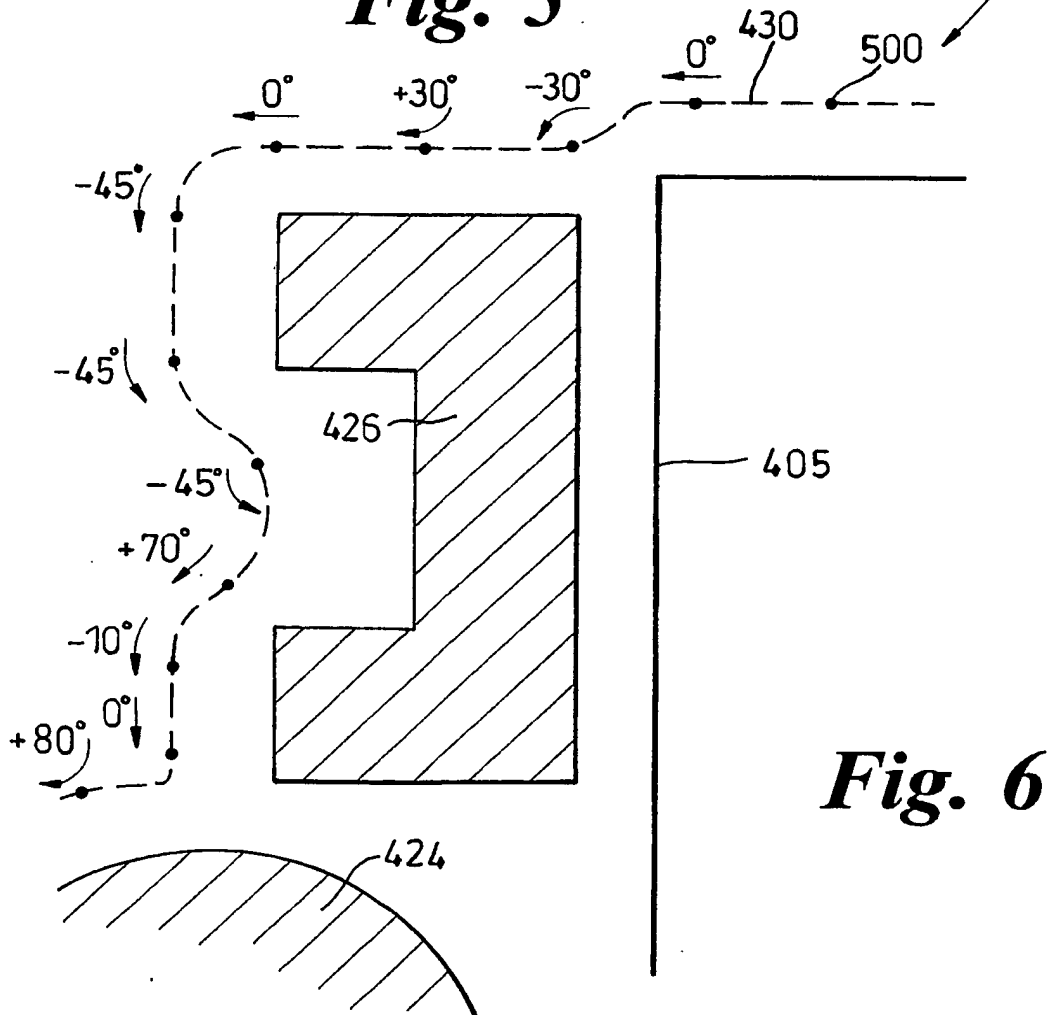
4/14



*Fig. 4*



**Fig. 5**



**Fig. 6**

	0	4	10	5	0	-10	-10	-20	-5	0	0	0	10	10	10	0	0	5	15	0	-10	-10	0	0
PATH DATA VECTOR																								
	20	8	-5	-15	-3	0	10	5	3	8	-10	0												
SUB-SAMPLED SET (1)																								
	14		-10		-2	8			6		-5													
SUB-SAMPLED SET (2)																								

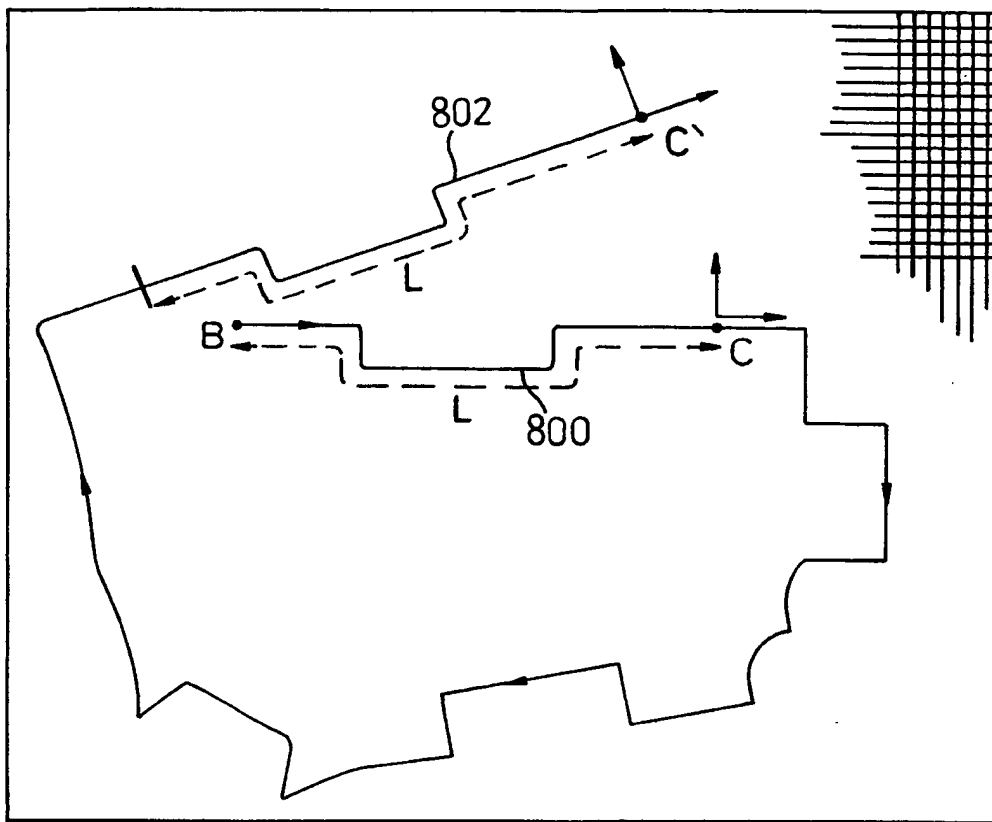
TABLE OF DIFFERENCES

PATH DATA	0	15	25	20	5	10	0	0
SUB-SAMPLED SET (1)	8	23	7	0				
SUB-SAMPLED SET (2)	16			3				

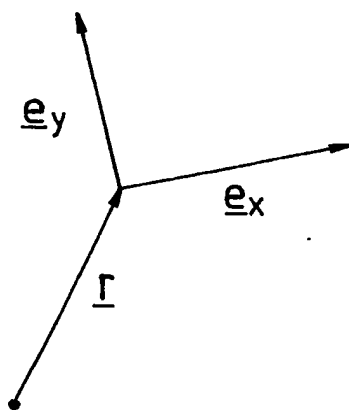
% MATCH

*Fig. 7*

7/14

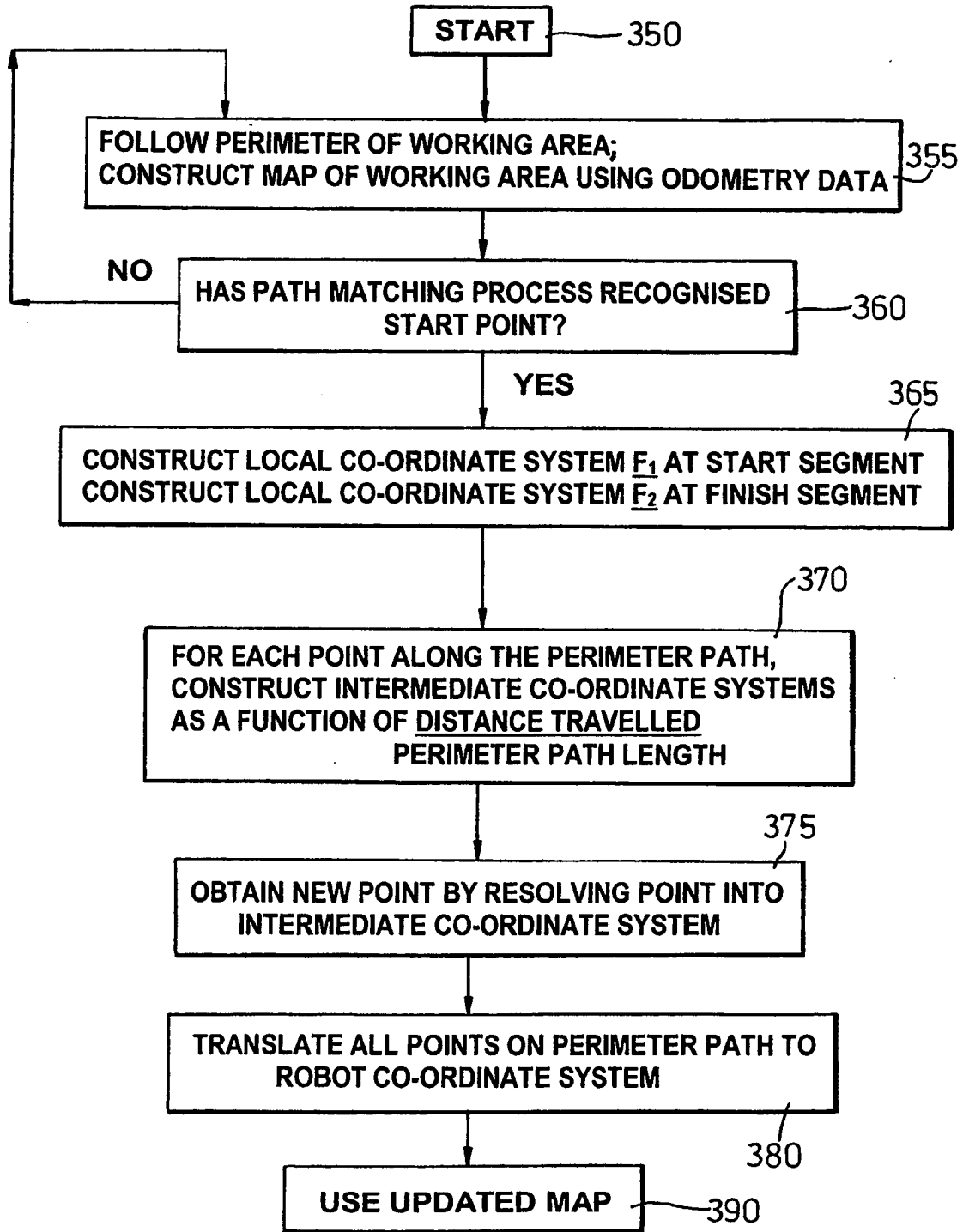


**Fig. 8**



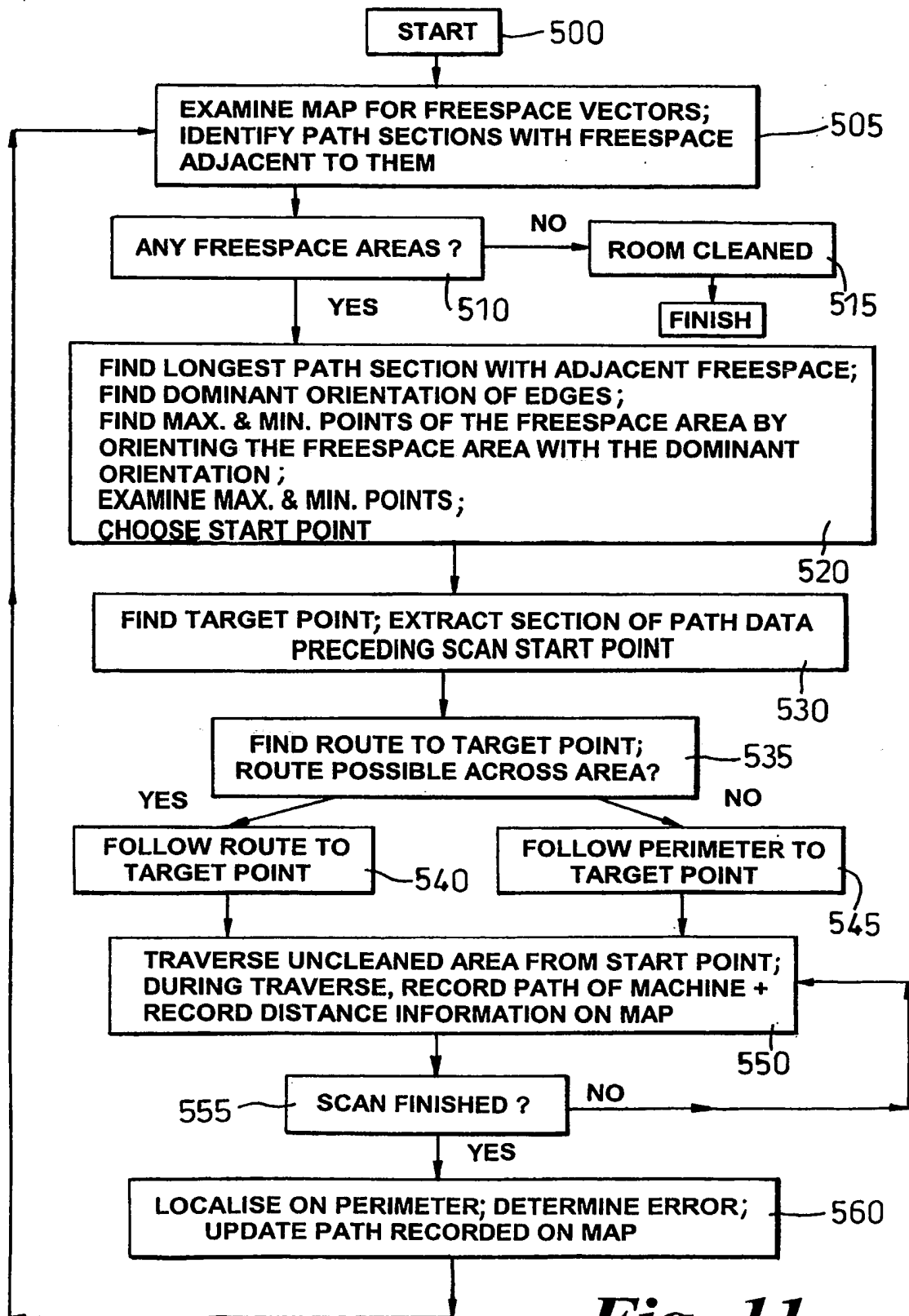
**Fig. 10**

8/14



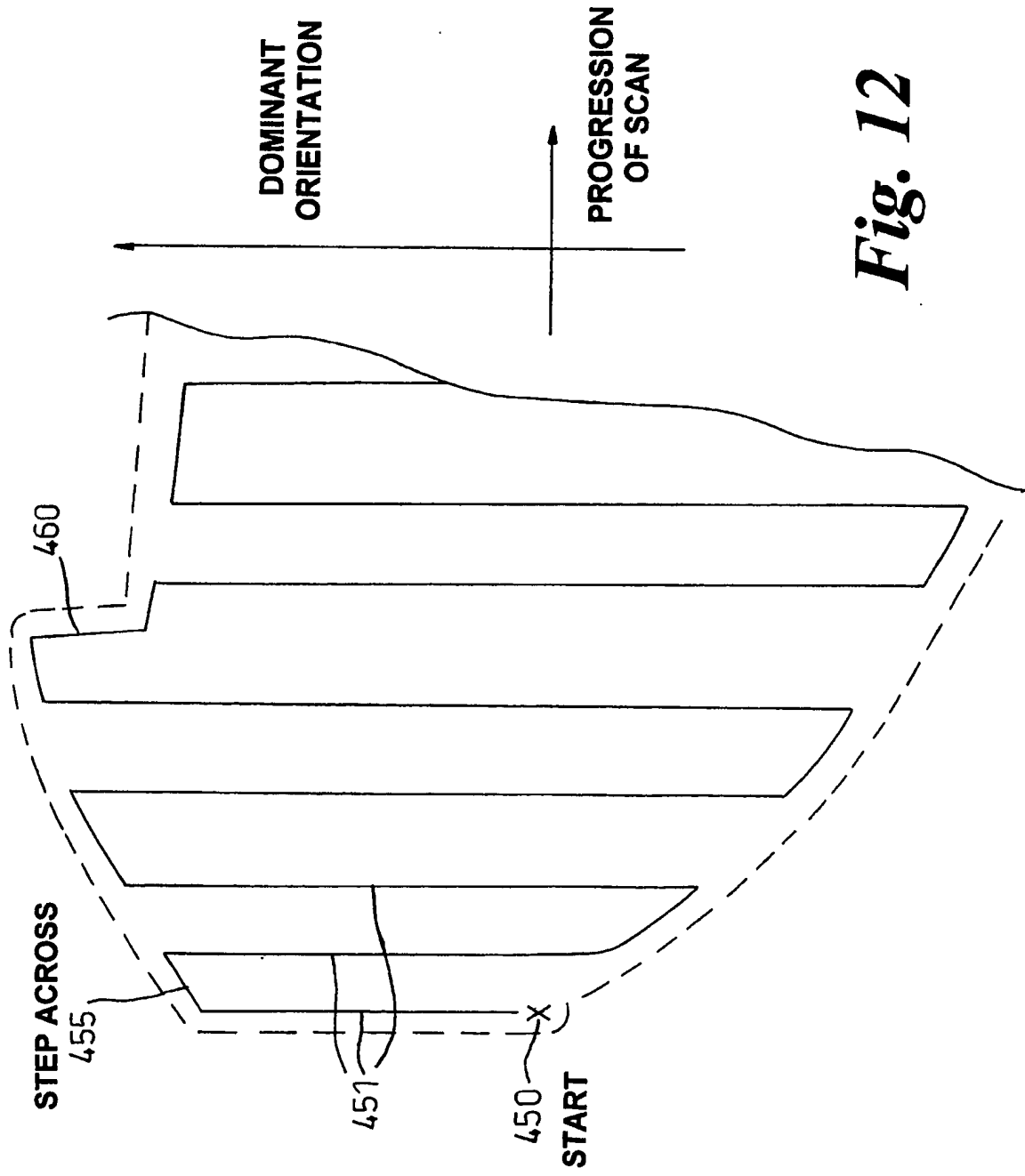
*Fig 9*

9/14



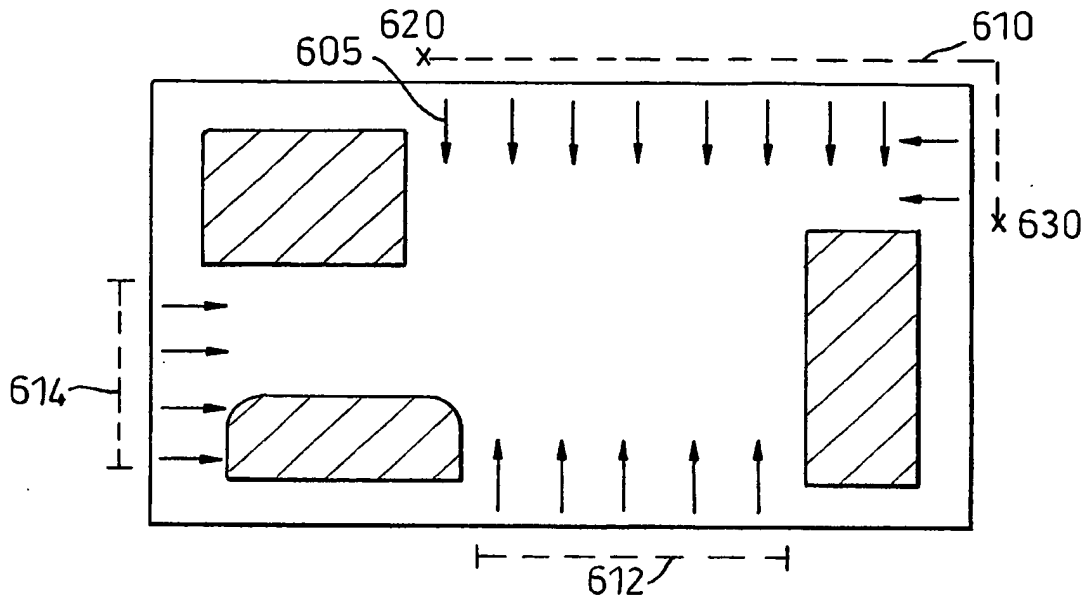
*Fig. 11*



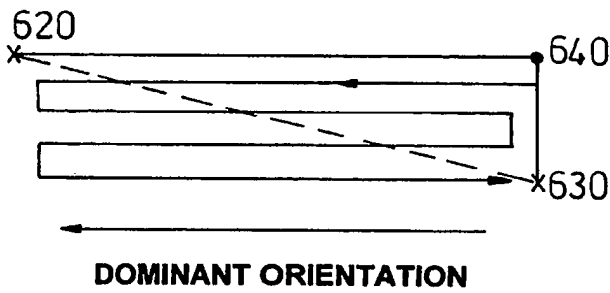


*Fig. 12*

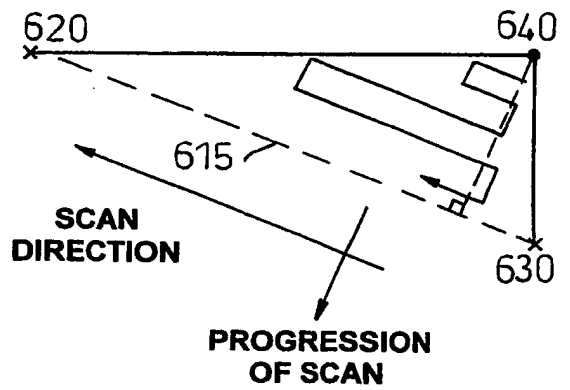
11/14



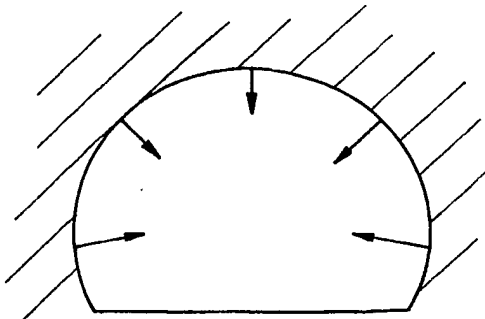
**Fig. 13**



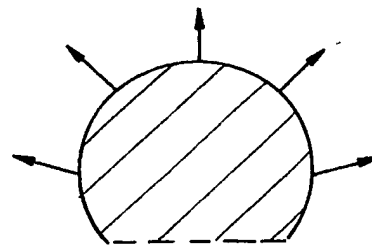
**Fig. 14**



**Fig. 14A**



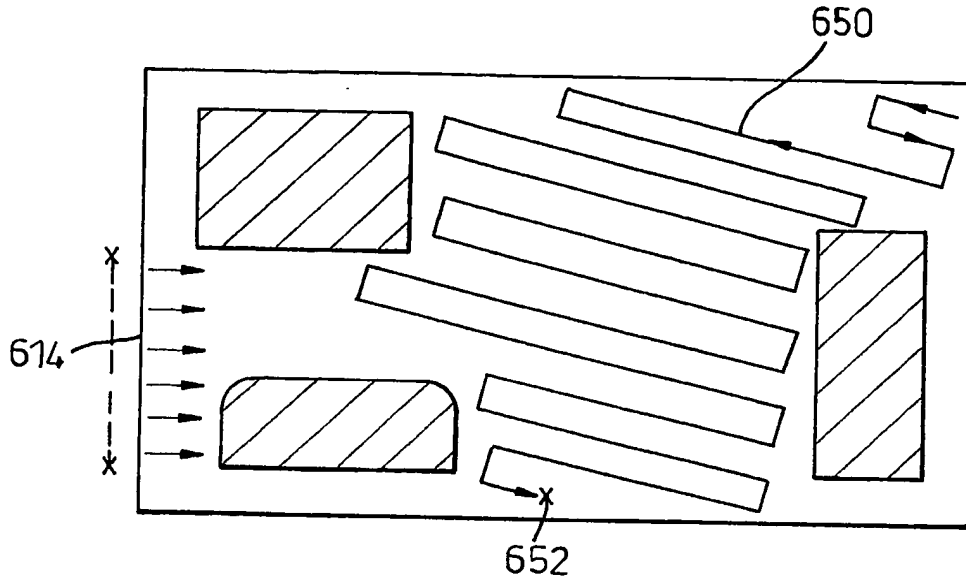
INTERNAL



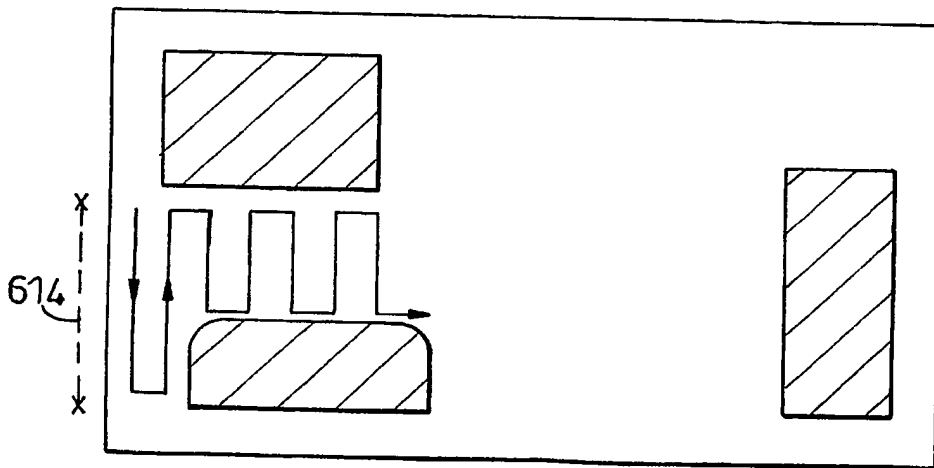
EXTERNAL

**Fig 17**

12/14

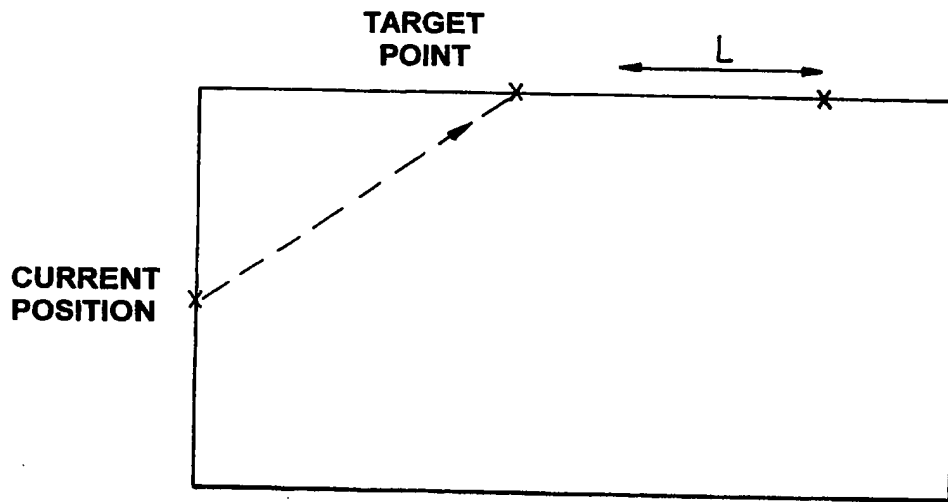


*Fig. 15*

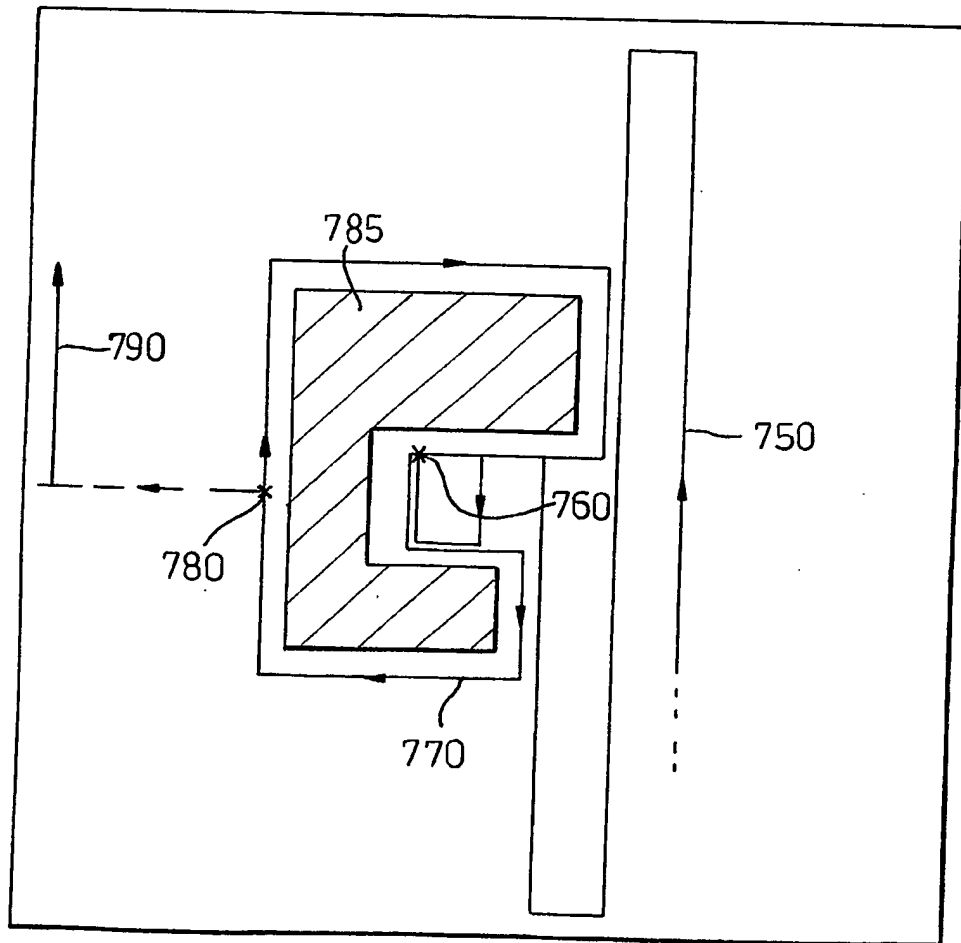


*Fig. 16*

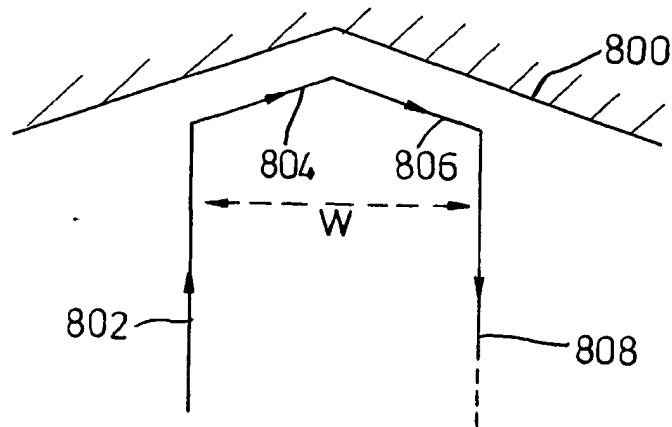
13/14



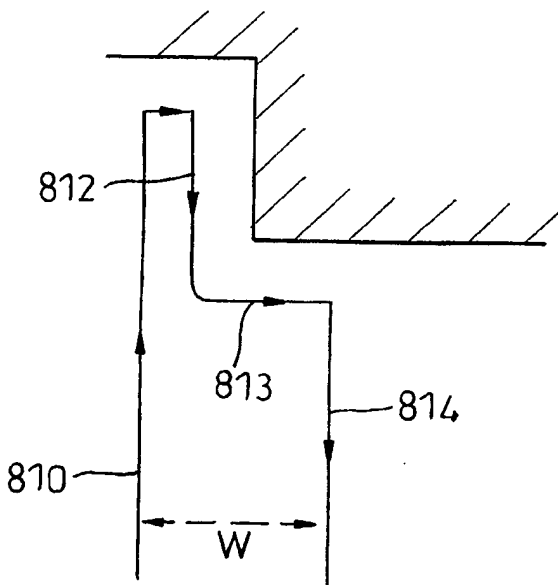
**Fig. 18**



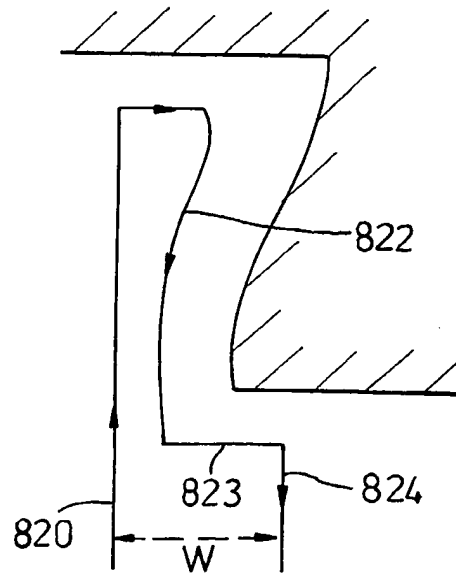
**Fig 19**



**Fig. 20**



**Fig 21**



**Fig. 22**

INTERNATIONAL SEARCH REPORT

PCT/GB 02/04955

A. CLASSIFICATION OF SUBJECT MATTER  
IPC 7 G05D1/02

According to International Patent Classification (IPC) or to both national classification and IPC

B. FIELDS SEARCHED

Minimum documentation searched (classification system followed by classification symbols)  
IPC 7 G05D A47L A01D

Documentation searched other than minimum documentation to the extent that such documents are included in the fields searched

Electronic data base consulted during the international search (name of data base and, where practical, search terms used)

EPO-Internal, WPI Data, PAJ

C. DOCUMENTS CONSIDERED TO BE RELEVANT

Category °	Citation of document, with indication, where appropriate, of the relevant passages	Relevant to claim No.
Y	WO 00 38025 A (NOTETRY LTD ;ALDRED MICHAEL DAVID (GB); BISSET DAVID LINDSEY (GB)) 29 June 2000 (2000-06-29) cited in the application the whole document	1,3,4,7, 13,14,16
Y	US 6 128 574 A (DIEKHANS NORBERT) 3 October 2000 (2000-10-03) column 1, line 41 -column 5, line 54	1,3,4,7, 13,14,16

Further documents are listed in the continuation of box C.

Patent family members are listed in annex.

° Special categories of cited documents:

- \*A\* document defining the general state of the art which is not considered to be of particular relevance
- \*E\* earlier document but published on or after the international filing date
- \*L\* document which may throw doubts on priority claim(s) or which is cited to establish the publication date of another citation or other special reason (as specified)
- \*O\* document referring to an oral disclosure, use, exhibition or other means
- \*P\* document published prior to the international filing date but later than the priority date claimed

- \*T\* later document published after the international filing date or priority date and not in conflict with the application but cited to understand the principle or theory underlying the invention
- \*X\* document of particular relevance; the claimed invention cannot be considered novel or cannot be considered to involve an inventive step when the document is taken alone
- \*Y\* document of particular relevance; the claimed invention cannot be considered to involve an inventive step when the document is combined with one or more other such documents, such combination being obvious to a person skilled in the art.
- \*&\* document member of the same patent family

Date of the actual completion of the international search

14 January 2003

Date of mailing of the international search report

27/01/2003

Name and mailing address of the ISA  
European Patent Office, P.B. 5818 Patentlaan 2  
NL - 2280 HV Rijswijk  
Tel. (+31-70) 340-2040, Tx. 31 651 epo nl,  
Fax: (+31-70) 340-3016

Authorized officer

Gardella, S

## INTERNATIONAL SEARCH REPORT

PCT/GB 02/04955

C.(Continuation) DOCUMENTS CONSIDERED TO BE RELEVANT		
Category °	Citation of document, with indication, where appropriate, of the relevant passages	Relevant to claim No.
A	<p>LANG S Y T ET AL: "Coordination of behaviours for mobile robot floor cleaning"</p> <p>INTELLIGENT ROBOTS AND SYSTEMS, 1998. PROCEEDINGS., 1998 IEEE/RSJ INTERNATIONAL CONFERENCE ON VICTORIA, BC, CANADA 13-17 OCT. 1998, NEW YORK, NY, USA, IEEE, US, 13 October 1998 (1998-10-13), pages 1236-1241, XP010311567  ISBN: 0-7803-4465-0  Paragraph 4. Environment Exploration and Motion Planning</p> <p style="text-align: center;">---</p>	1-16
A	<p>US 4 674 048 A (OKUMURA KATSUJI)  16 June 1987 (1987-06-16)  the whole document</p> <p style="text-align: center;">---</p>	1-16
A	<p>US 6 240 342 B1 (HELBACH JOERG ET AL)  29 May 2001 (2001-05-29)  claim 1</p> <p style="text-align: center;">-----</p>	1-16

INTERNATIONAL SEARCH REPORT

International Application No. PCT/GB 02 04955

FURTHER INFORMATION CONTINUED FROM PCT/ISA/ 210

Continuation of Box I.2

Claims Nos.: 17

Claim 17 does not include any technical feature but merely refers to the description and to the drawings.

The applicant's attention is drawn to the fact that claims, or parts of claims, relating to inventions in respect of which no international search report has been established need not be the subject of an international preliminary examination (Rule 66.1(e) PCT). The applicant is advised that the EPO policy when acting as an International Preliminary Examining Authority is normally not to carry out a preliminary examination on matter which has not been searched. This is the case irrespective of whether or not the claims are amended following receipt of the search report or during any Chapter II procedure.



INTERNATIONAL SEARCH REPORT

PCT/ISA 210/04955

**Box I Observations where certain claims were found unsearchable (Continuation of item 1 of first sheet)**

This International Search Report has not been established in respect of certain claims under Article 17(2)(a) for the following reasons:

- 1.  Claims Nos.:  
because they relate to subject matter not required to be searched by this Authority, namely:
  
- 2.  Claims Nos.: 17  
because they relate to parts of the International Application that do not comply with the prescribed requirements to such an extent that no meaningful International Search can be carried out, specifically:  
see FURTHER INFORMATION sheet PCT/ISA/210
  
- 3.  Claims Nos.:  
because they are dependent claims and are not drafted in accordance with the second and third sentences of Rule 6.4(a).

**Box II Observations where unity of invention is lacking (Continuation of item 2 of first sheet)**

This International Searching Authority found multiple inventions in this international application, as follows:

- 1.  As all required additional search fees were timely paid by the applicant, this International Search Report covers all searchable claims.
  
- 2.  As all searchable claims could be searched without effort justifying an additional fee, this Authority did not invite payment of any additional fee.
  
- 3.  As only some of the required additional search fees were timely paid by the applicant, this International Search Report covers only those claims for which fees were paid, specifically claims Nos.:
  
- 4.  No required additional search fees were timely paid by the applicant. Consequently, this International Search Report is restricted to the invention first mentioned in the claims; it is covered by claims Nos.:

Remark on Protest

- The additional search fees were accompanied by the applicant's protest.
- No protest accompanied the payment of additional search fees.

## INTERNATIONAL SEARCH REPORT

PCT/GB 02/04955

Patent document cited in search report		Publication date	Patent family member(s)	Publication date
WO 0038025	A	29-06-2000	GB 2344900 A	21-06-2000
			AU 1575300 A	12-07-2000
			GB 2361553 A	24-10-2001
			WO 0038025 A1	29-06-2000
US 6128574	A	03-10-2000	DE 19629618 A1	29-01-1998
			DE 59708415 D1	14-11-2002
			EP 0821296 A2	28-01-1998
US 4674048	A	16-06-1987	JP 60093522 A	25-05-1985
			JP 1708982 C	11-11-1992
			JP 3079723 B	19-12-1991
			JP 60093524 A	25-05-1985
			AT 44322 T	15-07-1989
			CA 1217836 A1	07-02-1987
			DE 3478824 D1	03-08-1989
			EP 0142594 A1	29-05-1985
US 6240342	B1	29-05-2001	DE 19804195 A1	05-08-1999
			WO 9940496 A1	12-08-1999
			DE 59900221 D1	04-10-2001
			EP 1053516 A1	22-11-2000
			JP 2002502997 T	29-01-2002



(11) Publication number: **2000353014 A**

Generated Document.

**PATENT ABSTRACTS OF JAPAN**

(51) Intl. Cl.: **G05D 1/02 A47L 11/00**

(21) Application number: **11162454**

(22) Application date: **09.06.99**

<p>(30) Priority:</p> <p>(43) Date of application publication: <b>19.12.00</b></p> <p>(84) Designated contracting states:</p>	<p>(71) Applicant: <b>TOYOTA AUTOM LOOM WORKS LTD</b></p> <p>(72) Inventor: <b>ICHIJO HISASHI</b></p> <p>(74) Representative:</p>
---	---

**(54) CLEANING ROBOT**

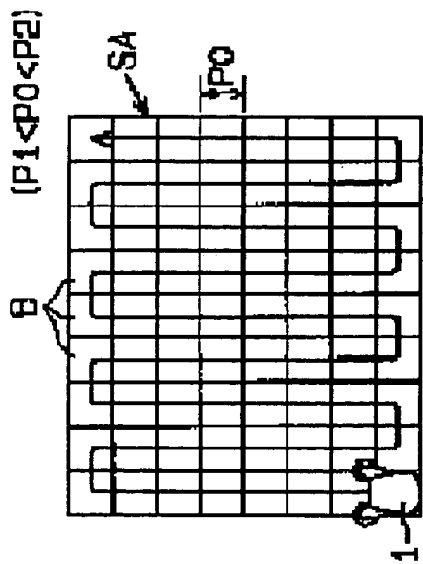
(57) Abstract:

**PROBLEM TO BE SOLVED:** To reduce omission of removing dust irrespective of trash quantity and to briefly complete cleaning in proper cleaning time according to the dust quantity.

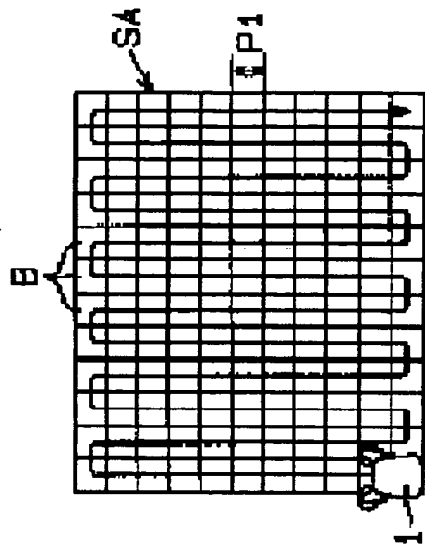
**SOLUTION:** A cleaning mode suitable for the dust quantity judged by looking over a cleaning area is inputted in a cleaning robot 1 by operating an input device by a

worker. Three stages, i.e., 'standard', 'much dust' and 'less dust' are prepared as the cleaning mode. A cleaning area SA is divided into meshes by its internal processing with roughness of division according to the inputted cleaning mode and many blocks B with length P of one side according to the cleaning mode are formed by the cleaning robot 1. Running of the cleaning robot 1 is controlled to successively move through respective blocks B by every frame and cleaning is performed while taking a turn route to be shown by an arrow. When the cleaning robot is in a 'much dust' mode, the pitch of turn becomes smaller, overlap quantity of cleaning becomes larger than the ones in a 'standard' mode and when the cleaning robot is in a 'less dust' mode, the pitch of turn becomes larger and the overlap quantity of cleaning becomes smaller than the ones in the 'standard' mode.

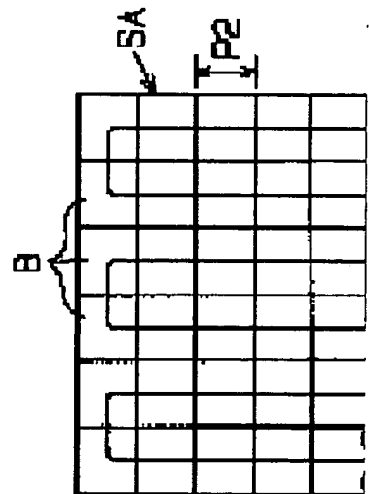
COPYRIGHT: (C)2000,JPO



(a)



(b)



(c)

(19)日本国特許庁 (JP)

(12) 公開特許公報 (A)

(11)特許出願公開番号  
特開2000-353014  
(P2000-353014A)

(43)公開日 平成12年12月19日 (2000. 12. 19)

(51)Int.Cl. <sup>7</sup>	識別記号	FI	7-71-1*(参考)
G 0 5 D 1/02		G 0 5 D 1/02	L 5H301
A 4 7 L 11/00		A 4 7 L 11/00	

審査請求 未請求 請求項の数 6 OL (全 14 頁)

(21)出願番号 特願平11-162454  
(22)出願日 平成11年6月9日 (1999. 6. 9)

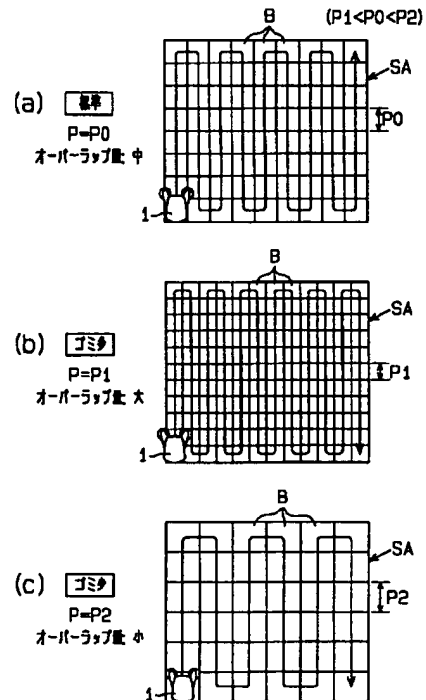
(71)出願人 000003218  
株式会社豊田自動織機製作所  
愛知県刈谷市豊田町2丁目1番地  
(72)発明者 一条 恒  
愛知県刈谷市豊田町2丁目1番地 株式会  
社豊田自動織機製作所内  
(74)代理人 100068755  
弁理士 恩田 博宣  
Fターム(参考) 5H301 AA02 AA10 BB11 CC03 CC06  
DD01 DD06 DD17 GG07 GG12  
GG17 GG28 GG29 HH10 JJ05  
KK18

(54)【発明の名称】 清掃ロボット

(57)【要約】

【課題】 ゴミ量の多少にかかわらずゴミの取り残しを少なくでき、しかもゴミ量に応じた適切な清掃時間で短く清掃を済ませる。

【解決手段】 作業者は清掃エリアを見渡して判断したゴミ量に合った清掃モードを入力装置を操作して清掃ロボット1に入力する。清掃モードは「標準」、「ゴミ多」、「ゴミ少」の3段階用意されている。清掃ロボット1は、入力された清掃モードに応じた分割の粗さでその内部処理で清掃エリアSAをメッシュ分割し、清掃モードに応じた一辺の長さPの多数のブロックBを作る。清掃ロボット1は各ブロックBを1升ずつ順番に移動するように走行制御され、矢印に示す折り返し経路をとりながら清掃を行う。「ゴミ多」のときは「標準」時より折り返しのピッチが小さく清掃のオーバーラップ量が大きくなり、「ゴミ少」のときは「標準」時より折り返しのピッチが大きく清掃のオーバーラップ量が小さくなる。



【特許請求の範囲】

【請求項1】 清掃面を清掃するための清掃部を備えた自走式の清掃ロボットであって、

清掃対象となる清掃エリアのうち少なくとも未清掃エリアのゴミ量の多少を把握するためのゴミ量情報を取得する情報取得手段と、

前記ゴミ量情報に基づきゴミ量が多いときほど清掃のオーバーラップ量を大きくするようにゴミ量の多少に応じて走行経路を決定する経路決定手段と、

前記走行経路で走行するように走行駆動部を制御する走行制御手段とを備えた清掃ロボット。

【請求項2】 前記経路決定手段は、予め設定された清掃エリア内に、ゴミ量の多少に応じた一定ピッチの通過点をゴミ量が多いときほど小さなピッチでマトリクス状に決め、該清掃エリア内の全ての通過点を順次通るように前記走行経路を決定する請求項1に記載の清掃ロボット。

【請求項3】 前記情報取得手段は、前記ゴミ量情報を入力するための入力操作手段である請求項1又は請求項2に記載の清掃ロボット。

【請求項4】 前記情報取得手段は、ゴミを検出するゴミ検出手段と、該ゴミ検出手段の検出結果に基づいて前記清掃エリアのうち少なくとも未清掃エリアのゴミ量を予測するゴミ量予測手段とを備える請求項1又は請求項2に記載の清掃ロボット。

【請求項5】 前記ゴミ量情報に基づき前記清掃部の駆動回転数をゴミ量が多いときほど高くするように速度制御する清掃速度制御手段を備えている請求項1～請求項4のいずれか一項に記載の清掃ロボット。

【請求項6】 前記ゴミ量情報に基づき走行速度をゴミ量が多いときほど遅くするように速度制御する走行速度制御手段を備えている請求項1～請求項5のいずれか一項に記載の清掃ロボット。

【発明の詳細な説明】

【0001】

【発明の属する技術分野】本発明は、自走式の清掃ロボットに関するものである。

【0002】

【従来の技術】この種の自走式の清掃ロボットが特開平9-269824号公報や特開平7-281752号公報等に開示されている。例えば特開平9-269824号公報には、清掃を開始する作業開始位置に対し、作業終了位置を向こう側にするか、手前側にするかをユーザが入力し、その入力情報に基づいて次の列に折り返す際にずれるピッチを決める清掃ロボットが開示されている。

【0003】また、特開平7-281752号公報には、汚れ検出部（床面反射率センサ）により床面の汚れ度合を検出し、汚れ度合に応じて走行駆動部を制御する清掃ロボットが開示されている。床面に汚れが少ないと

きは清掃液の滴下量を減らしたり、スポンジを遅く回転させながら高速前進し、床面に汚れが多いときは清掃液の滴下量を増やしたり、スポンジを高速に回転させながら低速前進するものであった。この清掃ロボットは主に床面の汚れを磨き落とす清掃作業をする。

【0004】また、清掃ロボットには、床面（清掃面）のゴミをブラシで掃き寄せながらダストボックスに取り込むスイーパ方式のものが知られている。

【0005】

【発明が解決しようとする課題】スイーパ方式の清掃ロボットは、床面のゴミを内側に掃き寄せするための左右のサイドブラシを本体前部に備え、内側に掃き寄せたゴミをダストボックスに掃き込むためのメインブラシを本体中央部に備える。そして、両ブラシを回転させながら清掃ロボットが床面を走行すると、通った部分の床面のゴミが取り除かれ、ほぼ車幅の範囲が清掃される。左右のサイドブラシによってゴミを掃き寄せ可能な範囲が1回の通過で清掃される清掃幅となる。

【0006】スイーパ方式の清掃ロボットでは、ゴミ量が多いときにサイドブラシにより掃き寄せ切れなかったゴミが残る心配がある。この種の取り残しのゴミは清掃幅の両端部に多く発生する。このため、清掃幅を多少オーバーラップさせる走行経路をとることで、ゴミの取り残しを防ぐことが期待できる。

【0007】しかし、オーバーラップ量を徒に増やすと清掃に必要な走行距離が長くなり、清掃作業効率が大幅に低下する問題を招く。また、オーバーラップ量が少なすぎるとゴミ量が多いときにゴミの取り残しが依然発生する問題がある。そのため、ゴミ量の多少にかかわらず、ゴミの取り残しのない確実な清掃を、なるべく短時間で済ませられる清掃ロボットが要望されていた。なお、スイーパ方式以外の清掃ロボットにおいても、一般に清掃幅の両端部にゴミや汚れが残り易かった。

【0008】本発明は、上記課題を解決するためになされたものであり、その目的は、ゴミ量の多少にかかわらずゴミの取り残しを少なくでき、しかもゴミ量に応じた適切な清掃時間で短く清掃を済ませることができ清掃ロボットを提供することにある。

【0009】

【課題を解決するための手段】上記目的を達成するために請求項1に記載の発明では、清掃面を清掃するための清掃部を備えた自走式の清掃ロボットであって、清掃対象となる清掃エリアのうち少なくとも未清掃エリアのゴミ量の多少を把握するためのゴミ量情報を取得する情報取得手段と、前記ゴミ量情報に基づきゴミ量が多いときほど清掃のオーバーラップ量を大きくするようにゴミ量の多少に応じて走行経路を決定する経路決定手段と、前記走行経路で走行するように走行駆動部を制御する走行制御手段とを備えている。

【0010】請求項2に記載の発明では、請求項1に記

載の発明において、前記経路決定手段は、予め設定された清掃エリア内に、ゴミ量の多少に応じた一定ピッチの通過点をゴミ量が多いときほど小さなピッチでマトリクス状に決め、該清掃エリア内の全ての通過点を順次通るように前記走行経路を決定することをその要旨とする。

【0011】請求項3に記載の発明では、請求項1又は請求項2に記載の発明において、前記情報取得手段は、前記ゴミ量情報を入力するための入力操作手段である。請求項4に記載の発明では、請求項1又は請求項2に記載の発明において、前記情報取得手段は、ゴミを検出するゴミ検出手段と、該ゴミ検出手段の検出結果に基づいて前記清掃エリアのうち少なくとも未清掃エリアのゴミ量を予測するゴミ量予測手段とを備える。

【0012】請求項5に記載の発明では、請求項1～請求項4のいずれか一項に記載の発明において、前記ゴミ量情報に基づき前記清掃部の駆動回転数をゴミ量が多いときほど高くするように速度制御する清掃速度制御手段を備えている。

【0013】請求項6に記載の発明では、請求項1～請求項5のいずれか一項に記載の発明において、前記ゴミ量情報に基づき走行速度をゴミ量が多いときほど遅くするように速度制御する走行速度制御手段を備えている。

【0014】(作用) 請求項1に記載の発明によれば、情報取得手段により取得されたゴミ量情報に基づき、ゴミ量の多少に応じてゴミ量が多いときほど清掃のオーバーラップ量を大きくするような走行経路が経路決定手段により決定される。清掃ロボットは走行駆動部が走行制御手段により制御されることで、経路決定手段により決定された走行経路を走行する。清掃ロボットは、ゴミ量が多いときにはオーバーラップ量が大きくなる走行経路で走行し、ゴミ量が少ないときにはオーバーラップ量が小さくなる走行経路で走行する。

【0015】請求項2に記載の発明によれば、請求項1の発明の作用に加え、経路決定手段は、予め設定された清掃エリア内にゴミ量が多いときほど小さなピッチとなるように一定ピッチの通過点をマトリクス状に決める。走行経路は、清掃エリア内の全ての通過点を順次通るように決定される。このため、人などの障害物を避ける比較的ランダムな走行経路をとっても、ゴミ量に応じた所定のオーバーラップ量が確保される。つまり、所定のオーバーラップ量が確保される走行制御が簡単となる。

【0016】請求項3に記載の発明によれば、請求項1又は請求項2の発明の作用に加え、ゴミ量情報は入力操作手段から作業者が入力操作することで清掃ロボットに入力される。

【0017】請求項4に記載の発明によれば、請求項1又は請求項2の発明の作用に加え、清掃ロボットはゴミ検出手段によってゴミを検出する。そして、ゴミ検出手段の検出結果からゴミ量予測手段が清掃エリアのうち少なくとも未清掃エリアのゴミ量を予測し、この予測デー

タがゴミ量情報として取得される。

【0018】請求項5に記載の発明によれば、請求項1～請求項4のいずれかの発明の作用に加え、清掃速度制御手段は、ゴミ量情報に基づいてゴミ量が多いときには清掃部の駆動回転数を高くし、ゴミ量が少ないときには清掃部の駆動回転数を低くする。

【0019】請求項6に記載の発明によれば、請求項1～請求項5のいずれかの発明の作用に加え、走行速度制御手段は、ゴミ量情報に基づいてゴミ量が多いときには走行速度を高くし、ゴミ量が少ないときには走行速度を低くする。

【0020】

【発明の実施の形態】(第1の実施形態) 以下、本発明を具体化した第1の実施形態を図1～図7に従って説明する。

【0021】図7、図8に示すように、清掃ロボット1は、本体2の底部に、前輪である駆動輪3と、後輪であるキャスタ輪4とを備える。左右の駆動輪3、3は本体2に配設された走行駆動部としての走行用モータ5、6によりそれぞれ独立に駆動される。本体2の前部左右にやや拡開しながら延出する2本のアーム部2aには清掃部としての円錐台形状のサイドブラシ7が設けられている。サイドブラシ7、7は左右のアーム部2aに配設された各サイドブラシモータ8、8により駆動され、図8に示す矢印方向に回転して左右のゴミを内側へ掃き寄せる機能を有する。また、本体2の底部には駆動輪(前輪)3より後方に清掃部としての円筒形状のメインブラシ9が配設されている。メインブラシ9は本体2に配設されたメインブラシモータ10により駆動され、図7に示す矢印方向に回転してゴミを前方へ掃き出す機能を有する。

【0022】本体2の前部には、メインブラシ9の直ぐ前方にダストボックス11が配設され、ダストボックス11のメインブラシ9と面する部位に吸引口11aが形成されている。図7に示すように本体2の後部には、バキュームモータ12と、このモータ12により駆動されるバキュームユニット(負圧発生装置)13とが配設されている。バキュームユニット13が駆動されることによりダストボックス11の内部が負圧となり、メインブラシ9によって前方へ掃き出されたゴミが吸引口11aからダストボックス11内に吸引除去される。ダストボックス11の吸引口11aにはゴミを吸引口11aに取り込む助けをするゴム製のリップ11bが設けられている。左右二つのサイドブラシ7、7によって掃き寄せ可能な範囲が清掃ロボット1が一回の通過で清掃可能な清掃幅Lで、本例では約1.4メートルである。

【0023】清掃ロボット1は、本体2の前部に3つの障害物センサ14と、本体2の左右側部に2つずつの障害物センサ15と、本体2の後部に3つの障害物センサ16を備える。三種類の障害物センサ14、15、16



によって、前方、側方および後方の障害物を検出する。特に本体2の側部にある2つの障害物センサ15によって、清掃ロボット1は壁に対する自身の角度を認知し、壁と平行な姿勢をとる姿勢補正をしながら壁に沿って走行することが可能である。また、本体2の後部にある3つの障害物センサ16は、バックするときに後方の障害物を検出するとともに、壁に到達してUターンするときに本体2の後部が壁に当たらないように壁を検出するのに使用される。

【0024】また、本体2の前部中央にはジャイロ17が内蔵されている。ジャイロ17は清掃ロボット1の向き(姿勢角度) $\theta$ を検出するためのものである。清掃ロボット1は、その時々の方きの検出値 $\theta$ と、その時々移動距離とから、原点位置からの経路上の変位量を累積演算して現在位置(x, y,  $\theta$ )を把握する。また、ジャイロ17の検出値 $\theta$ によって絶対方向(方角)も把握する。

【0025】本体2には後部上側に表示装置18が埋設されている。表示装置18の画面18aは入力操作手段としての入力装置19を兼ねたタッチパネルで構成され、画面18aの表示ボタンを操作することで入力操作が可能となっている。また、清掃ロボット1は、外部のパーソナルコンピュータ(以下、パソコンという)20(図6に示す)を使って遠隔操作をすることが可能となっており、本体2の上部には、パソコン20が接続されたLAN(例えばイントラネット)上の通信器51のアンテナ51aと無線通信をするためのアンテナ21が設けられている。また、本体2の前部中央にはカメラ22とライト23が設けられ、赤外線CCD素子を有するカメラ22がとらえた画像を、外部のパソコン20のモニタ20aを通して見ながら、例えば集中管理室などの他の場所から清掃ロボット1を遠隔操作する使い方が可能となっている。また、本体2の後部には作業者が清掃ロボット1を手動で移動させるときに使用するグリップ24が二本設けられている。

【0026】清掃ロボット1は電気式自走車で、本体2の後部下側にバッテリー25(図7に示す)を内蔵する。本体2の底面には、充電ステーションに設置された充電器(図示せず)から非接触で充電をするための被充電器26(図7に示す)が設けられている。また、本体2にはコントローラ27(図7に示す)が内蔵され、清掃ロボット1はコントローラ27によって通信制御および運行制御されるようになっている。

【0027】図6は、清掃ロボット1の電気的構成を示すブロック図である。コントローラ27は、2つのマイクロコンピュータ(以下、単にマイコンという)28、29を備える。マイコン28は清掃ロボット1と作業者との間における情報のやり取りを司るもので、マイコン28には表示装置18および入力装置19が接続されるとともに、アンテナ21が通信回路30を介して接続さ

れている。外部のパソコン20と清掃ロボット1との間のデータのやり取りは、各アンテナ21、51a間の無線通信によって行われる。

【0028】マイコン29は、清掃ロボット1の運行制御を司るためのものである。マイコン29はマイコン28とデータのやり取り可能に接続されている。マイコン29には、三種類の各障害物センサ14、15、16およびジャイロ17が入力ポート側に接続されている。また、マイコン29には、走行用モータ5、6、サイドブラシモータ8、8、メインブラシモータ10およびバキウムモータ13がそれぞれドライバ31~36を介して出力ポート側に接続されている。走行用モータ5、6はその回転数を検出するためのエンコーダ37、38を備える。各エンコーダ37、38はマイコン29の入力ポート側に接続されている。また、走行用モータ5、6、サイドブラシモータ8、8およびメインブラシモータ10については、ドライバ31~35による回転数制御が可能となっている。なお、経路決定手段はマイコン29によって構成される。また、清掃速度制御手段は各モータ8、10、コントローラ27及びドライバ33、34、35により構成される。さらに走行制御手段及び走行速度制御手段は、コントローラ27及びドライバ31、32により構成される。

【0029】マイコン29は、中央処理装置(以下、CPUという)39およびメモリ40を内蔵する。メモリ40には、清掃ロボット1を運行制御するために必要な各種プログラムデータが記憶されている。また、CPU39は、本体2の組付けられたコネクタ41を介してメモリカード42と接続されている。

【0030】メモリカード42には、清掃ロボット1に清掃対象となる部屋や場所などの清掃エリアの形状や広さを予め憶え込ませた清掃エリアのデータ(座標データ)が記憶されている。清掃エリアのデータは、外部のパソコン20による遠隔操作で清掃ロボット1を部屋の外周(内壁)に沿って一周させることで教え込まれたものである。予め記憶するティーチング用のプログラムに基づきマイコン29がジャイロ17とエンコーダ37、38からの各信号に基づきその時々位置座標を割り出して作成される。部屋内に柱など固定の障害物がある場合は、その固定の障害物の回りを一周させるとその範囲を除く領域が清掃エリアとされる。メモリカード42は複数の清掃エリアを記憶可能で、次回からは画面18aに表示される部屋の一覧表の中から、所望する部屋を選択操作するだけで、その選択した部屋の清掃エリアのデータがメモリカード42から読出される。清掃エリアデータ上の原点位置は例えば充電ステーションの位置を絶対位置の基準点として認識する。

【0031】CPU39はエンコーダ37、38からの入力信号に基づき清掃ロボット1の走行速度Vを検出する。また、CPU39はジャイロ17からの入力信号に

基づき清掃ロボット1の向き(姿勢角度) $\theta$ と、ヨーレート(姿勢角が変化するときの角速度) $\omega$ を検出する。また、CPU39は、原点位置からの移動経路に沿った位置の変化を逐次累積して現在位置( $x, y, \theta$ )を把握する。走行速度 $V$ およびヨーレート $\omega$ の各データは、清掃ロボット1を目標経路に乗せる走行制御に使用される。

【0032】表示装置18には、清掃ロボット1にゴミ量を教え込む表示画面が用意されている。この表示画面の画面18aでは、「標準」、「ゴミ多」、「ゴミ少」の3種類の清掃モードに対応する3つの操作ボタンが表示されるので、作業者は部屋を見渡して清掃エリア全体のゴミ量を把握し、ゴミ量に合った清掃モードの操作ボタンを押す。操作ボタンを押すことで、清掃ロボット1は清掃エリアのゴミ量の多少を把握するためのゴミ量情報として清掃モードを取得する。つまり、本実施形態では情報取得手段は、入力操作手段としての入力装置19により構成される。

【0033】ここで、掃除の善し悪しを決める要因として、清掃のオーバーラップ量(清掃重複部分)、ブラシ7,9の回転数、走行速度 $V$ の3つが挙げられる。本実施形態では、これら3つの要因をゴミの多少に応じて変化させる制御をする。つまり、ゴミ量が多いときほど、オーバーラップ量を大きく、ブラシ7,9の回転数を高く、走行速度 $V$ を遅くする。これらの3つの要因を制御するためのプログラムデータがメモリ40には記憶されている。すなわちメモリ40には、清掃のオーバーラップ量を制御するための経路制御プログラムと、ブラシ回転数を制御するための清掃回転数制御プログラムと、走行速度を制御するための車速制御プログラムの各プログラムデータが記憶されている。以下、各プログラムについて順次説明をする。

【0034】(1)経路制御プログラム

経路制御プログラムは、①経路設定ルーチンと、②走行制御ルーチンとからなる。

【0035】①経路設定ルーチン

経路設定ルーチンは、清掃モードに応じたオーバーラップ量となる経路で走行するうえで、必ず通る通過点を清掃エリア内にマトリクス状に点在するように設定するプログラムである。通過点のピッチ $P$ は清掃モード(「標準」、「ゴミ多」、「ゴミ少」)に応じて決まる。

【0036】通過点の決め方は、図2に示すように、清掃エリア $SA$ を多数の正方形のブロック $B$ にメッシュ分割し、メッシュ分割された各ブロック $B$ の中心点を通過点 $C$ とする。ブロックを $B_{ij}$ (但し、行番号 $i=1,2,\dots,m$ 、列番号 $j=1,2,\dots,n$ )で表わすと、 $B_{11}$ が原点位置に相当し、 $B_{11}$ の通過点(中心点)から1つずつ各通過点を順番に移動するようにして走行経路を決定する。

【0037】ブロック $B$ の一辺の長さ $P$ を清掃モード

(ゴミ量)に応じて変化させることで、通過点のピッチ $P$ をゴミ量に応じて変化させるようにする。すなわち、図1(a)に示すように清掃モード「標準」のときは、ブロック $B$ の一辺の長さ $P$ は $P=P_0$ 、図1(b)に示すように清掃モード「ゴミ多」のときは、ブロック $B$ の一辺の長さ $P$ は $P=P_1$ 、図1(c)に示すように清掃モード「ゴミ少」のときは、ブロック $B$ の一辺の長さ $P$ は $P=P_2$ である(但し、 $P_1 < P_0 < P_2$ )。本例でのより詳しいブロックサイズは、「標準」のときは $80 \times 80$  cm、「ゴミ多」のときは $50 \times 50$  cm、「ゴミ少」のときは $120 \times 120$  cmである。このブロックサイズ、つまり清掃エリアをメッシュ分割する分割の粗さは、左右のサイドブラシ7,7でカバーできる清掃幅(=1.4 m)に合わせて決められ、ゴミ量が少ないときでもオーバーラップするように設定されている。同図に示すように、清掃ロボット1はブロック $B$ を1升ずつ移動する経路をとり、ブロックサイズが清掃モード(ゴミ量)に応じて異なることによって、オーバーラップ量が清掃モードに応じて異なるようになっている。

【0038】図2に示す各通過点 $C$ は、必ず通る点に過ぎず、各通過点 $C$ をどの順序で移動するかを決めることで走行経路が決定される。そのため、ブロック $B_{ij}$ の1つずつに、中心点座標(通過点座標)のデータの他、ポテンシャルデータが付与される。ここで、ポテンシャルとは、進路を決定するうえでどの通過点 $C$ (つまりブロック $B$ )を選択するかを決めるためのブロック $B$ の重み付けである。

【0039】図4に示すように、清掃エリア $SA$ 内の未清掃のブロック $B$ にはポテンシャル値「0」を付与しておく。清掃の終わったブロック $B$ から順にポテンシャル値を「0」から「1」に変更する。また、図5に示すように清掃エリア $SA$ の形状が長方形以外の多角形(この例では六角形)の場合は、清掃エリア $SA$ を囲む長方形(例えば外接矩形) $R$ を求め、この長方形 $R$ をブロック分割する。そして、ブロック $B$ が清掃エリア $SA$ の外側にあるか内側にあるかを判断し、外側のブロック $B$ にはポテンシャル値「4」を付与し、内側のブロック $B$ にはポテンシャル値「0」を付与する。また、柱などの固定の障害物 $S$ の範囲となるブロックにはポテンシャル値「3」を付与する。また、ポテンシャル値「3」以外のブロックに障害物センサ14,15,16が障害物を検出したときは、その障害物が人などの移動物体であるとみなし、その障害物を避けたときはその障害物のあった未清掃のブロック $B$ のポテンシャル値を「2」とする。清掃ロボット1(CPU39)はポテンシャル値「0」を優先的に選んで走行経路を決定する。ポテンシャル値「2」のブロック $B$ についてはポテンシャル値「0」のブロック $B$ が無くなった後に清掃させるようにしている。経路決定にブロック分割方法(通過点設定方法)を採用するのは、障害物を避ける経路をとったときでも所

定のオーバーラップ量を維持しながら経路選択することが制御し易いからである。

#### 【0040】②走行制御ルーチン

走行制御ルーチンは、各ブロックBの中心点である通過点Cをどの順序で移動するかを決めて走行経路を決定するルーチンである。ポテンシャル「0」のブロックBを一筆書きの経路で順番に移動する場合、どの経路をとるかを決める制御である。本例では原則として、図1に示すように清掃ロボット1が清掃エリアSA内を一方方向の往動と復動を繰り返しながら折り返し時にピッチPずつずれる走行経路を採用する。

【0041】この基本経路を障害物に妨げられるとき以外守るために、本例では清掃ロボット1が現在のブロックBから次のブロックBに移動する際に選択し得る前後左右の4方向に優先順位を設定している。ジャイロ17で検出される絶対方向(方角)を採用し、清掃ロボット1が原点位置から発進するときの発進方向(方角)を前方向と定め、図2に示すように清掃ロボット1が左側面を壁に面する向きで発進する場合、壁側の方向を最優先順位とし、以下順に、前方向、後方向、反壁側の方向の順で、各方向に優先順に優先番号「1」、「2」、「3」、「4」を付している。図2に示すように清掃ロボット1が左側面を壁に面する向きで発進する場合、優先順位は図3に示すように、左方向「1」、前方向「2」、後方向「3」、右方向「4」ようになる。絶対方向を基準とするため、清掃ロボット1が原点位置から発進するときの前方向が北方向であれば、その後、清掃ロボット1の向きが変わっても、常に北方向が前方向となる。

【0042】この方向優先順位と前記ポテンシャル値との両方を考慮して進むべき次のブロックBを決定する。原則としてポテンシャル値を優先し、ポテンシャル値が同じブロックが複数存在する場合に方向優先順位を考慮し、そのうち優先番号の最も小さい方向に位置するブロックを次の目標点として選択する。

#### 【0043】(2) 清掃回転数制御プログラム

清掃回転数制御プログラムは、清掃モード(ゴミ量)に応じてサイドブラシ7、7とメインブラシ9の回転数を変える制御をする。すなわち、清掃モードが「標準」のときは各モータ8、10の回転数を標準時の回転数とする。清掃モードが「ゴミ多」のときは各モータ8、10の回転数を標準時の回転数より高くし、清掃モードが「ゴミ少」のときは各モータ8、10の回転数を標準時の回転数より低くする。

#### 【0044】(3) 車速制御プログラム

車速制御プログラムは、ゴミ量に応じて走行速度を変える制御をする。すなわち、清掃モードが「標準」のときは各モータ5、6の回転数を標準時の回転数とする。清掃モードが「ゴミ多」のときは各モータ5、6の回転数を標準時の回転数より低くし、清掃モードが「ゴミ少」

のときは各モータ5、6の回転数を標準時の回転数より高くする。

【0045】次に清掃ロボット1の使い方について説明する。まず清掃ロボット1を清掃すべき部屋の原点位置、例えば部屋のコーナに置く。清掃選択画面を選択すると、メモリカード42から登録データが読み出され、画面18aに登録された部屋の一覧が表示される。そして、画面18aの一覧の中から清掃すべき部屋を選択する。すると、CPU39はメモリカード42から選択された部屋の清掃エリアデータを読み出す。

【0046】次に画面18aをゴミ量指定画面に切替える。画面18a上には「標準」、「ゴミ多」、「ゴミ少」の3つの操作ボタンが表示されるので、作業者は部屋全体を見渡してゴミ量を判断し、ゴミ量に適した清掃モードの操作ボタンを押す。

【0047】すると、CPU39はまず内部処理で、選択された清掃モードに応じた分割の粗さで清掃エリアSAをメッシュ分割する。図1に示すような長方形の清掃エリアSAを例とすると、図1(a)に示すように「標準」が選択された場合、清掃エリアSAは一辺が $P=P0$ (本例では80cm)のブロックBに分割される。また、図1(b)に示すように「ゴミ多」を選択した場合、清掃エリアSAは一辺が $P=P1$ (本例では50cm)のブロックBに分割される。さらに図1(c)に示すように「ゴミ少」を選択した場合、清掃エリアSAは一辺が $P=P2$ (本例では120cm)のブロックBに分割される。ブロック分割後、各ブロックBの中心点の座標を計算し、清掃エリアSA内に通過点Cをマトリクス状に設定する(図2を参照)。なお、長方形以外の多角形の場合、その多角形を囲む長方形(例えば外接矩形)Rを求め、その長方形Rに対してメッシュ分割が施される(図5を参照)。

【0048】次にCPU39は各ブロックBにポテンシャル値を割り振る。清掃エリアSAの形状が長方形で内部に障害物もない図1の例では、図4に示すように全てのブロックにポテンシャル値「0」が付与される。また、清掃エリアSAが長方形以外の多角形の場合、図5に示すように、清掃エリアSAの外側のブロックBにはポテンシャル値「4」、内側のブロックBにはポテンシャル値「0」が付与される。また、清掃エリアの内側で固定の障害物SがあるブロックBにはポテンシャル値「3」が付与される。

【0049】そして、作業者が例えば画面18a上のボタン操作をして清掃開始指令をすると、清掃エリアデータから清掃エリアの外周経路の座標を割り出し、清掃ロボット1はまず清掃エリアの外周を一周する。このときの清掃ロボット1の走行経路を見て、作業者は清掃エリアが正しいかどうかを確認する。このとき清掃ロボット1は床面の清掃をせずに清掃エリアを清掃時より高速で一周する。なお、清掃エリアを一周するときに床面を清

掃させてもよい。

【0050】清掃エリアを一周し終わると、清掃ロボット1は清掃エリアの清掃を原点位置から開始する。清掃ロボット1は、各ブロックBに付与されたポテンシャル値と方向優先順位との2種類のデータに基づいて走行経路を決定する。つまり、現在のブロックBから次に進むべき隣のブロックBを決める場合、まず前後左右に隣接する4つブロックBの中からポテンシャル値「0」のブロックBを探し、ポテンシャル値「0」のブロックBが1つに決まればそのブロックBを次の目標点とする。一方、ポテンシャル値「0」のブロックBが複数ある場合は、方向優先順位のデータを参照して優先番号の数値が最も小さい方向に位置するブロックBを選択する。経路は次の進路変更点(折り返し点等)までを一度に演算し、次の進路変更点を目標点として走行制御を行い、途中で障害物を検出したり、次の進路変更点に達する度に、次の経路計画を実施する。

【0051】その結果、清掃ロボット1は、図1に示すように清掃エリア内を原点位置から壁に沿って真っ直ぐ走行し、壁に突き当たると1つ隣のブロック列へ移るように折り返す。これを1列ずつ順番に繰り返す。そして、清掃ロボット1は内部処理のデータ上で通過したブロックBのポテンシャル値を「0」から「1」に変更してゆく。

【0052】清掃のオーバーラップ量は、ブロックサイズ、つまりブロックBの一辺の長さである、通過点CのピッチPによって決まる。このため、図1(a)に示すように「標準」を選んだときは、ブロックサイズが中程度( $P=P_0$ )であることから、オーバーラップ量が中程度となる。このとき清掃ロボット1は標準速度で走行するとともに、各ブラシ7、9の回転数が標準速度に制御される。

【0053】これに対し、図1(b)に示すように「ゴミ多」を選んだときは、ブロックサイズが小さい( $P=P_1$ )ことから、オーバーラップ量が標準時より大きくなる。このとき清掃ロボット1は標準時より遅い速度でゆっくり走行するとともに、各ブラシ7、9の回転数が標準速度より高速に制御される。その結果、ゴミ量が多くても、丁寧な清掃が行われるので床面のゴミはきれいに取り除かれ、ゴミの取り残しがない。

【0054】また、図1(c)に示すように「ゴミ少」を選んだときは、ブロックサイズが大きい( $P=P_2$ )ことから、オーバーラップ量が標準時より小さくなる。このとき清掃ロボット1は標準時より高速で走行するとともに、各ブラシ7、9の回転数が標準速度より低速に制御される。このため、ゴミ量が少ないときは短い清掃経路と高速走行により短時間で清掃を終え、しかもブラシ7、9の消費電力を節約しても床面のゴミがきれいに取り除かれる。

【0055】また、清掃ロボット1は清掃中にその進行

方向に人などの移動物体を障害物として検出すると、通過点Cで方向転換し、その障害物を避ける進路をとる。このように障害物を避けながら走行経路を決めていくことになり、比較的ランダムな走行経路をとることもあり得るが、ブロックB(つまり通過点C)を1升ずつ順次移動する制御なので、どのような走行経路をとっても常に所定のオーバーラップ量が確保される。また、人などの移動する障害物を避けたときはそのブロックBのポテンシャル値に「2」を付与しておき、清掃を一応終えてポテンシャル値「0」のブロックが無くなった後、ポテンシャル値「2」のブロックを清掃するので、障害物を避けながら清掃をしても清掃の取りこぼしがない。

【0056】以上詳述したように本実施形態によれば、以下の効果が得られる。

(1) ゴミ量が多いときほどオーバーラップ量を大きくするように清掃モード(ゴミ量情報)に応じたオーバーラップ量で清掃がなされるように清掃ロボット1の走行経路を決めるので、ゴミの取り残しがほぼ無い確実な清掃を、ゴミ量の多少に応じたなるべく短い適切な時間で効率よく行うことができる。

【0057】(2) 清掃エリアSA内に清掃モードに応じた一定ピッチPで通過点Cをマトリクス状に設定し、通過点Cを順番に移動していくように走行経路を決める経路決定方法を採用するので、人などの障害物を避けるために比較的ランダムな走行経路をとったとしても、所定のオーバーラップ量が確保される走行制御が簡単で済む。

【0058】(3) 清掃エリアSAをメッシュ分割して得られる各ブロックの中心点を算出して通過点を決めるので、清掃モード(ゴミ量の多少)に応じて分割のメッシュの粗さを変更するという比較的簡単な処理で、マトリクス状に点在させる通過点Cを清掃モードに応じたピッチPで設定することができる。

【0059】(4) 各ブロックBに経路を選択する際の優先度の重み付けをし、また進路を決める際の方向に優先順位を設定したので、清掃ロボット1の走行経路として清掃効率のよい経路を決定することができる。例えば清掃エリアの隅から壁に沿って清掃を始め、一方向の往動と復動を繰り返しながら折り返し時にピッチPずつずれる図1に示すような折り返し経路をとることができる。また、障害物を避けてランダムな経路を仮にとるときでも、清掃エリアを清掃するうえで効率のよい経路で清掃できる。

【0060】(5) 作業者が見渡して清掃エリアのゴミ量を把握し、画面18aに表示される「標準」、「ゴミ多」、「ゴミ少」の3つの操作ボタンから1つを選ぶことで、清掃エリアのゴミ量情報を入力操作で清掃ロボット1に教え込む方法をとるので、清掃ロボット1に清掃エリアの正しいゴミ量の情報を与えることができる。よって、ゴミの取り残しのほぼ無い確実な清掃をなるべく

短時間で効率よく実現できる。

【0061】(6)人などの移動物体の障害物を避けたときにはその避けたブロックBのポテンシャル値を「2」としておくことで、他の部分を先に清掃した後、避けて未清掃のブロックBを後から清掃し直すことができる。また、柱や置物など元々部屋に存在する固定の障害物があるブロックBのポテンシャル値を「3」としているため、人などの移動物体の障害物を判別できる。

【0062】(7)清掃モード(ゴミ量の多少)に応じて各ブラシ7,9の回転数を変更するようにした。「ゴミ多」のときは各ブラシ7,9の回転数を高くするので、ゴミ量が多いときでもゴミの取り残しをほぼ無くすることができる。また、「ゴミ少」のときは各ブラシ7,9の回転数を低くするので、モータ8,10の消費電力を必要最小限にとどめられ、節電に寄与する。よって、バッテリー25の1回の充電で清掃できる清掃面積を広くすることができる。

【0063】(8)清掃モード(ゴミ量の多少)に応じて清掃ロボット1の走行速度を変更するようにした。「ゴミ多」のときは清掃ロボット1の走行速度を遅くするので、ゴミ量が多いときでもゴミの取り残しをほぼ無くすることができる。また、「ゴミ少」のときは清掃ロボット1の走行速度を速くするので、清掃時間の短縮や節電に寄与する。よって、この点からも、バッテリー25の1回の充電で清掃できる清掃面積を広くすることができる。

【0064】(9)清掃開始時の最初に清掃ロボット1が清掃エリアの外周を一周するので、作業者は清掃ロボット1の走行経路を見て正しい清掃エリアであるかどうかを確認できる。よって、清掃エリアを憶え込ませる際の設定ミスや、選択画面で部屋や場所を一覧の中から選択する際の実行ミス等によって、清掃エリアの一部分しか清掃されないという不具合が回避され易い。

【0065】(第2の実施形態)次に第2の実施形態を、図9～図11に基づいて説明する。前記第1の実施形態では、人が入力操作で清掃ロボット1にゴミ量を教え込む方法を採用したが、この実施形態では、清掃ロボット1自身が清掃エリアのゴミ量を割り出す。なお、前記第1の実施形態と同じ構成部分については、同一の符号を使用してその説明を省略し、特に異なる点についてのみ詳述する。

【0066】図9は、本実施形態における清掃ロボット1の電氣的構成を示すブロック図である。第1の実施形態における図6の構成と基本点に同じであるが、ゴミ量を検出する光式センサ50が追加されている点と、光式センサ50が検出したゴミの数を計数するためのカウンタ43がマイコン29に備えられている点が異なる。光式センサ50はマイコン29の入力ポート側に接続されている。

【0067】図10に示すように、光式センサ50はダ

ストボックス11の吸引口11aに取付けられている。すなわち、図10(a)に示すように、光式センサ50は、ダストボックス11に吸引口11aの幅方向両側に配置された投光器50aと受光器50bとからなる。図10(b)に示すように、光式センサ50は投光器50aからの光がメインブラシ9によってはじき飛ばされるゴミの通路付近を通るように位置設定されている。

【0068】図11に示すように、清掃開始時に清掃エリアSAを最初に外周経路①でまず一周試走するとき、床面の清掃も実施する。この一周分の試走で取り込んだゴミ量を検出し、そのゴミ量から清掃エリア全体のゴミ量を予測(推定)するようにしている。一周させる試走の際の清掃モードは「標準」で行う。

【0069】この試走時に、受光器50bが受光する光がゴミDによって遮られて途切れる回数をマイコン29がカウンタ43により計数する。マイコン29は、エンコーダ37,38からの信号値から求まる走行速度Vと、カウンタ43に単位時間当たりには計数されるゴミの計数値とから、単位床面積当たりのゴミの計数値を計算する。そして、単位床面積当たりのゴミの計数値からゴミ量の多少を判定し、この判定結果に基づき清掃エリア内の未清掃域を含む全体的なゴミ量の指標である清掃モードを割り出す。清掃モードは、前記第1の実施形態と同様で「標準」、「ゴミ多」、「ゴミ少」の3段階を採用する。そして、一周し終わった後、推定されたゴミ量に基づき割り出された清掃モードに基づき、清掃エリアSAのブロック分割、通過点設定(各ブロックの中心点座標の算出)、ポテンシャル値設定を、前記第1の実施形態と同様の処理方法で行う。なお、ゴミ検出手段は光式センサ50とカウンタ43とにより構成され、ゴミ量予測手段はマイコン29により構成される。

【0070】図11に示すように、一周した外周経路①の内側のエリアを折り返し経路②で清掃する。経路②の決め方は、前記第1の実施形態と同様で、ブロックに付与されたポテンシャル値と方向優先順位との2種類のデータに基づいて決定される。なお、一周したときに「ゴミ多」の判定がなされた場合は、もう一度外周の部分も清掃してもよい。

【0071】次に清掃ロボット1の動作を説明する。清掃ロボット1が清掃を開始すると、まず清掃エリアの外周を一周する。この試走のとき、ダストボックス11に吸引されるゴミが光式センサ50により検出される。マイコン29は光式センサ50により検出されたゴミの数をカウンタ43に計数するとともに、走行速度Vと単位時間当たりのゴミの計数値とから、単位床面積当たりのゴミ量(計数値)を求める。一周分の試走で単位床面積当たりのゴミ量が最も多かった箇所のゴミ量を清掃エリアのゴミ量として採用する。清掃エリアのゴミ量の多少の判定結果から、「標準」、「ゴミ多」、「ゴミ少」の3種類の清掃モードのうち1つが割り出される。なお、

清掃エリア全体のゴミ量の推定方法は、上記の方法に限定されず、例えば一周したときの平均的なゴミ量を採用したり、また複数箇所の単位床面積当たりのゴミ量から所定の計算ルールに従って、清掃エリア全体のゴミ量を割り出す方法を採用することもできる。

【0072】こうして試走時のゴミ量検出結果から清掃エリアSAのゴミ量を推定して清掃モードを割り出すと、前記第1の実施形態と同様にして、マイコン29は内部処理で清掃モード（ゴミ量の多少）に応じた分割粗さで清掃エリアSAをメッシュ分割する。すなわち、図1に示すように「標準」のときは分割のメッシュを粗さを $P=P0$ とし、「ゴミ多」のときには分割のメッシュの粗さを $P=P1$ とし、さらに「ゴミ少」のときには分割のメッシュの粗さを $P=P2$ とする。

【0073】以降の処理手順は前記第1の実施形態と同様である。すなわち、各ブロックBの中心点の座標を計算して清掃エリアSA内に通過点Cをマトリクス状に設定するとともに、各ブロックBにポテンシャル値を付与する。試走後、経路①の内側のエリアを経路②で走行する際の走行経路の決定の仕方は、前記第1の実施形態と同じである。障害物を検出したときには障害物を避けるが、そのときの進路変更の仕方や、ポテンシャル値「2」への置き換え等についても、前記第1の実施形態と全く同様である。

【0074】以上詳述したように本実施形態によれば、前記第1の実施形態で述べた(1)～(4)、(6)～(9)の効果が同様に得られる他、以下の効果が得られる。

(10) 清掃ロボット1が清掃エリアの外周経路を一周する試走のときに検出したゴミの計数値から清掃エリア全体のゴミ量を推定して清掃モードを割り出すので、ゴミ量の入力操作を不要にできる。また、前記第1の実施形態では、人によるゴミ量の判断ミスや、清掃モードを選択する際の入力操作ミス等の原因によって、清掃後にゴミが残る心配があったが、このような人のミスによる不具合を回避できる。

【0075】(11) 清掃エリアの外周を一周するときにゴミ量を推定するための試走を兼ねるので、ゴミを採集する試走を追加しても清掃の作業時間の追加とならない。また、試走により清掃エリアの外周一周分のゴミを採集するので、清掃エリアのゴミ量を偏りなく把握し易く、清掃エリアのゴミ量を正しく推定できる。

【0076】(12) ダストボックス11の吸引口11aに実際に取り込まれるゴミを計数するので、ゴミ量を正しく推定できる。すなわち、床面からの反射率によってゴミを検出する方法を探ると、汚れとゴミの区別がつかず正しいゴミ量を把握し難いが、実際に吸い取ったゴミのみを計数するので、ゴミ量を正しく検出できる。

【0077】(第3の実施形態)次に第3の実施形態を、図12、図13に基づいて説明する。前記第2の実

施形態では、ゴミ量の情報を取得する方法として光式センサ50を用い、清掃エリアの外周を一周したときに検出したゴミ量から清掃エリア全体のゴミ量を推定し、この推定結果に基づく清掃モードを途中で変更することはしなかった。これに対し、この実施形態では、清掃ロボット1が残りのエリアのゴミ量を推定しながら清掃をし、清掃の途中でゴミ量が増減したと判断すると、残りのエリアについて清掃モードを変更し、変更後の清掃モードに基づく清掃条件で清掃を実施する。なお、前記第1および第2の実施形態と同じ構成部分については、同一の符号を使用してその説明を省略し、特に異なる点についてのみ詳述する。

【0078】本実施形態における清掃ロボット1の電気的構成は、図9に示すものと同様である。最初の試走によるゴミ量検出結果から決まる清掃モードに基づく清掃エリアのブロック分割、通過点設定、ポテンシャル値設定等の処理内容も前記第2の実施形態と同様である。

【0079】経路②での本清掃を開始してからも、マイコン29は、光式センサ50により検出されたゴミの数をカウンタ43により計数し、走行速度Vと単位時間当たりのゴミの計数値とから、単位床面積当たりのゴミ量を算出する。そして、逐次求める単位床面積当たりのゴミ量から残りのエリアのゴミ量を推定する。清掃途中で残りのエリアのゴミ量が、現在採用している清掃モードのものとは異なるときは、残りのエリアについてその変更後の清掃モードに基づく清掃条件を採用する。

【0080】例えば図12に示すように、清掃エリアSAにゴミ量の多い領域DA（破線で示す）があった場合、最初に一周したときは領域DAを通らないので「標準」が割り出される。そして、同図に太線で示す標準時のオーバーラップ量となる経路で清掃をしても、清掃ロボット1が同図に示す領域DAに入る経路をとったときに、残りのエリアについて推定されたゴミ量に基づく清掃モードが「ゴミ多」と判定される。すると、マイコン29は図13に示すように残りのエリアを清掃モード「ゴミ多」に基づきブロック分割し直す。よって、領域DAのほぼ全域を含む残りのエリアについては、「ゴミ多」時のオーバーラップ量の経路で清掃が行われる。また、この際、清掃ロボット1の走行速度およびブラシ7、9の回転数は清掃モード「ゴミ多」に応じて速度制御される。

【0081】清掃途中で残りのエリアのゴミ量を推定し、清掃モードの変更を検出する度に、残りのエリアの清掃条件を変更後の清掃モードに基づくものに変更するので、清掃エリアにゴミ量の異なる分布が所々に存在しても、清掃エリアはきれいに清掃される。

【0082】以上詳述したように本実施形態によれば、前記第1および第2の実施形態で述べた(1)～(4)、(6)～(12)の効果が同様に得られる他、以下の効果が得られる。

【0083】(13) 清掃エリアにゴミ量の異なる分布が存在するときでも、残りのエリアのゴミ量を推定して清掃モードの変更を見出したときは、清掃条件を清掃途中で変更し、ゴミ量の異なるエリア毎に適切な清掃を施すことができるので、ゴミの取り残しのほぼ無い一層確実な清掃を実現できるうえ、清掃効率を一層高めることができる。

【0084】なお、実施形態は、上記に限定されず以下の態様で実施することもできる。

○ 通過点を決める方法は、清掃エリアをメッシュ分割して得られる各ブロックの中心点を求める方法に限定されない。例えばブロックの中心点でなくコーナーであってもよい。また、清掃エリアをメッシュ分割することなく通過点の座標のみを算出する方法をとることができる。

【0085】○ 走行経路の決定方法は、通過点を決めておく方法に限定されない。図1に示す折り返し経路を予めプログラムしておくパス方式でもよい。この場合、パスの間隔、すなわち折り返し時にずれるピッチを、ゴミ量情報に基づきゴミ量の多少に応じて変更する。

【0086】○ 清掃ロボットが走行した経路を記憶し、その走行経路軌跡に対して一定のオーバーラップ量が確保されるように走行経路を演算により割り出す走行経路決定方法を採用することができる。この場合、清掃エリアのメッシュ分割も、通過点の設定も不要である。

【0087】○ ゴミ量を予測(推定)するための試走経路は、清掃エリアの外周一周に限定されない。清掃経路の最初の所定距離を試走として採用してもよい。例えば一方向の往動と復動と繰り返す清掃経路において、最初の往動を試走とすることもできる。また、清掃エリアを横切る経路を採用することもできる。清掃エリアを横切る経路であれば、清掃エリアの全体的なゴミ量を正しく把握し易い。また、清掃エリアを縦横に横切るなど、横切る経路の本数を複数に設定するとよい。

【0088】○ ゴミ検出手段は、光式センサ50などのようなゴミの数を計数する検出手段に限定されない。ダストボックスに取り込んだゴミの重量を検出するものであってもよい。この場合、単位面積当たりに取り込んだゴミの重量からマイコン29は清掃エリアのゴミ量を推定すればよい。また、カメラで清掃エリアを撮影した画像データの画像処理によって清掃エリアのゴミ量を把握してもよい。例えばゴミの無いときの清掃エリアの画像を基準画像とし、その基準画像と、清掃開始時に撮影した画像との比較から部屋全体のゴミ量を把握するようにしてもよい。

【0089】○ 一方向の往動と復動を繰り返しながら所定ピッチずつずれる走行経路を基本とすることに限定されない。渦巻き状の経路としてもよい。一筆書きできる規則性のない経路であってもよい。また、清掃エリアを複数の小エリアに分け、各小エリアの清掃を1つずつ

順番に終えていく経路をとることもできる。

【0090】○ 入力操作手段は表示装置18とは別個の入力装置であってもよい。また、パソコン20を使って遠隔から清掃ロボットに対してゴミ量情報を入力できる構成であってもよい。また、清掃ロボットを比較的近くからリモコンを使って遠隔操作できるようにし、そのリモコンにゴミ量情報を入力するための入力操作手段を設けてもよい。

【0091】○ 清掃モードは3段階に限定されない。2段階もしくは4段階以上であっても構わない。なお、標準と、標準よりゴミが多いときと少ないときとの各モードが用意された3段階以上が好ましい。

【0092】○ 人通りの多少やゴミの発生し易さなど、部屋(場所)毎にゴミ量の多少が予め分かっている場合は、部屋毎にゴミ量情報を予め憶え込ませておき、部屋毎に通過点のピッチを定めておくなどし、オーバーラップ量を決めておく制御を採用することもできる。この場合、ゴミ量情報はメモリに予め記憶され、メモリに部屋毎のゴミ量情報を記憶させるための入力操作手段が情報取得手段となる。

【0093】○ 清掃エリアの設定方法は、清掃エリアを実際に走行させて清掃ロボットに憶えさせる方法に限定されない。レーザセンサを清掃ロボットに取付け、清掃ロボットを1回転させてレーザセンサで部屋の形状を認識させる方法を採用することもできる。

【0094】○ 清掃部は、サイドブラシやメインブラシのような回転式に限定されない。例えば箒のように一方向へ掃き寄せる運動をする方式のものでよい。

○ 清掃ロボットはスイーパ方式に限定されない。洗浄液で床面を磨く清掃ロボットに適用してもよい。また、ゴミを掃き寄せる駆動ブラシを備えない清掃ロボットであってもよい。例えば本体底部に掃除機の吸引口のみがあるタイプでもよい。

【0095】前記各実施形態及び各別例から把握される請求項以外の技術的思想(発明)を、以下に記載する。

(1) 請求項1~6のいずれかにおいて、清掃ロボットはスイーパ方式である。

【0096】(2) 請求項2において、前記経路決定手段は、予め設定された清掃エリアを、ゴミ量が多いときほど細くなるようにゴミ量の多少に応じた粗さでメッシュ分割し、分割された各ブロック中の所定点を前記通過点として求める。この構成によれば、通過点を比較的簡単な処理で求められる。

【0097】(3) 請求項2又は前記(2)の技術的思想において、清掃エリア内を一方向に往動・復動を繰り返しながら折り返し時にゴミ量に応じたピッチずつずれるように通過点を順番に移動するように走行経路を決定する。この場合、この走行経路をとることで、清掃エリアの片側から順序よく清掃が進められるので、清掃が効率よく行われる。

【0098】(4)前記(2)、(3)の技術的思想において、各ブロックに経路を決定するうえでの優先すべき重み付けを付与するとともに、清掃ロボットの移動方向の優先度を設定し、各ブロック毎の重み付け値と、清掃ロボットの移動方向の優先順位とに基づき前記走行経路を決定する。この構成によれば、清掃効率のよい走行経路を選択できる。

【0099】(5)請求項4において、前記ゴミ量予測手段は、清掃ロボットが前記清掃エリア内の試走経路を走行したときにおける前記ゴミ検出手段の検出結果に基づいて清掃エリアのうち少なくとも未清掃エリアのゴミ量を予測する。

【0100】(6)前記(5)の技術的思想において、前記試走経路は清掃エリアの外周経路である。この構成によれば、清掃エリアのうち未清掃エリアのゴミ量を正しく予測できる。

【0101】(7)請求項4及び前記(5)、(6)の技術的思想のいずれかにおいて、前記情報取得手段は、清掃エリアの清掃中に前記ゴミ検出手段が検出した検出結果に基づき前記ゴミ量予測手段が残りのエリアのゴミ量を予測し、予測されたゴミ量の多少の情報が現在採用する情報の内容と異なれば予測されたゴミ量の情報に応じたオーバーラップ量とするように走行経路を見直す経路見直し手段を備えている。この構成によれば、清掃途中でも適宜に適切なオーバーラップ量に変更でき、より効率のよい清掃を実現できる。

【0102】(8)請求項4及び前記(5)、(6)、(7)の技術的思想のいずれかにおいて、前記ゴミ検出手段は、清掃ロボットが取り込んだゴミの量を検出する。この構成によれば、清掃面の汚れをゴミと間違えることなく正しいゴミの量を検出できる。

【0103】

【発明の効果】以上詳述したように請求項1～請求項6に記載の発明によれば、ゴミ量が多いときほど清掃のオーバーラップ量を大きくとるようにゴミ量の多少に応じて走行経路を決めるので、ゴミ量の多少に応じた適切な短時間で確実に清掃をすることができる。

【0104】請求項2に記載の発明によれば、請求項1の発明の効果に加え、ゴミ量の多少に応じたピッチで清掃エリアに通過点をマトリクス状に決め、全ての通過点を順次通るように走行経路を決定するので、障害物を避けるなどのため比較的ランダムな走行経路をとっても、ゴミ量に応じた所定のオーバーラップ量を確保した走行制御がし易い。

【0105】請求項3に記載の発明によれば、請求項1又は請求項2の発明の効果に加え、清掃エリアを見渡して人が判断したゴミ量の情報を清掃ロボットに入力操作で教え込むので、清掃ロボットに適切なゴミ量情報を与えることができる。

【0106】請求項4に記載の発明によれば、請求項1又は請求項2の発明の効果に加え、ゴミ検出手段が検出したゴミの検出結果からゴミ量を予測してゴミ量情報を取得するので、人がゴミ量情報を教え込む操作を不要にすることができる。

【0107】請求項5に記載の発明によれば、請求項1～請求項4のいずれかの発明の効果に加え、ゴミ量が多いときほど清掃部の駆動回転数を高くするので、ゴミ量に応じた効率のよい清掃をすることができる。

【0108】請求項6に記載の発明によれば、請求項1～請求項5のいずれかの発明の効果に加え、ゴミ量が多いときほど走行速度を高くするので、ゴミ量に応じた効率のよい清掃をすることができる。

【図面の簡単な説明】

【図1】第1の実施形態における清掃ロボットの清掃経路を示す模式図。

【図2】清掃エリアのブロック分割図。

【図3】清掃ロボットの方向優先順位を説明する模式平面図。

【図4】ブロックのポテンシャル値を説明するデータ図。

【図5】同じく清掃エリアが多角形のときのデータ図。

【図6】清掃ロボットの電気的構成を示すブロック図。

【図7】清掃ロボットの側面図。

【図8】清掃ロボットの平面図。

【図9】第2の実施形態における清掃ロボットの電気的構成を示すブロック図。

【図10】光式センサを備えるダストボックスを示し、(a)は平面図、(b)は側面図である。

【図11】清掃ロボットの清掃経路を示す模式図。

【図12】第3の実施形態における清掃経路を示す模式図。

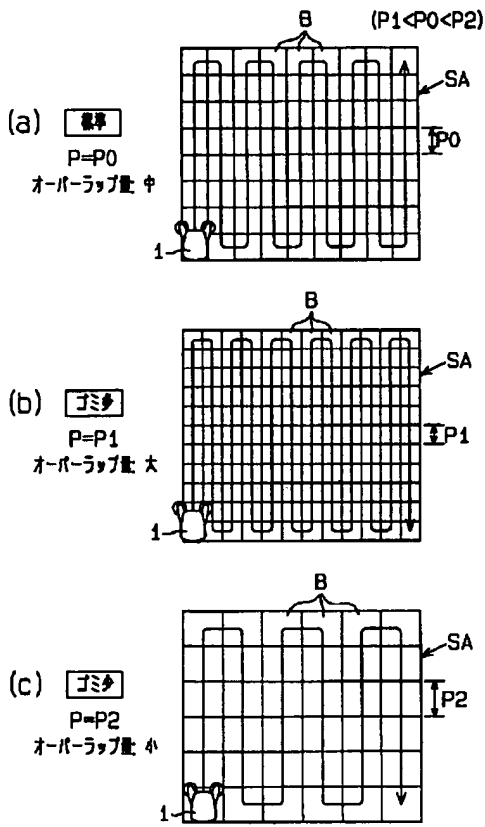
【図13】同じく清掃経路を示す模式図。

【符号の説明】

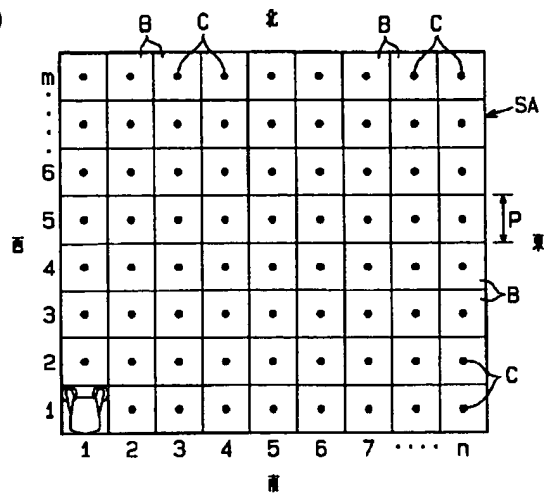
1…清掃ロボット、2…本体、5、6…走行駆動部としての走行用モータ、7…清掃部としてのサイドブラシ、8、10…清掃速度制御手段を構成するモータ、9…清掃部としてのメインブラシ、19…情報取得手段及び入力操作手段としての入力装置、27…走行制御手段、清掃速度制御手段及び走行速度制御手段を構成するコントローラ、29…経路決定手段、情報取得手段及びゴミ量予測手段としてのマイコン、31、32…走行制御手段及び走行速度制御手段を構成するドライバ、33、34、35…清掃速度制御手段を構成するドライバ、39…CPU、40…メモリ、42…メモ리카ード、50…情報取得手段及びゴミ検出手段を構成する光式センサ、43…情報取得手段及びゴミ検出手段を構成するカウンタ、SA…清掃エリア、C…通過点。



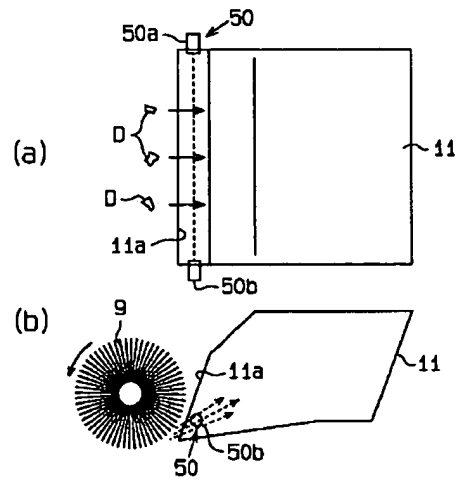
【図1】



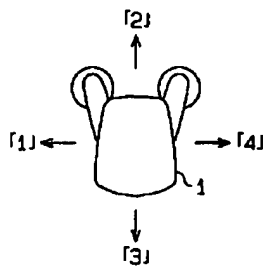
【図2】



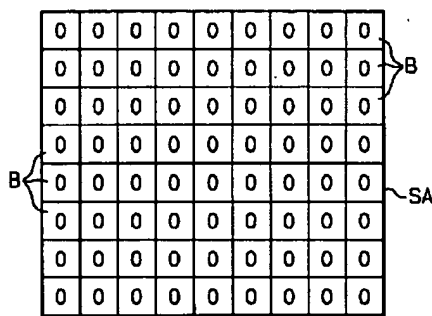
【図10】



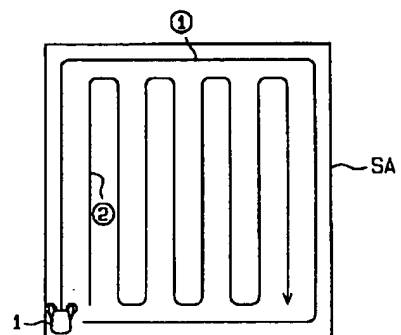
【図3】



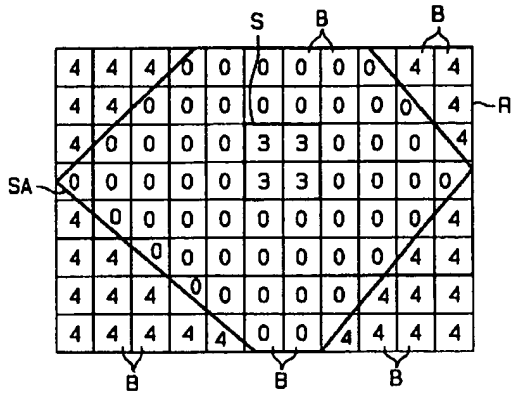
【図4】



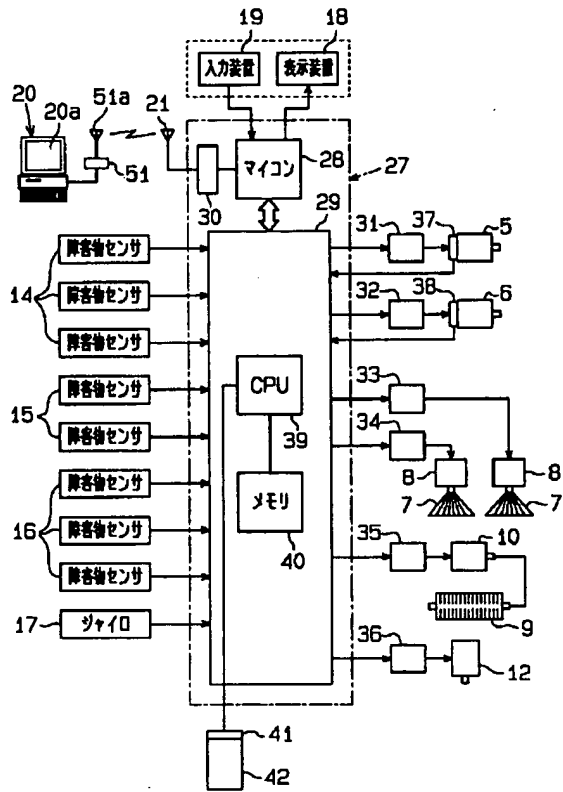
【図11】



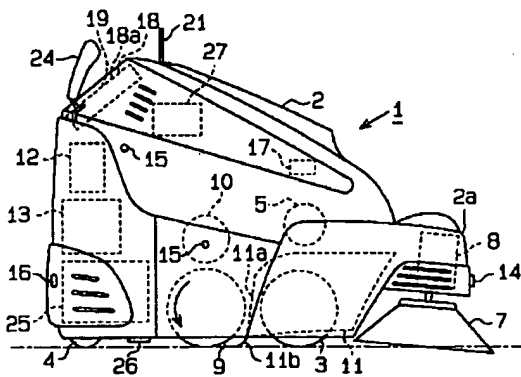
【図5】



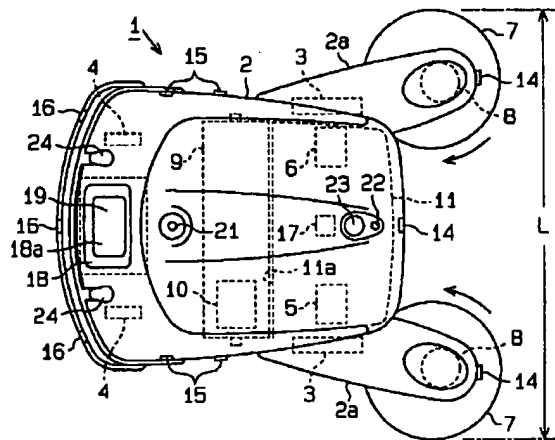
【図6】



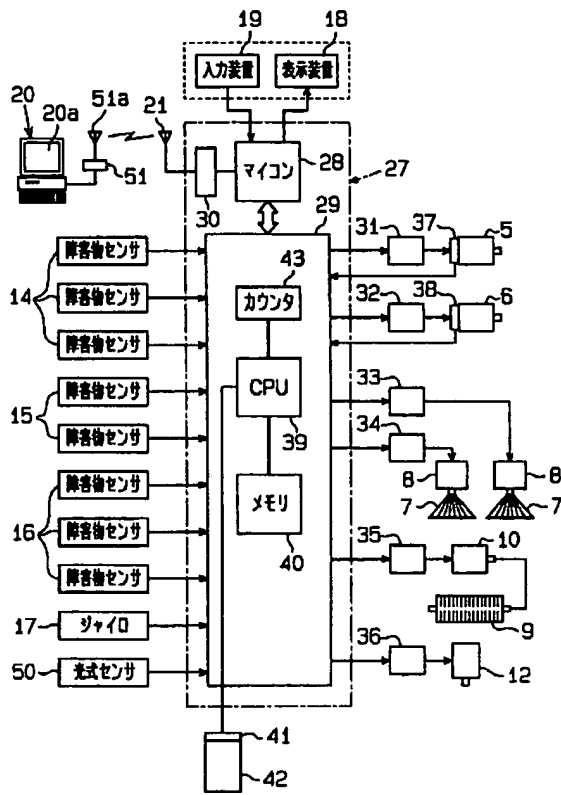
【図7】



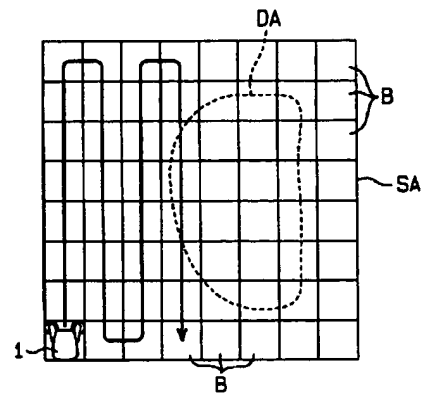
【図8】



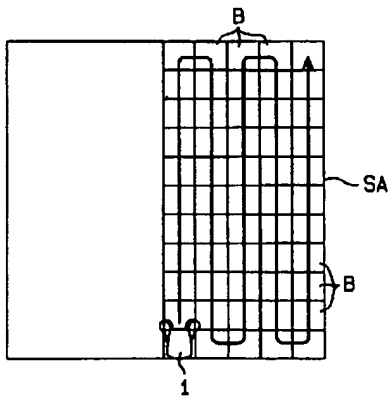
【図9】



【図12】



【図13】





09185410 A

(11) Publication number:

(19)

Generated Document.

PATENT ABSTRACTS OF JAPAN

(21) Application number: 08000393

(51) Intl. Cl.: G05D 1/02

(22) Application date: 08.01.96

(30) Priority:

(43) Date of application publication: 15.07.97

(84) Designated contracting states:

(71) Applicant: HITACHI ELECTRIC SYST:KK  
(72) Inventor: KITAMI HIDEYO  
AKISAWA YASURO  
(74) Representative:

(54) METHOD AND DEVICE FOR CONTROLLING TRAVELING OF AUTONOMOUS TRAVELING VEHICLE

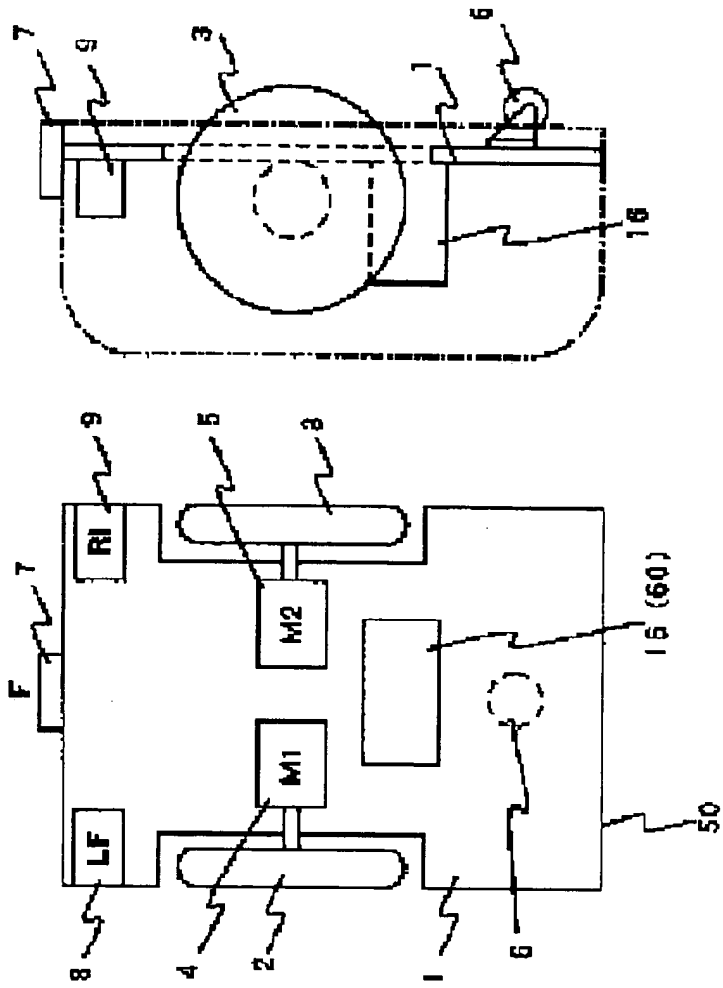
(57) Abstract:

PROBLEM TO BE SOLVED: To reduce cost by controlling the unit traveling means of autonomous traveling vehicle by using a traveling history coordinate while filling untraveled coordinates with a traveling history to simplify a device without using any traveling range

input device or position measuring instrument.

**SOLUTION:** A front sensor 7, right side sensor 9 and left side sensor 8 are loaded on the autonomous vehicle, the position of wall or obstacle detected by the sensor is record and besides, traveling is controlled while recording the traveling of autonomous vehicle. Namely, the vehicle moves forth toward the boundary of wall, etc., turns to left or right at 90° from the boundary when the boundary is detected, decides the range of traveling area after once turning around the boundary, successively travels out inside the untraveled area within the range of traveling area and stops when there is no untraveled area. Therefore, without using any traveling range input device for deciding the traveling range of autonomous vehicle or any position measuring instrument for measuring the position of autonomous vehicle itself, the vehicle can be traveled inside the traveling range surrounded by the boundary such as walls without overlapping any area while avoiding the obstacle.

**COPYRIGHT: (C)1997,JPO**



(19) 日本国特許庁 (JP)

(12) 公開特許公報 (A)

(11) 特許出願公開番号

特開平9-185410

(43) 公開日 平成9年(1997)7月15日

(51) Int.Cl. <sup>9</sup>	識別記号	庁内整理番号	F I	技術表示箇所
G 0 5 D 1/02			G 0 5 D 1/02	H L

審査請求 未請求 請求項の数 4 OL (全 11 頁)

(21) 出願番号 特願平8-393

(22) 出願日 平成8年(1996)1月8日

(71) 出願人 591001525

株式会社日立エレクトリックシステムズ  
茨城県日立市東金沢町一丁目15番25号

(72) 発明者 喜多見 英世

茨城県日立市東金沢町一丁目15番地25号  
株式会社日立エレクトリックシステムズ金  
沢事業所内

(72) 発明者 秋沢 安郎

茨城県日立市東金沢町一丁目15番地25号  
株式会社日立エレクトリックシステムズ金  
沢事業所内

(74) 代理人 弁理士 高田 幸彦 (外1名)

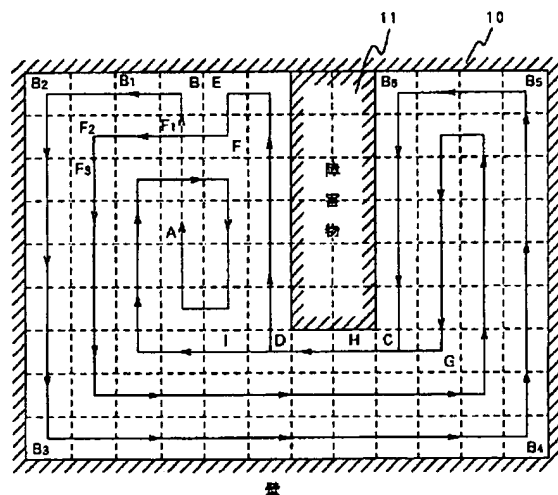
(54) 【発明の名称】 自律走行車の走行制御方法及び走行制御装置

(57) 【要約】 (修正有)

【課題】 走行範囲入力装置等を用いず単純化されコスト低減に結び付く自律車の走行制御方法及び装置を提供する。

【解決手段】 自律車の走行制御方法は、自律車の1走行単位を1単位座標とする基準座標上に、境界検出手段で検出した境界を1単位座標毎に境界座標として記録し、自律車が所定走行法によって走行し続けて、周囲すべての境界座標が認識記録された時点で、境界座標で描かれた閉じた走行領域を基準座標上に得て、かつ、自律車が走行し当該自律車の走行来歴として得られる該1走行単位毎の1単位座標を走行来歴座標として記録し、基準座標上の走行領域内を走行来歴座標で埋めながら自律車を継続走行させ、走行領域内における未走行座標の有無を把握し、走行領域内の未走行座標を埋めるように、自律車を走行領域内を隈なく走行させる。

図 4



## 【特許請求の範囲】

【請求項1】 自律走行車の座標保有手段が保有する1走行単位を1単位座標とする未走行座標上に、前記自律走行車が走行し当該自律走行車の走行来歴として得た前記1走行単位毎の前記1単位座標としての走行来歴座標を記録し、前記未走行座標を前記走行来歴座標で埋めながら前記自律走行車を継続走行させるよう、前記走行来歴座標を使って前記自律走行車の単位走行手段を制御することを特徴とする自律走行車の走行制御方法。

【請求項2】 1走行単位を1単位座標とする基準座標を保有する自律走行車を単位走行させて該1走行単位毎に境界を検出し、検出した該境界を前記1単位座標毎の境界座標として設定し、該境界座標を前記1走行単位毎に前記基準座標に記録することにより、前記基準座標上に前記境界座標で描かれた閉じた領域として前記自律走行車の走行領域座標を把握し、前記自律走行車が該走行領域座標内を走行して得られる前記1走行単位毎の走行来歴を前記自律走行車の前記1単位座標毎の走行来歴座標として設定し、該走行来歴座標を前記1走行単位毎に前記基準座標に記録することにより、前記走行領域座標のうちから前記走行来歴座標を差し引いて前記自律走行車が走行していない未走行領域として未走行座標を把握し、前記走行領域を隈なく走行させるために前記走行領域座標内の前記未走行座標を埋める走行を前記自律走行車に実行させるよう、前記自律走行車の前記単位走行を制御することを特徴とする自律走行車の走行制御方法。

【請求項3】 請求項2において、前記単位走行は、右優先走行制御法、左優先走行制御法、残方向直進優先走行制御法または直進優先走行制御法に基づく走行であることを特徴とする自律走行車の走行制御方法。

【請求項4】 所定走行手段を有し自律走行車を1走行単位毎に走行させる単位走行手段と、該単位走行手段により前記自律走行車が走行した前記1走行単位を1単位座標とする基準座標を保有する座標保有手段と、前記1走行単位毎に境界を検出する境界検出手段と、検出された該境界を前記1単位座標毎の境界座標として設定する境界座標設定手段と、該境界座標を前記1走行単位毎に前記基準座標に記録する境界記録手段と、前記境界座標で前記基準座標上に描かれた閉じた領域としての前記自律走行車の走行領域座標を演算する走行領域演算手段と、前記自律走行車の前記1走行単位毎の走行来歴を前記1単位座標毎の走行来歴座標に変換し前記1単位座標毎に前記基準座標に記録する来歴記録手段と、前記基準座標に前記境界座標及び前記走行来歴座標が記録されていない未走行座標を演算する未走行領域演算手

段と、

該未走行座標に基づいて当該未走行座標を埋める走行を実行させるよう前記単位走行手段を制御する走行制御手段と、

を備えることを特徴とする自律走行車の走行制御装置。

## 【発明の詳細な説明】

## 【0001】

【発明の属する技術分野】 本発明は、自律走行車の走行制御方法および走行制御装置に係り、自走式掃除機、自走式芝刈機などに関する。

## 【0002】

【従来の技術】 壁などに囲まれた領域内を障害物を避けながら自律走行する従来技術の自律走行車の走行制御装置としては、例えば特開平2-81210号公報に開示されるものがある。上記装置によれば、自律走行車の走行範囲を設定するための走行範囲入力装置や、自律走行車の自己位置を計測するための位置計測装置が設けられている。

## 【0003】

【発明が解決しようとする課題】 上記従来技術では、走行範囲入力装置や位置計測装置が使用されているので、構造が複雑となっている。従って本発明の目的は、走行範囲入力装置や位置計測装置を用いず単純化しコスト低減に結び付く自律走行車の走行制御方法及び装置を提供することにある。

## 【0004】

【課題を解決するための手段】 本発明の特徴は、自律走行車の座標保有手段が保有する1走行単位を1単位座標とする未走行座標上に、前記自律走行車が走行し当該自律走行車の走行来歴として得た前記1走行単位毎の前記1単位座標としての走行来歴座標を記録し、前記未走行座標を前記走行来歴座標で埋めながら前記自律走行車を継続走行させるよう、前記走行来歴座標を使って前記自律走行車の単位走行手段を制御する自律走行車の走行制御方法にある。

【0005】 また、本発明の別の特徴は、1走行単位を1単位座標とする基準座標を保有する自律走行車を単位走行させて該1走行単位毎に境界を検出し、検出した該境界を前記1単位座標毎の境界座標として設定し、該境界座標を前記1走行単位毎に前記基準座標に記録することにより、前記基準座標上に前記境界座標で描かれた閉じた領域として前記自律走行車の走行領域座標を把握し、前記自律走行車が該走行領域座標内を走行して得られる前記1走行単位毎の走行来歴を前記自律走行車の前記1単位座標毎の走行来歴座標として設定し、該走行来歴座標を前記1走行単位毎に前記基準座標に記録することにより、前記走行領域座標のうちから前記走行来歴座標を差し引いて前記自律走行車が走行していない未走行領域として未走行座標を把握し、前記走行領域を隈なく走行させるために前記走行領域座標内の前記未走行座標



を埋める走行を前記自律走行車に実行させるよう、前記自律走行車の前記単位走行を制御する自律走行車の走行制御方法にある。

【0006】そして、本発明による自律走行車の走行制御装置の特徴は、所定走行手段を有し自律走行車を1走行単位毎に走行させる単位走行手段と、該単位走行手段により前記自律走行車が走行した前記1走行単位を1単位座標とする基準座標を保有する座標保有手段と、前記1走行単位毎に境界を検出する境界検出手段と、検出された該境界を前記1単位座標毎の境界座標として設定する境界座標設定手段と、該境界座標を前記1走行単位毎に前記基準座標に記録する境界記録手段と、前記境界座標で前記基準座標上に描かれた閉じた領域としての前記自律走行車の走行領域座標を演算する走行領域演算手段と、前記自律走行車の前記1走行単位毎の走行来歴を前記1単位座標毎の走行来歴座標に変換し前記1単位座標毎に前記基準座標に記録する来歴記録手段と、前記基準座標に前記境界座標及び前記走行来歴座標が記録されていない未走行座標を演算する未走行領域演算手段と、該未走行座標に基づいて当該未走行座標を埋める走行を実行させるよう前記単位走行手段を制御する走行制御手段と、を備えるにある。

【0007】本発明によって、走行範囲入力装置や位置計測装置を使用せずに、走行領域内のどこからスタートしても障害物を回避しながら走行領域内を隈なく走行する自律走行車が得られる。

【0008】

【発明の実施の形態】以下、本発明の実施の形態について説明する。  
まず、本発明による自律走行車(以下、自律車と略す)の走行制御方法の基本思想としての特徴について説明する。特徴の1つである自律車の自己位置座標の設定は、例えば、プログラム上で定めた所定走行時間あるいは自律車が走行した所定距離を1区間とし、この1区間を1走行単位とし、該1走行単位を自律車の走行制御装置の記憶装置内に予め保有している基準座標上の1単位座標と定義し、任意の自律車の走行地点における自己位置座標が該基準座標における1点として設定される。

【0009】そして、自律車のスタート地点を初期自己位置座標としての座標(X, Y)を設定する。なお、この初期自己位置座標を該基準座標の中心点座標に設定すれば、自律車の走行範囲の制限が最も広くなり記憶装置の記録容量に左右される基準座標が最大限に有効に利用される。また、自律車の走行方向は、該スタート地点で自律車が向いている方向(一般には前進方向)が基準方向として認識される。従って、前進方向を基準にして、4方向(自律車の前後左右方向)が認識され、スタート地点の自己位置座標からどの方向に何区間(どれだけの座標点)走行したかが把握される。

【0010】次に、自律車には、前方、右側および左側

に存在する壁または障害物などの境界を検知する装置(以下センサと称す)が搭載され、自律車が1区間毎に走行して各センサが壁または障害物などの境界を検知した場合は、該境界(壁または障害物等)を1単位座標毎に境界座標(壁座標または障害物座標等)として認識し、かつ、これらの境界座標を基準座標に記録する。一方、自律車の自己位置座標として、自律車が1区間毎に走行した走行来歴を1単位座標毎に走行来歴座標として記録する。

【0011】そして、自律車が所定走行法によって走行し続けて、周囲の全ての境界座標が認識記録された時点において、境界座標で基準座標上に描かれた閉じた領域、すなわち、境界座標で囲まれた領域としての走行領域座標が得られ、走行領域座標で表わされた自律車の走行領域として把握されることになる。一方、自律車が走行し続けているときに、自律車が走行した走行来歴が1走行単位毎に把握され、該1走行単位毎の走行来歴が自律車の1単位座標毎の走行来歴座標として設定され、該走行来歴座標が基準座標に記録される。しかし、後述するように自律車が走行した走行来歴の全てを走行来歴座標として記録するものではない。そして、走行領域としての走行領域座標は、走行来歴としての走行来歴座標と走行していない未走行領域としての未走行座標とに区別される。すなわち、走行領域座標-走行来歴座標=未走行座標である。最終的に、走行領域座標内における未走行座標の有無を把握し、走行領域座標内の該未走行座標を埋めるような走行を実行させ、自律車を走行領域内を隈なく走行させる制御方法(走行領域を走破する制御方法)である。

【0012】また、本発明の別の特徴として、単位走行法としての「右優先走行制御法」または「左優先走行制御法」がある。右優先走行制御法とは、自律車が右側の壁または障害物づたいに必ず走行することを義務付ける規則である。この規則が守られれば一般に閉領域である走行領域を周回し、該走行領域を必ず把握することができる。この時、走行した来歴を同時に記録することも重要である。既に走行した個所に印を付けて重複を避けるためである。迷路からの脱出と似た原理である。

【0013】具体的には、自律車が1区間毎に走行し走行来歴を記録し到達した任意の走行地点で、記録された前述の各座標データに基づいて、該走行地点でこれから走行しようとする自己位置座標の前後左右の座標に対して、壁または障害物等がないか、走行来歴がないかなどを「右側、前方、左側、後方の優先順に判定を行い次に進む方向を決め進行する走行法」である。これが「右優先走行制御法」である。なお、「左優先走行制御法」は「左側、前方、右側、後方の優先順に判定を行い次に進む方向を決め進行する走行法」である。また、「直進優先走行

制御法)は「前方、右側、左側、後方の優先順)である。

【0014】まず、自律車は、スタート地点より1区間前進をくり返し壁などの境界を目指す。そして、前方センサが壁を検知したときに、壁に対して90度左に向かせた後に1区間前進させ「右優先走行制御法)で進行させる。(90度右に向かせた後に左優先走行制御法)でも可である。)その後、右側の壁づたいに走行すれば周回することができ、周回した時点で走行領域の決定を行うことにより、自律車が囲まれた閉領域としての走行領域を把握することができる。同時に壁づたいに走行し始めたら走行来歴を記録する。なお、スタート地点から壁などの境界を検知する迄の走行している間は、走行来歴を記録しない方が効率の良い走行ができる。

【0015】このように「右優先走行制御法)で走行し、壁または障害物を検知し走行来歴を記録し境界沿いを一周し、自律車が走行領域(走行領域座標)を把握した後は、一般的には、把握した境界(境界座標)の内側の走行来歴(走行来歴座標)のない未走行領域(未走行座標)を埋め尽くすように、右優先走行制御法)により走行来歴(走行来歴座標)を境界(境界座標)に置き換えた形で、該走行来歴(走行来歴座標)づたいに左回りに周回走行し、走行領域を走破することになる。

【0016】しかしながら、自律車の自己位置座標の前後左右の座標の全てに、走行来歴があると判定されるが、自己位置座標の前後左右の座標以外に走行来歴のない座標(または座標領域)が残っている場合が発生する。したがって、自律車の自己位置座標の前後左右の座標のすべてに走行来歴ありと判定された場合は、基準座標に描かれた走行領域内の走行来歴のない座標(または座標領域)が残っているかを判定し、残っていなければ自律車を停止する。

【0017】残っていれば、残っている座標領域内の座標の1点を代表座標値として選び(例えば一番大きい座標値)、自律車の自己位置座標と上記で選んだ代表座標のX方向とY方向とからどちらの差が大きいかを判定し、その方向で座標の大小比較を行い走行方向を仮決定し、さらに、直進優先走行制御法)で進む方向を決め、その方向に1区間進む(以下、これを「残方向直進優先走行制御法)と称す)。

【0018】次に、上記残方向直進優先走行制御法)にて走行中、自律車の自己位置の座標の前後左右の座標のうちどれか1つでも走行来歴がある座標でなくなったら、走行来歴のない座標領域に達したと判断し、直進優先走行制御法)にて進み、自律車の自己位置の前後左右の座標共走行来歴のある座標となった時点で、走行範囲の決定を行い、走行範囲内で走行来歴のない座標が残っているかを検索し、残っていなければ停止する。

【0019】更に残っていれば、残方向直進優先走行制御法)に戻り、直進優先走行制御法)、走行範囲の決定、走行範囲内で走行来歴のない座標が残っているかの検索を

繰り返しつつ、未走行座標を埋め尽くすように走行し、走行来歴のない座標がなくなった時点で停止する。以上の自律車の走行制御方法により、自律車はどこからスタートしても、効率良く、すなわち、重複走行を最小限に抑えて、自律車自身が障害物を含めて把握した境界に囲まれた走行領域内を走破することができる。

【0020】次に、本発明の実施の形態について、図面を参照し説明する。走行制御法のロジックをプログラムにし半導体記憶素子(ROM)に書き込み、走行制御する本発明による一実施例である。図1は、本発明による一実施例の自律車の走行制御装置を搭載した自律車を示す図である。自律車50は、車体フレーム1、左・右駆動輪2、3、補助輪6などを含む車体手段と、駆動輪を駆動する左・右モータ4、5などを含む駆動手段と、自律車の走行制御装置60などを含む制御手段とから構成される。そして、走行制御装置60は、狭義に解釈すれば後述するロジックコントローラ16に該当し、広義に解釈すれば壁または障害物を検出する前方センサ7、左センサ8、右センサ9およびロジックコントローラ16などを含めた装置に該当する。本実施例では前者として説明する。

【0021】図2は、本発明による一実施例の走行制御方法を示すフローチャートである。図3は、本発明の走行制御方法による一実施例の走行軌跡を示す図である。図2、図3を参照しながら本実施例について説明する。図3において、走行制御装置内の記録装置の基準座標に描かれた壁10に囲まれた走行領域内を、自律車が走行した場合の軌跡が示されている。図3の実施例では、A点に自律車を置き、A点のスタート地点において、自律車の前進方向(矢印の方向)は壁に平行な方向とし、本実施例の場合は、自律車の右側は壁に接しているものとする。

【0022】まず、A点に置かれた自律車の電源スイッチを入れると走行制御装置内の記録装置(RAM)に白紙状態の基準座標が保有され、該基準座標の中心点座標には、自律車が最初にスタートするスタート地点であるA点の初期自己位置座標が、設定される。自律車が始動されると図2のステップS1が実行されるとともに、自律車の右方に壁があるので右センサが作動し、右側に壁ありと検知され、自律車の自己位置座標の右側の座標に壁ありとして境界座標を記録し、壁などの境界を目指す、A点から1区間前進する。そして、B点に到達する。A点からB点の1区間だけ前進することによって初めて、1走行単位を1単位座標とする座標の1点が得られる。この場合、A点から1区間前進したが走行来歴を記録しないことにする。

【0023】また、自律車は必ずしも側壁に平行あるいは前方壁に垂直に走行するものでないので、自律車の走行姿勢制御が別途必要であるが、本実施例では側壁に平行あるいは前方壁に垂直に走行するものとし、走行姿勢

制御については割愛する。自律車が1区間前進したB点において、前方に壁があるので前方センサが作動し、ステップS2で前方に壁があると判定されると共に、右側に壁があるので右センサが作動する。即ち、前方センサ及び右センサから、前方及び右側に壁ありと検知される。また、自律車の自己位置座標の前方座標及び右側座標に壁ありとして境界座標を記録する。と同時にB点の自己位置座標に走行来歴を記録する。さらに、前方センサが作動したこと、換言すれば壁を検知したことを起点として、ステップS2'にて壁に対し90度左に自律車の向きを変える左転回を実行し、1区間前進しC点に至る。

【0024】次に、C点において、ステップS3の右優先走行制御法で判定する。即ち、右優先走行しようとするが、右センサから右側に壁ありと検知される。この時、自律車の自己位置座標の右側の座標に壁ありと記録する。そして、壁がなく走行来歴がないC1点へと1区間前進する。同時に、自己位置座標に走行来歴を記録する。上記を繰り返し、C1点からC2点に至る。C2点においては、自律車の前方及び右側に壁があるので、ステップS3の右優先走行制御法により自律車の自己位置座標の前方座標及び右側座標に壁ありと記録すると共に、自律車の自己位置座標に走行来歴を記録し、壁に対し90度左に向きを変え、1区間前進する。そしてステップS3の右優先走行制御法にて、C2~C3~C4点と継続走行し、図示のように周回しA点に至る。

【0025】A点において、右側には壁があるので右側壁を記録し、A点の自己位置座標に走行来歴を記録する。次にステップS4の自律車の自己位置座標の右側、前方、左側の座標に走行来歴があるかを記録装置内の座標データより判定し、A点の前方のB点に走行来歴があるので、この時点で壁沿いを一周したと判断し、ステップS5の走行領域の決定により、自律車が囲まれた閉領域としての走行領域を把握したことになる。

【0026】次に、ステップS6の右優先走行制御法により、右側の壁、前方の走行来歴から、自律車の自己位置座標に走行来歴を記録すると共に、90度左に向きを変え1区間前進する。D点において、自律車の自己位置座標に走行来歴を記録すると共に、ステップS7にて自律車の自己位置座標の前後左右の座標の内どれかに走行来歴のない座標があるかを判定し、前方の座標に走行来歴がないので、ステップS6の右優先走行制御法により前方に1区間進む。E点でもD点と同じ判定を行い同じ動作となる。

【0027】F点において、自律車の自己位置座標に走行来歴を記録すると共に、ステップS7の判定で自律車の自己位置座標の前後左右の座標のいずれにも走行来歴があるので、ステップS8にて走行領域内に走行来歴のない座標(または座標領域)が残っているかを判定し、走行来歴のない座標がないのでステップS15にて自律車

の走行を停止し、プログラムを終了する。

【0028】図4は、本発明の走行制御方法による他の実施例の走行軌跡を示す図である。壁10などに囲まれた走行領域内を、自律車が障害物11を避けながら走行した場合の軌跡を示している。図2は、走行制御方法を示すフローチャートである。図2、図4を参照しながら本実施例について説明する。

【0029】A点に置かれた自律車の電源スイッチが入りプログラムが開始されると、走行制御装置60内の記録装置に白紙状態の基準座標が保有される。また、このA点の座標が初期自己位置座標として基準座標の中心座標に記録される。そして、自律車が始動されるとA点でステップS1が実行され、自律車は1区間前進する。この1区間前進することにより、1走行単位を1単位座標とする座標の1点が得られる。そして、A点よりスタートした自律車は、ステップS2で前方に壁があると判定されるB点まで、1区間前進を繰り返す。

【0030】尚、A点からB点の間の自己位置座標は、常に、A点の初期自己位置座標を基準にして認識される。しかし、重複走行を避ける効率の良い「走行領域の走破」を意図し、A点からB点の間では、走行来歴としては記録されないプログラムとなっている。B点において前方センサが動作し、自律車が前方壁を検知したとき初めて、B点の自律車の自己位置座標の前方の座標に壁ありと記録すると共にB点の自律車の自己位置座標に走行来歴を記録する。

【0031】そして、初めてステップS2にて前方壁を検知したので、ステップS2'で、壁に対し90度左に向きを変え1区間前進する。B1点においてステップS4の自律車の自己位置座標の前方、右側、左側の座標に走行来歴があるかを記録装置内の座標データより判定される。そして、走行来歴がないので、ステップS3の右優先走行制御法により自律車の右側のみ壁があるので、自律車の自己位置座標の右側の座標に壁ありと記録すると共に、自律車の自己位置座標に走行来歴を記録し、B1点から1区間前進する。これを繰り返して進みB2点に至る。

【0032】また、B2点において、自律車の前方及び右側に壁があるので自律車の自己位置座標の前方及び右側の座標に壁ありと記録すると共に、自律車の自己位置座標に走行来歴を記録し、壁に対し90度左に向きを変え1区間前進する。そして、B2点~B6点~C点まで壁に沿って走行する。C点においては、自律車の自己位置座標の前方、右側、左側の座標の全てに壁がなく、かつ、走行来歴がない。したがって、右優先走行制御法に従って右側に優先して走行する。(換言すれば右転回走行である。)

すなわち、90度右に向きを変え、C点の自律車の自己位置座標に走行来歴を記録すると共に、1区間前進する。そして、C点からD点に至る。D点においても、右

優先走行制御法が有効に動作する。このようにステップS3～ステップS4を繰り返し、自律車は壁沿いを走行し、E点に至る。E点においては、右側には壁があり、前方のB点には走行来歴がある。したがって、ステップS4の判定において、自律車の自己位置座標の前方または右側または左側の座標に走行来歴があるかが判定され、初めて自己位置座標の前方の座標に走行来歴があると判定されステップS5に進む。すなわち、自律車の前方に走行来歴があるので、この時点で壁沿いを周回したと判断され、ステップS5にて走行領域の範囲が決定される。

【0033】次に、E点からF点にかけて、ステップS6の右優先走行制御法にて、自律車の前方には走行来歴があり、右側には壁があるので、自律車の自己位置座標の右側の座標に壁ありと記録し、自律車の自己位置座標に走行来歴を記録すると共に90度左に向きを変え、E点からF点へ1区間前進する。F点において、自律車の自己位置座標に走行来歴を記録すると共に、ステップS7にて自律車の自己位置座標の前後左右の座標のいずれかに、走行来歴がない座標があるかを判定するが、F点においては、壁または障害物も走行来歴も、前方及び左右の座標にないので、ステップS6の右優先走行制御法が動作する。すなわち、90度右に向きを変えF点からF1点へ1区間前進する。そして、F1点において、F点と同じ判定を行い、自律車の自己位置座標(F1点)の右側の座標(B点)に走行来歴があるので、走行来歴を境界に置き換えた形で、該走行来歴づたいに左回りに周回走行し始める。

【0034】なお、F1点は既に一度自律車が走行した点である。しかし、前述のようにA点からB点の間の自己位置座標は走行来歴としては記録されていないので、支障がないものとなっている。また、F2点からF3点にかけては、自律車の自己位置座標の前方及び右側の座標に走行来歴がある場合であるが、自律車の自己位置座標に走行来歴と記録すると共に、90度左に向きを変え、1区間前進する。このようにしてF3点から走行来歴を記録しつつ進みG点に至る。そして、G点にて自律車の自己位置座標に走行来歴を記録すると共にステップS7にて、自律車の自己位置座標の前方または後方または左側または右側の座標に走行来歴がない座標があるかが判定されると、どの方向にも走行来歴があると判定される。どの方向にも走行来歴があると判定されるが、未だ走行していない未走行領域(座標または座標領域)がA点の周辺部に存在するので、ステップS8にて、走行領域内の走行来歴のない走行範囲(座標または座標領域)の検索が実行される。本実施例の場合は、未走行領域内の一番大きい座標であるI点が検索される。そして、ステップS9の残方向直進優先走行制御法が実行される。

【0035】すなわち、ステップS9の残方向直進優先走行制御法により、G点において、90度右に向きを変

え1区間前進する。前進したC点において、ステップS10の自律車の自己位置座標の前方、後方、左側及び右側の座標に走行来歴があるかを判定し、どの方向にも走行来歴があるので、ステップS9の残方向直進優先走行制御法により1区間前進する。H点において、ステップS10の自律車の自己位置座標の前後左右の座標共走行来歴があるかを記録装置内の座標データにより判定し、走行来歴があるのは前方及び左側及び後方の座標だけなので、ステップS11の直進優先走行制御法により1区間前進する。ステップS11とステップS12とが繰り返えされて前進する。

【0036】D点において、ステップS12の自律車の自己位置座標の前後左右の座標ともに走行来歴があるかを判定し、自律車の自己位置座標の右側、左側及び後方に走行来歴があり前方にはないのでステップS11の直進優先走行制御法により1区間前進する。I点において、自律車の自己位置座標に走行来歴を記録すると共に、ステップS12の自律車の自己位置座標の前後左右の座標共走行来歴があるかを判定し、自律車の左側及び後方の座標にしか走行来歴がないので、ステップS11の直進優先走行制御法により1区間前進する。このように1区間ごとに直進優先走行制御法により進む。なお、自律車を、G点から未走行領域へ向かわせる方法として、ステップS8の走行領域内の走行範囲の検索により見つかった走行来歴のない未走行領域の中から、一番大きい座標値のI点を代表座標値として選ぶ。次に、残方向直進優先走行制御法により、自律車の自己位置座標と上記で選んだI点の座標のX方向とY方向とでどちらの差が大きいか(区間数が大きいか)を判定し、その方向(例えばY方向の方が大きければY方向)で座標の大小比較を行って走行方向を仮決定し、さらに、直進優先走行制御法で自律車の進む方向を決める方法である。

【0037】また、ステップS8の走行領域内の走行範囲の検索により見つかった走行来歴のない未走行領域の中から、一番小さい座標値を代表座標値として選び、上記と同じ残方向直進優先走行制御法により判定を行い、進む方向を決める方法も考えられる。最終的には、A点において、自律車の自己位置座標に走行来歴を記録すると共に、ステップS12にて、自律車の自己位置座標の前後左右の座標共走行来歴があるかを判定し、どの方向にも走行来歴があるので、ステップS13にて走行範囲を決定し、ステップS14にて走行範囲内で走行来歴のない座標が残っているかを判定し、走行来歴のない座標がないので、ステップS15で自律車を停止し、プログラムを終了する。

【0038】図5は、前方センサが1区間走行の途中で壁などを検知した場合の一実施例の走行制御方法を示す図である。前述の2つの実施例で、1区間走行の途中で前方センサ7が壁10または障害物11を検知した時の走行制御方法を示したものである。図5(a)において、

自律車50が前進し、1区間を走りきらない途中で、前方センサ7が壁を検知した場合、走りきらない区間も壁として記録する。そして、1つ前の1区間(1座標)まで後退し、後退したら、90度判定により求めた方向に向きを変える走行制御方法である。走りきらないで壁として認識した区間の座標データを用いて、例えば、右優先走行制御法により継続走行するものである。また、1区間を走りきらないうちに前方センサ7が壁を検知した場合にのみ、1走行単位の定義(例えば距離)を変えるプログラムとしても可である。さらに、図5(b)は、自律車が前進中に、右センサ9及び左センサ8が壁または障害物を検知し、次の1区間の途中で前方センサ7が壁を検知した場合は、走りきらない区間を壁として記録すると共に、1つ前の区間まで後退し、180度向きを変える走行制御方法である。

【0039】図6は、本発明による一実施例のロジックコントローラを示す図である。マイクロプロセッサ17、ROM18、RAM19などを、走行制御装置60としてのロジックコントローラ16に纏めたものである。すなわち、図2、図3、図4にて説明した走行制御方法のロジックを、プログラムとしてROM18に書き込み、かつ基準座標をRAM19に記録し、必要に応じてそれぞれを読み出して利用し、マイクロプロセッサ17が処理する実施例を接続ブロック図で示しているものである。また、図6において、12はバッテリー、13は電源スイッチ、14は押しボタン式の始動スイッチ、15は停止スイッチである。

【0040】したがって、単位走行手段は、前述の左・右モータ4、5やバッテリー12などを含む駆動手段と、マイクロプロセッサ17、ROM18などを含むロジックコントローラ16とに該当する。また、所定走行手段、境界座標設定手段、境界記録手段、走行領域演算手段、来歴記録手段、未走行領域演算手段および走行制御手段は、マイクロプロセッサ17、ROM18などを含むロジックコントローラ16に該当する。座標保有手段は、RAM19に該当し、境界検出手段は、前方センサ7、左センサ8、右センサ9と、マイクロプロセッサ17、ROM18などを含むロジックコントローラ16とに該当する。以上の本発明の特徴を簡潔に纏めれば、次のようになる。自律車の走行制御方法は、自律車が保有する、即ち、自律車の座標保有手段が保有する1走行単位を1単位座標とする白紙状態の基準座標上、即ち、未走行座標上に、自律車が走行し当該自律車の走行来歴として得られる該1走行単位毎の1単位座標を走行来歴座標として記録し、未走行座標を走行来歴座標で埋めながら自律車を継続走行させるよう、走行来歴座標を使って単位走行を制御する、即ち、自律車の単位走行手段を制御するものである。

【0041】具体的には、プログラム上で定めた自律車の単位走行時間で移動する単位区間を1走行単位とし、

その1走行単位を1単位座標とする白紙状態の基準座標を記録装置内に設定する。そして、自律車の任意のスタート地点を基準座標に設定すると共に、このスタート地点の自律車の前進方向を基準に4方向(自律車の前後左右の方向)についても定義する。これによってスタート地点からどの方向に何区間進んだかにより、自律車の自己位置座標を常に認識することができる。

【0042】そして、自律車を境界内の任意の地点より境界に向かって前進させ、境界を検知したら90°左または右に回転させ、境界沿いを一周させることにより、自律車自身が周囲を壁などに囲まれた領域の境界を把握することができる。さらに、自律車の自己位置座標を走行来歴と、壁または障害物などの境界を検知する装置が検知した壁や障害物の位置座標とを1区間ごとに記録し、これらの座標データに基づいて判定し、効率良く未走行領域を埋め尽くすように走行させるものである。

【0043】また、換言すれば、自律車に前方センサ7、右側方向きセンサ9、左側方向きセンサ8を搭載し、センサが検知した壁または障害物の位置を記録し、また、自律車の走行来歴を記録しながら、次の順序で走行制御するものである。a. 壁10などの境界に向って前進し、b. 境界を検知したら境界と90度左または右に向くよう転回し、c. 境界沿いを一周して走行領域の範囲を決定し、d. 走行領域の範囲内の未走行領域を順次走破し、e. 未走行領域がなくなった時点で自律車を停止する。

【0044】したがって、本発明によれば、自律車の走行範囲を決定するための走行範囲入力装置や自律車の自己位置を計測するための位置計測装置を使用することなく、壁などの境界に囲まれた走行領域内を障害物を避けながら重複することなく走行する自走式掃除機や自走式芝刈機などの自律走行作業車を得ることができる。

【0045】

【発明の効果】本発明によれば、走行範囲入力装置や位置計測装置を使用しないため、低コストで製作することができ、重複して走行することがないので作業効率が向上すると共に、バッテリー電源の節約にもなる。

【図面の簡単な説明】

【図1】本発明による一実施例の自律車の走行制御装置を搭載した自律車を示す図である。

【図2】本発明による一実施例の走行制御方法を示すフローチャートである。

【図3】本発明の走行制御方法による一実施例の走行軌跡を示す図である。

【図4】本発明の走行制御方法による他の実施例の走行軌跡を示す図である。

【図5】前方センサが1区間走行の途中で壁などを検知した場合の一実施例の走行制御方法を示す図である。

【図6】本発明による一実施例のロジックコントローラを示す図である。

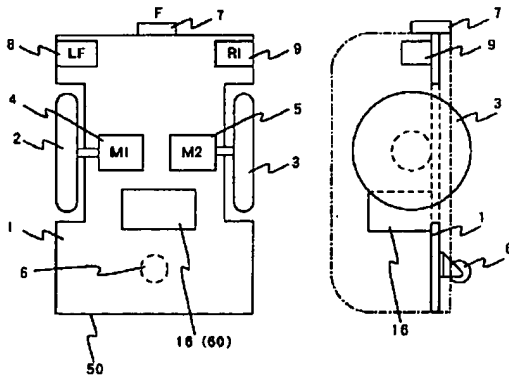
【符号の説明】

1…車体フレーム、2…左駆動輪、3…右駆動輪、4…左モータ、5…右モータ、6…補助輪、7…前方センサ、8…左センサ、9…右センサ、10…壁、11…障

害物、12…バッテリー、13…電源スイッチ、14…始動スイッチ、15…停止スイッチ、16…ロジックコントローラ、17…マイクロプロセッサ18…ROM、19…RAM、50…自律車、60…走行制御装置。

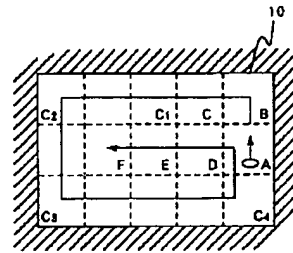
【図1】

図 1



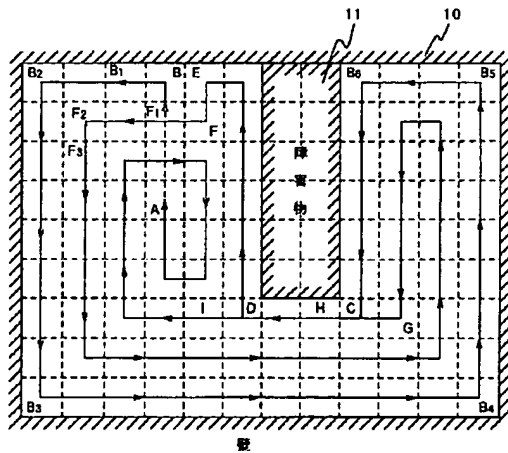
【図3】

図 3



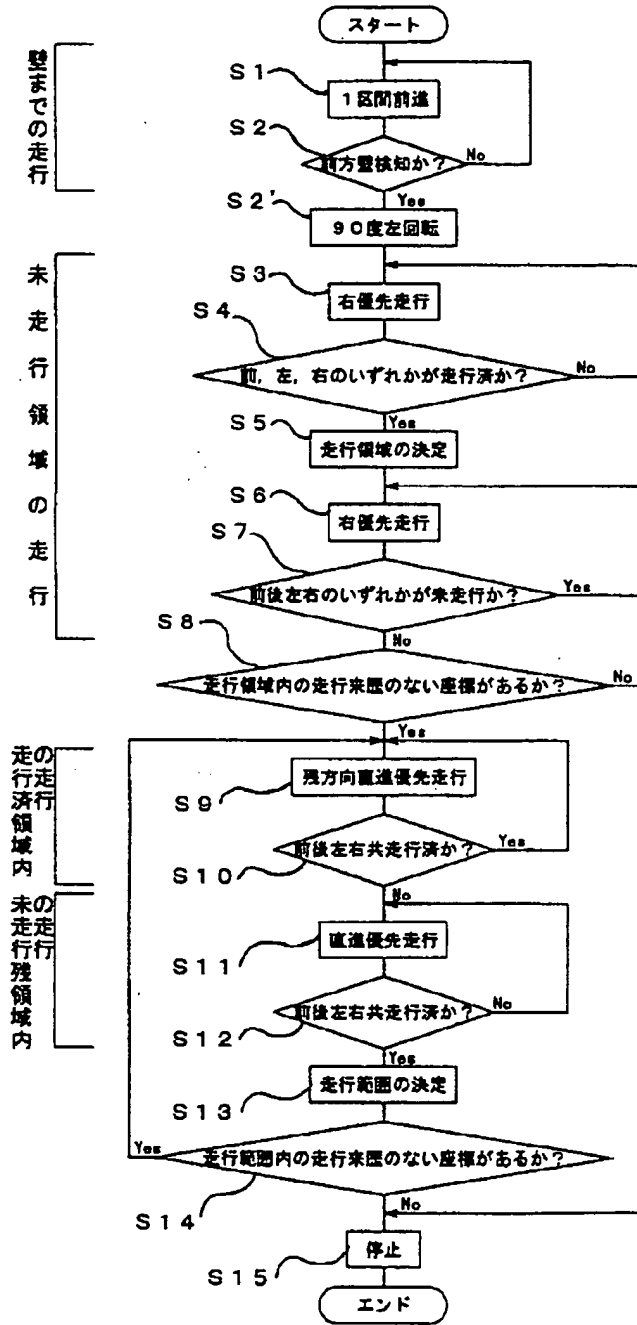
【図4】

図 4



【図2】

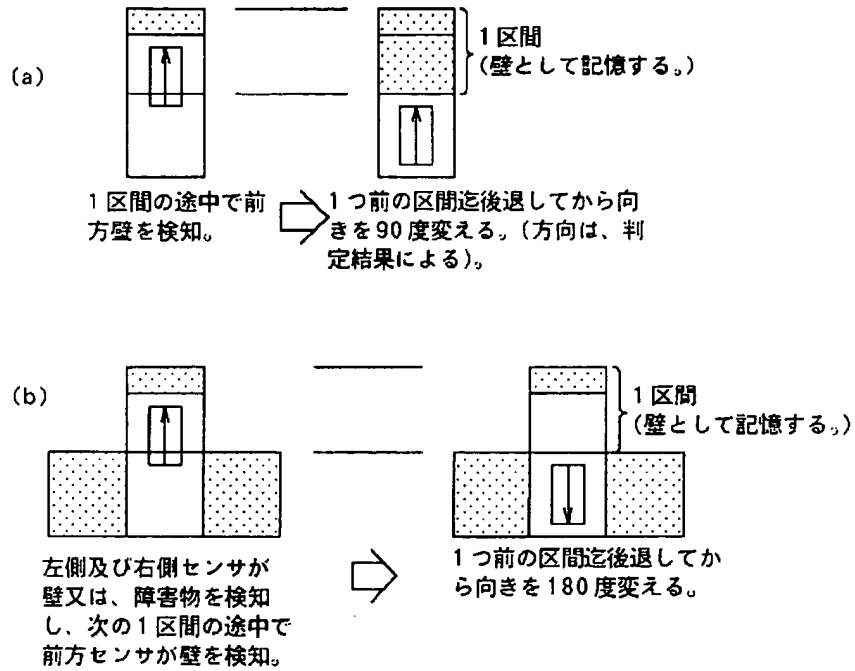
図 2



注) 1 自律車の前方, 右側方, 左側方のセンサーが壁などの境界や障害物を検知した場合, 1区間ごと壁や障害物の位置座標を記憶する。  
 2 1区間ごとに自律車の自己位置の座標に走行履歴を記憶する。  
 3 各判定は, 1区間ごとに行い, 次に進む方向を決めて, その方向に1区間進む。

【図5】

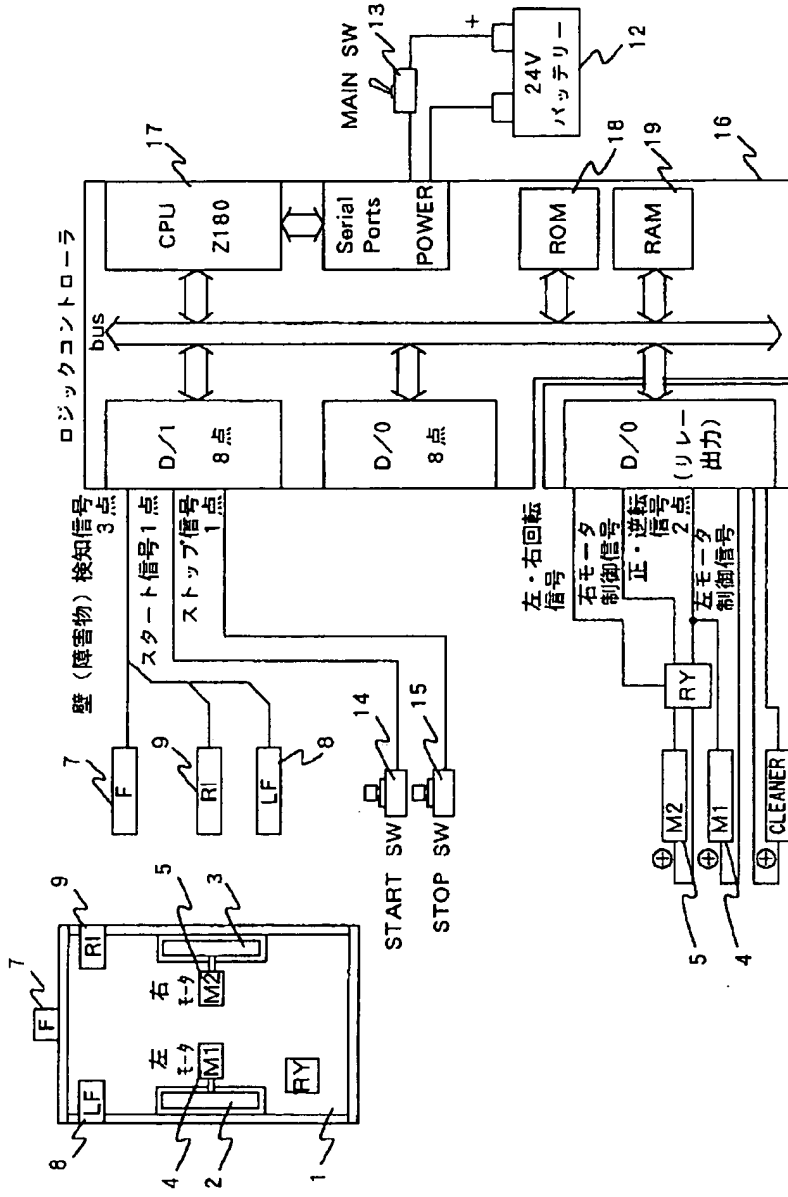
図 5





【図6】

図 6





(19)

09206258 A

(11) Publication number:

Generated Document.

**PATENT ABSTRACTS OF JAPAN**

(51) Intl. Cl.: A47L 11/38 G05D 1/02 G05D 1/10

(21) Application number: 08016776

(22) Application date: 01.02.96

<p>(30) Priority:</p> <p>(43) Date of application publication: 12.08.97</p> <p>(84) Designated contracting states:</p>	<p>(71) Applicant: FUJI HEAVY IND LTD</p> <p>(72) Inventor: TAJIMA SHIGEKI AOYAMA HAJIME</p> <p>(74) Representative:</p>
--	--

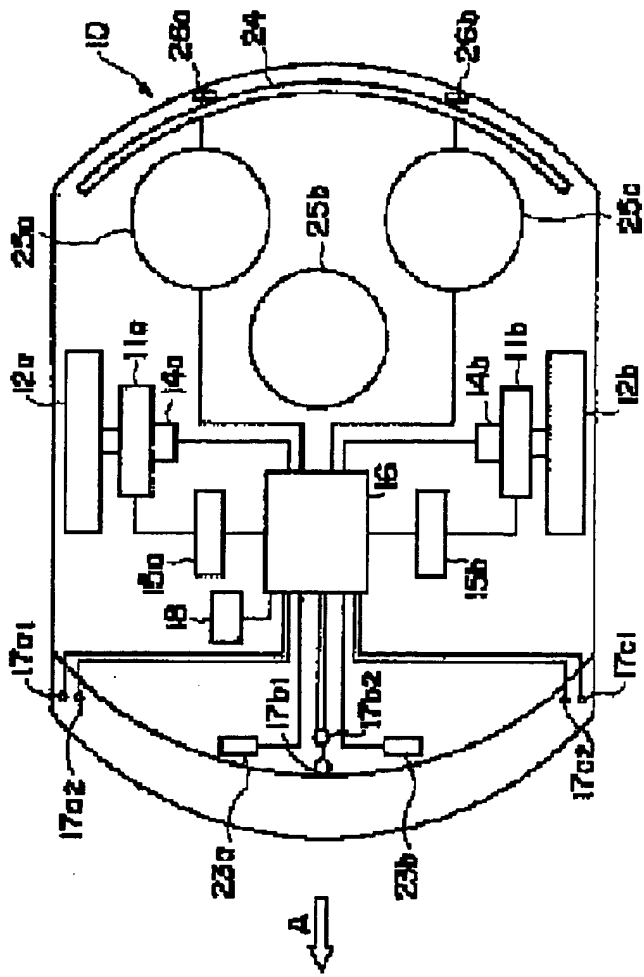
**(54) CONTROL METHOD FOR CLEANING ROBOT**

(57) Abstract:

**PROBLEM TO BE SOLVED:** To perform an avoiding operation according to an obstacle, when the obstacle is detected by a first obstacle detecting sensor, by extending the distance to a wall detected by a wall distance detection sensor, and then detecting the obstacle by a second obstacle detecting sensor, and stopping the traveling of a cleaning robot so as to perform a spin turn.

SOLUTION: Detection signals from right front obstacle sensors 17a1, 17a2, central front obstacle sensors 17b1, 17b2, left front obstacle sensors 17c1, 17c2, right/left wall detecting sensors 23a, 23b, etc., are inputted in a controller 16 of a cleaning robot. When the left/right front and central front obstacle detection sensors 17a1, 17c1, 17b1 detect an obstacle, the left/right wall detecting sensors 23a, 23b make the robot to perform a primary avoidance operation which extends the distance to a wall. When the second left/right front and central front obstacle detecting sensors 17c2, 17a2, 17b2 detect the obstacle, the traveling of the cleaning robot is made to stop so as to perform a secondary avoidance operation of performing spin turning at a prescribed angle.

COPYRIGHT: (C)1997,JPO



(19)日本国特許庁 (J P)

(12) 公開特許公報 (A)

(11)特許出願公開番号

特開平9-206258

(43)公開日 平成9年(1997)8月12日

(51)Int.Cl. <sup>6</sup>	識別記号	庁内整理番号	F I	技術表示箇所
A 4 7 L 11/38			A 4 7 L 11/38	
G 0 5 D 1/02			G 0 5 D 1/02	L
				S
		1/10	1/10	
// B 2 5 J 5/00			B 2 5 J 5/00	E
審査請求 未請求 請求項の数3 OL (全 10 頁)				

(21)出願番号 特願平8-16776

(22)出願日 平成8年(1996)2月1日

(71)出願人 000005348

富士重工業株式会社  
東京都新宿区西新宿一丁目7番2号

(72)発明者 田島茂樹  
東京都三鷹市大沢三丁目9番6号 株式会社スバル研究所内

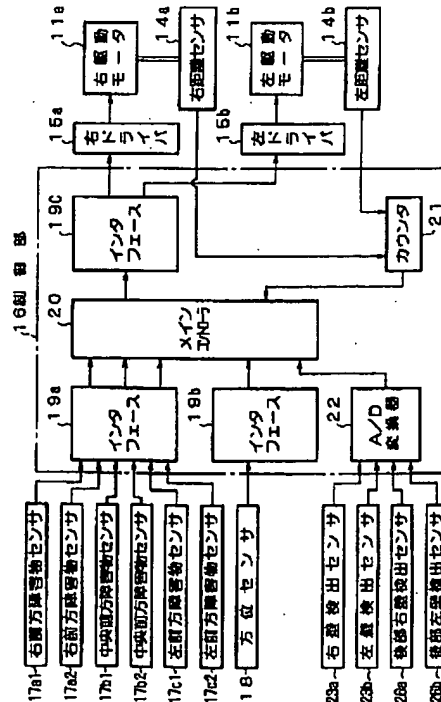
(72)発明者 青山元  
東京都三鷹市大沢三丁目9番6号 株式会社スバル研究所内

(74)代理人 弁理士 佐藤 一雄 (外3名)

(54)【発明の名称】 清掃ロボットの制御方法

(57)【要約】

【課題】 回避動作に無駄があり清掃効率が低かった。  
【解決手段】 遠距離の障害物を検出するセンサ17a 1~17c 1、近距離の障害物を検出するセンサ17a 2~17c 2、壁間距離を検出するセンサ23a及び23bを清掃ロボットに設け、センサ17a 1~17c 1が障害物を検出したときセンサ23a及び23bが検出する壁間距離を測る一次回避動作を行うステップと、この一次回避動作を行った後に、センサ17a 2~17c 2が障害物を検出したとき清掃ロボットの走行を停止させ所定角度でスピターンを行う二次回避動作を行うステップとを備える。



## 【特許請求の範囲】

【請求項1】清掃ロボットを壁沿いに走行させているときに障害物を回避する清掃ロボットの制御方法において、

前方の障害物を検出する第1の障害物検出センサと、前方の障害物を検出し前記第1の障害物検出センサよりも検出距離が短い第2の障害物検出センサと、壁までの距離を測定する壁間距離検出センサとを清掃ロボットに設け、

前記第1の障害物検出センサが障害物を検出したとき、前記壁間距離検出センサが検出する壁までの距離を上げる一次回避動作を行うステップと、

前記一次回避動作を行った後に、前記第2の障害物検出センサが障害物を検出したとき、清掃ロボットの走行を停止させ、所定角度でスピントーンを行う二次回避動作を行うステップと、

を備えることを特徴とする清掃ロボットの制御方法。

【請求項2】前記二次回避動作におけるスピントーンは、第1の角度で行う第1のスピントーンと、この第1のスピントーンを行った後に前記第2の障害物検出センサが障害物を検出したとき前記第1の角度よりも大きい第2の角度で行う第2のスピントーンとが含まれることを特徴とする請求項1記載の清掃ロボットの制御方法。

【請求項3】清掃ロボットを壁沿いに走行させているときに障害物を回避する清掃ロボットの制御方法において、

前方の障害物を検出する第1の障害物検出センサと、前方の障害物を検出し前記第1の障害物検出センサよりも検出距離が短い第2の障害物検出センサと、壁までの距離を測定する壁間距離検出センサと、走行方向を検出する方位センサとを清掃ロボットに設け、

清掃ロボットに目標走行方向と第1の壁間距離とを設定し、前記方位センサが検出する走行方向が前記目標走行方向を維持し、前記壁間距離検出センサが検出する壁までの距離が前記第1の壁間距離を維持するように清掃ロボットを走行させるステップと、

前記第1の障害物検出センサが障害物を検出した場合であって、前記方位センサが検出した走行方向が前記目標走行方向よりも壁に接近する方へずれており、さらにこのずれ角度が所定の接近角度以下の場合、前記第1の壁間距離よりも大きい第2の壁間距離を保つように設定を変更するステップと、

前記第1の障害物検出センサが障害物を検出した場合であって、前記方位センサが検出した走行方向が前記目標走行方向よりも壁に接近する方へずれており、さらにこのずれ角度が前記所定の接近角度よりも大きい場合は、前記第2の障害物検出センサが障害物を検出したときに清掃ロボットの走行を停止させ、壁までの距離が広がる方向へ第1の角度スピントーンさせ、第2の障害物検出センサが障害物をさらに検出したときは第1の角度より

も大きい第2の角度スピントーンさせるステップと、を備えたことを特徴とする清掃ロボットの制御方法。

## 【発明の詳細な説明】

## 【0001】

【発明の属する技術分野】本発明は、床面を自律して走行し、かつ自動清掃を行う清掃ロボットの制御方法に関する。

## 【0002】

【従来の技術】近年、自律走行機能及び自動清掃機能を併せ持つ清掃ロボットが提案されている。例えば、特開平4-260905号公報には、蓄電池を電源とするモータ、操舵輪、方位等を検出する各種センサ、これらの要素を制御するマイクロコンピュータ等を搭載して自律走行する機能に、洗浄液を床面に散水する散水口、床面を清掃する清掃ブラシ、集塵を吸い込む吸引ノズル、清掃後の汚水を吸引するスクイジ等を有する自動清掃機能を備えた清掃ロボットが記載されている。また、他の従来の清掃ロボットには、特願平6-221766号公報に記載されたように、廊下のように両側に壁がある床面を壁沿いに走行するものも存在する。

## 【0003】

【発明が解決しようとする課題】しかし、従来の清掃ロボットには次のような問題があった。図13に示されるように、壁1が平坦ではなく突起2等の障害物が存在した場合、どのような障害物であっても清掃ロボット3を4回スピントーンさせて回避しており、清掃効率の大幅な低下を招いていた。

【0004】本発明は、壁に突起等の小さい障害物がある場合、また大きい障害物がある場合にも、障害物に応じた回避動作を行い清掃効率を向上させることが可能な清掃ロボットの制御方法を提供することを目的とする。

## 【0005】

【課題を解決するための手段】本発明の清掃ロボットの制御方法は、清掃ロボットを壁沿いに走行させているときに障害物を回避する方法であって、前方の障害物を検出する第1の障害物検出センサと、前方の障害物を検出し前記第1の障害物検出センサよりも検出距離が短い第2の障害物検出センサと、壁までの距離を測定する壁間距離検出センサとを清掃ロボットに設け、前記第1の障害物検出センサが障害物を検出したとき、前記壁間距離検出センサが検出する壁までの距離を上げる一次回避動作を行うステップと、前記一次回避動作を行った後に、前記第2の障害物検出センサが障害物を検出したとき、清掃ロボットの走行を停止させ、所定角度でスピントーンを行う二次回避動作を行うステップとを備えることを特徴としている。

【0006】前記二次回避動作におけるスピントーンには、第1の角度で行う第1のスピントーンと、この第1のスピントーンを行った後に前記第2の障害物検出センサが障害物を検出したとき前記第1の角度よりも大きい

第2の角度で行う第2のスピンターンとが含まれていてもよい。

【0007】本発明の他の清掃ロボットの制御方法は、前方の障害物を検出する第1の障害物検出センサと、前方の障害物を検出し前記第1の障害物検出センサよりも検出距離が短い第2の障害物検出センサと、壁までの距離を測定する壁間距離検出センサと、走行方向を検出する方位センサとを清掃ロボットに設け、清掃ロボットに目標走行方向と第1の壁間距離とを設定し、前記方位センサが検出する走行方向が前記目標走行方向を維持し、前記壁間距離検出センサが検出する壁までの距離が前記第1の壁間距離を維持するように清掃ロボットを走行させるステップと、前記第1の障害物検出センサが障害物を検出した場合であって、前記方位センサが検出した走行方向が前記目標走行方向よりも壁に接近する方へずれており、さらにこのずれ角度が所定の接近角度以下の場合、前記第1の壁間距離よりも大きい第2の壁間距離を保つように設定を変更するステップと、前記第1の障害物検出センサが障害物を検出した場合であって、前記方位センサが検出した走行方向が前記目標走行方向よりも壁に接近する方へずれており、さらにこのずれ角度が前記所定の接近角度よりも大きい場合は、前記第2の障害物検出センサが障害物を検出したときに清掃ロボットの走行を停止させ、壁までの距離が広がる方向へ第1の角度スピンターンさせ、第2の障害物検出センサが障害物をさらに検出したときは第1の角度よりも大きい第2の角度スピンターンさせるステップとを備えている。

【0008】

【発明の実施の形態】以下、本発明の一実施の形態による清掃ロボットの制御方法について説明する。先ず、本実施の形態の制御方法により、障害物を回避する動作の概略について述べる。

【0009】図3に示すように、清掃ロボット10には障害物を検出したり障害物までの距離を検出する各種センサが設けられている。清掃ロボット10の前部中央には、300～2500mmの範囲の前方の障害物を検出する前方障害物センサ17b1と、300mm以下の範囲の障害物を検出する前方障害物センサ17b2とが設けられている。同様に、清掃ロボット10の左右両側には、300～2500mmの範囲の前方の障害物を検出する前方障害物センサ17a1及び17c1と、300mm以下の範囲の障害物を検出する前方障害物センサ17a2及び17c2とが設けられている。

【0010】また、図4に示されたように、中央に位置する前方障害物センサ17b1及び17b2は検出範囲が広い広角のセンサであり、清掃ロボット10の全幅の範囲内に含まれる殆ど全ての障害物を検出することができる。逆に、左右両側に設けられた前方障害物センサ17a1及び17a2と、前方障害物センサ17c1及び17c2は、検出範囲の広がり狭く、清掃ロボット1

0の幅よりもなるべく外へ拡がらないようにする必要があり。

【0011】さらに、清掃ロボット10の前部中央付近には、左右の壁までのそれぞれの距離を測定する左壁検出センサ23bと、右壁検出センサ23aとが設けられ、後部中央付近には清掃ロボット10が障害物を回避したことを確認するための後部左壁検出センサ26bと後部右壁検出センサ26aとが配置されている。このようなセンサを用いて障害物を検出しながら、次のように走行を制御する。

(1) 清掃ロボット10を、壁から約150mm離れた状態で走行を開始する。

【0012】壁際には、出入り口やドアのノブ、ストッパ等の小さな凹凸があるが、これらの殆どは100mmの範囲内にある。さらに、上記障害物センサには検出範囲が清掃ロボット10の幅よりも若干拡がることを考慮する必要がある。そこで、清掃ロボット10が壁際の小さい凹凸を障害物と検出して不必要な回避動作を行うことなく走行することができるように、予め壁から150mm程度離しておく。

(2) 清掃ロボット10が走行中に遠距離前方に障害物を検出した場合、走行速度を落として徐行するとともに、壁に対する清掃ロボット10の進行方向を判断する。図5(a)に示されたように、右壁1aへ近接していく角度が2度以下である場合は、右壁1aまで300mmの距離を保つように設定を変更する。前方障害物検出センサ17a1～c1が検出し得る2500mmの距離を走行する場合、この間に近接していく距離は90mm(=2500 \* tan 2deg)であり、右壁1aを障害物と誤認することはない。図5(b)に示されたように、左壁1bに近接していく場合も同様であり、図6に示されたように左壁1bまでの距離を300mmとする。

【0013】壁際には上述したドアのノブ等の凹凸の他に、消化器が存在することがある。しかし、一般の消化器の凸量は300mm以内である。そこで、障害物を検出した後は、壁間距離を300mmに設定して走行することで、消化器のような障害物も回避することとする。

(3) 壁間距離を300mmに設定して走行し、前方に障害物を検出しない場合には、回避動作が完了したと判断し、通常の走行速度に戻す。この後、後部右壁検出センサ26a又は後部左壁検出センサ26bにより障害物を回避したことを確認し、壁間距離を150mmに戻して走行を再開する。

(4) 壁間距離を300mmに設定しても依然として前方に障害物を検出する場合は、検出距離が短い障害物センサが障害物を検出した時に清掃ロボットの走行を停止する。停止状態で2度の角度で、その場スピンターンを行う。ここで、2度の角度でスピンターンを行うのは、障害物の大きさに応じてなるべく進路の変更量を小さくするためであり、±1度の変化があってもよい。

(5) 前方に障害物が存在しない場合は、障害物を回避する動作が完了したと判断して、通常走行動作に戻る。より具体的には、図7に示されるように、2度のスピントーンを行って障害物を回避したことを後部左壁検出センサ26bにより確認した後、左壁1bまでの距離が150mmを保つように走行する。

(6) 図8に示されたように左壁1bに300mm以上の障害物が存在する場合は、90度のスピントーンを4回行って回避する。

【0014】次に、本実施の形態による制御方法で制御の対象となる清掃ロボットの制御機構の構成を図1に示し、この制御機構を搭載した清掃ロボットの構成を図2に示す。

【0015】図2のように、矢印Aの方向に自走する清掃ロボット10に右車輪12a及び左車輪12bが配置され、それぞれが右駆動モータ11a及び左駆動モータ11bによって回転する。右駆動モータ11a及び左駆動モータ11bは、右ドライブ15a及び左ドライブ15bによって駆動される。制御装置16は、方位センサ18、右前方障害物センサ17a1及び17a2、中央前方障害物センサ17b1及び17b2、左前方障害物センサ17c1及び17c2、右壁検出センサ23a、左壁検出センサ23b、後部右壁検出センサ26a、後部左壁検出センサ26b、右距離センサ14a及び左距離センサ14bの検出結果に応じて、右ドライブ15a及び左ドライブ15bを制御する。

【0016】また、清掃ロボット10の後部には、回転自在な清掃ブラシ25a～25cが配置されている。清掃ブラシ25a～25cの前部には図示されていない散水口が設けられ、洗浄液が吐出される。清掃ブラシ25a～25cの後部には、汚水を吸引するためのスクイジ24が設けられている。

【0017】図1に、清掃ロボット10の制御機構をより詳細に示す。制御部16は、インタフェース19a～19c、メインコントローラ20、カウンタ21、A/D変換器22を有している。図2及び図3に示されたように、右前方障害物センサ17a1及び17a2が清掃ロボット10の前部右側に設けられ、中央前方障害物センサ17b1及び17b2が前部中央に、また左前方障害物センサ17c1及び17c2が清掃ロボット10の前部左側に設けられている。検出距離は、センサ17a1、17b1及び17c1は300～2500mmと長く、センサ17a2、17b2及び17c2は300mm未満と短い。これらのセンサが障害物を検出すると、その検出信号をインタフェース19aに入力する。

【0018】方位センサ18は、例えばジャイロを用いて、基準方位に対する清掃ロボット10の走行方位を検出して方位検出信号をインタフェース19bに入力する。

【0019】インタフェース19aは、センサ17a1

～17c1及び17a2～17c2から出力された信号を与えられ、増幅等の必要な処理を行ってメインコントローラ20に与える。インタフェース19bは、方位センサ18からの信号を与えられて増幅等を行い、メインコントローラ20に与える。

【0020】右壁検出センサ23a及び左壁検出センサ23bと、後部右壁検出センサ26a及び後部左壁検出センサ26bとがそれぞれ壁までの距離を検出しアナログ信号を出力すると、A/D変換器22に入力される。A/D変換器22は、このアナログ信号をデジタル信号に変換してメインコントローラ20に出力する。

【0021】メインコントローラ20には、清掃ロボット10の走行距離に関する情報も入力される。右距離センサ14aは、右駆動モータ11aの回転軸の回転をエンコーダ等で検出し、左距離センサ14bは、左駆動モータ11bの回転軸の回転をエンコーダ等で検出して、カウンタ21に入力する。カウンタ21は、所定時間内の回転数から、右車輪12aと左車輪12bの走行距離を算出してメインコントローラ20に出力する。

【0022】メインコントローラ20は、インタフェース19a及び19b、A/D変換器22、カウンタ21から与えられた情報に基づき、インタフェース19cに制御信号を出力する。インタフェース19cは、この制御信号に増幅等を行って右ドライブ15a及び左ドライブ15bに与える。右ドライブ15a及び左ドライブ15bは、この制御信号に基づいて右駆動モータ11a及び左駆動モータ11bの動作を制御する。

【0023】次に、本実施の形態による制御方法により、清掃ロボットが障害物を回避するときの動作の手順をフローチャートを用いて説明する。先ず、図9に壁に沿って走行している最中に障害物を回避する手順を示す。ステップ102として、検出距離が短い前方障害物センサ17a2～17c2が、清掃ロボット10の前方300mm以内の近接した位置に障害物を検出したか否かを判断する。障害物が検出された場合は、図10のフローチャートにおけるステップ202へ移行する。障害物が検出されないときは、ステップ104として右壁と左壁のいずれに沿って走行しているかを判断する。右壁に沿って走行している場合は、ステップ106で、検出距離が長い右前方障害物センサ17a1と中央前方障害物センサ17b1のいずれかが障害物を検出したか否かを判断する。左壁に沿って走行している場合は、ステップ108として、検出距離が長い左前方障害物センサ17c1と中央前方障害物センサ17b1のいずれかが障害物を検出したか否かを判断する。検出しないときは、ステップ122を経て124へ移行し、通常の壁沿い走行を続行する。ステップ126で、設定距離を走行し終わったか否かを判断し、走行し終えたときはステップ128として走行を停止する。走行が未だ終了していないときは、ステップ102へ戻る。



【0024】ステップ106又は108において障害物が検出されたときは、ステップ110へ移行し、清掃ロボット10の目標走行方向と、方位センサ18により検出した現在の走行方向とを比較する。

【0025】ステップ112で、壁から離れる方向か否かを判断し、離れる方向である場合はステップ118へ移行して徐行し、接近する方向である場合はステップ114へ移行する。ステップ114で、目標走行方向と現在の走行方向とのずれが2度以内か否かを判断し、2度以内であればステップ118で徐行し、さらにステップ120へ移行して目標壁間距離を150mmから300mmへ変更する。ステップ114で進行方向のずれが2度を越える場合は、ステップ116へ移行して徐行する。ここで、目標進行方向と現在の走行方向とのずれが2度以内とは、図12(a)又は(b)におけるハッチングされた領域にあることをいう。この領域にある場合に、ステップ118へ移行し、この領域外にある場合は2度を越えるとしてステップ116へ移行する。

【0026】ステップ124へ移行して壁沿い走行を行い、上述したステップ126で設定距離を走行したか否かを判断する。

【0027】上記ステップ102で、検出距離の短いセンサ17a2~17c2が300mm以内に障害物を検出したか否かを判断し、検出した場合は図10のステップ202へ移行する。ステップ202において、清掃ロボット10の走行を減速させ停止させる。ステップ204において、障害物から離れる方向に2度の角度でスピントーンを行う。ここで、2度スピントーンを行うときの動作手順は後述する。

【0028】ステップ206において、検出距離の短いセンサ17a2~17c2が300mm以内に障害物を検出したか否かの判断を行う。ステップ208で、障害物を検出したか否かを判断し、検出したときはステップ210へ移行する。ステップ210において、通常の障害物回避動作を行う。通常は、90度その場スピントーンを行う。ステップ208で障害物を検出していない場合は、上記ステップ122へ移行して徐行を解除し、ステップ124で壁沿い走行を再開する。

【0029】図11に、2度スピントーンの動作手順を示す。ステップ302として右駆動モータ11a及び左駆動モータ11bの回転を減速させた後停止させる。ステップ304において、清掃ロボット10の目標走行方向が0度であるか又は180度であるかを判断する。0度である場合は、ステップ306へ移行し、左壁に沿う走行であるか右壁に沿う走行であるかを判断する。左壁に沿う走行である場合は、ステップ308へ移行して、図示されたように0度の現在位置から+2度の方向へスピントーンを行う。右壁に沿う走行では、ステップ310において、0度の位置から-2度の方向へスピントーンを行う。

【0030】ステップ304で目標走行方向が180度であると判断した場合は、ステップ312へ移行する。ステップ312において、左壁に沿う走行であるか右壁に沿う走行であるかを判断する。左壁に沿う走行である場合は、ステップ314へ移行して180度の現在位置から-178度の方向へスピントーンを行う。右壁に沿う走行では、ステップ316において180度の位置から+178度の方向へスピントーンを行う。

【0031】上述したように、従来は前方に障害物を検出した場合はどのような障害物であっても図13に示されたように4回90度スピントーンを行っていたため清掃効率が低いという問題があった。これに対し、本実施の形態によれば、前方の障害物を検出するセンサとして検出距離の異なるものを2つ備え、遠方に障害物を検出したときは壁間距離を拡げ、近距離で障害物を検出した場合は、スピントーンを2度の角度で行い、その後も依然として障害物を検出した場合に90度スピントーンを行う。これにより、障害物に応じて無駄な回避動作を行わないようにし、清掃作業の効率を向上させることができる。

【0032】本実施の形態は一例であり、本発明を限定するものではない。例えば、本実施の形態では清掃ロボットの後部に壁間距離センサを備えて障害物を回避したことを確認するのに用いているが、必ずしも備える必要はない。また、障害物を検出したとき、壁間距離を大きくとったりスピントーンを行うという動作の他に徐行を行っているが、必ずしも徐行という動作を採り入れなくともよい。

【0033】

【発明の効果】以上説明したように、本発明の清掃ロボットの制御方法は、前方の障害物を検出するセンサとして検出距離の長いものと短いものとを設け、検出距離の長いセンサが障害物を検出したとき壁までの距離を拡げる一次回避動作を行わせ、この後も依然として検出距離の短いセンサが障害物を検出したときは停止してスピントーンを行うという二次回避動作を行わせるため、障害物に応じた必要な回避動作のみを行わせることで、清掃効率を向上させることができる。

【図面の簡単な説明】

【図1】本発明の一実施の形態による制御方法により制御される清掃ロボットの制御部の構成を示したブロック図。

【図2】同制御部を搭載した清掃ロボットの構成を示したブロック図。

【図3】同清掃ロボットの断面構造を示した横断面図。

【図4】同清掃ロボットのセンサの検出範囲を示した説明図。

【図5】同清掃ロボットの2度スピントーンの動作を、右壁に沿う走行時と左壁に沿う走行時とに分けて示した説明図。

【図6】同清掃ロボットが壁間距離を変更して障害物を回避する様子を示した説明図。

【図7】同清掃ロボットが2度スピターンを行い障害物を回避する様子を示した説明図。

【図8】同清掃ロボットが2度スピターンを行った後に、依然として障害物を検出し、さらに90度スピターンを行って障害物を回避する様子を示した説明図。

【図9】本発明の一実施の形態による制御方法において、壁沿い走行時に障害物を回避する手順を示したフローチャート。

【図10】同制御方法において、障害物を近接した位置で検出したときの回避手順を示したフローチャート。

【図11】同制御方法における2度スピターンの手順を示したフローチャート。

【図12】同制御方法において、目標走行方向と清掃ロボットの走行方向とのずれを示した説明図。

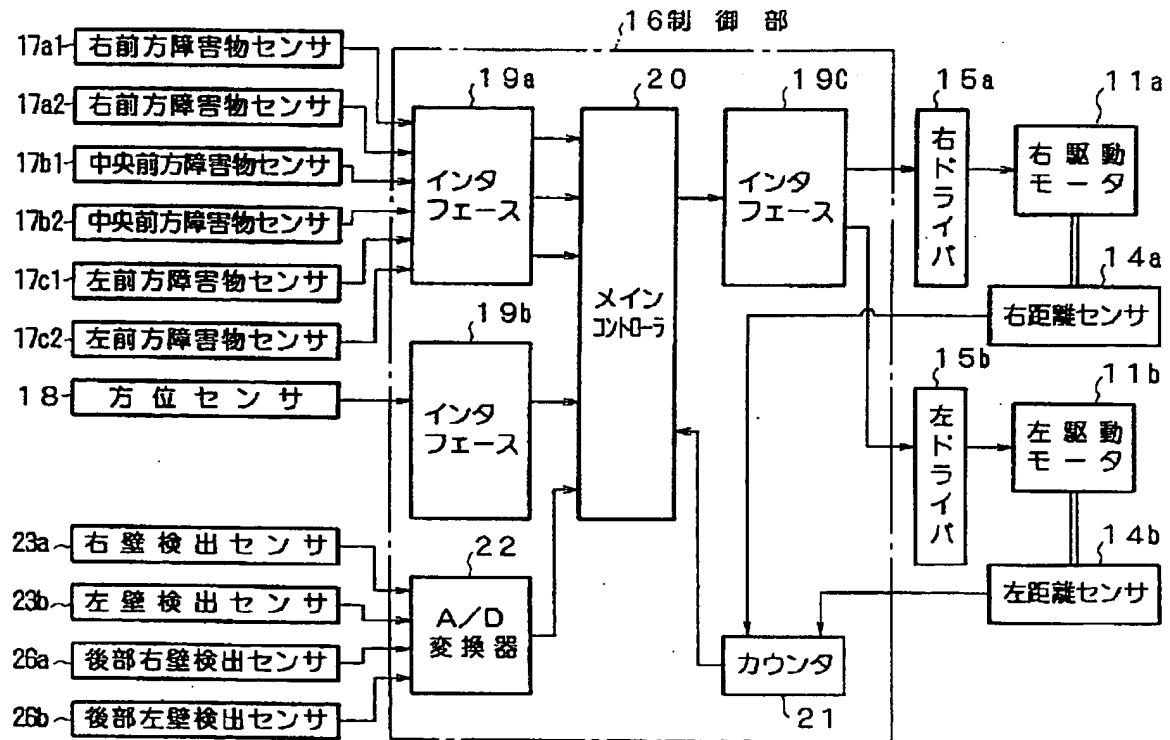
【図13】従来の清掃ロボットの制御方法により障害物を回避する動作を示した説明図。

【符号の説明】

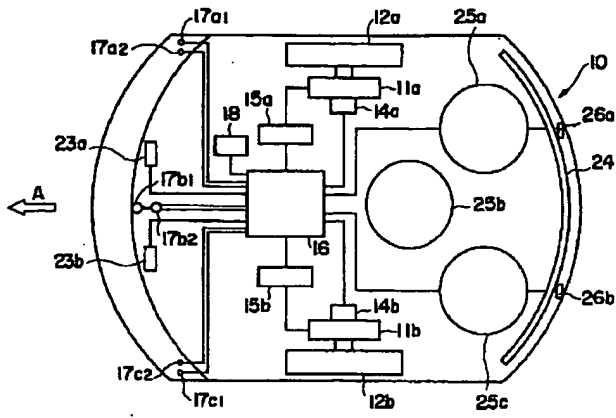
- 1 a 右壁
- 1 b 左壁
- 10 清掃ロボット

- 11 a 右駆動モータ
- 11 b 左駆動モータ
- 14 a 右距離センサ
- 14 b 左距離センサ
- 15 a 右ドライバ
- 15 b 左ドライバ
- 16 制御部
- 17 a 1、17 a 2 右前方障害物センサ
- 17 b 1、17 b 2 中央前方障害物センサ
- 17 c 1、17 c 2 左前方障害物センサ
- 18 方位センサ
- 19 a~19 c インタフェース
- 20 メインコントローラ
- 21 カウンタ
- 22 A/D変換器
- 23 a 右壁検出センサ
- 23 b 左壁検出センサ
- 24 スクイジ
- 25 a~25 c 清掃ブラシ
- 26 a 後部右壁検出センサ
- 26 b 後部左壁検出センサ

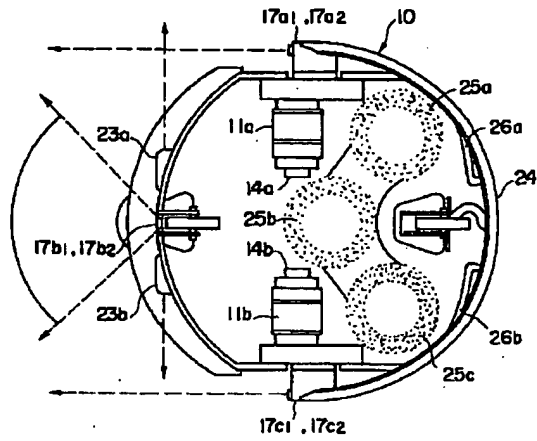
【図1】



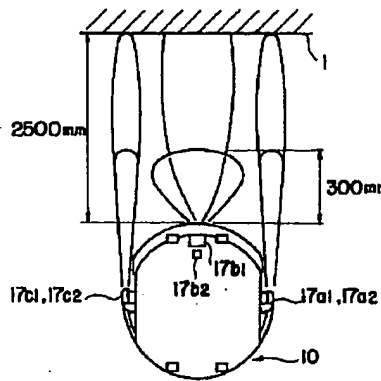
【図2】



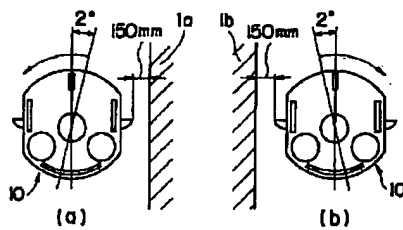
【図3】



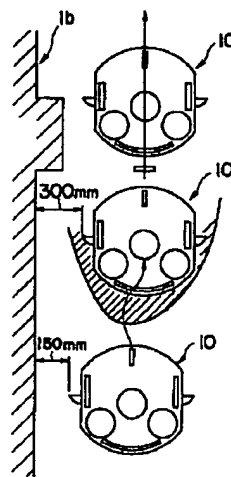
【図4】



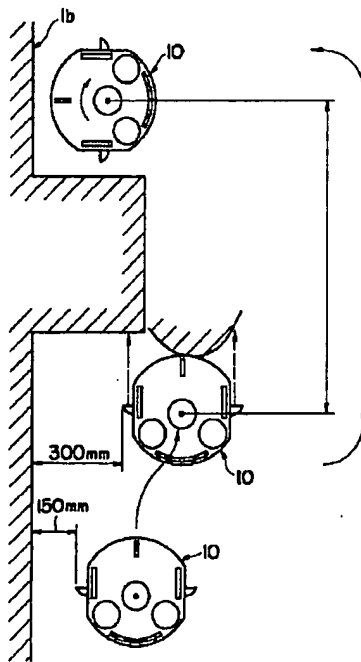
【図5】



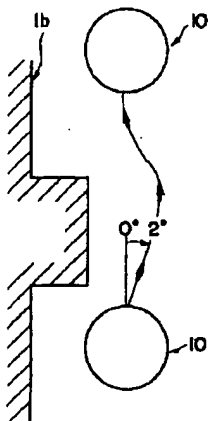
【図6】



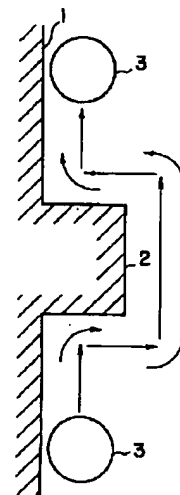
【図8】



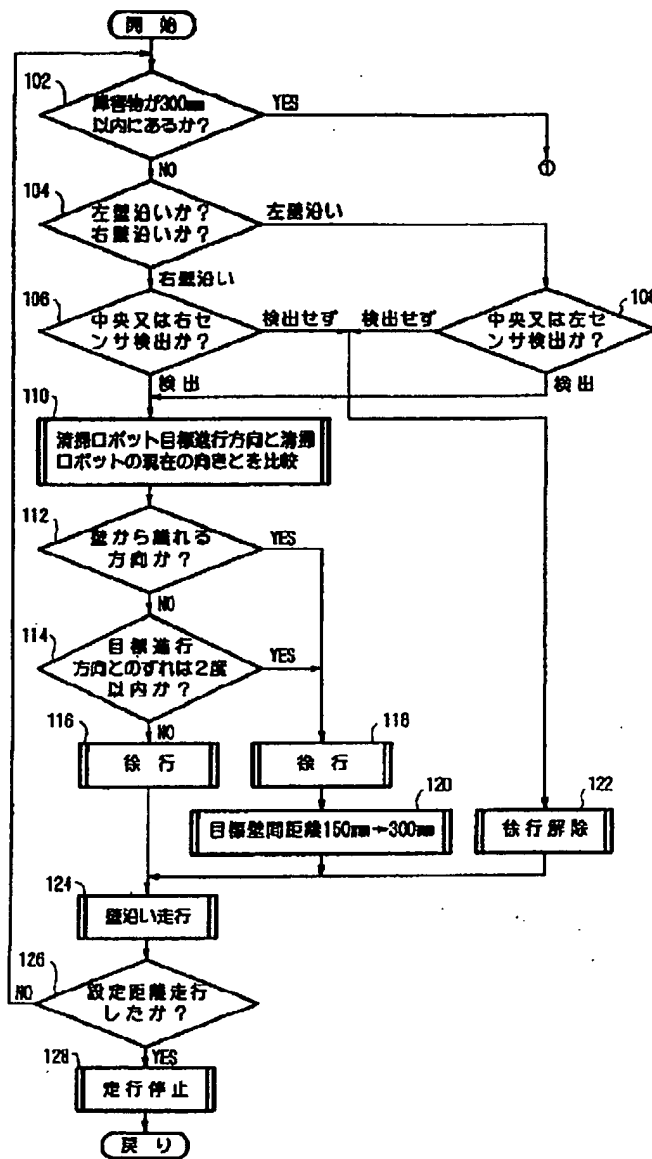
【図7】



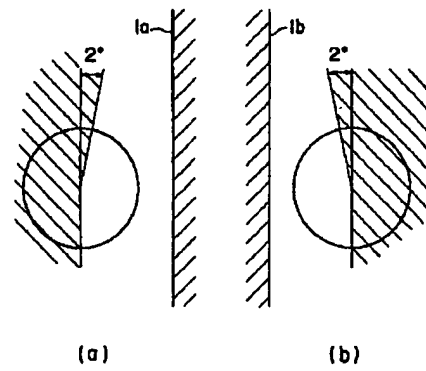
【図13】



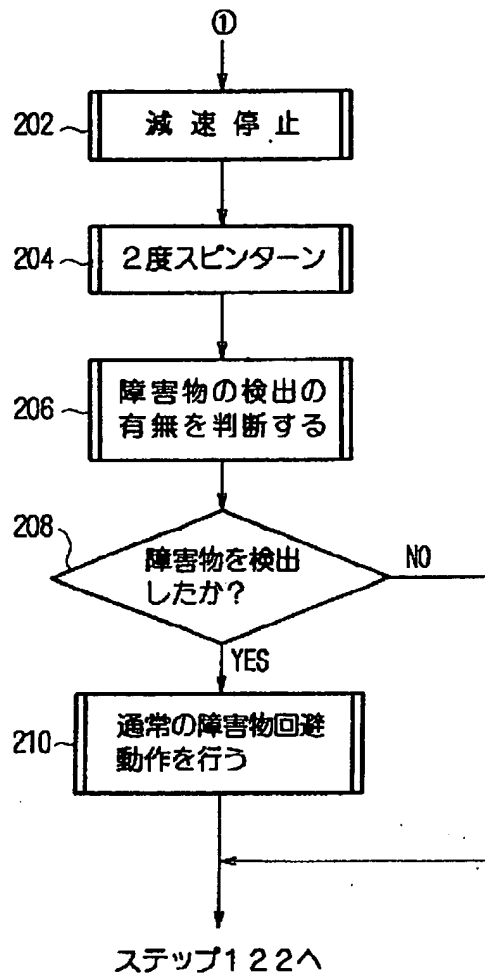
【図9】



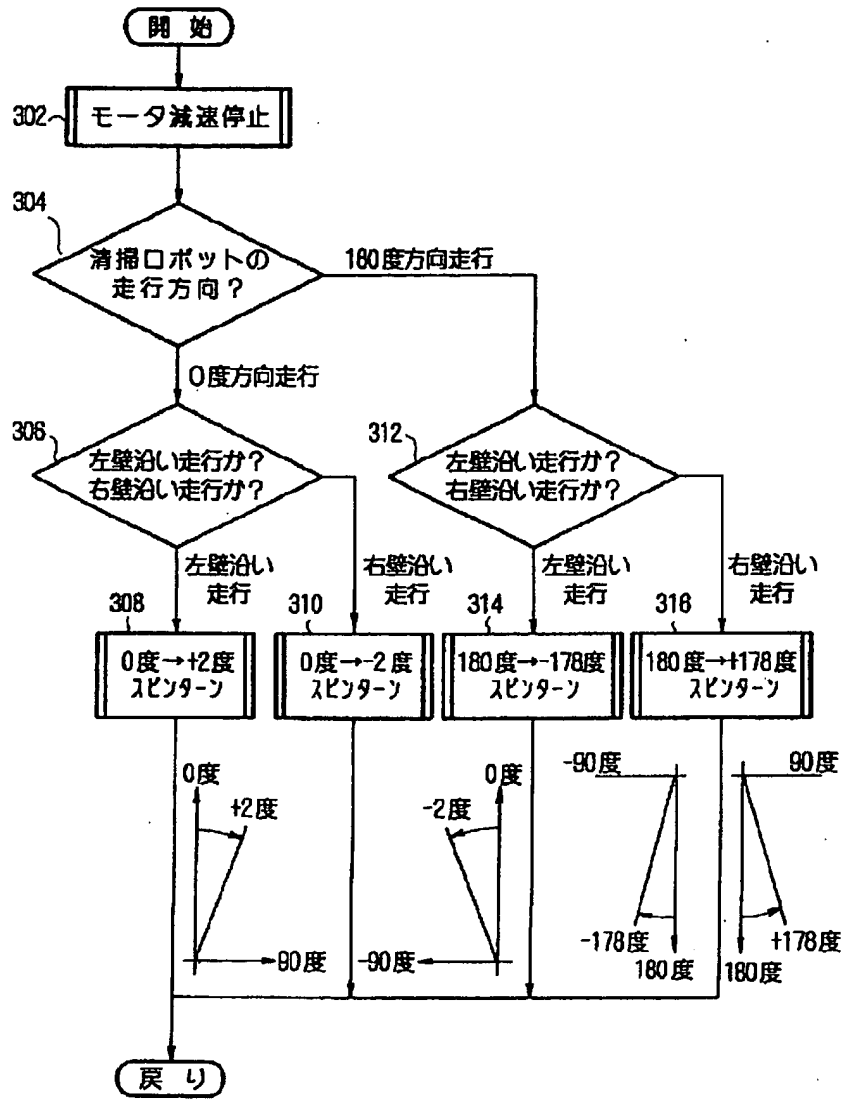
【図12】



【図10】



【図11】





(19)

(11) Publication number:

62154008 A

Generated Document.

PATENT ABSTRACTS OF JAPAN

(21) Application number: 60293095

(51) Intl. Cl.: G05D 1/02

(22) Application date: 27.12.85

(30) Priority:	
(43) Date of application publication:	09.07.87
(84) Designated contracting states:	
(71) Applicant:	HITACHI LTD
(72) Inventor:	OGASAWARA HITOSHI
(74) Representative:	

(54) TRAVEL CONTROL METHOD FOR SELF-TRAVEL ROBOT

(57) Abstract:

PURPOSE: To run a robot by approaching to a wall or hindrance a great deal by causing the robot to make a U-turn or go back at a pitch corresponding to a distance up to the wall or hindrance in the direction perpendicular to its straight travel direction when a reciprocating action at a fixed pitch, which includes an alternate straight travel and U-turn,

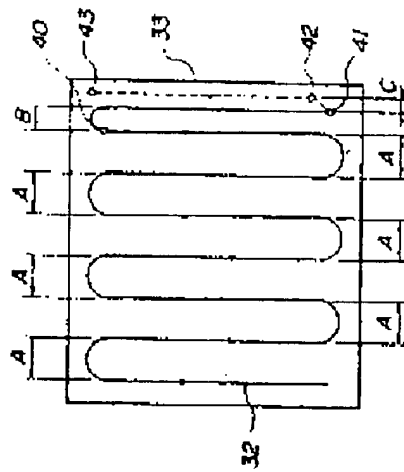
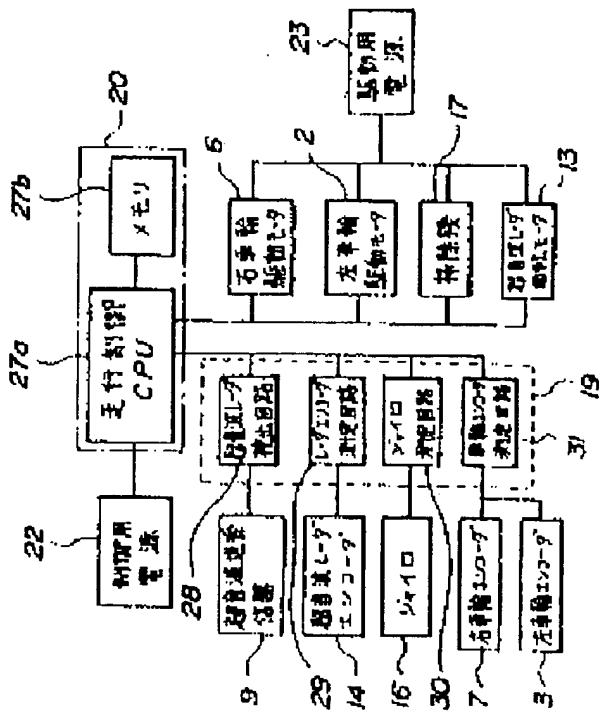
cannot be attained.

**CONSTITUTION:** Position coordinates of the self-cleaning robot and those of the wall or hindrance are stored in a memory 27b. A scene map expressing the position relationship between the robot and the wall or hindrance is generated, and therein the travel route of the self-cleaning robot is drawn. Namely, said robot is caused to make a U-turn and travel straight repeatedly, and to travel in zigzags at the 1st pitch. If the distance between the boundary in the prescribed area and the self-travel robot in the direction perpendicular to the straight travel direction comes to a value where the U-turn fails at the 1st pitch, the robot is caused to make a U-turn, or to go back or slew, and to travel at a pitch corresponding to said distance.

**COPYRIGHT:** (C)1987,JPO&Japio



BEST AVAILABLE COPY



⑫ 特許公報 (B 2)

平5-82603

⑬ Int. Cl. 5

G 05 D 1/02  
A 47 L 9/28  
G 05 D 1/02

識別記号

L  
A  
J

庁内整理番号

7828-3H  
7828-3H

⑭ 公告 平成5年(1993)11月19日

発明の数 1 (全12頁)

⑮ 発明の名称 自走ロボットの走行制御方法

⑯ 特 願 昭60-293095

⑰ 公 開 昭62-154008

⑱ 出 願 昭60(1985)12月27日

⑲ 昭62(1987)7月9日

⑳ 発 明 者 小 笠 原 均 神奈川県横浜市戸塚区吉田町292番地 株式会社日立製作所家電研究所内

㉑ 出 願 人 株式会社日立製作所 東京都千代田区神田駿河台4丁目6番地

㉒ 代 理 人 弁理士 武 顕次郎 外1名

審 査 官 栗 林 敏 彦

㉓ 参 考 文 献 特公 昭60-52443 (J P, B 2)

1

2

㉔ 特許請求の範囲

1 互いに独立に回転駆動される左車輪と右車輪とが取り付けられた本体フレームの端部に所定領域を作業する作業装置が取り付けられ、かつ、該本体フレームに走行方向、走行距離及び物体に対する距離、方向を測定する測定手段が載置された自走ロボットを、該測定手段の測定結果に基づいて、走行制御し、該自走ロボットが直進走行とUターンとを繰り返しながら該所定領域内をジグザグ走行するにした自走ロボットの走行制御方法において、

該作業装置の作業幅が該左車輪と該右車輪との間隔以上であつて、

該Uターンとしては、

15 該左車輪と右車輪の一方を停止状態とし、他方を前進駆動することにより、該左車輪と該右車輪との間隔に等しいピッチで該本体フレームの向きを逆転させる第1のUターンと、

20 該左車輪と該右車輪の一方を停止状態として他方を所定距離だけ後進駆動し、後進駆動した方の車輪を停止状態として停止状態とした車輪を前進駆動することにより、該左車輪と該右車輪との間隔よりも小さいピッチで該本体フレームの向きを逆転させる第2のUターンとが選択可能であり、

25 該自走ロボットの直進方向に垂直な方向での該所定領域の境界と該自走ロボットとの間の距離が

該第1のUターンが可能な距離であるときには、該第1のUターンを行なわせ、

5 該自走ロボットの直進方向に垂直な方向での該所定領域の境界と該自走ロボットとの間の距離が該第1のUターンが不可能な距離であるときには、該距離に応じた該左車輪と該右車輪の一方の前記後進駆動の距離で該第2のUターンを行なわせ、

10 該自走ロボットの直進方向に垂直な方向での該所定領域の境界と該自走ロボットとの間の距離が該第2のUターンも不可能な距離であるときには、該自走ロボットを該所定領域の境界側に寄せながら、該自走ロボットを後進させることを特徴とする自走ロボットの走行制御方法。

15 発明の詳細な説明

〔産業上の利用分野〕

本発明は、自律走行して掃除を行なう自動掃除機などに用いて好適な自走ロボットの走行制御方法に関する。

20 〔従来の技術〕

室内を自動掃除機によつて掃除する方法として、自動掃除機を、通常は直進走行させ、前方に壁や障害物があつて直進走行不能となつた場合には、Uターンさせ、直進とUターンとを繰り返して室内全体を同一ピッチで往復走行させるのが一般である。そして、自動掃除機が壁ぎわや障害物

のきわに達してUターンができなくなると、掃除が終了したと判定する。

しかしながら、自動掃除機がUターンするためにはそれだけの空間が必要であるから、自動掃除機が壁や障害物に近づいてUターンができず、掃除が終つたと判定しても、壁ぎわあるいは障害物のきわには、掃除されない部分がかかり残る場合がある。すなわち、自動掃除機を同一ピッチで往復走行させて掃除を行なうと、壁ぎわや障害物のきわまで充分には掃除ができないことになる。

かかる問題を解消する方法として、たとえば特開昭55-97608号公報に開示されるように、自動掃除機の走行方向に対して左右に移動可能な塵芥の吸引口ブラシを設け、横方向へ1ピッチ移動するためのUターンができないときは、吸引口ブラシのみ横方向に必要な距離だけ移動させる方法が知られている。この方法によると、自動掃除機が壁や障害物の近くに達してUターンができなくなると、吸引口ブラシのみを壁ぎわや障害物のきわまで移動させ、自動掃除機を逆走行させることによつて室内の隅々まで掃除できる。

〔発明が解決しようとする問題点〕

ところで、かかる従来技術によると、吸引口ブラシの位置および駆動タイミングを考慮した直進行、Uターンの走行制御と吸引口ブラシの駆動制御とが必要となり、制御が複雑になるとともに、制御に時間がかかるという問題があつた。また、吸引口ブラシの駆動装置が必要となるために、掃除機を搭載した自走ロボット本体が大型化、重量化し、機動性が損なわれて掃除時間が長くなってしまふし、この大型化、重量化と吸引口ブラシの駆動を必要とすることから、消費電力が増大するという問題があつた。

本発明の目的は、かかる従来技術の問題点を解消し、壁ぎわや障害物のきわの作業残りを失くし、迅速かつ簡単な自走ロボットの走行制御方法を提供するにある。

〔問題点を解決するための手段〕

自走ロボットが直進走行とUターンとの交互の動作による一定ピッチの往復動作ができなくなつたときに、該自走ロボットの自己位置から該自走ロボットの直進走行方向に直垂な方向での壁あるいは障害物までの距離に応じたピッチで、該自走ロボットをUターンあるいは後退させる。

〔作用〕

自走ロボット自体を壁あるいは障害物に充分近接して走行させる。

〔実施例〕

5 以下、本発明の対象となる自走ロボットを掃除機を搭載した自走ロボット（以下、自走掃除ロボットという）とし、本発明の実施例を説明するが、まず、自走掃除ロボットの構成について説明する。

10 第2図はこの自走掃除ロボットの一具体例を示す斜視図であつて、1は左車輪、2は左車輪駆動モータ、3は左車輪エンコーダ、4は歯車ケース、5は右車輪、6は右車輪駆動モータ、7は右車輪エンコーダ、8は歯車ケース、9は超音波送  
15 受信器、10は回転円板、11は回転軸、12はパラボラアンテナ、13は超音波レーダ回転モータ、14は超音波レーダエンコーダ、15は歯車ケース、16はジャイロ、17は掃除機、18はごみ吸引口、19は測定回路部、20は走行制御部、21は操作部、22は制御用電源、23は駆動用電源、24はロボット本体フレーム、25は  
20 キャスタ、26はロボットボディである。

同図において、ロボット本体フレーム24には、左右に左車輪1、右車輪5が、また、前部中央にキャスタ25が設けられている。左車輪1は、歯車ケース4に収納された歯車を介し、左車輪駆動モータ2と左車輪用エンコーダ3とに連結され、同様にして、右車輪5も、歯車ケース8に  
30 収納された歯車を介し、右車輪駆動モータ6と右車輪用エンコーダ7とに連結されている。これにより、左車輪1と右車輪5とは別々のモータによつて駆動され、夫々の車輪の回転数が別々のエンコーダで測定される。

また、ロボット本体フレーム24には、超音波レーダが搭載されている。これは、歯車ケース15に収納された歯車を介して超音波レーダ回転モータ13と回転軸11とが連結され、この回転軸11に、パラボラアンテナ12が一体となり、かつ超音波送受信器9が搭載された回転円板10と  
40 からなり、超音波レーダ回転モータ13によつて回転円板10（したがつて、パラボラアンテナ12）を回転軸11を中心に回転させながら、超音波送受信器9で破線で示す指向性の鋭い超音波の送受信を行なう。また、回転軸11は歯車ケース

15に収納された歯車を介して超音波レーダエンコーダ14に連結されており、この超音波レーダエンコーダ14によつて回転軸11の回転角、したがつて、超音波の発射方向が検出される。なお、歯車ケース15は回転軸11を支えるフレームともなつている。

超音波送受信器9から発射された超音波は壁や障害物などに当たると反射され、反射超音波のうちのパラボラアンテナ12に帰つてきたものが超音波送受信器9で受信されるが、超音波が発射されてから受信されるまでの時間と超音波レーダエンコーダ14によつて検出される超音波の発射方向とから、壁や障害物の位置が測定される。

さらに、ロボット本体フレーム24には、自走掃除ロボットの進行方向の角度変化を計測するためのジャイロ16、掃除機17、測定回路部19、走行制御部20、操作部21、走行制御部20のための制御用電源22、駆動用電源23なども搭載されており、超音波レーダの超音波送受信器9、回転円板10、パラボラアンテナ12や操作部21以外がロボットボディ26で覆われている。掃除機17には、ロボット本体フレーム24の幅にほぼ等しい幅のごみ吸口18が設けられ、自走掃除ロボットの走行とともに、床面(図示せず)でのロボット本体フレーム24の幅にほぼしい幅にわたつて塵芥を吸収する。測定回路部19は超音波レーダのデータ検出回路、ジャイロ16のデータ測定回路および左車輪エンコーダ3、右車輪エンコーダ7のデータ測定回路からなり、測定回路19からのデータを用いて走行制御部20は自走掃除ロボットの自己位置、壁や障害物の位置を計算し、計算結果にもとづいて自走掃除ロボットの走行を制御するものである。これら測定回路部19および走行制御部20の電源として制御用電源22が用いられる。左車輪駆動モータ2、右車輪駆動モータ6、超音波レーダ回転モータ13および掃除機17のモータなどの電源としては、駆動用電源23が用いられる。操作部21では、走行方法の切換え、自動走行と手動走行との切換えなどの操作を行なうことができる。

第3図は、第2図における走行制御系の全体を示すシステムブロック図であつて、27aはCPU(中央処理部)、27bはメモリ、28は超音波レーダ検出回路、29はレーダエンコーダ測

定回路、30はジャイロ測定回路、31は車輪エンコーダ測定回路であり、第2図に対応する部分には同一符号をつけている。

第3図において、測定回路部19は超音波送受信器9の出力信号を検出する超音波レーダ検出回路28と、超音波レーダエンコーダ14からのデータを測定するレーダエンコーダ測定回路29と、ジャイロ16からのデータを測定するジャイロ測定回路30と、左車輪エンコーダ3および右車輪エンコーダ7のデータを測定する車輪エンコーダ測定回路31とからなる。

一方、走行制御部20はCPU27aとメモリ27bとからなる。CPU27aは、測定回路部19の超音波レーダ検出回路28、レーダエンコーダ測定回路29、ジャイロ測定回路30および車輪エンコーダ測定回路31の出力データを周期的に取り込んで自走掃除ロボットの自己位置、壁や障害物の位置などを計算し、この結果をメモリ27bに格納するとともに、この結果に応じて左車輪駆動モータ2、右車輪駆動モータ6、超音波レーダ回転モータ13および掃除機17のモータの制御信号を形成する。

自走掃除ロボットは以上の構成をなすものである。

次に、かかる自走掃除ロボットを対象とした本発明の実施例を図面によつて説明する。

第1図は本発明による自走ロボットの制御方法の一実施例を示すフローチャートである。

この実施例は、後に説明する第9図に示すように、基本的には直進とUターンとを繰り返えし、自走掃除ロボットを走行経路32に沿つて移動させるものである。

第1図において、自走掃除ロボットの動作開始時には、CPU27aはメモリ27b(第3図)の内容をクリアし、掃除機17(第2図)のモータを起動させて掃除を開始させ、ステップ1に進む。

ステップ1では、自走掃除ロボットがUターン中であることを表わすフラグ(以下、Uターン中フラグという)をリセットする。

ステップ2では、室内での自走掃除ロボットの自己位置が検出される。ここで、自走掃除ロボットの自己位置の測定方法について説明する。

この自己位置は、左車輪エンコーダ3、右車輪

エンコーダ7およびジャイロ16の出力信号をもとに測定される。すなわち、左車輪エンコーダ3からは左車輪1(第2図)の回転速度を表わすデータ(パルス数)が出力され、車輪エンコーダ測定回路31でこのデータから左車輪1の回転数が測定されて、その結果、左車輪1の走行距離 $\Delta L_1$ が測定される。同様にして、右車輪エンコーダ7からは右車輪5(第2図)の回転速度を表わすデータが出力され、車輪エンコーダ測定回路31で右車輪5の走行距離 $\Delta L_2$ が測定される。また、ジャイロ16からは自走掃除ロボットの回転角度を表わす角度データが出力され、このデータからジャイロ測定回路30で、一定時間間隔 $\Delta t$ おきに、自走掃除ロボットの進行方向の角度変化量 $\Delta\theta$ が測定される。この一定時間間隔おきに、これらデータ $\Delta L_1$ 、 $\Delta L_2$ 、 $\Delta\theta$ がCPUに取り込まれ、これらデータを計算処理して自走掃除ロボットの自己位置データが得られる。

ここで、自己位置データを得るための計算方法について、第4図を用いて説明する。同図に示すように、自己位置データはX-Y座標系の座標として得られる。このX-Y座標は自走掃除ロボットが作業を行なうために部屋の床面に置かれたときに決まり、その置かれた位置を原点Oとし、そのときの直進走行すべき方向をY軸、これに垂直な方向をX軸とする。

同図において、いま、現時点 $t_0$ での自走掃除ロボットの自己位置を座標 $(x_0, y_0)$ の点aとし、この点aからY軸に対して角度 $\theta_0$ の方向に移動したところ、これより上記一定時間 $\Delta t$ 後には、自走掃除ロボットの左車輪1の走行距離が $\Delta L_1$ 、右車輪5の走行距離が $\Delta L_2$ 、進行方向の角度変化量が $\Delta\theta$ であったとすると、この一定時間 $\Delta t$ における自走掃除ロボットの走行距離 $\Delta L$ は、

$$\Delta L = \frac{1}{2} (\Delta L_1 + \Delta L_2) \quad \dots(1)$$

で表わされ、時点 $t_1 (= t_0 + \Delta t)$ における自走掃除ロボットの進行方向 $\theta_1$ は、

$$\theta_1 = \theta_0 + \Delta\theta \quad \dots(2)$$

となる。時点 $t_1$ における自走掃除ロボットの自己位置を点bとすると、この点bの座標 $(x_1, y_1)$ は次のように表わされる。

$$x_1 = x_0 - \Delta L \cdot \sin\left(\theta_0 + \frac{\Delta\theta}{2}\right) \quad \dots(3)$$

$$y_1 = y_0 + \Delta L \cdot \cos\left(\theta_0 + \frac{\Delta\theta}{2}\right) \quad \dots(4)$$

ここで、式(3)の右辺の $\Delta L$ の前の符号をマイナスとし、式(4)の右辺の $\Delta L$ の前の符号をプラスとしたのは、Y軸に対する角度は時計方向をマイナス、反時計方向をプラスとしたためである。自走掃除ロボットが原点Oにあるときの位置座標は $(0, 0)$ であつて進行方向は $0^\circ$ であり、一定時間 $\Delta t$ 毎に式(1)~(4)の計算を行なつて順次の自己位置とそこでの進行方向が得られる。

ステップ3では、壁や障害物の位置が検出される。ここで、壁や障害物の位置の測定方法について、同じく第4図を用いて説明する。

この測定は第2図で示した超音波レーダのデータを用いて行なわれる。いま、第4図において、自走掃除ロボットが点aにあるものとする、パラボラアンテナ12(第2図)が壁や障害物Sの超音波発射方向に垂直な面(以下、単に垂直面という)に向いたとき、超音波送受信器9(第2図)で反射された超音波はこの垂直面で反射されてこの超音波送受信器9で受信される。そこで、超音波が超音波送受信器9から発射されてから壁や障害物Sの垂直面で反射されてこの超音波送受信器9で受信されるまでの往復時間を $\Delta T$ とし、超音波の速度をVとすると、点aから壁もしくは障害物Sまでの距離 $L_s$ は、

$$L_s = \frac{1}{2} V \cdot \Delta T \quad \dots(5)$$

で表わされる。

また、超音波レーダエンコーダ14では、パラボラアンテナ12からの超音波の発射および受波方向 $\theta_s$ が測定される。この方向は自走掃除ロボットの進行方向から見たものであり、時計方向をマイナス、反時計方向をプラスとしている。

以上のデータ $L_s$ 、 $\theta_s$ と点aの座標 $(x_0, y_0)$ および点aでの自走掃除ロボットの進行方向 $\theta_0$ から、壁もしくは障害物Sの位置(正確には、超音波の反射面の位置)の座標 $(x_s, y_s)$ は次のように表わされる。

$$x_s = x_0 - L_s \cdot \sin(\theta_0 + \theta_s) \quad \dots(6)$$

$$y_s = y_0 + L_s \cdot \cos(\theta_0 + \theta_s) \quad \dots(7)$$

以上のようにして、設定されたX-Y座標系における自走掃除ロボットの自己位置座標と壁もしくは障害物の位置座標が求まる。

9

ステップ4では、ステップ2、3で以上のようにして得られた自走掃除ロボットと壁もしくは障害物の位置座標をメモリ27b(第3図)に格納し、壁や障害物の位置関係を表わす情景地図を作成し、そこに、自走掃除ロボットの走行経路を画

く。  
ステップ5では、Uターン中フラグがセットされているか否かを判定し、セットされていないければ、次のステップ6に進む。

ステップ6では、自走掃除ロボットの進行方向に直進走行を阻げる壁もしくは障害物があるか否かを判定する。先にも説明したよに、この実施例においても、自走掃除ロボットを直進走行とUターンとを繰り返しながら走行させるのであるが、CPU27a(第3図)は、自走掃除ロボットとその進行方向での壁もしくは障害物との間隔を計算して常時監視しており、この間隔が自走掃除ロボットのUターン可能な最初のものとなったとき、ステップ6で前方に壁もしくは障害物有りとは判定する。

ステップ7では、ステップ6で前方に壁もしくは障害物がないと判定されたとき、自走掃除ロボットを直進走行させる。この直進走行は、左車輪駆動モータ2と右車輪駆動モータ6(第2図)とを同時に回転させ、左車輪1と右車輪5(第2図)とを駆動することによって行なわれる。

ステップ7からはステップ2に戻るが、ステップ6で前方に壁もしくは障害物有りとは判定されない限り、ステップ2、3、4、5、6、7の一連の動作が繰り返えされ、自走掃除ロボットを直進走行させる。この直進走行中自走掃除ロボットと壁もしくは障害物の位置が検出され、夫々の位置座標が順次メモリ27b(第3図)に格納される。これによってメモリ27bでは、情景地図が次第に詳しくなり、そこに自走掃除ロボットの走行経路が画かれる。

ここで、第5図により、障害物がない室内において、ステップ6で前方に壁ありとは判定するまでの自走掃除ロボットの動作を説明する。

まず、自走掃除ロボットは走行開始する前の原点Oにあるときに、超音波レーダによって壁の位置を検出する。ここで、説明を簡単にするために、壁33、34、35、36はX軸、Y軸のいずれかに平行であるとする。自走掃除ロボットが

10

原点Oにあるときに超音波レーダによって検出されるのは、壁のX軸、Y軸上の部分(点33a、34a、35a、36a)と壁の角の部分(点33b、34b、35b、36b)である。自走掃除ロボットは原点Oから常にY軸の正方向に直進走行開始するものであり、この場合、上記のようにして、自走掃除ロボットの進行方向の壁の位置は点34aとして予じめ検出されているから、CPU27aによって壁の点34aと自走掃除ロボットとの間の距離を監視している。

自走掃除ロボットのCPU27aは、かかる直進走行の間も自己位置座標と壁の位置座標とを計算してメモリ27bに格納しており、壁33、34、35、36が順次検出されてメモリ27bで背景地図が次第に出来上っており、その情景地図内で自走掃除ロボットの走行経路32が画かれている。

直進走行中、ステップ6で前方に壁もしくは障害物有りとは判定すると、ステップ8に進む。

ステップ8では、自走掃除ロボットを停止させる。

ステップ9では、Uターン中フラグをセットする。

ステップ10では、Uターン方向の切り換えを行なう。

先にも説明したように、自走掃除ロボットは直進走行とUターンとを繰り返して行なわせるが、第5図では、軌跡32で示すように、最初のUターンの方向は右方向であるが、次のUターンは左方向に行なわれる。つまり、Uターンする毎にその方向は右、左と交互に変わり、これによって自走掃除ロボットはY軸方向に往復走行をしつつX軸方向に進むことになる。ステップ10では、このようにUターンの方向を設定する。通常、最初のUターンの方向は右方向に設定されるが、この方向のUターンが不可能な場合には、Uターンの方向を左方向とし、以下、右、左、右……と交互に方向を切り換える。

第1図に戻って、ステップ11~20では、第5図で示すX軸方向での自走掃除ロボットと壁33との間隔1がいかなる範囲に入るかを判定する。かかる範囲は、 $1 > l_1$ (ステップ11)、 $l_1 \geq 1 > l_2$ (ステップ12)、 $l_2 \geq 1 > l_3$ (ステップ13)、 $l_3 \geq 1 > l_4$ (ステップ14)、 $l_4 \geq 1 > l_5$ (ステップ15)、 $l_5 \geq 1$

$> l_0$  (ステップ16)、 $l_1 \geq 1 > l_1$  (ステップ17)、 $l_1 \geq 1 > l_1$  (ステップ18)、 $l_1 \geq 1 > l_1$  (ステップ19)、 $l_1 \geq 1 > l_1$  (ステップ20) がある。

第5図において、間隔1が充分大きいときには、自走掃除ロボットがUターンする前とUターンした後の直進走行経路のピッチはAであるとすると、このピッチAで自走掃除ロボットのUターンが可能な自走掃除ロボットと壁33との間隔1の最小値がステップ11における $l_1$ である。

かかるUターンの方法を第6図で説明する。同図において、1'はUターン前の左車輪、1''はUターン後の左車輪、2は右車輪、33は壁、26'はUターン前のロボットボディ、26''はUターン後のロボットボディ、37'、37''は夫々ロボットボディ26'、26''の左前先端部、38'、38''は夫々ロボットボディ26'、26''の左後先端部である。

同図において、自走掃除ロボットは右方向にUターンするものとする。この場合のUターンは、右車輪5を停止させて左車輪1'を前進方向に駆動し、ロボットボディ26'を右車輪5を中心に180°回転させる。かかるUターンを行なうことにより、ロボットボディ26'、26''の直進方向の中心線の間隔がピッチAであり、これは左車輪1'と右車輪5との間隔Wに等しい。掃除機17のごみ吸口18(第2図)の幅はロボットボディ26'、26''の幅にほぼ等しいから、Uターン前後の掃除範囲は図示する量Eだけオーバーラップする。

かかるUターンは、ロボットボディ26'の先端から車輪軸までの距離、右車輪5からロボットボディ26'の左前先端部37'までの距離および右車輪5からロボットボディ26'の左後先端部38'までの距離で決まる領域 $a_1, b_1, c_1, d_1$ 内に壁や障害物がないときに可能である。第6図によると、このようにUターンするために必要なロボットボディ26'の中心線R-Rから右方向の空間の最小幅 $l_1$ は、左車輪1'と右車輪5との間隔をW、右車輪5とロボットボディ26'の左前先端部37'との間隔をdとすると、

$$l_1 = \frac{1}{2}W + d \quad \dots(8)$$

となる。したがって、自走掃除ロボットと壁33との間隔(厳密には、ロボットボディ26'の中

心線R-Rと壁33との間隔)1が式(8)で表わされる間隔 $l_1$ よりも大きいとき、Uターン時に自走掃除ロボットが壁33に当たることはとない。

ステップ11は、 $1 > l_1$ の判定とともに、第6図の範囲 $a_1, b_1, c_1, d_1$ において、壁や障害物が存在するか否かの判定も行なう。

自走掃除ロボットと壁33との間隔1が $l_1$ 以下になると、上記のようなUターンができなくなり、壁33のきわに掃除残りが生ずる。

ステップ12、13、14、15から始まる一連の動作はUターン前後のピッチを小さくしてこの掃除残りを少なくするものである。この場合のUターン方法を第7図によつて説明する。同図において、5'はUターン前の右車輪、5''はUターン後の右車輪、26'''はUターン途中のロボットボディ、37'''はロボットボディ26'''の左前先端部であり、第6図に対応する部分には同一符号をつけている。

第7図において、まず、左車輪1'を停止させて右車輪5'を後進方向に駆動し、ロボットボディ26'を左車輪1'を中心にして右方向に回転させる。この動作は右車輪5'を右後方に引くものである。ロボットボディ26'の中心線R-Rに垂直な方向での右車輪5'の移動量Dを車輪引き幅という。第6図に示したUターンの場合には、右車輪5は停止しているから、車輪引き幅Dは零である。

次に、右車輪が引かれたロボットボディ26'''に対し、第6図の場合と同様に、右車輪5''を停止させて左車輪1'を前進方向に駆動する。これにより、ロボットボディ26'''は右車輪5''を中心に右方向に回転する。ロボットボディ26'''の中心線R'-R'がロボットボディ26'の中心線R-Rに平行となつたとき、すなわち自走掃除ロボットが180°回転したとき、左車輪1'の駆動を停止させてUターンを終了する。この場合でのUターン前後の自走掃除ロボットのピッチBは、左車輪1'と右車輪5'との間隔をWとすると、

$$B = W - D \quad \dots(9)$$

となる。したがって、第6図の場合よりも狭いピッチでUターンされることになる。このために、Uターン前後の掃除範囲のオーバーラップ量は第6図の場合の量Eよりも大きくなることはいうまで

もない。

この場合には、左車輪 1' と左後先端部 3 8' との間の距離、右車輪 5' と左前先端部 3 7'、左後先端部 3 8' との間の距離、ロボットボディ 2 6' の長さ、ロボットボディ 2 6' に対する右車輪 5'、左車輪 1' の位置、車輪引き幅 D などによつて決まる範囲 a<sub>2</sub>, b<sub>2</sub>, c<sub>2</sub>, d<sub>2</sub> 内に壁や障害物がないときに U ターンが可能となる。

また、第 7 図から明らかなように、右車輪 5' と左前先端部 3 7' との距離を d とすると、ロボットボディ 2 6 の中心線 R-R から右方向の空間幅 l と車輪引き幅 D との関係が、

$$l > d + (W - D) - \frac{W}{2} = d + (\frac{W}{2} - D) \dots (10)$$

(但し、W は左車輪 1' と右車輪 5' との間隔) であるとき、第 7 図で示す U ターンを行なつても自走掃除ロボットは壁 3 3 に当たることはない。

そこで、自走掃除ロボットと壁 3 3 との間隔 l が式 (8) で表わされる値 l<sub>1</sub> 以下となつたとき、式 (10) を満すようにこの間隔 l に応じて車輪引き幅 D を設定し、第 7 図に示したように U ターンを行なうことにより、ピッチを小さくして U ターンができ、壁 3 3 のきわまで掃除出来る。

この実施例では、第 1 図のステップ 12~15 に示すように、値 l<sub>1</sub> 以下で自走掃除ロボットと壁 3 3 との間隔 l がとる範囲を 4 つに区分し (すなわち、l<sub>1</sub> ≥ l > l<sub>2</sub>, l<sub>2</sub> ≥ l > l<sub>3</sub>, l<sub>3</sub> ≥ l > l<sub>4</sub>, l<sub>4</sub> ≥ l > l<sub>5</sub>)、各区分毎に、夫々 l<sub>2</sub>, l<sub>3</sub>, l<sub>4</sub>, l<sub>5</sub> に対して式 (10) を満足する車輪引き幅 D<sub>2</sub>, D<sub>3</sub>, D<sub>4</sub>, D<sub>5</sub> を設定している。

そこで、いま、自走掃除ロボットと壁 3 3 との間隔 l が l<sub>1</sub> ≥ l > l<sub>2</sub> の範囲にあるとすると、これであることがステップ 12 で判定され、ステップ 22 で車輪引き幅 D が値 D<sub>2</sub> と設定される。この間隔 l が値 l<sub>1</sub> 以下の他の範囲にあつてステップ 13~15 のいずれかでこれであることが判定されると、これに応じた車輪引き幅 D<sub>2</sub>~D<sub>5</sub> のいずれかがステップ 23、24 あるいは 25 で設定される。式 (10) から車輪引き幅 D が大きくなるに従い間隔 l が小さくなり自走掃除ロボットが壁 3 3 により近接した状態で U ターンが可能であるが D=W のときには、直径経路をもどることになるから、ステップ 15 での l<sub>5</sub> を d-W/2 よりも若干大きく、かつステップ 25 の D<sub>5</sub> を W よりも若干小さく設定する。なお、

l > l<sub>1</sub> の場合には、ステップ 11 でこれが判定され、ステップ 21 で車輪引き幅 D が値 0 の D<sub>1</sub> と設定される。

もちろん、ステップ 12~15 でも、ステップ 11 と同様に、第 7 図における範囲 a<sub>2</sub>, b<sub>2</sub>, c<sub>2</sub>, d<sub>2</sub> 内に壁もしくは障害物があるか否かの判定も行なう。

なお、左方向に U ターンする場合も同様である。

ところで、以上のような U ターンを行なう場合、ロボットボディ 2 6'、2 6'' を旋回されることから、U ターン終了後には、第 7 図に示すように、ロボットボディ 2 6'' と壁 3 3 との間に幅 N の隙間が生じ、この部分が掃除残りとなる。この幅 N は、ステップ 11~15 のいずれの U ターンを行なうようにしても、

$$N \geq d - \frac{W+w}{2} \dots (11)$$

となる。但し、d, W は第 6 図で示される幅であり、また、w はロボットボディ 2 6 の幅である。

ステップ 15~20 から始まる一連の動作は、この幅 N の隙間の掃除残しをも失くすようにするものである。これは、ロボットボディ 2 6 を後進走行させながら壁 3 3 のきわに寄せるものである。以下、この動作を後退旋回と呼ぶことにする。

以下、第 8 図によつて後退旋回動作を詳細に説明する。ここでは、進行方向に対して右側にある壁 3 3 に自走掃除ロボットをよせるものとする。

まず、ロボットボディ 2 6' に対し、右車輪 5' を停止させて左車輪 1' を後進駆動する。これにより、ロボットボディ 2 6' は右車輪 5' を中心にして左方向に旋回する。このとき、左車輪 1' は右後方に引かれたことになる。次に、旋回したロボットボディ 2 6' の左車輪 1' を停止させて右車輪 5' を後進駆動させる。これにより、ロボットボディ 2 6'' は左車輪 1' を中心にして右方向に旋回する。この旋回はロボットボディ 2 6'' の中心軸が旋回前の中心軸 R-R と平行になつたときに停止する。

かかる一連の旋回により、右車輪 5' は左車輪 1' と平行な方向に同量だけ引かれている。かかる旋回後の左車輪 1'、右車輪 5' の進行方向 (中心軸 R-R) に垂直な方向の移動量 C を両車輪引き幅という。

ロボットボディ 2 6' の長さ、ロボットボディ



2 6'に対する左車輪 1'、右車輪 5'の位置関係などで決まる後進旋回に必要な空間範囲 $a_s, b_s, c_s, d_s$ 内に壁や障害物がないときに、後進旋回が可能となる。また、左車輪 1'とロボットボディ 2 6'の右後先端部 3 9'との間隔を $d$ とし、両車輪 1', 5'の間隔を $W$ とすると、ロボットボディ 2 6'の中心軸R-Rから壁 3 3までの間隔 $l$ と両車輪引き幅 $C$ との関係が、

$$l > d + (C - \frac{W}{2}) \quad \dots(12)$$

であるとき、自走掃除ロボットは壁 3 3に当たらない。そこで、ロボットボディ 2 6'と壁 3 3との間隔がステップ15での値 $l_5$ よりも小さいとき、式(12)を満たすように間隔 $l$ に応じて両車輪引き幅 $C$ を設定し、第 8 図に示すように後進旋回を行なった後、ロボットボディ 2 6'を矢印方向に後進走行させることにより、壁 3 3のきわの掃除残しをなくすることができる。

この実施例では、第 1 図のステップ16~20に示すように、値 $l_5$ 以下のロボット本体 2 6'と壁 3 3との間隔 $l$ がとる範囲を $l_6 \geq l > l_5, l_7 \geq l > l_6, l_8 \geq l > l_7, l_9 \geq l > l_8, l_{10} \geq l > l_9$ の 5 つに区分し、各区分毎に、 $l_6, l_7, l_8, l_9, l_{10}$ に対応して式(12)を満足する両車輪引き幅 $C_6, C_7, C_8, C_9, C_{10}$ を設定している。

そこで、いま、ロボットボディ 2 6'と壁 3 3との間隔 $l$ が $l_6 \geq l > l_5$ であるとする(ステップ11~15では「no」と判定している)、これであることがステップ16で判定され、ステップ26で両車輪引き幅 $C$ が値 $C_6$ と設定される。ステップ17~20のいずれかで「yes」と判定された場合にも、それに応じてステップ27~30のいずれかで両車輪引き幅 $C$ が値 $C_7, C_8, C_9$ または $C_{10}$ に設定される。もちろんこのとき、ステップ16~20では、第 8 図で示した後進旋回に必要な空間範囲 $a_s, b_s, c_s, d_s$ 内に壁もしくは障害物があるか否かの判定も行なう。

ここで、第 6 図~第 8 図でのロボットボディ 2 6'に対し、長さを80cm、幅を50cm、各車輪 1', 5'の直径を10cm、車輪 1', 5'の間隔を30cm、ロボットボディ 2 6'の前先端から車輪軸までの距離を50cm、ロボットボディ 2 6'の後先端から車輪軸までの距離を30cmとしたときの第 1 図の間隔 $l_1 \sim l_{10}$ の値と車輪引き幅 $D_1 \sim D_{10}, C_6 \sim C_{10}$ の値

の一具体例を次表に示す。

施回の種類	壁までの距離	車輪引き幅
Uターン	$l_1 = 75\text{cm}$	$D_1 = 0\text{cm}$
	$l_2 = 70\text{cm}$	$D_2 = 5\text{cm}$
	$l_3 = 65\text{cm}$	$D_3 = 10\text{cm}$
	$l_4 = 60\text{cm}$	$D_4 = 15\text{cm}$
	$l_5 = 55\text{cm}$	$D_5 = 20\text{cm}$
後進施回	$l_6 = 50\text{cm}$	$D_6 = 15\text{cm}$
	$l_7 = 47\text{cm}$	$D_7 = 12\text{cm}$
	$l_8 = 44\text{cm}$	$D_8 = 9\text{cm}$
	$l_9 = 40\text{cm}$	$D_9 = 6\text{cm}$
	$l_{10} = 36\text{cm}$	$D_{10} = 3\text{cm}$

以上がステップ11~30の説明である。なお、左方向の壁に寄せる場合も同様である。

ステップ31では、ステップ21~25のいずれで設定された車輪引き幅 $D$ に応じて第 6 図あるいは第 7 図に示したようなUターンを開始させる。

ステップ32では、ステップ26~30で設定された両車輪引き幅に応じて第 8 図に示したような後進旋回を行なわせる。

ステップ31、32の処理が終ると、ステップ 2 に戻る。

以上のステップ 8~32の一連の処理は、ステップ 6 で前方に壁もしくは障害物があつて自走掃除ロボットが直進走行できなくなつたとき、Uターンあるいは後進旋回を開始させるまでのものである。したがつて、ステップ 6 で「yes」と判定されたときに、ステップ 8~32の一連の処理は 1 回しか行なわれぬ。

ステップ31あるいは32の処理によつて自走掃除ロボットがUターンあるいは後進旋回を開始すると、ステップ 9 で既にUターン中フラグがセットされているので、ステップ 5 でこれが判定され、ステップ33に進む。

ステップ33では、ジャイロ 1 6 (第 2 図) のデータをもとに、Uターンあるいは後進旋回が終了したか否かの判定を行なう。この判定はジャイロ 1 6 (第 2 図) からの角度情報をもとにして行なう。Uターンのときには、自走掃除ロボットが

180°方向転換したときに、後進旋回するときには、ロボットボディ26の中心線が後進旋回前の中心線と平行になったときに夫々Uターンが終了したと判定する。

Uターン中あるいは後進旋回中では、ステップ2、3、4、5、33の一連の処理が繰り返される。これらの動作中も自走掃除ロボットの自己位置座標と壁や障害物の位置座標が作成されてメモリ27b(第3図)に格納される。そして、Uターンあるいは後退旋回が終了すると、ステップ34でUターン中フラグがリセットされ、再びステップ2から処理が始まって直進走行を開始させる。

以上の処理により、自走掃除ロボットは第9図に示す走行経路32に沿うように走行制御される。すなわち、自走掃除ロボットは、壁33から充分離れているときには、直進走行と第6図に示したUターンとの交互の繰り返しにより、ピッチAでジグザグ走行し、壁33に近づいてこのUターンができなくなる点40に達すると、第7図に示したように、選択された車輪引き幅DでピッチBのUターンを行なう。そして、点41に達して壁33との間に距離 $l_5 \sim l_6$ がある場合には、第8図に示した後退旋回を行ない、これらが終了した点42から直進走行して壁33のきわまで掃除を行なう。

自走掃除ロボットは、点43に達すると、もはやUターンや後退旋回ができなくなる。この場合には、ステップ11~20では全て「no」と判定され、ステップ35に進む。

このステップ35では、室内全体での掃除が終了したか否かを判定する。この判定は、メモリ27b(第3図)で形成された情景地図と自走掃除ロボットが走行した経路とから未掃除エリアを探すことによつて行なわれる。第9図の場合には、掃除が終わったものと判定されるが、室内に障害物がある場合には、その後の部分が未掃除エリアとなり、部屋が四角形でない場合などでは、未掃除エリアが存在する場合がある。

ステップ36では、ステップ35で未掃除エリアが見つかり、自走掃除ロボットをその未掃除エリアに走行させる。

ステップ36からはステップ1に戻り、未掃除エリアに対して上記の動作が行われる。

以上のように、この実施例では、自走掃除ロボットを壁ぎわや障害物のきわまで簡単かつ正確に接点させることができ、壁や障害物のきわの掃除のやり残しをなくすることができる。また、従来技術のような進行方向に対して横方向に動く吸引口ブラシなどの機構部が不要となり、吸引口ブラシの位置や駆動のタイミングを考慮しなくてよいので、走行方法の判断や決定に要する時間を短縮できるし、ロボットボディも小型化にできる。したがって、超音波レーダで得られるまわりの壁や障害物の位置データ及び情景地図データの変化にすばやく対応できることになる。さらに、吸引口ブラシなどの駆動が不要なので、消費電力を削減できて経済的になる。

なお、第6図~第8図で壁について説明したが、障害物であつても同様である。また、上記実施例では、自走ロボットとして掃除機を搭載したものとしたが、塗装を行なうなど他の作業を行なうものであつてよいことは明らかである。

#### 〔発明の効果〕

以上説明したように、本発明によれば、自走ロボットを壁ぎわや障害物のきわまで簡単かつ正確に接近させることができ、該自走ロボットに載置される掃除機などの作業機器を制御することなく、壁ぎわや障害物のきわまでの作業が可能となるものであつて、作業機器の機構部や駆動部の簡略化が図かれて該自走ロボットの小型、軽量化や消費電力の削減が達成できるし、作業機器の位置や駆動タイミングを考慮することなしに自走ロボットの制御が可能となるものであるから、自走ロボットの走行方法の判断や決定を迅速に行なうことができるし、さらに、該自走ロボットの小型、軽量化にともない、部屋の壁や障害物に対応した該自走ロボットの動作変化を迅速に行なえ、作業時間を大幅に短縮できる。

#### 図面の簡単な説明

第1図は本発明による自走ロボットの走行制御方法の一実施例を示すフローチャート、第2図は自走ロボットの一具体例を示す構成図、第3図は第2図に示した自走ロボットにおける走行制御系の全体を示すシステムブロック図、第4図は自走ロボットの自己位置座標および壁や障害物の位置座標を得る方法を示す説明図、第5図は第3図におけるメモリで画かれる情景地図と自走ロボット

19

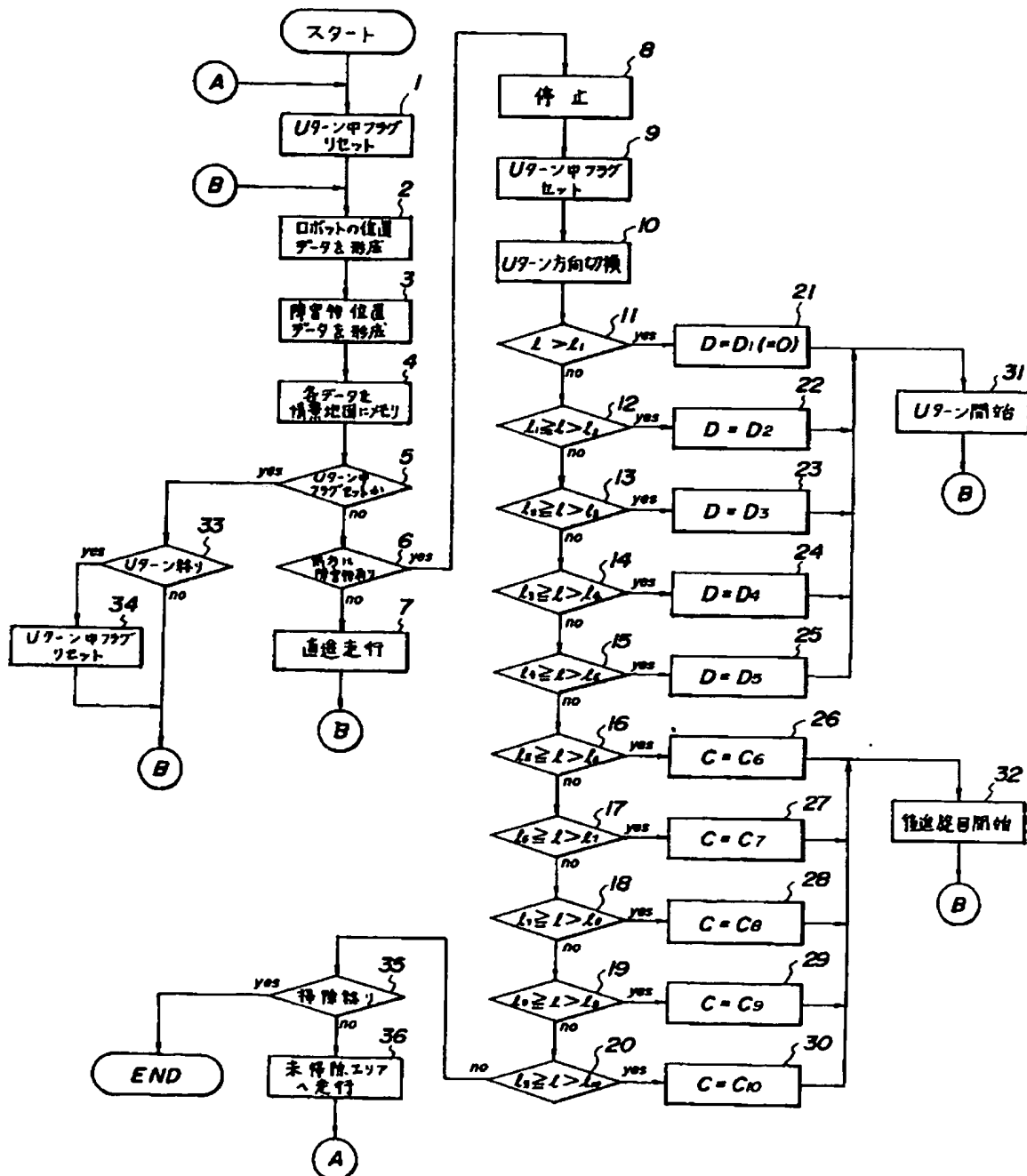
20

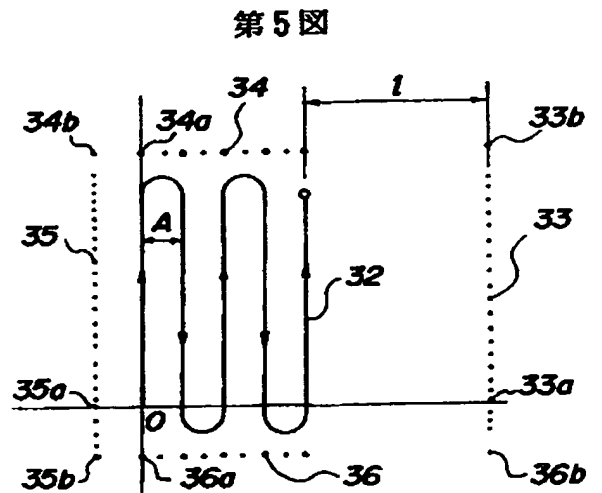
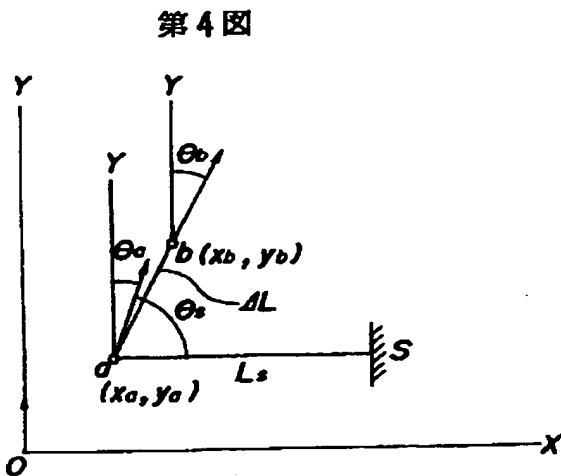
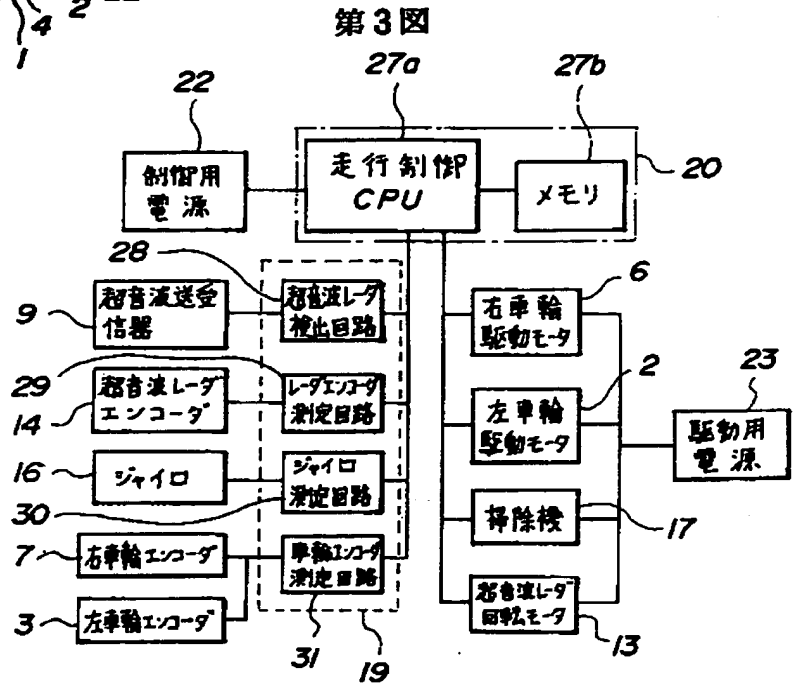
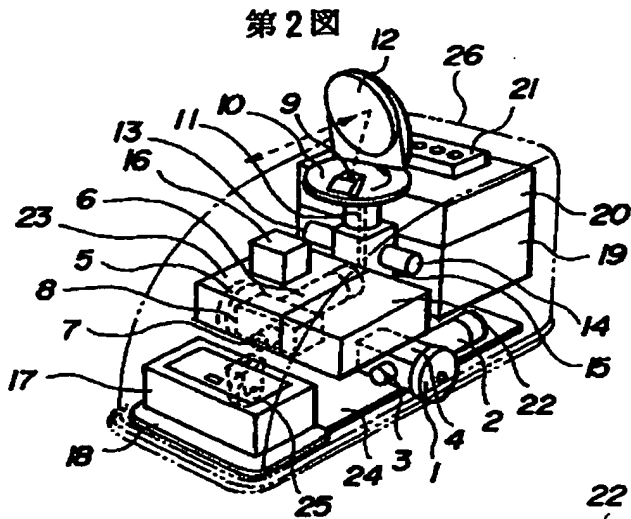
の走行経路とを示す説明図、第6図および第7図は夫々自走ロボットのUターン方法を示す説明図、第8図は自走ロボットの後退旋回方法を示す説明図、第9図は自走ロボットの走行方法の一例を示す説明図である。

1, 1', 1''...左車輪、3...左車輪用エンコー

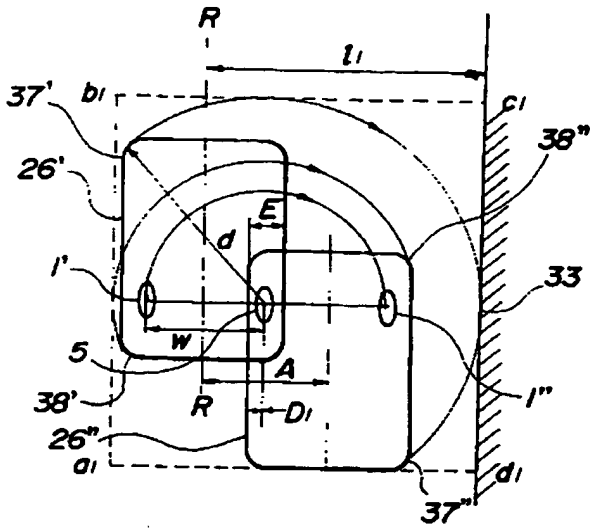
ダ、5, 5', 5''...右車輪、7...右車輪用エンコーダ、9...超音波送受信器、12...パラボラアンテナ、13...超音波レーダ回転モータ、14...超音波レーダエンコーダ、16...ジャイロ、17...掃除機、20...走行制御部、26, 26', 26''...ロボットボディ。

第1図

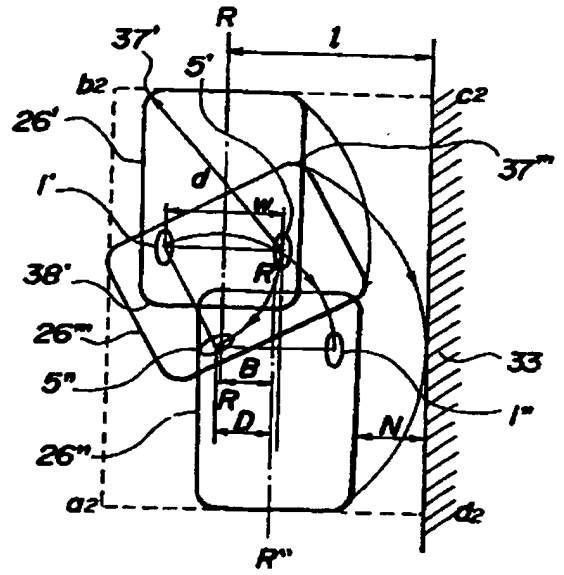




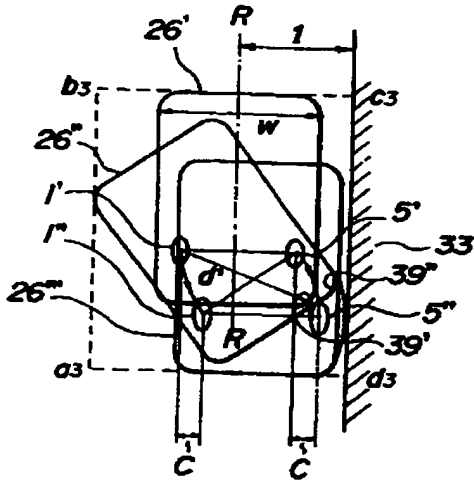
第 6 图



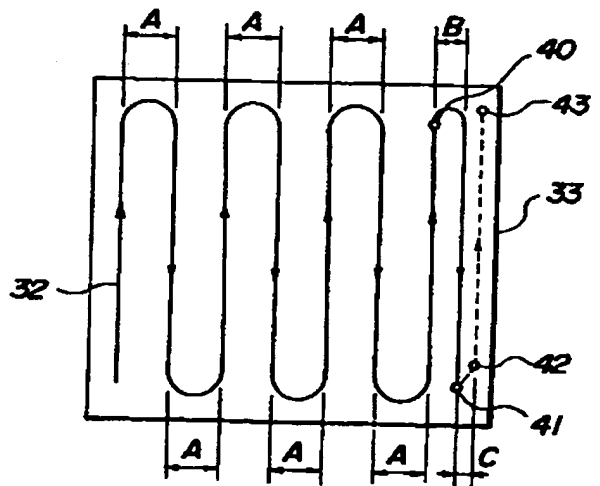
第 7 图

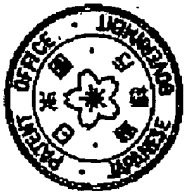


第 8 图



第 9 图





63241610 A

(11) Publication number:

Generated Document.

**PATENT ABSTRACTS OF JAPAN**

(21) Application number: 62074018

(51) Intl. Cl.: G05D 1/02 A47L 9/28

(22) Application date: 30.03.87

(30) Priority:

(43) Date of application publication: 06.10.88

(84) Designated contracting states:

(71) Applicant: HITACHI LTD

(72) Inventor: OGASAWARA HITOSHI  
OBATA MASAO

(74) Representative:

**(54) METHOD FOR CONTROLLING RUNNING OF SELF-RUNNING ROBOT**

(57) Abstract:

**PURPOSE:** To make a self-running robot closer to a wall by turning only running direction of wheels by 90° without changing of the direction of the self-running robot and making the robot run sideways along the wall or an obstacle when the self-running robot comes close to the wall and it can not carry out a U-turn.

CONSTITUTION: When the self-running robot comes so close to the wall of a room or the obstacle that it can not execute the U-turn, it is made to run sideways along the wall or the obstacle by turning only directions of the wheels 1 and 4 by 90° without changing the direction of the robot. The running distance in running sideways is changed according to the distance from the robot's own position to the wall of the room or the obstacle.

COPYRIGHT: (C)1988,JPO&Japio





(19) 日本国特許庁 ( J P )

(12) 特 許 公 報 ( B 2 )

(11) 特許出願公告番号

特公平7-86767

(24) (44) 公告日 平成7年(1995)9月20日

(51) Int.Cl. <sup>9</sup>	識別記号	庁内整理番号	F I	技術表示箇所
G 0 5 D 1/02		J		
A 4 7 L 9/00	1 0 2	Z		
	9/28	A		

発明の数1 (全 10 頁)

(21) 出願番号	特願昭62-74018	(71) 出願人	999999999 株式会社日立製作所 東京都千代田区神田駿河台4丁目6番地
(22) 出願日	昭和62年(1987)3月30日	(72) 発明者	小笠原 均 神奈川県横浜市戸塚区吉田町292番地 株 式会社日立製作所家電研究所内
(65) 公開番号	特開昭63-241610	(72) 発明者	小畑 征夫 神奈川県横浜市戸塚区吉田町292番地 株 式会社日立製作所家電研究所内
(43) 公開日	昭和63年(1988)10月6日	(74) 代理人	弁理士 小川 勝男 (外1名)
		審査官	加藤 雅夫
		(56) 参考文献	特開 昭63-131207 ( J P , A ) 特開 昭62-154008 ( J P , A ) 特開 昭59-128610 ( J P , A ) 実開 昭59-122606 ( J P , U ) 特公 昭60-52443 ( J P , B 2 )

(54) 【発明の名称】 自走ロボットの走行制御方法

1

【特許請求の範囲】

【請求項1】自走ロボット本体の向きを変化させないで車輪を旋回させる車輪旋回駆動装置と、この車輪旋回角度を測定する旋回角度測定装置と、車輪の走行距離測定装置と、走行方向を測定する方向測定装置と、超音波によって物体までの距離および方向を測定する超音波物体検知装置と、前記走行距離測定装置と方向測定装置とから得られる自己位置座標と超音波物体検知装置から得られる物体の位置座標とを記憶する記憶装置と、この記憶装置のデータをもとに前記車輪旋回駆動装置を制御する制御装置とを備えた自走ロボットにおいて、前記制御装置で、記憶装置に記憶した自己位置座標及び走行方向と物体の位置座標データとを読み出し、その自己位置座標と物体の位置座標データより、自走ロボットを走行前方に物体が有るまで直進走行させ、走行前方に物体が有れ

2

ば走行停止とUターンをさせる車輪駆動制御を行い、前記物体の位置座標データが、自走ロボットのUターン領域に有り、制御装置でUターンできないと判断した場合に、自走ロボット本体の向きを変化させないで、前記車輪旋回駆動装置を前記旋回角度測定装置での測定角度をもとに90°旋回させて車輪の走行方向を自走ロボット本体の向きに対して直角方向に向け、この車輪を、前記記憶装置に記憶されている自走ロボットの自己位置座標データと障害物などの物体の位置座標データをもとに、自己位置から物体までの距離に応じた距離だけ走行させ、自走ロボット本体を部屋の壁や障害物などの物体に向かって横方向に接近させることを特徴とした自走ロボットの走行制御方法。

【発明の詳細な説明】

【産業上の利用分野】

本発明は、自走ロボットに係り、特に部屋の壁ぎわ、あるいは障害物体のきわまで自走ロボットを接近させることに適した自走ロボットの走行制御方法に関する。

〔従来の技術〕

部屋の壁ぎわの掃除をする方法として、例えば特開昭55-97608号公報に示されるように、進行方向に対して左右に移動可能な吸引口ブラシを設け、横方向へ1ピッチ移動できないときは、吸引口ブラシのみ横方向に必要な間隔だけ移動させる方法である。しかし、この方法では、吸引口ブラシ装置の追加により制御に時間がかかることと、自動掃除機の本体の大型化することにより周囲環境への対応ができにくくなる点について配慮されていなかった。

〔発明が解決しようとする問題点〕

従来技術は、吸引口ブラシ装置とそれを駆動する装置が必要である。そのため、直進あるいはUターン走行で、吸引口ブラシの位置及び駆動のタイミングを考慮したロボットの走行制御と、吸引口ブラシの駆動制御が必要となるので制御が複雑になり、制御に時間が長くなる。かつロボット本体も大型化する。したがって、部屋の壁や障害物を避ける走行の対応性が悪くなる問題があった。

本発明の目的は、従来技術の進行方向に対して横方向に動く吸引口ブラシを設けずに掃除機構を簡単な構成とし、壁ぎわや障害物のぎわへ簡単な走行制御方法で正確に接近でき、壁ぎわや障害物のきわの掃除あるいは塗装作業などのやり残しをなくすことのできる自走ロボットの走行制御方法を提供することにある。

〔問題点を解決するための手段〕

上記目的は、自走ロボットを走行させる左右車輪及び駆動装置と、左右車輪を旋回軸心を中心に旋回する車輪旋回駆動装置と、車輪に連結して設けた車輪回転数を計測するエンコーダと、自走ロボットの走行方向変位を計測するジャイロを備えた自己位置測定装置と、超音波送受信器及び音波検出回路を備え、壁あるいは障害物の検出する物体検出装置と、自己位置と障害物の位置を記憶する記憶装置と、車輪の駆動制御、車輪の旋回駆動制御、自己位置及び障害物の位置座標の演算と記憶、自己位置座標と障害物の位置座標データより自走ロボットの直進走行とUターン可能かの判断等を行う制御装置を設けることで達成される。

〔作用〕

前記制御装置で、エンコーダでの車輪回転数データと、ジャイロでの走行方向変位データより自己位置座標と自走ロボットの進行方向を演算し、前記記憶装置に記憶させる。また超音波受信による物体検出装置での障害物データより壁または障害物の位置座標を演算し、同様に前記記憶装置に記憶させる。

そして制御装置では、自己位置座標と進行方向と記憶された壁、障害物座標データより、自走ロボットの前方あ

るいはUターン領域内に障害物が有るか判断する。前方に障害物の座標データがあれば、走行停止を行い、自走ロボットのUターン領域内に障害物データが無ければ左右車輪をUターン駆動を行わせる。

Uターン領域内に障害物データがあればUターンできないと判断し、制御装置ではロボットの向きを変えないで、前記車輪旋回駆動装置で車輪を旋回軸心を中心に車輪の向きだけを90°旋回させ、壁あるいは障害物に向けて横走行させる。

この横走行の走行距離は、前記自己位置座標と、Uターン領域内の障害物データの位置座標とにより、自走ロボットから壁あるいは障害物までの距離を演算し、上記横走行の走行距離を設定する。

したがって上記横走行では、Uターンでのロボットの前後先端部の旋回がないので、自走ロボットを壁や障害物にUターンの場合より近づけることができる。

〔実施例〕

以下、本発明の一実施例を、掃除を目的とした自走掃除ロボットの例で、図面により説明する。

第3図は、自走掃除ロボットの構成を示す斜視図であり、1は左車輪、2は左車輪駆動モータ、3は左車輪の横走行駆動部、4は右車輪、5は右車輪駆動モータ、6は右車輪の横走行駆動部、7は超音波送受信器、8は回転円板、9は回転円板8の回転軸、10は回転円板に固定されたパラボリアンテナ、11は超音波レーダ回転モータ、12は超音波レーダ用エンコーダ、13はジャイロ、14は掃除機、15はごみ吸口、16は掃除機モータ、17は測定回路部、18は走行制御部、19は制御用電源、20は駆動用電源、21はロボット本体フレーム、22はキャスト、23はロボットボディである。

第3図において、ロボット本体フレーム21には、左車輪1、右車輪4が、また前部中央にキャスト22が設けられている。左車輪1の横走行駆動部3及び右車輪4の横走行駆動部6の詳細図を第4図と第5図に示す。

第4図で、1は前記した左車輪、2は左車輪駆動モータ、4は右車輪、5は右車輪である。24は車輪1及び4を横走行させる車輪旋回モータ、25と26はかさ歯車、27と28はウォーム歯車、29はウォーム歯車軸、30は左車輪駆動かさ歯車、31は右車輪回転用かさ歯車、32は左車輪旋回軸、33は右車輪旋回軸、34は左右車輪が90°旋回したことを検出する旋回スイッチ、35は左右車輪が0°位置に戻ったことを検出する復帰スイッチ、36は車輪旋回の検出カムである。21はこれらの各部を固定あるいは設置した前記ロボット本体フレームである。第4図のAA断面が第5図である。第5図で1は前記左車輪、2は左車輪駆動モータ、21はロボット本体フレーム、27はウォーム歯車、29はウォーム軸、30は左車輪回転用かさ歯車、32は旋回軸、32aは旋回軸の軸心である。36は前記車輪旋回検出カムであり、旋回軸心32aに固定されている。37は車輪駆動軸、38及び39は車輪駆動軸37の上下に固定し

たかさ歯車、40は左車輪1に固定した歯車、41はウォーム歯車27とかみ合うホイール歯車、43は旋回軸の軸心32aを旋回可能に支持する軸受で本体フレーム21に固定されている。44は、車輪1及び車輪駆動軸37の回転数を計測する左車輪エンコーダ、45は軸37とエンコーダ44の軸を連結する連結部である。右車輪4の横走行部6は第5図の36の検出カムがないだけの同一構成である。

第5図で、左車輪1は、歯車40と車輪駆動用かさ歯車39と車輪駆動軸37と歯車38,30を介し、左車輪駆動モータ2と左車輪用エンコーダ44とに連結され、同様に右車輪4も第5図の構成で第4図の右車輪駆動モータ5とに連結されている。これにより、左車輪1と右車輪4とは別々のモータによって駆動され、これらの車輪の回転数が別々のエンコーダで測定される。

自掃掃除ロボットの壁ぎわへ近づく横走行は、ロボット本体フレーム21及び後で説明するロボットボディ23の向き、いわゆる自走掃除ロボットの進行方向を変えないで、左車輪1及び右車輪4の走行方向を90°旋回させ、横に走行させる。この車輪の90°旋回方向を次に述べる。

この左車輪1及び右車輪4の走行方向の90°旋回は、第4図の車輪旋回モータ24を駆動して行う。車輪旋回モータ24が回転すると、かさ歯車25,26を介してウォーム軸9を回転し、左右のウォーム歯車27と28同時に回転する。ウォーム歯車27の回転にともない、第5図のウォーム歯車27とかみ合うホイール歯車41が回転し、旋回軸32aが回転し、左車輪1の回転軸BBを形成する旋回軸32が旋回軸32aの軸心CCを軸に旋回する。この旋回方向は右旋回である。第5図では、左車輪1の90°旋回駆動部を示しているが、左車輪4の90°旋回駆動部も第5図と同一構成であり、したがって右車輪4は、左車輪のウォーム歯車27と同時に回転する第4図のウォーム歯車28の回転により軸心CCを軸に旋回する。また左車輪1及び右車輪4の旋回軸32の軸CCとした90°旋回角度は、第5図の旋回軸心32aに固定した検出カム36の回転によって、第4図の検出カム36に接触している旋回スイッチ34がONし、このON信号を第6図の車輪旋回角度検出回路52で検出して、その信号データを中央処理部46に伝達する。中央処理部46では、検出カム36のON信号を入力すると車輪旋回モータ24の駆動を停止して、左右車輪の90°旋回を終

る。ロボット本体フレーム21には、超音波レーダが搭載されている。第1図の超音波レーダ回転モータ11と回転円板8の回転軸9が連結され、11の回転によって回転円板8及びパラボラアンテナ10は回転軸9を中心に回転する。パラボラアンテナ10と超音波送受信器7では、破線で示す指向性の鋭い超音波の送受信を行う。回転軸9には超音波レーダエンコーダ12が連結されており、12によってパラボラアンテナからの超音波の発射方向が検出される。超音波送受信器7から発射された超音波は、部屋の

壁や障害物などに当たると反射され、反射超音波のうちのパラボラアンテナ10に帰ってきたものが超音波送受信器で受信され、超音波が発射されてから受信されるまでの時間と超音波レーダエンコーダ12によって検出される超音波の発射方向とから、壁や障害物の位置が測定される。

さらに、ロボット本体フレーム21には、第1図の自走掃除ロボットの進行方向の角度変化を計測するためのジャイロ13、掃除機14、測定回路部17、走行制御部18のための制御用電源19、駆動用電源20などが搭載されており、超音波レーダの超音波送受信器7、回転円板8、パラボラアンテナ10以外がロボットボディ23で覆われている。掃除機14には、掃除機モータ16とロボット本体フレーム21の幅にほぼ等しい幅のごみ吸口15が設けられ、自走掃除ロボットの走行とともに、ロボット本体フレーム21の幅の塵芥を吸収する。

第6図は、第3図における走行制御系の全体を示すシステムブロック図であり、46は中央処理部(CPU)、47はメモリ、48は超音波レーダ検出回路、49はレーダエンコーダ測定回路、50はジャイロ測定回路、51は車輪エンコーダ測定回路、52は車輪の90°旋回角度検出回路であり、他の部分は第3図、第4図、第5図と同一符号をつけている。

第3図の測定回路部17は、第6図の超音波送受信器7の出力信号を検出する超音波レーダ検出回路48と、超音波レーダエンコーダ12からのデータを測定するレーダエンコーダ測定回路49と、ジャイロ13からのデータを測定するジャイロ測定回路50と、左車輪エンコーダ44および右車輪エンコーダ44aのデータを測定する車輪エンコーダ測定回路51と、90°旋回スイッチ34及び復帰スイッチ35の信号を検出する車輪旋回角度検出回路とからなる。一方、走行制御部18は、前記中央処理部46とメモリ47とからなる。中央処理部46は、超音波レーダ検出回路48、レーダエンコーダ測定回路49、ジャイロ測定回路50、車輪エンコーダ測定回路51及び車輪旋回角度検出回路52からのデータを周期的に取り込んで自走掃除ロボットの自己位置と部屋の壁や障害物の位置を計算し、この結果をメモリ47に記憶する。この結果に応じて左右車輪駆動モータ2,5と、車輪旋回モータ24と、掃除機モータ16及び超音波レーダ回転モータ11などの制御信号を形成する。

次に以上の自走掃除ロボットの制御方法を示す。この実施例の走行制御は、第7図に示すように、基本的には直進とUターンとを繰り返して走行させ、部屋の壁や障害物にロボットが接近した時に壁や障害物のきわへ横方向に移動させるものである。

第1図と第2図は、本発明による自走ロボットの制御方法の実施例を示すフローチャートである。第1図において、自走掃除ロボットの動作開始時には、中央処理部46は、メモリ47の内容をクリアし、掃除機モータ16を起動させて掃除を開始させて、次のステップの自走掃除ロボ

ットをUターンさせるための制御フラグ（以下Uターンフラグという）のリセットと、ロボットを壁や障害物に向かって横に走行（以下横走行という）させるための制御フラグ（以下横走行フラグという）のリセットをする。次のステップでは、室内での自走掃除ロボットの自己位置が検出される。この自己位置は、一定時間間隔おきに、左車輪エンコーダ44と右車輪エンコーダ44a及びジャイロ13の出力信号をもとに測定される。左車輪エンコーダ44から左車輪1の回転速度を表すデータ（パルス数）が出力され、車輪エンコーダ測定回路51でこのデータから左車輪1の走行距離が測定される。同様に、右車輪エンコーダ44aから右車輪4の回転速度を表すデータ（パルス数）が出力され、このデータから車輪エンコーダ測定回路51で右車輪4の走行距離が測定される。またジャイロ13からは、一定時間間隔おきに、自走掃除ロボットの進行方向の角度変化量が測定される。この左右車輪の走行距離と進行方向の角度変化量が中央処理部46に取り込まれ、自己位置座標が計算される。第7図の53は、以上で検出した自己位置座標の軌跡を示したもので、自己位置データはX-Y座標として得られる。このX-Y座標は、自走掃除ロボットが作業を行うために部屋の床面に置かれたときに決まり、その置かれた位置を原点0とし、そのときのロボットの向いている方向をy軸、これに直角方向をx軸とする。ロボットの進行方向のX-Y座標上の角度が、ジャイロ13から測定される角度変化量の累積で計算される。そして一定時間間隔ごとに、自走掃除ロボットの自己位置座標が、前記左右車輪の平均走行距離と、上記進行方向のX-Y座標上の角度の三角関数との、積により次々に計算される。

次のステップでは、壁や障害物の位置が検出される。壁や障害物の位置の測定は、第3図、第6図の超音波レーダのデータを用いて行われる。第3図の超音波送受信器7及びパラボリアンテナ10は、ロボット上部で回転しながら、超音波の発射と受信を行っている。したがってパラボリアンテナ10が壁あるいは障害物の超音波発射方向に垂直な面に向いたとき、超音波送受信器7で発射された超音波はこの垂直面で反射されて、再びパラボリアンテナ10及び超音波送受信器7で受信される。そこで、超音波が超音波送受信器7から発射されてから壁や障害物の垂直面で反射され、再び超音波送受信器7で受信される往復時間と超音波の速度との積により、自走ロボットの自己位置から壁あるいは障害物までの距離が計測される。また壁あるいは障害物の方向は、超音波レーダエンコーダ12で、パラボリアンテナ10からの超音波の発射及び受波方向の測定により計測される。この壁あるいは障害物の位置座標は、第6図のメモリ47に記憶され、その一例を第7図に示す。第7図は、長方形の部屋の中で、ロボットが部屋の左下隅から走行を開始して、直進とUターンを繰り返して走行している間に検出した部屋の壁の位置を示したもので、54は左の壁、55は上の壁、56は

右の壁、57は手前の壁のデータである。

次のステップでは、以下で得られた自走掃除ロボットと壁もしくは障害物の位置座標をメモリ47に記憶し、壁や障害物の位置関係を表す情景地図を作成し、そこに自走掃除ロボットの走行経路を画く。その1例が第7図である。

次のステップでは、自走掃除ロボットの進行方向に直進走行を阻げる壁もしくは障害物があるか否かを判定する。先に説明したように、自走掃除ロボットは直進とUターンとを繰り返しながら走行するが、中央処理部46では、進行方向の壁もしくは障害物との間隔を第7図の情景地図とロボットの走行経路をもとに常時監視しており、この間隔がロボットボディ23の前先端寸法近くになったとき、壁もしくは障害物が有ると判定する。前方に壁もしくは障害物がなければ、ロボットを直進走行させる。この直進走行は、左車輪モータ2と右車輪モータを同時に回転させ、第5図の歯車30、歯車38、車輪駆動軸37、歯車39、歯車40の順に動力を伝達して、左車輪1及び右車輪4とを駆動することによって行われる。そして前方に壁もしくは障害物が有ると判定されない限り、直進走行の結合子Bにより処理は、前記ロボットの位置検出、障害物の位置検出、位置データの情景地図へのメモリ、前方障害物有るかの判断及び直進走行指令の動作が繰り返えされ、自走掃除ロボットを直進走行させる。この直進走行中、ロボットの位置座標と壁もしくは障害物の位置座標が検出され、それぞれの位置座標が順次メモリ47に記憶され、メモリ47では第7図に示す情景地図が次第に詳しくなり、そこに自走掃除ロボットの走行経路も画かれる。

直進走行中に、前方に壁もしくは障害物が有ると判定すると、次のステップで自走掃除ロボットを停止させ、Uターンあるいは横走行であることを示すフラグ（旋回中フラグという）をセットす。

次のステップでは、Uターン方向及び横走行方向の反転を行う。先に説明したように、自走掃除ロボットは、壁や障害物に近づくまでは直進走行とUターンとを繰り返して走行させ、壁や障害物にロボットが接近した時に、壁や障害物のきわへ横方向に走行させるが、第7図では、軌跡53で示すように、最初のUターン方向は右方向であるが、次のUターンは左方向に行われる。つまりUターンする毎にその方向は右と左に交互に変わり、これによって自走掃除ロボットはy軸方向に往復走行しつつx軸方向に進むことになる。ロボットが壁に接近して横走行をさせる時点第7図の57では、横走行の方向をどちらにするか決定する必要がある、この横走行の方向は、前のUターンでのUターン方向の逆の方向を指定する。すなわち第7図の57の横走行の方向は、前の58でのUターンが左Uターンであるので、その逆の右方向に指定する。前のUターンが右Uターンであれば、横走行の方向は左に指定する。

次のステップでは、Uターン可能かを判定する。ここで自走掃除ロボットのUターンの方法を第8図で説明する。第8図は右Uターンの例で、1aはUターン前の左車輪、1bはUターン後の左車輪、4aは右車輪、23aはUターン前のロボットボディ、23bはUターン後のロボットボディ、61aは自走掃除ロボット自己位置としている左右車輪の中央点のUターン前の位置、61bはUターン後の自己位置、62aと62bはロボットボディの左前先端部、63aと63bはロボットボディの左後先端部である。右Uターンは、右車輪4aを停止させて、左車輪1aを前進方向に駆動し、ロボットボディ23aを右車輪4aを中心に旋回させる。このUターンを行うことにより、掃除機14のごみ吸口15の幅はロボットボディ23a、23bの幅にほぼ等しいから、Uターン前後の掃除範囲はEbだけオーバーラップする。このUターンは、ロボットボディ23a、23bの先端から車輪軸までの距離と、右車輪4aを中心にしたロボットボディの前先端部62a、62b及び後先端部63a、63bの回転範囲で決まる領域a<sub>1</sub>b<sub>1</sub>c<sub>1</sub>d<sub>1</sub>内に壁や障害物がない時に可能である。Uターン可能であれば、Uターン走行を指令するUターンフラグをセットし、処理をBに戻す。Uターン中は、第1図のロボット位置座標の検出、障害物の位置検出、位置データの情景地図へのメモリ、次の旋回中かの判断yes、旋回走行終りかの判断NO、結合子Bへ戻る、動作を繰り返す。Uターンが終れば、上記旋回走行終りかの判断はyesとなり、つづいて旋回中フラグがリセットされ、前記直進走行の動作に移り、第8図の矢印65の方向に再び直進走行させる。以上のUターンの場合、壁64のきわに幅Eaの掃除残りが生じる。前ステップのUターン可能かの判断で、壁もしくは障害物が第8図の前記領域a<sub>1</sub>b<sub>1</sub>c<sub>1</sub>d<sub>1</sub>に有り、Uターンできない場合、次のステップの壁や障害物に向かって横走行の動作に移る。ここで横走行の動作を説明する。第9図は、右側に横走行する例であり、1cは横走行前の左車輪、1dは横走行させるために車輪のみ90°右旋回させた後の左車輪、1eは壁69に向かって横走行後の左車輪、1fは壁に接近した後車輪のみ逆に90°左旋回させて車輪の走行方向を横走行前と同じロボットの進行方向に戻した後の左車輪、4cは横走行前の右車輪、4dは横走行させるために車輪のみ90°右旋回させた後の右車輪、4eは壁69に向かって横走行後の右車輪、4fは壁に接近した後車輪のみ逆に90°左旋回させて走行方向を横走行前と同じ方向に戻した後の右車輪、23cは横走行前のロボットボディ、23dは横走行で壁69に接近した後のロボットボディ、67cと67dは第5図の左車輪の旋回時32aの軸心CCの横走行前と壁接近後の位置、68cと68dは右車輪の旋回軸の軸心CCの横走行前と壁接近後の位置、66cはこの自走掃除ロボットの自己位置と考えている位置で、上記左車輪の旋回軸心67cと右車輪の旋回軸心68cの中央点である。この66cはまた第1図の超音波レーダのパラボラアンテナ10の回転軸9の回転軸心と一致させて、自己位置座標と壁もしくは

障害物の検知位置とを関連させている。66dは同様に壁接近後の左右車輪の旋回軸心67dと68dの中央点である。69は部屋の壁である。横走行の動作は、まず左車輪1cと右車輪4cを、ロボットボディ23cの向きを変えないで、1dと4dまでの軸心67c、68cを中心にそれぞれ90°右旋回させる。左右車輪の90°旋回方法は、前に説明したように、第4図の車輪旋回モータ24を駆動し、第5図の旋回軸32を旋回させて行い、旋回角度90°の検出は検出カム36と旋回スイッチ34で検出する。

次にロボットの自己位置の点66cから壁69までの距離Lを第7図の情景地図の右側の壁56のデータから計算する。その壁までの距離Lに応じて、第9図の左車輪1dと右車輪4dを1eと4eまで、距離Lだけ壁69に向かって横に走行させる。この横走行によりロボットボディ23dを壁69にLcまで接近させる。次に左車輪1eと右車輪4eを1fと4fまで、前記90°右旋回とは逆に、90°左旋回させて、左右車輪の走行方向を、横走行前の状態に戻す。つづいて左車輪1fと4fは、ロボットボディ23dが壁69に沿うように後退させる。その後退走行は、第7図の59から60に示すように後方に壁58もしくは障害物が検知されるまで行われる。

以上が横走行の動作であるが、横走行に入る前に上記の横走行の走行距離lを決定しなければならない。そこで第1図のフローチャートに戻るが、前ステップのUターン可能かの判断でUターンできないと判定された場合、次のステップで横走行可能かの判断と横走行距離の決定を行う。この横走行距離lの演算方法を第2図に示し、第2図は第1図の横走行距離の決定という処理のサブルーチンである。第2図でL及びlは長さを表し、Lは第7図の57、第9図の66cで示す自走掃除ロボットの自己位置点から部屋の壁まで距離を、Laは第8図のUターン可能な壁までの距離の最小距離、Lbは第8図のロボットボディ23の幅から前に説明した掃除のオーバーラップ幅Ebを差し引いた長さ、Lcは第9図の横走行させた後のロボットボディ23dと壁とのすきま幅、lは横走行させるべき走行距離をそれぞれ示す。

第2図において、横走行の走行距離lは、自走掃除ロボットの自己位置から壁までの距離Lに応じて、LがLb < L ≤ Laの範囲の場合は、ロボットボディ23の幅から掃除のオーバーラップ幅Ebを引いた長さLbに決定される。また壁までの距離Lが、Lc < L ≤ Lbの範囲の場合は、走行距離lは、壁までの距離Lから横走行後のロボットボディと壁とのすきま幅Lcを引いた長さL-Lcに決定される。さらに壁までの距離LがL < Lcの場合、横走行はできないと判断して次の走行距離lをl = 0にする。横走行可能ならば、次に横走行を指令するフラグ（横走行フラグという）をセットし、結合子Bに戻る。

横走行中は、第1図のロボット位置座標の検出、障害物の位置検出、位置データの情景地図へのメモリ、次の旋回中フラグ有るかの判断yes、旋回走行終りかの判断NO、

結合子Bへ戻るのを動作を繰り返す。

横走行は、第7図に示すメモリ内の情景地図では57から59まで壁56に向かって横に走行し、つづいて壁56に沿って59から60まで後退走行する。

横走行の終ると第1図の巡回走行終りかの判断がyesとなり、次の巡回中フラグをリセットして結合子Bに戻る。

横走行が終り、第7図の60の点に達すると、もはやUターンや後退ができなくなり、かつ前方はすでに59から60の走行で掃除がすんでいるので直進走行の必要もない。したがって第1図の処理は、前方に障害物が有るかの判断がyes（第7図の走行経路53,57,59,60は障害物の1つと見なす）、Uターン可能かはNO,横走行可能かはNOと進み、次のステップで、掃除終りかを判定する。

この判定は、第6図のメモリ47に形成された第7図の例で示す情景地図と自走掃除ロボットが走行した経路とから未掃除エリアを探すことによって行われる。第7図の場合には、掃除が終わったものと判定されるが、室内に障害物があったり部屋が四角形でない場合などに、未掃除エリアが存在する場合がある。未掃除エリアが見つかる

と、自走掃除ロボットをその未掃除エリアに走行させ、つづいて処理を結合子Aに戻し、未掃除エリアに対して上記の直進, Uターン, 横走行等の動作が行われる。以上のように、この実施例では、自走掃除ロボットを壁ぎわや障害物のきわ（第9図のLc）まで簡単かつ正確に接近させることができ、壁や障害物のきわの掃除のやり残しをなくすることができる。また実施例では、横走行で左右車輪の巡回と回転という簡単な駆動制御だけですみ、従来のような吸引口ブラシの操作制御や吸引口を出したことによるロボットの外形形状の変化を考慮した走行制御をなくしてもよく、走行方法の判断や決定に要する時間を短縮でき、かつ吸引口ブラシの駆動装置が不要であるのでロボットボディも小形化できる。したがって、超音波レーダで得られるまわりの壁や障害物の位置データ及び情景地図データの変化にすばやく対応できることになる。

なお、第1図、第2図、第7図～第9図では、壁について説明したが、障害物であっても同様である。また、上記実施例では、自走ロボットとして掃除機を搭載したものとしたが、塗装を行うなどの他の作業を行うもの

【発明の効果】

以上説明したように、本発明によれば、自走ロボットを壁ぎわや障害物のきわまで簡単かつ正確に接近させることができる効果がある。

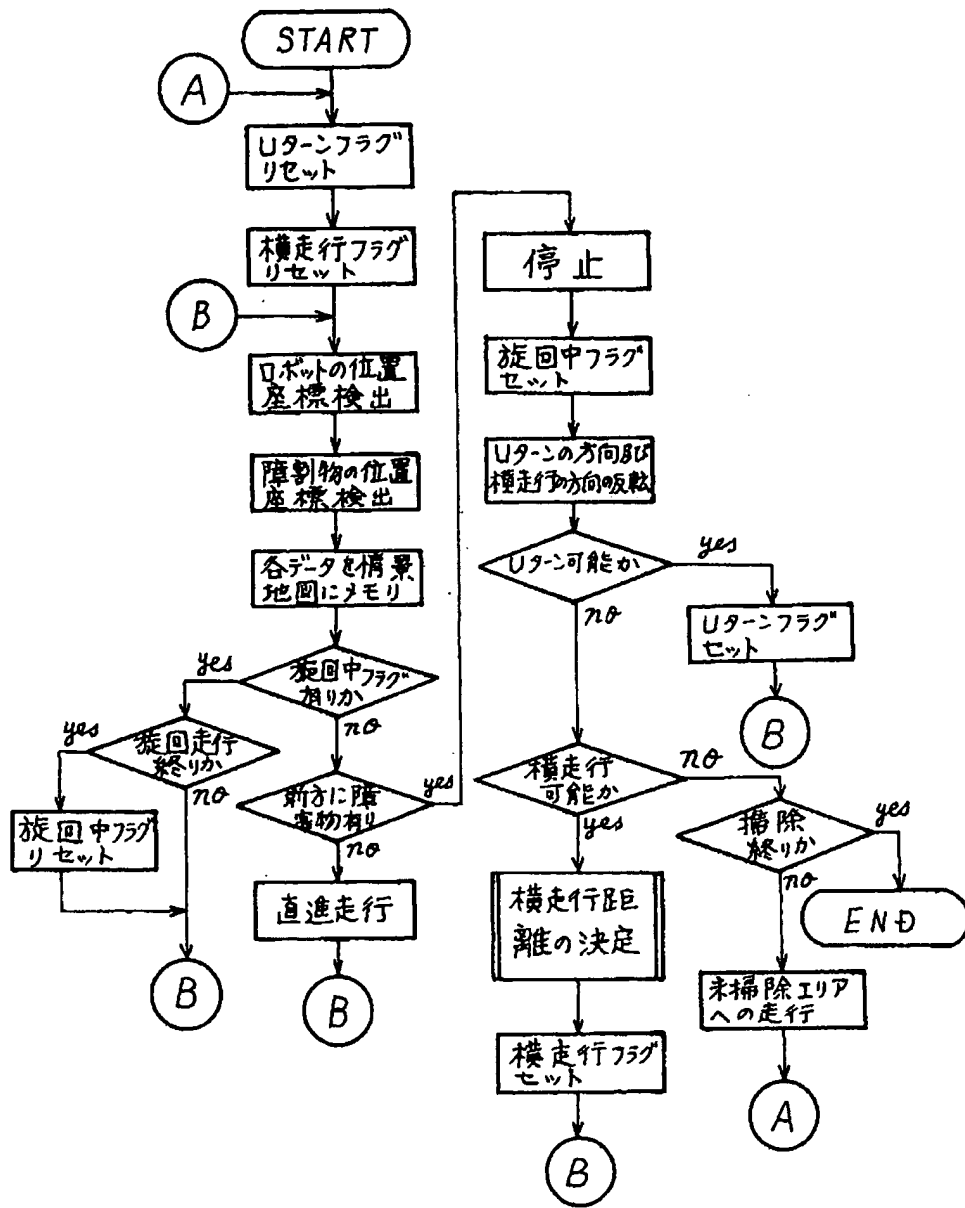
また自走ロボットに載置される掃除機及び塗装装置などの作業機器を制御する必要がなく、車輪のみ走行制御だけでよいので制御の簡略化ができ、かつ作業機器の機構部や駆動部の簡略化され自走ロボットの小型化も図れる。これら制御の簡略化と作業機器の簡略化及び自走ロボットの小型化とにより、自走ロボットの走行方法の判断や決定を迅速に行うことができ、部屋の壁や障害物に対応して自走ロボットの動作変化を迅速に行え、作業時間を大幅に短縮できる効果がある。

【図面の簡単な説明】

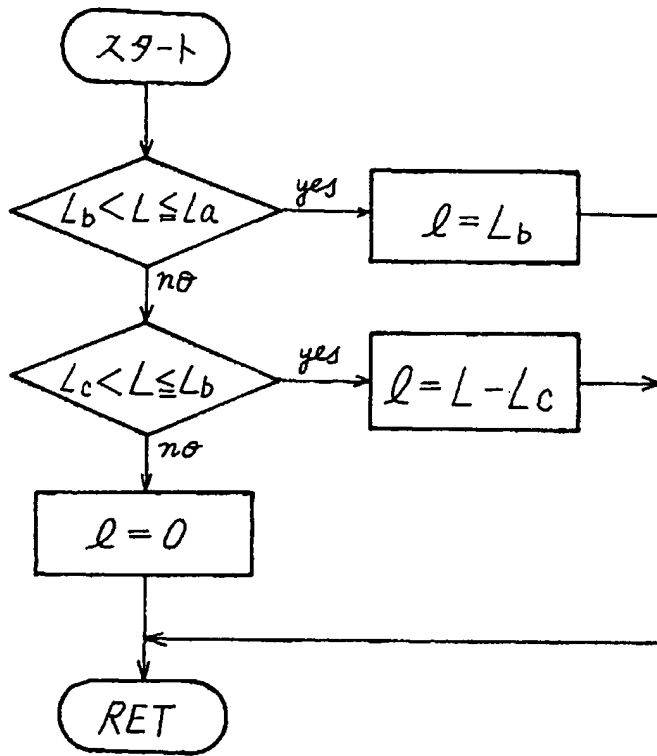
第1図と第2図は本発明による自走ロボットの走行制御方法の一実施例を示すフローチャート、第3図は自走ロボットの具体例を示す構成図、第4図と第5図は本発明の車輪駆動装置の一実施例を示す構成図、第6図は第3図、第4図、第5図に示した自走ロボットにおける走行制御系全体を示すシステムブロック図、第7図は自走ロボットの制御装置で認識される情景地図データを示す説明図、第8図は自走ロボットのUターン方法を示す説明図、第9図は本発明の自走ロボットの走行方法を示す説明図である。

- 1,1a～1f……左車輪、2……左車輪モータ、
- 3,6……横走行駆動部、4,4a～4f……右車輪、
- 5……右車輪モータ、7……超音波送受信器、
- 10……パラボラアンテナ、
- 12……超音波レーダエンコーダ、
- 13……ジャイロ、14……掃除機、
- 15……ごみ吸口、17……測定回路部、
- 18……走行制御部、
- 21……ロボット本体フレーム、
- 24……車輪巡回モータ、27,28……ウオーム歯車、
- 29……ウオーム軸、32……車輪巡回軸、
- 32a……巡回軸心、34……巡回スイッチ、
- 35……復帰スイッチ、
- 36……車輪巡回角度の検出カム、
- 37……車輪駆動軸、
- 30,38,39,40……かさ歯車、
- 44,44a……車輪エンコーダ、
- 46……中央処理部、
- 52……車輪巡回角度検出回路。

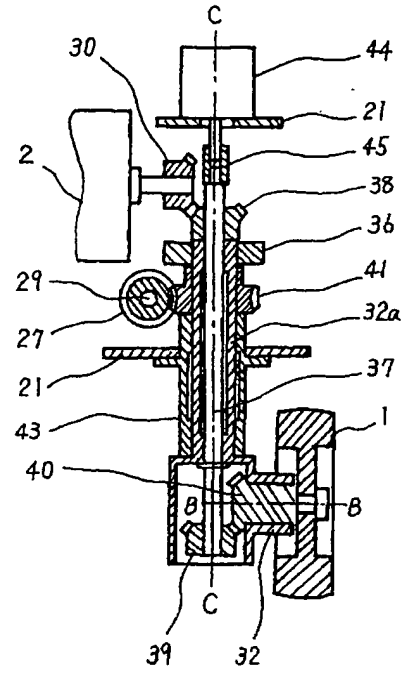
【第1図】



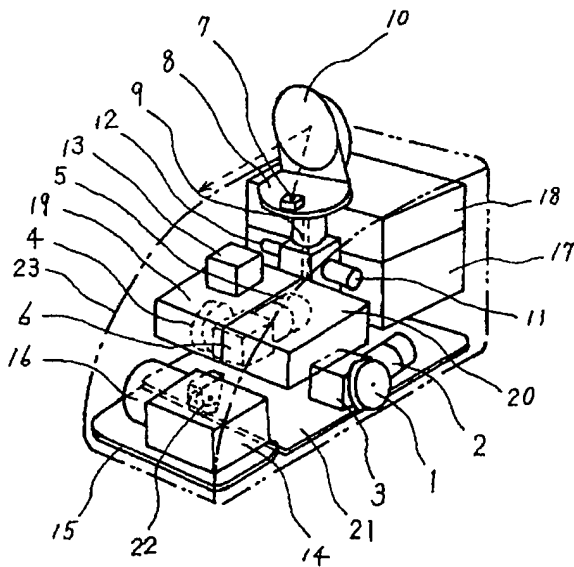
【第2図】



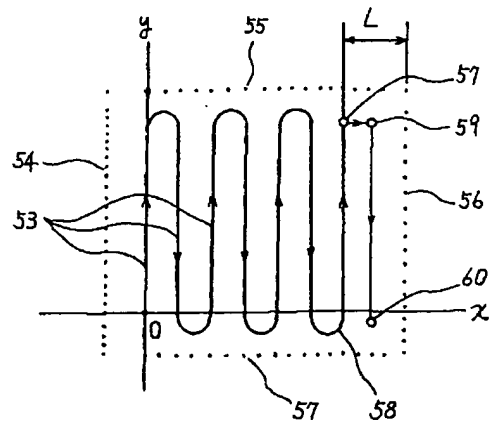
【第5図】



【第3図】



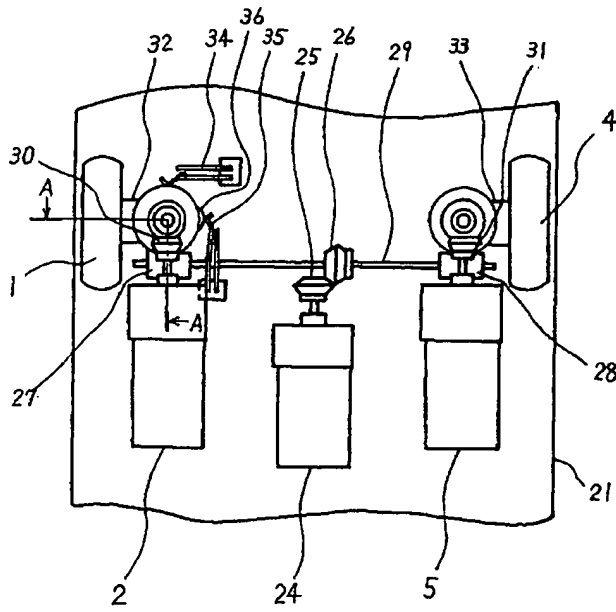
【第7図】



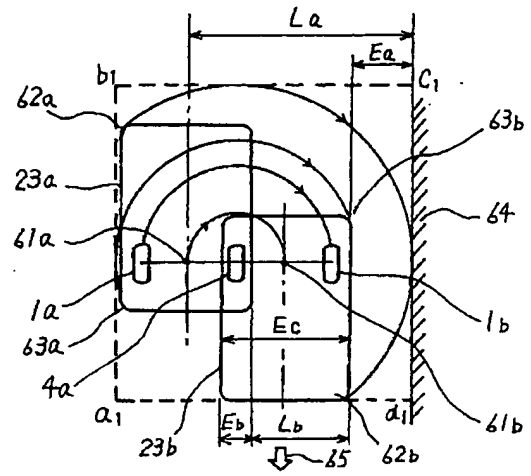
- 1 左車輪      6 横走行駆動部    14 掃除機
- 3 横走行駆動部    7 超音波送受信器    17 測定回路部
- 4 右車輪      13 ジョイント      18 走行制御部



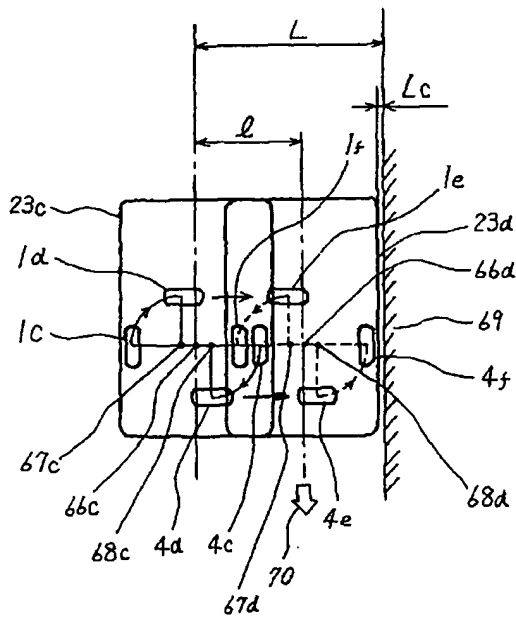
【第4図】



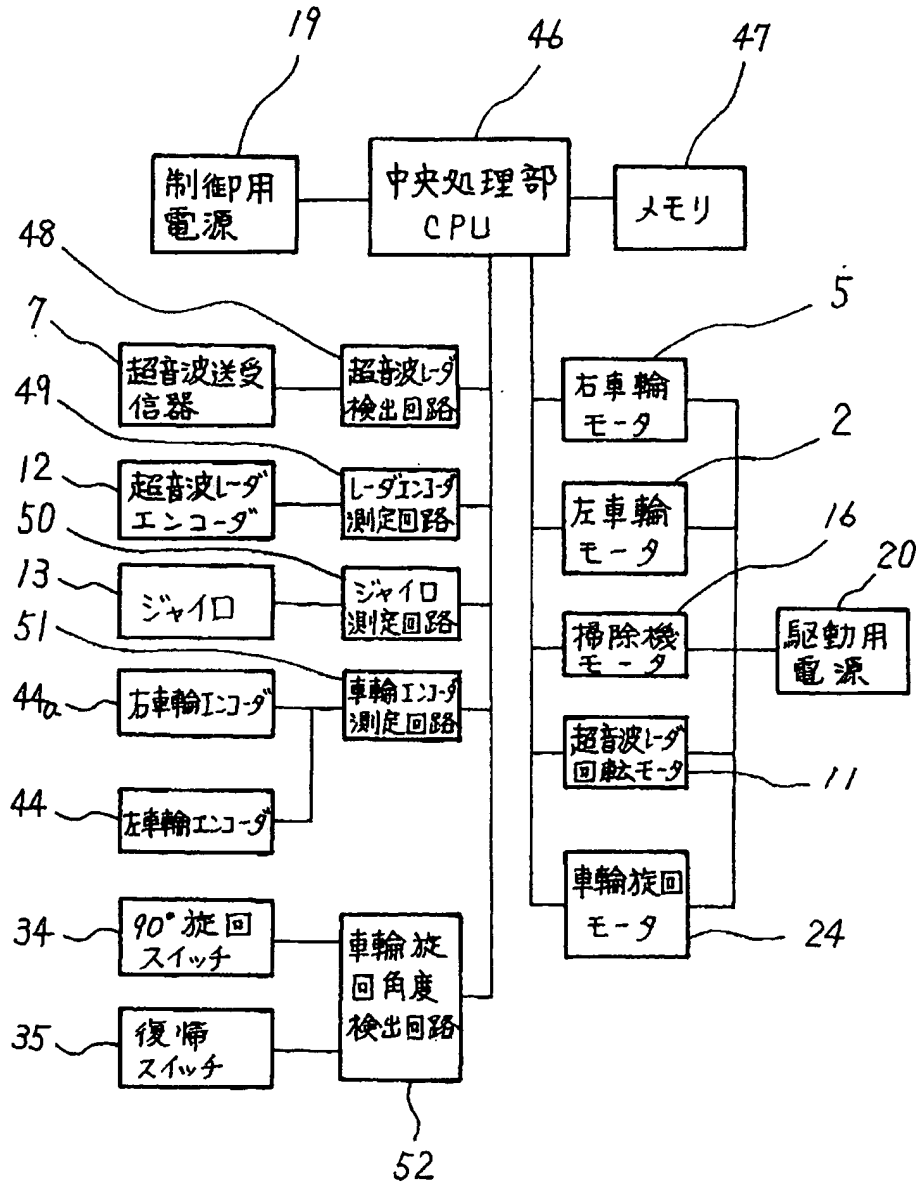
【第8図】



【第9図】



【第6図】





(19)

(11) Publication number:

10

Generated Document.

### PATENT ABSTRACTS OF JAPAN

(21) Application number: **09043901**

(51) Intl. Cl.: **G05D 1/02 A47L 11/00**

(22) Application date: **27.02.97**

<p>(30) Priority:</p> <p>(43) Date of application publication: <b>11.09.98</b></p> <p>(84) Designated contracting states:</p>	<p>(71) Applicant: <b>MINOLTA CO LTD</b></p> <p>(72) Inventor: <b>KAWAKAMI YUICHI</b></p> <p>(74) Representative:</p>
---	---

### (54) AUTONOMOUSLY TRAVELING VEHICLE

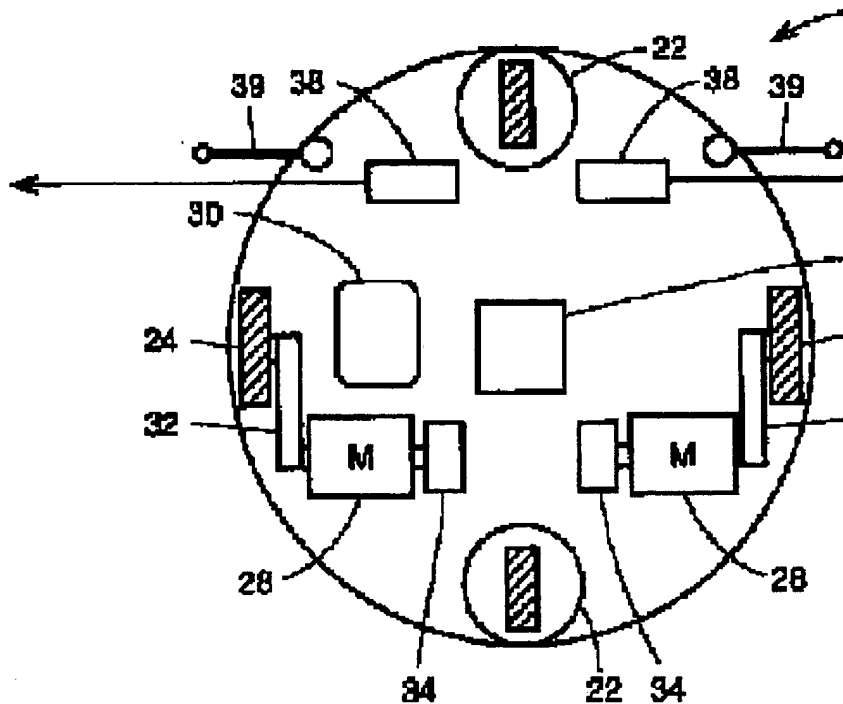
(57) Abstract:

**PROBLEM TO BE SOLVED:** To prevent stoppage in a state worse than a parallel state at the time of starting traveling even in the case that whether or not a car body is parallel with a wall is not certain after ending traveling by providing an angle detection means for detecting a direction angle where the car body is turned to, a driving means for moving the car body and a control means for controlling the driving means.

**SOLUTION:** This autonomously traveling vehicle is provided with a gyro sensor 36 for detecting the direction angle where the autonomously traveling vehicle 20 is turned to, a distance sensor 38 for measuring a distance to left and right objects without contacting, a contact distance measuring sensor 39 for measuring the distance to the left and right objects by contacting and a controller 30 for controlling the

traveling of the autonomously traveling vehicle 20 through a motor 28 and a driving wheel 24. Then, the direction angle is measured by using the gyro sensor 36 before traveling and traveling is started. Then, in the case of ending the traveling control of the autonomously traveling vehicle 20, after measuring the direction angle at the time, angle correction performed so as to turn the direction angle to the state before traveling.

COPYRIGHT: (C)1998,JPO



(19) 日本国特許庁 ( J P )

(12) 公開特許公報 ( A )

(11) 特許出願公開番号

特開平10-240343

(43) 公開日 平成10年(1998) 9月11日

(51) IntCl.<sup>6</sup>  
G 0 5 D 1/02  
A 4 7 L 11/00

識別記号

F I  
G 0 5 D 1/02 H  
A 4 7 L 11/00

審査請求 未請求 請求項の数10 O L (全 9 頁)

(21) 出願番号 特願平9-43901  
(22) 出願日 平成9年(1997) 2月27日

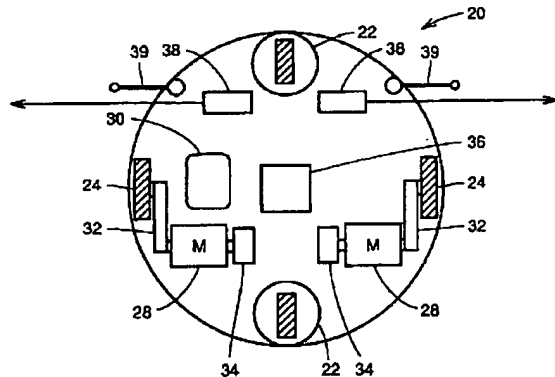
(71) 出願人 000006079  
ミノルタ株式会社  
大阪府大阪市中央区安土町二丁目3番13号  
大阪国際ビル  
(72) 発明者 川上 雄一  
大阪市中央区安土町二丁目3番13号大阪国  
際ビル ミノルタ株式会社内  
(74) 代理人 弁理士 深見 久郎 (外2名)

(54) 【発明の名称】 自律走行車

(57) 【要約】

【課題】 壁と平行となるよう走行および停止をする自律走行車を提供する。

【解決手段】 動力を受けて独立に駆動される左右各々の駆動輪24と、駆動輪24とともに自律走行車20を支持し、直進動作、Uターン動作を行なうための従属輪22と、左右各々の駆動輪24を駆動させるためのモータ28と、モータ28の回転を駆動輪24に伝えるための連結機構32と、モータ28の回転量および回転速度を検出するためのエンコーダ34と、自律走行車20の向いている方向角を検出するためのジャイロセンサ36と、左右の対象物までの距離を測定するための測距センサ38と、モータ28および駆動輪24を通じて自律走行車20を制御するためのコントローラ30を含む。



## 【特許請求の範囲】

【請求項 1】 車体と、  
前記車体に取り付けられ、前記車体の向いている方向角  
を検出するための角度検出手段と、  
前記車体を移動させるための駆動手段と、  
前記車体を直進および／または、回転動作させるため前  
記駆動手段を制御するための制御手段とを含み、  
前記制御手段は、前記角度検出手段の出力を受け、走行  
前の角度と走行後の角度との差より、走行後の前記車体  
の角度補正をするための第 1 の角度補正手段を含む、自  
律走行車。

【請求項 2】 前記車体に取り付けられ、車体側方に位置  
する壁との距離を測定するための距離検出手段をさらに  
含み、

前記制御手段は、前記距離検出手段の出力を受け、前記  
車体が前記壁と平行走行するように制御するための平行  
走行制御手段をさらに含む、請求項 1 に記載の自律走行  
車。

【請求項 3】 前記平行走行制御手段による制御のもと  
で、所定期間、前記車体が前記壁と平行走行しているこ  
とを判定するための測距俵い判定手段をさらに含み、  
前記制御手段は、前記測距俵い判定手段より前記車体が  
前記壁と平行走行しているとの判定結果を受けた後、前  
記角度検出手段の出力を受け、一定期間の前記車体の平  
均角度を求めるための角度平均算出手段と、  
前記角度平均算出手段より出力される前記平均角度と、  
前記角度検出手段より出力される走行後の角度との差よ  
り、走行後角度補正をするための第 2 の角度補正手段  
と、  
前記角度平均算出手段より前記車体の平均角度が求めら  
れる時点前に前記車体が走行停止した場合には、前記第  
1 の角度補正手段により走行後角度補正を行ない、前記  
角度平均算出手段により前記車体の平均角度が求められ  
た時点後に前記車体が走行停止した場合には、前記第 2  
の角度補正手段により走行後角度補正を行なうための停  
止モード変更手段とを含む、請求項 2 に記載の自律走行  
車。

【請求項 4】 前記測距俵い判定手段は、前記距離検出  
手段より出力される距離の所定期間内の最大値と最小値  
との差が所定値以内である場合に、前記車体が前記壁と  
平行走行しているとの判定を行なう、請求項 3 に記載の  
自律走行車。

【請求項 5】 前記測距俵い判定手段は、前記角度検出  
手段より出力される走行中の角度の所定期間内の最大値  
と最小値との差が所定値以内である場合に、前記車体が  
前記壁と平行走行しているとの判定を行なう、請求項 3  
に記載の自律走行車。

【請求項 6】 前記制御手段は、前記車体を右または左  
方向へ移動させるための制御信号の出力期間である右ま  
たは左方向への移動方向制御期間をそれぞれ計算するた

めの手段をさらに含み、

前記測距俵い判定手段は、所定期間内の前記制御手段よ  
り出力される右への移動方向制御期間と左への移動方向  
制御期間との割合がほぼ等しい場合に、前記車体が前記  
壁と平行走行しているとの判定を行なう、請求項 3 に記  
載の自律走行車。

【請求項 7】 前記制御手段は、前記角度平均算出手段  
より前記車体の平均角度が求められた時点後、前記平均  
角度および前記角度検出手段より出力される走行中の角  
度により走行中角度補正をするための第 3 の角度補正手  
段をさらに含み、

前記停止モード変更手段は、前記角度平均算出手段より  
前記車体の平均角度が求められる時点前に前記車体が走  
行停止した場合には、前記第 1 の角度補正手段により走  
行後角度補正を行ない、前記角度平均算出手段より前記  
車体の平均角度が求められた時点後、前記第 3 の角度補  
正手段により走行中の角度補正が開始されるまでに前記  
車体が走行停止した場合には、前記第 2 の角度補正手段  
により走行後角度補正を行ない、それ以降に前記車体が  
走行停止した場合には走行後角度補正を行なわない、請  
求項 3 から 6 のいずれかに記載の自律走行車。

【請求項 8】 前記車体に取り付けられ、前記壁との距  
離を前記壁に接触しながら測定するための距離接触検出  
手段をさらに含み、

前記距離検出手段は、前記壁との距離を非接触で測定す  
るための距離非接触検出手段を含み、

前記制御手段は、前記距離接触検出手段の出力を受け、  
前記車体が前記壁と平行走行するように制御するための  
接触平行走行制御手段と、  
前記距離非接触検出手段より出力される走行前の前記車  
体と前記壁との距離を受け、前記距離が所定値より大き  
い場合には、前記平行走行制御手段によりその位置から  
前記車体を走行を開始させ、前記距離が所定値より小さ  
い場合には、前記距離接触検出手段が壁に接触するまで  
前記車体を移動させてから、前記接触平行走行制御手段  
により前記車体を走行を開始させる手段とをさらに含  
む、請求項 2、3 または 7 に記載の自律走行車。

【請求項 9】 前記制御手段は、前記接触平行走行制御  
手段により、所定期間、前記車体が前記壁と平行走行し  
ていることを判定するための接触測距俵い判定手段をさら  
に含み、

前記接触測距俵い判定手段は、過去所定期間中の前記距  
離接触検出手段より出力される距離の最大値および最小  
値の差が所定値以内である場合に壁に平行に走行してい  
ると判断する、請求項 8 に記載の自律走行車。

【請求項 10】 前記制御手段は、前記距離検出手段の  
出力を受け、前記車体の進行方向と前記壁とのなす角が  
変化したことを検出するための壁角度変化検出手段をさら  
に含み、

前記平行走行制御手段は、さらに前記壁角度変化検出手

段の出力に応答し、前記平行制御手段により前記車体が壁と平行に走行するように制御を再開する、請求項7または8に記載の自律走行車。

【発明の詳細な説明】

【0001】

【発明の属する技術分野】本発明は、自律走行車に関し、特に、壁と平行に走行・停止する自律走行車に関する。

【0002】

【従来の技術】近年、自律走行車の研究が盛んに行なわれている。たとえば、直進動作、およびUターン動作を繰り返し行なうことにより、床面に隙間無くワックス掛けを行なう自律走行車がある。自律走行車の制御方法の一例として、車輪の回転数を検出することにより、直進および回転の制御を行なう方法がある。このような自律走行車では、直進精度およびUターン時の回転精度の向上が重要である。しかし、前述した制御方法を用いた自律走行車では、車輪の床に対するすべりがある場合、正確な動作が保障されない。この問題を解決する自律走行車として、特開平3-160507号公報に開示された自律走行車がある。この従来の自律走行車は、測距センサを用いて壁との距離を測定しながら、自律走行車の位置と方向とを求め、壁と平行に走行する。

【0003】

【発明が解決しようとする課題】しかし、壁との距離情報のみをもとに移動する自律走行車では、車体の向きを正確に検知することは困難である。このため、大局的には壁に沿って走行するが、常に車体の向きが壁に平行な状態にあるとは限らず、車体が壁に平行な状態で停止することは保障できない。前述の様に床面に隙間無くワックス掛けをする場合、床面を1回横切った位置で180°旋回をし、逆方向に、かつ前回のコースと平行に進むという動作を繰り返す。したがって、1回の走行終了時に車体の向きが壁と平行でないと、このような走行をする際の動作が不安定となる。

【0004】また、壁沿いを丁寧にワックス掛けするためには、車体の初期位置を厳密に指定する必要がある。

【0005】本発明は、これらのような問題点を解決するためになされたもので、請求項1に記載の発明の目的は、走行終了後に、車体が壁と平行かどうかは確実にない場合にも、走行開始時の平行状態より悪い状態で停止することが無い自律走行車を提供することである。

【0006】請求項2に記載の発明の目的は、請求項1に記載の発明の目的に加え、車体の床に対する滑りがおきた場合でも壁と平行に走行ができる自律走行車を提供することである。

【0007】請求項3および5に記載の発明の目的は、請求項2に記載の発明の目的に加え、壁と平行になるように走行停止する自律走行車を提供することである。

【0008】請求項4に記載の発明の目的は、請求項3

に記載の発明の目的に加え、直接的に平行状態を判定することができる自律走行車を提供することである。

【0009】請求項6に記載の発明の目的は、請求項3に記載の発明の目的に加え、壁との平行判定を安定に行なうことができる自律走行車を提供することである。

【0010】請求項7に記載の発明の目的は、請求項3、4または6のいずれかに記載の発明の目的に加え、高精度で壁と平行に走行および停止をすることができる自律走行車を提供することである。

【0011】請求項8および9に記載の発明の目的は、請求項2、3または7のいずれかに記載の発明の目的に加え、壁沿いの作業をさせる場合に、大まかに作業開始位置を指定することが可能な自律走行車を提供することである。

【0012】請求項10に記載の発明の目的は、請求項7または8のいずれかに記載の発明の目的に加え、常に壁と平行走行可能な自律走行車を提供することである。

【0013】

【課題を解決するための手段】請求項1に記載の発明は、車体と、上記車体に取り付けられ、上記車体の向いている方向角を検出するための角度検出手段と、上記車体を移動させるための駆動手段と、上記車体を直進および/または、回転動作させるため上記駆動手段を制御するための制御手段とを含み、上記制御手段は、上記角度検出手段の出力を受け、走行前の角度と走行後の角度との差より、走行後の上記車体の角度補正をするための第1の角度補正手段を含む。

【0014】請求項1に記載の発明によると、車体が壁と平行走行していない場合においても、走行後の車体角度を走行前の車体角度と等しくすることができる。これにより、走行終了時に、車体が壁と平行かどうかは確実にない場合にも、走行開始時の平行状態より悪い状態で停止することが無いという効果が得られる。

【0015】請求項2に記載の発明は、請求項1に記載の発明の構成に加え、上記車体に取付けられ、車体側方に位置する上記壁との距離を測定するための距離検出手段をさらに含み、上記制御手段は、上記距離検出手段の出力を受け、上記車体が上記壁と平行走行するように制御するための平行走行制御手段をさらに含む。

【0016】請求項2に記載の発明によると、請求項1に記載の発明の作用、効果に加え、距離検出手段を用いて、常に壁との距離を測定しながら、壁と平行になるように走行制御を行なう。これにより、車体の床に対する滑りがおきた場合でも壁と平行に走行ができる。

【0017】請求項3に記載の発明は、請求項2に記載の発明の構成に加え、上記平行走行制御手段による制御のもとで、所定期間、上記車体が上記壁と平行走行していることを判定するための測距検出判定手段をさらに含み、上記制御手段は、上記測距検出判定手段より上記車体が上記壁と平行走行しているとの判定結果を受けた

後、上記角度検出手段の出力を受け、一定期間の上記車体の平均角度を求めるための角度平均算出手段と、上記角度平均算出手段より出力される上記平均角度と、上記角度検出手段より出力される走行後の角度との差より、走行後角度補正をするための第2の角度補正手段と、上記角度平均算出手段より上記車体の平均角度が求められる時点前に上記車体が走行停止した場合には、上記第1の角度補正手段により走行後角度補正を行ない、上記角度平均算出手段により上記車体の平均角度が求められた時点後に上記車体が走行停止した場合には、上記第2の角度補正手段により走行後角度補正を行なうための停止モード変更手段とを含む。

【0018】請求項3に記載の発明によると、請求項2に記載の発明の作用、効果に加え、壁に平行走行した後は、停止後、壁と平行になるように車体の角度補正をする。これにより、次の走行開始時の車体角度が壁に平行になるように補正されるため、作業領域内を往復走行する際のUターン時に、ほぼ壁に平行な状態から走行を開始できる。

【0019】請求項4に記載の発明は、請求項3に記載の発明の構成に加え、上記測距値判定手段は、上記距離検出手段より出力される距離の所定期間内の最大値と最小値との差が所定値以内である場合に、上記車体が上記壁と平行走行しているとの判定を行なう。

【0020】請求項4に記載の発明によると、請求項3に記載の発明の作用、効果に加え、距離検出手段を用い、壁との距離が一定となるかどうかの測距値判定を行ないながら走行制御を行なう。距離検出手段を用いて壁との平行判定を行なうため、直接的に平行状態を判定することができる。

【0021】請求項5に記載の発明は、請求項3に記載の発明の構成に加え、上記測距値判定手段は、上記角度検出手段より出力される走行中の角度の所定期間内の最大値と最小値との差が所定値以内である場合に、上記車体が上記壁と平行走行しているとの判定を行なう。

【0022】請求項6に記載の発明は、請求項3に記載の発明の構成に加え、上記制御手段は、車体を右または左方向へ移動させるための制御信号の出力期間である右または左方向への移動方向制御期間をそれぞれ計算するための手段をさらに含み、上記測距値判定手段は、所定期間内の上記制御手段より出力される右への移動方向制御期間と左への移動方向制御期間との割合がほぼ等しい場合に、上記車体が上記壁と平行走行しているとの判定を行なう。

【0023】請求項6に記載の発明によると、請求項3に記載の発明の作用、効果に加え、自律走行車の左右への走行制御量の割合を用いて測距値判定を行なっている。制御手段による制御が駆動手段に反映されるまでの時間遅れが生じて車体が左右にふらついている場合でも、車体が大局的に直進走行していれば、左右への走行

制御量の割合は、ほぼ等しくなる。このため、走行制御量の割合を用いて壁との平行判定を安定に行なうことができる。

【0024】請求項7に記載の発明は、請求項3から6のいずれかに記載の発明の構成に加え、上記制御手段は、上記角度平均算出手段より上記車体の平均角度が求められた時点後、上記平均角度および上記角度検出手段より出力される走行中の角度により走行中角度補正をするための第3の角度補正手段をさらに含み、上記停止モード変更手段は、上記角度平均算出手段より上記車体の平均角度が求められる時点前に上記車体が走行停止した場合には、上記第1の角度補正手段により走行後角度補正を行ない、上記角度平均算出手段より上記車体の平均角度が求められた時点後、上記第3の角度補正手段により走行中の角度補正が開始されるまでに前記車体が走行停止した場合には、上記第2の角度補正手段により走行後角度補正を行ない、それ以降に前記車体が走行停止した場合には走行後角度補正を行なわない。

【0025】請求項7に記載の発明によると、請求項3から6のいずれかに記載の発明の作用、効果に加え、平行走行していると判定された後は、その間の車体の平均角度を用いて、走行および停止制御を行なう。このため、車体は常に同じ方向を向き、左右にふらつきながら走行することが無くなる。よって、高精度で壁と平行に走行および停止をすることができる。

【0026】請求項8に記載の発明は、請求項2、3または7のいずれかに記載の発明の構成に加え、車体に取り付けられ、壁との距離をこの壁に接触しながら測定するための距離接触検出手段をさらに含む。上記距離検出手段は、上記壁との距離を非接触で測定するための距離非接触検出手段を含む。上記制御手段は、上記距離接触検出手段の出力を受け、上記車体が上記壁と平行走行するように制御するための接触平行走行制御手段と、上記距離非接触検出手段より出力される走行前の上記車体と上記壁との距離を受け、上記距離が所定値より大きい場合には、上記平行走行制御手段によりその位置から上記車体を走行を開始させ、上記距離が所定値より小さい場合には、上記距離接触検出手段が壁に接触するまで上記車体を移動させてから、上記接触平行走行制御手段により上記車体を走行を開始させる手段とをさらに含む。

【0027】請求項8に記載の発明によると、請求項2、3または7のいずれかに記載の発明の作用、効果に加え、走行前の壁との距離が所定値より小さい場合には、壁に接触する位置まで移動させてから、走行を開始し、その後は接触走行制御手段の制御により走行する。これにより、壁沿いの作業をさせる場合に、厳密に作業開始位置を指定する必要がなく、大まかに作業開始位置を指定することが可能である。

【0028】請求項9に記載の発明は、請求項8に記載の発明の構成に加え、上記制御手段は、上記接触平行走



行制御手段により、所定期間、上記車体が上記壁と平行走行していることを判定するための接触測距値判定手段をさらに含み、上記接触測距値判定手段は、過去所定期間中の上記距離接触検出手段より出力される距離の最大値および最小値の差が所定値以内である場合に壁に平行に走行していると判断する。

【0029】請求項10に記載の発明は、請求項7または8のいずれかに記載の発明の構成に加え、上記制御手段は、上記距離検出手段の出力を受け、上記車体の進行方向と上記壁とのなす角が変化したことを検出するための壁角度変化検出手段をさらに含み、上記平行走行制御手段は、さらに上記壁角度変化検出手段の出力にตอบสนองし、上記平行制御手段により上記車体が壁と平行に走行するように制御を再開する。

【0030】請求項10に記載の発明によると、請求項7または8のいずれかに記載の発明の作用、効果に加え、車体の進行方向と壁のなす角が変化した場合に、距離検出手段を用いた走行制御を再開する。これにより、常に壁と平行走行できる。

【0031】

【発明の実施の形態】以下、図面を参照しつつ、本発明における実施の形態である自律走行車について説明する。

【0032】図1を参照して、自律走行車20は、動力を受けて独立に駆動される左右各々の駆動輪24と、駆動輪24とともに自律走行車20を支持し、直進動作、Uターン動作を行なうための従属輪22と、左右各々の駆動輪24を駆動するためのモータ28と、モータ28の回転を駆動輪24に伝えるための連結機構32と、モータ28の回転量および回転速度を検出するためのエンコーダ34と、自律走行車20の向いている方向角を検出するためのジャイロセンサ36と、左右の対象物までの距離を非接触で測定するための測距センサ38と、左右の対象物までの距離を接触して測定するための接触測距センサ39と、モータ28および駆動輪24を通じて自律走行車20の走行を制御するためのコントローラ30を含む。

【0033】図2を参照して、コントローラ30は、ジャイロセンサ36より出力される自律走行車20の方向角、または測距センサ38若しくは接触測距センサ39より出力される自律走行車20と壁との距離を受け、自律走行車20が壁に倣って走行しているか否かを判定するための倣い判定部42と、上記方向角、上記距離および倣い判定部42の判定結果を受け、モータ28の回転量や回転速度などの制御値を求め、駆動部41を制御し、かつ倣い判定部42を制御するための制御部40を含む。

【0034】駆動部41は、駆動輪24と、モータ28と、連結機構32を含む。図3から図9を参照して、動作説明を行なう。図3は、上から順に、自律走行車20

0の走行軌跡を表わすグラフと、測距センサ38より得られる自律走行車20と壁との距離を表わすグラフと、駆動部41を制御するための制御値を表わすグラフと、ジャイロセンサ36より得られる自律走行車20の方向角を表わすグラフとからなる。

【0035】図3から図5を参照して、自律走行車20の走行制御について説明する。走行前にジャイロセンサ36を用いて、方向角G0を測定し(S2)、走行を開始する(S4、図3(1))。次に、自律走行車20の走行制御を終了させるか否かの終了判定を行ない(S6)、終了させる場合には、走行を停止させ(S34)、その時の方向角G1を測定した後(S36)、自律走行車20の方向角が走行前の状態になるよう(G0-G1)だけ角度補正を行なう(S38、図3(8))。これにより、自律走行車20が壁と平行かどうかは確実でない場合にも、走行開始時の平行状態より悪い状態で停止することが無くなる。S6で走行制御を終了させない場合には、測距センサ38により検出される自律走行車20と壁との距離が走行開始時の距離と等しくなるように駆動部41を制御する(S8、図3(2)、(3)、(4))。所定期間、自律走行車20が壁と平行走行するまでS6からS8までの動作を繰り返す(S10)。所定期間、自律走行車20が壁と平行走行した後は測距値ができたものと判断し(S10、図3(5))、この後さらに一定期間のジャイロセンサ36の値の平均値(以下「ジャイロ平均GM」という)を測定する(S18、S20、S22、図3(6))。ジャイロ平均GMは、壁と平行な方向を示す。その間、自律走行車20が壁に平行走行しているか否かをS6からS10と同様に判定する(S12、S14、S16)。一定期間経過前に走行終了した場合は(S20にてNO、S12にてYES)S34以下の処理を行なう。上述した制御を「第1の補正モード」と呼び、その期間を図3に図示する。第1の補正モードでは、自律走行車20が壁と平行に走行するように制御を行ない、平行状態に達したときの自律走行車20の角度(ジャイロ平均GM)を求めることにより、壁と平行な方向を求める。

【0036】一定期間経過してジャイロ平均GMが求められた(S22)後、自律走行車20の走行終了判定が下りている場合には(S24にてYES)、走行を停止させ(S40)、その時の方向角G1をジャイロセンサ36の出力から測定し(S42)、自律走行車20の方向角が壁と平行になるよう(GM-G1)だけ角度補正を行なう(S44、図3(9))。上述したS40からS44までの制御を「第2の補正モード」とよび、その期間を図3に図示する。第2の補正モードでは、大局的には壁と平行走行しているが、局所的には壁と平行でない場合に停止したときの制御を示し、その場合は、壁と平行になるように自律走行車20の角度を停止後補正す

る。

【0037】走行終了判定が下りていない場合には（S24にてNO）、ジャイロセンサ36のジャイロ値がS22で求めたジャイロ平均GMと等しくなるまで、測距センサ38による走行制御を行なう（S26、S28、図3（7））。壁までの距離D0を測定する（S80）。以後は、基本的にジャイロ値を用いた走行制御を行なう。ただし、壁の方向が変化する場合に備え、以下のような制御を行なう。再度、測距センサ38を用いて壁までの距離D1を測定する（S84）。D0とD1とを比較して、自律走行車20の進行方向と壁とのなす角度が変化しているか否かの判定が行なわれる（S86）。壁とのなす角度が変化していない場合には（S86）、引き続きジャイロ値がGMとなるように走行制御を行ない（S88、図3（10））、壁とのなす角度が変化している場合には（S86）、測距センサ38による走行制御を再開する（S2）。こうした制御により、走行途中で壁の方向が変化しても自律走行車の進行方向を変えて、再び壁と平行走行できる。なお、ジャイロ値を用いた走行制御中、壁までの距離D1が測定され（S84）、壁とのなす角度が変化しているか否かの判定が常に行なわれ（S86）、その間に走行終了判定が降りた場合には（S82）、その位置で走行を停止させる

（S90）。この時には停止後角度補正は行なわない。上述した、S26からS28、およびS80からS90までの制御を「第3の補正モード」とよび、その期間を図3に図示する。第3の補正モードでは、ジャイロセンサ36を用いて、自律走行車20の進行方向の制御を行なう。これにより、局所的にも壁と平行な方向（ジャイロ平均GM）に自律走行車20を走行させることができる。このため、走行停止時においても角度補正をする必要が無く、常に壁に平行に停止することが可能である。

【0038】図6を参照して、ジャイロセンサ36のジャイロ値がGMとなるような走行制御方法（図4（S88））について詳述する。まず、ジャイロセンサ36を用いてジャイロ値Gを求める（S50）。ジャイロ値GとS22で求められているジャイロ平均GMとを比較し（S52）、ジャイロ値Gが所定の範囲Δ内の値であれば（ $GM-\Delta < G < GM+\Delta$ ）、直進させ（S56）、ジャイロ値Gが右にΔ以上ずれている場合には（ $G \leq GM-\Delta$ ）、左にカーブさせ（S54）、ジャイロ値Gが左にΔ以上ずれている場合には（ $G \geq GM+\Delta$ ）、右にカーブさせる（S58）。これにより、常に自律走行車20の移動方向をGMにすることができ、壁と平行に走行することが可能となる。

【0039】図7を参照して、図4（S10、S16）の測距値検出について説明する。測距値検出には、測距センサ38より出力される壁との距離（測距値）を用いて検出を行なう方法と、壁と平行になるよう走行制御を行なう場合（図4（S8、S14））の駆動部41

の制御値を用いて検出を行なう方法と、ジャイロセンサ36より出力されるジャイロ値を用いて検出を行なう方法との3種類がある。測距値（図7（イ））、およびジャイロ値（図7（ホ））を用いる方法は、所定期間範囲の最大値と最小値との差（図7（ロ）、（ヘ））が所定値以内であれば、その所定期間にわたりこの自律走行車20が壁に平行に走行しているとの判断を下す。制御値（図7（ハ））を用いる方法は、制御部40により駆動部41を駆動させるための信号により、自律走行車20を右カーブさせる時間と左カーブさせる時間との所定期間における割合（図7（ニ））がほぼ等しくなれば、所定期間壁に平行に走行しているとの判断を下す。なお、制御値は、エンコーダ34の出力値である回転量および回転速度より求められる。

【0040】図8および図9を参照して、作業領域内を往復走行する際の一連の動作について説明する。この一連の動作を、以下「ジグザグ走行」と呼ぶ。走行開始時に、自律走行車20の直進方向を基準として、ユーザーが、コースを移動させながらジグザグ走行をする方向を指定する（S60）。ジグザグ走行を左に向かって行なう場合には、右側の測距センサ38を用いて、右壁50との距離DRを測定する（S62）。距離DRが所定値Dより小さい場合（図8（B））には、接触測距センサ39が右壁50に接触するまで、自律走行車20を壁に近づけた後、図4と同様の走行制御（S74）を開始する。その際、1回目の直進動作では、図4の説明で述べた測距センサ38の代わりに、接触測距センサ39を用いて走行制御を行なう。距離DRが所定値D以上の場合には、その位置より、図4に示す動作手順にしたがって走行制御を開始する（S74）。ジグザグ走行を右に向かって行なう場合には、左側の測距センサ38を用いて、左壁52との距離DLを測定し（S68）、同様の制御を行なう（S70、S72、S74）。

【0041】以上のような自律走行車20により、直進精度を高め、壁と平行に走行・停止をすることができる。

#### 【図面の簡単な説明】

【図1】本発明の一実施の形態に係る自律走行車の構成図である。

【図2】本発明の一実施の形態に係る自律走行車の制御ブロック図である。

【図3】本発明の一実施の形態に係る自律走行車の走行軌跡および測定値を示すグラフである。

【図4】本発明の一実施の形態に係る自律走行車の走行制御を示す第1のフローチャートである。

【図5】本発明の一実施の形態に係る自律走行車の走行手順を示す図である。

【図6】本発明の一実施の形態に係る自律走行車の走行制御を示す第2のフローチャートである。

【図7】本発明の一実施の形態に係る自律走行車の測定

値を示すグラフである。

【図8】本発明の一実施の形態に係る自律走行車の走行手順を示す図である。

【図9】本発明の一実施の形態に係る自律走行車の走行制御を示すフローチャートである。

【符号の説明】

20 自律走行車

30 コントローラ

36 ジャイロセンサ

38 測距センサ

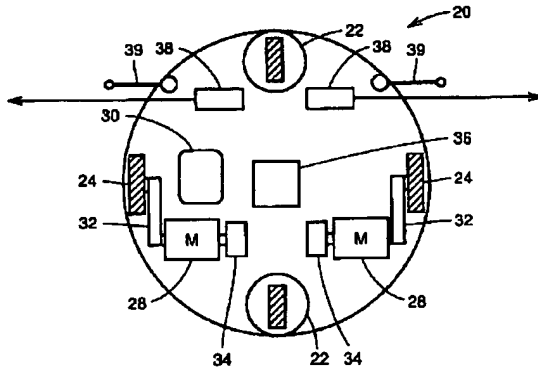
39 接触測距センサ

40 制御部

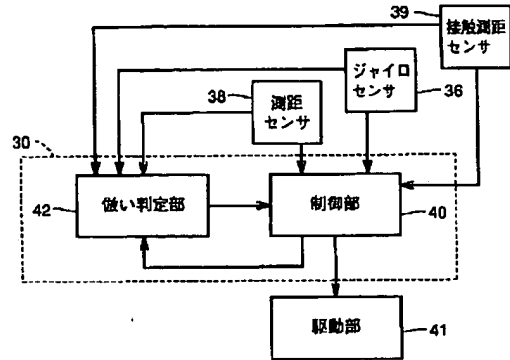
41 駆動部

42 検出判定部

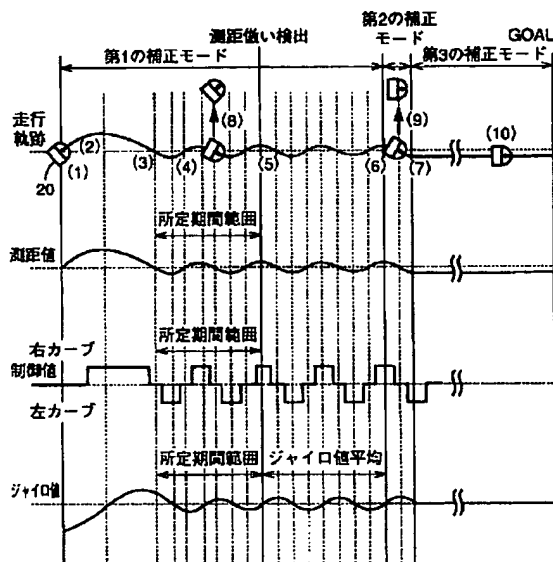
【図1】



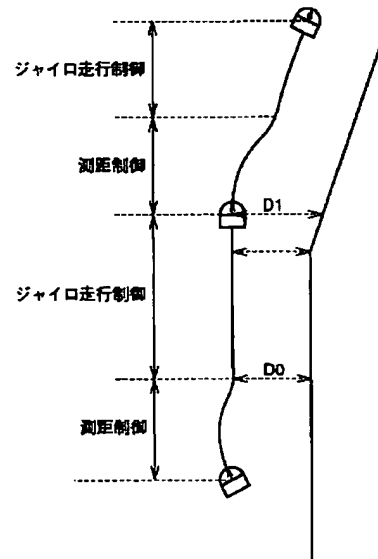
【図2】



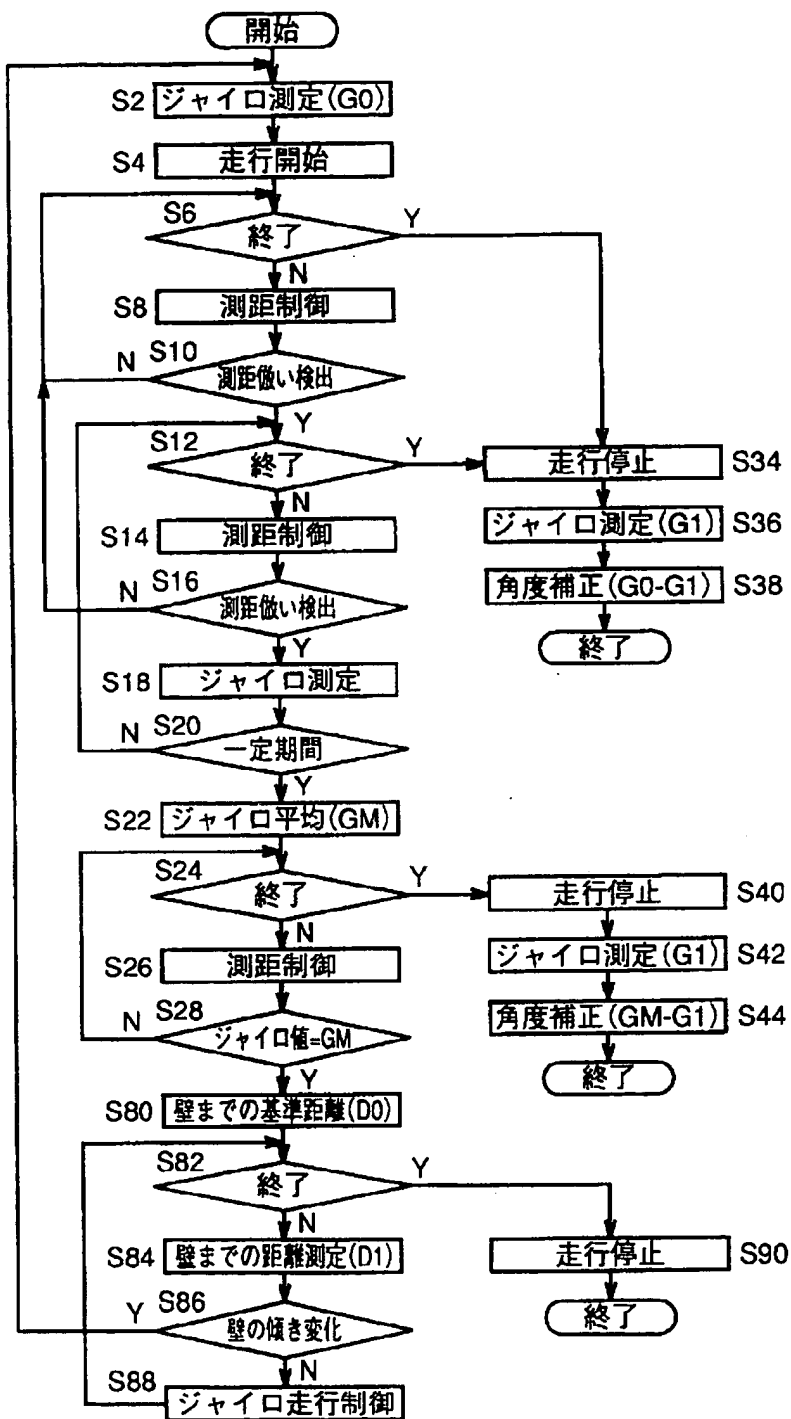
【図3】



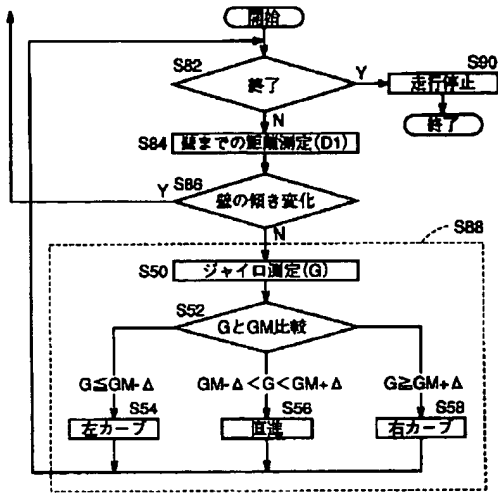
【図5】



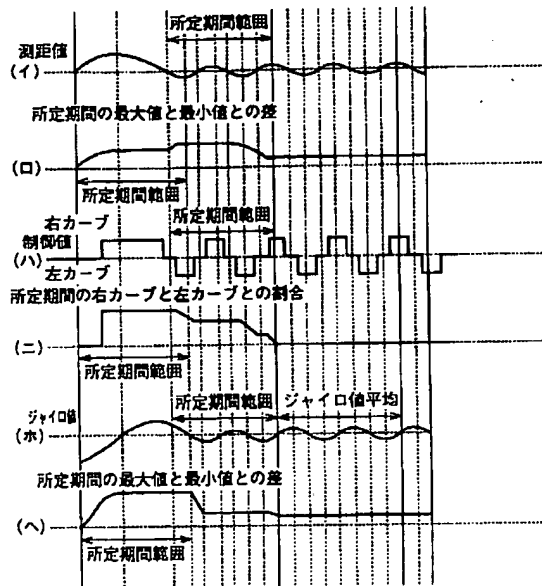
【図4】



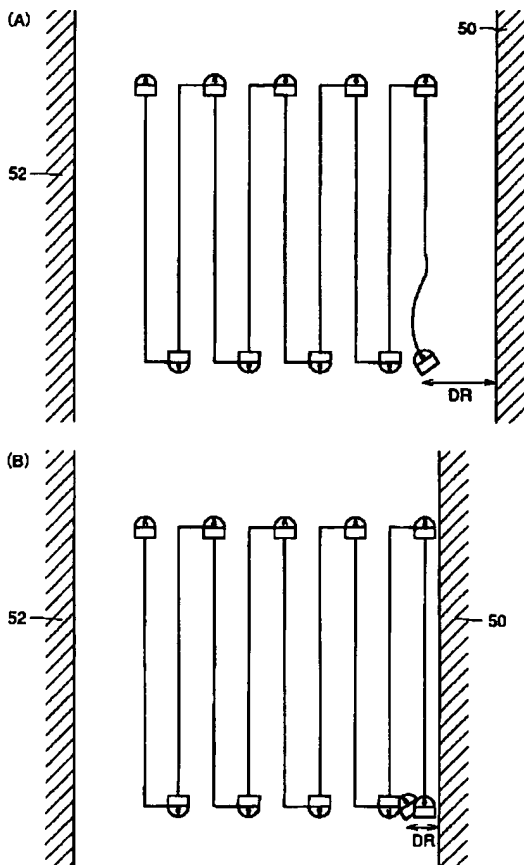
【図6】



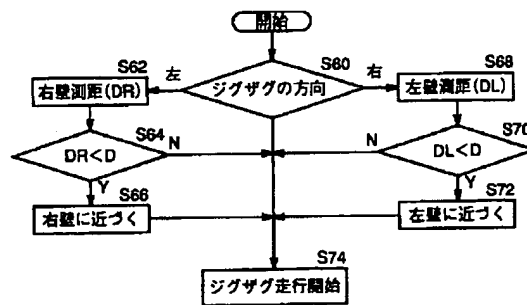
【図7】



【図8】



【図9】





(19)

(11) Publication number:

01

Generated Document.

## PATENT ABSTRACTS OF JAPAN

(21) Application number: **07338573**

(51) Intl. Cl.: **G05D 1/02**

(22) Application date: **26.12.95**

<p>(30) Priority:</p> <p>(43) Date of application publication: <b>11.07.97</b></p> <p>(84) Designated contracting states:</p>	<p>(71) Applicant: <b>HITACHI ELECTRIC S</b></p> <p>(72) Inventor: <b>AKISAWA YASURO KITAMI HIDEYO</b></p> <p>(74) Representative:</p>
---	--

### (54) METHOD FOR CONTROLLING TRAVELING OF AUTONOMOUS TRAVELING VEHICLE AND CONTROLLER THEREFOR

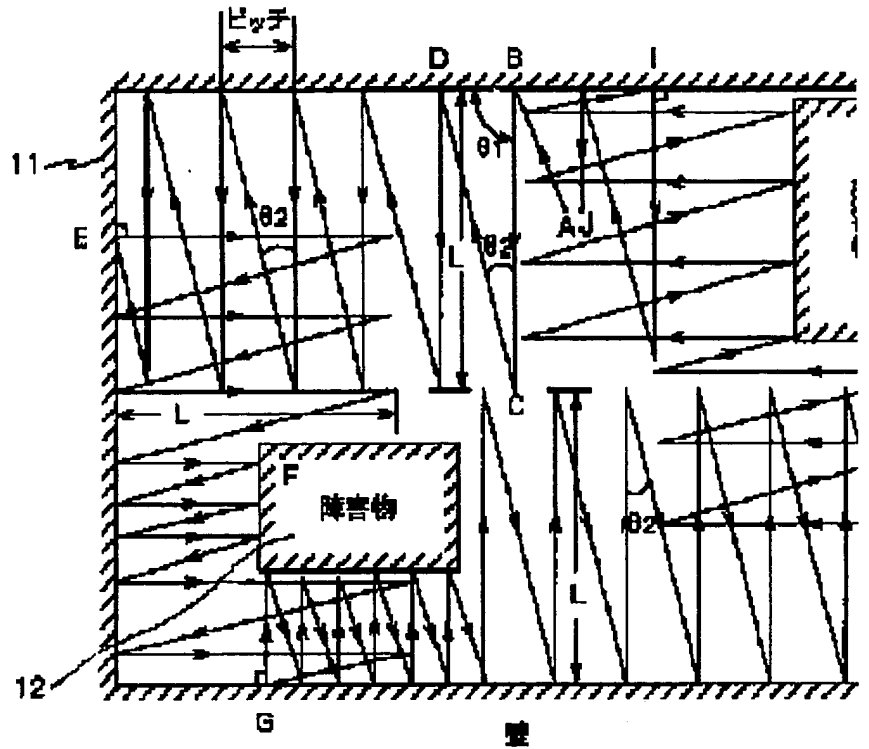
(57) Abstract:

**PROBLEM TO BE SOLVED:** To provide a traveling control method for an autonomous traveling vehicle simplified at its constitution and capable of efficiently traveling on a traveling area.

**SOLUTION:** The autonomous traveling vehicle capable of executing work on a plane of which the periphery is surrounded by a boundary such as a wall 11 is moved forward (a) to the boundary, and at the time of sensing the boundary, rotated and stopped (b) so as to be opposed to the boundary at a prescribed angle  $\theta 1$  on the sensing position. Then the vehicle is moved backward from the boundary by a prescribed distance L in the posture

state opposed to the boundary and stopped (c), the vehicle is rotated on the backward position by a prescribed angle  $\theta 2$  to turn its direction and then the processing is returned (d) to the process (a). Thus the traveling of the autonomous traveling vehicle is controlled by repeating the processes (a) to (d).

COPYRIGHT: (C)1997,JPO



(19) 日本国特許庁 (J P)

(12) 公開特許公報 (A)

(11) 特許出願公開番号

特開平9-179625

(43) 公開日 平成9年(1997)7月11日

(51) Int.Cl. <sup>6</sup>	識別記号	庁内整理番号	F I	技術表示箇所
G 0 5 D 1/02			G 0 5 D 1/02	J L

審査請求 未請求 請求項の数 4 O L (全 7 頁)

(21) 出願番号 特願平7-338573

(22) 出願日 平成7年(1995)12月26日

(71) 出願人 591001525

株式会社日立エレクトリックシステムズ  
茨城県日立市東金沢町1丁目15番25号

(72) 発明者 秋沢 安郎

茨城県日立市金沢町一丁目15番25号 株式  
会社日立エレクトリックシステムズ金沢事  
業所内

(72) 発明者 喜多見 英世

茨城県日立市東金沢町一丁目15番地25号  
株式会社日立エレクトリックシステムズ金  
沢事業所内

(74) 代理人 弁理士 高田 幸彦 (外1名)

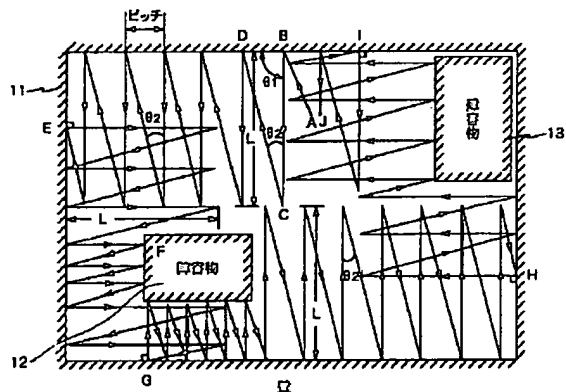
(54) 【発明の名称】 自律走行車の走行制御方法及び走行制御装置

(57) 【要約】

【課題】 構成が単純化され、かつ走行領域を効率良く走行する自律走行車の走行制御方法を提供する。

【解決手段】 自律走行車の走行制御方法は、a. 周囲を壁などの境界に囲まれた平面上で作業をする自律走行車を該境界に向かって前進させ、b. 前記境界を感知したならば、感知した位置にて当該境界に対し所定角  $\theta 1$  の角度で対向するよう前記自律走行車を回転させ、かつ停止させ、c. 前記境界に対向させられたときの姿勢の状態で、前記境界から前記自律走行車を所定距離 L 後退させ、かつ停止させ、d. 後退させた位置にて所定角  $\theta 2$  の角度だけ回転させて前記自律走行車の向きを変え、再び前記 a. 工程に戻るとい、上記 a, b, c, d 工程を繰返して、自律走行車の走行を制御するものである。

図 2





## 【特許請求の範囲】

【請求項1】下記各工程を繰返し、前記自律走行車の走行を制御することを特徴とする自律走行車の走行制御方法。周囲を壁などの境界に囲まれた平面上で作業をする自律走行車を該境界に向かって前進させる前進工程、前記境界を感知したならば、感知した位置にて当該境界に対し所定角 $\theta 1$ の角度で対向するよう前記自律走行車を回転させ、かつ停止させる対向工程、前記境界に対向させられたときの姿勢の状態、前記境界から前記自律走行車を所定距離 $L$ 後退させ、かつ停止させる後退工程、後退させた位置にて所定角 $\theta 2$ の角度だけ回転させて前記自律走行車の向きを変え、前記前進工程に戻る回転工程。

【請求項2】下記各工程を繰返し、前記自律走行車の走行を制御することを特徴とする自律走行車の走行制御方法。周囲を壁などの境界に囲まれた平面上で作業をする自律走行車を該境界に向かって前進させる前進工程、前記境界を感知したならば、感知した位置にて当該境界に対し所定角 $\theta 1$ の角度で対向するよう前記自律走行車を回転させ、かつ停止させる対向工程、前記境界に対向させられたときの姿勢の状態、前記境界から前記自律走行車を所定距離 $L$ 後退させ、かつ停止させる後退工程、後退させた位置にて横方向に所定幅距離だけ前記自律走行車を幅寄せし、前記前進工程に戻る幅寄せ工程。

【請求項3】請求項1または請求項2において、前記後退工程の途中で、前記自律走行車が障害物を感知したならば、感知した位置にて前記回転工程または幅寄せ工程へ移行することを特徴とする自律走行車の走行制御方法。

【請求項4】壁などの境界に向かって自律走行車を前進させる前進手段と、前記境界に達したことを判断し、判断した位置にて当該境界に対し所定角 $\theta 1$ の角度で対向するよう前記自律走行車を回転させ、かつ前記自律走行車を停止させる対向手段と、前記対向手段の動作終了を判断し、前記境界に対向したときの姿勢の状態、前記境界から前記自律走行車を所定距離 $L$ 後退させ、かつ前記自律走行車を停止させる後退手段と、前記後退手段の動作終了を判断し、後退させた位置にて所定角 $\theta 2$ の角度だけ回転させて前記自律走行車の向きを変える回転手段と、前記回転手段の動作終了を判断し、前記前進手段に戻る繰返し手段とを備え、自律走行車の走行を制御することを特徴とする自律走行車の走行制御装置。

## 【発明の詳細な説明】

## 【0001】

【発明の属する技術分野】本発明は、自走式掃除機、自

走式芝刈機など周囲を壁などの境界に囲まれた走行領域内を自律走行しながら隈なく作業をする自律走行車に関する。

## 【0002】

【従来の技術】自律走行車の走行を制御する従来技術としては、特開平3-27号公報に開示されたものがある。この技術は、自律走行車を走行原点から扇状に(極座標的に)走行させるものである。

【0003】また、一般的な技術としては、特開平2-10408号公報のようなものがある。この技術では、自己の現在位置を求めるために、自律走行車の移動方向および距離を検知する装置と演算装置とを用いている。

## 【0004】

【発明が解決しようとする課題】上記従来技術では、自律走行車を走行原点から扇状に走行させるため、屋内の部屋のような長方形の領域内を隈なく走行することは難しく、また、走行原点付近では走行が重なり、掃除、芝刈などの作業が不必要に重複することになる。

【0005】さらに、自律走行車の移動方向および距離を検知する装置などが必要で自律走行車としてコスト高となるため、掃除機や芝刈機には向かないものである。

【0006】したがって、本発明の目的は、構成が単純化され、かつ、走行領域を効率良く走行する自律走行車の走行制御方法及び走行制御装置を提供することにある。

## 【0007】

【課題を解決するための手段】上記目的を達成する自律走行車の走行制御方法は、下記各工程を繰返し、前記自律走行車の走行を制御するものである。

【0008】周囲を壁などの境界に囲まれた平面上で作業をする自律走行車を該境界に向かって前進させる前進工程、前記境界を感知したならば、感知した位置にて当該境界に対し所定角 $\theta 1$ の角度で対向するよう前記自律走行車を回転させ、かつ停止させる対向工程、前記境界に対向させられたときの姿勢の状態、前記境界から前記自律走行車を所定距離 $L$ 後退させ、かつ停止させる後退工程、後退させた位置にて所定角 $\theta 2$ の角度だけ回転させて前記自律走行車の向きを変え、前記前進工程に戻る回転工程である。

【0009】また、周囲を壁などの境界に囲まれた平面上で作業をする自律走行車を該境界に向かって前進させる前進工程、前記境界を感知したならば、感知した位置にて当該境界に対し所定角 $\theta 1$ の角度で対向するよう前記自律走行車を回転させ、かつ停止させる対向工程、前記境界に対向させられたときの姿勢の状態、前記境界から前記自律走行車を所定距離 $L$ 後退させ、かつ停止させる後退工程、後退させた位置にて横方向に所定幅距離だけ前記自律走行車を幅寄せし、前記前進工程に戻る幅寄せ工程でも良い。

【0010】一方、本発明による走行制御装置は、壁な

どの境界に向かって自律走行車を前進させる前進手段と、前記境界に達したことを判断し、判断した位置にて当該境界に対し所定角 $\theta 1$ の角度で対向するよう前記自律走行車を回転させ、かつ前記自律走行車を停止させる対向手段と、前記対向手段の動作終了を判断し、前記境界に対向したときの姿勢の状態、前記境界から前記自律走行車を所定距離 $L$ 後退させ、かつ前記自律走行車を停止させる後退手段と、前記後退手段の動作終了を判断し、後退させた位置にて所定角 $\theta 2$ の角度だけ回転させて前記自律走行車の向きを変える回転手段と、前記回転手段の動作終了を判断し、前記前進手段に戻す繰返し手段とを備え、自律走行車の走行を制御するものである。

【0011】本発明によれば、構成が単純化され、かつ、走行領域を効率良く走行する自律走行車の走行制御方法及び走行制御装置が得られる。

【0012】

【発明の実施の形態】以下、本発明の実施の形態について図面を参照し説明する。本発明による一実施例として、補助リレーおよび限時リレーをロジックコントローラとして構成した例を、以下図面を参照して説明する。なお、以下の説明において、自律走行車を自律車と呼称する。図1は、本発明による一実施例の走行制御装置を搭載した自律車を示す図である。自律車の走行装置、壁または障害物を感知する接触センサなどの配置を表わしたものである。

【0013】1は自律車の車体フレーム、2は左駆動輪、3は右駆動輪、4、5は各駆動輪を駆動するギヤドモータからなる左モータ及び右モータ、6は自由に移動方向が変わる補助輪である。また、接触センサは自律車の前部の左側に左センサ7、右側に右センサ8、中央に中央センサ9が配置され、後部は一括して後部センサ10が取り付けられている。これらの接触センサは、接触時に接点を閉路するa接点出力である。

【0014】自律車50を前進、後退、回転させる手段は、例えば、自律車の右左中央部に独立し設けられた2個の駆動輪2、3や、左右の駆動輪を独立し駆動する2個のモータ4、5などによって構成される。また、各モータ4、5の正転、逆転、停止を制御する手段は、自律車の運転及び停止を制御する各スイッチ(後述する)や各センサ7、8、9、10などからの信号を入力し自律車を制御する、自律車の走行制御装置としてのロジックコントローラ60などによって構成される。

【0015】図2は、本発明の一実施例の走行制御方法による自律車の走行軌跡を示す図である。大きさや位置の異なる障害物12、13を避けながら、境界としての壁11に囲まれた平面状の走行領域内を、自律車が走行する例を走行軌跡として表わしたものである。なお、障害物も境界の一つとして扱っても可である。

【0016】任意のA点よりスタートさせられた自律車50は、左右の駆動輪2、3を正転させ、壁11に向か

って前進する。このスタート時のときは、自律車50は、壁11に対し任意の角度を有して前進する。

【0017】前進した後のB点において、本実施例の場合は、右センサ8が壁11に接触し境界を感知する。接触すると感知信号により右駆動輪3のみ停止させる。このため自律車は、感知した位置にて時計方向に回転し、やがて、壁11に対し所定角 $\theta 1$ としての直角または所定角度で対向する。

【0018】本実施例の場合は、 $\theta 1 = 90$ (度)の直角としている。すなわち、自律車が、時計方向に回転すれば、左センサ7(および/または、中央センサ9)も壁11と接触するので、接触したことの感知信号に基づいて判断し、自律車を壁11に正対させるものである。なお、制御が比較的容易であるので、 $\theta 1 = 90$ (度)の直角とし壁に正対させているが、直角以外の所定角度でも可である。正対させたならば、一旦、その時点で自律車を停止する。

【0019】次に、左右駆動輪2、3を同時に逆転させ、壁11に正対した姿勢のまま、自律車を後退させる。この場合、後退中の時間を限時リレーで測定し、所定距離 $L$ だけ後退させる。そして、所定距離 $L$ だけ後退した位置のC点で、左右駆動輪2、3を正転に切り替える。このとき、左駆動輪2の正転を限時リレーによって一定時間遅らせることにより、所定角 $\theta 2$ の角度だけ自律車を左に向きを変えさせる。

【0020】そして、自律車は、所定角 $\theta 2$ を有して再び壁11に向かって、すなわち図示のD点へと前進する。ただし、図示のように所定角 $\theta 2$ は、壁11の垂線方向と自律車の前進方向との成す角度として表わしている。その後以上の動作を繰返すことにより、自律車は、壁に沿って、所定距離 $L$ に相当する幅と所定角 $\theta 2$ に相当する回転角度とから形成されるピッチで、ジグザグ走行をしながら左方向へ順次移動する。

【0021】左の壁のE点で、自律車の左センサ7が接触すると今度は左駆動輪2のみ停止させる。これにより、車体が反時計方向に回転し、右センサ8(および/または、中央センサ9)も接触するので、車体が左の壁と正対し、これを条件に左右駆動輪2、3を同時に逆転させ、左の壁に正対した向きで車体を後退させる。

【0022】以下、B点、C点、D点への走行と同様の走行を繰返すことにより、自律車は左の壁に沿って幅 $L$ のジグザグ運動をしながら図示のような走行軌跡を描きながら、図面上の下方方向へ順次移動する。

【0023】移動途中のF点で、車体の後部センサ10が障害物12に接触すると、この点で左右駆動輪2、3を正転に切り替え、C点と同様に車体を所定角 $\theta 2$ だけ左に向けて前進する。以下G点、H点、I点で、E点と同様に大きく反時計方向に回転し車体の向きを変え、壁に沿ってジグザグに走行し、A点に近いJ点に戻り、自律車はストップさせられる。

尚、右の壁に沿った障害物13の位置では、右センサ8により検知するので、壁11に接触した場合と同じ扱いとなる。即ち、境界としての障害物である。

【0024】以上を纏め本発明の特徴を説明すれば、次の通りである。本発明では、境界(または後述する境界線)を基準にして、自律車の向きを直角または所定の角度になるように姿勢制御するために、自律車の前方左側と前方右側に壁などの境界に接近したことを感知するセンサを搭載し、センサからの信号に基づき次の工程順序で自律車の走行制御を実行する。

【0025】a. 境界内の任意の位置より、任意の方向に境界に向かって前進する。

b. 境界に近づき前方左側または前方右側のセンサが境界を感知したならば、感知側に応じて自律車を左または右に回転させ、双方のセンサが境界を感知したならば、自律車の回転を停止し前進も停止する。これにより、自律車は境界に対しほぼ直角に対向した姿勢となる。右左のセンサの搭載位置あるいはセンサ感度に差を設ければ、境界に対し直角以外の所定の角度で対向させることもできる。

【0026】c. 境界に対向した姿勢の状態、所定距離後退し停止する。

d. 後退停止した位置で自律車を所定角度回転させて向きを変え、再び前進して、a, b, c, dの工程を繰返す走行制御である。

この走行制御方法により、自律車は境界の内側である走行領域内を、c工程の所定距離L(幅)とd工程の所定角 $\theta 2$ (回転角度)とで決まるピッチのジグザグ走行を実行する。幅としての所定距離Lと回転角度としての所定角 $\theta 2$ とを適切に設定することにより、境界で囲まれた走行領域内を効率良く、隈なく走行することが可能である。

【0027】また、自律車の後部に壁または障害物などを感知するセンサを搭載し、前述のc工程でこのセンサが感知したならば、その場でc工程を停止し、d工程に移行するようにすれば、走行領域内の障害物を避けたり、後退中の走行領域外へのはみ出しを回避したりすることが可能である。

【0028】以上の方法では、前述のようにジグザグ走行のピッチ(幅Lと回転角度 $\theta 2$ とで定まる一定距離)を、走行領域の広さ(大きさ)に応じて、その都度、適切に設定しなければならないが、ピッチは、幅と回転角度との二因子関数であり、ピッチを一定にするためには、回転角度を幅にほぼ反比例して変えるという二因子設定をしなければならず、取扱者の初期設定を容易にするために、どちらか一方の単独設定(一因子設定)として置くことができない。

【0029】この欠点を解決するために、上記方法のd工程で、所定角度を与えて自律車の向きを変える代り

に、向きは変えずに横方向に所定幅距離の幅寄せする幅寄せ工程を実行させる方法がある。即ち、例えば、自律車の横幅寸法(所定幅距離)の分だけ横にずらす方法である。望ましくは、所定幅距離としての作業幅(芝刈り機であれば芝が刈り取られる自律車の有効作業幅、掃除機であればゴミが吸い取られる自律車の有効作業幅)の寸法の分だけ横にずらす方法である。このようにすれば、ジグザグ走行のピッチは、自律車の幅寄せ寸法だけの一因子設定で決定されることになる。

【0030】上記の自律車の走行制御方法によって、自律車の移動方向および距離を検知する装置や自己の現在位置を知るための演算装置を使用することなく、周囲を壁などの境界に囲まれた平面領域内をできるだけ重複せずに、効率よく隈なく走行する自律車が得られる。なお、前進と後退とが逆であっても可であることは言うまでもない。尚、壁などのようにはっきりしている境界に代わり、地面に描かれた境界線を境界と見做し上記と同様に制御することも可であり、本発明は適用される。

【0031】図3は、本発明による一実施例の走行制御装置を示す図である。図1に示す構成の自律車に、図2に示すような走行軌跡で走行させるための走行制御装置としてのロジックコントローラ60の例である。本実施例では、複数の補助リレーと限時リレーとを用いたロジックコントローラ60の接続回路が示されている。

【0032】14はバッテリー電源、15は電源スイッチ、16は押しボタン式の自律車の停止スイッチ、17は押しボタン式の自律車の始動スイッチ、18は自律車前進用の補助リレー、19は自律車後退用の補助リレー、20は自律車の後退する所定距離Lを決めるための限時リレー、21は自律車の前進時に車体の向きを所定角 $\theta 2$ を回転させるため左駆動輪2の駆動を遅らせるための限時リレー、22は左センサ7の接点増幅用の補助リレー、23は右センサ8の接点増幅用の補助リレーである。

【0033】以下、このロジックコントローラ60の動作を説明する。停止スイッチ16を除き、電源スイッチ15、始動スイッチ17などのスイッチは開(OFF)の状態であり、補助リレー、限時リレーは非動作の状態であり、左モータ4、右モータ5とも停止している。次に、電源スイッチ15を投入し始動スイッチ17を押して閉(ON)にすると、補助リレー18が動作してセルフホールドが掛かる。このとき、補助リレー19は非動作の状態から始動されるので、ホールドは掛かっていない。また、限時リレー21が始動する。

【0034】補助リレー18が動作することにより、左モータ4、右モータ5を前進方向に回転させる正転回路に電圧が印加される。しかし、右モータ5は直ちに回転し始めるが、左モータ4は限時リレー21の遅延時間だけ遅れて、回転し始める。これによって、限時リレー21の遅延時間の間だけ、自律車は反時計方向に回転す

る。すなわち、限時リレー21の遅延時間を経過した後、初めて自律車は境界に向かって前進する。この前進動作状態を、a. 前進工程と定義する。

【0035】次に、自律車が前進し境界に達したと判断すると、即ち、右センサ8が壁を検知して動作(ON)すると、補助リレー23が動作(OFF)し、右モータ5が停止(OFF)する。これにより自律車は時計方向に回転する。そして、自律車が時計方向に回転するとやがて、左センサ7も壁を検知して動作(ON)する。(尚、左センサ7および/または中央センサ9としても可である。)左センサ7が動作(ON)すると、補助リレー22が動作(OFF)し、左モータ4も停止(OFF)する。すなわち、右センサ8と左センサ7の両方が動作(ON)した時点で、左モータ4、右モータ5は共に一旦停止(OFF)し、自律車が時計方向に回転し壁に対しほぼ直角に対向することになる。このような一連の対向動作状態を、b. 対向工程と定義する。

【0036】次に、自律車の対向工程が終了したと判断すると、即ち、右センサ8と左センサ7の両方が動作(ON)すると、補助リレー22および補助リレー23が動作(ON)し、補助リレー19が動作(ON)してセルフホールドが掛かる。このとき、補助リレー18のホールドが解かれる。同時に、限時リレー20が始動する。補助リレー19がON動作し補助リレー18がOFF動作をすることにより、左モータ4、右モータ5の逆転回路に電圧がかかり、自律車は後退し始める。この後退している間、限時リレー20が働き、限時リレー20の遅延時間が経過するまで、自律車は後退し続ける。そして、遅延時間が経過し限時リレー20の接点が動作(ON)すると、補助リレー18が再び動作(ON)し、即ち、補助リレー18がON動作し補助リレー19がOFF動作をすることにより、逆転回路が解消され自律車の後退は停止する。このような一連の後退動作状態を、c. 後退工程と定義する。

【0037】次に、自律車の後退工程が終了したと判断すると、即ち、限時リレー20が動作し補助リレー18が再び動作(ON)すると、補助リレー18はセルフホールドされ、補助リレー19のホールドは解かれる。また再び、限時リレー21が始動する。補助リレー18が動作することにより、左モータ4、右モータ5の正転回路に電圧が印加され、右モータ5は直ちに回転し始めるが、左モータ4は限時リレー21の遅延時間だけ遅れて、回転し始める。これによって限時リレー21の遅延時間の間だけ、自律車は反時計方向に回転する。このような一連の回転動作状態を、d. 回転工程と定義する。

【0038】そして、自律車の回転工程が終了したと判断すると、即ち、限時リレー21の遅延時間が経過すると、自律車は、再びa. 工程に戻って前進する。以上のa 前進、b 対向、c 後退、d 回転の各工程が繰り返されて、自律車は壁に沿ってジグザグ走行運動をする。そし

て、自律車の作業が終了した時点あるいは走行途中で、停止スイッチ16を押すとバッテリー電源14が切れ、すべての補助リレーのセルフホールドが解除され、限時リレーは復帰(リセット)し、自律車は停止する。

【0039】なお、前進中に左センサ7が壁を検知したときは、補助リレー22が動作して左モータ4が停止し、自律車は反時計方向に回転し、右センサ8が動作し壁に直角に対向し、左センサ7及び右センサ8が動作すると後退に移るとい各工程にしたがうことはいうまでもない。また、後退中に後部センサ10が障害物などを検知して動作すると、その時点で、限時リレー20の接点が動作したと同様の回転工程(または幅寄せ工程)を経て、自律車は一定時間回転後所定角度(または所定幅距離の幅寄せ)で前進に移る。

【0040】図4は、本発明による他の実施例の走行制御装置を示す図である。本実施例では、マイクロプロセッサを用いたロジックコントローラ60の接続ブロックが示されている。図において、ロジックコントローラ60は、マイクロプロセッサ25、ROM26、RAM27、インタフェースD/IおよびD/Oなどから構成される。この場合は、走行制御のロジックはプログラムとして作成しROM26に書き込み、マイクロプロセッサ25が該プログラムにしたがって、RAM27と情報をやり取りし、インタフェースD/IおよびD/Oを介して走行制御を行うものである。本実施例では、マイクロプロセッサ25で制御するので、図3の補助リレーシーケンスによる制御の実施例に比べて、より細かい走行制御が可能である。なお、前述した走行制御のロジックのプログラム等の説明は割愛する。

【0041】図5は、自律車を横方向に幅寄せする本発明による一実施例の走行制御方法を示す図である。例えば、前述の実施例で自律車が後退から前進に移るとき、図5に示すように、まず、左モータ4を停止して、右モータ5を正転させて、車体を左に90°回転させ、次に、右モータ5を停止して、左モータ4を正転させて、今度は車体を右に90°回転させて、元の向きに戻せば、自律車を元の位置から横方向に所定幅距離だけ、ほぼ車体の幅だけ(前述の自律車の作業幅だけ)、平行移動させることができる。

【0042】その後、前進させると、自律車は1回前に前進した走行軌跡に対し平行して、車体の幅だけ左側を走行することになる。このような制御を行えば、自律車をジグザグではなく、平行移動で図2と同様な走行を行わせることができる。図2に示したジグザグ走行の場合は、作業平面の広さや形状に応じて、幅としての所定距離Lと回転角度としての所定角 $\theta$ 2とを関連づけて決定する必要があるが、図5に示した平行移動では所定距離Lのみを決定すればよいので、作業者の取扱いが簡便になる。

【0043】ところで、前述したジグザグ走行のピッチ

は、所定角  $\theta 1 = 90$  (度) の場合であれば、幅  $L$  と回転角度  $\theta 2$  とから定まり、 $\text{ピッチ} = (\tan \theta 2) \times (\text{幅} L)$  である。従って、ピッチを前述の自律車の作業幅として予め設定すれば、上記の関係式から回転角度  $\theta 2$  が求められるので、幅  $L$  の単独設定(一因子設定)とすることも可である。

【0044】本発明によれば、自律車の移動距離や移動方向を検知するための加速度センサやジャイロ스코プや演算機などの装置を使用することなく、壁などの境界や障害物に接近または接触したことを検知する装置とロジックコントローラとで自律車の走行を制御し、境界に囲まれた平面領域内を障害物を避けながら動く、自走式掃除機や自走式芝刈機などの自律走行作業車を得ることができる。

【0045】加速度センサやジャイロ스코プを使用しないため、低コストで製作することができ、取扱いも簡単である。

【0046】

【発明の効果】自律走行車の構成が単純化され経済的で、取扱いも簡単で、かつ、走行領域を効率良く確実に走行する自律走行車が提供される。

【図面の簡単な説明】

【図1】本発明による一実施例の走行制御装置を搭載した自律車を示す図である。

【図2】本発明の一実施例の走行制御方法による自律車の走行軌跡を示す図である。

【図3】本発明による一実施例の走行制御装置を示す図である。

【図4】本発明による他の実施例の走行制御装置を示す図である。

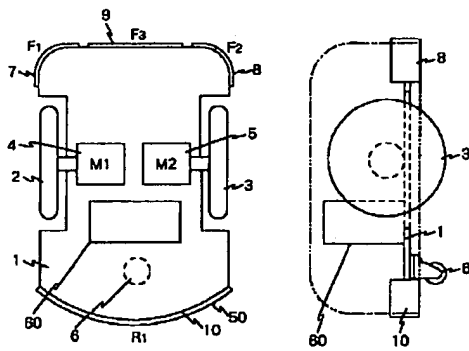
【図5】自律車を横方向に幅寄せする本発明による一実施例の走行制御方法を示す図である。

【符号の説明】

1…車体フレーム、2…左駆動輪、3…右駆動輪、4…左モータ、5…右モータ、6…補助輪、7…左センサ、8…右センサ、9…中央センサ、10…後部センサ、11…壁、12, 13…障害物、14…バッテリー電源、15…電源スイッチ、16…停止スイッチ、17…始動スイッチ、18, 19, 22, 23…補助リレー、20, 21…限時リレー、25…マイクロプロセッサ、26…ROM、50…自律車、60…ロジックコントローラ。

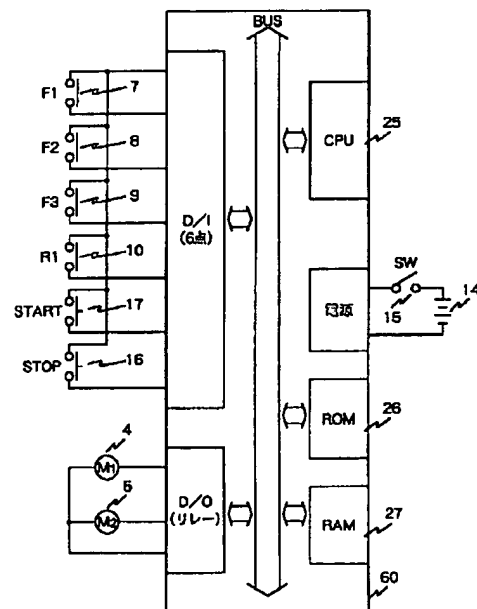
【図1】

図 1



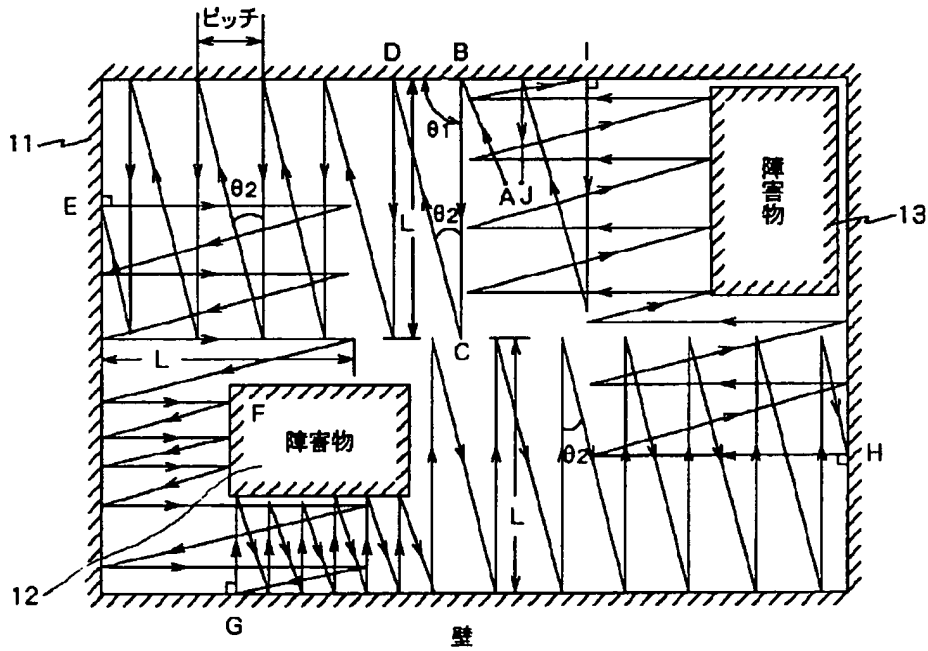
【図4】

図 4

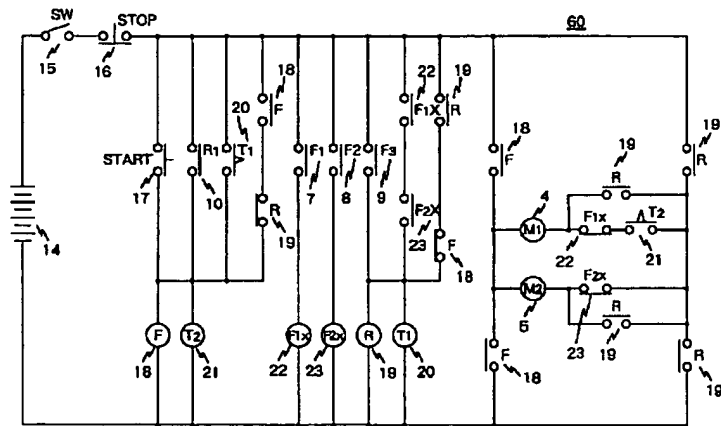


【図2】

図 2

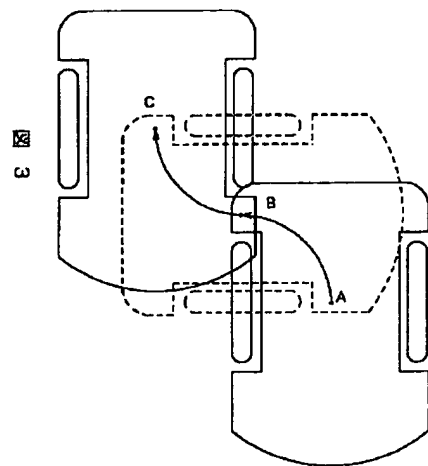


【図3】

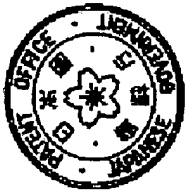


【図5】

図 5



車輪の移動  
 A: 最初の位置  
 B: 車体を左に90°回転させた(縦横)位置  
 C: 続いて車体を右に90°回転させて元の向きになった位置



(19) Publication number: **62120510 A**

Generated Document.

**PATENT ABSTRACTS OF JAPAN**

(51) Intl. Cl.: **G05D 1/02**

(21) Application number: **60259895**

(22) Application date: **21.11.85**

<p>(30) Priority:</p> <p>(43) Date of application publication: <b>01.06.87</b></p> <p>(84) Designated contracting states:</p>	<p>(71) Applicant: <b>HITACHI LTD</b></p> <p>(72) Inventor: <b>SHIOKAWA JUNJI OGASAWARA HITOSHI</b></p> <p>(74) Representative:</p>
---	---

**(54) CONTROL METHOD FOR AUTOMATIC CLEANER**

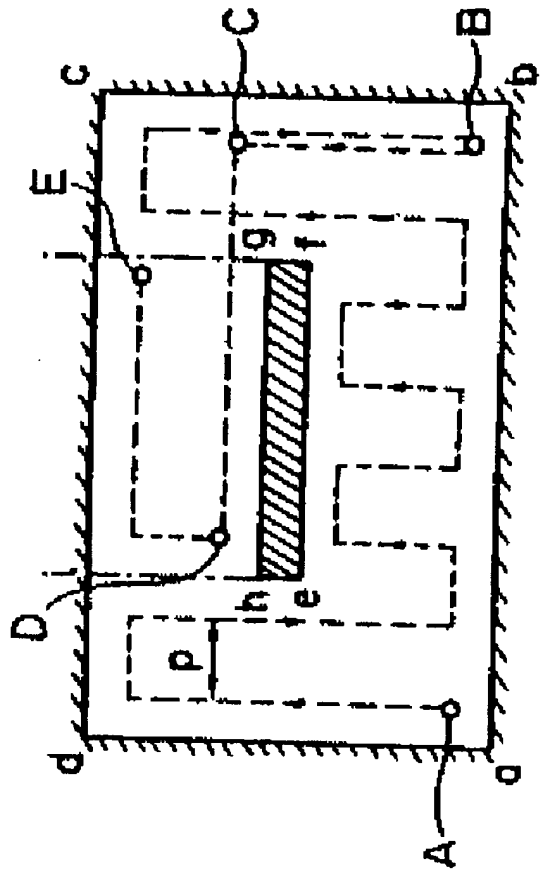
(57) Abstract:

**PURPOSE:** To attain the complete cleaning by driving zigzag an automatic cleaner within a room for production of a map showing the cleaned areas and a map showing the positions of obstacles and moving the cleaner to the nucleated areas for zigzag drive as soon as said both maps are produced.

**CONSTITUTION:** A room to be cleaned is enclosed by walls (ab, bc, cd and da) and an obstacle limited by sides (ef, fg, gh and he) exists in this room. An automatic cleaner is started at a start point A and moved straight and inverted at the side (cd) with a prescribed shift equal to pitch width (p). This inversion is carried out every time the cleaner gets close to walls or the obstacle. Then the driven areas are stored for production of a map to show the cleaned areas and a map to show the position of the obstacle. An uncleaned area is detected out of the map at a point B and a specific point D is decided. Then a route of points B-C-D is calculated and the cleaner is shifted to the point D. Thus the cleaner is driven zigzag in the same way. In such a way, the room can be completely cleaned.

**COPYRIGHT:** (C)1987,JPO&Japio





⑩ 日本国特許庁(JP)

⑪ 特許出願公告

⑫ 特許公報(B2)

平5-82602

⑬ Int. Cl.<sup>5</sup>

G 05 D 1/02  
A 47 L 9/28  
G 05 D 1/02

識別記号

L  
A  
J

庁内整理番号

7828-3H  
7828-3H

⑭ 公告 平成5年(1993)11月19日

発明の数 1 (全14頁)

⑮ 発明の名称 自動掃除機の制御方法

⑯ 特 願 昭60-259895

⑰ 公 開 昭62-120510

⑱ 出 願 昭60(1985)11月21日

⑲ 昭62(1987)6月1日

⑳ 発 明 者 塩 川 淳 司 神奈川県横浜市戸塚区吉田町292番地 株式会社日立製作所家電研究所内

㉑ 発 明 者 小 笠 原 均 神奈川県横浜市戸塚区吉田町292番地 株式会社日立製作所家電研究所内

㉒ 出 願 人 株式会社日立製作所 東京都千代田区神田駿河台4丁目6番地

㉓ 代 理 人 弁理士 武 顕次郎 外1名

㉔ 審 査 官 栗 林 敏 彦

㉕ 参 考 文 献 特開 昭55-97608 (JP, A) 特開 昭61-245215 (JP, A)

特公 昭60-52443 (JP, B2)

1

2

㉖ 特許請求の範囲

1 掃除部、駆動部、障害物検出部、位置検出部、演算制御部、記憶部および入出力部を備えた自動掃除機を自律走行させて、障害物のある室内を掃除させるようにした制御方法において、

該自動掃除機を直進走行させ、該障害物検出部の検出データをもとに壁や障害物が直進方向にあることが検出されると、該障害物の近傍で該自動掃除機を所定ピッチをもつて直進走行方向を逆転させるようにして、該自動掃除機を一方向へ連続的にジグザグ走行させて掃除を行なわせ、

かつ、該自動掃除機の走行にともなつて該位置検出部の検出データと該障害物検出部の検出データとで掃除を済ませた領域を表わす地図と壁や障害物の位置を表わす地図とを作成し、

該自動掃除機の一連の連続したジグザグ走行による掃除の終了とともに、これら地図から該障害物などによつて該自動掃除機の該一連の連続したジグザグ走行による掃除ができなかつた未掃除領域を検出し、該未掃除領域に該自動掃除機を移動させ、上記のジグザグ走行による掃除を行なわせることを特徴とする自動掃除機の制御方法。

発明の詳細な説明

〔発明の利用分野〕

本発明は、自律走行して掃除を行う自動掃除機に係り、特に障害物のある室内を無駄なく掃除するに好適な自動掃除機の制御方法に関する。

〔発明の背景〕

自律走行をして掃除を行う自動掃除機の一例として、例えば特開昭55-97608号に開示されるものがある。この従来例では、直進中超音波送受信機を用いて前方の障害物を検知すると、1ピッチずれて180°方向を変えて、また直進するという走行をくり返し、壁際まで来て掃除を完了するというものであつた。しかし、この方法では、室内に障害物がある場合、それをくまなく掃除することができないという欠点があつた。

〔発明の目的〕

本発明の目的は、上記従来技術の欠点を解消し、障害物が置かれていても、室内の掃除を自律的にくまなく行なうことを可能とした自動掃除機の制御方法を提供するにある。

〔発明の概要〕

この目的を達成するために、本発明は、壁や障害物を検知しつつ直進走行と壁や障害物での走行

方向の転換を繰り返して自動掃除機をジグザグ走行させ、かつ、該走行とともに、該掃除機が掃除した領域の地図と壁や障害物の位置を示す地図を形成し、該掃除機が走行することができなくなったときに、障害物などによって生じた未掃除領域を該地図から検出し、該掃除機を未掃除領域に移動させてジグザグ走行させるようにした点に特徴がある。

〔発明の実施例〕

以下、本発明の実施例を図面を用いて説明する。

第1図は本発明による自動掃除機の制御方法の一実施例を処理手順で概略的に示した流れ図である。また第2図は障害物が置かれた室内をこの実施例によつて自動掃除機が移動する走行軌跡を示した模式図であつて、掃除すべき室内は夫合壁である辺 $\overline{ab}$ ,  $\overline{bc}$ ,  $\overline{cd}$ ,  $\overline{da}$ で囲まれた領域であり、この室内に辺 $\overline{ef}$ ,  $\overline{fg}$ ,  $\overline{gh}$ ,  $\overline{he}$ で囲まれる障害物があるものとする。

第1図に示した実施例の処理手順を、第2図の模式図と照らし合わせて説明する。

処理101: まず、自動掃除機を、出発地点Aより出発させて直進させる。この自動掃除機が辺 $\overline{cd}$ で表わす壁際まで来ると、これを一旦停止させる。そして、自己の走行(掃除)していない方側へ所定のピッチ幅 $p$ ずらして方向を反転させ、逆方向へ直進させる。この走行方向の反転は壁や障害物に近づく毎に行なわせ、直進走行と方向反転とをくり返させる。

処理102: 処理101に於て、壁際などで停止後、ピッチ $p$ だけずれる事ができなくなると(すなわち、地点Bに来た時)、行き止まりと判定し、処理103へと制御を移す。

この地点Aから地点Bへの移動の間に、自動掃除機は、自ら走行(掃除)した領域を記憶し、さらに障害物や室内の壁の位置情報を記憶して掃除した領域の地図や、壁、障害物の地図を形成する。

処理103: まず、自己の掃除した領域を表わす地図をもとに、まだ掃除をしていない領域(未掃除エリア)があるかどうかを検索する。この場合自動掃除機は、自己が移動した横方向、縦方向の最大の範囲を判定し、これら範囲で決まる4角形の領域を掃除すべき領域とし、この掃除すべき

領域から実際に掃除した領域を除いた領域を未掃除エリアと判定する。第2図では、自動掃除機が横方向にaからbまで移動し、また、縦方向にaからdまで移動するから、頂点a, b, c, dで決まる4角の領域が掃除すべき領域であり、頂点e, f, j, iで決まる4角の領域が未掃除エリアである。そして未掃除エリアが見つかったと、次に、壁や障害物の位置を表わす地図からそのエリアに障害物があるか否かを検索する。そして、そこに障害物があれば、未掃除エリアから障害物を除いた領域を実際に掃除すべきエリアとする。未掃除エリアが無ければ制御を終了し、未掃除エリアがあれば制御を処理104に移す。第2図では、実際に掃除すべき未掃除エリアは頂点h, g, j, iで決まる4角い領域である。

処理104: まず、未掃除エリアの特定な地点Dを決定し、停止地点Bから移動するこの地点Dまでの走行径路を算出する。ここで、地点B-地点C-地点Dの径路を算出したとすると、自動掃除機を、この算出した径路に従つて誘導し、地点Dへ到達後、処理101の制御を行なう。そして、再び以上の処理をくり返す。

以上の手順で制御を行えば、自動掃除機は室内をくまなく動いて掃除を行う事ができる。

次に、このように制御可能な自動掃除機について説明する。

第3図は、この自動掃除機の構成を示す側断面図、また、第4図は第3図におけるA<sub>1</sub>-A<sub>2</sub>線平面断面図であり、1は自動掃除機、2, 3は車輪、4, 5は車輪軸、6, 7は車輪2, 3を駆動するモータ、8, 9はモータ6, 7の回転数を低減する減速機、10, 11は車輪2, 3の回転数を計測するためのロータリエンコーダ、12, 13, 14, 15, 16, 17は減速機8, 9とロータリエンコーダ10, 11をそれぞれ車輪軸4, 5に結合する傘歯車、18, 19はモータ6, 7の回転速度を電気信号に変換するタコジェネレータ、20, 21はタコジェネレータ18, 19より出力される電気信号をもとにモータ6, 7の速度を制御する速度制御装置、22は掃除機の吸口部、23は真空掃除機本体、24は自動掃除機1のヨー角速度を検出するためのジャイロ装置、25は回転しながら超音波を送受信して自動掃除機1と障害物や壁までの距離と方位を測定できる、

いわゆるレーダの構成を成す障害物検出装置、26は走行制御を行う制御装置、27は全システムに電力を供給する蓄電池である。

同図において、制御装置26は障害物検出装置25、ジャイロ装置24、ロータリエンコーダ10、11からのデータを処理して、自動掃除機1の位置、方位及び障害物、壁の位置などを検出して記憶し、かつ上記の位置、方位などの情報をもとに、予め入力してある掃除走行プログラムを実行するための、マイクロプロセッサ(CPU)、掃除走行プログラムを記述したROM、変数や、自動掃除機1が掃除した領域を表わす地図(以下、掃除地図という)、壁や障害物の位置を表わす地図(以下、障害物地図という)を一時的に蓄えておくRAM、入出力信号処理回路(インターフェース)から構成されたものである。

また、第5図は、第3図に示した自動掃除機のシステムブロック図であつて、26aは制御装置26のCPUで、ROM26bに記憶された走行制御プログラムを呼びだし、プログラムに従つて処理を実行する。26cは変数や走行制御に必要な地図を一時的に記憶しておくRAMである。26dは制御装置26に接続された外部の周辺機器からの信号をCPU26a内に取り込むための電気信号に変換し、また、CPU26aから出力される電気信号を外部機器に入力するための電気信号に変換するためのインターフェース回路である。

次に、自動掃除機1の走行中における、自己位\*

$$\begin{aligned} \text{座標} \quad \left[ \begin{array}{l} X_i = X_{i-1} + \Delta L \cdot \sin \left( \theta_{i-1} + \frac{\Delta \theta_i}{2} \right) \\ \dots (5) \\ Y_i = Y_{i-1} + \Delta L \cdot \cos \left( \theta_{i-1} + \frac{\Delta \theta_i}{2} \right) \\ \dots (6) \end{array} \right. \end{aligned}$$

従つて、自動掃除機1の初期地点 $(X_0, Y_0)$ と初期方位 $\theta_0$ が明らかであれば、自動掃除機1の任意の地点 $(X_i, Y_i)$ および方位角 $\theta_i$ は、初期地点より累積する事より次式で表わされる。

$$X_i = X_0 + \sum_{n=1}^i \Delta X_n \quad \dots (7)$$

$$Y_i = Y_0 + \sum_{n=1}^i \Delta Y_n \quad \dots (8)$$

\*置の計測と障害物の位置計測方法について簡単に説明する。

第6図は自動掃除機1がX-Y座標系を移動している状態を示す模式図である。ここでは、説明を簡単にするために、車輪2と車輪3だけを示し、これらの中間点の位置を自動掃除機の位置とする。

同図において、自動掃除機1がある時刻で地点 $(X_{i-1}, Y_{i-1})$ にあり、方位角が $\theta_{i-1}$ であるとし、単位時間 $\Delta t$ 経過したのち、地点 $(X_i, Y_i)$ に移動して方位角が $\theta_i$ になつたとする。また、左車輪2の単位時間 $\Delta t$ の移動距離を $\Delta L_2$ とし、右車輪3の移動距離を $\Delta L_3$ とすると、単位時間 $\Delta t$ における自動掃除機1の変位角 $\Delta \theta_i$ 、および移動距離 $\Delta L_i$ は、次式で表わされる。

$$\text{移動距離} \quad \Delta L_i = \frac{\Delta L_2 + \Delta L_3}{2} \quad \dots (1)$$

$$\text{変位角} \quad \Delta \theta_i = \Delta \omega \theta \cdot \Delta t \quad \dots (2)$$

ここでの角度 $\theta$ は反時計まわりを正方向とし、 $\Delta \omega \theta$ は移動車の単位時間 $\Delta t$ における旋回角速度である。

従つて、自動掃除機1が地点 $(X_{i-1}, Y_{i-1})$ に達するまでの移動距離を $L_{i-1}$ 、地点 $(X_{i-1}, Y_{i-1})$ と地点 $(X_i, Y_i)$ の直線距離を $\Delta L$ とすると、単位時間 $\Delta t$ 経過した時の全移動距離 $L_i$ 、方位角 $\theta_i$ および地点 $(X_i, Y_i)$ は夫々次式で表わされる。

$$\text{全移動距離} \quad L_i = L_{i-1} + \Delta L_i \quad \dots (3)$$

$$\text{方位角} \quad \theta_i = \theta_{i-1} + \Delta \theta_i \quad \dots (4)$$

$$\theta_i = \theta_0 + \sum_{n=1}^i \Delta \theta_n \quad \dots (9)$$

但し、 $\Delta t$ は微小であるとする。

上記の式において、左右の車輪2, 3の移動距離 $\Delta L_2, \Delta L_3$ はロータリエンコーダ10と11のパルス数をカウントする事により、また、角速度 $\Delta \omega \theta$ はジャイロ24の出力から得る事ができる。

また、第6図において、障害物検出装置25

が、座標 (X<sub>0</sub>, Y<sub>0</sub>) にあつた障害物を検出したとする。なお、障害物検出装置 2 5 は、指向性の強い超音波ビームを発進し、障害物に当たつてはね返つてくる超音波を受信するもので、超音波ビームが壁や障害物の面に対して垂直に当たつた場合あるいは壁や障害物のコーナ部に当たつた場合のみ受信するレーダの構成をなすものである。

第 6 図に示す様に、自動掃除機 1 の方位角が θ<sub>1</sub> の時点で、自動掃除機 1 から角度 α、距離 L<sub>0</sub> の場所に検出された障害物の座標 (X<sub>0</sub>, Y<sub>0</sub>) は次式をもつて与えられる。

$$X_0 = X_1 - L_0 \sin(\theta_1 + \alpha) \quad \dots(10)$$

$$Y_0 = Y_1 + L_0 \cos(\theta_1 + \alpha) \quad \dots(11)$$

なお障害物までの距離 L<sub>0</sub> は、超音波ビームを発信してから受信するまでの時間を計測する事により得られる。超音波ビームの伝播速度を V<sub>us</sub>、送信して受信するまでの時間を t<sub>bc</sub> とすると、障害物までの距離 L<sub>0</sub> は

$$L_0 = \frac{t_{bc}}{2} \cdot V_{us} \quad \dots(12)$$

で示される。また、角度 α は、車輪回転数を計測するロータリエンコーダ 1 0、又は 1 1 と同じものを、障害物検出装置 2 5 の回転軸に連結しておけば、容易に得る事ができる。

次に、障害物地図、および掃除地図の作成方法を説明する。

第 7 図は、制御装置 2 6 の RAM 2 6 c のメモリアreaであり、Ad 1, Ad 2, Ad 3 はメモリに割り当てられた番地を示すもので、Ad 1 は先に示した自動掃除機 1 の自己位置計測や障害物計測の計算のために一時的にデータや変数を記憶しておくための変数エリアの先頭番地である。Ad 2 は障害物地図の記憶に割り当てられたメモリアreaの先頭番地である。また、Ad 3 は掃除地図の記憶に割り当てられたメモリアreaの先頭番地である。第 8 図は第 7 図における地図を記憶するメモリアreaの拡大図、第 9 図はこのメモリアreaに掃除地図を形成して格納する方法を示す模式図である。

第 7 図に示す掃除地図や障害物地図を格納する RAM 2 6 c のメモリアreaは、第 8 図に示す様に、X 方向に H 個、Y 方向に V 個ずつ区分された一辺 Δa の正方形の多数の微小エリアの二次元の配列とする。そして、これら微小エリアに番地が

付され、各番地により、実際に自動掃除機 1 が走行する床面上の位置と微小エリアとを対応させる。自動掃除機 1 が使用開始される初期状態では、初期値として、各微小エリアに“0”ビットを書き込んでおく。障害物などが在る地点 (X<sub>0</sub>, Y<sub>0</sub>) が前述した方法で求められると、その地点 (X<sub>0</sub>, Y<sub>0</sub>) に当たる番地の微小エリアに“1”ビットを書き込んで行く。その微小エリアの番地 Ad<sub>ds</sub> は、自動掃除機 1 の起点となる微小エリアの番地を Ad 2 とすると、

$$Ad_{ds} = Ad_2 + X_0 / \Delta a + (Y_0 / \Delta a) \times H \quad \dots(13)$$

で得る事ができる。この様にして障害物地図は RAM 2 6 c 上に記憶できる。

掃除地図の場合も同様であり、自己の位置 (X<sub>i</sub>, Y<sub>i</sub>) が先の計測方法で計算されれば、その地点 (X<sub>i</sub>, Y<sub>i</sub>) に当たる番地 Ad<sub>di</sub> は

$$Ad_{di} = Ad_3 + X_i / \Delta a + (Y_i / \Delta a) \times H \quad \dots(14)$$

で計算されるので、その番地の微小エリアに“1”ビットを書き込んで行けば良い。ただし、第 9 図に示す様に、掃除地図の場合は、掃除機の吸口部 2 2 (第 3 図) の幅に対応した複数の番地の微小エリアに一度に“1”ビットを書き込んで行く。こうする事により、自己の掃除した場所を記憶させる事ができる。なお、第 9 図に於て、1 は自動掃除機、2, 3 は車輪である。

以上の様にして各地図が得られるが、第 1 図をより具体的に示した第 1 0 図により、この実施例をさらに具体的に説明する。なお、第 1 0 図において処理 S 2 ~ S 1 6 は第 1 図の処理 1 0 1 に対応し、処理 S 1 0, S 1 1, S 1 3, S 1 4 は同じく処理 1 0 2 に対応し、処理 S 1 7, S 1 8 は同じく処理 1 0 3 に対応し、処理 S 1 9, S 2 0 は同じく処理 1 0 4 に対応する。

S 1 : まず、RAM 2 6 c 内の、自己 (自動掃除機) の位置、方向のデータを初期設定するとともに、障害物地図、掃除地図を記憶するメモリアreaの各番地の微小エリアに“0”ビットを書き込み、障害物などで自動掃除機 1 を旋回する方向を決める変数 UT を“0”とする。

S 2 : ジャイロ 2 4 とロータリエンコーダ 1 0, 1 1 のデータをインターフェース回路 2 6 d を通じて CPU 2 6 a に取り込み、そのデータにより、先述した位置計測方法に従つて自動掃除機 1 の位置と方位 X<sub>i</sub>, Y<sub>i</sub>, θ<sub>i</sub> を算出し (式(3)~(9)を

用いる)、RAM 26 cに記憶する。

S 3:次に、障害物検出装置 25で障害物などを検知されると、障害物検出装置 25から得られるデータをもとに、自動掃除機 1と障害物までの距離 $L_0$ と角度(方向) $\alpha$ を先の計測方法に従って求め、さらに障害物の位置データ( $X_0$ ,  $Y_0$ )を、S 2で求めた $X_i$ ,  $Y_i$ ,  $\theta_i$ の情報を用い、先の式(II)、(III)より求める。そして、式(13)に従って、障害物地図を構成する番地Addを算出し、RAM 26 cのメモリアのその番地に障害物データとして“1”を書き込み、障害物地図を形成していく。

S 4: S 2で求めた自己位置データ $X_i$ ,  $Y_i$ をもとに、前記した要領で、掃除地図を作成する。

S 5:自動掃除機 1の走行方向に障害物があるかを、第 11図の様に、RAM 26 c上に作成された障害物地図を検索して判断させる。移動中の自動掃除機の位置( $X_i$ ,  $Y_i$ )は処理 S 2によって求められているから、今、座標軸 Y 軸と平行な向きに自動掃除機 1が向いていた場合を例にとると、自己の座標( $X_i$ ,  $Y_i$ )から、所定の閾値 $\Delta V$ だけ離れた場所( $X_i$ ,  $Y_i + \Delta V$ )に対応した障害物地図の番地を中心とし、横一列に一定数の番地の微小エリア内容が障害物データである“1”なる値が書き込まれているか検索する。そして、“1”なる値がなければ前方に障害物はないと判断し、“1”が書き込まれていれば、前方に障害物ありと判断する。

S 5': S 5で障害物なしと判断すると、S 5と同様に、今度は位置( $X_i$ ,  $Y_i + \Delta V$ )に対応した掃除地図のメモリアの番地を中心に横一列で一定数の番地の微小エリアの内容が、掃除したというデータである“1”があるかどうか検索する。この処理で一度掃除した領域へは自動掃除機 1は進入しない事になる。

S 6: S 5および S 5'で前方に障害物などがなく、かつ掃除してないと判断した場合は、自動掃除機 1が直進する様に、CPU 26 aからインターフェース回路 26 dを経て速度制御回路 20, 21へ速度指令を出力し、モータ 6, 7を駆動して車輪 2, 3を回転させる。

S 7: S 5で前方に障害物あり、または S 5'で前方が掃除した場所であると判断した場合は、自動掃除機 1を停止させる様に、CPU 26 aよ

りインターフェース 26 dを介して速度制御回路 20, 21に速度指令を出力しモータ 6, 7を停止させる。

S 8:自動掃除機 1の後記するUターンの方向の優先方向を決める変数UTの値が“0”か否かを判定する。

S 9:変数UTが“0”のとき変数UTを1とする。

S 10:そして自動掃除機 1が右Uターンでできるかを判定する。第 12図は右Uターン時の地図検索を示す模式図である。同図に示す様に、本実施例では、右Uターンの場合、一度自動掃除機 1の右車輪 2を図の様に左車輪 3を中心にして 2'の位置に来る様に後退させ、次いで、右車輪 2'を中心にして左車輪 3を回転させて、自動掃除機を 1'に示す姿勢にする。この場合、CPU 26 aより、インターフェース 26 dを介して速度制御回路 20, 21へ速度指令を送り、モータ 6, 7を駆動する。こうする事によつて、自動掃除機 1が往復走行を行う時、その吸口部 22(第 3図)は一定のずれ幅をもって移動する事になるとともに、第 12図に示した様に、既に掃除された部分と幅 $O_0$ だけオーバーラップして移動するこになるので吸い残しを防ぐ効果がある。また、左Uターンも右Uターンとは全く左右対称に逆の制御を行う事で達成できる。

上記したUターンをするためには、第 12図の斜線で囲んだ範囲内に障害物があつてはならない。従つて、第 12図で示した自動掃除機 1の姿勢の時点の現在位置( $X_i$ ,  $Y_i$ )を基点として、方形 K 1-K 2-K 3-K 4で囲まれる範囲に当たる RAM 26 cの障害物地図上の番地の内容をくまなく検索する。そして、検索した番地の中に、1個でも障害物のデータ、すなわち“1”の値が書き込まれている微小エリアがあれば、右Uターンは不可と判定させる。また、K 1-K 2-K 3-K 4に障害物データがない場合は、次に、第 12図に示す様に RAM 26 cに作成されている掃除地図での、[( $X_i$ ,  $Y_i$ )を基点として]、得られる格子で示す方形 $C_0$ の場所にあたる部分の番地を検索し、掃除したというデータである“1”という値が書き込まれていれば、右Uターンは不可という判定をする。こうする事で、一度掃除した領域側にUターンをさせる事を防ぎ、2度同じ場

## 11

所を掃除する無駄をなくす事ができ、効率的である。そして、掃除したデータが検索番地に書き込まれていなければ、ここで初めて、自動掃除機から見て右Uターンは可能と判断させる。

S 11：処理S 10で右Uターン不可と判断すると、今度は左右対称の逆方向に、S 10と同じ処理をほどこして左Uターン可能か否か判定する。

S 12：処理S 8でUTが“0”でないと判定すると、ここでUTの値を“0”とする。

S 13：処理S 11と同じ処理を行う。

S 14：処理S 10と同じ処理を行う。

S 15：処理S 10又はS 14で右Uターン可能と判断した場合は、第12図で示した様にして右Uターンする。

S 16：処理S 11又はS 13で左Uターン可能と判断した場合は、第12図で示したものと反対方向へ、左Uターンする。

S 17：S 10とS 11、又はS 13とS 14で、右にも左にもUターン不可と判断すると（この場合には、第2図では、自動掃除機1は地点Bにある）、後述する未掃除エリア検索を行う。

S 18：未掃除エリアが発見されればS 19へ処理を移行し、未掃除エリアがなければ掃除終了とする。

S 19：処理S 18で未掃除エリアありと判断すると、後述する経路探索方法に従って、未掃除エリアまで移動する経路を求める。

S 20：未掃除エリアまでS 19で求めた経路に従って移動する様、自動掃除機1を制御する。

これ以降、再びS 2の処理にもどって同様の制御をくりかえす。

以上の制御手順により、自動掃除機1を制御する。

次に、上記の処理S 17の未掃除エリア検索方法及び処理S 19の経路探索方法について説明する。

上記の制御手順に従って、自動掃除機1を制御すると、第2図に示した様に、自動掃除機1は、出発地点Aから破線で示した様にジグザグ走行をくり返し、地点Bに達する。この時点で左右どちらかにUターン可能か否かS 13及びS 14の処理で判定を行うが、自動掃除機1から見て左側は壁、すなわち障害物があるという事がRAM 2 6

## 12

c上に作成された障害物地図より判定される。また、自動掃除機1から見て右側は、既に一回走行して掃除をしている領域である事がRAM 2 6 c上に作成した掃除地図より判定され、右Uターン不可と判定する。これにより、処理S 17へと処理を移行する。

第13図は地点Bに達した時点でのRAM 2 6 cに作成された掃除地図を示し、第14図は同じくRAM 2 6 c上に作成された障害物地図を示す。特に、第14図に示す障害物地図は、X軸側からみて障害物のかげになった障害物の辺や範囲αで示す壁の部分は障害物検出装2 5（第3図）で検出されずに不明ではあるが、出発地点Aから地点Bに走行する間に、実際の掃除すべき部屋内の状態にほぼ近いものとなっている。

そこで、以上の様に作成された障害物地図及び掃除地図からどの様にして未掃除エリアを検出するかを述べる。

第13図及び第14図に示した正方形s-t-u-vを検索エリアと呼ぶ事にする。この検索エリアは、第15図に示す様に、地図の最小構成要素であるRAM 2 6 cのメモリアの微小エリアが、縦n個、横n個集まってなる正方形のエリアであり、自動掃除機1の吸口部2 2の断面積に対応した広さを持ち、未掃除エリア検索においてまとめて検索する範囲である。

この検索エリア内において、第16図に示す様な処理手順を実行する事によって未掃除エリアであるか否かの判断を行う。

S 21：検索エリアを矢印X'方向に順次ずらしながら矢印Y'方向に移動走査させ、このエリアに含まれる番地に掃除したデータがあるかないか、すなわち1なるデータが書き込まれているかどうか、RAM 2 6 c上に作成された掃除地図上を検索する。この場合、掃除地図上のX軸方向の最大幅(sk)とY軸方向の最大幅(sm)で決まる四角の領域を掃除すべき領域とし、検索エリアはこの領域全体にわたって検索するようにする。

S 22：処理S 21で、検索エリア内に掃除したデータが書き込まれていない場合、今度は掃除地図に検索エリアを設定した場所と同じ場所に当たるRAM 2 6 c上に作成された障害物地図上に検索エリアを設定し、その設定した検索エリア内の番地に、障害物のデータである“1”なる値が

書き込まれているか否かを検索する。

S 2 3 : 処理 S 2 1 で、検索したエリア内に掃除したというデータがなく、かつ処理 S 2 2 で障害物のデータが書き込まれていなければ、その検索エリアに当たる部分を未掃除エリアとする。

S 2 4 : 処理 S 2 1 で設定した検索エリア内の番地に掃除したデータありと判断するか、又は S 2 2 で、設定した検索エリア内に障害物データがあれば、その検索エリアを設定した場所は掃除したエリアとする。すなわち、障害物の領域も掃除した領域とする。

以上の処理 S 2 1 ~ S 2 4 を、第 1 3 図に示す方形 sklm の範囲内で、くまなく検索エリアを移動させて行えば、第 1 3 図に示す様に、検索エリアが未掃除エリアに入り込む。検索エリアが最初に未掃除エリアに入り込んだときのこの検索エリアの正方形のエリアを n とすると、このエリア n の中心点が、第 2 図で示したように、自動掃除機が未掃除エリアに移動するための目標地点 D である。

次に、このようにして見つけた未掃除エリアの地点 D に自動掃除機 1 を移動させるための経路を見つけるための、第 1 0 図の経路探索方法を第 1 7 図を用いて説明する。

第 1 7 図に於て、点 S ( $X_{ST}$ ,  $Y_{ST}$ ) は第 2 図の地点 B に相当する現在自動掃除機 1 が停止している地点、点 T ( $X_T$ ,  $Y_T$ ) は自動掃除機 1 がこれから移動するべき目標点 (第 2 図の地点 D に相当する) である。

ここで、まず中継点として X 座標が点 S の X 座標に等しく Y 座標が点 T の Y 座標に等しい点 A 1 ( $X_{ST}$ ,  $Y_T$ ) と X 座標が点 T の X 座標に等しく Y 座標が点 S の Y 座標に等しい点 A 2 ( $X_T$ ,  $Y_{ST}$ ) とを選ぶ。そして、経路 S-A 1-T (第 1 7 図に示した斜線の部分) に障害物があるかどうかを、幅 w をもって、RAM 2 6 c 上に作成されている障害物地図から検索する。幅 w は、自動掃除機 1 が、十分に通過できるだけの値である。すなわち、経路探索時には、幅 w のぶんだけ、まとめて、障害物地図上の番地を検索する。そうすれば、第 1 4 図に得られている様な障害物地図上を検索した場合、現在の自動掃除機 1 の停止点から未掃除エリアの目標地点 D までの地点 C を経由した経路を見つける事ができる。

以上に述べた経路探索により、第 2 図に示した様な単純な構成の室内ならば、短時間に経路を算出できる。以下、上記の経路探索方法を基本として、より多様な障害物のある室内に対応できる様に拡張した例を説明する。

第 1 8 図は、室内の左端に障害物 q-r-s-t が存在する場合の自動掃除機 1 の走行経路を示す模式図である。

同図において、まず、自動掃除機 1 は、出発地点 F より出発し、先に第 1 0 図で述べた制御方法で制御すると、第 1 8 図の様にジグザグ走行をくり返し、地点 G に至る。そして、第 1 3 図、第 1 4 図で説明した未掃除エリア検索方法で、未掃除エリア中での地点 J を囲む正方形のエリアを見つけ出す。この場合、第 1 7 図に示す移動目標点 T ( $X_T$ ,  $Y_T$ ) が第 1 8 図の地点 J に、自動掃除機 1 の現在の停止点 S ( $X_{ST}$ ,  $Y_{ST}$ ) が地点 G になる。この室内の状態では、先に述べた経路探索方法のみでは、障害物 q-r-s-t が経路を組み、経路を見つけ出す事ができない。そこで、経路探索方法を以下の様に拡張する。

まず、第 1 7 図に示したように、T ( $X_T$ ,  $Y_T$ ) と Y 座標が等しい点 P 1 ( $X$ ,  $Y_T$ ) と A 2 ( $X_T$ ,  $Y_{ST}$ ) と Y 座標が等しい点 P 2 ( $X$ ,  $Y_S$ ) を設定する。そして P 1 と P 2 の X 座標は常に等しくしておき、この X 座標の値を  $X_T$  から徐々に増加させる毎に、すなわち第 1 7 図の様に右側にずらしながら、点 P 1 と点 P 2 で結ばれる経路を、幅 w の範囲で、RAM 2 6 c 上に作成された障害物地図を検索し、もし検索した範囲内に障害物がなければ、その時の点 P 1 と点 P 2 を経路の中継点とし、経路を S-P 2-P 1-T と決定する。この処理を点 P 1 と点 P 2 の X 座標の値が  $X_S$  になるまでくり返しても経路が決定できない場合は、第 1 7 図に示す様に、点 P 1, P 2 の X 座標の値を  $X_T$  より始めて徐々に減少させ、すなわち P 1 と P 2 を互いに左側にずらし、P 1-P 2 で結ばれる幅 w の範囲で、障害物地図を検索し、そして検索した範囲内に障害物がなければ、その時の P 1 と P 2 を経路の中継点とし経路を S-P 2-P 1-T と決定する。この処理で、第 1 8 図の場合においては、地点 G-H-I-J を結ぶ経路が算出される。そして、自動掃除機 1 は、まず、この経路に沿って未掃除エリアの目標地点 J まで移動



し、それから未掃除エリアをジグザグ走行して地点Kまで移動したときに、その未掃除エリアの掃除を終了する。

なお、この場合、自動掃除機1は停止点Gから目標地点まで移動しているときも、掃除地図から未掃除の領域か否かを判定しており、例えば、第14図に示すように、中継点Cから目標地点Dまで移動する間に未掃除エリアを通過するときには、同時に掃除も行なう。

以下、上記した経路探索方法を、第17図と第19図の流れ図を用いて説明する。

S25: まず移動目標点 $T(X_T, Y_T)$ と現在の停止点 $S(X_S, Y_S)$ との間の中継点として、A1( $X_{S1}, Y_{S1}$ )及びA2( $X_{S2}, Y_{S2}$ )を設定する。

S26: そして、S-A1-T間に障害物があるかどうか、RAM26c上に作成された障害物地図上を検索する。

S27: S26に於て障害物はないと判断されると、S-A1-Tを経路と決定して経路探索を終了する。

S28: S26に於て障害物があると判断されると、次に、S-A2-T間に障害物があるかどうか、RAM26c上に作成された障害物地図上を検索する。

S29: S28に於て障害物がないと判断されると、S-A2-Tを経路と決定し、経路探索を終了する。

S30: S28に於て障害物があると判断されると、次にT-A1間、及びA2-S間に障害物があるかどうかRAM26c上に作成された障害物地図上を検索する。

S31: S30に於て障害物ありと判断した場合、経路は見つからないとして経路探索を終了する。

S32: S30に於て障害物はないと判断すると、経路の中継点として、P1( $X, Y_T$ )及びP2( $X, Y_{S2}$ )を設定する。

S33: S32で設定したP1とP2のX座標を、移動目標点であるT点のX座標 $X_T$ とする。

S34: 点P1-P2間に、障害物があるかどうか、RAM26c上の障害物地図上を検索する。

S35: S34に於て、障害物がないと判断して、経路をS-P2-P1-Tと決定し、経路探

索を終了する。

S36: S34に於て、障害物があると判断すると、次に、点P1, P2の現時点でのX座標に $\Delta X$ 増分したものを、点P1とP2の新たなX座標とする。

S37: そして、S36に於て設定した点P1, P2のX座標が、現在自動掃除機が停止している点 $S(X_S, Y_S)$ のX座標、すなわち $X_S$ と比較して、大きいか等しければ次の処理S38へ移り、小さければ、処理S34へともどつて処理をくり返す。

S38: ここで、点P1, P2のX座標を再び移動目標点 $T(X_T, Y_T)$ の $X_T$ とする。

S39: S34と同様の処理を行う。

S40: S35と同様の処理を行う。

S41: S39に於て、障害物があると判断すると、次に、点P1, P2の現時点でのX座標から $\Delta X$ 減じたものを、点P1, P2の新たなX座標とする。

S42: そして、S41に於て設定した点P1, P2のX座標が、 $X_{min}$ よりも小さいときは、処理S43へ移り、大きい等しければ処理S39へと戻つて処理をくり返す。なお、上記の $X_{min}$ は、第17図における左側の壁の位置のX座標の値であるとする。

S43: 経路は見つからないとして経路探索を終了する。

この実施例においては、経路探索は、S31, S43で打ち切る事にしたが、この後も、上記した原理をもとに拡張して行けば、より複雑な障害物の置き方になっている状態の室内に於ても、走行経路を見出す事ができる。しかも、この経路探索においては、X軸または、Y軸に平行な直線の組み合わせで経路を算出するとともに、最短経路を見つける事はできないが、そのために検索に必要な、複雑な座標変換等を行う必要がないために、高速に演算処理を行い、経路を算出でき実用的である。

〔発明の効果〕

以上説明した様に、本発明によれば、室内の障害物の形状等を教示する事なく、障害物のある部屋内の掃き残しなく掃除させる事ができ、人手に頼る事なく自動掃除機を提供できるし、

また、自動掃除機に、掃除した場所を記憶させ

る方式であるので、一度掃除した場所を再び掃除する事なく、効率的であるし、

また、経路探索において、最短距離を見つける事はしないが、その反面、経路探索に要する時間も大幅に短縮され、実用的かつ効率的な自動掃除機の制御方法を提供できるし、

また、本制御方式は、掃除機だけでなく、床面を塗装する等の場合にも、掃除機部を塗装機構に積み変えるだけでそのまま適用できる等上記従来技術の欠点を除いて優れた機能の自動掃除機の制御方法を提供することができる。

図面の簡単な説明

第1図は本発明による自動掃除機の制御方法の一実施例を処理手順で示す流れ図、第2図は自動掃除機が障害物のある室内を移動する走行軌跡を示す模式図、第3図は本発明に係る自動掃除機の側断面図、第4図は第3図におけるA<sub>1</sub>-A<sub>2</sub>線断面図、第5図は第3図に示した自動掃除機のシステムブロック図、第6図は自動掃除機の位置計測及び障害物計測を説明するための模式図、第7図は第5図におけるRAMのメモリ配置図、第8

図はこのRAM上の地図を記憶するエリアの拡大図、第9図は掃除地図の作成方法を示す模式図、第10図は第1図に示した自動掃除機の制御手順をさらに具体的に示す流れ図、第11図は自動掃除機の直進時における地図検索の状態を示す模式図、第12図は右Uターン時の地図検索を示す模式図、第13図は第6図におけるRAM上に作成された掃除地図を示す模式図、第14図は同じくRAM上に作成されてきた障害物地図を示す模式図、第15図は未掃除エリア検索時の検索エリアを示す模式図、第16図は未掃除エリア検索方法を示す流れ図、第17図および第18図は夫々経路探索方法を示す模式図、第19図は第18図に示した経路探索方法を説明する流れ図である。

5

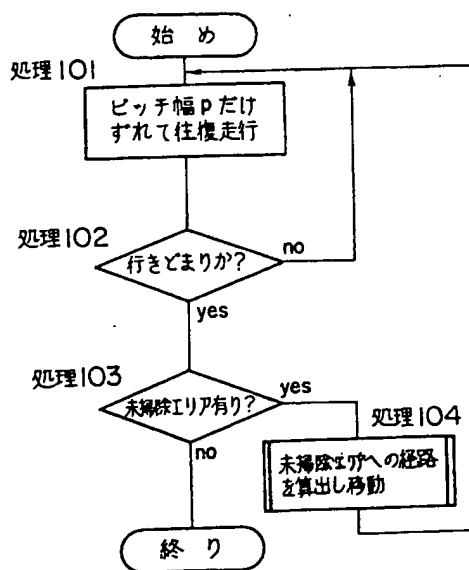
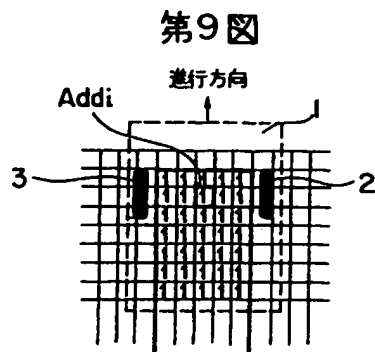
10

15

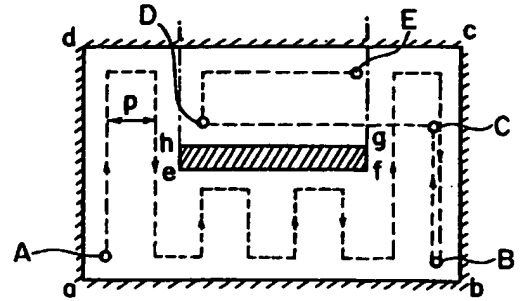
20

1…自動掃除機、2、3…車輪、6、7…モータ、8、9…減速機、10、11…ロータリエンコーダ、18、19…タコジェネレータ、20、21…速度制御装置、23…真空掃除機本体、24…ジャイロ装置、25…障害物検出装置、26…走行制御装置、27…蓄電池。

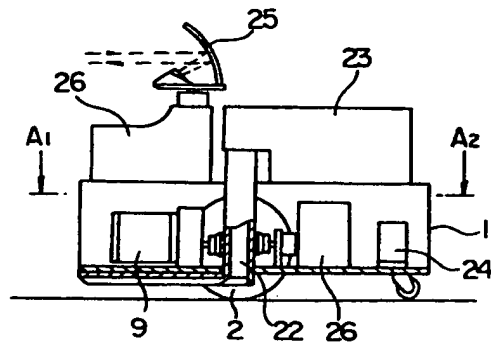
第1図



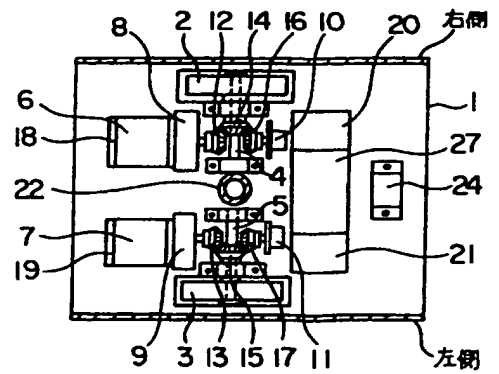
第2图



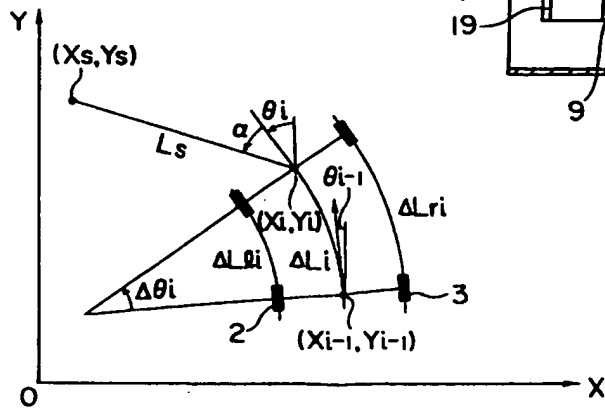
第3图



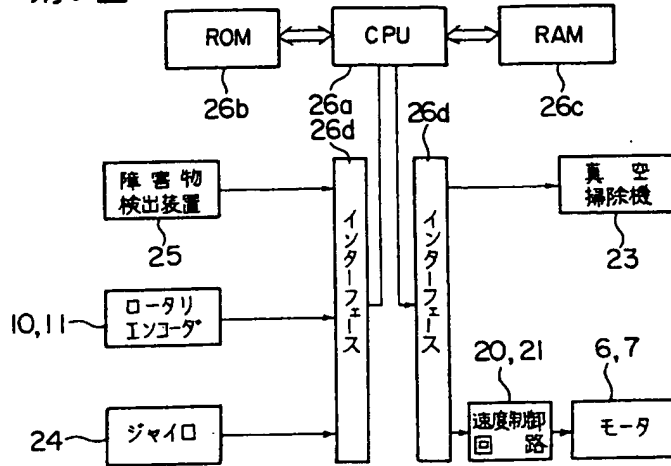
第4图



第6图



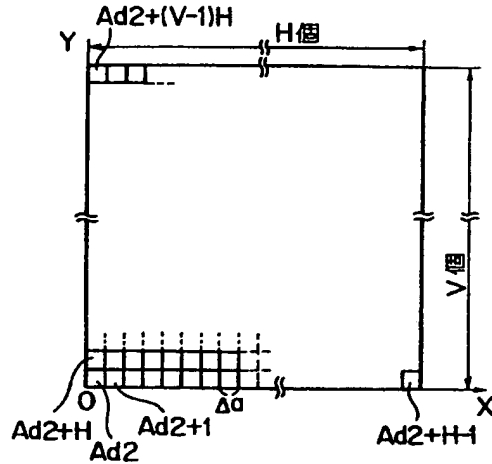
第5図



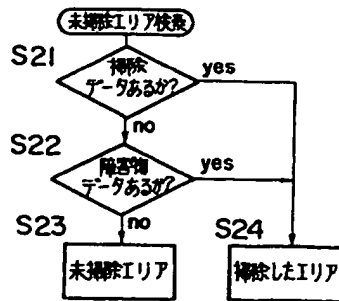
第7図



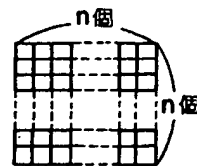
第8図



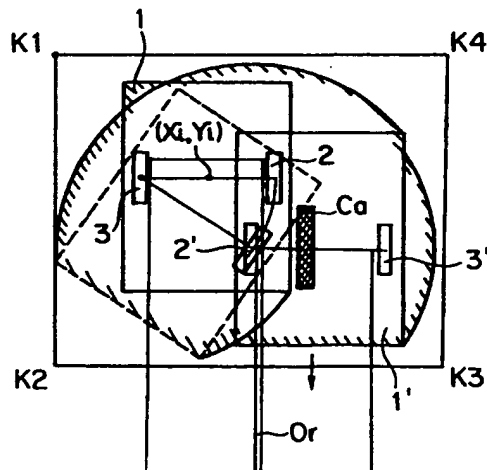
第16図



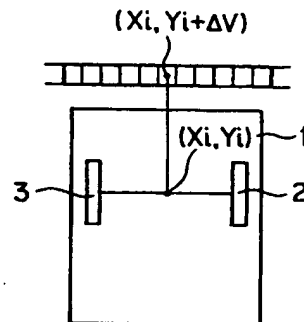
第15図



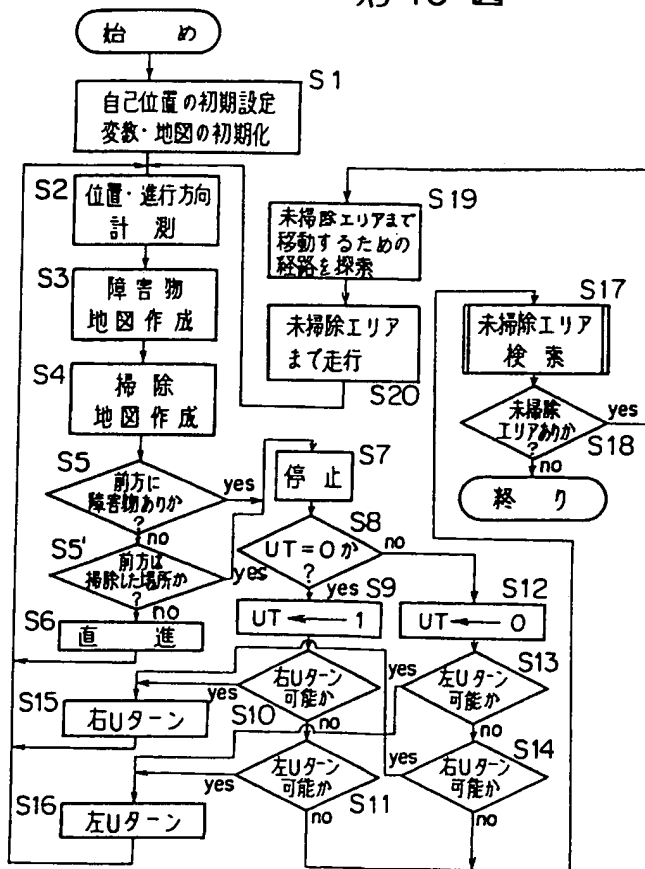
第12図



第11図



第10図

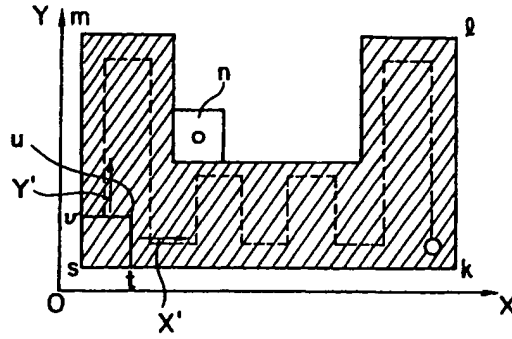


(13)

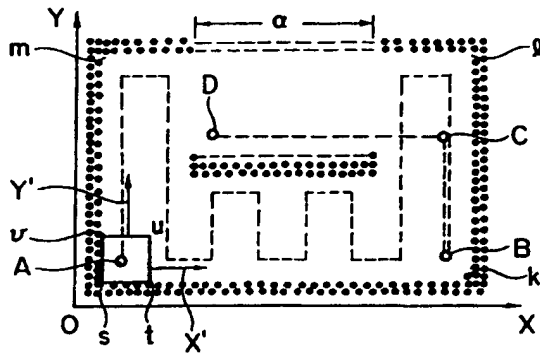
(13)

特公 平 5-82602

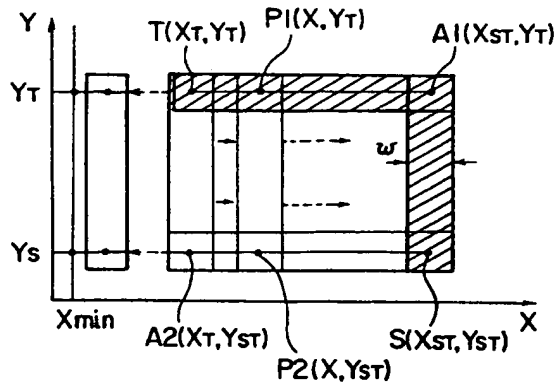
第13图



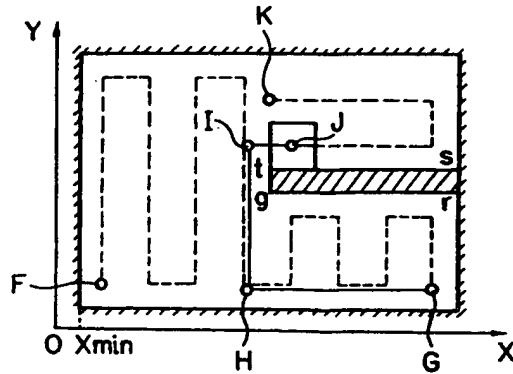
第14图



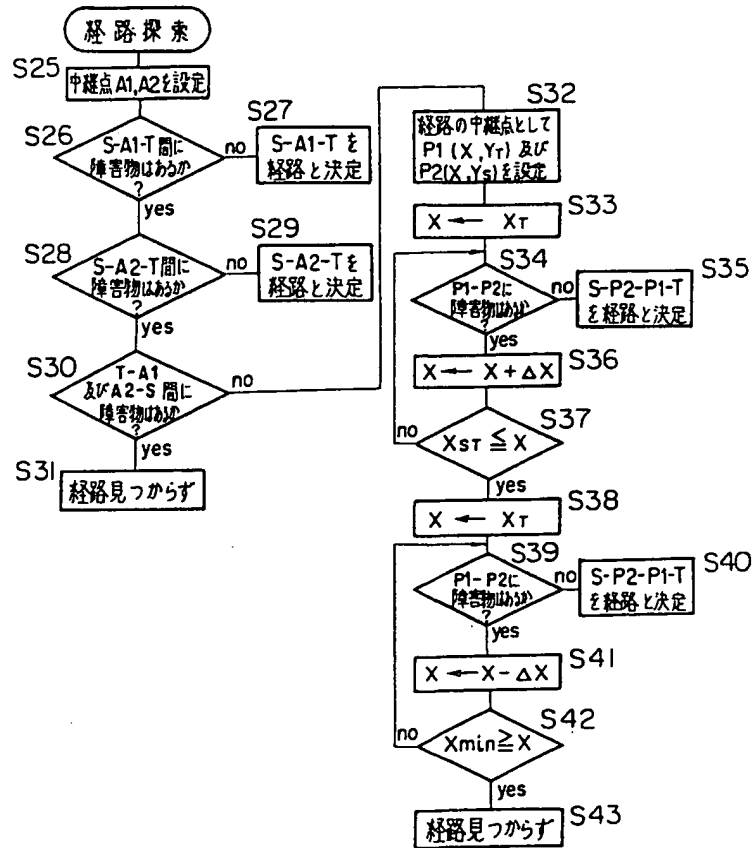
第17图



第18図



第19図





UNITED STATES PATENT AND TRADEMARK OFFICE

UNITED STATES DEPARTMENT OF COMMERCE  
United States Patent and Trademark Office  
Address: COMMISSIONER FOR PATENTS  
P.O. Box 1450  
Alexandria, Virginia 22313-1450  
www.uspto.gov

APPLICATION NO.	FILING DATE	FIRST NAMED INVENTOR	ATTORNEY DOCKET NO.	CONFIRMATION NO.
10/167,851	06/12/2002	Joseph L. Jones	DP-5 US	7777

27639 7590 09/03/2003

iROBOT CORPORATION  
63 SOUTH AVENUE  
BURLINGTON, MA 01803

EXAMINER

LEYKIN, RITA

ART UNIT PAPER NUMBER

2837

DATE MAILED: 09/03/2003

Please find below and/or attached an Office communication concerning this application or proceeding.



9m

Office Action Summary

Application No.

10/167,851

Applicant(s)

JONES ET AL.

Examiner

Rita Leykin

Art Unit

2837

-- The MAILING DATE of this communication appears on the cover sheet with the correspondence address --

Period for Reply

A SHORTENED STATUTORY PERIOD FOR REPLY IS SET TO EXPIRE 3 MONTH(S) FROM THE MAILING DATE OF THIS COMMUNICATION.

- Extensions of time may be available under the provisions of 37 CFR 1.136(a). In no event, however, may a reply be timely filed after SIX (6) MONTHS from the mailing date of this communication.
- If the period for reply specified above is less than thirty (30) days, a reply within the statutory minimum of thirty (30) days will be considered timely.
- If NO period for reply is specified above, the maximum statutory period will apply and will expire SIX (6) MONTHS from the mailing date of this communication.
- Failure to reply within the set or extended period for reply will, by statute, cause the application to become ABANDONED (35 U.S.C. § 133).
- Any reply received by the Office later than three months after the mailing date of this communication, even if timely filed, may reduce any earned patent term adjustment. See 37 CFR 1.704(b).

Status

- 1) [ ] Responsive to communication(s) filed on \_\_\_\_\_.
2a) [ ] This action is FINAL. 2b) [x] This action is non-final.
3) [ ] Since this application is in condition for allowance except for formal matters, prosecution as to the merits is closed in accordance with the practice under Ex parte Quayle, 1935 C.D. 11, 453 O.G. 213.

Disposition of Claims

- 4) [x] Claim(s) 1-41 is/are pending in the application.
4a) Of the above claim(s) \_\_\_\_\_ is/are withdrawn from consideration.
5) [ ] Claim(s) \_\_\_\_\_ is/are allowed.
6) [x] Claim(s) 1-21, 27-35 and 37-41 is/are rejected.
7) [x] Claim(s) 22-26 and 36 is/are objected to.
8) [ ] Claim(s) \_\_\_\_\_ are subject to restriction and/or election requirement.

Application Papers

- 9) [ ] The specification is objected to by the Examiner.
10) [ ] The drawing(s) filed on \_\_\_\_\_ is/are: a) [ ] accepted or b) [ ] objected to by the Examiner.
Applicant may not request that any objection to the drawing(s) be held in abeyance. See 37 CFR 1.85(a).
11) [ ] The proposed drawing correction filed on \_\_\_\_\_ is: a) [ ] approved b) [ ] disapproved by the Examiner.
If approved, corrected drawings are required in reply to this Office action.
12) [ ] The oath or declaration is objected to by the Examiner.

Priority under 35 U.S.C. §§ 119 and 120

- 13) [ ] Acknowledgment is made of a claim for foreign priority under 35 U.S.C. § 119(a)-(d) or (f).
a) [ ] All b) [ ] Some \* c) [ ] None of:
1. [ ] Certified copies of the priority documents have been received.
2. [ ] Certified copies of the priority documents have been received in Application No. \_\_\_\_\_.
3. [ ] Copies of the certified copies of the priority documents have been received in this National Stage application from the International Bureau (PCT Rule 17.2(a)).
\* See the attached detailed Office action for a list of the certified copies not received.
14) [ ] Acknowledgment is made of a claim for domestic priority under 35 U.S.C. § 119(e) (to a provisional application).
a) [ ] The translation of the foreign language provisional application has been received.
15) [ ] Acknowledgment is made of a claim for domestic priority under 35 U.S.C. §§ 120 and/or 121.

Attachment(s)

- 1) [x] Notice of References Cited (PTO-892)
2) [ ] Notice of Draftsperson's Patent Drawing Review (PTO-948)
3) [x] Information Disclosure Statement(s) (PTO-1449) Paper No(s) 2.
4) [ ] Interview Summary (PTO-413) Paper No(s). \_\_\_\_\_.
5) [ ] Notice of Informal Patent Application (PTO-152)
6) [ ] Other:

## DETAILED ACTION

### ***Claim Rejections - 35 USC § 112***

1. The following is a quotation of the second paragraph of 35 U.S.C. 112:

The specification shall conclude with one or more claims particularly pointing out and distinctly claiming the subject matter which the applicant regards as his invention.

2. Claims 15 and 21 are rejected under 35 U.S.C. 112, second paragraph, as being indefinite for failing to particularly point out and distinctly claim the subject matter which applicant regards as the invention.

In claim 15 the phrase "... predetermined number of sensor interactions is between approximately 5 and approximately 15" is vague. There is no clear definition of number of sensor interactions in "approximately 5" – which can be for instance 4, nor "approximately 15" gives clear maximum number of signals, that can be for instance 16. The above boundaries are rather a design choice.

In claim 21 the applicant is claiming means for determining the level of clutter. This claim is vague and indefinite because "the level of clutter" has no sufficient antecedent basis in the base claim 13. Also applicant does not point out, clutter of what, these means are going to detect.

### ***Drawings***

3. The drawings are objected to as failing to comply with 37 CFR 1.84(p)(5) because they include the following reference sign(s) not mentioned in the description: Fig. 8C and 8D. A proposed drawing correction, corrected drawings, or amendment to the specification to add the reference sign(s) in the description, are required in reply to

Art Unit: 2837

the Office action to avoid abandonment of the application. The objection to the drawings will not be held in abeyance.

### ***Specification***

The specification is objected because Brief Description of Drawings has no description for Fig. 8C and 8D. Correction is required.

### ***Claim Rejections - 35 USC § 103***

4. The following is a quotation of 35 U.S.C. 103(a) which forms the basis for all obviousness rejections set forth in this Office action:

(a) A patent may not be obtained though the invention is not identically disclosed or described as set forth in section 102 of this title, if the differences between the subject matter sought to be patented and the prior art are such that the subject matter as a whole would have been obvious at the time the invention was made to a person having ordinary skill in the art to which said subject matter pertains. Patentability shall not be negated by the manner in which the invention was made.

5. Claims 1-7, 9, 13-15, 27-29 and 37-41 are rejected under 35 U.S.C. 103(a) as being unpatentable over Noonan et al. US # 5,204,814 and Ueno et al. US # 6,076,025.

With respect to claims 1-3, 13, 37 and 38, Noonan et al. in Fig. 1A-1C provide layouts of guide paths for autonomous lawn mower to cover completely bounded area. Wherein, the guide path 1A represents a pattern for spot coverage mode. Fig. 1C represents a pattern that is required for obstacle following mode.

With respect to claim 30-35, Noonan et al. teach that rotational indicator 17 is monitored by the microcontroller to sense if the mover has bogged down or stalled. A tilt sensor 21 updates the microcontroller with the angle of vehicle and senses if the vehicle is in danger of tipping over, (see abstract and column 7, lines 16-31).

Noonan et al. do not teach a bouncing mode.

However, Ueno et al. teach a control system for mobile robot capable of detecting the boundary of the area to be covered, with its sensors and performs a spiral pattern running motion, which presents the spot-coverage pattern, that is required for controlled spot-coverage mode. Wherein, controller operates the system in such a way that, when the distance of the robot from the boundary detected by various sensing devices, is smaller than a preset value, the spiral running motion is canceled and random pattern running motion is started. The random pattern running motion includes turning from forward direction and run away from the detected boundary, (see column 2, lines 10-53). This represents the claimed bounce mode.

In Fig. 6c, Ueno et al. also show the movement of robot in the adjacent to the wall area. When the robot 1 comes close to the wall B, the detection signal that the robot is at about the predetermined distance from the wall B is outputted. This will stop the robot in its forward running and turn the robot from the detected obstacle, (see column 6, lines 45-67).

With respect to claim 13-15, 27 and 38 in Fig. 13 Ueno et al. show stored a motion scheme based on various sensors detecting signals, (see column 9, line 67 and column 10, lines 1-5, column 11, lines 1-5).

With respect to claims 4, 5, 6, 10, 11, 16-20 and 39 Ueno et al. teach generating running motion parameters, in accordance with the predetermined distances to obstacles or length of running time, (see abstract and column 2, lines 44, 45 and column 10, lines 36-40). Fig. 7A,B show the relationship between time and progress of work using various parameters of running pattern motion, (see column 7, lines 23-47).

Art Unit: 2837

Also examiner would like to mention that claimed approximate distances are rather a design choice.

With respect to claims 7, 29 and 41, Ueno et al. teach in column 3, lines 50-55 and column 4, lines 30-32, and column 10, lines 14-16 the presence to the contact sensor.

With respect to claims 8 and 40, according to the specification the IR sensors are well known.

With respect to claim 9, see column 1, lines 20-27.

With respect to claim 12, examiner takes an official notice that means for manually selecting an operational mode are well known in the art and are used in many different technologies.

With respect to claim 30-35, Ueno et al. teach in column 11, lines 15-25 an escape behavior control when the robot moves into a corner of the working area, by referencing the Japanese prior document # HEI 9-42879.

Hence, it has been obvious to one of ordinary skills in the art, at the time invention was made to combine teachings of Ueno et al. and Noonan et al. provide for robotic device capable of moving within the sensed boundaries of an area and also capable of escaping any collision with the detected obstacles.

The reason is to design an apparatus that will improve robot work efficiency.

***Allowable Subject Matter***

6. Claims 22-26 and 36 are objected to as being dependent upon a rejected base claim, but would be allowable if rewritten in independent form including all of the limitations of the base claim and any intervening claims.

7. The following is a statement of reasons for the indication of allowable subject matter. The prior art made of record in the attached form PTO-892 considered to be pertinent to the submitted application. However, none of the prior art teaches or suggest in combination:

- Means for detecting the level of clutter comprising tracking the number of interactions with obstacles over time;
- A control system that alternates between operational modes based upon a lack of sensor input;
- A mobile robot, that further comprising a wheel drop sensor, and is utilizing the rate of wheel drop sensor events, as an input to the control system.

Any inquiry concerning this communication or earlier communications from the examiner should be directed to Rita Leykin whose telephone number is (703)308-5828. The examiner can normally be reached on Monday-Friday 8:30-6:00.

If attempts to reach the examiner by telephone are unsuccessful, the examiner's supervisor, Robert Nappi can be reached on (703)308-3370.

Art Unit: 2837

Any inquiry of a general nature or relating to the status of this application or proceeding should be directed to the receptionist whose telephone number is (703)308-0956.

Rita Leykin  
Primary Examiner  
Art Unit 2837

A handwritten signature in cursive script that reads "Rita Leykin".

R.L.

**Notice of References Cited**

Application/Control No. 10/167,851	Applicant(s)/Patent Under Reexamination JONES ET AL.	
Examiner Rita Leykin	Art Unit 2837	Page 1 of 1

**U.S. PATENT DOCUMENTS**

*		Document Number Country Code-Number-Kind Code	Date MM-YYYY	Name	Classification
*	A	US-5,321,614	06-1994	Ashworth, Guy T. D.	701/26
*	B	US-5,204,814	04-1993	Noonan et al.	701/25
*	C	US-6,076,025	06-2000	Ueno et al.	701/23
	D	US-6,463,368	10-2002	Feiten et al.	701/23
*	E	US-5,548,511	08-1996	Bancroft, Allen J.	701/23
	F	US-6,574,536	06-2003	Kawagoe et al.	701/23
	G	US-6,370,453	04-2002	Sommer, Volker	701/23
*	H	US-5,682,313	10-1997	Edlund et al.	342/127
*	I	US-5,867,800	02-1999	Leif, Edlund	701/23
	J	US-5,086,535	02-1992	Grossmeyer et al.	15/319
	K	US-4,962,453	10-1990	Pong et al.	701/23
	L	US-5,341,540	08-1994	Soupert et al.	15/319
	M	US-5,942,869	08-1999	Katou et al.	318/568.12

**FOREIGN PATENT DOCUMENTS**

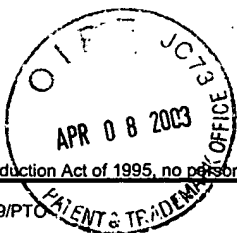
*		Document Number Country Code-Number-Kind Code	Date MM-YYYY	Country	Name	Classification
	N					
	O					
	P					
	Q					
	R					
	S					
	T					

**NON-PATENT DOCUMENTS**

*		Include as applicable: Author, Title Date, Publisher, Edition or Volume, Pertinent Pages)
	U	
	V	
	W	
	X	

\*A copy of this reference is not being furnished with this Office action. (See MPEP § 707.05(a).) Dates in MM-YYYY format are publication dates. Classifications may be US or foreign.





#2

PTO/SB/08A (04-03)  
Approved for use through 04/30/2003. OMB 0651-0031

U.S. Patent and Trademark Office; U.S. DEPARTMENT OF COMMERCE

Under the Paperwork Reduction Act of 1995, no persons are required to respond to a collection of information unless it contains a valid OMB control number.

Substitute for form 1449/PTO  <h2 style="text-align: center;">INFORMATION DISCLOSURE STATEMENT BY APPLICANT</h2> <p style="text-align: center;">(Use as many sheets as necessary)</p>	<h3 style="text-align: center;">Complete if Known</h3> <table border="1" style="width:100%; border-collapse: collapse;"> <tr><td>Application Number</td><td>10/167,851</td></tr> <tr><td>Filing Date</td><td>June 12, 2002</td></tr> <tr><td>First Named Inventor</td><td>JONES</td></tr> <tr><td>Art Unit</td><td></td></tr> <tr><td>Examiner Name</td><td></td></tr> <tr><td>Attorney Docket Number</td><td>DP-5 US</td></tr> </table>	Application Number	10/167,851	Filing Date	June 12, 2002	First Named Inventor	JONES	Art Unit		Examiner Name		Attorney Docket Number	DP-5 US
Application Number	10/167,851												
Filing Date	June 12, 2002												
First Named Inventor	JONES												
Art Unit													
Examiner Name													
Attorney Docket Number	DP-5 US												
Sheet 1 of 2													

U. S. PATENT DOCUMENTS					
Examiner Initials*	Cite No. <sup>1</sup>	Document Number	Publication Date MM-DD-YYYY	Name of Patentee or Applicant of Cited Document	Pages, Columns, Lines, Where Relevant Passages or Relevant Figures Appear
		Number-Kind Code <sup>2</sup> (if known)			
RL		US- 4674048	06-16-1987	Okumura	364/424
RL		US- 5109566	05-05-1992	Kobayashi et al.	15/319
RL		US- 5284522	02-08-1994	Kobayashi et al.	134/18
RL		US- 5321614	06-14-1994	Ashworth	364/424.02
RL		US- 5548511	08-20-1996	Bancroft	364/424.02
RL		US- 5682313	10-28-1997	Edlund et al.	364/424.027
RL		US- 5867800	02-02-1999	Leif	701/23
RL		US- 5935179	08-10-1999	Kleiner et al.	701/23
RL		US- 5940927	08-24-1999	Haegermarck et al.	15/319
RL		US- 6076025	06-13-2000	Ueno et al.	701/23
RL		US- 6389329-B1	05-14-2002	Colens	700/262
RL		US- 6459955-B1	10-01-2002	Bartsch et al.	700/245
RL		US- 6481515-B1	11-19-2002	Kirkpatrick et al.	180/28
RL		US- 5204814	04-20-1993	Noonan et al.	364/424.02
RL		US- 6240342-B1	05-29-2001	Fiegert et al.	701/25
		US-			
		US-			
		US-			
		US-			

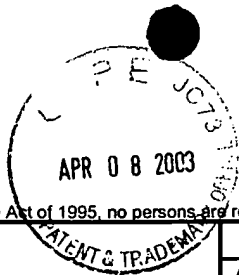
FOREIGN PATENT DOCUMENTS						
Examiner Initials*	Cite No. <sup>1</sup>	Foreign Patent Document	Publication Date MM-DD-YYYY	Name of Patentee or Applicant of Cited Document	Pages, Columns, Lines, Where Relevant Passages Or Relevant Figures Appear	T <sup>6</sup>
		Country Code <sup>3</sup> Number <sup>4</sup> Kind Code <sup>5</sup> (if known)				
RL		WO 99/59042 A	11-18-1999	Perless et al.		
RL		WO 02/39864 A1	05-23-2002	Aasen		
RL		WO 97/41451	11-06-1997	Kleiner et al.		
RL		WO 97/78410 A1	12-28-2000	Colens		
RL		WO 99/38056	07-29-1999	Bergvall et al.		
RL		WO 97/40734	11-06-1997	Haegermarck et		

Examiner Signature: <i>Rita Luykin</i>	Date Considered: 8/20/03
--	--------------------------

\*EXAMINER: Initial if reference considered, whether or not citation is in conformance with MPEP 609. Draw line through citation if not in conformance and not considered. Include copy of this form with next communication to applicant. <sup>1</sup> Applicant's unique citation designation number (optional). <sup>2</sup> See Kinds Codes of USPTO Patent Documents at [www.uspto.gov](http://www.uspto.gov) or MPEP 901.04. <sup>3</sup> Enter Office that issued the document, by the two-letter code (WIPO Standard ST.3). <sup>4</sup> For Japanese patent documents, the indication of the year of the reign of the Emperor must precede the serial number of the patent document. <sup>5</sup> Kind of document by the appropriate symbols as indicated on the document under WIPO Standard ST. 16 if possible. <sup>6</sup> Applicant is to place a check mark here if English language Translation is attached.

This collection of information is required by 37 CFR 1.97 and 1.98. The information is required to obtain or retain a benefit by the public which is to file (and by the USPTO to process) an application. Confidentiality is governed by 35 U.S.C. 122 and 37 CFR 1.14. This collection is estimated to take 2 hours to complete, including gathering, preparing, and submitting the completed application form to the USPTO. Time will vary depending upon the individual case. Any comments on the amount of time you require to complete this form and/or suggestions for reducing this burden, should be sent to the Chief Information Officer, U.S. Patent and Trademark Office, U.S. Department of Commerce, Washington, DC 20231. DO NOT SEND FEES OR COMPLETED FORMS TO THIS ADDRESS. SEND TO: Commissioner for Patents, Washington, DC 20231.

If you need assistance in completing the form, call 1-800-PTO-9199 (1-800-786-9199) and select option 2.



PTO/SB/08B (04-03)

Approved for use through 04/30/2003. OMB 0651-0031  
U.S. Patent and Trademark Office; U.S. DEPARTMENT OF COMMERCE

Under the Paperwork Reduction Act of 1995, no persons are required to respond to a collection of information unless it contains a valid OMB control number.

Substitute for form 1449/PTO

**INFORMATION DISCLOSURE  
STATEMENT BY APPLICANT***(Use as many sheets as necessary)***Compleat if Known**Sheet **2** of **2**

Application Number	10/167,851
Filing Date	June 12, 2002
First Named Inventor	JONES
Art Unit	
Examiner Name	
Attorney Docket Number	DP-5 US

**NON PATENT LITERATURE DOCUMENTS**

Examiner Initials*	Cite No. <sup>1</sup>	Include name of the author (in CAPITAL LETTERS), title of the article (when appropriate), title of the item (book, magazine, journal, serial, symposium, catalog, etc.), date, page(s), volume-issue number(s), publisher, city and/or country where published.	T <sup>2</sup>
RL		DOTY, Keith L. et al., "Sweep Strategies for a Sensory-Driven, Behavior-Based Vacuum Cleaning Agent," AAI 1995 Fall Symposium Series, US	

Examiner Signature	<i>Rita Sykes</i>	Date Considered	<i>8/20/03</i>
--------------------	-------------------	-----------------	----------------

\*EXAMINER: Initial if reference considered, whether or not citation is in conformance with MPEP 609. Draw line through citation if not in conformance and not considered. Include copy of this form with next communication to applicant.

<sup>1</sup> Applicant's unique citation designation number (optional). <sup>2</sup> Applicant is to place a check mark here if English language Translation is attached. This collection of information is required by 37 CFR 1.98. The information is required to obtain or retain a benefit by the public which is to file (and by the USPTO to process) an application. Confidentiality is governed by 35 U.S.C. 122 and 37 CFR 1.14. This collection is estimated to take 120 minutes to complete, including gathering, preparing, and submitting the completed application form to the USPTO. Time will vary depending upon the individual case. Any comments on the amount of time you require to complete this form and/or suggestions for reducing this burden, should be sent to the Chief Information Officer, U.S. Patent and Trademark Office, U.S. Department of Commerce, Washington, DC 20231. DO NOT SEND FEES OR COMPLETED FORMS TO THIS ADDRESS. SEND TO: Commissioner for Patents, Washington, DC 20231.

If you need assistance in completing the form, call 1-800-PTO-9199 (1-800-786-9199) and select option 2.

Silver Star Exhibit 1002 - 766

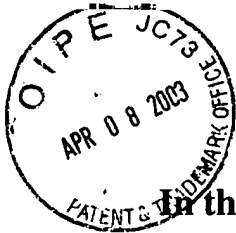
	Type	Hits	Search Text	DBs
1	BRS	22442	robot\$3 and (clean\$3 or vacuum\$5)	USPAT; US-PGPUB; EPO; JPO; DERWENT
2	BRS	341	(robot\$3 and (clean\$3 or vacuum\$5)) and (obstacle with (detect\$5 or sens\$3 or monitor\$3))	USPAT; US-PGPUB; EPO; JPO; DERWENT
3	BRS	78	((robot\$3 and (clean\$3 or vacuum\$5)) and (obstacle with (detect\$5 or sens\$3 or monitor\$3))) and (area with cover\$5)	USPAT; US-PGPUB; EPO; JPO; DERWENT
4	BRS	65	((robot\$3 and (clean\$3 or vacuum\$5)) and (obstacle with (detect\$5 or sens\$3 or monitor\$3))) and (area with cover\$5) and ((\$processor) or (\$controller))	USPAT; US-PGPUB; EPO; JPO; DERWENT
5	BRS	59	((robot\$3 and (clean\$3 or vacuum\$5)) and (obstacle with (detect\$5 or sens\$3 or monitor\$3))) and (area with cover\$5) and ((\$processor) or (\$controller)) and (lut or table or memory)	USPAT; US-PGPUB; EPO; JPO; DERWENT
6	BRS	19	((robot\$3 and (clean\$3 or vacuum\$5)) and (obstacle with (detect\$5 or sens\$3 or monitor\$3))) and (area with cover\$5) and ((\$processor) or (\$controller)) and (lut or table or memory) and spiral	USPAT; US-PGPUB; EPO; JPO; DERWENT
7	BRS	1	((robot\$3 and (clean\$3 or vacuum\$5)) and (obstacle with (detect\$5 or sens\$3 or monitor\$3))) and (area with cover\$5) and ((\$processor) or (\$controller)) and (lut or table or memory) and spiral) and ((switch\$5 or alternate)near3 mode) with obstacle)	USPAT; US-PGPUB; EPO; JPO; DERWENT
8	BRS	1	(robot\$3 and (clean\$3 or vacuum\$5)) and (obstacle with (detect\$5 or sens\$3 or monitor\$3)) and (obstacle with ((switch\$5 or alternat\$3) near3 mode\$2))	USPAT; US-PGPUB; EPO; JPO; DERWENT

	Type	Hits	Search Text	DBs
9	BRS	0	((robot\$3 and (clean\$3 or vacuum\$5)) and (obstacle with (detect\$5 or sens\$3 or monitor\$3)) and (obstacle with ((switch\$5 or alternat\$3) near3 mode\$2))) not (((robot\$3 and (clean\$3 or vacuum\$5)) and (obstacle with (detect\$5 or sens\$3 or monitor\$3))) and (area with cover\$5) and ((\$processor) or (\$controller))) and (lut or table or memory) and spiral) and (((switch\$5 or alternate)near3 mode) with obstacle))	USPAT; US-PGPUB; EPO; JPO; DERWENT
10	BRS	59	((robot\$3 and (clean\$3 or vacuum\$5)) and (obstacle with (detect\$5 or sens\$3 or monitor\$3))) and (area with cover\$5) and ((\$processor) or (\$controller)) and mode\$3	USPAT; US-PGPUB; EPO; JPO; DERWENT
11	BRS	7	((robot\$3 and (clean\$3 or vacuum\$5)) and (obstacle with (detect\$5 or sens\$3 or monitor\$3))) and (area with cover\$5) and ((\$processor) or (\$controller)) and mode\$3) and ((switch\$5 or alternate)near3 mode)	USPAT; US-PGPUB; EPO; JPO; DERWENT
12	BRS	2	((robot\$3 and (clean\$3 or vacuum\$5)) and (obstacle with (detect\$5 or sens\$3 or monitor\$3))) and (area with cover\$5) and ((\$processor) or (\$controller)) and mode\$3) and ((switch\$5 or alternate)near3 mode) ) and spiral	USPAT; US-PGPUB; EPO; JPO; DERWENT

	Type	Hits	Search Text	DBs
13	BRS	1	(((((robot\$3 and (clean\$3 or vacuum\$5)) and (obstacle with (detect\$5 or sens\$3 or monitor\$3))) and (area with cover\$5) and ((\$processor) or (\$controller)) and mode\$3) and ((switch\$5 or alternate)near3 mode) ) and spiral) not (((((robot\$3 and (clean\$3 or vacuum\$5)) and (obstacle with (detect\$5 or sens\$3 or monitor\$3))) and (area with cover\$5) and ((\$processor) or (\$controller))) and (lut or table or memory) and spiral) and (((switch\$5 or alternate)near3 mode) with obstacle))	USPAT; US-PGPUB; EPO; JPO; DERWENT
14	BRS	55	robot and (clean\$4 or mow\$3 or vacuum\$3) and (mov\$5 with spiral) and mode\$2	USPAT; US-PGPUB; EPO; JPO; DERWENT
15	BRS	12	(robot and (clean\$4 or mow\$3 or vacuum\$3) and (mov\$5 with spiral) and mode\$2) and ((alternat\$5 or switch\$5) with mode\$2)	USPAT; US-PGPUB; EPO; JPO; DERWENT
16	BRS	11	((robot and (clean\$4 or mow\$3 or vacuum\$3) and (mov\$5 with spiral) and mode\$2) and ((alternat\$5 or switch\$5) with mode\$2)) not (((((robot\$3 and (clean\$3 or vacuum\$5)) and (obstacle with (detect\$5 or sens\$3 or monitor\$3))) and (area with cover\$5) and ((\$processor) or (\$controller))) and (lut or table or memory) and spiral) and (((switch\$5 or alternate)near3 mode) with obstacle))	USPAT; US-PGPUB; EPO; JPO; DERWENT
17	BRS	2	5321614.pn.	USPAT; US-PGPUB; EPO; JPO; DERWENT
18	BRS	1	5321614.pn. and time and distance	USPAT; US-PGPUB; EPO; JPO; DERWENT
19	BRS	2	5204814.pn.	USPAT; US-PGPUB; EPO; JPO; DERWENT
20	BRS	1	5204814.pn. and manual	USPAT; US-PGPUB; EPO; JPO; DERWENT

	Type	Hits	Search Text	DBs
21	BRS	2	6076025.pn.	USPAT; US-PGPUB; EPO; JPO; DERWENT
22	BRS	0	6076025.pn. and manual	USPAT; US-PGPUB; EPO; JPO; DERWENT
23	BRS	1	5321614.pn. and manual	USPAT; US-PGPUB; EPO; JPO; DERWENT
24	BRS	4	5321614.pn. or 5204814.pn. or 6076025.pn. and (mode with (manual\$3))	USPAT; US-PGPUB; EPO; JPO; DERWENT
25	BRS	2	(5321614.pn. or 5204814.pn. or 6076025.pn.) and (mode with (manual\$3))	USPAT; US-PGPUB; EPO; JPO; DERWENT
26	BRS	46	((robot\$3 and (clean\$3 or vacuum\$5)) and (obstacle with (detect\$5 or sens\$3 or monitor\$3))) and (area with cover\$5) and ((\$processor) or (\$controller)) and (lut or table or memory) and ((signals or outputs) with (sensors or detectors))	USPAT; US-PGPUB; EPO; JPO; DERWENT
27	BRS	46	((((robot\$3 and (clean\$3 or vacuum\$5)) and (obstacle with (detect\$5 or sens\$3 or monitor\$3))) and (area with cover\$5) and ((\$processor) or (\$controller)) and (lut or table or memory) and ((signals or outputs) with (sensors or detectors))) and (follow\$3 or escap\$3)	USPAT; US-PGPUB; EPO; JPO; DERWENT
28	BRS	3	3800902.pn.	USPAT; US-PGPUB; EPO; JPO; DERWENT
29	BRS	1	3550714.pn.	USPAT; US-PGPUB; EPO; JPO; DERWENT
30	BRS	2	3095939.pn.	USPAT; US-PGPUB; EPO; JPO; DERWENT
31	BRS	1	(3800902.pn. or 3550714.pn. or 3095939.pn.) and (escap\$3 or follow\$3)	USPAT; US-PGPUB; EPO; JPO; DERWENT
32	BRS	6	3800902.pn. or 3550714.pn. or 3095939.pn.	USPAT; US-PGPUB; EPO; JPO; DERWENT
33	BRS	0	3550714.pn. and (obstacle with (sens\$3 or detect\$3 or monitor\$3)) and direction and area and follow\$3	USPAT; US-PGPUB; EPO; JPO; DERWENT

	Type	Hits	Search Text	DBs
34	BRS	0	3550714.pn. and (obstacle with (sens\$3 or detect\$3 or monitor\$3)) and direction	USPAT; US-PGPUB; EPO; JPO; DERWENT
35	BRS	0	3550714.pn. and (obstacle with (sens\$3 or detect\$3 or monitor\$3))	USPAT; US-PGPUB; EPO; JPO; DERWENT



**In the United States Patent and Trademark Office**

Serial Number: 10/167,851  
Application Filed: June 12, 2002  
Inventors: Joseph L. Jones & Philip R. Mass  
Assignee: iRobot Corporation  
Title: **METHOD AND SYSTEM FOR MULTI-MODE COVERAGE FOR AN AUTONOMOUS ROBOT**  
Attorney Docket: DP-5 US

2837  
RECEIVED  
APR -9 2003  
TC 2800 MAIL ROOM  
2/ JDS  
JHEW  
8/5/03

**Information Disclosure Statement**

Assistant Commissioner for Patents  
Washington, District of Columbia 20231

Sir:

Applicant submits the references listed on the attached Form PTO/SB/08A (2 sheets), copies of which are enclosed. Also enclosed is a copy of a Search Report in a corresponding foreign application.

This statement is being filed before the receipt of a first Office Action on the merits. Please apply any charges or credits to Deposit Account No. 50-1806

Very respectfully,

Glen D. Weinstein  
Reg. No. 43,981  
iRobot Corporation

April 4, 2003

iRobot Corporation  
63 South Avenue  
Burlington, MA 01803





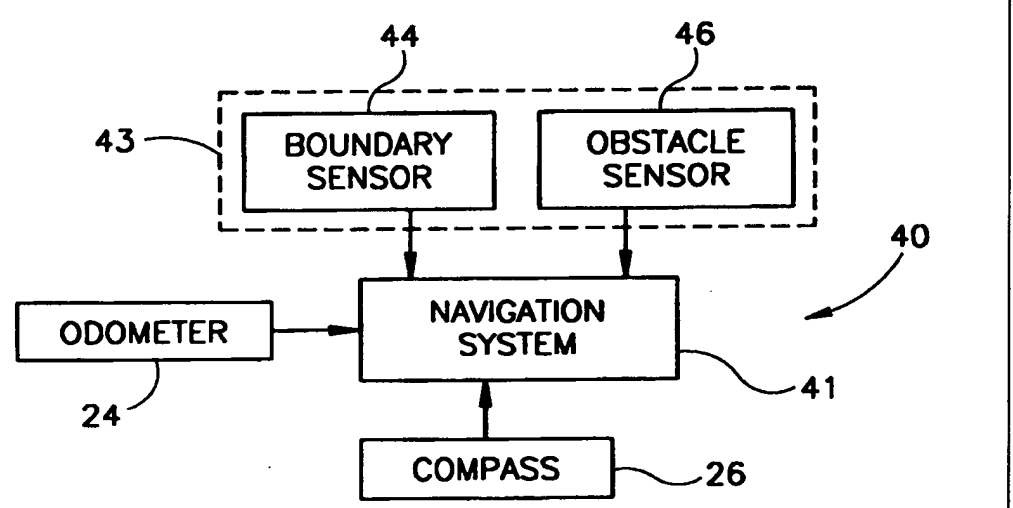
INTERNATIONAL APPLICATION PUBLISHED UNDER THE PATENT COOPERATION TREATY (PCT)

<p>(51) International Patent Classification <sup>6</sup> : <b>G05D 1/00</b></p>	<p><b>A1</b></p>	<p>(11) International Publication Number: <b>WO 99/59042</b> (43) International Publication Date: 18 November 1999 (18.11.99)</p>
<p>(21) International Application Number: PCT/IL99/00248 (22) International Filing Date: 11 May 1999 (11.05.99) (30) Priority Data: 124413 11 May 1998 (11.05.98) IL (71) Applicant (for all designated States except US): FRIENDLY MACHINES LTD. [IL/IL]; Beit Ya'acobi, Ha'atzmaut Street, 40500 Even Yehuda (IL). (72) Inventors; and (75) Inventors/Applicants (for US only): PELESS, Ehud [IL/IL]; Hatomer Street 8, 40500 Even Yehuda (IL). ABRAMSON, Shai [IL/IL]; Haerez Street 4, 42815 Pardessia (IL). FRIEDMAN, Ronen [IL/IL]; Hayedidut Street 10, 45297 Hod Hasharon (IL). PELEG, Ilan [IL/IL]; Arbel Street 36, 44862 Tsur Yigal (IL). (74) Agent: EITAN, PEARL, LATZER &amp; COHEN-ZEDEK; Gav Yam Center 2, Shenkar Street 7, 46725 Herzlia (IL).</p>		<p>(81) Designated States: AE, AL, AM, AT, AU, AZ, BA, BB, BG, BR, BY, CA, CH, CN, CU, CZ, DE, DK, EE, ES, FI, GB, GD, GE, GH, GM, HR, HU, ID, IL, IN, IS, JP, KE, KG, KP, KR, KZ, LC, LK, LR, LS, LT, LU, LV, MD, MG, MK, MN, MW, MX, NO, NZ, PL, PT, RO, RU, SD, SE, SG, SI, SK, SL, TJ, TM, TR, TT, UA, UG, US, UZ, VN, YU, ZA, ZW, ARIPO patent (GH, GM, KE, LS, MW, SD, SL, SZ, UG, ZW), Eurasian patent (AM, AZ, BY, KG, KZ, MD, RU, TJ, TM), European patent (AT, BE, CH, CY, DE, DK, ES, FI, FR, GB, GR, IE, IT, LU, MC, NL, PT, SE), OAPI patent (BF, BJ, CF, CG, CI, CM, GA, GN, GW, ML, MR, NE, SN, TD, TG).  Published With international search report.</p>

(54) Title: AREA COVERAGE WITH AN AUTONOMOUS ROBOT

(57) Abstract

There is therefore provided, in accordance with a preferred embodiment of the present invention, a robotic system for systematically moving about an area to be covered. The system includes at least one boundary marker (48) located along the outer edge of the area to be covered, a robot (40) with a navigation system (41) and a sensor unit (43). The navigation system (41) navigates the robot (40) in generally straight, parallel lines from an initial location and turns the robot (40) when the robot (40) encounters one of the boundary markers (48), thereby to systematically move about the area to be covered. The sensor unit (43) senses proximity to one of the at least one boundary marker (48).



**FOR THE PURPOSES OF INFORMATION ONLY**

Codes used to identify States party to the PCT on the front pages of pamphlets publishing international applications under the PCT.

AL	Albania	ES	Spain	LS	Lesotho	SI	Slovenia
AM	Armenia	FI	Finland	LT	Lithuania	SK	Slovakia
AT	Austria	FR	France	LU	Luxembourg	SN	Senegal
AU	Australia	GA	Gabon	LV	Larvia	SZ	Swaziland
AZ	Azerbaijan	GB	United Kingdom	MC	Monaco	TD	Chad
BA	Bosnia and Herzegovina	GE	Georgia	MD	Republic of Moldova	TG	Togo
BB	Barbados	GH	Ghana	MG	Madagascar	TJ	Tajikistan
BE	Belgium	GN	Guinea	MK	The former Yugoslav Republic of Macedonia	TM	Turkmenistan
BF	Burkina Faso	GR	Greece			TR	Turkey
BG	Bulgaria	HU	Hungary	ML	Mali	TT	Trinidad and Tobago
BJ	Benin	IE	Ireland	MN	Mongolia	UA	Ukraine
BR	Brazil	IL	Israel	MR	Mauritania	UG	Uganda
BY	Belarus	IS	Iceland	MW	Malawi	US	United States of America
CA	Canada	IT	Italy	MX	Mexico	UZ	Uzbekistan
CF	Central African Republic	JP	Japan	NE	Niger	VN	Viet Nam
CG	Congo	KE	Kenya	NL	Netherlands	YU	Yugoslavia
CH	Switzerland	KG	Kyrgyzstan	NO	Norway	ZW	Zimbabwe
CI	Côte d'Ivoire	KP	Democratic People's Republic of Korea	NZ	New Zealand		
CM	Cameroon			PL	Poland		
CN	China	KR	Republic of Korea	PT	Portugal		
CU	Cuba	KZ	Kazakstan	RO	Romania		
CZ	Czech Republic	LC	Saint Lucia	RU	Russian Federation		
DE	Germany	LI	Liechtenstein	SD	Sudan		
DK	Denmark	LK	Sri Lanka	SE	Sweden		
EE	Estonia	LR	Liberia	SG	Singapore		

## AREA COVERAGE WITH AN AUTONOMOUS ROBOT

### FIELD OF THE INVENTION

The present invention relates to autonomous robots generally and to autonomous robots which move through an area in particular.

5

### BACKGROUND OF THE INVENTION

Autonomous robots are known in the art and have been implemented as household appliances, such as a lawnmower or a vacuum cleaner. These household appliances operate by moving about an area to be processed such that the entire area is covered by the end of the operation.

10

Reference is now made to Figs. 1A and 1B which illustrate the operation of one exemplary autonomous robot, described in U.S. Patent Application 08/554,691, filed 7 November 1995 and assigned to the common assignees of the present invention. US Patent Application 08/554,691 is incorporated herein by reference. Fig. 1A illustrates the area in which the robot 10 operates and Fig. 1B illustrates the elements, in block diagram form, of robot 10.

15

The autonomous robot 10 operates within an area marked with boundary markers 12A. If there are fixed obstacles 14 in the area, such as flower beds, trees, columns, walls, etc., these obstacles are rimmed with further boundary markers 12B. The boundary markers 12 can be of any suitable type, such as an electrified wire, bar coded posts, a radioactive posts, etc. The term "marker" will be used  
20 herein for both posts and wires.

As shown in Fig. 1B, the robot 10 includes a navigation system 20 which receives data from an edge sensor 22 which senses when the robot 10 approaches a boundary marker 12 where, if the marker is a continuous wire, the term "marker" indicates the section of the wire near the current location of the robot. The navigation system 20 also receives data from an odometer 24 which measures the distance the robot 10 has moved and a compass 26 which measures the current location of the robot 10.

Initially, the robot 10 is placed within the area to be covered. The robot 10 moves toward the boundary (if it did not begin near it) and then, as indicated by arrows 32, moves along the boundary, following the boundary markers 12. During this process, the robot 10 uses the location information from the compass to produce a map 28 (Fig. 1B) of the area to be covered.

Once the map is complete, the robot 10 moves about the area to be covered. Whenever it approaches a boundary marker 12, as sensed by the edge sensor 22, the robot 10 changes direction and continues until it reaches another boundary marker 12. If the boundary marker 12 appeared close to, but not at, its expected position, navigation system 20 updates the map 28 to match the new information.

If the boundary marker 12 is sensed substantially within the area, as determined by a comparison of the output of the compass 26 and the information in the map 28, the boundary marker 12 must be one which surrounds the obstacle 14. The robot 10 changes direction and continues until it reaches another boundary marker 12. The robot 10 moves about the area to be covered until it has determined that all sections of the map 28 have been covered.

However, it will be appreciated that creating the map 28 of the shape of the area to be covered is time consuming. Due to the inaccuracies of the compass 26 and odometer 24, it is also typically error prone.

## SUMMARY OF THE INVENTION

Applicants have realized that, if the robot works systematically within the area to be covered, there is no need to create the map.

It is therefore an object of the present invention to provide an autonomous  
5 robot, for performing area coverage, which does not create a map of the area to be covered.

There is therefore provided, in accordance with a preferred embodiment of the present invention, a robotic system for systematically moving about an area to be covered. The system includes at least one boundary marker located along the  
10 outer edge of the area to be covered, a robot with a navigation system and a sensor unit. The navigation system navigates the robot in generally straight, parallel lines from an initial location and turns the robot when the robot encounters one of the boundary markers, thereby to systematically move about the area to be covered. The sensor unit senses proximity to one of the at least one boundary marker.

15 Additionally, in accordance with a preferred embodiment of the present invention, the sensor unit includes a unit for indicating proximity to an obstacle within the area to be covered and the navigation system includes a unit for turning the robot when the unit for indicating indicates proximity to an obstacle.

Moreover, in accordance with a preferred embodiment of the present  
20 invention, the unit for indicating is either a contact sensor or a proximity sensor.

Further, in accordance with a preferred embodiment of the present invention, the navigation system includes a unit for counting the number of laps needed to cover the area between an obstacle and a boundary marker.

Still further, in accordance with a preferred embodiment of the present invention, the system includes at least one obstacle marker located along the outer edge of the obstacle.

Moreover, in accordance with a preferred embodiment of the present invention, the at least one boundary marker is an electrified wire receiving a first signal and the at least one obstacle marker is an electrified wire receiving a second signal.

Alternatively, in accordance with a preferred embodiment of the present invention, the at least one boundary marker is a post having a first bar code and the at least one obstacle marker is a post having a second bar code.

There is also provided, in accordance with a preferred embodiment of the present invention, a robotic system for systematically moving about an area to be covered. The system includes at least one boundary marker located along the outer edge of the area to be covered, at least one obstacle marker located along the outer edge of an obstacle within the area to be covered, a robot for moving about the area to be covered and a sensor unit for sensing proximity to the boundary and obstacle markers and for differentiating between the boundary and obstacle markers.

**BRIEF DESCRIPTION OF THE DRAWINGS**

The present invention will be understood and appreciated more fully from the following detailed description taken in conjunction with the appended drawings in which:

5            Fig. 1A is a schematic illustration of an area to be covered and the initial movement of a prior art robot within the area;

            Fig. 1B is a block diagram illustration of the prior art robot;

            Fig. 2A is a schematic illustration of an area to be covered and the movement of a robot of the present invention within the area;

10           Fig. 2B is a block diagram illustration of a robot, constructed and operative in accordance with a preferred embodiment of the present invention;

            Fig. 3A is a schematic illustration of one embodiment of boundary and obstacle markers;

            Fig. 3B is a timing diagram operative for the embodiment of Fig. 3A;

15           Fig. 3C is a graphical illustration of the signal strength of a magnetic sensor as a function of distance from the markers of Fig. 3A; and

            Fig. 4 is a schematic illustration of an alternative embodiment of boundary and obstacle markers.

20



## DETAILED DESCRIPTION OF THE PRESENT INVENTION

Reference is now made to Figs. 2A and 2B which illustrate the movement of a robot 40 of the present invention and the elements of the robot, respectively. Similar reference numerals refer to similar elements.

5 In accordance with a preferred embodiment of the present invention, robot 40 does not create a map of the area to be covered. Instead, it systematically scans within the area, moving in a straight direction from one boundary marker to the next. To do so, it must initially be placed relatively close to one extreme edge of the boundary, for example at starting point 42, and faced in the desired direction of  
10 scanning.

As can be seen in Fig. 2B, the robot 40 utilizes the odometer 24 and compass 26 but comprises a navigation system 41 and a sensor system 43, shown as two sensors 44 and 46, for separately sensing the boundary and the obstacles, respectively. Accordingly, there can be two different types of markers, boundary  
15 markers 48 and obstacle markers 50. The boundary markers 48 and obstacle markers 50 can be of any suitable types, as detailed hereinbelow.

Alternatively, for obstacles which stick above the ground, such as trees and furniture, the obstacle sensors can be proximity and/or contact sensors. For this system, there is no need for obstacle markers and only boundary markers are  
20 utilized.

It will be appreciated that, without a map, robot 40 does not know its position within the area to be scanned; it only knows its absolute position. Using position information, robot 40 scans the area, moving in a generally straight line

from one marker to the next, as determined by sensor system 43. Using the output of compass 26, the navigation system 41 then turns robot 40 generally 180° whenever it encounters a new marker. The navigation system 41 also ensures that the new "lap" is beside, and possibly slightly overlapping, the previous lap, thereby  
5 to ensure full coverage of the area to be covered. This is described in detail in US Patent Application 08/554,691.

In general, robot 40 moves in generally straight, parallel lines between two boundary markers 48, as indicated by arrows 52. However, if sensor system 43 indicates that the robot 40 is close to an obstacle marker 50, the navigation system  
10 41 causes the scan to occur between boundary markers 48 and obstacle markers 50, as indicated by arrows 54, counting the number of laps until the obstacle is passed. The next lap, arrow 38, brings the robot 40 to a boundary marker 48 on the other side of the obstacle 14. The robot 40 then performs a scan in the opposite direction, between the boundary markers 48 and the obstacle markers 50,  
15 to cover the area behind the obstacle 14. This scan is shown with arrows 56 and involves the same number of laps as for the first side of the obstacle 14.

Once the scan behind the obstacle 14 is finished, the robot 40 follows the boundary markers 48 until it reaches the point, labeled 60, where it began the scan behind the obstacle 14, at which point, it continues normal scanning between  
20 boundary markers 48.

Alternatively, the scan behind the obstacle 14 can be performed without counting laps. Instead, the scan continues until the obstacle 14 has been passed. This requires noting the location of the robot 10 near the boundary when the robot

10 b gins the scan b hind the obstacle 14 so that the robot 10 can be returned to that location once the scan b hind the obstacle 14 is finished.

It will be appreciated that, by scanning systematically between boundary and obstacle markers, the present invention covers the area to be covered without  
5 having to produce a map of the area.

Reference is now made to Figs. 3A, 3B and 3C which respectively illustrate one set of boundary and obstacle markers formed of wires, a timing diagram for the markers and a graph of signal strength as a function of distance from the wire.

In this embodiment, both the boundary marker 48 and the multiple obstacle  
10 markers 50 are formed of wires connected to a power supply 60 via a wave generator 62. The wave generator 62 provides one type of signal for the boundary marker 48 and another type of signal to all of the obstacle markers 50.

For example, the signal for marker 48 might be of one frequency while the signal for markers 50 might be of a second frequency. In this embodiment, the  
15 wave generator 62 includes two separate elements, each of which produces one of the two frequencies and provides it to the appropriate set of wires.

Alternatively and as shown in Fig. 3B, the signals can be time shared. In this embodiment, a short synchronization pulse 64 is followed by a boundary signal 66 for marker 48 after which an obstacle signal 68 for markers 50 is provided. The  
20 sequence repeats. The marker is determined to be a boundary marker or an obstacle marker by the length of time from the most recent synchronization pulse 64.

It will be appreciated that, for both embodiments, the robot, labeled 70, has a single magnetic sensor 72 for sensing the signals from wave generator 62 and a

processor 74 for determining if the type of signal based on the frequency of the transmission, in the first embodiment, or based on the timing of the transmission, in the second embodiment. Alternatively, for the second embodiment, the robot 70 can have separate receivers, each tuned to the relevant frequency, and separate  
5 processors for each receiver to determine if the received signal is strong enough to indicate proximity.

Fig. 3C schematically illustrates the strength of the signal as a function of distance from the location of the wire. When the sensor 72 is on top of the wire, no signal is received (point 80). As the sensor 72 moves away from the wire, the  
10 signal increases sharply, reaching a peak 82 within 50cm. The signal then slowly decays as the sensor 72 moves further away from the wire. Thus, as the robot 70 approaches the wire, the signal will slowly increase in strength. Acceptable proximity can be defined as once peak 82 has been reached or any time after peak 82 has been reached.

15 Reference is now made to Fig. 4 which illustrates an alternative embodiment of the boundary and obstacle markers 48 and 50, respectively. In this embodiment, the markers are formed of posts, each having a different bar code written thereon. Fig. 4 uses squares to indicate the boundary markers 48 and circles to indicate obstacle markers 50. In this embodiment, as in the previous  
20 embodiment, there is a single sensor. In this case, the sensor is a bar code reader which provides one type of signal when it reads the boundary marker code and another type of signal when it reads the obstacle marker code.

Alternatively, the boundary markers 40 can be formed of a wire and the obstacle markers can be formed of bar coded posts, or vice versa. A further

alternative, discussed hereinabove, uses markers only for the boundary and contact or proximity sensors for sensing the proximity of an obstacle.

It will be appreciated that the markers can be formed of any suitable marking unit and that the robot includes a sensor or sensors capable of recognizing the information which the marking unit provides to determine proximity. Such  
5 sensors and marking units are discussed in detail in US Patent Application 08/554,691. The number of sensors used is of little importance to the present invention; however, the information from the types of sensors must be separable.

It will be appreciated by persons skilled in the art that the present invention  
10 is not limited by what has been particularly shown and described herein above. Rather the scope of the invention is defined by the claims that follow:

**CLAIMS**

1. A robotic system for systematically moving about an area to be covered,  
the system comprising:

5 at least one boundary marker located along the outer edge of  
the area to be covered;

a robot for systematically moving about said area to be  
covered, the robot including a navigation system for navigating said  
robot in generally straight, parallel lines from an initial location and  
for turning said robot when said robot encounters one of said at  
10 least one boundary marker; and

a sensor unit for sensing proximity to one of said at least one  
boundary marker.

2. A system according to claim 1 and wherein said sensor unit includes  
means for indicating proximity to an obstacle within said area to be  
15 covered and said navigation system includes means for turning said  
robot when said means for indicating indicate proximity to an obstacle.

3. A system according to claim 2 and wherein said means for indicating is  
one of a contact sensor and a proximity sensor.

4. A system according to claim 2 and wherein said navigation system  
20 includes means for counting the number of laps needed to cover the  
area between an obstacle and a boundary marker.

5. A system according to claim 2 and additionally comprising at least one  
obstacle marker located along the outer edge of said obstacle.

6. A system according to claim 4 and wherein said at least one boundary marker is an electrified wire receiving a first signal and said at least one obstacle marker is an electrified wire receiving a second signal.
7. A system according to claim 4 and wherein said at least one boundary marker is a post having a first bar code and said at least one obstacle marker is a post having a second bar code.
8. A robotic system for systematically moving about an area to be covered, the system comprising:
- at least one boundary marker located along the outer edge of the area to be covered;
  - at least one obstacle marker located along the outer edge of an obstacle within said area to be covered;
  - a robot for moving about said area to be covered; and
  - a sensor unit for sensing proximity to said boundary and obstacle markers and for differentiating between said boundary and obstacle markers.

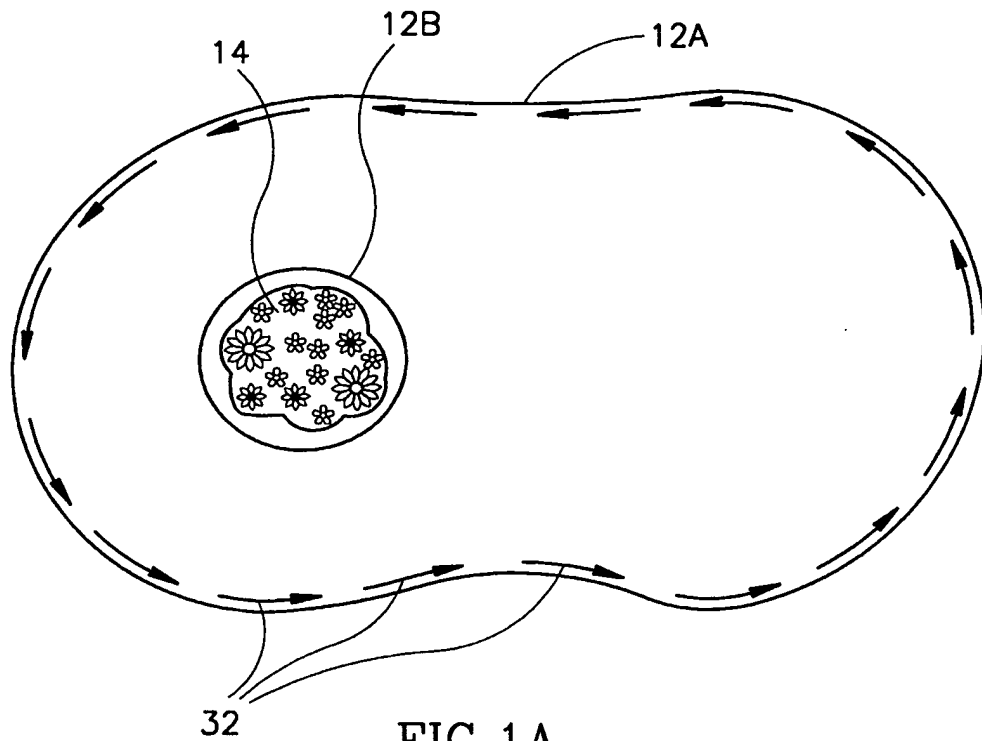


FIG. 1A  
PRIOR ART

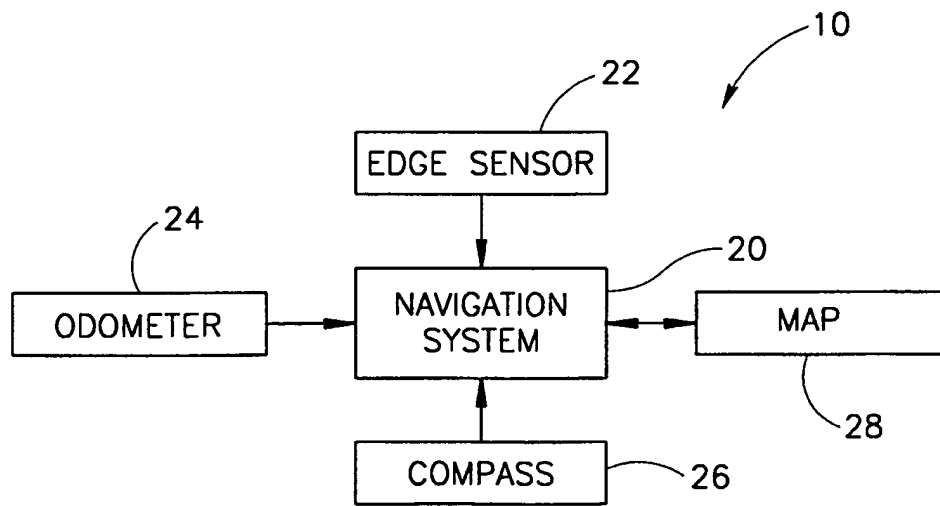


FIG. 1B  
PRIOR ART



2/4

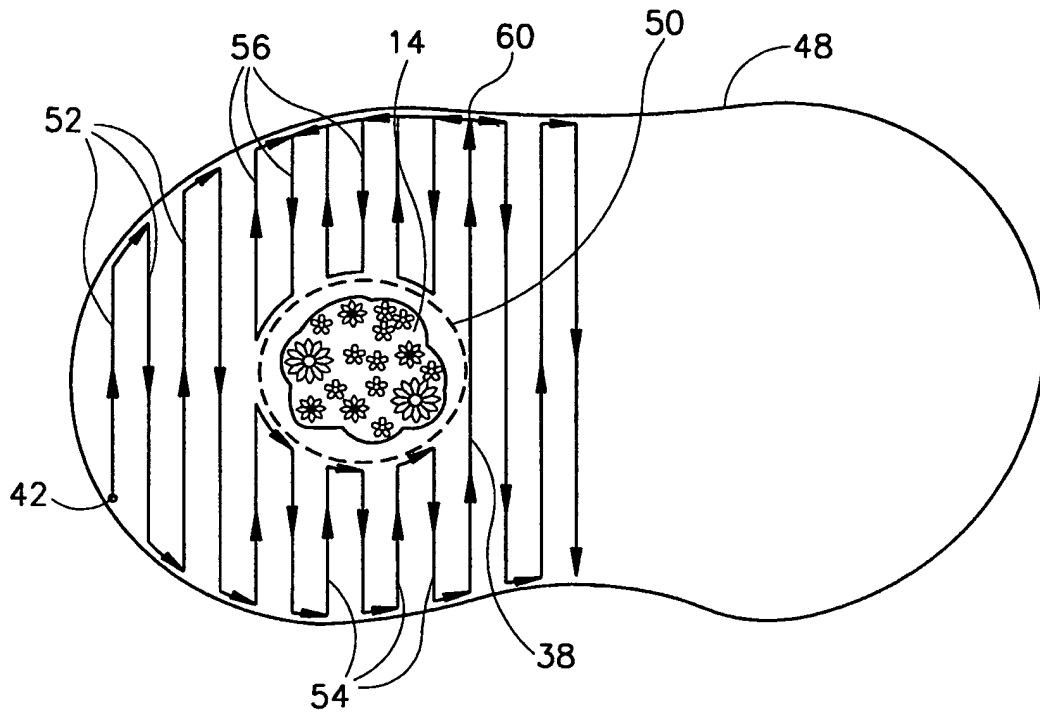


FIG.2A

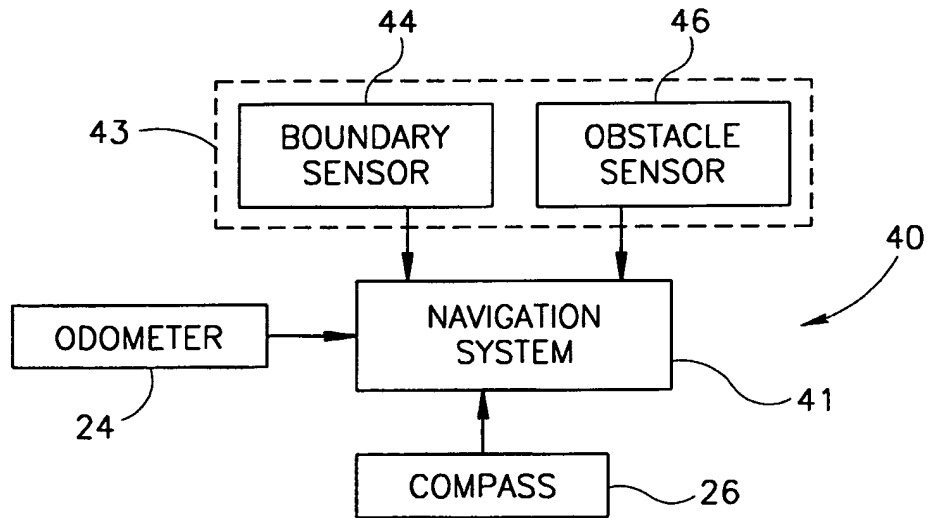


FIG.2B

3/4

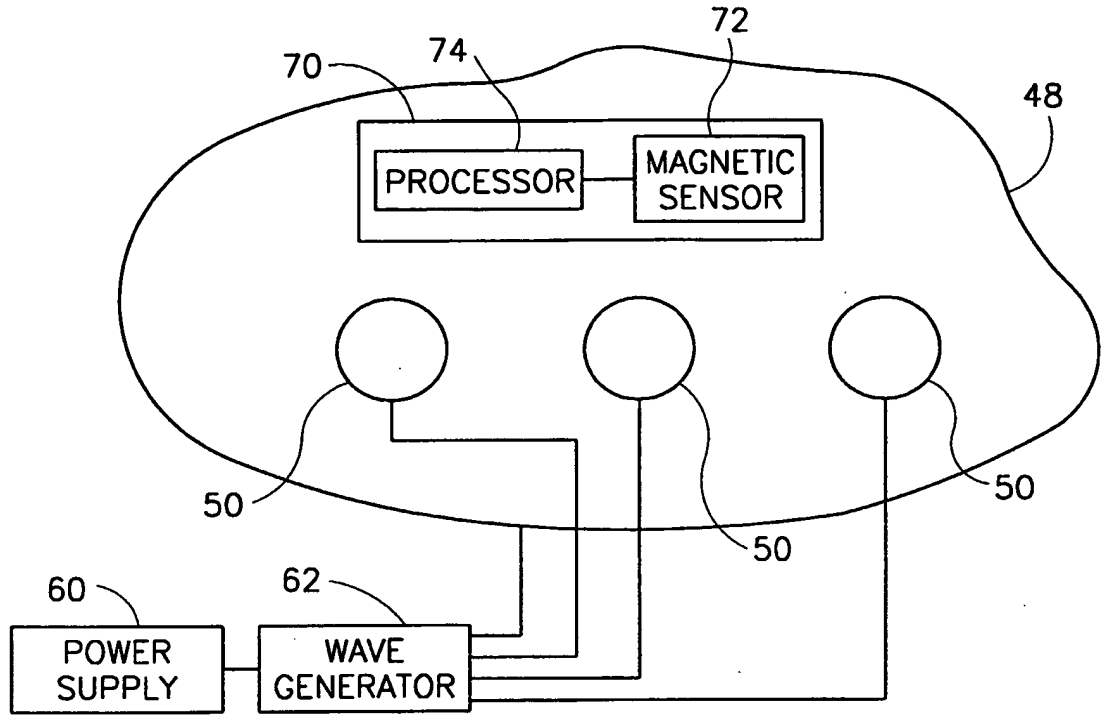


FIG.3A

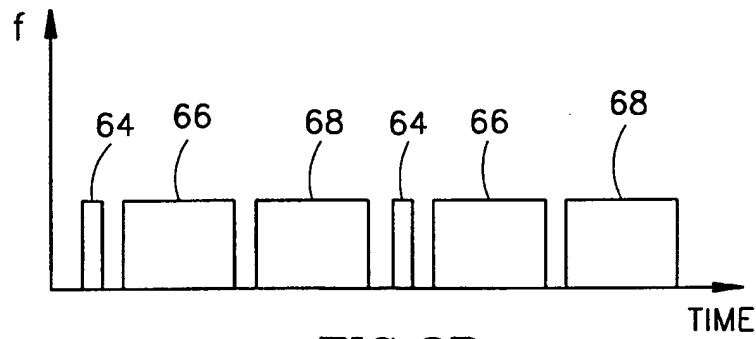


FIG.3B

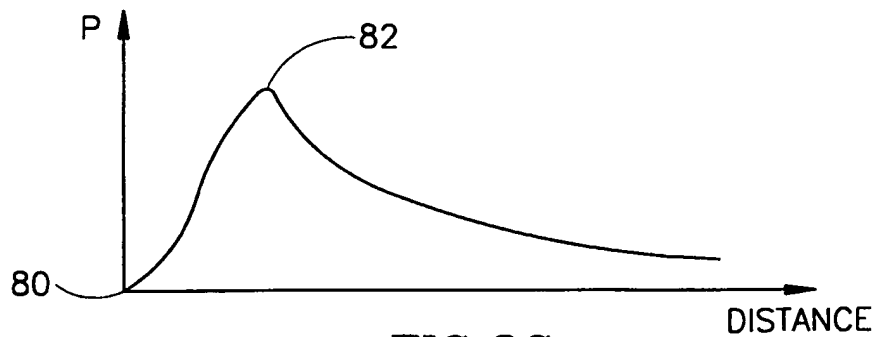


FIG.3C

4/4

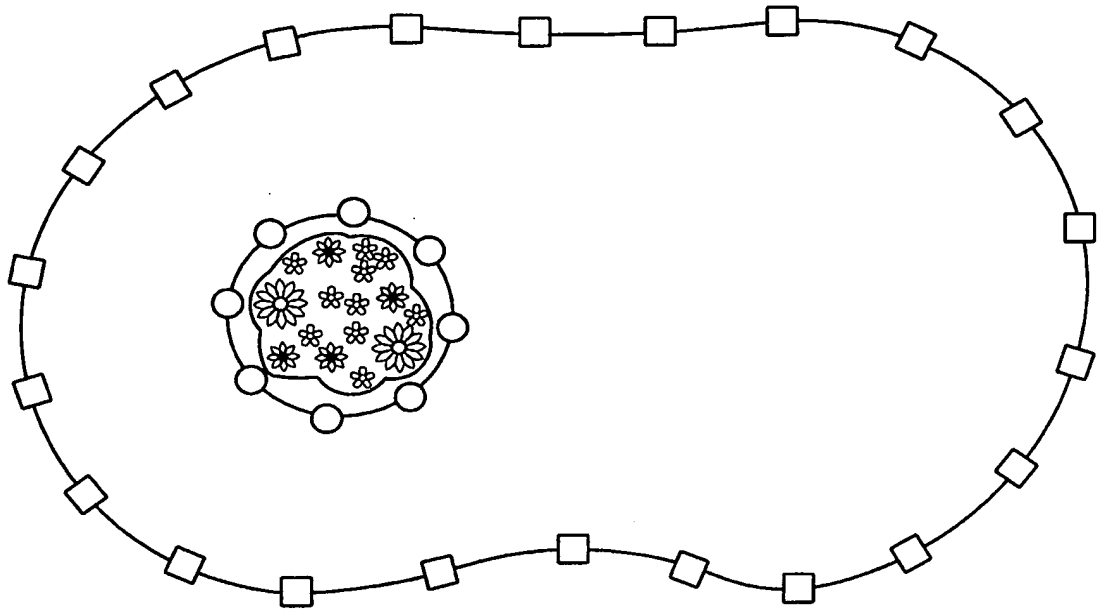


FIG.4

INTERNATIONAL SEARCH REPORT

International application No.  
PCT/IL99/00248

<p><b>A. CLASSIFICATION OF SUBJECT MATTER</b>                  IPC(6) : G05D 1/00                  US CL : 318/580                  According to International Patent Classification (IPC) or to both national classification and IPC</p>														
<p><b>B. FIELDS SEARCHED</b>                  Minimum documentation searched (classification system followed by classification symbols)                  U.S. : 318/587,580</p> <p>Documentation searched other than minimum documentation to the extent that such documents are included in the fields searched                  Microsoft Press Computer Dictionary</p> <p>Electronic data base consulted during the international search (name of data base and, where practicable, search terms used)                  APS                  search terms: autonomous robot, boundary marker, navigation system, proximity, sensor unit, robotic guidance system</p>														
<p><b>C. DOCUMENTS CONSIDERED TO BE RELEVANT</b></p> <table border="1"> <thead> <tr> <th>Category*</th> <th>Citation of document, with indication, where appropriate, of the relevant passages</th> <th>Relevant to claim No.</th> </tr> </thead> <tbody> <tr> <td>X</td> <td>US 4,829,442 A (KADONOFF et. al.) 09 May 1989, col.2, lines 3-5, 20-45, col.4, lines 22-43.</td> <td>1,2,8</td> </tr> <tr> <td>X</td> <td>US 4,996,468 A (FIELD et. al.) 26 June 1991, col.5, lines 42-52, col.6, lines 12-21, col.7, lines 11-56.</td> <td>3,5</td> </tr> <tr> <td>X</td> <td>US 5,170,352 A (MCTAMANEY et. al.) 08 December 1992, col.2, lines 46-61, col.3, lines 33-45, 63-68, col.4, lines 1-40, col.9, lines 41-54.</td> <td>4,5,6,7</td> </tr> </tbody> </table>			Category*	Citation of document, with indication, where appropriate, of the relevant passages	Relevant to claim No.	X	US 4,829,442 A (KADONOFF et. al.) 09 May 1989, col.2, lines 3-5, 20-45, col.4, lines 22-43.	1,2,8	X	US 4,996,468 A (FIELD et. al.) 26 June 1991, col.5, lines 42-52, col.6, lines 12-21, col.7, lines 11-56.	3,5	X	US 5,170,352 A (MCTAMANEY et. al.) 08 December 1992, col.2, lines 46-61, col.3, lines 33-45, 63-68, col.4, lines 1-40, col.9, lines 41-54.	4,5,6,7
Category*	Citation of document, with indication, where appropriate, of the relevant passages	Relevant to claim No.												
X	US 4,829,442 A (KADONOFF et. al.) 09 May 1989, col.2, lines 3-5, 20-45, col.4, lines 22-43.	1,2,8												
X	US 4,996,468 A (FIELD et. al.) 26 June 1991, col.5, lines 42-52, col.6, lines 12-21, col.7, lines 11-56.	3,5												
X	US 5,170,352 A (MCTAMANEY et. al.) 08 December 1992, col.2, lines 46-61, col.3, lines 33-45, 63-68, col.4, lines 1-40, col.9, lines 41-54.	4,5,6,7												
<p><input type="checkbox"/> Further documents are listed in the continuation of Box C.      <input type="checkbox"/> See patent family annex.</p>														
<table border="0"> <tr> <td>* Special categories of cited documents.</td> <td>*T* later document published after the international filing date or priority date and not in conflict with the application but cited to understand the principle or theory underlying the invention</td> </tr> <tr> <td>*A* document defining the general state of the art which is not considered to be of particular relevance</td> <td>*X* document of particular relevance; the claimed invention cannot be considered novel or cannot be considered to involve an inventive step when the document is taken alone</td> </tr> <tr> <td>*E* earlier document published on or after the international filing date</td> <td>*Y* document of particular relevance; the claimed invention cannot be considered to involve an inventive step when the document is combined with one or more other such documents, such combination being obvious to a person skilled in the art</td> </tr> <tr> <td>*L* document which may throw doubts on priority claim(s) or which is cited to establish the publication date of another citation or other special reason (as specified)</td> <td>*G* document member of the same patent family</td> </tr> <tr> <td>*O* document referring to an oral disclosure, use, exhibition or other means</td> <td></td> </tr> <tr> <td>*P* document published prior to the international filing date but later than the priority date claimed</td> <td></td> </tr> </table>			* Special categories of cited documents.	*T* later document published after the international filing date or priority date and not in conflict with the application but cited to understand the principle or theory underlying the invention	*A* document defining the general state of the art which is not considered to be of particular relevance	*X* document of particular relevance; the claimed invention cannot be considered novel or cannot be considered to involve an inventive step when the document is taken alone	*E* earlier document published on or after the international filing date	*Y* document of particular relevance; the claimed invention cannot be considered to involve an inventive step when the document is combined with one or more other such documents, such combination being obvious to a person skilled in the art	*L* document which may throw doubts on priority claim(s) or which is cited to establish the publication date of another citation or other special reason (as specified)	*G* document member of the same patent family	*O* document referring to an oral disclosure, use, exhibition or other means		*P* document published prior to the international filing date but later than the priority date claimed	
* Special categories of cited documents.	*T* later document published after the international filing date or priority date and not in conflict with the application but cited to understand the principle or theory underlying the invention													
*A* document defining the general state of the art which is not considered to be of particular relevance	*X* document of particular relevance; the claimed invention cannot be considered novel or cannot be considered to involve an inventive step when the document is taken alone													
*E* earlier document published on or after the international filing date	*Y* document of particular relevance; the claimed invention cannot be considered to involve an inventive step when the document is combined with one or more other such documents, such combination being obvious to a person skilled in the art													
*L* document which may throw doubts on priority claim(s) or which is cited to establish the publication date of another citation or other special reason (as specified)	*G* document member of the same patent family													
*O* document referring to an oral disclosure, use, exhibition or other means														
*P* document published prior to the international filing date but later than the priority date claimed														
Date of the actual completion of the international search 04 AUGUST 1999		Date of mailing of the international search report <b>31 AUG 1999</b>												
Name and mailing address of the ISA/US Commissioner of Patents and Trademarks Box PCT Washington, D.C. 20231 Facsimile No. (703) 305-3230		Authorized officer Victoria Robinson <i>Victoria R. Robinson</i> Telephone No. (703) 305-2875												

(12) INTERNATIONAL APPLICATION PUBLISHED UNDER THE PATENT COOPERATION TREATY (PCT)

(19) World Intellectual Property Organization  
International Bureau



(43) International Publication Date  
23 May 2002 (23.05.2002)

PCT

(10) International Publication Number  
WO 02/39864 A1

(51) International Patent Classification<sup>7</sup>: A47L 9/00,  
11/40, B62D 57/00

(21) International Application Number: PCT/NO01/00429

(22) International Filing Date: 29 October 2001 (29.10.2001)

(25) Filing Language: Norwegian

(26) Publication Language: English

(30) Priority Data:  
20005460 30 October 2000 (30.10.2000) NO  
20013685 27 July 2001 (27.07.2001) NO

(71) Applicant and  
(72) Inventor: AASEN, Torbjørn [NO/NO]; Hatlestadia 122,  
N-5227 Nesttun (NO).

(74) Agent: AS BERGEN PATENTKONTOR; C. Sundtsgt.  
36, N-5004 Bergen (NO).

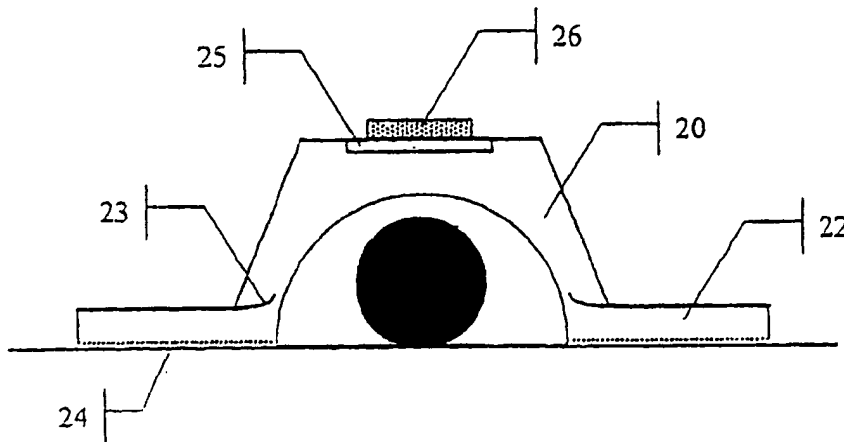
(81) Designated States (*national*): AE, AG, AL, AM, AT, AU, AZ, BA, BB, BG, BR, BY, BZ, CA, CH, CN, CO, CR, CU, CZ, DE, DK, DM, DZ, EC, EE, ES, FI, GB, GD, GE, GH, GM, HR, HU, ID, IL, IN, IS, JP, KE, KG, KP, KR, KZ, LC, LK, LR, LS, LT, LU, LV, MA, MD, MG, MK, MN, MW, MX, MZ, NO, NZ, OM, PH, PL, PT, RO, RU, SD, SE, SG, SI, SK, SL, TJ, TM, TR, TT, TZ, UA, UG, US, UZ, VN, YU, ZA, ZW.

(84) Designated States (*regional*): ARIPO patent (GH, GM, KE, LS, MW, MZ, SD, SL, SZ, TZ, UG, ZW), Eurasian patent (AM, AZ, BY, KG, KZ, MD, RU, TJ, TM), European patent (AT, BE, CH, CY, DE, DK, ES, FI, FR, GB, GR, IE, IT, LU, MC, NL, PT, SE, TR), OAPI patent (BF, BJ, CF, CG, CI, CM, GA, GN, GQ, GW, ML, MR, NE, SN, TD, TG).

Published:  
— with international search report

For two-letter codes and other abbreviations, refer to the "Guidance Notes on Codes and Abbreviations" appearing at the beginning of each regular issue of the PCT Gazette.

(54) Title: MOBILE ROBOT



WO 02/39864 A1

(57) Abstract: A mobile robot is described for random movement across a surface where a drive unit is arranged inside a top-hat. Cleaning equipment such as electrostatic dusters or equipment for vacuuming can be fixed to the top-hat so that the mobile robot functions as a cleaning robot.

Mobile robot

The present invention relates to a mobile robot. In particular, the invention relates to a mobile cleaning  
5 robot.

The collection of dust particles on surfaces, and especially on floors, is a general problem in dwellings, office landscapes, laboratories and the like. Such  
10 collections of dust are unpleasant and, on many occasions, also represent a health problem for many asthmatics. Therefore, the floor spaces must be regularly washed or vacuumed. In most cases this is carried out manually.

15 It is an object of the present invention to provide a solution for the automatic removal of dust, and the present invention provides a mobile robot that can carry out such work. This solution shall not completely replace manual cleaning work, but shall be an addition to this, and  
20 thereby shall reduce the need for manual cleaning.

Thus, it is an object of the present invention to provide a mobile robot which, during a given period of operation, can remove a substantial part of the dust particles that can be  
25 found on a floor surface, for example in an office landscape.

With present technology, one has knowledge of complicated mobile robots. Programmes can control the movements of the robot so that it can be moved in a desired movement pattern.

5

For example, US Patent No. 5,440,216 describes a robot which is capable of being automatically moved to a station for charging of its batteries. US Patent No. 5,787, 545 also describes a mobile robot for vacuuming.

10

However, both of these solutions are relatively complex and both use a processor for controlling the movement of the robot.

15 The object of the present invention is, however, to provide a very simple robot. This must be of a very simple design and construction, and it must be able to be produced so cheaply that individual people will be able to regard it as an inexpensive supplement to conventional cleaning  
20 equipment. This is not possible with the solutions that are described in the prior art.

Furthermore, it is an object of the present invention that the robot which is provided shall not comprise complicated  
25 control systems, and it is therefore an object not to make use of computer processors to control the movement of the robot.

In the two solutions which are indicated above, the drive  
30 unit itself is permanently built into the top-hat itself. An object of the present invention is, however, to achieve a "random direction of movement", and this is best achieved if a large number of different factors will influence the "choice of direction of movement". One way of achieving  
35 this is to let the robot be subjected to many "impact

moments", i.e. situations in which the robot, or the driving gear, collides with another object, which initiates a change in direction.

5 By arranging the drive unit in the top-hat in such a way that the drive unit is not fixed to the top-hat, but can be moved freely in relation to this, within an area which is limited by the top-hat, the number of impact points, or impact moments, will increase substantially, as the change  
10 in direction will also be initiated by the driving gear hitting the inside of the top-hat.

To our knowledge such systems are not described in the prior art, and therefore, with the present invention, a new  
15 movable robot is provided, and this can be used for many different applications. As the object of the development work with the robot was to develop a robot for cleaning, the examples which are given below are directed towards such an embodiment, but it must be pointed out that the  
20 invention comprises the robot per se, and the invention is not limited to robots which can be used for cleaning.

Thus, a central feature of the present invention is that the driving gear which brings about movement of the robot  
25 is not fixed to the top-hat itself.

A currently preferred embodiment of the drive unit in accordance with the invention is a ball in which, arranged inside the ball, is a driving gear which brings about a  
30 rotation of the ball.

Thus, the present invention is characterised in that it comprises a drive unit and a top-hat, where the drive unit is in contact with the surface, and that the drive unit is  
35 arranged inside and freely in relation to the top-hat, and



where the top-hat, which at least partially surrounds the drive unit, in the section which is turned towards the surface, extends further than the drive unit such that a space between the top-hat and the drive unit is established  
5 so that the drive unit freely pushes towards and randomly moves the top-hat over the surface.

More detailed embodiments of the invention are described in the subclaims 2-13.

10

A presently preferred embodiment of the robot comprises a cleaning robot for removal of dust from a surface, in which one or more cleaning cloths, which are in contact with the surface that is to be cleaned, are fastened to the top-hat  
15 in a removable fashion.

The present invention will now be described in more detail with reference to the enclosed figures, in which:

20 Fig. 1 shows, in a segment of a section, how a drive unit, in this embodiment a ball, is arranged inside a half-ball formed top-hat.

Fig. 2 shows a cleaning cloth fastened to the top-hat of  
25 the robot.

Fig. 3 shows how a vacuum suction unit is fitted to the top-hat of the robot.

30 Fig. 4 shows a simulation of the time it will take to achieve treatment of a given area.

Fig. 5 shows an alternative embodiment of a top-hat, and how a cleaning cloth is fastened to it.

35

Fig. 6 shows an alternative embodiment of the top-hat.

With reference to fig. 1, the central concept according to the invention is described. A moveable robot 10 is established by arranging a drive unit 12 inside a top-hat 14, and is placed on a surface 16 such as a floor 16. In the embodiment shown, the drive unit consists of a ball 12 with a ball-formed outer framework and an internal driving gear. To use a ball as a drive unit for the robot is the presently preferred embodiment, but it must be pointed out that other drive units can also be used, for example drive units which use wheels. The central concept is that the drive unit is not fixed to the top-hat.

The driving gear (not shown in the figures) which is used inside the ball can be of any kind, and thus the invention does not comprise the driving gear itself. For example, driving gears for balls, as described in WO 99/30876, WO 97/25239, and US Patent Nos. 4,733,737, 4,726,800, 4,541,814 and 4,501,569, can be used. The driving gear has electronic control circuits to start and stop the driving gear, and a power source, for example batteries. A presently preferred driving gear for the ball comprises a weight, the position of which can be changed by means of a driving gear, and where the weight moves along the inside of the framework of the ball so that the centre of gravity of the ball is changed as this brings about a movement of the ball. Thus the drive principle is based on a momentum of rotation.

It must be emphasised that to provide a cheap mobile robot is an object of the present invention, and the directions of the movements of the robot are therefore not controlled, i.e. no use is made of artificial neural networks or "fuzzy logic" or memory orientated control logic.

The top-hat 14 which in a preferred embodiment is half-ball shaped, as shown in fig. 1, has in the section which is turned towards the floor, a diameter which is somewhat larger than the diameter of the ball 12. The height of the top-hat 14 is preferably also somewhat larger than the diameter of the ball 12. This establishes a space 15 between top-hat 14 and ball 12. The ball 12 will be moved inside this space 15, and the combined action of the ball and the top-hat will make the robot 10 move as the ball 12 pushes against the top-hat 14. When the robot 10 hits an object, for example the leg of a chair or a section of a wall, the escape control of the robot 10 will be based on an infinite number of random searches. This implies that the direction changes "randomly" as the robot 10 hits an object. The joint action between the movement dynamics of the ball 12 and its collision with the walls is also defined by the space 15, i.e. collisions between the drive unit and top-hat cause the ball to get an arbitrary movement pattern independent of the objects the robot 10 collides with. Tests with the prototype has shown that the robot 10 is very capable of "coming free" from physical barriers on the floor.

The form of the ball 10 makes the ball 10 move with a low friction against the floor. The ball can be made from any material, but the material that constitutes the outer surface of the ball 10 must have sufficient friction against the floor so that the rotating movements of the ball result in the ball 10 being moved in relation to the floor.

The top-hat 14 can be manufactured in many different ways. The solution which is described above, with reference to fig. 1, is only one alternative. In this solution, the

whole ball is surrounded by the top-hat. Other representative embodiments of the top-hat are explained below.

5 A further aspect of the invention relates to a cleaning robot. The central concept here is that it is possible to fix the cleaning means to the top-hat. In testing of this "cleaning robot", the inventor has shown that by using electrostatic cloths, dust and dirt are removed effectively  
10 from the floor which is to be cleaned.

To establish a cleaning robot it must be possible to secure cleaning means to the top-hat.

15 Thus, fig.2 shows a top-hat where arranged to the lower section of the top-hat is a velcro system for securing of a cleaning cloth.

Alternative embodiments of the top-hat are shown in figures  
20 5 and 6. In figure 6, the top-hat is not a half-ball formed hat which surrounds the whole ball, but just a framework 20 which sets the limits of the area of movement 15 for the ball. This framework has a height which is sufficient for collisions between ball and framework to effecting a  
25 movement of the framework.

Furthermore, an embodiment is shown in fig. 5 in which the top-hat, in the section which is turned towards the floor, has a section 28 radially extending outwards to establish a  
30 surface onto which the cleaning cloth 30 can be fastened.

The presently most preferred embodiment of the invention is a combination of the features shown in figs. 5 and 6, i.e. the top-hat is just a framework, but with an outwardly  
35 extending section 28 for fastening of a cleaning cloth 30.

The cleaning cloth can, for example, be secured to the top-hat with velcro 26 (in most cases it is sufficient that the velcro is secured to the top-hat as the cloth material in itself will often attach itself to the Velcro). This  
5 solution implies that the cleaning cloth 30 lies pressed between the section 28 of the top-hat 12 and the floor 16, i.e. the cloth is arranged underneath the top-hat 12 itself. Therefore, arranged in the cleaning cloth, is an opening such that the drive unit is in contact with the  
10 floor.

The section 28 can have a circular shape, but other embodiments are also possible. For example, tested at present is a square section 28, with a square cloth 30, to  
15 see if this cleans more effectively along walls and in corners. Furthermore, it shall be mentioned that the dimensions of the cloth 30 do not need to be identical with the shape of the section 28. In a preferred embodiment, the cloth extends further than the section 28 so that the  
20 outermost part of the cloth will be more flexible (as it is not in contact with the section 28) such that it can be moved a small distance up adjoining surfaces (such as walls).

25 In a further alternative embodiment, the cleaning cloth itself is arranged over the top-hat. This embodiment is not shown in the figures.

If equipment with a considerable specific gravity in  
30 relation to the top-hat is to be fixed to the top-hat 14, for example a device for vacuum cleaning, the top-hat can be equipped with balls/wheels (not shown in the figures) down towards the floor so that the friction of the top-hat against the floor is reduced.

35

As mentioned previously, the movement pattern of the robot 10 is governed by the collisions which arise between the robot and objects in the room (chair legs, walls and the like), and by the collisions which occur between the drive  
5 unit and the inside of the top-hat. The robot will, therefore, after a given time have moved in an "arbitrary/random" pattern across the floor. Calculations can be made in which parameters such as the area and shape of the floor, furniture (chair legs and table legs, other  
10 office equipment and the like), area and extent of cleaning devices, the speed of the robot etc. is taken into account so that one can estimate the size of the fraction of the floor which will be treated during a given time. For example, one can estimate that 95% of the floor is treated  
15 at least once if the robot is allowed to move for 2 hours.

As the robot shall not completely replace conventional cleaning, an estimate of, for example 95%, will be sufficient in most cases. One can then imagine that the  
20 robot works in one office landscape a couple of hours every day after the personnel have finished their working day. See example 1 below.

Dusters can, for example, be used as cleaning means. It is  
25 preferred to use electrostatically charged dusters and these are available on the market. These will attract dust particles when they are pushed across the floor surfaces. As mentioned above, the shape of these dusters is adapted to the particular application together with the cleaning  
30 robot, i.e. possibly equipped with velcro adapted to the velcro of the robot, and they are equipped with an opening adapted for positioning of the top-hat and/or the drive unit.

Cleaning robots of this type, as is shown in fig. 2, can be of any size, but for the prototype which has been developed, the ball has a diameter of 10 cm, and the top-hat has a diameter, for the section which is turned towards  
5 the floor, of about 20 cm.

An embodiment is shown in fig. 3 where the cleaning equipment is a vacuum suction unit. In the embodiment shown in the figure, the top-hat itself is shaped as a vacuum  
10 suction unit, such that the drive unit pushes the vacuum suction unit along the floor surface. Again it is preferred that the cleaning robot is very simple, and to establish a vacuum suction, it is in principle sufficient with two chambers 20 and 22 in which a fan 26 establishes an under-  
15 pressure such that air is sucked through a one-way valve 23 by way of a number of openings 24 facing down towards the floor surface, and into the chamber 20. The air is filtered through a filter 25 before it exits from the chamber 20.

20 Alternatively, a vacuum suction unit is secured to a top-hat of the type shown in fig. 2 or fig. 6.

As the invention is exemplified with reference to application as a cleaning robot, i.e. equipped with either  
25 a duster or a vacuum cleaner, it shall be emphasised that the general concept of the invention consists of arranging a drive unit with a driving gear in a top-hat such that these together bring about a movement across the floor. Thus, the invention is not limited to robots which clean,  
30 but such cleaning robots as shown in the figures are at present the most preferred embodiments of the invention.

Example 1 - Simulation

A simulation based on a theoretical model is shown in fig.  
5 4.

$A_{tot}$  : The total area (cm<sup>2</sup>)  
 $K_b$  : Width of the cloth (cm)  
 $K_h$  : Speed of the cloth (cm/sec)  
 10  $A(i)$  : Area (cm<sup>2</sup>) which is covered;  $i$  is an index  
 which is updated every second.

$$A(i+1) = A(i) + (K_b * K_h) * \frac{A_{tot} - A(i)}{A_{tot}}$$

15 For every update (i.e. every second) a new area is added,  
 $K_b * K_h$ , which is adjusted with a factor which decreases  
 with the area that is already covered. With the parameter  
 values  $A_{tot} = 5m * 6m = 30m^2$  (300000 cm<sup>2</sup>),  $K_b = 20cm$  and  $K_h = 50cm/sec$   
 it will, for example, take 11½ min to cover 90% of the  
 20 area. Reference is made to fig. 4 which shows the  
 relationship between percentage area that is covered by the  
 electrostatic duster and operating time.



Claims

1. Mobile robot (10) for random movement across a surface (16) characterised in that it comprises a drive unit (12) and a top-hat (14), in which the drive unit (12) is in contact with the surface (16), and that the drive unit (12) is arranged inside and free in relation to the top-hat (14), and in which the top-hat (14), which at least partially surrounds the drive unit (12), in the section which is turned towards the surface (16) has an extension which is greater than the drive unit (12) such that a space (15) is established between the top-hat (14) and the drive unit (12) so that the drive unit (12) freely pushes against and randomly moves the top-hat (14) across the surface (16).
2. Mobile robot (10) in accordance with claim 1, characterised in that the top-hat (14) is shaped as a half-ball formed body.
3. Mobile robot (10) in accordance with claim 2, characterised in that the top-hat (14) is shaped as a framework.
4. Mobile robot (10) in accordance with one of the claims 1-3, characterised in that the drive unit (12) is in the shape of a ball (12) with an internal driving gear.
5. Mobile robot (10) in accordance with one of the claims 1-4, characterised in that it has no intelligent logic, but where the movement pattern is solely based on an infinite number of random searches.

6. Mobile robot (10) in accordance with one of the claims 1-5, characterised in that to the top-hat (14), or as a part of the top-hat (14), is arranged means for cleaning of the surface (16).

5

7. Mobile robot (10) in accordance with claim 6, characterised in that the mentioned means comprises one or more dusters (30).

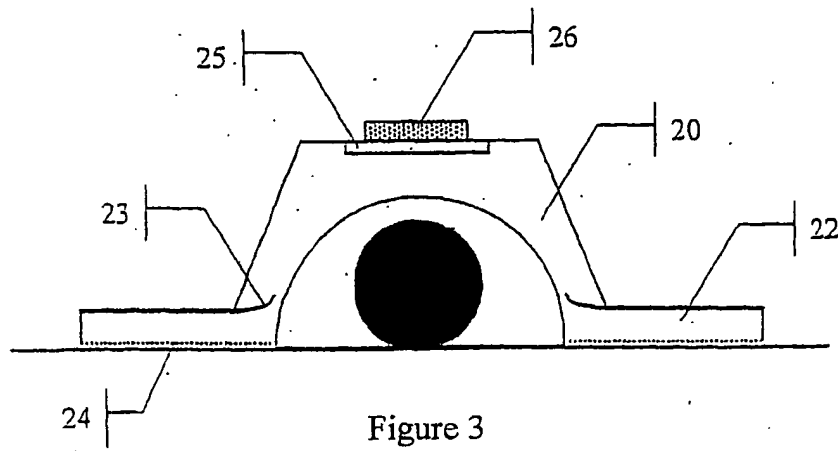
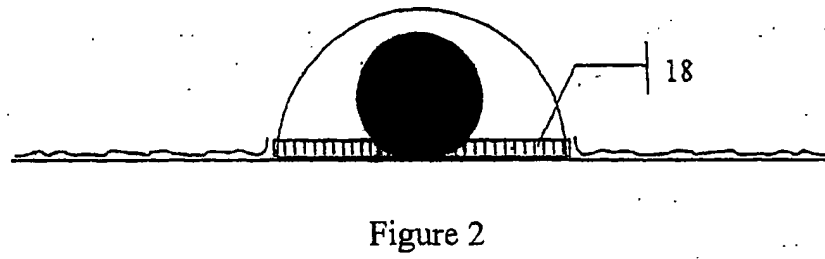
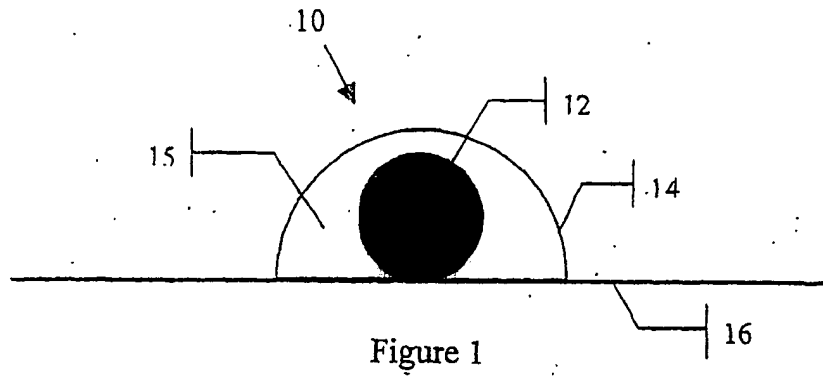
10 8. Mobile robot (10) in accordance with claim 6, characterised in that the dusters (30) are of the type electrostatic dusters.

15 9. Mobile robot (10) in accordance with one of the claims 1-8, characterised in that the cleaning cloths (30) are placed over the top-hat (14), and that they stretch over this such that a section of the cleaning cloths (30) is in contact with the surface (16) which is to be cleaned.

20 10. Mobile robot (10) in accordance with one of the claims 1-9, characterised in that an opening adapted for positioning of the top-hat (14) is cut out in the cleaning cloths (30), preferably in the centre of the cloth.

25 11. Mobile robot (10) in accordance with one of the claims 9-10, characterised in that, with the top-hat (14) comprising a section which extends over the floor surface (16), as described in fig. 5, the shape of the cleaning cloth (30) is adapted to this extension (28) such that the  
30 cleaning cloth (30) can be arranged on the underside of the extension (28), so that it is positioned between the top-hat (14) and the surface (16) which is to be cleaned.

12. Mobile robot (10) in accordance with claim 5,  
characterised in that the cleaning means comprises means  
for vacuum suction.
- 5 13. Mobile robot (10) in accordance with claim 12,  
characterised in that the top-hat (14) is shaped as a  
vacuum suction unit with two compartments (20) and (22)  
being arranged in the unit, and a fan (26) to establish an  
under-pressure in the compartments (20,22), so that air  
10 containing dust particles is sucked from the surroundings  
by way of openings (24) and into the compartments (20).



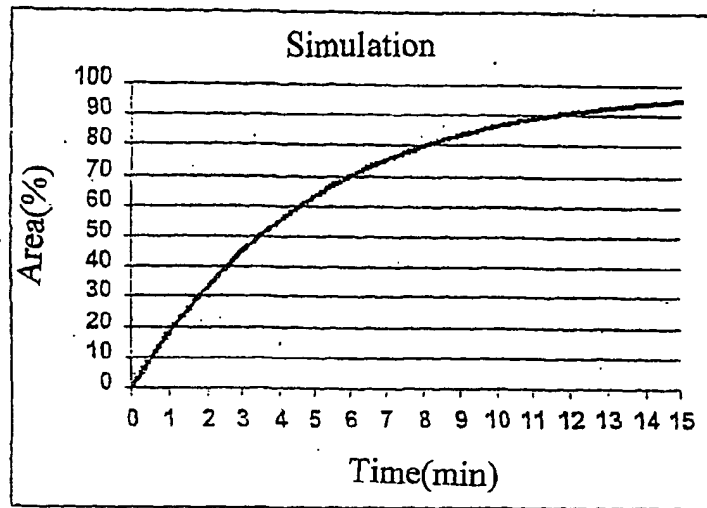


Figure 4

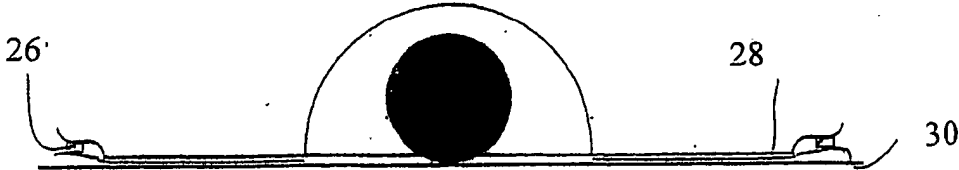


Figure 5

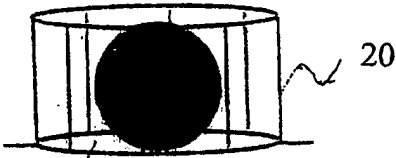


Figure 6

INTERNATIONAL SEARCH REPORT

International application No.  
PCT/NO 01/00429

<b>A. CLASSIFICATION OF SUBJECT MATTER</b>		
IPC7: A47L 9/00, A47L 11/40, B62D 57/00 According to International Patent Classification (IPC) or to both national classification and IPC		
<b>B. FIELDS SEARCHED</b>		
Minimum documentation searched (classification system followed by classification symbols)		
IPC7: A47L, B62D		
Documentation searched other than minimum documentation to the extent that such documents are included in the fields searched		
SE,DK,FI,NO classes as above		
Electronic data base consulted during the international search (name of data base and, where practicable, search terms used)		
EPO-INTERNAL, WPI DATA, PAJ		
<b>C. DOCUMENTS CONSIDERED TO BE RELEVANT</b>		
Category*	Citation of document, with indication, where appropriate, of the relevant passages	Relevant to claim No.
A	US 5440216 A (T.-S. KIM), 8 August 1995 (08.08.95), figure 1, abstract --	1-13
A	US 5787545 A (A. COLENS), 4 August 1998 (04.08.98), figures 4-6, abstract --	1-13
A	Patent Abstracts of Japan, abstract of JP 11-178765 A (HONDA MOTOR CO LTD), 6 July 1999 (06.07.99) -- -----	1-13
<input type="checkbox"/> Further documents are listed in the continuation of Box C. <input checked="" type="checkbox"/> See patent family annex.		
<p>* Special categories of cited documents:</p> <p>"A" document defining the general state of the art which is not considered to be of particular relevance</p> <p>"E" earlier application or patent but published on or after the international filing date</p> <p>"L" document which may throw doubts on priority claim(s) or which is cited to establish the publication date of another citation or other special reason (as specified)</p> <p>"O" document referring to an oral disclosure, use, exhibition or other means</p> <p>"P" document published prior to the international filing date but later than the priority date claimed</p> <p>"T" later document published after the international filing date or priority date and not in conflict with the application but cited to understand the principle or theory underlying the invention</p> <p>"X" document of particular relevance; the claimed invention cannot be considered novel or cannot be considered to involve an inventive step when the document is taken alone</p> <p>"Y" document of particular relevance; the claimed invention cannot be considered to involve an inventive step when the document is combined with one or more other such documents, such combination being obvious to a person skilled in the art</p> <p>"&amp;" document member of the same patent family</p>		
Date of the actual completion of the international search		Date of mailing of the international search report
28 February 2002		01-03-2002
Name and mailing address of the ISA/ Swedish Patent Office Box 5055, S-102 42 STOCKHOLM Facsimile No. +46 8 666 02 86		Authorized officer Jan-Axel Ylivaini / MRO Telephone No. +46 8 782 25 00

**INTERNATIONAL SEARCH REPORT**

Information on patent family members

International application No.

28/01/02

PCT/NO 01/00429

Patent document cited in search report	Publication date	Patent family member(s)	Publication date
US 5440216 A	08/08/95	DE 4340771 A	15/12/94
		GB 2278937 A,B	14/12/94
		GB 2313190 A,B	19/11/97
		GB 2313191 A,B	19/11/97
		GB 2313213 A,B	19/11/97
		GB 9323741 D	00/00/00
		GB 9716988 D	00/00/00
		GB 9716989 D	00/00/00
		GB 9716990 D	00/00/00
		JP 3006986 B	07/02/00
		JP 7008428 A	13/01/95
US 5787545 A	04/08/98	AT 184773 T	15/10/99
		AU 3073095 A	25/01/96
		BE 1008470 A	07/05/96
		DE 69512414 D,T	05/01/00
		DK 769923 T	03/04/00
		EP 0769923 A,B	02/05/97
		SE 0769923 T3	
		ES 2138227 T	01/01/00
		GR 3032193 T	27/04/00
		JP 10502274 T	03/03/98
		WO 9601072 A	18/01/96

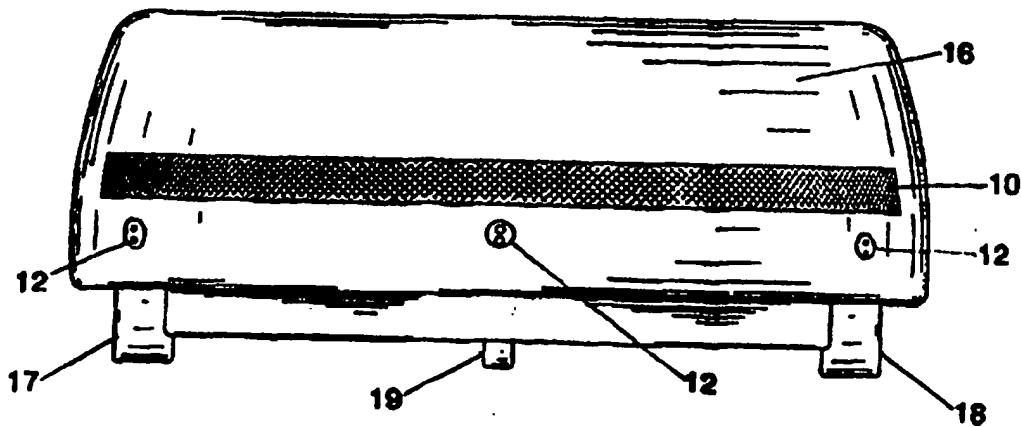




INTERNATIONAL APPLICATION PUBLISHED UNDER THE PATENT COOPERATION TREATY (PCT)

<p>(51) International Patent Classification <sup>6</sup> : G01S 15/93, G05D 1/03</p>	<p>A1</p>	<p>(11) International Publication Number: <b>WO 97/41451</b>  (43) International Publication Date: 6 November 1997 (06.11.97)</p>
<p>(21) International Application Number: PCT/SE97/00625 (22) International Filing Date: 14 April 1997 (14.04.97)  (30) Priority Data: 9601664-7 30 April 1996 (30.04.96) SE  (71) Applicant (for all designated States except US): AKTIEBO- LAGET ELECTROLUX [SE/SE]; Luxbacken 1, S-105 45 Stockholm (SE).  (72) Inventors; and (75) Inventors/Applicants (for US only): KLEINER, Mendel [SE/SE]; Högalid 1, S-436 51 Hovås (SE). RIISE, Björn [SE/SE]; Hjortvägen 3, S-191 46 Sollentuna (SE).  (74) Agents: HEDBERG, Åke et al.; Dr. Ludwig Brann Patentbyrå AB, P.O. Box 1344, S-751 43 Uppsala (SE).</p>	<p>(81) Designated States: AL, AM, AT, AU, AZ, BA, BB, BG, BR, BY, CA, CH, CN, CU, CZ, DE, DK, EE, ES, FI, GB, GE, GH, HU, IL, IS, JP, KE, KG, KP, KR, KZ, LC, LK, LR, LS, LT, LU, LV, MD, MG, MK, MN, MW, MX, NO, NZ, PL, PT, RO, RU, SD, SE, SG, SI, SK, TJ, TM, TR, TT, UA, UG, US, UZ, VN, YU, ARIPO patent (GH, KE, LS, MW, SD, SZ, UG), Eurasian patent (AM, AZ, BY, KG, KZ, MD, RU, TJ, TM), European patent (AT, BE, CH, DE, DK, ES, FI, FR, GB, GR, IE, IT, LU, MC, NL, PT, SE), OAPI patent (BF, BJ, CF, CG, CI, CM, GA, GN, ML, MR, NE, SN, TD, TG).</p> <p><b>Published</b> <i>With international search report. Before the expiration of the time limit for amending the claims and to be republished in the event of the receipt of amendments.</i></p>	

(54) Title: SYSTEM AND DEVICE FOR A SELF ORIENTING DEVICE



(57) Abstract

The invention discloses a proximity sensing system and an autonomous device, like a vacuum-cleaner, being provided with a pair of independent driven wheels (17, 18). The device contains for the proximity orientation and guiding a microprocessor system and a sonar system comprising at least an ultrasonic transmitter and an ultrasonic receiver. An additional mechanical touch sensor is also used in form of a forward directed bumper (16) carrying the transmitter as well as receiving microphone units. The mechanical bumper is actuating at least one touch sensor if the device makes contact to an obstacle in the course of the moving device. The transmitter is a stripe-shaped ultrasound transducer (10) positioned at the front of the device and transmitting ultrasonic waves with a narrow vertical distribution within a wide sector in front of the device. The receiver comprises a number of microphone units (12) provided with hollow pipes (12a, 12b) for the sound. The microphone units (12) together with the transmitter form an efficient sonar system for detecting echoes reflected from objects in the forward course of the moving device.

**FOR THE PURPOSES OF INFORMATION ONLY**

Codes used to identify States party to the PCT on the front pages of pamphlets publishing international applications under the PCT.

AL	Albania	ES	Spain	LS	Lesotho	SI	Slovenia
AM	Armenia	FI	Finland	LT	Lithuania	SK	Slovakia
AT	Austria	FR	France	LU	Luxembourg	SN	Senegal
AU	Australia	GA	Gabon	LV	Latvia	SZ	Swaziland
AZ	Azerbaijan	GB	United Kingdom	MC	Monaco	TD	Chad
BA	Bosnia and Herzegovina	GE	Georgia	MD	Republic of Moldova	TG	Togo
BB	Barbados	GH	Ghana	MG	Madagascar	TJ	Tajikistan
BE	Belgium	GN	Guinea	MK	The former Yugoslav Republic of Macedonia	TM	Turkmenistan
BF	Burkina Faso	GR	Greece			TR	Turkey
BG	Bulgaria	HU	Hungary	ML	Mali	TT	Trinidad and Tobago
BJ	Benin	IE	Ireland	MN	Mongolia	UA	Ukraine
BR	Brazil	IL	Israel	MR	Mauritania	UG	Uganda
BY	Belarus	IS	Iceland	MW	Malawi	US	United States of America
CA	Canada	IT	Italy	MX	Mexico	UZ	Uzbekistan
CF	Central African Republic	JP	Japan	NE	Niger	VN	Viet Nam
CG	Congo	KE	Kenya	NL	Netherlands	YU	Yugoslavia
CH	Switzerland	KG	Kyrgyzstan	NO	Norway	ZW	Zimbabwe
CI	Côte d'Ivoire	KP	Democratic People's Republic of Korea	NZ	New Zealand		
CM	Cameroon			PL	Poland		
CN	China	KR	Republic of Korea	PT	Portugal		
CU	Cuba	KZ	Kazakstan	RO	Romania		
CZ	Czech Republic	LC	Saint Lucia	RU	Russian Federation		
DE	Germany	LI	Liechtenstein	SD	Sudan		
DK	Denmark	LK	Sri Lanka	SE	Sweden		
EE	Estonia	LR	Liberia	SG	Singapore		

## SYSTEM AND DEVICE FOR A SELF ORIENTING DEVICE

Technical field

The present invention refers to a self orientating device, particular a vacuum-cleaning device, and more exactly to a system and a device for the orientation in the immediate surroundings by means of an ultrasonic sonar system offering an advantageous sensing of obstacles in the course of the moving autonomous device.

Background of the invention

For many years there has been a desire to provide, for instance, an autonomous apparatus for floor treatment, particularly a vacuum-cleaner, which is controlled by a sensing system sweeping around the horizon in analogy, for example, with a ship radar. Then the desire is, that the apparatus should be able to orientate itself in a room, such that it, for instance, will be able to perform a cleaning function according to a predetermined pattern or a predetermined strategy and at the same time avoid colliding with different obstacles, which may be arranged in the room, besides avoiding collisions with the walls of the room.

Such a system is disclosed in the International Patent Application WO 95/26512 by the same applicant and which is expressly incorporated here by reference.

Still the system according to WO 95/26512 is rather complicated and it additionally utilizes a number of transponder devices for the initial orientation. These transponders are localized at a number of points in the room to be cleaned and the transponders are used as reference points. Another characteristic of the system according to WO 95/26512 is the utilization of an ultrasound transmitter placed on top of the device. This transmitter is used both for localization of the transponders scattered around the room and is simultaneously used as a proximity sensing system for detecting possible obstacles near to the moving apparatus. One disadvantage of the disclosed apparatus is due to limited bandwidth and therefore there will

sometimes be present "dead" sectors.

Therefore there is a desire to find an improved apparatus for automatic polishing or vacuum-cleaning presenting an even better ability to find a clear way when performing its operation. The improved apparatus should also be simple and cheap to produce and thereby be able to present an appealing price to customers.

#### Summary of the invention

According to the present invention a proximity sensing system and device are provided for a self orientating device, particularly a vacuum-cleaner, which comprises a transmitter system cheap in production, which presents a large bandwidth, a high directivity resulting in high sensitivity at the receiver and at the same time constituting a very robust apparatus.

The present invention discloses a proximity sensing system and a device for an autonomous device being provided with a pair of motor driven wheels, the device comprising members for the proximity orientation and guiding of the device in the form of a microprocessor system and a proximity ultrasonic sensing system comprising at least one transmitting member and one receiving member and a mechanical sensing member in form of a forward directed bumper, wherein the mechanical sensing member is actuating at least one touch sensor if the device makes contact to an obstacle in the course of the moving device, the transmitting member is a stripe-shaped ultrasound transducer positioned at the front of the device and transmitting ultrasonic waves with a narrow vertical distribution within a wide sector in front of the device, and the receiving member comprises a number of microphone units provided with hollow pipes for the sound and forming a input portion of a receiving system for receiving echoes of the transmitted ultrasonic waves reflected from objects in the forward course of the moving device.

Further objects and advantages of the present invention are set forth by the dependent claims.

Description of the drawings

The invention will be described in form of a preferred embodiment by making reference to the accompanying drawings, in which:

- Fig. 1 demonstrates a top view of an autonomous device in an embodiment of a vacuum-cleaning robot incorporating the present invention;
- Fig. 2 demonstrates a side view of the device of Fig. 1;
- Fig. 3 demonstrates a side view of the device of Fig. 1;
- Fig. 4 demonstrates a hardware block diagram of the device according to Fig. 1 illustrating an embodiment incorporating the present invention;
- Fig. 5 shows a graph illustrating directivity of a sonar transducer utilized in the present system;
- Fig. 6 shows a graph illustrating directivity of a naked microphone for a sonar system;
- Fig. 7 shows a graph illustrating the directivity of a microphone provided with hollow pipes utilized in the present sonar system;
- Fig. 8 is a vertical cut of a microphone provided with hollow pipes for the received sound;
- Fig. 9 illustrates build-up of a stripe-shaped transducer;
- Fig. 10 shows a simplified sonar transmitter block diagram utilized in an embodiment of the present system;
- Fig. 11 shows a sonar receiver block diagram utilized in an embodiment of the present system;

Fig. 12 shows an example of received signal when no obstacle is present; and

Fig. 13 shows an example of received signal when obstacles are present at distances of 5 cm and 45 cm.

#### An illustrative preferred embodiment

##### General features

Figure 1 illustrates in a top view an illustrative embodiment of an autonomous vacuum-cleaning device, which by itself will move on a floor and vacuum-clean a room. In the front portion there is arranged an ultrasonic transmitter. The transmitter consists of a stripe-shaped transducer 10 about 25 mm wide and a length covering of the order 150° of the front perimeter of the device as illustrated in Fig. 2. As seen in Fig. 2, the strip-shaped transducer 10 is mounted above a number of microphone units 12, which together with the transducer 10 form an ultrasonic sonar system for the orientation of the device. The transducer is countersunk in a forward directed, movable bumper unit 16. The bumper 16 controls a left and a right bumper touch sensor, either one being actuated if the bumper makes contact with an obstacle. From Figs. 2 and 3 it will be seen that the device has two diametrically positioned wheels 17, 18 and a third wheel 19 at the back. The wheels 17, 18 are each independently driven by a separate motor equipped with a gearbox. The wheels 17, 18 are connected directly on the outgoing axis from the gearbox. The driven wheels 17 and 18 enables the device to also rotate around its own symmetry center. On each axis from the gearboxes connected to the wheels 17 and 18 respectively a slotted disc and a HP slotted disc encoder is mounted. The quadrature signals from the slotted disc encoders are connected to a microprocessor controlling the device. The third wheel 19 supports the back of the device. The direction of the wheel 19 will be dependent on the driving of the two wheels 17 and 18 as it may rotate around a vertical shaft. The device is balanced with a slightly larger weight on the rear half of the device, carrying for instance the batteries, such that it will always move with all three wheels

in contact with the floor. Due to this balancing the device may easily climb the edges of floor carpets and the like. The balance is also sensed by a tilt switch in the device.

In another embodiment the stripe-shaped transducer is divided into two stripe-shaped transducers, on upper portion and one lower portion. The number of microphone units then will be positioned between the two portions of the sonar transmitter.

In figure 4 is illustrated a hardware block diagram of the device according to Figures 1, 2 and 3. The hardware is essentially built around a data processor type MC68332 from Motorola Inc. The signals from the slotted disc encoders are connected to Timer Processor Unit (TPU) inputs of the MC68332. The processor (running in QDEC mode) giving position information with an accuracy of 2000 slots per revolution controls, via respective drivers, left and right wheel motors. The wheel motors are separately controlled by pulse-width modulated signals of 5 kHz generated by to more channels from the Timer Processor Unit in the main processor. The processor also controls two additional motors, one for the rotating brush and another for the fan generating the necessary vacuum for the general function of the vacuum-cleaner. Air from the fan motor is additionally in a known manner utilized for cooling purposes and the air is exhausted at a gilled outlet at the top of the device.

The processor is controlled by software stored in a number of different types of digital memories for example of type FEPROM, RAM or EEPROM, which are all well known to a person familiar to computer techniques. Communication with the control system may be obtained through a standard RS-232 interface. Additionally the processor has its own clocking system also known from prior art. The system as illustrated in Fig. 4 further comprises three touch switches, L-Bumper, R-Bumper and tilt switch, and a transmitter and a receiver for a sonar localization sensing system, which portions constitutes the part of the system involving the present invention and which will be described more in detail below.

The sonar localization system

In the illustrative embodiment the obstacle detection subsystem consists of an ultrasonic sonar and a bumper. The sonar is used for detection of obstacles in the path of the moving device, pinpointing the exact location of the nearest obstacle and sensing the presence of a floor. There is a semicircular capacitance film-transducer mounted on the perimeter of the device, together with three microphones, for detection of objects having an essentially vertical profile. For sensing floors and staircases there are additionally two piezoelectric beepers mounted in front of the two driven wheels, facing downwards, together with two additional microphones. The bumper has two touch switches, one for each side, and which are used for emergency stopping when an obstacle, still undetected by the sonar, has been hit.

The physical stripe-shape of the transducer gives it a beam pattern with a wide horizontal distribution, while the vertical distribution is rather narrow. A typical beam pattern for a 45 degree transducer is shown in Fig. 4 and demonstrates a pronounced narrowed pattern between  $-10^{\circ}$  to  $+10^{\circ}$  in the forward elevation angle. The use of a distributed sound source will minimize eventual dead zones and at the same time facilitate an easier detection in a near zone where an obstacle exists. Utilizing an omni-directional source implies that a part of the localization must be performed by triangulation which in turn implies that all microphone channels must have the same response and that the object to be located must preferably reflect equally in all directions.

An available transducer type is a single sided electrostatic transducer of Sell type, which works by electrostatic attraction. Fig. 9 shows a build up of a Sell transducer which comprises an electrically conducting corrugated back-plane 30 which is generally acoustically transparent, for instance in form of a wire mesh. The corrugation sets the air gap 32 and thereby both the transmitter sensitivity and its maximum emitted intensity.



The other electrode 34 consists of a movable film which is metallized on the side not in contact with the corrugated back-plane 30. In the preferred embodiment the stripe-shaped transducer 10 is formed by first attaching a corrugated copper film to the perimeter of the inner basic curved structure and on top of the corrugated copper film a plane insulated conductive film forming the moving part of the stripe-shaped electrostatic transducer. Thus the insulation of the conductive film is facing the corrugated copper film. The corrugated copper film has an adequate waffle pattern. Note that this preferred device is intended to transmit in the opposite direction compared to the general Sell type demonstrated in Fig. 9. In front of the transducer is additionally placed a protective wire mesh at a rectangular opening along the perimeter of the bumper 16, covering a forward angle of the order  $150^\circ$ . Thus the corrugated film constitutes one electrode and the insulated conductive film the other electrode of the transducer. The transmitter will be non-linear which implies that it rectifies an applied AC signal if a biasing voltage is not applied together with the AC signal. Documentation on Sell transducers is for instance found in IEE Transactions on Ultrasonics, Ferroelectrics and Frequency Control, #1 Vol 42, Jan 1995, which is expressly incorporated here by reference. The utilized transducer will be further described below.

The other important parts of the sonar system are the microphones. The microphones are mounted behind an arrangement of two vertically aligned hollow pipes for the sound in order to give them a desired directivity. In Fig. 6 is demonstrated the horizontal and vertical directivity of a microphone suitable for a sonar system. The diagram plots the generated relative voltage in a vertical plane  $-100^\circ$  to  $+100^\circ$  and similarly in a horizontal plane  $-100^\circ$  to  $+100^\circ$ . The directivity of a naked microphone is almost omni-directional, as indicated by the diagram of Fig. 6.

Introducing the vertically aligned horizontal hollow pipes or tubes together with the already obtained narrow vertical

distribution of the transmitter, echoes from the floor as well as from sharp edged carpets etc., will be heavily suppressed. Fig. 7 demonstrates the directivity for a microphone provided with two vertically aligned horizontal hollow tubes, or pipes, in a diagram similar to the diagram shown in Fig. 6. With the sound pipes the directivity in the vertical plane is greatly improved as can be seen in the diagram. This gives a much simplified detection of objects in the near zone, where echoes from the floor and the device itself are strongest.

Fig. 8 demonstrates a cross section of a microphone unit 12 with two hollow sound pipes. In the present embodiment the two pipes, 12a and 12b have a diameter of 2.5 mm and a center distance of 4.25 mm. The total diameter of the microphone unit is of the order 8 mm and the depth about 12 mm which means that the microphone element 12c is countersunked about 6mm into the microphone unit.

#### Detailed description

The Motorola central processor unit MC68332 directly generates the necessary pulse train to drive the transmitter. Since the transducer element is rectifying, the frequency of the generated sound is twice the frequency of the input signal. Fig. 9 illustrates a simplified block diagram of the sonar transmitter utilized in an preferred embodiment of the present system. In the presently preferred embodiment of the present invention the signal consists of three periods of 20 kHz with a duty cycle of 40% generated from channel 0 of the Timer Processor Unit (TPU), which is running in a Position-Synchronized Pulse Generator (PSP) mode. The time reference is determined by channel 1 running in Period Measurement With Additional Transition Detection (PMA) mode. (Further information on PSP and PMA is found in Application Notes TPUPN14/D and TPUPN15A/D). PMA requires a clock connected to E2CLK input and an input signal with evenly spaced pulses, plus an additional pulse at a specified point. This signal is generated by the PCS0 signal from the Queued Serial Module (QSM), also an integrated device in the MC68332 CPU. Frequency and duty

cycle of the transmitted burst can be varied by changing the programming of the PSP function. Burst length (number of pulses) is controlled by changing the programming of the PCS0 signal from QSM. All this is done in a software module (not shown) which will be obvious to a person skilled in the art.

In Fig. 10 is illustrated that the signal from the MC68332 CPU is output to a field effect switch, FET, having its source electrode connected to ground and via a transformer is driving the stripe-shaped ultrasound transducer. A primary 12 volts supply to the drain electrode of the field effect transistor, which keyed on its gate by the CPU MC68332, generates pulses of about 600 Vpp in the secondary winding of the transformer. The capacitance of the transducer and the inductance of the secondary winding form a parallel resonance circuit tuned to the operation frequency of the ultrasonic transmitter.

The receiver demonstrated in a simplified receiver block diagram in Fig. 11 uses an analog multiplexer to select one of the three main microphones 12 or an extra side microphone (not shown in the diagram) for a wall tracking, (or one of the two floor sensing microphones in front of the driven wheels 17, 18), as input to a bandpass-filter followed by an envelope detector. The microphones in the present embodiment are connected to individual amplifiers of about 40 dB gain. The bandpass-filter of the present embodiment is a 6 pole filter having a bandwidth of 15 kHz centered at 40 kHz and a filter gain of about 40 dB. The envelope detector like the preamplifiers and the bandpass-filter constitute a standard configuration well known to a person skilled in the art. The signal from the envelope detector is then fed to a 12 bit serial A/D-converter, under control of the QSM. Samples are stored at a rate of 40 kilosamples per second, starting one millisecond before and ending twentyfour milliseconds after the transmitted ultrasonic burst. Clocked by A/D transfers the QSM outputs the peripheral chip selects PCS0 and PCS1. PCS1 is issued at positions number eight and sixteen triggers an interrupt to the main CPU, indicating that there are

eight samples ready in the QSM receive registers. The QSM can hold sixteen received samples, corresponding to sixteen command words that control the transfer. After sixteen command words the QSM wraps back and restarts the command sequence. In this way the QSM synchronizes A/D conversions autonomously, interrupting the CPU (through TPU channel 2, in Discrete Input Output (DIO) mode), only when necessary. When the CPU has received all expected samples, the QSM is disabled. PCSO is issued at samples number one and nine, giving the base clock for the PMA function. An additional pulse is programmed at a desired position somewhere in between, (in this case at sample number six), to identify the "additional" transition. This triggers the PSP function in channel 0 to start the burst that generates the sound. The burst is only generated once per reception cycle and perfectly synchronized to the receiver A/D sampling clock, making it easy to correlate a sample number to an exact time relative to the transmitted burst.

#### Analyzing received data

The received raw data is divided in three parts used for different purposes. First the background noise level is calculated by using the data sampled before the burst is transmitted. Then the near zone is analyzed. The near zone in the present embodiment is the range from the perimeter of the device and up to about thirteen centimeters away, corresponding to about 750 microseconds. In this time window the received signal is heavily contaminated by echoes from the floor and from the device itself. In order to distinguish any obstacle in this region, a typical decay pattern for each microphone is maintained and subtracted from the received signal. In Fig. 12 is illustrated the relative echo amplitude for a microphone of the present embodiment with no obstacle present. In Fig. 13 is illustrated the relative echo amplitude of the same microphone with obstacles at distances 5 and 45 cm. After subtraction of the typical decay pattern the remaining peaks are compared to a fixed threshold and, if above this preset threshold, considered to be representing an obstacle. Last, the zone beyond the near zone is scanned

for peaks above a fixed threshold and offset by the calculated background noise level.

The exact location of an obstacle is not known by only using the information from each microphone since the detected object could be located anywhere on an ellipsis. To pinpoint the exact location of the nearest obstacle trigonometry is used in a standard geometrical way apparent to a person skilled in the art. Only the distance and angle to the nearest obstacle is calculated due to the complex mathematics that must be performed in real time. Also this is only done when travelling at low speed or stopped.

When traveling at high speed, the information from the different microphones is used as is, to get an approximation of the distance to obstacles, and then switch to low device speed when obstacles are close enough.

#### Navigation

Normally the device moves in a straight line until an obstacle is encountered. If no obstacle is detected within 40 cm from the front, or 10 cm from the sides, high speed is used. High speed for the present embodiment corresponds to about 40 cm/s. If any obstacle is seen within this section, low speed is used. Low speed is then set to about 14 cm/s. Detection of an obstacle within a distance of a few centimeters causes the device to stop. After stopping, the closest obstacle is checked and the angle to the object is used as argument for calculating a new direction for travel. If the obstacle is found far out on either side, a small base angle is used. On the other hand, if the hit is straight ahead, a base angle of 60 degrees is used. To the base angle, a random angle of up to 60 degrees is added. In this way the autonomous device can find its way through a narrow passage with small turns and still bounce efficiently between bare walls. The distance between stops and the number of turns is monitored so that the "free run mode" switches into "stuck, breakout mode" if the travelled distance does not exceed a set minimum after a

number of turns. Actually hitting anything "unseen" by the sonar and detected only by the bumper touch sensors causes the device to first backoff a few centimeters, and then continue as if the object is sensed on the corresponding side.

When the device has detected that it does not travel far enough between stops, it changes strategy into constantly turning and sensing the environment until a free passage is found or a full circle is covered. If after traveling a short distance another obstacle is detected the same procedure is repeated, continuing turning in the same direction. When a minimum distance is traveled without hitting a new obstacle, "free run mode" is reentered. On the other hand, if the device continues to find obstacles, it is turned off after a number of turns.

Normally when in the "stuck, breakout mode" the device switches off all other activities like for instance the rotating brush and the fan producing the vacuum, unless the airstream from this fan is needed for the cooling of the device circuitry as controlled by temperature sensors.

When performing a cleaning task the device starts by tracking the walls defining the room. In the preferred embodiment there are four sonar microphone units in the bumper below the ultrasonic transmitter. Three microphone units are used for the forward navigation while a fourth microphone unit placed at the right side of the bumper takes care of the wall tracking. After the general investigation of the room by doing a wall tracking round the room the device starts the cleaning operation in a random manner and will go on until it estimates that it has covered all the accessible surface.

For a random number generation a standard pseudo-random number generator of the congruential type is used. As seed an 11 bit random number is used in order to use different sequences each separate run. This random number is generated by using the least significant bit of the A/D converted value from each of the 11

analog inputs.

It will be understood by those skilled in the art that various modifications and changes may be made to the present invention without departure from the spirit and scope thereof defined by the appended claims.

## CLAIMS

1. A proximity sensing system for an autonomous device being provided with motor driven wheels (17, 18) for carrying out a specific cleaning function, said device comprising members for the orientation and guiding of the device by means of a microprocessor system forming a proximity sensing system which comprises at least one transmitting member and one receiving member and a mechanical sensing member (16) in form of a forward directed bumper, characterized in that

said transmitting member is a stripe-shaped ultrasound transducer (10) positioned at the front perimeter of the device and transmitting ultrasonic waves with a narrow vertical distribution within a wide sector in front of the device,

2. The system according to claim 1, characterized in that said transmitting member is a semicircular capacitance film-transducer (10) mounted on the perimeter of the device together with said receiving member having at least three ultrasonic microphone units.

3. The system according to claim 2, characterized in that said transmitting member is divided into two portions presenting an upper stripe-shaped ultrasound transducer and a lower stripe-shaped ultrasound transducer having between them the receiving member.

4. The system according to claim 2 or 3, characterized in that said transmitting member is countersunked in the front portion of the device to further limit the vertical distribution of transmitted and received signals.

5. The system according to claim 1 or 3, characterized in that said receiving member comprises a number of microphone units (12) provided with hollow pipes (12a, 12b) for the sound to further improve the directivity pattern for each microphone unit.

6. The system according to claim 5, characterized in that



said hollow pipes (12a, 12b) of the receiving microphone units are aligned vertically in respect to each other to produce an improved directivity in the vertical plane.

7. The system according to claim 5, characterized in that a further microphone unit (12) is pointed to one side of the device to be used in a wall tracking operation.
8. The system according to claim 2 or 3, characterized in that said transmitting member during each repeated transmission transmits a sequence of closely spaced pulses, the echoes of which will be integrated into one sampled reflection at a specific reflection distance by said receiving system.
9. The system according to any of the previous claims, characterized in that said mechanical sensing member (16) is actuating at least one touch sensor if the device makes contact to an obstacle in the course of the moving device,
10. A device for navigation of an autonomous device being provided with motor driven wheels (17, 18) for carrying out some specific cleaning function, said device comprising members for the proximity orientation and guiding of the device by means of a microprocessor system and a proximity sensing system which comprises at least one transmitting member and one receiving member and a mechanical sensing member in form of a forward directed bumper (16), characterized in that said transmitting member is a stripe-shaped ultrasound transducer (10) positioned at the front of the device and transmitting ultrasonic waves with a narrow vertical distribution within a wide sector in front of the device.
11. The device according to claim 10, characterized in that said transmitting member is a semicircular capacitance film-transducer mounted on the perimeter of the device together with said receiving member having at least three microphone units.

12. The device according to claim 11, characterized in that said transmitting member is divided into two portions presenting an upper stripe-shaped ultrasound transducer and a lower stripe-shaped ultrasound transducer having between them the receiving member.

13. The device according to claim 11 or 12, characterized in that said transmitting member is countersunked in the front portion of the device to further limit the vertical distribution of transmitted and received signals.

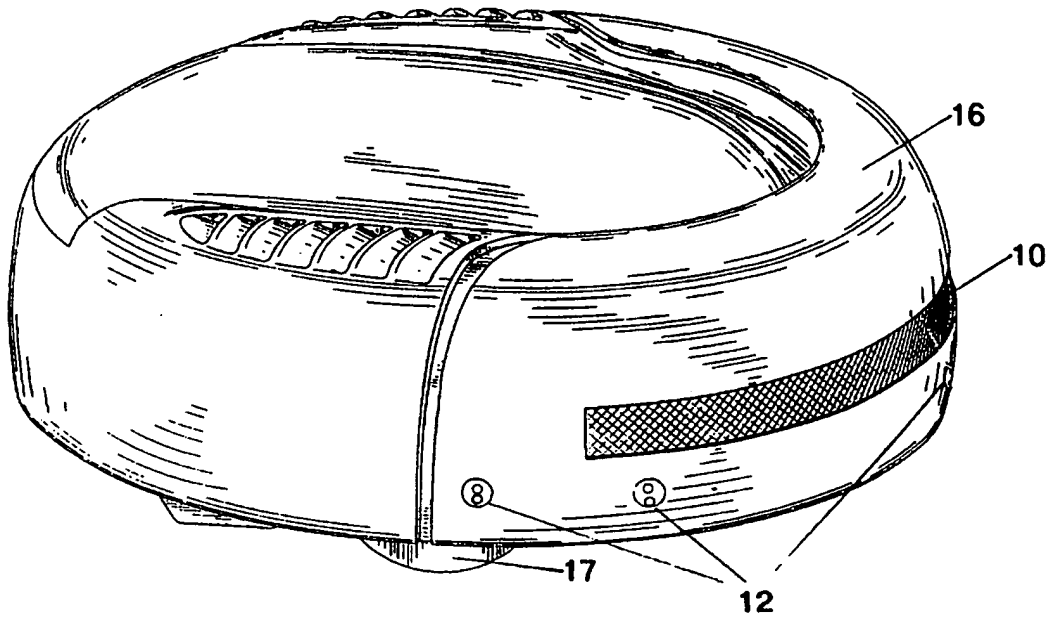
14. The system according to claim 10 or 12, characterized in that said receiving member comprises a number of microphone units (12) provided with hollow pipes (12a, 12b) for the sound to further improve the directivity pattern for each microphone unit.

15. The device according to claim 14, characterized in that said hollow pipes (12a, 12b) of the receiving microphone units (12) are aligned vertically in respect to each other to produce an improved directivity in the vertical plane.

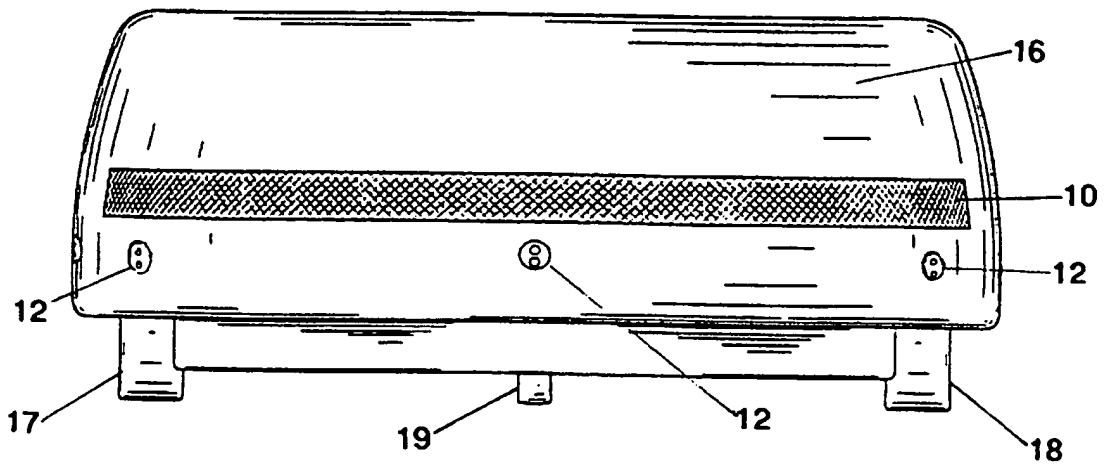
16. The device according to claim 14, characterized in that a further microphone unit (12) is pointed to one side of the device to be used in a wall tracking operation.

17. The device according to claim 11 or 12, characterized in that said transmitting member during each repeated transmission transmits a sequence of closely spaced pulses, the echoes of which will be integrated into one sampled reflection at a specific reflection distance by said receiving system.

18. The device according to any of the previous claims 10 to 16, characterized in that said mechanical sensing member (16) is actuating at least one touch sensor if the device makes contact to an obstacle in the course of the moving device.



**Fig. 1**



**Fig. 2**

**SUBSTITUTE SHEET**

2/7

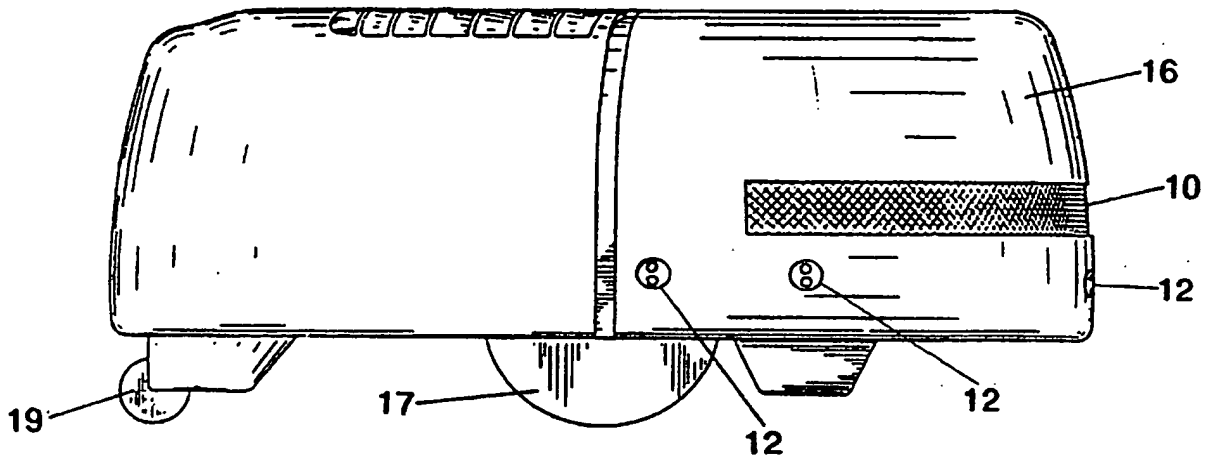


Fig. 3

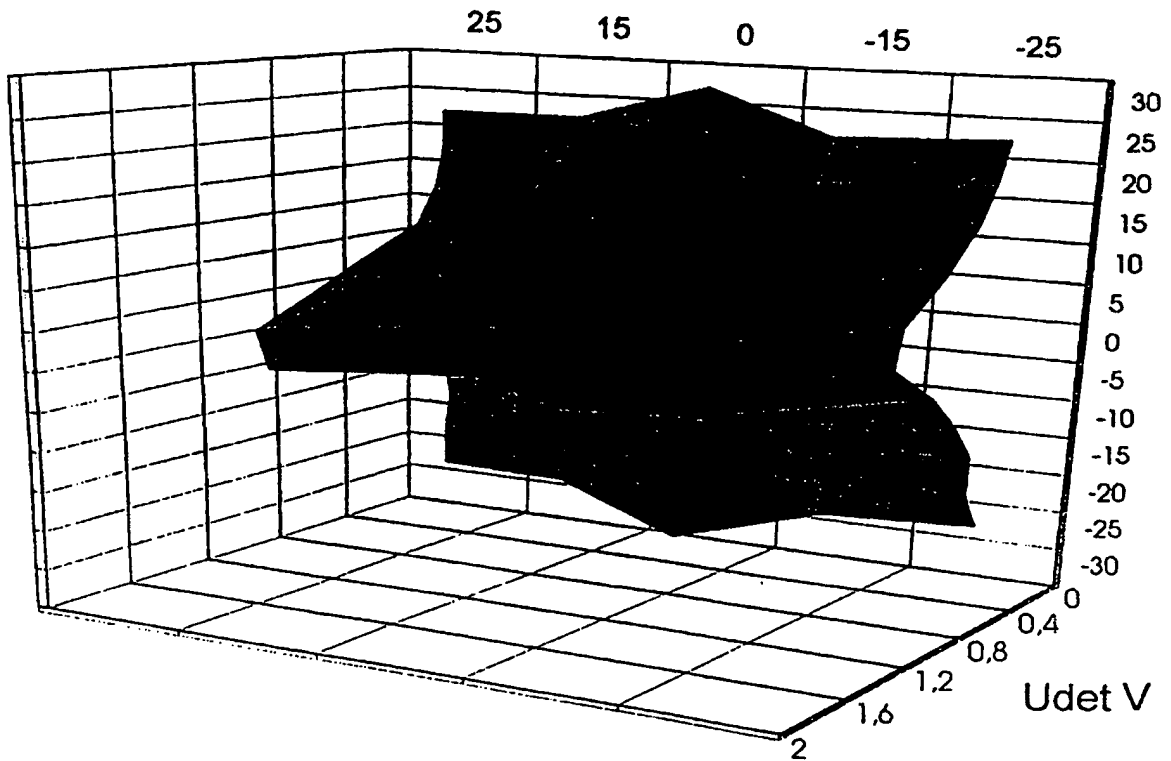


Fig. 5

**UBSTITUTE SHEET**

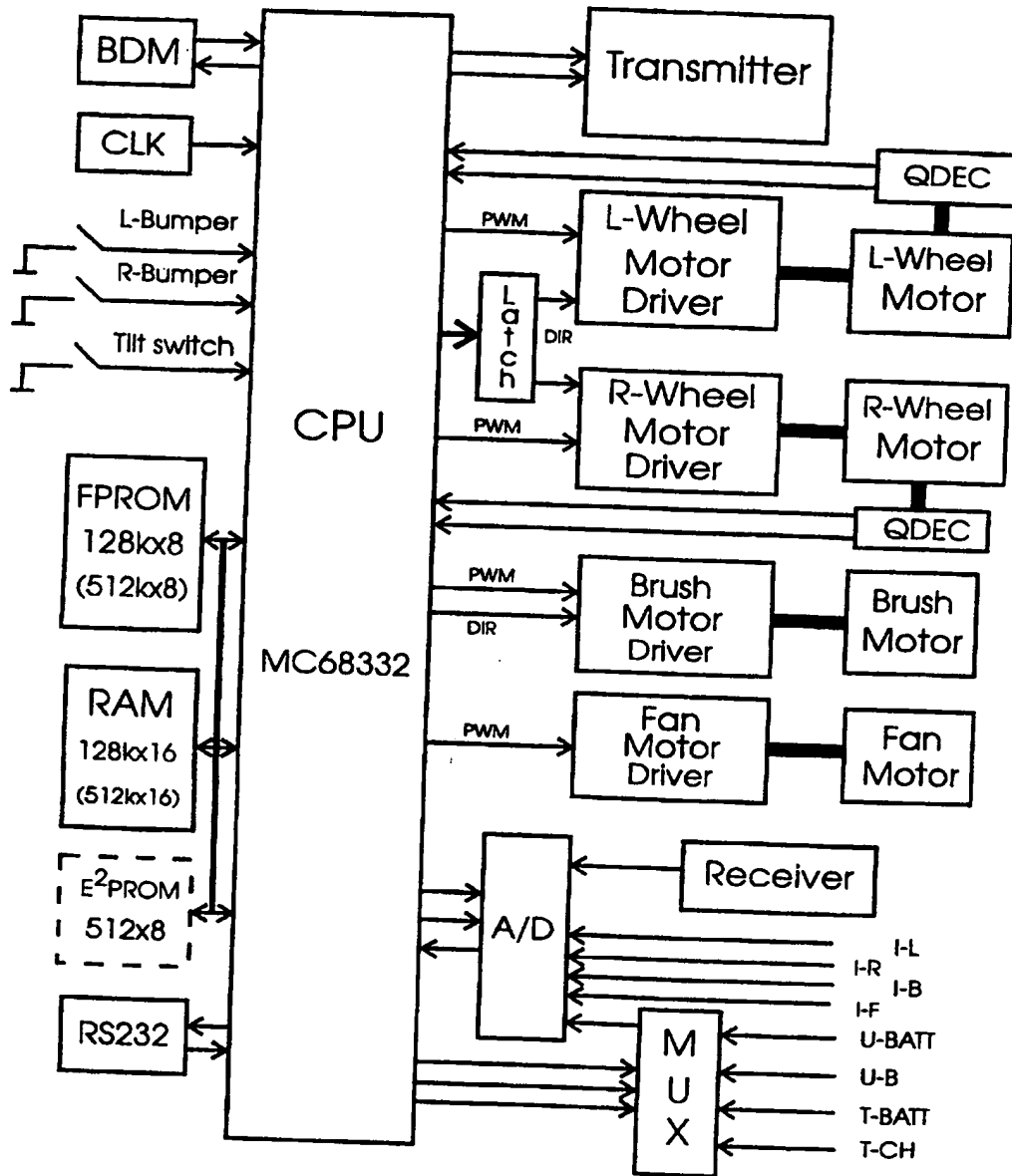


Fig. 4

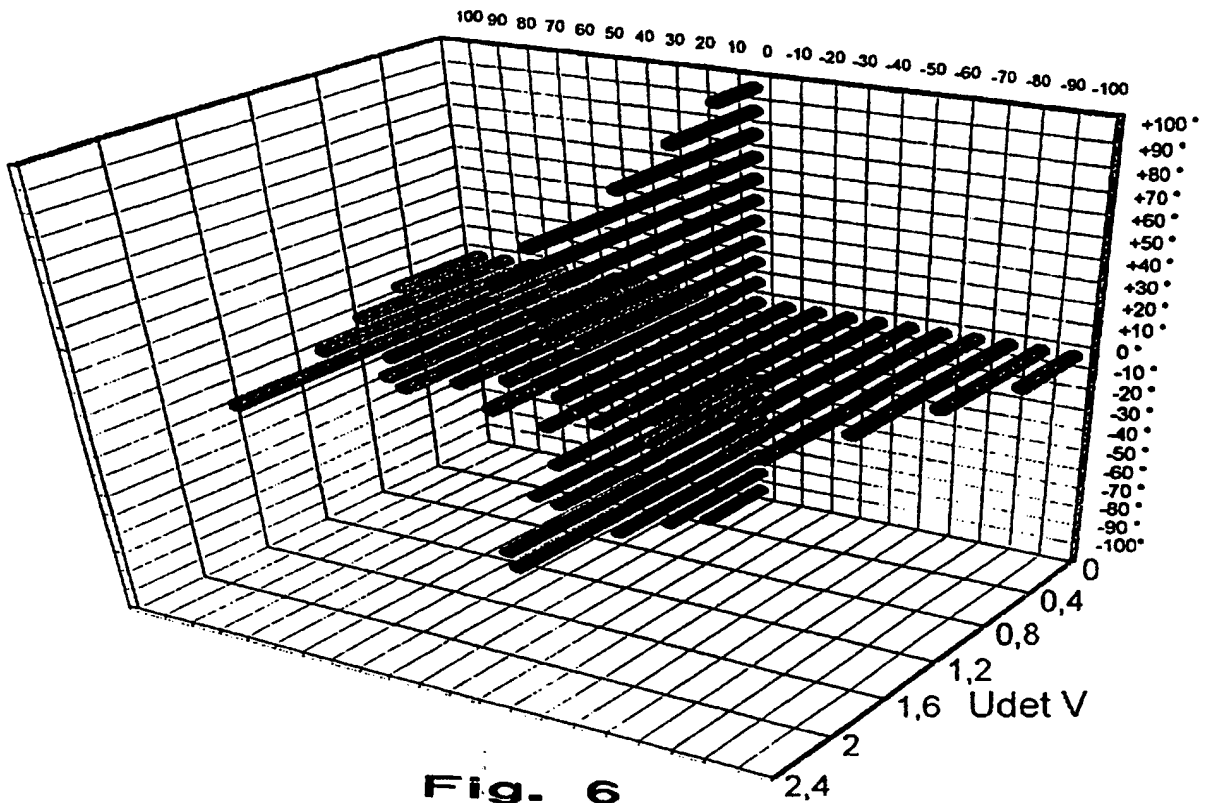


Fig. 6

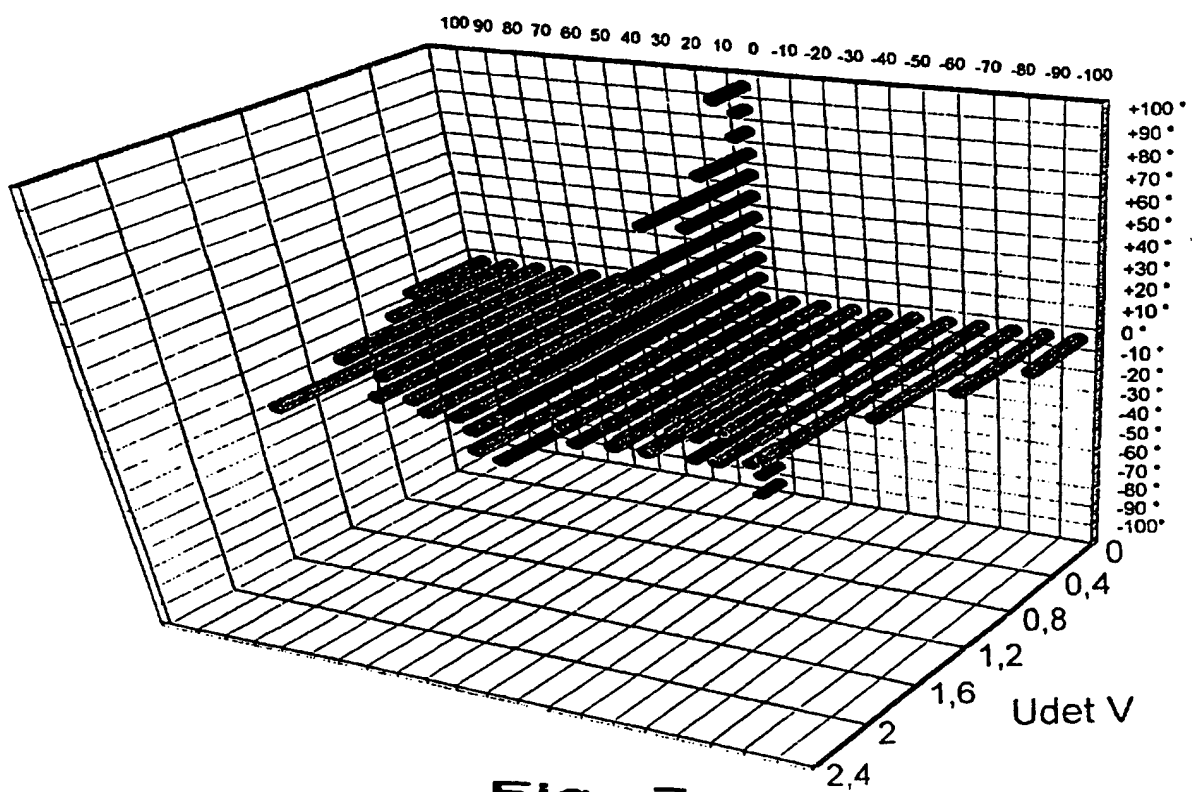


Fig. 7

**SUBSTITUTE SHEET**

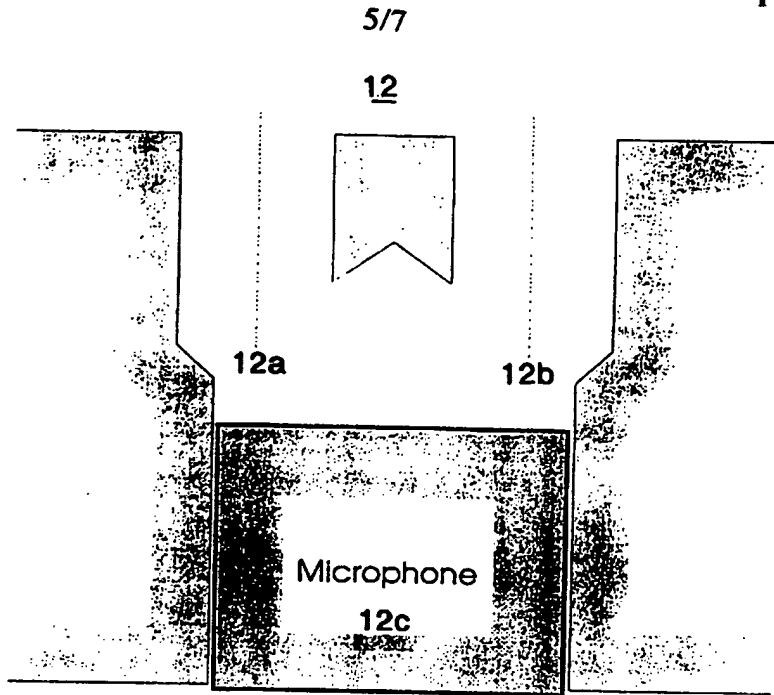


Fig. 8

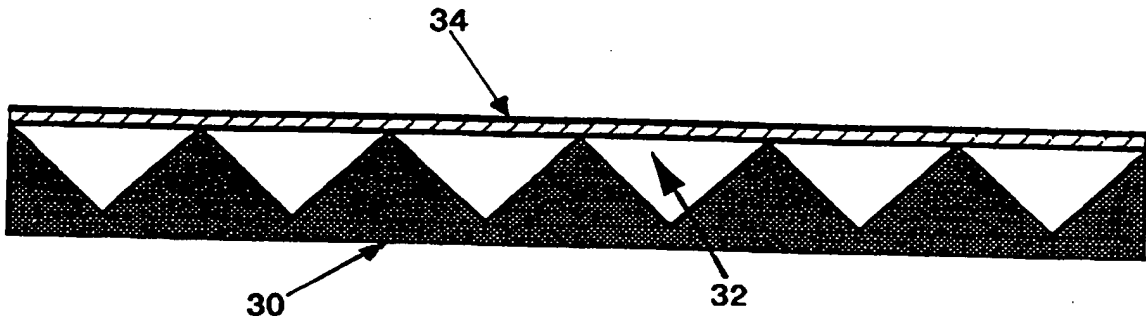


Fig. 9

**UBSTITUTE SHEET**

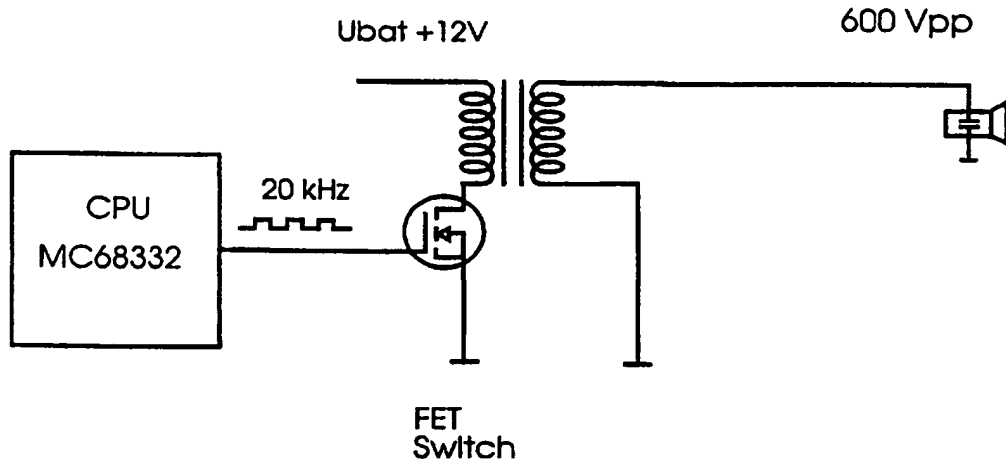


Fig. 10

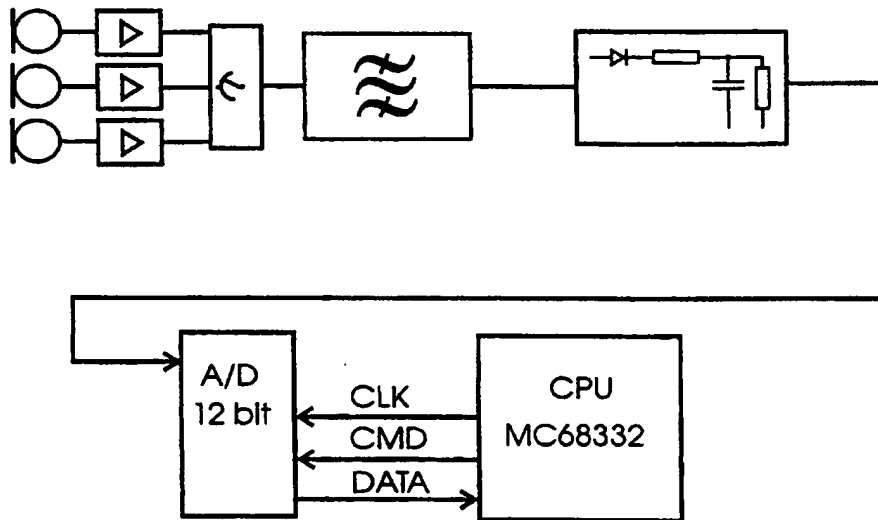


Fig. 11

**SUBSTITUTE SHEET**



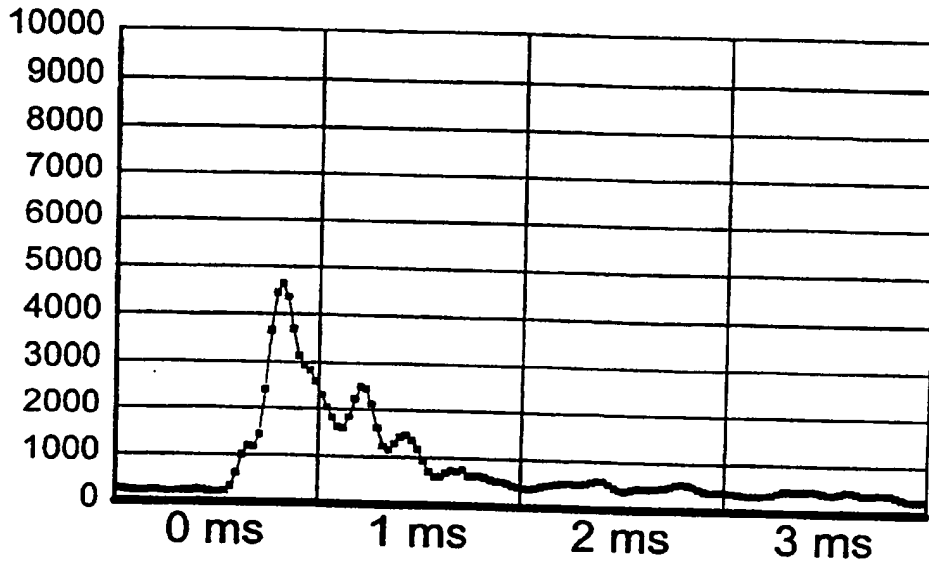


Fig. 12

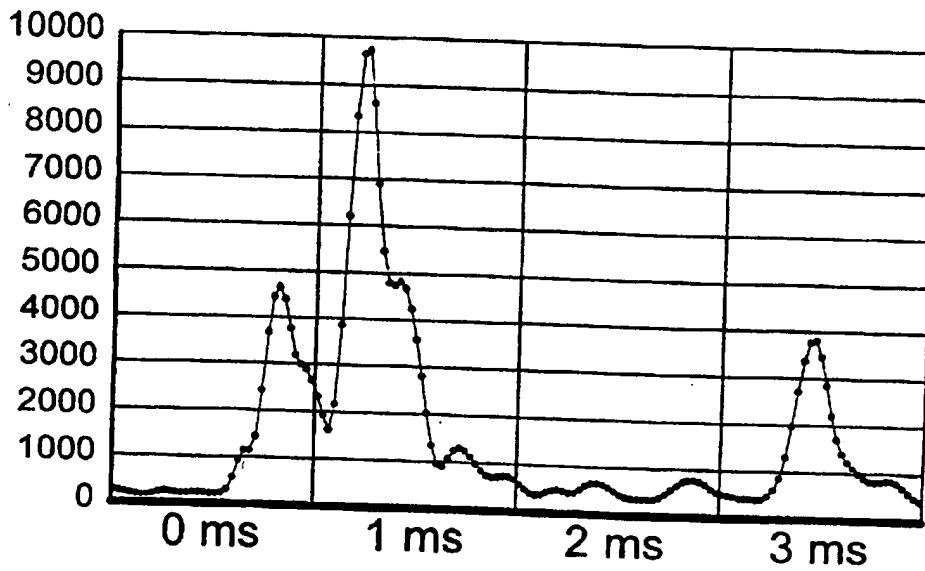


Fig. 13

**SUBSTITUTE SHEET**

## INTERNATIONAL SEARCH REPORT

International application No.

PCT/SE 97/00625

A. CLASSIFICATION OF SUBJECT MATTER		
IPC6: G01S 15/93, G05D 1/03 According to International Patent Classification (IPC) or to both national classification and IPC		
B. FIELDS SEARCHED		
Minimum documentation searched (classification system followed by classification symbols)		
IPC6: G01S, G05D		
Documentation searched other than minimum documentation to the extent that such documents are included in the fields searched		
SE,DK,FI,NO classes as above		
Electronic data base consulted during the international search (name of data base and, where practicable, search terms used)		
WPI		
C. DOCUMENTS CONSIDERED TO BE RELEVANT		
Category*	Citation of document, with indication, where appropriate, of the relevant passages	Relevant to claim No.
A	US 5377106 A (GERHARD DRUNK ET AL), 27 December 1994 (27.12.94), figures 11-16, abstract --	1-18
A	US 5276618 A (HOBART R. EVERETT, JR), 4 January 1994 (04.01.94), figure 1, abstract --	1-18
A	US 4751658 A (MARK B. KADONOFF ET AL), 14 June 1988 (14.06.88), figure 1, abstract --	1-18
<input checked="" type="checkbox"/> Further documents are listed in the continuation of Box C. <input checked="" type="checkbox"/> See patent family annex.		
<ul style="list-style-type: none"> <li>* Special categories of cited documents:</li> <li>"A" document defining the general state of the art which is not considered to be of particular relevance</li> <li>"E" earlier document but published on or after the international filing date</li> <li>"L" document which may throw doubts on priority claim(s) or which is cited to establish the publication date of another citation or other special reason (as specified)</li> <li>"O" document referring to an oral disclosure, use, exhibition or other means</li> <li>"P" document published prior to the international filing date but later than the priority date claimed</li> <li>"T" later document published after the international filing date or priority date and not in conflict with the application but cited to understand the principle or theory underlying the invention</li> <li>"X" document of particular relevance: the claimed invention cannot be considered novel or cannot be considered to involve an inventive step when the document is taken alone</li> <li>"Y" document of particular relevance: the claimed invention cannot be considered to involve an inventive step when the document is combined with one or more other such documents, such combination being obvious to a person skilled in the art</li> <li>"&amp;" document member of the same patent family</li> </ul>		
Date of the actual completion of the international search		Date of mailing of the international search report
4 Sept. 1997		08 -09- 1997
Name and mailing address of the ISA/ Swedish Patent Office Box 5055, S-102 42 STOCKHOLM Facsimile No. +46 8 666 02 86		Authorized officer  Göran Magnusson Telephone No. +46 8 782 25 00

Form PCT/ISA/210 (second sheet) (July 1992)

## INTERNATIONAL SEARCH REPORT

International application No.

PCT/SE 97/00625

C (Continuation). DOCUMENTS CONSIDERED TO BE RELEVANT		
Category*	Citation of document, with indication, where appropriate, of the relevant passages	Relevant to claim No.
A	US 5170352 A (LOUIS S. MCTAMANEY ET AL), 8 December 1992 (08.12.92), column 2, line 46 - line 51, figure 1  --	1-18
A	US 4638445 A (PAUL J. MATTABONI), 20 January 1987 (20.01.87), figures 1,7, abstract  -----	1-18

Form PCT/ISA/210 (continuation of second sheet) (July 1992)

**INTERNATIONAL SEARCH REPORT**  
 Information on patent family members

06/08/97

International application No.  
 PCT/SE 97/00625

Patent document cited in search report	Publication date	Patent family member(s)	Publication date
US 5377106 A	27/12/94	AT 129821 T DE 3709627 A DE 3854649 D EP 0378528 A,B JP 3500098 T WO 8807711 A	15/11/95 13/10/88 00/00/00 25/07/90 10/01/91 06/10/88
US 5276618 A	04/01/94	NONE	
US 4751658 A	14/06/88	AU 7434387 A EP 0271523 A JP 63502227 T WO 8707056 A	01/12/87 22/06/88 25/08/88 19/11/87
US 5170352 A	08/12/92	NONE	
US 4638445 A	20/01/87	NONE	

Form PCT/ISA/210 (patent family annex) (July 1992)

(12) DEMANDE INTERNATIONALE PUBLIÉE EN VERTU DU TRAITÉ DE COOPÉRATION  
EN MATIÈRE DE BREVETS (PCT)

(19) Organisation Mondiale de la Propriété  
Intellectuelle  
Bureau international



(43) Date de la publication internationale  
28 décembre 2000 (28.12.2000)

(10) Numéro de publication internationale  
WO 00/78410 A1

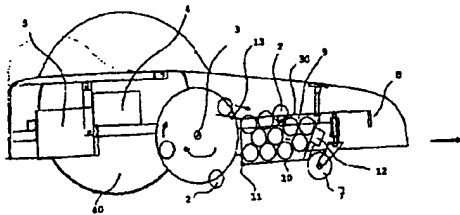
PCT

- (51) Classification internationale des brevets<sup>7</sup>: A63B 47/02, A01G 1/12
- (72) Inventeur; et  
(75) Inventeur/Déposant (pour US seulement): COLENS, André [BE/BE]; 5, rue du Baillois, B-1330 Rixensart (BE).
- (21) Numéro de la demande internationale: PCT/BE00/00064
- (74) Mandataire: COLENS Alain; Bureau Colens SPRL, 21, rue Franz Merjay, B-1050 Bruxelles (BE).
- (22) Date de dépôt international: 16 juin 2000 (16.06.2000)
- (25) Langue de dépôt: français
- (81) États désignés (national): AE, AL, AM, AT, AU, AZ, BA, BB, BG, BR, BY, CA, CH, CN, CR, CU, CZ, DE, DK, DM, DZ, EE, ES, FI, GB, GD, GE, GH, GM, HR, HU, ID, IL, IN, IS, JP, KE, KG, KP, KR, KZ, LC, LK, LR, LS, LT, LU, LV, MA, MD, MG, MK, MN, MW, MX, MZ, NO, NZ, PL, PT, RO, RU, SD, SE, SG, SI, SK, SL, TJ, TM, TR, TT, TZ, UA, UG, US, UZ, VN, YU, ZA, ZW.
- (26) Langue de publication: français
- (30) Données relatives à la priorité: 9900422 17 juin 1999 (17.06.1999) BE
- (71) Déposant (pour tous les États désignés sauf US): SOLAR & ROBOTICS S.A. [BE/BE]; 117, rue Franz Merjay, B-1050 Bruxelles (BE).
- (84) États désignés (régional): brevet ARIPO (GH, GM, KE, LS, MW, MZ, SD, SL, SZ, TZ, UG, ZW), brevet eurasien (AM, AZ, BY, KG, KZ, MD, RU, TJ, TM), brevet européen

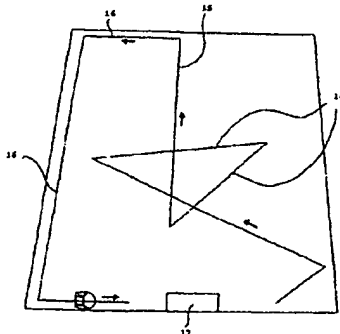
[Suite sur la page suivante]

(54) Title: DEVICE FOR AUTOMATICALLY PICKING UP OBJECTS

(54) Titre: DISPOSITIF AUTOMATIQUE DE RAMASSAGE D'OBJETS



(57) Abstract: The invention concerns a system for picking up objects (2) over a delimited surface consisting of an automatic mobile machine equipped with a motor and a power source, for example a rechargeable battery (5), and provided with an on-board computer (40). The machine carries a mechanical device for gripping and storing (1, 2, 13) objects in a container (9), a device for emptying said container, a device for detecting the limits of the surface for picking up. The system further comprises at least a station (17) for discharging the objects picked up and preferably a station for recharging the rechargeable batteries. Both said stations are advantageously integrated to each other. The objects to be picked up are for instance balls (2) on golf ball practice greens which can automatically be returned from the unloading station to the driving site.



(57) Abrégé: L'invention propose un système de ramassage d'objets (2) sur une surface délimitée constitué par un engin mobile automatique muni d'un moteur et d'une source d'énergie, par exemple une batterie rechargeable (5), et muni d'un ordinateur de bord (40). L'engin porte un dispositif mécanique de préhension et de stockage (1, 2, 13) des objets dans un réceptacle (9), un dispositif de vidage dudit réceptacle, un dispositif de détection des limites de la surface de ramassage. Le système comporte aussi au moins une station (17) de décharge des objets récoltés et de préférence une station de recharge des batteries rechargeables. Ces deux stations sont avantageusement intégrées l'une à l'autre. Les objets à ramasser sont par exemple des balles (2) sur des "practices" de golf balles qui peuvent être automatiquement renvoyées de la station de décharge vers l'emplacement de tir.



WO 00/78410 A1

(AT, BE, CH, CY, DE, DK, ES, FI, FR, GB, GR, IE, IT, LU, MC, NL, PT, SE), brevet OAPI (BF, BJ, CF, CG, CI, CM, GA, GN, GW, ML, MR, NE, SN, TD, TG).

*En ce qui concerne les codes à deux lettres et autres abréviations, se référer aux "Notes explicatives relatives aux codes et abréviations" figurant au début de chaque numéro ordinaire de la Gazette du PCT.*

**Publiée:**

- *Avec rapport de recherche internationale.*
- *Avant l'expiration du délai prévu pour la modification des revendications, sera republiée si des modifications sont reçues.*

-1-

### Dispositif automatique de ramassage d'objets

5 La plupart des clubs de golf possèdent un "practice",  
espace de gazon sur lequel les golfeurs peuvent  
s'entraîner.

10 Les golfeurs exercent leurs "drives" à partir d'un espace  
réservé et envoient les balles à des distances  
généralement comprises entre 50 et 200 mètres. Ces  
balles doivent être régulièrement ramassées et ramenées à  
l'espace de tir.

15 On connaît déjà des engins spécialement adaptés pour le  
ramassage des balles de golf, en particulier sur des  
practices. Ils font en général intervenir un système  
comportant des disques souples espacés de la largeur d'une  
balle de golf (voir par exemple brevet des Etats-Unis  
20 5.711.388). Les disques tournent et sont montés  
verticalement sur un axe horizontal perpendiculaire à la  
progression de l'engin, ce dernier étant tiré par un  
véhicule automoteur ou poussé à la main.

25 Si l'on ne veut pas avoir un nombre de balles prohibitif  
en circulation, le ramassage doit se faire régulièrement,  
ce qui entraîne un coût en main d'oeuvre important et une  
perturbation régulière des joueurs.

30 Il y a donc un réel besoin de disposer d'un système de  
ramassage de balles qui soit entièrement automatique et  
puisse fonctionner sans interrompre les joueurs et sans  
risque d'accidents dus aux tirs de balle.

**copie de confirmation**

-2-

La présente invention propose un système de ramassage et de retour des balles entièrement automatique, éliminant la main d'oeuvre et permettant aux joueurs de continuer à s'exercer durant le ramassage.

5

De manière plus générale, l'invention propose un système de ramassage d'objets sur une surface déterminée constitué par un engin mobile automatique à batterie rechargeable et muni d'un ordinateur de bord. L'engin porte un dispositif mécanique de préhension et de stockage des objets dans un réceptacle, un dispositif de vidage dudit réceptacle, un dispositif de détection des limites de la surface de ramassage. Le système comporte aussi au moins une station de recharge des batteries rechargeables et une station de décharge des objets récoltés.

10

15

Selon un aspect de l'invention, le système comprend un engin mobile autonome circulant de manière aléatoire ou pseudo aléatoire sur la surface ou les balles doivent être récoltées.

20

De manière connue, la surface est de préférence délimitée par un fil périphérique dans lequel circule un signal basse fréquence détecté par l'engin. D'autres systèmes de délimitation de la surface de travail peuvent être adoptés, y compris par obstacle physique, tels que décrits dans la demande PCT/BE91/00068 pour une tondeuse à gazon robotique.

25

30

L'engin de ramassage comportera un châssis et des éléments d'avancement et de guidage connus en soi, par exemple similaires à ceux décrits dans les demandes PCT/BE91/00068 et PCT/BE98/00038.



-3-

Le système de tonte des documents susmentionnés est remplacé par un système de ramassage de balles. Le système de ramassage de balles est constitué, par exemple, d'un rouleau formé d'une série de disques flexibles parallèles, de profil approprié, espacés d'une distance égale ou  
5 légèrement inférieure au diamètre d'une balle. Lors de l'avancement de la machine, le système de disques flexibles reposant sur le sol est entraîné passivement en rotation, et roule sur les balles se trouvant sur son passage. Le rouleau coince ces dernières entre deux  
10 disques flexibles adjacents qui par le mouvement circulaire ascendant, et l'effet d'éléments de déviation dans la partie descendante, les ramènent dans un panier collecteur supporté par l'engin. Le système de disques flexibles est de préférence monté sur une ou des  
15 articulations, ou est en tout cas monté de manière souple, permettant de garder le contact avec le sol en cas d'irrégularités de celui-ci. Le panier collecteur comprend à sa partie inférieure une ouverture commandée par l'ordinateur de bord.  
20

Selon un mode de réalisation, le système de disques flexibles comprend un axe articulé apte à se relever, par exemple à l'intervention d'un vérin. Lors d'un changement  
25 de direction, l'ordinateur commande le relèvement du système à disques souples afin d'éviter une friction importante avec le sol, et les dégradations de la surface d'herbe et la consommation énergétique supplémentaire qui peuvent en résulter.

30 Lorsque le panier est plein ou lorsque la machine doit recharger ses batteries, l'ordinateur commandant l'avancement de l'engin applique un algorithme de retour vers un point fixe (station). Le niveau limite de

-4-

remplissage en balles dans le panier collecteur peut par exemple être détecté par un système d'émetteur-récepteur IR connecté au micro-ordinateur.

5 Pour le retour à la station de recharge, selon un mode de réalisation, l'engin recherche le fil périphérique en suivant de manière aléatoire par exemple une trajectoire droite puis, ayant détecté ce dernier, le suit à une distance fixe jusqu'à atteindre la borne ou station de  
10 recharge. Cette dernière peut être avantageusement couplée et intégrée à la station de récupération des balles.

En effet selon un mode préféré de réalisation, après détection de la borne, p.e. par contact, la machine  
15 s'arrête, et se positionne éventuellement de manière plus précise. L'ordinateur commande l'ouverture de la trappe permettant au panier de se vider et maintient la machine en état de recharge jusqu'à ce que ses batteries soient complètement rechargées. Après recharge, l'engin repart  
20 pour un nouveau cycle de récolte en parcourant la surface du practice de manière aléatoire ou quasi aléatoire.

Selon d'autres modes de réalisation, actuellement moins préférés, l'engin peut rejoindre la station de recharge  
25 par d'autres moyens, par exemple par analyse d'un champ magnétique avec recharge éventuelle par induction (voir par exemple US 5.869.910), par guidage radio ou encore par détection de signaux infra-rouge.

30 Dans ce dernier cas, l'engin selon l'invention incorpore un système de guidage et de positionnement par rapport à une station fixe faisant par exemple intervenir au moins un faisceau infrarouge directionnel émis par la station fixe, le robot mobile étant muni d'un système de détection

-5-

(détecteurs) directionnel d'émission infra-rouge relié au microordinateur incorporé dans ledit robot, le robot se déplaçant sur une surface de travail de manière essentiellement aléatoire, le micro-ordinateur comprenant un algorithme apte à commander le retour à la station fixe par déplacement du robot vers la direction d'émission dudit faisceau infrarouge. Le faisceau infrarouge peut être un faisceau directionnel étroit et le système de détection peut être avantageusement situé sur le châssis au centre de rotation du robot, dirigés dans le sens du mouvement du robot, le positionnement précis dans la station fixe étant effectué par rotation de l'engin autour d'un axe vertical selon un algorithme basé sur la détection du faisceau étroit, par exemple de 2 à 15°.

Ce système peut faire intervenir au moins deux faisceaux de directionalité substantiellement différente émis à partir ou aux environs de la station fixe, le ou les faisceaux les moins directionnels servant à l'approche vers la station fixe, tandis que le ou les faisceaux plus directionnels sont utilisés pour l'étape ultime de positionnement précis du robot par rapport à cette station fixe.

L'engin selon l'invention peut fonctionner pendant les tirs de balles. Le profil de l'engin est bas et est peu important par rapport aux engins classiques tirés et la probabilité de collision avec une balle en est diminuée. De plus l'habillage de l'engin, par exemple en matière plastique éventuellement recouverte de mousse, est conçu de manière à pouvoir supporter sans endommagement l'impact de balles de golf.

-5-

On peut à certains moments souhaiter que la surface soit  
entièrement débarrassée de balles, par exemple pour tondre  
le gazon de manière classique. Dans ce cas la  
récupération en utilisant un système de trajectoire  
5 aléatoire ou quasi aléatoire n'est plus souhaitable. Un  
système de trajectoire systématique peut être adopté pour  
recouvrir l'ensemble du terrain en un temps optimal.

Par exemple, la machine peut suivre le fil périphérique à  
10 une certaine distance de celui-ci. Grâce à la mesure  
constante du champ d'un fil périphérique de délimitation  
de la surface de travail tel que décrit dans les brevets  
EP 0550 473 B1 et 0 744 093 B1, la machine calcule  
constamment sa distance par rapport au fil et peut  
15 incrémenter celle-ci après chaque tour. La récupération se  
déroulera en bandes parallèles à partir de la périphérie.

Plus précisément, selon cette dernière technique, au début  
la machine est positionnée le long du fil périphérique.  
20 Après le démarrage, l'ordinateur de bord mesure  
périodiquement, de manière connue, l'amplitude du signal  
émis par le fil périphérique. Cette mesure permet à  
l'ordinateur de bord de connaître la distance le séparant  
du fil et donc de contrôler la direction de la machine de  
25 manière à la garder à une distance fixe du fil.

Si la longueur du fil a été préalablement introduite dans  
la mémoire de l'ordinateur de bord, celui-ci peut  
déterminer avec une précision raisonnable le moment où un  
30 tour complet a été effectué par la tondeuse le long de ce  
fil. La tondeuse peut alors s'éloigner du fil d'une  
distance égale à la largeur de coupe de manière à pouvoir  
effectuer une nouvelle boucle à une distance du fil  
augmentée de la largeur de coupe. L'opération peut ainsi

-7-

se répéter en augmentant chaque fois la distance entre la tondeuse et le fil périphérique, idéalement jusqu'à arriver au centre de la zone à tondre.

5 Selon une variante de réalisation, il n'est pas nécessaire d'introduire dans l'ordinateur la longueur du fil susmentionné. La longueur peut en effet être déterminée par l'ordinateur de bord en intégrant les différences de  
10 vitesse entre les roues motrices de la machine (changements de direction) , jusqu'à ce que le changement cumulé atteigne ou dépasse 360 °. Dans ce but, le système peut également avantageusement intégrer un compas magnétique ou inertiel.

15 L'invention sera davantage décrite en se référant à l'exemple de réalisation qui suit se référant aux dessins en annexe présentés à titre d'exemples non limitatifs.

20 La fig. 1 est une vue du dessous de l'engin selon l'invention.

La fig. 2 est une vue latérale en coupe de l'engin selon la fig. 1.

25 La fig. 3 illustre le trajet suivi par l'engin

La fig. 4 illustre un exemple de station de recharge électrique et de décharge des balles de golf.

30 La fig. 5 illustre en détail un système de recharge.

-8-

La fig. 1 est une vue du dessous de l'engin selon l'invention. On illustre les disques flexibles 1, les balles 2 venant se coincer entre les disques, l'axe transversal de rotation 3 des disques, axe de préférence  
5 relié au châssis de manière non rigide, le boîtier comprenant l'électronique de commande et l'ordinateur de bord 4, les batteries 5, les moteurs de roue 6, les roulettes folles 7 montées à l'avant, le détecteur de fil périphérique 8, le détecteur optique de remplissage de  
10 panier 30,31 constitué d'un émetteur et d'un récepteur infrarouge.

La fig. 2 représente l'engin de la fig. 1 vue en coupe de profil. On distingue le panier 9 récepteur de balles, muni  
15 à sa paroi inférieure d'une ouverture pivotante autour de l'axe 11 et dont l'ouverture est commandée par le vérin 12. Les doigts 13 situés sur la trajectoire circulaire des balles coïncées extraient ces balles hors des disques de manière à les faire tomber dans le panier 9.

20 La fig. 3 montre un exemple de trajet de l'engin. celui-ci est typiquement aléatoire. Lorsqu'elle a fait le plein de balles, et/ou lorsque la batterie est suffisamment déchargée, l'engin recherche le fil  
25 périphérique 15 qu'elle suit jusqu'à détecter la station 17.

La fig. 4 illustre un mode de réalisation dans lequel la station est surélevée de manière à pouvoir introduire un  
30 container 18 destiné à recueillir les balles. Les rampes 19 permettent à la machine d'atteindre la plate-forme 20 où est située la station de recharge. La plate-forme 20

est munie d'une grille 21 par où les balles libérées par l'ouverture du panier 9 peuvent rejoindre le container ou le conduit de retour des balles.

5 A la fig. 5 on illustre la machine connectée à la station de recharge. En suivant le fil périphérique, et à l'endroit de la station, deux balais latéraux 23 de l'engin viennent en contact avec deux rails conducteurs 24 montés sur chaque flanc de la machine. Le fait de prévoir  
10 des rails sur les deux flancs permet à l'engin d'aborder la station dans les deux directions. Les balais 23 sont montés sur la station par l'intermédiaire du bras 25 fixé au boîtier de manière flexible en 26, permettant au bras de pivoter lorsque l'engin vient en contact. L'ordinateur  
15 de bord vérifie constamment la tension sur les balais 23. L'apparition d'une tension signale la présence des rails et donc de la station et permet à l'ordinateur d'arrêter l'engin.

20 Le système de décharge des balles peut être avantageusement couplé à un système de retour automatique des balles à proximité immédiate des joueurs. Ce système peut impliquer des conduits légèrement inclinés amenant  
25 les balles par gravité. Comme mentionné ci-dessus une station de recharge située sensiblement plus haut que la surface de tir, accessible via des rampes, conviendra particulièrement dans ce but.

30 On peut cependant également prévoir un bac récepteur à hauteur du sol ou une cuvette dans le sol, le bac ou la cuvette étant muni d'un système d'élévation des balles,

-10-

par exemple par vis sans fin, bande transporteuse ou moyens équivalents pour les amener dans des récipients ou des conduits de retour.

5 On comprendra aussi que le système décrit ci-avant peut être adapté pour la récolte d'autres objets que des balles de golf. En particulier, en modifiant le système, il pourrait s'agir de déchets ou de végétaux.

10 Ainsi le dispositif mécanique de préhension peut être constitué par un balai rotatif muni de picots, disposés radialement autour de l'axe dudit balai. Les picots sont aptes à percer des objets situés sur ladite surface, et lesdits objet sont entraînés dans le mouvement circulaire, détachés des picots par des éléments fixes s'engageant  
15 entre les picots et déviant les objets vers un dispositif de stockage. Il peut s'agir de feuilles mortes ou de morceaux de papier.

20 De même il est bien entendu que le système proposé par l'invention, peut être couplé à un système de tonte, éventuellement porté par le même châssis. Un engin automatique de tonte comme décrit dans les demandes PCT susmentionnées peut évoluer indépendamment, en utilisant  
25 cependant le même fil périphérique et la même station de recharge.

30 On comprendra également que le moteur du robot peut être associé à une source d'énergie autre qu'une batterie rechargeable, par exemple une pile à combustible, ou encore un moteur thermique ou hybride.



Selon une autre variante, le système selon la présente invention ne comporterait pas de moyen d'avancement propre mais serait tracté par un robot mobile de tonte auquel il serait éventuellement électriquement relié.

5

10

15

20

25

30

## Revendications :

- 5
1. Système de ramassage d'objets sur une surface déterminée constitué par un engin mobile automatique muni d'un ordinateur de bord, d'au moins un moteur associé à une source d'énergie, un dispositif mécanique de
- 10 préhension et de stockage des objets dans un réceptacle supporté par l'engin mobile, un dispositif de vidage dudit réceptacle, un dispositif de limitation de la surface de ramassage et une station de décharge des objets récoltés.
- 15 2. Système selon la revendication 1 caractérisé en ce que la source d'énergie est une batterie rechargeable et en ce qu'il est prévu au moins une station de recharge des batteries rechargeables.
- 20 3. Système selon la revendication 1 ou 2 dans lequel les objets sont des balles de golf.
4. Système selon n'importe laquelle des revendications précédentes dans lequel la station de recharge des
- 25 batteries et de décharge des balles est couplée.
5. Système selon n'importe laquelle des revendications précédentes dans lequel le dispositif de limitation de la surface est constitué par un fil localisé au périmètre de
- 30 cette surface et détectable par un détecteur porté par l'engin.

6. Système selon la revendication précédente dans lequel l'engin rejoint la ou les stations en suivant le fil de limitation de la surface, la ou les stations étant situées le long dudit fil ou une prolongation dudit fil.

5

7. Système selon la revendication précédente caractérisé en ce que la station de recharge est constituée par au moins un rail fixe situé le long dudit fil et apte à entrer en contact avec un des deux balais latéraux portés par l'engin mobile.

10

8. Système selon n'importe laquelle des revendications précédentes caractérisé en ce que la ou les stations de recharge se situent à proximité des joueurs.

15

9. Système selon n'importe laquelle des revendications précédentes dans lequel la ou les stations comprennent une cuvette de récupération des balles munies d'un système d'élévation de celles-ci et reliée à la surface de tirs au moins un conduit apte à ramener les balles à proximité immédiate des joueurs au moins partiellement par gravité.

20

10. Système selon n'importe laquelle des revendications précédentes dans lequel l'engin automatique évolue sur la surface de ramassage au moins partiellement de manière aléatoire.

25

11. Système selon la revendication 1 dans lequel le dispositif mécanique de préhension est constitué par un balai rotatif muni de picots, disposés radialement autour de l'axe dudit balai, les picots étant aptes à percer des objets situés sur ladite surface, lesdits objets entraînés

30

-14-

dans le mouvement circulaire étant détachés desdits picots par des éléments fixes s'engageant entre lesdits picots et déviant les objets vers ledit dispositif de stockage.

5 12. Système selon la revendication précédente dans lequel les objets ramassés sont des feuilles mortes.

13. Système selon la revendication 9 dans lequel les objets ramassés sont des feuilles de papier.

10

14. Engin de ramassage automatique adapté au système selon n'importe laquelle des revendications précédentes.

15 15. Engin selon la revendication précédente caractérisé en ce qu'il comprend des bras déflecteurs aptes à faire dévier lors du mouvement d'avancement de l'engin les objets à récolter vers le dispositif de préhension.

20 16. Système selon les revendications 1 à 12 ou engin de ramassage selon la revendication 12 à 15 caractérisé en ce qu'il comprend aussi un système de tonte automatique d'une surface d'herbe.

25 17. Méthode de ramassage d'objets sur une surface prédéterminée utilisant un système ou un engin selon les revendications 1 à 16.

30

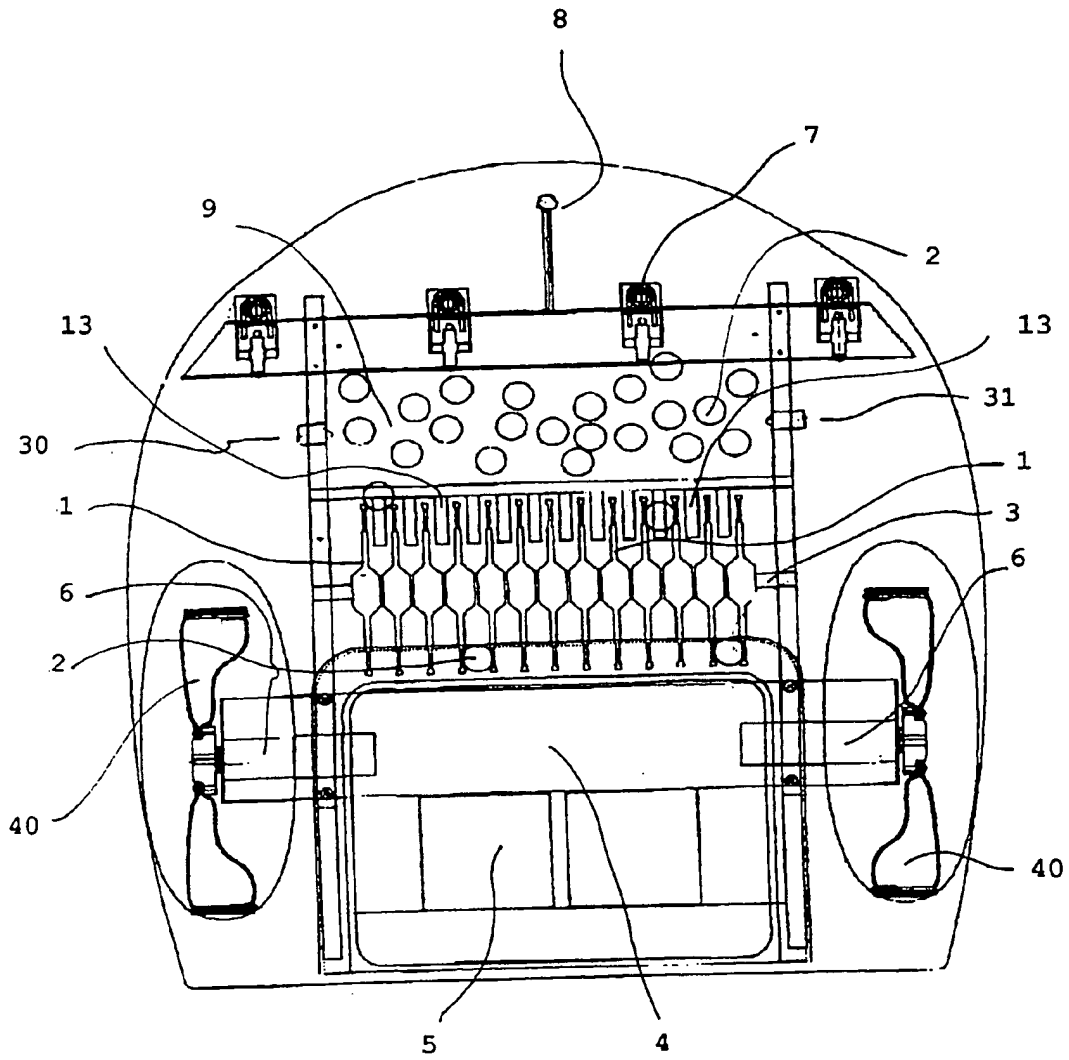


FIG. 1

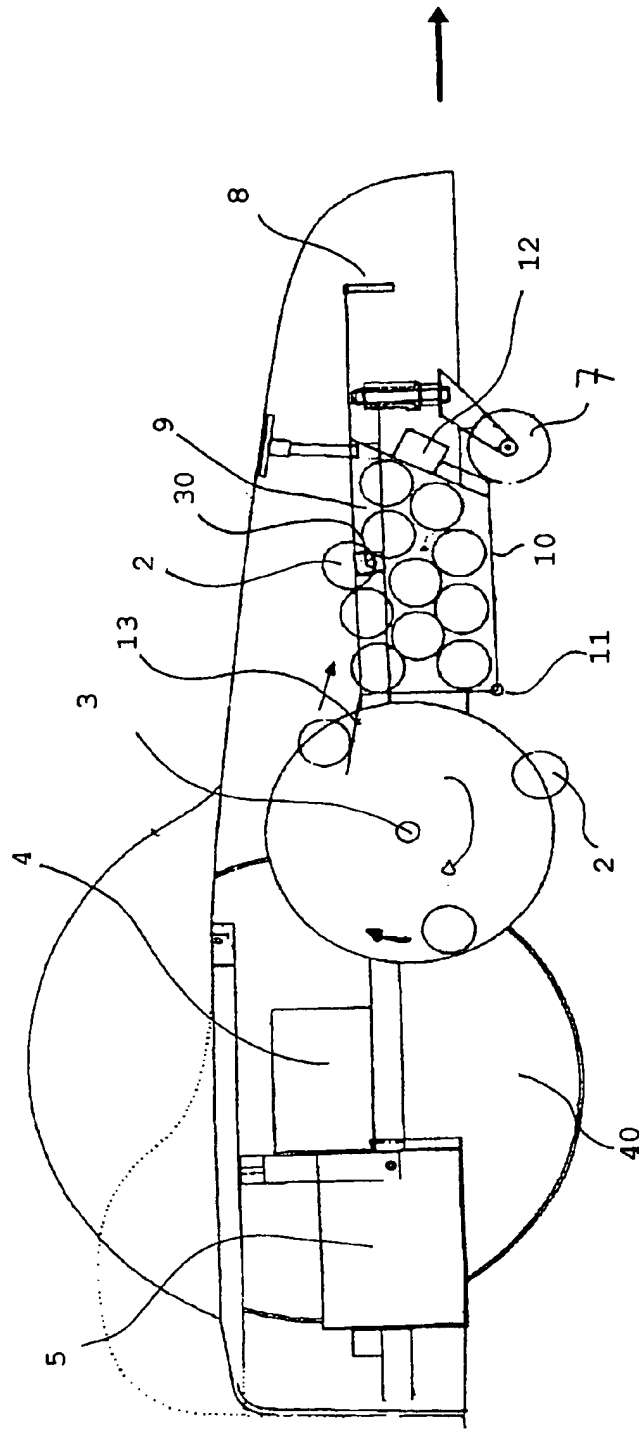


FIG. 2

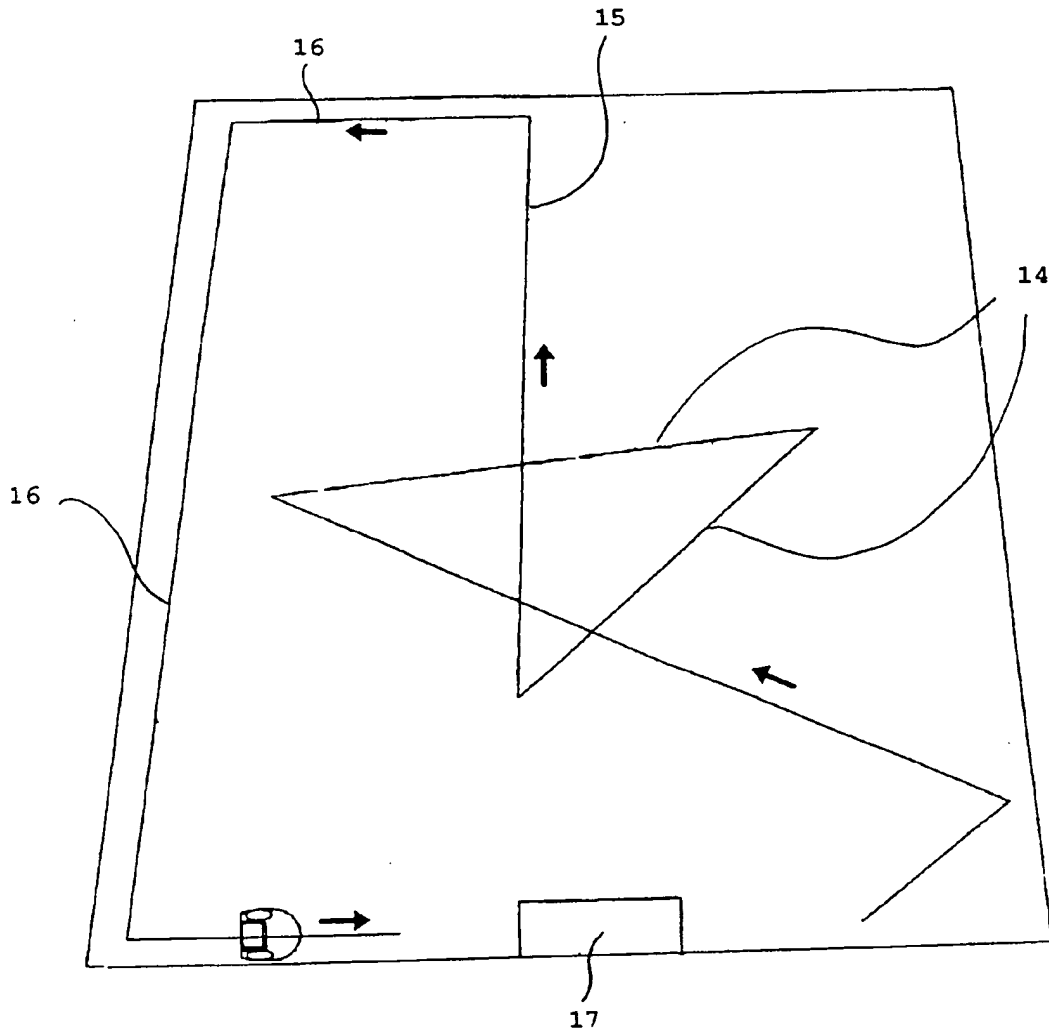


FIG. 3

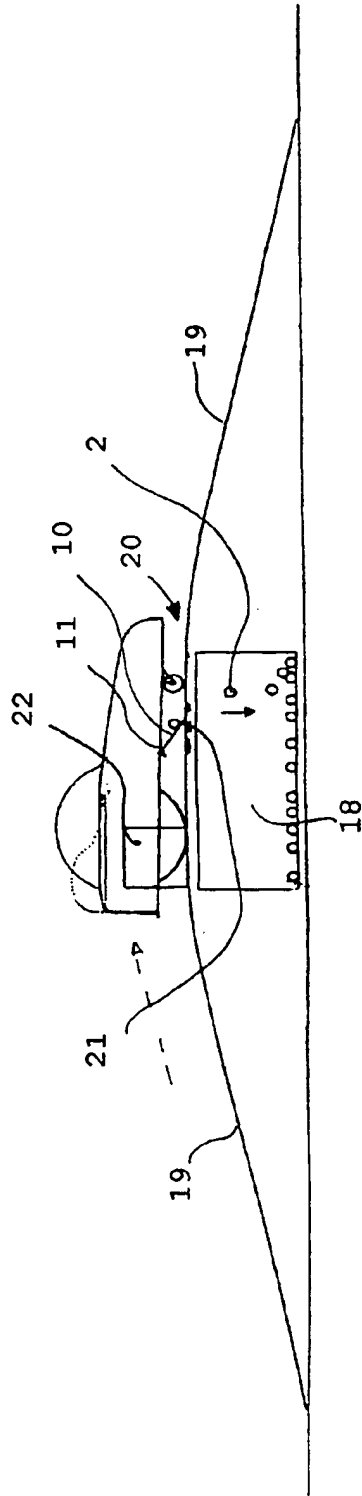


FIG. 4



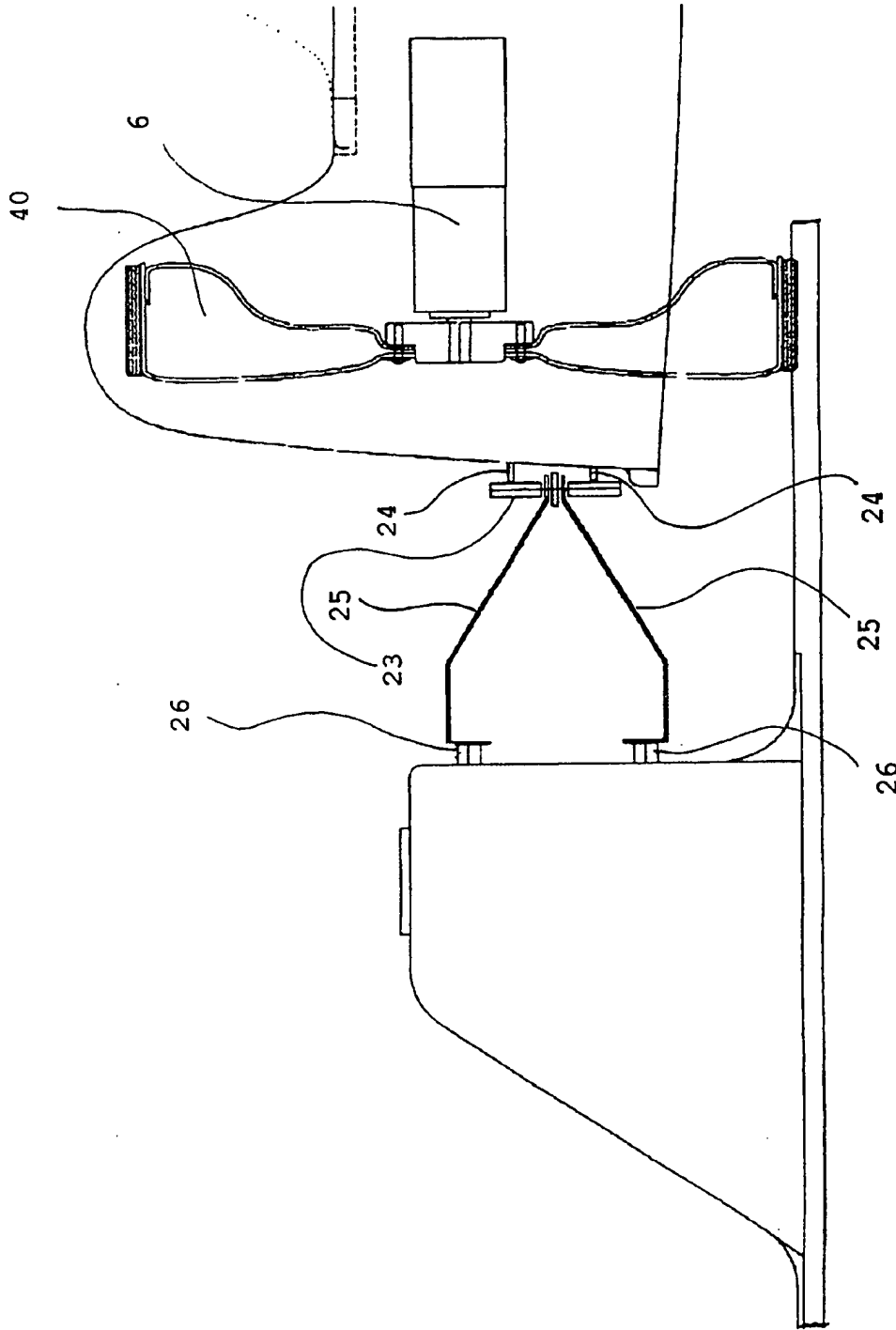


FIG. 5

INTERNATIONAL SEARCH REPORT

International Application No

PCT/BE 00/00064

<b>A. CLASSIFICATION OF SUBJECT MATTER</b> IPC 7 A63B47/02 A01G1/12		
According to International Patent Classification (IPC) or to both national classification and IPC		
<b>B. FIELDS SEARCHED</b>		
Minimum documentation searched (classification system followed by classification symbols) IPC 7 A63B A01D E01H A01G		
Documentation searched other than minimum documentation to the extent that such documents are included in the fields searched		
Electronic data base consulted during the international search (name of data base and, where practical, search terms used) EPO-Internal, PAJ, WPI Data		
<b>C. DOCUMENTS CONSIDERED TO BE RELEVANT</b>		
Category *	Citation of document, with indication, where appropriate, of the relevant passages	Relevant to claim No.
X	PATENT ABSTRACTS OF JAPAN vol. 1997, no. 02, 28 February 1997 (1997-02-28) -& JP 08 276037 A (HIYAMUTA SHOTA), 22 October 1996 (1996-10-22) abstract; figure 2	1,3,6, 14,15,17
A	---	5
A	DE 39 18 867 A (DRESSEN NORBERT) 19 October 1989 (1989-10-19) column 2, line 4 - line 62	1,2,4-7
A	PATENT ABSTRACTS OF JAPAN vol. 016, no. 461 (C-0988), 25 September 1992 (1992-09-25) -& JP 04 164464 A (TAKESHI NAKAGAWA), 10 June 1992 (1992-06-10) abstract	1,3, 11-13
	---	
	-/--	
<input checked="" type="checkbox"/> Further documents are listed in the continuation of box C.		
<input checked="" type="checkbox"/> Patent family members are listed in annex.		
* Special categories of cited documents :		
*A* document defining the general state of the art which is not considered to be of particular relevance *E* earlier document but published on or after the international filing date *L* document which may throw doubts on priority claim(s) or which is cited to establish the publication date of another citation or other special reason (as specified) *O* document referring to an oral disclosure, use, exhibition or other means *P* document published prior to the international filing date but later than the priority date claimed		
*T* later document published after the international filing date or priority date and not in conflict with the application but cited to understand the principle or theory underlying the invention *X* document of particular relevance; the claimed invention cannot be considered novel or cannot be considered to involve an inventive step when the document is taken alone *Y* document of particular relevance; the claimed invention cannot be considered to involve an inventive step when the document is combined with one or more other such documents, such combination being obvious to a person skilled in the art. *&* document member of the same patent family		
Date of the actual completion of the international search  16 October 2000		Date of mailing of the international search report  23/10/2000
Name and mailing address of the ISA European Patent Office, P.B. 5818 Patentaan 2 NL - 2280 HV Rijswijk Tel. (+31-70) 340-2040, Tx. 31 651 epo nl, Fax: (+31-70) 340-3016		Authorized officer  Millward, R

Form PCT/ISA/210 (second sheet) (July 1992)

INTERNATIONAL SEARCH REPORT

International Application No  
PCT/BE 00/00064

C.(Continuation) DOCUMENTS CONSIDERED TO BE RELEVANT		
Category *	Citation of document, with indication, where appropriate, of the relevant passages	Relevant to claim No.
A	DE 197 11 298 A (NOPPER HANS) 24 September 1998 (1998-09-24) column 1, line 23 - line 59; figure 1 ---	1,3, 11-13
P,A	US 5 980 392 A (COX ALVIN EMISON) 9 November 1999 (1999-11-09) column 3, line 44 -column 4, line 24 column 6, line 23 - line 43 -----	1,3,9, 10,14,17

1

**INTERNATIONAL SEARCH REPORT**

Information on patent family members

International Application No

PCT/BE 00/00064

Patent document cited in search report		Publication date	Patent family member(s)	Publication date
JP 08276037	A	22-10-1996	JP 2622367 B	18-06-1997
DE 3918867	A	19-10-1989	NONE	
JP 04164464	A	10-06-1992	NONE	
DE 19711298	A	24-09-1998	NONE	
US 5980392	A	09-11-1999	NONE	

# RAPPORT DE RECHERCHE INTERNATIONALE

Demar Internationale No

PCT/BE 00/00064

**A. CLASSEMENT DE L'OBJET DE LA DEMANDE**  
CIB 7 A63B47/02 A01G1/12

Selon la classification internationale des brevets (CIB) ou à la fois selon la classification nationale et la CIB

**B. DOMAINES SUR LESQUELS LA RECHERCHE A PORTE**

Documentation minimale consultée (système de classification suivi des symboles de classement)

CIB 7 A63B A01D E01H A01G

Documentation consultée autre que la documentation minimale dans la mesure où ces documents relèvent des domaines sur lesquels a porté la recherche

Base de données électronique consultée au cours de la recherche internationale (nom de la base de données, et si réalisable, termes de recherche utilisés)

EPO-Internal, PAJ, WPI Data

**C. DOCUMENTS CONSIDERES COMME PERTINENTS**

Catégorie *	Identification des documents cités, avec, le cas échéant, l'indication des passages pertinents	no. des revendications visées
X	PATENT ABSTRACTS OF JAPAN vol. 1997, no. 02, 28 février 1997 (1997-02-28) -& JP 08 276037 A (HIYAMUTA SHOTA), 22 octobre 1996 (1996-10-22) abrégé; figure 2	1,3,6, 14,15,17
A	---	5
A	DE 39 18 867 A (DRESSEN NORBERT) 19 octobre 1989 (1989-10-19) colonne 2, ligne 4 - ligne 62	1,2,4-7
A	PATENT ABSTRACTS OF JAPAN vol. 016, no. 461 (C-0988), 25 septembre 1992 (1992-09-25) -& JP 04 164464 A (TAKESHI NAKAGAWA), 10 juin 1992 (1992-06-10) abrégé	1,3, 11-13
	---	
	-/--	

Voir la suite du cadre C pour la fin de la liste des documents

Les documents de familles de brevets sont indiqués en annexe

\* Catégories spéciales de documents cités:

\*A\* document définissant l'état général de la technique, non considéré comme particulièrement pertinent

\*E\* document antérieur, mais publié à la date de dépôt international ou après cette date

\*L\* document pouvant jeter un doute sur une revendication de priorité ou cité pour déterminer la date de publication d'une autre citation ou pour une raison spéciale (telle qu'indiquée)

\*O\* document se référant à une divulgation orale, à un usage, à une exposition ou tous autres moyens

\*P\* document publié avant la date de dépôt international, mais postérieurement à la date de priorité revendiquée

\*T\* document ultérieur publié après la date de dépôt international ou la date de priorité et n'appartenant pas à l'état de la technique pertinent, mais cité pour comprendre le principe ou la théorie constituant la base de l'invention

\*X\* document particulièrement pertinent: l'invention revendiquée ne peut être considérée comme nouvelle ou comme impliquant une activité inventive par rapport au document considéré isolément

\*Y\* document particulièrement pertinent: l'invention revendiquée ne peut être considérée comme impliquant une activité inventive lorsque le document est associé à un ou plusieurs autres documents de même nature, cette combinaison étant évidente pour une personne du métier

\*Z\* document qui fait partie de la même famille de brevets

Date à laquelle la recherche internationale a été effectivement achevée

16 octobre 2000

Date d'expédition du présent rapport de recherche internationale

23/10/2000

Nom et adresse postale de l'administration chargée de la recherche internationale

Office Européen des Brevets, P.B. 5818 Patentlaan 2  
NL - 2280 HV Rijswijk  
Tel. (+31-70) 340-2040, Tx. 31 651 epo nl.  
Fax: (+31-70) 340-3016

Fonctionnaire autorisé

Millward, R

RAPPORT DE RECHERCHE INTERNATIONALE

Demar Internationale No  
PCT/BE 00/00064

C.(suite) DOCUMENTS CONSIDERES COMME PERTINENTS		
Catégorie	Identification des documents cités, avec, le cas échéant, l'indication des passages pertinents	no. des revendications visées
A	DE 197 11 298 A (NOPPER HANS) 24 septembre 1998 (1998-09-24) colonne 1, ligne 23 - ligne 59; figure 1 ---	1,3, 11-13
P,A	US 5 980 392 A (COX ALVIN EMISON) 9 novembre 1999 (1999-11-09) colonne 3, ligne 44 -colonne 4, ligne 24 colonne 6, ligne 23 - ligne 43 -----	1,3,9, 10,14,17

1

**RAPPORT DE RECHERCHE INTERNATIONALE**

Renseignements relatifs aux membres de familles de brevets

Demande Internationale No  
PCT/BE 00/00064

Document brevet cité au rapport de recherche	Date de publication	Membre(s) de la famille de brevet(s)	Date de publication
JP 08276037 A	22-10-1996	JP 2622367 B	18-06-1997
DE 3918867 A	19-10-1989	AUCUN	
JP 04164464 A	10-06-1992	AUCUN	
DE 19711298 A	24-09-1998	AUCUN	
US 5980392 A	09-11-1999	AUCUN	

Formulaire PCT/ISA/210 (annexe familles de brevets) (juillet 1992)



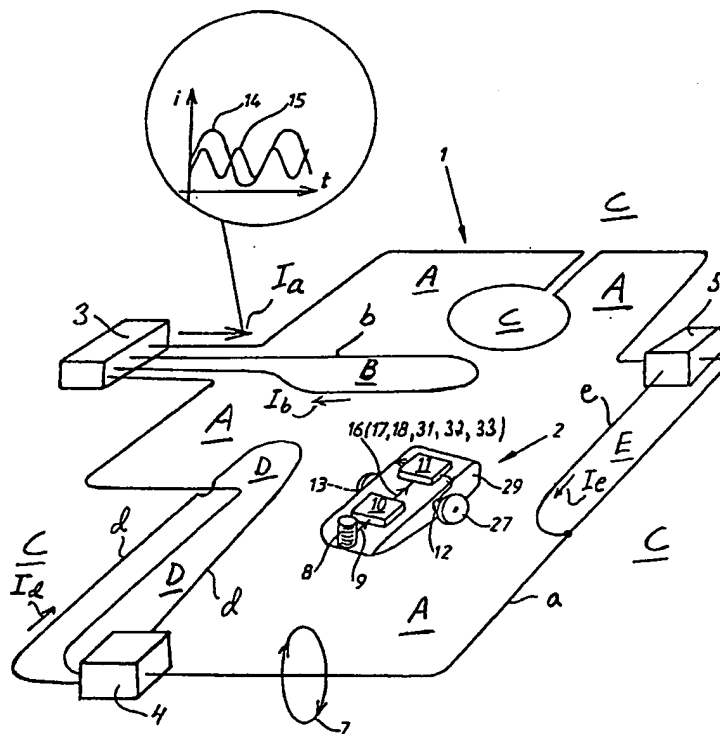
INTERNATIONAL APPLICATION PUBLISHED UNDER THE PATENT COOPERATION TREATY (PCT)

<p>(51) International Patent Classification <sup>6</sup> : <b>G05D 1/03</b></p>	<p><b>A1</b></p>	<p>(11) International Publication Number: <b>WO 99/38056</b> (43) International Publication Date: 29 July 1999 (29.07.99)</p>
<p>(21) International Application Number: PCT/SE98/02457 (22) International Filing Date: 30 December 1998 (30.12.98) (30) Priority Data: 9800017-7 8 January 1998 (08.01.98) SE 9801908-6 29 May 1998 (29.05.98) SE (71) Applicant (for all designated States except US): AKTIEBO- LAGET ELECTROLUX [SE/SE]; S-105 45 Stockholm (SE). (72) Inventors; and (75) Inventors/Applicants (for US only): BERGVALL, Bengt, Allan [SE/SE]; Blåvingevägen 1, S-561 48 Huskvarna (SE). PETERSSON, Ulf [SE/SE]; Tolleredshöjden 16, S-448 50 Tollered (SE). (74) Agents: ANDERSSON, Lars et al.; AB Electrolux, Huskvarna AB, S-433 81 Jonsered (SE).</p>	<p>(81) Designated States: AL, AM, AT, AT (Utility model), AU, AZ, BA, BB, BG, BR, BY, CA, CH, CN, CU, CZ, CZ (Utility model), DE, DE (Utility model), DK, DK (Utility model), EE, EE (Utility model), ES, FI, FI (Utility model), GB, GE, GH, GM, HR, HU, ID, IL, IS, JP, KE, KG, KP, KR, KZ, LC, LK, LR, LS, LT, LU, LV, MD, MG, MK, MN, MW, MX, NO, NZ, PL, PT, RO, RU, SD, SE, SG, SI, SK, SK (Utility model), SL, TJ, TM, TR, TT, UA, UG, US, UZ, VN, YU, ZW, ARIPO patent (GH, GM, KE, LS, MW, SD, SZ, UG, ZW), Eurasian patent (AM, AZ, BY, KG, KZ, MD, RU, TJ, TM), European patent (AT, BE, CH, CY, DE, DK, ES, FI, FR, GB, GR, IE, IT, LU, MC, NL, PT, SE), OAPI patent (BF, BJ, CF, CG, CI, CM, GA, GN, GW, ML, MR, NE, SN, TD, TG).</p> <p><b>Published</b> With international search report. In English translation (filed in Swedish).</p>	

(54) Title: ELECTRONIC SEARCH SYSTEM

(57) Abstract

An electronic search system (1) for a working tool (2), such as a lawn mower or vacuum-cleaner, in which system a border cable (a) is placed so that it separates an inner area (A) from an outer area (C). A first signal generator (3) feeds the border cable with current ( $I_a$ ), whose magnetic field (7) affects a sensing unit (8) located on the tool, so that the sensing unit emits signals (9) to a control unit (10), which directs the tool's motion in order to prevent it from remoting from the inner area (A). The current ( $I_a$ ) contains at least two alternating-current components (14, 15) of different frequency. At least one more cable, called search cable (b, d, e) is placed within the inner area (A+B+D+E), so that it separates a search area (B, D, E) and each search cable (b, d, e) respectively is fed by a signal generator (3, 4, 5) with an adapted current ( $I_b$ ,  $I_d$ ,  $I_e$ ), whose alternating-current components (14, 15) are virtually identical with the alternating-current components in the border cable (a), but where the current direction in each one of the search cables alternates in time in being either in phase or out of phase in relation to the current direction in the border cable (a), so that the magnetic fields in the different areas (A, B, C, D, E), which are separated by each cable respectively, will create at least three essentially unique time patterns, and hereby the control unit can separate the inner area (A), the outer area (C) and at least one search area (B, D, E).





**FOR THE PURPOSES OF INFORMATION ONLY**

Codes used to identify States party to the PCT on the front pages of pamphlets publishing international applications under the PCT.

AL	Albania	ES	Spain	LS	Lesotho	SI	Slovenia
AM	Armenia	FI	Finland	LT	Lithuania	SK	Slovakia
AT	Austria	FR	France	LU	Luxembourg	SN	Senegal
AU	Australia	GA	Gabon	LV	Latvia	SZ	Swaziland
AZ	Azerbaijan	GB	United Kingdom	MC	Monaco	TD	Chad
BA	Bosnia and Herzegovina	GE	Georgia	MD	Republic of Moldova	TG	Togo
BB	Barbados	GH	Ghana	MG	Madagascar	TJ	Tajikistan
BE	Belgium	GN	Guinea	MK	The former Yugoslav Republic of Macedonia	TM	Turkmenistan
BF	Burkina Faso	GR	Greece	ML	Mali	TR	Turkey
BG	Bulgaria	HU	Hungary	MN	Mongolia	TT	Trinidad and Tobago
BJ	Benin	IE	Ireland	MR	Mauritania	UA	Ukraine
BR	Brazil	IL	Israel	MW	Malawi	UG	Uganda
BY	Belarus	IS	Iceland	MX	Mexico	US	United States of America
CA	Canada	IT	Italy	NE	Niger	UZ	Uzbekistan
CF	Central African Republic	JP	Japan	NL	Netherlands	VN	Viet Nam
CG	Congo	KE	Kenya	NO	Norway	YU	Yugoslavia
CH	Switzerland	KG	Kyrgyzstan	NZ	New Zealand	ZW	Zimbabwe
CI	Côte d'Ivoire	KP	Democratic People's Republic of Korea	PL	Poland		
CM	Cameroon	KR	Republic of Korea	PT	Portugal		
CN	China	KZ	Kazakstan	RO	Romania		
CU	Cuba	LC	Saint Lucia	RU	Russian Federation		
CZ	Czech Republic	LI	Liechtenstein	SD	Sudan		
DE	Germany	LK	Sri Lanka	SE	Sweden		
DK	Denmark	LR	Liberia	SG	Singapore		
EE	Estonia						

## ELECTRONIC SEARCH SYSTEM

### Technical field

5           The subject invention refers to an electronic search system for a working tool, in which system a border cable, i.e. an electric cable, is placed above, under or on ground or floor, so that it separates an inner area within the border cable from an outer area, which working tool is preferably intended for attendance of ground or floor, such as grass-cutting, moss-scratching, watering,  
10 vacuum-cleaning, polishing, transportation etc., and a signal generator feeds the border cable with current, whose magnetic field affects at least one sensing unit located on the working tool, so that the sensing unit emits signals to a control unit, which in cooperation with an engine control, or a signal system for a driver, and at least one driving source directs the tool's movement in order to prevent it  
15 from remoting from the inner area.

### Background of the invention

          The idea to create a working tool, which manage completely by itself, such as a robot lawn mover or a robot vacuum-cleaner, is old. However, it has taken a long time before such kind of tool has reached the market. The solar  
20 cell driven lawn mover, called Solar Mower, is an example of that kind of product. It cuts the grass within a border cable, which has been placed in order to fence off the cutting area. Preferably the border cable is excavated into the ground. A signal generator feeds the border cable with current, whose magnetic field affects a sensing unit on the working tool. The sensing unit detects the  
25 intensity of the magnetic field and this intensity will increase when the working tool is coming closer and closer to the border cable. The microcomputer in the lawn mover is so programmed that the lawn mover reverses when a certain signal intensity has been achieved during the increasing of the signal intensity that

occurs when the sensing unit is approaching the border cable. The lawn mover will as said move backwards from the border cable and then turn and begin to cut in a direction away from the border cable. Consequently, the lawn mover turns  
5 when the powerful magnetic field at the border cable has caused a signal intensity of a certain degree. On the other hand, the microcomputer cannot in any way separate the magnetic field on the outside from that on the inside of the border cable. It means that if the lawn mover should slide outside the border cable, or be pushed outside the border cable, the lawn mover will remote from the border  
10 cable in the wrong direction, i.e. out from the cutting area. However, it stops after approximately 4 metres when the signal intensity has dropped too much. These and other disadvantages are described in closer detail in a not yet published swedish patent application 9703399-7. This application refers to an electronic bordering system and describes in full detail the technology of how to separate an  
15 outer area from an inner area, thus essentially eliminating the above mentioned disadvantages. On the other hand, by way of this system no additional area within the inner area can be separated. For example, this would be desirable if you wish to cut a certain surface area especially carefully, or, if you wish that the tool shall stay within a certain area during the night. Also, it might be desirable  
20 to separate a special area for use in connection with a docking station for automatic battery charging.

### **Purpose of the invention**

The purpose of the subject invention is to substantially reduce the above outlined problems.

### **25 Summary of the invention**

The above purpose is achieved in that the electronic search system in accordance with the invention is having the characteristics appearing from the appended claims.

The electronic search system in accordance with the invention is thus essentially characterized in that the first signal generator feeds the border cable with current containing at least two components of alternating-current with 5 different frequency, and the components are lying in a known relation of time to each other, e.g. a regularly varying time relation, and that at least one more cable, called search cable, is placed at least partly within the inner area, so that it separates at least one search area within the inner area, and each search cable respectively is fed by a signal generator with an adapted current whose 10 alternating-current components are virtually identical with the alternating-current components in the border cable, but where the direction of flow, at least for the alternating-current component with the higher frequency, in each of the search cables is alternating in time in being either in phase or out of phase in relation to the current flow direction in the border cable, so that the magnetic fields in the 15 different areas, which are separated by each cable respectively, are forming at least three essentially unique time patterns, and hereby the control unit can evaluate the difference in the signals caused by the magnetic field's different time patterns in the inner area, the outer area and at least one search area, and the control unit can therefore emit an area signal, which mainly takes up one of at 20 least three states depending on the position of the sensing unit in relation to the border cable or each search cable respectively, i.e. an outer area state, an inner area state or at least one search area state.

By means of the specific current that is fed onto the border cable, and by the adapted current that is fed onto one or several search cables, at least 25 three different areas can be separated, i.e. an outer area, an inner area and at least one search area. Owing to the fact that at least one more area, called search area, is added comparing with the above mentioned electronic bordering system, a number of additional possibilities are created. One or several search area/s could for instance be cut especially carefully in that the cutting tool remains for a 30 longer time within this/these certain area/s. The tool could stay in a certain search

area during the night. By way of a special "follow the cable" mode the tool can move on along a search cable to a docking station for automatic battery charging.

The possibility for the control unit to evaluate if the sensing unit is  
5 located inside or outside the border cable is created in that the signal generator feeds the border cable with current containing at least two alternating-current components of different frequency, and in that the components are lying in a known relation of time to each other. Furthermore the frequencies can preferably consist of multiples of each other, preferably equal number multiples of each  
10 other, and preferably the alternating-current components should stay in an essentially permanent time relation to each other. In order to increase the safety of the bordering system preferably an analogue signal is used, a so called quality signal, whose signal intensity is a measure of the intensity of the incoming signals of the control unit. Owing to this the tool can be shut off when the signal  
15 intensity is riskfully low. These and other characteristics and advantages of the invention will become more apparent from the detailed description of various embodiments with the support of the annexed drawing.

#### **Brief description of the drawing**

The invention will be described in closer detail in the following by  
20 way of various embodiments thereof with reference to the accompanying drawing.

Figure 1 shows in perspective a working tool, such as a lawn mover, placed on a lawn. By way of a border cable and a number of search cables the surface is divided into an outer area, an inner area and a number of search areas.

25 Figure 2 shows in perspective a working tool, such as a lawn mover placed on a lawn, on its way towards a docking station. The working tool follows a search cable and only the front part of the tool is shown.

Figure 3 shows straight from above a double docking station with two search cables connected.

Figure 4 shows schematically the currents fed to a border cable as well as to a search cable, and furthermore the signals picked up by the tool in the outer area, the inner area as well as in the search area. The search cable is fed with in phase and out of phase current according to a time-dependent pattern.

Figure 5 corresponds to figure 4 but there is yet another search cable, which is electrically distinguished. The two search cables are fed with in phase and out of phase current with different time patterns.

Figure 6 shows on the vertical axis the vertical magnetic field around a border cable as well as a search cable on the inside of the border cable. In the upper part of the figure the conductors of each cable are shown. The diagram shows the vertical magnetic field when the current of the search cable is in phase with the current of the border cable.

Figure 7 corresponds to figure 6 but shows the vertical magnetic field when the current of the search cable is out of phase with the current of the border cable.

Figure 8 shows enlarged the control unit, which is clearly evident without details from figure 1.

Figure 9 shows the ground area as a horizontal line. The inner area is separated by a current supplied border cable. Above this the resulting signal intensity of the control unit is shown in two versions. A continuous-line illustrates the signal intensity when an automatically controlled amplifier according to figure 8 is used. A dash-dotted line illustrates the signal intensity when such an amplifier circuit is not used. The picture is simplified by showing only the absolute value of the signal intensity and not showing the extremely local fall of the signal intensity straight above each section of the border cable.

Figure 10 shows somewhat simplified the electronic design of a signal generator, which feeds a border cable and a search cable with current.

Figure 11 shows schematically some important signals and the currents in the signal generator with the cables according to figure 10.

### Description of embodiments

In the schematical figure 1 numeral reference 1 designates an electronic search system according to the invention. Numeral reference 2 designates a working tool. It is intended to be a lawn mover, which is shown somewhat enlarged, for the sake of clarity. For the same reason only the components which are of interest for the electronic search system are shown. The remaining components, such as a knife disc for example, are lying concealed under the tool's cover 29. The border cable a is in this case preferably placed a bit under the ground. In other applications, such as a vacuum-cleaner, or a floor-polishing machine, it could be placed on the floor, or above the floor, for example underneath the sealing. The border cable is an electric cable, such as a common copper wire of single-core type, but naturally also double-core type can be used. The border cable a is connected to a signal generator 3. The border cable separates an inner area A from an outer area C. The bordering area can have a comparatively arbitrary form. In the upper part of the figure an island C is shown. The border cable is thus placed there in order to protrude into the area A. The island could for instance be a round flower bed. The signal generator feeds the border cable a with current generating a magnetic field 7, which is shown here in only one position. The small diagram shows the current intensity as a function of time for the components 14 and 15. The current shall contain at least two alternating-current components 14, 15 of different frequency. In the shown example the component 15 has twice as high frequency as the component 14. The components are superposed a direct current component, which is not advantageous, but still quite possible. The components are lying in a known time relation to each other, in this case a permanent time relation. However, it could also be a regularly varying time relation. On the other hand it cannot be an accidentally varying time relation. The tool 2 rests on three wheels, of which two are rear wheels 27,28. The front wheel is concealed under the cover 29 and is preferably a free-swinging link wheel. It means that the tool can be controlled in that each drive engine 12, 13 is driven in the suitable direction and with a suitable

rotational speed. Naturally the tool could also be designed in other ways, e.g. it could be equipped with one driving wheel and two steering wheels. Normally the tool is self-propelled, but it is also conceivable that it is propelled by a driver.

5           The tool is equipped with a sensing unit 8, here located on the one end, i.e. at the very front of the tool. The sensing unit comprises at least one coil 19. Preferably the coil 19 surrounds a ferrite rod 20, which is placed into the middle of the coil. The ferrite rod gives about 10 times amplification. The coil and the ferrite rod are shown in figure 8. The magnetic field 7 affects the sensing  
10 unit 8 so that it emits signals 9 to a control unit 10. The control unit 10 evaluates the signals 9 and emits an area signal 16 to an engine control 11. From the area signal 16 the engine control knows if the sensing unit is located within the inner area A or the outer area C or within at least one search area B, D, E. This is achieved in that the area signal 16 takes up one of at least three states depending  
15 on the position of the sensing unit 8 in relation to the border cable a or any one of the search cables b, d, e respectively, i.e. an outer area state 17, an inner area state 18 or at least one search area state 31, 32, 33. The engine control 11 provides the tool's driving engines 12, 13 with current for driving of the tool. Obviously the tool could also be run by an internal combustion engine. In the  
20 shown case the units 8, 10 and 11 are designed as separate units. But naturally they can be integrated into one or two units differently divided. In reality these units are of course placed under the cover 29. The engine control 11 could be replaced by a signal system for a driver, e.g. the signal system could by way of arrows indicate "turn left", "drive forward", "reverse", "turn right". This applies  
25 either in a case with a self-propelled working tool, which is the normal case, or in a case with a driver functioning as the driving source for propelling the tool.

A number of search cables b, d, e are placed at least partly within the inner area A+B+D+E. Each search cable separates a search area B, D, E within the inner area. The search cable b is placed entirely within the inner area and is  
30 connected to the signal generator 3, to which also the border cable a is connected. In each search cable an adapted current  $I_b$ ,  $I_d$ ,  $I_e$  is flowing. The adapted current



in each search cable could either be the same as in the other search cables or it could be individual. If the current is identical in two or several search cables the tool interprets these as identical, and it is reasonable to arrange it so if they have the same function, such as battery charging. Figure 2 shows in particular a docking station with a built-in signal generator. Its cable laying is in principle the same as that of signal generator 3, according to figure 1. For, the search cable b is placed entirely within the inner area. The search cable d for the signal generator 4 has been given a somewhat different laying. The search cable d is partly placed outside border cable a. Preferably the distance is so large that the magnetic field from border cable a is dominating the magnetic field from search cable d. Thereby the tool will stay essentially within the inner area on the inside of border cable a. When passing over to the "follow the cable" mode the tool will follow search cable d where this extends on the inside of border cable a. The signal generator 5 has a somewhat different arrangement of its search cable e. Search cable e is created by connecting a conductor e to the border cable a, so that a part of the border cable a will be integrated into search cable e, which separates the search area E. In this case it is important that the current in the border cable Ia is at least as strong as the current in search cable Ie, so that the tool senses the difference between the outer area C and the inner area E correctly. Accordingly, this solution offers shorter total length of cable but is more demanding from an electrical point of view. From an electrical point of view the most advantageous should be to place the search cable b essentially within the inner area A+B+D+E. The shown signal generators 3, 4, 5 are of two different types. The first signal generator 3 feeds the border cable with current Ia. The signal generator 3 can have a connected search cable b but must not necessarily. At least one second signal generator 4, 5 is placed at the border cable a and transmits an adapted current Id, Ie onto at least one search cable d, e. In that case the adapted current Id, Ie is preferably based on a sensing of the current Ia which the first signal generator 3 has transmitted to the border cable a. Hereby a synchronizing of the adapted current in relation to the current in the border cable can be made. Such

synchronizing is advantageous but not necessary. The synchronizing could also be made in other ways.

Figure 2 shows a signal generator 3 designed as a so called docking station for automatic battery-charging of a battery-operated tool 2. The signal generator 3 transmits current to a border cable a, which separates an inner area A+B. Furthermore it transmits an adapted current to the search cable b, which separates the search area B. This takes place in exactly the same way as earlier described. The docking system according to the figure is described in closer detail in a not yet published swedish patent application 9800017-7. The border cable a separates the ground area and is shown here on a substantially reduced scale from considerations of space. A signal generator feeds the border cable a with current containing at least two components of alternating-current with different frequency, and the components are lying in a known relation of time to each other. Hereby a control unit in the tool can evaluate the difference in signals from the sensing unit 8, caused by the magnetic field's different directions in the inner area A and the outer area C. It means that the tool can distinguish the inner area A from the outer area C and stay within the inner area. By way of the search cable a special area is now created, called search area B. This area is located within the inner area A. Preferably the signal generator feeds the search cable b with the same current containing at least two alternating-current components. During some part of the time the current in the both cables a and b are lying in phase with each other, i.e. in the same time relation, but during some part of the time the relation of time is changed so that they are lying out of phase with each other. In case the time proportions between the cables being in phase and being out of phase, or phase and anti-phase, are given a value differing from 50/50 %, the average of the picked up signals in the sensing unit 8 can be distinguished between area A and area B. Particularly suitable proportions between the times of in phase and out of phase, or the times of phase and anti-phase, is one quarter and three quarters or one third and two thirds respectively. Consequently, by way of this system the areas A, B and C can be separated from each other. The system

functions so that the control unit separates the different areas and not each cable a, b, as such.

The tool 2, usually a lawn mover, usually operates on the principle of random motion within the area A. It could also operate in a more systematic way. When its battery charge begins to run down it reacts in a special way when passing from area A to area B, or vice versa. The control unit takes note of the passage from area A to area B and the tool turns left with the intention of following the search cable b in a clockwise direction towards the docking station 3. In the opposite case, i.e. passage from area B to area A, the tool instead turns right with the intention of following the search cable in a clockwise direction. After this initial turn the tool will change over to a "follow the cable" mode as follows. After the tool has passed from area B to area A it turns immediately towards the opposite direction and moves back to area B and after moving from area A to area B it turns again and moves towards area A. This pattern will be repeated very frequently. The zigzag motion over the search cable b is hardly visible on a lawn, but the result will be that the cutting tool follows the search cable b in the desirable direction clockwise, so that it moves towards the docking station in the docking direction 34. Obviously the search cable b shall lie in the docking direction 34, at least the most adjacent part outside the docking station 3. Hereby is assured that the tool moves straight towards the station. Furthermore the search cable should be drawn over and above the station a suitable length, i.e. the first connecting part b', so that the tool follows the first connecting part b' on to the docking position. Since the tool is able to separate area A from area B it can also follow the search cable b in the desirable direction towards the station. Obviously, the search cable could as well be followed in an anti-clockwise direction, provided that the anti-clockwise connection, i.e. the second connecting part b" instead is drawn in the desirable docking direction 34. Furthermore, it might also be possible for the tool to stand still within the area B during a certain time of the day and night. The tool's microprocessor with a built-in clock is then

simply programmed to stop within the area B when the tool arrives there during the relevant time. Consequently, the above described electronic search system does not imply any docking system, even if docking is the most common application. Obviously the search system could also be combined with other docking systems than the above mentioned.

However, the docking system can also be designed for several docking directions. Nearest to think of might be a double docking station with a second docking direction, which is quite the opposite one to docking direction 34. Such a system is shown in figure 3. In this case a second search cable d' should lead in the opposite direction in relation to the first search cable b. The system is primarily intended for battery-charging and a ramp is arranged in the opposite direction compared with the one shown in figure 2. This arrangement enables two working tools to be recharged at the same time in a double docking station. When a tool has followed one of the search cables, for example b', and is docking, preferably the current in this search cable b' is shut-off, so that no other tool is trying to recharge at the already occupied part of the docking station. Obviously the search areas b and d could also be used for other purposes than battery-charging. The adapted current in search cable b could be the same as in search cable d' but it could also be different depending on the purpose of each search area.

As mentioned, in the tool's 2 control unit there is a "follow the cable" mode, which becomes activated by passage from one area to another area in combination with that at least one more condition is fulfilled, e.g. the "follow the cable" mode becomes activated when a battery-operated tool gets a low voltage of battery (condition) and passes from the inner area over to the search area or vice versa, resulting in that the tool follows a search cable b; b, d', which leads to a docking station 3; 3' for automatic battery charging. In the "follow the cable" mode the state of the area signal 16 affects the engine control 11 so that the inner area state 18 guides the tool more to the right, while the search area state 31, 32,

33 guides the tool more to the left, so that the tool follows the search cable between the two areas clockwise, e.g. this applies for docking in a clockwise direction. Instead, for docking in an anti-clockwise direction the following 5 procedure is applicable. In the "follow the cable" mode the state of the area signal 16 affects the engine control 11 so that the inner area state 18 guides the tool more to the left, while the search area state 31, 32, 33 guides the tool more to the right, so that the tool follows the search cable between the areas in an anti-clockwise direction. Obviously the "follow the cable" mode could also be 10 used to follow the border cable a. But this implies usually a lot of problems for the tool since the border cable extends near flower beds, house walls and the like. The tool could also run the risk of getting caught at the island shown in the upper part of figure 1. Thus the tool would go round and round this island.

Figure 4 and 5 illustrate how the different areas can be separated 15 from each other. The signs +, -, ? illustrate schematically the currents  $I_a$ ,  $I_b$  in the cables and the signals in the areas A, B, C along an imaginary horizontal time axis, so that each sign +, -, ? corresponds to a unit of time. On top of the figure 4 the current  $I_a$  in the border cable a is shown. This is a current, whose phase position represents a reference phase. It is therefore per definition an in 20 phase current, which is designated by a + sign. The current  $I_b$  in search cable b alternates in being either in phase or out of phase, where out of phase current is designated by a - sign. It means that at least the current direction of the alternating-current component 15 with the higher frequency alternates in being either in phase or out of phase in relation to the current direction in the border 25 cable a. Also the alternating-current component 14 with the lower frequency can alternate in being either in phase or out of phase in the same way as the component 15, however, this alteration is not necessary for the system. Each current  $I_a$ ,  $I_b$  individually generates magnetic fields 7 of a space varying intensity and direction. These magnetic fields' vertical components are added in every 30 point in the three areas A, B, C, and will cause a resulting space dependent signal in the sensing unit 8. The signals 9, which are emitted from the sensing

unit 8 in the tool 2 will thus be either in phase signals or out of phase signals, or a combination of in phase and out of phase signals according to a special pattern. The in phase signal is designated by a + sign and the out of phase signal by a - sign. In the outer area C all signals per definition are out of phase signals, i.e. -. In the inner area A near the border cable a all signals are instead in phase signals, i.e. +. Thus we can see that the signs will be inverted when passing the border cable a. Since the border cable is fed with current  $I_a$  containing at least two alternating-current components of different frequency, and lying in a known relation of time to each other, the magnetic field's vertical direction on the inside as well as on the outside of the border cable a can therefore be sensed. And since the direction is different said inversion takes place. The corresponding matter of fact is also valid for the search cable b, i.e. an inversion of the signals occurs when passing the cable b. We can see that within area B the same signal pattern as there is in the current  $I_b$  can be sensed. Just outside search cable b in the area A these signals are instead inverted, so that we get three + signs and one - sign etc. instead of three - signs and one + sign. In the part of area A, which neither lies near border cable a nor search cable b the relation of signals is somewhat more uncertain. The two currents'  $I_a$ ,  $I_b$  magnetic fields cancel each other out, so that only a weak resulting signal  $I$  is received in these areas. This is designated by a ? sign in the indefinite positions. It means that sometimes a + sign and sometimes a - sign is received where the ? sign is positioned. However, this implies no practical problems with the indication of each area respectively. In the column to the right, designated analogue levels, an analogue average value of the proportion of the in phase signals is shown, i.e. the proportion of the + signs in each line respectively. As for the center line, which is somewhat indefinite, the analogue level will thus be somewhere between 75-100 %. At the bottom of the figure is shown an example of the signification of analogue signal levels. For, suitable signal levels can be programmed into the evaluation unit 23 in the control unit 10, which is used for this purpose. The signal levels can be chosen in

many different ways and the example is showing a suitable method that offers large margins at each decipherment. Compare above column for analogue levels. Less than 12 %, i.e. 12 % of the + signs, are deciphered as area C. 13-49 % are deciphered as area B and more than 50 % are deciphered as area A. Consequently, in the evaluation unit the signals are deciphered as an analogue average of the proportion of in phase signals, or, as an analogue average of the proportion of out of phase signals, so that the evaluation unit creates the area signal 16. According to the example in figure 4 it takes up either an outer area state 17, an inner area state 18 or a search area state 31. The evaluation unit can also sense the signals as a digital pattern of in phase and out of phase signals, and based upon this create the area signal 16. In figure 4 the proportions of time for in phase current and out of phase current is determined to be 25 % respectively 75 %, which is an advantageous choice. The proportions could as well be transposed, but this should be somewhat less advantageous.

Figure 5 shows an example where the proportion of out of phase current in search cable b is 67 % and the proportion of in phase current is approximately 33 %. These values could also be transposed, which however would be less advantageous. In this case there is a further search cable d with current  $I_d$ . In the example it has been given 83 % out of phase current and 17 % in phase current, corresponding to 5 - signs and 1 + sign and so on. Referring to figure 4 the same reasoning is valid also in this case when we look at the resulting signals 9 in the tool within the different areas and the resulting analogue levels. Also in this case the analogue levels refer to the proportion of in phase signals, i.e. + signals. Furthest down in the figure is shown an example of the signification of analogue signal levels, where less than 8 % = outer area C, 9-25 % = search area D, 26-49 % = search area B, more than 50 % = area A. The evaluation unit creates the area signal 16 in the same way as earlier described. In this case it can take up an outer area state 17, an inner area state 18 or a search area state 31 or 32.

On top of the figure 6 the location of the border cable as well as the search cable becomes apparent and below there is shown a diagram in which the vertical axis illustrates the vertical magnetic field around each cable and the horizontal axis illustrates the distance between the cables. The figure 6 diagram illustrates the vertical magnetic field when the search cable is in phase with the border cable, and the figure 7 diagram illustrates the magnetic field when the search cable is out of phase. The diagrams refer to the magnetic fields at the illustrated cross-section of the cables. Also, at each cross-section is the designation of the cable and is the flow direction illustrated by a semicircular arrow. Hereby it becomes apparent if the flows strengthens or weakens each other and the resulting flow is given in each diagram. A positive vertical flow is marked by a + sign in the figure, and a negative flow by a - sign. In the areas where the flow is almost zero it is marked by a ? sign. These signs are the same as referred to in the figures 4 and 5. Figure 7 corresponds completely to figure 6 but shows the vertical flow when the search cable is out of phase with the border cable. By comparing figure 6 with figure 7, and compare with figures 4 and 5, the function of the system becomes more apparent.

Figure 8 shows more in detail how the signals from the sensing unit are processed in the control unit 10. It will also become apparent which signals are forwarded to the engine control 11. For, the purpose of the sensing unit is to detect at least two alternating-current components of different frequency, as mentioned by the examples given with 8 kHz and 16 kHz. It means that the coil 19 should have a resonance frequency lying in proximity to at least one of the frequencies of the alternating-current components. Preferably a resonance frequency lying between the frequencies of the components 14, 15 is chosen. In a test a coil with a copper wire around a ferrite core was used, and in sequence with the coil a capacitor was connected. Both components constitute a resonance circuit of approximately 11 kHz resonance frequency and a factor of merit, or Q-factor, of approximately 1,2. Thanks to the low factor of merit the coil is wide-banded, which is necessary for both frequencies to come through. No



trimming of the coil is required. Consequently, from the sensing unit a signal 9 is forwarded to the control unit 10. Initially the signal reaches a frequency divider 21, where it will be divided into at least two signal components 14', 15' with 5 different frequency corresponding to the frequencies of the alternating-current components 14, 15. After possible processing in a signal processing unit 22 the signal components are forwarded to an evaluation unit 23. The signal processing unit is used in order to give the signal components 14', 15' a more definite square form, and the need for this signal processing depends on the design of the 10 evaluation unit 23. An example of an evaluation unit is a so called latch, which has a clock input and a data-in input. In this case the signal with the lower frequency 14' is connected to the clock input. It means that when the 8 kHz makes a positive pass through zero the signal component 15' will be released from the data-in input and go on to the data-out output and be kept fixed until a 15 change occurs. This function is named "sample and hold". In an example the result will be that the outgoing area signal gets a certain voltage for in phase signals, while it gets another voltage for out of phase signals. Earlier is described how the evaluation unit 23, at least for the signal components 15' with the higher frequency, detects its signals, so that the evaluation unit creates the area signal 20 16. The sensing can occur either as an analogue average of the proportion of in phase signals or the proportion of out of phase signals, or as a sensing of a digital pattern of in phase and out of phase signals. Consequently, in this manner an area signal 16 is created, which takes up one of at least three distinct states, i.e. an outer area state 17, an inner area state 18 or at least one search area state 31, 32, 25 33. The above description is somewhat simply relating the basic function of the control unit 10 in one embodiment.

Furthermore, in the frequency divider 21 an amplification of the signal takes place, preferably in two resonance circuits, which i.a. consist of two trimable coils. During the amplification a certain degree of phase shift of each 30 signal frequency can occur. This could mean that the signal frequencies will not

stay in the desirable permanent time relation to each other. Therefore, in the signal processing unit 22 an adjusting phase shift of each signal can be made, so that the desirable time relation between the signals is maintained. How much 5 amplification the signal components 14', 15' need is varying depending on how far from the border cable the tool is located. It is therefore preferable to create a variable amplification, which is highest when the tool is located far from the cables and lowest when the tool is located near a cable. This is achieved in that one of the signal components, here 14', is forwarded to an amplifier 24, and after 10 rectifying in rectifier 25 the analogue amplifying signal 26 is brought back to the frequency divider 21, which also has a variable amplification. Compared with not having this special amplification circuit the amplifying signal 26 affects the variable amplification of the signals 14', 15', so that a considerably more constant signal intensity is achieved inside and close outside the inner area A. The 15 described circuit serves as an amplifier with automatic gain control (AGC). In this circuit it is preferable that the amplifier 24 has non-linear amplifying so that its amplification can be non-linearly affected by the ingoing signal's intensity. In figure 9 is shown that the signal intensity U of the signals 14' and 15' according to the continuous-line varies very little within the inner area A and falls slowly 20 out from the border cable in the outer area C. If this special amplification solution should not have been used, the signal intensity of the signals 14' and 15' would instead follow the dash-dotted line, which of course is much more disadvantageous.

In the middle of area A the relation between the signal intensities is 25 such that the signal intensities according to the continuous-line are approximately 100 times stronger than those according to the dash-dotted line.

It is important that the tool shuts off itself in case of too low signal intensity. Since the evaluation unit 23 operates in a "digital" way this will not function automatically. Therefore a special quality signal 26 is created. In the 30 shown example it is the same amplifying signal which is used in the amplification circuit. The analogue quality signal 26 has a signal intensity that is a measure of

the intensity of the ingoing signals 9 to the control unit, so that the tool can be shut-off at a too low quality signal, i.e. too low signal intensity. The quality signal could also have been picked up directly from the ingoing signals 9 and 5 then been rectified.

In another embodiment of the control unit 10 the picked up signals 9 from the sensing unit 8 can be analysed by way of a special software, so that signals from the inner area A can be separated from signals from the outer area C. Also in this case the supplied current in the border cable must contain at least two 10 alternating-current components of different frequency having a known time relation. On the other hand the signals 9 must not be divided into signal components in a frequency divider 21. The "sum signal" can be analysed directly, preferably after a certain amplification is made. In this case the control unit 10 is relatively similar to the control unit shown in figure 8. As described earlier the 15 signals 9 are amplified in the unit 21 but must not be divided into signal components 14', 15'. The best way to illustrate this is simply to cancel the signal 15' between the units 21 and 22 as well as the corresponding signal between the units 22 and 23 in figure 5. The evaluation unit 23 represents a microcomputer, or form part of a larger microcomputer, provided with a special software in order 20 to analyse the incoming signals 14', which are amplified signals 9. For the analysis an analogue-digital-converter is used. By comparing the signal with stored data the evaluation unit can determine if the sensing unit 8 is located in the inner area A or in the outer area C. Owing to the special current emitted to the border cable the signals from the inner area can be separated from the signals 25 from the outer area. Preferably a digital signal processor (DSP) is used for this purpose. The units 22, 23, 24 and 25 could be parts in a DSP-unit. This DSP-unit could also be integrated into unit 11.

Figure 10 shows somewhat simplified the electric design of a signal generator which feeds a border cable and a search cable with current, and figure 30 11 shows some important signals and currents in the signal generator. The unit 35 shows an oscillator with a frequency of 32 KHz. This frequency is fed to a binary

counter, i.e. unit 36, which divides the frequency, so that the highest frequency QA is 16 KHz and the next frequency QB is halved, i.e. 8 KHz. Both these are used in this case. Furthermore, two frequencies with considerably lower frequency QF and QG are used where QG is half the frequency of QF. The signal with the frequency of 8 KHz is conducted to a digital inverter 38, which creates a desirable curve-shape with plane, i.e. horizontal sections between the tops, compare figure 11. The signal is forwarded down to an EXCLUSIVE-OR-gate 40, and some part of it is forwarded to a resistance R1. The signal with the higher frequency is denominated G:16 KHz and is forwarded both to an EXCLUSIVE-OR-gate 39 and to a resistance R2. The component 37 is an AND-gate used for creating a phase inverting signal Sh. This is forwarded both to the component 39 and to the component 40. The phase inverting signal Sh has the appearance as shown in figure 11, where it has a higher level during a quarter of the time for inversion into out of phase, while the remaining three quarters has a lower level for in phase. Each frequency on their own is thus phase inverted in each component 39 and 40 respectively. This is due to the fact that each frequency signal in itself is binary and can be phase inverted, while a combination of both signals is trinary, and can not be treated in the same way.

The phase inverting signal Sh could also be created from its own oscillator. This might be relevant in the example according to figure 5, however, it might be somewhat more complicated than in the shown one. By means of the resistances R1 - R4 a conversion of each signal from digital to analogue form is achieved. The signal, which leaves the resistances R1 and R2, is thus of analogue form and can be put together into a border cable signal Sa. This signal is in voltage form and will be converted to current form in a voltage to current converter 41, so that the current Ia in the border cable is created. As illustrated in the figure the border cable a is included in a current circuit connected to a battery, here with 10 V output voltage. The circuit is closed via earth. The current in the border cable Ia is marked out in the figure. From each component 39 and 40 respectively comes signals, which are phase inverted by turns and having each a frequency

component on their own. In the resistances R4 and R3 respectively a conversion of the signal from digital to analogue form takes place. Thereafter the two signals coming from R3 and R4 will be summed up into a search cable signal Sb. This signal is of voltage form but will be converted in a voltage to current converter 42 into current, so that the current Ib in the search cable is created. These are the main features of the function of the signal generator, however, there are also some further built-in features, e.g. the resistances R9 and R10 are able to subdue deviation so that a voltage of 1 V instead of 9 V is distributed. The capacitors C1 and C2 can round the square edges in the alternating-current components' square waves in order to reduce electric disturbances. Accepted designations are used for the different electric components in figure 10.

Figure 11 shows thus some important signals and currents in the signal generator according to figure 10. On top of the figure is shown a signal F with the frequency of 8 KHz. There below is shown a signal G with the frequency of 16 KHz. Preferably these are lying in a permanent time relation to each other, as shown. There below is shown a summing-up of both above mentioned signals or currents, designated Ia/Sa, i.e. current in the border cable and the corresponding signal respectively in order to create the current flow. There below is shown a phase inverting signal Sh. The phase inverting signal Sh has two states; one state where no phase inversion occurs, which in this case is three quarters of the time, and another state used for phase inversion, in this case during one quarter of the time. By the phase inversion the curve-shape is changed so that the small positive "bump" comes up first in Ib compared with that it comes up last in Ia. To make the phase inversion during a part of the signal that is essentially horizontal is advantageous. In this example the phase inversion is thus thought to be made for the trinary signal Sa, while it in the real schedule according to figure 10 is made for each binary signal itself.

CLAIMS

1. An electronic search system (1) for a working tool (2), in which system a border cable (a), i.e. an electric cable, is placed above, under or on  
5 ground or floor, so that it separates an inner area (A) within the border cable (a) from an outer area (C), which working tool is preferably intended for attendance of ground or floor, such as grass-cutting, moss-scratching, watering, vacuum-cleaning, polishing, transportation etc., and a first signal generator (3; 3') feeds the border cable with current (Ia), whose magnetic field (7) affects at least  
10 one sensing unit (8) located on the working tool (2), so that the sensing unit (8) emits signals (9) to a control unit (10), which in cooperation with an engine control (11), or a signal system for a driver, and at least one driving source (12, 13) directs the tool's motion in order to prevent it from remoting from the inner area (A), c h a r a c t e r i z e d in that the first signal generator feeds the border  
15 cable with current (Ia) containing at least two alternating-current components (14, 15) of different frequency, and the components (14, 15) are lying in a known relation of time to each other, e.g. a regularly varying time relation, and at least one more cable, called search cable (b, d, e) is placed at least partly within the inner area (A+B+D+E), so that it separates at least one search area (B, D, E)  
20 within the inner area, and each search cable (b, d, e) respectively is fed by a signal generator (3, 4, 5) with an adapted current (Ib, Id, Ie), whose alternating-current components (14, 15) are virtually identical with the alternating-current components in the border cable (a), but where the direction of flow, at least for the alternating-current component (15) with the higher  
25 frequency, in each one of the search cables is alternating in time in being either in phase or out of phase in relation to the current flow direction in the border cable (a), so that the magnetic fields in the different areas (A, B, C, D, E), which are separated by each cable respectively, are forming at least three essentially unique timer patterns, and hereby the control unit can evaluate the difference in the  
30 signals (9) caused by the magnetic field's different time patterns in the inner area

(A), the outer area (C) and at least one search area (B, D, E), and the control unit can therefore emit an area signal (16), which mainly takes up one of at least three states depending on the position of the sensing unit (8) in relation to the border cable (a) or each search cable (b, d, e) respectively, i.e. an outer area state (17), an inner area state (18) or at least one search area state (31, 32, 33).

2. An electronic search system (1) according to claim 1, characterized in that the two alternating-current components' (14, 15) frequencies are multiples of each other, e.g. 8000 Hz and 16000 Hz, or 8000 Hz and 24000 Hz, or 8000 Hz and 32000 Hz.

3. An electronic search system (1) according to claim 2, characterized in that the two alternating-current components' (14, 15) frequencies are equal number multiples of each other, e.g. 8000 Hz and 16000 Hz or 8000 Hz and 32000 Hz.

4. An electronic search system (1) according to any one of the preceding claims, characterized in that the alternating-current components (14, 15) in the border cable (a) are lying in an essentially permanent time relation to each other.

5. An electronic search system (1) according to any one of the preceding claims, characterized in that the alternating-current components are composed of square waves.

6. An electronic search system (1) according to any one of the preceding claims, characterized in that each sensing unit comprises at least one coil (19).

7. An electronic search system (1) according to any one of the preceding claims, characterized in that the control unit (10) evaluates the signals (9) by dividing them in a frequency divider (21) into signal components (14', 15') with different frequency corresponding to the frequencies of the alternating-current components (14, 15), and the signal components are forwarded, after possible processing in a signal processing unit (22), to an evaluation unit (23), e.g. a so called latch, which at least for the signal component

(15') with the higher frequency, detects its signals as an analogue average of the proportion of in phase signals, or the proportion of out of phase signals, so that the evaluation unit creates the area signal (16).

5           8. An electronic search system (1) in accordance with any one of the preceding claims, characterized in that the control unit (10) evaluates the signals (9) by dividing them in a frequency divider (21) into signal components (14', 15'), with different frequency, corresponding to the frequencies of the alternating-current components (14, 15), and the signal components are  
10 forwarded, after possible processing in a signal processing unit (22) to an evaluation unit (23), e.g. a so called latch, which at least for the signal component (15') with the higher frequency, detects its signals as a digital pattern of in phase and out of phase signals, so that the evaluation unit can create the area signal (16).

15           9. An electronic search system (1) according to claim 7 or 8, characterized in that at least one of the signals (9, 14', 15') is rectified in a rectifier (25) and is forwarded to the engine control (11) as an analogue signal, a so called quality signal (26), whose signal intensity is a measure of the intensity of the ingoing signals (9) to the control unit, so that the tool can be shut-off at a  
20 too low quality signal, i.e. a too low signal intensity.

          10. An electronic search system (1) according to claim 7, 8 or 9, characterized in that at least one of the signal components (14', 15') is forwarded to an amplifier (24), whose amplification thus is affected by the ingoing signal's (14', 15') intensity, and after rectifying in rectifier (25) the  
25 analogue signal (26) is brought back to the frequency divider (21), which also has a variable amplification, and compared with not having this special amplification circuit the signal (26) affects the variable amplification of the signals (14', 15'), so that a considerably more constant signal intensity in these signals (14', 15') is achieved inside and near outside the inner area (A+B+D+E).



11. An electronic search system (1) in accordance with any one of the preceding claims, characterized in that the first signal generator (3; 3') transmits a current into a border cable (a) and in relation to the first current an adapted current into at least one search cable (b; b, d').

12. An electronic search system (1) according to any one of the preceding claims, characterized in that the first signal generator (3) feeds the border cable (a) with current (Ia) and in that at least one second signal generator (4, 5) is located at the border cable (a) and transmits the adapted current (Id, Ie) into at least one search cable (d, e).

13. An electronic search system (1) according to claim 12, characterized in that the adapted current (Id, Ie) is based on a sensing of the current (Ia), which the first signal generator (3) has transmitted into the border cable (a).

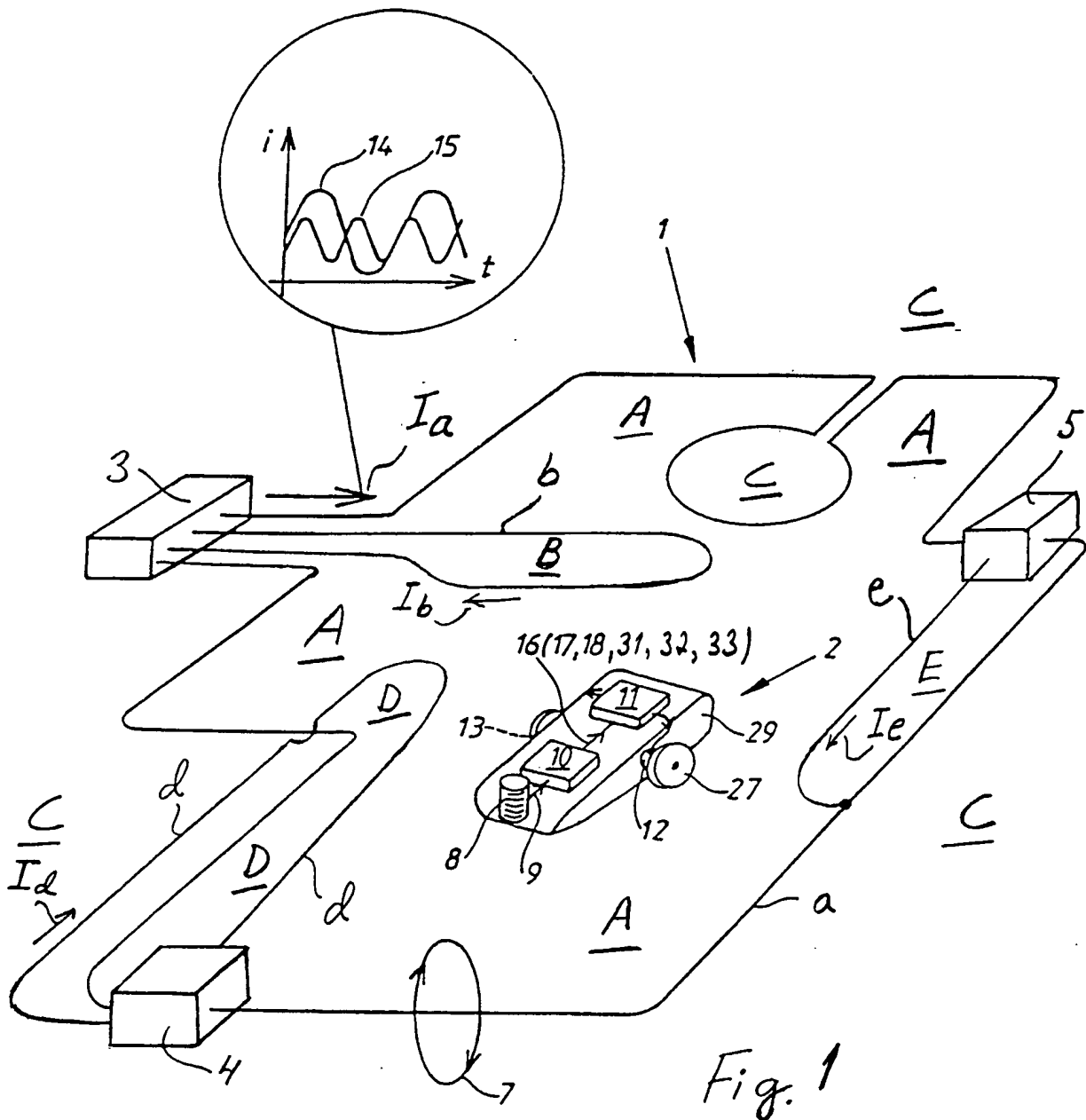
14. An electronic search system (1) according to any one of the preceding claims, characterized in that at least one search cable (b, d, e) is located essentially within the inner area (A+B+D+E).

15. An electronic search system (1) according to claim 14, characterized in that the search cable (e) is created by connecting a conductor (e) to the border cable (a), so that a part of the border cable (a) will be integrated into the search cable (e), which separates the search area (E).

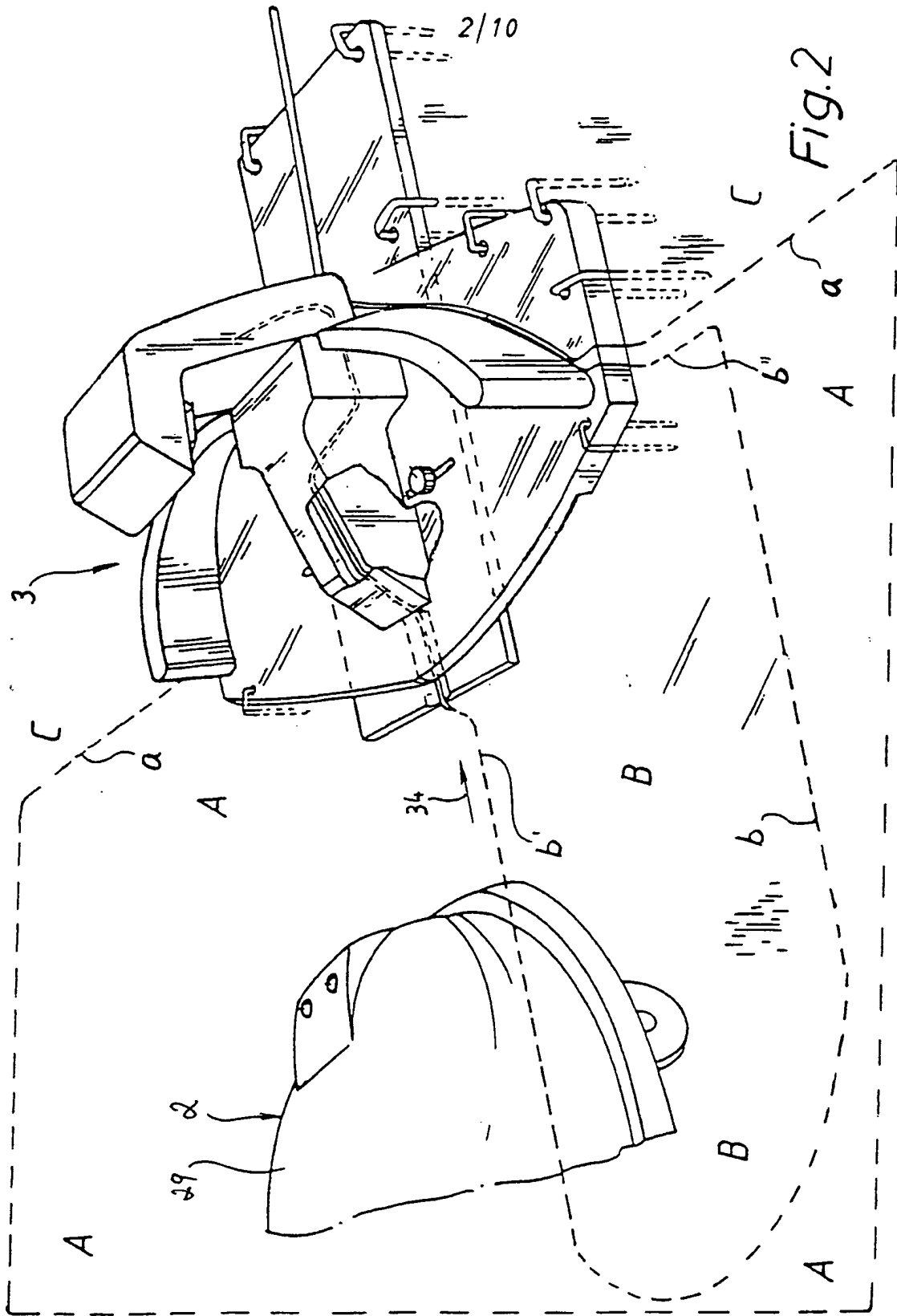
16. An electronic search system (1) according to any one of the preceding claims, characterized in that in the tool's (2) control unit there is a "follow the cable" mode, which becomes activated by passage from one area to another area in combination with that at least one more condition is fulfilled, e.g. the "follow the cable" mode becomes activated when a battery-operated tool gets a low voltage of battery (condition) and passes from the inner area over to the search area or vice versa, resulting in that the tool follows a search cable (b; b, d'), which leads to a docking station (3; 3') for automatic battery charging.

17. An electronic search system (1) according to claim 16, characterized in that in the "follow the cable" mode the state of the area signal (16) affects the engine control (11) so that the inner area state (18) guides the tool

1/10



SUBSTITUTE SHEET (RULE 26)



3/10

C

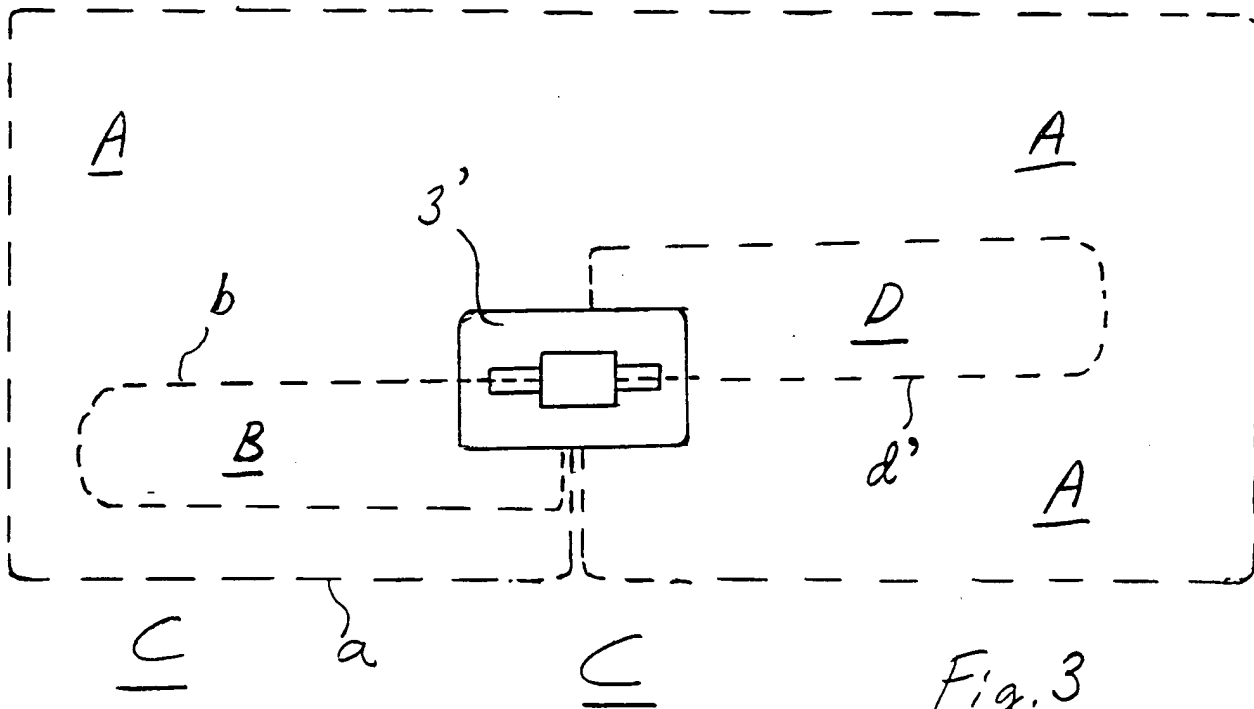


Fig. 3

4/10

Ia + + + + + + + + + + + + +

Ib - - - + - - - + - - - +

Signaler 9  
(redskap) i  
område:

		Analoga nivåer
C	- - - - - - - - - - - - -	0 %
A nära a	+ + + + + + + + + + + + +	100 %
A mellan a och b	+ + + ? + + + ? + + + ?	75-100 %
A nära b	+ + + - + + + - + + + -	75 %
B	- - - + - - - + - - - +	25 %

+ = medfassignal/medfasström

- = motfassignal/motfasström

Exempel på analoga signalnivåers innebörd:

< 12 % = C

13-49 % = B

> 50 % = A

Fig. 4

5/10

Ia	+	+	+	+	+	+	+	+	+	+	+
Ib	-	-	+	-	-	+	-	-	+	-	+
Id	-	-	-	-	-	+	-	-	-	-	+

Signaler 9  
(redskap) i  
område:

		Analoga nivåer
	C - - - - - - - - - - - - - -	0 %
nära a	A + + + + + + + + + + + + + +	100 %
mellan a och b eller d	A + + ? + + ? + + ? + + ?	67-100 %
nära b	A + + - + + - + + - + + -	67 %
	B - - + - - + - - + - - +	33 %
nära d	A + + + + + - + + + + + -	83 %
	D - - - - - + - - - - - +	17 %

Exempel på analoga signalnivåers innebörd:

- < 8 % = C
- 9-25 % = D
- 26-49 % = B
- > 50 % = A

Fig. 5

6/10

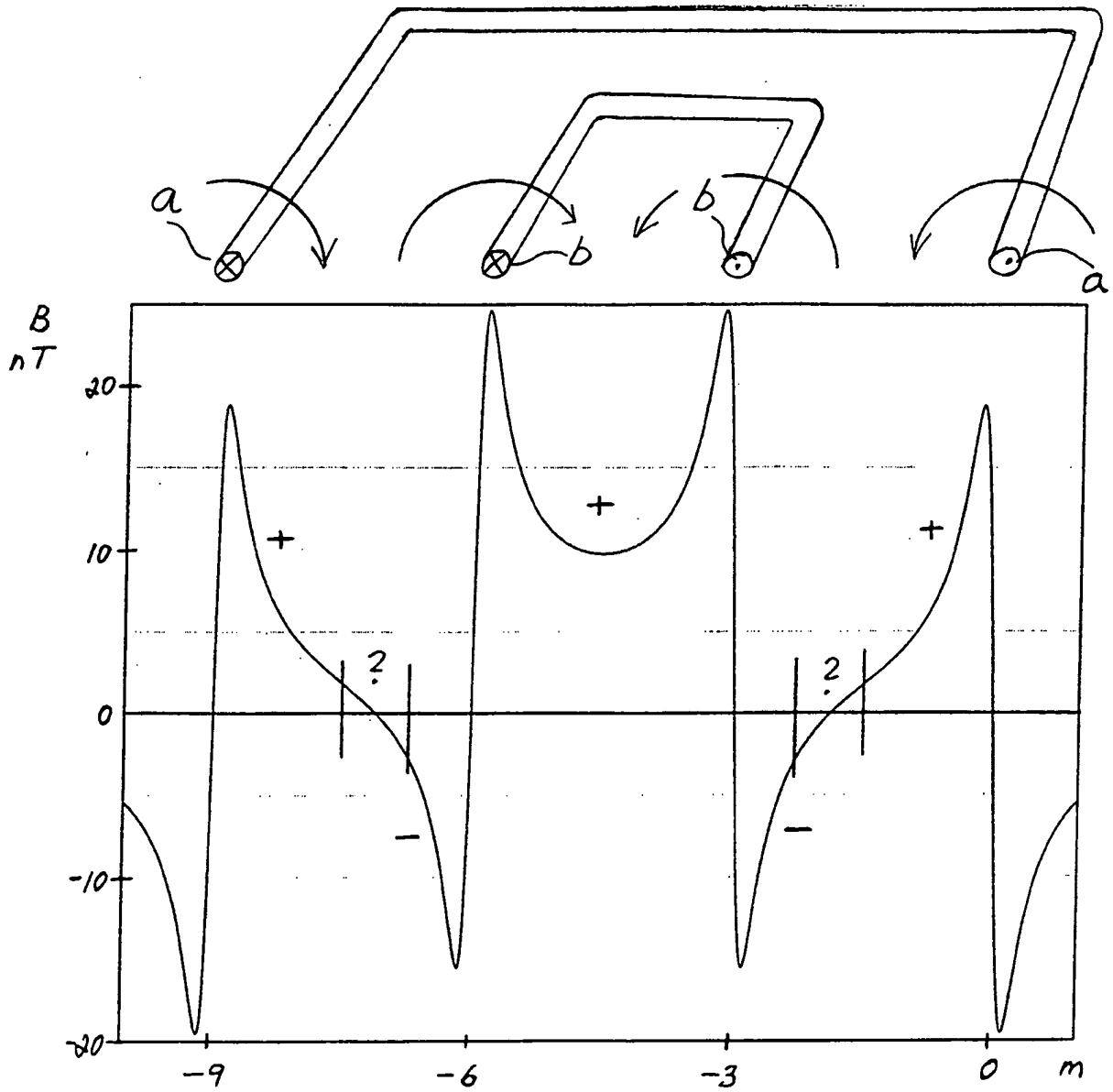


Fig. 6

7/10

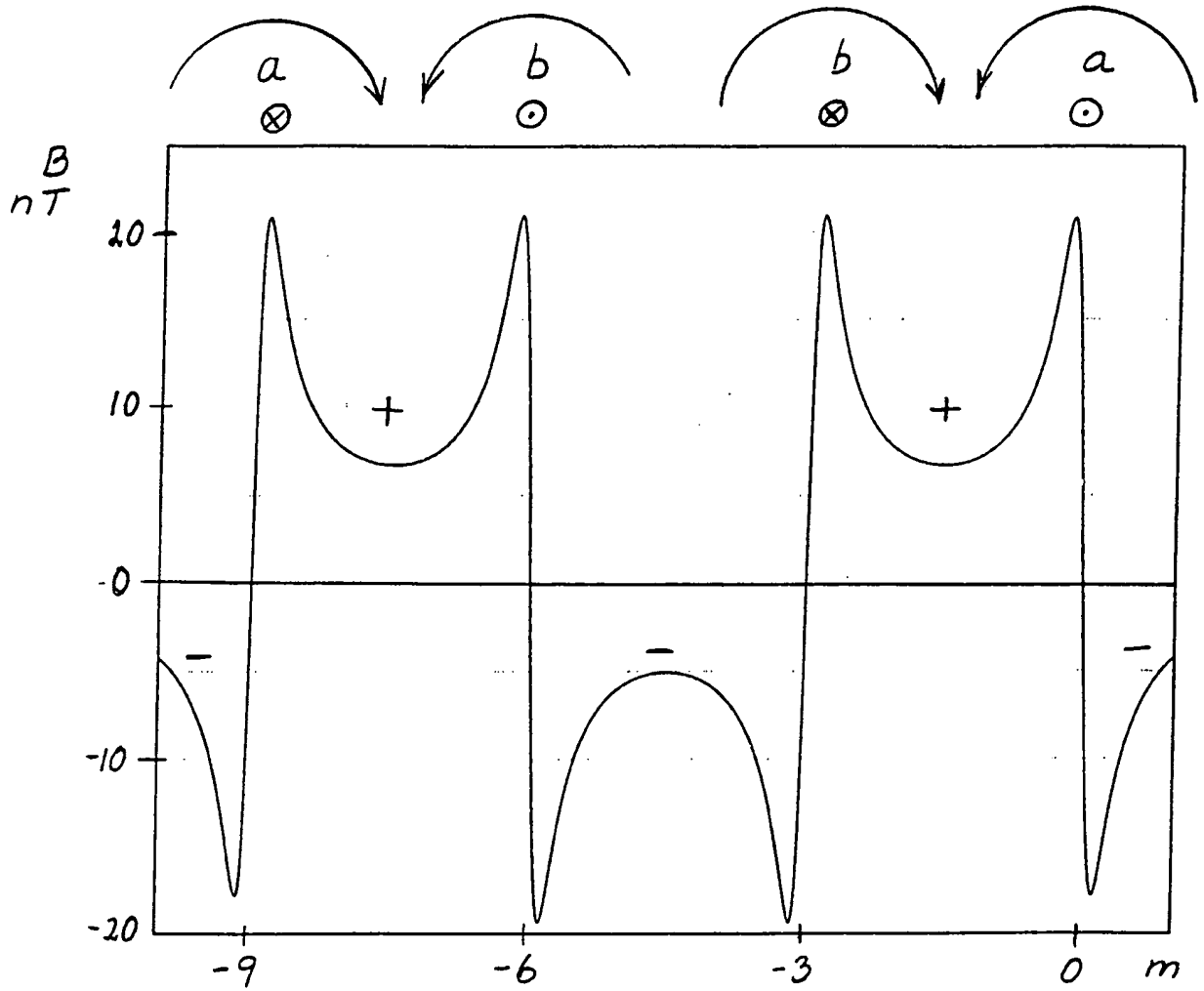


Fig. 7



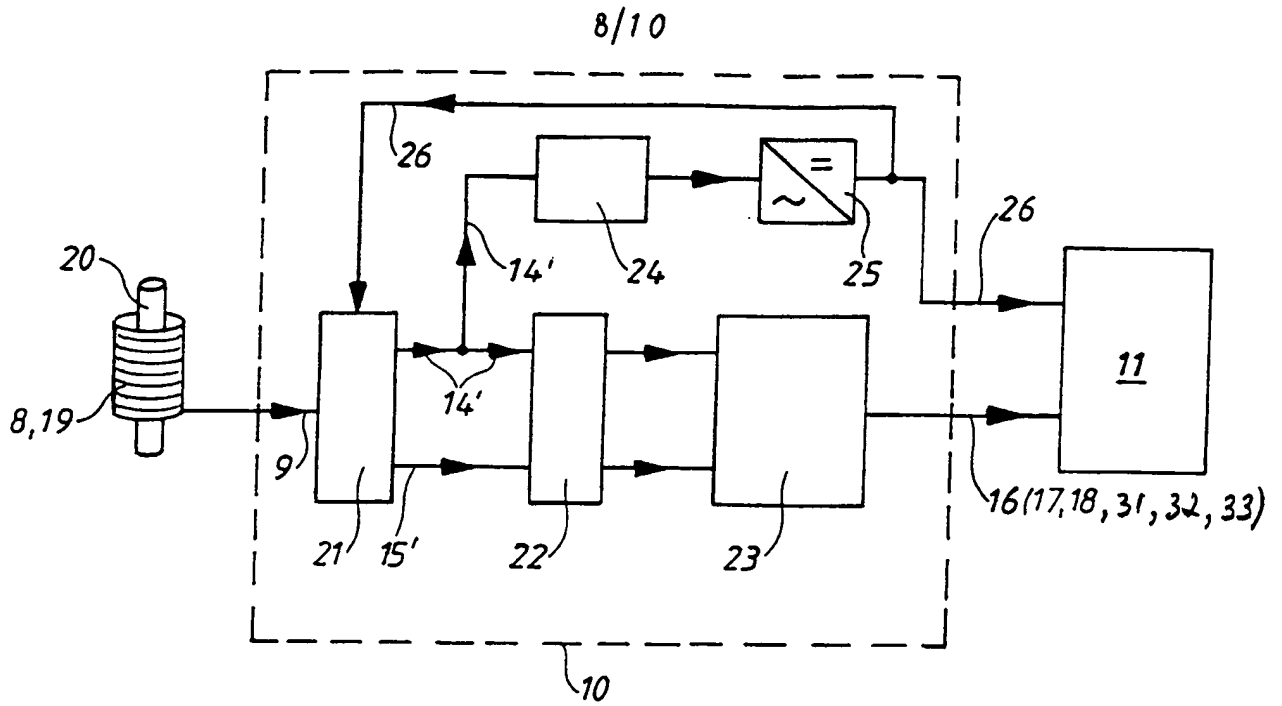


FIG. 8

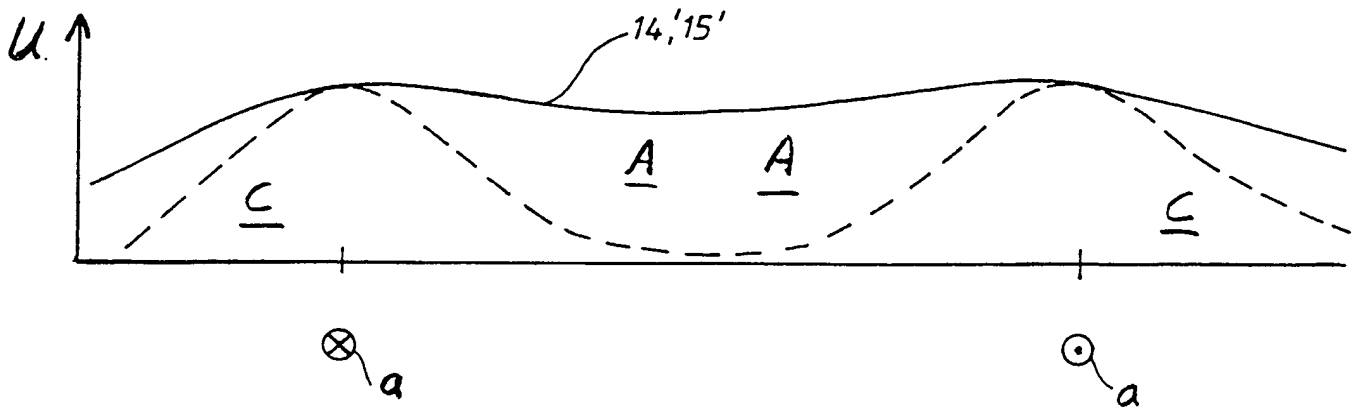


FIG. 9

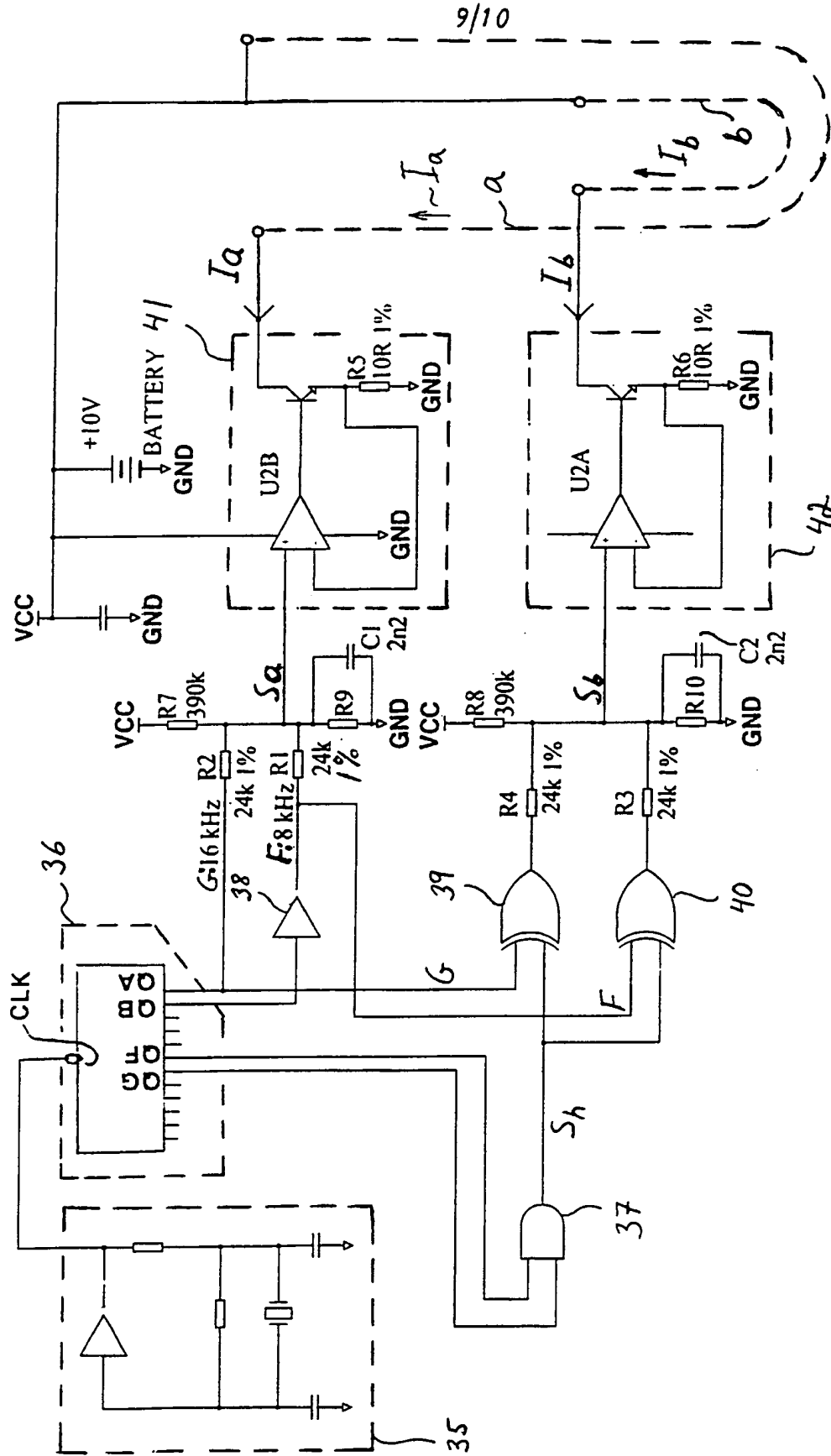
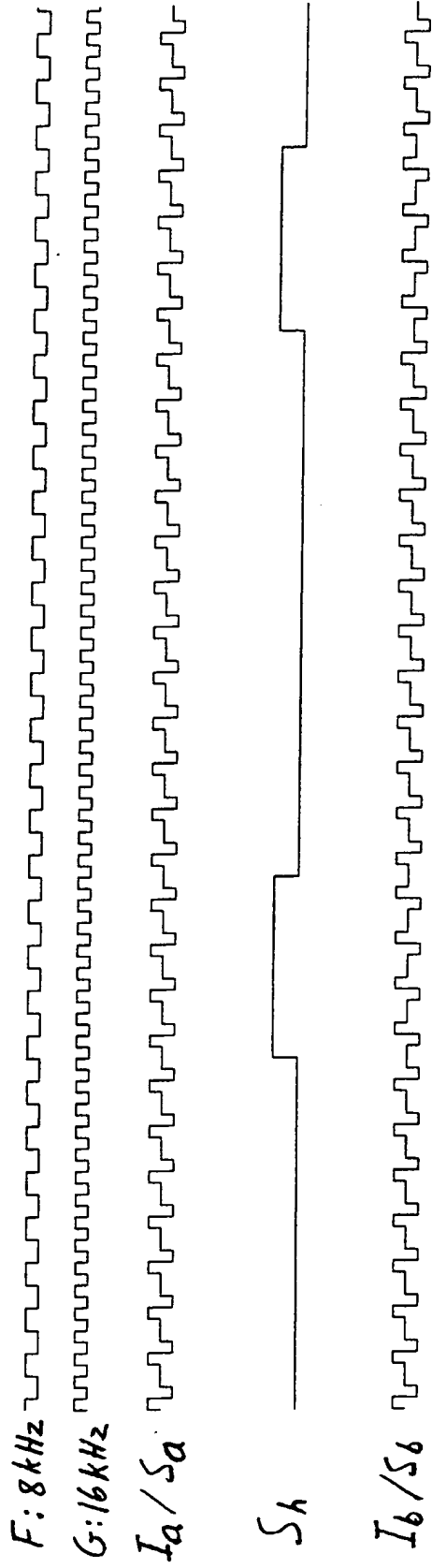


Fig. 10

SUBSTITUTE SHEET (RULE 26)



10/10

Fig. 11

## INTERNATIONAL SEARCH REPORT

International application No.

PCT/SE 98/02457

<b>A. CLASSIFICATION OF SUBJECT MATTER</b>		
<b>IPC6: G05D 1/03</b> According to International Patent Classification (IPC) or to both national classification and IPC		
<b>B. FIELDS SEARCHED</b>		
Minimum documentation searched (classification system followed by classification symbols)		
<b>IPC6: G05D, A01B, A01D</b>		
Documentation searched other than minimum documentation to the extent that such documents are included in the fields searched		
<b>SE,DK,FI,NO classes as above</b>		
Electronic data base consulted during the international search (name of data base and, where practicable, search terms used)		
<b>WPI</b>		
<b>C. DOCUMENTS CONSIDERED TO BE RELEVANT</b>		
Category*	Citation of document, with indication, where appropriate, of the relevant passages	Relevant to claim No.
A	US 4919224 A (J-M SHYU ET AL.), 24 April 1990 (24.04.90), column 7, line 18 - column 9, line 2 --	1-18
A	FR 2696569 A1 (SN ENO), 8 April 1994 (08.04.94), see the whole document --	1-18
A	US 3550714 A (S.L. BELLINGER), 29 December 1970 (29.12.70), column 2, line 3 - column 3, line 11 --	1-18
A	EP 0774702 A2 (FRIENDLY MACHINES LTD.), 21 May 1997 (21.05.97), column 8, line 17 - line 45 --	1-18
<input checked="" type="checkbox"/> Further documents are listed in the continuation of Box C. <input checked="" type="checkbox"/> See patent family annex.		
* Special categories of cited documents:		
"A"	document defining the general state of the art which is not considered to be of particular relevance	"T" later document published after the international filing date or priority date and not in conflict with the application but cited to understand the principle or theory underlying the invention
"E"	earlier document but published on or after the international filing date	"X" document of particular relevance: the claimed invention cannot be considered novel or cannot be considered to involve an inventive step when the document is taken alone
"L"	document which may throw doubts on priority claim(s) or which is cited to establish the publication date of another citation or other special reason (as specified)	"Y" document of particular relevance: the claimed invention cannot be considered to involve an inventive step when the document is combined with one or more other such documents, such combination being obvious to a person skilled in the art
"O"	document referring to an oral disclosure, use, exhibition or other means	"&" document member of the same patent family
"P"	document published prior to the international filing date but later than the priority date claimed	
Date of the actual completion of the international search		Date of mailing of the international search report
19 April 1999		29 -04- 1999
Name and mailing address of the ISA/ Swedish Patent Office Box 5055, S-102 42 STOCKHOLM Facsimile No. +46 8 666 02 86		Authorized officer Håkan Sandh Telephone No. +46 8 782 25 00

INTERNATIONAL SEARCH REPORT

International application No.  
PCT/SE 98/02457

C (Continuation). DOCUMENTS CONSIDERED TO BE RELEVANT		
Category*	Citation of document, with indication, where appropriate, of the relevant passages	Relevant to claim No.
A	US 4079801 A (J.S: BDOBSON), 21 March 1978 (21.03.78), abstract  ----- -----	1-18

**INTERNATIONAL SEARCH REPORT**  
 Information on patent family members

02/03/99

International application No.  
 PCT/SE 98/02457

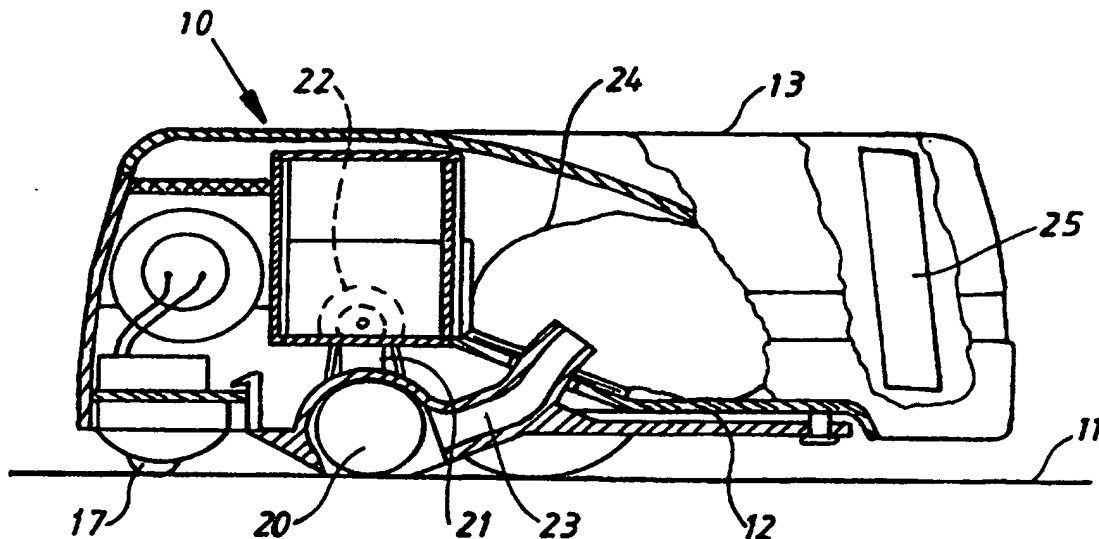
Patent document cited in search report	Publication date	Patent family member(s)	Publication date
US 4919224 A	24/04/90	DE 3816622 A,C FR 2631466 A	30/11/89 17/11/89
FR 2696569 A1	08/04/94	NONE	
US 3550714 A	29/12/70	DE 1457934 A	10/04/69
EP 0774702 A2	21/05/97	NONE	
US 4079801 A	21/03/78	DE 2448492 A,C GB 1459788 A	28/05/75 31/12/76



INTERNATIONAL APPLICATION PUBLISHED UNDER THE PATENT COOPERATION TREATY (PCT)

<p>(51) International Patent Classification <sup>6</sup> : A47L 9/04, 9/28</p>	<p>A1</p>	<p>(11) International Publication Number: <b>WO 97/40734</b> (43) International Publication Date: 6 November 1997 (06.11.97)</p>
<p>(21) International Application Number: PCT/SE97/00727 (22) International Filing Date: 29 April 1997 (29.04.97) (30) Priority Data: 9601658-9 30 April 1996 (30.04.96) SE (71) Applicant (for all designated States except US): AKTIEBO- LAGET ELECTROLUX (publ) [SE/SE]; S-105 45 Stock- holm (SE). (72) Inventors; and (75) Inventors/Applicants (for US only): HAEGERMARCK, An- ders [SE/SE]; Storrsvägen 3, S-142 31 Trångsund (SE). RIISE, Björn [SE/SE]; Hjortvägen 3, S-191 46 Sollentuna (SE). HULDEN, Jarl, Olof [SE/SE]; Hagalundsgatan 43, S- 171 50 Solna (SE). (74) Agents: ERIXON, Bo et al.; AB Electrolux, Group Patents &amp; Trademarks, S-105 45 Stockholm (SE).</p>		<p>(81) Designated States: AL, AM, AT, AU, AZ, BA, BB, BG, BR, BY, CA, CH, CN, CU, CZ, DE, DK, EE, ES, FI, GB, GE, HU, IL, IS, JP, KE, KG, KP, KR, KZ, LC, LK, LR, LS, LT, LU, LV, MD, MG, MK, MN, MW, MX, NO, NZ, PL, PT, RO, RU, SD, SE, SG, SI, SK, TJ, TM, TR, TT, UA, UG, US, UZ, VN, ARIPO patent (GH, KE, LS, MW, SD, SZ, UG), Eurasian patent (AM, AZ, BY, KG, KZ, MD, RU, TJ, TM), European patent (AT, BE, CH, DE, DK, ES, FI, FR, GB, GR, IE, IT, LU, MC, NL, PT, SE), OAPI patent (BF, BJ, CF, CG, CI, CM, GA, GN, ML, MR, NE, SN, TD, TG).  Published With international search report. In English translation (filed in Swedish).</p>

(54) Title: AUTONOMOUS DEVICE



(57) Abstract

An autonomous device (10) is adapted to automatically move on a work surface (11) removing dirt, such as gravel, sand, dust particles and the like, from said work surface. The device (10) comprises a chassis (12) provided with wheels and with a brush roller (20) rotated by a drive motor (22) during said movement for the purpose of brushing up the dirt towards a suction duct (23) wherefrom, by means of a suction air stream, the dirt is conveyed to a dust container (24). An electronic control device (25) is provided for the control of the drive motor (22) of the brush roller. If the movement of the brush roller (20) is blocked or obstructed to a predetermined extent the control device (25) is arranged to stop the brush roller motor (22) and then temporarily activate the motor (22) in the opposite direction and, finally, after another stop, to reconnect the brush roller motor (22) to operate in the original direction of rotation.

**FOR THE PURPOSES OF INFORMATION ONLY**

Codes used to identify States party to the PCT on the front pages of pamphlets publishing international applications under the PCT.

AL	Albania	ES	Spain	LS	Lesotho	SI	Slovenia
AM	Armenia	FI	Finland	LT	Lithuania	SK	Slovakia
AT	Austria	FR	France	LU	Luxembourg	SN	Senegal
AU	Australia	GA	Gabon	LV	Latvia	SZ	Swaziland
AZ	Azerbaijan	GB	United Kingdom	MC	Monaco	TD	Chad
BA	Bosnia and Herzegovina	GE	Georgia	MD	Republic of Moldova	TG	Togo
BB	Barbados	GH	Ghana	MG	Madagascar	TJ	Tajikistan
BE	Belgium	GN	Guinea	MK	The former Yugoslav Republic of Macedonia	TM	Turkmenistan
BF	Burkina Faso	GR	Greece			TR	Turkey
BG	Bulgaria	HU	Hungary	ML	Mali	TT	Trinidad and Tobago
BJ	Benin	IE	Ireland	MN	Mongolia	UA	Ukraine
BR	Brazil	IL	Israel	MR	Mauritania	UG	Uganda
BY	Belarus	IS	Iceland	MW	Malawi	US	United States of America
CA	Canada	IT	Italy	MX	Mexico	UZ	Uzbekistan
CF	Central African Republic	JP	Japan	NE	Niger	VN	Viet Nam
CG	Congo	KE	Kenya	NL	Netherlands	YU	Yugoslavia
CH	Switzerland	KG	Kyrgyzstan	NO	Norway	ZW	Zimbabwe
CI	Côte d'Ivoire	KP	Democratic People's Republic of Korea	NZ	New Zealand		
CM	Cameroon			PL	Poland		
CN	China	KR	Republic of Korea	PT	Portugal		
CU	Cuba	KZ	Kazakstan	RO	Romania		
CZ	Czech Republic	LC	Saint Lucia	RU	Russian Federation		
DE	Germany	LI	Liechtenstein	SD	Sudan		
DK	Denmark	LK	Sri Lanka	SE	Sweden		
EE	Estonia	LR	Liberia	SG	Singapore		



Autonomous device

The present invention relates to an autonomous device of the kind which is arranged to automatically move on a work surface, such as a floor, removing dirt, such as gravel, sand, dust particles and the like, from said work surface. More  
5 specifically, the invention relates to such autonomous device which comprises a chassis provided with wheels and with a brush roller rotated by a drive motor during said movement for the purpose of brushing up the dirt towards a suction duct wherefrom, by means of a suction air stream, the dirt is  
10 conveyed to a dust container. The device also includes an electronic control device for controlling the drive motor of the brush roller.

An autonomous device as described above is often referred to as vacuum cleaner robot due to the fact that the device can  
15 automatically move around on a work surface, according to a predetermined pattern or by random changes of the direction of movement, cleaning the surface from loose dirt, such as gravel, sand, threads, hair and small particle dust. Most often, the autonomous device is battery-driven which means that it cannot  
20 have the same capacity as a common vacuum cleaner powered from the mains. Basically, a vacuum cleaner robot comprises a chassis with wheels for the movement and often one or more additional support wheels which are not driven. For the drive of the drive wheels often a separate motor is provided for each  
25 drive wheel. In addition, there is provided a unit for the collection of dust comprising a suction nozzle, a suction fan with drive motor and a dust container as well as connection conduits therebetween. Finally, an electronic control device is provided for the coordination of all activities of the vacuum  
30 cleaner robot and for the determination of patterns of movement. In addition, the control device is used for the determination of possible obstacles in the near surroundings of the vacuum cleaner robot so that a collision with obstacles is avoided and so that the robot can free itself if getting stuck  
35 in a corner or the like.

As a result of the limited suction capacity, suitably, a brush roller is provided which rotates during the movement of

the device around the work surface brushing up dust particles towards a suction duct where the suction force takes over conveying the dust to the dust container. A suction force of any greater magnitude is not required at the work surface and  
5 the cleaning ability becomes reasonably good due to the joint action of the brush and the suction fan.

However, the rotating brush roller can give a problem when the surface consists of soft carpets provided with fringes. Upon movement of the device in over such a carpet the fringes  
10 can be brought with the brush to wind up on the roller and, in the worst case, to get stuck on the brush or between said brush and the adjacent brush roller housing. This can cause a problem with destroyed carpet fringes or cause damage to the brush roller or the accompanying drive motor.

15 The object of the invention is to eliminate the drawbacks indicated above and to provide an autonomous device which senses tendencies for carpet fringes or the like to get stuck in the rotating brush thereby controlling the device in such a way that a fringe in the process of getting stuck will be  
20 released. The object is solved in an autonomous device of the kind referred to by way of introduction which has obtained the characterizing features indicated in claim 1.

The invention will now be described more in detail in connection with an embodiment and with reference to the  
25 accompanying drawings, in which:

- Fig. 1 shows an autonomous device according to the invention in a lateral view, partly in section;  
Fig. 2 shows the device of Fig. 1 in a bottom view;  
Fig. 3 shows a block diagram of the components  
30 constituting the brush roller motor drive; and  
Fig. 4 shows a flow chart illustrating the control of the brush roller motor.

In Fig. 1 there is shown, in a lateral view partly in section, an autonomous device 10 arranged to automatically move  
35 on a floor 11 carrying out vacuuming of the same. The device comprises a chassis 12 on which functional units are mounted. The chassis 12 is covered by a cover 13 secured to the chassis by screws or the like, not shown. The device has the shape of a cylinder can and two drive wheels 14, 15 are rotatably

journalled on the chassis 12 such that their axis of rotation coincide with a line 16 through the center of the can. In addition to the drive wheels 14, 15 a third wheel 17 is provided designed as a pivot wheel. The driving of the drive  
5 wheels is performed by means of separate drive motors, not shown. One advantage with this arrangement is that by driving the drive wheels in opposite directions turning of the device around its center is easily brought about.

The autonomous device comprises a work unit arranged to  
10 carrying out vacuuming of the base on which the device is moving. The work unit comprises a rotating brush roller 20 driven by a drive motor 22 via a belt transmission, schematically designated by 21. Suitably, the drive motor 22 is a DC motor for low voltage, for example 12 volts. Adjacent to  
15 the brush roller 20, at a distance from the base, a suction duct 23 opens which connects to a dust container 24.

When the brush roller is rotated it will brush up dust from the base to the entrance of the suction duct 23 where the dust is caught by a suction air stream prevailing at the entrance  
20 and generated by a suction fan unit, not shown. The brush roller is rotated in a direction opposite to that of the drive wheels 14, 15 during movement in the forward direction (to the right in Fig. 1). This means that the brush roller rotates against the direction of movement of the device. In this way  
25 the brush roller will brush the dust in a forward direction which means that dust not immediately caught by the air suction stream will again by the brush roller be brushed up towards the entrance 23 to then be caught by the air suction stream.

For the control and coordination of all activities of the  
30 autonomous device there is provided an electronic control device 25. The device comprises a microprocessor of the type MC68332 mounted on a printed circuit board along with memory circuits needed as well as drive circuits for the various drive motors for the drive wheels 14, 15, the brush roller 20 and the  
35 suction fan unit. The printed circuit board is constructed in a conventional way and will not be discussed in any further detail.

The problem for the invention to solve is connected with the driving of the brush roller and the object is to see to it

that if the movement of the brush roller is completely blocked or considerably obstructed this condition is removed. During vacuuming the autonomous device is moving across a floor in randomly chosen directions for so long as to have every part  
5 surface of the floor being passed at least once. The floor comprises free surfaces with a hard floor coating as well as surfaces covered by soft carpets. During the movement across the floor the brush roller 20 is rotated at a speed considerably greater than the speed of the drive wheels 14, 15.  
10 When the device reaches a carpet fringe it may happen that one or several fringes get caught by the bristles on the roller to follow in the rotating movement. In this way the carpet fringe can be fed into the interior of the device bringing with it the end of the carpet causing the device to get stuck. Therefore,  
15 a program sequence has been put into the program memory of the control device with the meaning that if there is an indication of the brush roller getting stuck the brush roller motor is disconnected whereafter the motor is again transitorily switched on but in the opposite direction making it possible  
20 for the carpet fringe to be fed out. When the back drive has been completed the brush roller motor is again stopped and thereafter the drive is reconnected with the original direction of rotation. In the normal case this would be sufficient for the release of the brush roller and reestablishment of the  
25 function. Should this not be the case the procedure will be repeated. It is also possible that after several reversing procedures without result the device is permanently inactivated to be reactivated only by manual action. This control function is illustrated in the flow chart of fig. 4 which also includes  
30 a part relating the the sensing and correting of speed. As appears from the flow chart, firstly, the drive current of the brush roller motor is sensed and compared with a limit value. If the limit is exceeded the driving of the brush roller motor is stopped and then the motor is driven in the opposite  
35 direction. Thereafter, the drive current is again measured and if the limit is still exceeded the driving is stopped so that the brush roller is pricipally released. If after the backing procedure the limit is not exceeded it is determined if the predetermined backing movement is fully completed. If so, the

driving is stopped and the brush roller released. If the backing movement has not been completed the backing sequence is repeated until backing has been fully completed.

5 In Fig. 3 there is shown a block diagram over the driving of the brush roller motor 22. For the determination of if the brush roller motor has been blocked the current is measured in the drive circuits provided between the microprocessor 25 and the brush roller motor 22. The measurement value is converted into digital form in an A/D-converter 26.

10 Advantageously, the brush roller motor is driven at a speed below the maximum speed, e.g. at half the maximum speed. Because the device is to operate on a base with varying friction conditions it is desirable to keep the speed at a mainly constant level. Such regulation means that if vacuuming  
15 takes place on a hard floor an increase of the speed of the brush roller, which otherwise would occur, is avoided. At the same time it is possible to avoid the brush roller losing speed, with the resulting reduction in dust collection, during vacuuming on a soft carpet where the brush motor has to work  
20 harder.

For the speed to be kept constant it is a prerequisite that it is possible to measure the speed in a simple manner, if not continuously, yet with high periodicity. The invention makes use of the sensing of the EMF generated by the DC motor 22 when  
25 its drive voltage is transitory disconnected. This EMF-value is fed to the A/D-converter 26 to be converted into digital form prior to being applied to an input of the microprocessor 25. For the control of the DC motor 22 to operate at the desired speed a signal PWM is sent to a drive circuit 27 which in turn  
30 is connected to the brush roller motor 22. A signal DIR is sent from the microprocessor 25 to the drive circuit 27 for the determination of the direction of rotation of the motor, forward or backward. A signal EMF is sent to the drive circuit 27 for initiating of EMF-measurement when the driving has been  
35 transitory disconnected. For said EMF-measurement the drive voltage is being disconnected for about 10 milliseconds with a periodicity of about 100 milliseconds.

## C l a i m s

1. An autonomous device (10) adapted to automatically move on a work surface (11) removing dirt, such as gravel, sand, dust particles and the like, from said work surface, said device (10) comprising a chassis (12) provided with wheels and with a brush roller (20) rotated by a drive motor (22) during said movement for the purpose of brushing up the dirt towards a suction duct (23) wherefrom, by means of a suction air stream, the dirt is conveyed to a dust container (24), an electronic control device (25) being provided for the control of the drive motor (22) of the brush roller, characterized in that if the movement of the brush roller (20) is blocked or obstructed to a predetermined extent the control device (25) is arranged to stop the brush roller motor (22) and then transitorily activate the motor (22) in the opposite direction and, finally, to reconnect the brush roller motor (22) to operate in the original direction of rotation.
2. An autonomous device according to claim 1, characterized in that the control device (25) is arranged to measure, at a predetermined periodicity, the current through the brush roller motor (22) and to order backward drive of the brush roller motor if the motor current exceeds a predetermined limit.
3. An autonomous device according to claim 2, characterized in that the control device (25) is arranged to measure the motor current also during the backward drive and to stop the brush roller motor (22) if the motor current limit is exceeded.
4. An autonomous device according to any of the preceding claims, characterized in that the control device (25) is arranged to operate the brush roller motor (22) at a rated speed lower than the maximum speed and to keep the rated speed almost constant.
5. An autonomous device according to claim 4, characterized in that the brush roller motor (22) is a DC motor and the control device (25) is arranged to drive the brush roller motor (22) with a voltage that is pulse-width modulated.
6. An autonomous device according to claim 5, characterized in that the control device (25) is arranged to transitorily, at a predetermined periodicity, disconnect the drive voltage, the

control device (25) having an input on which the EMF generated by the motor (22) during the corresponding time slot is applied for the determination of the speed of the motor.

7. An autonomous device according to any of the preceding  
5 claims, **characterized** in that the normal direction of rotation of the brush roller (20) is opposite to that of the drive wheels (14, 15) of the device when the device (10) is moving on the work surface (11) and cleaning takes place.

8. An autonomous device according to any of the preceding  
10 claims, **characterized** in that the electronic control device (25) is a microcomputer.

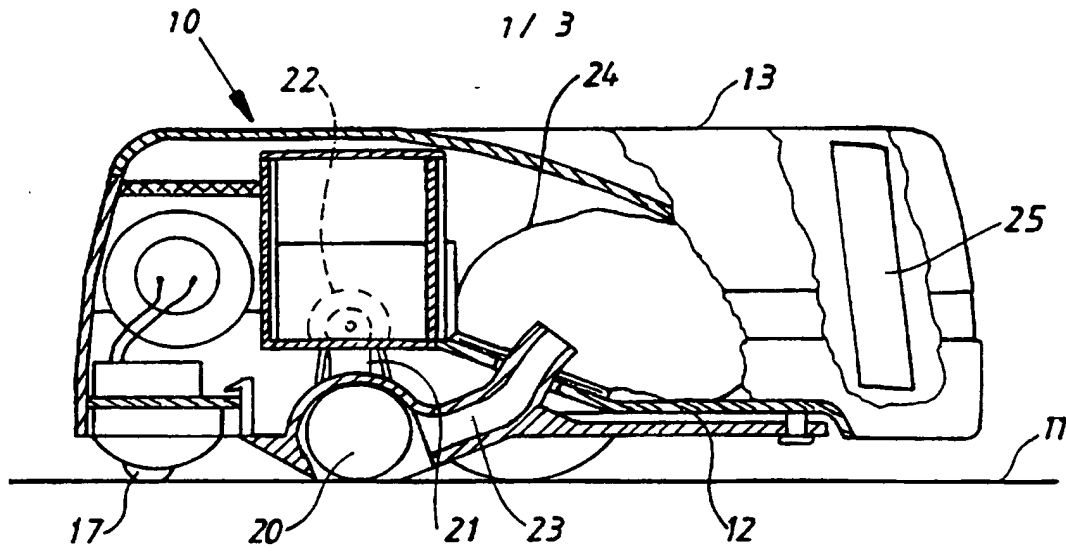


Fig. 1

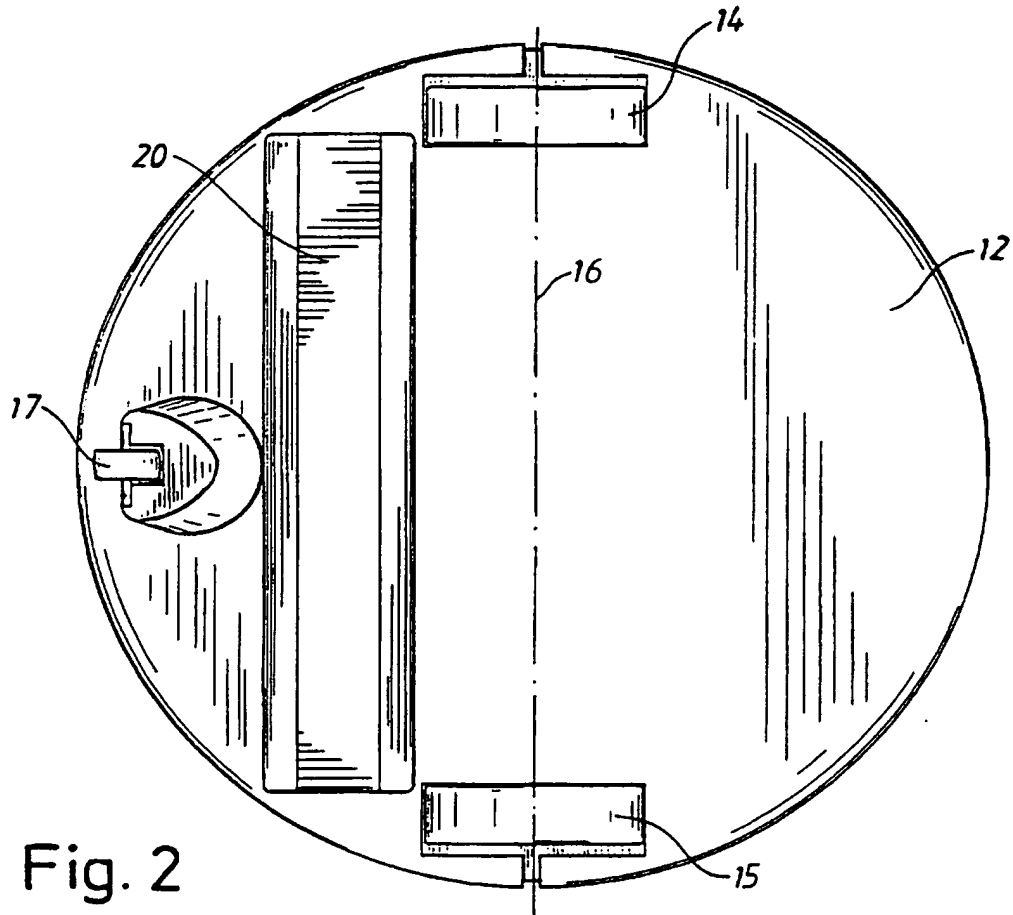


Fig. 2



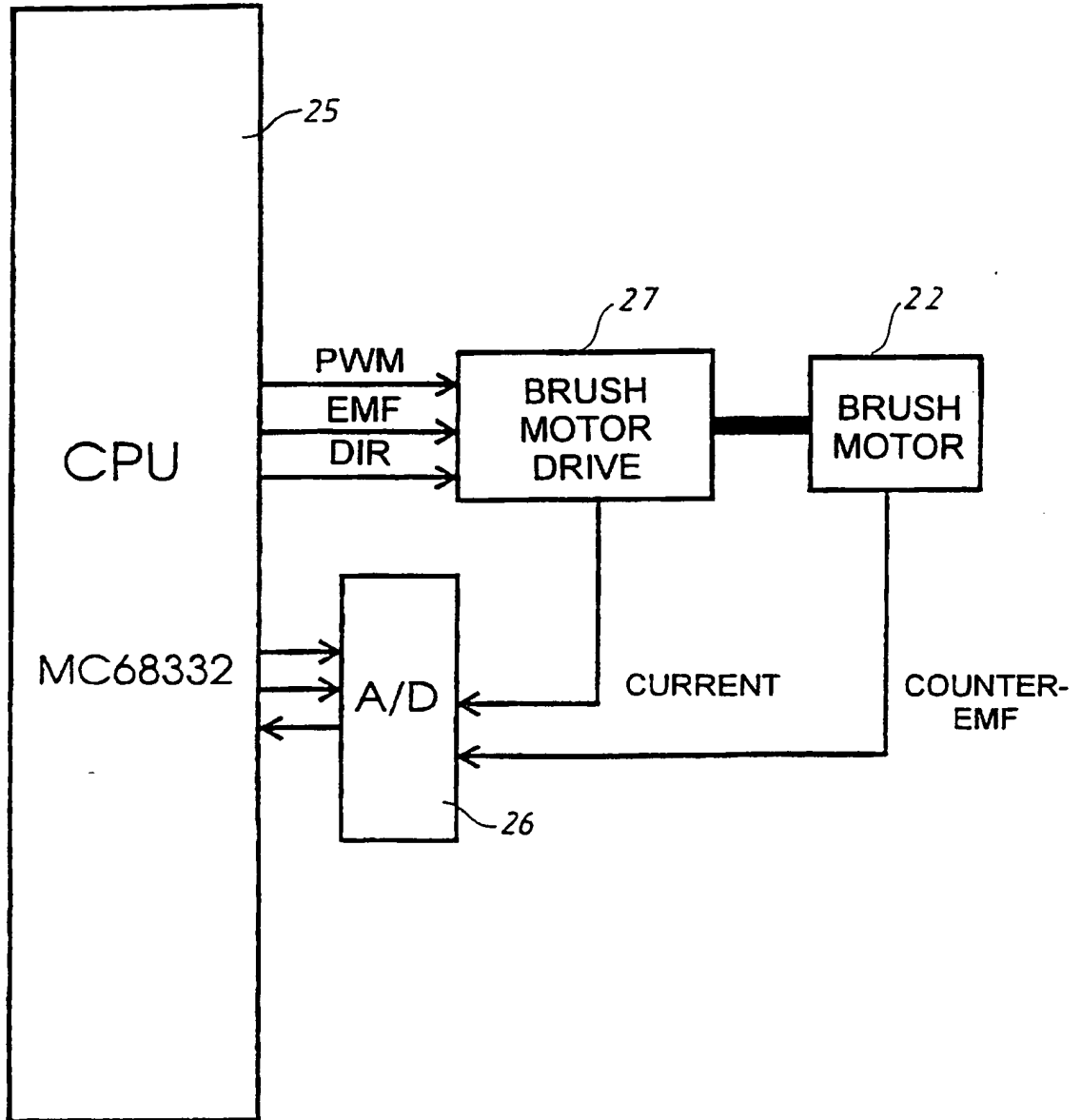


Fig. 3

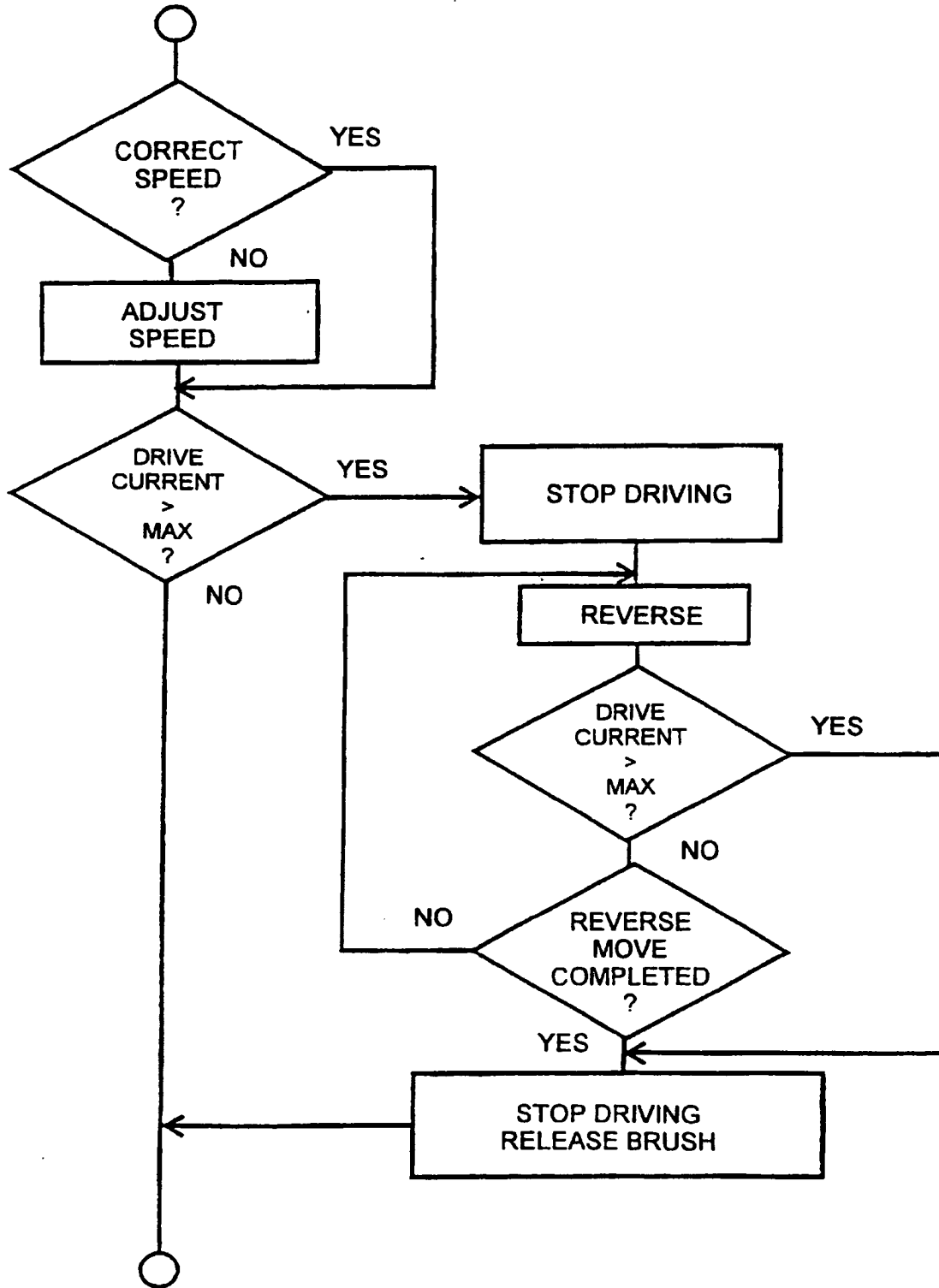


Fig. 4

## INTERNATIONAL SEARCH REPORT

International application No.

PCT/SE 97/00727

A. CLASSIFICATION OF SUBJECT MATTER		
IPC6: A47L 9/04, A47L 9/28 According to International Patent Classification (IPC) or to both national classification and IPC		
B. FIELDS SEARCHED		
Minimum documentation searched (classification system followed by classification symbols)		
IPC6: A47L		
Documentation searched other than minimum documentation to the extent that such documents are included in the fields searched		
SE,DK,FI,NO classes as above		
Electronic data base consulted during the international search (name of data base and, where practicable, search terms used)		
C. DOCUMENTS CONSIDERED TO BE RELEVANT		
Category*	Citation of document, with indication, where appropriate, of the relevant passages	Relevant to claim No.
A	US 5109566 A (KOBAYASHI ET AL), 5 May 1992 (05.05.92), figures 1-18 --	1
A	US 5341540 A (SOUPERT ET AL), 30 August 1994 (30.08.94), figures 1-4 --	1
A	WO 9526512 A1 (AKTIEBOLAGET ELECTROLUX), 5 October 1995 (05.10.95), figures 1-14 --	1
A	EP 0351801 A2 (MATSUSHITA ELECTRIC INDUSTRIAL CO. LTD.), 24 January 1990 (24.01.90), figure 2, abstract --	1
<input checked="" type="checkbox"/> Further documents are listed in the continuation of Box C. <input checked="" type="checkbox"/> See patent family annex.		
* Special categories of cited documents: "A" document defining the general state of the art which is not considered to be of particular relevance "E" earlier document but published on or after the international filing date "L" document which may throw doubts on priority claim(s) or which is cited to establish the publication date of another citation or other special reason (as specified) "O" document referring to an oral disclosure, use, exhibition or other means "P" document published prior to the international filing date but later than the priority date claimed "T" later document published after the international filing date or priority date and not in conflict with the application but cited to understand the principle or theory underlying the invention "X" document of particular relevance: the claimed invention cannot be considered novel or cannot be considered to involve an inventive step when the document is taken alone "Y" document of particular relevance: the claimed invention cannot be considered to involve an inventive step when the document is combined with one or more other such documents, such combination being obvious to a person skilled in the art "&" document member of the same patent family		
Date of the actual completion of the international search		Date of mailing of the international search report
27 June 1997		07 -08- 1997
Name and mailing address of the ISA/ Swedish Patent Office Box 5055, S-102 42 STOCKHOLM Facsimile No. +46 8 666 02 86		Authorized officer Jan-Axel Ylivainio Telephone No. +46 8 782 25 00

INTERNATIONAL SEARCH REPORT

International application No.  
PCT/SE 97/00727

C (Continuation). DOCUMENTS CONSIDERED TO BE RELEVANT

Category*	Citation of document, with indication, where appropriate, of the relevant passages	Relevant to claim No.
A	WO 8102830 A1 (MATSUSHITA ELECTRIC INDUSTRIAL CO. LTD.), 15 October 1981 (15.10.81), abstract  -----  -----	1

**INTERNATIONAL SEARCH REPORT**  
Information on patent family members

03/06/97

International application No.

PCT/SE 97/00727

Patent document cited in search report			Publication date	Patent family member(s)		Publication date
US	5109566	A	05/05/92	NONE		
US	5341540	A	30/08/94	AU	5839490 A	07/01/91
				CA	2058929 A	08/12/90
				DE	69008530 D	00/00/00
				EP	0476023 A,B	25/03/92
				EP	0584888 A	02/03/94
				FR	2648071 A,B	14/12/90
				FR	2695342 A,B	11/03/94
				JP	5502743 T	13/05/93
				WO	9014788 A	13/12/90
				FR	2656831 A	12/07/91
WO	9526512	A1	05/10/95	AU	2155495 A	17/10/95
				CA	2186223 A	05/10/95
				EP	0753160 A	15/01/97
				SE	502834 C	29/01/96
				SE	9401061 A	30/09/95
EP	0351801	A2	24/01/90	DE	6890525 U	15/04/93
				JP	2034137 A	05/02/90
				JP	8015470 B	21/02/96
				US	4977640 A	18/12/90
WO	8102830	A1	15/10/81	AU	528500 B	28/04/83
				AU	6925081 A	26/10/81
				DE	3142247 T	15/04/82
				GB	2086217 A,B	12/05/82
				JP	1490736 C	07/04/89
				JP	56139727 A	31/10/81
				JP	62019168 B	27/04/87
				US	4446595 A	08/05/84

06-13-02

Under the Paperwork Reduction Act of 1995, no persons are required to respond to a collection of information unless it displays a valid OMB control number.

# UTILITY PATENT APPLICATION TRANSMITTAL

Attorney Docket No.	DP-5 US
First Inventor	JONES
Title	Multi-Mode Coverage for an Autonomous
Express Mail Label No.	EU002256851 US

(Only for new nonprovisional applications under 37 CFR 1.53(b))

PTO  
 10/16/02  
 06/12/02

## APPLICATION ELEMENTS

See MPEP chapter 600 concerning utility patent application contents.

**ADDRESS TO:** Assistant Commissioner for Patents  
Box Patent Application  
Washington, DC 20231

- Fee Transmittal Form (e.g., PTO/SB/17)  
*(Submit an original and a duplicate for fee processing)*
- Applicant claims small entity status.  
See 37 CFR 1.27.
- Specification [Total Pages  ]  
*(preferred arrangement set forth below)*
  - Descriptive title of the invention
  - Cross Reference to Related Applications
  - Statement Regarding Fed sponsored R & D
  - Reference to sequence listing, a table, or a computer program listing appendix
  - Background of the Invention
  - Brief Summary of the Invention
  - Brief Description of the Drawings (if filed)
  - Detailed Description
  - Claim(s)
  - Abstract of the Disclosure
- Drawing(s) (35 U.S.C. 113) [ Total Sheets  ]
- Oath or Declaration [ Total Pages  ]
  - Newly executed (original or copy)
  - Copy from a prior application (37 CFR 1.63 (d))  
*(for continuation/divisional with Box 18 completed)*
  - DELETION OF INVENTOR(S)**  
Signed statement attached deleting inventor(s) named in the prior application, see 37 CFR 1.63(d)(2) and 1.33(b).
- Application Data Sheet. See 37 CFR 1.76

- CD-ROM or CD-R in duplicate, large table or Computer Program (*Appendix*)
- Nucleotide and/or Amino Acid Sequence Submission (if applicable, all necessary)
  - Computer Readable Form (CRF)
  - Specification Sequence Listing on:
    - CD-ROM or CD-R (2 copies); or
    - paper
  - Statements verifying identity of above copies

## ACCOMPANYING APPLICATION PARTS

- Assignment Papers (cover sheet & document(s))
- 37 CFR 3.73(b) Statement (when there is an assignee)  Power of Attorney
- English Translation Document (if applicable)
- Information Disclosure Statement (IDS)/PTO-1449  Copies of IDS Citations
- Preliminary Amendment
- Return Receipt Postcard (MPEP 503)  
*(Should be specifically itemized)*
- Certified Copy of Priority Document(s)  
*(if foreign priority is claimed)*
- Nonpublication Request under 35 U.S.C. 122 (b)(2)(B)(i). Applicant must attach form PTO/SB/35 or its equivalent.
- Other: .....

18.  CONTINUING APPLICATION, check appropriate box, and supply the requisite information below and in a preliminary amendment, or in an Application Data Sheet under 37 CFR 1.76:

Continuation     Divisional     Continuation-in-part (CIP)    of prior application No.: \_\_\_\_\_ / \_\_\_\_\_

Prior application information:    Examiner: \_\_\_\_\_    Group Art Unit: \_\_\_\_\_

**For CONTINUATION OR DIVISIONAL APPS only: The entire disclosure of the prior application, from which an oath or declaration is supplied under Box 5b, is considered a part of the disclosure of the accompanying continuation or divisional application and is hereby incorporated by reference. The incorporation can only be relied upon when a portion has been inadvertently omitted from the submitted application parts.**

## 19. CORRESPONDENCE ADDRESS

Customer Number or Bar Code Label        or     Correspondence address below  
*(Insert Customer No. or Attach bar code label here)*

Name			
Address			
City	State	Zip Code	
Country	Telephone	Fax	

Name (Print/Type)	Glen D. Weinstein	Registration No. (Attorney/Agent)	43,981
Signature		Date	06/12/2002

3951 U.S. PTO

Under the Paperwork Reduction Act of 1995, no persons are required to respond to a collection of information unless it displays a valid OMB control number.

# FEE TRANSMITTAL for FY 2002

Patent fees are subject to annual revision.

### Complete if Known

Application Number	
Filing Date	
First Named Inventor	Jones
Examiner Name	
Group Art Unit	
Attorney Docket No.	DP-5 US

TOTAL AMOUNT OF PAYMENT (\$) 559.00

### METHOD OF PAYMENT

1.  The Commissioner is hereby authorized to charge indicated fees and credit any overpayments to:

Deposit Account Number: 501806  
Deposit Account Name: iRobot Corporation

Charge Any Additional Fee Required Under 37 CFR 1.16 and 1.17

Applicant claims small entity status. See 37 CFR 1.27

2.  Payment Enclosed:

Check  Credit card  Money Order  Other

### FEE CALCULATION

#### 1. BASIC FILING FEE

Large Entity Code	Large Entity Fee (\$)	Small Entity Code	Small Entity Fee (\$)	Fee Description	Fee Paid
101	740	201	370	Utility filing fee	370.00
106	330	206	165	Design filing fee	
107	510	207	255	Plant filing fee	
108	740	208	370	Reissue filing fee	
114	160	214	80	Provisional filing fee	
<b>SUBTOTAL (1)</b>					<b>(\$) 370.00</b>

#### 2. EXTRA CLAIM FEES

Total Claims: 41  
Independent Claims: 3  
Multiple Dependent:

Extra Claims: 21  
Fee from below: 9.00  
Fee Paid: 189.00

Large Entity Code	Large Entity Fee (\$)	Small Entity Code	Small Entity Fee (\$)	Fee Description
103	18	203	9	Claims in excess of 20
102	84	202	42	Independent claims in excess of 3
104	280	204	140	Multiple dependent claim, if not paid
109	84	209	42	** Reissue independent claims over original patent
110	18	210	9	** Reissue claims in excess of 20 and over original patent

SUBTOTAL (2) (\$) 189.00

\*\*or number previously paid, if greater; For Reissues, see above

### FEE CALCULATION (continued)

#### 3. ADDITIONAL FEES

Fee Code	Large Entity Fee (\$)	Small Entity Fee Code	Small Entity Fee (\$)	Fee Description	Fee Paid
105	130	205	65	Surcharge - late filing fee or oath	
127	50	227	25	Surcharge - late provisional filing fee or cover sheet	
139	130	139	130	Non-English specification	
147	2,520	147	2,520	For filing a request for <i>ex parte</i> reexamination	
112	920*	112	920*	Requesting publication of SIR prior to Examiner action	
113	1,840*	113	1,840*	Requesting publication of SIR after Examiner action	
115	110	215	55	Extension for reply within first month	
116	400	216	200	Extension for reply within second month	
117	920	217	460	Extension for reply within third month	
118	1,440	218	720	Extension for reply within fourth month	
128	1,960	228	980	Extension for reply within fifth month	
119	320	219	160	Notice of Appeal	
120	320	220	160	Filing a brief in support of an appeal	
121	280	221	140	Request for oral hearing	
138	1,510	138	1,510	Petition to institute a public use proceeding	
140	110	240	55	Petition to revive - unavoidable	
141	1,280	241	640	Petition to revive - unintentional	
142	1,280	242	640	Utility issue fee (or reissue)	
143	460	243	230	Design issue fee	
144	620	244	310	Plant issue fee	
122	130	122	130	Petitions to the Commissioner	
123	50	123	50	Processing fee under 37 CFR 1.17(q)	
126	180	126	180	Submission of Information Disclosure Stmt	
581	40	581	40	Recording each patent assignment per property (times number of properties)	
146	740	246	370	Filing a submission after final rejection (37 CFR § 1.129(a))	
149	740	249	370	For each additional invention to be examined (37 CFR § 1.129(b))	
179	740	279	370	Request for Continued Examination (RCE)	
169	900	169	900	Request for expedited examination of a design application	

Other fee (specify) \_\_\_\_\_

\*Reduced by Basic Filing Fee Paid

SUBTOTAL (3) (\$)

### SUBMITTED BY

Name (Print/Type): Glen D. Weinstein  
Registration No. (Attorney/Agent): 43,981  
Telephone: 617.629.0055  
Signature:   
Date: 06/12/2002

**WARNING: Information on this form may become public. Credit card information should not be included on this form. Provide credit card information and authorization on PTO-2038.**

Burden Hour Statement: This form is estimated to take 0.2 hours to complete. Time will vary depending upon the needs of the individual case. Any comments on the amount of time you are required to complete this form should be sent to the Chief Information Officer, U.S. Patent and Trademark Office, Washington, DC 20231. DO NOT SEND FEES OR COMPLETED FORMS TO THIS ADDRESS. SEND TO: Assistant Commissioner for Patents, Washington, DC 20231.

Patent Application of  
Joseph L. Jones & Philip R. Mass  
for

**METHOD AND SYSTEM FOR MULTI-MODE COVERAGE  
FOR AN AUTONOMOUS ROBOT**

5 This application is entitled to the benefit of United  
States Provisional Application Ser. No. 60/297,718 filed June  
12, 2001.

10 FIELD OF THE INVENTION

This invention relates generally to autonomous vehicles  
or robots, and more specifically to methods and mobile  
robotic devices for covering a specific area as might be  
15 required of, or used as, robotic cleaners or lawn mowers.

DESCRIPTION OF PRIOR ART

For purposes of this description, examples will focus on  
the problems faced in the prior art as related to robotic  
20 cleaning (e.g., dusting, buffing, sweeping, scrubbing, dry  
mopping or vacuuming). The claimed invention, however, is  
limited only by the claims themselves, and one of skill in  
the art will recognize the myriad of uses for the present  
invention beyond indoor, domestic cleaning.

25 Robotic engineers have long worked on developing an  
effective method of autonomous cleaning. By way of



introduction, the performance of cleaning robots should concentrate on three measures of success: coverage, cleaning rate and perceived effectiveness. Coverage is the percentage of the available space visited by the robot during a fixed  
5 cleaning time, and ideally, a robot cleaner would provide 100 percent coverage given an infinite run time. Unfortunately, designs in the prior art often leave portions of the area uncovered regardless of the amount of time the device is allowed to complete its tasks. Failure to achieve complete  
10 coverage can result from mechanical limitations -- e.g., the size and shape of the robot may prevent it from reaching certain areas -- or the robot may become trapped, unable to vary its control to escape. Failure to achieve complete coverage can also result from an inadequate coverage  
15 algorithm. The coverage algorithm is the set of instructions used by the robot to control its movement. For the purposes of the present invention, coverage is discussed as a percentage of the available area visited by the robot during a finite cleaning time. Due to mechanical and/or algorithmic  
20 limitations, certain areas within the available space may be systematically neglected. Such systematic neglect is a significant limitation in the prior art.

A second measure of a cleaning robot's performance is the cleaning rate given in units of area cleaned per unit  
25 time. Cleaning rate refers to the rate at which the area of cleaned floor increases; coverage rate refers to the rate at

which the robot covers the floor regardless of whether the floor was previously clean or dirty. If the velocity of the robot is  $v$  and the width of the robot's cleaning mechanism (also called work width) is  $w$  then the robot's coverage rate is simply  $wv$ , but its cleaning rate may be drastically lower.

A robot that moves in a purely random fashion in a closed environment has a cleaning rate that decreases relative to the robot's coverage rate as a function of time. This is because the longer the robot operates the more likely it is to revisit already cleaned areas. The optimal design has a cleaning rate equivalent to the coverage rate, thus minimizing unnecessary repeated cleanings of the same spot. In other words, the ratio of cleaning rate to coverage rate is a measure of efficiency and an optimal cleaning rate would mean coverage of the greatest percentage of the designated area with the minimum number of cumulative or redundant passes over an area already cleaned.

A third metric of cleaning robot performance is the perceived effectiveness of the robot. This measure is ignored in the prior art. Deliberate movement and certain patterned movement is favored as users will perceive a robot that contains deliberate movement as more effective.

While coverage, cleaning rate and perceived effectiveness are the performance criteria discussed herein, a preferred embodiment of the present invention also takes into account the ease of use in rooms of a variety of shapes

and sizes (containing a variety of unknown obstacles) and the cost of the robotic components. Other design criteria may also influence the design, for example the need for collision avoidance and appropriate response to other hazards.

5 As described in detail in Jones, Flynn & Seiger, Mobile Robots: Inspiration to Implementation second edition, 1999, A K Peters, Ltd., and elsewhere, numerous attempts have been made to build vacuuming and cleaning robots. Each of these robots has faced a similar challenge: how to efficiently  
10 cover the designated area given limited energy reserves.

We refer to maximally efficient cleaning, where the cleaning rate equals the coverage rate, as deterministic cleaning. As shown in FIG. 1A, a robot 1 following a deterministic path moves in such a way as to completely cover  
15 the area 2 while avoiding all redundant cleaning.

Deterministic cleaning requires that the robot know both where it is and where it has been; this in turn requires a positioning system. Such a positioning system - a positioning system suitably accurate to enable deterministic  
20 cleaning might rely on scanning laser rangefinders, ultrasonic transducers, carrier phase differential GPS, or other methods - can be prohibitively expensive and involve user set-up specific to the particular room geometries. Also, methods that rely on global positioning are typically incapacitated  
25 by the failure of any part of the positioning system.

ABSTRACT

One example of using highly sophisticated (and expensive) sensor technologies to create deterministic cleaning is the RoboScrub device built by Denning Mobile Robotics and Windsor Industries, which used sonar, infrared detectors, bump sensors and high-precision laser navigation. RoboScrub's navigation system required attaching large bar code targets at various positions in the room. The requirement that RoboScrub be able to see at least four targets simultaneously was a significant operational problem. RoboScrub, therefore, was limited to cleaning large open areas.

Another example, RoboKent, a robot built by the Kent Corporation, follows a global positioning strategy similar to RobotScrub. RoboKent dispenses with RobotScrub's more expensive laser positioning system but having done so RoboKent must restrict itself only to areas with a simple rectangular geometry, e.g. long hallways. In these more constrained regions, position correction by sonar ranging measurements is sufficient. Other deterministic cleaning systems are described, for example, in U.S. Patent Nos. 4,119,900 (Kremnitz), 4,700,427 (Knepper), 5,353,224 (Lee et al.), 5,537,017 (Feiten et al.), 5,548,511 (Bancroft), 5,650,702 (Azumi).

Because of the limitations and difficulties of deterministic cleaning, some robots have relied on pseudo-deterministic schemes. One method of providing pseudo-

deterministic cleaning is an autonomous navigation method known as dead reckoning. Dead reckoning consists of measuring the precise rotation of each robot drive wheel (using for example optical shaft encoders). The robot can

5

then calculate its expected position in the environment given a known starting point and orientation. One problem with this technique is wheel slippage. If slippage occurs, the encoder on that wheel registers a wheel rotation even though that wheel is not driving the robot relative to the ground.

10

As shown in FIG. 1B, as the robot 1 navigates about the room, these drive wheel slippage errors accumulate making this type of system unreliable for runs of any substantial duration. (The path no longer consists of tightly packed rows, as compared to the deterministic coverage shown in FIG. 1A.)

15

The result of reliance on dead reckoning is intractable systematic neglect; in other words, areas of the floor are not cleaned.

20

One example of a pseudo-deterministic a system is the Cyre robot from Probotics, Inc. Cyre depends exclusively on dead reckoning and therefore takes heroic measures to maximize the performance of its dead reckoning system. Cyre must begin at a user-installed physical registration spot in a known location where the robot fixes its position and orientation. Cyre then keeps track of position as it moves

25

away from that spot. As Cyre moves, uncertainty in its position and orientation increase. Cyre must make certain to

return to a calibration spot before this error grows so large that it will be unlikely to locate a calibration spot. If a calibration spot is moved or blocked or if excessive wheel slippage occurs then Cye can become lost (possibly without realizing that it is lost). Thus Cye is suitable for use only in relatively small benign environments. Other examples of this approach are disclosed in U.S. Patent Nos. 5,109,566 (Kobayashi et al.) and 6,255,793 (Peless et al.).

Another approach to robotic cleaning is purely random motion. As shown in FIG. 1C, in a typical room without obstacles, a random movement algorithm will provide acceptable coverage given significant cleaning time. Compared to a robot with a deterministic algorithm, a random cleaning robot must operate for a longer time to achieve acceptable coverage. To have high confidence that the random-motion robot has cleaned 98% of an obstacle-free room, the random motion robot must run approximately five times as long as a deterministic robot with the same cleaning mechanism moving at the same speed.

The coverage limitations of a random algorithm can be seen in FIG. 1D. An obstacle in the room can create the effect of segmenting the room into a collection of chambers. The coverage over time of a random algorithm robot in such a room is analogous to the time density of gas released in one chamber of a confined volume. Initially, the density of gas is highest in the chamber where it is released and lowest in

more distant chambers. Similarly the robot is most likely to thoroughly clean the chamber where it starts, rather than more distant chambers, early in the process. Given enough time a gas reaches equilibrium with equal density in all chambers. Likewise given time, the robot would clean all areas thoroughly. The limitations of practical power supplies, however, usually guarantee that the robot will have insufficient time to clean all areas of a space cluttered with obstacles. We refer to this phenomenon as the robot diffusion problem.

As discussed, the commercially available prior art has not been able to produce an effective coverage algorithm for an area of unknown geometry. As noted above, the prior art either has relied on sophisticated systems of markers or beacons or has limited the utility of the robot to rooms with simple rectangular geometries. Attempts to use pseudo-deterministic control algorithms can leave areas of the space systematically neglected.

#### OBJECTS AND ADVANTAGES

It is an object of the present invention to provide a system and method to allow a mobile robot to operate in a plurality of modes in order to effectively cover an area.

It is an object of the present invention to provide a mobile robot, with at least one sensor, to operate in a

number of modes including spot-coverage, obstacle following and bounce.

It is a further object of the invention to provide a mobile robot that alternates between obstacle following and  
5 bounce mode to ensure coverage.

It is an object of the invention to return to spot-coverage after the robot has traveled a pre-determined distance.

It is an object of the invention to provide a mobile  
10 robot able to track the average distance between obstacles and use the average distance as an input to alternate between operational modes.

It is yet another object of the invention to optimize the distance the robot travels in an obstacle following mode as a function of the frequency of obstacle following and the work width of the robot, and to provide a minimum and maximum  
15 distance for operating in obstacle following mode.

It is an object of a preferred embodiment of the invention to use a control system for a mobile robot with an  
20 operational system program able to run a plurality of behaviors and using an arbiter to select which behavior is given control over the robot.

It is still another object of the invention to incorporate various escape programs or behavior to allow the  
25 robot to avoid becoming stuck.



Finally, it is an object of the invention to provide one or more methods for controlling a mobile robot to benefit from the various objects and advantages disclosed herein.

5

#### BRIEF DESCRIPTION OF THE DRAWINGS

These and further features of the present invention will be apparent with reference to the accompanying drawings, wherein:

10

FIGS. 1A-D illustrate coverage patterns of various robots in the prior art;

FIG. 2 is a top-view schematic representation of the basic components of a mobile robot used in a preferred embodiment of the invention;

15

FIG. 3 demonstrates a hardware block diagram of the robot shown in FIG. 2;

FIG. 4A is a diagram showing a method of determining the angle at which the robot encounters an obstacle; FIG. 4B is a diagram showing the orientation of a preferred embodiment of the robot control system;

20

FIG. 5 is a schematic representation of the operational modes of the instant invention;

25

FIG. 6A is a schematic representation of the coverage pattern for a preferred embodiment of SPIRAL behavior; FIG. 6B is a schematic representation of the coverage pattern for an alternative embodiment of SPIRAL behavior; FIG. 6C is a

schematic representation of the coverage pattern for yet another alternative embodiment of SPIRAL behavior;

FIG. 7 is a flow-chart illustration of the spot-coverage algorithm of a preferred embodiment of the invention;

5 FIGS. 8A & 8B are schematic representations of the coverage pattern for a preferred embodiment of operation in obstacle following mode;

FIG. 9A is a flow-chart illustration of the obstacle following algorithm of a preferred embodiment of the invention; FIG. 9B is a flow-chart illustration of a preferred algorithm for determining when to exit obstacle following mode.

10 FIG. 10 is a schematic representation of the coverage pattern for a preferred embodiment of BOUNCE behavior;

15 FIG. 11 is a flow-chart illustration of the room coverage algorithm of a preferred embodiment of the invention;

FIGS. 12A & 12B are flow-chart illustrations of an exemplary escape behavior;

20 FIG. 13A is a schematic representation of the coverage pattern a mobile robot with only a single operational mode; FIG. 13B is a schematic representation of the coverage pattern for a preferred embodiment of the instant invention using obstacle following and room coverage modes; and

25 FIG. 14 is a schematic representation of the coverage pattern for a preferred embodiment of the instant invention

using spot-coverage, obstacle following and room coverage modes.

#### DESCRIPTION OF INVENTION

5           In the present invention, a mobile robot is designed to provide maximum coverage at an effective coverage rate in a room of unknown geometry. In addition, the perceived effectiveness of the robot is enhanced by the inclusion of patterned or deliberate motion. In addition, in a preferred  
10 embodiment, effective coverage requires a control system able to prevent the robot from becoming immobilized in an unknown environment.

15           While the physical structures of mobile robots are known in the art, the components of a preferred, exemplary embodiment of the present invention is described herein. A preferred embodiment of the present invention is a substantially circular robotic sweeper containing certain features. As shown in FIG. 2, for example, the mobile robot  
20 10 of a preferred embodiment includes a chassis 11 supporting mechanical and electrical components. These components include various sensors, including two bump sensors 12 & 13 located in the forward portion of the robot, four cliff sensors 14 located on the robot shell 15, and a wall  
25 following sensor 16 mounted on the robot shell 15. In other embodiments, as few as one sensor may be used in the robot. One of skill in the art will recognize that the sensor(s) may

be of a variety of types including sonar, tactile, electromagnetic, capacitive, etc. Because of cost restraints, a preferred embodiment of the present invention uses bump (tactile) sensors 12 & 13 and reflective IR proximity sensors for the cliff sensors 14 and the wall-following sensor 16. Details of the IR sensors are described in U.S. Patent Application U.S.S.N. 09/768,773, which disclosure is hereby incorporated by reference.

A preferred embodiment of the robot also contains two wheels 20, motors 21 for driving the wheels independently, an inexpensive low-end microcontroller 22, and a rechargeable battery 23 or other power source known in the art. These components are well known in the art and are not discussed in detail herein. The robotic cleaning device 10 further includes one or more cleaning heads 30. The cleaning head might contain a vacuum cleaner, various brushes, sponges, mops, electrostatic cloths or a combination of various cleaning elements. The embodiment shown in FIG. 2 also includes a side brush 32.

As mentioned above, a preferred embodiment of the robotic cleaning device 10 comprises an outer shell 15 defining a dominant side, non-dominant side, and a front portion of the robot 10. The dominant side of the robot is the side that is kept near or in contact with an object (or obstacle) when the robot cleans the area adjacent to that object (or obstacle). In a preferred embodiment, as shown in

FIG. 1, the dominant side of the robot 10 is the right-hand side relative to the primary direction of travel, although in other embodiments the dominant side may be the left-hand side. In still other embodiments, the robot may be symmetric and thereby does not need a dominant side; however, in a preferred embodiment, a dominant side is chosen for reasons of cost. The primary direction of travel is as shown in FIG. 2 by arrow 40.

In a preferred embodiment, two bump sensors 12 & 13 are located forward of the wheels 20 relative to the direction of forward movement, shown by arrow 40. One bump sensor 13 is located on the dominant side of the robot 10 and the other bump sensor 12 is located on the non-dominant side of the robot 10. When both of these bump sensors 12 & 13 are activated simultaneously, the robot 10 recognizes an obstacle in the front position. In other embodiments, more or fewer individual bump sensors can be used. Likewise, any number of bump sensors can be used to divide the device into any number of radial segments. While in a preferred embodiment the bump sensors 12 & 13 are IR break beam sensors activated by contact between the robot 10 and an obstacle, other types of sensors can be used, including mechanical switches and capacitive sensors that detect the capacitance of objects touching the robot or between two metal plates in the bumper that are compressed on contact. Non-contact sensors, which allow the robot to sense proximity to objects without

physically touching the object, such as capacitive sensors or a curtain of IR light, can also be used.

It is useful to have a sensor or sensors that are not only able to tell if a surface has been contacted (or is nearby), but also the angle relative to the robot at which the contact was made. In the case of a preferred embodiment, the robot is able to calculate the time between the activation of the right and left bump switches 12 & 13, if both are activated. The robot is then able to estimate the angle at which contact was made. In a preferred embodiment shown in FIG. 4A, the bump sensor comprises a single mechanical bumper 44 at the front of the robot with sensors 42 & 43 substantially at the two ends of the bumper that sense the movement of the bumper. When the bumper is compressed, the timing between the sensor events is used to calculate the approximate angle at which the robot contacted the obstacle. When the bumper is compressed from the right side, the right bump sensor detects the bump first, followed by the left bump sensor, due to the compliance of the bumper and the bump detector geometry. This way, the bump angle can be approximated with only two bump sensors.

For example, in FIG. 4A, bump sensors 42 & 43 are able to divide the forward portion of the robot into six regions (I-VI). When a bump sensor is activated, the robot calculates the time before the other sensor is activated (if

at all). For example, when the right bump sensor 43 is activated, the robot measures the time ( $t$ ) before the left bump sensor 42 is activated. If  $t$  is less than  $t_1$ , then the robot assumes contact occurred in region IV. If  $t$  is greater than or equal to  $t_1$  and less than  $t_2$ , then the robot assumes contact was made in region V. If  $t$  is greater than or equal to  $t_2$  (including the case of where the left bump sensor 42 is not activated at all within the time monitored), then the robot assumes the contact occurred in region VI. If the bump sensors are activated simultaneously, the robot assumes the contact was made from straight ahead. This method can be used to divide the bumper into an arbitrarily large number of regions (for greater precision) depending on the timing used and geometry of the bumper. As an extension, three sensors can be used to calculate the bump angle in three dimensions instead of just two dimensions as in the preceding example.

A preferred embodiment also contains a wall-following or wall-detecting sensor 16 mounted on the dominant side of the robot 10. In a preferred embodiment, the wall following sensor is an IR sensor composed of an emitter and detector pair collimated so that a finite volume of intersection occurs at the expected position of the wall. This focus point is approximately three inches ahead of the drive wheel

in the direction of robot forward motion. The radial range of wall detection is about 0.75 inches.

A preferred embodiment also contains any number of IR cliff sensors 14 that prevent the device from tumbling over stairs or other vertical drops. These cliff sensors are of a construction similar to that of the wall following sensor but directed to observe the floor rather than a wall. As an additional safety and sensing measure, the robot 10 includes a wheel-drop sensor that is able to detect if one or more wheels is unsupported by the floor. This wheel-drop sensor can therefore detect not only cliffs but also various obstacles upon which the robot is able to drive, such as lamps bases, high floor transitions, piles of cords, etc.

Other embodiments may use other known sensors or combinations of sensors.

FIG. 3 shows a hardware block diagram of the controller and robot of a preferred embodiment of the invention. In a preferred embodiment, a Winbond W78XXX series processor is used. It is a microcontroller compatible with the MCS-51 family with 36 general purpose I/O ports, 256 bytes of RAM and 16K of ROM. It is clocked at 40MHz which is divided down for a processor speed of 3.3 MHz. It has two timers which are used for triggering interrupts used to process sensors and generate output signals as well as a watchdog timer. The lowest bits of the fast timer are also used as approximate random numbers where needed in the behaviors. There are also



two external interrupts which are used to capture the encoder inputs from the two drive wheels. The processor also has a UART which is used for testing and debugging the robot control program.

5 The I/O ports of the microprocessor are connected to the sensors and motors of the robot and are the interface connecting it to the internal state of the robot and its environment. For example, the wheel drop sensors are connected to an input port and the brush motor PWM signal is generated on an output port. The ROM on the microprocessor is used to store the coverage and control program for the robot. This includes the behaviors (discussed below), sensor processing algorithms and signal generation. The RAM is used to store the active state of the robot, such as the average bump distance, run time and distance, and the ID of the behavior in control and its current motor commands.

10 For purposes of understanding the movement of the robotic device, FIG. 4B shows the orientation of the robot 10 centered about the x and y axes in a coordinate plane; this coordinate system is attached to the robot. The directional movement of the robot 10 can be understood to be the radius at which the robot 10 will move. In order to rapidly turn away from the wall 100, the robot 10 should set a positive, small value of  $r$  ( $r_3$  in FIG. 4B); in order to rapidly turn toward the wall, the robot should set a negative, small value of  $r$  ( $r_1$  in FIG. 4B). On the other hand, to make slight

turns, the robot should set larger absolute values for  $r$  - positive values to move left (i.e. away from the wall,  $r_1$  in FIG. 4B) and negative values to move right (i.e. toward the wall,  $r_2$  in FIG. 4B). This coordinate scheme is used in the examples of control discussed below. The microcontroller 22 controlling differential speed at which the individual wheel motors 21 are run, determines the turning radius.

Also, in certain embodiments, the robot may include one or more user inputs. For example, as shown in FIG. 2, a preferred embodiment includes three simple buttons 33 that allow the user to input the approximate size of the surface to be covered. In a preferred embodiment, these buttons labeled "small," "medium," and "large" correspond respectively to rooms of 11.1, 20.8 and 27.9 square meters.

As mentioned above, the exemplary robot is a preferred embodiment for practicing the instant invention, and one of skill in the art is able to choose from elements known in the art to design a robot for a particular purpose. Examples of suitable designs include those described in the following U.S. Patents Nos: 4,306,329 (Yokoi), 5,109,566 (Kobayashi et al.), 5,293,955 (Lee), 5,369,347 (Yoo), 5,440,216 (Kim), 5,534,762 (Kim), 5,613,261 (Kawakami et al), 5,634,237 (Paranjpe), 5,781,960 (Kilstrom et al.), 5,787,545 (Colens), 5,815,880 (Nakanishi), 5,839,156 (Park et al.), 5,926,909 (McGee), 6,038,501 (Kawakami), 6,076,226 (Reed), all of which are hereby incorporated by reference.

FIG. 5 shows a simple block representation of the various operational modes of a device. In a preferred embodiment, and by way of example only, operational modes may include spot cleaning (where the user or robot designates a specific region for cleaning), edge cleaning, and room cleaning. Each operational mode comprises complex combinations of instructions and/or internal behaviors, discussed below. These complexities, however, are generally hidden from the user. In one embodiment, the user can select the particular operational mode by using an input element, for example, a selector switch or push button. In other preferred embodiments, as described below, the robot is able to autonomously cycle through the operational modes.

The coverage robot of the instant invention uses these various operational modes to effectively cover the area. While one of skill in the art may implement these various operational modes in a variety of known architectures, a preferred embodiment relies on behavior control. Here, behaviors are simply layers of control systems that all run in parallel. The microcontroller 22 then runs a prioritized arbitration scheme to resolve the dominant behavior for a given scenario. A description of behavior control can be found in Mobile Robots, supra, the text of which is hereby incorporated by reference.

In other words, in a preferred embodiment, the robot's microprocessor and control software run a number of behaviors

simultaneously. Depending on the situation, control of the robot will be given to one or more various behaviors. For purposes of detailing the preferred operation of the present invention, the behaviors will be described as (1) coverage behaviors, (2) escape behaviors or (3) user/safety behaviors. Coverage behaviors are primarily designed to allow the robot to perform its coverage operation in an efficient manner. Escape behaviors are special behaviors that are given priority when one or more sensor inputs suggest that the robot may not be operating freely. As a convention for this specification, behaviors discussed below are written in all capital letters.

1. Coverage Behaviors

FIGS. 6-14 show the details of each of the preferred operational modes: Spot Coverage, Wall Follow (or Obstacle Follow) and Room Coverage.

Operational Mode: Spot Coverage

Spot coverage or, for example, spot cleaning allows the user to clean an isolated dirty area. The user places the robot on the floor near the center of the area that requires cleaning and selects the spot-cleaning operational mode. The robot then moves in such a way that the immediate area within, for example, a defined radius, is brought into contact with the cleaning head or side brush of the robot.

In a preferred embodiment, the method of achieving spot  
 cleaning is a control algorithm providing outward spiral  
 movement, or SPIRAL behavior, as shown in FIG. 6A. In  
 general, spiral movement is generated by increasing the  
 5 turning radius as a function of time. In a preferred  
 embodiment, the robot 10 begins its spiral in a counter-  
 clockwise direction, marked in FIG. 6A by movement line 45,  
 in order to keep the dominant side on the outward, leading-  
 edge of the spiral. In another embodiment, shown in FIG. 6B,  
 10 spiral movement of the robot 10 is generated inward such that  
 the radius of the turns continues to decrease. The inward  
 spiral is shown as movement line 45 in FIG. 6B. It is not  
 necessary, however, to keep the dominant side of the robot on  
 the outside during spiral motion.

15 The method of spot cleaning used in a preferred  
 embodiment - outward spiraling - is set forth in FIG. 7.  
 Once the spiraling is initiated (step 201) and the value of  $r$   
 is set at its minimum, positive value (which will produce the  
 tightest possible counterclockwise turn), the spiraling  
 20 behavior recalculates the value of  $r$  as a function of  $\theta$ ,  
 where  $\theta$  represents the angular turning since the initiation  
 of the spiraling behavior (step 210). By using the equation  $r$   
 $= a\theta$ , where  $a$  is a constant coefficient, the tightness or  
 desired overlap of the spiral can be controlled. (Note that  
 25  $\theta$  is not normalized to  $2\pi$ ). The value of  $a$  can be chosen by

the equation  $a = \frac{d}{2\pi}$  ; where d is the distance between two consecutive passes of the spiral. For effective cleaning, a value for d should be chosen that is less than the width of the cleaning mechanism 30. In a preferred embodiment, a value of d is selected that is between one-half and two-thirds of the width of the cleaning head 30.

In other embodiments, the robot tracks its total distance traveled in spiral mode. Because the spiral will deteriorate after some distance, i.e. the centerpoint of the spiral motion will tend to drift over time due to surface dependant wheel slippage and/or inaccuracies in the spiral approximation algorithm and calculation precision. In certain embodiments, the robot may exit spiral mode after the robot has traveled a specific distance ("maximum spiral distance"), such as 6.3 or 18.5 meters (step 240). In a preferred embodiment, the robot uses multiple maximum spiral distances depending on whether the robot is performing an initial spiral or a later spiral. If the maximum spiral distance is reached without a bump, the robot gives control to a different behavior, and the robot, for example, then continues to move in a predominately straight line. (In a preferred embodiment, a STRAIGHT LINE behavior is a low priority, default behavior that propels the robot in an approximate straight line at a preset velocity of approximately 0.306 m/s when no other behaviors are active.

In spiral mode, various actions can be taken when an obstacle is encountered. For example, the robot could (a) seek to avoid the obstacle and continue the spiral in the counter-clockwise direction, (b) seek to avoid the obstacle and continue the spiral in the opposite direction (e.g. changing from counter-clockwise to clockwise), or (c) change operational modes. Continuing the spiral in the opposite direction is known as reflective spiraling and is represented in FIG. 6C, where the robot 10 reverses its movement path when it comes into contact with obstacle 101. In a preferred embodiment, as detailed in step 220, the robot 10 exits spot cleaning mode upon the first obstacle encountered by a bump sensor 12 or 13.

While a preferred embodiment describes a spiral motion for spot coverage, any self-bounded area can be used, including but not limited to regular polygon shapes such as squares, hexagons, ellipses, etc.

Operational Mode: Wall/Obstacle Following

Wall following or, in the case of a cleaning robot, edge cleaning, allows the user to clean only the edges of a room or the edges of objects within a room. The user places the robot 10 on the floor near an edge to be cleaned and selects the edge-cleaning operational mode. The robot 10 then moves in such a way that it follows the edge and cleans all areas brought into contact with the cleaning head 30 of the robot.

The movement of the robot 10 in a room 110 is shown in FIG. 8. In FIG. 8A, the robot 10 is placed along with wall 100, with the robot's dominant side next to the wall. The robot then runs along the wall indefinitely following movement path 46. Similarly, in FIG. 8B, the robot 10 is placed in the proximity of an obstacle 101. The robot then follows the edge of the obstacle 101 indefinitely following movement path 47.

In a preferred embodiment, in the wall-following mode, the robot uses the wall-following sensor 16 to position itself a set distance from the wall. The robot then proceeds to travel along the perimeter of the wall. As shown in FIGS. 8A & 8B, in a preferred embodiment, the robot 10 is not able to distinguish between a wall 100 and another solid obstacle 101.

The method used in a preferred embodiment for following the wall is detailed in FIG. 9A and provides a smooth wall following operation even with a one-bit sensor. (Here the one-bit sensor detects only the presence or absence of the wall within a particular volume rather than the distance between wall and sensor.) Other methods of detecting a wall or object can be used such as bump sensing or sonar sensors.

Once the wall-following operational mode, or WALL FOLLOWING behavior of a preferred embodiment, is initiated (step 301), the robot first sets its initial value for the steering at  $r_0$ . The WALL-FOLLOWING behavior then initiates



the emit-detect routine in the wall-follower sensor 16 (step 310). The existence of a reflection for the IR transmitter portion of the sensor 16 translates into the existence of an object within a predetermined distance from the sensor 16.

5 The WALL-FOLLOWING behavior then determines whether there has been a transition from a reflection (object within range) to a non-reflection (object outside of range) (step 320). If there has been a transition (in other words, the wall is now out of range), the value of  $r$  is set to its most negative  
10 value and the robot will veer slightly to the right (step 325). The robot then begins the emit-detect sequence again (step 310). If there has not been a transition from a reflection to a non-reflection, the wall-following behavior then determines whether there has been a transition from non-  
15 reflection to reflection (step 330). If there has been such a transition, the value of  $r$  is set to its most positive value and the robot will veer slightly left (step 335).

In the absence of either type of transition event, the wall-following behavior reduces the absolute value of  $r$  (step  
20 340) and begins the emit-detect sequence (step 310) anew. By decreasing the absolute value of  $r$ , the robot 10 begins to turn more sharply in whatever direction it is currently heading. In a preferred embodiment, the rate of decreasing the absolute value of  $r$  is a constant rate dependant on the  
25 distance traveled.

The wall follower mode can be continued for a predetermined or random time, a predetermined or random distance or until some additional criteria are met (e.g. bump sensor is activated, etc.). In one embodiment, the robot continues to follow the wall indefinitely. In a preferred embodiment, as shown in FIGS. 8C & 8D, minimum and maximum travel distances are determined, whereby the robot will remain in WALL-FOLLOWING behavior until the robot has either traveled the maximum distance (FIG. 8D) or traveled at least the minimum distance and encountered an obstacle (FIG. 8C). This implementation of WALL-FOLLOWING behavior ensures the robot spends an appropriate amount of time in WALL-FOLLOWING behavior as compared to its other operational modes, thereby decreasing systemic neglect and distributing coverage to all areas. By increasing wall following, the robot is able to move in more spaces, but the robot is less efficient at cleaning any one space. In addition, by tending to exit WALL-FOLLOWING behavior after obstacle detection, the robot increases its perceived effectiveness.

FIG. 9B is a flow-chart illustration showing this embodiment of determining when to exit WALL-FOLLOWING behavior. The robot first determines the minimum distance to follow the wall ( $d_{min}$ ) and the maximum distance to follow the wall ( $d_{max}$ ). While in wall (or obstacle) following mode, the control system tracks the distance the robot has traveled in that mode ( $d_{WF}$ ). If  $d_{WF}$  is greater than  $d_{max}$  (step 350), then the

robot exits wall-following mode (step 380). If, however,  $d_{WF}$  is less than  $d_{max}$  (step 350) and  $d_{WF}$  is less than  $d_{min}$  (step 360), the robot remains in wall-following mode (step 385). If  $d_{WF}$  is greater than  $d_{min}$  (step 360) and an obstacle is encountered (step 370), the robot exits wall-following mode (step 380).

Theoretically, the optimal distance for the robot to travel in WALL-FOLLOWING behavior is a function of room size and configuration and robot size. In a preferred embodiment, the minimum and maximum distances to remain in WALL-FOLLOWING are set based upon the approximate room size, the robots width and a random component, where by the average minimum travel distance is  $2w/p$ , where  $w$  is the width of the work element of the robot and  $p$  is the probability that the robot will enter WALL-FOLLOWING behavior in a given interaction with an obstacle. By way of example, in a preferred embodiment,  $w$  is approximately between 15 cm and 25 cm, and  $p$  is 0.095 (where the robot encounters 6 to 15 obstacles, or an average of 10.5 obstacles, before entering an obstacle following mode). The minimum distance is then set randomly as a distance between approximately 115 cm and 350 cm; the maximum distance is then set randomly as a distance between approximately 170 cm and 520 cm. In certain embodiments the ratio between the minimum distance to the maximum distance is 2:3. For the sake of perceived efficiency, the robot's initial operation in a obstacle following mode can be set to be longer than its later operations in obstacle following

mode. In addition, users may place the robot along the longest wall when starting the robot, which improves actual as well as perceived coverage.

The distance that the robot travels in wall following mode can also be set by the robot depending on the number and frequency of objects encountered (as determined by other sensors), which is a measure of room "clutter." If more objects are encountered, the robot would wall follow for a greater distance in order to get into all the areas of the floor. Conversely, if few obstacles are encountered, the robot would wall follow less in order to not over-cover the edges of the space in favor of passes through the center of the space. An initial wall-following distance can also be included to allow the robot to follow the wall a longer or shorter distance during its initial period where the WALL-FOLLOWING behavior has control.

In a preferred embodiment, the robot may also leave wall-following mode if the robot turns more than, for example, 270 degrees and is unable to locate the wall (or object) or if the robot has turned a total of 360 degrees since entering wall-following mode.

In certain embodiments, when the WALL-FOLLOWING behavior is active and there is a bump, the ALIGN behavior becomes active. The ALIGN behavior turns the robot counter-clockwise to align the robot with the wall. The robot always turns a minimum angle to avoid getting the robot getting into cycles

of many small turns. After it has turned through its minimum angle, the robot monitors its wall sensor and if it detects a wall and then the wall detection goes away, the robot stops turning. This is because at the end of the wall follower  
5 range, the robot is well aligned to start WALL-FOLLOWING. If the robot has not seen its wall detector go on and then off by the time it reaches its maximum angle, it stops anyway. This prevents the robot from turning around in circles when the wall is out of range of its wall sensor. When the most  
10 recent bump is within the side 60 degrees of the bumper on the dominant side, the minimum angle is set to 14 degrees and the maximum angle is 19 degrees. Otherwise, if the bump is within 30 degrees of the front of the bumper on the dominant side or on the non-dominant side, the minimum angle is 20  
15 degrees and the maximum angle is 44 degrees. When the ALIGN behavior has completed turning, it cedes control to the WALL-FOLLOWING behavior

Operational Mode: Room Coverage

The third operational mode is here called room-coverage  
20 or room cleaning mode, which allows the user to clean any area bounded by walls, stairs, obstacles or other barriers. To exercise this option, the user places the robot on the floor and selects room-cleaning mode. The robot then moves about the room cleaning all areas that it is able to reach.

25 In a preferred embodiment, the method of performing the room cleaning behavior is a BOUNCE behavior in combination

with the STRAIGHT LINE behavior. As shown in FIG. 10, the robot 10 travels until a bump sensor 12 and/or 13 is activated by contact with an obstacle 101 or a wall 100. The robot 10 then turns and continues to travel. A sample movement path is shown in FIG. 11 as line 48.

The algorithm for random bounce behavior is set forth in FIG. 10. The robot 10 continues its forward movement (step 401) until a bump sensor 12 and/or 13 is activated (step 410). The robot 10 then calculates an acceptable range of new directions based on a determination of which bump sensor or sensors have been activated (step 420). A determination is then made with some random calculation to choose the new heading within that acceptable range, such as 90 to 270 degrees relative to the object the robot encountered. The angle of the object the robot has bumped is determined as described above using the timing between the right and left bump sensors. The robot then turns to its new headings. In a preferred embodiment, the turn is either clockwise or counterclockwise depending on which direction requires the least movement to achieve the new heading. In other embodiments, the turn is accompanied by movement forward in order to increase the robot's coverage efficiency.

The statistics of the heading choice made by the robot can be distributed uniformly across the allowed headings, i.e. there is an equivalent chance for any heading within the acceptable range. Alternately we can choose statistics

based on a Gaussian or other distribution designed to preferentially drive the robot perpendicularly away from a wall.

In other embodiments, the robot could change directions at random or predetermined times and not based upon external sensor activity. Alternatively, the robot could continuously make small angle corrections based on long range sensors to avoid even contacting an object and, thereby cover the surface area with curved paths

In a preferred embodiment, the robot stays in room-cleaning mode until a certain number of bounce interactions are reached, usually between 6 and 13.

## 2. Escape Behaviors

There are several situations the robot may encounter while trying to cover an area that prevent or impede it from covering all of the area efficiently. A general class of sensors and behaviors called escape behaviors are designed to get the robot out of these situations, or in extreme cases to shut the robot off if it is determined it cannot escape. In order to decide whether to give an escape behavior priority among the various behaviors on the robot, the robot determines the following: (1) is an escape behavior needed; (2) if yes, which escape behavior is warranted?

By way of example, the following situations illustrate situations where an escape behavior is needed for an indoor cleaning robot and an appropriate behavior to run:

5 (i) Situation 1. The robot detects a situation where it might get stuck - for example, a high spot in a carpet or near a lamp base that acts like a ramp for the robot. The robot performs small "panic" turn behaviors to get out of the situation;

10 (ii) Situation 2. The robot is physically stuck - for example, the robot is wedged under a couch or against a wall, tangled in cords or carpet tassels, or stuck on a pile of electrical cords with its wheels spinning. The robot performs large panic turn behaviors and turns off relevant motors to escape from the obstruction;

15 (iii) Situation 3. The robot is in a small, confined area -- for example, the robot is between the legs of a chair or in the open area under a dresser, or in a small area created by placing a lamp close to the corner of a room. The robot edge follows using its bumper and/or performs panic turn behaviors to escape from the area; and

20 (iv) Situation 4. The robot has been stuck and cannot free itself - for example, the robot is in



one of the cases in category (ii), above, and has not been able to free itself with any of its panic behaviors. In this case, the robot stops operation and signals to the user for help. This preserves battery life and prevents damage to floors or furniture.

In order to detect the need for each escape situation, various sensors are used. For example:

- (i) Situation 1. (a) When the brush or side brush current rise above a threshold, the voltage applied to the relevant motor is reduced. Whenever this is happening, a stall rate variable is increased. When the current is below the threshold, the stall rate is reduced. If the stall level rises above a low threshold and the slope of the rate is positive, the robot performs small panic turn behaviors. It only repeats these small panic turn behaviors when the level has returned to zero and risen to the threshold again. (b) Likewise, there is a wheel drop level variable which is increased when a wheel drop event is detected and is reduced steadily over time. When a wheel drop event is detected and the wheel drop level is above a threshold (meaning there have been several wheel drops recently), the robot performs small or

large panic turn behaviors depending on the wheel drop level.

- 5 (ii) Situation 2. (a) When the brush stall rate rises above a high threshold and the slope is positive, the robot turns off the brush for 13 seconds and performs large panic turn behaviors at 1, 3, and 7 seconds. At the end of the 13 seconds, the brush is turned back on. (b) When the drive stall rate rises above a medium
- 10 threshold and the slope is positive, the robot performs large panic turn behaviors continuously. (c) When the drive stall rate rises above a high threshold, the robot turns off all of the motors for 15 seconds. At the
- 15 end of the 15 seconds, the motors are turned back on. (d) When the bumper of the robot is held in constantly for 5 seconds (as in a side wedging situation), the robot performs a large panic turn behavior. It repeats the panic turn
- 20 behavior every 5 seconds until the bumper is released. (e) When the robot has gotten no bumps for a distance of 20 feet, it assumes that it might be stuck with its wheels spinning. To free itself, it performs a spiral. If has still
- 25 not gotten a bump for 10 feet after the end of the spiral, performs a large panic turn

behavior. It continues this every 10 feet until it gets a bump.

5 (iii) Situation 3. (a) When the average distance between bumps falls below a low threshold, the robot performs edge following using its bumper to try to escape from the confined area. (b) When the average distance between bumps falls below a very low threshold, the robot performs large panic turn behaviors to orient it so that it may better be able to escape from the confined area.

10 (iv) Situation 4. (a) When the brush has stalled and been turned off several times recently and the brush stall rate is high and the slope is positive, the robot shuts off. (b) When the drive has stalled and the motors turned off several times recently and the drive stall rate is high and the slope is positive, the robot shuts off. (c) When any of the wheels are  
15 dropped continuously for greater than 2 seconds, the robot shuts off. (d) When many wheel drop events occur in a short time, the robot shuts off. (e) When any of the cliff sensors sense a cliff continuously for 10 seconds, the robot  
20 shuts off. (f) When the bump sensor is constantly depressed for a certain amount of  
25

time, for example 10 seconds, it is likely that the robot is wedged, and the robot shuts off.

As a descriptive example, FIGS. 12A & 12B illustrate the analysis used in a preferred embodiment for identifying the need for an escape behavior relative to a stalled brush motor, as described above in Situations 1, 2 and 4. Each time the brush current exceeds a given limit for the brush motor (step 402), a rate register is incremented by 1 (step 404); if no limit is detected, the rate register is decremented by 1 (step 406). A separate slope register stores the recent values for a recent time period such as 120 cycles. If the rate is above 600 (where 600 corresponds to one second of constant stall) (step 414) and the slope is positive (step 416), then the robot will run an escape behavior (step 420) if the escape behavior is enabled (step 418). The escape behaviors are disabled after running (step 428) until the rate has returned to zero (step 422), re-enabled (step 424) and risen to 600 again. This is done to avoid the escape behavior being triggered constantly at rates above 600.

If, however, the rate is above 2400 (step 410) and the slope is positive (step 412), the robot will run a special set of escape behaviors, shown in FIG. 12B. In a preferred embodiment, the brush motor will shut off (step 430), the "level" is incremented by a predetermined amount (50 to 90) (step 430), the stall time is set (step 430), and a panic

behavior (step 452) is preformed at 1 second (step 445), 4  
seconds (step 450) and 7 seconds (step 455) since the brush  
shut off. The control system then restarts the brush at 13  
seconds (steps 440 & 442). Level is decremented by 1 every  
5 second (steps 444). If level reaches a maximum threshold  
(step 435), the robot ceases all operation (step 437). In  
addition, the robot may take additional actions when certain  
stalls are detected, such as limiting the voltage to the  
motor to prevent damage to the motor.

10 A preferred embodiment of the robot has four escape  
behaviors: TURN, EDGE, WHEEL DROP and SLOW.

TURN. The robot turns in place in a random  
direction, starting at a higher velocity (approximately  
twice of its normal turning velocity) and decreasing to  
a lower velocity (approximately one-half of its normal  
turning velocity). Varying the velocity may aid the  
robot in escaping from various situations. The angle  
that the robot should turn can be random or a function  
of the degree of escape needed or both. In a preferred  
15 embodiment, in low panic situations the robot turns  
anywhere from 45 to 90 degrees, and in high panic  
situations the robot turns anywhere from 90 to 270  
degrees.

EDGE. The robot follows the edge using its bump  
25 sensor until (a) the robot turns 60 degrees without a  
bump or (b) the robot cumulatively has turned more than

170 degrees since the EDGE behavior initiated. The EDGE behavior may be useful if the average bump distance is low (but not so low as to cause a panic behavior). The EDGE behavior allows the robot to fit through the smallest openings physically possible for the robot and so can allow the robot to escape from confined areas.

WHEEL DROP. The robot back drives wheels briefly, then stops them. The back driving of the wheels helps to minimize false positive wheel drops by giving the wheels a small kick in the opposite direction. If the wheel drop is gone within 2 seconds, the robot continues normal operation.

SLOW. If a wheel drop or a cliff detector goes off, the robot slows down to speed of 0.235 m/s (or 77% of its normal speed) for a distance of 0.5m and then ramps back up to its normal speed.

In addition to the coverage behaviors and the escape behaviors, the robot also might contain additional behaviors related to safety or usability. For example, if a cliff is detected for more than a predetermined amount of time, the robot may shut off. When a cliff is first detected, a cliff avoidance response behavior takes immediate precedence over all other behaviors, rotating the robot away from the cliff until the robot no longer senses the cliff. In a preferred embodiment, the cliff detection event does not cause a change in operational modes. In other embodiments, the robot could

use an algorithm similar to the wall-following behavior to allow for cliff following.

The individual operation of the three operational modes has been described above; we now turn to the preferred mode of switching between the various modes.

In order to achieve the optimal coverage and cleaning efficiency, a preferred embodiment uses a control program that gives priority to various coverage behaviors. (Escape behaviors, if needed, are always given a higher priority.) For example, the robot 10 may use the wall following mode for a specified or random time period and then switch operational modes to the room cleaning. By switching between operational modes, the robotic device of the present invention is able to increase coverage, cleaning efficiency and perceived effectiveness.

By way of example, FIGS. 13A & 13B show a mobile robot 10 in a "dog bone" shaped environment in which two rooms & 116 of roughly equal dimensions are connected by a narrow passageway 105. (This example illustrates the robot diffusion problem discussed earlier.) This arrangement is a simplified version of typical domestic environments, where the "dog bone" may be generated by the arrangements of obstacles within the room. In FIG. 13A, the path of robot 10 is traced as line 54 as robot 10 operates on in random bounce mode. The robot 10 is unable to move from room 116 into 115

during the limited run because the robot's random behavior did not happen to lead the robot through passageway 105. This method leaves the coverage far less than optimal and the cleaning rate decreased due to the number of times the robot  
5 10 crosses its own path.

FIG. 13B shows the movement of a preferred embodiment of robot 10, whereby the robot cycles between BOUNCE and WALL FOLLOWING behaviors. As the robot follows path 99, each time the robot 10 encounters a wall 100, the robot follows the  
10 wall for a distance equal to twice the robot's diameter. The portions of the path 99 in which the robot 10 operates in wall following mode are labeled 51. This method provides greatly increased coverage, along with attendant increases in cleaning rate and perceived effectiveness.

Finally, a preferred embodiment of the present invention is detailed in FIG. 14, in which all three operational modes are used. In a preferred embodiment, the device 10 begins in spiral mode (movement line 45). If a reflective spiral pattern is used, the device continues in spiral mode until a  
15 predetermined or random number of reflective events has  
20 occurred. If a standard spiral is used (as shown in FIG. 14), the device should continue until any bump sensor event. In a preferred embodiment, the device immediately enters wall following mode after the triggering event.

25 In a preferred embodiment, the device then switches between wall following mode (movement lines 51) and random



bounce modes (movement lines 48) based on bump sensor events or the completion of the wall following algorithm. In one embodiment, the device does not return to spiral mode; in other embodiments, however, the device can enter spiral mode  
5 based on a predetermined or random event.

In a preferred embodiment, the robot keeps a record of the average distance traveled between bumps. The robot then calculates an average bump distance (ABD) using the following formula:  $(3/4 \times ABD) + (1/4 \times \text{most recent distance between bumps})$ . If the ABD is above a predetermined threshold, the  
10 robot will again give priority to the SPIRAL behavior. In still other embodiments, the robot may have a minimum number of bump events before the SPIRAL behavior will again be given priority. In other embodiments, the robot may enter SPIRAL  
15 behavior if it travels a maximum distance, for example 20 feet, without a bump event.

In addition, the robot can also have conditions upon which to stop all operations. For example, for a given room size, which can be manually selected, a minimum and maximum  
20 run time are set and a minimum total distance is selected. When the minimum time and the minimum distance have been reached the robot shuts off. Likewise, if the maximum time has been reached, the robot shuts off.

Of course, a manual control for selecting between  
25 operational modes can also be used. For example, a remote control could be used to change or influence operational

modes or behaviors. Likewise, a switch mounted on the shell itself could be used to set the operation mode or the switching between modes. For instance, a switch could be used to set the level of clutter in a room to allow the robot a more appropriate coverage algorithm with limited sensing ability.

One of skill in the art will recognize that portions of the instant invention can be used in autonomous vehicles for a variety of purposes besides cleaning. The scope of the invention should be determined by the appended claims and their legal equivalents, rather than by the examples given.

We claim:

1. A mobile robot comprising:

(a) means for moving the robot over a surface;

5 (b) an obstacle detection sensor;

(c) and a control system operatively connected to said  
obstacle detection sensor and said means for moving;

(d) said control system configured to operate the robot  
in a plurality of modes, said plurality of modes comprising:

10 a spot-coverage mode, an obstacle following mode whereby said  
robot travels adjacent to an obstacle, and a bounce mode  
whereby the robot travels substantially in a direction away  
from an obstacle after encountering an obstacle.

15 2. A mobile robot according to claim 1 in which said  
control system is configured to operate first in said spot-  
coverage mode, then alternate operation between said obstacle  
following mode and said bounce mode.

20 3. A mobile robot according to claim 2 in which said spot-  
coverage mode comprises substantially spiral movement.

4. A mobile robot according to claim 2 in which the control  
system is configured to return to spot-coverage mode after a  
25 predetermined traveling distance.

5. A mobile robot according to claim 2 in which the control system is configured to return to spot-coverage mode after a predetermined elapsed time.

5 6. A mobile robot according to claim 2 in which the control system is configured to return to spot-coverage mode if the average distance between obstacle interactions is above a predetermined threshold.

10 7. A mobile robot according to claim 1, whereby said obstacle detection sensor comprises a tactile sensor.

8. A mobile robot according to claim 7, whereby said obstacle detection sensor further comprises an IR sensor.

15 9. The mobile robot according to claim 1, whereby said obstacle following mode comprises alternating between decreasing the turning radius of the robot as a function of distance traveled such that the robot turns toward said  
20 obstacle until the obstacle detection sensor detects an obstacle, and decreasing the turning radius of the robot as a function of distance traveled such that the robot turns away from said obstacle until the obstacle detection system no longer detects an obstacle.

25

10. The mobile robot according to claim 1, whereby the robot operates in obstacle following mode for a distance greater than twice the work width of the robot and less than approximately ten times the work width of the robot.

5

11. The mobile robot according to claim 10, whereby the robot operates in obstacle following mode for a distance greater than twice the work width of the robot and less than five times the work width of the robot.

10

12. The mobile robot according to claim 1, further comprising a means for manually selecting an operational mode.

15

13. A mobile robot comprising:

(a) means for moving the robot over a surface;

(b) an obstacle detection sensor;

(c) and a control system operatively connected to said obstacle detection sensor and said means for moving;

20

(d) said control system configured to operate the robot in a plurality of modes, said plurality of modes comprising: an obstacle following mode whereby said robot travels adjacent to an obstacle, and a bounce mode whereby the robot travels substantially in a direction away from an obstacle after encountering an obstacle;

25

(e) whereby said control system is configured to alternate into said obstacle following mode after a predetermined number of sensor interactions.

5 14. A mobile robot according to claim 13, wherein said predetermined number of sensor interactions is randomly determined.

10 15. A mobile robot according to claim 13, wherein said predetermined number of sensor interactions is between approximately 5 and approximately 15.

15 16. A mobile robot according to claim 13, wherein said control system is configured to alternate into said bounce mode after the robot travels a predetermined distance in said obstacle following mode.

20 17. A mobile robot according to claim 13, wherein said control system is configured to alternate into said bounce mode upon either the robot has traveled a maximum distance or the robot has traveled a minimum distance and an obstacle has been encountered.

25 18. A mobile robot according to claim 17, wherein said minimum distance is at least 115 cm.

19. A mobile robot according to claim 18, wherein said maximum distance is less than 520 cm.

5 20. A mobile robot according to claim 13, wherein the control system alternates operational modes based on the distance traveled by said robot.

21. A mobile robot according to claim 13, further comprising a means for determining the level of clutter.

10 22. A mobile robot according to claim 21, wherein said means for determining the level of clutter comprises tracking the number of interactions with obstacles over time.

15 23. A mobile robot according to claim 22, further comprising a means for imputing the approximate area of the surface, wherein said means for determining the level of clutter further relates to the approximate area of the surface.

20 24. A mobile robot according to claim 22, wherein the level of clutter is correlated to the frequency at which the controller alternates operational modes.

25 25. A mobile robot according to claim 21, wherein the level of clutter is positively correlated to the minimum obstacle following distance.

26. A mobile robot according to claim 13, wherein the control system alternates between operational modes based upon a lack of sensor input.

5

27. A mobile robot according to claim 1, wherein said control system further comprises memory wherein an operational system program is stored, said operational system program comprising a plurality of behaviors and an arbiter to select which behavior is given control over the means for moving.

10

28. A mobile robot according to claim 27, further comprising an escape behavior.

29. A mobile robot according to claim 28, wherein said obstacle detection sensor comprises a tactile sensor, and wherein said escape behavior comprises operating in said obstacle following mode.

15  
20

30. A mobile robot according to claim 28, wherein said escape behavior is triggered by the rate of a motor stall event.



31. A mobile robot according to claim 30, wherein said escape behavior is triggered by an increase in said rate of a motor stall event.

5 32. A mobile robot according to claim 28, wherein said escape behavior is triggered by the duration of sensor input.

33. A mobile robot according to claim 28, wherein said escape behavior comprises shutting off the robot.

10

34. A mobile robot according to claim 28, wherein said escape behavior is triggered by a lack of sensor input.

FOR THE UNITED STATES DEPARTMENT OF JUSTICE

15

35. A mobile robot according to claim 13, further comprising a cliff detector, whereby said control system is configured to reduce the robot's velocity upon detection of a cliff.

20

36. A mobile robot according to claim 13, further comprising a wheel drop sensor, whereby said robot utilizes the rate of wheel drop sensor events as input to said control system.

37. A method of controlling a mobile-robot equipped with a sensor for detecting an obstacle, said method comprising the steps of:

25

a. moving in a spiral running motion;

- b. discontinuing said spiral running motion after the earlier of sensing and obstacle or traveling a predetermined distance;
- c. running in a substantially forward direction until an obstacle is detected;
- d. turning and running along said detected obstacle;
- e. turning away from said obstacle and running in a substantially forward direction; and
- f. thereafter repeating said step of running along said obstacle and said step of turning away from said obstacle.

38. The mobile-robot steering method according to claim 37, further comprising the step of repeating the spiral running motion after a predetermined number of sensor events.

39. The mobile-robot steering method according to claim 37, whereby the robot runs along said obstacle for at least a minimum distance but less than a maximum distance.

40. The mobile-robot steering method according to claim 39, whereby said obstacle sensor comprises an IR sensor able to detect said boundary.

41. The mobile-robot steering method according to claim 40, whereby said obstacle sensor further comprises a tactile sensor.

5

EXHIBIT 1002 - 975

ABSTRACT

A control system for a mobile robot (10) is provided to effectively cover a given area by operating in a plurality of modes, including an obstacle following mode (51) and a random bounce mode (49). In other embodiments, spot coverage, such as spiraling (45), or other modes are also used to increase effectiveness. In addition, a behavior based architecture is used to implement the control system, and various escape behaviors are used to ensure full coverage.

ABSTRACT

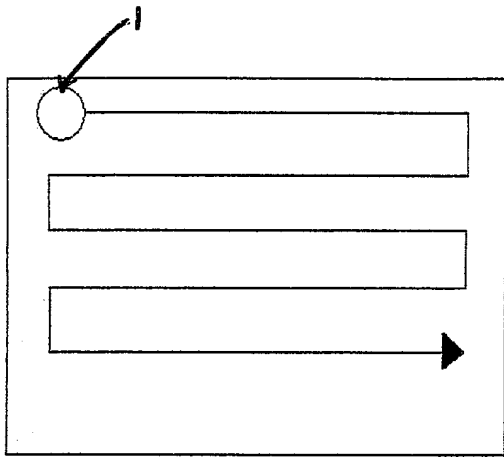


FIG. 1A

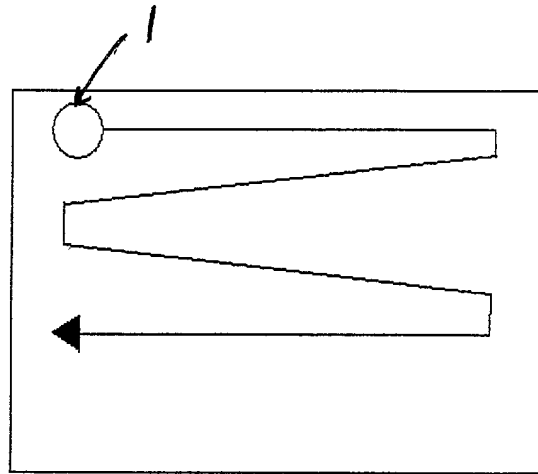


FIG. 1B

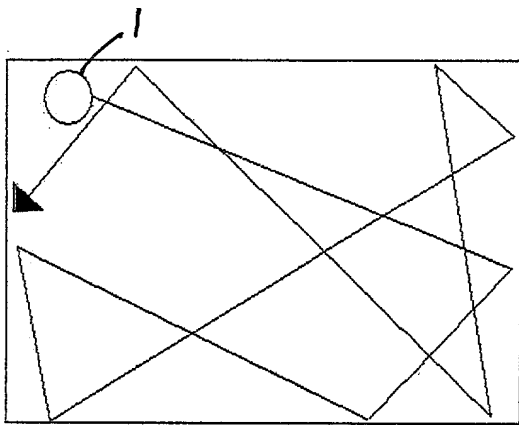


FIG. 1C

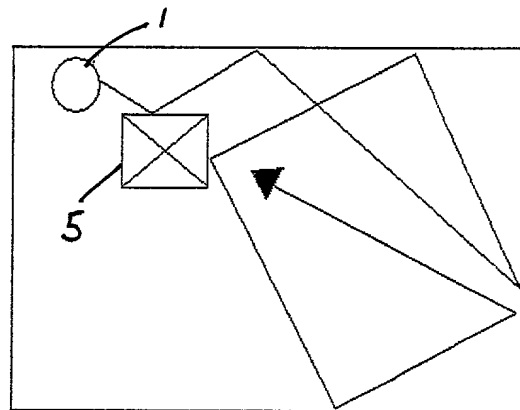


FIG. 1D

2025 RELEASE UNDER E.O. 14176

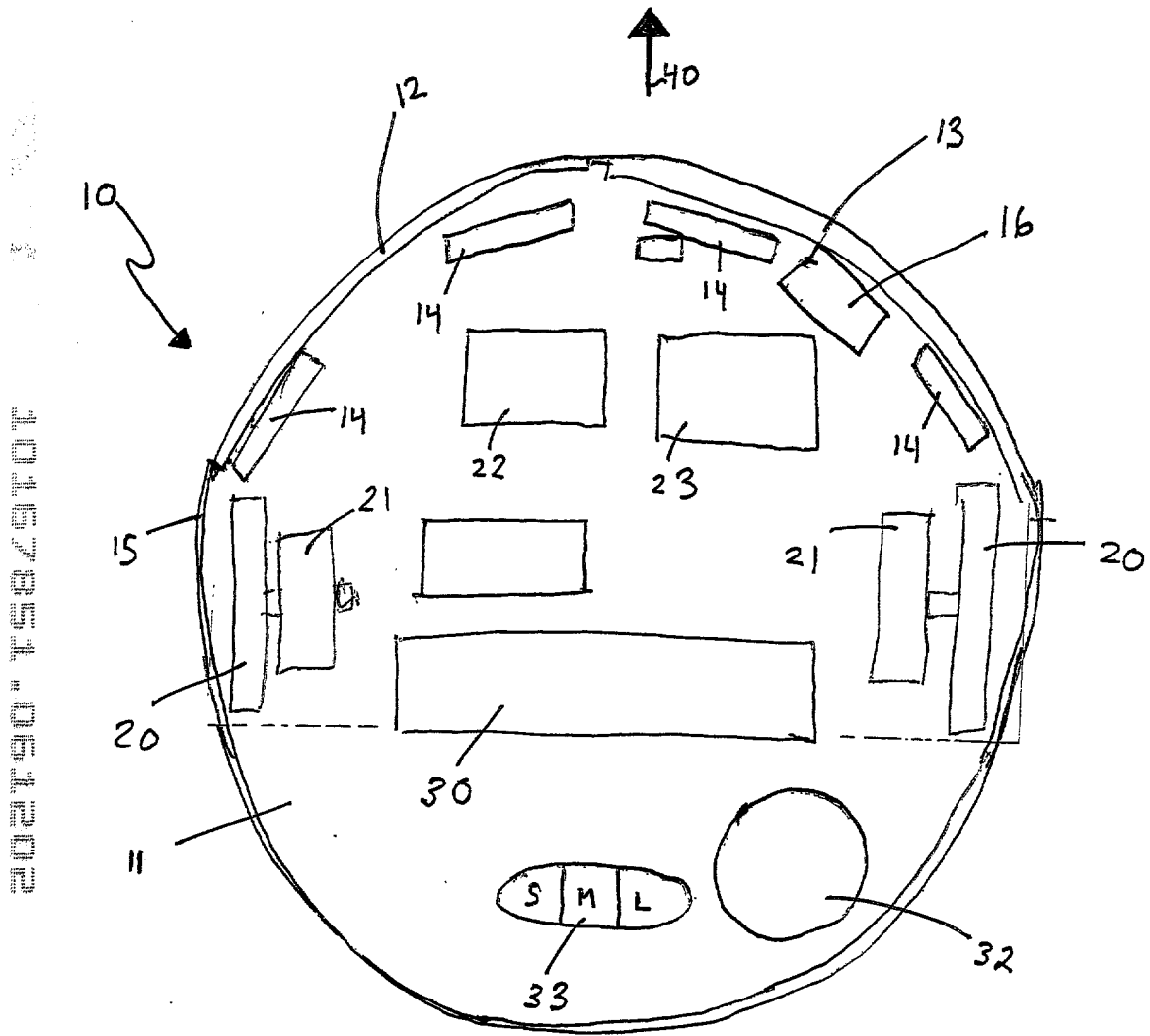
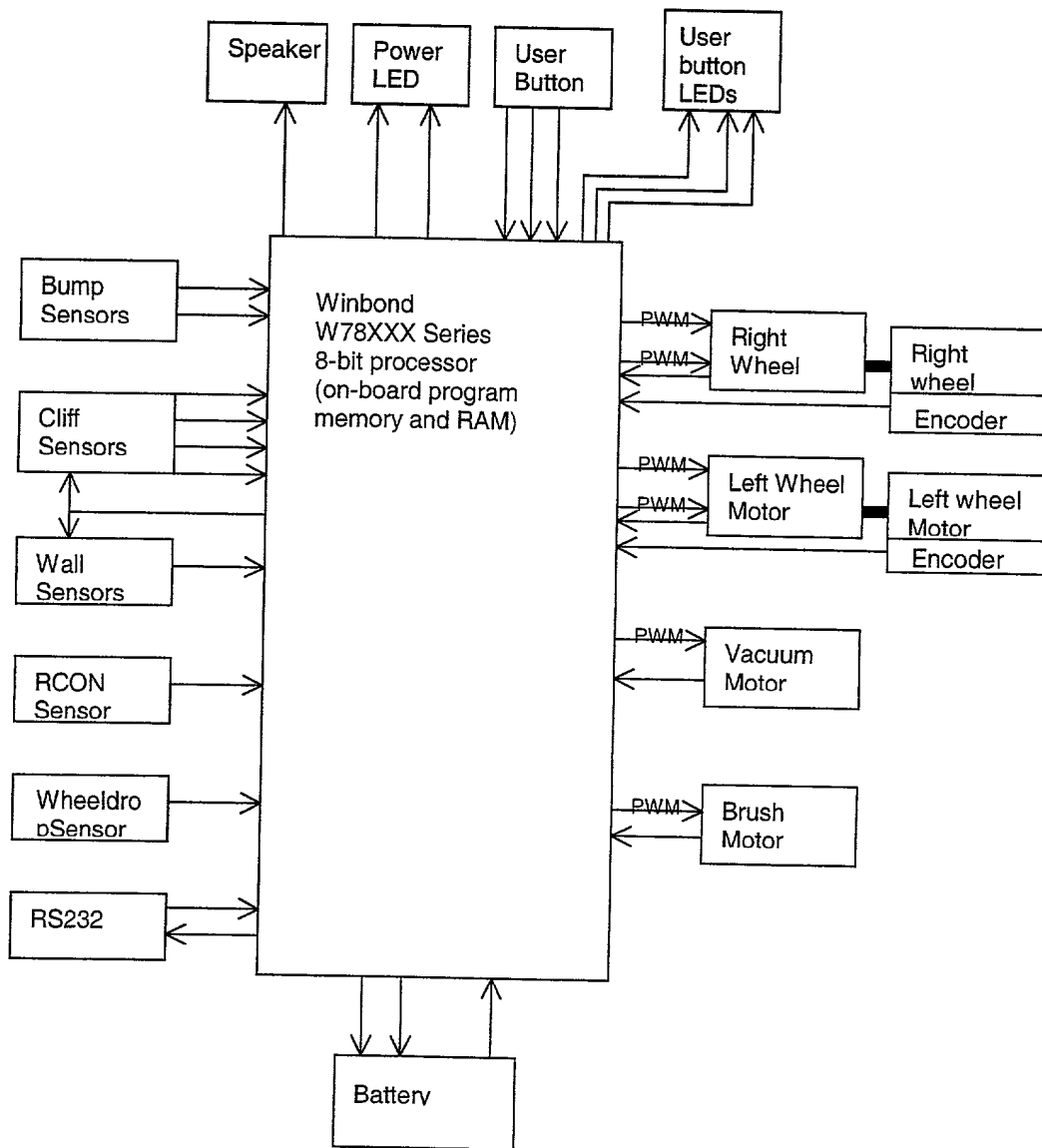


FIG. 2

FIG. 3



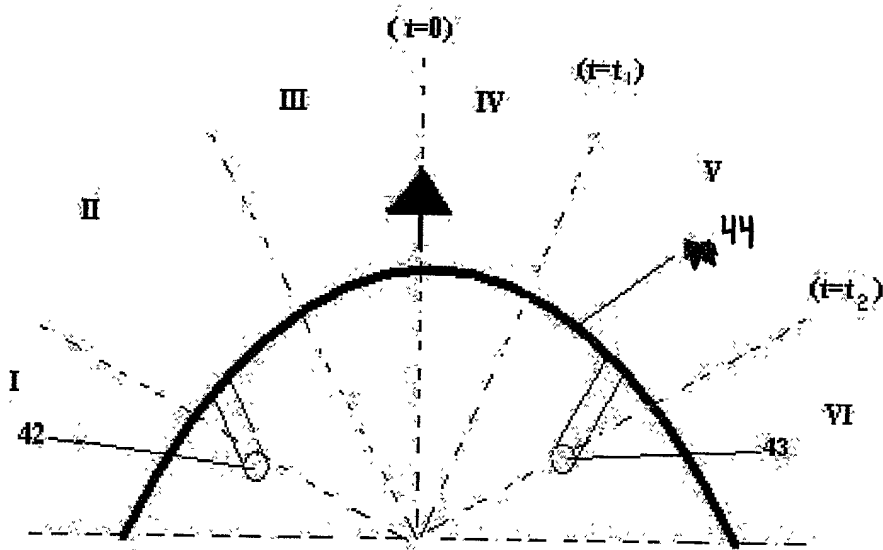


FIG. 4A

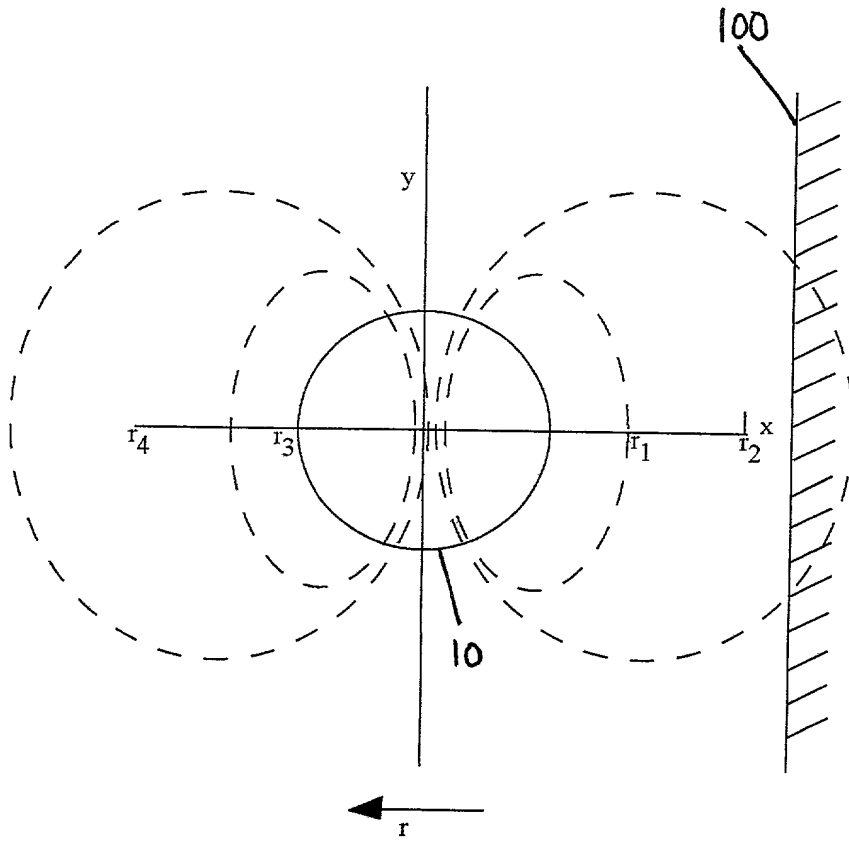


FIG. 4B

2025 RELEASE UNDER E.O. 14176



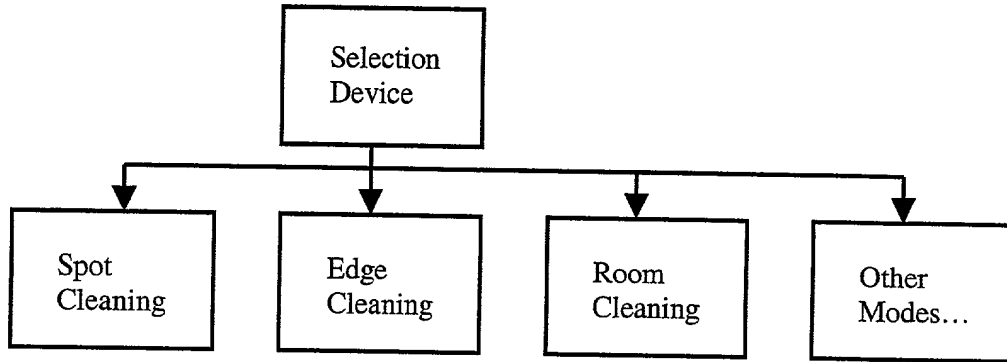


FIG. 5

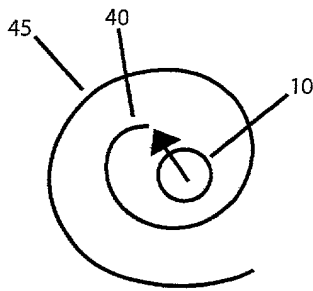


FIG. 6A

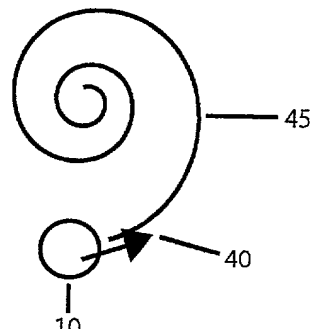


FIG. 6B

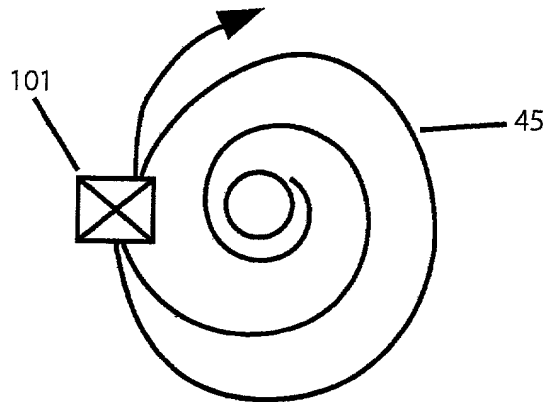


FIG. 6C

2025 RELEASE UNDER E.O. 14176

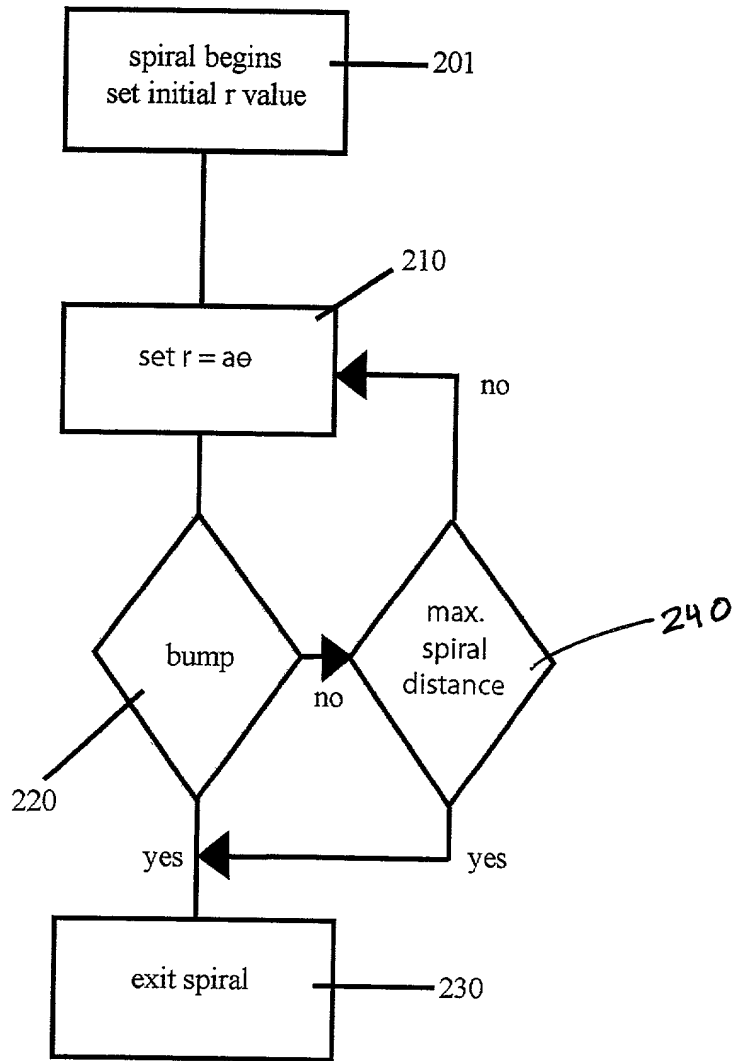


FIG. 7

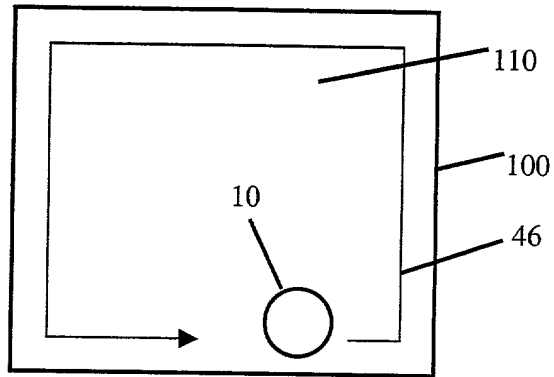


FIG. 8A

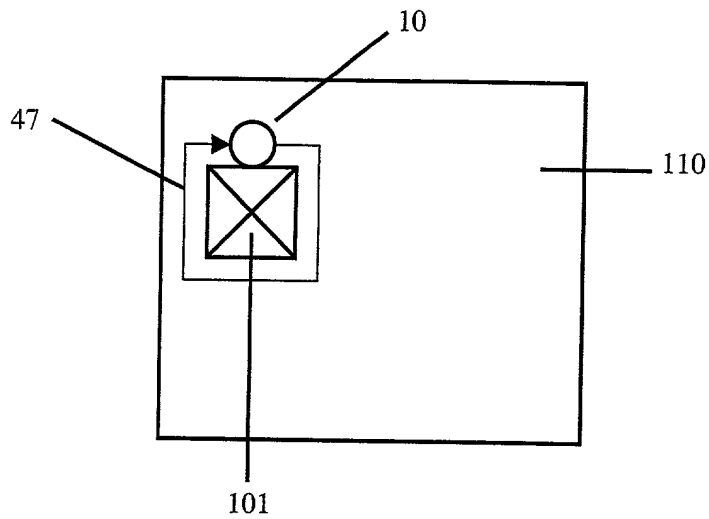
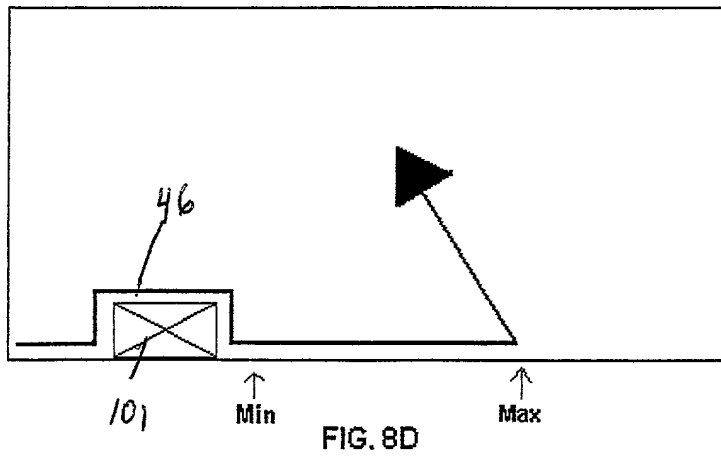
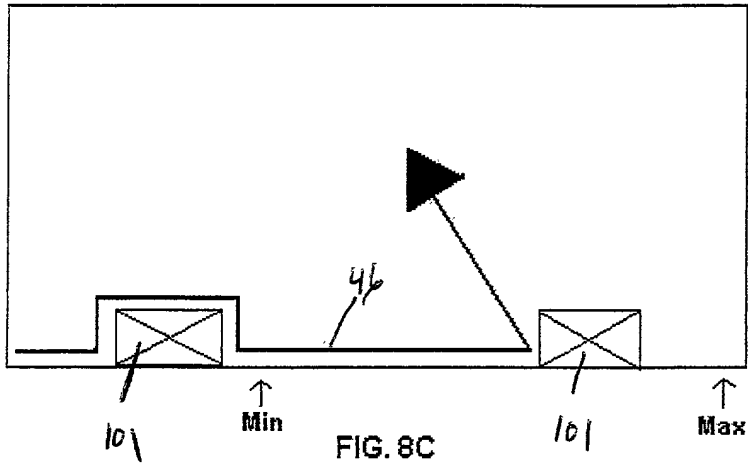


FIG. 8B

2025 RELEASE UNDER E.O. 14176

2025 RELEASE UNDER E.O. 14176



20190728/STP

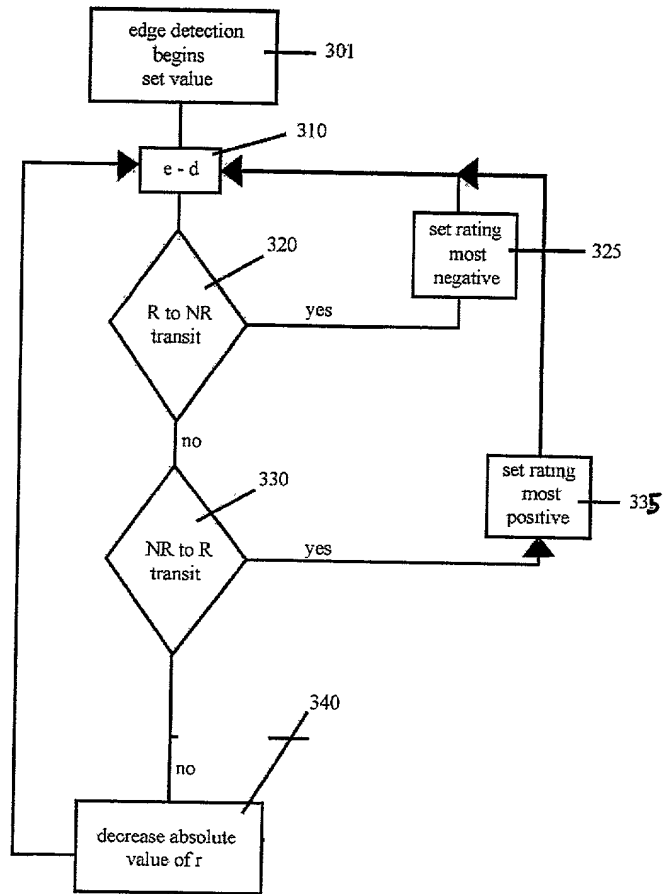


FIG. 9A

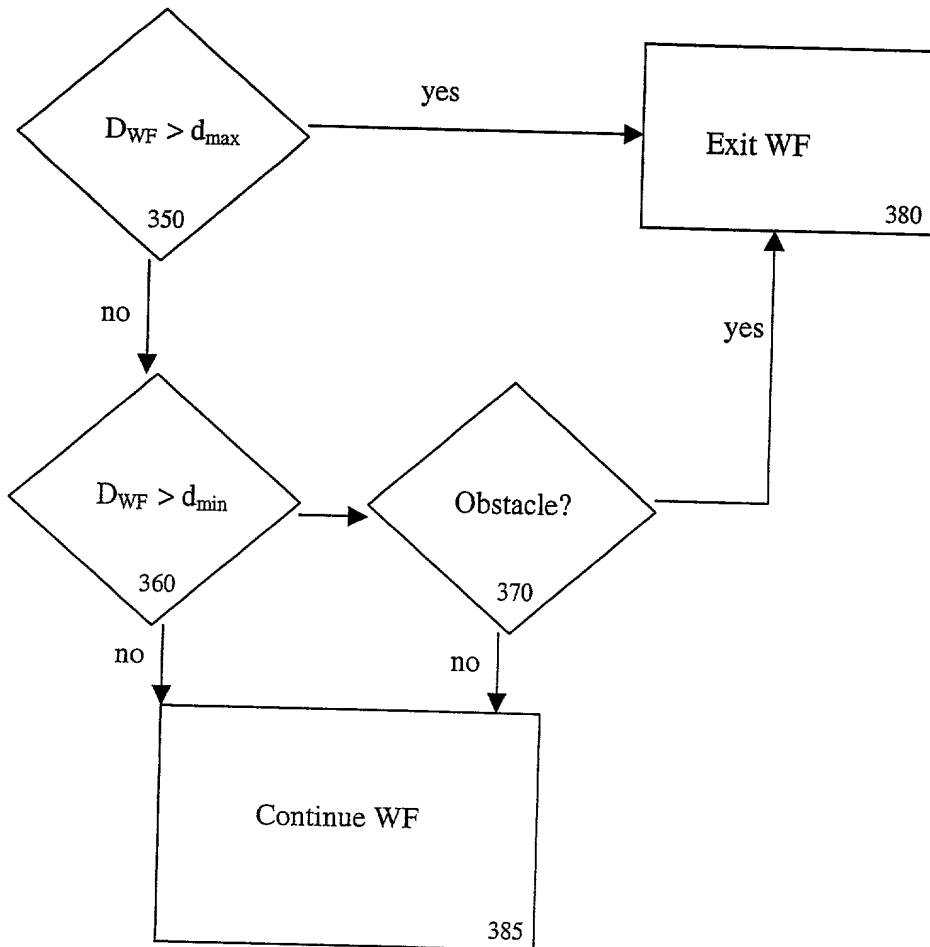


FIG. 9B

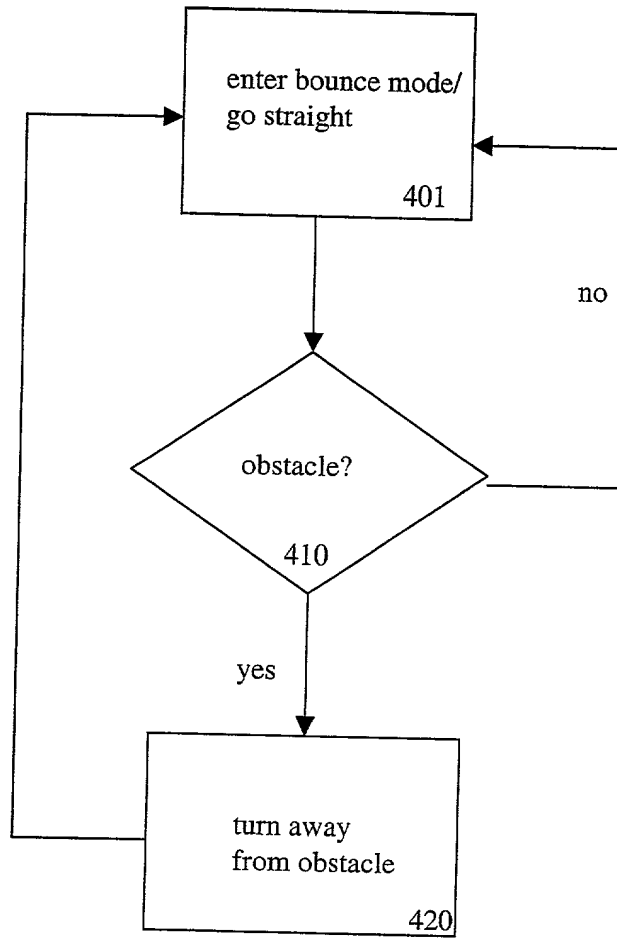


FIG. 10

2025 RELEASE UNDER E.O. 14176

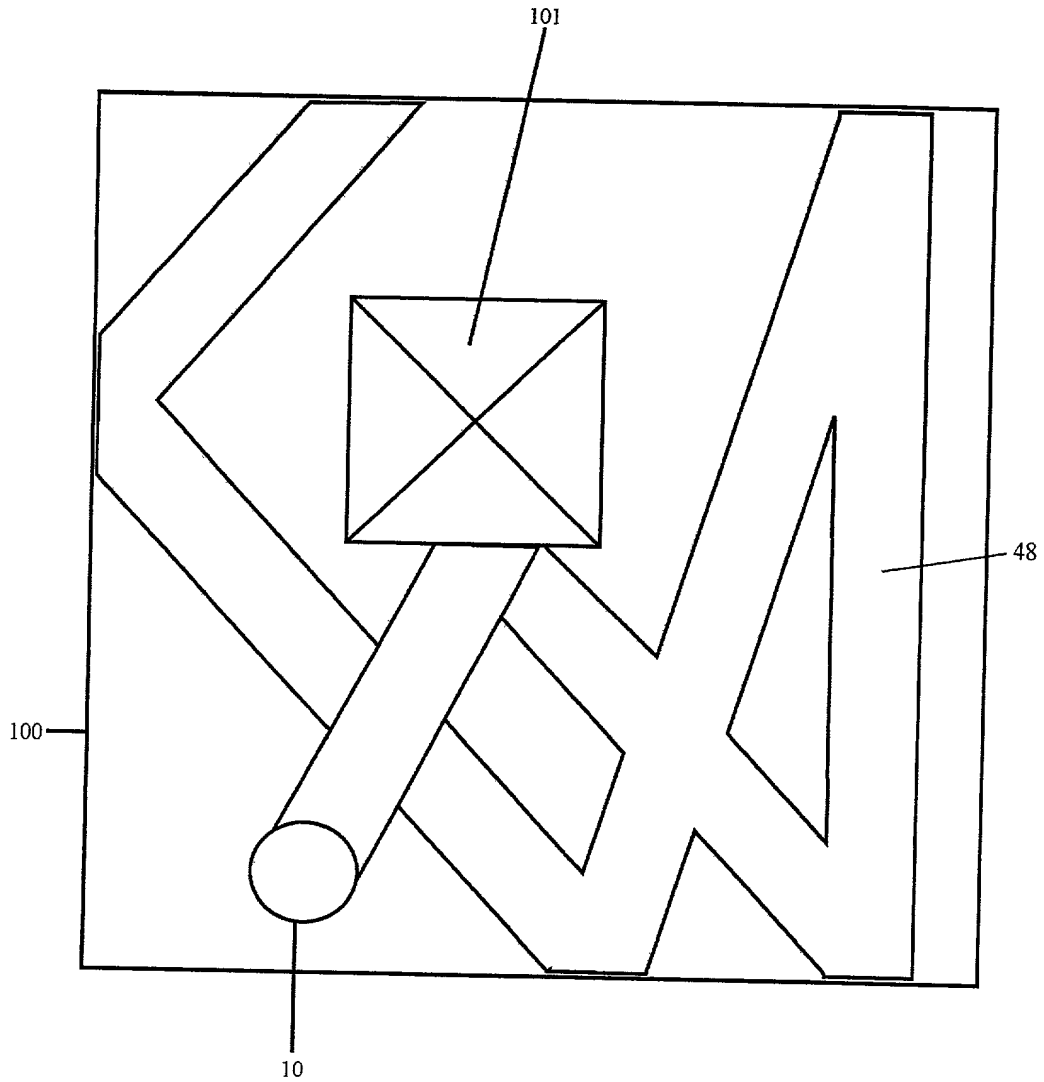


FIG. 11



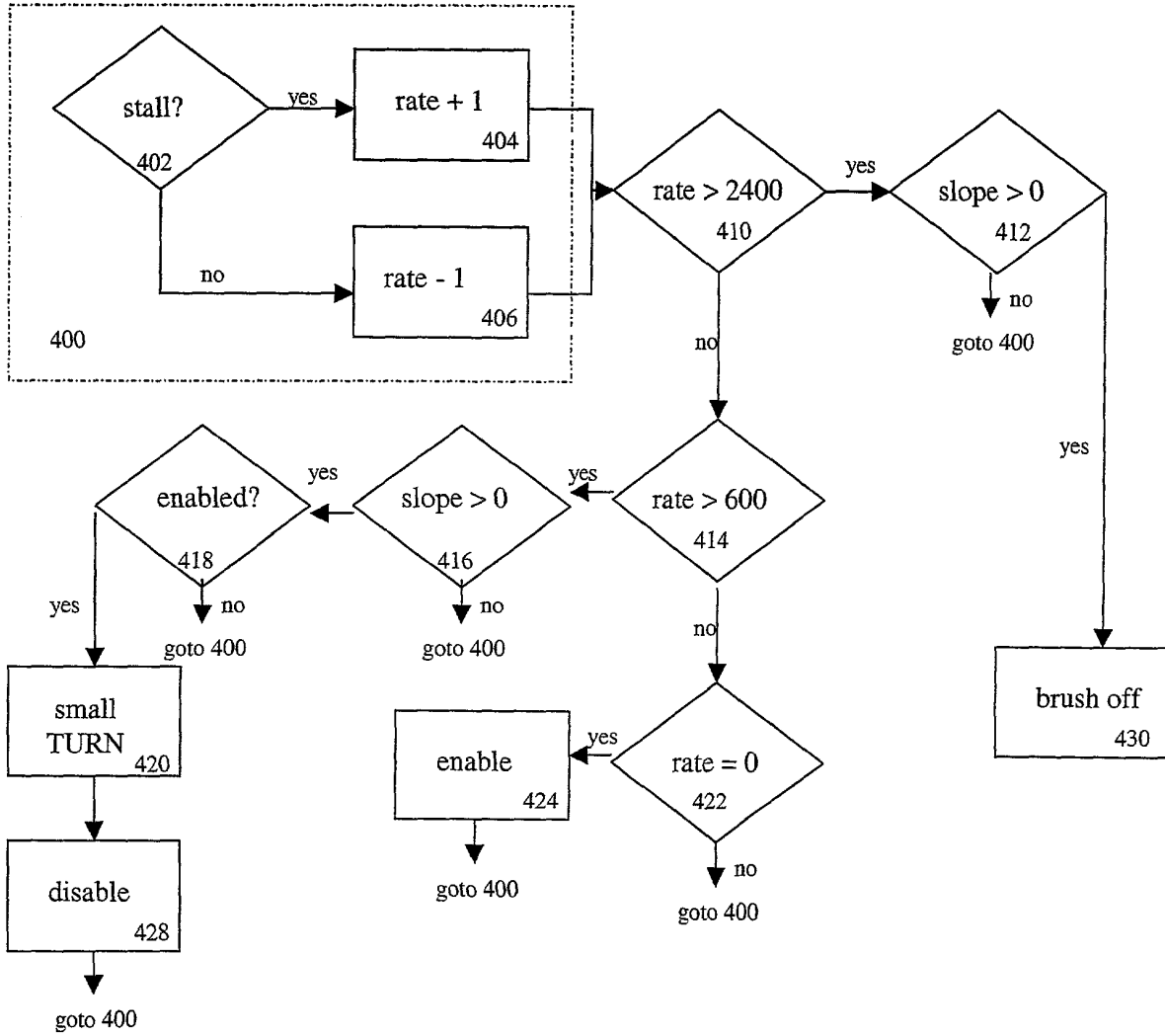


FIG. 12A

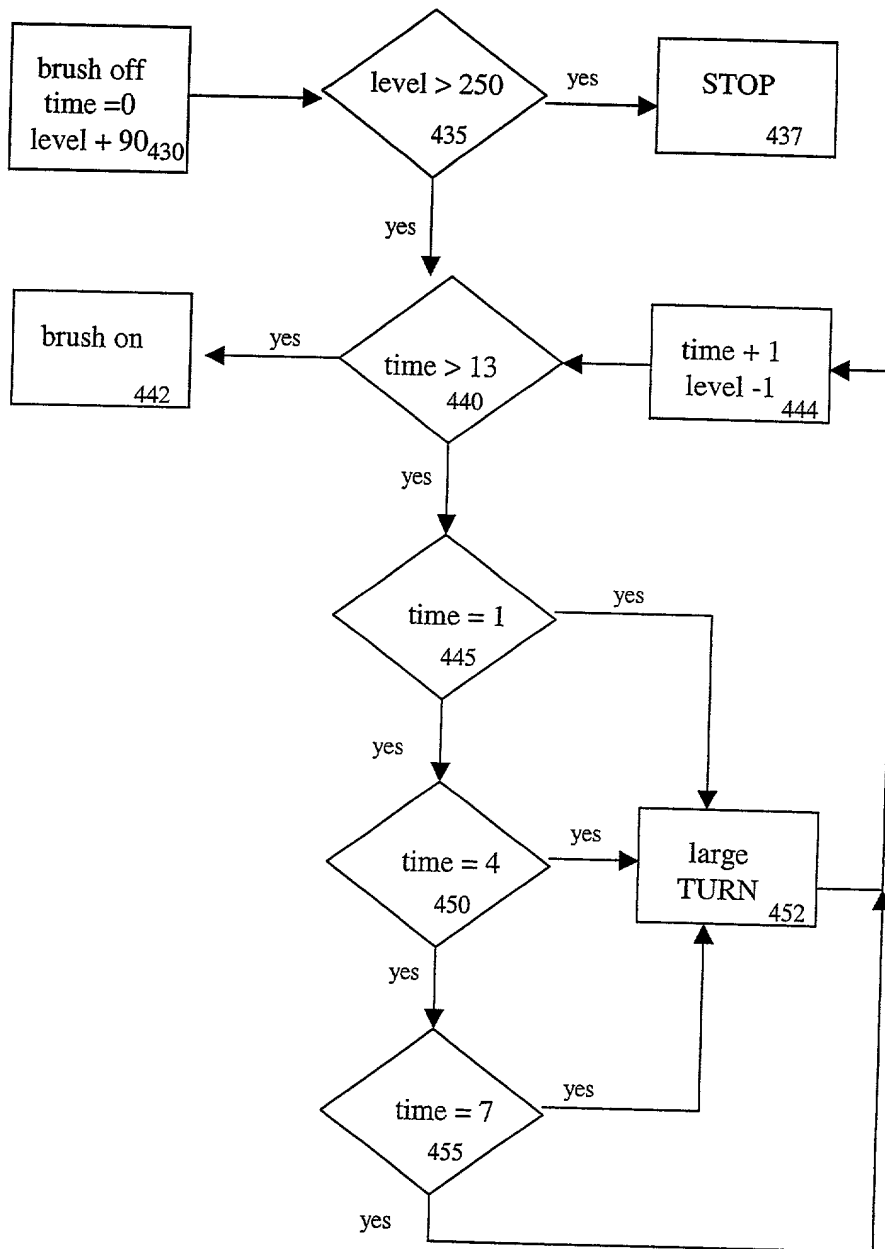


FIG. 12B

2025 RELEASE UNDER E.O. 14176

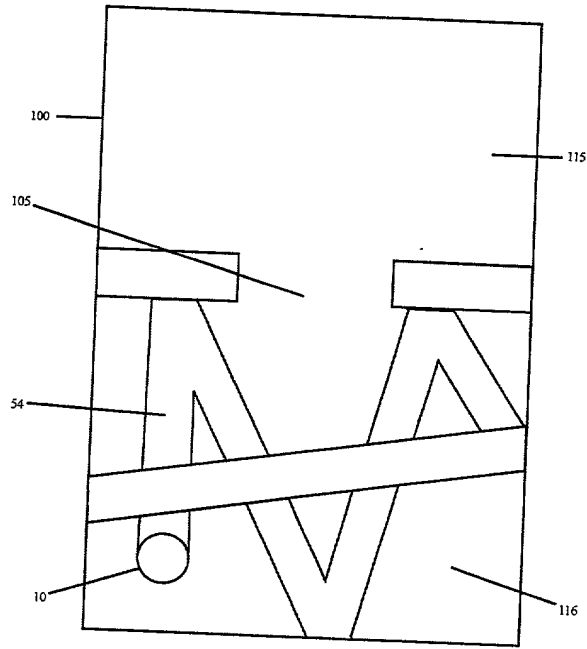


FIG. 13A

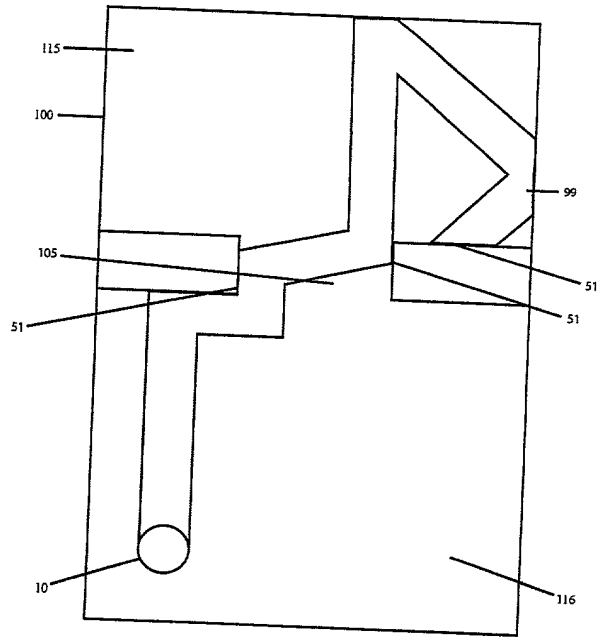


FIG. 13B

202190-1342910

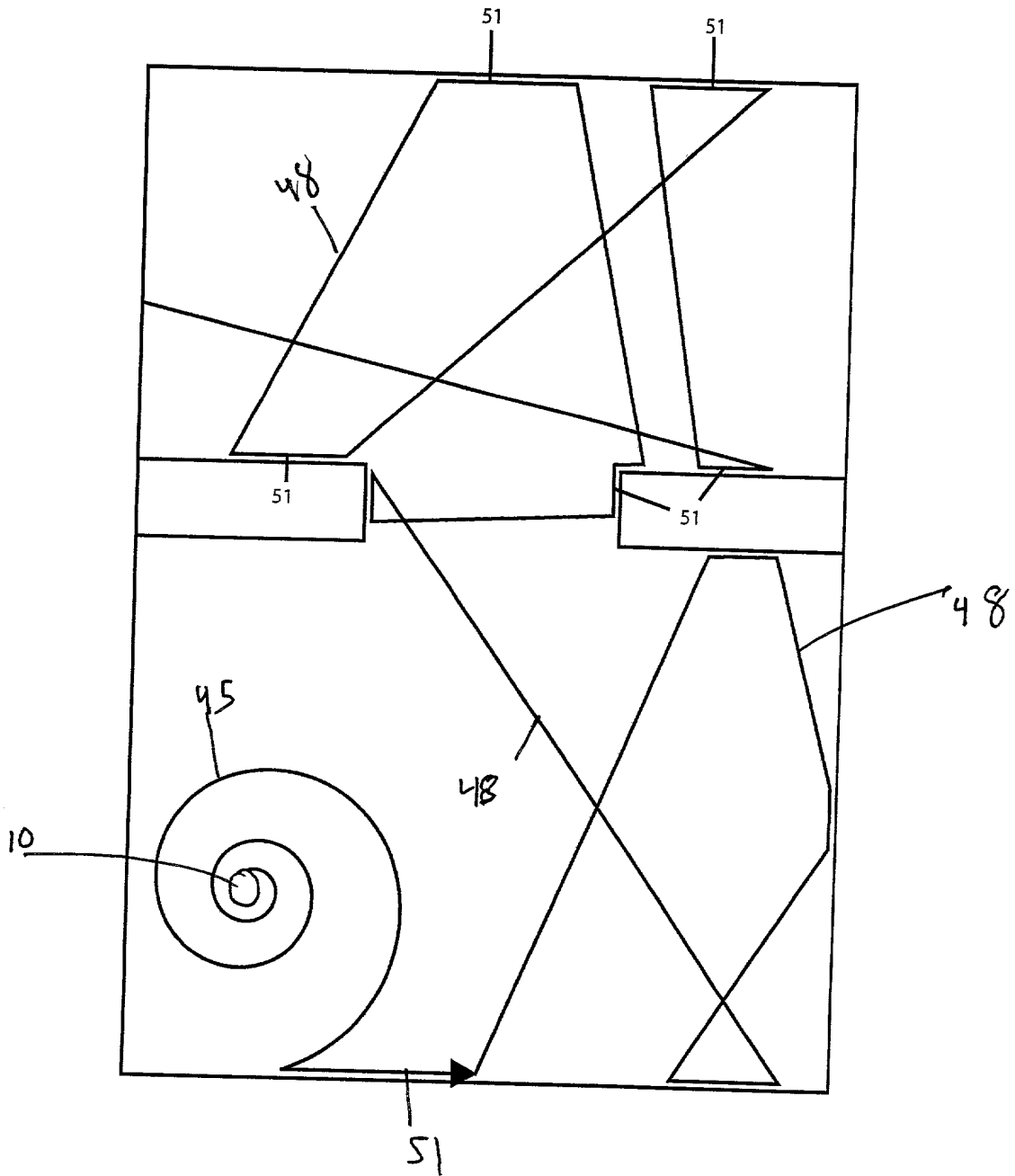



FIG. 14

Please type a plus sign (+) inside this box 

PTO/SB/81 (02-01)

Approved for use through 10/31/2002. OMB 0651-0035

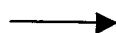
U.S. Patent and Trademark Office; U.S. DEPARTMENT OF COMMERCE

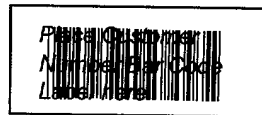
Under the Paperwork Reduction Act of 1995, no persons are required to respond to a collection of information unless it display a valid OMB control number.

## POWER OF ATTORNEY OR AUTHORIZATION OF AGENT

Application Number	
Filing Date	
First Named Inventor	JONES
Title	
Group Art Unit	
Examiner Name	
Attorney Docket Number	DP-5 US

I hereby appoint:

Practitioners at Customer Number 27639 



Practitioner(s) named below:


Name	Registration Number

as my/our attorney(s) or agent(s) to prosecute the application identified above, and to transact all business in the United States Patent and Trademark Office connected therewith.

Please change the correspondence address for the above-identified application to:

The above-mentioned Customer Number.

OR

Practitioners at Customer Number   

Place Customer  
Number Bar Code  
Label here

Firm or  
Individual Name

Address

Address

City

State

Zip

Country

Telephone

Fax

I am the:

Applicant/Inventor.

Assignee of record of the entire interest. See 37 CFR 3.71.  
Statement under 37 CFR 3.73(b) is enclosed. (Form PTO/SB/96).

### SIGNATURE of Applicant or Assignee of Record

Name

Joseph L. Jones

Signature

*Joseph L. Jones*

Date

6/11/02

NOTE: Signatures of all the inventors or assignees of record of the entire interest or their representative(s) are required. Submit multiple forms if more than one signature is required, see below\*.

Total of 2 forms are submitted.

Burden Hour Statement. This form is estimated to take 3 minutes to complete. Time will vary depending upon the needs of the individual case. Any comments on the amount of time you are required to complete this form should be sent to the Chief Information Officer, U.S. Patent and Trademark Office, Washington, DC 20231. DO NOT SEND FEES OR COMPLETED FORMS TO THIS ADDRESS. SEND TO: Assistant Commissioner for Patents, Washington, DC 20231.

Please type a plus sign (+) inside this box →

PTO/SB/81 (02-01)


Approved for use through 10/31/2002. OMB 0651-0035

U.S. Patent and Trademark Office; U.S. DEPARTMENT OF COMMERCE

Under the Paperwork Reduction Act of 1995, no persons are required to respond to a collection of information unless it display a valid OMB control number.

<b>POWER OF ATTORNEY OR AUTHORIZATION OF AGENT</b>	Application Number	
	Filing Date	
	First Named Inventor	JONES
	Title	
	Group Art Unit	
	Examiner Name	
Attorney Docket Number	DB-5 U.S.	

I hereby appoint:

Practitioners at Customer Number  → 

OR

Practitioner(s) named below:

Name	Registration Number
	27639

as my/our attorney(s) or agent(s) to prosecute the application identified above, and to transact all business in the United States Patent and Trademark Office connected therewith.

Please change the correspondence address for the above-identified application to:

The above-mentioned Customer Number.

OR

Practitioners at Customer Number  → 

Place Customer Number Bar Code Label here

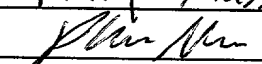
<input type="checkbox"/> Firm or Individual Name			
Address			
Address			
City	State	Zip	
Country			
Telephone	Fax		

I am the:

Applicant/Inventor.

Assignee of record of the entire interest. See 37 CFR 3.71.  
Statement under 37 CFR 3.73(b) is enclosed. (Form PTO/SB/96).

**SIGNATURE of Applicant or Assignee of Record**

Name	Philip Mass
Signature	
Date	6/12/02

NOTE: Signatures of all the inventors or assignees of record of the entire interest or their representative(s) are required. Submit multiple forms if more than one signature is required, see below\*.

\*Total of 2 forms are submitted.

Burden Hour Statement: This form is estimated to take 3 minutes to complete. Time will vary depending upon the needs of the individual case. Any comments on the amount of time you are required to complete this form should be sent to the Chief Information Officer, U.S. Patent and Trademark Office, Washington, DC 20231. DO NOT SEND FEES OR COMPLETED FORMS TO THIS ADDRESS. SEND TO: Assistant Commissioner for Patents, Washington, DC 20231.

Under the Paperwork Reduction Act of 1995, no persons are required to respond to a collection of information unless it contains a valid OMB control number.

<p><b>DECLARATION FOR UTILITY OR DESIGN PATENT APPLICATION (37 CFR 1.63)</b></p> <p><input checked="" type="checkbox"/> Declaration Submitted with Initial Filing      <b>OR</b>      <input type="checkbox"/> Declaration Submitted after Initial Filing (surcharge (37 CFR 1.16 (e)) required)</p>	<b>Attorney Docket Number</b>	DP-5 US
	<b>First Named Inventor</b>	JONES
	<b>COMPLETE IF KNOWN</b>	
	Application Number	
	Filing Date	
	Art Unit	
Examiner Name		

As the below named inventor, I hereby declare that:

My residence, mailing address, and citizenship are as stated below next to my name.

I believe I am the original and first inventor of the subject matter which is claimed and for which a patent is sought on the invention entitled:

**SYSTEM & METHOD FOR MULTI-MODE COVERAGE FOR AN AUTONOMOUS ROBOT**

*(Title of the Invention)*

the specification of which

is attached hereto

OR

was filed on (MM/DD/YYYY)  as United States Application Number or PCT International

Application Number  and was amended on (MM/DD/YYYY)  (if applicable).

I hereby state that I have reviewed and understand the contents of the above identified specification, including the claims, as amended by any amendment specifically referred to above.

I acknowledge the duty to disclose information which is material to patentability as defined in 37 CFR 1.56, including for continuation-in-part applications, material information which became available between the filing date of the prior application and the national or PCT international filing date of the continuation-in-part application.

I hereby claim foreign priority benefits under 35 U.S.C. 119(a)-(d) or (f), or 365(b) of any foreign application(s) for patent, inventor's or plant breeder's rights certificate(s), or 365(a) of any PCT international application which designated at least one country other than the United States of America, listed below and have also identified below, by checking the box, any foreign application for patent, inventor's or plant breeder's rights certificate(s), or any PCT international application having a filing date before that of the application on which priority is claimed.

Prior Foreign Application Number(s)	Country	Foreign Filing Date (MM/DD/YYYY)	Priority Not Claimed	Certified Copy Attached?	
				YES	NO
			<input type="checkbox"/>	<input type="checkbox"/>	<input type="checkbox"/>
			<input type="checkbox"/>	<input type="checkbox"/>	<input type="checkbox"/>
			<input type="checkbox"/>	<input type="checkbox"/>	<input type="checkbox"/>
			<input type="checkbox"/>	<input type="checkbox"/>	<input type="checkbox"/>

Additional foreign application numbers are listed on a supplemental priority data sheet PTO/SB/02B attached hereto:

Under the Paperwork Reduction Act of 1995, no persons are required to respond to a collection of information unless it contains a valid OMB control number.

**DECLARATION — Utility or Design Patent Application**Direct all correspondence to:  Customer Number or Bar Code Label  Correspondence address below

27639

Name

Address

City

State

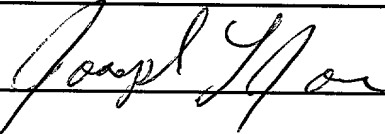
ZIP

Country

Telephone

Fax

I hereby declare that all statements made herein of my own knowledge are true and that all statements made on information and belief are believed to be true; and further that these statements were made with the knowledge that willful false statements and the like so made are punishable by fine or imprisonment, or both, under 18 U.S.C. 1001 and that such willful false statements may jeopardize the validity of the application or any patent issued thereon.

**NAME OF SOLE OR FIRST INVENTOR :** A petition has been filed for this unsigned inventorGiven Name  
(first and middle [if any])  
Joseph L.Family Name  
or Surname  
JonesInventor's  
Signature

Date

6/11/02

Acton

MA

US

US

Residence: City

State

Country

Citizenship

Mailing Address

9 Redwood Road

Acton

MA

01720

US

City

State

ZIP

Country

**NAME OF SECOND INVENTOR:** A petition has been filed for this unsigned inventorGiven Name  
(first and middle [if any])  
Philip R.Family Name  
or Surname  
MassInventor's  
Signature

Date

6/12/02

Boston

MA

US

US

Residence: City

State

Country

Citizenship

28 Fleet Street, #12

Mailing Address

Boston

MA

02113

US

City

State

ZIP

Country

 Additional inventors are being named on the \_\_\_\_\_ supplemental Additional Inventor(s) sheet(s) PTO/SB/02A attached hereto.



10/16/851  
06/12/02

PATENT NUMBER and  
ISSUE DATE

U.S. UTILITY Patent Application

2/10/02

APPL NUM	FILING DATE	CLASS	SUBCLASS	GAU	EXAMINER
10167851	06/12/2002	318	66.2	2837	Leukin

**\*\*APPLICANTS:** Jones Joseph; Mass Philip;

**\*\*CONTINUING DATA VERIFIED:**  
THIS APPLN CLAIMS BENEFIT OF 60/297,718 06/12/2001

**\*\* FOREIGN APPLICATIONS VERIFIED:**

PG-PUB  DO NOT PUBLISH  RESCIND

Foreign priority claimed  yes  no  
 35 USC 119 conditions met  yes  no  
 Verified and Acknowledged Examiners's initials

ATTORNEY DOCKET NO  
DP-5 US

TITLE : Method and system for multi-mode coverage for an autonomous robot

U.S. DEPT. OF COMM./PAT. & TM-PTO-436L (Rev. 12-94)

<b>NOTICE OF ALLOWANCE MAILED</b>		<b>CLAIMS ALLOWED</b>	
		Total Claims	Print Claim for O.G.
<b>ISSUE FEE</b>		<b>DRAWING</b>	
Amount Due	Date Paid	Sheets Drwg.	Figs. Drwg. Print Fig.
		Application Examiner	
<input type="checkbox"/> <b>TERMINAL DISCLAIMER</b>		<b>PREPARED FOR ISSUE</b>	
<p><b>WARNING:</b> The information disclosed herein may be restricted. Unauthorized disclosure may be prohibited by the United States Code Title 35, Sections 122, 181 and 368, Possession outside the U.S. Patent &amp; Trademark Office is restricted to authorized employees and contractors only.</p>			

FILED WITH:  DISK (CRF)  CD-ROM  
(Attached in pocket on right inside flap)



**ISSUING CLASSIFICATION**

ORIGINAL		CROSS REFERENCE(S)					
CLASS	SUBCLASS	CLASS	SUBCLASS (ONE SUBCLASS PER BLOCK)				
INTERNATIONAL CLASSIFICATION							
	/						
	/						
	/						
	/						
	/						

^ Continued on Issue Slip Inside File Jacket

**INDEX OF CLAIMS**

Rejected    - (Through numeral) ... Canceled    N ..... Non-elected    A ..... Appeal  
 Allowed    + ..... Restricted    I ..... Interference    O ..... Objected

Claim	Date	Claim	Date	Claim	Date
Final		Final		Final	
Original		Original		Original	
1		51		101	
2		52		102	
3		53		103	
4		54		104	
5		55		105	
6		56		106	
7		57		107	
8		58		108	
9		59		109	
10		60		110	
11		61		111	
12		62		112	
13		63		113	
14		64		114	
15		65		115	
16		66		116	
17		67		117	
18		68		118	
19		69		119	
20		70		120	
21		71		121	
22		72		122	
23		73		123	
24		74		124	
25		75		125	
26		76		126	
27		77		127	
28		78		128	
29		79		129	
30		80		130	
31		81		131	
32		82		132	
33		83		133	
34		84		134	
35		85		135	
36		86		136	
37		87		137	
38		88		138	
39		89		139	
40		90		140	
41		91		141	
42		92		142	
43		93		143	
44		94		144	
45		95		145	
46		96		146	
47		97		147	
48		98		148	
49		99		149	
50		100		150	

If more than 150 claims or 9 actions stapl additional sheet here

06-13-02

# UTILITY PATENT APPLICATION TRANSMITTAL

Attorney Docket No.	DP-5 US
First Inventor	JONES
Title	Multi-Mode Coverage for an Autonomous
Express Mail Label No.	EU002256851US

(Only for new nonprovisional applications under 37 CFR 1.53(b))

## APPLICATION ELEMENTS

See MPEP chapter 600 concerning utility patent application contents.

- Fee Transmittal Form (e.g., PTO/SB/17)  
*(Submit an original and a duplicate for fee processing)*
- Applicant claims small entity status.  
See 37 CFR 1.27.
- Specification [Total Pages  ]  
*(preferred arrangement set forth below)*
  - Descriptive title of the invention
  - Cross Reference to Related Applications
  - Statement Regarding Fed sponsored R & D
  - Reference to sequence listing, a table, or a computer program listing appendix
  - Background of the Invention
  - Brief Summary of the Invention
  - Brief Description of the Drawings (if filed)
  - Detailed Description
  - Claim(s)
  - Abstract of the Disclosure
- Drawing(s) (35 U.S.C. 113) [ Total Sheets  ]
- Oath or Declaration [ Total Pages  ]
  - Newly executed (original or copy)
  - Copy from a prior application (37 CFR 1.63 (d))  
*(for continuation/divisional with Box 18 completed)*
  - DELETION OF INVENTOR(S)**  
Signed statement attached deleting inventor(s) named in the prior application, see 37 CFR 1.63(d)(2) and 1.33(b).
- Application Data Sheet. See 37 CFR 1.76

## ADDRESS TO:

Assistant Commissioner for Patents  
Box Patent Application  
Washington, DC 20231

- CD-ROM or CD-R in duplicate, large table or Computer Program (Appendix)
- Nucleotide and/or Amino Acid Sequence Submission (if applicable, all necessary)
  - Computer Readable Form (CRF)
  - Specification Sequence Listing on:
    - CD-ROM or CD-R (2 copies); or
    - paper
  - Statements verifying identity of above copies

## ACCOMPANYING APPLICATION PARTS

- Assignment Papers (cover sheet & document(s))
- 37 CFR 3.73(b) Statement  Power of Attorney  
*(when there is an assignee)*
- English Translation Document (if applicable)
- Information Disclosure Statement (IDS)/PTO-1449  Copies of IDS Citations
- Preliminary Amendment
- Return Receipt Postcard (MPEP 503)  
*(Should be specifically itemized)*
- Certified Copy of Priority Document(s)  
*(if foreign priority is claimed)*
- Nonpublication Request under 35 U.S.C. 122 (b)(2)(B)(i). Applicant must attach form PTO/SB/35 or its equivalent.
- Other: .....

18.  CONTINUING APPLICATION, check appropriate box, and supply the requisite information below and in a preliminary amendment, or in an Application Data Sheet under 37 CFR 1.76:

Continuation  Divisional  Continuation-in-part (CIP) of prior application No.: \_\_\_\_\_ / \_\_\_\_\_

Prior application information: Examiner: \_\_\_\_\_ Group Art Unit: \_\_\_\_\_

For CONTINUATION OR DIVISIONAL APPS only: The entire disclosure of the prior application, from which an oath or declaration is supplied under Box 5b, is considered a part of the disclosure of the accompanying continuation or divisional application and is hereby incorporated by reference. The incorporation can only be relied upon when a portion has been inadvertently omitted from the submitted application parts.

## 19. CORRESPONDENCE ADDRESS

Customer Number or Bar Code Label  or  Correspondence address below  
*(Insert Customer No. or Attach bar code label here)*

Name			
Address			
City	State	Zip Code	
Country	Telephone	Fax	

Name (Print/Type)	Glen D. Weinstein	Registration No. (Attorney/Agent)	43,981
Signature		Date	06/12/2002

1c951 U.S. PTO  
06/12/02

Under the Paperwork Reduction Act of 1995, no persons are required to respond to a collection of information unless it displays a valid OMB control number.

# FEE TRANSMITTAL for FY 2002

Patent fees are subject to annual revision.

TOTAL AMOUNT OF PAYMENT (\$) 559.00

Complet if Kn wn

Application Number	
Filing Date	
First Named Inventor	Jones
Examiner Name	
Group Art Unit	
Attorney Docket No.	DP-5 US

### METHOD OF PAYMENT

1.  The Commissioner is hereby authorized to charge indicated fees and credit any overpayments to:

Deposit Account Number: 501806  
Deposit Account Name: iRobot Corporation

Charge Any Additional Fee Required Under 37 CFR 1.16 and 1.17  
 Applicant claims small entity status. See 37 CFR 1.27

2.  Payment Enclosed:  
 Check  Credit card  Money Order  Other

### FEE CALCULATION (continued)

3. ADDITIONAL FEES		Large Entity	Small Entity	Fee Description	Fee Paid
Fee Code	Fee (\$)	Fee Code	Fee (\$)		
105	130	205	65	Surcharge - late filing fee or oath	
127	50	227	25	Surcharge - late provisional filing fee or cover sheet	
139	130	139	130	Non-English specification	
147	2,520	147	2,520	For filing a request for <i>ex parte</i> reexamination	
112	920*	112	920*	Requesting publication of SIR prior to Examiner action	
113	1,840*	113	1,840*	Requesting publication of SIR after Examiner action	
115	110	215	55	Extension for reply within first month	
116	400	216	200	Extension for reply within second month	
117	920	217	460	Extension for reply within third month	
118	1,440	218	720	Extension for reply within fourth month	
128	1,960	228	980	Extension for reply within fifth month	
119	320	219	160	Notice of Appeal	
120	320	220	160	Filing a brief in support of an appeal	
121	280	221	140	Request for oral hearing	
138	1,510	138	1,510	Petition to institute a public use proceeding	
140	110	240	55	Petition to revive - unavoidable	
141	1,280	241	640	Petition to revive - unintentional	
142	1,280	242	640	Utility issue fee (or reissue)	
143	460	243	230	Design issue fee	
144	620	244	310	Plant issue fee	
122	130	122	130	Petitions to the Commissioner	
123	50	123	50	Processing fee under 37 CFR 1.17(q)	
126	180	126	180	Submission of Information Disclosure Stmt	
581	40	581	40	Recording each patent assignment per property (times number of properties)	
146	740	246	370	Filing a submission after final rejection (37 CFR § 1.129(a))	
149	740	249	370	For each additional invention to be examined (37 CFR § 1.129(b))	
179	740	279	370	Request for Continued Examination (RCE)	
169	900	169	900	Request for expedited examination of a design application	
Other fee (specify)					
*Reduced by Basic Filing Fee Paid					
<b>SUBTOTAL (3)</b>					<b>(\$)</b>

### FEE CALCULATION

1. BASIC FILING FEE

Large Entity Fee Code (\$)	Small Entity Fee Code (\$)	Fee Description	Fee Paid
101 740	201 370	Utility filing fee	370.00
106 330	206 165	Design filing fee	
107 510	207 255	Plant filing fee	
108 740	208 370	Reissue filing fee	
114 160	214 80	Provisional filing fee	
<b>SUBTOTAL (1)</b>			<b>(\$) 370.00</b>

2. EXTRA CLAIM FEES

Total Claims	Extra Claims	Fee from below	Fee Paid
41	-20** = 21	9.00	189.00
Independent Claims: 3	-3** = 0		
Multiple Dependent			

Large Entity Fee Code (\$)	Small Entity Fee Code (\$)	Fee Description	Fee Paid
103 18	203 9	Claims in excess of 20	
102 84	202 42	Independent claims in excess of 3	
104 280	204 140	Multiple dependent claim, if not paid	
109 84	209 42	** Reissue independent claims over original patent	
110 18	210 9	** Reissue claims in excess of 20 and over original patent	
<b>SUBTOTAL (2)</b>			<b>(\$) 189.00</b>

\*\*or number previously paid, if greater; For Reissues, see above

<b>SUBMITTED BY</b>		<b>Complete (if applicable)</b>	
Name (Print/Type)	Glen D. Weinstein	Registration No. (Attorney/Agent)	43,981
Signature		Telephone	617.629.0055
		Date	06/12/2002

**WARNING: Information on this form may become public. Credit card information should not be included on this form. Pr vide credit card information and authorization on PTO-2038.**

Burden Hour Statement: This form is estimated to take 0.2 hours to complete. Time will vary depending upon the needs of the individual case. Any comments on the amount of time you are required to complete this form should be sent to the Chief Information Officer, U.S. Patent and Trademark Office, Washington, DC 20231. DO NOT SEND FEES OR COMPLETED FORMS TO THIS ADDRESS. SEND TO: Assistant Commissioner for Patents, Washington, DC 20231.

202190-15829107

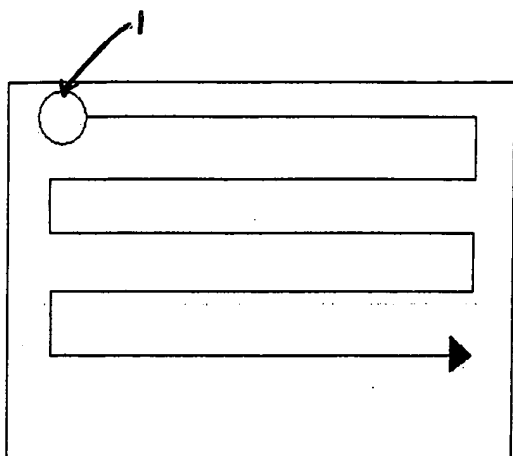


FIG. 1A

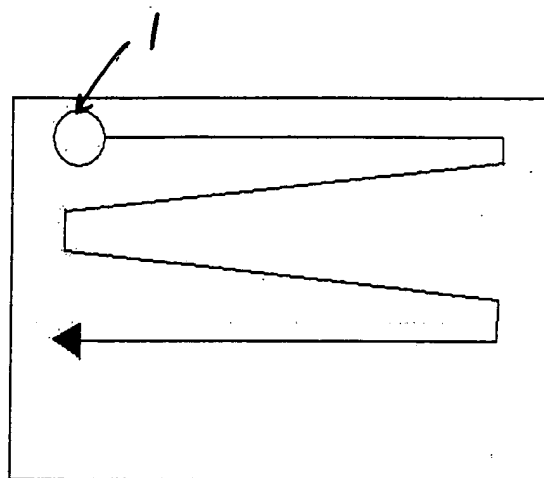


FIG. 1B

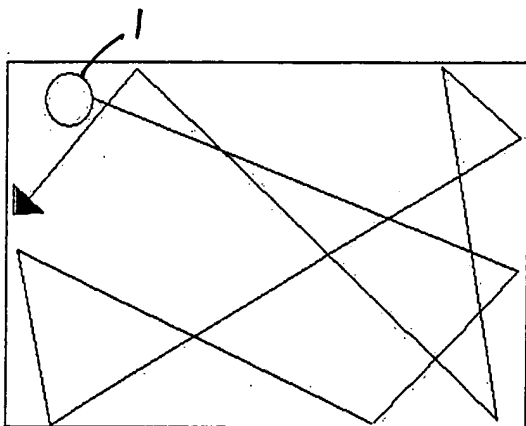


FIG. 1C

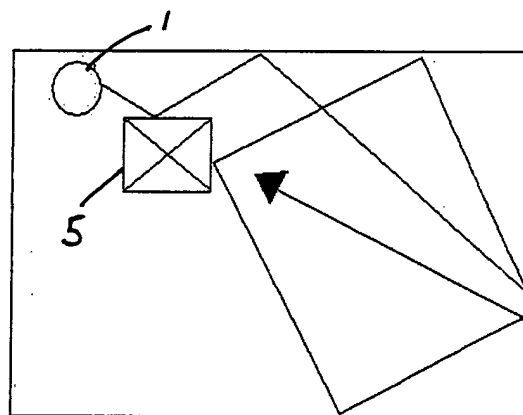


FIG. 1D

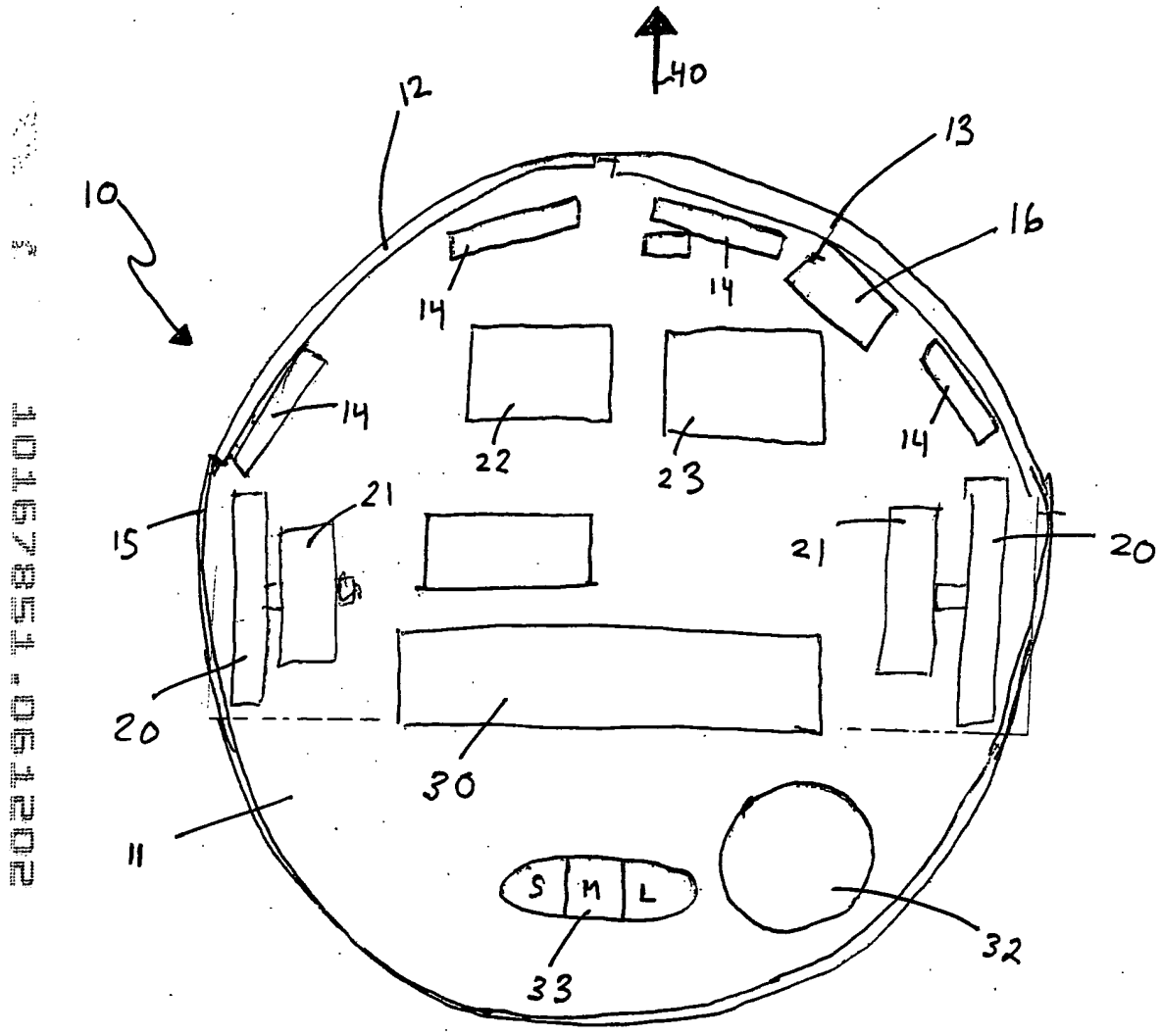
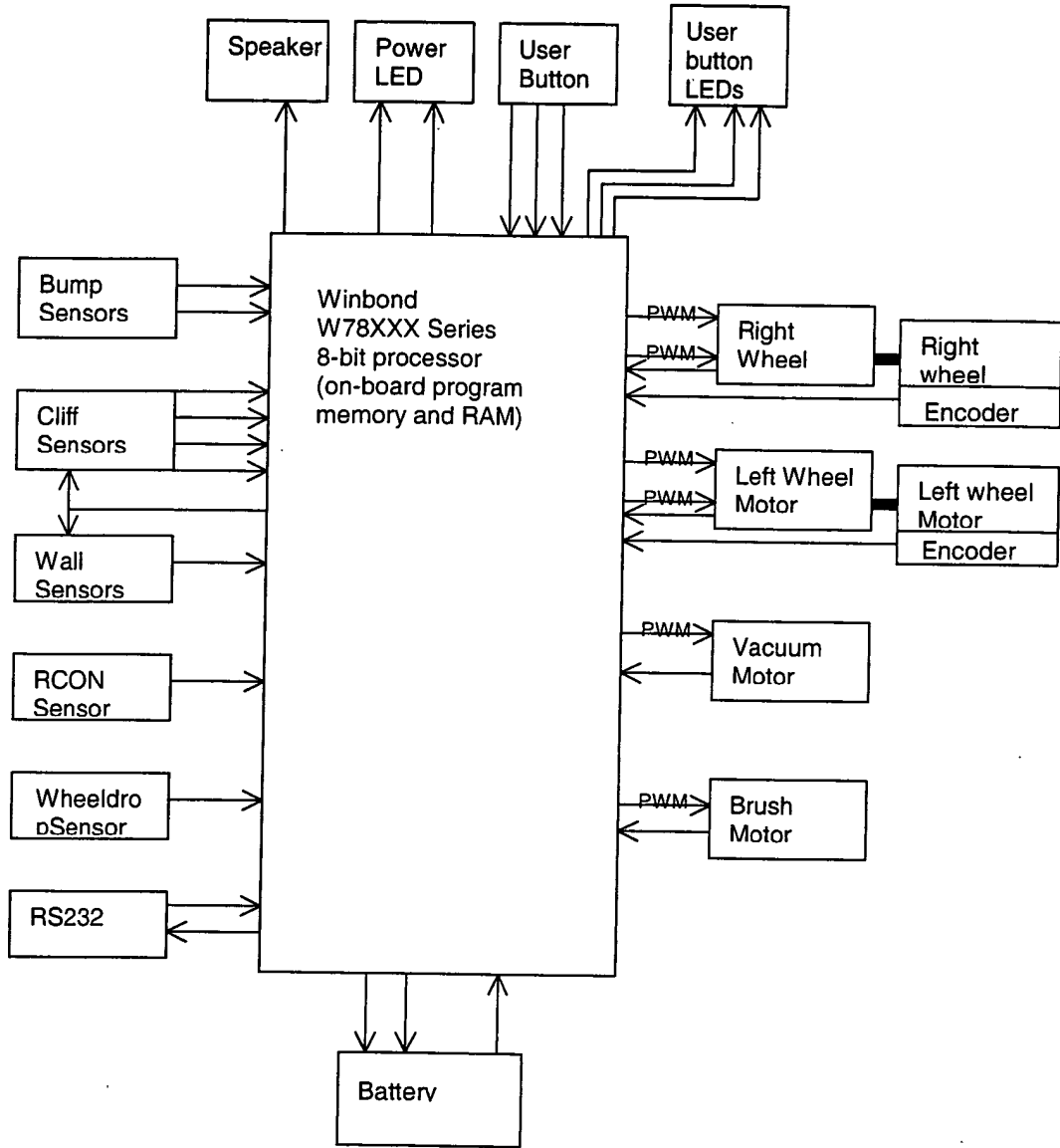


FIG. 2

202790-75849707  
10167851-061202

FIG. 3



2025011509101



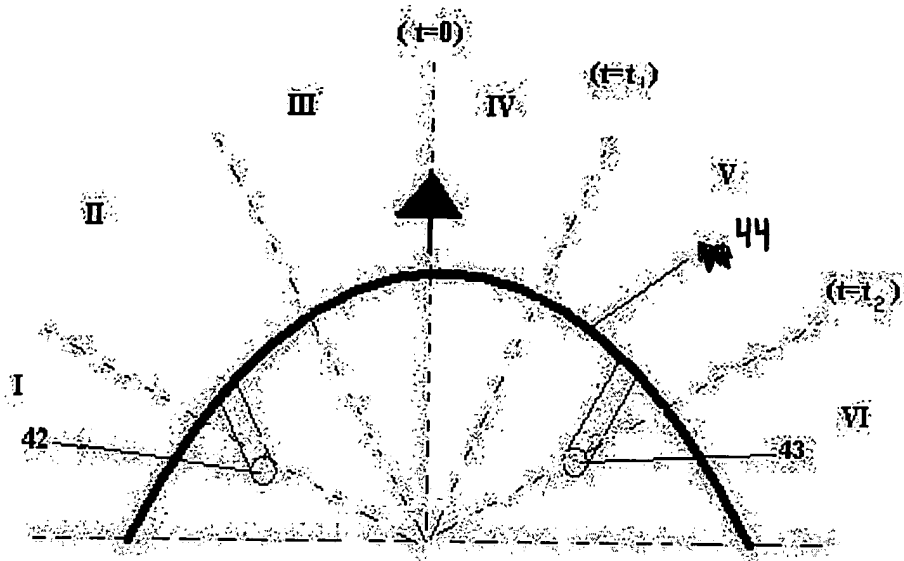


FIG. 4A

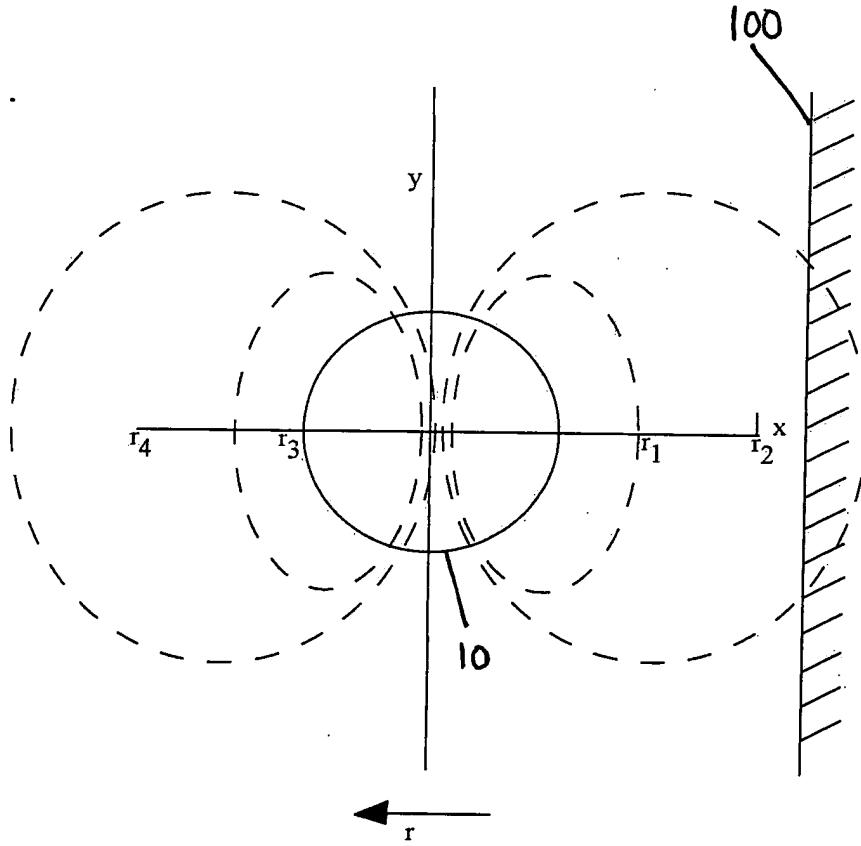


FIG. 4B

202190-15879T01

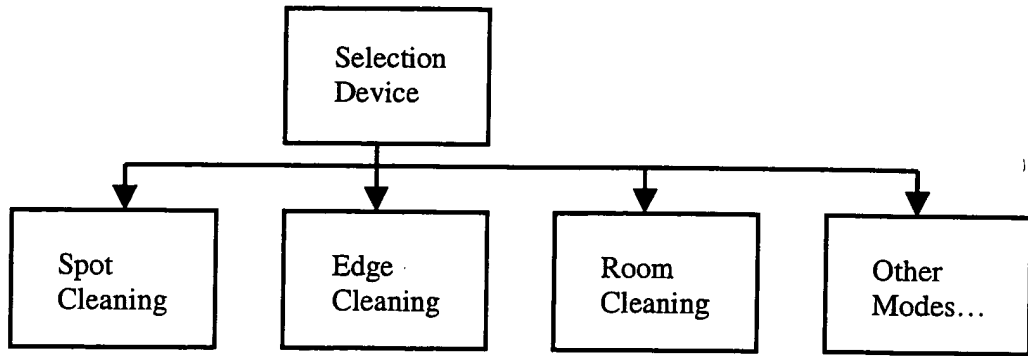


FIG. 5

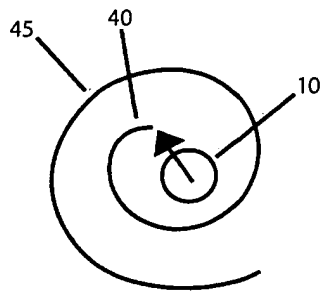


FIG. 6A

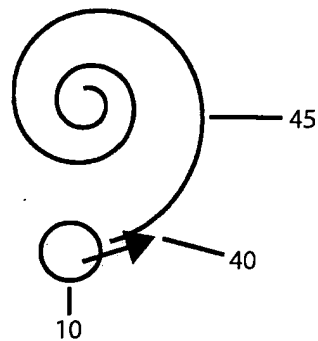


FIG. 6B

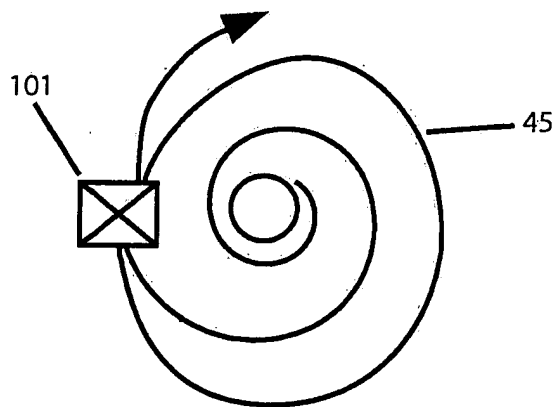


FIG. 6C

202190 T58Z9T0T  
10167851.051202

20250706 10:57:51

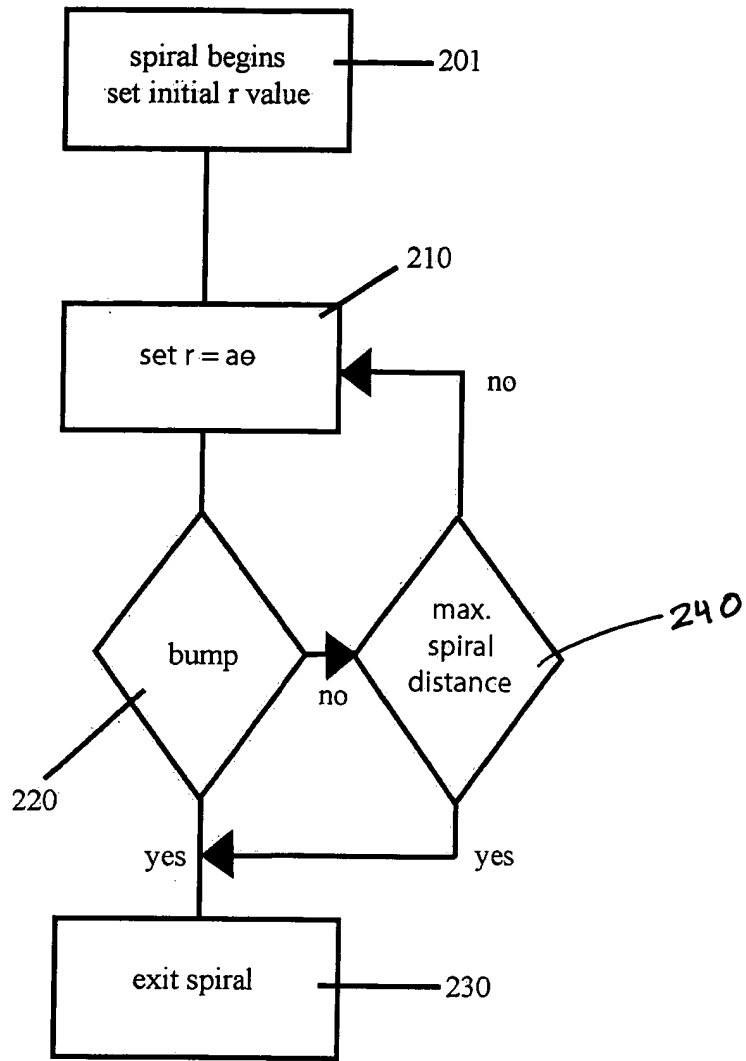


FIG. 7

10167851-051202

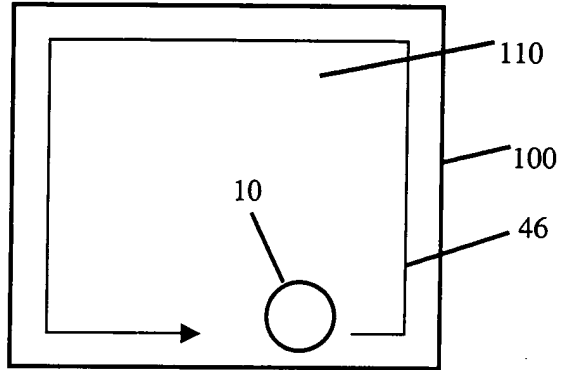


FIG. 8A

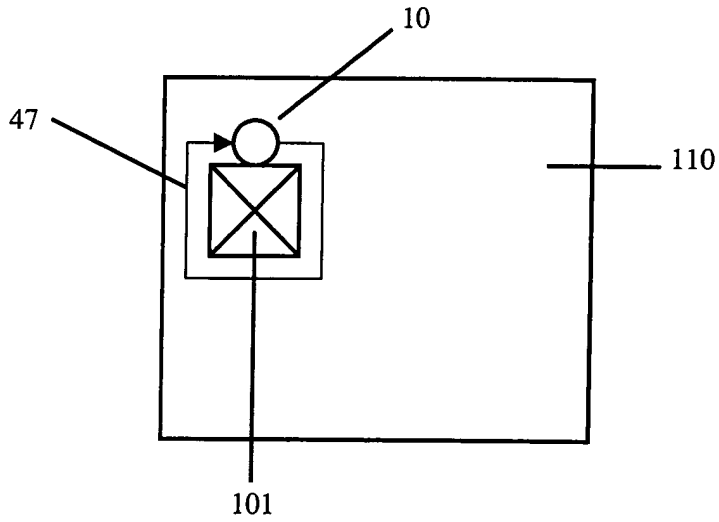
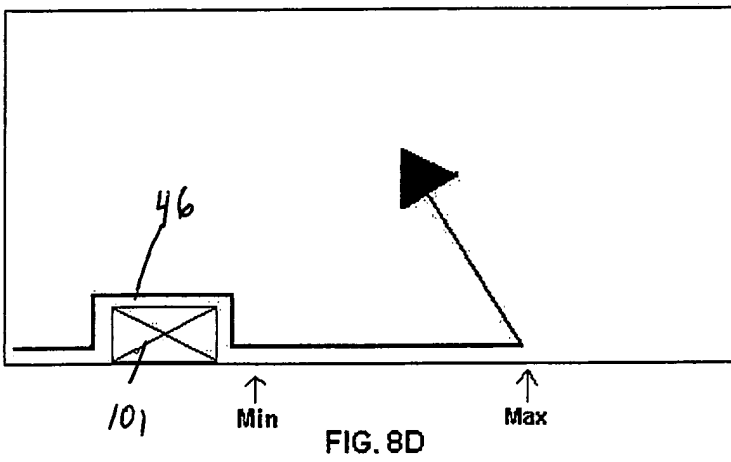
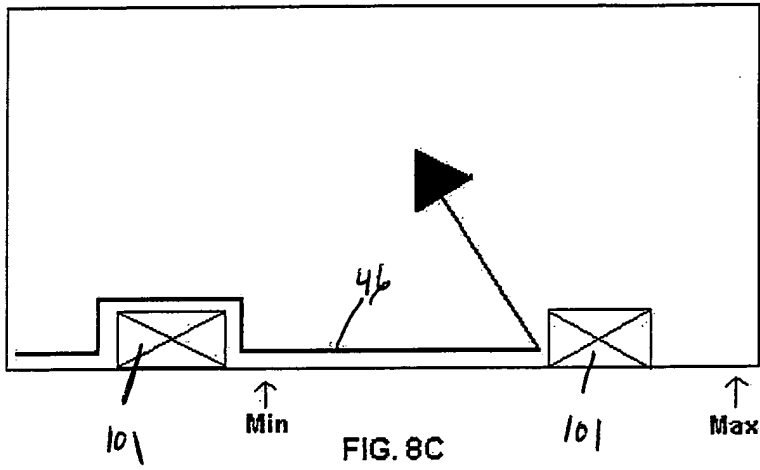


FIG. 8B

20250729-051202



10167851.061202

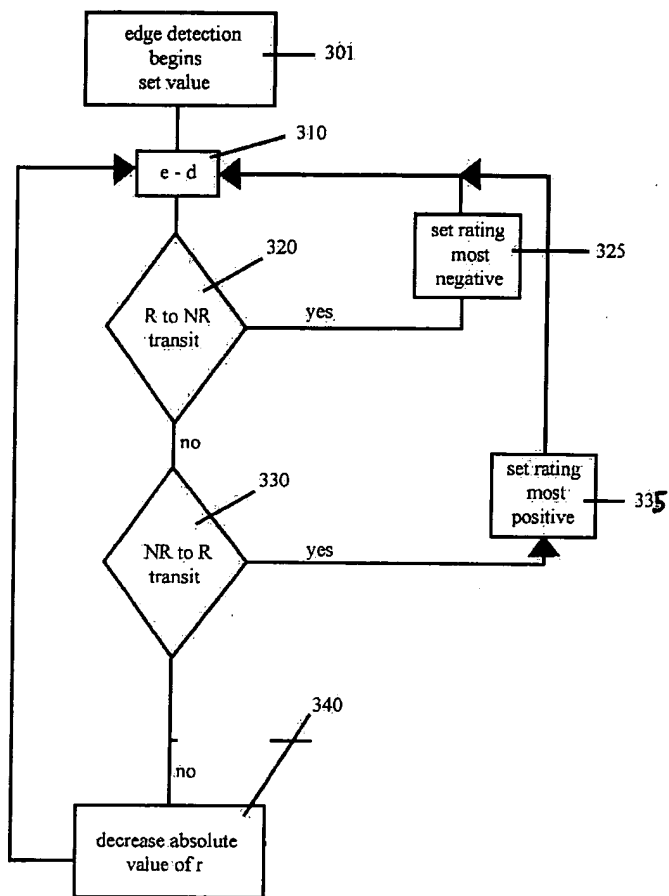


FIG. 9A

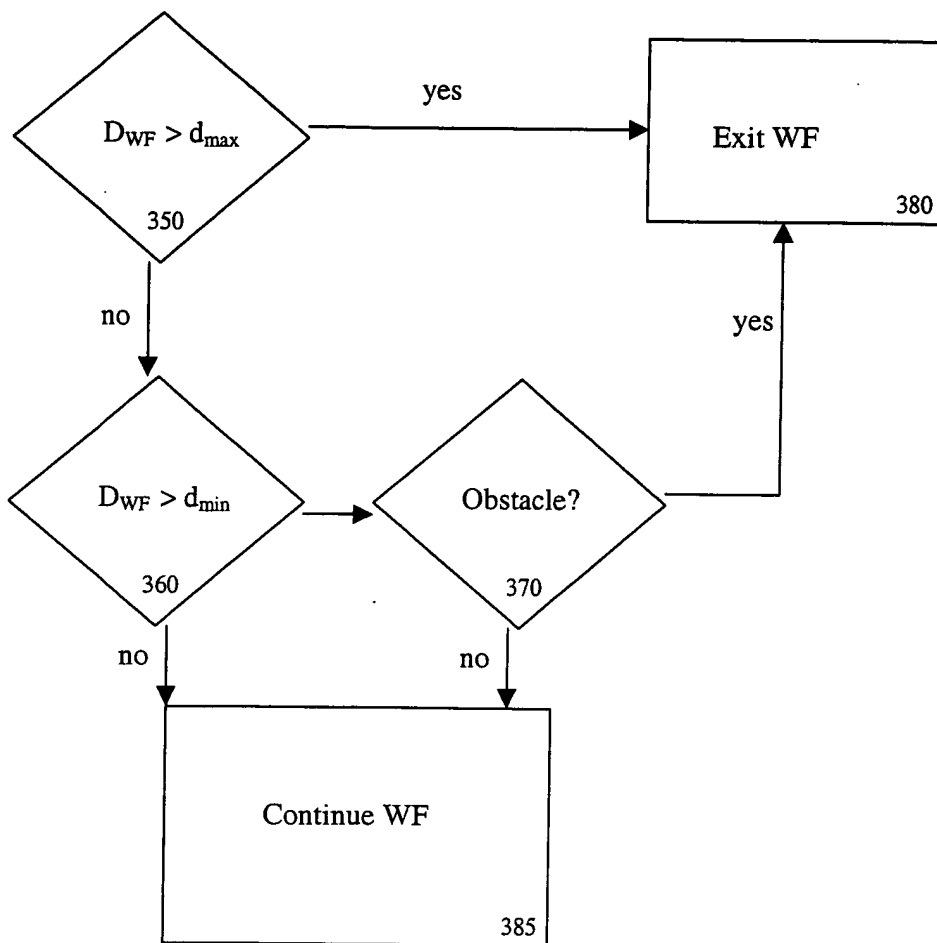


FIG. 9B

202190-15849101

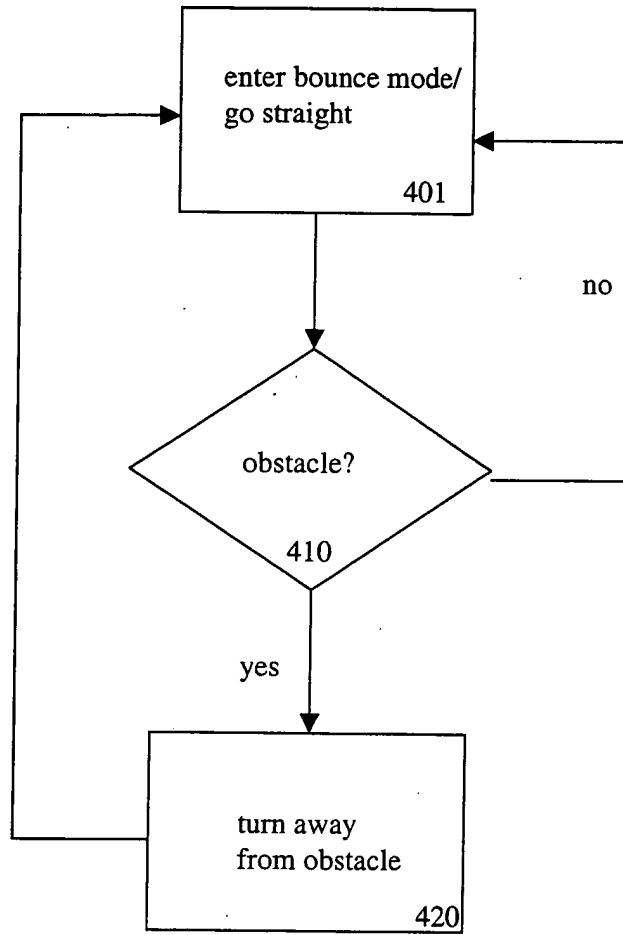


FIG. 10

10167851-061202



202190" F52Z9T0T  
10167851.051202

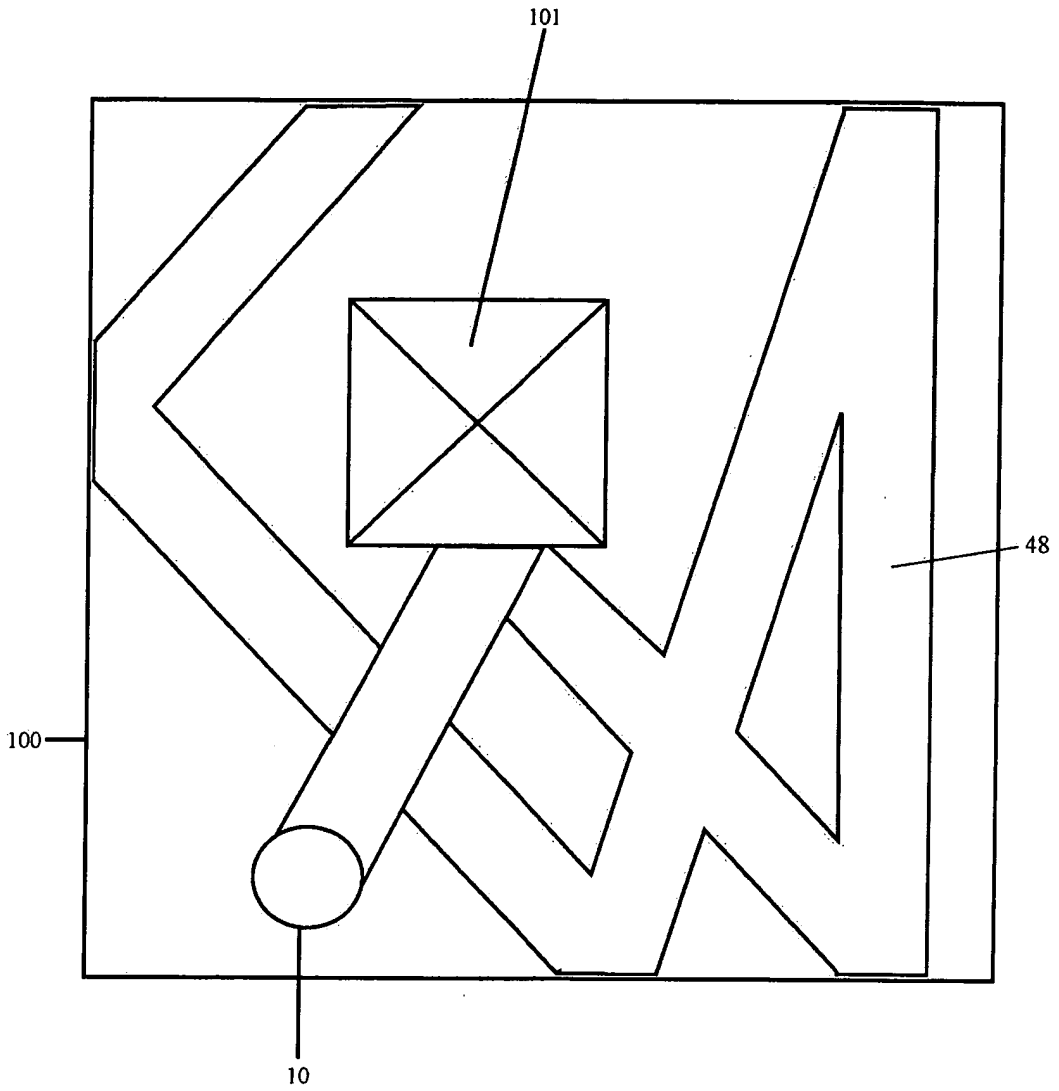


FIG. 11

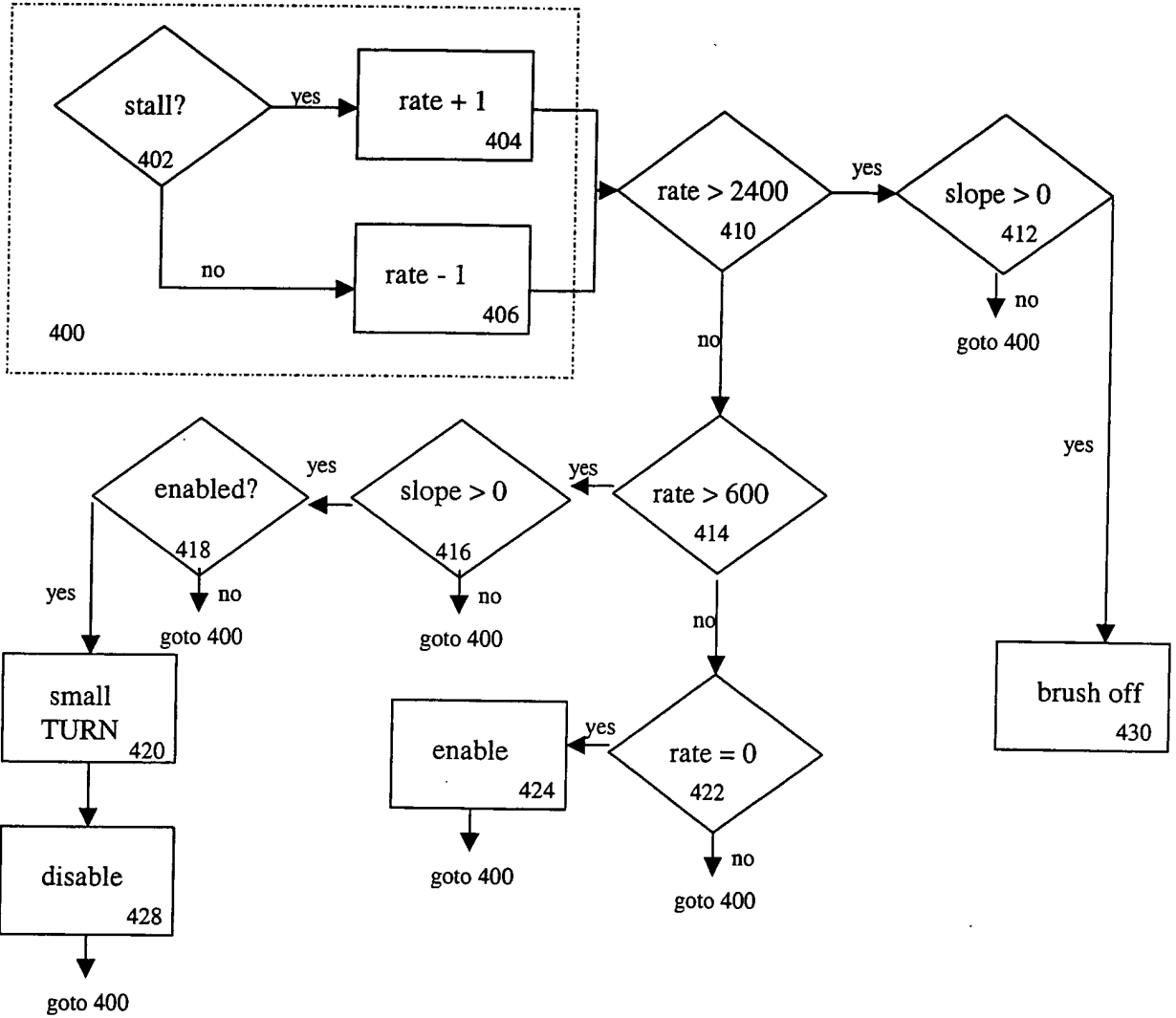


FIG. 12A

20250709 10167551.061202

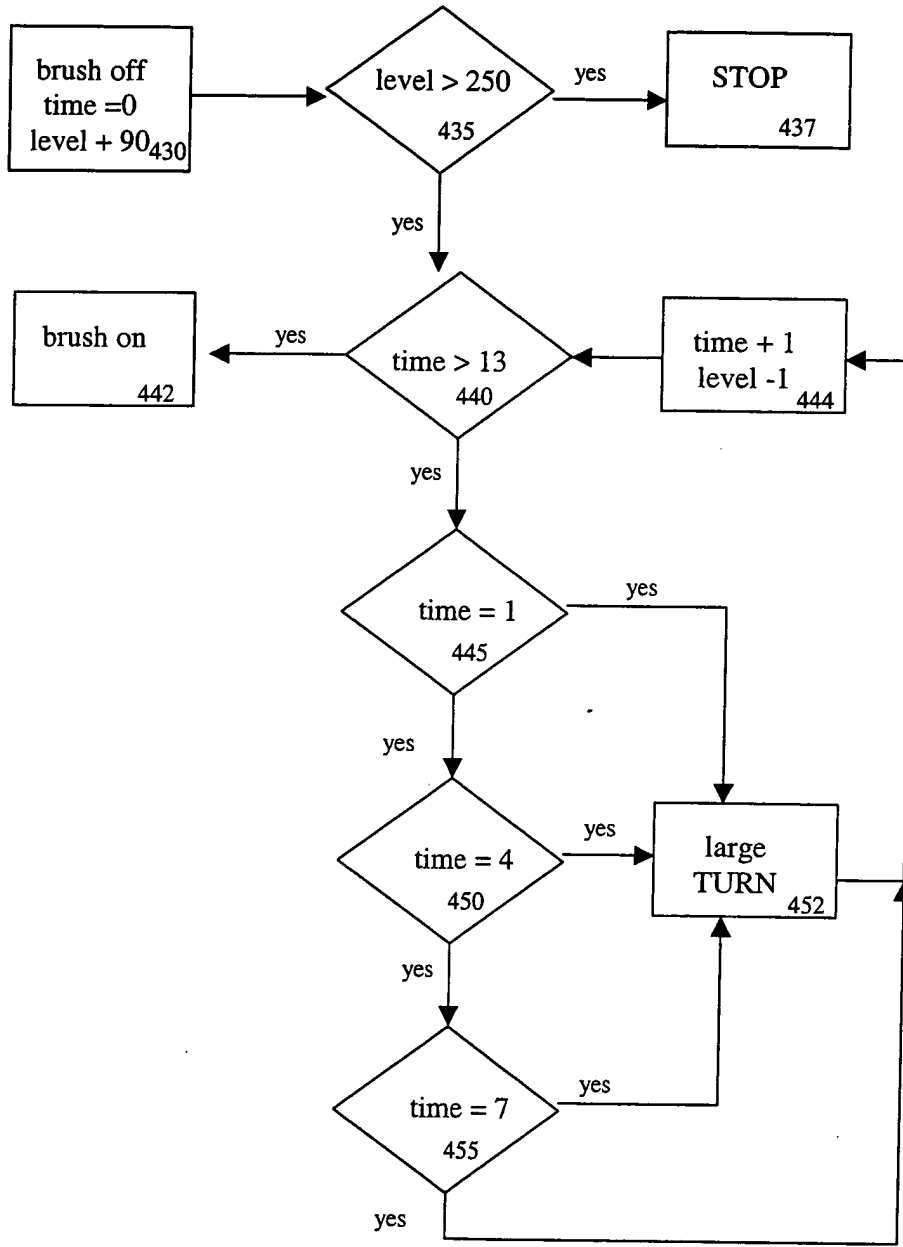


FIG. 12B

202190 TEST 1015

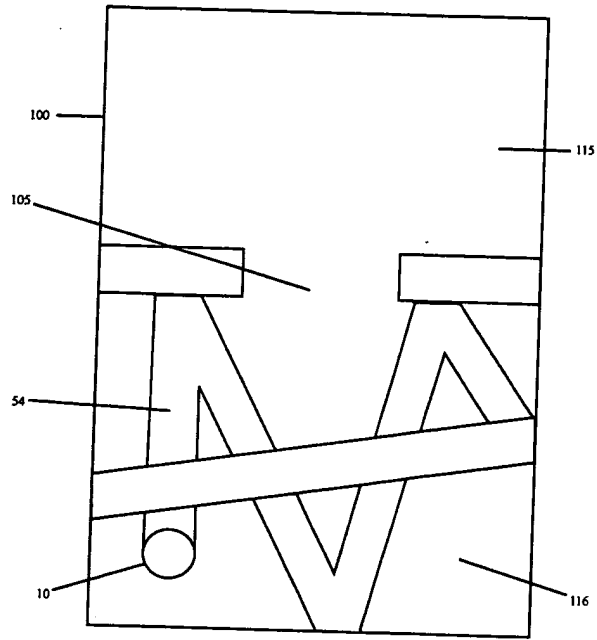


FIG. 13A

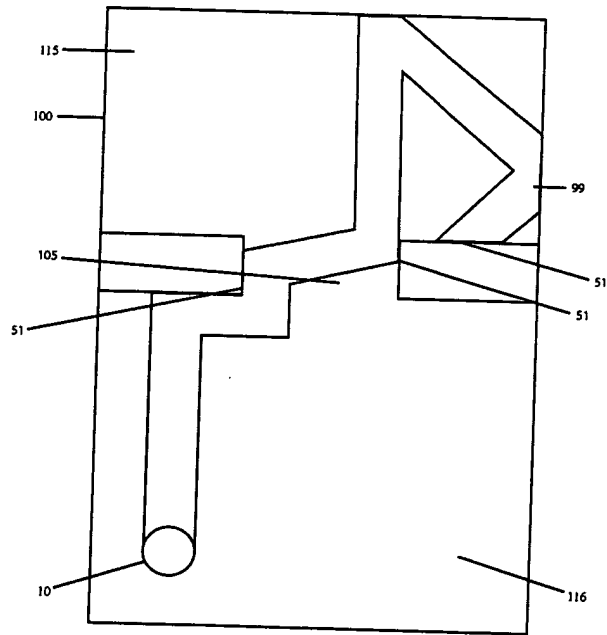


FIG. 13B

10167831-051202

10167851.061202

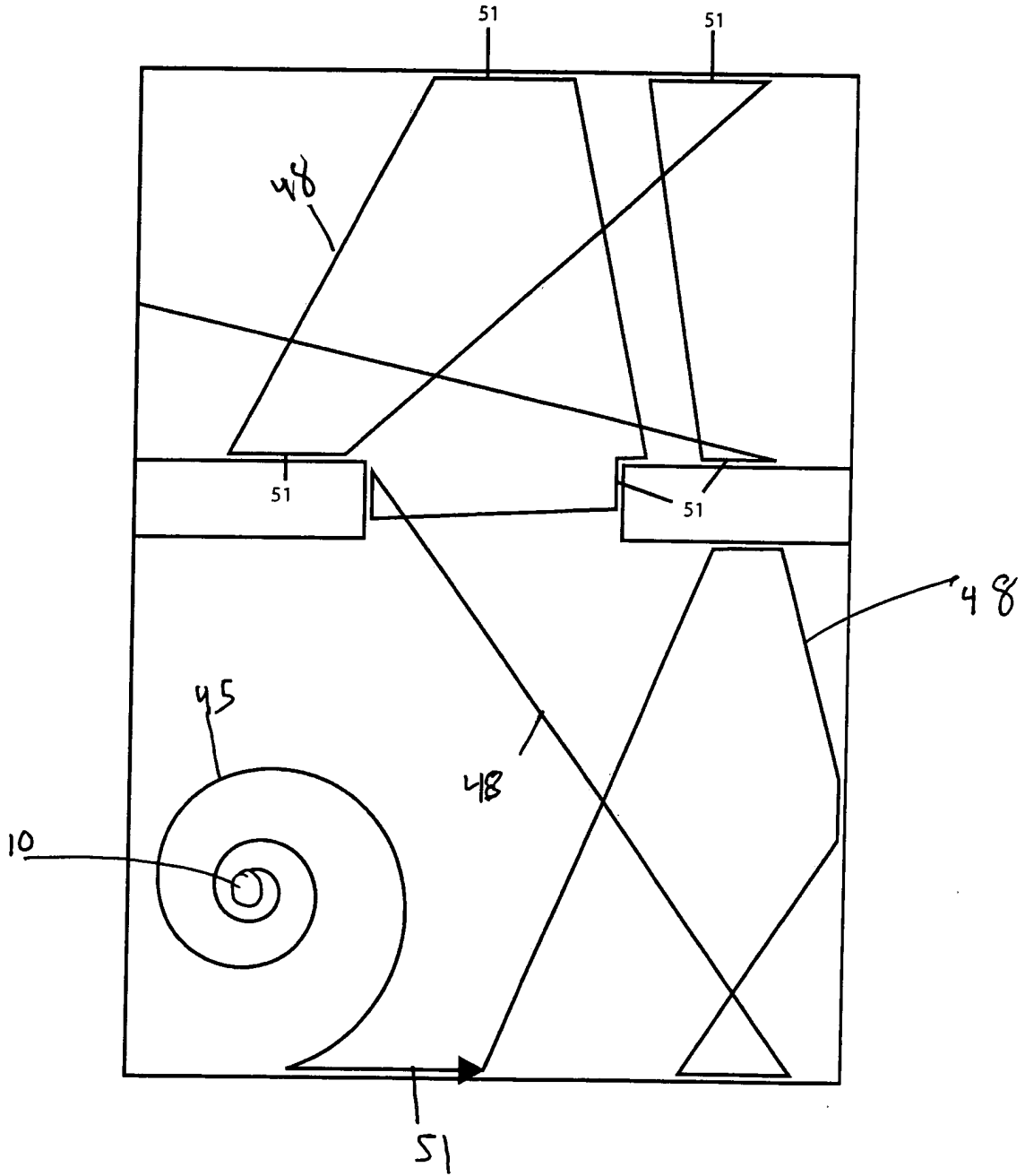


FIG. 14

Patent Application of  
Joseph L. Jones & Philip R. Mass  
for

**METHOD AND SYSTEM FOR MULTI-MODE COVERAGE  
FOR AN AUTONOMOUS ROBOT**

5

This application is entitled to the benefit of United States Provisional Application Ser. No. 60/297,718 filed June 12, 2001.

10

FIELD OF THE INVENTION

This invention relates generally to autonomous vehicles or robots, and more specifically to methods and mobile robotic devices for covering a specific area as might be required of, or used as, robotic cleaners or lawn mowers.

DESCRIPTION OF PRIOR ART

For purposes of this description, examples will focus on the problems faced in the prior art as related to robotic cleaning (e.g., dusting, buffing, sweeping, scrubbing, dry mopping or vacuuming). The claimed invention, however, is limited only by the claims themselves, and one of skill in the art will recognize the myriad of uses for the present invention beyond indoor, domestic cleaning.

25

Robotic engineers have long worked on developing an effective method of autonomous cleaning. By way of

introduction, the performance of cleaning robots should concentrate on three measures of success: coverage, cleaning rate and perceived effectiveness. Coverage is the percentage of the available space visited by the robot during a fixed  
5 cleaning time, and ideally, a robot cleaner would provide 100 percent coverage given an infinite run time. Unfortunately, designs in the prior art often leave portions of the area uncovered regardless of the amount of time the device is allowed to complete its tasks. Failure to achieve complete  
10 coverage can result from mechanical limitations -- e.g., the size and shape of the robot may prevent it from reaching certain areas -- or the robot may become trapped, unable to vary its control to escape. Failure to achieve complete coverage can also result from an inadequate coverage  
15 algorithm. The coverage algorithm is the set of instructions used by the robot to control its movement. For the purposes of the present invention, coverage is discussed as a percentage of the available area visited by the robot during a finite cleaning time. Due to mechanical and/or algorithmic  
20 limitations, certain areas within the available space may be systematically neglected. Such systematic neglect is a significant limitation in the prior art.

A second measure of a cleaning robot's performance is the cleaning rate given in units of area cleaned per unit  
25 time. Cleaning rate refers to the rate at which the area of cleaned floor increases; coverage rate refers to the rate at

10167851051202

which the robot covers the floor regardless of whether the floor was previously clean or dirty. If the velocity of the robot is  $v$  and the width of the robot's cleaning mechanism (also called work width) is  $w$  then the robot's coverage rate is simply  $wv$ , but its cleaning rate may be drastically lower.

A robot that moves in a purely randomly fashion in a closed environment has a cleaning rate that decreases relative to the robot's coverage rate as a function of time. This is because the longer the robot operates the more likely it is to revisit already cleaned areas. The optimal design has a cleaning rate equivalent to the coverage rate, thus minimizing unnecessary repeated cleanings of the same spot. In other words, the ratio of cleaning rate to coverage rate is a measure of efficiency and an optimal cleaning rate would mean coverage of the greatest percentage of the designated area with the minimum number of cumulative or redundant passes over an area already cleaned.

A third metric of cleaning robot performance is the perceived effectiveness of the robot. This measure is ignored in the prior art. Deliberate movement and certain patterned movement is favored as users will perceive a robot that contains deliberate movement as more effective.

While coverage, cleaning rate and perceived effectiveness are the performance criteria discussed herein, a preferred embodiment of the present invention also takes into account the ease of use in rooms of a variety of shapes

10157851051202



and sizes (containing a variety of unknown obstacles) and the cost of the robotic components. Other design criteria may also influence the design, for example the need for collision avoidance and appropriate response to other hazards.

5           As described in detail in Jones, Flynn & Seiger, Mobile Robots: Inspiration to Implementation second edition, 1999, A K Peters, Ltd., and elsewhere, numerous attempts have been made to build vacuuming and cleaning robots. Each of these robots has faced a similar challenge: how to efficiently  
10 cover the designated area given limited energy reserves.

We refer to maximally efficient cleaning, where the cleaning rate equals the coverage rate, as deterministic cleaning. As shown in FIG. 1A, a robot 1 following a deterministic path moves in such a way as to completely cover  
15 the area 2 while avoiding all redundant cleaning.

Deterministic cleaning requires that the robot know both where it is and where it has been; this in turn requires a positioning system. Such a positioning system - a  
20 positioning system suitably accurate to enable deterministic cleaning might rely on scanning laser rangefinders, ultrasonic transducers, carrier phase differential GPS, or other methods - can be prohibitively expensive and involve user set-up specific to the particular room geometries. Also, methods that rely on global positioning are typically incapacitated  
25 by the failure of any part of the positioning system.

One example of using highly sophisticated (and expensive) sensor technologies to create deterministic cleaning is the RoboScrub device built by Denning Mobile Robotics and Windsor Industries, which used sonar, infrared detectors, bump sensors and high-precision laser navigation. RoboScrub's navigation system required attaching large bar code targets at various positions in the room. The requirement that RoboScrub be able to see at least four targets simultaneously was a significant operational problem. RoboScrub, therefore, was limited to cleaning large open areas.

Another example, RoboKent, a robot built by the Kent Corporation, follows a global positioning strategy similar to RobotScrub. RoboKent dispenses with RobotScrub's more expensive laser positioning system but having done so RoboKent must restrict itself only to areas with a simple rectangular geometry, e.g. long hallways. In these more constrained regions, position correction by sonar ranging measurements is sufficient. Other deterministic cleaning systems are described, for example, in U.S. Patent Nos. 4,119,900 (Kremnitz), 4,700,427 (Knepper), 5,353,224 (Lee et al.), 5,537,017 (Feiten et al.), 5,548,511 (Bancroft), 5,650,702 (Azumi).

Because of the limitations and difficulties of deterministic cleaning, some robots have relied on pseudo-deterministic schemes. One method of providing pseudo-

10167851064202  
202490.F5BZ9TDT

deterministic cleaning is an autonomous navigation method known as dead reckoning. Dead reckoning consists of measuring the precise rotation of each robot drive wheel (using for example optical shaft encoders). The robot can then calculate its expected position in the environment given a known starting point and orientation. One problem with this technique is wheel slippage. If slippage occurs, the encoder on that wheel registers a wheel rotation even though that wheel is not driving the robot relative to the ground. As shown in FIG. 1B, as the robot 1 navigates about the room, these drive wheel slippage errors accumulate making this type of system unreliable for runs of any substantial duration. (The path no longer consists of tightly packed rows, as compared to the deterministic coverage shown in FIG. 1A.) The result of reliance on dead reckoning is intractable systematic neglect; in other words, areas of the floor are not cleaned.

One example of a pseudo-deterministic a system is the Cyre robot from Probotics, Inc. Cyre depends exclusively on dead reckoning and therefore takes heroic measures to maximize the performance of its dead reckoning system. Cyre must begin at a user-installed physical registration spot in a known location where the robot fixes its position and orientation. Cyre then keeps track of position as it moves away from that spot. As Cyre moves, uncertainty in its position and orientation increase. Cyre must make certain to

return to a calibration spot before this error grows so large that it will be unlikely to locate a calibration spot. If a calibration spot is moved or blocked or if excessive wheel slippage occurs then Cye can become lost (possibly without realizing that it is lost). Thus Cye is suitable for use only in relatively small benign environments. Other examples of this approach are disclosed in U.S. Patent Nos. 5,109,566 (Kobayashi et al.) and 6,255,793 (Peless et al.).

Another approach to robotic cleaning is purely random motion. As shown in FIG. 1C, in a typical room without obstacles, a random movement algorithm will provide acceptable coverage given significant cleaning time. Compared to a robot with a deterministic algorithm, a random cleaning robot must operate for a longer time to achieve acceptable coverage. To have high confidence that the random-motion robot has cleaned 98% of an obstacle-free room, the random motion robot must run approximately five times as long as a deterministic robot with the same cleaning mechanism moving at the same speed.

The coverage limitations of a random algorithm can be seen in FIG. 1D. An obstacle in the room can create the effect of segmenting the room into a collection of chambers. The coverage over time of a random algorithm robot in such a room is analogous to the time density of gas released in one chamber of a confined volume. Initially, the density of gas is highest in the chamber where it is released and lowest in

more distant chambers. Similarly the robot is most likely to thoroughly clean the chamber where it starts, rather than more distant chambers, early in the process. Given enough time a gas reaches equilibrium with equal density in all chambers. Likewise given time, the robot would clean all areas thoroughly. The limitations of practical power supplies, however, usually guarantee that the robot will have insufficient time to clean all areas of a space cluttered with obstacles. We refer to this phenomenon as the robot diffusion problem.

As discussed, the commercially available prior art has not been able to produce an effective coverage algorithm for an area of unknown geometry. As noted above, the prior art either has relied on sophisticated systems of markers or beacons or has limited the utility of the robot to rooms with simple rectangular geometries. Attempts to use pseudo-deterministic control algorithms can leave areas of the space systematically neglected.

#### OBJECTS AND ADVANTAGES

It is an object of the present invention to provide a system and method to allow a mobile robot to operate in a plurality of modes in order to effectively cover an area.

It is an object of the present invention to provide a mobile robot, with at least one sensor, to operate in a

10157851-051202

5

10

15

20

25

number of modes including spot-coverage, obstacle following and bounce.

It is a further object of the invention to provide a mobile robot that alternates between obstacle following and  
5 bounce mode to ensure coverage.

It is an object of the invention to return to spot-coverage after the robot has traveled a pre-determined distance.

It is an object of the invention to provide a mobile  
10 robot able to track the average distance between obstacles and use the average distance as an input to alternate between operational modes.

It is yet another object of the invention to optimize the distance the robot travels in an obstacle following mode as a function of the frequency of obstacle following and the work width of the robot, and to provide a minimum and maximum  
15 distance for operating in obstacle following mode.

It is an object of a preferred embodiment of the invention to use a control system for a mobile robot with an  
20 operational system program able to run a plurality of behaviors and using an arbiter to select which behavior is given control over the robot.

It is still another object of the invention to incorporate various escape programs or behavior to allow the  
25 robot to avoid becoming stuck.

Finally, it is an object of the invention to provide one or more methods for controlling a mobile robot to benefit from the various objects and advantages disclosed herein.

5

#### BRIEF DESCRIPTION OF THE DRAWINGS

These and further features of the present invention will be apparent with reference to the accompanying drawings, wherein:

FIGS. 1A-D illustrate coverage patterns of various robots in the prior art;

FIG. 2 is a top-view schematic representation of the basic components of a mobile robot used in a preferred embodiment of the invention;

FIG. 3 demonstrates a hardware block diagram of the robot shown in FIG. 2;

FIG. 4A is a diagram showing a method of determining the angle at which the robot encounters an obstacle; FIG. 4B is a diagram showing the orientation of a preferred embodiment of the robot control system;

FIG. 5 is a schematic representation of the operational modes of the instant invention;

FIG. 6A is a schematic representation of the coverage pattern for a preferred embodiment of SPIRAL behavior; FIG. 6B is a schematic representation of the coverage pattern for an alternative embodiment of SPIRAL behavior; FIG. 6C is a

10167851.061202

10

15

20

25

schematic representation of the coverage pattern for yet another alternative embodiment of SPIRAL behavior;

FIG. 7 is a flow-chart illustration of the spot-coverage algorithm of a preferred embodiment of the invention;

5 FIGS. 8A & 8B are schematic representations of the coverage pattern for a preferred embodiment of operation in obstacle following mode;

FIG. 9A is a flow-chart illustration of the obstacle following algorithm of a preferred embodiment of the invention; FIG. 9B is a flow-chart illustration of a preferred algorithm for determining when to exit obstacle following mode.

FIG. 10 is a schematic representation of the coverage pattern for a preferred embodiment of BOUNCE behavior;

FIG. 11 is a flow-chart illustration of the room coverage algorithm of a preferred embodiment of the invention;

FIGS. 12A & 12B are flow-chart illustrations of an exemplary escape behavior;

FIG. 13A is a schematic representation of the coverage pattern a mobile robot with only a single operational mode; FIG. 13B is a schematic representation of the coverage pattern for a preferred embodiment of the instant invention using obstacle following and room coverage modes; and

FIG. 14 is a schematic representation of the coverage pattern for a preferred embodiment of the instant invention

10157851 051203  
202490 7582907



using spot-coverage, obstacle following and room coverage modes.

#### DESCRIPTION OF INVENTION

5 In the present invention, a mobile robot is designed to provide maximum coverage at an effective coverage rate in a room of unknown geometry. In addition, the perceived effectiveness of the robot is enhanced by the inclusion of patterned or deliberate motion. In addition, in a preferred embodiment, effective coverage requires a control system able to prevent the robot from becoming immobilized in an unknown environment.

10 While the physical structures of mobile robots are known in the art, the components of a preferred, exemplary embodiment of the present invention is described herein. A preferred embodiment of the present invention is a substantially circular robotic sweeper containing certain features. As shown in FIG. 2, for example, the mobile robot 10 of a preferred embodiment includes a chassis 11 supporting mechanical and electrical components. These components include various sensors, including two bump sensors 12 & 13 located in the forward portion of the robot, four cliff sensors 14 located on the robot shell 15, and a wall following sensor 16 mounted on the robot shell 15. In other 25 embodiments, as few as one sensor may be used in the robot. One of skill in the art will recognize that the sensor(s) may

be of a variety of types including sonar, tactile, electromagnetic, capacitive, etc. Because of cost restraints, a preferred embodiment of the present invention uses bump (tactile) sensors 12 & 13 and reflective IR proximity sensors for the cliff sensors 14 and the wall-following sensor 16. Details of the IR sensors are described in U.S. Patent Application U.S.S.N. 09/768,773, which disclosure is hereby incorporated by reference.

A preferred embodiment of the robot also contains two wheels 20, motors 21 for driving the wheels independently, an inexpensive low-end microcontroller 22, and a rechargeable battery 23 or other power source known in the art. These components are well known in the art and are not discussed in detail herein. The robotic cleaning device 10 further includes one or more cleaning heads 30. The cleaning head might contain a vacuum cleaner, various brushes, sponges, mops, electrostatic cloths or a combination of various cleaning elements. The embodiment shown in FIG. 2 also includes a side brush 32.

As mentioned above, a preferred embodiment of the robotic cleaning device 10 comprises an outer shell 15 defining a dominant side, non-dominant side, and a front portion of the robot 10. The dominant side of the robot is the side that is kept near or in contact with an object (or obstacle) when the robot cleans the area adjacent to that object (or obstacle). In a preferred embodiment, as shown in

FIG. 1, the dominant side of the robot 10 is the right-hand side relative to the primary direction of travel, although in other embodiments the dominant side may be the left-hand side. In still other embodiments, the robot may be symmetric and thereby does not need a dominant side; however, in a preferred embodiment, a dominant side is chosen for reasons of cost. The primary direction of travel is as shown in FIG. 2 by arrow 40.

In a preferred embodiment, two bump sensors 12 & 13 are located forward of the wheels 20 relative to the direction of forward movement, shown by arrow 40. One bump sensor 13 is located on the dominant side of the robot 10 and the other bump sensor 12 is located on the non-dominant side of the robot 10. When both of these bump sensors 12 & 13 are activated simultaneously, the robot 10 recognizes an obstacle in the front position. In other embodiments, more or fewer individual bump sensors can be used. Likewise, any number of bump sensors can be used to divide the device into any number of radial segments. While in a preferred embodiment the bump sensors 12 & 13 are IR break beam sensors activated by contact between the robot 10 and an obstacle, other types of sensors can be used, including mechanical switches and capacitive sensors that detect the capacitance of objects touching the robot or between two metal plates in the bumper that are compressed on contact. Non-contact sensors, which allow the robot to sense proximity to objects without

10167851-054202

physically touching the object, such as capacitive sensors or a curtain of IR light, can also be used.

It is useful to have a sensor or sensors that are not only able to tell if a surface has been contacted (or is nearby), but also the angle relative to the robot at which the contact was made. In the case of a preferred embodiment, the robot is able to calculate the time between the activation of the right and left bump switches 12 & 13, if both are activated. The robot is then able to estimate the angle at which contact was made. In a preferred embodiment shown in FIG. 4A, the bump sensor comprises a single mechanical bumper 44 at the front of the robot with sensors 42 & 43 substantially at the two ends of the bumper that sense the movement of the bumper. When the bumper is compressed, the timing between the sensor events is used to calculate the approximate angle at which the robot contacted the obstacle. When the bumper is compressed from the right side, the right bump sensor detects the bump first, followed by the left bump sensor, due to the compliance of the bumper and the bump detector geometry. This way, the bump angle can be approximated with only two bump sensors.

For example, in FIG. 4A, bump sensors 42 & 43 are able to divide the forward portion of the robot into six regions (I-VI). When a bump sensor is activated, the robot calculates the time before the other sensor is activated (if

at all). For example, when the right bump sensor 43 is activated, the robot measures the time ( $t$ ) before the left bump sensor 42 is activated. If  $t$  is less than  $t_1$ , then the robot assumes contact occurred in region IV. If  $t$  is greater than or equal to  $t_1$  and less than  $t_2$ , then the robot assumes contact was made in region V. If  $t$  is greater than or equal to  $t_2$  (including the case of where the left bump sensor 42 is not activated at all within the time monitored), then the robot assumes the contact occurred in region VI. If the bump sensors are activated simultaneously, the robot assumes the contact was made from straight ahead. This method can be used to divide the bumper into an arbitrarily large number of regions (for greater precision) depending on the timing used and geometry of the bumper. As an extension, three sensors can be used to calculate the bump angle in three dimensions instead of just two dimensions as in the preceding example.

A preferred embodiment also contains a wall-following or wall-detecting sensor 16 mounted on the dominant side of the robot 10. In a preferred embodiment, the wall following sensor is an IR sensor composed of an emitter and detector pair collimated so that a finite volume of intersection occurs at the expected position of the wall. This focus point is approximately three inches ahead of the drive wheel

in the direction of robot forward motion. The radial range of wall detection is about 0.75 inches.

A preferred embodiment also contains any number of IR cliff sensors 14 that prevent the device from tumbling over stairs or other vertical drops. These cliff sensors are of a construction similar to that of the wall following sensor but directed to observe the floor rather than a wall. As an additional safety and sensing measure, the robot 10 includes a wheel-drop sensor that is able to detect if one or more wheels is unsupported by the floor. This wheel-drop sensor can therefore detect not only cliffs but also various obstacles upon which the robot is able to drive, such as lamps bases, high floor transitions, piles of cords, etc.

Other embodiments may use other known sensors or combinations of sensors.

FIG. 3 shows a hardware block diagram of the controller and robot of a preferred embodiment of the invention. In a preferred embodiment, a Winbond W78XXX series processor is used. It is a microcontroller compatible with the MCS-51 family with 36 general purpose I/O ports, 256 bytes of RAM and 16K of ROM. It is clocked at 40MHz which is divided down for a processor speed of 3.3 MHz. It has two timers which are used for triggering interrupts used to process sensors and generate output signals as well as a watchdog timer. The lowest bits of the fast timer are also used as approximate random numbers where needed in the behaviors. There are also

10167851.051202

two external interrupts which are used to capture the encoder inputs from the two drive wheels. The processor also has a UART which is used for testing and debugging the robot control program.

5           The I/O ports of the microprocessor are connected to the sensors and motors of the robot and are the interface connecting it to the internal state of the robot and its environment. For example, the wheel drop sensors are connected to an input port and the brush motor PWM signal is  
10 generated on an output port. The ROM on the microprocessor is used to store the coverage and control program for the robot. This includes the behaviors (discussed below), sensor processing algorithms and signal generation. The RAM is used to store the active state of the robot, such as the average  
15 bump distance, run time and distance, and the ID of the behavior in control and its current motor commands.

For purposes of understanding the movement of the robotic device, FIG. 4B shows the orientation of the robot  
20 centered about the x and y axes in a coordinate plane; this coordinate system is attached to the robot. The directional movement of the robot 10 can be understood to be the radius at which the robot 10 will move. In order to rapidly turn away from the wall 100, the robot 10 should set a positive, small value of  $r$  ( $r_1$  in FIG. 4B); in order to rapidly turn  
25 toward the wall, the robot should set a negative, small value of  $r$  ( $r_1$  in FIG. 4B). On the other hand, to make slight

10167851-051202

turns, the robot should set larger absolute values for  $r$  - positive values to move left (i.e. away from the wall,  $r_1$  in FIG. 4B) and negative values to move right (i.e. toward the wall,  $r_2$  in FIG. 4B). This coordinate scheme is used in the examples of control discussed below. The microcontroller controlling differential speed at which the individual wheel motors 21 are run, determines the turning radius.

Also, in certain embodiments, the robot may include one or more user inputs. For example, as shown in FIG. 2, a preferred embodiment includes three simple buttons 33 that allow the user to input the approximate size of the surface to be covered. In a preferred embodiment, these buttons labeled "small," "medium," and "large" correspond respectively to rooms of 11.1, 20.8 and 27.9 square meters.

As mentioned above, the exemplary robot is a preferred embodiment for practicing the instant invention, and one of skill in the art is able to choose from elements known in the art to design a robot for a particular purpose. Examples of suitable designs include those described in the following U.S. Patents Nos: 4,306,329 (Yokoi), 5,109,566 (Kobayashi et al.), 5,293,955 (Lee), 5,369,347 (Yoo), 5,440,216 (Kim), 5,534,762 (Kim), 5,613,261 (Kawakami et al), 5,634,237 (Paranjpe), 5,781,960 (Kilstrom et al.), 5,787,545 (Colens), 5,815,880 (Nakanishi), 5,839,156 (Park et al.), 5,926,909 (McGee), 6,038,501 (Kawakami), 6,076,226 (Reed), all of which are hereby incorporated by reference.



FIG. 5 shows a simple block representation of the various operational modes of a device. In a preferred embodiment, and by way of example only, operational modes may include spot cleaning (where the user or robot designates a specific region for cleaning), edge cleaning, and room cleaning. Each operational mode comprises complex combinations of instructions and/or internal behaviors, discussed below. These complexities, however, are generally hidden from the user. In one embodiment, the user can select the particular operational mode by using an input element, for example, a selector switch or push button. In other preferred embodiments, as described below, the robot is able to autonomously cycle through the operational modes.

The coverage robot of the instant invention uses these various operational modes to effectively cover the area. While one of skill in the art may implement these various operational modes in a variety of known architectures, a preferred embodiment relies on behavior control. Here, behaviors are simply layers of control systems that all run in parallel. The microcontroller 22 then runs a prioritized arbitration scheme to resolve the dominant behavior for a given scenario. A description of behavior control can be found in Mobile Robots, supra, the text of which is hereby incorporated by reference.

In other words, in a preferred embodiment, the robot's microprocessor and control software run a number of behaviors

simultaneously. Depending on the situation, control of the robot will be given to one or more various behaviors. For purposes of detailing the preferred operation of the present invention, the behaviors will be described as (1) coverage behaviors, (2) escape behaviors or (3) user/safety behaviors. Coverage behaviors are primarily designed to allow the robot to perform its coverage operation in an efficient manner. Escape behaviors are special behaviors that are given priority when one or more sensor inputs suggest that the robot may not be operating freely. As a convention for this specification, behaviors discussed below are written in all capital letters.

1. Coverage Behaviors

FIGS. 6-14 show the details of each of the preferred operational modes: Spot Coverage, Wall Follow (or Obstacle Follow) and Room Coverage.

Operational Mode: Spot Coverage

Spot coverage or, for example, spot cleaning allows the user to clean an isolated dirty area. The user places the robot on the floor near the center of the area that requires cleaning and selects the spot-cleaning operational mode. The robot then moves in such a way that the immediate area within, for example, a defined radius, is brought into contact with the cleaning head 30 or side brush 32 of the robot.

In a preferred embodiment, the method of achieving spot cleaning is a control algorithm providing outward spiral movement, or SPIRAL behavior, as shown in FIG. 6A. In general, spiral movement is generated by increasing the turning radius as a function of time. In a preferred embodiment, the robot 10 begins its spiral in a counter-clockwise direction, marked in FIG. 6A by movement line 45, in order to keep the dominant side on the outward, leading-edge of the spiral. In another embodiment, shown in FIG. 6B, spiral movement of the robot 10 is generated inward such that the radius of the turns continues to decrease. The inward spiral is shown as movement line 45 in FIG. 6B. It is not necessary, however, to keep the dominant side of the robot on the outside during spiral motion.

The method of spot cleaning used in a preferred embodiment - outward spiraling - is set forth in FIG. 7. Once the spiraling is initiated (step 201) and the value of  $r$  is set at its minimum, positive value (which will produce the tightest possible counterclockwise turn), the spiraling behavior recalculates the value of  $r$  as a function of  $\theta$ , where  $\theta$  represents the angular turning since the initiation of the spiraling behavior (step 210). By using the equation  $r = a\theta$ , where  $a$  is a constant coefficient, the tightness or desired overlap of the spiral can be controlled. (Note that  $\theta$  is not normalized to  $2\pi$ ). The value of  $a$  can be chosen by

202501-15829101

the equation  $a = \frac{d}{2\pi}$  ; where d is the distance between two consecutive passes of the spiral. For effective cleaning, a value for d should be chosen that is less than the width of the cleaning mechanism 30. In a preferred embodiment, a value of d is selected that is between one-half and two-thirds of the width of the cleaning head 30.

10 In other embodiments, the robot tracks its total distance traveled in spiral mode. Because the spiral will deteriorate after some distance, i.e. the centerpoint of the spiral motion will tend to drift over time due to surface dependant wheel slippage and/or inaccuracies in the spiral approximation algorithm and calculation precision. In certain embodiments, the robot may exit spiral mode after the robot has traveled a specific distance ("maximum spiral distance"), such as 6.3 or 18.5 meters (step 240). In a preferred embodiment, the robot uses multiple maximum spiral distances depending on whether the robot is performing an initial spiral or a later spiral. If the maximum spiral distance is reached without a bump, the robot gives control to a different behavior, and the robot, for example, then continues to move in a predominately straight line. (In a preferred embodiment, a STRAIGHT LINE behavior is a low priority, default behavior that propels the robot in an approximate straight line at a preset velocity of approximately 0.306 m/s when no other behaviors are active.

10167551061302  
20190729T01

5 In spiral mode, various actions can be taken when an obstacle is encountered. For example, the robot could (a) seek to avoid the obstacle and continue the spiral in the counter-clockwise direction, (b) seek to avoid the obstacle and continue the spiral in the opposite direction (e.g. changing from counter-clockwise to clockwise), or (c) change operational modes. Continuing the spiral in the opposite direction is known as reflective spiraling and is represented in FIG. 6C, where the robot 10 reverses its movement path 45 when it comes into contact with obstacle 101. In a preferred embodiment, as detailed in step 220, the robot 10 exits spot cleaning mode upon the first obstacle encountered by a bump sensor 12 or 13.

15 While a preferred embodiment describes a spiral motion for spot coverage, any self-bounded area can be used, including but not limited to regular polygon shapes such as squares, hexagons, ellipses, etc.

Operational Mode: Wall/Obstacle Following

20 Wall following or, in the case of a cleaning robot, edge cleaning, allows the user to clean only the edges of a room or the edges of objects within a room. The user places the robot 10 on the floor near an edge to be cleaned and selects the edge-cleaning operational mode. The robot 10 then moves in such a way that it follows the edge and cleans all areas  
25 brought into contact with the cleaning head 30 of the robot.

The movement of the robot 10 in a room 110 is shown in FIG. 8. In FIG. 8A, the robot 10 is placed along with wall 100, with the robot's dominant side next to the wall. The robot then runs along the wall indefinitely following movement path 46. Similarly, in FIG. 8B, the robot 10 is placed in the proximity of an obstacle 101. The robot then follows the edge of the obstacle 101 indefinitely following movement path 47.

In a preferred embodiment, in the wall-following mode, the robot uses the wall-following sensor 16 to position itself a set distance from the wall. The robot then proceeds to travel along the perimeter of the wall. As shown in FIGS. 8A & 8B, in a preferred embodiment, the robot 10 is not able to distinguish between a wall 100 and another solid obstacle 101.

The method used in a preferred embodiment for following the wall is detailed in FIG. 9A and provides a smooth wall following operation even with a one-bit sensor. (Here the one-bit sensor detects only the presence or absence of the wall within a particular volume rather than the distance between wall and sensor.) Other methods of detecting a wall or object can be used such as bump sensing or sonar sensors.

Once the wall-following operational mode, or WALL FOLLOWING behavior of a preferred embodiment, is initiated (step 301), the robot first sets its initial value for the steering at  $r_0$ . The WALL-FOLLOWING behavior then initiates

the emit-detect routine in the wall-follower sensor 16 (step 310). The existence of a reflection for the IR transmitter portion of the sensor 16 translates into the existence of an object within a predetermined distance from the sensor 16.

5 The WALL-FOLLOWING behavior then determines whether there has been a transition from a reflection (object within range) to a non-reflection (object outside of range) (step 320). If there has been a transition (in other words, the wall is now out of range), the value of  $r$  is set to its most negative  
10 value and the robot will veer slightly to the right (step 325). The robot then begins the emit-detect sequence again (step 310). If there has not been a transition from a reflection to a non-reflection, the wall-following behavior then determines whether there has been a transition from non-  
15 reflection to reflection (step 330). If there has been such a transition, the value of  $r$  is set to its most positive value and the robot will veer slightly left (step 335).

20 In the absence of either type of transition event, the wall-following behavior reduces the absolute value of  $r$  (step 340) and begins the emit-detect sequence (step 310) anew. By decreasing the absolute value of  $r$ , the robot 10 begins to turn more sharply in whatever direction it is currently heading. In a preferred embodiment, the rate of decreasing the absolute value of  $r$  is a constant rate dependant on the  
25 distance traveled.

The wall follower mode can be continued for a predetermined or random time, a predetermined or random distance or until some additional criteria are met (e.g. bump sensor is activated, etc.). In one embodiment, the robot  
5 continues to follow the wall indefinitely. In a preferred embodiment, as shown in FIGS. 8C & 8D, minimum and maximum travel distances are determined, whereby the robot will remain in WALL-FOLLOWING behavior until the robot has either traveled the maximum distance (FIG. 8D) or traveled at least  
10 the minimum distance and encountered an obstacle (FIG. 8C). This implementation of WALL-FOLLOWING behavior ensures the robot spends an appropriate amount of time in WALL-FOLLOWING behavior as compared to its other operational modes, thereby decreasing systemic neglect and distributing coverage to all  
15 areas. By increasing wall following, the robot is able to move in more spaces, but the robot is less efficient at cleaning any one space. In addition, by tending to exit WALL-FOLLOWING behavior after obstacle detection, the robot  
20 increases its perceived effectiveness.

20 FIG. 9B is a flow-chart illustration showing this embodiment of determining when to exit WALL-FOLLOWING behavior. The robot first determines the minimum distance to follow the wall ( $d_{min}$ ) and the maximum distance to follow the wall ( $d_{max}$ ). While in wall (or obstacle) following mode, the  
25 control system tracks the distance the robot has traveled in that mode ( $d_{wp}$ ). If  $d_{wp}$  is greater than  $d_{max}$  (step 350), then the



robot exits wall-following mode (step 380). If, however,  $d_{wp}$  is less than  $d_{max}$  (step 350) and  $d_{wp}$  is less than  $d_{min}$  (step 360), the robot remains in wall-following mode (step 385). If  $d_{wp}$  is greater than  $d_{min}$  (step 360) and an obstacle is encountered (step 370), the robot exits wall-following mode (step 380).

Theoretically, the optimal distance for the robot to travel in WALL-FOLLOWING behavior is a function of room size and configuration and robot size. In a preferred embodiment, the minimum and maximum distances to remain in WALL-FOLLOWING are set based upon the approximate room size, the robots width and a random component, where by the average minimum travel distance is  $2w/p$ , where  $w$  is the width of the work element of the robot and  $p$  is the probability that the robot will enter WALL-FOLLOWING behavior in a given interaction with an obstacle. By way of example, in a preferred embodiment,  $w$  is approximately between 15 cm and 25 cm, and  $p$  is 0.095 (where the robot encounters 6 to 15 obstacles, or an average of 10.5 obstacles, before entering an obstacle following mode). The minimum distance is then set randomly as a distance between approximately 115 cm and 350 cm; the maximum distance is then set randomly as a distance between approximately 170 cm and 520 cm. In certain embodiments the ratio between the minimum distance to the maximum distance is 2:3. For the sake of perceived efficiency, the robot's initial operation in a obstacle following mode can be set to be longer than its later operations in obstacle following

10167851.051202

mode. In addition, users may place the robot along the longest wall when starting the robot, which improves actual as well as perceived coverage.

The distance that the robot travels in wall following mode can also be set by the robot depending on the number and frequency of objects encountered (as determined by other sensors), which is a measure of room "clutter." If more objects are encountered, the robot would wall follow for a greater distance in order to get into all the areas of the floor. Conversely, if few obstacles are encountered, the robot would wall follow less in order to not over-cover the edges of the space in favor of passes through the center of the space. An initial wall-following distance can also be included to allow the robot to follow the wall a longer or shorter distance during its initial period where the WALL-FOLLOWING behavior has control.

In a preferred embodiment, the robot may also leave wall-following mode if the robot turns more than, for example, 270 degrees and is unable to locate the wall (or object) or if the robot has turned a total of 360 degrees since entering wall-following mode.

In certain embodiments, when the WALL-FOLLOWING behavior is active and there is a bump, the ALIGN behavior becomes active. The ALIGN behavior turns the robot counter-clockwise to align the robot with the wall. The robot always turns a minimum angle to avoid getting the robot getting into cycles

of many small turns. After it has turned through its minimum angle, the robot monitors its wall sensor and if it detects a wall and then the wall detection goes away, the robot stops turning. This is because at the end of the wall follower range, the robot is well aligned to start WALL-FOLLOWING. If the robot has not seen its wall detector go on and then off by the time it reaches its maximum angle, it stops anyway. This prevents the robot from turning around in circles when the wall is out of range of its wall sensor. When the most recent bump is within the side 60 degrees of the bumper on the dominant side, the minimum angle is set to 14 degrees and the maximum angle is 19 degrees. Otherwise, if the bump is within 30 degrees of the front of the bumper on the dominant side or on the non-dominant side, the minimum angle is 20 degrees and the maximum angle is 44 degrees. When the ALIGN behavior has completed turning, it cedes control to the WALL-FOLLOWING behavior

Operational Mode: Room Coverage

The third operational mode is here called room-coverage or room cleaning mode, which allows the user to clean any area bounded by walls, stairs, obstacles or other barriers. To exercise this option, the user places the robot on the floor and selects room-cleaning mode. The robot then moves about the room cleaning all areas that it is able to reach.

In a preferred embodiment, the method of performing the room cleaning behavior is a BOUNCE behavior in combination

10167881061202

with the STRAIGHT LINE behavior. As shown in FIG. 10, the robot 10 travels until a bump sensor 12 and/or 13 is activated by contact with an obstacle 101 or a wall 100. The robot 10 then turns and continues to travel. A sample movement path is shown in FIG. 11 as line 48.

The algorithm for random bounce behavior is set forth in FIG. 10. The robot 10 continues its forward movement (step 401) until a bump sensor 12 and/or 13 is activated (step 410). The robot 10 then calculates an acceptable range of new directions based on a determination of which bump sensor or sensors have been activated (step 420). A determination is then made with some random calculation to choose the new heading within that acceptable range, such as 90 to 270 degrees relative to the object the robot encountered. The angle of the object the robot has bumped is determined as described above using the timing between the right and left bump sensors. The robot then turns to its new headings. In a preferred embodiment, the turn is either clockwise or counterclockwise depending on which direction requires the least movement to achieve the new heading. In other embodiments, the turn is accompanied by movement forward in order to increase the robot's coverage efficiency.

The statistics of the heading choice made by the robot can be distributed uniformly across the allowed headings, i.e. there is an equivalent chance for any heading within the acceptable range. Alternately we can choose statistics

based on a Gaussian or other distribution designed to preferentially drive the robot perpendicularly away from a wall.

5 In other embodiments, the robot could change directions at random or predetermined times and not based upon external sensor activity. Alternatively, the robot could continuously make small angle corrections based on long range sensors to avoid even contacting an object and, thereby cover the surface area with curved paths

10 In a preferred embodiment, the robot stays in room-cleaning mode until a certain number of bounce interactions are reached, usually between 6 and 13.

## 2. Escape Behaviors

15 There are several situations the robot may encounter while trying to cover an area that prevent or impede it from covering all of the area efficiently. A general class of sensors and behaviors called escape behaviors are designed to get the robot out of these situations, or in extreme cases to shut the robot off if it is determined it cannot escape. In  
20 order to decide whether to give an escape behavior priority among the various behaviors on the robot, the robot determines the following: (1) is an escape behavior needed; (2) if yes, which escape behavior is warranted?

By way of example, the following situations illustrate situations where an escape behavior is needed for an indoor cleaning robot and an appropriate behavior to run:

5 (i) Situation 1. The robot detects a situation where it might get stuck - for example, a high spot in a carpet or near a lamp base that acts like a ramp for the robot. The robot performs small "panic" turn behaviors to get out of the situation;

10 (ii) Situation 2. The robot is physically stuck - for example, the robot is wedged under a couch or against a wall, tangled in cords or carpet tassels, or stuck on a pile of electrical cords with its wheels spinning. The robot performs large panic turn behaviors and turns off relevant motors to escape from the obstruction;

15 (iii) Situation 3. The robot is in a small, confined area -- for example, the robot is between the legs of a chair or in the open area under a dresser, or in a small area created by placing a lamp close to the corner of a room. The robot edge follows using its bumper and/or performs panic turn behaviors to escape from the area; and

20 (iv) Situation 4. The robot has been stuck and cannot free itself - for example, the robot is in

one of the cases in category (ii), above, and has not been able to free itself with any of its panic behaviors. In this case, the robot stops operation and signals to the user for help. This preserves battery life and prevents damage to floors or furniture.

In order to detect the need for each escape situation, various sensors are used. For example:

- (i) Situation 1. (a) When the brush or side brush current rise above a threshold, the voltage applied to the relevant motor is reduced. Whenever this is happening, a stall rate variable is increased. When the current is below the threshold, the stall rate is reduced. If the stall level rises above a low threshold and the slope of the rate is positive, the robot performs small panic turn behaviors. It only repeats these small panic turn behaviors when the level has returned to zero and risen to the threshold again. (b) Likewise, there is a wheel drop level variable which is increased when a wheel drop event is detected and is reduced steadily over time. When a wheel drop event is detected and the wheel drop level is above a threshold (meaning there have been several wheel drops recently), the robot performs small or

large panic turn behaviors depending on the wheel drop level.

- (ii) Situation 2. (a) When the brush stall rate rises above a high threshold and the slope is positive, the robot turns off the brush for 13 seconds and performs large panic turn behaviors at 1, 3, and 7 seconds. At the end of the 13 seconds, the brush is turned back on. (b) When the drive stall rate rises above a medium threshold and the slope is positive, the robot performs large panic turn behaviors continuously. (c) When the drive stall rate rises above a high threshold, the robot turns off all of the motors for 15 seconds. At the end of the 15 seconds, the motors are turned back on. (d) When the bumper of the robot is held in constantly for 5 seconds (as in a side wedging situation), the robot performs a large panic turn behavior. It repeats the panic turn behavior every 5 seconds until the bumper is released. (e) When the robot has gotten no bumps for a distance of 20 feet, it assumes that it might be stuck with its wheels spinning. To free itself, it performs a spiral. If has still not gotten a bump for 10 feet after the end of the spiral, performs a large panic turn

202490 "TEST" 061202



behavior. It continues this every 10 feet until it gets a bump.

5 (iii) Situation 3. (a) When the average distance between bumps falls below a low threshold, the robot performs edge following using its bumper to try to escape from the confined area. (b) When the average distance between bumps falls below a very low threshold, the robot performs large panic turn behaviors to orient it so that it may better be able to escape from the confined area.

10 (iv) Situation 4. (a) When the brush has stalled and been turned off several times recently and the brush stall rate is high and the slope is positive, the robot shuts off. (b) When the drive has stalled and the motors turned off several times recently and the drive stall rate is high and the slope is positive, the robot shuts off. (c) When any of the wheels are dropped continuously for greater than 2 seconds, the robot shuts off. (d) When many wheel drop events occur in a short time, the robot shuts off. (e) When any of the cliff sensors sense a cliff continuously for 10 seconds, the robot shuts off. (f) When the bump sensor is constantly depressed for a certain amount of

20250105 15:05:20

time, for example 10 seconds, it is likely that the robot is wedged, and the robot shuts off.

As a descriptive example, FIGS. 12A & 12B illustrate the analysis used in a preferred embodiment for identifying the need for an escape behavior relative to a stalled brush motor, as described above in Situations 1, 2 and 4. Each time the brush current exceeds a given limit for the brush motor (step 402), a rate register is incremented by 1 (step 404); if no limit is detected, the rate register is decremented by 1 (step 406). A separate slope register stores the recent values for a recent time period such as 120 cycles. If the rate is above 600 (where 600 corresponds to one second of constant stall) (step 414) and the slope is positive (step 416), then the robot will run an escape behavior (step 420) if the escape behavior is enabled (step 418). The escape behaviors are disabled after running (step 428) until the rate has returned to zero (step 422), re-enabled (step 424) and risen to 600 again. This is done to avoid the escape behavior being triggered constantly at rates above 600.

If, however, the rate is above 2400 (step 410) and the slope is positive (step 412), the robot will run a special set of escape behaviors, shown in FIG. 12B. In a preferred embodiment, the brush motor will shut off (step 430), the "level" is incremented by a predetermined amount (50 to 90) (step 430), the stall time is set (step 430), and a panic

behavior (step 452) is preformed at 1 second (step 445), 4  
seconds (step 450) and 7 seconds (step 455) since the brush  
shut off. The control system then restarts the brush at 13  
seconds (steps 440 & 442). Level is decremented by 1 every  
5 second (steps 444). If level reaches a maximum threshold  
(step 435), the robot ceases all operation (step 437). In  
addition, the robot may take additional actions when certain  
stalls are detected, such as limiting the voltage to the  
motor to prevent damage to the motor.

10 A preferred embodiment of the robot has four escape  
behaviors: TURN, EDGE, WHEEL DROP and SLOW.

TURN. The robot turns in place in a random  
direction, starting at a higher velocity (approximately  
twice of its normal turning velocity) and decreasing to  
a lower velocity (approximately one-half of its normal  
turning velocity). Varying the velocity may aid the  
robot in escaping from various situations. The angle  
that the robot should turn can be random or a function  
of the degree of escape needed or both. In a preferred  
embodiment, in low panic situations the robot turns  
20 anywhere from 45 to 90 degrees, and in high panic  
situations the robot turns anywhere from 90 to 270  
degrees.

EDGE. The robot follows the edge using its bump  
25 sensor until (a) the robot turns 60 degrees without a  
bump or (b) the robot cumulatively has turned more than

20250715091010

170 degrees since the EDGE behavior initiated. The EDGE behavior may be useful if the average bump distance is low (but not so low as to cause a panic behavior). The EDGE behavior allows the robot to fit through the smallest openings physically possible for the robot and so can allow the robot to escape from confined areas.

5 WHEEL DROP. The robot back drives wheels briefly, then stops them. The back driving of the wheels helps to minimize false positive wheel drops by giving the wheels a small kick in the opposite direction. If the wheel drop is gone within 2 seconds, the robot continues normal operation.

10 SLOW. If a wheel drop or a cliff detector goes off, the robot slows down to speed of 0.235 m/s (or 77% of its normal speed) for a distance of 0.5m and then ramps back up to its normal speed.

15 In addition to the coverage behaviors and the escape behaviors, the robot also might contain additional behaviors related to safety or usability. For example, if a cliff is detected for more than a predetermined amount of time, the robot may shut off. When a cliff is first detected, a cliff avoidance response behavior takes immediate precedence over all other behaviors, rotating the robot away from the cliff until the robot no longer senses the cliff. In a preferred embodiment, the cliff detection event does not cause a change in operational modes. In other embodiments, the robot could

use an algorithm similar to the wall-following behavior to allow for cliff following.

5 The individual operation of the three operational modes has been described above; we now turn to the preferred mode of switching between the various modes.

10 In order to achieve the optimal coverage and cleaning efficiency, a preferred embodiment uses a control program that gives priority to various coverage behaviors. (Escape behaviors, if needed, are always given a higher priority.) For example, the robot 10 may use the wall following mode for a specified or random time period and then switch operational modes to the room cleaning. By switching between operational modes, the robotic device of the present invention is able to increase coverage, cleaning efficiency and perceived effectiveness.

20 By way of example, FIGS. 13A & 13B show a mobile robot 10 in a "dog bone" shaped environment in which two rooms 115 & 116 of roughly equal dimensions are connected by a narrow passageway 105. (This example illustrates the robot diffusion problem discussed earlier.) This arrangement is a simplified version of typical domestic environments, where the "dog bone" may be generated by the arrangements of obstacles within the room. In FIG. 13A, the path of robot 10 is traced as line 54 as robot 10 operates on in random bounce mode. The robot 10 is unable to move from room 116 into 115

10167851.051202  
202190.F5BZ9T01

during the limited run because the robot's random behavior did not happen to lead the robot through passageway 105. This method leaves the coverage far less than optimal and the cleaning rate decreased due to the number of times the robot  
5 10 crosses its own path.

FIG. 13B shows the movement of a preferred embodiment of robot 10, whereby the robot cycles between BOUNCE and WALL FOLLOWING behaviors. As the robot follows path 99, each time the robot 10 encounters a wall 100, the robot follows the  
10 wall for a distance equal to twice the robot's diameter. The portions of the path 99 in which the robot 10 operates in wall following mode are labeled 51. This method provides greatly increased coverage, along with attendant increases in cleaning rate and perceived effectiveness.

202490-158290F2  
15  
20  
Finally, a preferred embodiment of the present invention is detailed in FIG. 14, in which all three operational modes are used. In a preferred embodiment, the device 10 begins in spiral mode (movement line 45). If a reflective spiral pattern is used, the device continues in spiral mode until a  
20 predetermined or random number of reflective events has occurred. If a standard spiral is used (as shown in FIG. 14), the device should continue until any bump sensor event. In a preferred embodiment, the device immediately enters wall following mode after the triggering event.

25 In a preferred embodiment, the device then switches between wall following mode (movement lines 51) and random

bounce modes (movement lines 48) based on bump sensor events or the completion of the wall following algorithm. In one embodiment, the device does not return to spiral mode; in other embodiments, however, the device can enter spiral mode  
5 based on a predetermined or random event.

In a preferred embodiment, the robot keeps a record of the average distance traveled between bumps. The robot then calculates an average bump distance (ABD) using the following formula:  $(3/4 \times ABD) + (1/4 \times \text{most recent distance between bumps})$ . If the ABD is above a predetermined threshold, the  
10 robot will again give priority to the SPIRAL behavior. In still other embodiments, the robot may have a minimum number of bump events before the SPIRAL behavior will again be given priority. In other embodiments, the robot may enter SPIRAL  
15 behavior if it travels a maximum distance, for example 20 feet, without a bump event.

In addition, the robot can also have conditions upon which to stop all operations. For example, for a given room size, which can be manually selected, a minimum and maximum  
20 run time are set and a minimum total distance is selected. When the minimum time and the minimum distance have been reached the robot shuts off. Likewise, if the maximum time has been reached, the robot shuts off.

Of course, a manual control for selecting between  
25 operational modes can also be used. For example, a remote control could be used to change or influence operational

101679510510101

modes or behaviors. Likewise, a switch mounted on the shell itself could be used to set the operation mode or the switching between modes. For instance, a switch could be used to set the level of clutter in a room to allow the robot  
5 a more appropriate coverage algorithm with limited sensing ability.

One of skill in the art will recognize that portions of the instant invention can be used in autonomous vehicles for a variety of purposes besides cleaning. The scope of the  
10 invention should be determined by the appended claims and their legal equivalents, rather than by the examples given.

10157851-061202



We claim:

1. A mobile robot comprising:

(a) means for moving the robot over a surface;

5 (b) an obstacle detection sensor;

(c) and a control system operatively connected to said  
obstacle detection sensor and said means for moving;

(d) said control system configured to operate the robot  
in a plurality of modes, said plurality of modes comprising:  
10 a spot-coverage mode, an obstacle following mode whereby said  
robot travels adjacent to an obstacle, and a bounce mode  
whereby the robot travels substantially in a direction away  
from an obstacle after encountering an obstacle.

15 2. A mobile robot according to claim 1 in which said  
control system is configured to operate first in said spot-  
coverage mode, then alternate operation between said obstacle  
following mode and said bounce mode.

20 3. A mobile robot according to claim 2 in which said spot-  
coverage mode comprises substantially spiral movement.

25 4. A mobile robot according to claim 2 in which the control  
system is configured to return to spot-coverage mode after a  
predetermined traveling distance.

5. A mobile robot according to claim 2 in which the control system is configured to return to spot-coverage mode after a predetermined elapsed time.

5 6. A mobile robot according to claim 2 in which the control system is configured to return to spot-coverage mode if the average distance between obstacle interactions is above a predetermined threshold.

10 7. A mobile robot according to claim 1, whereby said obstacle detection sensor comprises a tactile sensor.

8. A mobile robot according to claim 7, whereby said obstacle detection sensor further comprises an IR sensor.

15 9. The mobile robot according to claim 1, whereby said obstacle following mode comprises alternating between decreasing the turning radius of the robot as a function of distance traveled such that the robot turns toward said  
20 obstacle until the obstacle detection sensor detects an obstacle, and decreasing the turning radius of the robot as a function of distance traveled such that the robot turns away from said obstacle until the obstacle detection system no longer detects an obstacle.

25

20250115BZ9T01

10. The mobile robot according to claim 1, whereby the robot operates in obstacle following mode for a distance greater than twice the work width of the robot and less than approximately ten times the work width of the robot.

5

11. The mobile robot according to claim 10, whereby the robot operates in obstacle following mode for a distance greater than twice the work width of the robot and less than five times the work width of the robot.

10

12. The mobile robot according to claim 1, further comprising a means for manually selecting an operational mode.

15

13. A mobile robot comprising:

(a) means for moving the robot over a surface;

(b) an obstacle detection sensor;

(c) and a control system operatively connected to said obstacle detection sensor and said means for moving;

20

(d) said control system configured to operate the robot in a plurality of modes, said plurality of modes comprising: an obstacle following mode whereby said robot travels adjacent to an obstacle, and a bounce mode whereby the robot travels substantially in a direction away from an obstacle

25

after encountering an obstacle;

20250115 15:29:09

(e) whereby said control system is configured to alternate into said obstacle following mode after a predetermined number of sensor interactions.

5 14. A mobile robot according to claim 13, wherein said predetermined number of sensor interactions is randomly determined.

10 15. A mobile robot according to claim 13, wherein said predetermined number of sensor interactions is between approximately 5 and approximately 15.

10167851051202

16. A mobile robot according to claim 13, wherein said control system is configured to alternate into said bounce mode after the robot travels a predetermined distance in said obstacle following mode.

20 17. A mobile robot according to claim 13, wherein said control system is configured to alternate into said bounce mode upon either the robot has traveled a maximum distance or the robot has traveled a minimum distance and an obstacle has been encountered.

25 18. A mobile robot according to claim 17, wherein said minimum distance is at least 115 cm.

19. A mobile robot according to claim 18, wherein said maximum distance is less than 520 cm.

5 20. A mobile robot according to claim 13, wherein the control system alternates operational modes based on the distance traveled by said robot.

21. A mobile robot according to claim 13, further comprising a means for determining the level of clutter.

10 22. A mobile robot according to claim 21, wherein said means for determining the level of clutter comprises tracking the number of interactions with obstacles over time.

15 23. A mobile robot according to claim 22, further comprising a means for imputing the approximate area of the surface, wherein said means for determining the level of clutter further relates to the approximate area of the surface.

20 24. A mobile robot according to claim 22, wherein the level of clutter is correlated to the frequency at which the controller alternates operational modes.

25 25. A mobile robot according to claim 21, wherein the level of clutter is positively correlated to the minimum obstacle following distance.

10167851061002

26. A mobile robot according to claim 13, wherein the control system alternates between operational modes based upon a lack of sensor input.

5

27. A mobile robot according to claim 1, wherein said control system further comprises memory wherein an operational system program is stored, said operational system program comprising a plurality of behaviors and an arbiter to select which behavior is given control over the means for moving.

10

28. A mobile robot according to claim 27, further comprising an escape behavior.

29. A mobile robot according to claim 28, wherein said obstacle detection sensor comprises a tactile sensor, and wherein said escape behavior comprises operating in said obstacle following mode.

15  
20

30. A mobile robot according to claim 28, wherein said escape behavior is triggered by the rate of a motor stall event.

31. A mobile robot according to claim 30, wherein said escape behavior is triggered by an increase in said rate of a motor stall event.

5 32. A mobile robot according to claim 28, wherein said escape behavior is triggered by the duration of sensor input.

33. A mobile robot according to claim 28, wherein said escape behavior comprises shutting off the robot.

10

34. A mobile robot according to claim 28, wherein said escape behavior is triggered by a lack of sensor input.

35. A mobile robot according to claim 13, further comprising a cliff detector, whereby said control system is configured to reduce the robot's velocity upon detection of a cliff.

15

36. A mobile robot according to claim 13, further comprising a wheel drop sensor, whereby said robot utilizes the rate of wheel drop sensor events as input to said control system.

20

37. A method of controlling a mobile-robot equipped with a sensor for detecting an obstacle, said method comprising the steps of:

25

a. moving in a spiral running motion;

- b. discontinuing said spiral running motion after the earlier of sensing and obstacle or traveling a predetermined distance;
- c. running in a substantially forward direction until an obstacle is detected;
- d. turning and running along said detected obstacle;
- e. turning away from said obstacle and running in a substantially forward direction; and
- f. thereafter repeating said step of running along said obstacle and said step of turning away from said obstacle.

38. The mobile-robot steering method according to claim 37, further comprising the step of repeating the spiral running motion after a predetermined number of sensor events.

39. The mobile-robot steering method according to claim 37, whereby the robot runs along said obstacle for at least a minimum distance but less than a maximum distance.

40. The mobile-robot steering method according to claim 39, whereby said obstacle sensor comprises an IR sensor able to detect said boundary.

10167851 1061202  
2021501 15829101



41. The mobile-robot steering method according to claim 40, whereby said obstacle sensor further comprises a tactile sensor.

5

10167851-051202

ABSTRACT

A control system for a mobile robot (10) is provided to effectively cover a given area by operating in a plurality of modes, including an obstacle following mode (51) and a random bounce mode (49). In other embodiments, spot coverage, such as spiraling (45), or other modes are also used to increase effectiveness. In addition, a behavior based architecture is used to implement the control system, and various escape behaviors are used to ensure full coverage.

20250708 10157851-061202


Please type a plus sign (+) inside this box →

PTO/SB/81 (02-01)  
 Approved for use through 10/31/2002. OMB 0651-0035  
 U.S. Patent and Trademark Office; U.S. DEPARTMENT OF COMMERCE

Under the Paperwork Reduction Act of 1995, no persons are required to respond to a collection of information unless it display a valid OMB control number.

<b>POWER OF ATTORNEY OR AUTHORIZATION OF AGENT</b>	<b>Application Number</b>	
	<b>Filing Date</b>	
	<b>First Named Inventor</b>	JONES
	<b>Title</b>	
	<b>Group Art Unit</b>	
	<b>Examiner Name</b>	
	<b>Attorney Docket Number</b>	DP-5 US

I hereby appoint:

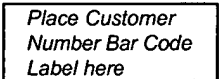
Practitioners at Customer Number  → 

Practitioner(s) named below:

Name	Registration Number

as my/our attorney(s) or agent(s) to prosecute the application identified above, and to transact all business in the United States Patent and Trademark Office connected therewith.

Please change the correspondence address for the above-identified application to:

The above-mentioned Customer Number.  
 OR  
 Practitioners at Customer Number  → 

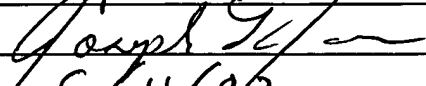
<input type="checkbox"/> Firm or Individual Name			
Address			
Address			
City	State	Zip	
Country			
Telephone	Fax		

I am the:

Applicant/Inventor.

Assignee of record of the entire interest. See 37 CFR 3.71.  
 Statement under 37 CFR 3.73(b) is enclosed. (Form PTO/SB/96).

**SIGNATURE of Applicant or Assignee of Record**

Name	Joseph L. Jones
Signature	
Date	6/11/02

NOTE: Signatures of all the inventors or assignees of record of the entire interest or their representative(s) are required. Submit multiple forms if more than one signature is required, see below\*.

Total of 2 forms are submitted.

Burden Hour Statement: This form is estimated to take 3 minutes to complete. Time will vary depending upon the needs of the individual case. Any comments on the amount of time you are required to complete this form should be sent to the Chief Information Officer, U.S. Patent and Trademark Office, Washington, DC 20231. DO NOT SEND FEES OR COMPLETED FORMS TO THIS ADDRESS. SEND TO: Assistant Commissioner for Patents, Washington, DC 20231.

Please type a plus sign (+) inside this box → 

PTO/SB/81 (02-01)


Approved for use through 10/31/2002. OMB 0651-0035

U.S. Patent and Trademark Office; U.S. DEPARTMENT OF COMMERCE

Under the Paperwork Reduction Act of 1995, no persons are required to respond to a collection of information unless it display a valid OMB control number.

<b>POWER OF ATTORNEY OR AUTHORIZATION OF AGENT</b>	<b>Application Number</b>	
	<b>Filing Date</b>	
	<b>First Named Inventor</b>	JONES
	<b>Title</b>	
	<b>Group Art Unit</b>	
	<b>Examiner Name</b>	
	<b>Attorney Docket Number</b>	DB-5 US

I hereby appoint:

Practitioners at Customer Number 27639 → 

OR

Practitioner(s) named below:

Name	Registration Number
	27639

as my/our attorney(s) or agent(s) to prosecute the application identified above, and to transact all business in the United States Patent and Trademark Office connected therewith.

Please change the correspondence address for the above-identified application to:

The above-mentioned Customer Number.

OR

Practitioners at Customer Number   → Place Customer Number Bar Code Label here

OR

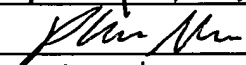
<input type="checkbox"/> Firm or Individual Name			
Address			
Address			
City	State	Zip	
Country			
Telephone	Fax		

I am the:

Applicant/Inventor.

Assignee of record of the entire interest. See 37 CFR 3.71. Statement under 37 CFR 3.73(b) is enclosed. (Form PTO/SB/96).

**SIGNATURE of Applicant or Assignee of Record**

Name	Philip Mass
Signature	
Date	6/12/02

NOTE: Signatures of all the inventors or assignees of record of the entire interest or their representative(s) are required. Submit multiple forms if more than one signature is required, see below\*.

\*Total of 2 forms are submitted.

Burden Hour Statement: This form is estimated to take 3 minutes to complete. Time will vary depending upon the needs of the individual case. Any comments on the amount of time you are required to complete this form should be sent to the Chief Information Officer, U.S. Patent and Trademark Office, Washington, DC 20231. DO NOT SEND FEES OR COMPLETED FORMS TO THIS ADDRESS. SEND TO: Assistant Commissioner for Patents, Washington, DC 20231.

Under the Paperwork Reduction Act of 1995, no persons are required to respond to a collection of information unless it contains a valid OMB control number.

<b>DECLARATION FOR UTILITY OR DESIGN PATENT APPLICATION</b> <b>(37 CFR 1.63)</b>  <input checked="" type="checkbox"/> Declaration Submitted with Initial Filing      OR <input type="checkbox"/> Declaration Submitted after Initial Filing (surcharge (37 CFR 1.16 (e)) required)	<b>Attorney Docket Number</b>	DP-5 US
	<b>First Named Inventor</b>	JONES
	<b>COMPLETE IF KNOWN</b>	
	<b>Application Number</b>	
	<b>Filing Date</b>	
	<b>Art Unit</b>	
	<b>Examiner Name</b>	

As the below named inventor, I hereby declare that:

My residence, mailing address, and citizenship are as stated below next to my name.

I believe I am the original and first inventor of the subject matter which is claimed and for which a patent is sought on the invention entitled:

SYSTEM & METHOD FOR MULTI-MODE COVERAGE FOR AN AUTONOMOUS ROBOT

(Title of the Invention)

The specification of which

is attached hereto

OR

was filed on (MM/DD/YYYY)

as United States Application Number or PCT International

Application Number

and was amended on (MM/DD/YYYY)

(if applicable).

I hereby state that I have reviewed and understand the contents of the above identified specification, including the claims, as amended by any amendment specifically referred to above.

I acknowledge the duty to disclose information which is material to patentability as defined in 37 CFR 1.56, including for continuation-in-part applications, material information which became available between the filing date of the prior application and the national or PCT international filing date of the continuation-in-part application.

I hereby claim foreign priority benefits under 35 U.S.C. 119(a)-(d) or (f), or 365(b) of any foreign application(s) for patent, inventor's or plant breeder's rights certificate(s), or 365(a) of any PCT international application which designated at least one country other than the United States of America, listed below and have also identified below, by checking the box, any foreign application for patent, inventor's or plant breeder's rights certificate(s), or any PCT international application having a filing date before that of the application on which priority is claimed.

Prior Foreign Application Number(s)	Country	Foreign Filing Date (MM/DD/YYYY)	Priority Not Claimed	Certified Copy Attached?	
				YES	NO
			<input type="checkbox"/>	<input type="checkbox"/>	<input type="checkbox"/>
			<input type="checkbox"/>	<input type="checkbox"/>	<input type="checkbox"/>
			<input type="checkbox"/>	<input type="checkbox"/>	<input type="checkbox"/>
			<input type="checkbox"/>	<input type="checkbox"/>	<input type="checkbox"/>

Additional foreign application numbers are listed on a supplemental priority data sheet PTO/SB/02B attached hereto:

Under the Paperwork Reduction Act of 1995, no persons are required to respond to a collection of information unless it contains a valid OMB control number.

**DECLARATION — Utility or Design Patent Application**

Direct all correspondence to: <input checked="" type="checkbox"/>		Customer Number or Bar Code Label	27639	OR	<input type="checkbox"/>	Correspondence address below	
<b>Name</b>							
<b>Address</b>							
<b>City</b>			<b>State</b>		<b>ZIP</b>		
<b>Country</b>		<b>Telephone</b>			<b>Fax</b>		
I hereby declare that all statements made herein of my own knowledge are true and that all statements made on information and belief are believed to be true; and further that these statements were made with the knowledge that willful false statements and the like so made are punishable by fine or imprisonment, or both, under 18 U.S.C. 1001 and that such willful false statements may jeopardize the validity of the application or any patent issued thereon.							
<b>NAME OF SOLE OR FIRST INVENTOR :</b>				<input type="checkbox"/> A petition has been filed for this unsigned inventor			
<b>Given Name</b> (first and middle [if any])				<b>Family Name</b> or Surname			
Joseph L.				Jones			
<b>Inv ntor's</b> <b>Signature</b>						<b>Date</b>	
<i>Joseph L. Jones</i>						6/11/02	
<b>Acton</b>		<b>MA</b>		<b>US</b>		<b>US</b>	
<b>Residence: City</b>		<b>State</b>		<b>Country</b>		<b>Citizenship</b>	
<b>Mailing Address</b> 9 Redwood Road							
<b>Acton</b>		<b>MA</b>		<b>01720</b>		<b>US</b>	
<b>City</b>		<b>State</b>		<b>ZIP</b>		<b>Country</b>	
<b>NAME OF SECOND INVENTOR:</b>				<input type="checkbox"/> A petition has been filed for this unsigned inventor			
<b>Given Name</b> (first and middle [if any])				<b>Family Name</b> or Surname			
Philip R.				Mass			
<b>Inv ntor's</b> <b>Signature</b>						<b>Date</b>	
<i>Philip R. Mass</i>						6/12/02	
<b>Boston</b>		<b>MA</b>		<b>US</b>		<b>US</b>	
<b>R sidence: City</b>		<b>State</b>		<b>Country</b>		<b>Citizenship</b>	
<b>Mailing Address</b> 28 Fleet Street, #12							
<b>Boston</b>		<b>MA</b>		<b>02113</b>		<b>US</b>	
<b>City</b>		<b>State</b>		<b>ZIP</b>		<b>C untry</b>	
<input type="checkbox"/> Additional inventors are being named on the ____ supplemental Additional Inventor(s) sheet(s) PTO/SB/02A attached hereto.							

PATENT APPLICATION SERIAL NO. \_\_\_\_\_

U.S. DEPARTMENT OF COMMERCE  
PATENT AND TRADEMARK OFFICE  
FEE RECORD SHEET

06/19/2002 DTESSEM1 00000005 501806 10167851

01 FC:201	370.00 CH
02 FC:203	189.00 CH

PTO-1556  
(5/87)

\*U.S. GPO: 2000-468-987/39595

Silver Star Exhibit 1002 - 1075

**PATENT APPLICATION FEE DETERMINATION RECORD**  
Effective October 1, 2001

Application or Docket Number

DP-5 115

**CLAIMS AS FILED - PART I**

**SMALL ENTITY TYPE**  OR **OTHER THAN SMALL ENTITY**

	(Column 1)	(Column 2)
TOTAL CLAIMS	41	
FOR	NUMBER FILED	NUMBER EXTRA
TOTAL CHARGEABLE CLAIMS	41 minus 20 = *	21
INDEPENDENT CLAIMS	3 minus 3 = *	
MULTIPLE DEPENDENT CLAIM PRESENT	<input type="checkbox"/>	

RATE	FEE		RATE	FEE
BASIC FEE	370.00	OR	BASIC FEE	740.00
X\$ 9=	169	OR	X\$18=	
X42=		OR	X84=	
+140=		OR	+280=	
TOTAL	559	OR	TOTAL	

\* If the difference in column 1 is less than zero, enter "0" in column 2

**CLAIMS AS AMENDED - PART II**

**SMALL ENTITY** OR **OTHER THAN SMALL ENTITY**

AMENDMENT A	(Column 1)	(Column 2)	(Column 3)
	CLAIMS REMAINING AFTER AMENDMENT	HIGHEST NUMBER PREVIOUSLY PAID FOR	PRESENT EXTRA
Total	*	Minus **	=
Independent	*	Minus ***	=
FIRST PRESENTATION OF MULTIPLE DEPENDENT CLAIM <input type="checkbox"/>			

RATE	ADDITIONAL FEE		RATE	ADDITIONAL FEE
X\$ 9=		OR	X\$18=	
X42=		OR	X84=	
+140=		OR	+280=	
TOTAL ADDIT. FEE		OR	TOTAL ADDIT. FEE	

AMENDMENT B	(Column 1)	(Column 2)	(Column 3)
	CLAIMS REMAINING AFTER AMENDMENT	HIGHEST NUMBER PREVIOUSLY PAID FOR	PRESENT EXTRA
Total	*	Minus **	=
Independent	*	Minus ***	=
FIRST PRESENTATION OF MULTIPLE DEPENDENT CLAIM <input type="checkbox"/>			

RATE	ADDITIONAL FEE		RATE	ADDITIONAL FEE
X\$ 9=		OR	X\$18=	
X42=		OR	X84=	
+140=		OR	+280=	
TOTAL ADDIT. FEE		OR	TOTAL ADDIT. FEE	

AMENDMENT C	(Column 1)	(Column 2)	(Column 3)
	CLAIMS REMAINING AFTER AMENDMENT	HIGHEST NUMBER PREVIOUSLY PAID FOR	PRESENT EXTRA
Total	*	Minus **	=
Independent	*	Minus ***	=
FIRST PRESENTATION OF MULTIPLE DEPENDENT CLAIM <input type="checkbox"/>			

RATE	ADDITIONAL FEE		RATE	ADDITIONAL FEE
X\$ 9=		OR	X\$18=	
X42=		OR	X84=	
+140=		OR	+280=	
TOTAL ADDIT. FEE		OR	TOTAL ADDIT. FEE	

\* If the entry in column 1 is less than the entry in column 2, write "0" in column 3.

\*\* If the "Highest Number Previously Paid For" IN THIS SPACE is less than 20, enter "20."

\*\*\*If the "Highest Number Previously Paid For" IN THIS SPACE is less than 3, enter "3."

The "Highest Number Previously Paid For" (Total or Independent) is the highest number found in the appropriate box in column 1.