



US006809490B2

(12) **United States Patent**
Jones et al.

(10) **Patent No.:** **US 6,809,490 B2**
(45) **Date of Patent:** **Oct. 26, 2004**

(54) **METHOD AND SYSTEM FOR MULTI-MODE
COVERAGE FOR AN AUTONOMOUS
ROBOT**

(75) Inventors: **Joseph L. Jones**, Acton, MA (US);
Philip R. Mass, Boston, MA (US)

(73) Assignee: **iRobot Corporation**, Burlington, MA
(US)

(*) Notice: Subject to any disclaimer, the term of this
patent is extended or adjusted under 35
U.S.C. 154(b) by 0 days.

5,940,927 A	8/1999	Haegermarck et al.	15/319
5,942,869 A *	8/1999	Katou et al.	318/568.12
6,076,025 A *	6/2000	Ueno et al.	701/23
6,076,226 A	6/2000	Reed	15/319
6,240,342 B1	5/2001	Fiegert et al.	701/25
6,327,741 B1	12/2001	Reed	15/319
6,370,453 B2 *	4/2002	Sommer	701/23
6,389,329 B1	5/2002	Colens	700/262
6,459,955 B1	10/2002	Bartsch et al.	700/245
6,463,368 B1 *	10/2002	Feiten et al.	701/23
6,481,515 B1	11/2002	Kirkpatrick et al.	180/25.1
6,493,612 B1	12/2002	Bisset et al.	701/23

(List continued on next page.)

FOREIGN PATENT DOCUMENTS

(21) Appl. No.: **10/167,851**

(22) Filed: **Jun. 12, 2002**

(65) **Prior Publication Data**

US 2003/0025472 A1 Feb. 6, 2003

JP	60259895	6/1987
JP	60293095	7/1987
JP	63-183032	7/1988
JP	62074018	10/1988
JP	2-6312	1/1990

(List continued on next page.)

Related U.S. Application Data

(60) Provisional application No. 60/297,718, filed on Jun. 12,
2001.

(51) **Int. Cl.**⁷ **B25J 5/00**

(52) **U.S. Cl.** **318/568.12**; 318/568.16;
318/568.17; 700/245

(58) **Field of Search** 318/568.12, 568.16,
318/568.17; 700/245

(56) **References Cited**

U.S. PATENT DOCUMENTS

4,674,048 A	6/1987	Okumura	364/424
4,962,453 A *	10/1990	Pong et al.	701/23
5,086,535 A *	2/1992	Grossmeyer et al.	15/319
5,109,566 A	5/1992	Kobayashi et al.	15/319
5,204,814 A *	4/1993	Noonan et al.	701/25
5,284,522 A	2/1994	Kobayashi et al.	134/18
5,321,614 A *	6/1994	Ashworth	701/26
5,341,540 A *	8/1994	Souper et al.	15/319
5,548,511 A *	8/1996	Bancroft	701/23
5,682,313 A *	10/1997	Edlund et al.	342/127
5,867,800 A *	2/1999	Leif	701/23
5,935,179 A	8/1999	Kleiner et al.	701/23

OTHER PUBLICATIONS

Doty, Keith L. et al., "Sweep Strategies for a Sensory-
Driven, Behavior-Based Vacuum Cleaning Agent," AAAI
1993 Fall Symposium Series, US.

Karcher RC 3000 Cleaning Robot—user Manual. Manufac-
turer: Alfred Karcher GmbH & Co., Cleaning Systems,
Alfred-Karcher-Str. 28-40, P.O. Box 160, D-71349 Win-
nenden, Germany, Dec. 2002.

Primary Examiner—Rita Leykin

(74) *Attorney, Agent, or Firm*—Glen D. Weinstein, Esq.;
Gesmer Updegrove LLP

(57) **ABSTRACT**

A control system for a mobile robot (10) is provided to
effectively cover a given area by operating in a plurality of
modes, including an obstacle following mode (51) and
a random bounce mode (49). In other embodiments, spot
coverage, such as spiraling (45), or other modes are also
used to increase effectiveness. In addition, a behavior based
architecture is used to implement the control system, and
various escape behaviors are used to ensure full coverage.

42 Claims, 16 Drawing Sheets

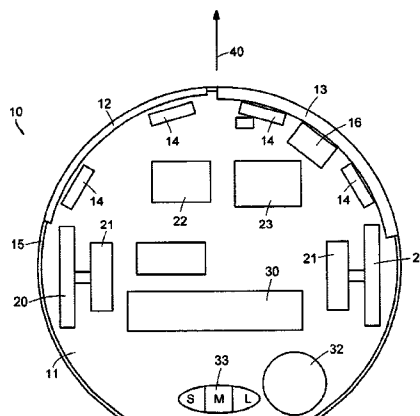

U.S. PATENT DOCUMENTS

6,493,613 B2 12/2002 Peless et al. 701/23
 6,574,536 B1 * 6/2003 Kawagoe et al. 701/23
 6,605,156 B1 8/2003 Clark et al. 134/6
 6,615,108 B1 9/2003 Peless et al. 700/245
 2001/0047231 A1 11/2001 Peless et al.

FOREIGN PATENT DOCUMENTS

JP 6-3251 1/1994
 JP 7-295636 11/1995
 JP 07338573 7/1997
 JP 08000393 7/1997
 JP 2555263 8/1997
 JP 08016776 8/1997
 JP 3375843 8/1998
 JP 09043901 9/1998
 JP 11-510935 9/1999
 JP 11162454 12/2000
 JP 2001-525567 12/2001
 JP 2002-204768 7/2002

JP 2002-323925 11/2002
 JP 2003-036116 2/2003
 JP 2003-052596 2/2003
 JP 2003-061882 3/2003
 WO WO 97/40734 11/1997
 WO WO 97/41451 A1 11/1997
 WO WO 97/41451 11/1997
 WO WO 99/38056 7/1999
 WO WO 99/59042 A 11/1999
 WO WO 00/38026 6/2000
 WO WO 00/38029 6/2000
 WO WO 97/78410 A1 12/2000
 WO WO 01/06904 A1 2/2001
 WO WO 02/39864 A1 5/2002
 WO WO 02/067744 A1 9/2002
 WO WO 02/075469 A1 9/2002
 WO WO 02/075470 A1 9/2002
 WO WO 03/040845 A1 5/2003
 WO WO 03/040846 A1 5/2003

* cited by examiner

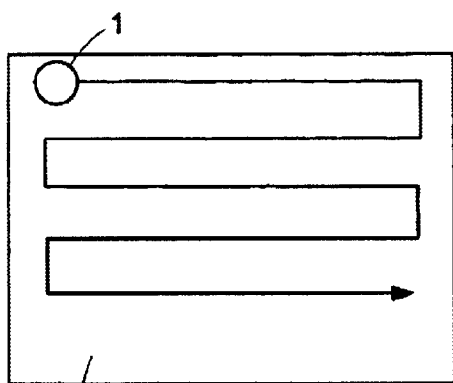

FIG. 1A

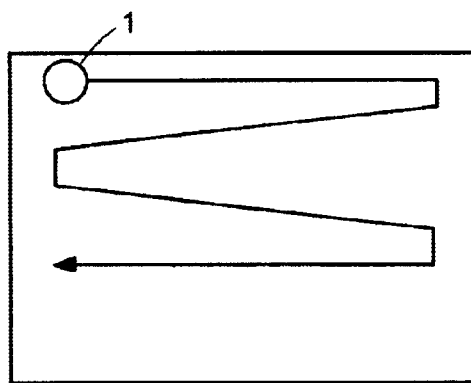

FIG. 1B

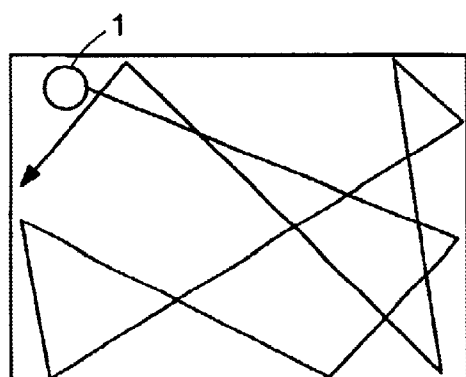

FIG. 1C

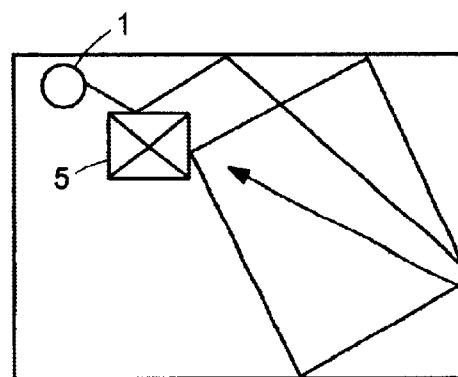

FIG. 1D

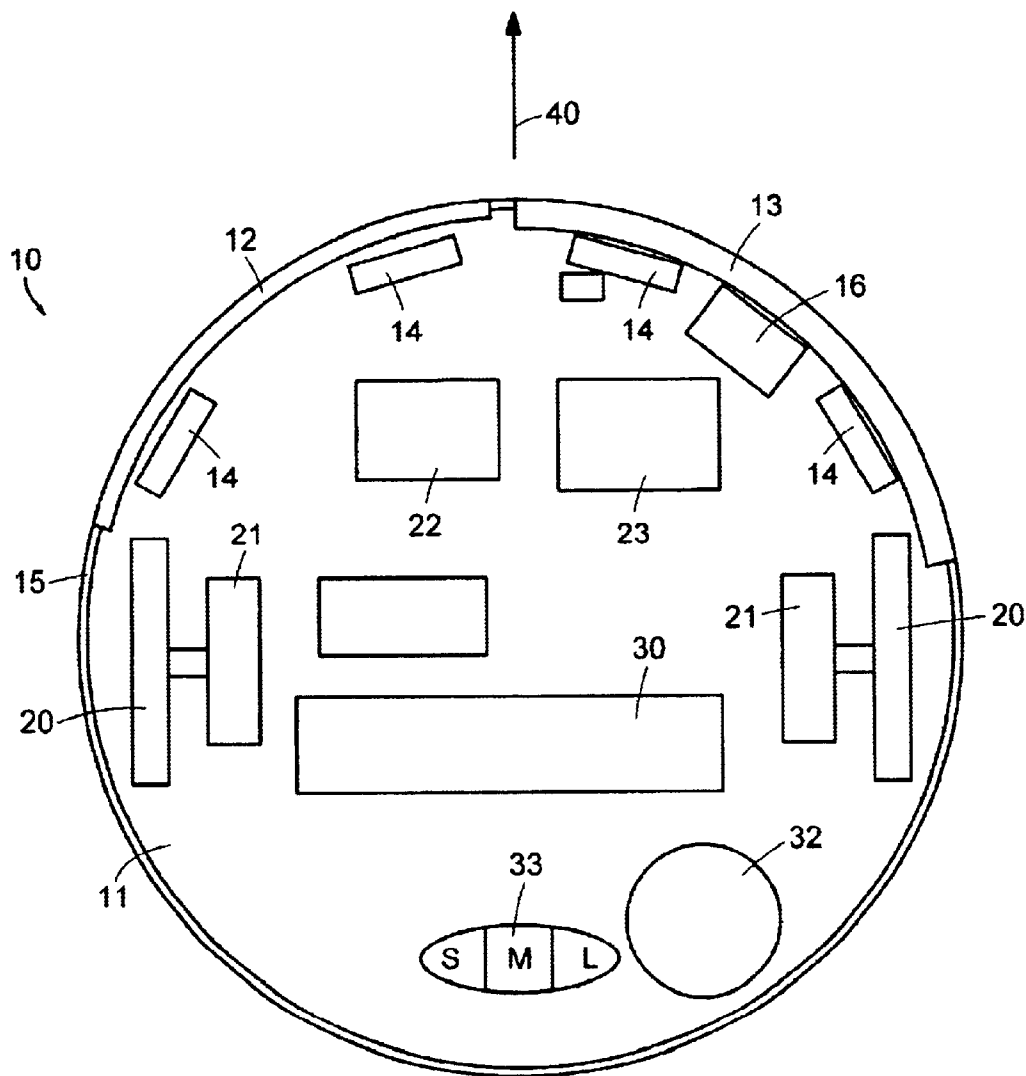

FIG. 2

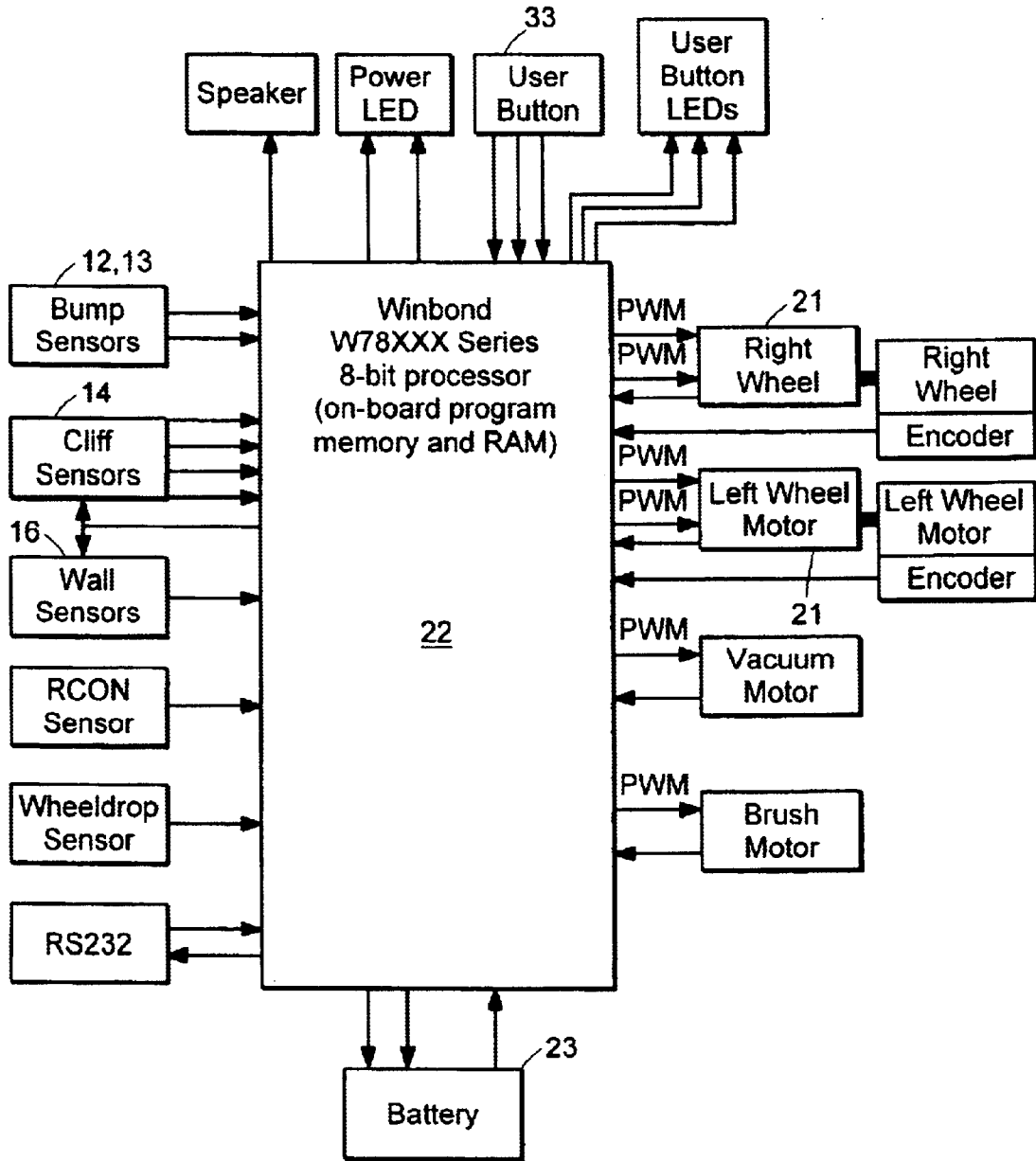

FIG. 3

Explore Litigation Insights

Docket Alarm provides insights to develop a more informed litigation strategy and the peace of mind of knowing you're on top of things.

Real-Time Litigation Alerts



Keep your litigation team up-to-date with **real-time alerts** and advanced team management tools built for the enterprise, all while greatly reducing PACER spend.

Our comprehensive service means we can handle Federal, State, and Administrative courts across the country.

Advanced Docket Research



With over 230 million records, Docket Alarm's cloud-native docket research platform finds what other services can't. Coverage includes Federal, State, plus PTAB, TTAB, ITC and NLRB decisions, all in one place.

Identify arguments that have been successful in the past with full text, pinpoint searching. Link to case law cited within any court document via Fastcase.

Analytics At Your Fingertips



Learn what happened the last time a particular judge, opposing counsel or company faced cases similar to yours.

Advanced out-of-the-box PTAB and TTAB analytics are always at your fingertips.

API

Docket Alarm offers a powerful API (application programming interface) to developers that want to integrate case filings into their apps.

LAW FIRMS

Build custom dashboards for your attorneys and clients with live data direct from the court.

Automate many repetitive legal tasks like conflict checks, document management, and marketing.

FINANCIAL INSTITUTIONS

Litigation and bankruptcy checks for companies and debtors.

E-DISCOVERY AND LEGAL VENDORS

Sync your system to PACER to automate legal marketing.