

(51) Int. Cl. <sup>6</sup>	ID Symbol	FI
G11B 23/107		G11B 23/107

Request for Examination: Not Requested Number of Claims: 1 OL (5 Pages Total)

(21) Application Number: H10-87141	(71) Applicant: 000005201 FUJIFILM Corporation 210 Nakanuma, Minami-Ashigara-shi, Kanagawa Prefecture
(22) Filing Date: March 31, 1998	(72) Inventor: Tsuyuki, Seiji c/o FUJIFILM Corporation 2-12-1 Ogi-cho, Odawara-shi, Kanagawa Prefecture
	(74) Representative: Yanagida, Masafumi; Attorney (and 1 other)

(54) Name of Invention: Magnetic Tape Cartridge

(57) Abstract

Problem: Increase reliability of a release operation of a releasing member in a reel rotation inhibiting means which restrains reel rotation when not in use.

Solution Means: A reel rotation inhibiting means 10, having an inhibiting member 4 moving toward and away from a reel 2 and restraining its rotation, a pressing means 5 pressing the inhibiting member 4 in an inhibiting direction, and a releasing member 6 which moves in accordance with a chucking operation of a drive side rotation driving means 11 and causes the inhibiting member 4 to move in a releasing direction, inhibiting rotation by the reel 2 and the inhibiting member 4 contacting at an engaging surface tilted conically relative to the reel 2 rotation center line.

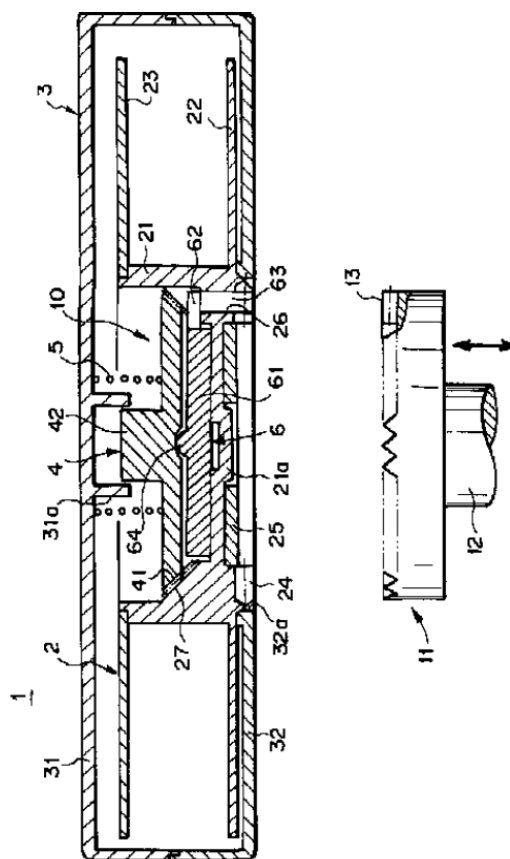

SONY Exhibit 1012  
SONY - FUJI

## Claims

[Claim 1] In a magnetic tape cartridge rotatably housing a single reel with magnetic tape wound thereon, providing a reel rotation inhibiting means allowing rotation of said reel during use, and restraining reel rotation when not in use, said reel rotation inhibiting means having an inhibiting member movable toward and away from said reel and restraining the reel rotation, a pressing means pressing said inhibiting member in an inhibiting direction, and a releasing member which moves in accordance with a chucking operation of a drive side rotation driving means and causes said inhibiting member to move in a releasing direction,

a magnetic tape cartridge characterized by inhibiting rotation by said reel and inhibiting member contacting at an engaging surface tilted conically relative to the reel rotation center line.

## Detailed Description of the Invention

[0001]

[Technical Field of the Invention] This invention relates to a magnetic tape cartridge, and particularly, in a magnetic tape cartridge rotatably housing a single reel with magnetic tape wound thereon, the structure of a reel rotation inhibiting means that place said reel in a rotation inhibited state when not in use.

[0002]

[Prior Art] Conventionally, as magnetic tape cartridges used as a recording medium utilized in an external memory device of computers, etc., a type is known with a single reel with magnetic tape wound thereon, and this reel being rotatably housed in a cartridge case. This magnetic tape is used for saving data of computers, etc., and has important information in its memory, and therefore, a reel rotation inhibiting means for restraining rotation of said reel is installed so that problems such as tape jamming do not occur, and so that magnetic tape is not unintentionally pulled out when not in use, such as during storage, etc.

[0003] Said reel rotation inhibiting means provides an inhibiting member which engages with a portion of the reel and restrains its rotation, and when the cartridge is loaded in a drive for an external memory device etc., said inhibiting means is provided such that the inhibiting status is released according to a chucking operation of the reel.

[0004]

[Problem the Invention Seeks to Solve]

Thus, because of requests to improve operation reliability for said reel rotation inhibiting means, to prevent dust particles from entering the cartridge case, etc., a structure can be conceived to separate this reel rotation inhibiting means into providing an inhibiting member which restrains reel rotation, a pressing member which presses this inhibiting member in an inhibiting direction, and a releasing member which moves in accordance with a chucking operation of a drive side rotation driving means and causes said inhibiting member to move in a releasing direction.

[0005] That is, while not in use, the inhibiting member restrains the reel to prevent unintentional rotation so that magnetic tape is not extracted. When the cartridge

is loaded to a drive and reel chucking is performed by a rotation driving means, the release member moves linked to this operation and operates to release said inhibiting member. In this condition, the reel becomes rotatable, and the magnetic tape can be extracted and wound.

[0006] And in a mechanism like the aforementioned, said inhibiting member moves toward and away from the reel as a rotating body and engages with a portion of it to restrain rotation. It is difficult to hold this inhibiting member matched to the reel rotation center and move it toward and away in a parallel manner, and to evenly contact the reel at the outer perimeter inhibiting portion. Also, if the inhibiting member center position shifts, the release operation by the releasing member can operate unevenly, with the possibility that the reel inhibited state cannot be reliably released.

[0007] The present invention was accomplished in light of the aforementioned point, and seeks to provide a magnetic tape cartridge in which the center position of the inhibiting means in the reel rotation inhibiting means is restricted to attain a reliable release operation.

[0008]

[Means of Solving the Problem] The magnetic tape cartridge in the present invention that solved the problem above, rotatably housing a single reel with magnetic tape wound thereon, providing a reel rotation inhibiting means allowing rotation of said reel during use, and restraining reel rotation when not in use, said reel rotation inhibiting means having an inhibiting member movable toward and away from said reel and restraining the reel rotation, a pressing means pressing said inhibiting member in an inhibiting direction, and a releasing member which moves in accordance with a chucking operation of a drive side rotation driving means and causes said inhibiting member to move in a releasing direction, characterized by inhibiting rotation by said reel and inhibiting member contacting at an engaging surface tilted conically relative to the reel rotation center line.

[0009]

[Effect of the Invention] According to the aforementioned present invention, because the inhibiting member is provided such that rotation is inhibited by the inhibiting member contacting the reel on an interface surface tilted conically relative to the rotation center, and in the inhibited state the inhibiting member is centered by said interface surface to match the center position to the reel rotation center, attaining a secure inhibited state, and enabling the entirety to evenly separate from the reel and move to a released state relative to a release operation of the release member, and enables securing operation reliability of the reel rotation inhibiting means.

[0010]

[Embodiments] Hereafter, the present invention is described in detail, based on embodiments shown in the figures. Figure 1 is a section view of a magnetic tape cartridge in this embodiment in a non-use state, Figure 2 is an exploded perspective view of key

components, and Figure 3 is a section view of key components in a use state.

[0011] A magnetic tape cartridge 1 comprises a single reel 2 with magnetic tape (not pictured) wound thereon, and rotatably housing said reel 2 in a cartridge case 3 comprising a top case 31 and a lower case 32 with an opening 32a at the center portion being secured by screws etc. Also, said magnetic tape cartridge 1 provides a reel rotation inhibiting means 10 that allows said reel 2 rotation during use, and restrains said reel 2 rotation during non-use.

[0012] Said reel 2 comprises a reel hub 21 having a bottomed cylindrical shape with magnetic tape wound onto its outer perimeter, and a lower flange portion 22 and an upper flange portion 23 extending in a disc shape in the diameter direction from the top and bottom edge perimeters of this reel hub 21. The reel hub 21 and the bottom flange portion 22 are molded as one body from synthetic resin, and are connected to the top flange portion by, for example, ultrasonic welding. Said reel hub 21 is closed at its center lower portion with a bottom wall 21a, the bottom surface perimeter of said bottom wall 21a having a reel gear 24 engraved in annular form. To the inner perimeter side of this reel gear 24 is attached a reel plate 25, comprising an annular metal plate for magnetic attraction. And said reel 2, reel gear 24 and reel plate 25 are positioned to face the cartridge case 3 bottom surface opening 32a. The reel 2 is pressed downward by a pressing member 5 described below.

[0013] Also, the drive side rotation driving means 11 provides an annular drive gear 13 and a magnet (not pictured) on the top end surface of the rotation shaft 12, and its chucking operation moves the rotation shaft 12 upward relative to the loaded magnetic tape cartridge 1, the drive gear 13 meshes with said reel gear 24, and a magnet attracts said reel plate 25 to hold the meshed state.

[0014] Next, the mechanism of said reel rotation inhibiting means 10 is described. This reel rotation inhibiting means 10 has an inhibiting member 4 that moves in the vertical direction movable toward and away from said reel 2, a pressing member 5 pressing said inhibiting member 4 in an inhibiting direction, and a release member 6 moving said inhibiting member 4 in a releasing direction.

[0015] The bottom wall 21a of said reel 2 has three insertion holes 26 passing through said reel gear 24 in the vertical direction, disposed at even intervals on the outer perimeter. Further, on the outer perimeter of the bottom wall 21a is an inhibiting gear 27 with internal teeth engraved at an angle relative to the reel hub 21 cylinder surface. The meshing surface (engaging surface) of this inhibiting gear 27 is a cone surface tilted downward relative to the reel 2 rotation center line. And the portion of said inhibiting gear 27 with said insertion holes 26 open are notched such that the release member 6 arm portions 62 are vertically movable. The reel 2 shown in Figure 2 is shown with only part of the bottom wall 21a cut away.

[0016] Said inhibiting member 4 is roughly disc-shaped and is disposed in the reel hub 21 of said reel 2

opposing its bottom wall 21a, and on the bottom surface outer perimeter an inhibiting gear 41 is engraved with external bevel teeth, and this inhibiting gear 41 can mesh with the inhibiting gear 27 on said reel 2. And a straight line vertical wall shaped protrusion 42 is formed extending upward on the top surface of the inhibiting member 4, and this protrusion 42 is inserted into a straight line sliding groove extending in the vertical direction in a guide portion 31a formed standing in the inner surface of an upper case 31 of a cartridge case 3, such that it is restricted to a non-rotatable state. Note that said protrusion 42 and guide portion 31a sliding groove can also be provided in a cross shape.

[0017] Further, a pressing member 5 by a coil spring is provided compressed between the top surface further toward the outer perimeter than the protrusion 42 on said inhibiting member 4 and the upper case 31 guide portion 31a inner surface on the outer perimeter side, pressing the inhibiting member 4 downward in the inhibiting direction in which its inhibiting gear 41 and the inhibiting gear 27 on the reel 2 engage.

[0018] Said release member 6 is interposed between said inhibiting member 4 and the reel valve 21 bottom wall 21a to be vertically movable, and arm portions 62 are formed extending in the radial direction at 3 locations on the outer perimeter of a disk portion 61 toward the center. Square rod shaped upward pushing portions 63 are respectively formed extending vertically on the bottom surface of the tips of said arm portions 62. Each upward pushing portion 63 is inserted through the insertion holes 26 open in said reel hub 21 such that they can respectively move to appear, and the tips are positioned facing the reel hub 21 bottom surface reel gear 24 tooth portion.

[0019] And at the lowermost position of said release member 6 (Figure 1), the upward pushing portion 63 bottom end surface is roughly at the tooth tip position, and the release member 6 is pressed according to the drive gear 13 meshing with said reel gear by the chucking operation of the drive side rotation drive means 11, being pushed upward at a prescribed stroke amount (Figure 3). Also this release member 6 rotates as one body with the reel 2 by fitting the upward pushing portions 62 into the insertion holes 26.

[0020] Also, inhibiting member 4 is pressed by said pressing member 5 such that its bottom surface contacts the top surface of said release member 6, and both are in sliding contact via a spherically shaped protrusion 64. The tip of this spherically shaped protrusion 64 contacts the center portion of a curved surface indentation provided at the center of the bottom surface of the inhibiting member, rotating in a state of being mutually positioned and with shifting etc. prevented.

[0021] Note that at least one of said inhibiting member 4 and said release member 6 can be formed from synthetic resins containing lubricants, such as molybdenum disulfide, polytetrafluoroethylene, graphite, potassium titanate whisker, silicone (various grades of dimethylpolysiloxane and their denatured products), etc., to improve its slidability. Also, in

addition to said lubricants, lubricants such as oleamide lubricant, erucic acid amide lubricant, stearic acid amide lubricant, bis fatty acid amide lubricant, nonionic surfactant based lubricant, hydrocarbon based lubricant, fatty acid based lubricant, ester based lubricant, alcohol based lubricant, metal soap, etc. can be added. Further, for the synthetic resin, it is favorable to use resins with superior anti-abrasive properties, such as PC (polycarbonate), POM (polyoxymethylene), PPS, aliphatic polyamides such as nylon 6 or nylon 66, aromatic polyamide, ultra-high-molecular-weight polyethylene, isotactic polypropylene, syndiotactic polypropylene, those of the imide group such as polyimide, polyamide imide, or polyetherimide, etc. This reduces the friction and abrasion of the sliding contact portions of both, enabling stable reel rotation by reduced drive resistance, and suppresses abrasion powder generation to secure reliable recording and playback performance. Also, said inhibiting member 4 and release member 6 can be in surface contact without said spherically shaped protrusion 64.

[0022] To explain the operation of said reel rotation inhibiting means 10, Figure 1 is a magnetic tape cartridge 1 during non-use such as in a storage state, and in this state, the inhibiting member 4, release member 6, and reel 2 have moved toward the bottom case 32 of the cartridge case 3 by the pressing force of the pressing member 5, and the bottom case 32 center opening 32a is closed and covered by the reel 2. The bottom surface of the release member 6 is at the lowermost state contacting the reel hub 21 bottom wall 21a, and the tips of its upward pushing portions 63 are protruding to match the reel gear 24 tooth tip position. The inhibiting member 4 contacting the top surface of the release member 6 is also in the lowered position, and its inhibiting gear 41 is engaged with the reel 2 inhibiting gear 27 to restrain reel 2 rotation during non-use, preventing extraction of the magnetic tape.

[0023] In the inhibited state above, the inhibiting member 4 is centered by the conical shaped inhibiting gear 41 on the inhibiting member 4 being meshed with the inhibiting gear 27 on the reel 2 in a state pressed by the pressing member 5, which restricts its center position to match the center rotation center of the reel 2, and is in an evenly meshed state around the entire perimeter, securely inhibiting rotation.

[0024] In contrast, when a magnetic tape cartridge 1 is loaded in a drive during cartridge use in Figure 3, the drive side rotation drive means 11 rotation shaft 12 approaches the bottom surface of the reel 2, and the chucking operation meshes the drive gear 13 with the reel gear 24 and moves the reel 2 slightly upward and holds it. This bring the tooth tip of said drive gear 13 in contact with the center of the ends of the upward pushing portions 63 on the release member 6, applying pressing pressure and pushing them upward. In

conjunction, the release member 6 moves upward against the pressing force of the pressing member 5, and the inhibiting member 4 also moves in the upward releasing direction as one body with this release member 6. This releases the engagement of the inhibiting gear 41 on the inhibiting member 4 and the inhibiting gear 27 on the reel 2, and the reel 2 becomes free to rotate. And the recording and playback device drive extracts or winds the magnetic tape.

[0025] Because the inhibiting member 4 is centered during said release operation, relative to the upward pushing via the spherically shaped protrusion 64 at the center portion of the release member 6, this release member 4 rises parallel and moves evenly for the entire perimeter, enabling securely releasing the engagement for the entire perimeter between said inhibiting gear 41 and inhibiting gear 27.

[0026] Note that engaged inhibition between said inhibiting member 4 and the reel 2 can use pressure contact between mutual conical surfaces of high abrasion tolerance material, and not by meshing gears. Also, a quantity more than 3 of insertion holes 26 and pushing pressure portions 63 can be disposed. Further, said upward pushing portions 63 are not limited to being a square rod shape, but can also be a round rod shape.

#### [Brief Description of the Drawings]

[Figure 1] A section front view of a magnetic tape cartridge in one embodiment of the present invention in non-use status.

[Figure 2] An exploded perspective view of important components of the magnetic tape cartridge in Figure 1.

[Figure 3] A section view of important components of the magnetic tape cartridge in Figure 1 in use status.

#### [Description of Symbols]

1	Magnetic tape cartridge
2	Reel
3	Cartridge case
4	Inhibiting member
5	Pressing member
6	Release member
10	Reel rotation inhibiting means
11	Drive side rotation driving means
12	Rotation shaft
13	Drive gear
21	Reel hub
21a	Bottom wall
24	Reel gear
26	Insertion hole
27	Inhibiting gear
41	Inhibiting gear
62	Arm portion
63	Upward pressing portion

Figure 1

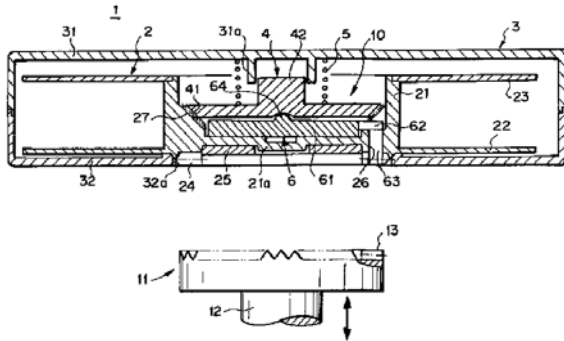

Figure 2

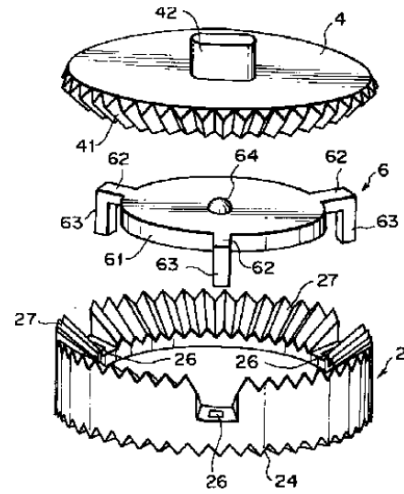
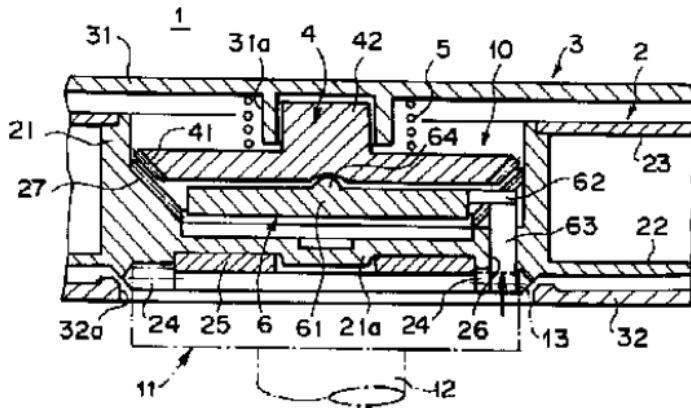

Figure 3



# Explore Litigation Insights

Docket Alarm provides insights to develop a more informed litigation strategy and the peace of mind of knowing you're on top of things.

## Real-Time Litigation Alerts



Keep your litigation team up-to-date with **real-time alerts** and advanced team management tools built for the enterprise, all while greatly reducing PACER spend.

Our comprehensive service means we can handle Federal, State, and Administrative courts across the country.

## Advanced Docket Research



With over 230 million records, Docket Alarm's cloud-native docket research platform finds what other services can't. Coverage includes Federal, State, plus PTAB, TTAB, ITC and NLRB decisions, all in one place.

Identify arguments that have been successful in the past with full text, pinpoint searching. Link to case law cited within any court document via Fastcase.

## Analytics At Your Fingertips



Learn what happened the last time a particular judge, opposing counsel or company faced cases similar to yours.

Advanced out-of-the-box PTAB and TTAB analytics are always at your fingertips.

## API

Docket Alarm offers a powerful API (application programming interface) to developers that want to integrate case filings into their apps.

## LAW FIRMS

Build custom dashboards for your attorneys and clients with live data direct from the court.

Automate many repetitive legal tasks like conflict checks, document management, and marketing.

## FINANCIAL INSTITUTIONS

Litigation and bankruptcy checks for companies and debtors.

## E-DISCOVERY AND LEGAL VENDORS

Sync your system to PACER to automate legal marketing.