

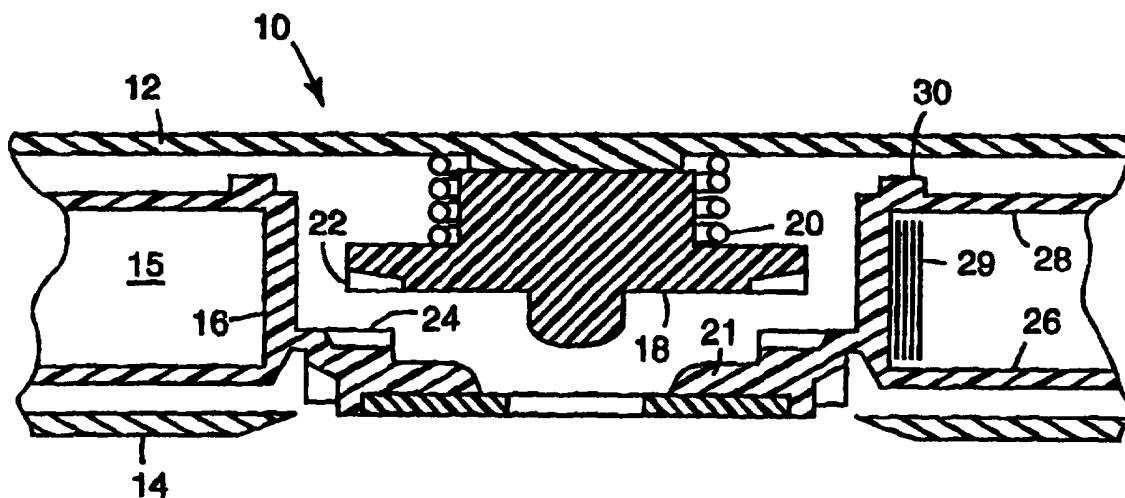

INTERNATIONAL APPLICATION PUBLISHED UNDER THE PATENT COOPERATION TREATY (PCT)

(51) International Patent Classification ⁶ : G11B 23/107	A1	(11) International Publication Number: WO 97/15925 (43) International Publication Date: 1 May 1997 (01.05.97)
<p>(21) International Application Number: PCT/US96/16434</p> <p>(22) International Filing Date: 16 October 1996 (16.10.96)</p> <p>(30) Priority Data: 08/548,706 26 October 1995 (26.10.95) US</p> <p>(71) Applicant: IMATION CORP. [US/US]; 1 Imation Place, P.O. Box 64898, Saint Paul, MN 55164-0898 (US).</p> <p>(72) Inventor: MARTIN, Robert, C.; P.O. Box 64898, Saint Paul, MN 55164-0898 (US).</p> <p>(74) Agent: DENNIS, Charles, L., II; Imation Legal Affairs, P.O. Box 64898, Saint Paul, MN 55164-0898 (US).</p>		<p>(81) Designated States: CN, DE, JP.</p> <p>Published <i>With international search report.</i></p>

(54) Title: STRUCTURE TO LIMIT EDGE CREASING IN A SCATTER-WOUND CARTRIDGE



(57) Abstract

Various structures are described to minimize tape edge creasing in a tape cartridge. Several structures prevent the flange from being pressed by the housing of the tape cartridge into the tape pack with sufficient force to crease the edges of any exposed tape strands. Use of various structures or alternative materials also can stiffen the flange, again reducing the likelihood of the flange deflecting into the tape pack.

FOR THE PURPOSES OF INFORMATION ONLY

Codes used to identify States party to the PCT on the front pages of pamphlets publishing international applications under the PCT.

AM	Armenia	GB	United Kingdom	MW	Malawi
AT	Austria	GE	Georgia	MX	Mexico
AU	Australia	GN	Guinea	NE	Niger
BB	Barbados	GR	Greece	NL	Netherlands
BE	Belgium	HU	Hungary	NO	Norway
BF	Burkina Faso	IE	Ireland	NZ	New Zealand
BG	Bulgaria	IT	Italy	PL	Poland
BJ	Benin	JP	Japan	PT	Portugal
BR	Brazil	KE	Kenya	RO	Romania
BY	Belarus	KG	Kyrgystan	RU	Russian Federation
CA	Canada	KP	Democratic People's Republic of Korea	SD	Sudan
CF	Central African Republic	KR	Republic of Korea	SE	Sweden
CG	Congo	KZ	Kazakhstan	SG	Singapore
CH	Switzerland	LI	Liechtenstein	SI	Slovenia
CI	Côte d'Ivoire	LK	Sri Lanka	SK	Slovakia
CM	Cameroon	LR	Liberia	SN	Senegal
CN	China	LT	Lithuania	SZ	Swaziland
CS	Czechoslovakia	LU	Luxembourg	TD	Chad
CZ	Czech Republic	LV	Latvia	TG	Togo
DE	Germany	MC	Monaco	TJ	Tajikistan
DK	Denmark	MD	Republic of Moldova	TT	Trinidad and Tobago
EE	Estonia	MG	Madagascar	UA	Ukraine
ES	Spain	ML	Mali	UG	Uganda
FI	Finland	MN	Mongolia	US	United States of America
FR	France	MR	Mauritania	UZ	Uzbekistan
GA	Gabon			VN	Viet Nam

STRUCTURE TO LIMIT EDGE CREASING IN A SCATTER-WOUND CARTRIDGE

Background of the Invention

5

Field of the Invention

The present invention relates to support mechanisms for tape in a tape cartridge, and in particular, to structures for supporting scatter-wound tape packs.

10

Description of the Related Art

The tape in many types of tape cartridges winds into a tape pack about the tape spool such that some portions of the tape project above or below the main body of the tape pack. This type of winding is called scatter-wound, as distinct from the smoother winding (with better alignment from one piece of tape to the next) found in some cartridges using belts or the like to assist in packing.

The tape spool in a 3480-style tape cartridge such as that shown in European Published Patent Application 0 588 219 (Martin et al.) is free to float within the cavity created by the base and cover. The only restraint against such motion is the low restraining force of a spring biasing a brake into engagement with the spool. However, during shipping and handling the inertia of the tape pack can easily overcome the force of the brake spring, causing the tape spool to contact the inner walls of the cavity. This contact can force the spool flanges to deflect into the tape pack, thereby creasing the edges of any tape strand which protrudes from the pack. Creases in the tape can result in high error counts on the edge tracks of the tape and the like. Even fairly routine shipping and handling of the cartridge can develop this problem.

This problem is usually most significant for the upper flange because the spool normally is biased toward the bottom of the cartridge

30

housing. This means that it already is resting flat against the bottom, so any forces tend to be evenly distributed over the entire lower flange. Thus, the lower flange is not likely to be significantly bent or distorted if the cartridge is struck on the bottom. In contrast, the gap between the top of the spool and the cover allows the spool to be thrown against the cover, and, in particular, to be thrown against the cover at varying angles. This means that the outer diameter of the flange may be the only part of the spool contacting the cover. Since the flange is a cantilever beam, a force applied only to the outer diameter deflects the flange much more than a force applied to the inner diameter or the entire flange. This deflection causes the flange to press against the tape pack, potentially creasing the edge of any tape strand(s) projecting above the main body of the tape pack.

Efforts have been made to limit the amount of tape which can protrude from the tape pack by tightly controlling the spacing and taper of the spool flanges. The effectiveness of this approach has been limited by the molding and assembly tolerances encountered during manufacture of the spool and assembly of the drive. As a consequence of this, some past spool designs allow tapes to become creased within the recording part of the tape, thus resulting in high error counts.

Summary of the Invention

The present invention significantly reduces creasing by modifying the tape spool or cover to limit contact between the flange and the cartridge cover. A ring or ridge of material is added to the upper surface of the flange near its inner diameter. If the cartridge is bumped, causing the spool move toward the cover, this ring will define the primary line of contact of the spool with the inner surface of the cover. Preferably, the height of the ring is such that only the ring will contact the cover. However, it is acceptable for the very outer diameter of the flange to also contact,

provided the geometry is such that the outer diameter is not significantly deflected by the contact. As a result, the inner surface of the flange will not be deflected into the tape pack.

5 The ring or ridge preferably is placed close to the inner diameter of the flange. This provides the maximum transfer of force directly to the spool hub, with the minimum deflection of the flange.

Alternatively, a ring or ridge of material can be added to the cover of the tape cartridge instead of or in addition to the ring on the flange.

10 According to another embodiment of the invention, the upper flange is made stiffer to resist deflection into the tape pack. One method is to make the flange out of a material with a higher flexural modulus, such as glass reinforced material. Another method is to provide the flange with radial ribs which resist deflection.

15 As will be apparent, these various embodiments are not mutually exclusive, and can be combined as desired to achieve the desired effect, which is preventing the flange from creasing the tape edges projecting from the main body of the tape pack.

Brief Description of the Drawings

20 Fig. 1 is a partial cross-section of a cartridge according to a first embodiment of the invention.

Fig. 2 is a partial cross-section of a cartridge according to a second embodiment of the invention.

25 Fig. 3 is a partial cross-section of a cartridge according to a third embodiment of the invention.

Detailed Description of the Preferred Embodiments

30 Fig. 1 depicts a cartridge 10 with a cover 12 and a base 14 defining a cavity 15 therebetween in which a tape spool 16 is rotatably mounted. A brake 18 also is positioned in the cavity 15 and is biased by a brake spring

Explore Litigation Insights

Docket Alarm provides insights to develop a more informed litigation strategy and the peace of mind of knowing you're on top of things.

Real-Time Litigation Alerts



Keep your litigation team up-to-date with **real-time alerts** and advanced team management tools built for the enterprise, all while greatly reducing PACER spend.

Our comprehensive service means we can handle Federal, State, and Administrative courts across the country.

Advanced Docket Research



With over 230 million records, Docket Alarm's cloud-native docket research platform finds what other services can't. Coverage includes Federal, State, plus PTAB, TTAB, ITC and NLRB decisions, all in one place.

Identify arguments that have been successful in the past with full text, pinpoint searching. Link to case law cited within any court document via Fastcase.

Analytics At Your Fingertips



Learn what happened the last time a particular judge, opposing counsel or company faced cases similar to yours.

Advanced out-of-the-box PTAB and TTAB analytics are always at your fingertips.

API

Docket Alarm offers a powerful API (application programming interface) to developers that want to integrate case filings into their apps.

LAW FIRMS

Build custom dashboards for your attorneys and clients with live data direct from the court.

Automate many repetitive legal tasks like conflict checks, document management, and marketing.

FINANCIAL INSTITUTIONS

Litigation and bankruptcy checks for companies and debtors.

E-DISCOVERY AND LEGAL VENDORS

Sync your system to PACER to automate legal marketing.