



Antrag auf Erteilung eines europäischen Patents / Request for grant of a European patent / Requête en délivrance d'un brevet européen 1

Bestätigung einer bereits durch Telefax eingereichten Anmeldung / Confirmation of an application already filed by facsimile / Confirmation d'une demande déjà déposée par télex
Wenn ja, Datum der Übermittlung des Telefax und Name der Einreichungsbehörde / If yes, facsimile date and name of the authority with which the documents were filed / Si oui, date d'envoi du télex et nom de l'autorité de dépôt

Ja / Yes / Oui

Datum / Date

Behörde / Authority / Autorité

Nur für amtlichen Gebrauch / For official use only / Cadre réservé à l'administration			
Anmeldenummer / Application No / N° de la demande	MKEY	1	00124448.2
Tag des Eingangs (Regel 24(2)) / Date of receipt (Rule 24(2)) / Date de réception (règle 24(2))	DREC	2	08. 11. 00
Tag des Eingangs beim EPA (Regel 24(4)) / Date of receipt at EPO (Rule 24(4)) / Date de réception à l'OEB (règle 24(4))	RENA	3	
Anmeldetag / Date of filing / Date de dépôt		4	
Tabulatoren-Positionen / Tabulation marks / Arrêts de tabulation			
Es wird die Erteilung eines europäischen Patents und gemäß Artikel 94 die Prüfung der Anmeldung beantragt / Grant of a European patent, and examination of the application under Article 94, are hereby requested / Il est demandé la délivrance d'un brevet européen et, conformément à l'article 94, l'examen de la demande	EXAM 4	5	<input checked="" type="checkbox"/> Prüfungsantrag in einer zugelassenen Nichtamtssprache (siehe Merkblatt II, 5) / Request for examination in an admissible non-EPO language (see Notes II, 5) / Requête en examen dans une langue non officielle autorisée (voir notice II, 5)
Zeichen des Anmelders oder Vertreters (max 15 Positionen) / Applicant's or representative's reference (maximum 15 spaces) / Référence du demandeur ou du mandataire (max 15 caractères ou espaces)	AREF	6	EP20062-013/do
Anmelder / Applicant / Demandeur Name / Nom		7	Fuji Photo Film Co., Ltd.
Anschrift / Address / Adresse		8	210 Nakanuma, Minamiashigara-shi, Kanagawa-ken, Japan
APPR 01 # 2024024			
# DEST #			
Zustellanschrift / Address for correspondence / Adresse pour la correspondance		9	
PADR			
Staat des Wohnsitzes oder Sitzes / State of residence or of principal place of business / Etat du domicile ou du siège		10	Japan
Staatsangehörigkeit / Nationality / Nationalité		11	Japan
Telefon / Telephone / Téléphone		12	
Telex / Télex		13	
Telefax / Fax / Téléfax		13	
Weitere(r) Anmelder auf Zusatzblatt / Additional applicant(s) on additional sheet / Autre(s) demandeur(s) sur feuille additionnelle		14	
Vertreter / Representative / Mandataire Name / Nom		15	Grünecker, Kinkeldey, Stockmair & Schwanhäusser Anwaltssozietät
(Nur einen Vertreter angeben, der in das europäische Patentregister eingetragen ist und an den zugestellt wird / Name only one representative who is to be listed in the Register of European Patents and to whom notification is to be made / N'indiquer qu'un seul mandataire, qui sera inscrit au Registre européen des brevets et auquel signification sera faite)			(association no. 72)
FREP 01 10072110#			
Geschäftsanschrift / Address of place of business / Adresse professionnelle		16	Maximilianstraße 58 80538 München Rep. Fed. d'Allemagne
Telefon / Telephone / Téléphone		17	089/21 23 50
Telex / Télex		18	
Telefax / Fax / Téléfax		18	089/22 02 87
Weitere(r) Vertreter auf Zusatzblatt / Additional representative(s) on additional sheet / Autre(s) mandataire(s) sur feuille additionnelle		19	

EPA/EPO/OEB Form 1001 1 07 99

TRAN | FILL | FN

EP20062-013/do

Raum für Zeichen des Anmelders / Space for applicant's reference / Espace réservé à la référence du demandeur

SONY Exhibit 1009
SONY v. FUJI

<p>Vollmacht / Authorisation / Pouvoir ist beigefügt / is enclosed / joint</p>	20																
<p>ist registriert unter Nummer / has been registered under No / a été enregistré sous le n°</p>	21	GENA															
<p>Erfinder / Inventor / Inventeur</p> <p>Anmelder ist (sind) alleinige(r) Erfinder / The applicant(s) is (are) the sole inventor(s) / Le(s) demandeur(s) est (sont) le (les) seul(s) inventeur(s)</p>	22	INVT 20 # #															
<p>Erfindernennung in gesondertem Schriftstück / Designation of inventor attached / Voir la designation de l'inventeur ci-jointe</p>	23	<input checked="" type="checkbox"/>															
<p>Bezeichnung der Erfindung / Title of invention / Titre de l'invention</p>	24	MAGNETIC TAPE CARTRIDGE															
<table border="1" style="margin-left: auto; margin-right: auto; border-collapse: collapse;"> <tr> <td style="padding: 2px;">TIDE</td> <td style="padding: 2px;">TIEN</td> <td style="padding: 2px;">TIFR</td> </tr> </table>	TIDE	TIEN	TIFR	25													
TIDE	TIEN	TIFR															
<p>Prioritätserklärung / Declaration of priority / Déclaration de priorité</p>	25	PRIO															
<p>01 # # #</p> <p>02 # # #</p> <p>03 # # #</p> <p>04 # # #</p>	25	<table style="width: 100%; border-collapse: collapse;"> <tr> <td style="width: 20%; border: 1px solid black;">Staat / State / Etat</td> <td style="width: 30%; border: 1px solid black;">Anmeldetag / Date of filing / Date de dépôt</td> <td style="width: 50%; border: 1px solid black;">Aktenzeichen / Application No / N° de la demande</td> </tr> <tr> <td style="border: 1px solid black;">1 Japan</td> <td style="border: 1px solid black;">November 8, 1999</td> <td style="border: 1px solid black;">317166/1999</td> </tr> <tr> <td style="border: 1px solid black;">2 Japan</td> <td style="border: 1px solid black;">November 9, 1999</td> <td style="border: 1px solid black;">318464/1999</td> </tr> <tr> <td style="border: 1px solid black;">3</td> <td></td> <td></td> </tr> <tr> <td style="border: 1px solid black;">4</td> <td></td> <td></td> </tr> </table>	Staat / State / Etat	Anmeldetag / Date of filing / Date de dépôt	Aktenzeichen / Application No / N° de la demande	1 Japan	November 8, 1999	317166/1999	2 Japan	November 9, 1999	318464/1999	3			4		
Staat / State / Etat	Anmeldetag / Date of filing / Date de dépôt	Aktenzeichen / Application No / N° de la demande															
1 Japan	November 8, 1999	317166/1999															
2 Japan	November 9, 1999	318464/1999															
3																	
4																	
<p>Weitere Prioritätserklärung(en) auf Zusatzblatt / Additional declaration(s) of priority on additional sheet / Autre(s) déclaration(s) de priorité sur feuille additionnelle</p>	25a	<input type="checkbox"/>															
<p>Es wird hiermit erklärt, daß die Anmeldung eine vollständige Übersetzung der früheren Anmeldung ist (Regel 38(4) / It is hereby declared that the application is a complete translation of the previous application (Rule 38(4) / Il est déclaré par la présente que la demande est une traduction intégrale de la demande antérieure (règle 38(4)</p>	25a	PRIO 6															
<p>Biologisches Material Biological material</p> <p>Die Erfindung bezieht sich auf bzw verwendet biologisches Material, das nach Regel 28 hinterlegt worden ist</p> <p>The invention relates to and/or uses biological material deposited under Rule 28</p>	26	<p>Matière biologique</p> <p>L'invention concerne et/ou utilise de la matière biologique, déposée conformément à la règle 28</p>															
<p>Die Angaben nach Regel 28(1)c) (falls noch nicht bekannt, die Hinterlegungsstelle und das (die) Bezugszeichen (Nummer, Symbole usw.) des Hinterlegers) sind in den technischen Anwendungsunterlagen enthalten auf / The particulars referred to in Rule 28(1)c) (if not yet known, the depository institution and the identification reference(s) [number, symbols etc.] of the depositor) are given in the technical documents in the application on / Les indications visées à la règle 28(1)c) (si pas encore connues, l'autorité de dépôt et la (les) référence(s) d'identification [numéro ou symboles etc.] du déposant) figurent dans les pièces techniques de la demande à la /aux</p>	27	<table style="width: 100%; border-collapse: collapse;"> <tr> <td style="width: 50%; border: 1px solid black;">Seite(n) / page(s)</td> <td style="width: 50%; border: 1px solid black;">Zeile(n) / line(s) / ligne(s)</td> </tr> </table>	Seite(n) / page(s)	Zeile(n) / line(s) / ligne(s)													
Seite(n) / page(s)	Zeile(n) / line(s) / ligne(s)																
<p>werden später mitgeteilt / will be submitted later /seront communiquées ultérieurement</p>	27a	<input type="checkbox"/>															
<p>Die Empfangsbescheinigung(en) der Hinterlegungsstelle ist (sind) beigefügt / The receipt(s) of deposit issued by the depository institution is (are) enclosed / Let(s) récépissé(s) de dépôt délivré(s) par l'autorité de dépôt est (sont) joint(s)</p>	27b	<input type="checkbox"/>															
<p>wird (werden) nachgereicht / will be filed later /sera (seront) produit(s) ultérieurement</p>	27c	<input type="checkbox"/>															

<p>Falls das biologische Material nicht vom Anmelder, sondern von einem Dritten hinterlegt wurde / Where the biological material has been deposited by a person other than the applicant / Lorsque la matière biologique a été déposée par une personne autre que le demandeur</p> <p>Ermächtigung nach Regel 28(1)d) / Authorisation under Rule 28(1)d) / L'autorisation en vertu de la règle 28(1)d)</p> <p>ist beigefügt / is enclosed / est jointe</p> <p>wird nachgereicht / will be filed later / sera produite ultérieurement</p>	<p>28 Name und Anschrift des Hinterlegers / Name and address of depositor / Nom et adresse du déposant</p> <p>28a <input type="checkbox"/></p> <p>28b <input type="checkbox"/></p>
<p>Verzicht auf die Verpflichtung des Antragstellers nach Regel 28(3) in gesondertem Schriftstück / Waiver of the right to an undertaking from the requester pursuant to Rule 28(3) attached</p>	<p>29 <input type="checkbox"/> Renonciation, sur document distinct, à l'engagement du requérant au titre de la règle 28(3)</p>
<p>Gemäß Regel 28(4) wird hiermit mitgeteilt, daß der Zugang zu dem in den Feldern 26 und 27 genannten biologischen Material nur durch Herausgabe einer Probe an einen Sachverständigen hergestellt wird / It is hereby declared under Rule 28(4) that the availability of the biological material referred to in Sections 26 and 27 shall be effected only by the issue of a sample to an expert</p> <p style="text-align: right;">BIOM 3</p>	<p>30 <input type="checkbox"/> Conformément à la règle 28(4) il est déclaré par la présente que l'accessibilité à la matière biologique mentionnée aux rubriques 26 et 27 ne peut réalisée que par la remise d'un échantillon à un expert</p>
<p>Nucleotid- und Aminosäuresequenzen / Nucleotide and amino acid sequences / Séquences de nucléotides et d'acides aminés</p> <p style="text-align: right;">SEQL 1</p> <p>Die Beschreibung enthält ein Sequenzprotokoll nach Regel 27a(1) / The description contains a sequence listing in accordance with Rule 27a(1) / La description contient une liste de séquences selon la règle 27bis(1)</p> <p>Der vorgeschriebene Datenträger ist beigefügt / The prescribed data carrier is enclosed / Le support de données prescrit est joint</p> <p>Es wird hiermit erklärt, daß die auf dem Datenträger gespeicherte Information mit dem schriftlichen Sequenzprotokoll übereinstimmt (Regel 27a(2)) / It is hereby stated that the information recorded on the data carrier is identical to the written sequence listing (Rule 27a(2)) / Il est déclaré par la présente que l'information figurant sur le support de données est identique à celle que contient la liste de séquences écrite (règle 27bis(2))</p>	<p>31 <input type="checkbox"/></p> <p><input type="checkbox"/></p> <p><input type="checkbox"/></p>
<p>Benennung der Vertragsstaaten und Erklärungen hierzu</p> <p>1 Hiermit werden sämtliche Vertragsstaaten des EPU benannt, die diesem bei Einreichung dieser Anmeldung angehören*</p> <p>Mit der Zahlung des siebenfachen Betrags einer Benennungsgebühr gelten die Benennungsgebühren für alle Vertragsstaaten als entrichtet (Art. 2 Nr. 3 GebO)</p> <p>2 Es ist derzeit beabsichtigt, weniger als sieben Benennungsgebühren für folgende Vertragsstaaten zu entrichten (<i>bitte Ländercodes und Vertragsstaaten angeben</i>*)</p> <p>(1) <input type="checkbox"/></p> <p>(2) <input type="checkbox"/></p> <p>(3) <input type="checkbox"/></p>	<p>Designation of contracting states and associated declarations</p> <p style="text-align: right;">DEST</p> <p>1 All states which are contracting states to the EPC at the filing of this application are hereby designated*</p> <p>Payment of seven times the amount of the designation fee is deemed to constitute payment of the designation fees for all the contracting states (Art. 2, No. 3, RFees)</p> <p>2 It is currently intended to pay fewer than seven designation fees for the following contracting states (<i>please indicate country codes and contracting states</i>*)</p> <p>(4) <input type="checkbox"/></p> <p>(5) <input type="checkbox"/></p> <p>(6) <input type="checkbox"/></p>
<p>Es wird beantrag, für die unter Nr. 2 nicht aufgeführten Vertragsstaaten von der Zustellung von der Mitteilung nach Regel 85a(1) und Regel 69(1) abzusehen</p> <p>3 Wird ein automatischer Abbuchungsauftrag erteilt (Feld 43), so wird das EPA beauftrag, bei Ablauf der Grundfrist nach Artikel 79(2) den siebenfachen Betrag einer Benennungsgebühr abzubuchen. Ist eine Erklärung unter Nr. 2 abgegeben worden, so sollen die Benennungsgebühren nur für die dort angegebenen Vertragsstaaten abgebucht werden, sofern dem EPA nicht bis zum Ablauf der Grundfrist ein anderslautender Auftrag zugeht</p>	<p>Désignation d'Etats contractants et déclarations à ce propos</p> <p><input checked="" type="checkbox"/> 1 Sont désignés tous les Etats qui sont des Etats contractants de la CBE à la date du dépôt de la présente demande*</p> <p>Les taxes de désignation sont réputées acquittées pour tous les Etats contractants dès lors qu'un montant correspondant à sept fois la taxe de désignation a été acquitté (art. 2, point 3 du RRT)</p> <p><input type="checkbox"/> 2 Il est actuellement envisagé de payer moins de sept taxes de désignation pour les Etats contractants suivants (<i>prérez d'indiquer codes de pays et Etats contractants</i>*)</p> <p>Prière de ne pas procéder à la signification des notifications prévues par les règles 85bis(1) et 69(1) pour les Etats contractants n'ayant pas été mentionnés au n° 2</p> <p><input checked="" type="checkbox"/> 3 Si un ordre de prélèvement automatique est donné (rubrique 43), il est demandé à l'OEB de prélever, à l'expiration du délai normal visé à l'article 79(2), un montant correspondant à sept fois la taxe de désignation. Si une déclaration a été faite au n° 2, les taxes de désignation ne sont prélevées que pour les Etats contractants qui y sont indiqués, sauf instruction contraire reçue par l'OEB avant l'expiration du délai normal</p>

* Stand bei Drucklegung: 19 Vertragsstaaten, und zwar / Status when this form was printed: 19 contracting states, namely / Situation à la date d'impression: 19 Etats contractants, à savoir: AT Österreich / Austria / Autriche, BE Belgien / Belgium / Belgique, CH/LI Schweiz und Liechtenstein / Switzerland and Liechtenstein / Suisse et Liechtenstein, CY Zypern / Cyprus / Chypre, DE Deutschland / Germany / Allemagne, DK Danemark / Denmark / Danemark, ES Spanien / Spain / Espagne, FI Finnland / Finland / Finlande, FR Frankreich / France / France, GB Vereinigtes Königreich / United Kingdom / Royaume-Uni, GR Griechenland / Greece / Grèce, IE Irland / Ireland / Irlande, IT Italien / Italy / Italie, LU Luxemburg / Luxembourg / Luxembourg, MC Monaco / Monaco, NL Niederlande / Netherlands / Pays-Bas, PT Portugal / Portugal / Portugal, SE Schweden / Sweden / Suede

EP 20062-013/do

<p>Verschiedene Anmelder für verschiedene Vertragsstaaten / Different applicants for different contracting states / Différents demandeurs pour différents Etats contractants</p> <p>APPR 02 # _____ # _____</p>	<p>33 Name(n) des (der) Anmelder(s) und benannte Vertragsstaaten / Name(s) of applicant(s) and designated contracting states / Nom(s) du (des) demandeur(s) et des Etats contractants désignés</p>																		
<p>Erstreckung des europäischen Patents Extension of the European patent</p> <p>Diese Anmeldung gilt als Antrag, die europäische Patentanmeldung und das darauf erteilte europäische Patent auf alle Nicht-Vertragsstaaten des EPU zu erstrecken mit denen am Tag ihrer Einreichung „Erstreckungsabkommen“ bestehen (derzeit Albanien, Litauen, Lettland, Rumänien, Slowenien, ehemalige jugoslawische Republik Mazedonien). Die Erstreckung wird jedoch nur wirksam, wenn die vorgeschriebene Erstreckungsgebühr entrichtet wird</p> <p>This application is deemed to be a request to extend the European patent application and the European patent granted in respect of it to all non-contracting states to the EPC with which "extension agreements" exist on the date on which the application is filed (Present situation Albania, Lithuania, Latvia, Romania, Slovenia, former Yugoslav Republic of Macedonia) However, the extension only takes effect if the prescribed extension fee is paid</p> <p style="text-align: right;">EXPT</p> <p>Es ist derzeit beabsichtigt, die Erstreckungsgebühr für die nachfolgend angekreuzten Staaten zu entrichten / It is currently intended to pay the extension fee for the states marked below with a cross / Il est actuellement envisagé de payer la taxe d'extension pour les Etats dont le nom est coché ci-après</p> <table style="width:100%; border-collapse: collapse;"> <tr> <td style="width:80%;">Albanien / Albania / Albanie</td> <td style="width:20%; text-align: center;">AL</td> <td style="width:10%; text-align: center;"><input type="checkbox"/></td> </tr> <tr> <td>Litauen / Lithuania / Lituanie</td> <td style="text-align: center;">LT</td> <td style="text-align: center;"><input type="checkbox"/></td> </tr> <tr> <td>Lettland / Latvia / Lettonie</td> <td style="text-align: center;">LV</td> <td style="text-align: center;"><input type="checkbox"/></td> </tr> <tr> <td>Rumänien / Romania / Roumanie</td> <td style="text-align: center;">RO</td> <td style="text-align: center;"><input type="checkbox"/></td> </tr> <tr> <td>Slowenien / Slovenia / Slovénie</td> <td style="text-align: center;">SI</td> <td style="text-align: center;"><input type="checkbox"/></td> </tr> <tr> <td>Ehemalige jugoslawische Republik Mazedonien / Former Yugoslav Republic of Macedonia / Ex-Republicue yougoslave de Macédoine</td> <td style="text-align: center;">MK</td> <td style="text-align: center;"><input type="checkbox"/></td> </tr> </table> <p><small>(Platz für Staaten, mit denen nach Drucklegung dieses Formblatts „Erstreckungsabkommen“ in Kraft treten) / (Space for states with which "extension agreements" enter into force after this form has been printed) / (Prévu pour des Etats à l'égard desquels des «accords d'extension» entreraient en vigueur après l'impression du présent formulaire)</small></p>	Albanien / Albania / Albanie	AL	<input type="checkbox"/>	Litauen / Lithuania / Lituanie	LT	<input type="checkbox"/>	Lettland / Latvia / Lettonie	LV	<input type="checkbox"/>	Rumänien / Romania / Roumanie	RO	<input type="checkbox"/>	Slowenien / Slovenia / Slovénie	SI	<input type="checkbox"/>	Ehemalige jugoslawische Republik Mazedonien / Former Yugoslav Republic of Macedonia / Ex-Republicue yougoslave de Macédoine	MK	<input type="checkbox"/>	<p>34 <input checked="" type="checkbox"/> Extension des effets du brevet européen</p> <p>La présente demande est réputée constituer une requête en extension des effets de la demande de brevet européen et du brevet européen délivré sur la base de cette demande à tous les Etats non parties à la CBE avec lesquels il existe un «accord d'extension» à la date du dépôt de la demande (Situation actuelle Albanie, Lituanie, Lettonie, Roumanie, Slovénie, ex-République yougoslave de Macédoine) Toutefois, l'extension ne produit ses effets que s'il est acquitté la taxe d'extension prescrite</p>
Albanien / Albania / Albanie	AL	<input type="checkbox"/>																	
Litauen / Lithuania / Lituanie	LT	<input type="checkbox"/>																	
Lettland / Latvia / Lettonie	LV	<input type="checkbox"/>																	
Rumänien / Romania / Roumanie	RO	<input type="checkbox"/>																	
Slowenien / Slovenia / Slovénie	SI	<input type="checkbox"/>																	
Ehemalige jugoslawische Republik Mazedonien / Former Yugoslav Republic of Macedonia / Ex-Republicue yougoslave de Macédoine	MK	<input type="checkbox"/>																	
<p>Die Anmeldung ist eine Teilanmeldung / The application is a divisional application / La présente demande constitue une demande divisionnaire</p> <table style="width:100%; border-collapse: collapse;"> <tr> <td style="width:30%; border: 1px solid black;">DFIL 9</td> <td style="width:40%; border: 1px solid black;">#</td> <td style="width:30%;"></td> </tr> <tr> <td style="border: 1px solid black;">PANR</td> <td style="border: 1px solid black;">#</td> <td></td> </tr> </table>	DFIL 9	#		PANR	#		<p>35 <input type="checkbox"/> _____ Nummer der früheren Anmeldung No. of earlier application Numéro de la demande initiale</p>												
DFIL 9	#																		
PANR	#																		
<p>Es handelt sich um eine Anmeldung nach Artikel 61(1)(b) / The application is an Article 61(1)(b) application / La présente demande constitue une demande selon l'article 61(1)(b)</p> <table style="width:100%; border-collapse: collapse;"> <tr> <td style="width:30%; border: 1px solid black;">DFIL 9</td> <td style="width:40%; border: 1px solid black;">#</td> <td style="width:30%;"></td> </tr> <tr> <td style="border: 1px solid black;">EANR</td> <td style="border: 1px solid black;">#</td> <td></td> </tr> </table>	DFIL 9	#		EANR	#		<p>36 <input type="checkbox"/> _____ Nummer der früheren Anmeldung No. of earlier application Numéro de la demande initiale</p>												
DFIL 9	#																		
EANR	#																		
<p>Patentansprüche / Claims / Revendications</p> <p style="text-align: right;">CLMS</p>	<p>37 <input type="checkbox"/> 4 Zahl der Patentansprüche Number of claims Nombre de revendications</p>																		
<p>Zur Veröffentlichung mit der Zusammenfassung wird vorgeschlagen Abbildung Nr. / It is proposed that the abstract be published together with figure No. / Il est proposé de publier avec l'abrégé la figure n°</p> <p style="text-align: right;">DRAW 2</p>	<p>39 <input type="checkbox"/> 1 Nummer / Number / Numéro</p>																		

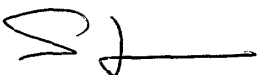
<p>Zusätzliche Abschrift(en) der im europäischen Recherchenbericht angeführten Schriftstücke wird (werden) beantragt / Additional copy(ies) of the documents cited in the European search report is (are) requested / Prière de fournir une (des) copie(s) supplémentaire(s) des documents cités dans le rapport de recherche européenne</p>	40	<p>Anzahl der zusätzlichen Sätze von Abschriften / Number of additional sets of copies / Nombre de jeux supplémentaires de copies</p> <p>1</p>
<p>Es wird die Rückerstattung der Recherchegebühr gemäß Art. 10 GebO beantragt / Refund of the search fee is requested pursuant to Article 10 of the Rules relating to Fees / Le remboursement de la taxe de recherche est demandé en vertu de l'article 10 du règlement relatif aux taxes</p> <p>Eine Kopie des Recherchenberichts ist beigefügt / A copy of the search report is attached / Une copie du rapport de recherche est jointe</p>	41 42	
<p>Automatischer Abbuchungsauftrag (nur möglich für Inhaber von beim EPA geführten laufenden Konten)</p> <p>Das EPA wird hiermit beauftragt, fallig werdende Gebühren und Auslagen nach Maßgabe der Vorschriften über das automatische Abbuchungsverfahren vom nebenstehenden laufenden Konto abzubuchen. In bezug auf die Benennungsgebühren wird auf Feld 32.3 verwiesen. Das EPA wird ferner beauftragt, die Erstreckungsgebühren für jeden in Feld 34 angekreuzten »Erstreckungsstaat« bei Ablauf der Grundfrist zu ihrer Zahlung abzubuchen, sofern ihm nicht bis dahin ein anderslautender Auftrag zugeht</p> <p>Für automatischen Abbuchungsauftrag: For automatic debit order: Pour l'ordre de prélèvement automatique :</p>	43	<p>Ordre de prélèvement automatique (possibilité offerte uniquement aux titulaires de comptes courants ouverts auprès de l'OEB)</p> <p>Par la présente, il est demandé à l'OEB de prélever du compte courant ci-dessous les taxes et frais venant à échéance, conformément à la réglementation relative à la procédure de prélèvement automatique. Pour les taxes de désignation, se reporter à la rubrique 32.3. Il est en outre demandé à l'OEB de prélever, à l'expiration du délai normal prévu pour leur paiement, les taxes d'extension pour chaque «Etat autorisant l'extension» coché à la rubrique 34, sauf instruction contraire reçue avant l'expiration de ce délai.</p> <p>Nummer des laufenden Kontos / Deposit account number / Numéro du compte courant</p> <p>Name des Kontoinhabers / Account holder's name / Nom du titulaire du compte</p> <p>DECA</p>
<p>Eventuelle Rückzahlungen auf das nebenstehende beim EPA geführte laufende Konto / Reimbursement, if any, to EPO deposit account opposite / Remboursements éventuels à effectuer sur le compte courant ci-contre ouvert auprès de l'OEB</p>	44	<p>Nummer des laufenden Kontos / Deposit account number / Numéro du compte courant</p> <p>Name des Kontoinhabers / Account holder's name / Nom du titulaire du compte</p> <p>28 000 437 Grünecker, Kinkeld et al.</p>
<p>Die vorgeschriebene Liste über die diesem Antrag beigefügten Unterlagen ergibt sich aus der vorbereiteten Empfangsbescheinigung (Seite 6 dieses Antrages)</p>	45	<p>La liste prescrite des documents joints à cette requête figure sur le récépissé préétabli (page 6 de la présente requête)</p>
<p>Unterschrift(en) des (der) Anmelders(s) oder Vertreters(s) / Signature(s) of applicant(s) or representative(s) / Signature(s) du (des) demandeur(s) ou du (des) mandataire(s)</p> <p>Munich</p> <p>Ort / Place / Lieu</p> <p>November 8, 2000</p> <p>Datum / Date</p> <p> (T. Schuster)</p> <p>Name des (der) Unterzeichneten bitte in Druckschrift wiederholen. Bei juristischen Personen bitte die Stellung des (der) Unterzeichneten innerhalb der Gesellschaft in Druckschrift angeben / Please print name under signature. In the case of legal persons, the position of the signatory within the company should also be printed / Le ou les noms des signataires doivent être indiqués en caractères d'imprimerie. S'il s'agit d'une personne morale, la position occupée au sein de celle-ci par le ou les signataires doit être indiquée en caractères d'imprimerie</p>	46	<p>Für Angestellte nach Artikel 133(3) Satz 1 mit allgemeiner Vollmacht / For employees under Article 133(3), 1st sentence, having a general authorisation / Pour les employés mentionnés à l'article 133(3), 1^{ère} phrase, munis d'un pouvoir général</p> <p>Nr / No / n°</p> <p>EP20062-013/do</p>

Empfangsbescheinigung / Receipt for documents / Récépissé de documents 6

(Liste der diesem Antrag beigefügten Unterlagen)

(Checklist of enclosed documents)

(Liste des documents annexés à la présente requête)

Es wird hiermit der Empfang der unten bezeichneten Dokumente bescheinigt / Receipt of the documents indicated below is hereby acknowledged / Nous attestons le dépôt des documents désignés ci-dessous

Wird im Falle der Einreichung der europäischen Patentanmeldung bei einer nationalen Behörde diese Empfangsbescheinigung vom Europäischen Patentamt übersandt, so ist sie als Mitteilung gemäß Regel 24(4) anzusehen (siehe Feld RENA) **Nach Erhalt der Mitteilung nach Regel 24(4) sind alle weiteren Unterlagen, die die Anmeldung betreffen, nur noch unmittelbar beim EPA einzureichen.** / If this receipt is issued by the European Patent Office and the European patent application was filed with a national authority it serves as a communication under Rule 24(4) (see Section RENA) **Once the communication under Rule 24(4) has been received, all further documents relating to the application must be sent directly to the European Patent Office.** / Si, en cas de dépôt de la demande de brevet européen auprès d'un service national, l'Office européen des brevets délivre le présent récépissé de documents, ce récépissé est réputé être la notification visée à la règle 24(4) (cf. rubrique RENA) **Dès que la notification visée à la règle 24(4) a été reçue, tous les autres documents relatifs à la demande doivent être adressés directement à l'OEB.**

Grünecker, Kinkeldey, Stockmair
& Schwanhäusser
Anwaltssozietät
Maximilianstr. 58
D-80538 München
Germany

Nur für amtlichen Gebrauch / For official use only / Cadre réservé à l'administration

Datum / Date



Europäisches Patentamt
European Patent Office
Office européen des brevets
D-80298 München
D. Barbe A. Langgarter

Unterschrift / Amts et officiel

Anmeldenummer / Application No. / N° de la demande	00124448.2
Tag des Eingangs (Regel 24(2)) / Date of receipt (Rule 24(2)) / Date de réception (règle 24(2))	DREC 08.11.00
Zeichen des Anmelders/Vertreters / Applicant's/ Representative's ref. / Référence du demandeur ou du mandataire	AREF

Nur nach Einreichung der Anmeldung bei einer nationalen Behörde / Only after filing of the application with a national authority. / Seulement après le dépôt de la demande auprès d'un service national

Tag des Eingangs beim EPA (Regel 24(4)) / Date of receipt at EPO (Rule 24(4)) / Date de réception à l'OEB (règle 24(4))	RENA
---	------

A. Anmeldeunterlagen und Prioritätsbeleg(e) / Application documents and priority document(s) / Pièces de la demande et document(s) de priorité	47	Stückzahl / Number of copies / Nombre d'exemplaires	Blattzahl* eines Stücks / Number of sheets* in each copy / Nombre de feuilles* par exemplaire	Gesamtzahl der Abbildungen* / Total number of figures* / Nombre total de figures*
1 Beschreibung (ohne Sequenzprotokollteil) / Description (excluding sequence listing part) / Description (sauf partie réservée au listage des séquences)		3	21	
2 Patentansprüche / Claim(s) / Revendications(s)		3	4	
3 Zeichnung(en) / Drawing(s) / Dessins	DRAW 1 #	3	4	5
4 Sequenzprotokollteil der Beschreibung / Sequence listing part of description / Partie de la description réservée au listage des séquences				
5 Zusammenfassung / Abstract / Abrege		3	1	
6 Übersetzung der Anmeldeunterlagen / Translation of the application documents / Traduction des pièces de la demande				
7 Prioritätsbeleg(e) / Priority document(s) / Document(s) de priorité				
8 Übersetzung des (der) Prioritätsbelegs/belege / Translation of priority document(s) / Traduction du (des) document(s) de priorité				

B. Der Anmeldung in der eingereichten Fassung liegen folgende Unterlagen bei: / This application as filed is accompanied by the items below: / A la présente demande sont annexées les pièces suivantes:	48	
1 Einzelvollmacht / Specific authorisation / Pouvoir particulier		<input type="checkbox"/>
2 Allgemeine Vollmacht / General authorisation / Pouvoir general		<input type="checkbox"/>
3 Erfindernennung / Designation of inventor / Designation de l'inventeur		<input checked="" type="checkbox"/>
4 Früherer Recherchenbericht / Earlier search report / Rapport de recherche antérieure		<input type="checkbox"/>
5 Gebühreuzahlungsvordruck (EPA Form 1010) / Voucher for the settlement of fees (EPO Form 1010) / Bordereau de règlement de taxes (OEB Form 1010)		<input checked="" type="checkbox"/> Währung Betrag / Currency Amount / Monnaie Montant (Ausfüllung freigestellt / optional / facultatif)
6 Scheck (nicht bei Einreichung bei den nationalen Behörden) / Cheque (not when filing with national authorities) / Cheque (pas de cheque en cas de dépôt auprès des services nationaux)		€ 837,- (A)
7 Datenträger für Sequenzprotokoll / Data carrier for sequence listing / Support de données pour liste de séquences		<input type="checkbox"/>
8 Zusatzblatt / Additional sheet / Feuille additionnelle		<input type="checkbox"/>
9 Sonstige Unterlagen (bitte hier spezifizieren) / Other documents (please specify here) / Autres documents (veuillez préciser)		<input type="checkbox"/>

C. Kopien dieser Empfangsbescheinigung / Copies of this receipt for documents / Copies du présent récépissé de documents	49	2 Anzahl der Kopien / Number of copies / Nombre de copies
--	----	---

* Die Richtigkeit der Angabe der Blattzahl und der Gesamtzahl der Abbildungen wurde bei Eingang nicht geprüft / No check was made on receipt that the number of sheets and the total number of figures indicated were correct. / L'exactitude du nombre de feuilles et du nombre total de figures n'a pas été contrôlée lors du dépôt

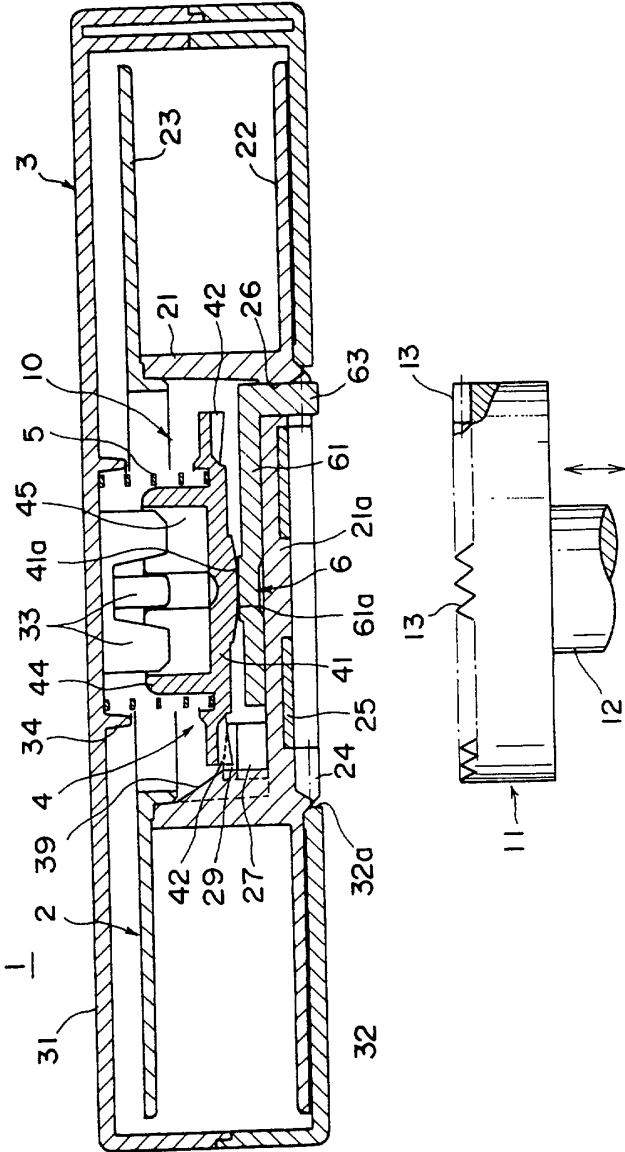
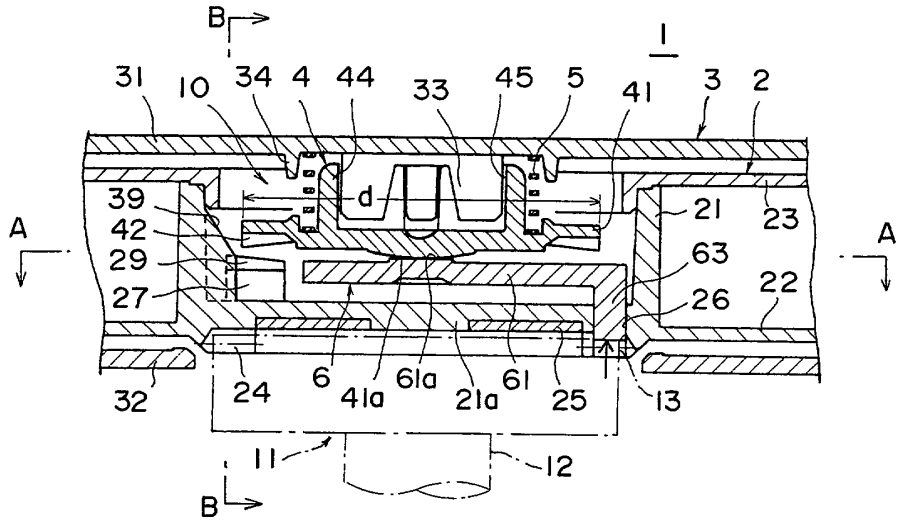
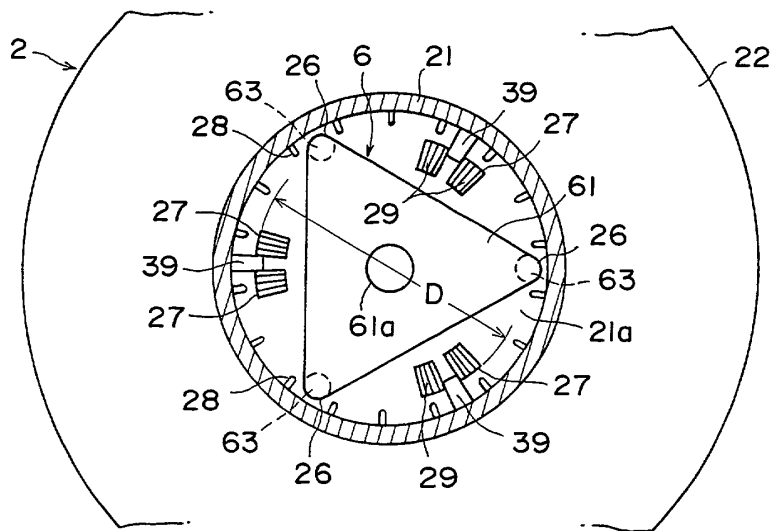

FIG. 1

F I G . 2



F I G . 3



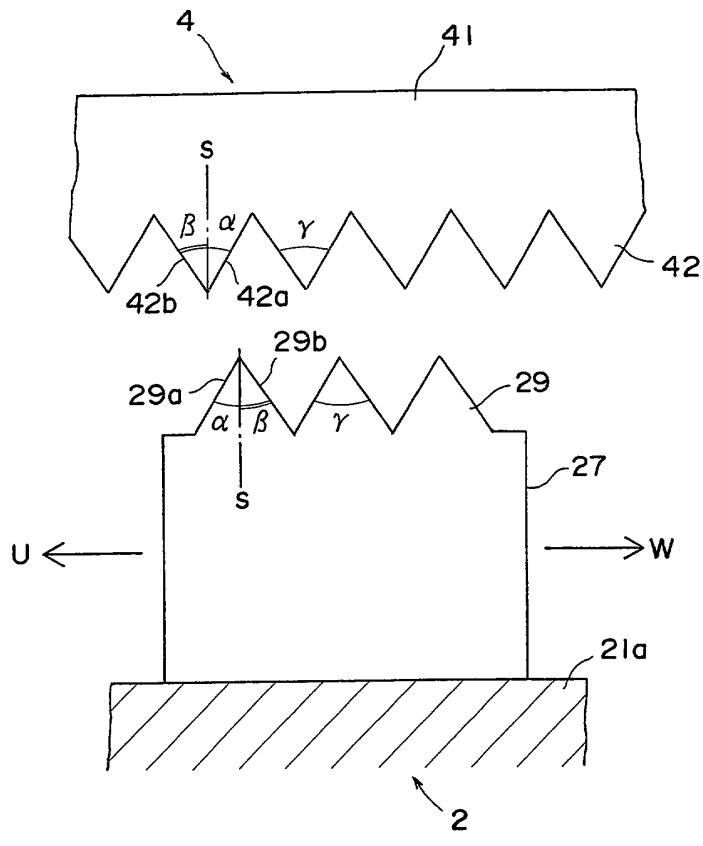

F I G . 4

FIG. 5

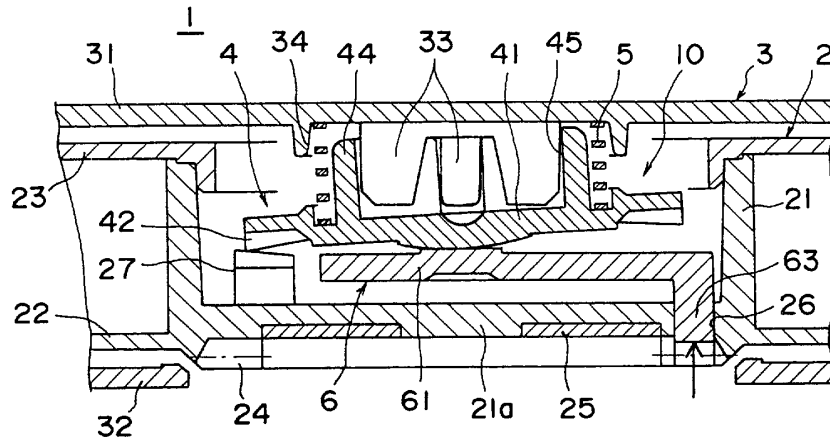

PRIOR ART

ERFINDERNENNUNG / DESIGNATION OF INVENTOR / DESIGNATION DE L'INVENTEUR

(falls Anmelder nicht oder nicht allein der Erfinder ist) / (where the applicant is not the inventor or is not the sole inventor) / (si le demandeur n'est pas l'inventeur ou l'unique inventeur)

Zeichen des Anmelders oder Vertreters Applicant's or representative's reference Référence du demandeur ou du mandataire (max. 15 Positionen / max. 15 spaces / 15 caractères au maximum)	Nr. der Anmeldung oder, falls noch nicht bekannt, Bezeichnung der Erfindung Application N° or, if not yet known, title of the invention N° de la demande ou, si ce dernier n'est pas encore connu, titre de l'invention
EP20062-013/do	MAGNETIC TAPE CARTRIDGE
	EPO - Munich 58 08. Nov. 2000

In Sachen der obenbezeichneten europäischen Patentanmeldung nennt (nennen) der (die) Unterzeichnete(n)¹
 In respect of the above European patent application I (we), the undersigned¹
 En ce qui concerne la demande de brevet européen susmentionnée le (s) soussigné(s)¹

Fuji Photo Film Co., Ltd.
 210 Nakanuma, Minamiashigara-shi, Kanagawa-ken, Japan

als Erfinder²:
 do hereby designate as inventor(s)²:
 désigne(nt) en tant qu'inventeur(s)²:

Daisuke TAKAHASHI Hideaki SHIGA Seiji TSUYUKI

Address of all inventors: c/o Fuji Photo Film Co., Ltd., 2-12-1 Oogi-cho, Odawara-shi,
 Kanagawa-ken, Japan

(Weiterer Erfinder sind auf einem gesonderten Blatt angegeben) / (Additional inventors indicated on supplementary sheet) /
 (Les autres inventeurs sont mentionnés sur une feuille supplémentaire).

Der (Die) Anmelder hat das Recht auf das europäische Patent erlangt³
 The applicant(s) has (have) acquired the right to the European patent³
 Le(s) demandeur(s) a (ont) acquis le droit au brevet européen³

gemäß Vertrag vom _____
 under an agreement date 19.07.2000
 par contrat en date du _____

als Arbeitgeber
 as employer(s)
 en qualité d'employeur(s)

durch Erbfolge
 as successor(s) in title
 par transfer successoral

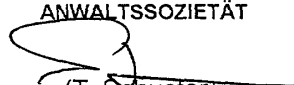
Ort/Place/Lieu Munich	Datum/Date 08.11.2000
Unterschrift(en) des (der) Anmelder(s) oder Vertreter(s) / Signature(s) of applicant(s) or representatives(s) / Signature(s) du (des) demandeur(s) ou du (des) mandataire(s)	GRÜNECKER, KINKELDEY, STOCKMAIR & SCHWANHÄUSSER ANWALTSOZIELTÄT  (T. Schuster)

Name des (der) Unterzeichneten bitte mit der Schreibmaschine wiederholen. Bei juristischen Personen bitte die Stellung des (der) Unterzeichneten innerhalb der Gesellschaft mit Schreibmaschine angeben / Please type name under signature in case of legal persons, the position of the signer within the company should also be typed / Le ou les noms des signataires doivent être également dactylographiés. S'il s'agit d'une personne morale, la position occupée au sein de celle-ci par le ou les signataires sera indiquée à la machine à écrire

Fußnoten befinden sich auf der Rückseite / Footnotes overleaf / Le texte des renvois figure au verso

EP20062-013/do

08.11.2000

Fuji Photo Film Co., Ltd.
210 Nakanuma, Minamiashigara-shi,
Kanagawa-ken, Japan

MAGNETIC TAPE CARTRIDGE

MAGNETIC TAPE CARTRIDGE

EPO-Munich
58

08. Nov. 2000

BACKGROUND OF THE INVENTION

Field of the Invention

5 This invention relates to a magnetic tape cartridge comprising a cartridge casing and a single reel which is housed in the cartridge casing for rotation and around which a magnetic tape is wound, and more particularly to a structure of a reel stopper means for preventing rotation of the reel when the
10 magnetic tape cartridge is not being used.

Description of the Related Art

 As a recording medium for use in an external memory of a computer or the like, there has been known a magnetic tape cartridge comprising a magnetic tape wound around a single reel
15 and a cartridge casing in which the reel is housed for rotation. Since the magnetic tape is used for storing data in a computer or the like and important information is stored on the magnetic tape, the magnetic tape cartridge is provided with a reel stopper means which prevents rotation of the reel when the
20 magnetic tape cartridge is not being used, e.g., when the magnetic tape cartridge is being stored, so that trouble such as tape jam does not occur and the magnetic tape is not accidentally drawn out.

 The reel stopper means is provided with a brake member
25 which is adapted to be engaged with the reel to prevent rotation of the reel and is disengaged from the reel to permit rotation

of the reel in response to a reel chucking action of the reel drive means of a tape drive such as an external memory when the magnetic tape cartridge is loaded in the tape drive.

In order to improve reliability of the action of the reel stopper means and to prevent dust from entering the cartridge casing, the reel stopper means may be, for instance, of a structure comprising a brake member which restricts rotation of the reel, an urging member which urges the brake member toward a locking position in which the brake member restricts rotation of the reel, and a release member which is moved in response to a reel chucking action of the reel drive means of a tape drive to move the brake member toward a release position in which the brake member releases the reel to permit rotation of the same.

That is, when the magnetic tape cartridge is not being used, the brake member locks the reel so that the reel is not accidentally rotated and the magnetic tape is not accidentally drawn out, and when the magnetic tape cartridge is loaded in a tape drive, the release member drives the brake member to release the reel in response to a reel chucking action of the reel drive means of the tape drive. In this state, the reel can be rotated and loading/unloading of the magnetic tape is permitted.

In such a structure, it is advantageous in simplifying the structure that the release member is adapted to be brought into abutment against a part of the reel drive means of the

tape drive and the reel drive means pushes a part of the release member to drive the brake member to release the reel when the reel drive means chucks the reel. However, in this case, when the release member drives the brake member to release the reel, 5 the brake member can be inclined as shown in Figure 5 and the gear teeth on the brake member can be brought into contact with the rear teeth on the reel while the reel is rotated, which results in generation of noise, obstruction of rotation of the reel and unstable magnetic tape loading/unloading action.

10 As a cause of the brake member being inclined, that the brake member becomes off-centered and comes to be inclined when the brake member is moved to the locking position where the braking gear thereon is brought into engagement with an engagement gear on the reel and the brake member is moved to 15 the release position in this state can be conceived. Further, that the brake member was incorporated in the magnetic tape cartridge inclined relative to the reel when the magnetic tape cartridge was assembled can be conceived.

20 When the braking gear teeth on the brake member are like sawteeth in shape and the surface of each tooth facing against the tape-unwinding direction of the reel is substantially normal, though rotation of the reel in the tape-unwinding direction can be surely prevented, there is fear that the magnetic tape is cut when the reel is rotated in the tape- 25 winding direction due to drop impact when the magnetic tape cartridge drops.

That is, when the braking gear and the engagement gear are engaged with each other at a substantially normal surface facing against the tape-unwinding direction, the reel cannot be rotated in the tape-unwinding direction. Further, a leader member such as a leader pin is fixed to the end of the magnetic tape wound around the reel, and the leader member is held near the tape draw-out opening of the cartridge casing when the magnetic tape cartridge is not being used. When the brake member is moved and the braking gear is disengaged from the engagement gear due to drop impact with the reel rotated in the tape-winding direction under inertia, a tape winding force acts on the magnetic tape whose end is fixed by the leader member. Since the reel cannot be rotated in the tape-unwinding direction or the direction in which the tension on the magnetic is released, the tape winding force acting on the magnetic tape can stretch the tape to deteriorate the magnetic recording and reproducing characteristics, remove the leader member from the magnetic tape, cut the magnetic tape, or displace the leader member from the predetermined position to disable the regular tape draw-out action, thereby deteriorating the reliability of the magnetic tape cartridge.

SUMMARY OF THE INVENTION

In view of the foregoing observations and description, the primary object of the present invention is to provide a magnetic tape cartridge in which the braking gear of the reel stopper means is suppressed from being brought into contact

with the reel when the reel stopper means is in the release position.

Another object of the present invention is to provide a magnetic tape cartridge in which the reel can be surely
5 prevented from being rotated while occurrence of the magnetic tape being cut can be prevented when the magnetic tape cartridge is not being used.

In accordance with a first aspect of the present invention, there is provided a magnetic tape cartridge
10 comprising a magnetic tape wound around a single reel, a cartridge casing in which the reel is housed for rotation and a reel stopper means which locks the reel not to rotate when the magnetic tape cartridge is not being used and releases the
15 reel to permit rotation thereof when the magnetic tape cartridge is to be used, wherein the improvement comprises that the reel stopper means comprises a braking member which is movable between a locking position where it is in contact with the reel to restrict rotation of the reel and a releasing position where it is away from the reel to permit rotation of
20 the same, an urging member which urges the braking member toward the locking position, and a releasing member which is rotated integrally with the reel and moves the braking member toward the releasing position in response to a reel chucking action of the reel drive means of a tape drive, and the braking member
25 is provided with a braking gear which is adapted to be engaged, to restrict rotation of the reel, with an engagement gear tooth

on an engagement projection formed on the reel while the reel is provided with a guide member which centers the braking member with respect to the reel.

It is preferred that the guide member comprises guide ribs which are formed on the inner surface of the reel hub at at least three places, each having an inclined surface which inclines downward from the upper portion of the inner surface of the reel hub toward the center of the reel.

In the magnetic tape cartridge in accordance with the first aspect of the present invention, when the braking member is moved downward from the releasing position to the locking position, the braking member is centered by the guide members so that the braking gear is brought into mesh with the engagement gear teeth with the braking member held horizontal, whereby the braking member is prevented from being inclined in the locking position. When the braking member is subsequently moved to the releasing position by the releasing member, the braking member is held horizontal up to the releasing position. Accordingly, the phenomenon that the braking member is inclined can be suppressed, whereby the braking gear is prevented from contacting the engagement gear teeth to generate noise or to obstruct rotation of the reel.

Further, during assembly of the magnetic tape cartridge, the braking member is automatically centered in the reel hub by the guide members and is incorporated in place in the reel, whereby assembly of the magnetic tape cartridge is facilitated.

In accordance with a second aspect of the present invention, there is provided a magnetic tape cartridge comprising a magnetic tape wound around a single reel, a cartridge casing in which the reel is housed for rotation and
5 a reel stopper means which locks the reel not to rotate when the magnetic tape cartridge is not being used and releases the reel to permit rotation thereof when the magnetic tape cartridge is to be used, wherein the improvement comprises that the reel stopper means comprises a braking member which is
10 movable between a locking position where it is in contact with the reel to restrict rotation of the reel and a releasing position where it is away from the reel to permit rotation of the same, an urging member which urges the braking member toward the locking position, and a releasing member which is rotated
15 integrally with the reel and moves the braking member toward the releasing position in response to a reel chucking action of the reel drive means of a tape drive, and the braking member is provided with a braking gear which is adapted to be engaged, to restrict rotation of the reel, with an engagement gear on
20 an engagement projection formed on the reel, the outer diameter of the engagement gear being larger than that of the braking gear.

In the magnetic tape cartridge in accordance with the second aspect of the present invention, when the braking member
25 is moved downward from the releasing position to the locking position, the braking member is centered by the difference

between the outer diameters of the engagement gear and the
braking gear so that the braking gear is brought into mesh with
the engagement gear teeth with the braking member held
horizontal, whereby the braking member is prevented from being
5 inclined in the locking position. When the braking member is
subsequently moved to the releasing position by the releasing
member, the braking member is held horizontal up to the
releasing position. Accordingly, the phenomenon that the
braking member is inclined can be suppressed, whereby the
10 braking gear is prevented from contacting the engagement gear
teeth to generate noise or to obstruct rotation of the reel.

In accordance with a third aspect of the present
invention, there is provided a magnetic tape cartridge
comprising a magnetic tape wound around a single reel, a
15 cartridge casing in which the reel is housed for rotation and
a reel stopper means which locks the reel not to rotate when
the magnetic tape cartridge is not being used and releases the
reel to permit rotation thereof when the magnetic tape
cartridge is to be used, wherein the improvement comprises that
20 the reel stopper means comprises a braking member which is
movable between a locking position where it is in contact with
the reel to restrict rotation of the reel and a releasing
position where it is away from the reel to permit rotation of
the same, an urging member which urges the braking member toward
25 the locking position, and a releasing member which is rotated
integrally with the reel and moves the braking member toward

the releasing position in response to a reel chucking action of the reel drive means of a tape drive, the braking member is provided with a braking gear which is adapted to be engaged, to restrict rotation of the reel, with an engagement gear tooth
5 on an engagement projection formed on the reel, and each of the gear teeth of the braking gear has a first inclined surface which is brought into abutment against the engagement gear teeth when the reel is rotated in the tape-unwinding direction with the braking gear and the engagement gear tooth in mesh
10 with each other and a second inclined surface which is brought into abutment against the engagement gear teeth when the reel is rotated in the tape-winding direction with the braking gear and the engagement gear tooth in mesh with each other, the first and second inclined surfaces forming therebetween an apical
15 angle not larger than 90° , and the interior angle between the first inclined surface and the vertical being not larger than the interior angle between the second inclined surface and the vertical.

In the magnetic tape cartridge in accordance with the
20 third aspect of the present invention, since the apical angle of the braking gear tooth is not larger than 90° and the interior angle for the first inclined surface of the braking gear tooth which is brought into abutment against the engagement gear teeth when the reel is rotated in the unwinding direction and
25 the interior angle for the second inclined surface which is brought into abutment against the engagement gear teeth when

the reel is rotated in the winding direction are not smaller than 30° with the former smaller than the latter, rotation of the reel can be surely prevented and when the reel is rotated in the winding direction due to drop impact or the like and
5 an excessive winding force acts on the magnetic tape, the braking member is moved toward the releasing position along the first inclined surface and the braking gear is disengaged from the engagement gear teeth, whereby the reel is rotated in the unwinding direction to reduce the tension on the magnetic
10 tape, and the magnetic tape can be prevented from being stretched or cut.

BRIEF DESCRIPTION OF THE DRAWINGS

Figure 1 is a perspective view showing a state of a magnetic tape cartridge in accordance with an embodiment of
15 the present invention when the magnetic tape cartridge is not being used,

Figure 2 is a fragmentary cross-sectional view of the magnetic tape cartridge shown in Figure 1 when the magnetic tape cartridge is being used,

20 Figure 3 is a cross-sectional view taken along line A-A in Figure 2,

Figure 4 is a cross-sectional view taken along line B-B in Figure 2, and

25 Figure 5 is a fragmentary cross-sectional view showing a state of a magnetic tape cartridge where the braking member is inclined.

DESCRIPTION OF THE PREFERRED EMBODIMENT

A magnetic tape cartridge 1 in accordance with an embodiment of the present invention will be described with reference to the drawings, hereinbelow.

5 The magnetic tape cartridge 1 comprises a cartridge casing 3 formed by fastening together upper and lower casing halves 31 and 32 by screws or the like. A single reel 2 around which a magnetic tape (not shown) is wound is housed for rotation in the cartridge casing 3. The lower casing half 32
10 is provided with a central opening 32a. The magnetic tape cartridge 1 is further provided with a reel stopper means 10 which permits rotation of the reel 2 when the magnetic tape cartridge 1 is being used and restricts rotation of the reel 2 when the magnetic tape cartridge 1 is not being used.

15 The reel 2 comprises a reel hub 21 which is a cylindrical member having a closed bottom and around which the magnetic tape is wound, and lower and upper flanges 22 and 23. The reel hub 21 and the lower flange 22 are integrally formed by synthetic resin molding. The upper flange 23 is bonded to the
20 reel hub 21, for instance, by ultrasonic welding. The reel hub 21 is provided with a bottom wall 21a at the lower end portion thereof and a reel gear 24 for rotating the reel 2 is annularly formed on the lower surface of the bottom wall 21a, and annular reel plate 25 which is magnetically attracted by a reel drive
25 means 11 of a recording and reproducing apparatus is mounted on the lower surface of the bottom wall 21a inside the reel

gear 24. The reel 2 is urged downward by an urging means 5 to be described later.

The reel drive means 11 is provided with an annular drive gear 13 and a magnet (not shown) disposed on the top surface of a rotary shaft 12. When the magnetic tape cartridge 1 loaded in a bucket of the tape drive is moved downward toward the rotary shaft 12, the drive gear 13 is brought into mesh with the reel gear 24 and the reel plate 25 is magnetically attracted against the magnet to hold the drive gear 13 and the reel gear 24 in mesh with each other. In this manner, the reel drive means 11 chucks the reel 2.

The mechanism of the reel stopper means 10 will be described, hereinbelow. The reel stopper means 10 comprises a braking member 4 which is movable up and down between a locking position where it is in contact with the reel 2 to restrict rotation of the reel 2 and a releasing position where it is away from the reel 2 to permit rotation of the same, an urging member 5 which urges the braking member 4 toward the locking position, and a releasing member 6 which moves the braking member 4 toward the releasing position.

As shown in Figure 3, three through holes 26 are formed in the bottom wall 21a of the reel 2 at regular angular intervals in the circumferential direction to extend through the portion at which the reel gear 24 is formed. On the upper surface of the bottom wall 21a, there are erected three pairs of (six) engagement projections 27 at regular angular intervals in the

circumferential direction among the through holes 26. The upper end of each engagement projection 27 is formed into an engagement gear teeth 29 as shown in Figure 4. The through holes 26 may be larger than three in number and the engagement projections 27 may be larger three pairs in number. Further, the upper end of each engagement projection 27 may be formed into a single gear tooth.

The braking member 4 has a disc portion 41 which is disposed in the reel hub 21 opposed to the bottom wall 21a, and an annular braking gear 42 is formed on the lower surface of the disc portion 41 along the outer peripheral edge thereof. The braking gear 42 is adapted to be engaged with the engagement gear 29 on the engagement projections 27. The central part of the lower surface of the disc portion 41 is convex downward and forms a sliding portion 41a which is pressed against a sliding portion 61a on the upper surface of a body portion 61 of a releasing member 6 to be described later.

The outer diameter D of the engagement gear formed by the engagement gear teeth 29 on the engagement projections 27 on the reel 2 (Figure 3) is larger than the outer diameter d (Figure 2) of the braking gear 42 on the braking member 4. The braking gear 42 and the engagement gear 29 are conical in shape and the height of each tooth is higher at the outer periphery thereof. Accordingly, the braking gear 42 is engaged with the engagement gear 42 at their outer peripheries first.

When the braking gear 42 on the braking member 4 is

brought into mesh with the engagement gear 29 on the engagement
projections 27, the outer periphery of the braking member 4
is guided by guide members 39 formed on the inner surface of
the reel hub 21 of the reel 2. The guide members 39 are
5 respectively provided between each pair of engagement
projections 27, and accordingly three guide members 39 are
provided on the inner surface of the reel hub 21. Each guide
member 39 is in the form of a rib having an inclined surface
which gradually inclines downward from the upper portion of
10 the inner surface of the reel hub 21 toward the engagement
projections 27, and the guide members 39 center the braking
gear 42 when the outer periphery of the braking gear 42 is
brought into contact with the inclined surfaces.

As shown in Figure 4, each gear tooth of the braking gear
15 42 of the braking member 4 and each engagement gear tooth 29
on the engagement projection 27 are triangular in cross-section.
The gear tooth of the braking gear 42 has a first inclined
surface 42a which faces against the tape-unwinding direction
U and abuts against a first inclined surface 29a of the
20 engagement gear tooth 29 on the engagement projection 27 which
faces toward the tape-unwinding direction U, and a second
inclined surface 42b which faces against the tape-winding
direction W and abuts against a second inclined surface 29b
of the engagement gear tooth 29 on the engagement projection
25 27 which faces toward the tape-winding direction W. When the
reel 2 is rotated in the tape-unwinding direction U with the

braking gear 42 in mesh with the engagement gear teeth 29 on the engagement projection 27, the first inclined surfaces 42a of the gear teeth of the braking gear 42 are brought into abutment against the first inclined surfaces 29a of the engagement gear teeth 29, and when the reel 2 is rotated in the tape-winding direction W with the braking gear 42 in mesh with the engagement gear teeth 29 on the engagement projection 27, the second inclined surfaces 42b of the gear teeth of the braking gear 42 are brought into abutment against the second inclined surfaces 29b of the engagement gear teeth 29. Each of the gear tooth 42 and the gear tooth 29 is not larger than 90° in apical angle γ , and the interior angle α between the first inclined surface 42a (or 29a) and the vertical S and the interior angle β between the second inclined surface 42b (or 29b) and the vertical S are not smaller than 30°. Further, the interior angle α for the first inclined surface 42a (29a) is not larger than the interior angle β for the second inclined surface 42b (29b). That is, $60^\circ \leq \gamma \leq 90^\circ$, $30^\circ \leq \alpha \leq 45^\circ$, and $30^\circ \leq \beta \leq 60^\circ$.

A projection 44 extends upward from the upper surface of the disc portion 41 of the braking member 4, and a cross-shaped engagement groove 45 is formed in the projection 44 to extend in the vertical direction. An engagement projection 33 extending downward from the inner surface of the upper casing half 31 of the cartridge casing 3 is in engagement with the engagement groove 45 of the braking member 4, whereby

the braking member 4 is held in the cartridge casing 3 to be movable up and down but not to be rotatable.

A coiled spring (urging member) 5 is compressed between a portion of the upper surface of the disc portion 41 around the projection 44 and a spring retainer portion 34 formed on the upper casing half 31 around the engagement projection 33, whereby the braking member 4 is urged toward the locking position where the braking gear 42 is engaged with the engagement gear teeth 29 on the engagement projections 27.

10 The releasing member 6 is disposed to be movable up and down between the braking member 4 and the bottom wall 21a of the reel hub 21 and comprises a substantially triangular plate-like body portion 61. A cylindrical leg portion 63 extends downward from the lower surface of the body portion 61 at each corner thereof. The leg portions 63 are passed through the through holes 26 in the bottom wall 21a of the reel 2 to be movable up and down. The engagement projections 27 are positioned between the leg portions 63 outside the body portion 61 of the releasing member 6. The leg portions 63 may also be rectangular or ellipsoidal in cross-section.

When the releasing member 6 is in its lowermost position shown in Figure 1, the lower ends of the leg portions 63 project downward from the lower surface of the reel 2 through the portion at which the reel gear 24 is formed, and when the drive gear 13 is brought into engagement with the reel gear 24 in response to a chucking action of the reel drive means 11, the

leg portions 63 are pushed upward by a predetermined stroke as shown in Figure 2, whereby the braking gear 42 of the braking member 4 is disengaged from the engagement gear teeth 29 of the engagement projections 27 and rotation of the reel 2 is permitted. Since the leg portions 63 are passed through the through holes 26 the releasing member 6 is rotated together with the reel 2.

The reel 2 is provided with guide members 28 (Figure 3) which guide the releasing member 6 when the leg portions 63 are inserted into the through holes 26. Each of the guide members 28 guides a corner of the body portion 61 of the releasing member 6 and comprises a pair of guide ribs formed on the inner surface of the reel hub 21 to extend in the vertical direction near one of the through holes 26. Reinforcing ribs like the guide ribs are provided on the entire inner surface of the reel hub 21.

Operation of the reel stopper means 10 will be described, hereinbelow. Figure 1 shows a state of the magnetic tape cartridge 1 when it is not being used (e.g., when it is stored). In the state shown in Figure 1, the braking member 4, the releasing member 6 and the reel 2 are held in the lower casing half 32 of the cartridge casing 3 under the force of the urging member 5 and the central opening 32a of the lower casing half 32 is closed by the reel 2. The releasing member 6 is in its lowermost position where its lower surface is in abutment against the upper surface of the bottom wall 21a of the reel

hub 21 and the lower end portions of the leg portions 63 project downward beyond the tips of the teeth of the reel gear 24. The braking member 4 is in abutment against the releasing member 6 and in its locking position where the braking gear 42 is in mesh with the engagement gear teeth 29 of the engagement projections 27 on the reel 2, whereby rotation of the reel 2 is restricted and the magnetic tape is prevented from being drawn out.

As shown in Figure 2, when the magnetic tape cartridge 1 is loaded in a tape drive, the rotary shaft 12 of the reel drive means 11 of the tape drive is moved toward the lower surface of the reel 2 and the drive gear 13 is brought into mesh with the reel gear 24 with the reel 2 slightly pushed upward, whereby the leg portions 63 of the releasing member 6 are pushed upward by the tips of the teeth of the drive gear 13. Thus, the releasing member 6 is moved upward overcoming the force of the urging member 5 and the braking member 4 is moved upward together with the releasing member 6, whereby the braking gear 42 is disengaged from the engagement gear teeth 29 of the engagement projections 27 and rotation of the reel 2 is permitted. In this state, the braking member 4 in its upper position is away from the guide members 39 and does not restrict rotation of the reel 2 when the magnetic tape is loaded/unloaded.

When the braking member 4 is moved downward from the releasing position to the locking position, the braking member

4 is centered by the guide members 39 on the reel 2 so that the braking gear 42 is brought into mesh with the engagement gear teeth 29 with the braking member 4 held horizontal, whereby the braking member 4 is prevented from being inclined in the locking position. When the braking member 4 is subsequently moved upward to the releasing position by the releasing member 6, the braking member 4 is held horizontal up to the releasing position. Accordingly, the phenomenon that the braking member 4 is inclined as shown in Figure 5 can be suppressed, whereby the braking gear 42 is prevented from contacting the engagement gear teeth 29 to generate noise or to obstruct rotation of the reel 2. Further, during assembly of the magnetic tape cartridge 1, the braking member 4 is automatically centered in the reel hub 2 by the guide members 39 and is incorporated in place in the reel 2, whereby assembly of the magnetic tape cartridge 1 is facilitated.

Even if the guide members 39 are not provided, since the outer diameter D of the engagement gear formed by the engagement gear teeth 29 on the engagement projections 27 on the reel 2 is larger than the outer diameter d of the braking gear 42 on the braking member 4, the braking member 4 is centered with respect to the reel hub 2 when it is moved from the releasing position to the locking position by virtue of the difference in diameter so that the braking gear 42 is brought into mesh with the engagement gear teeth 29 with the braking member 4 held horizontal, whereby the braking member 4 is prevented from

being inclined in the locking position.

Further, when the reel 2 is rotated in the winding direction W due to drop impact or the like and an excessive winding force acts on the magnetic tape, the braking member 4 is moved upward along the first inclined surfaces 42a and 29a since the interior angles α for the first inclined surfaces 42a and 29a which are brought into abutment against each other when the reel 2 is rotated in the unwinding direction U are not smaller than 30° and the braking gear 42 is disengaged from the engagement gear teeth 29, whereby the reel 2 is rotated in the unwinding direction U to reduce the tension on the magnetic tape, and the magnetic tape can be prevented from being stretched or cut.

Further, since the interior angles β for the second inclined surfaces 42b and 29b of the braking gear 42 and the engagement gear teeth 29 are not smaller than 30° , the reel 2 can be anyhow rotated even if the braking member 4 is in the locking position, though the rotation of the reel 2 is restricted. Accordingly, when the magnetic tape is accidentally drawn out from the cartridge casing 3 during storage or the like of the magnetic tape cartridge 1, the magnetic tape can be rewound into the cartridge casing 3.

The effect of reducing the tension on the magnetic tape can be obtained when the interior angle α is not smaller than 30° . However when the interior angle α is larger than 45° , the locking force for preventing rotation of the reel 2 in the

unwinding direction becomes too weak. That is, in order to ensure both the effect of reducing the tension on the magnetic tape and the sufficient locking force, it is necessary that the apical angle γ is not larger than 90° and the interior angles α for the first inclined surfaces 42a and 29a which are brought into abutment against each other when the reel 2 is rotated in the unwinding direction U are smaller than the interior angles β for the second inclined surfaces 42b and 29b which are brought into abutment against each other when the reel 2 is rotated in the winding direction W.

The height of the gear teeth of the braking gear 42 and that of the engagement gear teeth 29 are set according to the distance between the locking position and the releasing position of the braking member 4. For a given height of the teeth, the number of the teeth is reduced and the one-pitch length is increased as the apical angle γ increases. Accordingly, when the apical angle γ is set not to be larger than 90° , the number of the gear teeth of the braking gear 42 is increased and the one-pitch length is reduced, whereby slack of the magnetic tape or the tension on the magnetic tape can be proper when the braking gear 42 is engaged with the engagement gear teeth 29.

In addition, all of the contents of Japanese Patent Application Nos. 11(1999)-317166, 11(1999)-318464 and 2000-322841 are incorporated into this specification by reference.

08. Nov. 2000

What is claimed is;

1. A magnetic tape cartridge comprising a magnetic tape wound around a single reel, a cartridge casing in which the reel is housed for rotation and a reel stopper means which locks
5 the reel not to rotate when the magnetic tape cartridge is not being used and releases the reel to permit rotation thereof when the magnetic tape cartridge is to be used, wherein the improvement comprises that

the reel stopper means comprises a braking member which
10 is movable between a locking position where it is in contact with the reel to restrict rotation of the reel and a releasing position where it is away from the reel to permit rotation of the same, an urging member which urges the braking member toward the locking position, and a releasing member which is rotated
15 integrally with the reel and moves the braking member toward the releasing position in response to a reel chucking action of the reel drive means of a tape drive, and the braking member is provided with a braking gear which is adapted to be engaged, to restrict rotation of the reel, with an engagement gear tooth
20 on an engagement projection formed on the reel while the reel is provided with a guide member which centers the braking member with respect to the reel.

2. A magnetic tape cartridge as defined in Claim 1 in which the guide member comprises guide ribs which are formed
25 on the inner surface of the reel hub at at least three places, each having an inclined surface which inclines downward from

the upper portion of the inner surface of the reel hub toward the center of the reel.

3. A magnetic tape cartridge comprising a magnetic tape wound around a single reel, a cartridge casing in which the
5 reel is housed for rotation and a reel stopper means which locks the reel not to rotate when the magnetic tape cartridge is not being used and releases the reel to permit rotation thereof when the magnetic tape cartridge is to be used, wherein the improvement comprises that

10 the reel stopper means comprises a braking member which is movable between a locking position where it is in contact with the reel to restrict rotation of the reel and a releasing position where it is away from the reel to permit rotation of the same, an urging member which urges the braking member toward
15 the locking position, and a releasing member which is rotated integrally with the reel and moves the braking member toward the releasing position in response to a reel chucking action of the reel drive means of a tape drive, and the braking member is provided with a braking gear which is adapted to be engaged,
20 to restrict rotation of the reel, with an engagement gear on an engagement projection formed on the reel, the outer diameter of the engagement gear being larger than that of the braking gear.

4. A magnetic tape cartridge comprising a magnetic tape
25 wound around a single reel, a cartridge casing in which the reel is housed for rotation and a reel stopper means which locks

the reel not to rotate when the magnetic tape cartridge is not being used and releases the reel to permit rotation thereof when the magnetic tape cartridge is to be used, wherein the improvement comprises that

5 the reel stopper means comprises a braking member which is movable between a locking position where it is in contact with the reel to restrict rotation of the reel and a releasing position where it is away from the reel to permit rotation of the same, an urging member which urges the braking member toward
10 the locking position, and a releasing member which is rotated integrally with the reel and moves the braking member toward the releasing position in response to a reel chucking action of the reel drive means of a tape drive,

 the braking member is provided with a braking gear which
15 is adapted to be engaged, to restrict rotation of the reel, with an engagement gear tooth on an engagement projection formed on the reel, and

 each of the gear teeth of the braking gear has a first inclined surface which is brought into abutment against the
20 engagement gear teeth when the reel is rotated in the tape-unwinding direction with the braking gear and the engagement gear tooth in mesh with each other and a second inclined surface which is brought into abutment against the engagement gear teeth when the reel is rotated in the
25 tape-winding direction with the braking gear and the engagement gear tooth in mesh with each other, the first and second

• 4 2

inclined surfaces forming therebetween an apical angle not larger than 90° , and the interior angle between the first inclined surface and the vertical being not larger than the interior angle between the second inclined surface and the
5 vertical.

ABSTRACT OF THE DISCLOSURE

08. Nov. 2000

A magnetic tape cartridge includes a magnetic tape wound
around a single reel, a cartridge casing in which the reel is
housed for rotation and a reel stopper which locks the reel
not to rotate when the magnetic tape cartridge is not being
5 used and releases the reel to permit to rotate when the magnetic
tape cartridge is to be used. The reel stopper includes a
braking member which is movable between a locking position
where it is in contact with the reel to restrict rotation of
10 the reel and a releasing position where it is away from the
reel to permit rotation of the same, an urging member which
urges the braking member toward the locking position, and a
releasing member which is rotated integrally with the reel and
moves the braking member toward the releasing position in
15 response to a reel chucking action of the reel drive means of
a tape drive. The braking member is provided with a braking
gear which is adapted to be engaged, to restrict rotation of
the reel, with an engagement gear tooth on an engagement
projection formed on the reel while the reel is provided with
20 a guide member which centers the braking member with respect
to the reel.



P. B. 5818 - Patentlaan 2
 2280 HV Rijswijk (ZH)
 ☎ +31 70 340 2040
 TX 31651 epo nl
 FAX +31 70 340 3016

**Europäisches
 Patentamt**

Eingangsstelle

**European
 Patent Office**

Receiving
 Section

**Office européen
 des brevets**

Section de
 Dépôt

Grünecker, Kinkeldey,
 Stockmair & Schwanhäusser
 Anwaltssozietät
 Maximilianstrasse 58
 80538 München
 ALLEMAGNE



Datum/Date
 22/01/01

Zeichen/Ref./Réf. EP20062-013/do	Anmeldung Nr./Application No./Demande n°./Patent Nr./Patent No./Brevet n°. 00124448.2-2210/
Anmelder/Applicant/Demandeur/Patentinhaber/Proprietor/Titulaire Fuji Photo Film Co., Ltd.	

COMMUNICATION pursuant to the decision of the President of the EPO
 dated 09.03.2000 (OJ EPO 5/2000, 227)

Please be informed that the following priority document(s) has (have)
 been included in the file of the above-mentioned European patent
 application pursuant to Rule 38(4) EPC:

State:	Date of filing:	Application no:
JP	08.11.99	JPA 31716699
JP	09.11.99	JPA 31846499

RECEIVING SECTION





P.B. 5818 - Patentlaan 2
 2280 HV Rijswijk (ZH)
 ☎ + 31 70 340 2040
 TX 31651 epo nl
 FAX + 31 70 340 3016

**Europäisches
 Patentamt**

Eingangsstelle

**European
 Patent Office**

Receiving
 Section

**Office européen
 des brevets**

Section de
 Dépôt

Grünecker, Kinkeldey,
 Stockmair & Schwanhäusser
 Anwaltssozietät
 Maximilianstrasse 58
 80538 München
 ALLEMAGNE

Datum/Date
 28/03/01

Zeichen/Ref./Réf. EP20062-013/do	Anmeldung Nr./Application No./Demande n°./Patent Nr./Patent No./Brevet n°. 00124448.2-2210 / 1098320
Anmelder/Applicant/Demandeur/Patentinhaber/Proprietor/Titulaire Fuji Photo Film Co., Ltd.	

NOTIFICATION OF EUROPEAN PUBLICATION NUMBER AND INFORMATION ON THE APPLICATION OF ARTICLE 67(3) EPC

The Receiving Section hereby informs you that the technical preparations for publication of the above-mentioned European patent application have been completed.

The provisional protection under Art. 67(1) and (2) EPC in the individual Contracting States becomes effective only when the conditions referred to in Art. 67(3) EPC have been fulfilled (for further information, see EPO brochure "National Law relating to the EPC").

This application will be published on 09.05.01 without the European search report. The publication will be mentioned in European Patent Bulletin number 2001/19

The publication number is: 1098320

The title of the invention in the three official languages of the European Patent Office is worded as follows:

- Magnetbandkassette
- Magnetic tape cartridge
- Cassette à bande magnétique

In all future communications to the EPO, please quote the application number as indicated above, i.e. including the final four figures (which identify the Directorate responsible for the subsequent procedure). Amendments to a European patent application or European patent must be filed in the language of the proceedings.

REMARK: An issue of the published European patent application will be forwarded to you directly from our printer.

RECEIVING SECTION





DOCUMENTS CONSIDERED TO BE RELEVANT			
Category	Citation of document with indication, where appropriate, of relevant passages	Relevant to claim	CLASSIFICATION OF THE APPLICATION (Int.Cl.7)
X	EP 0 926 676 A (FUJI PHOTO FILM CO LTD) 30 June 1999 (1999-06-30)	4	G11B23/107 G11B23/04
Y	* abstract; claims 1-39; figures * ---	1-3	
Y	EP 0 284 687 A (SHAPE INC) 5 October 1988 (1988-10-05)	1,2	
A	* abstract; claims 1-8; figures * ---	3,4	
Y	WO 97 15925 A (IMATION CORP) 1 May 1997 (1997-05-01)	3	
A	* abstract; figures * ---	1,2,4	
X	US 5 901 916 A (MCALLISTER JEFFREY S ET AL) 11 May 1999 (1999-05-11)	4	
A	* abstract; figures * * column 3, line 3 - column 4, line 28 * ---	1-3	
A	US 5 366 173 A (LAMMERS GERALD B ET AL) 22 November 1994 (1994-11-22)	1,3,4	
A	* abstract; figures * ---		
A	"Cartridge reel brake" IBM TECHNICAL DISCLOSURE BULLETIN,US,IBM CORP. NEW YORK, vol. 28, no. 10, March 1986 (1986-03), page 4552 XP002099977 ISSN: 0018-8689 * the whole document * ---	1,3,4	TECHNICAL FIELDS SEARCHED (Int.Cl.7) G11B
E	EP 1 054 403 A (TDK CORP) 22 November 2000 (2000-11-22)	3	
E	* abstract; claims 1-3; figures * ---		
E	EP 1 058 259 A (TDK CORP) 6 December 2000 (2000-12-06)	3	
E	* abstract; claims 1-5; figures * ---		
	-/--		
The present search report has been drawn up for all claims			
Place of search THE HAGUE		Date of completion of the search 17 July 2001	Examiner Declat, M
CATEGORY OF CITED DOCUMENTS X : particularly relevant if taken alone Y : particularly relevant if combined with another document of the same category A : technological background O : non-written disclosure P : intermediate document T : theory or principle underlying the invention E : earlier patent document, but published on, or after the filing date D : document cited in the application L : document cited for other reasons & : member of the same patent family, corresponding document			

1

EPO FORM 1503 03/82 (P04C01)



DOCUMENTS CONSIDERED TO BE RELEVANT			
Category	Citation of document with indication, where appropriate, of relevant passages	Relevant to claim	CLASSIFICATION OF THE APPLICATION (Int.Cl.7)
P, A	WO 99 65032 A (TAKAHASHI DAISUKE ;SHIGA HIDEAKI (JP); TSUYUKI SEIJI (JP); ISHIHAR) 16 December 1999 (1999-12-16) * abstract; figures * & EP 1 098 321 A 9 May 2001 (2001-05-09) -----	1-4	
			TECHNICAL FIELDS SEARCHED (Int.Cl.7)
The present search report has been drawn up for all claims			
Place of search THE HAGUE		Date of completion of the search 17 July 2001	Examiner Declat, M
CATEGORY OF CITED DOCUMENTS X : particularly relevant if taken alone Y : particularly relevant if combined with another document of the same category A : technological background O : non-written disclosure P : intermediate document		T : theory or principle underlying the invention E : earlier patent document, but published on, or after the filing date D : document cited in the application L : document cited for other reasons & : member of the same patent family, corresponding document	

1

EPO FORM 1503 03/82 (P04C01)



P.B.5818 – Patentlaan 2
 2280 HV Rijswijk (ZH)
 ☎ +31 70 340 2040
 TX 31651 epo.nl
 FAX +31 70 340 3016

**Europäisches
 Patentamt**

Zweigstelle
 in Den Haag
 Recherchen-
 abteilung

**European
 Patent Office**

Branch at
 The Hague
 Search
 division

**Office européen
 des brevets**

Département à
 La Haye
 Division de la
 recherche

Grünecker, Kinkeldey,
 Stockmair & Schwanhäusser
 Anwaltssozietät
 Maximilianstrasse 58
 80538 München
 ALLEMAGNE

Datum/Date
 30.07.01

Zeichen/Ref./Réf. EP20062-013/do	Anmeldung Nr./Application No./Demande n°./Patent Nr./Patent No./Brevet n°. 00124448.2-1239-
Anmelder/Applicant/Demandeur/Patentinhaber/Proprietor/Titulaire Fuji Photo Film Co., Ltd.	

COMMUNICATION

The European Patent Office herewith transmits as an enclosure the European search report for the above-mentioned European patent application.

If applicable, copies of the documents cited in the European search report are attached.

Additional set(s) of copies of the documents cited in the European search report is (are) enclosed as well.

The following specifications given by the applicant have been approved by the Search Division:

abstract title

The abstract was modified by the Search Division and the definitive text is attached to this communication.

The following figure will be published together with the abstract: 1

REFUND OF THE SEARCH FEE

If applicable under Article 10 Rules relating to fees, a separate communication from the Receiving Section on the refund of the search fee will be sent later.



**ANNEX TO THE EUROPEAN SEARCH REPORT
ON EUROPEAN PATENT APPLICATION NO.**

EP 00 12 4448

This annex lists the patent family members relating to the patent documents cited in the above-mentioned European search report. The members are as contained in the European Patent Office EDP file on
The European Patent Office is in no way liable for these particulars which are merely given for the purpose of information.

17-07-2001

Patent document cited in search report	Publication date	Patent family member(s)	Publication date
EP 0926676 A	30-06-1999	JP 11185437 A	09-07-1999
EP 0284687 A	05-10-1988	IE 321687 L JP 63251983 A KR 9100101 Y	30-09-1988 19-10-1988 18-01-1991
WO 9715925 A	01-05-1997	DE 19681617 T	08-10-1998
US 5901916 A	11-05-1999	GB 2334945 A JP 11317049 A	08-09-1999 16-11-1999
US 5366173 A	22-11-1994	NONE	
EP 1054403 A	22-11-2000	JP 2000331454 A JP 2000339909 A	30-11-2000 08-12-2000
EP 1058259 A	06-12-2000	JP 2000339910 A JP 2001052464 A	08-12-2000 23-02-2001
WO 9965032 A	16-12-1999	JP 2000067558 A EP 1098321 A	03-03-2000 09-05-2001

EPO FORM P0459

For more details about this annex : see Official Journal of the European Patent Office, No. 12/82



P. B. 5818 - Patentlaan 2
 2280 HV Rijswijk (ZH)
 ☎ + 31 70 340 2040
 TX 31651 epo nl
 FAX + 31 70 340 3016

**Europäisches
 Patentamt**

Eingangsstelle

**European
 Patent Office**

Receiving
 Section

**Office européen
 des brevets**

Section de
 Dépôt

Grünecker, Kinkeldey,
 Stockmair & Schwanhäusser
 Anwaltssozietät
 Maximilianstrasse 58
 80538 München
 ALLEMAGNE



Datum/Date
 18/09/01

Zeichen/Ref./Réf. EP20062-013/do	Anmeldung Nr./Application No./Demande n°./Patent Nr./Patent No./Brevet n°. 00124448.2-1239 / 1098320
Anmelder/Applicant/Demandeur/Patentinhaber/Proprietor/Titulaire Fuji Photo Film Co., Ltd.	

**COMMUNICATION PURSUANT TO RULE 50 EPC
 REMINDER OF PAYMENT OF THE DESIGNATION FEES (ART. 79(2) EPC)
 AND OF THE EXAMINATION FEE (ART. 94(2) EPC)**

The date on which the European Patent Bulletin mentions the publication of the European search report for the above-mentioned European patent application is: 12.09.01.

Your attention is drawn to Article 79(2) and (3) EPC as well as Article 94(2) and (3) EPC according to which within SIX MONTHS after the above-mentioned publication date of the search report

- the designation fee(s) must be paid,
- a written request for examination must be filed as well as the examination fee must be paid. (A written request for examination has been filed already.)

The current rate of the designation fee for each contracting state designated is:

EUR	DEM	GBP	FRF	CHF	NLG	SEK	BEF/LUF	ITL
76	148,64	50	498,53	120	167,48	700	3066	147157
ATS	ESP	GRD	DKK	PTE	IEP	FIM	CYP	
1045,78	12645	25897	570	15236,60	59,85	451,88	45	

If the application has been filed on or after 01 July 1999 the payment of seven times the amount of the designation fee is deemed to constitute payment of the designation fees for all contracting states (see OJ EPO 06/1999, 405).

--/2

REGISTERED LETTER

EPO Form 1081 (03.01)
 003

DE* 7011006 13/09/01



The current rate of the examination fee is:

EUR	DEM	GBP	FRF	CHF	NLG	SEK	BEF/LUF	ITL
1431	2798,79	944	9386,74	2220	3153,51	13170	57726	2770802
ATS	ESP	GRD	DKK	PTE	IEP	FIM	CYP	
19690,99	238098	487613	10730	286889,70	1127	8508,34	844	

If at least one designation fee and the examination fee are not paid within the period laid down in Article 79(2) or 94(2) EPC, the application shall be deemed to be withdrawn (Arts. 79(3), 94(3) EPC).

Any extension fees are also payable within the above-mentioned period.

Please keep in mind that with effect from 01.01.2002 the fees can only be paid in EURO.

NOTE TO USERS OF THE AUTOMATIC DEBITING PROCEDURE:

1) Designation fees

If the application has been filed up to 30 June 1999, the designation fees for the contracting states marked under no. 2 of section 32 of the Request for Grant (EPO Form 1001 (11.98) will be debited on the last day of the period pursuant to Art. 79(2) EPC, unless the EPO receives prior instructions to the contrary.

If the application has been filed on or after 01 July 1999, seven times the amount of the designation fee will be debited on the last day of the period pursuant to Art. 79(2) EPC. However, if contracting states are marked under no. 2 of section 32 of the Request for Grant (EPO Form 1001 (07.99)), the designation fees only for these contracting states will be debited unless instructions to the contrary have reached the EPO within the basic period for paying the designation fees.

2) Examination fee

Unless the EPO receives prior instructions to the contrary, the examination fee will be debited on the last day of the period for payment.

For further details see the Arrangements for the automatic debiting procedure, Supplement to OJ EPO 02/1999.

RECEIVING SECTION



Anmeldung Nr./Application No./Demande n°./Patent Nr./Patent No./Brevet n°.	Blatt/Page/Feuille
00124448.2	2

GRÜNECKER KINKELDEY STOCKMAIR & SCHWANHÄUSSER

ANWALTSSOZIELTÄT

EPO-Munich
54

16. Okt. 2001

GKS & S MAXIMILIANSTRASSE 58 D-80538 MÜNCHEN GERMANY

EUROPEAN PATENT OFFICE
ERHARDTSTR. 27

80298 MUENCHEN

RECHTSANWÄLTE
LAWYERS

MÜNCHEN
DR. HELMUT EICHMANN
GERHARD BARTH
DR. ULRICH BLUMENRÖDER, LL.M.
CHRISTA NIKLAS-FALTER
DR. MAXIMILIAN KINKELDEY, LL.M.
SONJA SCHÄFFLER
DR. KARSTEN BRANDT
ANJA FRANKE, LL.M.
UTE STEPHANI
DR. BERND ALLEKOTTE, LL.M.
DR. ELVIRA PFRANG, LL.M.

PATENTANWÄLTE
EUROPEAN PATENT ATTORNEYS

MÜNCHEN
DR. HERMANN KINKELDEY
PETER H. JAKOB
WOLFHARD MEISTER
HANS HILGERS
DR. HENNING MEYER-PLATH
ANNELIE EHNOLD
THOMAS SCHÜSTER
DR. KLARA GOLDBACH
MARTIN AUFENANGER
GOTTFRIED KLITZSCH
DR. HEIKE VOGELSAANG-WENKE
REINHARD KNAUER
DIETMAR KÜHL
DR. FRANZ-JOSEF ZIMMER
BETTINA K. REICHEL
DR. ANTON K. PFAU
DR. UDO WEIGELT
RAINER BERTRAM
JENS KOCH, M.S. (U of PA) M.S.
BERND ROTHAMEL
DR. DANIELA KINKELDEY
DR. MARIA ROSARIO VEGA LASO
THOMAS W. LAUBENTHAL

PATENTANWÄLTE
EUROPEAN PATENT ATTORNEYS

BERLIN
PROF. DR. MANFRED BÖNING
DR. PATRICK ERK, M.S. (MIT)*
*PATENTANWALT

KÖLN
DR. MARTIN DROPMANN

CHEMNITZ
MANFRED SCHNEIDER

—
OF COUNSEL
PATENTANWÄLTE

AUGUST GRÜNECKER
DR. GÜNTER BEZOLD
DR. WALTER LANGHOFF

—
DR. WILFRIED STOCKMAIR
(-1996)

IHR ZEICHEN / YOUR REF.

UNSER ZEICHEN / OUR REF.
EP 20062/Kal

DATUM / DATE
16.10.01

European Patent Application No.: 00 124 448.2
Applicant: FUJI PHOTO FILM CO., LTD.

The following official fees are herewith paid with the enclosed EPO Form 1010:

- Examination Fee
- Designation Fee for DE, FR, GB

Please debit our account no. 28 00 04 37 with the total amount of EUR1.659,--.

Zur Kasse

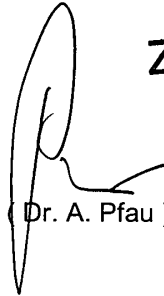
(Dr. A. Pfau)

Encl.
-EPO Form 1010

GRÜNECKER KINKELDEY
STOCKMAIR & SCHWANHÄUSSER
MAXIMILIANSTR. 58
D-80538 MÜNCHEN
GERMANY

TEL. +49 89 21 23 50
FAX (GR 3) +49 89 22 02 87
FAX (GR 4) +49 89 21 86 92 93
<http://www.grunecker.de>
e-mail: postmaster@grunecker.de

DEUTSCHE BANK MÜNCHEN
No. 17 51734
BLZ 700 700.10
SWIFT: DEUT DE MM



P.B. 5818 - Patentlaan 2
2280 HV Rijswijk (ZH)
☎ (070) 3 40 20 40
FAX (070) 3 40 30 16

**Europäisches
Patentamt**

**European
Patent Office**

**Office européen
des brevets**

Generaldirektion 1

Directorate General 1

Direction générale 1

Grünecker, Kinkeldey,
Stockmair & Schwanhäusser
Anwaltssozietät
Maximilianstrasse 58
80538 München
ALLEMAGNE



epoline® Customer Services

Tel.: +31 (0)70 340 45 00

Date

29-04-2002

Reference EP20062-013/do	Application No./Patent No. 00124448.2-1239
Applicant/Proprietor Fuji Photo Film Co., Ltd.	

Communication pursuant to Rule 85a(1) EPC

The designation fees (for) **AT BE CH CY DK ES FI GR IE IT LU MC NL PT SE TR** have not been paid in due time (Art. 79(2) EPC).

You can still validly pay the fee(s) within a period of grace of **one month** after notification of this communication, together with a surcharge of 50% (Rule 85a(1) EPC).
The surcharge is limited to a maximum of EUR 650,00 (Art. 2, item 3b Rules relating to Fees.).

If the fee(s) **with surcharge** has (have) not been paid in due time, then, in accordance with Rule 69(1) EPC, you will be informed that

- the application is deemed to be withdrawn.
- the designation of the above-mentioned Contracting State(s) is deemed to be withdrawn.

The designation fee for each Contracting State designated is **EUR 75,00**.

If the application was filed on or after 1 July 1999, payment of seven times the amount of the designation fee constitutes payment of the designation fees for all contracting states (see OJ EPO 6/1999, 405).

Examination Division



Salvador Françoise
Tel +31703403582



P.B.5818 - Patentaan 2
2280 HV Rijswijk (ZH)
☎ (070) 3 40 20 40
FAX (070) 3 40 30 16

**Europäisches
Patentamt**

**European
Patent Office**

**Office européen
des brevets**

Generaldirektion 1

Directorate General 1

Direction générale 1

Grünecker, Kinkeldey,
Stockmair & Schwanhäusser
Anwaltssozietät
Maximilianstrasse 58
80538 München
ALLEMAGNE



epoline® Customer Services

Tel.: +31 (0)70 340 45 00

Date

15-07-2002

Reference EP20062-013/do	Application No./Patent No. 00124448.2-1239
Applicant/Proprietor Fuji Photo Film Co., Ltd.	

Noting of loss of rights (R. 69(1) EPC)

In the European patent application cited above, the designation(s) of the following Contracting State(s):

AT BE CH LI CY DK ES FI GR IE IT LU MC NL PT SE TR

is (are) deemed to be withdrawn because no designation fee in respect of those State(s) was validly paid within the time limits laid down in Article 79(2) and Rules 85a and 25(2) EPC (Art. 79(3) EPC).

Possibility of appeal

If the applicant considers that the finding of the European Patent Office is inaccurate, he may, within **two months** after notification of this communication, apply in writing for a decision on this matter by the European Patent Office (R. 69(2) EPC). The application can only cause the finding to be set aside if loss of rights has not actually occurred.

Examining Division



Françoise Salvador



00124448.2 - 1239

SEPU: 12.09.01

25.10.02

PACT:

Loss of particular rights

DEST/AT 15.07.02 (=LOPR(2))
DEST/BE 15.07.02 (=LOPR(2))
DEST/CH 15.07.02 (=LOPR(2))
DEST/CY 15.07.02 (=LOPR(2))
DEST/DK 15.07.02 (=LOPR(2))
DEST/ES 15.07.02 (=LOPR(2))
DEST/FI 15.07.02 (=LOPR(2))
DEST/GR 15.07.02 (=LOPR(2))
DEST/IE 15.07.02 (=LOPR(2))
DEST/IT 15.07.02 (=LOPR(2))
DEST/LU 15.07.02 (=LOPR(2))
DEST/MC 15.07.02 (=LOPR(2))
DEST/NL 15.07.02 (=LOPR(2))
DEST/PT 15.07.02 (=LOPR(2))
DEST/SE 15.07.02 (=LOPR(2))
DEST/TR 15.07.02 (=LOPR(2))

1. The time limit under Rule 69(2) EPC has expired. No appeal or application under Article 122 or Rule 69(2) EPC has been filed.

The loss of particular rights has become final.

13.03.02

2. Loss of particular rights and coding that finding has become final (LOPR 3).

.....
Date 01-11-2002

Hermans-Silege, Véroniq

.....
Formalities Officer



EPA/EPO/OEB
D-80298 München
+49 89 2399-0
TX 523 656 epmu d
FAX +49 89 2399-4465

Europäisches
Patentamt

European
Patent Office

Office européen
des brevets

Generaldirektion 2

Directorate General 2

Direction Générale 2

Grünecker, Kinkeldey,
Stockmair & Schwanhäusser
Anwaltssozietät
Maximilianstrasse 58
80538 München
ALLEMAGNE

Telephone numbers: Branch at The Hague

Primary Examiner +31 70 340-2489
(substantive examination)

Formalities Officer / Assistant +31 70 340-2691
(Formalities and other matters)



Application No. 00 124 448.2 - 1239	Ref. EP20062-013/do	Date 19.08.2003
Applicant Fuji Photo Film Co., Ltd.		

Communication pursuant to Article 96(2) EPC

The examination of the above-identified application has revealed that it does not meet the requirements of the European Patent Convention for the reasons enclosed herewith. If the deficiencies indicated are not rectified the application may be refused pursuant to Article 97(1) EPC.

You are invited to file your observations and insofar as the deficiencies are such as to be rectifiable, to correct the indicated deficiencies within a period

of 4 months

from the notification of this communication, this period being computed in accordance with Rules 78(2) and 83(2) and (4) EPC.

One set of amendments to the description, claims and drawings is to be filed within the said period on separate sheets (Rule 36(1) EPC).

Failure to comply with this invitation in due time will result in the application being deemed to be withdrawn (Article 96(3) EPC).



DECLAT M G R
Primary Examiner
for the Examining Division

Enclosure(s): 4 page/s reasons (Form 2906)

**Bescheid/Protokoll (Anlage)**Datum
Date 19.08.2003
Date**Communication/Minutes (Annex)**Blatt
Sheet 1
Feuille**Notification/Procès-verbal (Annexe)**Anmelde-Nr.:
Application No.: 00 124 448.2
Demande n°:

The examination is being carried out on the **following application documents**:

Text for the Contracting States:

DE FR GB

Description, pages:

1-21 as originally filed

Claims, No.:

1-4 as originally filed

Drawings, sheets:

1/4-4/4 as originally filed

- 1) The following documents (D) are referred to in this communication; the numbering will be adhered to in the rest of the procedure:

D1: EP 0 926 676 A

D2: EP 0 284 687 A

D3: WO 97 15925 A

D4: US 5 901 916 A

- 2) The common features linking together the independent claims 1, 3 and 4 are known from document D1.
Document D1 discloses a magnetic tape cartridge comprising a magnetic tape wound around a single reel, a cartridge casing, and reel stopper means; the reel stopper means comprises: a braking member movable between a locking position and a releasing position, an urging member urging the braking member toward the locking position, and a releasing member which is rotated integrally with the reel and moves the braking member toward the releasing position in response to a reel



chucking action of the reel drive means of a tape drive, the braking member being provided with a braking gear which is adapted to be engaged, to restrict rotation of the reel, with an engagement gear tooth on an engagement projection formed on the reel.

In view of this prior art, it is not clear what the common inventive concept between the independent claims 1, 3 and 4 should be. See in particular Article 82 and Rule 30 EPC (unity of invention).

The applicant is accordingly invited to submit a new independent claim directed to a magnetic tape cartridge, and to comment on inventive step.

- 3) Furthermore, the present application does not meet the requirements of Article 52(1) EPC and is therefore not allowable, because the subject-matter of independent claim 4 is not new in the sense of Article 54(1) and (2) EPC, for the following reasons:
 - 3.1) Document D1 discloses a magnetic tape cartridge comprising the features as mentioned in paragraph 2, and further comprising:

each of the gear teeth of the braking gear has a first inclined surface, adapted to be engaged in the tape unwinding direction, and a second inclined surface, adapted to be engaged in the tape winding direction, the first and second inclined surfaces forming therebetween an apical angle not larger than 90°, and the interior angle between the first inclined surface and the vertical being not larger than the interior angle between the second inclined surface and the vertical. See document D1: essentially the figures.
 - 3.2) Furthermore, also document D4 discloses the subject-matter of claim 1. See document D4: abstract; column 3, line 3 to column 4, line 28; figures.
- 4) The present application does not meet the requirements of Article 52(1) EPC, because the subject-matter of claims 1-3 does not involve an inventive step in the sense of Article 56 EPC, for the following reasons:
 - 4.1) Document D1, which is considered to represent the most relevant state of the art (see also paragraph 2), discloses a magnetic tape cartridge, from which the



subject-matter of claim 1 differs in that the reel is provided with a guide member which centers the braking member with respect to the reel.

However, these features have already been employed for the same purpose in a similar cartridge, see document D2: abstract; claims 1-8; figures. It would be obvious to the person skilled in the art, namely when the same result is to be achieved, to apply these features with corresponding effect to a cartridge according to document D1, thereby arriving at a cartridge according to claim 1. The subject-matter of claim 1 does therefore not involve an inventive step (Articles 52(1) and 56 EPC).

- 4.2) The subject-matter of dependent claim 2 is also known from document D2 (Article 56 EPC).
- 4.3) Document D1, which is considered to represent the most relevant state of the art (see paragraph 2) discloses a magnetic tape cartridge, from which the subject-matter of independent claim 3 differs in that the outer diameter of the engagement gear (on the reel) is larger than that of the braking gear (on the braking member).

However, these features have already been employed for the same purpose in a similar cartridge, see document D3: abstract; figures. It would be obvious to the person skilled in the art, namely when the same result is to be achieved, to apply these features with corresponding effect to a cartridge according to document D1, thereby arriving at a cartridge according to claim 3. The subject-matter of claim 3 does therefore not involve an inventive step (Articles 52(1) and 56 EPC).

- 5) It is not at present apparent which part of the application could serve as a basis for a new, allowable claim. Should the applicant nevertheless regard some particular matter as patentable, an independent claim should be filed taking account of Rule 29(1) EPC. The applicant should also indicate in the letter of reply the difference of the subject-matter of the new claim vis-à-vis the state of the art and the significance thereof.
- 6) In case the applicant files new claims he is asked to attend to the outstanding matter mentioned in the following paragraphs 7 to 12.

**Bescheid/Protokoll (Anlage)**Datum
Date 19.08.2003
Date**Communication/Minutes (Annex)**Blatt
Sheet 4
Feuille**Notification/Procès-verbal (Annexe)**Anmelde-Nr.:
Application No.: 00 124 448.2
Demande n°:

- 7) To meet the requirements of Rule 29(1) EPC an independent claim should be properly cast in the two part form, with those features which in combination are part of the prior art (see e.g. document D1) being placed in the preamble.
- 8) The features of the claims should be provided with reference signs placed in parentheses to increase the intelligibility of the claims (Rule 29(7) EPC). This applies to both the preamble and characterising portion (see the Guidelines, C-III, 4.11).
- 9) To meet the requirements of Rule 27(1)(b) EPC, the documents D1-D4 should be identified in the description and the relevant background art disclosed therein should be briefly discussed.
- 10) When filing amended claims the applicant should at the same time bring the description into conformity with the amended claims. Care should be taken during revision, especially of the introductory portion and any statements of problem or advantage, not to add subject-matter which extends beyond the content of the application as originally filed (Article 123(2) EPC).
- 11) In the brief description of the figures, Figure 5 should be identified as prior art (see page 10, lines 24-26).
- 12) In the last paragraph of the description (see page 21, lines 23-26) 3 documents are cited (probably application nos.), "all of the contents" of these documents being "incorporated into the specification by reference". See Guidelines, C-II, 4.18: the subject-matter of these documents (with publication nos.) should be disclosed if these documents are essential (Article 83 EPC) ,or the expression "incorporated ... by reference" should be deleted.

GRÜNECKER KINKELDEY STOCKMAIR & SCHWANHÄUSSER

ANWALTSSOZIELÄT

EPO - Munich
16

16. Dez. 2003

GKS & S MAXIMILIANSTRASSE 58 D-80538 MÜNCHEN GERMANY

European Patent Office
Erhardtstr. 27

80298 München

RECHTSANWÄLTE
LAWYERS
MÜNCHEN
DR. HELMUT EICHMANN
GERHARD BARTH
DR. ULRICH BLUMENRÖDER, LL.M.
CHRISTA NIKLAS-FALTER
DR. MAXIMILIAN KINKELDEY, LL.M.
DR. KARSTEN BRANDT
ANJA FRANKE, LL.M.
UTE STEPHANI
DR. BERND ALLEKOTTE, LL.M.
DR. ELVIRA PFANG, LL.M.
KARIN LOCHNER
BABETT ERTLE
CHRISTINE NEUHIERL
SABINE PRÜCKNER

PATENTANWÄLTE
EUROPEAN PATENT ATTORNEYS
MÜNCHEN
DR. HERMANN KINKELDEY
PETER H. JAKOB
WOLFHARD MEISTER
HANS HILGERS
DR. HENNING MEYER-PLATH
ANNELIE EHNOLD
THOMAS SCHUSTER
DR. KLARA GOLDBACH
MARTIN AUFENANGER
GOTTFRIED KLITZSCH
DR. HEIKE VOGELANG-WENKE
REINHARD KNAUER
DIETMAR KUHLE
DR. FRANZ-JOSEF ZIMMER
BETTINA K. REICHEL
DR. ANTON K. PFAU
DR. UDO WEIGELT
RAINER BERTRAM
JENS KOCH, M.S. (U of PA) M.S.
BERND ROTHAEHEL
DR. DANIELA KINKELDEY
THOMAS W. LAUBENTHAL
DR. ANDREAS KAYSER
DR. JENS HAMMER
DR. THOMAS EICKELKAMP
JOCHEN KILCHERT
DR. THOMAS FRIEDE

PATENTANWÄLTE
EUROPEAN PATENT ATTORNEYS
BERLIN
PROF. DR. MANFRED BÖNING
DR. PATRICK ERK, M.S. (MIT)
KÖLN
DR. MARTIN DROPMANN
CHEMNITZ
MANFRED SCHNEIDER

OF COUNSEL
PATENTANWÄLTE
AUGUST GRÜNECKER
DR. GUNTER BEZOLD

DR. WILFRIED STOCKMAIR
(-1996)

IHR ZEICHEN / YOUR REF.

UNSER ZEICHEN / OUR REF.

DATUM / DATE

EP20062JK052cl

16.12.2003

Application No.: 00 124 448.2-1239
Applicant: FUJI POTO FILM CO., LTD.

In response to the Official Communication dated August 19, 2003:

We respectfully submit herewith a new set of claims 1 to 6 which should replace, at least for the time being, the previously filed set of claims 1 to 4, comprising only one independent claim 1 being based on the technical teaching that can be taken from the original independent claim 1 and the original figure 4 of the present application.

The Examining Division is hereby informed that the applicant intends to file a divisional application for the subject-matter not covered by this application in the near future. Furthermore, the Examining Division is respectfully requested to allow the postponement of filing a revised description adapted to the newly filed set of claims 1 to 6 until the allowability of the subject-matter of the newly filed set of claims has been announced.

GRÜNECKER KINKELDEY
STOCKMAIR & SCHWANHÄUSSER
MAXIMILIANSTR. 58
D-80538 MÜNCHEN
GERMANY

TEL. +49 89 21 23 50
FAX +49 89 22 02 87
FAX +49 89 21 86 92 93
<http://www.grunecker.de>
e-mail: info@grunecker.de

DEUTSCHE BANK MÜNCHEN
No. 17 51734
BLZ 700 700 10
SWIFT: DEUT DE MM

According to the disclosure of the newly filed set of claims, the newly filed independent claim 1 is based, as indicated above, on the technical teaching that can be taken from the original independent claim 4, wherein the wording thereof has been somewhat revised due to clarity and conciseness thereof.

The newly filed dependent claim 2 comprises the features which have been deleted from the original independent claim 4, since they are not essential for the technical teaching of the newly filed independent claim 1. The newly filed dependent claim 3 comprises the technical teaching that can be taken from page 14, last paragraph to page 15, first paragraph, of the original description and figure 4 of the present application. The newly filed dependent claim 4 comprises the "characterizing feature" of the original independent claim 1. The newly filed dependent claim 5 is based on the original dependent claim 2, wherein the wording thereof has been somewhat revised. The newly filed dependent claim 6 comprises the "characterizing feature" of the original independent claim 3.

Here, the newly filed independent claim 1 has been delimited over the cited prior art document EP 0 926 676 A1 (D1) and reference signs have been incorporated in the newly filed set of claims.

Thus, the present invention relates to:

"a magnetic tape cartridge comprising a magnetic tape wound around a single reel, a cartridge casing for housing the reel and a reel stopper means for locking the reel or permitting rotation thereof, wherein the reel stopper means comprises a braking member being moveable between a locking position and a releasing position, an urging member for urging the braking member toward the locking position, and a releasing member being rotated integrally with the reel for moving the braking member toward the releasing position in response to a reel chucking action of a reel drive means of a tape drive, and wherein the braking member is provided with a braking gear comprising gear teeth being adapted to

be engaged with at least one engagement gear tooth of an engagement projection formed on the reel”.

From D1 a magnetic tape cartridge as indicated above is shown, wherein the magnetic tape cartridge comprises a single reel (102), a casing (103) and a reel stopper means (110). Here, the reel stopper means (110) comprises a brake member (104) being movable up and down away from and towards the reel (102), an urging member (105) urging the brake member (104) towards the reel (102) and a brake release member (106) moving the brake member (104) away from the reel (102).

As clearly shown in figures 8, 11 and 13 of D1 the teeth of the brake member (104) comprise, respectively, two abutment surfaces with an equal inclination, so that the teeth of the brake member (104) could provide the same force on a single reel (102) in both directions thereof, namely, winding and unwinding direction.

It is an objective of the present invention to improve a magnetic tape coverage as indicated above so as to assure different forces applying from the brake member to the single reel in the winding and unwinding direction of the single reel.

This objective is solved according to the present invention by a magnetic tape cartridge as indicated above, wherein:

“each of the gear teeth of the braking gear comprises a first inclined surface being directed towards a tape-unwinding direction and a second inclined surface being directed towards a tape-winding direction, wherein an interior angle between the first inclined surface and a vertical is smaller than an interior angle between the second inclined surface and the vertical”.

D1 does not mention nor render obvious that the abutment surfaces of the teeth should be differently inclined, so that different forces are provided in the winding and unwinding direction of the single reel in order to prevent the magnetic tape from being stretched or cut and at the same time to ensure sufficient locking force between the brake member (104) and the single reel (102). Thus, the characterizing features of the newly filed independent claim 1 is not known nor rendered obvious by D1.

Since D1 does not show nor render obvious the objective and the solution as claimed in the newly filed independent claim 1 of the present application, the technical teaching of the present application is new and appears to be inventive with regard to D1.

Furthermore, the cited prior art document EP 0 284 687 A2 (D2) discloses a tape cartridge comprising a spool (62), a brake button (60) and projecting means (70) with projections or centering ribs (70').

From D2 the technical teaching of the newly filed independent claim 1 is also not shown nor rendered obvious, so that the technical teaching of the newly filed independent claim 1 is also new and appears to be inventive with regard to D2.

The cited prior art documents WO 97 15925 A1 (D3) and US 5,901,916 A (D4) disclose a tape cartridge comprising a housing, a tape supply reel, reel gear and a reel lock, wherein the reel lock has been urged by a brake spring towards a locking means (24) of D3 (44 of D4) provided at the tape supply reel.

As clearly shown in the figures of D3 and D4 each of the teeth of the reel lock comprises equally inclined abutment surfaces. Therefore, the technical teaching of the newly filed independent claim 1 is also not shown nor rendered obvious by D3 and D4.

Thus, the technical teaching of the newly filed independent claim 1 is also new and appears to be inventive with regard to D3 and D4.

Since none of the cited prior art documents D1 to D4 show or render obvious the technical teaching of the newly filed independent claim 1, it seems to be impossible for a skilled person to obtain or deduce the technical teaching of the newly filed independent claim 1 from a combination of the cited prior art documents.

Therefore, the technical teaching of the newly filed independent claim 1 is new and appears to be inventive with regard to a combination of the cited prior art and meets the requirements of Articles 52(1), 54 and 56 EPC.

In view of the foregoing, the Examining Division is respectfully requested to briefly announce that the subject-matter of the newly filed set of claims 1 to 6 is considered allowable.

In case the Examining Division has further reservations, it is respectfully requested to conduct an Informal Interview in the Primary Examiner's Office. Very precautionarily, it is requested to proceed with Oral Proceedings according to Article 116 EPC in case the Examining Division intends to reject the application.

(J. Koch)

Encl.: New set of claims 1 to 6

European Patent Application No. 00 124 448.2-1239
Applicant: FUJI PHOTO FILM CO., LTD.
EP20062JK052

NEW CLAIMS

1. A magnetic tape cartridge (1) comprising a magnetic tape wound around a single reel (2), a cartridge casing (3) for housing the reel (2) and a reel stopper means (10) for locking the reel (2) or permitting rotation thereof, wherein the reel stopper means (10) comprises a braking member (4) being moveable between a locking position and a releasing position, an urging member (5) for urging the braking member (4) toward the locking position, and a releasing member (6) being rotated integrally with the reel (2) for moving the braking member (4) toward the releasing position in response to a reel chucking action of a reel drive means (11) of a tape drive, and wherein the braking member (4) is provided with a braking gear (42) comprising gear teeth being adapted to be engaged with at least one engagement gear tooth (29) of an engagement projection (27) formed on the reel (2), **characterized in that** each of the gear teeth of the braking gear (42) comprises a first inclined surface (42a) being directed towards a tape-unwinding direction (U) and a second inclined surface (42b) being directed towards a tape-winding direction (W), wherein an interior angle (α) between the first inclined surface (42a) and a vertical (s) is smaller than an interior angle (β) between the second inclined surface (42b) and the vertical (s).
2. A magnetic tape cartridge (1) according to claim 1, **characterized in that** the inclined surfaces (42a,42b) form therebetween an apical angle (γ) being smaller than 90° .
3. A magnetic tape cartridge (1) according to claim 1 or 2, **characterized in that** the at least one engagement gear tooth (29) comprises a first and a second inclined surface (29a,29b) being respectively corresponded to the first and second inclined surface (42a,42b) of the gear teeth of the braking gear (42).

4. A magnetic tape cartridge (1) according to at least one of the claims 1 to 3, **characterized in that** the reel (2) is provided with a guide member (28,39) for centering the braking member (4) with respect to the reel (2).
5. A magnetic tape cartridge (1) according to claim 4, **characterized in that** the guide member (39) comprises guide ribs being formed on an inner surface of a reel hub (21) at at least three places, wherein each guide ribs comprises an inclined surface inclining downward from an upper portion of the inner surface of the reel hub (21) toward a center of the reel (2).
6. A magnetic tape cartridge (1) according to at least one of the claims 1 to 5, **characterized in that** an outer diameter (D) of an engagement gear comprising the at least one engagement gear tooth (29) is larger than an outer diameter (d) of the braking gear (42).



EPA/EPO/OEB
D-80298 München
+49 89 2399-0
TX 523 656 epmu d
FAX +49 89 2399-4465

Europäisches
Patentamt

European
Patent Office

Office européen
des brevets

Generaldirektion 2

Directorate General 2

Direction Générale 2

Grünecker, Kinkeldey,
Stockmair & Schwanhäusser
Anwaltssozietät
Maximilianstrasse 58
80538 München
ALLEMAGNE

Telephone numbers: Branch at The Hague

Primary Examiner +31 70 340-2489
(substantive examination)

Formalities Officer / Assistant +31 70 340-3813
(Formalities and other matters)



Application No. 00 124 448.2 - 1239	Ref. EP20062-013/do	Date 03.01.2006
Applicant FUJI PHOTO FILM CO., LTD.		

Communication pursuant to Article 96(2) EPC

The examination of the above-identified application has revealed that it does not meet the requirements of the European Patent Convention for the reasons enclosed herewith. If the deficiencies indicated are not rectified the application may be refused pursuant to Article 97(1) EPC.

You are invited to file your observations and insofar as the deficiencies are such as to be rectifiable, to correct the indicated deficiencies within a period

of 4 months

from the notification of this communication, this period being computed in accordance with Rules 78(2) and 83(2) and (4) EPC.

One set of amendments to the description, claims and drawings is to be filed within the said period on separate sheets (Rule 36(1) EPC).

Failure to comply with this invitation in due time will result in the application being deemed to be withdrawn (Article 96(3) EPC).



Declat, M
Primary Examiner
for the Examining Division

Enclosure(s): 2 page/s reasons (Form 2906)

**Bescheid/Protokoll (Anlage)**Datum
Date 03.01.2006
Date**Communication/Minutes (Annex)**Blatt
Sheet 1
Feuille**Notification/Procès-verbal (Annexe)**Anmelde-Nr.:
Application No.: 00 124 448.2
Demande n°:

The examination is being carried out on the **following application documents**:

Description, Pages

1-21 as originally filed

Claims, Numbers

1-6 received on 16.12.2003 with letter of 16.12.2003

Drawings, Sheets

1/4-4/4 as originally filed

1. Present independent claim 1 is based on independent claim 4 as originally filed. The applicant has replaced a first feature "the interior angle between the first inclined surface and the vertical being **not larger than** the interior angle between the second inclined surface and the vertical" by "... **is smaller**..." to distinguish the subject-matter of present independent claim from document D1. Basis for this can be found in the description, see page 21, lines 1-10.

2. The applicant has deleted the following feature in claim 1:

"the first and second inclined surfaces forming therebetween an **apical angle not larger than 90°**".

This feature is presented as essential in the disclosure of the invention, indispensable as such for the function of the invention in the light of the technical problem which it seeks to solve. See the description, same passage as mentioned before (page 21, lines 1-10). See also several other passages of the description, e.g. page 9, line 5 to page 10, line 11; page

**Bescheid/Protokoll (Anlage)**

Datum
Date 03.01.2006
Date

Communication/Minutes (Annex)

Blatt
Sheet 2
Feuille

Notification/Procès-verbal (Annexe)

Anmelde-Nr.:
Application No.: 00 124 448.2
Demande n°:

15, lines 10-19; page 21, lines 17-22.

The deletion of this feature introduces subject-matter which extends beyond the content of the application as filed, contrary to Article 123(2) EPC.

See also the Guidelines, C-VI, 5.3.10.

This feature should be (re)introduced in present claim 1, and present claim 2 should be deleted.

3. The requirements as mentioned in the first communication dated 19.08.2003, paragraphs 9-12, all concerning the revision of the description, still have to be fulfilled.

GRÜNECKER KINKELDEY STOCKMAIR & SCHWANHÄUSSER

ANWALTSSOZIELTÄT

EPO - Munich
16
08. Mai 2006

GKS & S MAXIMILIANSTRASSE 58 D-80538 MÜNCHEN GERMANY

European Patent Office
Erhardtstraße 27

80298 München

RECHTSANWÄLTE
LAWYERS

MÜNCHEN
DR. HELMUT EICHMANN
GERHARD BARTH
DR. ULRICH BLUMENRÖDER, LL.M.
CHRISTA NIKLAS-FALTER
DR. MAXIMILIAN KINKELDEY, LL.M.
DR. KARSTEN BRANDT
ANJA FRANKE, LL.M.
UTE STEPHANI
DR. BERND ALLEKOTTE, LL.M.
DR. ELVIRA BERTRAM, LL.M.
KARIN LOCHNER
BABETT ERTLE
CHRISTINE NEUHIERL
SABINE PRÜCKNER
CORNELIA SCHMITT
BERNHARD MEHNERT, DIPL. ING.
PETRA LÜBBE
DR. SONJA BRÖTJE
SONJA SCHÄFFLER

PATENTANWÄLTE
EUROPEAN PATENT ATTORNEYS

MÜNCHEN
DR. HERMANN KINKELDEY
PETER H. JAKOB
HANS HILGERS
ANNELIE EHNOLD
THOMAS SCHUSTER
DR. KLARA GOLDBACH
MARTIN AUFENANGER
GOTTFRIED KLITZSCH
DR. HEIKE VOGELSANG-WENKE
REINHARD KNAUER
DIETMAR KUHLE
DR. FRANZ-JOSEF ZIMMER
BETTINA K. REICHELT
DR. ANTON K. PFAU
DR. UDO WEIGELT
RAINER BERTRAM
JENS KOCH, M. S. (U of PA) M. S.
BERND ROTHAEML
THOMAS W. LAUBENTHAL
DR. ANDREAS KAYSER
DR. JENS HAMMER
DR. THOMAS EICKELKAMP
DR. CARLO TORTI*
DR. MORITZ HÖFFE
*EUROPEAN PATENT ATTORNEY

PATENTANWÄLTE
EUROPEAN PATENT ATTORNEYS

BERLIN
PROF. DR. MANFRED BÖNING
DR. PATRICK ERK, M.S. (MIT)
KÖLN
DR. MARTIN DROPMANN
CHEMNITZ
DR. CARMEN STEINIGER*
*PATENTANWÄLTIN
ALICANTE
WOLFHARD MEISTER
DR. ANDREAS TORKA*
*RECHTSANWALT
OF COUNSEL
DR. HENNING MEYER-PLATH
DR. WILFRIED STOCKMAIR
(-1996)

IHR ZEICHEN / YOUR REF.

UNSER ZEICHEN / OUR REF.
EP20062GK052clu

DATUM / DATE
May 8, 2006

European Patent Application No. 00 124 448.2-1239
Applicant: Fuji Photo Film Co., Ltd.

In response to the Official Communication dated January 3, 2006:

We respectfully submit herewith a new set of claims 1 – 5, which should replace, at least for the time being, the previously filed set of claims 1 – 6.

The newly filed independent claim 1 is based on the technical teaching of the previously filed independent claim 1 and dependent claim 2, wherein the newly filed set of claims 1 – 5 has been amended taking the Examining Division's consideration into account – that means re-incorporating the technical teaching of the previously filed dependent claim 2 into the newly filed independent claim 1 and renumbering the remaining dependent claims 3 – 6 into newly filed dependent claims 2 – 5.

Furthermore, newly revised description pages 1 and 4 – 18 are respectfully submitted herewith, which should replace, at least for the time being, the previously filed description pages 1 and 4 – 21. The newly filed description pages have been amended in accordance with European patent practice and adapted to the newly filed set of claims, in particular, the cited prior art documents D1 – D4 have been mentioned in the newly filed introductory part. A

GRÜNECKER KINKELDEY
STOCKMAIR & SCHWANHÄUSSER
MAXIMILIANSTR. 58
D-80538 MÜNCHEN
GERMANY

TEL. +49 89 21 23 50
FAX +49 89 22 02 87
FAX +49 89 21 86 92 93
<http://www.grunecker.de>
e-mail: info@grunecker.de

DEUTSCHE BANK MÜNCHEN
No. 17 51734
BLZ 700 700 10
SWIFT: DEUT DE MM

copy of the handwritten amendments of the newly filed description pages is also respectfully submitted herewith.

Based on the documents now on file, the Examining Division is respectfully requested to briefly announce that the newly filed set of claims, in particular, the newly filed independent claim, is allowable and to issue an Official Communication under Rule 51(4) EPC.



(G. Kritzsch)

Encl.: New set of claims 1 – 5
Revised description pages 1 and 4 – 18
Copy of the handwritten amendments

MAGNETIC TAPE CARTRIDGE

~~BACKGROUND OF THE INVENTION~~

~~Field of the Invention~~

This invention relates to a magnetic tape cartridge ~~according to the preamble part of the independent claim 1. comprising a cartridge casing and a single reel which is housed~~ in the cartridge casing for rotation and around which a magnetic tape is wound, and more particularly to a structure of a reel stopper means for preventing rotation of the reel when the ~~magnetic tape cartridge is not being used.~~

~~Description of the Related Art~~

As a recording medium for use in an external memory of a computer or the like, there has been known a magnetic tape cartridge comprising a magnetic tape wound around a single reel and a cartridge casing in which the reel is housed for rotation. Since the magnetic tape is used for storing data in a computer or the like and important information is stored on the magnetic tape, the magnetic tape cartridge is provided with a reel stopper means which prevents rotation of the reel when the magnetic tape cartridge is not being used, e.g., when the magnetic tape cartridge is being stored, so that trouble such as tape jam does not occur and the magnetic tape is not accidentally drawn out.

The reel stopper means is provided with a brake member which is adapted to be engaged with the reel to prevent rotation of the reel and is disengaged from the reel to permit rotation

That is, when the braking gear and the engagement gear are engaged with each other at a substantially normal surface facing against the tape-unwinding direction, the reel cannot be rotated in the tape-unwinding direction. Further, a leader member such as a leader pin is fixed to the end of the magnetic tape wound around the reel, and the leader member is held near the tape draw-out opening of the cartridge casing when the magnetic tape cartridge is not being used. When the brake member is moved and the braking gear is disengaged from the engagement gear due to drop impact with the reel rotated in the tape-winding direction under inertia, a tape winding force acts on the magnetic tape whose end is fixed by the leader member. Since the reel cannot be rotated in the tape-unwinding direction or the direction in which the tension on the magnetic is released, the tape winding force acting on the magnetic tape can stretch the tape to deteriorate the magnetic recording and reproducing characteristics, remove the leader member from the magnetic tape, cut the magnetic tape, or displace the leader member from the predetermined position to disable the regular tape draw-out action, thereby deteriorating the reliability of the magnetic tape cartridge.

~~SUMMARY OF THE INVENTION~~

* →

~~In view of the foregoing observations and description,~~
the primary object of the present invention is to provide a magnetic tape cartridge in which the braking gear of the reel stopper means is suppressed from being brought into contact

*

From EP 0 926 676 A1 a magnetic tape cartridge as indicated above is known, wherein the magnetic tape cartridge comprises a single reel, a casing and a reel stopper means. Here, the reel stopper means comprises a brake member being movable up and down away from and towards the reel, an urging member urging the brake member towards the reel and a brake release member moving the brake member away from the reel. The teeth of the brake member comprise, respectively, two abutment surfaces with an equal inclination, so that the teeth of the brake member could provide the same force on a single reel in both directions thereof, namely, winding and unwinding direction.

EP 0 284 687 A2 discloses a tape cartridge comprising a spool, a brake button and projecting means with projections or centering ribs.

WO 97 15925 A1 and US 5,901,916 A disclose a tape cartridge comprising a housing, a tape supply reel, reel gear and a reel lock, wherein the reel lock has been urged by a brake spring towards a locking means provided at the tape supply reel. Here, each of the teeth of the reel lock comprises equally inclined abutment surfaces.

It is an objective of the present invention to improve a magnetic tape coverage as indicated above so as to assure different forces applying from the brake member to the single reel in the winding and unwinding direction of the single reel.

with the reel when the reel stopper means is in the release position.

Another object of the present invention is to provide a magnetic tape cartridge in which the reel can be surely prevented from being rotated while occurrence of the magnetic tape being cut can be prevented when the magnetic tape cartridge ~~is not being used.~~

~~The objective is solved according to the present invention in accordance with a first aspect of the present invention, there is provided a magnetic tape cartridge comprising a magnetic tape wound around a single reel, a cartridge casing in which the reel is housed for rotation and a reel stopper means which locks the reel not to rotate when the magnetic tape cartridge is not being used and releases the reel to permit rotation thereof when the magnetic tape cartridge is to be used, wherein the improvement comprises that the reel stopper means comprises a braking member which is movable between a locking position where it is in contact with the reel to restrict rotation of the reel and a releasing position where it is away from the reel to permit rotation of the same, an urging member which urges the braking member toward the locking position, and a releasing member which is rotated integrally with the reel and moves the braking member toward the releasing position in response to a reel chucking action of the reel drive means of a tape drive, and the braking member is provided with a braking gear which is adapted to be engaged, ~~to restrict rotation of the reel, with an engagement gear tooth~~~~

by < independent claim 1 ; "wherein" instead of "ch. i. th." >

~~on an engagement projection formed on the reel while the reel~~
is provided with a guide member which centers the braking member
with respect to the reel.

It is preferred that the guide member comprises guide
ribs which are formed on the inner surface of the reel hub at
at least three places, each having an inclined surface which
inclines downward from the upper portion of the inner surface
of the reel hub toward the center of the reel.

In the magnetic tape cartridge in accordance with the
first aspect of the present invention, when the braking member
is moved downward from the releasing position to the locking
position, the braking member is centered by the guide members
so that the braking gear is brought into mesh with the
engagement gear teeth with the braking member held horizontal,
whereby the braking member is prevented from being inclined
in the locking position. When the braking member is
subsequently moved to the releasing position by the releasing
member, the braking member is held horizontal up to the
releasing position. Accordingly, the phenomenon that the
braking member is inclined can be suppressed, whereby the
braking gear is prevented from contacting the engagement gear
teeth to generate noise or to obstruct rotation of the reel.

Further, during assembly of the magnetic tape cartridge,
the braking member is automatically centered in the reel hub
by the guide members and is incorporated in place in the reel,
~~whereby assembly of the magnetic tape cartridge is facilitated.~~

~~In accordance with a second aspect of the present invention, there is provided a magnetic tape cartridge comprising a magnetic tape wound around a single reel, a cartridge casing in which the reel is housed for rotation and a reel stopper means which locks the reel not to rotate when the magnetic tape cartridge is not being used and releases the reel to permit rotation thereof when the magnetic tape cartridge is to be used, wherein the improvement comprises that the reel stopper means comprises a braking member which is movable between a locking position where it is in contact with the reel to restrict rotation of the reel and a releasing position where it is away from the reel to permit rotation of the same, an urging member which urges the braking member toward the locking position, and a releasing member which is rotated integrally with the reel and moves the braking member toward the releasing position in response to a reel chucking action of the reel drive means of a tape drive, and the braking member is provided with a braking gear which is adapted to be engaged, to restrict rotation of the reel, with an engagement gear on an engagement projection formed on the reel, the outer diameter of the engagement gear being larger than that of the braking gear.~~

~~In the magnetic tape cartridge in accordance with the second aspect of the present invention, when the braking member is moved downward from the releasing position to the locking position, the braking member is centered by the difference~~

~~between the outer diameters of the engagement gear and the~~
braking gear so that the braking gear is brought into mesh with
the engagement gear teeth with the braking member held
horizontal, whereby the braking member is prevented from being
inclined in the locking position. When the braking member is
subsequently moved to the releasing position by the releasing
member, the braking member is held horizontal up to the
releasing position. Accordingly, the phenomenon that the
braking member is inclined can be suppressed, whereby the
braking gear is prevented from contacting the engagement gear
teeth to generate noise or to obstruct rotation of the reel.

In accordance with a third aspect of the present
invention, there is provided a magnetic tape cartridge
comprising a magnetic tape wound around a single reel, a
cartridge casing in which the reel is housed for rotation and
a reel stopper means which locks the reel not to rotate when
the magnetic tape cartridge is not being used and releases the
reel to permit rotation thereof when the magnetic tape
cartridge is to be used, wherein the improvement comprises that
the reel stopper means comprises a braking member which is
movable between a locking position where it is in contact with
the reel to restrict rotation of the reel and a releasing
position where it is away from the reel to permit rotation of
the same, an urging member which urges the braking member toward
the locking position, and a releasing member which is rotated
~~integrally with the reel and moves the braking member toward~~

~~the releasing position in response to a reel chucking action~~
of the reel drive means of a tape drive, the braking member is provided with a braking gear which is adapted to be engaged, to restrict rotation of the reel, with an engagement gear tooth on an engagement projection formed on the reel, and each of the gear teeth of the braking gear has a first inclined surface which is brought into abutment against the engagement gear teeth when the reel is rotated in the tape-unwinding direction with the braking gear and the engagement gear tooth in mesh with each other and a second inclined surface which is brought into abutment against the engagement gear teeth when the reel is rotated in the tape-winding direction with the braking gear and the engagement gear tooth in mesh with each other, the first and second inclined surfaces forming therebetween an apical angle not larger than 90° , and the interior angle between the first inclined surface and the vertical being not larger than the interior angle between the second inclined surface and the vertical.

~~In the magnetic tape cartridge in accordance with the~~
According to the above mentioned,
~~third aspect of the present invention,~~ since the apical angle of the braking gear tooth is not larger than 90° and the interior angle for the first inclined surface of the braking gear tooth which is brought into abutment against the engagement gear teeth when the reel is rotated in the unwinding direction and the interior angle for the second inclined surface which is brought into abutment against the engagement gear teeth when

g

the reel is rotated in the winding direction are not smaller than 30° with the former smaller than the latter, rotation of the reel can be surely prevented and when the reel is rotated in the winding direction due to drop impact or the like and an excessive winding force acts on the magnetic tape, the braking member is moved toward the releasing position along the first inclined surface and the braking gear is disengaged from the engagement gear teeth, whereby the reel is rotated in the unwinding direction to reduce the tension on the magnetic tape, and the magnetic tape can be prevented from being stretched or cut.

** →

~~BRIEF DESCRIPTION OF THE DRAWINGS~~

Figure 1 is a perspective view showing a state of a magnetic tape cartridge in accordance with an embodiment of the present invention when the magnetic tape cartridge is not being used,

Figure 2 is a fragmentary cross-sectional view of the magnetic tape cartridge shown in Figure 1 when the magnetic tape cartridge is being used,

Figure 3 is a cross-sectional view taken along line A-A in Figure 2,

Figure 4 is a cross-sectional view taken along line B-B in Figure 2, and

Figure 5 is a fragmentary cross-sectional view showing a state of a magnetic tape cartridge where the braking member is inclined.

✱✱

Further preferred embodiments of the present invention are laid down in the further subclaims. In the following, the present invention is explained in greater detail by means of several embodiments thereof in conjunction with the accompanying drawings, wherein:

~~DESCRIPTION OF THE PREFERRED EMBODIMENT~~

A magnetic tape cartridge 1 in accordance with an embodiment of the present invention will be described with reference to the drawings, hereinbelow.

The magnetic tape cartridge 1 comprises a cartridge casing 3 formed by fastening together upper and lower casing halves 31 and 32 by screws or the like. A single reel 2 around which a magnetic tape (not shown) is wound is housed for rotation in the cartridge casing 3. The lower casing half 32 is provided with a central opening 32a. The magnetic tape cartridge 1 is further provided with a reel stopper means 10 which permits rotation of the reel 2 when the magnetic tape cartridge 1 is being used and restricts rotation of the reel 2 when the magnetic tape cartridge 1 is not being used.

The reel 2 comprises a reel hub 21 which is a cylindrical member having a closed bottom and around which the magnetic tape is wound, and lower and upper flanges 22 and 23. The reel hub 21 and the lower flange 22 are integrally formed by synthetic resin molding. The upper flange 23 is bonded to the reel hub 21, for instance, by ultrasonic welding. The reel hub 21 is provided with a bottom wall 21a at the lower end portion thereof and a reel gear 24 for rotating the reel 2 is annularly formed on the lower surface of the bottom wall 21a, and annular reel plate 25 which is magnetically attracted by a reel drive means 11 of a recording and reproducing apparatus is mounted on the lower surface of the bottom wall 21a inside the reel

gear 24. The reel 2 is urged downward by an urging means 5 to be described later.

The reel drive means 11 is provided with an annular drive gear 13 and a magnet (not shown) disposed on the top surface of a rotary shaft 12. When the magnetic tape cartridge 1 loaded in a bucket of the tape drive is moved downward toward the rotary shaft 12, the drive gear 13 is brought into mesh with the reel gear 24 and the reel plate 25 is magnetically attracted against the magnet to hold the drive gear 13 and the reel gear 24 in mesh with each other. In this manner, the reel drive means 11 chucks the reel 2.

The mechanism of the reel stopper means 10 will be described, hereinbelow. The reel stopper means 10 comprises a braking member 4 which is movable up and down between a locking position where it is in contact with the reel 2 to restrict rotation of the reel 2 and a releasing position where it is away from the reel 2 to permit rotation of the same, an urging member 5 which urges the braking member 4 toward the locking position, and a releasing member 6 which moves the braking member 4 toward the releasing position.

As shown in Figure 3, three through holes 26 are formed in the bottom wall 21a of the reel 2 at regular angular intervals in the circumferential direction to extend through the portion at which the reel gear 24 is formed. On the upper surface of the bottom wall 21a, there are erected three pairs of (six) engagement projections 27 at regular angular intervals in the

circumferential direction among the through holes 26. The upper end of each engagement projection 27 is formed into an engagement gear teeth 29 as shown in Figure 4. The through holes 26 may be larger than three in number and the engagement projections 27 may be larger three pairs in number. Further, the upper end of each engagement projection 27 may be formed into a single gear tooth.

The braking member 4 has a disc portion 41 which is disposed in the reel hub 21 opposed to the bottom wall 21a, and an annular braking gear 42 is formed on the lower surface of the disc portion 41 along the outer peripheral edge thereof. The braking gear 42 is adapted to be engaged with the engagement gear 29 on the engagement projections 27. The central part of the lower surface of the disc portion 41 is convex downward and forms a sliding portion 41a which is pressed against a sliding portion 61a on the upper surface of a body portion 61 of ~~a~~^{the} releasing member 6 to be described later.

~~The~~^{An} outer diameter D of the engagement gear formed by the engagement gear teeth 29 on the engagement projections 27 on the reel 2 (Figure 3) is larger than ~~the~~^{an} outer diameter d (Figure 2) of the braking gear 42 on the braking member 4. The braking gear 42 and the engagement gear 29 are conical in shape and the height of each tooth is higher at the outer periphery thereof. Accordingly, the braking gear 42 is engaged with the engagement gear ~~42~~^{teeth 29} at their outer peripheries first.

When the braking gear 42 on the braking member 4 is

brought into mesh with the engagement gear 29 on the engagement projections 27, the outer periphery of the braking member 4 is guided by guide members 39 formed on the inner surface of the reel hub 21 of the reel 2. The guide members 39 are respectively provided between each pair of engagement projections 27, and accordingly three guide members 39 are provided on the inner surface of the reel hub 21. Each guide member 39 is in the form of a rib having an inclined surface which gradually inclines downward from the upper portion of the inner surface of the reel hub 21 toward the engagement projections 27, and the guide members 39 center the braking gear 42 when the outer periphery of the braking gear 42 is brought into contact with the inclined surfaces.

As shown in Figure 4, each gear tooth of the braking gear 42 of the braking member 4 and each engagement gear tooth 29 on the engagement projection 27 are triangular in cross-section. The gear tooth of the braking gear 42 has a first inclined surface 42a which faces against the tape-unwinding direction U and abuts against a first inclined surface 29a of the engagement gear tooth 29 on the engagement projection 27 which faces toward the tape-unwinding direction U, and a second inclined surface 42b which faces against the tape-winding direction W and abuts against a second inclined surface 29b of the engagement gear tooth 29 on the engagement projection 27 which faces toward the tape-winding direction W. When the reel 2 is rotated in the tape-unwinding direction U with the

braking gear 42 in mesh with the engagement gear teeth 29 on the engagement projection 27, the first inclined surfaces 42a of the gear teeth of the braking gear 42 are brought into abutment against the first inclined surfaces 29a of the engagement gear teeth 29, and when the reel 2 is rotated in the tape-winding direction W with the braking gear 42 in mesh with the engagement gear teeth 29 on the engagement projection 27, the second inclined surfaces 42b of the gear teeth of the braking gear 42 are brought into abutment against the second inclined surfaces 29b of the engagement gear teeth 29. Each of the gear tooth 42 and the gear tooth 29 is not larger than 90° in apical angle γ , and ^{an} ~~the~~ interior angle α between the first inclined surface 42a (or 29a) and ^a ~~the~~ vertical S and ^{an} ~~the~~ interior angle β between the second inclined surface 42b (or 29b) and the vertical S are not smaller than 30°. Further, the interior angle α for the first inclined surface 42a (29a) is not larger than the interior angle β for the second inclined surface 42b (29b). That is, $60^\circ \leq \gamma \leq 90^\circ$, $30^\circ \leq \alpha \leq 45^\circ$, and $30^\circ \leq \beta \leq 60^\circ$.

A projection 44 extends upward from the upper surface of the disc portion 41 of the braking member 4, and a cross-shaped engagement groove 45 is formed in the projection 44 to extend in the vertical direction. An engagement projection 33 extending downward from the inner surface of the upper casing half 31 of the cartridge casing 3 is in engagement with the engagement groove 45 of the braking member 4, whereby

the braking member 4 is held in the cartridge casing 3 to be movable up and down but not to be rotatable.

A coiled spring (urging member) 5 is compressed between a portion of the upper surface of the disc portion 41 around the projection 44 and a spring retainer portion 34 formed on the upper casing half 31 around the engagement projection 33, whereby the braking member 4 is urged toward the locking position where the braking gear 42 is engaged with the engagement gear teeth 29 on the engagement projections 27.

The releasing member 6 is disposed to be movable up and down between the braking member 4 and the bottom wall 21a of the reel hub 21 and comprises ~~a~~^{the} substantially triangular plate-like body portion 61. A cylindrical leg portion 63 extends downward from the lower surface of the body portion 61 at each corner thereof. The leg portions 63 are passed through the through holes 26 in the bottom wall 21a of the reel 2 to be movable up and down. The engagement projections 27 are positioned between the leg portions 63 outside the body portion 61 of the releasing member 6. The leg portions 63 may also be rectangular or ellipsoidal in cross-section.

When the releasing member 6 is in its lowermost position shown in Figure 1, the lower ends of the leg portions 63 project downward from the lower surface of the reel 2 through the portion at which the reel gear 24 is formed, and when the drive gear 13 is brought into engagement with the reel gear 24 in response to a chucking action of the reel drive means 11, the

leg portions 63 are pushed upward by a predetermined stroke as shown in Figure 2, whereby the braking gear 42 of the braking member 4 is disengaged from the engagement gear teeth 29 of the engagement projections 27 and rotation of the reel 2 is permitted. Since the leg portions 63 are passed through the through holes 26 the releasing member 6 is rotated together with the reel 2.

The reel 2 is provided with guide members 28 (Figure 3) which guide the releasing member 6 when the leg portions 63 are inserted into the through holes 26. Each of the guide members 28 guides a corner of the body portion 61 of the releasing member 6 and comprises a pair of guide ribs formed on the inner surface of the reel hub 21 to extend in the vertical direction near one of the through holes 26. Reinforcing ribs like the guide ribs are provided on the entire inner surface of the reel hub 21.

Operation of the reel stopper means 10 will be described, hereinbelow. Figure 1 shows a state of the magnetic tape cartridge 1 when it is not being used (e.g., when it is stored). In the state shown in Figure 1, the braking member 4, the releasing member 6 and the reel 2 are held in the lower casing half 32 of the cartridge casing 3 under the force of the urging member 5 and the central opening 32a of the lower casing half 32 is closed by the reel 2. The releasing member 6 is in its lowermost position where its lower surface is in abutment against the upper surface of the bottom wall 21a of the reel

hub 21 and the lower end portions of the leg portions 63 project downward beyond the tips of the teeth of the reel gear 24. The braking member 4 is in abutment against the releasing member 6 and in its locking position where the braking gear 42 is in mesh with the engagement gear teeth 29 of the engagement projections 27 on the reel 2, whereby rotation of the reel 2 is restricted and the magnetic tape is prevented from being drawn out.

As shown in Figure 2, when the magnetic tape cartridge 1 is loaded in a tape drive, the rotary shaft 12 of the reel drive means 11 of the tape drive is moved toward the lower surface of the reel 2 and the drive gear 13 is brought into mesh with the reel gear 24 with the reel 2 slightly pushed upward, whereby the leg portions 63 of the releasing member 6 are pushed upward by the tips of the teeth of the drive gear 13. Thus, the releasing member 6 is moved upward overcoming the force of the urging member 5 and the braking member 4 is moved upward together with the releasing member 6, whereby the braking gear 42 is disengaged from the engagement gear teeth 29 of the engagement projections 27 and rotation of the reel 2 is permitted. In this state, the braking member 4 in its upper position is away from the guide members 39 and does not restrict rotation of the reel 2 when the magnetic tape is loaded/unloaded.

When the braking member 4 is moved downward from the releasing position to the locking position, the braking member

4 is centered by the guide members 39 on the reel 2 so that the braking gear 42 is brought into mesh with the engagement gear teeth 29 with the braking member 4 held horizontal, whereby the braking member 4 is prevented from being inclined in the locking position. When the braking member 4 is subsequently moved upward to the releasing position by the releasing member 6, the braking member 4 is held horizontal up to the releasing position. Accordingly, the phenomenon that the braking member 4 is inclined as shown in Figure 5 can be suppressed, whereby the braking gear 42 is prevented from contacting the engagement gear teeth 29 to generate noise or to obstruct rotation of the reel 2. Further, during assembly of the magnetic tape cartridge 1, the braking member 4 is automatically centered in the reel hub 2 by the guide members 39 and is incorporated in place in the reel 2, whereby assembly of the magnetic tape cartridge 1 is facilitated.

Even if the guide members 39 are not provided, since the outer diameter D of the engagement gear formed by the engagement gear teeth 29 on the engagement projections 27 on the reel 2 is larger than the outer diameter d of the braking gear 42 on the braking member 4, the braking member 4 is centered with respect to the reel hub 2 when it is moved from the releasing position to the locking position by virtue of the difference in diameter so that the braking gear 42 is brought into mesh with the engagement gear teeth 29 with the braking member 4 held horizontal, whereby the braking member 4 is prevented from

being inclined in the locking position.

Further, when the reel 2 is rotated in the winding direction W due to drop impact or the like and an excessive winding force acts on the magnetic tape, the braking member 4 is moved upward along the first inclined surfaces 42a and 29a since the interior angles α for the first inclined surfaces 42a and 29a which are brought into abutment against each other when the reel 2 is rotated in the unwinding direction U, are not smaller than 30° , and the braking gear 42 is disengaged from the engagement gear teeth 29, whereby the reel 2 is rotated in the unwinding direction U to reduce the tension on the magnetic tape, and the magnetic tape can be prevented from being stretched or cut.

Further, since the interior angles β for the second inclined surfaces 42b and 29b of the braking gear 42 and the engagement gear teeth 29 are not smaller than 30° , the reel 2 can be anyhow rotated even if the braking member 4 is in the locking position, though the rotation of the reel 2 is restricted. Accordingly, when the magnetic tape is accidentally drawn out from the cartridge casing 3 during storage or the like of the magnetic tape cartridge 1, the magnetic tape can be rewound into the cartridge casing 3.

The effect of reducing the tension on the magnetic tape can be obtained when the interior angle α is not smaller than 30° . However when the interior angle α is larger than 45° , the locking force for preventing rotation of the reel 2 in the

unwinding direction becomes too weak. That is, in order to ensure both the effect of reducing the tension on the magnetic tape and the sufficient locking force, it is necessary that ~~the~~^{an} apical angle γ is not larger than 90° and the interior angles α for the first inclined surfaces 42a and 29a, which are brought into abutment against each other when the reel 2 is rotated in the unwinding direction U, are smaller than the interior angles β for the second inclined surfaces 42b and 29b, which are brought into abutment against each other when the reel 2 is rotated in the winding direction W.

The height of the gear teeth of the braking gear 42 and that of the engagement gear teeth 29 are set according to the distance between the locking position and the releasing position of the braking member 4. For a given height of the teeth, the number of the teeth is reduced and the one-pitch length is increased as the apical angle γ increases. Accordingly, when the apical angle γ is set not to be larger than 90° , the number of the gear teeth of the braking gear 42 is increased and the one-pitch length is reduced, whereby slack of the magnetic tape or the tension on the magnetic tape can be proper when the braking gear 42 is engaged with the engagement gear teeth 29.

~~In addition, all of the contents of Japanese Patent Application Nos. 11(1999)-317166, 11(1999)-318464 and 2000-322841 are incorporated into this specification by reference.~~

MAGNETIC TAPE CARTRIDGE

This invention relates to a magnetic tape cartridge according to the preamble of independent claim 1.

~~comprising a cartridge casing and a single reel which is housed in the cartridge casing for rotation and around which a magnetic tape is wound, and more particularly to a structure of a reel stopper means for preventing rotation of the reel when the magnetic tape cartridge is not being used.~~

As a recording medium for use in an external memory of a computer or the like, there has been known a magnetic tape cartridge comprising a magnetic tape wound around a single reel and a cartridge casing in which the reel is housed for rotation. Since the magnetic tape is used for storing data in a computer or the like and important information is stored on the magnetic tape, the magnetic tape cartridge is provided with a reel stopper means which prevents rotation of the reel when the magnetic tape cartridge is not being used, e.g., when the magnetic tape cartridge is being stored, so that trouble such as tape jam does not occur and the magnetic tape is not accidentally drawn out.

The reel stopper means is provided with a brake member which is adapted to be engaged with the reel to prevent rotation of the reel and is disengaged from the reel to permit rotation

That is, when the braking gear and the engagement gear are engaged with each other at a substantially normal surface facing against the tape-unwinding direction, the reel cannot be rotated in the tape-unwinding direction. Further, a leader member such as a leader pin is fixed to the end of the magnetic tape wound around the reel, and the leader member is held near the tape draw-out opening of the cartridge casing when the magnetic tape cartridge is not being used. When the brake member is moved and the braking gear is disengaged from the engagement gear due to drop impact with the reel rotated in the tape-winding direction under inertia, a tape winding force acts on the magnetic tape whose end is fixed by the leader member. Since the reel cannot be rotated in the tape-unwinding direction or the direction in which the tension on the magnetic is released, the tape winding force acting on the magnetic tape can stretch the tape to deteriorate the magnetic recording and reproducing characteristics, remove the leader member from the magnetic tape, cut the magnetic tape, or displace the leader member from the predetermined position to disable the regular tape draw-out action, thereby deteriorating the reliability of the magnetic tape cartridge.

From EP 0 926 676 A1 a magnetic tape cartridge as indicated above is known, wherein the magnetic tape cartridge comprises a single reel, a casing and a reel stopper means. Here, the reel stopper means comprises a brake member being movable up and down away from and towards the reel, an urging member urging the brake member towards the reel and a brake release member moving the brake member away from the reel. The teeth of the brake member comprise, respectively, two abutment surfaces with an equal inclination, so that the teeth of the brake member could provide the same force on a single reel in both directions thereof, namely, winding and unwinding direction.

EP 0 284 687 A2 discloses a tape cartridge comprising a spool, a brake button and projecting means with projections or centering ribs.

WO 97 15925 A1 and US 5,901,916 A disclose a tape cartridge comprising a housing, a tape supply reel, reel gear and a reel lock, wherein the reel lock has been urged by a brake spring towards a locking means provided at the tape supply reel. Here, each of the teeth of the reel lock comprises equally inclined abutment surfaces.

It is an objective of the present invention to improve a magnetic tape coverage as indicated above so as to assure different forces applying from the brake member to the single reel in the winding and unwinding direction of the single reel.

The objective is solved according to the present invention by a magnetic tape cartridge comprising a magnetic tape wound around a single reel, a cartridge casing for housing the reel and a reel stopper means for locking the reel or permitting rotation thereof, wherein the reel stopper means comprises a braking member being moveable between a locking position and a releasing position, an urging member for urging the braking member toward the locking position, and a releasing member being rotated integrally with the reel for moving the braking member toward the releasing position in response to a reel chucking action of a reel drive means of a tape drive, and wherein the braking member is provided with a braking gear comprising gear teeth being adapted to be engaged with at least one engagement gear tooth of an engagement projection formed on the reel, wherein each of the gear teeth of the braking gear comprises a first inclined surface being directed towards a tape-unwinding direction and a second inclined surface being directed towards a tape-winding direction, wherein an interior angle between the first inclined surface and a vertical is smaller than an interior angle between the second inclined surface and the vertical, and the inclined surfaces form therebetween an apical angle being smaller than 90°.

~~the releasing position in response to a reel chucking action~~
of the reel drive means of a tape drive, the braking member is provided with a braking gear which is adapted to be engaged, to restrict rotation of the reel, with an engagement gear tooth on an engagement projection formed on the reel, and each of the gear teeth of the braking gear has a first inclined surface which is brought into abutment against the engagement gear teeth when the reel is rotated in the tape-unwinding direction with the braking gear and the engagement gear tooth in mesh with each other and a second inclined surface which is brought into abutment against the engagement gear teeth when the reel is rotated in the tape-winding direction with the braking gear and the engagement gear tooth in mesh with each other, the first and second inclined surfaces forming therebetween an apical angle not larger than 90° , and the interior angle between the first inclined surface and the vertical being not larger than the interior angle between the second inclined surface and the vertical.

According to the above mentioned, since the apical angle of the braking gear tooth is not larger than 90° and the interior angle for the first inclined surface of the braking gear tooth which is brought into abutment against the engagement gear teeth when the reel is rotated in the unwinding direction and the interior angle for the second inclined surface which is brought into abutment against the engagement gear teeth when

the reel is rotated in the winding direction are not smaller than 30° with the former smaller than the latter, rotation of the reel can be surely prevented and when the reel is rotated in the winding direction due to drop impact or the like and an excessive winding force acts on the magnetic tape, the braking member is moved toward the releasing position along the first inclined surface and the braking gear is disengaged from the engagement gear teeth, whereby the reel is rotated in the unwinding direction to reduce the tension on the magnetic tape, and the magnetic tape can be prevented from being stretched or cut.

Further preferred embodiments of the present invention are laid down in the further subclaims. In the following, the present invention is explained in greater detail by means of several embodiments thereof in conjunction with the accompanying drawings, wherein:

Figure 1 is a perspective view showing a state of a magnetic tape cartridge in accordance with an embodiment of the present invention when the magnetic tape cartridge is not being used,

Figure 2 is a fragmentary cross-sectional view of the magnetic tape cartridge shown in Figure 1 when the magnetic tape cartridge is being used,

Figure 3 is a cross-sectional view taken along line A-A in Figure 2,

Figure 4 is a cross-sectional view taken along line B-B in Figure 2, and

Figure 5 is a fragmentary cross-sectional view showing a state of a magnetic tape cartridge where the braking member is inclined.

A magnetic tape cartridge 1 in accordance with an embodiment of the present invention will be described with reference to the drawings, hereinbelow.

The magnetic tape cartridge 1 comprises a cartridge casing 3 formed by fastening together upper and lower casing halves 31 and 32 by screws or the like. A single reel 2 around which a magnetic tape (not shown) is wound is housed for rotation in the cartridge casing 3. The lower casing half 32 is provided with a central opening 32a. The magnetic tape cartridge 1 is further provided with a reel stopper means 10 which permits rotation of the reel 2 when the magnetic tape cartridge 1 is being used and restricts rotation of the reel 2 when the magnetic tape cartridge 1 is not being used.

The reel 2 comprises a reel hub 21 which is a cylindrical member having a closed bottom and around which the magnetic tape is wound, and lower and upper flanges 22 and 23. The reel hub 21 and the lower flange 22 are integrally formed by synthetic resin molding. The upper flange 23 is bonded to the reel hub 21, for instance, by ultrasonic welding. The reel hub 21 is provided with a bottom wall 21a at the lower end portion thereof and a reel gear 24 for rotating the reel 2 is annularly formed on the lower surface of the bottom wall 21a, and annular reel plate 25 which is magnetically attracted by a reel drive means 11 of a recording and reproducing apparatus is mounted on the lower surface of the bottom wall 21a inside the reel

gear 24. The reel 2 is urged downward by an urging means 5 to be described later.

The reel drive means 11 is provided with an annular drive gear 13 and a magnet (not shown) disposed on the top surface of a rotary shaft 12. When the magnetic tape cartridge 1 loaded in a bucket of the tape drive is moved downward toward the rotary shaft 12, the drive gear 13 is brought into mesh with the reel gear 24 and the reel plate 25 is magnetically attracted against the magnet to hold the drive gear 13 and the reel gear 24 in mesh with each other. In this manner, the reel drive means 11 chucks the reel 2.

The mechanism of the reel stopper means 10 will be described, hereinbelow. The reel stopper means 10 comprises a braking member 4 which is movable up and down between a locking position where it is in contact with the reel 2 to restrict rotation of the reel 2 and a releasing position where it is away from the reel 2 to permit rotation of the same, an urging member 5 which urges the braking member 4 toward the locking position, and a releasing member 6 which moves the braking member 4 toward the releasing position.

As shown in Figure 3, three through holes 26 are formed in the bottom wall 21a of the reel 2 at regular angular intervals in the circumferential direction to extend through the portion at which the reel gear 24 is formed. On the upper surface of the bottom wall 21a, there are erected three pairs of (six) engagement projections 27 at regular angular intervals in the

circumferential direction among the through holes 26. The upper end of each engagement projection 27 is formed into an engagement gear teeth 29 as shown in Figure 4. The through holes 26 may be larger than three in number and the engagement projections 27 may be larger three pairs in number. Further, the upper end of each engagement projection 27 may be formed into a single gear tooth.

The braking member 4 has a disc portion 41 which is disposed in the reel hub 21 opposed to the bottom wall 21a, and an annular braking gear 42 is formed on the lower surface of the disc portion 41 along the outer peripheral edge thereof. The braking gear 42 is adapted to be engaged with the engagement gear 29 on the engagement projections 27. The central part of the lower surface of the disc portion 41 is convex downward and forms a sliding portion 41a which is pressed against a sliding portion 61a on the upper surface of a body portion 61 of the releasing member 6 to be described later.

An outer diameter D of the engagement gear formed by the engagement gear teeth 29 on the engagement projections 27 on the reel 2 (Figure 3) is larger than an outer diameter d (Figure 2) of the braking gear 42 on the braking member 4. The braking gear 42 and the engagement gear 29 are conical in shape and the height of each tooth is higher at the outer periphery thereof. Accordingly, the braking gear 42 is engaged with the engagement gear teeth 29 at their outer peripheries first.

When the braking gear 42 on the braking member 4 is

brought into mesh with the engagement gear 29 on the engagement projections 27, the outer periphery of the braking member 4 is guided by guide members 39 formed on the inner surface of the reel hub 21 of the reel 2. The guide members 39 are respectively provided between each pair of engagement projections 27, and accordingly three guide members 39 are provided on the inner surface of the reel hub 21. Each guide member 39 is in the form of a rib having an inclined surface which gradually inclines downward from the upper portion of the inner surface of the reel hub 21 toward the engagement projections 27, and the guide members 39 center the braking gear 42 when the outer periphery of the braking gear 42 is brought into contact with the inclined surfaces.

As shown in Figure 4, each gear tooth of the braking gear 42 of the braking member 4 and each engagement gear tooth 29 on the engagement projection 27 are triangular in cross-section. The gear tooth of the braking gear 42 has a first inclined surface 42a which faces against the tape-unwinding direction U and abuts against a first inclined surface 29a of the engagement gear tooth 29 on the engagement projection 27 which faces toward the tape-unwinding direction U, and a second inclined surface 42b which faces against the tape-winding direction W and abuts against a second inclined surface 29b of the engagement gear tooth 29 on the engagement projection 27 which faces toward the tape-winding direction W. When the reel 2 is rotated in the tape-unwinding direction U with the

braking gear 42 in mesh with the engagement gear teeth 29 on the engagement projection 27, the first inclined surfaces 42a of the gear teeth of the braking gear 42 are brought into abutment against the first inclined surfaces 29a of the engagement gear teeth 29, and when the reel 2 is rotated in the tape-winding direction W with the braking gear 42 in mesh with the engagement gear teeth 29 on the engagement projection 27, the second inclined surfaces 42b of the gear teeth of the braking gear 42 are brought into abutment against the second inclined surfaces 29b of the engagement gear teeth 29. Each of the gear tooth 42 and the gear tooth 29 is not larger than 90° in apical angle γ , and an interior angle α between the first inclined surface 42a (or 29a) and a vertical S and an interior angle β between the second inclined surface 42b (or 29b) and the vertical S are not smaller than 30° . Further, the interior angle α for the first inclined surface 42a (29a) is not larger than the interior angle β for the second inclined surface 42b (29b). That is, $60^\circ \leq \gamma \leq 90^\circ$, $30^\circ \leq \alpha \leq 45^\circ$, and $30^\circ \leq \beta \leq 60^\circ$.

A projection 44 extends upward from the upper surface of the disc portion 41 of the braking member 4, and a cross-shaped engagement groove 45 is formed in the projection 44 to extend in the vertical direction. An engagement projection 33 extending downward from the inner surface of the upper casing half 31 of the cartridge casing 3 is in engagement with the engagement groove 45 of the braking member 4, whereby

the braking member 4 is held in the cartridge casing 3 to be movable up and down but not to be rotatable.

A coiled spring (urging member) 5 is compressed between a portion of the upper surface of the disc portion 41 around the projection 44 and a spring retainer portion 34 formed on the upper casing half 31 around the engagement projection 33, whereby the braking member 4 is urged toward the locking position where the braking gear 42 is engaged with the engagement gear teeth 29 on the engagement projections 27.

The releasing member 6 is disposed to be movable up and down between the braking member 4 and the bottom wall 21a of the reel hub 21 and comprises the substantially triangular plate-like body portion 61. A cylindrical leg portion 63 extends downward from the lower surface of the body portion 61 at each corner thereof. The leg portions 63 are passed through the through holes 26 in the bottom wall 21a of the reel 2 to be movable up and down. The engagement projections 27 are positioned between the leg portions 63 outside the body portion 61 of the releasing member 6. The leg portions 63 may also be rectangular or ellipsoidal in cross-section.

When the releasing member 6 is in its lowermost position shown in Figure 1, the lower ends of the leg portions 63 project downward from the lower surface of the reel 2 through the portion at which the reel gear 24 is formed, and when the drive gear 13 is brought into engagement with the reel gear 24 in response to a chucking action of the reel drive means 11, the

leg portions 63 are pushed upward by a predetermined stroke as shown in Figure 2, whereby the braking gear 42 of the braking member 4 is disengaged from the engagement gear teeth 29 of the engagement projections 27 and rotation of the reel 2 is permitted. Since the leg portions 63 are passed through the through holes 26 the releasing member 6 is rotated together with the reel 2.

The reel 2 is provided with guide members 28 (Figure 3) which guide the releasing member 6 when the leg portions 63 are inserted into the through holes 26. Each of the guide members 28 guides a corner of the body portion 61 of the releasing member 6 and comprises a pair of guide ribs formed on the inner surface of the reel hub 21 to extend in the vertical direction near one of the through holes 26. Reinforcing ribs like the guide ribs are provided on the entire inner surface of the reel hub 21.

Operation of the reel stopper means 10 will be described, hereinbelow. Figure 1 shows a state of the magnetic tape cartridge 1 when it is not being used (e.g., when it is stored). In the state shown in Figure 1, the braking member 4, the releasing member 6 and the reel 2 are held in the lower casing half 32 of the cartridge casing 3 under the force of the urging member 5 and the central opening 32a of the lower casing half 32 is closed by the reel 2. The releasing member 6 is in its lowermost position where its lower surface is in abutment against the upper surface of the bottom wall 21a of the reel

hub 21 and the lower end portions of the leg portions 63 project downward beyond the tips of the teeth of the reel gear 24. The braking member 4 is in abutment against the releasing member 6 and in its locking position where the braking gear 42 is in mesh with the engagement gear teeth 29 of the engagement projections 27 on the reel 2, whereby rotation of the reel 2 is restricted and the magnetic tape is prevented from being drawn out.

As shown in Figure 2, when the magnetic tape cartridge 1 is loaded in a tape drive, the rotary shaft 12 of the reel drive means 11 of the tape drive is moved toward the lower surface of the reel 2 and the drive gear 13 is brought into mesh with the reel gear 24 with the reel 2 slightly pushed upward, whereby the leg portions 63 of the releasing member 6 are pushed upward by the tips of the teeth of the drive gear 13. Thus, the releasing member 6 is moved upward overcoming the force of the urging member 5 and the braking member 4 is moved upward together with the releasing member 6, whereby the braking gear 42 is disengaged from the engagement gear teeth 29 of the engagement projections 27 and rotation of the reel 2 is permitted. In this state, the braking member 4 in its upper position is away from the guide members 39 and does not restrict rotation of the reel 2 when the magnetic tape is loaded/unloaded.

When the braking member 4 is moved downward from the releasing position to the locking position, the braking member

4 is centered by the guide members 39 on the reel 2 so that the braking gear 42 is brought into mesh with the engagement gear teeth 29 with the braking member 4 held horizontal, whereby the braking member 4 is prevented from being inclined in the locking position. When the braking member 4 is subsequently moved upward to the releasing position by the releasing member 6, the braking member 4 is held horizontal up to the releasing position. Accordingly, the phenomenon that the braking member 4 is inclined as shown in Figure 5 can be suppressed, whereby the braking gear 42 is prevented from contacting the engagement gear teeth 29 to generate noise or to obstruct rotation of the reel 2. Further, during assembly of the magnetic tape cartridge 1, the braking member 4 is automatically centered in the reel hub 2 by the guide members 39 and is incorporated in place in the reel 2, whereby assembly of the magnetic tape cartridge 1 is facilitated.

Even if the guide members 39 are not provided, since the outer diameter D of the engagement gear formed by the engagement gear teeth 29 on the engagement projections 27 on the reel 2 is larger than the outer diameter d of the braking gear 42 on the braking member 4, the braking member 4 is centered with respect to the reel hub 2 when it is moved from the releasing position to the locking position by virtue of the difference in diameter so that the braking gear 42 is brought into mesh with the engagement gear teeth 29 with the braking member 4 held horizontal, whereby the braking member 4 is prevented from

being inclined in the locking position.

Further, when the reel 2 is rotated in the winding direction W due to drop impact or the like and an excessive winding force acts on the magnetic tape, the braking member 4 is moved upward along the first inclined surfaces 42a and 29a since the interior angles α for the first inclined surfaces 42a and 29a, which are brought into abutment against each other when the reel 2 is rotated in the unwinding direction U, are not smaller than 30° , and the braking gear 42 is disengaged from the engagement gear teeth 29, whereby the reel 2 is rotated in the unwinding direction U to reduce the tension on the magnetic tape, and the magnetic tape can be prevented from being stretched or cut.

Further, since the interior angles β for the second inclined surfaces 42b and 29b of the braking gear 42 and the engagement gear teeth 29 are not smaller than 30° , the reel 2 can be anyhow rotated even if the braking member 4 is in the locking position, though the rotation of the reel 2 is restricted. Accordingly, when the magnetic tape is accidentally drawn out from the cartridge casing 3 during storage or the like of the magnetic tape cartridge 1, the magnetic tape can be rewound into the cartridge casing 3.

The effect of reducing the tension on the magnetic tape can be obtained when the interior angle α is not smaller than 30° . However when the interior angle α is larger than 45° , the locking force for preventing rotation of the reel 2 in the

unwinding direction becomes too weak. That is, in order to ensure both the effect of reducing the tension on the magnetic tape and the sufficient locking force, it is necessary that an apical angle γ is not larger than 90° and the interior angles α for the first inclined surfaces 42a and 29a, which are brought into abutment against each other when the reel 2 is rotated in the unwinding direction U, are smaller than the interior angles β for the second inclined surfaces 42b and 29b, which are brought into abutment against each other when the reel 2 is rotated in the winding direction W.

The height of the gear teeth of the braking gear 42 and that of the engagement gear teeth 29 are set according to the distance between the locking position and the releasing position of the braking member 4. For a given height of the teeth, the number of the teeth is reduced and the one-pitch length is increased as the apical angle γ increases. Accordingly, when the apical angle γ is set not to be larger than 90° , the number of the gear teeth of the braking gear 42 is increased and the one-pitch length is reduced, whereby slack of the magnetic tape or the tension on the magnetic tape can be proper when the braking gear 42 is engaged with the engagement gear teeth 29.

Application No.: 00 124 448.2-1239
Applicant: Fuji Photo Film Co., Ltd.
Our Ref.: EP20062GK052
Date: May 08, 2006

NEW CLAIMS

1. A magnetic tape cartridge (1) comprising a magnetic tape wound around a single reel (2), a cartridge casing (3) for housing the reel (2) and a reel stopper means (10) for locking the reel (2) or permitting rotation thereof, wherein the reel stopper means (10) comprises a braking member (4) being moveable between a locking position and a releasing position, an urging member (5) for urging the braking member (4) toward the locking position, and a releasing member (6) being rotated integrally with the reel (2) for moving the braking member (4) toward the releasing position in response to a reel chucking action of a reel drive means (11) of a tape drive, and wherein the braking member (4) is provided with a braking gear (42) comprising gear teeth being adapted to be engaged with at least one engagement gear tooth (29) of an engagement projection (27) formed on the reel (2), **characterized in that** each of the gear teeth of the braking gear (42) comprises a first inclined surface (42a) being directed towards a tape-unwinding direction (U) and a second inclined surface (42b) being directed towards a tape-winding direction (W), wherein an interior angle (α) between the first inclined surface (42a) and a vertical (s) is smaller than an interior angle (β) between the second inclined surface (42b) and the vertical (s), and the inclined surfaces (42a,42b) form therebetween an apical angle (γ) being smaller than 90° .
2. A magnetic tape cartridge (1) according to claim 1, **characterized in that** the at least one engagement gear tooth (29) comprises a first and a second inclined surface (29a,29b) being respectively corresponded to the first and second inclined surface (42a,42b) of the gear teeth of the braking gear (42).

3. A magnetic tape cartridge (1) according to claim 1 or 2, **characterized in that** the reel (2) is provided with a guide member (28,39) for centering the braking member (4) with respect to the reel (2).
4. A magnetic tape cartridge (1) according to claim 3, **characterized in that** the guide member (39) comprises guide ribs being formed on an inner surface of a reel hub (21) at at least three places, wherein each guide ribs comprises an inclined surface inclining downward from an upper portion of the inner surface of the reel hub (21) toward a center of the reel (2).
5. A magnetic tape cartridge (1) according to at least one of the claims 1 to 4, **characterized in that** an outer diameter (D) of an engagement gear comprising the at least one engagement gear tooth (29) is larger than an outer diameter (d) of the braking gear (42).

~~MAGNETIC TAPE CARTRIDGE~~

Druckexemplar

This invention relates to a magnetic tape cartridge according to the preamble of independent claim 1.

~~comprising a cartridge casing and a single reel which is housed in the cartridge casing for rotation and around which a magnetic tape is wound, and more particularly to a structure of a reel stopper means for preventing rotation of the reel when the magnetic tape cartridge is not being used.~~

As a recording medium for use in an external memory of a computer or the like, there has been known a magnetic tape cartridge comprising a magnetic tape wound around a single reel and a cartridge casing in which the reel is housed for rotation. Since the magnetic tape is used for storing data in a computer or the like and important information is stored on the magnetic tape, the magnetic tape cartridge is provided with a reel stopper means which prevents rotation of the reel when the magnetic tape cartridge is not being used, e.g., when the magnetic tape cartridge is being stored, so that trouble such as tape jam does not occur and the magnetic tape is not accidentally drawn out.

The reel stopper means is provided with a brake member which is adapted to be engaged with the reel to prevent rotation of the reel and is disengaged from the reel to permit rotation

of the reel in response to a reel chucking action of the reel drive means of a tape drive such as an external memory when the magnetic tape cartridge is loaded in the tape drive.

In order to improve reliability of the action of the reel stopper means and to prevent dust from entering the cartridge casing, the reel stopper means may be, for instance, of a structure comprising a brake member which restricts rotation of the reel, an urging member which urges the brake member toward a locking position in which the brake member restricts rotation of the reel, and a release member which is moved in response to a reel chucking action of the reel drive means of a tape drive to move the brake member toward a release position in which the brake member releases the reel to permit rotation of the same.

That is, when the magnetic tape cartridge is not being used, the brake member locks the reel so that the reel is not accidentally rotated and the magnetic tape is not accidentally drawn out, and when the magnetic tape cartridge is loaded in a tape drive, the release member drives the brake member to release the reel in response to a reel chucking action of the reel drive means of the tape drive. In this state, the reel can be rotated and loading/unloading of the magnetic tape is permitted.

In such a structure, it is advantageous in simplifying the structure that the release member is adapted to be brought into abutment against a part of the reel drive means of the

tape drive and the reel drive means pushes a part of the release member to drive the brake member to release the reel when the reel drive means chucks the reel. However, in this case, when the release member drives the brake member to release the reel, 5 the brake member can be inclined as shown in Figure 5 and the gear teeth on the brake member can be brought into contact with the rear teeth on the reel while the reel is rotated, which results in generation of noise, obstruction of rotation of the reel and unstable magnetic tape loading/unloading action.

10 As a cause of the brake member being inclined, that the brake member becomes off-centered and comes to be inclined when the brake member is moved to the locking position where the braking gear thereon is brought into engagement with an engagement gear on the reel and the brake member is moved to 15 the release position in this state can be conceived. Further, that the brake member was incorporated in the magnetic tape cartridge inclined relative to the reel when the magnetic tape cartridge was assembled can be conceived.

20 When the braking gear teeth on the brake member are like sawteeth in shape and the surface of each tooth facing against the tape-unwinding direction of the reel is substantially normal, though rotation of the reel in the tape-unwinding direction can be surely prevented, there is fear that the magnetic tape is cut when the reel is rotated in the tape- 25 winding direction due to drop impact when the magnetic tape cartridge drops.

That is, when the braking gear and the engagement gear are engaged with each other at a substantially normal surface facing against the tape-unwinding direction, the reel cannot be rotated in the tape-unwinding direction. Further, a leader member such as a leader pin is fixed to the end of the magnetic tape wound around the reel, and the leader member is held near the tape draw-out opening of the cartridge casing when the magnetic tape cartridge is not being used. When the brake member is moved and the braking gear is disengaged from the engagement gear due to drop impact with the reel rotated in the tape-winding direction under inertia, a tape winding force acts on the magnetic tape whose end is fixed by the leader member. Since the reel cannot be rotated in the tape-unwinding direction or the direction in which the tension on the magnetic is released, the tape winding force acting on the magnetic tape can stretch the tape to deteriorate the magnetic recording and reproducing characteristics, remove the leader member from the magnetic tape, cut the magnetic tape, or displace the leader member from the predetermined position to disable the regular tape draw-out action, thereby deteriorating the reliability of the magnetic tape cartridge.

From EP 0 926 676 A1 a magnetic tape cartridge as indicated above is known, wherein the magnetic tape cartridge comprises a single reel, a casing and a reel stopper means. Here, the reel stopper means comprises a brake member being movable up and down away from and towards the reel, an urging member urging the brake member towards the reel and a brake release member moving the brake member away from the reel. The teeth of the brake member comprise, respectively, two abutment surfaces with an equal inclination, so that the teeth of the brake member could provide the same force on a single reel in both directions thereof, namely, winding and unwinding direction.

EP 0 284 687 A2 discloses a tape cartridge comprising a spool, a brake button and projecting means with projections or centering ribs.

WO 97 15925 A1 and US 5,901,916 A disclose a tape cartridge comprising a housing, a tape supply reel, reel gear and a reel lock, wherein the reel lock has been urged by a brake spring towards a locking means provided at the tape supply reel. Here, each of the teeth of the reel lock comprises equally inclined abutment surfaces.

It is an objective of the present invention to improve a magnetic tape coverage as indicated above so as to assure different forces applying from the brake member to the single reel in the winding and unwinding direction of the single reel.

The objective is solved according to the present invention by a magnetic tape cartridge comprising a magnetic tape wound around a single reel, a cartridge casing for housing the reel and a reel stopper means for locking the reel or permitting rotation thereof, wherein the reel stopper means comprises a braking member being moveable between a locking position and a releasing position, an urging member for urging the braking member toward the locking position, and a releasing member being rotated integrally with the reel for moving the braking member toward the releasing position in response to a reel chucking action of a reel drive means of a tape drive, and wherein the braking member is provided with a braking gear comprising gear teeth being adapted to be engaged with at least one engagement gear tooth of an engagement projection formed on the reel, wherein each of the gear teeth of the braking gear comprises a first inclined surface being directed towards a tape-unwinding direction and a second inclined surface being directed towards a tape-winding direction, wherein an interior angle between the first inclined surface and a vertical is smaller than an interior angle between the second inclined surface and the vertical, and the inclined surfaces form therebetween an apical angle being smaller than 90°.

~~the releasing position in response to a reel chucking action~~
of the reel drive means of a tape drive, the braking member is provided with a braking gear which is adapted to be engaged, to restrict rotation of the reel, with an engagement gear tooth on an engagement projection formed on the reel, and each of the gear teeth of the braking gear has a first inclined surface which is brought into abutment against the engagement gear teeth when the reel is rotated in the tape-unwinding direction with the braking gear and the engagement gear tooth in mesh with each other and a second inclined surface which is brought into abutment against the engagement gear teeth when the reel is rotated in the tape-winding direction with the braking gear and the engagement gear tooth in mesh with each other, the first and second inclined surfaces forming therebetween an apical angle not larger than 90° , and the interior angle between the first inclined surface and the vertical being not larger than the interior angle between the second inclined surface and the vertical.

According to the above mentioned, since the apical angle of the braking gear tooth is not larger than 90° and the interior angle for the first inclined surface of the braking gear tooth which is brought into abutment against the engagement gear teeth when the reel is rotated in the unwinding direction and the interior angle for the second inclined surface which is brought into abutment against the engagement gear teeth when

the reel is rotated in the winding direction are not smaller than 30° with the former smaller than the latter, rotation of the reel can be surely prevented and when the reel is rotated in the winding direction due to drop impact or the like and an excessive winding force acts on the magnetic tape, the braking member is moved toward the releasing position along the first inclined surface and the braking gear is disengaged from the engagement gear teeth, whereby the reel is rotated in the unwinding direction to reduce the tension on the magnetic tape, and the magnetic tape can be prevented from being stretched or cut.

Further preferred embodiments of the present invention are laid down in the further subclaims. In the following, the present invention is explained in greater detail by means of several embodiments thereof in conjunction with the accompanying drawings, wherein:

Figure 1 is a perspective view showing a state of a magnetic tape cartridge in accordance with an embodiment of the present invention when the magnetic tape cartridge is not being used,

Figure 2 is a fragmentary cross-sectional view of the magnetic tape cartridge shown in Figure 1 when the magnetic tape cartridge is being used,

Figure 3 is a cross-sectional view taken along line A-A in Figure 2,

Figure 4 is a cross-sectional view taken along line B-B in Figure 2, and

Figure 5 is a fragmentary cross-sectional view showing a state of a magnetic tape cartridge where the braking member is inclined.

A magnetic tape cartridge 1 in accordance with an embodiment of the present invention will be described with reference to the drawings, hereinbelow.

The magnetic tape cartridge 1 comprises a cartridge casing 3 formed by fastening together upper and lower casing halves 31 and 32 by screws or the like. A single reel 2 around which a magnetic tape (not shown) is wound is housed for rotation in the cartridge casing 3. The lower casing half 32 is provided with a central opening 32a. The magnetic tape cartridge 1 is further provided with a reel stopper means 10 which permits rotation of the reel 2 when the magnetic tape cartridge 1 is being used and restricts rotation of the reel 2 when the magnetic tape cartridge 1 is not being used.

The reel 2 comprises a reel hub 21 which is a cylindrical member having a closed bottom and around which the magnetic tape is wound, and lower and upper flanges 22 and 23. The reel hub 21 and the lower flange 22 are integrally formed by synthetic resin molding. The upper flange 23 is bonded to the reel hub 21, for instance, by ultrasonic welding. The reel hub 21 is provided with a bottom wall 21a at the lower end portion thereof and a reel gear 24 for rotating the reel 2 is annularly formed on the lower surface of the bottom wall 21a, and annular reel plate 25 which is magnetically attracted by a reel drive means 11 of a recording and reproducing apparatus is mounted on the lower surface of the bottom wall 21a inside the reel

gear 24. The reel 2 is urged downward by an urging means 5 to be described later.

The reel drive means 11 is provided with an annular drive gear 13 and a magnet (not shown) disposed on the top surface of a rotary shaft 12. When the magnetic tape cartridge 1 loaded in a bucket of the tape drive is moved downward toward the rotary shaft 12, the drive gear 13 is brought into mesh with the reel gear 24 and the reel plate 25 is magnetically attracted against the magnet to hold the drive gear 13 and the reel gear 24 in mesh with each other. In this manner, the reel drive means 11 chucks the reel 2.

The mechanism of the reel stopper means 10 will be described, hereinbelow. The reel stopper means 10 comprises a braking member 4 which is movable up and down between a locking position where it is in contact with the reel 2 to restrict rotation of the reel 2 and a releasing position where it is away from the reel 2 to permit rotation of the same, an urging member 5 which urges the braking member 4 toward the locking position, and a releasing member 6 which moves the braking member 4 toward the releasing position.

As shown in Figure 3, three through holes 26 are formed in the bottom wall 21a of the reel 2 at regular angular intervals in the circumferential direction to extend through the portion at which the reel gear 24 is formed. On the upper surface of the bottom wall 21a, there are erected three pairs of (six) engagement projections 27 at regular angular intervals in the

circumferential direction among the through holes 26. The upper end of each engagement projection 27 is formed into an engagement gear teeth 29 as shown in Figure 4. The through holes 26 may be larger than three in number and the engagement projections 27 may be larger three pairs in number. Further, the upper end of each engagement projection 27 may be formed into a single gear tooth.

The braking member 4 has a disc portion 41 which is disposed in the reel hub 21 opposed to the bottom wall 21a, and an annular braking gear 42 is formed on the lower surface of the disc portion 41 along the outer peripheral edge thereof. The braking gear 42 is adapted to be engaged with the engagement gear 29 on the engagement projections 27. The central part of the lower surface of the disc portion 41 is convex downward and forms a sliding portion 41a which is pressed against a sliding portion 61a on the upper surface of a body portion 61 of the releasing member 6 to be described later.

An outer diameter D of the engagement gear formed by the engagement gear teeth 29 on the engagement projections 27 on the reel 2 (Figure 3) is larger than an outer diameter d (Figure 2) of the braking gear 42 on the braking member 4. The braking gear 42 and the engagement gear 29 are conical in shape and the height of each tooth is higher at the outer periphery thereof. Accordingly, the braking gear 42 is engaged with the engagement gear teeth 29 at their outer peripheries first.

When the braking gear 42 on the braking member 4 is

brought into mesh with the engagement gear 29 on the engagement projections 27, the outer periphery of the braking member 4 is guided by guide members 39 formed on the inner surface of the reel hub 21 of the reel 2. The guide members 39 are respectively provided between each pair of engagement projections 27, and accordingly three guide members 39 are provided on the inner surface of the reel hub 21. Each guide member 39 is in the form of a rib having an inclined surface which gradually inclines downward from the upper portion of the inner surface of the reel hub 21 toward the engagement projections 27, and the guide members 39 center the braking gear 42 when the outer periphery of the braking gear 42 is brought into contact with the inclined surfaces.

As shown in Figure 4, each gear tooth of the braking gear 42 of the braking member 4 and each engagement gear tooth 29 on the engagement projection 27 are triangular in cross-section. The gear tooth of the braking gear 42 has a first inclined surface 42a which faces against the tape-unwinding direction U and abuts against a first inclined surface 29a of the engagement gear tooth 29 on the engagement projection 27 which faces toward the tape-unwinding direction U, and a second inclined surface 42b which faces against the tape-winding direction W and abuts against a second inclined surface 29b of the engagement gear tooth 29 on the engagement projection 27 which faces toward the tape-winding direction W. When the reel 2 is rotated in the tape-unwinding direction U with the

braking gear 42 in mesh with the engagement gear teeth 29 on the engagement projection 27, the first inclined surfaces 42a of the gear teeth of the braking gear 42 are brought into abutment against the first inclined surfaces 29a of the engagement gear teeth 29, and when the reel 2 is rotated in the tape-winding direction W with the braking gear 42 in mesh with the engagement gear teeth 29 on the engagement projection 27, the second inclined surfaces 42b of the gear teeth of the braking gear 42 are brought into abutment against the second inclined surfaces 29b of the engagement gear teeth 29. Each of the gear tooth 42 and the gear tooth 29 is not larger than 90° in apical angle γ , and an interior angle α between the first inclined surface 42a (or 29a) and a vertical S and an interior angle β between the second inclined surface 42b (or 29b) and the vertical S are not smaller than 30° . Further, the interior angle α for the first inclined surface 42a (29a) is not larger than the interior angle β for the second inclined surface 42b (29b). That is, $60^\circ \leq \gamma \leq 90^\circ$, $30^\circ \leq \alpha \leq 45^\circ$, and $30^\circ \leq \beta \leq 60^\circ$.

A projection 44 extends upward from the upper surface of the disc portion 41 of the braking member 4, and a cross-shaped engagement groove 45 is formed in the projection 44 to extend in the vertical direction. An engagement projection 33 extending downward from the inner surface of the upper casing half 31 of the cartridge casing 3 is in engagement with the engagement groove 45 of the braking member 4, whereby

the braking member 4 is held in the cartridge casing 3 to be movable up and down but not to be rotatable.

A coiled spring (urging member) 5 is compressed between a portion of the upper surface of the disc portion 41 around the projection 44 and a spring retainer portion 34 formed on the upper casing half 31 around the engagement projection 33, whereby the braking member 4 is urged toward the locking position where the braking gear 42 is engaged with the engagement gear teeth 29 on the engagement projections 27.

The releasing member 6 is disposed to be movable up and down between the braking member 4 and the bottom wall 21a of the reel hub 21 and comprises the substantially triangular plate-like body portion 61. A cylindrical leg portion 63 extends downward from the lower surface of the body portion 61 at each corner thereof. The leg portions 63 are passed through the through holes 26 in the bottom wall 21a of the reel 2 to be movable up and down. The engagement projections 27 are positioned between the leg portions 63 outside the body portion 61 of the releasing member 6. The leg portions 63 may also be rectangular or ellipsoidal in cross-section.

When the releasing member 6 is in its lowermost position shown in Figure 1, the lower ends of the leg portions 63 project downward from the lower surface of the reel 2 through the portion at which the reel gear 24 is formed, and when the drive gear 13 is brought into engagement with the reel gear 24 in response to a chucking action of the reel drive means 11, the

leg portions 63 are pushed upward by a predetermined stroke as shown in Figure 2, whereby the braking gear 42 of the braking member 4 is disengaged from the engagement gear teeth 29 of the engagement projections 27 and rotation of the reel 2 is permitted. Since the leg portions 63 are passed through the through holes 26 the releasing member 6 is rotated together with the reel 2.

The reel 2 is provided with guide members 28 (Figure 3) which guide the releasing member 6 when the leg portions 63 are inserted into the through holes 26. Each of the guide members 28 guides a corner of the body portion 61 of the releasing member 6 and comprises a pair of guide ribs formed on the inner surface of the reel hub 21 to extend in the vertical direction near one of the through holes 26. Reinforcing ribs like the guide ribs are provided on the entire inner surface of the reel hub 21.

Operation of the reel stopper means 10 will be described, hereinbelow. Figure 1 shows a state of the magnetic tape cartridge 1 when it is not being used (e.g., when it is stored). In the state shown in Figure 1, the braking member 4, the releasing member 6 and the reel 2 are held in the lower casing half 32 of the cartridge casing 3 under the force of the urging member 5 and the central opening 32a of the lower casing half 32 is closed by the reel 2. The releasing member 6 is in its lowermost position where its lower surface is in abutment against the upper surface of the bottom wall 21a of the reel

hub 21 and the lower end portions of the leg portions 63 project downward beyond the tips of the teeth of the reel gear 24. The braking member 4 is in abutment against the releasing member 6 and in its locking position where the braking gear 42 is in mesh with the engagement gear teeth 29 of the engagement projections 27 on the reel 2, whereby rotation of the reel 2 is restricted and the magnetic tape is prevented from being drawn out.

As shown in Figure 2, when the magnetic tape cartridge 1 is loaded in a tape drive, the rotary shaft 12 of the reel drive means 11 of the tape drive is moved toward the lower surface of the reel 2 and the drive gear 13 is brought into mesh with the reel gear 24 with the reel 2 slightly pushed upward, whereby the leg portions 63 of the releasing member 6 are pushed upward by the tips of the teeth of the drive gear 13. Thus, the releasing member 6 is moved upward overcoming the force of the urging member 5 and the braking member 4 is moved upward together with the releasing member 6, whereby the braking gear 42 is disengaged from the engagement gear teeth 29 of the engagement projections 27 and rotation of the reel 2 is permitted. In this state, the braking member 4 in its upper position is away from the guide members 39 and does not restrict rotation of the reel 2 when the magnetic tape is loaded/unloaded.

When the braking member 4 is moved downward from the releasing position to the locking position, the braking member

4 is centered by the guide members 39 on the reel 2 so that the braking gear 42 is brought into mesh with the engagement gear teeth 29 with the braking member 4 held horizontal, whereby the braking member 4 is prevented from being inclined in the locking position. When the braking member 4 is subsequently moved upward to the releasing position by the releasing member 6, the braking member 4 is held horizontal up to the releasing position. Accordingly, the phenomenon that the braking member 4 is inclined as shown in Figure 5 can be suppressed, whereby the braking gear 42 is prevented from contacting the engagement gear teeth 29 to generate noise or to obstruct rotation of the reel 2. Further, during assembly of the magnetic tape cartridge 1, the braking member 4 is automatically centered in the reel hub 2 by the guide members 39 and is incorporated in place in the reel 2, whereby assembly of the magnetic tape cartridge 1 is facilitated.

Even if the guide members 39 are not provided, since the outer diameter D of the engagement gear formed by the engagement gear teeth 29 on the engagement projections 27 on the reel 2 is larger than the outer diameter d of the braking gear 42 on the braking member 4, the braking member 4 is centered with respect to the reel hub 2 when it is moved from the releasing position to the locking position by virtue of the difference in diameter so that the braking gear 42 is brought into mesh with the engagement gear teeth 29 with the braking member 4 held horizontal, whereby the braking member 4 is prevented from

being inclined in the locking position.

Further, when the reel 2 is rotated in the winding direction W due to drop impact or the like and an excessive winding force acts on the magnetic tape, the braking member 4 is moved upward along the first inclined surfaces 42a and 29a since the interior angles α for the first inclined surfaces 42a and 29a, which are brought into abutment against each other when the reel 2 is rotated in the unwinding direction U, are not smaller than 30° , and the braking gear 42 is disengaged from the engagement gear teeth 29, whereby the reel 2 is rotated in the unwinding direction U to reduce the tension on the magnetic tape, and the magnetic tape can be prevented from being stretched or cut.

Further, since the interior angles β for the second inclined surfaces 42b and 29b of the braking gear 42 and the engagement gear teeth 29 are not smaller than 30° , the reel 2 can be anyhow rotated even if the braking member 4 is in the locking position, though the rotation of the reel 2 is restricted. Accordingly, when the magnetic tape is accidentally drawn out from the cartridge casing 3 during storage or the like of the magnetic tape cartridge 1, the magnetic tape can be rewound into the cartridge casing 3.

The effect of reducing the tension on the magnetic tape can be obtained when the interior angle α is not smaller than 30° . However when the interior angle α is larger than 45° , the locking force for preventing rotation of the reel 2 in the

unwinding direction becomes too weak. That is, in order to ensure both the effect of reducing the tension on the magnetic tape and the sufficient locking force, it is necessary that an apical angle γ is not larger than 90° and the interior angles α for the first inclined surfaces 42a and 29a, which are brought into abutment against each other when the reel 2 is rotated in the unwinding direction U, are smaller than the interior angles β for the second inclined surfaces 42b and 29b, which are brought into abutment against each other when the reel 2 is rotated in the winding direction W.

The height of the gear teeth of the braking gear 42 and that of the engagement gear teeth 29 are set according to the distance between the locking position and the releasing position of the braking member 4. For a given height of the teeth, the number of the teeth is reduced and the one-pitch length is increased as the apical angle γ increases. Accordingly, when the apical angle γ is set not to be larger than 90° , the number of the gear teeth of the braking gear 42 is increased and the one-pitch length is reduced, whereby slack of the magnetic tape or the tension on the magnetic tape can be proper when the braking gear 42 is engaged with the engagement gear teeth 29.

Application No.: ~~00-124-448.2-1239~~
Applicant: ~~Fuji Photo Film Co., Ltd.~~
Our Ref.: ~~EP20062GK052~~
Date: ~~May 08, 2006~~

Druckexemplar

~~NEW~~ CLAIMS

1. A magnetic tape cartridge (1) comprising a magnetic tape wound around a single reel (2), a cartridge casing (3) for housing the reel (2) and a reel stopper means (10) for locking the reel (2) or permitting rotation thereof, wherein the reel stopper means (10) comprises a braking member (4) being moveable between a locking position and a releasing position, an urging member (5) for urging the braking member (4) toward the locking position, and a releasing member (6) being rotated integrally with the reel (2) for moving the braking member (4) toward the releasing position in response to a reel chucking action of a reel drive means (11) of a tape drive, and wherein the braking member (4) is provided with a braking gear (42) comprising gear teeth being adapted to be engaged with at least one engagement gear tooth (29) of an engagement projection (27) formed on the reel (2), **characterized in that** each of the gear teeth of the braking gear (42) comprises a first inclined surface (42a) being directed towards a tape-unwinding direction (U) and a second inclined surface (42b) being directed towards a tape-winding direction (W), wherein an interior angle (α) between the first inclined surface (42a) and a vertical (s) is smaller than an interior angle (β) between the second inclined surface (42b) and the vertical (s), and the inclined surfaces (42a,42b) form therebetween an apical angle (γ) being smaller than 90° .
2. A magnetic tape cartridge (1) according to claim 1, **characterized in that** the at least one engagement gear tooth (29) comprises a first and a second inclined surface (29a,29b) being respectively corresponded to the first and second inclined surface (42a,42b) of the gear teeth of the braking gear (42).

3. A magnetic tape cartridge (1) according to claim 1 or 2, **characterized in that** the reel (2) is provided with a guide member (28,39) for centering the braking member (4) with respect to the reel (2).
4. A magnetic tape cartridge (1) according to claim 3, **characterized in that** the guide member (39) comprises guide ribs being formed on an inner surface of a reel hub (21) at at least three places, wherein each guide ribs comprises an inclined surface inclining downward from an upper portion of the inner surface of the reel hub (21) toward a center of the reel (2).
5. A magnetic tape cartridge (1) according to at least one of the claims 1 to 4, **characterized in that** an outer diameter (D) of an engagement gear comprising the at least one engagement gear tooth (29) is larger than an outer diameter (d) of the braking gear (42).

1/4

~~EPO Munich~~
~~58~~
~~08 Nov. 2000~~

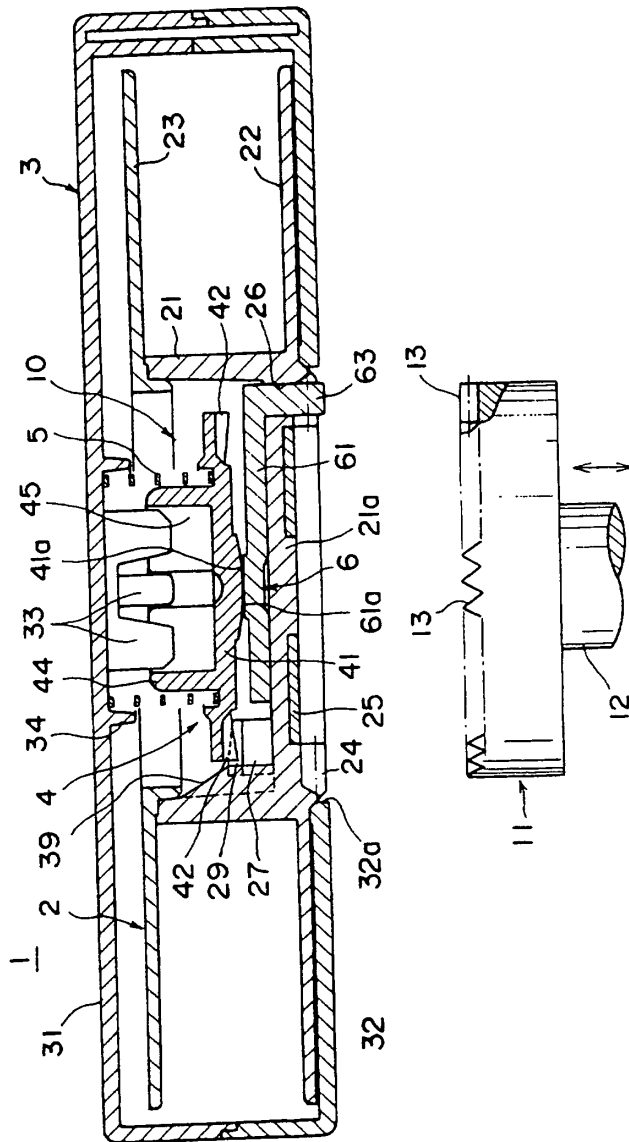

FIG. 1

2/4

FIG. 2

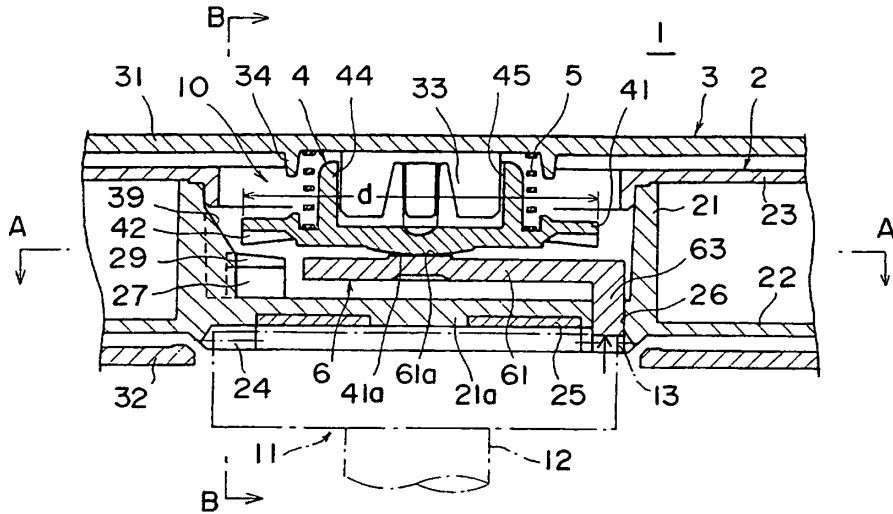
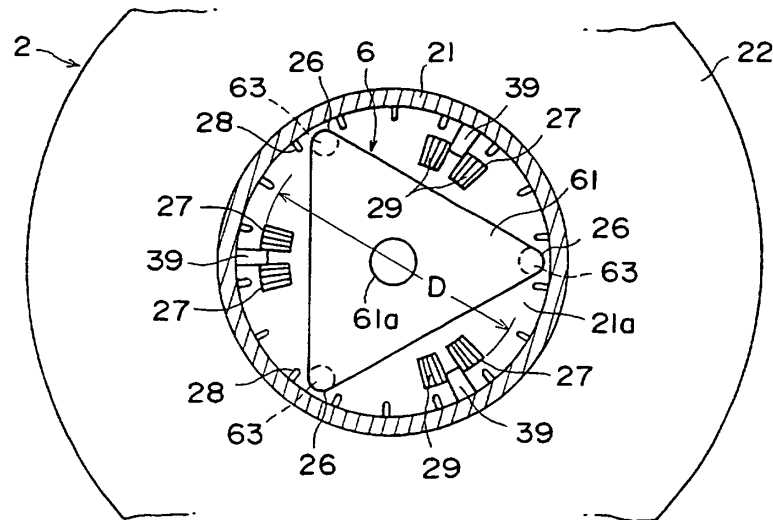
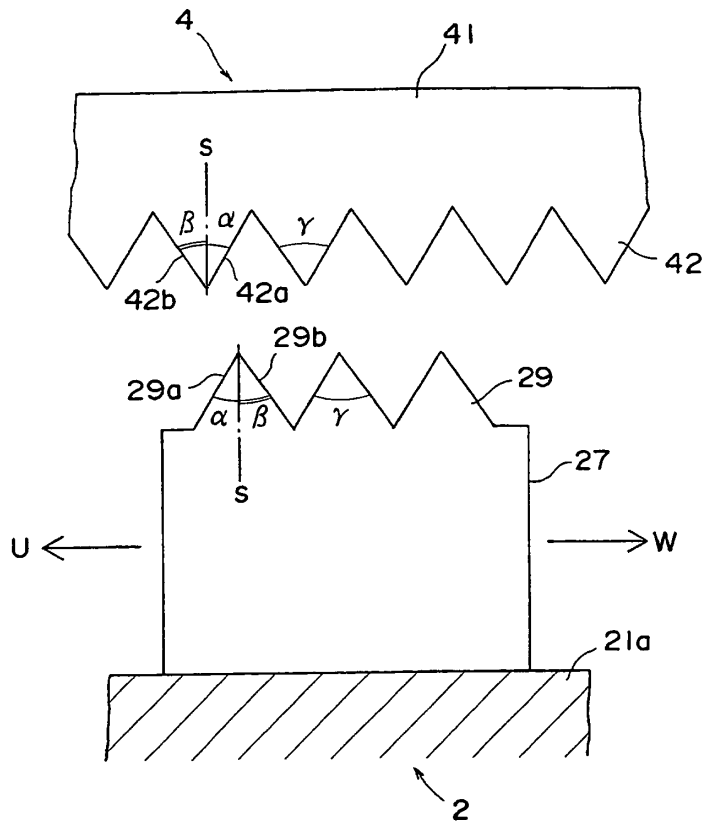

FIG. 3



3/4



F I G . 4

4/4

FIG. 5

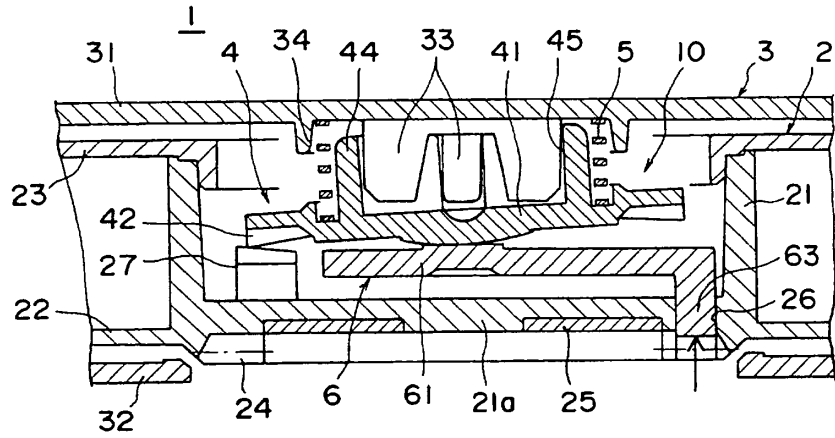

PRIOR ART



EPA/EPO/OEB
D-80298 München
+49 89 2399-0
TX 523 656 epmu d
FAX +49 89 2399-4465

Europäisches
Patentamt

European
Patent Office

Office européen
des brevets

Generaldirektion 2

Directorate General 2

Direction Générale 2

Grünecker, Kinkeldey,
Stockmair & Schwanhäusser
Anwaltssozietät
Maximilianstrasse 58
80538 München
ALLEMAGNE



Application No. 00 124 448.2 - 1232	Ref. EP20062-013/do	Date 29.09.2006
Applicant FUJI PHOTO FILM CO., LTD.		

Communication under Rule 51(4) EPC

You are informed that the Examining Division intends to grant a European patent on the basis of the above application with the text and drawings as indicated below:

In the text for the Contracting States:
DE FR GB

Description, Pages

2, 3 as originally filed
1, 4-18 received on 08.05.2006 with letter of 08.05.2006

Claims, Numbers

1-5 received on 08.05.2006 with letter of 08.05.2006

Drawings, Sheets

1/4-4/4 as originally filed

A copy of relevant documents is enclosed

The title of the invention in the three official languages of the European Patent Office, the international patent classification, the designated Contracting States, the registered name of the applicant and the bibliographic data are shown on the attached EPO Form 2056.

You are requested within a **non-extendable** period of four months of notification of this communication



1.	to file 1 set of translations of the claim(s) in the two other EPO official languages;		EUR
2a.	to pay the fee for grant including the fee for printing up to and including 35 pages; Reference 007		750.00
2b.	to pay the printing fee for the 36th and each additional page; number of pages: 0	Reference 008	0.00
3.	to pay the additional claim fee(s) (Rule 51(7) EPC); number of claims fees payable: 0	Reference 016	0.00
		Total amount	750.00

Concerning the possibility of a request for accelerated grant pursuant to Article 97(6) EPC, reference is made to OJ EPO 2001, 459.

If you do not approve the text intended for grant but wish to request amendments or corrections, the procedure described in Rule 51(5) EPC is to be followed.

If this communication is based upon an auxiliary request, and you reply within the time limit set that you maintain the main or a higher ranking request which is not allowable, the application will be refused (Article 97(1) EPC, see also Legal Advice 15/05 (rev. 02), OJ 6/2005, 357).

If the enclosed claims contain amendments proposed by the Examining Division, and you reply within the time limit set that you cannot accept these amendments, refusal of the application under Article 97(1) EPC would result in the case that agreement cannot be reached on the text for grant.

In all cases except those of the previous two paragraphs, if the grant, printing or claims fees are not paid, or the translations not filed, in due time, the European patent application will be deemed to be withdrawn (Rule 51(8) EPC).

For all payments you are requested to use EPO Form 1010 or to refer to the relevant reference number.

After publication, the European patent specification can be downloaded free of charge from the EPO publication server <https://publications.european-patent-office.org> or ordered only from the Vienna sub-office upon payment of a fee (OJ EPO 2005, 126).

Upon request in writing each proprietor will receive the certificate for the European patent **together with one copy** of the patent specification only if the request is filed within the time limit of Rule 51(4) EPC. If such request has been previously filed, it has to be confirmed within the time limit of Rule 51(4) EPC. The requested copy is free of charge. If the request is filed after expiry of the Rule 51(4) EPC time limit, the certificate will be delivered without a copy of the patent specification.

Translation of the priority document(s)

If the translation of the priority document(s), as required by Article 88(1) EPC, or the declaration according to Rule 38(5) EPC has not yet been filed, Form 2530 will be despatched separately. The translation is to be filed within the above mentioned time limit (Rule 38(5) EPC).

Note on payment of renewal fees



If a renewal fee falls due between notification of the present communication and the proposed date of publication of the mention of the grant of the European patent, publication will be effected only after the renewal fee and any additional fee have been paid (Rule 51(9) EPC).

Under Article 86(4) EPC, renewal fees are payable to the European Patent Office until the year in which the mention of the grant of the European patent is published.

Filing of translations in the Contracting States

Pursuant to Article 65(1) EPC the following Contracting States require a translation of the specification of the European patent in their/one of their official language(s) (Rule 51(10) EPC), **insofar** this specification will not be published in their/one of their official language(s)

- within **three** months of publication of the mention of such decision:

DE	GERMANY	GB	UNITED KINGDOM
FR	FRANCE		

The date on which the European Patent Bulletin publishes the mention of the grant of the European patent will be indicated in the decision on the grant of the European patent (EPO Form 2006).

The translation must be filed with the national Patent Offices of the Contracting or Extension States in accordance with the provisions applying thereto in the State concerned. Further details (e.g. appointment of a national representative or indication of an address for service within the country) are given in the EPO information brochure "National law relating to the EPC", and in the supplementary information published in the Official Journal of the EPO, or available on the EPO website.

Failure to supply such translation to the Contracting and Extension States in time and in accordance with the requirements may result in the patent being deemed to be void ab initio in the State concerned.

Note to users of the automatic debiting procedure

Unless the EPO receives prior instructions to the contrary, the fee(s) will be debited on the last day of the period of payment. For further details see the Arrangements for the automatic debiting procedure (see Supplement to OJ EPO 2, 2002).



Date 29.09.2006

Sheet 4

Application No.: 00 124 448.2

Examining Division:

Chairman: Holubov, Carol
2nd Examiner: Sozzi, Roberto
1st Examiner: Declat, Marcel



Mendoza, Maika
For the Examining Division
Tel. No.: +31 70 340 - 1069

Branch at The Hague

Enclosure(s): Form 2056
24 Copies of the relevant documents



ADDITIONAL SHEET +++ IMPORTANT INFORMATION +++

1. For communications under Rule 51(4) EPC issued on or after 01.04.2005 the time limit of four months is not extendable anymore:

According to Rule 51(4) EPC as amended the time limit set in the communication under Rule 51(4) EPC will be four months in all applications without possibility of extension.

Amended Rule 51(4) EPC applies to all applications for which a communication under Rule 51(4) EPC is issued on or after 01.04.2005.

2. A copy of the patent specification will only be annexed to the European Patent certificate upon special request within the time limit of the 51(4) EPC communication:

Under Rule 54 EPC as amended and the decision of the President of the EPO dated 22.12.2004 (OJ EPO 2005, 122) each proprietor will receive the certificate for the European patent together with a copy of the patent specification upon request in writing and only if the request is filed within the time limit of Rule 51(4) EPC. If such request has been previously filed, it has to be confirmed within the time limit of Rule 51(4) EPC. The requested copy is free of charge.

If the request is filed after expiry of the Rule 51(4) EPC time limit, the certificate will be delivered without a copy of the patent specification.

After publication, the European patent specification can be downloaded free of charge from the EPO publication server <https://publications.european-patent-office.org> or ordered from the Vienna sub-office upon payment of a fee (OJ EPO 2005, 126).

As before, upon payment of an administrative fee a duplicate copy of the European patent certificate with the patent specification attached or a certified copy of the patent specification will also be supplied.

Annex to EPO Form 2004, Communication under Rule 51(4) EPC

Bibliographical data of European patent application No. 00 124 448.2

For the intended grant of a European patent, the bibliographical data are set out below, for information:

Title of invention: - Magnetbandkassette
 - Magnetic tape cartridge
 - Cassette à bande magnétique

Classification: INV. G11B23/107 G11B23/04

Date of filing: 08.11.2000

Priority claimed: JP / 08.11.1999 / JPA31716699
 JP / 09.11.1999 / JPA31846499

Contracting States*
for which fees have
been paid: DE FR GB

Extension States*
for which fees have
been paid:

Applicant(s):** FUJI PHOTO FILM CO., LTD.
 210 Nakanuma,
 Minami-Ashigara-shi, Kanagawa-ken
 JP

Inventor(s): Takahashi, Daisuke,
 Fuji Photo Film Co., Ltd.
 2-12-1 Oogi-cho,
 Odawara-shi
 Kanagawa-ken
 JP

 Shiga, Hideaki,
 Fuji Photo Film Co., Ltd.
 2-12-1 Oogi-cho,
 Odawara-shi
 Kanagawa-ken
 JP

 Tsuyuki, Seiji,
 Fuji Photo Film Co., Ltd.
 2-12-1 Oogi-cho,
 Odawara-shi
 Kanagawa-ken
 JP

*) In case the time limits pursuant to Article 79(2) and Rule 85a EPC have not yet expired, **all Contracting States/Extension States** have been mentioned.

**) In case two or more applicants have designated different Contracting States, this is indicated here.



P.B.5818 - Patentlaan 2
 2280 HV Rijswijk (ZH)
 ☎ (070) 3 40 20 40
 FAX (070) 3 40 30 16

**Europäisches
 Patentamt**

**European
 Patent Office**

**Office européen
 des brevets**

Generaldirektion 1

Directorate General 1

Direction générale 1

Grünecker, Kinkeldey,
 Stockmair & Schwanhäusser
 Anwaltssozietät
 Maximilianstrasse 58
 80538 München
 ALLEMAGNE



EPO Customer Services
 Tel.: +31 (0)70 340 45 00

Date	25-10-2006
------	------------

Reference EP20062-013/do	Application No./Patent No. 00124448.2 - 1232
Applicant/Proprietor FUJI PHOTO FILM CO., LTD.	

Invitation to file a translation of the previous application (Rule 38(5) and 51(4) EPC)

You are herewith requested to file, within the period of **four months** from notification of the communication under Rule 51(4) EPC of 29.09.06 a translation of the following previous application(s), whose priority is claimed, into one of the official languages of the European Patent Office:

- JP 317166/1999 from 08.11.1999

- JP 318464/1999 from 09.11.1999

-

If the time-limit set under Rule 51(4) EPC is extended, the same extension applies to the time-limit for filing the translation of the previous application under Rule 38(5) EPC. (This applies only for cases falling under Rule 51(4) EPC in force until 31.03.2005).

In lieu of the translation of a previous application, a declaration that the European patent application is a complete translation of said previous application can also be submitted.

For the Examining Division



Mendoza, Maika

DECLARATION

I, Mayumi Takano, of Yanagida & Associates, 7F
Sin-Yokohama KS Bldg., 3-18-3 Shin-Yokohama, Kohoku-ku,
Yokohama-shi, Kanagawa, JAPAN, hereby certify that the attached
is my English translation of the documents and certify that my
translation is a true and correct translation to the best of
my knowledge and belief.

Mayumi Takano
Mayumi Takano

Dated this 26th day of January, 2007

Translation of Japanese Priority Document serial number 318 464,
as filed on 09 November 1999

(Name of Documents) Petition for Patent Application
(File Number) P24839J
(To) Takahiko Kondo, Commissioner,
 Patent Office
(International Classification) G11B 23/027
(Title of Invention) Magnetic Tape Cartridge
(Inventor)
 (Post Office Address or Resident Address)
 c/o Fuji Photo Film Co., Ltd.,
 12-1, Oogi-cho 2-chome, Odawara-shi,
 Kanagawa-ken, Japan
(Name) Seiji Tsuyuki
(Applicant)
 (Code Number) 000005201
(Name) Fuji Photo Film Co., Ltd.
(Attorney)
 (Code Number) 100073184
(Patent Attorney)
(Name) Masashi Yanagida
(Attorney)
 (Code Number) 100090468
(Patent Attorney)
(Name) Tsuyoshi Sakuma
(Indication of Fees)
 (Advance Payment Register No.) 008969
 (Prepaid Amount) ¥ 21,000
(List of Documents Submitted)
 (Name of Document) Specification 1
 (Name of Document) Drawings 1
 (Name of Document) Abstract 1
 (General Power No.) 9814441
(Filing Proof) Requested

[Name of Document] SPECIFICATION

[Title of Invention] Magnetic Tape Cartridge

[Scope of Demand for Patent]

1. A magnetic tape cartridge comprising a magnetic tape wound around a single reel, a cartridge casing in which the reel is rotatably housed and a reel stopper means which locks the reel not to rotate when the magnetic tape cartridge is not being used and releases the reel to permit rotation thereof when the magnetic tape cartridge is to be used, wherein the improvement comprises that

the reel stopper means comprises a braking member which is movable between a locking position where it is in contact with the reel to restrict rotation of the reel and a releasing position where it is away from the reel to permit rotation of the same, an urging member which urges the braking member toward the locking position, and a releasing member which is rotated integrally with the reel and moves the braking member toward the releasing position in response to a reel chucking action of the reel drive means of a tape drive, and

the braking member is provided with a braking gear which is adapted to be engaged, to restrict rotation of the reel, with an engagement gear tooth on an engagement projection formed on the reel while the reel is provided with a guide member which centers the braking member with respect to the reel.

2. A magnetic tape cartridge comprising a magnetic tape wound around a single reel, a cartridge casing in which the reel is rotatably housed and a reel stopper means which locks the reel not to rotate when the magnetic tape cartridge is not being used and releases the reel to permit rotation thereof when the magnetic tape cartridge is to be used, wherein the improvement comprises that

the reel stopper means comprises a braking member which is movable between a locking position where it is in contact with the reel to restrict rotation of the reel and a releasing position where it is away from the reel to permit rotation of the same, an urging member which urges the braking member toward the locking position, and a releasing member which is rotated integrally with the reel and moves the braking member toward the releasing position in response to a reel chucking action of the reel drive means of a tape drive, and

the braking member is provided with a braking gear which is adapted to be engaged, to restrict rotation of the reel, with an engagement gear on an engagement projection formed on the reel, the outer diameter of the engagement gear being formed larger than that of the braking gear.

[Detailed Description of the Invention]

[0001]

[Technical Field of the Invention]

This invention relates to a magnetic tape cartridge comprising a cartridge casing and a single reel which is rotatably housed in the cartridge casing and around which a magnetic tape is wound, and more particularly to a structure of a reel stopper means for preventing rotation of the reel when the magnetic tape cartridge is not being used.

[0002]

[Description of the Related Art]

Conventionally, as a recording medium for use in an external memory of a computer or the like, there has been known a magnetic tape cartridge comprising a magnetic tape wound around a single reel and a cartridge casing in which the reel is rotatably housed. Since the magnetic tape is used for storing data in a computer or the like and important information is stored on the magnetic tape, the magnetic tape cartridge is provided with a reel stopper means which prevents rotation of the reel when the magnetic tape cartridge is not being used, e.g., when the magnetic tape cartridge is being stored, so that trouble such as tape jam does not occur and the magnetic tape is not accidentally drawn out.

[0003]

The reel stopper means is provided with a brake member which is adapted to be engaged with a part of the reel to prevent

rotation of the reel and is disengaged from the reel to permit rotation of the reel in response to a reel chucking action of the reel drive means of a tape drive such as an external memory when the magnetic tape cartridge is loaded in the tape drive.

[0004]

[Problems to be solved by the Invention]

However, in order to respond to demands to improve the reliability of the action of the reel stopper means and to prevent dust from entering the cartridge casing, the reel stopper means may be, for instance, of a structure comprising a brake member which restricts rotation of the reel, an urging member which urges the brake member toward a locking position, and a release member which is moved in response to a reel chucking action of the reel drive means of a tape drive to move the brake member toward a releasing position.

[0005]

That is, when the magnetic tape cartridge is not being used, the brake member locks the reel so that the reel is not accidentally rotated and the magnetic tape is not accidentally drawn out, and when the magnetic tape cartridge is loaded in a tape drive and a reel chucking action is performed by the reel drive means, the release member drives the brake member to release the reel from the locking position in response to the reel chucking action of the reel drive means of the tape

drive. In this state, the reel can be rotated in the releasing position and loading/unloading of the magnetic tape is permitted.

[0006]

In such a mechanism, it is advantageous in terms of simplicity of structure for the release member to comprise a body portion that abuts the brake member and a leg portion, of which the leading end is adapted to be brought into abutment against a part of the reel drive means of the tape drive through through holes formed on the reel. If this structure is adopted, the reel drive means pushes the leg portion of the release member to drive the brake member to release the reel when the reel drive means of the tape drive chucks the reel. However, in this case, when the release member drives the brake member to release the reel, the brake member can be inclined, which may result in generation of noise and obstruction of rotation of the reel.

[0007]

Specifically, as shown in Figure 4, a reel stopper means 10 comprises: a braking member 4 which is vertically movable between a locking position, where it is in contact with a reel 2 to restrict rotation of the reel 2, and a releasing position, where it is away from the reel 2 to permit rotation of the same; an urging member 5 which urges the braking member 4 toward the

locking position; and a releasing member 6 which moves the braking member 4 toward the releasing position. The reel 2 has a reel gear 24 which engages with a rotation gear of the reel drive means of the tape drive (not shown) and through holes 26 are provided to penetrate through a part of the reel gear 24 in the vertical direction. Engagement projections 27 of which leading ends have a shape of a gear tooth are erected on the upper surface of the reel gear 24. The braking member 4 has a braking gear 42 which is adapted to be engaged with an engagement gear tooth on the engagement projections 27 along the outer periphery of the braking member 4. A cross-shaped engagement groove 45 provided inside an upper projection 44 is formed to engage with a supporting portion 33 of an upper casing half 3, whereby the braking member 4 is held in the cartridge casing 3 to be movable up and down but not to be rotatable. An urging member 5 is compressed between the braking member 4 and the upper casing half 31 by a coiled spring. The releasing member 6 comprises a cylindrical leg portion 63 extending downward from the lower surface of a substantially triangular plate-like body portion 61 at each corner thereof and the leg portions 63 are passed through the through holes 26 of the reel 2 to be movable up and down.

[0008]

When the magnetic tape cartridge is not being used and

in the locked state, the braking gear 42 is in mesh with the engagement gear tooth of the engagement projections 27 on the reel 2, whereby rotation of the reel 2 is restricted. When the magnetic tape cartridge 1 is used, the drive gear is brought into mesh with the reel gear 24 in response to a reel chucking action, whereby the leg portions 63 of the releasing member 6 are pushed upward by the tips of the teeth of the drive gear. Thus, the braking member 4 is integrally moved upward with the releasing member 6 in the releasing direction, whereby the braking gear 42 is disengaged from the engagement projections 27 and rotation of the reel 2 is enabled.

[0009]

In the released state described above, there is a problem in obtaining stable loading/unloading action of the magnetic tape, as the braking member 4 is unstable as it is in a state in which the center of the lower surface thereof is in sliding contact with the center of the releasing member 6. The reel 2 rotates or stops rotating in accordance with loading/unloading of the magnetic tape, and the force thereof acts on the braking member 4 through the releasing member 6. Therefore, when the braking member 4 becomes inclined as shown in Figure 4 due to various forces being exerted thereon, the braking gear 42 of the braking member 4 is brought into contact with the engagement gear tooth of the engagement projections

27 on the reel 2, resulting in generation of noise and obstruction of rotation of the reel.

[0010]

As a cause of the brake member 4 being inclined, there are cases in which the brake member 4 becomes off-centered and comes to be inclined when the brake member 4 is moved to the locking position where the braking gear 42 thereon is brought into engagement with the engagement projections 27 and the brake member is moved to the release position in this state, to cause the above problem. Further, there are cases in which the brake member 4 is inaccurately incorporated in the magnetic tape cartridge inclined relative to the reel 2 when the magnetic tape cartridge is assembled, causing the above problem.

[0011]

In view of the foregoing observations and description, the object of the present invention is to provide a magnetic tape cartridge in which the braking gear of the reel stopper means is suppressed from being brought into contact with the engagement projections by inclination of the braking member of the reel stopper means.

[0012]

[Means used to solve the Problems]

In accordance with a first aspect of the present invention, there is provided a magnetic tape cartridge

comprising a magnetic tape wound around a single reel, a cartridge casing in which the reel is rotatably housed and a reel stopper means which locks the reel not to rotate when the magnetic tape cartridge is not being used and releases the reel to permit rotation thereof when the magnetic tape cartridge is to be used, wherein the improvement comprises that the reel stopper means comprises a braking member which is movable between a locking position where it is in contact with the reel to restrict rotation of the reel and a releasing position where it is away from the reel to permit rotation of the same, an urging member which urges the braking member toward the locking position, and a releasing member which is rotated integrally with the reel and moves the braking member toward the releasing position in response to a reel chucking action of the reel drive means of a tape drive, and the braking member is provided with a braking gear which is adapted to be engaged, to restrict rotation of the reel, with an engagement gear tooth on an engagement projection formed on the reel while the reel is provided with a guide member which centers the braking member with respect to the reel.

[0013]

It is preferred that the guide member comprises guide ribs which are formed on the inner surface of the reel hub at at least three places, each having an inclined surface which

inclines downward from the upper portion of the inner surface of the reel hub toward the center of the reel in the direction of the engagement gear tooth on the engagement projection.

[0014]

Furthermore, in accordance with a second aspect of the present invention, there is provided a magnetic tape cartridge in which the reel stopper means comprises a braking member which is movable between a locking position where it is in contact with the reel to restrict rotation of the reel and a releasing position where it is away from the reel to permit rotation of the same, an urging member which urges the braking member toward the locking position, and a releasing member which is rotated integrally with the reel and moves the braking member toward the releasing position in response to a reel chucking action of the reel drive means of a tape drive, and the braking member is provided with a braking gear which is adapted to be engaged, to restrict rotation of the reel, with an engagement gear tooth on an engagement projection formed on the reel, the outer diameter of the engagement gear being formed larger than that of the braking gear.

[0015]

[Advantageous Effects of the Invention]

In the magnetic tape cartridge in accordance with the first aspect of the present invention, as the reel is provided

with a guide member which centers the braking member, which is movable between a locking position where it is in contact with the reel to restrict rotation of the reel and a releasing position, with respect to the reel, when the braking member is moved downward from the releasing position to the locking position, the braking member is centered by the guide members so that the braking gear is accurately brought into mesh with the engagement gear teeth on the engagement projection with the braking member held horizontal, whereby the braking member is prevented from being inclined in the locking position. When the braking member is subsequently moved to the releasing position by the releasing member, the braking member is held horizontal up to the releasing position. Accordingly, the phenomenon that the braking member is inclined can be suppressed, whereby the braking gear is prevented from contacting the engagement projection to generate noise or to obstruct rotation of the reel.

[0016]

Further, during initial assembly of the magnetic tape cartridge, the braking member is automatically centered in the reel hub by the guide members and is incorporated in place in the reel, whereby engagement of the braking gear and the engagement gear can be easily conducted accurately. Therefore, generation of noise and the like can be prevented, and

improvement of assembly efficiency can be realized.

[0017]

Meanwhile, in the magnetic tape cartridge in accordance with the second aspect of the present invention, as the outer diameter of the engagement gear teeth on the engagement projection formed on the reel is formed larger than that of the braking gear of the braking member which meshes with the engagement gear teeth, when the braking member is moved downward from the releasing position to the locking position, the braking member is centered by the difference between the outer diameters of the engagement gear and the braking gear so that the braking gear is brought into mesh with the engagement gear teeth on the engagement member with the braking member held horizontal, whereby the braking member is prevented from being inclined in the locking position. When the braking member is subsequently moved to the releasing position by the releasing member, the braking member is held horizontal up to the releasing position. Accordingly, the phenomenon that the braking member is inclined can be suppressed, whereby the braking gear is prevented from contacting the engagement projection to generate noise or to obstruct rotation of the reel.

[0018]

[Description of the Preferred Embodiments]

A magnetic tape cartridge 1 in accordance with an embodiment of the present invention will be described with reference to the drawings, hereinbelow. Figure 1 is a cross-sectional view showing the state of a magnetic tape cartridge in accordance with an embodiment of the present invention when the magnetic tape cartridge is not being used, Figure 2 is a fragmentary cross-sectional view of the magnetic tape cartridge shown in Figure 1 when the magnetic tape cartridge is being used, and Figure 3 is a cross-sectional view taken along line A-A in Figure 2.

[0019]

The magnetic tape cartridge 1 comprises a cartridge casing 3 formed by fastening together upper and lower casing halves 31 and 32 by screws or the like. A single reel 2 around which a magnetic tape (not shown) is wound is rotatably housed in the cartridge casing 3. The lower casing half 32 is provided with a central opening 32a. The magnetic tape cartridge 1 is further provided with a reel stopper means 10 which permits rotation of the reel 2 when the magnetic tape cartridge 1 is being used and restricts rotation of the reel 2 when the magnetic tape cartridge 1 is not being used.

[0020]

The reel 2 comprises a reel hub 21 which is a cylindrical member having a closed bottom and around which the magnetic

tape is wound, and lower and upper flanges 22 and 23 which project from the upper and lower leading ends of the reel hub 21 in the radial direction as discoid shapes. The reel hub 21 and the lower flange 22 are integrally formed by synthetic resin molding. The upper flange 23 is bonded to the reel hub 21, for instance, by ultrasonic welding. The reel hub 21 is provided with a bottom wall 21a at the lower end portion at the center thereof and a reel gear 24 for rotating the reel 2 is annularly formed on the lower surface of the bottom wall 21a, and a metal annular reel plate 25 which is magnetically attractable is mounted on the lower surface of the bottom wall 21a inside the reel gear 24. The reel gear 24 and the reel plate 25 are provided to face the central opening 32a of the bottom surface of the cartridge casing 3. The reel 2 is urged downward by an urging means 5 to be described later.

[0021]

The reel drive means 11 is provided with an annular drive gear 13 and a magnet (not shown) disposed on the top surface of a rotary shaft 12. When the magnetic tape cartridge 1 loaded in a bucket of the tape drive (the chucking action thereof is not shown) is moved downward toward the rotary shaft 12, the drive gear 13 is brought into mesh with the reel gear 24 and the reel plate 25 is magnetically attracted against the magnet to hold the drive gear 13 and the reel gear 24 in mesh with

each other.

[0022]

Next, the mechanism of the reel stopper means 10 will be described, hereinbelow. The reel stopper means 10 comprises a braking member 4 which is movable up and down between a locking position where it is in contact with the reel 2 to restrict rotation of the reel 2 and a releasing position where it is away from the reel 2 to permit rotation of the same, an urging member 5 which urges the braking member 4 toward the locking position, and a releasing member 6 which moves the braking member 4 toward the releasing position.

[0023]

As shown in Figure 3, three through holes 26 are formed in the bottom wall 21a of the reel 2 at regular angular intervals in the circumferential direction to extend through the portion at which the reel gear 24 is formed. On the upper surface of the bottom wall 21a, there are erected three pairs of (six) engagement projections 27 at regular angular intervals in the circumferential direction among the through holes 26 with different phase positions from the through holes 26. The upper end of each engagement projection 27 is formed into an engagement gear teeth 27a. The through holes 26 may be larger than three in number and the engagement projections 27 may be larger than three pairs in number. Further, the engagement

gear teeth 27a of each engagement projection 27 may be formed into a shape of single gear tooth.

[0024]

The braking member 4 has a disc portion 41 which is disposed in the reel hub 21 of the reel 2 opposed to the bottom wall 21a, and an annular braking gear 42 is formed on the lower surface of the disc portion 41 along the outer peripheral edge thereof. The braking gear 42 is adapted to be engaged with the engagement gear 27a on the engagement projections 27. The central part of the lower surface of the disc portion 41 is convex downward and forms a sliding portion 41a which is pressed against a sliding portion 61a on the upper surface of a body portion 61 of a releasing member 6 to be described later.

[0025]

The outer diameter D of the engagement gear formed by the engagement gear teeth 27a on the engagement projections 27 on the reel 2 (Figure 3) is larger than the outer diameter d (Figure 2) of the braking gear 42 on the braking member 4, which meshes with the engagement gear teeth 27a. The braking gear 42 and the engagement gear teeth 27a are conical in shape and the height of each tooth is higher at the outer periphery thereof. Accordingly, the braking gear 42 is engaged with the engagement gear 27 at their outer peripheries first.

[0026]

When the braking gear 42 on the braking member 4 is brought into mesh with the engagement gear 27a on the engagement projections 27, the outer periphery of the braking member 4 is guided by guide members 29 formed on the inner surface of the reel hub 21 of the reel 2. The guide members 29 are respectively provided between each pair of engagement projections 27, and accordingly three guide members 29 are provided on the inner surface of the reel hub 21. Each guide member 29 is in the form of a rib having an inclined surface which gradually inclines downward from the upper portion of the inner surface of the reel hub 21 toward the engagement projections 27, and the guide members 29 center the braking gear 42 when the outer periphery of the braking gear 42 is brought into contact with the inclined surfaces.

[0027]

A projection 44 extends upward from the upper surface of the disc portion 41 of the braking member 4, and a cross-shaped engagement groove 45 is formed in the projection 44 to extend in the vertical direction. A supporting portion 33 (a rotation restriction projection) extending downward from the inner surface of the upper casing half 31 of the cartridge casing 3 is in engagement with the engagement groove 45 of the braking member 4, whereby the braking member 4 is held in the cartridge casing 3 to be movable up and down but not to be

rotatable.

[0028]

An urging member 5 is compressed between a portion of the upper surface of the disc portion 41 around the projection 44 of the braking member 4 and a spring retainer portion 34 formed on the upper casing half 31 around the supporting portion 33 by a coiled spring, whereby the braking member 4 is urged toward the locking position where the braking gear 42 is engaged with the engagement gear teeth 27a on the engagement projections 27.

[0029]

The releasing member 6 is disposed to be movable up and down between the braking member 4 and the bottom wall 21a of the reel hub 21 and comprises a substantially triangular plate-like body portion 61. A cylindrical leg portion 63 extends downward from the lower surface of the body portion 61 at each corner thereof. The leg portions 63 are passed through the through holes 26 in the bottom wall 21a of the reel 2 to be movable up and down and the leading ends thereof are positioned such that they face the tooth portion of the reel gear 24 located at the lower surface of the reel 2. The engagement projections 27 are positioned between the leg portions 63 outside the body portion 61 of the releasing member 6. The leg portions 63 may also be rectangular or ellipsoidal

in cross-section.

[0030]

When the releasing member 6 is in its lowermost position shown in Figure 1, the lower ends of the leg portions 63 project downward from the lower surface of the reel 2 through the portion at which the reel gear 24 is formed, and when the drive gear 13 is brought into engagement with the reel gear 24 in response to a chucking action of the reel drive means 11, the releasing member 6 and the leg portions 63 are pushed upward by a predetermined stroke as shown in Figure 2. Since the leg portions 63 are passed through the through holes 26 the releasing member 6 is rotated together with the reel 2.

[0031]

The reel 2 is provided with guide members 28 (Figure 3) which guide the releasing member 6 in the insertion direction when the leg portions 63 of the releasing member 6 are inserted into the through holes 26. Each of the guide members 28 guides a corner of the substantially triangular plate-like body portion 61 of the releasing member 6 and comprises a pair of guide ribs formed on the inner surface of the reel hub 21 to extend in the vertical direction (the insertion direction of the leg portions 63) near one of the through holes 26. Reinforcing ribs like the guide ribs are provided on the entire inner surface of the reel hub 21.

[0032]

The operation of the reel stopper means 10 will be described, hereinbelow. Figure 1 shows a state of the magnetic tape cartridge 1 when it is not being used (e.g., when it is stored). In the state shown in Figure 1, the braking member 4, the releasing member 6 and the reel 2 are held in the lower casing half 32 of the cartridge casing 3 under the force of the urging member 5 and the central opening 32a of the lower casing half 32 is closed by the reel 2. The releasing member 6 is in its lowermost position where its lower surface is in abutment against the upper surface of the bottom wall 21a of the reel hub 21 and the lower end portions of the leg portions 63 project downward beyond the tips of the teeth of the reel gear 24. The braking member 4 is in abutment against the upper surface of the releasing member 6 and in its locking position where the braking gear 42 is in mesh with the engagement gear teeth 27a of the engagement projections 27 on the reel 2, whereby rotation of the reel 2 is restricted and the magnetic tape is prevented from being drawn out.

[0033]

As shown in Figure 2, when the magnetic tape cartridge 1 is loaded in a tape drive, the rotary shaft 12 of the reel drive means 11 of the tape drive is moved toward the lower surface of the reel 2 and the drive gear 13 is brought into

mesh with the reel gear 24 with the reel 2 slightly pushed upward in accordance with the chucking operation, whereby the leg portions 63 of the releasing member 6 are pushed upward by the tips of the teeth of the drive gear 13. Thus, the releasing member 6 is moved upward overcoming the force of the urging member 5 and the braking member 4 is moved upward together with the releasing member 6, whereby the braking gear 42 is disengaged from the engagement projections 27 and rotation of the reel 2 is permitted. In this state, the braking member 4 in its upper position is away from the guide members 29 and does not restrict rotation of the reel 2 when the magnetic tape is loaded/unloaded in accordance with driving of a recording and reproducing apparatus.

[0034]

When the braking member 4 is moved downward from the releasing position to the locking position, the braking member 4 is centered by the guide members 29 on the reel 2 so that the braking gear 42 is brought into mesh with the engagement gear teeth 27a with the braking member 4 held horizontal, whereby the braking member 4 is prevented from being inclined in the locking position. When the braking member 4 is subsequently moved upward to the releasing position by the releasing member 6, the braking member 4 is held horizontal up to the releasing position. Accordingly, the phenomenon

that the braking member 4 is inclined in the releasing position as shown in Figure 5 can be suppressed, whereby the braking gear 42 is prevented from contacting the engagement gear teeth 27a to generate noise or to obstruct rotation of the reel 2. Further, during assembly of the magnetic tape cartridge 1, the braking member 4 is automatically centered in the reel hub 2 by the guide members 29, even if the braking member is inserted slightly misaligned, and is incorporated in place in the reel 2, whereby assembly of the magnetic tape cartridge 1 is facilitated.

[0035]

Even if the guide members 29 are not provided, since the outer diameter D of the engagement gear teeth 27a on the engagement projections 27 on the reel 2 is formed larger than the outer diameter d of the braking gear 42 on the braking member 4, the braking member 4 is centered with respect to the reel hub 2 when it is moved from the releasing position to the locking position by virtue of the difference in diameter of the braking gear 42 and the engagement gear teeth 27a so that the braking gear 42 is brought into mesh with the engagement gear teeth 27a with the braking member 4 held horizontal, whereby the braking member 4 is prevented from being inclined in the locking position and contacting the engagement gear teeth 27a.

[Brief Description of the Drawings]

Figure 1 is a front cross-sectional view showing a state of a magnetic tape cartridge in accordance with an embodiment of the present invention when the magnetic tape cartridge is not being used,

Figure 2 is a fragmentary cross-sectional view of the magnetic tape cartridge shown in Figure 1 when the magnetic tape cartridge is being used,

Figure 3 is a cross-sectional view taken along line A-A in Figure 2, and

Figure 4 is a fragmentary cross-sectional view showing a state of a magnetic tape cartridge where the braking member is inclined.

[Explanation of the Reference Numerals]

- 1 magnetic tape cartridge
- 2 reel
- 3 cartridge casing
- 4 braking member
- 5 urging member
- 6 releasing member
- 10 reel stopper means
- 11 reel drive means
- 13 drive gear

- 21 reel hub
- 24 reel gear
- 26 through hole
- 27 engagement projection
- 27a engagement gear
- 29 guide member
- 42 braking gear
- 61 body portion
- 63 leg portion
- d diameter of braking gear
- D diameter of engagement gear

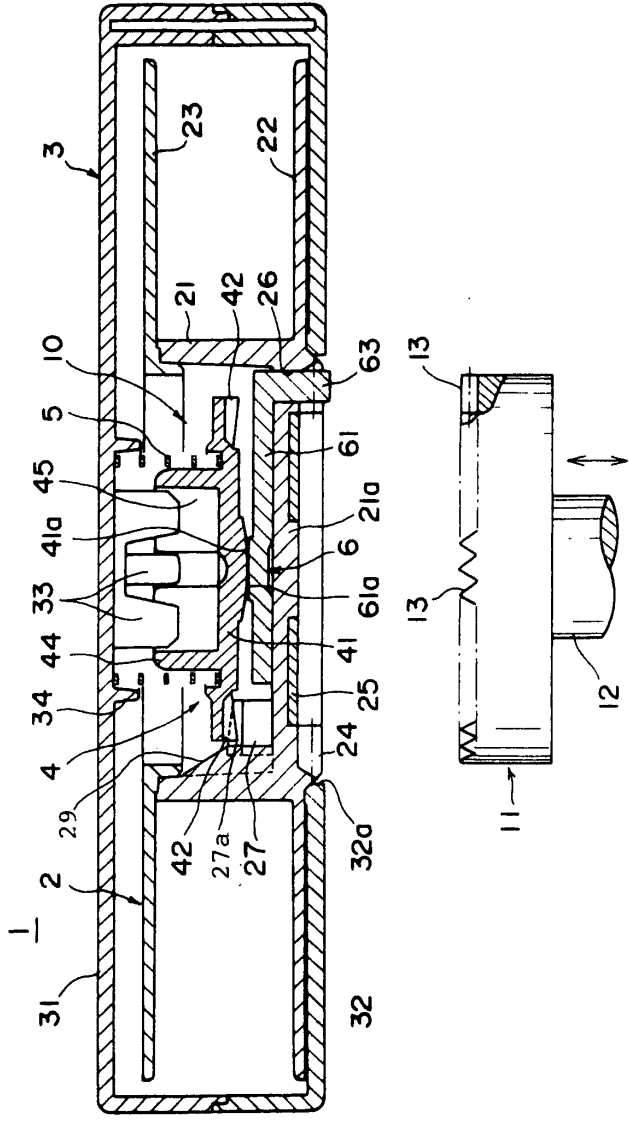
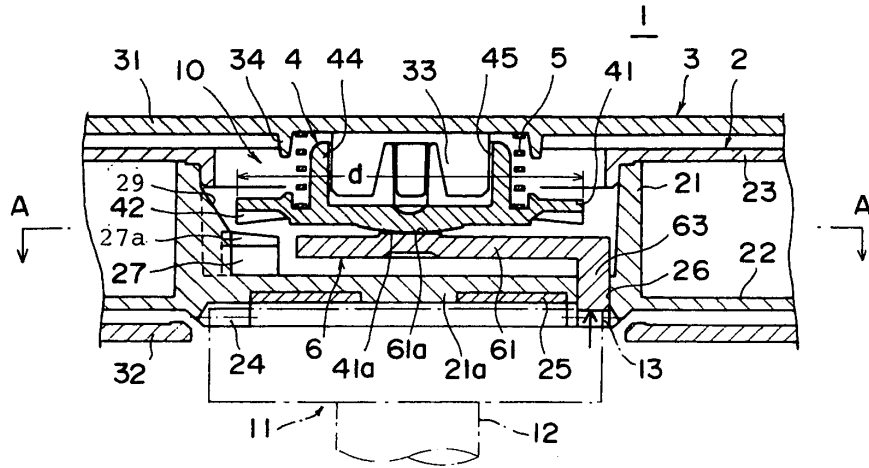

FIG. 1

F I G . 2



F I G . 3

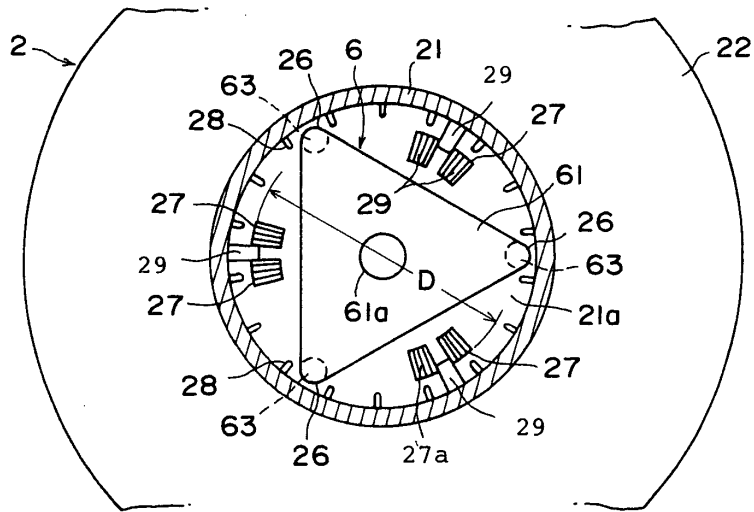
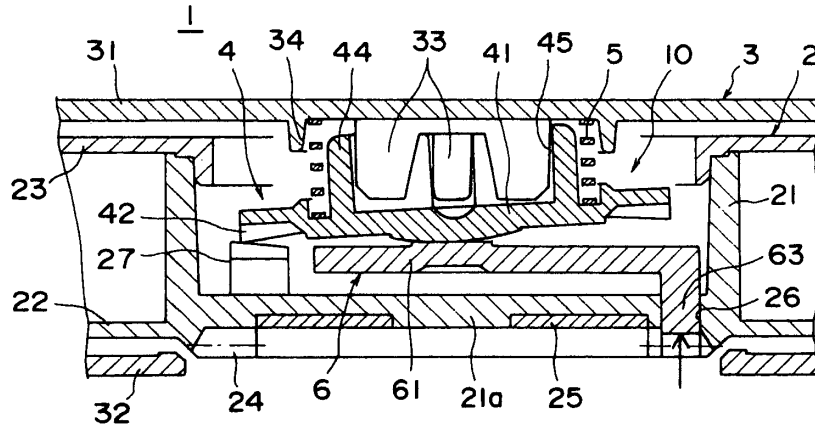

FIG. 4 .



[Name of Document] Abstract

[Abstract]

[Objective]

To provide a magnetic tape cartridge in which a brake member of a reel stopper means is suppressed from being inclined to improve problems such as generation of noise and obstruction of rotation of a reel due to contact between a braking gear of the braking member and an engagement gear of the reel.

[Constitution]

A reel stopper means 10 includes a braking member 4 which is movable between a locking position where it is in contact with a reel 2 to restrict rotation of the reel 2 and a releasing position where it is away from the reel 2 to permit rotation of the same, an urging member 5 which urges the braking member 4 toward the locking position, and a releasing member 6 which moves the braking member 4 toward the releasing position in response to a reel chucking action of a reel drive means 11 of a tape drive. The braking member 4 is provided with a braking gear 27 which is adapted to be engaged with an engagement gear tooth 27a on an engagement projection 27 formed on the reel 2 while the reel 2 is provided with a guide member 29 which centers the braking member 4 with respect to the reel 2, whereby the braking member 4 may be held horizontal in the locking position and suppressed from being inclined in the releasing

• • • •

position.

[Selected Figure] Figure 1

DECLARATION

I, Mayumi Takano, of Yanagida & Associates, 7F
Sin-Yokohama KS Bldg., 3-18-3 Shin-Yokohama, Kohoku-ku,
Yokohama-shi, Kanagawa, JAPAN, hereby certify that the attached
is my English translation of the documents and certify that my
translation is a true and correct translation to the best of
my knowledge and belief.

Mayumi Takano
Mayumi Takano

Dated this 26th day of January, 2007

Translation of Japanese Priority Document serial number 317 166,
as filed on 08 November 1999

(Name of Documents) Petition for Patent Application
(File Number) P24840J
(To) Takahiko Kondo, Commissioner,
 Patent Office
(International Classification) G11B 23/027
(Title of Invention) Magnetic Tape Cartridge
(Inventor)
 (Post Office Address or Resident Address)
 c/o Fuji Photo Film Co., Ltd.,
 12-1, Oogi-cho 2-chome, Odawara-shi,
 Kanagawa-ken, Japan
(Name) Daisuke Takahashi
(Inventor)
 (Post Office Address or Resident Address)
 c/o Fuji Photo Film Co., Ltd.,
 12-1, Oogi-cho 2-chome, Odawara-shi,
 Kanagawa-ken, Japan
(Name) Hideaki Shiga
(Applicant)
 (Code Number) 000005201
(Name) Fuji Photo Film Co., Ltd.
(Attorney)
 (Code Number) 100073184
(Patent Attorney)
(Name) Masashi Yanagida
(Attorney)
 (Code Number) 100090468
(Patent Attorney)
(Name) Tsuyoshi Sakuma
(Indication of Fees)
 (Advance Payment Register No.) 051529
 (Prepaid Amount) ¥ 21,000
(List of Documents Submitted)
 (Name of Document) Specification 1
 (Name of Document) Drawings 1
 (Name of Document) Abstract 1

(General Power No.) 9814441

(Filing Proof) Requested

[Name of Document] SPECIFICATION

[Title of Invention] Magnetic Tape Cartridge

[Scope of Demand for Patent]

1. A magnetic tape cartridge comprising a magnetic tape wound around a single reel, a cartridge casing in which the reel is rotatably housed and a reel stopper means which locks the reel not to rotate when the magnetic tape cartridge is not being used and releases the reel to permit rotation thereof when the magnetic tape cartridge is to be used, wherein the improvement comprises that

the reel stopper means comprises a braking member which is movable between a locking position where it is in contact with the reel to restrict rotation of the reel and a releasing position where it is away from the reel to permit rotation of the same, an urging member which urges the braking member toward the locking position, and a releasing member which is rotated integrally with the reel and moves the braking member toward the releasing position in response to a reel chucking action of the reel drive means of a tape drive,

the braking member is provided with a braking gear which is adapted to be engaged, to restrict rotation of the reel, with an engagement gear tooth on an engagement projection formed on the reel, and the apical angle of the braking gear tooth is less than or equal to 90° and interior angles of leading

ends with respect to the vertical of both sides of inclined surfaces are less than or equal to 30° with the interior angle for the inclined surfaces facing the unwinding direction of the reel being less than or equal to the interior angle for the inclined surfaces facing the winding direction of the reel.

[Detailed Description of the Invention]

[0001]

[Technical Field of the Invention]

This invention relates to a magnetic tape cartridge comprising a cartridge casing and a single reel which is rotatably housed in the cartridge casing and around which a magnetic tape is wound, and more particularly to a structure of a reel stopper means for preventing rotation of the reel when the magnetic tape cartridge is not being used.

[0002]

[Description of the Related Art]

Conventionally, as a recording medium for use in an external memory of a computer or the like, there has been known a magnetic tape cartridge comprising a magnetic tape wound around a single reel and a cartridge casing in which the reel is rotatably housed. Since the magnetic tape is used for storing data in a computer or the like and important information is stored on the magnetic tape, the magnetic tape cartridge

is provided with a reel stopper means which prevents rotation of the reel when the magnetic tape cartridge is not being used, e.g., when the magnetic tape cartridge is being stored, so that trouble such as tape jam does not occur and the magnetic tape is not accidentally drawn out.

[0003]

The reel stopper means is provided with a brake member which is adapted to be engaged with a part of the reel to prevent rotation of the reel and is disengaged from the reel to permit rotation of the reel in response to a reel chucking action of the reel drive means of a tape drive such as an external memory when the magnetic tape cartridge is loaded in the tape drive.

[0004]

[Problems to be solved by the Invention]

However, in order to respond to demands to improve the reliability of the action of the reel stopper means and to prevent dust from entering the cartridge casing, the reel stopper means may be, for instance, of a structure comprising a brake member which restricts rotation of the reel, an urging member which urges the brake member toward a locking position, and a release member which is moved in response to a reel chucking action of the reel drive means of a tape drive to move the brake member toward a releasing position.

[0005]

That is, when the magnetic tape cartridge is not being used, the brake member locks the reel so that the reel is not accidentally rotated and the magnetic tape is not accidentally drawn out, and when the magnetic tape cartridge is loaded in a tape drive and a reel chucking action is performed by the reel drive means, the release member drives the brake member to release the reel from the locking position in response to the reel chucking action of the reel drive means of the tape drive. In this state, the reel can be rotated in the releasing position and loading/unloading of the magnetic tape is permitted.

[0006]

In the structure as mentioned above, as the brake member is provided with a braking gear which is adapted to be engaged with an engagement gear tooth of engagement projections formed on the reel to restrict rotation of the reel, the braking gear teeth on the brake member are like sawteeth in shape and the surface of each tooth facing against the tape-unwinding direction of the reel is substantially normal, rotation of the reel in the tape-unwinding direction can be surely prevented. However, there is a possibility that the magnetic tape will be cut when the reel is rotated in the tape-winding direction due to impact when the magnetic tape cartridge is dropped.

[0007]

That is, when the braking gear and the engagement gear are engaged with each other at a substantially normal gear surface facing against the tape-unwinding direction, the reel cannot be rotated in the tape-unwinding direction. Further, a leader member such as a leader pin is fixed to the end of the magnetic tape wound around the reel, and the leader member is held near the tape draw-out opening of the cartridge casing when the magnetic tape cartridge is not being used. When the brake member is moved to the releasing position and the braking gear is disengaged from the engagement gear due to drop impact with the reel on which the magnetic tape is wound rotated in the tape-winding direction under inertia, a tape winding force acts on the magnetic tape whose end is fixed by the leader member. Since the reel cannot be rotated in the tape-unwinding direction or the direction in which the tension on the magnetic is released, the tape winding force acting on the magnetic tape can stretch the tape to deteriorate the magnetic recording and reproducing characteristics, remove the leader member from the magnetic tape, cut the magnetic tape, or displace the leader member from the predetermined position to disable the regular tape draw-out action, thereby deteriorating the reliability of the magnetic tape cartridge.

[0008]

In view of the foregoing observations and description,

the object of the present invention is to provide a magnetic tape cartridge in which the reel can be surely prevented from being rotated by the brake member of a reel stopper means so that the magnetic tape is not accidentally drawn out while occurrence of the magnetic tape being cut can be prevented.

[0009].

[Means used to solve the Problems]

In accordance with the present invention, there is provided a magnetic tape cartridge comprising a magnetic tape wound around a single reel, a cartridge casing in which the reel is rotatably housed and a reel stopper means which locks the reel not to rotate when the magnetic tape cartridge is not being used and releases the reel to permit rotation thereof when the magnetic tape cartridge is to be used, wherein the improvement comprises that the reel stopper means comprises a braking member which is movable between a locking position where it is in contact with the reel to restrict rotation of the reel and a releasing position where it is away from the reel to permit rotation of the same, an urging member which urges the braking member toward the locking position, and a releasing member which is rotated integrally with the reel and moves the braking member toward the releasing position in response to a reel chucking action of the reel drive means of a tape drive, the braking member is provided with a braking

gear which is adapted to be engaged, to restrict rotation of the reel, with an engagement gear tooth on an engagement projection formed on the reel, and the apical angle of the braking gear tooth is less than or equal to 90° and interior angles of leading ends with respect to the vertical of both sides of inclined surfaces are less than or equal to 30° , with the interior angle for the inclined surfaces facing the unwinding direction of the reel being less than or equal to the interior angle for the inclined surfaces facing the winding direction of the reel.

[0010]

[Advantageous Effects of the Invention]

In the magnetic tape cartridge in accordance with the present invention, since the apical angle of the braking gear tooth of the brake member, which is adapted to be engaged with an engagement gear tooth of engagement projections formed on the reel to restrict rotation of the reel, is less than or equal to 90° and the interior angle for one of the inclined surfaces of the braking gear tooth which is brought into abutment against the engagement gear teeth when the reel is rotated in the unwinding direction and the interior angle for the other inclined surface which is brought into abutment against the engagement gear teeth when the reel is rotated in the winding direction are greater than or equal to 30° with the former being

smaller than the latter, rotation of the reel can be surely prevented as the braking gear is brought into engagement with the engagement gear. When the reel is rotated in the winding direction due to drop impact or the like and an excessive winding force acts on the magnetic tape, the braking member is moved toward the releasing position along the inclined surface facing the unwinding direction of the reel and the braking gear is disengaged from the engagement gear teeth, whereby the reel is rotated in the unwinding direction to reduce the excessive tension on the magnetic tape. Thereby, the magnetic tape can be prevented from being stretched, disengaged or cut, and the reliability of the magnetic tape cartridge can be assured by securing the magnetic recording and reproducing characteristics and regular tape draw-out action of the magnetic tape.

[0011]

[Description of the Preferred Embodiments]

A magnetic tape cartridge 1 in accordance with an embodiment of the present invention will be described with reference to the drawings, hereinbelow. Figure 1 is a cross-sectional view showing a state of a magnetic tape cartridge in accordance with an embodiment of the present invention when the magnetic tape cartridge is not being used, Figure 2 is a fragmentary cross-sectional view of the magnetic tape cartridge shown in

Figure 1 when the magnetic tape cartridge is being used, and Figure 3 is a cross-sectional view taken along line A-A in Figure 2.

[0012]

The magnetic tape cartridge 1 comprises a cartridge casing 3 formed by fastening together upper and lower casing halves 31 and 32 by screws or the like. A single reel 2 around which a magnetic tape (not shown) is wound is rotatably housed in the cartridge casing 3. The lower casing half 32 is provided with a central opening 32a. The magnetic tape cartridge 1 is further provided with a reel stopper means 10 which permits rotation of the reel 2 when the magnetic tape cartridge 1 is being used and restricts rotation of the reel 2 when the magnetic tape cartridge 1 is not being used.

[0013]

The reel 2 comprises a reel hub 21 which is a cylindrical member having a closed bottom and around which the magnetic tape is wound, and lower and upper flanges 22 and 23 which project from the upper and lower leading ends of the reel hub 21 in the radial direction as discoid shapes. The reel hub 21 and the lower flange 22 are integrally formed by synthetic resin molding. The upper flange 23 is bonded to the reel hub 21, for instance, by ultrasonic welding. The reel hub 21 is provided with a bottom wall 21a at the lower end portion at

the center thereof and a reel gear 24 for rotating the reel 2 is annularly formed on the lower surface of the bottom wall 21a, and a metal annular reel plate 25 which is magnetically attractable is mounted on the lower surface of the bottom wall 21a inside the reel gear 24. The reel gear 24 and the reel plate 25 are provided to face the central opening 32a of the bottom surface of the cartridge casing 3. The reel 2 is urged downward by an urging means 5 to be described later.

[0014]

The reel drive means 11 is provided with an annular drive gear 13 and a magnet (not shown) disposed on the top surface of a rotary shaft 12. When the magnetic tape cartridge 1 loaded in a bucket of the tape drive (the chucking action thereof is not shown) is moved downward toward the rotary shaft 12, the drive gear 13 is brought into mesh with the reel gear 24 and the reel plate 25 is magnetically attracted against the magnet to hold the drive gear 13 and the reel gear 24 in mesh with each other.

[0015]

Next, the mechanism of the reel stopper means 10 will be described, hereinbelow. The reel stopper means 10 comprises a braking member 4 which is movable up and down between a locking position where it is in contact with the reel 2 to restrict rotation of the reel 2 and a releasing position

where it is away from the reel 2 to permit rotation of the same, an urging member 5 which urges the braking member 4 toward the locking position, and a releasing member 6 which moves the braking member 4 toward the releasing position.

[0016]

As shown in Figure 3, three through holes 26 are formed in the bottom wall 21a of the reel 2 at regular angular intervals in the circumferential direction to extend through the portion at which the reel gear 24 is formed. On the upper surface of the bottom wall 21a, there are erected three pairs of (six) engagement projections 27 at regular angular intervals in the circumferential direction among the through holes 26 with different phase positions from the through holes 26. The upper end of each engagement projection 27 is formed into an engagement gear teeth 29. The through holes 26 may be larger than three in number and the engagement projections 27 may be larger than three pairs in number. Further, the upper end engagement gear teeth 27a of each engagement projection 27 may be formed into a shape of single gear tooth.

[0017]

The braking member 4 has a disc portion 41 which is disposed in the reel hub 21 of the reel 2 opposed to the bottom wall 21a, and an annular braking gear 42 is formed on the lower surface of the disc portion 41 along the outer peripheral edge

thereof. The braking gear 42 is adapted to be engaged with the engagement gear 29 on the engagement projections 27. The central part of the lower surface of the disc portion 41 is convex downward and forms a sliding portion 41a which is pressed against a sliding portion 61a on the upper surface of a body portion 61 of a releasing member 6 to be described later.

[0018]

As shown in Figure 4 (a cross-sectional view taken along line B-B in Figure 2), each gear tooth of the braking gear 42 of the braking member 4 and each engagement gear tooth 29 on the engagement projection 27 are triangular in cross-section. The gear tooth of the braking gear 42 and the engagement gear tooth 29 have inclined surfaces 42a and 29a which face against the tape-unwinding direction U and engage with each other when the reel 2 rotates in the tape-unwinding direction U, and the other inclined surfaces 42b and 29b which face against the tape-winding direction W and engage with each other when the reel 2 rotates in the tape-winding direction W, respectively. Each of the gear tooth 42 and the gear tooth 29 is less than or equal to 90° in apical angle γ , and the interior angle α between the inclined surfaces 42a and 29a and the vertical S and the interior angle β between the inclined surfaces 42b and 29b and the vertical S are greater than or equal to 30° . Further, the interior angle α for the inclined surfaces 42a and 29a

facing the unwinding direction U of the reel 2 is less than or equal to the interior angle β for the inclined surfaces 42b and 29b facing the winding direction W of the reel 2. That is, $60^\circ \leq \gamma \leq 90^\circ$, $30^\circ \leq \alpha \leq 45^\circ$, and $30^\circ \leq \beta \leq 60^\circ$.

[0019]

The gear teeth of the braking gear 42 and the engagement gear teeth 29 are formed to be conical so that the outer peripheries are higher in length, whereby these outer peripheries engage with each other first of all.

[0020]

A projection 44 extends upward from the upper surface of the disc portion 41 of the braking member 4, and a cross-shaped engagement groove 45 is formed in the projection 44 to extend in the vertical direction. A supporting portion 33 (a rotation restriction projection) extending downward from the inner surface of the upper casing half 31 of the cartridge casing 3 is in engagement with the engagement groove 45 of the braking member 4, whereby the braking member 4 is held in the cartridge casing 3 to be movable up and down but not to be rotatable.

[0021]

An urging member 5 formed by a coiled spring is compressed between a portion of the upper surface of the disc portion 41 around the projection 44 of the braking member 4 and a spring

retainer portion 34 formed on the upper casing half 31 around the supporting portion 33, whereby the braking member 4 is urged toward the locking position where the braking gear 42 is engaged with the engagement gear teeth 29 on the engagement projections 27.

[0022]

The releasing member 6 is disposed to be movable up and down between the braking member 4 and the bottom wall 21a of the reel hub 21 and comprises a substantially triangular plate-like body portion 61. A cylindrical leg portion 63 extends downward from the lower surface of the body portion 61 at each corner thereof. The leg portions 63 are passed through the through holes 26 in the bottom wall 21a of the reel 2 to be movable up and down and the leading ends thereof are positioned to face the tooth portion of the reel gear 24 located at the lower surface of the reel 2. The engagement projections 27 are positioned between the leg portions 63 outside the body portion 61 of the releasing member 6. The leg portions 63 may also be rectangular or ellipsoidal in cross-section.

[0023]

When the releasing member 6 is in its lowermost position shown in Figure 1, the lower ends of the leg portions 63 project downward from the lower surface of the reel 2 through the portion at which the reel gear 24 is formed, and when the drive

gear 13 is brought into engagement with the reel gear 24 in response to a chucking action of the reel drive means 11, the releasing member 6 and the leg portions 63 are pushed upward by a predetermined stroke as shown in Figure 2. Since the leg portions 63 are passed through the through holes 26 the releasing member 6 is rotated together with the reel 2.

[0024]

The reel 2 is provided with guide members 28 (Figure 3) which guide the releasing member 6 in the insertion direction when the leg portions 63 of the releasing member 6 are inserted into the through holes 26. Each of the guide members 28 guides a corner of the substantially triangular plate-like body portion 61 of the releasing member 6 and comprises a pair of guide ribs formed on the inner surface of the reel hub 21 to extend in the vertical direction (the insertion direction of the leg portions 63) near one of the through holes 26. Reinforcing ribs like the guide ribs are provided on the entire inner surface of the reel hub 21.

[0025]

The operation of the reel stopper means 10 will be described, hereinbelow. Figure 1 shows a state of the magnetic tape cartridge 1 when it is not being used (e.g., when it is stored). In the state shown in Figure 1, the braking member 4, the releasing member 6 and the reel 2 are held in the lower

casing half 32 of the cartridge casing 3 under the force of the urging member 5 and the central opening 32a of the lower casing half 32 is closed by the reel 2. The releasing member 6 is in its lowermost position where its lower surface is in abutment against the upper surface of the bottom wall 21a of the reel hub 21 and the lower end portions of the leg portions 63 project downward beyond the tips of the teeth of the reel gear 24. The braking member 4 is in abutment against the upper surface of the releasing member 6 and in its locking position where the braking gear 42 is in mesh with the engagement gear teeth 29 of the engagement projections 27 on the reel 2, whereby rotation of the reel 2 is restricted and the magnetic tape is prevented from being drawn out.

[0026]

As shown in Figure 2, when the magnetic tape cartridge 1 is loaded in a tape drive, the rotary shaft 12 of the reel drive means 11 of the tape drive is moved toward the lower surface of the reel 2 and the drive gear 13 is brought into mesh with the reel gear 24 with the reel 2 slightly pushed upward in accordance with the chucking operation, whereby the leg portions 63 of the releasing member 6 are pushed upward by the tips of the teeth of the drive gear 13. Thus, the releasing member 6 is moved upward overcoming the force of the urging member 5 and the braking member 4 is moved upward together with

the releasing member 6, whereby the braking gear 42 is disengaged from the engagement projections 27 and rotation of the reel 2 is permitted. In this state, the magnetic tape is loaded/unloaded in accordance with driving of a recording and reproducing apparatus.

[0027]

Further, by configuring the braking gear 42 and the engagement gear 29 to have the gear shape of the structure shown in Figure 4, when the reel 2 is rotated in the winding direction W due to drop impact or the like and an excessive winding force acts on the magnetic tape, the braking member 4 is moved upward along the inclined surfaces 42a and 29a overcoming the force of the urging member 5 since the interior angles α for the inclined surfaces 42a and 29a which are facing the unwinding direction U of the braking gear 42 and the engagement gear 29 are greater than or equal to 30° and the braking gear 42 is disengaged from the engagement gear teeth 29, whereby the reel 2 is rotated in the unwinding direction U, that is, the direction in which the magnetic tape becomes slack, to reduce the tension on the magnetic tape, and the magnetic tape can be prevented from being stretched or cut.

[0028]

Further, since the interior angles β for the inclined surfaces 42b and 29b facing the winding direction W of the

braking gear 42 and the engagement gear teeth 29 are greater than or equal to 30° , the reel 2 can be rotated in any state, even if the braking member 4 is in the locking position, whereby the magnetic tape can be rewound into the cartridge casing 3.

[0029]

The effect of reducing the tension on the magnetic tape can be obtained when the interior angle α is greater than or equal to 30° . However when the interior angle α is larger than 45° , the locking force for preventing rotation of the reel 2 in the unwinding direction U becomes too weak. That is, in order to ensure both the effect of reducing the tension on the magnetic tape and sufficient locking force in the state that the inclined surfaces 42a and 29a are brought into engagement with the inclined surfaces 42b and 29b, it is necessary for the apical angle γ to be less than or equal to 90° and for the interior angles α for the inclined surfaces 42a and 29a which face the unwinding direction U of the reel 2 to be smaller than the interior angles β for the inclined surfaces 42b and 29b which face the winding direction W of the reel 2.

[0030]

The height of the gear teeth of the braking gear 42 and that of the engagement gear teeth 29 are set appropriately according to the distance between the locking position and the releasing position of the braking member 4. For a given height

of the teeth, the number of the teeth is reduced and the one-pitch length is increased as the apical angle γ increases. Accordingly, when the apical angle γ is set not to be larger than 90° , the number of the gear teeth of the braking gear 42 is increased and the one-pitch length is reduced, whereby the resolution in the rotation direction is reduced and slack of the magnetic tape or the tension on the magnetic tape can be proper when the braking gear 42 is engaged with the engagement gear teeth 29.

[Brief Description of the Drawings]

Figure 1 is a front cross-sectional view showing a state of a magnetic tape cartridge in accordance with an embodiment of the present invention when the magnetic tape cartridge is not being used,

Figure 2 is a fragmentary cross-sectional view of the magnetic tape cartridge shown in Figure 1 when the magnetic tape cartridge is being used,

Figure 3 is a cross-sectional view taken along line A-A in Figure 2, and

Figure 4 is a cross-sectional view taken along line B-B in Figure 2.

[Explanation of the Reference Numerals]

1 magnetic tape cartridge
2 reel
3 cartridge casing
4 braking member
5 urging member
6 releasing member
10 reel stopper means
11 reel drive means
13 drive gear
21 reel hub
24 reel gear
26 through hole
27 engagement projection
29 engagement gear
33 supporting portion
42 braking gear
63 leg portion

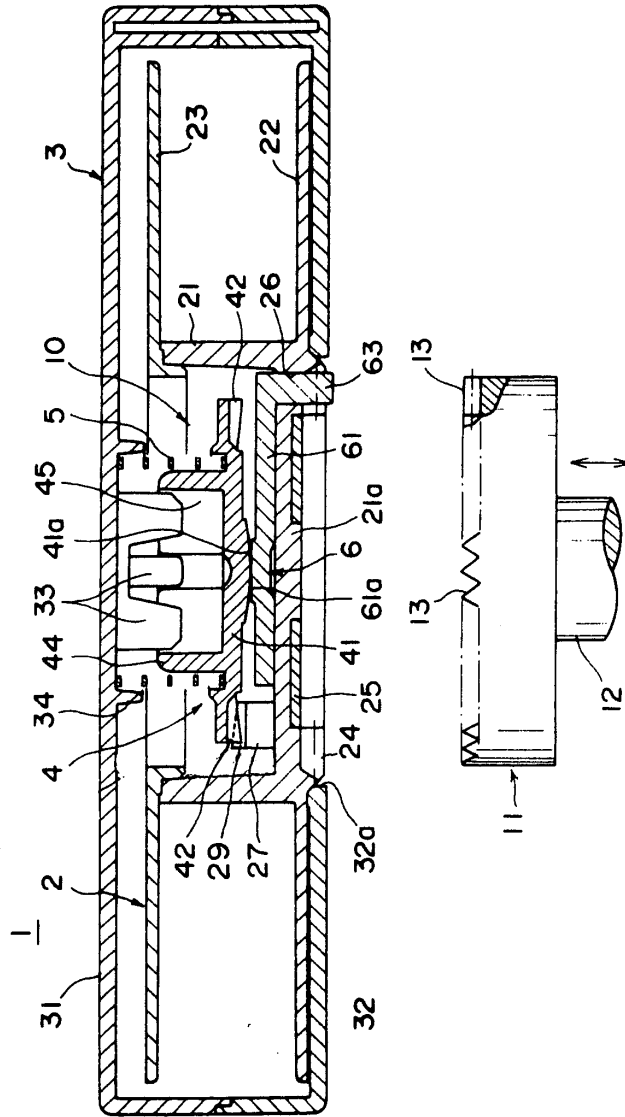
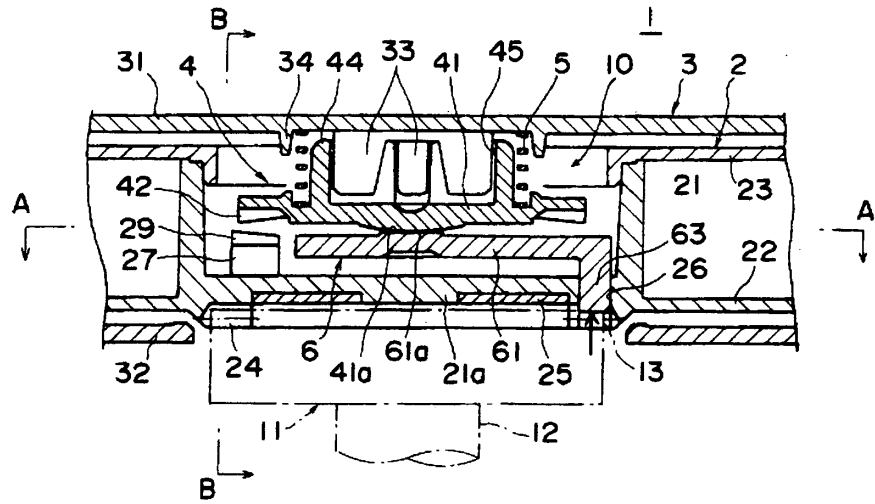
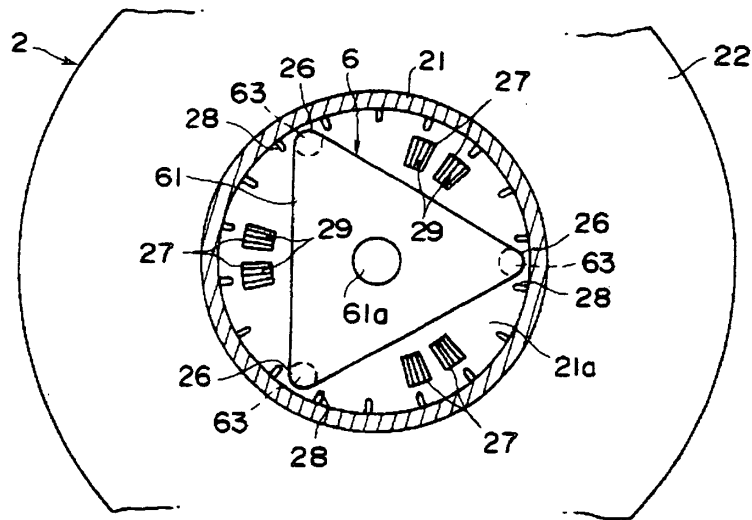

FIG. 1

F I G . 2



F I G . 3



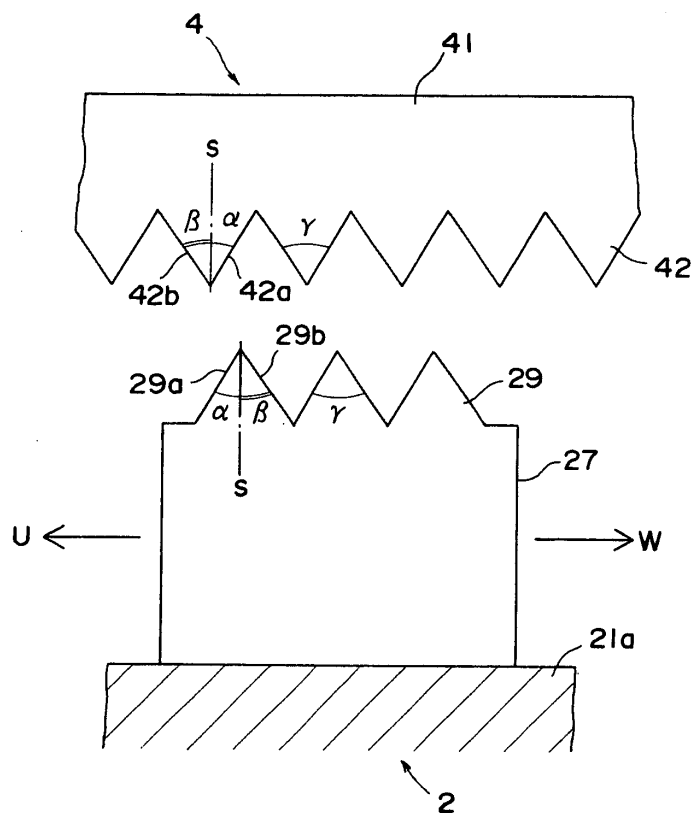

F I G . 4

[Name of Document] Abstract

[Abstract]

[Objective]

To provide a magnetic tape cartridge in which the reel can be surely prevented from being rotated by a brake member of a reel stopper means so that the magnetic tape is not accidentally drawn out while occurrence of the magnetic tape being cut due to drop impact can be prevented.

[Constitution]

A reel stopper means 10 includes a braking member 4 which is movable between a locking position where it is in contact with a reel 2 to restrict rotation of the reel 2 and a releasing position where it is away from the reel 2 to permit rotation of the same, an urging member 5 which urges the braking member 4 toward the locking position, and a releasing member 6 moves the braking member 4 toward the releasing position in response to a reel chucking action of a reel drive means 11 of a tape drive. The apical angle γ of a braking gear tooth 42 of the braking member 4 which engages with an engagement gear 29 of an engagement projection 27 of the reel 2 is less than or equal to 90° and interior angles α and β of leading ends with respect to the vertical s of both sides of inclined surfaces are less than or equal to 30° , with the interior angle α for the inclined surface facing the unwinding direction U of the reel 2 is less

than or equal to the interior angle β for the inclined surface facing the winding direction W of the reel 2, whereby the reel 2 is rotatable in the direction in which the magnetic tape becomes slack to reduce the excessive tension on the magnetic tape.

[Selected Figure] Figure 4

GRÜNECKER KINKELDEY STOCKMAIR & SCHWANHÄUSSER

ANWALTSSOZIELTÄT

EPO - Munich
39

01. Feb. 2007

GKS & S MAXIMILIANSTRASSE 58 D-80538 MÜNCHEN GERMANY

European Patent Office
Erhardtstraße 27

80298 München

Attn. Mr. Eric Bihl / Ust.

RECHTSANWÄLTE
LAWYERS

MÜNCHEN
DR. HELMUT EICHMANN
GERHARD BARTH
DR. ULRICH BLUMENRÖDER, LL.M.
CHRISTA NIKLAS-FALTER
DR. MAXIMILIAN KINKELDEY, LL.M.
DR. KARSTEN BRANDT
ANJA FRANKE, LL.M.
UTE STEPHANI
DR. BERND ALLEKOTTE, LL.M.
DR. ELVIRA BERTRAM, LL.M.
KARIN LOCHNER
BABETT ERTL
CHRISTINE NEUHIERL
SABINE PRÜCKNER
CORNELIA SCHMITT
BERNHARD MEHNERT, DIPL.ING.
PETRA LÜBBE
DR. SONJA BRÖTJE
SONJA SCHÄFFLER
DR. HOLGER GAUSS
DR. NICOLÁS SCHMITZ

PATENTANWÄLTE
EUROPEAN PATENT ATTORNEYS

MÜNCHEN
DR. HERMANN KINKELDEY
PETER H. JAKOB
HANS HILGERS
ANNELE EHNOLD
THOMAS SCHUSTER
DR. KLARA GOLDBACH
MARTIN AUFENANGER
GOTTFRIED KLITZSCH
DR. HEIKE VOGELSANG-WENKE
REINHARD KNAUER
DIETMAR KUHL
DR. FRANZ-JOSEF ZIMMER
BETTINA K. REICHELT
DR. ANTON K. PFAU
DR. UDO WEIGELT
RAINER BERTRAM
JENS KOCH, M.S. (J of PA) M.S.
BERND ROTHAEHEL
THOMAS W. LAUBENTHAL
DR. ANDREAS KAYSER
DR. JENS HAMMER
DR. THOMAS EICKELKAMP
DR. CARLO TORTI*
DR. PETER MILTÉNYI
DR. MORITZ HÖFFE

*EUROPEAN PATENT ATTORNEY

PATENTANWÄLTE
EUROPEAN PATENT ATTORNEYS

BERLIN
PROF. DR. MANFRED BÖNING
DR. PATRICK ERK, M. S. (MIT)
KÖLN
DR. MARTIN DROPMANN
CHEMNITZ
DR. CARMEN STEINIGER*
*PATENTANWÄLTIN
ALICANTE
WOLFHARD MEISTER
DR. ANDREAS TORKA*
*RECHTSANWALT
—
OF COUNSEL
DR. HENNING MEYER-PLATH
—
DR. WILFRIED STOCKMAIR
(-1996)

IHR ZEICHEN / YOUR REF.

UNSER ZEICHEN / OUR REF.

DATUM / DATE

UM4357DK906aml
(referring to the recordal matter
only)

February 1, 2007

All Active European Patent Applications, all Active European Patents within the Nine-months-opposition Period and all Active European Patents within an Opposition Procedure

Applicant/Owner: Fuji Photo Film Co., Ltd.

First, the applicant/owner of the above-mentioned patents/patent applications has changed its name and address to

FUJIFILM Holdings Corporation
210, Nakanuma
Minami-Ashigara-shi
Kanagawa
Japan

Then, the above-mentioned patents/patent applications have been assigned to

FUJIFILM Corporation
26-30, Nishiazabu 2-chome
Minato-ku
Tokyo
Japan

GRÜNECKER KINKELDEY
STOCKMAIR & SCHWANHÄUSSER
MAXIMILIANSTR. 58
D-80538 MÜNCHEN
GERMANY

TEL. +49 89 21 23 50
FAX +49 89 22 02 87
FAX +49 89 21 86 92 93
<http://www.grunecker.de>
e-mail: info@grunecker.de

DEUTSCHE BANK MÜNCHEN
No. 17 51734
BLZ 700 700 10
SWIFT: DEUT DE MM

We request that you register the change of name and address and the assignment against all active applications/patents as mentioned above. The registered representatives shall remain listed.

As evidence for the name change and the assignment we herewith enclose

- Certificate of Partial Closed Records in the Japanese language and verified English translation
- Declaration of Assignment/Declaration of Acceptance

Furthermore, we herewith enclose

- Power of Attorney, signed by the new owner/applicant

We hereby explicitly confirm that we are acting on behalf of the current and as well as of the new owner/applicant.

Please debit our deposit account no. 28000437 with the EPO with the required amount of the official fees.

We look forward to receiving the official confirmations regarding the recordal of the above-mentioned assignments.

(Kuhl)

Encl.
Certificate
Declaration of Assignment/Declaration of Acceptance
Power of Attorney

閉鎖事項一部証明書

神奈川県南足柄市中沼210番地
 富士フィルムホールディングス株式会社
 会社法人番号 0703-01-004138

商号	富士写真フィルム株式会社	
	富士フィルムホールディングス株式会社	平成18年10月1日変更 平成18年10月16日登記
本店	神奈川県南足柄市中沼210番地	
公告をする方法	東京都において発行する日本経済新聞に掲載する	
	電子公告の方法により行う。 http://www.fujifilm.co.jp/ 事故その他やむを得ない事由によって電子公告による公告をすることができない場合は、日本経済新聞に掲載して行う。	平成18年6月29日変更 平成18年7月10日登記
	電子公告の方法により行う。 http://www.fujifilmholdings.com/ 事故その他やむを得ない事由によって電子公告による公告をすることができない場合は、日本経済新聞に掲載して行う。	平成18年10月1日変更 平成18年10月16日登記
貸借対照表に係る情報の提供を受けるために必要な事項	http://www.fujifilm.co.jp/	
会社成立の年月日	昭和9年1月20日	
単元株式数	100株	
発行可能株式総数	8億株	
発行済株式の総数並びに種類及び数	発行済株式の総数 5億1462万5728株	
株券を発行する旨の定め	当会社の株式については、株券を発行する	平成17年法律第87号第136条の規定により平成18年5月2日登記

整理番号 マ363517

* 下線のあるものは抹消事項であることを示す。

1 / 10

神奈川県南足柄市中沼210番地
 富士フィルムホールディングス株式会社
 会社法人番号 0203-01-004138

	当社は、株式に係る株券を発行する 平成18年 6月29日変更 平成18年 7月10日登記
資本金の額	金403億6337万3192円
株主名簿管理人の 氏名又は名称及び 住所並びに営業所	東京都千代田区丸の内一丁目4番3号 ユーエフジェイ信託銀行株式会社 東京都千代田区丸の内一丁目4番3号 ユーエフジェイ信託銀行株式会社証券代行部 東京都千代田区丸の内一丁目4番5号 三菱UFJ信託銀行株式会社 東京都千代田区丸の内一丁目4番5号 三菱UFJ信託銀行株式会社証券代行部 平成17年10月 1日変更 平成17年10月 7日登記
役員に関する事項	取締役 古 森 重 隆 平成16年 6月29日重任
	取締役 古 森 重 隆 平成17年 6月29日重任
	取締役 古 森 重 隆 平成17年 7月13日登記
	取締役 古 森 重 隆 平成18年 6月29日重任
	取締役 古 森 重 隆 平成18年 7月10日登記
	取締役 麻 生 興 太 郎 平成16年 6月29日重任
	取締役 麻 生 興 太 郎 平成17年 6月29日退任
	取締役 麻 生 興 太 郎 平成17年 7月13日登記
取締役 林 伸 幸 平成16年 6月29日重任	
取締役 林 伸 幸 平成17年 6月29日重任	
取締役 林 伸 幸 平成17年 7月13日登記	
取締役 林 伸 幸 平成18年 6月29日退任	
取締役 林 伸 幸 平成18年 7月10日登記	

神奈川県南足柄市中沼210番地
 富士フイルムホールディングス株式会社
 会社法人番号 0203-01-004138

取締役	三川 秋一	平成16年 6月29日重任
		平成17年 6月29日退任
		平成17年 7月13日登記
取締役	森内 成典	平成16年 6月29日重任
取締役	森内 成典	平成17年 6月29日重任
		平成17年 7月13日登記
		平成18年 6月29日退任
		平成18年 7月10日登記
取締役	福永 英喜	平成16年 6月29日重任
		平成17年 6月29日退任
		平成17年 7月13日登記
取締役	高橋 俊雄	平成16年 6月29日重任
取締役	高橋 俊雄	平成17年 6月29日重任
		平成17年 7月13日登記
取締役	高橋 俊雄	平成18年 6月29日重任
		平成18年 7月10日登記
取締役	福永 英喜	平成16年 6月29日重任
取締役	福永 英喜	平成17年 6月29日重任
		平成17年 7月13日登記
		平成18年 6月29日退任
		平成18年 7月10日登記

整理番号 マ363517

* 下線のあるものは抹消事項であることを示す。

3 / 10

神奈川県南足柄市中沼210番地
 富士フィルムホールディングス株式会社
 会社法人番号 0203-01-004138

取締役	加藤久豊	平成16年 6月29日重任
取締役	加藤久豊	平成17年 6月29日重任
		平成17年 7月13日登記
取締役	加藤久豊	平成18年 6月29日重任
		平成18年 7月10日登記
取締役	内田洋祐	平成16年 6月29日就任
		平成17年 6月29日重任
		平成17年 7月13日登記
取締役	米田剛	平成16年 6月29日就任
取締役	米田剛	平成17年 6月29日重任
		平成17年 7月13日登記
		平成18年 6月29日退任
		平成18年 7月10日登記
取締役	佐々木格	平成16年 6月29日就任
取締役	佐々木格	平成17年 6月29日重任
		平成17年 7月13日登記
取締役	佐々木格	平成18年 6月29日重任
		平成18年 7月10日登記
取締役	原 宏	平成16年 6月29日就任
取締役	原 宏	平成17年 6月29日重任
		平成17年 7月13日登記

整理番号 マ363517

* 下線のあるものは抹消事項であることを示す。

4 / 10

神奈川県南足柄市中沼2-1-0番地
 富士フィルムホールディングス株式会社
 会社法人番号 0203-01-004138

		平成16年 6月29日退任
		平成18年 7月10日登記
取締役	池上 真平	平成16年 6月29日就任
取締役	池上 真平	平成17年 6月29日重任
		平成17年 7月13日登記
取締役	池上 真平	平成18年 6月29日重任
		平成18年 7月10日登記
取締役	中村 孝太郎	平成16年 6月29日就任
取締役	中村 孝太郎	平成17年 6月29日重任
		平成17年 7月13日登記
取締役	中村 孝太郎	平成18年 6月29日重任
		平成18年 7月10日登記
取締役	大西 貴	平成16年 6月29日重任
		平成17年 6月29日退任
		平成17年 7月13日登記
取締役	犬塚 奎一	平成17年 6月29日就任
		平成17年 7月13日登記
		平成18年 6月29日退任
		平成18年 7月10日登記
取締役	高木 信成	平成17年 6月29日就任
		平成17年 7月13日登記
取締役	高木 信成	平成18年 6月29日重任
		平成18年 7月10日登記

整理番号 マ363517

* 下線のあるものは抹消事項であることを示す。

5 / 10

神奈川県南足柄市中沼2-10番地
 富士フイルムホールディングス株式会社
 会社法人番号 0203-01-004138

		平成18年 9月30日辞任
		平成18年10月16日登記
取締役	<u>神 山 宏 三</u>	平成17年 6月29日就任
		平成17年 7月13日登記
取締役	<u>神 山 宏 三</u>	平成18年 6月29日重任
		平成18年 7月10日登記
		平成18年 9月30日辞任
		平成18年10月16日登記
取締役	<u>杉 崎 力</u>	平成17年 6月29日就任
		平成17年 7月13日登記
取締役	<u>杉 崎 力</u>	平成18年 6月29日重任
		平成18年 7月10日登記
		平成18年 9月30日辞任
		平成18年10月16日登記
取締役	<u>佐 々 木 登</u>	平成17年 6月29日就任
		平成17年 7月13日登記
取締役	<u>佐 々 木 登</u>	平成18年 6月29日重任
		平成18年 7月10日登記
		平成18年 9月30日辞任
		平成18年10月16日登記
取締役	<u>阿 部 久 正</u>	平成18年 6月29日就任
		平成18年 7月10日登記
		平成18年 9月30日辞任
		平成18年10月16日登記
取締役	<u>三 井 皎 生</u>	平成18年 6月29日就任
		平成18年 7月10日登記

整理番号 マ363517

* 下線のあるものは抹消事項であることを示す。

6 / 10

神奈川県南足柄市中沼2-1-0番地
 富士フィルムホールディングス株式会社
 会社法人番号 0203-01-004138

		平成18年 9月30日辞任
		平成18年10月16日登記
取締役	戸田 雄三	平成18年 6月29日就任
		平成18年 7月10日登記
		平成18年 9月30日辞任
		平成18年10月16日登記
取締役	有馬利男	平成18年10月 1日就任
		平成18年10月16日登記
取締役	岡村 信興	平成18年10月 1日就任
		平成18年10月16日登記
取締役	北地 博介	平成18年10月 1日就任
(社外取締役)		平成18年10月16日登記
特別取締役	古森重隆	平成18年10月 2日就任
		平成18年10月16日登記
特別取締役	高橋一俊雄	平成18年10月 2日就任
		平成18年10月16日登記
特別取締役	佐々木 格	平成18年10月 2日就任
		平成18年10月16日登記
特別取締役	池上 眞平	平成18年10月 2日就任
		平成18年10月16日登記
特別取締役	有馬利男	平成18年10月 2日就任
		平成18年10月16日登記
東京都渋谷区広尾四丁目1番16-1103号 代表取締役 古森重隆		平成16年 6月29日重任
東京都渋谷区広尾四丁目1番16-1103号 代表取締役 古森重隆		平成17年 6月29日重任
		平成17年 7月13日登記

整理番号 マ363517

* 下線のあるものは抹消事項であることを示す。

7 / 10

神奈川県南足柄市中沼210番地
 富士フィルムホールディングス株式会社
 会社法人番号 0203-01-004138

東京都渋谷区広尾四丁目1番16-1103号 代表取締役 古森重隆	平成18年 6月29日重任 平成18年 7月10日登記
神奈川県伊勢原市上粕屋1104番地 代表取締役 麻生興太郎	平成16年 6月29日就任 平成17年 6月29日退任 平成17年 7月13日登記
静岡県富士宮市北山5180番地の20 代表取締役 林一伸 幸	平成16年 6月29日就任
静岡県富士宮市北山5180番地の20 代表取締役 林一伸 幸	平成17年 6月29日重任 平成17年 7月13日登記 平成18年 6月29日退任 平成18年 7月10日登記
神奈川県横浜市都筑区森崎町28番11号 303号 代表取締役 清木倫太郎	平成18年 6月29日就任 平成18年 7月10日登記
監査役 赤石禎裕	平成15年 6月27日重任 平成18年 6月29日辞任 平成18年 7月10日登記
監査役 三木正弘	平成16年 6月29日就任
監査役 神谷健一	平成14年 6月27日重任 平成17年 6月29日退任 平成17年 7月13日登記
監査役 児島章郎	平成15年 6月27日重任

整理番号 マ363517

* 下線のあるものは抹消事項であることを示す。

8 / 10

神奈川県南足柄市中沼2-10番地
 富士フィルムホールディングス株式会社
 会社法人番号 0203-01-004138

		平成18年 6月29日辞任
		平成18年 7月10日登記
	監査役 古沢 熙 一 郎	平成15年 6月27日就任
	監査役 古沢 熙 一 郎 (社外監査役)	平成18年 7月10日社外 監査役の登記
	監査役 大塚 奎 一	平成18年 6月29日就任
		平成18年 7月10日登記
	監査役 小川 大 介 (社外監査役)	平成18年 6月29日就任
		平成18年 7月10日登記
	会計監査人 監査法人 監査法人	平成18年 7月10日会計 監査人の登記
会社分割	平成18年10月2日東京都港区西麻布二丁目2-6番30号富士フィルム株式 会社に分割	平成18年10月10日登記
吸収合併	宮城県黒川郡大和町松坂平一丁目6番地富士フィルムマイクロデバイス株式会 社を合併	平成18年 3月31日登記
	宮城県黒川郡大和町松坂平一丁目6番地エフティホールディングス株式会 社を合併	平成18年 3月31日登記
取締役会設置会社 に関する事項	取締役会設置会社	平成17年法律第87号第1 36条の規定により平成18 年 5月 2日登記
監査役設置会社 に関する事項	監査役設置会社	平成17年法律第87号第1 36条の規定により平成18 年 5月 2日登記
監査役会設置会社 に関する事項	監査役会設置会社	平成18年 7月10日登記

整理番号 マ363517

* 下線のあるものは抹消事項であることを示す。

9 / 10

神奈川県南足柄市中沼2-1-0番地
 富士フィルムホールディングス株式会社
 会社法人等番号 0203-01-004138

特別取締役に関する事項	特別取締役による議決の定めがある 平成18年10月2日設定	平成18年10月16日登記
会計監査人設置会社に関する事項	会計監査人設置会社	平成18年7月10日登記
登記記録に関する事項	平成元年法務省令第15号附則第3項の規定により	平成17年2月18日移記
	平成18年10月1日東京都港区西麻布二丁目26番30号に本店移転	平成18年11月6日登記 平成18年11月6日閉鎖

これは登記簿に記載されている閉鎖された事項の一部であることを証明した書面である。

(横浜地方法務局小田原支局管轄)

平成18年12月26日

東京法務局港出張所

登記官

白井正彦



整理番号 マ363517

* 下線のあるものは抹消事項であることを示す。

10/10

Statement

I, Yuji Orita, a Japanese citizen residing at 7-13, Nishi-Shimbashi 1-chome, Minato-ku, Tokyo 105-8408, Japan, do hereby state:

THAT I am well acquainted with the Japanese and English languages; and

THAT the attached English document is a true and accurate translation of a certificate of partial closed records of FUJIFILM Holdings Corporation, from Japanese to English.

Date:

January 16, 2007

A handwritten signature in black ink, appearing to read 'Yuji Orita', written over a horizontal line.

Yuji Orita

FUJIFILM Holdings Corporation
 Company number 0203-01-004138
 210, Nakanuma, Minami-Ashigara-shi, Kanagawa

Certificate of Partial Closed Records

Trade name	<u>Fuji Photo Film Co., Ltd.</u>	
	FUJIFILM Holdings Corporation	Changed October 1, 2006
		Registered October 16, 2006
Location of head office	210, Nakanuma, Minami-Ashigara-shi, Kanagawa	
Method of public notice	The statement is executed by publication in the <i>Nihon Keizai Shimbun</i> issued in Tokyo.	
	<u>Notices will be posted in electric format.</u> http://www.fujifilm.co.jp/ <u>Notices will be published in the <i>Nihon Keizai Shimbun</i> when it is impossible to make electric notification for unavoidable reasons.</u>	Changed June 29, 2006
		Registered July 10, 2006
	Notices will be posted in electric format. http://www.fujifilmholdings.com/ Notices will be published in the <i>Nihon Keizai Shimbun</i> when it is impossible to make electric notification for unavoidable reasons.	Changed October 1, 2006
		Registered October 16, 2006
Matters necessary for obtaining information relating to the balance sheet	http://www.fujifilm.co.jp/	
Date of incorporation	January 20, 1934	
Number of shares of one unit	100 shares	
Total number of shares that can be issued	800 million shares	
Total number of shares issued giving type of stock and number of shares of each type	Total number of issued shares 514,625,728 shares	
Rules for issuance of share certificates	<u>Certificates of shares shall be issued for shares of the Company.</u>	
		Registered May 2, 2006 under Article 136 of Law No.87 of 2005

FUJIFILM Holdings Corporation
 Company number 0203-01-004138
 210, Nakanuma, Minami-Ashigara-shi, Kanagawa

	Share certificates shall be issued for shares of the Company. Changed June 29, 2006, and registered July 10, 2006	
Amount of capital	40,363,373,192 yen	
Name, address and place of business of transfer agent	<u>1-4-3, Marunouchi, Chiyada-ku, Tokyo</u> <u>UFJ Trust Bank Limited</u> <u>1-4-3, Marunouchi, Chiyada-ku, Tokyo</u> <u>Stock Transfer Agency Department, UFJ Trust Bank Limited</u>	
	1-4-5, Marunouchi, Chiyada-ku, Tokyo Mitsubishi UFJ Trust and Banking Corporation 1-4-5, Marunouchi, Chiyada-ku, Tokyo Securities Transfer Department, Mitsubishi UFJ Trust and Banking Corporation Changed October 1, 2005, and registered October 7 2005.	
Matters relating to officers	<u>Director</u> <u>Shigetaka Komori</u>	Reappointed June 29, 2004
	<u>Director</u> <u>Shigetaka Komori</u>	Reappointed June 29, 2005
	Director Shigetaka Komori	Registered July 13, 2005
		Reappointed June 29, 2006
		Registered July 10, 2006
	<u>Director</u> <u>Kotaro Aso</u>	Reappointed June 29, 2004
		Retired June 29, 2005
		Registered July 13, 2005
	<u>Director</u> <u>Nobuyuki Hayashi</u>	Reappointed June 29, 2004
		Reappointed June 29, 2005
	Registered July 13, 2005	
	Retired June 29, 2006	
	Registered July 10, 2006	

	<u>Director</u> <u>Akikazu Mikawa</u>	Reappointed June 29, 2004
		Retired June 29, 2005
		Registered July 13, 2005
	<u>Director</u> <u>Shigenori Moriuchi</u>	Reappointed June 29, 2004
	<u>Director</u> <u>Shigenori Moriuchi</u>	Reappointed June 29, 2005
		Registered July 13, 2005
		Retired June 29, 2006
		Registered July 10, 2006
	<u>Director</u> <u>Keigo Shioya</u>	Reappointed June 29, 2004
		Retired June 29, 2005
		Registered July 13, 2005
	<u>Director</u> <u>Toshio Takahashi</u>	Reappointed June 29, 2004
<u>Director</u> <u>Toshio Takahashi</u>	Reappointed June 29, 2005	
	Registered July 13, 2005	
Director Toshio Takahashi	Reappointed June 29, 2006	
	Registered July 10, 2006	
<u>Director</u> <u>Hidenobu Fukunaga</u>	Reappointed June 29, 2004	
<u>Director</u> <u>Hidenobu Fukunaga</u>	Reappointed June 29, 2005	
	Registered July 13, 2005	
	Retired June 29, 2006	
	Registered July 10, 2006	

	<u>Director</u> <u>Hisatoyo Kato</u>	Reappointed June 29, 2004
	<u>Director</u> <u>Hisatoyo Kato</u>	Reappointed June 29, 2005
	<u>Director</u> <u>Hisatoyo Kato</u>	Registered July 13, 2005
	<u>Director</u> <u>Hisatoyo Kato</u>	Reappointed June 29, 2006
	<u>Director</u> <u>Hisatoyo Kato</u>	Registered July 10, 2006
	<u>Director</u> <u>Yousuke Uchida</u>	Appointed June 29, 2004
		Retired June 29, 2005
		Registered July 13, 2005
	<u>Director</u> <u>Atsushi Yoneda</u>	Appointed June 29, 2004
	<u>Director</u> <u>Atsushi Yoneda</u>	Reappointed June 29, 2005
		Registered July 13, 2005
		Retired June 29, 2006
		Registered July 10, 2006
	<u>Director</u> <u>Tadashi Sasaki</u>	Appointed June 29, 2004
	<u>Director</u> <u>Tadashi Sasaki</u>	Reappointed June 29, 2005
		Registered July 13, 2005
	<u>Director</u> <u>Tadashi Sasaki</u>	Reappointed June 29, 2006
		Registered July 10, 2006
	<u>Director</u> <u>Hiroshi Hara</u>	Appointed June 29, 2004
	<u>Director</u> <u>Hiroshi Hara</u>	Reappointed June 29, 2005
		Registered July 13, 2005

FUJIFILM Holdings Corporation
 Company number 0203-01-004138
 210, Nakanuma, Minami-Ashigara-shi, Kanagawa

		Retired June 29, 2006
		Registered July 10, 2006
	<u>Director</u> <u>Shinpei Ikenoue</u>	Appointed June 29, 2004
	<u>Director</u> <u>Shinpei Ikenoue</u>	Reappointed June 29, 2005
	<u>Director</u> <u>Shinpei Ikenoue</u>	Registered July 13, 2005
	<u>Director</u> <u>Shinpei Ikenoue</u>	Reappointed June 29, 2006
	<u>Director</u> <u>Shinpei Ikenoue</u>	Registered July 10, 2006
	<u>Director</u> <u>Kohtaro Nakamura</u>	Appointed June 29, 2004
	<u>Director</u> <u>Kohtaro Nakamura</u>	Reappointed June 29, 2005
	<u>Director</u> <u>Kohtaro Nakamura</u>	Registered July 13, 2005
	<u>Director</u> <u>Kohtaro Nakamura</u>	Reappointed June 29, 2006
	<u>Director</u> <u>Kohtaro Nakamura</u>	Registered July 10, 2006
	<u>Director</u> <u>Minoru Ohnishi</u>	Reappointed June 29, 2004
		Retired June 29, 2005
		Registered July 13, 2005
	<u>Director</u> <u>Keiichi Inuzuka</u>	Appointed June 29, 2005
	<u>Director</u> <u>Keiichi Inuzuka</u>	Registered July 13, 2005
	<u>Director</u> <u>Keiichi Inuzuka</u>	Retired June 29, 2006
	<u>Director</u> <u>Keiichi Inuzuka</u>	Registered July 10, 2006
	<u>Director</u> <u>Nobuhira Takagi</u>	Appointed June 29, 2005
	<u>Director</u> <u>Nobuhira Takagi</u>	Registered July 13, 2005
	<u>Director</u> <u>Nobuhira Takagi</u>	Reappointed June 29, 2006
	<u>Director</u> <u>Nobuhira Takagi</u>	Registered July 10, 2006

		Resigned September 30, 2006
		Registered October 16, 2006
	<u>Director</u> <u>Koji Kamiyama</u>	Appointed June 29, 2005
		Registered July 13, 2005
	<u>Director</u> <u>Koji Kamiyama</u>	Reappointed June 29, 2006
		Registered July 10, 2006
		Resigned September 30, 2006
		Registered October 16, 2006
	<u>Director</u> <u>Tsutomu Sugisaki</u>	Appointed June 29, 2005
		Registered July 13, 2005
	<u>Director</u> <u>Tsutomu Sugisaki</u>	Reappointed June 29, 2006
		Registered July 10, 2006
		Resigned September 30, 2006
		Registered October 16, 2006
	<u>Director</u> <u>Noboru Sasaki</u>	Appointed June 29, 2005
		Registered July 13, 2005
	<u>Director</u> <u>Noboru Sasaki</u>	Reappointed June 29, 2006
		Registered July 10, 2006
		Resigned September 30, 2006
		Registered October 16, 2006
	<u>Director</u> <u>Hisamasa Abe</u>	Appointed June 29, 2006
		Registered July 10, 2006
		Resigned September 30, 2006
		Registered October 16, 2006
	<u>Director</u> <u>Akio Mitsui</u>	Appointed June 29, 2006
		Registered July 10, 2006

FUJIFILM Holdings Corporation
 Company number 0203-01-004138
 210, Nakanuma, Minami-Ashigara-shi, Kanagawa

		Resigned September 30, 2006
		Registered October 16, 2006
<u>Director</u>	<u>Yuzo Toda</u>	Appointed June 29, 2006
		Registered July 10, 2006
		Resigned September 30, 2006
		Registered October 16, 2006
Director	Toshio Arima	Appointed October 1, 2006
		Registered October 16, 2006
Director	Nobuoki Okamura	Appointed October 1, 2006
		Registered October 16, 2006
Director	Teisuke Kitayama (is an outside director)	Appointed October 1, 2006
		Registered October 16, 2006
Special Director	Shigetaka Komori	Appointed October 2, 2006
		Registered October 16, 2006
Special Director	Toshio Takahashi	Appointed October 2, 2006
		Registered October 16, 2006
Special Director	Tadashi Sasaki	Appointed October 2, 2006
		Registered October 16, 2006
Special Director	Shinpei Ikenoue	Appointed October 2, 2006
		Registered October 16, 2006
Special Director	Toshio Arima	Appointed October 2, 2006
		Registered October 16, 2006
<u>Representative Director</u>	<u>Shigetaka Komori</u> <u>4-1-16-1103, Hiroo Shibuya-ku, Tokyo</u>	Reappointed June 29, 2004
<u>Representative Director</u>	<u>Shigetaka Komori</u> <u>4-1-16-1103, Hiroo Shibuya-ku, Tokyo</u>	Reappointed June 29, 2005
		Registered July 13, 2005

	Representative Director <u>Shigetaka Komori</u> 4-1-16-1103, Hiroo Shibuya-ku, Tokyo	Reappointed June 29, 2006 Registered July 10, 2006
	Representative Director <u>Kotaro Aso</u> 1104, Kamikasuya, Isehara-shi, Kanagawa	Appointed June 29, 2004 Retired June 29, 2005 Registered July 13, 2005
	Representative Director <u>Nobuyuki Hayashi</u> 5180-20, Kitayama, Fujinomiya-shi, Shizuoka	Appointed June 29, 2004
	Representative Director <u>Nobuyuki Hayashi</u> 5180-20, Kitayama, Fujinomiya-shi, Shizuoka	Reappointed June 29, 2005 Registered July 13, 2005 Retired June 29, 2006 Registered July 10, 2006
	Representative Director <u>Toshio Takahashi</u> 48-11-303, Chigasaki Chuo, Tsuzuki-ku, Yokohama-shi, Kanagawa	Appointed June 29, 2006 Registered July 10, 2006
	Auditor <u>Yoshihiro Akaishi</u>	Reappointed June 27, 2003 Resigned June 29, 2006 Registered July 10, 2006
	Auditor Masahiro Miki	Appointed June 29, 2004
	Auditor <u>Kenichi Kamiya</u>	Reappointed June 27, 2002 Retired June 29, 2005 Registered July 13, 2005
	Auditor <u>Akiro Kojima</u>	Reappointed June 27, 2003

		Resigned June 29, 2006
		Registered July 10, 2006
	<u>Auditor Kiichiro Furusawa</u>	Appointed June 27, 2003
	Auditor Kiichiro Furusawa (is an outside auditor)	Registered as outside auditor on July 10, 2006
	Auditor Keiichi Inuzuka	Appointed June 29, 2006
		Registered July 10, 2006
	Auditor Daisuke Ogawa (is an outside auditor)	Appointed June 29, 2006
		Registered July 10, 2006
	Accounting auditor Ernst & Young ShinNihon	Registered as accounting auditor on July 10, 2006
Company spin-off	Spun-off into FUJIFILM Corporation at 26-30, Nishiazabu 2-chome, Minato-ku, Tokyo on October 2, 2006	Registered October 10, 2006
Merger	Merged FUJIFILM Microdevices Co., Ltd. at 1-6, Matsusakadaira, Taiwa-cho, Kurokawa-gun, Miyagi	Registered March 31, 2006
	Merged FT Holdings Co., Ltd. at 1-6, Matsusakadaira, Taiwa-cho, Kurokawa-gun, Miyagi	Registered March 31, 2006
Matters relating to the Company establishing a Board of Directors	Company establishing a Board of Directors	Registered May 2, 2006 under Article 136 of Law No.87 of 2005
Matters relating to the Company establishing auditors	Company establishing auditors	Registered May 2, 2006 under Article 136 of Law No.87 of 2005
Matters relating to the Company establishing the auditor system	Company establishing the auditor system	Registered July 10, 2006

FUJIFILM Holdings Corporation
 Company number 0203-01-004138
 210, Nakanuma, Minami-Ashigara-shi, Kanagawa

Matters relating to special directors	There is a provision concerning resolutions by special directors. Established October 2, 2006, and registered October 16, 2006
Matters relating to the Company establishing an accounting auditor system	Company establishing an accounting auditor system Registered July 10, 2006
Matters concerning the registered record	Based on the provision of Paragraph 3 of the supplementary regulation of the 1989 Ministerial Ordinance No. 15 of the Ministry of Justice Transferred February 18, 2005
	On October 1, 2006, the head office was transferred to 26-30, Nishiazabu 2-chome, Minato-ku, Tokyo. Registered November 6, 2006 Closed November 6, 2006

This certifies that the above are partial matters recorded on the register and closed.

(Under the jurisdiction of the Odawara Branch Office, Yokohama District Legal Affairs Bureau)

November 14, 2006
 Minato Branch Office, Tokyo Legal Affairs Bureau
 Registrar Masahiko Shirai

DECLARATION OF ASSIGNMENT

We have assigned

**all active European patent applications,
all active European patents within the nine-months opposition period and
all active European patents within an opposition procedure**

currently standing in the name of Fuji Photo Film Co., Ltd.

to

Name and address
of assignee: FUJIFILM Corporation
26-30, Nishiazabu 2-chome
Minato-ku
Tokyo
Japan

and agree that this assignment will be recorded in the European Patent Office.

Place/Date: TOKYO / January 25, 2007

Signature of Assignor:

(FUJIFILM Holdings Corporation)

Name of signatory: Kazuyoshi Hoshi

Title of signatory: Senior Manager, IP Strategy Group, Corporate R&D Div.

DECLARATION OF ACCEPTANCE

We herewith agree to this assignment and request to be registered as the owner/applicant of all the active European patent applications, all the European patents within the nine-months opposition period and of all the European patents within an opposition procedure at the European Patent Office.

Place/Date: TOKYO / January 25, 2007

Signature of Assignor:

(FUJIFILM Corporation)

Name of signatory: Kazuyoshi Hoshi

Title of signatory: General Manager, Intellectual Property Technology Div.

(no legalization)

Vollmacht — Power of Attorney**Zusammenschluß Nr. 72 / Association No. 72**

handelnd unter - acting under

Grünecker, Kinkeldey, Stockmair & Schwanhäusser

wird hiermit in Sachen - are in the matter of

**Recordal of Transfer in Ownership
against all pending European Patent Applications and European Patents
within the nine-months opposition period/pending opposition procedure**

Vertretenvollmacht erteilt für das Anmelde- und Schutzbewilligungsverfahren, für das erteilte bzw. eingetragene Schutzrecht sowie für das Einspruchs-, Widerspruchs-, Nichtigkeits-, Beschwerde-, Zwangslizenz- oder Lösungsverfahren vor dem Deutschen Patentamt, dem Europäischen Patentamt, dem Bundespatentgericht, dem HABM und dem Bundesgerichtshof. Die Vollmacht schließt die Bestellung zum Inlandsvertreter gemäß §§ 25 PatG sowie 96 MarkenG ein und umfasst auch das Verfahren nach dem Vertrag über die internationale Zusammenarbeit auf dem Gebiet des Patentwesens (PCT) ein. Die Bevollmächtigten sind berechtigt, Untervollmachten zu erteilen.

Auf Grund dieser Vollmacht sind sie insbesondere zu folgenden Rechtsgeschäften und Verfügungen ermächtigt: Alle Mitteilungen, Bescheide, Beschlüsse und Urteile der Patentämter und der Gerichte in Empfang zu nehmen, Rechtsmittel oder Rechtsbefehle einzulegen oder zurückzunehmen, Vergleiche abzuschließen, auf die Anmeldung oder das Schutzrecht ganz oder teilweise zu verzichten, die Beschränkung des Schutzrechts zu beantragen, eine Lizenzbereitschaftserklärung abzugeben oder einen von einem Gegner erhobenen Anspruch anzuerkennen, in Markensachen Widerspruch gegen die Löschung der Marke oder Aberkennung des Schutzes der Marke und gegen die Eintragung sowie gegen die Schutzbewilligung anderer Marken zu erheben und die Löschung bzw. Schutzentziehung anderer Marken zu beantragen, gestellte Anträge zurückzunehmen, Zahlungen für den Auftraggeber zu leisten und in Empfang zu nehmen sowie Strafanträge zu stellen.

Den Rechtsanwälten wird hiermit zusätzlich

Vollmacht erteilt

- zur Prozeßführung (u.a. nach §§ 81 ff ZPO) einschließlich der Befugnis zur Erhebung und Zurücknahme von Widerklagen,
- zur Vertretung in sonstigen Verfahren (insbesondere Beschlagnahmeverfahren nach §§ 146 MarkenG, 142a PatG, 25a GebrMG, 14a GeschmMG und 111a UrhG) und bei außergerichtlichen Verhandlungen aller Art,
- zur Begründung und Aufhebung von Vertragsverhältnissen und zur Abgabe von einseitigen Willenserklärungen (z.B. Kündigungen),
- zur Vertretung und Verteidigung in Strafsachen und Bußgeldsachen (§§ 302, 374 StPO) einschließlich der Vorverfahren sowie zur Stellung von Strafanträgen- und anderen nach der Strafprozeßordnung zulässigen Anträgen (insbesondere Strafanträge nach dem PatG, GebrMG, GeschmMG, MarkenG und UrhG).

Die Vollmacht gilt für alle Instanzen und erstreckt sich auch auf Neben- und Folgeverfahren aller Art (z.B. Arreste und einstweilige Verfügungen, Kostenfestsetzungs-, Zwangsvollstreckungs-, Interventions-, Zwangsversteigerungs-, Zwangsverwaltungs- und Hinterlegungsverfahren sowie Konkurs- und Vergleichsverfahren über das Vermögen des Gegners). Sie umfaßt insbesondere die Befugnis, Zustellungen zu bewirken und entgegenzunehmen, die Vollmacht ganz oder teilweise auf andere zu übertragen (Untervollmacht), Rechtsmittel einzulegen, zurückzunehmen oder auf sie zu verzichten, den Rechtsstreit oder außergerichtliche Verhandlungen durch Vergleich, Verzicht oder Anerkenntnis zu erledigen, Geld, Wertsachen und Urkunden, insbesondere auch den Streitgegenstand und die von dem Gegner, von der Justizkasse oder von sonstigen Stellen zu erstattenden Beträge entgegenzunehmen.

Erfüllungsort für alle Ansprüche aus den der Vollmacht zugrundeliegenden Rechtsverhältnissen und Gerichtsstand ist München.

Tokyo, January 24, 2007

Ort/Place; Datum/Date

Keine Beglaubigung erforderlich - No legalization

Hereby appointed

to act for me/us in proceedings concerning applications, registrations, granted or registered industrial or intellectual property, rights, and in proceedings concerning opposition, nullity, appeal, compulsory license, rectification, revocation or cancellation in the German Patent Office, the European Patent Office, before the Federal Patent Court, the OHIM and the Federal Court of Justice. This authorization includes the appointment as representative pursuant to §§ 25 PatG and 96 MarkenG and also pertains to the procedure under the Patent Cooperation Treaty (PCT). The authorized attorneys are authorized to grant powers of substitution.

By virtue of this authorization they are especially empowered to carry out the following legal transactions and disposals: to receive all communications, official actions and decisions of the Patent Offices and the Courts; to lodge or withdraw legal measures or legal remedies; to conclude agreements; to fully or partially disclaim the application or the property right; to apply for the restriction of a property right; to deliver a declaration of "readiness to license" or to acknowledge a claim raised by an opposing party; in matters of trade marks to contest an application for the cancellation or revocation of an entry in the Register in respect of a trade mark, to enter opposition against the registration of other trade marks including internationally registered marks, and to apply for the cancellation or revocation of an entry in the Register in respect of other trade marks including internationally registered marks; to withdraw applications; to make and receive payments on behalf of the client(s); and to file motions for criminal prosecution.

The attorneys-at-law are additionally

hereby appointed

- to represent me/us in litigation (inter alia according to §§ 81 et seq. ZPO) including to file and to withdraw countersuits,
- to act for me/us in other proceedings (especially seizure proceedings according to §§ 146 MarkenG, 142a PatG, 25a GebrMG, 14a GeschmMG and 111a UrhG) and in extrajudicial negotiations of all kinds,
- to enter into and to terminate agreements on my/our behalf and to make unilateral declarations (e.g. notices of termination),
- to act for me/us in criminal and administrative penalty proceedings (§§ 302, 374 StPO) including the pre-trial proceedings and to file motions for prosecution as well as other motions available under the Code of Criminal Procedure (especially motions for prosecution according to the PatG, GebrMG, GeschmMG, MarkenG and UrhG).

This Power of Attorney is valid for all instances and extends to all ancillary and subsequent proceedings of all kinds (i.e. preliminary injunction, taxation of costs, enforcement and intervention proceedings, execution sales by public auction, bailment as well as bankruptcy proceedings of an opponent). The Power of Attorney especially comprises the right to effect service and to accept service, to confer the Power of Attorney entirely or partly to other persons, to file and withdraw appeals or to waive the right to an appeal, to settle suits or extrajudicial negotiations by settlement, waiver or acknowledgment, to accept money, valuables, and documents, especially the subject of litigation and monies to be reimbursed by the opponent, the court cashier, or other institutions.

The place of settlement and venue for all claims arising out of the legal relationship existing by virtue of the Power of Attorney is Munich.

FUJIFILM Corporation, represented by

Name : Kazuyoshi Hoshi
Title : General Manager
Intellectual Property Technology Div.
Intellectual Property Div.
R & D Management HQ

(Namen und Vornamen voll ausschreiben, bei Firmen genaue, eingetragene Firmenbezeichnung angeben.) (First names and surnames of individual persons are to be written in full; corporate bodies are to sign in the form in which they are registered.)

00 124 448.2

FUJI PHOTO FILM CO., LTD.

Patentansprüche

1. Magnetbandkassette (1), aufweisend ein um eine Einzelspule (2) geschlungenes Magnetband, ein Kassettengehäuse (3) zum Unterbringen der Spule (2) und eine Spulenanschlageinrichtung (10) zum Verriegeln der Spule (2) oder zum Gestatten der Drehung derselben, wobei die Spulenanschlageinrichtung (10) ein Bremsteil (4) aufweist, das zwischen einer Verriegelungsposition und einer Freigabeposition bewegbar ist, ein Vorspannteil (5) zum Vorspannen des Bremsteils (4) in die Richtung zu der Verriegelungsposition, und ein Freigabeteil (6), das einstückig mit der Spule (2) gedreht wird, zum Bewegen des Bremsteils (4) in Richtung zu der Freigabeposition in Abhängigkeit von einer Spulenspannwirkung einer Spulen-antriebseinrichtung (11) eines Bandantriebs, und wobei das Bremsteil (4) mit einem Bremszahnrad (42) versehen ist, das Zahnradzähne aufweist, die vorgesehen sind, um mit zumindest einem Eingriffszahnradzahn (29) eines Eingriffsvor-sprungs (27), gebildet an der Spule (2) in Eingriff zu sein, **dadurch gekenn-zeichnet, dass** jedes der Zahnradzähne des Bremszahnrades (42) aufweist eine erste geneigte Oberfläche (42a), die in die Richtung zu einer Bandabwicklungs-richtung (U) gerichtet ist und eine zweite geneigte Oberfläche (42b), die in die Richtung zu einer Bandaufwickelrichtung (W) gerichtet ist, wobei ein Innenwinkel (α) zwischen der ersten geneigten Oberfläche (42a) und einer Vertikalen (s) kleiner ist als ein Innenwinkel (β) zwischen der zweiten geneigten Oberfläche (42b) und der Vertikalen (s), und die geneigten Oberflächen (42a, 42b) dazwischen einen spitzen Winkel (γ) bildet, der kleiner als 90° ist.
2. Magnetbandkassette (1) nach Anspruch 1, **dadurch gekennzeichnet, dass** zu-mindest ein Eingriffszahnradzahn (29) eine erste und eine zweite geneigte Ober-fläche (29a, 29b) aufweist, jeweils entsprechend der ersten und der zweiten ge-neigten Oberfläche (42a, 42b) der Zahnradzähne des Bremszahnrades (42) ent-sprechen.
3. Magnetbandkassette (1) nach Anspruch 1 oder 2, **dadurch gekennzeichnet, dass** die Spule (2) mit einem Führungsteil (28, 39) zum Zentrieren des Bremsteils (4) in Bezug auf die Spule (2) versehen ist.

4. Magnetbandkassette (1) nach Anspruch 3, **dadurch gekennzeichnet, dass** das Führungsteil (39) Führungsrippen auf einer Innenoberfläche einer Spulennabe (21) an zumindest drei Stellen aufweist, wobei jede Führungsrippe eine geneigte Oberfläche aufweist, die von einem oberen Abschnitt der Innenoberfläche der Spulennabe (21) in Richtung zu einer Mitte der Spule (2) geneigt ist.

5. Magnetbandkassette (1) nach zumindest einem der Ansprüche 1 bis 4, **dadurch gekennzeichnet, dass** ein Außendurchmesser (D) eines Eingriffszahnrades, das zumindest einen Eingriffszahnradzahn (29) aufweist, größer als ein Außendurchmesser (d) des Bremszahnrades (42) ist.

REVENDEICATIONS

5 1. Cartouche à bande magnétique (1) comprenant une bande magnétique
enroulée autour d'une seule bobine (2), un boîtier de cartouche (3) permettant de
loger la bobine (2) et un moyen d'arrêt de la bobine (10) permettant de bloquer la
bobine (2) ou permettant sa rotation, le moyen d'arrêt de la bobine (10) comprenant
un élément de freinage (4) mobile entre une position de blocage et une position de
desserrage, un élément de poussée (5) permettant de pousser l'élément de freinage
10 (4) vers la position de blocage, et un élément de desserrage (6) tourné intégralement
avec la bobine (2) pour déplacer l'élément de freinage (4) vers la position de
desserrage en réponse à une action de mandrinage de la bobine d'un moyen
d'entraînement de bobine (11) d'un entraînement de bande, et l'élément de freinage
(4) étant muni d'un pignon de freinage (42) comprenant des dents conçues pour
15 s'emboîter avec au moins une dent de pignon d'engagement (29) d'une saillie
d'engagement (27) formée sur la bobine (2), caractérisée en ce que chacune des
dents du pignon de freinage (42) comprend une première surface inclinée (42a)
orientée dans une direction de déroulage de la bande (U) et une seconde surface
inclinée (42b) orientée dans une direction d'enroulage de la bande (W), un angle
20 interne (α) entre la première surface inclinée (42a) et une verticale (s) étant inférieur
à un angle interne (β) entre la seconde surface inclinée (42b) et la verticale (s) et les
surfaces inclinées (42a, 42b) forment entre elles un angle apical (γ) inférieur à 90° .

2. Cartouche à bande magnétique (1) selon la revendication 1, caractérisée en
ce que la (au moins une) dent de pignon d'engagement (29) comprend une première
25 et une seconde surface inclinée (29a, 29b) correspondant respectivement à la
première et à la seconde surface inclinée (42a, 42b) des dents du pignon de freinage
(42).

3. Cartouche à bande magnétique (1) selon la revendication 1 ou 2,
caractérisée en ce que la bobine (2) est munie d'un élément de guidage (28, 39)
30 permettant de centrer l'élément de freinage (4) par rapport à la bobine (2).

4. Cartouche à bande magnétique (1) selon la revendication 3, caractérisée en
ce que l'élément de guidage (39) comprend des nervures de guidage formées sur
une surface interne d'un moyeu de bobine (21) au niveau d'au moins trois
emplacements, chaque nervure de guidage comprenant une surface inclinée vers le

bas d'une portion supérieure de la surface interne du moyeu de bobine (21) vers un centre de la bobine (2).

5. Cartouche à bande magnétique (1) selon au moins l'une des revendications 1 à 4, caractérisée en ce qu'un diamètre externe (D) d'un pignon d'engagement comprenant la (au moins une) dent de pignon d'engagement (29) est supérieur à un diamètre externe (d) du pignon de freinage (42).

GRÜNECKER KINKELDEY STOCKMAIR & SCHWANHÄUSSER

ANWALTSSOZIELTÄT

EPO - Munich
39

01. Feb. 2007

GKS & S MAXIMILIANSTRASSE 58 D-80538 MÜNCHEN GERMANY

European Patent Office
Erhardtstraße 27

80298 München

RECHTSANWÄLTE
LAWYERS

MÜNCHEN
DR. HELMUT EICHMANN
GERHARD BARTH
DR. ULRICH BLUMENRÖDER, LL. M.
CHRISTA NIKLAS-FALTER
DR. MAXIMILIAN KINKELDEY, LL. M.
DR. KARSTEN BRANDT
ANJA FRANKE, LL. M.
UTE STEPHANI
DR. BERND ALLEKOTTE, LL. M.
DR. ELVIRA BERTRAM, LL. M.
KARIN LOCHNER
BABETT ERTLE
CHRISTINE NEUHIERL
SABINE PRÜCKNER
CORNELIA SCHMITT
BERNHARD MEHNERT, DIPL. ING.
PETRA LÜBBE
DR. SONJA BRÖTJE
SONJA SCHÄFFLER
DR. HOLGER GAUSS
DR. NICOLÁS SCHMITZ

PATENTANWÄLTE
EUROPEAN PATENT ATTORNEYS

MÜNCHEN
DR. HERMANN KINKELDEY
PETER H. JAKOB
HANS HILGERS
ANNELIE EHNOLD
THOMAS SCHÜSTER
DR. KLARA GOLDBACH
MARTIN AUFENANGER
GOTTFRIED KLITZSCH
DR. HEIKE VOGELSANG-WENKE
REINHARD KNAUER
DIETMAR KUHLE
DR. FRANZ-JOSEF ZIMMER
BETTINA K. REICHELT
DR. ANTON K. PFAU
DR. UDO WEIGELT
RAINER BERTRAM
JENS KOCH, M. S. (U of PA) M. S.
BERND ROTHAEHEL
THOMAS W. LAUBENTHAL
DR. ANDREAS KAYSER
DR. JENS HAMMER
DR. THOMAS EICKELKAMP
DR. CARLO TORTI*
DR. PETER MILTÉNYI
DR. MORITZ HÖFFE
*EUROPEAN PATENT ATTORNEY

PATENTANWÄLTE
EUROPEAN PATENT ATTORNEYS

BERLIN
PROF. DR. MANFRED BÖNING
DR. PATRICK ERK, M. S. (MIT)
KÖLN
DR. MARTIN DROPMANN
CHEMNITZ
DR. CARMEN STEINIGER*
*PATENTANWALT
ALICANTE
WOLFHARD MEISTER
DR. ANDREAS TORKA*
*RECHTSANWALT
OF COUNSEL
DR. HENNING MEYER-PLATH
DR. WILFRIED STOCKMAIR
(-1996)

IHR ZEICHEN / YOUR REF.

UNSER ZEICHEN / OUR REF.
EP20062NN904gwr

DATUM / DATE
01.02.2007

European Patent Application No. 00 124 448.2-2210
Applicant: Fuji Photo Film Co., Ltd.

In response to the Communication under Rule 51(4) EPC dated 29 September 2006:

The following documents are submitted herewith:

- French and German translations of the claims
- EPO Form 1010
- Translations of two (2) Priority Documents

Please debit our account no. 28 00 04 37 with the official printing fee of EUR 750,--.

We herewith request one copy of the printed patent specification when issuing the certificate.

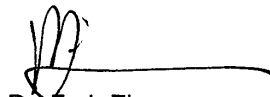

Dr. F.-J. Zimmer
- Patent Attorney -

Encl.

Zur Kasse
(A) € 750,-

GRÜNECKER KINKELDEY
STOCKMAIR & SCHWANHÄUSSER
MAXIMILIANSTR. 58
D-80538 MÜNCHEN
GERMANY

TEL. +49 89 21 23 50
FAX +49 89 22 02 87
FAX +49 89 21 86 92 93
<http://www.grunecker.de>
e-mail: info@grunecker.de

DEUTSCHE BANK MÜNCHEN
No. 17 51734
BLZ 700 700 10
SWIFT: DEUT DE MM



European Patent Office
Postbus 5818
2280 HV RIJSWJK
NETHERLANDS
Tel.: +31 70 340 2040
Fax: +31 70 340 3016

Europäisches
Patentamt

European
Patent Office

Office européen
des brevets

Grünecker, Kinkeldey,
Stockmair & Schwanhäusser
Anwaltssozietät
Maximilianstrasse 58
80538 München
ALLEMAGNE



EPO Customer Services

Tel.: +31 (0)70 340 45 00

Date

09.02.07

Reference EP20062-013/do	Application No./Patent No. 00124448.2 - 1232
Applicant/Proprietor FUJIFILM Corporation	

Communication

concerning the registration of amendments relating to

- a transfer (Rules 20 and 61 EPC)
 entries pertaining to the applicant/the proprietor (Rule 92(1)(f) EPC)

As requested, the entries pertaining to the applicant of the above-mentioned European patent application / to the proprietor of the above-mentioned European patent have been amended to the following:

DE FR GB
FUJIFILM Corporation
26-30, Nishiazabu 2-chome
Minato-ku
Tokyo/JP

The registration of the changes has taken effect on 01.02.07.

In the case of a published application/a patent, the change will be recorded in the Register of European Patents and published in the European Patent Bulletin (Section I.12/II.12).

Your attention is drawn to the fact that, in the case of the registration of a transfer, any automatic debit order only ceases to be effective from the date of its express revocation (cf. point 14(c) of the Arrangements for the automatic debiting procedure, Supplement to OJ EPO 2/2002).

Transfer Service

Tel.: +49 (0)89 2399 2780





European Patent Office
Postbus 5818
2280 HV RIJSWIJK
NETHERLANDS
Tel.: +31 70 340 2040
Fax: +31 70 340 3016

Europäisches
Patentamt

European
Patent Office

Office européen
des brevets

Grünecker, Kinkeldey,
Stockmair & Schwanhäusser
Anwaltssozietät
Maximilianstrasse 58
80538 München
ALLEMAGNE



EPO Customer Services

Tel.: +31 (0)70 340 45 00

Date

08.03.07

Reference EP20062-013/do	Application No./Patent No. 00124448.2 - 1232 / 1098320
Applicant/Proprietor FUJIFILM Corporation	

Decision to grant a European patent pursuant to article 97(2) EPC

Following examination of European patent application No. 00124448.2 a European patent with the title and the supporting documents indicated in the communication pursuant to Rule 51(4) EPC dated 29.09.06 is hereby granted in respect of the designated Contracting States.

Patent No. : 1098320
Date of filing : 08.11.00
Priority claimed : 08.11.99/JPA 31716699
09.11.99/JPA 31846499

Designated Contracting States
and Proprietor(s) : DE FR GB
FUJIFILM Corporation
26-30, Nishiazabu 2-chome
Minato-ku
Tokyo/JP

This decision will take effect on the date on which the European Patent Bulletin mentions the grant (Art. 97(4) and (5) EPC).

The mention of the grant will be published in European Patent Bulletin 07/14 of 04.04.07.

Examining Division

Declat M

Sozzi R

Holubov C



Registered letter
EPO Form 2006A 07.02 02.03.07

to EPO postal service: 02.03.07

ANMERKUNG ZUR ENTSCHEIDUNG ÜBER DIE ERTEILUNG
EINES EUROPÄISCHEN PATENTS (EPA Form 2006)

- 1. EPA Informationsbroschüre "Nationales Recht zum EPÜ"**
Diese Broschüre enthält nützliche Informationen zu den formalen Erfordernissen und den Handlungen, die vor den Patentbehörden der Vertragsstaaten vorzunehmen sind, um Rechte in diesen Staaten zu erlangen. Da diese Handlungen einem ständigen Wandel unterworfen sind, sollte immer nur die neueste Ausgabe der Broschüre benutzt werden. Nachträgliche Informationen werden im Amtsblatt veröffentlicht.
- 2. Übersetzung der europäischen Patentschrift nach Artikel 65(1) des Europäischen Patentübereinkommens**
Sie werden erneut darauf hingewiesen, dass bestimmte Vertragsstaaten nach Artikel 65(1) EPÜ eine Übersetzung der europäischen Patentschrift verlangen; hierauf wird in der Mitteilung gemäss Regel 51(6) verwiesen. **Die Nichteinreichung dieser Übersetzung kann zur Folge haben, dass das Patent in dem betreffenden Staat/in den betreffenden Staaten als von Anfang an nicht eingetreten gilt.** Weitere Einzelheiten entnehmen Sie bitte der oben genannten Broschüre.
- 3. Zahlung von Jahresgebühren für europäische Patente**
Nach Artikel 141 EPU können "nationale" Jahresgebühren für das europäische Patent für die Jahre erhoben werden, die an das Jahr anschliessen, in dem der Hinweis auf die Erteilung des europäischen Patents im "Europäischen Patentblatt" bekanntgemacht wird. Weitere Einzelheiten entnehmen Sie bitte der oben genannten Broschüre.

NOTE RELATING TO THE DECISION TO GRANT A
EUROPEAN PATENT (EPO Form 2006)

- 1. EPO Information Brochure "National law relating to the EPC"**
This brochure provides useful information regarding formal requirements and the steps to be taken before the patent authorities of the Contracting States in order to acquire rights in those states. Since the necessary steps are subject to change the latest edition of the brochure should always be used. Subsequent information is published in the Official Journal.
- 2. Translation of the European patent specification under Article 65(1) of the European Patent Convention**
Your attention is again drawn to the requirements regarding translation of the European patent specification laid down by a number of Contracting States under Article 65(1) EPC, to which reference is made in the communication under Rule 51(6). **Failure to supply such translation(s) may result in the patent being deemed to be void "ab initio" in the State(s) in question.** For further details you are recommended to consult the above-mentioned brochure.
- 3. Payment of renewal fees for European patents**
Under Article 141 EPC "national" renewal fees in respect of a European patent may be imposed for the years which follow that in which the mention of the grant of the European patent is published in the "European Patent Bulletin". For further details you are recommended to consult the above-mentioned brochure.

REMARQUE RELATIVE A LA DECISION DE DELIVRANCE
D'UN BREVET EUROPEEN (OEB Form 2006)

- 1. Brochure d'information de l'OEB "Droit national relatif à la CBE"**
Cette brochure fournit d'utiles renseignements sur les conditions de forme requises et sur les actes à accomplir auprès des offices de brevet des Etats contractants aux fins d'obtenir des droits dans les Etats contractants. Etant donné que les actes indispensables sont susceptibles de modifications, il serait bon de toujours consulter la dernière édition de la brochure. Toute information ultérieure est publiée au Journal Officiel.
- 2. Traduction du fascicule du brevet européen en vertu de l'article 65(1) de la Convention sur le brevet européen**
Votre attention est de nouveau attirée sur l'obligation faite par certains Etats contractants, en vertu de l'article 65(1) CBE, de fournir une traduction du fascicule du brevet européen, à laquelle il est fait référence dans la notification établie conformément à la règle 51(6). **Si la(les) traduction(s) n'est(ne sont) pas fournie(s), le brevet européen peut, dès l'origine, être réputé sans effet dans cet(ces) Etat(s).** Pour plus de détails, nous vous renvoyons à la brochure susmentionnée.
- 3. Paiement des taxes annuelles pour le brevet européen**
Conformément à l'article 141 CBE, les taxes annuelles "nationales" dues au titre du brevet européen peuvent être perçues pour les années suivant celle au cours de laquelle la mention de la délivrance du brevet européen est publiée au "Bulletin européen des brevets". Pour plus de détails, nous vous renvoyons à la brochure susmentionnée.



European Patent Office
Postbus 5818
2280 HV RIJSWIJK
NETHERLANDS
Tel. +31 (0)70 340-2040
Fax +31 (0)70 340-3016



Grünecker, Kinkeldey,
Stockmair & Schwanhäusser
Anwaltssozietät
Maximilianstrasse 58
80538 München
ALLEMAGNE

**For any questions about
this communication:**
Tel.: +31 (0)70 340 45 00

Date 08.02.08

Reference EP20062-013/do	Application No./Patent No. 00124448.2 - 1232 / 1098320
Applicant/Proprietor FUJIFILM Corporation	

Communication regarding the expiry of the time limit within which notice of opposition may be filed

You are hereby informed that on expiry of the nine-month time limit from the publication of the mention of the grant of European patent No. 1098320 no notice of opposition had reached the files.

The entry in the Register of European Patents will be automatically generated by the electronic data processing system.

For the Examining Division



EPPU 02: 04.04.07 1232