

(51) Int. Cl. <sup>6</sup>	ID Symbol	FI
G11B 23/107		G11B 23/107

Request for Examination: Not Requested Number of Claims: 2 FD (7 Pages Total)

(21) Application Number: H10-90784	(71) Applicant: 000005810 Hitachi Maxell, Ltd. 1-1-88 Ushitora, Ibaraki City, Osaka
(22) Filing Date: March 18, 1998	(72) Inventor: Mizutani, Hikaru Hitachi Maxell, Ltd. 1-1-88 Ushitora, Ibaraki City, Osaka
	(74) Representative: Oriyose, Takeshi; Attorney Continued on Last Page

(54) Name of Invention: Single Reel Type Magnetic Tape Cartridge

(57) Abstract

Problem: In a single reel type magnetic tape cartridge provided with a reel lock mechanism, to improve lock release reliability and durability during use.

Solution Means: A lock release member 21, a lock member 19, and a spring 20 are disposed between a tape reel 2 hub bottom wall 11 and a main body case 1 top wall 12. A plurality of leg pieces 35 provided to the lock release member 21 protrude downward from a hub bottom wall 11 leg piece protrusion hole 37. During use, when a tape drive drive shaft D operates the lock release member 21 by pressing it upward via the leg pieces 35, the lock member 19 is pressed upward in a horizontal position without tilting, releasing engagement of the hub bottom wall 11 with a lock tooth 25.

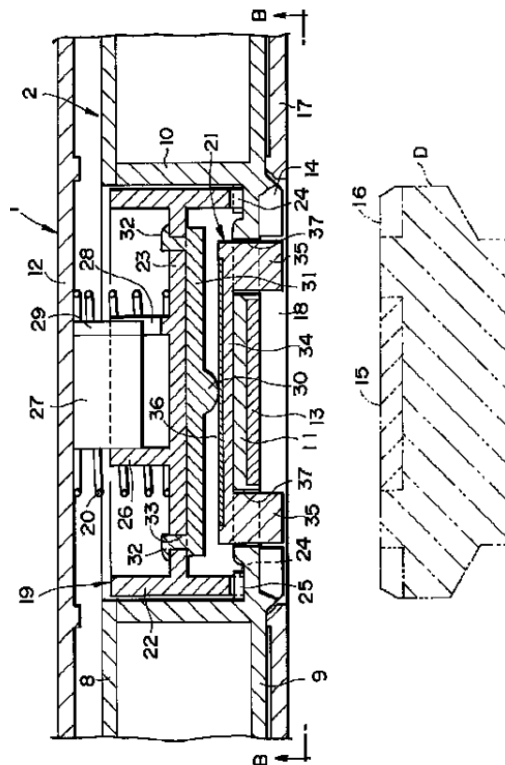

## Claims

[Claim 1] In a magnetic tape cartridge with one tape reel 2 rotatably housed in the interior of a main body case 1 over a drive shaft insertion port 18 on a case bottom wall 17, the tape reel 2 having a bottomed cylindrical hub 10 with a top surface opening at the center, and the outer bottom surface of a hub bottom wall 11 of this hub 10 facing the drive shaft insertion port 18,

providing a reel lock mechanism which prevents free rotation of the tape reel 2 during non-use, between the hub bottom wall 11 inner top surface and the main body case top wall 12, a single reel type magnetic tape cartridge in which

said reel lock mechanism is provided with a lock member 19 which is linked and guided by a guide protrusion 27 provided on the interior of the top wall 12 such that vertical sliding is enabled, but relative rotation is disabled, a spring 20 applying downward pushing force on the lock member 19, and a lock release member 21 disposed between the lock member 19 and the hub bottom wall 11 inner top surface,

the lock member 19 having a cylindrical body built into the hub 10 interior in concentric circle form, and a spring receiving wall 23 provided in the interior of this cylindrical body 22,

respectively providing on the bottom end surface of the cylindrical body 22 and the inner top surface of the hub bottom wall 11, lock teeth 24 and 25, which mutually engage protrusions and recesses to prevent rotation of the tape reel 2, the lock release member 21 is disposed between the bottom surface of the spring receiving wall 23 in the cylindrical body 22 and the hub bottom wall 11 inner top surface, and is provided with a base 34 comprising abrasion tolerant synthetic resin, a metal plate 36 layered on the top surface of the base 34, and a plurality of same length leg pieces 35 provided protruding downward from the base 34,

each leg piece 35 respectively protrudes a bottom edge thereof downward from the outer bottom surface of the hub bottom wall 11 via leg piece protrusion holes 37 provided in the hub bottom wall 11,

the spring receiving wall 23 bottom surface and the metal plate 36 top surface are in point contact via a protrusion 30 provided protruding from the center of one or the other of either the spring receiving wall 23 bottom surface or the metal plate 36,

and the hub bottom wall 11 outer bottom surface is annularly provided with drive teeth 14 on the outer periphery area beyond said leg piece protrusion holes 37, which engage with drive teeth 16 on a tape drive drive shaft D.

[Claim 2] A single reel type magnetic tape cartridge described in Claim 1, in which the plurality of leg pieces 35 are provided arranged at positions equidistant from the base 34 bottom surface center and at mutually equal intervals.

## Detailed Description of the Invention

[0001]

### Technical Field of the Invention

This invention is related to a single reel type magnetic tape cartridge represented by magnetic recording media for computer data recorders, with improvement of a reel lock mechanism thereof.

[0002]

### Prior Art

In this type of magnetic tape cartridge, there are those provided with a reel lock mechanism in the form shown in Fig. 6. Here, a tape reel 53 comprises an upper flange 50, a lower flange 51, and a cylindrical hub 52 formed integrated with the lower flange 51, and free rotation of the tape reel 53 during non-use is prevented by a lock member 54 positioned inside the hub 52. To the bottom surface center of the hub 52 inner bottom wall is secured an iron plate 55 which is magnetically attracted to a drive shaft in a tape drive, and drive teeth 56 are provided on its periphery wall to engage with drive teeth on the tape drive drive shaft.

[0003] The lock member 54 has a circular seat plate 58 for receiving the bottom end of a compression coil-shaped coil 57, and the top and bottom of the center portion of the seat plate 58 have a slide boss 59 and a passive pin 60. The slide boss 59 is guided to engage with a guide protrusion 63 provided on an upper wall 61 of the main body case 1 to enable vertical sliding but to disable rotation. The bottom surface of the seat plate 58, and the top surface of the seat 62 provided to protrude in the interior bottom of the hub 52, have mutually engaging lock teeth 64 and 65. Therefore in the state when the lock teeth 64 and 65 are mutually engaged, the tape reel 53 cannot rotate. During use, the passive pin 60 exposed at the bottom surface center of the tape reel 53 is thrust upward by the tape drive drive shaft, releasing the mutual engagement of the lock teeth 64 and 65. Simultaneously, the tape reel 53 is magnetically attracted onto the drive shaft via the iron plate 55, and the rotation force thereof is transmitted to the tape reel 53 via the drive teeth 56.

[0004]

### Problem the Invention Seeks to Solve

In said tape cartridge, because the lock member 54 passive pin 60 is directly thrust upward by the drive shaft to disengage the mutual engagement status of the lock teeth 64 and 65, the lock status sometimes is not reliably released. In the status when the lock member is operated to separate above the seat 62, the entire lock member 54 may tilt and the lock teeth 64 on the seat plate 58 and the lock teeth 65 on the seat 62 may be abutting and engaged at the lower end of the tilt. When this occurs, the drive shaft will spin free and cannot reliably rotationally drive the tape reel 53.

[0005] The guide protrusion 63 engages with the slide boss 59, and thus is useful for suppressing tilting movement of the lock member 54. However, to smoothly vertically slide the lock member, there must be a certain amount of clearance maintained between the slide boss 59 and the guide protrusion 63 sliding surfaces, and lock member 54 tilt motion for this clearance amount cannot be avoided. This is also a factor for the lock member 54 to tilt. As previously described, if the lock release for the tape reel 53 remains insufficient, abnormal tension operates on the magnetic tape, leading to severe incidents such as tape breaks. Also, the lock teeth 64 and 65 could become missing or damaged, or abnormally abraded, making the reel lock unreliable.

[0006] The purpose of the present invention is to always reliably switch the reel lock mechanism to the lock release status, to prevent operation that would pull out the magnetic tape outside of the case while still in reel lock status, thus resolving occurrences of major incidents such as tape breaks, missing or damaged lock teeth, etc., and improving reliability. Another purpose of the present invention is to provide a single reel type magnetic tape cartridge which enables improving durability of the lock release member.

[0007]

#### Means of Solving the Problem

The magnetic tape cartridge in the present invention, as shown in Fig. 1 and Fig. 2, has one tape reel 2 rotatably housed in a main body case 1 on a drive shaft insertion port 18 on a case bottom wall 17, and a reel lock mechanism for preventing free rotation of the tape reel 2 during non-use is provided between the hub bottom wall 11 inner top surface of a hub 10, provided at the center of the tape reel 2, and a main body case 1 top wall 12. This reel lock mechanism provides, as shown in Fig. 1: a lock member 19 which is guided to engage with a guide protrusion 27, provided on the main body case 1 upper wall 12 interior surface such that vertical sliding is enabled but relative rotation is disabled; a spring 20 applying downward pressing force on the lock member 19; and a lock release member 21 disposed between the lock member 19 and the hub bottom wall 11 inner top surface.

[0008] The lock member 19 is provided with a cylindrical body 22 built into the hub 10 interior in concentric circle form, and a spring receiving wall 23 provided in the interior of this cylindrical body 22. And on the bottom end surface of the cylindrical body 22 and the inner top surface of the hub bottom wall 11 are respectively provided lock teeth 24 and 25, which mutually engage protrusions and recesses to prevent rotation of the tape reel 2.

[0009] Said lock release member 21 is disposed between the bottom surface of the spring receiving wall 23 in the cylindrical body 22 and the hub bottom wall 11 inner top surface, and is provided with a base 34 comprising abrasion tolerant synthetic resin, a metal plate 36 layered on the top surface of the base 34, and a plurality of same length leg pieces 35 provided protruding downward from the base 34. Each leg piece 35 protrudes a bottom edge thereof downward from the outer bottom surface of the hub bottom wall 11 via leg piece protrusion holes 37 provided in the hub bottom wall 11. The plurality of leg pieces 35 are provided arranged at positions equidistant from the base 34 bottom surface center and at mutually equal intervals.

[0010] The spring receiving wall 23 bottom surface and the metal plate 36 top surface are in point contact via a protrusion 30 provided protruding from the center of one or the other of either the spring receiving wall 23 bottom surface or the metal plate 36. The hub bottom wall 11 outer bottom surface is annularly provided with drive teeth 14 on the outer periphery area beyond said leg piece protrusion holes 37, which engage with drive teeth 16 on a tape drive shaft D.

[0011]

#### Operation

During non-use, as shown in Fig. 1 the tape reel 2 is engaged

is energized downward by the spring 20, and is thus held with rotation disabled. The lock release member 21 has its leg pieces 35 protruding downward from the outer bottom surface of the hub bottom wall 11 via the leg piece protrusion holes 37. When leg pieces 35 in this condition are subjected to an upward push operation of the tape drive shaft D, as shown in Fig. 3 the lock member 19 is pressed upward in opposition to the spring 20, the lock teeth 24 and 25 mutually separate, and the reel lock status is released.

[0012] The purpose of performing an upward push operation of the lock member 19 via the lock release member 21 is to enable the lock member 19 to always be horizontal during the upward push operation. For this purpose, the lock release member 21 is provided with a plurality of same-length leg pieces 35 which are subjected to an upward push operation by the drive shaft D. For example, when directly performing an upward push operation of the lock member 19 with the drive shaft D, if the center of the lock member 19 and of the drive shaft D are not correctly matched, the lock member 19 will tilt in some diameter direction. But if an upward push operation is performed to the lock release member 21 via a plurality of same-length leg pieces 35, even if there is a minimal amount of position shift between the center of the lock release member 21 and the drive shaft D, the lock release member 21 can be pushed upward horizontally. Thus, the lock member 19 can be pushed upward horizontally for the amount that the lock release member 21 was pushed upward, and its lock teeth 24 will reliably separate from the lock teeth 25.

[0013] A metal plate 36 is layered on the top surface of the base 34 of the lock release member 21, and the metal plate 36 and the spring receiving wall 23 bottom surface are in point contact via a protrusion 30 provided protruding from the center of one or the other of either the spring receiving wall 23 bottom surface or the metal plate 36. Therefore, even during high speed rotation of the tape reel 2, friction resistance can be reduced between the tape reel 2 and the simultaneously rotating lock release member 21 and the stopped lock member 19, and effectively prevents friction damage on the lock member 19 and the lock release member 21.

[0014] Leg pieces 35 of the lock release member 21 are formed with abrasion tolerant synthetic resin, and does not cause missing, lost, or damaged drive teeth 16 on the drive shaft D, and effectively prevents abrasion damage caused by sliding motion of leg pieces 35 and the drive shaft D top surface. The metal plate 36 effectively reinforces the base 34 made of abrasion tolerant synthetic resin, and even when the lock release member 21 is made thinner to accommodate a very narrow space, its deformation can be prevented, and the lock member 19 upward pushing function can be stably and reliably attained.

[0015]

#### Embodiment

Fig. 1 to Fig. 4 show one embodiment of a single reel type magnetic tape cartridge in the present invention. In Fig. 2, the magnetic tape cartridge houses one tape reel 2 in the interior of a rectangular box shaped main body case 1, and a magnetic tape 3 (simply called tape hereafter) is wrapped

loading pin 4 which performs the tape 3 extraction operation. The loading pin 4 is housed to the interior of the tape extraction port 5 opening at the front right corner of the main body case 1, and both the top and bottom ends are positioned by being engaged and held by holders 6 and 6. The tape extraction port 5 can be opened and closed by a shutter 7 that can freely slide open and closed.

[0016] As shown in Fig.1, the tape reel 2 comprises an upper flange 8, a lower flange 9, and a bottomed cylindrical hub 10 open in the upward direction molded and integrated with the lower flange 9. The upper flange 8 is fixed by welding to the top end of the hub 10 to prevent separation. A reel lock mechanism for preventing free rotation of the tape reel during non-use is disposed between the tape reel 2 hub bottom wall 11 inner top surface and the main body case top wall 12. A magnetic body 13 such as a circular iron plate is fixed to the center of the hub bottom wall 11 outer bottom surface, and drive teeth 14 are annularly provided in a state surrounding the perimeter of the magnetic body 13 (see Fig. 4). The drive teeth 14 are formed as one group of gear teeth extending in the radiating direction, which engage with drive teeth 16 provided around the perimeter of a magnet 15 provided on the top end surface of the tape drive drive shaft D, receiving the rotation force of the drive shaft D. The drive teeth 14 are exposed on the case outer surface via a drive shaft insertion port 18 provided in the case bottom wall 17.

[0017] In Fig. 1 and Fig. 3, the reel lock mechanism comprises the tape reel 2 hub bottom wall 11, a lock member 19 assembled into the space between this and the opposing main body case 1 top wall 12 thereabove, a compression coil shaped spring 20 disposed between the lock member 19 and the top wall 12, a lock release member 21 disposed between the lock member 19 and the hub bottom wall 11 inner top surface, etc.

[0018] The lock member 19 has a cylindrical body 22 built into the interior of the tape reel 2 hub 10 in concentric circle form, and a horizontal spring receiving wall 23, formed integrated in the interior of this cylindrical body 22, and is provided with lock teeth 24 around the entire circumference of the bottom end of the cylindrical body 22, and these lock teeth 24 engage with lock teeth 25 provided in a radiating manner in the outer perimeter area of the inner top surface of the hub bottom wall 11.

[0019] A cylindrical slide boss 26 is provided to the spring receiving wall 23 top surface center protruding upward, and this slide boss 26 is externally fitted to a guide protrusion 27 provided to the top wall 12 inner surface in a hanging manner. A vertical groove 28 is placed at a portion of the circumference at the top end of the slide boss 26, and by fitting this vertical groove 28 onto a vertical rib 29 provided at a portion of the circumference of the guide protrusion 27, the lock member 19 is linked and guided by the guide protrusion 27 such that vertical sliding is enabled, but relative rotation is disabled. Regarding this feature, for example the slide boss 26 hole can be formed in a polygon, and the guide protrusion 27 can be formed to have a corresponding polygon cross section.

[0020] The lock member 19 prevents rotation of the tape reel by the lock teeth 24 engaging with the lock teeth 25 in the

maintained by a spring 20 mounted between the top wall 12 and the spring receiving wall 23 in a state of surrounding the outer perimeter of the guide protrusion 27 and the slide boss 26, and is held by [the spring 20] applying downward pushing force.

[0021] To make the vibration resistance as small as possible between the spring receiving wall 23 and the lock release member 21 during tape reel 2 rotation drive, the lock member 19 spring receiving wall 23 bottom surface center provides a conical or partial spherical protrusion 30. By this protrusion 30, the lock member 19 spring receiving wall 23 bottom surface and the lock release member 21 top portion are brought into point contact. In the example shown in the figure, the protrusion 30 is provided to the center of the bottom surface of a round plate 31 separate from the lock member 19, and this round plate 31 is stacked against the spring receiving wall 23 bottom surface, and is secured by a plurality of engaging tabs 32 provided on the round plate 31 being inserted and engaged into engaging holes 33 provided in the spring receiving wall 23, thus setting the protrusion 30 at the spring receiving wall 23 bottom surface center position. By thus forming the lock member 19 and the protrusion 30 separately and then integrating the two, the material of the two can be changed. For example, the protrusion 30 which requires abrasion tolerance can be molded of polyacetal or other resin, and the lock member 19 can be molded of cheaper ABS resin, PS resin, etc.

[0022] The lock release member 21 is molded with a circular base 34 from synthetic resin with superior abrasion tolerance and self-lubrication such as acetal resin, nylon resin, etc., integrated with a plurality (three shown in the figure) of same-length leg pieces 35 which are provided protruding downward from [the base 34] bottom surface starting near the outer periphery end. Each leg piece 35 is at an equidistant position from the base 34 bottom surface center, and is provided protruding at mutually equal intervals. That is, as shown in Fig. 4, a plurality of leg pieces 35 is provided at equal intervals on the same virtual circle C drawn centered on the bottom surface of the base 34.

[0023] A metal plate 36 is layered and integrated on the top surface of this base 34. The metal plate 36 is molded as an insert on the top surface of the base 34 simultaneous with the molding thereof. Although, the metal plate 36 can be integrated by adhering with adhesive to the top surface of the base 34 instead.

[0024] The lock release member 21 base 34 is received and supported by the hub bottom wall 11 inner top surface, and each leg piece 35 protrudes downward from the hub bottom wall 11 outer bottom surface via a leg piece protrusion hole 37 in the hub bottom wall 11. The leg piece protrusion holes 37 are provided positioned between the hub bottom wall 11 drive teeth 14 and the magnetic body 13.

[0025] In the reel lock mechanism comprised as above, as shown in Figure 1, the lock member 19 is held by the guide protrusion 27 to disable rotation, and is always pushed down by the spring 20. Further, the lock teeth 24 and 25, provided to the lock member 19 and the hub bottom wall 11, are mutually engaged. Therefore, the tape reel 2 in non-use status can be held locked with rotation disabled.

shutter 7 and the loading pin 4 is captured by the loading mechanism. Simultaneously, as shown in Figure 3, the tape reel 2 is attracted downward against a magnet 15 on the driveshaft D via the magnetic body 13, and simultaneously the drive shaft D drive teeth 16 and the tape reel 2 drive teeth 14 are engaged. When performing this engagement operation, the lock release member 21 leg pieces 35 are thrust upward by the drive shaft D, and are pushed inside the leg piece protrusion holes 37. Thus, the lock release member 21 pushes the lock member 19 upward in opposition to the spring 20, mutually separating the lock teeth 24 and 25 that were thus far engaged, releasing the reel lock status. As a result, the tape reel 2 becomes rotatable and tape extraction or rewind drive can be performed. Thereafter when the drive shaft separates from the tape reel 2, the tape reel 2 stays locked.

[0027] In the embodiment above, a protrusion 30 separate from the spring receiving wall 23 was provided at the bottom surface center of the spring receiving wall 23, but a protrusion 30 can instead be molded and integrated to protrude at the spring receiving wall 23 bottom surface center. When doing so, it is preferable to mold the lock member 19 from polyacetal resin etc. having abrasion tolerance and self-lubrication. As shown in Figure 5, the bottom surface of the spring receiving wall 23 can be formed flat, and a protrusion 30 can be formed mounded upward at the center of the metal plate 36 on the lock release member 21.

[0028]

#### Effect of the Invention

According to this invention, a lock release member 21 is disposed between a lock member 19 and a hub bottom wall 11, and by performing a pushing up operation with drive shaft D on a plurality of leg pieces 35 provided on the lock release member 21, the reel lock status by the lock member 19 can be released. Therefore, because the lock member 19 can be prevented from tilting during the lock release operation, the lock teeth 24 on the lock member 19 will reliably separate from the lock teeth 25 on the hub bottom wall 11. Thus, an extraction operation of the tape 3 while the tape reel 2 is still locked can be prevented, and incidents such as tape breaks can be prevented.

[0029] The lock release member 21 comprises a composite body, of a base 34 comprising an abrasion tolerant synthetic resin, and a metal plate 36. The top surface of the lock release member 21 which performs a pushing up operation on the lock member 19 is comprised of a metal plate 36, and by providing a protrusion 30 on one or the other of either the center of this metal plate 36 or on the spring receiving wall 23 bottom surface center, the metal plate 36 and the spring receiving wall 23 are in point contact. Therefore, even during high speed rotation of the tape reel 2, friction resistance between the lock member 19 and the lock release member 21 can be reduced, with superior durability against friction, and durability can be improved.

[0030] Because the lock release member 21 leg pieces 35 are formed of abrasion tolerant synthetic resin, this does not cause missing, lost, or damaged drive teeth 16 on the drive shaft D, and can prevent abrasion damage to the leg pieces 35 from sliding motion with the top end surface of the drive shaft D. and this feature is superior in durability.

rigidity of the lock release member 21, which is advantageous.

[0031] Upon lock release, because a plurality of leg pieces 35 are subjected to a pushing upward operation at a position separated from the reel center, the lock release member 21 tilting in a diameter direction can be reliably prevented, enabling performing a pushing upward operation stably supporting the lock member 19 horizontally, and the tape reel 2 lock release can be reliably performed.

#### Brief Description of the Drawings

Figure 1: This is a section view along line A-A in Figure 2.

Figure 2: This is an internal plane view of a magnetic tape cartridge.

Figure 3: This is a vertical section front view of the lock release status.

Figure 4: This is an arrow view along line B-B in Figure 1.

Figure 5: This is a vertical section front view of another embodiment corresponding to Figure 1.

Figure 6: This is a vertical section front view showing a comparison example of a reel lock mechanism.

#### Description of the Symbols

1	Main body case
2	Tape reel
10	Hub
11	Hub bottom wall
12	Main body case top wall
14	Tape reel drive teeth
16	Drive shaft drive teeth
17	Case bottom wall
18	Drive shaft insertion port
19	Lock member
20	Spring
21	Lock release member
22	Cylindrical body
23	Spring receiving wall
27	Guide protrusion
30	Protrusion
34	Base
35	Leg piece
36	Metal plate
37	Leg piece protrusion hole
D	Drive shaft

# Explore Litigation Insights

Docket Alarm provides insights to develop a more informed litigation strategy and the peace of mind of knowing you're on top of things.

## Real-Time Litigation Alerts



Keep your litigation team up-to-date with **real-time alerts** and advanced team management tools built for the enterprise, all while greatly reducing PACER spend.

Our comprehensive service means we can handle Federal, State, and Administrative courts across the country.

## Advanced Docket Research



With over 230 million records, Docket Alarm's cloud-native docket research platform finds what other services can't. Coverage includes Federal, State, plus PTAB, TTAB, ITC and NLRB decisions, all in one place.

Identify arguments that have been successful in the past with full text, pinpoint searching. Link to case law cited within any court document via Fastcase.

## Analytics At Your Fingertips



Learn what happened the last time a particular judge, opposing counsel or company faced cases similar to yours.

Advanced out-of-the-box PTAB and TTAB analytics are always at your fingertips.

## API

Docket Alarm offers a powerful API (application programming interface) to developers that want to integrate case filings into their apps.

## LAW FIRMS

Build custom dashboards for your attorneys and clients with live data direct from the court.

Automate many repetitive legal tasks like conflict checks, document management, and marketing.

## FINANCIAL INSTITUTIONS

Litigation and bankruptcy checks for companies and debtors.

## E-DISCOVERY AND LEGAL VENDORS

Sync your system to PACER to automate legal marketing.