

Computer Systems Technology

U.S. DEPARTMENT OF
COMMERCE
National Institute of
Standards and
Technology

NIST



NIST
PUBLICATIONS

The 3480 Type Tape Cartridge: Potential Data Storage Risks, and Care and Handling Procedures to Minimize Risks

Mark P. Williamson

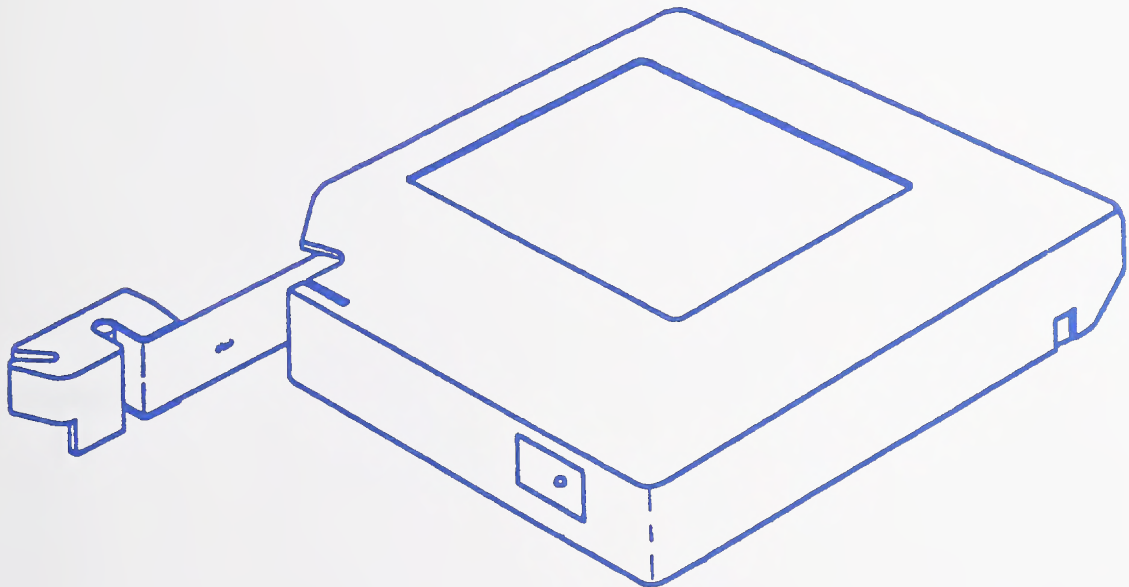

QC

100

U57

500-199

1991

UNCLASSIFIED
U.S. GOVERNMENT
INFORMATION

C.2



1115
500-199
100
100

The 3480 Type Tape Cartridge: Potential Data Storage Risks, and Care and Handling Procedures to Minimize Risks

Mark P. Williamson

Computer Systems Laboratory
National Institute of Standards and Technology
Gaithersburg, MD 20899

Sponsored by:
National Environmental Satellite Data Information Service
National Oceanic and Atmospheric Administration

November 1991



U.S. DEPARTMENT OF COMMERCE
Robert A. Mosbacher, Secretary
NATIONAL INSTITUTE OF STANDARDS
AND TECHNOLOGY
John W. Lyons, Director

Reports on Computer Systems Technology

The National Institute of Standards and Technology (NIST) has a unique responsibility for computer systems technology within the Federal government. NIST's Computer Systems Laboratory (CSL) develops standards and guidelines, provides technical assistance, and conducts research for computers and related telecommunications systems to achieve more effective utilization of Federal information technology resources. CSL's responsibilities include development of technical, management, physical, and administrative standards and guidelines for the cost-effective security and privacy of sensitive unclassified information processed in Federal computers. CSL assists agencies in developing security plans and in improving computer security awareness training. This Special Publication 500 series reports CSL research and guidelines to Federal agencies as well as to organizations in industry, government, and academia.

National Institute of Standards and Technology Special Publication 500-199
Natl. Inst. Stand. Technol. Spec. Publ. 500-199, 59 pages (Nov. 1991)
CODEN: NSPUE2

U.S. GOVERNMENT PRINTING OFFICE
WASHINGTON: 1991

For sale by the Superintendent of Documents, U.S. Government Printing Office, Washington, DC 20402

Cover

The figure on the cover is reproduced with permission from American National Standard X3.180 - 1990, copyright 1991 by the American National Standards Institute. Copies of this standard may be purchased from ANSI at 11 West 42nd Street, New York, NY 10036

Disclaimer

The conclusions and statements contained in this document are based on information gathered by NIST from available literature and interviews with 3480 type tape cartridge technology users, manufacturers, and other expert sources. No data were taken, nor were any experiments performed in NIST laboratories.

In this publication the terms "3480 type media," "3480 type technology," "3480 type tape drive," and "3480 tape cartridge" will be used to refer to all ANSI X3.180 - 1990 compatible, 12.65 mm (0.5 in), 18-track parallel recorded, chromium dioxide, recording media and the tape drive subsystems. If a specific manufacturer is intended, that manufacturer will be noted. However, the inclusion or omission of any manufacturer's name is only cited for clarity and does not imply endorsement or criticism.

Acknowledgments

Since this publication is based on the experiences and opinions of many 3480 type technology users and manufacturers, it is difficult to mention everyone who so generously contributed to this publication. However, the author greatly appreciates those individuals' time and contributions.

Special thanks are due to Mr. William Callicott of NOAA, Dr. P.C. Hariharan of STX, Dr. R.L. Bradshaw of IBM, Mr. John Felton of Carlisle Memory Products, Mr. Gerrit Nijssen of BASF, and Mr. Gerald Taylor of StorageTek.

Appreciation is also due to Mrs. Natalie Willman, Dr. Leslie Smith, Dr. Gordon Lyon, and Mr. Tom Bagg of NIST.

Executive Summary

The 3480 type media were introduced to the data storage industry in 1984. Early problems were reported due to premature degradation of the polyester polyurethane binder. In addition, the lack of guidelines for proper care and handling increased the risks associated with the storage of data on the 3480 type media.

After approximately 7 years experience, media manufacturers have significantly improved their binder formulations. Furthermore, 3480 type media users from government and industry have experienced the dependability and, conversely, the problems associated with the storage of data on the 3480 type media.

The major potential risks associated with the storage of data on the 3480 type media have been the premature degradation of the polyester polyurethane binders and the lack of care and handling guidelines and maintenance procedures to minimize the potential occurrence of chemical, mechanical, and/or magnetic failure mechanisms. In addition, questions have been raised about the potential health and environmental hazards, as well as the long-term stability, associated with the use of chromium dioxide (CrO₂) media.

Problems were reported due to the premature degradation of the polyester polyurethane binder that holds the magnetic CrO₂ particles to the polyethylene terephthalate (PET) substrate. Although the industry has significantly improved their binder formulations, it is important to remember that any manufacturer could produce a bad batch of tapes. The cost of the 3480 type media, as compared to the value of the data it contains, is insignificant. Therefore, to reduce the risks associated with this failure mechanism, the data managers should be selective in the quality of media on which they store their data. In addition, when cost effective, sampling and multiple off-site backups of data are prudent.

The risk associated with the storage of data on any type of magnetic media is directly proportional to the diligence used in its proper care and handling. Proper maintenance of the environment, as well as the observation of some simple rules in the usage, storage, and transportation can greatly reduce the risk associated with the storage of data on magnetic media. Otherwise, chemical, mechanical, and/or magnetic failure of these media are possible.

In general, magnetic tapes wound under tension will stretch in the direction of the stress and elongate with time until the elongation has relieved the stress. This elongation of the magnetic tape causes the tape pack to loosen. Tapes without an evenly tensioned pack may experience slippage of adjacent tape layers and a folding over of layers of tape to fill physical voids when subjected to the large accelerations used in 9-track open reel tape drives. Temperature variations in the storage library can also cause a loose tape pack [1]. Therefore, it is necessary to retension the 9-track open reel tapes prior to usage. The 3480 type tape drives subject the tape to lower accelerations when tape motion is initiated. In addition, the 3480 type tape drives will detect a loose tape pack and automatically retension the tape. However, the harmful effects of a loose tape pack have led to suggestions that tapes must be periodically retensioned during storage to restore proper tension even when usage of the tape is not required [2].

The IBM Corporation has quantitatively examined the necessity for periodic retensioning of the 3480 type media [3], [4]. IBM's experiment involved the accelerated aging of two identical groups of experimental 3480 type tape cartridges. One set of tapes was not retensioned, while the other was retensioned. The analysis of the two sets of tapes showed equal chemical and mechanical changes. However, the tapes that were retensioned showed a catastrophic increase in the error rate which IBM attributed to the renewal of mechanical stresses and the binder-particle interaction.

Based on interviews with magnetic media users, there is little evidence that users actually retension their tapes periodically. Not only does periodic retensioning introduce a large expense and effort into the maintenance of a data library, published literature indicates that these activities not be necessary [1],[3],[4].

In the June 9, 1986 issue of ComputerWorld magazine, an article entitled "Taking Chances with New Tapes" states that CrO₂ which is used in the 3480 type media degrades in the presence of moisture and oxygen to chromium hexavalent which is toxic. This suggests that the toxic nature of chromium dioxide may present health hazards to the user and environmental hazards when the tapes are disposed of in a landfill. In addition, this article states that CrO₂ may have poor long-term storage characteristics, since this material has a fairly short half-life [5]. The Du Pont Corporation, which has been the primary manufacturer of CrO₂ particles of audio, video, and instrumentation tape applications for 20 years, responded to this article with a white paper that was published as a Technical Committee X3B5, Digital Magnetic Tape document [6]. Their conclusions are that CrO₂ tapes present neither a hazard to the health of the user, nor to the environment, when the tapes are discarded in landfills. Du Pont also asserted that CrO₂ media is well suited for the long-term storage of data. Most of the 3480 type media experts, users, and manufacturers interviewed agree with this conclusion.

Based on the opinions and observations of 3480 type media users and manufacturers, there seems to be a low risk associated with the storage of data on 3480 type media, provided the proper care and handling procedures are used. The 3480 type technology manufacturers indicate that there is a very high probability that the 3480 type media will retain data for at least 10 years. Some 3480 type media experts, users, and manufacturers interviewed believe that this is a conservative estimate.

The predicated 10-year length of time in which the 3480 type media can retain data is expected to be greater than the length of time before the 3480 type recording systems are superseded by more advanced products. For example, IBM introduced the 18-track, parallel 3480 recording system in 1984. Now, approximately 7 years later, IBM has introduced the next generation 3490E which uses the same media with a 36-track, parallel-serpentine recording system. Nevertheless, if a data center is still using the 3480 type technology after 10 years, it would be prudent to migrate the data to new media at that time.

Table of Contents

1	Introduction	1
2	3480 Type Recording System	3
2.1	3480 Type Tape Structure	3
2.2	3480 Type Cartridge Assembly	5
2.3	3480 Type Tape Drive Assembly	6
2.4	3480 Type Methods of Recording and Error Correction.....	8
3	Potential Failure Mechanisms	10
3.1	Chemical	10
3.2	Mechanical.....	11
3.2.1	Stick	12
3.2.2	Embossment by Debris.....	12
3.2.3	Inter-Layer Slip	12
3.2.4	Cinching.....	13
3.2.5	Creep	13
3.3	Magnetic	13
3.3.1	Temperature Effects on Magnetization	13
3.3.2	Magnetostriction	14
3.3.3	Stray Magnetic Fields	14
4	General Care and Handling Guidelines	15
4.1	Environment.....	15
4.1.1	Operational Environment	15
4.1.2	Storage Environment	16
4.1.3	Transportation Environment.....	16

4.2	Operational and Storage Environmental Maintenance.....	17
4.3	Transportation Guidelines	18
	4.3.1 Packaging for Transportation	18
	4.3.2 Handling During Transportation.....	19
	4.3.3 Conditioning to New Environments.....	19
4.4	General Care and Handling Tips	20
4.5	3480 Type Tape Drive Maintenance	21
	4.5.1 3480 Type Cleaning Cartridge.....	21
	4.5.2 Wet Cleaning	21
4.6	Fire Protection Recommendations	22
4.7	Water Protection Recommendations	23
4.8	Contamination Migration Avoidance Recommendations.....	24
5	Retensioning 3480 Type Tape Cartridges	25
6	Chromium Dioxide's Toxic Nature	27
	6.1 Potential Health Risks.....	27
	6.2 Potential Disposal Problems	27
7	Information from Users.....	28
	7.1 Internal Revenue Service	28
	7.2 National Center for Atmospheric Research	28
	7.3 Mobil Exploration and Producing Services Inc.	29
	7.4 Shell Oil Company	29
	7.5 Social Security Administration	30
	7.6 The Church of Jesus Christ of Latter Day Saints	31
	7.7 Western Geophysical	31

8	Information from Manufacturers.....	33
8.1	3M	33
8.2	BASF	33
8.3	Carlisle Memory Products.....	34
8.4	Du Pont	34
8.5	IBM... ..	35
8.6	StorageTek.....	35
9	Information from Other Sources	36
9.1	National Media Laboratory.....	36
9.2	Battelle	36
10	Conclusions.....	39
A	Definitions	40
B	References	43
C	Other References	45

List of Figures

Figure 1	3480 Type Tape Structure	4
Figure 2	3480 Type Tape Cartridge Assembly	5
Figure 3	3480 Type Tape Drive Assembly	7
Figure 4	3480 Type Tape Usable Recording Area.....	9
Figure 5	Temperature and Humidity Table	16
Figure 6	Summary of User Information	32
Figure 7	Summary of Manufacturer and Other Source Information	37

1. Introduction

The National Oceanic and Atmospheric Administration (NOAA) has accumulated extensive historical records of oceanic and atmospheric currents and weather extending back through most of the 20th century, and in some instances, into the middle 19th century. Included are both in-situ and satellite observations covering ocean, atmosphere and land. These records, which span the industrial revolution and subsequent periods of rapid economic development, are invaluable in baseline scientific studies, model verification, and assessment of environmental trends.

Much of NOAA's data and information at its data centers are still held in hard copy form (e.g., paper or microfilm). Altogether, over 90 million records of handwritten and printed text and drawings, atlases and maps, numerical tables, etc., have been identified as worth retaining. Digitizing and migrating these material into automated systems will be a massive task, but an essential one. In their current form, the records are neither stable nor easily accessible and, therefore, not really useful.

In addition, NOAA retains over 241,000 reels of magnetic tape, of which approximately 60,000 units are the 3480 type tape cartridges. Eighty percent of the 9-track open reel tapes have never been backed up, and 40% of these tapes are now at the end of their typical life span. Some permanent tape damage on 9-track open reel tapes has already been documented, resulting in the loss of valuable satellite data. The only immediate approach to this problem is bulk transcription to new tapes, and eventual migration to modern and more cost-efficient media.

In 1985, NOAA began copying its archive information to the 3480 type technology in lieu of using the 9-track open reel tapes. This was done to take advantage of the smaller volume required to store the media, and to exploit the enhanced error correction and performance of the 3480 type technology. However, soon after NOAA began using these media, the industry began reporting problems associated with the premature degradation of the polyester polyurethane binders which hold the magnetic chromium dioxide particles (CrO_2) to the polyethylene terephthalate (PET) substrate. NOAA has not experienced any of these problems in its operations. However, there is concern that the archiving of satellite data has unknown risk because of the lack of documented experiences related to the 3480 type media.

The National Institute of Standards and Technology (NIST), under the sponsorship of NOAA, has undertaken an appraisal of the potential risks associated with the storage of data on the 3480 type media. This study discusses the findings of the appraisal and, in addition, summarizes reasonable procedures for the care and handling of the 3480 type media in order to minimize the potential risks. This report is intended to inform data managers of the potential chemical, mechanical, and magnetic failure mechanisms associated with the 3480 type media and to summarize the experiences and recommendations of major 3480 type technology users and manufactures.

In addition, recommendations from applicable scientific literature and the opinions of other media experts are included. This document is a guideline and reference for data managers who are attempting to minimize potential risks associated with the storage of valuable data on the 3480 type tape cartridges.

2. 3480 Type Recording System

To reliably store data on computer magnetic storage systems it is necessary to study the reliability of the entire system (e.g., tape, cartridge, error correction, transport, etc.). While most scientific documents focus their attention on the reliability and life expectancy of the magnetic tape components (e.g., substrate, magnetic particles, binder formulations), it is important that the data managers keep a systems point of view. The 3480 type technology systems have employed several new features which provide a substantial improvement in performance and reliability over the 9-track open reel systems. These new features include: the cartridge, a tape-lifter ("puffer"), and powerful error correction capabilities. The following sections discuss the 3480 type tape structure, the 3480 type cartridge assembly, the 3480 type tape drive assembly, and the 3480 type methods of recording and error correction.

2.1 3480 Type Tape Structure

The 3480 type tape consists of acicular chromium dioxide (CrO_2) particles dispersed in a polyester polyurethane binder onto a polyethylene terephthalate (PET) substrate. Some 3480 type tapes have a back-coating consisting of carbon particles, which helps to reduce problems associated with static electricity.

The actual formulas of the binders are considered proprietary information by each media manufacturer. However, typical ingredients include: binder material, solvents, softener, wetting agents, anti-static agents, lubricants, and abrasive agents [7]. Some older tape technology binder formulations included fungicides. Fungicides are not required for the 3480 type tape technology since chromium is itself a fungicide.

According to the ANSI X3.180-1990 standard, the 3480 type media must be not less than 165 meters (541 feet) long and the total thickness at any point along the tape must be between $25.9 \mu\text{m}$ and $33.7 \mu\text{m}$ ($1020 \mu\text{in}$ and $1330 \mu\text{in}$). The width specification of the 3480 type tape is $12.65 \text{ mm} \pm 0.025 \text{ mm}$ ($0.4980 \text{ in} \pm 0.0010 \text{ in}$).

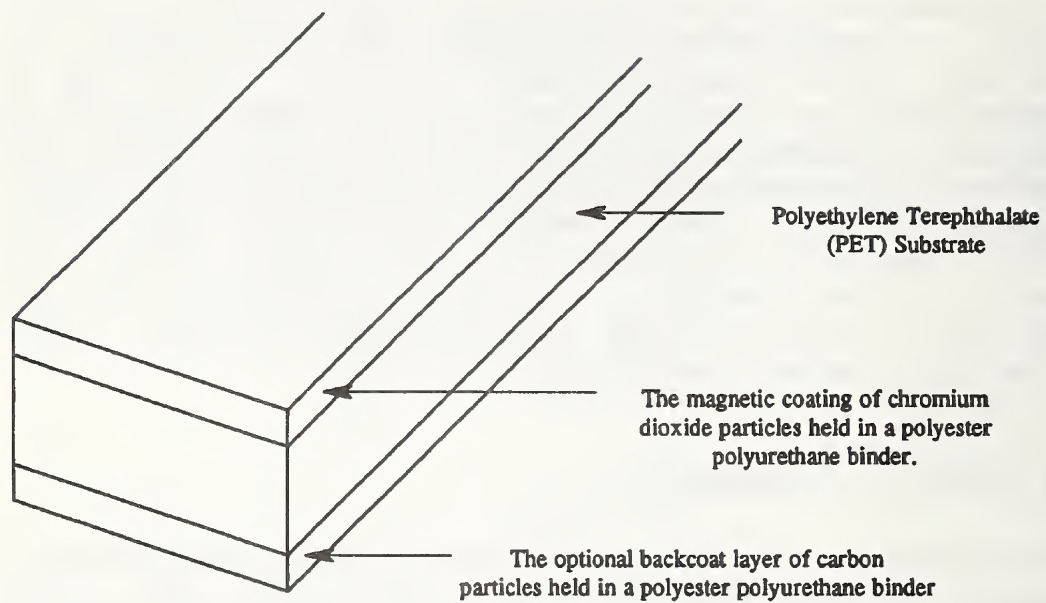

Figure 1. 3480 Type Tape Structure.

2.2 3480 Type Tape Cartridge Assembly

The 3480 type tape is housed in a single reel cartridge. The tape is mechanically fed from this cartridge to a take-up reel in the tape drive. The cartridge provides some environmental protection, as well as less intimate user-to-tape contact. The cartridge components include: case, write-protect mechanism, reel for the magnetic tape, locking mechanism for the reel, magnetic tape wound on the hub of the reel, leader block, and latching mechanism for the leader block [8].

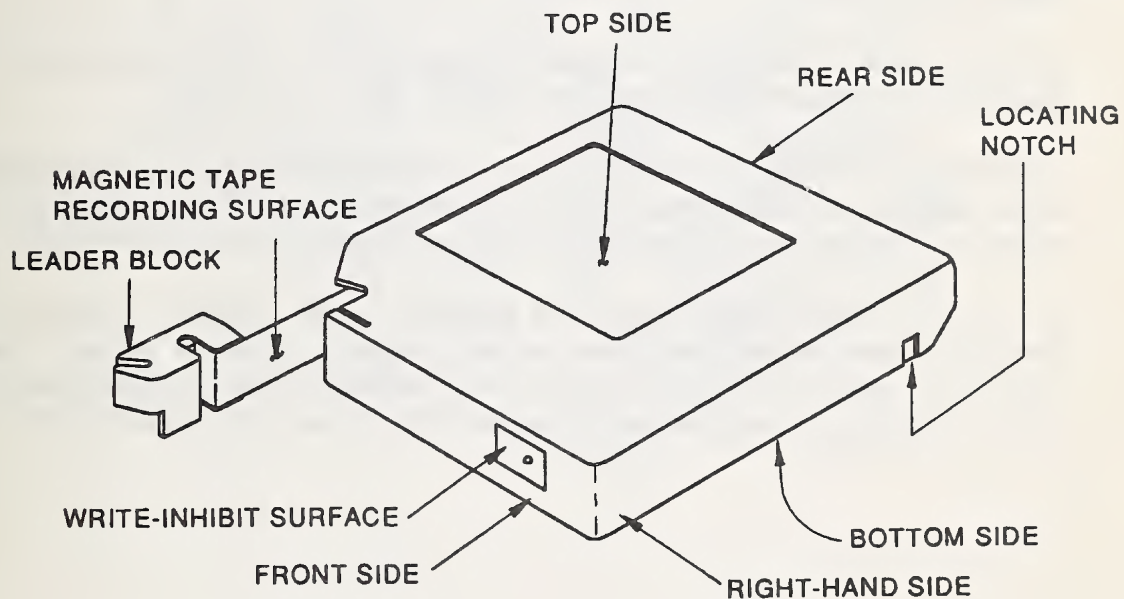

Figure 2. 3480 Type Tape Cartridge Assembly.

This material is reproduced with permission from American National Standard X3.180-1990, copyright 1991 by the American National Standards Institute. Copies of this standard may be purchased from ANSI at 11 West 42nd Street, New York, N.Y. 10036

2.3 3480 Type Tape Drive Assembly

The tape drive assembly consists of the cartridge loader, tape threader arm, tungsten carbide cleaning blades, read/write head, puffer, take-up reel, and tension transducer.

When the 3480 type tape cartridge is loaded into the cartridge loader, the automatic threader arm's pin inserts into the leader block and threads the tape past the cleaner blades and read/write head to the take-up reel. Tape tension is controlled and maintained by the tension transducer.

Unlike the open reel tape drives, the 3480 type tape drive moves the tape without the use of capstans or vacuum columns [9]. The 3480 type technology digital servo control system and new thin film head technology permit low acceleration tape motion, which eliminates the need for vacuum columns, capstans, and beginning of tape/end of tape reflective markers [10].

The 3480 read/write head is a combination of magnetoresistive thin-film read elements, planar thin film write turns, and ferrite pole-pieces [11].

An additional feature of the 3480 type tape drive is the tungsten carbide cleaning blades which scrape the recording surface of the tape to remove debris. This cleaning action is assisted by a vacuum that sucks away the debris loosened by the cleaning blades [11].

The 3480 type tape drives also include a tape-lifter, called a "puffer." The puffer introduces a jet of air between the head and tape whenever the tape is stopped. This film of air between the tape and head prevents intimate contact, which effectively reduces problems with machine drag and the possibility of head-to-tape adhesion [4].

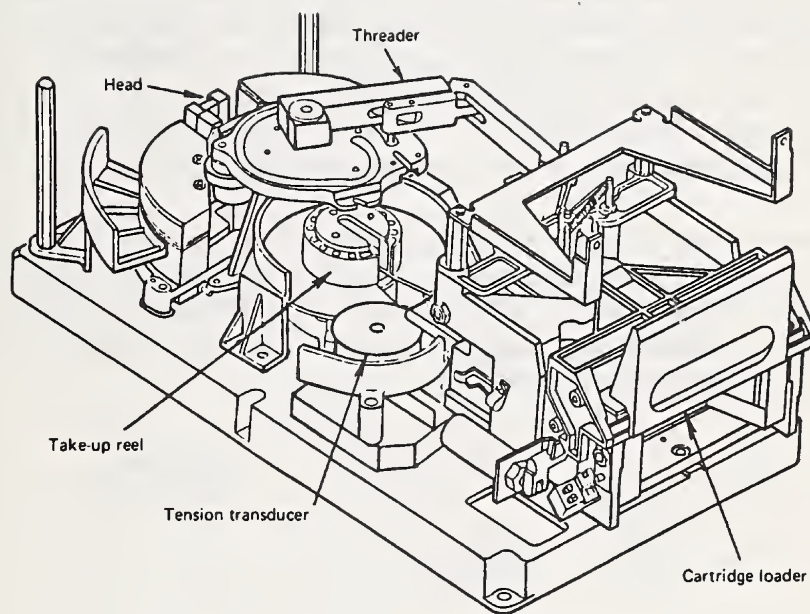

Figure 3. 3480 Type Tape Drive Assembly.

*Courtesy of the IBM Corporation
Copyright IBM Corporation 1984, 1987, 1989 All Rights Reserved*

2.4 3480 Type Methods of Recording and Error Correction

The 3480 type tape systems record data on 18 tracks in parallel. These systems feature a three million byte per second instantaneous data rate, and a linear data density of 1491 Bpmm (approx. 38 kBpi.) [8],[12]. The result is approximately 200 million bytes per cartridge capacity. Since media manufacturers vary in the actual length of their tape per cartridge, the overall capacities vary slightly.

Magnetic tape systems use error correction codes (ECC) to improve data integrity and performance. The 3480 type systems use an ECC scheme called adaptive cross-parity (AXP). The 3480 type media's 18 tracks are divided into two interleaved groups of nine tracks. Each group consists of seven data tracks and two error check tracks. This method can correct up to three erased tracks of data in any one group of nine tracks and up to four erased tracks of data in the 18 tracks together. This ECC scheme has interacting vertical-parity check bits and cross-parity check bits, which provide robustness due to redundancy in the correction of errors [8], [12].

Data are verified and corrected during the write process by the 3480 type tape drive's ECC. As a result, gross manufacturing failures in the media are detected during the write process. In other words, if you can write a 3480 type tape cartridge, you can read it. This philosophy assumes that no chemical, mechanical, and/or magnetic modes of failure have occurred during storage.

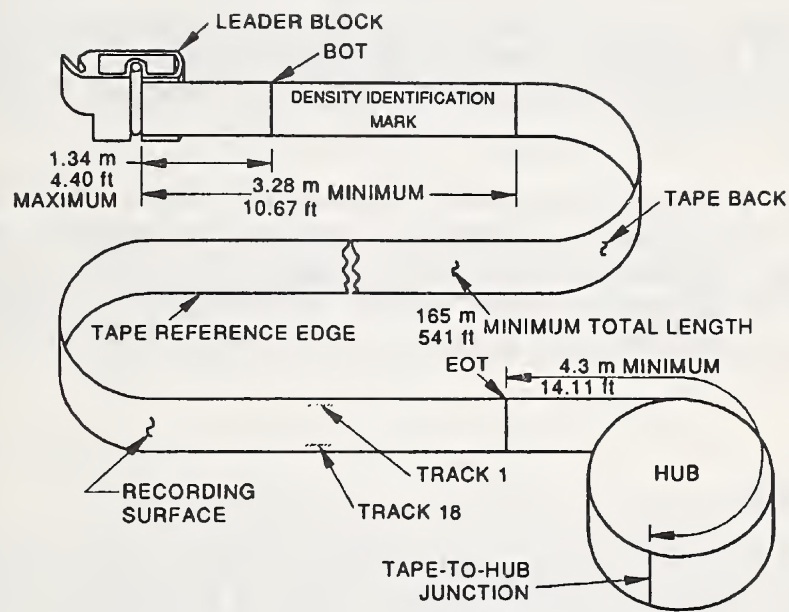

Figure 4. 3480 Type Tape Usable Recording Area.

This material is reproduced with permission from American National Standard X3.180-1990, copyright 1991 by the American National Standards Institute. Copies of this standard may be purchased from ANSI at 11 West 42nd Street, New York, N.Y. 10036

3. Potential Failure Mechanisms

There are a number of hazards which can lead to catastrophic failures of magnetic media, resulting in the inability to recover the data written on the media. Removable magnetic media are, by their nature, subject to the function of interchanging data both within and among various computer installations. This makes the environmental and handling conditions to which they are exposed relatively uncontrolled [4]. Poor maintenance of the environment and improper care and handling procedures may lead to chemical, mechanical, and/or magnetic failure of the media and, consequently, the loss of data.

Excursions in temperature and humidity have the most harmful effects on magnetic media, and cause the majority of chemical, mechanical, and magnetic failures. The 3480 type tape cartridges are no exception. Magnetic tapes are manufactured in an environment of approximately 18 °C (65 °F) and 40% RH. The most optimum condition would be to maintain these media in this steady-state environment at all times.

3.1 Chemical

Based on extensive work involving iron oxide based magnetic tapes, one of the most likely modes of failure on a 3480 type tape cartridge is the premature degradation of the polyester polyurethane binder which holds the CrO₂ particles to the PET substrate. Under the proper environmental and handling conditions, the PET substrate displays relatively low levels of hydrolytic cleavage. However, the polyester polyurethane binder under the same conditions undergoes a much higher degree of hydrolysis. This may result in a softening, embrittlement, and/or loss of adhesion of the binder layer to the PET substrate [1]. This work refers only to binders containing gamma-ferric oxide (gamma-Fe₂O₃). Some aspects of the formulation are different for CrO₂ tapes. The conclusion that the same mechanisms are equally important to the 3480 type media is by analogy, but a reasonable conclusion.

The binder degradation is caused by hydrolysis, which is the breakdown of an ester to its parent carboxylic acid and alcohol. The chemical reactions of water with polymer materials, and the hydrolytic action on the polyester polyurethane tape binders has been studied in depth [13], [14], [15]. Some important conclusions of these studies are discussed below.

Hydrolytic degradation will cause the production of carboxylic acids and alcohol. This chemical reaction will cause the tapes to become sticky and, in the worst cases, will lead to the shedding of gummy and sticky chemical byproducts. These chemical byproducts will lead to extensive mechanical failures. Furthermore, hydrolytically produced debris may contaminate the mechanical components of the tape drive and, as a result, contaminate other media and other drives (see sec. 4.8). In addition, sticky tapes will have an increase in their frictional characteristics, which can lead to mechanical failures causing the data signals to be read in error. The errors caused by hydrolytic degradation are more obvious with the higher density data capacities of modern data storage technologies, such as the 3480 type technology.

Hydrolysis is caused primarily by poor environments. Although the effect of high temperature and humidity are stressed, extreme cold temperatures will cause the tape's binder to become brittle and the PET to shrink. Also, adjacent layers of tape may adhere to one another. In addition, problems during usage with static electricity will occur in extreme dry environments.

Therefore, the suggested environment for the long term storage of data has been determined to be approximately 18 °C (65 °F), and 40% RH, which is a compromise between conflicting demands [2].

3.2 Mechanical

Steady-state environmental conditions are also important for the mechanical stability of the 3480 tape media. Variations in environmental conditions can cause expansion and contraction of the 3480 type media. This shrinking and stretching of the tape can be caused by thermal expansion (variations in temperature), and/or hygroscopic expansion (the motion of water in and out of the tape).

Chemical degradation, variations in temperature and humidity, and poor handling procedures can cause mechanical distortions of the tape. These distortions may then lead to errors due to the disruption in the physical positioning of the data bits, the inability of the transport to properly move the tape, changes in the frictional characteristics of the tape, and/or the physical destruction of the media. Some of these mechanical modes of failure are: stick, embossment of debris, inter-layer slip, cinching, and creep.

3.2.1 Stick

With increased temperature, the polyester polyurethane binders tend to become softer. Also, the presence of moisture will affect the frictional characteristics of the 3480 type media. The usual result of these effects is the adherence of the tape to the tape drive components. Adherence, or stick, will cause the tape to be snapped off of the tape drive components when tape motion is initiated. Consequently, temporary errors may occur due to the tape drive's inability to track the data. Permanent errors may be caused by the removal of the recorded surface from the substrate [3], [4].

Layers of tape which are sticky due to hydrolytic degradation may also adhere to the adjacent layer of tape. The result may be only temporary errors caused by a jerky tape motion, or permanent errors caused by the magnetic coating being pulled off of the tape.

3.2.2 Embossment by Debris

Hard, nonadherent debris from the surrounding environment can become trapped in the tape pack. The 3480 type tape is wound under tension on a reel in the cartridge. The layers of tape conform to the profile of the layers underneath. Therefore, the winding of the tape over a particle will propagate mechanical deformations throughout many layers of tape. Many errors can be caused by a single contaminant that causes a disruption at the tape-head interface. In other words, a mechanical deformation will change the spacing between the tape and the head, resulting in a magnetic signal loss. Mechanical distortions in the tape pack profile can also cause curvature or cupping problems during long-term storage that may impact tape performance [4]. Tape curvature is the departure from a flat surface along the length of a tape, while tape cupping is the departure from a flat surface along the width of a tape [8].

3.2.3 Inter-Layer Slip

A 3480 type tape cartridge in storage, transportation, or usage may be exposed to variations in temperature and humidity. As a result, expansion and contraction of the tape will cause an uneven tape tension throughout the tape pack. Physical voids between layers of tape will be created, resulting in a loose tape pack. When tape drive motion is initiated, the layers of tape may slip causing rapid acceleration, which may result in mechanical destruction of the tape (see sec. 3.2.4).

In addition, the 3480 type tape drives have no mechanical buffering, such as vacuum columns or capstan, so the control circuitry can only tolerate a limited amount of shifting or slippage of the tape layers before read errors occur due to the mispositioning of data. When the 3480 type tape drives detect a loose tape pack, they will display a message "LOCATING" and the drive will retension the tape [16].

3.2.4 Cinching

The 3480 type tape cartridges that are not maintained in a steady-state temperature and humidity environment will experience expansion and contraction leading to inter-layer slip. Since physical voids exist between layers of tape, the upper layer can buckle and pile up between adjacent layers when tape motion is initiated. To avoid this mode of failure, 3480 type tape cartridges should always be conditioned to the operating environment at least 24 hours before usage is attempted.

3.2.5 Creep

Any magnetic tape under the imposed stresses of winding and usage is expected to creep in the direction of stress and elongate with time until the elongation has relieved the stress. This can lead to read errors due to the changes in the physical positioning of the data. Soft hub designs, which absorb some of these stresses, and the proper maintenance of the environment will delay the onset of creep [1].

3.3 Magnetic

The magnetization loss of the 3480 type media that occurs with time is approximately of the same order of magnitude as that of the 9-track open reel tapes. One media manufacturer reports that the magnetic signals on a 3480 type tape cartridge can decay over 18% and the system will still be able to correctly read the data, even without the 3480 type tape drive's error correction capabilities. With the 3480 type tape drive's error correction, higher signal amplitude loss can be tolerated.

3.3.1 Temperature Effects on Magnetization

In general, the magnetic signals recorded on a tape will decrease in amplitude over time. The 9-track open reel tapes, which employ gamma ferric oxide particles ($\gamma\text{-Fe}_2\text{O}_3$), are capable of retaining their magnetization up to a temperature of approximately 675 °C (1247 °F). CrO_2 particles that are used in the 3480 type tape cartridges will lose their magnetization at a temperature of approximately 135 °C (200 °F). This temperature is known as the Curie temperature [2]. As a practical matter, loss of magnetization due to high temperatures is never seen because chemical and mechanical failures of the media will be observed at temperatures well below the Curie temperature.

3.3.2 Magnetostriction

Magnetic signals will decay when exposed to sharp mechanical bending. This phenomena is known as magnetostriction. Due to the mechanical design of the way the 3480 type tape drive handles the tape, it is unlikely that demagnetization as a result of mechanical bending will occur [16].

3.3.3 Stray Magnetic Fields

Previous studies showed that the data contained on magnetic tapes can be erased by devices which emit magnetic field energy such as, anti-hijacking metal detection devices, airport signal fields, x-ray energy, and other electromagnetic devices [2]. Magnetic fields can erase data, since these fields are used for the recording, erasing, and overwriting of the data on magnetic tape. However, to erase data the strength of the erasing field must exceed the coercivity of the magnetic media. The coercivity, which is measured in ampere-turn per meter (A/m) (oersteds (Oe)), is the media's ability to resist erasure of its recorded information. CrO₂ tapes, such as the 3480 type media, have a coercivity of approximately 43.768×10^3 A/m (550 Oe), while the 9-track open reel tapes coercivity is approximately 29.842×10^3 A/m (375 Oe). As a result, the 3480 is less susceptible to erasure from stray magnetic fields than are 9-track open reel tapes. In either case, the risk of stray magnetic fields erasing the recorded information on magnetic media is low.

4. General Care and Handling Guidelines

The 3480 type tape cartridges are typically shipped from the manufacturer in cartons containing three rows of 10 cartridges [16]. Each row is sealed in a plastic protective enclosure to protect the tapes from contamination during shipment. Once unpacked, the 3480 type tape cartridges are vulnerable to handling, storage and shipping hazards. The maintenance of the proper environment during usage, storage, and transportation is essential to reduce the risks associated with the storage of data on the 3480 type media. The following sections discuss optimal environmental conditions, and guidelines on how to maintain them. In addition, guidelines are given for equipment maintenance and disaster protection avoidance.

4.1 Environment

The primary consideration for the protection of the data stored on 3480 type tape cartridges is the control of the usage, storage, and transportation environments. The proper temperature, humidity, and debris-free environment must be closely and continuously controlled and maintained. Cleanliness of the computer and storage rooms is essential to the proper operation of any magnetic media and their subsystems. Dust and dirt will not only cause the loss of data, but will also reduce the life of both the media and the subsystem (see sec. 3.2.2). Therefore, diligent housekeeping is required [16].

4.1.1 Operational Environment

The 3480 type tape cartridges used for data interchange should be used under the following temperature and humidity conditions [2], [8]:

Temperature: 16 °C to 32 °C (60 °F to 90 °F).

Relative Humidity: 40% to 60%.

Tape temperatures in excess of 48 °C (120 °F) may cause tape damage and permanent data loss.

4.1.2 Storage Environment

The 3480 type tape cartridges should be stored under the following conditions [2], [8]:

Temperature: 17 °C to 20 °C (62 °F to 68 °F).

Relative Humidity: 35 % to 45 %.

4.1.3 Transportation Environment

During shipping and transportation of recorded 3480 type media, the temperature and humidity should be kept within the following limits [2], [8]:

Temperature: 5 °C to 32 °C (40 °F to 90 °F).

Relative Humidity: 20% to 80%.

	Operation	Storage	Transport
Temperature °C (°F)	16 to 32 (60 to 90)	17 to 20 (62 to 68)	5 to 32 (40 to 90)
Relative Humidity %	40 to 60	35 to 45	20 to 80

Figure 5. Temperature and Humidity Table.

4.2 Operational and Storage Environmental Maintenance

The primary concern for the care and handling of any magnetic media is the environmental maintenance of the computer room and storage library. When the facility for your computer and storage vaults is designed, one or more of the following documents should be referenced to ensure a debris-free, temperature and humidity controlled environment [16]:

- Cray Research Inc. - Site Design and Operation Guide
- Amdahl Physical Planning Manual - Publication MM-108334-10
- IBM Installation Manual - Publication Gc22-7072-1
- Unisys Installation Manual - Publication MA5227
- Memorex Engineering Specification - Publication 9885-4920
- Federal Air Standard 209B for Airborne Contaminants

Although the 3480 type tape is protected by its cartridge, corrosive agents such as chloride ions and ozone may damage the media. Chloride ions are a commonly found agent in cleaners, and ozone is generated by laser printers. In addition, closely situated photo laboratories and other chemical supply areas may increase the risks associated with these contaminating agents. Relocate printers and other contamination-producing equipment outside the 3480 type tape cartridge usage and storage areas.

Furthermore, ventilation system intakes which are situated near contaminant sources, such as loading docks where diesel engines are idling or photo laboratory and other chemical supply area fumes, can also introduce contaminants into the environment.

The following are general tips for the maintenance of the computer room and storage environment:

- Computer rooms and storage vaults should have positive air pressure. That is, conditioned air should blow toward you when you open the door to enter the facility.
- Never remove more than a few tiles from the raised floor as this will defeat the original air flow design of the room. Be sure to replace and firmly reseal the tiles as soon as the under-floor work is complete.
- Access to the computer room and storage vaults should be limited to essential personnel, both for security purposes and to keep dirt and dust to a minimum.
- Schedule the preventive maintenance of the air conditioning systems for a climatically moderate time of the year.
- Computer room and storage vault floors should be cleaned periodically with a

mop dampened with water. Never bring buckets of water into the 3480 type tape cartridge usage or storage area.

- Do not use wax or cleaning agents on the computer room or storage vault floors. This action contaminates the environment with solvents, wax particles and debris from the buffer and its motor.
- Do not shut down the air conditioners on weekends or holidays. This puts the magnetic media through temperature and humidity excursions that can cause the media to fatigue and break down.

4.3 Transportation Guidelines

Exposure to harsh temperature and humidity conditions during transportation may induce failure mechanisms which will destroy the data stored on the 3480 type tape cartridge. Practicality dictates that the proper precautions to be taken are proportional to the value of the data. When the data contained on the 3480 type tape cartridge is irreplaceable or of justifiable value, the tape cartridges should be taken directly from the computer usage or storage room to an air conditioned vehicle.

Any media intended for the interchange of data is, by its nature, exposed to relatively uncontrolled environments and handling conditions [3]. These conditions can be especially harsh during transportation. Therefore, when the value of the data dictates, air conditioned vehicles should be contracted, and guidelines should be set forth which reduce the potential hazards associated with the transportation of 3480 type media [2], [8].

4.3.1 Packaging for Transportation

- Pack the 3480 type tape cartridge into a rigid container containing adequate shock absorbent material.
- The shipping container should have a clean interior and a construction that provides sealing to prevent the entrance of dirt and water.
- Seal every 3480 type tape cartridge in a "zip-lock" polyethylene bag.
- The orientation of the cartridge inside the container should be vertical.

- The shipping container should have a nominal spacing of not less than 80 mm (3.15 in) between the 3480 type tape cartridge and the outer surface of the container. This will minimize the risk of corruption of data caused by stray magnetic fields [8].
- Mark the container clearly to indicate its correct orientation and the fragile nature of its contents.
- Procure special containers which meet the above requirements

4.3.2 Handling During Transportation

- The transit time of 3480 type tape cartridges should be as short as practical, preferably, no longer than 5 days.
- Do not leave 3480 media that are to be shipped on the loading dock. The 3480 type tape cartridges should be taken directly from the computer room to an air conditioned vehicle.
- Avoid mechanical loads that would distort the 3480 type cartridge shape.
- Avoid dropping the 3480 type tape cartridge.
- Keep the 3480 type tape cartridges out of direct sunlight.

4.3.3 Conditioning to New Environments

The 3480 type tape cartridges exposed to temperature excursions may experience inter-layer slip (see sec. 3.2.3) which can cause other failures such as cinching (see sec. 3.2.4).

The 3480 type tape drives have no mechanical buffering or capstan, so the control circuitry can only tolerate a limited amount of shifting or slippage of the tape layers. Not only may this tension problem cause mechanical damage to the tape, but it is expensive to wait for the drive to retension the tape.

To eliminate this problem, let the 3480 type tape cartridges stabilize for at least 24 hours to the computer room environment before using them.

4.4 General Care and Handling Tips

- Leave the 3480 type tape cartridges in their protective packaging until you are ready to use them.
- Visually inspect every cartridge when unwrapping and ensure that the leader block is latched. If the leader block must be manually latched into the cartridge, be certain that the large, rounded end is inserted first. Excessive force will be required if the slotted end is inserted first and the cartridge may be damaged.
- Do not use sharp instruments to unpack cartridges.
- Condition the 3480 type media to the operating environment for at least 24 hours.
- Keep the outside of the cartridge clean and free of damage. The external surface of a cartridge may be cleaned with a lint-free cloth dampened with isopropyl alcohol.
- Keep the 3480 type tape cartridges in racks when not in use.
- Store the 3480 type tape cartridges in a vertical position.
- Do not attempt to carry more than one cartridge at a time. The cartridges do not have detents to interlock with corresponding detents on other cartridges which may be stacked on top of it. Therefore, stacks of 3480 type tape cartridges are not structurally stable and will topple.
- Do not manually unspool the tape from the cartridge.
- Do not attempt to pull the leader block from the cartridge.
- If you must pull the leader block from the cartridge, use the brake release (winder) tool supplied in the leader block replacement kit. Without this tool, you can easily damage the tape and reduce cartridge reliability.
- If the tape must be removed from the cartridge for inspection or some specific purpose, do not touch the recording surface. Even clean skin contains body oils and oil residues which attract contaminants that will cause data errors. Use lint-free gloves when handling any type of magnetic tape.
- Do not force the 3480 type tape cartridge into the drive. If it does not insert smoothly, something is wrong and forcing it may cause damage.

- Keep the 3480 type tape cartridges away from any heating devices (e.g., radiators, space heaters, etc.).
- Never return to service a 3480 type tape cartridge which has been dropped, contaminated, or damaged in any way.

4.5 3480 Type Tape Drive Maintenance

Cleanliness of the 3480 type tape drives is important. The accumulation of dust, dirt, and tape byproducts on the tape drive components may reduce the life and reliability of the equipment. Furthermore, these contaminants will corrupt the tapes used on poorly maintained drives by migrating dirt and debris to them (see sec. 4.8).

4.5.1 3480 Type Cleaning Cartridge

The 3480 type tape drives prompt the user to insert a 3480 type tape cleaning cartridge periodically. When this cleaning cartridge was introduced, it was recommended that its usage be limited to 500 cleaning passes. The cartridge has 500 small circles, one to be filled in for each use. When the circles are all marked, the cleaning cartridge is to be discarded and replaced with a clean one. Some users have questioned, "Can the cleaning cartridge recontaminate the drive once it becomes dirty?"

Some cleaning cartridge and drive manufacturers recommend a reduction in the number of uses to 100 passes. This suggestion is based on the fact that the cleaning efficiency drops as the ribbon gets dirty. It is prudent to discard the cleaning cartridge after 100 cleaning passes.

4.5.2 Wet Cleaning

It is recommended that the 3480 type tape drives be "wet cleaned" periodically by a trained and certified service technician. Wet cleaning involves the cleaning of tape drive components, such as the cleaning blades and the take-up reel, with reagent grade isopropyl alcohol and lint-free tissues. Poorer grades of isopropyl alcohol should not be used since they may contain contaminants.

This type of cleaning, as well as the periodic replacement of vacuum lines and air filters, should be specified in the tape drive service contract.

It would be useful if a recommendation could be made on the number of usage hours before wet cleaning should be performed. However, variations in environmental cleanliness and tape quality make it impossible to make such a recommendation.

Instead, the wet cleaning frequency requirements for a specific 3480 type tape drive should be determined by visual inspection and consultation with a qualified service technician.

4.6 Fire Protection Recommendations

Carbon dioxide (CO₂) is a good extinguisher for computer tape fire protection, since it is clean and will not harm the 3480 type media. However, the use of CO₂ is limited to the use of extinguishers and cannot be used in automatic systems because it is lethal to humans.

CO₂ is heavier than Oxygen (O₂), and therefore sinks to the bottom of a room. Exhaust vents are generally located near the ceiling, and do a good job of removing any O₂ displaced by the CO₂ released during fire extinction operations. If a person were to walk into one of these rooms which has not been ventilated after the fire is extinguished, that person could suffocate.

Properly designed Halon 1301 systems can be used in areas inhabited by people without endangering their lives. Furthermore, Halon is clean and does not damage the 3480 type media. However, Halon depletes the Earth's ozone layer. As a result, the United States Environmental Protection Agency has initiated a program to phase out the use of Halon systems. Future changeover of Halon to its replacement could simply be a change in the gas used.

Water fire protection systems are currently the most acceptable option for tape vault extinguisher systems. Water is harmful to 3480 type media, but is not immediately destructive to the data stored on these media.

The following are some general tips for computer room and storage vault fire protection [2]:

- Minimize the storage of paper, wood, cleaning fluids, and all other combustible materials in the tape storage area.
- Keep the tape storage area orderly, clean and unencumbered so that the spread of a fire is slowed and fire fighting can be performed efficiently.
- Do not use open flame producers, such as matches and lighters in the tape storage areas. Smoking should always be prohibited in these areas.
- Areas in which 3480 type tapes are to be stored should be designed with the maximum protection against fire as a major consideration.
- Ensure that fire and smoke detection/suppressive systems are installed and

- Ensure that fire and smoke detection/suppressive systems are installed and functioning properly. Periodic inspection is required.
- Store duplicate copies of tapes containing vital information in alternate off-site locations. When secondary copies exist, tertiary copies can be made when the primary tapes are exposed to disaster conditions.

4.7 Water Protection Recommendations

The cartridge surrounding the 3480 type tape provides some protection from the ingress of water. The 3480 type tape cartridges exposed to water require immediate attention due to the fact that water may cause tape layers to adhere to one another. This layer-to-layer adhesion can make the recovery of data impossible. When the layers of tape are pulled apart, the magnetic coating may be pulled off the PET substrate, resulting in data loss.

The most obvious way to protect a data library of 3480 type media from any disaster is to maintain secondary off-site backups. If disaster strikes the primary tapes, tertiary tapes can be made from the off-site secondary tapes and the damaged tapes can be discarded.

The probability of both sets of information being destroyed is unlikely. However, if no backup of information exists, data on water damage tapes may be recovered. Some anecdotal accounts and conventional recommendations suggest that data on tapes can be recovered using the following procedures [2].

- Release the leader block and drain the water from the cartridge.
- Rinse the tape cartridges with clean, preferably distilled, water.
- Dry the tapes by vacuum drying. Do not force-dry the tapes with heat. This may cause hydrolytic degradation.
- Allow the tapes to dry under the normally recommended storage temperature and humidity conditions for at least 48 hours.
- Clean the damaged tapes with a device employing lint-free tissues. Do not run damaged tapes over cleaning blades.
- Copy the data to new tape cartridges and discard the water damaged tapes.
- Do not use the main or backup library drive for this copying activity since water damaged tapes may contaminate the tape drive (see sec. 4.8).

These activities introduce a large expense and effort to recover data. The probability of recovering 100% of the data is low. It is strongly recommended that the method of protection by multiple off-site backups be used.

However, if disaster does strike a library with no off-site library backup, the media manufacturer should be consulted immediately. Since the media manufacturer's tape formula is proprietary, they would be the best authority on the methods required for recovery.

4.8 Contamination Migration Avoidance Recommendations

Dust, dirt, and tape byproducts can migrate from one tape or tape drive throughout an entire library. This migration of contaminants can readily destroy data.

For example, if a 3480 type tape cartridge that is experiencing hydrolytic degradation comes into the data center from a field collection site and is read on the computer rooms 3480 type tape drive, sticky, gummy tape byproducts may contaminate the drive. If other tapes are then read or written on that same drive, they will be contaminated as well. It is possible for the spread of such contaminants to destroy a major part of the main and backup libraries unless some means is used to avoid this risk.

To avoid the migration of contamination, tapes and tape drives should be separated into groups. These groups should consist of the following: import/export, main library, and backup library. Each of the tapes in a group should only be used on a tape drive from that same group. This will prevent the physical contact of tapes which are used in the field for data collection, main library tapes, and backup library tapes. Diligent observation of this care and handling technique will greatly reduce the risk associated with the migration of contamination.

5. Retensioning 3480 Type Tape Cartridges

The PET substrate used in both 9-track open reel tapes and the 3480 type tape cartridges is highly stable both chemically and mechanically under the proper storage environmental conditions. However, the PET substrate wound under stress, as in the case of magnetic tapes, will creep in the direction of the stress and elongate with time until the elongation has relieved the applied stress. This elongation will cause the tape pack to loosen. Variations in temperature and humidity will also cause a loose tape pack because of hygroscopic and thermal expansion. A tape which has a loose tape pack may experience inter-layer slip and cinching when subjected to large accelerations such as those used in 9-track open reel tape drives. As a result, it is necessary to retension 9-track open reel tapes prior to their usage to restore the proper tension to the tape pack. The 3480 type tape drives subject the tape to a lower acceleration when tape motion is initiated. In fact, the 3480 type tape drive will detect a loose tape pack and automatically retension the 3480 type tape cartridge.

The harmful effects caused by a loose tape pack have led to suggestions that tapes be periodically rewound to restore tension [2]. Winding magnetic tapes under tension causes them to creep and elongate, which leads to changes in the tape's physical dimensions. Constantly renewing these applied stresses may cause the tape to experience further dimensional changes and distortions which could potentially make the media unreadable [1].

The IBM Corporation quantitatively examined the necessity for the periodic retensioning of the 3480 type tape cartridges [3], [4]. IBM's experiment involved the accelerated aging of two identical groups of experimental 3480 type tape cartridges at 35 °C (95 °F) and 67% RH. Both groups of tapes were stored in this environment for 62 days. However, one group was retensioned every 2 weeks (two full read passes on an IBM 3480 tape drive), while the other group was not retensioned. The analysis of the two groups of tapes showed that both groups experienced the same chemical and mechanical degradation. Nevertheless, the two groups did not yield the same error rate. In fact, the group of 3480 type tape cartridges that were retensioned experienced catastrophic error rate failure.

The explanation for this dramatic decrease in performance is the 3480 type tape cartridge's increased sensitivity to tension-induced distortions. The magnetic coating of the group of tapes that were not retensioned effectively became harder and more resistant to applied stresses, while the other tapes were having the stresses renewed.

However, these mechanical deformations alone did not produce the catastrophic failure. IBM points out that the tapes stored without retensioning for the initial 62 days continued to perform without an increase in raw errors even after 10 subsequent retensioning passes. Since the other group of tapes failed after five to six retensioning passes, indications are that aging under reduced stress may improve the 3480 type media's resistance to applied stresses. Thermal aging of the media may have caused an increase in the binder interaction with the CrO₂ particles. The increased particle interaction may result in a harder coating, which is more resistive to the compressive forces exerted by overlaying wraps of tape. IBM's results show a resistance to applied-stress-induced failure with the tapes that were not retensioned, and a cohesive failure of the coating leading to the generation of debris and a rapid deterioration of the raw error rate in the retensioned tapes [3],[4].

In conclusion, not only does periodic retensioning introduce a large expense and effort into the maintenance of a library, published literature indicates that these activities may not be necessary [1],[3],[4]. Furthermore, based on interviews with magnetic media users, there is little evidence that users actually retension their tapes periodically.

6. Chromium Dioxide's Toxic Nature

CrO₂, which is the magnetic particles used in the 3480 type media, degrades in the presence of atmospheric water and oxygen to hexavalent chromium (Cr⁶⁺) which is toxic. As a result, the United States Environmental Protection Agency (EPA) has set forth a maximum leachability requirement. Leachability is the propensity of the binder to release CrO₂ particles to the environment.

6.1 Potential Health Risks

To satisfy tape performance specifications and comply with the EPA leachability requirements, the CrO₂ particles are completely encapsulated by the binder of the tape coating. As a result, users are not exposed to chromium during routine usage. CrO₂ particles do not become airborne. The Du Pont and IBM Corporation's measurements of nearby atmosphere during usage of CrO₂ tape showed chromium levels to be non-detectable. In addition, employees in the Du Pont CrO₂ tape manufacturing plants have not had any incidence of skin irritation or sensitization for more than 20 years of operation. Du Pont also performed a 2 week oral intubation study of ground-up CrO₂ tapes on laboratory rats. The rats showed no adverse effects. Skin patch tests on humans with tape showed no irritation or skin sensitization [6].

6.2 Potential Disposal Problems

All CrO tape sold in the United States must satisfy the EPA leachability requirement in order to be disposed of as normal trash. Each 3480 type tape cartridge manufacturer determines whether their product can be disposed of as normal trash. However, Du Pont analyzed a large number of commercially available CrO₂ audio, video, and data (3480 type media) tapes for compliance with the EPA regulation for ordinary landfill disposal. According to Du Pont, all the tapes tested complied with the leachability requirements [6].

7. Information from Users

7.1 Internal Revenue Service

- Limited experience. IRS has only used 3480 type media since December of 1990.
- To date they have 19,500 3480 type tape cartridges. Future expectations include approximately 150,000 3480 type tape cartridges at the Martinsburg, WV facility.
- Wait and see on the retensioning issue.
- "3480 type media is faster, more dense, and less susceptible to damage than the open-reel tapes."
- Off site backup, no sampling of data integrity.

7.2 National Center for Atmospheric Research

- Started using the 3480 type media in 1986.
- NCAR has 102,000 3480 type tape cartridges.
- NCAR reports very good results with the 3480 type media. They have had only two unrecoverable errors since 1986.
- NCAR sees a few bad cartridges in every shipment of 10,000 new cartridges. Problems have been with leader block detachment and cracked cases.
- NCAR expects to be able to store data on 3480 type media for at least 10 years.
- Long-term storage tapes never leave the library and are only used on long-term storage drives. Import/export tapes are used on import/export drives for interchange of data. This minimizes the migration of possible contamination.
- Random sampling of data integrity.
- No retensioning of the tape cartridges.

- Armed water fire protection.
- Single vendor for tape cartridges.

7.3 Mobil Exploration and Producing Services Inc.

- MEPSI started to transfer their geophysical data to 3480 type media in June of 1989.
- They have 80,000 3480 type tape cartridges. In addition, most other divisions of Mobil Oil Company and its contractors use 3480 type media.
- After internal studies of the 3480 type technology, MEPSI concluded that the 3480 type media was more stable than open reel tapes because it is in a cartridge and less susceptible to human and environmental damage.
- No problems found with the 3480 type media thus far.
- Seed the library with tapes containing test data. Then go back and read these "Tracer tapes" once a year. If problems exist, check the tapes from the same time period and copy the data to new media. "The media is cheap, the data is what is expensive."
- MEPSI believes the main problem with 3480 type media is hydrolysis, which is driven by bad environments. "You must maintain a clean, temperature and humidity controlled environment."
- MEPSI retensions their tapes every few years. It is their opinion that this is important. "We are aware of some 3480 type tape cartridge users who have not retensioned their tapes and have had read errors after 4 years."

7.4 Shell Oil Company

- Shell has been using the 3480 type media since the end of 1987.
- They have 804,000 3480 type tape cartridges.
- Early in their 3480 type media program they had some problems like leader block detachment and other tape manufacturer's defects. However, they have had less problems with the 3480 type media than with the open reel tapes.
- Shell had some tapes contaminated with ethylene glycol from a cooling system. The data were recovered and the tapes were thrown out. "We never put damaged or reconditioned tapes back into service."

- Shell also had some 3480 type tape cartridges with degradation due to hydrolysis which contaminated a drive with debris. The drive in turn contaminated other cartridges which propagated the contamination to other drives.
- Shell expects to store data on 3480 type media for at least 10 years. "Within 10 years we will be migrating to a newer, more dense media."
- The reasons Shell chose the 3480 type media were as follows:
 - 1) Cartridge form (less susceptible to damage)
 - 2) Silos
- No retensioning of the 3480 type tape cartridges. "Retensioning is too expensive and too time consuming."

7.5 Social Security Administration

- SSA has 3 years of experience with the 3480 type tape cartridges.
- They have 173,000 3480 type tape cartridges.
- In addition, SSA expects to add 21 silos with 5,000 cartridges in each.
- SSA has had very few problems associated with the storage of data on 3480 type tape cartridges. The few problems which have been observed have been due to misuse or leader block detachment.
- Single vendor for tape cartridges.
- SSA uses an unarmed water fire protection system.
- The 3480 type media was chosen for the following reasons:
 - 1) SSA feels the 3480 type media is more stable and reliable than open reel tapes.
 - 2) Less subject to operator damage.
 - 3) Silos.
- SSA does not retension their 3480 type tape cartridges.

7.6 The Church of Jesus Christ of Latter Day Saints

- Started migrating data from open-reel tapes to 3480 type media in June, 1990.
- They have 25,000 3480 type tape cartridges.
- In general, they have had no problems associated with the storage of data on 3480 type tape cartridges thus far.
- The 3480 type media was chosen for the following reasons:
 - 1) Cost.
 - 2) Durability.
 - 3) Less storage space.
 - 4) Less operator handling of the tape.
- They expect to maintain data on 3480 type tape cartridges for at least 10 years.
- 3480 type tape cartridges in long-term storage will be retensioned every 3 years.
- Temperature, humidity, and storage vault cleanliness is maintained according to the standards.
- Multiple off-site backups.

7.7 Western Geophysical

- WG started using the 3480 type media in 1984. They were IBM's first customer. Today they are the largest 3480 type media user in private industry.
- They have 1,200,000 3480 type tape cartridges in long-term storage.
- In addition, they have 225,000 3480 type cartridges in 6-month storage.
- Many thousands of 3480 type cartridges used for data collection go directly to Western Geophysical's customers.
- WG expects to store data on 3480 type media for 20 to 30 years.
- "3480 type media is a 100% improvement over open-reel tapes. We don't have tape errors with the 3480."
- Tapes which are used to collect data in the field go directly into long-term storage.

- No retensioning of tapes.
- WG maintains a clean, temperature and humidity controlled environment.
- No sampling of data integrity.
- "The 3480 type media are excellent for long-term storage. The only bad thing we can say about the 3480 type technology is that the capacity is too small and the transfer rate is too low."
- WG had some early problems with tape manufacturers producing tapes with bad binders. 40,000 3480 type tape cartridges had to be replaced due to binder breakdown. "If you buy good tapes, and you use the proper care and handling procedures, you won't have any problem with the 3480 type media."
- WG uses off-line retensioners on their boats. "We can't afford the time it takes the 3480 type drives to retension when a loose tape pack occurs."

	Year	#	Retension	Off-site backups	Data Sampling	Problems
IRS	1990	19,500	wait and see	yes	no	no
NCAR	1986	102,000	no	no	yes	very few
Mobil	1989	80,000	yes	no	yes	no
Shell	1987	804,000	no	no	no	< 9-track
SSA	1988	173,000	no	yes	no	very few
CJCLDS	1990	25,000	yes	yes	yes	no
WG	1984	1,200,000	no	no	no	< 9-track

Figure 6. Summary of User Information.

8. Information from Manufacturers

8.1 3M

- Based on 3M's aging tests, 10 years is a safe length of time to store data on 3480 type tape cartridges.
- Some binder formulations are hydrolytically unstable.
- Periodic retensioning of the 3480 type media may not be necessary.
- The signal amplitude loss over time by the CrO₂ pigment is of the same order of magnitude as it is with other recording pigments.

8.2 BASF

- There is a very high probability the 3480 type media will retain data for at least 10 years.
- BASF soaked a 3480 type tape cartridge in tap water for 24 hours. The cartridge was drained for 1 week and cleaned. There were no problems recovering the data.
- "We are still of the opinion that the guidelines published in the NBS Special Publication 500 - 101, page 83 are also valid for archival storage of the 3480 type media."
- Periodic retensioning of the 3480 type media may not be necessary.
- Accelerated aging at 50 °C and 75% RH for several weeks. Testing simulated aging up to 20 years. Only 9% of signal degradation was observed after 10 years of simulated aging. Most of the degradation was observed in the first 2 years. There were some raw errors, but the powerful ECC (up to four tracks in error on a read) permitted full data recovery after 20 years of simulated aging.
- In the service contract, specify periodic wet cleaning of the 3480 type tape drives. The tape drive components, especially the cleaner blades, accumulate debris.

8.3 Carlisle Memory Products

- The industry has had a history of problems associated with the binder formulations for the 3480 type media.
- Carlisle says that provided the proper care and handling procedures are used, the data stored on 3480 type media will last longer than that on open-reel tapes, up to 20 or 25 years.
- Problems commonly found with returned tapes:
 - stretched tapes.
 - badly slit tape edge.
 - indentations from debris.
 - leader block detachment.
 - contamination.
- Most problems found with the 3480 type tape cartridges are caused by major failure mechanism, and are immediately obvious.
- "A user should always have multiple backups."
- It is very important to wet clean the tape drives often.
- Do not use the 3480 type cleaner cartridges more than 100 times each. Cleaner cartridges used more than 100 times will recontaminate the drives.
- Periodic cleaning is needed for the 3480 type media.

8.4 Du Pont

- A 10-year data life expectancy of the 3480 type media is probably a very conservative estimate.
- Most 3480 type media failures are caused by hydrolysis, embossment of debris, and user misuse, not from decay of magnetization.
- "3480 type media is excellent for long-term storage provided the proper care and handling procedures are used."
- "We also have CrO₂ video tapes from 1970 which produce a picture equal in quality to the day it was recorded."

8.5 IBM

- "In general, the 3480 type media is much better than the open-reel tapes."
- IBM has seen many failures caused by the embossment of debris and user misuse.
- Temperature excursions are more destructive than humidity changes. Inter-layer slip is caused by changes in temperature. "You must let your tapes acclimate to the operating environment for at least 24 hours."
- The right binder formulation reduces problems with hydrolysis. As a result, the generation of debris and mechanical distortions are reduced.
- Tapes and drives should be separated into groups to prevent the migration of contamination. These groups should consist of the following: Import/export, main library, and backup library. Each of the tapes in a group should only be used on a group tape drive.
- IBM landfill tests show there are no problems associated with the disposal of the 3480 type media.
- The fatty acids in the lubricants are the only component likely to attract biological infestation. However, chromium is a good fungicide. Therefore, biological infestation of the 3480 type media is not a problem.
- Shipping 3480 type tape cartridges in a "zip-lock" polyethylene bag is a good idea (to avoid contamination).
- IBM performed sniffer tests and chromium particle counts. Their results showed no health risks associated with the usage of the 3480 type media.

8.6 StorageTek

- Most of the problems StorageTek has seen are due to user misuse.
- "We have not seen many problems due to the embossment of debris. However, we have seen chemical degradation, and mechanical damage which have caused problems."
- Keeping the tape drive clean is vital. Wet cleaning is required periodically.
- "Caution, every tape manufacturer can put out a bad batch of tapes now and again. There still may be some problems with binder formulations."

9. Information from Other Sources

9.1 National Media Laboratory

- There is little risk associated with the storage of data on the 3480 type media for at least 10 years.
- The life expectancy of the 3480 type media is much greater than the product life expectancy.
- Chloride and ozone are harmful agents to the 3480 type tape cartridges.
- "The 3480 type tape drive's ECC is very powerful. If you can write the tape, chances are you won't have any problems reading it later."

9.2 Battelle

- The 3480 type media is very stable with respect to environmental contaminants.
- Good stability compared to other types of media.
- The cartridge protects the tape from the outside environment. However, naked 3480 type tape exposed to chloride showed less harmful effects than other types of tape.
- The effects of ozone are minimal.

	Life Span (Yrs)	Retention	Drive Wet Cleaning	Stability
3M	10	no	yes	> 9-track
BASF	10	no	yes	> 9-track
Carlisle	20	yes	yes	> 9-track
Du Pont	10	no	n/a	> 9-track
IBM	10	no	yes	> 9-track
StorageTek	X	X	yes	> 9-track
NML	10	unknown	yes	= 9-track
Battelle	X	X	n/a	> 9-track

X - no opinion

Figure 7. Summary of Manufacturer and Other Source Information.

10. Conclusions

After approximately 7 years experience, 3480 type media users from government and industry have experienced the dependability and, conversely, the problems associated with the storage of data on the 3480 type tape cartridges.

The risks associated with the storage of data on the 3480 type media are relatively low, provided the proper care and handling procedures are observed. The two major risks associated with the storage of data on the 3480 type media are manufacturer defects and user misuse.

Manufacturers have produced tapes which have experienced premature degradation of the magnetic coating binders, causing users to lose valuable data. Although the manufacturers have improved their binder formulations, any manufacturer could still produce a bad batch of tapes. Since the actual cost of the media is insignificant compared to the value of the data it contains, data managers should be very selective in the quality of media purchased for their libraries.

Once quality media has been obtained, the risk associated with the storage of data on the 3480 type media is directly proportional to the diligence used in its care and handling. Proper maintenance of the environment, as well as the observation of some simple rules in the usage, storage, and transportation can greatly reduce the risks associated with the storage of data on the media. Otherwise, chemical, mechanical, and/or magnetic failures of this type of media are possible, which may result in the permanent loss of data.

Provided that the media is of good quality, and the proper care and handling procedures are observed, there is a low risk associated with the storage of data on the 3480 type tape cartridges. While there is no quantitative data, the opinion of 3480 type technology manufacturers is that there is a high probability that the 3480 type media will retain data for at least 10 years.

A. Definitions

Abrasivity - The magnetic tape's ability to wear away the read/write head.

Acicular - Needle shaped.

Adhesion - The ability of one material to stick to another material.

ANSI - The American National Standards Institute.

ASLE - American Society of Lubrication Engineers.

Asperities - Projecting imperfections on the surface of the tape.

Binder - A formula of organic materials used to bond the magnetic particles to the substrate.

Bit - A magnetic transition which represents one recorded cell of information.

Bit Density - Bits per unit length, area, or volume.

Block - A group of bytes acted on as a unit.

BPI - Bits per inch.

BPMM - Bits per millimeter.

Byte - A group of eight data bits (9 encoded bits).

Capstan - The drive shaft in a tape drive which moves the tape through the transport.

Cinching - The tape folds over as a result of inter-layer slip.

Coating - The magnetic layer of a magnetic tape.

Cohesion - A materials ability to remain bound to itself.

Creep - Time-dependent strain at constant stress (stretching or relaxation).

CrO₂ - Chromium dioxide.

Cupping - The departure from a flat surface along the width of the tape.

Curvature - The departure from a flat surface along the length of the tape.

Degauss - To return the magnetization of the media or the head to a zero state.

Drag - When the tape contacts tape drive components, there is a tension differential across the real area of contact which is caused by friction.

Dropout - The ANSI X3.180-1990 standard defines a dropout as a loss in the read signal amplitude. A dropout exists on the magnetic tape when the base-to-peak read signal amplitude is 25% or less of half the average signal amplitude for the proceeding 25.4 mm (1.0 in) of tape.

ECC - Error Correction Coding, a sequence of bytes for the detection and correction of errors.

ECMA - European Computer Manufacturers Association.

Erasure - A process by which data is removed from the recording media.

Error - Information not accurately reproduced.

Flux transition - Transition in the lines of magnetic force.

FTPI - Flux transitions per inch.

FTPMM - Flux transitions per millimeter.

GCR - Group coded recording, a recording format which collects eight data bits (one byte) and encodes them into nine bits prior to recording them onto the magnetic tape.

Glass transition temperature - Actually a range of temperatures, below which polymer materials exist in a hard glass-like state. Above this temperature range, polymer materials become rubbery.

Head - A transducer for converting electrical signals into magnetic signals, when writing, and visa versa, when reading, on magnetic tape.

IEEE - Institute of Electrical and Electronics Engineers

ILS - Inter-layer slip.

ISO - International Standards Organization.

Magnetoresistive - The change in electrical resistance of a conductor due to a change in the applied magnetic force.

Permanent Error - An error that is repeatable in the same location.

Oersted - A unit of magnetic field strength.

Signal Amplitude - The amplitude of the electrical signal produced by the magnetic head.

Substrate - PET film which the magnetic coating is applied.

Temporary Error - Errors that are not repeatable.

TC X3B5 - Technical Committee for digital magnetic tape.

Track - A longitudinal area on the tape along which a series of magnetic signals can be recorded.

B. References

- [1.] L.E. Smith, "Factors Governing the Long Term Stability of Polyester-Based Recording Media," In Press, 1991.
- [2.] S.B. Geller, "Care and Handling of Computer Magnetic Storage Media," Natl. Bur. Stand. (US) Special Publ. 500-101, June 1983.
- [3.] R.L. Bradshaw and T.W. Reid, "Archival Stability of IBM 3480/3490 Cartridge Tapes," IEEE Trans. Mag., Vol. 27, No. 4, July 1991.
- [4.] R.L. Bradshaw, "Archival Stability of Flexible Magnetic Media," IBM Corp., Paper Presented at Assoc. Canadian Archivists, Annual Meeting, Fredericton, NB, Canada, May 30 - June 3, 1989.
- [5.] ComputerWorld Magazine, "Taking Chances with New Tapes," June 9, 1986.
- [6.] Du Pont, Magnetic Products Division, "Chromium Dioxide Magnetic Tape For High Density Data Cartridges," X3B5/86-161, HI/TC 86-12, Rev. A 7-8-86.
- [7.] F. Jorgensen, "The Complete Handbook of Magnetic Recording, 3rd edition," Tab Professional and Reference Books, 1988.
- [8.] American National Standard Institute, "Magnetic Tape and Cartridge For Information Interchange - 18-Track, Parallel, 1/2 inch (12.65 mm), 37871 cpi (1491 cpmm), Group-Coded Requirements for Recording," X3.180-1990.
- [9.] IBM, "IBM 3480 Magnetic Tape Subsystem," IBM Corporation, 1984.
- [10.] IBM, "IBM Product Announcement 184-051," IBM Corporation, March 22, 1984
- [11.] D.J. Winarski, W.W. Chow, J.G. Bullock, F.B. Froehlich, T.G. Osterday, "Mechanical Design of the Cartridge and Transport for the IBM 3480 Magnetic Tape Subsystem," IBM J. Res. Develop., Vol. 30, No. 6, Nov. 1986.
- [12.] A.M. Patel, "Adaptive cross-parity code for high-density magnetic tape subsystem," IBM J. Res. Develop., Vol. 29, No.6, Nov. 1985.

- [13.] E.F. Cuddihy, "Aging of Magnetic Recording Tape," IEEE Trans. on Mag., Vol. MAG-16, No. 4, 11p, July 1980.
- [14.] E.F. Cuddihy, "Hygroscopic Properties of Magnetic Recording Tape." IEEE Trans. on Mag., Vol. MAG-12, No. 2, 9p, March 1976.
- [15.] H.N. Bertram, E.F. Cuddihy, "Kinetics of the Humid Aging of Magnetic Recording Tape," IEEE Trans. on Mag., Vol. MAG-18, No. 5, 7p, September 1982.
- [16.] BASF, "3480 Cartridge Care and Handling," Internal Technical Bulletin.

C. Other References

R.C. Schneider, "Write Equalization in High-Linear-Density Magnetic Recording," IBM J. Res. Develop., Vol. 29, No. 6, Nov. 1985.

D.M. Cannon, W.R. Dempwolf, J.M. Schmalhorst, F.B. Shelledy, R.D. Silkensen, "Design and Performance of a Magnetic Head for a High-Density Tape Drive," IBM J. Res. Develop., Vol 30, No. 3, May 1986.

D.W. Brown, R.E. Lowry, L.E. Smith, "Prediction of the Long Term Stability of Polyester-Based Recording Media," NBSIR 82-2530, June 1982.

D.W. Brown, R.E. Lowry, L.E. Smith, "Prediction of the Long Term Stability of Polyester-Based Recording Media," NBSIR 83-2750, Aug. 1983.

D.W. Brown, R.E. Lowry, L.E. Smith, "Prediction of the Long Term Stability of Polyester-Based Recording Media," NBSIR 84-2988, Dec. 1984.

D.W. Brown, R.E. Lowry, L.E. Smith, "Prediction of the Long Term Stability of Polyester-Based Recording Media," NBSIR 86-3474, June 1986.

T.E. Weir, Jr., "3480 Class Tape Cartridge Drives and Archival Data Storage: Technology Assessment Report," National Archives Technical Information Paper No. 4, June 1988.

B. Bhushan, B.S. Sharma, R.L. Bradshaw, "Friction in Magnetic Tapes I: Assessment of Relevant Theory," ASLE Trans. Vol. 27, 1, 33-44, April 1983.

B. Bhushan, R.L. Bradshaw, B.S. Sharma, "Friction in Magnetic Tapes II: Role of Physical Properties," ASLE Trans. Vol. 27, 2, 89-100, April 1983.

R.L. Bradshaw, B. Bhushan, "Friction in Magnetic Tapes III: Role of Chemical Properties," ASLE Trans. Vol. 27, 3, 207-219, April 1983.

R.L. Bradshaw, B. Bhushan, C. Kalthoff, M. Warne, "Chemical and Mechanical Performance of Flexible Magnetic Tape Containing Chromium Dioxide," IBM J. Res. Develop., Vol. 30, No. 2, March 1986.

R.L. Bradshaw, S.J. Falcone, "Polyester-Polyurethane Interactions with Chromium Dioxide," *Polymers in Information Storage Technology*, Edited by K.L. Mittal, Plenum Publishing Corporation, 1989.

Du Pont, "Toxicology of Du Pont Halon 1301 Fire Extinguishant, " E.I. Du Pont De Nemours & Co., 1971.

Du Pont, "Du Pont Chromium Dioxide Magnetic Crystals," Product Information E-97190, 1988.

Ampex, "A Guide to Media & Formats," Ampex Recording Media Corp., T50-02, 1990.

National Archives and Records Administration, "Managing Electronic Records," NARA Instructional Guide Series, 1990.

A.S. Hoagland, "Trends and Projections in Magnetic Recording Storage on Particulate Media," *IEEE Trans. on Mag.*, Vol. MAG-16, No. 1, Jan. 1980.

C.J. Weschler, H.C. Shields, "The Impact of Ventilation and Indoor Air Quality on Electronic Equipment," *ASHRAE Trans.*, Vol. 97, Pt. 1, 1991.

B. Bhushan, "Overview of Challenger Space Shuttle Tape-Data Recovery Study," *IEEE Trans. on Mag.*, Vol. MAG-23, No. 5, Sept. 1987.

H.J. Schroeder, "Maximum Storage Temperatures and Humidities for Magnetic Tape, Discrepancies between Standards for Fire Protected Equipment and ECMA or ISO for Magnetic Tape," X3B5/90-061, 1990.

S.B. Geller, "The Effects of Magnetic Fields on Magnetic Storage Media Used in Computers," NBS Technical Note 735, July 1972.

S.B. Geller, "Erasing Myths About Magnetic Media," *Datamation*, March 1976.

P. Maestro, D. Andriamandroso, G. Demazeau, M. Pouchard, P. Hagenmuller, "New Improvements of CrO₂ Related Magnetic Recording Materials," *IEEE Trans. on Mag.*, Vol. MAG-18, No. 5, Sept. 1982.

S. Uren, K. O'Grady, R.W. Chantrell, J. Popplewell, "Texture and Angular Dependence of Magnetic Viscosity in Digital Recording Media," *IEEE Trans. on Mag.*, Vol. 25, No. 5, Sept. 1989.

M. Essig, M.W. Muller, E. Schwab, "Structural Analysis of the Stabilization Layer of Chromium Dioxide Particles," *IEEE Trans. on Mag.*, Vol. 26, No. 1, Jan. 1990.

H. Auweter, R. Feser, H. Jakusch, M.W. Muller, N. Muller, E. Schwab, R.J. Veitch, "Chromium Dioxide Particles for Magnetic Recording," IEEE Trans. on Mag., Vol. 26, No. 1, Jan. 1990.

M.W. Muller, E. Schwab, R.J. Veitch, "Magnetic Analysis of High Coercivity Chromium Dioxide Particles," IEEE Trans. on Mag., Vol. 26, No. 5, Sept. 1990.

R.M. Kloepper, B. Finkelstein, D. Braunstein, "Time Decay of Magnetization in Particulate Media," IEEE Trans. on Mag., Vol. MAG-20, No. 5, Sept. 1984.

V.M. Tobin, S.B. Oseroff, S. Schultz, "Effect of Magnetic Viscosity on the Angular Dependence of Coercive Field in Particulate Recording Media," IEEE Trans. on Mag., Vol. 25, No. 5, Sept. 1989.

S.B. Oseroff, D. Franks, "Magnetization Time Decay in Particulate Media," IEEE Trans. on Mag., Vol. MAG-23, No. 5, Sept. 1987.

R.H. Dee, R.F.M. Thornley, "Thermal Effects in Shielded MR Heads for Tape Applications," Storage Technology Corp. April, 1991.

N. Bertram, A. Eshel, "Recording Media Archival Attributes (Magnetic)," Rome Air Development Center/Ampex Corp., RADC-TR-80-123, April 1980.

B. Bhushan, D. Bogy, N.S. Eiss Jr., F.E. Talke, "Tribology and Mechanics of Magnetic Storage Systems," ASLE Special Pub., SP-16, 1984.

F. Kalil, "Magnetic Tape Recording for the Eighties," NASA Reference Pub. 1075, April 1982.

B. Bhushan, "Tribology and Mechanics of Magnetic Storage Devices," Springer-Verlag, New York, 1990.

NIST-114A
(REV. 3-90)

U.S. DEPARTMENT OF COMMERCE
NATIONAL INSTITUTE OF STANDARDS AND TECHNOLOGY

BIBLIOGRAPHIC DATA SHEET

1. PUBLICATION OR REPORT NUMBER NIST/SP-500/199
2. PERFORMING ORGANIZATION REPORT NUMBER
3. PUBLICATION DATE November 1991

4. TITLE AND SUBTITLE
The 3480 Type Tape Cartridge: Potential Data Storage Risks, and Care and Handling Procedures to Minimize Risks

5. AUTHOR(S)
Mark P. Williamson

6. PERFORMING ORGANIZATION (IF JOINT OR OTHER THAN NIST, SEE INSTRUCTIONS) U.S. DEPARTMENT OF COMMERCE NATIONAL INSTITUTE OF STANDARDS AND TECHNOLOGY GAITHERSBURG, MD 20899	7. CONTRACT/GRANT NUMBER
	8. TYPE OF REPORT AND PERIOD COVERED Final

9. SPONSORING ORGANIZATION NAME AND COMPLETE ADDRESS (STREET, CITY, STATE, ZIP)
National Oceanic and Atmospheric Administration
Suitland, Maryland 20233

10. SUPPLEMENTARY NOTES

11. ABSTRACT (A 200-WORD OR LESS FACTUAL SUMMARY OF MOST SIGNIFICANT INFORMATION. IF DOCUMENT INCLUDES A SIGNIFICANT BIBLIOGRAPHY OR LITERATURE SURVEY, MENTION IT HERE.)
The 3480 type media was introduced to the data storage industry in 1984. Early problems were reported due to premature degradation of the polyester polyurethane binder. In addition, the lack of guidelines for proper care and handling increased the risks associated with the storage of data on the 3480 type media.

After approximately seven years experience, media manufacturers have significantly improved their binder formulations. Furthermore, 3480 type media users from government and industry have experienced the dependability and, conversely, the problems associated with the storage of data on the 3480 type media.

The National Institute of Standards and Technology (NIST), under the sponsorship of the National Oceanic and Atmospheric Administration (NOAA), has undertaken an appraisal of the potential risks associated with the storage of data on the 3480 type media. In addition, the study summarizes reasonable procedures for the care and handling of the 3480 type media in order to minimize potential risks. This information is intended to inform data managers of the potential chemical, mechanical, and magnetic failure mechanisms associated with the 3480 type media, and to summarize the experiences and recommendations of major 3480 type technology users and manufacturers.

~~The conclusions of the NIST study are based on information gathered by NIST from pertinent scientific literature, and interviews with 3480 type technology users and manufacturers.~~

12. KEY WORDS (6 TO 12 ENTRIES; ALPHABETICAL ORDER; CAPITALIZE ONLY PROPER NAMES; AND SEPARATE KEY WORDS BY SEMICOLONS)
care and handling; failure mechanisms; magnetic media; potential risks; storage data; 3480 type tape cartridge

13. AVAILABILITY <input checked="" type="checkbox"/> UNLIMITED FOR OFFICIAL DISTRIBUTION. DO NOT RELEASE TO NATIONAL TECHNICAL INFORMATION SERVICE (NTIS). <input checked="" type="checkbox"/> ORDER FROM SUPERINTENDENT OF DOCUMENTS, U.S. GOVERNMENT PRINTING OFFICE, WASHINGTON, DC 20402. <input checked="" type="checkbox"/> ORDER FROM NATIONAL TECHNICAL INFORMATION SERVICE (NTIS), SPRINGFIELD, VA 22161.	14. NUMBER OF PRINTED PAGES 59	15. PRICE
--	-----------------------------------	-----------

**ANNOUNCEMENT OF NEW PUBLICATIONS ON
COMPUTER SYSTEMS TECHNOLOGY**

Superintendent of Documents
Government Printing Office
Washington, DC 20402

Dear Sir:

Please add my name to the announcement list of new publications to be issued in the series: National Institute of Standards and Technology Special Publication 500-.

Name _____

Company _____

Address _____

City _____ State _____ Zip Code _____

(Notification key N-503)

NIST *Technical Publications*

Periodical

Journal of Research of the National Institute of Standards and Technology—Reports NIST research and development in those disciplines of the physical and engineering sciences in which the Institute is active. These include physics, chemistry, engineering, mathematics, and computer sciences.

Papers cover a broad range of subjects, with major emphasis on measurement methodology and the basic technology underlying standardization. Also included from time to time are survey articles on topics closely related to the Institute's technical and scientific programs. Issued six times a year.

Nonperiodicals

Monographs—Major contributions to the technical literature on various subjects related to the Institute's scientific and technical activities.

Handbooks—Recommended codes of engineering and industrial practice (including safety codes) developed in cooperation with interested industries, professional organizations, and regulatory bodies.

Special Publications—Include proceedings of conferences sponsored by NIST, NIST annual reports, and other special publications appropriate to this grouping such as wall charts, pocket cards, and bibliographies.

Applied Mathematics Series—Mathematical tables, manuals, and studies of special interest to physicists, engineers, chemists, biologists, mathematicians, computer programmers, and others engaged in scientific and technical work.

National Standard Reference Data Series—Provides quantitative data on the physical and chemical properties of materials, compiled from the world's literature and critically evaluated. Developed under a worldwide program coordinated by NIST under the authority of the National Standard Data Act (Public Law 90-396). NOTE: The Journal of Physical and Chemical Reference Data (JPCRD) is published bi-monthly for NIST by the American Chemical Society (ACS) and the American Institute of Physics (AIP). Subscriptions, reprints, and supplements are available from ACS, 1155 Sixteenth St., NW., Washington, DC 20056.

Building Science Series—Disseminates technical information developed at the Institute on building materials, components, systems, and whole structures. The series presents research results, test methods, and performance criteria related to the structural and environmental functions and the durability and safety characteristics of building elements and systems.

Technical Notes—Studies or reports which are complete in themselves but restrictive in their treatment of a subject. Analogous to monographs but not so comprehensive in scope or definitive in treatment of the subject area. Often serve as a vehicle for final reports of work performed at NIST under the sponsorship of other government agencies.

Voluntary Product Standards—Developed under procedures published by the Department of Commerce in Part 10, Title 15, of the Code of Federal Regulations. The standards establish nationally recognized requirements for products, and provide all concerned interests with a basis for common understanding of the characteristics of the products. NIST administers this program as a supplement to the activities of the private sector standardizing organizations.

Consumer Information Series—Practical information, based on NIST research and experience, covering areas of interest to the consumer. Easily understandable language and illustrations provide useful background knowledge for shopping in today's technological marketplace.

Order the above NIST publications from: Superintendent of Documents, Government Printing Office, Washington, DC 20402.

Order the following NIST publications—FIPS and NISTIRs—from the National Technical Information Service, Springfield, VA 22161.

Federal Information Processing Standards Publications (FIPS PUB)—Publications in this series collectively constitute the Federal Information Processing Standards Register. The Register serves as the official source of information in the Federal Government regarding standards issued by NIST pursuant to the Federal Property and Administrative Services Act of 1949 as amended, Public Law 89-306 (79 Stat. 1127), and as implemented by Executive Order 11717 (38 FR 12315, dated May 11, 1973) and Part 6 of Title 15 CFR (Code of Federal Regulations).

NIST Interagency Reports (NISTIR)—A special series of interim or final reports on work performed by NIST for outside sponsors (both government and non-government). In general, initial distribution is handled by the sponsor; public distribution is by the National Technical Information Service, Springfield, VA 22161, in paper copy or microfiche form.

U.S. Department of Commerce
National Institute of Standards and Technology
Gaithersburg, MD 20899

Official Business
Penalty for Private Use \$300