



(12) **United States Patent**  
**Rojas**

(10) **Patent No.:** **US 7,535,890 B2**  
(45) **Date of Patent:** **May 19, 2009**

(54) **SYSTEM AND METHOD FOR INSTANT VOIP MESSAGING**

2007/0112925 A1\* 5/2007 Malik ..... 709/206  
2007/0174403 A1\* 7/2007 Barry ..... 709/207

(75) Inventor: **Michael J. Rojas**, North Canton, OH (US)

(73) Assignee: **Ayalogic, Inc.**, Akron, OH (US)

(\* ) Notice: Subject to any disclaimer, the term of this patent is extended or adjusted under 35 U.S.C. 154(b) by 799 days.

(21) Appl. No.: **10/740,030**

(22) Filed: **Dec. 18, 2003**

(65) **Prior Publication Data**

US 2005/0135333 A1 Jun. 23, 2005

(51) **Int. Cl.**  
**H04L 12/66** (2006.01)

(52) **U.S. Cl.** ..... **370/352**; 709/206

(58) **Field of Classification Search** ..... 370/354,  
370/352

See application file for complete search history.

(56) **References Cited**

**U.S. PATENT DOCUMENTS**

6,763,226	B1 *	7/2004	McZeal, Jr. ....	455/90.2
2003/0087632	A1 *	5/2003	Sagi et al. ....	455/414
2003/0126207	A1 *	7/2003	Creamer et al. ....	709/204
2004/0030046	A1 *	2/2004	Schultes et al. ....	525/71
2004/0122906	A1 *	6/2004	Goodman et al. ....	709/206
2004/0128356	A1 *	7/2004	Bernstein et al. ....	709/206
2004/0252679	A1 *	12/2004	Williams et al. ....	370/356
2005/0053230	A1 *	3/2005	Gierachf ..... 379/406.06	
2005/0105697	A1 *	5/2005	Hollowell et al. ....	379/88.13
2006/0167883	A1 *	7/2006	Boukobza ..... 707/10	
2006/0268750	A1 *	11/2006	Weiner ..... 370/260	

**OTHER PUBLICATIONS**

http://www.cisco.com/warp/public/cc/pd/nemsw/callmn/prodlit/cm33\_ds.htm; "Data Sheet Cisco CallManager Version 3.3", Nov. 22, 2002.

http://www.cisco.com/en/US/products/hw/switches/ps1925/products\_data\_sheet\_09186a00800a3c3d.html; "Data Sheet Cisco MGX 8000 Series" (date unknown).

http://www.hsteliann.com/english/?zone=3100-V21P; "Telephone 3100-V21P", 2003.

http://www.linuxdevices.com/articles.AT5199947519.html; "Device Profile: snom 100 VoIP phone", May 15, 2002.

http://www.pingtel.com/pr\_xpressa.jsp; No limits with the advanced industry standard SIP phone; Dec. 8, 2003.

AudioCoded Enabling Technology Products, TPM-1100 VoP Media Gateway Modules, copyright 2003.

\* cited by examiner

*Primary Examiner*—Creighton Smith

(74) *Attorney, Agent, or Firm*—Scully, Scott, Murphy & Presser, P.C.

(57) **ABSTRACT**

There is provided an instant voice messaging system (and method) for delivering instant messages over a packet-switched network, the system comprising: a client connected to the network, the client selecting one or more recipients, generating an instant voice message therefor, and transmitting the selected recipients and the instant voice message therefor over the network; and a server connected to the network, the server receiving the selected recipients and the instant voice message therefor, and delivering the instant voice message to the selected recipients over the network, the selected recipients being enabled to audibly play the instant voice message.

**70 Claims, 9 Drawing Sheets**

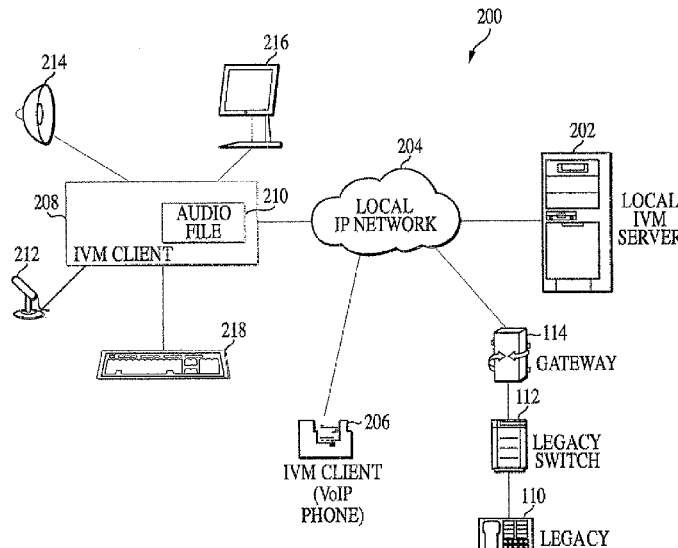

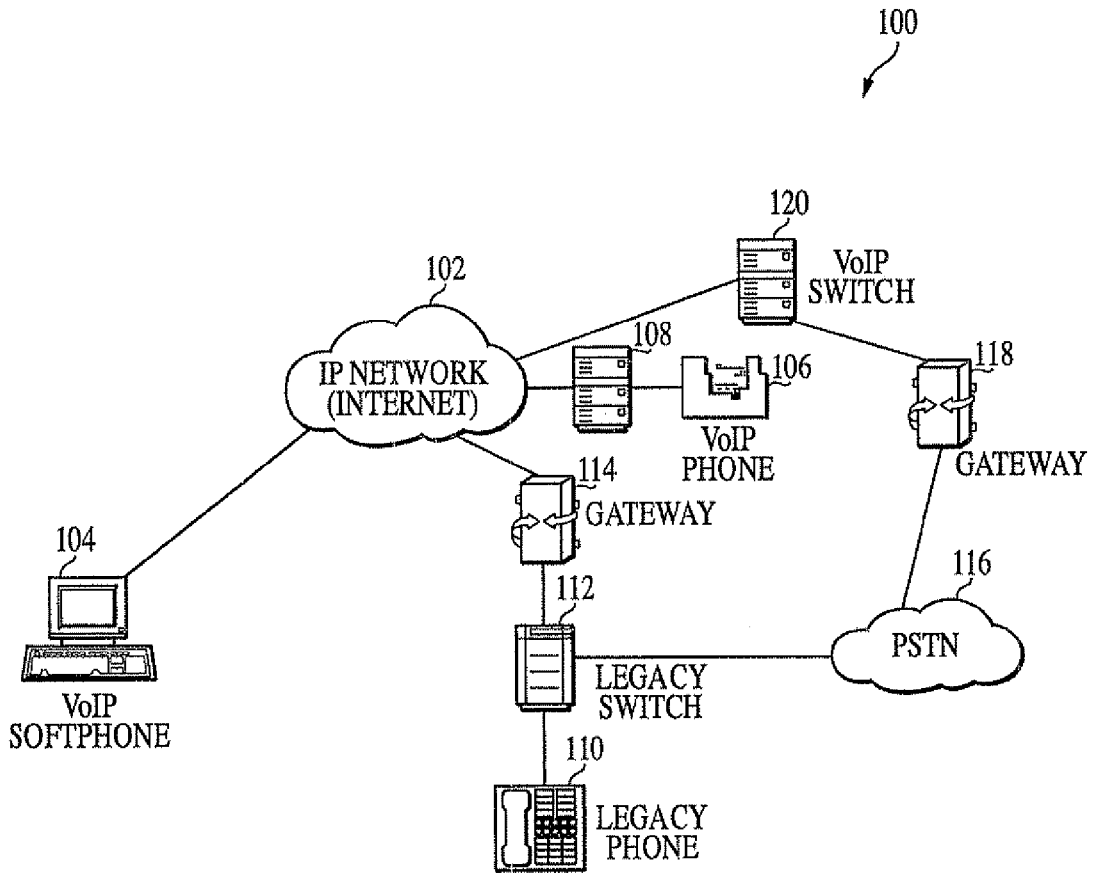

FIG. 1  
(PRIOR ART)

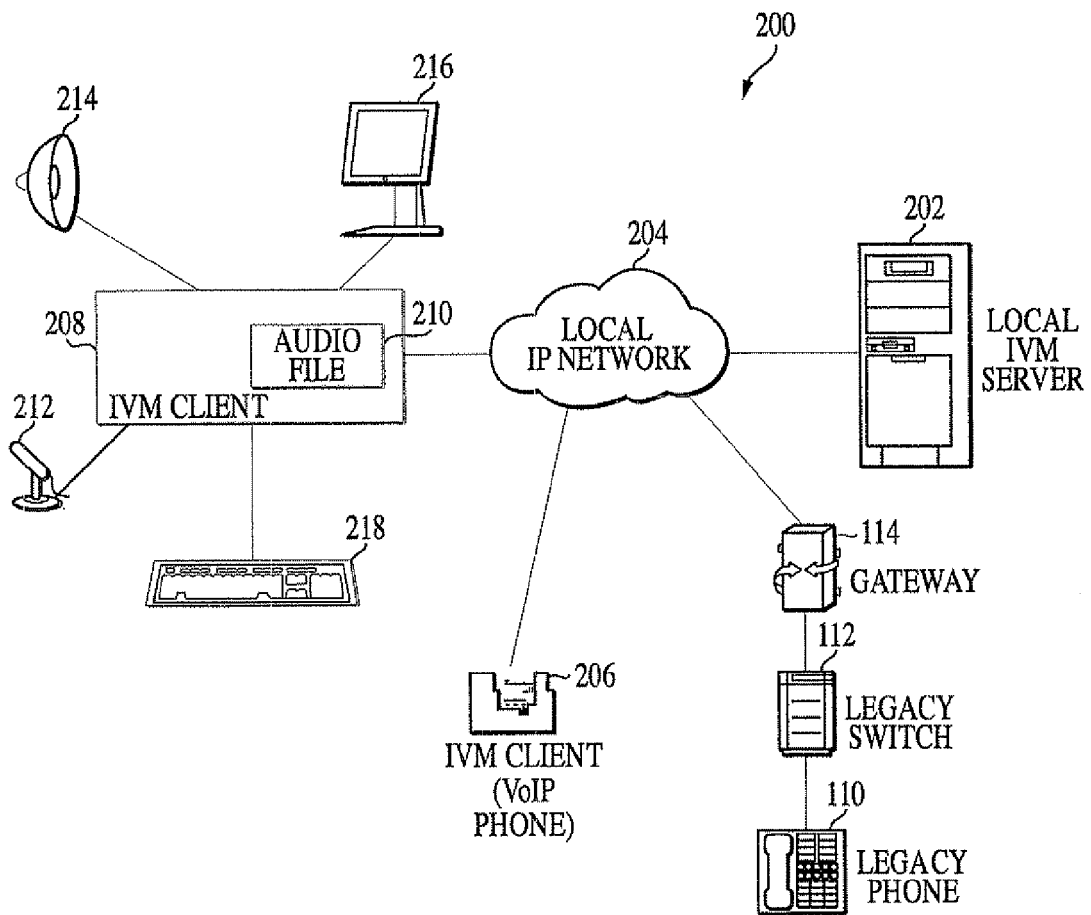

FIG. 2

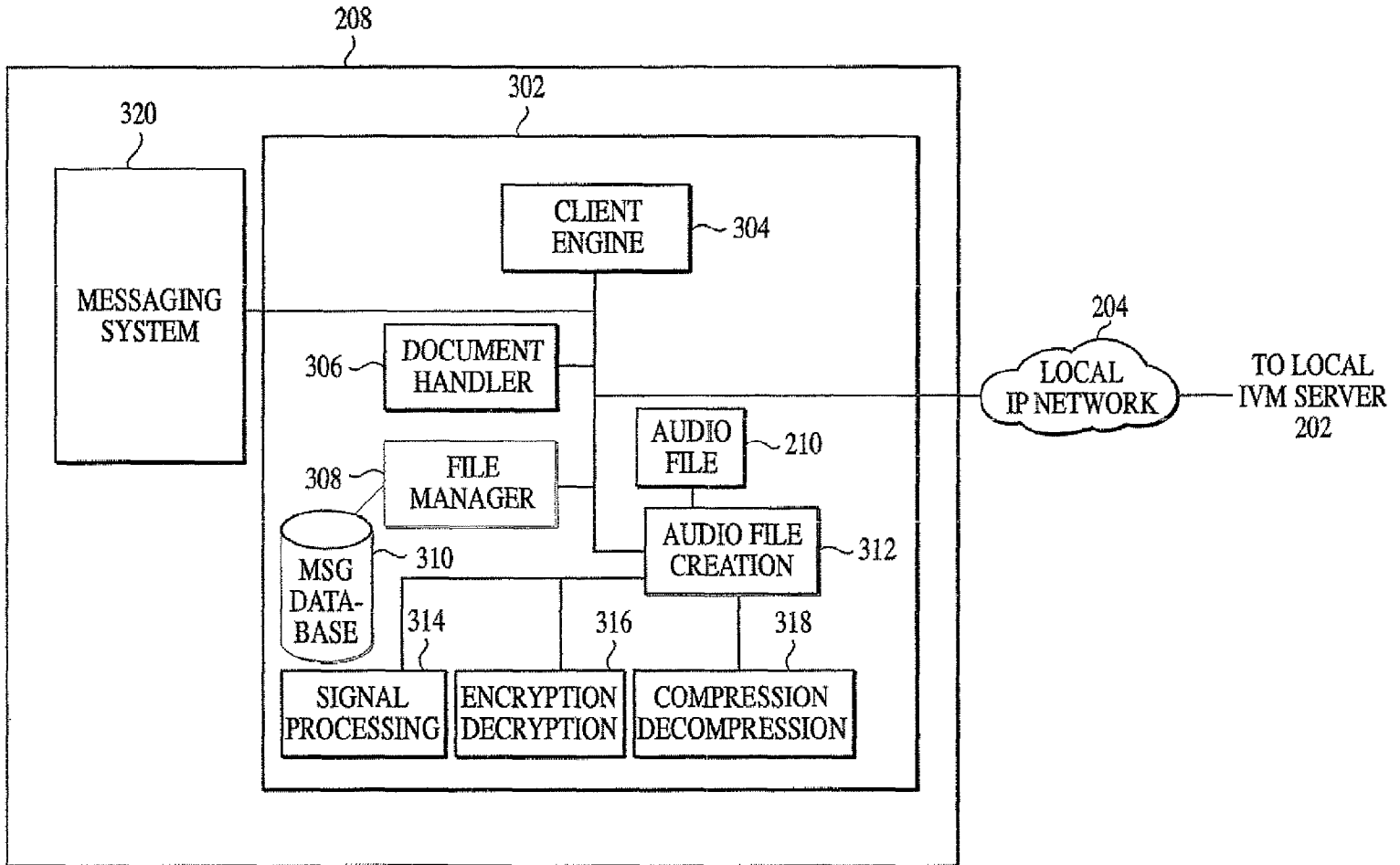

FIG. 3

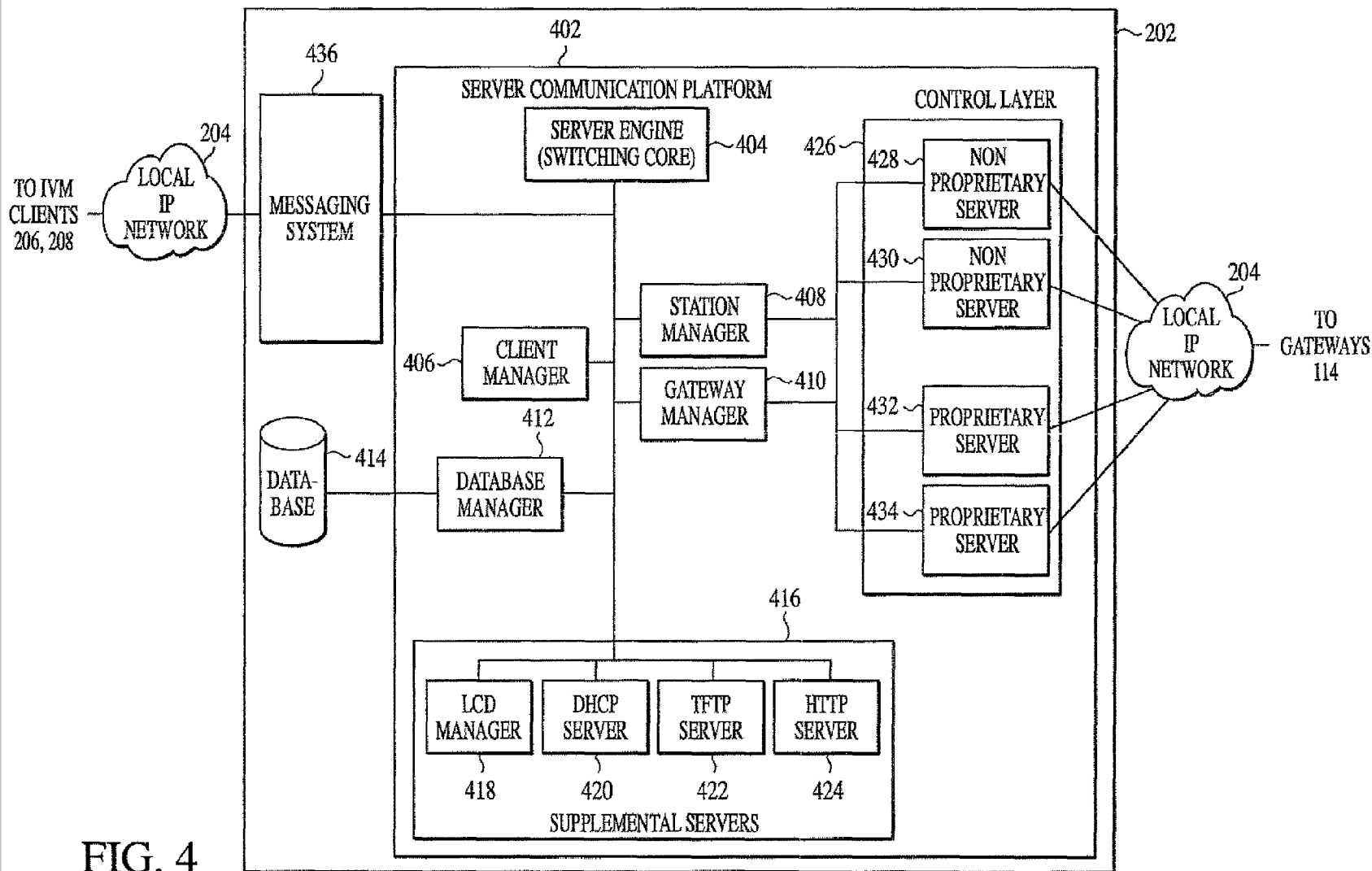

FIG. 4

# Explore Litigation Insights

Docket Alarm provides insights to develop a more informed litigation strategy and the peace of mind of knowing you're on top of things.

## Real-Time Litigation Alerts



Keep your litigation team up-to-date with **real-time alerts** and advanced team management tools built for the enterprise, all while greatly reducing PACER spend.

Our comprehensive service means we can handle Federal, State, and Administrative courts across the country.

## Advanced Docket Research



With over 230 million records, Docket Alarm's cloud-native docket research platform finds what other services can't. Coverage includes Federal, State, plus PTAB, TTAB, ITC and NLRB decisions, all in one place.

Identify arguments that have been successful in the past with full text, pinpoint searching. Link to case law cited within any court document via Fastcase.

## Analytics At Your Fingertips



Learn what happened the last time a particular judge, opposing counsel or company faced cases similar to yours.

Advanced out-of-the-box PTAB and TTAB analytics are always at your fingertips.

## API

Docket Alarm offers a powerful API (application programming interface) to developers that want to integrate case filings into their apps.

## LAW FIRMS

Build custom dashboards for your attorneys and clients with live data direct from the court.

Automate many repetitive legal tasks like conflict checks, document management, and marketing.

## FINANCIAL INSTITUTIONS

Litigation and bankruptcy checks for companies and debtors.

## E-DISCOVERY AND LEGAL VENDORS

Sync your system to PACER to automate legal marketing.