

COFDM: AN OVERVIEW

William Y. Zou
Public Broadcasting Service
1320 Braddock Place
Alexandria, VA

Yiyun Wu
Communications Research Centre
3701 Carling Ave. Box 11490, Station H
Ottawa, Ontario, Canada, K2H 8S2

Abstract

The research and development of OFDM/COFDM for digital television broadcasting has received considerable attention and has made a great deal of progress in Europe. OFDM/COFDM has already been implemented in digital audio broadcasting and is being considered for terrestrial digital television and HDTV broadcasting. The advantages of COFDM claimed by the advocates in Europe have also caught the attention of U.S. broadcasters and generated enthusiasm although a digital modulation technique called 8-VSB has been selected by the FCC Advisory Committee on Advanced Television Service (ACATS) for the final testing. There is considerable debate in the industry over the use of COFDM vs. VSB or QAM for terrestrial HDTV broadcasting.

In this paper, the history of research and development on OFDM and COFDM is reviewed. Then, the basic principles, performance and implementation of OFDM and COFDM are examined. Analysis is given to enable the selection of key elements for meeting the constraints of the required applications. Based on the ATV channel model, performance expectation of COFDM under imperfect channel conditions and implementation issues are examined in details.

1. Introduction

After more than thirty years of research and development, orthogonal frequency division multiplexing (OFDM) has been widely implemented in high speed digital communications. Due to the recent advances of digital signal processing (DSP) and very large scale integrated circuit (VLSI) technologies, the initial obstacles of OFDM implementation, such as massive complex computation, and high speed memory do not exist anymore. Meanwhile, the use of fast Fourier transform (FFT) algorithms eliminates arrays of sinusoidal generators and coherent demodulation required in parallel data systems and make the implementation of the technology cost effective. Another reason for the growing popularity of OFDM is that only very recently its optimal performance has been proven theoretically.^{1,2}

Although it has long been used for digital data transmission, OFDM/COFDM has been studied in Europe and elsewhere for potential digital HDTV terrestrial broadcasting. Various projects and prototypes of OFDM/COFDM systems have been engaged and demonstrated publicly. Among them are HD-DIVINE (Digital Video Narrowband Emission) developed by Nordic countries, DIAMOND developed by Thomson-CFS/LER, STERNE (Systeme de Television en Radiodiffusion Numerique) by CCETT (a joint venture of France Telecom and TDF), dTTb (digital Terrestrial Television broadcasting) by Commission of the European Communities (CEC), EP-DVB (European Project on Digital Video Broadcasting) by European national administrations and private industry, SPECTRE (Special Purpose Extra Channels for Terrestrial Radiocommunication Enhancements) by NTL of U.K. and HDTV (Hierarchical Digital TV Transmission) in Germany. COFDM research has also been carried out by NHK and a few Japanese electronic manufacturers.

In North America, the FCC Advisory Committee on Advanced Television Service officially accepted an 8-VSB modulation technique developed by Zenith/the Grand Alliance for the final testing. However, the advisory committee indicated that it will study

and monitor the development of coded OFDM (COFDM). Encouraged by the potential advantages of COFDM, some U. S. and Canadian broadcasters have decided to investigate the technology. Recently, several U. S. and Canadian broadcaster organizations formed a consortium and issued a Request for Quote to solicit potential bidders to build COFDM hardware for evaluation.³

The debate on COFDM versus vestigial sideband (VSB) modulation or quadrature amplitude modulation (QAM) for terrestrial HDTV broadcasting has been engaged in the past and there is no sign that it will end soon. One reason is that neither COFDM nor VSB has a clear advantage in all of the performance aspects. Some differences may be based on specific system implementation. Another reason is that neither approach had been tested in the field extensively. Recently, the proposed 8-VSB modulation subsystem has been tested in Charlotte, NC by PBS, MSTV, and CableLabs. It is expected that the test results will provide valuable information on the performance of the 8-VSB system.

In this paper, an overview of OFDM/COFDM research and development is presented. The motivations of using OFDM/COFDM and their applications are discussed. The principles of the technology are examined in details. Analysis is given on how to select key system elements. In addition, the performance expectations of COFDM under imperfect channel conditions and implementation issues are examined.

2. OFDM History

The concept of using parallel data transmission and frequency division multiplexing was published in the mid 60s.^{4,5} Some early development can be traced back in the 50s.⁶ A U.S. patent was filed and issued in January, 1970.⁷ The idea was to use parallel data and frequency division multiplexing (FDM) with overlapping subchannels to avoid the use of high speed equalization and to combat impulsive noise, and multipath distortion as well as to fully use the available bandwidth. The initial applications were in military communications. In the telecommunication field the terms of discrete multi-tone (DMT), multichannel modulation, and multicarrier modulation (MCM) are widely used and sometimes they are interchangeable with OFDM. In OFDM, each carrier is orthogonal to the other carriers. However, this condition is not always maintained in MCM.

An example of the early OFDM applications was the AN/GSC-10 (KATHRYN) variable rate data modem built for the high-frequency radio.^{8,9} Up to 34 parallel low rate channels using PSK modulation were generated by a frequency multiplexed set of subchannels. Orthogonal frequency assignment was used with channel spacing of 82 Hz to provide guard time between successive signaling elements. OFDM was also used in other high-frequency military systems, such as KINEPLEX⁶ and ANDEFT.¹⁰

For a large number of subchannels, the arrays of sinusoidal generators and coherent demodulators required in a parallel system become unreasonably expensive and complex. The receiver needs precise phasing of the demodulating carriers and sampling times in order to keep crosstalk between subchannels acceptable. Weinstein and Ebert applied the discrete Fourier transform (DFT) to parallel data transmission systems as part of the modulation and demodulation processes.¹¹ In addition to eliminating the banks of subcarrier oscillators and coherent demodulators required by FDM,

a completely digital implementation could be built around special-purpose hardware performing the fast Fourier transform (FFT). Recent advances in VLSI technology make high speed large size FFT chips commercially affordable.¹²

In the 1980s, OFDM had been studied for high-speed modems, digital mobile communications, and high density recording. Hirosaki explored the OFDM techniques for multiplexed QAM using DFT.^{13,14} He also designed an 19.2 kbps voiceband data modem using multiplexed QAM.¹⁵ In this system a pilot tone was used for stabilizing carrier and clock frequency control and trellis coding was implemented to reduce the required carrier-to-noise ratio (CNR). Various speed modems were developed for telephone networks.^{16,17,18,19}

To combat frequency selective fading, and Doppler shift in mobile channel, OFDM has been used to spread out a fade over many symbols. OFDM can effectively randomize burst errors caused by the Rayleigh fading, so that instead of several adjacent symbols being completely destroyed, many symbols are only slightly distorted. This allows the precise reconstruction of a majority of them. In addition, by using guard interval the sensitivity of the system to delay spread can be reduced.²⁰

In non-transmission applications, Feig et al, explored discrete multi-tone techniques using DFT for application in the linearized magnetic storage channel.^{21,22,23}

In the 1990s, OFDM has been exploited for wideband data communications over mobile radio FM channels, high-bit-rate digital subscriber lines (HDSL), asymmetric digital subscriber lines (ADSL), very high-speed digital subscriber lines (VHDSL), digital audio broadcasting (DAB), digital television and HDTV terrestrial broadcasting.⁵⁵

Casas et al, proposed OFDM/FM for data communication over mobile radio channels.²⁴ It claimed that OFDM/FM systems could be implemented simply and inexpensively by retrofitting existing FM radio systems.

Chow et al, studied the multi-tone modulation with discrete Fourier transform in transceiver design and showed that it is an excellent method for delivering of high speed data to customers, both in terms of performance and cost, for ADSL (1.536 Mbps), HDSL (1.6 Mbps), and VHDSL (100 Mbps).^{25,26}

More recently, OFDM, especially COFDM, has been studied and implemented for digital television and HDTV terrestrial broadcasting as well as digital audio terrestrial/satellite broadcasting.^{27,28,29,30,31,54} The successful demonstrations of DAB gave researchers encouragement to further explore OFDM and COFDM for television broadcasting. The goals of using COFDM for terrestrial broadcasting are not only for fixed reception but also for potential mobile and portable receivers.³²

3. Basic Principles of OFDM

3.1 Parallel Data Transmission and Multiple Carriers

In a conventional serial data system, the symbols are transmitted sequentially, with the frequency spectrum of each data symbol allowed to occupy the entire available bandwidth.

A parallel data transmission system offers possibilities for alleviating many of the problems encountered with serial systems. A parallel system is one in which several sequential streams of data are transmitted simultaneously, so that at any instant many data elements are being transmitted. In such a system, the spectrum of an individual data element normally occupies only a small part of the available bandwidth.

A parallel approach has the advantage of spreading out a frequency selective fade over many symbols. This effectively randomizes burst errors caused by fading or impulse interference, so that, instead of several adjacent symbols being completely destroyed, many symbols

are only slightly distorted. This allows successful reconstruction of a majority of them even without forward error correction (FEC). Because of dividing an entire channel bandwidth into many narrow subbands, the frequency response over each individual subbands is relatively flat. Since each subchannel covers only a small fraction of the original bandwidth, equalization is potentially simpler than in a serial system. A simple equalization algorithm can minimize mean-square distortion on each subchannel, and the implementation of differential encoding may make it possible to avoid equalization altogether.¹¹

In a classical parallel data system, the total signal frequency band is divided into N non-overlapping frequency subchannels. Each subchannel is modulated with a separate symbol and, then, the N subchannels are frequency division multiplexed. There are three schemes that can be use to separate subbands:

1. Use filters to completely separate subbands. This method was borrowed from the conventional FDM technology. The limitation of filter implementation forces the bandwidth of each subband to be equal to $(1+\alpha)f_m$, where α is the roll-off factor and f_m is the Nyquist bandwidth. Another disadvantage is that it is difficult to assemble a set of matched filter when the number of carriers are large.

2. Use staggered QAM to increase the efficiency of band usage. In this way the individual spectra of the modulated carriers still use an excess bandwidth of α , but they are overlapped at the 3-dB frequency. The advantage is that the composite spectrum is flat. The separability or orthogonality is achieved by staggering the data (offset the data by half a symbol). The requirement for filter design is less critical than that for the first scheme.

3. Use the discrete Fourier transform (DFT) to modulate and demodulate parallel data. The individual spectra are now sinc functions and are not bandlimited. The FDM is achieved, not by bandpass filtering, but by baseband processing. Using this method, both transmitter and receiver can be implemented using efficient FFT techniques which reduce the number of operations from N^2 in DFT down to about $N \log N$.

As is well known, orthogonal signals can be separated at the receiver by correlation techniques; hence, intersymbol interference among channels can be eliminated. This can be achieved by carefully selecting carrier spacing, such as letting the carrier spacing equal to the reciprocal of the useful symbol period.

OFDM can be simply defined as a form of multicarrier modulation where its carrier spacing is carefully selected so that each subcarrier is orthogonal to the other subcarriers.

3.2 Signal Representation of OFDM Using IDFT/DFT

Consider a data sequence $(d_0, d_1, d_2, \dots, d_{N-1})$, where each d_n is a complex number $d_n = a_n + jb_n$. If a discrete Fourier transform (DFT) is performed, the result is a vector $D = (D_0, D_1, \dots, D_{N-1})$ of N complex numbers,

$$D_m = \sum_{n=0}^{N-1} d_n e^{-j(2\pi mn/N)} = \sum_{n=0}^{N-1} d_n e^{-j2\pi f_n t_m}, \quad m = 0, 1, 2, N-1 \quad (1)$$

where $f_n = n/(N\Delta t)$, $t_m = m\Delta t$ and Δt is an arbitrarily chosen symbol duration of the serial data sequence d_n . The real part of the vector D has components

$$Y_m = \sum_{n=0}^{N-1} (a_n \cos 2\pi f_n t_m + b_n \sin 2\pi f_n t_m), \quad m=0,1, \dots, N-1. \quad (2)$$

If these components are applied to a low-pass filter at time intervals Δt , a signal is obtained that closely approximates the frequency division multiplexed signal

$$y(t) = \sum_{n=0}^{N-1} (a_n \cos 2\pi f_n t + b_n \sin 2\pi f_n t), \quad 0 \leq t \leq N\Delta t. \quad (3)$$

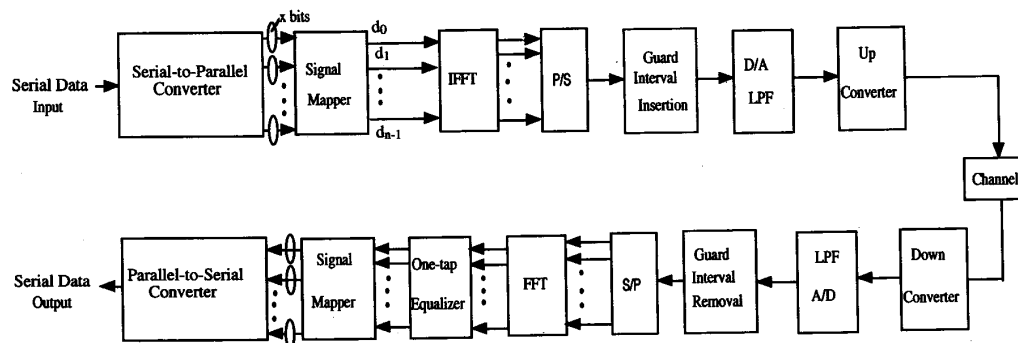

Fig. 1 FFT-based OFDM System

Fig. 1 illustrates the process of a typical FFT-based OFDM system. The incoming serial data is first converted from serial to parallel and grouped into x bits each to form a complex number. The number x determines the signal constellation of the corresponding subcarrier, such as 16 QAM or 32 QAM. The complex numbers are modulated in a baseband fashion by the inverse FFT (IFFT) and converted back to serial data for transmission. A guard interval is inserted between symbols to avoid intersymbol interference (ISI) caused by multipath distortion. The discrete symbols are converted to analog and low-pass filtered for RF upconversion. The receiver performs the inverse process of the transmitter. An one-tap equalizer is used to correct channel distortion. The tap coefficients of the filter are calculated based on channel information.

Fig. 2(a) shows the spectrum of an OFDM subchannel and Fig. 2(b) presents an OFDM spectrum. By carefully selecting the carrier spacing, the OFDM signal spectrum can be made flat and the orthogonality among the subchannels can be guaranteed.

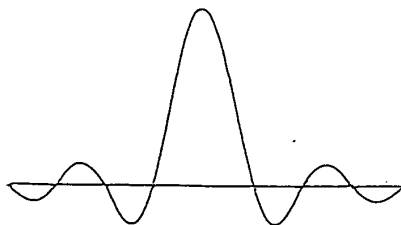

Fig. 2(a) Spectrum of An OFDM Subchannel

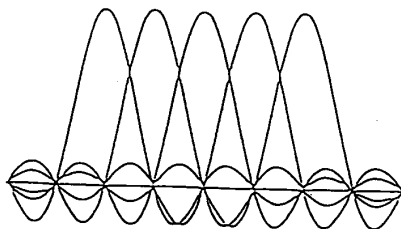

Fig. 2(b) OFDM Spectrum

3.3 Guard Interval and Its Implementation

The orthogonality of subchannels in OFDM can be maintained and individual subchannels can be completely separated by the FFT at the receiver when there are no intersymbol interference (ISI) and intercarrier interference (ICI) introduced by transmission channel distortion. In practice these conditions can not be obtained. Since the spectra of an OFDM signal is not strictly band limited ($\text{sinc}(f)$ function), linear distortions such as multipath cause each subchannel to spread energy into the adjacent channels and consequently cause ISI. A simple solution is to increase the symbol duration or the number of carriers so that the distortion becomes insignificant. However, this method may be difficult to implement in terms of carrier stability, Doppler shift, FFT size and latency.

One way to prevent ISI is to create a cyclically extended guard interval,² where each OFDM symbol is preceded by a periodic extension of the signal itself. The total symbol duration is $T_{\text{total}} = T_g + T$, where T_g is the guard interval and T is the useful symbol duration. When the guard interval is longer than the channel impulse response, or the multipath delay, the ISI can be eliminated. However, the ICI, or in-band fading, still exists. The ratio of the guard interval to useful symbol duration is application-dependent. Since the insertion of guard interval will reduce data throughput, T_g is usually less than $T/4$.³⁰

The reasons to use a cyclic prefix for the guard interval are:

1) to maintain the receiver carrier synchronization; some signal instead of a long silence must always be transmitted;

2) cyclic convolution can still be applied between the OFDM signal and the channel response to model the transmission system.^{2,48}

Fig. 3 gives the time and frequency representation of OFDM using guard interval. With the two-dimensional signal representation, the symbols are overlapped in the frequency domain and are separated by the guard interval in the time domain. This arrangement also matches the television channel characteristics well (e.g. in the television channel the time dispersion is large and frequency dispersion is less critical).

3.4 Choice of key Elements

After settling the channel bandwidth, guard interval, and data throughput, a few key elements can be determined.

a. Useful Symbol Duration

The useful symbol duration T affects the carrier spacing and coding latency. To maintain the data throughput, a longer useful symbol duration results in an increase of the number of carriers and the size of FFT (assuming that the signal constellation is fixed). In practice,

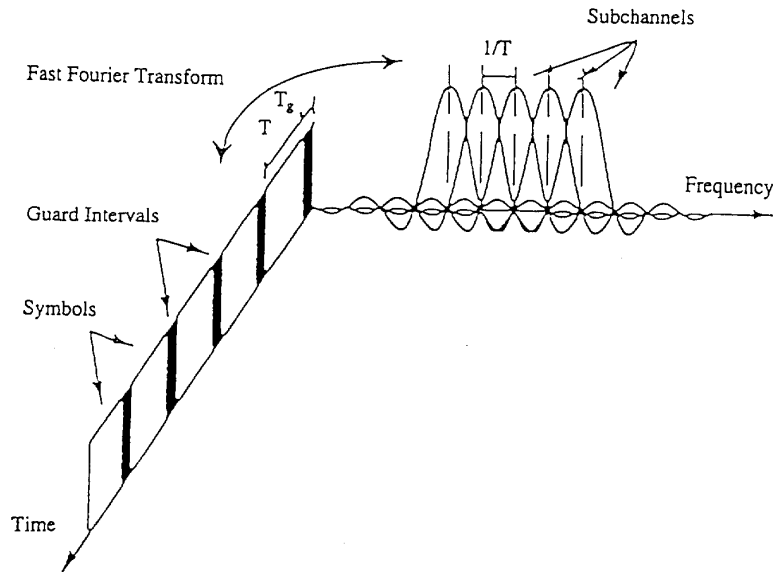

Fig. 3 Time and Frequency Representation of OFDM Using Guard Interval

carrier offset and phase stability may affect how close two carriers can be placed. If the application is for the mobile reception, the carrier spacing must be large enough to make the Doppler shift negligible. Generally, the useful symbol duration should be chosen so that the channel is stable for the duration of a symbol.

b. Number of Carriers

The number of subcarriers can be determined based on the channel bandwidth, data throughput and useful symbol duration. The carriers are spaced by the reciprocal of the useful symbol duration. The number of carriers corresponds to the number of complex points being processed in FFT. In HDTV applications, the number of subcarriers are in the range of several thousands so as to accommodate the data rate and guard interval requirement.

c. Modulation Scheme

The modulation scheme used in an OFDM system can be selected based on the requirement of power or spectrum efficiency. The type of modulation can be specified by the complex number $d_n = a_n + b_n$ defined in section 3.1. The symbols a_n and b_n take on values of $\pm 1, \pm 3, \dots$ depending on the number of signal points in the signal constellations. For example, a_n and b_n can be selected to $(\pm 1, \pm 3)$ for 16 QAM and ± 1 for QPSK. In general, the selection of modulation scheme applying to each subchannel depends solely on the compromise between the data rate requirement and transmission robustness. Another advantage of OFDM is that different modulation schemes can be used on different subchannels for layered services.

3.5 Coded OFDM

By using time and frequency diversity OFDM provides a means to transmit data in a frequency selective channel. However, it does not suppress fading itself. Depending on their position in the frequency domain, individual subchannels could be affected by fading. This requires the use of channel coding to further protect transmitted data. Among those channel coding techniques, trellis coded modulation (TCM)⁴⁵ combined with frequency and time interleaving is considered the most effective means for a frequency selective fading channel.

TCM combines coding and modulation to achieve high coding gain without affecting the bandwidth of the signal. In a TCM encoder, each symbol of n bits is mapped into a constellation of $n+1$ bits, using a set-partitioning rule.⁴⁵ This process increases the constellation size and effectively adds additional redundancy to trellis-code the signal. A TCM code can be decoded with a soft decision Viterbi decoding algorithm,⁴⁶ which exploits the soft decision nature of the received signal. The coding gain for a two-dimensional TCM code over a Gaussian channel is about 3 dB for a bit error rate (BER) of 10^{-5} .

It should be mentioned that one of the advantages of OFDM is that it can convert a wideband frequency selective fading channel into a series of narrowband and frequency non-selective fading subchannels by using parallel and multicarrier transmission. Coding OFDM subcarriers sequentially by using specially designed TCM codes for frequency non-selective fading channel is the major reason for using COFDM for terrestrial broadcasting. However, the searching of the best TCM code is still on going.

Although trellis codes produce improvements in the signal-to-noise ratio (S/N), they do not perform well with impulsive or burst noise. Besides electromechanical sources of burst noise, burst noise is also caused by NTSC co-channel interference and phase noise which can cause data-dependent crosstalk. In general, transmission errors have a strong time/frequency correlation. Interleaving plays an essential role in channel coding by providing diversity in the time domain. Interleaving breaks the correlation and enables the decoder to eliminate or reduce local fading throughout the band and over the whole depth of the time interleaving. Interleaving depth should be large enough to break long straight errors.

4. COFDM Performance Expectation

In this section the performance expectation of COFDM in terrestrial digital television broadcasting is examined.

4.1 ATV Channel Model

It should be noted that for the additive white Gaussian noise channel, COFDM and single carrier modulation have comparable performance.^{55,56} However, the broadcasting channels for HDTV

consist of various other impairments. The signals arriving at the receiver are impacted by random noise, impulse noise, multipath distortion, fading, and interference. Through theoretical analyses and field measurements, HDTV transmission channel models have been established.^{33,34,35} It is well known and proven that digital transmission offers better performance than its analog counterpart in terms of random noise and interference.³⁶ However, other impairments such as multipath distortion and fading are considered very challenging to the success of digital television terrestrial broadcast.

Due to the multipath propagation, the cancellation of different paths creates a field of moderate peaks separated by holes of various depths (fading) ranging from a few dB to more than 50 dB deep. As indicated by the FCC, the majority of ATV channels will be allocated in the UHF bands. At the high end of the UHF band, the wavelengths are very short (around 0.5 m). The characteristics of these holes and peaks can be modeled by a statistical distribution known as a Rayleigh distribution.⁴⁶

4.2 Multipath/fading

It is believed that with properly designed guard interval, interleaving and channel coding, COFDM is capable of handling very strong echoes.⁵⁶ The BER improvement resulted from multiple echoes was indicated by the computer simulations and laboratory demonstrations.^{37,53} With the assumption of withstanding strong multipath propagation, COFDM might allow the use of omnidirectional antenna in urban areas and mobile reception where C/N is sufficiently high.

In addition to channel fading, time-variant signals caused by transmitter tower swaying, airplane fluttering and even tree swaying generate dynamic ghosts and consequently produce errors in digital transmission. With its parallel transmission structure as well as the use of trellis coding, COFDM systems might present advantages in fading and time-variant channel environment.⁵³

4.3 Phase Noise and Jitter

A COFDM system is much more affected by carrier frequency errors.³⁸ A small frequency offset at receiver compromises the orthogonality between the subchannels, giving a degradation in system performance that increases rapidly with frequency offset and with the number of subcarriers. Phase noise and jitter can be influenced by transmitter up-converter, receiver down-converter, and tuner. A possible solution is the use of pilots which can be used to track phase noise in the demodulation. However, this is done under the penalty of reducing the payload data throughput.

4.4 Carrier Recovery/Equalization

In the severe channel conditions, such as low C/N, strong interference and fading, COFDM signal must be designed to provide robust carrier recovery. Carrier frequency detection could be one of the biggest limitations in COFDM design. The use of pilots and reference symbols are efficient methods for carrier recovery and subchannel equalization. A pilot can be a sine wave or a known binary sequence. A reference symbol can be a chirp or a pseudo-random sequence.

The two-dimensional signal feature in COFDM makes pilot and reference symbol insertion very flexible. Pilots can be inserted in the frequency domain (fixed carriers) and reference symbols in the time domain (fixed data packets). Because they are transmitted at the predetermined positions in the signal frame structure, it can be captured at the receiver whenever the frame synchronization is recovered. In a frequency-selective channel, high correlation between the complex fading envelopes of the pilots and data must be ensured. The appropriate complex correction can be obtained by interpolating among the pilots. Cimini reported that interpolation in real and imaginary parts of the complex fading envelopes outperformed the interpolation in amplitude and phase.²⁰

For single carrier systems, equalization is done in the time domain. For a QAM system with a N-tap equalizer, there are about N

complex multiplication, or 4N real multiplication-accumulations per input symbol. For a VSB system, its symbol rate needs to be twice that of a QAM system for the same data throughput. Assuming the same echo range as for the QAM system, an 2N-tap real equalizer is required, which has a computational complexity of about 2N multiplication-accumulations per input symbol.

For a COFDM system, assuming multipath delay is less than the guard interval, a frequency domain one-tap equalizer could be used for each subchannel to correct the amplitude and phase distortions. This corresponds to four real multiplication-accumulations per data symbol. Additionally, the FFT operation requires a computational complexity that is proportional to $C \cdot \log_2 M$, where M is the size of the FFT and C is a constant between 1.5 to 4 depending on the FFT implementation.

The number of pilots and reference symbols used in a COFDM system determine the trade-off between payload capacity and transmission robustness. Simulation results indicated that an OFDM system with equalization performed better than that of a single carrier system with a linear equalizer.³⁸

4.5 NTSC Interference

For digital television and HDTV broadcasting, the potential interference to and from the conventional NTSC needs to be considered. For a COFDM system, the robustness to NTSC interference depends on the degree of the error correction coding implemented and the amount of interleaving applied.⁵⁵ To further reduce the impact of interference from NTSC, one can also explore the unique NTSC signal spectrum. The NTSC spectrum consists of a visual carrier, a color subcarrier and an aural carrier. Each of the visual and color signals is made up of the discrete components spaced by the line frequency of 15,750 kHz. The visual and color parts are offset relative to one another by half the line frequency. Based on this knowledge of the NTSC spectrum, COFDM carrier spacing can be chosen and offset between the NTSC frequency components, such as $7.875 \cdot n$ kHz, where n is a positive nonzero integer. However, this concept needs to be proven.

Another approach to combat NTSC interference is using spectrum shaping. This can be achieved by not using the COFDM carriers in certain spectral regions (the corresponding values in the FFT data array are set to zero) where strong NTSC signal energy are expected, such as the visual, color and aural carriers. Combined with error protection, spectrum shaping can tolerate significantly high levels of interference.⁴⁷ Obviously, the gain is obtained at the expense of data throughput. The data throughput can be increased using larger constellation with higher transmission power. Recently, Trellis coding and Viterbi decoding are considered as a better way to deal with interference.^{31,59}

For interference from COFDM into NTSC, spectrum shaping has few advantages. Removing those carriers relating to the NTSC visual, color and audio carriers does not affect much about the desired NTSC signal since those are the most robust part of NTSC signal. Subjective test results also indicated that there is almost no impact on NTSC over the OFDM parameters such as spectrum shaping, and the behavior of the OFDM signal interference is similar to that of random noise.^{39,60}

4.6 Impulse Interference

COFDM is more immune to impulse noise than a single carrier system because a COFDM signal is integrated over a long symbol period and the impact of impulse noise is much less than that for single carrier systems. As a matter of fact, the immunity of impulse noise was one of the original motivations for MCM. Test reported to the CCITT showed that the threshold level for impulse noise at which errors occur can be as much as 11 dB higher for MCM than that of a single carrier system.⁴⁰ Meanwhile, studies indicated that the best approach of impulse noise reduction for OFDM involves a combination of soft and hard error protection.⁴¹

Explore Litigation Insights

Docket Alarm provides insights to develop a more informed litigation strategy and the peace of mind of knowing you're on top of things.

Real-Time Litigation Alerts



Keep your litigation team up-to-date with **real-time alerts** and advanced team management tools built for the enterprise, all while greatly reducing PACER spend.

Our comprehensive service means we can handle Federal, State, and Administrative courts across the country.

Advanced Docket Research



With over 230 million records, Docket Alarm's cloud-native docket research platform finds what other services can't. Coverage includes Federal, State, plus PTAB, TTAB, ITC and NLRB decisions, all in one place.

Identify arguments that have been successful in the past with full text, pinpoint searching. Link to case law cited within any court document via Fastcase.

Analytics At Your Fingertips



Learn what happened the last time a particular judge, opposing counsel or company faced cases similar to yours.

Advanced out-of-the-box PTAB and TTAB analytics are always at your fingertips.

API

Docket Alarm offers a powerful API (application programming interface) to developers that want to integrate case filings into their apps.

LAW FIRMS

Build custom dashboards for your attorneys and clients with live data direct from the court.

Automate many repetitive legal tasks like conflict checks, document management, and marketing.

FINANCIAL INSTITUTIONS

Litigation and bankruptcy checks for companies and debtors.

E-DISCOVERY AND LEGAL VENDORS

Sync your system to PACER to automate legal marketing.