

**American National Standard**

*for Telecommunications –  
Network and Customer  
Installation Interfaces –  
Asymmetric Digital Subscriber  
Line (ADSL) Metallic Interface*

ANSI T1.413-1995 ▼



**11 West 42nd Street  
New York, New York**

Copyright American National Standards Institute  
Provided by IHS  
No reproduction or distribution allowed without permission from IHS

Order Number: W1806785  
Sold to: MICHAEL J NEWTON [029940100001] - MIKE.NEWTON@ALSTON  
Not for Resale, 2016-02-12 18:06:09 UTC

American National Standard  
for Telecommunications –  
  
Network and Customer Installation Interfaces –  
Asymmetric Digital Subscriber Line (ADSL) Metallic Interface

Secretariat  
**Alliance for Telecommunications Industry Solutions**

Approved August 18, 1995  
**American National Standards Institute, Inc.**

**Abstract**

This standard presents the electrical characteristics of the Asymmetric Digital Subscriber Line (ADSL) signals appearing at the network interface. The physical interface between the network and the customer installation is also described. The transport medium for the signals is a single twisted-wire pair that supports both Message Telecommunications Service (POTS) and full-duplex (simultaneous two-way) and simplex (from the network to the customer installation) digital services.

This interface standard provides the minimal set of requirements for satisfactory transmission between the network and the customer installation. Equipment may be implemented with additional functions and procedures.

## American National Standard

Approval of an American National Standard requires verification by ANSI that the requirements for due process, consensus, and other criteria for approval have been met by the standards developer.

Consensus is established when, in the judgment of the ANSI Board of Standards Review, substantial agreement has been reached by directly and materially affected interests. Substantial agreement means much more than a simple majority, but not necessarily unanimity. Consensus requires that all views and objections be considered, and that a concerted effort be made toward their resolution.

The use of American National Standards is completely voluntary; their existence does not in any respect preclude anyone, whether he has approved the standards or not, from manufacturing, marketing, purchasing, or using products, processes, or procedures not conforming to the standards.

The American National Standards Institute does not develop standards and will in no circumstances give an interpretation of any American National Standard. Moreover, no person shall have the right or authority to issue an interpretation of an American National Standard in the name of the American National Standards Institute. Requests for interpretations should be addressed to the secretariat or sponsor whose name appears on the title page of this standard.

**CAUTION NOTICE:** This American National Standard may be revised or withdrawn at any time. The procedures of the American National Standards Institute require that action be taken periodically to reaffirm, revise, or withdraw this standard. Purchasers of American National Standards may receive current information on all standards by calling or writing the American National Standards Institute.

**NOTE** – The user's attention is called to the possibility that compliance with this standard may require use of an invention covered by patent rights.

By publication of this standard, no position is taken with respect to the validity of this claim or of any patent rights in connection therewith. The patent holder has, however, filed a statement of willingness to grant a license under these rights on reasonable and nondiscriminatory terms and conditions to applicants desiring to obtain such a license. Details may be obtained from the publisher.

Published by

**American National Standards Institute  
11 West 42nd Street, New York, New York 10036**

Copyright ©1995 by Alliance for Telecommunications Industry Solutions  
All rights reserved.

No part of this publication may be reproduced in any form, in an electronic retrieval system or otherwise, without prior written permission of the publisher.

Printed in the United States of America

APS3C1295/135

**Contents**

	Page
Foreword .....	vii
<b>1</b> Scope and purpose .....	<b>1</b>
1.1 Scope .....	1
1.2 Purpose .....	1
<b>2</b> Normative references .....	<b>2</b>
<b>3</b> Definitions, abbreviations, acronyms and symbols.....	<b>3</b>
3.1 Definitions.....	3
3.2 Abbreviations, acronyms and symbols.....	3
<b>4</b> Reference models .....	<b>6</b>
4.1 System reference model.....	6
4.2 ATU-C transmitter reference model.....	7
4.3 ATU-R transmitter reference model.....	8
<b>5</b> Transport capacity .....	<b>9</b>
5.1 Simplex bearers.....	9
5.2 Duplex bearers .....	13
5.3 Combined options.....	14
5.4 ADSL system overheads and aggregate data rates.....	17
5.5 Classification by ATM options .....	21
<b>6</b> ATU-C functional characteristics .....	<b>22</b>
6.1 ATU-C input and output V interfaces .....	22
6.2 Framing .....	23
6.3 Scramblers .....	35
6.4 Forward error correction .....	35
6.5 Tone ordering .....	36
6.6 Constellation encoder – with trellis coding .....	37
6.7 Constellation encoder – without trellis coding .....	45
6.8 Gain scaling.....	45
6.9 Modulation.....	46
6.10 Cyclic prefix .....	47
6.11 Transmitter dynamic range.....	48
6.12 Transmitter spectral response .....	48
6.13 Transmit power spectral density and aggregate power level .....	49
<b>7</b> ATU-R functional characteristics .....	<b>51</b>
7.1 ATU-R input and output data interfaces .....	51
7.2 Framing .....	52
7.3 Scramblers .....	57
7.4 Forward error correction.....	57
7.5 Tone ordering .....	57
7.6 Constellation encoder – with trellis coding .....	57
7.7 Constellation encoder – without trellis coding .....	57
7.8 Gain scaling.....	58
7.9 Modulation.....	58
7.10 Cyclic prefix .....	59
7.11 Transmitter dynamic range.....	60
7.12 Transmitter spectral response .....	61
7.13 Transmit power spectral density and aggregate power level .....	62



	Page
<b>8</b>	ADSL – POTS splitter functional characteristics .....63
<b>9</b>	ATU-R to service module ( $T_{SM}$ ) interface requirements .....64
9.1	$T_A$ interface definitions.....64
9.2	$T_B$ interface definitions.....65
<b>10</b>	Electrical characteristics .....67
10.1	dc characteristics .....67
10.2	Voice-band characteristics .....67
10.3	ADSL band .....69
10.4	ADSL noise the interference into circuit POTS.....70
<b>11</b>	Operations and maintenance .....71
11.1	Embedded operations channel (eoc) requirements.....71
11.2	In-service performance monitoring and surveillance .....78
11.3	Metallic testing .....84
11.4	Out-of-service testing .....84
11.5	Requirements to support OAM of the segment between ATU-R and SM .....84
<b>12</b>	Initialization .....87
12.1	Overview.....87
12.2	Activation and acknowledgment – ATU-C .....89
12.3	Activation and acknowledgment – ATU-R.....92
12.4	Transceiver training – ATU-C .....93
12.5	Transceiver training – ATU-R .....96
12.6	Channel analysis – ATU-C .....98
12.7	Channel analysis – ATU-R .....102
12.8	Exchange – ATU-C.....105
12.9	Exchange – ATU-R.....108
<b>13</b>	On-line adaptation and reconfiguration .....112
13.1	The ADSL overhead control (aoc) channel .....112
13.2	High-level on-line adaptation – Bit swapping.....112
13.3	Changes to data rates and reconfiguration .....115
<b>14</b>	Signaling requirements.....115
<b>15</b>	Loop plant, Impairments, and testing.....116
15.1	Test loops .....117
15.2	Impairments and their simulation in testing .....119
15.3	Test procedures.....121
<b>16</b>	Physical characteristics .....127
16.1	Wiring polarity integrity .....127
16.2	Connector .....127
16.3	Wiring requirements for a remotely located POTS splitter/ATU-R .....128
16.4	Maximum distance for a remotely located unit .....128
<b>17</b>	Environmental conditions .....129
17.1	Protection .....129
17.2	Electromagnetic compatibility.....129

	Page
<b>Tables</b>	
1	ADSL sub-channel rate restrictions for default bearer rates.....10
2	ADSL sub-channel rate restrictions 2.048 Mbit/s (optional) .....11
3	Downstream ATM data cell bit rates.....12
4	Maximum optional duplex bearer channels supported by transport class ..... 14
5	Optional duplex ATM data cell bit rates for LS2 .....14
6	Bearer channel options by transport class for bearer rates based on downstream multiples of 1.536 Mbit/s ..... 15
7	Bearer channel options by transport class – Optional bearer rates based on downstream multiples of 2.048 Mbit/s .....16
8	Bearer channel options by transport class for optional ATM bearer rates ..... 17
9	Internal overhead channel functions and rates.....18
10	Determination of aggregate downstream bit rate. ....19
11	Determination of aggregate upstream bit rate .....20
12	Determination of aggregate bit rate for ATM transport .....21
13	Interface data rates for duplex channels (default configurations).....23
14	Definition of indicator bits, ATU-C transmitter .....25
15	eoc frame stucture.....26
16	Default fast and interleaved data buffer allocations for ATU-C transmitter – Configurations for bearers based on multiples of 1.536 Mbit/s .....27
17	Default fast and interleaved data buffer allocations for ATU-C transmitter – Optional configurations for bearers based on multiples of 2.048 Mbit/s.....28
18	Default FEC coding parameters and interleave depth for ATU-C transmitter – Default configurations for bearers based on multiples of 1.536 Mbit/s .....30
19	Default FEC coding parameters and interleave depth for ATU-C transmitter – Optional configurations for bearers based on multiples of 2.048 Mbit/s.....31
20	Fast byte format.....32
21	Synch byte format, interleaved data buffer .....33
22	Convolutional interleaving example for $N = 5$ , $D = 2$ .....36
23	Forming the binary word $u$ .....37
24	Relation between 4-dimensional and 2-dimensional cosets.....42
25	Determining the top 2 bits of $X$ and $Y$ .....44
26	Default FEC coding parameters and interleave depth – ATU-R transmitter.....54

	Page
27	Fast byte format for synchronization – Fast data buffer .....56
28	Synch byte format for synchronization – Interleaved data buffer .....57
29	Minimum voice-band return losses at PTSN and POTS interfaces.....68
30	eoc bit functions.....71
31	eoc opcode messages.....74
32	ATU-R data-registers.....75
33	Sync and no sync interpretation (downstream) .....85
34	Sync and no sync interpretation for single SM .....85
35	Sync and no sync Interpretation for multiple SMs .....86
36	Assignment of 48 bits of C-MSGs1 .....100
37	Assignment of 48 bits of R-MSGs1 .....103
38	Assignment of 48 bits of C-MSGs2.....106
39	Bit pattern for C-RATES2 .....107
40	Assignment of 32 bits of R-MSGs2.....109
41	Bit pattern for R-RATES2 .....110
42	aoc message headers .....112
43	Bit swap request commands .....113
44	Extended bit swap request .....114
45	ATU classification by category .....117
46	Loop sets and maximum rates for category I and category II testing....117
47	Crosstalk tests for category I .....123
48	Crosstalk tests for category II .....123
49	Test loops, interferers, and data rates for impulse tests for category I ....124
50	Test loops, interferers, and data rates for impulse tests for category II ....124
51	Test loops, interferers, and data rates for POTS tests for category I ....125
52	Test loops, interferers, and data rates for POTS tests for category II ...125
53	Minimum test time for crosstalk .....126
54	Pin assignments for 8-position jack and plug (RJ 31X) at U-R.....127
55	Pin assignments for 8-position jack and plug at remote location.....128
<b>Figures</b>	
1	ADSL functional reference model.....6
2	ATU-C transmitter reference diagram .....7
3	ATU-R transmitter reference diagram .....8
4	ATU-C V interfaces (rates for default configuration).....22
5	ADSL superframe structure – ATU-C transmitter .....24

	Page
6	“Fast” byte format – ATU-C transmitter – fast data buffer .....25
7	“Synch” byte format – ATU-C transmitter – interleaved data buffer .....26
8	Fast data buffer – ATU-C transmitter .....28
9	Interleaved data buffer – ATU-C transmitter.....29
10	Conversion of $u$ to $v$ and $w$ .....38
11	Finite state machine for Wei’s encoder .....39
12	Trellis diagram .....40
13	Constituent 2-dimensional cosets for Wei’s code.....41
14	Constellation labels for $b = 2$ and $b = 4$ .....43
15	Constellation labels for $b = 3$ .....44
16	Constellation labels for $b = 5$ .....45
17	ATU-C transmitter PSD mask.....48
18	ATU-C transmitter PSD mask: pass band detail .....50
19	ATU-R data interfaces .....51
20	Fast data buffer – ATU-R transmitter .....53
21	Interleaved data buffer – ATU-R transmitter.....54
22	ATU-R transmitter PSD mask.....61
23	ADSL entrance unit block diagram .....66
24	Test setup for transmission and impedance measurements .....67
25	Measurement method for longitudinal output voltage.....69
26	Measurement method for longitudinal balance above 25 kHz.....70
27	In-service surveillance of the ADSL link shown from the standpoint of the ATU-C.....79
28	OAM capabilities for the segment between ATU-R and the service module.....84
29	Overview of initialization .....87
30	Timing diagram of activation and acknowledgment (12.2-12.3).....89
31	Timing diagram of transceiver training (12.4-12.5).....93
32	Timing diagram of channel analysis (12.6-12.7).....98
33	C-RATES1 and R-RATES1 (12.6.2 and 12.7.4).....99
34	Timing diagram of exchange (12.8-12.9).....105
35	Format of the bit swap request message .....113
36	Format of the bit swap acknowledge .....114
37	Overview of test setup .....116
38	Test loops .....118
39	Test impulse #1 .....120

	Page
40	Test impulse #2 ..... 120
41	Laboratory test setup for measuring performance margins..... 121
42	High impedance crosstalk injection circuit..... 122
43	Interface on the customer premises side of the U-R ..... 127
44	Wiring for a remotely located POTS splitter/ATU-R ..... 128
<b>Annexes</b>	
A	ATU-C and ATU-R state diagrams ..... 130
B	Power spectral density of crosstalk disturbers ..... 137
C	Characteristics of test impulse waveforms ..... 147
D	Vendor identification numbers ..... 153
E	Resistance and insertion loss characteristics of typical telephone cables ..... 154
F	Overvoltage, surge protection, and EMC ..... 156
G	Examples of ADSL services and applications ..... 157
H	Aspects of ADSL systems based 2048 Mkbit/s ..... 160
I	Items for further study..... 169
J	Bibliography..... 170

**Foreword** (This foreword is not part of American National Standard T1.413-1995.)

This specification of the layer 1 characteristics of the Asymmetrical Digital Subscriber Line (ADSL) interface to metallic loops was initiated under the auspices of the Accredited Standards Committee on Telecommunications, T1. The specification should be of interest and benefit to network providers and customers using multimedia services.

A single twisted pair of telephone wires is used to connect two ADSL units: one at the central office end (an ATU-C) and one at the remote end (an ATU-R). This standard has been written to define the transport capability of these units on a wide variety of wire pairs and with typical impairments, and to help ensure proper interfacing and interworking when the two units are manufactured and provided independently.

The ADSL simultaneously conveys all of the following: a downstream simplex bearer, a duplex bearer, a baseband analog duplex channel, and ADSL line overhead for framing, error control, operations, and maintenance. Nominal downstream bearer rates from 1.536 to 7 Mbit/s may be programmed. Duplex bearer aggregate rates from 16 to 640 kbit/s may be programmed.

Two categories of performance are specified. Category I performance is required for compliance with this standard; performance enhancement options are not required for category I equipment. Category II is a higher level of performance (i.e., longer lines and greater impairments). Category II characteristics are not required for compliance with this standard. Three optional enhancements – trellis coding, transmit power boost, and echo cancellation – are defined for Category II equipment.

A future issue of this standard may address the items listed in annex J.

There are nine annexes to this standard; four are normative, and are considered part of the standard; five are informative, and are provided for information only.

Suggestions for improvements of this standard are welcome. They should be sent to the Alliance for Telecommunications Industries Solutions, 1200 G Street, NW, Suite 500, Washington, DC 20005.

This standard was processed and approved for submission to ANSI by Accredited Standards Committee on Telecommunications T1. Committee approval of the standard does not necessarily imply that all committee members voted for its approval. At the time it approved this standard, committee T1 had the following members:

A. K. Reilly, Chairman  
G. H. Peterson, Vice-Chairman  
O. J. Gusella, Jr., Secretary  
  
R. Welborn, Senior Editor  
J. Bingham, Technical Editor

*Organization Represented**Name of Representative***EXCHANGE CARRIERS**

Ameritech Services, Inc. ....	Laurence A. Young Stephen P. Murphy (Alt.)
Bell Atlantic Corporation .....	John W. Seazholtz Roger Nucho (Alt.)

<i>Organization Represented</i>	<i>Name of Representative</i>
Bellcore.....	James C. Staats
	E. R. Hapeman (Alt.)
BellSouth Telecommunications, Inc. ....	William J. McNamara, III
	Malcolm Threlkeld, Jr. (Alt.)
Cincinnati Bell Telephone .....	Thomas C. Grimes
	Renee W. Cagle (Alt.)
GTE Telephone Operations .....	Bernard J. Harris
	Richard L. Cochran (Alt.)
National Telephone Cooperative Association .....	Joseph M. Flanagan
NYNEX .....	James F. Baskin
	Jim Papadopoulos (Alt.)
Pacific Bell .....	Sal R. Tesoro
Puerto Rico Telephone Company.....	Segundo Ruiz
	Alberto E. Morales (Alt.)
Southwestern Bell Corporation .....	C. C. Bailey
	Joseph Mendoza (Alt.)
Sprint – Local Telecommunications Division.....	Robert P. McCabe
	Harold L. Fuller (Alt.)
US Telephone Association (USTA) .....	Dennis Byrne
	Paul K. Hart (Alt.)
US WEST.....	James L. Eitel
	Darryl Debault (Alt.)
<b>INTEREXCHANGE CARRIERS</b>	
AT&T Communications .....	Charles A. Dvorak
	Dennis Thovson (Alt.)
Comsat Corporation .....	Mark T. Neibert
	Thanos Kipreos (Alt.)
MCI Telecommunications Corporation.....	Jim Joerger
	Peter Guggina (Alt.)
Sprint – Long Distance Division .....	Tom G. Croda
	Peter J. May (Alt.)
Stentor Resource Centre, Inc.....	Michel Duchesne
	B. Sambasivan (Alt.)
Unitel Communications, Inc. ....	David H. Whyte
	George Tadros (Alt.)
Wiltel, Inc. ....	Robert Bentley
	Howard Meiseles (Alt.)
<b>MANUFACTURERS</b>	
ADC Telecommunications, Inc. ....	Ron Weitnauer
	Don Berryman (Alt.)
Alcatel Network Systems, Inc.....	Bob Cabbage
	Dale Krisher (Alt.)
AMP, Inc. ....	George Lawrence
	Jack Bradbery (Alt.)
Apple Computer, Inc. ....	David Michael
Ascom Timeplex, Inc. ....	L. H. Eberl
	Richard Koepper (Alt.)
AT&T Network Systems .....	John H. Bobsin
	Dave R. Andersen (Alt.)
DSC Communications Corporation.....	Peter Waal
	Allen Adams (Alt.)
ECl Telecom, Inc. ....	Ron Murphy
	Charles T. Throop (Alt.)
Ericsson, Inc. ....	Linda Troy
	Al Way (Alt.)
Fujitsu America, Inc.....	Kenneth T. Coit
	Ashok Saraf (Alt.)
General DataComm, Inc. ....	Frederick Lucas
	Frederick Cronin (Alt.)
Harris Corporation .....	Allen Jackson
	Yogi Mltery (Alt.)
Hekimian Laboratories.....	William H. Duncan
	Mike F. Toohig (Alt.)
Hewlett-Packard .....	Don C. Loughry
	Richard van Gelder (Alt.)

<i>Organization Represented</i>	<i>Name of Representative</i>
Hitachi Telecomm USA, Inc. ....	Bryan Hall
	Pat Kunza (Alt.)
IBM Corporation .....	William C. Bergman
	Rao J. Cherukuri (Alt.)
Mitel Corporation .....	John Needham
	F. Audet (Alt.)
Motorola, Inc. ....	Edmund J. Downey
	Dan Grossman (Alt.)
NEC America, Inc. ....	Donovan Nak
	Masaki Omura (Alt.)
Northern Telecom, Inc. ....	Mel N. Woinsky
	Subhash Patel (Alt.)
Picturetel Corporation .....	Marshall Schachtman
	David Lindbergh (Alt.)
Reliance Comm/Tec .....	Mark Scott
	Leroy Baker (Alt.)
Rockwell International Corporation .....	Quent C. Cassen
	Carl J. Stehman (Alt.)
Siemens Stromberg-Carlson .....	Michael A. Pierce
	Robert Poignant (Alt.)
Telecom Solutions .....	M. J. Narasimha
	Don Chislow (Alt.)
Telecommunications Techniques Corporation .....	Bernard E. Worne
Tellabs Operations, Inc. ....	R. Michael Schafer
	Michael J. Birck (Alt.)
Transwitch Corporation .....	Daniel C. Upp
	Praveen Goli (Alt.)
<b>GENERAL INTEREST</b>	
Ashford Associates .....	Donald A. Ashford
Brooktree Corporation .....	Douglas M. Brady
	Rick Hall (Alt.)
BT North America, Inc. ....	Ron Stotz
C.S.I. Telecommunications .....	Michael S. Newman
	William J. Buckley (Alt.)
Cable Television Labs, Inc. ....	Rhonda Hilton
	James S. Meditch (Alt.)
Capital Cities/ABC, Inc. ....	Warner W. Johnston
Defense Information Systems Agency .....	C. Joseph Pasquariello
	Gary L. Koerner (Alt.)
EDS Corporation .....	Dell Schipper
GTE Mobile Communications .....	John C. Chiang
	Steve Pankow (Alt.)
National Communications System .....	Dennis Bodson
National Institute of Standards and Technology .....	David Cypher
	Leslie A. Collica (Alt.)
National Telecommunications and Information Administration/Institute for Telecommunication Sciences (NTIA/ITS) .....	William F. Utlaut
	Neal B. Seitz (Alt.)
NTT America, Inc. ....	Kazuo Imai
	Satoshi Ueda (Alt.)
Rural Electrification Administration .....	Donald M. Van Bellinger
	George J. Bagnall (Alt.)
U.S. General Services Administration .....	Keith Thurston
	Patrick Plunkett (Alt.)



At the time it approved this standard Technical Subcommittee T1E1 on Carrier-to-Customer Premises Equipment Interfaces, which is responsible for the development of this standard, had the following members:

J. W. Smith, Chairman  
T. G. Croda, Vice-Chairman  
L. Katz, Secretary

<i>Organization Represented</i>	<i>Name of Representative</i>
ADC Telecommunications, Inc. ....	Steve Larsen
Adtran.....	Joe Charboneau (Alt.)
Alcatel Network Systems (ANS).....	Michael D. Turner
Ameritech Services, Inc. ....	Jerry D. Moore (Alt.)
AMP, Inc. ....	Bill Crane
Ascom Timeplex, Inc. ....	Joe Smith (Alt.)
AT&T Communications .....	Larry J. Carl
AT&T Network Systems .....	Thomas J. Starr (Alt.)
Bell Atlantic .....	George Lawrence
Bellcore.....	Henry Line (Alt.)
Bellsouth Telecommunications, Inc. ....	L. H. Eberl
C.S.I. Telecommunications .....	E. Polansky
Cable Television Labs, Inc.....	W. E. Goodson (Alt.)
Comsat Corporation .....	Mohammad Vakili
Dantel, Inc.....	Jonathan Smith (Alt.)
ECI Telecom, Inc.....	Trone Bishop
EDS Corporation .....	Lita B. Gwinn (Alt.)
Ericsson, Inc. ....	Ralph E. Jensen
Exar Corporation .....	James C. Staats (Alt.)
General DataComm, Inc. ....	Gary J. Tennyson
GTE Telephone Operations .....	Philip J. Kyees (Alt.)
Harris Corporation .....	William J. Buckley
Hekimian Laboratories .....	Michael S. Newman (Alt.)
Hewlett-Packard .....	Rhonda Hilton
IBM Corporation .....	C. R. Baugh (Alt.)
Level One Communications, Inc.....	Thanos Kipreos
MCI Telecommunications Corporation.....	Dattakumar Chitre (Alt.)
Mitel Corporation.....	J. Pierre Sicard
Motorola, Inc. ....	Norm Epstein (Alt.)
National Communications System.....	Charles T. Throop
NEC America, Inc. ....	Ron Murphy (Alt.)
	Douglas Zolnick
	Linda Troy
	Hans-Joerg Firzlen (Alt.)
	M. Kursat Kimyacioglu
	Yu Hao Lin (Alt.)
	Hugh Golberg
	Emil Ghelberg (Alt.)
	Norman Epstein
	Percy E. Pool (Alt.)
	Harby Sehmar
	Yogi Mistry (Alt.)
	William H. Duncan
	Joseph E. Murtha (Alt.)
	Richard van Gelder
	William C. Bergman
	Rao J. Cherukuri (Alt.)
	Andrew Sorowka
	Kirk Hayden (Alt.)
	Curtis Brownmiller
	Stephen J. Engelman (Alt.)
	C. Seto
	John Needham (Alt.)
	Mort Stern
	Ciaran Connell (Alt.)
	Gary Rekstad
	Donovan Nak

x

<i>Organization Represented</i>	<i>Name of Representative</i>
Newbridge Networks Corporation.....	Gordon Beall
Northern Telecom, Inc. ....	Don Morrison (Alt.)
NYNEX .....	Mel N. Woinsky
	Severin Godo (Alt.)
	Leo Katz
	F. T. Burns (Alt.)
Pacific Bell.....	Sal R. Tesoro
Pairgain Technologies .....	Bruce Kimble
	Mike Lefkowitz (Alt.)
Performance Telecom .....	Kevin Mullaney
	Jim Seago (Alt.)
Ratelco, Inc.....	Alvin G. Graham
	Mark Resler (Alt.)
Reliance Comm/Tec .....	Leroy Baker
	Bill Chen (Alt.)
Rockwell International Corporation .....	Quent C. Cassen
Siemens Stromberg-Carlson.....	Gunter Neumeier
	Michael A. Pierce (Alt.)
Southwestern Bell Corporation .....	Rolyn Callahan
	John E. Roquet (Alt.)
Sprint – Local Telecommunications Division.....	Irvin Youngberg
	Harold L. Fuller (Alt.)
Sprint – Long Distance Division .....	Tom G. Croda
	Robert E. Lagrand, Jr. (Alt.)
Stentor Resource Centre, Inc.....	Frank McCaughey
	P. Norman Smith (Alt.)
Telecom Reliability Services .....	William Bush
Telecom Solutions.....	Kishan Shenoi
	M. J. Narasimha (Alt.)
Telecommunications Techniques Corporation .....	Bernard E. Worne
Telident, Inc. ....	Martin B. Moody
Thomas & Betts Corporation.....	Greg Steinman
	Francis J. Fiederlein (Alt.)
US Telephone Association (USTA) .....	Gerald Stearns
US WEST.....	Don Bowey
	Charles I. Cook (Alt.)
Westell, Inc. ....	Ken Hohhof
	Ron Koval (Alt.)

The T1E1.4 Working Group, which had technical responsibility during the development of this standard, had the following participants:

Tom Starr, Chairman  
 Dave Little, Vice-Chairman  
 Phillip J. Kyees, Secretary  
 John A. C. Bingham, Editor

Ephraim Arnon  
 Jim Aslanis  
 Mark Astor  
 F. Autrique  
 Jein Baek  
 LeRoy Baker  
 Chuck Balogh  
 Steve Barrett  
 Bob Beemen  
 Guy Benhaim  
 Larry Bishop  
 Steven Blumenfeld  
 R.T. Boblin  
 Holton Bond  
 Les Brown  
 Curtis Brownmiller  
 William Buckley  
 Roger W. Cain  
 Larry Carl  
 Guy Cerulli  
 Joe Charboneau  
 W.I.H. Chen  
 Yong Choong  
 Jacky Chow  
 Pete Chow  
 John Cioffi  
 Nigel G. Cole  
 Claran Connell  
 Charles Cook  
 Graham C. Copley  
 Larry Corbett  
 J. Francois Crepin  
 Kim Currie  
 Stan Davies  
 Dawn Diflumeri-Kelly  
 Miroslav Dokic  
 Thomas Eames  
 Lou Eberl  
 Lawrence Ebringer  
 Edward S. Ehrlich  
 Mark Elder  
 Norman Epstein  
 Dan Essig  
 Rocky Flaminio  
 David L. Foote  
 Ronald Fortino  
 Kevin Foster  
 James Freeman  
 Hans-Joerg Frizlen  
 Alan Gatherer  
 Al Gharakhanian  
 Emil Gheiberg  
 Mike Gilbert  
 Hugh Goldberg  
 Neville L. Golding  
 Toni Gooch  
 David Goodman  
 Albert Gottlieb  
 Peter T. Griffiths

Rick Gross  
 John Gruber  
 Bernard Harris  
 Paul Hartman  
 Brian Henrichs  
 Cary Hester  
 Stephan Heuser  
 Minnie Ho  
 Leon Hofer  
 Ken Hohhof  
 David Holien  
 Jack Holloway  
 Hal Holzwarth  
 T. Russell Hsing  
 Les Humphrey  
 Gannon Hwu  
 Ben Itri  
 Ken Jacobson  
 Ralph Jensen  
 David Jones  
 M.L. Jones  
 Leo Katz  
 Larry Kayser  
 Dan Kelly  
 Ken Kerpez  
 Frederick Kiko  
 Bruce Kimble  
 Thanos Kipreos  
 Robert Kniskern  
 Darrell Knobloch  
 Neil Knudsen  
 Yosef Kofman  
 Jouni Koljonen  
 John Kuzin  
 Robert LaGrand  
 Alvin Lai  
 T.K. Lala  
 Mike Lassandrello  
 Robert Lawrence  
 Avi Lichtash  
 Ze'ev Lichtenstein  
 Tim Lindenfelser  
 J. W. Lechleider  
 Jim Leeson  
 Mike Lefkowitz  
 Anatoli Loewen  
 Norb Lucash  
 Gary Luckett  
 Ahmed Madani  
 Lorenzo Magnone  
 Katsu Makihara  
 Harry Mann  
 Gervase Markham  
 Doug W. Marshall  
 Sean Martin  
 R.K. Maxwell  
 Jack Maynard  
 John McCarter  
 Brian McConnell

Ron McConnell  
 Richard A. McLaughlin  
 W.J. McNamara  
 Peter Melsa  
 Denis J.S. Mestdagh  
 Harry Mildonian  
 Steven Monti  
 Jerry Moore  
 Doug Moran  
 Bill Murphy  
 Frank Nabavi  
 Donovan Nak  
 Gunter F. Neumeier  
 Ralph Noel  
 Stephen Oh  
 Jean-Yves Ouellet  
 Eric Paneth  
 Panos Papmchalis  
 Raj Paripatyadar  
 Ike Park  
 Matt Pendleton  
 Larry Perron  
 Patrick Petillo  
 Ed Polansky  
 Carl Posthuma  
 John Proakis  
 Jack Quinnell  
 Ali Rahjou  
 Boaz Rippin  
 Tom Rostkowski  
 Charles T. Sacco  
 Ken Sakanashi  
 Uri Salomon  
 Henry Samueli  
 Wayne Sanderson  
 Ed Scarlett  
 Kevin Scheider  
 Rakib Selim  
 Susan Setzer  
 Krishna Shetty  
 Guy Shochet  
 Moshe Sholomorich  
 Tzvi Shukhman  
 Warren Siceloff  
 Richard Silva  
 Charles Simmons  
 Kamran Sistanizadeh  
 Don Skinfill  
 Jonathan Smith  
 Larry M. Smith  
 P. Norman Smith  
 Stephan A. Smith  
 Tetsuo Soejima  
 John W. Soltes  
 Massimo Sorbara  
 Andrew Sorowka  
 John Sramek  
 Jim Staats  
 Chris Stacey

Gerry Stearns  
William Stewart  
Henri Suyderhoud  
K.R. Swaminathan  
Erv Symons  
Hiroshi Takatori  
Gary Tennyson  
Rainer Thoenes  
Brent Thompson  
C. Terry Throop  
Vernon Tice  
Po Tong

Richard L. Townsend  
Bob Tracey  
Mike Turner  
Andy Turudic  
Michael Tzannes  
John Ulanskas  
Mohammad Vakili  
Craig Valenti  
Dale Veeneman  
Peter Voss  
Josef Waldinger  
David L. Waring

Steven Warwick  
J.J. Werner  
Alan Weisberger  
Greg Whelan  
Frank Wiener  
Bernard E. Worne  
Rick Younce  
Gavin Young  
Irvin Youngberg  
Mark L. Younge

American National Standard  
for Telecommunications –

# Network and Customer Installation Interfaces – Asymmetric Digital Subscriber Line (ADSL) Metallic Interface

## 1 Scope and purpose

### 1.1 Scope

This standard describes the interface between the telecommunications network and the customer installation in terms of their interaction and electrical characteristics. The requirements of this standard apply to a single asymmetric digital subscriber line (ADSL). ADSL allows the provision of Plain Old Telephone Service (POTS) and a variety of digital channels. In the direction from the network to the customer premises the digital channels may consist of full duplex low-speed channels and simplex high-speed channels; in the other direction only low-speed channels are provided.

The transmission system is designed to operate on two-wire twisted metallic cable pairs with mixed gauges. The standard is based on the use of cables without loading coils, but bridged taps are acceptable with the exception of unusual situations.

Functions included in the Service Modules, other than those associated with the ATU-R to Service Module interface, are beyond the scope of this standard.

Specifically, this standard:

- describes the transmission technique used to support the simultaneous transport of POTS and both simplex and full-duplex digital channels on a single twisted-pair;
- defines the combined options and ranges of the digital simplex and full-duplex channels provided;
- defines the line code and the spectral composition of the signals transmitted by both ATU-C and ATU-R;
- specifies the receive signals at both the ATU-C and ATU-R;
- describes the electrical and mechanical specifications of the network interface;
- describes the organization of transmitted and received data into frames;
- defines the functions of the operations channel;
- defines the ATU-R to service module(s) interface functions.

### 1.2 Purpose

This interface standard defines the minimal set of requirements to provide satisfactory simultaneous transmission between the network and the customer interface of POTS and a variety of high-speed simplex and low-speed full duplex channels. The standard permits network providers an expanded use of existing copper facilities. All Layer 1 aspects required to ensure compatibility between equipment in the network and equipment at a remote location are specified. Equipment may be implemented with additional functions and procedures.

ANSI T1.413-1995

**2 Normative references**

The following standards contain provisions that, through reference in this text, constitute provisions of this American National Standard. At the time of publication, the editions indicated were valid. All standards are subject to revision, and parties to agreements based on this American National Standard are encouraged to investigate the possibility of applying the most recent editions of the standards indicated below.

ANSI T1.231-1993; *Telecommunications – In-service Layer 1 digital transmission performance monitoring*

ANSI T1.401-1993; *Telecommunications – Interface between carriers and customer installations – Analog voice-grade switched access lines using loop-start and ground-start signaling.*

ANSI T1.601-1992, *Telecommunications – Integrated Services Digital Network (ISDN) – Basic access interface for use on metallic loops for application on the network side of the NT (Layer 1 specification)*

ANSI/EIA/TIA-571-1991, *Environmental considerations for telephone terminals*

ANSI/EIA RS-422A-1978, *Electrical characteristics of balanced voltage digital interface circuits, 1978*

IEEE Standard 455-1985, *Test procedures for measuring longitudinal balance of telephone equipment operating in the voice band*<sup>1)</sup>

Technical Report No. 28, *A Technical Report on High-bit rate digital subscriber lines*, Committee T1-Telecommunications, February 1994<sup>2)</sup>

<sup>1)</sup> Available from IEEE, 445 Hoes Lane, Piscataway, NJ 08855-1331.

<sup>2)</sup> Available from Alliance for Telecommunications Industry Solutions, 1200 G Street, NW, Suite 500, Washington, DC 20005.

### 3 Definitions, abbreviations, acronyms and symbols

#### 3.1 Definitions

**3.1.1 aggregate data rate:** data rate transmitted by an ADSL system in any one direction; it includes both net data rate and data rate overhead used by the system for crc, eoc, synchronization of the various data streams, and fixed indicator bits for OAM; it does not include FEC redundancy.

**3.1.2 bearer channel:** a user data stream of a specified data rate that is transported transparently by an ADSL system, and carries a bearer service; sometimes abbreviated to bearer.

**3.1.3 bearer service:** the transport of data at a certain rate without regard to its content, structure, or protocol.

**3.1.4 bridged taps:** sections of unterminated twisted-pair cable connected in parallel across the cable under consideration.

**3.1.5 Category I:** a default set of requirements that shall be met by all compliant equipment.

**3.1.6 Category II:** an enhanced set of requirements that may be met by the provision of certain options.

**3.1.7 channelization:** allocation of the net data rate to bearer channels.

**3.1.8 downstream :** ATU-C to ATU-R direction.

**3.1.9 loading coils:** inductors placed in series with the cable at regular intervals in order to improve the voice-band response.

**3.1.10 net data rate:** total data rate that is available to user data in any one direction; for the downstream direction this is the sum of the net simplex and duplex data rates.

**3.1.11 splitter:** a low-pass/high-pass pair of filters that separate high (ADSL) and low (POTS) frequency signals.

**3.1.12 transport class:** the set of bearer channel data rates and multiplex configurations that may be simultaneously transported on a given loop, based on the maximum aggregate data rate supported by that loop.

**3.1.13 upstream:** ATU-R to ATU-C direction

#### 3.2 Abbreviations, acronyms and symbols

ADC	analog to digital converter
ADSL	asymmetric digital subscriber line
AEX	byte inserted in the transmitted ADSL frame structure to provide synchronization capacity that is shared among ASX channels
AGC	automatic gain control
aoc	ADSL overhead control channel
AS0 – 3	downstream simplex sub-channel designators
ASX	any one of the simplex channels AS0 to AS3
ATM	asynchronous transfer mode
ATU-C	ADSL transceiver unit, central office end
ATU-R	ADSL transceiver unit, remote terminal end
$B_F$	the number of bytes in a data stream allocated to the fast (i.e., non-interleaved) buffer

## ANSI T1.413-1995

$B_i$	the number of bytes in a data stream allocated to the interleaved buffer
BRA	basic rate access
CI	customer installation
CO	central office
CSA	carrier serving area
CSA loops	a set of loops within the CSA that are defined by T1 technical report TR-028-1994
crc-8f	cyclic redundancy check using CRC-8 code – fast data
crc-8i	cyclic redundancy check using CRC-8 code – interleaved data
DAC	digital to analog converter
dBm	dB milliwatt; 0 dBm = 1 milliwatt
DMT:	discrete multitone
DSL	digital subscriber line
EC	echo canceling
eoc	embedded operations channel
ERL	echo return loss, as defined by IEEE Std 743-1984
es	errored second
FDM	frequency-division multiplexing
febe-f	far-end block error count – fast data
febe-i	far-end block error count – interleaved data
fecc-f	forward error correction count – fast data
fecc-i	forward error correction count – interleaved data
FEC:	forward error correction
FEXT	far-end cross talk
HDSL	high-rate digital subscriber line
ib0 – 23	indicator Bit(s)
ID code	vendor identification code
IDFT	inverse discrete fourier transform
ISDN	Integrated Services Digital Network
ISDN – BRA	ISDN basic rate access
kbit/s	kilo bits per second
LEX	byte inserted in the transmitted ADSL frame structure to provide synchronization capacity that is shared among LSX and ASX channels
lof	loss of frame
lopr	loss of power
los	loss of signal
LS0 – 2	duplex sub-channel designators
ms	millisecond
NI	network interface
$N_{m,f}$	number of bytes in a fast mux data frame
$N_{m,i}$	number of bytes in an interleaved mux data frame
NEXT	near-end cross talk
OAM	operations, administration and maintenance
OSI	open systems interconnection (7 layer model)
POTS	plain old telephone service (also known as message telecommunications service, MTS)
PRD	pseudo-random downstream
PRU	pseudo-random upstream
PSD	power spectral density
PSTN	public switched telephone network
PRBS	pseudo-random bit sequence
$P_{dsf}$	number of FEC parity bytes for fast buffer
$P_{dsi}$	number of FEC parity bytes for interleaved buffer
QAM	quadrature amplitude modulation
rdi	remote defect indication
RT	remote terminal
sc0 – 7	synchronization control bit(s)
sef	severely errored frame
sefs	severely errored frame second
SINAD	signal-to-noise plus distortion (ratio)
SM	service module



SONET	synchronous optical network
SRL	singing return loss, as defined by IEEE Std 743-1984
SRL low	SRL in a band from approximately 260 to 500 Hz
SRL high	SRL in a band from approximately 2200 to 3400 Hz
STM	synchronous transfer mode
T-SM	interface(s) between ATU-R and SM(s)
U-C:	loop interface – central office end
U-R	loop interface – remote terminal end
VDT	video dial tone
V	logical interface between ATU-C and a digital network element such as one or
more	switching systems
VIP	video information provider
4QAM	4-point QAM (i.e., two bits per symbol)
⊕:	exclusive-or; modulo-2 addition

ANSI T1.413-1995

## 4 Reference models

### 4.1 System reference model

The system reference model shown in figure 1 illustrates the functional blocks required to provide ADSL service.

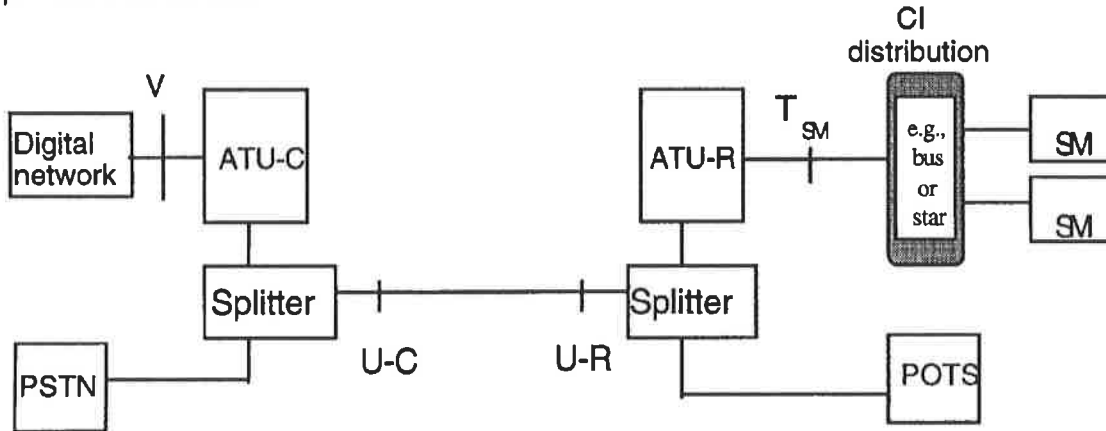

#### NOTES

- 1 The V interface is defined in terms of logical functions; not physical.
- 2 The V interface may consist of interface(s) to one or more switching systems.
- 3 Implementation of the V and T<sub>SM</sub> interfaces is optional when interfacing elements are integrated into a common element.
- 4 The splitter function may be integrated into the ATU.
- 5 A digital carrier facility (e.g., SONET extension) may be interposed at the V interface when the ATU-C is located at a remote site.
- 6 The nature of the CI distribution (e.g., bus or star, type of media) is for further study.
- 7 More than one type of T<sub>SM</sub> interface may be defined, and more than one type of T-sm interface may be provided from an ATU-R.
- 8 Due to the asymmetry of the signals on the line, the transmitted signals shall be distinctly specified at the U-R and U-C reference points.
- 9 A future issue of this standard may deal with CI distribution requirements.

**Figure 1 – ADSL functional reference model**

## 4.2 ATU-C transmitter reference model

Figure 2 is a block diagram of an ADSL Transceiver Unit-Central office (ATU-C) transmitter showing the functional blocks and interfaces that are referenced in the following clauses.

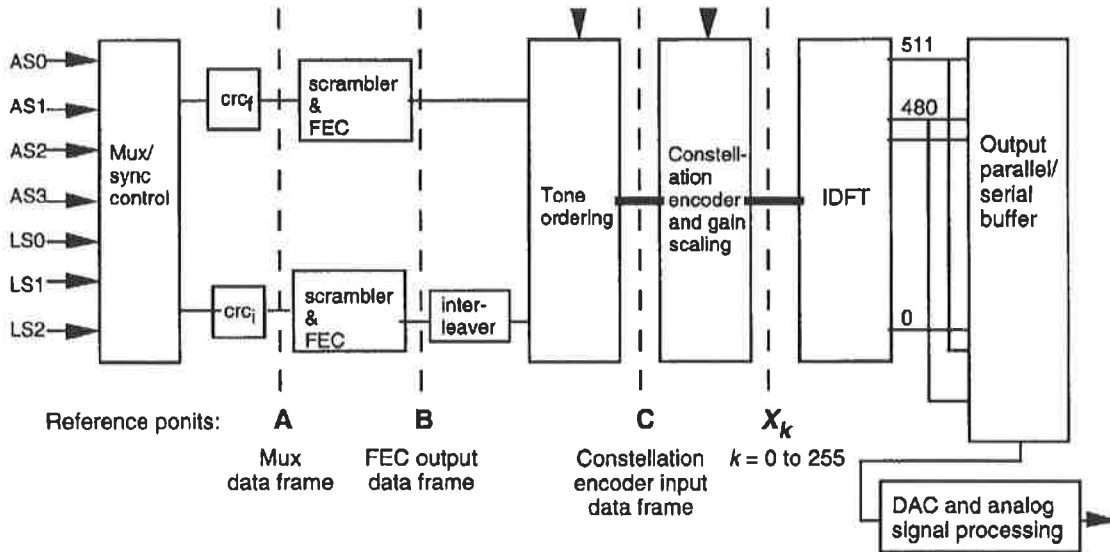
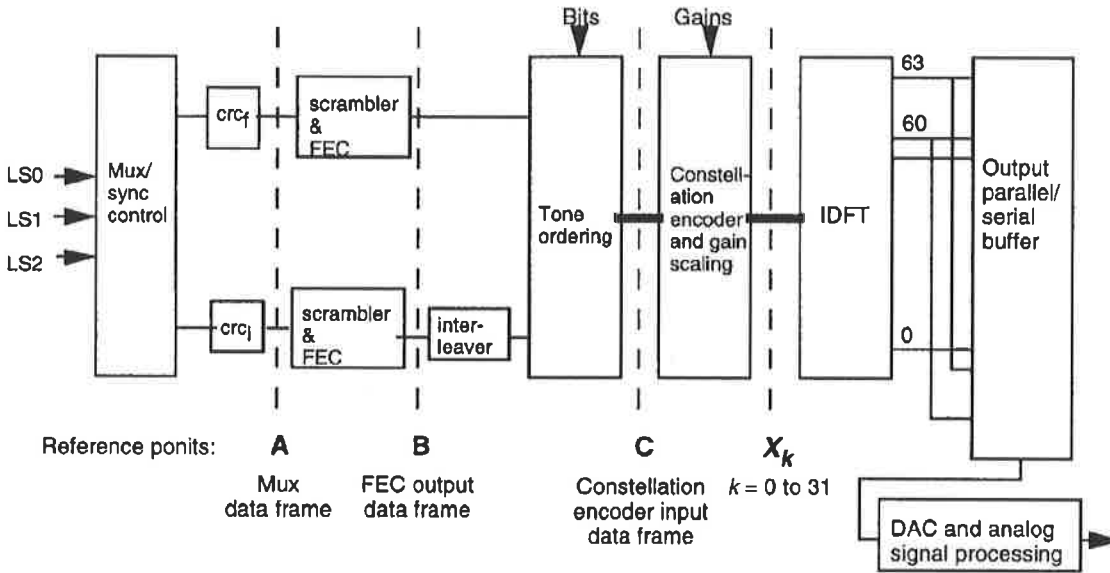

Figure 2 - ATU-C transmitter reference diagram

ANSI T1.413-1995

**4.3 ATU-R transmitter reference model**

Figure 3 is a block diagram of an ATU-R transmitter showing the functional blocks and interfaces that are referenced in the following clauses.



**Figure 3 – ATU-R transmitter reference diagram**

## 5 Transport capacity

An ADSL system may transport up to seven bearer channels (bearers) simultaneously:

- up to four independent downstream simplex bearers (unidirectional downstream);
- up to three duplex bearers (bi-directional, downstream and upstream).

The three duplex bearers may alternatively be configured as independent unidirectional simplex bearers, and the rates of the bearers in the two directions (downstream and upstream) do not need to match.

All bearer channel data rates can be programmed in any combination of multiples of 32 kbit/s. Other data rates (non-integer multiples of 32 kbit/s) can also be supported, but will be limited by the ADSL system's available capacity for synchronization (see notes 1 and 2).

Four transport classes are defined for the downstream simplex bearers based on multiples of 1.536 Mbit/s up to 6.144 Mbit/s. Data rates are also defined for duplex bearers to carry a control channel and ISDN channels (basic rate and 384 kbit/s). The ADSL data multiplexing format is flexible enough to allow other transport data rates, such as channelizations based on existing 1.544 or 2.048 Mbit/s formats, and to allow definition of other channelizations in the future in order to accommodate evolving Synchronous or Asynchronous Transfer Modes (STM or ATM) network formats (singly or in combination).

The maximum net data rate transport capacity of an ADSL system will depend on the characteristics of the loop on which the system is deployed and on certain configurable options that affect overhead (see note 3).

Each bearer channel shall be individually assigned to an ADSL sub-channel for transport, and the ADSL sub-channel rate shall be configured during the initialization and training procedure to match the bearer rate.

The transport capacity of an ADSL system per se is defined only as that of the high-speed data streams. When, however, an ADSL system is installed on a line that also carries POTS signals the overall capacity is that of POTS plus ADSL (see clauses 8 and 10 for details on POTS related requirements).

### NOTES

- 1 Part of the ADSL system overhead is shared among the bearer channels for synchronization. The remainder of each channel's data rate that exceeds a multiple of 32 kbit/s shall be transported in this shared overhead.
- 2 The rates for the downstream simplex bearer channels are based on unframed 1.536 Mbit/s structures in order to be consistent with the expected evolution of network switching. ADSL deployments may need to interwork with DS1 (1.544 Mbit/s) data. The ADSL system overhead and data synchronization (see 6.2.2) provides enough capacity to support the framed DS1 data streams transparently (i.e., the entire DS1 signal is passed through the ADSL transmission path without interpretation or removal of the framing bits and other overhead).
- 3 One part of the ADSL initialization and training sequence estimates the loop characteristics to determine whether the number of bytes per Discrete MultiTone (DMT) frame required for the requested configuration's aggregate data rate can be transmitted across the given loop. The net data rate is then the aggregate data rate minus ADSL system overhead. Part of the ADSL system overhead is dependent on the configurable options, such as allocation of user data streams to interleaving or non-interleaving data buffers within the ADSL frame (discussed in 6.2, 6.4.2, 7.2, and 7.4.2), and part of it is fixed.

### 5.1 Simplex bearers

Simplex bearers in the downstream direction are specified herein; the use of upstream simplex bearers is for further study.

ANSI T1.413-1995

**5.1.1 Data rates for downstream simplex bearers based on multiples of 1.536 Mbit/s**

The default data rates for the four possible simplex bearer channels that may be transported downstream over an ADSL system are

- 1.536 Mbit/s;
- 3.072 Mbit/s;
- 4.608 Mbit/s;
- 6.144 Mbit/s.

The ADSL system may use up to four sub-channels, named AS0, AS1, AS2, and AS3, to transport the downstream simplex bearer channels. An ADSL sub-channel's rate shall match the rate of the bearer channel that it transports, subject to the restrictions given in table 1.

**Table 1 – ADSL sub-channel rate restrictions for default bearer rates**

Sub-channel designations	Sub-channel data rate	Allowed values of $n_x$
AS0	$n_0 \times 1.536$ Mbit/s	$n_0 = 0, 1, 2, 3, \text{ or } 4$
AS1	$n_1 \times 1.536$ Mbit/s	$n_1 = 0, 1, 2, \text{ or } 3$
AS2	$n_2 \times 1.536$ Mbit/s	$n_2 = 0, 1, \text{ or } 2$
AS3	$n_3 \times 1.536$ Mbit/s	$n_3 = 0 \text{ or } 1$
NOTE – Rates equivalent to multiple DS1s are also supported.		

The maximum number of sub-channels that may be active at any given time and the maximum number of bearer channels that can be transported simultaneously by an ADSL system will depend on the transport class (as described in 5.1.1.1 through 5.1.1.4) that can be supported by the specific loop and on the configuration of the active sub-channels. Switching on demand among the configurations allowed by a given transport class is for further study.

To comply with this standard the AS0 sub-channel and at least transport classes 1 (5.1.1.1) and 4 (5.1.1.4) shall be supported. Support of sub-channels AS1, AS2, AS3, and transport classes 2, 3, and 2M is optional.

**5.1.1.1 Downstream simplex bearer configurations for transport class 1 (shortest range, highest capacity)**

The net simplex bearer capacity on transport class 1 is 6.144 Mbit/s, which may be composed of any combination of one to four bearer channels with  $n \times 1.536$  Mbit/s rates. Systems shall support at least a 6.144 Mbit/s bearer channel on sub-channel AS0. The following transport class 1 configurations are optional:

- one 4.608 Mbit/s bearer channel and one 1.536 Mbit/s bearer channel;
- two 3.072 Mbit/s bearer channels;
- one 3.072 Mbit/s bearer channel and two 1.536 Mbit/s bearer channels;
- four 1.536 Mbit/s bearer channels.

**5.1.1.2 Downstream simplex bearer configurations for optional transport class 2**

The net simplex bearer capacity on transport class 2 is 4.608 Mbit/s, which may be composed of any combination of one to three bearer channels with  $n \times 1.536$  Mbit/s rates. Systems, at their option, may provide any and all bearer rates. Transport class 2 configuration options are:

- one 4.608 Mbit/s bearer channel;
- one 3.072 Mbit/s bearer channel and one 1.536 Mbit/s bearer channel;
- three 1.536 Mbit/s bearer channels.

ADSL sub-channel AS3 shall not be used in this configuration.

### 5.1.1.3 Downstream simplex bearer configurations for optional transport class 3

The net simplex bearer capacity on transport class 3 is 3.072 Mbit/s, which may be composed of one or two bearer channels with  $n \times 1.536$  Mbit/s rates. Systems, at their option, may provide either or both bearer rates. Transport class 3 configuration options are:

- one 3.072 Mbit/s bearer channel;
- two 1.536 Mbit/s bearer channels.

ADSL sub-channels AS2 and AS3 shall not be used in this configuration.

### 5.1.1.4 Downstream simplex bearer configurations for transport class 4 (longest range, lowest capacity)

Only one downstream simplex bearer option can be supported in transport class 4. The bearer channel capacity of one 1.536 Mbit/s bearer channel shall be transported on sub-channel AS0.

### 5.1.2 Optional data rates for downstream simplex bearers based on multiples of 2.048 Mbit/s

ADSL equipment may include channelization options other than those defined in 5.1.1. For example, the rate structure outlined in this subclause accommodates a digital hierarchy based on multiples of 2.048 Mbit/s.

This 2.048 Mbit/s rate structure is optional, both in implementation of equipment and in the provision of service. Equipment or service implementation at the 1.536 Mbit/s rate (or multiples) but not the 2.048 Mbit/s rate would still fully conform to the standard. Information related to 2.048 Mbit/s applications may be found in annex H.

Bearer channels based on 2.048 Mbit/s that may optionally be transported downstream over an ADSL system are

- 2.048 Mbit/s;
- 4.096 Mbit/s;
- 6.144 Mbit/s.

The entire framed 2.048 Mbit/s structure is treated as a bearer data stream; the use of a lower payload rate is for further study.

An ADSL system supporting these options may use up to three of the downstream simplex sub-channels, AS0, AS1, and AS2, to transport the bearer channels. An ADSL sub-channel's rate shall match the rate of the bearer channel that it transports, subject to the restrictions given in table 2.

**Table 2 – ADSL Sub-channel rate restrictions 2.048 Mbit/s (optional)**

Sub-channel designations	Sub-channel data rate	Allowable values of $n_x$
AS0	$n_0 \times 2.048$ Mbit/s (optional)	$n_0 = 0, 1, 2, \text{ or } 3$
AS1	$n_1 \times 2.048$ Mbit/s (optional)	$n_1 = 0, 1, \text{ or } 2$
AS2	$n_2 \times 2.048$ Mbit/s (optional)	$n_2 = 0 \text{ or } 1$

## ANSI T1.413-1995

The maximum number of sub-channels that may be active at any given time, and the maximum number of bearer channels that can be transported simultaneously by an ADSL system depends on the transport class (as described in 5.1.2.1 through 5.1.2.3) that can be supported by the specific loop on which the system is deployed, and the configuration of the active sub-channels.

**5.1.2.1 Downstream simplex bearer configurations for optional transport class 2M-1**

The simplex bearer capacity on the optional transport class 2M-1 is 6.144 Mbit/s, which may be composed of any combination of one to three bearer channels with  $n \times 2.048$  Mbit/s rates. Systems, at their option, may provide any and all bearer rates. Transport class 2M-1 configuration options are:

- one 6.144 Mbit/s bearer channel;
- one 4.096 Mbit/s bearer channel and one 2.048 Mbit/s bearer channel;
- three 2.048 Mbit/s bearer channels.

**5.1.2.2 Downstream simplex bearer configurations for optional transport class 2M-2**

The combined simplex bearer capacity on optional transport class 2M-2 is 4.096 Mbit/s, which may be composed of one or two bearer channels with  $n \times 2.048$  Mbit/s rates. Systems, at their option, may provide either or both bearer rates. Transport class 2M-2 configuration options are:

- one 4.096 Mbit/s bearer channel;
- two 2.048 Mbit/s bearer channels.

ADSL sub-channel AS2 shall not be used in this configuration.

**5.1.2.3 Downstream simplex bearer configurations for optional transport class 2M-3**

Only one downstream simplex bearer option – 2.048 Mbit/s transported on ADSL sub-channel AS0 – can be supported in transport class 2M-3.

**5.1.3 Options for transporting downstream simplex ATM data streams**

ADSL equipment may also provide the capability to transport ATM data as a single downstream simplex data stream.

If this capability is provided the ADSL bearer channel rates shall be based on

- $n \times 1.536$  Mbit/s user data content, where  $n = 1 - 4$ ;
- AAL1 cell format (ATM Adaption Layer 1), in which each 53-byte ATM cell transports 47 bytes of user data, yielding ATM data cell bit rates of  $n \times 1.536$  Mbit/s  $\times 53/47$ ;
- rounding the ATM data cell bit rate up to the nearest integer multiple of 32 kbit/s by insertion of idle cells (and possibly OAM cells as suggested by CCITT Rec. I.610) by an ATM cell processor on the network side of the V-interface.

Only the ADSL downstream simplex sub-channel AS0 shall be used, resulting in a single configuration option for the downstream simplex bearer, and its rate depends on the transport class as specified in table 3.

**Table 3 – Downstream ATM data cell bit rates**

Transport class	Bearer channel rate	ATM data cell bit rate
1	6.944 Mbit/s	6.928340 Mbit/s
2	5.216 Mbit/s	5.196255 Mbit/s
3	3.488 Mbit/s	3.464170 Mbit/s
4	1.760 Mbit/s	1.732085 Mbit/s



#### 5.1.4 Upstream simplex bearers

Upstream simplex bearers are for further study.

#### 5.2 Duplex bearers

Up to three duplex bearer channels may be transported simultaneously by an ADSL system. One of these is the mandatory control (C) channel. Data rates for this channel, which shall always be active, are specified in 5.2.1.

Depending on the maximum aggregate rate that can be supported on the specific loop and on the options implemented, specific limitations apply to the other two optional duplex ADSL sub-channels. Only certain allowed combinations of these may be active in any given configuration; these are defined in 5.2.2.

##### 5.2.1 Data rates for the control channel (mandatory duplex channel)

The C channel shall transport CI to CI (e.g., control of services) and CI-to-network signaling (i.e., call setup and selection of services) for the downstream simplex bearer services, and it may also transport some or all of the CI-to-network signaling for the optional duplex services. For transport classes 4 and 2M-3 the C channel shall operate at 16 kbit/s, and be transported within the ADSL synchronization overhead (see 6.2); for all other classes it shall operate at 64 kbit/s, and be transported on ADSL sub-channel LS0.

##### 5.2.2 Data rates for the optional duplex bearer channels

Two optional duplex bearer channels may be transparently transported by an ADSL system, depending on the service offered by the network provider.

If these bearer channels are transported the sub-channel assignments and data rates shall be:

- ADSL sub-channel LS1 at 160 kbit/s;
- ADSL sub-channel LS2 at 384 kbit/s or 576 kbit/s.

The duplex options for the four transport classes are given in table 4.

ANSI T1.413-1995

**Table 4 – Maximum optional duplex bearer channels supported by transport class**

Transport class	Optional duplex bearers that may be transported (note 1)	Active ADSL sub-channels
1 or 2M-1 (minimum range)	Configuration 1: 160 kbit/s + 384 kbit/s; Configuration 2: 576 kbit/s only	LS1, LS2 LS2 only
2, 3 or 2M-2 (mid range)	Configuration 1: 160 kbit/s only Configuration 2: 384 kbit/s only (see note 2)	LS1 only LS2 only
4 or 2M-3 (maximum range)	160 kbit/s only	LS1 only
NOTES		
1 When the 160 kbit/s optional duplex bearer is used to transport ISDN BRA, all signaling associated with the ISDN BRA (160 kbit/s) is carried by the D channel of the 2B + D signal embedded in the 160 kbit/s. Signaling for the 576 kbit/s, 384 kbit/s and non-ISDN 160 kbit/s duplex bearers may be included in the C channel, which is shared with the signaling for the downstream simplex bearer channels.		
2 Whether transport classes 2, 3, or 2M-2 should support the 576 kbit/s optional duplex bearer is for further study.		

### 5.2.3 Options for transporting duplex ATM data streams on the optional duplex channel LS2

ADSL equipment providers may also at their discretion, provide the capability to transport an ATM cell stream on the optional duplex LS2 channel.

If this duplex ATM transport capability is provided, the bearer channel rates shown in table 5 shall be based on:

- 384 kbit/s or 576 kbit/s user data content;
- AAL1 or AAL5 cell format (ATM Adaption Layer 1: each 53-byte ATM cell transports 47 bytes of user data) yielding ATM data cell bit rates of  $384 \times (53/47)$  kbit/s or  $576 \times (53/47)$  kbit/s;
- rounding the ATM data cell bit rate to the nearest integer multiple of 32 kbit/s by insertion of idle cells (and possibly OAM cells as suggested by CCITT Recommendation I.610) by an ATM cell processor on the network side of the V-interface and on the service module side of the T-interface.

**Table 5 – Optional duplex ATM data cell bit rates for LS2**

ADSL optional LS2 channel rate	ATM data cell bit rate
448 kbit/s	443.0213 kbit/s
672 kbit/s	649.5320 kbit/s

– The configuration options for each transport class are based on the default (non-ATM) data rates. Use of the optional ATM rates may reduce the loop reach or limit the configuration options possible on a given loop.

## 5.3 Combined options

### 5.3.1 Options for bearer channel rates based on downstream multiples of 1.536 Mbit/s

As specified in 5.1 and 5.2, different ADSL sub-channel and bearer configuration options may be provided for each of the transport classes. Within a given transport class, the allowable downstream simplex bearer and duplex bearer configurations may be treated independently. The net data rates (i.e., maximum bearer capacities) based on multiples of 1.536 Mbit/s for transport classes 1 and 4 (and for optional classes 2 and 3 if they are provided), shall be as summarized in table 6.

**Table 6 – Bearer channel options by transport class for bearer rates based on downstream multiples of 1.536 Mbit/s**

<b>Transport class:</b>	<b>1</b>	<b>2</b>	<b>3</b>	<b>4</b>
<b>Downstream simplex bearers:</b>				
Maximum capacity	6.144 Mbit/s	4.608 Mbit/s	3.072 Mbit/s	1.536 Mbit/s
Bearer channel options	1.536 Mbit/s, 3.072 Mbit/s, 4.608 Mbit/s, 6.144 Mbit/s	1.536 Mbit/s, 3.072 Mbit/s, 4.608 Mbit/s	1.536 Mbit/s, 3.072 Mbit/s	1.536 Mbit/s
Maximum active sub-channels	4 (AS0,AS1, AS2,AS3)	3 (AS0, AS1, AS2)	2 (AS0, AS1)	1 (AS0 only)
<b>Duplex bearers:</b>				
Maximum capacity	640 kbit/s	608 kbit/s	608 kbit/s	176 kbit/s
Bearer channel options	576 kbit/s, 384 kbit/s, 160 kbit/s, C (64 kbit/s)	see note 384 kbit/s, 160 kbit/s, C (64 kbit/s)	see note 384 kbit/s, 160 kbit/s, C (64 kbit/s)	160 kbit/s, C (16 kbit/s)
Max. active sub-channels	3 (LS0, LS1, LS2)	2 (LS0,LS1) or (LS0, LS2)	2 (LS0,LS1) or (LS0, LS2)	2 (LS0,LS1)
NOTE – Whether transport classes 2 or 3 should support the 576 kbit/s optional duplex bearer is for further study.				

The configuration shall be specified by the  $B_F$  and  $B_I$  parameters (described in 6.2, 7.2, and 12.8) for each bearer channel.

### 5.3.2 Options for bearer channel rates based on downstream multiples of 2.048 Mbit/s

The maximum bearer capacities for the three possible transport classes for the optional bearer rates based on 2.048 Mbit/s are summarized in table 7.

ANSI T1.413-1995

**Table 7 – Bearer channel options by transport class – optional bearer rates based on downstream multiples of 2.048 Mbit/s**

<b>Transport class:</b>	<b>2M-1</b>	<b>2M-2</b>	<b>2M-3</b>
<b>Downstream simplex bearers</b>			
Maximum capacity	6.144 Mbit/s	4.096 Mbit/s	2.048 Mbit/s
Bearer channel options	2.048 Mbit/s, 4.096 Mbit/s, 6.144 Mbit/s	2.048 Mbit/s, 4.096 Mbit/s	2.048 Mbit/s
Max. active sub-channels	3 (AS0,AS1,AS2)	2 (AS0,AS1)	1 (AS0 only)
<b>Duplex bearers</b>			
Maximum capacity	640 kbit/s	608 kbit/s	176 kbit/s
Bearer channel options	576 kbit/s, 384 kbit/s, 160 kbit/s, C (64 kbit/s)	see note 384 kbit/s, 160 kbit/s, C (64 kbit/s)	160 kbit/s, C (16 kbit/s)
Max. active sub-channels	3 (LS0, LS1, LS2)	2 (LS0,LS1 or LS0, LS2)	2 (LS0, LS1)
NOTE – Whether transport class 2M-2 should support the 576 kbit/s optional duplex bearer is for further study.			

The configuration shall be specified by the  $B_F$  and  $B_I$  parameters (described in 6.2, 7.2, and 12.8) for each bearer channel.

### 5.3.3 Options for bearer channel options transporting ATM cell streams

For optional bearer rates transporting an ATM cell stream in the downstream simplex channel, up to four transport classes can be defined. These are roughly equivalent to the default bearer transport classes. Only one configuration option is expected to be supported by each transport class: that of the single downstream simplex channel carrying the ATM data and the single mandatory duplex channel to carry signaling and service control traffic. Equipment and service providers may optionally provide duplex bearers over loops that can support a higher aggregate ADSL rate than those representative of the transport classes. The optional ATM bearer rates are summarized in table 8.

**Table 8 – Bearer channel options by transport class for optional ATM bearer rates**

<b>Transport class:</b>	<b>1</b>	<b>2</b>	<b>3</b>	<b>4</b>
<b>Downstream simplex bearers</b>				
Aggregate ATM data cell bit rate	6.928340 Mbit/s	5.196255 Mbit/s	3.464170 Mbit/s	1.732085 Mbit/s
Bearer channel rate (see note 1)	6.944 Mbit/s	5.216 Mbit/s	3.488 Mbit/s	1.760 Mbit/s
Maximum active subchannels	1 (AS0 only)	1 (AS0 only)	1 (AS0 only)	1 (AS0 only)
<b>Duplex bearers</b>				
Maximum capacity	64 kbit/s	64 kbit/s	64 kbit/s	16 kbit/s
Bearer channel options	C (64 kbit/s)	C (64 kbit/s)	C (64 kbit/s)	C (16 kbit/s)
Maximum active subchannels	1 (LS0)	1 (LS0)	1 (LS0)	1 (LS0) (see note 2)
<b>NOTES</b>				
1 The bearer channel rate is equal to the ATM data cell bit rate rounded up to the nearest integer multiple of 32 kbit/s (an ATM cell processor on the network side of the V-interface performs the rate adjustment by inserting idle cells).				
2 The 16 kbit/s C channel is carried entirely within the synchronization overhead as described in 6.2; the LS0 sub-channel does not appear as a separate byte within the ADSL frame.				

**5.4 ADSL system overheads and aggregate bit rates**

The aggregate bit rate transmitted by the ADSL system shall include capacity for the following:

- the transported simplex bearer channels;
- the transported duplex bearer channels;
- ADSL system overhead, which includes:
  - capacity for synchronization of the simplex and duplex bearers;
  - synchronization control for the bearers transported with interleaving delay (interleave data buffer) and with no interleaving delay ("fast", or low-latency, data buffer);
  - an ADSL embedded operations channel, eoc (see note );
  - an ADSL overhead control channel, aoc (for on-line adaptation and reconfiguration, as described in clause 13);
  - crc check bytes;
  - fixed indicator bits for OAM (Operations, Administration and Maintenance);
  - FEC redundancy bytes.

**NOTES**

1 For the downstream simplex bearer rates based on 1.536 Mbit/s, the maximum capacity available to eoc is approximately 23.7 kbit/s for transport classes 1, 2, and 3, and approximately 10.7 kbit/s for transport class 4. Actual eoc capacities will depend on the bearer channel rates and the data synchronization implementation.

2 In addition to the digital transport listed throughout this clause, the ADSL shall also permit the transport of POTS as a baseband analog signal.

## ANSI T1.413-1995

The organization of all the above data streams into ADSL frames and ADSL superframes shall be as given in 6.2 for the downstream data transmitted and in 7.2 for the upstream data.

The internal overhead channels and their rates shall be as shown in table 9.

**Table 9 – Internal overhead channel functions and rates**

	Downstream rate maximum / minimum / default		Upstream rate maximum / minimum / default	
	Transport classes 1, 2, 3, 2M-1, or 2M-2 (minimum and mid range loops)	Transport class 4 or 2M-3 (maximum range loop)	Transport classes 1, 2, 3, 2M-1, or 2M-2 (minimum and mid range loops)	Transport class 4 or 2M-3 (maximum range loop)
Synchronization capacity, shared among all bearers (see note 2)	128 / 64 / 96 kbit/s	96 / 64 / 96 kbit/s (see note 3)	64 / 32 / 64 kbit/s	64 / 32 / 64 kbit/s
Synchronization control and crc, interleave buffer	32 kbit/s	32 kbit/s	32 kbit/s	32 kbit/s
Synchronization control and crc, fast buffer, plus eoc and indicator bits	32 kbit/s	32 kbit/s	32 kbit/s	32 kbit/s
<b>Total</b>	<b>192 / 128 / 160 kbit/s</b>	<b>160 / 128 / 160 kbit/s</b>	<b>128 / 96 / 128 kbit/s</b>	<b>128 / 96 / 128 kbit/s</b>

**NOTES**

1 The overhead required for FEC is not shown in this table.

2 The shared synchronization capacity includes 32 kbit/s shared among duplex bearers within the interleave buffer, 32 kbit/s shared among bearers within the fast buffer, an additional 32 kbit/s shared with downstream simplex bearers within the interleave buffer, and an additional 32 kbit/s shared with downstream simplex bearers within the fast buffer. The maximum rate occurs when at least one downstream simplex bearer is allocated to each type of buffer; the minimum rate occurs when all bearers are allocated to one buffer type. Default rate allocates bearers according to defaults described in 6.2 and assumes that all optional duplex bearers are implemented.

3 Only one downstream simplex bearer is available in transport class 4 or 2M-3 (maximum range loops); the 64 kbit/s for synchronization of the simplex bearer to ADSL framing can appear in only one of the ADSL buffers (fast or interleaved).

The aggregate transmitted bit rate will depend on the transport class and implementation of optional duplex channels; components of the aggregate transmitted bit rate are summarized in table 10 for downstream transmission and in table 11 for upstream.

Table 10 – Determination of aggregate downstream bit rate

	1.536 or 2.048 Mbit/s bearers	Default bearer channels ( $n \times 1.536$ Mbit/s)			Optional bearers based on 2.048 Mbit/s (see note 1)	
	Transport class 1	Transport class 2 (see note 2)	Transport class 3 (see note 2)	Transport class 4	Transport class 2M-2 (see note 2)	Transport class 2M-3
Total downstream simplex bearer capacity	6.144 Mbit/s	4.608 Mbit/s	3.072 Mbit/s	1.536 Mbit/s	4.096 Mbit/s	2.048 Mbit/s
Duplex C channel	64 kbit/s	64 kbit/s	64 kbit/s	(see note 3)	64 kbit/s	(see note 3)
Total for optional duplex bearers	0, 160, 384, 544, or 576 kbit/s (see note 4)	0, 160, or 384 kbit/s	0, 160, or 384 kbit/s	0 or 160 kbit/s	0, 160, or 384 kbit/s	0 or 160 kbit/s
Total bearer channel capacity	6.208-6.784 Mbit/s	4.672-5.056 Mbit/s	3.136-3.520 Mbit/s	1.536-1.696 Mbit/s (see note 5)	4.160-4.544 Mbit/s	2.048-2.208 Mbit/s (see note 5)
Overhead range (from table 9)	128 – 192 kbit/s	128 – 192 kbit/s	128 – 192 kbit/s	128 – 160 kbit/s	128 – 192 kbit/s	128 – 160 kbit/s
Aggregate rate range (typical)	6.336-6.976 Mbit/s (6.912 Mbit/s)	4.800-5.248 Mbit/s (5.216 Mbit/s)	3.264-3.712 Mbit/s (3.680 Mbit/s)	1.664-1.856 Mbit/s (1.824 Mbit/s)	4.288-4.736 Mbit/s (4.704 Mbit/s)	2.176-2.368 Mbit/s (2.336 Mbit/s)

## NOTES

- 1 The optional transport class 2M-1 for bearers based on 2.048 Mbit/s has the same combined rates as the default transport class 1.
- 2 If it is determined that transport classes 2, 3, and 2M-2 can support the 576 kbit/s optional duplex bearer, then the maximum total bearer channel capacity and maximum aggregate rate will increase by 32 kbit/s for these classes.
- 3 The 16 kbit/s duplex C channel is transported entirely within the overhead dedicated to synchronization capacity.
- 4 544 kbit/s is required when a 160 kbit/s and a 384 kbit/s optional duplex bearer are both included.
- 5 The duplex C channel is not included in total bearer channel rates for transport classes 4 and 2M-3; it is included in the overhead.
- 6 The overhead required for FEC is not shown in this table.

ANSI T1.413-1995

**Table 11 – Determination of aggregate upstream bit rate**

	<b>Transport class 1 or 2M-1</b>	<b>Transport classes 2, 3 or 2M-2 (see note 1)</b>	<b>Transport class 4 or 2M-3</b>
Duplex C channel	64 kbit/s	64 kbit/s	(see note 2)
Total for optional duplex bearers	0, 160, 384, 544, or 576 kbit/s (see note 3)	0, 160, or 384 kbit/s	0 or 160 kbit/s
Total bearer channel capacity	64 – 640 kbit/s	64 – 448 kbit/s	0 – 160 kbit/s
Overhead range (from table 9)	96 – 128 kbit/s	96 – 128 kbit/s	96 – 128 kbit/s
Aggregate rate range (typical)	160 – 768 kbit/s (768 kbit/s)	160 – 576 kbit/s (576 kbit/s)	96 – 288 kbit/s (288 kbit/s)

**NOTES**

- 1 If it is determined that transport classes 2, 3, and 2M-2 can support the 576 kbit/s optional duplex bearer, then the maximum total bearer channel capacity and maximum aggregate rate will increase by 32 kbit/s for these classes.
- 2 For transport classes 4 and 2M-3, the duplex C channel is 16 kbit/s; this is not included in the total bearer channel rates because it is transported entirely within the overhead dedicated to synchronization capacity.
- 3 544 kbit/s obtained when both optional duplex bearers are included.
- 4 The overhead required for FEC is not shown in this table.



### 5.4.1 Aggregate bit rates for transporting ATM cells

The aggregate transmitted bit rate when an ATM data stream is transported depends on the transport class and allocation of channels to interleaved and non-interleaved data buffers (see 6.2). Components of the aggregate transmitted bit rate are summarized in table 12.

**Table 12 – Determination of aggregate bit rate for ATM transport**  
( $n \times 1.536 \text{ Mbit/s} \times 53/47$  optional bearer channels)

Transport class	1	2	3	4
Total assigned downstream simplex bearer capacity	6.944 Mbit/s	5.216 Mbit/s	3.488 Mbit/s	1.760 Mbit/s
Duplex C channel	64 kbit/s	64 kbit/s	64 kbit/s	(see note 1)
Total for Optional Duplex Bearers	0 kbit/s	0 kbit/s	0 kbit/s	0 kbit/s
Total Bearer Channel Capacity	7.008 Mbit/s	5.280 Mbit/s	3.552 Mbit/s	1.760 Mbit/s (see note 1)
Overhead Range (from table 9, see note 2)	128 – 160 kbit/s	128 – 160 kbit/s	128 – 160 kbit/s	128 – 160 kbit/s
Aggregate Rate Range	7.136 to 7.168 Mbit/s	5.408 to 5.440 Mbit/s	3.680 to 3.712 Mbit/s	1.888 to 1.920 Mbit/s
<p><b>NOTES</b></p> <p>1 The duplex C channel is not included in total bearer channel rate for Transport Class 4; it is included in the overhead.</p> <p>2 Maximum overhead is 160 kbit/s for all transport classes because only one downstream simplex channel is allowed.</p>				

### 5.5 Classification by ATU options

Subclause 15.1 describes a further classification, which ties together transport payload and loop range based upon whether or not certain options available for the ATU transceivers are used. Category I describes loop ranges and transport payloads using a basic transceiver with no options required. Category II describes loop ranges and transport payloads using options for trellis coding, power boost, and echo cancellation.

ANSI T1.413-1995

## 6 ATU-C functional characteristics

### 6.1 ATU-C input and output V interfaces

The functional data interfaces at the ATU-C are shown in figure 4. Input interfaces for the high-speed downstream simplex bearer channels are designated AS0 through AS3; input/output interfaces for the duplex bearer channels are designated LS0 through LS2. There may also be a duplex interface for operations, maintenance and control of the ADSL system.

The data rates of the input and output data interfaces at the ATU-C for the default configurations are specified in this clause. The data rate at a given interface shall match the rate of the bearer channel configured to that interface.

The total net bearer capacity that can be transmitted in the downstream direction corresponds to the transport class as described in 5.3; the mix of data rates at the downstream simplex input interfaces shall be limited to a combination whose net bit rate does not exceed the net downstream simplex bearer capacity for the given transport class. Similarly, the rate of the duplex bearer at the LS0 interface and the availability of the LS1 and LS2 options shall correspond to the transport class as discussed in 5.3.

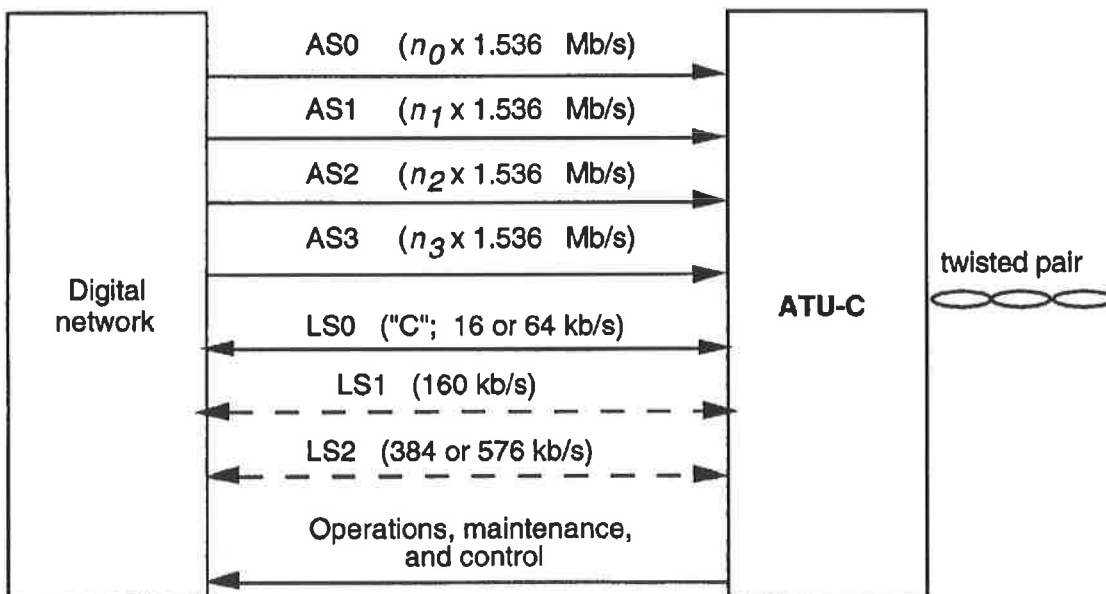

NOTE - - - - - Optional duplex channels  
(LS1 and LS2)

Figure 4 – ATU-C V interfaces (rates for default configuration)

#### 6.1.1 Downstream simplex channels – transmit bit rates

There are four input interfaces at the ATU-C for the high-speed downstream simplex channels based on multiples of 1.536 Mbit/s: AS0, AS1, AS2 and AS3 (ASX in general). The data rates at these interfaces shall be as defined in table 1.

Similarly, there are three interfaces for the optional high-speed downstream simplex channels based on multiples of 2.048 Mbit/s: AS0, AS1, and AS2 (ASX in general). The data rates at these interfaces are defined in table 2.

### 6.1.2 Transmit and receive bit rates for the duplex channels

Both input and output data interfaces shall be supplied at the ATU-C for the duplex bearers supported by the ADSL system.

NOTE – Two of the duplex channels are optional, as described in 5.2.2; the rate of the third duplex channel depends on the transport class, as defined in 5.2.1.

Table 13 shows the data rates that shall be supported by both the input and output interfaces at the ATU-C for the duplex channels for the default configurations.

**Table 13 – Interface data rates for duplex channels (default configurations)**

Duplex channel	Data rate
LS0 (see note 1)	16 or 64 kbit/s
LS1 (see note 2)	160 kbit/s
LS2	384 kbit/s or 576 kbit/s
Operations, maintenance, and control	vendor specific

NOTES

1 LS0 is also known as the "C" or control channel. It carries the signaling associated with the ASX data streams and it may also carry some or all of the signaling associated with the other duplex data streams. When LS1 transports ISDN BRA, the signaling for LS1 is contained within the ISDN BRA D channel. If LS1 is used to transport a non-ISDN BRA data stream, then its signaling will also be contained in the C channel.

2 LS1 may be used to carry ISDN BRA. Refer to 6.2.3 for a description of the frame format used within LS1 when it carries this service.

### 6.1.3 Payload transfer delay

The one-way transfer delay for payload bits in all bearers (simplex and duplex) from the V reference point to the  $T_{SM}$  reference point for channels assigned to the fast buffer shall be no more than 2 ms, and for channels assigned to the interleave buffer it shall default to no more than 20 ms. The same requirement applies in the opposite direction, from the  $T_{SM}$  reference point to the V reference point.

## 6.2 Framing

This subclause specifies framing of the downstream signal (ATU-C transmitter). The upstream framing (ATU-R transmitter) is specified in 7.2.

### 6.2.1 Data symbols

Figure 2 shows a functional block diagram of the ATU-C transmitter with reference points for data framing. Up to four downstream simplex data channels and up to three duplex data channels shall be synchronized to the 4 kHz ADSL DMT symbol rate, and multiplexed into two separate data buffers (fast and interleaved). A cyclic redundancy check (crc), scrambling, and forward error correction (FEC) coding shall be applied to the contents of each buffer separately, and the data from the interleaved buffer shall then be passed through an interleaving function. The two data streams shall then be tone ordered as defined in 6.5, and combined into a data symbol that is input to the constellation encoder. After constellation encoding, the data shall be modulated to produce an analog signal for transmission across the customer loop.

## ANSI T1.413-1995

A bit-level framing pattern shall not be inserted into the data symbols of the frame or superframe structure. DMT symbol, or frame, boundaries are delineated by the cyclic prefix inserted by the modulator (see 6.10). Superframe boundaries are determined by the synchronization symbol, which shall also be inserted by the modulator, and which carries no user data (see 6.9.3).

Because of the addition of FEC redundancy bytes and data interleaving, the data symbols (i.e., bit-level data prior to constellation encoding) have different structural appearance at the three reference points through the transmitter. As shown in figure 2, the reference points for which data framing will be described in the following subclauses are

- *A (Mux data frame)*: the multiplexed, synchronized data after the crc has been inserted (synchronization is described in 6.2.2, crc is specified in 6.2.1.3). Mux data frames shall be generated at a nominal 4 kHz rate (i.e., each 250  $\mu$ sec).
- *B (FEC output data frame)*: the data frame generated at the output of the FEC encoder at the DMT symbol rate, where an FEC block may span more than one DMT symbol period.
- *C (constellation encoder input data frame)*: the data frame presented to the constellation coder.

### 6.2.1.1 Superframe structure

ADSL uses the superframe structure shown in figure 5. Each superframe is composed of 68 ADSL data frames, numbered from 0 to 67, which shall be encoded and modulated into DMT symbols, followed by a synchronization symbol, which carries no user or overhead bit-level data and is inserted by the modulator (see 6.9.3) only to establish superframe boundaries. From the bit-level and user data perspective, the DMT symbol rate is 4000 baud (period = 250  $\mu$ sec), but in order to allow for the insertion of the sync symbol the transmitted DMT symbol rate shall be  $69/68 \times 4000$  baud. Each data frame within the superframe contains data from the fast buffer and the interleaved buffer. The size of each buffer depends on the assignment of bearer channels made during initialization (see 6.2.1 and 12.8.4). (On-line reassignment of bearer channels is for further study.)

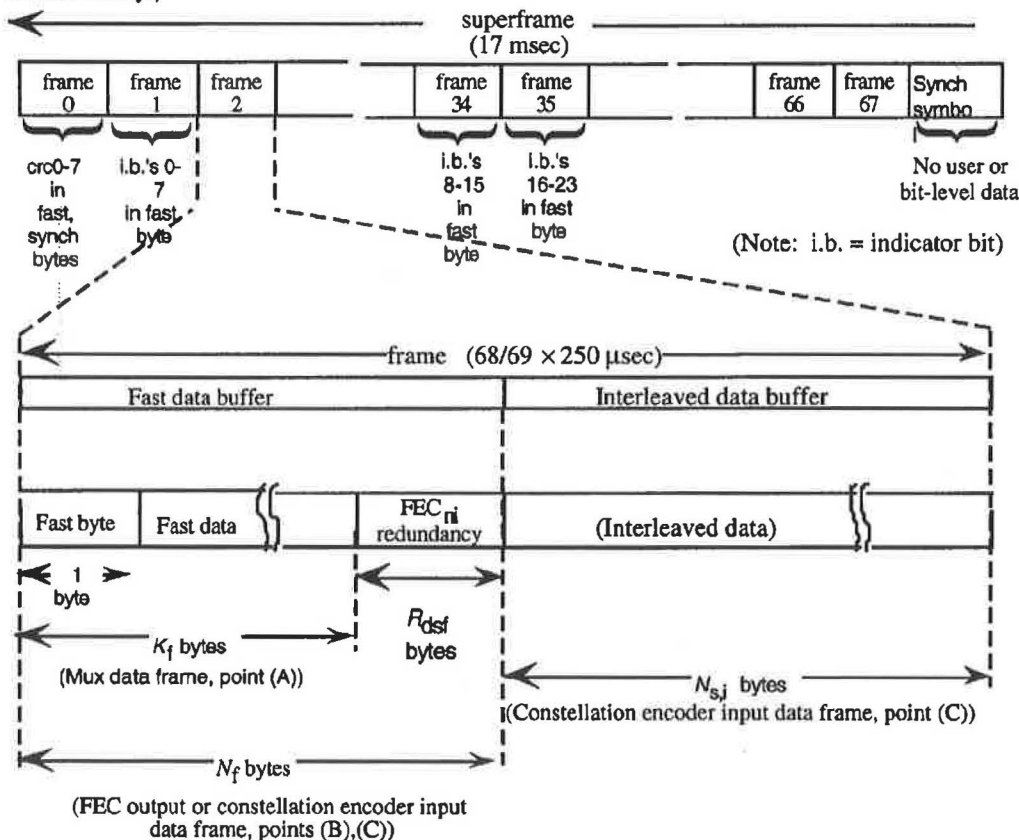

Figure 5 – ADSL superframe structure – ATU-C transmitter

Eight bits per ADSL superframe shall be reserved for the crc on the fast data buffer (crc0-crc7), and 24 indicator bits (ib0-ib23) shall be assigned for OAM functions. As shown in figures 5 and 6, the "fast" byte of the fast data buffer carries the crc check bits in frame 0 and the fixed overhead bit assignments in frames 1, 34, and 35. The "fast" byte in other frames is assigned in even-/odd-frame pairs to either the eoc or to synchronization control of the bearer channels assigned to the fast buffer.

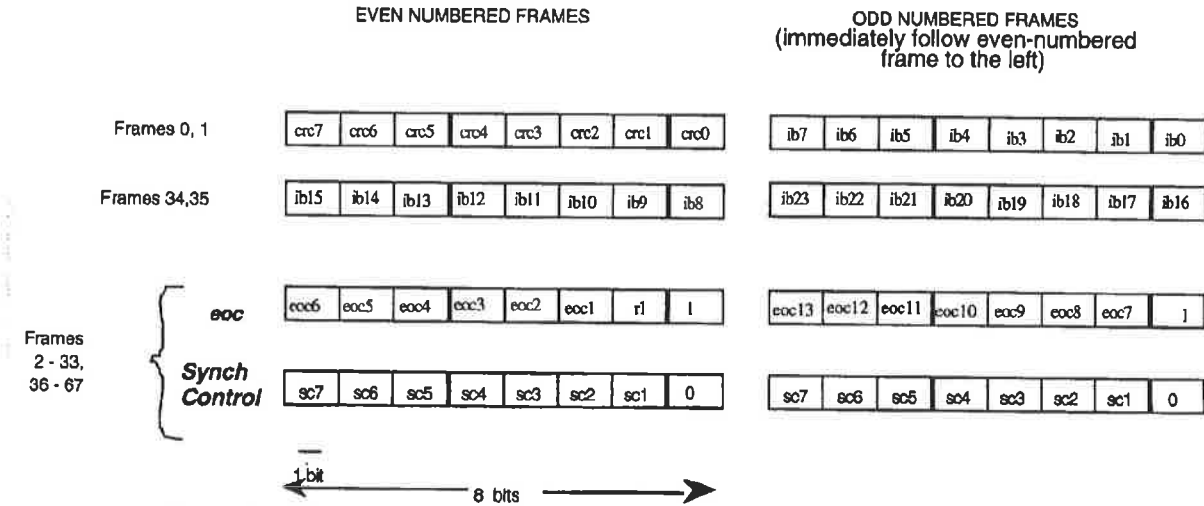

Figure 6 - "Fast" byte format - ATU-C transmitter - fast data buffer

The indicator bits are defined in table 14.

Table 14 - Definition of indicator bits, ATU-C transmitter (fast data buffer, downstream direction)

Indicator bit	Definition
ib0 - ib7	reserved for future use
ib8	febe-i
ib9	fecc-i
ib10	febe-ni
ib11	fecc-ni
ib12	los
ib13	rdi
ib14 - ib23	reserved for future use

NOTE - See clause 11 for definitions of the bits and their use.

If bit 0 of the "fast" byte in an even-numbered frame (other than frames 0 and 34) is "1", then the "fast" byte of that frame and the odd-numbered frame that immediately follows is used to carry a 13-bit "eoc frame", which is defined in table 15, and on additional bit, r1, which is reserved for future use (set to 1 until assigned otherwise).

Table 15 – eoc frame structure

Bit designation	eoc bit allocation
eoc1, eoc2	Address (11 = ATU-C, 00 = ATU-R, 01 and 10 reserved)
eoc3	Data/message indicator bit: "0" = information field contains op code for ADSL eoc message, "1" = information field contains binary or ASCII data.
eoc4	Odd ("1") / Even ("0") byte indicator for multibyte transmission in data read or write mode
eoc5	Autonomous ATU-R message indicator bit (see note): "0" = autonomous ATU-R message, "1" = ATU-R response to current eoc protocol state.
eoc6 – eoc13	Information field.

NOTE – The only autonomous message currently defined for the ATU-R is the "dying gasp" (11.1.4.4). Other uses of the eoc5 bit are for further study.

The eoc protocol and message formats are described in 11.1.

Bit 0 of the "fast" byte in an even-numbered frame (other than frames 0 and 34) shall be set to "0", to indicate that the "fast" bytes of that frame and the odd-numbered frame that immediately follows are used for synchronization control within their respective frames (the "fast" byte format for synch control is described in 6.2.2.1).

Eight bits per ADSL superframe shall be used for the crc on the interleaved data buffer (crc0 – crc7). As shown in figures 6 and 7, the "synch" byte of the interleaved data buffer carries the crc check bits for the previous superframe in frame 0. In all other frames (1 through 67), the "synch" byte shall be used for synchronization control of the bearer channels assigned to the interleaved data buffer, or to carry an ADSL overhead control (aoc) channel. When any bearer data streams appear in the interleave buffer, then the aoc data shall be carried in the LEX byte, and the "synch" byte shall designate when the LEX byte contains aoc data and when it contains data bytes from the bearer data streams. When no bearer data streams are allocated to the interleave data buffer, i.e., all  $B_1(\text{ASX}) = B_1(\text{LSX}) = 0$ , then the "synch" byte shall carry the aoc data directly (AEX and LEX bytes, described in 6.2.1.2, do not exist in the interleave buffer in this case). The format of the "synch" byte is described in 6.2.2.2.

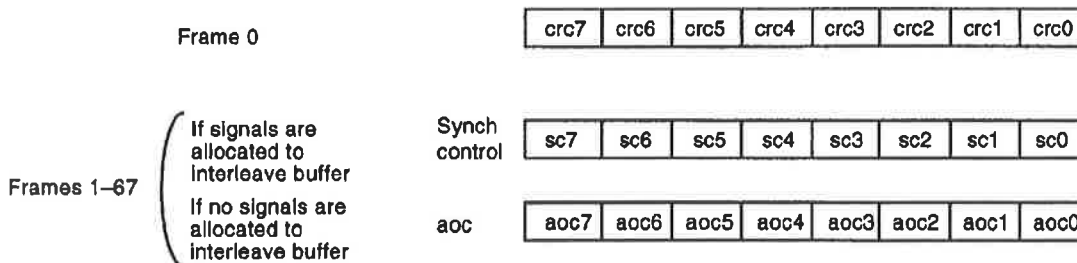

Figure 7 – "Synch" byte format – ATU-C transmitter – interleaved data buffer

### 6.2.1.2 Frame structure

Each frame of data shall be encoded into a multicarrier symbol, as described in 6.3 through 6.6. As is shown in figure 2, each frame is composed of a fast data buffer and an interleaved data buffer, and the frame structure has a different appearance at each of the reference points (A, B, and C). The bytes of the fast buffer shall be clocked into the constellation encoder first, followed by the bytes of the interleaved data buffer. Bytes are clocked least significant bit first.

Each user data stream shall be assigned to either the fast or the interleaved buffer during initialization (see 12.6.1), and a pair of bytes,  $[B_F, B_I]$ , shall be transmitted for each data stream, where  $B_F$  and  $B_I$  designate the number of bytes allocated to the fast and interleaved buffers, respectively.

The seven possible  $[B_F, B_I]$  pairs to specify the downstream bearer channel rates are

- $B_F(ASX), B_I(ASX)$  for  $X = 0, 1, 2$  and  $3$ , for the downstream simplex channels;
- $B_F(LSX), B_I(LSX)$  for  $X = 0, 1$  and  $2$ , for the (downstream transport of the) duplex channels.

The rules for allocation are:

- for any data stream,  $X$ , except the 16 kbit/s C channel option, either  $B_F(X) =$  the data rate (in kbit/s) of the fast buffer and  $B_I(X) = 0$ , or  $B_F(X) = 0$  and  $B_I(X) =$  the data rate (in kbit/s) of the interleaved buffer;
- for the 16 kbit/s C channel option,  $B_F(LS0) = 255$  (binary 11111111) and  $B_I(LS0) = 0$ , or  $B_F(LS0) = 0$  and  $B_I(LS0) = 255$ .

Configurations (i.e., sets of  $[B_F, B_I]$ ) for the four possible transport classes are given in table 16 for the default configuration (bearers based on 1.536 Mbit/s), and in table 17 for the three possible transport classes for the bearer channel optional rates based on 2.048 Mbit/s.

On-line reconfiguration (e.g., changing the mix of data channel rates or re-allocation of user data streams between fast and interleaved data buffers, or both) is for further study.

**Table 16 – Default fast and interleaved data buffer allocations for ATU-C transmitter – Configurations for bearers based on multiples of 1.536 Mbit/s**

Signal	$B_I$ (Interleaved data buffer)				$B_F$ (fast data buffer)			
	Transport class 1	Transport class 2	Transport class 3	Transport class 4	Transport class 1	Transport class 2	Transport class 3	Transport class 4
AS0	96	96	48	48	0	0	0	0
AS1	96	48	48	0	0	0	0	0
AS2	0	0	0	0	0	0	0	0
AS3	0	0	0	0	0	0	0	0
LS0	2	2	2	255 (see note)	0	0	0	0
LS1	0	0	0	0	5	0	0	5
LS2	0	0	0	0	12	12	12	0

NOTE – For loop transport class 4,  $B_F(LS0) = 255$  or  $B_I(LS0) = 255$  indicates a 16 kbit/s C channel, which is carried entirely within the synchronization control overhead (LEX byte) as described in 6.2.2; thus, the LS0 sub-channel does not appear as a separate byte within the ADSL frame.

ANSI T1.413-1995

**Table 17 – Default fast and interleaved data buffer allocations for ATU-C transmitter – Optional configurations for bearers based on multiples of 2.048 Mbit/s**

Signal	$B_I$ (Interleaved data buffer)			$B_F$ (fast data buffer)		
	Transport class 2M-1	Transport class 2M-2	Transport class 2M-3	Transport class 2M-1	Transport class 2M-2	Transport class 2M-3
AS0	64	64	64	0	0	0
AS1	64	64	0	0	0	0
AS2	64	0	0	0	0	0
LS0	2	2	255 (see note)	0	0	0
LS1	0	0	0	5	0	5
LS2	0	0	0	12	12	0

NOTE – For transport class 2M-3,  $B_F(\text{LS0}) = 255$  or  $B_I(\text{LS0}) = 255$  indicates a 16 kbit/s C channel, which is carried entirely within the synchronization control overhead (LEX byte) as described in 6.2.2; thus, the LS0 sub-channel does not appear as a separate byte within the ADSL frame.

**6.2.1.2.1 Fast data buffer**

The frame structure of the fast data buffer shall be as shown in figure 8 for the three reference points that are defined in figure 2.

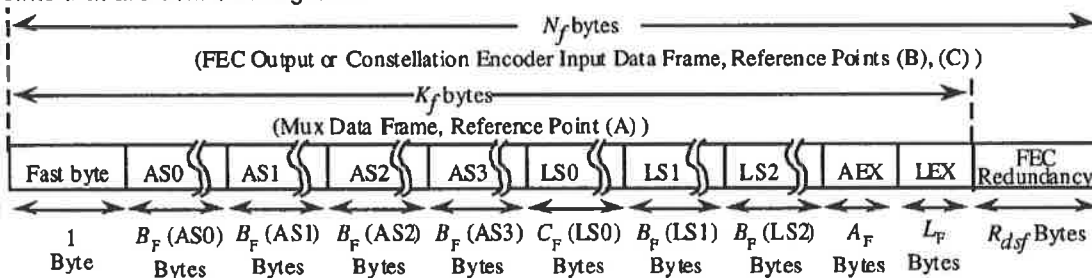

$$C_F(\text{LS0}) = \begin{cases} 0 & \text{if } B_F(\text{LS0}) = 255 \text{ (Binary 11111111)}, \\ B_F(\text{LS0}) & \text{otherwise.} \end{cases}$$

$$N_f = K_f + R_{dsf},$$

where  $R_{dsf}$  = number of FEC Redundancy Bytes.

$$\text{and } K_f = 1 + \sum_{i=0}^3 B_F(\text{AS}_i) + A_F + \sum_{j=0}^2 B_F(\text{LS}_j) + L_F,$$

$$\text{where } A_F = \begin{cases} 0 & \text{if } \sum_{i=0}^3 B_F(\text{AS}_i) = 0, \\ 1 & \text{otherwise,} \end{cases}$$

$$L_F = \begin{cases} 0 & \text{if } \sum_{i=0}^3 B_F(\text{AS}_i) = \sum_{j=0}^2 B_F(\text{LS}_j) = 0, \\ 1 & \text{otherwise} \end{cases}$$

(Note:  $L_F = 1$  when  $B_F(\text{LS0}) = 255$ )

**Figure 8 – Fast data buffer – ATU-C transmitter**

At reference point A (Mux data frame) in figure 2, the fast buffer shall always contain at least the "fast" byte. This is followed by  $B_F(\text{AS0})$  bytes of channel AS0, then  $B_F(\text{AS1})$  bytes of channel AS1,  $B_F(\text{AS2})$  bytes of channel AS2 and  $B_F(\text{AS3})$  bytes of channel AS3. Next come the bytes for any duplex (LSX) channels allocated to the fast buffer. If any  $B_F(\text{ASX})$  is non-zero, then both an



AEX and an LEX byte follow the bytes of the last LSX channel, and if any  $B_F(\text{LSX})$  is non-zero, the LEX byte shall be included.

Note that when  $B_F(\text{LS0}) = 255$ , no bytes are included for the LS0 channel. Instead, the 16 kbit/s C channel shall be transported in every other LEX byte on average, using the synch byte to denote when to add the LEX byte to the LS0 data stream.

$R_{\text{dsf}}$  FEC redundancy bytes shall be added to the mux data frame (reference point A) to produce the FEC output data frame (reference point B), where  $R_{\text{dsf}}$  is given in the RATES1 options used during initialization. For the default configurations given in tables 16 and 17  $R_{\text{dsf}} = 4$ ; for other configuration options, the value shall be given to the ATU-C in some manner (for example, via a host control port). When no data streams are allocated to the fast buffer  $R_{\text{dsf}} = 0$  (no FEC redundancy bytes are added). Because the data from the fast buffer is not interleaved, the constellation encoder input data frame (reference point C) is identical to the FEC output data frame (reference point B).

### 6.2.1.2.2 Interleaved data buffer

The frame structure of the interleaved data buffer is shown in figure 9 for reference points A and B, which are defined in figure 2.

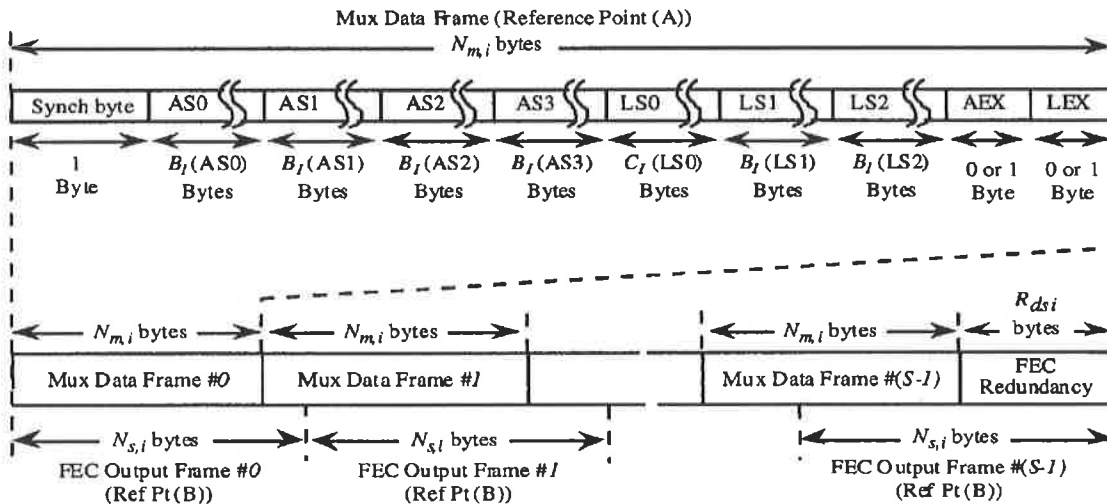

$$C_I(\text{LS0}) = 0 \text{ if } B_I(\text{LS0}) = 255 \text{ (Binary 11111111)}, \\ = B_I(\text{LS0}) \text{ otherwise.}$$

$$N_{m,i} = 1 + \sum_{i=0}^3 B_I(\text{AS}_i) + A_I + \sum_{j=0}^2 B_I(\text{LS}_j) + L_I,$$

$$\text{where } A_I = 0 \text{ if } \sum_{i=0}^3 B_I(\text{AS}_i) = 0,$$

$$= 1 \text{ otherwise,}$$

$$\text{and } L_I = 0 \text{ if } \sum_{i=0}^3 B_I(\text{AS}_i) = \sum_{j=0}^2 B_I(\text{LS}_j) = 0,$$

$$= 1 \text{ otherwise.}$$

$$\text{(Note: } L_I = 1 \text{ when } B_I(\text{LS0}) = 255)$$

$$\text{and } N_{s,i} = N_{m,i} + R_{\text{dsf}} / S,$$

where  $R_{\text{dsf}}$  = number of FEC Redundancy Bytes,

and  $S$  = number of DMT symbols per FEC codeword.

Figure 9 – Interleaved data buffer, ATU-C transmitter

ANSI T1.413-1995

At reference point A, the mux data frame, the interleaved data buffer shall always contain at least the "synch" byte. The rest of the buffer shall be built in the same manner as the fast buffer, substituting  $B_1$  in place of  $B_F$ . The length of each mux data frame is  $N_{m,i}$  bytes, as defined in figure 9.

The FEC coder shall take in  $S$  mux data frames and append  $R_{ds1}$  FEC redundancy bytes to produce the FEC codeword of length  $N_{FEC,i} = S \times N_{m,i} + R_{ds1}$  bytes. The FEC output data frames shall contain  $N_{s,i} = N_{FEC,i} / S$  bytes, where  $N_{s,i}$  is an integer. When  $S > 1$ , then for the  $S$  frames in an FEC codeword, the FEC output data frame (reference point B) shall partially overlap two mux data frames for all except the last frame, which shall contain the  $R_{ds1}$  FEC redundancy bytes.

The FEC output data frames are interleaved to a specified interleave depth. The interleaving process (see 6.4.2) delays each byte of a given FEC output data frame a different amount, so that the constellation encoder input data frames will contain bytes from many different FEC data frames. At reference point A in the transmitter, mux data frame 0 of the interleaved data buffer is aligned with the ADSL superframe and mux data frame 0 of the fast data buffer (this is not true at reference point C). At the receiver, the interleaved data buffer will be delayed by  $S \times$  interleave depth  $\times$  250 msec (16 msec for the defaults given in tables 18 and 19) with respect to the fast data buffer, and frame 0 (containing the crc bits for the interleaved data buffer) will appear a fixed number of frames after the beginning of the receiver superframe.

The FEC coding overhead, the number of symbols per FEC codeword, and the Interleave depth are listed in tables 18 and 19 for the default configurations (i.e., for all ASX signals plus LSO allocated to the interleave buffer) in tables 16 and 17. These defaults correspond to the default data rates. For other rates and configurations, the coding parameters shall be given to the ATU-C in some manner (for example, via a host control port).

**Table 18 – Default FEC coding parameters and Interleave depth for ATU-C transmitter – Default configurations for bearers based on multiples of 1.536 Mbit/s**

Transport class	$R_{ds1}$ (FEC redundancy bytes)	$S$ (symbols per codeword)	Interleave depth (FEC codewords)
Transport class 1	16	1	64
Transport class 2	12	1	64
Transport class 3	16	2	32
Transport class 4	16	4	16
Synch byte only	4	4	16

**Table 19 – Default FEC coding parameters and interleave depth for ATU-C transmitter – Optional configurations for bearers based on multiples of 2.048 Mbit/s**

Transport class	$R_{\text{del}}$ (FEC redundancy bytes)	$S$ (symbols per codeword)	Interleave depth (FEC codewords)
2M-1	16	1	64
2M-2	12	1	64
2M-3	12	2	32

### 6.2.1.3 Cyclic redundancy check (crc)

Two cyclic redundancy checks (crcs) – one for the fast data buffer and one for the interleaved data buffer – are generated for each superframe and transmitted in the first frame of the following superframe. Eight bits per buffer type (fast or interleaved) per superframe are allocated to the crc check bits. These bits are computed from the  $k$  message bits using the equation:

$$\text{crc}(D) = M(D) D^8 \text{ modulo } G(D),$$

where:

$M(D) = m_0 D^{k-1} \oplus m_1 D^{k-2} \oplus \dots \oplus m_{k-2} D \oplus m_{k-1}$ , is the message polynomial

$G(D) = D^8 \oplus D^4 \oplus D^3 \oplus D^2 \oplus 1$ , is the generating polynomial,

$\text{crc}(D) = c_0 D^7 \oplus c_1 D^6 \oplus \dots \oplus c_6 D \oplus c_7$ , is the check polynomial,

$\oplus$  indicates modulo-2 addition (exclusive-or)

and  $D$  is the delay operator.

That is, crc is the remainder when  $M(D) D^8$  is divided by  $G$ .

The crc check bits are transported in the "fast byte" (8 bits) of frame 0 in the fast data buffer, and the "synch byte" (8 bits) of frame 0 in the interleaved data buffer.

The bits covered by the crc include

- fast data buffer:
  - *frame 0*: ASX bytes ( $X = 0, 1, 2, 3$ ), LSX bytes ( $X = 0, 1, 2$ ), followed by any AEX and LEX bytes.
  - *all other frames*: "fast" byte, followed by ASX bytes ( $X = 0, 1, 2, 3$ ), LSX bytes ( $X = 0, 1, 2$ ), and any AEX and LEX bytes.
- interleaved data buffer:
  - *frame 0*: ASX bytes ( $X = 0, 1, 2, 3$ ), LSX bytes ( $X = 0, 1, 2$ ), followed by any AEX and LEX bytes.
  - *all other frames*: "synch" byte, followed by ASX bytes ( $X = 0, 1, 2, 3$ ), LSX bytes ( $X = 0, 1, 2$ ), and any AEX and LEX bytes.

Each byte shall be clocked into the crc least significant bit first.

The crc field length will vary with the allocation of bytes to the fast and interleaved data buffers (the numbers of bytes in ASX and LSX vary according to the  $[B_p, B_i]$  pairs; AEX is present in a given buffer only if at least one ASX is allocated to that buffer; LEX is present in a given buffer only if at least one ASX or one LSX is allocated to that buffer).

Because of the flexibility in assignment of bearer channels to the fast and interleaved data buffers, crc field lengths over an ADSL superframe will vary from approximately 530 bits to approximately 119,000 bits.

ANSI T1.413-1995

## 6.2.2 Synchronization

The input data streams are synchronized to the ADSL clock using the synchronization control byte and the AEX and LEX bytes. Forward-error-correction coding shall always be applied to the synchronization control byte(s).

### 6.2.2.1 Synchronization for the fast data buffer

Synchronization control for the fast data buffer can occur in frames 2 through 33 and 36 through 67 of an ADSL superframe as described in 6.2.1.1, where the "fast" byte may be used as the synchronization control byte.

The format of the "fast" byte when used as synchronization control for the fast data buffer is given in table 20.

**Table 20 – Fast byte format**

Bits	Designation	Codes
sc7, sc6	ASX channel designator	"00" : channel AS0 "01" : channel AS1 "10" : channel AS2 "11" : channel AS3
sc5, sc4	Synchronization control for the designated ASX channel	"00" : do nothing "01" : add AEX byte to designated ASX channel "11" : add AEX and LEX bytes to ASX channel "10" : delete last byte from designated ASX channel
sc3, sc2	LSX channel designator	"00" : channel LS0 "01" : channel LS1 "10" : channel LS2 "11" : no synchronization action; if sc5, sc4 is not equal to "11", LEX may carry LS2 "start of frame" verification pointer (see 6.2.4)
sc1	Synchronization control for the designated LSX channel	"1" : add LEX byte to designated LSX channel "0" : delete last byte from designated LSX channel
sc0	Synch/eoc designator	"0" : perform synchronization control as indicated in sc7-sc1 "1" : this byte of current (even-numbered) frame and of frame that immediately follows is an eoc frame

No synchronization action shall be taken for those frames for which the "fast" byte is used for crc, fixed indicator bits, or eoc.

#### NOTES

1 ADSL deployments may need to interwork with DS1 (1.544 Mbit/s) or DS1C (3.152 Mbit/s) rates. The synchronization control option that allows adding up to two bytes to an ASX bearer channel provides sufficient overhead capacity to transport combinations of DS1 or DS1C channels transparently (without interpreting or stripping and regenerating the framing embedded within the DS1 or DS1C). The synchronization control algorithm shall, however, guarantee that the fast byte in some minimum number of frames is available to carry eoc frames, so that a minimum eoc rate (4 kbit/s) may be maintained.

2 When the data rate of the C channel is 16 kbit/s, the LS0 sub-channel is transported in the LEX byte, using the "add LEX byte to designated LSX channel", with LS0 as the designated channel, every other frame on average.

### 6.2.2.2 Synchronization for the interleaved data buffer

Synchronization control for the interleaved data buffer can occur in frames 1 through 67 of an ADSL superframe as described in 6.2.1.1, where the "synch" byte may be used as the synchronization control byte.

The format of the "synch" byte when used as synchronization control for the interleaved data buffer shall be as given in table 21. In the case where no signals are allocated to the interleaved data buffer, the "synch" byte shall carry the aoc data directly, as shown in figure 17 in 6.2.1.1.

**Table 21 – Synch byte format – Interleaved data buffer**

Bits	Designation	Codes
sc7, sc6	ASX channel designator	"00" : channel AS0 "01" : channel AS1 "10" : channel AS2 "11" : channel AS3
sc5, sc4	Synchronization control for the designated ASX channel	"00" : do nothing "01" : add AEX byte to designated ASX channel "11" : add AEX and LEX bytes to ASX channel "10" : delete last byte from designated ASX channel
sc3, sc2	LSX channel designator	"00" : channel LS0 "01" : channel LS1 "10" : channel LS2 "11" : do nothing to any LSX channel
sc1	Synchronization control for the designated LSX channel	"1" : add LEX byte to designated LSX channel "0" : delete last byte from designated LSX channel
sc0	Synch/aoc designator	"0" : perform synchronization control as indicated in sc7-sc1 "1" : LEX byte carries ADSL overhead control channel data; synchronization control may be allowed for "add AEX" or "delete" as indicated in sc7-sc1

No synchronization action shall be taken during frame 0, where the "synch" byte is used for crc, and the LEX byte carries the aoc.

#### NOTES

1 ADSL deployments may need to interwork with DS1 (1.544 Mbit/s) or DS1C (3.152 Mbit/s) rates. The synchronization control option that allows adding up to two bytes to an ASX bearer channel provides sufficient overhead capacity to transport combinations of DS1 or DS1C channels transparently (without interpreting or stripping and regenerating the framing embedded within the DS1 or DS1C).

2 When the data rate of the C channel is 16 kbit/s, the LS0 sub-channel is transported in the LEX byte, using the "add LEX byte to designated LSX channel", with LS0 as the designated channel, every other frame on average.

ANSI T1.413-1995

**6.2.3 Frame format of ISDN basic access over LS1**

When the LS1 channel transports ISDN Basic Access, the framing for this channel shall be a binary equivalent of the frame structure specified for information flow across the ISDN Basic Access Interface point, as specified in ANSI T1.601.

This frame structure within the LS1 channel may be fixed in state SL3 for the downstream direction, and in state SN3 for the upstream direction. During states where the network, or NT1 is not ready, (as generally conveyed by the *act* bit set to 0), the 2B+D fields shall be set to all ones before scrambling. If the ATU is unable to provide SN3 or SL3, then the LS1 channel bytes shall be filled with all ones. State definitions for SN3, SL3, and the *act* bit are specified in ANSI T1.601.

The ISDN Basic Access maintenance definitions and positions, as prescribed by ANSI T1.601, shall retain their definitions across the LS1 channel.

**6.2.4 Framing for 384 / 576 kbit/s applications over LS2 (optional)**

When the LS2 channel transports 384 or 576 kbit/s applications that require frame integrity, and the LS2 channel is allocated to the non-interleaved data buffer, the ADSL system may, as an option, provide byte and frame integrity of the bearer service channel.

If this option is provided, the ADSL system shall provide byte integrity by mapping the bearer service channel's bytes into ADSL sub-channel LS2 bytes (i.e., mapping bytes across the V- and T-interfaces).

The ADSL system shall provide frame integrity by

- transmitting a non-zero value for the LS2 frame-size parameter during initialization to indicate to the receiver that the LS2 channel should provide frame integrity;
- locally generating framing indication at the receiver, and passing this framing along with the LS2 data stream to the service module at the CI or to the network at the network side of the ADSL link;
- transmitting a frame verification pointer when certain conditions allow across the "U" Interface;
- statistically verifying the bearer service channel framing to the locally-generated framing indication at the receiver.

The LS2 frame-size parameter, FS(LS2), shall be in bytes per (bearer service) frame. For example, for 384 kbit/s service:

- $B_F(\text{LS2}) = 384 \text{ kbit/s} / (32 \text{ kbit/s/byte/ADSL frame}) = 12 \text{ bytes per ADSL frame};$
- $\text{FS}(\text{LS2}) = 384 \text{ kbit/s} / (64 \text{ kbit/s/byte/bearer service frame}) = 6 \text{ bytes per bearer service frame}.$

FS(LS2) shall be set to zero (0) to indicate that framing is not required for the service transported by ADSL sub-channel LS2, or that the transmitter does not provide this option. In either case, no frame verification pointers will be sent by the transmitter.

The ATU-C transmitter may transmit a frame verification pointer when all of the following conditions are satisfied:

- a) LS2 is allocated to the fast data buffer;
- b) the LS2 frame size is non-zero;
- c) no synchronization action is required on any of the ADSL LSX sub-channels in the current frame;
- d) the LEX byte is not used for "add 2" synchronization for any of the ADSL ASX sub-channels in the current frame;
- e) the transmitter has a valid verification pointer value available for the current frame.

## NOTES

- 1 Condition (c) is satisfied when bits sc3, sc2 (table 21) in the fast byte of frames 2 through 33 or 36 through 67 are "11" and bit sc0 is "0", or the fast byte of the current frame carries crc or indicator bits (i.e., frame numbers 0, 1, 34, and 35).
- 2 Condition (d) is satisfied when bits sc5, sc4 in the fast byte of frames 2 through 33 or 37 through 67 are "00", "01", or "10" and bit sc0 is "0".
- 3 The transmitter is not required to transmit a verification pointer in all frames that satisfy conditions (c) and (d).

The frame verification pointer, when transmitted, shall be placed in the LEX byte and shall contain the number of the byte within the current frame's LS2 sub-channel that is the first byte of a bearer service frame, with the first byte of the LS2 sub-channel being byte number zero (0).

When conditions (a) through (d) above are satisfied but the transmitter does not have a verification pointer value to insert, the LEX byte shall be filled with binary 1's to indicate that it does not contain a verification pointer. The receiver shall use the verification pointer only when it falls within a valid range for the configured LS2 rate (i.e., 0 through  $[B_F(LS2)-1]$ ).

### 6.3 Scramblers

The binary data streams output from the fast and interleaved buffers shall be scrambled separately using the following algorithm for both:

$$d_n' = d_n \oplus d_{n-16}' \oplus d_{n-23}'$$

where  $d_n$  is the  $n$ -th output from the fast or interleaved buffer (i.e., input to the scrambler), and  $d_n'$  is the  $n$ -th output from the corresponding scrambler.

These scramblers shall be applied to the serial data streams without reference to any framing or symbol synchronization. Descrambling in receivers can likewise be performed independent of symbol synchronization.

### 6.4 Forward error correction

#### 6.4.1 Reed-Solomon coding

$R$  (i.e.,  $R_{\text{dsf}}$  or  $R_{\text{dsi}}$ ) redundant check bytes  $c_0, c_1, \dots, c_{R-2}, c_{R-1}$  shall be appended to  $K$  message bytes  $m_0, m_1, \dots, m_{K-2}, m_{K-1}$  to form a Reed-Solomon code word of size  $N = K + R$  bytes. The check bytes are computed from the message byte using the equation:

$$C(D) = M(D) D^R \text{ modulo } G(D)$$

where:

$$M(D) = m_0 D^{K-1} \oplus m_1 D^{K-2} \oplus \dots \oplus m_{K-1} D \oplus m_K \text{ is the message polynomial,}$$

$$C(D) = c_0 D^{R-1} \oplus c_1 D^{R-2} \oplus \dots \oplus c_{R-2} D \oplus c_{R-1} \text{ is the check polynomial,}$$

and  $G(D) = \prod (D \oplus a^i)$  is the generator polynomial of the Reed-Solomon code, where the index of the product runs from  $i=0$  to  $R-1$ . That is,  $C(D)$  is the remainder obtained from dividing  $M(D) D^R$  by  $G(D)$ . The arithmetic is performed in the Galois Field GF(256), where  $a$  is a primitive element that satisfies the primitive binary polynomial  $x^8 \oplus x^4 \oplus x^3 \oplus x^2 \oplus 1$ . A data byte ( $d_7, d_6, \dots, d_1, d_0$ ) is identified with the Galois Field element  $d_7 a^7 \oplus d_6 a^6 \oplus \dots \oplus d_1 a \oplus d_0$ .

The number of check bytes  $R$ , and the codeword size  $N$  vary, as explained in 6.2.

ANSI T1.413-1995

### 6.4.2 Interleaving

The Reed-Solomon codewords in the interleave buffer shall be convolutionally interleaved. The interleaving depth varies, as explained in 6.2, but it shall always be a power of 2. Convolutional interleaving is defined by the rule:

Each of the  $N$  bytes  $B_0, B_1, \dots, B_{N-1}$  in a Reed-Solomon codeword is delayed by an amount that varies linearly with the byte index. More precisely, byte  $B_i$  (with index  $i$ ) is delayed by  $(D-1) * i$  bytes, where  $D$  is the interleave depth.

An example for  $N = 5, D = 2$  is shown in table 22, where  $B_i^j$  denotes the  $i$ -th byte of the  $j$ -th codeword.

**Table 22 – Convolutional interleaving example for  $N = 5, D = 2$**

<b>Inter-leaver input</b>	$B_0^j$	$B_1^j$	$B_2^j$	$B_3^j$	$B_4^j$	$B_0^{j+1}$	$B_1^{j+1}$	$B_2^{j+1}$	$B_3^{j+1}$	$B_4^{j+1}$
<b>Inter-leaver output</b>	$B_0^j$	$B_3^{j+1}$	$B_1^j$	$B_4^{j+1}$	$B_2^j$	$B_0^{j+1}$	$B_3^j$	$B_1^{j+1}$	$B_4^j$	$B_2^{j+1}$

With the above-defined rule, and the chosen interleaving depths (powers of 2), the output bytes from the interleaver always occupy distinct time slots when  $N$  is odd. When  $N$  is even, a dummy byte shall be added at the beginning of the codeword at the input to the interleaver. The resultant odd-length codeword is then convolutionally interleaved, and the dummy byte then removed from the output of the interleaver.

### 6.5 Tone ordering

A DMT time-domain signal has a high peak-to-average ratio (its amplitude distribution is almost Gaussian), and large values may be clipped by the digital-to-analog converter. The error signal caused by clipping can be considered as an additive negative impulse for the time sample that was clipped. The clipping error power is almost equally distributed across all tones in the symbol in which clipping occurs. Clipping is therefore most likely to cause errors on those tones that, in anticipation of higher received SNRs, have been assigned the largest number of bits (and therefore have the densest constellations). These occasional errors can be reliably corrected by the FEC coding if the tones with the largest number of bits have been assigned to the interleave buffer.

The numbers of bits and the relative gains to be used for every tone are calculated in the ATU-R receiver, and sent back to the ATU-C according to a defined protocol (see 12.9.8). The pairs of numbers are typically stored, in ascending order of frequency or tone number  $i$ , in a bit and gain table.

The "tone-ordered" encoding shall assign the first  $B_F$  bytes ( $8B_F$  bits) from the symbol buffer (see 6.2) to the tones with the smallest number of bits assigned to them, and the remaining  $B_I$  bytes ( $8B_I$  bits) to the remaining tones.

The ordered bit table  $b'_i$  shall be based on the original bit table  $b_i$  as follows:

For  $k = 0$  to 15

From the bit table, find the set of all  $i$  with the number of bits per tone  $b_i = k$

Assign  $b'_i$  to the ordered bit allocation table in ascending order of  $i$



A complementary de-ordering procedure should be performed in the ATU-R receiver. It is not necessary, however, to send the results of the ordering process to the receiver because the bit table was originally generated in the ATU-R, and therefore that table has all the information necessary to perform the de-ordering.

## 6.6 Constellation encoder – with trellis coding

Block processing of Wei's 16-state 4-dimensional trellis code is optional to improve system performance. An algorithmic constellation encoder shall be used to construct constellations with a maximum number of bits equal to  $N_{\text{downmax}} (\leq 15)$ .

### 6.6.1 Bit extraction

Data bytes from the DMT symbol buffer shall be extracted according to a re-ordered bit allocation table  $b'_i$ , least significant bit first. Because of the 4-dimensional nature of the code, the extraction is based on pairs of consecutive  $b'_i$ , rather than on individual ones, as in the non-trellis-coded case. Furthermore, due to the constellation expansion associated with coding, the bit allocation table specifies  $b'_i$ , the number of coded bits per tone, which can be any integer from 2 to 15. Given a pair  $(x,y)$  of consecutive  $b'_i$ ,  $x+y-1$  bits (reflecting a constellation expansion of 1 bit per 4 dimensions, or one half bit per tone) are extracted from the DMT symbol buffer. These  $z = x+y-1$  bits ( $t_z, t_{z-1}, \dots, t_1$ ) are used to form the binary word  $u$  as shown in table 23. The tone ordering procedure ensures  $x \leq y$ . Single-bit constellations are not allowed because they can be replaced by 2-bit constellations with the same average energy. Refer to 6.6.2 for the reason behind the special form of the word  $u$  for the case  $x = 0, y > 1$ .

**Table 23 – Forming the binary word  $u$**

Condition	Binary word / comment
$x > 1, y > 1$	$u = (t_z, t_{z-1}, \dots, t_1)$
$x = 1, y \geq 1$	Condition not allowed
$x = 0, y > 1$	$u = (t_z, t_{z-1}, \dots, t_2, 0, t_1, 0)$
$x = 0, y \leq 1$	Bit extraction not necessary, no message bits being sent

The last two 4-dimensional symbols in the DMT symbol shall be chosen to force the constellation state to the zero state. For each of these symbols, the 2 LSBs of  $u$  are pre-determined, and only  $x+y-3$  bits are extracted from the DMT symbol buffer.

### 6.6.2 Bit conversion

The binary word  $u = (u_z, u_{z-1}, \dots, u_1)$  determines two binary words  $v = (v_z, v_{z-1}, \dots, v_0)$  and  $w = (w_x, w_{x-1}, \dots, w_0)$ , which are used to look up two constellation points in the encoder constellation table. For the usual case of  $x > 1$  and  $y > 1$ ,  $z = z = x+y-1$ , and  $v$  and  $w$  contain  $x$  and  $y$  bits respectively. For the special case of  $x = 0$  and  $y > 0$ ,  $z = z+2 = y+1$ ,  $v = (v_1, v_0) = 0$  and  $w = (w_x, w_{x-1}, \dots, w_0)$ . The bits  $(u_z, u_{z-1}, u_1)$  determine  $(v_1, v_0)$  and  $(w_x, w_0)$  according to figure 10.

ANSI T1.413-1995

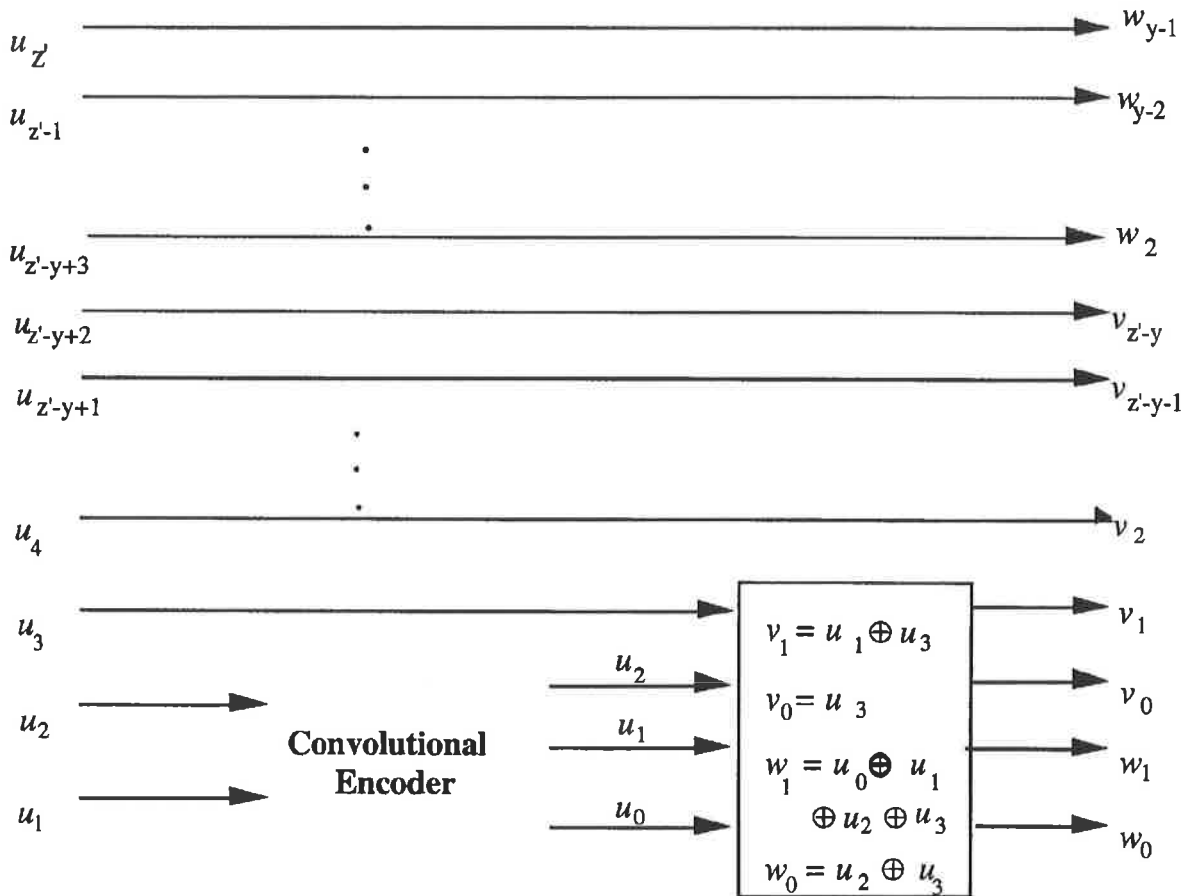
Figure 10 – Conversion of  $u$  to  $v$  and  $w$ 

The convolutional encoder shown in figure 10 is a systematic encoder (i.e.  $u_1$  and  $u_2$  are passed through unchanged) as shown in figure 11. The states ( $S_3$ ,  $S_2$ ,  $S_1$ ,  $S_0$ ) are used to label the states of the trellis shown in figure 12. At the beginning of a DMT symbol period the states are initialized to (0, 0, 0, 0).

The remaining bits of  $v$  and  $w$  are obtained from the less significant and more significant parts of  $(u_2, u_{z-1}, \dots, u_4)$ , respectively. When  $x > 1$  and  $y > 1$ ,  $v = (u_{z-y+2}, u_{z-y+1}, \dots, u_4, v_1, v_0)$  and  $w = (u_2, u_{z-1}, \dots, u_{z-y+3}, w_1, w_0)$ . The bit extraction and conversion algorithms have been judiciously designed so that when  $x = 0$ ,  $v_1 = v_0 = 0$ .

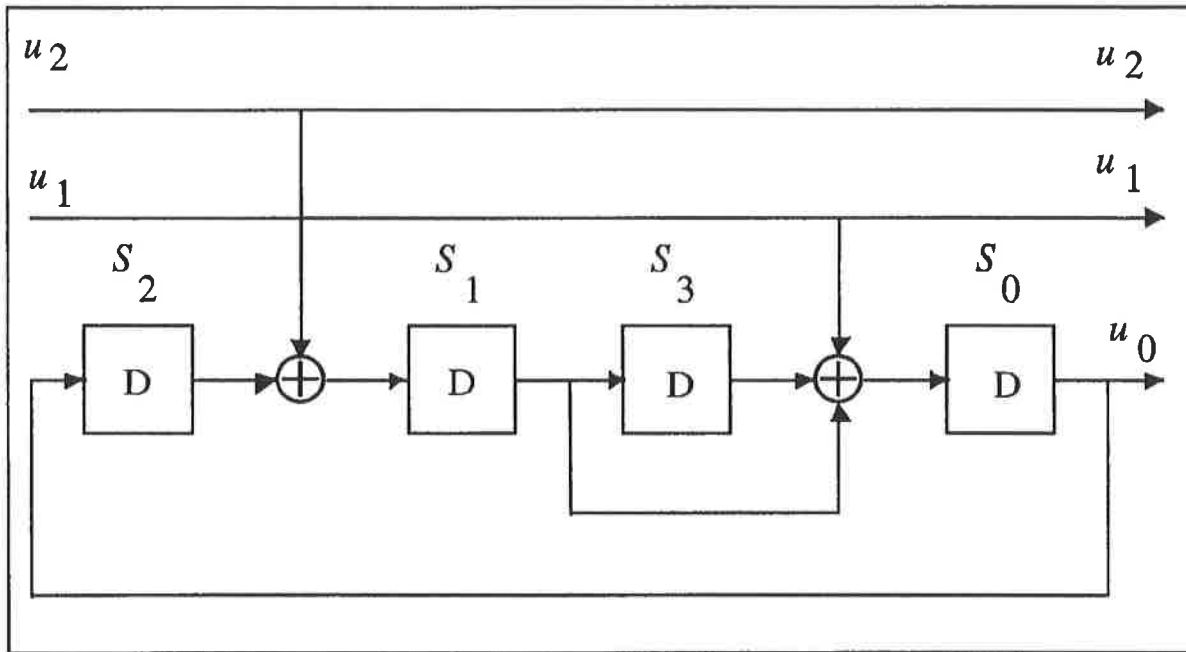

**Figure 11 – Finite state machine for Wei's encoder**

In order to force the final state to the zero state (0,0,0,0), the 2 LSBs  $u_1$  and  $u_2$  of the final two 4-dimensional symbol in the DMT symbol are constrained to  $u_1 = S_1 = S_3$ , and  $u_2 = S_2$ .

ANSI T1.413-1995

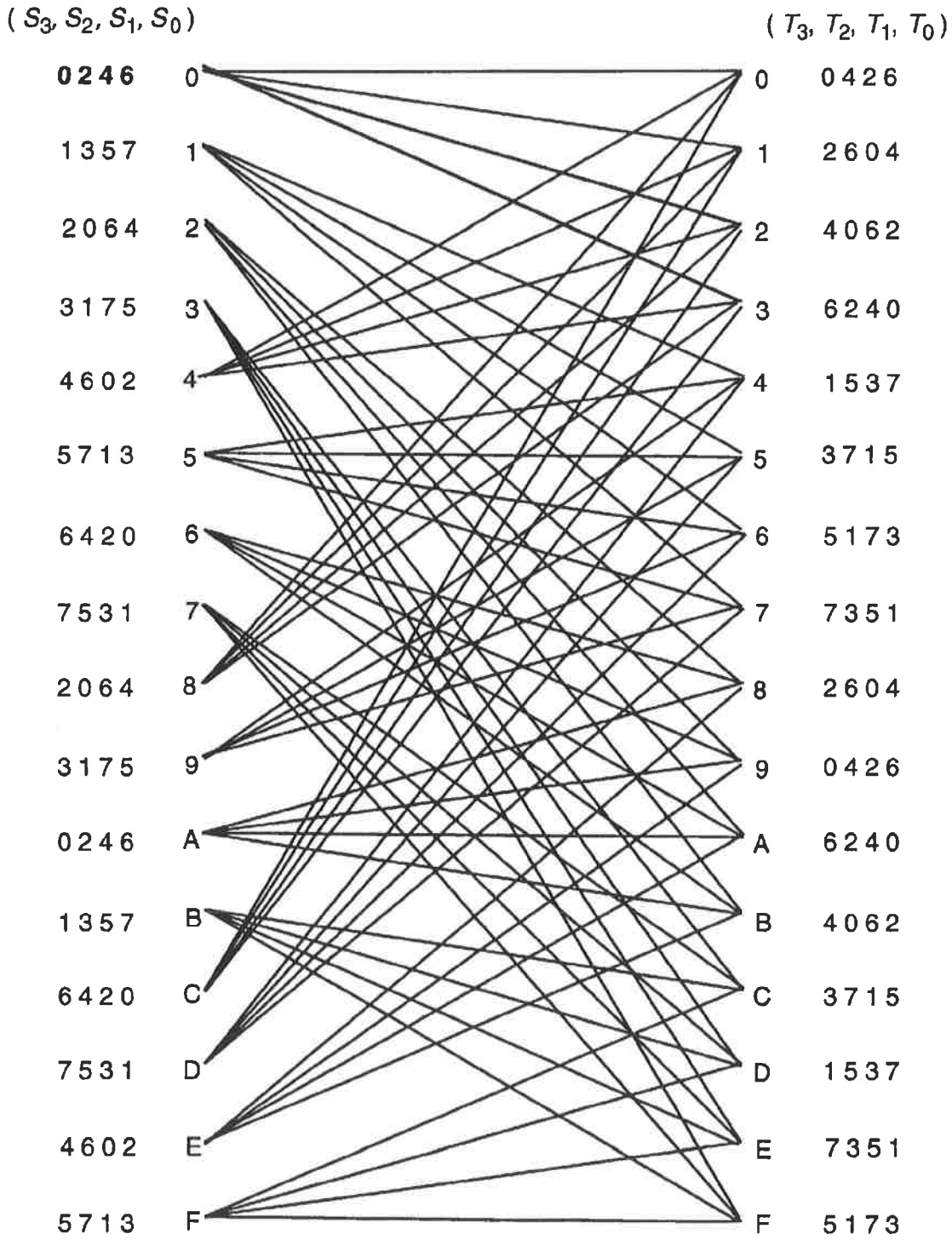
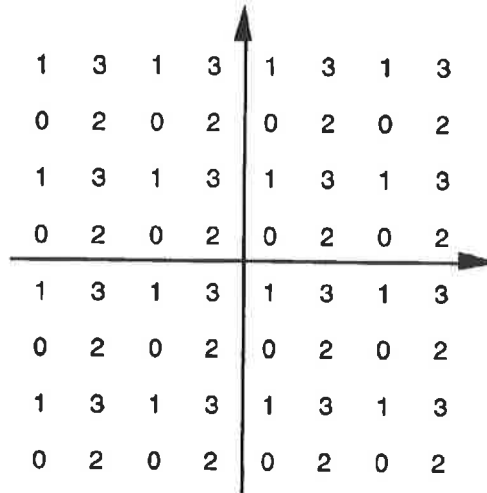

Figure 12 – Trellis diagram

### 6.6.3 Coset partition and trellis diagram

In a trellis code modulation system, the expanded constellation is labeled and partitioned into subsets ("cosets") using a technique called mapping by set-partitioning. The four-dimensional cosets in Wei's code can each be written as the union of two Cartesian products of two 2-dimensional cosets. For example,  $C_4^0 = (C_2^0 \times C_2^1) \cup (C_2^2 \times C_2^3)$ . The four constituent 2-dimensional cosets, denoted by  $C_2^0, C_2^1, C_2^2, C_2^3$ , are shown in figure 13.



**Figure 13 – Constituent 2-dimensional cosets for Wei's code**

The encoding algorithm ensures that the 2 least significant bits of a constellation point comprise the index  $i$  of the 2-dimensional coset  $C_2^i$  in which the constellation point lies. The bits  $(v_1, v_0)$  and  $(w_1, w_0)$  are in fact the binary representations of this index.

The three bits  $(u_2, u_1, u_0)$  are used to select one of the 8 possible four-dimensional cosets. The 8 cosets are labeled  $C_4^i$  where  $i$  is the integer with binary representation  $(u_2, u_1, u_0)$ . The additional bit  $u_3$  (see figure 10) determines which one of the two Cartesian products of 2-dimensional cosets in the 4-dimensional coset is chosen. The relationship is shown in table 24. The bits  $(v_1, v_0)$  and  $(w_1, w_0)$  are computed from  $(u_3, u_2, u_1, u_0)$  using the linear equations given in figure 10.

ANSI T1.413-1995

Table 24 – Relation between 4-dimensional and 2-dimensional cosets

4-D Coset	$u_3 u_2 u_1 u_0$	$v_1 v_0$	$w_1 w_0$	2-D Cosets
$C_4^0$	0 0 0 0 1 0 0 0	0 0 1 1	0 0 1 1	$C_2^0 \times C_2^0$ $C_3^3 \times C_3^3$
$C_4^4$	0 1 0 0 1 1 0 0	0 0 1 1	1 1 0 0	$C_2^0 \times C_2^3$ $C_3^3 \times C_3^0$
$C_4^2$	0 0 1 0 1 0 1 0	1 0 0 1	1 0 0 1	$C_2^2 \times C_2^2$ $C_3^1 \times C_3^1$
$C_4^6$	0 1 1 0 1 1 1 0	1 0 0 1	0 1 1 0	$C_2^2 \times C_2^1$ $C_3^1 \times C_3^2$
$C_4^1$	0 0 0 1 1 0 0 1	0 0 1 1	1 0 0 1	$C_2^0 \times C_2^2$ $C_3^3 \times C_3^1$
$C_4^5$	0 1 0 1 1 1 0 1	0 0 1 1	0 1 1 0	$C_2^0 \times C_2^1$ $C_3^3 \times C_3^2$
$C_4^3$	0 0 1 1 1 0 1 1	1 0 0 1	0 0 1 1	$C_2^2 \times C_2^0$ $C_3^1 \times C_3^3$
$C_4^7$	0 1 1 1 1 1 1 1	1 0 0 1	1 1 0 0	$C_2^2 \times C_2^3$ $C_3^1 \times C_3^0$

Figure 12 shows the trellis diagram based on the finite state machine in figure 11, and the one-to-one correspondence between  $(u_2, u_1, u_0)$  and the 4-dimensional cosets. In the figures,  $S = (S_3, S_2, S_1, S_0)$  represents the current state, while  $T = (T_3, T_2, T_1, T_0)$  represents the next state in the finite state machine.  $S$  is connected to  $T$  in the constellation diagram by a branch determined by the values of  $u_2$  and  $u_1$ . The branch is labeled with the 4-dimensional coset specified by the values of  $u_2, u_1$  (and  $u_0 = S_0$ , see figure 11). To make the constellation diagram more readable, the indices of the 4-dimensional coset labels are listed next to the starting and end points of the branches, rather than on the branches themselves. The leftmost label corresponds to the uppermost branch for each state. The constellation diagram is used when decoding the trellis code by the Viterbi algorithm.

#### 6.6.4 Constellation encoder

For a given sub-channel, the encoder shall select an odd-integer point  $(X, Y)$  from the square-grid constellation based on the  $b$  bits  $\{v_{b-1}, v_{b-2}, \dots, v_1, v_0\}$ . For convenience of description, these  $b$  bits are identified with an integer label whose binary representation is  $(v_{b-1}, v_{b-2}, \dots, v_1, v_0)$ . For example, for  $b=2$ , the four constellation points are labeled 0,1,2,3 corresponding to  $(v_1, v_0) = (0,0), (0,1), (1,0), (1,1)$ , respectively.

##### 6.6.4.1 Even values of $b$

For even values of  $b$ , the integer values  $X$  and  $Y$  of the constellation point  $(X, Y)$  shall be determined from the  $b$  bits  $\{v_{b-1}, v_{b-2}, \dots, v_1, v_0\}$  as follows.  $X$  and  $Y$  are the odd integers with two's-complement binary representations  $(v_{b-1}, v_{b-3}, \dots, v_1, 1)$  and  $(v_{b-2}, v_{b-4}, \dots, v_0, 1)$ , respectively. The most significant bits (MSBs),  $v_{b-1}$  and  $v_{b-2}$ , are the sign bits for  $X$  and  $Y$ , respectively. Figure 14 shows example constellations for  $b = 2$  and  $b = 4$ .

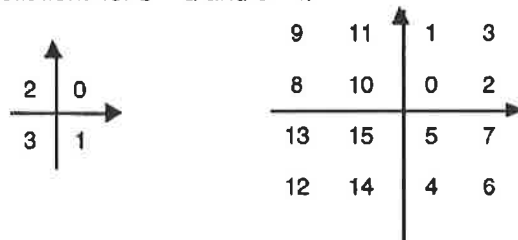

Figure 14 – Constellation labels for  $b = 2$  and  $b = 4$

The 4-bit constellation can be obtained from the 2-bit constellation by replacing each label  $n$  by the  $2 \times 2$  block of labels:

$$\begin{array}{cc} 4n+1 & 4n+3 \\ 4n & 4n+2 \end{array}$$

The same procedure can be used to construct the larger even-bit constellations recursively.

The constellations obtained for even values of  $b$  are square in shape. The least significant bits  $\{v_1, v_0\}$  represent the coset labeling of the constituent 2-dimensional cosets used in the 4-dimensional Wei trellis code.

##### 6.6.4.2 Odd values of $b$ , $b = 3$

Figure 15 shows the constellation for the case  $b = 3$ .

ANSI T1.413-1995

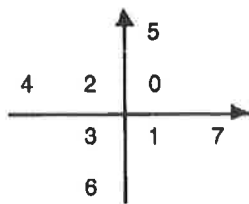
Figure 15 – Constellation labels for  $b = 3$ 

### 6.6.4.3 Odd values of $b$ , $b > 3$

If  $b$  is odd and greater than 3, the 2 MSBs of  $X$  and the 2 MSBs of  $Y$  are determined by the 5 MSBs of the  $b$  bits. Let  $c = (b+1)/2$ , then  $X$  and  $Y$  have the two's-complement binary representations  $(X_c, X_{c-1}, v_{b-4}, v_{b-6}, \dots, v_3, v_1, 1)$  and  $(Y_c, Y_{c-1}, v_{b-5}, v_{b-7}, v_{b-9}, \dots, v_2, v_0, 1)$ , where  $X_c$  and  $Y_c$  are the sign bits of  $X$  and  $Y$  respectively. The relationship between  $X_c, X_{c-1}, Y_c, Y_{c-1}$  and  $v_{b-1}, v_{b-2}, \dots, v_{b-5}$  is shown in the table 25.

Table 25 – Determining the top 2 bits of  $X$  and  $Y$ 

$v_{b-1}, v_{b-2}, \dots, v_{b-5}$	$X_c, X_{c-1}$	$Y_c, Y_{c-1}$
00000	00	00
00001	00	00
00010	00	00
00011	00	00
00100	00	11
00101	00	11
00110	00	11
00111	00	11
01000	11	00
01001	11	00
01010	11	00
01011	11	00
01100	11	11
01101	11	11
01110	11	11
01111	11	11
10000	01	00
10001	01	00
10010	10	00
10011	10	00
10100	00	01
10101	00	10
10110	00	01
10111	00	10
11000	11	01
11001	11	10
11010	11	01
11011	11	10
11100	01	11
11101	01	11
11110	10	11
11111	10	11



Figure 16 shows the constellation for the case  $b = 5$ .

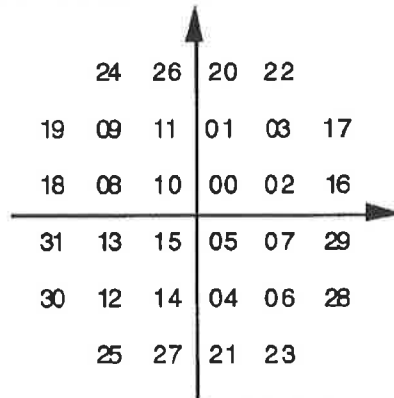

Figure 16 – Constellation labels for  $b = 5$

The 7-bit constellation shall be obtained from the 5-bit constellation by replacing each label  $n$  by the  $2 \times 2$  block of labels:

$$\begin{array}{cc} 4n+1 & 4n+3 \\ 4n & 4n+2 \end{array}$$

The same procedure shall then be used to construct the larger odd-bit constellations recursively. Note also that the least significant bits  $\{v_1, v_0\}$  represent the coset labeling of the constituent 2-dimensional cosets used in the 4-dimensional Wei trellis code.

## 6.7 Constellation encoder – without trellis coding

An algorithmic constellation encoder shall be used to construct constellations with a maximum number of bits equal to  $N_{\text{downmax}} (\leq 15)$ . The constellation encoder shall not use trellis coding with this option.

### 6.7.1 Bit extraction

Data bytes from the DMT symbol buffer shall be extracted according to a re-ordered bit allocation table  $b'_i$ , least significant bit first. The number of bits per tone,  $b'_i$ , can take any non-negative integer values not exceeding  $N_{\text{downmax}}$ , with the exception of  $b'_i = 1$ . For a given tone  $b'_i = b$  bits are extracted from the DMT symbol buffer, and these bits form a binary word  $\{v_{b-1}, v_{b-2}, \dots, v_1, v_0\}$ .

### 6.7.2 Constellation encoder

The constellation encoder shall be as specified in 6.6.4.

## 6.8 Gain scaling

A gain adjuster,  $g_i$  is used to effect a frequency-variable transmit power spectral density (PSD). It may have two factors:

- a gross gain adjustment of either 1.414 or 2.0 (i.e., 3 or 6 dB), which may be required for sub-carriers # 51 and above (see 12.9.8);
- a fine gain adjustment with a range of approximately 0.8 to 1.2 (i.e., 0 +1.5 dB), which may be used to equalize the expected error rates for all the sub-channels.

Each point,  $(X_i, Y_i)$ , or complex number,  $Z_i = X_i + jY_i$ , output from the encoder is multiplied by  $g_i$ :  
 $Z_i' = g_i Z_i$

ANSI T1.413-1995

NOTE – The  $g_i$  define a scaling of the root mean square (rms) sub-carrier levels relative to those used in C-MEDLEY (see 12.6.6). They are independent of any methods that manufacturers may use to simplify implementation (e.g., constellation nesting).

## 6.9 Modulation

### 6.9.1 Sub-carriers

The frequency spacing,  $\Delta f$ , between sub-carriers shall be 4.3125 kHz, with a tolerance of + 50 ppm.

#### 6.9.1.1 Data sub-carriers

The channel analysis signal defined in 12.6.6 allows for a maximum of 255 carriers (at frequencies  $n\Delta f$ ,  $n = 1$  to 255) to be used. If echo cancelling (EC) is used to separate downstream and upstream signals, then the lower limit on  $n$  is determined by the ADSL/POTS splitting filters; if frequency division multiplexing (FDM) is used the lower limit is set by the down – up splitting filters. The cut-off frequencies of these filters are completely at the discretion of the manufacturer because, in either case, the range of usable  $n$  is determined during the channel estimation.

#### 6.9.1.2 Pilot

Carrier #64 ( $f = 276$  kHz) shall be reserved for a pilot; that is  $b_{64} = 0$  and  $g_{64} = 1$ . The data modulated onto the pilot sub-carrier shall be a constant {0,0}. Use of this pilot allows resolution of sample timing in a receiver modulo-8 samples. Therefore a gross timing error that is an integer multiple of 8 samples could still persist after a micro-interruption (e.g., a temporary short-circuit, open circuit or severe line hit); correction of such timing errors is made possible by the use of the synchronization symbol defined in 6.9.3.

#### 6.9.1.3 Nyquist frequency

The carrier at the Nyquist frequency (#256) shall not be used for data; other possible uses are for further study.

### 6.9.2 Modulation by the inverse discrete Fourier transform (IDFT)

The modulating transform defines the relationship between the 512 real values  $x_k$  and the  $Z_i'$

$$x_k = \sum_{i=0}^{511} \exp\left(\frac{j\pi ki}{256}\right) Z_i' \quad \text{for } k = 0 \text{ to } 511$$

The encoder and scaler generate only 255 complex values of  $Z_i'$  (plus zero at dc, and one real value if the Nyquist frequency is used). In order to generate real values of  $x_k$  these values shall be augmented so that the vector  $Z$  has Hermitian symmetry. That is,

$$Z_i' = \text{conj}(Z_{512-i}') \quad \text{for } i = 257 \text{ to } 511$$

### 6.9.3 Synchronization symbol

The synchronization symbol permits recovery of the frame boundary after micro-interruptions that might otherwise force retraining.

The symbol rate,  $f_{\text{symp}} = 4$  kHz, the carrier separation,  $\Delta f = 4.3125$  kHz, and the IDFT size,  $N = 512$ , are such that a cyclic prefix of 40 samples could be used. That is,

$$(512 + 40) \times 4.0 = 512 \times 4.3125 = 2208$$

The cyclic prefix shall, however, be shortened to 32 samples, and a synchronization symbol (with a nominal length of 544 samples) inserted after every 68 data symbols. That is,

$$(512 + 32) \times 69 = (512 + 40) \times 68$$

The data pattern used in the synchronization symbol shall be the pseudo-random sequence PRD, ( $d_n$ , for  $n = 1$  to 512) defined by

$$\begin{aligned} d_n &= 1 && \text{for } n = 1 \text{ to } 9 \\ d_n &= d_{n-4} \oplus d_{n-9} && \text{for } n = 10 \text{ to } 512 \end{aligned}$$

The first pair of bits ( $d_1$  and  $d_2$ ) shall be used for the dc and Nyquist sub-carriers (the power assigned to them is, of course, zero, so the bits are effectively ignored); the first and second bits of subsequent pairs are then used to define the  $X_i$  and  $Y_i$ , for  $i = 1$  to 255 as follows:

$d_{2i+1}, d_{2i+2}$	$X_i, Y_i$
0 0	+ +
0 1	+ -
1 0	- +
1 1	- -

#### NOTES

- 1 The period of the PRD is only 511 bits, so  $d_{512} = d_1$ .
- 2 The  $d_1 - d_9$  are re-initialized for each symbol, so each symbol of C-REVERB1 uses the same data.

Bits 129 and 130, which modulate the pilot carrier ( $i = 64$ ), shall be overwritten by {0,0}: generating the {+,+} constellation.

The minimum set of sub-carriers to be used is the set used for data transmission (i.e., those for which  $b_i > 0$ ); sub-carriers for which  $b_i = 0$  may be used at a reduced PSD as defined in 6.13.4. The data modulated onto each sub-carrier shall be as defined above; it shall not depend on which sub-carriers are used.

#### 6.10 Cyclic prefix

The last 32 samples of the output of the IDFT ( $x_k$  for  $k = 480$  to 511) shall be prepended to the block of 512 samples and read out to the digital-to-analog converter (DAC) in sequence. That is, the subscripts,  $k$ , of the DAC samples in sequence are 480.....511,0.....511.

The cyclic prefix shall be used for data and synchronization symbols beginning with the R-RATES1 segment of the initialization sequence, as defined in 12.7.4.

ANSI T1.413-1995

## 6.11 Transmitter dynamic range

The transmitter includes all analog transmitter functions: the D/A converter, the anti-aliasing filter, the hybrid circuitry, and the POTS splitter. The transmitted signal shall conform to the frequency requirements as described in 6.9.1 for frequency spacing.

### 6.11.1 Maximum clipping rate

The maximum output signal of the transmitter shall be such that the probability of the signal being clipped is no greater than  $10^{-7}$ .

### 6.11.2 Noise/Distortion floor

The Signal to Noise plus Distortion (SINAD) ratio of the transmitted signal in a given sub-carrier is defined as the ratio of the rms value of the full-amplitude tone in that sub-carrier to the rms sum of all the non-tone signals in the 4.3125 kHz frequency band centered on the sub-carrier frequency. The SINAD is characterized for each sub-carrier used for transmission:  $SINAD_i$  represents the signal to noise plus distortion available on the transmitted signal in the  $i$ th sub-carrier.

Over the transmission frequency band, the SINAD of the transmitter in any sub-carrier shall be no less than  $(3N_{downi} + 20)$  dB, where  $N_{downi}$  is defined as the size of the constellation (in bits) to be used on sub-carrier  $i$ . The minimum transmitter SINAD shall be at least 38dB (corresponding to an  $N_{downi}$  of 6) for any sub-carrier.

## 6.12 Transmitter spectral response

Figure 17 shows a representative spectral response mask for the transmitted signal. The pass band is defined as the frequency range over which the modem transmits. The low frequency stop band is defined as the POTS band; the high frequency stop band is defined as frequencies greater than 2.208 Mhz.

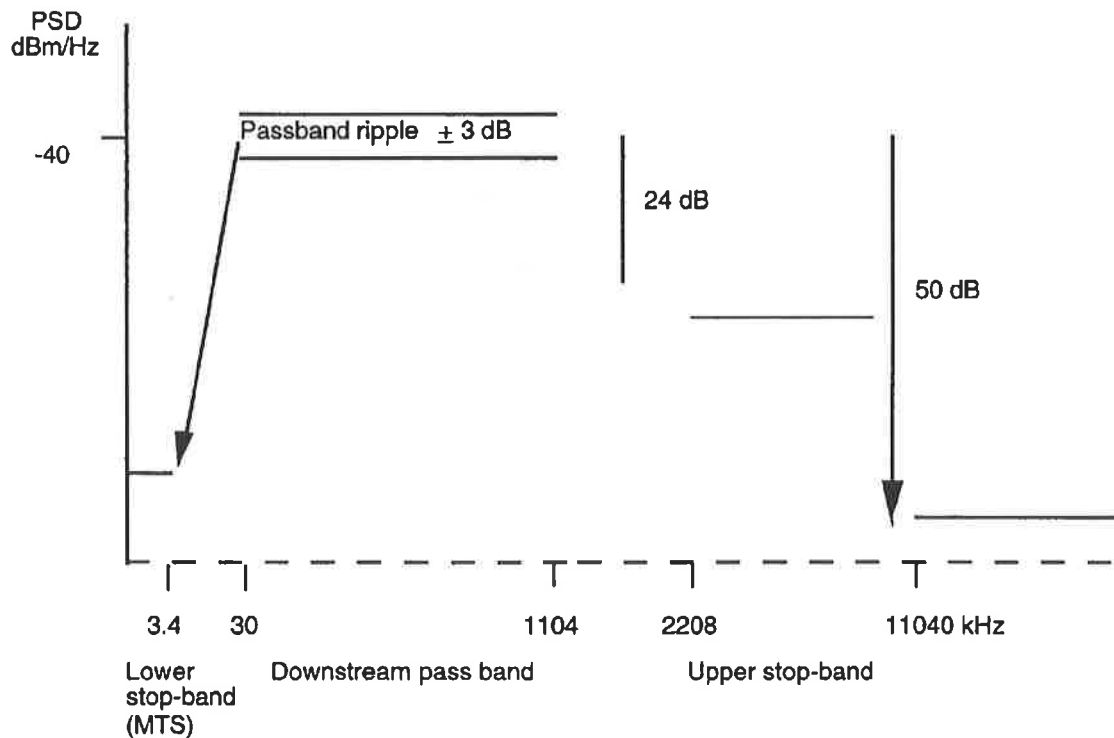

Figure 17 – ATU-C transmitter PSD mask

**6.12.1 Pass band response**

The pass band ripple shall be no greater than 3 dB, and the group delay variation over the pass band shall not exceed 50  $\mu$ sec.

**6.12.2 Low frequency stop band rejection**

The spectral characteristics of the output in the POTS band shall conform to the specifications in 10.7.

**6.12.3 High frequency stop band rejection**

The PSD in the band above 2.208 MHz shall be at least 24 dB below the spectral density of the pass-band mask. (see 12.4.3). The PSD in the band above 11.04 MHz shall be at least 50 dB below the spectral density of the pass-band mask.

**6.13 Transmit power spectral density and aggregate power level**

There are three different PSD masks for the ATU-C transmit signal, depending on the type of signal sent. In all cases the power in the voice-band that is delivered to the Public Switched Telephone Network (PSTN) interface shall conform to the specification given in 10.7

**6.13.1 All initialization signals (except C-ECT) starting with C-REVERB1**

The PSD in the band from 25 to 1100 kHz, shall not exceed  $-40$  dBm/Hz for a total power of not greater than 20 dBm. The power in the voice band delivered to the PSTN interface shall conform to the requirements of 10.7. If measurement of the upstream power indicates that power cut-back is necessary, then the PSD should be set at  $-42$ ,  $-44$ ,  $-46$ ,  $-48$ ,  $-50$ , or  $-52$  dBm/Hz (see 12.4.3).

**6.13.2 C-ECT**

Because C-ECT is a vendor defined signal (see 12.4.5), the PSD specification shall be interpreted only as a maximum. This maximum level is  $-40$  dBm/Hz for the band from 18 to 1100 kHz. Sub-carriers 1 – 5 may be used, but the power in the voice-band that is delivered to the PSTN interface shall conform to the specification given in 10.7.

**6.13.3 Steady-state data signal**

The PSD in the band from 25 to 1100 kHz shall normally (i.e., without power cut-back or power boost) be  $-40$  dBm/Hz with a maximum of  $-37$  dBm/Hz; levels lower than  $-40$  dBm/Hz on some carriers are discretionary. The normal aggregate power level shall not exceed  $(-4 + 10 \log(ncdown))$  dBm, where *ncdown* is the number of sub-carriers used (20.4 dBm if all sub-carriers are used). The PSD and aggregate power may, however, be changed in any of the following circumstances:

a) Power cut-back: in this case the PSD and the aggregate power level will be reduced by *n* multiples of 2 dB (*n* = 0 to 5) so that they are as follows

$$\begin{aligned} \text{- PSDmax} &= -37 - 2n \text{ dBm/Hz} \\ \text{- Total power} &= -4 - 2n + 10\log(ncdown) \text{ dBm} \end{aligned}$$

b) the bits and gains table (see R-B&G in 12.9.8) from ATU-R during initialization may eliminate some of the sub-carriers, and finely adjust (i.e., within  $\pm 3$  dB range) the level of others in order to equalize expected error rates on each of the sub-channels;

## ANSI T1.413-1995

- c) a power boost: the PSD and aggregate power shall not exceed the following
- PSD<sub>max</sub> =  $-37$  dBm/Hz for  $0 < i \leq 50$ ; that is, frequency below 220 kHz  
 $-31$  dBm/Hz for  $51 \leq i < 256$ ; that is frequency above 220 kHz.
  - Total power = the sum of the powers ( $-4 + 10 \log(nc_{down1})$ ) and ( $2 + 10 \log(nc_{down2})$ ),

where  $nc_{down1}$  and  $nc_{down2}$  are the number of sub-carriers used in the sub-bands  $i = 0$  to 50, and  $i = 51$  to 255, respectively

These specifications are shown in figure 18, where the possible power cut-back in multiples of 2 dBm and power boost of 6 dBm above 220 kHz are illustrated .

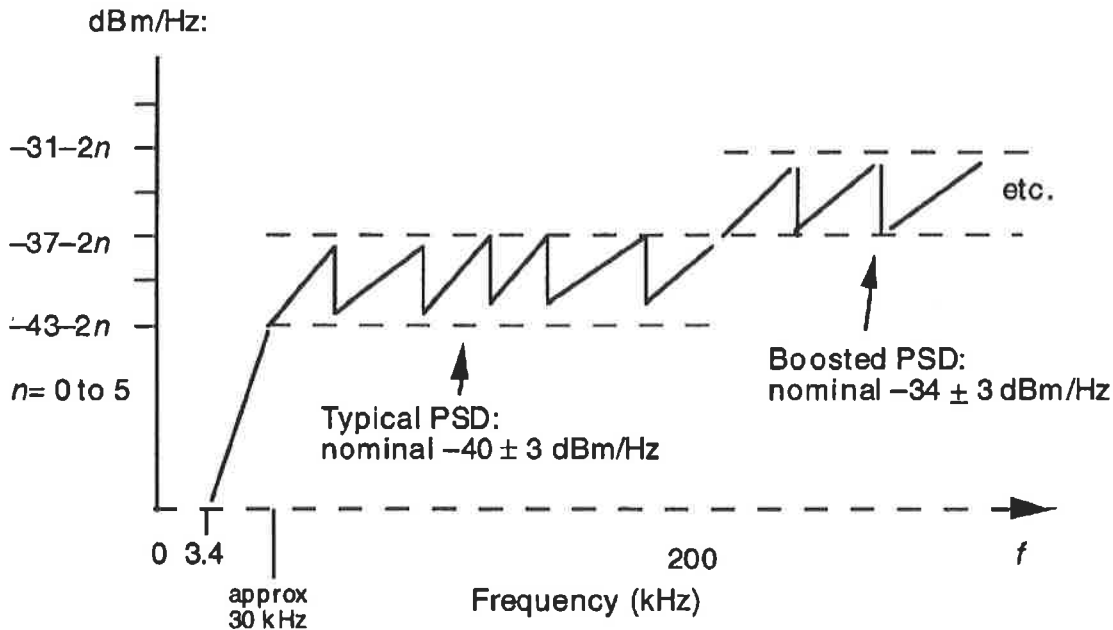

Figure 18 – ATU-C transmitter PSD mask: pass-band detail

#### 6.13.4 Synchronization symbol

The PSD of those sub-carriers for which  $b_i > 0$  or  $b_i = 0$  and  $g_i > 0$  shall be the same as for the initialization signal C-REVERB1; that is, nominally  $-40$  dBm/Hz. The PSD for those sub-carriers for which  $b_i = 0$  and  $g_i = 0$  shall be no higher than  $-48$  dBm/Hz.

The PSD of a synchronization symbol thus differs from that of the data signals surrounding it by the  $g_i$ , which are applied only to the data carriers. These  $g_i$  were calculated for the multipoint constellations in order to equalize the expected error rate on all sub-channels, and are therefore irrelevant for most of the 4QAM signals of the synchronization symbol.

## 7 ATU-R functional characteristics

### 7.1 ATU-R input and output data interfaces

The functional data interfaces at the ATU-R are shown in figure 19 . Output interfaces for the high-speed downstream simplex bearer channels are designated AS0 through AS3; input – output interfaces for the duplex bearer channels are designated LS0 through LS2. There may also be a functional interface to transport maintenance indicators from the SMs (service modules) to the ATU-R; this interface may physically be combined with the LS0 upstream interface.

The data rates of the input and output data interfaces at the ATU-R for the default configurations are specified in this clause.

The total net bearer capacity that can be transmitted in the upstream direction depends on the loop characteristics. The rate of the duplex bearer at the LS0 interface and the availability of the LS1 and LS2 options correspond to the transport class as discussed in 5.3, for the default configurations.

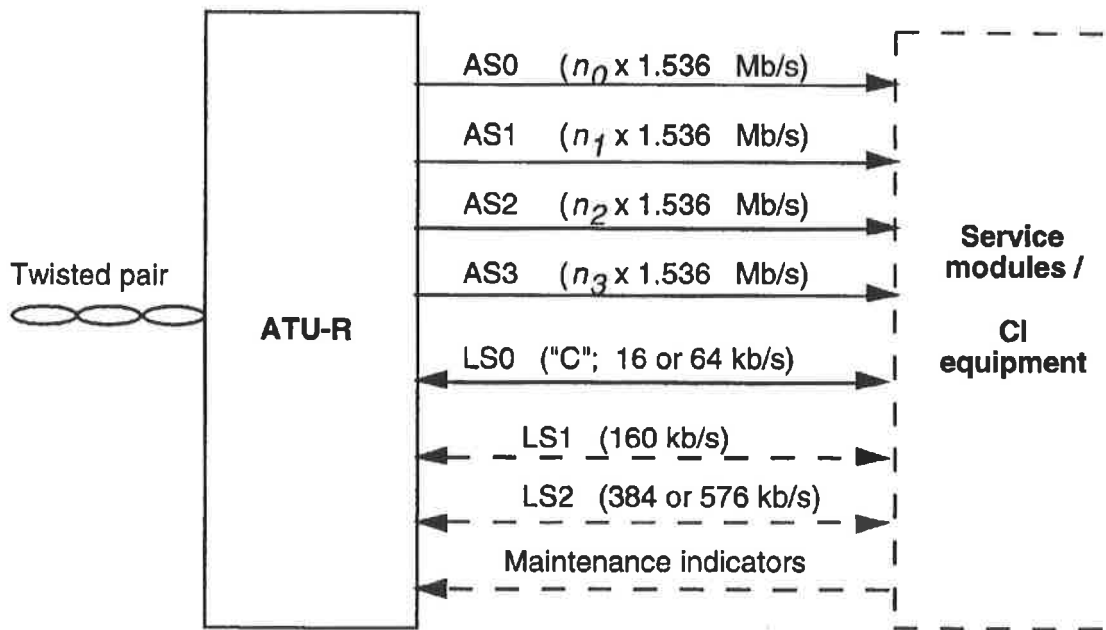

NOTE - indicates optional duplex channels (LS1 and LS2).

Figure 19 – ATU-R data interfaces

#### 7.1.1 Downstream simplex channels – Transceiver bit rates

The simplex channels are transported in the downstream direction only; therefore their data interfaces at the ATU-R operate only as outputs. The rates are the same as those for the ATU-C transmitter, as specified in 6.1.1.

ANSI T1.413-1995

### 7.1.2 Duplex channels – Transceiver bit rates

The duplex channels are transported in both directions, so the ATU-R shall provide both input and output data interfaces. The rates are the same as for the ATU-C, as specified in 6.1.2.

## 7.2 Framing

Framing of the upstream signal (ATU-R transmitter) is specified in this subclause; it closely follows the downstream framing (ATU-C transmitter), which is specified in 6.2, but with the following exceptions:

- there are no ASX channels or an AEX byte;
- a maximum of three channels exist, so that only three  $B_F, B_I$  pairs are specified;
- the default FEC coding parameters and interleave depth differ (see table 26);
- four bits of the "fast" and "synch" bytes are unused (corresponding to the bit positions used by the ATU-C transmitter to specify synchronization control for the ASX channels) (see tables 27 and 28);
- if the LS2 frame integrity option is installed, condition (d) in 6.2.4 does not apply for the insertion of an LS2 frame verification pointer.

### 7.2.1 Data symbols

The ATU-R transmitter is functionally similar to the ATU-C transmitter, as specified in 6.2.1, with the exception that up to three duplex data channels are synchronized to the 4 kHz ADSL DMT symbol rate (instead of up to four simplex and three duplex channels as is the case for the ATU-C) and multiplexed into the two separate buffers (fast and interleaved). The ATU-R transmitter and its associated reference points for data framing are identical to the structure shown in figure 2, with the exception that the AS0..AS3 channels do not appear at the input of the Mux/Synch Control.

#### 7.2.1.1 Superframe structure

The superframe structure of the ATU-R transmitter shall be identical to that of the ATU-C transmitter, as specified in 6.2.1.1.

#### 7.2.1.2 Frame structure

Each frame of data shall be encoded into a multicarrier symbol, as described in 7.3 through 7.6. As specified for the ATU-C and shown in figure 2, each frame is composed of a fast data buffer and an interleaved data buffer, and the frame structure has a different appearance at each of the reference points (A, B, and C). The bytes of the fast buffer shall be clocked into the constellation encoder first, followed by the bytes of the interleaved data buffer. Bytes are clocked least significant bit first.

The assignment of user data streams to the fast and interleaved buffers shall be configured during initialization (see 12.6) with the exchange of a  $(B_F, B_I)$  pair for each data stream, where  $B_F$  designates the number of bytes of a given data stream to allocate to the fast buffer, and  $B_I$  designates the number of bytes allocated to the interleaved data buffer.

The three possible  $(B_F, B_I)$  pairs are  $B_F(LSX), B_I(LSX)$  for  $X = 0, 1$  and 2, for the duplex channels; they are specified as for the ATU-C in 6.2.1.2.

The three values of the  $(B_F, B_I)$  pairs for the default configurations shall be as specified for the ATU-C in table 16.



### 7.2.1.2.1 Fast data buffer

The frame structure of the fast data buffer is shown in figure 20 for the three reference points that are defined in figure 2. This structure is the same as that specified for the ATU-C with the following exceptions:

- ASX bytes do not appear;
- the AEX byte does not appear;
- $R_{usf}$  FEC redundancy bytes are used (as contrasted with  $R_{dst}$ ).

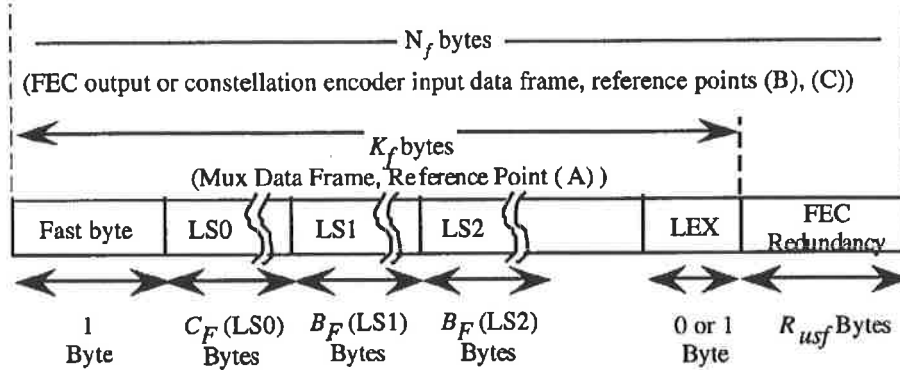

$$K_f = 1 + \sum_{j=0}^2 B_F(LS_j) + L_F, \quad C_F(LS_0) = \begin{cases} 0, & B_F(LS_0) = 255, \\ B_F(LS_0) & \text{otherwise.} \end{cases}$$

$$\text{where } L_F = \begin{cases} 0, & \sum_{j=0}^2 B_F(LS_j) = 0, \\ 1 & \text{otherwise} \end{cases}, \quad N_f = K_f + R_{usf}$$

where  $R_{usf}$  = # FEC Redundancy Bytes

NOTE -  $L_F = 1$  when  $B_F(LS_0) = 255$ .

Figure 20 - Fast data buffer - ATU-R transmitter

At reference point A in figure 2, the mux data frame, the fast buffer always contains at least the "fast" byte. This is followed by  $B_F(LS_0)$  bytes of channel LS0, then  $B_F(LS_1)$  bytes of channel LS1, and  $B_F(LS_2)$  bytes of channel LS2, and if any  $B_F(LS_X)$  is non-zero, an LEX byte.

When  $B_F(LS_0) = 255$  (Binary 11111111), no separate bytes are included for the LS0 channel. Instead, the 16 kbit/s C channel is transported in every other LEX byte on average, using the synch byte to denote when to add the LEX byte to the LS0 data stream.

$R_{usf}$  FEC redundancy bytes are added to the mux data frame (reference point A) to produce the FEC output data frame (reference point B), where  $R_{usf}$  is given in the C-RATES1 signal options received from the ATU-C during initialization (see clause 12).  $R_{usf}$  is equal to 4 for the default configurations specified in 6.2.1.2. When no data streams are allocated to the fast buffer,  $R_{usf} = 0$  (no FEC redundancy bytes are added). Because the data from the fast buffer is not interleaved, the constellation encoder input data frame (reference point C) is identical to the FEC output data frame (reference point B).

### 7.2.1.2.2 Interleaved data buffer

The frame structure of the interleaved data buffer is shown in figure 21 for the three reference points that are defined in figure 2. This structure is the same as that specified for the ATU-C, with the following exceptions:

- ASX bytes do not appear;
- the AEX byte does not appear;
- $R_{usf}$  FEC redundancy bytes are used (contrastd with  $R_{dst}$ ).

ANSI T1.413-1995

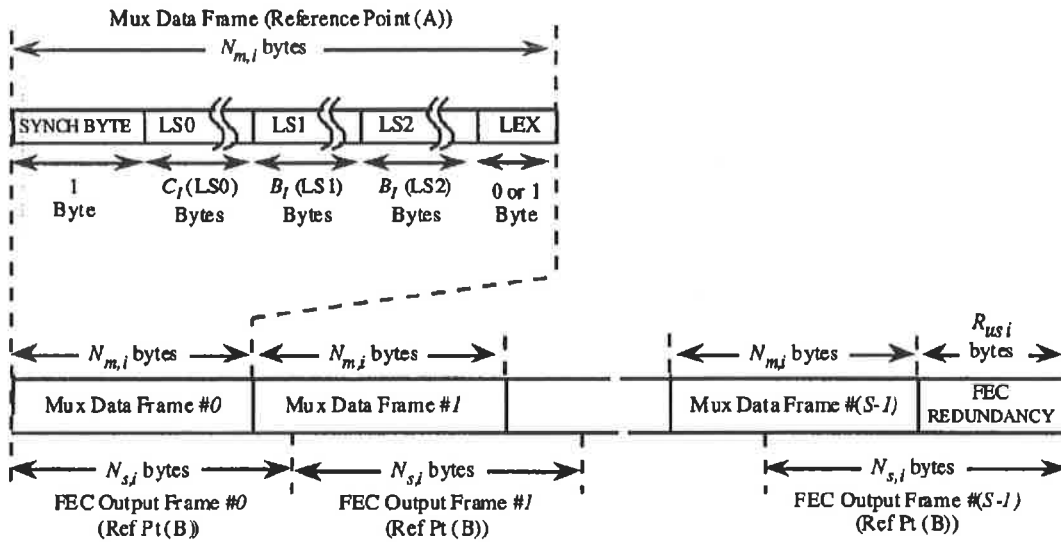

$$N_{m,i} = 1 + \sum_{j=0}^2 B_I(LS_j) + L_I$$

$$\text{where } L_I = \begin{cases} 0, & \sum_{j=0}^2 B_I(LS_j) = 0, \\ 1 & \text{otherwise.} \end{cases}$$

(Note:  $L_I = 1$  when  $B_I(LS_0) = 255$ )

$$C_I(LS_0) = 0, B_I(LS_0) = 255 \text{ (Binary 11111111),} \\ B_I(LS_0) \text{ otherwise.}$$

$$N_{s,i} = (S * N_{m,i} + R_{usi}) / S,$$

where  $R_{usi}$  = # FEC Redundancy Bytes,  
and  $S$  = # DMT symbols per FEC codeword.

Figure 21 – Interleaved data buffer – ATU-R transmitter

The FEC coding overhead, the number of symbols per FEC codeword, and the interleave depth are given in the C-RATES1 options received from the ATU-C during initialization (see clause 12). For the default configurations specified in 6.2.1.2, the coding parameters are given in table 26 .

Table 26 – Default FEC coding parameters and interleave depth – ATU-R transmitter

	$R_{usi}$ (FEC redundancy bytes)	S (symbols per codeword)	Interleave depth (FEC codewords)
Transport classes 1, 2M-1	16	8	8
Transport classes 2, 3, 2M-2	16	16	4
Transport classes 4, 2M-3	16	16	4
Synch byte only	4	4	16

### 7.2.1.3 Cyclic redundancy check (crc)

Two cyclic redundancy checks (crcs) – one for the fast data buffer and one for the interleaved data buffer – are generated for each superframe and transmitted in the first frame of the following superframe. Eight bits per buffer type (fast or interleaved) per superframe are allocated to the crc check bits.

The crc bits are transported in the "fast byte" (8 bits) of frame 0 in the fast data buffer, and the "synch byte" (8 bits) of frame 0 in the interleaved data buffer.

The bits covered by the crc include;

- for the fast data buffer:
  - *frame 0*: LSX bytes ( $X = 0, 1, 2$ ), followed by the LEX byte;
  - *all other frames*: "fast" byte, followed by LSX bytes ( $X = 0, 1, 2$ ), and LEX byte.
- for the interleaved data buffer:
  - *frame 0*: LSX bytes ( $X = 0, 1, 2$ ), followed by the LEX byte;
  - *all other frames*: "synch" byte, followed by LSX bytes ( $X = 0, 1, 2$ ), and LEX byte.

Each byte shall be clocked into the crc least significant bit first.

The crc-generating polynomial, and the method of generating the crc byte are the same as for the downstream data; these are specified in 6.2.1.3.

### 7.2.2 Synchronization

The input data streams shall be synchronized to the ADSL clock using the synchronization control byte and the LEX byte. Forward-error-correction coding is always applied to the synchronization control byte(s).

ANSI T1.413-1995

**7.2.2.1 Synchronization for the fast data buffer**

Synchronization control for the fast data buffer can occur in frames 2 through 33 and 36 through 67 of an ADSL superframe as described in 7.2.1.1, where the "fast" byte may be used as the synchronization control byte.

The format of the "fast" byte when used as synchronization control for the fast data buffer shall be as given in table 27.

In the case where no signals are allocated to the interleaved data buffer, the "synch" byte shall carry the aoc data directly as shown in figure 7.

**Table 27 – Fast byte format for synchronization – Fast data buffer**

Bit	Application	Specific usage
sc7-sc4	not used	set to "0" until specified otherwise
sc3, sc2	LSX channel designator	"00" : channel LS0 "01" : channel LS1 "10" : channel LS2 "11" : do nothing to any LSX channel
sc1	Synchronization control for the designated LSX channel	"1" : add LEX byte to designated LSX channel "0" : delete last byte from designated LSX channel
sc0	Synch/eoc designator	"0" : perform synchronization control as indicated in sc7-sc1 "1" : this byte of current (even-numbered) frame and of frame that immediately follows is an eoc frame

No synchronization action shall be taken for those frames in which the "fast" byte is used for crc, fixed indicator bits, or eoc.

When the data rate of the C channel is 16 kbit/s, the LS0 sub-channel shall be transported in the LEX byte, using the "add LEX byte to designated LSX channel", with LS0 as the designated channel, every other frame on average.

**7.2.2.2 Synchronization for the interleaved data buffer**

Synchronization control for the interleaved data buffer can occur in frames 1 through 67 of an ADSL superframe as described in 7.2.1.1, where the "synch" byte may be used as the synchronization control byte.

The format of the "synch" byte when used as synchronization control for the interleaved data buffer is given in table 28.

**Table 28 – Synch byte format for synchronization – Interleaved data buffer**

Bit	Application	Specific usage
sc7-sc4	not used	set to "0" until specified otherwise
sc3, sc2	LSX channel designator	"00" : channel LS0 "01" : channel LS1 "10" : channel LS2 "11" : do nothing to any LSX channel
sc1	Synchronization control for the designated LSX channel	"1" : add LEX byte to designated LSX channel "0" : delete last byte from designated LSX channel
sc0	Synch/aoc designator	"0" : perform synchronization control as indicated in sc3-sc1 "1" : LEX byte carries ADSL overhead control channel data; a delete synchronization control may be allowed as indicated in sc3-sc1

No synchronization action shall be taken during frame 0, where the "synch" byte is used for crc, and the LEX byte carries aoc.

When the data rate of the C channel is 16 kbit/s, the LS0 sub-channel shall be transported in the LEX byte, using the "add LEX byte to designated LSX channel", with LS0 as the designated channel, every other frame on average.

### 7.3 Scramblers

The binary data streams output from the fast and interleaved buffers shall be scrambled separately using the same algorithm as for the downstream signal, specified in 6.3

### 7.4 Forward error correction

The upstream data are Reed-Solomon coded and interleaved using the same algorithm as for the downstream data, specified in 6.4.

### 7.5 Tone ordering

The tone ordering algorithm shall be the same as for the downstream data, specified in 6.5.

### 7.6 Constellation encoder – with trellis coding

Block processing of Wei's 16-state 4-dimensional trellis code to improve system performance is optional. If it is implemented, an algorithmic constellation encoder shall be used to construct constellations with a maximum number of bits equal to  $N_{upmax}$ , where  $N_{upmax} \leq 15$ .

The encoding algorithm is the same as that used for downstream data (with the substitution of the constellation limit of  $N_{upmax}$  for  $N_{downmax}$ ), specified in 6.6.

### 7.7 Constellation encoder – without trellis coding

An algorithmic constellation encoder shall be used to construct constellations with a maximum number of bits equal to  $N_{upmax}$ , where  $15 \geq N_{upmax} \geq 8$ . The encoding algorithm is the same as that used for downstream data (with the substitution of the constellation limit of  $N_{upmax}$  for  $N_{downmax}$ ), which is specified in 6.7. The constellation encoder does not use trellis coding with this option.

ANSI T1.413-1995

**7.8 Gain scaling**

Each point  $(X_i, Y_i)$  or complex number,  $Z_i = X_i + jY_i$ , output from the encoder is multiplied by the fine gain adjuster,  $g_i$ :

$$Z_i' = g_i Z_i$$

The  $g_i$  define a scaling of the rms sub-carrier levels relative to those used in R-MEDLEY (see 12.7.8). They are independent of any methods that manufacturers may use to simplify implementation (e.g., constellation nesting).

**7.9 Modulation**

The frequency spacing,  $\Delta f$ , between sub-carriers shall be 4.3125 kHz with a tolerance of + 50 ppm.

**7.9.1 Sub-carriers****7.9.1.1 Data sub-carriers**

The channel analysis signal, defined in 11.5.2, allows for a maximum of 31 carriers (at frequencies  $n\Delta f$ ,  $n=1$  to 31) to be used. The lower limit on  $n$  is determined by the ADSL-POTS splitting filters; if FDM is used to separate the upstream and downstream signals, the upper limit on  $n$  is set by the down-up splitting filters. The cut-off frequencies of these filters are completely at the discretion of the manufacturer because in either case the range of usable  $n$  is determined during the channel estimation.

**7.9.1.2 Pilot**

Carrier #16 ( $f = 69.0$  kHz) shall be reserved for a pilot; that is  $b_{16} = 0$  and  $g_{16} = 1$ . The data modulated onto the pilot sub-carrier shall be a constant  $\{0,0\}$ . Use of this pilot allows resolution in a receiver of sample timing modulo-8 samples. Therefore a gross timing error that is an integer multiple of 8 samples, could still persist after a micro-interruption (e.g., a temporary short-circuit, open circuit or severe line hit); correction of these is made possible by the use of the synchronization symbol defined in 7.7.4.

**7.9.1.3 Nyquist frequency**

The carrier at the Nyquist frequency (#32) shall not be used for data; other possible uses are for further study.

**7.9.2 Modulation by the inverse discrete fourier transform**

The modulating transform defines the relationship between the 64 real values  $x_k$  and the  $Z_i'$

$$x_k = \sum_{i=0}^{63} \exp(j\pi ki/32) Z_i'$$

The encoder and scaler generate only 31 complex values of  $Z_i'$  (plus zero at dc and one real value if the Nyquist frequency is used). In order to generate real values of  $x_k$  these values shall be augmented so that the vector  $Z$  has Hermitian symmetry. That is,

$$Z_i' = \text{conj} [Z_{64-i}'] \quad \text{for } i = 33 \text{ to } 63$$

### 7.9.3 Synchronization symbol

The synchronization symbol permits recovery of the frame boundary after micro-interruptions that might otherwise force retraining.

The symbol rate,  $f_{\text{symbol}} = 4$  kHz, the sub-carrier separation,  $\Delta f = 4.3125$  kHz, and the IDFT size,  $N = 64$ , are such that a cyclic prefix of 5 samples could be used. That is,

$$(64 + 5) \times 4.0 = 64 \times 4.3125 = 276$$

The cyclic prefix, however, is shortened to 4 samples, and a synchronization symbol (with a nominal length of 68 samples) is inserted after every 68 data symbols. That is,

$$(64 + 4) \times 69 = (64 + 5) \times 68$$

The data pattern used in the synchronization symbol is the pseudo-random sequence PRU ( $d_n$ , for  $n = 1$  to 64), defined by

$$\begin{aligned} d_n &= 1 && \text{for } n = 1 \text{ to } 6 \\ d_n &= d_{n6} = d_{n6} && \text{for } n = 7 \text{ to } 64 \end{aligned}$$

The bits shall be used as follows: the first pair of bits ( $d_1$  and  $d_2$ ) is used for the dc and Nyquist sub-carriers (the power assigned to them is, of course, zero, so the bits are effectively ignored); then the first and second bits of subsequent pairs are used to define the  $X_i$  and  $Y_i$ , for  $i = 1$  to 31 as follows:

$d_{2i-1}$	$d_{2i2}$	$X_i$	$Y_i$
0	0	+	+
0	1	+	-
1	0	-	+
1	1	-	-

#### NOTES

- 1 The period of PRU is only 63 bits, so  $d_{64} = d_1$ .
- 2 The  $d_1 - d_6$  are re-initialized for each symbol, so each symbol of C-REVERB1 uses the same data.

Bits 33 and 34, which modulate the pilot carrier ( $i=16$ ) are overwritten by {0,0}, generating the {+,+} constellation.

The minimum set of sub-carriers to be used is the set used for data transmission (i.e., those for which  $b_i > 0$ ); sub-carriers for which  $b_i = 0$  may be used at a reduced PSD as defined in 7.13.4. The data modulated onto each sub-carrier shall be as defined above; it shall not depend on which sub-carriers are used.

### 7.10 Cyclic prefix

The cyclic prefix shall be used for data and synchronization symbols beginning with segment R-RATES1 of the initialization sequence, as defined in 12.7.2.1

## ANSI T1.413-1995

The last 4 samples of the output of the IDFT ( $x_k$  for  $k = 61$  to  $63$ ) shall be prepended to the block of 64 samples and read out to the DAC in sequence. That is, the subscripts,  $k$ , of the DAC samples in sequence are 60...63,0...63.

**7.11 Transmitter dynamic range**

The transmitter includes all analog transmitter functions: the D/A converter, the anti-aliasing filter, the hybrid circuitry, and the POTS splitter. The transmitted signal shall conform to the frequency requirements described in 7.9.1 for frequency spacing.

**7.11.1 Maximum clipping rate**

The maximum output signal of the transmitter shall be such that the probability of the signal being clipped is no greater than  $10^{-7}$ .

**7.11.2 Noise/Distortion floor**

The Signal to Noise plus Distortion (SINAD) ratio of the transmitted signal in a given sub-carrier is defined as the ratio of the rms value of the full-amplitude tone in that sub-carrier to the rms sum of all the non-tone signals in the 4.3125 kHz frequency band centered on the tone frequency. The SINAD is characterized for each sub-carrier used for transmission: SINAD $_i$  represents the signal to noise plus distortion available on the transmitted signal in the  $i$ th sub-carrier.

Over the transmission frequency band, the SINAD of the transmitter in any sub-carrier (or DMT tone) shall be no less than  $(3N_{\text{upl}} + 20)$  dB, where  $N_{\text{upl}}$  is defined as the size of the constellation (in bits) to be used in sub-carrier  $i$ . The minimum transmitter SINAD shall be at least 38 dB (corresponding to an  $N_{\text{upl}}$  of 6) for any sub-carrier.



## 7.12 Transmitter spectral response

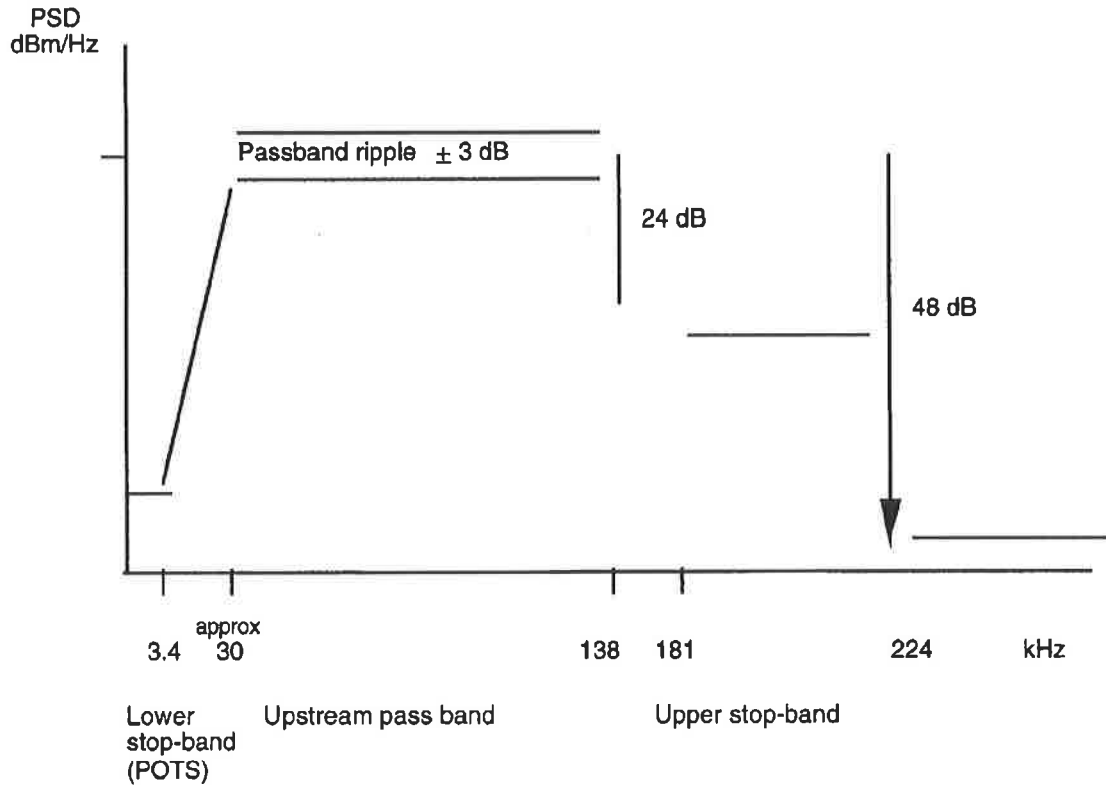

**Figure 22 – ATU-R transmitter PSD mask**

Figure 22 shows a representative spectral response mask for the transmitted signal. For purposes of this discussion, the pass band is defined as the frequency range over which the modem transmits. The low frequency stop band is defined as the POTS band. The high frequency stop band is defined as frequencies greater than 181 kHz, which is approximately  $10\Delta f$  above the maximum pass band frequency (138 kHz).

### 7.12.1 Pass band response

The pass band ripple shall be no greater than + 3 dB, and the group delay variation over the pass band shall not exceed 50  $\mu$ s.

### 7.12.2 Low frequency stop band rejection

The spectral characteristics of the output in the POTS band shall conform to the specifications in 10.3.

### 7.12.3 High frequency stop band rejection

The PSD in the band above 181 kHz shall be at least 24 dB below the spectral density of the pass-band mask. (see 12.4.3) The PSD in the band above 224 kHz (138 kHz+ 86 kHz) shall be at least 48 dB below the spectral density of the pass-band mask.

ANSI T1.413-1995

**7.13 Transmit power spectral density and aggregate power level**

There are three different PSD masks for the ATU-R transmit signal, depending on the type of signal sent. In all cases the power in the voice-band that is delivered to the POTS interface shall conform to the specification given in 10.2.

**7.13.1 All initialization signals (except R-ECT) starting with R-REVERB1**

The PSD in the band from 25 to 138 kHz, shall not exceed  $-38$  dBm/Hz for a total power of not greater than 13 dBm. The power in the voice band delivered to the POTS interface shall conform to the requirements of 10.4.

**7.13.2 R-ECT**

Because R-ECT is a vendor-defined signal (see 12.5.4), the PSD specification shall be interpreted only as a maximum. This maximum level is  $-38$  dBm/Hz for the band from 18 – 138 kHz. Sub-carriers 1 – 4 may be used, but the power in the voice-band that is delivered to the POTS interface shall conform to the specification given in 10.4.

**7.13.3 Steady-state data signal**

The transmit PSD in the frequency region from 25 – 138 kHz shall normally be  $-38$  dBm/Hz with a maximum of  $-35$  dBm/Hz; levels lower than  $-38$  dBm/Hz on some sub-carriers are discretionary. The aggregate power level shall not exceed  $(-2 + 10 \log n_{cup})$  dBm, where  $n_{cup}$  is the number of sub-carriers used (13 dBm if all sub-carriers are used). The bits and gains table (see C-B&G in 12.8.7), calculated by, and sent from the ATU-C during initialization, may eliminate some of the sub-carriers, and finely adjust (i.e., within a  $\pm 3$  dB range) the level of others in order to equalize expected error rates on each of the sub-channels.

**7.13.4 Synchronization symbol**

The PSD of those sub-carriers for which  $b_i > 0$  or  $b_i = 0$  and  $g_i > 0$  shall be the same as for the initialization signal R-REVERB1; that is, nominally  $-38$  dBm/Hz. The PSD for those sub-carriers for which  $b_i = 0$  and  $g_i = 0$  shall be no higher than  $-48$  dBm/Hz.

The PSD of a synchroniazation symbol thus differs from that of the data signals surrounding it by the  $g_i$ , which are applied only to the data carriers. These  $g_i$  are calculated for the multipoint constellations in order to equalize the expected error rate on all sub-channels, and are therefore irrelevant for most of the 4QAM signals of the synchronization symbol.

## 8 ADSL – POTS splitter functional characteristics

When ADSL is provided with POTS on the same twisted pair an ADSL – POTS splitting function shall be performed at each end of the line.

At the ATU-R the splitting functions are

- combining the POTS and the ATU-R transmit signals towards the U-R;
- separating the POTS and ADSL signals received from the U-R;
- protecting the POTS from voice-band interference from signals generated by both the ATU-R and ATU-C;
- protecting both ATU-R and ATU-C receivers from all POTS-related signals, particularly dial pulses, ringing and ring trip.

Protection of the ADSL receivers from those components of POTS-related signals that fall in the voice-band may be partially performed by the receivers themselves.

These functions shall be performed while meeting all requirements for POTS performance, such as echo and singing return loss, as specified in 10.1. Furthermore, these functions shall be performed in such a way that if either ATU is turned off, or if power is lost, continuity through the voice-band path is maintained, and telephone service is not interrupted.

The combination and separation of POTS and ADSL signals is achieved by low-pass and high-pass filtering. The POTS signal occupies the band up to 3.4 kHz; the bands occupied by the ADSL upstream and downstream signals are vendor options, but leakage of the signals into the voice-band shall be constrained as defined in 10.4.

The functional characteristics of the ADSL – POTS splitter at the ATU-C are the same as those at the ATU-R, but the performance requirements may be different because of the different relative levels of signals and interferences.

ANSI T1.413-1995

## 9 ATU-R to service module ( $T_{SM}$ ) interface requirements

Two distinctive T-interfaces are defined, see figure 23. The  $T_A$  interface preserves the ADSL channelization and the entire payload. The TTL-type signals at the  $T_A$  interface with separate clocks for each channel are intended for connection of the ADSL transceiver to other elements that are located within a few centimeters. The  $T_B$  interface is intended to provide a simple point-to-point connection of the ATU-R to a service module, which may be 50 meters distant (greater distances are for further study). Both interfaces are optional and not necessary for compliance with the standard. An additional composite, single-channel T interface is for further study.

Functionally, the  $T_A$ -interface preserves ADSL channelization and the entire payload, and the  $T_B$ -interface is designed as a simple point-to-point interface between the ADSL entrance unit and the service module. Future issues of this standard may update this interface or specify a multipoint ATU-R to SM interface. In particular, an additional composite, single channel T-interface is for further study, and the  $T_A$ -interface may or may not be included in future issues of the standard.

### 9.1 $T_A$ -interface definitions

The  $T_A$ -interface consists of a DATA and a clock (CLK) line for each of the four simplex ASX channels and for each direction of each of the three duplex LSX channels. The CLKs emanating from the ATU-R will not necessarily be smooth nor synchronous to one another. Any clock smoothing will be performed at the ATU-R to SM interface card.

The routing of proper ASX and LSX channels shall be performed by the ATU-R to SM interface card. An optional C-channel processor is specified for a multiple interface card configuration. The LS0 DATA and CLK from the ATU-R are passed to the C-channel processor before passing to the individual interface cards. The demultiplexing process of the LS0 channel can be performed by either the C-channel processor or by the individual SM's. Inversely, the upstream LS0 DATA and CLK from each interface card are collected and formatted at the C-channel processor, which in turn outputs a single upstream LS0 DATA and CLK to the ATU-R for transmission back to the ATU-C. DATAs and CLKs to and from the C-channel processor will be at standard logic levels, as specified in 9.1.1.

$T_A$ -interface signals and timing are defined as follows:

#### – ASX Channels:

- *Signal Levels:* Standard TTL logic levels;
- *Data:* NRZ;
- *Clock:* Standard logic levels, 50% ( $\pm 15\%$ ) duty cycle;
- *Clock polarity:* Data changes on rising clock edge;
- *Nominal clock frequency:* 1.536 MHz, 1.544 MHz, 3.072 MHz, 4.608 MHz, or 6.144 MHz, depending on configuration (2.048 MHz optional).

#### – LSX Channels:

- *Signal levels:* Standard TTL logic levels;
- *Data:* NRZ;
- *Clock:* Standard logic levels, 50% ( $\pm 15\%$ ) duty cycle;
- *Clock polarity:* Data changes on rising clock edge;
- *Nominal clock frequency:* 16 kHz, 64 kHz, 160 kHz, 384 kHz, or 576 kHz, depending on configuration.

## 9.2 T<sub>B</sub>-interface definitions

The T<sub>B</sub>-interface allows a point-to-point connection that is at most 50 meters from the ADSL entrance unit to the SM; greater distances are for further study. The T<sub>B</sub>-interface is located at the output of the ATU-R to SM interface card and consists of three separate simplex channels:

- a downstream ASX channel to the SM;
- a downstream LS0 channel to the SM;
- an upstream LS0 channel from the SM.

The optional LS1 (ISDN-BRA) channel and LS2 (H0) channel interfaces may also be provided at the T<sub>B</sub>-interface.

T<sub>B</sub>-interface signals and timing are defined as follows:

- ASX channel:
  - *Wire type*: Transformer-balanced, twisted-pair wire;
  - *Coding*: B8ZS;
  - *Bit rates*: 1.544, 1.536, 3.072, 4.608, or 6.144 Mbit/s depending on configuration (2.048 Mbit/s optional with G.703 Interface);
  - *Maximum transmit level*: 3 volts peak.
- LS0 channel:
  - *Wire type*: Transformer-balanced, twisted-pair wire;
  - *Coding*: Biphase (Manchester);
  - *Bit Rates*: 16 or 64 kbit/s depending on configuration;
  - *Interface*: EIA RS-422.
- LS1 Channel (optional) interface: ISDN-BRA U or S/T interface.
- LS2 channel (optional) interface: Partially filled T1 with same specifications as the ASX channel above.

ANSI T1.413-1995

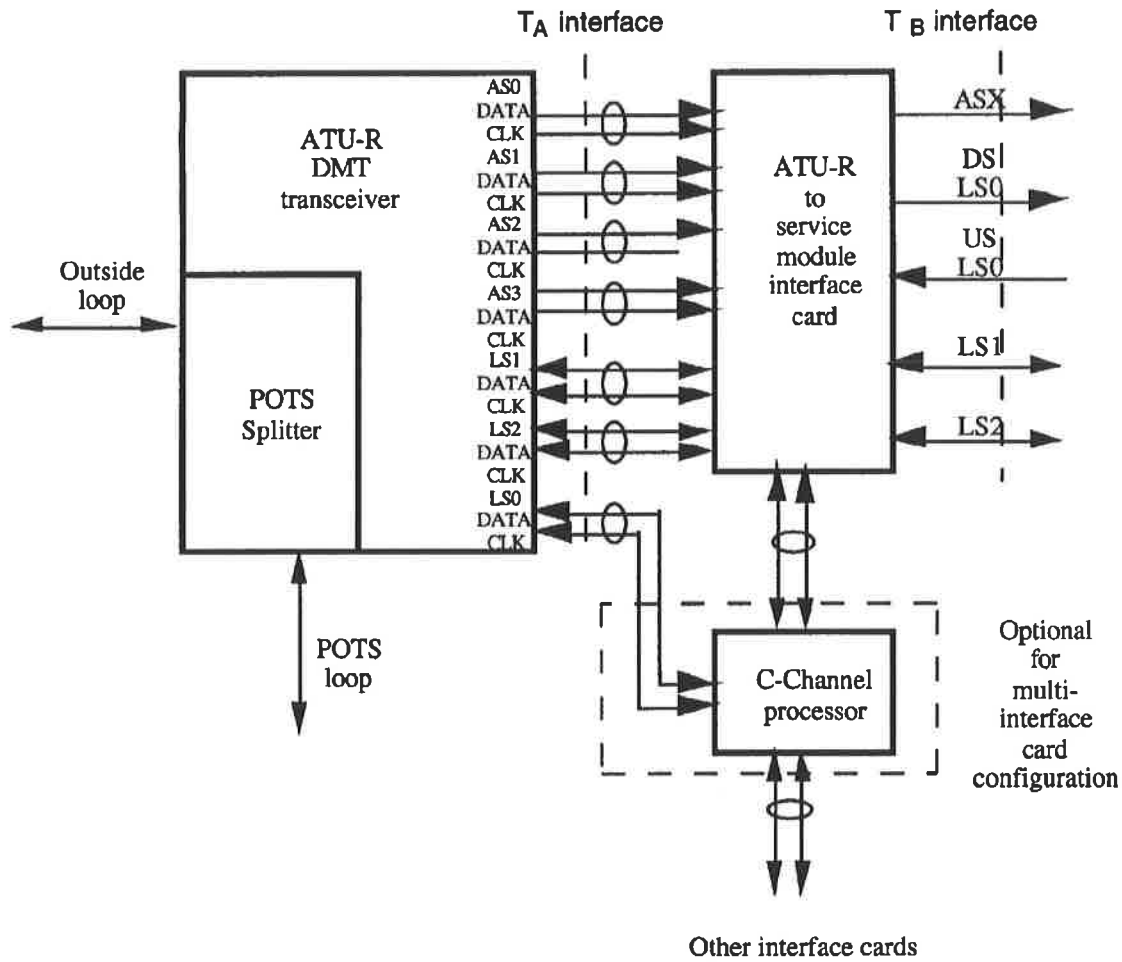

Figure 23 – ADSL entrance unit block diagram

## 10 Electrical characteristics

### 10.1 dc characteristics

All requirements of this standard shall be met in the presence of all POTS loop currents from 0 mA to 100 mA. Splitters shall pass POTS tip-to-ring dc voltages of 0 V to 105 V and ringing signals of 40 V to 150 V rms at any frequency from 15.3 Hz to 68 Hz with a dc component in the range from 0 V to 105 V.

The dc resistance from tip-to-ring at the PSTN interface with the U-C interface shorted, or at the POTS interface with the U-R interface shorted, shall be less than or equal to 25 ohms. The dc resistance from tip to ground and from ring to ground at the PSTN interface with the U-C interface open, or at the POTS interface with the U-R interface open shall be greater than or equal to 5 megohms.

### 10.2 Voice-band characteristics

#### 10.2.1 Metallic (differential mode)

A common test setup shall be used for measurement of the voice-band insertion loss, attenuation distortion, delay distortion, return loss, and noise and distortion. All measurements shall be performed between the PSTN and POTS interfaces of the ATU-C and ATU-R, respectively, with a variety of reference loops between the U-C and U-R reference points. The following loops shall be used:

- a null loop;
- ANSI T1.601 resistance-designed loops 7, 9, and 13;
- Committee T1 TR 28 CSA loops 4, 6, 7, and 8;
- 26 AWG wire pairs of lengths 0.5 kft, 2.0 kft, and 5.0 kft.

Figure 24 defines the test configuration and the value of the test components for all electrical characteristics defined in this clause unless otherwise specified; not all equipment will be required for all tests.

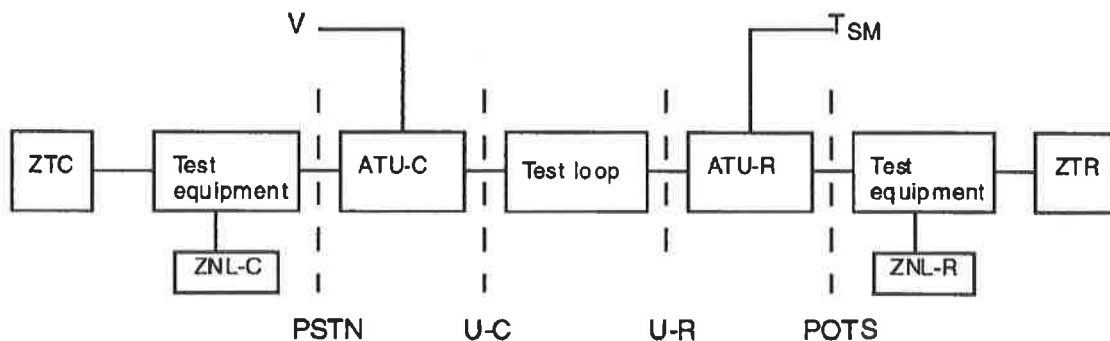

Where:

- ZTC = 900 ohms in series with 2.16  $\mu$ F for return loss measurements.  
 = 900 ohms for loss and noise measurements.
- ZTR = 600 ohms.
- ZNL-C = 800 ohms in parallel with the series connection of a 100 ohm resistor and a 50 nF capacitor.
- ZNL-R = 1330 ohms in parallel with the series connection of a 348 ohm resistor and a 100 nF capacitor (provisional values).

**Figure 24 – Test setup for transmission and impedance measurements**

ANSI T1.413-1995

**10.2.1.1 Insertion loss**

For each of the test loops specified in 10.1.2, and using the test set-up shown in figure 24, the insertion loss from the PSTN interface to the POTS interface shall be measured with and without the ATU-C and ATU-R connected to the test loop. The impedance of the test equipment at the PSTN interface shall be 900 ohms, and the impedance at the POTS interface shall be 600 ohms.

The increase in insertion loss at 1004 Hz on any of the test loops, due to the addition of the splitters shall be  $\leq 1.0$  dB.

**10.2.1.2 Attenuation distortion**

The variation of insertion loss with frequency of the combination of both POTS splitters shall be measured using the test setup shown in figure 24. The impedance of the test equipment at the PSTN interface shall be 900 ohms, and the impedance of the test equipment at the POTS interface shall be 600 ohms. The added attenuation distortion of the combined POTS splitters relative to loss at 1 kHz measured using each of the test loops identified above shall be not more than  $\pm 1.0$  dB at any frequency between 0.2 kHz and 3.4 kHz.

**10.2.1.3 Delay distortion**

The delay distortion of the POTS splitters shall be measured using the test setup of figure 24. The increase in envelope delay distortion between 0.6 kHz and 3.2 kHz caused by the two POTS splitters in each of the test loops shall be less than 200  $\mu$ S.

**10.2.1.4 Return loss**

The ERL, SRL-low and SRL-high shall be measured at the PSTN and POTS interfaces, for each of the 10 loops (except the null loop), under the following conditions:

- at the PSTN interface with both the ATU-C and ATU-R splitters installed and the ATU-R terminated in ZTR;
- at the PSTN interface with the ATU-C splitter installed and the ATU-R terminated in ZTR;
- at the POTS interface with both splitters installed and the ATU-C terminated in ZTC;
- at the POTS interface with the ATU-R splitter installed and the ATU-C terminated in ZTC.

The ERL, SRL-low and SRL-high for each of these conditions shall exceed the values contained in table 29 for each loop.

**Table 29 – Minimum voice-band return losses at PSTN and POTS interfaces**

Measurement location	ATU-C splitter	ATU-R splitter	ERL (dB)	SRL-low (dB)	SRL-high (dB)
PSTN	in	in	8	5	5
PSTN	in	out	8	5	5
POTS	in	in	6	5	5
POTS	out	in	6	5	5

Furthermore, it is desirable that the mean values of the ERL, SRL-low and SRL-high over the full suite of 10 loops be degraded as little as possible from the mean values with no splitters present. The permissible amount of degradation is for further study.

**10.2.1.5 Noise and distortion**

The distortion contributed by the two POTS splitters shall be measured using the test configuration of figure 24 and the null loop.



With an applied holding tone at  $-9$  dBm, the Signal-to-C-notched noise ratio shall exceed 42 dB, and the second- and third-order intermodulation distortion products shall be at least 57 dB and 60 dB, respectively, below the received signal level.

NOTE – While these measurements are often made with a holding tone level of  $-13$  dBm, a level of  $-9$  dBm is specified for this application because it represents the maximum allowed signal power from a voice-band modem onto a POTS line.

## 10.2.2 Longitudinal (common mode)

### 10.2.2.1 Longitudinal output voltage

The ATU-C shall present to the U-C interface, and similarly the ATU-R shall present to the U-R interface, a longitudinal component whose rms voltage in any 4 kHz band averaged in any 1 second period, is less than  $-50$  dBv over the frequency range 100 Hz to 1 MHz.

Figure 25 defines a measurement method for longitudinal output voltage. For direct use of this test configuration, the ATU shall be able to generate a signal in the absence of a received signal. The ground reference for these measurements shall be the building or green wire ground at the ATU.

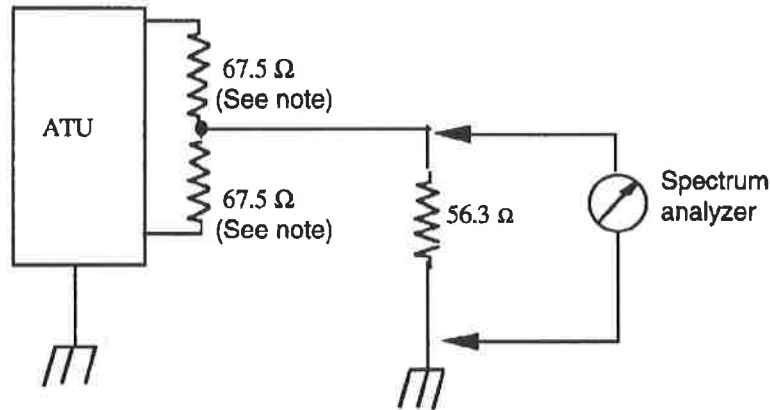

NOTE – These resistors shall be matched to better than 0.1% tolerance.

Figure 25 – Measurement method for longitudinal output voltage

### 10.2.2.2 Longitudinal balance

Longitudinal balance at the PSTN and POTS interfaces shall be  $> 58$  dB from 0.2 kHz to 1 kHz and  $> 53$  dB at 3 kHz, measured in accordance with IEEE Standard 455.

## 10.3 ADSL band

### 10.3.1 Return loss

At the U-C and U-R reference points the nominal impedance in the ADSL band shall be 100 ohms. The return loss relative to 100 ohms in the frequency range from 30 – 1100 kHz shall be  $\geq 10$  dB.

ANSI T1.413-1995

### 10.3.2 Longitudinal balance

Longitudinal balance at the U-C and U-R interfaces shall be > 40 dB over the frequency range 20 kHz to 1100 kHz with the PSTN and POTS interfaces terminated with ZTC and ZTR respectively. Longitudinal balance is given by the equation

$$LBal = 20 \log \left| \frac{e_l}{e_m} \right| \text{ dB}$$

where:

$e_l$  = the applied longitudinal voltage (referenced to the building or green wire ground of the ATU);

$e_m$  = the resultant metallic voltage appearing across a terminating resistor.

Figure 26 defines a measurement method for longitudinal balance in the ADSL band. For direct use of this test configuration, measurements shall be performed with the ATU powered up but inactive, driving 0 Volts.

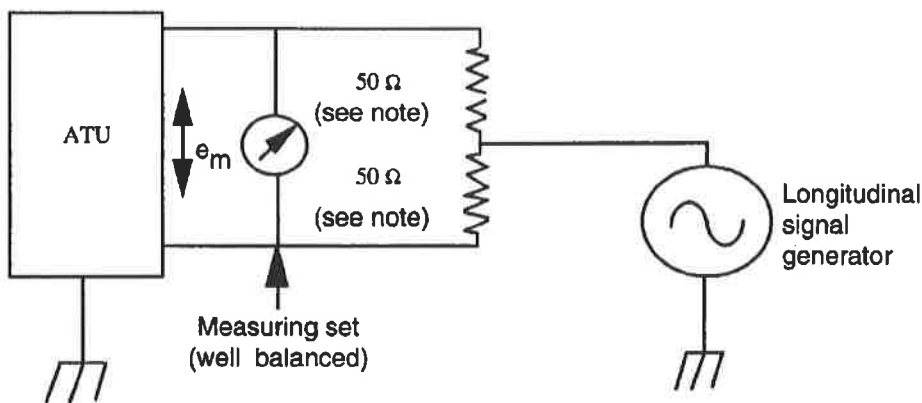

NOTE – These resistors to be matched to better than 0.03% tolerance

**Figure 26 – Measurement method for longitudinal balance above 25 kHz**

## 10.4 ADSL noise interference into the POTS circuit

### 10.4.1 Steady state noise

The idle channel noise on the POTS circuit shall not exceed 18 dBmC at either the POTS or the PSTN interfaces with the ADSL system installed whether operating or not operating.

The power at any single frequency less than 15 kHz as measured by test equipment with a bandwidth of 30 Hz shall not exceed the greater of 0 dBm or 10 dB below the measured idle channel noise.

### 10.4.2 Impulse noise

During initialization and operation of the ADSL system, with no holding tone applied to the circuit under test, there shall be no more than fifteen counts in fifteen minutes at a threshold of 47 dBmCO at either the PSTN or the POTS interface.

During initialization and operation of the ADSL system, with a  $-13$  dBm0 holding tone at 1004 Hz applied to the circuit under test, there shall be no more than fifteen counts in *fifteen minutes* at a threshold of 65 dBmCO at either the PSTN or the POTS interface.

These impulse noise requirements shall be met with each of the test loops specified in 10.2.1 with the ADSL system forced to re-initialize once per minute during the test interval.

## 11 Operations and maintenance

### 11.1 Embedded operations channel (eoc) requirements

An embedded operations channel for communication between the ATU-C and ATU-R shall be used for in-service and out-of-service maintenance, and for the retrieval of a limited amount of ATU-R status information and ADSL performance monitoring parameters. The eoc may also be used in the future to extend maintenance and performance monitoring to the service module(s) at the customer premises. The eoc channel is shared with user channel synchronization control of the fast data buffer. This clause describes the eoc functions, protocol, and commands. Insertion of eoc frames within the ADSL data frames is described in 6.2 and 7.2.

#### 11.1.1 eoc organization and protocol

The ADSL eoc is organized into eoc frames, which are transmitted within the synchronization control overhead of the fast data buffer, to allow the ATU-C (acting as master of the link) to invoke commands and the ATU-R (acting as slave) to respond to the commands.

When it is not required for synchronization control, crc, or fixed indicator bits, the "fast" byte of two successive ADSL frames, beginning with an even-numbered frame as described in 6.2 and 7.2, shall be used to transmit one eoc frame, consisting of 13 bits. For the allowable user data configurations (see 5.3), up to 32 eoc frames can be transmitted per ADSL superframe. The eoc channel rate will vary from some minimum rate that will be dependent on the vendor's synchronization control algorithm (to implement the synchronization control described in 6.2) to about 23.7 kbit/s.

The ATU-C, as master, determines the eoc rate of the ADSL link; therefore only one eoc frame shall be inserted in the upstream direction (by the ATU-R) for each received eoc frame. One exception to this is for the "dying gasp" message, which is the only autonomous message currently allowed from the ATU-R and is inserted as soon as upstream "fast" bytes are available.

The 13 bits of the eoc frame are defined in table 30. The assignment of these bits to positions within the "fast byte" is defined in 6.2 and 7.2. The eoc protocol states are defined in 11.1.4.

Table 30 – eoc bit functions

Bit position	#Bits	Description	Notes
1,2	2	Address field	Can address 4 locations
3	1	Data (0) or opcode (1) field	Data used for read/write
4	1	Byte parity field Odd (1) or even (0)	Multibyte transmission
5	1	Unspecified for ATU-C (set to 1) (see note) Autonomous ATU-R message (0) or ATU-R response to eoc protocol (1)	Reserved for future use at ATU-C Used by ATU-R to send "dying gasp"
6-13	8	Information field	58 opcodes, 8 bits data
NOTE – The only autonomous message currently defined for the ATU-R is the "dying gasp" (11.1.4.4). Other uses of the eoc5 bit are for further study.			

ANSI T1.413-1995

### 11.1.2 eoc frame structure

The eoc frame shall contain 5 fields, defined in the following subclauses.

#### 11.1.2.1 Address field

The two bits of the address field can address up to four locations. Only two locations are presently defined:

- 11 for the ATU-C;
- 00 for the ATU-R.

10 and 01 are reserved for future use.

#### 11.1.2.2 Data or opcode field

A 1 in this field indicates that the information field of the current eoc frame contains data; a 0 that it contains an operation code for an ADSL eoc message.

#### 11.1.2.3 Byte parity field

For the first byte of data that is to be either read or written, this bit shall be set to 1 to indicate "odd" byte. For the next byte, it is set to 0 to indicate "even" byte and so on, alternately. This bit helps to speed up multi-byte reads and writes of data by eliminating the need for intermediate opcodes to indicate to the far end that the previous byte was successfully received.

#### 11.1.2.4 Unspecified bit (ATU-C) / ATU-R autonomous message field

At the ATU-C, this field is reserved for future use, and until specified otherwise shall be set to 1 in all eoc frames transmitted by the ATU-C. At the ATU-R, a 1 in this field shall designate that the current eoc frame is an eoc protocol response (slave) message; a 0 that it is an autonomous message that does not disturb the current state of the eoc protocol at either the ATU-C or the ATU-R. The only autonomous message currently defined for the ATU-R is the "dying gasp" (11.1.4.4).

#### 11.1.2.5 Information field

Up to 58 different messages or 8 bits of binary or ASCII data may be encoded in the information field.

The message set is restricted to codes that provide a minimum Hamming distance of 2 between all opcodes, and a minimum distance of 3 between certain critical codes and all other codes.

### 11.1.3 eoc message sets

The ATU-C sends commands to the ATU-R to perform certain functions. Some of these functions require the ATU-R to activate changes in the circuitry (e.g., to send crc bits that are corrupt). Other functions that can be invoked are to read from and write into data registers located at the ATU-R. The data registers are used for reading status- or performance-monitoring parameters from the ATU-R, or for limited maintenance extensions to the CI wiring distribution network or service modules.

Some of these commands are "latching", meaning that a subsequent command shall be required to release the ATU-R from that state. Thus, multiple ADSL eoc-initiated actions can be in effect simultaneously. A separate command, "Return To Normal", shall be used to unlatch all latched states. This command is also used to bring the ADSL system to a known state, the idle state, when no commands are active in the ATU-R location. To maintain the latched state, the command "Hold State" shall be continually sent.

The ATU-C always issues the commands, and the ATU-R responds by acknowledging to the ATU-C that the message was received correctly.

### 11.1.3.1 eoc message set requirements

Messages that may be sent by the ATU-R and ATU-C in response to correctly received messages are:

- *Hold State*: This message shall be sent by the ATU-C to the ATU-R to maintain the ATU-R eoc processor and any active ADSL eoc-controlled operations (such as latching commands) in their present state;
- *Return to Normal (Idle Code)*: This message releases all outstanding eoc-controlled operations (latched conditions) at the ATU-R and returns the ADSL eoc processor to its initial state. This code is also the message sent during idle states;
- *Unable to Comply Acknowledgment*: The ATU-R shall send this message when it receives an ADSL eoc message that it cannot perform either because it does not recognize or implement the command or because the command is unexpected, given the current state of the ADSL eoc interface. An example of an unexpected command is one that indicates that the information field contains data, but that was not preceded by a "Write Data" command;
- *Request Corrupt crc*: This message requests the ATU-R to send corrupt crcs to the ATU-C until canceled by the "Request End of Corrupt crc" or "Return to Normal" message. In order to allow multiple ADSL eoc-initiated actions to be in effect simultaneously, the "Request corrupt crc" command shall be latching;
- *Request End of Corrupt crc*: This message requests the ATU-R to stop sending corrupt crcs toward the ATU-C;
- *Notify Corrupted crc*: This message notifies the ATU-R that intentionally corrupted crcs will be sent from the ATU-C until cancellation is indicated by "Notify End of Corrupted crc" or "Return to Normal";
- *Notify End of Corrupted crc*: This message notifies the ATU-R that the ATU-C has stopped sending corrupted crcs;
- *Perform Self Test*: This message requests the ATU-R to perform a self test. The result of the self test is stored in a register at the ATU-R. After the ATU-R self test, the ATU-C reads the test results from the ATU-R register;
- *Write Data (Register #)*: This message directs the ATU-R to enter the Data Write Protocol state and receive data in the register specified by the Opcode;
- *Read Data (Register #)*: This message directs the ATU-R to enter the Data Read Protocol state to transmit data to the ATU-C from the register specified by the Opcode;
- *Next Byte*: This message is sent by the ATU-C in data read or data write mode after the ATU-R has acknowledged the previously sent read or write data command. This message is continually sent by the ATU-C when it is in the data read or data write mode, toggling bit four for multi-byte data, until all data have been read;
- *End of Data*: This message is sent by the ATU-C after it has sent all bytes of data to the ATU-R. This message is also sent by the ATU-R in response to a "Next Byte" message from the ATU-C that is received after all bytes have been read or written from the currently addressed ATU-R register;
- *Vendor Proprietary Opcodes*: Four opcodes have been reserved for vendor proprietary use. The ATU-C shall read the ID (identification) code register of the ATU-R to ensure compatibility between the ATUs before using proprietary opcodes;
- *Undefined Command Codes*: All command codes not defined are reserved for future use, and shall not be used for any purpose.

ANSI T1.413-1995

**11.1.3.2 eoc opcode messages****Table 31 – eoc opcode messages**

(HEX)	Opcode meaning	Notes
01	Hold state	To continue sending corrupt crcs
F0	Return all active conditions to normal	Also used as "idle code"
02	Perform "self test"	Self test results are stored in register
04	Unable to comply (UTC)	Unrecognizable command
07	Request corrupt crc (see note)	
08	Request end of corrupt crc	
0B	Notify corrupt crc (see note)	
0D	Notify end of corrupt crc	
0E	End of data	
10	Next byte	
E7	Dying Gasp	Sent by ATU-R only
(20,23,25,26) (29,2A,2C,2F) (31,32,34,37) (38,3B,3D,3E)	Write data register numbers 0 through F	
(40,43,45,46) (49,4A,4C,4F) (51,52,54,57) (58,5B,5D,5E)	Read data register numbers 0 through F	
(19,1A,1C,1F)	Vendor proprietary protocols	
NOTE – Latching conditions.		

The eoc opcode messages specified in table 31 guarantee a minimum Hamming distance of 2 (by requiring odd parity for all but two critical codes) between all opcodes, a minimum Hamming distance of 3 between the "Return to Normal" (or "idle") code and all other codes, and a minimum Hamming distance of 3 between the "Dying Gasp" code and all other codes.

The following hexadecimal codes, which still maintain a minimum Hamming distance of 2, shall not be used unless specified at some future time: 13, 15, 16, 80, 83, 85, 86, 89, 8A, 8C, 8F.

### 11.1.3.3 Data registers in the ATU-R

Table 32 summarizes the ATU-R data registers and their applications.

**Table 32 – ATU-R data registers**

REG # (HEX)	USE	LENGTH	DESCRIPTION
0	Read (R)	6 bits	ID code (ATU-R): bits 0-3: vendor IDs 0 through F, bits 4,5: reserved for future use (set to 0)
1	R	6 bits	version number : bits 0-3: version numbers 0 through F, bits 4,5: reserved for future use (set to 0)
2	R	256 bits	Serial #
3	R	1 byte	Self test results
4	Read/Write (R/W)	Vendor Defined	Vendor defined
5	R/W	Vendor Defined	Vendor defined
6	R	1 byte	line attenuation
7	R	1 byte	Estimated margin
8	R	30 bytes	ATU-R Configuration (Note 1) : one byte each for $B_F(AS0)$ , $B_I(AS0)$ , $B_F(AS1)$ , $B_I(AS1)$ , $B_F(AS2)$ , $B_I(AS2)$ , $B_F(AS3)$ , $B_I(AS3)$ , $B_F(LS0)$ , $B_I(LS0)$ , $B_F(LS1)$ , $B_I(LS1)$ , $B_F(LS2)$ , $B_I(LS2)$ FS(LS2) (downstream), $B_F(LS0)$ , $B_I(LS0)$ , $B_F(LS1)$ , $B_I(LS1)$ , $B_F(LS2)$ , $B_I(LS2)$ FS(LS2) (upstream), $R_{dsf}$ , $R_{dsi}$ , $S$ , $I$ (downstream), $R_{usf}$ , $R_{usi}$ , $S$ , $I$ (upstream)
9	R	4 bits	Service module maintenance indicators (Note 2): bit 0: SM downstream sync bit 1: SM downstream no sync bit 2: SM upstream sync bit 3: SM upstream no sync
A – F	reserved	reserved	

**NOTES**

- 1 ATU configuration parameter set ( $B_F()$ ,  $B_I()$ , FS(LS2),  $R_{dsf}$ ,  $R_{dsi}$ ,  $R_{usf}$ ,  $R_{usi}$ ,  $S$ ,  $I$ ) are defined in 6.2 and 7.2.
- 2 SM sync – no sync indicators defined in 11.5.
- 3 Registers A through F are reserved for future use; ATU-R shall respond UTC (unable to comply) if requested to read or write one of these registers.

### 11.1.4 eoc protocol states

The ADSL eoc protocol operates in a repetitive command and response mode. The ATU-C acts as the master and issues commands; the ATU-R acts as slave, and responds to the commands issued by the ATU-C. Three identical properly-addressed consecutive messages shall be received before an action is initiated. Only one command and only three or fewer messages, under the control of the ATU-C, shall be outstanding (i.e., unacknowledged) at any one time. (This restriction on the number of messages guarantees that an ATU-R with fewer opportunities to insert eoc frames into the upstream path will be able to acknowledge all eoc messages from the ATU-C.)

## ANSI T1.413-1995

Three types of responses are allowed from the ATU-R; therefore three command and response protocol states are allowed on the ADSL eoc. The three states are:

- message/echo-response protocol state;
- message/unable-to-Comply-response protocol state;
- message/data-response protocol state.

In addition to these three states, one autonomous message shall be allowed from the ATU-R to the ATU-C to indicate "dying gasp". This message does not change the protocol state, nor does it count as a response to any ATU-C message; however, other actions (e.g., an automatic reset at the ATU-C) taken as a result of receiving this message may lead to a change of state (e.g., back to idle).

The eoc protocol shall enter the Message/Echo-response protocol state when the ATUs transition from the initialization and training sequence to steady state transmission. The ATU-C shall continuously send an appropriately addressed message. In order to cause the desired action in the addressed location, the ATU-C shall continue to send the message until it receives three identical consecutive eoc frames from the addressed location. The command and response protocol for that message shall be completed before a new message, which may induce a different protocol state in the ATU-R, may be issued.

#### 11.1.4.1 Message / echo-response protocol state

To initiate an action at the ATU-R, the ATU-C shall begin sending eoc messages with the Data/opcode set to 0, and with the appropriate message opcode in the information field.

The ATU-R shall initiate action when, and only when, three identical, consecutive, and properly addressed eoc frames that contain a message recognized by the ATU-R have been received. The ATU-R shall respond to all received messages. The response shall be an echo of the received ADSL eoc message. The combination of the ATU-C sending an ADSL eoc frame and the ATU-R echoing the frame back comprises the message/echo-response protocol state.

For the ATU-C to confirm correct reception of the message by the ATU-R, the message / echo-response ADSL eoc protocol state shall be repeated until the master node receives three identical and consecutive echoes. This serves as an implicit acknowledgment to the ATU-C that the ATU-R has correctly received the transmitted message and is acting on it. This completes the Message / Echo-response protocol mode.

Because eoc frames are inserted into ADSL frames only when the "fast byte" is available, the amount of time it takes to complete a message under error-free conditions will depend on the vendor's synchronization control algorithm, on the number of signals allocated to the fast buffer, and on the rates of those signals.

The ATU-C may continuously send the activating message after the receipt of the three valid echoes, or alternatively, it may switch to sending the "Hold State" message. If the message was one of the latching commands, then the ATU-R shall maintain the commanded condition until the ATU-C issues the appropriate command that ends the specific latched condition or until the ATU-C issues the "Return to Normal" command (at which time all latched conditions in the ATU-R shall be terminated).

#### 11.1.4.2 Message / unable-to-comply response protocol state

When the ATU-R does not support a message that it has received three times identically and consecutively, it shall respond with the Unable-To-Comply (UTC) ADSL eoc response message with its own address in lieu of a third identical and consecutive echo. In this manner the ATU-R will switch to the message / UTC-response protocol state.



The transmission by the ATU-R and reception by the ATU-C of three identical, consecutive, properly-addressed Unable-To-Comply messages constitutes notification to the ATU-C that the ATU-R does not support the requested function, at which time the ATU-C may abandon its attempt.

#### 11.1.4.3 Message / data-response protocol state

The ATU-C can either write data into, or read data from the ATU-R memory.

##### 11.1.4.3.1 Data read protocol

To read data from the ATU-R, the ATU-C shall send an appropriate read opcode message to the ATU-R that specifies the register to be read. After receiving three identical and consecutive acknowledgments, the ATU-C shall request the first byte to be sent from the ATU-R by sending "Next Byte" messages with bit four set to 1, indicating a request for an "odd" byte. The ATU-R shall respond to these "Next Byte" messages by echoing them until it has received three such messages consecutively and identically. Beginning with the third such reception, the ATU-R shall respond by sending the first byte of the register in the information field of an ADSL eoc frame with bit four set to 1 to indicate "odd byte" and with bit 3 set to 0 to indicate that the eoc frame is a data frame (as opposed to a frame that contains an opcode in the information field). The ATU-C continues to send the "Next Byte" message with bit four set to "odd byte", and the ATU-R continues to respond with a data frame containing the first byte of data and bit four equal to "odd byte", until the ATU-C has received three consecutive and identical data frames with bit four set to "odd byte".

If there are more data to be read, the ATU-C shall request the second byte of data by sending "Next Byte" messages with bit four set to 0 ("even byte"). The ATU-R echoes all messages received until three such "Next Byte" messages have been received, and on the third consecutive and identical "Next Byte" message, the ATU-R starts sending data frames containing the second byte of the register with bit four set to 0. The ATU-C continues to send the "Next Byte" message with bit four set to "even byte", and the ATU-R continues to respond with a data frame containing the identical data frames with bit four set to "even byte".

The process continues for the third and all subsequent bytes with the value of bit four toggling from "odd byte" to "even byte" or vice versa, on each succeeding byte. Each time bit four is toggled, the ATU-R shall echo for two correct frames, and starts sending the data frame on the third reception. The process ends only when all data in the register have been read.

To continue reading data, once the ATU-R is in the data read mode, the only message that the ATU-C is allowed to send is the "Next Byte" message with bit four toggling. To end the data read mode abnormally, the ATU-C shall send either "Hold State" or "Return to Normal", depending on whether any latched states are to be retained. If the ATU-R receives any other message three times consecutively and identically while it is in data read mode, then it shall go into a UTC mode.

If, after all bytes have been read from the ATU-R register, the ATU-C continues to send the "Next Byte" message with bit four toggled, then the ATU-R shall send an "End of Data" message (with bit three set to 1 indicating opcode).

The data read mode ends either when the ATU-C has received the last requested data byte three times consecutively and identically, or when the ATU-C has received three consecutive "End of Data" messages with bit three set to 1. The ATU-C shall then switch over to a known state with the "Hold State" or "Return to Normal" message, and the ATU-R shall release the register and end the data read mode.

ANSI T1.413-1995

**11.1.4.3.2 Data write protocol**

To write data to the ATU-R's memory, the ATU-C shall send a "Write Data" opcode message to the ATU-R that specifies the register to be written. When the ATU-R acknowledges with three consecutive echo messages, the ATU-C shall send the first byte of data. The ATU-R shall acknowledge the receipt of the byte with an echo of the message. After the ATU-C is satisfied with three identical and consecutive correct echo responses, it shall start sending the next byte of data. Each time the ATU-C receives three identical and consecutive correct data echo responses, it shall switch to sending the next byte of data. It shall also toggle the "odd/even" bit accordingly. ("Next Byte" messages are not used in the Data Write mode). The ATU-C shall end the write mode with the "End of Data" message indicating to the ATU-R to release the register and end the data write mode.

**11.1.4.4 "dying gasp"**

When circuits in the ATU-R detect that electrical power has been shut off, the ATU-R shall insert eoc frames into the ADSL upstream data to implement a "dying gasp". The "dying gasp" eoc frames shall have bit 5 set to 0 to indicate autonomous message, bit 3 set to 1 to indicate opcode, and shall contain the "dying gasp" opcode (see table 31) in the information field. At least six of these frames are inserted in the next (twelve) available ADSL upstream "fast" bytes beginning with an even-numbered frame, regardless of the number of eoc frames received in the downstream channel.

Sending the "dying gasp" shall not cause the ATU-R to change the eoc protocol state, nor shall receiving it cause the ATU-C to immediately change state.

**11.2 In-service performance monitoring and surveillance**

The following terminology is used in this standard (see figure 27):

- *Near-end*: Near-end means performance of the loop-side received signal at the input of the ATUs;
- *Far-end*: Far-end means performance of the downstream loop-side received signal at the input of the ATU-R, where this performance is reported to the ATU-C in upstream overhead indicators (see figure 27). Far-end also means performance of the upstream loop-side received signal at the input of the ATU-C, where this performance is reported to the ATU-R in downstream overhead indicators; this case is a mirror image of the above;
- *Primitives*: Primitives are basic measures of performance, usually obtained from digital signal line codes and frame formats, or as reported in overhead indicators from the far-end. Performance primitives are categorized as events, anomalies and defects. Primitives may also be basic measures of other quantities (e.g., ac or battery power), usually obtained from equipment indicators;
- *Events*: Events are bit error related primitives that do not affect service performance (fec and fecc);
- *Anomalies*: Anomalies are bit error related primitives that affect service performance (crc and febe);
- *Defects*: Defects are signal or framing related primitives that are more disruptive to service than anomalies (los, sef, rdi).

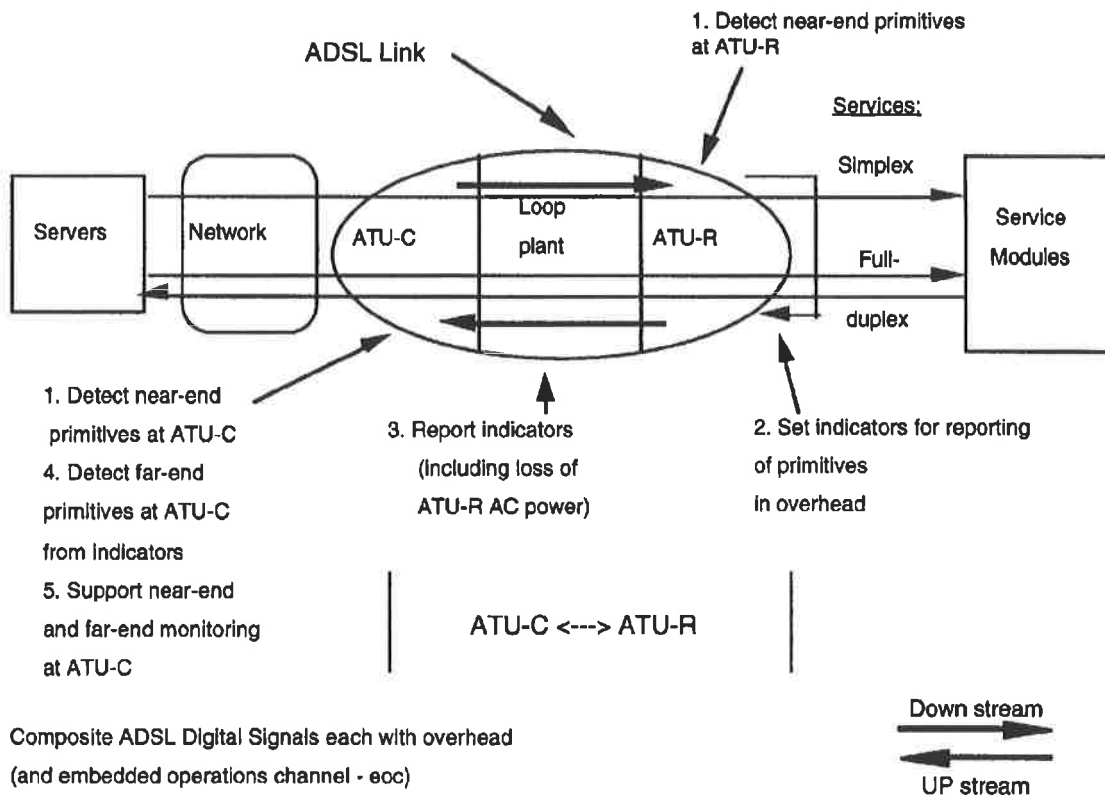

**Figure 27 – In-service surveillance of the ADSL link shown from the standpoint of the ATU-C**

## 11.2.1 Digital transmission related primitives

### 11.2.1.1 Near-end events

Two near-end events are defined:

- *Forward error correction (fec)-i*: An fec-i event occurs when a received FEC code for the interleaved data stream indicates that errors have been corrected;
- *Forward error correction (fec)-ni*: An fec-ni event occurs when a received FEC code for the non-interleaved data stream indicates that errors have been corrected.

### 11.2.1.2 Far-end events

Similarly, two far-end events are defined:

- *Far-end forward error correction (ffec)-i*: ffec-i shall be reported by the fecc-i indicator, which is coded with one indicator bit (1 indicating that no event is present in the previous superframe; 0 indicating that an event is present) in the overhead, and reported once per ADSL superframe.
- *Far-end forward error correction (ffec)-ni*: ffec-ni shall be reported by the fecc-ni indicator, which is coded and reported in the same way as an fecc-i.

ANSI T1.413-1995

**11.2.1.3 Near-end anomalies**

Two near-end anomalies are defined:

- *Cyclical redundancy check (crc)-i error*: A crc-i anomaly occurs when a received CRC-8 code for the interleaved data stream is not identical to the corresponding locally generated code;
- *Cyclical redundancy check (crc)-ni error*: A crc-ni anomaly occurs when a received CRC-8 code for the non-interleaved data stream is not identical to the corresponding locally generated code.

**11.2.1.4 Far-end anomalies**

Similarly, two far-end anomalies are defined:

- *Far-end block error (febe)-i*: A crc-i anomaly detected at the far-end shall be reported by the febe-i indicator, which is coded with one indicator bit ( 1 indicating that no event is present in the previous superframe; 0 indicating that an event is present) in the overhead, and reported once per ADSL superframe;
- *Far-end block error (febe)-ni*: A crc-ni anomaly detected at the far-end shall be reported by the febe-ni indicator, which is coded and reported in the same way as an febe-i.

**11.2.1.5 Near-end defects**

Two near-end defects are defined:

- *Loss-of-signal (los)*: A pilot tone reference power shall be established by averaging the ADSL pilot tone power for 0.1 after the start of steady state data transmission (i.e., after initialization). An LOS defect then occurs when the received ADSL pilot tone power, averaged over a 0.1 s period, is 6 dB or more below the reference power. An LOS defect shall terminate when the received pilot tone power, averaged over a 0.1 s period is less than 6 dB below the reference;
- *Severely errored frame (sef)*: An sef defect occurs when the content of two consecutively received ADSL synchronization symbols does not match the expected content. An sef defect terminates when the content of two consecutively received ADSL synchronization symbols matches the expected content.

**11.2.1.6 Far-end defects**

- *Loss-of-signal (los)*: An LOS defect as detected at the far-end shall be reported by the los indicator, which is coded with one indicator bit (1 indicating that no defect is being reported; 0 indicating that a defect is being reported) in the overhead, and reported for six consecutive ADSL superframes;

A far-end los defect occurs when 4 or more out of 6 contiguous los indicators are received set to 0. A far-end los defect terminates when 4 or more out of 6 contiguously received los indicators are set to 1;

- *Remote defect indication (rdi)*: An sef defect is reported by the rdi indicator, which is coded with one indicator bit (1 indicating that no event is present in the previous superframe; 0 indicating that an event is present) in the overhead, and reported once per ADSL superframe. An rdi defect occurs when a received rdi indicator is set to 0. An rdi defect terminates when a received rdi indicator is set to 1.

## 11.2.2 Other primitives

### 11.2.2.1 Other near-end primitives

Three other near-end primitives are defined:

- *Attenuation (atn)*: An atn primitive is the difference in dB between the power received at the near-end and that transmitted from the far-end. Signal power in dBm is the sum of all active DMT subcarrier powers averaged over a 1 s period. An atn primitive is expressed as an integer number of dB ranging from a minimum of 0 to a maximum of 60 dB, so as to correspond to a sensible range of atn;
- *Signal-to-Noise ratio (snr) margin*: An snr margin primitive represents the amount of increased noise (in dB) relative to the noise power that the system is designed to tolerate and still meet the target BER of  $10^{-7}$ , accounting for all coding (e.g., Trellis code, FEC) gains included in the design. An snr margin primitive is expressed as an integer number of dB ranging from a minimum of x dB to a max. of y dB, with x and y for further study so as to correspond to a sensible range of SNR;
- *Loss-of-power (lpr)*: An lpr primitive occurs when ATU power drops to a level equal to or below the manufacturer-determined minimum power level required to ensure proper operation of the ATU. An lpr primitive terminates when the power level exceeds the manufacturer-determined minimum power level.

### 11.2.2.2 Other far-end primitives

Similarly, three other far-end primitives are defined:

- *Attenuation (atn)*: An atn primitive as detected at the far-end shall be reported by the atn indicator. A far end atn primitive occurs when one atn indicator is received with value not less than x and not more than y dB, with the values of x and y for further study. The atn indicator is reported in an eoc message;
- *Signal-to-noise Ratio (snr) margin*: An snr margin primitive as detected at the far-end shall be reported by the snr margin indicator in an eoc message. A far-end snr margin primitive occurs when one snr margin indicator is received with value not less than x and not more than y dB, with the values of x and y for further study;
- *Loss-of-power (lpr)*: An lpr primitive as detected at the far-end shall be reported by the lpr indicator. A far-end lpr primitive occurs when 4 out of 6 contiguous lpr indicators are received. A far-end lpr primitive terminates if the near signal remains present, i.e., if the received 4 out of 6 contiguous lpr indicators are not followed by any near-end los defects in the next 0.5 s (see los defect definition in 11.2.1.5);

The lpr indicator is coded as an 8 bit emergency priority message in the ATU-R to ATU-C overhead, and is reported in the next 6 available outgoing eoc frames (see the eoc protocol for "dying gasp" in 11.1.4.4).

## 11.2.3 Failures and failure count parameters

### 11.2.3.1 Near-end failures and failure count parameters

At the ATU-R, near-end failures shall be manifested as LOS or LOF failure (e.g., red light), no failures (e.g., green light), and LPR (e.g., no lights); failure count parameters are optional.

The following near-end failures and failure count parameters are required at the ATU-C:

- *Loss-of-signal (LOS)*: An LOS failure is declared after  $2.5 \pm 0.5$  seconds of contiguous los defect, or, if los defect is present when the criteria for LOF failure declaration have been met (see LOF definition below). An LOS failure is cleared after  $10 \pm 0.5$  seconds of no los defect. An LOS failure count is the number of occurrences of an LOS failure event,

## ANSI T1.413-1995

where a failure event occurs when the failure is declared, and ends when the failure clears;

– *Loss-of-frame (LOF)*: An LOF failure is declared after  $2.5 \pm 0.5$  seconds of contiguous sef defect, except when an los defect or failure is present (see LOS definition above). A LOF failure is cleared when LOS failure is declared, or after  $10 \pm 0.5$  seconds of no sef defect. An LOF failure count is the number of occurrences of an LOF failure event, where a failure event occurs when the failure is declared, and ends when the failure clears;

– *Loss-of-power (LPR)*: An LPR failure is declared after the occurrence of an lpr primitive, followed by other-to-be determined conditions. This definition is under study. An LPR failure count is the number of occurrences of an LPR failure event, where a failure event occurs when the failure is declared, and ends when the failure clears.

### 11.2.3.2 Far-end failures and failure count parameters

The following far-end failures and failure count parameters are required at the ATU-C (ATU-R is at the far-end), and are optional at the ATU-R (ATU-C is at the far-end).

– *Loss-of-signal (LOS)*: A far-end LOS failure is declared after  $2.5 \pm 0.5$  seconds of contiguous far-end los defect, or, if far-end los defect is present when the criteria for LOF failure declaration have been met (see below). A far-end LOS failure is cleared after  $10 \pm .5$  seconds of no far-end los defect. An LOS failure count is the number of occurrences of an LOS failure event, where a failure event occurs when the failure is declared, and ends when the failure clears;

– *Remote failure indication (RFI)*: An RFI failure is declared after  $2.5 \pm 0.5$  seconds of contiguous rdi defect, except when a far-end los defect or failure is present (see above). A RFI failure is cleared when far-end LOS failure is declared, or after  $10 \pm 0.5$  seconds of no rdi defect. An RFI failure count is the number of occurrences of a RFI failure event, where a failure event occurs when the failure is declared, and ends when the failure clears;

– *Loss-of-power (LPR)*: An LPR failure is declared after receiving a far-end lpr (dying gasp-like) primitive followed by  $2.5 \pm 0.5$  seconds of contiguous near-end los defect. AN LPR failure is cleared after  $10 \pm 0.5$  seconds of no near-end los defect. An LPR failure count is the number of occurrences of an LPR failure event, where a failure event occurs when the failure is declared, and ends when the failure clears.

### 11.2.4 Quality-of-service (QOS) parameter

#### 11.2.4.1 Near-end QOS parameter

The near-end errored-second (ES) parameter is a count of one-second intervals containing one or more crc-i or crc-ni anomalies, or one or more los or sef defects. It is required at the ATU-C, and is optional at the ATU-R.

#### 11.2.4.2 Far-end QOS parameter

The far-end errored-second (ES) parameter is a count of one-second intervals containing one or more febe-i or febe-ni anomalies, or one or more far-end los or rdi defects. It is required at the ATU-C (ATU-R is at the far-end), and is optional at the ATU-R (ATU-C is at the far-end).

### 11.2.5 Test parameters

The attenuation (ATN) and signal-to-noise ratio (SNR) margin test parameters apply to on-demand test requests; e.g., to check for adequate physical media performance margin at acceptance and after repair verification, or at any other time following the execution of initialization and training sequence of the ADSL system. ATN and SNR, as measured by the receivers at both the ATU-C and the ATU-R shall be externally accessible from the ATU-C, but they are not required to be continuously monitored.

### 11.2.5.1 Near-end test parameters

The following near-end test parameters are required at the ATU-C, and are optional at the ATU-R.

- *Attenuation (ATN)*: An atn primitive is the difference in dB between transmitted and received signal power. Signal power in dBm is the sum of all active DMT subcarrier powers averaged over a 1 s period. An atn primitive is expressed as an integer number of dB ranging from a min. of x to a max. of y dB, x and y for further study so as to correspond to a sensible range of atn. An attenuation parameter is an instance of an atn primitive in response to an on-demand ATN test request;

- *Signal-to-noise ratio (SNR) margin*: An instance of an snr primitive (dB), in response to an on-demand SNR margin test request.

### 11.2.5.2 Far-end test parameters

The following far-end test parameters are required at the ATU-C (ATU-R is at the far-end), and are optional at the ATU-R (ATU-C is at the far-end):

- *Attenuation (ATN)*: An instance of a far-end atn primitive (dB);

- *Signal-to-noise ratio (SNR) margin*: An instance of a far-end atn primitive (dB).

## 11.2.6 Performance monitoring functions

Near-end functions are required at the ATU-C, and are optional at the ATU-R. Far-end functions are required at the ATU-C (ATU-R is at the far-end), and are optional at the ATU-R (ATU-C is at the far-end).

### 11.2.6.1 Performance data storage

The following data registers are defined:

- A current 15 minute and a current 1 day register shall be provided for each near-end and for each far-end failure count and QOS parameter;
- A previous 15 minute and a previous 1 day register shall be provided for each near-end and for each far-end failure count and QOS parameter;
- A current and a previous register shall be provided for each near-end and for each far-end test parameter;
- A shared resource of 96 individual 15-minute registers per failure count and QOS parameter shall be assignable on-demand to a specific ADSL link. These registers shall not exceed about 10 % of the total dedicated failure count and QOS parameter memory resource requirements for all links over which this resource is shared.

#### NOTES

- Register sizes shall either accommodate maximum event counts or values, or have a minimum size of 16 bits;
- Register operation (e.g., pegging at the maximum value, resetting, setting of invalid data flag, etc.) shall comply with clause 9 of ANSI T1.231;
- Register invalid data flags shall be set if the ATUs are powered down during all or part of the accumulation interval (15 minutes or one day).

ANSI T1.413-1995

**11.2.6.2 Performance data reporting**

Performance data shall be reportable on demand (not scheduled) when queried by an operations entity.

**11.3 Metallic testing**

For further study

**11.4 Out-of-service testing**

For further study

**11.5 Requirements to support OAM of the segment between ATU-R and SM**

Requirements are expressed in terms of various indications for each direction of the segment between ATU-R and SM (downstream ATU-R to SM, and upstream SM to ATU-R). Downstream indications are also reported upstream from SMs to the ATU-R.

OAM of the ATU-R/ SM segment is null for SMs integrated in the ATU-R. For non-integrated SMs, requirements are as shown in figure 28.

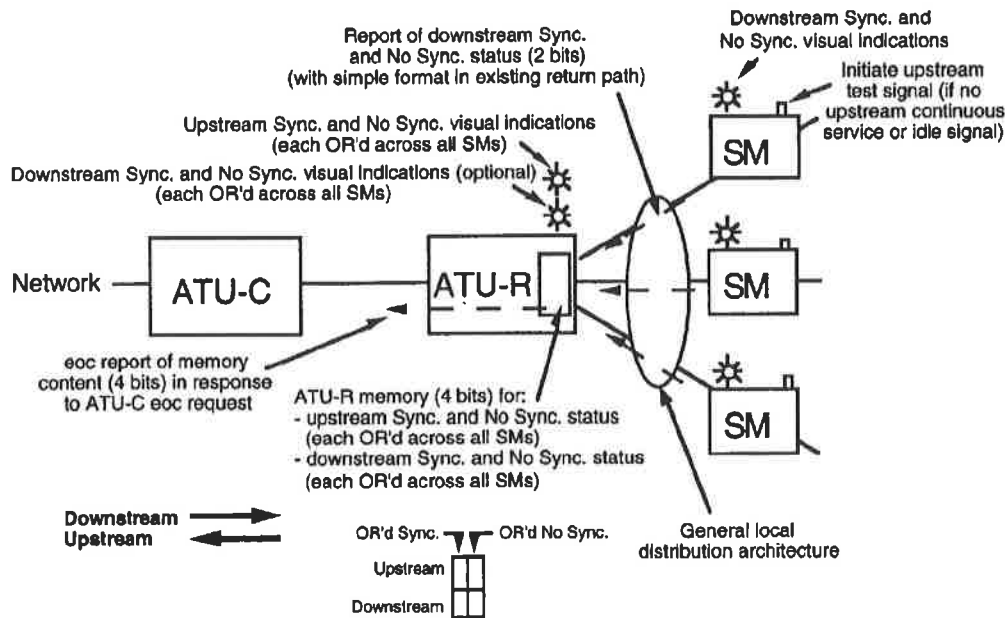

NOTE – Visual indicators are shown as an example; not all implementations may provide them.

**Figure 28 – OAM capabilities for the segment between ATU-R and the service module**

**11.5.1 SM requirements**

The requirements for the service module (SM) are:

- It shall detect separate downstream sync and no sync conditions. No sync is detected after  $2.5 \pm 0.5$  seconds of persistent inability to acquire sync. Sync is detected after sync acquisition followed by  $10 \pm .5$  seconds of persistent retention of sync;
- It shall provide downstream sync and no sync indications, with corresponding interpretations. Exemplary interpretations are shown in table 33;



c) It shall report separate downstream sync and no sync status from SM to ATU-R (2 bits) in a simple format (for further study) on an existing return path (for further study) (e.g., control channel). For a single SM, the 2 bits shall have the interpretation specified in table 34. These interpretations are consistent with the indications in SM requirement (b) above;

**Table 33 – Sync and no sync interpretation (downstream)**

Sync	No sync	Interpretation
off	off	SM not powered
off	on	SM powered but not synchronized
on	off	SM synchronized
on	on	Invalid

**Table 34 – Sync and no sync interpretation for single SM**

Sync bit	No sync bit	Interpretation
0	0	SM not powered
0	1	SM powered but not synchronized
1	0	SM synchronized
1	1	Invalid

d) For services with upstream signals to which the ATU-R cannot continuously synchronize, the SM shall be able to send either an idle signal, or a locally-initiated test signal to the ATU-R for a (for further study) (e.g., 5) minute time-out period. The formats of these signals shall enable the ATU-R to synchronize to them in the same manner as for upstream service signals;

e) It shall be able to send a control channel (CC) acknowledge (ACK) message to the network in response to a CC query message from the network. Message formats are for further study.

### 11.5.2 ATU-R requirements

The requirements for the ATU-R are:

a) It shall detect separate upstream sync and no sync conditions (see requirement (d) below). No sync is detected after  $2.5 \pm 0.5$  seconds of persistent inability to acquire sync. Sync is detected after sync acquisition followed by  $10 \pm 0.5$  seconds of persistent retention of sync. Sync conditions from all SMs shall be logically OR'd into 1 bit, and no sync conditions from all SMs shall be logically OR'd into another bit;

b) It shall store the upstream OR'd sync. and OR'd no sync status (2 bits). For multiple SMs, the two bits shall have the interpretation specified in table 35;

**Table 35 – Sync and no sync interpretation for multiple SMs**

Sync bit	No sync bit	Interpretation
0	0	No SMs powered
0	1	At least 1 SM powered but not synchronized
1	0	At least 1 SM synchronized
1	1	Some SMs synchronized, others powered but not synchronized

c) It shall provide upstream OR'd sync and OR'd no sync indications (see requirement (d) below), consistent with the bit interpretations in ATU-R requirement (b) above. One example is:

Sync	No. Sync.	Interpretation
off	off	No SMs powered
off	on (e.g., red)	At least 1 SM powered but not synchronized
on (e.g., green)	off	At least 1 SM synchronized
on (e.g., green)	on (e.g., red)	Some SMs synchronized, others powered but not synchronized

d) Sync and no sync indications in ATU-R requirements (a) to (c) in this list apply to upstream service signals to which the ATU-R can continuously synchronize. Otherwise, an upstream idle signal, or the test signal in SM requirement (d) of 11.5.1 above shall be detected. With upstream idle signals, ATU-R detection, storage and indications and interpretations are as per ATU-R requirements (a) to (c) above. The same is true with the upstream test signal, during the time the test signal is being sent;

e) It shall detect separate downstream sync and no sync status reports from SMs, and logically OR each across all SMs, where OR'ing is as described in ATU-R requirement (a) in this list;

f) It shall store the downstream OR'd sync and OR'd no sync status (2 bits). For multiple SMs, the 2 bits shall have the same interpretation as for the upstream case in ATU-R requirement (b) in this list;

g) It shall provide downstream OR'd sync and OR'd no sync indications consistent with ATU-R requirement (c) in this list;

h) In response to an eoc request message from the ATU-C, it shall send a single eoc report of the upstream and downstream OR'd sync and OR'd no sync status to the ATU-C (4 bits).

### 11.5.3 ATU-C requirements

As per the ATU-R requirement 11.5.2(h), when requested by the network, the ATU-C shall be able to send an eoc message to retrieve the upstream and downstream OR'd sync and OR'd no sync status (4 bits), and to receive the corresponding eoc status report from the ATU-R.

## 12 Initialization

### 12.1 Overview

#### 12.1.1 Basic functions of initialization

ADSL transceiver initialization is required in order for a physically connected ATU-R and ATU-C pair to establish a communications link. Establishment may be initiated by the ATU-C or the ATU-R as follows:

- An ATU-C, after power-up or loss of signal, and an optional self-test, may transmit activation tones (12.2) and await a response from the ATU-R (12.3.3). It shall make no more than two attempts; if no response is received it shall wait for an activation request from the ATU-R (12.3.1) or an instruction from the network to retry;
- An ATU-R, after power-up and an optional self-test, may repeatedly transmit activate request (12.3). If, however, the ATU-R receives C-TONE it shall remain silent for approximately one minute (12.3.2), unless it detects an activation signal (12.2.2).

In order to maximize the throughput and reliability of this link, ADSL transceivers shall determine certain relevant attributes of the connecting channel and establish transmission and processing characteristics suitable to that channel. The time line of figure 29 provides an overview of this process. In figure 29 each receiver can determine the relevant attributes of the channel through the transceiver training and channel analysis procedures. Certain processing and transmission characteristics can also be established at each receiver during this time. During the exchange process each receiver shares with its corresponding far-end transmitter certain transmission settings that it expects to see. Specifically, each receiver communicates to its far-end transmitter the number of bits and relative power levels to be used on each DMT sub-carrier, as well as any messages and final data rates information. For highest performance these settings shall be based on the results obtained through the transceiver training and channel analysis procedures.

#### ATU-C

<b>Activation and acknowledgment</b> (12.2)	<b>Transceiver training</b> (12.4)	<b>Channel analysis</b> (12.6)	<b>Exchange</b> (12.8)
--	---------------------------------------	-----------------------------------	---------------------------

#### ATU-R

<b>Activation and acknowledgment</b> (12.3)	<b>Transceiver training</b> (12.5)	<b>Channel analysis</b> (12.7)	<b>Exchange</b> (12.9)
--	---------------------------------------	-----------------------------------	---------------------------

time →

**Figure 29 – Overview of initialization**

Determination of channel attribute values and establishment of transmission characteristics requires that each transceiver produce, and appropriately respond to, a specific set of precisely-timed signals. This clause describes these initialization signals, along with the rules that determine the proper starting and ending time for each signal. This description is made through the definition of initialization states in which each transceiver will reside, and the definition of initialization signals that each transceiver will generate.

A state and the signal generated while in that state have the same name, which may sometimes, for clarity, be prefixed by "state" or "signal".

The sequence of generated downstream and upstream signals for a successful initialization procedure is shown by the time-lines of figures 30 – 33. The dashed arrow indicates that the change of state is caused by a successful reception of a specific signal. For example, in figure 32 ATU-R shall stay in state R-REVERB3 until it finishes receiving C-CRC2, at which point it shall move to R-SEGUE2 after an appropriate delay (see 12.7.2).

## ANSI T1.413-1995

The description of a signal will consist of three parts:

- The first part is a description of the voltage waveform that the transmitter shall produce at its output when in the corresponding state;

The output voltage waveform of a given initialization signal is described using the DMT transmitter reference model shown in figure 2. Figure 2 is not a requirement or suggestion for building a DMT transmitter. Rather, it is a model for facilitating accurate and concise DMT signal waveform descriptions. In figure 2  $X_k$  is DMT sub-carrier  $k$  (defined in the frequency domain), and  $x_k$  is the  $k$ th IDFT output sample (defined in the time domain). The DAC and analog processing block of figure 2 construct the continuous transmit voltage waveform corresponding to the discrete digital input samples. More precise specifications for this analog block arise indirectly from the analog transmit signal linearity and power spectral density specifications of 10.1. The use of figure 2 as a transmitter reference model allows all initialization signal waveforms to be described through the sub-carrier sequence  $X_{kn}$  required to produce that signal. Allowable differences in the characteristics of different digital to analog and analog processing blocks will produce somewhat different continuous-time voltage waveforms for the same initialization signal. However, a compliant transmitter will produce initialization signals whose underlying DMT sub-carrier sequences match exactly those provided in the signal descriptions of 12.2 to 12.9;

- The second is a statement of the required duration, expressed in DMT symbol periods, of the signal. This signal duration may be a constant or may depend upon the detected state of the far end transceiver. The duration of a single DMT symbol period depends on whether the cyclic prefix is being used; some initialization signals contain a cyclic prefix, and some do not. ATU-C signals up to and including C-SEGUE1 are transmitted without a cyclic prefix; those from C-RATES1 on are transmitted with a prefix. Similarly, ATU-R signals up to and including R-SEGUE1 do not use a prefix; those from R-REVERB3 on do. The duration of any signal in seconds is therefore the defined number of symbol periods times the duration of the symbol being used;
- The third part of a signal's description is a statement of the rule specifying the next state.

### 12.1.2 Transparency to methods of separating upstream and downstream signals.

Manufacturers may choose to implement this standard using either frequency-division-multiplexing (FDM) or echo canceling (EC) to separate upstream and downstream signals. The initialization procedure described here ensures compatibility between these different implementations by specifying all upstream and downstream control signals to be in the appropriate, but narrower, frequency bands that would be used by an FDM transceiver, and by defining a time period during which an EC transceiver can train its echo canceler.

### 12.1.3 Resetting during initialization and data transmission

If errors or malfunctions are detected or timeout limits are exceeded at various points in the initialization sequence, the ATU-C and ATU-R shall return to the initial states C-QUIET1 and R-ACT-REQ, respectively, for retraining. Furthermore, some errors detected during data transmission (i.e., after a successful initialization) may also require retraining. An example of an overall state diagram is shown in annex A, but the specific retraining procedures are for further study.

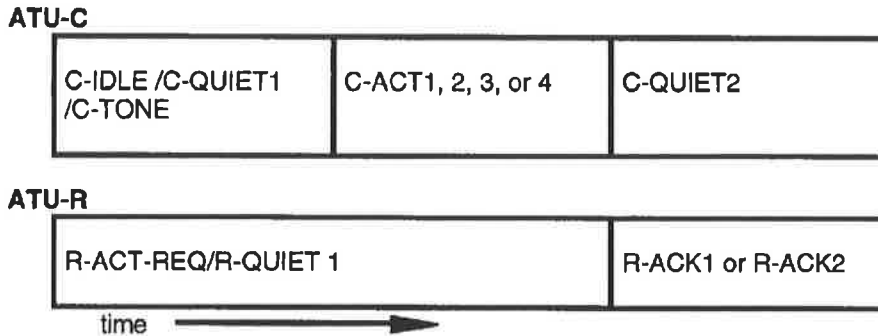

**Figure 30 – Timing diagram of activation and acknowledgment (12.2-12.3)**

## 12.2 Activation and acknowledgment – ATU-C

A host controller may be used to monitor the ATU-C activities and keep track of the state of the ATU-C if errors or malfunctions occur that require resetting to C-QUIET1, and retraining.

### 12.2.1 Pre-activate states

There are three mandatory pre-activation states at the ATU-C:

- C-QUIET1;
- C-IDLE;
- C-TONE.

The transitions between these and other vendor-optional states are shown in figure A.1, and described in annex A.

#### 12.2.1.1 C-QUIET1

Upon power-up and after an optional self-test the ATU-C shall enter state C-QUIET1.

NOTE – QUIET and IDLE signals are defined as zero output voltage from the DAC of figure 2.

When the ATU-C is in C-QUIET1, either a command from the host controller or a successful detection of R-ACT-REQ (defined as detecting 128 consecutive symbols of active R-ACT-REQ signal followed by silent symbols) shall cause it to go to state C-ACT (see 12.2.2). To ensure full compatibility between FDM and EC systems, the ATU-C transmitter shall remain in state C-QUIET1 until the ATU-C receiver no longer detects the R-ACT-REQ signal. (i.e., detects the first symbol of R-QUIET1).

Alternatively, the host controller may command the ATU-C to enter C-IDLE.

#### 12.2.1.2 C-IDLE

The ATU-C shall enter C-IDLE from C-QUIET1 in response to a host command. The difference between states C-QUIET1 and C-IDLE is that the ATU-C receiver reacts to R-ACT-REQ in C-QUIET1, but ignores it in C-IDLE.

If R-ACT-REQ is detected while in C-IDLE state, the host controller may elect to go to state C-TONE.

ANSI T1.413-1995

The ATU-C shall stay in C-IDLE indefinitely until the host controller issues the appropriate command to go to either state C-TONE (12.2.1.3), C-QUIET1 (12.2.1.1), C-ACT (12.2.2), or C-SELFTTEST.

NOTE – C-SELFTTEST is not defined herein; it is a vendor-option that does not affect compatibility.

### 12.2.1.3 C-TONE

The ATU-C shall transmit C-TONE to instruct the ATU-R not to transmit R-ACT-REQ. C-TONE is a single frequency sinusoid at  $f_{C-TONE} = 310.5$  kHz.

Referring to figure 2, C-TONE is defined as

$$X_k = \begin{cases} 0, & k \neq 72, 0 \leq k \leq 256 \\ A_{C-TONE}, & k = 72 \end{cases}$$

where  $A_{C-TONE}$  shall be such that the transmit power level is  $-4$  dBm (approximately  $-40$  dBm/Hz over  $4.3125$  kHz) for the first 64 symbols, and  $-28$  dBm for the second 64 symbols. This signal shall be transmitted for 128 consecutive symbols, and no cyclic prefix is used. C-IDLE immediately follows C-TONE.

### 12.2.2 C-Activate

To allow for inter-operability between FDM and EC systems, and among different vendors with different implementation of such systems, four activate signals, C-ACT1 to C-ACT4 are defined. These shall be used to distinguish different system requirements for loop timing and use of a pilot tone. These four signals are mutually exclusive; any given ATU-C shall transmit one and only one. Throughout the remainder of this document the generic term C-ACT will refer to the appropriate state and signal.

Loop timing is defined as the combination of the slaving of an ADC clock to the received signal (i.e., to the other transceiver's DAC clock), and tying the local DAC and ADC clocks together. Only one of the two transceivers can perform loop timing.

#### 12.2.2.1 C-ACT1

The ATU-C shall transmit C-ACT1 to initiate a communication link to the ATU-R when the ATU-C will perform loop-timing, and the ATU-C cannot accept a pilot during R-QUIET3/R-PILOT1.

C-ACT1 is a single frequency sinusoid at  $f_{C-ACT1} = 207$  kHz. Referring to figure 2, C-ACT1 is defined by

$$X_k = \begin{cases} 0, & k \neq 48, 0 \leq k \leq 256 \\ A_{C-ACT1}, & k = 48 \end{cases}$$

where  $A_{C-ACT1}$  shall be such that the transmit power level is  $-4$  dBm (approximately  $-40$  dBm/Hz over  $4.3125$  kHz) for the first 64 symbols, and  $-28$  dBm for the second 64 symbols. This signal shall be transmitted for 128 consecutive symbols without a cyclic prefix. C-QUIET2 immediately follows C-ACT1.

#### 12.2.2.2 C-ACT2

The ATU-C shall transmit C-ACT2 to initiate a communication link to the ATU-R when the ATU-C will not perform loop-timing, and the ATU-C cannot accept a pilot during R-QUIET3/R-PILOT1.

C-ACT2 is a single frequency sinusoid at  $f_{C-ACT2} = 189.75$  kHz, defined by

$$X_k = \begin{cases} 0, k \neq 44, 0 \leq k \leq 256 \\ A_{C-ACT2}, k = 44 \end{cases}$$

The level and duration of C-ACT2 shall be the same as those of C-ACT1. C-QUIET2 immediately follows C-ACT2.

### 12.2.2.3 C-ACT3

The ATU-C shall transmit C-ACT3 to initiate a communication link to the ATU-R when the ATU-C will perform loop-timing, and the ATU-C requests a pilot from the ATU-R during R-QUIET3/R-PILOT1. The decision whether to transmit R-PILOT1 is at the discretion of the vendor of the ATU-R.

C-ACT3 is a single frequency sinusoid at  $f_{C-ACT3} = 224.25$  kHz, defined by

$$X_k = \begin{cases} 0, k \neq 52, 0 \leq k \leq 256 \\ A_{C-ACT3}, k = 52 \end{cases}$$

The level and duration of C-ACT3 shall be the same as those of C-ACT1.

### 12.2.2.4 C-ACT4

The ATU-C shall transmit C-ACT4 to initiate a communication link to the ATU-R when the ATU-C will not perform loop-timing, and the ATU-C requests a pilot from the ATU-R during R-QUIET3/R-PILOT1. The decision whether to transmit R-PILOT1 is at the discretion of the vendor of the ATU-R.

C-ACT4 is a single frequency sinusoid at  $f_{C-ACT4} = 258.75$  kHz, defined by

$$X_k = \begin{cases} 0, k \neq 60, 0 \leq k \leq 256 \\ A_{C-ACT4}, k = 60 \end{cases}$$

The level and duration of C-ACT4 shall be the same as those of C-ACT1.

### 12.2.3 C-QUIET2

The purpose of C-QUIET2 is to allow the detection of R-ACK1 without the need to train the ATU-C echo canceller. The duration of C-QUIET2 is 128 symbols.

After C-QUIET2, ATU-C shall enter one of three states:

- *C-REVEILLE*: If the ATU-C detects R-ACK (see 12.3.3) it shall enter the state C-REVEILLE. Even if the ATU-C detects R-ACK in fewer than 128 symbols, the full duration of C-QUIET2 shall be maintained;
- *C-ACT*: If the ATU-C fails to detect R-ACK, and the state C-ACT has not been entered more than twice the ATU-C shall enter the state C-ACT. (A counter, which is reset upon entering C-QUIET1, should keep track of how many times ATU-C goes from C-QUIET2 and back to C-ACT);
- *C-QUIET1*: If the ATU-C does not detect R-ACK after returning twice to C-ACT it shall return to C-QUIET1.

ANSI T1.413-1995

**12.3 Activation and acknowledgment – ATU-R**

As in the ATU-C, a host controller may be used to monitor the ATU-R activities, and keep track of the state of the ATU-R if errors or malfunctions occur that require resetting to R-ACT-REQ.

**12.3.1 R-ACT-REQ**

R-ACT-REQ is used when it is desirable for the ATU-R to initiate a communication link to the ATU-C. One example is when a customer at ATU-R requests a service. R-ACT-REQ is transmitted after power-up and an optional successful self-test (see annex A). It is a single sinusoid at  $f_{R-ACT-REQ} = 34.5$  kHz, which, referring to figure 3, is defined by

$$X_k = \begin{cases} 0, k \neq 8, 0 \leq k \leq 32 \\ A_{R-ACT-REQ}, k = 8 \end{cases}$$

where  $A_{R-ACT-REQ}$  shall be such that the transmit power level is  $-2$  dBm (approximately  $-38$  dBm/Hz over 4.3125 kHz) for the first 64 symbols and  $-22$  dBm for the second 64 symbols, and  $A_{R-ACT-REQ} = 0$  for the next 896 symbols. This signal is transmitted for 1024 consecutive symbols.

The ATU-R shall stay in R-ACT-REQ indefinitely (i.e., transmitting the single tone signal for 128 symbols, then shutting the signal off for 896 symbols, and then repeating the process) until either

- a successful detection of C-ACT signal from the ATU-C, in which case the ATU-R shall enter R-ACK as soon as the full duration of C-ACT signal has been detected;
- a successful detection of C-TONE signal from the ATU-C, in which case the ATU-R shall enter R-QUIET1.

**12.3.2 R-QUIET1**

The duration of R-QUIET1 depends upon whether the ATU-R detects C-ACT:

- if the ATU-R detects C-ACT it shall immediately enter R-ACK;
- if it does not, it shall remain quiet for 240,000 symbols (approximately 60 seconds) and then re-enter R-ACT-REQ.

**12.3.3 R-Acknowledge**

R-Acknowledge is transmitted by the ATU-R, as an acknowledgment of the detection of C-ACT, in order to continue initiating a communication link to the ATU-C. Three acknowledge signals are defined. The uses of R-ACK1 and R-ACK2 are defined; the use of R-ACK3 is for further study. Throughout the rest of this document the generic term R-ACK will refer to the appropriate state and signal.

**12.3.3.1 R-ACK1**

R-ACK1 signifies that the ATU-R cannot accept a pilot during C-QUIET3, C-QUIET4, or C-QUIET5. It is a single sinusoid at  $f_{R-ACK1} = 43.125$  kHz defined by

$$X_k = \begin{cases} 0, k \neq 10, 0 \leq k \leq 32 \\ A_{R-ACK1}, k = 10 \end{cases}$$



where  $A_{R-ACK1}$  shall be such that the transmit power level is  $-2$  dBm (approximately  $-38$  dBm/Hz over  $4.3125$  kHz) for the first 64 symbols and  $-22$  dBm for the second 64 symbols. This signal shall be transmitted for 128 consecutive symbols. R-QUIET2 follows immediately after R-ACK1.

### 12.3.3.2 R-ACK2

R-ACK2 signifies that the ATU-R requires a pilot during C-QUIET3, C-QUIET4, and C-QUIET5. It is a single sinusoid at  $f_{R-ACK2} = 34.5$  kHz defined by

$$X_k = \begin{cases} 0, k \neq 12, 0 \leq k \leq 32 \\ A_{R-ACK2}, k = 12 \end{cases}$$

The level and duration of R-ACK2 shall be the same as those of R-ACK1.

### 12.3.3.3 R-ACK3

R-ACK3 is reserved for future initialization options. It is a single sinusoid at  $f_{R-ACK3} = 60.375$  kHz defined by

$$X_k = \begin{cases} 0, k \neq 14, 0 \leq k \leq 32 \\ A_{R-ACK3}, k = 14 \end{cases}$$

The level and duration of R-ACK3 shall be the same as those of R-ACK1.

## 12.4 Transceiver training – ATU-C

This subclause and 12.5 define the signals transmitted during transceiver training by the ATU-C and ATU-R, respectively. Synchronization of the mutual training begins with the transmission of R-REVERB1 (see 12.5.2), and is maintained throughout training by both transceivers counting the number of symbols from that point on. Thus C-REVEILLE always coincides with R-QUIET2, C-QUIET5 or C-PILOT3 coincides with R-ECT, and so on.

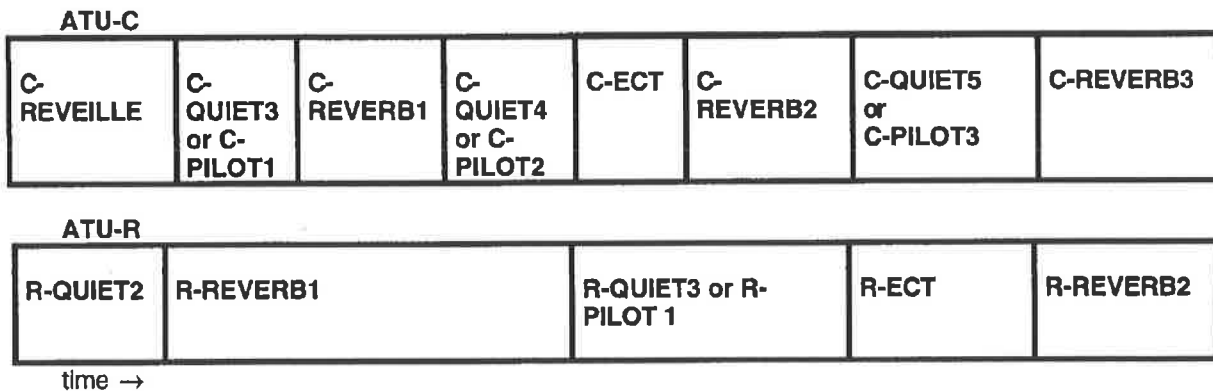

**Figure 31 – Timing diagram of transceiver training (12.4-12.5)**

### 12.4.1 C-REVEILLE

C-REVEILLE is a single frequency sinusoid at  $f_{C-REVEILLE} = 241.5$  kHz. Referring to figure 2, C-REVEILLE is defined by

$$X_k = \begin{cases} 0, k \neq 56, 0 \leq k \leq 256 \\ A_{C-REVEILLE}, k = 56 \end{cases}$$

## ANSI T1.413-1995

where  $A_{C-REVEILLE}$  shall be such that the transmit power level is  $-4$  dBm for the first 64 symbols, and  $-28$  dBm for the second 64 symbols. C-REVEILLE shall be used as an acknowledgment of the detection of R-ACK and as a transition to C-QUIET3 or C-PILOT1; it shall be transmitted for 128 consecutive symbols without cyclic prefix.

If the R-ACK1 was detected earlier the ATU-C shall enter C-QUIET3; if R-ACK2 was detected it shall enter C-PILOT1

**12.4.2 C-QUIET3**

During C-QUIET3, or C-PILOT1 as appropriate, the ATU-C shall measure the aggregate received upstream power on sub-carriers 7 – 18 of R-REVERB1, and thereby calculate a downstream PSD.

Upon detection of the first symbol of R-REVERB1 the ATU-C shall start a timer: this establishes synchronization of the subsequent transitions between states at ATU-C and ATU-R. After 512 symbols the ATU-C shall go to C-REVERB1. Thus the minimum duration of C-QUIET3 is 512 symbols, but it will exceed this by the round-trip propagation and signal-processing time plus the amount of time required by ATU-R to detect C-QUIET3 and respond by transmitting R-REVERB1 (see 12.5.2).

C-REVERB1 follows C-QUIET3.

**12.4.3 C-PILOT1**

C-PILOT1 is a single frequency sinusoid at  $f_{C-PILOT1} = 276$  kHz, defined by

$$X_k = \begin{cases} 0, & k \neq 64, 0 \leq k \leq 256 \\ A_{C-PILOT1}, & k = 64 \end{cases}$$

where  $A_{C-PILOT1}$  shall be such that the transmit power level is  $-4$  dBm.

The duration of C-PILOT1 shall be defined in the same way as that of C-QUIET3. C-REVERB1 follows C-PILOT1.

**12.4.4 C-REVERB1**

C-REVERB1 is a signal that allows the ATU-R receiver to adjust its automatic gain control (AGC) to an appropriate level. The data pattern used in C-REVERB1 shall be the pseudo-random downstream sequence (PRD),  $d_n$  for  $n = 1$  to 512, defined in 6.9.3 and repeated here for convenience:

$$\begin{aligned} d_n &= 1 && \text{for } n = 1 \text{ to } 9 \\ d_n &= d_{n-4} \oplus d_{n-9} && \text{for } n = 10 \text{ to } 512 \end{aligned}$$

The bits shall be used as follows: the first pair of bits ( $d_1$  and  $d_2$ ) is used for the dc and Nyquist sub-carriers (the power assigned to them is, of course, zero, so the bits are effectively ignored); then the first and second bits of subsequent pairs are used to define the  $X_i$  and  $Y_i$ , for  $i = 1$  to 255 as follows:

$d_{2i+1}, d_{2i+2}$	$X_i, Y_i$
0 0	+ +
0 1	+ -
1 0	- +
1 1	- -

**NOTES**

1 The period of PRD is only 511 bits, so  $d_{512} = d_1$ .

2 The  $d_1$  to  $d_9$  are re-initialized for each symbol, so each symbol of C-REVERB1 uses the same data.

Bits 129 and 130, which modulate the pilot carrier ( $i = 64$ ), shall be overwritten by {0,0} generating the {+,+} constellation.

The nominal transmit PSD for C-REVERB1 is  $-40$  dBm/Hz. If, however, the total upstream power measured on sub-carriers 7 – 18 is greater than 3 dBm, then the PSD for C-REVERB1 and all subsequent downstream signals shall be as follows:

Upstream received power	< 3	4	5	6	7	8	9	dBm
Max downstream PSD	-40	-42	-44	-46	-48	-50	-52	dBm/Hz

This chosen level shall become the reference level for all subsequent gain calculations.

The duration of C-REVERB1 is 512 (repeating) symbols without cyclic prefix. If the R-ACK1 was detected earlier the ATU-C shall then enter C-QUIET4; if R-ACK2 was detected it shall enter C-PILOT2.

**12.4.5 C-QUIET4**

The duration of C-QUIET4 is 3072 symbols. C-ECT follows C-QUIET4.

**12.4.6 C-PILOT2**

The C-PILOT2 signal is the same as C-PILOT1; the duration is 3072 symbols.

**12.4.7 C-ECT**

C-ECT is a vendor-defined signal that is used to train the echo canceller at ATU-C for EC implementations. Vendors of FDM versions have complete freedom to define their C-ECT signal. The duration of C-ECT, however, is fixed at 512 symbols. The receiver at ATU-R should ignore this signal. C-REVERB2 follows C-ECT.

NOTE – The level of the ADSL signal in the frequency band from 0 to about 10 kHz that leaks through the POTS low-pass filter is tightly limited (see 10.4). Therefore it is recommended that sub-carriers 1 – 4 not be used for C-ECT, or, at least, that they be transmitted at a much lower level.

**12.4.8 C-REVERB2**

C-REVERB2 is a signal that allows the ATU-R receiver to perform synchronization and to train any receiver equalizer. C-REVERB2 is the same as C-REVERB1 (see 12.4.3). The duration of C-REVERB2 is 1536 (repeating) symbols without cyclic prefix. If the R-ACK1 was detected earlier the ATU-C shall enter C-QUIET5; if R-ACK2 was detected it shall enter C-PILOT3

**12.4.9 C-QUIET5**

The duration of C-QUIET5 is 512 symbols. C-REVERB3 follows C-QUIET5.

ANSI T1.413-1995

**12.4.10 C-PILOT3**

C-PILOT3 is the same as C-PILOT1 (12.4.3).

**12.4.11 C-REVERB3**

C-REVERB3 is a second training signal, which allows the ATU-R receiver to perform or maintain synchronization and to further train any receiver equalizer. C-REVERB3 is the same as C-REVERB2 (see 12.4.6). The duration of C-REVERB3 is 1024 (repeating) symbols without cyclic prefix. This is the last segment of transceiver training. C-SEGUE1 follows immediately.

**12.5 Transceiver training – ATU-R****12.5.1 R-QUIET2**

The minimum duration of R-QUIET2 is 128 DMT symbols. The ATU-R shall progress to R-REVERB1 only after it has detected the whole of C-REVEILLE and any part of the following C-QUIET3 or C-PILOT1 that is needed for reliable detection. The time for detection of these signals shall not exceed 128 symbols each. If the ATU-R does not detect both signals within 128 symbols each it shall reset to R-ACT-REQ.

**12.5.2 R-REVERB1**

R-REVERB1 is used to allow the ATU-C to

- measure the upstream wideband power in order to adjust the ATU-C transmit power level;
- adjust its receiver gain control;
- synchronize its receiver and train its equalizer.

The data pattern used in R-REVERB1 shall be the pseudo-random upstream sequence PRU defined in 7.9.3 and repeated here for convenience:

$$\begin{aligned} d_n &= 1 && \text{for } n = 1 \text{ to } 6 \\ d_n &= d_{n-5} \oplus d_{n-6} && \text{for } n = 7 \text{ to } 64 \end{aligned}$$

The bits are used as follows: the first pair of bits ( $d_1$  and  $d_2$ ) is used for the dc and Nyquist sub-carriers (the power assigned to them is, of course, zero, so the bits are effectively ignored); then the first and second bits of subsequent pairs are used to define the  $X_i$  and  $Y_i$  for  $i = 1$  to 31 as defined for C-REVERB1 in 12.4.4.

**NOTES**

- 1 The period of PRD is only 63 bits, so  $d_{64} = d_1$ .
- 2 The  $d_1$  to  $d_6$  are re-initialized for each symbol, so each symbol of R-REVERB1 uses the same data.

Bits 33 and 34, which modulate the pilot carrier ( $i = 16$ ), shall be overwritten by {0,0}: generating the (+ +) constellation.

The nominal transmit PSD for R-REVERB1 and all subsequent upstream signals is  $-38$  dBm/Hz.

R-REVERB1 is a periodic signal, without cyclic prefix, that is transmitted consecutively for 4096 symbols. The first 512 symbols coincide with C-QUIET3 or C-PILOT1 signal in time, the second 512 symbols coincide with C-REVERB1, and the last 3072 symbols coincide with C-QUIET4 or C-PILOT2.

If C-ACT1 or C-ACT2 was detected earlier the ATU-R shall enter R-QUIET3 immediately after R-REVERB1; if C-ACT3 or C-ACT4 was detected the ATU-R may enter R-PILOT1 or R-QUIET3 at the vendor's discretion.

### 12.5.3 R-QUIET3

The duration of R-QUIET3 is nominally 2048 symbols, of which the first 512 symbols coincide with C-ECT in time, and the next 1536 symbols coincide with C-REVERB2. The final symbol of R-QUIET3 may be shortened by any number of samples that is an integer multiple of four in order to accommodate transmitter to receiver frame alignment. R-ECT immediately follows R-QUIET3.

### 12.5.4 R-PILOT1

R-PILOT1 is a single frequency sinusoid at  $f_{R-PILOT1} = 69$  kHz, defined by

$$X_k = \begin{cases} 0, & k \neq 16, 0 \leq k \leq 256 \\ A_{R-PILOT1}, & k = 16 \end{cases}$$

where  $A_{R-PILOT1}$  shall be such that the transmit power level is  $-2$  dBm.

The nominal duration of R-PILOT1 is the same as that of R-QUIET3, but it may be shortened by any number of samples that is an integer multiple of four in order to accommodate transmitter to receiver frame alignment. R-ECT immediately follows R-PILOT1.

### 12.5.5 R-ECT

R-ECT, similar to C-ECT, is a vendor-defined signal that may be used to train an echo canceller at ATU-R. Vendors of FDM versions have absolute freedom to define the R-ECT signal. The duration of R-ECT, however, is fixed at 512 DMT symbols. The receiver at ATU-C should ignore this signal. R-REVERB2 follows R-ECT.

NOTE – The level of the ADSL signal in the frequency band from 0 to about 10 kHz that leaks through the POTS low-pass filter is tightly limited (see 10.4). Therefore it is recommended that sub-carriers 1 – 4 not be used for R-ECT, or, at least, that they be transmitted at a much lower level.

### 12.5.6 R-REVERB2

The signal R-REVERB2 is the same as R-REVERB1 (see 12.5.2); it can be used by ATU-C to perform timing recovery and receiver equalizer training.

NOTE – Some implementations of ATU-R transmitters may change the symbol timing between R-REVERB1 and R-REVERB2 (see 12.5.3 and 12.5.4); this would require a corresponding shift of any receiver timing acquired during R-REVERB1.

The duration of R-REVERB2 is 1024 symbols. This signal is the last segment of transceiver training. ATU-R then begins channel analysis, and starts transmitting R-SEGUE1.

ANSI T1.413-1995

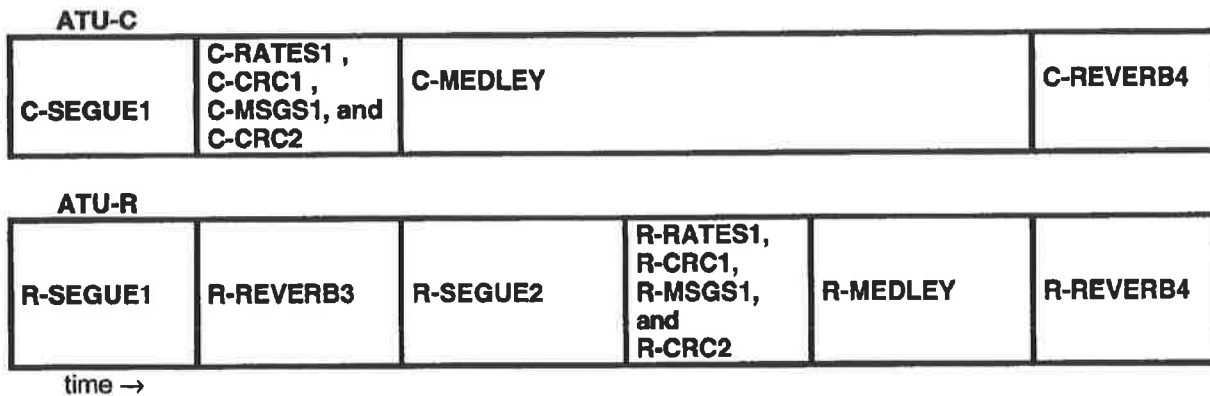

Figure 32 – Timing diagram of channel analysis (12.6-12.7)

### 12.6 Channel analysis (ATU-C)

During channel analysis the synchronization between ATU-C and ATU-R may be broken during R-REVERB3, which has an indefinite duration; this potential timeout is described in 12.7.2. Furthermore, if during channel analysis any CRC check sum indicates an error in any of the control data, this shall trigger a reset to C-QUIET1.

#### 12.6.1 C-SEGUE1

Except for the pilot tone, C-SEGUE1 is generated from a tone-by-tone 180 degree phase reversal of C-REVERB1 (i.e. + maps to -, and - maps to +, for each of the 4-QAM signal constellation). The duration of C-SEGUE1 is 10 (repeating) symbol periods. Following C-SEGUE1, ATU-C enters state C-RATES1.

#### 12.6.2 C-RATES1

C-RATES1 is the first ATU-C signal for which a cyclic prefix (defined in 6.10) is used. The purpose of C-RATES1 is to transmit four options for data rates and formats to the ATU-R. Each option consists of three fields:

- $B_F$  lists the number of bytes in the fast buffer for each of AS0, AS1, AS2, AS3, LS0, LS1, LS2, LS0 (upstream), LS1 (upstream), LS2 (upstream) channels, in that order;  $B_F$  has a total of 80 ( $= 10 \times 8$ ) bits. The first 8 bits of  $B_F$  specify the number of bytes in AS0, the second 8 bits specify the number of bytes in AS1, and so on. Each byte of  $B_F$  is transmitted with least significant bit first;
- $B_I$  similarly lists the number of bytes in the interleaved buffer;
- $\{R_F, R_I, S, I, FS(LS2)\}$  is a ten-byte quantity comprising
  - $R_F$ , the number of parity bytes per symbol in the fast buffer (downstream);
  - $R_I$ , the number of parity bytes per symbol in the interleave buffer (downstream);
  - $S$ , the number of symbols per codeword (downstream);
  - $I$ , the interleave depth (downstream) in codewords for the interleave buffer;
  - $FS(LS2)$ , the frame size (in bytes) of the bearer service transported in the LS2 channel;
- the same five quantities  $\{R_F, R_I, S, I, FS(LS2)\}$  in the upstream direction (one-byte each, in that order).

The four options are transmitted in order of decreasing preference. C-RATES1 is preceded by a 4-byte prefix of [01010101 01010101 01010101 01010101]. Figure 33 summarizes C-RATES1 and R-RATES1 (see 12.7.4).

C-RATES1	Prefix	Option 1			Option 2			Option 3			Option 4		
		$B_F$	$B_I$	RRSI	$B_F$	$B_I$	RRSI	$B_F$	$B_I$	RRSI	$B_F$	$B_I$	RRSI
Number of bytes	4	10	10	10	10	10	10	10	10	10	10	10	10

R-RATES1	Prefix	Option 1			Option 2			Option 3			Option 4		
		$B_F$	$B_I$	RRSI	$B_F$	$B_I$	RRSI	$B_F$	$B_I$	RRSI	$B_F$	$B_I$	RRSI
Number of bytes	4	3	3	5	3	3	5	3	3	5	3	3	5

Figure 33 – C-RATES1 and R-RATES1 (12.6.2 and 12.7.4)

Only one bit of information is transmitted in each symbol of C-RATES1: a zero bit is encoded to one symbol of C-REVERB1 and a one bit is encoded to one symbol of C-SEGUE1. Since there are a total of 992 bits of C-RATES1 information, the duration of C-RATES1 is 992 symbols. The 992 bits are to be transmitted in the order shown in figure 33, with the least significant bit first. That is, the least significant bit of option 1,  $B_F$ , is to be transmitted during the 33rd symbol of C-RATES1, after the prefix. Following C-RATES1, the ATU-C shall enter state C-CRC1.

### 12.6.3 C-CRC1

C-CRC1 is a cyclic redundancy code for detection of errors in the reception of C-RATES1 at the ATU-R. The CRC bits are computed from the C-RATES1 bits using the equation:

$$c(D) = a(D) D^{16} \text{ modulo } g(D),$$

where

$$a(D) = a_0 D^{959} \oplus a_1 D^{958} \dots \oplus a_{959}$$

is the message polynomial formed from the 960 bits of C-RATES1, with  $a_0$  the least significant bit of the first byte of C-RATES1 (i.e., option 1  $B_F$ );

$$g(D) = D^{16} \oplus D^{12} \oplus D^5 \oplus 1$$

is the CRC generator polynomial, and

$$c(D) = c_0 D^{15} \oplus c_1 D^{14} \dots \oplus c_{14} D \oplus c_{15}$$

is the CRC check polynomial.

The 16 bits  $c_0 - c_{15}$  are transmitted ( $c_0$  first and  $c_{15}$  last) in 16 symbol periods using the method described in 12.6.2. Following C-CRC1, the ATU-C shall enter state C-MSG1.

### 12.6.4 C-MSG1

C-MSG1 transmits a 48-bit message signal to the ATU-R. This message includes vendor identification, ATU-C transmit power level used, trellis code option, echo canceller option, etc. The message,  $m$ , is defined by:

$$m = \{m_{47}, m_{30}, \dots, m_1, m_0\}$$

with  $m_0$  being transmitted first. The message components are defined in the following sub-clauses, and their assigned positions within the composite message,  $m$ , are defined in table 36.

A total of 48 symbol periods are used to communicate the 48-bit message, using the encoding method described in 12.6.2. Following C-MSG1, the ATU-C shall enter state C-CRC2.

ANSI T1.413-1995

**Table 36 – Assignment of 48 bits of C-MSGS1**

Suffix(ces) of $m_i$	Parameter
47 – 44	reserved for future use
43 – 28	vendor identification
27,26	reserved for future use
25 – 18	version number
17	constellation coding option
16	echo canceling option
15,14	reserved for future use
13,12	maximum possible transmit PSD
11,10,9	reserved for future use
8,7,6	transmit PSD during initialization
5,4	reserved for future use
3 – 0	maximum numbers of bits per sub-carrier supported
NOTES	
1 All bits "reserved for future use" shall be set to 0 until defined.	
2 Within the separate fields the least significant bits have the lowest subscripts.	

**12.6.4.1 Vendor identification – Bits 43 – 28**

The vendor ID is binarily coded. Thirty-seven codes have so far been assigned; they are defined in annex D. Bits 47 – 44, the most significant bits (MSBs), may be used to identify more vendors in the future.

**12.6.4.2 Version number – Bits 25 – 18**

To facilitate upgrades in the future, six bits are reserved to allow any vendor to include a version number for each unit. When an ATU-C connects to an ATU-R with the same vendor ID, this may serve to simplify upgrades, diagnostics, maintenance, etc.

**12.6.4.3 Constellation coding option – Bit 17**

$m_{17} = 0$  shall indicate no trellis coding capability,  $m_{17} = 1$  shall indicate trellis coding capability.

**12.6.4.4 Echo cancellation option – Bit 16**

$m_{16} = 0$  shall indicate no echo cancellation,  $m_{16} = 1$  shall indicate echo cancellation.

**12.6.4.5 Maximum possible transmit PSD – Bits 13,12**

As defined in 6.13.3, the ATU-C may transmit, under some circumstances and in some frequency bands, at a PSD as high as  $-34$  dBm/Hz. The ability to do this shall be signaled to the ATU-R so that it may calculate the optimum loading. The coding rules for  $m_{13}, m_{12}$  are

$m_{13}$	$m_{12}$	Max. PSD dBm/Hz
1	1	-34
1	0	-36
0	1	-38
0	0	-40



**12.6.4.6 Transmit PSD during initialization – Bits 8,7,6**

The ATU-C shall report the level of C-REVERB1 chosen as a result of the calculation described in 12.4.3. The encoding rules for  $m_8$ ,  $m_7$ ,  $m_6$  are:

$m_8$	$m_7$	$m_6$	PSD dBm/Hz
1	1	1	-40
1	1	0	-42
1	0	1	-44
1	0	0	-46
0	1	1	-48
0	1	0	-50
0	0	1	-52

**12.6.4.7 Maximum numbers of bits per sub-carrier supported – Bits 3 – 0**

The  $N_{\text{downmax}}$  (transmit) capability shall be encoded onto  $\{m_3 - m_0\}$  with a conventional binary representation (e.g., 1101 = 13)

The maximum number of bits for the upstream data,  $N_{\text{upmax}}$ , that the ATU-C receiver can support need not be signaled to the ATU-R; it will be implicit in the bits and gains message, C-B&G, which is transmitted after channel analysis.

**12.6.5 C-CRC2**

C-CRC2 is a cyclic redundancy code for detection of errors in the reception of C-MSG1 at the ATU-R. The CRC polynomial is generated in the same way as defined in 12.6.3. These 16 bits shall be transmitted in 16 symbol periods using the method described in 12.6.2. Following C-CRC2, the ATU-C shall enter state C-MEDLEY.

**12.6.6 C-MEDLEY**

C-MEDLEY is a wideband pseudo-random signal used for estimation at the ATU-R of the downstream SNR. The data to be transmitted shall be derived from the pseudo-random sequence, PRD, and modulated as defined in 6.9.3 and 12.4.4. In contrast to C-REVERB1, however, the data sequence continues from one symbol to the next (i.e.,  $d_1$  to  $d_9$  are not re-initialized for each symbol); since PRD is of length 511, and 512 bits are used for each symbol, the sub-carrier vector for C-MEDLEY therefore changes from one symbol period to the next. The pilot sub-carrier is over-written by the (+,+) signal constellation.

C-MEDLEY shall be transmitted for 16384 symbol periods. Following C-MEDLEY the ATU-C shall enter the state C-REVERB4.

**12.6.7 C-REVERB4**

C-REVERB4 is similar to C-REVERB2 (see 12.4.6), the only difference being the addition of a cyclic prefix on every symbol. C-REVERB4 continues into the exchange procedure, and its duration is not fixed. The timeout features of C-REVERB4 are defined in 12.8.1

ANSI T1.413-1995

## 12.7 Channel analysis – ATU-R

During channel analysis there are two situations where the ATU-R will reset itself to R-ACT-REQ: a timeout and a detected error in the received control data. A timeout occurs if the time in R-REVERB3 exceeds the limit of 4000 symbols. Also, if any C-CRC checksum indicates there is an error in the received control data, then it shall trigger a reset to R-ACT-REQ.

### 12.7.1 R-SEGUE1

Except for the pilot tone, R-SEGUE1 is generated from a tone-by-tone 180 degree phase reversal of R-REVERB1 (i.e. + maps to -, and -maps to +, for each of the 4-QAM signal constellation). The duration of R-SEGUE1 is 10 symbol periods. Following R-SEGUE1 the ATU-R shall enter state R-REVERB3.

### 12.7.2 R-REVERB3

R-REVERB3 is similar to R-REVERB1 (see 12.5.2); the only difference is the addition of a cyclic prefix to every symbol. The duration of R-REVERB3 is not fixed but has a maximum of 4000 symbols. If C-SEGUE1 is not detected within 4000 symbols the ATU-R shall timeout and reset to R-ACT-REQ. After detection of C-SEGUE1 through C-CRC2, the ATU-R shall continue to send R-REVERB3 for 20 additional symbols before entering R-SEGUE2.

### 12.7.3 R-SEGUE2

The signal R-SEGUE2 is the same as R-SEGUE1 (see 12.7.1). The duration of R-SEGUE2 is 10 symbol periods. Following R-SEGUE2 the ATU-R shall enter state R-RATES1.

### 12.7.4 R-RATES1

The purpose of R-RATES1 for the upstream channel is the same as that of C-RATES1 for the downstream channel (see 12.6.2). Each option consists of three fields:

- $B_F$  lists the number of bytes in the fast buffer for each of LS0, LS1, LS2, in that order;  $B_F$  has a total of 24 ( $= 3 \times 8$ ) bits. The first 8 bits of  $B_F$  specify the number of bytes in LS0, the second 8 bits specify the number of bytes in LS1, and so on. Each byte of  $B_F$  is transmitted with least significant bit first;
- $B_I$  similarly lists the number of bytes in the interleaved buffer;
- $\{R_F, R_I, S, I, FS(LS2)\}$  is a five-byte quantity comprising
  - $R_F$ , the number of parity bytes per symbol in the fast buffer (upstream);
  - $R_I$ , the number of parity bytes per symbol in the interleave buffer (upstream);
  - $S$ , the number of symbols per codeword (upstream);
  - $I$ , the interleave depth (upstream) in codewords for the interleave buffer;
  - $FS(LS2)$ , the frame size (in bytes) of the bearer service transported in the LS2 channel.

The four options are transmitted in order of decreasing preference. Figure 33 defines R-RATES1 as well as C-RATES1. For the present issue of the standard, ATU-C has control over all the data rates, so R-RATES1 is copied from the appropriate fields of C-RATES1.

Only one bit of information shall be transmitted during each symbol period of R-RATES1: a zero bit is encoded to one symbol of R-REVERB1 and a one bit is encoded to one symbol of R-SEGUE1. Since there are a total of 384 bits of RATES1 information, the length of R-RATES1 is 384 symbols. The 384 bits are to be transmitted in the order shown in figure 33, with the least significant bit first. That is, the least significant bit of option 1,  $B_F$  (see table 32), is to be transmitted during the 33rd symbol of R-RATES1, after the prefix. Following R-RATES1, the ATU-R shall enter state R-CRC1.

**12.7.5 R-CRC1**

R-CRC1 is a cyclic redundancy code intended for detection of an error in the reception of R-RATES1 at the ATU-C. The CRC polynomial  $c(D)$  and generator polynomial  $g(D)$  are the same as for C-CRC1 (see 12.6.3). The 16 bits  $c_0$  to  $c_{15}$  are transmitted ( $c_0$  first and  $c_{15}$  last) in 16 symbol periods using the same method as R-RATES1 (see 12.7.4). Following R-CRC1, the ATU-R shall enter state R-MSGS1.

**12.7.6 R-MSGS1**

R-MSGS1 transmits a 48-bit message signal to the ATU-C. This message includes vendor identification, trellis code option, echo canceller option, etc. The message,  $m$ , is defined by:

$$m = \{m_{47}, m_{30}, \dots, m_1, m_0\}$$

with  $m_0$ , the least significant bit, being transmitted first. The message components are defined in the following subclauses, and their assigned positions within the composite message,  $m$ , are defined in table 37.

A total of 48 symbol periods shall be used to communicate the 48-bit message, using the encoding method described in 12.6.2. Following R-MSGS1, the ATU-R shall enter state R-CRC2.

**Table 37 – Assignment of 48 bits of R-MSGS1**

Suffix(es) of $m_i$	Parameter
47 – 44	Reserved for future use
43 – 28	Vendor Identification
27,26	Reserved for future use
25 – 18	Version Number
17	Constellation coding option
16	Echo cancelling option
15 – 4	Reserved for future use
3 – 0	Maximum numbers of bits per sub-carrier supported
NOTES	
1 All bits "reserved for future use" shall be set to 0 until defined.	
2 Within the separate fields the least significant bits have the lowest subscripts.	

**12.7.6.1 Vendor identification – Bits 43 – 28**

The vendor ID is coded in binary as defined in 12.6.4.1

**12.7.6.2 Version number – Bits 25 – 18**

The version number is encoded as defined in 12.6.4.2

**12.7.6.3 Trellis coding option – Bit 17**

$m_{17} = 0$  shall indicate no trellis coding capability;  $m_{17} = 1$  shall indicate trellis coding capability.

**12.7.6.4 Echo cancellation option – Bit 16**

$m_{16} = 0$  shall indicate no echo cancellation;  $m_{16} = 1$  shall indicate echo cancellation.

ANSI T1.413-1995

**12.7.6.5 Maximum numbers of bits per sub-carrier supported – Bits 3 – 0**

The  $N_{\text{upmax}}$  (transmit) capability shall be encoded onto  $\{m_3 - m_0\}$  with a conventional binary representation (e.g., 1101 = 13)

NOTE – The maximum number of bits for the downstream data,  $N_{\text{downmax}}$ , that the ATU-R receiver can support need not be signaled to the ATU-C; it will be implicit in the bits and gains message, R-B&G, which is transmitted after channel analysis.

**12.7.7 R-CRC2**

R-CRC2 is a cyclic redundancy code for detection of errors in the reception of R-MSG1 at the ATU-C. The CRC polynomial is generated in exactly the same way as described in 12.6.3. These 16 bits are transmitted in 16 symbol periods using the method described in 12.7.4. Following R-CRC2, the ATU-R shall enter state R-MEDLEY.

**12.7.8 R-MEDLEY**

R-MEDLEY is a wideband pseudo-random signal used for estimation of the upstream SNR at the ATU-C. The data to be transmitted are derived from the pseudo-random sequence PRU defined in 12.5.2, continuing from one symbol to the next. Because the sequence is of length 63, and 64 bits are used for each symbol, the sub-carrier vector for R-MEDLEY changes from one symbol period to the next. The pilot sub-carrier is over-written by the (+,+) signal constellation. R-MEDLEY is transmitted for 16384 symbol periods. Following R-MEDLEY the ATU-R shall enter state R-REVERB4.

**12.7.9 R-REVERB4**

R-REVERB4 is the same as R-REVERB3 (see 12.7.2). The duration of R-REVERB4 is 128 symbols. This signal marks the end of channel analysis, and R-SEGUE3 immediately follows R-REVERB4.

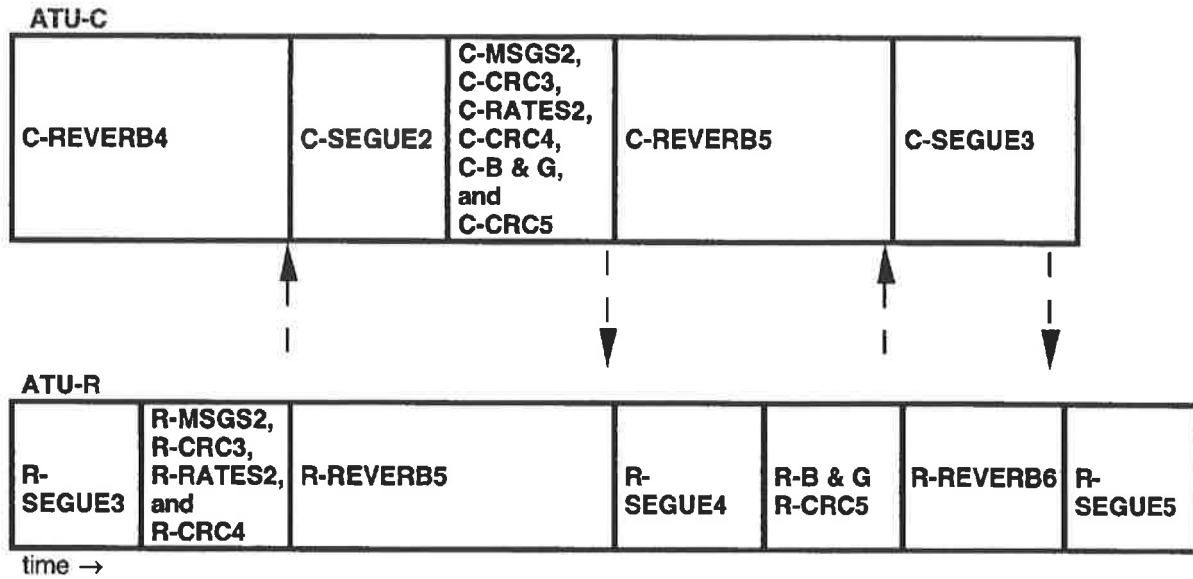

Figure 34 – Timing diagram of exchange (12.8-12.9)

## 12.8 Exchange – ATU-C

During exchange there are two events that shall cause the ATU-C to reset to C-QUIET1: timeouts and error detection by a CRC checksum. The exchange procedure is partly synchronized between ATU-C and ATU-R, and partly interactive. During the interactive part (C-REVERB4 and C-REVERB5) a timeout shall occur when the time in that state exceeds 4000 symbols.

### 12.8.1 C-REVERB4

If the ATU-C does not detect R-SEGUE3 within 4000 symbols, it shall timeout and reset to C-QUIET1. After detection of R-SEGUE3 and R-MSG2, R-CRC3, R-RATES2, and R-CRC4, the ATU-C shall continue to transmit C-REVERB4 for another 80 symbols before progressing to state C-SEGUE2 (see 12.8.2).

### 12.8.2 C-SEGUE2

The signal C-SEGUE2 is the same as C-SEGUE1 (see 12.6.1). The duration of C-SEGUE2 is 10 symbol periods. Following C-SEGUE2 the ATU-C shall enter state C-MSG2.

### 12.8.3 C-MSG2

C-MSG2 transmits a 32-bit message signal to the ATU-R. This message includes the total number of bits per symbol supported, the estimated upstream loop attenuation, and the performance margin with the selected rate option. The message,  $m$ , is defined by:

$$m = \{m_{31}, m_{30}, \dots, m_1, m_0\}$$

with  $m_0$  being transmitted first. The message components are defined in the following sub-clauses, and their assigned positions within the composite message,  $m$ , are defined in table 38

ANSI T1.413-1995

**Table 38 – Assignment of 32 bits of C-MSG2**

Suffix(es) of $m_i$	Parameter
31 – 26	Estimated average loop attenuation
25 – 21	Reserved for future use
20 – 16	Performance margin with selected rate option
15 – 9	Reserved for future use
8 – 0	Total number of bits supported
NOTES	
1 All bits "reserved for future use" shall be set to 0 until defined.	
2 Within the separate fields the least significant bits have the lowest subscripts.	

A total of 4 symbol periods shall be used to communicate the 32 bit message, with 8 bits transmitted on each symbol. Two bits are encoded onto each of the sub-carriers numbered 43 through 46 using the 4QAM constellation labeling given in 6.9.3 (for the synchronization symbol) and 12.4.3 (for C-REVERB1). The same two bits are also encoded in the same way onto a set of backup carriers, namely, sub-carriers 37 through 40. The least significant byte of the message is transmitted in the first symbol of C-MSG2, with the two least significant bits of each byte encoded onto carriers 43 and 37. In addition, the pilot, sub-carrier 64, shall be modulated with (+,+). Following C-MSG2, the ATU-C shall enter state C-CRC3.

#### 12.8.3.1 Estimated average upstream loop attenuation

During channel analysis the ATU-C estimates the upstream channel gain in preparation for computing the SNR for each tone; it shall also calculate the average loop attenuation. This attenuation, rounded to the nearest 0.5 dB, is then encoded into bits 31 – 26 of C-MSG2 as the integer binary representation of twice the attenuation (e.g., if the average attenuation is 16.5 dB then  $\{m_{31} - m_{26}\} = 100001$ ).

#### 12.8.3.2 Performance margin with selected rate option

The ATU-C receiver shall calculate the performance margin for each of the rates options sent from the ATU-R during R-RATES1, and then select one of the options with a satisfactory margin. This margin (rounded to the nearest dB) is encoded into bits 20 – 16 of C-MSG2 using a conventional binary representation (e.g., if the margin is 9 dB then  $\{m_{20} - m_{16}\} = 01001$ ).

#### 12.8.3.3 Total number of bits per symbol supported

The ATU-C receiver shall also calculate the maximum number of bits per symbol that the upstream channel can support with a performance margin of 6 dB at an error rate of  $10^{-7}$ . This number is encoded into bits 8 – 0 using a conventional binary representation (e.g., if the maximum number of bits that can be supported is 127 (data rate = 508 kbit/s),  $\{m_8 - m_0\} = 001111111$ ).

#### 12.8.4 C-CRC3

C-CRC3 is a cyclic redundancy code for detection of errors in the reception of C-MSG2 at the ATU-R. The CRC polynomial  $c(D)$  and generator polynomial  $g(D)$  are the same as for CRC1, as defined in 12.6.3. These bits are transmitted in 2 symbol periods using the method described in 12.8.3. Following C-CRC3, the ATU-C shall enter state C-RATES2.

#### 12.8.5 C-RATES2

C-RATES2 is the reply to R-RATES1 (see 12.7.4). It combines the downstream rate information contained in R-RATES2 (in the form of one selected option) with the option number of the highest upstream data rate that can be supported based on the measured SNR of the upstream channel. It thus transmits the final decision on the rates that will be used in both directions. The length of C-RATES2 is equal to 8 bits, and the bit pattern for C-RATES2 is shown in table 39. Other bit patterns that are not specified in the table are reserved for future use. If none of the options requested during C-RATES1 and R-RATES1 can be implemented, ATU-C shall transmit the all-

options-fall code defined in table 39, and then return to C-QUIET1 for retraining. One symbol period is used to transmit these 8 bits using the method described in 12.8.3. Following C-RATES2, the ATU-C shall enter state C-CRC4.

**Table 39 – Bit pattern for C-RATES2**

(Downstream, upstream)	Bit pattern for C-RATES2 (MSB first) (note 1)
(option 1, option 1)	00010001
(option 1, option 2)	00010010
(option 1, option 3)	00010100
(option 1, option 4)	00011000
(option 2, option 1)	00100001
(option 2, option 2)	00100010
(option 2, option 3)	00100100
(option 2, option 4)	00101000
(option 3, option 1)	01000001
(option 3, option 2)	01000010
(option 3, option 3)	01000100
(option 3, option 4)	01001000
(option 4, option 1)	10000001
(option 4, option 2)	10000010
(option 4, option 3)	10000100
(option 4, option 4)	10001000
all options fail (Note 2)	00000000

NOTES

- 1 All other bit patterns that are not shown are reserved for future use.
- 2 If it is determined that none of the four options can be implemented with the connection the ATU-C shall return to C-QUIET1 for retraining.

### 12.8.6 C-CRC4

C-CRC4 is a cyclic redundancy code for detection of errors in the reception of C-RATES2 at the ATU-R. Its relation to C-RATES2 is the same as that of C-CRC3 to C-MSG2. Following C-CRC4, the ATU-C shall enter state C-B&G.

### 12.8.7 C-B&G

C-B&G shall be used to transmit to the ATU-R the bits and gains,  $\{b_1, g_1, b_2, g_2, \dots, b_{31}, g_{31}\}$ , that are to be used on the upstream carriers.  $b_i$  indicates the number of bits to be coded by the ATU-R transmitter onto the  $i$ th upstream carrier;  $g_i$  indicates the scale factor, relative to the gain that was used for that carrier during the transmission of R-MEDLEY, that shall be applied to the  $i$ th upstream carrier. Because no bits or energy will be transmitted at dc or one-half the sampling rate,  $b_0, g_0, b_{32}$ , and  $g_{32}$  are all presumed to be zero and shall not be transmitted.

Each  $b_i$  shall be represented as an unsigned 4-bit integer, with valid  $b_i$ s lying in the range of zero to  $N_{\text{upmax}}$ , the maximum number of bits that the ATU-R is prepared to modulate onto any sub-carrier, which is communicated in R-MSG1.

Each  $g_i$  shall be represented as an unsigned 12-bit fixed-point quantity, with the binary point assumed just to the right of the third most significant bit. For example, a  $g_i$  with binary representation (most significant bit listed first) 01000000 0000 would instruct the ATU-R to scale the constellation for carrier  $i$ , by a gain factor of 2, so that the power in that carrier shall be 6 dB higher than it was during R-MEDLEY.

ANSI T1.413-1995

For sub-carriers where no data are transmitted and the receiver will never allocate bits (e.g., out-of-band channels), both  $b_i$  and  $g_i$  shall be set to zero (0000 and 00000000 000, respectively). For sub-carriers where no data are currently to be transmitted, but the receiver may allocate bits later (e.g., as a result of an SNR improvement), the  $b_i$  shall be set to zero (0000) and the  $g_i$  to 1 (00100000 0000).

A total of 62 bytes of bits and gains information is to be transmitted during C-B&G, and a total of 62 symbol periods is required, using the method described in 12.8.2. Following C-B&G the ATU-C enters state C-CRC5.

### 12.8.8 C-CRC5

C-CRC5 is a cyclic redundancy code for detection of errors in the reception of C-B&G at the ATU-R. Its relation to C-B&G is the same as that of C-CRC3 to C-MSG2. Following C-CRC5, the ATU-C shall enter state C-REVERB5.

### 12.8.9 C-REVERB5

C-REVERB5 is the same as C-REVERB4 (see 12.6.7). The duration of C-REVERB5 depends upon the state of the ATU-R and the internal processing of the ATU-C. The ATU-C shall transmit C-REVERB5 until it has received, checked the reliability of, and established the downstream bits and gains information contained in R-B&G. The ATU-C shall enter state C-SEGUE3 as soon as it is prepared to transmit according to the conditions specified in R-B&G.

### 12.8.10 C-SEGUE3

C-SEGUE3 is used to notify the ATU-R that the ATU-C is about to enter the steady-state state C-SHOWTIME. The signal C-SEGUE3 is the same as C-SEGUE1 (see 12.6.1). The duration of C-SEGUE3 is 10 symbol periods. Following C-SEGUE3 the ATU-C has completed initialization and enters state C-SHOWTIME.

## 12.9 Exchange – ATU-R

During exchange there are two cases where the ATU-R shall reset itself: timeouts and error detection by a CRC checksum. Both shall trigger a reset to R-ACT-REQ. The exchange procedure is partly synchronized between ATU-C and ATU-R, and partly interactive. During the interactive parts (R-REVERB5 and R-REVERB6) a timeout shall occur when the time in either state exceeds 4000 symbols.

### 12.9.1 R-SEGUE3

The signal R-SEGUE3 is the same as R-SEGUE1 (see 12.7.1). The duration of R-SEGUE3 is 10 symbol periods. Following R-SEGUE3 the ATU-R shall enter state R-MSG2.

### 12.9.2 R-MSG2

R-MSG2 transmits a 32-bit message signal to the ATU-C. This message includes the total number of bits per symbol supported, the estimated upstream loop attenuation, and the performance margin with the selected rate option. The message,  $m$ , is defined by:

$$m = \{m_{31}, m_{30}, \dots, m_1, m_0\}$$

with  $m_0$  being transmitted first. The message components are defined in the following sub-clauses, and their assigned positions within the composite message,  $m$ , are defined in table 40.



**Table 40 – Assignment of 32 bits of R-MSGS2**

Suffix(ces) of $m_i$	Parameter
31 – 25	Estimated average loop attenuation
24 – 21	Reserved for future use
20 – 16	Performance margin with selected rate option
15 – 12	Reserved for future use
11 – 0	Total number of bits supported
NOTES	
1 All bits "reserved for future use" shall be set to 0 until defined.	
2 Within the separate fields the least significant bits have the lowest subscripts.	

A total of 4 symbol periods shall be used to communicate the 32 bit message, with 8 bits transmitted on each symbol. Two bits are encoded onto each of the sub-carriers numbered 6 through 9 using the 4QAM constellation labeling given in 6.9.3 (for the synchronization symbol) and 12.4.3 (for C-REVERB1). The same two bits are also encoded in the same way onto a set of backup carriers, namely, sub-carriers 10 through 13. The least significant byte of the message is transmitted in the first symbol of R-MSGS2, with the two least significant bits of each byte encoded onto carriers 6 and 10. In addition, the pilot, sub-carrier 16, shall be modulated with (+,+). Following R-MSGS2, the ATU-R shall enter state R-CRC3.

#### 12.9.2.1 Estimated average (upstream) loop attenuation

During channel analysis the ATU-R receiver estimates the downstream channel gain in preparation for computing the SNR for each tone; it shall also calculate the average loop attenuation. This attenuation, rounded to the nearest 0.5 dB, is then encoded into bits 31–25 of R-MSGS2 as the integer binary representation of twice the attenuation (e.g., if the average attenuation is 21.5 dB then  $\{m_{31}, \dots, m_{25}\} = 0101011$ ).

#### 12.9.2.2 Performance margin with selected rate option

The ATU-R receiver shall calculate the performance margin for each of the rates options sent from the ATU-C during C-RATES1, and then select one of the options with a satisfactory margin. This margin (rounded to the nearest dB) is encoded into bits 20 – 16 of R-MSGS2 using a conventional binary representation (e.g., if the margin is 9 dB then  $\{m_{20}, \dots, m_{16}\} = 01001$ ).

#### 12.9.2.3 Total number of bits per symbol supported

The ATU-R receiver shall also calculate the maximum number of bits per symbol that the downstream channel can support with a performance margin of 6 dB at an error rate of  $10^{-7}$ . This number is encoded into bits 11–0 using a conventional binary representation (e.g., if the maximum number of bits that can be supported is 1724 (data rate = 6896 kbit/s),  $\{m_{11}, \dots, m_0\} = 11010111100$ ).

#### 12.9.3 R-CRC3

R-CRC3 is a cyclic redundancy code for detection of errors in the reception of R-MSGS2 at the ATU-C. The CRC polynomial  $c(D)$  and generator polynomial  $g(D)$  are as described in 12.6.3. These bits are transmitted in 2 symbol periods using the method described in 12.9.2. Following R-CRC3, the ATU-R shall enter state R-RATES2.

ANSI T1.413-1995

**12.9.4 R-RATES2**

R-RATES2 is the reply to C-RATES1 based on the results of the downstream channel analysis. Instead of listing the  $B_F$ ,  $B_i$  as in C-RATES1, the ATU-R sends back only the option number of the highest data rate that can be supported based on the measured SNR of the downstream channel. As in C-RATES2, 4 bits are used for the option number. A total of 8 bits are used for R-RATES2, and the bit patterns are shown in table 41. Other bit patterns that are not specified in the table are reserved for future use. If none of the options requested during C-RATES1 can be implemented, ATU-R then returns to R-ACT-REQ for retraining. One symbol period is used to transmit these 8 bits using the method described in 12.9.2. Following R-RATES2, the ATU-R shall enter state R-CRC4.

**Table 41 – Bit pattern for R-RATES2**

Downstream	Bit pattern for R-RATES2 (MSB first) (note 1)
option 1	00010001
option 2	00100010
option 3	01000100
option 4	10001000
all options fail (note 2)	00000000
NOTES	
1 All other bit patterns that are not shown are reserved for future use.	
2 If it is determined that none of the four options can be implemented with the connection, the ATU-R shall return to R-ACT-REQ for retraining.	

**12.9.5 R-CRC4**

R-CRC4 is a cyclic redundancy code for detection of errors in the reception of R-RATES2 at the ATU-C. Its relation to R-RATES2 is the same as that of R-CRC3 to R-MSGS2. Following R-CRC4, the ATU-R shall enter state R-REVERB5.

**12.9.6 R-REVERB5**

R-REVERB5 is the same as R-REVERB3 (see 12.7.2). The duration of R-REVERB5 depends upon the state of the ATU-C and the internal processing of the ATU-R, but has a maximum of 4000 symbols. The ATU-R shall transmit R-REVERB5 until it has received and checked the reliability of the upstream bits and gains information contained in C-B&G. After the ATU-R has received C-CRC5, it shall continue to transmit R-REVERB5 for another 64 symbols. It shall then enter R-SEGUE4. If it has not successfully detected all the control signals within 4000 symbols it shall timeout and reset to R-ACT-REQ.

**12.9.7 R-SEGUE4**

The purpose of R-SEGUE4 is to notify the ATU-C that the ATU-R is about to enter R-B&G. R-SEGUE4 is the same as R-SEGUE3 (see 12.9.1). The duration of R-SEGUE4 is 10 symbol periods. Following R-SEGUE4 the ATU-R enters state R-B&G.

**12.9.8 R-B&G**

The purpose of R-B&G is to transmit to the ATU-C the bits and gains information,  $\{b_1, g_1, b_2, g_2, \dots, b_{255}, g_{255}\}$ , to be used on the downstream sub-carriers.  $b_i$  indicates the number of bits to be coded by the ATU-C transmitter onto the  $i$ th downstream sub-carrier,  $g_i$  indicates the scale factor that shall be applied to the  $i$ th downstream sub-carrier, relative to the gain that was used for that carrier during the transmission of C-MEDLEY. Because no bits or energy will be transmitted at DC or one-half the sampling rate,  $b_0, g_0, b_{256}$ , and  $g_{256}$  are all presumed to be zero, and are not transmitted.

Each  $b_i$  is represented as an unsigned 4-bit integer, with valid  $b_i$  lying in the range of zero to  $N_{\text{downmax}}$ , the maximum number of bits that the ATU-C is prepared to modulate onto any sub-carrier, which is communicated in C-MSG51.

Each  $g_i$  is represented as an unsigned 12-bit fixed-point quantity, with the binary point assumed just to the right of the third most significant bit. For example, a  $g_i$  with binary representation (most significant bit listed first) 0100 0000 0000 would instruct the ATU-C to scale the constellation for carrier  $i$  by a gain factor of 2, so that the power in that carrier shall be 6 dB higher than it was during C-MEDLEY.

For sub-carriers where no data are transmitted and the receiver will never allocate bits (e.g., out-of-band channels), both  $b_i$  and  $g_i$  will be set to zero (0000 and 00000000 000, respectively). For sub-carriers where no data are currently to be transmitted, but the receiver may allocate bits later (e.g., as a result of an SNR improvement), the  $b_i$  will be set to zero (0000) and the  $g_i$  to 1 (00100000 0000)

A total of 510 bytes of bits and gains information is to be transmitted during R-B&G, so that a total of 510 symbol periods is required. The transmission format is the same as described in 12.9.2. Following R-B&G the ATU-R shall enter state R-CRC5.

### 12.9.9 R-CRC5

R-CRC5 is a cyclic redundancy code for detection of errors in the reception of R-B&G at the ATU-C. Its relation to R-B&G is the same as that of R-CRC3 to R-MSG52. Following R-CRC5, the ATU-R shall enter state R-REVERB6.

### 12.9.10 R-REVERB6

R-REVERB6 is the same as R-REVERB3 (see 12.7.2). The duration of R-REVERB6 depends upon the state of the ATU-C and the internal processing of the ATU-R, but has a maximum of 4000 symbols. The ATU-R shall transmit R-REVERB6 until it has detected all ten symbols of C-SEGUE3; it shall then enter R-SEGUE5. If it has not successfully detected C-SEGUE3 within 4000 symbols it shall timeout and reset to R-ACT-REQ.

### 12.9.11 R-SEGUE5

The purpose of R-SEGUE5 is to notify the ATU-C that the ATU-R is about to enter the steady-state state R-SHOWTIME. R-SEGUE5 is identical to R-SEGUE3 (see 12.9.1). The duration of R-SEGUE5 is 10 symbol periods. Following R-SEGUE5 the ATU-R has completed initialization and shall enter state R-SHOWTIME.

ANSI T1.413-1995

**13 On-line adaptation and reconfiguration****13.1 The ADSL overhead control (aoc) channel**

As stated in 6.2 and 7.2, when any bearer data streams appear in the interleave buffer, then the aoc channel data is carried in the LEX byte, and the "synch" byte shall designate when the LEX byte contains aoc channel data and when it contains a data byte from the bearer data streams. When no bearer data streams are allocated to the interleave data buffer (i.e., all  $B_1$  (ASX) = 0 and all  $B_1$  (LSX) = 0 for the downstream case or all  $B_1$  (LSX) = 0 for the upstream case, respectively), then the "synch" byte carries the aoc channel data directly, because the LEX byte does not exist in the interleave buffer in this case.

**13.1.1 aoc message header**

The type and length of an aoc message is determined by a byte-length header. In particular, the aoc channel sends all binary zeros in the idle mode, and a valid aoc message always begins with a non-zero byte. Table 42 summarizes the current valid aoc message headers. For example, in the case of a bit swap, the aoc header "11111111" will be detected, and the next byte of aoc data shall determine whether the message is a bit swap request or a bit swap acknowledge (see 13.2). In the case when a standardized function, such as a bit swap, is requested but cannot be performed by either the ATU-C or the ATU-R for whatever the reason, an unable to comply message ("11110000") is issued. Future aoc headers can be added when new aoc messages/functions are identified. Also, a block of aoc header values ("1100xxxx") is set aside for vendor specific aoc messages.

**Table 42 – aoc message headers**

Value	Interpretation
00000000	Idle mode
00001111	Reconfiguration commands
1100xxxx	Reserved for vendor specific commands
11110000	Unable to comply
11111100	Extended bit swap request
11111111	Bit swap commands

**13.1.2 aoc protocol**

All aoc messages are transmitted 5 consecutive times for extra security. A transceiver unit shall only act on an aoc message if it has received three identical messages in a time period spanning 5 of that particular message. When a receiving unit detects an unrecognizable command, no action shall be taken by the receiving unit. The transmitting unit (the originating unit of the aoc command) is responsible for any time outs and/or local recovery schemes, when no acknowledgment to its request has been detected over a reasonable period of time. Individual vendors of ADSL transceivers may implement any recovery scheme(s) of their choice.

**13.2 High-level on-line adaptation – Bit swapping**

Bit swapping enables an ADSL system to change the number of bits assigned to a subcarrier, or change the transmit energy of a subcarrier without interrupting data flow.

Either ATU may initiate a bit swap; the swapping procedures in the upstream and downstream channels are independent, and may take place simultaneously.

### 13.2.1 Bit swap channel

The bit swap process uses the aoc channel, described in 13.1. All bit swap messages shall be repeated five consecutive times over this channel.

### 13.2.2 Superframe counting

The transceivers coordinate the bit swaps as follows:

- The ATU-C and ATU-R transmitters shall start their counters immediately after transmitting C-SEGUE3 and R-SEGUE5, respectively; this marks the transition between initialization and steady state operation;
- Each transmitter shall increment its counter after sending each ADSL superframe (see 6.2);
- Correspondingly, each receiver shall start its counter immediately after receiving C-SEGUE3 or R-SEGUE5, respectively, and then increment it after receiving each superframe.

Synchronization of the corresponding transmitter and receiver superframe counters is maintained using the synch symbol in the ADSL frame structure. Any form of restart that requires a transition from initialization to steady state shall reset the superframe counter.

### 13.2.3 Bit swap request

Message header	Message field 1 (16 bits)		Message field 2 (16 bits)		Message field 3 (16 bits)		Message field 4 (16 bits)	
11111111 (8 bits)	Command (8 bits)	Subchannel index (8bits)	Command (8 bits)	Subchannel index (8bits)	Command (8 bits)	Subchannel index (8bits)	Command (8 bits)	Subchann index (8bits)

**Figure 35 – Format of the bit swap request message**

The receiver shall initiate a bit swap by sending a bit swap request back to the transmitter via the aoc channel. This request tells the transmitter what subcarriers are to be modified. Figure 35 illustrates the format of the bit swap request message, which contains the following:

- an aoc message header consisting of 8 binary ones;
- message fields 1 – 4, each of which each consists of an eight bit command followed by a related eight-bit subchannel index. Valid eight-bit commands for the bit swap message shall be as shown in table 43. The eight-bit subchannel index is counted from low to high frequencies with the lowest frequency subcarrier having the number zero.

**Table 43 – Bit swap request commands**

Value	Interpretation
00000000	Do nothing
00000001	Increase the allocated number of bits by one.
00000010	Decrease the allocated number of bits by one.
00000011	Change the transmitted power by the factor +1 dB
00000100	Change the transmitted power by the factor +2 dB
00000101	Change the transmitted power by the factor +3 dB
00000110	Change the transmitted power by the factor –1 dB
00000111	Change the transmitted power by the factor –2 dB
00001xxx	Reserved for vendor specific commands

## ANSI T1.413-1995

The bit swap request message (i.e., header and message fields) is transmitted five consecutive times.

### 13.2.4 Extended bit swap request

Because a single-bit sub-carrier is not allowed, an extended bit swap request containing 6 fields shall be used when decreasing the number of bits on a sub-carrier from 2 to 0, or when increasing the number of bits on a sub-carrier from 0 to 2. The format of this extended bit swap request is similar to that of the bit swap request (13.2.3), but the number of message fields is increased to 6, and, as shown in table 44, the message header is 11111100.

**Table 44 – Extended bit swap request**

Message Header (8 bits)	Message Field #1 (16 bits)	Message Field #2 (16 bits)	Message Field #3 (16 bits)	Message Field #4 (16 bits)	Message Field #5 (16 bits)	Message Field #6 (16 bits)
11111100						

The extended bit swap request is transmitted 5 consecutive times

### 13.2.5 Bit swap acknowledge

Message header (8 bits) 11111111	Command (8 bits) 11111111	Bit swap superframe counter number (8 bits)
--	---------------------------------	---

**Figure 36 – Format of the bit swap acknowledge**

The transmitter shall act on a bit swap request when it has received three identical bit swap request messages. The transmitter shall then send a bit swap acknowledge. Figure 36 shows the format of the bit swap acknowledge message, which contains the following:

- an aoc message header containing 8 binary ones;
- one message field that consists of eight binary ones followed by the eight bit superframe counter number, which indicates when the bit swap is to take place. In particular, the new bit and/or transmit energy table(s) shall take effect starting from the first frame (frame 0) of an ADSL superframe, after the specified superframe counter number has been reached. In other words, if the bit swap superframe counter number contained in the bit swap acknowledge message is  $n$ , then the new table(s) shall take effect starting from frame 0 of the  $(n+1)$ th ADSL superframe.

The bit swap acknowledge is transmitted five consecutive times.

### 13.2.6 Bit swap – Receiver

The receiver shall act on a bit swap request when it has received three identical bit swap acknowledge messages. The receiver shall then wait until the superframe counter equals the value specified in the bit swap acknowledge. Then, beginning with frame 0 of the next ADSL superframe the receiver shall

- change the bit assignment of the appropriate subcarriers, and perform tone re-ordering based on the new sub-carrier bit assignment;
- update applicable receiver parameters of the appropriate subcarriers to account for a change in their transmitted energy

### 13.2.7 Bit swap – Transmitter

After transmitting the bit swap acknowledge, the transmitter shall wait until the superframe counter equals the value specified in the bit swap acknowledge. Then, beginning with frame 0 of the next ADSL superframe, the transmitter shall

- change the bit assignment of the appropriate subcarriers, and perform tone re-ordering based on the new sub-carrier bit assignment;
- change the transmit energy in the appropriate subcarriers by the desired factor.

### 13.3 Changes to data rates and reconfiguration

Specification of changes to data rates and reconfiguration on demand is for further study.

## 14 Signaling requirements

ADSL supports both simplex and duplex bearer channels in a variety of configurations (see 5.1).

Bearer service is defined as the CI to CI service (e.g., 1.536 Mbit/s unrestricted digital information) that is selected and is carried over a particular bearer channel on an ADSL system. ADSL bearer channels may support a variety of bearer services.

Two methods of signaling protocols for controlling bearer service are recognized for ADSL:

- *In-band signaling*: This is defined as a signaling protocol controlling a bearer service carried over an ADSL bearer channel, where the signaling protocol is within the same ADSL bearer channel as the bearer service. For example, a data protocol stack, such as TCP/IP or OSI, may employ network layer and higher layer signaling protocols within a bearer service transported over ADSL. In-band signaling protocols are carried transparently, and are neither affected nor interpreted by the ADSL system;
- *Out-of-band signaling*: This is defined as a signaling protocol controlling a bearer service carried over an ADSL bearer channel, where the signaling protocol is carried in a different ADSL bearer channel than the bearer service. In this case, the ADSL C channel shall be used to carry the signaling protocol.

When the LS1 duplex channel is used to carry an ISDN BRA (2B+D+overhead) payload, the ISDN BRA multiplex is carried transparently. For the ISDN bearer services carried on the BRA, the signaling is within the BRA D channel and is neither affected nor interpreted by the ADSL system.

ANSI T1.413-1995

**15 Loop plant, impairments, and testing**

The methods in this clause test ADSL system transmission performance. These laboratory methods evaluate a system's ability to minimize digital bit errors caused by interference from:

- crosstalk coupling from other systems;
- background noise;
- impulse noise;
- POTS signaling.

These potential sources of impairment are simulated in a laboratory set-up that includes test loops, test sets, and interference injection equipment, as well as the test system itself. Figure 37 shows the general arrangement for testing.

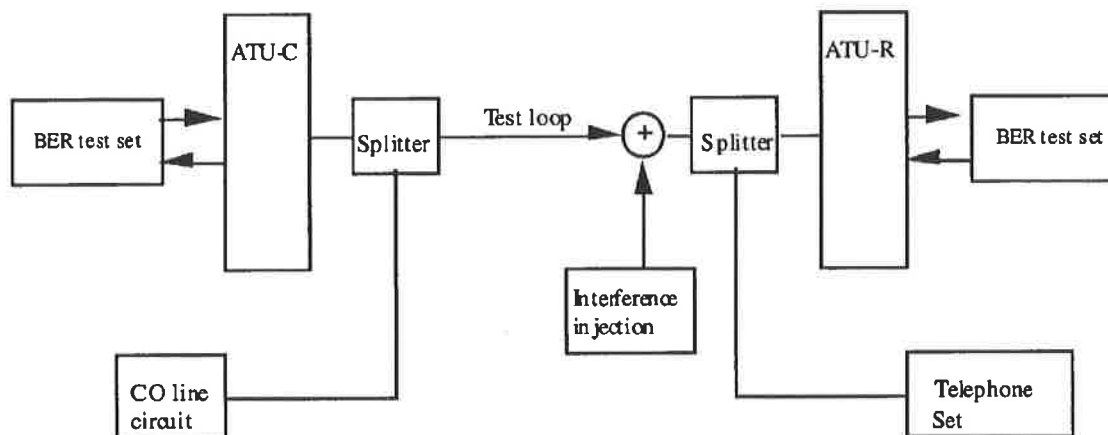

**Figure 37 – Overview of test setup**

The crosstalk and impulse noise interfering signals are simulations that are derived from a consideration of real loop conditions and measurements. The test procedure is to inject the interference into the test loops and measure the effect on system performance by a bit error test simultaneously run on the system information channels.

For crosstalk an initial, or reference, power level for the interference represents the expected worst case. If the interference power can be increased without exceeding a specified error threshold, the system has a positive performance margin. Performance margin, expressed in dB, is the difference between the interference level at which the error threshold is reached, and the reference (or 0 dB) level.

The specified error threshold with crosstalk interference is a BER of  $10^{-7}$ ; the minimum performance margin is 6 dB.

In the case of impulse noise, an increasing interference level is similarly applied up to the error threshold, and the estimated performance is computed from this information. Because the impulse noise characteristics of the loop plant are not completely understood, the estimation method is based on measured data from several sites. The estimated number of error-causing impulses is compared to a 0.14 % errored-seconds (ES) criterion. The test procedure makes separate determinations of crosstalk margins and impulse error thresholds, although a background crosstalk interference is applied during impulse tests.

The digital channel BER measurement shall be made while including impairments such as POTS signaling interference and crosstalk from other telephone lines. Tests shall be performed using signaling and alerting activities done with an electro-mechanical telephone set and either CO lines or a CO simulator.



## 15.1 Test loops

ADSL transmission at 1.536 Mbit/s is assessed in terms of performance against an objective of coverage over all copper loops without load coils conforming to Revised Resistance Design (RRD) rules as defined in Bellcore SR-TSV-002275. For test purposes, the RRD loops are represented by loops 7, 9 and 13 specified in 4.5.1 and figure 8 of ANSI T1.601. The primary cable constants are listed in tables G1 – G8 of ANSI T1.601. An additional loop (Loop #0) with a length of less than 10 feet is added to the T1.601 test loops.

ADSL transmission at 6.144 Mbit/s is assessed in terms of performance against an objective of coverage over loops that conform to Carrier Serving Area (CSA) design rules (a subset of RRD loops). For testing purposes, the CSA loops are represented by loops 4, 6, 7, and 8 shown in figures 13 and 14 of Committee T1 Technical Report No. 28.

For 10 or 24 disturber NEXT interference from T1 lines in adjacent binder groups, ADSL transmission is assessed with a mid-CSA loop.

The ADSL control channel and other duplex channels are evaluated with all test loops.

For convenience the configurations of the test loops are shown in figure 38, and their attenuation characteristics are given in annex E.

Table 45 describes a classification that ties together transport payload and loop range based on whether certain options available for the ATU transceivers are used. Category I (basic) describes loop ranges and transport payloads using basic transceivers with no options required. Category II (enhanced) describes loop ranges and transport payloads using options for trellis coding, transmit power boost, and echo cancellation.

**Table 45 – ATU classification by category**

Characteristics	Category I (basic)	Category II (optional)
Performance (see note 1)	see note 2	see note 2
Trellis option	off	on required
EC/FDM	optional	EC
Power boost	off	required capable

### NOTES

- 1 Performance is defined as loop reach shown as a function of bit rate in table 46 and crosstalk as shown in tables 47–52.
- 2 The specific combinations of loops and rates shown in table 46, and crosstalk shown in tables 47 – 52 shall be tested for either category I or category II ATUs, as indicated.

**Table 46 – Loop sets and maximum rates for category I and category II testing**

Loop sets	ATU category	Maximum rate (kbit/s)	
		Simplex	Duplex
T1.601 (7,13)	I	1544	16 + 160
CSA (4,6,7), Mid-CSA	I	6144	64 + 160
T1.601 (7,9,13)	II	1544	16 + 160
CSA (4,6,8), Mid-CSA	II	6144	64 + 576

ANSI T1.413-1995

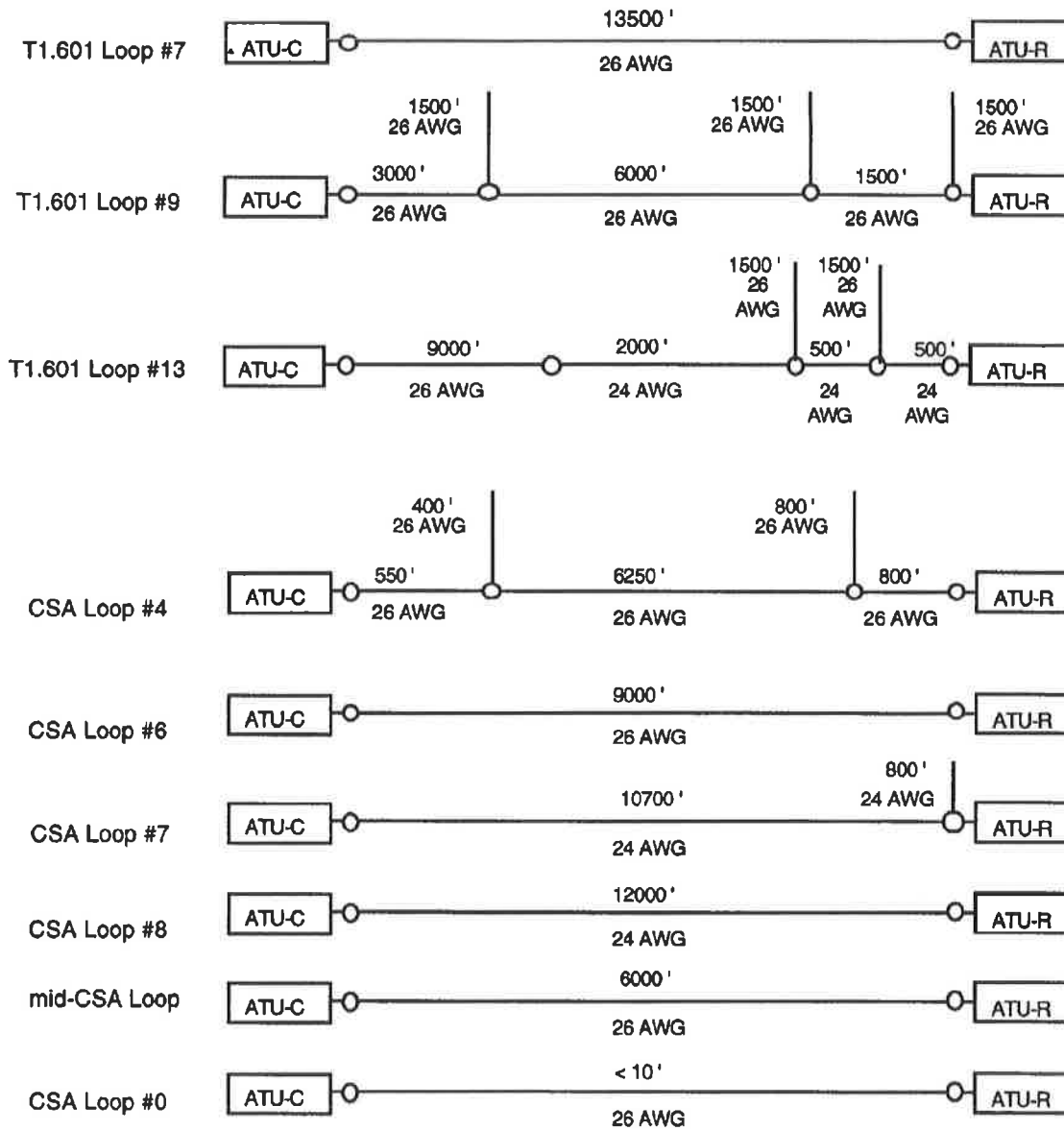

NOTES

- 1 AWG = American Wire Gauge.
- 2 Distances are in feet ('): 100'

Figure 38 – Test loops

## 15.2 Impairments and their simulation in testing

### 15.2.1 Crosstalk

Crosstalk spectral compatibility is tested using simulations of the interference caused by coupling from other transmission systems sharing the same cable. Four combinations of white noise and NEXT from the following systems are used:

- DSL;
- HDSL;
- ADSL;
- T1 line (adjacent binder group).

For each of these the Power Spectral Density (PSD) of the transmitted signal and of the induced crosstalk is calculated for the appropriate number of disturbers and crosstalk model. The detailed analysis of the PSD and the model are provided in annex B.

The interferers used for the tests are

- 10 or 24 disturber DSL NEXT;
- 10 or 20 disturber HDSL NEXT;
- 10 or 24 disturber ADSL NEXT and FEXT;
- 4, 10 or 24 disturber T1 NEXT (adjacent binder group).

The resulting noise power spectra for these interferers are shown in annex B, where the derivation of the spectrum is described for each of these sources.

### 15.2.2 Impulse noise

There are two impulse waveforms defined for testing. These are reconstructions of actual recorded impulses observed in field tests, and represent the single most likely waveforms at specific sites. These waveforms are shown in figures 39 and 40 as approximations only. The two impulse waveforms for testing purposes are described in annex C with the amplitudes specified at 160 nanosecond intervals.

ANSI T1.413-1995

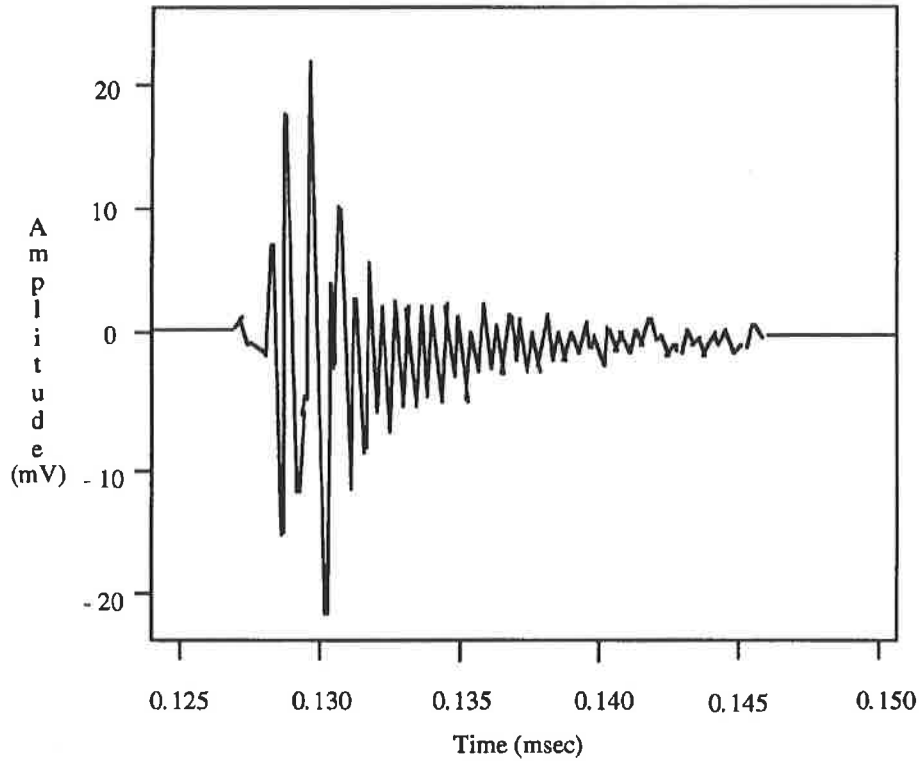

Figure 39 – Test Impulse #1

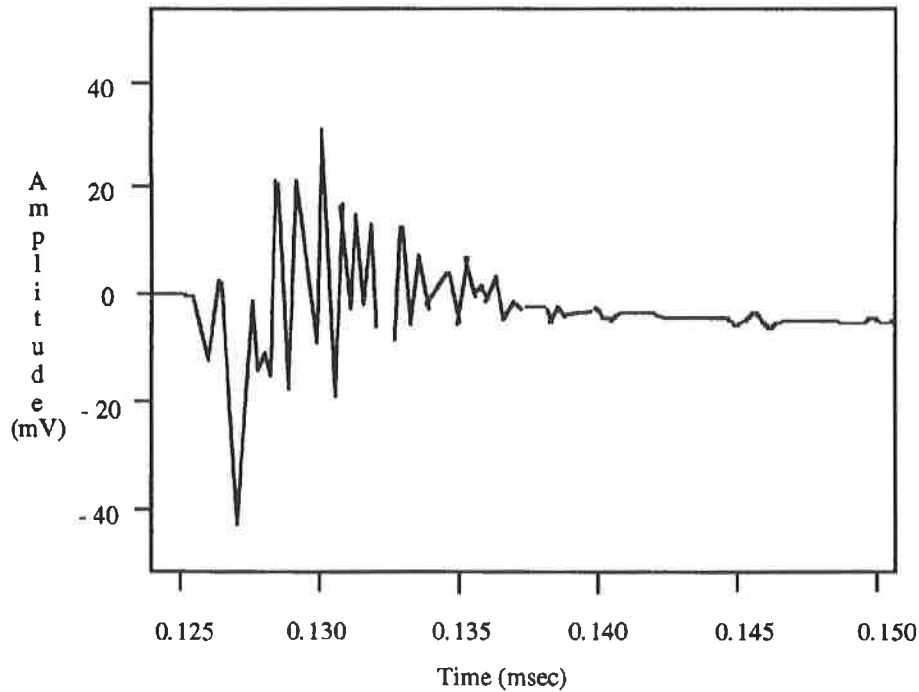

Figure 40 – Test Impulse #2

## 15.3 Test procedures

### 15.3.1 Test setup

Figure 41 shows the test setup for measuring performance margins on ADSL systems. The test system consists of a central office transceiver (ATU-C), a remote end transceiver (ATU-R), and associated POTS splitters. The two transceivers are connected together by the test loop. Calibrated simulated crosstalk is injected through a high impedance network across the tip and ring of the loop at the input of one of the transceivers. Impulse noise from a waveform generator is similarly injected. Crosstalk and impulses are injected at the ATU-R for simplex channel tests, and at both the ATU-C and ATU-R for duplex channel tests.

Pseudo-random binary data from the transmitter of the bit error ratio (BER) test set is presented at the simplex channel input of the ATU-C, and the received clock and data outputs from the ATU-R are connected to the receiver of the same or a similar BER test set. The test set measures for BER or errored-seconds (ES), as needed. Similar error testing is done in both directions for the duplex channels at the rates needed for the particular system under test.

A telephone set is connected to the telephone jack of the splitter at the ATU-R end, and a working telephone line circuit is connected to the telephone jack on the splitter at the ATU-C end.

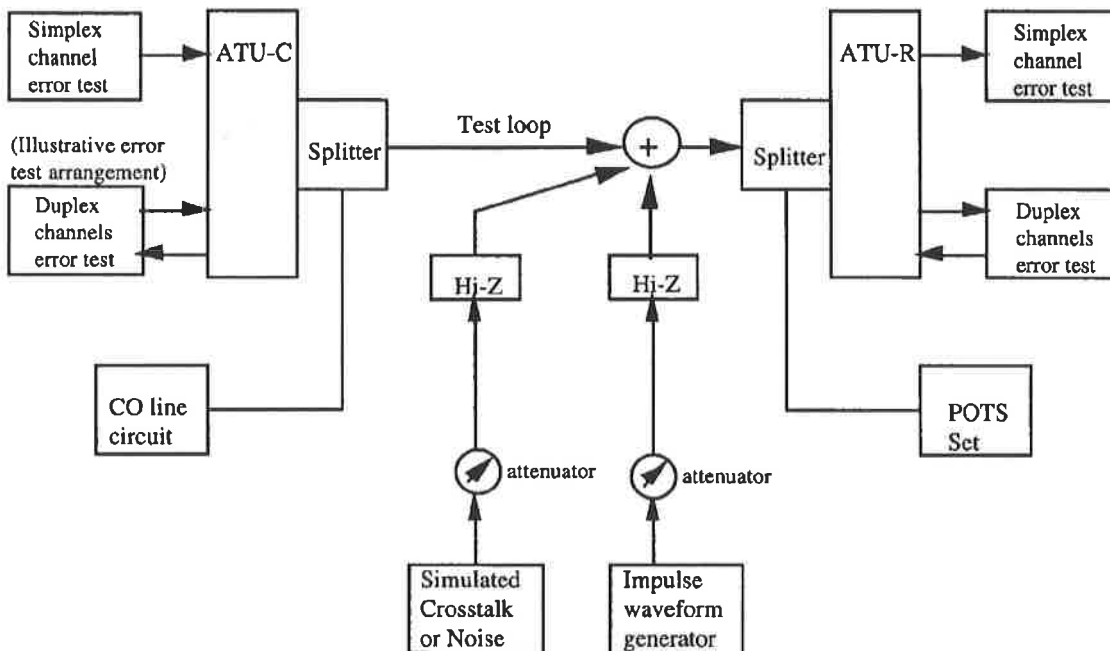

Figure 41 – Laboratory test setup for measuring performance margins

#### 15.3.1.1 Crosstalk noise injection

Simulated crosstalk, XT (NEXT and/or FEXT) is introduced into the test loop at the ATU-R so as to achieve the appropriate voltage level without disturbing the impedance of the test loop or the transceiver. This is done with a balanced series feed of high impedance. One method for both test and calibration is shown in figure 42. The Thevenin impedance of all noise-coupling circuits connected to the test loop shall be greater than 4000 ohms.

The simulated XT should ideally have the power and spectral density defined by the equations for  $P_{\text{NEXT}}$  or  $P_{\text{FEXT}}$  in annex B. It is acknowledged, however, that if the method of generating the simulated XT is similar to that shown in figure 42, then its accuracy will depend on the design of the filter used to shape the white noise. Therefore a calculated XT PSD may be defined for which a tolerance on  $f_0$  of +2 % is allowed at each null. Then the accuracy of the simulated XT shall be

## ANSI T1.413-1995

within +1 dB of the calculated XT for all frequencies at which the calculated value is less than 45 dB below the peak value. The total power of the simulated XT shall be within +0.5 dB of the specified value using the same calibration termination.

The crest factor of the simulated XT shall be equal to or greater than 5.

The simulated XT PSD shall be verified using the calibration termination shown in figure 42 and a selective voltmeter or true RMS meter with a bandwidth of approximately 3 kHz. For DSL and HDSL crosstalk the circuit shall be calibrated for 1.3 dB less crosstalk than specified in annex B, in order to compensate for the use of 100 ohm terminations instead of 135 ohms.

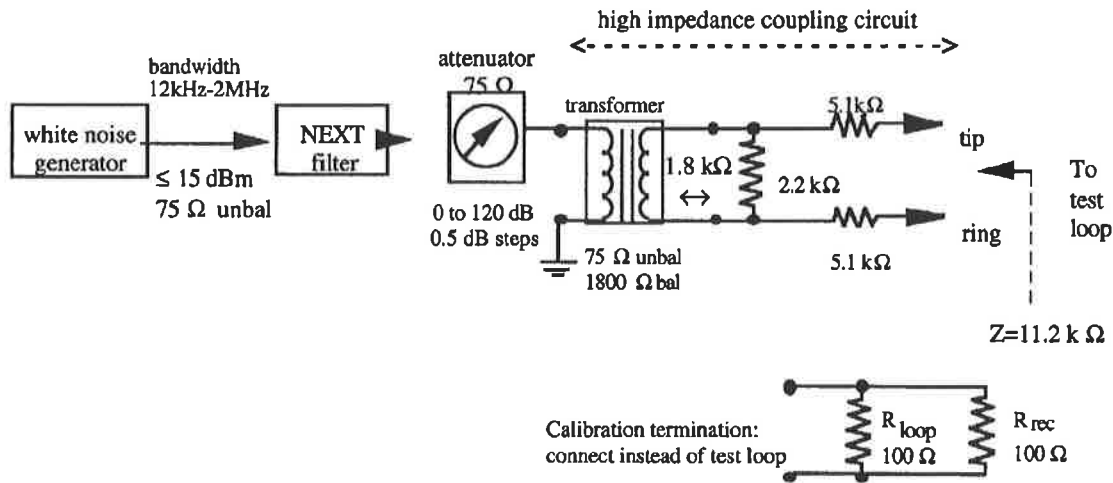

**Figure 42 – High impedance crosstalk injection circuit**

The characteristics of the white noise generator in figure 42 are crucial to the accuracy of the tests; consideration should be given to the following factors:

- *The probability distribution of the peak amplitude:* The noise shall be Gaussian within all frequency bands;
- *Crest factor:* This is an indication of the number of standard deviations to which the noise follows a Gaussian distribution; the required minimum is for further study, but is provisionally set at 5;
- *The frequency spectrum:* If the noise is generated using digital methods the sequence repetition rate will affect the correlation of the samples, and hence the frequency spectrum.

### 15.3.1.2 Impulse noise injection

The same coupling circuit as is used in 15.3.1.1 is used for impulse noise injection. The amplitude level of the impulses may be measured with an oscilloscope.

### 15.3.1.3 Error testing

The error test set(s) shall be capable of testing at all channel rates available in the test system (see clause 5). A test pattern of length  $2^{23}-1$  shall be used.

### 15.3.2 Test conditions

#### 15.3.2.1 Crosstalk interference

Tables 47 and 48 show the combinations of test loops, numbers of interferers, and data rates to be tested for category I and category II ATUs, respectively.

**Table 47 – Crosstalk tests for category I**

Test loops	Maximum simplex rate (Mbit/s)	Maximum duplex rate (kbit/s)	Margin (dB)	Crosstalk (note)			
				ADSL NEXT and FEXT	HDSL NEXT	DSL NEXT	T1 NEXT adj. binder
T1.601 (7,13)	1.544	16 + 160	6	–	–	24	–
CSA (4)	6.144	64 + 160	6	24	–	24	–
CSA (6)	6.144	64 + 160	6	–	20	–	–
CSA (7)	6.144	64 + 160	6	10	–	10	–
Mid-CSA loop	6.144	64 + 160	3	–	–	–	10

NOTE – The indicated interferers for each test are summed together with AWGN with PSD of – 140 dBm/Hz to form a composite power spectral density.

**Table 48 – Crosstalk tests for category II**

Test loops	Maximum simplex rate (Mbit/s)	Maximum duplex rate (kbit/s)	Margin (dB)	Crosstalk (note 1)			
				ADSL NEXT and FEXT	HDSL NEXT	DSL NEXT	T1 NEXT adj. binder
T1.601 (7,9,13)	1.544	16 + 160	6	–	–	24	–
CSA (4,6,8)	6.144	64 + 576	6	10	10	24	–
CSA (6)	6.144	64 + 576	0	–	–	–	4 (note 2)
Mid-CSA loop	6.144	64 + 576	6	–	–	10	24

**NOTES**

1 The indicated interferers for each test are summed together with AWGN with PSD of – 140 dBm/Hz to form a composite power spectral density.

2 In this case the higher transmit power option may be used.

#### 15.3.2.2 Impulse test

Tables 49 and 50 show the combinations of test loops, interferers, and data rates to be tested.

ANSI T1.413-1995

**Table 49 – Test loops, Interferers, and data rates for Impulse tests for category I**

Test loops	Duplex rate (Mbit/s)	Simplex rate (kbit/s)	Interferers		
			Impulse 1	Impulse 2	crosstalk (note)
T1.601 (7,13)	1.544	16 + 160	y	y	y
CSA (4,6,7)	6.144	64 + 160	y	y	y
Mid-CSA (6 kft)	6.144	64 + 160	y	y	y

NOTE – The type of crosstalk interference applicable for each test is taken from the corresponding test in table 47. The total power of the applied interference shall be fixed at 4 dB below the reference level.

**Table 50 – Test loops, interferers, and data rates for impulse tests for category II**

Test loops	Duplex rate (Mbit/s)	Simplex rate (kbit/s)	Interferers		
			Impulse 1	Impulse 2	crosstalk (note)
T1.601 (7,9,13)	1.544	16 + 160	y	y	y
CSA (4,6,8)	6.144	64 + 576	y	y	y
Mid-CSA (6 kft)	6.144	64 + 576	y	y	y

NOTE – The type of crosstalk interference applicable for each test is taken from the corresponding test in table 48. The total power of the applied interference shall be fixed at 4 dB below the reference level.

**15.3.2.3 POTS**

The interference due to POTS service on the same line is generated by use of actual telephones and central office circuits connected in the normal way to the system under test. The following POTS signaling and alerting activities shall be performed:

- call phone at ATU-R and allow to ring 25 times;
- pick up ringing phone at ATU-R, 25 times;
- perform off-hook and on-hook activity on phone at ATU-R, 25 times;
- perform pulse and tone dialing.

Tables 51 and 52 show the combinations of test loops, interferers, and data rates to be tested for categories I and II.



**Table 51 – Test loops, interferers, and data rates for POTS tests category I**

Test loops	Maximum simplex rate	Maximum duplex rate	Interferers	
			POTS signaling	Crosstalk (note)
ANSI (7,13)	1.544 Mbit/s	16 + 160 kbit/s	y	y
CSA (4,6,7)	6.144 Mbit/s	64 + 160 kbit/s	y	y
Mid-CSA loop	6.144 Mbit/s	64 + 160 kbit/s	y	y

NOTE – The type of crosstalk interference applicable for each test is taken from the corresponding test in table 46. The total power of the applied interference shall be fixed 4 dB below the reference or 0 dB margin level.

**Table 52 – Test loops, interferers, and data rates for POTS tests category II**

Test loops	Maximum simplex rate	Maximum duplex rate	Interferers	
			POTS signaling	Crosstalk (note)
ANSI (7,9,13)	1.544 Mbit/s	16 + 160 kbit/s	y	y
CSA (4,6,8)	6.144 Mbit/s	64 + 576 kbit/s	y	y
CSA (6)	6.144 Mbit/s	64 + 576 kbit/s	y	y
Mid-CSA loop	6.144 Mbit/s	64 + 576 kbit/s	y	y

NOTE – The type of crosstalk interference applicable for each test is taken from the corresponding test in table 48. The total power of the applied interference shall be at a fixed level of 4 dB down from the reference or 0 dB margin level.

### 15.3.3 Test methods

With the test set-up as shown in figure 42, the test combinations described in 15.3.2 shall be tested as follows:

#### 15.3.3.1 Crosstalk

Before testing, the ADSL units are trained with the crosstalk interference specified in 15.2.2 and 15.3.2.1 present. The simulated crosstalk power is injected at the appropriate reference level. The power levels given in 15.2.1 for each type of crosstalk are considered the 0 dB margin for that type and number of disturbers. For example, the 0 dB margin level for 24-disturber DSL crosstalk was -52.6 dBm. Margin measurements are made by changing, in whole dB steps, the power level of the crosstalk injected at the transceiver and monitoring the BER over the test loops. A tested system has positive margin for a given type of crosstalk on a given loop if the system was able to operate at a BER  $\leq 1E-7$  with injected crosstalk power greater than the 0 dB margin level.

The criteria for margin level determination shall include a check that the ADSL unit can train at the margin level.

The minimum testing times to determine BERs with 95% confidence are shown in table 53.

ANSI T1.413-1995

**Table 53 – Minimum test time for crosstalk**

Bit rate	Minimum test time
above 6 Mbit/s	100 seconds
1.544 Mbit/s to 6 Mbit/s	500 seconds
less than 1.544	20 minutes

**15.3.3.2 Impulse noise**

Before testing, the ADSL units are trained with the crosstalk interference specified in 15.3.2.2 present. The test procedure consists of injecting the selected impulse waveform at varying amplitude levels and random phase. At each level the impulse is applied 15 times with a spacing of at least one second while an error measurement is made on the ADSL channels. The amplitude ( $u_e$ ) in millivolts at which half the impulses cause an error is determined for each waveform

Using the above amplitude determinations, the following equation gives the estimated probability that a second will be errored:

$$E = 0.0037 P(u > u_{e1}) + 0.0208 P(u > u_{e2})$$

$$\text{where: } P(u > u_e) = \frac{25}{u_e^2}, \quad \text{for } 5 \text{ mV} \leq u_e \leq 40 \text{ mV}$$

$$P(u > u_e) = \frac{0.625}{u_e}, \quad \text{for } u_e > 40 \text{ mV}$$

$u_{e1}$  refers to waveform 1

$u_{e2}$  refers to waveform 2

The resulting value shall be less than the es criterion of 0.14%.

**15.3.3.3 POTS Interference**

Before testing, the ADSL units are trained with the crosstalk interference specified in 15.3.2.3 present. Signaling disturbances are created through use of the CO line connected to the splitter at the ATU-C, and the telephone set connected to the telephone jack of the splitter at the ATU-R. During these activities, monitor the ADSL channels while noting any test conditions that cause errored seconds.

## 16 Physical characteristics

### 16.1 Wiring polarity integrity

ADSL operation shall be independent of the polarity of the pair of wires connecting the ATU-C and ATU-R.

### 16.2 Connector

For single mountings, the connection of the POTS splitter to the existing CI wiring interface shall be as specified in table 54 and shown in figure 43 using an 8-pin plug and jack (RJ31X) equipped with shorting bars. In this configuration the cord connecting the POTS splitter and ATU-R unit shall be hard wired. The use of a separate POTS splitter physically separated from the ATU-R is not precluded by this standard. The layer 1 requirements for the ATU-R-to-splitter interface may be defined in a later issue of the standard. For multiple mountings, other connection arrangements may be appropriate.

**Table 54 – Pin assignments for 8-position jack and plug (RJ31X) at U-R**

Pin no.	Assignment for jack	Assignment for plug
1	Tip or ring to POTS distribution	Tip or ring to POTS splitter (out)
2	No connection	No connection
3	No connection	No connection
4	Tip or ring from network interface	Tip or ring to POTS splitter (in)
5	Tip or ring from network interface	Tip or ring to POTS splitter (in)
6	No connection	No connection
7	No connection	No connection
8	Tip or ring to POTS distribution	Tip or ring to POTS splitter (out)

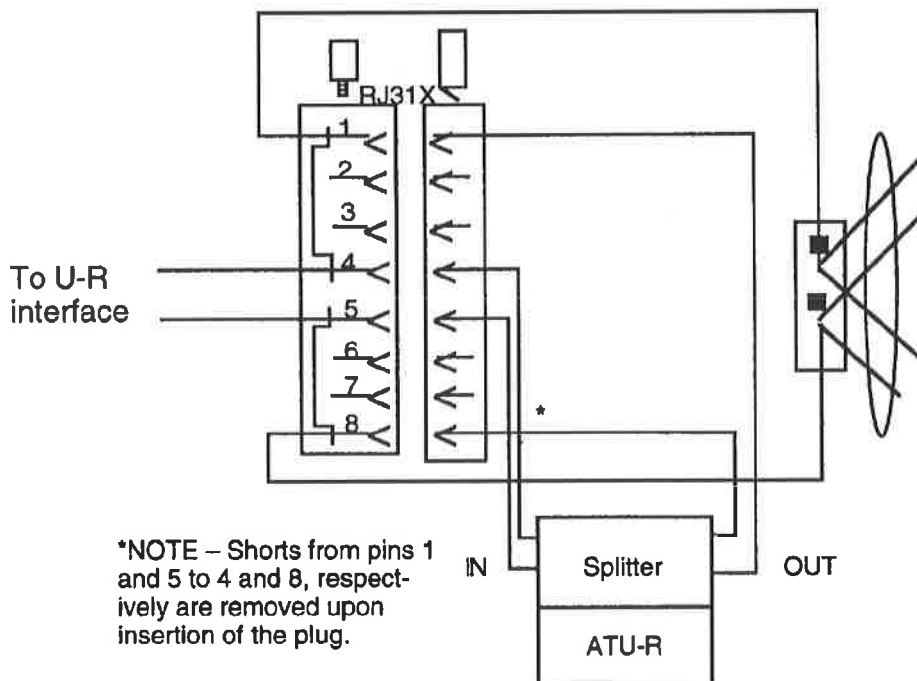

**Figure 43 – Interface on the customer premises side of the U-R**

ANSI T1.413-1995

**16.3 Wiring requirements for a remotely located POTS splitter/ATU-R**

It is recommended for a remotely located POTS splitter/ATU-R unit that the plug and jack arrangement specified in 16.2 be used. The connections between plug 1 and jack 2 are as specified in table 55, and illustrated in figure 44. The pin connections for plug 2 shall be as specified in table 54. In this configuration the cord connecting the POTS splitter and ATU-R unit shall be hard wired.

**Table 55 – Pin assignments for 8-position jack and plug at remote location**

Pin no.	Assignment for jack 2
1	From pin 1 of plug 1 to pin 1 of jack 2
2	No connection
3	No connection
4	From pin 4 of plug 1 to pin 4 of jack 2
5	From pin 5 of plug 1 to pin 5 of jack 2
6	No connection
7	No connection
8	From pin 8 of plug 1 to pin 8 of jack 2

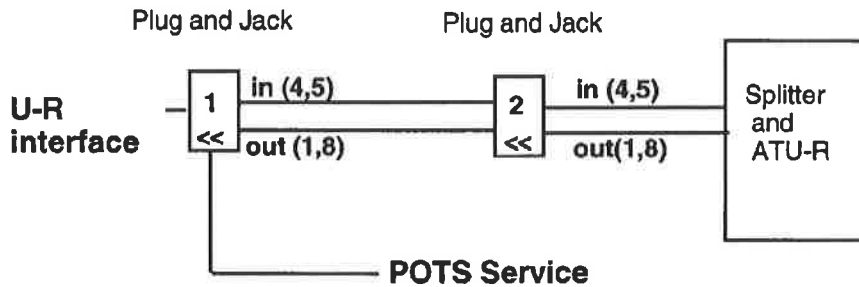
**Figure 44 – Wiring for a remotely located POTS splitter/ATU-R****16.4 Maximum distance for a remotely located unit**

The distance between plug and jack 1 and the remotely located POTS splitter and ATU-R unit shall not exceed (for further study) feet when the two pairs, (4,5) and (1,8), are in a common sheath.

**17 Environmental conditions**

**17.1 Protection**

Material referring to protection may be found in annex F of this standard.

**17.2 Electromagnetic compatibility**

Material referring to electromagnetic compatibility may be found in annex F of this standard.

ANSI T1.413-1995

## Annex A (normative)

### ATU-C and ATU-R state diagrams

#### A.1 Introduction

This annex provides state diagrams for the ATU-C and ATU-R, some portions of which are mandatory to guarantee interworking between different manufacturers' units, and some portions of which are presented here as an example only – their functions may be required or desired, but the implementation is left to the vendor.

#### A.2 Definitions

The following terms and abbreviations are used in this annex. Where states or events have been defined elsewhere in this standard, the definitions are referenced here for convenience.

- C-ACT: See 12.2.2.
- C-TONE: See 12.2.1.3.
- R-ACT-REQ: See 12.3.1.
- R-ACK: See 12.3.3.
- lof-rs: Loss of ADSL frame synch/resynch event. This event occurs when some algorithm, which may be vendor-specific, determines that a resynch attempt is required. Note that this lof-rs event is probably (but not required to be) related to the sef (severely errored frame) defect defined for operations and maintenance (11.3).
- LOF: Loss of ADSL frame synchronization declared after sef time-out (near-end severely errored frame defect, defined in 11.3).
- LOS; Loss of received signal at "U" interface declared after los time-out (near-end loss of received signal defect, defined in 11.3).
- high BER: High bit error rate in received data: detected by thresholding #crc errors (near-end crc-8i and crc-8ni error anomalies, defined in 11.3) over some period of time.
- host control channel: An ATU-C configuration control channel from some host controller, such as an ACOT (ADSL Central Office Terminal), which controls one or more ATU-C line units. Note that this channel has no relationship or direct interworking with the 64 or 16 kbit/s "C" bearer channel, which is sometimes also called a control channel.
- reconfig1: A channelization reconfiguration that can be accomplished without resetting certain key portions of the data framing, transmitter, or receiver functions (clauses 6 and 7), and thus can be performed without disrupting channels that would not change as a result of the reconfiguration. For example, if four 1.536 Mbit/s simplex channels are currently active and are all allocated to the interleave data buffer, then a reconfiguration that requires two of them to remain active, and the other two to be replaced by a 3.088 Mbit/s channel would qualify as a reconfig1.
- reconfig2: A channelization reconfiguration that requires resetting of some key portion of the data framing, transmitter, or receiver functions (clauses 6 and 7), and which thus cannot be achieved without loss of some user data. This reconfiguration request will require a fast retrain. Examples are:
  - a change from the default bearer channel rates to optional rates, such as a request for a reconfiguration from a single 6.144 Mbit/s simplex bearer to a 6.312 Mbit/s simplex bearer, which requires a change in aggregate transmitted bit rate, FEC codeword size, and resetting the interleave/deinterleave functions;
  - If four 1.536 Mbit/s simplex channels are currently active and are all allocated to the interleave data buffer, then a reconfiguration that requires one or more of them to move to the fast data buffer would

require a fast retrain to allocate the extra AEX byte for the fast data buffer, to change the FEC codeword parameters of the interleaved data buffer, and to reset the interleave/deinterleave functions.

### A.3 State diagrams

State diagrams are given in figure A.1 for the ATU-C, and in figure A.2 for the ATU-R. States are indicated by ovals, with the name of the state given within the oval. The states are defined in table A.1 for the ATU-C and in table A.2 for the ATU-R. Transitions between states are indicated by arrows, with the event causing the transition listed next to the arrow. For some events, the source of the event is indicated with letter(s) and a colon preceding the event name; a key to the source events is provided at the bottom of each figure. Mandatory states and events are indicated with **boldface type**; those states and events in normal face type are provided here as an example, with the form of their implementation left to the vendor.

In the state diagram for the ATU-C, a C-IDLE state would be desired to guarantee a quiet mode, which may be useful prior to provisioning, to allow certain tests (e.g., MLT), or to discontinue service. A selftest function is desirable, but it may be a vendor/customer option to define when selftest occurs (e.g., always at power-up or only under CO control), and which transition to take after successfully completing selftest (e.g., enter C-IDLE, or enter C-QUIET1, or enter C-Activate/Init/Train).

A variety of "host controller" commands (events preceded by "c:") are shown as non-mandatory in the ATU-C state diagram to provide example events and transitions between states. The way in which these events are implemented is left to the vendor, since many options are possible (e.g., separate host controller port on the ATU-C, switches or other front-panel controls, fixed options).

A "Retrain" state is shown as non-mandatory in both state diagrams (fast retrain is still under study). A "Resync" state is shown as non-mandatory in both state diagrams, to be left as a vendor option that may use vendor proprietary algorithms.

ANSI T1.413-1995

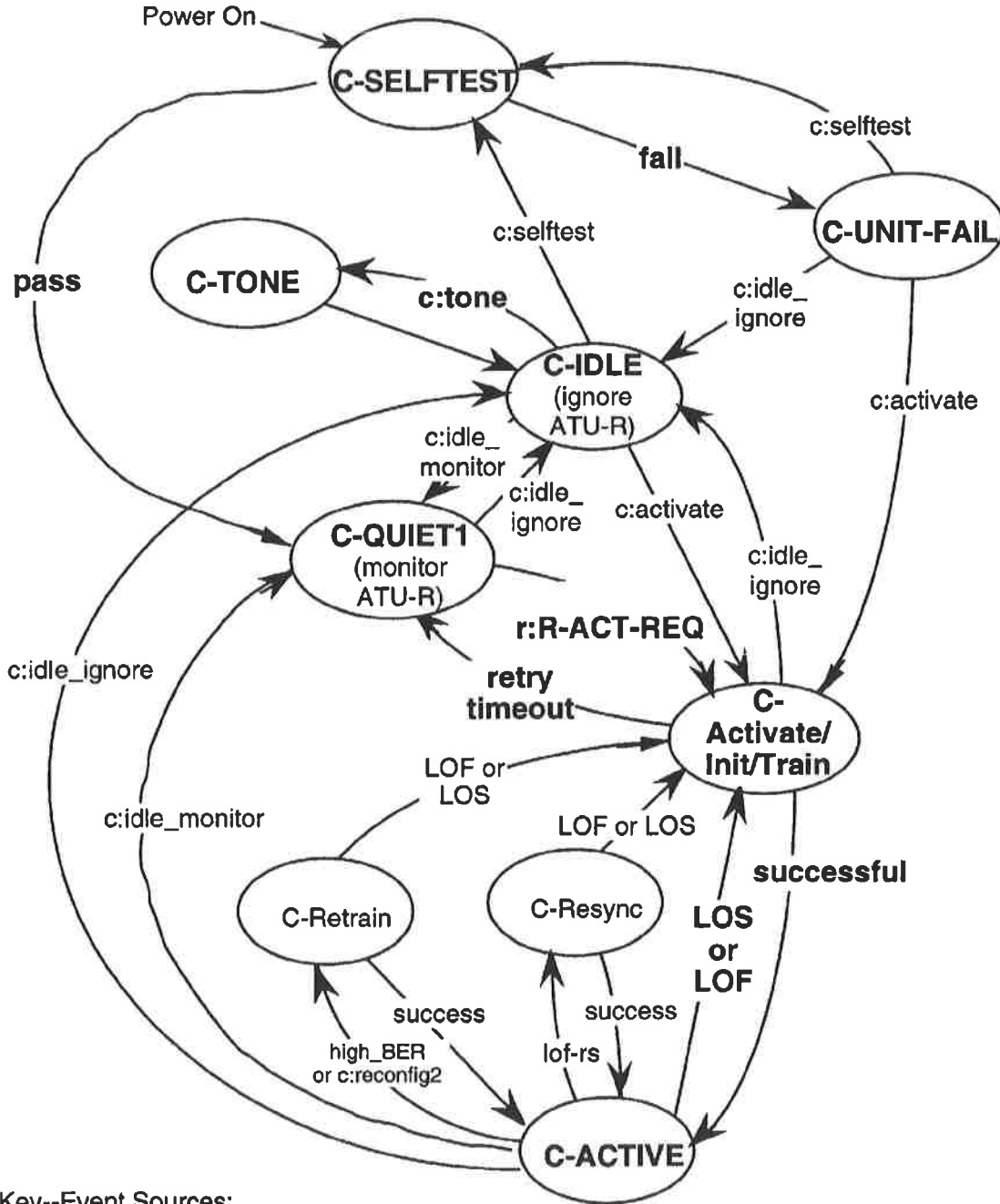

Key--Event Sources:

- c:\_\_\_ host controller command
- r:\_\_\_ received from ATU-R

State Definitions in table A.1

Terms defined in clause A.1

Figure A.1 – State diagram for the ATU-C





ANSI T1.413-1995

Table A.1 – ATU-C state definitions

State name	Description
<b>C-SELFTEST</b>	Unit performs selftest. Transmitter and receiver off (quiet at U-C interface); no response to host control channel (e.g., ACOT)
<b>C-UNIT-FAIL</b>	(selftest failed) Monitor host control channel if possible (could allow ATU host controller to retrieve selftest results)
<b>C-IDLE</b> (12.2.2) (idle; ignore ATU-R)	Transmitter and receiver off (no response to R-ACT-REQ). Monitor host control channel
<b>C-TONE</b>	Transmit C-TONE tone and transition back to C-IDLE
<b>C-QUIET1</b> (12.2.1) (idle; monitor ATU-R)	Transmitter off Receiver on, monitoring for R-ACT-REQ; if detected, transition to C-Activate/Init/Train state Monitor host control channel
<b>C-Activate/Init/Train</b> (Starts with State C-ACT of 12.2; includes 12.2, 12.4, 12.6, 12.8)	Initialize Train_Try_Counter while (--Train_Try_Counter >= 0) { Transmit C-ACT (12.2.2) Start timer If receive R-ACK before timer expires proceed with initialization/training If successful, transition to C-ACTIVE } Transition to C-QUIET1
<b>C-ACTIVE</b> (Steady State Data Transmission; 6, 11.2, 11.3, 13)	Perform steady state bit pump functions (user data channels active) Allow bit swaps and non-intrusive reconfigurations (reconfig1) Monitor host control channel Monitor alarms, eoc, aoc If LOS or LOF event, transition to C-Activate/Init/Train
<b>C-Resync</b> (non-mandatory; vendor proprietary)	(State is entered when some algorithm, possibly based on loss of ADSL synch framing, determines that resync is required) Declare sef (defined in 11.3) – user data transmission has been disrupted If signal present (i.e., not los) Attempt to find synch pattern and realign (vendor proprietary) If successful, remove sef and transition to C-ACTIVE else time-out on sef, declare LOF event, transition to C-Activate/Init/Train else time-out on los, declare LOS event, transition to C-Activate/Init/Train

**Table A.1 (concluded)**

C-Retrain (fast retrain for further study)	(State can only be entered if received signal is still present and if ADSL frame synch is still maintained) Declare sef (defined in 11.3) – user data transmission has been disrupted If signal present (i.e., not los) Channel ID and bit allocation calculation Reset Data Framing and V-interface circuits If successful, remove sef and return to C-ACTIVE else time-out on sef, declare LOF event, transition to C-Activate/Init/Train else time-out on los, declare LOS event, transition to C-Activate/Init/Train
---	---

**Table A.2 – ATU-R state definitions**

State name	Description
<b>R-SELFTTEST</b>	Unit performs selftest. Transmitter and receiver off (quiet at U-R interface) If selftest passes, transition to R-ACT-REQ else transition to R-UNIT-FAIL
<b>R-UNIT-FAIL</b>	(selftest failed – no exit from this state, except to cycle power)
<b>R-ACT-REQ</b> (12.3.1)	Receiver on, monitoring for C-ACT or C-TONE while (C-ACT not received AND C-TONE not received) { Transmit R-ACT-REQ for 128 symbols (see 12.3.1) No transmission for 896 symbols } If (C-ACT was received) transition to R-Init/Train If (C-TONE was received) transition to R-QUIET1
<b>R-QUIET1</b> (12.3.2) (Idle; monitor ATU-C)	Transmitter off; Receiver on, monitoring for C-ACT Start timer (60 seconds, see 12.3.2) At timeout transition to R-ACT-REQ
<b>R-Init/Train</b> (Starts with State R-ACK of 12.3; includes 12.3, 12.5, 12.7, 12.9)	Transmit R-ACK Proceed with Initialization and Training Sequence If successful, transition to R-ACTIVE else transition to R-ACT-REQ
<b>R-ACTIVE</b> (Steady State Data Transmission; 7, 11.2, 11.3, 13)	Perform steady state bit pump functions (user data channels active) Allow bit swaps and non-intrusive reconfigurations (reconfig1) Monitor alarms, eoc, aoc If LOS or LOF event, transition to R-ACT-REQ
R-Resync (non-mandatory; vendor proprietary)	(State is entered when some algorithm, probably based on loss of ADSL synch framing, determines that resync is required) Declare sef (defined in 11.3) – user data transmission has been disrupted If signal present (i.e., not los) Attempt to find synch pattern and realign (vendor proprietary) If successful, remove sef and transition to R-ACTIVE else time-out on sef, declare LOF event, transition to R-ACT-REQ else time-out on los, declare LOS event, transition to R-ACT-REQ

ANSI T1.413-1995

**Table A.2 (concluded)**

<b>R-Retrain</b> <b>(fast retrain for further study)</b>	(State can only be entered if received signal is still present and if ADSL frame synch is still maintained) Declare sef (defined in 11.3) – user data transmission has been disrupted Reset Data Framing and T-interface circuits If signal present (i.e., not los) Channel ID and bit allocation calculation If successful, remove sef and transition to R-ACTIVE else time-out on sef, declare LOF event, transition to R-ACT-REQ else time-out on los, declare LOS event, transition to R-ACT-REQ
---	---

## Annex B (normative)

### Power spectral density of crosstalk disturbers

Crosstalk margin measurements were made for four types of disturbers, DSLs, HDSLs, T1s and ADSL lines. DSL, HDSL, and ADSL crosstalk is from pairs within the same binder group; T1 crosstalk is from pairs in an adjacent binder group.

#### B.1 Simulated DSL power spectral density and Induced NEXT

The power spectral density (PSD) of Basic Access DSL disturbers is expressed as:

$$PSD_{DSL-Disturber} = K_{DSL} \times \frac{2}{f_o} \times \frac{\left[ \sin\left(\frac{\pi f}{f_o}\right) \right]^2}{\left(\frac{\pi f}{f_o}\right)^2} \times \frac{1}{1 + \left(\frac{f}{f_{3dB}}\right)^4}, \quad f_{3dB} = 80 \text{ kHz}, 0 \leq f < \infty$$

where  $f_o = 80 \text{ kHz}$ ,  $K_{DSL} = \frac{5}{9} \times \frac{V_p^2}{R}$ ,  $V_p = 2.50 \text{ Volts}$  and  $R = 135 \text{ Ohms}$

This equation gives the single-sided PSD; that is, the integral of PSD, with respect to  $f$ , from 0 to infinity, gives the power in Watts.  $PSD_{DSL-Disturber}$  is the PSD of an 80 kbaud 2B1Q signal with random equiprobable levels, with full-baud square-topped pulses and with 2nd order Butterworth filtering ( $f_{3dB} = 80 \text{ kHz}$ ).

The PSD of the DSL NEXT can be expressed as:

$$PSD_{DSL-NEXT} = PSD_{DSL-Disturber} \left( x_n f^{\frac{3}{2}} \right) \quad 0 \leq f < \infty, n = 1, 10, 24, 49$$

where  $x_n = 0.882 \times 10^{-14} \times N^{0.6}$

The integration of  $PSD_{DSL-Disturber}$  and  $PSD_{DSL-NEXT}$  over various frequency ranges of interest are presented in table B.1.

ANSI T1.413-1995

**Table B.1 – DSL transmit and Induced NEXT power**

Frequency Range	Transmit Power dBm	Next Power dBm 10 disturbers	NEXT Power dBm 24 disturbers
0 – 0.16 MHz	13.6	- 54.9	- 52.6
0 – 0.32 MHz	13.6	- 54.9	- 52.6
0 – 1.544 MHz	13.6	- 54.9	- 52.6

Figure B.1 shows the theoretical PSD of 24 Disturber DSL NEXT.

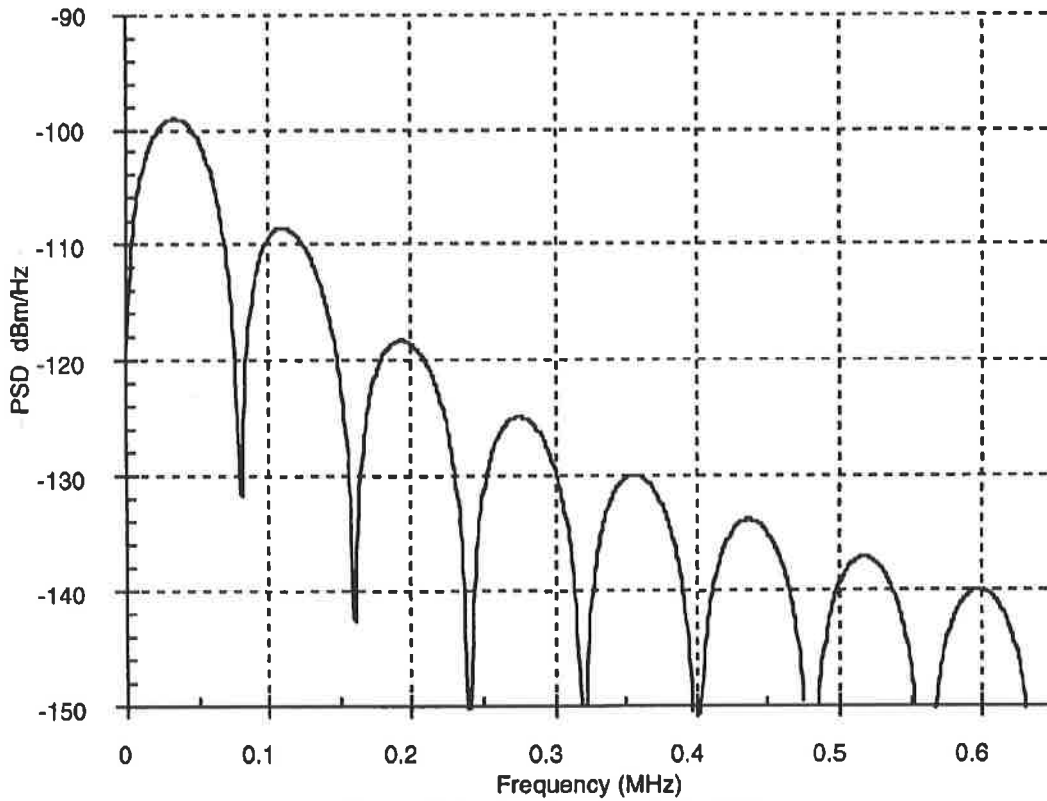
**Figure B.1 – 24-disturber DSL NEXT**

**B.2 Simulated HDSL power spectral density and induced NEXT**

The PSD of HDSL disturbers is expressed as:

$$PSD_{\text{HDSL-Disturber}} = K_{\text{HDSL}} \times \frac{2}{f_o} \times \frac{\left[ \sin\left(\frac{\pi f}{f_o}\right) \right]^2}{\left(\frac{\pi f}{f_o}\right)^2} \times \frac{1}{1 + \left(\frac{f}{f_{3dB}}\right)^8}, \quad f_{3dB} = 196 \text{ kHz}, 0 \leq f < \infty$$

where  $f_o = 392 \text{ kHz}$ ,  $K_{\text{HDSL}} = \frac{5}{9} \times \frac{V_p^2}{R}$ ,  $V_p = 2.70 \text{ Volts}$ , and  $R = 135 \text{ Ohms}$

This equation gives the single-sided PSD; that is, the integral of PSD, with respect to  $f$ , from 0 to infinity, gives the power in Watts.  $PSD_{\text{HDSL-Disturber}}$  is the PSD of a 392 kbaud 2B1Q signal with random equiprobable levels, with full-band square-topped pulses and with 4th order Butterworth filtering ( $f_{3dB} = 196 \text{ kHz}$ ).

The PSD of the HDSL NEXT can be expressed as:

$$PSD_{\text{HDSL-NEXT}} = PSD_{\text{HDSL-Disturber}} \left( x_n f^{\frac{3}{2}} \right), \quad 0 \leq f < \infty, n = 1, 10, 24, 49$$

where  $x_1$ ,  $x_{10}$ ,  $x_{24}$ , and  $x_{49}$  are defined in B.1

The integration of  $PSD_{\text{HDSL-Disturber}}$  over various frequency ranges of interest is presented in table B.2 along with the induced NEXT power.

**Table B.2 – HDSL transmit and induced NEXT power**

Frequency range	Transit power dBm	NEXT Power 10 disturbers dBm	NEXT Power 20 disturbers dBm
0 – 0.196 MHz	13.4	– 46.9	– 45.1
0 – 0.392 MHz	13.6	– 46.3	– 44.5
0 – 0.784 MHz	13.6	– 46.3	– 44.5
0 – 1.544 MHz	13.6	– 46.3	– 44.5
0 – 1.568 MHz	13.6	– 46.3	– 44.5

ANSI T1.413-1995

Figure B.2. shows the theoretical PSD of 10-Disturber HDSL NEXT.

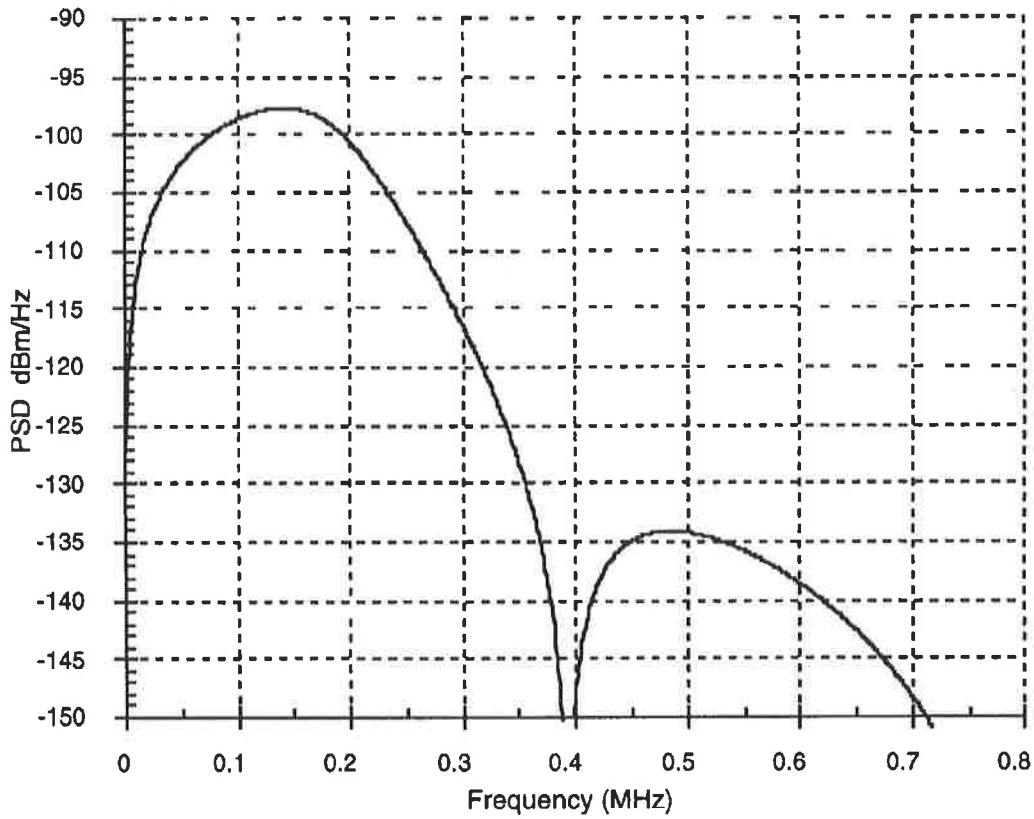

Figure B.2 – 10-disturber HDSL NEXT



### B.3 Simulated T1 line power spectral density and induced NEXT

The PSD of the T1 line disturber is assumed to be the 50% duty-cycle random Alternate Mark Inversion (AMI) code at 1.544 Mbit/s. The single-sided PSD has the following expression:

$$PSD_{T1-Disturber} = \frac{V_p^2}{R_L} \times \frac{2}{f_o} \left[ \frac{\sin\left(\frac{\pi f}{f_o}\right)}{\left(\frac{\pi f}{f_o}\right)} \right]^2 \sin^2\left(\frac{\pi f}{2f_o}\right) \times \frac{1}{1 + \left(\frac{f}{f_{3dB}}\right)^6} \times \frac{f^2}{f^2 + f_{3dB}^2}, \quad 0 \leq f < \infty$$

The total power of the transmit T1 signal is computed by:

$$P_{T1-total} = \frac{1}{4} \frac{V_p^2}{R_L}$$

It is assumed that the transmitted pulse passes through a low-pass shaping filter. The shaping filter is chosen as a third order low-pass Butterworth filter with 3 dB point at 3.0 MHz. The filter magnitude squared transfer function is:

$$\left| H_{shaping}(f) \right|^2 = \frac{1}{1 + \left(\frac{f}{f_{3dB}}\right)^6}$$

In addition, the coupling transformer is modeled as a high-pass filter with 3 dB point at 40 kHz as:

$$\left| H_{Transformer}(f) \right|^2 = \frac{f^2}{f^2 + f_{3dB}^2}$$

Furthermore, it is assumed that  $V_p = 3.6$  Volts,  $R_L = 100$  Ohms, and  $f_o = 1.544$  MHz.

The PSD of the T1 NEXT can be expressed as:

$$PSD_{T1-NEXT} = PSD_{T1-Disturber} \left( x_n f^{\frac{3}{2}} \right), \quad 0 \leq f < \infty, n = 4, 10, 24$$

where  $x_1$ ,  $x_{10}$ , and  $x_{24}$ , are defined in B.1

The T1 transmit and induced NEXT powers using  $n$ -crosstalk models ( $X_n$ ) are presented in table B.3, and the PSDs of 4, 10, and 24 T1 NEXT disturbers are shown in figure B.3.

**Table B.3 – T1 transmit and induced NEXT power with shaping and coupling transformer**

Frequency Range	Transmit Power dBm	NEXT Power 4 disturbers dBm	NEXT Power 10 disturbers dBm	NEXT Power 24 disturbers dBm
0 – 1.544 MHz	14.1	– 50.2	– 47.8	– 45.5
0 – 3 MHz	14.6	– 48.3	– 45.9	– 43.6
0 – 10 MHz	14.6	– 48.0	– 45.6	– 43.3

For testing, the T1 NEXT powers in table B.3 and PSD curves in figure B.3 have been adjusted downward by a total of 15.5 dB to take account of (a) the reduced coupling from an adjacent binder group (10 dB) and (b) an average separation between disturbing T1 transmitter and ADSL receiver (5.5 dB)

ANSI T1.413-1995

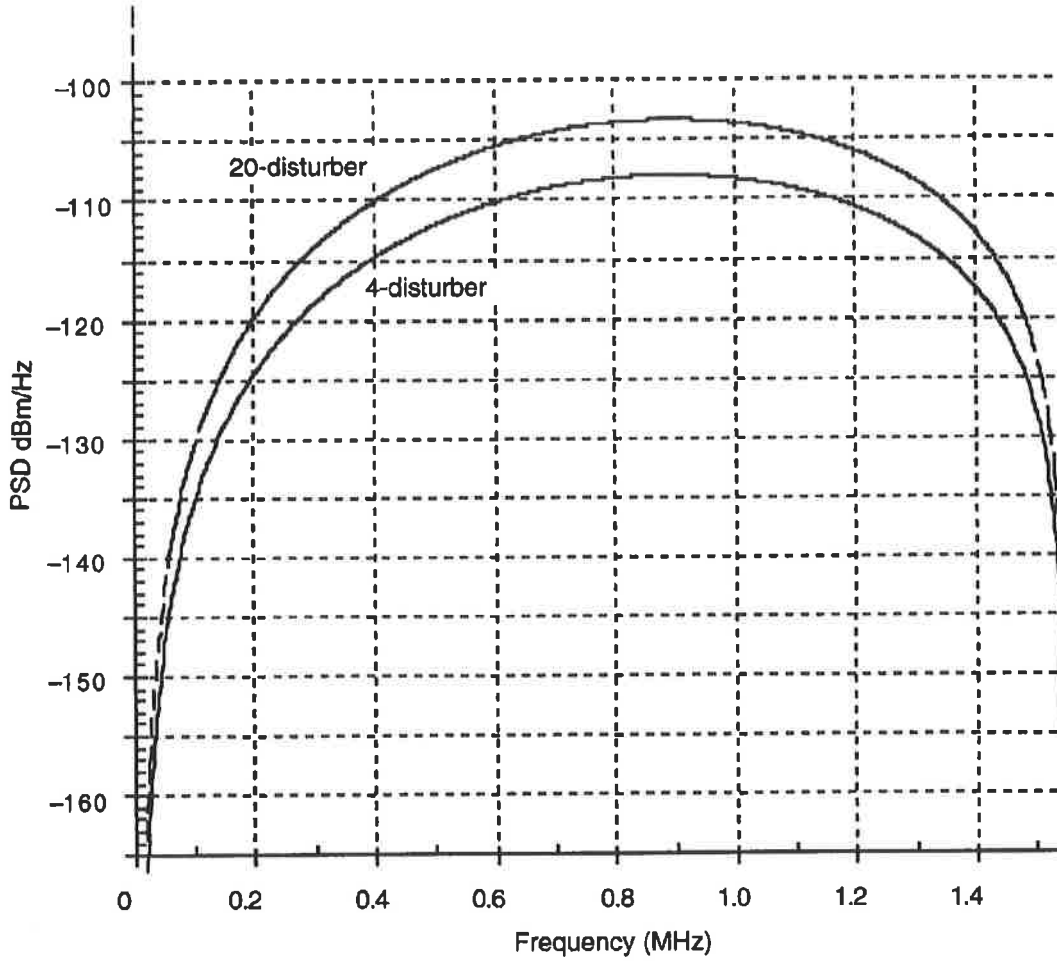

Figure B.3 – 4 and 20-disturber T1 NEXT

#### B.4 Simulated ADSL power spectral density and induced FEXT

The PSD of ADSL disturbers is expressed as:

$$PSD_{\text{ADSL-Disturber}} = K_{\text{ADSL}} \times \frac{2}{f_0} \times \frac{\left[ \sin\left(\frac{\pi f}{f_0}\right) \right]^2}{\left(\frac{\pi f}{f_0}\right)^2} \times |LPF(f)|^2 \times |HPF(f)|^2, \quad 0 \leq f < \infty$$

where  $f_0 = 2.208 \times 10^6$  Hz,  $K_{\text{ADSL}} = 0.1104$  Watts,

This equation gives the single sided PSD, where  $K_{\text{ADSL}}$  is the total transmitted power in Watts for the downstream ADSL transmitter before shaping filters, and is set such that the ADSL PSD will not exceed the maximum allowed PSD.  $f_0$  is the sampling frequency in Hz and

$$|LPF(f)|^2 = \frac{1}{1 + \left(\frac{f}{f_{3dB}}\right)^8}, \quad f_{3dB} = 1.104 \times 10^6 \text{ Hz}$$

is a fourth order low pass filter with a 3 dB point at 1104 kHz, and

$$|HPF(f)|^2 = \frac{f^8}{f^8 + f_{3dB}^8}, \quad f_{3dB} = 20 \times 10^3 \text{ Hz}$$

is a fourth order high pass filter with a 3 dB point at 20 kHz, separating ADSL from POTS. With this set of parameters the  $PSD_{\text{ADSL}}$  is the PSD of a downstream transmitter that uses all the channels.

The FEXT loss model is:

$$|H_{\text{FEXT}}(f)|^2 = |H_{\text{channel}}(f)|^2 \times k \times l \times f^2$$

where  $H_{\text{channel}}(f)$  is the channel transfer function,  $k$  is the coupling constant and is  $3.083 \times 10^{-20}$  for 10, 1% worst-case disturbers,  $l$  is the coupling path length in feet and equals 9000 ft for CSA #6, and  $f$  is in Hz. The FEXT noise PSD is therefore:

$$PSD_{\text{ADSL-FEXT}} = PSD_{\text{ADSL}} \times |H_{\text{FEXT}}(f)|^2$$

The integration of  $PSD_{\text{ADSL}}$  and  $PSD_{\text{ADSL-FEXT}}$  over the various frequency ranges is shown in table B.4.

**Table B.4 –  $PSD_{\text{ADSL}}$  and  $PSD_{\text{ADSL-FEXT}}$  power with shaping and coupling transformer**

Frequency range	Transmit power dBm	FEXT Power 10 disturbers dBm	FEXT power 24 disturbers dBm
0 – 1.104 MHz	19.0	– 69.6	– 67.3
0 – 2.204 MHz	19.2	– 69.6	– 67.3
0 – 4.416 MHz	19.2	– 69.6	– 67.3

ANSI T1.413-1995

Figure B.4 shows the theoretical PSD of 10-disturber downstream ADSL FEXT on CSA loop #6.

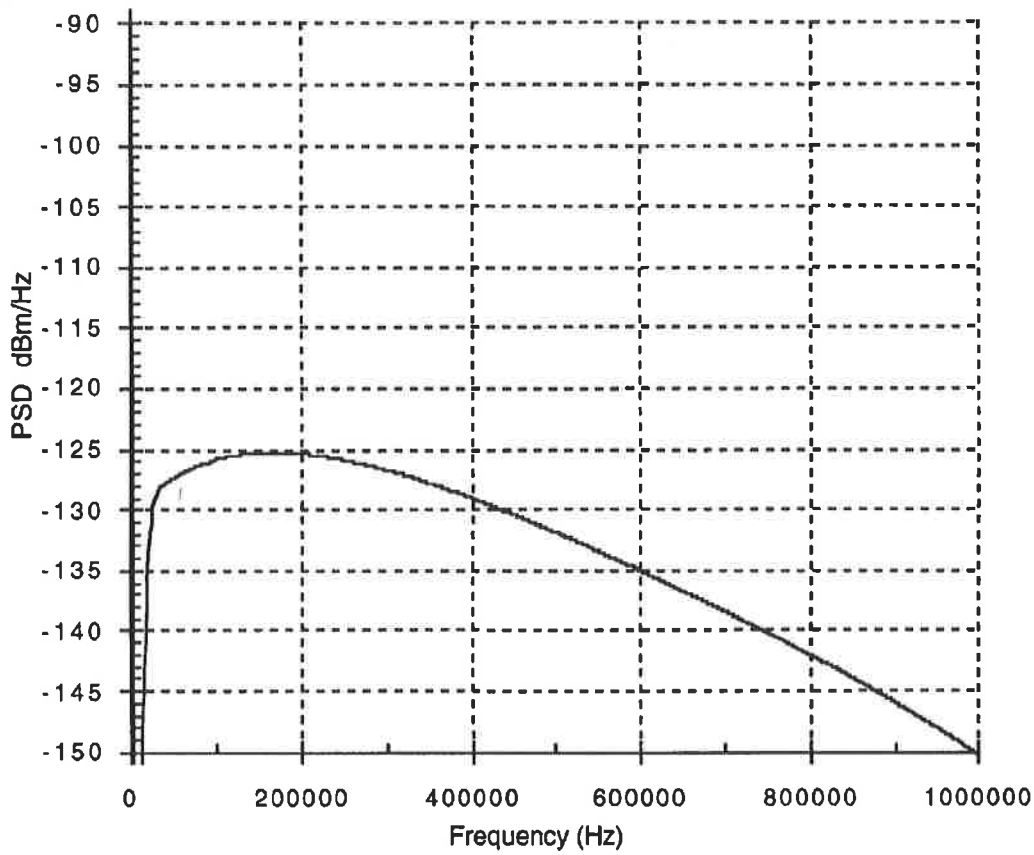

Figure B.4 – Theoretical 10-disturber ADSL FEXT

### B.5 Simulated ADSL-Induced NEXT into the downstream signal

The upstream ADSL signal nominally occupies the band from 25 to 138 kHz, but the upper sidelobes of the pass-band signal beyond 138 kHz may also contribute to the NEXT into the downstream signal. Their effect will depend on the method of anti-aliasing used in the remote transmitter, which issue is addressed in 7.12.3. The PSD of the upstream ADSL NEXT can be expressed as:

$$PSD_{ADSL-NEXT} = PSD_{ADSL,us-Disturber} \left( x_n f^{\frac{3}{2}} \right), \quad 0 \leq f < \infty$$

where  $x_n$  is defined in B.1.  $PSD_{ADSL,us-disturber}$  is difficult to define precisely because of the various sidelobes of the passband signals. For simplicity, the transmit PSD mask given in 7.12 will be used; i.e., -38 dBm/Hz from 28 kHz to 138 kHz, -62 dBm/Hz at 181.125 kHz, and -86 dBm/Hz at 224.25 kHz, with a straight-line fit on a logarithmic scale for the transmit PSDs between 138 kHz and 181.125 kHz, and between 181.125 kHz and 224.25 kHz. This transmit PSD is multiplied by the  $(\text{sinc})^2$  term with  $f_o = 276$  kHz to get the final  $PSD_{ADSL,us-disturber}$ . In particular,  $PSD_{ADSL,us-disturber}$  can be expressed as:

$$PSD_{ADSL,us-Disturber} = K_{mask} \times \frac{\left[ \sin\left(\frac{\pi f}{f_o}\right) \right]^2}{\left(\frac{\pi f}{f_o}\right)^2}, \quad 0 \leq f < \infty$$

where  $f_o = 276 \times 10^3$  Hz,

$$K_{mask} = \begin{cases} -38 \text{ dBm/Hz} & 28 \text{ kHz} \leq f \leq 138 \text{ kHz} \\ -38 - 24 \left( \frac{f - 138000}{43125} \right) \text{ dBm/Hz} & f > 138 \text{ kHz} \end{cases}$$

ANSI T1.413-1995

Figure B.5 shows the theoretical PSD of 10-disturber ADSL NEXT.

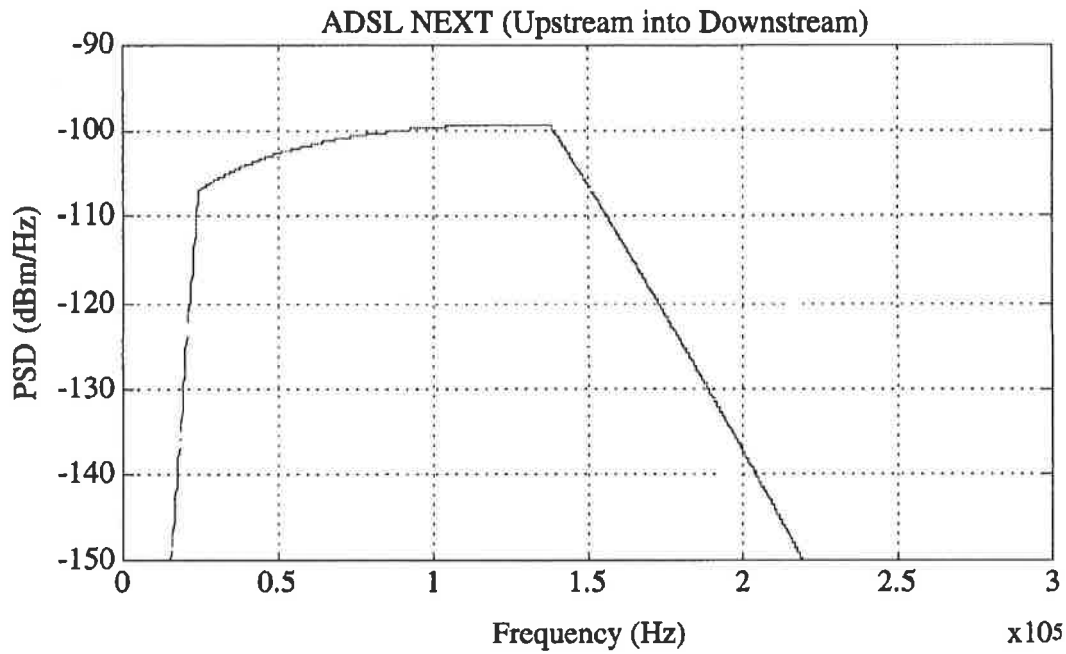
**Figure B.5 – Theoretical 10-disturber ADSL NEXT**

**Annex C**  
(normative)

**Characteristics of test impulse waveforms**

The two test impulse waveforms specified in clause 15 of the standard are described in tables C.1 and C.2 with the impulse wave amplitude given in millivolts at 160 nanosecond time intervals. The specific means of generating these waveforms for test purposes is left to the implementor.

001 0000 0000 0000

ANSI T1.413-1995

Table C.1 – Impulse number 1

Interval #	Amplitude mV	Interval #	Amplitude mV	Interval #	Amplitude mV
1	0.0000	51	-6.3934	101	0.1598
2	0.0000	52	1.7582	102	-1.7582
3	0.0000	53	2.2377	103	0.1598
4	0.0000	54	-4.9549	104	0.4795
5	0.0000	55	2.2377	105	-1.2787
6	0.0000	56	1.7582	106	0.7992
7	0.0000	57	-5.5943	107	1.2787
8	0.0000	58	1.4385	108	-0.7992
9	0.0000	59	2.3975	109	0.0000
10	0.9590	60	-3.6762	110	-0.3197
11	-0.4795	61	1.4385	111	-2.2377
12	-1.2787	62	0.4795	112	-1.1188
13	-1.1188	63	-5.7541	113	-0.7992
14	-1.4385	64	-0.4795	114	-1.5984
15	-1.5984	65	0.3197	115	0.1598
16	-2.2377	66	-3.3566	116	0.4795
17	-1.4385	67	2.3975	117	-0.9590
18	7.6721	68	2.3975	118	0.0000
19	6.7131	69	-3.1967	119	-0.3197
20	-16.6229	70	0.7992	120	-1.5984
21	-12.9467	71	0.6393	121	0.0000
22	18.7008	72	-3.5164	122	0.4795
23	9.5902	73	1.1188	123	-0.7992
24	-13.5861	74	1.7582	124	0.4795
25	-5.2746	75	-2.3975	125	0.7992
26	-6.3934	76	1.2787	126	-0.9590
27	-1.9180	77	0.9590	127	-0.9590
28	23.0164	78	-3.3566	128	-0.4795
29	3.9959	79	0.0000	129	-0.6393
30	-23.4959	80	0.1598	130	0.4795
31	-3.1967	81	-3.0369	131	1.1188
32	4.3156	82	1.1188	132	0.0000
33	-3.0369	83	1.5984	133	0.0000
34	10.7090	84	-2.0779	134	0.0000
35	2.2377	85	0.1598	135	0.0000
36	-12.9467	86	0.3197	136	0.0000
37	3.1967	87	-2.5574	137	0.0000
38	1.9180	88	0.1598	138	0.0000
39	-9.9098	89	0.1598	139	0.0000
40	5.5943	90	-2.0779	140	0.0000
41	5.9139	91	0.6393		
42	-6.7131	92	0.9590		
43	2.3975	93	-1.7582		
44	1.2787	94	-0.1598		
45	-8.4713	95	-0.6393		
46	2.5574	96	-3.0369		
47	2.8771	97	-0.3197		
48	-6.0738	98	0.4795		
49	2.2377	99	-1.4385		
50	1.7582	100	0.4795		



Table C.2 – Impulse number 2

Interval #	Amplitude mV	Interval #	Amplitude mV	Interval #	Amplitude mV
1	0.0000	51	0.6404	101	0.6404
2	0.0000	52	15.5295	102	0.6404
3	0.0000	53	18.8916	103	-0.4803
4	0.0000	54	-3.8424	104	-0.3202
5	0.0000	55	-3.0419	105	-0.9606
6	0.0000	56	11.6872	106	-2.8818
7	0.0000	57	-0.3202	107	-2.5616
8	0.0000	58	-7.5246	108	-0.8005
9	0.0000	59	13.4483	109	-0.4803
10	-0.6404	60	18.4113	110	-0.8005
11	0.9606	61	-0.4803	111	-0.4803
12	0.1601	62	-3.0419	112	-0.9606
13	-5.4433	63	9.7660	113	-1.1207
14	-12.3276	64	11.2069	114	-0.6404
15	-12.1675	65	4.0025	115	-0.4803
16	0.0000	66	0.6404	116	-0.9606
17	5.2832	67	0.6404	117	-1.4409
18	0.1601	68	1.7611	118	-1.6010
19	-20.8128	69	3.3621	119	-1.2808
20	-45.3078	70	5.6034	120	-0.9606
21	-46.7487	71	7.8448	121	-0.9606
22	-28.9778	72	2.5616	122	-1.2808
23	-13.4483	73	-4.6428	123	-1.1207
24	0.6404	74	0.6404	124	-1.1207
25	0.9606	75	10.7266	125	-1.4409
26	-14.4089	76	8.3251	126	-1.4409
27	-13.7685	77	1.9212	127	-1.4409
28	-9.4458	78	3.6823	128	-2.0813
29	-17.4507	79	4.3227	129	-2.4015
30	-2.5616	80	0.3202	130	-1.9212
31	26.5763	81	2.7217	131	-1.4409
32	16.1699	82	7.2044	132	-1.1207
33	-17.7709	83	3.2020	133	-1.2808
34	-17.1305	84	-2.7217	134	-1.9212
35	13.6084	85	-1.4409	135	-2.2414
36	27.0566	86	1.2808	136	-2.2414
37	18.0911	87	1.4409	137	-2.5616
38	14.2488	88	0.8005	138	-3.0419
39	5.6034	89	0.1601	139	-3.0419
40	-8.1650	90	0.0000	140	-2.5616
41	12.4877	91	1.1207	141	-1.2808
42	37.3029	92	1.1207	142	-0.1601
43	9.6059	93	0.6404	143	-0.6404
44	-18.8916	94	1.1207	144	-2.5616
45	5.1231	95	0.6404	145	-3.2020
46	22.2537	96	-1.1207	146	-3.0419
47	1.1207	97	-0.8005	147	-2.5616
48	-0.9606	98	0.1601	148	-2.0813
49	20.4926	99	-1.2808	149	-1.4409
50	14.2488	100	-1.4409	150	-1.6010

ANSI T1.413-1995

Table C.2 (continued)

Interval #	Amplitude mV	Interval #	Amplitude mV	Interval #	Amplitude mV
151	-1.9212	201	-0.8005	251	-1.2808
152	-1.9212	202	-0.9606	252	-1.6010
153	-2.0813	203	-1.6010	253	-1.6010
154	-2.4015	204	-2.4015	254	-1.4409
155	-2.5616	205	-2.5616	255	-0.4803
156	-2.5616	206	-2.8818	256	0.4803
157	-1.9212	207	-2.7217	257	0.4803
158	-1.6010	208	-1.9212	258	-0.4803
159	-1.6010	209	-1.1207	259	-0.9606
160	-1.9212	210	-0.9606	260	-1.1207
161	-1.9212	211	-1.1207	261	-1.4409
162	-2.0813	212	-1.4409	262	-1.2808
163	-2.2414	213	-1.7611	263	-0.1601
164	-2.5616	214	-2.4015	264	0.3202
165	-2.7217	215	-2.5616	265	0.0000
166	-2.2414	216	-2.2414	266	-0.4803
167	-1.2808	217	-1.7611	267	-0.4803
168	-1.2808	218	-1.7611	268	-0.4803
169	-2.2414	219	-1.4409	269	-0.6404
170	-3.0419	220	-0.9606	270	-0.4803
171	-2.8818	221	-0.8005	271	-0.1601
172	-2.5616	222	-0.9606	272	0.0000
173	-2.2414	223	-1.6010	273	0.0000
174	-1.9212	224	-2.2414	274	-0.1601
175	-1.9212	225	-2.4015	275	-0.1601
176	-2.2414	226	-2.2414	276	-0.4803
177	-2.5616	227	-1.9212	277	-0.6404
178	-2.7217	228	-1.4409	278	-0.3202
179	-2.5616	229	-0.4803	279	0.1601
180	-2.4015	230	0.0000	280	0.4803
181	-2.2414	231	-0.6404	281	0.3202
182	-2.0813	232	-1.6010	282	-0.1601
183	-1.7611	233	-1.7611	283	-0.3202
184	-1.6010	234	-1.6010	284	-0.4803
185	-1.7611	235	-1.9212	285	-0.6404
186	-2.2414	236	-1.9212	286	-0.4803
187	-3.0419	237	-1.4409	287	0.1601
188	-3.2020	238	-0.4803	288	0.6404
189	-2.7217	239	0.0000	289	0.6404
190	-1.9212	240	0.0000	290	0.4803
191	-1.2808	241	-0.6404	291	0.0000
192	-0.9606	242	-1.6010	292	-0.6404
193	-1.1207	243	-2.4015	293	-0.6404
194	-2.0813	244	-1.9212	294	-0.4803
195	-2.8818	245	-0.9606	295	-0.1601
196	-3.0419	246	-0.4803	296	0.4803
197	-2.7217	247	-0.1601	297	0.6404
198	-2.7217	248	-0.1601	298	0.4803
199	-2.0813	249	0.0000	299	0.6404
200	-1.4409	250	-0.8005	300	0.4803

Table C.2 (continued)

Interval #	Amplitude mV	Interval #	Amplitude mV	Interval #	Amplitude mV
301	-0.1601	351	0.8005	401	0.9606
302	-0.9606	352	1.4409	402	0.6404
303	-0.9606	353	1.6010	403	0.4803
304	-0.1601	354	1.2808	404	0.6404
305	0.6404	355	0.6404	405	0.6404
306	0.8005	356	0.0000	406	0.4803
307	0.8005	357	-0.4803	407	0.3202
308	0.4803	358	-0.6404	408	0.1601
309	0.1601	359	0.0000	409	0.3202
310	-0.1601	360	0.8005	410	0.4803
311	-0.3202	361	1.4409	411	0.9606
312	-0.1601	362	1.6010	412	1.2808
313	0.0000	363	1.2808	413	0.9606
314	0.1601	364	0.6404	414	0.1601
315	0.6404	365	0.0000	415	-0.1601
316	0.8005	366	-0.4803	416	0.0000
317	0.6404	367	-0.1601	417	0.4803
318	0.4803	368	0.1601	418	0.8005
319	0.0000	369	0.9606	419	0.6404
320	-0.4803	370	1.4409	420	0.4803
321	-0.4803	371	1.6010	421	0.8005
322	0.1601	372	1.1207	422	0.8005
323	0.8005	373	0.3202	423	0.4803
324	0.8005	374	-0.4803	424	0.1601
325	0.6404	375	-0.4803	425	0.0000
326	0.1601	376	0.1601	426	0.0000
327	0.4803	377	0.8005	427	0.1601
328	0.4803	378	1.1207	428	0.3202
329	0.3202	379	1.1207	429	0.6404
330	-0.3202	380	0.9606	430	0.9606
331	-0.4803	381	0.6404	431	0.8005
332	0.0000	382	0.1601	432	0.3202
333	0.6404	383	0.0000	433	0.1601
334	1.1207	384	0.1601	434	0.0000
335	1.2808	385	0.6404	435	0.1601
336	0.6404	386	1.1207	436	0.1601
337	0.1601	387	0.9606	437	0.1601
338	-0.1601	388	0.6404	438	0.1601
339	0.0000	389	0.6404	439	0.6404
340	0.0000	390	0.6404	440	1.1207
341	0.1601	391	0.3202	441	0.9606
342	0.3202	392	0.0000	442	0.4803
343	0.8005	393	0.4803	443	0.0000
344	1.2808	394	1.1207	444	-0.3202
345	1.2808	395	1.1207	445	-0.3202
346	0.9606	396	0.6404	446	0.0000
347	0.1601	397	0.1601	447	0.1601
348	-0.8005	398	0.0000	448	0.6404
349	-0.9606	399	0.1601	449	0.9606
350	-0.1601	400	0.8005	450	0.8005

ANSI T1.413-1995

**Table C.2 (concluded)**

Interval #	Amplitude mV	Interval #	Amplitude mV	Interval #	Amplitude mV
451	0.6404	461	0.0000	471	0.0000
452	0.0000	462	- 0.9606	472	0.0000
453	- 0.8005	463	- 1.1207	473	0.0000
454	- 0.8005	464	- 0.4803	474	0.0000
455	0.0000	465	0.4803	475	0.0000
456	0.4803	466	1.1207	476	0.0000
457	0.6404	467	1.1207	477	0.0000
458	0.6404	468	0.6404	478	0.0000
459	0.8005	469	0.0000	479	0.0000
460	0.6404	470	0.0000	480	0.0000

## Annex D (normative)

### Vendor identification numbers

Sixteen bits (hex coded from 0000 to FFFF) are reserved for vendor identification; these shall be used by the ATU-C in C-MSG1 (see 12.6.4), and by the ATU-R in R-MSG1 (see 12.7.6). The numbers (with 0000 and 0001 reserved) were randomly assigned to the thirty-seven initially identified companies as follows:

Numerical (hexadecimal) order	Alphabetical order for the first 37
0002 Westell, Inc.	Adtran 0012
0003 ECI Telecom	Alcatel Network System, Inc. 0022
0004 Texas Instruments	Amati Communications Corp. 0006
0005 Intel	Analog Devices 001C
0006 Amati Communcations Corp.	ADC Telecommunications 0014
0007 General Data Communications (GDC) Inc.	AT&T Network Systems 000A
0008 Level One Communications	AT&T – Paradyne 0011
0009 Crystal Semiconductor	AWA 0021
000A AT&T – Network Systems	Aware, Inc. 000B
000B Aware, Inc.	Brooktree 000C
000C Brooktree	Crystal Semiconductor 0009
000D NEC	DSC 0018
000E Samsung	ECI Telecom 0003
000F Northern Telecom, Inc.	Ericsson Systems 001E
0010 PairGain Technologies	Exar Corporation 001A
0011 AT&T – Paradyne	Fujitsu Network Trans. Systems 0026
0012 Adtran	GDC, Inc. 0007
0013 INC	IBM Corp. 0016
0014 ADC Telecommunications	INC 0013
0015 Motorola	Intel 0005
0016 IBM Corp.	Italtel 0024
0017 Newbridge Networks Corp.	Level One Communications 0008
0018 DSC	Motorola 0015
0019 Teltrend	National Semiconductor 0023
001A Exar Corp.	NEC 000D
001B Siemens Stromberg-Carlson	Newbridge Networks Corp. 0017
001C Analog Devices	Nokia 001D
001D Nokia	Northern Telecom, Inc. 000F
001E Ericsson Systems	Orckit Communications, Inc. 0020
001F Tellabs Operations, Inc.	PairGain Technologies 0010
0020 Orckit Communications, Inc.	Samsung 000E
0021 AWA	Siemens Stromberg-Carlson 001B
0022 Alcatel Network Systems, Inc.	SAT 0025
0023 National Semiconductor Corp.	Tellabs Operations, Inc. 001F
0024 Italtel	Teltrend 0019
0025 SAT – Société Anonyme de Télécommunications	Texas Instruments 0004
0026 Fujitsu Network Transmission Systems	Westell, Inc. 0002
0027 MITEL	MITEL 0027
0028 Conklin Instrument Corp.	Conklin Instrument Corp. 0028

ANSI T1.413-1995

**Annex E**  
(informative)

**Resistance and insertion loss characteristics of typical telephone cables**

The tables E.1, E.2, and E.3 provide the calculated resistance and insertion loss between 100 ohm terminations of the loops shown in figure 38.

NOTE – The primary constants of both polyethylene insulated cable (PIC) and pulp insulated cable, at 0°F, 70°F, and 120°F, are specified in annex G of ANSI T1.601.

**Table E.1 – Resistance and insertion loss values for test loops at 70°F**

Loop #	Resist- -ance ohms	Insertion loss dB										
		Frequency kHz										
		20	40	100	200	260	300	400	500	600	780	1100
T1.601 # 7	1127	29.8	36.7	45.2	52.8	57.3	60.2	67.7	74.8	81.7	93.0	110
T1.601 # 9	877	27.6	36.4	52.5	47.5	55.7	62.0	60.3	71.5	72.2	82.7	96.2
T1.601 #13	909	26.6	34.1	47.9	48.3	55.7	61.3	62.2	71.4	74.1	85.3	100
CSA # 4	634	17.6	22.0	29.6	39.6	40.1	42.5	49.2	50.2	53.8	55.7	70.7
CSA # 6	751	20.0	24.4	30.1	35.2	38.2	40.2	45.1	49.9	54.4	62.0	73.6
CSA #7	562	17.3	20.9	26.8	39.3	37.8	38.6	43.1	49.9	57.9	60.2	72.7
CSA #8	630	19.2	22.8	27.7	34.4	38.3	40.8	46.9	52.4	57.4	65.4	77.8
Mid-CSA	501	13.3	16.2	20.0	23.4	25.4	26.8	30.1	33.2	36.3	41.3	49.1

**Table E.2 – Resistance and Insertion loss in dB for test loops 90°F**

Loop #	Resist- -ance ohms	Insertion loss dB										
		Frequency kHz										
		20	40	100	200	260	300	400	500	600	780	1100
T1.601 # 7	1176	30.6	37.9	46.9	54.6	59.1	62.1	69.6	76.6	83.4	95.0	113
T1.601 # 9	915	28.4	37.5	53.4	49.1	57.2	63.1	61.9	72.8	73.6	84.2	98.1
T1.601 # 13	948	27.4	35.2	49.0	49.9	57.2	62.5	63.7	72.8	75.6	87.0	102
CSA # 4	658	18.0	22.6	30.4	40.3	41.0	43.5	50.0	50.9	54.3	56.6	71.6
CSA # 6	784	20.5	25.2	31.2	36.4	39.4	41.4	46.4	51.1	55.6	63.3	75.2
CSA # 7	586	17.9	21.6	27.7	40.0	38.7	39.5	44.1	50.9	58.8	61.4	74.0
CSA # 8	657	19.8	23.6	28.7	35.4	39.3	41.8	47.9	53.5	58.6	66.8	79.4
Mid-CSA	523	13.8	16.7	20.7	24.2	26.2	27.6	30.9	34.0	37.1	42.2	50.1

**Table E.3 – Resistance and insertion loss in dB for test loops 120° F**

Loop #	Resistance ohms	Insertion loss dB										
		Frequency kHz										
		20	40	100	200	260	300	400	500	600	780	1100
T1.601 # 7	1250	31.9	39.6	49.4	57.4	61.8	64.8	72.3	79.3	86.1	97.9	116
T1.601 # 9	972	29.5	39.1	54.7	51.5	59.5	65.5	64.1	74.7	75.7	86.4	101
T1.601 # 13	1008	28.5	36.8	50.7	52.3	59.5	64.5	66.0	74.9	77.9	89.4	105
CSA # 4	704	18.9	23.8	32.2	41.9	42.8	45.2	51.5	52.8	56.0	58.7	74.1
CSA # 6	833	21.4	26.3	32.8	38.2	41.2	43.2	48.2	52.9	57.4	65.3	77.5
CSA # 7	623	18.7	22.6	29.1	41.2	40.0	40.9	45.5	52.5	60.2	63.2	76.0
CSA # 8	699	20.7	24.8	30.2	36.7	40.8	43.3	49.4	55.1	60.4	68.8	81.7
Mid-CSA	555	14.4	17.5	21.8	25.5	27.5	28.8	32.1	35.2	38.3	43.5	51.6

ANSI T1.413-1995

**Annex F**  
(informative)

**Overvoltage, surge protection, and EMC**

This standard describes the electrical characteristics of the ADSL access signals appearing at the NI, and the physical interface between the network and the CI. Phenomena such as lightning and overvoltages due to inductive interference or power crosses lie beyond the scope of this standard. However, these and other topics are discussed in the following readily available documents.

– ANSI/IEEE C62.42-1986, *Guide for the application of gas tube arrester low-voltage surge-protective devices*;

– Technical reference TR-EOP-000001, *Lightning, radio frequency and 60-Hz disturbances at the Bell operating company network interface*, Issue 2, Bellcore, Piscataway, N.J., June 1987.

Both the above documents contain useful information on the application of surge arresters and the loop electrical environment.

– ANSI/EIA/TIA 571-1991, *Environmental considerations for telephone terminals*.

This standard discusses the normal operating environment of the telephone terminal equipment, fire hazards, and protection.

– ANSI/UL 1459-1992, *Standard for telephone equipment*. This standard deals with safety considerations for telephone equipment.

– Bodle, D.W. ; Gresh, P.A. *Lightning surges in paired telephone cable facilities*. Bell Syst. Tech. J. 40: 1961 March.

– Gresh, P.A. *Physical and transmission characteristics of customer loop plant*. Bell Syst. Tech. J. 48: 1969 December.

– Heirman, Donald N. *Time variations and harmonic content of inductive interference in urban/suburban and residential/rural telephone plants*. IEEE, 1976 Annals No. 512C0010.

– Carrol, R. L.; Miller, P. S. *Loop transients at the customer station*. Bell Syst. Tech. J. 59(9): 1980 November.

– Carrol, R. L. *Loop transients measurements in Cleveland, South Carolina*. Bell Syst. Tech. J. 59(9): 1980 November.

– *Measurement of transients at the subscriber termination of a telephone loop*, CCITT, COM V-No. 53 (November 1983)

– Batorsky, D. V.; Burke M.E., 1980 *Bell system noise survey of the loop plant*. AT&T Bell Lab. Tech. J. 63(5): 1984 May-June.

– Koga, Hiraki; Motomitsu, Tamio *Lightning-induced surges in paired telephone subscriber cable in Japan*. IEEE Trans. Electromag. Comp. EMC-27: 1985 August.

– Clarke, Gord; Coleman, Mike. *Study sheds light on overvoltage protection*. Telephony. 1986 November 24.

The power emitted by the ADSL is limited by the requirements in this standard. Notwithstanding any information contained or implied in this standard, it is assumed that the ADSL will comply with applicable FCC requirements on emission of electromagnetic energy. These requirements may be found in the Title 47, Code of Federal Regulations, Part 15 and Part 68, and other FCC documents.



## Annex G (informative)

### Examples of ADSL services and applications

#### G.1 Services and applications

Figure G.1 presents a basic network architecture for ADSL.

The market for ADSL services and applications can be segmented in various ways. Some potential application groups include: *entertainment, educational/institutional, telecommuting, small businesses and gaming.*

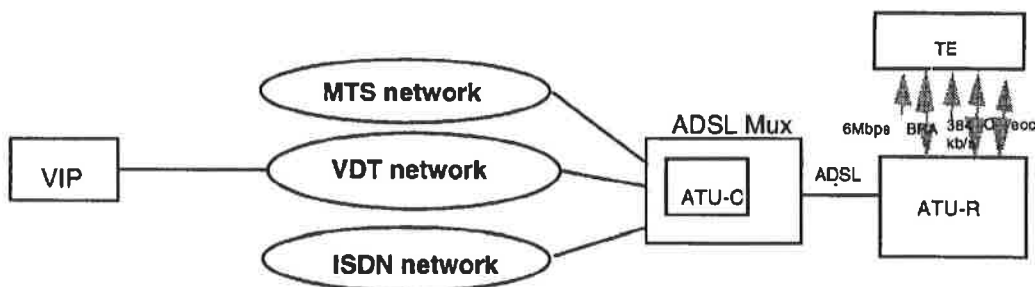

VDT – Video-dialtone  
VIP – Video information Provider

**Figure G.1 – Basic network architecture for ADSL**

ADSL based services can offer users one major new innovation: real-time interactive multimedia services. In addition, the ability to support other application groups is important given that many homes are limited to a single copper pair.

The digital video revolution is opening opportunities for new classes of residential applications. Some of the potential applications can be grouped into the following categories, with examples of each group:

- Entertainment:
  - *movies on demand*: end-user dials into a service provider's network to access a listed movie;
  - *music on demand*: end-user dials into a service provider's network to access listed music;
  - *interactive TV*: end-user can access live and/or stored video/graphics, search with the help of pull-down menus, select a channel or channels of choice, and view more than one channel.
  
- Educational/Institutional:
  - *distant classrooms*: end-user can participate in a class remotely and interactively;
  - *on-line books and manuals*: end-user can access books and manuals on-line with the capability to turn pages, go to a certain page, search with key words or subjects, highlight the lines on-line, or make scratch-notes on the side of the book or on a scratchpad;
  - *medical and health consultation*: end-user (hospital, say) can consult with, and transmit medical images to, a doctor at a remote site.

## ANSI T1.413-1995

- Telecommuting:
  - *work-at-home*: end-user (an employee, say) can access employer's workstations, printers, facsimile machines on LANs/WANs etc.;
  - *video-conferencing*: end-user can participate in a video-conference remotely with video in downstream and audio in upstream along with the workstation and screen-sharing access.
- Small businesses:
  - *video-conferencing*: similar characteristics as Telecommuting;
  - *credit-card picture/signature verifications*: small businesses can access a bank's or credit-card company's authorization database, which transmits the card-holder's picture and signature to avoid fraud.
- Games:
  - *interactive games (user-to-server)*: end-user is able to play a game interactively from a remote server with various controls;
  - *interactive games (user-to-user)*: one end-user is able to play a game interactively with another distant end-user with various controls;
  - *off-track betting*: an individual can bet remotely on a live event from home.

**G.2 ADSL applications characteristics**

For the ADSL services listed in G.1, it is assumed that POTS will always be available with a control channel (C) and asymmetric channel (approximately 1.5, 3 or 6 Mbit/s). User will be able to subscribe to 2B + D and 3B4 kbit/s services. Some of the characteristics for the above listed services and applications are listed below for information only:

- Entertainment:
  - *movies on demand*:
    - high-quality video ( $\geq 1.5$  Mbit/s) plus audio ( $\geq 64$  kbit/s) downstream;
    - remote control with pause, forward, reverse capability (approx. 100 bits/s) upstream;
  - *music on demand*:
    - high-quality audio (384 kbit/s compressed or 1.5 Mbit/s with 16 bits PCM) downstream;
    - remote control with pause, forward, reverse capability (approx. 100 bits/s) upstream;
  - *interactive TV*:
    - high-quality video ( $\geq 1.5$  Mbit/s) plus normal audio ( $\geq 64$  kbit/s) downstream;
    - mouse or jockey control ( $\geq 16$  kbit/s) upstream;
- Educational/Institutional:
  - *distant classrooms*:
    - high-quality video ( $> 3$  Mbit/s) plus audio (384 kbit/s) downstream;
    - audio (384 kbit/s) upstream;
  - *on-line books and manuals*:
    - high-quality video ( $> 3$  Mbit/s) plus data downstream;
    - mouse control for pull-down menus (max. of 64 kbit/s) upstream;
  - *medical and health consultation*:
    - high-quality video ( $> 1.5$  Mbit/s) plus voice plus data downstream;
    - mouse-like controls to zoom-in and out on the graphical image being transmitted ( $\geq 64$  kbit/s) upstream;

- Telecommuting:
  - *work-at-home*:
    - high-quality video ( $> 1.5$  Mbit/s) plus voice plus data downstream;
    - audio (384 kbit/s) plus data upstream;
  - *video-conferencing*:
    - medium-quality video ( $\geq 1.5$  Mbit/s) plus graphics plus data plus voice downstream;
    - graphics plus data plus voice (384 kbit/s total) upstream;
- Small businesses:
  - *screen-sharing*:
    - high-quality graphics (384 kbit/s) plus data plus voice downstream;
    - voice plus graphics (384 kbit/s) plus data upstream;
  - *video-conferencing*:
    - medium-quality video (1.5 Mbit/s) plus graphics plus data plus voice downstream;
    - video (1.5 Mbit/s) plus graphics plus data plus voice upstream;
  - *credit-card picture/signature verifications*:
    - high-quality graphics plus data plus voice (384 kbit/s for all together) downstream;
    - voice plus graphics plus data (384 kbit/s total) upstream;
- Games:
  - *interactive games (user-to-server and user-to-user)*:
    - high-speed video ( $\geq 3$  to 6 Mbit/s) plus audio downstream;
    - speech-recognition, audio, jockey or mouse controls ( $\leq 64$  kbit/s) upstream;
  - *off-track betting*:
    - high-quality video ( $\geq 3$  to 6 Mbit/s) plus audio plus data downstream;
    - audio plus data plus control ( $\leq 16$  kbit/s) upstream.

Figure G.2 shows a mapping of downstream and upstream channel capacities with the services that can be supported.

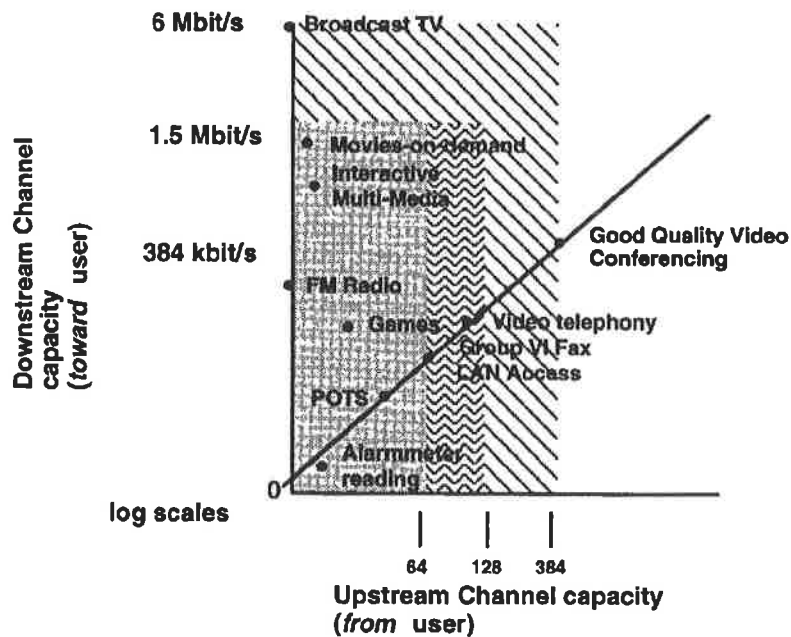

Figure G.2 – Applications based on upstream and downstream channel capacity

ANSI T1.413-1995

## Annex H (informative)<sup>3)</sup>

### Aspects of ADSL systems based on data rates at multiples of 2.048 Mbit/s

#### H.1 Scope

This annex provides clarification on options within the main body of the standard that relate to systems operating in a 2.048 Mbit/s environment (hereafter referred to as 2.048 Mbit/s applications). Note that only transport class 2M-3 is considered here.

#### H.2 Bearer channel allocations

The transport class and configuration of those allocations that are appropriate for 2.048 Mbit/s applications are shown in table H.1. The noise models and test loops presented in this annex are for bearer channel allocations as shown in table H.1.

**Table H.1 – Bearer channel allocations for 2.048 Mbit/s applications**

Transport class 2M-3 configuration	Simplex downstream rate (kbit/s)	Duplex rate(s) (kbit/s)
1	2048	160 (Note) 16 (C) (inc. analog POTS)
2	2048	16 (C) (inc. analog POTS)

NOTE – This rate is designed to accommodate ISDN-BRA (2B + D + overhead). Some carriers use a concatenated concept of V ref. points (e.g. concatenation of V<sub>1</sub> + V<sub>5</sub>). Therefore, it might be desirable to limit the latency to a value of 1.25 ms per digital section and per ADSL system.

#### H.3 Noise models

Two noise sources are described for the testing of ADSL systems. These are frequency-domain sources that model the steady-state operating environment caused by crosstalk from adjacent wire pairs due to differing transmission systems. The two models differ because of the need to cater to countries that may or may not have HDB3-based primary rate systems operating at 2048 kbit/s in their access networks. Model A is for the case where no such interferers exist, while model B includes the crosstalk coupling effects of these types of systems.

##### H.3.1 Injection method

Test noise is applied as described in 15.3.1.1.

##### H.3.2 Crosstalk noise sources

The power spectral density of the crosstalk noise sources used for performance testing is given in figure H.1 for model A, and in figure H.2 for model B. Model A includes discrete tones, which represent radio frequency interference that is commonly observed, especially on wire pairs routed above ground. Further details of the specification of these noise models are shown in tables H.2 to H.4.

The resulting wideband noise power over the frequency range 1 kHz to 1.5 MHz for model A is  $-49.4 \pm 0.5$  dBm and for model B is  $-43.0 \pm 0.5$  dBm.

The noise probability density function shall be approximately Gaussian with a crest factor  $\geq 5$ .

<sup>3)</sup> This is an informative annex. However, the minimum requirements for performing the tests described in this informative annex are indicated by the word "shall."

The accuracy of the power spectral density shall be within  $\pm 1$  dB over the frequency range 1 kHz to 1.5 MHz, when measured with a resolution bandwidth of 1 kHz.

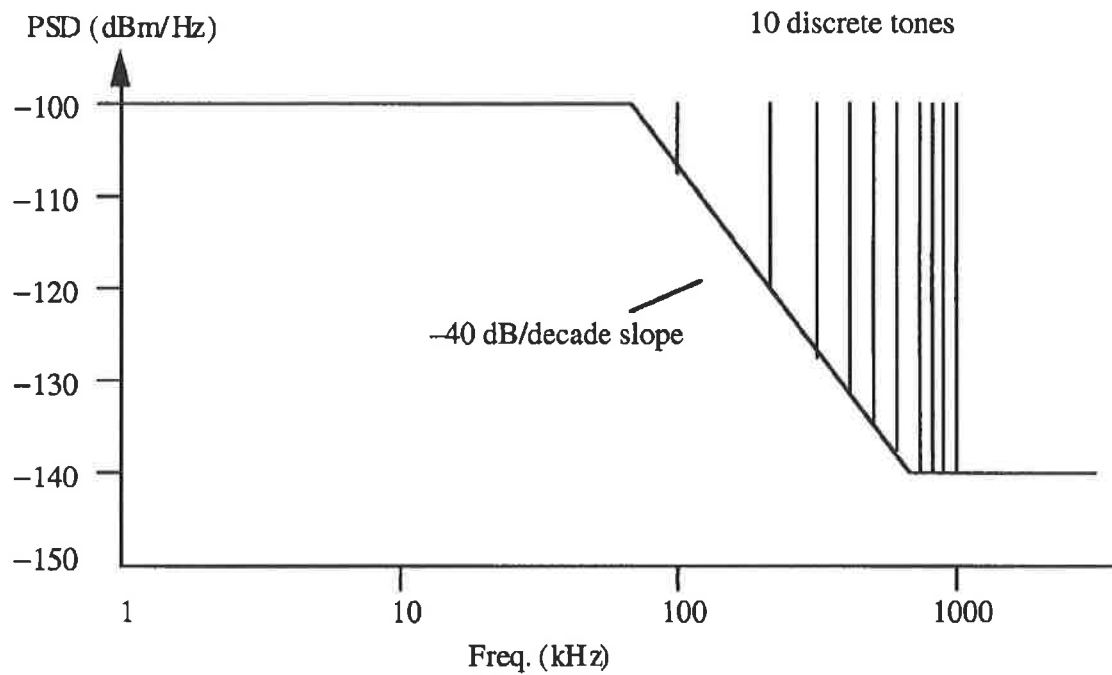

Figure H.1 – Single-sided noise power spectral density into 100  $\Omega$  for model A

Table H.2 – Coordinates for noise model A

Freq. kHz	PSD dBm/Hz	PSD $\mu\text{V}/\sqrt{\text{Hz}}$
1	-100	3.16
79.5	-100	3.16
795	-140	0.03
1500	-140	0.03

ANSI T1.413-1995

**Table H.3 – Tone frequencies and powers for noise model A**

Freq. kHz	Power dBm
99	-70
207	-70
333	-70
387	-70
531	-70
603	-70
711	-70
801	-70
909	-70
981	-70

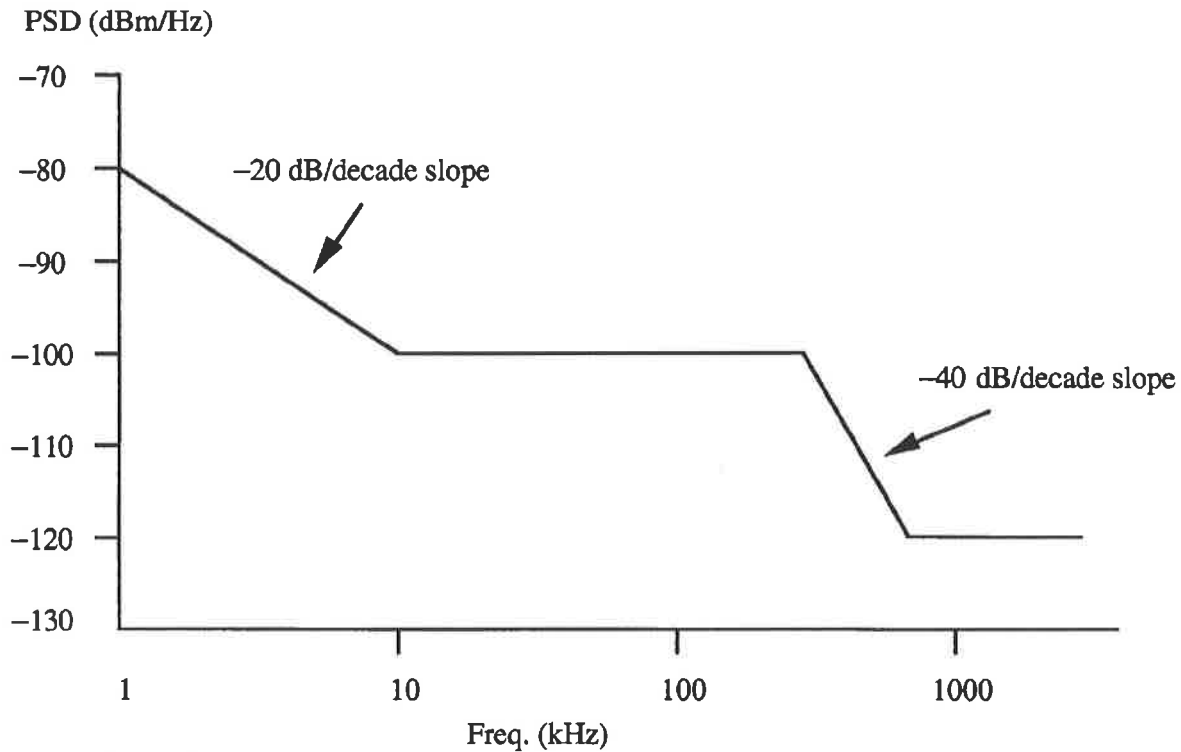
**Figure H.2 – Single sided noise power spectral density into 100  $\Omega$  for model B****Table H.4 – Co-ordinates for noise model B**

Freq. kHz	PSD dBm/Hz	PSD mV/ $\sqrt{\text{Hz}}$
1	-80	31.62
10	-100	3.16
300	-100	3.16
711	-115	0.56
1500	-115	0.56

#### H.4 Test loops

To test the performance of the ADSL system incorporating the bearer channel capabilities outlined in clause H.2, the test loops specified in figure H.3 shall be used. The power spectral density of the ADSL downstream transmission shall be as described in 6.13 of the standard with the exception that the power boost option shall not be used for test purposes.

The variation of the primary line constants (R, L and C) with frequency for the different reference cable types are given in tables H.9 – H.13. Note that the capacitance, C, is constant with frequency, and the conductance, G, is assumed zero. The RLC values are quoted per km at a temperature of 20°C and are measured values that have been smoothed.

Note also that there are adjustable sections (marked 'X') in figure H.3. The nominal lengths of these sections, which are shown in tables H.5 – H.8, are calculated from the reference RLC values for each cable type shown in tables H.9 – H.13. For repeatability of measurement results, however, the lengths of these sections shall be adjusted for each individual test loop to give the overall insertion loss shown in tables H.5 – H.8. Insertion loss is measured at 300 kHz with 100  $\Omega$  (balanced resistive) source and termination impedances.

ANSI T1.413-1995

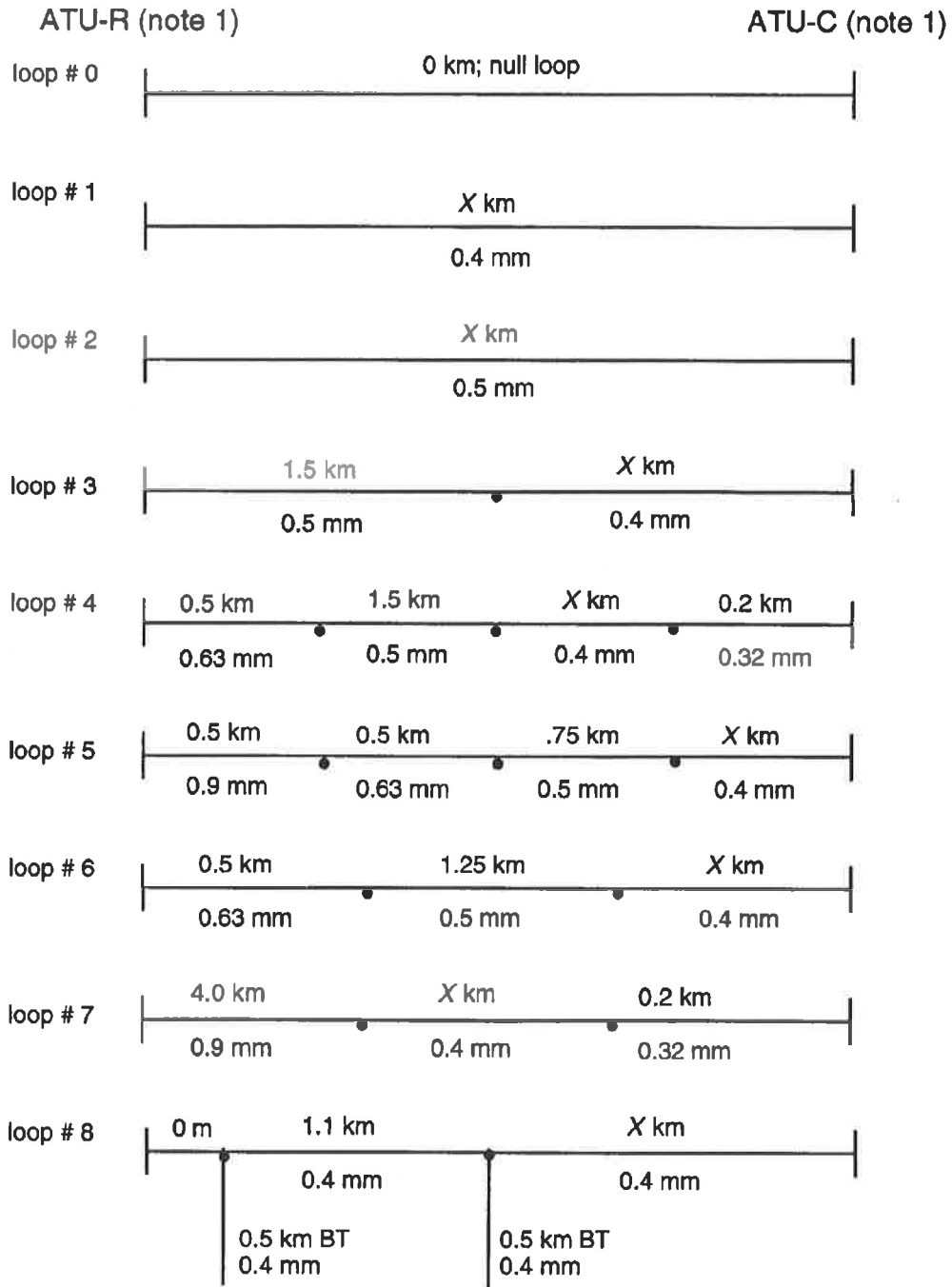

**NOTES**

- 1 These test loops are shown with the ATU-Rs on the left; this is in contrast to fig. 38, where the ATU-Rs are on the right.
- 2 All cable is Polyethylene insulated.
- 3 1 km = 3.28 kft.
- 4 BT = Bridged tap (i.e., section of unterminated cable).

**Figure H.3 – Test loop set for transport class 2M-3 configuration 1 or 2 operation with noise model A or B**



**Table H.5 – Loop-set insertion loss and nominal lengths for 2M-3 configuration 1 (noise model A)**

Loop #	Nominal value of adjustable length 'X' km	Loop insertion loss at 300 kHz
		dB
1	3.45	49.0
2	4.55	49.0
3	2.30	49.0
4	1.80	49.0
5	2.40	49.0
6	2.25	49.0
7	1.35	49.0
8	1.50	43.0

**Table H.6 – Loop-set insertion loss and nominal length for 2M-3 configuration 2 (noise model A)**

Loop #	Nominal value of adjustable length 'X' km	Loop insertion loss at 300 kHz
		dB
1	3.60	51.0
2	4.80	51.0
3	2.50	51.0
4	2.00	51.0
5	2.55	51.0
6	2.40	51.0
7	1.55	51.0
8	2.10	51.0

**Table H.7 – Loop-set insertion loss and nominal lengths for 2M-3 configuration 1 (noise model B)**

Loop #	Nominal value of adjustable length 'X' km	Loop insertion loss at 300 kHz
		dB
1	2.45	35.0
2	3.20	34.0
3	1.30	35.0
4	0.80	35.0
5	1.40	35.0
6	1.25	35.0
7	0.40	35.0
8	1.00	35.0

ANSI T1.413-1995

**Table H.8 – Loop-set insertion loss and nominal lengths for 2M-3 configuration 2 (noise model B)**

Loop #	Nominal value of adjustable length 'X'	Loop insertion loss at 300 kHz
	km	dB
1	2.55	36.0
2	3.40	36.0
3	1.40	36.0
4	0.90	36.0
5	1.50	36.0
6	1.35	36.0
7	0.50	36.0
8	1.10	36.0

**Table H.9 – RLC values for 0.32, 0.4, and 0.5 mm PE cables**

Freq kHz	0.32 mm cable C = 40 nF/km		0.4 mm cable C = 50 nF/km		0.5 mm cable C = 50 nF/km	
	R Ω/km	L μH/km	R Ω/km	L μH/km	R Ω/km	L μH/km
0.	409.000	607.639	280.000	587.132	280.000	587.132
2.5	409.009	607.639	280.007	587.075	280.007	587.075
10.	409.140	607.639	280.110	586.738	280.110	586.738
20.	409.557	607.639	280.440	586.099	280.440	586.099
30.	410.251	607.639	280.988	585.322	280.988	585.322
40.	411.216	607.639	281.748	584.443	281.748	584.443
50.	412.447	607.639	282.718	583.483	282.718	583.483
100.	422.302	607.631	290.433	577.878	290.433	577.878
150.	437.337	607.570	302.070	571.525	302.070	571.525
200.	456.086	607.327	316.393	564.889	316.393	564.889
250.	477.229	606.639	332.348	558.233	332.348	558.233
300.	499.757	605.074	349.167	551.714	349.167	551.714
350.	522.967	602.046	366.345	545.431	366.345	545.431
400.	546.395	596.934	383.562	539.437	383.562	539.437
450.	569.748	589.337	400.626	533.759	400.626	533.759
500.	592.843	579.376	417.427	528.409	417.427	528.409
550.	615.576	567.822	433.904	523.385	433.904	523.385
600.	637.885	555.867	450.027	518.677	450.027	518.677
650.	659.743	544.657	465.785	514.272	465.785	514.272
700.	681.138	534.942	481.180	510.153	481.180	510.153
750.	702.072	526.991	496.218	506.304	496.218	506.304
800.	722.556	520.732	510.912	502.707	510.912	502.707
850.	742.601	515.919	525.274	499.343	525.274	499.343
900.	762.224	512.264	539.320	496.197	539.320	496.197
950.	781.442	509.503	553.064	493.252	553.064	493.252
1000.	800.272	507.415	566.521	490.494	566.521	490.494
1050.	818.731	505.831	579.705	487.908	579.705	487.908
1100.	836.837	504.623	592.628	485.481	592.628	485.481

NOTE – G = 0 at all frequencies.

Table H.10 – RLC values for 0.63 and 0.9 mm PE cables

Freq kHz	0.63 mm cable C = 45 nF/km		0.9 mm cable C = 40 nF/km	
	R Ω/km	L μH/km	R Ω/km	L μH/km
0.	113.000	699.258	55.000	750.796
2.5	113.028	697.943	55.088	745.504
10.	113.442	693.361	56.361	731.961
20.	114.737	687.008	59.941	716.775
30.	116.803	680.714	64.777	703.875
40.	119.523	674.593	70.127	692.707
50.	122.768	668.690	75.586	682.914
100.	143.115	642.718	100.769	647.496
150.	164.938	622.050	121.866	625.140
200.	185.689	605.496	140.075	609.652
250.	204.996	592.048	156.273	598.256
300.	222.961	580.960	170.987	589.504
350.	239.764	571.691	184.556	582.563
400.	255.575	563.845	197.208	576.919
450.	270.533	557.129	209.104	572.237
500.	284.753	551.323	220.365	568.287
550.	298.330	546.260	231.081	564.910
600.	311.339	541.809	241.326	561.988
650.	323.844	537.868	251.155	559.435
700.	335.897	534.358	260.615	557.183
750.	347.542	531.212	269.745	555.183
800.	358.819	528.378	278.577	553.394
850.	369.758	525.813	287.138	551.784
900.	380.388	523.480	295.452	550.327
950.	390.734	521.352	303.538	549.002
1000.	400.816	519.402	311.416	547.793
1050.	410.654	517.609	319.099	546.683
1100.	420.264	515.956	326.602	545.663

NOTE – G = 0 at all frequencies.

ANSI T1.413-1995

**H.5 ADSL/POTS splitter impedances**

The design impedance for the POTS port of the splitter is application specific, and therefore outside the scope of this informative annex. Of particular importance are return loss and resultant sidetone levels. It is expected that some 2.048 Mbit/s applications will require that the splitter matches to a complex telephony impedance. Significant differences may exist between particular applications; examples are:

- telephony impedances;
- telephony return loss;
- out of (POTS) band signalling systems (e.g., subscriber private metering 11 kHz to 50 kHz);
- low frequency telemetry.

**H.6 Testing**

Performance testing is outlined in the main body of the standard (see clause 15). Note that differences exist here with respect to the crosstalk noise sources (see H.3.2) and the test loops (see clause H.4), and the addition of a maximum stress linearity test (see H.6.1). Further details appropriate for testing are given in the main body of the standard.

**H.6.1 Maximum stress linearity test**

This test stresses the ADSL system to ensure that adequate linearity is achieved in implementations. A modified Loop #1 from the loop-set given in figure H.3 is used for this test. The modification is detailed in table H.14. An additive white Gaussian noise source with a power spectral density of  $-140 \pm 1$  dBm/Hz over the frequency range 1 kHz to 1.5 MHz is applied at the ATU-R in place of the crosstalk source. A resolution bandwidth of 1 kHz is used for calibration of the power spectral density.

**Table H.11 – Insertion loss (and nominal length) for Loop #1**

Transport class 2M-3 configuration	Nominal value of adjustable length 'X' of Loop #1 km	Loop insertion loss at 300 kHz dB
1	4.35	62.0
2	4.70	67.0

**Annex I**  
(informative)

**Items for further study**

The following is a partial list of items in the text of the standard that are indicated as being for further study

- the nature of the premises distribution (e.g., bus or star, type of media);
- the use of upstream simplex bearer(s) (downstream simplex bearers are already specified);
- switching on demand among the configurations allowed by a given transport class and on-line reassignment of bearer channels;
- the entire framed 2.048 Mbit/s (optional) structure is treated as a bearer data stream; the use of a lower payload rate is for further study;
- support of the 576 kbit/s optional duplex rate in the default mode of transport classes 2, 3, and 2M – 2;
- other uses of the eoc5 bit besides the presently defined ATU-R "dying gasp";
- the use of R-ACK3;
- the effects of the POTS splitter on voice-band performance;
- other payload data rates;
- location of the POTS splitters separate from the ATUs;
- on-line change of data rates and reconfigurations;
- sensitivity of pilot tones to single-frequency interference;
- further definition of impulse noise performance requirements;
- the impact of ADSL signal transfer delay on ISDN transport.

ANSI T1.413-1995

**Annex J**  
(informative)

**Bibliography**

Bellcore SR-TSZ-002275, *BOC Notes on the LEC Networks-1990*, Issue 2, April 1994<sup>4</sup>

CCITT Rec. I.610, *B-ISDN Operation and Maintenance Principles and Functions*; June 1992<sup>5</sup>

<sup>4</sup> Available from Bellcore, Customer Service, 8 Corporate Place, PYA 3A-184, Piscataway, NJ 08854-41560.

<sup>5</sup> Available from the American National Standards Institute, 11 West 42nd Street, New York, NY 10036.