

FORM PTO-1390
(REV 10-01-00)

U.S. DEPARTMENT OF COMMERCE PATENT AND TRADEMARK OFFICE

ATTORNEY'S DOCKET NUMBER

TRANSMITTAL LETTER TO THE UNITED STATES
DESIGNATED/ELECTED OFFICE (DO/EO/US)
CONCERNING A FILING UNDER 35 U.S.C. 371

41001

U.S. APPLICATION NO. (If known, see 37 CFR 1.5)

09/673270

INTERNATIONAL APPLICATION NO.
PCT/EP98/02184

INTERNATIONAL FILING DATE
14 April 1998

PRIORITY DATE CLAIMED

TITLE OF INVENTION
Method and Apparatus for Fine Frequency Synchronization in Multi-Carrier Demodulation Systems

APPLICANT(S) FOR DO/EO/US
Ernst Eberlein, Sabah Badri, Stefan Lipp, Stephan Buchholz, Albert Heuberger, Heinz Gerhaeuser

Applicant herewith submits to the United States Designated/Elected Office (DO/EO/US) the following items and other information:

1. This is a **FIRST** submission of items concerning a filing under 35 U.S.C. 371.
 2. This is a **SECOND** or **SUBSEQUENT** submission of items concerning a filing under 35 U.S.C. 371.
 3. This express request to begin national examination procedures (35 U.S.C. 371(f)) at any time rather than delay examination until the expiration of the applicable time limit set in 35 U.S.C. 371(b) and PCT Articles 22 and 39(1).
 4. A proper Demand for International Preliminary Examination was made by the 19th month from the earliest claimed priority date.
 5. A copy of the International Application as filed (35 U.S.C. 371(c)(2))
 - a. is transmitted herewith (required only if not transmitted by the International Bureau).
 - b. has been transmitted by the International Bureau.
 - c. is not required, as the application was filed in the United States Receiving Office (RO/US).
 6. A translation of the International Application into English (35 U.S.C. 371(c)(2)).
 7. Amendments to the claims of the International Application under PCT Article 19 (35 U.S.C. 371(c)(3))
 - a. are transmitted herewith (required only if not transmitted by the International Bureau).
 - b. have been transmitted by the International Bureau.
 - c. have not been made; however, the time limit for making such amendments has NOT expired.
 - d. have not been made and will not be made.
 8. A translation of the amendments to the claims under PCT Article 19 (35 U.S.C. 371(c)(3)).
 9. An oath or declaration of the inventor(s) (35 U.S.C. 371(c)(4)).
 10. A translation of the annexes to the International Preliminary Examination Report under PCT Article 36 (35 U.S.C. 371(c)(5)).
- Items 11. to 16. below concern document(s) or information included:**
11. An Information Disclosure Statement under 37 CFR 1.97 and 1.98.
 12. An assignment document for recording. A separate cover sheet in compliance with 37 CFR 3.28 and 3.31 is included.
 13. A **FIRST** preliminary amendment.
 A **SECOND** or **SUBSEQUENT** preliminary amendment.
 14. A substitute specification.
 15. A change of power of attorney and/or address letter.
 16. Other items or information:
 - (a) Copy of International Application as filed (14 April 1998).
 - (b) Copy of International Search Report (12 January 1999).
 - (c) Copy of Published International Application (21 October 1999).
 - (d) Copy of International Preliminary Examination Report (19 July 2000).

				CALCULATIONS PTO USE ONLY		
17. <input checked="" type="checkbox"/> The following fees are submitted: BASIC NATIONAL FEE (37 CFR 1.492 (a) (1) - (5)) : Neither international preliminary examination fee (37 CFR 1.482) nor international search fee (37 CFR 1.445(a)(2)) paid to USPTO and International Search Report not prepared by the EPO or JPO \$1000.00 International preliminary examination fee (37 CFR 1.482) not paid to USPTO but International Search Report prepared by the EPO or JPO..... \$860.00 International preliminary examination fee (37 CFR 1.482) not paid to USPTO but international search fee (37 CFR 1.445(a)(2)) paid to USPTO \$710.00 International preliminary examination fee paid to USPTO (37 CFR 1.482) but all claims did not satisfy provisions of PCT Article 33(1)-(4) \$690.00 International preliminary examination fee paid to USPTO (37 CFR 1.482) and all claims satisfied provisions of PCT Article 33(1)-(4) \$100.00 ENTER APPROPRIATE BASIC FEE AMOUNT =				\$	860.00	
Surcharge of \$130.00 for furnishing the oath or declaration later than <input type="checkbox"/> 20 <input checked="" type="checkbox"/> 30 months from the earliest claimed priority date (37 CFR 1.492(e)).				\$	130.00	
CLAIMS	NUMBER FILED	NUMBER EXTRA	RATE			
Total claims	16 - 20 =	0	X \$18.00	\$	0.00	
Independent claims	4 - 3 =	1	X \$80.00	\$	80.00	
MULTIPLE DEPENDENT CLAIM(S) (if applicable)			+ \$270.00	\$	0.00	
TOTAL OF ABOVE CALCULATIONS =				\$	1,070.00	
Reduction of 1/2 for filing by small entity, if applicable. A Small Entity Statement must also be filed (Note 37 CFR 1.9, 1.27, 1.28).				\$	(0.00)	
SUBTOTAL =				\$	1,070.00	
Processing fee of \$130.00 for furnishing the English translation later than <input type="checkbox"/> 20 <input type="checkbox"/> 30 months from the earliest claimed priority date (37 CFR 1.492(f)).				\$	0.00	
TOTAL NATIONAL FEE =				\$	1,070.00	
Fee for recording the enclosed assignment (37 CFR 1.21(h)). The assignment must be accompanied by an appropriate cover sheet (37 CFR 3.28, 3.31). \$40.00 per property				\$	0.00	
TOTAL FEES ENCLOSED =				\$	1,070.00	
				Amount to be refunded:	\$	
				charged:	\$	

- a. A check in the amount of \$ 1,070.00 to cover the above fees is enclosed.
- b. Please charge my Deposit Account No. _____ in the amount of \$ _____ to cover the above fees. A duplicate copy of this sheet is enclosed.
- c. The Commissioner is hereby authorized to charge any additional fees which may be required, or credit any overpayment to Deposit Account No. 18-2220. A duplicate copy of this sheet is enclosed.

NOTE: Where an appropriate time limit under 37 CFR 1.494 or 1.495 has not been met, a petition to revive (37 CFR 1.137(a) or (b)) must be filed and granted to restore the application to pending status.

SEND ALL CORRESPONDENCE TO:
 Roylance, Abrams, Berdo & Goodman, L.L.P.
 1300 19th Street, N.W., Suite 600
 Washington, DC 20036

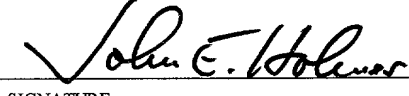
 SIGNATURE:
 John E. Holmes
 NAME
29,392
 REGISTRATION NUMBER

41001

PATENT

IN THE UNITED STATES PATENT AND TRADEMARK OFFICE

In re Application of:	:	
	:	
Ernst Eberlein et al.	:	Group Art Unit:
	:	
Serial No.: Not Assigned	:	Examiner:
	:	
Filed: Herewith	:	
	:	
For: Method and Apparatus for Fine Frequency	:	
Synchronization in Multi-Carrier Demodulation	:	
Systems	:	

PRELIMINARY AMENDMENT

Assistant Commissioner for Patents
Washington, D.C. 20231

Sir:

This Preliminary Amendment is being filed concurrently with the U.S. national stage entry under 35 U.S.C. § 371 of International Application No. PCT/EP98/02184, which has an International Filing Date of April 14, 1998. Prior to examination and calculation of the filing fees, please amend the national stage application as follows:

IN THE SPECIFICATION:

Please delete the current specification comprising pages 1-40 and 48 (as amended in the International Preliminary Examination Report dated July 19, 2000) and replace it with the accompanying substitute specification.

IN THE CLAIMS:

Please cancel claims 1-18 annexed to the International Preliminary Examination Report dated July 19, 2000, and substitute the following new claims 19-34:

- 19. A method of performing a fine frequency synchronization compensating for a carrier frequency deviation from an oscillator frequency in a multi-carrier demodulation system of the type capable of carrying out a differential phase

006577-0222/950

decoding of multi-carrier modulated signals, said signals comprising a plurality of symbols, each symbol being defined by phase differences between simultaneous carriers having different frequencies, said method comprising the steps of:

- a) determining a phase difference between phases of the same carrier in different symbols;
- b) determining a frequency offset by eliminating phase shift uncertainties related to the transmitted information from said phase difference making use of a M-PSK decision device; and
- c) performing a feedback correction of said carrier frequency deviation based on said determined frequency offset.

20. A method of performing a fine frequency synchronization compensating for a carrier frequency deviation from an oscillator frequency in a multi-carrier demodulation system of the type capable of carrying out a differential phase decoding of multi-carrier modulated signals, said signals comprising a plurality of symbols, each symbol being defined by phase differences between simultaneous carriers having different frequencies, said method comprising the steps of:

- a) determining respective phase of the same carrier in different symbols;
- b) eliminating phase shift uncertainties related to the transmitted information from said phases to determine respective phase deviations making use of a M-PSK decision device;
- c) determining a frequency offset by determining a phase difference between said phase deviations; and
- d) performing a feedback correction of said carrier frequency deviation based on said determined frequency offset.

006277-02E2950

21. The method according to claim 19, wherein

said steps a) and b) are performed for a plurality of carriers in said symbols,

an averaged frequency offset is determined by averaging said determined frequency offsets of said plurality of carriers, and

said feedback correction of said frequency deviation is performed based on said averaged frequency offset in said step c).

22. The method according to claim 20, wherein

said steps a), b) and c) are performed for a plurality of carriers in said symbols,

an averaged frequency offset is determined by averaging said determined frequency offsets of said plurality of carriers, and

said feedback correction of said frequency deviation is performed based on said averaged frequency offset.

23. The method according to claim 19, wherein said step a) comprises the step of determining a phase difference between phases of the same carrier in symbols which are adjacent in the time axis direction.

24. The method according to claim 19, wherein said step b) comprises the step of eliminating phase shift uncertainties corresponding to M-ary phase shifts.

25. The method according to claim 20, wherein said step a) comprises the step of determining respective phases of the same carrier in symbols which are adjacent in the time axis direction.

09673270-112900
005211 02E/960

26. The method according to claim 20, wherein said step b) comprises the step of eliminating M-ary phase shifts.

27. An apparatus for performing a fine frequency synchronization compensating for a carrier frequency deviation from an oscillator frequency, for a multi-carrier demodulation system of the type capable of carrying out a differential phase decoding of multi-carrier modulated signals, said signals comprising a plurality of symbols, each symbol being defined by phase differences between simultaneous carriers having different frequencies, said apparatus comprising:

means for determining a phase difference between phases of the same carrier in different symbols;

M-PSK decision device for determining a frequency offset by eliminating phase shift uncertainties related to the transmitted information from said phase difference; and

means for performing a feedback correction of said frequency deviation based on said determined frequency offset.

28. An apparatus for performing a fine frequency synchronization compensating for a carrier frequency deviation from an oscillator frequency, for a multi-carrier demodulation system of the type capable of carrying out a differential phase decoding of multi-carrier modulated signals, said signals comprising a plurality of symbols, each symbol being defined by phase differences between simultaneous carriers having different frequencies, said apparatus comprising:

means for determining respective phases of the same carrier in different symbols;

M-PSK decision device for eliminating phase shift uncertainties related to the transmitted information from said phases to determine respective phase deviations;

0962929-1-1005

means for determining a frequency offset by determining a phase difference between said phase deviations;

means for performing a feedback correction of said frequency deviation based on said determined frequency offset.

29. The apparatus according to claim 27, further comprising:

means for determining an averaged frequency offset by averaging determined frequency offsets of a plurality of carriers, wherein

said means for performing a feedback correction performs said feedback correction of said frequency deviation based on said averaged frequency offset.

30. The apparatus according to claim 28, further comprising:

means for determining an averaged frequency offset by averaging determined frequency offsets of a plurality of carriers, wherein

said means for performing a feedback correction performs said feedback correction of said frequency deviation based on said averaged frequency offset.

31. The apparatus according to claim 27, wherein said means for determining a phase difference comprises means for determining a phase difference between phases of the same carrier in symbols which are adjacent in the time axis direction.

32. The apparatus according to claim 28, wherein said means for determining respective phases comprises means for determining respective phases of the same carrier in symbols which are adjacent in the time axis direction.

33. The apparatus according to claim 27, wherein said means for performing a feedback correction of said frequency deviation comprises a numerical controlled oscillator and a complex multiplier.
34. The apparatus according to claim 33, wherein said means for performing a feedback correction of said frequency deviation further comprises a low path filter preceding said numerical controlled oscillator.

REMARKS

By the present Preliminary Amendment, claims 1-18 annexed to the International Preliminary Examination Report dated July 19, 2000 are being cancelled and replaced with new claims 19-34. In the new claims, multiple dependencies and parenthetical reference numerals have been eliminated.

A substitute specification is being submitted to facilitate processing of this application. A marked-up copy of the substitute specification is also being provided to show the new changes which are beyond those previously made during the international stage. The substitute specification contains no new matter.

Early and favorable action on this application is respectfully requested. Should the Examiner have any questions, the Examiner is invited to contact the undersigned attorney at the local telephone number listed below.

Respectfully submitted,

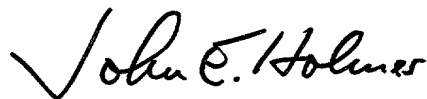

John E. Holmes
Attorney for Applicant
Reg. No. 29,392

Roylance, Abrams, Berdo & Goodman
1300 19th Street, N.W., Suite 600
Washington, D.C. 20036-2680
(202) 659-9076

Dated: October 13, 2000

8/PRTS

09/673270

529 Rec'd PCT/PTO 13 OCT 2000

METHOD AND APPARATUS FOR FINE FREQUENCY SYNCHRONIZATION IN
MULTI-CARRIER DEMODULATION SYSTEMS

FIELD OF THE INVENTION

The present invention relates to methods and apparatus for performing a fine frequency synchronization in multi-carrier demodulation systems, and in particular to methods and apparatus for performing a fine frequency synchronization compensating for a carrier frequency deviation from an oscillator frequency in a multi-carrier demodulation system of the type capable of carrying out a differential phase decoding of multi-carrier modulated signals, wherein the signals comprise a plurality of symbols, each symbol being defined by phase differences between simultaneous carriers having different frequencies.

BACKGROUND OF THE INVENTION

In a multi carrier transmission system (MCM, OFDM), the effect of a carrier frequency offset is substantially more considerable than in a single carrier transmission system. MCM is more sensitive to phase noise and frequency offset which occurs as amplitude distortion and inter carrier interference (ICI). The inter carrier interference has the effect that the subcarriers are no longer orthogonal in relation to each other. Frequency offsets occur after power on or also later due to frequency deviation of the oscillators used for downconversion into baseband. Typical accuracies for the frequency of a free running oscillator are about ± 50 ppm of the carrier frequency. With a carrier frequency in the S-band of 2.34 Ghz, for example, there will be a maximum local oscillator (LO) frequency deviation of above 100 kHz (117.25 kHz). The above named effects result in high requirements on the algorithm used for frequency offset correction.

005277 "09/673270"

DESCRIPTION OF PRIOR ART

Most prior art algorithms for frequency synchronization divide frequency correction into two stages. In the first stage, a coarse synchronization is performed. In the second stage, a fine correction can be achieved. A frequently used algorithm for coarse synchronization of the carrier frequency uses a synchronization symbol which has a special spectral pattern in the frequency domain. Such a synchronization symbol is, for example, a CAZAC sequence (CAZAC = Constant Amplitude Zero Autocorrelation). Through comparison, i.e. the correlation, of the power spectrum of the received signal with that of the transmitted signal, the frequency carrier offset can be coarsely estimated. These prior art algorithms all work in the frequency domain. Reference is made, for example, to Ferdinand Claßen, Heinrich Meyr, "Synchronization Algorithms for an OFDM System for Mobile Communication", ITG-Fachtagung 130, Codierung für Quelle, Kanal und Übertragung, pp. 105 - 113, Oct. 26-28, 1994; and Timothy M. Schmidl, Donald C. Cox, "Low-Overhead, Low-Complexity [Burst] Synchronization for OFDM", in Proceedings of the IEEE International Conference on Communication ICC 1996, pp. 1301-1306 (1996).

For the coarse synchronization of the carrier frequency, Paul H. Moose, "A Technique for Orthogonal Frequency Division Multiplexing Frequency Offset Correction", IEEE Transaction On Communications, Vol. 42, No. 10, October 1994, suggest increasing the spacing between the subcarriers such that the subcarrier distance is greater than the maximum frequency difference between the received and transmitted carriers. The subcarrier distance is increased by reducing the number of sample values which are transformed by the Fast Fourier Transform. This corresponds to a reduction of the number of sampling values which are transformed by the Fast Fourier Transform.

SUMMARY OF THE INVENTION

It is an object of the present invention to provide methods and apparatus for performing a fine frequency synchronization which allow a fine frequency synchronization compensating for a carrier frequency deviation from an oscillator frequency in a MCM transmission system which makes use of MCM signals in which information is differential phase encoded between simultaneous sub-carriers having different frequencies.

In accordance with a first aspect, the present invention provides a method of performing a fine frequency synchronization compensating for a carrier frequency deviation from an oscillator frequency in a multi-carrier demodulation system of the type capable of carrying out a differential phase decoding of multi-carrier modulated signals, the signals comprising a plurality of symbols, each symbol being defined by phase differences between simultaneous carriers having different frequencies, the method comprising the steps of:

determining a phase difference between phases of the same carrier in different symbols;

determining a frequency offset by eliminating phase shift uncertainties corresponding to codeable phase shifts from the phase difference; and

performing a feedback correction of the carrier frequency deviation based on the determined frequency offset.

In accordance with a second aspect, the present invention provides a method of performing a fine frequency synchronization compensating for a carrier frequency deviation from an oscillator frequency in a multi-carrier demodulation

system of the type capable of carrying out a differential phase decoding of multi-carrier modulated signals, the signals comprising a plurality of symbols, each symbol being defined by phase differences between simultaneous carriers having different frequencies, the method comprising the steps of:

determining respective phases of the same carrier in different symbols;

eliminating phase shift uncertainties corresponding to codeable phase shifts from the phases to determine respective phase deviations;

determining a frequency offset by determining a phase difference between the phase deviations; and

performing a feedback correction of said carrier frequency deviation based on the determined frequency offset.

In accordance with a third aspect, the present invention provides a method of performing a fine frequency synchronization compensating for a carrier frequency deviation from an oscillator frequency in a multi-carrier demodulation system of the type capable of carrying out a differential phase decoding of multi-carrier modulated signals, the signals comprising a plurality of symbols, each symbol being defined by phase differences between simultaneous carriers having different frequencies, the method comprising the steps of:

for a plurality of carriers in the symbols:

determining a phase difference between phases of the same carrier in different symbols; and

determining a frequency offset by eliminating phase shift uncertainties corresponding to codeable phase shifts from

005277 02E2950

the phase difference;

determining and averaged frequency offset by averaging the determined frequency offset of the plurality of carriers; and

performing a feedback correction of the frequency deviation based on the averaged frequency offset.

In accordance with a fourth aspect, the present invention provides a method of performing a fine frequency synchronization compensating for a carrier frequency deviation from an oscillator frequency in a multi-carrier demodulation system of the type capable of carrying out a differential phase decoding of multi-carrier modulated signals, the signals comprising a plurality of symbols, each symbol being defined by phase differences between simultaneous carriers having different frequencies, the method comprising the steps of:

for a plurality of carriers in the symbols:

determining respective phases of the same carrier in different symbols;

eliminating phase shift uncertainties corresponding to codeable phase shifts from said phases to determine respective phase deviations; and

determining a frequency offset by determining a phase difference between the phase deviations;

determining an averaged frequency offset by averaging the determined frequency offsets of the plurality of carriers; and

performing a feedback correction of the frequency deviation based on the averaged frequency offset.

005211-0222950

In accordance with a fifth aspect, the present invention provides an apparatus for performing a fine frequency synchronization compensating for a carrier frequency deviation from an oscillator frequency, for a multi-carrier demodulation system of the type capable of carrying out a differential phase decoding of multi-carrier modulated signals, the signals comprising a plurality of symbols, each symbol being defined by phase differences between simultaneous carriers having different frequencies, the apparatus comprising:

means for determining a phase difference between phases of the same carrier in different symbols;

means for determining a frequency offset by eliminating phase shift uncertainties corresponding to codeable phase shifts from the phase difference; and

means for performing a feedback correction of the frequency deviation based on the determined frequency offset.

In accordance with a sixth aspect, the present invention provides an apparatus for performing a fine frequency synchronization compensating for a carrier frequency deviation from an oscillator frequency, for a multi-carrier demodulation system of the type capable of carrying out a differential phase decoding of multi-carrier modulated signals, said signals comprising a plurality of symbols, each symbol being defined by phase differences between simultaneous carriers having different frequencies, the apparatus comprising:

means for determining respective phases of the same carrier in different symbols;

means for eliminating phase shift uncertainties corresponding to codeable phase shifts from the phases to

005271290

determine respective phase deviations;

means for determining a frequency offset by determining a phase difference between the phase deviations; and

means for performing a feedback correction of the frequency deviation based on the determined frequency offset.

In accordance with a seventh aspect, the present invention provides an apparatus for performing a fine frequency synchronization compensating for a carrier frequency deviation from an oscillator frequency, for a multi-carrier demodulation system of the type capable of carrying out a differential phase decoding of multi-carrier modulated signals, the signals comprising a plurality of symbols, each symbol being defined by phase differences between simultaneous carriers having different frequencies, the apparatus comprising:

means for determining a phase difference between phases of the same carrier in different symbols;

means for determining a frequency offset by eliminating phase shift uncertainties corresponding to codeable phase shifts from the phase difference;

means for determining an averaged frequency offset by averaging determined frequency offsets of a plurality of carriers; and

means for performing a feedback correction of the frequency deviation based on the averaged frequency offset.

In accordance with an eighth aspect, the present invention provides an apparatus for performing a fine frequency synchronization compensating for a carrier frequency deviation from an oscillator frequency, for a multi-carrier demodulation system of the type capable of carrying out a

005271 02E2960

differential phase decoding of multi-carrier modulated signals, the signals comprising a plurality of symbols, each symbol being defined by phase differences between simultaneous carriers having different frequencies, the apparatus comprising:

means for determining respective phases of the same carrier in different symbols;

means for eliminating phase shift uncertainties corresponding to codeable phase shifts from the phases to determine respective phase deviations;

means for determining a frequency offset by determining a phase difference between the phase deviations;

means for determining an averaged frequency offset by averaging determined frequency offsets of a plurality of carriers; and

means for performing a feedback correction of the frequency deviation based on the averaged frequency offset.

The present invention relates to methods and apparatus for performing a fine frequency synchronization compensating for a carrier frequency deviation from an oscillator frequency. This fine frequency synchronization is preferably performed after completion of a coarse frequency synchronization, such that the frequency offsets after the coarse frequency synchronization are smaller than half the sub-carrier distance in the MCM signal. Since the frequency offsets which are to be corrected by the inventive fine frequency synchronization methods and apparatus, a correction of the frequency offsets by using a phase rotation with differential decoding and de-mapping in the time axis can be used. The frequency offsets are detected by determining the frequency differences between time contiguous sub-carrier symbols along the time axis. The frequency error is

005217 02262950

calculated by measuring the rotation of the I-Q cartesian coordinates of each sub-carrier and, in preferred embodiments, averaging them over all n sub-carriers of a MCM symbol.

Firstly, the phase ambiguity or uncertainty is eliminated by using a M-PSK decision device and correlating the output of the decision device with the input signal for a respective sub-carrier symbol. Thus, the phase offset for a sub-carrier symbol is determined and can be used for restructuring the frequency error in form of a feed-backward structure. Alternatively, the phase offsets of the sub-carrier symbols of one MCM symbol can be averaged over all of the active carriers of a MCM symbol, wherein the averaged phase offset is used to restructure the frequency error.

In accordance with the present invention, the determination of the frequency offset is performed in the frequency domain. The feedback correction in accordance with the inventive fine frequency synchronization is performed in the time domain. To this end, a differential decoder in the time domain is provided in order to detect frequency offsets of sub-carriers on the basis of the phases of timely successive sub-carrier symbols of different MCM symbols.

BRIEF DESCRIPTION OF THE DRAWINGS

In the following, preferred embodiments of the present invention will be explained in detail on the basis of the drawings enclosed, in which:

Figure 1 shows a schematic overview of a MCM transmission system to which the present application can be applied;

Figures 2A and 2B show schematic views representing a scheme for differential mapping in the time axis and a

Figure 13 shows a schematic block diagram for illustrating the position and the functionality of an echo phase offset correction unit;

Figure 14 shows a schematic block diagram of a preferred form of an echo phase offset correction device; and

Figure 15 shows schematic views for illustrating a projection performed by another echo phase offset correction algorithm.

DETAILED DESCRIPTION OF THE EMBODIMENTS

Before discussing the present invention in detail, the mode of operation of a MCM transmission system is described referring to figure 1.

Referring to Figure 1, at 100 a MCM transmitter is shown that substantially corresponds to a prior art MCM transmitter. A description of such a MCM transmitter can be found, for example, in William Y. Zou, Yiyan Wu, "COFDM: AN OVERVIEW", IEEE Transactions on Broadcasting, vol. 41, No. 1, March 1995.

A data source 102 provides a serial bitstream 104 to the MCM transmitter. The incoming serial bitstream 104 is applied to a bit-carrier mapper 106 which produces a sequence of spectra 108 from the incoming serial bitstream 104. An inverse fast Fourier transform (IFFT) 110 is performed on the sequence of spectra 108 in order to produce a MCM time domain signal 112. The MCM time domain signal forms the useful MCM symbol of the MCM time signal. To avoid intersymbol interference (ISI) caused by multipath distortion, a unit 114 is provided for inserting a guard interval of fixed length between adjacent MCM symbols in time. In accordance with a preferred embodiment of the

present invention, the last part of the useful MCM symbol is used as the guard interval by placing same in front of the useful symbol. The resulting MCM symbol is shown at 115 in Figure 1 and corresponds to a MCM symbol 160 depicted in Figure 11.

Figure 11 shows the construction of a typical MCM signal having a frame structure. One frame of the MCM time signal is composed of a plurality of MCM symbols 160. Each MCM symbol 160 is formed by an useful symbol 162 and a guard interval 164 associated therewith. As shown in Figure 11, each frame comprises one reference symbol 166. The present invention can advantageously be used with such a MCM signal, however, such a signal structure being not necessary for performing the present invention as long as the transmitted signal comprises a useful portion and at least one reference symbol.

In order to obtain the final frame structure shown in Figure 11, a unit 116 for adding a reference symbol for each pre-determined number of MCM symbols is provided.

In accordance with the present invention, the reference symbol is an amplitude modulated bit sequence. Thus, an amplitude modulation of a bit sequence is performed such that the envelope of the amplitude modulated bit sequence defines a reference pattern of the reference symbol. This reference pattern defined by the envelope of the amplitude modulated bit sequence has to be detected when receiving the MCM signal at a MCM receiver. In a preferred embodiment of the present invention, a pseudo random bit sequence having good autocorrelation properties is used as the bit sequence that is amplitude modulated.

The choice of length and repetition rate of the reference symbol depends on the properties of the channel through which the MCM signal is transmitted, e.g. the coherence time of the channel. In addition, the repetition rate and the

006677" 022E/950

length of the reference symbol, in other words the number of useful symbols in each frame, depends on the receiver requirements concerning mean time for initial synchronization and mean time for resynchronization after synchronization loss due to a channel fade.

The resulting MCM signal having the structure shown at 118 in Figure 1 is applied to the transmitter front end 120. Roughly speaking, at the transmitter front end 120, a digital/analog conversion and an up-converting of the MCM signal is performed. Thereafter, the MCM signal is transmitted through a channel 122.

Following, the mode of operation of a MCM receiver 130 is shortly described referring to Figure 1. The MCM signal is received at the receiver front end 132. In the receiver front end 132, the MCM signal is down-converted and, furthermore, an analog/digital conversion of the down-converted signal is performed.

The down-converted MCM signal is provided to a symbol frame/carrier frequency synchronization unit 134.

A first object of the symbol frame/carrier frequency synchronization unit 134 is to perform a frame synchronization on the basis of the amplitude-modulated reference symbol. This frame synchronization is performed on the basis of a correlation between the amplitude-demodulated reference symbol and a predetermined reference pattern stored in the MCM receiver.

A second object of the symbol frame/carrier frequency synchronization unit is to perform a coarse frequency synchronization of the MCM signal. To this end, the symbol frame/carrier frequency synchronization unit 134 serves as a coarse frequency synchronization unit for determining a coarse frequency offset of the carrier frequency caused, for example, by a difference of the frequencies between the

006277-022E2950

shifts between two sub-carrier symbols.

A second method of differential mapping is shown in Figure 2B. The present invention is adapted for MCM transmission system using the mapping scheme shown in Figure 2B. This mapping scheme is based on a differential mapping inside one MCM symbol along the frequency axis. A number of MCM symbols 200 is shown in Figure 2B. Each MCM symbol 200 comprises a number of sub-carrier symbols 202. The arrows 204 in Figure 2B illustrate information encoded between two sub-carrier symbols 202. As can be seen from the arrows 204, this mapping scheme is based on a differential mapping within one MCM symbol along the frequency axis direction.

In the embodiment shown in Figure 2B, the first sub-carrier ($k=0$) in an MCM symbol 200 is used as a reference sub-carrier 206 (shaded) such that information is encoded between the reference sub-carrier and the first active carrier 208. The other information of a MCM symbol 200 is encoded between active carriers, respectively.

Thus, for every MCM symbol an absolute phase reference exists. In accordance with Figure 2B, this absolute phase reference is supplied by a reference symbol inserted into every MCM symbol ($k=0$). The reference symbol can either have a constant phase for all MCM symbols or a phase that varies from MCM symbol to MCM symbol. A varying phase can be obtained by replicating the phase from the last subcarrier of the MCM symbol preceding in time.

In Figure 3 a preferred embodiment of a device for performing a differential mapping along the frequency axis is shown. Referring to Figure 3, assembly of MCM symbols in the frequency domain using differential mapping along the frequency axis according to the present invention is described.

Figure 3 shows the assembly of one MCM symbol with the

following parameters:

N_{FFT} designates the number of complex coefficients of the discrete Fourier transform, number of subcarriers respectively.

K designates the number of active carriers. The reference carrier is not included in the count for K .

According to Figure 3, a quadrature phase shift keying (QPSK) is used for mapping the bitstream onto the complex symbols. However, other M-ary mapping schemes (MPSK) like 2-PSK, 8-PSK, 16-QAM, 16-APSK, 64-APSK etc. are possible.

Furthermore, for ease of filtering and minimization of aliasing effects some subcarriers are not used for encoding information in the device shown in Figure 3. These subcarriers, which are set to zero, constitute the so-called guard bands on the upper and lower edges of the MCM signal spectrum.

At the input of the mapping device shown in Figure 3, complex signal pairs $b_0[k]$, $b_1[k]$ of an input bitstream are received. K complex signal pairs are assembled in order to form one MCM symbol. The signal pairs are encoded into the K differential phase shifts $\phi[k]$ needed for assembly of one MCM symbol. In this embodiment, mapping from Bits to the 0, 90, 180 and 270 degrees phase shifts is performed using Gray Mapping in a quadrature phase shift keying device 220.

Gray mapping is used to prevent that differential detection phase errors smaller than 135 degrees cause double bit errors at the receiver.

Differential phase encoding of the K phases is performed in a differential phase encoder 222. At this stage of processing, the K phases $\phi[k]$ generated by the QPSK Gray mapper are differentially encoded. In principal, a feedback

loop 224 calculates a cumulative sum over all K phases. As starting point for the first computation (k = 0) the phase of the reference carrier 226 is used. A switch 228 is provided in order to provide either the absolute phase of the reference subcarrier 226 or the phase information encoded onto the preceding (i.e. z^{-1} , where z^{-1} denotes the unit delay operator) subcarrier to a summing point 230. At the output of the differential phase encoder 222, the phase information $\theta[k]$ with which the respective subcarriers are to be encoded is provided. In preferred embodiments of the present invention, the subcarriers of a MCM symbol are equally spaced in the frequency axis direction.

The output of the differential phase encoder 222 is connected to a unit 232 for generating complex subcarrier symbols using the phase information $\theta[k]$. To this end, the K differentially encoded phases are converted to complex symbols by multiplication with

$$\text{factor} * e^{j[2\pi(\theta[k] + \text{PHI})]} \quad (\text{Eq.1})$$

wherein factor designates a scale factor and PHI designates an additional angle. The scale factor and the additional angle PHI are optional. By choosing $\text{PHI} = 45^\circ$ a rotated DQPSK signal constellation can be obtained.

Finally, assembly of a MCM symbol is effected in an assembling unit 234. One MCM symbol comprising N_{FFT} subcarriers is assembled from $N_{\text{FFT}} - K - 1$ guard band symbols which are "zero", one reference subcarrier symbol and K DQPSK subcarrier symbols. Thus, the assembled MCM symbol 200 is composed of K complex values containing the encoded information, two guard bands at both sides of the N_{FFT} complex values and a reference subcarrier symbol.

The MCM symbol has been assembled in the frequency domain. For transformation into the time domain an inverse discrete Fourier transform (IDFT) of the output of the assembling

unit 234 is performed by a transformator 236. In preferred embodiments of the present invention, the transformator 236 is adapted to perform a fast Fourier transform (FFT).

Further processing of the MCM signal in the transmitter as well as in the receiver is as described above referring to Figure 1.

At the receiver a de-mapping device 142 (Figure 1) is needed to reverse the operations of the mapping device described above referring to Figure 3. The implementation of the demapping device is straightforward and, therefore, need not be described herein in detail.

The differential mapping along the frequency axis direction is suitable for multi-carrier (OFDM) digital broadcasting over rapidly changing multi path channels. In accordance with this mapping scheme, there is no need for a channel stationarity exceeding one multi-carrier symbol. However, differential mapping into frequency axis direction may create a new problem. In multi path environments, path echoes succeeding or preceding the main path can lead to systematic phase offsets between sub-carriers in the same MCM symbol. Thus, it will be preferred to provide a correction unit in order to eliminate such phase offsets. Because the channel induced phase offsets between differential demodulated symbols are systematic errors, they can be corrected by an algorithm. In principle, such an algorithm must calculate the echo induced phase offset from the signal space constellation following the differential demodulation and subsequently correct this phase offset.

Examples for such echo phase correction algorithms are described at the end of this specification referring to Figures 12 to 15.

Next, the fine frequency synchronization in accordance with the present invention will be described referring to Figures

4 to 8. As mentioned above, the fine frequency synchronization in accordance with the present invention is performed after completion of the coarse frequency synchronization. Preferred embodiments of the coarse frequency synchronization which can be performed by the symbol frame/carrier frequency synchronization unit 134 are described hereinafter referring to Figures 9 and 10 after having described the fine frequency synchronization in accordance with the present invention.

With the fine frequency synchronization in accordance with the present invention frequency offsets which are smaller than half the sub-carrier distance can be corrected. Since the frequency offsets are low and equal for all sub-carriers the problem of fine frequency synchronization is reduced to sub-carrier level. Figure 4 is a schematical view of MCM symbols 200 in the time-frequency plane. Each MCM symbol 200 consists of 432 sub-carrier symbols C_1 to C_{432} . The MCM symbols are arranged along the time axis, the first MCM symbol 200 shown in Figure 4 having associated therewith a time T_1 , the next MCM symbol having associated therewith a time T_2 and so on. In accordance with a preferred embodiment of the present invention, the fine frequency synchronization is based on a phase rotation which is derived from the same sub-carrier of two MCM symbols which are adjacent in the time axis direction, for example C_1/T_1 and C_1/T_2 .

In the following, the present invention is described referring to QPSK mapping (QPSK = Quadrature Phase Shift Keying). However, it is obvious that the present invention can be applied to any MPSK mapping, wherein M designates the number of phase states used for encoding, for example 2, 4, 8, 16

Figure 5 represents a complex coordinate system showing a QPSK constellation for each sub-carrier with frequency offset. The four possible phase positions of a first MCM symbol, MCM-symbol-1 are shown at 300. Changing from the

sub-carrier (sub-carrier n) of this MCM symbol to the same sub-carrier of the next MCM symbol, MCM-symbol-2, the position in the QPSK constellation will be unchanged in case there is no frequency offset. If a frequency offset is present, which is smaller than half the distance between sub-carriers, as mentioned above, this frequency offset causes a phase rotation of the QPSK constellation of MCM-symbol-2 compared with MCM-symbol-1. The new QPSK constellation, that is the four possible phase positions for the subject sub-carrier of MCM-symbol-2 are shown at 302 in Figure 5. This phase rotation θ can be derived from the following equation:

$$C_n(kT_{MCM}) = e^{j2\pi f_{offset} T_{MCM}} C_n((k-1)T_{MCM})$$
$$\theta = 2\pi f_{offset} T_{MCM} \quad (\text{Eq. 2})$$

C_n designates the QPSK constellation of a sub-carrier n in a MCM symbol. n is an index running from 1 to the number of active sub-carriers in the MCM symbol. Information regarding the frequency offset is contained in the term $e^{j2\pi f_{offset} T_{MCM}}$ of equation 2. This frequency offset is identical for all sub-carriers. Therefore, the phase rotation θ is identical for all sub-carriers as well. Thus, averaging overall sub-carrier of a MCM symbol can be performed.

Figure 6 shows a block diagram of a MCM receiver in which the present invention is implemented. An analog/digital converter 310 is provided in order to perform an analog/digital conversion of a down-converted signal received at the receiver front end 132 (Figure 1). The output of the analog/digital converter 310 is applied to a low path filter and decimator unit 312. The low path filter is an impulse forming filter which is identical to an impulse forming filter in the MCM transmitter. In the decimator, the signal is sampled at the MCM symbol frequency. As described above referring to Figure 1, guard intervals in the MCM signal are removed by a guard interval removal unit 132. Guard intervals are inserted between two

006277-022E/950

MCM symbols in the MCM transmitter in order to avoid inter-symbol interference caused by channel memory.

The output of the guard interval removal unit 132 is applied to a MCM demodulator 314 which corresponds to the fast Fourier transformator 140 shown in Figure 1. Following the MCM demodulator 314 a differential decoding unit 316 and a demapping unit 318 are provided. In the differential decoding unit 316, phase information is recovered using differential decoding. In the demapping unit 318, demapping along the frequency axis direction is performed in order to reconstruct a binary signal from the complex signal input into the demapping unit 318.

The output of the MCM demodulator 314 is also applied to fine frequency error detector 320. The fine frequency error detector 320 produces an frequency error signal from the output of the MCM demodulator. In the depicted embodiment, the output of the fine frequency error detector 320 is applied to a numerical controlled oscillator 322 via a loop filter 324. The loop filter 324 is a low path filter for filtering superimposed interference portions of a higher frequency from the slowly varying error signal. The numerical controlled oscillator 322 produces a carrier signal on the basis of the filtered error signal. The carrier signal produced by the numerical controlled oscillator 322 is used for a frequency correction which is performed by making use of a complex multiplier 326. The inputs to the complex multiplier 326 are the output of the low path filter and decimator unit 312 and the output of the numerical controlled oscillator 322.

A description of a preferred embodiment of the fine frequency error detector 320 is given hereinafter referring to Figure 7.

The fine frequency error detector 320 comprises a differential detector in the time axis 330. The output of

00672270 119900

the MCM demodulator 314, i.e. the FFT output (FFT = Fast Fourier Transform) is applied to the input of the differential detector 330 which performs a differential detection in the time axis in order to derive information on a frequency offset from the same sub-carrier of two subsequently arriving MCM symbols. In the embodiment shown in Figure 7, the number of active sub-carriers is 432. Thus, the differential detector 330 performs a correlation between the first and the 433rd sample. The first sample is associated with MCM-symbol-1 (Figure 5), whereas the 433rd sample is associated with MCM-symbol-2 (Figure 5). However, both these samples are associated with the same sub-carrier.

To this end, the input signal Y_k is applied to a z^{-1} -block 332 and thereafter to a unit 334 in order to form the complex conjugate of the output of the z^{-1} -block 332. A complex multiplier 336 is provided in order to multiply the output of the unit 334 by the input signal Y_k . The output of the multiplier 336 is a signal Z_k .

The function of the differential detector 330 can be expressed as follows:

$$Z_k = Y_{k+K} \cdot Y_k^* \tag{Eq.3}$$

$$Y = [Y_1, Y_2, \dots, Y_k, \dots] \tag{Eq.4}$$

$$Y = [C_1/T_1, C_2/T_1, \dots, C_{432}/T_1, C_1/T_2, \dots] \tag{Eq.5}$$

Y_k designates the output of the MCM modulator 314, i.e. the input to the differential detector 330, at a time k . Z_k designates the output of the differential detector 330. K designates the number of active carriers.

The output Z_k of the differential detector 330 contains a M -fold uncertainty corresponding to codeable phase shifts. In case of the QPSK this M -fold uncertainty is a 4-fold uncertainty, i.e. 0° , 90° , 180° and 270° . This phase shift

09673270 112900

uncertainty is eliminated from Z_k making use of a M-PSK decision device 340. Such decision devices are known in the art and, therefore, have not to be described here in detail. The output of the decision device 340 (\hat{a}_k)* represents the complex conjugate of the codeable phase shift decided by the decision device 340. This output of the decision device 340 is correlated with the output of the differential detector 330 by performing a complex multiplication using a multiplier 342.

The output the multiplier 342 represents the phase offset for the respective sub-carriers. This phase offsets for the respective sub-carriers are averaged over one MCM symbol in an averaging unit 344 in accordance with a preferred embodiment of the present invention. The output of the averaging units 344 represent the output of the fine frequency error detector 320.

The mathematical description for this procedure is as follows:

$$f_{offset} = \frac{1}{2\pi K T_{MCM}} \arg \left\{ \sum_{n=1}^K Z_n \cdot \left(\hat{a}_n \right)^* \right\} \quad (\text{Eq. 6})$$

In accordance with preferred embodiments of the present invention, the frequency control loop has a backward structure. In the embodiment shown in Figure 6, the feedback loop is connected between the output of the MCM demodulator 314 and the input of the guard interval removal unit 132.

In Figure 8, a block diagram of a MCM receiver comprising a coarse frequency correction unit 350 and a fine frequency correction unit as described above is shown. As shown in Figure 8, a common complex multiplier 326 can be used in order to perform the coarse frequency correction and the fine frequency correction. As shown in Figure 8, the multiplier 326 can be provided preceding the low path filter and decimator unit 312. Depending on the position of the

multiplier 326, a hold unit has to be provided in the fine frequency synchronization feedback loop. In an alternative embodiment, it is possible to use two separate multipliers for the coarse frequency correction and for the fine frequency correction. In such a case, the multiplier for the coarse frequency correction will be arranged preceding the low path filter and decimator unit, whereas the multiplier for the fine frequency correction will be arranged following the low path filter and decimator unit.

Following, preferred embodiments for implementing a coarse frequency synchronization will be described referring to Figures 9 and 10.

As it is shown in Figure 9, the output of the receiver front end 132 is connected to an analog/digital converter 310. The down-converted MCM signal is sampled at the output of the analog/digital converter 310 and is applied to a frame/timing synchronization unit 360. In a preferred embodiment, a fast running automatic gain control (AGC) (not shown) is provided preceding the frame/timing synchronization unit in order to eliminate fast channel fluctuations. The fast AGC is used in addition to the normally slow AGC in the signal path, in the case of transmission over a multipath channel with long channel impulse response and frequency selective fading. The fast AGC adjusts the average amplitude range of the signal to the known average amplitude of the reference symbol.

As described above, the frame/timing synchronization unit uses the amplitude-modulated sequence in the received signal in order to extract the framing information from the MCM signal and further to remove the guard intervals therefrom. After the frame/timing synchronization unit 360 it follows a coarse frequency synchronization unit 362 which estimates a coarse frequency offset based on the amplitude-modulated sequence of the reference symbol of the MCM signal. In the coarse frequency synchronization unit 362, a frequency

offset of the carrier frequency with respect to the oscillator frequency in the MCM receiver is determined in order to perform a frequency offset correction in a block 364. This frequency offset correction in block 364 is performed by a complex multiplication.

The output of the frequency offset correction block 364 is applied to the MCM demodulator 366 formed by the Fast Fourier Transformator 140 and the carrier-bit mapper 142 shown in Figure 1.

In order to perform the coarse frequency synchronization described herein, an amplitude-demodulation has to be performed on a preprocessed MCM signal. The preprocessing may be, for example, the down-conversion and the analog/digital conversion of the MCM signal. The result of the amplitude-demodulation of the preprocessed MCM signal is an envelope representing the amplitude of the MCM signal.

For the amplitude demodulation a simple $\alpha_{\max} + \beta_{\min}$ -method can be used. This method is described for example in Palachels A.: DSP-mP Routine Computes Magnitude, EDN, October 26, 1989; and Adams, W. T., and Bradley, J.: Magnitude Approximations for Microprocessor Implementation, IEEE Micro, Vol. 3, No. 5, October 1983.

It is clear that amplitude determining methods different from the described $\alpha_{\max} + \beta_{\min}$ -method can be used. For simplification, it is possible to reduce the amplitude calculation to a detection as to whether the current amplitude is above or below the average amplitude. The output signal then consists of a -1/+1 sequence which can be used to determine a coarse frequency offset by performing a correlation. This correlation can easily be performed using a simple integrated circuit (IC).

In addition, an oversampling of the signal received at the RF front end can be performed. For example, the received

signal can be expressed with two times oversampling.

In accordance with a first embodiment, a carrier frequency offset of the MCM signal from an oscillator frequency in the MCM receiver is determined by correlating the envelope obtained by performing the amplitude-demodulation as described above with a predetermined reference pattern.

In case there is no frequency offset, the received reference symbol $r(k)$ will be:

$$r(k) = S_{AM}(k) + n(k) \tag{Eq.7}$$

wherein $n(k)$ designates "additive Gaussian noise" and S_{AM} denotes the AM sequence which has been sent. In order to simplify the calculation the additive Gaussian noise can be neglected. It follows:

$$r(k) \cong S_{AM}(k) \tag{Eq.8}$$

In case a constant frequency offset Δf is present, the received signal will be:

$$\tilde{r}(k) = S_{AM}(k) \cdot e^{j2\pi\Delta f k T_{MCM}} \tag{Eq.9}$$

Information regarding the frequency offset is derived from the correlation of the received signal $\tilde{r}(k)$ with the AM sequence S_{AM} which is known in the receiver:

$$\sum_{k=1}^{\frac{L}{2}} \tilde{r}(k) \cdot S_{AM}^*(k) = \sum_{k=1}^{\frac{L}{2}} |S_{AM}(k)|^2 e^{j2\pi\Delta f k T_{MCM}} \tag{Eq.10}$$

Thus, the frequency offset is:

$$\Delta f = \frac{1}{2\pi T_{MCM}} \arg \left(\sum_{k=1}^{\frac{L}{2}} r(k) \cdot S_{AM}^*(k) \right) - \frac{1}{2\pi T_{MCM}} \arg \left(\sum_{k=1}^{\frac{L}{2}} |S_{AM}(k)|^2 \right) \tag{Eq.11}$$

Since the argument of $|S_{AM}(k)|^2$ is zero the frequency offset

005211 0202/960

is:

$$\Delta f = \frac{1}{2\pi T_{MCM}} \arg \left(\sum_{k=1}^{\frac{L}{2}} \tilde{r}(k) \cdot S_{AM}^* \right) \quad (\text{Eq. 12})$$

In accordance with a second embodiment of the coarse frequency synchronization algorithm, a reference symbol comprising at least two identical sequences 370 as shown in Figure 10 is used. Figure 10 shows the reference symbol of a MCM signal having two identical sequences 370 of a length of L/2 each. L designates the number of values of the two sequences 370 of the reference symbol.

As shown in Figure 10, within the amplitude-modulated sequence, there are at least two identical sections devoted to the coarse frequency synchronization. Two such sections, each containing L/2 samples, are shown at the end of the amplitude-modulated sequence in Figure 10. The amplitude-modulated sequence contains a large number of samples. For a non-ambiguous observation of the phase, only enough samples to contain a phase rotation of 2π should be used. This number is defined as L/2 in Figure 10.

Following, a mathematical derivation of the determination of a carrier frequency deviation is presented. In accordance with Figure 10, the following equation applies for the two identical sequences 370:

$$s\left(0 < k \leq \frac{L}{2}\right) \equiv s\left(\frac{L}{2} < k \leq L\right) \quad (\text{Eq. 13})$$

If no frequency offset is present, the following equation 14 will be met by the received signal:

$$r\left(k + \frac{L}{2}\right) \equiv r(k) \quad 0 < k \leq \frac{L}{2} \quad (\text{Eq. 14})$$

r(k) designates the values of the identical sequences. k is an index from one to L/2 for the respective samples.

005277-0222950

If there is a frequency offset of, for example, Δf , the received signal is:

$$\tilde{r}(k) = r(k) \cdot e^{j2\pi\Delta f k T_{MCM}} \quad (\text{Eq.15})$$

$$\tilde{r}\left(k + \frac{L}{2}\right) = r(k) \cdot e^{j2\pi\Delta f \left(k + \frac{L}{2}\right) T_{MCM}} \quad (\text{Eq.16})$$

$\tilde{r}(k)$ designates sample values of the received portion which are based on the identical sequences. Information regarding the frequency offset is derived from the correlation of the received signal $\tilde{r}(k+L/2)$ with the received signal $\tilde{r}(k)$. This correlation is given by the following equation:

$$\sum_{k=1}^{\frac{L}{2}} \tilde{r}^*\left(k + \frac{L}{2}\right) \tilde{r}(k) = \sum_{k=1}^{\frac{L}{2}} |r(k)|^2 e^{-j2\pi\Delta f \frac{L}{2} T_{MCM}} \quad (\text{Eq.17})$$

\tilde{r}^* designates the complex conjugate of the sample values of the portion mentioned above.

Thus, the frequency offset is

$$\Delta f = \frac{1}{2\pi \frac{L}{2} T_{MCM}} \arg\left(\sum_{k=1}^{\frac{L}{2}} \tilde{r}\left(k + \frac{L}{2}\right) \cdot \tilde{r}^*(k)\right) - \frac{1}{2\pi \frac{L}{2} T_{MCM}} \arg\left(\sum_{k=1}^{\frac{L}{2}} |\tilde{r}(k)|^2\right) \quad (\text{Eq.18})$$

Since the argument of $|\tilde{r}(k)|^2$ equals zero, the frequency offset becomes

$$\Delta f = \frac{1}{2\pi \frac{L}{2} T_{MCM}} \arg\left(\sum_{k=1}^{\frac{L}{2}} \tilde{r}\left(k + \frac{L}{2}\right) \cdot \tilde{r}^*(k)\right) \quad (\text{Eq.19})$$

Thus, it is clear that in both embodiments, described above, the frequency position of the maximum of the resulting output of the correlation determines the estimated value of the offset carrier. Furthermore, as it is also shown in Figure 9, the correction is performed in a feed forward structure.

006277-02E2950

In case of a channel with strong reflections, for example due to a high building density, the correlations described above might be insufficient for obtaining a suitable coarse frequency synchronization. Therefore, in accordance with a third embodiment of the present invention, corresponding values of the two portions which are correlated in accordance with a second embodiment, can be weighting with corresponding values of stored predetermined reference patterns corresponding to said two identical sequences of the reference symbol. This weighting can maximize the probability of correctly determining the frequency offset. The mathematical description of this weighting is as follows:

$$\Delta f = \frac{1}{2\pi \frac{L}{2} T_{MCM}} \arg \left(\sum_{k=1}^{\frac{L}{2}} \left[\tilde{r} \left(k + \frac{L}{2} \right) \cdot \tilde{r}^*(k) \right] \cdot \left[S_{AM}(k) S_{AM}^* \left(k + \frac{L}{2} \right) \right] \right) \quad (\text{Eq. 20})$$

S_{AM} designates the amplitude-modulated sequence which is known in the receiver, and S_{AM}^* designates the complex conjugate thereof.

If the above correlations are calculated in the frequency domain, the amount of

$$\sum_{k=1}^{\frac{L}{2}} \left[\tilde{r} \left(k + \frac{L}{2} \right) \cdot \tilde{r}^*(k) \right] \cdot \left[S_{AM}(k) S_{AM}^* \left(k + \frac{L}{2} \right) \right] \quad (\text{Eq. 21})$$

is used rather than the argument. This amount is maximized as a function of a frequency correction. The position of the maximum determines the estimation of the frequency deviation. As mentioned above, the correction is performed in a feed forward structure.

Preferred embodiments for performing an echo phase offset correction when using a differential mapping in the frequency axis will be described hereinafter referring to Figures 12 to 15.

Systematic phase shifts stemming from echoes in multipath

006677-02EE2950

environments may occur between subcarriers in the same MCM symbol. This phase offsets can cause bit errors when demodulating the MCM symbol at the receiver. Thus, it is preferred to make use of an algorithm to correct the systematic phase shifts stemming from echoes in multipath environments.

In Figure 12, scatter diagrams at the output of a differential demapper of a MCM receiver are shown. As can be seen from the left part of Figure 12, systematic phase shifts between subcarriers in the same MCM symbol cause a rotation of the demodulated phase shifts with respect to the axis of the complex coordinate system. In the right part of Figure 12, the demodulated phase shifts after having performed an echo phase offset correction are depicted. Now, the positions of the signal points are substantially on the axis of the complex coordinate system. These positions correspond to the modulated phase shifts of 0° , 90° , 180° and 270° , respectively.

An echo phase offset correction algorithm (EPOC algorithm) must calculate the echo induced phase offset from the signal space constellation following the differential demodulation and subsequently correct this phase offset.

For illustration purposes, one may think of the simplest algorithm possible which eliminates the symbol phase before computing the mean of all phases of the subcarriers. To illustrate the effect of such an EPOC algorithm, reference is made to the two scatter diagrams of subcarriers symbols contained in one MCM symbol in Figure 12. This scatter diagrams have been obtained as result of an MCM simulation. For the simulation a channel has been used which might typically show up in single frequency networks. The echoes of this channel stretched to the limits of the MCM guard interval. The guard interval was chosen to be 25% of the MCM symbol duration in this case.

Figure 13 represents a block diagram for illustrating the position and the functionality of an echo phase offset correction device in a MCM receiver. The signal of a MCM transmitter is transmitted through the channel 122 (Figures 1 and 13) and received at the receiver frontend 132 of the MCM receiver. The signal processing between the receiver frontend and the fast Fourier transformator 140 has been omitted in Figure 13. The output of the fast Fourier transformator is applied to the de-mapper, which performs a differential de-mapping along the frequency axis. The output of the de-mapper are the respective phase shifts for the subcarriers. The phase offsets of this phase shifts which are caused by echoes in multipath environments are visualized by a block 400 in Figure 13 which shows an example of a scatter diagram of the subcarrier symbols without an echo phase offset correction.

The output of the de-mapper 142 is applied to the input of an echo phase offset correction device 402. The echo phase offset correction device 402 uses an EPOC algorithm in order to eliminate echo phase offsets in the output of the de-mapper 142. The result is shown in block 404 of Figure 13, i.e. only the encoded phase shifts, 0° , 90° , 180° or 270° are present at the output of the correction device 402. The output of the correction device 402 forms the signal for the metric calculation which is performed in order to recover the bitstream representing the transmitted information.

A first embodiment of an EPOC algorithm and a device for performing same is now described referring to Figure 14.

The first embodiment of an EPOC algorithm starts from the assumption that every received differentially decoded complex symbol is rotated by an angle due to echoes in the multipath channel. For the subcarriers equal spacing in frequency is assumed since this represents a preferred embodiment. If the subcarriers were not equally spaced in frequency, a correction factor would have to be introduced

into the EPOC algorithm.

Figure 14 shows the correction device 402 (Figure 13) for performing the first embodiment of an EPOC algorithm.

From the output of the de-mapper 142 which contains an echo phase offset as shown for example in the left part of Figure 12, the phase shifts related to transmitted information must first be discarded. To this end, the output of the de-mapper 142 is applied to a discarding unit 500. In case of a DQPSK mapping, the discarding unit can perform a " $(.)^4$ " operation. The unit 500 projects all received symbols into the first quadrant. Therefore, the phase shifts related to transmitted information is eliminated from the phase shifts representing the subcarrier symbols. The same effect could be reached with a modulo-4 operation.

Having eliminated the information related symbol phases in unit 500, the first approach to obtain an estimation would be to simply compute the mean value over all symbol phases of one MCM symbol. However, it is preferred to perform a threshold decision before determining the mean value over all symbol phases of one MCM symbol. Due to Rayleigh fading some of the received symbols may contribute unreliable information to the determination of the echo phase offset. Therefore, depending on the absolute value of a symbol, a threshold decision is performed in order to determine whether the symbol should contribute to the estimate of the phase offset or not.

Thus, in the embodiment shown in Figure 14, a threshold decision unit 510 is included. Following the unit 500 the absolute value and the argument of a differentially decoded symbol is computed in respective computing units 512 and 514. Depending on the absolute value of a respective symbol, a control signal is derived. This control signal is compared with a threshold value in a decision circuit 516. If the absolute value, i.e. the control signal thereof, is smaller

than a certain threshold, the decision circuit 516 replaces the angle value going into the averaging operation by a value equal to zero. To this end, a switch is provided in order to disconnect the output of the argument computing unit 514 from the input of the further processing stage and connects the input of the further processing stage with a unit 518 providing a constant output of "zero".

An averaging unit 520 is provided in order to calculate a mean value based on the phase offsets φ_i determined for the individual subcarrier symbols of a MCM symbol as follows:

$$\bar{\varphi} = 1/K \sum_{i=1}^K \varphi_i \quad (\text{Eq.22})$$

In the averaging unit 520, summation over K summands is performed. The output of the averaging unit 520 is provided to a hold unit 522 which holds the output of the averaging unit 520 K times. The output of the hold unit 522 is connected with a phase rotation unit 524 which performs the correction of the phase offsets of the K complex signal points on the basis of the mean value $\bar{\varphi}$.

The phase rotation unit 524 performs the correction of the phase offsets by making use of the following equation:

$$v_k' = v_k \cdot e^{-j\bar{\varphi}} \quad (\text{Eq.23})$$

In this equation, v_k' designates the K phase corrected differentially decoded symbols for input into the soft-metric calculation, whereas v_k designates the input symbols. As long as a channel which is quasi stationary during the duration of one MCM symbols can be assumed, using the mean value over all subcarriers of one MCM symbol will provide correct results.

A buffer unit 527 may be provided in order to buffer the

complex signal points until the mean value of the phase offsets for one MCM symbol is determined. The output of the phase rotation unit 524 is applied to the further processing stage 526 for performing the soft-metric calculation.

With respect to the results of the above echo phase offset correction, reference is made again to Figure 12. The two plots stem from a simulation which included the first embodiment of an echo phase offset correction algorithm described above. At the instant of the scatter diagram snapshot shown in the left part of Figure 12, the channel obviously distorted the constellation in such a way, that a simple angle rotation is a valid assumption. As shown in the right part of Figure 12, the signal constellation can be rotated back to the axis by applying the determined mean value for the rotation of the differentially detected symbols.

A second embodiment of an echo phase offset correction algorithm is described hereinafter. This second embodiment can be preferably used in connection with multipath channels that have up to two strong path echoes. The algorithm of the second embodiment is more complex than the algorithm of the first embodiment.

What follows is a mathematical derivation of the second embodiment of a method for echo phase offset correction. The following assumptions can be made in order to ease the explanation of the second embodiment of an EPOC algorithm.

In this embodiment, the guard interval of the MCM signal is assumed to be at least as long as the impulse response $h[q]$, $q = 0, 1, \dots, Q_h-1$ of the multipath channel.

At the transmitter every MCM symbol is assembled using frequency axis mapping explained above. The symbol of the reference subcarrier equals 1, i.e. 0 degree phase shift. The optional phase shift PHI equals zero, i.e. the DQPSK

signal constellation is not rotated.

Using an equation this can be expressed as

$$a_k = a_{k-1} a_k^{inc} \tag{Eq.24}$$

with

k : index $k = 1, 2, \dots, K$ of the active subcarrier;

$a_k^{inc} = e^{j\frac{\pi}{2}m}$: complex phase increment symbol; $m=0, 1, 2, 3$ is the QPSK symbol number which is derived from Gray encoding pairs of 2 Bits;

$a_0 = 1$: symbol of the reference subcarrier.

At the DFT output of the receiver the decision variables

$$e_k = a_k H_k \tag{Eq.25}$$

are obtained with

$$H_k = \sum_{i=0}^{Q_h-1} h[i] \cdot e^{-j\frac{2\pi}{K}ki} \tag{Eq.26}$$

being the DFT of the channel impulse response $h[q]$ at position k .

With $|a_k|^2 = 1$ the differential demodulation yields

$$v_k = e_k \cdot e_{k-1}^* = a_k^{inc} H_k H_{k-1}^* \tag{Eq.27}$$

For the receiver an additional phase term φ_k is introduced, which shall be used to correct the systematic phase offset caused by the channel. Therefore, the final decision variable at the receiver is

$$v'_k = v_k \cdot e^{j\varphi_k} = a_k^{inc} \cdot e^{j\varphi_k} \cdot H_k \cdot H_{k-1}^* \tag{Eq.28}$$

As can be seen from the Equation 28, the useful information

DOCKET # 02EE0960

a_k^{inc} is weighted with the product $e^{j\psi_k \cdot H_k \cdot H_{k-1}^*}$ (rotation and effective transfer function of the channel). This product must be real-valued for an error free detection. Considering this, it is best to choose the rotation angle to equal the negative argument of $H_k \cdot H_{k-1}^*$. To derive the desired algorithm for 2-path channels, the nature of $H_k \cdot H_{k-1}^*$ is investigated in the next section.

It is assumed that the 2-path channel exhibits two echoes with energy content unequal zero, i.e. at least two dominant echoes. This assumption yields the impulse response

$$h[q] = c_1 \delta_0[q] + c_2 \delta_0[q - q_0] \quad (\text{Eq. 29})$$

with

c_1, c_2 : complex coefficients representing the path echoes;

q_0 : delay of the second path echo with respect to the first path echo;

δ_0 : Dirac pulse; $\delta_0[k] = 1$ for $k = 0$
 $\delta_0[k] = 0$ else

The channel transfer function is obtained by applying a DFT to Equation 29:

$$H_k = H\left(e^{j\frac{2\pi}{K}k}\right) = c_1 + c_2 \cdot e^{-j\frac{2\pi}{K}kq_0} \quad (\text{Eq. 30})$$

With Equation 30 the effective transfer function for differential demodulation along the frequency axis is:

$$\begin{aligned} H_k \cdot H_{k-1}^* &= \left(c_1 + c_2 e^{-j\frac{2\pi}{K}kq_0}\right) \cdot \left(c_1^* + c_2^* e^{+j\frac{2\pi}{K}(k-1)q_0}\right) \\ &= c_a + c_b \cos\left(\frac{\pi}{K}q_0(2k-1)\right) \end{aligned} \quad (\text{Eq. 31})$$

Assuming a noise free 2-path channel, it can be observed

002277 02262950

from Equation 31 that the symbols on the receiver side are located on a straight line in case the symbol $1+j0$ has been sent (see above assumption). This straight line can be characterized by a point

$$c_a = |c_1|^2 + |c_2|^2 \cdot e^{-j\frac{2\pi}{K}q_0} \tag{Eq.32}$$

and the vector

$$c_b = 2c_1c_2^* \cdot e^{-j\frac{\pi}{K}q_0} \tag{Eq.33}$$

which determines its direction.

With the above assumptions, the following geometric derivation can be performed. A more suitable notation for the geometric derivation of the second embodiment of an EPOC algorithm is obtained if the real part of the complex plane is designated as $x = \text{Re}\{z\}$, the imaginary part as $y = \text{Im}\{z\}$, respectively, i.e. $z = x+jy$. With this new notation, the straight line, on which the received symbols will lie in case of a noise-free two-path channel, is

$$f(x) = a + b \cdot x \tag{Eq.34}$$

with

$$a = \text{Im}\{c_a\} - \frac{\text{Re}\{c_a\}}{\text{Re}\{c_b\}} \cdot \text{Im}\{c_b\} \tag{Eq.35}$$

and

$$b = -\frac{\text{Im}\{c_a\} - \frac{\text{Re}\{c_a\}}{\text{Re}\{c_b\}} \cdot \text{Im}\{c_b\}}{\text{Re}\{c_a\} - \frac{\text{Im}\{c_a\}}{\text{Im}\{c_b\}} \cdot \text{Re}\{c_b\}} \tag{Eq.36}$$

Additional noise will spread the symbols around the straight line given by Equations 34 to 36. In this case Equation 36

006277-02EE-960

is the regression curve for the cluster of symbols.

For the geometric derivation of the second embodiment of an EPOC algorithm, the angle φ_k from Equation 28 is chosen to be a function of the square distance of the considered symbol from the origin:

$$\varphi_k = f_k(|z|^2) \tag{Eq.37}$$

Equation 37 shows that the complete signal space is distorted (torsion), however, with the distances from the origin being preserved.

For the derivation of the algorithm of the second embodiment, $f_k(\cdot)$ has to be determined such that all decision variables v'_k (assuming no noise) will come to lie on the real axis:

$$\text{Im}\left\{(x + jf(x)) \cdot e^{j\varphi_k(|z|^2)}\right\} = 0 \tag{Eq.38}$$

Further transformations of Equation 38 lead to a quadratic equation which has to be solved to obtain the solution for φ_k .

In case of a two-path channel, the echo phase offset correction for a given decision variable v_k is

$$v'_k = v_k \cdot e^{j\varphi_k} \tag{Eq.39}$$

with

$$\varphi_k = \begin{cases} -\text{atan}\left(\frac{a + b\sqrt{|v_k|^2(1+b^2) - a^2}}{-ab + \sqrt{|v_k|^2(1+b^2) - a^2}}\right) & \text{for } |v_k|^2 \geq \frac{a^2}{1+b^2} \\ \text{atan}\left(\frac{1}{b}\right) & \text{for } |v_k|^2 < \frac{a^2}{1+b^2} \end{cases} \tag{Eq.40}$$

005211 03E2960

From the two possible solutions of the quadratic equation mentioned above, Equation 40 is the one solution that cannot cause an additional phase shift of 180 degrees.

The two plots in Figure 15 show the projection of the EPOC algorithm of the second embodiment for one quadrant of the complex plane. Depicted here is the quadratic grid in the sector $|\arg(z)| \leq \pi/4$ and the straight line $y = f(x) = a + b \cdot x$ with $a = -1.0$ and $b = 0.5$ (dotted line). In case of a noise-free channel, all received symbols will lie on this straight line if $1 + j0$ was sent. The circle shown in the plots determines the boarder line for the two cases of Equation 40. In the left part, Figure 15 shows the situation before the projection, in the right part, Figure 15 shows the situation after applying the projection algorithm. By looking on the left part, one can see, that the straight line now lies on the real axis with $2 + j0$ being the fix point of the projection. Therefore, it can be concluded that the echo phase offset correction algorithm according to the second embodiment fulfills the design goal.

Before the second embodiment of an EPOC algorithm can be applied, the approximation line through the received symbols has to be determined, i.e. the parameters a and b must be estimated. For this purpose, it is assumed that the received symbols lie in sector $|\arg(z)| \leq \pi/4$, if $1 + j0$ was sent. If symbols other than $1 + j0$ have been sent, a modulo operation can be applied to project all symbols into the desired sector. Proceeding like this prevents the necessity of deciding on the symbols in an early stage and enables averaging over all signal points of one MCM symbol (instead of averaging over only $\frac{1}{4}$ of all signal points).

For the following computation rule for the EPOC algorithm of the second embodiment, x_i is used to denote the real part of the i -th signal point and y_i for its imaginary part, respectively ($i = 1, 2, \dots, K$). Altogether, K values are available for the determination. By choosing the method of

least squares, the straight line which has to be determined can be obtained by minimizing

$$(a, b) = \underset{(\tilde{a}, \tilde{b})}{\operatorname{argmin}} \sum_{i=1}^K (y_i - (\tilde{a} + \tilde{b} \cdot x_i))^2 \quad (\text{Eq. 41})$$

The solution for Equation 41 can be found in the laid open literature. It is

$$b = \frac{\sum_{i=1}^K (x_i - \bar{x}) \cdot y_i}{\sum_{i=1}^K (x_i - \bar{x})^2}, \quad a = \bar{y} - \bar{x} \cdot b \quad (\text{Eq. 42})$$

with mean values

$$\bar{x} = \frac{1}{N} \sum_{i=1}^K x_i, \quad \bar{y} = \frac{1}{N} \sum_{i=1}^K y_i \quad (\text{Eq. 43})$$

If necessary, an estimation method with higher robustness can be applied. However, the trade-off will be a much higher computational complexity.

To avoid problems with the range in which the projection is applicable, the determination of the straight line should be separated into two parts. First, the cluster's centers of gravity are moved onto the axes, following, the signal space is distorted. Assuming that a and b are the original parameters of the straight line and α is the rotation angle, $f_K(\cdot)$ has to be applied with the transformed parameters

$$b' = \frac{b \cdot \cos(\alpha) - \sin(\alpha)}{\cos(\alpha) + b \cdot \sin(\alpha)}, \quad a' = a \cdot (\cos(\alpha) - b' \cdot \sin(\alpha)) \quad (\text{Eq. 44})$$

Besides the two EPOC algorithms explained above section, different algorithms can be designed that will, however, most likely exhibit a higher degree of computational complexity.

005477 02279960

Claims

1. A method of performing a fine frequency synchronization compensating for a carrier frequency deviation from an oscillator frequency in a multi-carrier demodulation system (130) of the type capable of carrying out a differential phase decoding of multi-carrier modulated signals, said signals comprising a plurality of symbols (200), each symbol being defined by phase differences between simultaneous carriers (202) having different frequencies, said method comprising the steps of:

determining a phase difference between phases of the same carrier in different symbols;

determining a frequency offset by eliminating phase shift uncertainties corresponding to codeable phase shifts from said phase difference; and

performing a feedback correction of said carrier frequency deviation based on said determined frequency offset.

2. A method of performing a fine frequency synchronization compensating for a carrier frequency deviation from an oscillator frequency in a multi-carrier demodulation system (130) of the type capable of carrying out a differential phase decoding of multi-carrier modulated signals, said signals comprising a plurality of symbols (200), each symbol being defined by phase differences between simultaneous carriers (202) having different frequencies, said method comprising the steps of:

determining respective phase of the same carrier in different symbols;

eliminating phase shift uncertainties corresponding to

codeable phase shifts from said phases to determine respective phase deviations;

determining a frequency offset by determining a phase difference between said phase deviations;

performing a feedback correction of said carrier frequency deviation based on said determined frequency offset.

3. A method of performing a fine frequency synchronization compensating for a carrier frequency deviation from an oscillator frequency in a multi-carrier demodulation system (130) of the type capable of carrying out a differential phase decoding of multi-carrier modulated signals, said signals comprising a plurality of symbols (200), each symbol being defined by phase differences between simultaneous carriers (202) having different frequencies, said method comprising the steps of:

for a plurality of carriers (202) in said symbols (200):

determining a phase difference between phases of the same carrier in different symbols; and

determining a frequency offset by eliminating phase shift uncertainties corresponding to codeable phase shifts from said phase difference;

determining an averaged frequency offset (f_{offset}) by averaging said determined frequency offsets of said plurality of carriers (202); and

performing a feedback correction of said frequency deviation based on said averaged frequency offset (f_{offset}).

4. A method of performing a fine frequency synchronization

compensating for a carrier frequency deviation from an oscillator frequency in a multi-carrier demodulation system (130) of the type capable of carrying out a differential phase decoding of multi-carrier modulated signals, said signals comprising a plurality of symbols (200), each symbol being defined by phase differences between simultaneous carriers (202) having different frequencies, said method comprising the steps of:

for a plurality of carriers (202) in said symbols (200):

determining respective phases of the same carrier in different symbols;

eliminating phase shift uncertainties corresponding to codeable phase shifts from said phases to determine respective phase deviations; and

determining a frequency offset by determining a phase difference between said phase deviations;

determining an averaged frequency offset by averaging said determined frequency offsets of said plurality of carriers; and

performing a feedback correction of said frequency deviation based on said averaged frequency offset.

5. The method according to claims 1 or 3, wherein said step of determining a phase difference comprises the step of determining a phase difference between phases of the same carrier (202) in symbols (200) which are adjacent in the time axis direction.
6. The method according to claims 1 or 3, wherein said step of determining a frequency offset comprises the step of eliminating phase shift uncertainties corresponding to M-ary phase shifts.

000000000000000000000000000000000000

7. The method according to claims 2 or 4, wherein said step of determining respective phases comprises the step of determining respective phases of the same carrier (202) in symbols (200) which are adjacent in the time axis direction.

8. The method according to claims 2 or 4, wherein said step of eliminating phase shift uncertainties comprises the step of eliminating M-ary phase shifts.

9. An apparatus for performing a fine frequency synchronization compensating for a carrier frequency deviation from an oscillator frequency, for a multi-carrier demodulation system (130) of the type capable of carrying out a differential phase decoding of multi-carrier modulated signals, said signals comprising a plurality of symbols (200), each symbol being defined by phase differences between simultaneous carriers (202) having different frequencies, said apparatus comprising:

means (330) for determining a phase difference between phases of the same carrier (202) in different symbols (200);

means (340, 342) for determining a frequency offset by eliminating phase shift uncertainties corresponding to codeable phase shifts from said phase difference; and

means for performing a feedback correction of said frequency deviation based on said determined frequency offset.

10. An apparatus for performing a fine frequency synchronization compensating for a carrier frequency deviation from an oscillator frequency, for a multi-carrier demodulation system (130) of the type capable of carrying out a differential phase decoding of

006277 0222950

multi-carrier modulated signals, said signals comprising a plurality of symbols (200), each symbol being defined by phase differences between simultaneous carriers (202) having different frequencies, said apparatus comprising:

means for determining respective phases of the same carrier in different symbols;

means for eliminating phase shift uncertainties corresponding to codeable phase shifts from said phases to determine respective phase deviations;

means for determining a frequency offset by determining a phase difference between said phase deviations;

means for performing a feedback correction of said frequency deviation based on said determined frequency offset.

11. An apparatus for performing a fine frequency synchronization compensating for a carrier frequency deviation from an oscillator frequency, for a multi-carrier demodulation system (130) of the type capable of carrying out a differential phase decoding of multi-carrier modulated signals, said signals comprising a plurality of symbols (200), each symbol being defined by phase differences between simultaneous carriers (202) having different frequencies, said apparatus comprising:

means (330) for determining a phase difference between phases of the same carrier (202) in different symbols;

means (340, 342) for determining a frequency offset by eliminating phase shift uncertainties corresponding to codeable phase shifts from said phase difference;

means (344) for determining an averaged frequency offset (f_{offset}) by averaging determined frequency offsets of a

plurality of carriers; and

means for performing a feedback correction of said frequency deviation based on said averaged frequency offset.

12. An apparatus for performing a fine frequency synchronization compensating for a carrier frequency deviation from an oscillator frequency, for a multi-carrier demodulation system (130) of the type capable of carrying out a differential phase decoding of multi-carrier modulated signals, said signals comprising a plurality of symbols (200), each symbol (200) being defined by phase differences between simultaneous carriers (202) having different frequencies, said apparatus comprising:

means for determining respective phases of the same carrier in different symbols;

means for eliminating phase shift uncertainties corresponding to codeable phase shifts from said phases to determine respective phase deviations;

means for determining a frequency offset by determining a phase difference between said phase deviations;

means for determining an averaged frequency offset by averaging determined frequency offsets of a plurality of carriers; and

means for performing a feedback correction of said frequency deviation based on said averaged frequency offset.

13. The apparatus according to claims 9 or 11, wherein said means (330) for determining a phase difference comprises means for determining a phase difference between phases

of the same carrier in symbols which are adjacent in the time axis direction.

14. The apparatus according to claims 10 or 12, wherein said means for determining respective phases comprises means for determining respective phases of the same carrier in symbols which are adjacent in the time axis direction.
15. The apparatus according to claims 9 or 11, wherein said means (340, 342) for determining a frequency offset comprises a M-ary phase shift keying decision device (340) and a complex multiplier (342).
16. The apparatus according to claims 10 or 12, wherein said means for eliminating phase shift uncertainties comprises a M-ary phase shift keying decision device and a complex multiplier.
17. The apparatus according to one of claims 9 to 16, wherein said means for performing a feedback correction of said frequency deviation comprises a numerical controlled oscillator (322) and a complex multiplier (326).
18. The apparatus according to claim 17, wherein said means for performing a feedback correction of said frequency deviation further comprises a low path filter (324) preceding said numerical controlled oscillator (322).

006677 02222222

**METHOD AND APPARATUS FOR FINE FREQUENCY SYNCHRONIZATION IN
MULTI-CARRIER DEMODULATION SYSTEMS**

ABSTRACT

A method and an apparatus relate to a fine frequency synchronization compensating for a carrier frequency deviation from an oscillator frequency in a multi-carrier demodulation system 130 of the type capable of carrying out a differential phase decoding of multi-carrier modulated signals, the signals comprising a plurality of symbols 200, each symbol being defined by phase differences between simultaneous carriers 202 having different frequencies. A phase difference between phases of the same carrier 202 in different symbols 200 is determined. Thereafter, a frequency offset is determined by eliminating phase shift uncertainties corresponding to codeable phase shifts from the phase difference. Finally, a feedback correction of the carrier frequency deviation is performed based on the determined frequency offset. Alternatively, an averaged frequency offset can be determined by averaging determined frequency offsets of a plurality of carriers 202. Then, the feedback correction of the frequency deviation is performed based on the averaged frequency offset.

03627" 02262960

**METHOD AND APPARATUS FOR FINE FREQUENCY SYNCHRONIZATION IN
MULTI-CARRIER DEMODULATION SYSTEMS**

5

FIELD OF THE INVENTION

10 The present invention relates to methods and apparatus for
performing a fine frequency synchronization in multi-carrier
demodulation systems, and in particular to methods and appa-
ratus for performing a fine frequency synchronization com-
15 pensating for a carrier frequency deviation from an oscilla-
tor frequency in a multi-carrier demodulation system of the
type capable of carrying out a differential phase decoding
of multi-carrier modulated signals, wherein the signals com-
prise a plurality of symbols, each symbol being defined by
20 phase differences between simultaneous carriers having dif-
ferent frequencies.

BACKGROUND OF THE INVENTION

25 In a multi carrier transmission system (MCM, OFDM), the ef-
fect of a carrier frequency offset is substantially more
considerable than in a single carrier transmission system.
MCM is more sensitive to phase noise and frequency offset
which occurs as amplitude distortion and inter carrier in-
30 terference (ICI). The inter carrier interference has the ef-
fect that the subcarriers are no longer orthogonal in rela-
tion to each other. Frequency offsets occur after power on
or also later due to frequency deviation of the oscillators
used for downconversion into baseband. Typical accuracies
35 for the frequency of a free running oscillator are about ± 50
ppm of the carrier frequency. With a carrier frequency in
the S-band of 2.34 GHz, for example, there will be a maximum
local oscillator (LO) frequency deviation of above 100 kHz
(117.25 kHz). The above named effects result in high re-

quirements on the algorithm used for frequency offset correction.

5

DESCRIPTION OF PRIOR ART

Most prior art algorithms for frequency synchronization divide frequency correction into two stages. In the first stage, a coarse synchronization is performed. In the second stage, a fine correction can be achieved. A frequently used algorithm for coarse synchronization of the carrier frequency uses a synchronization symbol which has a special spectral pattern in the frequency domain. Such a synchronization symbol is, for example, a CAZAC sequence (CAZAC = Constant Amplitude Zero Autocorrelation). Through comparison, i.e. the correlation, of the power spectrum of the received signal with that of the transmitted signal, the frequency carrier offset can be coarsely estimated. These prior art algorithms all work in the frequency domain. Reference is made, for example, to Ferdinand Claßen, Heinrich Meyr, "Synchronization Algorithms for an OFDM System for Mobile Communication", ITG-Fachtagung 130, Codierung für Quelle, Kanal und Übertragung, pp. 105 - 113, Oct. 26-28, 1994; and Timothy M. Schmidl, Donald C. Cox, "Low-Overhead, Low-Complexity [Burst] Synchronization for OFDM", in Proceedings of the IEEE International Conference on Communication ICC 1996, pp. 1301-1306 (1996).

For the coarse synchronization of the carrier frequency, Paul H. Moose, "A Technique for Orthogonal Frequency Division Multiplexing Frequency Offset Correction", IEEE Transaction On Communications, Vol. 42, No. 10, October 1994, suggest increasing the spacing between the subcarriers such that the subcarrier distance is greater than the maximum frequency difference between the received and transmitted carriers. The subcarrier distance is increased by reducing the number of sample values which are transformed by the Fast Fourier Transform. This corresponds to a reduction of

the number of sampling values which are transformed by the Fast Fourier Transform.

WO 9205646 A relates to methods for the reception of orthogonal frequency division multiplexed signals comprising data which are preferably differentially coded in the direction of the time axis. Phase drift of the demodulated samples from one block to the next is used to indicate the degree of local oscillator frequency error. Phase drift is assessed by multiplying complex values by the complex conjugate of an earlier sample demodulated from the same OFDM carrier and using the resulting measure to steer the local oscillator frequency via a frequency locked loop.

SUMMARY OF THE INVENTION

It is an object of the present invention to provide methods and apparatus for performing a fine frequency synchronization which allow a fine frequency synchronization compensating for a carrier frequency deviation from an oscillator frequency in a MCM transmission system which makes use of MCM signals in which information is differential phase encoded between simultaneous sub-carriers having different frequencies.

In accordance with a first aspect, the present invention provides a method of performing a fine frequency synchronization compensating for a carrier frequency deviation from an oscillator frequency in a multi-carrier demodulation system of the type capable of carrying out a differential phase decoding of multi-carrier modulated signals, the signals comprising a plurality of symbols, each symbol being defined by phase differences between simultaneous carriers having different frequencies, the method comprising the steps of:

determining a phase difference between phases of the same carrier in different symbols;

determining a frequency offset by eliminating phase shift uncertainties [going back to phase shifts due to the definition of symbols] related to the transmitted information from the phase difference making use of a M-PSK decision device;
5 and

performing a feedback correction of the carrier frequency deviation based on the determined frequency offset.

10 In accordance with a second aspect, the present invention provides a method of performing a fine frequency synchronization compensating for a carrier frequency deviation from an oscillator frequency in a multi-carrier demodulation system of the type capable of carrying out a differential phase
15 decoding of multi-carrier modulated signals, the signals comprising a plurality of symbols, each symbol being defined by phase differences between simultaneous carriers having different frequencies, the method comprising the steps of:

20 determining respective phases of the same carrier in different symbols;

eliminating phase shift uncertainties related to the transmitted information from the phases to determine respective
25 phase deviations making use of a M-PSK decision device;

determining a frequency offset by determining a phase difference between the phase deviations; and

30 performing a feedback correction of said carrier frequency deviation based on the determined frequency offset.

In accordance with a third aspect, the present invention provides an apparatus for performing a fine frequency synchronization compensating for a carrier frequency deviation
35 from an oscillator frequency, for a multi-carrier demodulation system of the type capable of carrying out a differential phase decoding of multi-carrier modulated signals, the signals comprising a plurality of symbols, each symbol being

defined by phase differences between simultaneous carriers having different frequencies, the apparatus comprising:

5 means for determining a phase difference between phases of the same carrier in different symbols;

[means] M-PSK decision device for determining a frequency offset by eliminating phase shift uncertainties [going back to phase shifts due to the definition of symbols] related to the transmitted information from the phase difference [making use of a M-PSK decision device]; and

10

means for performing a feedback correction of the frequency deviation based on the determined frequency offset.

15

In accordance with a fourth aspect, the present invention provides an apparatus for performing a fine frequency synchronization compensating for a carrier frequency deviation from an oscillator frequency, for a multi-carrier demodulation system of the type capable of carrying out a differential phase decoding of multi-carrier modulated signals, said signals comprising a plurality of symbols, each symbol being defined by phase differences between simultaneous carriers having different frequencies, the apparatus comprising:

20

25 means for determining respective phases of the same carrier in different symbols;

M-PSK decision device for eliminating phase shift uncertainties [going back to phase shifts due to the definition of symbols] related to the transmitted information from the phases to determine respective phase deviations;

30

means for determining a frequency offset by determining a phase difference between the phase deviations; and

35

means for performing a feedback correction of the frequency deviation based on the determined frequency offset.

The present invention relates to methods and apparatus for performing a fine frequency synchronization compensating for a carrier frequency deviation from an oscillator frequency. This fine frequency synchronization is preferably performed
5 after completion of a coarse frequency synchronization, such that the frequency offsets after the coarse frequency synchronization are smaller than half the sub-carrier distance in the MCM signal. Since the frequency offsets which are to be corrected by the inventive fine frequency synchronization
10 methods and apparatus, a correction of the frequency offsets by using a phase rotation with differential decoding and demapping in the time axis can be used. The frequency offsets are detected by determining the frequency differences between time contiguous sub-carrier symbols along the time
15 axis. The frequency error is calculated by measuring the rotation of the I-Q cartesian coordinates of each sub-carrier and, in preferred embodiments, averaging them over all n sub-carriers of a MCM symbol.

20 Firstly, the phase ambiguity or uncertainty is eliminated by using a M-PSK decision device and correlating the output of the decision device with the input signal for a respective sub-carrier symbol. Thus, the phase offset for a sub-carrier symbol is determined and can be used for restructuring the
25 frequency error in form of a feed-backward structure. Alternatively, the phase offsets of the sub-carrier symbols of one MCM symbol can be averaged over all of the active carriers of a MCM symbol, wherein the averaged phase offset is used to restructure the frequency error.

30 In accordance with the present invention, the determination of the frequency offset is performed in the frequency domain. The feedback correction in accordance with the inventive fine frequency synchronization is performed in the time
35 domain. To this end, a differential decoder in the time domain is provided in order to detect frequency offsets of sub-carriers on the basis of the phases of timely successive sub-carrier symbols of different MCM symbols.

BRIEF DESCRIPTION OF THE DRAWINGS

5 In the following, preferred embodiments of the present invention will be explained in detail on the basis of the drawings enclosed, in which:

10 Figure 1 shows a schematic overview of a MCM transmission system to which the present application can be applied;

15 Figures 2A and 2B show schematic views representing a scheme for differential mapping in the time axis and a scheme for differential mapping in the frequency axis;

Figure 3 shows a functional block diagram for performing a differential mapping in the frequency axis;

20 Figure 4 shows a representation of time variation of all sub-carriers in MCM symbols;

25 Figure 5 shows a QPSK-constellation for each sub-carrier with a frequency offset;

Figure 6 shows a general block diagram illustrating the position of the inventive fine frequency synchronization device in a MCM receiver;

30 Figure 7 shows a block diagram of the fine frequency error detector shown in Figure 6;

35 Figure 8 shows a block diagram of a MCM receiver comprising a coarse frequency synchronization unit and a fine frequency synchronization unit;

Figure 9 shows a block diagram of a unit for performing a coarse frequency synchronization;

Figure 10 shows a schematic view of a reference symbol used for performing a coarse frequency synchronization;

5 Figure 11 shows a schematic view of a typical MCM signal having a frame structure;

10 Figure 12 shows scatter diagrams of the output of an differential de-mapper of a MCM receiver for illustrating the effect of an echo phase offset correction;

15 Figure 13 shows a schematic block diagram for illustrating the position and the functionality of an echo phase offset correction unit;

20 Figure 14 shows a schematic block diagram of a preferred form of an echo phase offset correction device; and

25 Figure 15 shows schematic views for illustrating a projection performed by another echo phase offset correction algorithm.

DETAILED DESCRIPTION OF THE EMBODIMENTS

30 Before discussing the present invention in detail, the mode of operation of a MCM transmission system is described referring to figure 1.

Referring to Figure 1, at 100 a MCM transmitter is shown that substantially corresponds to a prior art MCM transmitter. A description of such a MCM transmitter can be found, 35 for example, in William Y. Zou, Yiyan Wu, "COFDM: AN OVERVIEW", IEEE Transactions on Broadcasting, vol. 41, No. 1, March 1995.

5 A data source 102 provides a serial bitstream 104 to the MCM transmitter. The incoming serial bitstream 104 is applied to a bit-carrier mapper 106 which produces a sequence of spectra 108 from the incoming serial bitstream 104. An inverse fast Fourier transform (IFFT) 110 is performed on the sequence of spectra 108 in order to produce a MCM time domain signal 112. The MCM time domain signal forms the useful MCM symbol of the MCM time signal. To avoid intersymbol interference (ISI) caused by multipath distortion, a unit 114 is provided for inserting a guard interval of fixed length between adjacent MCM symbols in time. In accordance with a preferred embodiment of the present invention, the last part of the useful MCM symbol is used as the guard interval by placing same in front of the useful symbol. The resulting MCM symbol is shown at 115 in Figure 1 and corresponds to a MCM symbol 160 depicted in Figure 11.

20 Figure 11 shows the construction of a typical MCM signal having a frame structure. One frame of the MCM time signal is composed of a plurality of MCM symbols 160. Each MCM symbol 160 is formed by an useful symbol 162 and a guard interval 164 associated therewith. As shown in Figure 11, each frame comprises one reference symbol 166. The present invention can advantageously be used with such a MCM signal, however, such a signal structure being not necessary for performing the present invention as long as the transmitted signal comprises a useful portion and at least one reference symbol.

30 In order to obtain the final frame structure shown in Figure 11, a unit 116 for adding a reference symbol for each predetermined number of MCM symbols is provided.

35 In accordance with the present invention, the reference symbol is an amplitude modulated bit sequence. Thus, an amplitude modulation of a bit sequence is performed such that the envelope of the amplitude modulated bit sequence defines a reference pattern of the reference symbol. This reference pattern defined by the envelope of the amplitude modulated

bit sequence has to be detected when receiving the MCM signal at a MCM receiver. In a preferred embodiment of the present invention, a pseudo random bit sequence having good autocorrelation properties is used as the bit sequence that is amplitude modulated.

The choice of length and repetition rate of the reference symbol depends on the properties of the channel through which the MCM signal is transmitted, e.g. the coherence time of the channel. In addition, the repetition rate and the length of the reference symbol, in other words the number of useful symbols in each frame, depends on the receiver requirements concerning mean time for initial synchronization and mean time for resynchronization after synchronization loss due to a channel fade.

The resulting MCM signal having the structure shown at 118 in Figure 1 is applied to the transmitter front end 120. Roughly speaking, at the transmitter front end 120, a digital/analog conversion and an up-converting of the MCM signal is performed. Thereafter, the MCM signal is transmitted through a channel 122.

Following, the mode of operation of a MCM receiver 130 is shortly described referring to Figure 1. The MCM signal is received at the receiver front end 132. In the receiver front end 132, the MCM signal is down-converted and, furthermore, an analog/digital conversion of the down-converted signal is performed.

The down-converted MCM signal is provided to a symbol frame/carrier frequency synchronization unit 134.

A first object of the symbol frame/carrier frequency synchronization unit 134 is to perform a frame synchronization on the basis of the amplitude-modulated reference symbol. This frame synchronization is performed on the basis of a correlation between the amplitude-demodulated reference sym-

bol [an] and a predetermined reference pattern stored in the MCM receiver.

5 A second object of the symbol frame/carrier frequency synchronization unit is to perform a coarse frequency synchronization of the MCM signal. To this end, the symbol frame/carrier frequency synchronization unit 134 serves as a coarse frequency synchronization unit for determining a coarse frequency offset of the carrier frequency caused, for example, by a difference of the frequencies between the local oscillator of the transmitter and the local oscillator of the receiver. The determined frequency is used in order to perform a coarse frequency correction. The mode of operation of the coarse frequency synchronization unit is described in detail referring to Figures 9 and 10 hereinafter.

15 As described above, the frame synchronization unit 134 determines the location of the reference symbol in the MCM symbol. Based on the determination of the frame synchronization unit 134, a reference symbol extracting unit 136 extracts the framing information, i.e. the reference symbol, from the MCM symbol coming from the receiver front end 132. After the extraction of the reference symbol, the MCM signal is applied to a guard interval removal unit 138. The result of the signal processing performed hereherto in the MCM receiver are the useful MCM symbols.

25 The useful MCM symbols output from the guard interval removal unit 138 are provided to a fast Fourier transform unit 140 in order to provide a sequence of spectra from the useful symbols. Thereafter, the sequence of spectra is provided to a carrier-bit mapper 142 in which the serial bitstream is recovered. This serial bitstream is provided to a data sink 144.

35 Next, referring to Figures 2A and 2B, two modes for differential mapping are described. In Figure 2A, a first method of differential mapping along the time axis is shown. As can be seen from Figure 2A, a MCM symbol consists of K sub-

carriers. The sub-carriers comprise different frequencies and are, in a preferred embodiment, equally spaced in the frequency axis direction. When using differential mapping along the time axis, one or more bits are encoded into phase and/or amplitude shifts between two sub-carriers of the same center frequency in adjacent MCM symbols. The arrows depicted between the sub-carrier symbols correspond to information encoded in amplitude and/or phase shifts between two sub-carrier symbols.

A second method of differential mapping is shown in Figure 2B. The present invention is adapted for MCM transmission system using the mapping scheme shown in Figure 2B. This mapping scheme is based on a differential mapping inside one MCM symbol along the frequency axis. A number of MCM symbols 200 is shown in Figure 2B. Each MCM symbol 200 comprises a number of sub-carrier symbols 202. The arrows 204 in Figure 2B illustrate information encoded between two sub-carrier symbols 202. As can be seen from the arrows 204, this mapping scheme is based on a differential mapping within one MCM symbol along the frequency axis direction.

In the embodiment shown in Figure 2B, the first sub-carrier ($k=0$) in an MCM symbol 200 is used as a reference sub-carrier 206 (shaded) such that information is encoded between the reference sub-carrier and the first active carrier 208. The other information of a MCM symbol 200 is encoded between active carriers, respectively.

Thus, for every MCM symbol an absolute phase reference exists. In accordance with Figure 2B, this absolute phase reference is supplied by a reference symbol inserted into every MCM symbol ($k=0$). The reference symbol can either have a constant phase for all MCM symbols or a phase that varies from MCM symbol to MCM symbol. A varying phase can be obtained by replicating the phase from the last subcarrier of the MCM symbol preceding in time.

In Figure 3 a preferred embodiment of a device for performing a differential mapping along the frequency axis is shown. Referring to Figure 3, assembly of MCM symbols in the frequency domain using differential mapping along the frequency axis according to the present invention is described.

Figure 3 shows the assembly of one MCM symbol with the following parameters:

10 NFFT designates the number of complex coefficients of the discrete Fourier transform, number of subcarriers respectively.

15 K designates the number of active carriers. The reference carrier is not included in the count for K.

According to Figure 3, a quadrature phase shift keying (QPSK) is used for mapping the bitstream onto the complex symbols. However, other M-ary mapping schemes (MPSK) like 2-PSK, 8-PSK, 16-QAM, 16-APSK, 64-APSK etc. are possible.

Furthermore, for ease of filtering and minimization of aliasing effects some subcarriers are not used for encoding information in the device shown in Figure 3. These subcarriers, which are set to zero, constitute the so-called guard bands on the upper and lower edges of the MCM signal spectrum.

At the input of the mapping device shown in Figure 3, complex signal pairs $b_0[k]$, $b_1[k]$ of an input bitstream are received. K complex signal pairs are assembled in order to form one MCM symbol. The signal pairs are encoded into the K differential phase shifts $\phi[k]$ needed for assembly of one MCM symbol. In this embodiment, mapping from Bits to the 0, 90, 180 and 270 degrees phase shifts is performed using Gray Mapping in a quadrature phase shift keying device 220.

Gray mapping is used to prevent that differential detection phase errors smaller than 135 degrees cause double bit errors at the receiver.

5 Differential phase encoding of the K phases is performed in a differential phase encoder 222. At this stage of processing, the K phases $\phi[k]$ generated by the QPSK Gray mapper are differentially encoded. In principal, a feedback loop 224 calculates a cumulative sum over all K phases. As starting point for the first computation ($k = 0$) the phase of the reference carrier 226 is used. A switch 228 is provided in order to provide either the absolute phase of the reference subcarrier 226 or the phase information encoded onto the preceding (i.e. z^{-1} , where z^{-1} denotes the unit delay operator) subcarrier to a summing point 230. At the output of the differential phase encoder 222, the phase information $\theta[k]$ with which the respective subcarriers are to be encoded is provided. In preferred embodiments of the present invention, the subcarriers of a MCM symbol are equally spaced in the frequency axis direction.

The output of the differential phase encoder 222 is connected to a unit 232 for generating complex subcarrier symbols using the phase information $\theta[k]$. To this end, the K differentially encoded phases are converted to complex symbols by multiplication with

$$\text{factor} * e^{j[2*\pi*(\theta[k]+PHI)]} \quad (\text{Eq.1})$$

30 wherein factor designates a scale factor and PHI designates an additional angle. The scale factor and the additional angle PHI are optional. By choosing $PHI = 45^\circ$ a rotated DQPSK signal constellation can be obtained.

35 Finally, assembly of a MCM symbol is effected in an assembling unit 234. One MCM symbol comprising N_{FFT} subcarriers is assembled from $N_{FFT}-K-1$ guard band symbols which are "zero", one reference subcarrier symbol and K DQPSK subcarrier symbols. Thus, the assembled MCM symbol 200 is composed of K

complex values containing the encoded information, two guard bands at both sides of the N_{FFT} complex values and a reference subcarrier symbol.

5 The MCM symbol has been assembled in the frequency domain. For transformation into the time domain an inverse discrete Fourier transform (IDFT) of the output of the assembling unit 234 is performed by a transformator 236. In preferred
10 embodiments of the present invention, the transformator 236 is adapted to perform a fast Fourier transform (FFT).

Further processing of the MCM signal in the transmitter as well as in the receiver is as described above referring to Figure 1.

15 At the receiver a de-mapping device 142 (Figure 1) is needed to reverse the operations of the mapping device described above referring to Figure 3. The implementation of the de-mapping device is straightforward and, therefore, need not
20 be described herein in detail.

The differential mapping along the frequency axis direction is suitable for multi-carrier (OFDM) digital broadcasting over rapidly changing multi path channels. In accordance
25 with this mapping scheme, there is no need for a channel stationarity exceeding one multi-carrier symbol. However, differential mapping into frequency axis direction may create a new problem. In multi path environments, path echoes succeeding or preceding the main path can lead to systematic phase offsets between sub-carriers in the same MCM symbol. Thus, it will be preferred to provide a correction unit in order to eliminate such phase offsets. Because the channel induced phase offsets between differential demodulated symbols are systematic errors, they can be corrected by an algorithm.
30 In principle, such an algorithm must calculate the echo induced phase offset from the signal space constellation following the differential demodulation and subsequently correct this phase offset.
35

Examples for such echo phase correction algorithms are described at the end of this specification referring to Figures 12 to 15.

5 Next, the fine frequency synchronization in accordance with the present invention will be described referring to Figures 4 to 8. As mentioned above, the fine frequency synchronization in accordance with the present invention is performed after completion of the coarse frequency synchronization.
10 Preferred embodiments of the coarse frequency synchronization which can be performed by the symbol frame/carrier frequency synchronization unit 134 are described hereinafter referring to Figures 9 and 10 after having described the fine frequency synchronization in accordance with the present invention.
15

with the fine frequency synchronization in accordance with the present invention frequency offsets which are smaller than half the sub-carrier distance can be corrected. Since
20 the frequency offsets are low and equal for all sub-carriers the problem of fine frequency synchronization is reduced to sub-carrier level. Figure 4 is a schematical view of MCM symbols 200 in the time-frequency plane. Each MCM symbol 200 consists of 432 sub-carrier symbols C_1 to C_{432} . The MCM symbols are arranged along the time axis, the first MCM symbol
25 200 shown in Figure 4 having associated therewith a time T_1 , the next MCM symbol having associated therewith a time T_2 and so on. In accordance with a preferred embodiment of the present invention, the fine frequency synchronization is
30 based on a phase rotation which is derived from the same sub-carrier of two MCM symbols which are adjacent in the time axis direction, for example C_1/T_1 and C_1/T_2 .

In the following, the present invention is described referring to QPSK mapping (QPSK = Quadrature Phase Shift Keying).
35 However, it is obvious that the present invention can be applied to any MPSK mapping, wherein M designates the number of phase states used for encoding, for example 2, 4, 8, 16
....

Figure 5 represents a complex coordinate system showing a QPSK constellation for each sub-carrier with frequency offset. The four possible phase positions of a first MCM symbol, MCM-symbol-1 are shown at 300. Changing from the sub-carrier (sub-carrier n) of this MCM symbol to the same sub-carrier of the next MCM symbol, MCM-symbol-2, the position in the QPSK constellation will be unchanged in case there is no frequency offset. If a frequency offset is present, which is smaller than half the distance between sub-carriers, as mentioned above, this frequency offset causes a phase rotation of the QPSK constellation of MCM-symbol-2 compared with MCM-symbol-1. The new QPSK constellation, that is the four possible phase positions for the subject sub-carrier of MCM-symbol-2 are shown at 302 in Figure 5. This phase rotation θ can be derived from the following equation:

$$C_n(kT_{MCM}) = e^{j2\pi f_{offset}T_{MCM}} C_n((k-1)T_{MCM})$$
$$\theta = 2\pi f_{offset}T_{MCM} \quad (\text{Eq.2})$$

C_n designates the QPSK constellation of a sub-carrier n in a MCM symbol. n is an index running from 1 to the number of active sub-carriers in the MCM symbol. Information regarding the frequency offset is contained in the term $e^{j2\pi f_{offset}T_{MCM}}$ of equation 2. This frequency offset is identical for all sub-carriers. Therefore, the phase rotation θ is identical for all sub-carriers as well. Thus, averaging overall sub-carrier of a MCM symbol can be performed.

Figure 6 shows a block diagram of a MCM receiver in which the present invention is implemented. An analog/digital converter 310 is provided in order to perform an analog/digital conversion of a down-converted signal received at the receiver front end 132 (Figure 1). The output of the analog/digital converter 310 is applied to a low path filter and decimator unit 312. The low path filter is an impulse forming filter which is identical to an impulse forming filter in the MCM transmitter. In the decimator, the signal is

sampled at the MCM symbol frequency. As described above referring to Figure 1, guard intervals in the MCM signal are removed by a guard interval removal unit 132. Guard intervals are inserted between two MCM symbols in the MCM transmitter in order to avoid intersymbol interference caused by channel memory.

The output of the guard interval removal unit 132 is applied to a MCM demodulator 314 which corresponds to the fast Fourier transformator 140 shown in Figure 1. Following the MCM demodulator 314 a differential decoding unit 316 and a demapping unit 318 are provided. In the differential decoding unit 316, phase information is recovered using differential decoding. In the demapping unit 318, demapping along the frequency axis direction is performed in order to reconstruct a binary signal from the complex signal input into the demapping unit 318.

The output of the MCM demodulator 314 is also applied to fine frequency error detector 320. The fine frequency error detector 320 produces an frequency error signal from the output of the MCM demodulator. In the depicted embodiment, the output of the fine frequency error detector 320 is applied to a numerical controlled oscillator 322 via a loop filter 324. The loop filter 324 is a low pass filter for filtering superimposed interference portions of a higher frequency from the slowly varying error signal. The numerical controlled oscillator 322 produces a carrier signal on the basis of the filtered error signal. The carrier signal produced by the numerical controlled oscillator 322 is used for a frequency correction which is performed by making use of a complex multiplier 326. The inputs to the complex multiplier 326 are the output of the low pass filter and decimator unit 312 and the output of the numerical controlled oscillator 322.

A description of a preferred embodiment of the fine frequency error detector 320 is given hereinafter referring to Figure 7.

The fine frequency error detector 320 comprises a differential detector in the time axis 330. The output of the MCM demodulator 314, i.e. the FFT output (FFT = Fast Fourier Transform) is applied to the input of the differential detector 330 which performs a differential detection in the time axis in order to derive information on a frequency offset from the same sub-carrier of two subsequently arriving MCM symbols. In the embodiment shown in Figure 7, the number of active sub-carriers is 432. Thus, the differential detector 330 performs a correlation between the first and the 433rd sample. The first sample is associated with MCM-symbol-1 (Figure 5), whereas the 433rd sample is associated with MCM-symbol-2 (Figure 5). However, both these samples are associated with the same sub-carrier.

To this end, the input signal Y_k is applied to a z^{-1} -block 332 and thereafter to a unit 334 in order to form the complex conjugate of the output of the z^{-1} -block 332. A complex multiplier 336 is provided in order to multiply the output of the unit 334 by the input signal Y_k . The output of the multiplier 336 is a signal Z_k .

The function of the differential detector 330 can be expressed as follows:

$$Z_k = Y_{k+K} \cdot Y_k^* \quad (\text{Eq. 3})$$

$$Y = [Y_1, Y_2, \dots, Y_k, \dots] \quad (\text{Eq. 4})$$

$$Y = [C_1 / T_1, C_2 / T_1, \dots, C_{432} / T_1, C_1 / T_2, \dots] \quad (\text{Eq. 5})$$

Y_k designates the output of the MCM modulator 314, i.e. the input to the differential detector 330, at a time k . Z_k designates the output of the differential detector 330. K designates the number of active carriers.

5 The output Z_k of the differential detector 330 contains a M-fold uncertainty corresponding to codeable phase shifts. In case of the QPSK this M-fold uncertainty is a 4-fold uncertainty, i.e. 0° , 90° , 180° and 270° . This phase shift uncertainty is eliminated from Z_k making use of a M-PSK decision device 340. Such decision devices are known in the art and, therefore, have not to be described here in detail. The output of the decision device 340 (\hat{a}_k)* represents the complex conjugate of the codeable phase shift decided by the decision device 340. This output of the decision device 340 is correlated with the output of the differential detector 330 by performing a complex multiplication using a multiplier 342.

15 The output the multiplier 342 represents the phase offset for the respective sub-carriers. This phase offsets for the respective sub-carriers are averaged over one MCM symbol in an averaging unit 344 in accordance with a preferred embodiment of the present invention. The output of the averaging units 344 represent the output of the fine frequency error detector 320.

The mathematical description for this procedure is as follows:

25

$$f_{offset} = \frac{1}{2\pi K T_{MCM}} \arg \left\{ \sum_{n=1}^K Z_n \cdot \left(\hat{a}_n \right)^* \right\} \quad (\text{Eq. 6})$$

30 In accordance with preferred embodiments of the present invention, the frequency control loop has a backward structure. In the embodiment shown in Figure 6, the feedback loop is connected between the output of the MCM demodulator 314 and the input of the guard interval removal unit 132.

35 In Figure 8, a block diagram of a MCM receiver comprising a coarse frequency correction unit 350 and a fine frequency correction unit as described above is shown. As shown in Figure 8, a common complex multiplier 326 can be used in or-

der to perform the coarse frequency correction and the fine frequency correction. As shown in Figure 8, the multiplier 326 can be provided preceding the low pass filter and decimator unit 312. Depending on the position of the multiplier 326, a hold unit has to be provided in the fine frequency synchronization feedback loop. In an alternative embodiment, it is possible to use two separate multipliers for the coarse frequency correction and for the fine frequency correction. In such a case, the multiplier for the coarse frequency correction will be arranged preceding the low path filter and decimator unit, whereas the multiplier for the fine frequency correction will be arranged following the low path filter and decimator unit.

Following, preferred embodiments for implementing a coarse frequency synchronization will be described referring to Figures 9 and 10.

As it is shown in Figure 9, the output of the receiver front end 132 is connected to an analog/digital converter 310. The down-converted MCM signal is sampled at the output of the analog/digital converter 310 and is applied to a frame/timing synchronization unit 360. In a preferred embodiment, a fast running automatic gain control (AGC) (not shown) is provided preceding the frame/timing synchronization unit in order to eliminate fast channel fluctuations. The fast AGC is used in addition to the normally slow AGC in the signal path, in the case of transmission over a multipath channel with long channel impulse response and frequency selective fading. The fast AGC adjusts the average amplitude range of the signal to the known average amplitude of the reference symbol.

As described above, the frame/timing synchronization unit uses the amplitude-modulated sequence in the received signal in order to extract the framing information from the MCM signal and further to remove the guard intervals therefrom. After the frame/timing synchronization unit 360 it follows a coarse frequency synchronization unit 362 which estimates a

coarse frequency offset based on the amplitude-modulated sequence of the reference symbol of the MCM signal. In the coarse frequency synchronization unit 362, a frequency offset of the carrier frequency with respect to the oscillator
5 frequency in the MCM receiver is determined in order to perform a frequency offset correction in a block 364. This frequency offset correction in block 364 is performed by a complex multiplication.

10 The output of the frequency offset correction block 364 is applied to the MCM demodulator 366 formed by the Fast Fourier Transformator 140 and the carrier-bit mapper 142 shown in Figure 1.

15 In order to perform the coarse frequency synchronization described herein, an amplitude-demodulation has to be performed on a preprocessed MCM signal. The preprocessing may be, for example, the down-conversion and the analog/digital conversion of the MCM signal. The result of the amplitude-
20 demodulation of the preprocessed MCM signal is an envelope representing the amplitude of the MCM signal.

For the amplitude demodulation a simple $\alpha_{\max+}$ $\beta_{\min-}$ method can be used. This method is described for example in
25 [Palachels] Palacherla A.: [DSP- μ P] DSP- μ P Routine Computes Magnitude, EDN, October 26, 1989; and Adams, W. T., and Bradley, J.: Magnitude Approximations for Microprocessor Implementation, IEEE Micro, Vol. 3, No. 5, October 1983.

30 It is clear that amplitude determining methods different from the described $\alpha_{\max+}$ $\beta_{\min-}$ method can be used. For simplification, it is possible to reduce the amplitude calculation to a detection as to whether the current amplitude is above or below the average amplitude. The output signal
35 then consists of a -1/+1 sequence which can be used to determine a coarse frequency offset by performing a correlation. This correlation can easily be performed using a simple integrated circuit (IC).

In addition, an oversampling of the signal received at the RF front end can be performed. For example, the received signal can be expressed with two times oversampling.

5

In accordance with a first embodiment, a carrier frequency offset of the MCM signal from an oscillator frequency in the MCM receiver is determined by correlating the envelope obtained by performing the amplitude-demodulation as described above with a predetermined reference pattern.

10

In case there is no frequency offset, the received reference symbol $r(k)$ will be:

$$15 \quad r(k) = S_{AM}(k) + n(k) \quad (\text{Eq.7})$$

wherein $n(k)$ designates "additive Gaussian noise" and S_{AM} denotes the AM sequence which has been sent. In order to simplify the calculation the additive Gaussian noise can be neglected. It follows:

20

$$r(k) \cong S_{AM}(k) \quad (\text{Eq.8})$$

In case a constant frequency offset Δf is present, the received signal will be:

25

$$\tilde{r}(k) = S_{AM}(k) \cdot e^{j2\pi\Delta f k T_{MCM}} \quad (\text{Eq.9})$$

Information regarding the frequency offset is derived from the correlation of the received signal $\tilde{r}(k)$ with the AM sequence S_{AM} which is known in the receiver:

30

$$\sum_{k=1}^{\frac{L}{2}} \tilde{r}(k) \cdot S_{AM}^*(k) = \sum_{k=1}^{\frac{L}{2}} |S_{AM}(k)|^2 e^{j2\pi\Delta f k T_{MCM}} \quad (\text{Eq.10})$$

35

Thus, the frequency offset is:

$$\Delta f = \frac{1}{2\pi T_{MCM}} \arg \left(\sum_{k=1}^{\frac{L}{2}} r(k) \cdot S_{AM}^*(k) \right) - \frac{1}{2\pi T_{MCM}} \arg \left(\sum_{k=1}^{\frac{L}{2}} |S_{AM}(k)|^2 \right) \quad (\text{Eq. 11})$$

5 Since the argument of $|S_{AM}(k)|^2$ is zero the frequency offset is:

$$\Delta f = \frac{1}{2\pi T_{MCM}} \arg \left(\sum_{k=1}^{\frac{L}{2}} \tilde{r}(k) \cdot S_{AM}^*(k) \right) \quad (\text{Eq. 12})$$

10 In accordance with a second embodiment of the coarse frequency synchronization algorithm, a reference symbol comprising at least two identical sequences 370 as shown in Figure 10 is used. Figure 10 shows the reference symbol of a MCM signal having two identical sequences 370 of a length of L/2 each. L designates the number of values of the two sequences 370 of the reference symbol.

15 As shown in Figure 10, within the amplitude-modulated sequence, there are at least two identical sections devoted to the coarse frequency synchronization. Two such sections, each containing L/2 samples, are shown at the end of the amplitude-modulated sequence in Figure 10. The amplitude-modulated sequence contains a large number of samples. For a non-ambiguous observation of the phase, only enough samples to contain a phase rotation of 2π should be used. This number is defined as L/2 in Figure 10.

20 Following, a mathematical derivation of the determination of a carrier frequency deviation is presented. In accordance with Figure 10, the following equation applies for the two identical sequences 370:

$$s \left(0 < k \leq \frac{L}{2} \right) \equiv s \left(\frac{L}{2} < k \leq L \right) \quad (\text{Eq. 13})$$

If no frequency offset is present, the following equation 14 will be met by the received signal:

$$5 \quad r\left(k + \frac{L}{2}\right) \equiv r(k) \quad 0 < k \leq \frac{L}{2} \quad (\text{Eq.14})$$

$r(k)$ designates the values of the identical sequences. k is an index from one to $L/2$ for the respective samples.

10 If there is a frequency offset of, for example, Δf , the received signal is:

$$\tilde{r}(k) = r(k) \cdot e^{j2\pi\Delta f k T_{MCM}} \quad (\text{Eq.15})$$

$$15 \quad \tilde{r}\left(k + \frac{L}{2}\right) = r(k) \cdot e^{j2\pi\Delta f \left(k + \frac{L}{2}\right) T_{MCM}} \quad (\text{Eq.16})$$

$r(k)$ designates sample values of the received portion which are based on the identical sequences. Information regarding the frequency offset is derived from the correlation of the received signal $\tilde{r}\left(k + \frac{L}{2}\right)$ with the received signal $\tilde{r}(k)$. This correlation is given by the following equation:

$$\sum_{k=1}^{\frac{L}{2}} \tilde{r}^*\left(k + \frac{L}{2}\right) \tilde{r}(k) = \sum_{k=1}^{\frac{L}{2}} |r(k)|^2 e^{-j2\pi\Delta f \frac{L}{2} T_{MCM}} \quad (\text{Eq.17})$$

25 \tilde{r}^* designates the complex conjugate of the sample values of the portion mentioned above.

Thus, the frequency offset is

$$30 \quad \Delta f = \frac{1}{2\pi \frac{L}{2} T_{MCM}} \arg\left(\sum_{k=1}^{\frac{L}{2}} \tilde{r}\left(k + \frac{L}{2}\right) \cdot \tilde{r}^*(k)\right) - \frac{1}{2\pi \frac{L}{2} T_{MCM}} \arg\left(\sum_{k=1}^{\frac{L}{2}} |\tilde{r}(k)|^2\right) \quad (\text{Eq.18})$$

since the argument of $|\tilde{r}(k)|^2$ equals zero, the frequency offset becomes

$$\Delta f = \frac{1}{2\pi \frac{L}{2} T_{MCM}} \arg \left(\sum_{k=1}^{\frac{L}{2}} \tilde{r} \left(k + \frac{L}{2} \right) \cdot \tilde{r}^*(k) \right) \quad (\text{Eq. 19})$$

Thus, it is clear that in both embodiments, described above, the frequency position of the maximum of the resulting output of the correlation determines the estimated value of the offset carrier. Furthermore, as it is also shown in Figure 9, the correction is performed in a feed forward structure.

In case of a channel with strong reflections, for example due to a high building density, the correlations described above might be insufficient for obtaining a suitable coarse frequency synchronization. Therefore, in accordance with a third embodiment of the present invention, corresponding values of the two portions which are correlated in accordance with a second embodiment, can be weighting with corresponding values of stored predetermined reference patterns corresponding to said two identical sequences of the reference symbol. This weighting can maximize the probability of correctly determining the frequency offset. The mathematical description of this weighting is as follows:

$$\Delta f = \frac{1}{2\pi \frac{L}{2} T_{MCM}} \arg \left(\sum_{k=1}^{\frac{L}{2}} \left[\tilde{r} \left(k + \frac{L}{2} \right) \cdot \tilde{r}^*(k) \right] \cdot \left[S_{AM}(k) S_{AM}^* \left(k + \frac{L}{2} \right) \right] \right) \quad (\text{Eq. 20})$$

S_{AM} designates the amplitude-modulated sequence which is known in the receiver, and S_{AM}^* designates the complex conjugate thereof.

006277-022E/960

If the above correlations are calculated in the frequency domain, the amount of

$$\sum_{k=1}^{\frac{L}{2}} \left[\tilde{r} \left(k + \frac{L}{2} \right) \cdot \tilde{r}^* (k) \right] \cdot \left[S_{AM} (k) S_{AM}^* \left(k + \frac{L}{2} \right) \right] \quad (\text{Eq.21})$$

5

is used rather than the argument. This amount is maximized as a function of a frequency correction. The position of the maximum determines the estimation of the frequency deviation. As mentioned above, the correction is performed in a feed forward structure.

10

Preferred embodiments for performing an echo phase offset correction when using a differential mapping in the frequency axis will be described hereinafter referring to Figures 12 to 15.

15

Systematic phase shifts stemming from echoes in multipath environments may occur between subcarriers in the same MCM symbol. This phase offsets can cause bit errors when demodulating the MCM symbol at the receiver. Thus, it is preferred to make use of an algorithm to correct the systematic phase shifts stemming from echoes in multipath environments.

20

In Figure 12, scatter diagrams at the output of a differential demapper of a MCM receiver are shown. As can be seen from the left part of Figure 12, systematic phase shifts between subcarriers in the same MCM symbol cause a rotation of the demodulated phase shifts with respect to the axis of the complex coordinate system. In the right part of Figure 12, the demodulated phase shifts after having performed an echo phase offset correction are depicted. Now, the positions of the signal points are substantially on the axis of the complex coordinate system. These positions correspond to the modulated phase shifts of 0°, 90°, 180° and 270°, respectively.

35

An echo phase offset correction algorithm (EPOC algorithm) must calculate the echo induced phase offset from the signal space constellation following the differential demodulation and subsequently correct this phase offset.

5

For illustration purposes, one may think of the simplest algorithm possible which eliminates the symbol phase before computing the mean of all phases of the subcarriers. To illustrate the effect of such an EPOC algorithm, reference is made to the two scatter diagrams of subcarriers symbols contained in one MCM symbol in Figure 12. This scatter diagrams have been obtained as result of an MCM simulation. For the simulation a channel has been used which might typically show up in single frequency networks. The echoes of this channel stretched to the limits of the MCM guard interval. The guard interval was chosen to be 25% of the MCM symbol duration in this case.

10
15
20
25
30
35

Figure 13 represents a block diagram for illustrating the position and the functionality of an echo phase offset correction device in a MCM receiver. The signal of a MCM transmitter is transmitted through the channel 122 (Figures 1 and 13) and received at the receiver frontend 132 of the MCM receiver. The signal processing between the receiver frontend and the fast Fourier transformator 140 has been omitted in Figure 13. The output of the fast Fourier transformator is applied to the de-mapper, which performs a differential demapping along the frequency axis. The output of the de-mapper are the respective phase shifts for the subcarriers. The phase offsets of this phase shifts which are caused by echoes in multipath environments are visualized by a block 400 in Figure 13 which shows an example of a scatter diagram of the subcarrier symbols without an echo phase offset correction.

The output of the de-mapper 142 is applied to the input of an echo phase offset correction device 402. The echo phase offset correction device 402 uses an EPOC algorithm in order

to eliminate echo phase offsets in the output of the de-mapper 142. The result is shown in block 404 of Figure 13, i.e. only the encoded phase shifts, 0° , 90° , 180° or 270° are present at the output of the correction device 402. The output of the correction device 402 forms the signal for the metric calculation which is performed in order to recover the bitstream representing the transmitted information.

A first embodiment of an EPOC algorithm and a device for performing same is now described referring to Figure 14.

The first embodiment of an EPOC algorithm starts from the assumption that every received differentially decoded complex symbol is rotated by an angle due to echoes in the multipath channel. For the subcarriers equal spacing in frequency is assumed since this represents a preferred embodiment. If the subcarriers were not equally spaced in frequency, a correction factor would have to be introduced into the EPOC algorithm.

Figure 14 shows the correction device 402 (Figure 13) for performing the first embodiment of an EPOC algorithm.

From the output of the de-mapper 142 which contains an echo phase offset as shown for example in the left part of Figure 12, the phase shifts related to transmitted information must first be discarded. To this end, the output of the de-mapper 142 is applied to a discarding unit 500. In case of a DQPSK mapping, the discarding unit can perform a " $(.)^4$ " operation. The unit 500 projects all received symbols into the first quadrant. Therefore, the phase shifts related to transmitted information is eliminated from the phase shifts representing the subcarrier symbols. The same effect could be reached with a modulo-4 operation.

Having eliminated the information related symbol phases in unit 500, the first approach to obtain an estimation would be to simply compute the mean value over all symbol phases of one MCM symbol. However, it is preferred to perform a

threshold decision before determining the mean value over all symbol phases of one MCM symbol. Due to Rayleigh fading some of the received symbols may contribute unreliable information to the determination of the echo phase offset.

5 Therefore, depending on the absolute value of a symbol, a threshold decision is performed in order to determine whether the symbol should contribute to the estimate of the phase offset or not.

10 Thus, in the embodiment shown in Figure 14, a threshold decision unit 510 is included. Following the unit 500 the absolute value and the argument of a differentially decoded symbol is computed in respective computing units 512 and 514. Depending on the absolute value of a respective symbol,
15 a control signal is derived. This control signal is compared with a threshold value in a decision circuit 516. If the absolute value, i.e. the control signal thereof, is smaller than a certain threshold, the decision circuit 516 replaces the angle value going into the averaging operation by a value equal to zero. To this end, a switch is provided in
20 order to disconnect the output of the argument computing unit 514 from the input of the further processing stage and connects the input of the further processing stage with a unit 518 providing a constant output of "zero".

25 An averaging unit 520 is provided in order to calculate a mean value based on the phase offsets φ_i determined for the individual subcarrier symbols of a MCM symbol as follows:

30
$$\bar{\varphi} = 1 / K \sum_{i=1}^K \varphi_i \quad (\text{Eq.22})$$

In the averaging unit 520, summation over K summands is performed. The output of the averaging unit 520 is provided to a hold unit 522 which holds the output of the averaging unit
35 520 K times. The output of the hold unit 522 is connected with a phase rotation unit 524 which performs the correction

of the phase offsets of the K complex signal points on the basis of the mean value $\bar{\varphi}$.

The phase rotation unit 524 performs the correction of the phase offsets by making use of the following equation:

$$v'_k = v_k \cdot e^{-j\bar{\varphi}} \quad (\text{Eq.23})$$

In this equation, v'_k designates the K phase corrected differentially decoded symbols for input into the soft-metric calculation, whereas v_k designates the input symbols. As long as a channel which is quasi stationary during the duration of one MCM symbols can be assumed, using the mean value over all subcarriers of one MCM symbol will provide correct results.

A buffer unit 527 may be provided in order to buffer the complex signal points until the mean value of the phase offsets for one MCM symbol is determined. The output of the phase rotation unit 524 is applied to the further processing stage 526 for performing the soft-metric calculation.

With respect to the results of the above echo phase offset correction, reference is made again to Figure 12. The two plots stem from a simulation which included the first embodiment of an echo phase offset correction algorithm described above. At the instant of the scatter diagram snapshot shown in the left part of Figure 12, the channel obviously distorted the constellation in such a way, that a simple angle rotation is a valid assumption. As shown in the right part of Figure 12, the signal constellation can be rotated back to the axis by applying the determined mean value for the rotation of the differentially detected symbols.

A second embodiment of an echo phase offset correction algorithm is described hereinafter. This second embodiment can be preferably used in connection with multipath channels that have up to two strong path echoes. The algorithm of the

second embodiment is more complex than the algorithm of the first embodiment.

5 what follows is a mathematical derivation of the second embodiment of a method for echo phase offset correction. The following assumptions can be made in order to ease the explanation of the second embodiment of an EPOC algorithm.

10 In this embodiment, the guard interval of the MCM signal is assumed to be at least as long as the impulse response $h[q]$, $q = 0, 1, \dots, Qh-1$ of the multipath channel.

15 At the transmitter every MCM symbol is assembled using frequency axis mapping explained above. The symbol of the reference subcarrier equals 1, i.e. 0 degree phase shift. The optional phase shift PHI equals zero, i.e. the DQPSK signal constellation is not rotated.

20 Using an equation this can be expressed as

$$a_k = a_{k-1} a_k^{inc}$$

(Eq.24)

25 with
k : index $k = 1, 2, \dots, K$ of the active subcarrier;

$a_k^{inc} = e^{j\frac{\pi}{2}m}$: complex phase increment symbol; $m=0, 1, 2, 3$ is the QPSK symbol number which is derived from Gray encoding pairs of 2 Bits;

30 $a_0 = 1$: symbol of the reference subcarrier.

At the DFT output of the receiver the decision variables

35
$$e_k = a_k H_k$$
 (Eq.25)

are obtained with

005270-11290

$$H_k = \sum_{i=0}^{Q_h-1} h[i] \cdot e^{-j\frac{2\pi}{K}ki} \quad (\text{Eq.26})$$

5 being the DFT of the channel impulse response $h[q]$ at position k .

with $|ak|^2 = 1$ the differential demodulation yields

$$v_k = e_k \cdot e_{k-1}^* = a_k^{inc} H_k H_{k-1}^* \quad (\text{Eq.27})$$

10

For the receiver an additional phase term φ_k is introduced, which shall be used to correct the systematic phase offset caused by the channel. Therefore, the final decision variable at the receiver is

15

$$v'_k = v_k \cdot e^{j\varphi_k} = a_k^{inc} \cdot e^{j\varphi_k} \cdot H_k \cdot H_{k-1}^*$$

(Eq.28)

20 As can be seen from the Equation 28, the useful information a_k^{inc} is weighted with the product $e^{j\varphi_k} \cdot H_k \cdot H_{k-1}^*$ (rotation and effective transfer function of the channel). This product must be real-valued for an error free detection. Considering this, it is best to choose the rotation angle to equal the negative argument of $H_k \cdot H_{k-1}^*$. To derive the desired algorithm for 2-path channels, the nature of $H_k \cdot H_{k-1}^*$ is investigated in the next section.

25

It is assumed that the 2-path channel exhibits two echoes with energy content unequal zero, i.e. at least two dominant echoes. This assumption yields the impulse response

30

$$h[q] = c_1 \delta_0[q] + c_2 \delta_0[q - q_0] \quad (\text{Eq.29})$$

with

- c_1, c_2 : complex coefficients representing the path echoes;
- q_0 : delay of the second path echo with respect to the first path echo;
- 5 δ_0 : Dirac pulse; $\delta_0[k] = 1$ for $k = 0$
 $\delta_0[k] = 0$ else

The channel transfer function is obtained by applying a DFT to Equation 29:

10

$$H_k = H\left(e^{j\frac{2\pi}{K}k}\right) = c_1 + c_2 \cdot e^{-j\frac{2\pi}{K}kq_0} \quad (\text{Eq. 30})$$

With Equation 30 the effective transfer function for differential demodulation along the frequency axis is:

15

$$\begin{aligned} H_k \cdot H_{k-1}^* &= \left(c_1 + c_2 e^{-j\frac{2\pi}{K}kq_0}\right) \cdot \left(c_1^* + c_2^* e^{+j\frac{2\pi}{K}(k-1)q_0}\right) \\ &= c_a + c_b \cos\left(\frac{\pi}{K}q_0(2k-1)\right) \end{aligned} \quad (\text{Eq. 31})$$

Assuming a noise free 2-path channel, it can be observed from Equation 31 that the symbols on the receiver side are located on a straight line in case the symbol $1+j0$ has been send (see above assumption). This straight line can be characterized by a point

25 $c_a = |c_1|^2 + |c_2|^2 \cdot e^{-j\frac{2\pi}{K}q_0} \quad (\text{Eq. 32})$

and the vector

$$c_b = 2c_1c_2^* \cdot e^{-j\frac{\pi}{K}q_0} \quad (\text{Eq. 33})$$

30

which determines its direction.

006277-022E-960

with the above assumptions, the following geometric derivation can be performed. A more suitable notation for the geometric derivation of the second embodiment of an EPOC algorithm is obtained if the real part of the complex plane is designated as $x = \text{Re}\{z\}$, the imaginary part as $y = \text{Im}\{z\}$, respectively, i.e. $z = x+jy$. With this new notation, the straight line, on which the received symbols will lie in case of a noise-free two-path channel, is

10 $f(x) = a + b \cdot x$ (Eq.34)

with

15 $a = \text{Im}\{c_a\} - \frac{\text{Re}\{c_a\}}{\text{Re}\{c_b\}} \cdot \text{Im}\{c_b\}$ (Eq.35)

and

15 $b = - \frac{\text{Im}\{c_a\} - \frac{\text{Re}\{c_a\}}{\text{Re}\{c_b\}} \cdot \text{Im}\{c_b\}}{\text{Re}\{c_a\} - \frac{\text{Im}\{c_a\}}{\text{Im}\{c_b\}} \cdot \text{Re}\{c_b\}}$ (Eq.36)

20 Additional noise will spread the symbols around the straight line given by Equations 34 to 36. In this case Equation 36 is the regression curve for the cluster of symbols.

25 For the geometric derivation of the second embodiment of an EPOC algorithm, the angle φ_k from Equation 28 is chosen to be a function of the square distance of the considered symbol from the origin:

30 $\varphi_k = f_k(|z|^2)$ (Eq.37)

Equation 37 shows that the complete signal space is distorted (torsion), however, with the distances from the origin being preserved.

For the derivation of the algorithm of the second embodiment, $f_k(\cdot)$ has to be determined such that all decision variables v'_k (assuming no noise) will come to lie on the real axis:

5

$$\text{Im}\{(x + jf(x)) \cdot e^{jf_k(|z|^2)}\} = 0 \tag{Eq.38}$$

Further transformations of Equation 38 lead to a quadratic equation which has to be solved to obtain the solution for φ_k .

10

In case of a two-path channel, the echo phase offset correction for a given decision variable v_k is

15

$$v'_k = v_k \cdot e^{j\varphi_k} \tag{Eq.39}$$

with

$$\varphi_k = \begin{cases} -a \tan\left(\frac{a + b\sqrt{|v_k|^2(1+b^2) - a^2}}{-ab + \sqrt{|v_k|^2(1+b^2) - a^2}}\right) & \text{for } |v_k|^2 \geq \frac{a^2}{1+b^2} \\ a \tan\left(\frac{1}{b}\right) & \text{for } |v_k|^2 < \frac{a^2}{1+b^2} \end{cases} \tag{Eq.40}$$

20

From the two possible solutions of the quadratic equation mentioned above, Equation 40 is the one solution that cannot cause an additional phase shift of 180 degrees.

25

The two plots in Figure 15 show the projection of the EPOC algorithm of the second embodiment for one quadrant of the complex plane. Depicted here is the quadratic grid in the sector $|\arg(z)| \leq \pi/4$ and the straight line

30

$y = f(x) = a + b \cdot x$ with $a = -1.0$ and $b = 0.5$ (dotted line). In case of a noise-free channel, all received symbols will lie on this straight line if 1+j0 was send. The circle shown in the plots determines the boarder line for the two cases

of Equation 40. In the left part, Figure 15 shows the situation before the projection, in the right part, Figure 15 shows the situation after applying the projection algorithm. By looking on the left part, one can see, that the straight line now lies on the real axis with $2+j0$ being the fix point of the projection. Therefore, it can be concluded that the echo phase offset correction algorithm according to the second embodiment fulfills the design goal.

10 Before the second embodiment of an EPOC algorithm can be applied, the approximation line through the received symbols has to be determined, i.e. the parameters a and b must be estimated. For this purpose, it is assumed that the received symbols lie in sector $|\arg(z)| \leq \pi / 4$, if $1+j0$ was sent. If
15 symbols other than $1+j0$ have been sent, a modulo operation can be applied to project all symbols into the desired sector. Proceeding like this prevents the necessity of deciding on the symbols in an early stage and enables averaging over all signal points of one MCM symbol (instead of averaging
20 over only $\frac{1}{4}$ of all signal points).

For the following computation rule for the EPOC algorithm of the second embodiment, x_i is used to denote the real part of the i -th signal point and y_i for its imaginary part, respectively ($i = 1, 2, \dots, K$). Altogether, K values are available for the determination. By choosing the method of least squares, the straight line which has to be determined can be
25 obtained by minimizing

30
$$(a, b) = \arg \min_{(\tilde{a}, \tilde{b})} \sum_{i=1}^K (y_i - (\tilde{a} + \tilde{b} \cdot x_i))^2 \quad (\text{Eq. 41})$$

The solution for Equation 41 can be found in the laid open literature. It is

$$b = \frac{\sum_{i=1}^K (x_i - \bar{x}) \cdot y_i}{\sum_{i=1}^K (x_i - \bar{x})^2}, \quad a = \bar{y} - \bar{x} \cdot b \quad (\text{Eq. 42})$$

with mean values

$$\bar{x} = \frac{1}{N} \sum_{i=1}^K x_i, \quad \bar{y} = \frac{1}{N} \sum_{i=1}^K y_i \quad (\text{Eq. 43})$$

If necessary, an estimation method with higher robustness can be applied. However, the trade-off will be a much higher computational complexity.

10

To avoid problems with the range in which the projection is applicable, the determination of the straight line should be separated into two parts. First, the cluster's centers of gravity are moved onto the axes, following, the signal space is distorted. Assuming that a and b are the original parameters of the straight line and α is the rotation angle, $f_K(\cdot)$ has to be applied with the transformed parameters

15

$$b' = \frac{b \cdot \cos(\alpha) - \sin(\alpha)}{\cos(\alpha) + b \cdot \sin(\alpha)}, \quad a' = a \cdot (\cos(\alpha) - b' \cdot \sin(\alpha))$$

20

(Eq. 44)

Besides the two EPOC algorithms explained above section, different algorithms can be designed that will, however, most likely exhibit a higher degree of computational complexity.

25

METHOD AND APPARATUS FOR FINE FREQUENCY SYNCHRONIZATION IN
MULTI-CARRIER DEMODULATION SYSTEMS

5

FIELD OF THE INVENTION

10 The present invention relates to methods and apparatus for performing a fine frequency synchronization in multi-carrier demodulation systems, and in particular to methods and apparatus for performing a fine frequency synchronization compensating for a carrier frequency deviation from an oscillator frequency in a multi-carrier demodulation system of the type capable of carrying out a differential phase decoding of multi-carrier modulated signals, wherein the signals comprise a plurality of symbols, each symbol being defined by phase differences between simultaneous carriers having different frequencies.

15
20

BACKGROUND OF THE INVENTION

25 In a multi carrier transmission system (MCM, OFDM), the effect of a carrier frequency offset is substantially more considerable than in a single carrier transmission system. MCM is more sensitive to phase noise and frequency offset which occurs as amplitude distortion and inter carrier interference (ICI). The inter carrier interference has the effect that the subcarriers are no longer orthogonal in relation to each other. Frequency offsets occur after power on or also later due to frequency deviation of the oscillators used for downconversion into baseband. Typical accuracies for the frequency of a free running oscillator are about ± 50 ppm of the carrier frequency. With a carrier frequency in the S-band of 2.34 GHz, for example, there will be a maximum local oscillator (LO) frequency deviation of above 100 kHz (117.25 kHz). The above named effects result in high requirements on the algorithm used for frequency offset correction.

30
35
40

DESCRIPTION OF PRIOR ART

5 Most prior art algorithms for frequency synchronization di-
vide frequency correction into two stages. In the first
stage, a coarse synchronization is performed. In the second
stage, a fine correction can be achieved. A frequently used
algorithm for coarse synchronization of the carrier fre-
10 quency uses a synchronization symbol which has a special
spectral pattern in the frequency domain. Such a synchroni-
zation symbol is, for example, a CAZAC sequence (CAZAC =
Constant Amplitude Zero Autocorrelation). Through compari-
son, i.e. the correlation, of the power spectrum of the re-
15 ceived signal with that of the transmitted signal, the fre-
quency carrier offset can be coarsely estimated. These prior
art algorithms all work in the frequency domain. Reference
is made, for example, to Ferdinand Claßen, Heinrich Meyr,
"Synchronization Algorithms for an OFDM System for Mobile
20 Communication", ITG-Fachtagung 130, Codierung für Quelle,
Kanal und Übertragung, pp. 105 - 113, Oct. 26-28, 1994; and
Timothy M. Schmidl, Donald C. Cox, "Low-Overhead, Low-
Complexity [Burst] Synchronization for OFDM", in Proceedings
of the IEEE International Conference on Communication ICC
25 1996, pp. 1301-1306 (1996).

For the coarse synchronization of the carrier frequency,
Paul H. Moose, "A Technique for Orthogonal Frequency Divi-
30 sion Multiplexing Frequency Offset Correction", IEEE Trans-
action On Communications, Vol. 42, No. 10, October 1994,
suggest increasing the spacing between the subcarriers such
that the subcarrier distance is greater than the maximum
frequency difference between the received and transmitted
carriers. The subcarrier distance is increased by reducing
35 the number of sample values which are transformed by the
Fast Fourier Transform. This corresponds to a reduction of
the number of sampling values which are transformed by the
Fast Fourier Transform.

the phase difference making use of a M-PSK decision device;
and

5 performing a feedback correction of the carrier frequency
deviation based on the determined frequency offset.

In accordance with a second aspect, the present invention
provides a method of performing a fine frequency synchroni-
zation compensating for a carrier frequency deviation from
10 an oscillator frequency in a multi-carrier demodulation sys-
tem of the type capable of carrying out a differential phase
decoding of multi-carrier modulated signals, the signals
comprising a plurality of symbols, each symbol being defined
by phase differences between simultaneous carriers having
15 different frequencies, the method comprising the steps of:

determining respective phases of the same carrier in differ-
ent symbols;

20 eliminating phase shift uncertainties related to the trans-
mitted information from the phases to determine respective
phase deviations making use of a M-PSK decision device;

determining a frequency offset by determining a phase dif-
25 ference between the phase deviations; and

performing a feedback correction of said carrier frequency
deviation based on the determined frequency offset.

30 In accordance with a third aspect, the present invention
provides an apparatus for performing a fine frequency syn-
chronization compensating for a carrier frequency deviation
from an oscillator frequency, for a multi-carrier demodula-
tion system of the type capable of carrying out a differen-
35 tial phase decoding of multi-carrier modulated signals, the
signals comprising a plurality of symbols, each symbol being
defined by phase differences between simultaneous carriers
having different frequencies, the apparatus comprising:

means for determining a phase difference between phases of the same carrier in different symbols;

5 M-PSK decision device for determining a frequency offset by eliminating phase shift uncertainties related to the transmitted information from the phase difference; and

means for performing a feedback correction of the frequency deviation based on the determined frequency offset.

10

In accordance with a fourth aspect, the present invention provides an apparatus for performing a fine frequency synchronization compensating for a carrier frequency deviation from an oscillator frequency, for a multi-carrier demodulation system of the type capable of carrying out a differential phase decoding of multi-carrier modulated signals, said signals comprising a plurality of symbols, each symbol being defined by phase differences between simultaneous carriers having different frequencies, the apparatus comprising:

15

20

means for determining respective phases of the same carrier in different symbols;

25

M-PSK decision device for eliminating phase shift uncertainties related to the transmitted information from the phases to determine respective phase deviations;

30

means for determining a frequency offset by determining a phase difference between the phase deviations; and

means for performing a feedback correction of the frequency deviation based on the determined frequency offset.

35

The present invention relates to methods and apparatus for performing a fine frequency synchronization compensating for a carrier frequency deviation from an oscillator frequency. This fine frequency synchronization is preferably performed after completion of a coarse frequency synchronization, such that the frequency offsets after the coarse frequency syn-

chronization are smaller than half the sub-carrier distance in the MCM signal. Since the frequency offsets which are to be corrected by the inventive fine frequency synchronization methods and apparatus, a correction of the frequency offsets by using a phase rotation with differential decoding and demapping in the time axis can be used. The frequency offsets are detected by determining the frequency differences between time contiguous sub-carrier symbols along the time axis. The frequency error is calculated by measuring the rotation of the I-Q cartesian coordinates of each sub-carrier and, in preferred embodiments, averaging them over all n sub-carriers of a MCM symbol.

Firstly, the phase ambiguity or uncertainty is eliminated by using a M-PSK decision device and correlating the output of the decision device with the input signal for a respective sub-carrier symbol. Thus, the phase offset for a sub-carrier symbol is determined and can be used for restructuring the frequency error in form of a feed-backward structure. Alternatively, the phase offsets of the sub-carrier symbols of one MCM symbol can be averaged over all of the active carriers of a MCM symbol, wherein the averaged phase offset is used to restructure the frequency error.

In accordance with the present invention, the determination of the frequency offset is performed in the frequency domain. The feedback correction in accordance with the inventive fine frequency synchronization is performed in the time domain. To this end, a differential decoder in the time domain is provided in order to detect frequency offsets of sub-carriers on the basis of the phases of timely successive sub-carrier symbols of different MCM symbols.

BRIEF DESCRIPTION OF THE DRAWINGS

In the following, preferred embodiments of the present invention will be explained in detail on the basis of the drawings enclosed, in which:

- 5
10
15
20
25
30
35
- Figure 1 shows a schematic overview of a MCM transmission system to which the present application can be applied;
- Figures 2A and 2B show schematic views representing a scheme for differential mapping in the time axis and a scheme for differential mapping in the frequency axis;
- Figure 3 shows a functional block diagram for performing a differential mapping in the frequency axis;
- Figure 4 shows a representation of time variation of all sub-carriers in MCM symbols;
- Figure 5 shows a QPSK-constellation for each sub-carrier with a frequency offset;
- Figure 6 shows a general block diagram illustrating the position of the inventive fine frequency synchronization device in a MCM receiver;
- Figure 7 shows a block diagram of the fine frequency error detector shown in Figure 6;
- Figure 8 shows a block diagram of a MCM receiver comprising a coarse frequency synchronization unit and a fine frequency synchronization unit;
- Figure 9 shows a block diagram of a unit for performing a coarse frequency synchronization;
- Figure 10 shows a schematic view of a reference symbol used for performing a coarse frequency synchronization;
- Figure 11 shows a schematic view of a typical MCM signal having a frame structure;

PETITIONER SIRIUS XM RADIO INC.

5 Figure 12 shows scatter diagrams of the output of an differential de-mapper of a MCM receiver for illustrating the effect of an echo phase offset correction;

10 Figure 13 shows a schematic block diagram for illustrating the position and the functionality of an echo phase offset correction unit;

15 Figure 14 shows a schematic block diagram of a preferred form of an echo phase offset correction device; and

20 Figure 15 shows schematic views for illustrating a projection performed by another echo phase offset correction algorithm.

25 DETAILED DESCRIPTION OF THE EMBODIMENTS

Before discussing the present invention in detail, the mode of operation of a MCM transmission system is described referring to figure 1.

25 Referring to Figure 1, at 100 a MCM transmitter is shown that substantially corresponds to a prior art MCM transmitter. A description of such a MCM transmitter can be found, for example, in William Y. Zou, Yiyan Wu, "COFDM: AN
30 OVERVIEW", IEEE Transactions on Broadcasting, vol. 41, No. 1, March 1995.

35 A data source 102 provides a serial bitstream 104 to the MCM transmitter. The incoming serial bitstream 104 is applied to a bit-carrier mapper 106 which produces a sequence of spectra 108 from the incoming serial bitstream 104. An inverse fast Fourier transform (IFFT) 110 is performed on the sequence of spectra 108 in order to produce a MCM time domain signal 112. The MCM time domain signal forms the useful MCM

symbol of the MCM time signal. To avoid intersymbol interference (ISI) caused by multipath distortion, a unit 114 is provided for inserting a guard interval of fixed length between adjacent MCM symbols in time. In accordance with a preferred embodiment of the present invention, the last part of the useful MCM symbol is used as the guard interval by placing same in front of the useful symbol. The resulting MCM symbol is shown at 115 in Figure 1 and corresponds to a MCM symbol 160 depicted in Figure 11.

5
10

Figure 11 shows the construction of a typical MCM signal having a frame structure. One frame of the MCM time signal is composed of a plurality of MCM symbols 160. Each MCM symbol 160 is formed by an useful symbol 162 and a guard interval 164 associated therewith. As shown in Figure 11, each frame comprises one reference symbol 166. The present invention can advantageously be used with such a MCM signal, however, such a signal structure being not necessary for performing the present invention as long as the transmitted signal comprises a useful portion and at least one reference symbol.

15
20

In order to obtain the final frame structure shown in Figure 11, a unit 116 for adding a reference symbol for each predetermined number of MCM symbols is provided.

25

In accordance with the present invention, the reference symbol is an amplitude modulated bit sequence. Thus, an amplitude modulation of a bit sequence is performed such that the envelope of the amplitude modulated bit sequence defines a reference pattern of the reference symbol. This reference pattern defined by the envelope of the amplitude modulated bit sequence has to be detected when receiving the MCM signal at a MCM receiver. In a preferred embodiment of the present invention, a pseudo random bit sequence having good autocorrelation properties is used as the bit sequence that is amplitude modulated.

30
35

The choice of length and repetition rate of the reference symbol depends on the properties of the channel through which the MCM signal is transmitted, e.g. the coherence time of the channel. In addition, the repetition rate and the length of the reference symbol, in other words the number of useful symbols in each frame, depends on the receiver requirements concerning mean time for initial synchronization and mean time for resynchronization after synchronization loss due to a channel fade.

5
10

The resulting MCM signal having the structure shown at 118 in Figure 1 is applied to the transmitter front end 120. Roughly speaking, at the transmitter front end 120, a digital/analog conversion and an up-converting of the MCM signal is performed. Thereafter, the MCM signal is transmitted through a channel 122.

15

Following, the mode of operation of a MCM receiver 130 is shortly described referring to Figure 1. The MCM signal is received at the receiver front end 132. In the receiver front end 132, the MCM signal is down-converted and, furthermore, an analog/digital conversion of the down-converted signal is performed.

20

The down-converted MCM signal is provided to a symbol frame/carrier frequency synchronization unit 134.

25

A first object of the symbol frame/carrier frequency synchronization unit 134 is to perform a frame synchronization on the basis of the amplitude-modulated reference symbol. This frame synchronization is performed on the basis of a correlation between the amplitude-demodulated reference symbol and a predetermined reference pattern stored in the MCM receiver.

30

35

A second object of the symbol frame/carrier frequency synchronization unit is to perform a coarse frequency synchronization of the MCM signal. To this end, the symbol frame/carrier frequency synchronization unit 134 serves as a

0967270 112900

coarse frequency synchronization unit for determining a coarse frequency offset of the carrier frequency caused, for example, by a difference of the frequencies between the local oscillator of the transmitter and the local oscillator of the receiver. The determined frequency is used in order to perform a coarse frequency correction. The mode of operation of the coarse frequency synchronization unit is described in detail referring to Figures 9 and 10 hereinafter.

As described above, the frame synchronization unit 134 determines the location of the reference symbol in the MCM symbol. Based on the determination of the frame synchronization unit 134, a reference symbol extracting unit 136 extracts the framing information, i.e. the reference symbol, from the MCM symbol coming from the receiver front end 132. After the extraction of the reference symbol, the MCM signal is applied to a guard interval removal unit 138. The result of the signal processing performed herehereto in the MCM receiver are the useful MCM symbols.

The useful MCM symbols output from the guard interval removal unit 138 are provided to a fast Fourier transform unit 140 in order to provide a sequence of spectra from the useful symbols. Thereafter, the sequence of spectra is provided to a carrier-bit mapper 142 in which the serial bitstream is recovered. This serial bitstream is provided to a data sink 144.

Next, referring to Figures 2A and 2B, two modes for differential mapping are described. In Figure 2A, a first method of differential mapping along the time axis is shown. As can be seen from Figure 2A, a MCM symbol consists of K sub-carriers. The sub-carriers comprise different frequencies and are, in a preferred embodiment, equally spaced in the frequency axis direction. When using differential mapping along the time axis, one or more bits are encoded into phase and/or amplitude shifts between two sub-carriers of the same center frequency in adjacent MCM symbols. The arrows depicted between the sub-carrier symbols correspond to infor-

mation encoded in amplitude and/or phase shifts between two sub-carrier symbols.

5 A second method of differential mapping is shown in Figure 2B. The present invention is adapted for MCM transmission system using the mapping scheme shown in Figure 2B. This mapping scheme is based on a differential mapping inside one MCM symbol along the frequency axis. A number of MCM symbols 200 is shown in Figure 2B. Each MCM symbol 200 comprises a number of sub-carrier symbols 202. The arrows 204 in Figure 2B illustrate information encoded between two sub-carrier symbols 202. As can be seen from the arrows 204, this mapping scheme is based on a differential mapping within one MCM symbol along the frequency axis direction.

15 In the embodiment shown in Figure 2B, the first sub-carrier ($k=0$) in an MCM symbol 200 is used as a reference sub-carrier 206 (shaded) such that information is encoded between the reference sub-carrier and the first active carrier 208. The other information of a MCM symbol 200 is encoded between active carriers, respectively.

25 Thus, for every MCM symbol an absolute phase reference exists. In accordance with Figure 2B, this absolute phase reference is supplied by a reference symbol inserted into every MCM symbol ($k=0$). The reference symbol can either have a constant phase for all MCM symbols or a phase that varies from MCM symbol to MCM symbol. A varying phase can be obtained by replicating the phase from the last subcarrier of the MCM symbol preceding in time.

35 In Figure 3 a preferred embodiment of a device for performing a differential mapping along the frequency axis is shown. Referring to Figure 3, assembly of MCM symbols in the frequency domain using differential mapping along the frequency axis according to the present invention is described.

Figure 3 shows the assembly of one MCM symbol with the following parameters:

NFFT designates the number of complex coefficients of the discrete Fourier transform, number of subcarriers respectively.

5

K designates the number of active carriers. The reference carrier is not included in the count for K.

10 According to Figure 3, a quadrature phase shift keying (QPSK) is used for mapping the bitstream onto the complex symbols. However, other M-ary mapping schemes (MPSK) like 2-PSK, 8-PSK, 16-QAM, 16-APSK, 64-APSK etc. are possible.

15 Furthermore, for ease of filtering and minimization of aliasing effects some subcarriers are not used for encoding information in the device shown in Figure 3. These subcarriers, which are set to zero, constitute the so-called guard bands on the upper and lower edges of the MCM signal spectrum.

20

At the input of the mapping device shown in Figure 3, complex signal pairs $b_0[k]$, $b_1[k]$ of an input bitstream are received. K complex signal pairs are assembled in order to form one MCM symbol. The signal pairs are encoded into the K differential phase shifts $\phi[k]$ needed for assembly of one MCM symbol. In this embodiment, mapping from Bits to the 0, 90, 180 and 270 degrees phase shifts is performed using Gray Mapping in a quadrature phase shift keying device 220.

25

Gray mapping is used to prevent that differential detection phase errors smaller than 135 degrees cause double bit errors at the receiver.

35 Differential phase encoding of the K phases is performed in a differential phase encoder 222. At this stage of processing, the K phases $\phi[k]$ generated by the QPSK Gray mapper are differentially encoded. In principal, a feedback loop 224 calculates a cumulative sum over all K phases. As starting point for the first computation ($k = 0$) the phase of the

reference carrier 226 is used. A switch 228 is provided in order to provide either the absolute phase of the reference subcarrier 226 or the phase information encoded onto the preceding (i.e. z^{-1} , where z^{-1} denotes the unit delay operator) subcarrier to a summing point 230. At the output of the differential phase encoder 222, the phase information $\theta[k]$ with which the respective subcarriers are to be encoded is provided. In preferred embodiments of the present invention, the subcarriers of a MCM symbol are equally spaced in the frequency axis direction.

The output of the differential phase encoder 222 is connected to a unit 232 for generating complex subcarrier symbols using the phase information $\theta[k]$. To this end, the K differentially encoded phases are converted to complex symbols by multiplication with

$$\text{factor} * e^{j*[2*\pi*(\theta[k]+PHI)]} \quad (\text{Eq.1})$$

wherein factor designates a scale factor and PHI designates an additional angle. The scale factor and the additional angle PHI are optional. By choosing $PHI = 45^\circ$ a rotated DQPSK signal constellation can be obtained.

Finally, assembly of a MCM symbol is effected in an assembling unit 234. One MCM symbol comprising N_{FFT} subcarriers is assembled from $N_{FFT}-K-1$ guard band symbols which are "zero", one reference subcarrier symbol and K DQPSK subcarrier symbols. Thus, the assembled MCM symbol 200 is composed of K complex values containing the encoded information, two guard bands at both sides of the N_{FFT} complex values and a reference subcarrier symbol.

The MCM symbol has been assembled in the frequency domain. For transformation into the time domain an inverse discrete Fourier transform (IDFT) of the output of the assembling unit 234 is performed by a transformator 236. In preferred embodiments of the present invention, the transformator 236 is adapted to perform a fast Fourier transform (FFT).

Further processing of the MCM signal in the transmitter as well as in the receiver is as described above referring to Figure 1.

5

At the receiver a de-mapping device 142 (Figure 1) is needed to reverse the operations of the mapping device described above referring to Figure 3. The implementation of the de-mapping device is straightforward and, therefore, need not be described herein in detail.

10

The differential mapping along the frequency axis direction is suitable for multi-carrier (OFDM) digital broadcasting over rapidly changing multi path channels. In accordance with this mapping scheme, there is no need for a channel stationarity exceeding one multi-carrier symbol. However, differential mapping into frequency axis direction may create a new problem. In multi path environments, path echoes succeeding or preceding the main path can lead to systematic phase offsets between sub-carriers in the same MCM symbol. Thus, it will be preferred to provide a correction unit in order to eliminate such phase offsets. Because the channel induced phase offsets between differential demodulated symbols are systematic errors, they can be corrected by an algorithm. In principle, such an algorithm must calculate the echo induced phase offset from the signal space constellation following the differential demodulation and subsequently correct this phase offset.

15

20

25

Examples for such echo phase correction algorithms are described at the end of this specification referring to Figures 12 to 15.

30

Next, the fine frequency synchronization in accordance with the present invention will be described referring to Figures 4 to 8. As mentioned above, the fine frequency synchronization in accordance with the present invention is performed after completion of the coarse frequency synchronization. Preferred embodiments of the coarse frequency synchroniza-

35

tion which can be performed by the symbol frame/carrier frequency synchronization unit 134 are described hereinafter referring to Figures 9 and 10 after having described the fine frequency synchronization in accordance with the present invention.

With the fine frequency synchronization in accordance with the present invention frequency offsets which are smaller than half the sub-carrier distance can be corrected. Since the frequency offsets are low and equal for all sub-carriers the problem of fine frequency synchronization is reduced to sub-carrier level. Figure 4 is a schematical view of MCM symbols 200 in the time-frequency plane. Each MCM symbol 200 consists of 432 sub-carrier symbols C_1 to C_{432} . The MCM symbols are arranged along the time axis, the first MCM symbol 200 shown in Figure 4 having associated therewith a time T_1 , the next MCM symbol having associated therewith a time T_2 and so on. In accordance with a preferred embodiment of the present invention, the fine frequency synchronization is based on a phase rotation which is derived from the same sub-carrier of two MCM symbols which are adjacent in the time axis direction, for example C_1/T_1 and C_1/T_2 .

In the following, the present invention is described referring to QPSK mapping (QPSK = Quadrature Phase Shift Keying). However, it is obvious that the present invention can be applied to any MPSK mapping, wherein M designates the number of phase states used for encoding, for example 2, 4, 8, 16
.....

Figure 5 represents a complex coordinate system showing a QPSK constellation for each sub-carrier with frequency offset. The four possible phase positions of a first MCM symbol, MCM-symbol-1 are shown at 300. Changing from the sub-carrier (sub-carrier n) of this MCM symbol to the same sub-carrier of the next MCM symbol, MCM-symbol-2, the position in the QPSK constellation will be unchanged in case there is no frequency offset. If a frequency offset is present, which is smaller than half the distance between sub-carriers, as

mentioned above, this frequency offset causes a phase rotation of the QPSK constellation of MCM-symbol-2 compared with MCM-symbol-1. The new QPSK constellation, that is the four possible phase positions for the subject sub-carrier of MCM-symbol-2 are shown at 302 in Figure 5. This phase rotation θ can be derived from the following equation:

$$C_n(kT_{MCM}) = e^{j2\pi f_{offset}T_{MCM}} C_n((k-1)T_{MCM})$$
$$\theta = 2\pi f_{offset}T_{MCM} \quad (\text{Eq. 2})$$

10

C_n designates the QPSK constellation of a sub-carrier n in a MCM symbol. n is an index running from 1 to the number of active sub-carriers in the MCM symbol. Information regarding the frequency offset is contained in the term $e^{j2\pi f_{offset}T_{MCM}}$ of equation 2. This frequency offset is identical for all sub-carriers. Therefore, the phase rotation θ is identical for all sub-carriers as well. Thus, averaging overall sub-carrier of a MCM symbol can be performed.

20

Figure 6 shows a block diagram of a MCM receiver in which the present invention is implemented. An analog/digital converter 310 is provided in order to perform an analog/digital conversion of a down-converted signal received at the receiver front end 132 (Figure 1). The output of the analog/digital converter 310 is applied to a low path filter and decimator unit 312. The low path filter is an impulse forming filter which is identical to an impulse forming filter in the MCM transmitter. In the decimator, the signal is sampled at the MCM symbol frequency. As described above referring to Figure 1, guard intervals in the MCM signal are removed by a guard interval removal unit 132. Guard intervals are inserted between two MCM symbols in the MCM transmitter in order to avoid intersymbol interference caused by channel memory.

35

The output of the guard interval removal unit 132 is applied to a MCM demodulator 314 which corresponds to the fast Fourier transformator 140 shown in Figure 1. Following the MCM

demodulator 314 a differential decoding unit 316 and a de-
mapping unit 318 are provided. In the differential decoding
unit 316, phase information is recovered using differential
decoding. In the demapping unit 318, demapping along the
5 frequency axis direction is performed in order to recon-
struct a binary signal from the complex signal input into
the demapping unit 318.

The output of the MCM demodulator 314 is also applied to
10 fine frequency error detector 320. The fine frequency error
detector 320 produces an frequency error signal from the
output of the MCM demodulator. In the depicted embodiment,
the output of the fine frequency error detector 320 is ap-
plied to a numerical controlled oscillator 322 via a loop
15 filter 324. The loop filter 324 is a low pass filter for
filtering superimposed interference portions of a higher
frequency from the slowly varying error signal. The numeri-
cal controlled oscillator 322 produces a carrier signal on
the basis of the filtered error signal. The carrier signal
20 produced by the numerical controlled oscillator 322 is used
for a frequency correction which is performed by making use
of a complex multiplier 326. The inputs to the complex mul-
tiplier 326 are the output of the low pass filter and deci-
mator unit 312 and the output of the numerical controlled
25 oscillator 322.

A description of a preferred embodiment of the fine fre-
quency error detector 320 is given hereinafter referring to
Figure 7.

30 The fine frequency error detector 320 comprises a differen-
tial detector in the time axis 330. The output of the MCM
demodulator 314, i.e. the FFT output (FFT = Fast Fourier
Transform) is applied to the input of the differential de-
35 tector 330 which performs a differential detection in the
time axis in order to derive information on a frequency off-
set from the same sub-carrier of two subsequently arriving
MCM symbols. In the embodiment shown in Figure 7, the number
of active sub-carriers is 432. Thus, the differential detec-

tor 330 performs a correlation between the first and the 433rd sample. The first sample is associated with MCM-symbol-1 (Figure 5), whereas the 433rd sample is associated with MCM-symbol-2 (Figure 5). However, both these samples
5 are associated with the same sub-carrier.

To this end, the input signal Y_k is applied to a z^{-1} -block 332 and thereafter to a unit 334 in order to form the complex conjugate of the output of the z^{-1} -block 332. A complex
10 multiplier 336 is provided in order to multiply the output of the unit 334 by the input signal Y_k . The output of the multiplier 336 is a signal Z_k .

The function of the differential detector 330 can be expressed as follows:
15

$$Z_k = Y_{k+K} \cdot Y_k^* \quad (\text{Eq. 3})$$

$$Y = [Y_1, Y_2, \dots, Y_k, \dots] \quad (\text{Eq. 4})$$

20

$$Y = [C_1 / T_1, C_2 / T_1, \dots, C_{432} / T_1, C_1 / T_2, \dots] \quad (\text{Eq. 5})$$

Y_k designates the output of the MCM modulator 314, i.e. the input to the differential detector 330, at a time k . Z_k designates the output of the differential detector 330. K designates the number of active carriers.
25

The output Z_k of the differential detector 330 contains a M -fold uncertainty corresponding to codeable phase shifts. In case of the QPSK this M -fold uncertainty is a 4-fold uncertainty, i.e. 0° , 90° , 180° and 270° . This phase shift uncertainty is eliminated from Z_k making use of a M -PSK decision device 340. Such decision devices are known in the art and, therefore, have not to be described here in detail. The output of the decision device 340 (\hat{a}_k)* represents the complex
35 conjugate of the codeable phase shift decided by the decision device 340. This output of the decision device 340 is

correlated with the output of the differential detector 330 by performing a complex multiplication using a multiplier 342.

5 The output the multiplier 342 represents the phase offset for the respective sub-carriers. This phase offsets for the respective sub-carriers are averaged over one MCM symbol in an averaging unit 344 in accordance with a preferred embodiment of the present invention. The output of the averaging
10 units 344 represent the output of the fine frequency error detector 320.

The mathematical description for this procedure is as follows:

15

$$f_{offset} = \frac{1}{2\pi K T_{MCM}} \arg \left\{ \sum_{n=1}^K Z_n \cdot \left(\hat{a}_n \right)^* \right\} \quad (\text{Eq. 6})$$

In accordance with preferred embodiments of the present invention, the frequency control loop has a backward structure. In the embodiment shown in Figure 6, the feedback loop
20 is connected between the output of the MCM demodulator 314 and the input of the guard interval removal unit 132.

In Figure 8, a block diagram of a MCM receiver comprising a
25 coarse frequency correction unit 350 and a fine frequency correction unit as described above is shown. As shown in Figure 8, a common complex multiplier 326 can be used in order to perform the coarse frequency correction and the fine frequency correction. As shown in Figure 8, the multiplier
30 326 can be provided preceding the low pass filter and decimator unit 312. Depending on the position of the multiplier 326, a hold unit has to be provided in the fine frequency synchronization feedback loop. In an alternative embodiment, it is possible to use two separate multipliers for the
35 coarse frequency correction and for the fine frequency correction. In such a case, the multiplier for the coarse frequency correction will be arranged preceding the low path

filter and decimator unit, whereas the multiplier for the fine frequency correction will be arranged following the low path filter and decimator unit.

- 5 Following, preferred embodiments for implementing a coarse frequency synchronization will be described referring to Figures 9 and 10.

10 As it is shown in Figure 9, the output of the receiver front end 132 is connected to an analog/digital converter 310. The down-converted MCM signal is sampled at the output of the analog/digital converter 310 and is applied to a frame/timing synchronization unit 360. In a preferred embodiment, a fast running automatic gain control (AGC) (not shown) is provided preceding the frame/timing synchronization unit in order to eliminate fast channel fluctuations. The fast AGC is used in addition to the normally slow AGC in the signal path, in the case of transmission over a multipath channel with long channel impulse response and frequency selective fading. The fast AGC adjusts the average amplitude range of the signal to the known average amplitude of the reference symbol.

15
20
25 As described above, the frame/timing synchronization unit uses the amplitude-modulated sequence in the received signal in order to extract the framing information from the MCM signal and further to remove the guard intervals therefrom. After the frame/timing synchronization unit 360 it follows a coarse frequency synchronization unit 362 which estimates a coarse frequency offset based on the amplitude-modulated sequence of the reference symbol of the MCM signal. In the coarse frequency synchronization unit 362, a frequency offset of the carrier frequency with respect to the oscillator frequency in the MCM receiver is determined in order to perform a frequency offset correction in a block 364. This frequency offset correction in block 364 is performed by a complex multiplication.

The output of the frequency offset correction block 364 is applied to the MCM demodulator 366 formed by the Fast Fourier Transformator 140 and the carrier-bit mapper 142 shown in Figure 1.

5

In order to perform the coarse frequency synchronization described herein, an amplitude-demodulation has to be performed on a preprocessed MCM signal. The preprocessing may be, for example, the down-conversion and the analog/digital conversion of the MCM signal. The result of the amplitude-demodulation of the preprocessed MCM signal is an envelope representing the amplitude of the MCM signal.

15 For the amplitude demodulation a simple $\alpha_{\max+}$ $\beta_{\min-}$ method can be used. This method is described for example in Palacherla A.: DSP- μ P Routine Computes Magnitude, EDN, October 26, 1989; and Adams, W. T., and Bradley, J.: Magnitude Approximations for Microprocessor Implementation, IEEE Micro, Vol. 3, No. 5, October 1983.

20

It is clear that amplitude determining methods different from the described $\alpha_{\max+}$ $\beta_{\min-}$ method can be used. For simplification, it is possible to reduce the amplitude calculation to a detection as to whether the current amplitude is above or below the average amplitude. The output signal then consists of a -1/+1 sequence which can be used to determine a coarse frequency offset by performing a correlation. This correlation can easily be performed using a simple integrated circuit (IC).

30

In addition, an oversampling of the signal received at the RF front end can be performed. For example, the received signal can be expressed with two times oversampling.

35 In accordance with a first embodiment, a carrier frequency offset of the MCM signal from an oscillator frequency in the MCM receiver is determined by correlating the envelope obtained by performing the amplitude-demodulation as described above with a predetermined reference pattern.

In case there is no frequency offset, the received reference symbol $r(k)$ will be:

5
$$r(k) = S_{AM}(k) + n(k) \tag{Eq.7}$$

wherein $n(k)$ designates "additive Gaussian noise" and S_{AM} denotes the AM sequence which has been sent. In order to simplify the calculation the additive Gaussian noise can be neglected. It follows:

10
$$r(k) \cong S_{AM}(k) \tag{Eq.8}$$

In case a constant frequency offset Δf is present, the received signal will be:

15
$$\tilde{r}(k) = S_{AM}(k) \cdot e^{j2\pi\Delta f k T_{MCM}} \tag{Eq.9}$$

Information regarding the frequency offset is derived from the correlation of the received signal $\tilde{r}(k)$ with the AM sequence S_{AM} which is known in the receiver:

20
$$\sum_{k=1}^{\frac{L}{2}} \tilde{r}(k) \cdot S_{AM}^*(k) = \sum_{k=1}^{\frac{L}{2}} |S_{AM}(k)|^2 e^{j2\pi\Delta f k T_{MCM}} \tag{Eq.10}$$

25 Thus, the frequency offset is:

$$\Delta f = \frac{1}{2\pi T_{MCM}} \arg \left(\sum_{k=1}^{\frac{L}{2}} r(k) \cdot S_{AM}^*(k) \right) - \frac{1}{2\pi T_{MCM}} \arg \left(\sum_{k=1}^{\frac{L}{2}} |S_{AM}(k)|^2 \right) \tag{Eq.11}$$

30 since the argument of $|S_{AM}(k)|^2$ is zero the frequency offset is:

00527 02E2950

$$\Delta f = \frac{1}{2\pi T_{MCM}} \arg \left(\sum_{k=1}^{\frac{L}{2}} \tilde{r}(k) \cdot S_{AM}^* \right) \quad (\text{Eq. 12})$$

In accordance with a second embodiment of the coarse frequency synchronization algorithm, a reference symbol comprising at least two identical sequences 370 as shown in Figure 10 is used. Figure 10 shows the reference symbol of a MCM signal having two identical sequences 370 of a length of L/2 each. L designates the number of values of the two sequences 370 of the reference symbol.

As shown in Figure 10, within the amplitude-modulated sequence, there are at least two identical sections devoted to the coarse frequency synchronization. Two such sections, each containing L/2 samples, are shown at the end of the amplitude-modulated sequence in Figure 10. The amplitude-modulated sequence contains a large number of samples. For a non-ambiguous observation of the phase, only enough samples to contain a phase rotation of 2π should be used. This number is defined as L/2 in Figure 10.

Following, a mathematical derivation of the determination of a carrier frequency deviation is presented. In accordance with Figure 10, the following equation applies for the two identical sequences 370:

$$s\left(0 < k \leq \frac{L}{2}\right) \equiv s\left(\frac{L}{2} < k \leq L\right) \quad (\text{Eq. 13})$$

If no frequency offset is present, the following equation 14 will be met by the received signal:

$$r\left(k + \frac{L}{2}\right) \equiv r(k) \quad 0 < k \leq \frac{L}{2} \quad (\text{Eq. 14})$$

r(k) designates the values of the identical sequences. k is an index from one to L/2 for the respective samples.

If there is a frequency offset of, for example, Δf, the received signal is:

$$\tilde{r}(k) = r(k) \cdot e^{j2\pi\Delta f k T_{MCM}} \tag{Eq.15}$$

$$\tilde{r}\left(k + \frac{L}{2}\right) = r(k) \cdot e^{j2\pi\Delta f \left(k + \frac{L}{2}\right) T_{MCM}} \tag{Eq.16}$$

10

r(k) designates sample values of the received portion which are based on the identical sequences. Information regarding the frequency offset is derived from the correlation of the received signal $\tilde{r}\left(k + \frac{L}{2}\right)$ with the received signal $\tilde{r}(k)$.

15 This correlation is given by the following equation:

$$\sum_{k=1}^{\frac{L}{2}} \tilde{r}^*\left(k + \frac{L}{2}\right) \tilde{r}(k) = \sum_{k=1}^{\frac{L}{2}} |r(k)|^2 e^{-j2\pi\Delta f \frac{L}{2} T_{MCM}} \tag{Eq.17}$$

\tilde{r}^* designates the complex conjugate of the sample values of the portion mentioned above.

20

Thus, the frequency offset is

$$\Delta f = \frac{1}{2\pi \frac{L}{2} T_{MCM}} \arg\left(\sum_{k=1}^{\frac{L}{2}} \tilde{r}\left(k + \frac{L}{2}\right) \cdot \tilde{r}^*(k)\right) - \frac{1}{2\pi \frac{L}{2} T_{MCM}} \arg\left(\sum_{k=1}^{\frac{L}{2}} |\tilde{r}(k)|^2\right) \tag{Eq.18}$$

25

Since the argument of $|\tilde{r}(k)|^2$ equals zero, the frequency offset becomes

005211"0202/960

$$\Delta f = \frac{1}{2\pi \frac{L}{2} T_{MCM}} \arg \left(\sum_{k=1}^{\frac{L}{2}} \tilde{r} \left(k + \frac{L}{2} \right) \cdot \tilde{r}^*(k) \right) \quad (\text{Eq.19})$$

Thus, it is clear that in both embodiments, described above, the frequency position of the maximum of the resulting output of the correlation determines the estimated value of the offset carrier. Furthermore, as it is also shown in Figure 9, the correction is performed in a feed forward structure.

In case of a channel with strong reflections, for example due to a high building density, the correlations described above might be insufficient for obtaining a suitable coarse frequency synchronization. Therefore, in accordance with a third embodiment of the present invention, corresponding values of the two portions which are correlated in accordance with a second embodiment, can be weighting with corresponding values of stored predetermined reference patterns corresponding to said two identical sequences of the reference symbol. This weighting can maximize the probability of correctly determining the frequency offset. The mathematical description of this weighting is as follows:

$$\Delta f = \frac{1}{2\pi \frac{L}{2} T_{MCM}} \arg \left(\sum_{k=1}^{\frac{L}{2}} \left[\tilde{r} \left(k + \frac{L}{2} \right) \cdot \tilde{r}^*(k) \right] \cdot \left[S_{AM}(k) S_{AM}^* \left(k + \frac{L}{2} \right) \right] \right) \quad (\text{Eq.20})$$

S_{AM} designates the amplitude-modulated sequence which is known in the receiver, and S_{AM}^* designates the complex conjugate thereof.

If the above correlations are calculated in the frequency domain, the amount of

$$\sum_{k=1}^{\frac{L}{2}} \left[\tilde{r} \left(k + \frac{L}{2} \right) \cdot \tilde{r}^*(k) \right] \cdot \left[S_{AM}(k) S_{AM}^* \left(k + \frac{L}{2} \right) \right] \quad (\text{Eq.21})$$

is used rather than the argument. This amount is maximized as a function of a frequency correction. The position of the maximum determines the estimation of the frequency deviation. As mentioned above, the correction is performed in a feed forward structure.

Preferred embodiments for performing an echo phase offset correction when using a differential mapping in the frequency axis will be described hereinafter referring to Figures 12 to 15.

Systematic phase shifts stemming from echoes in multipath environments may occur between subcarriers in the same MCM symbol. This phase offsets can cause bit errors when demodulating the MCM symbol at the receiver. Thus, it is preferred to make use of an algorithm to correct the systematic phase shifts stemming from echoes in multipath environments.

In Figure 12, scatter diagrams at the output of a differential demapper of a MCM receiver are shown. As can be seen from the left part of Figure 12, systematic phase shifts between subcarriers in the same MCM symbol cause a rotation of the demodulated phase shifts with respect to the axis of the complex coordinate system. In the right part of Figure 12, the demodulated phase shifts after having performed an echo phase offset correction are depicted. Now, the positions of the signal points are substantially on the axis of the complex coordinate system. These positions correspond to the modulated phase shifts of 0° , 90° , 180° and 270° , respectively.

An echo phase offset correction algorithm (EPOC algorithm) must calculate the echo induced phase offset from the signal space constellation following the differential demodulation and subsequently correct this phase offset.

For illustration purposes, one may think of the simplest algorithm possible which eliminates the symbol phase before

computing the mean of all phases of the subcarriers. To illustrate the effect of such an EPOC algorithm, reference is made to the two scatter diagrams of subcarriers symbols contained in one MCM symbol in Figure 12. This scatter diagrams
5 have been obtained as result of an MCM simulation. For the simulation a channel has been used which might typically show up in single frequency networks. The echoes of this channel stretched to the limits of the MCM guard interval. The guard interval was chosen to be 25% of the MCM symbol
10 duration in this case.

Figure 13 represents a block diagram for illustrating the position and the functionality of an echo phase offset correction device in a MCM receiver. The signal of a MCM transmitter is transmitted through the channel 122 (Figures 1 and 13) and received at the receiver frontend 132 of the MCM receiver. The signal processing between the receiver frontend and the fast Fourier transformator 140 has been omitted in
15 Figure 13. The output of the fast Fourier transformator is applied to the de-mapper, which performs a differential de-mapping along the frequency axis. The output of the de-mapper are the respective phase shifts for the subcarriers. The phase offsets of this phase shifts which are caused by
20 echoes in multipath environments are visualized by a block 400 in Figure 13 which shows an example of a scatter diagram of the subcarrier symbols without an echo phase offset correction.

The output of the de-mapper 142 is applied to the input of an echo phase offset correction device 402. The echo phase offset correction device 402 uses an EPOC algorithm in order to eliminate echo phase offsets in the output of the de-mapper 142. The result is shown in block 404 of Figure 13,
30 i.e. only the encoded phase shifts, 0° , 90° , 180° or 270° are present at the output of the correction device 402. The output of the correction device 402 forms the signal for the metric calculation which is performed in order to recover the bitstream representing the transmitted information.
35

A first embodiment of an EPOC algorithm and a device for performing same is now described referring to Figure 14.

5 The first embodiment of an EPOC algorithm starts from the assumption that every received differentially decoded complex symbol is rotated by an angle due to echoes in the multipath channel. For the subcarriers equal spacing in frequency is assumed since this represents a preferred embodiment. If the subcarriers were not equally spaced in frequency, a correction factor would have to be introduced into the EPOC algorithm.

10 Figure 14 shows the correction device 402 (Figure 13) for performing the first embodiment of an EPOC algorithm.

15 From the output of the de-mapper 142 which contains an echo phase offset as shown for example in the left part of Figure 12, the phase shifts related to transmitted information must first be discarded. To this end, the output of the de-mapper 142 is applied to a discarding unit 500. In case of a DQPSK mapping, the discarding unit can perform a " $(.)^4$ " operation. The unit 500 projects all received symbols into the first quadrant. Therefore, the phase shifts related to transmitted information is eliminated from the phase shifts representing the subcarrier symbols. The same effect could be reached with a modulo-4 operation.

25 Having eliminated the information related symbol phases in unit 500, the first approach to obtain an estimation would be to simply compute the mean value over all symbol phases of one MCM symbol. However, it is preferred to perform a threshold decision before determining the mean value over all symbol phases of one MCM symbol. Due to Rayleigh fading some of the received symbols may contribute unreliable information to the determination of the echo phase offset. Therefore, depending on the absolute value of a symbol, a threshold decision is performed in order to determine

whether the symbol should contribute to the estimate of the phase offset or not.

Thus, in the embodiment shown in Figure 14, a threshold decision unit 510 is included. Following the unit 500 the absolute value and the argument of a differentially decoded symbol is computed in respective computing units 512 and 514. Depending on the absolute value of a respective symbol, a control signal is derived. This control signal is compared with a threshold value in a decision circuit 516. If the absolute value, i.e. the control signal thereof, is smaller than a certain threshold, the decision circuit 516 replaces the angle value going into the averaging operation by a value equal to zero. To this end, a switch is provided in order to disconnect the output of the argument computing unit 514 from the input of the further processing stage and connects the input of the further processing stage with a unit 518 providing a constant output of "zero".

An averaging unit 520 is provided in order to calculate a mean value based on the phase offsets φ_i determined for the individual subcarrier symbols of a MCM symbol as follows:

$$\bar{\varphi} = 1 / K \sum_{i=1}^K \varphi_i \quad (\text{Eq.22})$$

In the averaging unit 520, summation over K summands is performed. The output of the averaging unit 520 is provided to a hold unit 522 which holds the output of the averaging unit 520 K times. The output of the hold unit 522 is connected with a phase rotation unit 524 which performs the correction of the phase offsets of the K complex signal points on the basis of the mean value $\bar{\varphi}$.

The phase rotation unit 524 performs the correction of the phase offsets by making use of the following equation:

$$v_k' = v_k \cdot e^{-j\bar{\varphi}} \quad (\text{Eq.23})$$

In this equation, v'_k designates the K phase corrected differentially decoded symbols for input into the soft-metric calculation, whereas v_k designates the input symbols. As long as a channel which is quasi stationary during the duration of one MCM symbols can be assumed, using the mean value over all subcarriers of one MCM symbol will provide correct results.

5
10 A buffer unit 527 may be provided in order to buffer the complex signal points until the mean value of the phase offsets for one MCM symbol is determined. The output of the phase rotation unit 524 is applied to the further processing stage 526 for performing the soft-metric calculation.

15
20 With respect to the results of the above echo phase offset correction, reference is made again to Figure 12. The two plots stem from a simulation which included the first embodiment of an echo phase offset correction algorithm described above. At the instant of the scatter diagram snapshot shown in the left part of Figure 12, the channel obviously distorted the constellation in such a way, that a simple angle rotation is a valid assumption. As shown in the right part of Figure 12, the signal constellation can be rotated back to the axis by applying the determined mean value for the rotation of the differentially detected symbols.

25
30 A second embodiment of an echo phase offset correction algorithm is described hereinafter. This second embodiment can be preferably used in connection with multipath channels that have up to two strong path echoes. The algorithm of the second embodiment is more complex than the algorithm of the first embodiment.

35 what follows is a mathematical derivation of the second embodiment of a method for echo phase offset correction. The following assumptions can be made in order to ease the explanation of the second embodiment of an EPOC algorithm.

In this embodiment, the guard interval of the MCM signal is assumed to be at least as long as the impulse response $h[q]$, $q = 0, 1, \dots, Q_h-1$ of the multipath channel.

5

At the transmitter every MCM symbol is assembled using frequency axis mapping explained above. The symbol of the reference subcarrier equals 1, i.e. 0 degree phase shift. The optional phase shift PHI equals zero, i.e. the DQPSK signal constellation is not rotated.

10

Using an equation this can be expressed as

15 (Eq.24)
$$a_k = a_{k-1} a_k^{inc}$$

with

k : index $k = 1, 2, \dots, K$ of the active subcarrier;

20
$$a_k^{inc} = e^{j\frac{\pi}{2}m}$$
 : complex phase increment symbol; $m=0, 1, 2, 3$ is the QPSK symbol number which is derived from Gray encoding pairs of 2 Bits;

$a_0 = 1$: symbol of the reference subcarrier.

25

At the DFT output of the receiver the decision variables

$$e_k = a_k H_k \tag{Eq.25}$$

30 are obtained with

$$H_k = \sum_{i=0}^{Q_h-1} h[i] \cdot e^{-j\frac{2\pi}{K}ki} \tag{Eq.26}$$

35 being the DFT of the channel impulse response $h[q]$ at position k .

006217" 022E2960

with $|a_k|^2 = 1$ the differential demodulation yields

$$v_k = e_k \cdot e_{k-1}^* = a_k^{inc} H_k H_{k-1}^* \tag{Eq.27}$$

5 For the receiver an additional phase term φ_k is introduced, which shall be used to correct the systematic phase offset caused by the channel. Therefore, the final decision variable at the receiver is

10
$$v'_k = v_k \cdot e^{j\varphi_k} = a_k^{inc} \cdot e^{j\varphi_k} \cdot H_k \cdot H_{k-1}^*$$

(Eq.28)

As can be seen from the Equation 28, the useful information a_k^{inc} is weighted with the product $e^{j\varphi_k} \cdot H_k \cdot H_{k-1}^*$ (rotation and
15 effective transfer function of the channel). This product must be real-valued for an error free detection. Considering this, it is best to choose the rotation angle to equal the negative argument of $H_k \cdot H_{k-1}^*$. To derive the desired algorithm for 2-path channels, the nature of $H_k \cdot H_{k-1}^*$ is investi-
20 gated in the next section.

It is assumed that the 2-path channel exhibits two echoes with energy content unequal zero, i.e. at least two dominant echoes. This assumption yields the impulse response

25
$$h[q] = c_1 \delta_0[q] + c_2 \delta_0[q - q_0] \tag{Eq.29}$$

with

- 30 c_1, c_2 : complex coefficients representing the path echoes;
 q_0 : delay of the second path echo with respect to the first path echo;
 δ_0 : Dirac pulse; $\delta_0[k] = 1$ for $k = 0$
 $\delta_0[k] = 0$ else

35

The channel transfer function is obtained by applying a DFT to Equation 29:

$$H_k = H\left(e^{j\frac{2\pi}{K}k}\right) = c_1 + c_2 \cdot e^{-j\frac{2\pi}{K}kq_0} \quad (\text{Eq. 30})$$

5

With Equation 30 the effective transfer function for differential demodulation along the frequency axis is:

$$\begin{aligned} H_k \cdot H_{k-1}^* &= \left(c_1 + c_2 e^{-j\frac{2\pi}{K}kq_0} \right) \cdot \left(c_1^* + c_2^* e^{+j\frac{2\pi}{K}(k-1)q_0} \right) \\ &= c_a + c_b \cos\left(\frac{\pi}{K} q_0(2k - 1)\right) \end{aligned} \quad (\text{Eq. 31})$$

10

Assuming a noise free 2-path channel, it can be observed from Equation 31 that the symbols on the receiver side are located on a straight line in case the symbol $1+j0$ has been send (see above assumption). This straight line can be characterized by a point

15

$$c_a = |c_1|^2 + |c_2|^2 \cdot e^{-j\frac{2\pi}{K}q_0} \quad (\text{Eq. 32})$$

20 and the vector

$$c_b = 2c_1c_2^* \cdot e^{-j\frac{\pi}{K}q_0} \quad (\text{Eq. 33})$$

which determines its direction.

25

With the above assumptions, the following geometric derivation can be performed. A more suitable notation for the geometric derivation of the second embodiment of an EPOC algorithm is obtained if the real part of the complex plane is designated as $x = \text{Re}\{z\}$, the imaginary part as $y = \text{Im}\{z\}$, respectively, i.e. $z = x+jy$. With this new notation, the straight line, on which the received symbols will lie in case of a noise-free two-path channel, is

30

00527" 02E2960

$$f(x) = a + b \cdot x \tag{Eq. 34}$$

with

5

$$a = \text{Im}\{c_a\} - \frac{\text{Re}\{c_a\}}{\text{Re}\{c_b\}} \cdot \text{Im}\{c_b\} \tag{Eq. 35}$$

and

10

$$b = - \frac{\text{Im}\{c_a\} - \frac{\text{Re}\{c_a\}}{\text{Re}\{c_b\}} \cdot \text{Im}\{c_b\}}{\text{Re}\{c_a\} - \frac{\text{Im}\{c_a\}}{\text{Im}\{c_b\}} \cdot \text{Re}\{c_b\}} \tag{Eq. 36}$$

Additional noise will spread the symbols around the straight line given by Equations 34 to 36. In this case Equation 36 is the regression curve for the cluster of symbols.

15

For the geometric derivation of the second embodiment of an EPOC algorithm, the angle φ_k from Equation 28 is chosen to be a function of the square distance of the considered symbol from the origin:

20

$$\varphi_k = f_k(|z|^2) \tag{Eq. 37}$$

25

Equation 37 shows that the complete signal space is distorted (torsion), however, with the distances from the origin being preserved.

30

For the derivation of the algorithm of the second embodiment, $f_k(\cdot)$ has to be determined such that all decision variables v'_k (assuming no noise) will come to lie on the real axis:

$$\text{Im}\{(x + jf(x)) \cdot e^{jf_k(|z|^2)}\} = 0 \tag{Eq. 38}$$

005217 04222960

Further transformations of Equation 38 lead to a quadratic equation which has to be solved to obtain the solution for φ_k .

- 5 In case of a two-path channel, the echo phase offset correction for a given decision variable v_k is

$$v_k' = v_k \cdot e^{j\varphi_k} \tag{Eq. 39}$$

- 10 with

$$\varphi_k = \begin{cases} -a \tan\left(\frac{a + b\sqrt{|v_k|^2(1 + b^2) - a^2}}{-ab + \sqrt{|v_k|^2(1 + b^2) - a^2}}\right) & \text{for } |v_k|^2 \geq \frac{a^2}{1 + b^2} \\ a \tan\left(\frac{1}{b}\right) & \text{for } |v_k|^2 < \frac{a^2}{1 + b^2} \end{cases} \tag{Eq. 40}$$

- 15 From the two possible solutions of the quadratic equation mentioned above, Equation 40 is the one solution that cannot cause an additional phase shift of 180 degrees.

The two plots in Figure 15 show the projection of the EPOC
 20 algorithm of the second embodiment for one quadrant of the complex plane. Depicted here is the quadratic grid in the sector $|\arg(z)| \leq \pi / 4$ and the straight line $y = f(x) = a + b \cdot x$ with $a = -1.0$ and $b = 0.5$ (dotted line). In case of a noise-free channel, all received symbols will
 25 lie on this straight line if $1+j0$ was send. The circle shown in the plots determines the boarder line for the two cases of Equation 40. In the left part, Figure 15 shows the situation before the projection, in the right part, Figure 15 shows the situation after applying the projection algorithm.
 30 By looking on the left part, one can see, that the straight line now lies on the real axis with $2+j0$ being the fix point of the projection. Therefore, it can be concluded that the echo phase offset correction algorithm according to the second embodiment fulfills the design goal.

005277 0222380

Before the second embodiment of an EPOC algorithm can be applied, the approximation line through the received symbols has to be determined, i.e. the parameters a and b must be estimated. For this purpose, it is assumed that the received symbols lie in sector $|\arg(z)| \leq \pi / 4$, if $1+j0$ was sent. If symbols other than $1+j0$ have been sent, a modulo operation can be applied to project all symbols into the desired sector. Proceeding like this prevents the necessity of deciding on the symbols in an early stage and enables averaging over all signal points of one MCM symbol (instead of averaging over only $\frac{1}{4}$ of all signal points).

For the following computation rule for the EPOC algorithm of the second embodiment, x_i is used to denote the real part of the i-th signal point and y_i for its imaginary part, respectively ($i = 1, 2, \dots, K$). Altogether, K values are available for the determination. By choosing the method of least squares, the straight line which has to be determined can be obtained by minimizing

$$(a, b) = \arg \min_{(\tilde{a}, \tilde{b})} \sum_{i=1}^K (y_i - (\tilde{a} + \tilde{b} \cdot x_i))^2 \quad (\text{Eq. 41})$$

The solution for Equation 41 can be found in the laid open literature. It is

$$b = \frac{\sum_{i=1}^K (x_i - \bar{x}) \cdot y_i}{\sum_{i=1}^K (x_i - \bar{x})^2}, \quad a = \bar{y} - \bar{x} \cdot b \quad (\text{Eq. 42})$$

with mean values

$$\bar{x} = \frac{1}{N} \sum_{i=1}^K x_i, \quad \bar{y} = \frac{1}{N} \sum_{i=1}^K y_i \quad (\text{Eq. 43})$$

006677-02EEZ950

If necessary, an estimation method with higher robustness can be applied. However, the trade-off will be a much higher computational complexity.

5 To avoid problems with the range in which the projection is applicable, the determination of the straight line should be separated into two parts. First, the cluster's centers of gravity are moved onto the axes, following, the signal space is distorted. Assuming that a and b are the original parameters of the straight line and α is the rotation angle, $f_k(\cdot)$ has to be applied with the transformed parameters

$$b' = \frac{b \cdot \cos(\alpha) - \sin(\alpha)}{\cos(\alpha) + b \cdot \sin(\alpha)}, \quad a' = a \cdot (\cos(\alpha) - b' \cdot \sin(\alpha))$$

(Eq.44)

15 Besides the two EPOC algorithms explained above section, different algorithms can be designed that will, however, most likely exhibit a higher degree of computational complexity.

00627"02E2B50

ABSTRACT

5 A method and an apparatus relate to a fine frequency syn-
chronization compensating for a carrier frequency deviation
from an oscillator frequency in a multi-carrier demodulation
system of the type capable of carrying out a differential
phase decoding of multi-carrier modulated signals, the sig-
nals comprising a plurality of symbols, each symbol being
10 defined by phase differences between simultaneous carriers
having different frequencies. A phase difference between
phases of the same carrier in different symbols is deter-
mined. Thereafter, a frequency offset is determined by
eliminating phase shift uncertainties related to the trans-
15 mitted information from the phase difference making use of a
M-PSK decision device. Finally, a feedback correction of the
carrier frequency deviation is performed based on the deter-
mined frequency offset. Alternatively, an averaged frequency
offset can be determined by averaging determined frequency
20 offsets of a plurality of carriers. Then, the feedback cor-
rection of the frequency deviation is performed based on the
averaged frequency offset.

005277-0222/960

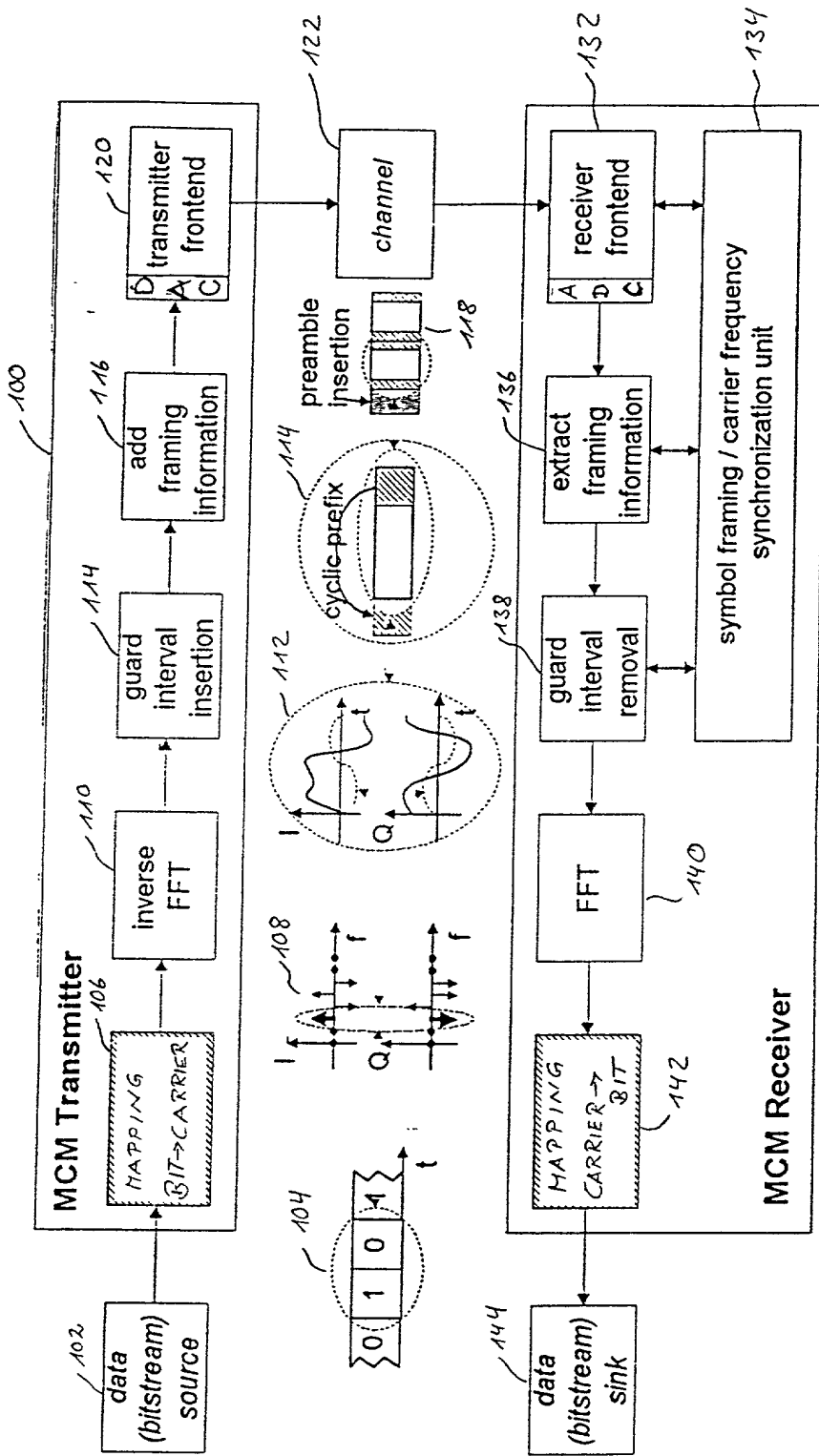
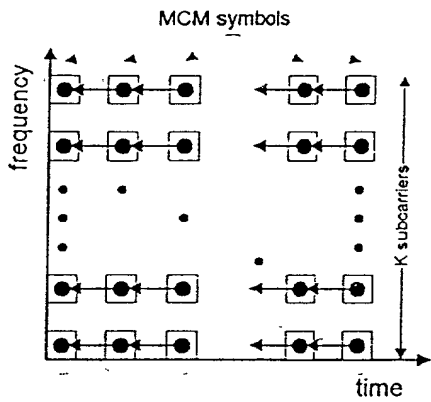
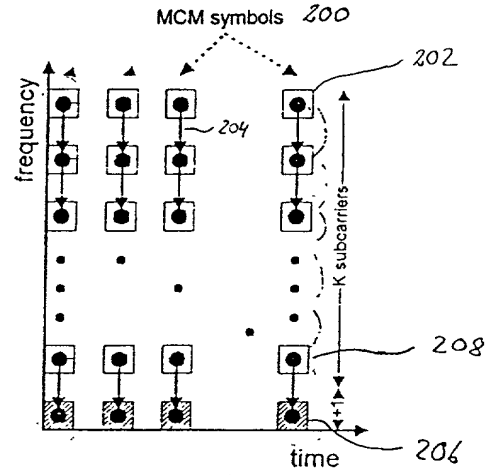

Fig. 1



- = MCM symbol
- = subcarrier

Fig. 2A



- = MCM symbol
- = subcarrier
- ▨ = reference subcarrier

Fig. 2B

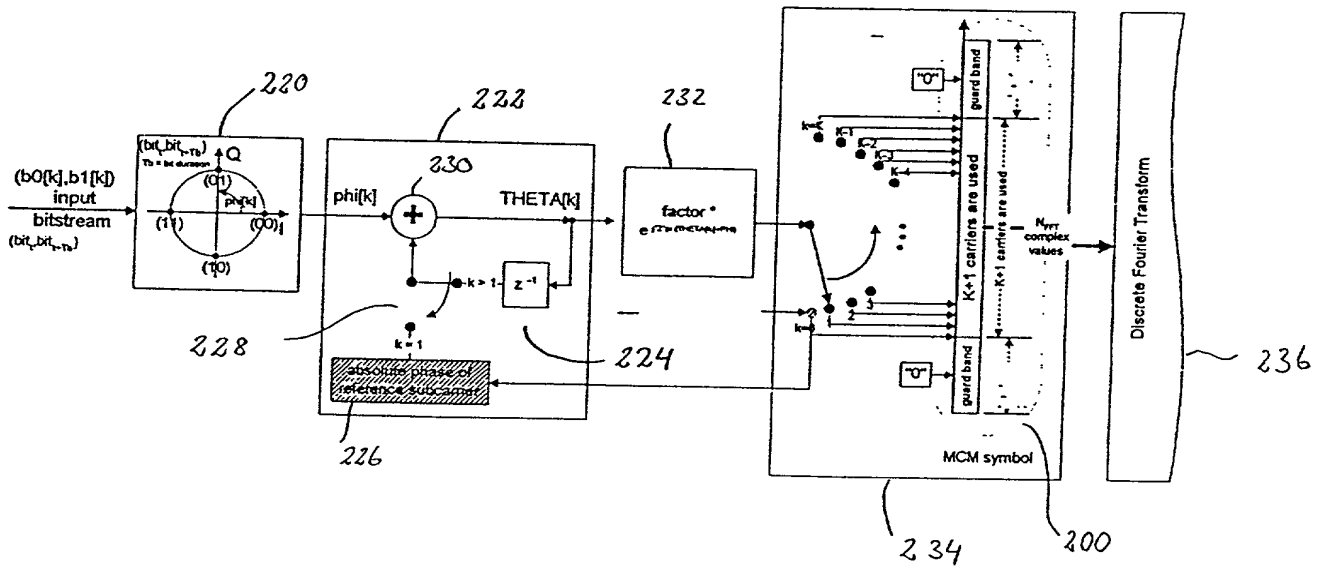
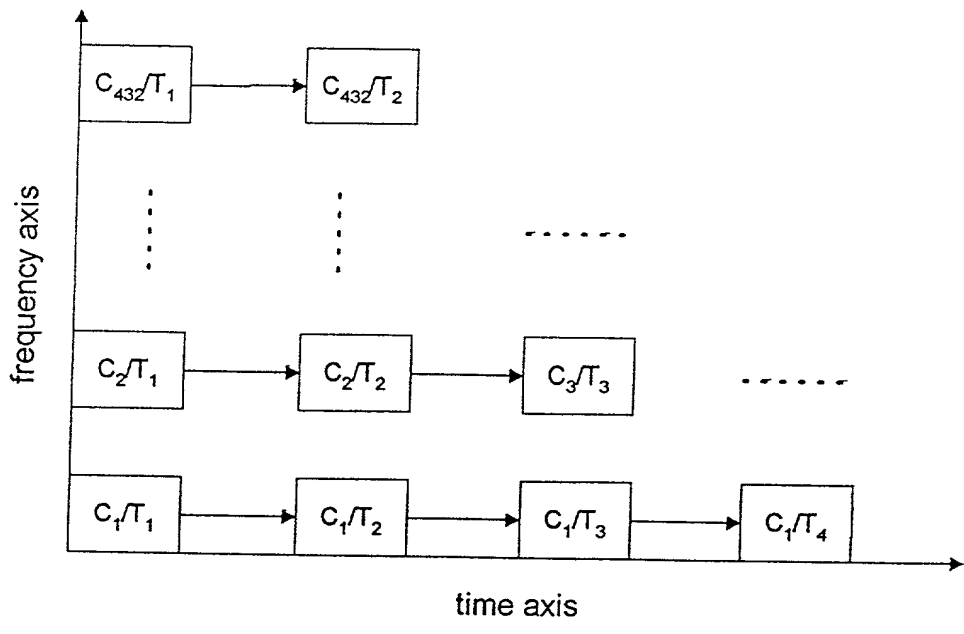

Fig. 3

00527 02262950



200

Fig 4

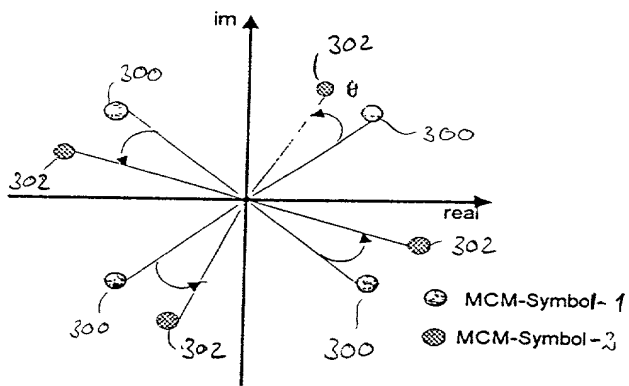

Fig. 5

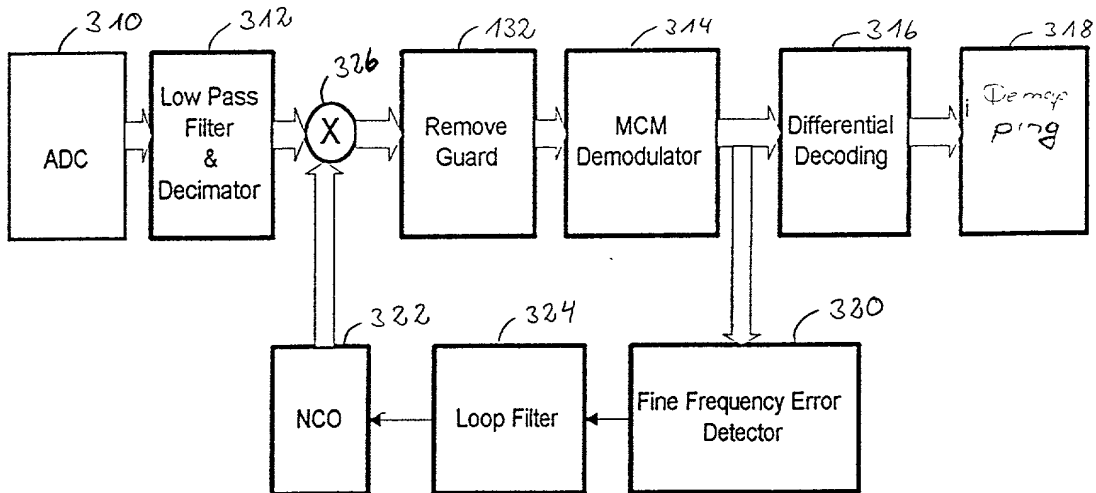

Fig. 6

005017 02E2960

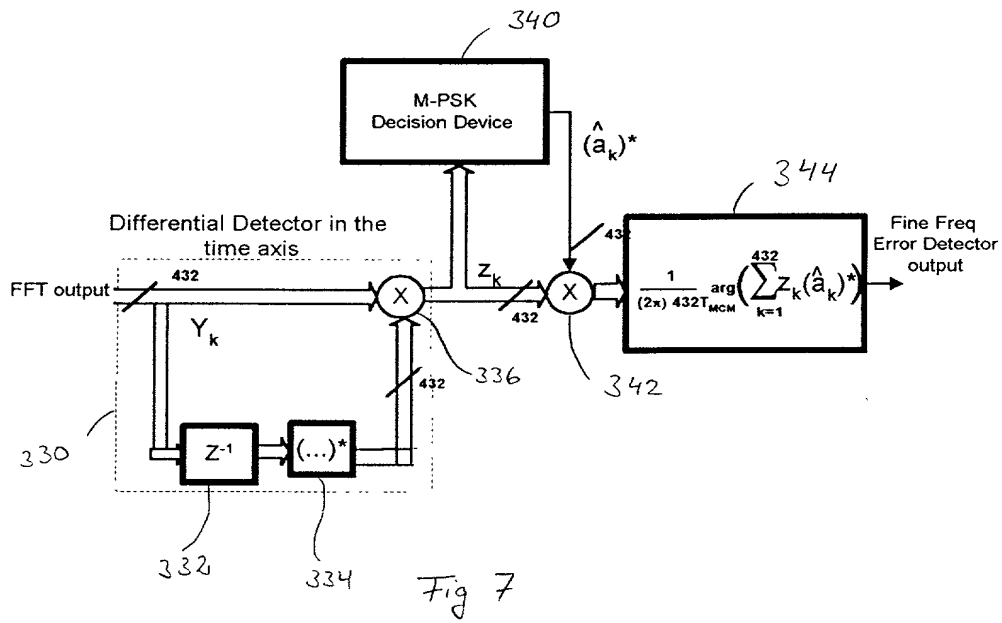

Fig. 7

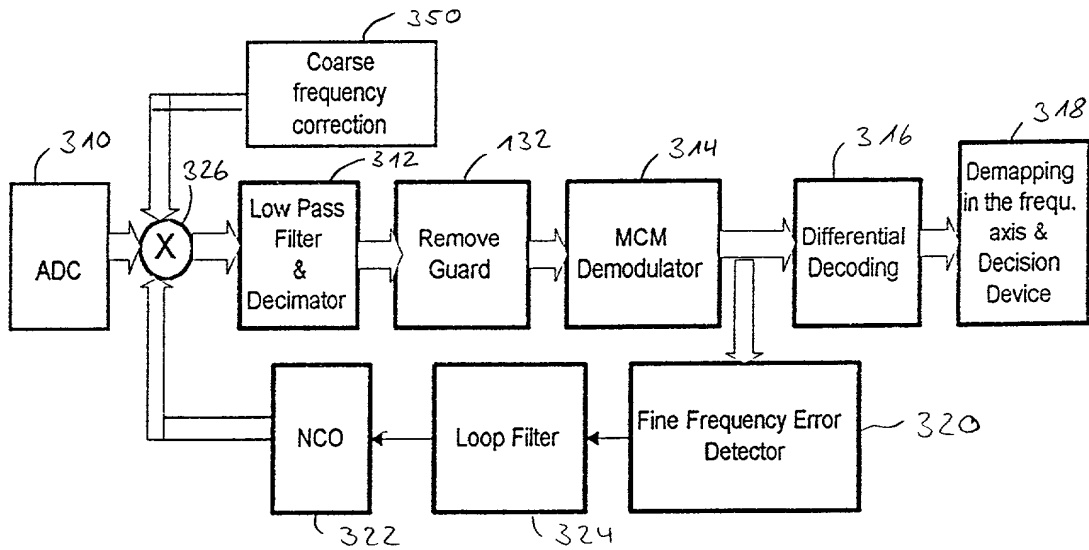

Fig. 8

006211 04227960

00527 0222960

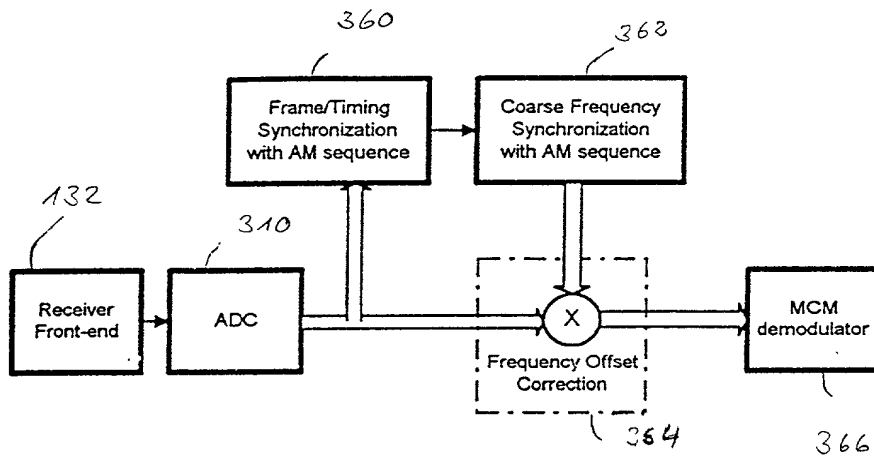

Fig. 9

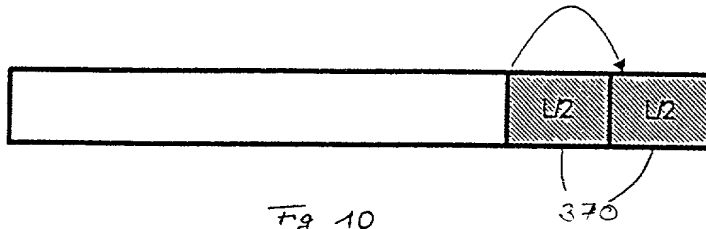

Fig 10

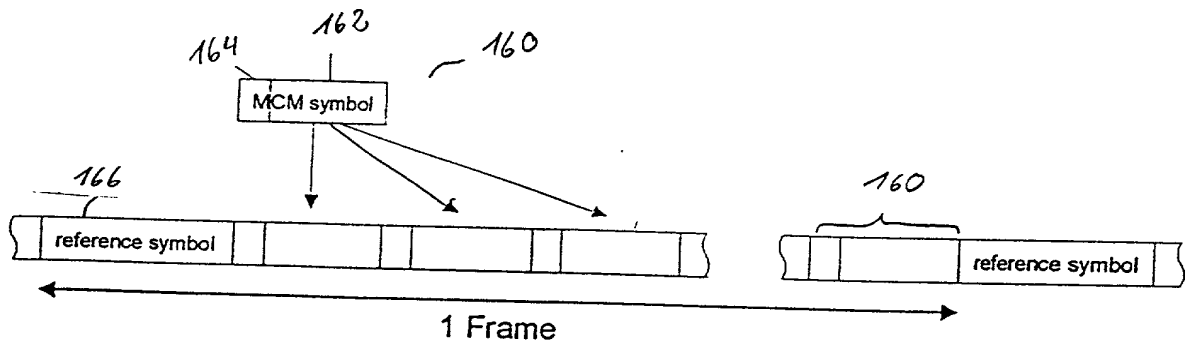

Fig. 11

006277-02E/960

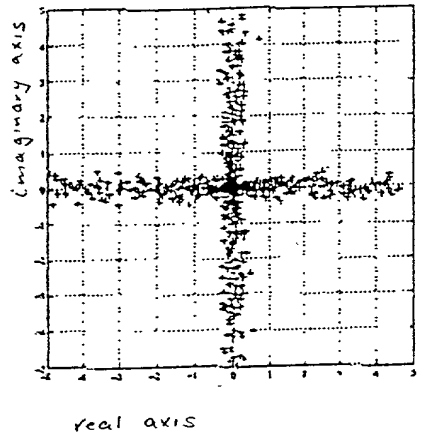
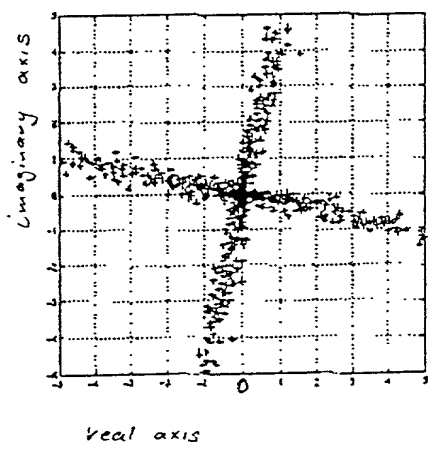

Fig. 12

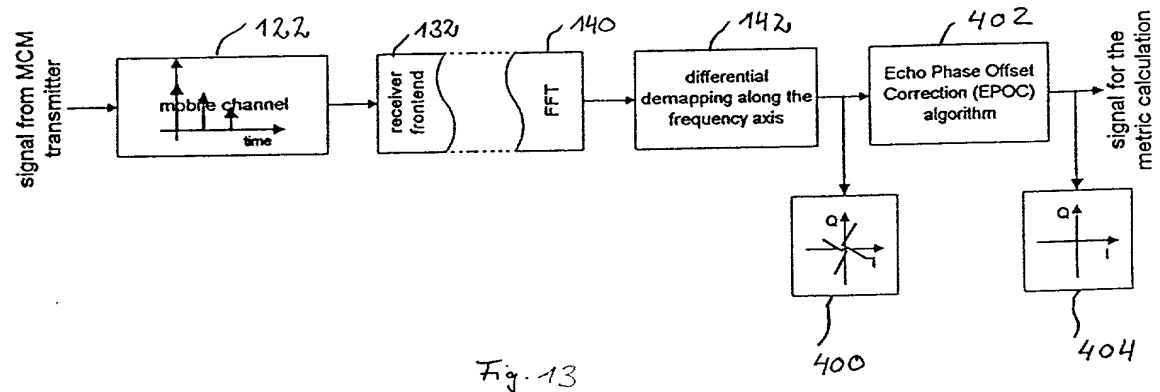

Fig. 13

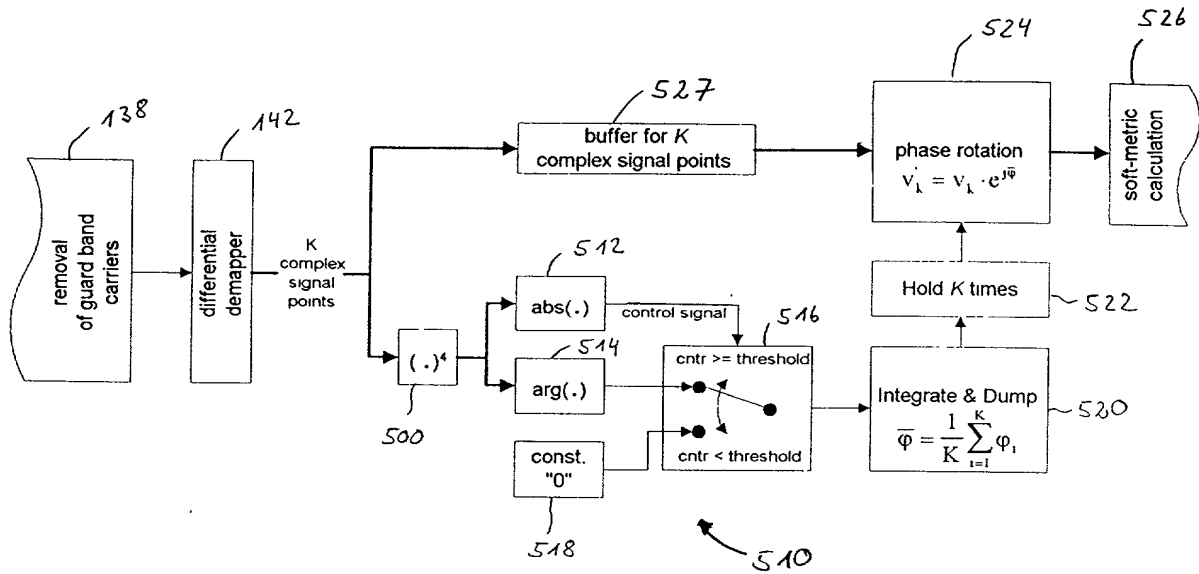

Fig 14

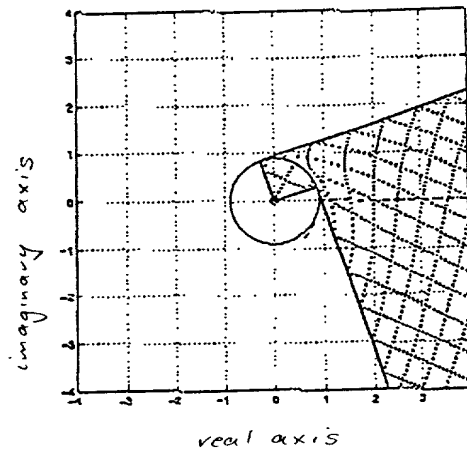
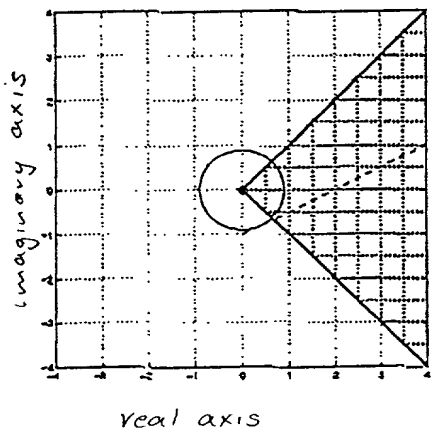

Fig 15

00527 0664960

71980404 PLS

Please type a plus sign (+) inside this box →

PTO/SB/01 (12-97)
Approved for use through 9/30/00. OMB 0651-0032
Patent and Trademark Office; U.S. DEPARTMENT OF COMMERCE

Under the Paperwork Reduction Act of 1995, no persons are required to respond to a collection of information unless it contains a valid OMB control number.

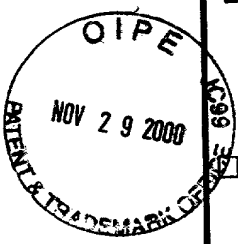

DECLARATION FOR UTILITY OR DESIGN PATENT APPLICATION (37 CFR 1.63) <input type="checkbox"/> Declaration Submitted with Initial Filing OR <input checked="" type="checkbox"/> Declaration Submitted after Initial Filing (surcharge (37 CFR 1.16 (e)) required)	Attorney Docket Number	41001
	First Named Inventor	Ernst Eberlein
	<i>COMPLETE IF KNOWN</i>	
	Application Number	/
	Filing Date	
	Group Art Unit	
	Examiner Name	

00673270 "119900

As a below named inventor, I hereby declare that:

My residence, post office address, and citizenship are as stated below next to my name.

I believe I am the original, first and sole inventor (if only one name is listed below) or an original, first and joint inventor (if plural names are listed below) of the subject matter which is claimed and for which a patent is sought on the invention entitled:

Method and Apparatus for Fine Frequency Synchronization in Multi-Carrier Demodulation Systems

the specification of which *(Title of the Invention)*

is attached hereto OR was filed on (MM/DD/YYYY) **04/14/98** as United States Application Number or PCT International Application Number **PCT/EP98/02184** and was amended on (MM/DD/YYYY) _____ (if applicable).

I hereby state that I have reviewed and understand the contents of the above identified specification, including the claims, as amended by any amendment specifically referred to above.

I acknowledge the duty to disclose information which is material to patentability as defined in 37 CFR 1.56.

I hereby claim foreign priority benefits under 35 U.S.C. 119(a)-(d) or 365(b) of any foreign application(s) for patent or inventor's certificate, or 365(a) of any PCT international application which designated at least one country other than the United States of America, listed below and have also identified below, by checking the box, any foreign application for patent or inventor's certificate, or of any PCT international application having a filing date before that of the application on which priority is claimed.

Prior Foreign Application Number(s)	Country	Foreign Filing Date (MM/DD/YYYY)	Priority Not Claimed	Certified Copy Attached?	
				YES	NO
			<input type="checkbox"/>	<input type="checkbox"/>	<input checked="" type="checkbox"/>
			<input type="checkbox"/>	<input type="checkbox"/>	<input checked="" type="checkbox"/>
			<input type="checkbox"/>	<input type="checkbox"/>	<input type="checkbox"/>
			<input type="checkbox"/>	<input type="checkbox"/>	<input type="checkbox"/>

Additional foreign application numbers are listed on a supplemental priority data sheet PTO/SB/02B attached hereto:

I hereby claim the benefit under 35 U.S.C. 119(e) of any United States provisional application(s) listed below.

Application Number(s)	Filing Date (MM/DD/YYYY)

Additional provisional application numbers are listed on a supplemental priority data sheet PTO/SB/02B attached hereto.

[Page 1 of 2]

Burden Hour Statement: This form is estimated to take 0.4 hours to complete. Time will vary depending upon the needs of the individual case. Any comments on the amount of time you are required to complete this form should be sent to the Chief Information Officer, Patent and Trademark Office, Washington, DC 20231. DO NOT SEND FEES OR COMPLETED FORMS TO THIS ADDRESS. SEND TO: Assistant Commissioner for Patents, Washington, DC 20231.

Please type a plus sign (+) inside this box →

PTO/SB/01 (12-97)
Approved for use through 9/30/00. OMB 0651-0032
Patent and Trademark Office; U.S. DEPARTMENT OF COMMERCE

Under the Paperwork Reduction Act of 1995, no persons are required to respond to a collection of information unless it contains a valid OMB control number.

DECLARATION — Utility or Design Patent Application

I hereby claim the benefit under 35 U.S.C. 120 of any United States application(s), or 365(c) of any PCT international application designating the United States of America, listed below and, insofar as the subject matter of each of the claims of this application is not disclosed in the prior United States or PCT International application in the manner provided by the first paragraph of 35 U.S.C. 112, I acknowledge the duty to disclose information which is material to patentability as defined in 37 CFR 1.56 which became available between the filing date of the prior application and the national or PCT international filing date of this application.

U.S. Parent Application or PCT Parent Number	Parent Filing Date (MM/DD/YYYY)	Parent Patent Number (if applicable)

Additional U.S. or PCT international application numbers are listed on a supplemental priority data sheet PTO/SB/02B attached hereto.

As a named inventor, I hereby appoint the following registered practitioner(s) to prosecute this application and to transact all business in the Patent and Trademark Office connected therewith:

Customer Number → Place Customer Number Bar Code Label here
OR
 Registered practitioner(s) name/registration number listed below

Name	Registration Number	Name	Registration Number
David S. Abrams	22,576	Stacey J. Longanecker	33,952
Robert H. Berdo	19,415	Joseph J. Bucznski	35,084
Alfred N. Goodman	26,458	Wayne C. Jaeschke, Jr.	38,503
Mark S. Bicks	28,770	Tara Laster Hoffman	P-46,510
John E. Holmes	29,392	Jeffrey J. Howell	46,402
Garrett V. Davis	32,023	Marcus R. Mickney	44,941
Lance G. Johnson	32,531	Christian C. Michel	46,300

Additional registered practitioner(s) named on supplemental Registered Practitioner Information sheet PTO/SB/02C attached hereto.

Direct all correspondence to: Customer Number OR Correspondence address below

Name	John E. Holmes					
Address	Roylance, Abrams, Berdo & Goodman, L.L.P.					
Address	1300 19th Street, N.W., Suite 600					
City	Washington	State	D.C.	ZIP	20036	
Country	USA	Telephone	(202)659-9076		Fax	(202)659-9344

I hereby declare that all statements made herein of my own knowledge are true and that all statements made on information and belief are believed to be true; and further that these statements were made with the knowledge that willful false statements and the like so made are punishable by fine or imprisonment, or both, under 18 U.S.C. 1001 and that such willful false statements may jeopardize the validity of the application or any patent issued thereon.

Name of Sole or First Inventor: A petition has been filed for this unsigned inventor

Given Name (first and middle (if any))			Family Name or Surname				
Ernst			Eberlein				
Inventor's Signature					Date		
Residence: City	Grossenseebach	State		Country	Germany	Citizenship	German
Post Office Address	Waldstrasse 28 b						
Post Office Address							
City	Grossenseebach	State		ZIP	D-91091	Country	Germany

Additional inventors are being named on the _____ supplemental Additional Inventor(s) sheet(s) PTO/SB/02A attached hereto

Please type a plus sign (+) inside this box →

PTO/SB/02A (3-97)
 Approved for use through 9/30/98. OMB 0651-0032
 Patent and Trademark Office; U.S. DEPARTMENT OF COMMERCE

Under the Paperwork Reduction Act of 1995, no persons are required to respond to a collection of information unless it contains a valid OMB control number.

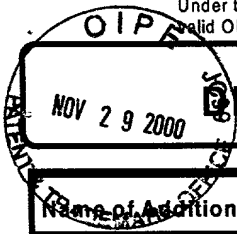

DECLARATION

ADDITIONAL INVENTOR(S)
 Supplemental Sheet
 Page 1 of 2

Name of Additional Joint Inventor, if any:		<input type="checkbox"/> A petition has been filed for this unsigned inventor					
Given Name (first and middle [if any])				Family Name or Surname			
Sabah				Badri			
Inventor's Signature						Date	
Residence: City		Erlangen		State		Country	
						Germany	
Citizenship		Moroccan					
Post Office Address		Sebaldustrasse 8					
Post Office Address							
City		Erlangen		State		ZIP	
						D-91058	
Country		Germany					
Name of Additional Joint Inventor, if any:		<input type="checkbox"/> A petition has been filed for this unsigned inventor					
Given Name (first and middle [if any])				Family Name or Surname			
Stefan				Lipp			
Inventor's Signature						Date	
Residence: City		Erlangen		State		Country	
						Germany	
Citizenship		German					
Post Office Address		Steinweg 9 a					
Post Office Address							
City		Erlangen		State		ZIP	
						D-91058	
Country		Germany					
Name of Additional Joint Inventor, if any:		<input type="checkbox"/> A petition has been filed for this unsigned inventor					
Given Name (first and middle [if any])				Family Name or Surname			
Stephan				Buchholz			
Inventor's Signature		<i>Stephan Buchholz</i>				Date	
						11/20/00	
Residence: City		Muenchen		State		Country	
						Germany	
Citizenship		German					
Post Office Address		Kerschbacher Strasse 8					
Post Office Address							
City		Muenchen		State		ZIP	
						D-81447	
Country		Germany					

Burden Hour Statement: This form is estimated to take 0.4 hours to complete. Time will vary depending upon the needs of the individual case. Any comments on the amount of time you are required to complete this form should be sent to the Chief Information Officer, Patent and Trademark Office, Washington, DC 20231. DO NOT SEND FEES OR COMPLETED FORMS TO THIS ADDRESS. SEND TO: Assistant Commissioner for Patents, Washington, DC 20231.

006217 02E2960

Please type a plus sign (+) inside this box →

PTO/SB/02A (3-97)
 Approved for use through 9/30/98. OMB 0651-0032
 Patent and Trademark Office; U.S. DEPARTMENT OF COMMERCE

Under the Paperwork Reduction Act of 1995, no persons are required to respond to a collection of information unless it contains a valid OMB control number.

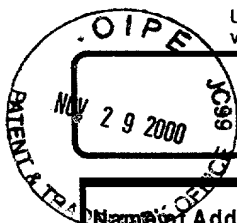

DECLARATION	ADDITIONAL INVENTOR(S) Supplemental Sheet Page <u>2</u> of <u>2</u>
--------------------	---

Name of Additional Joint Inventor, if any:		<input type="checkbox"/> A petition has been filed for this unsigned inventor					
Given Name (first and middle [if any])				Family Name or Surname			
Albert				Heuberger			
Inventor's Signature						Date	
Residence: City	Erlangen	State		Country	Germany	Citizenship	German
Post Office Address	Hausaeckerweg 18						
Post Office Address							
City	Erlangen	State		ZIP	D-91056	Country	Germany
Name of Additional Joint Inventor, if any:		<input type="checkbox"/> A petition has been filed for this unsigned inventor					
Given Name (first and middle [if any])				Family Name or Surname			
Heinz				Gerhaeuser			
Inventor's Signature						Date	
Residence: City	Waischenfeld	State		Country	Germany	Citizenship	German
Post Office Address	Saugendorf 17						
Post Office Address							
City	Waischenfeld	State		ZIP	D-91344	Country	Germany
Name of Additional Joint Inventor, if any:		<input type="checkbox"/> A petition has been filed for this unsigned inventor					
Given Name (first and middle [if any])				Family Name or Surname			
Inventor's Signature						Date	
Residence: City		State		Country		Citizenship	
Post Office Address							
Post Office Address							
City		State		ZIP		Country	

006017 0205/980

Burden Hour Statement: This form is estimated to take 0.4 hours to complete. Time will vary depending upon the needs of the individual case. Any comments on the amount of time you are required to complete this form should be sent to the Chief Information Officer, Patent and Trademark Office, Washington, DC 20231. DO NOT SEND FEES OR COMPLETED FORMS TO THIS ADDRESS. SEND TO: Assistant Commissioner for Patents, Washington, DC 20231.

74380404 PUS

Please type a plus sign (+) inside this box →

PTO/SB/01 (12-97)

Approved for use through 9/30/00. OMB 0651-0032
Patent and Trademark Office; U.S. DEPARTMENT OF COMMERCE

Under the Paperwork Reduction Act of 1995, no persons are required to respond to a collection of information unless it contains a valid OMB control number.

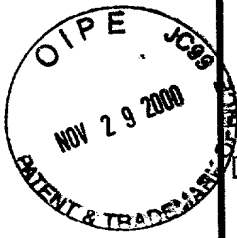

DECLARATION FOR UTILITY OR DESIGN PATENT APPLICATION (37 CFR 1.63)

Attorney Docket Number	41001
First Named Inventor	Ernst Eberlein
COMPLETE IF KNOWN	
Application Number	/
Filing Date	
Group Art Unit	
Examiner Name	

Declaration Submitted with Initial Filing OR Declaration Submitted after Initial Filing (surcharge (37 CFR 1.16 (e)) required)

As a below named inventor, I hereby declare that:

My residence, post office address, and citizenship are as stated below next to my name.

I believe I am the original, first and sole inventor (if only one name is listed below) or an original, first and joint inventor (if plural names are listed below) of the subject matter which is claimed and for which a patent is sought on the invention entitled:

Method and Apparatus for Fine Frequency Synchronization in Multi-Carrier Demodulation Systems

the specification of which *(Title of the Invention)*

is attached hereto
OR
 was filed on (MM/DD/YYYY) **04/14/98** as United States Application Number or PCT International Application Number **PCT/EP98/02184** and was amended on (MM/DD/YYYY) (if applicable).

I hereby state that I have reviewed and understand the contents of the above identified specification, including the claims, as amended by any amendment specifically referred to above.

I acknowledge the duty to disclose information which is material to patentability as defined in 37 CFR 1.56.

I hereby claim foreign priority benefits under 35 U.S.C. 119(a)-(d) or 365(b) of any foreign application(s) for patent or inventor's certificate, or 365(a) of any PCT international application which designated at least one country other than the United States of America, listed below and have also identified below, by checking the box, any foreign application for patent or inventor's certificate, or of any PCT international application having a filing date before that of the application on which priority is claimed.

Prior Foreign Application Number(s)	Country	Foreign Filing Date (MM/DD/YYYY)	Priority Not Claimed	Certified Copy Attached?	
				YES	NO
			<input type="checkbox"/>	<input type="checkbox"/>	<input checked="" type="checkbox"/>
			<input type="checkbox"/>	<input type="checkbox"/>	<input checked="" type="checkbox"/>
			<input type="checkbox"/>	<input type="checkbox"/>	<input type="checkbox"/>
			<input type="checkbox"/>	<input type="checkbox"/>	<input type="checkbox"/>

Additional foreign application numbers are listed on a supplemental priority data sheet PTO/SB/02B attached hereto:

I hereby claim the benefit under 35 U.S.C. 119(e) of any United States provisional application(s) listed below.

Application Number(s)	Filing Date (MM/DD/YYYY)

Additional provisional application numbers are listed on a supplemental priority data sheet PTO/SB/02B attached hereto.

Burden Hour Statement: This form is estimated to take 0.4 hours to complete. Time will vary depending upon the needs of the individual case. Any comments on the amount of time you are required to complete this form should be sent to the Chief Information Officer, Patent and Trademark Office, Washington, DC 20231. DO NOT SEND FEES OR COMPLETED FORMS TO THIS ADDRESS. SEND TO: Assistant Commissioner for Patents, Washington, DC 20231.

005677 0/2E/960

Please type a plus sign (+) inside this box →

PTO/SB/02A (3-97)
 Approved for use through 9/30/98. OMB 0651-0032
 Patent and Trademark Office; U.S. DEPARTMENT OF COMMERCE

Under the Paperwork Reduction Act of 1995, no persons are required to respond to a collection of information unless it contains a valid OMB control number.

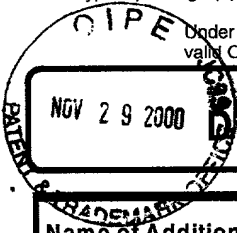

DECLARATION **ADDITIONAL INVENTOR(S)**
 Supplemental Sheet
 Page 2 of 2

0967270-1250
 50
 60

Name of Additional Joint Inventor, if any:		<input type="checkbox"/> A petition has been filed for this unsigned inventor					
Given Name (first and middle [if any])			Family Name or Surname				
Albert			Heuberger				
Inventor's Signature					Date	11/21/00	
Residence: City	Erlangen	State		Country	Germany	Citizenship	German
Post Office Address	Hausaeckerweg 18						
Post Office Address							
City	Erlangen	State		ZIP	D-91056	Country	Germany
Name of Additional Joint Inventor, if any:		<input type="checkbox"/> A petition has been filed for this unsigned inventor					
Given Name (first and middle [if any])			Family Name or Surname				
Heinz			Gerhaeuser				
Inventor's Signature					Date	11/21/00	
Residence: City	Waischenfeld	State		Country	Germany	Citizenship	German
Post Office Address	Saugendorf 17						
Post Office Address							
City	Waischenfeld	State		ZIP	D-91344	Country	Germany
Name of Additional Joint Inventor, if any:		<input type="checkbox"/> A petition has been filed for this unsigned inventor					
Given Name (first and middle [if any])			Family Name or Surname				
Inventor's Signature					Date		
Residence: City		State		Country		Citizenship	
Post Office Address							
Post Office Address							
City		State		ZIP		Country	

Burden Hour Statement: This form is estimated to take 0.4 hours to complete. Time will vary depending upon the needs of the individual case. Any comments on the amount of time you are required to complete this form should be sent to the Chief Information Officer, Patent and Trademark Office, Washington, DC 20231. DO NOT SEND FEES OR COMPLETED FORMS TO THIS ADDRESS. SEND TO: Assistant Commissioner for Patents, Washington, DC 20231.

Please type a plus sign (+) inside this box →

PTO/SB/02A (3-97)
Approved for use through 9/30/98. OMB 0651-0032
Patent and Trademark Office; U.S. DEPARTMENT OF COMMERCE

Under the Paperwork Reduction Act of 1995, no persons are required to respond to a collection of information unless it contains a valid OMB control number.

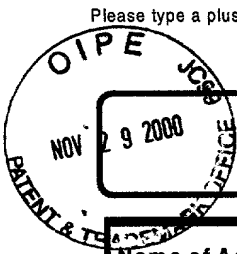

DECLARATION **ADDITIONAL INVENTOR(S) Supplemental Sheet**
Page 1 of 2

Name of Additional Joint Inventor, if any:		<input type="checkbox"/> A petition has been filed for this unsigned inventor					
Given Name (first and middle [if any])			Family Name or Surname				
<u>Sabah</u>			<u>Badri</u>				
Inventor's Signature	<u>S. Badri</u>				Date	11/22/00	
Residence: City	<u>Erlangen</u>	State	Country	Germany	Citizenship	Moroccan	
Post Office Address	<u>Sebaldusstrasse 8</u>						
Post Office Address							
City	<u>Erlangen</u>	State	ZIP	<u>D-91058</u>	Country	Germany	
Name of Additional Joint Inventor, if any:		<input type="checkbox"/> A petition has been filed for this unsigned inventor					
Given Name (first and middle [if any])			Family Name or Surname				
<u>Stefan</u>			<u>Lipp</u>				
Inventor's Signature	<u>S. Lipp</u>				Date	11/22/00	
Residence: City	<u>Erlangen</u>	State	Country	Germany	Citizenship	German	
Post Office Address	<u>Steinweg 9 a</u>						
Post Office Address							
City	<u>Erlangen</u>	State	ZIP	<u>D-91058</u>	Country	Germany	
Name of Additional Joint Inventor, if any:		<input type="checkbox"/> A petition has been filed for this unsigned inventor					
Given Name (first and middle [if any])			Family Name or Surname				
<u>Stephan</u>			<u>Buehholz</u>				
Inventor's Signature	<u>S. Buehholz</u>				Date		
Residence: City	<u>Muenchen</u>	State	Country	Germany	Citizenship	German	
Post Office Address	<u>Kerschbacher Strasse 8</u>						
Post Office Address							
City	<u>Muenchen</u>	State	ZIP	<u>D-81447</u>	Country	Germany	

OBJECT "02EE2960" 200 300 400

Burden Hour Statement: This form is estimated to take 0.4 hours to complete. Time will vary depending upon the needs of the individual case. Any comments on the amount of time you are required to complete this form should be sent to the Chief Information Officer, Patent and Trademark Office, Washington, DC 20231. DO NOT SEND FEES OR COMPLETED FORMS TO THIS ADDRESS. SEND TO: Assistant Commissioner for Patents, Washington, DC 20231.

Please type a plus sign (+) inside this box →

PTO/SB/01 (12-97)
Approved for use through 9/30/00. OMB 0651-0032
Patent and Trademark Office; U.S. DEPARTMENT OF COMMERCE

Under the Paperwork Reduction Act of 1995, no persons are required to respond to a collection of information unless it contains a valid OMB control number.

DECLARATION — Utility or Design Patent Application

I hereby claim the benefit under 35 U.S.C. 120 of any United States application(s), or 365(c) of any PCT international application designating the United States of America, listed below and, insofar as the subject matter of each of the claims of this application is not disclosed in the prior United States or PCT International application in the manner provided by the first paragraph of 35 U.S.C. 112, I acknowledge the duty to disclose information which is material to patentability as defined in 37 CFR 1.56 which became available between the filing date of the prior application and the national or PCT international filing date of this application.

U.S. Parent Application or PCT Parent Number	Parent Filing Date (MM/DD/YYYY)	Parent Patent Number (if applicable)

Additional U.S. or PCT international application numbers are listed on a supplemental priority data sheet PTO/SB/02B attached hereto.

As a named inventor, I hereby appoint the following registered practitioner(s) to prosecute this application and to transact all business in the Patent and Trademark Office connected therewith:

Customer Number → Place Customer Number Bar Code Label here
OR
 Registered practitioner(s) name/registration number listed below

Name	Registration Number	Name	Registration Number
David S. Abrams	22,576	Stacey J. Longanecker	39,952
Robert H. Berdo	19,415	Joseph J. Buczvnski	35,084
Alfred N. Goodman	26,458	Wayne C. Jaeschke, Jr.	38,503
Mark S. Bicks	28,770	Tara Laster Hoffman	2,46,510
John E. Holmes	29,392	Jeffrey J. Howell	46,402
Garrett V. Davis	32,023	Marcus R. Mickney	44,941
Lance G. Johnson	32,531	Christian C. Michel	46,300

Additional registered practitioner(s) named on supplemental Registered Practitioner Information sheet PTO/SB/02C attached hereto.

Direct all correspondence to: Customer Number OR Correspondence address below

Name	John E. Holmes				
Address	Roylance, Abrams, Berdo & Goodman, L.L.P.				
Address	1300 19th Street, N.W., Suite 600				
City	Washington	State	D.C.	ZIP	20036
Country	USA	Telephone	(202)659-9076	Fax	(202)659-9344

I hereby declare that all statements made herein of my own knowledge are true and that all statements made on information and belief are believed to be true; and further that these statements were made with the knowledge that willful false statements and the like so made are punishable by fine or imprisonment, or both, under 18 U.S.C. 1001 and that such willful false statements may jeopardize the validity of the application or any patent issued thereon.

Name of Sole or First Inventor: A petition has been filed for this unsigned inventor

Given Name (first and middle [if any])	Family Name or Surname
Ernst	Eberlein

Inventor's Signature		Date	11/21/00
Residence: City	Grossenseebach	State	Country: Germany
Post Office Address	Waldstrasse 28 b		
Post Office Address			
City	Grossenseebach	State	ZIP: D-91091
		Country	Germany

Additional inventors are being named on the _____ supplemental Additional Inventor(s) sheet(s) PTO/SB/02A attached hereto

OFFICE OF THE COMMISSIONER OF PATENTS AND TRADEMARKS

14

FORM PTO-1390
(REV 10-01-00)

U.S. DEPARTMENT OF COMMERCE PATENT AND TRADEMARK OFFICE

ATTORNEY'S DOCKET NUMBER

TRANSMITTAL LETTER TO THE UNITED STATES
DESIGNATED/ELECTED OFFICE (DO/EO/US)
CONCERNING A FILING UNDER 35 U.S.C. 371

41001

U.S. APPLICATION NO. (If known, see 37 CFR 1.5)

09/673270

INTERNATIONAL APPLICATION NO.
PCT/EP98/02184

INTERNATIONAL FILING DATE
14 April 1998

PRIORITY DATE CLAIMED

TITLE OF INVENTION
Method and Apparatus for Fine Frequency Synchronization in Multi-Carrier Demodulation Systems

APPLICANT(S) FOR DO/EO/US
Ernst Eberlein, Sabah Badri, Stefan Lipp, Stephan Buchholz, Albert Heuberger, Heinz Gerhaeuser

Applicant herewith submits to the United States Designated/Elected Office (DO/EO/US) the following items and other information:

- 1. This is a **FIRST** submission of items concerning a filing under 35 U.S.C. 371.
 - 2. This is a **SECOND** or **SUBSEQUENT** submission of items concerning a filing under 35 U.S.C. 371.
 - 3. This express request to begin national examination procedures (35 U.S.C. 371(f)) at any time rather than delay examination until the expiration of the applicable time limit set in 35 U.S.C. 371(b) and PCT Articles 22 and 39(1).
 - 4. A proper Demand for International Preliminary Examination was made by the 19th month from the earliest claimed priority date.
 - 5. A copy of the International Application as filed (35 U.S.C. 371(c)(2))
 - a. is transmitted herewith (required only if not transmitted by the International Bureau).
 - b. has been transmitted by the International Bureau.
 - c. is not required, as the application was filed in the United States Receiving Office (RO/US).
 - 6. A translation of the International Application into English (35 U.S.C. 371(c)(2)).
 - 7. Amendments to the claims of the International Application under PCT Article 19 (35 U.S.C. 371(c)(3))
 - a. are transmitted herewith (required only if not transmitted by the International Bureau).
 - b. have been transmitted by the International Bureau.
 - c. have not been made; however, the time limit for making such amendments has NOT expired.
 - d. have not been made and will not be made.
 - 8. A translation of the amendments to the claims under PCT Article 19 (35 U.S.C. 371(c)(3)).
 - 9. An oath or declaration of the inventor(s) (35 U.S.C. 371(c)(4)).
 - 10. A translation of the annexes to the International Preliminary Examination Report under PCT Article 36 (35 U.S.C. 371(c)(5)).
- Items 11. to 16. below concern document(s) or information included:**
- 11. An Information Disclosure Statement under 37 CFR 1.97 and 1.98.
 - 12. An assignment document for recording. A separate cover sheet in compliance with 37 CFR 3.28 and 3.31 is included.
 - 13. A **FIRST** preliminary amendment.
 A **SECOND** or **SUBSEQUENT** preliminary amendment.
 - 14. A substitute specification.
 - 15. A change of power of attorney and/or address letter.
 - 16. Other items or information:
 - (a) Copy of International Application as filed (14 April 1998).
 - (b) Copy of International Search Report (12 January 1999).
 - (c) Copy of Published International Application (21 October 1999).
 - (d) Copy of International Preliminary Examination Report (19 July 2000).

09/673270

17. The following fees are submitted:
BASIC NATIONAL FEE (37 CFR 1.492 (a) (1) - (5)) :
 Neither international preliminary examination fee (37 CFR 1.482) nor international search fee (37 CFR 1.445(a)(2)) paid to USPTO and International Search Report not prepared by the EPO or JPO \$1000.00
 International preliminary examination fee (37 CFR 1.482) not paid to USPTO but International Search Report prepared by the EPO or JPO..... \$860.00
 International preliminary examination fee (37 CFR 1.482) not paid to USPTO but international search fee (37 CFR 1.445(a)(2)) paid to USPTO \$710.00
 International preliminary examination fee paid to USPTO (37 CFR 1.482) but all claims did not satisfy provisions of PCT Article 33(1)-(4) \$690.00
 International preliminary examination fee paid to USPTO (37 CFR 1.482) and all claims satisfied provisions of PCT Article 33(1)-(4) \$100.00

CALCULATIONS		PTO USE ONLY
ENTER APPROPRIATE BASIC FEE AMOUNT =		\$ 860.00
Surcharge of \$130.00 for furnishing the oath or declaration later than <input type="checkbox"/> 20 <input checked="" type="checkbox"/> 30 months from the earliest claimed priority date (37 CFR 1.492(e)).		\$ 130.00
CLAIMS	NUMBER FILED	NUMBER EXTRA
Total claims	16 - 20 =	0
Independent claims	4 - 3 =	1
MULTIPLE DEPENDENT CLAIM(S) (if applicable)		+ \$270.00
TOTAL OF ABOVE CALCULATIONS =		\$ 1,070.00
Reduction of 1/2 for filing by small entity, if applicable. A Small Entity Statement must also be filed (Note 37 CFR 1.9, 1.27, 1.28).		\$ (0.00)
SUBTOTAL =		\$ 1,070.00
Processing fee of \$130.00 for furnishing the English translation later than <input type="checkbox"/> 20 <input type="checkbox"/> 30 months from the earliest claimed priority date (37 CFR 1.492(f)).		\$ 0.00
TOTAL NATIONAL FEE =		\$ 1,070.00
Fee for recording the enclosed assignment (37 CFR 1.21(h)). The assignment must be accompanied by an appropriate cover sheet (37 CFR 3.28, 3.31). \$40.00 per property		\$ 0.00
TOTAL FEES ENCLOSED =		\$ 1,070.00
		Amount to be refunded: \$
		charged: \$

ENTER APPROPRIATE BASIC FEE AMOUNT =

Surcharge of \$130.00 for furnishing the oath or declaration later than 20 30 months from the earliest claimed priority date (37 CFR 1.492(e)).

CLAIMS	NUMBER FILED	NUMBER EXTRA	RATE
Total claims	16 - 20 =	0	X \$18.00
Independent claims	4 - 3 =	1	X \$80.00

MULTIPLE DEPENDENT CLAIM(S) (if applicable) + \$270.00

TOTAL OF ABOVE CALCULATIONS = \$ 1,070.00

Reduction of 1/2 for filing by small entity, if applicable. A Small Entity Statement must also be filed (Note 37 CFR 1.9, 1.27, 1.28). \$ (0.00)

SUBTOTAL = \$ 1,070.00

Processing fee of \$130.00 for furnishing the English translation later than 20 30 months from the earliest claimed priority date (37 CFR 1.492(f)). \$ 0.00

TOTAL NATIONAL FEE = \$ 1,070.00

Fee for recording the enclosed assignment (37 CFR 1.21(h)). The assignment must be accompanied by an appropriate cover sheet (37 CFR 3.28, 3.31). \$40.00 per property + \$ 0.00

TOTAL FEES ENCLOSED = \$ 1,070.00

	Amount to be refunded:	\$
	charged:	\$

- a. A check in the amount of \$ 1,070.00 to cover the above fees is enclosed.
- b. Please charge my Deposit Account No. _____ in the amount of \$ _____ to cover the above fees. A duplicate copy of this sheet is enclosed.
- c. The Commissioner is hereby authorized to charge any additional fees which may be required, or credit any overpayment to Deposit Account No. 18-2220. A duplicate copy of this sheet is enclosed.

NOTE: Where an appropriate time limit under 37 CFR 1.494 or 1.495 has not been met, a petition to revive (37 CFR 1.137(a) or (b)) must be filed and granted to restore the application to pending status.

SEND ALL CORRESPONDENCE TO:
 Roylance, Abrams, Berdo & Goodman, L.L.P.
 1300 19th Street, N.W., Suite 600
 Washington, DC 20036

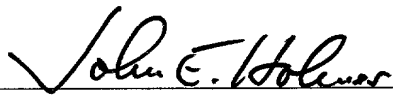
 SIGNATURE:
 John E. Holmes
 NAME
 29,392
 REGISTRATION NUMBER

41001

PATENT

IN THE UNITED STATES PATENT AND TRADEMARK OFFICE

In re Application of:	:	
	:	
Ernst Eberlein et al.	:	Group Art Unit:
	:	
Serial No.: Not Assigned	:	Examiner:
	:	
Filed: Herewith	:	
	:	
For: Method and Apparatus for Fine Frequency	:	
Synchronization in Multi-Carrier Demodulation	:	
Systems	:	

PRELIMINARY AMENDMENT

Assistant Commissioner for Patents
Washington, D.C. 20231

Sir:

This Preliminary Amendment is being filed concurrently with the U.S. national stage entry under 35 U.S.C. § 371 of International Application No. PCT/EP98/02184, which has an International Filing Date of April 14, 1998. Prior to examination and calculation of the filing fees, please amend the national stage application as follows:

IN THE SPECIFICATION:

Please delete the current specification comprising pages 1-40 and 48 (as amended in the International Preliminary Examination Report dated July 19, 2000) and replace it with the accompanying substitute specification.

IN THE CLAIMS:

Please cancel claims 1-18 annexed to the International Preliminary Examination Report dated July 19, 2000, and substitute the following new claims 19-34:

- 19. A method of performing a fine frequency synchronization compensating for a carrier frequency deviation from an oscillator frequency in a multi-carrier demodulation system of the type capable of carrying out a differential phase

006577-02EE/950

decoding of multi-carrier modulated signals, said signals comprising a plurality of symbols, each symbol being defined by phase differences between simultaneous carriers having different frequencies, said method comprising the steps of:

- a) determining a phase difference between phases of the same carrier in different symbols;
- b) determining a frequency offset by eliminating phase shift uncertainties related to the transmitted information from said phase difference making use of a M-PSK decision device; and
- c) performing a feedback correction of said carrier frequency deviation based on said determined frequency offset.

20. A method of performing a fine frequency synchronization compensating for a carrier frequency deviation from an oscillator frequency in a multi-carrier demodulation system of the type capable of carrying out a differential phase decoding of multi-carrier modulated signals, said signals comprising a plurality of symbols, each symbol being defined by phase differences between simultaneous carriers having different frequencies, said method comprising the steps of:

- a) determining respective phase of the same carrier in different symbols;
- b) eliminating phase shift uncertainties related to the transmitted information from said phases to determine respective phase deviations making use of a M-PSK decision device;
- c) determining a frequency offset by determining a phase difference between said phase deviations; and
- d) performing a feedback correction of said carrier frequency deviation based on said determined frequency offset.

006277-02E2950

21. The method according to claim 19, wherein

said steps a) and b) are performed for a plurality of carriers in said symbols,

an averaged frequency offset is determined by averaging said determined frequency offsets of said plurality of carriers, and

said feedback correction of said frequency deviation is performed based on said averaged frequency offset in said step c).

22. The method according to claim 20, wherein

said steps a), b) and c) are performed for a plurality of carriers in said symbols,

an averaged frequency offset is determined by averaging said determined frequency offsets of said plurality of carriers, and

said feedback correction of said frequency deviation is performed based on said averaged frequency offset.

23. The method according to claim 19, wherein said step a) comprises the step of determining a phase difference between phases of the same carrier in symbols which are adjacent in the time axis direction.

24. The method according to claim 19, wherein said step b) comprises the step of eliminating phase shift uncertainties corresponding to M-ary phase shifts.

25. The method according to claim 20, wherein said step a) comprises the step of determining respective phases of the same carrier in symbols which are adjacent in the time axis direction.

09673270-112900
006211 02E/960

26. The method according to claim 20, wherein said step b) comprises the step of eliminating M-ary phase shifts.

27. An apparatus for performing a fine frequency synchronization compensating for a carrier frequency deviation from an oscillator frequency, for a multi-carrier demodulation system of the type capable of carrying out a differential phase decoding of multi-carrier modulated signals, said signals comprising a plurality of symbols, each symbol being defined by phase differences between simultaneous carriers having different frequencies, said apparatus comprising:

means for determining a phase difference between phases of the same carrier in different symbols;

M-PSK decision device for determining a frequency offset by eliminating phase shift uncertainties related to the transmitted information from said phase difference; and

means for performing a feedback correction of said frequency deviation based on said determined frequency offset.

28. An apparatus for performing a fine frequency synchronization compensating for a carrier frequency deviation from an oscillator frequency, for a multi-carrier demodulation system of the type capable of carrying out a differential phase decoding of multi-carrier modulated signals, said signals comprising a plurality of symbols, each symbol being defined by phase differences between simultaneous carriers having different frequencies, said apparatus comprising:

means for determining respective phases of the same carrier in different symbols;

M-PSK decision device for eliminating phase shift uncertainties related to the transmitted information from said phases to determine respective phase deviations;

means for determining a frequency offset by determining a phase difference between said phase deviations;

means for performing a feedback correction of said frequency deviation based on said determined frequency offset.

29. The apparatus according to claim 27, further comprising:

means for determining an averaged frequency offset by averaging determined frequency offsets of a plurality of carriers, wherein

said means for performing a feedback correction performs said feedback correction of said frequency deviation based on said averaged frequency offset.

30. The apparatus according to claim 28, further comprising:

means for determining an averaged frequency offset by averaging determined frequency offsets of a plurality of carriers, wherein

said means for performing a feedback correction performs said feedback correction of said frequency deviation based on said averaged frequency offset.

31. The apparatus according to claim 27, wherein said means for determining a phase difference comprises means for determining a phase difference between phases of the same carrier in symbols which are adjacent in the time axis direction.

32. The apparatus according to claim 28, wherein said means for determining respective phases comprises means for determining respective phases of the same carrier in symbols which are adjacent in the time axis direction.

33. The apparatus according to claim 27, wherein said means for performing a feedback correction of said frequency deviation comprises a numerical controlled oscillator and a complex multiplier.
34. The apparatus according to claim 33, wherein said means for performing a feedback correction of said frequency deviation further comprises a low path filter preceding said numerical controlled oscillator.

REMARKS

By the present Preliminary Amendment, claims 1-18 annexed to the International Preliminary Examination Report dated July 19, 2000 are being cancelled and replaced with new claims 19-34. In the new claims, multiple dependencies and parenthetical reference numerals have been eliminated.

A substitute specification is being submitted to facilitate processing of this application. A marked-up copy of the substitute specification is also being provided to show the new changes which are beyond those previously made during the international stage. The substitute specification contains no new matter.

Early and favorable action on this application is respectfully requested. Should the Examiner have any questions, the Examiner is invited to contact the undersigned attorney at the local telephone number listed below.

Respectfully submitted,

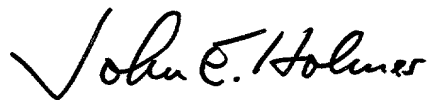

John E. Holmes
Attorney for Applicant
Reg. No. 29,392

Roylance, Abrams, Berdo & Goodman
1300 19th Street, N.W., Suite 600
Washington, D.C. 20036-2680
(202) 659-9076

Dated: October 13, 2000

8/PRTS

09/673270
529 Rec'd PCT/PTO 13 OCT 2000

METHOD AND APPARATUS FOR FINE FREQUENCY SYNCHRONIZATION IN
MULTI-CARRIER DEMODULATION SYSTEMS

FIELD OF THE INVENTION

The present invention relates to methods and apparatus for performing a fine frequency synchronization in multi-carrier demodulation systems, and in particular to methods and apparatus for performing a fine frequency synchronization compensating for a carrier frequency deviation from an oscillator frequency in a multi-carrier demodulation system of the type capable of carrying out a differential phase decoding of multi-carrier modulated signals, wherein the signals comprise a plurality of symbols, each symbol being defined by phase differences between simultaneous carriers having different frequencies.

BACKGROUND OF THE INVENTION

In a multi carrier transmission system (MCM, OFDM), the effect of a carrier frequency offset is substantially more considerable than in a single carrier transmission system. MCM is more sensitive to phase noise and frequency offset which occurs as amplitude distortion and inter carrier interference (ICI). The inter carrier interference has the effect that the subcarriers are no longer orthogonal in relation to each other. Frequency offsets occur after power on or also later due to frequency deviation of the oscillators used for downconversion into baseband. Typical accuracies for the frequency of a free running oscillator are about ± 50 ppm of the carrier frequency. With a carrier frequency in the S-band of 2.34 GHz, for example, there will be a maximum local oscillator (LO) frequency deviation of above 100 kHz (117.25 kHz). The above named effects result in high requirements on the algorithm used for frequency offset correction.

005277 "09/673270"

DESCRIPTION OF PRIOR ART

Most prior art algorithms for frequency synchronization divide frequency correction into two stages. In the first stage, a coarse synchronization is performed. In the second stage, a fine correction can be achieved. A frequently used algorithm for coarse synchronization of the carrier frequency uses a synchronization symbol which has a special spectral pattern in the frequency domain. Such a synchronization symbol is, for example, a CAZAC sequence (CAZAC = Constant Amplitude Zero Autocorrelation). Through comparison, i.e. the correlation, of the power spectrum of the received signal with that of the transmitted signal, the frequency carrier offset can be coarsely estimated. These prior art algorithms all work in the frequency domain. Reference is made, for example, to Ferdinand Claßen, Heinrich Meyr, "Synchronization Algorithms for an OFDM System for Mobile Communication", ITG-Fachtagung 130, Codierung für Quelle, Kanal und Übertragung, pp. 105 - 113, Oct. 26-28, 1994; and Timothy M. Schmidl, Donald C. Cox, "Low-Overhead, Low-Complexity [Burst] Synchronization for OFDM", in Proceedings of the IEEE International Conference on Communication ICC 1996, pp. 1301-1306 (1996).

For the coarse synchronization of the carrier frequency, Paul H. Moose, "A Technique for Orthogonal Frequency Division Multiplexing Frequency Offset Correction", IEEE Transaction On Communications, Vol. 42, No. 10, October 1994, suggest increasing the spacing between the subcarriers such that the subcarrier distance is greater than the maximum frequency difference between the received and transmitted carriers. The subcarrier distance is increased by reducing the number of sample values which are transformed by the Fast Fourier Transform. This corresponds to a reduction of the number of sampling values which are transformed by the Fast Fourier Transform.

SUMMARY OF THE INVENTION

It is an object of the present invention to provide methods and apparatus for performing a fine frequency synchronization which allow a fine frequency synchronization compensating for a carrier frequency deviation from an oscillator frequency in a MCM transmission system which makes use of MCM signals in which information is differential phase encoded between simultaneous sub-carriers having different frequencies.

In accordance with a first aspect, the present invention provides a method of performing a fine frequency synchronization compensating for a carrier frequency deviation from an oscillator frequency in a multi-carrier demodulation system of the type capable of carrying out a differential phase decoding of multi-carrier modulated signals, the signals comprising a plurality of symbols, each symbol being defined by phase differences between simultaneous carriers having different frequencies, the method comprising the steps of:

determining a phase difference between phases of the same carrier in different symbols;

determining a frequency offset by eliminating phase shift uncertainties corresponding to codeable phase shifts from the phase difference; and

performing a feedback correction of the carrier frequency deviation based on the determined frequency offset.

In accordance with a second aspect, the present invention provides a method of performing a fine frequency synchronization compensating for a carrier frequency deviation from an oscillator frequency in a multi-carrier demodulation

00527 0322/950

system of the type capable of carrying out a differential phase decoding of multi-carrier modulated signals, the signals comprising a plurality of symbols, each symbol being defined by phase differences between simultaneous carriers having different frequencies, the method comprising the steps of:

determining respective phases of the same carrier in different symbols;

eliminating phase shift uncertainties corresponding to codeable phase shifts from the phases to determine respective phase deviations;

determining a frequency offset by determining a phase difference between the phase deviations; and

performing a feedback correction of said carrier frequency deviation based on the determined frequency offset.

In accordance with a third aspect, the present invention provides a method of performing a fine frequency synchronization compensating for a carrier frequency deviation from an oscillator frequency in a multi-carrier demodulation system of the type capable of carrying out a differential phase decoding of multi-carrier modulated signals, the signals comprising a plurality of symbols, each symbol being defined by phase differences between simultaneous carriers having different frequencies, the method comprising the steps of:

for a plurality of carriers in the symbols:

determining a phase difference between phases of the same carrier in different symbols; and

determining a frequency offset by eliminating phase shift uncertainties corresponding to codeable phase shifts from

005277 02E2950

the phase difference;

determining and averaged frequency offset by averaging the determined frequency offset of the plurality of carriers; and

performing a feedback correction of the frequency deviation based on the averaged frequency offset.

In accordance with a fourth aspect, the present invention provides a method of performing a fine frequency synchronization compensating for a carrier frequency deviation from an oscillator frequency in a multi-carrier demodulation system of the type capable of carrying out a differential phase decoding of multi-carrier modulated signals, the signals comprising a plurality of symbols, each symbol being defined by phase differences between simultaneous carriers having different frequencies, the method comprising the steps of:

for a plurality of carriers in the symbols:

determining respective phases of the same carrier in different symbols;

eliminating phase shift uncertainties corresponding to codeable phase shifts from said phases to determine respective phase deviations; and

determining a frequency offset by determining a phase difference between the phase deviations;

determining an averaged frequency offset by averaging the determined frequency offsets of the plurality of carriers; and

performing a feedback correction of the frequency deviation based on the averaged frequency offset.

In accordance with a fifth aspect, the present invention provides an apparatus for performing a fine frequency synchronization compensating for a carrier frequency deviation from an oscillator frequency, for a multi-carrier demodulation system of the type capable of carrying out a differential phase decoding of multi-carrier modulated signals, the signals comprising a plurality of symbols, each symbol being defined by phase differences between simultaneous carriers having different frequencies, the apparatus comprising:

means for determining a phase difference between phases of the same carrier in different symbols;

means for determining a frequency offset by eliminating phase shift uncertainties corresponding to codeable phase shifts from the phase difference; and

means for performing a feedback correction of the frequency deviation based on the determined frequency offset.

In accordance with a sixth aspect, the present invention provides an apparatus for performing a fine frequency synchronization compensating for a carrier frequency deviation from an oscillator frequency, for a multi-carrier demodulation system of the type capable of carrying out a differential phase decoding of multi-carrier modulated signals, said signals comprising a plurality of symbols, each symbol being defined by phase differences between simultaneous carriers having different frequencies, the apparatus comprising:

means for determining respective phases of the same carrier in different symbols;

means for eliminating phase shift uncertainties corresponding to codeable phase shifts from the phases to

005271290

determine respective phase deviations;

means for determining a frequency offset by determining a phase difference between the phase deviations; and

means for performing a feedback correction of the frequency deviation based on the determined frequency offset.

In accordance with a seventh aspect, the present invention provides an apparatus for performing a fine frequency synchronization compensating for a carrier frequency deviation from an oscillator frequency, for a multi-carrier demodulation system of the type capable of carrying out a differential phase decoding of multi-carrier modulated signals, the signals comprising a plurality of symbols, each symbol being defined by phase differences between simultaneous carriers having different frequencies, the apparatus comprising:

means for determining a phase difference between phases of the same carrier in different symbols;

means for determining a frequency offset by eliminating phase shift uncertainties corresponding to codeable phase shifts from the phase difference;

means for determining an averaged frequency offset by averaging determined frequency offsets of a plurality of carriers; and

means for performing a feedback correction of the frequency deviation based on the averaged frequency offset.

In accordance with an eighth aspect, the present invention provides an apparatus for performing a fine frequency synchronization compensating for a carrier frequency deviation from an oscillator frequency, for a multi-carrier demodulation system of the type capable of carrying out a

005271 02E2960

differential phase decoding of multi-carrier modulated signals, the signals comprising a plurality of symbols, each symbol being defined by phase differences between simultaneous carriers having different frequencies, the apparatus comprising:

means for determining respective phases of the same carrier in different symbols;

means for eliminating phase shift uncertainties corresponding to codeable phase shifts from the phases to determine respective phase deviations;

means for determining a frequency offset by determining a phase difference between the phase deviations;

means for determining an averaged frequency offset by averaging determined frequency offsets of a plurality of carriers; and

means for performing a feedback correction of the frequency deviation based on the averaged frequency offset.

The present invention relates to methods and apparatus for performing a fine frequency synchronization compensating for a carrier frequency deviation from an oscillator frequency. This fine frequency synchronization is preferably performed after completion of a coarse frequency synchronization, such that the frequency offsets after the coarse frequency synchronization are smaller than half the sub-carrier distance in the MCM signal. Since the frequency offsets which are to be corrected by the inventive fine frequency synchronization methods and apparatus, a correction of the frequency offsets by using a phase rotation with differential decoding and de-mapping in the time axis can be used. The frequency offsets are detected by determining the frequency differences between time contiguous sub-carrier symbols along the time axis. The frequency error is

005217 02262950

calculated by measuring the rotation of the I-Q cartesian coordinates of each sub-carrier and, in preferred embodiments, averaging them over all n sub-carriers of a MCM symbol.

Firstly, the phase ambiguity or uncertainty is eliminated by using a M-PSK decision device and correlating the output of the decision device with the input signal for a respective sub-carrier symbol. Thus, the phase offset for a sub-carrier symbol is determined and can be used for restructuring the frequency error in form of a feed-backward structure. Alternatively, the phase offsets of the sub-carrier symbols of one MCM symbol can be averaged over all of the active carriers of a MCM symbol, wherein the averaged phase offset is used to restructure the frequency error.

In accordance with the present invention, the determination of the frequency offset is performed in the frequency domain. The feedback correction in accordance with the inventive fine frequency synchronization is performed in the time domain. To this end, a differential decoder in the time domain is provided in order to detect frequency offsets of sub-carriers on the basis of the phases of timely successive sub-carrier symbols of different MCM symbols.

BRIEF DESCRIPTION OF THE DRAWINGS

In the following, preferred embodiments of the present invention will be explained in detail on the basis of the drawings enclosed, in which:

Figure 1 shows a schematic overview of a MCM transmission system to which the present application can be applied;

Figures 2A and 2B show schematic views representing a scheme for differential mapping in the time axis and a

Figure 13 shows a schematic block diagram for illustrating the position and the functionality of an echo phase offset correction unit;

Figure 14 shows a schematic block diagram of a preferred form of an echo phase offset correction device; and

Figure 15 shows schematic views for illustrating a projection performed by another echo phase offset correction algorithm.

DETAILED DESCRIPTION OF THE EMBODIMENTS

Before discussing the present invention in detail, the mode of operation of a MCM transmission system is described referring to figure 1.

Referring to Figure 1, at 100 a MCM transmitter is shown that substantially corresponds to a prior art MCM transmitter. A description of such a MCM transmitter can be found, for example, in William Y. Zou, Yiyang Wu, "COFDM: AN OVERVIEW", IEEE Transactions on Broadcasting, vol. 41, No. 1, March 1995.

A data source 102 provides a serial bitstream 104 to the MCM transmitter. The incoming serial bitstream 104 is applied to a bit-carrier mapper 106 which produces a sequence of spectra 108 from the incoming serial bitstream 104. An inverse fast Fourier transform (IFFT) 110 is performed on the sequence of spectra 108 in order to produce a MCM time domain signal 112. The MCM time domain signal forms the useful MCM symbol of the MCM time signal. To avoid intersymbol interference (ISI) caused by multipath distortion, a unit 114 is provided for inserting a guard interval of fixed length between adjacent MCM symbols in time. In accordance with a preferred embodiment of the

present invention, the last part of the useful MCM symbol is used as the guard interval by placing same in front of the useful symbol. The resulting MCM symbol is shown at 115 in Figure 1 and corresponds to a MCM symbol 160 depicted in Figure 11.

Figure 11 shows the construction of a typical MCM signal having a frame structure. One frame of the MCM time signal is composed of a plurality of MCM symbols 160. Each MCM symbol 160 is formed by an useful symbol 162 and a guard interval 164 associated therewith. As shown in Figure 11, each frame comprises one reference symbol 166. The present invention can advantageously be used with such a MCM signal, however, such a signal structure being not necessary for performing the present invention as long as the transmitted signal comprises a useful portion and at least one reference symbol.

In order to obtain the final frame structure shown in Figure 11, a unit 116 for adding a reference symbol for each pre-determined number of MCM symbols is provided.

In accordance with the present invention, the reference symbol is an amplitude modulated bit sequence. Thus, an amplitude modulation of a bit sequence is performed such that the envelope of the amplitude modulated bit sequence defines a reference pattern of the reference symbol. This reference pattern defined by the envelope of the amplitude modulated bit sequence has to be detected when receiving the MCM signal at a MCM receiver. In a preferred embodiment of the present invention, a pseudo random bit sequence having good autocorrelation properties is used as the bit sequence that is amplitude modulated.

The choice of length and repetition rate of the reference symbol depends on the properties of the channel through which the MCM signal is transmitted, e.g. the coherence time of the channel. In addition, the repetition rate and the

006677" 022E/950

length of the reference symbol, in other words the number of useful symbols in each frame, depends on the receiver requirements concerning mean time for initial synchronization and mean time for resynchronization after synchronization loss due to a channel fade.

The resulting MCM signal having the structure shown at 118 in Figure 1 is applied to the transmitter front end 120. Roughly speaking, at the transmitter front end 120, a digital/analog conversion and an up-converting of the MCM signal is performed. Thereafter, the MCM signal is transmitted through a channel 122.

Following, the mode of operation of a MCM receiver 130 is shortly described referring to Figure 1. The MCM signal is received at the receiver front end 132. In the receiver front end 132, the MCM signal is down-converted and, furthermore, an analog/digital conversion of the down-converted signal is performed.

The down-converted MCM signal is provided to a symbol frame/carrier frequency synchronization unit 134.

A first object of the symbol frame/carrier frequency synchronization unit 134 is to perform a frame synchronization on the basis of the amplitude-modulated reference symbol. This frame synchronization is performed on the basis of a correlation between the amplitude-demodulated reference symbol and a predetermined reference pattern stored in the MCM receiver.

A second object of the symbol frame/carrier frequency synchronization unit is to perform a coarse frequency synchronization of the MCM signal. To this end, the symbol frame/carrier frequency synchronization unit 134 serves as a coarse frequency synchronization unit for determining a coarse frequency offset of the carrier frequency caused, for example, by a difference of the frequencies between the

006277-022E/950

shifts between two sub-carrier symbols.

A second method of differential mapping is shown in Figure 2B. The present invention is adapted for MCM transmission system using the mapping scheme shown in Figure 2B. This mapping scheme is based on a differential mapping inside one MCM symbol along the frequency axis. A number of MCM symbols 200 is shown in Figure 2B. Each MCM symbol 200 comprises a number of sub-carrier symbols 202. The arrows 204 in Figure 2B illustrate information encoded between two sub-carrier symbols 202. As can be seen from the arrows 204, this mapping scheme is based on a differential mapping within one MCM symbol along the frequency axis direction.

In the embodiment shown in Figure 2B, the first sub-carrier ($k=0$) in an MCM symbol 200 is used as a reference sub-carrier 206 (shaded) such that information is encoded between the reference sub-carrier and the first active carrier 208. The other information of a MCM symbol 200 is encoded between active carriers, respectively.

Thus, for every MCM symbol an absolute phase reference exists. In accordance with Figure 2B, this absolute phase reference is supplied by a reference symbol inserted into every MCM symbol ($k=0$). The reference symbol can either have a constant phase for all MCM symbols or a phase that varies from MCM symbol to MCM symbol. A varying phase can be obtained by replicating the phase from the last subcarrier of the MCM symbol preceding in time.

In Figure 3 a preferred embodiment of a device for performing a differential mapping along the frequency axis is shown. Referring to Figure 3, assembly of MCM symbols in the frequency domain using differential mapping along the frequency axis according to the present invention is described.

Figure 3 shows the assembly of one MCM symbol with the

following parameters:

N_{FFT} designates the number of complex coefficients of the discrete Fourier transform, number of subcarriers respectively.

K designates the number of active carriers. The reference carrier is not included in the count for K .

According to Figure 3, a quadrature phase shift keying (QPSK) is used for mapping the bitstream onto the complex symbols. However, other M-ary mapping schemes (MPSK) like 2-PSK, 8-PSK, 16-QAM, 16-APSK, 64-APSK etc. are possible.

Furthermore, for ease of filtering and minimization of aliasing effects some subcarriers are not used for encoding information in the device shown in Figure 3. These subcarriers, which are set to zero, constitute the so-called guard bands on the upper and lower edges of the MCM signal spectrum.

At the input of the mapping device shown in Figure 3, complex signal pairs $b_0[k]$, $b_1[k]$ of an input bitstream are received. K complex signal pairs are assembled in order to form one MCM symbol. The signal pairs are encoded into the K differential phase shifts $\phi[k]$ needed for assembly of one MCM symbol. In this embodiment, mapping from Bits to the 0, 90, 180 and 270 degrees phase shifts is performed using Gray Mapping in a quadrature phase shift keying device 220.

Gray mapping is used to prevent that differential detection phase errors smaller than 135 degrees cause double bit errors at the receiver.

Differential phase encoding of the K phases is performed in a differential phase encoder 222. At this stage of processing, the K phases $\phi[k]$ generated by the QPSK Gray mapper are differentially encoded. In principal, a feedback

loop 224 calculates a cumulative sum over all K phases. As starting point for the first computation (k = 0) the phase of the reference carrier 226 is used. A switch 228 is provided in order to provide either the absolute phase of the reference subcarrier 226 or the phase information encoded onto the preceding (i.e. z^{-1} , where z^{-1} denotes the unit delay operator) subcarrier to a summing point 230. At the output of the differential phase encoder 222, the phase information $\theta[k]$ with which the respective subcarriers are to be encoded is provided. In preferred embodiments of the present invention, the subcarriers of a MCM symbol are equally spaced in the frequency axis direction.

The output of the differential phase encoder 222 is connected to a unit 232 for generating complex subcarrier symbols using the phase information $\theta[k]$. To this end, the K differentially encoded phases are converted to complex symbols by multiplication with

$$\text{factor} * e^{j[2\pi(\theta[k] + \text{PHI})]} \quad (\text{Eq.1})$$

wherein factor designates a scale factor and PHI designates an additional angle. The scale factor and the additional angle PHI are optional. By choosing $\text{PHI} = 45^\circ$ a rotated DQPSK signal constellation can be obtained.

Finally, assembly of a MCM symbol is effected in an assembling unit 234. One MCM symbol comprising N_{FFT} subcarriers is assembled from $N_{\text{FFT}} - K - 1$ guard band symbols which are "zero", one reference subcarrier symbol and K DQPSK subcarrier symbols. Thus, the assembled MCM symbol 200 is composed of K complex values containing the encoded information, two guard bands at both sides of the N_{FFT} complex values and a reference subcarrier symbol.

The MCM symbol has been assembled in the frequency domain. For transformation into the time domain an inverse discrete Fourier transform (IDFT) of the output of the assembling

unit 234 is performed by a transformator 236. In preferred embodiments of the present invention, the transformator 236 is adapted to perform a fast Fourier transform (FFT).

Further processing of the MCM signal in the transmitter as well as in the receiver is as described above referring to Figure 1.

At the receiver a de-mapping device 142 (Figure 1) is needed to reverse the operations of the mapping device described above referring to Figure 3. The implementation of the demapping device is straightforward and, therefore, need not be described herein in detail.

The differential mapping along the frequency axis direction is suitable for multi-carrier (OFDM) digital broadcasting over rapidly changing multi path channels. In accordance with this mapping scheme, there is no need for a channel stationarity exceeding one multi-carrier symbol. However, differential mapping into frequency axis direction may create a new problem. In multi path environments, path echoes succeeding or preceding the main path can lead to systematic phase offsets between sub-carriers in the same MCM symbol. Thus, it will be preferred to provide a correction unit in order to eliminate such phase offsets. Because the channel induced phase offsets between differential demodulated symbols are systematic errors, they can be corrected by an algorithm. In principle, such an algorithm must calculate the echo induced phase offset from the signal space constellation following the differential demodulation and subsequently correct this phase offset.

Examples for such echo phase correction algorithms are described at the end of this specification referring to Figures 12 to 15.

Next, the fine frequency synchronization in accordance with the present invention will be described referring to Figures

4 to 8. As mentioned above, the fine frequency synchronization in accordance with the present invention is performed after completion of the coarse frequency synchronization. Preferred embodiments of the coarse frequency synchronization which can be performed by the symbol frame/carrier frequency synchronization unit 134 are described hereinafter referring to Figures 9 and 10 after having described the fine frequency synchronization in accordance with the present invention.

With the fine frequency synchronization in accordance with the present invention frequency offsets which are smaller than half the sub-carrier distance can be corrected. Since the frequency offsets are low and equal for all sub-carriers the problem of fine frequency synchronization is reduced to sub-carrier level. Figure 4 is a schematical view of MCM symbols 200 in the time-frequency plane. Each MCM symbol 200 consists of 432 sub-carrier symbols C_1 to C_{432} . The MCM symbols are arranged along the time axis, the first MCM symbol 200 shown in Figure 4 having associated therewith a time T_1 , the next MCM symbol having associated therewith a time T_2 and so on. In accordance with a preferred embodiment of the present invention, the fine frequency synchronization is based on a phase rotation which is derived from the same sub-carrier of two MCM symbols which are adjacent in the time axis direction, for example C_1/T_1 and C_1/T_2 .

In the following, the present invention is described referring to QPSK mapping (QPSK = Quadrature Phase Shift Keying). However, it is obvious that the present invention can be applied to any MPSK mapping, wherein M designates the number of phase states used for encoding, for example 2, 4, 8, 16

Figure 5 represents a complex coordinate system showing a QPSK constellation for each sub-carrier with frequency offset. The four possible phase positions of a first MCM symbol, MCM-symbol-1 are shown at 300. Changing from the

sub-carrier (sub-carrier n) of this MCM symbol to the same sub-carrier of the next MCM symbol, MCM-symbol-2, the position in the QPSK constellation will be unchanged in case there is no frequency offset. If a frequency offset is present, which is smaller than half the distance between sub-carriers, as mentioned above, this frequency offset causes a phase rotation of the QPSK constellation of MCM-symbol-2 compared with MCM-symbol-1. The new QPSK constellation, that is the four possible phase positions for the subject sub-carrier of MCM-symbol-2 are shown at 302 in Figure 5. This phase rotation θ can be derived from the following equation:

$$C_n(kT_{MCM}) = e^{j2\pi f_{offset} T_{MCM}} C_n((k-1)T_{MCM})$$
$$\theta = 2\pi f_{offset} T_{MCM} \quad (\text{Eq. 2})$$

C_n designates the QPSK constellation of a sub-carrier n in a MCM symbol. n is an index running from 1 to the number of active sub-carriers in the MCM symbol. Information regarding the frequency offset is contained in the term $e^{j2\pi f_{offset} T_{MCM}}$ of equation 2. This frequency offset is identical for all sub-carriers. Therefore, the phase rotation θ is identical for all sub-carriers as well. Thus, averaging overall sub-carrier of a MCM symbol can be performed.

Figure 6 shows a block diagram of a MCM receiver in which the present invention is implemented. An analog/digital converter 310 is provided in order to perform an analog/digital conversion of a down-converted signal received at the receiver front end 132 (Figure 1). The output of the analog/digital converter 310 is applied to a low path filter and decimator unit 312. The low path filter is an impulse forming filter which is identical to an impulse forming filter in the MCM transmitter. In the decimator, the signal is sampled at the MCM symbol frequency. As described above referring to Figure 1, guard intervals in the MCM signal are removed by a guard interval removal unit 132. Guard intervals are inserted between two

006277-02E/950

MCM symbols in the MCM transmitter in order to avoid inter-symbol interference caused by channel memory.

The output of the guard interval removal unit 132 is applied to a MCM demodulator 314 which corresponds to the fast Fourier transformator 140 shown in Figure 1. Following the MCM demodulator 314 a differential decoding unit 316 and a demapping unit 318 are provided. In the differential decoding unit 316, phase information is recovered using differential decoding. In the demapping unit 318, demapping along the frequency axis direction is performed in order to reconstruct a binary signal from the complex signal input into the demapping unit 318.

The output of the MCM demodulator 314 is also applied to fine frequency error detector 320. The fine frequency error detector 320 produces an frequency error signal from the output of the MCM demodulator. In the depicted embodiment, the output of the fine frequency error detector 320 is applied to a numerical controlled oscillator 322 via a loop filter 324. The loop filter 324 is a low path filter for filtering superimposed interference portions of a higher frequency from the slowly varying error signal. The numerical controlled oscillator 322 produces a carrier signal on the basis of the filtered error signal. The carrier signal produced by the numerical controlled oscillator 322 is used for a frequency correction which is performed by making use of a complex multiplier 326. The inputs to the complex multiplier 326 are the output of the low path filter and decimator unit 312 and the output of the numerical controlled oscillator 322.

A description of a preferred embodiment of the fine frequency error detector 320 is given hereinafter referring to Figure 7.

The fine frequency error detector 320 comprises a differential detector in the time axis 330. The output of

00672270 119900

the MCM demodulator 314, i.e. the FFT output (FFT = Fast Fourier Transform) is applied to the input of the differential detector 330 which performs a differential detection in the time axis in order to derive information on a frequency offset from the same sub-carrier of two subsequently arriving MCM symbols. In the embodiment shown in Figure 7, the number of active sub-carriers is 432. Thus, the differential detector 330 performs a correlation between the first and the 433rd sample. The first sample is associated with MCM-symbol-1 (Figure 5), whereas the 433rd sample is associated with MCM-symbol-2 (Figure 5). However, both these samples are associated with the same sub-carrier.

To this end, the input signal Y_k is applied to a z^{-1} -block 332 and thereafter to a unit 334 in order to form the complex conjugate of the output of the z^{-1} -block 332. A complex multiplier 336 is provided in order to multiply the output of the unit 334 by the input signal Y_k . The output of the multiplier 336 is a signal Z_k .

The function of the differential detector 330 can be expressed as follows:

$$Z_k = Y_{k+K} \cdot Y_k^* \tag{Eq.3}$$

$$Y = [Y_1, Y_2, \dots, Y_k, \dots] \tag{Eq.4}$$

$$Y = [C_1/T_1, C_2/T_1, \dots, C_{432}/T_1, C_1/T_2, \dots] \tag{Eq.5}$$

Y_k designates the output of the MCM modulator 314, i.e. the input to the differential detector 330, at a time k . Z_k designates the output of the differential detector 330. K designates the number of active carriers.

The output Z_k of the differential detector 330 contains a M -fold uncertainty corresponding to codeable phase shifts. In case of the QPSK this M -fold uncertainty is a 4-fold uncertainty, i.e. 0° , 90° , 180° and 270° . This phase shift

09673270 112900

uncertainty is eliminated from Z_k making use of a M-PSK decision device 340. Such decision devices are known in the art and, therefore, have not to be described here in detail. The output of the decision device 340 (\hat{a}_k)* represents the complex conjugate of the codeable phase shift decided by the decision device 340. This output of the decision device 340 is correlated with the output of the differential detector 330 by performing a complex multiplication using a multiplier 342.

The output the multiplier 342 represents the phase offset for the respective sub-carriers. This phase offsets for the respective sub-carriers are averaged over one MCM symbol in an averaging unit 344 in accordance with a preferred embodiment of the present invention. The output of the averaging units 344 represent the output of the fine frequency error detector 320.

The mathematical description for this procedure is as follows:

$$f_{offset} = \frac{1}{2\pi K T_{MCM}} \arg \left\{ \sum_{n=1}^K Z_n \cdot \left(\hat{a}_n \right)^* \right\} \quad (\text{Eq. 6})$$

In accordance with preferred embodiments of the present invention, the frequency control loop has a backward structure. In the embodiment shown in Figure 6, the feedback loop is connected between the output of the MCM demodulator 314 and the input of the guard interval removal unit 132.

In Figure 8, a block diagram of a MCM receiver comprising a coarse frequency correction unit 350 and a fine frequency correction unit as described above is shown. As shown in Figure 8, a common complex multiplier 326 can be used in order to perform the coarse frequency correction and the fine frequency correction. As shown in Figure 8, the multiplier 326 can be provided preceding the low path filter and decimator unit 312. Depending on the position of the

multiplier 326, a hold unit has to be provided in the fine frequency synchronization feedback loop. In an alternative embodiment, it is possible to use two separate multipliers for the coarse frequency correction and for the fine frequency correction. In such a case, the multiplier for the coarse frequency correction will be arranged preceding the low path filter and decimator unit, whereas the multiplier for the fine frequency correction will be arranged following the low path filter and decimator unit.

Following, preferred embodiments for implementing a coarse frequency synchronization will be described referring to Figures 9 and 10.

As it is shown in Figure 9, the output of the receiver front end 132 is connected to an analog/digital converter 310. The down-converted MCM signal is sampled at the output of the analog/digital converter 310 and is applied to a frame/timing synchronization unit 360. In a preferred embodiment, a fast running automatic gain control (AGC) (not shown) is provided preceding the frame/timing synchronization unit in order to eliminate fast channel fluctuations. The fast AGC is used in addition to the normally slow AGC in the signal path, in the case of transmission over a multipath channel with long channel impulse response and frequency selective fading. The fast AGC adjusts the average amplitude range of the signal to the known average amplitude of the reference symbol.

As described above, the frame/timing synchronization unit uses the amplitude-modulated sequence in the received signal in order to extract the framing information from the MCM signal and further to remove the guard intervals therefrom. After the frame/timing synchronization unit 360 it follows a coarse frequency synchronization unit 362 which estimates a coarse frequency offset based on the amplitude-modulated sequence of the reference symbol of the MCM signal. In the coarse frequency synchronization unit 362, a frequency

offset of the carrier frequency with respect to the oscillator frequency in the MCM receiver is determined in order to perform a frequency offset correction in a block 364. This frequency offset correction in block 364 is performed by a complex multiplication.

The output of the frequency offset correction block 364 is applied to the MCM demodulator 366 formed by the Fast Fourier Transformator 140 and the carrier-bit mapper 142 shown in Figure 1.

In order to perform the coarse frequency synchronization described herein, an amplitude-demodulation has to be performed on a preprocessed MCM signal. The preprocessing may be, for example, the down-conversion and the analog/digital conversion of the MCM signal. The result of the amplitude-demodulation of the preprocessed MCM signal is an envelope representing the amplitude of the MCM signal.

For the amplitude demodulation a simple $\alpha_{\max} + \beta_{\min}$ -method can be used. This method is described for example in Palachels A.: DSP-mP Routine Computes Magnitude, EDN, October 26, 1989; and Adams, W. T., and Bradley, J.: Magnitude Approximations for Microprocessor Implementation, IEEE Micro, Vol. 3, No. 5, October 1983.

It is clear that amplitude determining methods different from the described $\alpha_{\max} + \beta_{\min}$ -method can be used. For simplification, it is possible to reduce the amplitude calculation to a detection as to whether the current amplitude is above or below the average amplitude. The output signal then consists of a -1/+1 sequence which can be used to determine a coarse frequency offset by performing a correlation. This correlation can easily be performed using a simple integrated circuit (IC).

In addition, an oversampling of the signal received at the RF front end can be performed. For example, the received

signal can be expressed with two times oversampling.

In accordance with a first embodiment, a carrier frequency offset of the MCM signal from an oscillator frequency in the MCM receiver is determined by correlating the envelope obtained by performing the amplitude-demodulation as described above with a predetermined reference pattern.

In case there is no frequency offset, the received reference symbol $r(k)$ will be:

$$r(k) = S_{AM}(k) + n(k) \tag{Eq.7}$$

wherein $n(k)$ designates "additive Gaussian noise" and S_{AM} denotes the AM sequence which has been sent. In order to simplify the calculation the additive Gaussian noise can be neglected. It follows:

$$r(k) \cong S_{AM}(k) \tag{Eq.8}$$

In case a constant frequency offset Δf is present, the received signal will be:

$$\tilde{r}(k) = S_{AM}(k) \cdot e^{j2\pi\Delta f k T_{MCM}} \tag{Eq.9}$$

Information regarding the frequency offset is derived from the correlation of the received signal $\tilde{r}(k)$ with the AM sequence S_{AM} which is known in the receiver:

$$\sum_{k=1}^{\frac{L}{2}} \tilde{r}(k) \cdot S_{AM}^*(k) = \sum_{k=1}^{\frac{L}{2}} |S_{AM}(k)|^2 e^{j2\pi\Delta f k T_{MCM}} \tag{Eq.10}$$

Thus, the frequency offset is:

$$\Delta f = \frac{1}{2\pi T_{MCM}} \arg \left(\sum_{k=1}^{\frac{L}{2}} r(k) \cdot S_{AM}^*(k) \right) - \frac{1}{2\pi T_{MCM}} \arg \left(\sum_{k=1}^{\frac{L}{2}} |S_{AM}(k)|^2 \right) \tag{Eq.11}$$

Since the argument of $|S_{AM}(k)|^2$ is zero the frequency offset

005211 0202/960

is:

$$\Delta f = \frac{1}{2\pi T_{MCM}} \arg \left(\sum_{k=1}^{\frac{L}{2}} \tilde{r}(k) \cdot S_{AM}^* \right) \quad (\text{Eq. 12})$$

In accordance with a second embodiment of the coarse frequency synchronization algorithm, a reference symbol comprising at least two identical sequences 370 as shown in Figure 10 is used. Figure 10 shows the reference symbol of a MCM signal having two identical sequences 370 of a length of L/2 each. L designates the number of values of the two sequences 370 of the reference symbol.

As shown in Figure 10, within the amplitude-modulated sequence, there are at least two identical sections devoted to the coarse frequency synchronization. Two such sections, each containing L/2 samples, are shown at the end of the amplitude-modulated sequence in Figure 10. The amplitude-modulated sequence contains a large number of samples. For a non-ambiguous observation of the phase, only enough samples to contain a phase rotation of 2π should be used. This number is defined as L/2 in Figure 10.

Following, a mathematical derivation of the determination of a carrier frequency deviation is presented. In accordance with Figure 10, the following equation applies for the two identical sequences 370:

$$s\left(0 < k \leq \frac{L}{2}\right) \equiv s\left(\frac{L}{2} < k \leq L\right) \quad (\text{Eq. 13})$$

If no frequency offset is present, the following equation 14 will be met by the received signal:

$$r\left(k + \frac{L}{2}\right) \equiv r(k) \quad 0 < k \leq \frac{L}{2} \quad (\text{Eq. 14})$$

r(k) designates the values of the identical sequences. k is an index from one to L/2 for the respective samples.

005277-0222950

If there is a frequency offset of, for example, Δf , the received signal is:

$$\tilde{r}(k) = r(k) \cdot e^{j2\pi\Delta f k T_{MCM}} \quad (\text{Eq.15})$$

$$\tilde{r}\left(k + \frac{L}{2}\right) = r(k) \cdot e^{j2\pi\Delta f \left(k + \frac{L}{2}\right) T_{MCM}} \quad (\text{Eq.16})$$

$\tilde{r}(k)$ designates sample values of the received portion which are based on the identical sequences. Information regarding the frequency offset is derived from the correlation of the received signal $\tilde{r}(k+L/2)$ with the received signal $\tilde{r}(k)$. This correlation is given by the following equation:

$$\sum_{k=1}^{\frac{L}{2}} \tilde{r}^*\left(k + \frac{L}{2}\right) \tilde{r}(k) = \sum_{k=1}^{\frac{L}{2}} |r(k)|^2 e^{-j2\pi\Delta f \frac{L}{2} T_{MCM}} \quad (\text{Eq.17})$$

\tilde{r}^* designates the complex conjugate of the sample values of the portion mentioned above.

Thus, the frequency offset is

$$\Delta f = \frac{1}{2\pi \frac{L}{2} T_{MCM}} \arg\left(\sum_{k=1}^{\frac{L}{2}} \tilde{r}\left(k + \frac{L}{2}\right) \cdot \tilde{r}^*(k)\right) - \frac{1}{2\pi \frac{L}{2} T_{MCM}} \arg\left(\sum_{k=1}^{\frac{L}{2}} |\tilde{r}(k)|^2\right) \quad (\text{Eq.18})$$

Since the argument of $|\tilde{r}(k)|^2$ equals zero, the frequency offset becomes

$$\Delta f = \frac{1}{2\pi \frac{L}{2} T_{MCM}} \arg\left(\sum_{k=1}^{\frac{L}{2}} \tilde{r}\left(k + \frac{L}{2}\right) \cdot \tilde{r}^*(k)\right) \quad (\text{Eq.19})$$

Thus, it is clear that in both embodiments, described above, the frequency position of the maximum of the resulting output of the correlation determines the estimated value of the offset carrier. Furthermore, as it is also shown in Figure 9, the correction is performed in a feed forward structure.

006277-02E2950

In case of a channel with strong reflections, for example due to a high building density, the correlations described above might be insufficient for obtaining a suitable coarse frequency synchronization. Therefore, in accordance with a third embodiment of the present invention, corresponding values of the two portions which are correlated in accordance with a second embodiment, can be weighting with corresponding values of stored predetermined reference patterns corresponding to said two identical sequences of the reference symbol. This weighting can maximize the probability of correctly determining the frequency offset. The mathematical description of this weighting is as follows:

$$\Delta f = \frac{1}{2\pi \frac{L}{2} T_{MCM}} \arg \left(\sum_{k=1}^{\frac{L}{2}} \left[\tilde{r} \left(k + \frac{L}{2} \right) \cdot \tilde{r}^*(k) \right] \cdot \left[S_{AM}(k) S_{AM}^* \left(k + \frac{L}{2} \right) \right] \right) \quad (\text{Eq. 20})$$

S_{AM} designates the amplitude-modulated sequence which is known in the receiver, and S_{AM}^* designates the complex conjugate thereof.

If the above correlations are calculated in the frequency domain, the amount of

$$\sum_{k=1}^{\frac{L}{2}} \left[\tilde{r} \left(k + \frac{L}{2} \right) \cdot \tilde{r}^*(k) \right] \cdot \left[S_{AM}(k) S_{AM}^* \left(k + \frac{L}{2} \right) \right] \quad (\text{Eq. 21})$$

is used rather than the argument. This amount is maximized as a function of a frequency correction. The position of the maximum determines the estimation of the frequency deviation. As mentioned above, the correction is performed in a feed forward structure.

Preferred embodiments for performing an echo phase offset correction when using a differential mapping in the frequency axis will be described hereinafter referring to Figures 12 to 15.

Systematic phase shifts stemming from echoes in multipath

006277-02EE2950

environments may occur between subcarriers in the same MCM symbol. This phase offsets can cause bit errors when demodulating the MCM symbol at the receiver. Thus, it is preferred to make use of an algorithm to correct the systematic phase shifts stemming from echoes in multipath environments.

In Figure 12, scatter diagrams at the output of a differential demapper of a MCM receiver are shown. As can be seen from the left part of Figure 12, systematic phase shifts between subcarriers in the same MCM symbol cause a rotation of the demodulated phase shifts with respect to the axis of the complex coordinate system. In the right part of Figure 12, the demodulated phase shifts after having performed an echo phase offset correction are depicted. Now, the positions of the signal points are substantially on the axis of the complex coordinate system. These positions correspond to the modulated phase shifts of 0° , 90° , 180° and 270° , respectively.

An echo phase offset correction algorithm (EPOC algorithm) must calculate the echo induced phase offset from the signal space constellation following the differential demodulation and subsequently correct this phase offset.

For illustration purposes, one may think of the simplest algorithm possible which eliminates the symbol phase before computing the mean of all phases of the subcarriers. To illustrate the effect of such an EPOC algorithm, reference is made to the two scatter diagrams of subcarriers symbols contained in one MCM symbol in Figure 12. This scatter diagrams have been obtained as result of an MCM simulation. For the simulation a channel has been used which might typically show up in single frequency networks. The echoes of this channel stretched to the limits of the MCM guard interval. The guard interval was chosen to be 25% of the MCM symbol duration in this case.

Figure 13 represents a block diagram for illustrating the position and the functionality of an echo phase offset correction device in a MCM receiver. The signal of a MCM transmitter is transmitted through the channel 122 (Figures 1 and 13) and received at the receiver frontend 132 of the MCM receiver. The signal processing between the receiver frontend and the fast Fourier transformator 140 has been omitted in Figure 13. The output of the fast Fourier transformator is applied to the de-mapper, which performs a differential de-mapping along the frequency axis. The output of the de-mapper are the respective phase shifts for the subcarriers. The phase offsets of this phase shifts which are caused by echoes in multipath environments are visualized by a block 400 in Figure 13 which shows an example of a scatter diagram of the subcarrier symbols without an echo phase offset correction.

The output of the de-mapper 142 is applied to the input of an echo phase offset correction device 402. The echo phase offset correction device 402 uses an EPOC algorithm in order to eliminate echo phase offsets in the output of the de-mapper 142. The result is shown in block 404 of Figure 13, i.e. only the encoded phase shifts, 0° , 90° , 180° or 270° are present at the output of the correction device 402. The output of the correction device 402 forms the signal for the metric calculation which is performed in order to recover the bitstream representing the transmitted information.

A first embodiment of an EPOC algorithm and a device for performing same is now described referring to Figure 14.

The first embodiment of an EPOC algorithm starts from the assumption that every received differentially decoded complex symbol is rotated by an angle due to echoes in the multipath channel. For the subcarriers equal spacing in frequency is assumed since this represents a preferred embodiment. If the subcarriers were not equally spaced in frequency, a correction factor would have to be introduced

into the EPOC algorithm.

Figure 14 shows the correction device 402 (Figure 13) for performing the first embodiment of an EPOC algorithm.

From the output of the de-mapper 142 which contains an echo phase offset as shown for example in the left part of Figure 12, the phase shifts related to transmitted information must first be discarded. To this end, the output of the de-mapper 142 is applied to a discarding unit 500. In case of a DQPSK mapping, the discarding unit can perform a " $(.)^4$ " operation. The unit 500 projects all received symbols into the first quadrant. Therefore, the phase shifts related to transmitted information is eliminated from the phase shifts representing the subcarrier symbols. The same effect could be reached with a modulo-4 operation.

Having eliminated the information related symbol phases in unit 500, the first approach to obtain an estimation would be to simply compute the mean value over all symbol phases of one MCM symbol. However, it is preferred to perform a threshold decision before determining the mean value over all symbol phases of one MCM symbol. Due to Rayleigh fading some of the received symbols may contribute unreliable information to the determination of the echo phase offset. Therefore, depending on the absolute value of a symbol, a threshold decision is performed in order to determine whether the symbol should contribute to the estimate of the phase offset or not.

Thus, in the embodiment shown in Figure 14, a threshold decision unit 510 is included. Following the unit 500 the absolute value and the argument of a differentially decoded symbol is computed in respective computing units 512 and 514. Depending on the absolute value of a respective symbol, a control signal is derived. This control signal is compared with a threshold value in a decision circuit 516. If the absolute value, i.e. the control signal thereof, is smaller

than a certain threshold, the decision circuit 516 replaces the angle value going into the averaging operation by a value equal to zero. To this end, a switch is provided in order to disconnect the output of the argument computing unit 514 from the input of the further processing stage and connects the input of the further processing stage with a unit 518 providing a constant output of "zero".

An averaging unit 520 is provided in order to calculate a mean value based on the phase offsets φ_i determined for the individual subcarrier symbols of a MCM symbol as follows:

$$\bar{\varphi} = 1/K \sum_{i=1}^K \varphi_i \quad (\text{Eq.22})$$

In the averaging unit 520, summation over K summands is performed. The output of the averaging unit 520 is provided to a hold unit 522 which holds the output of the averaging unit 520 K times. The output of the hold unit 522 is connected with a phase rotation unit 524 which performs the correction of the phase offsets of the K complex signal points on the basis of the mean value $\bar{\varphi}$.

The phase rotation unit 524 performs the correction of the phase offsets by making use of the following equation:

$$v_k' = v_k \cdot e^{-j\bar{\varphi}} \quad (\text{Eq.23})$$

In this equation, v_k' designates the K phase corrected differentially decoded symbols for input into the soft-metric calculation, whereas v_k designates the input symbols. As long as a channel which is quasi stationary during the duration of one MCM symbols can be assumed, using the mean value over all subcarriers of one MCM symbol will provide correct results.

A buffer unit 527 may be provided in order to buffer the

complex signal points until the mean value of the phase offsets for one MCM symbol is determined. The output of the phase rotation unit 524 is applied to the further processing stage 526 for performing the soft-metric calculation.

With respect to the results of the above echo phase offset correction, reference is made again to Figure 12. The two plots stem from a simulation which included the first embodiment of an echo phase offset correction algorithm described above. At the instant of the scatter diagram snapshot shown in the left part of Figure 12, the channel obviously distorted the constellation in such a way, that a simple angle rotation is a valid assumption. As shown in the right part of Figure 12, the signal constellation can be rotated back to the axis by applying the determined mean value for the rotation of the differentially detected symbols.

A second embodiment of an echo phase offset correction algorithm is described hereinafter. This second embodiment can be preferably used in connection with multipath channels that have up to two strong path echoes. The algorithm of the second embodiment is more complex than the algorithm of the first embodiment.

What follows is a mathematical derivation of the second embodiment of a method for echo phase offset correction. The following assumptions can be made in order to ease the explanation of the second embodiment of an EPOC algorithm.

In this embodiment, the guard interval of the MCM signal is assumed to be at least as long as the impulse response $h[q]$, $q = 0, 1, \dots, Q_h-1$ of the multipath channel.

At the transmitter every MCM symbol is assembled using frequency axis mapping explained above. The symbol of the reference subcarrier equals 1, i.e. 0 degree phase shift. The optional phase shift PHI equals zero, i.e. the DQPSK

a_k^{inc} is weighted with the product $e^{j\psi_k \cdot H_k \cdot H_{k-1}^*}$ (rotation and effective transfer function of the channel). This product must be real-valued for an error free detection. Considering this, it is best to choose the rotation angle to equal the negative argument of $H_k \cdot H_{k-1}^*$. To derive the desired algorithm for 2-path channels, the nature of $H_k \cdot H_{k-1}^*$ is investigated in the next section.

It is assumed that the 2-path channel exhibits two echoes with energy content unequal zero, i.e. at least two dominant echoes. This assumption yields the impulse response

$$h[q] = c_1 \delta_0[q] + c_2 \delta_0[q - q_0] \quad (\text{Eq. 29})$$

with

c_1, c_2 : complex coefficients representing the path echoes;

q_0 : delay of the second path echo with respect to the first path echo;

δ_0 : Dirac pulse; $\delta_0[k] = 1$ for $k = 0$
 $\delta_0[k] = 0$ else

The channel transfer function is obtained by applying a DFT to Equation 29:

$$H_k = H\left(e^{j\frac{2\pi}{K}k}\right) = c_1 + c_2 \cdot e^{-j\frac{2\pi}{K}kq_0} \quad (\text{Eq. 30})$$

With Equation 30 the effective transfer function for differential demodulation along the frequency axis is:

$$\begin{aligned} H_k \cdot H_{k-1}^* &= \left(c_1 + c_2 e^{-j\frac{2\pi}{K}kq_0}\right) \cdot \left(c_1^* + c_2^* e^{+j\frac{2\pi}{K}(k-1)q_0}\right) \\ &= c_a + c_b \cos\left(\frac{\pi}{K}q_0(2k-1)\right) \end{aligned} \quad (\text{Eq. 31})$$

Assuming a noise free 2-path channel, it can be observed

002227-0262960

from Equation 31 that the symbols on the receiver side are located on a straight line in case the symbol $1+j0$ has been sent (see above assumption). This straight line can be characterized by a point

$$c_a = |c_1|^2 + |c_2|^2 \cdot e^{-j\frac{2\pi}{K}q_0} \tag{Eq.32}$$

and the vector

$$c_b = 2c_1c_2^* \cdot e^{-j\frac{\pi}{K}q_0} \tag{Eq.33}$$

which determines its direction.

With the above assumptions, the following geometric derivation can be performed. A more suitable notation for the geometric derivation of the second embodiment of an EPOC algorithm is obtained if the real part of the complex plane is designated as $x = \text{Re}\{z\}$, the imaginary part as $y = \text{Im}\{z\}$, respectively, i.e. $z = x+jy$. With this new notation, the straight line, on which the received symbols will lie in case of a noise-free two-path channel, is

$$f(x) = a + b \cdot x \tag{Eq.34}$$

with

$$a = \text{Im}\{c_a\} - \frac{\text{Re}\{c_a\}}{\text{Re}\{c_b\}} \cdot \text{Im}\{c_b\} \tag{Eq.35}$$

and

$$b = -\frac{\text{Im}\{c_a\} - \frac{\text{Re}\{c_a\}}{\text{Re}\{c_b\}} \cdot \text{Im}\{c_b\}}{\text{Re}\{c_a\} - \frac{\text{Im}\{c_a\}}{\text{Im}\{c_b\}} \cdot \text{Re}\{c_b\}} \tag{Eq.36}$$

Additional noise will spread the symbols around the straight line given by Equations 34 to 36. In this case Equation 36

006277-02EE-960

is the regression curve for the cluster of symbols.

For the geometric derivation of the second embodiment of an EPOC algorithm, the angle φ_k from Equation 28 is chosen to be a function of the square distance of the considered symbol from the origin:

$$\varphi_k = f_k(|z|^2) \tag{Eq.37}$$

Equation 37 shows that the complete signal space is distorted (torsion), however, with the distances from the origin being preserved.

For the derivation of the algorithm of the second embodiment, $f_k(\cdot)$ has to be determined such that all decision variables v'_k (assuming no noise) will come to lie on the real axis:

$$\text{Im}\left\{(x + jf(x)) \cdot e^{j\varphi_k(|z|^2)}\right\} = 0 \tag{Eq.38}$$

Further transformations of Equation 38 lead to a quadratic equation which has to be solved to obtain the solution for φ_k .

In case of a two-path channel, the echo phase offset correction for a given decision variable v_k is

$$v'_k = v_k \cdot e^{j\varphi_k} \tag{Eq.39}$$

with

$$\varphi_k = \begin{cases} -\text{atan}\left(\frac{a + b\sqrt{|v_k|^2(1+b^2) - a^2}}{-ab + \sqrt{|v_k|^2(1+b^2) - a^2}}\right) & \text{for } |v_k|^2 \geq \frac{a^2}{1+b^2} \\ \text{atan}\left(\frac{1}{b}\right) & \text{for } |v_k|^2 < \frac{a^2}{1+b^2} \end{cases} \tag{Eq.40}$$

005211 03E2960

From the two possible solutions of the quadratic equation mentioned above, Equation 40 is the one solution that cannot cause an additional phase shift of 180 degrees.

The two plots in Figure 15 show the projection of the EPOC algorithm of the second embodiment for one quadrant of the complex plane. Depicted here is the quadratic grid in the sector $|\arg(z)| \leq \pi/4$ and the straight line $y = f(x) = a+b \cdot x$ with $a = -1.0$ and $b = 0.5$ (dotted line). In case of a noise-free channel, all received symbols will lie on this straight line if $1+j0$ was sent. The circle shown in the plots determines the boarder line for the two cases of Equation 40. In the left part, Figure 15 shows the situation before the projection, in the right part, Figure 15 shows the situation after applying the projection algorithm. By looking on the left part, one can see, that the straight line now lies on the real axis with $2+j0$ being the fix point of the projection. Therefore, it can be concluded that the echo phase offset correction algorithm according to the second embodiment fulfills the design goal.

Before the second embodiment of an EPOC algorithm can be applied, the approximation line through the received symbols has to be determined, i.e. the parameters a and b must be estimated. For this purpose, it is assumed that the received symbols lie in sector $|\arg(z)| \leq \pi/4$, if $1+j0$ was sent. If symbols other than $1+j0$ have been sent, a modulo operation can be applied to project all symbols into the desired sector. Proceeding like this prevents the necessity of deciding on the symbols in an early stage and enables averaging over all signal points of one MCM symbol (instead of averaging over only $\frac{1}{4}$ of all signal points).

For the following computation rule for the EPOC algorithm of the second embodiment, x_i is used to denote the real part of the i -th signal point and y_i for its imaginary part, respectively ($i = 1, 2, \dots, K$). Altogether, K values are available for the determination. By choosing the method of

least squares, the straight line which has to be determined can be obtained by minimizing

$$(a, b) = \underset{(\tilde{a}, \tilde{b})}{\operatorname{argmin}} \sum_{i=1}^K (y_i - (\tilde{a} + \tilde{b} \cdot x_i))^2 \quad (\text{Eq. 41})$$

The solution for Equation 41 can be found in the laid open literature. It is

$$b = \frac{\sum_{i=1}^K (x_i - \bar{x}) \cdot y_i}{\sum_{i=1}^K (x_i - \bar{x})^2}, \quad a = \bar{y} - \bar{x} \cdot b \quad (\text{Eq. 42})$$

with mean values

$$\bar{x} = \frac{1}{N} \sum_{i=1}^K x_i, \quad \bar{y} = \frac{1}{N} \sum_{i=1}^K y_i \quad (\text{Eq. 43})$$

If necessary, an estimation method with higher robustness can be applied. However, the trade-off will be a much higher computational complexity.

To avoid problems with the range in which the projection is applicable, the determination of the straight line should be separated into two parts. First, the cluster's centers of gravity are moved onto the axes, following, the signal space is distorted. Assuming that a and b are the original parameters of the straight line and α is the rotation angle, $f_K(\cdot)$ has to be applied with the transformed parameters

$$b' = \frac{b \cdot \cos(\alpha) - \sin(\alpha)}{\cos(\alpha) + b \cdot \sin(\alpha)}, \quad a' = a \cdot (\cos(\alpha) - b' \cdot \sin(\alpha)) \quad (\text{Eq. 44})$$

Besides the two EPOC algorithms explained above section, different algorithms can be designed that will, however, most likely exhibit a higher degree of computational complexity.

Claims

1. A method of performing a fine frequency synchronization compensating for a carrier frequency deviation from an oscillator frequency in a multi-carrier demodulation system (130) of the type capable of carrying out a differential phase decoding of multi-carrier modulated signals, said signals comprising a plurality of symbols (200), each symbol being defined by phase differences between simultaneous carriers (202) having different frequencies, said method comprising the steps of:

determining a phase difference between phases of the same carrier in different symbols;

determining a frequency offset by eliminating phase shift uncertainties corresponding to codeable phase shifts from said phase difference; and

performing a feedback correction of said carrier frequency deviation based on said determined frequency offset.

2. A method of performing a fine frequency synchronization compensating for a carrier frequency deviation from an oscillator frequency in a multi-carrier demodulation system (130) of the type capable of carrying out a differential phase decoding of multi-carrier modulated signals, said signals comprising a plurality of symbols (200), each symbol being defined by phase differences between simultaneous carriers (202) having different frequencies, said method comprising the steps of:

determining respective phase of the same carrier in different symbols;

eliminating phase shift uncertainties corresponding to

005277 0222/960

codeable phase shifts from said phases to determine respective phase deviations;

determining a frequency offset by determining a phase difference between said phase deviations;

performing a feedback correction of said carrier frequency deviation based on said determined frequency offset.

3. A method of performing a fine frequency synchronization compensating for a carrier frequency deviation from an oscillator frequency in a multi-carrier demodulation system (130) of the type capable of carrying out a differential phase decoding of multi-carrier modulated signals, said signals comprising a plurality of symbols (200), each symbol being defined by phase differences between simultaneous carriers (202) having different frequencies, said method comprising the steps of:

for a plurality of carriers (202) in said symbols (200):

determining a phase difference between phases of the same carrier in different symbols; and

determining a frequency offset by eliminating phase shift uncertainties corresponding to codeable phase shifts from said phase difference;

determining an averaged frequency offset (f_{offset}) by averaging said determined frequency offsets of said plurality of carriers (202); and

performing a feedback correction of said frequency deviation based on said averaged frequency offset (f_{offset}).

4. A method of performing a fine frequency synchronization

compensating for a carrier frequency deviation from an oscillator frequency in a multi-carrier demodulation system (130) of the type capable of carrying out a differential phase decoding of multi-carrier modulated signals, said signals comprising a plurality of symbols (200), each symbol being defined by phase differences between simultaneous carriers (202) having different frequencies, said method comprising the steps of:

for a plurality of carriers (202) in said symbols (200):

determining respective phases of the same carrier in different symbols;

eliminating phase shift uncertainties corresponding to codeable phase shifts from said phases to determine respective phase deviations; and

determining a frequency offset by determining a phase difference between said phase deviations;

determining an averaged frequency offset by averaging said determined frequency offsets of said plurality of carriers; and

performing a feedback correction of said frequency deviation based on said averaged frequency offset.

5. The method according to claims 1 or 3, wherein said step of determining a phase difference comprises the step of determining a phase difference between phases of the same carrier (202) in symbols (200) which are adjacent in the time axis direction.
6. The method according to claims 1 or 3, wherein said step of determining a frequency offset comprises the step of eliminating phase shift uncertainties corresponding to M-ary phase shifts.

006211 022E/960

7. The method according to claims 2 or 4, wherein said step of determining respective phases comprises the step of determining respective phases of the same carrier (202) in symbols (200) which are adjacent in the time axis direction.
8. The method according to claims 2 or 4, wherein said step of eliminating phase shift uncertainties comprises the step of eliminating M-ary phase shifts.
9. An apparatus for performing a fine frequency synchronization compensating for a carrier frequency deviation from an oscillator frequency, for a multi-carrier demodulation system (130) of the type capable of carrying out a differential phase decoding of multi-carrier modulated signals, said signals comprising a plurality of symbols (200), each symbol being defined by phase differences between simultaneous carriers (202) having different frequencies, said apparatus comprising:
- means (330) for determining a phase difference between phases of the same carrier (202) in different symbols (200);
- means (340, 342) for determining a frequency offset by eliminating phase shift uncertainties corresponding to codeable phase shifts from said phase difference; and
- means for performing a feedback correction of said frequency deviation based on said determined frequency offset.
10. An apparatus for performing a fine frequency synchronization compensating for a carrier frequency deviation from an oscillator frequency, for a multi-carrier demodulation system (130) of the type capable of carrying out a differential phase decoding of

006277 0222950

multi-carrier modulated signals, said signals comprising a plurality of symbols (200), each symbol being defined by phase differences between simultaneous carriers (202) having different frequencies, said apparatus comprising:

means for determining respective phases of the same carrier in different symbols;

means for eliminating phase shift uncertainties corresponding to codeable phase shifts from said phases to determine respective phase deviations;

means for determining a frequency offset by determining a phase difference between said phase deviations;

means for performing a feedback correction of said frequency deviation based on said determined frequency offset.

11. An apparatus for performing a fine frequency synchronization compensating for a carrier frequency deviation from an oscillator frequency, for a multi-carrier demodulation system (130) of the type capable of carrying out a differential phase decoding of multi-carrier modulated signals, said signals comprising a plurality of symbols (200), each symbol being defined by phase differences between simultaneous carriers (202) having different frequencies, said apparatus comprising:

means (330) for determining a phase difference between phases of the same carrier (202) in different symbols;

means (340, 342) for determining a frequency offset by eliminating phase shift uncertainties corresponding to codeable phase shifts from said phase difference;

means (344) for determining an averaged frequency offset (f_{offset}) by averaging determined frequency offsets of a

plurality of carriers; and

means for performing a feedback correction of said frequency deviation based on said averaged frequency offset.

12. An apparatus for performing a fine frequency synchronization compensating for a carrier frequency deviation from an oscillator frequency, for a multi-carrier demodulation system (130) of the type capable of carrying out a differential phase decoding of multi-carrier modulated signals, said signals comprising a plurality of symbols (200), each symbol (200) being defined by phase differences between simultaneous carriers (202) having different frequencies, said apparatus comprising:

means for determining respective phases of the same carrier in different symbols;

means for eliminating phase shift uncertainties corresponding to codeable phase shifts from said phases to determine respective phase deviations;

means for determining a frequency offset by determining a phase difference between said phase deviations;

means for determining an averaged frequency offset by averaging determined frequency offsets of a plurality of carriers; and

means for performing a feedback correction of said frequency deviation based on said averaged frequency offset.

13. The apparatus according to claims 9 or 11, wherein said means (330) for determining a phase difference comprises means for determining a phase difference between phases

005007" 02020900

of the same carrier in symbols which are adjacent in the time axis direction.

14. The apparatus according to claims 10 or 12, wherein said means for determining respective phases comprises means for determining respective phases of the same carrier in symbols which are adjacent in the time axis direction.
15. The apparatus according to claims 9 or 11, wherein said means (340, 342) for determining a frequency offset comprises a M-ary phase shift keying decision device (340) and a complex multiplier (342).
16. The apparatus according to claims 10 or 12, wherein said means for eliminating phase shift uncertainties comprises a M-ary phase shift keying decision device and a complex multiplier.
17. The apparatus according to one of claims 9 to 16, wherein said means for performing a feedback correction of said frequency deviation comprises a numerical controlled oscillator (322) and a complex multiplier (326).
18. The apparatus according to claim 17, wherein said means for performing a feedback correction of said frequency deviation further comprises a low path filter (324) preceding said numerical controlled oscillator (322).

006677 02222222

**METHOD AND APPARATUS FOR FINE FREQUENCY SYNCHRONIZATION IN
MULTI-CARRIER DEMODULATION SYSTEMS**

5

FIELD OF THE INVENTION

10 The present invention relates to methods and apparatus for
performing a fine frequency synchronization in multi-carrier
demodulation systems, and in particular to methods and appa-
ratus for performing a fine frequency synchronization com-
15 pensating for a carrier frequency deviation from an oscilla-
tor frequency in a multi-carrier demodulation system of the
type capable of carrying out a differential phase decoding
of multi-carrier modulated signals, wherein the signals com-
prise a plurality of symbols, each symbol being defined by
20 phase differences between simultaneous carriers having dif-
ferent frequencies.

BACKGROUND OF THE INVENTION

25 In a multi carrier transmission system (MCM, OFDM), the ef-
fect of a carrier frequency offset is substantially more
considerable than in a single carrier transmission system.
MCM is more sensitive to phase noise and frequency offset
which occurs as amplitude distortion and inter carrier in-
30 terference (ICI). The inter carrier interference has the ef-
fect that the subcarriers are no longer orthogonal in rela-
tion to each other. Frequency offsets occur after power on
or also later due to frequency deviation of the oscillators
used for downconversion into baseband. Typical accuracies
35 for the frequency of a free running oscillator are about ± 50
ppm of the carrier frequency. With a carrier frequency in
the S-band of 2.34 GHz, for example, there will be a maximum
local oscillator (LO) frequency deviation of above 100 kHz
(117.25 kHz). The above named effects result in high re-

quirements on the algorithm used for frequency offset correction.

5

DESCRIPTION OF PRIOR ART

Most prior art algorithms for frequency synchronization divide frequency correction into two stages. In the first stage, a coarse synchronization is performed. In the second stage, a fine correction can be achieved. A frequently used algorithm for coarse synchronization of the carrier frequency uses a synchronization symbol which has a special spectral pattern in the frequency domain. Such a synchronization symbol is, for example, a CAZAC sequence (CAZAC = Constant Amplitude Zero Autocorrelation). Through comparison, i.e. the correlation, of the power spectrum of the received signal with that of the transmitted signal, the frequency carrier offset can be coarsely estimated. These prior art algorithms all work in the frequency domain. Reference is made, for example, to Ferdinand Claßen, Heinrich Meyr, "Synchronization Algorithms for an OFDM System for Mobile Communication", ITG-Fachtagung 130, Codierung für Quelle, Kanal und Übertragung, pp. 105 - 113, Oct. 26-28, 1994; and Timothy M. Schmidl, Donald C. Cox, "Low-Overhead, Low-Complexity [Burst] Synchronization for OFDM", in Proceedings of the IEEE International Conference on Communication ICC 1996, pp. 1301-1306 (1996).

For the coarse synchronization of the carrier frequency, Paul H. Moose, "A Technique for Orthogonal Frequency Division Multiplexing Frequency Offset Correction", IEEE Transaction On Communications, Vol. 42, No. 10, October 1994, suggest increasing the spacing between the subcarriers such that the subcarrier distance is greater than the maximum frequency difference between the received and transmitted carriers. The subcarrier distance is increased by reducing the number of sample values which are transformed by the Fast Fourier Transform. This corresponds to a reduction of

the number of sampling values which are transformed by the Fast Fourier Transform.

WO 9205646 A relates to methods for the reception of orthogonal frequency division multiplexed signals comprising data which are preferably differentially coded in the direction of the time axis. Phase drift of the demodulated samples from one block to the next is used to indicate the degree of local oscillator frequency error. Phase drift is assessed by multiplying complex values by the complex conjugate of an earlier sample demodulated from the same OFDM carrier and using the resulting measure to steer the local oscillator frequency via a frequency locked loop.

SUMMARY OF THE INVENTION

It is an object of the present invention to provide methods and apparatus for performing a fine frequency synchronization which allow a fine frequency synchronization compensating for a carrier frequency deviation from an oscillator frequency in a MCM transmission system which makes use of MCM signals in which information is differential phase encoded between simultaneous sub-carriers having different frequencies.

In accordance with a first aspect, the present invention provides a method of performing a fine frequency synchronization compensating for a carrier frequency deviation from an oscillator frequency in a multi-carrier demodulation system of the type capable of carrying out a differential phase decoding of multi-carrier modulated signals, the signals comprising a plurality of symbols, each symbol being defined by phase differences between simultaneous carriers having different frequencies, the method comprising the steps of:

determining a phase difference between phases of the same carrier in different symbols;

determining a frequency offset by eliminating phase shift uncertainties [going back to phase shifts due to the definition of symbols] related to the transmitted information from the phase difference making use of a M-PSK decision device;
5 and

performing a feedback correction of the carrier frequency deviation based on the determined frequency offset.

10 In accordance with a second aspect, the present invention provides a method of performing a fine frequency synchronization compensating for a carrier frequency deviation from an oscillator frequency in a multi-carrier demodulation system of the type capable of carrying out a differential phase
15 decoding of multi-carrier modulated signals, the signals comprising a plurality of symbols, each symbol being defined by phase differences between simultaneous carriers having different frequencies, the method comprising the steps of:

20 determining respective phases of the same carrier in different symbols;

eliminating phase shift uncertainties related to the transmitted information from the phases to determine respective
25 phase deviations making use of a M-PSK decision device;

determining a frequency offset by determining a phase difference between the phase deviations; and

30 performing a feedback correction of said carrier frequency deviation based on the determined frequency offset.

In accordance with a third aspect, the present invention provides an apparatus for performing a fine frequency synchronization compensating for a carrier frequency deviation
35 from an oscillator frequency, for a multi-carrier demodulation system of the type capable of carrying out a differential phase decoding of multi-carrier modulated signals, the signals comprising a plurality of symbols, each symbol being

defined by phase differences between simultaneous carriers having different frequencies, the apparatus comprising:

5 means for determining a phase difference between phases of the same carrier in different symbols;

[means] M-PSK decision device for determining a frequency offset by eliminating phase shift uncertainties [going back to phase shifts due to the definition of symbols] related to
10 the transmitted information from the phase difference [making use of a M-PSK decision device]; and

15 means for performing a feedback correction of the frequency deviation based on the determined frequency offset.

In accordance with a fourth aspect, the present invention provides an apparatus for performing a fine frequency synchronization compensating for a carrier frequency deviation from an oscillator frequency, for a multi-carrier demodulation system of the type capable of carrying out a differential phase decoding of multi-carrier modulated signals, said signals comprising a plurality of symbols, each symbol being defined by phase differences between simultaneous carriers having different frequencies, the apparatus comprising:

25 means for determining respective phases of the same carrier in different symbols;

30 M-PSK decision device for eliminating phase shift uncertainties [going back to phase shifts due to the definition of symbols] related to the transmitted information from the phases to determine respective phase deviations;

35 means for determining a frequency offset by determining a phase difference between the phase deviations; and

means for performing a feedback correction of the frequency deviation based on the determined frequency offset.

The present invention relates to methods and apparatus for performing a fine frequency synchronization compensating for a carrier frequency deviation from an oscillator frequency. This fine frequency synchronization is preferably performed
5 after completion of a coarse frequency synchronization, such that the frequency offsets after the coarse frequency synchronization are smaller than half the sub-carrier distance in the MCM signal. Since the frequency offsets which are to be corrected by the inventive fine frequency synchronization
10 methods and apparatus, a correction of the frequency offsets by using a phase rotation with differential decoding and demapping in the time axis can be used. The frequency offsets are detected by determining the frequency differences between time contiguous sub-carrier symbols along the time
15 axis. The frequency error is calculated by measuring the rotation of the I-Q cartesian coordinates of each sub-carrier and, in preferred embodiments, averaging them over all n sub-carriers of a MCM symbol.

20 Firstly, the phase ambiguity or uncertainty is eliminated by using a M-PSK decision device and correlating the output of the decision device with the input signal for a respective sub-carrier symbol. Thus, the phase offset for a sub-carrier symbol is determined and can be used for restructuring the
25 frequency error in form of a feed-backward structure. Alternatively, the phase offsets of the sub-carrier symbols of one MCM symbol can be averaged over all of the active carriers of a MCM symbol, wherein the averaged phase offset is used to restructure the frequency error.

30 In accordance with the present invention, the determination of the frequency offset is performed in the frequency domain. The feedback correction in accordance with the inventive fine frequency synchronization is performed in the time
35 domain. To this end, a differential decoder in the time domain is provided in order to detect frequency offsets of sub-carriers on the basis of the phases of timely successive sub-carrier symbols of different MCM symbols.

BRIEF DESCRIPTION OF THE DRAWINGS

5 In the following, preferred embodiments of the present invention will be explained in detail on the basis of the drawings enclosed, in which:

10 Figure 1 shows a schematic overview of a MCM transmission system to which the present application can be applied;

15 Figures 2A and 2B show schematic views representing a scheme for differential mapping in the time axis and a scheme for differential mapping in the frequency axis;

Figure 3 shows a functional block diagram for performing a differential mapping in the frequency axis;

20 Figure 4 shows a representation of time variation of all sub-carriers in MCM symbols;

25 Figure 5 shows a QPSK-constellation for each sub-carrier with a frequency offset;

Figure 6 shows a general block diagram illustrating the position of the inventive fine frequency synchronization device in a MCM receiver;

30 Figure 7 shows a block diagram of the fine frequency error detector shown in Figure 6;

35 Figure 8 shows a block diagram of a MCM receiver comprising a coarse frequency synchronization unit and a fine frequency synchronization unit;

Figure 9 shows a block diagram of a unit for performing a coarse frequency synchronization;

Figure 10 shows a schematic view of a reference symbol used for performing a coarse frequency synchronization;

5 Figure 11 shows a schematic view of a typical MCM signal having a frame structure;

10 Figure 12 shows scatter diagrams of the output of an differential de-mapper of a MCM receiver for illustrating the effect of an echo phase offset correction;

15 Figure 13 shows a schematic block diagram for illustrating the position and the functionality of an echo phase offset correction unit;

20 Figure 14 shows a schematic block diagram of a preferred form of an echo phase offset correction device; and

25 Figure 15 shows schematic views for illustrating a projection performed by another echo phase offset correction algorithm.

DETAILED DESCRIPTION OF THE EMBODIMENTS

30 Before discussing the present invention in detail, the mode of operation of a MCM transmission system is described referring to figure 1.

Referring to Figure 1, at 100 a MCM transmitter is shown that substantially corresponds to a prior art MCM transmitter. A description of such a MCM transmitter can be found, 35 for example, in William Y. Zou, Yiyan Wu, "COFDM: AN OVERVIEW", IEEE Transactions on Broadcasting, vol. 41, No. 1, March 1995.

5 A data source 102 provides a serial bitstream 104 to the MCM transmitter. The incoming serial bitstream 104 is applied to a bit-carrier mapper 106 which produces a sequence of spectra 108 from the incoming serial bitstream 104. An inverse fast Fourier transform (IFFT) 110 is performed on the sequence of spectra 108 in order to produce a MCM time domain signal 112. The MCM time domain signal forms the useful MCM symbol of the MCM time signal. To avoid intersymbol interference (ISI) caused by multipath distortion, a unit 114 is provided for inserting a guard interval of fixed length between adjacent MCM symbols in time. In accordance with a preferred embodiment of the present invention, the last part of the useful MCM symbol is used as the guard interval by placing same in front of the useful symbol. The resulting MCM symbol is shown at 115 in Figure 1 and corresponds to a MCM symbol 160 depicted in Figure 11.

20 Figure 11 shows the construction of a typical MCM signal having a frame structure. One frame of the MCM time signal is composed of a plurality of MCM symbols 160. Each MCM symbol 160 is formed by an useful symbol 162 and a guard interval 164 associated therewith. As shown in Figure 11, each frame comprises one reference symbol 166. The present invention can advantageously be used with such a MCM signal, however, such a signal structure being not necessary for performing the present invention as long as the transmitted signal comprises a useful portion and at least one reference symbol.

30 In order to obtain the final frame structure shown in Figure 11, a unit 116 for adding a reference symbol for each predetermined number of MCM symbols is provided.

35 In accordance with the present invention, the reference symbol is an amplitude modulated bit sequence. Thus, an amplitude modulation of a bit sequence is performed such that the envelope of the amplitude modulated bit sequence defines a reference pattern of the reference symbol. This reference pattern defined by the envelope of the amplitude modulated

bit sequence has to be detected when receiving the MCM signal at a MCM receiver. In a preferred embodiment of the present invention, a pseudo random bit sequence having good autocorrelation properties is used as the bit sequence that is amplitude modulated.

The choice of length and repetition rate of the reference symbol depends on the properties of the channel through which the MCM signal is transmitted, e.g. the coherence time of the channel. In addition, the repetition rate and the length of the reference symbol, in other words the number of useful symbols in each frame, depends on the receiver requirements concerning mean time for initial synchronization and mean time for resynchronization after synchronization loss due to a channel fade.

The resulting MCM signal having the structure shown at 118 in Figure 1 is applied to the transmitter front end 120. Roughly speaking, at the transmitter front end 120, a digital/analog conversion and an up-converting of the MCM signal is performed. Thereafter, the MCM signal is transmitted through a channel 122.

Following, the mode of operation of a MCM receiver 130 is shortly described referring to Figure 1. The MCM signal is received at the receiver front end 132. In the receiver front end 132, the MCM signal is down-converted and, furthermore, an analog/digital conversion of the down-converted signal is performed.

The down-converted MCM signal is provided to a symbol frame/carrier frequency synchronization unit 134.

A first object of the symbol frame/carrier frequency synchronization unit 134 is to perform a frame synchronization on the basis of the amplitude-modulated reference symbol. This frame synchronization is performed on the basis of a correlation between the amplitude-demodulated reference sym-

bol [an] and a predetermined reference pattern stored in the MCM receiver.

5 A second object of the symbol frame/carrier frequency synchronization unit is to perform a coarse frequency synchronization of the MCM signal. To this end, the symbol frame/carrier frequency synchronization unit 134 serves as a coarse frequency synchronization unit for determining a coarse frequency offset of the carrier frequency caused, for example, by a difference of the frequencies between the local oscillator of the transmitter and the local oscillator of the receiver. The determined frequency is used in order to perform a coarse frequency correction. The mode of operation of the coarse frequency synchronization unit is described in detail referring to Figures 9 and 10 hereinafter.

15 As described above, the frame synchronization unit 134 determines the location of the reference symbol in the MCM symbol. Based on the determination of the frame synchronization unit 134, a reference symbol extracting unit 136 extracts the framing information, i.e. the reference symbol, from the MCM symbol coming from the receiver front end 132. After the extraction of the reference symbol, the MCM signal is applied to a guard interval removal unit 138. The result of the signal processing performed hereherto in the MCM receiver are the useful MCM symbols.

25 The useful MCM symbols output from the guard interval removal unit 138 are provided to a fast Fourier transform unit 140 in order to provide a sequence of spectra from the useful symbols. Thereafter, the sequence of spectra is provided to a carrier-bit mapper 142 in which the serial bitstream is recovered. This serial bitstream is provided to a data sink 144.

35 Next, referring to Figures 2A and 2B, two modes for differential mapping are described. In Figure 2A, a first method of differential mapping along the time axis is shown. As can be seen from Figure 2A, a MCM symbol consists of K sub-

carriers. The sub-carriers comprise different frequencies and are, in a preferred embodiment, equally spaced in the frequency axis direction. When using differential mapping along the time axis, one or more bits are encoded into phase and/or amplitude shifts between two sub-carriers of the same center frequency in adjacent MCM symbols. The arrows depicted between the sub-carrier symbols correspond to information encoded in amplitude and/or phase shifts between two sub-carrier symbols.

A second method of differential mapping is shown in Figure 2B. The present invention is adapted for MCM transmission system using the mapping scheme shown in Figure 2B. This mapping scheme is based on a differential mapping inside one MCM symbol along the frequency axis. A number of MCM symbols 200 is shown in Figure 2B. Each MCM symbol 200 comprises a number of sub-carrier symbols 202. The arrows 204 in Figure 2B illustrate information encoded between two sub-carrier symbols 202. As can be seen from the arrows 204, this mapping scheme is based on a differential mapping within one MCM symbol along the frequency axis direction.

In the embodiment shown in Figure 2B, the first sub-carrier ($k=0$) in an MCM symbol 200 is used as a reference sub-carrier 206 (shaded) such that information is encoded between the reference sub-carrier and the first active carrier 208. The other information of a MCM symbol 200 is encoded between active carriers, respectively.

Thus, for every MCM symbol an absolute phase reference exists. In accordance with Figure 2B, this absolute phase reference is supplied by a reference symbol inserted into every MCM symbol ($k=0$). The reference symbol can either have a constant phase for all MCM symbols or a phase that varies from MCM symbol to MCM symbol. A varying phase can be obtained by replicating the phase from the last subcarrier of the MCM symbol preceding in time.

In Figure 3 a preferred embodiment of a device for performing a differential mapping along the frequency axis is shown. Referring to Figure 3, assembly of MCM symbols in the frequency domain using differential mapping along the frequency axis according to the present invention is described.

Figure 3 shows the assembly of one MCM symbol with the following parameters:

10 NFFT designates the number of complex coefficients of the discrete Fourier transform, number of subcarriers respectively.

15 K designates the number of active carriers. The reference carrier is not included in the count for K.

According to Figure 3, a quadrature phase shift keying (QPSK) is used for mapping the bitstream onto the complex symbols. However, other M-ary mapping schemes (MPSK) like 2-PSK, 8-PSK, 16-QAM, 16-APSK, 64-APSK etc. are possible.

Furthermore, for ease of filtering and minimization of aliasing effects some subcarriers are not used for encoding information in the device shown in Figure 3. These subcarriers, which are set to zero, constitute the so-called guard bands on the upper and lower edges of the MCM signal spectrum.

At the input of the mapping device shown in Figure 3, complex signal pairs $b_0[k]$, $b_1[k]$ of an input bitstream are received. K complex signal pairs are assembled in order to form one MCM symbol. The signal pairs are encoded into the K differential phase shifts $\phi[k]$ needed for assembly of one MCM symbol. In this embodiment, mapping from Bits to the 0, 90, 180 and 270 degrees phase shifts is performed using Gray Mapping in a quadrature phase shift keying device 220.

Gray mapping is used to prevent that differential detection phase errors smaller than 135 degrees cause double bit errors at the receiver.

5 Differential phase encoding of the K phases is performed in a differential phase encoder 222. At this stage of processing, the K phases $\phi[k]$ generated by the QPSK Gray mapper are differentially encoded. In principal, a feedback loop 224 calculates a cumulative sum over all K phases. As starting point for the first computation ($k = 0$) the phase of the reference carrier 226 is used. A switch 228 is provided in order to provide either the absolute phase of the reference subcarrier 226 or the phase information encoded onto the preceding (i.e. z^{-1} , where z^{-1} denotes the unit delay operator) subcarrier to a summing point 230. At the output of the differential phase encoder 222, the phase information $\theta[k]$ with which the respective subcarriers are to be encoded is provided. In preferred embodiments of the present invention, the subcarriers of a MCM symbol are equally spaced in the frequency axis direction.

The output of the differential phase encoder 222 is connected to a unit 232 for generating complex subcarrier symbols using the phase information $\theta[k]$. To this end, the K differentially encoded phases are converted to complex symbols by multiplication with

$$\text{factor} * e^{j[2*\pi*(\theta[k]+PHI)]} \quad (\text{Eq.1})$$

30 wherein factor designates a scale factor and PHI designates an additional angle. The scale factor and the additional angle PHI are optional. By choosing $PHI = 45^\circ$ a rotated DQPSK signal constellation can be obtained.

35 Finally, assembly of a MCM symbol is effected in an assembling unit 234. One MCM symbol comprising N_{FFT} subcarriers is assembled from $N_{FFT}-K-1$ guard band symbols which are "zero", one reference subcarrier symbol and K DQPSK subcarrier symbols. Thus, the assembled MCM symbol 200 is composed of K

complex values containing the encoded information, two guard bands at both sides of the N_{FFT} complex values and a reference subcarrier symbol.

5 The MCM symbol has been assembled in the frequency domain. For transformation into the time domain an inverse discrete Fourier transform (IDFT) of the output of the assembling unit 234 is performed by a transformator 236. In preferred
10 embodiments of the present invention, the transformator 236 is adapted to perform a fast Fourier transform (FFT).

Further processing of the MCM signal in the transmitter as well as in the receiver is as described above referring to Figure 1.

15 At the receiver a de-mapping device 142 (Figure 1) is needed to reverse the operations of the mapping device described above referring to Figure 3. The implementation of the de-mapping device is straightforward and, therefore, need not
20 be described herein in detail.

The differential mapping along the frequency axis direction is suitable for multi-carrier (OFDM) digital broadcasting over rapidly changing multi path channels. In accordance
25 with this mapping scheme, there is no need for a channel stationarity exceeding one multi-carrier symbol. However, differential mapping into frequency axis direction may create a new problem. In multi path environments, path echoes succeeding or preceding the main path can lead to systematic phase offsets between sub-carriers in the same MCM symbol. Thus, it will be preferred to provide a correction unit in order to eliminate such phase offsets. Because the channel induced phase offsets between differential demodulated symbols are systematic errors, they can be corrected by an algorithm.
30 In principle, such an algorithm must calculate the echo induced phase offset from the signal space constellation following the differential demodulation and subsequently correct this phase offset.
35

Examples for such echo phase correction algorithms are described at the end of this specification referring to Figures 12 to 15.

5 Next, the fine frequency synchronization in accordance with the present invention will be described referring to Figures 4 to 8. As mentioned above, the fine frequency synchronization in accordance with the present invention is performed after completion of the coarse frequency synchronization.
10 Preferred embodiments of the coarse frequency synchronization which can be performed by the symbol frame/carrier frequency synchronization unit 134 are described hereinafter referring to Figures 9 and 10 after having described the fine frequency synchronization in accordance with the present invention.
15

with the fine frequency synchronization in accordance with the present invention frequency offsets which are smaller than half the sub-carrier distance can be corrected. Since
20 the frequency offsets are low and equal for all sub-carriers the problem of fine frequency synchronization is reduced to sub-carrier level. Figure 4 is a schematical view of MCM symbols 200 in the time-frequency plane. Each MCM symbol 200 consists of 432 sub-carrier symbols C_1 to C_{432} . The MCM symbols are arranged along the time axis, the first MCM symbol
25 200 shown in Figure 4 having associated therewith a time T_1 , the next MCM symbol having associated therewith a time T_2 and so on. In accordance with a preferred embodiment of the present invention, the fine frequency synchronization is
30 based on a phase rotation which is derived from the same sub-carrier of two MCM symbols which are adjacent in the time axis direction, for example C_1/T_1 and C_1/T_2 .

In the following, the present invention is described referring to QPSK mapping (QPSK = Quadrature Phase Shift Keying).
35 However, it is obvious that the present invention can be applied to any MPSK mapping, wherein M designates the number of phase states used for encoding, for example 2, 4, 8, 16
....

Figure 5 represents a complex coordinate system showing a QPSK constellation for each sub-carrier with frequency offset. The four possible phase positions of a first MCM symbol, MCM-symbol-1 are shown at 300. Changing from the sub-carrier (sub-carrier n) of this MCM symbol to the same sub-carrier of the next MCM symbol, MCM-symbol-2, the position in the QPSK constellation will be unchanged in case there is no frequency offset. If a frequency offset is present, which is smaller than half the distance between sub-carriers, as mentioned above, this frequency offset causes a phase rotation of the QPSK constellation of MCM-symbol-2 compared with MCM-symbol-1. The new QPSK constellation, that is the four possible phase positions for the subject sub-carrier of MCM-symbol-2 are shown at 302 in Figure 5. This phase rotation θ can be derived from the following equation:

$$C_n(kT_{MCM}) = e^{j2\pi f_{offset}T_{MCM}} C_n((k-1)T_{MCM})$$
$$\theta = 2\pi f_{offset}T_{MCM} \quad (\text{Eq.2})$$

C_n designates the QPSK constellation of a sub-carrier n in a MCM symbol. n is an index running from 1 to the number of active sub-carriers in the MCM symbol. Information regarding the frequency offset is contained in the term $e^{j2\pi f_{offset}T_{MCM}}$ of equation 2. This frequency offset is identical for all sub-carriers. Therefore, the phase rotation θ is identical for all sub-carriers as well. Thus, averaging overall sub-carrier of a MCM symbol can be performed.

Figure 6 shows a block diagram of a MCM receiver in which the present invention is implemented. An analog/digital converter 310 is provided in order to perform an analog/digital conversion of a down-converted signal received at the receiver front end 132 (Figure 1). The output of the analog/digital converter 310 is applied to a low path filter and decimator unit 312. The low path filter is an impulse forming filter which is identical to an impulse forming filter in the MCM transmitter. In the decimator, the signal is

sampled at the MCM symbol frequency. As described above referring to Figure 1, guard intervals in the MCM signal are removed by a guard interval removal unit 132. Guard intervals are inserted between two MCM symbols in the MCM transmitter in order to avoid intersymbol interference caused by channel memory.

The output of the guard interval removal unit 132 is applied to a MCM demodulator 314 which corresponds to the fast Fourier transformator 140 shown in Figure 1. Following the MCM demodulator 314 a differential decoding unit 316 and a demapping unit 318 are provided. In the differential decoding unit 316, phase information is recovered using differential decoding. In the demapping unit 318, demapping along the frequency axis direction is performed in order to reconstruct a binary signal from the complex signal input into the demapping unit 318.

The output of the MCM demodulator 314 is also applied to fine frequency error detector 320. The fine frequency error detector 320 produces an frequency error signal from the output of the MCM demodulator. In the depicted embodiment, the output of the fine frequency error detector 320 is applied to a numerical controlled oscillator 322 via a loop filter 324. The loop filter 324 is a low pass filter for filtering superimposed interference portions of a higher frequency from the slowly varying error signal. The numerical controlled oscillator 322 produces a carrier signal on the basis of the filtered error signal. The carrier signal produced by the numerical controlled oscillator 322 is used for a frequency correction which is performed by making use of a complex multiplier 326. The inputs to the complex multiplier 326 are the output of the low pass filter and decimator unit 312 and the output of the numerical controlled oscillator 322.

A description of a preferred embodiment of the fine frequency error detector 320 is given hereinafter referring to Figure 7.

The fine frequency error detector 320 comprises a differential detector in the time axis 330. The output of the MCM demodulator 314, i.e. the FFT output (FFT = Fast Fourier Transform) is applied to the input of the differential detector 330 which performs a differential detection in the time axis in order to derive information on a frequency offset from the same sub-carrier of two subsequently arriving MCM symbols. In the embodiment shown in Figure 7, the number of active sub-carriers is 432. Thus, the differential detector 330 performs a correlation between the first and the 433rd sample. The first sample is associated with MCM-symbol-1 (Figure 5), whereas the 433rd sample is associated with MCM-symbol-2 (Figure 5). However, both these samples are associated with the same sub-carrier.

To this end, the input signal Y_k is applied to a z^{-1} -block 332 and thereafter to a unit 334 in order to form the complex conjugate of the output of the z^{-1} -block 332. A complex multiplier 336 is provided in order to multiply the output of the unit 334 by the input signal Y_k . The output of the multiplier 336 is a signal Z_k .

The function of the differential detector 330 can be expressed as follows:

$$Z_k = Y_{k+K} \cdot Y_k^* \quad (\text{Eq. 3})$$

$$Y = [Y_1, Y_2, \dots, Y_k, \dots] \quad (\text{Eq. 4})$$

$$Y = [C_1 / T_1, C_2 / T_1, \dots, C_{432} / T_1, C_1 / T_2, \dots] \quad (\text{Eq. 5})$$

Y_k designates the output of the MCM modulator 314, i.e. the input to the differential detector 330, at a time k . Z_k designates the output of the differential detector 330. K designates the number of active carriers.

5 The output Z_k of the differential detector 330 contains a M-fold uncertainty corresponding to codeable phase shifts. In case of the QPSK this M-fold uncertainty is a 4-fold uncertainty, i.e. 0° , 90° , 180° and 270° . This phase shift uncertainty is eliminated from Z_k making use of a M-PSK decision device 340. Such decision devices are known in the art and, therefore, have not to be described here in detail. The output of the decision device 340 (\hat{a}_k)* represents the complex conjugate of the codeable phase shift decided by the decision device 340. This output of the decision device 340 is correlated with the output of the differential detector 330 by performing a complex multiplication using a multiplier 342.

15 The output the multiplier 342 represents the phase offset for the respective sub-carriers. This phase offsets for the respective sub-carriers are averaged over one MCM symbol in an averaging unit 344 in accordance with a preferred embodiment of the present invention. The output of the averaging units 344 represent the output of the fine frequency error detector 320.

The mathematical description for this procedure is as follows:

25

$$f_{offset} = \frac{1}{2\pi K T_{MCM}} \arg \left\{ \sum_{n=1}^K Z_n \cdot \left(\hat{a}_n \right)^* \right\} \quad (\text{Eq. 6})$$

30 In accordance with preferred embodiments of the present invention, the frequency control loop has a backward structure. In the embodiment shown in Figure 6, the feedback loop is connected between the output of the MCM demodulator 314 and the input of the guard interval removal unit 132.

35 In Figure 8, a block diagram of a MCM receiver comprising a coarse frequency correction unit 350 and a fine frequency correction unit as described above is shown. As shown in Figure 8, a common complex multiplier 326 can be used in or-

der to perform the coarse frequency correction and the fine
frequency correction. As shown in Figure 8, the multiplier
326 can be provided preceding the low pass filter and deci-
mator unit 312. Depending on the position of the multiplier
5 326, a hold unit has to be provided in the fine frequency
synchronization feedback loop. In an alternative embodiment,
it is possible to use two separate multipliers for the
coarse frequency correction and for the fine frequency cor-
rection. In such a case, the multiplier for the coarse fre-
10 quency correction will be arranged preceding the low path
filter and decimator unit, whereas the multiplier for the
fine frequency correction will be arranged following the low
path filter and decimator unit.

15 Following, preferred embodiments for implementing a coarse
frequency synchronization will be described referring to
Figures 9 and 10.

As it is shown in Figure 9, the output of the receiver front
20 end 132 is connected to an analog/digital converter 310. The
down-converted MCM signal is sampled at the output of the
analog/digital converter 310 and is applied to a
frame/timing synchronization unit 360. In a preferred em-
bodiment, a fast running automatic gain control (AGC) (not
25 shown) is provided preceding the frame/timing synchroniza-
tion unit in order to eliminate fast channel fluctuations.
The fast AGC is used in addition to the normally slow AGC in
the signal path, in the case of transmission over a mul-
tipath channel with long channel impulse response and fre-
30 quency selective fading. The fast AGC adjusts the average
amplitude range of the signal to the known average amplitude
of the reference symbol.

As described above, the frame/timing synchronization unit
35 uses the amplitude-modulated sequence in the received signal
in order to extract the framing information from the MCM
signal and further to remove the guard intervals therefrom.
After the frame/timing synchronization unit 360 it follows a
coarse frequency synchronization unit 362 which estimates a

coarse frequency offset based on the amplitude-modulated sequence of the reference symbol of the MCM signal. In the coarse frequency synchronization unit 362, a frequency offset of the carrier frequency with respect to the oscillator frequency in the MCM receiver is determined in order to perform a frequency offset correction in a block 364. This frequency offset correction in block 364 is performed by a complex multiplication.

10 The output of the frequency offset correction block 364 is applied to the MCM demodulator 366 formed by the Fast Fourier Transformator 140 and the carrier-bit mapper 142 shown in Figure 1.

15 In order to perform the coarse frequency synchronization described herein, an amplitude-demodulation has to be performed on a preprocessed MCM signal. The preprocessing may be, for example, the down-conversion and the analog/digital conversion of the MCM signal. The result of the amplitude-demodulation of the preprocessed MCM signal is an envelope representing the amplitude of the MCM signal.

20 For the amplitude demodulation a simple $\alpha_{\max+}$ $\beta_{\min-}$ method can be used. This method is described for example in [Palachels] Palacherla A.: [DSP- μ P] DSP- μ P Routine Computes Magnitude, EDN, October 26, 1989; and Adams, W. T., and Bradley, J.: Magnitude Approximations for Microprocessor Implementation, IEEE Micro, Vol. 3, No. 5, October 1983.

30 It is clear that amplitude determining methods different from the described $\alpha_{\max+}$ $\beta_{\min-}$ method can be used. For simplification, it is possible to reduce the amplitude calculation to a detection as to whether the current amplitude is above or below the average amplitude. The output signal then consists of a -1/+1 sequence which can be used to determine a coarse frequency offset by performing a correlation. This correlation can easily be performed using a simple integrated circuit (IC).

In addition, an oversampling of the signal received at the RF front end can be performed. For example, the received signal can be expressed with two times oversampling.

5

In accordance with a first embodiment, a carrier frequency offset of the MCM signal from an oscillator frequency in the MCM receiver is determined by correlating the envelope obtained by performing the amplitude-demodulation as described above with a predetermined reference pattern.

10

In case there is no frequency offset, the received reference symbol $r(k)$ will be:

15
$$r(k) = S_{AM}(k) + n(k) \quad (\text{Eq.7})$$

wherein $n(k)$ designates "additive Gaussian noise" and S_{AM} denotes the AM sequence which has been sent. In order to simplify the calculation the additive Gaussian noise can be neglected. It follows:

20

$$r(k) \cong S_{AM}(k) \quad (\text{Eq.8})$$

In case a constant frequency offset Δf is present, the received signal will be:

25

$$\tilde{r}(k) = S_{AM}(k) \cdot e^{j2\pi\Delta f k T_{MCM}} \quad (\text{Eq.9})$$

Information regarding the frequency offset is derived from the correlation of the received signal $\tilde{r}(k)$ with the AM sequence S_{AM} which is known in the receiver:

30

$$\sum_{k=1}^{\frac{L}{2}} \tilde{r}(k) \cdot S_{AM}^*(k) = \sum_{k=1}^{\frac{L}{2}} |S_{AM}(k)|^2 e^{j2\pi\Delta f k T_{MCM}} \quad (\text{Eq.10})$$

35

Thus, the frequency offset is:

$$\Delta f = \frac{1}{2\pi T_{MCM}} \arg \left(\sum_{k=1}^{\frac{L}{2}} r(k) \cdot S_{AM}^*(k) \right) - \frac{1}{2\pi T_{MCM}} \arg \left(\sum_{k=1}^{\frac{L}{2}} |S_{AM}(k)|^2 \right) \quad (\text{Eq. 11})$$

5 Since the argument of $|S_{AM}(k)|^2$ is zero the frequency offset is:

$$\Delta f = \frac{1}{2\pi T_{MCM}} \arg \left(\sum_{k=1}^{\frac{L}{2}} \tilde{r}(k) \cdot S_{AM}^*(k) \right) \quad (\text{Eq. 12})$$

10 In accordance with a second embodiment of the coarse frequency synchronization algorithm, a reference symbol comprising at least two identical sequences 370 as shown in Figure 10 is used. Figure 10 shows the reference symbol of a MCM signal having two identical sequences 370 of a length of L/2 each. L designates the number of values of the two sequences 370 of the reference symbol.

15 As shown in Figure 10, within the amplitude-modulated sequence, there are at least two identical sections devoted to the coarse frequency synchronization. Two such sections, each containing L/2 samples, are shown at the end of the amplitude-modulated sequence in Figure 10. The amplitude-modulated sequence contains a large number of samples. For a non-ambiguous observation of the phase, only enough samples to contain a phase rotation of 2π should be used. This number is defined as L/2 in Figure 10.

20 Following, a mathematical derivation of the determination of a carrier frequency deviation is presented. In accordance with Figure 10, the following equation applies for the two identical sequences 370:

$$s \left(0 < k \leq \frac{L}{2} \right) \equiv s \left(\frac{L}{2} < k \leq L \right) \quad (\text{Eq. 13})$$

If no frequency offset is present, the following equation 14 will be met by the received signal:

$$5 \quad r\left(k + \frac{L}{2}\right) \equiv r(k) \quad 0 < k \leq \frac{L}{2} \quad (\text{Eq.14})$$

$r(k)$ designates the values of the identical sequences. k is an index from one to $L/2$ for the respective samples.

10 If there is a frequency offset of, for example, Δf , the received signal is:

$$\tilde{r}(k) = r(k) \cdot e^{j2\pi\Delta f k T_{MCM}} \quad (\text{Eq.15})$$

$$15 \quad \tilde{r}\left(k + \frac{L}{2}\right) = r(k) \cdot e^{j2\pi\Delta f \left(k + \frac{L}{2}\right) T_{MCM}} \quad (\text{Eq.16})$$

$r(k)$ designates sample values of the received portion which are based on the identical sequences. Information regarding the frequency offset is derived from the correlation of the received signal $\tilde{r}\left(k + \frac{L}{2}\right)$ with the received signal $\tilde{r}(k)$. This correlation is given by the following equation:

$$20 \quad \sum_{k=1}^{\frac{L}{2}} \tilde{r}^*\left(k + \frac{L}{2}\right) \tilde{r}(k) = \sum_{k=1}^{\frac{L}{2}} |r(k)|^2 e^{-j2\pi\Delta f \frac{L}{2} T_{MCM}} \quad (\text{Eq.17})$$

25 \tilde{r}^* designates the complex conjugate of the sample values of the portion mentioned above.

Thus, the frequency offset is

$$30 \quad \Delta f = \frac{1}{2\pi \frac{L}{2} T_{MCM}} \arg\left(\sum_{k=1}^{\frac{L}{2}} \tilde{r}\left(k + \frac{L}{2}\right) \cdot \tilde{r}^*(k)\right) - \frac{1}{2\pi \frac{L}{2} T_{MCM}} \arg\left(\sum_{k=1}^{\frac{L}{2}} |\tilde{r}(k)|^2\right) \quad (\text{Eq.18})$$

If the above correlations are calculated in the frequency domain, the amount of

$$\sum_{k=1}^{\frac{L}{2}} \left[\tilde{r} \left(k + \frac{L}{2} \right) \cdot \tilde{r}^* (k) \right] \cdot \left[S_{AM} (k) S_{AM}^* \left(k + \frac{L}{2} \right) \right] \quad (\text{Eq.21})$$

5

is used rather than the argument. This amount is maximized as a function of a frequency correction. The position of the maximum determines the estimation of the frequency deviation. As mentioned above, the correction is performed in a feed forward structure.

10

Preferred embodiments for performing an echo phase offset correction when using a differential mapping in the frequency axis will be described hereinafter referring to Figures 12 to 15.

15

Systematic phase shifts stemming from echoes in multipath environments may occur between subcarriers in the same MCM symbol. This phase offsets can cause bit errors when demodulating the MCM symbol at the receiver. Thus, it is preferred to make use of an algorithm to correct the systematic phase shifts stemming from echoes in multipath environments.

20

In Figure 12, scatter diagrams at the output of a differential demapper of a MCM receiver are shown. As can be seen from the left part of Figure 12, systematic phase shifts between subcarriers in the same MCM symbol cause a rotation of the demodulated phase shifts with respect to the axis of the complex coordinate system. In the right part of Figure 12, the demodulated phase shifts after having performed an echo phase offset correction are depicted. Now, the positions of the signal points are substantially on the axis of the complex coordinate system. These positions correspond to the modulated phase shifts of 0°, 90°, 180° and 270°, respectively.

35

An echo phase offset correction algorithm (EPOC algorithm) must calculate the echo induced phase offset from the signal space constellation following the differential demodulation and subsequently correct this phase offset.

5

For illustration purposes, one may think of the simplest algorithm possible which eliminates the symbol phase before computing the mean of all phases of the subcarriers. To illustrate the effect of such an EPOC algorithm, reference is made to the two scatter diagrams of subcarriers symbols contained in one MCM symbol in Figure 12. This scatter diagrams have been obtained as result of an MCM simulation. For the simulation a channel has been used which might typically show up in single frequency networks. The echoes of this channel stretched to the limits of the MCM guard interval. The guard interval was chosen to be 25% of the MCM symbol duration in this case.

10
15
20
25
30
35

Figure 13 represents a block diagram for illustrating the position and the functionality of an echo phase offset correction device in a MCM receiver. The signal of a MCM transmitter is transmitted through the channel 122 (Figures 1 and 13) and received at the receiver frontend 132 of the MCM receiver. The signal processing between the receiver frontend and the fast Fourier transformator 140 has been omitted in Figure 13. The output of the fast Fourier transformator is applied to the de-mapper, which performs a differential demapping along the frequency axis. The output of the de-mapper are the respective phase shifts for the subcarriers. The phase offsets of this phase shifts which are caused by echoes in multipath environments are visualized by a block 400 in Figure 13 which shows an example of a scatter diagram of the subcarrier symbols without an echo phase offset correction.

The output of the de-mapper 142 is applied to the input of an echo phase offset correction device 402. The echo phase offset correction device 402 uses an EPOC algorithm in order

to eliminate echo phase offsets in the output of the de-mapper 142. The result is shown in block 404 of Figure 13, i.e. only the encoded phase shifts, 0° , 90° , 180° or 270° are present at the output of the correction device 402. The output of the correction device 402 forms the signal for the metric calculation which is performed in order to recover the bitstream representing the transmitted information.

5
10 A first embodiment of an EPOC algorithm and a device for performing same is now described referring to Figure 14.

15 The first embodiment of an EPOC algorithm starts from the assumption that every received differentially decoded complex symbol is rotated by an angle due to echoes in the multipath channel. For the subcarriers equal spacing in frequency is assumed since this represents a preferred embodiment. If the subcarriers were not equally spaced in frequency, a correction factor would have to be introduced into the EPOC algorithm.

20 Figure 14 shows the correction device 402 (Figure 13) for performing the first embodiment of an EPOC algorithm.

25 From the output of the de-mapper 142 which contains an echo phase offset as shown for example in the left part of Figure 12, the phase shifts related to transmitted information must first be discarded. To this end, the output of the de-mapper 142 is applied to a discarding unit 500. In case of a DQPSK mapping, the discarding unit can perform a " $(.)^4$ " operation. The unit 500 projects all received symbols into the first quadrant. Therefore, the phase shifts related to transmitted information is eliminated from the phase shifts representing the subcarrier symbols. The same effect could be reached with a modulo-4 operation.

35 Having eliminated the information related symbol phases in unit 500, the first approach to obtain an estimation would be to simply compute the mean value over all symbol phases of one MCM symbol. However, it is preferred to perform a

threshold decision before determining the mean value over all symbol phases of one MCM symbol. Due to Rayleigh fading some of the received symbols may contribute unreliable information to the determination of the echo phase offset.

5 Therefore, depending on the absolute value of a symbol, a threshold decision is performed in order to determine whether the symbol should contribute to the estimate of the phase offset or not.

10 Thus, in the embodiment shown in Figure 14, a threshold decision unit 510 is included. Following the unit 500 the absolute value and the argument of a differentially decoded symbol is computed in respective computing units 512 and 514. Depending on the absolute value of a respective symbol,
15 a control signal is derived. This control signal is compared with a threshold value in a decision circuit 516. If the absolute value, i.e. the control signal thereof, is smaller than a certain threshold, the decision circuit 516 replaces the angle value going into the averaging operation by a value equal to zero. To this end, a switch is provided in
20 order to disconnect the output of the argument computing unit 514 from the input of the further processing stage and connects the input of the further processing stage with a unit 518 providing a constant output of "zero".

25 An averaging unit 520 is provided in order to calculate a mean value based on the phase offsets φ_i determined for the individual subcarrier symbols of a MCM symbol as follows:

30
$$\bar{\varphi} = 1 / K \sum_{i=1}^K \varphi_i \quad (\text{Eq.22})$$

In the averaging unit 520, summation over K summands is performed. The output of the averaging unit 520 is provided to a hold unit 522 which holds the output of the averaging unit
35 520 K times. The output of the hold unit 522 is connected with a phase rotation unit 524 which performs the correction

of the phase offsets of the K complex signal points on the basis of the mean value $\bar{\varphi}$.

The phase rotation unit 524 performs the correction of the phase offsets by making use of the following equation:

$$v'_k = v_k \cdot e^{-j\bar{\varphi}} \quad (\text{Eq.23})$$

In this equation, v'_k designates the K phase corrected differentially decoded symbols for input into the soft-metric calculation, whereas v_k designates the input symbols. As long as a channel which is quasi stationary during the duration of one MCM symbols can be assumed, using the mean value over all subcarriers of one MCM symbol will provide correct results.

A buffer unit 527 may be provided in order to buffer the complex signal points until the mean value of the phase offsets for one MCM symbol is determined. The output of the phase rotation unit 524 is applied to the further processing stage 526 for performing the soft-metric calculation.

With respect to the results of the above echo phase offset correction, reference is made again to Figure 12. The two plots stem from a simulation which included the first embodiment of an echo phase offset correction algorithm described above. At the instant of the scatter diagram snapshot shown in the left part of Figure 12, the channel obviously distorted the constellation in such a way, that a simple angle rotation is a valid assumption. As shown in the right part of Figure 12, the signal constellation can be rotated back to the axis by applying the determined mean value for the rotation of the differentially detected symbols.

A second embodiment of an echo phase offset correction algorithm is described hereinafter. This second embodiment can be preferably used in connection with multipath channels that have up to two strong path echoes. The algorithm of the

second embodiment is more complex than the algorithm of the first embodiment.

5 what follows is a mathematical derivation of the second embodiment of a method for echo phase offset correction. The following assumptions can be made in order to ease the explanation of the second embodiment of an EPOC algorithm.

10 In this embodiment, the guard interval of the MCM signal is assumed to be at least as long as the impulse response $h[q]$, $q = 0, 1, \dots, Qh-1$ of the multipath channel.

15 At the transmitter every MCM symbol is assembled using frequency axis mapping explained above. The symbol of the reference subcarrier equals 1, i.e. 0 degree phase shift. The optional phase shift PHI equals zero, i.e. the DQPSK signal constellation is not rotated.

20 Using an equation this can be expressed as

$$a_k = a_{k-1} a_k^{inc}$$

(Eq.24)

25 with
k : index $k = 1, 2, \dots, K$ of the active subcarrier;

$a_k^{inc} = e^{j\frac{\pi}{2}m}$: complex phase increment symbol; $m=0, 1, 2, 3$ is the QPSK symbol number which is derived from Gray encoding pairs of 2 Bits;

30 $a_0 = 1$: symbol of the reference subcarrier.

At the DFT output of the receiver the decision variables

35
$$e_k = a_k H_k$$
 (Eq.25)

are obtained with

005673270-112900

$$H_k = \sum_{i=0}^{Q_h-1} h[i] \cdot e^{-j\frac{2\pi}{K}ki} \quad (\text{Eq.26})$$

5 being the DFT of the channel impulse response $h[q]$ at position k .

with $|ak|^2 = 1$ the differential demodulation yields

$$v_k = e_k \cdot e_{k-1}^* = a_k^{inc} H_k H_{k-1}^* \quad (\text{Eq.27})$$

10

For the receiver an additional phase term φ_k is introduced, which shall be used to correct the systematic phase offset caused by the channel. Therefore, the final decision variable at the receiver is

15

$$v'_k = v_k \cdot e^{j\varphi_k} = a_k^{inc} \cdot e^{j\varphi_k} \cdot H_k \cdot H_{k-1}^*$$

(Eq.28)

20 As can be seen from the Equation 28, the useful information a_k^{inc} is weighted with the product $e^{j\varphi_k} \cdot H_k \cdot H_{k-1}^*$ (rotation and effective transfer function of the channel). This product must be real-valued for an error free detection. Considering this, it is best to choose the rotation angle to equal the negative argument of $H_k \cdot H_{k-1}^*$. To derive the desired algorithm for 2-path channels, the nature of $H_k \cdot H_{k-1}^*$ is investigated in the next section.

25

It is assumed that the 2-path channel exhibits two echoes with energy content unequal zero, i.e. at least two dominant echoes. This assumption yields the impulse response

30

$$h[q] = c_1 \delta_0[q] + c_2 \delta_0[q - q_0] \quad (\text{Eq.29})$$

with

- c_1, c_2 : complex coefficients representing the path echoes;
- q_0 : delay of the second path echo with respect to the first path echo;
- 5 δ_0 : Dirac pulse; $\delta_0[k] = 1$ for $k = 0$
 $\delta_0[k] = 0$ else

The channel transfer function is obtained by applying a DFT to Equation 29:

10

$$H_k = H\left(e^{j\frac{2\pi}{K}k}\right) = c_1 + c_2 \cdot e^{-j\frac{2\pi}{K}kq_0} \quad (\text{Eq. 30})$$

With Equation 30 the effective transfer function for differential demodulation along the frequency axis is:

15

$$\begin{aligned} H_k \cdot H_{k-1}^* &= \left(c_1 + c_2 e^{-j\frac{2\pi}{K}kq_0}\right) \cdot \left(c_1^* + c_2^* e^{+j\frac{2\pi}{K}(k-1)q_0}\right) \\ &= c_a + c_b \cos\left(\frac{\pi}{K}q_0(2k-1)\right) \end{aligned} \quad (\text{Eq. 31})$$

Assuming a noise free 2-path channel, it can be observed from Equation 31 that the symbols on the receiver side are located on a straight line in case the symbol $1+j0$ has been send (see above assumption). This straight line can be characterized by a point

25 $c_a = |c_1|^2 + |c_2|^2 \cdot e^{-j\frac{2\pi}{K}q_0} \quad (\text{Eq. 32})$

and the vector

$$c_b = 2c_1c_2^* \cdot e^{-j\frac{\pi}{K}q_0} \quad (\text{Eq. 33})$$

30

which determines its direction.

006277-022E-960

with the above assumptions, the following geometric derivation can be performed. A more suitable notation for the geometric derivation of the second embodiment of an EPOC algorithm is obtained if the real part of the complex plane is designated as $x = \text{Re}\{z\}$, the imaginary part as $y = \text{Im}\{z\}$, respectively, i.e. $z = x+jy$. With this new notation, the straight line, on which the received symbols will lie in case of a noise-free two-path channel, is

10 $f(x) = a + b \cdot x$ (Eq.34)

with

15 $a = \text{Im}\{c_a\} - \frac{\text{Re}\{c_a\}}{\text{Re}\{c_b\}} \cdot \text{Im}\{c_b\}$ (Eq.35)

and

15 $b = - \frac{\text{Im}\{c_a\} - \frac{\text{Re}\{c_a\}}{\text{Re}\{c_b\}} \cdot \text{Im}\{c_b\}}{\text{Re}\{c_a\} - \frac{\text{Im}\{c_a\}}{\text{Im}\{c_b\}} \cdot \text{Re}\{c_b\}}$ (Eq.36)

20 Additional noise will spread the symbols around the straight line given by Equations 34 to 36. In this case Equation 36 is the regression curve for the cluster of symbols.

25 For the geometric derivation of the second embodiment of an EPOC algorithm, the angle φ_k from Equation 28 is chosen to be a function of the square distance of the considered symbol from the origin:

30 $\varphi_k = f_x(|z|^2)$ (Eq.37)

Equation 37 shows that the complete signal space is distorted (torsion), however, with the distances from the origin being preserved.

For the derivation of the algorithm of the second embodiment, $f_k(\cdot)$ has to be determined such that all decision variables v'_k (assuming no noise) will come to lie on the real axis:

5

$$\text{Im}\{(x + jf(x)) \cdot e^{jf_k(|z|^2)}\} = 0 \tag{Eq.38}$$

Further transformations of Equation 38 lead to a quadratic equation which has to be solved to obtain the solution for φ_k .

10

In case of a two-path channel, the echo phase offset correction for a given decision variable v_k is

15

$$v'_k = v_k \cdot e^{j\varphi_k} \tag{Eq.39}$$

with

$$\varphi_k = \begin{cases} -a \tan\left(\frac{a + b\sqrt{|v_k|^2(1+b^2) - a^2}}{-ab + \sqrt{|v_k|^2(1+b^2) - a^2}}\right) & \text{for } |v_k|^2 \geq \frac{a^2}{1+b^2} \\ a \tan\left(\frac{1}{b}\right) & \text{for } |v_k|^2 < \frac{a^2}{1+b^2} \end{cases} \tag{Eq.40}$$

20

From the two possible solutions of the quadratic equation mentioned above, Equation 40 is the one solution that cannot cause an additional phase shift of 180 degrees.

25

The two plots in Figure 15 show the projection of the EPOC algorithm of the second embodiment for one quadrant of the complex plane. Depicted here is the quadratic grid in the sector $|\arg(z)| \leq \pi/4$ and the straight line

30

$y = f(x) = a + b \cdot x$ with $a = -1.0$ and $b = 0.5$ (dotted line). In case of a noise-free channel, all received symbols will lie on this straight line if 1+j0 was send. The circle shown in the plots determines the boarder line for the two cases

of Equation 40. In the left part, Figure 15 shows the situation before the projection, in the right part, Figure 15 shows the situation after applying the projection algorithm. By looking on the left part, one can see, that the straight line now lies on the real axis with $2+j0$ being the fix point of the projection. Therefore, it can be concluded that the echo phase offset correction algorithm according to the second embodiment fulfills the design goal.

10 Before the second embodiment of an EPOC algorithm can be applied, the approximation line through the received symbols has to be determined, i.e. the parameters a and b must be estimated. For this purpose, it is assumed that the received symbols lie in sector $|\arg(z)| \leq \pi / 4$, if $1+j0$ was sent. If
15 symbols other than $1+j0$ have been sent, a modulo operation can be applied to project all symbols into the desired sector. Proceeding like this prevents the necessity of deciding on the symbols in an early stage and enables averaging over all signal points of one MCM symbol (instead of averaging
20 over only $\frac{1}{4}$ of all signal points).

For the following computation rule for the EPOC algorithm of the second embodiment, x_i is used to denote the real part of the i -th signal point and y_i for its imaginary part, respectively ($i = 1, 2, \dots, K$). Altogether, K values are available for the determination. By choosing the method of least squares, the straight line which has to be determined can be
25 obtained by minimizing

30
$$(a, b) = \arg \min_{(\tilde{a}, \tilde{b})} \sum_{i=1}^K (y_i - (\tilde{a} + \tilde{b} \cdot x_i))^2 \quad (\text{Eq. 41})$$

The solution for Equation 41 can be found in the laid open literature. It is

$$b = \frac{\sum_{i=1}^K (x_i - \bar{x}) \cdot y_i}{\sum_{i=1}^K (x_i - \bar{x})^2}, \quad a = \bar{y} - \bar{x} \cdot b \quad (\text{Eq. 42})$$

with mean values

$$\bar{x} = \frac{1}{N} \sum_{i=1}^K x_i, \quad \bar{y} = \frac{1}{N} \sum_{i=1}^K y_i \quad (\text{Eq. 43})$$

If necessary, an estimation method with higher robustness can be applied. However, the trade-off will be a much higher computational complexity.

10

To avoid problems with the range in which the projection is applicable, the determination of the straight line should be separated into two parts. First, the cluster's centers of gravity are moved onto the axes, following, the signal space is distorted. Assuming that a and b are the original parameters of the straight line and α is the rotation angle, $f_K(\cdot)$ has to be applied with the transformed parameters

15

$$b' = \frac{b \cdot \cos(\alpha) - \sin(\alpha)}{\cos(\alpha) + b \cdot \sin(\alpha)}, \quad a' = a \cdot (\cos(\alpha) - b' \cdot \sin(\alpha))$$

20

(Eq. 44)

Besides the two EPOC algorithms explained above section, different algorithms can be designed that will, however, most likely exhibit a higher degree of computational complexity.

25

METHOD AND APPARATUS FOR FINE FREQUENCY SYNCHRONIZATION IN
MULTI-CARRIER DEMODULATION SYSTEMS

5

FIELD OF THE INVENTION

10 The present invention relates to methods and apparatus for performing a fine frequency synchronization in multi-carrier demodulation systems, and in particular to methods and apparatus for performing a fine frequency synchronization compensating for a carrier frequency deviation from an oscillator frequency in a multi-carrier demodulation system of the type capable of carrying out a differential phase decoding of multi-carrier modulated signals, wherein the signals comprise a plurality of symbols, each symbol being defined by phase differences between simultaneous carriers having different frequencies.

20

BACKGROUND OF THE INVENTION

25 In a multi carrier transmission system (MCM, OFDM), the effect of a carrier frequency offset is substantially more considerable than in a single carrier transmission system. MCM is more sensitive to phase noise and frequency offset which occurs as amplitude distortion and inter carrier interference (ICI). The inter carrier interference has the effect that the subcarriers are no longer orthogonal in relation to each other. Frequency offsets occur after power on or also later due to frequency deviation of the oscillators used for downconversion into baseband. Typical accuracies for the frequency of a free running oscillator are about ± 50 ppm of the carrier frequency. With a carrier frequency in the S-band of 2.34 GHz, for example, there will be a maximum local oscillator (LO) frequency deviation of above 100 kHz (117.25 kHz). The above named effects result in high requirements on the algorithm used for frequency offset correction.

40

DESCRIPTION OF PRIOR ART

5 Most prior art algorithms for frequency synchronization di-
vide frequency correction into two stages. In the first
stage, a coarse synchronization is performed. In the second
stage, a fine correction can be achieved. A frequently used
algorithm for coarse synchronization of the carrier fre-
10 quency uses a synchronization symbol which has a special
spectral pattern in the frequency domain. Such a synchroni-
zation symbol is, for example, a CAZAC sequence (CAZAC =
Constant Amplitude Zero Autocorrelation). Through compari-
son, i.e. the correlation, of the power spectrum of the re-
15 ceived signal with that of the transmitted signal, the fre-
quency carrier offset can be coarsely estimated. These prior
art algorithms all work in the frequency domain. Reference
is made, for example, to Ferdinand Claßen, Heinrich Meyr,
"Synchronization Algorithms for an OFDM System for Mobile
20 Communication", ITG-Fachtagung 130, Codierung für Quelle,
Kanal und Übertragung, pp. 105 - 113, Oct. 26-28, 1994; and
Timothy M. Schmidl, Donald C. Cox, "Low-Overhead, Low-
Complexity [Burst] Synchronization for OFDM", in Proceedings
of the IEEE International Conference on Communication ICC
25 1996, pp. 1301-1306 (1996).

For the coarse synchronization of the carrier frequency,
Paul H. Moose, "A Technique for Orthogonal Frequency Divi-
30 sion Multiplexing Frequency Offset Correction", IEEE Trans-
action On Communications, Vol. 42, No. 10, October 1994,
suggest increasing the spacing between the subcarriers such
that the subcarrier distance is greater than the maximum
frequency difference between the received and transmitted
carriers. The subcarrier distance is increased by reducing
35 the number of sample values which are transformed by the
Fast Fourier Transform. This corresponds to a reduction of
the number of sampling values which are transformed by the
Fast Fourier Transform.

WO 9205646 A relates to methods for the reception of orthogonal frequency division multiplexed signals comprising data which are preferably differentially coded in the direction of the time axis. Phase drift of the demodulated samples from one block to the next is used to indicate the degree of local oscillator frequency error. Phase drift is assessed by multiplying complex values by the complex conjugate of an earlier sample demodulated from the same OFDM carrier and using the resulting measure to steer the local oscillator frequency via a frequency locked loop.

SUMMARY OF THE INVENTION

It is an object of the present invention to provide methods and apparatus for performing a fine frequency synchronization which allow a fine frequency synchronization compensating for a carrier frequency deviation from an oscillator frequency in a MCM transmission system which makes use of MCM signals in which information is differential phase encoded between simultaneous sub-carriers having different frequencies.

In accordance with a first aspect, the present invention provides a method of performing a fine frequency synchronization compensating for a carrier frequency deviation from an oscillator frequency in a multi-carrier demodulation system of the type capable of carrying out a differential phase decoding of multi-carrier modulated signals, the signals comprising a plurality of symbols, each symbol being defined by phase differences between simultaneous carriers having different frequencies, the method comprising the steps of:

determining a phase difference between phases of the same carrier in different symbols;

determining a frequency offset by eliminating phase shift uncertainties related to the transmitted information from

006677" 0222960

the phase difference making use of a M-PSK decision device;
and

5 performing a feedback correction of the carrier frequency
deviation based on the determined frequency offset.

In accordance with a second aspect, the present invention
provides a method of performing a fine frequency synchroni-
zation compensating for a carrier frequency deviation from
10 an oscillator frequency in a multi-carrier demodulation sys-
tem of the type capable of carrying out a differential phase
decoding of multi-carrier modulated signals, the signals
comprising a plurality of symbols, each symbol being defined
by phase differences between simultaneous carriers having
15 different frequencies, the method comprising the steps of:

determining respective phases of the same carrier in differ-
ent symbols;

20 eliminating phase shift uncertainties related to the trans-
mitted information from the phases to determine respective
phase deviations making use of a M-PSK decision device;

determining a frequency offset by determining a phase dif-
25 ference between the phase deviations; and

performing a feedback correction of said carrier frequency
deviation based on the determined frequency offset.

30 In accordance with a third aspect, the present invention
provides an apparatus for performing a fine frequency syn-
chronization compensating for a carrier frequency deviation
from an oscillator frequency, for a multi-carrier demodula-
tion system of the type capable of carrying out a differen-
35 tial phase decoding of multi-carrier modulated signals, the
signals comprising a plurality of symbols, each symbol being
defined by phase differences between simultaneous carriers
having different frequencies, the apparatus comprising:

means for determining a phase difference between phases of the same carrier in different symbols;

5 M-PSK decision device for determining a frequency offset by eliminating phase shift uncertainties related to the transmitted information from the phase difference; and

means for performing a feedback correction of the frequency deviation based on the determined frequency offset.

10

In accordance with a fourth aspect, the present invention provides an apparatus for performing a fine frequency synchronization compensating for a carrier frequency deviation from an oscillator frequency, for a multi-carrier demodulation system of the type capable of carrying out a differential phase decoding of multi-carrier modulated signals, said signals comprising a plurality of symbols, each symbol being defined by phase differences between simultaneous carriers having different frequencies, the apparatus comprising:

15

20

means for determining respective phases of the same carrier in different symbols;

25

M-PSK decision device for eliminating phase shift uncertainties related to the transmitted information from the phases to determine respective phase deviations;

30

means for determining a frequency offset by determining a phase difference between the phase deviations; and

means for performing a feedback correction of the frequency deviation based on the determined frequency offset.

35

The present invention relates to methods and apparatus for performing a fine frequency synchronization compensating for a carrier frequency deviation from an oscillator frequency. This fine frequency synchronization is preferably performed after completion of a coarse frequency synchronization, such that the frequency offsets after the coarse frequency syn-

chronization are smaller than half the sub-carrier distance in the MCM signal. Since the frequency offsets which are to be corrected by the inventive fine frequency synchronization methods and apparatus, a correction of the frequency offsets by using a phase rotation with differential decoding and demapping in the time axis can be used. The frequency offsets are detected by determining the frequency differences between time contiguous sub-carrier symbols along the time axis. The frequency error is calculated by measuring the rotation of the I-Q cartesian coordinates of each sub-carrier and, in preferred embodiments, averaging them over all n sub-carriers of a MCM symbol.

Firstly, the phase ambiguity or uncertainty is eliminated by using a M-PSK decision device and correlating the output of the decision device with the input signal for a respective sub-carrier symbol. Thus, the phase offset for a sub-carrier symbol is determined and can be used for restructuring the frequency error in form of a feed-backward structure. Alternatively, the phase offsets of the sub-carrier symbols of one MCM symbol can be averaged over all of the active carriers of a MCM symbol, wherein the averaged phase offset is used to restructure the frequency error.

In accordance with the present invention, the determination of the frequency offset is performed in the frequency domain. The feedback correction in accordance with the inventive fine frequency synchronization is performed in the time domain. To this end, a differential decoder in the time domain is provided in order to detect frequency offsets of sub-carriers on the basis of the phases of timely successive sub-carrier symbols of different MCM symbols.

BRIEF DESCRIPTION OF THE DRAWINGS

In the following, preferred embodiments of the present invention will be explained in detail on the basis of the drawings enclosed, in which:

- 5
10
15
20
25
30
35
- Figure 1 shows a schematic overview of a MCM transmission system to which the present application can be applied;
- Figures 2A and 2B show schematic views representing a scheme for differential mapping in the time axis and a scheme for differential mapping in the frequency axis;
- Figure 3 shows a functional block diagram for performing a differential mapping in the frequency axis;
- Figure 4 shows a representation of time variation of all sub-carriers in MCM symbols;
- Figure 5 shows a QPSK-constellation for each sub-carrier with a frequency offset;
- Figure 6 shows a general block diagram illustrating the position of the inventive fine frequency synchronization device in a MCM receiver;
- Figure 7 shows a block diagram of the fine frequency error detector shown in Figure 6;
- Figure 8 shows a block diagram of a MCM receiver comprising a coarse frequency synchronization unit and a fine frequency synchronization unit;
- Figure 9 shows a block diagram of a unit for performing a coarse frequency synchronization;
- Figure 10 shows a schematic view of a reference symbol used for performing a coarse frequency synchronization;
- Figure 11 shows a schematic view of a typical MCM signal having a frame structure;

PETITIONER SIRIUS XM RADIO INC.

5 Figure 12 shows scatter diagrams of the output of an differential de-mapper of a MCM receiver for illustrating the effect of an echo phase offset correction;

10 Figure 13 shows a schematic block diagram for illustrating the position and the functionality of an echo phase offset correction unit;

15 Figure 14 shows a schematic block diagram of a preferred form of an echo phase offset correction device; and

20 Figure 15 shows schematic views for illustrating a projection performed by another echo phase offset correction algorithm.

25 DETAILED DESCRIPTION OF THE EMBODIMENTS

Before discussing the present invention in detail, the mode of operation of a MCM transmission system is described referring to figure 1.

25 Referring to Figure 1, at 100 a MCM transmitter is shown that substantially corresponds to a prior art MCM transmitter. A description of such a MCM transmitter can be found, for example, in William Y. Zou, Yiyan Wu, "COFDM: AN
30 OVERVIEW", IEEE Transactions on Broadcasting, vol. 41, No. 1, March 1995.

35 A data source 102 provides a serial bitstream 104 to the MCM transmitter. The incoming serial bitstream 104 is applied to a bit-carrier mapper 106 which produces a sequence of spectra 108 from the incoming serial bitstream 104. An inverse fast Fourier transform (IFFT) 110 is performed on the sequence of spectra 108 in order to produce a MCM time domain signal 112. The MCM time domain signal forms the useful MCM

symbol of the MCM time signal. To avoid intersymbol interference (ISI) caused by multipath distortion, a unit 114 is provided for inserting a guard interval of fixed length between adjacent MCM symbols in time. In accordance with a preferred embodiment of the present invention, the last part of the useful MCM symbol is used as the guard interval by placing same in front of the useful symbol. The resulting MCM symbol is shown at 115 in Figure 1 and corresponds to a MCM symbol 160 depicted in Figure 11.

5
10

Figure 11 shows the construction of a typical MCM signal having a frame structure. One frame of the MCM time signal is composed of a plurality of MCM symbols 160. Each MCM symbol 160 is formed by an useful symbol 162 and a guard interval 164 associated therewith. As shown in Figure 11, each frame comprises one reference symbol 166. The present invention can advantageously be used with such a MCM signal, however, such a signal structure being not necessary for performing the present invention as long as the transmitted signal comprises a useful portion and at least one reference symbol.

15
20

In order to obtain the final frame structure shown in Figure 11, a unit 116 for adding a reference symbol for each predetermined number of MCM symbols is provided.

25

In accordance with the present invention, the reference symbol is an amplitude modulated bit sequence. Thus, an amplitude modulation of a bit sequence is performed such that the envelope of the amplitude modulated bit sequence defines a reference pattern of the reference symbol. This reference pattern defined by the envelope of the amplitude modulated bit sequence has to be detected when receiving the MCM signal at a MCM receiver. In a preferred embodiment of the present invention, a pseudo random bit sequence having good autocorrelation properties is used as the bit sequence that is amplitude modulated.

30
35

The choice of length and repetition rate of the reference symbol depends on the properties of the channel through which the MCM signal is transmitted, e.g. the coherence time of the channel. In addition, the repetition rate and the length of the reference symbol, in other words the number of useful symbols in each frame, depends on the receiver requirements concerning mean time for initial synchronization and mean time for resynchronization after synchronization loss due to a channel fade.

5
10

The resulting MCM signal having the structure shown at 118 in Figure 1 is applied to the transmitter front end 120. Roughly speaking, at the transmitter front end 120, a digital/analog conversion and an up-converting of the MCM signal is performed. Thereafter, the MCM signal is transmitted through a channel 122.

15

Following, the mode of operation of a MCM receiver 130 is shortly described referring to Figure 1. The MCM signal is received at the receiver front end 132. In the receiver front end 132, the MCM signal is down-converted and, furthermore, an analog/digital conversion of the down-converted signal is performed.

20

The down-converted MCM signal is provided to a symbol frame/carrier frequency synchronization unit 134.

25

A first object of the symbol frame/carrier frequency synchronization unit 134 is to perform a frame synchronization on the basis of the amplitude-modulated reference symbol. This frame synchronization is performed on the basis of a correlation between the amplitude-demodulated reference symbol and a predetermined reference pattern stored in the MCM receiver.

30

35

A second object of the symbol frame/carrier frequency synchronization unit is to perform a coarse frequency synchronization of the MCM signal. To this end, the symbol frame/carrier frequency synchronization unit 134 serves as a

005270 0222/960

coarse frequency synchronization unit for determining a coarse frequency offset of the carrier frequency caused, for example, by a difference of the frequencies between the local oscillator of the transmitter and the local oscillator of the receiver. The determined frequency is used in order to perform a coarse frequency correction. The mode of operation of the coarse frequency synchronization unit is described in detail referring to Figures 9 and 10 hereinafter.

As described above, the frame synchronization unit 134 determines the location of the reference symbol in the MCM symbol. Based on the determination of the frame synchronization unit 134, a reference symbol extracting unit 136 extracts the framing information, i.e. the reference symbol, from the MCM symbol coming from the receiver front end 132. After the extraction of the reference symbol, the MCM signal is applied to a guard interval removal unit 138. The result of the signal processing performed herehereto in the MCM receiver are the useful MCM symbols.

The useful MCM symbols output from the guard interval removal unit 138 are provided to a fast Fourier transform unit 140 in order to provide a sequence of spectra from the useful symbols. Thereafter, the sequence of spectra is provided to a carrier-bit mapper 142 in which the serial bitstream is recovered. This serial bitstream is provided to a data sink 144.

Next, referring to Figures 2A and 2B, two modes for differential mapping are described. In Figure 2A, a first method of differential mapping along the time axis is shown. As can be seen from Figure 2A, a MCM symbol consists of K sub-carriers. The sub-carriers comprise different frequencies and are, in a preferred embodiment, equally spaced in the frequency axis direction. When using differential mapping along the time axis, one or more bits are encoded into phase and/or amplitude shifts between two sub-carriers of the same center frequency in adjacent MCM symbols. The arrows depicted between the sub-carrier symbols correspond to infor-

mation encoded in amplitude and/or phase shifts between two sub-carrier symbols.

5 A second method of differential mapping is shown in Figure 2B. The present invention is adapted for MCM transmission system using the mapping scheme shown in Figure 2B. This mapping scheme is based on a differential mapping inside one MCM symbol along the frequency axis. A number of MCM symbols 200 is shown in Figure 2B. Each MCM symbol 200 comprises a number of sub-carrier symbols 202. The arrows 204 in Figure 2B illustrate information encoded between two sub-carrier symbols 202. As can be seen from the arrows 204, this mapping scheme is based on a differential mapping within one MCM symbol along the frequency axis direction.

15 In the embodiment shown in Figure 2B, the first sub-carrier ($k=0$) in an MCM symbol 200 is used as a reference sub-carrier 206 (shaded) such that information is encoded between the reference sub-carrier and the first active carrier 208. The other information of a MCM symbol 200 is encoded between active carriers, respectively.

25 Thus, for every MCM symbol an absolute phase reference exists. In accordance with Figure 2B, this absolute phase reference is supplied by a reference symbol inserted into every MCM symbol ($k=0$). The reference symbol can either have a constant phase for all MCM symbols or a phase that varies from MCM symbol to MCM symbol. A varying phase can be obtained by replicating the phase from the last subcarrier of the MCM symbol preceding in time.

35 In Figure 3 a preferred embodiment of a device for performing a differential mapping along the frequency axis is shown. Referring to Figure 3, assembly of MCM symbols in the frequency domain using differential mapping along the frequency axis according to the present invention is described.

Figure 3 shows the assembly of one MCM symbol with the following parameters:

NFFT designates the number of complex coefficients of the discrete Fourier transform, number of subcarriers respectively.

5

K designates the number of active carriers. The reference carrier is not included in the count for K.

10 According to Figure 3, a quadrature phase shift keying (QPSK) is used for mapping the bitstream onto the complex symbols. However, other M-ary mapping schemes (MPSK) like 2-PSK, 8-PSK, 16-QAM, 16-APSK, 64-APSK etc. are possible.

15 Furthermore, for ease of filtering and minimization of aliasing effects some subcarriers are not used for encoding information in the device shown in Figure 3. These subcarriers, which are set to zero, constitute the so-called guard bands on the upper and lower edges of the MCM signal spectrum.

20

At the input of the mapping device shown in Figure 3, complex signal pairs $b_0[k]$, $b_1[k]$ of an input bitstream are received. K complex signal pairs are assembled in order to form one MCM symbol. The signal pairs are encoded into the K differential phase shifts $\phi[k]$ needed for assembly of one MCM symbol. In this embodiment, mapping from Bits to the 0, 90, 180 and 270 degrees phase shifts is performed using Gray Mapping in a quadrature phase shift keying device 220.

25

Gray mapping is used to prevent that differential detection phase errors smaller than 135 degrees cause double bit errors at the receiver.

35 Differential phase encoding of the K phases is performed in a differential phase encoder 222. At this stage of processing, the K phases $\phi[k]$ generated by the QPSK Gray mapper are differentially encoded. In principal, a feedback loop 224 calculates a cumulative sum over all K phases. As starting point for the first computation ($k = 0$) the phase of the

reference carrier 226 is used. A switch 228 is provided in order to provide either the absolute phase of the reference subcarrier 226 or the phase information encoded onto the preceding (i.e. z^{-1} , where z^{-1} denotes the unit delay operator) subcarrier to a summing point 230. At the output of the differential phase encoder 222, the phase information $\theta[k]$ with which the respective subcarriers are to be encoded is provided. In preferred embodiments of the present invention, the subcarriers of a MCM symbol are equally spaced in the frequency axis direction.

The output of the differential phase encoder 222 is connected to a unit 232 for generating complex subcarrier symbols using the phase information $\theta[k]$. To this end, the K differentially encoded phases are converted to complex symbols by multiplication with

$$\text{factor} * e^{j*[2*\pi*(\theta[k]+PHI)]} \quad (\text{Eq.1})$$

wherein factor designates a scale factor and PHI designates an additional angle. The scale factor and the additional angle PHI are optional. By choosing $PHI = 45^\circ$ a rotated DQPSK signal constellation can be obtained.

Finally, assembly of a MCM symbol is effected in an assembling unit 234. One MCM symbol comprising N_{FFT} subcarriers is assembled from $N_{FFT}-K-1$ guard band symbols which are "zero", one reference subcarrier symbol and K DQPSK subcarrier symbols. Thus, the assembled MCM symbol 200 is composed of K complex values containing the encoded information, two guard bands at both sides of the N_{FFT} complex values and a reference subcarrier symbol.

The MCM symbol has been assembled in the frequency domain. For transformation into the time domain an inverse discrete Fourier transform (IDFT) of the output of the assembling unit 234 is performed by a transformator 236. In preferred embodiments of the present invention, the transformator 236 is adapted to perform a fast Fourier transform (FFT).

Further processing of the MCM signal in the transmitter as well as in the receiver is as described above referring to Figure 1.

5

At the receiver a de-mapping device 142 (Figure 1) is needed to reverse the operations of the mapping device described above referring to Figure 3. The implementation of the de-mapping device is straightforward and, therefore, need not be described herein in detail.

10

The differential mapping along the frequency axis direction is suitable for multi-carrier (OFDM) digital broadcasting over rapidly changing multi path channels. In accordance with this mapping scheme, there is no need for a channel stationarity exceeding one multi-carrier symbol. However, differential mapping into frequency axis direction may create a new problem. In multi path environments, path echoes succeeding or preceding the main path can lead to systematic phase offsets between sub-carriers in the same MCM symbol. Thus, it will be preferred to provide a correction unit in order to eliminate such phase offsets. Because the channel induced phase offsets between differential demodulated symbols are systematic errors, they can be corrected by an algorithm. In principle, such an algorithm must calculate the echo induced phase offset from the signal space constellation following the differential demodulation and subsequently correct this phase offset.

15

20

25

Examples for such echo phase correction algorithms are described at the end of this specification referring to Figures 12 to 15.

30

Next, the fine frequency synchronization in accordance with the present invention will be described referring to Figures 4 to 8. As mentioned above, the fine frequency synchronization in accordance with the present invention is performed after completion of the coarse frequency synchronization. Preferred embodiments of the coarse frequency synchroniza-

35

tion which can be performed by the symbol frame/carrier frequency synchronization unit 134 are described hereinafter referring to Figures 9 and 10 after having described the fine frequency synchronization in accordance with the present invention.

With the fine frequency synchronization in accordance with the present invention frequency offsets which are smaller than half the sub-carrier distance can be corrected. Since the frequency offsets are low and equal for all sub-carriers the problem of fine frequency synchronization is reduced to sub-carrier level. Figure 4 is a schematical view of MCM symbols 200 in the time-frequency plane. Each MCM symbol 200 consists of 432 sub-carrier symbols C_1 to C_{432} . The MCM symbols are arranged along the time axis, the first MCM symbol 200 shown in Figure 4 having associated therewith a time T_1 , the next MCM symbol having associated therewith a time T_2 and so on. In accordance with a preferred embodiment of the present invention, the fine frequency synchronization is based on a phase rotation which is derived from the same sub-carrier of two MCM symbols which are adjacent in the time axis direction, for example C_1/T_1 and C_1/T_2 .

In the following, the present invention is described referring to QPSK mapping (QPSK = Quadrature Phase Shift Keying). However, it is obvious that the present invention can be applied to any MPSK mapping, wherein M designates the number of phase states used for encoding, for example 2, 4, 8, 16
.....

Figure 5 represents a complex coordinate system showing a QPSK constellation for each sub-carrier with frequency offset. The four possible phase positions of a first MCM symbol, MCM-symbol-1 are shown at 300. Changing from the sub-carrier (sub-carrier n) of this MCM symbol to the same sub-carrier of the next MCM symbol, MCM-symbol-2, the position in the QPSK constellation will be unchanged in case there is no frequency offset. If a frequency offset is present, which is smaller than half the distance between sub-carriers, as

mentioned above, this frequency offset causes a phase rotation of the QPSK constellation of MCM-symbol-2 compared with MCM-symbol-1. The new QPSK constellation, that is the four possible phase positions for the subject sub-carrier of MCM-symbol-2 are shown at 302 in Figure 5. This phase rotation θ can be derived from the following equation:

$$C_n(kT_{MCM}) = e^{j2\pi f_{offset}T_{MCM}} C_n((k-1)T_{MCM})$$
$$\theta = 2\pi f_{offset}T_{MCM} \quad (\text{Eq. 2})$$

10

C_n designates the QPSK constellation of a sub-carrier n in a MCM symbol. n is an index running from 1 to the number of active sub-carriers in the MCM symbol. Information regarding the frequency offset is contained in the term $e^{j2\pi f_{offset}T_{MCM}}$ of equation 2. This frequency offset is identical for all sub-carriers. Therefore, the phase rotation θ is identical for all sub-carriers as well. Thus, averaging overall sub-carrier of a MCM symbol can be performed.

15

20

Figure 6 shows a block diagram of a MCM receiver in which the present invention is implemented. An analog/digital converter 310 is provided in order to perform an analog/digital conversion of a down-converted signal received at the receiver front end 132 (Figure 1). The output of the analog/digital converter 310 is applied to a low path filter and decimator unit 312. The low path filter is an impulse forming filter which is identical to an impulse forming filter in the MCM transmitter. In the decimator, the signal is sampled at the MCM symbol frequency. As described above referring to Figure 1, guard intervals in the MCM signal are removed by a guard interval removal unit 132. Guard intervals are inserted between two MCM symbols in the MCM transmitter in order to avoid intersymbol interference caused by channel memory.

25

30

35

The output of the guard interval removal unit 132 is applied to a MCM demodulator 314 which corresponds to the fast Fourier transformator 140 shown in Figure 1. Following the MCM

demodulator 314 a differential decoding unit 316 and a demapping unit 318 are provided. In the differential decoding unit 316, phase information is recovered using differential decoding. In the demapping unit 318, demapping along the frequency axis direction is performed in order to reconstruct a binary signal from the complex signal input into the demapping unit 318.

10 The output of the MCM demodulator 314 is also applied to fine frequency error detector 320. The fine frequency error detector 320 produces an frequency error signal from the output of the MCM demodulator. In the depicted embodiment, the output of the fine frequency error detector 320 is applied to a numerical controlled oscillator 322 via a loop filter 324. The loop filter 324 is a low pass filter for filtering superimposed interference portions of a higher frequency from the slowly varying error signal. The numerical controlled oscillator 322 produces a carrier signal on the basis of the filtered error signal. The carrier signal produced by the numerical controlled oscillator 322 is used for a frequency correction which is performed by making use of a complex multiplier 326. The inputs to the complex multiplier 326 are the output of the low pass filter and decimator unit 312 and the output of the numerical controlled oscillator 322.

A description of a preferred embodiment of the fine frequency error detector 320 is given hereinafter referring to Figure 7.

30 The fine frequency error detector 320 comprises a differential detector in the time axis 330. The output of the MCM demodulator 314, i.e. the FFT output (FFT = Fast Fourier Transform) is applied to the input of the differential detector 330 which performs a differential detection in the time axis in order to derive information on a frequency offset from the same sub-carrier of two subsequently arriving MCM symbols. In the embodiment shown in Figure 7, the number of active sub-carriers is 432. Thus, the differential detec-

tor 330 performs a correlation between the first and the 433rd sample. The first sample is associated with MCM-symbol-1 (Figure 5), whereas the 433rd sample is associated with MCM-symbol-2 (Figure 5). However, both these samples
5 are associated with the same sub-carrier.

To this end, the input signal Y_k is applied to a z^{-1} -block 332 and thereafter to a unit 334 in order to form the complex conjugate of the output of the z^{-1} -block 332. A complex
10 multiplier 336 is provided in order to multiply the output of the unit 334 by the input signal Y_k . The output of the multiplier 336 is a signal Z_k .

The function of the differential detector 330 can be expressed as follows:
15

$$Z_k = Y_{k+K} \cdot Y_k^* \quad (\text{Eq. 3})$$

$$Y = [Y_1, Y_2, \dots, Y_k, \dots] \quad (\text{Eq. 4})$$

20

$$Y = [C_1 / T_1, C_2 / T_1, \dots, C_{432} / T_1, C_1 / T_2, \dots] \quad (\text{Eq. 5})$$

Y_k designates the output of the MCM modulator 314, i.e. the input to the differential detector 330, at a time k . Z_k designates the output of the differential detector 330. K designates the number of active carriers.
25

The output Z_k of the differential detector 330 contains a M -fold uncertainty corresponding to codeable phase shifts. In case of the QPSK this M -fold uncertainty is a 4-fold uncertainty, i.e. 0° , 90° , 180° and 270° . This phase shift uncertainty is eliminated from Z_k making use of a M -PSK decision device 340. Such decision devices are known in the art and, therefore, have not to be described here in detail. The output of the decision device 340 $(\hat{a}_k)^*$ represents the complex conjugate of the codeable phase shift decided by the decision device 340. This output of the decision device 340 is
35

correlated with the output of the differential detector 330 by performing a complex multiplication using a multiplier 342.

5 The output the multiplier 342 represents the phase offset for the respective sub-carriers. This phase offsets for the respective sub-carriers are averaged over one MCM symbol in an averaging unit 344 in accordance with a preferred embodiment of the present invention. The output of the averaging
10 units 344 represent the output of the fine frequency error detector 320.

The mathematical description for this procedure is as follows:

15

$$f_{offset} = \frac{1}{2\pi K T_{MCM}} \arg \left\{ \sum_{n=1}^K Z_n \cdot \left(\hat{a}_n \right)^* \right\} \quad (\text{Eq. 6})$$

In accordance with preferred embodiments of the present invention, the frequency control loop has a backward structure. In the embodiment shown in Figure 6, the feedback loop
20 is connected between the output of the MCM demodulator 314 and the input of the guard interval removal unit 132.

In Figure 8, a block diagram of a MCM receiver comprising a
25 coarse frequency correction unit 350 and a fine frequency correction unit as described above is shown. As shown in Figure 8, a common complex multiplier 326 can be used in order to perform the coarse frequency correction and the fine frequency correction. As shown in Figure 8, the multiplier
30 326 can be provided preceding the low pass filter and decimator unit 312. Depending on the position of the multiplier 326, a hold unit has to be provided in the fine frequency synchronization feedback loop. In an alternative embodiment, it is possible to use two separate multipliers for the
35 coarse frequency correction and for the fine frequency correction. In such a case, the multiplier for the coarse frequency correction will be arranged preceding the low path

filter and decimator unit, whereas the multiplier for the fine frequency correction will be arranged following the low path filter and decimator unit.

- 5 Following, preferred embodiments for implementing a coarse frequency synchronization will be described referring to Figures 9 and 10.

10 As it is shown in Figure 9, the output of the receiver front end 132 is connected to an analog/digital converter 310. The down-converted MCM signal is sampled at the output of the analog/digital converter 310 and is applied to a frame/timing synchronization unit 360. In a preferred embodiment, a fast running automatic gain control (AGC) (not shown) is provided preceding the frame/timing synchronization unit in order to eliminate fast channel fluctuations. The fast AGC is used in addition to the normally slow AGC in the signal path, in the case of transmission over a multipath channel with long channel impulse response and frequency selective fading. The fast AGC adjusts the average amplitude range of the signal to the known average amplitude of the reference symbol.

15
20
25 As described above, the frame/timing synchronization unit uses the amplitude-modulated sequence in the received signal in order to extract the framing information from the MCM signal and further to remove the guard intervals therefrom. After the frame/timing synchronization unit 360 it follows a coarse frequency synchronization unit 362 which estimates a coarse frequency offset based on the amplitude-modulated sequence of the reference symbol of the MCM signal. In the coarse frequency synchronization unit 362, a frequency offset of the carrier frequency with respect to the oscillator frequency in the MCM receiver is determined in order to perform a frequency offset correction in a block 364. This frequency offset correction in block 364 is performed by a complex multiplication.

The output of the frequency offset correction block 364 is applied to the MCM demodulator 366 formed by the Fast Fourier Transformator 140 and the carrier-bit mapper 142 shown in Figure 1.

5

In order to perform the coarse frequency synchronization described herein, an amplitude-demodulation has to be performed on a preprocessed MCM signal. The preprocessing may be, for example, the down-conversion and the analog/digital conversion of the MCM signal. The result of the amplitude-demodulation of the preprocessed MCM signal is an envelope representing the amplitude of the MCM signal.

15 For the amplitude demodulation a simple $\alpha_{\max+}$ $\beta_{\min-}$ method can be used. This method is described for example in Palacherla A.: DSP- μ P Routine Computes Magnitude, EDN, October 26, 1989; and Adams, W. T., and Bradley, J.: Magnitude Approximations for Microprocessor Implementation, IEEE Micro, Vol. 3, No. 5, October 1983.

20

It is clear that amplitude determining methods different from the described $\alpha_{\max+}$ $\beta_{\min-}$ method can be used. For simplification, it is possible to reduce the amplitude calculation to a detection as to whether the current amplitude is above or below the average amplitude. The output signal then consists of a -1/+1 sequence which can be used to determine a coarse frequency offset by performing a correlation. This correlation can easily be performed using a simple integrated circuit (IC).

30

In addition, an oversampling of the signal received at the RF front end can be performed. For example, the received signal can be expressed with two times oversampling.

35 In accordance with a first embodiment, a carrier frequency offset of the MCM signal from an oscillator frequency in the MCM receiver is determined by correlating the envelope obtained by performing the amplitude-demodulation as described above with a predetermined reference pattern.

In case there is no frequency offset, the received reference symbol $r(k)$ will be:

5
$$r(k) = S_{AM}(k) + n(k) \tag{Eq.7}$$

wherein $n(k)$ designates "additive Gaussian noise" and S_{AM} denotes the AM sequence which has been sent. In order to simplify the calculation the additive Gaussian noise can be neglected. It follows:

10
$$r(k) \cong S_{AM}(k) \tag{Eq.8}$$

In case a constant frequency offset Δf is present, the received signal will be:

15
$$\tilde{r}(k) = S_{AM}(k) \cdot e^{j2\pi\Delta f k T_{MCM}} \tag{Eq.9}$$

Information regarding the frequency offset is derived from the correlation of the received signal $\tilde{r}(k)$ with the AM sequence S_{AM} which is known in the receiver:

20
$$\sum_{k=1}^{\frac{L}{2}} \tilde{r}(k) \cdot S_{AM}^*(k) = \sum_{k=1}^{\frac{L}{2}} |S_{AM}(k)|^2 e^{j2\pi\Delta f k T_{MCM}} \tag{Eq.10}$$

25 Thus, the frequency offset is:

$$\Delta f = \frac{1}{2\pi T_{MCM}} \arg \left(\sum_{k=1}^{\frac{L}{2}} r(k) \cdot S_{AM}^*(k) \right) - \frac{1}{2\pi T_{MCM}} \arg \left(\sum_{k=1}^{\frac{L}{2}} |S_{AM}(k)|^2 \right) \tag{Eq.11}$$

30 since the argument of $|S_{AM}(k)|^2$ is zero the frequency offset is:

00527 02E2950

$$\Delta f = \frac{1}{2\pi T_{MCM}} \arg \left(\sum_{k=1}^{\frac{L}{2}} \tilde{r}(k) \cdot S_{AM}^* \right) \quad (\text{Eq. 12})$$

In accordance with a second embodiment of the coarse frequency synchronization algorithm, a reference symbol comprising at least two identical sequences 370 as shown in Figure 10 is used. Figure 10 shows the reference symbol of a MCM signal having two identical sequences 370 of a length of L/2 each. L designates the number of values of the two sequences 370 of the reference symbol.

As shown in Figure 10, within the amplitude-modulated sequence, there are at least two identical sections devoted to the coarse frequency synchronization. Two such sections, each containing L/2 samples, are shown at the end of the amplitude-modulated sequence in Figure 10. The amplitude-modulated sequence contains a large number of samples. For a non-ambiguous observation of the phase, only enough samples to contain a phase rotation of 2π should be used. This number is defined as L/2 in Figure 10.

Following, a mathematical derivation of the determination of a carrier frequency deviation is presented. In accordance with Figure 10, the following equation applies for the two identical sequences 370:

$$s\left(0 < k \leq \frac{L}{2}\right) \equiv s\left(\frac{L}{2} < k \leq L\right) \quad (\text{Eq. 13})$$

If no frequency offset is present, the following equation 14 will be met by the received signal:

$$r\left(k + \frac{L}{2}\right) \equiv r(k) \quad 0 < k \leq \frac{L}{2} \quad (\text{Eq. 14})$$

r(k) designates the values of the identical sequences. k is an index from one to L/2 for the respective samples.

If there is a frequency offset of, for example, Δf, the received signal is:

$$\tilde{r}(k) = r(k) \cdot e^{j2\pi\Delta f k T_{MCM}} \tag{Eq.15}$$

$$\tilde{r}\left(k + \frac{L}{2}\right) = r(k) \cdot e^{j2\pi\Delta f \left(k + \frac{L}{2}\right) T_{MCM}} \tag{Eq.16}$$

10

r(k) designates sample values of the received portion which are based on the identical sequences. Information regarding the frequency offset is derived from the correlation of the received signal $\tilde{r}\left(k + \frac{L}{2}\right)$ with the received signal $\tilde{r}(k)$.

15 This correlation is given by the following equation:

$$\sum_{k=1}^{\frac{L}{2}} \tilde{r}^*\left(k + \frac{L}{2}\right) \tilde{r}(k) = \sum_{k=1}^{\frac{L}{2}} |r(k)|^2 e^{-j2\pi\Delta f \frac{L}{2} T_{MCM}} \tag{Eq.17}$$

\tilde{r}^* designates the complex conjugate of the sample values of the portion mentioned above.

20

Thus, the frequency offset is

$$\Delta f = \frac{1}{2\pi \frac{L}{2} T_{MCM}} \arg\left(\sum_{k=1}^{\frac{L}{2}} \tilde{r}\left(k + \frac{L}{2}\right) \cdot \tilde{r}^*(k)\right) - \frac{1}{2\pi \frac{L}{2} T_{MCM}} \arg\left(\sum_{k=1}^{\frac{L}{2}} |\tilde{r}(k)|^2\right) \tag{Eq.18}$$

25

Since the argument of $|\tilde{r}(k)|^2$ equals zero, the frequency offset becomes

005211"0202/560

$$\Delta f = \frac{1}{2\pi \frac{L}{2} T_{MCM}} \arg \left(\sum_{k=1}^{\frac{L}{2}} \tilde{r} \left(k + \frac{L}{2} \right) \cdot \tilde{r}^*(k) \right) \quad (\text{Eq.19})$$

Thus, it is clear that in both embodiments, described above, the frequency position of the maximum of the resulting output of the correlation determines the estimated value of the offset carrier. Furthermore, as it is also shown in Figure 9, the correction is performed in a feed forward structure.

In case of a channel with strong reflections, for example due to a high building density, the correlations described above might be insufficient for obtaining a suitable coarse frequency synchronization. Therefore, in accordance with a third embodiment of the present invention, corresponding values of the two portions which are correlated in accordance with a second embodiment, can be weighting with corresponding values of stored predetermined reference patterns corresponding to said two identical sequences of the reference symbol. This weighting can maximize the probability of correctly determining the frequency offset. The mathematical description of this weighting is as follows:

$$\Delta f = \frac{1}{2\pi \frac{L}{2} T_{MCM}} \arg \left(\sum_{k=1}^{\frac{L}{2}} \left[\tilde{r} \left(k + \frac{L}{2} \right) \cdot \tilde{r}^*(k) \right] \cdot \left[S_{AM}(k) S_{AM}^* \left(k + \frac{L}{2} \right) \right] \right) \quad (\text{Eq.20})$$

S_{AM} designates the amplitude-modulated sequence which is known in the receiver, and S_{AM}^* designates the complex conjugate thereof.

If the above correlations are calculated in the frequency domain, the amount of

$$\sum_{k=1}^{\frac{L}{2}} \left[\tilde{r} \left(k + \frac{L}{2} \right) \cdot \tilde{r}^*(k) \right] \cdot \left[S_{AM}(k) S_{AM}^* \left(k + \frac{L}{2} \right) \right] \quad (\text{Eq.21})$$

is used rather than the argument. This amount is maximized as a function of a frequency correction. The position of the maximum determines the estimation of the frequency deviation. As mentioned above, the correction is performed in a feed forward structure.

Preferred embodiments for performing an echo phase offset correction when using a differential mapping in the frequency axis will be described hereinafter referring to Figures 12 to 15.

Systematic phase shifts stemming from echoes in multipath environments may occur between subcarriers in the same MCM symbol. This phase offsets can cause bit errors when demodulating the MCM symbol at the receiver. Thus, it is preferred to make use of an algorithm to correct the systematic phase shifts stemming from echoes in multipath environments.

In Figure 12, scatter diagrams at the output of a differential demapper of a MCM receiver are shown. As can be seen from the left part of Figure 12, systematic phase shifts between subcarriers in the same MCM symbol cause a rotation of the demodulated phase shifts with respect to the axis of the complex coordinate system. In the right part of Figure 12, the demodulated phase shifts after having performed an echo phase offset correction are depicted. Now, the positions of the signal points are substantially on the axis of the complex coordinate system. These positions correspond to the modulated phase shifts of 0° , 90° , 180° and 270° , respectively.

An echo phase offset correction algorithm (EPOC algorithm) must calculate the echo induced phase offset from the signal space constellation following the differential demodulation and subsequently correct this phase offset.

For illustration purposes, one may think of the simplest algorithm possible which eliminates the symbol phase before

computing the mean of all phases of the subcarriers. To illustrate the effect of such an EPOC algorithm, reference is made to the two scatter diagrams of subcarriers symbols contained in one MCM symbol in Figure 12. This scatter diagrams
5 have been obtained as result of an MCM simulation. For the simulation a channel has been used which might typically show up in single frequency networks. The echoes of this channel stretched to the limits of the MCM guard interval. The guard interval was chosen to be 25% of the MCM symbol
10 duration in this case.

Figure 13 represents a block diagram for illustrating the position and the functionality of an echo phase offset correction device in a MCM receiver. The signal of a MCM transmitter is transmitted through the channel 122 (Figures 1 and 13) and received at the receiver frontend 132 of the MCM receiver. The signal processing between the receiver frontend and the fast Fourier transformator 140 has been omitted in
15 Figure 13. The output of the fast Fourier transformator is applied to the de-mapper, which performs a differential de-mapping along the frequency axis. The output of the de-mapper are the respective phase shifts for the subcarriers. The phase offsets of this phase shifts which are caused by
20 echoes in multipath environments are visualized by a block 400 in Figure 13 which shows an example of a scatter diagram of the subcarrier symbols without an echo phase offset correction.

The output of the de-mapper 142 is applied to the input of an echo phase offset correction device 402. The echo phase offset correction device 402 uses an EPOC algorithm in order to eliminate echo phase offsets in the output of the de-mapper 142. The result is shown in block 404 of Figure 13,
30 i.e. only the encoded phase shifts, 0° , 90° , 180° or 270° are present at the output of the correction device 402. The output of the correction device 402 forms the signal for the metric calculation which is performed in order to recover the bitstream representing the transmitted information.
35

A first embodiment of an EPOC algorithm and a device for performing same is now described referring to Figure 14.

5 The first embodiment of an EPOC algorithm starts from the assumption that every received differentially decoded complex symbol is rotated by an angle due to echoes in the multipath channel. For the subcarriers equal spacing in frequency is assumed since this represents a preferred embodiment. If the subcarriers were not equally spaced in frequency, a correction factor would have to be introduced into the EPOC algorithm.

10 Figure 14 shows the correction device 402 (Figure 13) for performing the first embodiment of an EPOC algorithm.

15 From the output of the de-mapper 142 which contains an echo phase offset as shown for example in the left part of Figure 12, the phase shifts related to transmitted information must first be discarded. To this end, the output of the de-mapper 142 is applied to a discarding unit 500. In case of a DQPSK mapping, the discarding unit can perform a " $(.)^4$ " operation. The unit 500 projects all received symbols into the first quadrant. Therefore, the phase shifts related to transmitted information is eliminated from the phase shifts representing the subcarrier symbols. The same effect could be reached with a modulo-4 operation.

20 Having eliminated the information related symbol phases in unit 500, the first approach to obtain an estimation would be to simply compute the mean value over all symbol phases of one MCM symbol. However, it is preferred to perform a threshold decision before determining the mean value over all symbol phases of one MCM symbol. Due to Rayleigh fading some of the received symbols may contribute unreliable information to the determination of the echo phase offset. Therefore, depending on the absolute value of a symbol, a threshold decision is performed in order to determine

whether the symbol should contribute to the estimate of the phase offset or not.

Thus, in the embodiment shown in Figure 14, a threshold decision unit 510 is included. Following the unit 500 the absolute value and the argument of a differentially decoded symbol is computed in respective computing units 512 and 514. Depending on the absolute value of a respective symbol, a control signal is derived. This control signal is compared with a threshold value in a decision circuit 516. If the absolute value, i.e. the control signal thereof, is smaller than a certain threshold, the decision circuit 516 replaces the angle value going into the averaging operation by a value equal to zero. To this end, a switch is provided in order to disconnect the output of the argument computing unit 514 from the input of the further processing stage and connects the input of the further processing stage with a unit 518 providing a constant output of "zero".

An averaging unit 520 is provided in order to calculate a mean value based on the phase offsets φ_i determined for the individual subcarrier symbols of a MCM symbol as follows:

$$\bar{\varphi} = 1 / K \sum_{i=1}^K \varphi_i \quad (\text{Eq.22})$$

In the averaging unit 520, summation over K summands is performed. The output of the averaging unit 520 is provided to a hold unit 522 which holds the output of the averaging unit 520 K times. The output of the hold unit 522 is connected with a phase rotation unit 524 which performs the correction of the phase offsets of the K complex signal points on the basis of the mean value $\bar{\varphi}$.

The phase rotation unit 524 performs the correction of the phase offsets by making use of the following equation:

$$v_k' = v_k \cdot e^{-j\bar{\varphi}} \quad (\text{Eq.23})$$

In this equation, v'_k designates the K phase corrected differentially decoded symbols for input into the soft-metric calculation, whereas v_k designates the input symbols. As long as a channel which is quasi stationary during the duration of one MCM symbols can be assumed, using the mean value over all subcarriers of one MCM symbol will provide correct results.

5
10 A buffer unit 527 may be provided in order to buffer the complex signal points until the mean value of the phase offsets for one MCM symbol is determined. The output of the phase rotation unit 524 is applied to the further processing stage 526 for performing the soft-metric calculation.

15
20 With respect to the results of the above echo phase offset correction, reference is made again to Figure 12. The two plots stem from a simulation which included the first embodiment of an echo phase offset correction algorithm described above. At the instant of the scatter diagram snapshot shown in the left part of Figure 12, the channel obviously distorted the constellation in such a way, that a simple angle rotation is a valid assumption. As shown in the right part of Figure 12, the signal constellation can be rotated back to the axis by applying the determined mean value for the rotation of the differentially detected symbols.

25
30 A second embodiment of an echo phase offset correction algorithm is described hereinafter. This second embodiment can be preferably used in connection with multipath channels that have up to two strong path echoes. The algorithm of the second embodiment is more complex than the algorithm of the first embodiment.

35 what follows is a mathematical derivation of the second embodiment of a method for echo phase offset correction. The following assumptions can be made in order to ease the explanation of the second embodiment of an EPOC algorithm.

In this embodiment, the guard interval of the MCM signal is assumed to be at least as long as the impulse response $h[q]$, $q = 0, 1, \dots, Q_h-1$ of the multipath channel.

5

At the transmitter every MCM symbol is assembled using frequency axis mapping explained above. The symbol of the reference subcarrier equals 1, i.e. 0 degree phase shift. The optional phase shift PHI equals zero, i.e. the DQPSK signal constellation is not rotated.

10

Using an equation this can be expressed as

15 (Eq.24)
$$a_k = a_{k-1} a_k^{inc}$$

with

k : index $k = 1, 2, \dots, K$ of the active subcarrier;

20
$$a_k^{inc} = e^{j\frac{\pi}{2}m}$$
 : complex phase increment symbol; $m=0, 1, 2, 3$ is the QPSK symbol number which is derived from Gray encoding pairs of 2 Bits;

$a_0 = 1$: symbol of the reference subcarrier.

25

At the DFT output of the receiver the decision variables

$$e_k = a_k H_k \tag{Eq.25}$$

30 are obtained with

$$H_k = \sum_{i=0}^{Q_h-1} h[i] \cdot e^{-j\frac{2\pi}{K}ki} \tag{Eq.26}$$

35 being the DFT of the channel impulse response $h[q]$ at position k .

006217" 022E2960

with $|a_k|^2 = 1$ the differential demodulation yields

$$v_k = e_k \cdot e_{k-1}^* = a_k^{inc} H_k H_{k-1}^* \tag{Eq.27}$$

5 For the receiver an additional phase term φ_k is introduced, which shall be used to correct the systematic phase offset caused by the channel. Therefore, the final decision variable at the receiver is

$$10 \quad v'_k = v_k \cdot e^{j\varphi_k} = a_k^{inc} \cdot e^{j\varphi_k} \cdot H_k \cdot H_{k-1}^* \tag{Eq.28}$$

As can be seen from the Equation 28, the useful information a_k^{inc} is weighted with the product $e^{j\varphi_k} \cdot H_k \cdot H_{k-1}^*$ (rotation and effective transfer function of the channel). This product must be real-valued for an error free detection. Considering this, it is best to choose the rotation angle to equal the negative argument of $H_k \cdot H_{k-1}^*$. To derive the desired algorithm for 2-path channels, the nature of $H_k \cdot H_{k-1}^*$ is investigated in the next section.

It is assumed that the 2-path channel exhibits two echoes with energy content unequal zero, i.e. at least two dominant echoes. This assumption yields the impulse response

$$25 \quad h[q] = c_1 \delta_0[q] + c_2 \delta_0[q - q_0] \tag{Eq.29}$$

with

- 30 c_1, c_2 : complex coefficients representing the path echoes;
- q_0 : delay of the second path echo with respect to the first path echo;
- δ_0 : Dirac pulse; $\delta_0[k] = 1$ for $k = 0$
 $\delta_0[k] = 0$ else

35

The channel transfer function is obtained by applying a DFT to Equation 29:

$$H_k = H\left(e^{j\frac{2\pi}{K}k}\right) = c_1 + c_2 \cdot e^{-j\frac{2\pi}{K}kq_0} \quad (\text{Eq. 30})$$

5

With Equation 30 the effective transfer function for differential demodulation along the frequency axis is:

$$\begin{aligned} H_k \cdot H_{k-1}^* &= \left(c_1 + c_2 e^{-j\frac{2\pi}{K}kq_0}\right) \cdot \left(c_1^* + c_2^* e^{+j\frac{2\pi}{K}(k-1)q_0}\right) \\ &= c_a + c_b \cos\left(\frac{\pi}{K}q_0(2k-1)\right) \end{aligned} \quad (\text{Eq. 31})$$

10

Assuming a noise free 2-path channel, it can be observed from Equation 31 that the symbols on the receiver side are located on a straight line in case the symbol $1+j0$ has been send (see above assumption). This straight line can be characterized by a point

15

$$c_a = |c_1|^2 + |c_2|^2 \cdot e^{-j\frac{2\pi}{K}q_0} \quad (\text{Eq. 32})$$

20 and the vector

$$c_b = 2c_1c_2^* \cdot e^{-j\frac{\pi}{K}q_0} \quad (\text{Eq. 33})$$

which determines its direction.

25

With the above assumptions, the following geometric derivation can be performed. A more suitable notation for the geometric derivation of the second embodiment of an EPOC algorithm is obtained if the real part of the complex plane is designated as $x = \text{Re}\{z\}$, the imaginary part as $y = \text{Im}\{z\}$, respectively, i.e. $z = x+jy$. With this new notation, the straight line, on which the received symbols will lie in case of a noise-free two-path channel, is

30

005271" 02E2950

$$f(x) = a + b \cdot x \tag{Eq. 34}$$

with

5

$$a = \text{Im}\{c_a\} - \frac{\text{Re}\{c_a\}}{\text{Re}\{c_b\}} \cdot \text{Im}\{c_b\} \tag{Eq. 35}$$

and

$$b = - \frac{\text{Im}\{c_a\} - \frac{\text{Re}\{c_a\}}{\text{Re}\{c_b\}} \cdot \text{Im}\{c_b\}}{\text{Re}\{c_a\} - \frac{\text{Im}\{c_a\}}{\text{Im}\{c_b\}} \cdot \text{Re}\{c_b\}} \tag{Eq. 36}$$

Additional noise will spread the symbols around the straight line given by Equations 34 to 36. In this case Equation 36 is the regression curve for the cluster of symbols.

15

For the geometric derivation of the second embodiment of an EPOC algorithm, the angle φ_k from Equation 28 is chosen to be a function of the square distance of the considered symbol from the origin:

20

$$\varphi_k = f_k(|z|^2) \tag{Eq. 37}$$

Equation 37 shows that the complete signal space is distorted (torsion), however, with the distances from the origin being preserved.

25

For the derivation of the algorithm of the second embodiment, $f_k(\cdot)$ has to be determined such that all decision variables v'_k (assuming no noise) will come to lie on the real axis:

30

$$\text{Im}\{(x + jf(x)) \cdot e^{jf_k(|z|^2)}\} = 0 \tag{Eq. 38}$$

005217 04222960

Further transformations of Equation 38 lead to a quadratic equation which has to be solved to obtain the solution for φ_k .

- 5 In case of a two-path channel, the echo phase offset correction for a given decision variable v_k is

$$v'_k = v_k \cdot e^{j\varphi_k} \tag{Eq. 39}$$

- 10 with

$$\varphi_k = \begin{cases} -a \tan\left(\frac{a + b\sqrt{|v_k|^2(1 + b^2) - a^2}}{-ab + \sqrt{|v_k|^2(1 + b^2) - a^2}}\right) & \text{for } |v_k|^2 \geq \frac{a^2}{1 + b^2} \\ a \tan\left(\frac{1}{b}\right) & \text{for } |v_k|^2 < \frac{a^2}{1 + b^2} \end{cases} \tag{Eq. 40}$$

- 15 From the two possible solutions of the quadratic equation mentioned above, Equation 40 is the one solution that cannot cause an additional phase shift of 180 degrees.

20 The two plots in Figure 15 show the projection of the EPOC algorithm of the second embodiment for one quadrant of the complex plane. Depicted here is the quadratic grid in the sector $|\arg(z)| \leq \pi / 4$ and the straight line $y = f(x) = a + b \cdot x$ with $a = -1.0$ and $b = 0.5$ (dotted line). In case of a noise-free channel, all received symbols will lie on this straight line if $1+j0$ was send. The circle shown in the plots determines the boarder line for the two cases of Equation 40. In the left part, Figure 15 shows the situation before the projection, in the right part, Figure 15 shows the situation after applying the projection algorithm. 25 By looking on the left part, one can see, that the straight line now lies on the real axis with $2+j0$ being the fix point of the projection. Therefore, it can be concluded that the echo phase offset correction algorithm according to the second embodiment fulfills the design goal. 30

005277 0222380

Before the second embodiment of an EPOC algorithm can be applied, the approximation line through the received symbols has to be determined, i.e. the parameters a and b must be estimated. For this purpose, it is assumed that the received symbols lie in sector $|\arg(z)| \leq \pi / 4$, if $1+j0$ was sent. If symbols other than $1+j0$ have been sent, a modulo operation can be applied to project all symbols into the desired sector. Proceeding like this prevents the necessity of deciding on the symbols in an early stage and enables averaging over all signal points of one MCM symbol (instead of averaging over only $\frac{1}{4}$ of all signal points).

For the following computation rule for the EPOC algorithm of the second embodiment, x_i is used to denote the real part of the i-th signal point and y_i for its imaginary part, respectively ($i = 1, 2, \dots, K$). Altogether, K values are available for the determination. By choosing the method of least squares, the straight line which has to be determined can be obtained by minimizing

$$(a, b) = \arg \min_{(\tilde{a}, \tilde{b})} \sum_{i=1}^K (y_i - (\tilde{a} + \tilde{b} \cdot x_i))^2 \quad (\text{Eq. 41})$$

The solution for Equation 41 can be found in the laid open literature. It is

$$b = \frac{\sum_{i=1}^K (x_i - \bar{x}) \cdot y_i}{\sum_{i=1}^K (x_i - \bar{x})^2}, \quad a = \bar{y} - \bar{x} \cdot b \quad (\text{Eq. 42})$$

with mean values

$$\bar{x} = \frac{1}{N} \sum_{i=1}^K x_i, \quad \bar{y} = \frac{1}{N} \sum_{i=1}^K y_i \quad (\text{Eq. 43})$$

If necessary, an estimation method with higher robustness can be applied. However, the trade-off will be a much higher computational complexity.

5 To avoid problems with the range in which the projection is applicable, the determination of the straight line should be separated into two parts. First, the cluster's centers of gravity are moved onto the axes, following, the signal space is distorted. Assuming that a and b are the original parameters of the straight line and α is the rotation angle, $f_k(\cdot)$ has to be applied with the transformed parameters

$$b' = \frac{b \cdot \cos(\alpha) - \sin(\alpha)}{\cos(\alpha) + b \cdot \sin(\alpha)}, \quad a' = a \cdot (\cos(\alpha) - b' \cdot \sin(\alpha))$$

(Eq.44)

15 Besides the two EPOC algorithms explained above section, different algorithms can be designed that will, however, most likely exhibit a higher degree of computational complexity.

00627"02E2950

ABSTRACT

5 A method and an apparatus relate to a fine frequency syn-
chronization compensating for a carrier frequency deviation
from an oscillator frequency in a multi-carrier demodulation
system of the type capable of carrying out a differential
phase decoding of multi-carrier modulated signals, the sig-
nals comprising a plurality of symbols, each symbol being
10 defined by phase differences between simultaneous carriers
having different frequencies. A phase difference between
phases of the same carrier in different symbols is deter-
mined. Thereafter, a frequency offset is determined by
eliminating phase shift uncertainties related to the trans-
15 mitted information from the phase difference making use of a
M-PSK decision device. Finally, a feedback correction of the
carrier frequency deviation is performed based on the deter-
mined frequency offset. Alternatively, an averaged frequency
offset can be determined by averaging determined frequency
20 offsets of a plurality of carriers. Then, the feedback cor-
rection of the frequency deviation is performed based on the
averaged frequency offset.

005277-0222/960

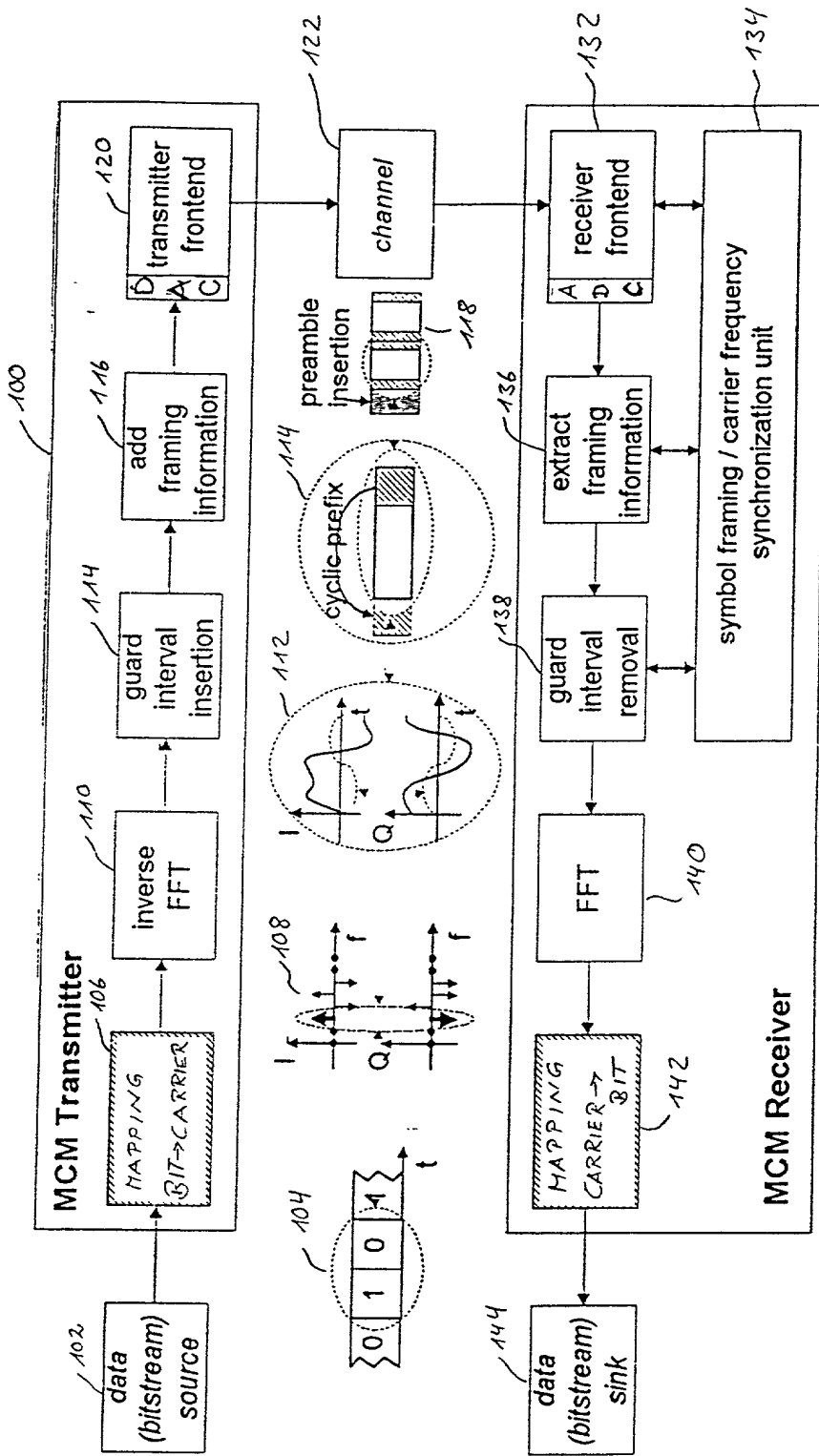
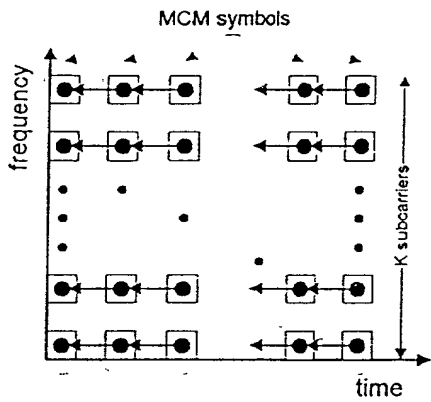
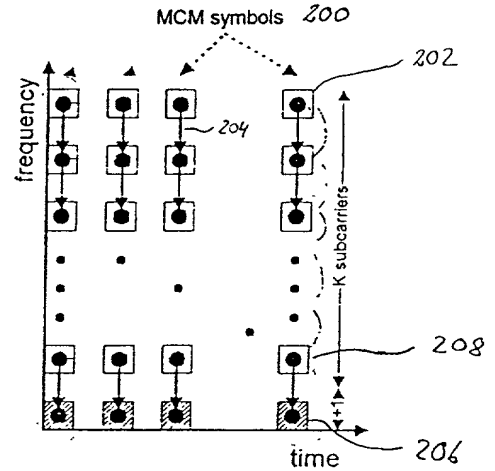

Fig. 1



- = MCM symbol
- = subcarrier

Fig. 2A



- = MCM symbol
- = subcarrier
- = reference subcarrier

Fig. 2B

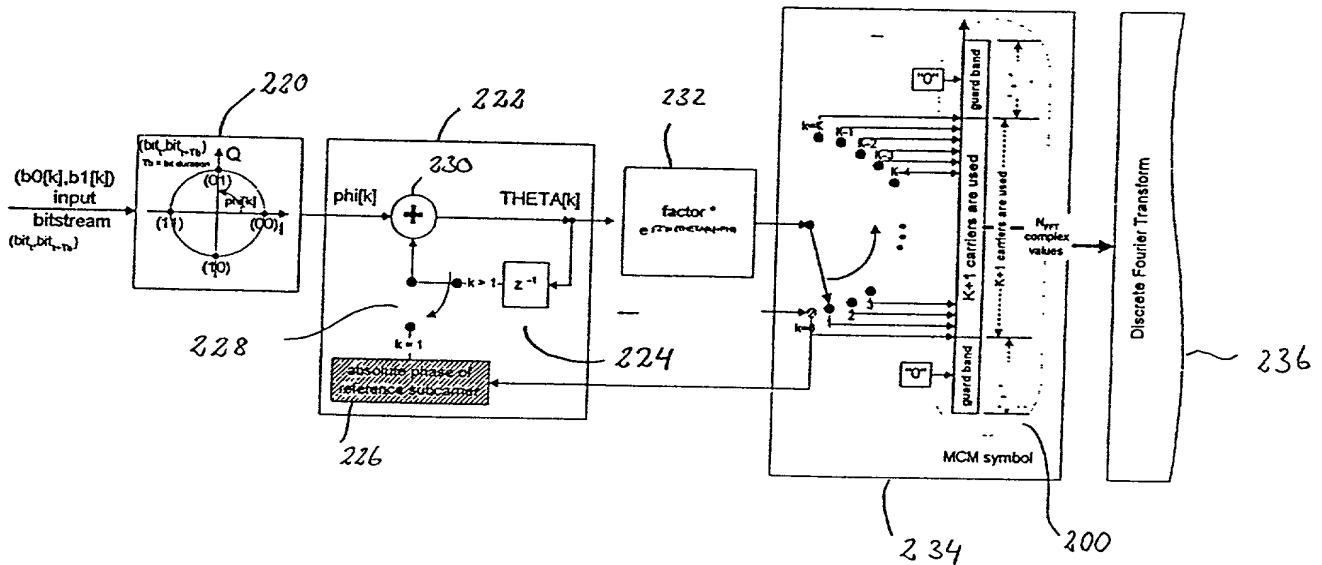
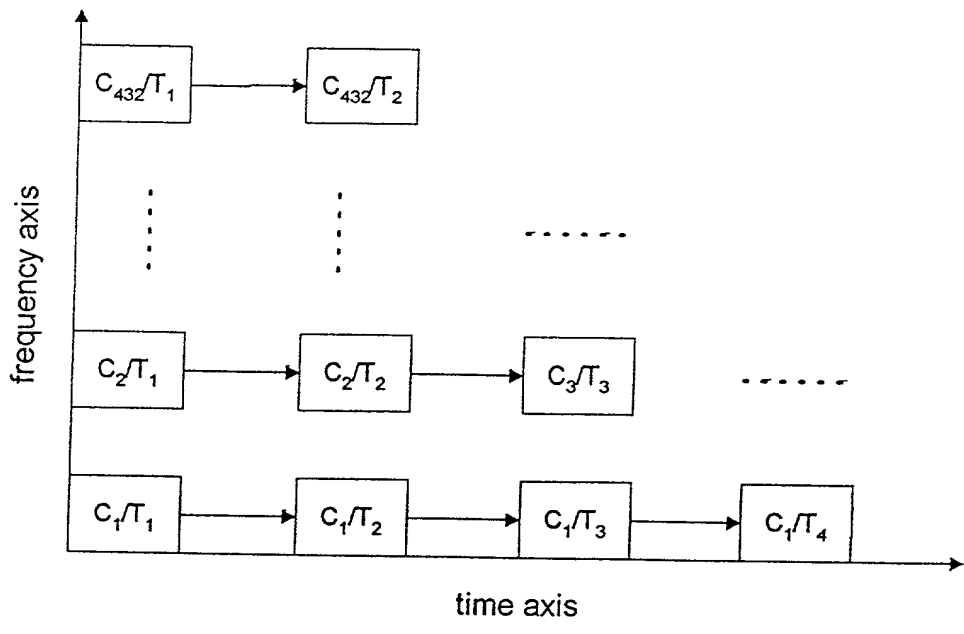

Fig. 3

00527 02262950



200

Fig 4

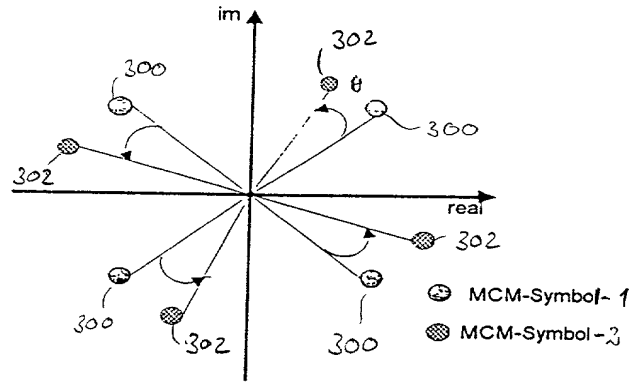

Fig. 5

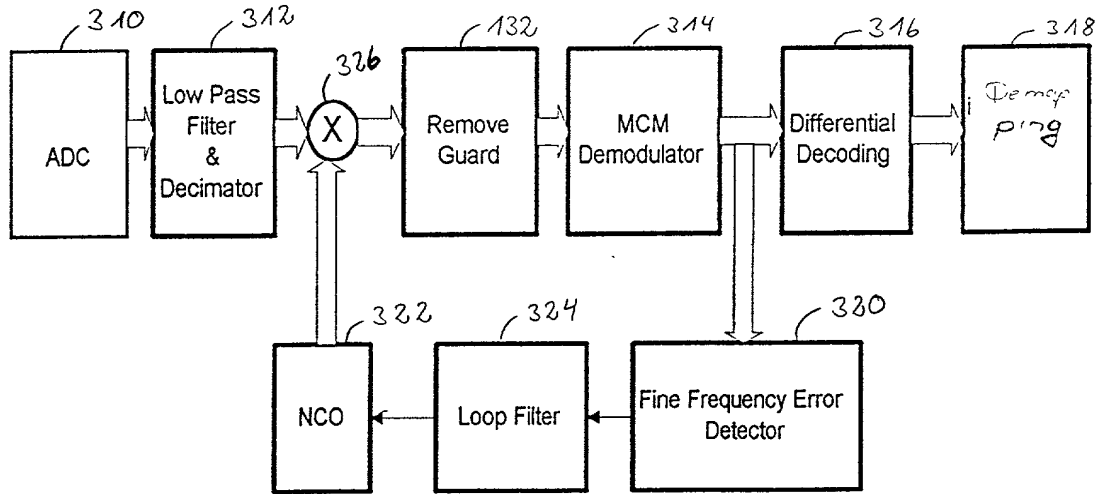

Fig. 6

005071 02E2960

006211 04227960

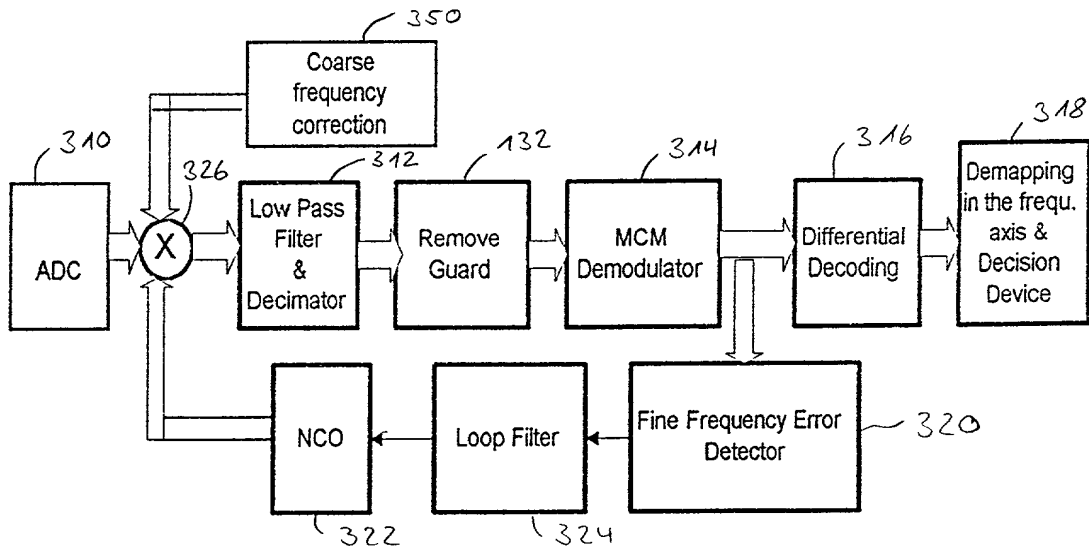
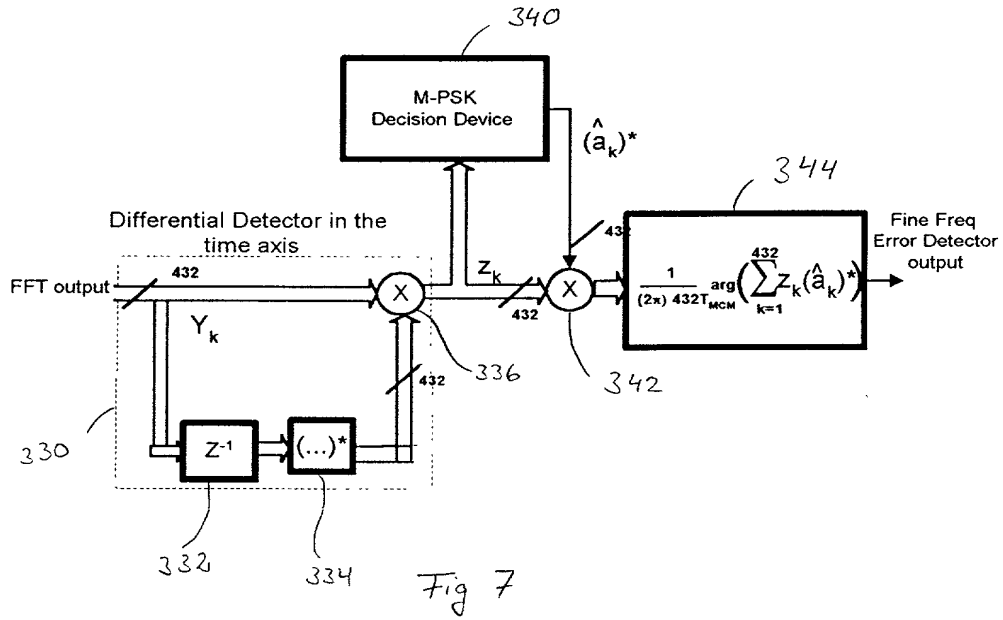

Fig. 8

00527 0222960

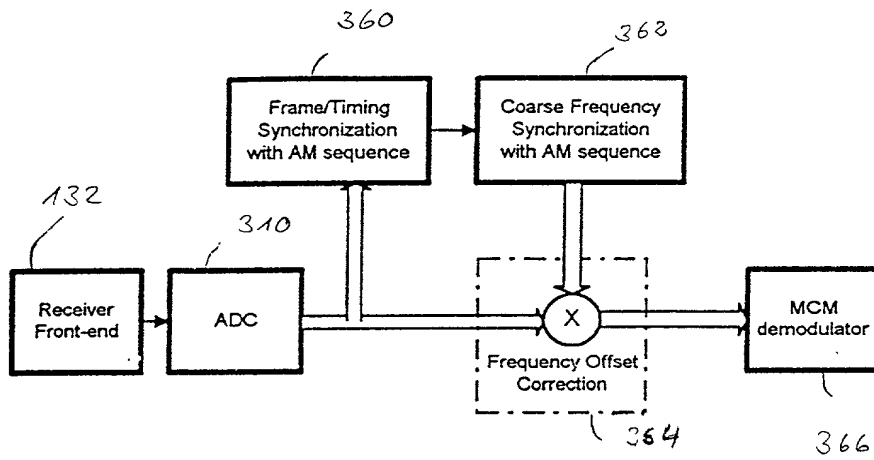

Fig. 9

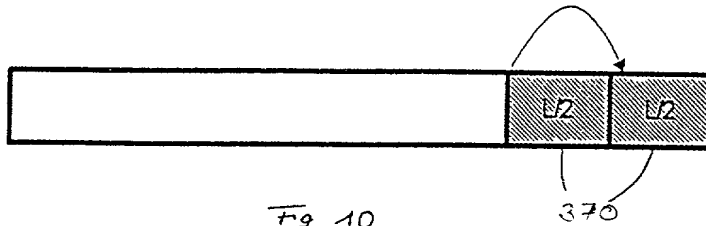

Fig 10

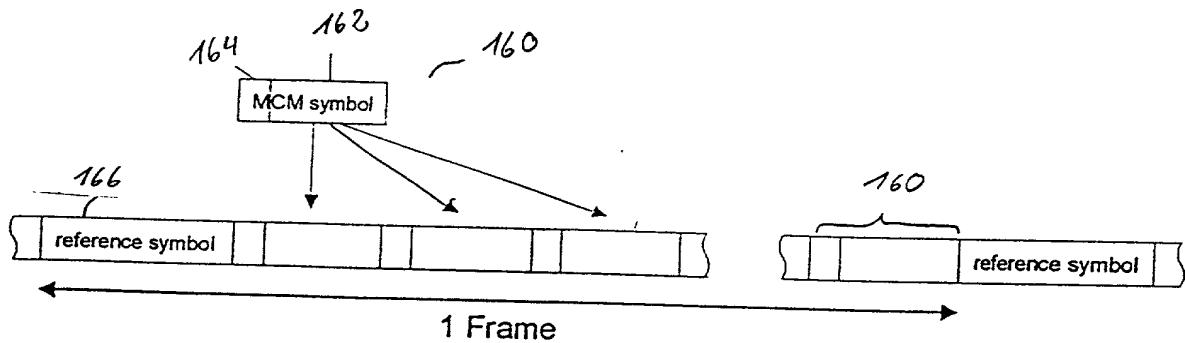

Fig. 11

006277-02E/960

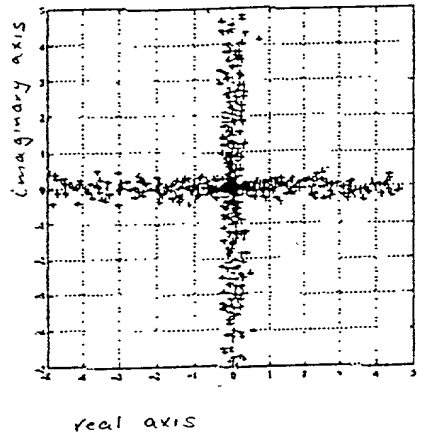
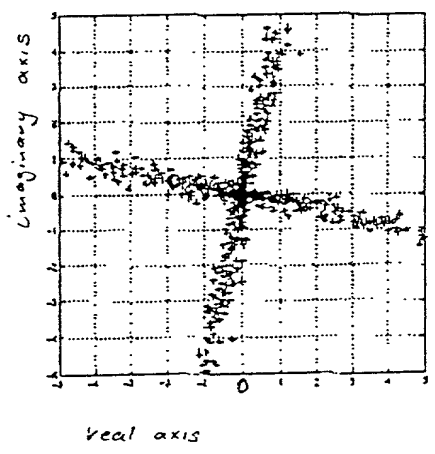

Fig. 12

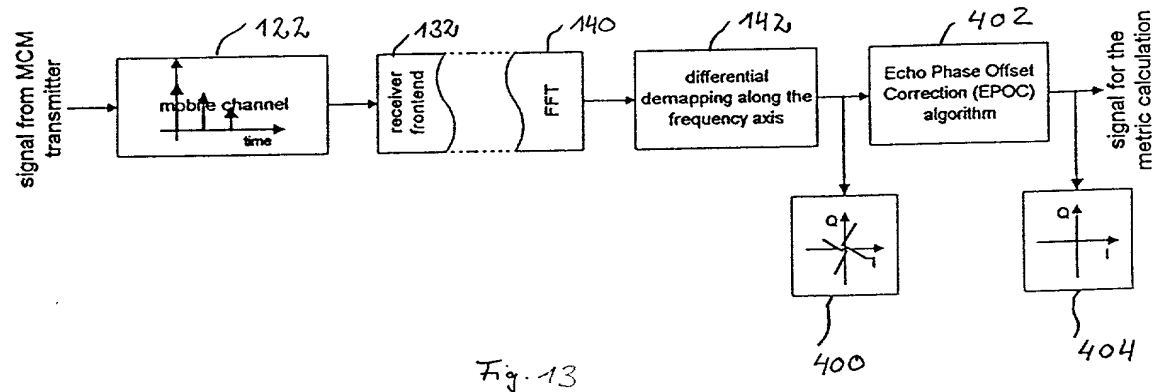

Fig. 13

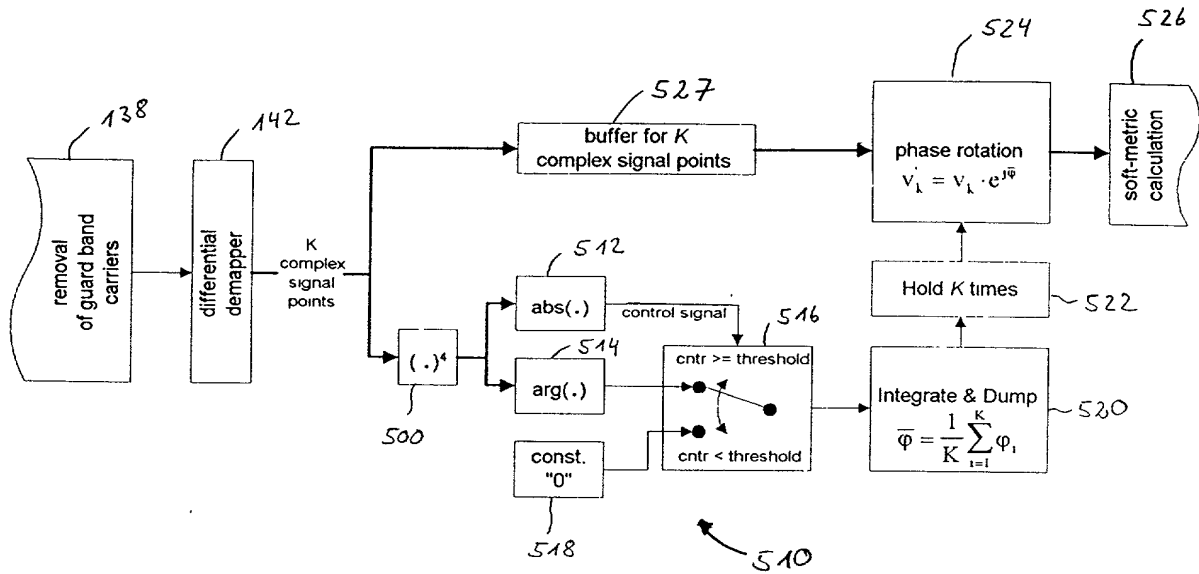

Fig 14

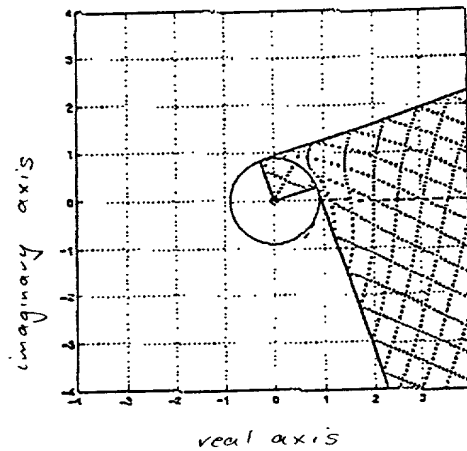
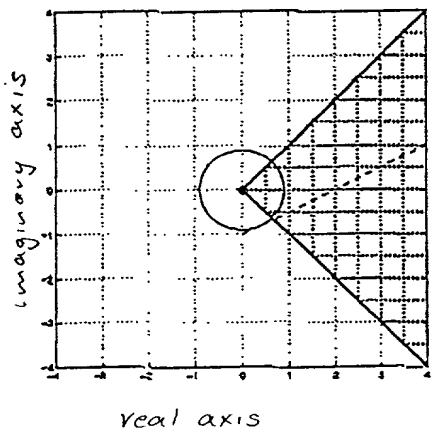

Fig 15

00527 06E/960

71980404 PLS

Please type a plus sign (+) inside this box →

PTO/SB/01 (12-97)
Approved for use through 9/30/00. OMB 0651-0032
Patent and Trademark Office; U.S. DEPARTMENT OF COMMERCE

Under the Paperwork Reduction Act of 1995, no persons are required to respond to a collection of information unless it contains a valid OMB control number.

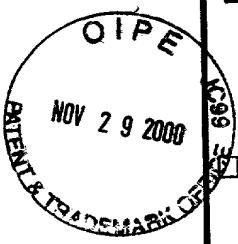

DECLARATION FOR UTILITY OR DESIGN PATENT APPLICATION (37 CFR 1.63) <input type="checkbox"/> Declaration Submitted with Initial Filing OR <input checked="" type="checkbox"/> Declaration Submitted after Initial Filing (surcharge (37 CFR 1.16 (e)) required)	Attorney Docket Number	41001
	First Named Inventor	Ernst Eberlein
	COMPLETE IF KNOWN	
	Application Number	/
	Filing Date	
	Group Art Unit	
	Examiner Name	

As a below named inventor, I hereby declare that:
My residence, post office address, and citizenship are as stated below next to my name.

I believe I am the original, first and sole inventor (if only one name is listed below) or an original, first and joint inventor (if plural names are listed below) of the subject matter which is claimed and for which a patent is sought on the invention entitled:

Method and Apparatus for Fine Frequency Synchronization in Multi-Carrier Demodulation Systems

the specification of which *(Title of the Invention)*
 is attached hereto OR
 was filed on (MM/DD/YYYY) **04/14/98** as United States Application Number or PCT International Application Number **PCT/EP98/02184** and was amended on (MM/DD/YYYY) (if applicable).

I hereby state that I have reviewed and understand the contents of the above identified specification, including the claims, as amended by any amendment specifically referred to above.

I acknowledge the duty to disclose information which is material to patentability as defined in 37 CFR 1.56.

I hereby claim foreign priority benefits under 35 U.S.C. 119(a)-(d) or 365(b) of any foreign application(s) for patent or inventor's certificate, or 365(a) of any PCT international application which designated at least one country other than the United States of America, listed below and have also identified below, by checking the box, any foreign application for patent or inventor's certificate, or of any PCT international application having a filing date before that of the application on which priority is claimed.

Prior Foreign Application Number(s)	Country	Foreign Filing Date (MM/DD/YYYY)	Priority Not Claimed	Certified Copy Attached?	
				YES	NO
			<input type="checkbox"/>	<input type="checkbox"/>	<input checked="" type="checkbox"/>
			<input type="checkbox"/>	<input type="checkbox"/>	<input checked="" type="checkbox"/>
			<input type="checkbox"/>	<input type="checkbox"/>	<input type="checkbox"/>
			<input type="checkbox"/>	<input type="checkbox"/>	<input type="checkbox"/>

Additional foreign application numbers are listed on a supplemental priority data sheet PTO/SB/02B attached hereto:
I hereby claim the benefit under 35 U.S.C. 119(e) of any United States provisional application(s) listed below.

Application Number(s)	Filing Date (MM/DD/YYYY)

Additional provisional application numbers are listed on a supplemental priority data sheet PTO/SB/02B attached hereto.

[Page 1 of 2]

Burden Hour Statement: This form is estimated to take 0.4 hours to complete. Time will vary depending upon the needs of the individual case. Any comments on the amount of time you are required to complete this form should be sent to the Chief Information Officer, Patent and Trademark Office, Washington, DC 20231. DO NOT SEND FEES OR COMPLETED FORMS TO THIS ADDRESS. SEND TO: Assistant Commissioner for Patents, Washington, DC 20231.

00673270 "119900

Please type a plus sign (+) inside this box →

PTO/SB/01 (12-97)
Approved for use through 9/30/00. OMB 0651-0032
Patent and Trademark Office; U.S. DEPARTMENT OF COMMERCE

Under the Paperwork Reduction Act of 1995, no persons are required to respond to a collection of information unless it contains a valid OMB control number.

DECLARATION — Utility or Design Patent Application

I hereby claim the benefit under 35 U.S.C. 120 of any United States application(s), or 365(c) of any PCT international application designating the United States of America, listed below and, insofar as the subject matter of each of the claims of this application is not disclosed in the prior United States or PCT International application in the manner provided by the first paragraph of 35 U.S.C. 112, I acknowledge the duty to disclose information which is material to patentability as defined in 37 CFR 1.56 which became available between the filing date of the prior application and the national or PCT international filing date of this application.

U.S. Parent Application or PCT Parent Number	Parent Filing Date (MM/DD/YYYY)	Parent Patent Number (if applicable)

Additional U.S. or PCT international application numbers are listed on a supplemental priority data sheet PTO/SB/02B attached hereto.

As a named inventor, I hereby appoint the following registered practitioner(s) to prosecute this application and to transact all business in the Patent and Trademark Office connected therewith: Customer Number OR Registered practitioner(s) name/registration number listed below

Place Customer Number Bar Code Label here

Name	Registration Number	Name	Registration Number
David S. Abrams	22,576	Stacey J. Longanecker	33,952
Robert H. Berdo	19,415	Joseph J. Bucznski	35,084
Alfred N. Goodman	26,458	Wayne C. Jaeschke, Jr.	38,503
Mark S. Bicks	28,770	Tara Laster Hoffman	P-46,510
John E. Holmes	29,392	Jeffrey J. Howell	46,402
Garrett V. Davis	32,023	Marcus R. Mickney	44,941
Lance G. Johnson	32,531	Christian C. Michel	46,300

Additional registered practitioner(s) named on supplemental Registered Practitioner Information sheet PTO/SB/02C attached hereto.

Direct all correspondence to: Customer Number OR Correspondence address below

Name	John E. Holmes					
Address	Roylance, Abrams, Berdo & Goodman, L.L.P.					
Address	1300 19th Street, N.W., Suite 600					
City	Washington	State	D.C.	ZIP	20036	
Country	USA	Telephone	(202)659-9076		Fax	(202)659-9344

I hereby declare that all statements made herein of my own knowledge are true and that all statements made on information and belief are believed to be true; and further that these statements were made with the knowledge that willful false statements and the like so made are punishable by fine or imprisonment, or both, under 18 U.S.C. 1001 and that such willful false statements may jeopardize the validity of the application or any patent issued thereon.

Name of Sole or First Inventor: A petition has been filed for this unsigned inventor

Given Name (first and middle (if any))			Family Name or Surname				
Ernst			Eberlein				
Inventor's Signature					Date		
Residence: City	Grossenseebach	State		Country	Germany	Citizenship	German
Post Office Address	Waldstrasse 28 b						
Post Office Address							
City	Grossenseebach	State		ZIP	D-91091	Country	Germany

Additional inventors are being named on the _____ supplemental Additional Inventor(s) sheet(s) PTO/SB/02A attached hereto

0651-0032-9000

Please type a plus sign (+) inside this box →

PTO/SB/02A (3-97)
 Approved for use through 9/30/98. OMB 0651-0032
 Patent and Trademark Office; U.S. DEPARTMENT OF COMMERCE

Under the Paperwork Reduction Act of 1995, no persons are required to respond to a collection of information unless it contains a valid OMB control number.

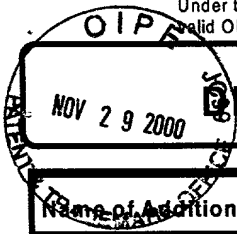

DECLARATION

ADDITIONAL INVENTOR(S)
 Supplemental Sheet
 Page 1 of 2

Name of Additional Joint Inventor, if any:		<input type="checkbox"/> A petition has been filed for this unsigned inventor					
Given Name (first and middle [if any])			Family Name or Surname				
Sabah			Badri				
Inventor's Signature					Date		
Residence: City	Erlangen	State		Country	Germany	Citizenship	Moroccan
Post Office Address	Sebaldustrasse 8						
Post Office Address							
City	Erlangen	State		ZIP	D-91058	Country	Germany
Name of Additional Joint Inventor, if any:		<input type="checkbox"/> A petition has been filed for this unsigned inventor					
Given Name (first and middle [if any])			Family Name or Surname				
Stefan			Lipp				
Inventor's Signature					Date		
Residence: City	Erlangen	State		Country	Germany	Citizenship	German
Post Office Address	Steinweg 9 a						
Post Office Address							
City	Erlangen	State		ZIP	D-91058	Country	Germany
Name of Additional Joint Inventor, if any:		<input type="checkbox"/> A petition has been filed for this unsigned inventor					
Given Name (first and middle [if any])			Family Name or Surname				
Stephan			Buchholz				
Inventor's Signature	<i>Stephan Buchholz</i>				Date	11/20/00	
Residence: City	Muenchen	State		Country	Germany	Citizenship	German
Post Office Address	Kerschbacher Strasse 8						
Post Office Address							
City	Muenchen	State		ZIP	D-81447	Country	Germany

Burden Hour Statement: This form is estimated to take 0.4 hours to complete. Time will vary depending upon the needs of the individual case. Any comments on the amount of time you are required to complete this form should be sent to the Chief Information Officer, Patent and Trademark Office, Washington, DC 20231. DO NOT SEND FEES OR COMPLETED FORMS TO THIS ADDRESS. SEND TO: Assistant Commissioner for Patents, Washington, DC 20231.

006217 0252/980

Please type a plus sign (+) inside this box →

PTO/SB/02A (3-97)
 Approved for use through 9/30/98. OMB 0651-0032
 Patent and Trademark Office; U.S. DEPARTMENT OF COMMERCE

Under the Paperwork Reduction Act of 1995, no persons are required to respond to a collection of information unless it contains a valid OMB control number.

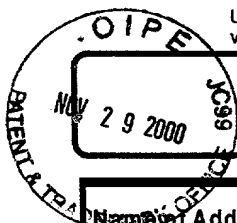

DECLARATION	ADDITIONAL INVENTOR(S) Supplemental Sheet Page <u>2</u> of <u>2</u>
--------------------	---

Name of Additional Joint Inventor, if any:		<input type="checkbox"/> A petition has been filed for this unsigned inventor					
Given Name (first and middle [if any])				Family Name or Surname			
Albert				Heuberger			
Inventor's Signature						Date	
Residence: City	Erlangen	State		Country	Germany	Citizenship	German
Post Office Address	Hausaeckerweg 18						
Post Office Address							
City	Erlangen	State		ZIP	D-91056	Country	Germany
Name of Additional Joint Inventor, if any:		<input type="checkbox"/> A petition has been filed for this unsigned inventor					
Given Name (first and middle [if any])				Family Name or Surname			
Heinz				Gerhaeuser			
Inventor's Signature						Date	
Residence: City	Waischenfeld	State		Country	Germany	Citizenship	German
Post Office Address	Saugendorf 17						
Post Office Address							
City	Waischenfeld	State		ZIP	D-91344	Country	Germany
Name of Additional Joint Inventor, if any:		<input type="checkbox"/> A petition has been filed for this unsigned inventor					
Given Name (first and middle [if any])				Family Name or Surname			
Inventor's Signature						Date	
Residence: City		State		Country		Citizenship	
Post Office Address							
Post Office Address							
City		State		ZIP		Country	

006017 0202/980

Burden Hour Statement: This form is estimated to take 0.4 hours to complete. Time will vary depending upon the needs of the individual case. Any comments on the amount of time you are required to complete this form should be sent to the Chief Information Officer, Patent and Trademark Office, Washington, DC 20231. DO NOT SEND FEES OR COMPLETED FORMS TO THIS ADDRESS. SEND TO: Assistant Commissioner for Patents, Washington, DC 20231.

74380404 PUS

Please type a plus sign (+) inside this box →

PTO/SB/01 (12-97)

Approved for use through 9/30/00. OMB 0651-0032
Patent and Trademark Office; U.S. DEPARTMENT OF COMMERCE

Under the Paperwork Reduction Act of 1995, no persons are required to respond to a collection of information unless it contains a valid OMB control number.

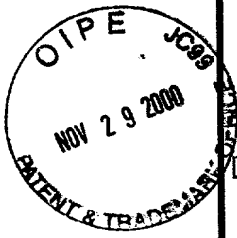

DECLARATION FOR UTILITY OR DESIGN PATENT APPLICATION (37 CFR 1.63)

Attorney Docket Number	41001
First Named Inventor	Ernst Eberlein
COMPLETE IF KNOWN	
Application Number	/
Filing Date	
Group Art Unit	
Examiner Name	

Declaration Submitted with Initial Filing OR Declaration Submitted after Initial Filing (surcharge (37 CFR 1.16 (e)) required)

As a below named inventor, I hereby declare that:

My residence, post office address, and citizenship are as stated below next to my name.

I believe I am the original, first and sole inventor (if only one name is listed below) or an original, first and joint inventor (if plural names are listed below) of the subject matter which is claimed and for which a patent is sought on the invention entitled:

Method and Apparatus for Fine Frequency Synchronization in Multi-Carrier Demodulation Systems

the specification of which (Title of the Invention)

is attached hereto OR was filed on (MM/DD/YYYY) **04/14/98** as United States Application Number or PCT International Application Number **PCT/EP98/02184** and was amended on (MM/DD/YYYY) (if applicable).

I hereby state that I have reviewed and understand the contents of the above identified specification, including the claims, as amended by any amendment specifically referred to above.

I acknowledge the duty to disclose information which is material to patentability as defined in 37 CFR 1.56.

I hereby claim foreign priority benefits under 35 U.S.C. 119(a)-(d) or 365(b) of any foreign application(s) for patent or inventor's certificate, or 365(a) of any PCT international application which designated at least one country other than the United States of America, listed below and have also identified below, by checking the box, any foreign application for patent or inventor's certificate, or of any PCT international application having a filing date before that of the application on which priority is claimed.

Prior Foreign Application Number(s)	Country	Foreign Filing Date (MM/DD/YYYY)	Priority Not Claimed	Certified Copy Attached?	
				YES	NO
			<input type="checkbox"/>	<input type="checkbox"/>	<input checked="" type="checkbox"/>
			<input type="checkbox"/>	<input type="checkbox"/>	<input checked="" type="checkbox"/>
			<input type="checkbox"/>	<input type="checkbox"/>	<input type="checkbox"/>
			<input type="checkbox"/>	<input type="checkbox"/>	<input type="checkbox"/>

Additional foreign application numbers are listed on a supplemental priority data sheet PTO/SB/02B attached hereto:
I hereby claim the benefit under 35 U.S.C. 119(e) of any United States provisional application(s) listed below.

Application Number(s)	Filing Date (MM/DD/YYYY)

Additional provisional application numbers are listed on a supplemental priority data sheet PTO/SB/02B attached hereto.

Burden Hour Statement: This form is estimated to take 0.4 hours to complete. Time will vary depending upon the needs of the individual case. Any comments on the amount of time you are required to complete this form should be sent to the Chief Information Officer, Patent and Trademark Office, Washington, DC 20231. DO NOT SEND FEES OR COMPLETED FORMS TO THIS ADDRESS. SEND TO: Assistant Commissioner for Patents, Washington, DC 20231.

005677 0425/950

Please type a plus sign (+) inside this box →

PTO/SB/02A (3-97)
 Approved for use through 9/30/98. OMB 0651-0032
 Patent and Trademark Office; U.S. DEPARTMENT OF COMMERCE

Under the Paperwork Reduction Act of 1995, no persons are required to respond to a collection of information unless it contains a valid OMB control number.

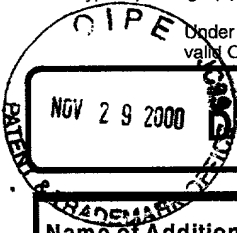

DECLARATION **ADDITIONAL INVENTOR(S)**
 Supplemental Sheet
 Page 2 of 2

05672270 112500
 500
 600

Name of Additional Joint Inventor, if any:		<input type="checkbox"/> A petition has been filed for this unsigned inventor					
Given Name (first and middle [if any])			Family Name or Surname				
Albert			Heuberger				
Inventor's Signature					Date	11/21/00	
Residence: City	Erlangen	State		Country	Germany	Citizenship	German
Post Office Address	Hausaeckerweg 18						
Post Office Address							
City	Erlangen	State		ZIP	D-91056	Country	Germany
Name of Additional Joint Inventor, if any:		<input type="checkbox"/> A petition has been filed for this unsigned inventor					
Given Name (first and middle [if any])			Family Name or Surname				
Heinz			Gerhaeuser				
Inventor's Signature					Date	11/21/00	
Residence: City	Waischenfeld	State		Country	Germany	Citizenship	German
Post Office Address	Saugendorf 17						
Post Office Address							
City	Waischenfeld	State		ZIP	D-91344	Country	Germany
Name of Additional Joint Inventor, if any:		<input type="checkbox"/> A petition has been filed for this unsigned inventor					
Given Name (first and middle [if any])			Family Name or Surname				
Inventor's Signature					Date		
Residence: City		State		Country		Citizenship	
Post Office Address							
Post Office Address							
City		State		ZIP		Country	

Burden Hour Statement: This form is estimated to take 0.4 hours to complete. Time will vary depending upon the needs of the individual case. Any comments on the amount of time you are required to complete this form should be sent to the Chief Information Officer, Patent and Trademark Office, Washington, DC 20231. DO NOT SEND FEES OR COMPLETED FORMS TO THIS ADDRESS. SEND TO: Assistant Commissioner for Patents, Washington, DC 20231.

Please type a plus sign (+) inside this box →

PTO/SB/02A (3-97)
 Approved for use through 9/30/98. OMB 0651-0032
 Patent and Trademark Office; U.S. DEPARTMENT OF COMMERCE

Under the Paperwork Reduction Act of 1995, no persons are required to respond to a collection of information unless it contains a valid OMB control number.

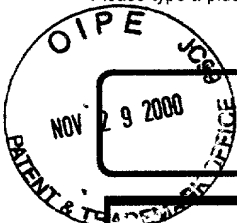

DECLARATION	ADDITIONAL INVENTOR(S) Supplemental Sheet Page <u>1</u> of <u>2</u>
--------------------	---

OBJECT "02EE2960"
 200
 300
 400

Name of Additional Joint Inventor, if any:		<input type="checkbox"/> A petition has been filed for this unsigned inventor					
Given Name (first and middle [if any])				Family Name or Surname			
<u>Sabah</u>				<u>Badri</u>			
Inventor's Signature	<u>S. Badri</u>					Date	11/22/00
Residence: City	<u>Erlangen</u>	State		Country	Germany	Citizenship	Moroccan
Post Office Address	<u>Sebaldusstrasse 8</u>						
Post Office Address							
City	<u>Erlangen</u>	State		ZIP	<u>D-91058</u>	Country	Germany
Name of Additional Joint Inventor, if any:		<input type="checkbox"/> A petition has been filed for this unsigned inventor					
Given Name (first and middle [if any])				Family Name or Surname			
<u>Stefan</u>				<u>Lipp</u>			
Inventor's Signature	<u>S. Lipp</u>					Date	11/22/00
Residence: City	<u>Erlangen</u>	State		Country	Germany	Citizenship	German
Post Office Address	<u>Steinweg 9 a</u>						
Post Office Address							
City	<u>Erlangen</u>	State		ZIP	<u>D-91058</u>	Country	Germany
Name of Additional Joint Inventor, if any:		<input type="checkbox"/> A petition has been filed for this unsigned inventor					
Given Name (first and middle [if any])				Family Name or Surname			
<u>Stephan</u>				<u>Buehholz</u>			
Inventor's Signature	<u>S. Buehholz</u>					Date	
Residence: City	<u>Muenchen</u>	State		Country	Germany	Citizenship	German
Post Office Address	<u>Kerschbacher Strasse 8</u>						
Post Office Address							
City	<u>Muenchen</u>	State		ZIP	<u>D-81447</u>	Country	Germany

Burden Hour Statement: This form is estimated to take 0.4 hours to complete. Time will vary depending upon the needs of the individual case. Any comments on the amount of time you are required to complete this form should be sent to the Chief Information Officer, Patent and Trademark Office, Washington, DC 20231. DO NOT SEND FEES OR COMPLETED FORMS TO THIS ADDRESS. SEND TO: Assistant Commissioner for Patents, Washington, DC 20231.

Please type a plus sign (+) inside this box →

PTO/SB/01 (12-97)
Approved for use through 9/30/00. OMB 0651-0032
Patent and Trademark Office; U.S. DEPARTMENT OF COMMERCE

Under the Paperwork Reduction Act of 1995, no persons are required to respond to a collection of information unless it contains a valid OMB control number.

DECLARATION — Utility or Design Patent Application

I hereby claim the benefit under 35 U.S.C. 120 of any United States application(s), or 365(c) of any PCT international application designating the United States of America, listed below and, insofar as the subject matter of each of the claims of this application is not disclosed in the prior United States or PCT International application in the manner provided by the first paragraph of 35 U.S.C. 112, I acknowledge the duty to disclose information which is material to patentability as defined in 37 CFR 1.56 which became available between the filing date of the prior application and the national or PCT international filing date of this application.

U.S. Parent Application or PCT Parent Number	Parent Filing Date (MM/DD/YYYY)	Parent Patent Number (if applicable)

Additional U.S. or PCT international application numbers are listed on a supplemental priority data sheet PTO/SB/02B attached hereto.

As a named inventor, I hereby appoint the following registered practitioner(s) to prosecute this application and to transact all business in the Patent and Trademark Office connected therewith:

Customer Number → Place Customer Number Bar Code Label here
OR
 Registered practitioner(s) name/registration number listed below

Name	Registration Number	Name	Registration Number
David S. Abrams	22,576	Stacey J. Longanecker	39,952
Robert H. Berdo	19,415	Joseph J. Buczvnski	35,084
Alfred N. Goodman	26,458	Wayne C. Jaeschke, Jr.	38,503
Mark S. Bicks	28,770	Tara Laster Hoffman	2,46,510
John E. Holmes	29,392	Jeffrey J. Howell	46,402
Garrett V. Davis	32,023	Marcus R. Mickney	44,941
Lance G. Johnson	32,531	Christian C. Michel	46,300

Additional registered practitioner(s) named on supplemental Registered Practitioner Information sheet PTO/SB/02C attached hereto.

Direct all correspondence to: Customer Number OR Correspondence address below

Name	John E. Holmes				
Address	Roylance, Abrams, Berdo & Goodman, L.L.P.				
Address	1300 19th Street, N.W., Suite 600				
City	Washington	State	D.C.	ZIP	20036
Country	USA	Telephone	(202)659-9076	Fax	(202)659-9344

I hereby declare that all statements made herein of my own knowledge are true and that all statements made on information and belief are believed to be true; and further that these statements were made with the knowledge that willful false statements and the like so made are punishable by fine or imprisonment, or both, under 18 U.S.C. 1001 and that such willful false statements may jeopardize the validity of the application or any patent issued thereon.

Name of Sole or First Inventor: A petition has been filed for this unsigned inventor

Given Name (first and middle [if any])	Family Name or Surname
Ernst	Eberlein

Inventor's Signature		Date	11/21/00
Residence: City	Grossenseebach <small>State</small>	Country	Germany
		Citizenship	German
Post Office Address	Waldstrasse 28 b		
Post Office Address			
City	Grossenseebach <small>State</small>	ZIP	D-91091
		Country	Germany

Additional inventors are being named on the _____ supplemental Additional Inventor(s) sheet(s) PTO/SB/02A attached hereto

OFFICE OF THE COMMISSIONER OF PATENTS AND TRADEMARKS

14

kw