



US007061997B1

(12) **United States Patent**  
Eberlein et al.

(10) **Patent No.:** US 7,061,997 B1  
(45) **Date of Patent:** Jun. 13, 2006

(54) **METHOD AND APPARATUS FOR FINE FREQUENCY SYNCHRONIZATION IN MULTI-CARRIER DEMODULATION SYSTEMS**

5,345,440 A \* 9/1994 Gledhill et al. .... 370/210

(Continued)

FOREIGN PATENT DOCUMENTS

(75) Inventors: **Ernst Eberlein**, Grossenseebach (DE); **Sabah Badri**, Erlangen (DE); **Stefan Lipp**, Erlangen (DE); **Stephan Buchholz**, Munich (DE); **Albert Heuberger**, Erlangen (DE); **Heinz Gerhaeuser**, Waischenfeld (DE)

EP 0822682 2/1998

(Continued)

OTHER PUBLICATIONS

(73) Assignee: **Fraunhofer-Gesellschaft zur Foerderung der angewandten Forschung e.V.**, Munich (DE)

Keller and Hanzo; "Orthogonal Frequency Division Multiplex Synchronisation Techniques for Wireless Local Area Networks", *IEEE International Symposium on Personal, Indoor and Mobile Radio Communications*, pp. 963-967 (Oct. 1996).

(\* ) Notice: Subject to any disclaimer, the term of this patent is extended or adjusted under 35 U.S.C. 154(b) by 0 days.

(Continued)

Primary Examiner—Stephen Chin  
Assistant Examiner—Cicely Ware

(21) Appl. No.: 09/673,270

(74) Attorney, Agent, or Firm—Roylance, Abrams, Berdo & Goodman, L.L.P.

(22) PCT Filed: Apr. 14, 1998

(86) PCT No.: PCT/EP98/02184

(57) **ABSTRACT**

§ 371 (c)(1),  
(2), (4) Date: Nov. 29, 2000

A method and an apparatus relating to a fine frequency synchronization compensating for a carrier frequency deviation from an oscillator frequency in a multi-carrier demodulation system of the type capable of carrying out a differential phase decoding of multi-carrier modulated signals, the signals comprising a plurality of symbols, each symbol being defined by phase differences between simultaneous carriers having different frequencies. A phase difference between phases of the same carrier in different symbols is determined. Thereafter, a frequency offset is determined by eliminating phase shift uncertainties related to the transmitted information from the phase difference making use of a M-PSK decision device. Finally, a feedback correction of the carrier frequency deviation is performed based on the determined frequency offset. Alternatively, an averaged frequency offset can be determined by averaging determined frequency offsets of a plurality of carriers. Then, the feedback correction of the frequency deviation is performed based on the averaged frequency offset.

(87) PCT Pub. No.: WO99/53667

PCT Pub. Date: Oct. 21, 1999

(51) **Int. Cl.**  
*H03D 3/22* (2006.01)  
*H01J 11/00* (2006.01)

(52) **U.S. Cl.** ..... 375/332; 370/210

(58) **Field of Classification Search** ..... 375/332, 375/200; 370/203, 200, 207, 480, 210  
See application file for complete search history.

(56) **References Cited**

U.S. PATENT DOCUMENTS

4,347,483 A \* 8/1982 Flaszka et al. .... 331/12  
5,267,273 A \* 11/1993 Dartois et al. .... 375/355

7 Claims, 13 Drawing Sheets

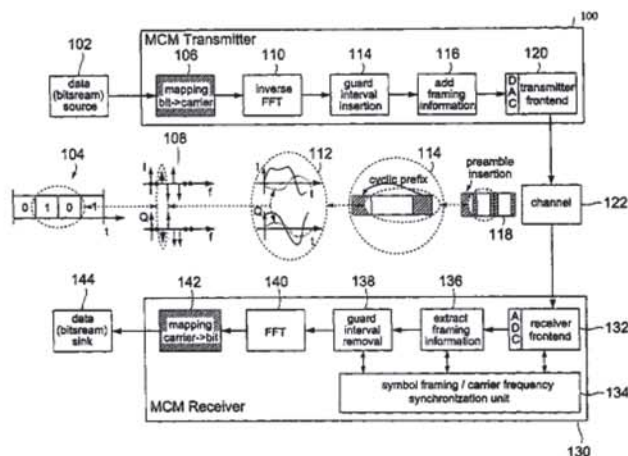

U.S. PATENT DOCUMENTS

5,694,389	A *	12/1997	Seki et al. ....	370/208
5,771,224	A	6/1998	Seki et al. ....	370/206
6,192,068	B1 *	2/2001	Fattouche et al. ....	375/130
6,219,333	B1 *	4/2001	Ahn .....	370/203
6,226,337	B1 *	5/2001	Klank et al. ....	375/367

FOREIGN PATENT DOCUMENTS

JP	8265293	10/1996
JP	1041991	2/1998
WO	9205646	4/1992
WO	9800946	1/1998

OTHER PUBLICATIONS

Moose, "A Technique for Orthogonal Frequency Division Multiplexing Frequency Offset Correction", *IEEE Transactions on Communications*, vol. 42, No. 10, pp. 2908-2914 (Oct. 1994).

Classen and Meyr, "Synchronization Algorithms for an OFDM System for Mobile Communication", *Condierung für Quelle, Kanal and Übertragung: ITG-Fachbericht*, pp. 105-114 (Oct. 1994).

Schmidl and Cox, "Low-Overhead, Low-Complexity [Burst] Synchronization for OFDM", *Proc. IEEE Int. Conf. on Commun.*, pp. 1301-1306 (1996).

Zou and Wu, "COFDM: An Overview", *IEEE Transactions on Broadcasting*, vol. 41, No. 1, pp. 1-8 (Mar. 1995).

Palacherla, "DSP- $\mu$ P Routine Computes Magnitude", *EDN Electrical Design News*, vol. 34, No. 22, pp. 225-226 (Oct. 1989).

Adams and Brady, "Magnitude Approximations for Micro-processor Implementation", *IEEE Micro*, vol. 3, No. 5, pp. 27-31 (Oct. 1983).

Luise and Regiannini, "Carrier Frequency Acquisition and Tracking for OFDM Systems", *IEEE Transactions on Communications*, vol. 44, No. 11, pp. 1590-1598 (Nov. 1996).

Tuisel and Kammeyer, "Carrier-Recovery for Multicarrier-Transmission Over Mobile Radio Channels", *Int. Conf. on Acoustics, Speech and Signal Processing (ICASSP 92)*, San Francisco, Band 4, pp. 677-680 (1992).

Moose, "Differentially Coded Multi-Frequency Modulation for Digital Communications", *Signal Processing V—Theories and Applications*, Proceedings of EUSIPCO-90 Fifth European Signal Processing Conference, Barcelona, Spain, vol. III, pp. 1807-1810 (Sep. 1990).

\* cited by examiner

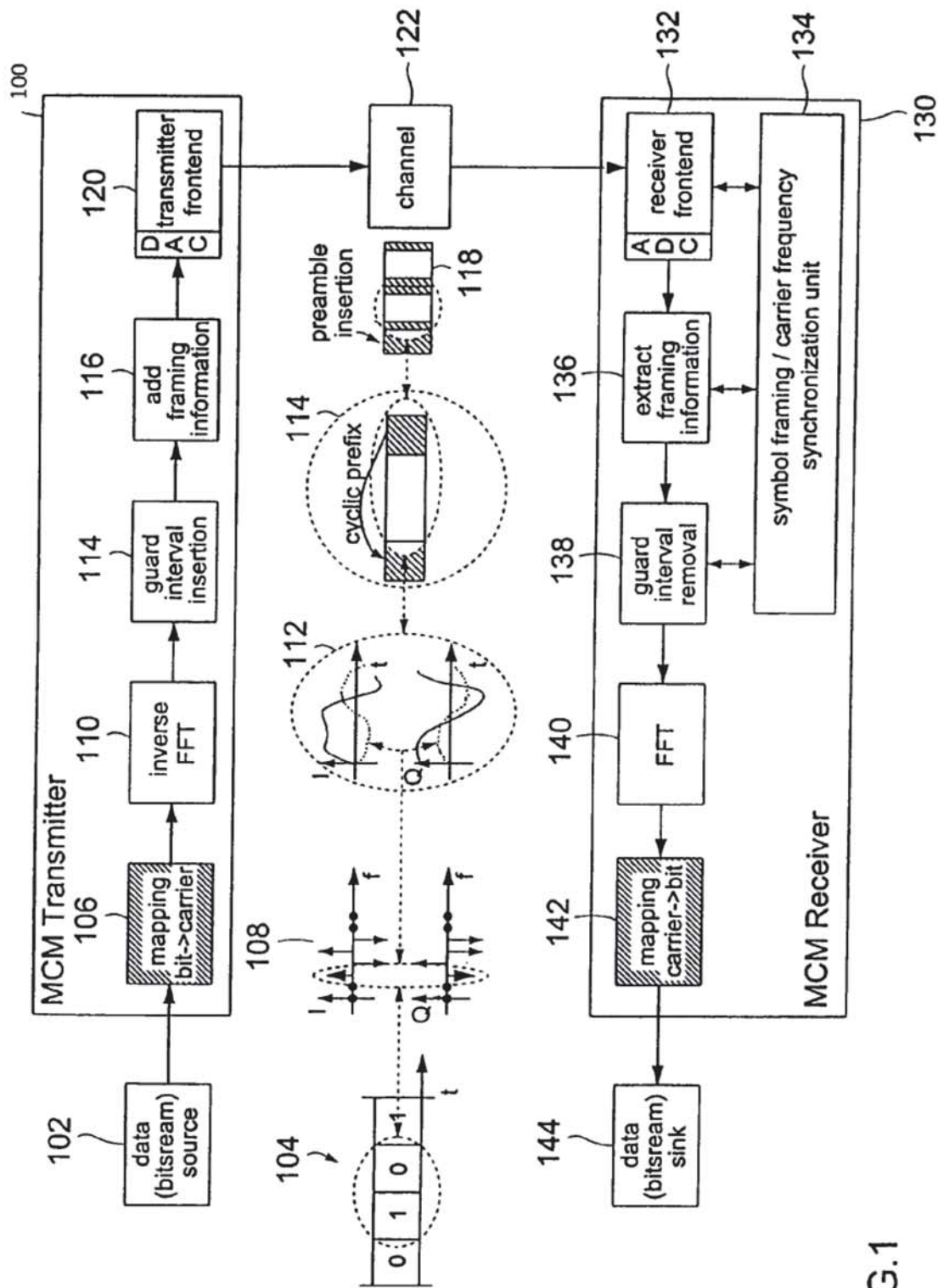

FIG.1

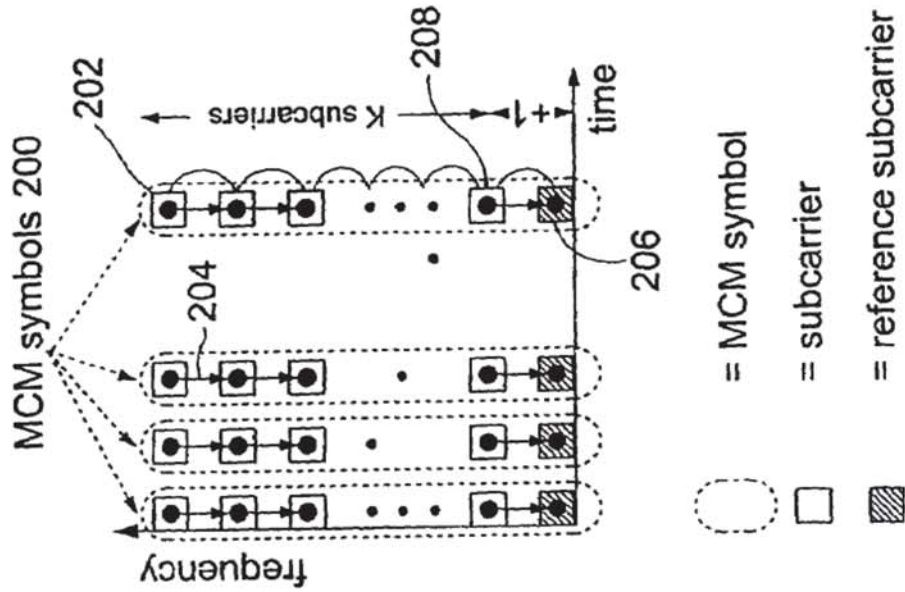

FIG. 2A

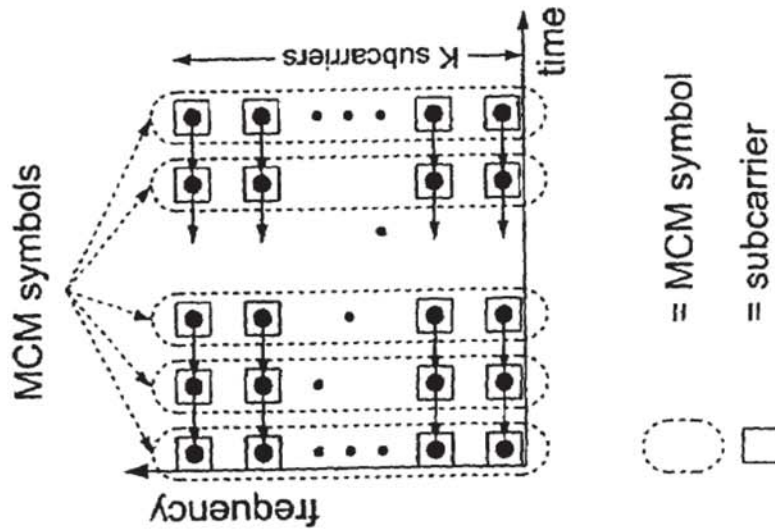

FIG. 2B

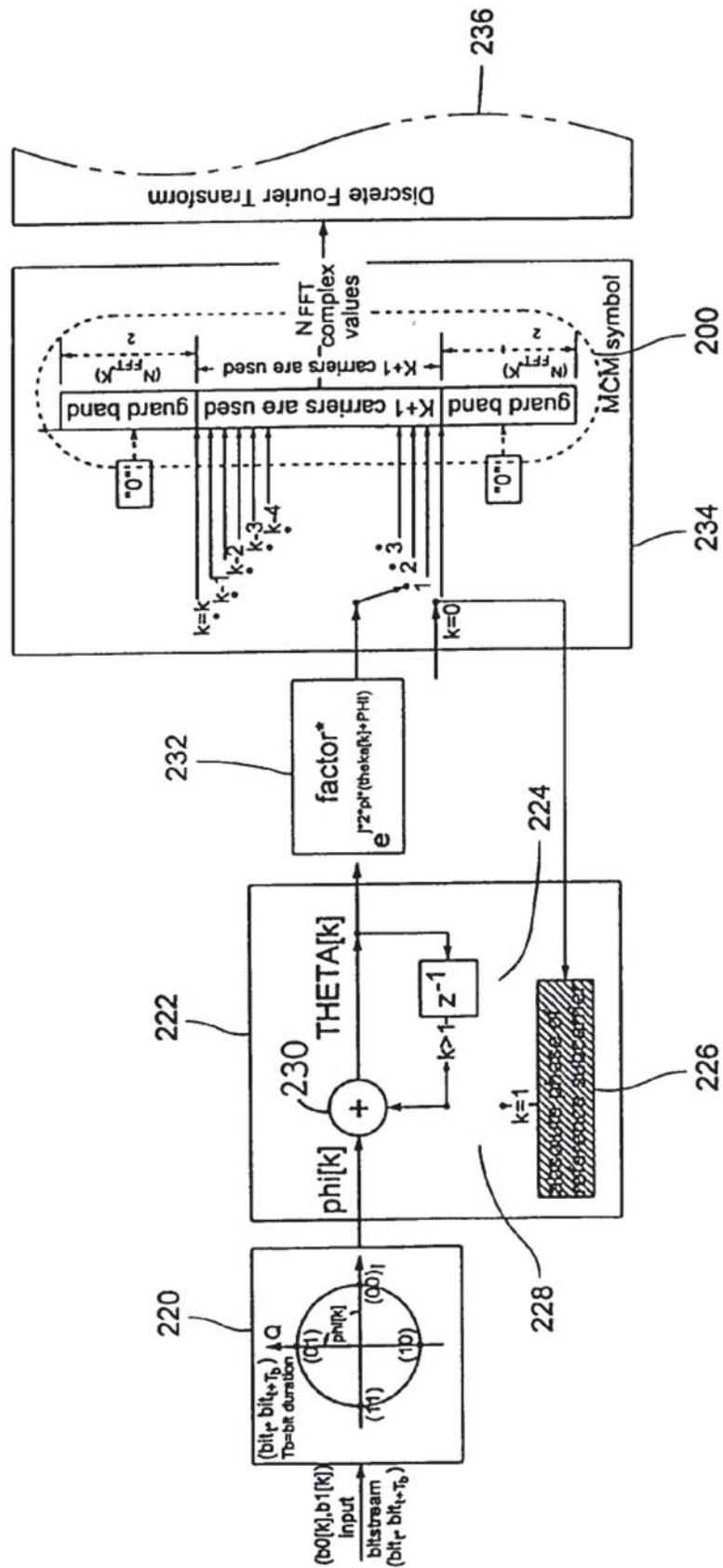

FIG.3

# Explore Litigation Insights

Docket Alarm provides insights to develop a more informed litigation strategy and the peace of mind of knowing you're on top of things.

## Real-Time Litigation Alerts



Keep your litigation team up-to-date with **real-time alerts** and advanced team management tools built for the enterprise, all while greatly reducing PACER spend.

Our comprehensive service means we can handle Federal, State, and Administrative courts across the country.

## Advanced Docket Research



With over 230 million records, Docket Alarm's cloud-native docket research platform finds what other services can't. Coverage includes Federal, State, plus PTAB, TTAB, ITC and NLRB decisions, all in one place.

Identify arguments that have been successful in the past with full text, pinpoint searching. Link to case law cited within any court document via Fastcase.

## Analytics At Your Fingertips



Learn what happened the last time a particular judge, opposing counsel or company faced cases similar to yours.

Advanced out-of-the-box PTAB and TTAB analytics are always at your fingertips.

## API

Docket Alarm offers a powerful API (application programming interface) to developers that want to integrate case filings into their apps.

## LAW FIRMS

Build custom dashboards for your attorneys and clients with live data direct from the court.

Automate many repetitive legal tasks like conflict checks, document management, and marketing.

## FINANCIAL INSTITUTIONS

Litigation and bankruptcy checks for companies and debtors.

## E-DISCOVERY AND LEGAL VENDORS

Sync your system to PACER to automate legal marketing.