

03/05/03  
J11002 U.S. PTO

Steven P. Shurtz  
312 321 4230  
E-mail SPShurtz@brinkshofer.com

10383219 . 030503  
03-07-03

BRINKS  
HOFER  
GILSON  
& LIONE

"Express Mail" mailing label number EL594 257 797 US  
Date of Deposit March 5, 2003

A PROFESSIONAL CORPORATION  
INTELLECTUAL PROPERTY ATTORNEYS

NBC TOWER - SUITE 3600  
455 N. CITYFRONT PLAZA DRIVE  
CHICAGO, ILLINOIS 60611-5599  
brinkshofer.com  
FAX 312-321-4299  
TELEPHONE 312-321-4200

March 5, 2003

SAN JOSE, CA  
INDIANAPOLIS, IN  
ANN ARBOR, MI  
ARLINGTON, VA

Attn: Box Patent Application  
Commissioner for Patents  
Washington, D.C. 20231

J11002 U.S. PTO  
10/383219  
03/05/03

Re: **STATOR ASSEMBLY MADE FROM A  
MOLDED WEB OF CORE SEGMENTS  
AND MOTOR USING SAME**  
Our Case No. 8864/33

Dear Sir:

Enclosed is a specification, including claims and drawings, for a patent application, filed via "Express Mail Post Office to Addressee" service to obtain a filing date pursuant to 37 C.F.R. §§ 1.10 and 1.53(b). The declaration and filing fee are not included at the present time.

Sincerely,

Steven P. Shurtz  
Reg. No. 31,424

SPS:sr  
Enclosures

"Express Mail" mailing label number EL 594 257 797 US

Date of Deposit: March 5, 2003

Our Case No. 8864/33

IN THE UNITED STATES PATENT AND TRADEMARK OFFICE  
APPLICATION FOR UNITED STATES LETTERS PATENT

INVENTOR: GRIFFITH D. NEAL

TITLE: STATOR ASSEMBLY MADE FROM A  
MOLDED WEB OF CORE  
SEGMENTS AND MOTOR USING  
SAME

ATTORNEYS: STEVEN P. SHURTZ  
REG. NO. 31,424  
BRINKS HOFER GILSON & LIONE  
P.O. BOX 10395  
CHICAGO, ILLINOIS 60610  
(312) 321-4200

-1-

## STATOR ASSEMBLY MADE FROM A MOLDED WEB OF CORE SEGMENTS AND MOTOR USING SAME

### REFERENCE TO EARLIER FILED APPLICATION

5           The present application is a continuation-in-part of Application Serial No. 09/798,511, filed March 2, 2001, and entitled Stator Assembly Made From A Plurality Of Toroidal Core Arc Segments And Motor Using Same, which is hereby incorporated by reference.

### FIELD OF THE INVENTION

10           The present invention relates generally to a stator assembly used in a dynamoelectric machine such as a motor or a generator. It relates particularly to a spindle motor such as used in a hard disc drive, and to the construction and arrangement of a stator assembly made from a plurality of arc segments.

### BACKGROUND OF THE INVENTION

15           Computers commonly use disc drives for memory storage purposes. Disc drives include a stack of one or more magnetic discs that rotate and are accessed using a head or read-write transducer. Typically, a high speed motor such as a spindle motor is used to rotate the discs.

20           In conventional spindle motors, stators have been made by laminating together stamped pieces of steel. These stamped pieces of steel are generally circular in nature, but also have "poles" extending either inwardly or outwardly, depending on whether the rotor is on the inside or surrounds the stator. The stamped pieces are laminated together and then coated with insulation. Wire is then wound around the poles to form stator windings.

25           An example of a conventional spindle motor 1 is shown in FIG. 1. The motor 1 includes a base 2 which is usually made from die cast aluminum, a stator 4, a shaft 6, bearings 7 and a disc support member 8, also referred to as a hub. A magnet 3 and flux return ring 5 are attached to the disc support member 8. The stator 4 is separated from the base 2 using an insulator (not shown) and attached to the base 2 using a glue. Distinct structures are  
30

-2-

5 formed in the base 2 and the disc support member 8 to accommodate the bearings 7. One end of the shaft 6 is inserted into the bearing 7 positioned in the base 2 and the other end of the shaft 6 is placed in the bearing 7 located in the hub 8. A separate electrical connector 9 may also be inserted into the base 2.

Each of these parts must be fixed at predefined tolerances with respect to one another. Accuracy in these tolerances can significantly enhance motor performance.

10 In operation, the disc stack is placed upon the hub. The stator windings are selectively energized and interact with the permanent magnet to cause a defined rotation of the hub. As hub 8 rotates, the head engages in reading or writing activities based upon instructions from the CPU in the computer.

15 Manufacturers of disc drives are constantly seeking to improve the speed with which data can be accessed. To an extent, this speed depends upon the efficiency of the spindle motor, as existing magneto-resistive head technology is capable of accessing data at a rate greater than the speed offered by the highest speed spindle motor currently in production. The efficiency of the spindle motor is dependent upon the dimensional consistency or tolerances between the various components of the motor. Greater  
20 dimensional consistency between components leads to a smaller gap between the stator 4 and the magnet 3, producing more force, which provides more torque and enables faster acceleration and higher rotational speeds.

25 The conventional method of forming stators has a number of drawbacks. First, most steel is manufactured in rolled sheets and thus has a grain orientation. The grain orientation has an effect on the magnetic flux properties of the steel. In circular stamped pieces of steel, the grain orientation differs at different points around the circle. Compared from the radius line of the circle, the grain orientation is sometimes aligned along the  
30 radius, sometimes transverse to it, and mostly at a varying angle to the radius. The un-aligned grain structure of conventional stators causes the magnetic



-3-

flux values to differ in parts of the stator, and thus the motor does not have consistent and uniform torque properties as it rotates.

Another drawback with using circular steel pieces is that, especially for inward facing poles, it has been difficult to wind the wire windings tightly because of the cramped space to work inside of the laminated stator core. The cramped working space creates a lower limit on the size of the stator and thus the motor. The limited working space also results in a low packing density of wire. The packing density of wire coiled around the poles affects the amount of power generated by the motor. Increasing packing density increases the power and thus the efficiency of the spindle motor.

An important factor in motor design is to reduce stack up tolerances in the motor. Stack up tolerances reduce the overall dimensional consistency between the components. Stack up tolerances refer to the sum of the variation of all the tolerances of all the parts, as well as the overall tolerance that relates to the alignment of the parts relative to one another. One source of stack up tolerances is from the circular stator body. Generally, the thickness of rolled steel is not uniform across the width of the roll. Sometimes the edges are thicker or thinner than the center. In a stator made from circular stamped pieces, the thicknesses of individual laminations are thus different from one side to the other. When stacked together, this creates a stack up tolerance problem. Furthermore, the circular stampings leave a lot of wasted steel that is removed and must be recycled or discarded.

Another important factor in motor design is the lowering of the operating temperature of the motor. Increased motor temperature affects the electrical efficiency of the motor and bearing life. As temperature increases, resistive losses in wire increase, thereby reducing total motor power. Furthermore, the Arrhenius equation predicts that the failure rate of an electrical device is exponentially related to its operating temperature. The frictional heat generated by bearings increases with speed. Also, as bearings get hot they expand, and the bearing cages get stressed and may deflect, causing non-uniform rotation, reducing bearing life. This non-uniform rotation causes a further problem of limiting the ability of the servo system controlling



stator cores and the non-uniform grain structure in the steel compared to the magnetic flux in the stator during operation of the motor.

Some of these problems have been addressed by motor manufacturing methods in which individual stator arc segments are made and wound with wire to form poles, and these segments are then assembled to form a complete stator. While this process allows for higher packing density, it has several drawbacks. Somehow the individual segments have to be assembled and held in place to form the stator. In addition, the individual wires of the different poles have to be connected together for the poles that are of the same phase. These numerous wires tend to get in the way during the assembly process, slowing down the manufacturing process.

U.S. Patent No. 6,049,153 to Nishiyama describes the use of crimping or welding to attach segments together. This process deforms the steel and reduces the level of magnetic flux produced by the laminations. The process also requires numerous wire interconnections when the poles are wound as discrete components, and it does not offer improvements in wire routing.

U.S. Patent No. 5,729,072 to Hirano describes the use of welding or an adhesive to hold the segments together. A disadvantage of this approach is that the stator poles must be handled as separate elements during stator construction. This requires complicated assembly equipment and a slow manufacturing process.

U.S. Patent No. 6,265,804 to Nitta describes the use of plastic insulation in combination with segmented stators. This approach does not improve on the problem of how to assemble and hold the individual segments in place, nor does it aid in connecting the various wires.

U.S. Patent No. 6,167,610 to Nakahara describes a method of making a rotary motor where a length of steel strip has thin portions between blocks of pole teeth. Wire is wound on the pole teeth while the steel strip is straight. Later the thin sections are bent to allow the poles to form a stator. One problem with this design is that when the thin portions are bent, the stress on the steel reduces the flux capacity of the connecting steel, forming the back iron. Also, the stamping of such a length of steel strip would be expensive

and result in large amount of scrap. Thus, a need exists for a method of making motors overcoming the aforementioned problems.

#### BRIEF SUMMARY OF THE INVENTION

5 A method of making stator assemblies has been invented which overcomes many of the foregoing problems. In addition, unique stator assemblies and other components of a motor have been invented. In one aspect, the invention is a stator assembly comprising a plurality of discrete stator segments each at least partially encased with a phase change material, wherein the phase change material also comprises a bridge between adjacent  
10 segments to link adjacent segments into a continuous strip; and the linked stator segments being arranged and secured together to form the stator assembly.

In a second aspect, the invention is a combination of stator arc segments and a flexible carrier used to link said stator arc segments during a winding operation comprising: a) a plurality of stator arc segments; and b) a phase change material constituting said flexible carrier adhered to the stator arc segments which links said segments in a uniform and predetermined position with respect to one another.  
15

In another aspect the invention is a method of making a stator assembly comprising: a) providing at least two stator arc segments linked together by a phase change material and each constituting a pole and having a first side surface and a second side surface; b) winding wire on the poles; c) aligning said stator arc segments to form a toroidal core, wherein each said side surface of one segment is in contact with an opposing side surface of  
20 another segment; and d) substantially encapsulating said toroidal core with a monolithic body of phase change material to form said stator assembly.  
25

In another aspect the invention is a method of making a stator assembly comprising: a) providing at least two stator arc segments linked together by a phase change material and each providing a pole and having a

-7-

5 first side surface and a second side surface; b) winding wire on each pole of each arc segment; c) aligning said stator arc segments to form a toroidal core, wherein each said side surface of one segment is in contact with an opposing side surface of another segment; and d) placing a retaining member on the exterior of the toroidal core to unitize the structure.

In yet another aspect, the invention is a series of discrete stator segments each substantially encapsulated with, and linked together by bridges made from, an injection molded thermoplastic material.

10 With the unique linked but discrete segment assemblies, wire can be wound around the poles with a high packing density, yet at the same time the segments can be maintained in their proper order so that one continuous piece of wire can be used to wind all poles in the same series or phase, making it unnecessary to later connect wires from individual windings to one another. The invention provides the foregoing and other features, and the advantages of the invention will become further apparent from the following detailed description of  
15 the presently preferred embodiments, read in conjunction with the accompanying drawings. The detailed description and drawings are merely illustrative of the invention and do not limit the scope of the invention, which is defined by the appended claims and equivalents thereof.

## 20 BRIEF DESCRIPTION OF SEVERAL VIEWS OF THE DRAWINGS

FIG. 1 is an exploded, partial cross-sectional and perspective view of a conventional prior art high speed motor.

25 FIG. 2 is perspective view of a stator arc segment being loaded into an injection mold prior to injecting a phase change material to make a limited series of stator arc segments of the present invention.

FIG. 3 is a perspective, partial cross-sectional view of an encapsulated stator arc segment of FIG. 2.

FIG. 4 is a perspective view of the encapsulated stator arc segment of FIG. 2.

30 FIG. 5 is a perspective view of a series of encapsulated stator arc segments of FIGS. 2-4 linked together by a thermoplastic webbing.

-8-

FIG. 6 is a perspective view of the series of stator arc segments of FIG. 5 during wire winding.

FIG. 7 is a perspective view of an injection molded stator assembly using the linked serial of webbed stator arc segments of FIG. 6.

5 FIG. 8a is a cross-sectional view of a toroidal core made from the linked series of stator arc segments after the wire winding shown in FIG. 5 in an injection mold assembly, prior to injecting a phase change material.

10 FIG. 8b is a cross-sectional view of the toroidal core of FIG. 8a in an injection mold assembly after injecting a phase change material, resulting in the stator assembly of FIG. 7.

FIG. 9 is an exploded, partial cross-sectional and perspective view of a motor using the encapsulated webbed stator of FIG. 7.

15 FIG. 10 is a perspective view of a stator assembly of a second embodiment of the present invention using a steel band to unitize the webbed stator arc segments.

#### DETAILED DESCRIPTION OF THE DRAWINGS AND PREFERRED EMBODIMENTS OF THE INVENTION

20 A preferred embodiment of a motor of the present invention and portions of the motor at different stages of manufacture are shown in FIGS. 2-7 and 9. The spindle motor 100 (FIG. 9) is designed for rotating a disc or stack of discs in a computer hard drive. Motor 100 is formed by using an injection molded stator assembly 40, that is formed by injection molding a plurality of stator arc segments 20 (FIG. 2) aligned to form a toroidal core 17 (FIG. 7). Although the embodiment described here uses individual arc segments, one of ordinary skill in the art will understand that groups of two, 25 three or any greater number of arc segments may be used. The preferred motor of the present invention may be smaller, has a grain structure that is more uniformly aligned, and allows for greater packing density of wire and reduces waste of steel in the manufacturing process, as compared with 30 conventional motors, thereby increasing power and reducing stack up

tolerances and manufacturing costs and producing other advantages discussed below.

Referring to FIG. 2, a stator arc segment 20 is first constructed, using steel laminations 11. The stator arc segment 20 is made of steel pieces that are stamped out of rolled steel. The stamped steel pieces are arc segments, but also have a pole 21 extending inwardly or outwardly depending on whether the rotor is inside or surrounds the stator. In the embodiment shown in FIG. 2, the pole 21 is shown extending inwardly. The stamped pieces are then coated with encapsulating material 22 which provides electrical insulation and laminates the pieces together to form a stator arc segment 20, and links other arc segments into a continuous strip via webbing 23.

The encapsulating material 22 is preferably formed of a phase change material, meaning a material that can be used in a liquid phase to envelope the stator, but which later changes to a solid phase. There are two types of phase change materials that will be most useful in practicing the invention: temperature activated and chemically activated. A temperature activated phase change material will become molten at a higher temperature, and then solidify at a lower temperature. However, in order to be practical, the phase change material must be molten at a temperature that is low enough that it can be used to encapsulate a toroidal core. Preferred phase change materials will be changed from a liquid to a solid in the range of about 200 °F to about 700 °F, more preferably in the range of about 550 °F to about 650 °F. The most preferred temperature activated phase change materials are thermoplastics. The preferred thermoplastic will become molten at a temperature at which it is injection-moldable, and then will be solid at normal operating temperatures for the motor. An example of a phase change material that changes phases due to a chemical reaction, and which could be used to form the body, is an epoxy. Other suitable phase change materials may be classified as thermosetting materials.

As shown in FIG. 2 the segments 20 can be placed in a multi-cavity mold 28 to increase productivity. In the preferred embodiment the individual laminations 11 making up the segments are not interconnected but loosely

-10-

stacked together before insertion into the mold 28. After the thermoplastic solidifies, the overmolded segments are ejected from their cavities. New laminations are inserted into the cavities and the process repeats. In the preferred embodiment, a continuous strip of segments is formed by linking the webbing from successive molding operation. This is done by designing the tool to insert a section of the plastic webbing of the outermost segment molded in the prior cycle with the new laminations to be molded. When the plastic encapsulates the new segments it can mechanically lock with or, depending upon design, re-melt, the webbing from the prior cycle, thus making a continuous strip, as shown in FIG. 5. The series has segments 20 with poles 21A, 21B and 21C arranged next to one another as they will be in the finished stator assembly.

The stator arc segments 20 are preferably molded into a continuous strip where the webbing acts as a carrier to link the segments together. In the preferred embodiment the encapsulating material 22 forms wire retaining flanges 24 to prevent wire from slipping off the pole. In a preferred embodiment, winding posts 25 as well as webbing 23 allow orientation of wire as it transfers across multiple poles.

By precisely aligning the stator arc segments 20, the webbing 23 can also be used to guide the wire between common phase poles, thus eliminating the need for interconnections commonly used on segmented stator motors. This greatly enhances the efficiency for winding wire 15 around the poles 21 and significantly reduces the cost.

The webbing can be deflected to allow the gap between adjoining poles to be increased as is shown in FIG. 6. This allows wire 15 to be wound around the poles 21 of the stator arc segments 20 using a fly winder 34 that has a set of needles 35. The wire 15 is wound around one pole 21 and is then wound around another pole 21 in its phase until all poles 21 in the same phase are wound with the same wire 15. Poles 21 in other phases are also similarly wound. Having only arc segments, rather than a full toroidal core, and spreading the spacing between the adjoining segments for needle 35 to





change material should have a CLTE that is intermediate the maximum and minimum CLTE of the toroidal core and other motor components where the body is in contact with those other components and they are made of a different material than the core. Also, the CLTE's of the body and toroidal core should match throughout the temperature range of the motor during its operation. An advantage of this method is that a more accurate tolerance may be achieved between the body and the components of the toroidal core because the CLTE of the body matches the CLTE of the toroidal core components more closely. Most often the toroidal core components will be metal, and most frequently steel and copper. Other motor parts are often made of aluminum and steel.

Most thermoplastic materials have a relatively high CLTE. Some thermoplastic materials may have a CLTE at low temperatures that is similar to the CLTE of metal. However, at higher temperatures the CLTE does not match that of the metal. A preferred thermoplastic material will have a CLTE of less than  $2 \times 10^{-5}$  in/in/°F, more preferably less than  $1.5 \times 10^{-5}$  in/in/°F, throughout the expected operating temperature of the motor, and preferably throughout the range of 0-250°F. Most preferably, the CLTE will be between about  $0.8 \times 10^{-5}$  in/in/°F and about  $1.2 \times 10^{-5}$  in/in/°F throughout the range of 0-250°F. (When the measured CLTE of a material depends on the direction of measurement, the relevant CLTE for purposes of defining the present invention is the CLTE in the direction in which the CLTE is lowest. However, if a material has a rate of expansion in one direction that is more than five times greater than the expansion rate in one of the other directions, then the CLTE for purposes of defining the present invention is average of the CLTEs in each of the three X, Y and Z directions.

The CLTE of common solid parts used in a motor are as follows:

	<u>23°C</u>	<u>250°F</u>
Steel	0.5	0.8 (x10 <sup>-5</sup> in/in/°F)
Aluminum	0.8	1.4
Ceramic	0.3	0.4





retract as shown in FIG. 8b, and the phase change material fills in the area vacated as the pins retract. The phase change material is then allowed to cool and solidify into a monolithic body 42 that substantially encapsulates the toroidal core 17. The preferred thickness of the body 42 depends on the aspect ratio of the toroidal core 17. Preferably the injection molding operation is controlled in the manner described in U.S. Patent Application Serial No. 09/983,002, filed October 17, 2001, which is hereby incorporated by reference in its entirety.

The injection molded stator assembly 40 is then used to construct the rest of the motor 100 (FIG. 9). The motor 100 includes a hub 108, which serves as a disc support member, the stator assembly 40, a base 102, a shaft 106 and bearings 107.

As shown in FIG. 9, a shaft 106 is connected to the hub or disc support member 108 and is surrounded by bearings 107, which are adjacent against the base 102 of the motor. A rotor or magnet 103 is fixed to the inside of the hub 108 on a flange so as to be in operable proximity to the stator assembly. The magnet 103 is preferably a permanent magnet, as described below.

Referring to FIG. 9, the bearings 107 include an upper bearing 46 and a lower bearing 48. Also, each bearing 107 has an outer surface 50 and an inner surface 52. The outer surface 50 of the upper bearing 46 contacts the hub 108 and the outer surface 50 of the lower bearing 48 contacts the support base 102. The inner surfaces 52 of the bearings 46 and 48 contact the shaft 106. The bearings are preferably annular shaped. The inner surfaces 52 of the bearings 107 may be press fit onto the shaft 106. A glue may also be used. The outer surface 50 of the bearings 107 may be press fit into the interior portion of the base 102. A glue may also be used. The bearings in the embodiment shown in FIG. 9 are ball bearings. Alternatively other types of bearings, such as hydrodynamic or combinations of hydrodynamic and magnetic bearings, may be used. The bearings are typically made of stainless steel.

The shaft 106 is concentrically disposed within the interior portion of the stator assembly 40 and the base 102. The bearings 107 surround

portions of the shaft 106. As described above, the inner surfaces 52 of the bearings are in contact with the shaft 106. The shaft 106 includes a top portion and a bottom portion. The top portion of the shaft 106 is fixed to the hub 108. The bottom portion of the shaft 106 is free to rotate inside the lower bearing. Thus, in this embodiment, the shaft 106 is freely rotatable relative to the base 102. The shaft 106 is preferably cylindrical shaped. The shaft 106 may be made of stainless steel.

5

Referring to FIG. 9, the hub 108 is concentrically disposed around the stator assembly 40 and the base 102. The hub 108 is fixed to the shaft 106 and is spaced apart from the stator assembly 40 and the base 102. The hub 108 includes a flux return ring 105 and the magnet 103. The flux return ring 105 and magnet 103 are glued to the hub 108. As shown in FIG. 9, the magnet 103 concentrically surrounds the stator assembly 40. In this embodiment the magnet 103 and stator assembly 40 are generally coplanar when the motor 100 is assembled.

10

15

The magnet 103 is preferably a sintered part and is one solid piece. The magnet 103 is placed in a magnetizer which puts a plurality of discrete North and South poles onto the magnet 103, dependant on the number of poles 21 on the toroidal core 17. The flux return ring 105 is preferably made of a magnetic steel. The hub is preferably made of aluminum. Also, the hub may be made of a magnetic material to replace the flux return ring. Other motor designs using an encapsulated stator that can be made by the present invention are disclosed in U.S. Patent Application Serial No. 09/470,434, filed December 22, 1999, and U.S. Patent No. 6,501,616, both of which are incorporated herein by reference.

20

25

Although the embodiment described here uses encapsulation of the segments 20 used to form a stator assembly, one of ordinary skill in the art will understand that other methods of unitizing the structure may be used. One example, as shown in Fig. 10, is the use of a steel collar 200 to fixture the discrete stator segments 220, six of which are used in this embodiment. This process, commonly referred to as "hot banding," requires heating the steel collar 200 to a temperature above the stator temperature. Via thermal

30

expansion the collar grows larger than the toroidal core diameter so that it can be placed around the circumference of the core. As the collar cools, its diameter reduces, creating an interference force on the segments effectively unitizing the structure. The segments 220 are similar to stator segments 20, each encapsulated in a thermoplastic material 222 and having retaining flanges 224 and winding posts 225 for holding wire.

**Advantages of the Present invention**

An advantageous feature of the preferred embodiment is provided by the fact that the stator assembly 40 is formed from stator arc segments 20 that are aligned to form a toroidal core 17 and substantially encapsulated with a monolithic body 42 to form a stator assembly 40. Using stator arc segments 20 provides a more uniform grain structure to the toroidal core 17. The grain orientation of prior art circular stampings varies a great deal at different points around the circle. By using arc segments, a more uniform grain structure may be obtained. The grain orientation has an effect on the magnetic flux properties of the steel. By making all the arc segments have the same orientation compared to the grain structure of the steel from which they are stamped, the grain structure in the core is more uniform and the magnetic flux is more uniform and the motor 100 of the present invention has more consistent and uniform torque properties as it rotates. This also leads to greater motor efficiency and performance.

The ability to manipulate the webbing to separate the pole faces allows for a smaller slot gap than can be traditionally employed with needle wound motors. This reduction in slot gap can be used to reduce cogging torque as well as reduce wind noise and associated vibration. Additionally, the ability to wind each phase with a continuous strip of wire, as opposed to winding distinct poles and then connecting terminal ends of the windings as is presently done with other segmented stators, offers a compelling cost savings.

The preferred motor also has greater packing density of wire 15. In the disclosed embodiment of the invention, the toroidal core 17 is made of

sections, one for each pole 21. It should be understood that the disclosed method can use any number of stator arc segments 20 greater than at least two. With prior art circular stamped stators, there is a limitation of the spacing between each pole 21 to allow the needle 35 feeding the winding wire 15 to enter and exit the gap. Additionally, in traditional small motors (less than 1.5 inches outer diameter), it is difficult to wind three phases of wire concurrently. Furthermore, this geometry makes the process of applying uniform, evenly spaced turns difficult to achieve. With the present invention, since the faces of the poles can be separated, there is more room to work, and a needle 35 feeding the winding wire 15 can thus pack the windings more tightly. The webbing 23 allows easier packaging and transportation of the poles and also allows for the winding to be done more efficiently. Increasing the packing density of wire 15 increases the magnetic field, thereby providing more electromotive force and increased power to the motor 100.

The limited working space for winding wire 15 around the poles 21 in circular stamped stators limits the size of motors as well. Since the disclosed method allows for increased working room, smaller motors may be made with the present method compared to prior art methods. The use of flanges 24 and posts 25 molded onto the segments can be used to keep the wire organized around the perimeter of the assembly while it is being overmolded.

The disclosed spindle motor 100 minimizes stack up tolerances. Since in the present embodiment only single poles are being used, the laminations can be stamped from portions of the steel roll that has a more consistent thickness. Thus, the resulting stacked stator arc segment 20 will have reduced stack up tolerances. Reducing the stack up tolerances optimizes dimensional consistency and thereby enables higher rotational speeds with lower vibration induced runout. Furthermore, since arc segments are used instead of circular stampings, they can be more closely laid out when being stamped, reducing the amount of resulting scrap.

Further, in the prior art, to prevent a motor from seizing when it gets hot, larger than desired gaps between the magnet 3 and the stator assembly 4 were used so that when pieces expanded from being heated, the magnet



would not contact the stator. If the magnet contacted the stator, the contact would generate magnetic particulate which can damage the read/write heads in a hard disc drive incorporating the motor, and interfere with their ability to read or record data on the discs. Also, if the body has a CLTE greater than  
 5 that of the steel laminations in the stator, the gap has to be large enough so that the expansion of the body as the motor heats up does not cause the body to contact the rotating magnet (even though the steel laminations are not close to contacting the magnet). With the preferred embodiment of the present invention, with the CLTE of the body matching that of the steel  
 10 laminations, much smaller gaps, as low as 0.005 inches, and more preferably as low as 0.003 inches, can be utilized. As the body 42 expands, it only expands at the same rate as the laminations, and does not grow to the point that the body 42 diminishes the gap size to zero. Thus, the only gap that is needed is one sufficient for expansion of the steel laminations. These smaller  
 15 gaps make the motor 100 more efficient, as the electrical efficiency of the motor decreases with larger distances between the stator and the rotating magnet.

Through the use of the present embodiment, a particular plastic may be chosen for the body 42 that has properties of Rockwell hardness, flex  
 20 modulus, and elongation that are specifically designed to counteract the vibratory frequencies generated by the motor 100. Thus, the disclosed spindle motor 100 substantially reduces motor vibration. This reduced vibration allows information on a disc to be stored closer together, thereby enabling higher data density.

The preferred embodiment of the invention has numerous advantages compared to the prior art. The length of the connected segments of the present invention can be any length desired, and in fact can be hundreds of feet long and supplied from large rolls that are cut to length while making  
 25 motors. At the same time, the individual poles can be easily handled and oriented with respect to one another.  
 30

The encapsulating material 22 naturally provides insulation between the wire and the laminations, thus alleviating any concern that nicks in the

enamel coating on the wire can cause a short. The windings on poles that will be in phase do not need to be connected to one another in a second operation after the winding step, as a continuous length of wire for each phase is used. There is good heat transfer between the wire and the steel laminations, and hence to the external portion of the motor, so that it can be dissipated easily.

It is contemplated that numerous modifications may be made to the motor and method for making the motor of the present invention without departing from the spirit and scope of the invention as defined in the claims. For example, the arc segments 20 need not be formed of laminations. While the exemplary embodiment shown in the drawings has twelve stator arc segments 20, those skilled in the art will appreciate that the same method can be used to make stator assemblies with two stator arc segments or any number greater than two. While the segments 20 are encapsulated by injection molding the phase change material around the laminations 11, the segments 20 could be encased in other ways with a bridging material. Additional components such as enhancement magnets or flux shields can be encapsulated in the plastic 22 during the overmolding of the steel laminations 11. Furthermore, the body 42 can encapsulate more than just the toroidal core. The body 42 can also encapsulate or form the base 102 of the motor without departing from the scope of the invention. Accordingly, while the present invention has been described herein in relation to several embodiments, the foregoing disclosure is not intended or to be construed to limit the present invention or otherwise to exclude any such other embodiments, arrangements, variations, or modifications and equivalent arrangements. Rather, the present invention is limited only by the claims appended hereto and the equivalents thereof.

## CLAIMS

1. A stator assembly, comprising:
  - a) a plurality of discrete stator segments each at least partially encased with a phase change material, wherein the phase change material also comprises a bridge between adjacent segments to link adjacent segments into a continuous strip; and
  - b) the linked stator segments being arranged and secured together to form the stator assembly.
2. The stator assembly of claim 1 wherein the bridges produce such a continuous linkage between segments that the bridges may be used to orient and manipulate the segments during wire winding.
3. The stator assembly of claim 1 wherein wire having a packing density of greater than 80 percent is wound around the poles.
4. The stator assembly of claim 1 wherein the bridges between adjoining segments can be used to orient and position wire relative to the poles.
5. The stator assembly of claim 1 wherein the phase change material has a thermal conductivity of at least 0.4 watts/meter<sup>°K</sup> at 23°C.
6. The stator assembly of claim 1 wherein the discrete stator segments are each made from a plurality of steel laminations.
7. The stator assembly of claim 1 wherein the phase change material comprises polyamide.
8. The stator assembly of claim 1 wherein the stator segments are held in a torodial shape by a retaining member.
9. The stator assembly of claim 8 wherein the retaining member comprises a metal band.

-22-

10. The stator assembly of claim 1 wherein the stator segments are held in a toroidal shape by an overmolded thermoplastic material.

11. A method of making a stator assembly comprising:

5 a) providing at least two stator arc segments linked together by a phase change material and each constituting a pole and having a first side surface and a second side surface;

b) winding wire on the poles;

10 c) aligning said stator arc segments to form a toroidal core, wherein each said side surface of one segment is in contact with an opposing side surface of another segment; and

d) substantially encapsulating said toroidal core with a monolithic body of phase change material to form said stator assembly.

12. The method of claim 11 wherein the phase change material forming the monolithic body has a coefficient of thermal expansion of less than  $2 \times 10^{-5}$  in/in/°F throughout the range of 0-250°F.

13. The method of claim 11 wherein the phase change material forming the monolithic body has a coefficient of thermal expansion of less than  $1.5 \times 10^{-5}$  in/in/°F throughout the range of 0-250°F.

14. The method of claim 11 wherein the phase change material forming the monolithic body has a thermal conductivity of at least 0.4 watts/meter°K at 23°C.

15. The method of claim 11 wherein the phase change material is filled with about 30% or more boron nitride.

16. The method of claim 11 wherein the phase change material is filled with about 30% or more aluminum oxide.

17. The method of claim 11 wherein the phase change material linking adjoining segments has a length X, wherein X is the length of uncoiled wire necessary to align said stator arc segments to form said toroidal core.

-23-

18. The method of claim 11 wherein said phase change material is selected from the group consisting of thermoplastics and thermosetting materials.

5 19. The method of claim 11 wherein prior to said substantially encapsulating, said toroidal core is clamped in an injection mold cavity to maintain the toroidal shape.

20. The method of claim 11 wherein said step of substantially encapsulating the core is performed by injection molding said phase change material around said toroidal core.

10 21. A method of making a stator assembly comprising:  
a) providing at least two stator arc segments linked together by a phase change material and each providing a pole and having a first side surface and a second side surface;  
b) winding wire on each pole of each arc segment;  
15 c) aligning said stator arc segments to form a toroidal core, wherein each said side surface of one segment is in contact with an opposing side surface of another segment; and  
d) placing a retaining member on the exterior of the toroidal core to unitize the structure.

20 22. The stator assembly of claim 1 where the stator arc segments are at least partially encapsulated in the phase charge material.

23. The method of claim 21 where the retaining member comprises a metal band.

25 24. The method of claim 21 wherein each of said stator arc segments comprise a plurality of discrete steel laminations held together by the phase change material.

25. A motor made from the stator assembly of claim 1.



ABSTRACT OF THE DISCLOSURE

A plurality of stator arc segments 20 are linked together by a phase change material 22 enabling simplified winding and higher slot fill. Once wound this continuous structure can be formed into a toroidal core 17 for a stator assembly 40 used to make a motor 100. In a preferred embodiment, a monolithic body 42 of phase change material substantially encapsulates the conductors and holds the stator arc segments 20 in contact with each other in the toroidal core 17. Hard disc drives using the motor 100, and methods of constructing the motor 100 are also disclosed.

5

10

Patent Application for: STATOR ASSEMBLY MADE FROM A MOLDED WEB OF CORE SEGMENTS  
AND MOTOR USING SAME  
Inventor(s): Griffith D. Neal  
Attorney Docket No. and Serial No.8864/33

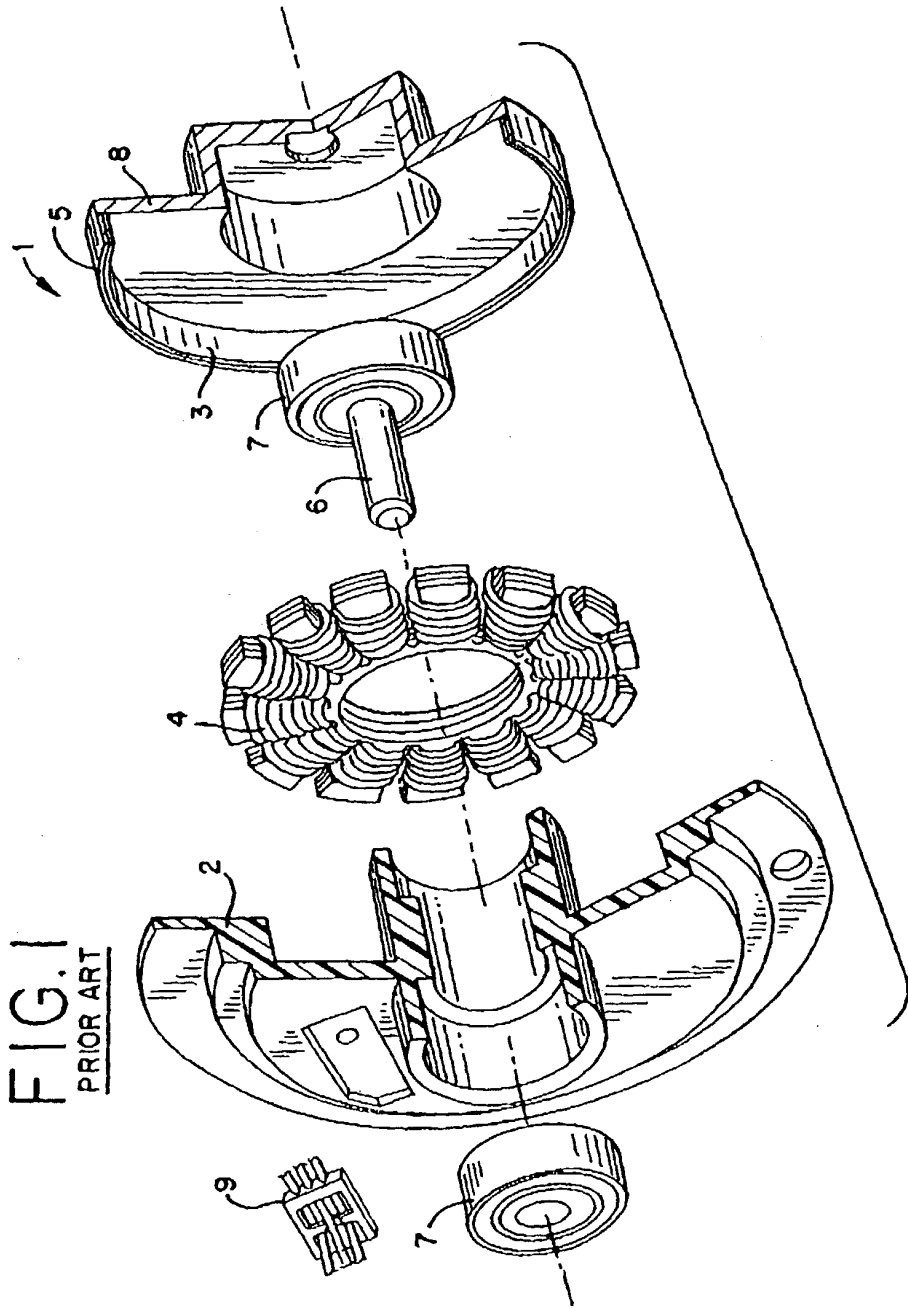



Patent Application for: STATOR ASSEMBLY MADE FROM A MOLDED WEB OF CORE SEGMENTS  
AND MOTOR USING SAME  
Inventor(s): Griffith D. Neal  
Attorney Docket No. and Serial No.8864/33

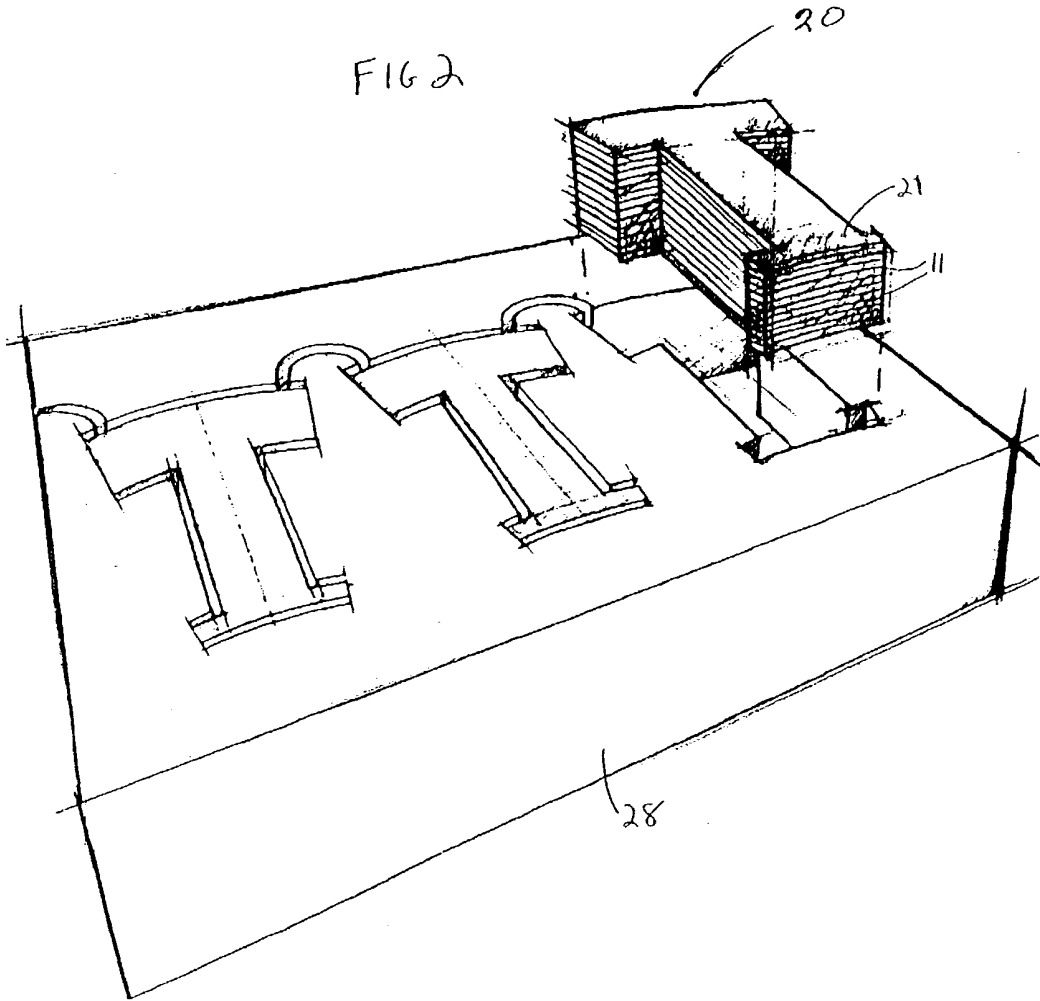

Patent Application for: STATOR ASSEMBLY MADE FROM A MOLDED WEB OF CORE SEGMENTS  
AND MOTOR USING SAME  
Inventor(s): Griffith D. Neal  
Attorney Docket No. and Serial No.8864/33

FIG 3

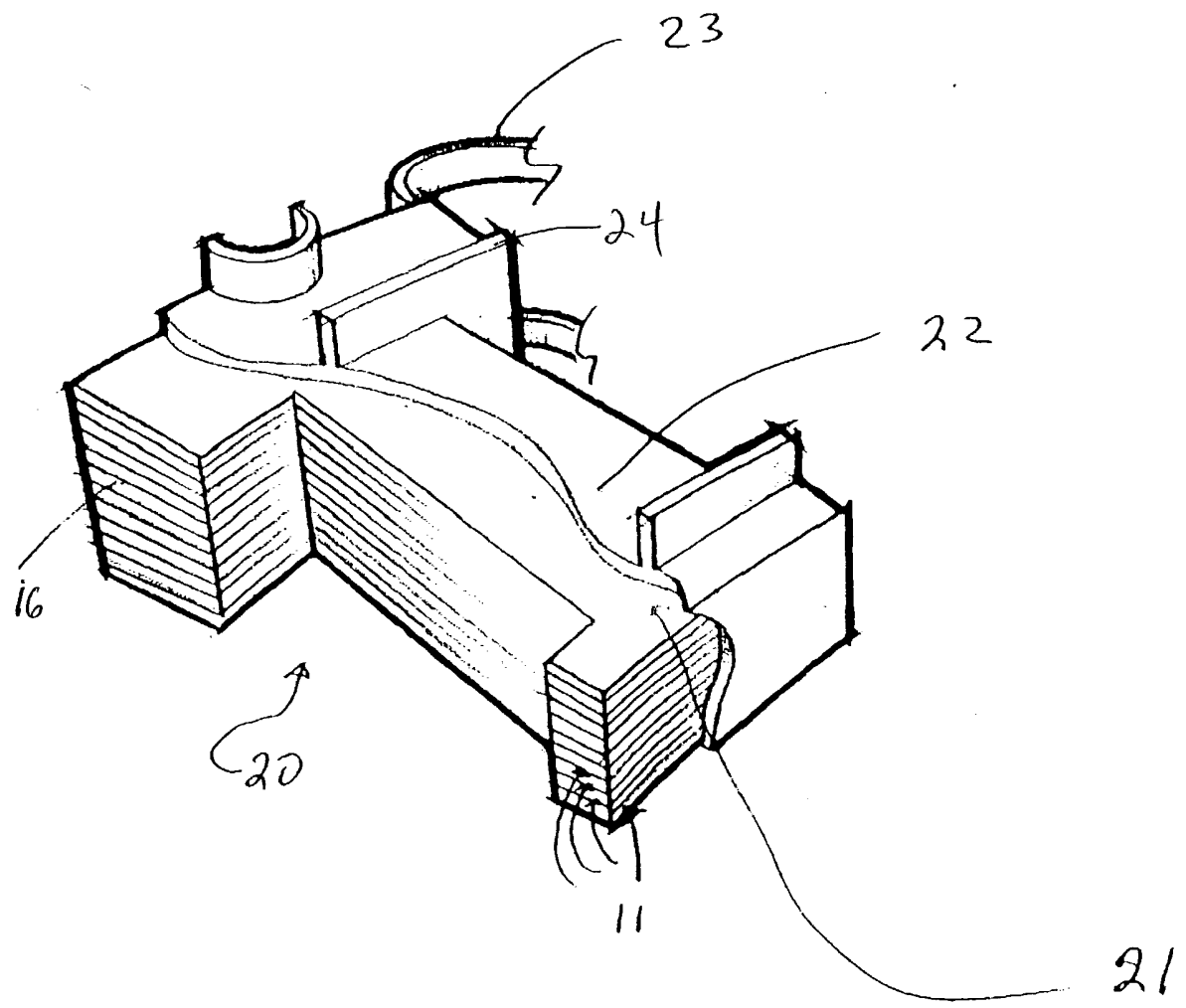

Patent Application for: STATOR ASSEMBLY MADE FROM A MOLDED WEB OF CORE SEGMENTS  
AND MOTOR USING SAME

Inventor(s): Griffith D. Neal

Attorney Docket No. and Serial No.8864/33

FIG 4

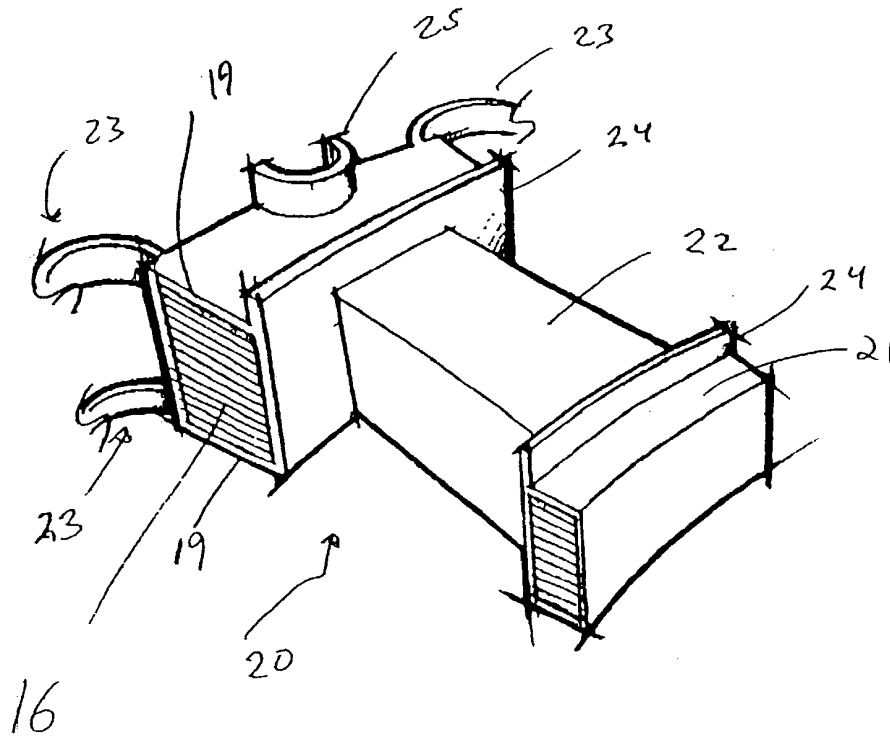

10393219.030503

Patent Application for: STATOR ASSEMBLY MADE FROM A MOLDED WEB OF CORE SEGMENTS  
AND MOTOR USING SAME  
Inventor(s): Griffith D. Neal  
Attorney Docket No. and Serial No.8864/33

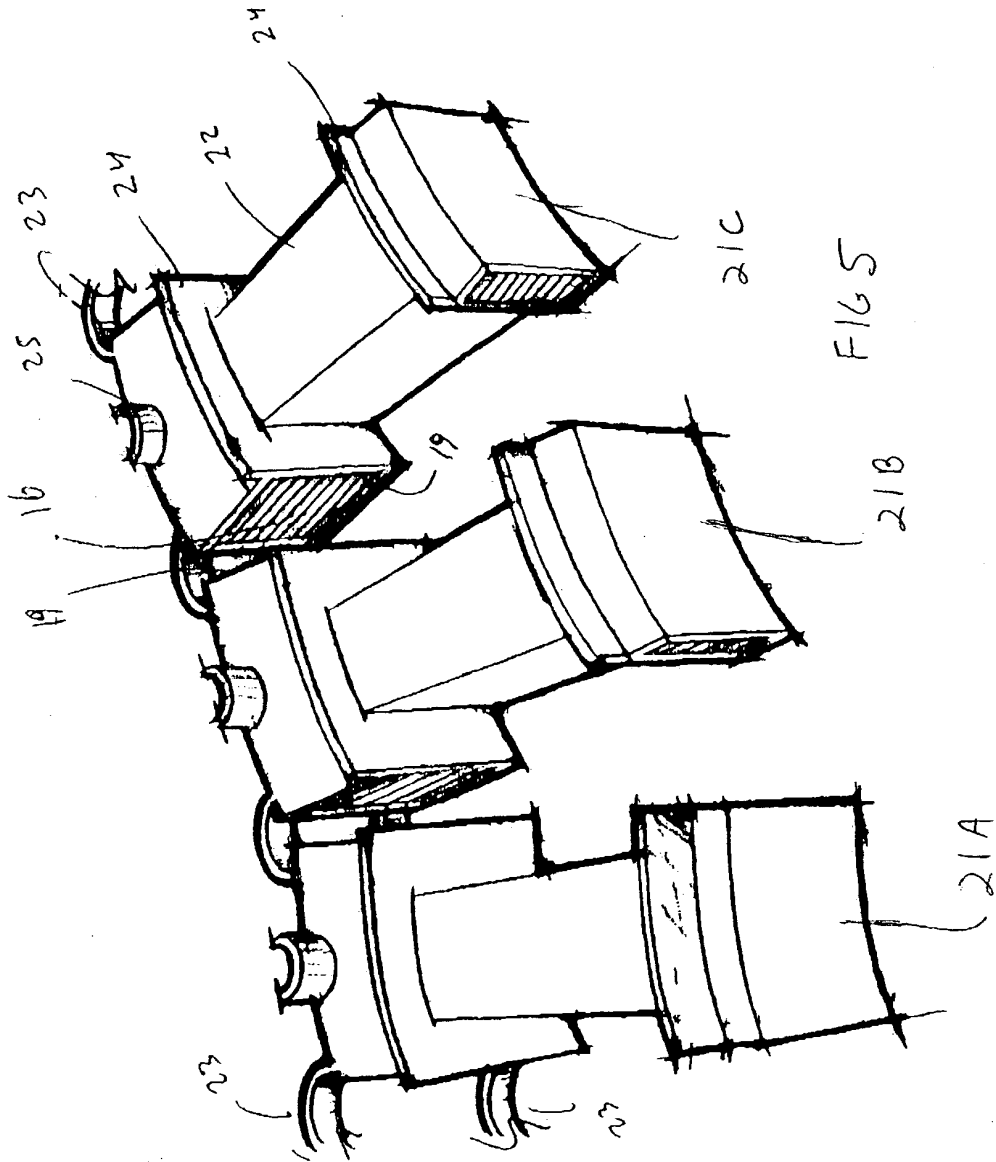

Patent Application for: STATOR ASSEMBLY MADE FROM A MOLDED WEB OF CORE SEGMENTS  
AND MOTOR USING SAME

Inventor(s): Griffith D. Neal  
Attorney Docket No. and Serial No.8864/33

FIG 6

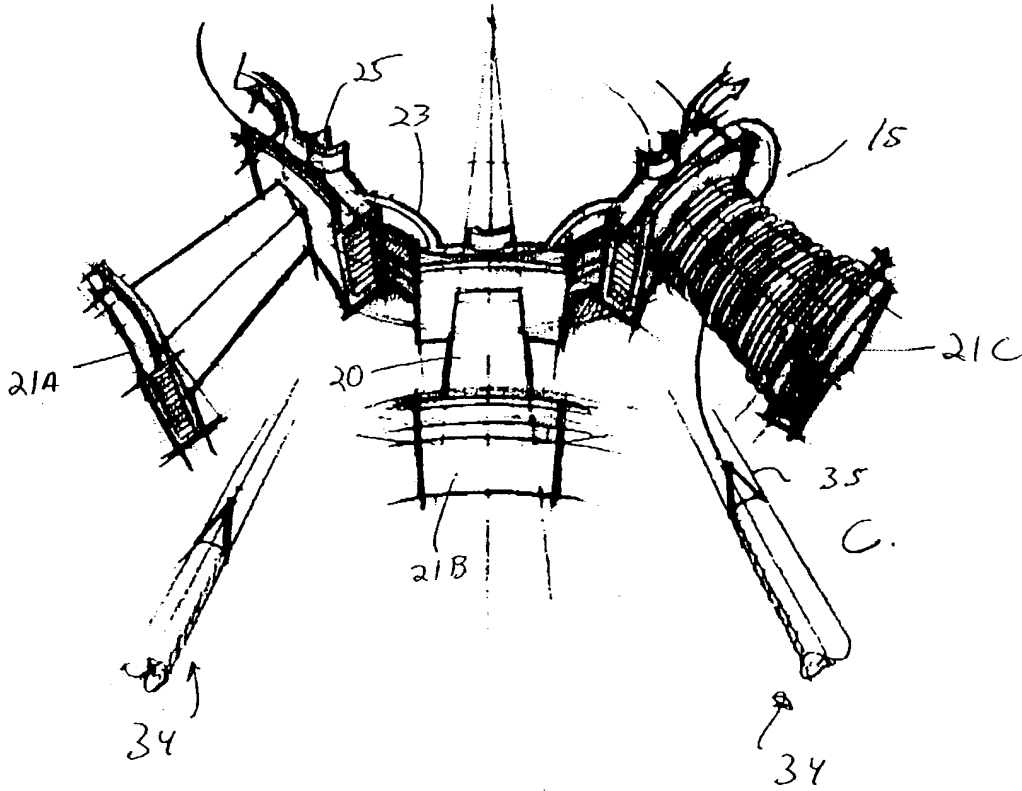

Patent Application for: STATOR ASSEMBLY MADE FROM A MOLDED WEB OF CORE SEGMENTS  
AND MOTOR USING SAME

Inventor(s): Griffith D. Neal  
Attorney Docket No. and Serial No.8864/33

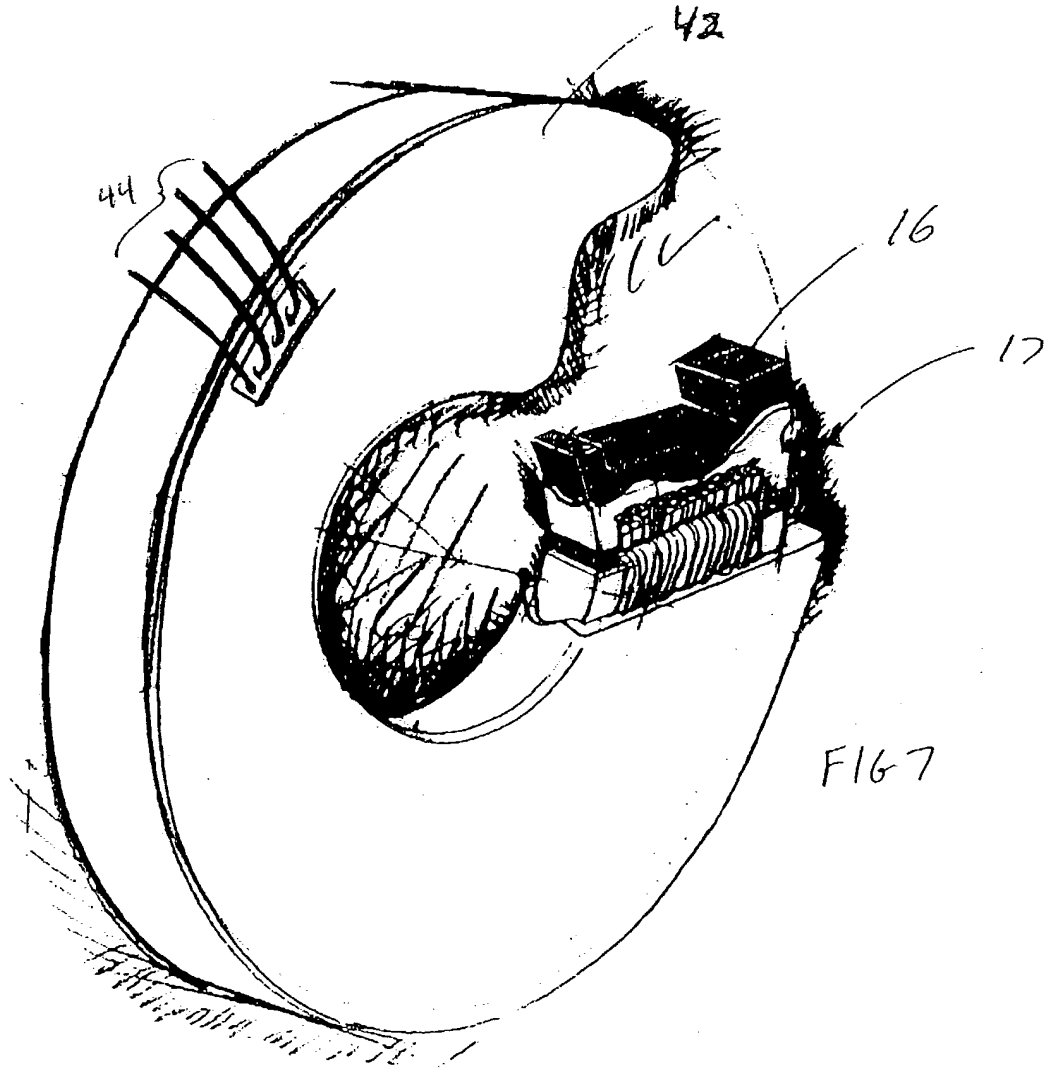

Patent Application for: STATOR ASSEMBLY MADE FROM A MOLDED WEB OF CORE SEGMENTS AND MOTOR USING SAME

Inventor(s): Griffith D. Neal

Attorney Docket No. and Serial No.8864/33

Fig. 8a

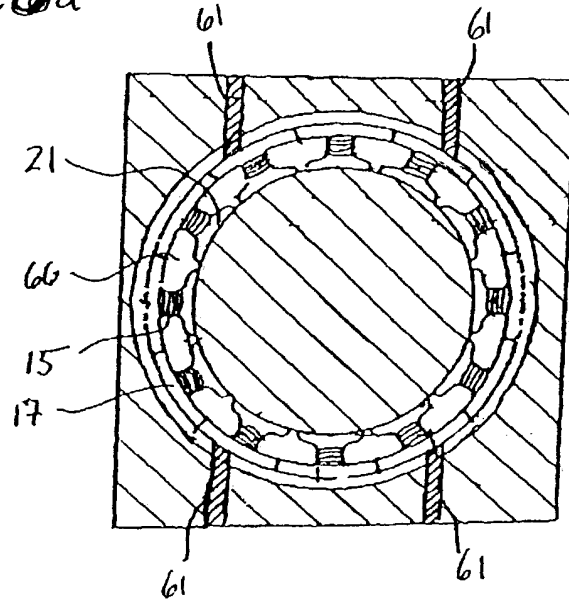
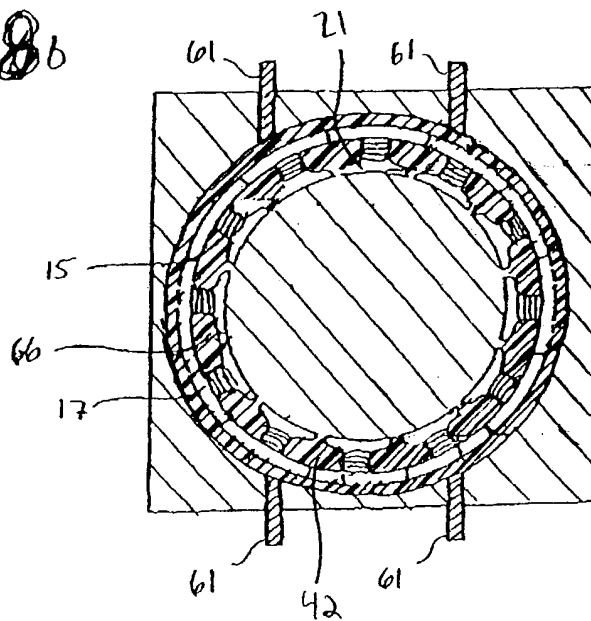

Fig. 8b







Patent Application for: STATOR ASSEMBLY MADE FROM A MOLDED WEB OF CORE SEGMENTS  
AND MOTOR USING SAME

Inventor(s): Griffith D. Neal

Attorney Docket No. and Serial No.8864/33

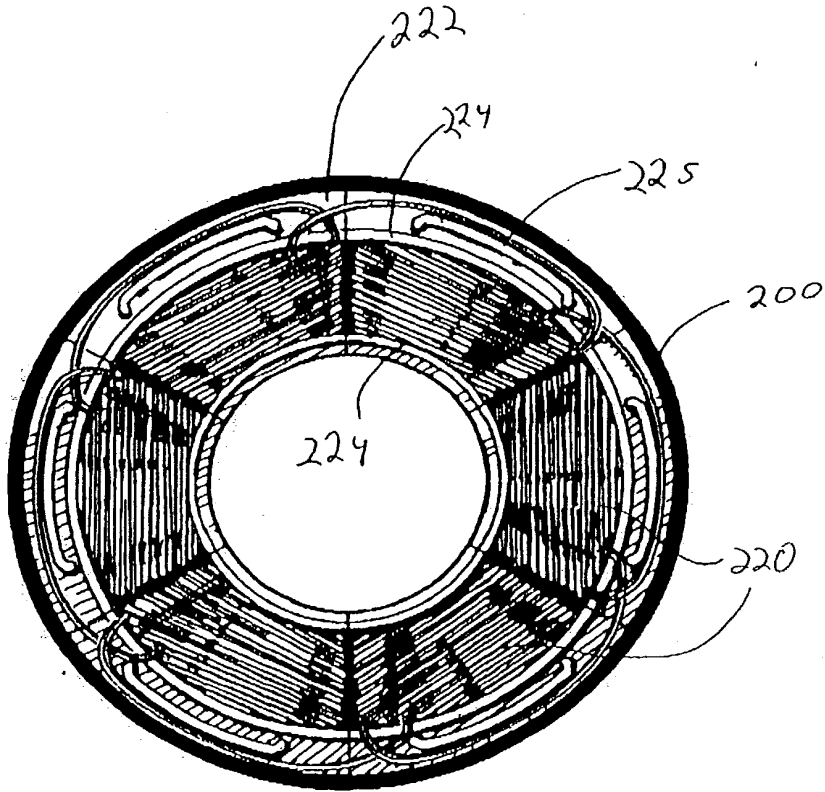

FIG 10

# PATENT APPLICATION FEE DETERMINATION RECORD

Effective January 1, 2003

Application or Docket Number

8864/33

## CLAIMS AS FILED - PART I

(Column 1)                      (Column 2)

TOTAL CLAIMS	32	
FOR	NUMBER FILED	NUMBER EXTRA
TOTAL CHARGEABLE CLAIMS	32 minus 20 = *	12
INDEPENDENT CLAIMS	6 minus 3 = *	3
MULTIPLE DEPENDENT CLAIM PRESENT <input type="checkbox"/>		

**SMALL ENTITY TYPE**  OR

**OTHER THAN SMALL ENTITY**

RATE	FEE
BASIC FEE	375.00
X\$ 9=	
X42=	
+140=	
TOTAL	

RATE	FEE
BASIC FEE	750.00
X\$18=	216
X84=	252
+280=	280
TOTAL	744

\* If the difference in column 1 is less than zero, enter "0" in column 2

## CLAIMS AS AMENDED - PART II

(Column 1)                      (Column 2)                      (Column 3)

AMENDMENT A	CLAIMS REMAINING AFTER AMENDMENT		HIGHEST NUMBER PREVIOUSLY PAID FOR	PRESENT EXTRA
	Total	*	Minus	**
	Independent	*	Minus	***
	FIRST PRESENTATION OF MULTIPLE DEPENDENT CLAIM <input type="checkbox"/>			

**SMALL ENTITY** OR

**OTHER THAN SMALL ENTITY**

RATE	ADDITIONAL FEE
X\$ 9=	
X42=	
+140=	
TOTAL ADDIT. FEE	

RATE	ADDITIONAL FEE
X\$18=	
X84=	
+280=	
TOTAL ADDIT. FEE	

AMENDMENT B	CLAIMS REMAINING AFTER AMENDMENT		HIGHEST NUMBER PREVIOUSLY PAID FOR	PRESENT EXTRA
	Total	*	Minus	**
	Independent	*	Minus	***
	FIRST PRESENTATION OF MULTIPLE DEPENDENT CLAIM <input type="checkbox"/>			

RATE	ADDITIONAL FEE
X\$ 9=	
X42=	
+140=	
TOTAL ADDIT. FEE	

RATE	ADDITIONAL FEE
X\$18=	
X84=	
+280=	
TOTAL ADDIT. FEE	

AMENDMENT C	CLAIMS REMAINING AFTER AMENDMENT		HIGHEST NUMBER PREVIOUSLY PAID FOR	PRESENT EXTRA
	Total	*	Minus	**
	Independent	*	Minus	***
	FIRST PRESENTATION OF MULTIPLE DEPENDENT CLAIM <input type="checkbox"/>			

RATE	ADDITIONAL FEE
X\$ 9=	
X42=	
+140=	
TOTAL ADDIT. FEE	

RATE	ADDITIONAL FEE
X\$18=	
X84=	
+280=	
TOTAL ADDIT. FEE	

\* If the entry in column 1 is less than the entry in column 2, write "0" in column 3.  
 \*\* If the "Highest Number Previously Paid For" IN THIS SPACE is less than 20, enter "20."  
 \*\*\* If the "Highest Number Previously Paid For" IN THIS SPACE is less than 3, enter "3."  
 The "Highest Number Previously Paid For" (Total or Independent) is the highest number found in the appropriate box in column 1.

**UNITED STATES PATENT AND TRADEMARK OFFICE**

UNITED STATES DEPARTMENT OF COMMERCE  
 United States Patent and Trademark Office  
 Address: COMMISSIONER OF PATENTS AND TRADEMARKS  
 P.O. Box 1450  
 Alexandria, Virginia 22313-1450  
 www.uspto.gov

APPLICATION NUMBER	FILING/RECEIPT DATE	FIRST NAMED APPLICANT	ATTORNEY DOCKET NUMBER
10/383,219	03/05/2003	Griffith D. Neal	8864/33

BRINKS HOFER GILSON & LIONE  
 A PROFESSIONAL CORPORATION INTL. PROP. ATTORNEYS  
 NBC TOWER - SUITE 3600  
 455 N. CITYFRONT PLAZA DRIVE  
 CHICAGO, IL 60611-5599

**CONFIRMATION NO. 9248**
**FORMALITIES LETTER**

\*OC00000009982014\*

Date Mailed: 05/07/2003

**NOTICE TO FILE MISSING PARTS OF NONPROVISIONAL APPLICATION**
**FILED UNDER 37 CFR 1.53(b)**
*Filing Date Granted*
**Items Required To Avoid Abandonment:**

An application number and filing date have been accorded to this application. The item(s) indicated below, however, are missing. Applicant is given **TWO MONTHS** from the date of this Notice within which to file all required items and pay any fees required below to avoid abandonment. Extensions of time may be obtained by filing a petition accompanied by the extension fee under the provisions of 37 CFR 1.136(a).

- The statutory basic filing fee is missing.  
*Applicant must submit \$ 750 to complete the basic filing fee for a non-small entity. If appropriate, applicant may make a written assertion of entitlement to small entity status and pay the small entity filing fee (37 CFR 1.27).*
- The oath or declaration is missing.  
*A properly signed oath or declaration in compliance with 37 CFR 1.63, identifying the application by the above Application Number and Filing Date, is required.*
- To avoid abandonment, a late filing fee or oath or declaration surcharge as set forth in 37 CFR 1.16(e) of \$130 for a non-small entity, must be submitted with the missing items identified in this letter.

The application is informal since it does not comply with the regulations for the reason(s) indicated below.

The required item(s) identified below must be timely submitted to avoid abandonment:

- Replacement drawings in compliance with 37 CFR 1.84 and 37 CFR 1.121 are required. The drawings submitted are not acceptable because:
  - The drawings must be reasonably free from erasures and must be free from alterations, overwriting, interlineations, folds, and copy marks. See Figure(s) Fig 8A, 8B and 9.
  - The drawings have a line quality that is too light to be reproduced (weight of all lines and letters must be heavy enough to permit adequate reproduction) or text that is illegible (reference characters, sheet numbers, and view numbers must be plain and legible) see 37 CFR 1.84(l) and (p)(1)); See Figure(s) Fig 6 and 7.

**Items Required To Avoid Processing Delays:**

The item(s) indicated below are also required and should be submitted with any reply to this notice to avoid further processing delays.

- Additional claim fees of **\$468** as a non-small entity, including any required multiple dependent claim fee, are required. Applicant must submit the additional claim fees or cancel the additional claims for which fees are due.

**SUMMARY OF FEES DUE:**

Total additional fee(s) required for this application is **\$1348** for a Large Entity

- **\$750** Statutory basic filing fee.
- **\$130** Late oath or declaration Surcharge.
- Total additional claim fee(s) for this application is **\$468**
  - **\$216** for **12** total claims over 20 .
  - **\$252** for **3** independent claims over 3 .

---

*A copy of this notice **MUST** be returned with the reply.*



Customer Service Center  
Initial Patent Examination Division (703) 308-1202

PART 3 - OFFICE COPY

4



**FIG.1**  
**PRIOR ART**

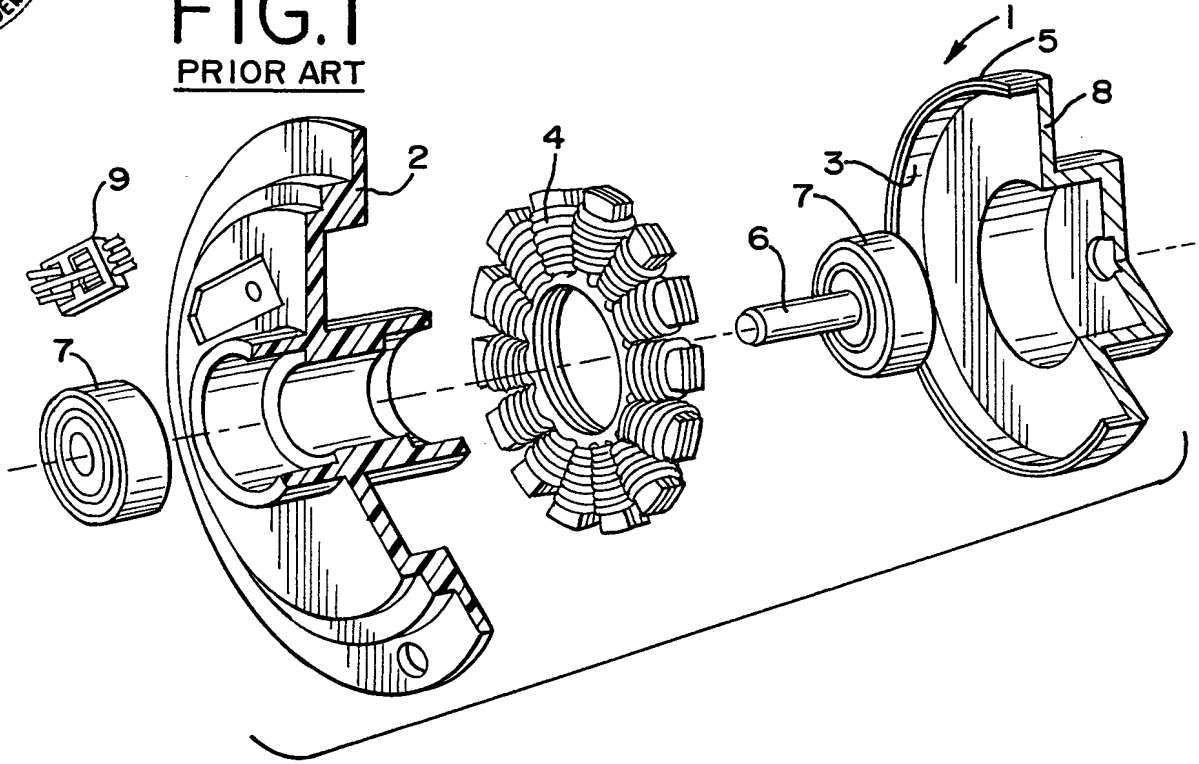

**FIG.2**

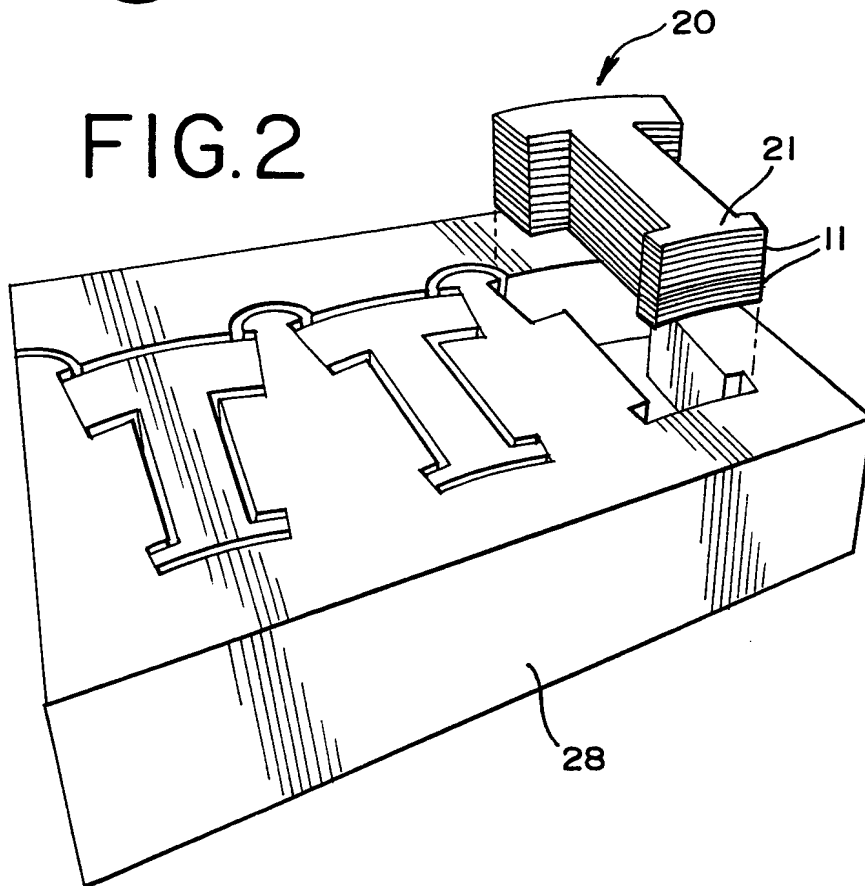

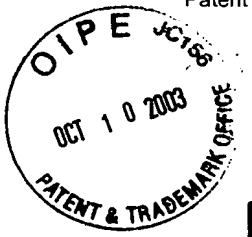

FIG.3

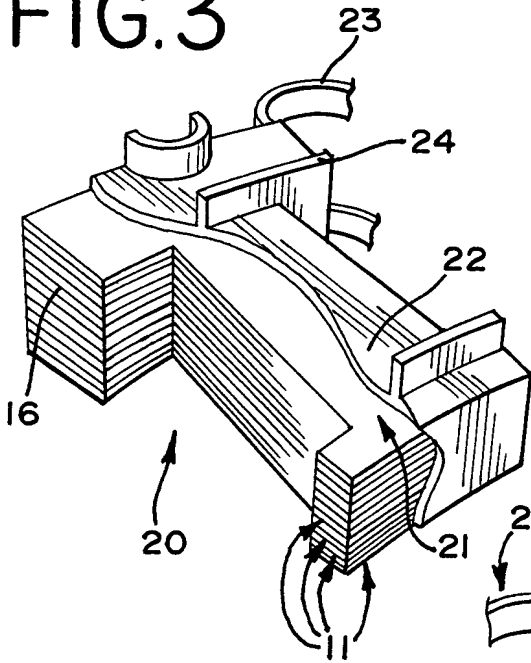

FIG.4

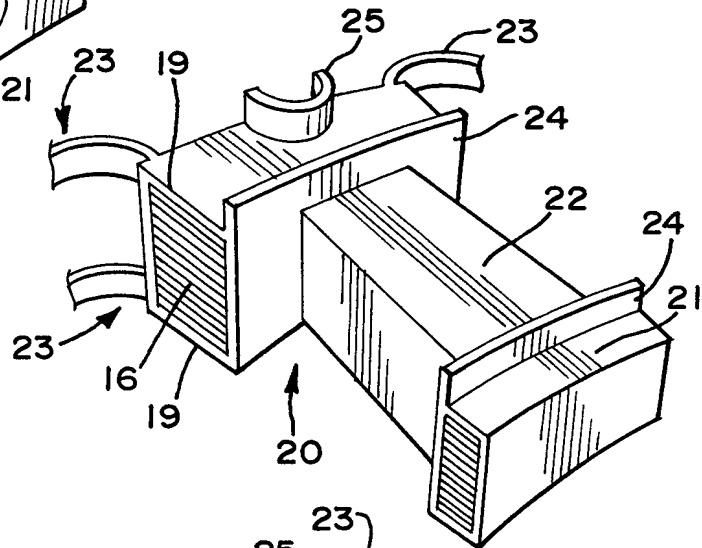

FIG.5

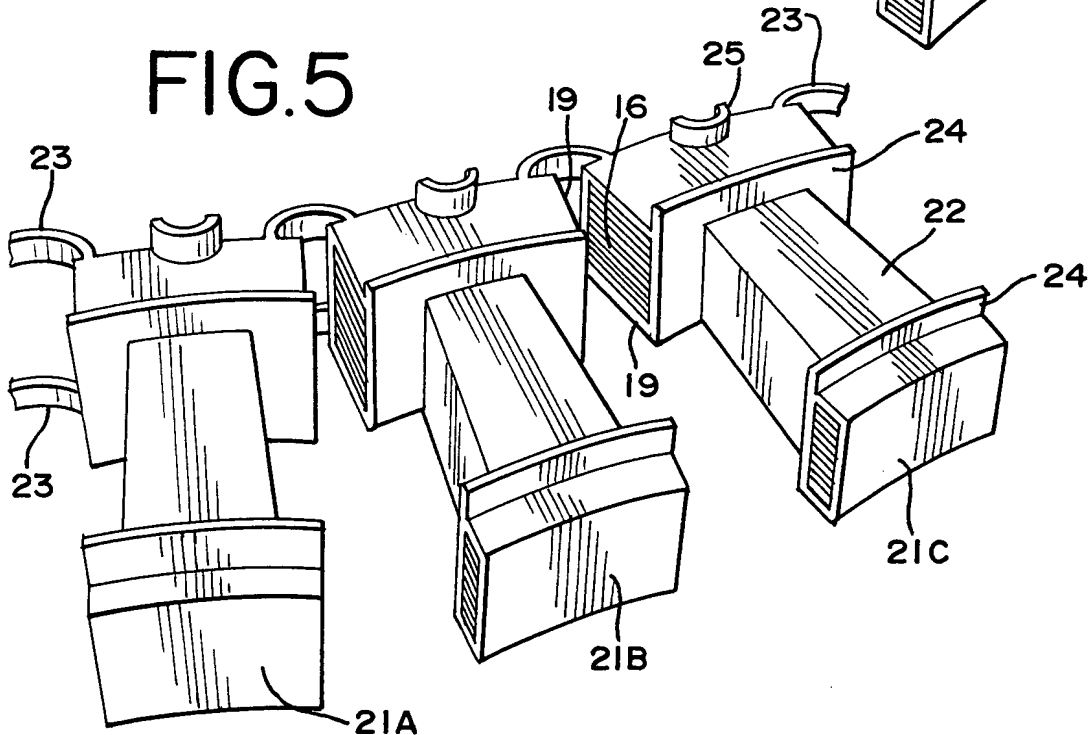



FIG.6

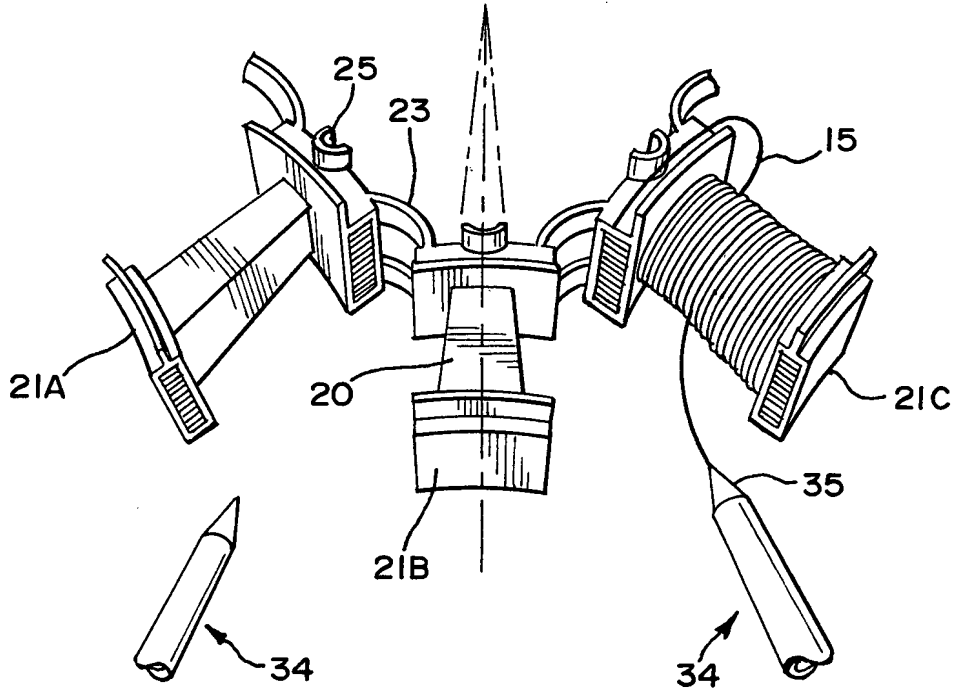

FIG.7

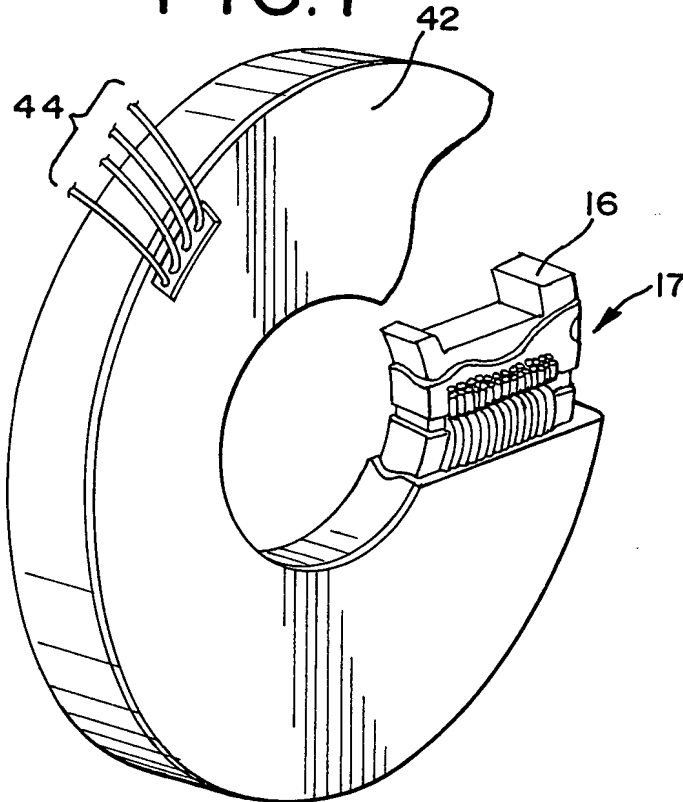



FIG. 8a

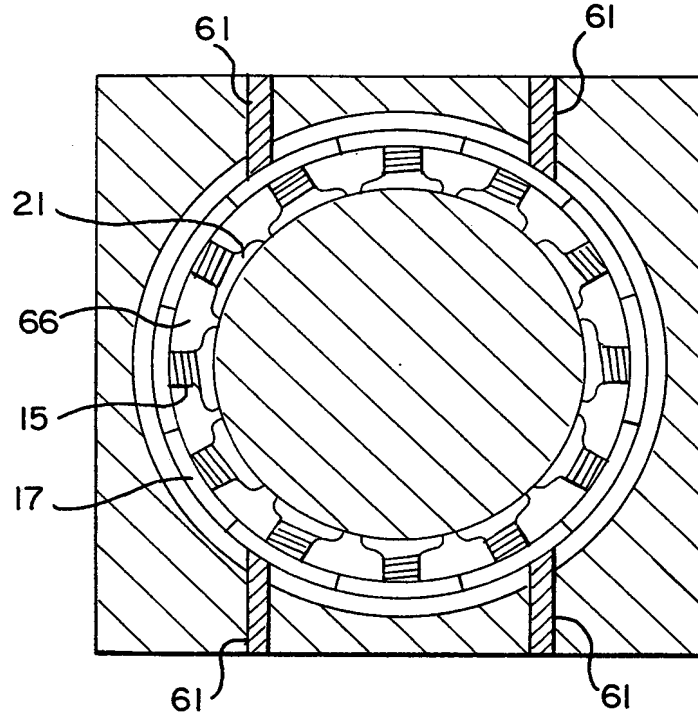
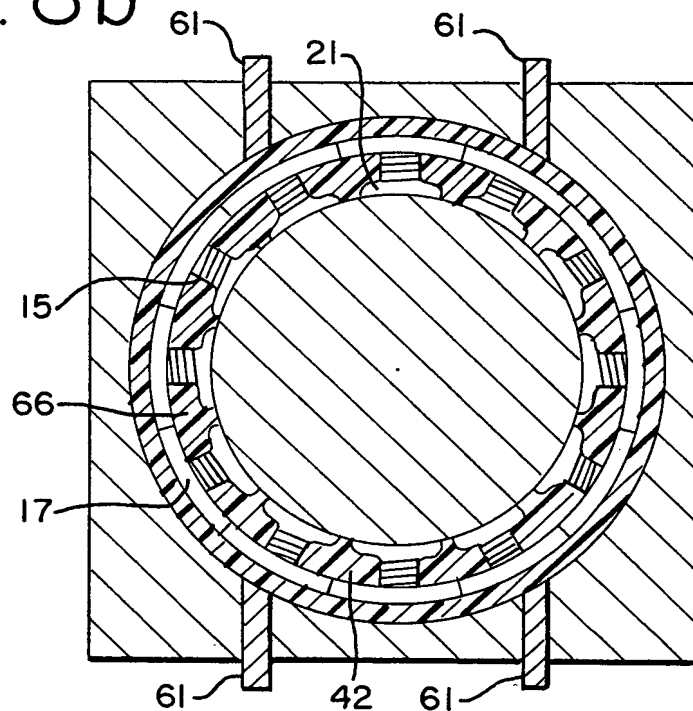

FIG. 8b









4

Case No. 8864/33

**DECLARATION FOR PATENT APPLICATION**

As a below named inventor, I hereby declare that:

My residence, post office address and citizenship are as stated below next to my name.

I believe I am the original, first and sole inventor (if only one name is listed below) or an original, first and joint inventor (if plural names are listed below) of the subject matter which is claimed and for which a patent is sought on the invention entitled Stator Assembly Made From a Molded Web of Core Segements and Motor Using Same, the specification of which:

- is attached hereto.
- was filed on March 5, 2003 as Application Serial No. 10/383,219.
- and was amended on \_\_\_\_\_ (if applicable).

I hereby state that I have reviewed and understand the contents of the above-identified specification, including the claims, as amended by any amendment referred to above.

I acknowledge the duty to disclose information which is material to the patentability as defined in Title 37, Code of Federal Regulations, § 1.56(a).

I hereby claim foreign priority benefits under 35 U.S.C. § 119(a)-(d) or § 365(b) of any foreign application(s) for patent or inventor's certificate or § 365(a) of any PCT International application which designated at least one country other than the United States, listed below and have also identified below, by checking the box, any foreign application for patent or inventor's certificate, or PCT International application having a filing date before that of the application on which priority is claimed:

<u>Prior Foreign Application(s)</u>			<u>Priority Claimed</u>	
None			<input type="checkbox"/>	<input type="checkbox"/>
(Number)	(Country)	(Day/Month/Year Filed)	Yes	No

I hereby claim the benefit under 35 U.S.C. § 119(e) of any United States provisional application(s) listed below:

None	
(Application Serial No.)	(Filing Date)

I hereby claim the benefit under 35 U.S.C. § 120 of any United States application(s), or § 365(c) of any PCT International application designating the United States, listed below and, insofar as the subject matter of each of the claims of this application is not disclosed in the prior United States or PCT International application in the manner provided by the first paragraph of 35 U.S.C. § 112, I acknowledge the duty to disclose information which is material to patentability as defined in 37 CFR § 1.56 which became available between the filing date of the prior application and the national or PCT International filing date of this application:

(Application Serial No.)	(Filing Date)	(Status-patented, pending, abandoned)

I hereby declare that all statements made herein of my own knowledge are true and that all statements made on information and belief are believed to be true; and further that these statements were made with the knowledge that willful false statements and the like so made are punishable by fine or imprisonment, or both, under Section 1001 of Title 18 of the United States Code and that such willful false statements may jeopardize the validity of the application or any patent issued thereon.

Inventor's Signature *Griffith D. Neal* Date: 8/13/03  
 Full name of sole or first inventor Griffith D. Neal  
 Residence Alameda, California  
 Citizenship United States of America  
 Post Office Address 1334 Bay Street, Alameda, California 94501

BRINKS HOFER GILSON & LIONE  
P.O. Box 10395  
Chicago, IL 60610  
(312) 321-4200

Inventor(s): GRIFFITH D. NEAL  
 Title: STATOR ASSEMBLY MADE FROM A MOLDED WEB OF CORE SEGMENTS AND MOTOR USING SAME

**POWER OF ATTORNEY**

The specification of the above-identified patent application:

- is attached hereto  
 was filed on March 5, 2003 as application Serial No. 10/383,219

I hereby revoke all previously granted powers of attorney in the above-identified patent application and appoint the following attorneys to prosecute said patent application and to transact all business in the Patent and Trademark Office connected therewith:

Steven P. Shurtz - 31,424  
 Jeffery M. Duncan - 31,609

Please address all correspondence and telephone calls to Steven P. Shurtz in care of:

Brinks Hofer Gilson & Lione  
 P.O. Box 10395  
 Chicago, IL 60610  
 (312)321-4200

The undersigned hereby authorizes the U.S. attorneys named herein to accept and follow instructions from GRIFFITH D. NEAL as to any action to be taken in the Patent and Trademark Office regarding this application without direct communication between the U.S. attorney and the undersigned. In the event of a change in the persons from whom instructions may be taken, the U.S. attorneys named herein will be so notified by the undersigned.

ENCAP MOTOR CORPORATION, a CORPORATION, certifies that it is the assignee of the entire right, title and interest in the patent application identified above by virtue of either:

- An assignment from the inventor(s) of the patent application identified above, a copy of which is attached hereto.  
 OR  
 An assignment from the inventor(s) of the patent application identified above. The assignment was recorded in the Patent and Trademark Office at Reel \_\_\_\_\_, frame \_\_\_\_\_.  
 OR  
 A chain of title from the inventor(s), of the patent application identified above, to the current assignee as shown below:
1. From \_\_\_\_\_ To: \_\_\_\_\_  
 The document was recorded in the Patent and Trademark Office at Reel \_\_\_\_\_, frame \_\_\_\_\_, or a copy thereof is attached.
  2. From \_\_\_\_\_ To: \_\_\_\_\_  
 The document was recorded in the Patent and Trademark Office at Reel \_\_\_\_\_, frame \_\_\_\_\_, or a copy thereof is attached.

Additional documents in the chain of title are listed on a supplemental sheet.

The undersigned has reviewed the assignment or all the documents in the chain of title of the patent application identified above and, to the best of undersigned's knowledge and belief, title is in the assignee identified above.

The undersigned (whose title is supplied below) is empowered to act on behalf of the assignee.

I hereby declare that all statements made herein of my own knowledge are true, and that all statements made on information and belief are believed to be true; and further, that these statements are made with the knowledge that willful false statements, and the like so made, are punishable by fine or imprisonment, or both, under Section 1001, Title 18 of the United States Code, and that such willful false statements may jeopardize the validity of the application or any patent issuing thereon.

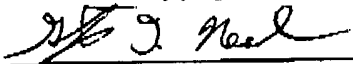
Signature:  Date: 8/13/03  
 Name: Griffith D. Neal  
 Title: CEO

Rev. Nov. 98

4

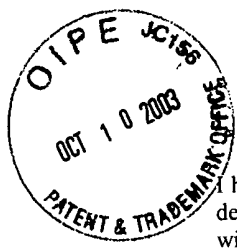

I hereby certify that this correspondence is being deposited with the United States Postal Service, with sufficient postage, as first class mail in an envelope addressed to:

Commissioner for Patents  
P.O. Box 1450  
Alexandria, VA 22313  
on October 7, 2003

\_\_\_\_\_  
Date of Deposit

\_\_\_\_\_  
Steven P. Shurtz, Reg. No. 31,424

\_\_\_\_\_  
Name of applicant, assignee or  
Registered Representative

*Steven P. Shurtz*

\_\_\_\_\_  
Signature

10/7/03

\_\_\_\_\_  
Date of Signature

**Case No. 8864/33**

**IN THE UNITED STATES PATENT AND TRADEMARK OFFICE**

In re Application of:

Griffith D. Neal

Serial No: 10/383,219

Examiner: Unassigned

Filed: March 5, 2003

Group Art Unit: Unassigned

For: STATOR ASSEMBLY MADE  
FROM A MOLDED WEB OF  
CORE SEGMENTS AND  
MOTOR USING SAME

**PETITION AND FEE FOR EXTENSION OF TIME (37 CFR § 1.136(a))**

Commissioner for Patents  
P.O. Box 1450  
Alexandria, VA 22313-1450

Dear Sir:

This is a petition for an extension of the time to respond to Notice to File Missing Parts dated May 7, 2003 for a period of 3 month(s).

Applicant:

claims small entity status. See 37 C.F.R. §1.27.

10/16/2003 MBELETE1 00000114 10383219

01 FC:2253

475.00 0P

Am. Honda v. IV II - IPR2018-00619  
PET\_HONDA\_1003-0048

is other than small entity

	<u>Extension Months</u>	<u>Other Than Small Entity</u>	<u>Small Entity</u>
<input type="checkbox"/>	One Month	\$110.00	\$55.00
<input type="checkbox"/>	Two Months	\$420.00	\$210.00
<input checked="" type="checkbox"/>	Three Months	\$950.00	\$475.00
<input type="checkbox"/>	Four Months	\$1,480.00	\$740.00
<input type="checkbox"/>	Five Months	\$2,010.00	\$1,005.00

**Fee Payment**

- Attached is a check for \$\_\_\_\_\_ for the Petition fee.
- Attached is a credit card authorization form for \$475 for the Petition fee.
- Charge Petition fee to Deposit Account No. 23-1925. A duplicate copy of this Petition is attached.
- Charge any additional fee required or credit for any excess fee paid to Deposit Account No. 23-1925. A duplicate copy of this Petition is attached.

Respectfully submitted,

Dated: October 7, 2003

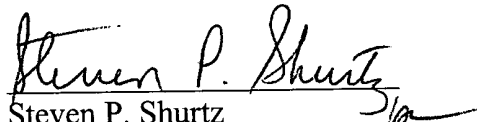
  
 Steven P. Shurtz  
 Registration No. 31,424  
 Attorney for Applicant

BRINKS HOFER GILSON & LIONE  
 P.O. BOX 10395  
 CHICAGO, IL 60610  
 (312)321-4200

**PATENT APPLICATION FEE DETERMINATION RECORD**

Effective January 1, 2003

Application or Docket Number

10383219  
8864/33

**CLAIMS AS FILED - PART I**

(Column 1) (Column 2)

TOTAL CLAIMS	32	
FOR	NUMBER FILED	NUMBER EXTRA
TOTAL CHARGEABLE CLAIMS	32 minus 20 = *	12
INDEPENDENT CLAIMS	6 minus 3 = *	3
MULTIPLE DEPENDENT CLAIM PRESENT <input type="checkbox"/>		

\* If the difference in column 1 is less than zero, enter "0" in column 2

SMALL ENTITY TYPE

OR OTHER THAN SMALL ENTITY

RATE	FEE	OR	RATE	FEE
BASIC FEE	375.00		BASIC FEE	750.00
X\$ 9=			X\$18=	216
X42=			X84=	252
+140=			+280=	280
TOTAL			TOTAL	744

**CLAIMS AS AMENDED - PART II**

(Column 1) (Column 2) (Column 3)

AMENDMENT A	CLAIMS REMAINING AFTER AMENDMENT		HIGHEST NUMBER PREVIOUSLY PAID FOR	PRESENT EXTRA
	Total	* Minus	**	=
	Independent	* Minus	***	=
FIRST PRESENTATION OF MULTIPLE DEPENDENT CLAIM <input type="checkbox"/>				

SMALL ENTITY OR

OTHER THAN SMALL ENTITY

RATE	ADDITIONAL FEE	OR	RATE	ADDITIONAL FEE
X\$ 9=			X\$18=	
X42=			X84=	
+140=			+280=	
TOTAL ADDIT. FEE			TOTAL ADDIT. FEE	

(Column 1) (Column 2) (Column 3)

AMENDMENT B	CLAIMS REMAINING AFTER AMENDMENT		HIGHEST NUMBER PREVIOUSLY PAID FOR	PRESENT EXTRA
	Total	* Minus	**	=
	Independent	* Minus	***	=
FIRST PRESENTATION OF MULTIPLE DEPENDENT CLAIM <input type="checkbox"/>				

RATE	ADDITIONAL FEE	OR	RATE	ADDITIONAL FEE
X\$ 9=			X\$18=	
X42=			X84=	
+140=			+280=	
TOTAL ADDIT. FEE			TOTAL ADDIT. FEE	

(Column 1) (Column 2) (Column 3)

AMENDMENT C	CLAIMS REMAINING AFTER AMENDMENT		HIGHEST NUMBER PREVIOUSLY PAID FOR	PRESENT EXTRA
	Total	* Minus	**	=
	Independent	* Minus	***	=
FIRST PRESENTATION OF MULTIPLE DEPENDENT CLAIM <input type="checkbox"/>				

RATE	ADDITIONAL FEE	OR	RATE	ADDITIONAL FEE
X\$ 9=			X\$18=	
X42=			X84=	
+140=			+280=	
TOTAL ADDIT. FEE			TOTAL ADDIT. FEE	

\* If the entry in column 1 is less than the entry in column 2, write "0" in column 3.

\*\* If the "Highest Number Previously Paid For" IN THIS SPACE is less than 20, enter "20."

\*\*\* If the "Highest Number Previously Paid For" IN THIS SPACE is less than 3, enter "3."

The "Highest Number Previously Paid For" (Total or Independent) is the highest number found in the appropriate box in column 1.

RECEIVED  
CENTRAL FAX CENTER  
OCT 21 2004

PTO/SB/122 (08-03)  
Approved for use through 11/30/2005. OMB 0851-0036  
U.S. Patent and Trademark Office; U.S. DEPARTMENT OF COMMERCE

Under the Paperwork Reduction Act of 1995, no persons are required to respond to a collection of information unless it displays a valid OMB control number.

<p align="center"><b>CHANGE OF CORRESPONDENCE ADDRESS Application</b></p> <p>Address to: Commissioner for Patents P.O. Box 1450 Alexandria, VA 22313-1450.</p>	Application Number	10/383,219
	Filing Date	3/5/03
	First Named Inventor	Griffith Neal
	Art Unit	3729
	Examiner Name	Thiem D. Phan
	Attorney Docket Number	8864/33

Please change the Correspondence Address for the above-identified patent application to:

Customer Number: 00757

OR

<input type="checkbox"/> Firm or Individual Name			
Address			
Address			
City	State	Zip	
Country			
Telephone	Fax		

This form cannot be used to change the data associated with a Customer Number. To change the data associated with an existing Customer Number use "Request for Customer Number Data Change" (PTO/SB/124).

I am the:

Applicant/Inventor

Assignee of record of the entire interest. Statement under 37 CFR 3.73(b) is enclosed. (Form PTO/SB/96).

Attorney or Agent of record. Registration Number 31,424

Registered practitioner named in the application transmittal letter in an application without an executed oath or declaration. See 37 CFR 1.33(a)(1). Registration Number \_\_\_\_\_

Typed or Printed Name: Steven P. Shurtz

Signature: Steven P. Shurtz

Date: 10/20/04 Telephone: 312 321 4230

NOTE: Signatures of all the inventors or assignees of record of the entire interest or their representative(s) are required. Submit multiple forms if more than one signature is required, see below.

\*Total of \_\_\_\_\_ forms are submitted.

This collection of information is required by 37 CFR 1.33. The information is required to obtain or retain a benefit by the public which is to file (and by the USPTO to process) an application. Confidentiality is governed by 35 U.S.C. 122 and 37 CFR 1.14. This collection is estimated to take 3 minutes to complete, including gathering, preparing, and submitting the completed application form to the USPTO. Time will vary depending upon the individual case. Any comments on the amount of time you require to complete this form and/or suggestions for reducing this burden, should be sent to the Chief Information Officer, U.S. Patent and Trademark Office, U.S. Department of Commerce, P.O. Box 1450, Alexandria, VA 22313-1450. DO NOT SEND FEES OR COMPLETED FORMS TO THIS ADDRESS. SEND TO: Commissioner for Patents, P.O. Box 1450, Alexandria, VA 22313-1450.

If you need assistance in completing the form, call 1-800-PTO-9199 and select option 2.

**This Page is Inserted by IFW Indexing and Scanning  
Operations and is not part of the Official Record**

**BEST AVAILABLE IMAGES**

Defective images within this document are accurate representations of the original documents submitted by the applicant.

Defects in the images include but are not limited to the items checked:

- BLACK BORDERS
- IMAGE CUT OFF AT TOP, BOTTOM OR SIDES
- FADED TEXT OR DRAWING
- BLURRED OR ILLEGIBLE TEXT OR DRAWING
- SKEWED/SLANTED IMAGES
- COLOR OR BLACK AND WHITE PHOTOGRAPHS
- GRAY SCALE DOCUMENTS
- LINES OR MARKS ON ORIGINAL DOCUMENT
- REFERENCE(S) OR EXHIBIT(S) SUBMITTED ARE POOR QUALITY
- OTHER: \_\_\_\_\_

**IMAGES ARE BEST AVAILABLE COPY.**

**As rescanning these documents will not correct the image problems checked, please do not report these problems to the IFW Image Problem Mailbox.**





UNITED STATES PATENT AND TRADEMARK OFFICE

UNITED STATES DEPARTMENT OF COMMERCE  
 United States Patent and Trademark Office  
 Address: COMMISSIONER FOR PATENTS  
 P.O. Box 1450  
 Alexandria, Virginia 22313-1450  
 www.uspto.gov

**\*BIBDATASHEET\***

**CONFIRMATION NO. 9248**

Bib Data Sheet

<b>SERIAL NUMBER</b> 10/383,219	<b>FILING OR 371(c) DATE</b> 03/05/2003 <b>RULE</b>	<b>CLASS</b> 029	<b>GROUP ART UNIT</b> 3729	<b>ATTORNEY DOCKET NO.</b> 8864/33
------------------------------------	-----------------------------------------------------------	---------------------	-------------------------------	---------------------------------------

**APPLICANTS**  
 Griffith D. Neal, Alameda, CA;

**\*\* CONTINUING DATA \*\*\*\*\***  
 This application is a CIP of 09/798,511 03/02/2001

**\*\* FOREIGN APPLICATIONS \*\*\*\*\***

**IF REQUIRED, FOREIGN FILING LICENSE GRANTED\*\* SMALL ENTITY \*\***  
**\*\* 05/06/2003**

Foreign Priority claimed <input type="checkbox"/> yes <input type="checkbox"/> no	<b>STATE OR COUNTRY</b> CA	<b>SHEETS DRAWING</b> 5	<b>TOTAL CLAIMS</b> 32	<b>INDEPENDENT CLAIMS</b> 6	
35 USC 119 (a-d) conditions met <input type="checkbox"/> yes <input type="checkbox"/> no <input type="checkbox"/> Met after Allowance					
Verified and Acknowledged	Examiner's Signature _____	Initials _____			

**ADDRESS**  
 00757

**TITLE**  
 Stator assembly made from a molded web of core segments and motor using same

<b>FILING FEE RECEIVED</b> 687	FEES: Authority has been given in Paper No. _____ to charge/credit DEPOSIT ACCOUNT No. _____ for following:	<input type="checkbox"/> All Fees
		<input type="checkbox"/> 1.16 Fees ( Filing )
		<input type="checkbox"/> 1.17 Fees ( Processing Ext. of time )
		<input type="checkbox"/> 1.18 Fees ( Issue )
		<input type="checkbox"/> Other _____
		<input type="checkbox"/> Credit



UNITED STATES PATENT AND TRADEMARK OFFICE

A

UNITED STATES DEPARTMENT OF COMMERCE  
United States Patent and Trademark Office  
Address: COMMISSIONER FOR PATENTS -  
P.O. Box 1450  
Alexandria, Virginia 22313-1450  
www.uspto.gov

APPLICATION NO.	FILING DATE	FIRST NAMED INVENTOR	ATTORNEY DOCKET NO.	CONFIRMATION NO.
10/383,219	03/05/2003	Griffith D. Neal	8864/33	9248

757                      7590                      03/29/2005

BRINKS HOFER GILSON & LIONE  
P.O. BOX 10395  
CHICAGO, IL 60610

EXAMINER

PHAN, THIEM D

ART UNIT	PAPER NUMBER
3729	

3729

DATE MAILED: 03/29/2005

Please find below and/or attached an Office communication concerning this application or proceeding.

<b>Office Action Summary</b>	<b>Application No.</b> 10/383,219	<b>Applicant(s)</b> NEAL, GRIFFITH D. <span style="float: right;">07</span>	
	<b>Examiner</b> Tim Phan	<b>Art Unit</b> 3729	

**-- The MAILING DATE of this communication appears on the cover sheet with the correspondence address --**  
**Period for Reply**

A SHORTENED STATUTORY PERIOD FOR REPLY IS SET TO EXPIRE 1 MONTH(S) FROM THE MAILING DATE OF THIS COMMUNICATION.

- Extensions of time may be available under the provisions of 37 CFR 1.136(a). In no event, however, may a reply be timely filed after SIX (6) MONTHS from the mailing date of this communication.
- If the period for reply specified above is less than thirty (30) days, a reply within the statutory minimum of thirty (30) days will be considered timely.
- If NO period for reply is specified above, the maximum statutory period will apply and will expire SIX (6) MONTHS from the mailing date of this communication.
- Failure to reply within the set or extended period for reply will, by statute, cause the application to become ABANDONED (35 U.S.C. § 133). Any reply received by the Office later than three months after the mailing date of this communication, even if timely filed, may reduce any earned patent term adjustment. See 37 CFR 1.704(b).

**Status**

- 1)  Responsive to communication(s) filed on 05 March 2003.
- 2a)  This action is **FINAL**.                      2b)  This action is non-final.
- 3)  Since this application is in condition for allowance except for formal matters, prosecution as to the merits is closed in accordance with the practice under *Ex parte Quayle*, 1935 C.D. 11, 453 O.G. 213.

**Disposition of Claims**

- 4)  Claim(s) 1-32 is/are pending in the application.
  - 4a) Of the above claim(s) \_\_\_\_\_ is/are withdrawn from consideration.
- 5)  Claim(s) \_\_\_\_\_ is/are allowed.
- 6)  Claim(s) \_\_\_\_\_ is/are rejected.
- 7)  Claim(s) \_\_\_\_\_ is/are objected to.
- 8)  Claim(s) 1-32 are subject to restriction and/or election requirement.

**Application Papers**

- 9)  The specification is objected to by the Examiner.
- 10)  The drawing(s) filed on \_\_\_\_\_ is/are: a)  accepted or b)  objected to by the Examiner.  
 Applicant may not request that any objection to the drawing(s) be held in abeyance. See 37 CFR 1.85(a).  
 Replacement drawing sheet(s) including the correction is required if the drawing(s) is objected to. See 37 CFR 1.121(d).
- 11)  The oath or declaration is objected to by the Examiner. Note the attached Office Action or form PTO-152.

**Priority under 35 U.S.C. § 119**

- 12)  Acknowledgment is made of a claim for foreign priority under 35 U.S.C. § 119(a)-(d) or (f).
  - a)  All    b)  Some \*    c)  None of:
    - 1.  Certified copies of the priority documents have been received.
    - 2.  Certified copies of the priority documents have been received in Application No. \_\_\_\_\_.
    - 3.  Copies of the certified copies of the priority documents have been received in this National Stage application from the International Bureau (PCT Rule 17.2(a)).

\* See the attached detailed Office action for a list of the certified copies not received.

**Attachment(s)**

- 1)  Notice of References Cited (PTO-892)
- 2)  Notice of Draftsperson's Patent Drawing Review (PTO-948)
- 3)  Information Disclosure Statement(s) (PTO-1449 or PTO/SB/08)  
 Paper No(s)/Mail Date \_\_\_\_\_.
- 4)  Interview Summary (PTO-413)  
 Paper No(s)/Mail Date. \_\_\_\_\_.
- 5)  Notice of Informal Patent Application (PTO-152)
- 6)  Other: \_\_\_\_\_.

**DETAILED ACTION**

***Election/Restrictions***

1. Restriction to one of the following inventions is required under 35 U.S.C. 121:
  - I. Claims 1-10, 25 and 28-32, drawn to a stator assembly, classified in class 310, subclass 254;
  - II. Claims 11-20 and 26, drawn to a method of making a stator assembly, classified in class 29, subclass 596;
  - III. Claims 21-24 and 27, drawn to another method of making a stator assembly, classified in class 29, subclass 606.

Inventions II and I are related as process of making and product made. The inventions are distinct if either or both of the following can be shown: (1) that the process as claimed can be used to make other and materially different product or (2) that the product as claimed can be made by another and materially different process (MPEP § 806.05(f)). In the instant case the process as claimed can be used to make other and materially different product, such as forming a stator assembly by substantially encapsulating the toroidal core.

Inventions III and I are related as process of making and product made. The inventions are distinct if either or both of the following can be shown: (1) that the process as claimed can be

Art Unit: 3729

used to make other and materially different product or (2) that the product as claimed can be made by another and materially different process (MPEP § 806.05(f)). In the instant case the process as claimed can be used to make other and materially different product, such as unitize the stator structure by placing a retaining member on the exterior of the toroidal core.

Inventions II and III are related as combination and subcombination. Inventions in this relationship are distinct if it can be shown that (1) the combination as claimed does not require the particulars of the subcombination as claimed for patentability, and (2) that the subcombination has utility by itself or in other combinations (MPEP § 806.05(c)). In the instant case, the combination as claimed does not require the particulars of the subcombination as claimed because the method of making a stator assembly as recited in Group II does not require the retaining member thereof, as required by Group III. The subcombination, Invention III, has separate utility such as unitize the toroidal structure by placing a retaining member on the exterior of the toroidal core .

Because these inventions are distinct for the reasons given above and have acquired a separate status in the art as shown by their different classification, restriction for examination purposes as indicated is proper.

Because these inventions are distinct for the reasons given above and have acquired a separate status in the art because of their recognized divergent subject matter, restriction for examination purposes as indicated is proper.

Because these inventions are distinct for the reasons given above and the search required for each Group is not required for other Groups, restriction for examination purposes as indicated is proper.

2. A telephone call was made to the office of Steven P. Shurtz (312-321-4230 & 801-444-3933) on March 21, 2005 to request an oral election to the above restriction requirement, but did not result in an election being made.

Applicant is advised that the reply to this requirement to be complete must include an election of the invention to be examined even though the requirement be traversed (37 CFR 1.143).

Any inquiry concerning this communication or earlier communications from the examiner should be directed to Tim Phan whose telephone number is 571-272-4568. The examiner can normally be reached on M - F, 9AM - 5PM.

If attempts to reach the examiner by telephone are unsuccessful, the examiner's supervisor, Peter Vo can be reached on 571-272-4690. The fax phone number for the organization where this application or proceeding is assigned is 703-872-9306.

Information regarding the status of an application may be obtained from the Patent Application Information Retrieval (PAIR) system. Status information for published applications may be obtained from either Private PAIR or Public PAIR. Status information for unpublished applications is available through Private PAIR only. For more information about the PAIR

Art Unit: 3729

system, see <http://pair-direct.uspto.gov>. Should you have questions on access to the Private PAIR system, contact the Electronic Business Center (EBC) at 866-217-9197 (toll-free).



**A. DEXTER TUGBANG  
PRIMARY EXAMINER**

Tim Phan  
Examiner  
Art Unit 3729

tp  
March 22, 2005

**Index of Claims**



**Application No.**

10/383,219

**Examiner**

Tim Phan

**Applicant(s)**

NEAL, GRIFFITH D.

**Art Unit**

3729

√	Rejected
=	Allowed

-	(Through numeral) Cancelled
+	Restricted

N	Non-Elected
I	Interference

A	Appeal
O	Objected

Claim		Date	
Final	Original		
	3/22/05		
1	+		
2			
3			
4			
5			
6			
7			
8			
9			
10			
11			
12			
13			
14			
15			
16			
17			
18			
19			
20			
21			
22			
23			
24			
25			
26			
27			
28			
29			
30			
31			
32	+		
33			
34			
35			
36			
37			
38			
39			
40			
41			
42			
43			
44			
45			
46			
47			
48			
49			
50			

Claim		Date	
Final	Original		
51			
52			
53			
54			
55			
56			
57			
58			
59			
60			
61			
62			
63			
64			
65			
66			
67			
68			
69			
70			
71			
72			
73			
74			
75			
76			
77			
78			
79			
80			
81			
82			
83			
84			
85			
86			
87			
88			
89			
90			
91			
92			
93			
94			
95			
96			
97			
98			
99			
100			

Claim		Date	
Final	Original		
101			
102			
103			
104			
105			
106			
107			
108			
109			
110			
111			
112			
113			
114			
115			
116			
117			
118			
119			
120			
121			
122			
123			
124			
125			
126			
127			
128			
129			
130			
131			
132			
133			
134			
135			
136			
137			
138			
139			
140			
141			
142			
143			
144			
145			
146			
147			
148			
149			
150			





UNITED STATES PATENT AND TRADEMARK OFFICE

UNITED STATES DEPARTMENT OF COMMERCE  
 United States Patent and Trademark Office  
 Address: COMMISSIONER FOR PATENTS  
 P.O. Box 1450  
 Alexandria, Virginia 22313-1450  
 www.uspto.gov

**\*BIBDATASHEET\***

**CONFIRMATION NO. 9248**

Bib Data Sheet

SERIAL NUMBER 10/383,219	FILING DATE 03/05/2003  RULE	CLASS 029	GROUP ART UNIT 3729	ATTORNEY DOCKET NO. 8864/33
-----------------------------	---------------------------------------	--------------	------------------------	-----------------------------------

APPLICANTS

Griffith D. Neal, Alameda, CA;

\*\* CONTINUING DATA \*\*\*\*\*

This application is a CIP of 09/798,511 03/02/2001

Yes *MM*

\*\* FOREIGN APPLICATIONS \*\*\*\*\*

No *MM*

IF REQUIRED, FOREIGN FILING LICENSE GRANTED \*\* SMALL ENTITY \*\*

\*\* 05/06/2003

Foreign Priority claimed <input type="checkbox"/> yes <input checked="" type="checkbox"/> no	STATE OR COUNTRY CA	SHEETS DRAWING 5	TOTAL CLAIMS 32	INDEPENDENT CLAIMS 6
35 USC 119 (a-d) conditions met <input type="checkbox"/> yes <input checked="" type="checkbox"/> no <input type="checkbox"/> Met after Allowance	Examined and Acknowledged	Examiner's Signature <i>MM</i>	Initials <i>MM</i>	

ADDRESS

00757  
 BRINKS HOFER GILSON & LIONE  
 P.O. BOX 10395  
 CHICAGO , IL  
 60610

TITLE

Stator assembly made from a molded web of core segments and motor using same

FILING FEE RECEIVED 687	FEES: Authority has been given in Paper No. _____ to charge/credit DEPOSIT ACCOUNT No. _____ for following:	<input type="checkbox"/> All Fees <input type="checkbox"/> 1.16 Fees ( Filing ) <input type="checkbox"/> 1.17 Fees ( Processing Ext. of time ) <input type="checkbox"/> 1.18 Fees ( Issue ) <input type="checkbox"/> Other _____
----------------------------	-------------------------------------------------------------------------------------------------------------------	----------------------------------------------------------------------------------------------------------------------------------------------------------------------------------------------------------------------------------------------



Handwritten: 3729 / cf

CERTIFICATE OF MAILING UNDER 37 C.F.R. §1.8

I hereby certify that this correspondence is being deposited with the United States Postal Service as first class mail, with sufficient postage, in an envelope addressed to: Mail Stop Amendment, Commissioner for Patents, P. O. Box 1450, Alexandria, VA 22313-1450, on the below date:  
Date: April 29, 2005 Name: Steven P. Shurtz, Reg. No. 31,424 Signature: /Steven P. Shurtz/

BRINKS  
HOFER  
GILSON  
& LIONE

IN THE UNITED STATES PATENT AND TRADEMARK OFFICE

In re Appln. of: Griffith D. Neal  
Appln. No.: 10/383,219  
Filed: March 5, 2003  
For: STATOR ASSEMBLY MADE FROM A  
MOLDED WEB OF CORE SEGMENTS AND  
MOTOR USING SAME

Examiner: Thiem D. Phan  
Group Art Unit: 3729

Attorney Docket No: 8864-33

Mail Stop Amendment  
Commissioner for Patents  
P. O. Box 1450  
Alexandria, VA 22313-1450

TRANSMITTAL

Sir:

Attached is/are:

- Transmittal Letter (in duplicate); Amendment
- Return Receipt Postcard

Fee calculation:

- No additional fee is required.
- An extension fee in an amount of \$\_\_\_ for a \_\_\_-month extension of time under 37 C.F.R. § 1.136(a).
- A petition or processing fee in an amount of \$\_\_\_ under 37 C.F.R. § 1.17(\_\_\_\_).
- An additional filing fee has been calculated as shown below:

					Small Entity		Not a Small Entity		
	Claims Remaining After Amendment		Highest No. Previously Paid For	Present Extra	Rate	Add'l Fee	or	Rate	Add'l Fee
Total	34	Minus	32	2	x \$25=	50		x \$50=	0
Indep.	6	Minus	6	0	x 100=			x \$200=	0
First Presentation of Multiple Dep. Claim									
					+\$180=			+\$360=	
					Total	\$50		Total	\$0

Fee payment:

- A credit card authorization in the amount of \$ 50.00 to cover the above-identified fee(s) is enclosed.
- Please charge Deposit Account No. 23-1925 in the amount of \$ . A copy of this Transmittal is enclosed for this purpose.
- The Director is hereby authorized to charge payment of any additional filing fees required under 37 CFR § 1.16 and any patent application processing fees under 37 CFR § 1.17 associated with this paper (including any extension fee required to ensure that this paper is timely filed), or to credit any overpayment, to Deposit Account No. 23-1925.

Respectfully submitted,

April 29, 2005  
Date

/Steven P. Shurtz/  
Steven P. Shurtz  
(Registration No. 31,424)  
Brinks Hofer Gilson Lione  
P.O. Box 10395  
Chicago, IL. 60610



I hereby certify that this correspondence is being deposited with the United States Postal Service, with sufficient postage, as first class mail in an envelope addressed to:

Commissioner for Patents  
P.O. Box 1450  
Alexandria, VA 22313  
on April 29, 2005

Date of Deposit

Steven P. Shurtz, Reg. No. 31,424

Name of applicant, assignee or  
Registered Representative

/Steven P. Shurtz/

Signature  
April 29, 2005

Date of Signature

Case No. 8864/33

**IN THE UNITED STATES PATENT AND TRADEMARK OFFICE**

In re Application of:

Griffith D. Neal

Serial No.: 10/383,219

Examiner: Thiem D. Phan  
Group Art Unit: 3729

Filed: March 5, 2003

For: STATOR ASSEMBLY  
MADE FROM A  
MOLDED WEB OF  
CORE SEGMENTS AND  
MOTOR USING SAME

**AMENDMENT**

Mail Stop Amendment  
Commissioner for Patents  
P.O. Box 1450  
Alexandria, VA 22313-1450

05/04/2005 SDEH001 00000020 10383219  
01 FC:2202 50.00 GP

Dear Sir:

In response to the Office Action mailed March 29, 2005, please enter the following amendment and consider the following remarks.

Amendments to the claims are reflected in the listing of claims which begins on page 2 of this paper.

Remarks begin on page 7 of the paper.

## Amendments to the Claims

Please amend claim 8 and add new claims 33-34 as follows. A complete listing of the claims with proper claim identifiers follows.

### Listing of Claims

1. (Original) A stator assembly, comprising:
  - a) a plurality of discrete stator segments each at least partially encased with a phase change material, wherein the phase change material also comprises a bridge between adjacent segments to link adjacent segments into a continuous strip; and
  - b) the linked stator segments being arranged and secured together to form the stator assembly.
2. (Original) The stator assembly of claim 1 wherein the bridges produce such a continuous linkage between segments that the bridges may be used to orient and manipulate the segments during wire winding.
3. (Original) The stator assembly of claim 1 wherein wire having a packing density of greater than 80 percent is wound around the poles.
4. (Original) The stator assembly of claim 1 wherein the bridges between adjoining segments can be used to orient and position wire relative to the poles.
5. (Original) The stator assembly of claim 1 wherein the phase change material has a thermal conductivity of at least 0.4 watts/meter<sup>2</sup>K at 23°C.
6. (Original) The stator assembly of claim 1 wherein the discrete stator segments are each made from a plurality of steel laminations.
7. (Original) The stator assembly of claim 1 wherein the phase change material comprises polyamide.
8. (Currently amended) The stator assembly of claim 1 wherein the stator segments are held in a ~~[[torodial]]~~ toroidal shape by a retaining member.

9. (Original) The stator assembly of claim 8 wherein the retaining member comprises a metal band.

10. (Original) The stator assembly of claim 1 wherein the stator segments are held in a toroidal shape by an overmolded thermoplastic material.

11. (Original) A method of making a stator assembly comprising:

a) providing at least two stator arc segments linked together by a phase change material and each constituting a pole and having a first side surface and a second side surface;

b) winding wire on the poles;

c) aligning said stator arc segments to form a toroidal core, wherein each said side surface of one segment is in contact with an opposing side surface of another segment; and

d) substantially encapsulating said toroidal core with a monolithic body of phase change material to form said stator assembly.

12. (Original) The method of claim 11 wherein the phase change material forming the monolithic body has a coefficient of thermal expansion of less than  $2 \times 10^{-5}$  in/in/°F throughout the range of 0-250°F.

13. (Original) The method of claim 11 wherein the phase change material forming the monolithic body has a coefficient of thermal expansion of less than  $1.5 \times 10^{-5}$  in/in/°F throughout the range of 0-250°F.

14. (Original) The method of claim 11 wherein the phase change material forming the monolithic body has a thermal conductivity of at least 0.4 watts/meter<sup>2</sup>K at 23°C.

15. (Original) The method of claim 11 wherein the phase change material is filled with about 30% or more boron nitride.

16. (Original) The method of claim 11 wherein the phase change material is filled with about 30% or more aluminum oxide.

17. (Original) The method of claim 11 wherein the phase change material linking adjoining segments has a length X, wherein X is the length of uncoiled wire necessary to align said stator arc segments to form said toroidal core.

18. (Original) The method of claim 11 wherein said phase change material is selected from the group consisting of thermoplastics and thermosetting materials.

19. (Original) The method of claim 11 wherein prior to said substantially encapsulating, said toroidal core is clamped in an injection mold cavity to maintain the toroidal shape.

20. (Original) The method of claim 11 wherein said step of substantially encapsulating the core is performed by injection molding said phase change material around said toroidal core.

21. (Original) A method of making a stator assembly comprising:

- a) providing at least two stator arc segments linked together by a phase change material and each providing a pole and having a first side surface and a second side surface;
- b) winding wire on each pole of each arc segment;
- c) aligning said stator arc segments to form a toroidal core, wherein each said side surface of one segment is in contact with an opposing side surface of another segment; and
- d) placing a retaining member on the exterior of the toroidal core to unitize the structure.

22. (Original) The stator assembly of claim 1 where the stator arc segments are at least partially encapsulated in the phase charge material.

23. (Original) The method of claim 21 where the retaining member comprises a metal band.

24. (Original) The method of claim 21 wherein each of said stator arc segments comprise a plurality of discrete steel laminations held together by the phase change material.

25. (Original) A motor made from the stator assembly of claim 1.

26. (Original) A motor made using a stator assembly made from the method of claim 11.

27. (Original) A motor made using a stator assembly made by the method of claim 21.

28. (Original) A combination of stator arc segments and a flexible carrier used to link said stator arc segments during a winding operation comprising:

- a) a plurality of stator arc segments; and
- b) a phase change material constituting said flexible carrier adhered to the stator arc segments which links said segments in a uniform and predetermined position with respect to one another.

29. (Original) The combination of claim 28 wherein the stator arc segments each comprise a plurality of steel laminations and wherein the steel laminations are electrically insulated from the wire applied during winding by a portion of the phase change material formed monolithically with the flexible carrier.

30. (Original) The combination of claim 29 where the phase change material has a dielectric strength of at least 250 volts per one thousandth of an inch of thickness.

31. (Original) A plurality of arc segments for a stator assembly, the arc segments connected to one another by a web of phase change material at least partially encapsulating the stator arc segments.

32. (Original) A series of discrete stator segments each substantially encapsulated with, and linked together by bridges made from, an injection molded thermoplastic material.

33. (New) The stator assembly of claim 1 wherein the bridge is formed by interconnecting two mating sections formed from the phase change material.

34. (New) The combination of claim 28 wherein the flexible carrier links said segments by connecting two mating sections formed in said carrier.



### Remarks

In the outstanding Office Action, claims 1-32 were subject to a three way restriction requirement. Applicant elects to prosecute the claims in Group I, claims 1-10, 25 and 28-32, and new claims 33-34 dependent on claims 1 and 28 respectively. This election is made with traverse.

The restriction between Group I and Group II is predicated on the basis that the claimed process of claims 11-20 and 26 can be used to make a materially different product than the product of claims 1-10, 25 and 28-32 in that the process can be used to form a stator assembly by substantially encapsulating the toroidal core. However, claim 10 calls for the stator segments to be held in a toroidal shape by an overmolded thermoplastic material. As explained in the specification, substantial encapsulation is achieved by overmolding with a thermoplastic material. Hence, the product of claim 10 is not a materially different product than the product formed by the process of claim 11. Thus the claims of Group II should be prosecuted with the claims of Group I.

The restriction between Group I and Group III is predicated on the basis that the claimed process of claims 21-24 and 27 can be used to make a materially different product than the product of claims 1-10, 25 and 28-32 in that the process can be used to unitize a stator structure by placing a retaining member on the exterior of the toroidal core. However, claim 8 calls for the stator segments to be held in a toroidal shape by a retaining member. Hence, the product of claim 8 is not a materially different product than the product formed by the process of claim 21. Thus the claims of Group III should be prosecuted with the claims of Group I.

Since all of the claims should be prosecuted in the present case, the forgoing listing of claims does not shown any of the claims as being withdrawn.

Respectfully submitted,

/Steven P. Shurtz/

Steven P. Shurtz  
Registration No. 31,424  
Attorney for Applicant

Dated: April 29, 2005  
BRINKS HOFER GILSON & LIONE  
P.O. Box 10395  
Chicago, IL 60610  
(312) 321-4200  
Direct Dial: (801) 444-3933

**PATENT APPLICATION FEE DETERMINATION RECORD**  
Effective January 1, 2003

Application or Docket Number

10383219  
8864/33

**CLAIMS AS FILED - PART I**

	(Column 1)	(Column 2)
TOTAL CLAIMS	32	
FOR	NUMBER FILED	NUMBER EXTRA
TOTAL CHARGEABLE CLAIMS	32 minus 20 =	12
INDEPENDENT CLAIMS	6 minus 3 =	3
MULTIPLE DEPENDENT CLAIM PRESENT <input type="checkbox"/>		

\* If the difference in column 1 is less than zero, enter "0" in column 2

SMALL ENTITY TYPE  OR OTHER THAN SMALL ENTITY

RATE	FEE		RATE	FEE
BASIC FEE	375.00	OR	BASIC FEE	750.00
X\$ 9=		OR	X\$18=	216
X42=		OR	X84=	252
+140=		OR	+280=	280
TOTAL		OR	TOTAL	744

5-3-05 **CLAIMS AS AMENDED - PART II**

	(Column 1)	(Column 2)	(Column 3)
AMENDMENT A	CLAIMS REMAINING AFTER AMENDMENT	HIGHEST NUMBER PREVIOUSLY PAID FOR	PRESENT EXTRA
Total	34	32	2
Independent	6	6	
FIRST PRESENTATION OF MULTIPLE DEPENDENT CLAIM <input type="checkbox"/>			

SMALL ENTITY OR OTHER THAN SMALL ENTITY

RATE	ADDITIONAL FEE		RATE	ADDITIONAL FEE
25		OR		
X\$ 9=	50.00	OR	X\$18=	
X42=		OR	X84=	
+140=		OR	+280=	
TOTAL ADDIT. FEE	50.00	OR	TOTAL ADDIT. FEE	

	(Column 1)	(Column 2)	(Column 3)
AMENDMENT B	CLAIMS REMAINING AFTER AMENDMENT	HIGHEST NUMBER PREVIOUSLY PAID FOR	PRESENT EXTRA
Total			
Independent			
FIRST PRESENTATION OF MULTIPLE DEPENDENT CLAIM <input type="checkbox"/>			

RATE	ADDITIONAL FEE		RATE	ADDITIONAL FEE
X\$ 9=		OR	X\$18=	
X42=		OR	X84=	
+140=		OR	+280=	
TOTAL ADDIT. FEE		OR	TOTAL ADDIT. FEE	

	(Column 1)	(Column 2)	(Column 3)
AMENDMENT C	CLAIMS REMAINING AFTER AMENDMENT	HIGHEST NUMBER PREVIOUSLY PAID FOR	PRESENT EXTRA
Total			
Independent			
FIRST PRESENTATION OF MULTIPLE DEPENDENT CLAIM <input type="checkbox"/>			

RATE	ADDITIONAL FEE		RATE	ADDITIONAL FEE
X\$ 9=		OR	X\$18=	
X42=		OR	X84=	
+140=		OR	+280=	
TOTAL ADDIT. FEE		OR	TOTAL ADDIT. FEE	

\* If the entry in column 1 is less than the entry in column 2, write "0" in column 3.  
 \*\* If the "Highest Number Previously Paid For" IN THIS SPACE is less than 20, enter "20."  
 \*\*\* If the "Highest Number Previously Paid For" IN THIS SPACE is less than 3, enter "3."  
 The "Highest Number Previously Paid For" (Total or Independent) is the highest number found in the appropriate box in column 1.

Best Available Copy



UNITED STATES PATENT AND TRADEMARK OFFICE

UNITED STATES DEPARTMENT OF COMMERCE  
United States Patent and Trademark Office  
Address: COMMISSIONER FOR PATENTS  
P.O. Box 1450  
Alexandria, Virginia 22313-1450  
www.uspto.gov

APPLICATION NO.	FILING DATE	FIRST NAMED INVENTOR	ATTORNEY DOCKET NO.	CONFIRMATION NO.
10/383,219	03/05/2003	Griffith D. Neal	8864/33	9248

757                      7590                      06/15/2005  
BRINKS HOFER GILSON & LIONE  
P.O. BOX 10395  
CHICAGO, IL 60610

EXAMINER

MULLINS, BURTON S

ART UNIT	PAPER NUMBER
2834	

2834

DATE MAILED: 06/15/2005

Please find below and/or attached an Office communication concerning this application or proceeding.

**Office Action Summary**

<b>Application No.</b> 10/383,219	<b>Applicant(s)</b> NEAL, GRIFFITH D. 
<b>Examiner</b> Burton S. Mullins	<b>Art Unit</b> 2834

**-- The MAILING DATE of this communication appears on the cover sheet with the correspondence address --**  
**Period for Reply**

A SHORTENED STATUTORY PERIOD FOR REPLY IS SET TO EXPIRE 3 MONTH(S) FROM THE MAILING DATE OF THIS COMMUNICATION.

- Extensions of time may be available under the provisions of 37 CFR 1.136(a). In no event, however, may a reply be timely filed after SIX (6) MONTHS from the mailing date of this communication.
- If the period for reply specified above is less than thirty (30) days, a reply within the statutory minimum of thirty (30) days will be considered timely.
- If NO period for reply is specified above, the maximum statutory period will apply and will expire SIX (6) MONTHS from the mailing date of this communication.
- Failure to reply within the set or extended period for reply will, by statute, cause the application to become ABANDONED (35 U.S.C. § 133). Any reply received by the Office later than three months after the mailing date of this communication, even if timely filed, may reduce any earned patent term adjustment. See 37 CFR 1.704(b).

**Status**

- 1)  Responsive to communication(s) filed on 03 May 2005.
- 2a)  This action is FINAL.                      2b)  This action is non-final.
- 3)  Since this application is in condition for allowance except for formal matters, prosecution as to the merits is closed in accordance with the practice under *Ex parte Quayle*, 1935 C.D. 11, 453 O.G. 213.

**Disposition of Claims**

- 4)  Claim(s) 1-34 is/are pending in the application.  
4a) Of the above claim(s) 11-24, 26 and 27 is/are withdrawn from consideration.
- 5)  Claim(s) 1-10, 25 and 33 is/are allowed.
- 6)  Claim(s) 28, 31 and 32 is/are rejected.
- 7)  Claim(s) 29, 30 and 34 is/are objected to.
- 8)  Claim(s) \_\_\_\_\_ are subject to restriction and/or election requirement.

**Application Papers**

- 9)  The specification is objected to by the Examiner.
- 10)  The drawing(s) filed on 10 October 2003 is/are: a)  accepted or b)  objected to by the Examiner.  
Applicant may not request that any objection to the drawing(s) be held in abeyance. See 37 CFR 1.85(a).  
Replacement drawing sheet(s) including the correction is required if the drawing(s) is objected to. See 37 CFR 1.121(d).
- 11)  The oath or declaration is objected to by the Examiner. Note the attached Office Action or form PTO-152.

**Priority under 35 U.S.C. § 119**

- 12)  Acknowledgment is made of a claim for foreign priority under 35 U.S.C. § 119(a)-(d) or (f).  
a)  All    b)  Some \*    c)  None of:  
1.  Certified copies of the priority documents have been received.  
2.  Certified copies of the priority documents have been received in Application No. \_\_\_\_\_.  
3.  Copies of the certified copies of the priority documents have been received in this National Stage application from the International Bureau (PCT Rule 17.2(a)).  
\* See the attached detailed Office action for a list of the certified copies not received.

**Attachment(s)**

- 1)  Notice of References Cited (PTO-892)
- 2)  Notice of Draftsperson's Patent Drawing Review (PTO-948)
- 3)  Information Disclosure Statement(s) (PTO-1449 or PTO/SB/08)  
Paper No(s)/Mail Date \_\_\_\_\_
- 4)  Interview Summary (PTO-413)  
Paper No(s)/Mail Date. \_\_\_\_\_
- 5)  Notice of Informal Patent Application (PTO-152)
- 6)  Other: \_\_\_\_\_

## DETAILED ACTION

### *Election/Restrictions*

1. Applicant's election with traverse of Group I (claims 1-10, 25, 28-32 and new claims 33-34) in the reply filed on May 3, 2005 is acknowledged. The traversal is on the ground that the product of claim 10 is not materially different from the process of claim 11. This is not found persuasive because the product claim includes a "strip" which is not included in the process claim.

The requirement is still deemed proper and is therefore made FINAL. Claims 11-24 and 26-27 are withdrawn.

### *Information Disclosure Statement*

2. The US patent references submitted in the information disclosure statement filed on July 11, 2001 in the parent case (S.N. 09/798,511) have been considered. However, the foreign references and non-patent literature have not been considered because copies are not readily available nor are they in the parent electronic file. If applicant wishes to have the references of record in the parent considered and printed on the face of the patent of the child, he should submit copies of the foreign and non-patent literature together with a list of all the references on a form PTO-1449 for the examiner to initial.

***Claim Rejections - 35 USC § 102***

3. The following is a quotation of the appropriate paragraphs of 35 U.S.C. 102 that form the basis for the rejections under this section made in this Office action:

A person shall be entitled to a patent unless –

(b) the invention was patented or described in a printed publication in this or a foreign country or in public use or on sale in this country, more than one year prior to the date of application for patent in the United States.

4. Claims 28 and 31 are rejected under 35 U.S.C. 102(b) as being anticipated by Ryder et al. (US 2,607,816). Ryder teaches a combination of stator arc segments and a flexible carrier used to link said stator arc segments during a winding operation comprising: a) a plurality of stator arc segments (cell dividers/pole pieces) 12; and b) a phase change material constituting a ring 24 of plastic material (c.3, lines 55-66) which comprises a flexible carrier adhered to the stator arc segments 12 and linking the segments in a uniform and predetermined position with respect to one another. Regarding claim 31, the ring 24 of plastic material can be considered a “web” since it connects the arc segments 12 in a pattern and partially encapsulates them by extending into spaces between adjacent segments (c.3, lines 66-69).

***Claim Rejections - 35 USC § 103***

5. The following is a quotation of 35 U.S.C. 103(a) which forms the basis for all obviousness rejections set forth in this Office action:

(a) A patent may not be obtained though the invention is not identically disclosed or described as set forth in section 102 of this title, if the differences between the subject matter sought to be patented and the prior art are such that the subject matter as a whole would have been obvious at the time the invention was made to a person having ordinary skill in the art to which said subject matter pertains. Patentability shall not be negated by the manner in which the invention was made.

6. Claim 32 is rejected under 35 U.S.C. 103(a) as being unpatentable over Hallerback (US 3,827,141) in view of Tanaka et al. (US 4,015,154). Hallerback teaches a series of discrete stator

Art Unit: 2834

segments (teeth) 1 each substantially encapsulated with, and linked together by bridges made from a plastic molding 5 (c.4, lines 64-67) during winding and thereafter definitively molded together into a unit (c.4, line 68-c.5, line 2). However, Hallerback does not specify that his molding compound is injection molded thermoplastic material.

Tanaka teaches injection molding of a stator core with plural teeth 14 using a thermosetting and thermoplastic resin mixture, the latter of which can be polystyrene (c.4, lines 64-66) and provides high accuracy molding due to its fluidity (c.4, lines 30-55).

It would have been obvious to one having ordinary skill to modify Hallerback and provide a molding compound comprising injection molded thermoplastic per Tanaka since this would have provided high accuracy, fluid molding.

*Allowable Subject Matter*

7. Claims 1-10, 25 and 33 are allowed. Regarding claim 1, the prior art does not teach the claimed stator assembly including plural discrete stator segments each at least partially encased with a phase change material, wherein the phase change material also comprises a bridge between adjacent segments to link adjacent segments into a continuous strip, as shown in Fig.5 of applicant's drawings and described on p.10, lines 13-14. In particular, neither Ryder, Hallerback nor Tanaka teaches stator segments linked by phase change material into a continuous strip but instead have their respective segments arranged in a circular fashion in a mold. In Horski (US '334), stator segments 38 are not linked to adjacent segments to form a continuous strip, but instead the segments appear to be overmolded by phase change material 40 while in the mold. Kazama teaches connection of stator core segments by means of concavities



Art Unit: 2834

& convexities 8a/8b which are part of the magnetic core. The resin molded onto the core segments in embodiments 11 and 12 (Figs.14-16) does not comprise a bridge portion.

8. Claims 29-30 and 34 are objected to as being dependent upon a rejected base claim, but would be allowable if rewritten in independent form including all of the limitations of the base claim and any intervening claims. The prior art does not teach or suggest that the stator arc segments comprise steel laminations electrically insulated from the wire by a portion of the phase change material formed monolithically with the flexible carrier (claim 29); or that the flexible carrier links segments by connecting two mating sections formed in the carrier (claim 34).

### *Conclusion*

9. The prior art made of record and not relied upon is considered pertinent to applicant's disclosure.

10. Any inquiry concerning this communication or earlier communications from the examiner should be directed to Burton S. Mullins whose telephone number is 571-272-2029. The examiner can normally be reached on Monday-Friday, 9 am to 5 pm. If attempts to reach the examiner by telephone are unsuccessful, the examiner's supervisor, Darren Schuberg can be reached on 571-272-2044. The fax phone number for the organization where this application or proceeding is assigned is 703-872-9306. Information regarding the status of an application may be obtained from the Patent Application Information Retrieval (PAIR) system. Status information for published applications may be obtained from either Private PAIR or Public PAIR. Status information for unpublished applications is available through Private PAIR only.

Art Unit: 2834

For more information about the PAIR system, see <http://pair-direct.uspto.gov>. Should you have questions on access to the Private PAIR system, contact the Electronic Business Center (EBC) at 866-217-9197 (toll-free).

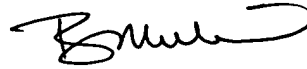

Burton S. Mullins  
Primary Examiner  
Art Unit 2834

bsm  
13 June 2005

<b>Notice of References Cited</b>	Application/Control No. 10/383,219	Applicant(s)/Patent Under Reexamination NEAL, GRIFFITH D.	
	Examiner Burton S. Mullins	Art Unit 2834	Page 1 of 1

**U.S. PATENT DOCUMENTS**

*	Document Number Country Code-Number-Kind Code	Date MM-YYYY	Name	Classification
A	US-3,827,141 A	08-1974	Hallerback, Stig Lennart	29/596
B	US-4,818,911 A	04-1989	Taguchi et al.	310/259
C	US-2,607,816 A	08-1952	RYDER FRANK A; et. al.	310/42
D	US-4,015,154 A	03-1977	Tanaka et al.	310/42
E	US-6,658,721 B2	12-2003	Kazama et al.	29/596
F	US-6,111,334 A	08-2000	Horski et al.	310/254
G	US-			
H	US-			
I	US-			
J	US-			
K	US-			
L	US-			
M	US-			

**FOREIGN PATENT DOCUMENTS**

*	Document Number Country Code-Number-Kind Code	Date MM-YYYY	Country	Name	Classification
N	04295256 A	10-1992	JP	Kieda et al.	H02K 15/02
O	11-38937	08-1988	JP	Nishiyama	H02K 1/06
P					
Q					
R					
S					
T					

**NON-PATENT DOCUMENTS**

*	Include as applicable: Author, Title Date, Publisher, Edition or Volume, Pertinent Pages)
U	
V	
W	
X	

\*A copy of this reference is not being furnished with this Office action. (See MPEP § 707.05(a).)  
Dates in MM-YYYY format are publication dates. Classifications may be US or foreign.

PAT-NO: JP401138937A  
DOCUMENT-IDENTIFIER: JP 01138937 A  
TITLE: MANUFACTURE OF INDUCTION MOTOR STATOR  
PUBN-DATE: May 31, 1989

INVENTOR-INFORMATION:  
NAME  
NISHIYAMA, HIROAKI  
IRIE, SHINICHIRO

ASSIGNEE-INFORMATION:  
NAME SHIBAURA ENG WORKS CO LTD COUNTRY  
N/A

APPL-NO: JP63213278

APPL-DATE: August 27, 1988

INT-CL (IPC): H02K001/06, H02K001/16 , H02K001/18

US-CL-CURRENT: 29/596

ABSTRACT:

PURPOSE: To facilitate a winding work of a toroidal winding by resin mold forming from the outside of a stator core at the time of constituting said stator core by joining of split cores.

CONSTITUTION: A toroidal winding 15, which winds a yoke part 41 via an insulating means, is applied to every slot 12 of each divisionally formed split core 11. Then, respective split cores 11, to which said winding 15 has been applied, are butt-joined into an annular stator core 10 by welding in the butt part outer periphery side of split end faces 11a, 11b. After that, a molded material 18 composed of synthetic resin material is injected to the

outside of  
said stator core 10 to cover said outside in the manner of embedding  
said  
winding 15 while leaving the tooth part 13 inner peripheral end face  
of the  
stator core 10 forming an opposed face at least to a rotor so that  
the whole  
stator core is molded into an integral body. In this manner, it is  
possible to  
obtain a stator having the reduced whole thickness including a  
winding.

COPYRIGHT: (C)1989, JPO&Japio

⑩ 日本国特許庁 (J P)

⑪ 特許出願公開

⑫ 公開特許公報 (A)

平1-138937

⑬ Int. Cl.<sup>4</sup>

H 02 K 1/06  
1/16  
1/18

識別記号

庁内整理番号

B-6340-5H  
C-6340-5H  
E-6340-5H

⑭ 公開 平成1年(1989)5月31日

審査請求 有 発明の数 1 (全5頁)

⑮ 発明の名称 誘導電動機の固定子の製作方法

⑯ 特 願 昭63-213278

⑰ 出 願 昭54(1979)4月13日

⑱ 特 願 昭54-45663の分割

⑲ 発 明 者 西 山 博 明 福井県小浜市駅前町13番10号 株式会社芝浦製作所小浜工場内

⑳ 発 明 者 入 江 真 一 郎 福井県小浜市駅前町13番10号 株式会社芝浦製作所小浜工場内

㉑ 出 願 人 株式会社芝浦製作所 東京都港区赤坂1丁目1番12号

㉒ 代 理 人 弁理士 蔦田 瑋子 外1名

明 細 書

1. 発明の名称 誘導電動機の固定子の製作方法

2. 特許請求の範囲

1. 磁鉄部の内周に歯部によって形成された多数のスロットを有する固定子コアを複数に分割形成し、この分割コアの各スロット毎に磁鉄部を巻回するトロイダル状の巻線を施して、この分割コア同士を接合した後、固定子コアの少なくとも回転子との対向面をなす歯部内周端面を残して巻線を埋め込むように樹脂モールド成形して一体化することを特徴とする誘導電動機の固定子の製作方法。

3. 発明の詳細な説明

本発明は、薄型の誘導電動機の固定子の製作方法に関するものである。

従来より、誘導電動機における固定子の回転磁界をつくる巻線は、通常固定子コアの回転子

との対向面側に形成されたスロットの二つに渡っておさめられているもので、スロットからスロットへの波りの部分である所謂コイルエンド部分が固定子コアの両側面よりはみ出した状態となっており、このコイルエンド部分の寸法が加わって全体として軸方向にかなり大きな幅を持つものである。

近年、電動機の小型軽量化に伴って薄型化の要求が強まり、固定子コアに多数のスロットを有する誘導電動機においても、その要求に応えるべく種々の提案がなされている。例えば、①固定子コアの径を大きくして積厚を薄くし軸方向の幅を減少させる方法、あるいは②固定子コアからはみ出したコイルエンド部分を小さく整形する方法、③巻線を固定子コアの径方向のスロットにおさめた固定子を用いる軸方向ギャップ(アキシアルギャップ)方式等が知られている。しかし前記①の方法では、電動機の外径が大きくなり、②の方法ではコイルエンドの整形にきわめて手数がかり、また③の方法では、電

動機の外径がかなり大となり、しかも構造上高出力の電動機には適さない等、それぞれ問題があった。

そこで、固定子コアに多数のスロットを有する誘導電動機の薄型化の方法として、特に固定子コアの各スロット毎にトロイダル状の巻線を施すことにより、従来と同じコア積厚で固定子全体の厚みを大幅に低減することを提案している。

前記構造の誘導電動機を実施するにおいては、これに使用するトロイダル状の巻線を施した固定子を容易かつ能率よく製作できることが重要であるが、例えばトロイダル状の巻線装置を用いて環状の固定子コアに巻線することにより製作するのは、一旦小さなボビンに巻取る必要がある上、比較的狭いスロット毎に巻線しなければならないために装置が複雑化し高速化が望めない等の問題がある。

そのため、前記の固定子の製造を容易にするために、固定子コアを分割形成しておいて、こ

すなわち、本発明の誘導電動機の固定子の製作方法は、継鉄部の内周に歯部によって形成された多数のスロットを有する固定子コアを複数に分割形成し、この分割コアの各スロット毎に継鉄部を巻回するトロイダル状の巻線を施して、この分割コア同士を接合した後、固定子コアの少なくとも回転子との対抗面をなす歯部内周端面を残して巻線を埋め込むように樹脂モールド成形して一体化することを特徴とする。

次に本発明の実施例を第1図～第7図に基づいて説明する。

第1図は本発明により製造された固定子(1)を示し、第7図は本発明により製造された固定子(1)を使った誘導電動機の概略を示す。

そして、前記固定子(1)の製造においては、まず、回転子(2)と対向する内周側において軸方向の多数のスロット(12)を隔設する歯部(13)と継鉄部(14)とからなる固定子コア(10)を、図に示すように例えば歯部(13)の中央で2分割等の周方向複数に分割形成しておく。この分割コ

アの分割コアの各スロット毎に継鉄部を巻回する巻線を施した後、各分割コアを環状に接合固定することとしたものであるが、このように分割コアを接合することした場合、磁束にムラが生じてコアに電磁振動が発生し易くなり、特に分割コア同士がその突合せ部分の外周側で溶接により接合されていても微振動が発生するもので、これを例えばファンの駆動モータに使用した場合には、前記モータの振動がファンから空間へと伝わり騒音が発生する等の問題が生じる。

また、固定子コアの継鉄部にトロイダル状の巻線を施した場合、巻線への通電によって生じる磁界の磁束が外方へ流れて漏洩するのを防止する必要もある。

これに鑑み、本発明では、トロイダル状の巻線の巻回作業を容易にすべく、固定子コアを分割コアの接合によって構成する場合において、この固定子コアの外側より樹脂モールド成形することにより、固定子コアの電磁振動等を減少して、その実施を可能にせんとしたものである。

ア(11)(11)を構成する各積層板は、従来の固定子コアと同様に接着その他の手段により絶縁状態で接合され、また各分割コア(11)(11)同士の接合面となる分割端面(11a)(11b)は絶縁されない。

次に第2図に示すように前記の分割形成された各分割コア(11)(11)の各スロット(12)毎に、絶縁手段を介して継鉄部(14)を巻回するトロイダル状の巻線(15)を施す。この場合、同図のように銅線等の素線を直接巻線ボビン(16)から引き出して各スロット(12)毎の継鉄部(14)に巻回することにより、容易に巻線(15)を施すことができる。

また前記巻線(15)と各分割コア(11)(11)との間の絶縁手段(17)としては、分割コア(11)(11)のうち少なくとも巻線(15)が施される部分に絶縁材料を塗装して形成するか、または合成樹脂等の絶縁材料により歯部(13)および継鉄部(14)の分割コア形状に略対応した第6図(a)及び(b)のような形状の割形の絶縁被膜体(17a)

(17b)を両側より被着しておくもので、特に前記絶縁被嵌体(17a)(17b)には、巻線状態を良好にするつば(17c)を設けておくことができ、さらにつば(17c)に口出線用の導電部材を設けておくことができる。

そして前記のトロイダル状の巻線(15)によれば、巻線(15)自体が巻装の圧力で内心に向って密になり最小寸法となるほか、巻線(15)が緩んだりして飛出すものもなくなり、後述の樹脂モールドに際して、流されたり表面に露出する等の問題が生じることがなく、樹脂モールドを容易確実になし得る。さらに、継鉄部(14)と巻線(15)との間に前記のように絶縁部材を介装した場合、絶縁部材が巻線(15)によって継鉄部(14)に強く押し付けられてコアとの間に隙間を生じることとも少なくなる。

次に前記のように巻線(15)を施した各分割コア(11)(11)を、第3図のように分割端面(11a)(11b)の突合せ部外周側での溶接、あるいは分割端面(11a)(11b)に形成された凹凸の嵌合によ

系やエポキシ系の熱硬化性樹脂にガラス繊維や無機質フィラー等を混合した合成樹脂材等が用いられる。なお、前記モールド材料(18)の注入圧力は、モールド材料の粘度等によっても異なるが、通常10kg/cm<sup>2</sup>程度に設定する。

そして、前記の樹脂モールドにおいては、合成樹脂材(18)がかなりの圧力で注入されるが、巻線(15)は固定子コア(10)の各スロット(12)毎の継鉄部(14)にトロイダル状に巻装されているため、固定子コア(10)に対して強く密に巻着した状態に保持されていて、モールド材料(18)が比較的粘度の高い樹脂材であっても、モールド材料(18)によって流されたり傷が付く等の不良が生じない。また前記の分割コア(11)(11)同士の間が仮止め程度のものであっても、外側に包被成形されたモールド材料(18)により強固に接合固定されて、全体が確実に固定一体化されることになり、これによって第1図および第5図のごとくスロット(12)毎に巻線(15)を施した固定子(1)を問題なく得ることができる。

り突合せ接合し、環状の固定子コア(10)とする。

そして前記の分割コア(11)(11)の接合後、周知の樹脂モールド法によって、固定子コア(10)の少なくとも回転子(2)との対向面をなす歯部(13)内周端面を残して巻線(15)を埋め込むように合成樹脂材よりなるモールド材料(18)を外側に注入包被させて全体を成形一体化する。すなわち、第4図に示すように分割コア(11)(11)の接合による固定子コア(10)をモールド型(20)内にセットしておき、このモールド型(20)内にモールド材料(18)を圧入し、外側を包被させて成形固定する。この樹脂モールドによって電動機のフレーム部分も一体形成する。

この樹脂モールド法としては、例えば特開昭52-98909号公報や特開昭53-107605号公報等にも見られるように、インジェクションモールド等の周知のモールド法を利用すればよく、またモールド材料(18)としても、この種の合成樹脂製電動機等において一般に使用されている合成樹脂材、例えばポリエステル

上記のように製造される固定子(1)は第7図に例示するように誘導電動機に使用されるもので、同図の(3)(3)は回転子(2)の軸(4)を支承する軸受、(5)はモールド材料によるフレーム部分を示す。

以上のように、本発明の方法によれば、各スロット毎に継鉄部を巻回するトロイダル状の巻線(15)を施した分割コアを接合した後、少なくとも回転子との対向面をなす歯部内周端面を残して巻線(15)を埋め込むように外側より樹脂モールド成形して固定するので、分割コアをその分割端面同士を突合せ接合した状態に確実に固定保持でき、それゆえ固定子コアを分割形成しているにも拘らず、磁束のムラによる固定子コアの電磁振動、つまりは電動機の振動を減少できることになる。

したがって本発明によれば、前記のように固定子コアを複数に分割形成して、この分割コアの各スロット毎にトロイダル状の巻線(15)を施すことが何等問題なく可能となり、トロイダル状の



巻線であるにも拘らず、その巻線作業を能率化でき、トロイダル状の巻線が施された固定子の製作効率を高めることができる。すなわち、固定子コアが分割形成されているので、巻線を継鉄部に対し直接強固に、つまり密に、また高速度で巻装できることになり、そのため、樹脂モールドを容易にすることができるとともに、その製作時間の短縮を図ることができる。

また前記のモールド材料の樹脂が固定子コアの外側に回った巻線を保護でき、併せて樹脂の占める寸法が磁束の外方への漏洩も防止できることになる。しかも、巻線がその巻装圧力によって継鉄部に対し内心に向かって密に巻装されているため、空隙を生じることが少なく、樹脂の外側から機械的な衝撃を受けても、樹脂のみが外力を受けることなく、内心に向かって衝撃が分散され、結果として丈夫なフレームを構成することができる。

このように本発明によると、固定子コアを分割形成したことによるコア振動を低減でき、以

て固定子コアの分割形成を可能にでき、この固定子コアのスロット毎にトロイダル状の巻線を施して、巻線を含めて全体の厚みを大幅に縮小した固定子を容易かつ安価に得ることができることになる。

4. 図面の簡単な説明

第1図は本発明により製造された固定子の縦断面図、第2図は分割コアに巻線を施す状態の略示正面図、第3図は固定子の巻線構造を示す略示正面図、第4図はモールド状態を示す縦断面図、第5図は製造された固定子の一部欠截斜視図、第6図(a)(b)は絶縁被嵌体を例示する一部の斜視図、第7図は本発明による固定子使用の誘導電動機を示す縦断面図である。

(1) …固定子、(2) …回転子、(10)…固定子コア、(11)(11)…分割コア、(12)…スロット、(13)…歯部、(14)…継鉄部、(15)…巻線、(18)…モールド材料、(20)…モールド型。

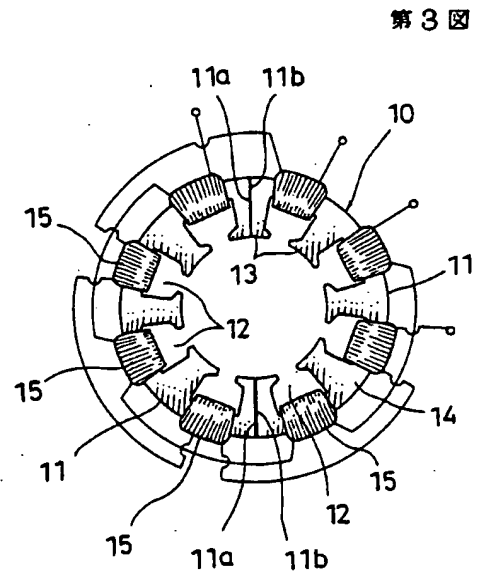
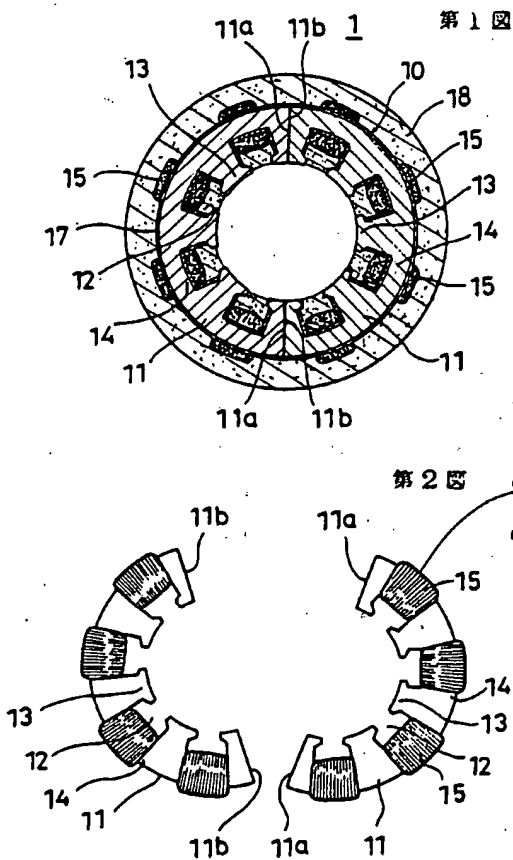

第5圖

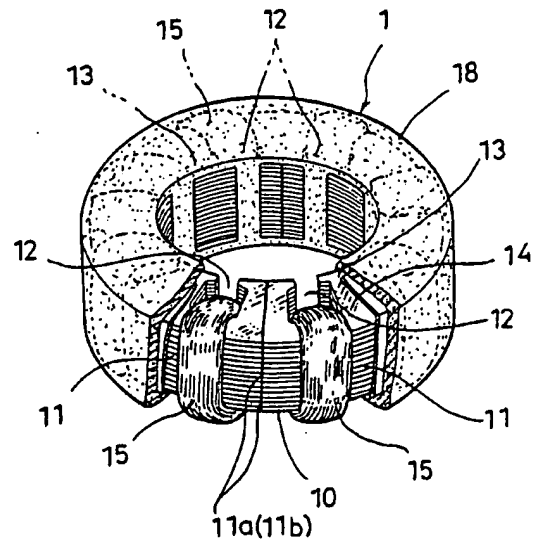

第4圖

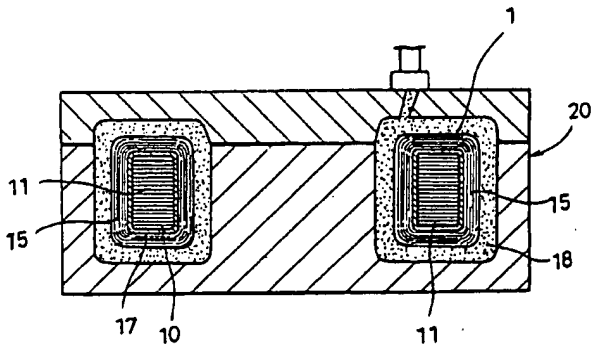

第7圖

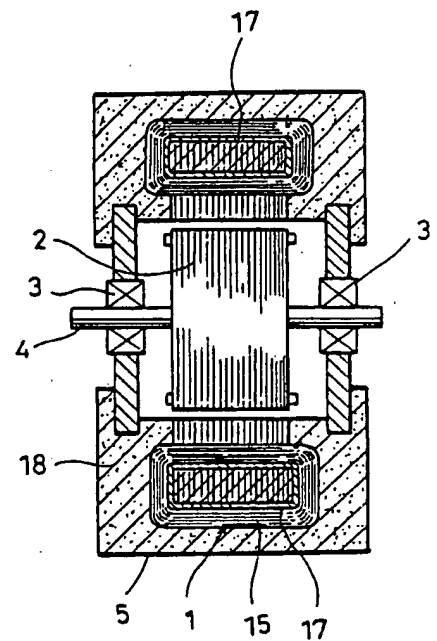

第6圖

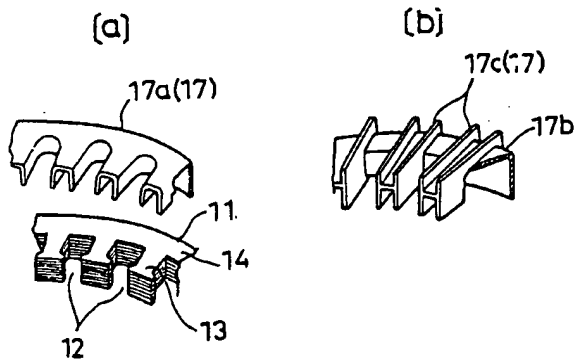

PAT-NO: JP404295256A  
DOCUMENT-IDENTIFIER: JP 04295256 A  
TITLE: STATOR FOR MOTOR  
PUBN-DATE: October 20, 1992

INVENTOR-INFORMATION:

NAME  
KIEDA, KOUKI  
UZAWA, KEN  
MIYAGAWA, HIDEAKI

ASSIGNEE-INFORMATION:

NAME	COUNTRY
mitsubishi electric corp	N/A

APPL-NO: JP03056724

APPL-DATE: March 20, 1991

INT-CL (IPC): H02K015/02, H02K001/18

ABSTRACT:

PURPOSE: To provide a stator for motor split into an outer ring yoke and an inner ring pole part in which machining and assembling of the inner ring pole part are facilitated and fabrication cost is lowered.

CONSTITUTION: Predetermined number of pole coupling boards 14 comprising pole pieces 12 coupled through coupling pieces 13 and the pole pieces 12 are laminated and then the coupling pieces 13 are removed through press thus a pole piece 11 is formed. The pole piece 11 is then placed in a molding die and integrally molded of insulating resin 16 through which respective pole pieces 11 are coupled each other to form an inner ring pole section 10 around which a

coil is wound. Finally, the inner ring pole section 10 is coupled with an outer ring yoke section 7 thus a stator 8 is made.

COPYRIGHT: (C)1992,JPO&Japio

(19) 日本国特許庁 (J P)

(12) 公開特許公報 (A)

(11) 特許出願公開番号

特開平4-295256

(43) 公開日 平成4年(1992)10月20日

(51) Int.Cl. <sup>5</sup>	識別記号	庁内整理番号	F I	技術表示箇所
H 0 2 K 15/02	D	8325-5H		
1/18	E	7254-5H		

審査請求 未請求 請求項の数1(全 3 頁)

(21) 出願番号 特願平3-56724

(22) 出願日 平成3年(1991)3月20日

(71) 出願人 000006013

三菱電機株式会社

東京都千代田区丸の内二丁目2番3号

(72) 発明者 木枝綱希

中津川市駒場町1番3号 三菱電機株式会社  
中津川製作所内

(72) 発明者 鶴沢 憲

中津川市駒場町1番3号 三菱電機株式会社  
中津川製作所内

(72) 発明者 宮川秀明

中津川市駒場町1番3号 三菱電機株式会社  
中津川製作所内

(74) 代理人 弁理士 高田 守 (外1名)

(54) 【発明の名称】 電動機の固定子

(57) 【要約】

【目的】 外輪ヨークと内輪磁極部とに二分割された電動機の固定子において、内輪磁極部の加工および組立性を容易にし製造コストを下げる。

【構成】 磁極片12を連結ピース13にて連結してなる磁極連結板14と磁極片12とを所定枚数積層した後、上記連結ピース13をプレスにて除去しポールピース11を形成する。そして、成形金型に入れ絶縁樹脂16にて一体成形し絶縁樹脂16を介して各ポールピース11を連結することにて内輪磁極部10を形成し、この内輪磁極部にコイルを巻く。最後に内輪磁極部10を外輪ヨーク部7に結合し固定子8ができる。

【効果】 内輪磁極部の取り扱いが連結ピースにて一体となっているので容易、且つ加工および組立性が簡略化され、製造コストが安価になる。

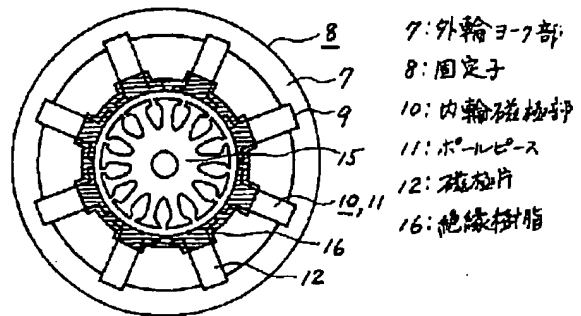

- 7: 外輪ヨーク部
- 8: 固定子
- 10: 内輪磁極部
- 11: ポールピース
- 12: 磁極片
- 16: 絶縁樹脂

1

【特許請求の範囲】

【請求項1】 薄板を積層し、外輪部を形成する外輪ヨーク部と、この外輪ヨーク部に嵌合固定され、磁極を構成する磁極片が積層されたポールピースを周方向にそれぞれ所定の間隔をもって配列されてなる内輪磁極部とを備え、上記内輪磁極部を磁極片が連結ピースにて連結されてなる磁極連結板と磁極片とを積層した後、上記連結ピースを除去することにてポールピースを形成し、このポールピースを絶縁樹脂を介して連結することにて形成したことを特徴とする電動機の固定子。

【発明の詳細な説明】

【0001】

【産業上の利用分野】 この発明は、外軸ヨーク部と内輪磁極部とに分割された電動機の固定子に関するものである。

【0002】

【従来の技術】 従来、この種の電動機の固定子としては、図6に示すようにそれぞれ柱体1の先端に幅広な磁極部2を形成し、この各磁極部2の極面3を内側にして環状に配列し、図示されない外輪ヨークに上記柱体1の基端面を接触させて嵌合された複数個のポールピース4を各磁極部2にて保形部材5を介して連結しているものが知られている（例えば、実開昭51-5903号公報参照）。

【0003】

【発明が解決しようとする課題】 上記のような従来の電動機の固定子では、ポールピース4がそれぞれ完全に独立して積層により形成されており、保形部材5による一体成形にての連結作業が複雑で作業効率が非常に悪いという課題があった。

【0004】 この発明に係る課題を解決するためになされたもので、各ポールピースが関連をもって積層により形成され、保形部材を介しての連結作業が簡単にでき、作業効率のよい電動機の固定子を得ることを目的とする。

【0005】

【課題を解決するための手段】 この発明に係る電動機の固定子は、薄板を積層し、外輪部を形成する外輪ヨーク部と、この外輪ヨーク部に嵌合され、磁極を構成する磁極片が積層されたポールピースを周方向にそれぞれ所定の間隔をもって配列されてなる内輪磁極部とを備え、上記内輪磁極部を磁極片が連結ピースにて連結されてなる磁極連結板と磁極片とを積層した後、上記連結ピースを除去することにてポールピースを形成し、このポールピースを絶縁樹脂を介して連結することにて形成したものである。

【0006】

【作用】 この発明においては、薄板を積層し、外輪部を形成する外輪ヨーク部と、この外輪ヨーク部に嵌合され、磁極を構成する磁極片が積層されたポールピースを

2

周方向にそれぞれ所定の間隔をもって配列されてなる内輪磁極部とを備え、上記内輪磁極部を磁極片が連結ピースにて連結されてなる磁極連結板と磁極片とを積層した後、上記連結ピースを除去することにてポールピースを形成し、このポールピースを絶縁樹脂を介して連結することにて形成したことより、連結ピースが除去されたポールピースは絶縁樹脂にて一体に成形され、所定間隔をもって連結される。

【0007】

10 【実施例】 図1～図5はこの発明の一実施例を示す図であり、図において7は固定子8の外輪ヨーク部で、電磁鋼板等の薄板が複数板積層された円筒状よりなる。9はこの外輪ヨーク部の内部に設けられた凹部溝で、側壁は後述される内輪磁極部中心に一致するように構成されている。10は内輪磁極部、11はこの内輪磁極部を形成するポールピースで、磁極を構成する磁極片12が連結ピース13と一体に成形された磁極連結板14および磁極片12単品が所定枚数積層されてなる。なお、この場合磁極連結板14は図3に示すように内輪磁極部10の下面に所定枚数積層されている。15は上記内輪磁極部10と所定間隔をもって内設される回転子、16は絶縁樹脂で、上記ポールピース11に一体に成形固着され、ポールピース11を絶縁樹脂を介して連結するものである。

30 【0008】 上記のように構成された電動機の固定子においては、電磁鋼板をプレス工程にて外輪ヨーク部7、磁極片12、磁極連結板14および回転子15を一括して同時に打ち抜き、所定枚数積層する。なお、この場合プレス工程の金型内において上記各部品は自動的に必要枚数打ち抜かれ、例えば磁極連結板14が積層部分に対し上部あるいは下部位置に必要な枚数のみ積層され、それ以外は磁極片12が積層される。そして、固定子8および回転子15の1個分に相当する打ち抜きが終了すると、上記プレス工程の中で各部分がかしめ等の手段により結合され、外輪ヨーク部7、内輪磁極部10および回転子15が形成される。さらに、上記内輪磁極部10はプレス等により連結ピース13が除去加工され、治具（図示せず）に固定後、図示されない一体成形金型に供給され、絶縁樹脂16にて一体成形固着されることにて、各ポールピース11は絶縁樹脂16を介し所定間隔をもって連結される。そして、内輪磁極部10の各ポールピース11間に図示されないコイルが巻回された後、内輪磁極部10が外輪ヨーク部7の凹部溝9に圧入嵌合されることにて固定子8が形成される。

40 【0009】 なお、上記実施例では磁極連結板14の連結ピース13をプレス加工にて除去したが、切削加工、レーザー加工あるいはガス切断等の方法にての除去加工でも上記実施例と同様の効果が得られる。

【0010】

50 【発明の効果】 この発明は以上説明したとおり、薄板を

積層し、外輪部を形成する外輪ヨーク部とこの外輪ヨーク部に嵌合され、磁極を構成する磁極片が積層されたポールピースを周方向にそれぞれ所定の間隔をもって配列されてなる内輪磁極部とを備え、上記内輪磁極部を磁極片が連結ピースにて連結されてなる磁極連結板と磁極片とを積層した後、上記連結ピースを除去することにてポールピースを形成し、このポールピースを絶縁樹脂を介して連結することにて形成したことより、ポールピースの絶縁樹脂にての連結までが連結ピースにより内輪磁極部が一体にて取り扱い、且つ保持できるので各工程が簡略化され、自動化が容易になり、コストを安価にできる。

【図面の簡単な説明】

【図1】この発明の一実施例を示す平面図である。

【図2】この発明の一実施例を示す平面図と側面図である。

る。

【図3】この発明の一実施例を示す内輪磁極部の斜視図である。

【図4】この発明の一実施例を示す内輪磁極部の平面図である。

【図5】この発明の一実施例を示し、絶縁樹脂にて成形後の内輪磁極部の部分平面図である。

【図6】従来の電動機の固定子を示す平面図である。

【符号の説明】

- 7 外輪ヨーク部
- 8 固定子
- 10 内輪磁極部
- 11 ポールピース
- 13 磁極連結板
- 16 絶縁樹脂

【図1】

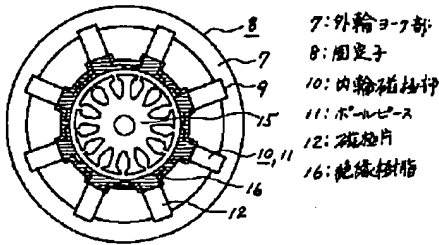

【図2】

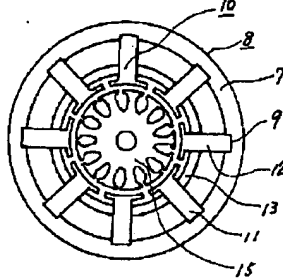

【図4】

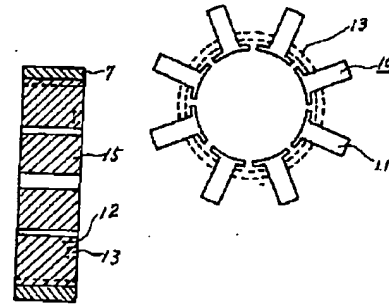

【図3】

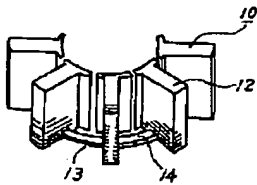

【図5】



【図6】

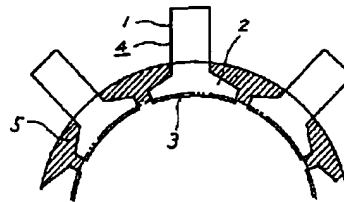





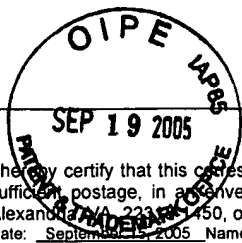

2834

CERTIFICATE OF MAILING UNDER 37 C.F.R. §1.8

I hereby certify that this correspondence is being deposited with the United States Postal Service as first class mail, with sufficient postage, in an envelope addressed to: Mail Stop Amendment, Commissioner for Patents, P. O. Box 1450, Alexandria, VA, 22313-1450, on the below date:

Date: September 15, 2005 Name: Steven P. Shurtz, Reg. No. 31,424 Signature: /Steven P. Shurtz/

**BRINKS  
HOFFER  
GILSON  
& LIONE**

**IN THE UNITED STATES PATENT AND TRADEMARK OFFICE**

In re Appln. of: **Griffith D. Neal**

Appln. No.: **10/383,219**

Filed: **March 5, 2003**

For: **STATOR ASSEMBLY MADE FROM A  
MOLDED WEB OF CORE SEGMENTS AND  
MOTOR USING SAME**

Examiner: **Burton S. Mullins**

Group Art Unit: **2834**

Attorney Docket No: **8864-33**

Mail Stop Amendment  
Commissioner for Patents  
P. O. Box 1450  
Alexandria, VA 22313-1450

**TRANSMITTAL**

Sir:

**Attached is/are:**

- Transmittal Letter (in duplicate); Amendment.
- Return Receipt Postcard

**Fee calculation:**

- No additional fee is required.
- An extension fee in an amount of \$\_\_\_ for a \_\_\_-month extension of time under 37 C.F.R. § 1.136(a).
- A petition or processing fee in an amount of \$\_\_\_ under 37 C.F.R. § 1.17(\_\_\_\_).
- An additional filing fee has been calculated as shown below:

					Small Entity		Not a Small Entity		
	Claims Remaining After Amendment		Highest No. Previously Paid For	Present Extra	Rate	Add'l Fee	or	Rate	Add'l Fee
Total	15	Minus	34	0	x \$25=			x \$50=	0
Indep.	3	Minus	6	0	x 100=			x \$200=	0
First Presentation of Multiple Dep. Claim					+ \$180=			+ \$360=	
					Total			Total	\$0

**Fee payment:**

- A credit card authorization in the amount of \$\_\_\_ to cover the above-identified fee(s) is enclosed.
  - Please charge Deposit Account No. 23-1925 in the amount of \$ . A copy of this Transmittal is enclosed for this purpose.
  - The Director is hereby authorized to charge payment of any additional filing fees required under 37 CFR § 1.16 and any patent application processing fees under 37 CFR § 1.17 associated with this paper (including any extension fee required to ensure that this paper is timely filed), or to credit any overpayment, to Deposit Account No. 23-1925.
- Respectfully submitted,

September 15, 2005  
Date

/Steven P. Shurtz/  
Steven P. Shurtz  
(Registration No. 31,424)  
Brinks Hofer Gilson Lione  
P.O. Box 10395  
Chicago, IL. 60610



I hereby certify that this correspondence is being deposited with the United States Postal Service, with sufficient postage, as first class mail in an envelope addressed to:

Commissioner for Patents  
P.O. Box 1450  
Alexandria, VA 22313  
on September 15, 2005

\_\_\_\_\_  
Date of Deposit

\_\_\_\_\_  
Steven P. Shurtz, Reg. No. 31,424

\_\_\_\_\_  
Name of applicant, assignee or  
Registered Representative

\_\_\_\_\_  
/Steven P. Shurtz/

\_\_\_\_\_  
Signature

\_\_\_\_\_  
September 15, 2005

\_\_\_\_\_  
Date of Signature

Case No. 8864/33

**IN THE UNITED STATES PATENT AND TRADEMARK OFFICE**

In re Application of:

Griffith D. Neal

Serial No.: 10/383,219

Filed: March 5, 2003

For: STATOR ASSEMBLY  
MADE FROM A  
MOLDED WEB OF  
CORE SEGMENTS AND  
MOTOR USING SAME

Examiner: Burton S. Mullins  
Group Art Unit: 2834

**AMENDMENT**

Mail Stop Amendment  
Commissioner for Patents  
P.O. Box 1450  
Alexandria, VA 22313-1450

Dear Sir:

In response to the Office Action mailed June 15, 2005, please enter the following amendment and consider the following remarks.

Amendments to the claims are reflected in the listing of claims which begins on page 2 of this paper.

Remarks begin on page 5 of the paper.

## Amendments to the Claims

Please cancel claims 11-24, 26-28 and 31-32 without prejudice to filing the claims in a continuing application. Please amend claims 22, 29 and 34 as follows, again without prejudice to presenting the unamended claims in a continuing application. A complete listing of the claims with proper claim identifiers follows.

### **Listing of Claims**

1. (Original) A stator assembly, comprising:
  - a) a plurality of discrete stator segments each at least partially encased with a phase change material, wherein the phase change material also comprises a bridge between adjacent segments to link adjacent segments into a continuous strip; and
  - b) the linked stator segments being arranged and secured together to form the stator assembly.
2. (Original) The stator assembly of claim 1 wherein the bridges produce such a continuous linkage between segments that the bridges may be used to orient and manipulate the segments during wire winding.
3. (Original) The stator assembly of claim 1 wherein wire having a packing density of greater than 80 percent is wound around the poles.
4. (Original) The stator assembly of claim 1 wherein the bridges between adjoining segments can be used to orient and position wire relative to the poles.
5. (Original) The stator assembly of claim 1 wherein the phase change material has a thermal conductivity of at least 0.4 watts/meter<sup>°K</sup> at 23°C.
6. (Original) The stator assembly of claim 1 wherein the discrete stator segments are each made from a plurality of steel laminations.
7. (Original) The stator assembly of claim 1 wherein the phase change material comprises polyamide.

8. (Previously presented) The stator assembly of claim 1 wherein the stator segments are held in a toroidal shape by a retaining member.

9. (Original) The stator assembly of claim 8 wherein the retaining member comprises a metal band.

10. (Original) The stator assembly of claim 1 wherein the stator segments are held in a toroidal shape by an overmolded thermoplastic material.

11-24. (Canceled)

25. (Original) A motor made from the stator assembly of claim 1.

26-28. (Canceled)

29. (Currently amended) [[The combination of claim 28]] A combination of stator arc segments and a flexible carrier used to link said stator arc segments during a winding operation comprising:

a) a plurality of stator arc segments; and

b) a phase change material constituting said flexible carrier adhered to the stator arc segments which links said segments in a uniform and predetermined position with respect to one another; wherein the stator arc segments each comprise a plurality of steel laminations and wherein the steel laminations are electrically insulated from the wire applied during winding by a portion of the phase change material formed monolithically with the flexible carrier.

30. (Original) The combination of claim 29 where the phase change material has a dielectric strength of at least 250 volts per one thousandth of an inch of thickness.

31-32. (Canceled)

33. (Previously presented) The stator assembly of claim 1 wherein the bridge is formed by interconnecting two mating sections formed from the phase change material.

34. (Currently amended) [[The combination of claim 28]] A combination of stator arc segments and a flexible carrier used to link said stator arc segments during a winding operation comprising:

a) a plurality of stator arc segments; and

b) a phase change material constituting said flexible carrier adhered to the stator arc segments which links said segments in a uniform and predetermined position with respect to one another; wherein the flexible carrier links said segments by connecting two mating sections formed in said carrier.



## Remarks

In the Outstanding Office action claims 1-10, 25 and 33 were allowed, and claims 29, 30 and 34 were indicated as allowable if rewritten in independent form. Claims 29 and 34 have been rewritten. Claim 30 is dependent on claim 29. Since claim 29 is now allowable, it is believed that the objection to claim 30 should be withdrawn.

The rejections of claims 28, 31 and 32 in the outstanding Office Action is traversed. However, since those claims are canceled, the rejection is moot.

Since all of the remaining claims have been indicated as being allowable, the case is believed to be in condition for allowance.

The Examiner noted that he had considered the U.S. references cited in the Information Disclosure Statement filed on July 21, 2001 in the parent case, and invited Applicant to submit copies of the non-U.S. references, and a form PTO 1449 listing the same. While Applicant is unsure of the relevance of the references, Applicant's attorney will put together such a filing.

Respectfully submitted,

/Steven P. Shurtz/

Steven P. Shurtz  
Registration No. 31,424  
Attorney for Applicant

Dated: September 15, 2005  
BRINKS HOFER GILSON & LIONE  
P.O. Box 10395  
Chicago, IL 60610  
(312) 321-4200  
Direct Dial: (801) 444-3933

**Index of Claims**



Application No.

10/383,219

Examiner

Tim Phan

Applicant(s)

NEAL, GRIFFITH D.

Art Unit

3729

✓	Rejected
=	Allowed

-	(Through numeral) Cancelled
+	Restricted

N	Non-Elected
I	Interference

A	Appeal
O	Objected

Claim		Date	
Final	Original		
	3/22/06		
1			
2			
3			
4			
5			
6			
7			
8			
9			
10			
11			
12			
13			
14			
15			
16			
17			
18			
19			
20			
21			
22			
23			
24			
25			
26			
27			
28			
29			
30			
31			
32			
33			
34			
35			
36			
37			
38			
39			
40			
41			
42			
43			
44			
45			
46			
47			
48			
49			
50			

Claim		Date	
Final	Original		
51			
52			
53			
54			
55			
56			
57			
58			
59			
60			
61			
62			
63			
64			
65			
66			
67			
68			
69			
70			
71			
72			
73			
74			
75			
76			
77			
78			
79			
80			
81			
82			
83			
84			
85			
86			
87			
88			
89			
90			
91			
92			
93			
94			
95			
96			
97			
98			
99			
100			

Claim		Date	
Final	Original		
101			
102			
103			
104			
105			
106			
107			
108			
109			
110			
111			
112			
113			
114			
115			
116			
117			
118			
119			
120			
121			
122			
123			
124			
125			
126			
127			
128			
129			
130			
131			
132			
133			
134			
135			
136			
137			
138			
139			
140			
141			
142			
143			
144			
145			
146			
147			
148			
149			
150			

Under the Paperwork Reduction Act of 1995, no persons are required to respond to a collection of information unless it displays a valid OMB control number.

**PATENT APPLICATION FEE DETERMINATION RECORD**

Application or Docket Number

10/382,219

Substitute for Form PTO-875

**CLAIMS AS FILED - PART I**

	(Column 1)	(Column 2)
FOR	NUMBER FILED	NUMBER EXTRA
BASIC FEE (37 CFR 1.16(a))		
TOTAL CLAIMS (37 CFR 1.16(c))	minus 20 =	*
INDEPENDENT CLAIMS (37 CFR 1.16(b))	minus 3 =	*
MULTIPLE DEPENDENT CLAIM PRESENT (37 CFR 1.16(d))		

SMALL ENTITY

RATE	FEE
	\$ _____
X \$ _____ =	
X \$ _____ =	
+ \$ _____ =	
TOTAL	

OTHER THAN SMALL ENTITY

RATE	FEE
	\$ _____
X \$ _____ =	
X \$ _____ =	
+ \$ _____ =	
TOTAL	

\* If the difference in column 1 is less than zero, enter "0" in column 2.

**CLAIMS AS AMENDED - PART II**

AMENDMENT A

	(Column 1)	(Column 2)	(Column 3)
	CLAIMS REMAINING AFTER AMENDMENT	HIGHEST NUMBER PREVIOUSLY PAID FOR	PRESENT EXTRA
Total (37 CFR 1.16(c))	15	34	= /
Independent (37 CFR 1.16(b))	2	6	= /
FIRST PRESENTATION OF MULTIPLE DEPENDENT CLAIM (37 CFR 1.16(d))			

SMALL ENTITY

RATE	ADDITIONAL FEE
X \$ 25 =	
X \$ 100 =	
+ \$ 180 =	
TOTAL ADD'L FEE	

OTHER THAN SMALL ENTITY

RATE	ADDITIONAL FEE
X \$ 50 =	
X \$ 200 =	
+ \$ 360 =	
TOTAL ADD'L FEE	

AMENDMENT B

	(Column 1)	(Column 2)	(Column 3)
	CLAIMS REMAINING AFTER AMENDMENT	HIGHEST NUMBER PREVIOUSLY PAID FOR	PRESENT EXTRA
Total (37 CFR 1.16(c))			=
Independent (37 CFR 1.16(b))			=
FIRST PRESENTATION OF MULTIPLE DEPENDENT CLAIM (37 CFR 1.16(d))			

SMALL ENTITY

RATE	ADDITIONAL FEE
X \$ 25 =	
X \$ 100 =	
+ \$ 180 =	
TOTAL ADD'L FEE	

OTHER THAN SMALL ENTITY

RATE	ADDITIONAL FEE
X \$ 50 =	
X \$ 200 =	
+ \$ 360 =	
TOTAL ADD'L FEE	

AMENDMENT C

	(Column 1)	(Column 2)	(Column 3)
	CLAIMS REMAINING AFTER AMENDMENT	HIGHEST NUMBER PREVIOUSLY PAID FOR	PRESENT EXTRA
Total (37 CFR 1.16(c))			=
Independent (37 CFR 1.16(b))			=
FIRST PRESENTATION OF MULTIPLE DEPENDENT CLAIM (37 CFR 1.16(d))			

SMALL ENTITY

RATE	ADDITIONAL FEE
X \$ 25 =	
X \$ 100 =	
+ \$ 180 =	
TOTAL ADD'L FEE	

OTHER THAN SMALL ENTITY

RATE	ADDITIONAL FEE
X \$ 50 =	
X \$ 200 =	
+ \$ 360 =	
TOTAL ADD'L FEE	

\* If the entry in column 1 is less than the entry in column 2, write "0" in column 3.  
 \*\* If the "Highest Number Previously Paid For" IN THIS SPACE is less than 20, enter "20".  
 \*\*\* If the "Highest Number Previously Paid For" IN THIS SPACE is less than 3, enter "3".  
 The "Highest Number Previously Paid For" (Total or Independent) is the highest number found in the appropriate box in column 1.

This collection of information is required by 37 CFR 1.16. The information is required to obtain or retain a benefit by the public which is to file (and by the USPTO to process) an application. Confidentiality is governed by 35 U.S.C. 122 and 37 CFR 1.14. This collection is estimated to take 12 minutes to complete, including gathering, preparing, and submitting the completed application form to the USPTO. Time will vary depending upon the individual case. Any comments on the amount of time you require to complete this form and/or suggestions for reducing this burden, should be sent to the Chief Information Officer, U.S. Patent and Trademark Office, U.S. Department of Commerce, P.O. Box 1450, Alexandria, VA 22313-1450. DO NOT SEND FEES OR COMPLETED FORMS TO THIS ADDRESS. SEND TO: Commissioner for Patents, P.O. Box 1450, Alexandria, VA 22313-1450.

If you need assistance in completing the form, call 1-800-PTO-9199 and select option 2



2834

CERTIFICATE OF MAILING UNDER 37 C.F.R. §1.8

I hereby certify that this correspondence is being deposited with the United States Postal Service as first class mail, with sufficient postage, in an envelope addressed to: Mail Stop Amendment, Commissioner for Patents, P. O. Box 1450, Alexandria, VA 22313-1450, on the below date:  
Date: September 22, 2005 Name: Steven P. Shurtz Signature: /Steven P. Shurtz/

IN THE UNITED STATES PATENT AND TRADEMARK OFFICE

In re Appln. of: Griffith D. Neal  
Appln. No.: 10/383,219  
Filed: March 5, 2003  
For: STATOR ASSEMBLY MADE FROM A MOLDED WEB OF CORE SEGMENTS AND MOTOR USING SAME

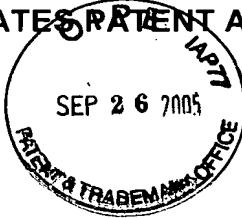

Examiner: Burton S. Mullins  
Art Unit: 2834

Attorney Docket No: 8864-33

INFORMATION DISCLOSURE STATEMENT

Applicant hereby cites references A1-A137 identified on the attached PTO 1449 form.

Applicant is enclosing Form PTO-1449 (four pages), along with a copy of each listed reference for which a copy is required under 37 C.F.R. §1.98(a)(2). For those references not in English, an English language Abstract has been provided for the convenience of the Examiner. The Examiner indicated that he previously reviewed the U.S. documents listed on the Information Disclosure Statement filed in the parent case. The attached PTO 1449 form lists those references, as well as references otherwise made of record in the parent case. Applicant respectfully requests the Examiner's consideration of the references on the attached PTO 1449 form that he has not already considered, and entry into the record of this application all of the documents listed on the attached PTO 1449 form.

By submitting this Statement, Applicant is attempting to fully comply with the duty of candor and good faith mandated by 37 C.F.R. §1.56. As such, this Statement is not

BRINKS  
HOFFER  
GILSON  
& LIONE

09/27/2005 2:04 PM  
01 FC:1806  
00000034 10383219  
180.00 DP

intended to constitute an admission that any of the enclosed references, or other information referred to therein, constitutes "prior art" or is otherwise "material to patentability," as that phrase is defined in 37 C.F.R. §1.56(a).

Applicant has calculated a processing fee in the amount of \$180.00 to be due under 37 C.F.R. §1.17(p) in connection with the filing of this Statement. Applicant has enclosed a credit card charge authorization covering this fee as indicated in the Transmittal accompanying this Statement.

Respectfully submitted,

September 22, 2005

Date

/Steven P. Shurtz/

Steven P. Shurtz, Reg. No. 31,424



CERTIFICATE OF MAILING UNDER 37 C.F.R. §1.8

I hereby certify that this correspondence is being deposited with the United States Postal Service as first class mail, with sufficient postage, in an envelope addressed to: Commissioner for Patents, P. O. Box 1450, Alexandria, VA 22313-1450, on the below date:  
Date: September 22, 2005 Name: Steven P. Shurtz Signature: /Steven P. Shurtz/

BRINKS  
HOFER  
GILSON  
& LIONE

IN THE UNITED STATES PATENT AND TRADEMARK OFFICE

In re Appln. of: Griffith D. Neal

Appln. No.: 10/383,219

Filed: March 5, 2003

For: STATOR ASSEMBLY MADE FROM A  
MOLDED WEB OF CORE SEGMENTS  
AND MOTOR USING SAME

Examiner: Burton S. Mullins

Art Unit: 2834

Attorney Docket No: 8864-33

Mail Stop Amendment  
Commissioner for Patents  
P. O. Box 1450  
Alexandria, VA 22313-1450

TRANSMITTAL

Sir:

Attached is/are:

- Information Disclosure Statement; Form PTO 1449; cited references A116-A137.
- Return Receipt Postcard

Fee calculation:

- No additional fee is required.
- Small Entity.
- An extension fee in an amount of \$\_\_\_\_\_ for a \_\_\_\_\_-month extension of time under 37 C.F.R. § 1.136(a).
- A petition or processing fee in an amount of \$\_\_\_\_\_ under 37 C.F.R. § 1.17(\_\_\_\_\_).
- An additional filing fee has been calculated as shown below:

					Small Entity		Not a Small Entity		
	Claims Remaining After Amendment		Highest No. Previously Paid For	Present Extra	Rate	Add'l Fee	or	Rate	Add'l Fee
Total		Minus			x \$25=			x \$50=	
Indep.		Minus			x 100=			x \$200=	
First Presentation of Multiple Dep. Claim					+ \$180=			+ \$360=	
					Total	\$		Total	\$

Fee payment:

- A check in the amount of \$\_\_\_\_\_ is enclosed.
- Please charge Deposit Account No. 23-1925 in the amount of \$\_\_\_\_\_. A copy of this Transmittal is enclosed for this purpose.
- Payment by credit card in the amount of \$180.00 (Form PTO-2038 is attached).
- The Director is hereby authorized to charge payment of any additional filing fees required under 37 CFR § 1.16 and any patent application processing fees under 37 CFR § 1.17 associated with this paper (including any extension fee required to ensure that this paper is timely filed), or to credit any overpayment, to Deposit Account No. 23-1925.

Respectfully submitted,

September 22, 2005  
Date

/Steven P. Shurtz/  
Steven P. Shurtz (Reg. No. 31,424)

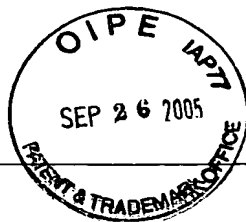

FORM PTO-1449	SERIAL NO. 10/383,219	CASE NO. 8864/33
<b>LIST OF PATENTS AND PUBLICATIONS FOR APPLICANT'S INFORMATION DISCLOSURE STATEMENT</b>	FILING DATE March 5, 2003	GROUP ART UNIT 2834
(use several sheets if necessary)	APPLICANT: Griffith D. Neal	

**REFERENCE DESIGNATION U.S. PATENT DOCUMENTS**

EXAMINER INITIAL	DOCUMENT NUMBER <small>Number-Kind Code (if known)</small>	DATE	NAME	CLASS/ SUBCLASS	FILING DATE
	A1	3,590,328	06/29/1971	Bert L. Frescura	
	A2	3,638,055	01/25/1972	Zimmermann	
	A3	3,802,066	4/09/1974	Barrett	
	A4	3,874,073	04/01/1975	Dochterman et al.	
	A5	3,908,138	9/23/1975	Shieh	
	A6	3,942,054	03/02/1976	Kristen et al.	
	A7	3,979,530	09/07/1976	Schwider et al.	
	A8	4,128,527	12/05/1978	Kinjo et al.	
	A9	4,173,822	11/13/1979	Futterer et al.	
	A10	4,352,897	10/05/1982	Ogata et al.	
	A11	4,365,180	12/21/1982	Licata et al.	
	A12	4,372,035	2/08/1983	McMillen	
	A13	4,387,311	06/07/1983	Kobayashi et al.	
	A14	4,492,889	01/08/1985	Fukushi et al.	
	A15	4,572,979	02/25/1986	Haar et al.	
	A16	4,643,346	2/17/1987	Gotoh	
	A17	4,679,313	07/14/1987	Schultz et al.	
	A18	4,712,035	12/08/1987	Forbes et al.	
	A19	4,760,299	07/26/1988	Dickie et al.	
	A20	4,801,833	01/31/1989	Dye	
	A21	4,853,576	08/01/1989	Mayumi et al.	
	A22	4,858,073	08/15/1989	Gregory	
	A23	4,868,970	09/26/1989	Schultz et al.	
	A24	4,954,739	09/04/1990	Schultz et al.	
	A25	4,990,809	2/05/1991	Artus et al.	
	A26	5,008,572	04/16/1991	Marshall et al.	
	A27	5,036,580	08/06/1991	Fox et al.	
	A28	5,073,735	12/17/1991	Takagi	
	A29	5,075,585	12/24/1991	Teruyama et al.	
	A30	5,121,021	06/09/1992	Ward	
	A31	5,134,327	07/28/1992	Sumi et al.	
	A32	5,142,103	08/25/1992	Stine	
	A33	5,147,982	09/15/1992	Steffen	
	A34	5,191,698	03/09/1003	Sumi et al.	
	A35	5,206,554	04/27/1993	Perrot	
	A36	5,268,607	12/07/1993	McManus	

EXAMINER	DATE CONSIDERED
----------	-----------------

EXAMINER: Initial if reference considered, whether or not citation is in conformance with MPEP 609; Draw line through citation if not in conformance and not considered. Include copy of this form with next communication to applicant.

Rev. Dec.-99

C:\Documents and Settings\mdolinsk\Local Settings\Temporary Internet Files\OLK843\8864-33 PTO 1449 SPS.doc

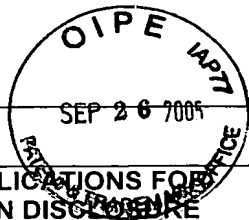

FORM PTO-1449	SERIAL NO. 09/798,511	CASE NO. 8864/20
<b>LIST OF PATENTS AND PUBLICATIONS FOR APPLICANT'S INFORMATION DISCLOSURE STATEMENT</b> (use several sheets if necessary)	FILING DATE March 2, 2001	GROUP ART UNIT
APPLICANT(S): Griffith D. Neal		

## REFERENCE DESIGNATION

## U.S. PATENT DOCUMENTS

EXAMINER INITIAL	DOCUMENT NUMBER <small>Number-Kind Code (if known)</small>	DATE	NAME	CLASS/ SUBCLASS	FILING DATE
	A37	5,334,897	08/02/1994	Ineson et al.	
	A38	5,345,129	09/06/1994	Molnar	
	A39	5,382,852	01/17/1995	Yuhi et al.	
	A40	5,396,210	03/07/1995	Purohit et al.	
	A41	5,400,218	03/21/1995	Val	
	A42	5,414,317	05/09/1995	Reid et al.	
	A43	5,459,190	10/17/1995	Nakamura et al.	
	A44	5,461,772	10/31/1995	Puri	
	A45	5,500,780	03/19/1996	Boutaghou et al.	
	A46	5,506,458	04/09/1996	Pace et al.	
	A47	5,541,787	07/30/1996	Jabbari et al.	
	A48	5,548,458	08/20/1996	Pelstring et al.	
	A49	5,558,445	09/24/1996	Chen et al.	
	A50	5,579,188	11/26/1996	Dunfield et al.	
	A51	5,587,617	12/24/1996	Dunfield et al.	
	A52	5,592,731	1/14/1997	Huang et al.	
	A53	5,598,048	01/28/1997	Dunfield et al.	
	A54	5,610,463	03/11/1997	Dunfield et al.	
	A55	5,619,083	04/08/1997	Dunfield et al.	
	A56	5,619,389	04/08/1997	Dunfield et al.	
	A57	5,621,372	04/15/1997	Purohit	
	A58	5,633,545	05/27/1997	Albrecht et al.	
	A59	5,666,242	09/09/1997	Edwards et al.	
	A60	5,668,427	09/16/1997	Morita	
	A61	5,672,927	09/30/1997	Viskochil	
	A62	5,675,196	10/07/1997	Huang et al.	
	A63	5,694,268	12/02/1997	Dunfield et al.	
	A64	5,698,919	12/16/1998	Obara	
	A65	5,728,600	03/17/1998	Saxelby, Jr. et al.	
	A66	5,729,072	3/17/1998	Hirano et al.	
	A67	5,729,404	03/17/1998	Dunfield et al.	
	A68	5,742,450	04/21/1998	Moser	
	A69	5,751,085	05/12/1998	Hayashi	
	A70	5,751,514	05/12/1998	Hyde et al.	
	A71	5,766,535	06/16/1998	Ong	
	A72	5,783,888	07/21/1998	Yamano	
	A73	5,806,169	09/15/1998	Trago et al.	
	A74	5,814,412	09/29/1998	Terada et al.	
	A75	5,850,318	12/15/1998	Dunfield	
	A76	5,859,486	1/12/1999	Nakahara et al.	

EXAMINER	DATE CONSIDERED
----------	-----------------

EXAMINER: Initial if reference considered, whether or not citation is in conformance with MPEP 609; Draw line through citation if not in conformance and not considered. Include copy of this form with next communication to applicant.

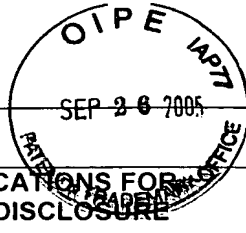

FORM PTO-1449	SERIAL NO. 09/798,511	CASE NO. 8864/20
<b>LIST OF PATENTS AND PUBLICATIONS FOR APPLICANT'S INFORMATION DISCLOSURE STATEMENT</b>	FILING DATE March 2, 2001	GROUP ART UNIT
(use several sheets if necessary)	APPLICANT(S): Griffith D. Neal	

**REFERENCE DESIGNATION U.S. PATENT DOCUMENTS**

EXAMINER INITIAL	DOCUMENT NUMBER <small>Number-Kind Code (if known)</small>	DATE	NAME	CLASS/ SUBCLASS	FILING DATE
	A77	5,875,540	3/02/1999	Sargent et al.	
	A78	5,880,179	03/09/1999	Ito et al.	
	A79	5,881,447	03/16/1999	Molnar	
	A80	5,898,252	3/27/1999	Tanaka et al.	
	A81	5,918,360	7/06/1999	Fornes et al.	
	A82	5,942,824	08/24/1999	Shioya et al.	
	A83	5,949,172	9/07/1999	Katagiri	
	A84	5,958,466	09/28/1999	Ong	
	A85	5,973,424	10/26/1999	Engelberger et al.	
	A86	5,982,057	11/09/1999	Imada et al.	
	A87	5,986,365	11/16/1999	Kuwert et al.	
	A88	5,986,377	11/16/1999	Yamada et al.	
	A89	5,990,247	11/23/1999	Terada et al.	
	A90	6,002,185	12/14/1999	Nakao et al.	
	A91	6,019,516	02/01/2000	Leuthold et al.	
	A92	6,020,661	02/01/2000	Trago et al.	
	A93	6,034,841	03/07/2000	Albrecht et al.	
	A94	6,043,583	03/28/2000	Kurosawa et al.	
	A95	6,049,153	4/11/2000	Nishiyama et al.	
	A96	6,071,014	06/06/2000	Lee et al.	
	A97	6,075,304	06/13/2000	Nakatsuka	
	A98	6,153,959	11/28/2000	Lorenzo	
	A99	6,163,952	12/26/2000	Takehara	
	A100	US 6,167,610 B1	01/02/2001	Nakahara et al.	
	A101	US 6,201,334 B1	03/13/2001	Sargeant et al.	
	A102	US 6,265,800 B1	07/24/2001	Kimura et al.	
	A103	US 6,265,804 B1	07/24/2001	Nitta et al.	
	A104	US 6,300,695 B1	10/09/2001	Neal	
	A105	US 6,362,554 B1	03/26/2002	Neal	
	A106	US 6,437,464 B1	08/20/2002	Neal	
	A107	US 6,501,616 B1	12/31/2002	Neal	
	A108	US 2003/0081347 A1	05/01/2003	Neal	
	A109	US 6,617,721 B1	09/09/2003	Neal	
	A110	US 6,753,628 B1	06/22/2004	Neal	
	A111	US 6,844,636 B2	01/18/2005	Neal	
	A112	US 6,892,439 B1	05/17/2005	Neal	
	A113	US 6,911,166 B2	06/28/2005	Neal	
	A114	US 2005/0134124 A1	06/23/2005	Lieu	
	A115	US 6,941,640 B2	09/13/2005	Neal	

EXAMINER	DATE CONSIDERED
----------	-----------------

EXAMINER: Initial if reference considered, whether or not citation is in conformance with MPEP 609; Draw line through citation if not in conformance and not considered. Include copy of this form with next communication to applicant.

FORM PTO-1449	SERIAL NO. 09/798,511	CASE NO. 8864/20
LIST OF PATENTS AND PUBLICATIONS FOR APPLICANT'S INFORMATION DISCLOSURE STATEMENT	FILING DATE March 2, 2001	GROUP ART UNIT
	APPLICANT(S): Griffith D. Neal	

## FOREIGN PATENT DOCUMENTS

EXAMINER INITIAL		DOCUMENT NUMBER <small>Number-Kind Code (if known)</small>	DATE	COUNTRY	CLASS/ SUBCLASS	TRANSLATION	
						YES	NO
	A116	DT 25 39 492 A1	03/10/77	Germany		Abstract	
	A117	870.878	01/15/79	Belgium		Abstract	
	A118	891.258	03/16/82	Belgium		Abstract	
	A119	SU 1334297	08/30/87	Soviet Union		Abstract	
	A120	SU 1494148	07/15/89	Soviet Union		Abstract	
	A121	2 647 958	12/07/90	France		Abstract	
	A122	WO 92/06532	04/16/92	PCT			
	A123	05336722	12/17/93	Japan		Abstract	
	A124	WO 96/20501	07/04/96	PCT			
	A125	WO 96/33533	10/24/96	PCT			
	A126	WO 97/39870	10/30/97	PCT			
	A127	EP 0 747 943 A2	12/11/96	EPO			
	A128	10070870	03/10/98	Japan		Abstract	
	A129	410271719	10/09/98	Japan		Abstract	
	A130	EP 0 883 171 A1	12/09/98	EPO		Abstract	
	A131	11082508	03/26/99	Japan		Abstract	

EXAMINER INITIAL	OTHER ART (Including Author, Title, Date, Pertinent Pages, etc.)	
	A132	LNP Engineering Plastics, Advertisement entitled "Konduit™ Thermally Conductive Composites," undated (2 pages)
	A133	Product Information from Dupont Engineering Polymers entitled "Electrical/Electronic Thermoplastic Encapsulation," undated, Publ. Reorder No.: H-58633 (R, 96.7), 20 pages.
	A134	LNP Engineering Plastics, Press Release entitled "LNP Introduces First-Ever Line of Thermally Conductive Compounds," January 28, 1999 (2 pages)
	A135	Buchanan Motor Works, Inc., article from the Internet entitled "Epoxy Seal - Prevents Down Time and Keeps Equipment Running Longer," 07/14/99, < <a href="http://www.bmwworks.com/VIP.htm">http://www.bmwworks.com/VIP.htm</a> >, 1 page.
	A136	The Epoxylite Corporation, article from the Internet entitled "Vacuum Pressure Impregnation (VPI) Systems", 11/19/99, < <a href="http://www.epoxylite.com/EpoxyliteEquipment.htm">http://www.epoxylite.com/EpoxyliteEquipment.htm</a> >, 3 pages.
	A137	Neeltran Inc., article from the Internet entitled "Vacuum Pressure Impregnation (VPI)", 11/19/99, < <a href="http://www.neeltran.thomasregister.com/olc/neeltran/neel9.htm">http://www.neeltran.thomasregister.com/olc/neeltran/neel9.htm</a> > 2 pages.

EXAMINER	DATE CONSIDERED
----------	-----------------

EXAMINER: Initial if reference considered, whether or not citation is in conformance with MPEP 609; Draw line through citation if not in conformance and not considered. Include copy of this form with next communication to applicant.



(12) **DEMANDE DE BREVET EUROPEEN**

(43) Date de publication: 09.12.1998. Bulletin 1998/50 (51) Int Cl.<sup>6</sup>: H01L 21/56

(21) Numéro de dépôt: 98401318.5

(22) Date de dépôt: 02.06.1998

<p>(84) Etats contractants désignés:  <b>AT BE CH CY DE DK ES FI FR GB GR IE IT LI LU MC NL PT SE</b>          Etats d'extension désignés:  <b>AL LT LV MK RO SI</b></p> <p>(30) Priorité: 03.06.1997 FR 9706808</p> <p>(71) Demandeur: <b>SGS-THOMSON MICROELECTRONICS S.A.</b>  <b>94250 Gentilly (FR)</b></p>	<p>(72) Inventeurs:          • <b>Exposito, Juan</b>  <b>38330 St. Nazaire les Eymes (FR)</b>          • <b>Herard, Laurent</b>  <b>38000 Grenoble (FR)</b>          • <b>Cigada, Andrea</b>  <b>20155 Milan (IT)</b></p> <p>(74) Mandataire: <b>Casalonga, Axel</b>  <b>BUREAU D.A. CASALONGA - JOSSE</b>  <b>Morassistrasse 8</b>  <b>80469 München (DE)</b></p>
----------------------------------------------------------------------------------------------------------------------------------------------------------------------------------------------------------------------------------------------------------------------------------------------------------------------------------	--------------------------------------------------------------------------------------------------------------------------------------------------------------------------------------------------------------------------------------------------------------------------------------------------------------------------------------------------------------------------------------------------------

(54) **Procédé de fabrication de boîtiers semi-conducteurs comprenant un circuit intégré**

(57) Procédé de fabrication de boîtiers semi-conducteurs comprenant respectivement un substrat, une pastille formant un circuit intégré et fixée sur une zone du substrat, des moyens de connexion électrique reliant la pastille à un groupe de zones de connexion électrique extérieure situées sur une face du substrat, ainsi qu'un enrobage d'encapsulation. Le procédé consiste à réaliser de façon matricielle une multiplicité de groupes de zones de connexion (104a) sur une plaque commune de substrat (102), correspondant à autant de zones (109) de fixation de pastilles, à fixer une pastille (103) sur chaque zone (109) de fixation de la plaque commu-

ne de substrat, à relier électriquement chaque pastille (103) aux zones (104a) de connexion électrique associées, de façon à obtenir un assemblage (111) plaque de substrat-pastilles connectés. Le procédé consiste, dans une seconde étape à disposer cet assemblage (111) dans un moule (112) et à injecter une matière d'enrobage (106) dans le moule de façon à obtenir, en une seule opération de moulage, un bloc parallélépipédique (117), puis, dans une étape ultérieure, à découper ledit bloc parallélépipédique (117) au travers de son épaisseur en unités constituant chacune un boîtier semi-conducteur.

**FIG.6**

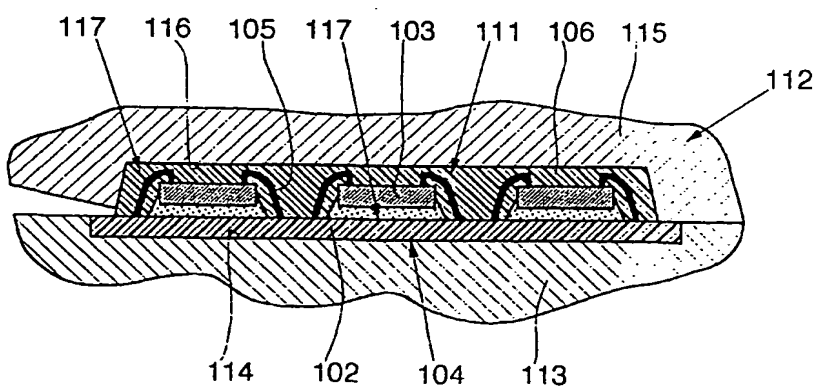

EP 0 883 171 A1



## Description

La présente invention concerne un procédé de fabrication de boîtiers semi-conducteurs comprenant respectivement un substrat, une pastille formant un circuit intégré et fixé sur une zone du substrat, des moyens de connexion électrique reliant la pastille à des zones de connexion électrique extérieure situées sur une face du substrat, ainsi qu'un enrobage d'encapsulation en résine.

En principe et de façon habituelle, les zones de connexion électrique extérieure et la pastille sont disposées de part et d'autre du substrat et l'enrobage enveloppe, d'un côté du substrat, la pastille et les moyens de connexion électrique.

Dans la technique de fabrication actuellement utilisée, on réalise individuellement l'enrobage de chacune des pastilles fixées et connectées sur une plaque de substrat en disposant cette plaque dans un moule qui présente autant de cavités individuelles que de pastilles. Puis on coupe le substrat entre chaque enrobage. Cette solution nécessite la fabrication, l'utilisation et le stockage d'autant de moules différents d'injection d'enrobage que l'on a de boîtiers différents présentant des dimensions de pastilles différentes et des dispositions différentes de ces pastilles sur une plaque de substrat. De même, il faut disposer d'un outil de découpe particulier attribué à chaque dimension de pastille et à chaque dimension de plaque de substrat.

Le but de la présente invention est de proposer un procédé de fabrication de boîtiers semi-conducteurs susceptibles de permettre des économies de fabrication et d'obtenir une plus grande flexibilité de production.

Le procédé selon l'invention est destiné à la fabrication de boîtiers semi-conducteurs comprenant respectivement un substrat, une pastille formant un circuit intégré et fixée sur une zone du substrat, des moyens de connexion électrique reliant la pastille à un groupe de zones de connexion électrique extérieure situées sur une face du substrat, ainsi qu'un enrobage d'encapsulation.

Selon l'invention, le procédé consiste à réaliser de façon matricielle une multiplicité de groupes de zones de connexion sur une plaque commune de substrat, correspondant à autant de zones de fixation de pastilles, à fixer une pastille sur chaque zone de fixation de la plaque commune de substrat, à relier électriquement chaque pastille aux zones de connexion électrique associées, de façon à obtenir un assemblage plaque de substrat-pastilles connectés. Selon l'invention, le procédé consiste, dans une seconde étape, à disposer cet assemblage dans un moule et à injecter une matière d'enrobage dans le moule de façon à obtenir, en une seule opération de moulage, un bloc parallélépipédique, et, dans une étape ultérieure, à découper ledit bloc parallélépipédique au travers de son épaisseur en unités constituant chacune un boîtier semi-conducteur.

Selon une variante préférée de l'invention, le pro-

céde consiste à réaliser la découpe du bloc parallélépipédique par sciage.

Selon l'invention, le procédé consiste de préférence à coller le bloc parallélépipédique sur une bande auto-collante pelable et à réaliser l'opération de sciage en engageant la scie au travers du bloc au-delà de sa face collée sur cette bande.

Selon l'invention, le procédé consiste, de préférence, à coller la face du bloc parallélépipédique exempte de zones de connexion sur la bande autocollante.

Selon l'invention, le procédé consiste de préférence à déposer des billes ou boules en matériau de soudage sur les zones de connexion.

La présente invention sera mieux comprise à l'étude d'un procédé de fabrication de boîtiers semi-conducteurs décrit à titre d'exemple non limitatif et illustré par le dessin sur lequel :

- la figure 1 représente schématiquement une coupe transversale d'un boîtier semi-conducteur obtenu par le procédé selon l'invention ;
- la figure 2 représente une vue frontale dudit boîtier ;
- la figure 3 montre schématiquement une première étape du procédé selon l'invention et représente en coupe transversale une plaque de substrat munie de pastilles ;
- la figure 4 représente une vue frontale de la face de ladite plaque de substrat apposée aux pastilles ;
- la figure 5 montre schématiquement une étape suivante du procédé selon l'invention et représente ladite plaque de substrat munie de pastilles connectées électriquement par des fils ;
- la figure 6 montre schématiquement une étape suivante de l'invention consistant en l'encapsulation dans un moule représenté en coupe desdites pastilles et desdits fils ;
- la figure 7 représente une vue arrière du bloc sortant dudit moule ;
- la figure 8 montre schématiquement une étape suivante du procédé selon l'invention et représente une coupe transversale dudit bloc ;
- et la figure 9 montre schématiquement une étape suivante du procédé selon l'invention et représente une coupe transversale dudit bloc lors d'une opération de sciage de ce bloc.

En se reportant aux figures 1 et 2, on voit qu'un boîtier semi-conducteur parallélépipédique, repéré d'une manière générale par la référence 1, obtenu par le procédé de fabrication qui va maintenant être décrit, comprend un substrat plat 2 par exemple de contour carré, une pastille 3 fixée à une face 2a du substrat 2 grâce à une couche mince de colle 3a, une multiplicité de zones 4 de connexion électrique extérieures réparties sur la face 2b du substrat 2 opposée à sa face 2a, des moyens de connexion électrique reliant sélectivement la pastille 3 et les zones de connexion électrique 4 et comprenant des fils de connexion électrique 5 aboutissant au subs-

trat 2 et des connexions internes à ce substrat non représentées, ainsi qu'un enrobage en résine 6 d'encapsulation de la pastille 3 et des fils de connexion 5, cet enrobage 6 étant situé du côté de la face 2a du substrat 2. En outre, le boîtier semi-conducteur 1 est muni de gouttes ou boules de connexion 7 sur chacune des zones de connexion électrique 4, en vue de la soudure et de la connexion électrique du boîtier semi-conducteur 1 par exemple aux pistes d'une plaque de circuit imprimé.

En se reportant à la figure 4, on voit que le procédé de fabrication décrit consiste à réaliser, sur une face 102a d'une plaque commune de substrat 102 rectangulaire, une multiplicité de groupes 104 de zones de connexion électrique 104a et de moyens de connexion électrique traversant la plaque commune de substrats 102 et reliés aux zones 104a.

Dans l'exemple représenté, les groupes 104 sont disposés sous une présentation en forme de matrice sur la face 102a et sont au nombre de cinq dans le sens de la largeur de la plaque commune de substrat 102 et au nombre de vingt dans le sens de sa longueur, l'espace séparant les groupes des cinquième et sixième rangées, dixième et onzième rangées et quizième et seizième rangées dans le sens de la longueur de la plaque commune de substrat 102 étant plus large de manière à former quatre ensembles 108 de vingt cinq groupes 104 espacés de la longueur de la plaque commune de substrat 102.

En se reportant à la figure 5, on voit que l'étape suivante du procédé de fabrication décrit consiste à fixer une multiplicité de pastilles 103 respectivement sur des zones de fixation 109 de la face 102b de la plaque commune de substrat 102 opposée à sa face 102a, à l'aide de minces couches de colle 103a. Les pastilles 103 se trouvent alors disposées sous une présentation en forme de matrice correspondant au travers de la plaque commune de substrat 102 aux groupes 104 de zones de connexion électrique 104a.

En se reportant à la figure 5, on voit que l'étape suivante du procédé de fabrication décrit consiste à relier sélectivement les plots de connexion 110 des pastilles 103 aux moyens de connexion de la plaque commune de substrat 102 en leur connectant les extrémités de fils de connexion électrique 105 qui se trouvent alors en l'air, de façon à relier les plots de chaque pastille 103 sélectivement aux zones de connexion électrique 104 des groupes 104 qui leur sont respectivement associées. On obtient alors un assemblage connecté repéré d'une manière générale par la référence 111; comprenant la plaque commune de substrat 102 et les pastilles 103 connectées comme décrit ci-dessus.

Comme le montre la figure 6, l'étape suivante du procédé de fabrication décrit consiste à disposer l'assemblage 111 à l'intérieur d'un moule d'injection 112 comprenant une partie 113 qui présente une cavité 114 recevant dans son épaisseur la plaque commune de substrat 102 et une partie 115 qui présente quatre cavi-

tés 116 dans lesquelles s'étendent respectivement, à distance de ses parois, les pastilles 103 et les fils de connexion 105 correspondant des ensembles 108.

Cette étape consiste ensuite à injecter à l'intérieur de la cavité 116 une résine d'encapsulation des pastilles 103 et des fils de connexion 105 de façon à obtenir en une seule opération de moulage quatre enrobages 106 contre la face 102a de la plaque de substrat 102. On obtient alors un bloc sensiblement parallélépipédique repéré d'une manière générale par la référence 117, à multipastilles 103 associées dans les enrobages 106 à la plaque commune de substrat 102.

En se reportant à la figure 5, on voit que dans une étape ultérieure le procédé de fabrication décrit peut consister à déposer une goutte ou boule de connexion 107 sur chaque zone de connexion 104 de la face 102a de la plaque de substrat 102.

En se reportant à la figure 9, on voit que l'étape suivante du procédé de fabrication décrit consiste à fixer la face 106a de l'enrobage 106 du bloc parallélépipédique 107, opposée à la face 102a de la plaque commune de substrat 102 incluse dans ce bloc, sur un support plan 118 par l'intermédiaire d'une bande pelable 119 à deux faces autocollantes.

Puis, le procédé de fabrication décrit consiste à couper longitudinalement et transversalement le bloc parallélépipédique 107, dans le sens de son épaisseur, à l'aide d'une scie 120, le long des lignes de séparation longitudinales et transversales 121 et 122 s'étendant entre lesdits différents groupes 104 de zones de connexion électrique 104a auxquelles sont respectivement associées les pastilles 103. Au cours de cette opération, la scie 120 est engagée au travers du bloc parallélépipédique 107 au-delà de sa face 106a collée sur la bande 119 de manière à effectuer l'opération de découpe complètement.

Lorsque l'opération de découpe par sciage ci-dessus est effectuée, on peut alors décoller de la bande 119 les différents morceaux du bloc parallélépipédique 117, chacun de ces morceaux correspondant à un boîtier semi-conducteur 1 tel que décrit précédemment en référence aux figures 1 et 2.

Le procédé de fabrication qui vient d'être décrit présente l'avantage de pouvoir fabriquer dans un même moule adapté pour recevoir une plaque commune de substrat 102 déterminée, des boîtiers semi-conducteurs 1 de dimensions différentes.

En effet, sur différentes plaques communes de substrat 102, on peut prévoir des nombres différents de groupes 104 de zones de connexion électrique 104a couvrant des surfaces différents, adaptées en correspondance aux dimensions des pastilles 103 associées, en les disposant comme dans l'exemple décrit précédemment, selon des matrices adaptées aux surfaces que lesdits groupes de zones de connexion et lesdites pastilles occupent.

Il conviendra alors d'adapter uniquement les distances entre les différentes lignes 121 et 122 de découpe

aux surfaces afin d'obtenir des boîtiers semi-conducteurs dont le pourtour présente des dimensions souhaitées.

## Revendications

- 5
1. Procédé de fabrication de boîtiers semi-conducteurs (1) comprenant respectivement un substrat, une pastille formant un circuit intégré et fixée sur 10  
une zone du substrat, des moyens de connexion électrique reliant la pastille à un groupe de zones de connexion électrique extérieure situées sur une face du substrat, ainsi qu'un enrobage d'encapsulation, caractérisé par le fait qu'il consiste : 15
- à réaliser de façon matricielle une multiplicité de groupes (104) de zones de connexion (104a) sur une plaque commune de substrat (102), correspondant à autant de zones (109) 20  
de fixation de pastilles,
  - à fixer une pastille (103) sur chaque zone (109) de fixation de la plaque commune de substrat,
  - à relier électriquement chaque pastille (103) 25  
aux zones (104a) de connexion électrique associées, de façon à obtenir un assemblage (111) plaque de substrat-pastilles connectés,
- et qu'il consiste, dans une seconde étape : 30
- à disposer cet assemblage (111) dans un moule (112) et à injecter une matière d'enrobage (106) dans le moule de façon à obtenir, en une seule opération de moulage, un bloc parallélépipédique (117) présentant d'un côté ledit substrat, 35
  - à déposer des billes ou boules (107) en matériau de soudage sur les zones de connexion (104a) du substrat (102) opposées à la matière d'enrobage moulée (106),
  - et à découper ledit bloc parallélépipédique 40  
(117) au travers de l'épaisseur dudit substrat (102) et de la matière d'enrobage (106) en unités constituant chacune un boîtier semi-conducteur (1). 45
2. Procédé selon la revendication 1, caractérisé par le fait qu'il consiste à réaliser la découpe dudit bloc parallélépipédique (117) par sciage (120).
3. Procédé selon l'une des revendications 1 et 2, caractérisé par le fait qu'il consiste à coller la face (106a) dudit bloc parallélépipédique (117) exempte de zones de connexion et opposée auxdites billes de connexion (107) sur une bande autocollante pe- 50  
lable (119) et à réaliser l'opération de sciage en en- 55  
gageant la scie (120) au travers du bloc (117) au-delà de sa face collée sur ladite bande (119).

FIG.1

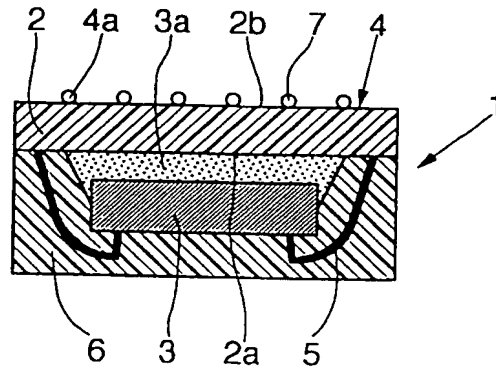
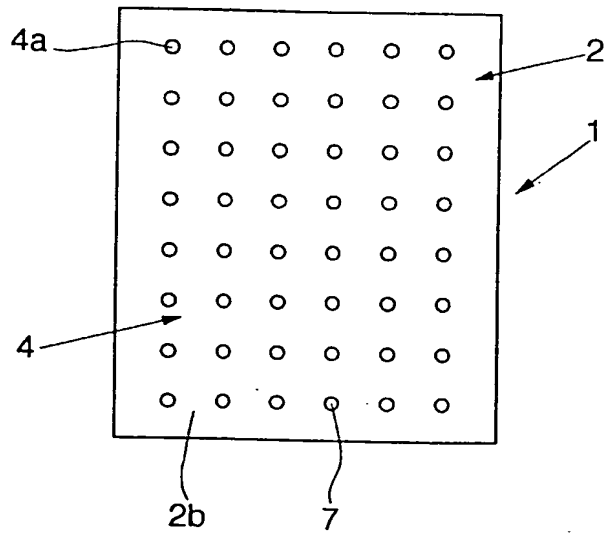
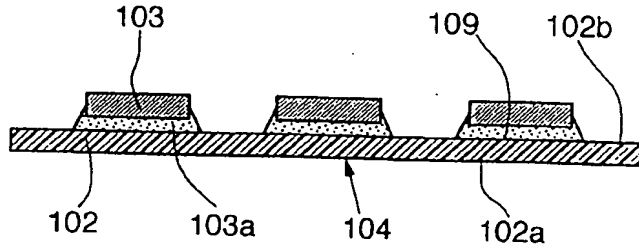

FIG.2



**FIG.3**



**FIG.5**

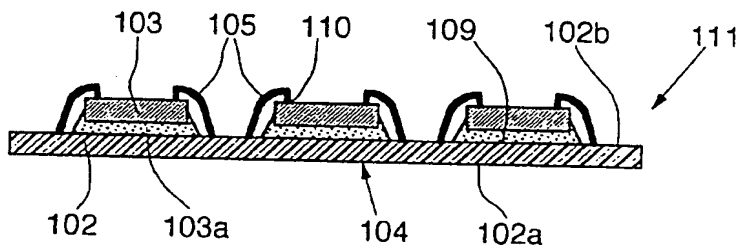

**FIG.6**

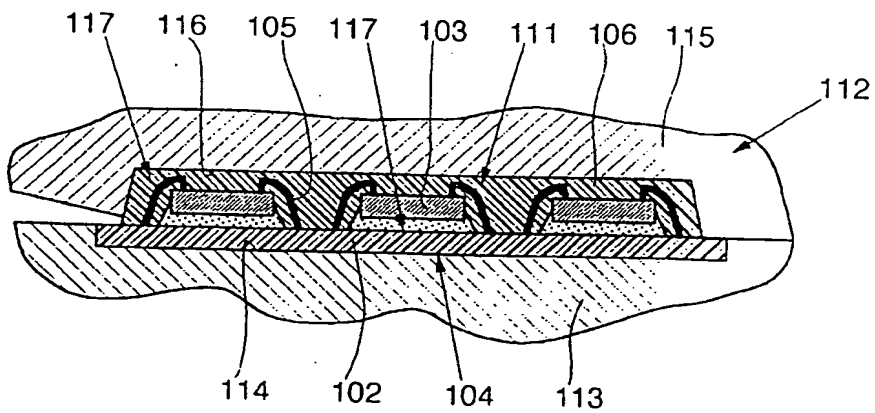

**FIG.4**

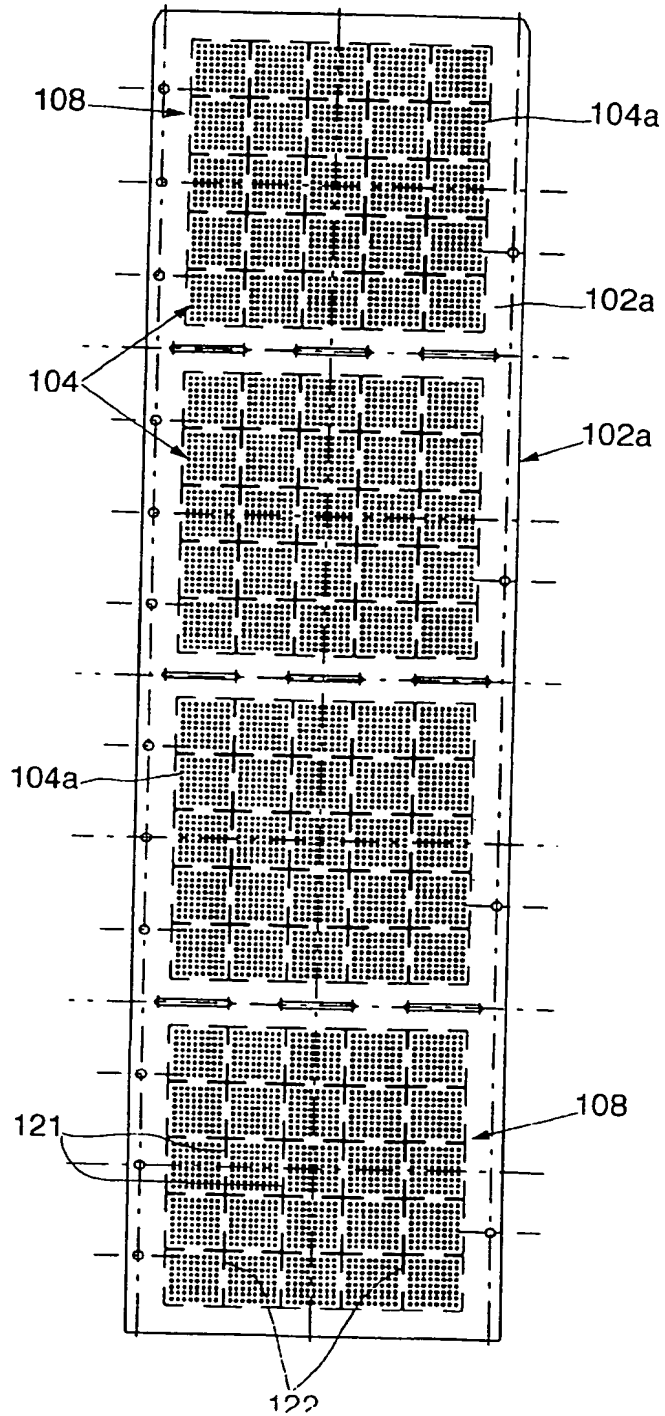

**FIG.4**

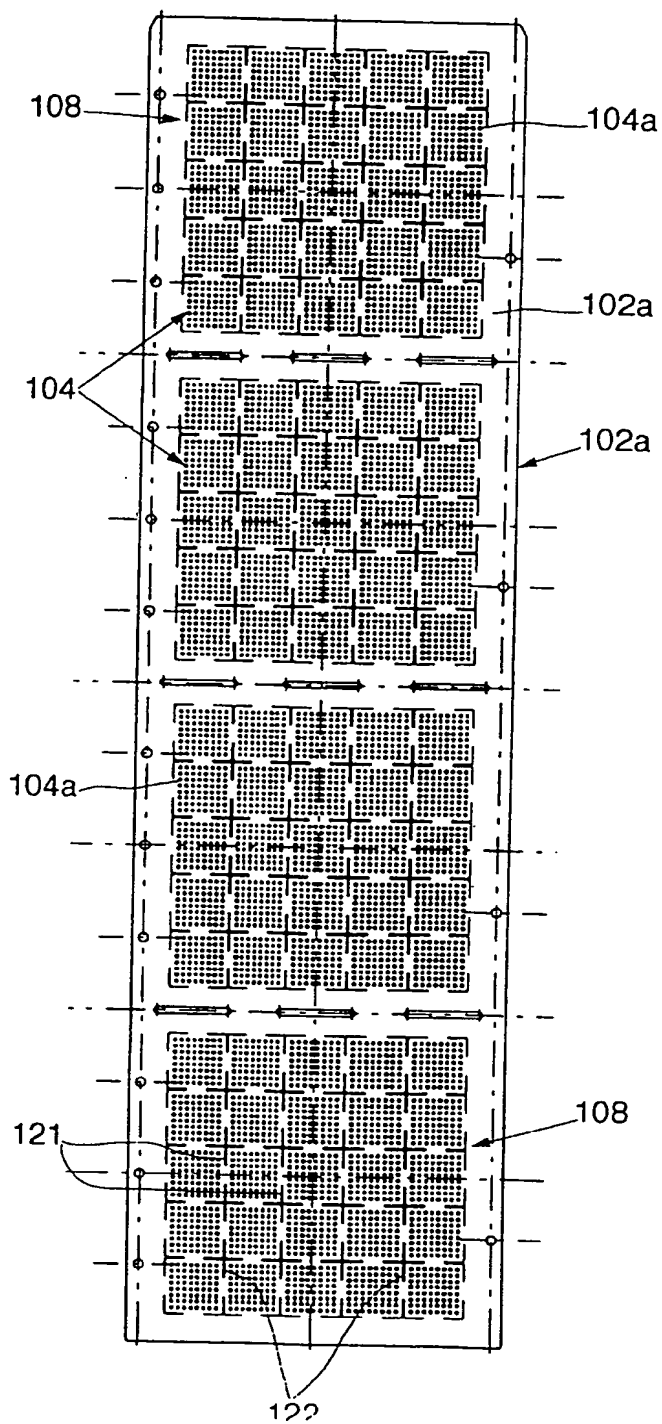

**FIG.7**

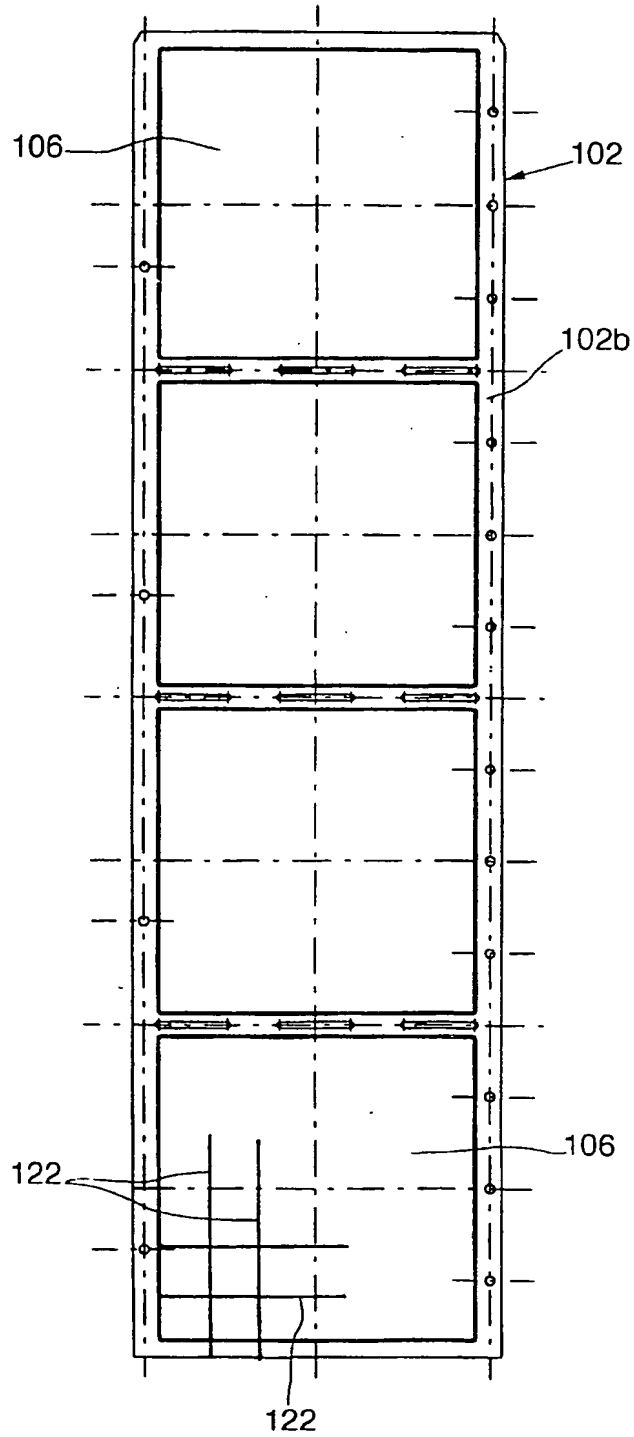



FIG.8

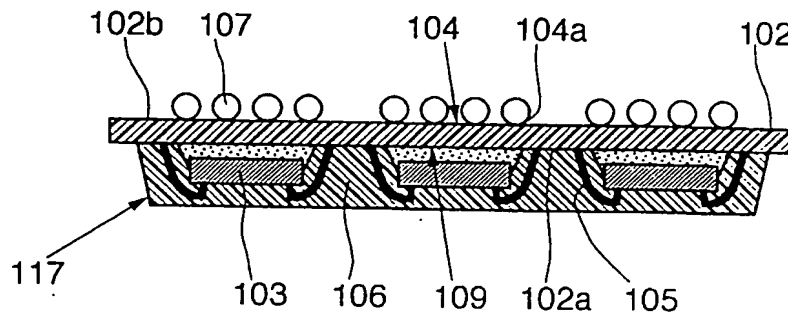
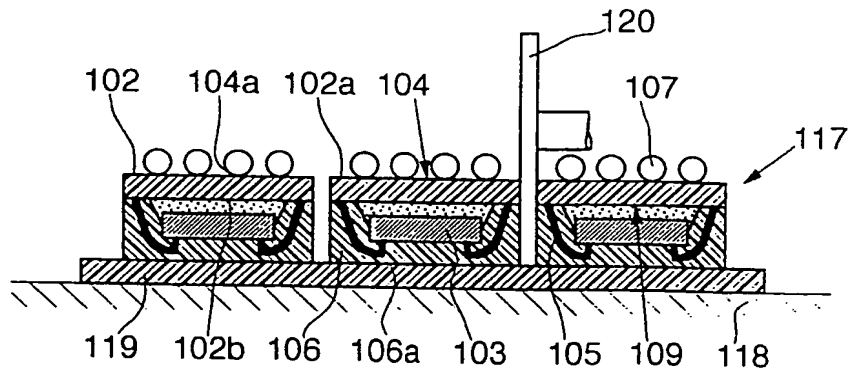

FIG.9



Office européen  
des brevets

## RAPPORT DE RECHERCHE EUROPEENNE

Numéro de la demande  
EP 98 40 1318

DOCUMENTS CONSIDERES COMME PERTINENTS			
Catégorie	Citation du document avec indication, en cas de besoin, des parties pertinentes	Revendication concernée	CLASSEMENT DE LA DEMANDE (Int.CI.6)
X	EP 0 751 561 A (HITACHI CHEMICAL CO LTD) 2 janvier 1997	1,2	H01L21/56
A	* page 14, ligne 15 - ligne 51; figures 19,20,22 * * page 15, ligne 41 - page 16, ligne 16 *	3	
X	PATENT ABSTRACTS OF JAPAN vol. 097, no. 006, 30 juin 1997 -& JP 09 036151 A (JAPAN AVIATION ELECTRON IND LTD), 7 février 1997 * abrégé *	1,2	
A	PATENT ABSTRACTS OF JAPAN vol. 097, no. 007, 31 juillet 1997 -& JP 09 082741 A (SEIKO EPSON CORP), 28 mars 1997 * le document en entier *	1-3	
A	DE 36 19 636 A (BOSCH GMBH ROBERT) 17 décembre 1987 * le document en entier *	1,2	DOMAINES TECHNIQUES RECHERCHES (Int.CI.6)
			H01L
Le présent rapport a été établi pour toutes les revendications			
Lieu de la recherche LA HAYE		Date d'achèvement de la recherche 31 août 1998	Examineur Zeisler, P
CATEGORIE DES DOCUMENTS CITES		T : théorie ou principe à la base de l'invention E : document de brevet antérieur, mais publié à la date de dépôt ou après cette date D : cité dans la demande L : cité pour d'autres raisons & : membre de la même famille, document correspondant	
X : particulièrement pertinent à lui seul Y : particulièrement pertinent en combinaison avec un autre document de la même catégorie A : arrière-plan technologique O : divulgation non-écrite P : document intercalaire			

EPO FORM 1503 03.92 (Pv)(C02)

1/9/1

DIALOG(R)File 351:Derwent WPI  
(c) 2005 Thomson Derwent. All rts. reserv.

012184848 \*\*Image available\*\*  
WPI Acc No: 1998-601761/199851  
XRAM Acc No: C98-180095  
XRPX Acc No: N98-469151

**Motor structure - has elastic body layer provided using synthetic resin on outer surface of stator and winding wire except inner circumference of stator**

Patent Assignee: MATSUSHITA DENKI SANGYO KK (MATU )  
Number of Countries: 001 Number of Patents: 001  
Patent Family:

Patent No	Kind	Date	Applicat No	Kind	Date	Week
JP 10271719	A	19981009	JP 9767674	A	19970321	199851 B

Priority Applications (No Type Date): JP 9767674 A 19970321

Patent Details:

Patent No	Kind	Lan	Pg	Main IPC	Filing Notes
JP 10271719	A		4	H02K-001/18	

Abstract (Basic): JP 10271719 A

The structure includes a stator core (2) having a number of slots in which winding wire is wound. Elastic body layer (5) is provided by layering synthetic resin on the outer circumference of stator and the winding wire except the inner circumference of the stator opposing a rotor. Stator winding wire (1) is wound in the slots of the stator core through the elastic body layer.

ADVANTAGE - Reduces noise due to vibration during operation.  
Enables easy manufacture of stator.

Dwg.1/4

Title Terms: MOTOR; STRUCTURE; ELASTIC; BODY; LAYER; SYNTHETIC; RESIN; OUTER; SURFACE; STATOR; WIND; WIRE; INNER; CIRCUMFERENCE; STATOR

Derwent Class: A85; V06; X11

International Patent Class (Main): H02K-001/18

International Patent Class (Additional): H02K-003/34; H02K-015/12

File Segment: CPI; EPI

Manual Codes (CPI/A-N): A12-E08B

Manual Codes (EPI/S-X): V06-M07A; V06-M08B; V06-M11C; X11-J01A; X11-J02B;

X11-J08C

Polymer Indexing (PS):

<01>

\*001\* 018; P0000

\*002\* 018; ND01; Q9999 Q7443 Q7421 Q7330; B9999 B3930-R B3838 B3747; K9416; K9676-R; K9483-R; B9999 B3985 B3974 B3963 B3930 B3838

B3747;

Q9999 Q6622 Q6611

?

(51)Int.Cl. <sup>8</sup>	識別記号	F I	
H 0 2 K	1/18	H 0 2 K	1/18 E
	3/34		3/34 C
	15/12		15/12 D

審査請求 未請求 請求項の数 6 O L (全 4 頁)

(21)出願番号	特願平9-67674	(71)出願人	000005821 松下電器産業株式会社 大阪府門真市大字門真1006番地
(22)出願日	平成9年(1997)3月21日	(72)発明者	小林 佳生 大阪府門真市大字門真1006番地 松下電器産業株式会社内
		(72)発明者	浅野 能成 大阪府門真市大字門真1006番地 松下電器産業株式会社内
		(72)発明者	水上 裕文 大阪府門真市大字門真1006番地 松下電器産業株式会社内
		(74)代理人	弁理士 滝本 智之 (外1名)

(54)【発明の名称】 モールドモータ固定子及びその製造方法

(57)【要約】

【課題】 各種電気機器に使用されるモールドモータにおいて、低騒音及び低振動にすることを目的とする。

【解決手段】 固定子鉄心2の内周面7を除く全ての表面に、電気絶縁性の弾性体層5を施したものである。これにより、モールドモータ単体及びモールドモータを各種電気機器に取り付けた状態で、低騒音・低振動なモールドモータが提供可能となる。

- 1...固定子巻線
- 2...固定子鉄心
- 3...フレーム
- 4...ハウジング
- 5...弾性体層
- 6...回転子
- 7...内周面

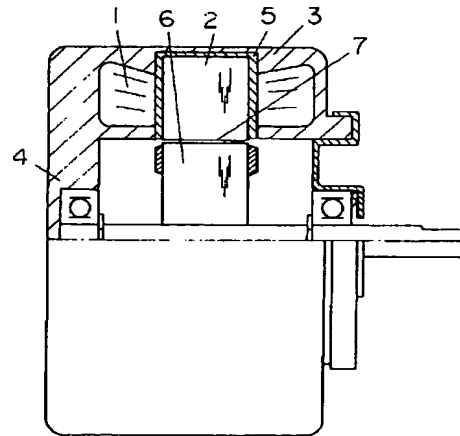

【特許請求の範囲】

【請求項1】複数のスロットを有する固定子鉄子と、前記固定子鉄心の回転子と対向する内周面を除く表面を包囲する電気絶縁性の弾性体層と、前記電気絶縁性の弾性体層を介して前記固定子鉄心のスロット内に収納されて巻装される固定子巻線と、前記固定子鉄心の内周面を除いて前記電気絶縁性の弾性体層及び前記固定子巻線を共に包囲して一体に成形した合成樹脂とからなることを特徴とするモールドモータ固定子。

【請求項2】電気絶縁性の弾性体層がシリコンゴムまたはポリウレタン樹脂で構成されていることを特徴とする請求項1記載のモールドモータ固定子。

【請求項3】複数のスロットを有する固定子鉄心の回転子と対向する内周面を除く表面を包囲して電気絶縁性の弾性体層を一体成形する第1の工程と、前記電気絶縁性の弾性体層を介して前記固定子鉄心のスロット内に収納される固定子巻線を巻装する第2の工程と、前記固定子鉄心の内周面を除いて前記弾性体層及び前記固定子巻線を共に包囲して合成樹脂により一体に成形する第3の工程とからなることを特徴とするモールドモータ固定子の製造方法。

【請求項4】電気絶縁性の弾性体層がシリコンゴムまたはポリウレタン樹脂で構成されていることを特徴とする請求項3記載のモールドモータ固定子の製造方法。

【請求項5】固定子巻線を巻装する第2の工程の後で、前記固定子巻線をワニスで固着し、しかる後に固定子鉄心の内周面を除いて弾性体層及び固定子巻線を共に包囲して合成樹脂により一体に成形する第3の工程へ移行することを特徴とする請求項3または4記載のモールドモータ固定子の製造方法。

【請求項6】固定子巻線が自己融着電線からなり、固定子巻線を巻装する第2の工程の後で、前記固定子巻線を自己融着させ、しかる後に固定子鉄心の内周面を除いて弾性体層及び固定子巻線を共に包囲して合成樹脂により一体に成形する第3の工程へ移行することを特徴とする請求項3または4記載のモールドモータ固定子の製造方法。

【発明の詳細な説明】

【0001】

【発明の属する技術分野】本発明は、防振構造のモールドモータ固定子及びその製造方法に関する。

【0002】

【従来の技術】巻線を巻装した固定子鉄心に回転子を挿通し、巻線と固定子鉄心外周部に回転子を支持する軸受挿入用ハウジングとフレームを合成樹脂などで外装したいわゆるモールドモータは、エアコン送風用などの用途で使用されてきている。

【0003】従来のモールドモータの例を示すと図4のように、固定子巻線1を巻装した固定子鉄心2にフレーム3及びハウジング4を合成樹脂にて一体成形して外装

するため、巻線1を巻装した固定子鉄心2はフレーム3及びハウジング4を構成する合成樹脂と直接接触している。

【0004】

【発明が解決しようとする課題】モールドモータにおいては、その主な使用目的が室内用の空気調和機などであり長時間にわたって人の近くでモールドモータは連続運転されるため、モールドモータの単体及びモールドモータを空気調和機などの機器に取り付けた状態で、特に低騒音、低振動であることが要求される。しかしながら従来の技術では、固定子巻線1を巻装した固定子鉄心2はフレーム3及びハウジング4と直接接触しているため、固定子巻線1を巻装した固定子鉄心2の振動がフレーム3及びハウジング4に直接伝達され、モールドモータの表面に振動及び騒音が発生するという問題があった。

【0005】

【課題を解決するための手段】この課題を解決するために本発明は、固定子鉄心の内周面を除く全ての表面を包囲して電気絶縁性のある弾性体層を形成したものである。この弾性体層により、モールドモータ単体及びモールドモータを空気調和機等の機器に取り付けた状態で、低騒音、低振動なモールドモータとすることが可能となる。

【0006】

【発明の実施の形態】本発明の請求項1及び2に記載の発明は、複数のスロットを有する固定子鉄心と、前記固定子鉄心の回転子と対向する内周面を除く表面を包囲するシリコンゴムまたはポリウレタン樹脂の電気絶縁性の弾性体層と、前記電気絶縁性の弾性体層を介して前記固定子鉄心のスロット内に収納されて巻装される固定子巻線と、前記固定子鉄心の内周面を除いて前記電気絶縁性の弾性体層及び前記固定子巻線を共に包囲して一体に成形した合成樹脂とからなるものであり、電気絶縁性を有する弾性体層が固定子鉄心に発生する振動を減衰させるという機能を有する。

【0007】請求項3及び4に記載の発明は、複数のスロットを有する固定子鉄心の回転子と対向する内周面を除く表面を包囲してシリコンゴムまたはポリウレタン樹脂の電気絶縁性の弾性体層を一体成形する第1の工程と、前記電気絶縁性の弾性体層を介して前記固定子鉄心のスロット内に収納される固定子巻線を巻装する第2の工程と、前記固定子鉄心の内周面を除いて前記弾性体層及び前記固定子巻線を共に包囲して合成樹脂により一体に成形する第3の工程とからなることを特徴とするモールドモータ固定子の製造方法であり、請求項1または2記載のモールドモータ固定子を製造することができる。

【0008】請求項5に記載の発明は、固定子巻線を巻装する第2の工程の後で、前記固定子巻線をワニスなどで固着し、しかる後に固定子鉄心の内周面を除いて弾性体層及び固定子巻線を共に包囲して合成樹脂により一体

に成形する第3の工程へ移行することを特徴とする請求項3記載のモールドモータ固定子の製造方法であり、固定子巻線が固着されているため、より一層の低振動及び低騒音のモールドモータ固定子が製造できる。

【0009】請求項6に記載の発明は、固定子巻線が自己融着電線からなり、固定子巻線を巻装する第2の工程の後で、前記固定子巻線を自己融着させ、しかる後に固定子鉄心の内周面を除いて弾性体層及び固定子巻線を共に包囲して合成樹脂により一体に成形する第3の工程へ移行することを特徴とする請求項3記載のモールドモータ固定子の製造方法であり、固定子巻線を自己融着電線を使用することにより固着し、請求項5記載の発明と同等の低振動及び低騒音のモールドモータ固定子が容易に製造できる。

【0010】

【実施例】以下、本発明の実施例について図1から図3を参照して説明する。なお、図4に示す従来のモールドモータと同じ構成部分については、図4に記載した符号と同じ符号をつけることとする。

【0011】図1は本発明のモールドモータ固定子を使用したモールドモータの断面図である。図1において電気絶縁性の弾性体層5は、固定子巻線1を巻装した固定子鉄心2に発生した振動がフレーム3及びハウジング4に直接伝達されることを防止する。なお弾性体層5の材質としてはシリコンゴムとかポリウレタン樹脂などの電気絶縁性で、しかも弾力性のある物質がよい。そして固定子巻線1は巻線自身の振動を防止するためにワニスなどで固着するとよい。勿論ワニス以外でも固定子巻線1自身が自己融着性のある皮膜を有していてもよい。

【0012】次に本発明の実施例におけるモールドモータの製造方法につき説明する。まず、図2に示す固定子鉄心2を、第1の工程で図3に示すように、回転子6と対向する内周面7を除いて他の全ての表面を電気絶縁性の弾性体層5で包囲する。そして、弾性体層5で覆われた固定子鉄心2に、図1に示すように第2の工程で固定子巻線1を施して、ワニスを塗り、固定子巻線1を固める。次いで、固定子巻線1、固定子鉄心2及び弾性体層5を包囲し、かつ回転子6を支持する軸受挿入用のハウジング4ならびにフレーム3を形成するように第3の工程で合成樹脂材により一体に形成する。

【0013】以上のように本発明の製造方法においては固定子鉄心2に第1の工程で弾性体層5を設け、しかる後、第2の工程で固定子鉄心2に固定子巻線1を巻装する。上記固定子巻線1を固定子鉄心2に巻装後、第3の工程で合成樹脂によりモールドしてモールドモータを完成するもので、容易に本発明のモールドモータを製造し得るものである。

【0014】

【発明の効果】上記説明から明らかなように、請求項1または2記載の発明によれば、固定子鉄心の内周面を除

く全ての表面を包囲するシリコンゴムまたはポリウレタン樹脂の電気絶縁性の弾性体層と、前記弾性体層を介して固定子鉄心に巻装された固定子巻線と、前記固定子鉄心及び弾性体層ならびに固定子巻線を前記固定子鉄心の内周面を除いて合成樹脂により一体成形し、合成樹脂の外皮部分を有するモールドモータ固定子であり、モールドモータ単体及び空気調和機などの機器に取り付けた状態で、低騒音及び低振動なモールドモータとすることができる。

【0015】請求項3または4記載の発明は、複数のスロットを有する固定子鉄心の回転子と対向する内周面を除く表面を包囲して電気絶縁性の弾性体層を一体成形する第1の工程と、前記電気絶縁性の弾性体層を介して前記固定子鉄心のスロット内に収納される固定子巻線を巻装する第2の工程と、前記固定子鉄心の内周面を除いて前記弾性体層及び前記固定子巻線を共に包囲して合成樹脂により外皮部分を一体に成形する第3の工程とからなることを特徴とするモールドモータ固定子の製造方法であり、低振動及び低騒音のモールドモータ固定子を容易に製造することができる。

【0016】請求項5記載の発明は、請求項3または4記載のモールドモータ固定子の製造方法で、固定子巻線をワニスなどで固着した後に合成樹脂による外皮部分を一体成形する製造方法であり、固定子巻線の振動が固着されることにより制御されるのでより低騒音かつ低振動なモールドモータ固定子を容易に製造することができる。

【0017】請求項6記載の発明は、請求項3または4記載のモールドモータ固定子の製造方法であって、固定子巻線として自己融着銅線を使用したものであり、固定子巻線を固着して振動を抑制したより低騒音かつ低振動のモールドモータを容易に製造することができる。

【図面の簡単な説明】

【図1】本発明の一実施例におけるモールドモータの半裁断面図

【図2】(a)同固定子鉄心の平面図

(b)同固定子鉄心の側面半裁断面図

【図3】(a)同固定子鉄心に電気絶縁性のある弾性体層を施した固定子鉄心の平面図

(b)同固定子鉄心の半裁断面図

【図4】従来のモールドモータの半裁断面図

【符号の説明】

- 1 固定子巻線
- 2 固定子鉄心
- 3 フレーム
- 4 ハウジング
- 5 弾性体層
- 6 回転子
- 7 内周面

【図1】

- 1・固定子巻線
- 2・固定子鉄心
- 3・フレーム
- 4・ハウジング
- 5・弾性体層
- 6・回転子
- 7・内周面

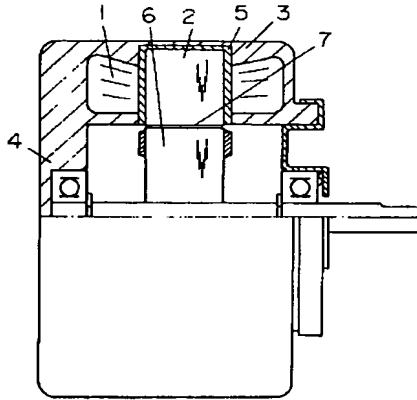

【図3】

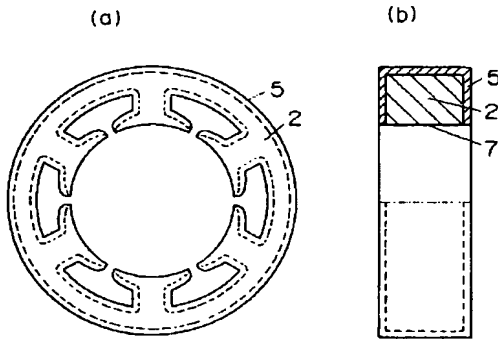

【図2】

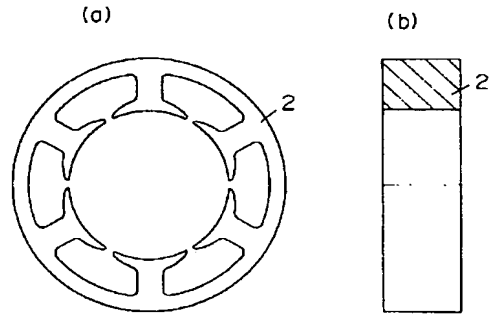

【図4】

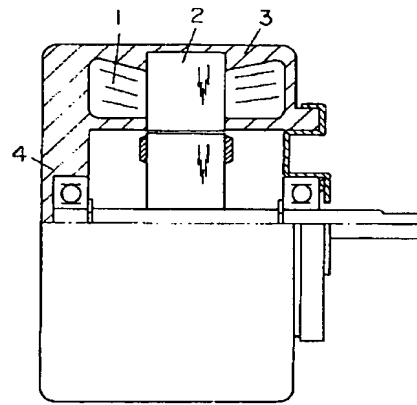

# EUROPEAN PATENT OFFICE

## Patent Abstracts of Japan

PUBLICATION NUMBER : 10070870

PUBLICATION DATE : 10-03-98

APPLICATION DATE : 27-08-96

APPLICATION NUMBER : 08225387

APPLICANT : MITSUBISHI ELECTRIC CORP;

INVENTOR : AKUTSU SATORU;

INT.CL. : H02K 21/14 H02K 1/18 H02K 9/00  
H02K 29/00

TITLE : SPINDLE MOTOR

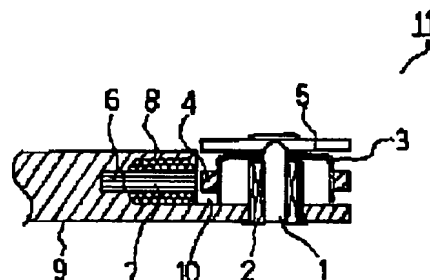

**ABSTRACT :** **PROBLEM TO BE SOLVED:** To prevent deformation of optical disc due to heat occurred in a spindle motor, by providing a stator core arranged oppositely to a rotor magnet with a predetermined gap between them and stator coils wound round a plurality of tooth poles, thereby constituting a stator, and by fixing the bearing of a rotation shaft by including the stator in a base.

**SOLUTION:** Rotor magnets 4 are fixed along the outer face of circumference of a rotor 3 rotating around a rotation shaft as a center. And a stator is formed by a stator core 6 consisting of a plurality of tooth poles 7 made of a magnetic material arranged opposite to the rotor magnets 4 in radial direction with a predetermined gap provided between them. And the stator is included in a base 9 made of a resin and a bearing 2 of a rotation shaft 1 is fixed. By doing this, expansion or deformation of an optical disc due to heat generated by a spindle motor 11 can be prevented.

**COPYRIGHT:** (C)1998,JPO



(19) 日本国特許庁 (J P)

(12) 公開特許公報 (A)

(11) 特許出願公開番号

特開平10-70870

(43) 公開日 平成10年(1998) 3月10日

(51) Int.Cl. <sup>6</sup>	識別記号	庁内整理番号	F I	技術表示箇所
H 0 2 K 21/14			H 0 2 K 21/14	M
	1/18		1/18	E
	9/00		9/00	Z
	29/00		29/00	Z

審査請求 未請求 請求項の数 3 O L (全 6 頁)

(21) 出願番号	特願平8-225387	(71) 出願人	000006013 三菱電機株式会社 東京都千代田区丸の内二丁目2番3号
(22) 出願日	平成8年(1996) 8月27日	(72) 発明者	菊田 一夫 東京都千代田区丸の内二丁目2番3号 三菱電機株式会社内
		(72) 発明者	阿久津 悟 東京都千代田区丸の内二丁目2番3号 三菱電機株式会社内
		(74) 代理人	弁理士 宮田 金雄 (外3名)

(54) 【発明の名称】 スピンドルモータ

(57) 【要約】

【課題】 放熱性に優れ、スピンドルモータの発生する熱によるスピンドルモータの性能への悪影響や光ディスクの膨張変形等を防止できるスピンドルモータを得る。

【解決手段】 回転軸に固定され回転軸を中心に回転するロータと、このロータの円周外面に沿って固定されたロータ磁石と、ロータ磁石との間にラジアル方向に所定の隙間を設けて対向配置した複数の歯極を設けた磁性材からなるステータコアと歯極に巻回したステータコイルとを設けたステータと、このステータを内包して成形すると共に回転軸の軸受けを固定した樹脂製のベースとを備えた。

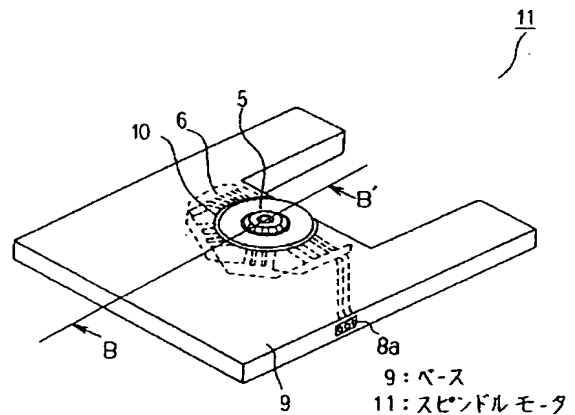

## 【特許請求の範囲】

【請求項1】 回転軸に固定され前記回転軸を中心に回転するロータと、このロータの円周外面に沿って固定されたロータ磁石と、前記ロータ磁石との間にラジアル方向に所定の隙間を設けて対向配置した複数の歯極を設けた磁性材からなるステータコアと前記歯極に巻回したステータコイルとを設けたステータと、このステータを内包して成形すると共に前記回転軸の軸受けを固定した樹脂製のベースとを備えたことを特徴とするスピンドルモータ。

【請求項2】 ベースは、ステータコイルのコイルリード及びコイル末端を内包すると共に前記コイル末端を側面に電気接続可能に配置していることを特徴とする請求項1に記載のスピンドルモータ。

【請求項3】 回転軸に固定され前記回転軸を中心に回転するロータと、このロータの円周外面に沿って固定されたロータ磁石と、前記ロータ磁石との間にラジアル方向に所定の隙間を設けて対向配置した複数の歯極を設けた磁性材からなるステータコアと前記歯極に巻回したステータコイルとを設けたステータと、このステータを樹脂モールドしたモールドステータと、このモールドステータを窪み部の内壁に密着して固定し、かつ前記回転軸の軸受けを前記モールドステータの内径中心位置に固定した金属製のベースとを備えたことを特徴とするスピンドルモータ。

## 【発明の詳細な説明】

## 【0001】

【発明の属する技術分野】この発明は、ディスク状の記録媒体に記録された情報を再生するディスク装置に係り、例えば、光ディスク装置に搭載されるスピンドルモータに関するものである。

## 【0002】

【従来の技術】図5は従来の光ディスク装置の全体斜視図である。図5において、40は不図示の光ディスクを回転させるためのスピンドルモータである。その構成の詳細は後述する。41は光ディスクに記録された情報を読み出す光ピックアップ部、42は光ディスクを着脱するためのトレイである。このトレイ42には、スピンドルモータ40に設けられたハブ部をトレイ42の光ディスク装着部から突出させるための略U字状の切り欠き部42aが設けられている。43はスピンドルモータ40やトレイ42を取り付け又は収納するためのフレーム、44は光ディスク装置であり、上述の符号40～43を付した構成を含む。

【0003】図6は図5に示す線分AA'によるスピンドルモータ40の断面図である。図6において、40aは回転軸、40bは回転軸40aの軸受け、40cは光ディスクをチャッキングするためのハブ部であり、回転軸40aの先端に固定されている、40dは軸受け40bに固定された積層形のステータコアである。40eは

磁界を発生させるためのステータコイルであり、ステータコア40dの歯極に巻回している。40fはロータであり、回転軸40aに固定されている。40gはロータ40fの内周面に取り付けられたロータ磁石であり、その内周面からステータコア40dの歯極に対向して配置している。40hは軸受け40bをカシメ止め等により固定するベースである。40はスピンドルモータであり、上述の符号40a～40hを付した構成を含む。このスピンドルモータ40は、ステータコア40dの歯極とロータ磁石40gとの間に隙間を設けたラジアルギャップ形であると共に、回転子であるロータ40fをステータコア40dの外側に設けた、所謂アウトロータ型のスピンドルモータである。

【0004】次に、動作を図5及び図6により説明する。光ディスクを図5に示すトレイ42に載せ、このトレイ42を矢印方向に移動し、光ディスク装置44にトレイ42と共に光ディスクを収納するとスピンドルモータ40が上方方向に移動し、図6に示すハブ部40cが切り欠き部42aから突出し、このハブ部40cが光ディスクをチャッキングする。

【0005】図6に示すステータコイル40eに電流が流れることにより、ステータコア40dの歯極が磁化されて磁界が発生し、この磁界によりロータ磁石40gを取り付けられたロータ40fが回転軸40aを中心に回転する。このロータ40fの回転によりハブ部40cにチャッキングされた光ディスクが回転する。光ピックアップ部41が回転する光ディスクに記録された情報を読み取ることで情報の再生がなされる。

## 【0006】

【発明が解決しようとする課題】従来の光ディスク装置44に搭載した従来のスピンドルモータ40は、主にステータコイル40eの内部抵抗による発熱により、ステータコイル40eやステータコア40dの温度が上昇する。特に、アウトロータ型のスピンドルモータ40は、図6に示すようにロータ40fがステータコア40dやステータコイル40e等を覆っているため、ステータコア40dやステータコイル40eの温度上昇は大きくなる。この温度が非常に高くなると、スピンドルモータ40の性能に悪影響を与えるという問題点がある。

又、スピンドルモータ40は通常、光ディスクに非常に近い位置に配置されるので、スピンドルモータ40付近の局所的な温度上昇によって、光ディスクが局部的に膨張変形したり、又、この膨張変形により光ディスク回転時の面振れが大きくなり、光ピックアップ部41の読み取り精度に悪影響を与えるという問題点がある。

【0007】特に、今日、光ディスクに記録された情報の高速読み取り、高速転送化が要望されており、その為にスピンドルモータ40の高速回転化が要求されている。スピンドルモータ40を高速回転させるためには、ステータコイル40eに流す電流値を大きくすればよい

が、そうすると上述の発熱の問題が大きくなる。

【0008】この発明は上述のような問題点を解決するためになされたもので、放熱性に優れ、スピンドルモータの発生する熱によるスピンドルモータの性能への悪影響や光ディスクの膨張変形等を防止できるスピンドルモータを得ることを目的とする。

【0009】

【課題を解決するための手段】この発明によるスピンドルモータは、回転軸に固定され前記回転軸を中心に回転するロータと、このロータの円周外面に沿って固定されたロータ磁石と、前記ロータ磁石との間にラジアル方向に所定の隙間を設けて対向配置した複数の歯極を設けた磁性材からなるステータコアと前記歯極に巻回したステータコイルとを設けたステータと、このステータを内包して成形すると共に前記回転軸の軸受けを固定した樹脂製のベースとを備えたものである。

【0010】さらに、次の発明によるスピンドルモータは、ベースは、ステータコイルのコイルリード及びコイル末端を内包すると共に前記コイル末端を側面に電気接続可能に配置しているものである。

【0011】又、次の発明によるスピンドルモータは、回転軸に固定され前記回転軸を中心に回転するロータと、このロータの円周外面に沿って固定されたロータ磁石と、前記ロータ磁石との間にラジアル方向に所定の隙間を設けて対向配置した複数の歯極を設けた磁性材からなるステータコアと前記歯極に巻回したステータコイルとを設けたステータと、このステータを樹脂モールドしたモールドステータと、このモールドステータを窪み部の内壁に密着して固定し、かつ前記回転軸の軸受けを前記モールドステータの内径中心位置に固定した金属製のベースとを備えたものである。

【0012】

【発明の実施の形態】

実施の形態1. この発明のスピンドルモータの一実施の形態について説明する。図1は実施の形態1によるスピンドルモータを示す全体斜視図、図2は図1に示す線分BB'における断面図である。図1及び図2において、1は回転軸、2は回転軸1の軸受け、3は回転軸1に固定したロータ、4はロータ3の円周外面に接着剤等で固定したロータ磁石である。上述のロータ3は後述するステータコアの歯極に生じる磁界とロータ磁石4とにより駆動力を得て回転軸1を中心に回転する。5は不図示の光ディスクをチャッキングするためのハブ部であり、回転軸1の先端に固定している。6はロータ3の円周外面の外側から、歯極7をロータ磁石4との間に所定の隙間を設けて対向配置した磁性材料からなるステータコア、8は歯極7に巻回したステータコイル、8aはステータコイル8のコイルリードを接続するコネクタ又は端子台等のコイル末端である。ステータコア6と歯極7に巻回したステータコイル8とによりステータを構成する。9

はエポキシ樹脂製のベースであり、上述のステータを内包して樹脂モールド成形している。但し、歯極7のロータ磁石4との対向面は、樹脂により内包しないようにすると共に、コイル末端8aを内包して側面に配置し不図示のモータ制御回路と電気的接続を可能にしている。

又、ベース9は、図1に示すように歯極7の対向面に沿って、ハブ部5の外径よりも若干大きな略円筒状の窪み部10が設けて有り、この窪み部10に軸受け2を固定すると共にロータ3を収納している。11はスピンドルモータであり、上述の符号1~10を付した構成を含む。

【0013】このスピンドルモータ11は、図6に示すスピンドルモータ40と同様にラジアルギャップ形であるが、スピンドルモータ40と異なり、回転子であるロータ3をステータコア6の内側に設けた、所謂インナーロータ型のスピンドルモータである。さらに、このスピンドルモータ11は、基盤となるベース9に設けた窪み部10に、回転軸1、軸受け2、ロータ3を収納すると共にステータコア6、ステータコイル8を内包する等スピンドルモータ11の主要部をベース9に埋め込んだビルトイン型の構造としたスピンドルモータである。

【0014】次に、動作を図によりを説明する。この実施の形態1によるスピンドルモータ11も図6に示す従来のスピンドルモータ40と同様に光ディスク装置に搭載されて使用される。又、スピンドルモータ11の駆動原理は従来のスピンドルモータ40と同様である。即ち、図2に示すステータコイル8に電流が流れることによりステータコア6の歯極7が磁化されて磁界が発生し、この磁界によりロータ磁石4が駆動されロータ3が回転軸1を中心に回転する。このロータ3の回転によりハブ部5にチャッキングされた光ディスクが回転する。

【0015】ここで、図2に示すように、ステータコイル8の全体をベース9に内包しているため、ステータコイル8に生じる熱はベース9に効率的に熱伝導する。このベース9が放熱板としての役割を果たし、ステータコイル8に生じる熱はベース9により効率的に放熱されるためステータコイル8の温度上昇は抑制される。したがって、スピンドルモータ11の温度上昇も抑制される。又、従来のスピンドルモータ40と異なり、ロータ3がステータコア6及びステータコイル8を覆っていないのでロータ3内に熱がこもる虞がなく、スピンドルモータ11の温度上昇はより抑制される。したがって、このスピンドルモータ11を搭載する光ディスク装置自体の内部温度の上昇も抑制できる。

【0016】尚、この実施の形態1では、ベース9をエポキシ樹脂によりモールド成形したが、エポキシ樹脂に限らず熱硬化性の樹脂であればよく、熱伝導性のよい樹脂が好ましい。又、この実施の形態1では、コイル末端8aをベース9の側面に配置したが、コイル末端8aの配置位置はベース9の側面に限定するのではなく、ベ

ース9の上面や下面等々、モータ制御回路と電気的接続が容易となる位置に配置してかまわない。

【0017】上述のように、この実施の形態1によるスピンドルモータ11によれば、ステータコイル8及びステータコア6を内包してエポキシ樹脂等でモールド成形したベース9により、ステータコイル8に生じる熱はベース9に効率的に熱伝導し、このベース9の放熱作用によりステータコイル8及びステータコア6の温度上昇が抑制されるので、ディスク駆動モータ11の温度上昇を抑制できる。したがって、温度上昇によるディスク駆動モータ11の性能への悪影響を防止でき、かつ、スピンドルモータ11を光ディスク装置に搭載した場合にスピンドルモータ11に近接して配置する光ディスクの膨張変形を抑制できる。

【0018】又、コイル端末8aを電気的接続が可能にベース9の側面に内包したので、コイルリード及びコイル端末の処理が容易になると共に、モータ制御回路との電気的接続が容易にできる。

【0019】実施の形態2。この発明のスピンドルモータの他の実施の形態について説明する。図3は実施の形態2によるスピンドルモータを示す全体斜視図であり、図4は図3に示す線分CC'における断面図である。図3及び図4において、図1又は図2と同一符号は同等又は相当のものを示し説明を省略する。12はエポキシ樹脂等により樹脂モールド成形されたモールドステータであり、磁性材料からなるステータコア6及び歯極7に巻回したステータコイル8からなるステータを内包している。但し、歯極7のロータ磁石4との対向面は樹脂により内包されないようにしている。12aはモールドステータ12の内径側に設けた孔部であり、この孔部12aにロータ3がロータ磁石4と歯極7との間に所定の隙間を設けて配置される。13はアルミニウム製のベースであり、モールドステータ12の側面外形と同様の形状の窪み部14を設け、この窪み部14の内壁と下面にモールドステータ12を接着剤により密着させて固定すると共に、ロータ3がモールドステータ12の孔部12a内に収納されるように、モールドステータ12の孔部12aの内径中心の位置に軸受け2をカシメ止等により固定している。11aはスピンドルモータであり、上述の符号12～14を付した構成及び符号1～8を付した構成を含む。

【0020】次に、動作を図により説明する。この実施の形態2によるスピンドルモータ11aも図1に示すスピンドルモータ11と同様に光ディスク装置に搭載されて使用される。又、スピンドルモータ11aの駆動原理は従来のスピンドルモータ40及び上述の実施の形態1によるスピンドルモータ11と同様である。即ち、図4に示すステータコイル8に電流が流れることによりステータコア6の歯極7が磁化されて磁界が発生し、この磁界によりロータ磁石4が駆動されロータ3が回転軸1を

中心に回転する。このロータ3の回転によりハブ部5にチャッキングされた不図示の光ディスクが回転する。

【0021】ここで、図4に示すように、モールドステータ12はステータコイル8を内包すると共に、ベース13の窪み部14の内壁に密着しているので、ステータコイル8に生じる熱はモールドステータ12を形成する樹脂を介してベース13に熱伝導する。このアルミニウム製のベース13が放熱板としての役割を果たすことにより、ステータコイル8に生じる熱はモールドステータ12を形成する樹脂を介してベース13により効率的に放熱されるのでステータコイル8の温度上昇は抑制される。したがってスピンドルモータ11aの温度上昇も抑制される。又、図6に示す従来のスピンドルモータ40と異なり、ロータ3がステータコア6及びステータコイル8を覆っていないのでロータ3内に熱がこもる虞がなく、スピンドルモータ11aの温度上昇はより抑制される。したがって、このスピンドルモータ11aを搭載する不図示の光ディスク装置自体の内部温度の上昇を抑制できる。

【0022】尚、この実施の形態2ではベース13をアルミニウム製としたが、これに限らず、熱伝導性のよい金属を用いてもかまわない。又、この実施の形態2ではコイル端末8aをベース13の上側に引き出しているが、窪み部14にベース13の下側に貫通する孔を設け、コイル端末8aをベース13の下側に引き出してもかまわない。

【0023】上述のように、この実施の形態2によるスピンドルモータ11aによれば、ステータコイル8及びステータコア6を内包したモールドステータ12をベース13の窪み部14の内壁と下面に密着させてベース13に収納したので、ステータコイル8に生じる熱をモールドステータ12を形成する樹脂を介してベース13に熱伝導させ、このアルミニウム製のベース13の放熱作用によりステータコイル8及びステータコア6の温度上昇が抑制されるので、スピンドルモータ11aの温度上昇を抑制できる。したがって、温度上昇によるスピンドルモータ11aの性能への悪影響を防止でき、かつ、スピンドルモータ11aを光ディスク装置に搭載した場合にスピンドルモータ11aに近接して配置する光ディスクの膨張変形を抑制できる。

【0024】又、ベース13をアルミニウム製とし、ベース13の剛性を大きくしたので、実施の形態1に示すスピンドルモータ11に比べ、回転に伴う振動等による悪影響を防止でき、スピンドルモータ11aの信頼性を向上することができる。

【0025】

【発明の効果】上述のように、この発明によるスピンドルモータは、回転軸に固定され回転軸を中心に回転するロータと、このロータの円周外面に沿って固定されたロータ磁石と、ロータ磁石との間にラジアル方向に所定の

隙間を設けて対向配置した複数の歯極を設けた磁性材からなるステータコアと歯極に巻回したステータコイルとを設けたステータと、このステータを内包して成形すると共に回転軸の軸受けを固定した樹脂製のベースとを備えたので、ベースがステータコイルに生じる熱を放熱する放熱板となり、ステータコイルの温度上昇を抑制するのでスピンドルモータの温度上昇を抑制できる。したがって、スピンドルモータの性能への悪影響を防止でき、このスピンドルモータを光ディスク装置に搭載して使用しても光ディスクの膨張変形を抑制できるという効果を奏する。

【0026】さらに、次の発明によるスピンドルモータは、ベースは、ステータコイルのコイルリード及びコイル末端を内包すると共にコイル末端を側面に電気接続可能に配置しているため、コイルリード及びコイル末端の処理が容易になると共に、電気的な接続が容易となる。

【0027】又、次の発明によるスピンドルモータは、回転軸に固定され回転軸を中心に回転するロータと、このロータの円周外面に沿って固定されたロータ磁石と、ロータ磁石との間にラジアル方向に所定の隙間を設けて対向配置した複数の歯極を設けた磁性材からなるステータコアと歯極に巻回したステータコイルとを設けたステータと、このステータを樹脂モールドしたモールドステータと、このモールドステータを窪み部の内壁に密着して固定し、かつ回転軸の軸受けをモールドステータの内

径中心位置に固定した金属製のベースとを備えたので、ステータコイルに生じる熱がモールドステータの樹脂を介して金属製のベースに熱伝導し、この金属製のベースが放熱板となり、ステータコイルの温度上昇を抑制するのでスピンドルモータの温度上昇を抑制できる。したがって、スピンドルモータの性能への悪影響を防止でき、このスピンドルモータを光ディスク装置に搭載して使用しても光ディスクの膨張変形を抑制できるという効果を奏する。又、回転軸を固定するベースを金属製とし、ベースの剛性を大きくしたので、回転に伴う振動等による悪影響を防止でき、スピンドルモータの信頼性を向上することができる。

【図面の簡単な説明】

【図1】 この発明の実施の形態1によるスピンドルモータを示す斜視図。

【図2】 図1の線分B-B'断面図。

【図3】 この発明の実施の形態2によるスピンドルモータを示す斜視図。

【図4】 図3の線分C-C'断面図。

【図5】 従来のスピンドルモータを搭載した光ディスク装置を示す全体斜視図。

【図6】 図5の線分A-A'断面図。

【符号の説明】

- 9 ベース、 11、11a スピンドルモータ、 1
- 2 モールドステータ、 13 ベース

【図1】

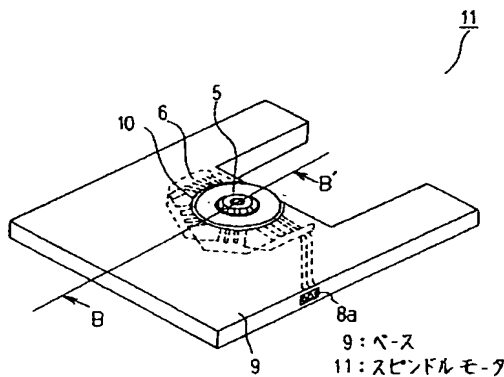

【図2】

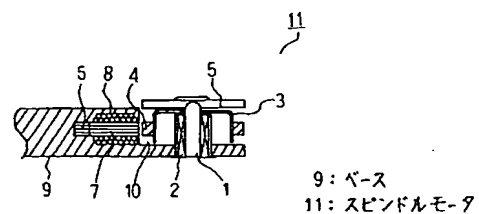

【図4】

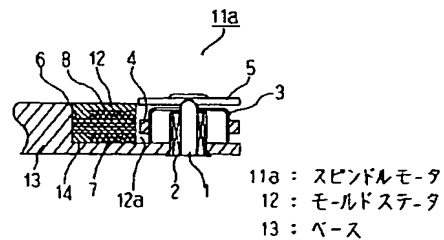

【図6】

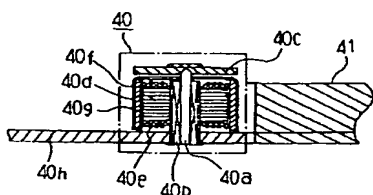

【図3】

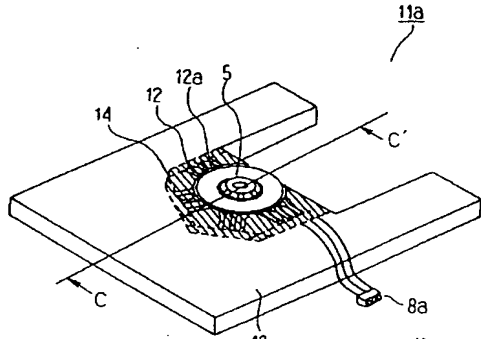

11a : スピンドルモータ  
12 : モールドステータ  
13 : ベース

【図5】

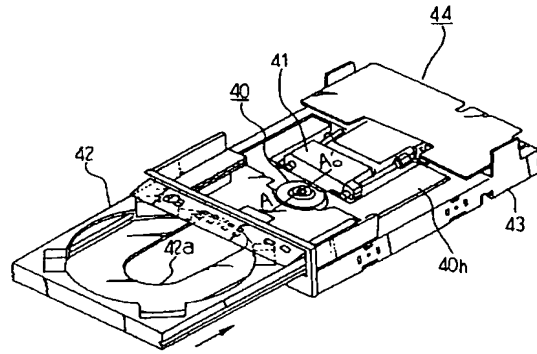



(12) **EUROPEAN PATENT APPLICATION**

(43) Date of publication:  
**11.12.1996 Bulletin 1996/50**

(51) Int. Cl.<sup>6</sup>: **H01L 21/56**

(21) Application number: **96303045.7**

(22) Date of filing: **30.04.1996**

(84) Designated Contracting States:  
**DE FR GB IT NL**

(30) Priority: **02.05.1995 US 434336**

(71) Applicant: **TEXAS INSTRUMENTS  
 INCORPORATED**  
 Dallas, Texas 75243 (US)

(72) Inventors:  
 • **Bolanos, Mario A.**  
 Plano, TX 75023 (US)  
 • **Libres, Jeremias L.**  
 Dallas, TX 75243 (US)

• **Bednarz, George A.**  
 Plano, TX 75023 (US)  
 • **Chee, Tay Liang,**  
 c/o Texas Instruments Inc.  
 Dallas, TX 75243 (US)  
 • **Lim, Julius,**  
 c/o Texas Instruments Inc.  
 Dallas, TX 75243 (US)

(74) Representative: **Holt, Michael**  
 Texas Instruments Limited,  
 Kempton Point,  
 68 Staines Road West  
 Sunbury-on-Thames, Middlesex TW16 7AX (GB)

(54) **Improvements in or relating to integrated circuits**

(57) A method and apparatus for encapsulating an integrated circuit die and leadframe assembly. A pre-packaged sproutless mold compound insert 71 is placed in a rectangular receptacle 91 in a bottom mold chase 81. The receptacle is coupled to a plurality of die cavities 85 by runners 87. Leadframe strip assemblies containing leadframes, integrated circuit dies, and bond wires coupling the leadframes and dies are placed over the bottom mold chase 81 such that the integrated circuit dies are each centered over a bottom mold die cavity 85. A top mold chase 90 is placed over the bottom mold chase 81 and the mold compound package 71. The top mold chase 90 has die cavities 95 corresponding to those in the bottom mold chase 81. The mold compound insert 71 is preferably packaged in a plastic film 75 which has heat sealed edges 77. The mold compound is forced through the package 75 and heat seals 77 during the molding process by the pressure applied by a rectangular plunger 101. The sproutless mold compound insert is packaged so that the mold compound will exit the packaging only where runners intersect the receptacle. The sproutless mold compound insert requires no alignment or cutting tools within the mold station. The plunger is applied using variable speed and pressure to control the rate the mold compound fills the cavities in the top and bottom mold chases, thereby avoiding voids in the completed packages and minimizing wire sweep of the bond wires of the integrated circuit assemblies.

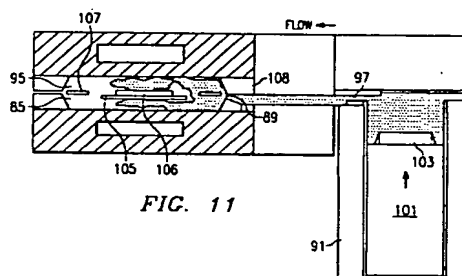

FIG. 11

EP 0 747 943 A2

## Description

### FIELD OF THE INVENTION

This invention relates generally to the field of integrated circuits, and more particularly to the encapsulation packaging of integrated circuits using transfer molding techniques.

### BACKGROUND OF THE INVENTION

In producing integrated circuits, it is desirable to provide packaged integrated circuits having plastic or resin packages which encapsulate the die and a portion of the lead frame and leads. These packages have been produced in a variety of ways, a few of which will be described here.

Conventional molding techniques take advantage of the physical characteristics of the mold compounds. For integrated circuit package molding applications, these compounds are typically thermoset compounds. These compounds consist of an epoxy novolac resin or similar material combined with a filler, such as alumina, and other materials to make the compound suitable for molding, such as accelerators, curing agents, fillers, and mold release agents.

The transfer molding process as known in the prior art takes advantage of the viscosity characteristics of the molding compound to fill cavity molds containing the die and leadframe assemblies with the mold compound, which then cures around the die and leadframe assemblies to form a hermetic package which is relatively inexpensive and durable, and a good protective package for the integrated circuit.

FIG. 1 depicts the viscosity characteristic curve of a typical mold compound. The Y axis depicts the viscosity of the compound. The X axis represents the time elapsed from a starting point where heat is applied. The mold compound transitions from a high viscosity or hard state to a state where it has very low viscosity after an initial time lapse. The low viscosity stage lasts only a limited time period, typically 20 to 30 seconds, then the compound becomes higher in viscosity and begins to set, or cure. For the entire period the mold compound is heated. The mold compound is thermoset material, so that after being heated for a time period longer than the low viscosity time period it will cure or set.

Transfer molding operations have three stages which correspond to the three phases of viscosity shown in FIG. 1. First there is a preheat stage required to move the mold compound from its hard initial state to the low viscosity state. Second is a transfer stage, where the compound is low in viscosity and easily transported and directed into cavities and runners. This transfer process should be rapid and be completed before the mold compound begins to set. Finally there is a cure stage that occurs following the transfer stage.

FIG. 2 depicts a conventional single plunger transfer mold press 11. The press consists of a plunger or

ram 13 that is operated under hydraulic pressure, a top platen 15, a top mold chase 17, a bottom platen 19, and a bottom mold chase 21. A fixed head 23 supports the plunger and a movable head 18 support the top platen, and allows the top platen to be removed for loading and unloading the mold from the top. Mold heaters 25 provide heat to the mold in both the top and bottom platens. An automated mold controller, although not shown, is usually coupled to the press. The top and bottom platens are steel and receive the stresses of the pressing operation, both are heated to provide the temperature needed to perform the transfer molding operation.

FIG. 3 depicts a typical bottom mold chase. In FIG. 3, a top view of bottom mold chase 21 is shown. There are six primary runners 31, each will support a pair of leadframe strips holding wire bonded dies and lead assemblies over each cavity 33. The cavities are formed along the runners 31, which are cylindrical shaped paths that extend from the mold pot 32 and into the rows of cavities. Each cavity is coupled to the runners by a secondary runner 35 which ends in a gate 37, a small opening that lets the mold compound into the cavity. The size and shape of the gate is critical to the speed and control of the transfer and filling stages of the molding process.

FIG. 4 is a detailed drawing of a single runner 31 with a single die cavity 33 shown. The secondary runner 35 is shown coupling the primary runner to the gate 37 and to the die cavity 33. Runner 31 is coupled to the pot 32.

FIG. 5 depicts a cross section BB from FIG. 4. This cross section is taken across the primary runner 31 and along secondary runner 35, and depicts the sloped shape of secondary runner 35 up to the gate 37. The lead frame 51 of a typical bonded part is shown over the bottom mold chase cavity and under the top mold chase cavity 34. Die 53 is shown with the bond wires 55 coupling it to leadframe 51.

The operation of the conventional single pot transfer mold will now be described with reference to FIGS. 2-5. To begin a new molding operation, the mold press is opened and the top and bottom mold chases 17 and 21 are separated. The leadframe and die assemblies are loaded into the bottom mold chases. The mold compound is preheated using an R/F heater or other heater before being placed into the heated mold.

The top and bottom platens are closed, bringing the top and bottom mold chases together. The top and bottom mold chases 17 and 21 are patterned to define a cavity around each die, with the lead frames extending outside the cavity and a space formed around each die. Several leadframe strips each having a row of dies 53 which are bonded to their respective lead frames 51 are placed over the cavities 33 in the bottom mold chase 21. A pellet of resin or similar material mold compound is placed in the mold pot within the top mold chase 17. After an initial heating stage to put the mold compound into its low viscosity state, the plunger or ram 13 is used to begin the transfer phase of the operation. The



plunger 13 is brought down through the top mold chase 17 onto the mold compound pellet at a predetermined rate, forcing the mold compound into the primary runners 31. As the runners fill with mold compound the compound will begin filling the secondary runners 35, entering the gates 37 beneath the leadframe and die assemblies 51 and filling the cavities 33.

At the end of the transfer stage the mold compound should fill each cavity 33, preferably at the same time and before the mold compound begins to cure. The rate of the downward force brought by the plunger 13 is varied during the transfer phase to help control the transfer process. Experimental use of the press 11 with a particular mold and compound combination will provide the best combination of pressure and transfer speed which can then be programmed into the automatic press controls to uniformly repeat the process.

After the transfer stage, the packaged parts are cured. Curing the molded parts typically takes 1 to 3 minutes of sitting in the heated mold without disturbance. The compound cure is fairly rapid and may be enhanced by adding curing agents to the compound. At the end of the curing cycle the press is opened and the molded parts and the mold compound sprue or flash in the runners and pot are ejected. This is done by having ejection pins extending through the bottom mold chase 21 and bottom platen 19 push upward under pressure at the same instant, popping the molded parts and sprue out of the bottom mold chase 21. The packaged parts are then removed to other areas where they are separated and trim and form operations performed on the parts.

There are several critical requirements that are to be met in a commercially successful package molding operation. The cavities should be completely and uniformly filled. Using the single plunger mold of FIGS. 2-5 the cavity fill stage is difficult to perform uniformly across such a large mold using the single pot and the long primary runners to transport the mold compound. A problem commonly observed in a single plunger single pot mold operation using a mold such as shown in FIG. 2 is an unacceptable void rate. Voids are areas within the mold cavity that are not filled with compound. These can be areas where the compound fails to flow or where air or other materials are trapped and cause hollow spaces in the packaged part. Voids can be produced if the transfer rate of the mold compound is too slow during the molding process or if air or moisture is trapped in one or more the cavities during the transfer stage.

A second critical requirement is that the wire sweep defect rate be minimized below an acceptable level. Wire sweep occurs as the mold compound enters the cavity through the gates. The mold compound is dense and pulls at the fine wires that couple the bond pads of the die to the leads of the lead frame. These wires will bend under the pressure due to the flow of mold compound. As an example, suppose that in a typical lead frame and die assembly, an average wire sweep of less

than 6% is specified. A straight line from the lead frame lead to the bond pad has a sweep of 0%. So if after assembly and mold any wires on a packaged unit are found to have more than 6% sweep, the unit is out of specification, and is considered to be a bad unit. Wire sweep is specified as a maximum allowable parameter and is a big concern in production of integrated circuits, because if the bond wires are moved too much, a wire short between two or more adjacent bond wires often occurs. Alternatively, bond wires sometimes break away. Either condition results in a faulty unit.

Although the wire sweep defect rate which is observed in the single plunger molding presses is adequate for producing low to moderate pin count DIP and flat quad packaged devices, as the device pin counts continue to increase and lead frames become finer in lead to lead pitch, the wire sweep parameter becomes increasingly critical. While it is possible to build 200 pin flat quad devices using these techniques, as the pin count goes towards 400 pins the prior art transfer molding presses using a single mold pot will no longer be economically suitable, due to the low yield and high wire sweep defect rates.

A further disadvantage with a single plunger mold and pellet compound arrangement is that the performance in the two critical areas are inversely dependent on each other. That is, in attempting to perfect the molding process using a single plunger mold, it has been observed that steps taken to reduce wire sweep defects typically increase the void rate, and vice versa. In other words, if the wire sweep defect rate is lowered, the void rate tends to increase. The wire sweep rate can be lowered, for example, by slowing the transfer rate of the mold compound into the cavities. However, doing this tends to increase the void rate. Voids can be reduced by increasing the flow rate into the cavities, but this will tend to increase the wire sweep defect rate.

It has been further observed that the wire sweep and void problems tend to be more severe as the number of cavities and the distance of runners increases. Nonuniform fill can occur along a lengthy runner having many cavities. The cavity closest to the pot will have a faster fill rate than the others. The cavity farthest from the pot will tend to fill at the end of the transfer period, and the rate will be lower because much of the compound has been diverted to other cavities and because the compound is starting to harden. As a result, difficult and time consuming fine tuning of each mold press is required to establish an operation mode which will fill all of the cavities at an acceptable rate, during the low viscosity period, without increasing wire sweep defects to an unacceptable level, particularly for the near and far cavities.

Further, the use of the thermoset molding compound results in a process where the sprue, flash or waste that is left in the pot, the runners and between the devices themselves cannot be reused.

Thermoset materials can only be used once in a molding operation, so the excess material must be dis-

carded. Thus the sprue and waste left in the long runners and in the mold pot cannot be recycled.

Also, the conventional molding compound acts as a strong abrasive. During molding, the mold compound is forced out of the mold pot and into the primary runners. The abrasive nature of the mold compound results in rapid wear of the mold pot and the runners, and the plunger or ram itself. This results in expensive rework or replacement of the mold chases on a frequent basis.

An alternative approach for reducing the problems known to the single plunger molding presses of the prior art is to construct a multipellet, multiplunger mold station to replace the single plunger system. A portion of the bottom mold chase of a typical prior art multiplunger mold is shown in FIG. 6. Mold chase 61 has several die cavities 63, grouped in pairs. Runners 67 couple each pair of die cavities to a mold pot 69. Gates 65 enable the mold compound to be transferred into and fill the cavities.

In operation, each of the mold pots 69 receives a so called "mini-pellet" of mold compound. The press is a more complex press than that shown in FIG. 2, and has a plunger for each of the mold pots. The plungers may operate from the top or from underneath the mold. Each mold pot 69 and the short runners 67 act exactly as the single plunger mold of FIG. 2 in operation. The individual plungers are used to start the transfer process, the cavities fill with mold compound as the plunger is pushed into the mold pot, and the transfer phase is completed in a few seconds.

The multiplunger mold process has some advantages over the single pot molding process. The use of the smaller pellets and the shorter runs eliminate the long runners and nonuniform fill times associated with a single plunger press. The pellets used are smaller and therefore do not require preheating, as the mold platens can provide sufficient heat to transition the mini-pellets into the low viscosity state. The wire sweep defect rate can be lowered by providing exact control of the plunger or ram insertion rate, so that the fill is done at a speed which prevents voids while minimizing wire sweep problems. An automated multiplunger press can vary the operation of the plungers during the transfer stage to obtain optimal results.

The nonuniform fill and wire sweep problems associated with the cavities nearest and farthest from the single center pot of the single plunger mold presses are eliminated. Mold compound waste is reduced by the shorter runners.

The disadvantages of the multiplunger molding process are primarily that it requires the use of the mini-pellets. The mini-pellet form of the molding compound is far more expensive per kilogram than the single large pellets used by the single transfer mold. Also, the multiplunger molding station is extremely expensive to manufacture, operate and maintain. The automation of a press with so many plungers is more complex and expensive than the single mold press.

In addition to the added costs, the need for many

plungers results in a molding station that has a lower parts per hour throughput than for a conventional single pot mold press. Also the multiple plunger molding system requires complex control and loading and unloading mechanisms. The result is that each station has lower overall throughput than a single plunger mold station, although tighter process control can be achieved. Because the throughput is lowered, additional stations are needed to maintain the same relative level of productivity. High productivity is required to keep the per unit costs low. The need for additional expensive and complex molding stations increases the cost disadvantages for the multiplunger molding systems.

An alternative is a multigang, multipot mold system. This arrangement borrows the simplicity of the single pot mold and adds the multiple pellet idea of the multiplunger mold by having multiple plungers ganged together and using multiple pots in the mold chase, each feeding two to four cavities with mold compound. By reducing the transfer distance it is hoped wire sweep and void rate problems can be improved. However, tight process control is not available because the plungers all travel at the same speed and pressure unless an external controller is installed. So this alternative has the disadvantages of requiring the mini-pellets of mold compound, while not providing the highly automated process control of a multi-plunger mold system.

Both single plunger and multiplunger mold presses have other disadvantages that are common. The mold compound is an abrasive material. The mold pot and the primary runners receive an abrasive force each time the press is operated. These areas wear quickly and the expensive mold chases must be replaced periodically as a result.

Also, both processes require pelletized mold compound. This material is fairly difficult to produce in the large form, and even more expensive to produce in the minipellet form. The compound is extruded into a rod, which is powdered, and the powder is then pelletized. This is an expensive and complex manufacturing process.

Both pellets and mini-pellets are subject to contamination by moisture and air. It is necessary to perform the molding process under pressure to eliminate trapped air and prevent the formation of voids. Moisture can become trapped in either form of pellet. Moisture contamination of the molding compound can result in additional voids and scrapped devices. Moisture contamination also contributes to package cracking during cure and afterwards to early failure of devices.

U.S. Patent No. 5,098,626, issued March 24, 1992, and entitled "Method for Packing a Measured Quantity of Thermosetting Resin And Operating a Mold for Encapsulating a Component", provides another alternative wherein the mold compound is packaged in individually sealed units. These units each contain mold compound in a quantity needed for a single cavity or pair of cavities for integrated circuit packages. Each of these units is a bag or tube containing mold compound

and ending in a bulge or sprout. During molding the bulge or sprout is placed at the end of a runner which feeds a cavity. The sprout is cut and the mold compound is pressed out of the bag into the cavity by individual or multiple plungers.

The '626 patent approach is similar to a multi-plunger mold system in that small quantities of mold compound, each of which are individually loaded, are provided. The patent provides a moisture and contamination free packaging system which can be used with an automated loading system. However, like the mini-pellets, many of these bags are required for each run. The abrasion problems are reduced, because the pots and plungers are protected by the packaging. Also, improved uniform fill and reduced wire sweep are possible. But the throughput problems and increased expense for each molding station remain, and the costs for each press are increased further by the added complexity. Also, the packaging of the mold compound in small quantities each in an individual package may lead to an expensive raw material for molding.

Further, the spouted bags of the '636 are fitted into the runner openings. The bags are supplied attached to a tape or spool for continuous feed loading. However, this particular feature of the sprouted bag containers means that the bags and the tape or spool must be custom designed for each particular mold, and if the mold design is changed, a different bag design must be used. Also, the complexity of loading a bag for each cavity or each pair of cavities adds to the precision and cost of the loading equipment used. Further, the molding equipment must include a cutter device for each cavity that cuts the sprout of the bag prior to the transfer stage of molding.

Accordingly, a need thus exists for a transfer molding system which eliminates the problems of the prior art transfer molding systems while retaining a high part throughput rate, low raw material costs, and which is simple to operate, maintain, and uses molding stations that are relatively inexpensive to build.

The new system should be compatible with existing single pot transfer mold presses to allow a retrofitting of existing integrated circuit assembly lines. The system should reduce waste of mold compound and reduce the abrasive impact of the mold compound on the equipment used. The new molding system should provide uniform cavity fill and reduced wire sweep defect rates. The system should be general, such that different mold designs can be used with a common mold compound package.

#### SUMMARY OF THE INVENTION

A system for transfer molding the packages of integrated circuits using mold compound prepackaged in a sproutless protective package is provided. The mold compound is packaged in a thin packaging that is sealed at the edges, or is made as a seamless bag or tube. The packaging will protect the mold compound

and contain it during normal handling and storage, but under the heat, pressure, or the combination of heat and pressure of particular molding processes the package will become penetrable and the mold compound can be expelled through it. The package is placed in a simple mold pot or receptacle, and when the packaged compound is compressed the compound emerges from the package only at places adjacent to the mold runners during the transfer molding process. The protective packaging ensures that the mold compound is free from moisture and air contamination and is easily produced, stored and shipped.

An improved mold design is used in combination with the packaged sproutless mold compound inserts. The mold chases include rectangular receptacles for receiving the packets of prepackaged mold compound. A plunger is provided for each of the receptacles. Each package cavity is preferably equidistant from the receptacle containing mold compound, providing improved uniformity of fill and allowing for complete fill of the cavities with reduced wire sweep as compared to the transfer molds of the prior art. The plunger is inserted and the mold compound is forced through the protective packaging into short runners coupling the mold receptacle to the cavities. The number of devices packaged per run is increased because the mold pots of the single or multiple plunger molds of the prior art are eliminated, providing additional area for die cavities.

The mold compound is placed inside the mold receptacle within the protective package, so that the equipment abrasion problems associated with conventional prior art transfer molding operations are reduced or eliminated. Since the runners are shortened, the amount of mold compound which is flash or sprue for each run is reduced, thus reducing waste and lowering production costs. The improved mold design is compatible with automated loading, molding and unloading systems for increased automation and improved throughput. The molding station requires only a few plungers and is inexpensive to build and maintain. Existing molding equipment may be retrofitted to use the new system. The mold compound package may be automatically loaded into the mold chases by using existing autoloading equipment. Since the mold compound will automatically be delivered to the runners regardless of the position of the sproutless mold compound insert, no alignment or precise loading equipment is required. Also, since the mold compound is pushed through the packaging, no cutters or opening tooling are required. The prepackaged sproutless mold compound system is easily combined with a process controller to achieve tight process control. The use of the sproutless prepackaged mold system with a process controller results in a mold process with balanced cavity fill, reduced wire sweep and low void defect rates.

#### BRIEF DESCRIPTION OF THE DRAWINGS

The present invention will now be further described

by way of example with reference to the accompanying drawings in which:

FIG. 1 depicts the viscosity characteristic curve for conventional mold compound;

FIG. 2 depicts a conventional single plunger mold press;

FIG. 3 depicts the bottom mold chase and runners of a mold used with the conventional mold press of FIG. 2;

FIG. 4 depicts a section of the bottom mold chase of FIG. 3 in more detail;

FIG. 5 depicts a cross section of the runner of the bottom mold chase shown in FIG. 4;

FIG. 6 depicts a bottom mold chase and runner of a conventional multiplunger mold;

FIG. 7 depicts a sproutless mold compound package of the invention;

FIG. 8 depicts a bottom mold and chase of the mold system of the invention;

FIG. 9 depicts a top mold and chase of the mold system of the invention;

FIG. 10 depicts the plunger used with the top and bottom mold and the prepackaged mold compound of the invention; and

FIG. 11 depicts the plunger, prepackaged mold compound and mold cavity in cross section during the transfer stage of the molding process.

Corresponding numerals are used for corresponding elements in the drawings, unless otherwise indicated in the text.

#### DETAILED DESCRIPTION OF PREFERRED EMBODIMENTS

FIG. 7 depicts a prepackaged sproutless mold compound insert 71 in a first preferred embodiment of the mold compound of the invention. In a first embodiment, a prepackaged mold compound insert is composed of conventional resin or resin filler mold compound in a solid form. Alternative molding compounds may be used, such as liquids, epoxies, adhesives, resins in liquid form, powdered mold compound, as examples. The mold compound material may be made from powdered mold compound or from extruded mold compound directly, eliminating the need for the expensive pelletizing steps required for the pellets of the prior art mold compounds. The shape of the prepackaged mold compound is determined by the design of the mold being used, here a rectangular pillow-like shape is shown, but any other shape can be used and should be used to advantage with different mold designs.

The mold compound material 73 is preferably packaged in a pre-formed package 71. Ends 76 are sealed. Top 74 is wider than the mold compound 73 and provides a lip on either side of the mold compound 73. A corresponding bottom piece is likewise provided. Top and bottom pieces 74 and 75 are sealed together at the edges 77 and the top and bottom are also sealed at the

ends 76. Ends 76 and edges 77 are seals that couple the bottom (not shown) to the top 74 using, for example, conventional heat sealing techniques for plastic packaging. Alternative sealing techniques such as ultrasonic seals, adhesives, and pressure seals or crimped seals can be used.

Alternatives to the package of FIG. 7 include tubes and bags of various shapes. For example, the shapes can include ovoid, circular, oval, and others may be imagined. The mold design and runner placement will determine the shape of the mold compound insert 71. The insert can be packaged such that precision placement of the insert into the mold is not necessary; the insert can be sized so that as the mold closes the insert falls into the proper place, providing a self aligning feature not available in the sprouted bags of the prior art. In contrast, the sprouted bags or packets of the prior art require that the runners and mold compound inserts be carefully aligned.

The sproutless mold compound package of FIG. 7 provides the advantages of making the mold compound impervious to contaminants such as water that could interfere with the molding process. Since the prepackaged mold compound pieces 73 are self packaged, storage and shipping packing materials may be inexpensive and no additional protective layers are needed. The protection of the mold compound from moisture prevents many of the package cracking problems and voids associated with moisture contaminated mold compound. The top 74 may be opaque and may carry labeling information in text and machine readable forms, such as bar codes or so called UPC labels. This labeling on the mold compound package 71 provides an easy mechanism for checking that the correct type of mold compound is being used for a particular packaging operation. Also, the packaging affords the opportunity to use alternative mold compounds because the mold plunger and mold receptacle or pot are not in direct contact with the compound.

A critical element to the operation of the molding process using the prepackaged molding compound is the packaging material. The requirements for the packaging of the mold compound have been established for an integrated circuit assembly process using industrial standard requirements for molding compounds and for the resulting integrated circuit packages. The package should not create residue or glue like substances in the mold during molding. The mold compound packaging should not contaminate the mold runners or receptacle. The material used in the packaging should not add to ionic contamination of the resulting packages, that is the material should not have an ionic content higher than that of the molding compounds in use in the integrated circuit packaging art. The material should not melt during the molding process, so it should have a melting temperature at least ten degrees Celsius greater than the molding temperatures. Typically, the material needs to have a melting point greater than 200 degrees Celsius.

Also, the packaging material should only allow the molding compound to exit the package at selected points adjacent to the runners, and it should not open prematurely during the preheat phase of the molding operation. So the seals should not open and emit molding compound prematurely. However, once the edge seals are permeable the mold compound should flow out of the package with a minimum of resistance to flow. The material should not tear in normal handling or shipping, but should have the capacity to stretch into the runners when compressed during the molding process as described above. The material should be capable of vacuum sealing and of maintaining the vacuum during storage.

Materials which meet these requirements, and are also economical in use, can be used to wrap the mold compound as shown in FIG. 7. Possible materials include polymer films, elastomers, synthetic rubber, foils and metal films, and the like. Although many materials may exist that could meet these requirements, it is now known that certain plastic films meet the requirements listed above. Plastic films such as those used in food storage, freezing and preparation, are particularly well suited to this application. The melting point, strength, vacuum capability and moisture and air barrier requirements for the mold compound packaging are all met by such films. The films are inexpensive and easy to purchase and use in a production environment. One preferred film is MYLAR™ polyester film, such as for example MYLAR™ 40 XM 963-AT, a polyester film for packaging available from DuPont, DuPont de Nemours Int. S.A., Geneva, Switzerland; or DuPont (U.K.) Ltd, Maylands Avenue, GB-Hemel Hempstead, England. Another preferred film is ICI™ polyester film. Similar films are commercially available from a variety of vendors.

Once the appropriate material is selected, the film should be applied to the mold compound to create the necessary packaged mold compound insert. The mold compound can be packaged in solid or liquid form. The package can be made a variety of ways, but one process that has been shown to be advantageous is as follows. An extruded piece of mold compound is placed over the bottom piece of film. The bottom piece is wider and longer than the mold compound. Top piece 74 is placed over the bottom piece of film. Top piece 74 is also longer and wider than the bottom piece. Heating blocks or other sealing means can be applied to those areas where the film exceeds the size of the mold compound 73. After the seal is formed, the top 74 is cut outside of the seals to form the package as shown in FIG. 7. The size of this lip is again determined by the mold design. If other support means is provided, this lip is not required at all. The lip can then be eliminated altogether.

Alternative packages include seamless envelopes that are filled from one end, tubes, straws, rounds, discs, etc. The key points are that the package be made such that in normal use the mold compound is protected and a vacuum is maintained, and that the molding can

be done with the package still on the mold compound, that is the mold compound is automatically dispensed from the package.

The key feature of the package 71 of FIG.7 is that there is no need for a nozzle, top or sprout. The mold compound is packaged such that it will leave the package under compression during the molding process. As will be shown below, the mold compound will automatically exit the package at the runners, so no alignment or precise positioning of the sproutless mold compound package is required.

Alternative means of packaging the mold compound are feasible. A tube of the plastic packaging material of the preferred embodiment can be sealed at one end and filled with a piece of extrusion, solid or liquid molding compound. The tube can be plastic film as described above, or any alternative material which meets the requirements for the packaging materials.

Preferably, the package 71 is sealed in the final stages under a vacuum. This may be accomplished, for example, by sealing the edges 77 and one end 76, then moving the partially sealed package 71 to a vacuum chamber where the seals can be completed.

The advantage of vacuum sealing is that it eliminates voids caused by air trapped in the package. If air is allowed to be packaged with the mold compound, as the mold compound is pushed out of the package the air will also be pushed out of the package and into the die cavities, where voids can be formed as a result. Also, moisture is removed under the vacuum. Moisture contamination in molding compound leads to package cracking and early device failure.

Whatever means is used to package the mold compound, the sealing mechanism should be provided such that under pressure, or heat and pressure, the sealed package will allow the mold compound to escape. However, under normal handling, the package should be impervious to air, water, ionic contamination, and should not burst or leak out the packaged molding compound.

FIG. 8 depicts a portion of a bottom mold 82, comprising a mold chase 81 for transfer molding integrated circuit packages, such as for example DIP or flat quad type high pin count integrated circuit packages, using the mold compound package of FIG. 7. Bottom mold 81 holds two cavity bars 83, each of which has several die cavities 85 coupled to primary runners 87 and each cavity having a gate 89. A rectangular mold compound receptacle 91 is provided through the mold chase 81. This receptacle 91 is open at the bottom for allowing a plunger or ram to enter the mold chase and to apply pressure to a prepackaged mold compound insert resting at the top of receptacle 91, to force the mold compound into the runners and the cavities. A typical mold system would include two to four of these mold chase pairs 83, so it would have two to four receptacles 91, and cavities along both sides of each receptacle. In some cases, more chases can be used, such as 6 or 8 chases in a single mold. The number of chases

depends on the mold press.

FIG. 9 depicts a portion of a top mold 92 for use with the bottom mold of FIG. 8 and the prepackaged mold compound of FIG. 7. In FIG. 9, top mold chase 91 carries top mold cavity bars 93, each of which is provided with a row of cavities 95 which are positioned to be placed over the bottom mold chase cavities 87. Delivery runners 97 are positioned with an outer end which will meet an associated primary runner 87 in the bottom mold chase, and an inner end which will lie over the receptacle 91.

FIG. 10 depicts the plunger 101 which is used with the top mold 92 of FIG. 9 and the bottom mold 82 of FIG. 8. The top of plunger 101 is sized so as to fit within the receptacle 91 in the bottom mold 82. The top of the plunger will compress the plastic mold compound package 71 against the top mold chase 92 in an even manner along the mold compound package. The top of plunger 101 is machined and beveled to form a tip 103. Tip 103 has two slots at the sides so that a small area at the edge of the top and sides are spaced beneath the top surface a short distance. This area will compress against the sides of the plastic package 71. As the plastic package 71 is compressed with the plunger 101, the plastic can deform into this spacing and compress further without holding the top surface of the plunger away from the top mold surface.

FIG. 11 depicts a cross-sectional view of a die 106, die pad 105 and leadframe 107 assembly located in a cavity of the mold during the transfer stage, and the operation of the mold compound and plunger. The cavity is formed by the top and bottom mold chase cavities 95 and 85. Also shown is the mold compound package 71, and the plunger 101 and tip 103, all in cross section during the transfer operation.

In operation, the prepackaged molding system including the mold compound package shown in FIG. 7, the bottom mold chase of FIG. 8, the top mold chase of FIG. 9, and the plunger of FIG. 10, operates as follows. The mold is opened so that the top mold and top mold chase is separated from the bottom mold and bottom chase and the bottom mold cavity rows 83 may be accessed from above. Lead frame and die assemblies are placed over the bottom mold chases 81 such that a single leadframe and die with its bond wires is centered over each cavity 85. A mold compound insert 71 is placed in each receptacle 91 in the bottom mold. These placements are preferably performed by an automatic pick and place mechanism, as is known in the prior art, but alternatively may be performed manually. The mold compound inserts are preferably loaded substantially simultaneously across the mold, or almost so, so that the total amount of time they are heated is similar. This prevents premature curing of the first loaded inserts.

The bottom and top molds may be heated as in the conventional transfer molding stations, and the heat in the mold itself is sufficient to transition the mold compound 73 into the transfer phase without preheating, so the preheating step required with the prior art single pot

molding press is eliminated.

After the bottom mold chases are loaded and the molding compound packages are in place in the bottom mold receptacles, the mold is closed and the top mold chases are brought into contact with the leadframe and die assemblies and the mold compound packages.

Delivery runners 97 in the top mold cavity bars 93 are now positioned so that the inside ends of these runners are over the top edges of the mold compound packages.

The mold compound may be heated for a short time to reach the low viscosity state. When molding smaller packages, this heating is not required as the heat already in the mold will rapidly make the low volume of mold compound in the insert transition to the low viscosity state. When the mold is closed, if the mold compound package is heat sealed as described above, the seal in edges 77 of the molding compound packages opens, that is, the heat relaxes the seal so it is penetrable. This relaxing of the seal should occur after the mold is closed, and should be fairly complete. If a sealing method other than a heat seal is used, it should provide a seal that opens in response to either heat, pressure, or both. The mold is typically heated to a temperature of 175 degrees Celsius when resin or resin filler molding compound is used in either powdered solid or liquid states.

After the heat seals are relaxed and the mold compound enters the low viscosity state, the plunger 101 of FIG. 10 is applied.

In a preferred embodiment, the plunger travels 101 through the bottom mold platen and into the bottom mold receptacles 91, compressing the mold compound packages from underneath. Alternatively, the mold compound could be compressed from above, with the receptacles formed in the top mold platen. In this case, the insert would be loaded with the top plastic layer 74 down, that is, adjacent to the bottom mold chases. Either arrangement will work to transfer the mold compound into the primary runners. If the material used for the package is not heat sealed, the pressure will cause the material to burst and open in the only places where the mold compound can escape, that is, where the runners meet the receptacle. In other areas the mold compound is compressed against the receptacle walls and cannot escape, so the package is not burst open at those places.

The sproutless mold compound package is compressed by the action of the plunger and as it is compressed the mold compound package will begin to push at the edges of the receptacle 91. As the only exits available to the mold compound are the runners 97 in the top mold cavity bars 93, the compound will pass through the now penetrable heat seal at the edge of the plastic package 71 and into the primary runners 97. The delivery runners each feed a primary runner 87 in the bottom mold cavity bars 83. A circular coupling area at the inner end of the primary runners meets the outer end of the delivery runners 97, and the mold compound is trans-

ferred to the secondary runners 87. The mold compound then enters the cavities 85 over the gates 89, and begins filling the individual package cavities 85. Alternative mold designs could compress the compound insert with mechanisms other than plungers, such as compressed air, liquid, rams, screws, etc., and still obtain all the advantages of the use of the invention.

The advantage of the sproutless mold compound packaging and mold design of the invention is now apparent. The mold compound is delivered to the mold runners from the prepackaged packaging without sprouts or nozzles or bulges. No cutting or opening means is required to direct or force the mold compound out of the packaging. The packaging and mold system has all the advantages of the sprouted bags of the prior art, but additionally is simpler for loading and molding. Also, the mold compound inserts can be made in universal sizes, since the mold compound is automatically delivered to the runners in the correct places, no alignment or precise loading equipment is needed, and a single size and shaped mold compound insert of the invention can be used with many different mold designs without modification.

The sproutless mold compound insert of the invention provides many advantages in addition to the ones mentioned above in enabling flexible mold design. The mold cavities of FIGS. 8 and 9 depict runners intersecting the mold receptacle from a perpendicular direction. Alternatively, the ends of the mold receptacle could also supply runners from the sproutless package. The sproutless package could be made rectangular, round, oval, or serpentine as required by a particular mold design. The width to length aspect ratio of the compound packaged is totally flexible. The cross section is also widely adaptable. Additionally, the seam that is used to seal the mold compound insert can be minimized or reduced to nearly zero width, and if a seamless tube is provided it can be eliminated; depending on the materials and sealing process chosen.

FIG. 11 shows a cross sectional view of the transfer stage of the molding process. The operation of tip 103 can be seen, as the plastic package sides are compressed into the slots machined into the plunger 101 so that the compression can continue without interference. The compound travels into the delivery runner 97, then into the primary runner 87, over the gate 89, and into the cavity 108 formed by the top and bottom chase cavities 95 and 85.

After the cavities are filled with the compound, the molding process continues as a conventional transfer molding process. A curing time may be required to complete the packages. After the packages are cured, the top mold is moved away from the bottom mold. Small release plungers, not shown, are activated to push upwards and release the packaged devices from the cavities 85, and the sprue or flash is released from the runners 87. The mold compound package 71 is now empty and resting in the receptacle 91, and it too is removed. The need to clean the receptacle 91 and the

plunger 101 is greatly reduced because the packaging of the invention serves to isolate the plunger and the receptacle from the mold compound.

The plungers 101 are easily controlled with a variable rate of compression to achieve a tight process control parameter during the transfer phase. This leads to uniform fill of the cavities, which are evenly spaced and equidistant from the source of the mold compound, and the transfer speed can be controlled to eliminate voids while minimizing pad tilt and wire sweep defects. The transfer speed and transfer pressure can be controlled by fitting an independent process controller circuit to the mold system to allow multi-step, variable speed and variable pressure capability. This equipment can be retrofitted to an existing mold press.

An advantage of the prepackaged sproutless mold system of the invention is that it provides balanced fill capability. It can be seen that each primary runner 97 and secondary runner 87 is the same length. Also, because the cavities are all equidistant from the source of mold compound, receptacle 91, the problems of non-uniform fill and wire sweep associated with the single pot mold systems of the prior art are eliminated using the molding system of the invention. The design allows balanced cavity filling to be achieved.

Further, because the mold compound is prepackaged in a protective package, the mold receptacle 91, the plunger 101, and to some extent the primary runners 97 are protected from the abrasive mold compound, so that the wear rate is greatly reduced. This results in longer mold life and reduced repair and replacement costs over the life of the mold surfaces, thus lowering the unit cost.

It can further be seen that as another advantage of the use of the invention, the mold receptacle 91 takes a small amount of area compared to the large single pot and primary runners of the single pot transfer molds of the prior art. This is an advantage in that additional space is available for cavities and additional units may be molded during each run. The density for the system is improved over the prior art.

The mold design and mold compound package is also compatible with existing autoloading systems for transfer molds, so that the prepackaged molding system may be retrofitted into an existing automated transfer mold assembly line for a reasonable cost. The plunger design and mold design results in a need for two to four plungers per mold, which is cheaper to build and maintain than the multiple plungers needed for a mini-pellet multiple plunger system.

Further advantages are that the mold compound packages are reasonable in cost and may be produced in volume for a lower price per kilogram than the mini-pellets required by the prior art or the multiple packets required by the sprouted bag encapsulation system. It is believed that as the volume increases the prepackaged mold compound inserts of the invention may be produced at a price similar to the pellets of the single pot molding systems of the prior art.

Because the throughput rate of the prepackaged insert mold system is high, the number of stations required for a particular throughput rate is lower than the multiple plunger stations used with either the minipellet of the sprouted bag encapsulation systems of the prior art. Accordingly, the capital costs required to achieve a particular productivity level are less than either of these approaches.

Another advantage is that the mold compound system of the invention provides an efficient use of the molding compound. The runners are short from the receptacle 91 to the cavities 85. The amount of mold compound left in the pencil package can be minimized by careful design of the plunger so that almost all of the compound is transferred from the plastic package to the runners. The amount of sprue or flash left in the runners is far less than a single pot transfer mold and somewhat less than the mold compound waste resulting from a multiple pot multiplunger system.

While this invention has been described with reference to illustrative embodiments, this description is not intended to be construed in a limiting sense. Various modifications and combinations of the illustrative embodiments, as well as other embodiments of the invention, will be apparent to persons skilled in the art upon reference to the description.

#### Claims

1. A method for encapsulating integrated circuit lead frame and die assemblies, comprising the steps of:

providing a lower cavity region within a lower mold chase;

providing a mold compound receptacle spaced apart from said lower cavity region, for receiving a mold compound insert;

providing at least one runner coupling said mold compound receptacle to said lower cavity region;

providing an upper cavity region corresponding to a lower cavity region in said lower mold chase;

placing a leadframe and die assembly on said lower mold chase such that said lower cavity region receives and supports an integrated circuit die coupled to a lead frame by bond wires; placing a mold compound insert in said mold compound receptacle;

placing said upper mold cavity region over said lower cavity region such that the upper and lower cavity regions are brought into contact, the leadframe and die assemblies lying between and within the upper and lower cavity regions;

compressing said mold compound insert such that said mold compound exits the mold compound insert and begins to move into said runner; and

continuing to compress said mold compound insert until said mold compound transfers into said runner and fills each of said upper and lower mold cavity regions with said mold compound;

wherein said mold compound insert comprises mold compound packaged in a sproutless packaging, the sproutless packaging being burst open where the runner intersects the mold compound receptacle by the pressure caused when the mold compound insert is compressed.

2. The method of Claim 1, wherein said step of providing a mold compound insert further comprises the step of providing a sproutless mold compound insert which is packaged in a plastic film.
3. The method of Claim 2, wherein said step of providing a sproutless mold compound insert packaged in a plastic film further comprises the step of providing a mold compound piece covered in a plastic film that has a heat seal, said heat seal becoming penetrable during the molding process, such that the mold compound exits the plastic package through said heat seal in response to said compressing step.
4. The method of Claims 1 to 3 wherein said step of providing a mold compound insert comprises providing a thermoset resin packaged in a sproutless package.
5. The method of Claims 1 to 4 wherein said step of providing a mold compound insert comprises providing a thermoset resin packaged in a sproutless plastic film.
6. The method of Claim 4 or Claim 5 wherein said step of providing mold compound comprises providing a thermoset resin packaged in a sproutless plastic film that is heat sealed at the edges.
7. The method of Claims 1 to 6, wherein said lower cavity region is coupled to said runner by a gate region, said gate region restricting the flow of said mold compound into said upper and lower cavity regions such that the fill rate of said upper and lower cavity regions with said mold compound is a predetermined rate.
8. The method of Claim 1, wherein said step of providing a runner coupling said mold compound receptacle to each of said upper and lower cavity regions comprises providing a plurality of runners that are substantially equal in length such that the distance from a plurality of lower cavity regions to said mold receptacles is substantially equidistant.



9. The method of Claims 2 to 8, wherein said step of providing mold compound packaged in said plastic film comprises providing an abrasive material, said plastic film isolating said abrasive material from said plunger and said receptacle. 5
10. An apparatus for encapsulating integrated circuit devices, comprising:
- an upper mold platen supporting at least one upper mold chase; 10
  - at least one upper cavity region within said at least one upper mold chase;
  - a lower mold platen supporting at least one lower mold chase, said upper and lower mold chases being engageable with one another; 15
  - at least one lower cavity region within said at least one lower mold chase, the or each lower cavity regions corresponding to one of said upper cavity regions; 20
  - at least one integrated circuit die and lead-frame assemblies positioned within said upper and lower cavity regions such that each die is centered over one of said lower cavity regions and covered by a space defined by the corresponding one of said upper cavity regions; 25
  - at least one mold receptacle containing a sproutless mold compound insert;
  - runners associated with each of said lower cavity regions coupling said at least one mold receptacle to said lower cavity regions; 30
  - gates associated with each one of said lower cavity regions and positioned between said lower cavity regions and said runner;
  - at least one plunger associated with said at least one mold receptacle for applying pressure to a mold compound insert within said receptacle, said mold compound insert bursting in response to said pressure and mold compound within said mold compound insert being pushed into said runners and eventually filling said upper and lower cavity regions with mold compound, such that said integrated circuits die and leadframe assemblies are encapsulated in mold compound responsive to pressure applied by said at least one plunger. 45
11. The apparatus of claim 10, wherein said mold compound insert is a sproutless mold compound insert. 50
12. The apparatus of Claim 10 or Claim 11, wherein said mold compound insert is packaged in a plastic film.
13. The apparatus of Claims 10 to 12, wherein said mold compound insert is packaged in a plastic film that has a heat seal which becomes penetrable during the molding process such that the mold compound exits the plastic package through said heat seal in response to the application of said plunger.
14. The apparatus of Claims 10 to 13 wherein said mold compound insert comprises a thermoset resin mold compound in a package.
15. The apparatus of Claims 10 to 14 wherein said mold compound insert comprises a thermoset resin packaged in a plastic film.
16. The apparatus of Claims 10 to 15 wherein said mold compound insert comprises a thermoset resin packaged in a plastic film that is heat sealed at the edges.
17. The apparatus of Claims 10 to 16, wherein said lower cavity regions are coupled to said runners by gate regions which restrict the flow of said mold compound into said cavity regions such that the fill rate of said cavities with said mold compound is a predetermined rate.
18. The apparatus of Claims 10 to 17, wherein said plurality of runners coupling said mold compound receptacle to each of said lower cavity regions are each substantially equal in length such that the distance from the lower cavity regions to said mold receptacles is equidistant.
19. A sproutless mold compound insert for encapsulating components in a molding process, comprising:
- a piece of extruded mold compound;
  - an upper piece of material wider and longer than said piece of extruded mold compound and placed over said extruded mold compound;
  - a lower piece of material wider and longer than said piece of extruded mold compound and placed under said extruded mold compound;
  - a seal between said upper and lower piece of material at the areas wider and longer than said piece of extruded mold compound;
  - wherein said seal is formed under a vacuum such that said sproutless mold compound insert contains a vacuum, and said mold compound is released from said sproutless mold compound insert when said sproutless mold compound is compressed during molding.
20. The sproutless mold compound insert of Claim 19, wherein at least one of said upper and lower piece of material comprise a plastic film.
21. The sproutless mold compound insert of Claim 19 or Claim 20, wherein said plastic film comprises a Mylar™ film.
22. The sproutless mold compound insert of Claim 19

or Claim 20, wherein said plastic films comprises an ICI™ film.

- 23. The sproutless mold compound insert of Claims 19 to 22, wherein said seal is a heat seal that opens in response to the heat of a transfer mold. 5
- 24. The sproutless mold compound insert of Claims 19 to 23, wherein at least one of said upper and lower pieces of material has a melting point of greater than about 200 degrees Celsius. 10
- 25. The sproutless mold compound insert of Claim 24, wherein said at least one of said upper and lower pieces of material is a polyester film. 15

20

25

30

35

40

45

50

55

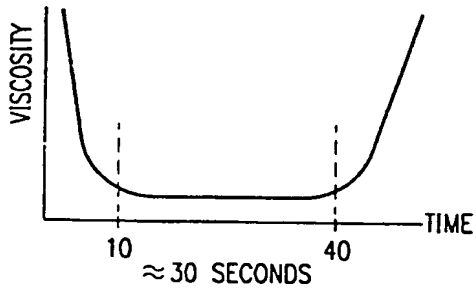

FIG. 1  
(PRIOR ART)

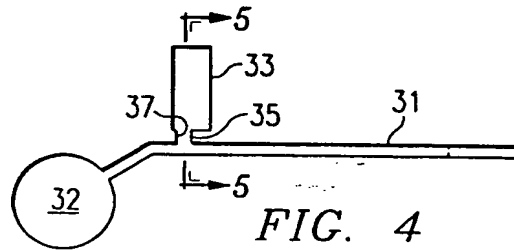

FIG. 4  
(PRIOR ART)

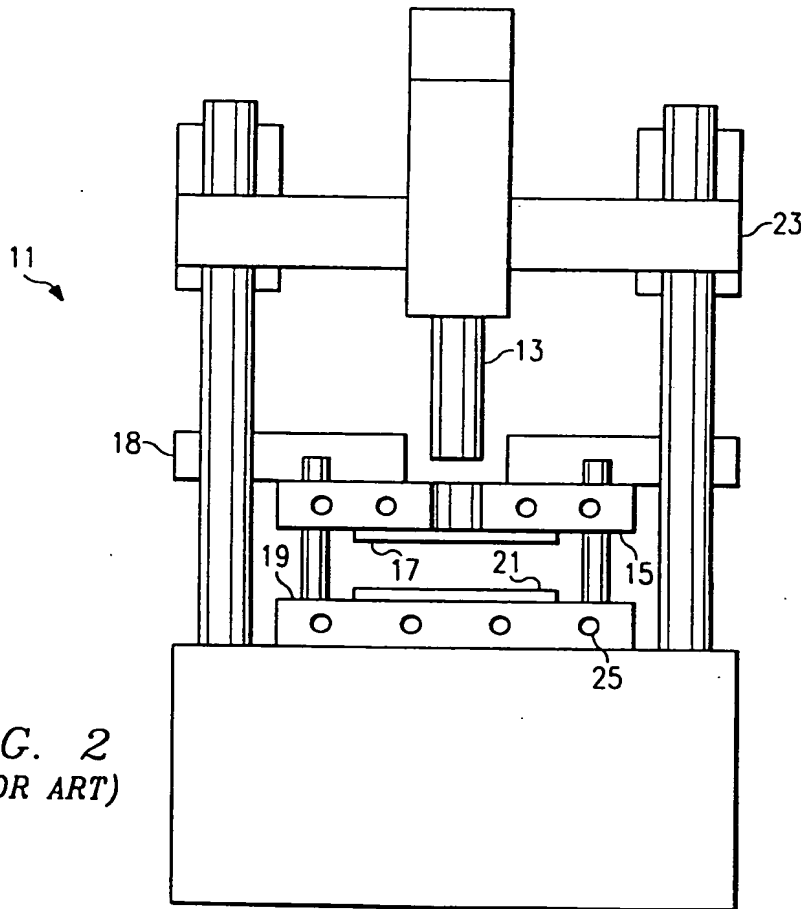

FIG. 2  
(PRIOR ART)

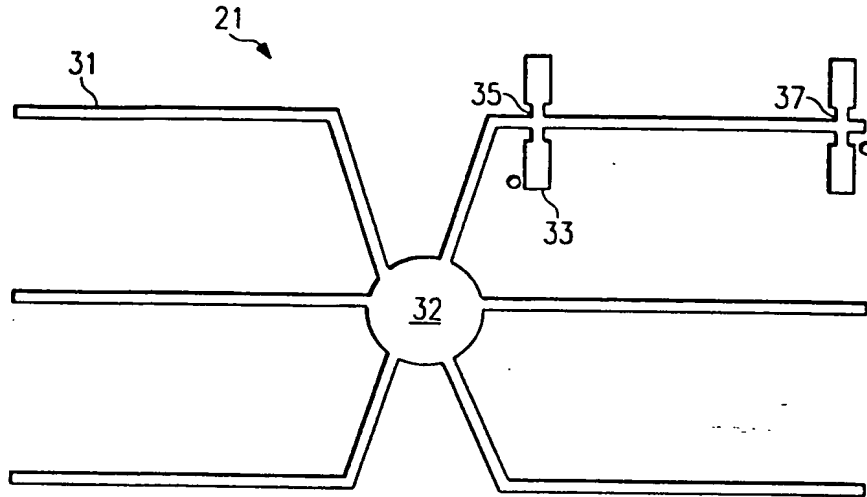

FIG. 3  
(PRIOR ART)

FIG. 5  
(PRIOR ART)

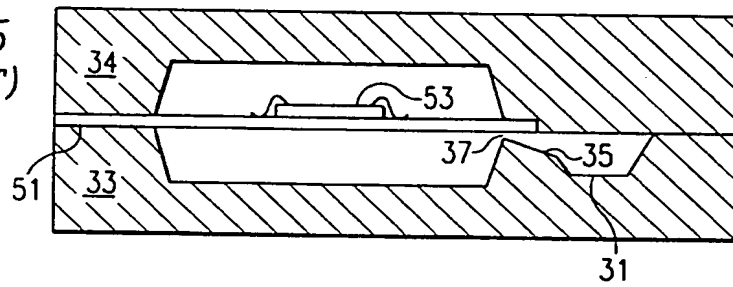
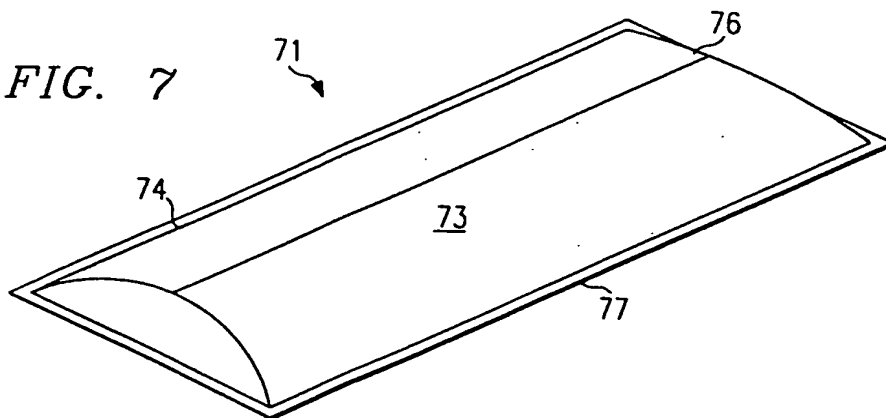

FIG. 7



Because the throughput rate of the prepackaged insert mold system is high, the number of stations required for a particular throughput rate is lower than the multiple plunger stations used with either the mini-pellet of the sprouted bag encapsulation systems of the prior art. Accordingly, the capital costs required to achieve a particular productivity level are less than either of these approaches.

Another advantage is that the mold compound system of the invention provides an efficient use of the molding compound. The runners are short from the receptacle 91 to the cavities 85. The amount of mold compound left in the pencil package can be minimized by careful design of the plunger so that almost all of the compound is transferred from the plastic package to the runners. The amount of sprue or flash left in the runners is far less than a single pot transfer mold and somewhat less than the mold compound waste resulting from a multiple pot multiplunger system.

While this invention has been described with reference to illustrative embodiments, this description is not intended to be construed in a limiting sense. Various modifications and combinations of the illustrative embodiments, as well as other embodiments of the invention, will be apparent to persons skilled in the art upon reference to the description.

#### Claims

1. A method for encapsulating integrated circuit lead frame and die assemblies, comprising the steps of:

providing a lower cavity region within a lower mold chase;  
 providing a mold compound receptacle spaced apart from said lower cavity region, for receiving a mold compound insert;  
 providing at least one runner coupling said mold compound receptacle to said lower cavity region;  
 providing an upper cavity region corresponding to a lower cavity region in said lower mold chase;  
 placing a leadframe and die assembly on said lower mold chase such that said lower cavity region receives and supports an integrated circuit die coupled to a lead frame by bond wires;  
 placing a mold compound insert in said mold compound receptacle;  
 placing said upper mold cavity region over said lower cavity region such that the upper and lower cavity regions are brought into contact, the leadframe and die assemblies lying between and within the upper and lower cavity regions;  
 compressing said mold compound insert such that said mold compound exits the mold compound insert and begins to move into said runner; and

continuing to compress said mold compound insert until said mold compound transfers into said runner and fills each of said upper and lower mold cavity regions with said mold compound;

wherein said mold compound insert comprises mold compound packaged in a sproutless packaging, the sproutless packaging being burst open where the runner intersects the mold compound receptacle by the pressure caused when the mold compound insert is compressed.

2. The method of Claim 1, wherein said step of providing a mold compound insert further comprises the step of providing a sproutless mold compound insert which is packaged in a plastic film.
3. The method of Claim 2, wherein said step of providing a sproutless mold compound insert packaged in a plastic film further comprises the step of providing a mold compound piece covered in a plastic film that has a heat seal, said heat seal becoming penetrable during the molding process, such that the mold compound exits the plastic package through said heat seal in response to said compressing step.
4. The method of Claims 1 to 3 wherein said step of providing a mold compound insert comprises providing a thermoset resin packaged in a sproutless package.
5. The method of Claims 1 to 4 wherein said step of providing a mold compound insert comprises providing a thermoset resin packaged in a sproutless plastic film.
6. The method of Claim 4 or Claim 5 wherein said step of providing mold compound comprises providing a thermoset resin packaged in a sproutless plastic film that is heat sealed at the edges.
7. The method of Claims 1 to 6, wherein said lower cavity region is coupled to said runner by a gate region, said gate region restricting the flow of said mold compound into said upper and lower cavity regions such that the fill rate of said upper and lower cavity regions with said mold compound is a predetermined rate.
8. The method of Claim 1, wherein said step of providing a runner coupling said mold compound receptacle to each of said upper and lower cavity regions comprises providing a plurality of runners that are substantially equal in length such that the distance from a plurality of lower cavity regions to said mold receptacles is substantially equidistant.

9. The method of Claims 2 to 8, wherein said step of providing mold compound packaged in said plastic film comprises providing an abrasive material, said plastic film isolating said abrasive material from said plunger and said receptacle. 5
10. An apparatus for encapsulating integrated circuit devices, comprising:
- an upper mold platen supporting at least one upper mold chase; 10
  - at least one upper cavity region within said at least one upper mold chase;
  - a lower mold platen supporting at least one lower mold chase, said upper and lower mold chases being engageable with one another; 15
  - at least one lower cavity region within said at least one lower mold chase, the or each lower cavity regions corresponding to one of said upper cavity regions; 20
  - at least one integrated circuit die and lead-frame assemblies positioned within said upper and lower cavity regions such that each die is centered over one of said lower cavity regions and covered by a space defined by the corresponding one of said upper cavity regions; 25
  - at least one mold receptacle containing a sproutless mold compound insert;
  - runners associated with each of said lower cavity regions coupling said at least one mold receptacle to said lower cavity regions; 30
  - gates associated with each one of said lower cavity regions and positioned between said lower cavity regions and said runner;
  - at least one plunger associated with said at least one mold receptacle for applying pressure to a mold compound insert within said receptacle, said mold compound insert bursting in response to said pressure and mold compound within said mold compound insert being pushed into said runners and eventually filling said upper and lower cavity regions with mold compound, such that said integrated circuits die and leadframe assemblies are encapsulated in mold compound responsive to pressure applied by said at least one plunger. 45
11. The apparatus of claim 10, wherein said mold compound insert is a sproutless mold compound insert. 50
12. The apparatus of Claim 10 or Claim 11, wherein said mold compound insert is packaged in a plastic film.
13. The apparatus of Claims 10 to 12, wherein said mold compound insert is packaged in a plastic film that has a heat seal which becomes penetrable during the molding process such that the mold compound exits the plastic package through said heat seal in response to the application of said plunger.
14. The apparatus of Claims 10 to 13 wherein said mold compound insert comprises a thermoset resin mold compound in a package.
15. The apparatus of Claims 10 to 14 wherein said mold compound insert comprises a thermoset resin packaged in a plastic film.
16. The apparatus of Claims 10 to 15 wherein said mold compound insert comprises a thermoset resin packaged in a plastic film that is heat sealed at the edges.
17. The apparatus of Claims 10 to 16, wherein said lower cavity regions are coupled to said runners by gate regions which restrict the flow of said mold compound into said cavity regions such that the fill rate of said cavities with said mold compound is a predetermined rate.
18. The apparatus of Claims 10 to 17, wherein said plurality of runners coupling said mold compound receptacle to each of said lower cavity regions are each substantially equal in length such that the distance from the lower cavity regions to said mold receptacles is equidistant.
19. A sproutless mold compound insert for encapsulating components in a molding process, comprising:
- a piece of extruded mold compound;
  - an upper piece of material wider and longer than said piece of extruded mold compound and placed over said extruded mold compound;
  - a lower piece of material wider and longer than said piece of extruded mold compound and placed under said extruded mold compound;
  - a seal between said upper and lower piece of material at the areas wider and longer than said piece of extruded mold compound; 55
  - wherein said seal is formed under a vacuum such that said sproutless mold compound insert contains a vacuum, and said mold compound is released from said sproutless mold compound insert when said sproutless mold compound is compressed during molding.
20. The sproutless mold compound insert of Claim 19, wherein at least one of said upper and lower piece of material comprise a plastic film.
21. The sproutless mold compound insert of Claim 19 or Claim 20, wherein said plastic film comprises a Mylar™ film.
22. The sproutless mold compound insert of Claim 19

or Claim 20, wherein said plastic films comprises an ICI™ film.

23. The sproutless mold compound insert of Claims 19 to 22, wherein said seal is a heat seal that opens in response to the heat of a transfer mold. 5

24. The sproutless mold compound insert of Claims 19 to 23, wherein at least one of said upper and lower pieces of material has a melting point of greater than about 200 degrees Celsius. 10

25. The sproutless mold compound insert of Claim 24, wherein said at least one of said upper and lower pieces of material is a polyester film. 15

20

25

30

35

40

45

50

55

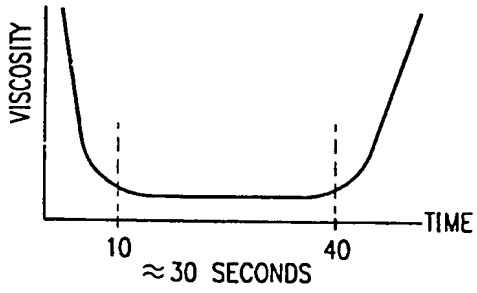

FIG. 1  
(PRIOR ART)

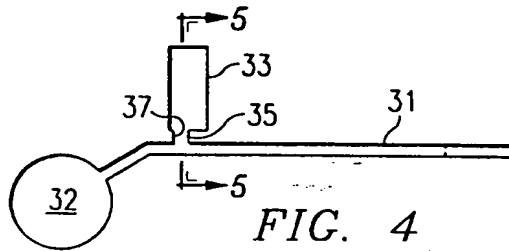

FIG. 4  
(PRIOR ART)

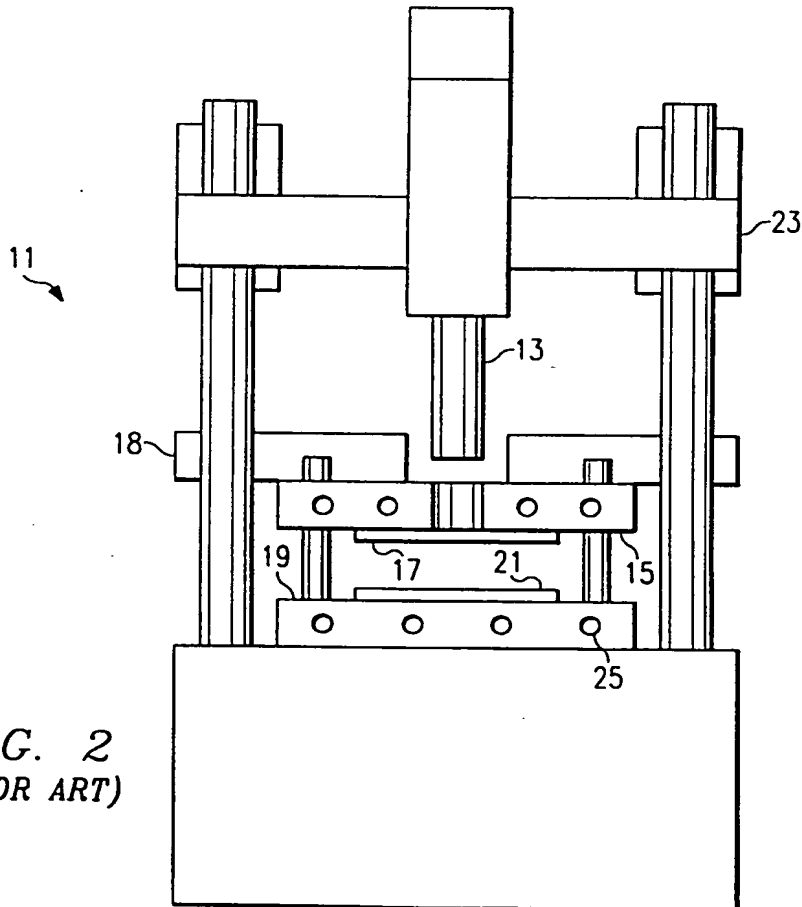

FIG. 2  
(PRIOR ART)



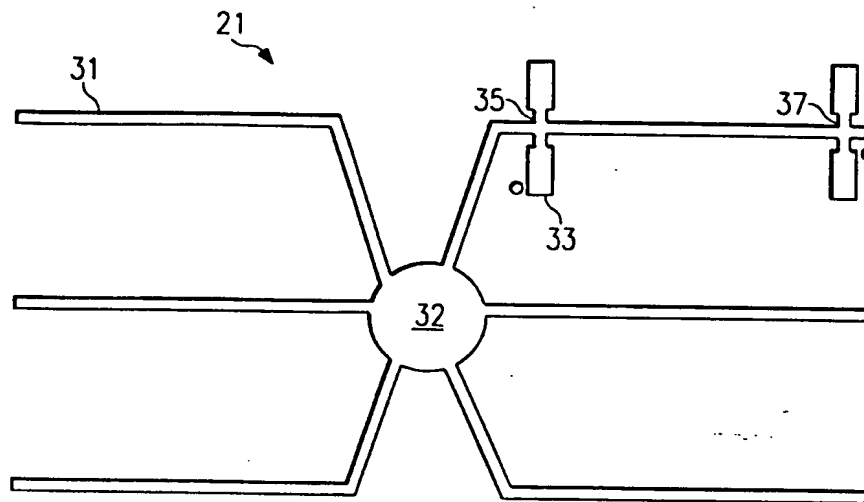

FIG. 3  
(PRIOR ART)

FIG. 5  
(PRIOR ART)

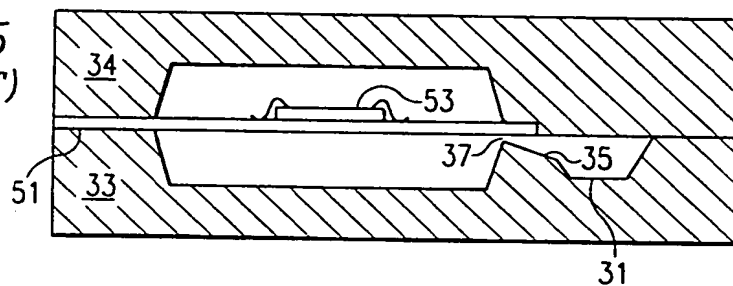

FIG. 7

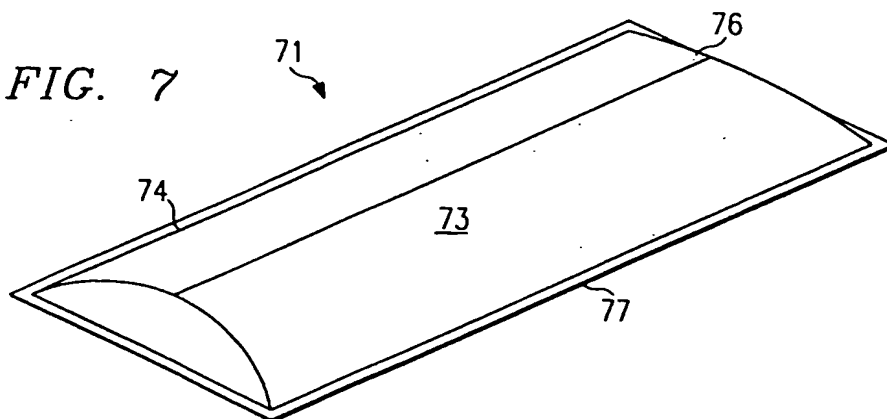

FIG. 6  
(PRIOR ART)

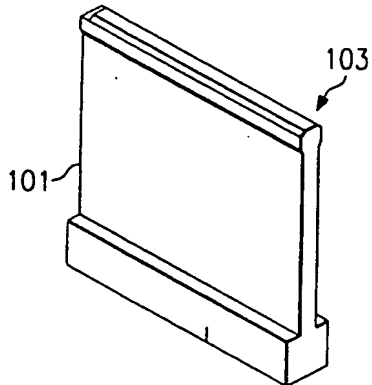
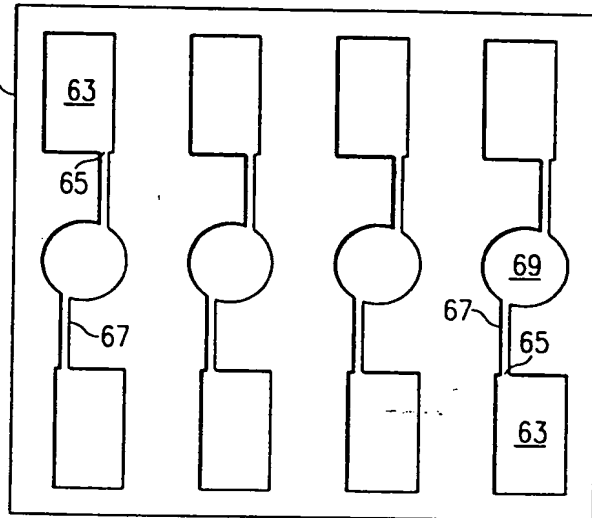

FIG. 10

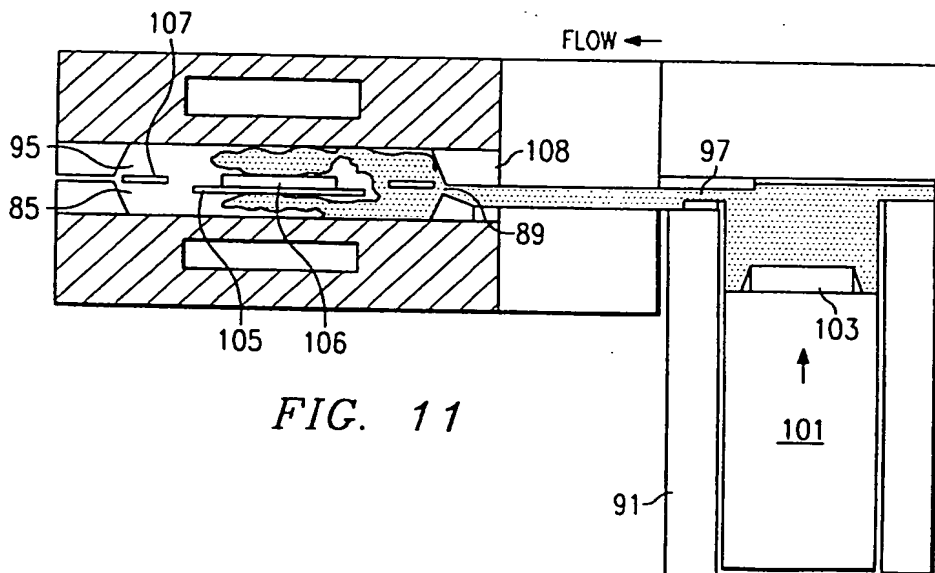
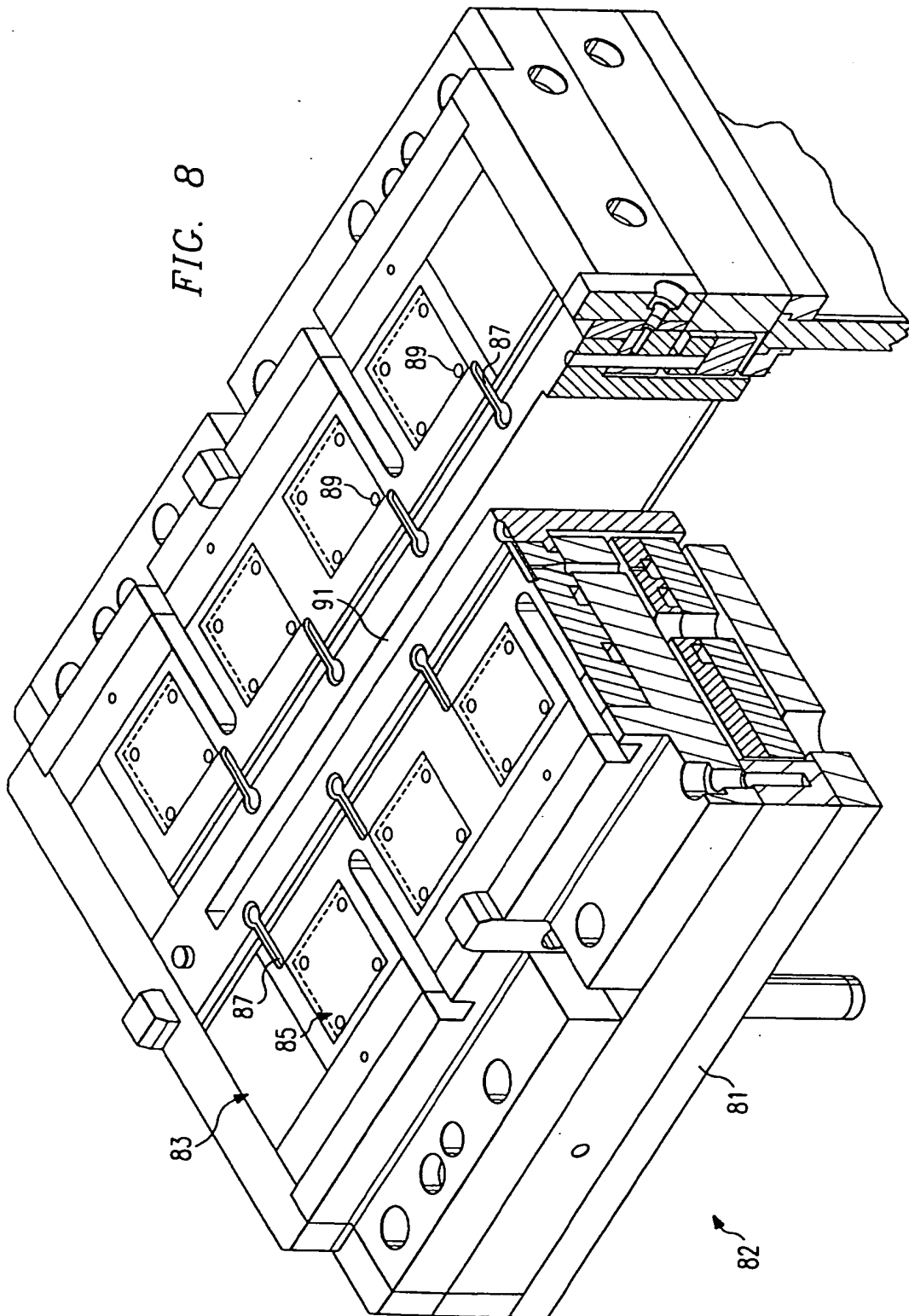

FIG. 11



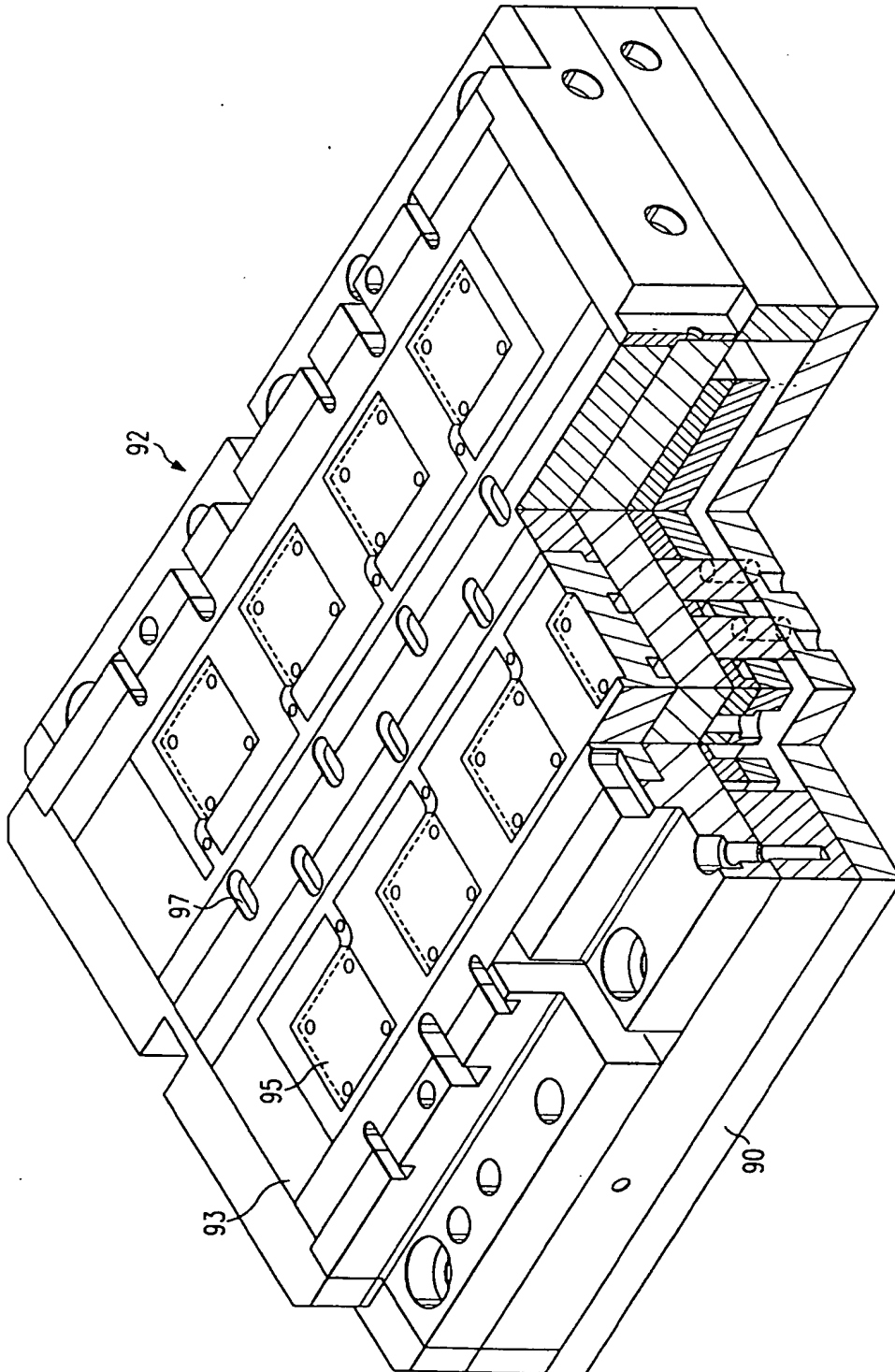
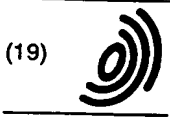

FIG. 9



Europäisches Patentamt  
European Patent Office  
Office européen des brevets



(11) EP 0 747 943 A3

(12) EUROPEAN PATENT APPLICATION

(88) Date of publication A3:  
18.02.1998 Bulletin 1998/08

(51) Int. Cl.<sup>6</sup>: H01L 21/56

(43) Date of publication A2:  
11.12.1996 Bulletin 1996/50

(21) Application number: 96303045.7

(22) Date of filing: 30.04.1996

(84) Designated Contracting States:  
DE FR GB IT NL

(30) Priority: 02.05.1995 US 434336

(71) Applicant:  
TEXAS INSTRUMENTS INCORPORATED  
Dallas, Texas 75243 (US)

(72) Inventors:  
• Bolanos, Mario A.  
Plano, TX 75023 (US)  
• Libres, Jeremias L.  
Dallas, TX 75243 (US)

• Bednarz, George A.  
Plano, TX 75023 (US)  
• Chee, Tay Liang,  
c/o Texas Instruments Inc.  
Dallas, TX 75243 (US)  
• Lim, Julius,  
c/o Texas Instruments Inc.  
Dallas, TX 75243 (US)

(74) Representative: Holt, Michael  
Texas Instruments Limited,  
Kempton Point,  
68 Staines Road West  
Sunbury-on-Thames, Middlesex TW16 7AX (GB)

(54) Improvements in or relating to integrated circuits

(57) A method and apparatus for encapsulating an integrated circuit die and leadframe assembly. A pre-packaged sproutless mold compound insert 71 is placed in a rectangular receptacle 91 in a bottom mold chase 81. The receptacle is coupled to a plurality of die cavities 85 by runners 87. Leadframe strip assemblies containing leadframes, integrated circuit dies, and bond wires coupling the leadframes and dies are placed over the bottom mold chase 81 such that the integrated circuit dies are each centered over a bottom mold die cavity 85. A top mold chase 90 is placed over the bottom mold chase 81 and the mold compound package 71. The top mold chase 90 has die cavities 95 corresponding to those in the bottom mold chase 81. The mold compound insert 71 is preferably packaged in a plastic film 75 which has heat sealed edges 77. The mold compound is forced through the package 75 and heat seals 77 during the molding process by the pressure applied by a rectangular plunger 101. The sproutless mold compound insert is packaged so that the mold compound will exit the packaging only where runners intersect the receptacle. The sproutless mold compound insert requires no alignment or cutting tools within the mold station. The plunger is applied using variable speed and pressure to control the rate the mold compound fills the cavities in the top and bottom mold chases, thereby avoiding voids in the completed packages and minimiz-

ing wire sweep of the bond wires of the integrated circuit assemblies.

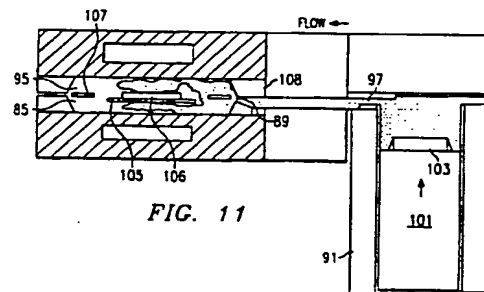

FIG. 11

EP 0 747 943 A3

EP 0 747 943 A3



European Patent Office

EUROPEAN SEARCH REPORT

Application Number  
EP 96 30 3045

DOCUMENTS CONSIDERED TO BE RELEVANT			
Category	Citation of document with indication, where appropriate, of relevant passages	Relevant to claim	CLASSIFICATION OF THE APPLICATION (Int.Cl.6)
X	US 5 043 199 A (KUBOTA AKIHIRO ET AL)	1,2,4,5,9-12,14,15,17	H01L21/56
A	* column 5, line 3 - column 6, line 9; figures 5A-5C,6 *	19	
X	PATENT ABSTRACTS OF JAPAN vol. 015, no. 003 (E-1019), 7 January 1991 & JP 02 260438 A (NITTO DENKO CORP), 23 October 1990,	1,2,9	
A	* abstract *	19	
D,A	US 5 098 626 A (PAS IRENEUS J T M) * column 5, line 4 - line 27; figure 5 *	1,9	
			TECHNICAL FIELDS SEARCHED (Int.Cl.6)
			H01L
The present search report has been drawn up for all claims			
Place of search THE HAGUE		Date of completion of the search 19 December 1997	Examiner Zeisler, P
CATEGORY OF CITED DOCUMENTS		T : theory or principle underlying the invention E : earlier patent document, but published on, or after the filing date D : document cited in the application L : document cited for other reasons ..... & : member of the same patent family, corresponding document	
X : particularly relevant if taken alone Y : particularly relevant if combined with another document of the same category A : technological background O : non-written disclosure P : intermediate document			

EPO FORM 1503 03/92 (P4/C01)

PCT

WORLD INTELLECTUAL PROPERTY ORGANIZATION  
International Bureau



INTERNATIONAL APPLICATION PUBLISHED UNDER THE PATENT COOPERATION TREATY (PCT)

(51) International Patent Classification 6 : B29C 45/06, H01L 21/56, 21/00	A1	(11) International Publication Number: WO 97/39870 (43) International Publication Date: 30 October 1997 (30.10.97)
-------------------------------------------------------------------------------	----	-----------------------------------------------------------------------------------------------------------------------

(21) International Application Number: PCT/SG97/00017  
 (22) International Filing Date: 24 April 1997 (24.04.97)  
 (30) Priority Data: 9609523-7 25 April 1996 (25.04.96) SG  
 (71)(72) Applicant and Inventor: BERGHOFF, Hans, Lothar [DE/SG]; 72 Cheng Soon Garden, Singapore (SG).  
 (74) Agent: ELLA CHEONG & G. MIRANDAH; P.O. Box 0931, Raffles City, Singapore 911732 (SG).

(81) Designated States: AL, AM, AT, AU, AZ, BA, BB, BG, BR, BY, CA, CH, CN, CU, CZ, DE, DK, EE, ES, FI, GB, GE, GH, HU, IL, IS, JP, KE, KG, KP, KR, KZ, LC, LK, LR, LS, LT, LU, LV, MD, MG, MK, MN, MW, MX, NO, NZ, PL, PT, RO, RU, SD, SE, SG, SI, SK, TJ, TM, TR, TT, UA, UG, US, UZ, VN, YU, ARIPO patent (GH, KE, LS, MW, SD, SZ, UG), Eurasian patent (AM, AZ, BY, KG, KZ, MD, RU, TJ, TM), European patent (AT, BE, CH, DE, DK, ES, FI, FR, GB, GR, IE, IT, LU, MC, NL, PT, SE), OAPI patent (BF, BJ, CF, CG, CI, CM, GA, GN, ML, MR, NE, SN, TD, TG).

Published  
 With international search report.  
 Before the expiration of the time limit for amending the claims and to be republished in the event of the receipt of amendments.

(54) Title: INJECTION MOLDING APPARATUS AND METHOD

(57) Abstract

An injection molding apparatus having a plurality of molding presses (10), such as transfer molding presses for encapsulating integrated circuits, are mounted on an indexable rotary table (70). Stationary loading and unloading stations (60, 62, 64) are arranged at spaced angular locations around the table for loading an insert into the mold cavities, for loading a molding material pallet, and for unloading a molded product when the molding presses are successively aligned with each station. A controller (80) is provided to rotate with the molding presses (10) for individually controlling functions thereof such as opening and closing of the presses and temperature and pressure in the molds. Another controller is provided in a stationary control panel for controlling, for example, functions of the stations and receiving input from a user, and communication is provided between the two controllers.

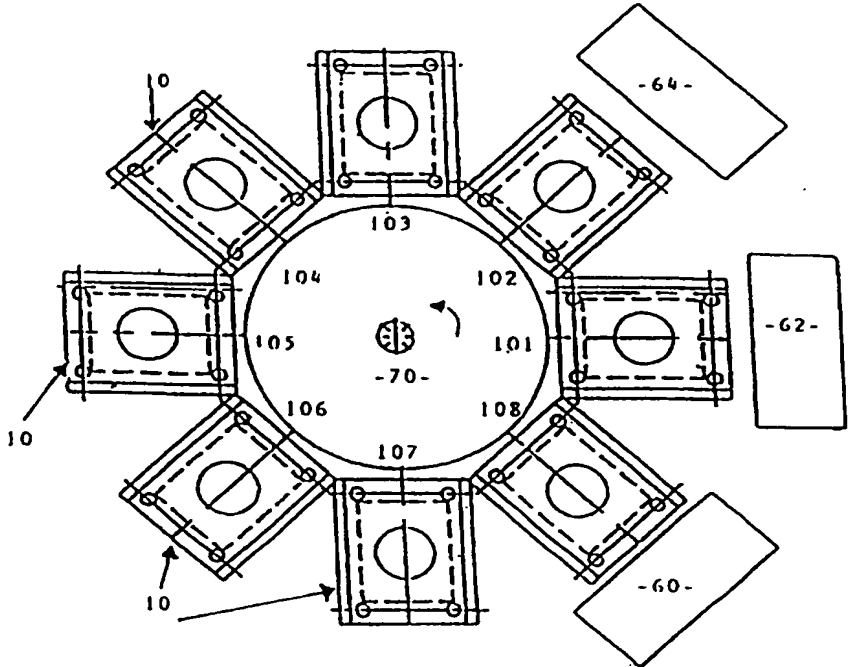

**FOR THE PURPOSES OF INFORMATION ONLY**

Codes used to identify States party to the PCT on the front pages of pamphlets publishing international applications under the PCT.

AL	Albania	ES	Spain	LS	Lesotho	SI	Slovenia
AM	Armenia	FI	Finland	LT	Lithuania	SK	Slovakia
AT	Austria	FR	France	LU	Luxembourg	SN	Senegal
AU	Australia	GA	Gabon	LV	Latvia	SZ	Swaziland
AZ	Azerbaijan	GB	United Kingdom	MC	Monaco	TD	Chad
BA	Bosnia and Herzegovina	GE	Georgia	MD	Republic of Moldova	TG	Togo
BB	Barbados	GH	Ghana	MG	Madagascar	TJ	Tajikistan
BE	Belgium	GN	Guinea	MK	The former Yugoslav Republic of Macedonia	TM	Turkmenistan
BF	Burkina Faso	GR	Greece	ML	Mali	TR	Turkey
BG	Bulgaria	HU	Hungary	MN	Mongolia	TT	Trinidad and Tobago
BJ	Benin	IE	Ireland	MR	Mauritania	UA	Ukraine
BR	Brazil	IL	Israel	MW	Malawi	UG	Uganda
BY	Belarus	IS	Iceland	MX	Mexico	US	United States of America
CA	Canada	IT	Italy	NE	Niger	UZ	Uzbekistan
CF	Central African Republic	JP	Japan	NL	Netherlands	VN	Viet Nam
CG	Congo	KE	Kenya	NO	Norway	YU	Yugoslavia
CH	Switzerland	KG	Kyrgyzstan	NZ	New Zealand	ZW	Zimbabwe
CI	Côte d'Ivoire	KP	Democratic People's Republic of Korea	PL	Poland		
CM	Cameroon	KR	Republic of Korea	PT	Portugal		
CN	China	KZ	Kazakistan	RO	Romania		
CU	Cuba	LC	Saint Lucia	RU	Russian Federation		
CZ	Czech Republic	LI	Liechtenstein	SD	Sudan		
DE	Germany	LK	Sri Lanka	SE	Sweden		
DK	Denmark	LR	Liberia	SG	Singapore		
EE	Estonia						



- 1 -

**INJECTION MOLDING APPARATUS AND METHOD**

This invention relates to an apparatus and method for injection molding, for example for encapsulating integrated circuits.

5 Injection molding apparatus, such as a transfer molding installation for encapsulating integrated circuits, typically involves a plurality of molding presses associated with a plurality of movable robots for loading and unloading the molding presses. For example, a row of molding presses may be arranged with a loading robot and unloading robot movable along the row to insert integrated circuit leadframes into  
10 the molds and remove the encapsulated integrated circuits after molding. However, several difficulties are associated with this type of arrangement, one of those being potential interference between the loading and unloading robots, for example, in accessing one of the plurality of molding presses.

Accordingly, the present invention provides an injection molding apparatus  
15 comprising a plurality of molding presses each adapted to receive at least one mold, each mold defining a cavity shaped for the formation of a molded product, the plurality of molding presses being mounted for rotational movement about a common axis with respect to a plurality of stations arranged around the plurality of molding presses, the molding apparatus being adapted to sequentially align ones of said plurality of molding  
20 presses with one of said stations for loading of molding material and unloading of a molded product.

The present invention also provides an integrated circuit encapsulation apparatus comprising a plurality of transfer molding presses mounted on a rotatable index table, each molding press being adapted to receive at least one mold defining a  
25 cavity adapted to receive an integrated circuit die and attached leadframe for encapsulation thereof, and a plurality of stations arranged around the rotatable index table wherein indexed rotation of the table is effective to align ones of the molding presses with one of the stations, said stations including an insert loading station for loading an integrated circuit die and attached leadframe into a mold of a mold press

- 2 -

aligned therewith, a molding compound loading station for loading an encapsulation material into a pot of an aligned molding press, and an unloading station for removing an encapsulated integrated circuit from a mold of an aligned molding press.

In a preferred form of the invention, the molding presses and stations are  
5 arranged on a rotating index table, such that when a first molding press is aligned with the unloading station, a second molding press is aligned with the mold cleaning station, and a third molding press aligned with the loading and compound molding compound loading stations. Align all stations with respect to each other.

Preferably, the apparatus includes a first controller circuit mounted for  
10 movement with the molding presses, for independently controlling the opening and closing thereof. A second controller circuit may be provided to control functions of the stations, with the first and second controller circuits communicating by way of a rotating electrical connection. A similar rotating electrical connection may be provided to power the molding presses in the event that they are electrically operated.  
15 Alternatively, if the molding presses are hydraulic or pneumatic, then a rotatable hydraulic or pneumatic connection may be provided between a pressurised fluid source and hydraulic/pneumatic circuits of the molding presses and their counterparts.

In accordance with the present invention there is also provided a method for encapsulating integrated circuits, wherein at least one injection molding press and  
20 associated encapsulation mold is mounted for rotational movement into successive alignment with a plurality of respective stations arranged around the at least one molding press, comprising the steps of:

rotationally aligning the press with a first said station and thereat loading an integrated circuit die into the associated mold;

25 rotationally aligning the press with a second said station and thereat loading the press with an encapsulation material;

performing a transfer molding operation wherein said integrated circuit die is encapsulated with said material in said mold; and

rotationally aligning the press with a third said station and thereat unloading the

- 3 -

encapsulated integrated circuit from the mold cleaning station.

Preferably a plurality of injection molding presses are used to repeatedly cycle through the method steps, such that when one of the steps is being performed on one press, another of the steps is being performed on another press.

5 The invention is described in greater detail herein below by way of example only, with reference to the accompany drawings, wherein:

Figure 1 is a schematic block diagram illustrating a prior art injection molding arrangement;

10 Figures 2A, 2B and 2C show an exemplary transfer molding press illustrating the operation thereof for encapsulation of an integrated circuit and leadframe;

Figure 3 is a plan view of an injection molding arrangement according to one form of the invention; and

Figure 4 is a cross-sectional view of the injection molding arrangement of Figure 3.

15 Referring firstly to Figure 1, there is shown a schematic layout of an injection molding arrangement of the prior art, comprising four molding presses 10. The molding presses 10 are arranged in a row, all facing the same direction. An area indicated by reference numeral 12 represents a region of movement along the front of the molding presses 10 of a loading robot, which requires access to the front of each of the molding  
20 presses. Similarly, reference numeral 14 indicates a region for movement of an unloading robot which also requires access to the front of each molding press 10. A cleaning robot is arranged to move in an area 16 along the rear of the molding presses. Further, mechanisms are arranged at 18 and 20 for passing an integrated circuit and attached leadframe from a magazine storage (not shown) to the loading robot 12, and for passing  
25 an encapsulating material pellet to the loading robot 12, respectively. Also, unloading mechanisms are arranged at 22 and 24 for receiving the encapsulated integrated circuits from the unloading robot, degating the leadframe, and passing the encapsulated integrated circuit to a storage area.

Figures 2A, 2B and 2C are cross-sectional views of an exemplary transfer

- 4 -

molding press 30 adapted to receive two molds 32. Each mold 32 is arranged within the molding press 30, and comprises upper and lower mold parts 32a,32b which fit together to define a mold cavity 34.

The molding press 30 is shown in Figure 2A in a closed position, having been  
5 loaded with integrated circuit leadframes 36 within the respective mold cavities 34, and a pellet of encapsulating material 40 in a gangpot 36. Encapsulation of the integrated circuits 36 is achieved by heating the encapsulating material pellet 40 and pressing it within the gangpot using a transfer plunger 38, which causes the pellet 40 to liquefy and flow into the mold cavities 34 through small passages between the gangpot and the mold  
10 cavities (see Figure 2B). After allowing the encapsulating material to solidify again, the molding press 30 is opened (Figure 2C), wherein the mold parts 32a,32b are separated. The encapsulated integrated circuits 50 are lifted from the mold cavity by way of ejector pins 42, so as to expose them for removal from the molding press. After removal of the encapsulated integrated circuits 50, the open molding press is ready to receive new  
15 leadframe inserts 36 and encapsulating material pellet 40 to repeat the encapsulating process.

The operation of the prior molding system shown in Figure 1 for encapsulating integrated circuit leadframes is described below.

First, one or more pre-heated integrated circuit leadframes are loaded into a  
20 molding press 10, which has a temperature of about 160°C to 200°C, by the loading robot arm which services all of the molding presses 10. The same loading robot is used to insert a pre-formed epoxy resin pellet into the gangpot of the molding press, after which the press is closed (such as shown in Figure 2A). The epoxy resin is then transferred from the gangpot to fill the mold cavities by pressing the resin pellet against  
25 the hot mold surface using the transfer plunger (Figure 2B). The resin is cured in the mold for about 20 to 90 seconds, after which the molding press is opened and the encapsulated integrated circuit is ejected from the mold cavities (Figure 2C). In order to remove the encapsulated integrated circuits from the molding press, the unloading robot must wait until the loading robot is out of the way, and vice versa, which can waste

- 5 -

significant time depending on the relevant positions of the loading and unloading robots and the molds to which they require access at a given time. Also, with the cleaning robot 16 arranged to the rear of the molding presses, there are robot arms on both sides of the row of molding presses which can make inspection and maintenance quite  
5 difficult.

The injection molding system of embodiments of the present invention provides rotational movement of the molding presses relative to loading and unloading stations, rather than movement of the loading and unloading mechanisms (robot arms). Figure 3 is a plan view of an injection molding apparatus according to one form of the invention,  
10 and Figure 4 is a cross-sectional view through the molding apparatus of Figure 3.

A plurality of molding presses 10 (Figure 3) are arranged equally spaced and mounted around the circumferential perimeter of a circular rotatable index table 70. The molding presses 10 are mounted to face outwardly with respect to the index table axis, such that the mold cavities within the molds of the molding presses are accessible when  
15 the molding presses are open. The index table 70 is rotatable in this case in an anti-clockwise direction, and is indexable so that each of the molding presses 10 can be aligned to each of a plurality of equally spaced angular positions 101 to 108. Stations 60, 62 and 64 shown in Figure 3 are positioned around the molding presses mounted on the index table, with each station positioned so as to align with a molding press 10 when  
20 in one of the angular positions 101 to 108. In this case, an unloading station 60, such as a pick and place robot arm is positioned so as to align with a molding press when in the angular position represented by reference numeral 108. An insert loading station 62 is positioned so as to align with a molding press at angular position 101, and an encapsulation material pellet loading station 64 is arranged so as to align with a molding  
25 press at angular position 102. For anti-clockwise rotation of index table 70, the insert loading station 62 is arranged in the anti-clockwise direction around the table axis in comparison to unloading station 60, and pellet loading station 64 arranged to the anti-clockwise side of insert loading station 62.

Operation of the molding apparatus can be best understood by considering a

- 6 -

single molding press 10 on the indexed rotatory table 10, beginning at angular position 101 which is aligned with the insert loading station 62. At this position, the molding press 10 is open, such as illustrated at 10b in Figure 4, to allow a pre-heated integrated circuit die and attached leadframe to be placed within the one or more molds of the molding press using a pick and place robot arm of the loading station 62. Following loading of the leadframe, the index table 70 is rotated so as to align the molding press with the pellet loading station 64, where a pellet of encapsulation material is loaded into the gangpot of the molding press. After loading of the pellet, the index table is again rotated so that the molding press passes to angular position 103, where the press is closed and the transfer molding operation takes place. As the molding press successively passes through angular positions 104, 105 and 106, the encapsulation material within the mold cavities is allowed to set, and at angular position 107 the molding press is opened for access to the encapsulated integrated circuits. Finally, the molding press rotates to angular position 108 where it is aligned with unloading station 60 which operates to remove the encapsulated integrated circuits from the molding press using, for example, a pick and place unit. After unloading, the encapsulated integrated circuit is passed to a degating station and storage magazine and mold cleaning (not shown). Following the unloading operation at angular position 108, the molding press then returns to position 101 to repeat the encapsulation process.

Each of the molding presses 10 disposed around the index table 70 can simultaneously perform the operations described above, the stage within the encapsulation process for a given molding press being determined by its angular position with respect to the stations 60,62,64.

Since no interference can occur between the loading and unloading operations, the injection molding apparatus and method of the preferred embodiment of the present invention can result in an increase in production time savings as compared with the prior art system described hereinabove.

It will be recognised by those skilled in the art that any suitable number of molding presses can be arranged around the index table, with four, six or eight molding

- 7 -

presses being preferred. Further, more than a single set of the loading and unloading stations 60,62 and 64 can be arranged around the index table. For example, another unloading station 60 could be placed at position 104, with loading stations 62 and 64 placed at positions 105 and 106 respectively. The desirability of that type of arrangement may depend upon the number of molding presses on the index table and the curing time required for the molding material. Additionally, if regular cleaning of the molds is required, a cleaning station can be interposed between the unloading station 60 and loading station 62 for closing of the molds following each molding operation as is known to those in the injection molding art.

10 In order to control the opening and closing of the molding presses, an electrical controller 80 may be placed for rotation with the presses 10 and index table 70. A suitably programmed microprocessor, PLC or the like can be employed, is known in the art. In the preferred embodiment, the controller 80 mounted on the table is also programmed to individually control the mold temperature and mold pressure of each  
15 molding press. A second controller may be provided in order to control the functions of the stations 60,62,64, which may also comprise, for example, a computer or microprocessor circuit. The second controller is preferably contained in a control panel (not shown) which is stationary with respect to the stations 60,62,64. The control panel would include facilities for a user to input desired mold temperatures and  
20 pressures and the like. To facilitate coordination and communication between the two controller circuits, an electrical connection is required for communication between the controllers which allows the controller mounted on the index table 70 to rotate. Accordingly, a rotatable electrical connection can be employed, for example having annular electrical contacts coaxial with the index table axis, with brush-type contacts  
25 arranged to bear against the annular contacts for electrical connection therewith. For example, a similar contact technique as employed for connection to electrical motor moving armature windings could be used. Also, if the molding presses 10 operate using hydraulic or pneumatic power, then a connection is required between the hydraulic or pneumatic circuits of the presses and a source of pressurised hydraulic or pneumatic

- 8 -

fluid. For this purpose, a hydraulic or pneumatic pressure pipe can be provided in the base 75 of the molding apparatus and coaxial with the rotatable table, having a rotatable connection to a pipe connecting with the hydraulic/pneumatic circuits of the presses mounted on the index table.

5       As an alternative to the rotatable electrical connector for passing signals between the fixed and rotatable controller circuits, a wireless infrared or radio signal transmission and reception system for passing signals between the controllers could also be employed.

10       The foregoing detailed description of the invention has been put forward by way of example only, and is not intended to be considered limiting to the invention which is defined in the appended claims.



- 9 -

## THE CLAIMS DEFINING THE INVENTION ARE AS FOLLOWS:-

1. An injection molding apparatus comprising a plurality of molding presses each adapted to receive at least one mold, each mold defining a cavity shaped for the formation of a molded product, the plurality of molding presses being mounted for rotational movement about a common axis with respect to a plurality of stations arranged around the plurality of molding presses, the molding apparatus being adapted to sequentially align one of said plurality of molding presses with one of said stations for loading of molding material and unloading of a molded product.
- 10 2. Molding apparatus according to claim 1, wherein said plurality of molding presses are mounted on a rotatable platter, the rotational movement of which is indexable so as to align said molding presses and said stations.
- 15 3. Molding apparatus according to claim 1, wherein each said molding press comprises a transfer molding press.
4. Molding apparatus according to claim 3, wherein each mold cavity is adapted to receive an insert comprising an integrated circuits and leadframe for encapsulation.
- 20 5. Molding apparatus according to claim 2, further comprising a controlling means including a controller circuit mounted for movement with said molding presses for controlling operation of said molding presses.
- 25 6. A molding apparatus as claimed in claim 5, wherein said controller circuit individually controls opening and closing of said molding presses, in use.
7. A molding apparatus as claimed in claim 6, wherein said controlling means operates to independently control mold temperature and pressure of each of the

- 10 -

plurality of molding presses.

8. A molding apparatus as claimed in claim 7, including a pivotable electrical connection between said controller circuit and a central controller of said controlling means which is not mounted for movement with said rotatable platter.

9. A molding apparatus as claimed in claim 8, including a pivotable hydraulic connection between a pressurised hydraulic fluid source and hydraulic circuits of said molding presses.

10

10. A molding apparatus as claimed in claim 8, wherein functions of said plurality of stations are controlled by said central controller.

11. A molding apparatus as claimed in any preceding claim, wherein said plurality of stations include an insert loading station for loading an integrated circuit die and attached leadframe into a mold of a mold press aligned therewith.

12. An integrated circuit encapsulation apparatus comprising a plurality of transfer molding presses mounted on a rotatable index table, each molding press being adapted to receive at least one mold defining a cavity adapted to receive an integrated circuit die and attached leadframe for encapsulation thereof, and a plurality of stations arranged around the rotatable index table wherein indexed rotation of the table is effective to align ones of the molding presses with ones of the stations, said stations including an insert loading station for loading an integrated circuit die and attached leadframe into a mold of a mold press aligned therewith, a molding compound loading station for loading an encapsulation material into a pot of an aligned molding press, and an unloading station for removing an encapsulated integrated circuit from a mold of an aligned molding press.

13. An integrated circuit encapsulation apparatus according to claim 12, further

- 11 -

comprising a first controller circuit, mounted for movement with said table, for controlling functions of said plurality of presses, and a second controller circuit for controlling said stations, and a pivotable electrical connection for communication of signals between said first and second controller circuits regardless of the rotational  
5 orientation of said table.

14. An integrated circuit encapsulation apparatus according to claim 13, wherein said first controller circuit, in use, individually controls mold temperature and pressure of each of the plurality of molding presses.

10

15. A method for encapsulating integrated circuits, wherein at least one injection molding press and associated encapsulation mold is mounted for rotational movement into successive alignment with a plurality of respective stations arranged around the at least one molding press, comprising the steps of:

15 rotationally aligning the press with a first said station and thereat loading an integrated circuit die into the associated mold;

rotationally aligning the press with a second said station and thereat loading the press with an encapsulation material;

performing a transfer molding operation wherein said integrated circuit die is  
20 encapsulated with said material in said mold; and

rotationally aligning the press with a third said station and thereat unloading the encapsulated integrated circuit from the mold.

16. A method as claimed in claim 15, wherein a plurality of injection molding presses  
25 are used to repeatedly cycle through the steps, such that when one of the steps is being performed on one press, another of the steps is being performed on another press.

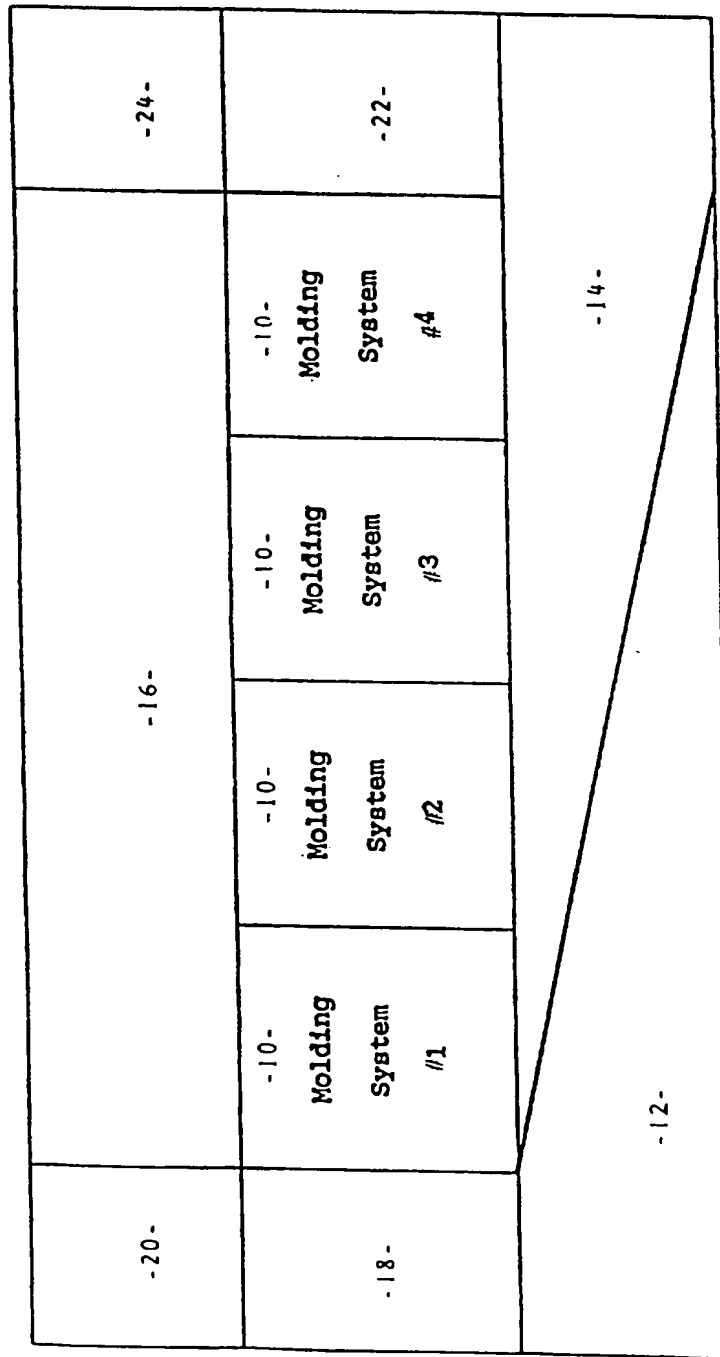
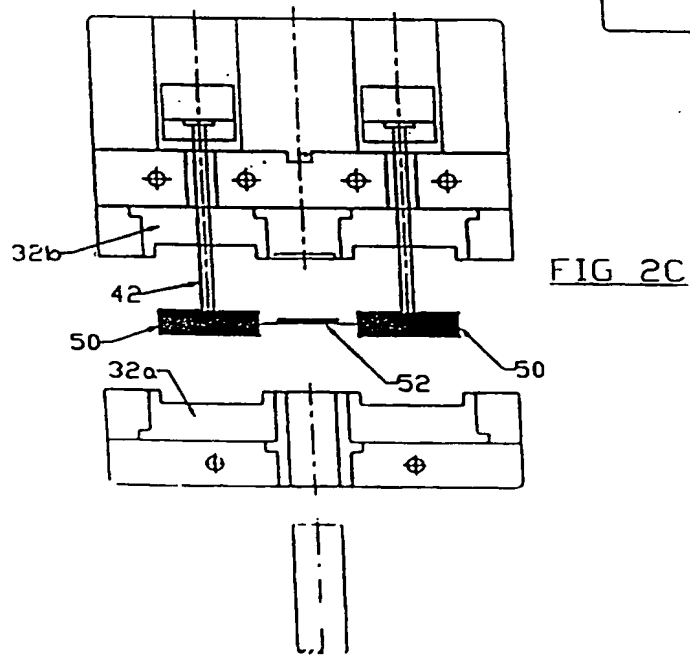
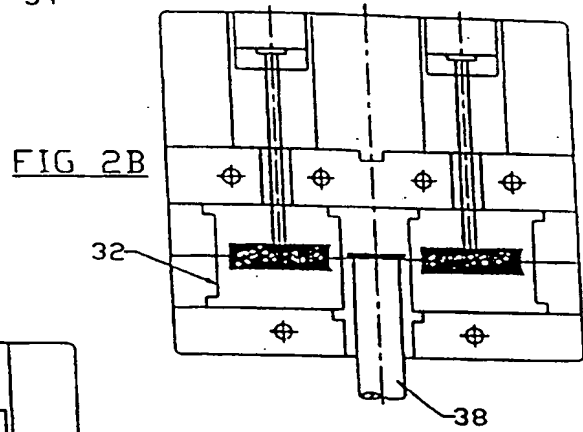
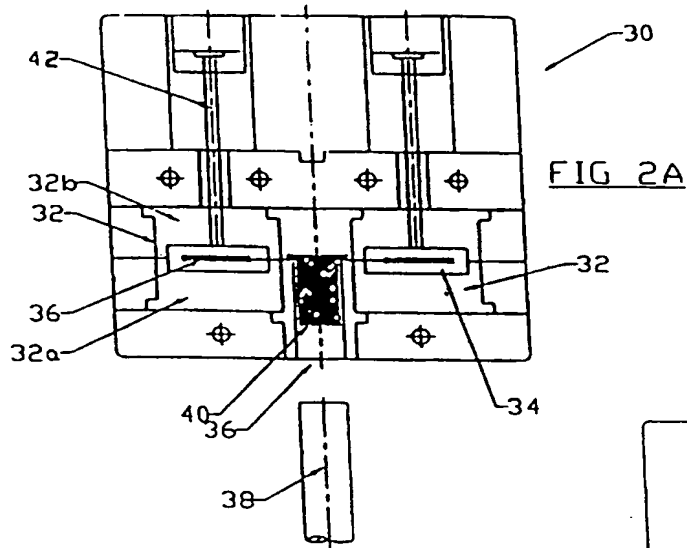

FIG. 1.

2/3



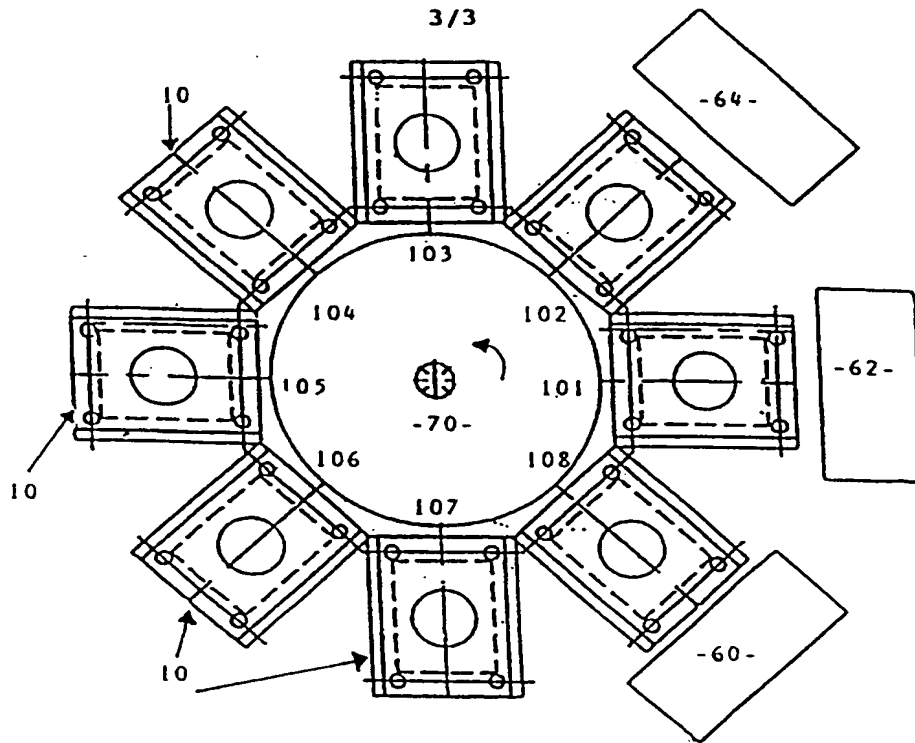

FIG. 3

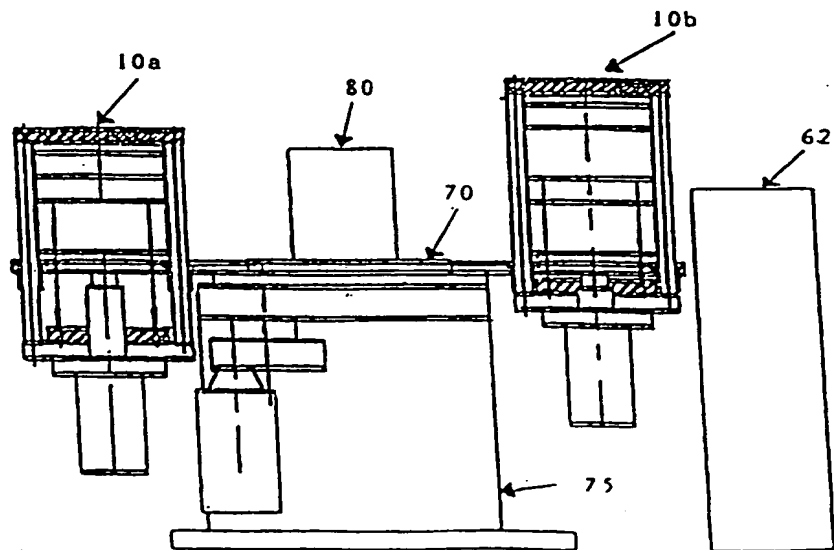

FIG. 4

**INTERNATIONAL SEARCH REPORT**

International application No.

PCT/SG 97/00017

<p><b>A. CLASSIFICATION OF SUBJECT MATTER</b>                  IPC<sup>6</sup>: B 29 C 45/06; H 01 L 21/56, 21/00                  According to International Patent Classification (IPC) or to both national classification and IPC</p>																										
<p><b>B. FIELDS SEARCHED</b>                  Minimum documentation searched (classification system followed by classification symbols)                  IPC<sup>6</sup>: B 29 C 45/00, 45/02, 45/03, 45/04, 45/06, 45/14, 45/17, 45/76, 45/78, 45/80;                  H 01 L 21/00, 21/56                  Documentation searched other than minimum documentation to the extent that such documents are included in the fields searched                  Electronic data base consulted during the international search (name of data base and, where practicable, search terms used)</p>																										
<p><b>C. DOCUMENTS CONSIDERED TO BE RELEVANT</b></p> <table border="1"> <thead> <tr> <th>Category*</th> <th>Citation of document, with indication, where appropriate, of the relevant passages</th> <th>Relevant to claim No.</th> </tr> </thead> <tbody> <tr> <td>A</td> <td>WO 86/01 145 A1 (LRC) 27 February 1986 (27.02.86), totality.</td> <td></td> </tr> <tr> <td>A</td> <td>EP 0 042 012 A1 (HETTINGA) 23 December 1981 (23.12.81), totality.</td> <td></td> </tr> <tr> <td>A</td> <td>US 4 424 015 A (BLACK) 03 January 1984 (03.01.84), totality.</td> <td></td> </tr> <tr> <td>A</td> <td>US 4 720 253 A (KOENTGES) 19 January 1988 (19.01.88), totality.</td> <td></td> </tr> <tr> <td>A</td> <td>DE 717 122 C (FALK) 15 January 1942 (15.01.42), totality.</td> <td></td> </tr> <tr> <td>A</td> <td>WO 95/18 461 A1 (FICO) 06 July 1995 (06.07.95), totality.</td> <td></td> </tr> <tr> <td></td> <td align="center">----</td> <td></td> </tr> </tbody> </table>			Category*	Citation of document, with indication, where appropriate, of the relevant passages	Relevant to claim No.	A	WO 86/01 145 A1 (LRC) 27 February 1986 (27.02.86), totality.		A	EP 0 042 012 A1 (HETTINGA) 23 December 1981 (23.12.81), totality.		A	US 4 424 015 A (BLACK) 03 January 1984 (03.01.84), totality.		A	US 4 720 253 A (KOENTGES) 19 January 1988 (19.01.88), totality.		A	DE 717 122 C (FALK) 15 January 1942 (15.01.42), totality.		A	WO 95/18 461 A1 (FICO) 06 July 1995 (06.07.95), totality.			----	
Category*	Citation of document, with indication, where appropriate, of the relevant passages	Relevant to claim No.																								
A	WO 86/01 145 A1 (LRC) 27 February 1986 (27.02.86), totality.																									
A	EP 0 042 012 A1 (HETTINGA) 23 December 1981 (23.12.81), totality.																									
A	US 4 424 015 A (BLACK) 03 January 1984 (03.01.84), totality.																									
A	US 4 720 253 A (KOENTGES) 19 January 1988 (19.01.88), totality.																									
A	DE 717 122 C (FALK) 15 January 1942 (15.01.42), totality.																									
A	WO 95/18 461 A1 (FICO) 06 July 1995 (06.07.95), totality.																									
	----																									
<p><input type="checkbox"/> Further documents are listed in the continuation of Box C.      <input checked="" type="checkbox"/> See patent family annex.</p>																										
<p>* Special categories of cited documents:                  "A" document defining the general state of the art which is not considered to be of particular relevance                  "E" earlier document but published on or after the international filing date                  "L" document which may throw doubts on priority claim(s) or which is cited to establish the publication date of another citation or other special reason (as specified)                  "O" document referring to an oral disclosure, use, exhibition or other means                  "P" document published prior to the international filing date but later than the priority date claimed                  "T" later document published after the international filing date or priority date and not in conflict with the application but cited to understand the principle or theory underlying the invention                  "X" document of particular relevance: the claimed invention cannot be considered novel or cannot be considered to involve an inventive step when the document is taken alone                  "Y" document of particular relevance: the claimed invention cannot be considered to involve an inventive step when the document is combined with one or more other such documents, such combination being obvious to a person skilled in the art                  "&amp;" document member of the same patent family</p>																										
<p>Date of the actual completion of the international search                  17 September 1997 (17.09.97)</p>		<p>Date of mailing of the international search report                  19 September 1997 (19.09.97)</p>																								
<p>Name and mailing address of the ISA/AT                  AUSTRIAN PATENT OFFICE                  Kohlmarkt 8-10                  A-1014 Vienna                  Facsimile No. 1/53424/535</p>		<p>Authorized officer                  Mayer                  Telephone No. 1/53424/469</p>																								

Form PCT/ISA/210 (second sheet) (July 1992)

**INTERNATIONAL SEARCH REPORT**  
Information on patent family members

International application No.  
PCT/SG 97/00017

Je Recherchenbericht angeführtes Patentdokument Patent document cited in search report Document de brevet cité dans le rapport de recherche	Datum der Veröffentlichung Publication date Date de publication	Mitglied(er) der Patentfamilie Patent family member(s) Membre(s) de la famille de brevets	Datum der Veröffentlichung Publication date Date de publication
WO A1 8601145	27-02-86	AT E 44681 EP CO 3571576 EP A1 190276 EP B1 190276 EP AC 8420508 EP A 164804 EP T2 61503015 EP A 4726757 EP AO 8420507 EP AO 8420506 EP AO 8420505	15-08-89 24-08-89 10-08-86 19-07-89 19-09-84 00-00-00 00-00-00 00-00-00 00-00-00 00-00-00 00-00-00
EP A1 42012	23-12-81	EP CO 3070704 EP B1 42012 EP A 17088 EP A 4307057	04-07-85 09-08-85 03-08-84 03-12-81
US A 4424015	03-01-84	CA A1 1178759 CA A2 1184710 EP A 60540 EP A 60540 EP A 60540 EP A 60540 EP A 60540 EP A 60540 EP A 4527570	04-11-84 04-11-84 17-09-84 17-09-84 17-09-84 17-09-84 17-09-84 17-09-84 08-08-85
US A 4720253	19-01-88	EP A1 3505156 EP A2 191445 EP A3 191445	21-08-86 20-08-86 01-04-87
DE 717122		keine - none - rien	
WO A1 9518461	06-07-95	EP A 1139497 EP A1 9238435 EP A 9238435	01-01-97 26-10-96 17-07-96



PCT

WORLD INTELLECTUAL PROPERTY ORGANIZATION  
International Bureau



INTERNATIONAL APPLICATION PUBLISHED UNDER THE PATENT COOPERATION TREATY (PCT)

(51) International Patent Classification <sup>6</sup> : <b>H01R 43/00</b>	<b>A1</b>	(11) International Publication Number: <b>WO 96/33533</b> (43) International Publication Date: 24 October 1996 (24.10.96)
(21) International Application Number: PCT/US96/05363 (22) International Filing Date: 16 April 1996 (16.04.96) (30) Priority Data: 08/424,151 17 April 1995 (17.04.95) US (71) Applicant: INTEGRATED PACKAGING ASSEMBLY CORPORATION [US/US]; 2221 Old Oakland Road, San Jose, CA 95131 (US). (72) Inventor: FEHR, Gerald, K.; 10196 English Oak Way, Cupertino, CA 95014 (US). (74) Agent: BOYS, Donald, R.; P.O. Box 187, Aromas, CA 95004 (US).	(81) Designated States: CN, JP, KR, European patent (AT, BE, CH, DE, DK, ES, FI, FR, GB, GR, IE, IT, LU, MC, NL, PT, SE).  Published With international search report.	

(54) Title: ENCAPSULATED IC PACKAGE AND METHOD FOR FORMING

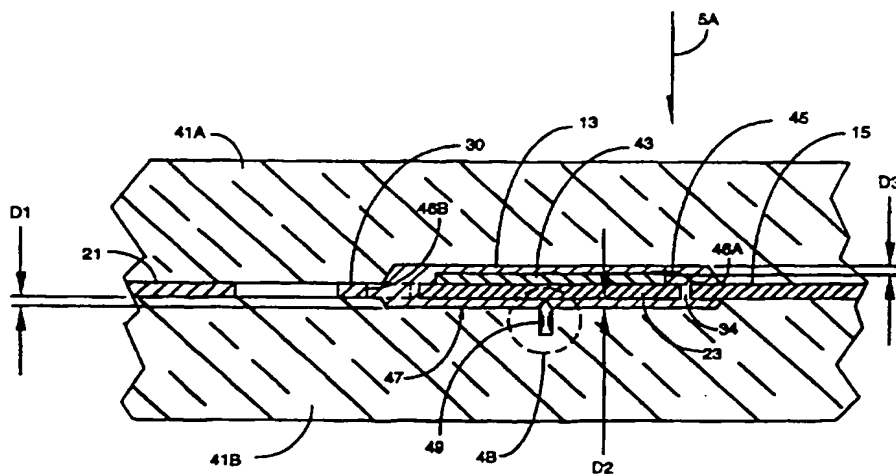

(57) Abstract

A mold (41a, 41b) provided for use in encapsulating integrated circuit (IC) dies (43) attached to die attach pads (23) of lead frames (21), and methods of production. The mold (41a, 41b) has one or more support elements (49) in cavities of the mold (41a, 41b) for supporting the die attach pad (23) portions of the lead frame (21) while the mold (41a, 41b) is closed on the lead frame (21) and encapsulation material is injected to encapsulate the IC dies (43) and die attach pads (23). The support elements (49) are, in a preferred embodiment, pins extending from the surface of the cavities, in the mold (41a, 41b), and the pins keep the die attach pads (23) from moving into contact with surfaces of the cavities. In another embodiment, the support elements (49) are retractable. In still another embodiment, support elements (49) are beads bonded to a lead frame strip (21) or dimples provided to a lead frame strip (21).

**FOR THE PURPOSES OF INFORMATION ONLY**

Codes used to identify States party to the PCT on the front pages of pamphlets publishing international applications under the PCT.

AM	Armenia	GB	United Kingdom	MW	Malawi
AT	Austria	GE	Georgia	MX	Mexico
AU	Australia	GN	Guinea	NE	Niger
BB	Barbados	GR	Greece	NL	Netherlands
BE	Belgium	HU	Hungary	NO	Norway
BF	Burkina Faso	IE	Ireland	NZ	New Zealand
BG	Bulgaria	IT	Italy	PL	Poland
BJ	Benin	JP	Japan	PT	Portugal
BR	Brazil	KE	Kenya	RO	Romania
BY	Belarus	KG	Kyrgyzstan	RU	Russian Federation
CA	Canada	KP	Democratic People's Republic of Korea	SD	Sudan
CF	Central African Republic	KR	Republic of Korea	SE	Sweden
CG	Congo	KZ	Kazakhstan	SG	Singapore
CH	Switzerland	LI	Liechtenstein	SI	Slovenia
CI	Côte d'Ivoire	LK	Sri Lanka	SK	Slovakia
CM	Cameroon	LR	Liberia	SN	Senegal
CN	China	LT	Lithuania	SZ	Swaziland
CS	Czechoslovakia	LU	Luxembourg	TD	Chad
CZ	Czech Republic	LV	Latvia	TG	Togo
DE	Germany	MC	Monaco	TJ	Tajikistan
DK	Denmark	MD	Republic of Moldova	TT	Trinidad and Tobago
EE	Estonia	MG	Madagascar	UA	Ukraine
ES	Spain	ML	Mali	UG	Uganda
FI	Finland	MN	Mongolia	US	United States of America
FR	France	MR	Mauritania	UZ	Uzbekistan
GA	Gabon			VN	Viet Nam

**ENCAPSULATED IC PACKAGE AND METHOD FOR FORMING****Field of the Invention**

The present invention is in the area of integrated circuit (IC) manufacturing, and pertains in particular to apparatus and methods for encapsulating integrated circuits on lead frames to form IC packages with leads for mounting to electronic circuitry.

**Background of the Invention**

In general, the plastic encapsulation of ICs to form packages ICs with electrical leads is as follows: Typically, ICs in die form are attached to mounting areas called islands, or die attach pads, on strips called lead frames. In this specification the die attach pad terminology will be used. The lead frames are made of a thin, flat, electrically conductive material and typically have several individual die attach pads, each for supporting an individual IC during a molding operation wherein the individual dies are encapsulated in plastic material, leaving electrical leads protruding from the plastic encapsulation.

In many cases, densely packaged ICs are manufactured to maximize connectivity by utilizing all four sides of the chip. Around the perimeter of each die attach pad a typical lead frame has a pattern of individual conductive leads extending toward, but not contacting, the die attach pad. The die attach pads and individual leads are formed by selective removal of material in the lead frame, such as by stamping. The number of the leads at a frame with a single die attach pad depends directly on the configuration of the particular IC die to be mounted, this is, the number and location of electrical terminations to the die.

- 2 -

A typical IC may have over one hundred or more external terminations, and each frame will have a corresponding number of individual leads. The width of each lead and the separation between adjacent leads is dependant, among other things, on the package size of the finished IC. The thickness of each lead is the thickness of the lead frame and is predicated on the current carrying capacity required.

A plastic package with external leads for connecting to, for example, a printed circuit board, is typically formed by an encapsulation process. Mating molds are placed on each side of the lead frame and liquid-phase polymer is injected to encapsulate IC dies attached to the die attach pads in each frame. The lead frame is designed to dam the flow of liquid-phase polymer as it moves to the outer edges of each individual mold, stopping at the points where each mold contacts surfaces of the lead frame. To stop the flow of liquid-phase polymer between leads the lead frame has a pattern of dam bars between individual leads, so a contiguous band of material is formed around the periphery of the island. This contiguous band prevents the polymer from flooding the entire leadframe, and also allows the lead frame to be one contiguous piece of material until subsequent trimming operations are performed.

After the polymer solidifies and the molds are removed, a following operation in the manufacturing process removes the excess plastic in the region around the mold outline and the dam bars. This is termed de-junking in the art. A de-damming process then removes the dam bar between each lead, providing electronic integrity for each lead. De-damming is a process of removing all or part of each dam bar by use of a punch with a pattern of teeth conforming to the pattern of the dam bars in the lead frame. Typically, the de-damming and de-junking can be done in a single step.

In following processing each lead exposed from the edge of the

plastic package is further treated such as by plating, and the individual packages are trimmed from the lead frame strip. Finally, the leads are formed, such as for Surface Mount Technology (SMT) applications.

In state-of-the-art manufacturing, automated machines are used to perform the encapsulation process. Automated machines are marketed by a number of manufacturers, including several Japanese manufacturers, and include molds made to close over one or more lead frames, as described above, whereinafter an encapsulation material is injected and caused to solidify. The encapsulation material is typically a liquid-phase polymer material.

In the encapsulation process, the molds are typically designed to minimize the amount of material that must be injected. As a result, typical dimensions from the inside surface of a formation cavity of an upper half of a mold to the top of a die attached to a die attach pad, and from the inside surface of a formation cavity of a lower half of a mold to the underside of a die attach pad during injection of the liquid-phase polymer while the halves of the mold are closed, are relatively small. A typical dimension for these planned clearances is about .010 inches, which is about a quarter of a millimeter.

For a number of reasons, among them gravity, flow path of injected polymer, and native distortion of lead frames before insertion in a molding machine, the die attach pad to which a die is attached sometimes contacts the inside cavity surface of one of the mold halves, most usually the lower half of the mold, and after solidification of the polymer and trimming operations, individual packaged ICs are discovered to have exposed die attach pads in the package. These defective packages are rejects. It is believed that the principal villain in this failure mode is the location of points of injection of liquid-phase encapsulation material, together with the mold design, which determines the path of liquid phase material when

- 4 -

filling the molds. The moving material flows against the lead frame and tends to alter the position of the die attach pads, and, of course the dies attached to them.

This defect is particularly problematic in encapsulation of relatively thin packages, such as those with a package thickness 1.4 mm thick and below, and those packages, including these thin packages, where the ratio of the horizontal area of the package to the thickness of the package is relatively high. The problem is also more noticeable for those packages that are subject to relatively high stress during mounting to a printed circuit board.

Relatively frequent occurrence of this defect demands rigorous inspection procedures to find the defective packages, and the net loss is a relatively expensive proposition in IC packaging operations.

What is clearly needed is apparatus and a method to ensure that a positive gap is maintained from dies and die attach pads to nearby mold surfaces during the time that liquid-phase polymer is injected and the time the polymer is solidified, such that liquid polymer can be always expected to fill the space so formed, and to solidify leaving an even thickness of solid polymer material between the die attach pad and attached die and nearby mold surfaces, so a finished package does not have any exposed surface of the die or the die attach pad.

#### Summary of the Invention

In a preferred embodiment, a method is provided for molding an integrated circuit (IC) package, comprising steps of (a) attaching an IC die to a die attach pad of a lead frame; (b) bonding wires from the IC die to leads of the lead frame; (c) placing the lead frame between an upper and a lower portion of a mold having matching mold cavities

- 5 -

for forming an encapsulation volume around the lead frame and attached IC die; (d) providing a support element in one of the mold cavities for spacing the die attach pad and attached die from an adjacent surface of the one of the mold cavities; (e) closing the portions of the mold on the lead frame such that the die attach pad and attached die is spaced from the adjacent surface; and (f) injecting encapsulation material into the encapsulation volume.

In one embodiment the support element is a single element positioned substantially in the center of the mold cavity in the lower mold portion when the mold portions are closed, and the support element so positioned may be a dimple provided in the die attach pad of the lead frame, or a bead of material affixed to the die attach pad. In another embodiment the support element is a pin engaged in a hole provided for the purpose in the mold cavity in the lower mold portion, the pin having an extended portion extending into the mold cavity. The pin may be tapered on the extended portion to minimize contact area with a lead frame strip.

In other embodiments there are plural support elements, and elements may be made to be retractable, so the support elements may be retracted after injection, allowing encapsulation material to also fill the volume occupied by the support elements before retraction.

Supporting the die attach pad during the molding operation for encapsulating IC packages ensures that die attach pads will not move during the molding operations and be exposed in finished packages, significantly reducing the reject rate for such operations.

#### Brief Description of the Drawings

Fig. 1 is an isometric view of a Quad IC package in the prior art.

- 6 -

Fig. 2 is a somewhat idealized plan view of a portion of a lead frame in the prior art.

Fig. 3 is an elevation section view of a lead frame with die attached, and with a mold closed on the lead frame, as in the prior art, taken generally along the line 3-3 of Fig. 2.

Fig. 4A is an elevation cross section similar to Fig. 3, showing a mold closed on a lead frame in an embodiment of the present invention.

Fig. 4B is an enlargement of the area of Fig. 4 enclosed in a dotted circle and labeled "4B", showing the support extension according to an embodiment of the present invention.

Fig. 5A is a plan view of the lower portion of a mold as seen in the direction of arrow "5A" of Fig. 4A.

Fig. 6A is plan view of a lead frame strip similar to Fig. 2, but illustrating a strip in an embodiment of the present invention.

Fig. 6B is a section view of the lead frame strip of Fig. 6A taken along line 6B-6B of Fig. 6A.

Fig. 7 is a section view of a lower half of a mold in an embodiment of the present invention, showing a retractable support element, and an apparatus for extending and retracting the support element.

#### Description of the Preferred Embodiments

Fig. 1 is an isometric view of a conventional QFP IC package 11. Typically, body 13 of IC package 11 is formed of plastic material by a method of transfer molding. Die 43 is inside, and completely encapsulated by the plastic molded body. The die contains the circuitry that defines the electrical functions of a particular IC, and the circuitry of the IC is connected to the outside environment through



individual conductive leads 15. The leads, as show by this example, are formed into J-bends for surface mount technology (SMT) application in another process. The leads are typically formed from a highly conductive material that is receptive to bending and forming while maintaining structural integrity. The molded package protects the sensitive and fragile circuitry on the IC die and fixes the arrangement of individual leads.

Fig. 2 is an idealized plan view of one frame 22 of a typical lead frame strip 21 before the process of die attach and encapsulation. Strip 21 comprises several lead frames identical to frame 22 whereon individual IC packages are constructed. The layout of Fig. 2 is intentionally simplified to illustrate the principles involved. As is well-known in the art, different lead frames for differently-designed dies typically have a different number of die attach pads in a strip. The lead frames are made of a conductive material, typically a malleable metal material, and formed in thin sheets. The sheet thickness of lead frame strip 21 provides the thickness of the resulting leads from a finished IC package.

In the example of lead frame 22, a plurality of leads 15 are provided approaching, but not contacting, die attach pad 23. Gap 34 serves to electrically isolate die attach pad 23 from each lead. Die attach pad 23 is supported in this example by legs 25 that are contiguous to lead frame strip 21, typically formed to attach at the corners of the island. Lead frame 22 also defines the outer edges of the plastic encapsulation by means of structures between leads 15 to stop the flow of the liquid-phase polymer in the encapsulation process. These structures comprise dam bars 30, and their placement between leads provides a contiguous strip of material around each island, illustrated by broken line 7.

The necessity for dam bars 30 means that at this stage all leads

- 8 -

15 surrounding island 23 are electrically connected to one another. The dam bars are subsequently removed (after encapsulation) by trimming punches in a separate process. The later removal of the dam bars provides electrical isolation from each lead to the others.

In a die attach process, individual IC dies are affixed to each die attach pad, substantially centered and aligned so the four edges of the die at each frame are parallel to the edges of the die attach pad of the lead frame. In this process, conductive wires are bonded from each contact termination along each of the four edges of the die to the corresponding leads along the four edges of the die attach pad. These wires form the electrical connection in a finished IC package from the circuitry in the integrated circuit to the electrical leads that are subsequently bonded to circuitry and other devices on a printed circuit board.

Fig. 3 is a cross-sectional view of lead frame 21 taken along section line 3-3 of Fig. 2 after die placement, wire bonding, and encapsulation, with the encapsulation mold in place and filled with polymer 50. IC die 43 is shown attached to die attach pad 23 and wires 45 are bonded between each contact pad in the die and its corresponding lead. Wires 45 span gap 34 between each mounting pad on the IC die and its respective lead.

After die attach and wire bonding, lead frame strip 21 is positioned between two opposing, typically symmetrical molds portions 41A and 41B. Within the body of each of the portions of the mold, at each cavity, there is typically one or more passages into a cavity for entry of injected liquid-phase polymer and one or more passages for bleeding off displaced air. These passages are not shown in Fig. 3, but are typically located at the corners of the molds. Further, the passages may be in either or both of the portions of the mold, and may vary in number for molds intended for different lead

frames and packages. The location of the passages is an important characteristic in the flow characteristic in mold filling, which is believed to strongly influence the way die attach pads may move in the molding process.

Molds 41A and 41B are positioned and centered on each die 43, and liquid-phase polymer is injected and flows until it (hopefully) fills all of the volume around the die and the die attach pad. When the polymer has solidified, molds 41A and 41B are removed and lead frame strip 21, with the encapsulated and bonded die 43, is ready for trimming to produce individual IC packages.

In Fig. 3, dimensions D1 and D3 represent the clearances between the die attach pad or the IC die, and adjacent, nearby mold surfaces, which are, in this example, the bottom surfaces of the cavities of each of the upper and lower mold portions. These dimensions, to minimize material usage, as described above, may be as small as .010 inch, or sometimes even less. As also described above, there are a number of agents of distortion, such as prestressed lead frame material, the forces induced by the flow of polymer material into the closed mold, and the force due to ever-present gravity. The result is that the die attach pad is sometimes moved to contact the inside surface of one of the cavities in one of the portions of the mold, such as inside surface 47 of lower mold 41B. When this happens, and the polymer material solidifies with the die attach pad thus out of position, the resulting package has an exposed die attach pad or die, and is a reject.

Fig. 4A is a cross section of a mold set closed on a lead frame, similar to the cross section of Fig. 3, but according to an embodiment of the present invention. This embodiment of the invention is intended for those situations in which the failure mode is exposure of the die attach pad at what is considered the bottom of the resulting

- 10 -

package.

In this embodiment, the lower half of the mold, on the inside bottom surface 47 of each of the cavities of the mold, has at least one extended support element 49 having protrusion distance D2 equal to D1. In one embodiment, there is a single support element 49, centrally located in the mold cavity, and die attach pad 51 is supported by being urged against this element during injection of the liquid-phase polymer. In other preferred embodiments there are more such support elements, arranged in a typically regular pattern, extending from surface 47. More than one, for example, four, support elements have been found to be advantageous for use with many wide-area, thin packages.

Fig. 4B is an enlargement of the area in the dotted circle labeled 4B in Fig. 4A, showing the shape of support element 49, which is a cylindrical pin having a diameter of about .010 inch, with one end engaged in a cylindrical hole 53 formed substantially perpendicular to surface 47 of the mold cavity, for the purpose of engaging and retaining the support element (pin).

In this embodiment, the hole is made about .001 inch larger in diameter than the pin, so the pin is easily engaged in the hole, and the pin is silver-soldered into the hole. It has been found that making the hole smaller, and forcing the pin in the hole is generally not satisfactory, because the pin is quite small and subject to damage in forced insertion. It will be apparent to those with skill in the art that there are a number of other ways the support pin might be installed, and a number of ways the pin may be bonded in the hole.

As seen in Fig. 4A, the exposed length of support pin 49 after insertion in the lower die cavity (about .010 inch in this embodiment) is tapered to a generally conical shape, ending in a rounded end, to support die attach pad 51 in the encapsulation process. The tapered

aspect presents a very small area for contact with the die attach pad, tending to minimize possible exposure of the die attach pad at the point of support after solidification of the injected polymer and removal of the encapsulated lead frame from the mold. The somewhat rounded end is provided because it was found in practice that a sharp pointed-pin tended to wear relatively more quickly than a rounded end, which shortens the extension (protrusion) length of the support pin. It has been found in practice that there is essentially no exposure after removal, because some small amount of polymer material intrudes into the area between the support and the die attach pad.

Fig. 5A is a plan view of one lower mold cavity for a mold according to the present invention, in the direction of arrow 5A of Fig. 4A. Pin 49 is shown substantially in the center of the cavity, where it will support the die attach pad in the encapsulation process at approximately the center of the die attach pad. Fig. 5B is a plan view similar to Fig. 5A, showing four support pins 65, 67, 69, and 71 arranged in a rectangular array extending from surface 47 of the mold cavity of mold portion 41B. The four-pin approach has been found in practice to be preferable, especially for wide area, thin packages, but there are situations in which one support pin will do.

In an alternative embodiment of the invention, support for positioning the die attach pad in a closed mold is provided by alteration of the lead frame, rather than of one or the other of the portions of the mold. Fig. 6A is a plan view of a lead frame 73 in a lead frame strip 75, having a die attach pad 77 in very much the same shape as pad 23 of Fig. 2. In die attach pad 77, in the stamping process of manufacturing the lead frame strip, four small dimples 79, 81, 83, and 85 have been provided.

Fig. 6B is a cross-section of frame 73 along the section line

- 12 -

6B-6B of Fig. 6A, intersecting two of the four dimples in the die attach pad, illustrating the depth of the dimples in the direction orthogonal to the plane of the die attach pad. Dimension D4 in this case is the same as the extension distance of the support pins in other embodiments described above. It should be remembered that some dimensions are exaggerated in these figures to provide clear description of certain features of the invention. It will be apparent to those with skill in the art that there are other ways to provide a support for the die attach pad during injection, such as by bonding small particles of material, for example plastic beads, to a die attach pad before use. In this method, the beads are encapsulated and become a part of the finished package. The bonding of such beads to a pad, however, is considered by the inventor to be a more troublesome process than dimpling the lead frame. And dimpling the lead frame is generally less desirable than using supports in the mold cavities, because the mold cavities need to be altered only once for a large number of lead frames.

In the embodiments described thus far herein, support has been provided in all cases between a die attach pad and a surface of a lower mold portion, that is, on the side of an enclosed lead frame strip away from the die attached to a die attach pad. In some embodiments, however, the die attach pad may be urged upward, that is, toward the die contacting the surface of the cavity in the upper mold portion. It has been contemplated by the inventors, in fact, to alter the injection flow pattern to cause this particular distortion pattern, and to thwart the failure mode by providing the support extensions on the inside surface of the upper mold portion rather than the lower. In this case, the extensions would not necessarily contact the die itself, but might be positioned to contact the die attach pad outside the area to which the die is attached. Dimples, beads, or other

support elements might be provided on the die side of die attach pads on lead frames to accomplish the same purpose, according to the present invention.

For cases where no indentation in the package is acceptable under any circumstance, retractable pins may be used in mold cavities. Fig. 7 is a cross section of a lower mold half 59 showing a retractable support pin 55. In this case, support pin 55 is not pointed at the upper end, but substantially flat, and extends into a hole with sufficient clearance that the pin may be retracted entirely into the hole.

In this embodiment, pin 55 has a second, and larger, diameter, with slot opening 61 through the pin at ninety degrees to the vertical axis of the pin. A cam bar 63 extends through this slot and is guided in another slot in lower mold half 59. Moving the cam bar in one direction extends pin 55 to the specified height to support a die attach pad during a molding injection operation, and moving the cam bar in the other direction retracts the support pin to a position wherein the upper end is flush with cavity surface 47. Spring 56 aids in retracting the pin. It will be apparent to those with skill in the art that there are a number of ways known in the mechanical arts that pins may be extended and retracted.

The pin in this embodiment retracts after liquid-phase polymer is injected and before it solidifies. At the time of retraction the mold is filled, and the presence of the polymer material tends to help support the die attach pad. After retraction, the polymer material hardens, and there is no hole of the sort left by a permanent pin. In other embodiments multiple retractable pins may be used.

It will be apparent to those with skill in the art that there are a number of alterations that might be made in details of the invention without departing from the spirit and scope of the invention. For example, there are many different package designs in the art, and the

- 14 -

nominal clearance between a die attach pad or an attached die and the nearby surface of a mold cavity may be different for many of these designs. The length of a support element for the die attach pad would be matched substantially to this nominal dimension for each design. As another example, it was described above that one such support seemed to be sufficient for most purposes, but more than one support could be used in many cases. With plural supports there are also many possibilities for the placement and spacing of the supports. Just a few representative examples have been provided in this disclosure. There are also many shapes and forms a support might take other than the conical end shape described herein as a preferred embodiment. There are similarly many other alteration that might be made without departing from the spirit and scope of the invention.



What is claimed is:

1. A method for molding an integrated circuit (IC) package, comprising steps of:
  - (a) attaching an IC die to a die attach pad of a lead frame;
  - (b) bonding wires from the IC die to leads of the lead frame;
  - (c) placing the lead frame between an upper and a lower portion of a mold having matching mold cavities for forming an encapsulation volume around the lead frame and attached IC die;
  - (d) providing a support element in one of the mold cavities for spacing the die attach pad and attached die from an adjacent surface of the one of the mold cavities;
  - (e) closing the portions of the mold on the lead frame such that the die attach pad and attached die is spaced from the adjacent surface; and
  - (f) injecting encapsulation material into the encapsulation volume.
2. The method of claim 1 wherein the support element is a single element positioned substantially in the center of the mold cavity in the lower mold portion when the mold portions are closed.
3. The method of claim 2 wherein the support element is a dimple provided in the die attach pad of the lead frame.
4. The method of claim 2 wherein the support element is a bead of material affixed to the die attach pad.
5. The method of claim 2 wherein the support element is a pin engaged in a hole provided for the purpose in the mold cavity in the

- 16 -

lower mold portion, the pin having an extended portion extending into the mold cavity.

6. The method of claim 5 wherein the pin is tapered on the extended portion.

7. The method of claim 1 wherein plural support elements are provided.

8. The method of claim 7 wherein the plural support elements are dimples provided in the die attach pad of the lead frame.

9. The method of claim 7 wherein the plural support elements are beads of material affixed to the die attach pad of the lead frame.

10. The method of claim 7 wherein the plural support elements are pins engaged in holes provided for the purpose in one of the mold cavities, the pins having each an extended portion extending into the mold cavity.

11. The method of claim 10 wherein the pins each are tapered on the extended portion.

12. The method of claim 1 wherein the support element is a retractable support element, and further comprising a step (g) for retracting the support element after the encapsulation material is solidified.

13. A mold for use in encapsulating an IC die mounted on a die

- 17 -

attach pad of a lead frame, comprising:

a first portion having a first cavity for forming a first part of an encapsulation volume around the IC die and the die attach pad on the side of the die attach pad to which the die is attached;

a second portion having a second cavity with a bottom surface, the second cavity for forming a second part of the encapsulation volume on the side of the die attach pad opposite the side to which the die is attached; and

a support element in one of the cavities for spacing the die attach pad and attached die from an adjacent surface of one of the mold cavities.

14. A mold as in claim 13 wherein the support element is a single element positioned substantially in the center of the second cavity.

15. A mold as in claim 14 wherein the support element is a pin engaged in a hole provided for the purpose in the bottom surface of the second cavity, the pin having an extended portion extending into the second cavity.

16. A mold as in claim 15 wherein the pin is tapered on the extended portion.

17. A mold as in claim 13 wherein plural support elements are provided extending from the bottom surface of one of the cavities.

18. A mold as in claim 13 wherein the plural support elements are each pins engaged in holes in the bottom surface of one of the cavities, each pin having an extended portion extending into the adjacent mold cavity.

- 18 -

19. A mold as in claim 18 wherein the pins are each tapered on the extended portion.
20. A mold as in claim 17 wherein the plural support elements extend from the bottom surface of the second cavity.
21. A mold as in claim 13 wherein the support element is a retractable support element, and further comprising apparatus for extending and retracting the support element.
22. A lead frame strip comprising:  
at least one lead frame having a die attach pad and leads positioned adjacent to the die attach pad; and  
a spacing element protruding from the die attach pad for spacing the die attach pad from surfaces of cavities in a mold in a process of encapsulating dies attached to the die attach pads to make packaged integrated circuits.
23. A lead frame as in claim 22 wherein the support element is a dimple formed in the die attach pad.
24. A lead frame as in claim 22 wherein the support element is a bead of material bonded to the die attach pad.

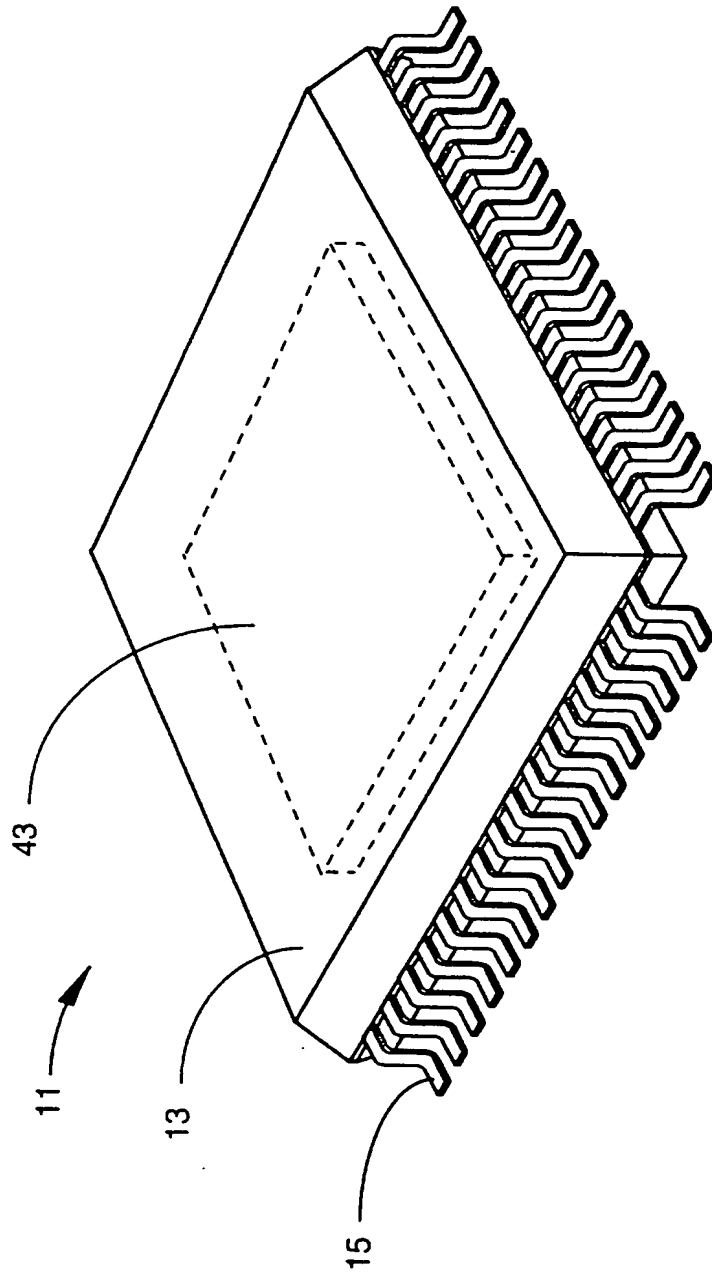

Fig. 1 (Prior Art)

2/9

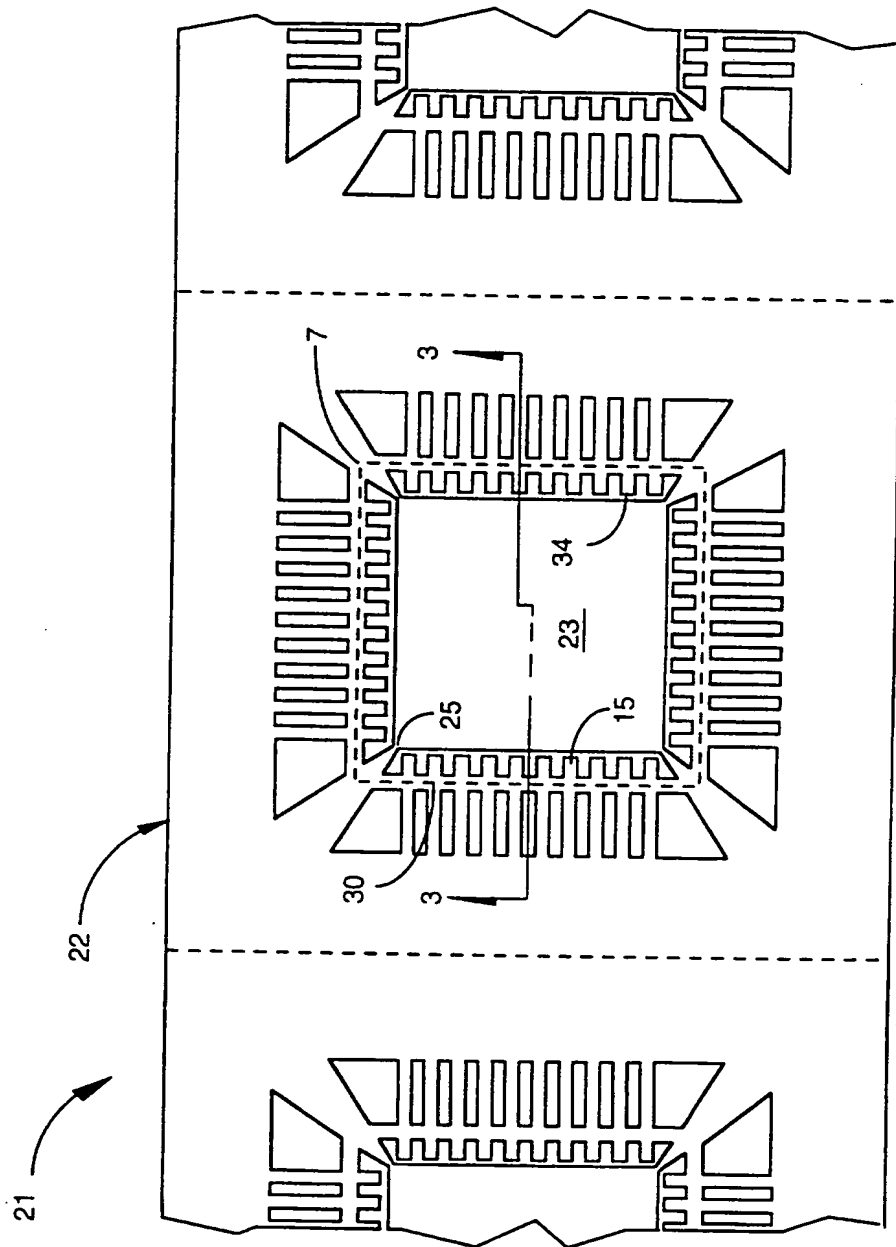

Fig. 2 (Prior Art)

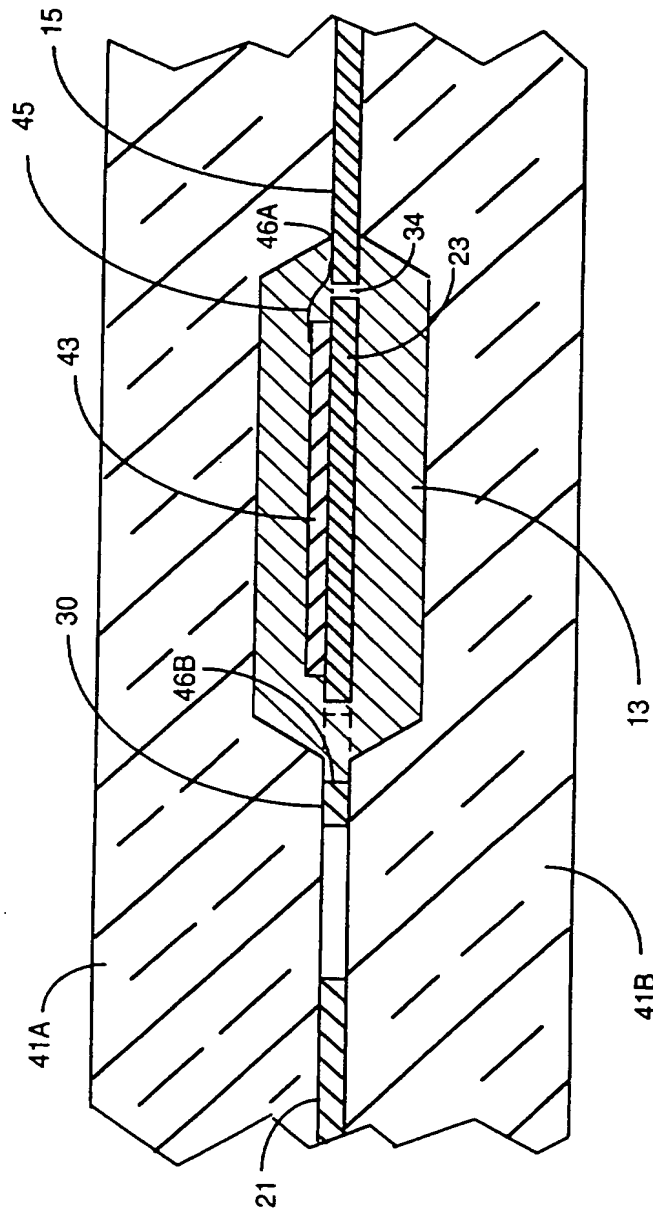

Fig. 3 (Prior Art)





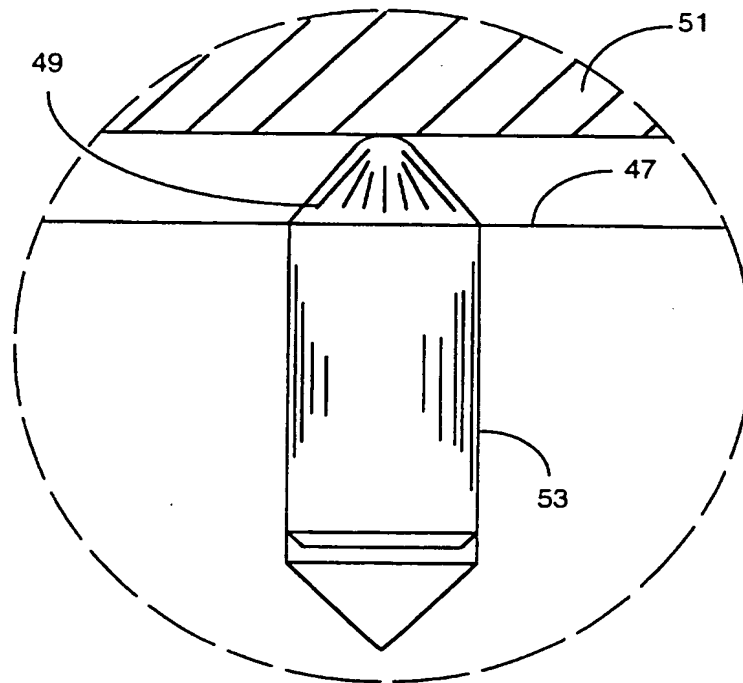

Fig. 4B

6/9

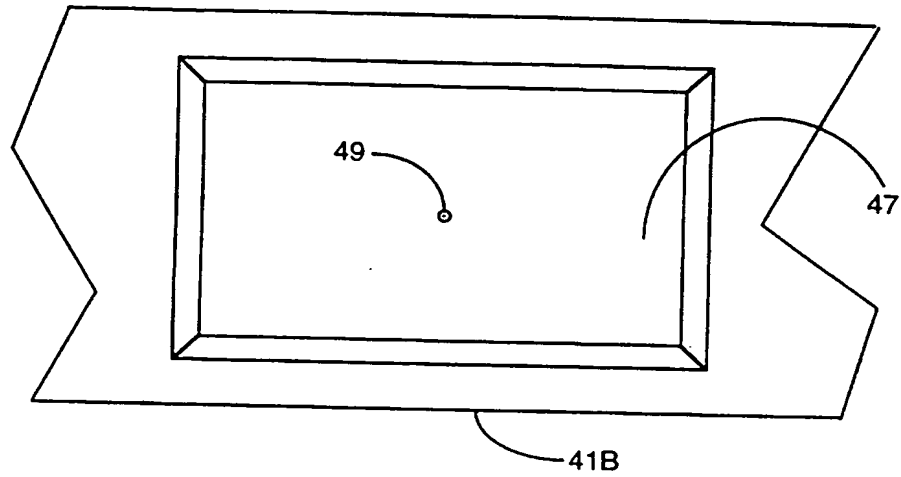

Fig. 5A

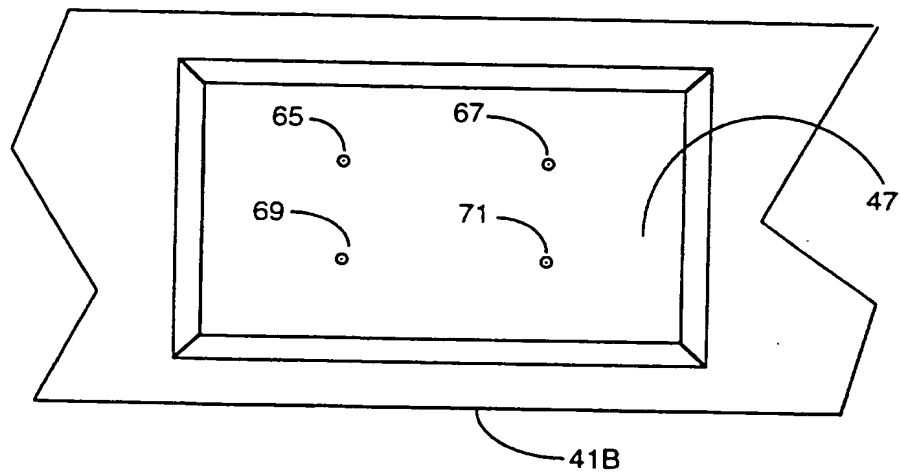

Fig. 5B

7/9

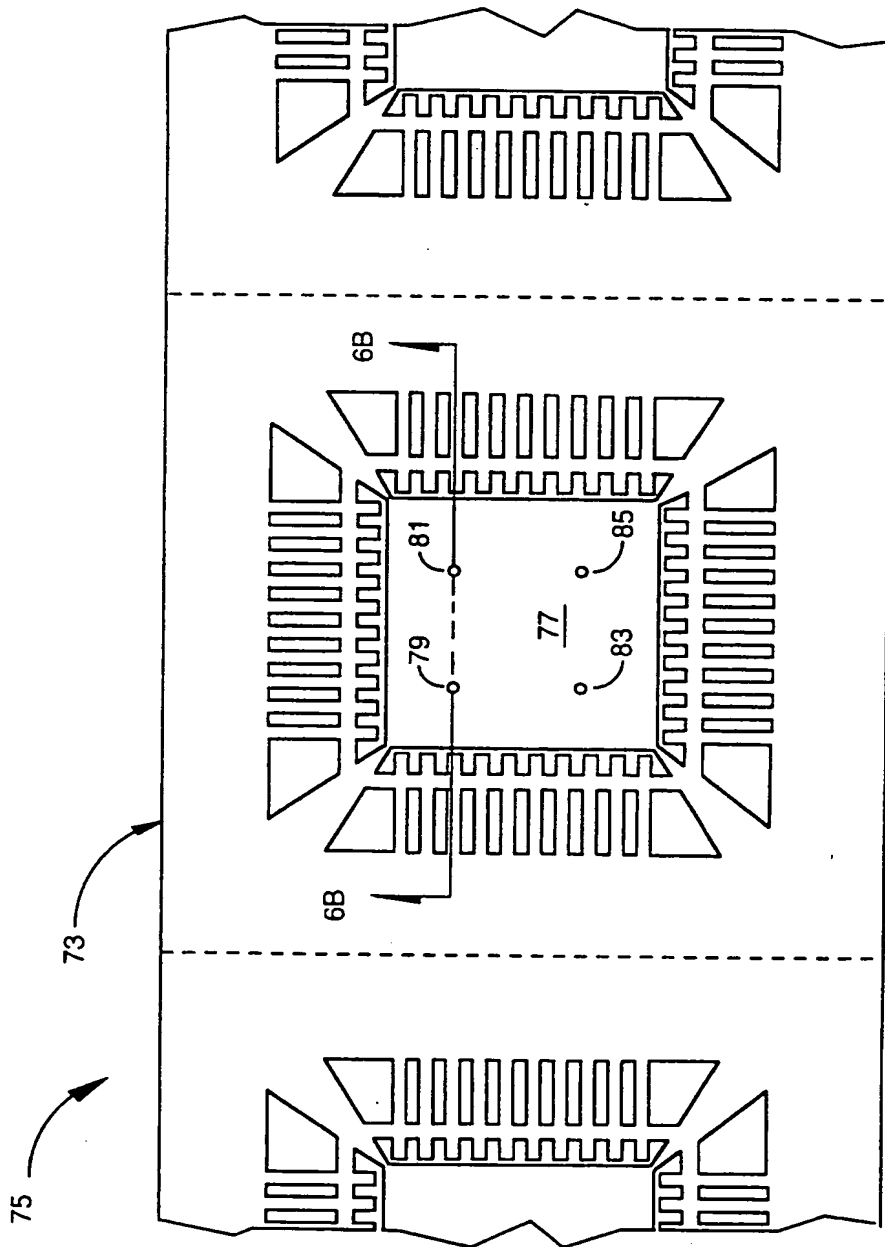

Fig. 6A

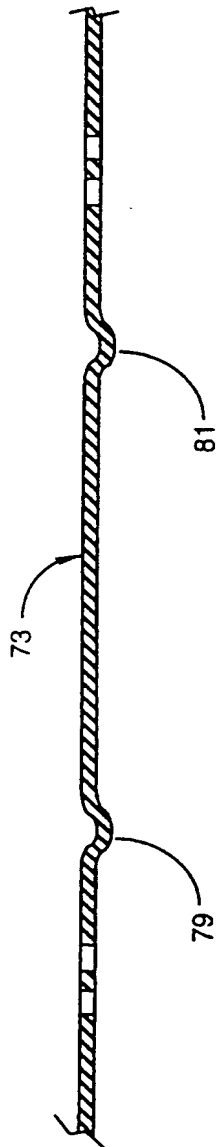

Fig. 6B

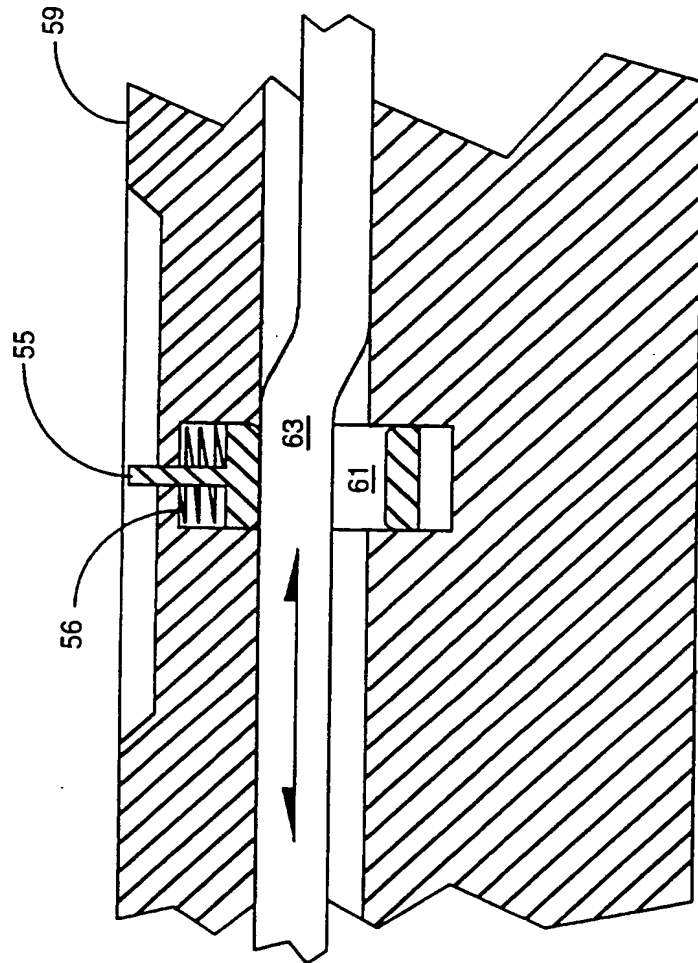

Fig. 7

INTERNATIONAL SEARCH REPORT

International application No.  
PCT/US96/05363

**A. CLASSIFICATION OF SUBJECT MATTER**  
 IPC(6) :H01R 43/00  
 US CL :29/827, 841; 264/272.17; 425/116; 174/52.4  
 According to International Patent Classification (IPC) or to both national classification and IPC

**B. FIELDS SEARCHED**

Minimum documentation searched (classification system followed by classification symbols)  
 U.S. : 29/827, 841, 856; 264/272.17, 272.15; 425/116, 121; 174/52.4, 52.5, 52.6; 257/676, 696

Documentation searched other than minimum documentation to the extent that such documents are included in the fields searched

Electronic data base consulted during the international search (name of data base and, where practicable, search terms used)

**C. DOCUMENTS CONSIDERED TO BE RELEVANT**

Category*	Citation of document, with indication, where appropriate, of the relevant passages	Relevant to claim No.
X --- Y	US, A, 4,751,611 (ARAI ET AL.) 14 JUNE 1988, SEE COL. 2, LINES 28-37 AND FIG. 1	1-2,13-14 ----- 3-12,15-21
Y	US, A, 4,783,428 (KALFUS) 08 NOVEMBER 1988, SEE FIG. 3	1-12,15-21
A	US, A, 5,218,759 (JUSKEY ET AL.) 15 JUNE 1993	1-12
A	US, A, 4,803,030 (KOBAYASHI) 07 FEBRUARY 1989	1-12

Further documents are listed in the continuation of Box C.  See patent family annex.

* Special categories of cited documents:	*T	later document published after the international filing date or priority date and not in conflict with the application but cited to understand the principle or theory underlying the invention
*A* document defining the general state of the art which is not considered to be of particular relevance	*X*	document of particular relevance; the claimed invention cannot be considered novel or cannot be considered to involve an inventive step when the document is taken alone
*E* earlier document published on or after the international filing date	*Y*	document of particular relevance; the claimed invention cannot be considered to involve an inventive step when the document is combined with one or more other such documents, such combination being obvious to a person skilled in the art
*L* document which may throw doubts on priority claim(s) or which is cited to establish the publication date of another citation or other special reason (as specified)	*A*	document member of the same patent family
*O* document referring to an oral disclosure, use, exhibition or other means		
*P* document published prior to the international filing date but later than the priority date claimed		

Date of the actual completion of the international search 11 JULY 1996	Date of mailing of the international search report <b>30 JUL 1996</b>
---------------------------------------------------------------------------	--------------------------------------------------------------------------

Name and mailing address of the ISA/US Commissioner of Patents and Trademarks Box PCT Washington, D.C. 20231 Facsimile No. (703) 305-3230	Authorized officer <i>Sheldon Venev</i> ADRIAN L. COLEY Patent Specialist Group 3200 Telephone No. (703) 308-1412
-------------------------------------------------------------------------------------------------------------------------------------------------------	----------------------------------------------------------------------------------------------------------------------------------

INTERNATIONAL SEARCH REPORT

International application No.  
PCT/US96/05363

C (Continuation). DOCUMENTS CONSIDERED TO BE RELEVANT		
Category*	Citation of document, with indication, where appropriate, of the relevant passages	Relevant to claim No.
A	US, A, 5,043,535 (LIN) 27 AUGUST 1991, SEE FIGS. 1 AND 3	1-21
X --- Y	US, A, 5,397,915 (NOSE) 14 MARCH 1995, SEE ENTIRE DOCUMENT	22 ----- 7-12,23-24
Y	US, A, 5,053,855 (MICHII ET AL.) 01 OCTOBER 1991, SEE COL. 2, LINES 19-23 AND FIG. 1	22-24
X --- Y	US, A, 5,389,739 (MILLS) 14 FEBRUARY 1995, SEE FIGS 4 AND 6 COL. 6, LINES 14-31	22 ----- 23-24
A	US, A, 5,175,610 (KOBAYASHI) 29 DECEMBER 1992	22-24

**This Page is Inserted by IFW Indexing and Scanning  
Operations and is not part of the Official Record**

**BEST AVAILABLE IMAGES**

Defective images within this document are accurate representations of the original documents submitted by the applicant.

Defects in the images include but are not limited to the items checked:

- BLACK BORDERS
- IMAGE CUT OFF AT TOP, BOTTOM OR SIDES
- FADED TEXT OR DRAWING
- BLURRED OR ILLEGIBLE TEXT OR DRAWING
- SKEWED/SLANTED IMAGES
- COLOR OR BLACK AND WHITE PHOTOGRAPHS
- GRAY SCALE DOCUMENTS
- LINES OR MARKS ON ORIGINAL DOCUMENT
- REFERENCE(S) OR EXHIBIT(S) SUBMITTED ARE POOR QUALITY
- OTHER: \_\_\_\_\_

**IMAGES ARE BEST AVAILABLE COPY.**

**As rescanning these documents will not correct the image problems checked, please do not report these problems to the IFW Image Problem Mailbox.**





INTERNATIONAL APPLICATION PUBLISHED UNDER THE PATENT COOPERATION TREATY (PCT)

<p>(51) International Patent Classification<sup>6</sup> : H01L 23/31, 21/56</p>	<p>A1</p>	<p>(11) International Publication Number: <b>WO 96/20501</b> (43) International Publication Date: 4 July 1996 (04.07.96)</p>
<p>(21) International Application Number: PCT/US95/16059 (22) International Filing Date: 11 December 1995 (11.12.95) (30) Priority Data: 08/364,087 27 December 1994 (27.12.94) US (71) Applicant: NATIONAL SEMICONDUCTOR CORPORATION [US/US]; M/S 16-135, 1090 Kifer Road, Sunnyvale, CA 94086-3737 (US). (72) Inventor: WEILER, Peter, M.; 3476 Greer, Palo Alto, CA 94303 (US). (74) Agent: CONSER, Eugene; National Semiconductor Corporation, M/S 16-135, 1090 Kifer Road, Sunnyvale, CA 94086-3737 (US).</p>		<p>(81) Designated States: DE, KR, European patent (AT, BE, CH, DE, DK, ES, FR, GB, GR, IE, IT, LU, MC, NL, PT, SE).  Published With international search report.</p>

(54) Title: AN INTEGRATED CIRCUIT PACKAGE ENCAPSULATED BY FIBER LADEN MOLDING MATERIAL AND ITS METHOD OF MANUFACTURING

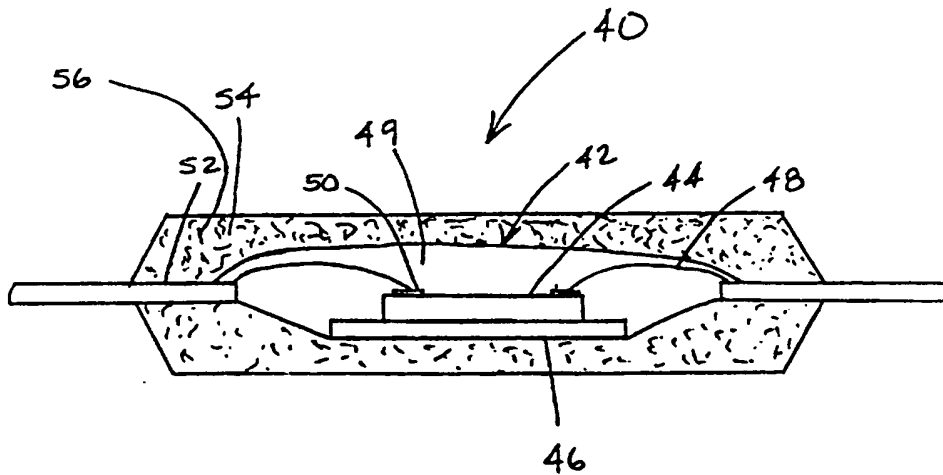

(57) Abstract

An integrated circuit package (40) encapsulated by a fiber (56) or other such particle laden molding material (54) is disclosed herein. The package (40) includes a support member (46) which supports an IC chip (44). An array of bonding wires (48) electrically interconnects respective input/output terminals on the IC chip to conductive leads (52) defined by the support member (46). The IC chip (44), bonding wires (48) and portions of the support member (46) are encapsulated by an overall fiber laden molding material (54). In a method of the invention, an intermediate assembly which includes the IC chip (44), support member (46) and bonding wires (48) is encapsulated by supporting the assembly in a mold cavity and injecting a fiber (56) or other such particle laden molding material (54) into the cavity and around the assembly. A mold including a unique movable gate is also disclosed herein.

*FOR THE PURPOSES OF INFORMATION ONLY*

Codes used to identify States party to the PCT on the front pages of pamphlets publishing international applications under the PCT.

AM	Armenia	GB	United Kingdom	MW	Malawi
AT	Austria	GE	Georgia	MX	Mexico
AU	Australia	GN	Guinea	NE	Niger
BB	Barbados	GR	Greece	NL	Netherlands
BE	Belgium	HU	Hungary	NO	Norway
BF	Burkina Faso	IE	Ireland	NZ	New Zealand
BG	Bulgaria	IT	Italy	PL	Poland
BJ	Benin	JP	Japan	PT	Portugal
BR	Brazil	KE	Kenya	RO	Romania
BY	Belarus	KG	Kyrgyzstan	RU	Russian Federation
CA	Canada	KP	Democratic People's Republic of Korea	SD	Sudan
CF	Central African Republic	KR	Republic of Korea	SE	Sweden
CG	Congo	KZ	Kazakhstan	SG	Singapore
CH	Switzerland	LI	Liechtenstein	SI	Slovenia
CI	Côte d'Ivoire	LK	Sri Lanka	SK	Slovakia
CM	Cameroon	LR	Liberia	SN	Senegal
CN	China	LT	Lithuania	SZ	Swaziland
CS	Czechoslovakia	LU	Luxembourg	TD	Chad
CZ	Czech Republic	LV	Latvia	TG	Togo
DE	Germany	MC	Monaco	TJ	Tajikistan
DK	Denmark	MD	Republic of Moldova	TT	Trinidad and Tobago
EE	Estonia	MG	Madagascar	UA	Ukraine
ES	Spain	ML	Mali	UG	Uganda
FI	Finland	MN	Mongolia	US	United States of America
FR	France	MR	Mauritania	UZ	Uzbekistan
GA	Gabon			VN	Viet Nam

**AN INTEGRATED CIRCUIT PACKAGE ENCAPSULATED BY FIBER  
LADEN MOLDING MATERIAL AND ITS METHOD OF  
MANUFACTURING**

5

By Inventor

Peter M. Weiler

**Background of the Invention**

10

The present invention relates generally to an integrated circuit package and more particularly to an integrated circuit package which is encapsulated in a high strength and/or high thermal conductivity molding material which includes fibers or other such strength enhancing particulate material.

15

A typical integrated circuit package is comprised of (1) an IC chip including an array of chip input/output terminals, (2) means for supporting the chip, for example, either a leadframe or substrate, including an array of electrically conductive leads, (3) bonding wires electrically connecting the chip input/output terminals with respective ones of the electrically conductive leads, and (4) plastic material encapsulating the IC chip, support means and bonding wires. This overall package is typically manufactured by first supporting the IC chip on the support member. The bonding wires are then attached to electrically interconnect the input/output terminals of the IC chip to the electrically conductive leads of the support member. This subassembly is then placed in a cooperating mold to encapsulate the IC chip, support

20  
25

means and bonding wires in plastic.

Attention is now directed to Figure 1, which diagrammatically illustrates an intermediate step in the production of a prior art IC package of the type described immediately above. An intermediate IC assembly, which is generally indicated by the reference numeral 10, is shown prepared for overall encapsulation. Intermediate IC assembly 10 includes an IC chip 12 including an array of chip input/output terminals 13. Chip 12 is supported on a suitable support member 14 which can be, for example, a leadframe or a dielectric substrate. The support member includes an array of electrically conductive leads 16 electrically connected to respective chip input/output terminals by an array of bonding wires 18.

Still referring to Figure 1, a mold for use in encapsulating intermediate IC assembly 10 is generally indicated by the reference numeral 20. Mold 20 includes a runner 22 which leads from an external supply of molding material (not shown) to a mold cavity 24 for accommodating a flow of molding material 26 into mold cavity 24. A fixed gate 28 is located in runner 22 at the point where the runner enters mold cavity 26. The fixed gate 28 is in actuality formed as a narrowed passage within the runner 22 which serves to ease the separation of runner 22 from the finished molded package and has the undesirable result of restricting the flow of molding material into the mold cavity 24 through the runner 22. Intermediate IC assembly 10 is supported within mold cavity 24 for overall encapsulation by the molding material. Molding material 26, in order to be useful for this application, must be quite viscous and of a consistency which will not

clog fixed gate 28 as it passes through the latter and onward into the mold cavity. As the molding material is injected into the cavity it flows around the intermediate IC assembly including bonding wires 18, IC chip 12 and at least a portion 29 of electrically conductive leads 16  
5 which are within the mold cavity.

Following the injection of the molding material into the mold cavity, the mold material is allowed to harden. After hardening, the mold material forms a monolithic structure which includes a package  
10 portion 30 surrounding the IC assembly and a runner portion 32 formed within the runner. Upon removal of the IC package from the mold, which is not shown, runner portion 32 must be broken away from package portion 30.

15 While the method of producing a prior art integrated circuit package, as depicted in Figure 1, does produce an IC package which is generally satisfactory for its intended purpose, certain disadvantages due to the method of manufacture exist which limit the final capabilities of the IC package thereby produced with regard to its strength and  
20 thermal conductivity. These disadvantages are directly related to fixed gate 28 in mold 20 and the plastic molding compound used to form package portion 30, and will be described immediately hereinafter.

A first disadvantage, which may increase production costs, lies in  
25 the fact that the fixed gate, as discussed above, leaves runner portion 32 of the molding material attached to package portion 30 of the molding material which encapsulates the actual IC. The runner portion must be broken away from the package portion upon removal of the IC

package from the mold. If the molding material is made significantly stronger, the runner portion will be more difficult to remove and the package could be damaged, in some cases, by the breaking away of the runner portion.

5

A second and even more significant disadvantage of the fixed gate mold is related to the limited types of molding materials which are amenable to use with it. When considering thermal and strength properties of a representative IC package, the composition of the molding material encapsulating the package is of primary consideration. In the prior art method presented above, the molding material must be quite viscous and possess a smooth consistency to allow it to pass through fixed gate 28 in runner 22 without clogging the gate. This restricts the available molding materials suitable for use to a rather narrow range which excludes most types of fillers including fibers of any type.

As will be seen hereinafter, the present invention removes the limitations in molding materials required by a fixed gate mold thereby to allow the use of a much broader range of molding materials and provide IC packages which possess previously unattainable characteristics with regard to strength and thermal properties.

Summary of the Invention

As will be described in more detail hereinafter, there is disclosed herein an integrated circuit package, its method of manufacture, and a  
5 unique mold used by the method wherein the aforescribed restrictions in molding materials used to encapsulate the package are eliminated. These packages, like the package illustrated in Figure 1, include an IC chip having an array of chip input/output terminals, a support member having an array of electrically conductive leads and  
10 supporting the IC chip, and an array of bonding wires electrically connecting the chip input/output terminals with respective ones of the electrically conductive leads. However, in accordance with the present invention, the overall integrated circuit package including the IC chip, the bonding wires and portions of the electrically conductive leads are  
15 encapsulated by a molding material laden with a fiber or other suitable type of particulate.

In the manufacture of an integrated circuit package, a method of encapsulating an intermediate assembly is disclosed. The intermediate  
20 assembly includes a support member having an array of electrically conductive leads, an IC chip having an array of chip input/output terminals, and an array of bonding wires. The IC chip is supported on the support member and the bonding wires electrically interconnect the conductive leads with respective ones of the chip input/output  
25 terminals. The intermediate assembly is encapsulated by providing a mold assembly which defines a mold cavity, supporting the intermediate assembly including the IC chip and the bonding wires in the mold cavity, injecting a fiber or other such particle laden molding

material into the mold cavity and around the intermediate assembly and allowing the molding material to harden.

5 A mold for use in manufacturing an integrated circuit package, in accordance with the method described above which utilizes a fiber or other such particle laden molding material, is also disclosed herein. The mold defines a mold cavity and a material transfer passage which leads into the cavity, the material transfer passage being suitably configured to allow a flow of the fiber or other such particle laden molding material  
10 through the material transfer passage. In accordance with the present invention, the mold further includes means for selectively blocking the flow of the molding material to prevent the flow of the latter into or out of the mold cavity through the material transfer passage once the cavity has been filled with and prior to the hardening of the molding material.

15



Brief Description of the Drawings

The present invention may be understood by reference to the following detailed description taken in conjunction with the drawings, in  
5 which:

FIGURE 1 is a cross-sectional diagrammatic elevational view which illustrates an intermediate step in the manufacture of a prior art integrated circuit assembly.  
10

FIGURE 2 is a cross-sectional diagrammatic elevational view which illustrates an IC package manufactured in accordance with the present invention.

15 FIGURE 3 is a cross-sectional diagrammatic elevational view of a mold including a movable gate which is used in a method of the present invention.

FIGURE 4 is a cross-sectional diagrammatic elevational view of the  
20 mold illustrated in Figure 4 including an intermediate IC assembly in place in the mold cavity, shown to illustrate an intermediate step in the method of the present invention for manufacturing an IC assembly.

FIGURE 5 is a cross-sectional diagrammatic elevational view  
25 similar to Figure 4, which illustrates the completion of the encapsulation of the IC package of the present invention.

Detailed Description of the Invention

Having described Figure 1 previously, attention is immediately directed to Figure 2, which illustrates an integrated circuit package manufactured in accordance with a method of the present invention and generally designated by reference numeral 40. Package 40 includes an intermediate assembly 42 which itself includes an IC chip 44, a support member 46, an array of bonding wires 48 and a hardened plastic blob 49. IC chip 44 includes an array of chip input/output terminals 50 each one of which is connected to a respective one of a plurality of electrically conductive leads 52, which are integral with support member 46, by a respective one of bonding wires 48. Support member 46 may be a leadframe or a substrate, either of which are typical of the support members used in the prior art. Blob 49 covers the bonding wires in a protective manner consistent with and described in U.S. Patent Application Serial No. 08/225,900, filed April 11, 1994 and entitled Plastic Encapsulating Integrated Circuit Package Having Protective Barrier For Its Bonding Wires, and Method, which application is assigned to the assignee of the present invention and is incorporated herein by reference. The function of the blob will be described in detail herein in conjunction with a description of a method of manufacturing the IC package of the present invention, which follows hereinafter.

Continuing to refer to Figure 1 and in accordance with the present invention, intermediate assembly 42 is encapsulated by a molding material 54. Molding material 54 may incorporate a wide variety of new components not previously seen in IC packages, for example, such as fillers. These IC packages will provide advantages over prior art IC

packages based upon the characteristics of the components present in molding material 54. In the present example, molding material 54 is laden with a plurality of fibers 56 which may include, for example, glass fibers or aluminum nitride fibers. The addition of these fibers provides  
5 specific advantages in comparison to prior art IC packages, some of which will now be discussed.

A first advantage realized as a direct result of the incorporation of fibers into the molding material is an IC package possessing a strength  
10 not seen heretofore. While the imparting of strength to materials which contain fibers such as these is well known in the art, they have not been seen in materials used in the overall encapsulation of an IC package due to the problems encountered in the method of encapsulation of the package, which problems are solved by the present invention.

15 A second advantage resulting from inclusion of fibers in the molding material lies in the thermal conductivity of the package. Significant heat is produced by IC chips of certain types such as, for example, power amplifiers. It is therefore a continuing goal of IC  
20 package designers to provide packages capable of conducting ever increasing levels of thermal energy away from the IC chip through the package materials themselves. The aforementioned glass and aluminum nitride fibers typically possess a higher thermal conductivity than the molding material or resin to which they would be added. Consequently,  
25 the thermal conductivity of the molding material, which is laden with the fibers, will increase. The result is a package having a higher thermal conductivity which is capable of removing an increased amount of thermal energy from the IC chip or, for that matter, any device

within the package which produces heat.

While the present invention contemplates the utilization of a fiber laden plastic encapsulant, the present invention is not limited thereto. Any suitable and compatible strength enhancing and/or thermally  
5 conductive particulate is contemplated by the present invention including, for example, aluminum nitride, graphite, or fiberglass.

Reference is now made to Figure 3 which illustrates a mold for use  
10 in encapsulating an IC package manufactured in accordance with the present invention and generally designated by reference numeral 60. Mold 60 includes an upper mold half 62 and a lower mold half 64. Lower mold half 64 includes a material transfer passage 66 which leads from an external source of molding material (not shown) to a cavity 68  
15 defined within the mold itself. In one possible configuration, a movable gate 70 is positioned in a gate channel 72 at a point 74 where the material transfer passage adjoins the mold cavity. Gate 70 is designed to move vertically from an open position, allowing the flow of molding material through the full width of material transfer passage 66 to a  
20 closed position (shown in phantom) which completely blocks passage 66 to prevent any further flow of molding material either into or out of cavity 68. Gate 70 includes a surface 72 which defines a portion of the package outline when the gate is in its closed position, as shown. This unique gate, unlike the prior art fixed gate shown and described above,  
25 opens to the full width of the material transfer passage, permitting molding materials which would clog the prior art fixed gate to flow through the passage, past the movable gate and into the mold cavity. Movable gate 70 allows the use of molding materials which are new in

the encapsulation of IC packages such as, for instance, those containing fibers.

5 Many configurations of a mold including a movable gate may be provided which are useful in the method of the present invention. For example, the gate may be positioned at a different location in the material transfer passage, the gate may move horizontally to block the passage or may include a shape which is altered from the preferred embodiment which is shown and described herein. All of these  
10 configurations and variations are considered to be within the scope of the present invention. The use of this mold in a method of the present invention will be described immediately hereinafter.

Turning now to Figure 4 and in accordance with a method of the  
15 present invention, an intermediate assembly 80 is placed within mold cavity 68 of mold 60, which was previously described in the discussion relating to Figure 3. Intermediate assembly 80 includes an IC chip 82 having an array of chip input/output terminals 83. Chip 82 is supported on a suitable support member 84 which can be, for example,  
20 a leadframe or a dielectric substrate. The support member includes an array of electrically conductive leads 86 electrically connected to respective chip input/output terminals by an array of bonding wires 88. A hardened plastic blob 90 protects the bonding wires, in accordance with previously referenced U.S. Application 08/225,900, against the  
25 inflow of a fiber laden molding material 92 when it is injected into the mold cavity. Without the protection offered by the plastic blob, the bonding wires would be washed by the inflow of molding material possibly becoming disconnected or shorting to one another. Wire wash

has been a significant concern in the manufacture of prior art IC packages and, in this instance, it is vital to protect the bonding wires against wire wash since a fiber laden molding material will place much greater wash stresses on the bonding wires. Other means of protecting the bonding wires against wire wash may be developed such as, for example, a hollow plastic enclosure which surrounds the intermediate assembly. These means are considered to be within the scope of the invention as claimed.

Continuing to refer to Figure 4 and with movable gate 70 in its opened position, fiber laden molding material 92 is injected into mold cavity 68 through passage 66. Since movable gate 70 is in its opened position, the entire width of the passage is presented to the flow of molding material whereby to avoid clogging of the passage by the fibers carried in the material. The molding material, in its viscous state, fills passage 66 to surround intermediate assembly 80.

Referring to Figure 5, movable gate 70 is moved to its closed position prior to the hardening of molding material 90, as illustrated. The closing of the gate separates a first portion 90a of molding material which remains in the material transfer passage from a second portion 90b which encapsulates the intermediate assembly. In this particular configuration of movable gate 70, surface 72 of the gate actually defines a portion of the package outline of the encapsulating molding material. After the gate is closed the molding material is allowed to harden and the IC package is removed from the mold (not shown). It is mentioned here that first portion 92a of the molding material within the material transfer passage is separated from second portion 92b of the package

itself by closed gate 70 such that the first portion does not need to be broken away from the IC package, thereby avoiding the risk of damage to the package. This is particularly advantageous considering the increased strength of the fiber laden molding material.

5

It should be understood that the IC package and mold of the present invention may be embodied in many other specific forms and produced by other methods without departing from the spirit or scope of the present invention. Therefore, the present examples are to be considered as illustrative and not restrictive, and the invention is not to be limited to the details given herein, but may be modified within the scope of the appended claims.

10

What is claimed is:

1. In the manufacture of an integrated circuit package, a  
5 method of encapsulating an intermediate assembly which includes a  
support member having an array of electrically conductive leads, an IC  
chip having an array of chip input/output terminals and an array of  
bonding wires, said IC chip being supported on the support member and  
said bonding wires electrically interconnecting the conductive leads  
10 with respective ones of the chip input/output terminals, said method  
comprising the steps of:

a) providing a mold assembly which defines a mold  
cavity;

15

b) supporting said intermediate assembly including the  
IC chip and the bonding wires in said mold cavity;

c) injecting into the mold cavity and around the  
20 intermediate assembly a particulate laden molding material; and

d) allowing said molding material to harden.

2. A method according to Claim 1 including the step of  
25 providing a protective barrier over said bonding wires sufficient to  
prevent said bonding wires from moving against the force of the  
particulate laden molding material as the latter is injected into said  
mold cavity and caused to flow over the intermediate assembly.



3. A method according to Claim 1 wherein the step of providing a mold assembly includes the step of providing a material transfer passage leading into said mold cavity and wherein the step of  
5 injecting the molding material into the mold cavity includes the step of injecting the molding material through the material transfer passage.

4. A method according to Claim 3 including the step of closing the material transfer passage after injecting the molding material into  
10 the mold cavity and prior to its hardening.

5. A method according to Claim 4 wherein the step of closing said material transfer passage includes the steps of providing a gate within said passage movable between a first position for opening the  
15 passage and a second position for closing the passage, and moving said gate between its first position to open the passage and allow the flow of molding material through said material transfer passage and into said mold cavity and a second position to block the material transfer passage after the mold cavity has been filled with said molding material.

20

6. A method according to Claim 5 wherein said mold cavity defines a package outline and said movable gate in its closed position defines a portion of said outline.

25

7. A method according to Claim 1 wherein said particulate laden molding material includes fibers.

8. A method according to Claim 7 wherein said fibers have a

high thermal coefficient.

9. A method according to Claim 8 wherein the fibers are glass fibers.

5

10. A method according to Claim 8 wherein the fibers are aluminum nitride.

11. A method according to Claim 2 wherein the step of providing said protective barrier includes forming a hardened plastic blob over said bonding wires.

12. In the manufacture of an integrated circuit package, a method of encapsulating an intermediate assembly which includes a support member having an array of electrically conductive leads, an IC chip having an array of chip input/output terminals and an array of bonding wires, said IC chip being supported on the support member and said bonding wires electrically interconnecting the conductive leads with respective ones of the chip input/output terminals, said method comprising the steps of:

a) providing a mold assembly which defines a mold cavity, a material transfer passage leading into said mold cavity and a gate movable between a first position for opening said passage and a second position for closing said passage and defining part of said cavity;

b) supporting said intermediate assembly including the IC chip and the bonding wires in said mold cavity;

c) while maintaining said gate in its first, passage-opened position, injecting a molding material through the material transfer passage and into the mold cavity around the intermediate assembly;

5

d) thereafter, but before the molding material within said cavity hardens, moving said gate to its second passage-closed position; and

10

e) allowing said molding material to harden after closing said gate.

13. A method according to the method of Claim 12 wherein a protective barrier consisting of a hardened plastic blob is provided over said bonding wires sufficient to prevent said bonding wires from moving against the force of the molding material as it flows over the intermediate assembly and the injected molding material is particle laden.

20

14. A method according to the method of Claim 13 wherein the particles are fibers.

15. An integrated circuit package comprising:

25

a) an IC chip including an array of chip input/output terminals;

b) a support member including an array of electrically conductive leads which are provided for connection with the input/output terminals of said IC chip, said support member supporting said IC chip including its array of chip input/output terminals;

5

c) an array of bonding wires electrically connecting said chip input/output terminals with respective ones of said electrically conductive leads; and

10

d) a particle laden molding material encapsulating the overall package including said IC chip, said bonding wires, and portions of said support member including portions of said electrically conductive leads.

15

16. An integrated circuit package in accordance with Claim 15 including a protective barrier disposed over said bonding wires between the latter and said molding material, said protective barrier being designed so that, during formation of the package, it prevents said bonding wires from moving against the force of said molding material as the latter is caused to flow in place over the IC chip, support member and bonding wires.

20

17. An integrated circuit package in accordance with Claim 15 wherein said particle laden molding material includes fibers.

25

18. An integrated circuit package in accordance with Claim 17 wherein said fibers include a high thermal coefficient.

19. An integrated circuit package in accordance with Claim 18 wherein the fibers are glass fibers.

20. An integrated circuit package in accordance with Claim 18  
5 wherein the fiber members are aluminum nitride.

21. An integrated circuit assembly in accordance with Claim 16 wherein said protective barrier includes a hardened plastic blob formed over said bonding wires.

10

22. A mold for use in manufacturing an integrated circuit package encapsulated in a molding material which itself includes a plurality of fiber or other such particulate members, said mold defining a mold cavity and a material transfer passage which leads into said  
15 cavity, said material transfer passage being suitably configured to allow a flow of said molding material therethrough, said mold further including means for selectively blocking the flow of the molding material to prevent the flow of the latter into or out of the mold cavity through the material transfer passage once the cavity has been filled  
20 with and prior to the hardening of the molding material.

23. A mold in accordance with Claim 22 wherein the mold includes an upper mold half and a lower mold half.

24. A mold in accordance with Claim 23 wherein said material  
25 transfer passage is defined within one of said mold halves.

25. A mold in accordance with Claim 22 wherein said blocking

means includes a gate selectively movable between an open position which allows the flow of molding material through the material transfer passage into the mold cavity and a closed position which blocks the material transfer passage to prevent further flow of the molding material into or out of the mold cavity through the material transfer passage.

26. A mold in accordance with Claim 25 wherein said mold cavity defines a package outline and said movable gate in its closed position defines a portion of said outline.

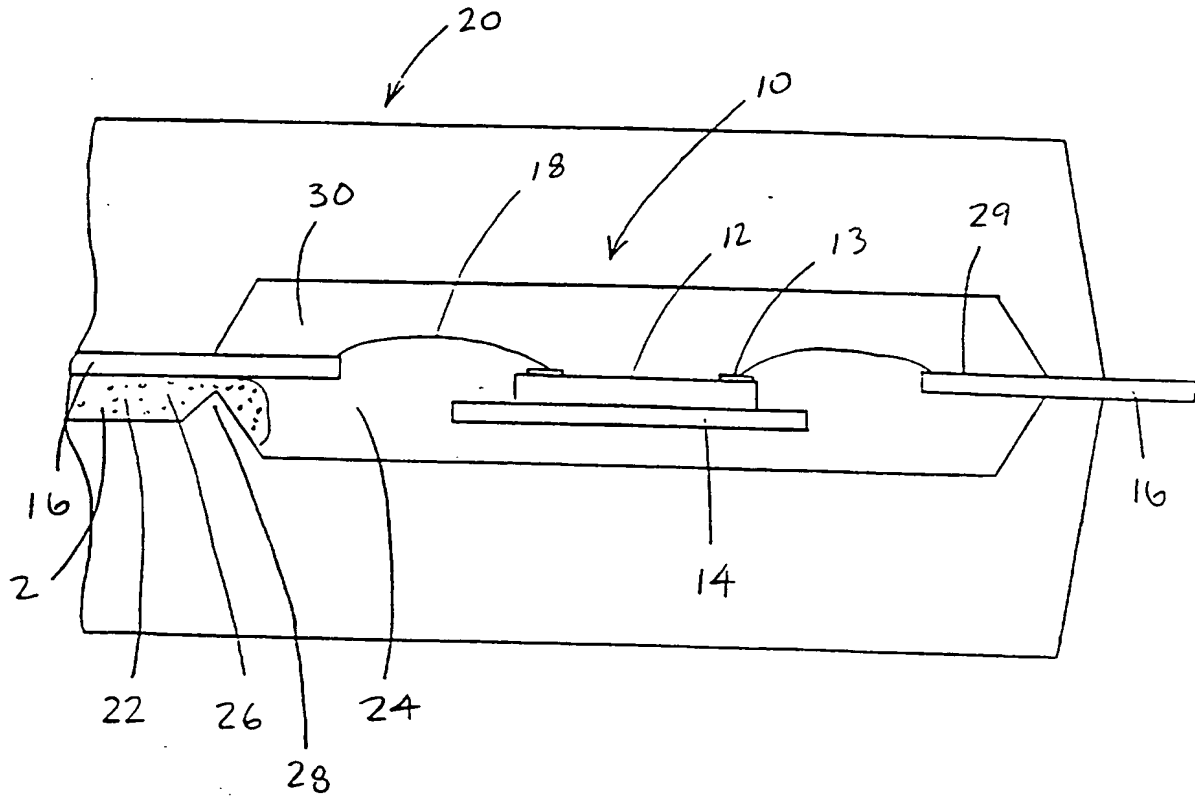

FIGURE 1

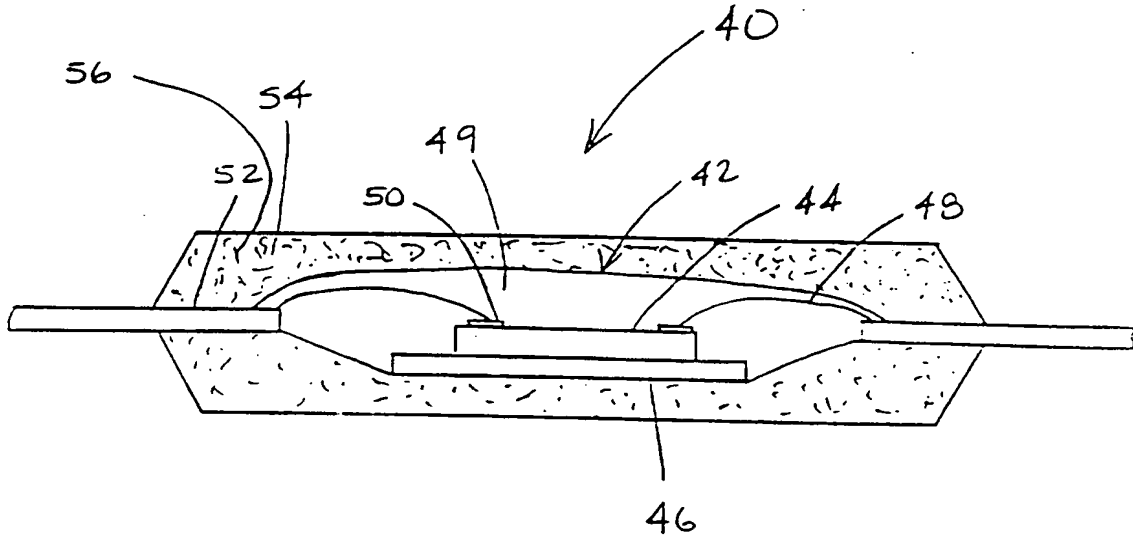

FIGURE 2



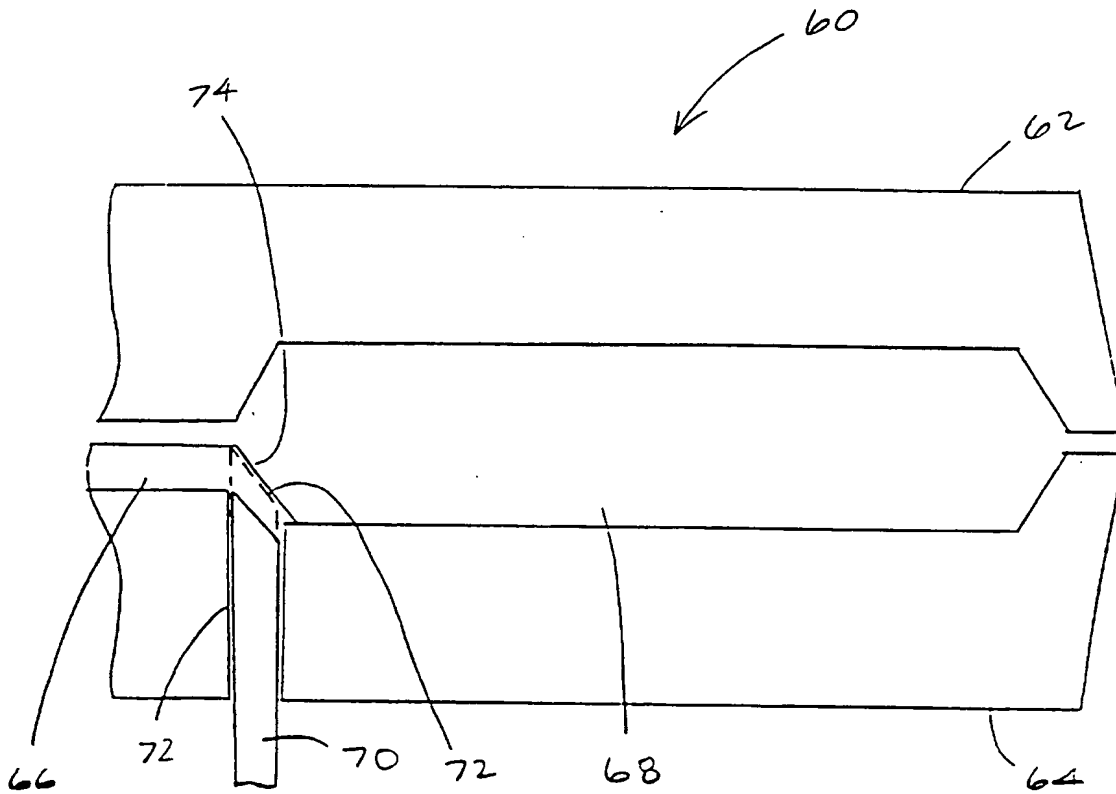

FIGURE 3

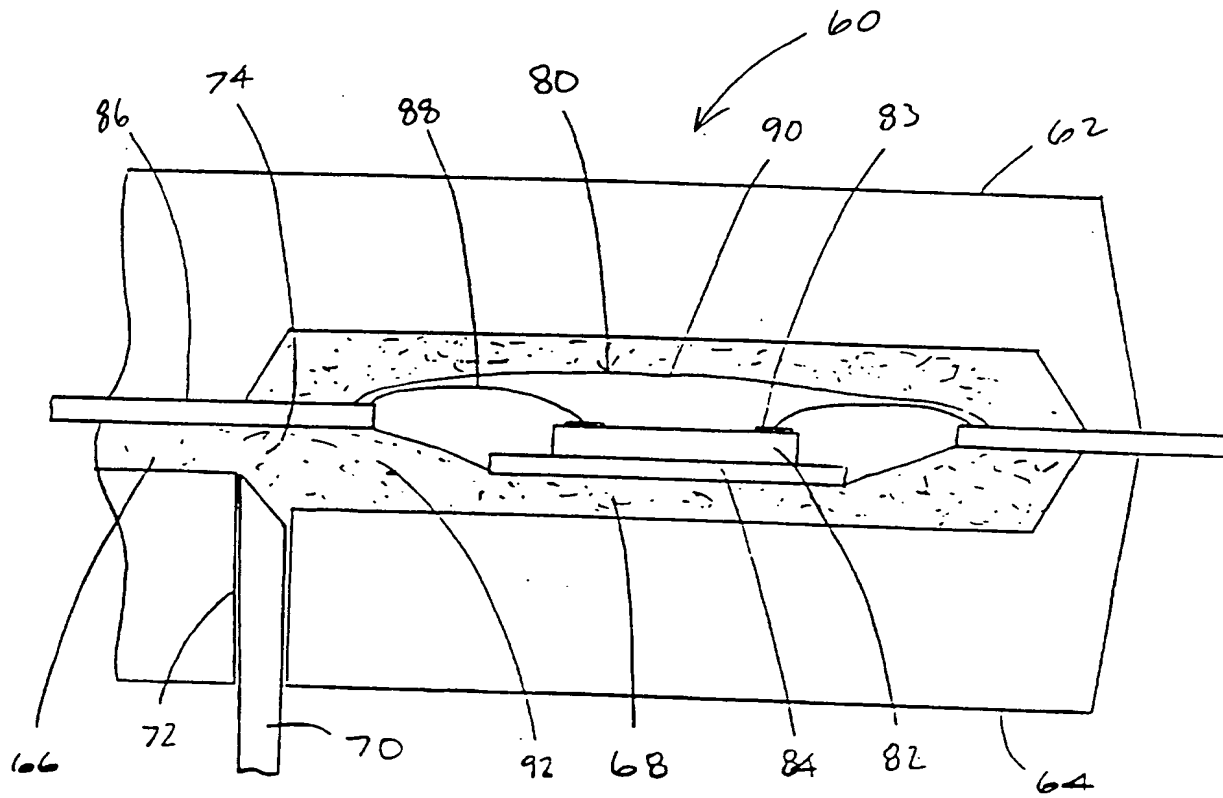

FIGURE 4

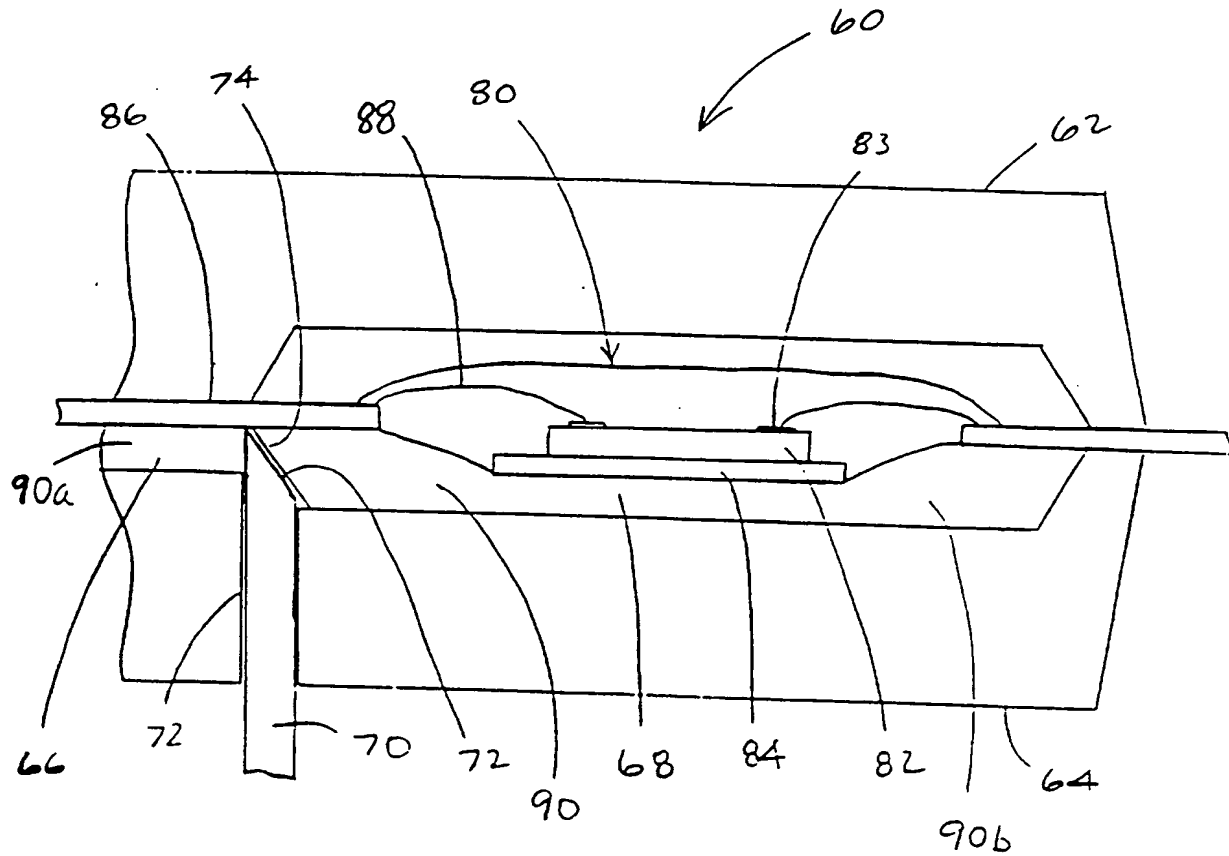

FIGURE 5

INTERNATIONAL SEARCH REPORT

International Application No  
PCT/US 95/16059

A. CLASSIFICATION OF SUBJECT MATTER  
IPC 6 H01L23/31 H01L21/56

According to International Patent Classification (IPC) or to both national classification and IPC

B. FIELDS SEARCHED

Minimum documentation searched (classification system followed by classification symbols)  
IPC 6 H01L

Documentation searched other than minimum documentation to the extent that such documents are included in the fields searched

Electronic data base consulted during the international search (name of data base and, where practical, search terms used)

C. DOCUMENTS CONSIDERED TO BE RELEVANT

Category	Citation of document, with indication, where appropriate, of the relevant passages	Relevant to claim No.
X	PATENT ABSTRACTS OF JAPAN vol. 012, no. 348 (E-659), 19 September 1988 & JP,A,63 104455 (OKI ELECTRIC IND CO LTD), 9 May 1988, see abstract	1,3,7-9, 15,17-19
Y	---	10,20
X	FR,A,1 572 077 (ITT INDUSTRIES INC) 20 June 1969 see the whole document	1,2,11, 16,21
Y	---	3-6,13, 14
A	US,A,5 331 205 (PRIMEAUX WILLIAM F) 19 July 1994 see the whole document	1,2, 11-13, 16,21
	---	
	-/--	

Further documents are listed in the continuation of box C.

Patent family members are listed in annex.

\* Special categories of cited documents :

- \*A\* document defining the general state of the art which is not considered to be of particular relevance
- \*E\* earlier document but published on or after the international filing date
- \*L\* document which may throw doubts on priority claim(s) or which is cited to establish the publication date of another citation or other special reason (as specified)
- \*O\* document referring to an oral disclosure, use, exhibition or other means
- \*P\* document published prior to the international filing date but later than the priority date claimed

\*T\* later document published after the international filing date or priority date and not in conflict with the application but cited to understand the principle or theory underlying the invention

\*X\* document of particular relevance; the claimed invention cannot be considered novel or cannot be considered to involve an inventive step when the document is taken alone

\*Y\* document of particular relevance; the claimed invention cannot be considered to involve an inventive step when the document is combined with one or more other such documents, such combination being obvious to a person skilled in the art.

\*&\* document member of the same patent family

Date of the actual completion of the international search

3 April 1996

Date of mailing of the international search report

17. 04. 96

Name and mailing address of the ISA  
European Patent Office, P.B. 5118 Patentlaan 2  
NL - 2280 HV Rijswijk  
Tel. (+ 31-70) 340-2040, Tx. 31 651 epo nl,  
Fax: (+ 31-70) 340-3016

Authorized officer

Zeisler, P

INTERNATIONAL SEARCH REPORT

International Application No  
PCT/US 95/16059

C.(Continuation) DOCUMENTS CONSIDERED TO BE RELEVANT		
Category *	Citation of document, with indication, where appropriate, of the relevant passages	Relevant to claim No.
X	PATENT ABSTRACTS OF JAPAN vol. 010, no. 175 (E-413), 20 June 1986 & JP,A,61 024241 (NIPPON DENKI KK), 1 February 1986,	12,22-26
Y	see the whole document	3-6,13, 14
	---	
X	PATENT ABSTRACTS OF JAPAN vol. 008, no. 044 (E-229), 25 February 1984 & JP,A,58 201333 (NIPPON DENKI KK), 24 November 1983, see the whole document	12,22-26
	---	
X	PATENT ABSTRACTS OF JAPAN vol. 017, no. 694 (M-1531), 17 December 1993 & JP,A,05 237864 (NEC CORP), 17 September 1993, see the whole document	12,22-26
	---	
Y	PATENT ABSTRACTS OF JAPAN vol. 010, no. 192 (E-417), 5 July 1986 & JP,A,61 035542 (NEC CORP), 20 February 1986, see abstract	10,20
	-----	

1

# INTERNATIONAL SEARCH REPORT

Information on patent family members

International Application No

**PCT/US 95/16059**

Patent document cited in search report	Publication date	Patent family member(s)	Publication date
FR-A-1572077	20-06-69	CH-A- 483724	31-12-69
		DE-A- 1764554	26-08-71
		GB-A- 1206759	30-09-70
		NL-A- 6810225	22-01-69
-----			
US-A-5331205	19-07-94	NONE	
-----			

**This Page is Inserted by IFW Indexing and Scanning  
Operations and is not part of the Official Record**

**BEST AVAILABLE IMAGES**

Defective images within this document are accurate representations of the original documents submitted by the applicant.

Defects in the images include but are not limited to the items checked:

- BLACK BORDERS**
- IMAGE CUT OFF AT TOP, BOTTOM OR SIDES**
- FADED TEXT OR DRAWING**
- BLURRED OR ILLEGIBLE TEXT OR DRAWING**
- SKEWED/SLANTED IMAGES**
- COLOR OR BLACK AND WHITE PHOTOGRAPHS**
- GRAY SCALE DOCUMENTS**
- LINES OR MARKS ON ORIGINAL DOCUMENT**
- REFERENCE(S) OR EXHIBIT(S) SUBMITTED ARE POOR QUALITY**
- OTHER:** \_\_\_\_\_

**IMAGES ARE BEST AVAILABLE COPY.**

**As rescanning these documents will not correct the image problems checked, please do not report these problems to the IFW Image Problem Mailbox.**



INTERNATIONAL APPLICATION PUBLISHED UNDER THE PATENT COOPERATION TREATY (PCT)

(51) International Patent Classification 5 : H02N 2/00, H01L 41/22	A1	(11) International Publication Number: WO 92/06532
		(43) International Publication Date: 16 April 1992 (16.04.92)

(21) International Application Number: PCT/US90/06539  
(22) International Filing Date: 13 November 1990 (13.11.90)

(30) Priority data:  
589,850 28 September 1990 (28.09.90) US

(71) Applicant: CATERPILLAR INC. [US/US]; 100 Northeast Adams Street, Peoria, IL 61629-6490 (US).

(72) Inventors: GRAWAY, Charles, E. ; 210 E. Orchard Place, Peoria, IL 61603 (US). KELLEY, Kurtis, C. ; 914 Birchwood Drive, Washington, IL 61571 (US).

(74) Agents: NOE, Stephen, L. et al.; Caterpillar Inc., 100 Northeast Adams Street, Peoria, IL 61629-6490 (US).

(81) Designated States: AT (European patent), AU, BE (European patent), BR, CA, CH, CH (European patent), DE, DE (European patent), DK, DK (European patent), ES, ES (European patent), FI, FR (European patent), GB, GB (European patent), GR (European patent), HU, IT (European patent), JP, KR, LU (European patent), NL, NL (European patent), NO, RO, SE, SE (European patent), SU\*.

Published  
With international search report.

(54) Title: COATING SURROUNDING A PIEZOELECTRIC SOLID STATE MOTOR STACK

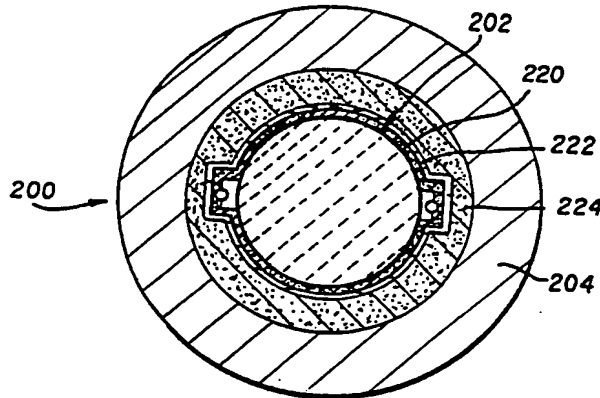

(57) Abstract

An encapsulated piezoelectric solid state motor stack (100, 200) having a plurality of piezoelectric disks interleaved with a plurality of electrodes (102, 202). A first elastomer (220) is used for encapsulating the stack to prevent arc-over. A second elastomer (224) is used for encasing the combination of the encapsulating elastomer and the stack. An elastomer grease (222) is sandwiched between the encapsulating elastomer and the encasing elastomer for reducing friction between the combination and the encasing elastomer. The friction is induced by an axial displacement produced between first and second end surfaces of the stack when the electrodes are biased by a source of electrical potential. The structure also includes a protective housing (104, 204) including a diaphragm (118). The housing (104, 204) cylindrically encases the combination of the stack (102, 202), the encapsulating elastomer (220), the elastomer grease (222) and the encasing elastomer (224), and the one end thereof. The diaphragm (118) is attached to the housing (104 and 114) for encasing the other end of the combination.

- See back of page



+ DESIGNATIONS OF "SU"

Any designation of "SU" has effect in the Russian Federation. It is not yet known whether any such designation has effect in other States of the former Soviet Union.

*FOR THE PURPOSES OF INFORMATION ONLY*

Codes used to identify States party to the PCT on the front pages of pamphlets publishing international applications under the PCT.

AT	Austria	ES	Spain	MG	Madagascar
AU	Australia	FI	Finland	ML	Mali
BB	Barbados	FR	France	MN	Mongolia
BE	Belgium	GA	Gabon	MR	Mauritania
BF	Burkina Faso	GB	United Kingdom	MW	Malawi
BG	Bulgaria	GN	Guinea	NL	Netherlands
BJ	Benin	GR	Greece	NO	Norway
BR	Brazil	HU	Hungary	PL	Poland
CA	Canada	IT	Italy	RO	Romania
CF	Central African Republic	JP	Japan	SD	Sudan
CG	Congo	KP	Democratic People's Republic of Korea	SE	Sweden
CH	Switzerland	KR	Republic of Korea	SN	Senegal
CI	Côte d'Ivoire	LI	Liechtenstein	SU+	Soviet Union
CM	Cameroon	LK	Sri Lanka	TD	Chad
CS	Czechoslovakia	LU	Luxembourg	TC	Togo
DE	Germany	MC	Monaco	US	United States of America
DK	Denmark				

**COATING SURROUNDING A PIEZOELECTRIC  
SOLID STATE MOTOR STACK**

**5 BACKGROUND OF THE INVENTION**

**1. Field of the Invention**

10 The field of the invention relates generally to an encapsulation structure for solid state motor actuators, and more particularly to a process for encapsulating piezoelectric solid state motor stacks.

**2. Related Art**

15

For decades electroexpansive materials have been employed in stacked structures for producing actuation used for fuel injection and valve control in diesel engines, for example. Commercially manufactured solid state motor stacks, or actuators, are produced using piezoelectric disks interleaved with metal foil electrodes. Application of high voltage, low current power to alternately biased electrodes causes each of the piezoelectric disks to expand or axially distort. The additive deflection of the stacked disks is typically amplified by hydraulics to effectuate useful actuation.

20 An example of a conventional electromechanical actuator having an active element of electroexpansive material is found in United States Patent No. 30 3,501,099 to Glendon M. Benson. Benson's 1970 patent is directed to both an actuation amplification structure and a method for manufacturing piezoelectric stacks. Sheets of ceramic material are rolled, 35 compacted and punched into ceramic disks. After a

compressing combined with lapping/polishing results in low disk yield due to the time elements of the two step process and disk breakage during the lapping step.

5           Various environmental design considerations are important in piezoelectric stack manufacturing. Device operating temperature ranges and external mechanical stresses are the most serious of these factors.

10           Conventional stacks are limited to a maximum operating temperature of about 75° celsius, measured at the outside of the stack housing. Heat generated by the stack itself is compounded by the extreme heat generated by the engine upon which the housed stack is typically mounted. Stack temperatures can reach  
15           upward of 40°-50°C above the measured engine temperature.

          On the other hand, structural defects typically lead to conventional stack failure due to shear and torsional stresses applied to the stack during  
20           operation and/or installation. Structural stack failure is most commonly attributed to fatigue cracking of the ceramic disks. Separation between disks/electrodes is also a frequent problem.

          Piezoelectric stack insulation has been  
25           introduced between the disk/electrode stack and the housing in an attempt to minimize some of the above mentioned problems.

          United States Patent No. 4,011,474 to Cormac G. O'Neill discloses several methods for improving stack  
30           insulation to avoid operation breakdowns. Arc-over is allegedly avoided by maintaining contact between the piezoelectric stack and the insulating material. In a first embodiment, O'Neill teaches introducing a pressurized insulating fluid such as oil, into the  
35           housing of a piezoelectric stack. The fluid is

pressurized so as to maintain contact between the fluid and the stack during radial shrinkage, or axial expansion, upon the application of an applied voltage.

5 In a second embodiment, O'Neill applies a solid polyurethane coating to the stack. The coating is kept in contact with the stack by a pressurized insulating fluid to prevent separation during operation and arc-over associated therewith.

10 A third O'Neill embodiment maintains contact between the stack and a solid insulating coating by winding a filament or tape around the coated stack. The tape is wound around the coating to preload the coating to prevent separation of the coating from the stack. The winding of the tape is spaced to allow for  
15 expansion of the polyurethane coating during operation of the stack.

The present invention constitutes an improvement over conventional encapsulation technology. Benefits, such as increased stack operational temperature range,  
20 endurance, output, and lifetime, are achieved by the present invention.

#### 25 SUMMARY OF THE INVENTION

The present invention is directed to an encapsulated piezoelectric solid state motor stack having a plurality of piezoelectric disks interleaved with a plurality of electrodes. A first elastomer is  
30 used for encapsulating the stack to prevent arc-over. A second elastomer is used for encasing the combination of the encapsulating elastomer and the stack. An elastomer grease is sandwiched between the encapsulating elastomer and the encasing elastomer for  
35 reducing friction between the combination and the

encasing elastomer. The friction is induced by an axial displacement produced between first and second end surfaces of the stack when the electrodes are biased by a source of electrical potential.

5           The structure also includes a protective housing and a diaphragm. The housing cylindrically encases the combination of the stack, the encapsulating elastomer, the elastomer grease and the encasing elastomer. The housing also encases one end of the  
10 combination. The diaphragm is attached to the housing for encasing the other end of the combination.

          The present invention is also directed to a method for encapsulating a piezoelectric solid state motor stack having a plurality of disks interleaved  
15 with electrodes. The method includes the step of encapsulating the stack with a first material, followed by encasing the combination of the first material and the stack within a protective housing, and then sandwiching a lubricant between the  
20 combination and the protective housing for reducing friction between the combination and the protective housing.

#### 25    **BRIEF DESCRIPTION OF THE DRAWINGS**

          The invention will be better understood if reference is made to the accompanying drawings in which:

30           **FIG. 1** shows a side-sectional view of a housed, encapsulated piezoelectric solid state motor stack in connection with the present invention;

**FIG. 2** shows a top-sectional view of the housed piezoelectric stack of Figure 1 taken through line  
35    A-A;

FIG. 3 is a flow chart of the basic steps in a method for encapsulating a piezoelectric stack in connection with the present invention;

5 FIG. 4 is a flow chart of the basic steps in a method for pre-encapsulation preparation of a piezoelectric stack in connection with the present invention;

10 FIG. 5 is a flow chart of the basic steps in a method for preparation of a desiccator for use in the encapsulation of a piezoelectric stack in connection with the present invention;

15 FIG. 6 is a flow chart of the basic steps in a method for applying an elastomer in the encapsulation of a piezoelectric stack in connection with the present invention; and

20 FIG. 7 is a flow chart of the basic steps in a method for the final housing assembly of a piezoelectric stack in connection with the present invention.

#### DETAILED DESCRIPTION OF THE PREFERRED EMBODIMENTS

25 Broadly, the present method for encapsulating piezoelectric stacks is designed for an automated manufacturing process to yield high-quality, high-durability solid state motor stacks in great volume. The piezoelectric encapsulation steps of the present process have refined the technology by employing  
30 careful cleaning and inspection operations which result in stacks that can displace 0.13% in fast response times of 100 microseconds, and produce driving forces greater than 35 MPa. Unlike  
35 conventional piezoelectric solid state motor stacks, which have relatively limited temperature ranges,

-7-

stacks encapsulated according to the present invention have an extended operational temperature range between about  $-40^{\circ}\text{C}$  and  $+100^{\circ}\text{C}$  (measured externally; plus an additional  $40^{\circ}$  to  $50^{\circ}\text{C}$  measured internally).

5 Encapsulated piezoelectric solid state motor stacks of the present invention are high-force devices that can be used to improve engine performance, reduce emissions, and reduce engine noise. The utility of the present invention is not, however, limited to  
10 encapsulating stacks for engine valve and fuel injector actuation. Encapsulated stacks of the present invention may be used in brake or shock absorbing systems, for example. Moreover, the invention may be used to encapsulate a wide variety of  
15 devices or systems which operate in high temperature, or otherwise extreme environments.

It should be understood that the present invention is directed to a piezoelectric solid state motor stack encapsulation structure and the method of  
20 encapsulating the stack structure. However, the terms solid state motor stack and electroexpansive actuator, for example, are synonymous. Throughout this discussion, the piezoelectric solid state motor stacks will be commonly referred to as "stacks."

25 FIG. 1 shows an encapsulated solid state motor stack, 100, in connection with the present invention. An electrode/ceramic disk stack 102 is centered in a housing 104. The steel case, or housing 104, is cylindrical in shape with a hollow cylindrical cavity  
30 for housing the solid state stack. Throughports 106 are bored in the top end of the housing to permit bus lead wires 108 to exit the housing. Threads 110 attach the piezoelectric solid state motor housing to an engine head. Plateau 112 represents a hexagonal  
35 cross section, if viewed from the top of FIG. 1. This

hexagonal structure is not shown in the figure, but is used for tightening and loosening the piezoelectric solid state motor housing on the engine head.

5 The preferred embodiment of the assembled piezoelectric solid state electrode/disk stack 102 is described in the concurrently filed, commonly assigned co-pending application Serial No. (Attorney Docket No. 1246.010000/90-220), titled "Piezoelectric Solid State Motor Stack", the entire disclosure of which is  
10 incorporated herein by reference.

FIG. 2 is a cross-sectional view taken through line A-A of the piezoelectric solid state motor stack and housing of FIG. 1. The details of FIG. 2 will be covered during the following discussion of the  
15 encapsulation process.

A generalized stack encapsulation process 300 is shown in FIG. 3. As shown at block 302, the stack undergoes a cleaning process. In one embodiment, excess gloss and contaminants are removed from the  
20 exterior of the assembled stack and bus bar structure by a conventional grit blasting technique. The stack is ultrasonically cleaned in a methanol bath. The cleaned stack is then heat dried at block 304.

Block 306 represents a series of pre-  
25 encapsulation steps. This pre-encapsulation process 400 is shown in more detail at FIG. 4. The bus wires are electrically shorted at block 402 to prevent electrostatic charging of the stack, because of its inherent capacitive characteristics. The stack is  
30 then placed in a conventional vacuum desiccator fixture to remove volatile contaminants, as shown at block 404. The stack is then cooled before applying a primer, as indicated at 406, and in accordance with primer manufacturer instructions.

35



A coating of primer is applied to the exterior of the stack and bus bar structure at block 408 in preparation for the silicone coating process. Dow Corning SilGuard Primer No. 1200 or an equivalent may be used. The primer is cured (at block 410) in accordance with conventional curing techniques, according to manufacturer specifications.

The details of the desiccator preparation step of block 308 in FIG. 3 are shown at process 500 of FIG. 5. The stack is aligned in a modified alignment fixture at block 502 such that a small axial compressive load can be applied to the stack as shown at block 504. The alignment fixture should comprise a cylindrical case including a bottom/end section and a load screw for applying an axial compression to the stack. The bottom has two openings to permit the bus leads to pass therethrough. In addition, the inner diameter of the alignment fixture case should be slightly larger than the outside diameter of the stack in order to permit proper encapsulation. Stoppers must then be inserted in the holes at the base of the alignment fixture to seal around the bus bar leads. The composition of the alignment fixture case and port stoppers is not crucial to the invention. However, their composition must not be such that contamination of the stack or chemical reactions occur therewith.

The prepared alignment fixture is then positioned in the vacuum desiccator as shown at block 508. The axial load is released and the desiccator is then sealed as shown at blocks 510 and 512, respectively. A vacuum is then created in the desiccator as shown at block 514, to draw out a sufficient volume of air so that the elastomer will fill the voids in the stack when the vacuum is released.

35

The application of an elastomer, shown in block 310 in FIG. 3 will be described in further detail with reference to process 600 in FIG. 6. A silicone elastomer, Dow Corning SilGuard 184, for example, is mixed as per the manufacturer's suggested directions. This preparation is shown at block 602. The silicone elastomer mix is then injected into the desiccator through a glass tube and then into the spaces between the stack and the inside wall of the alignment fixture case as shown at 606. The vacuum desiccator is then gradually pressurized, and an axial load of at least about 1500 psi is applied to the stack by the load screw attached to the assembly fixture case as shown at blocks 608 and 610, respectively.

As shown at blocks 612 and 614, respectively, the excess silicone elastomer is drained from the alignment fixture and the stoppers removed. The silicone elastomer encapsulant is then cured in an oven, as shown at block 616.

In the presently preferred embodiment, curing is accomplished at about 65°C for approximately 4 hours. The present inventors have found that curing time is inversely proportional to the curing temperature and that the maximum cure temperature is approximately 100°C. More significantly, the inventors have found that cure temperature at this stage directly affects the minimum operating temperature of the motor stack. They have found that the lower the cure temperature, the lower the minimum operating temperature that they can achieve.

The fixture is then allowed to cool as shown at block 618 and the elastomer thickness measured as shown at 620. A determination is made, see block 622, whether the desired thickness of the silicone elastomer encapsulant has been reached. This

-11-

determination is based on whether the bus bar and tab structures are sufficiently covered so as to prevent arc-over. If the desired thickness is not reached as indicated at 624, the stack is then dipped in  
5 elastomer as shown at block 628. Steps 616, 618, 620, 622 and 628 are repeated until the desired thickness is reached as shown at 632. The stack is then removed from the fixture as shown at block 634.

The two end coatings of silicone elastomer  
10 encapsulant are trimmed, as shown at 636. Once trimmed, the layer of silicone elastomer, shown at 220 of FIG. 2, coats the cylindrical surface of the assembled stack 202, as well as the bus bar and electrode tab structure. Trimming exposes the end  
15 surfaces of the assembled stack to permit direct transfer of translational motion from the stack to a diaphragm member during actuation. Otherwise, the untrimmed end coating of elastomer would act as a compliant layer.

20 The sequence at 700 of FIG. 7 represents the final assembly of the stack in the housing. Poling of the stack, as shown at block 702, is done once the stack is assembled, in accordance with guidelines provided by the ceramic manufacturer. In the  
25 presently preferred embodiment, poling is done at an elevated temperature, for example 145°C. The poling voltage signal is applied to the stack in three stages. During the first stage a 0-volt to 1200-volt charge is applied linearly. This voltage is held  
30 constant during the second stage. Finally, at the third stage the voltage is linearly reduced to 0-volts during a five-minute period. The stack is then cooled to room temperature. The poling technique is  
35 conventional and is a function of the ceramic material used.

-12-

Referring again to FIG. 2, a thin coat of Dow Corning silicone vacuum grease 222 is applied to the surface of the silicone elastomer encapsulant 220. Enough grease should be applied to prevent adhesion of the silicone encapsulant 220 to potting material 224. The application of the grease to the stack is shown at block 704.

As depicted by 706, the bus wires are soldered to the bus bars and a layer of shrink-wrap tubing is applied as an insulator.

The coated, assembled stack is then inserted into housing 104 and centered. Once in position, a potting material is injected into the cavity between the stack and the housing (a thickness of approximately 4-5 mm). See block 710. In addition, the potting material's thermoconductive characteristics should be sufficient to conduct heat generated by the stack to the inside of the housing wall. Emerson Cummings Eccosil Model 5954 is preferred for the potting material, because it includes aluminum oxide for enhanced thermal conductivity. The potting material is cured according to conventional techniques, as shown at block 712.

In FIG. 2, the potting material is shown at numeral 224, sandwiched between the grease 222 and the inner cylindrical surface of housing 204. Again, the silicone elastomer encapsulant is shown at 220. Silicone grease coating is shown at 222. Finally, silicone potting material is shown at 224.

As shown in block diagram 714, surface 114 of housing 104 and the exposed surface of ceramic end cap 116 must be simultaneously ground to facilitate proper alignment of steel diaphragm 118 to the end of the stack housing assembly. The diaphragm 118 may then be laser-welded to surface 114 of housing 104 as depicted at 716.

The diaphragm is preferably made of stainless steel and has a thickness of about 0.25mm. The steel diaphragm functions to protect the stack from external contaminants. In addition, the diaphragm prevents the electrode/disk stack from rotating within the housing.

Typically, a piston or spring is abutted against the bottom of the stack when the housed stack is installed on an engine head, for example. During installation, the housed stack is screwed onto the engine head and the diaphragm transfers stresses to the housing. If no diaphragm were present, the friction between the ceramic end-cap of the stack and the piston would cause the stack to rotate. Rotation of the stack would in turn cause disks to shear, and separate, and the silicone encapsulant would rupture. Such structural defects would detrimentally affect stack operation.

While various embodiments of the present invention have been described above, it should be understood that they have been presented by way of example, and not limitation. Thus the breadth and scope of the present invention should not be limited by any of the above-described exemplary embodiments, but should be defined only in accordance with the following claims and their equivalents.

30

35

WE CLAIM:

1. An encapsulated piezoelectric solid state motor stack (100,200) having a plurality of disks interleaved with electrodes (102), comprising:  
5 first means (220) for encapsulating the stack;  
second means (224,204) for encasing the combination of said first means and the stack; and  
10 third means (222) sandwiched between said first and second means for reducing friction between said combination and said second means induced by an axial displacement produced between first and second end surfaces of the stack when the electrodes are  
15 biased by a source of electrical potential.
2. An encapsulated piezoelectric solid state motor stack (200) according to claim 1, wherein said first means (220) comprises an elastomer.  
20
3. An encapsulated piezoelectric solid state motor stack (200) according to claim 2, wherein said first elastomer comprises silicone.
- 25 4. An encapsulated piezoelectric solid state motor stack (200) according to claim 1, wherein said second means comprises:  
an elastomer (224) surrounding said combination and said third means; and  
30 a protective housing (104,204) including a diaphragm (118), wherein said housing cylindrically encases said combination and said third means and one end thereof, said diaphragm being attached to said housing for encasing the other end of said  
35 combination.

5. An encapsulated piezoelectric solid state motor stack (200) according to claim 4, wherein said elastomer comprises silicone and aluminum oxide to enhance the thermal conductivity of said silicone.

5

6. An encapsulated piezoelectric solid state motor stack (200) according to claim 1, wherein said third means (222) comprises a grease.

10

7. An encapsulated piezoelectric solid state motor stack (200) according to claim 6, wherein said grease comprises silicone.

8. An encapsulated piezoelectric solid state motor stack according to claim 2, wherein said second means comprises:

a metal housing (204); and  
a second elastomer (224) comprising silicone and aluminum oxide to enhance the thermal conductivity of said silicone.

20

9. A method for encapsulating a piezoelectric solid state motor stack (100,200) having a plurality of disks interleaved with electrodes (102), comprising the steps of:

25

encapsulating the stack with a first material (220);

encasing the combination of said first material and the stack within a protective housing (204); and

30

sandwiching a lubricant (222) between said combination and said protective housing for reducing friction between said combination and said protective housing, wherein said friction is caused by biasing

35

the stack to produce an axial displacement between first and second end surfaces of the stack.

5           10. A method for encapsulating a piezoelectric solid state motor stack (100,200) according to the method of claim 9, wherein said encapsulating step further comprises the steps of:

                  grit blasting the stack to remove debris;  
                  cleaning the stack to remove unwanted  
10       contaminants;  
                  applying said first material (220) to the stack; and  
                  curing said first material.

15           11. A method for encapsulating a piezoelectric solid state motor stack (100,200) according to the method of claim 10, wherein said application step further comprises the steps of:

                  applying a primer to the stack;  
20       curing said primer; and  
                  applying an elastomer (220) to said primed stack.

25           12. A method for encapsulating a piezoelectric solid state motor stack (100,200) according to the method of claim 9, wherein said sandwiching step further comprises the steps of:

                  coating said lubricant (222) on said  
                  combination;  
30       aligning said coated combination in said protective housing (204);  
                  introducing a potting material (224) between said coated combination and said protective housing;  
                  and  
35       curing said potting material.



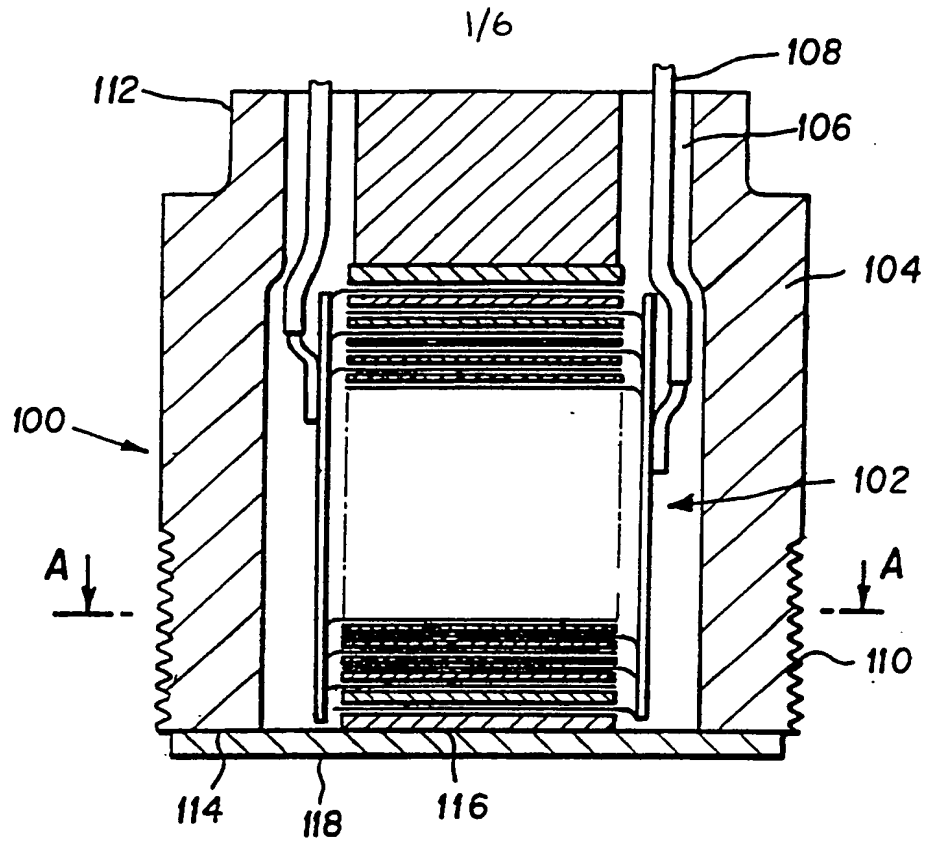

FIG. 1

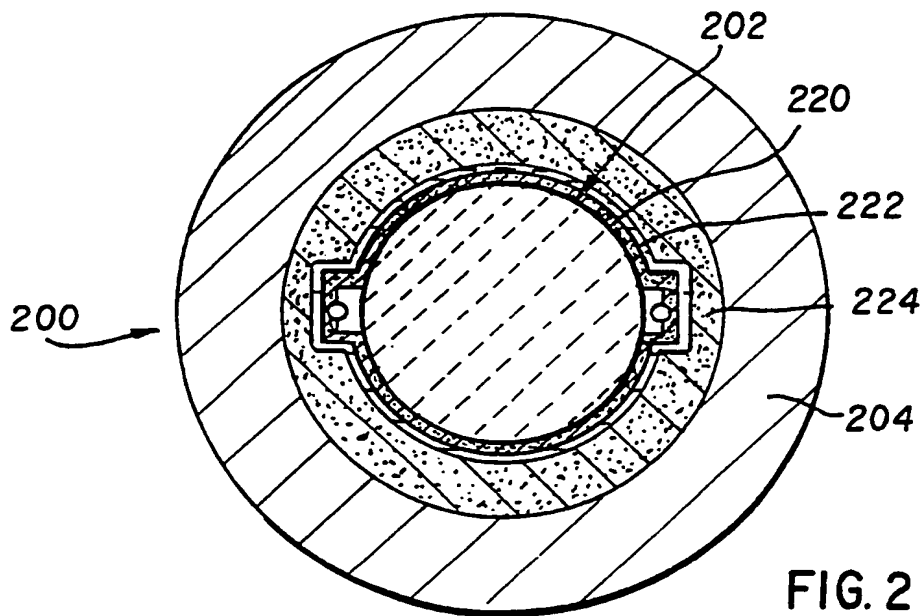

FIG. 2

FIG. 3

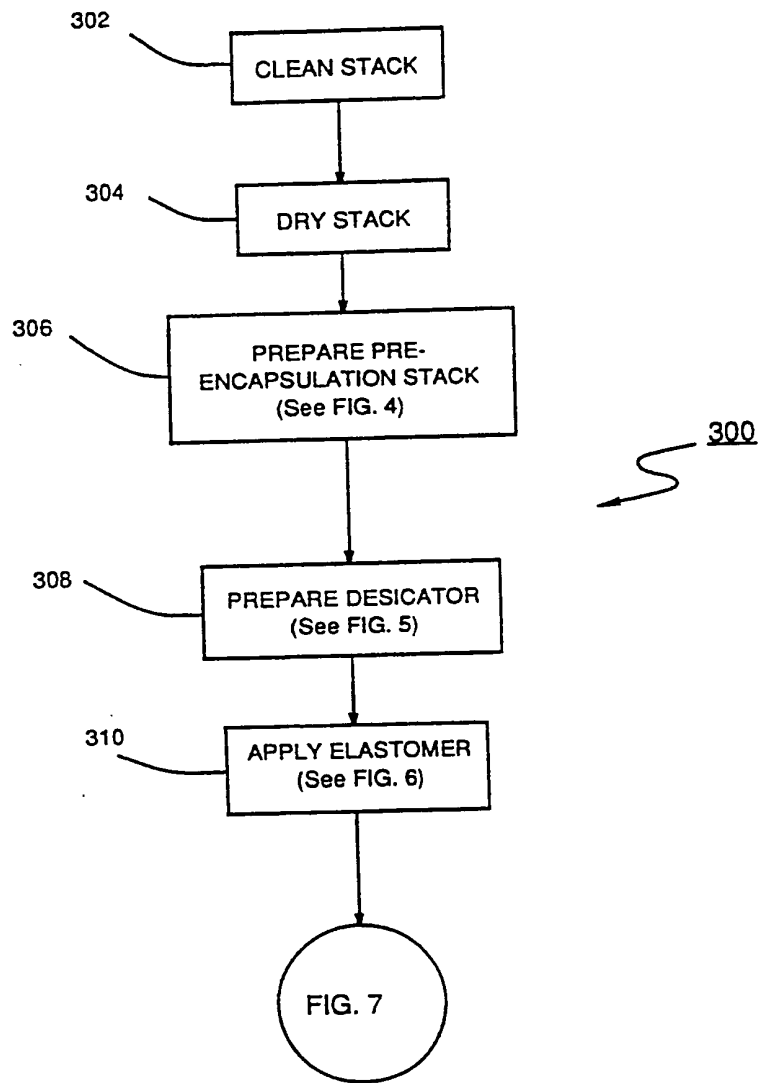

FIG. 4

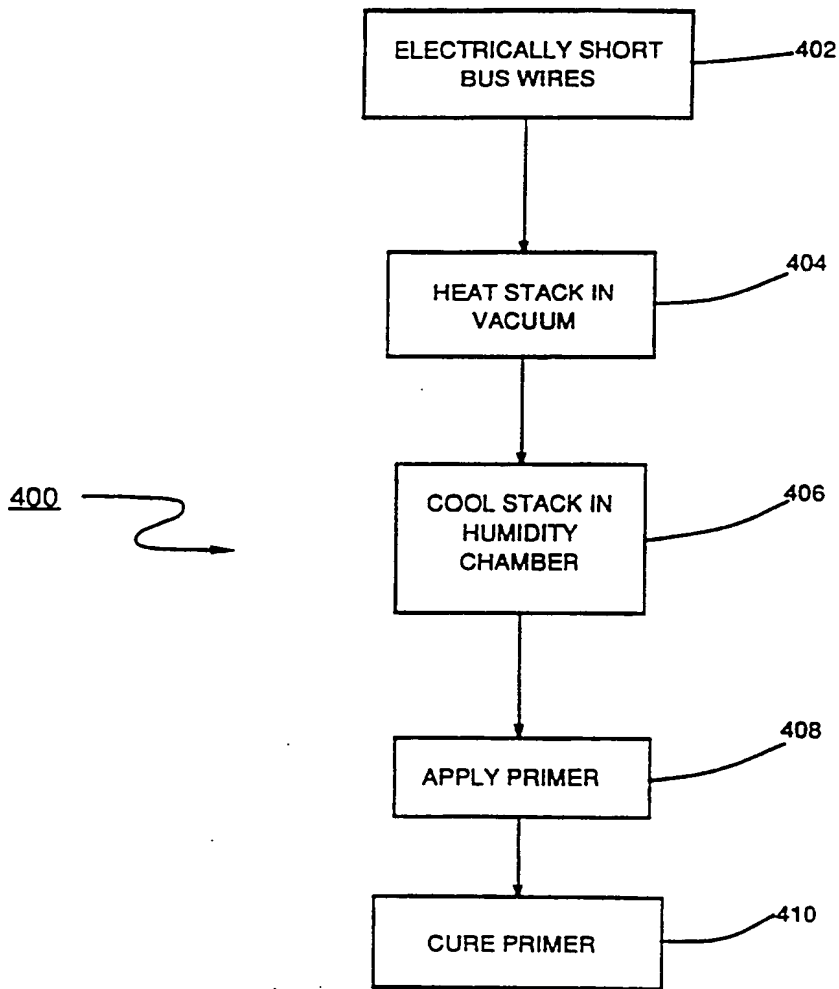

FIG. 5

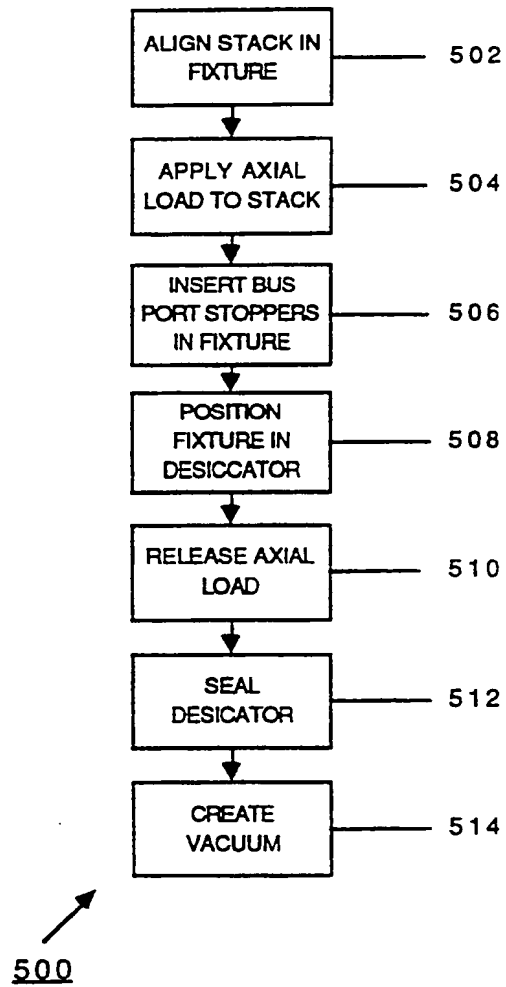

FIG. 6

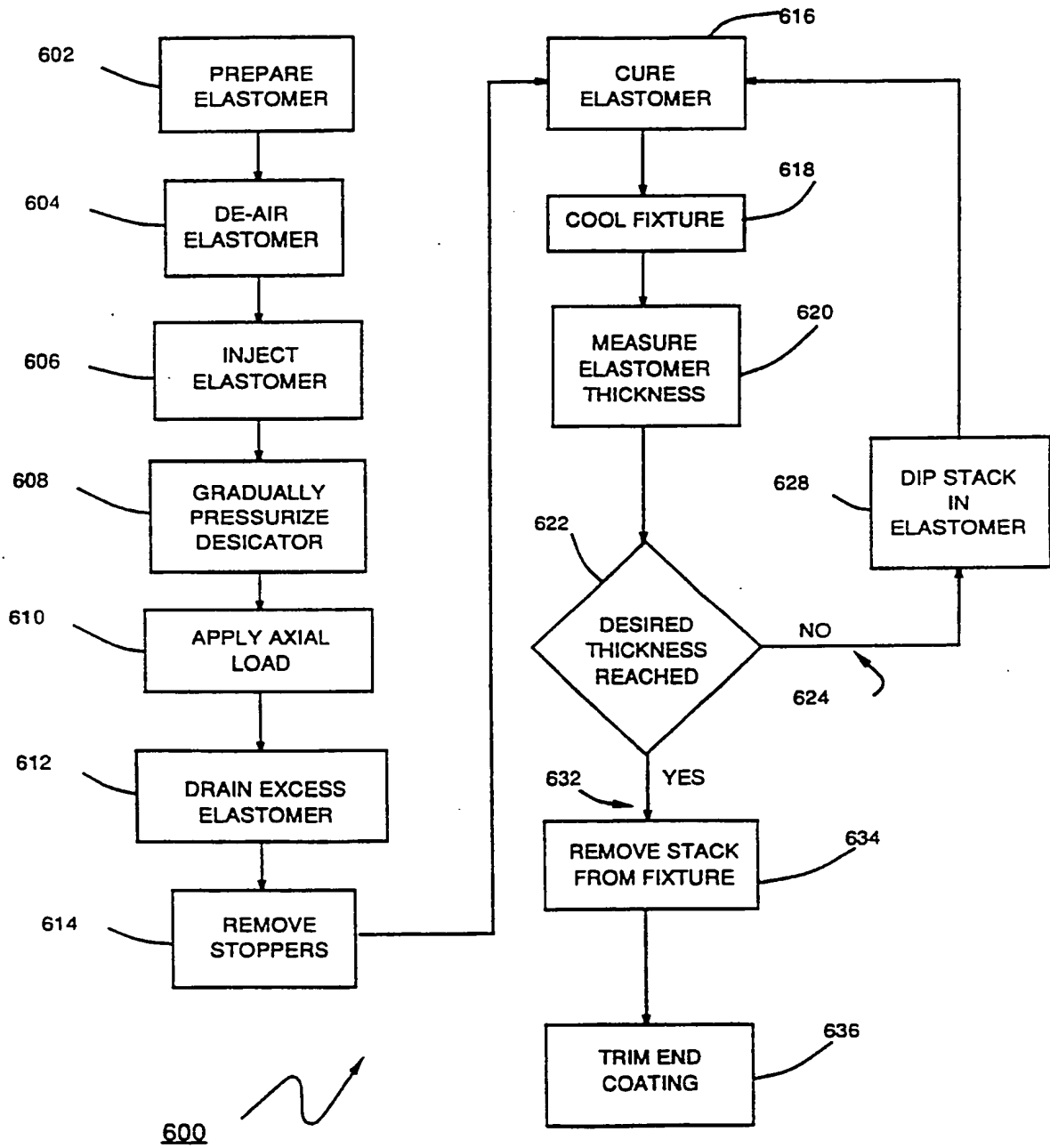
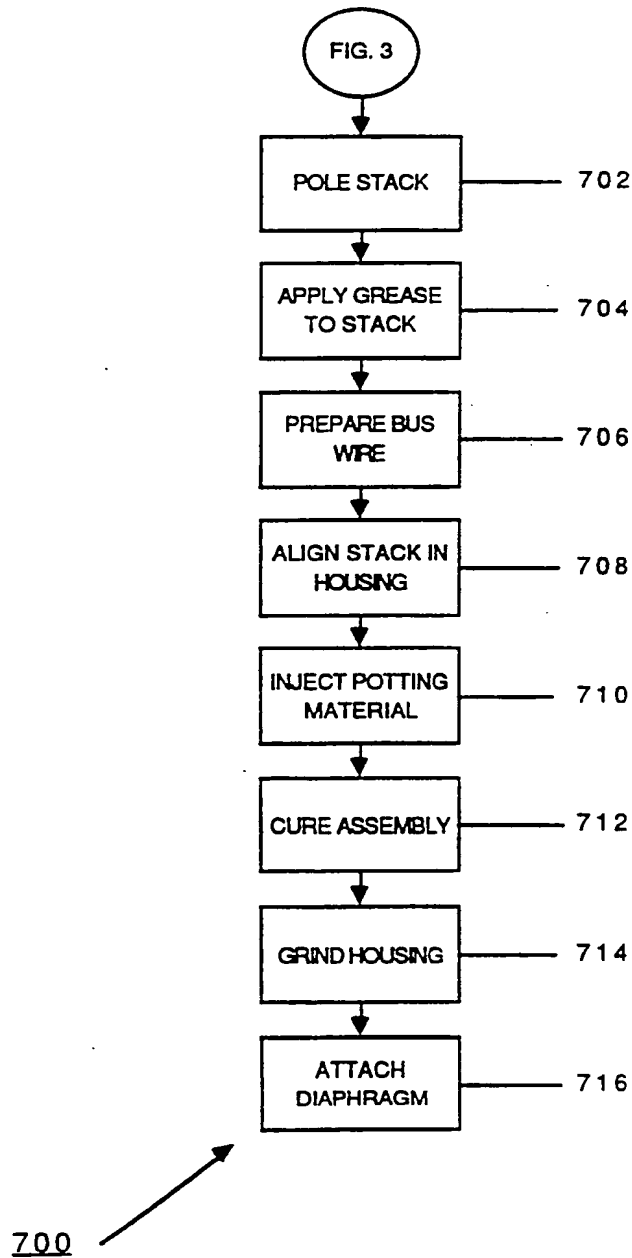

FIG. 7



# INTERNATIONAL SEARCH REPORT

International Application No

PCT/US 90/06539

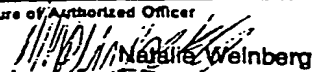
<b>I. CLASSIFICATION OF SUBJECT MATTER</b> (if several classification symbols apply, indicate all) <sup>8</sup>		
According to International Patent Classification (IPC) or to both National Classification and IPC		
IPC <sup>5</sup> : H 02 N 2/00, H 01 L 41/22		
<b>II. FIELDS SEARCHED</b>		
Minimum Documentation Searched <sup>7</sup>		
Classification System	Classification Symbols	
IPC <sup>5</sup>	H 02 N 2/00, H 01 L 41/00	
Documentation Searched other than Minimum Documentation to the extent that such Documents are included in the Fields Searched <sup>6</sup>		
<b>III. DOCUMENTS CONSIDERED TO BE RELEVANT <sup>9</sup></b>		
Category <sup>10</sup>	Citation of Document <sup>11</sup> with indication, where appropriate, of the relevant passages <sup>12</sup>	Relevant to Claim No. <sup>13</sup>
A	US, A, 4 382 243 (BABITZKA et al.) 03 May 1983 (03.05.83), see abstract; column 2, lines 29-44; fig. 1.	1, 9
A	US, A, 3 501 099 (BENSON) 17 March 1970 (17.03.70), see abstract; column 10, line 52 - column 11, line 62 (cited in the application).	1, 9
A	US, A, 4 011 474 (O'NEILL) 08 March 1977 (08.03.77), see abstract; column 2, lines 30-36 (cited in the application).	1, 9
<p><sup>14</sup> Special categories of cited documents: <sup>16</sup></p> <p><sup>15</sup> "A" document defining the general state of the art which is not considered to be of particular relevance</p> <p><sup>17</sup> "E" earlier document but published on or after the international filing date</p> <p><sup>18</sup> "L" document which may throw doubt on priority claim(s) or which is cited to establish the publication date of another citation or other special reason (as specified)</p> <p><sup>19</sup> "O" document referring to an oral disclosure, use, exhibition or other means</p> <p><sup>20</sup> "P" document published prior to the international filing date but later than the priority date claimed</p> <p><sup>21</sup> "T" later document published after the international filing date or priority date and not in conflict with the application but cited to understand the principle or theory underlying the invention</p> <p><sup>22</sup> "X" document of particular relevance: the claimed invention cannot be considered novel or cannot be considered to involve an inventive step</p> <p><sup>23</sup> "Y" document of particular relevance: the claimed invention cannot be considered to involve an inventive step when the document is combined with one or more other such documents, such combination being obvious to a person skilled in the art.</p> <p><sup>24</sup> "A" document member of the same patent family</p>		
<b>IV. CERTIFICATION</b>		
Date of the Actual Completion of the International Search		Date of Mailing of this International Search Report
14 May 1991		02. 07. 91
International Searching Authority		Signature of Authorized Officer
EUROPEAN PATENT OFFICE		 Natalie Weinberg

Form PCT/ISA/210 (second sheet) (January 1985)

**This Page is Inserted by IFW Indexing and Scanning  
Operations and is not part of the Official Record**

**BEST AVAILABLE IMAGES**

Defective images within this document are accurate representations of the original documents submitted by the applicant.

Defects in the images include but are not limited to the items checked:

- BLACK BORDERS**
- IMAGE CUT OFF AT TOP, BOTTOM OR SIDES**
- FADED TEXT OR DRAWING**
- BLURRED OR ILLEGIBLE TEXT OR DRAWING**
- SKEWED/SLANTED IMAGES**
- COLOR OR BLACK AND WHITE PHOTOGRAPHS**
- GRAY SCALE DOCUMENTS**
- LINES OR MARKS ON ORIGINAL DOCUMENT**
- REFERENCE(S) OR EXHIBIT(S) SUBMITTED ARE POOR QUALITY**
- OTHER:** \_\_\_\_\_

**IMAGES ARE BEST AVAILABLE COPY.**

**As rescanning these documents will not correct the image problems checked, please do not report these problems to the IFW Image Problem Mailbox.**



August 2, 2000

?s pn=fr 2647958  
S4 1 PN=FR 2647958  
?t s4/19/

4/19/1

DIALOG(R)File 351:DERWENT WPI  
(c) 2000 Derwent Info Ltd. All rts. reserv.

008527414 \*\*Image available\*\*  
WPI Acc No: 1991-031498/199105  
XRAM Acc No: C91-013428  
XRPX Acc No: N91-024356

**Plastic integrated circuit encapsulation box - has staggered connection pins on grids on levels injection moulded to form cavity in which chip is encapsulated and sealed**

Patent Assignee: THOMSON COMPOSANTS (CSFC )

Inventor: HENRICLEME M

Number of Countries: 001 Number of Patents: 001

Patent Family:

Patent No	Kind	Date	Applicat No	Kind	Date	Week
FR 2647958	A	19901207	FR 897092	A	19890530	199105 B

Priority Applications (No Type Date): FR 897092 A 19890530

Abstract (Basic): FR 2647958 A

Integrated circuit plastic encapsulation box is formed by: a) preparing at least two metal connection grids (20,22) b) placing the two grids (20,22) in a mould so their ends (21',23') are on at least two different levels near cavity reserved for the circuit chip (14) c) injection moulding a material to form the chip reception cavity (12), encapsulate the connection grids but leave the connection ends (21'23') (21,23) free within the cavity and external to the box. d) Place the chip (14) in the cavity (12) e) Solder connection moves from the chip to the connection grid (21'23') f) Close the cavity with an hermetic lid (16).

ADVANTAGE - Encapsulation costs are reduced using plastic moulding techniques. Operating temp. range is increased by sepn. of encapsulation material expansion/contraction forces from the chip. Connection density is increased and hermetic sealing is improved. (14pp Dwg.No.1/3)

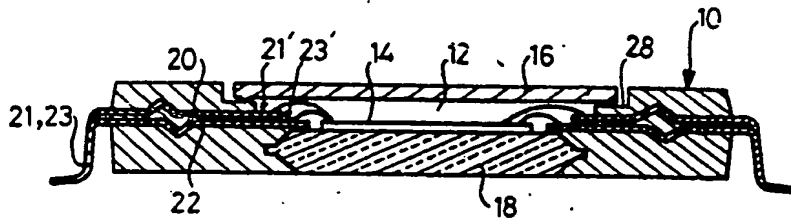

Title Terms: PLASTIC; INTEGRATE; CIRCUIT; ENCAPSULATE; BOX; STAGGER;  
CONNECT; PIN; GRID; LEVEL; INJECTION; MOULD; FORM; CAVITY; CHIP;  
ENCAPSULATE; SEAL

Derwent Class: A85; L03; U11

International Patent Class (Additional): H01L-021/56; H01L-023/06;  
H05K-003/34

File Segment: CPI; EPI

Manual Codes (CPI/A-N): A11-B12A; A12-E05; A12-E07C; L04-C21; L04-F05

Manual Codes (EPI/S-X): U11-D01A1; U11-E02A1

Plasdoc Codes (KS): 0231 2455 2465 2545 2628 2666 2738 3279

Polymer Fragment Codes (PF):

①9 RÉPUBLIQUE FRANÇAISE  
INSTITUT NATIONAL  
DE LA PROPRIÉTÉ INDUSTRIELLE  
PARIS

①1 N° de publication :  
à utiliser que pour les  
commandes de reproduction

**2 647 958**

②1 N° d'enregistrement national :

**89 07092**

⑤1 Int Cl<sup>8</sup> : H 01 L 21/56, 23/067; H 05 K 3/34.

⑫

## DEMANDE DE BREVET D'INVENTION

A1

②2 Date de dépôt : 30 mai 1989.

③0 Priorité :

④3 Date de la mise à disposition du public de la demande : BOPI « Brevets » n° 49 du 7 décembre 1990.

⑥0 Références à d'autres documents nationaux apparentés :

⑦1 Demandeur(s) : Société dite : THOMSON COMPOSANTS MILITAIRES ET SPATIAUX — FR.

⑦2 Inventeur(s) : Henri-Clément Mabboux, Thomson-CSF S.C.P.I.

⑦3 Titulaire(s) :

⑦4 Mandataire(s) : Michel Guérin, Thomson-CSF S.C.P.I.

⑤4 Boîtier plastique pour circuit intégré avec grilles en quinconce sur deux niveaux et procédé de fabrication.

⑤7 L'invention concerne les boîtiers d'encapsulation de circuits intégrés. Pour bénéficier du faible coût de fabrication des boîtiers de plastique moulé tout en améliorant leurs performances, on propose selon l'invention de préparer un boîtier moulé 10 avec une cavité 12 et deux grilles de connexion 21, 23, 21', 23' superposées, en quinconce, le moulage étant fait avant de mettre la puce. La puce est ensuite mise en place dans la cavité, des fils de liaison sont soudés entre la puce et les extrémités des deux grilles. On augmente la densité de broches d'interconnexions utilisables grâce aux deux niveaux de grille: la résistance à la pénétration de l'humidité est renforcée car on peut utiliser une matière plastique à fort coefficient de rétreint sans risquer d'endommager la puce; en effet, la puce n'est plus enrobée de matière plastique; elle reste à l'air libre; protégée par un capot de fermeture 16 du boîtier.

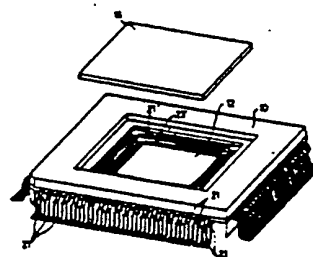

FR 2 647 958 - A1

Vente des fascicules à l'IMPRIMERIE NATIONALE, 27, rue de la Convention — 75732 PARIS CEDEX 15

BOITIER PLASTIQUE POUR CIRCUIT-INTEGRE  
AVEC GRILLES EN QUINCONCE SUR DEUX NIVEAUX  
ET PROCEDE DE FABRICATION

L'invention concerne l'encapsulation des circuits-intégrés.

Deux grands types d'encapsulation sont utilisés actuellement pour les circuits-intégrés, selon les applications envisagées.

5 Pour les applications les plus courantes, on utilise des boîtiers en matière plastique moulée réalisés de la manière suivante: on prépare une grille de connexion métallique qui servira à la fois de support à une puce de circuit-intégré et de broches de connexion extérieure au boîtier; on reporte la puce 10 sur cette grille par collage ou soudage; on relie la puce par des fils aux différentes broches de la grille; et on enrobe la puce et les fils de matière plastique, par moulage.

Cette technique donne satisfaction mais présente certaines faiblesses, en particulier sur les points suivants: il y a risque 15 de pénétration d'humidité dans le boîtier par infiltration aux interfaces entre la grille et la matière plastique; la matière plastique est directement en contact avec la puce de silicium et exerce des contraintes mécaniques sur la puce, surtout lorsqu'elle est de grande surface; la gamme de température de 20 fonctionnement correct est limitée (en général de  $-40^{\circ}\text{C}$  à  $+85^{\circ}\text{C}$ ); la dissipation thermique est limitée car la conductivité thermique de la matière plastique est relativement mauvaise; enfin, le nombre de broches d'entrée-sortie du boîtier est limité du fait que les fils de liaison entre la puce et les broches 25 doivent rester écartés les uns des autres d'un certain pas minimum; le moulage plastique impose ce pas minimum.

Pour éviter ces diverses limitations, on a proposé, pour 30 les applications plus délicates, d'encapsuler les circuits-intégrés dans des boîtiers de céramique. Cette technique consiste à sérigraphier des conducteurs sur des feuilles de céramique crue, à cuire ensemble les feuilles de céramique pour

constituer un substrat de céramique, à coller ou souder une puce de circuit-intégré sur une face du substrat, à relier la puce aux conducteurs sérigraphiés qui l'entourent, à fermer le substrat par un capot scellé hermétiquement, et à souder à l'extérieur du boîtier des broches de connexion venant en contact avec des extrémités affleurantes des conducteurs sérigraphiés.

Dans cette technique plus sophistiquée, les infiltrations d'humidité sont réduites au minimum, car les feuilles de céramique cuites sont parfaitement étanches et la soudure du capot (en général une soudure de métal sur de la céramique) est également très étanche; il n'y a pas de contrainte mécanique sur la puce car elle n'est pas enrobée de matière plastique mais elle reste à l'air; l'absence de matière plastique permet un fonctionnement à température ambiante plus élevée (jusqu'à +125°C par exemple et dans certains cas 200°C); le pas des conducteurs sérigraphiés peut être plus petit que les pas d'une grille de connexion et l'absence de moulage par injection permet de diminuer la distance entre fils de connexion voisins (fils de connexion entre la puce et le substrat); enfin, la dissipation thermique est améliorée car la conduction thermique de la céramique est bien meilleure que celle de la matière plastique moulée.

Mais évidemment cette technique d'encapsulation en boîtier céramique est beaucoup plus coûteuse que le moulage plastique.

La présente invention pour but de proposer une nouvelle technique d'encapsulation permettant de profiter du faible coût de la technique de moulage plastique tout en minimisant les inconvénients de cette technique.

On propose selon l'invention un nouveau boîtier et un procédé d'encapsulation correspondant; le procédé consiste à :

- préparer au moins deux grilles métalliques de connexion;
- placer les grilles dans un moule de telle manière que leurs extrémités arrivent sur au moins deux niveaux différents à proximité d'un emplacement réservé à une puce de circuit-intégré,

- injecter une matière plastique de moulage dans le moule, le moule étant conformé de manière à : empêcher le recouvrement des extrémités des grilles à proximité de l'emplacement réservé, ménager une cavité de réception de puce dans cet emplacement, et laisser dépasser la grille hors du moule pour constituer des broches de connexion extérieures;

- placer une puce dans la cavité;

- souder des fils de connexion entre la puce et les extrémités des grilles de connexion;

- fermer la cavité par un capot hermétique.

Le boîtier selon l'invention est donc constitué de la manière suivante : il comprend un corps de matière plastique moulée avec une cavité intérieure de réception d'une puce, et, dans cette cavité, autour de la puce, au moins deux séries d'extrémités de grille de connexion non recouvertes par la matière plastique du corps et placées sur au moins deux niveaux différents, la puce étant raccordée par des fils à ces extrémités, et la cavité étant fermée par un capot scellé hermétiquement.

Les extrémités de la grille de l'un des niveaux sont de préférence décalées ou disposées en quinconce par rapport à celles du deuxième niveau, c'est-à-dire que deux fils voisins partant de la puce seront soudés respectivement sur deux extrémités de grille de niveaux différents.

La technique proposée selon l'invention présente les avantages suivants : tout d'abord le coût est faible puisqu'il fait intervenir essentiellement un moulage de matière plastique et non un substrat de céramique sérigraphiée; ensuite on peut utiliser comme matière plastique de moulage une matière à fort coefficient de rétreint au refroidissement, de sorte que l'étanchéité aux interfaces entre matière plastique et grilles est améliorée; cela n'était pas possible avec les moulages classiques dans lesquels la puce était directement en contact avec la matière plastique à cause des contraintes excessives qu'une matière plastique à fort coefficient de rétreint aurait

imposé à la puce; de manière générale, les contraintes sur la puce sont réduites grâce à l'invention; enfin, la densité de broches de connexion extérieures peut être très élevée grâce à l'utilisation de plusieurs niveaux de grille de connexion.

5 Il n'aurait été que très difficilement possible d'utiliser plusieurs niveaux de grille avec des boîtiers de matière plastique moulés classiquement par enrobage complet d'une puce et de ses fils, et un aspect important de l'invention réside dans la découverte qu'il devient pratiquement possible de le  
10 faire avec un boîtier moulé avec une cavité, dans lequel la puce n'est mise en place qu'après moulage. En effet, il devient facile de mettre en place la puce et ses fils alors que les deux niveaux de grille sont fixés en place dans la matière plastique qui les enrobe.

15 Le capot hermétique qui ferme la cavité est de préférence réalisé dans la même matière plastique que le corps du boîtier; il est de préférence soudé par ultrasons, éventuellement avec adjonction d'une matière de collage telle qu'une résine époxy.

20 On peut de plus envisager que la cavité contenant la puce et ses fils soit noyée dans une résine de protection souple (qui n'exerce pas de contraintes mécanique sur la puce et ses fils); cette résine serait mise en place avant fermeture du capot; elle aurait l'avantage de diminuer la sensibilité à l'humidité.

25 On peut aussi prévoir qu'il y a plus de deux niveaux de grilles de connexion.

30 Une embase en matériau à forte conductivité thermique peut être insérée dans le moule avant injection de matière plastique; cette embase formerait le fond de la cavité et servirait de support et de drain thermique pour la puce; le matériau peut être du cuivre ou du nitrure d'aluminium, ce dernier matériau ayant l'avantage d'avoir un coefficient de dilatation très proche de celui du silicium, permettant ainsi de réduire encore les contraintes qui s'exercent sur la puce  
35 lorsqu'il y a des variations de température au cours du fonctionnement.

Les grilles de connexion présentent de préférence, là où elles sont noyées dans la matière plastique, des formes tordues ou matricées augmentant la longueur des chemins de trajet de l'humidité aux interfaces grille/plastique et assurant une meilleure résistance à l'arrachage en cas de traction des broches extérieures du boîtier.

D'autres caractéristiques et avantages de l'invention apparaîtront à la lecture de la description détaillée qui suit et qui est faite en référence aux dessins annexés dans lesquels :

- la figure 1 représente une coupe transversale du boîtier selon l'invention;
- la figure 2 représente une vue de dessus de ce boîtier;
- la figure 3 représente une vue de dessus en perspective du boîtier.

Le boîtier comporte un corps principal 10 en matière plastique moulée, définissant une cavité 12 ouverte vers le haut, cette cavité servant de logement à une puce monolithique 14 et étant fermée en haut par un capot de fermeture hermétique 16.

Dans l'exemple représenté, mais ce n'est pas obligatoire, une embase 18 moulée dans le corps 10 sert de support à la puce 14. Cette embase est réalisée dans un matériau ayant de bonnes propriétés de conduction thermique (cuivre par exemple) ou mieux dans un matériau ayant à la fois des bonnes propriétés de conduction thermique et une bonne compatibilité avec la puce, notamment en ce qui concerne les coefficients de dilatation thermique respectifs. Le nitrure d'aluminium est un matériau approprié à cet égard pour les puces de silicium.

L'embase 18 a été noyée dans la matière plastique lors de l'opération de moulage du corps 10, la surface supérieure de l'embase affleurant de préférence dans la cavité 12 pour en constituer le fond et la surface inférieure de l'embase affleurant à l'arrière du boîtier pour pouvoir venir en contact ultérieurement avec un radiateur d'évacuation de chaleur.

Dans le corps du boîtier 10 sont moulés au moins deux grilles de connexion 20 et 22; ces grilles sont en métal conducteur; elles font saillie à l'extérieur du boîtier pour constituer les broches de connexion extérieures du boîtier. De  
5 préférence, les broches de connexion extérieures des deux grilles sont en quinconce, c'est-à-dire que les broches d'une grille sont décalées latéralement par rapport aux broches de l'autre grille, de sorte qu'en pratique une broche d'une grille est située en  
10 gros entre deux broches de l'autre grille. On a représenté sur la figure 2 les broches extérieures 21 de la grille 20 en quinconce avec les broches extérieures 23 de la grille 22. On voit bien aussi la disposition décalée des broches sur la figure 3. Un décalage des broches d'un niveau à un autre pourrait être fait avec plus de deux grilles également pour augmenter la densité de  
15 broches du boîtier.

A l'intérieur de la cavité 12, les extrémités des conducteurs de la grille sont dénudées superficiellement, c'est-à-dire qu'elles ne sont pas entièrement enrobées par la matière plastique du corps 10; elles peuvent toutefois être  
20 recouvertes par une résine rajoutée dans la cavité après mise en place de la puce et de ses fils de connexion.

La cavité 12 a de préférence une forme de cuvette en gradins, les extrémités des grilles reposant sur ces gradins, chaque niveau de grille correspondant à un gradin respectif.  
25 Dans l'exemple représenté, la cuvette a deux gradins au dessus de l'embase de réception de puce et entourant cette embase : un gradin 24 pour les extrémités 21' de la grille 20 et un gradin 26 pour les extrémités 23' de la grille 22.

Les extrémités de grille à l'intérieur de la cavité 12 sont également réparties en quinconce, c'est-à-dire que leurs  
30 positions sont alternées, de manière qu'un fil de liaison entre la puce 14 et une extrémité 21' faisant partie de la grille 20 (et donc reposant sur le gradin 24) soit adjacent à un fil de liaison entre la puce et une extrémité 23' faisant partie de la  
35 grille 22 (et donc reposant sur le gradin 26).



Les fils de liaison entre la puce et les extrémités de grilles ont été représentés sur la figure 1 mais non sur les autres figures pour ne pas surcharger le dessin.

5 Dans l'exemple représenté, la cavité en forme de cuvette à gradins comprend un gradin supplémentaire 28 servant à recevoir le capot de fermeture 16 de la cavité.

10 Les conducteurs des grilles ont de préférence, là où ils sont noyés dans la matière plastique de moulage du corps 10, une forme tordue destinée à allonger le chemin de pénétration de l'humidité aux interfaces plastique/grille, et destinée également à augmenter la résistance à l'arrachement des grilles en cas de traction par rapport au boîtier.

15 Le procédé d'encapsulation selon l'invention se déroule de la manière suivante : on prépare d'abord les différentes grilles de connexion, ici les deux grilles 20 et 22. Elles sont faites classiquement par estampage d'une plaque métallique. Les grilles sont planes au départ et les différents conducteurs qui les constituent sont reliés les uns aux autres pendant la majeure partie du procédé; les extrémités constituant les broches extérieures ne seront séparées les unes des autres et recourbées pour former des broches indépendantes qu'en fin de procédé.

20 L'embase de support 18 (si on en utilise) et les grilles sont mises en place dans un moule à injection. La conformation du moule est telle que les extrémités intérieures des grilles 20 et 25 22 restent dénudées après l'opération de moulage, de même que la surface supérieure de l'embase 18, c'est-à-dire la surface qui recevra la puce 14. Les extrémités extérieures des grilles, destinées à former les broches extérieures de connexion, dépassent hors du moule de même que les barres de liaison entre ces broches (barres non représentées qu'il faudra couper pour 30 séparer les broches les unes des autres). La surface inférieure de l'embase reste également dénudée après l'opération de moulage. Enfin, le moule définit la cavité 12 qui reste libre de toute matière plastique et qui a de préférence une forme en gradins 35 comme expliqué ci-dessus.

Les grilles sont maintenues en place dans le moule de manière que leurs extrémités du côté intérieur, autour de la cavité, soient disposées sur deux niveaux (ou plus s'il y a plus de deux grilles). En pratique les grilles sont planes pendant le moulage et les grilles sont donc superposées sur deux plans parallèles dans le moule. C'est également pendant l'opération de moulage que sont définies et maintenues les positions relatives des grilles pour aboutir à une disposition décalée ou en quinconce.

Le moulage est fait par injection d'une matière plastique thermoplastique, de préférence ayant un coefficient de rétreint assez fort au refroidissement, pour enserrer fortement les grilles 20 et 22. On choisira de préférence une matière plastique tenant à haute température (supérieure à 200°C).

Après démoulage, on colle ou on soude une puce 14 dans le fond de la cavité réservée, sur l'embase si une embase est présente. On soude des fils de liaison entre la puce et les extrémités dénudées des grilles 20 et 22.

On peut alors déposer dans la cavité 12 une résine de protection qui vient noyer la puce et ses fils. On peut aussi laisser la puce et ses fils à l'air libre.

On ferme alors la cavité avec le capot 16 qui est de préférence constitué dans la même matière que le corps 10 du boîtier. La soudure est de préférence une soudure par ultrasons, éventuellement aidée par une résine de collage.

On termine le montage en coupant les barres de liaison (non représentées) entre broches extérieures et en recourbant ces broches pour leur donner une forme désirée. La figure 3 représente un exemple de forme donnée à ces broches. On y voit la disposition en quinconce des deux niveaux de grille, et on voit la cuvette en gradins portant sur chaque gradin un niveau respectif de grille.

## REVENDEICATIONS

1. Procédé d'encapsulation de circuit-intégré, caractérisé en ce qu'il comprend les opérations suivantes :

- préparer au moins deux grilles métalliques de connexion (20, 22);

5 - placer les grilles dans un moule de telle manière que leurs extrémités (21', 23') arrivent sur au moins deux niveaux différents à proximité d'un emplacement réservé à une puce de circuit-intégré (14),

10 - injecter une matière plastique de moulage dans le moule, le moule étant conformé de manière à : empêcher le recouvrement des extrémités (21', 23') des grilles à proximité de l'emplacement réservé, ménager une cavité (12) de réception de puce dans cet emplacement, et laisser dépasser la grille hors du moule pour constituer des broches de connexion extérieures (21, 23);

- placer une puce (14) dans la cavité (12);

- souder des fils de connexion entre la puce et les extrémités (21', 23') des grilles de connexion;

- fermer la cavité par un capot hermétique (16).

20 2. Procédé d'encapsulation selon la revendication 1, caractérisé en ce que la matière plastique de moulage est une matière plastique à fort coefficient de rétreint au refroidissement.

25 3. Procédé d'encapsulation selon l'une des revendications 1 et 2, caractérisé en ce que les extrémités de grilles autour de l'emplacement réservé à la puce sont disposées et maintenues en quinconce pendant l'opération de moulage.

30 4. Procédé d'encapsulation selon l'une des revendications 1 à 3, caractérisé en ce que les grilles sont maintenues pendant

l'opération de moulage de manière que les broches extérieures soient disposées en quinconce.

5 5. Procédé d'encapsulation selon l'une des revendications 1 à 4, caractérisé en ce que la cavité a une forme de cuvette à gradins (24, 26) les extrémités de grilles reposant sur ces gradins autour de l'emplacement réservé à la puce.

10 6. Procédé d'encapsulation selon l'une des revendications 1 à 5, caractérisé en ce qu'une embase thermiquement conductrice (18) est placée dans le boîtier pendant l'opération de moulage, cette embase étant destinée à servir de support et de drain thermique à la puce.

15 7. Procédé d'encapsulation selon l'une des revendications 1 à 6, caractérisé en ce qu'une résine de protection souple est déposée dans la cavité après mise en place de la puce et de ses fils de liaison et avant fermeture de la cavité par le capot.

20 8. Procédé d'encapsulation selon l'une des revendications 1 à 7, caractérisé en ce que le capot de fermeture est réalisé dans la même matière plastique que celle qui a servi au moulage, et qu'il est soudé par ultrasons au dessus de la cavité.

25 9. Boîtier d'encapsulation de circuit-intégré, caractérisé en ce qu'il comprend un corps (10) de matière plastique moulée avec une cavité intérieure (12) de réception d'une puce (14), et, dans cette cavité, autour de la puce, au moins deux séries d'extrémités (21', 23') de grilles de connexion  
30 non recouvertes par la matière plastique du corps et placées sur au moins deux niveaux différents (24, 26), la puce étant raccordée par des fils à ces extrémités, et la cavité étant fermée par un capot (16) scellé hermétiquement.

35 10. Boîtier selon la revendication 9, caractérisé en ce que

les extrémités (21') de la grille de l'un des niveaux sont de préférence disposées en quinconce par rapport à celles (23') d'une grille d'un deuxième niveau, c'est-à-dire que deux fils voisins partant de la puce seront soudés respectivement sur deux extrémités de grille de niveaux différents.

11. Boîtier selon l'une des revendications 9 et 10, caractérisé en ce qu'il comporte une embase (18) en matériau à forte conductivité thermique servant de support et de drain thermique à la puce.

12. Boîtier selon l'une des revendications 9 à 11, caractérisé en ce que le capot est réalisé dans la même matière que le corps du boîtier.

13. Boîtier selon l'une des revendications 9 à 12, caractérisé en ce que la cavité fermée par le capot est remplie de résine de protection souple.

14. Boîtier selon l'une des revendications 9 à 13, caractérisé en ce que les conducteurs des grilles présentent, là où ils sont noyés dans la matière plastique du corps (10), des formes tordues ou matricées pour allonger le chemin de pénétration de l'humidité à l'interface plastique/grille, et pour augmenter la résistance à l'arrachage.

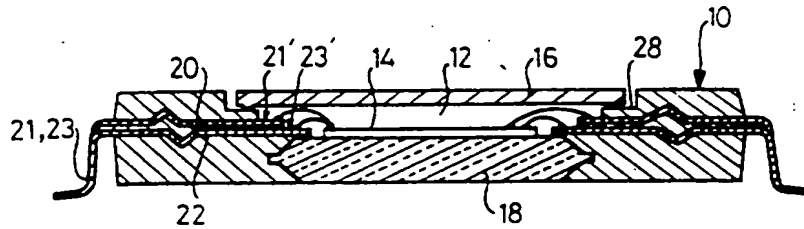

FIG.1

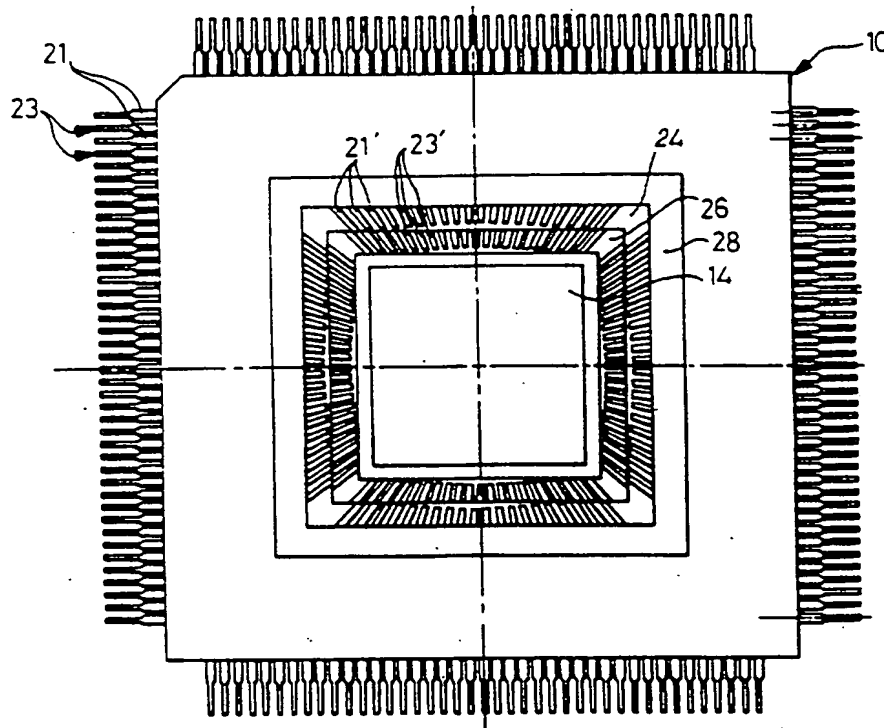
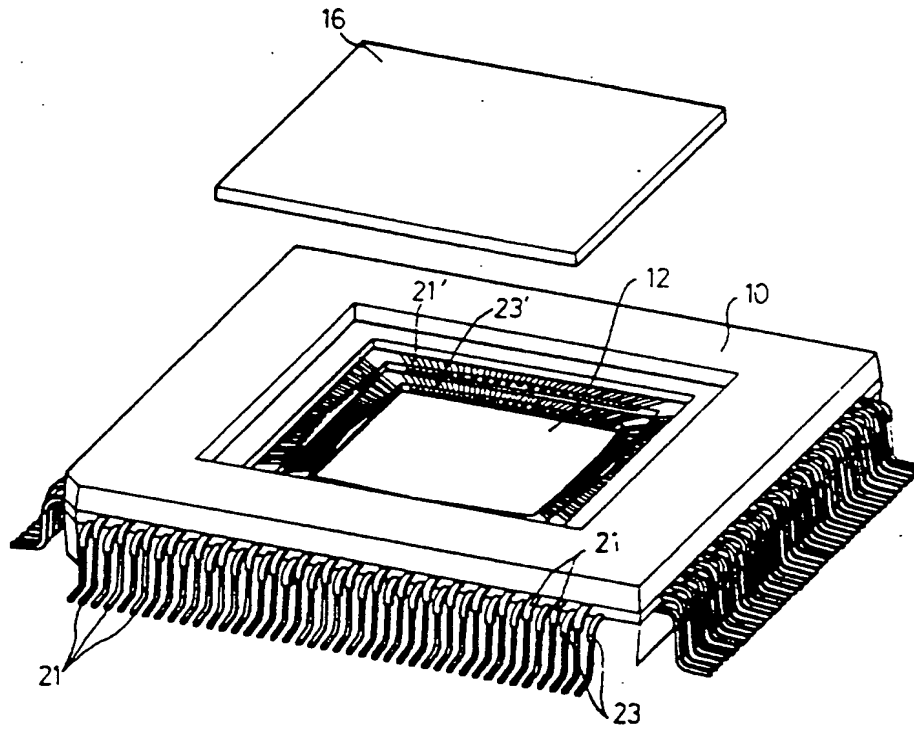

FIG.2



FIG\_3

?s pn=su 1494148  
S1 1 PN=SU 1494148  
?t s1/19/

1/19/1

DIALOG(R)File 351:DERWENT WPI  
(c) 2000 Derwent Info Ltd. All rts. reserv.

008259270 \*\*Image available\*\*  
WPI Acc No: 1990-146271/199019  
XRPX Acc No: N90-113318

**Immersion electric motor stator winding encapsulation - provides air-tight entrance in plugs on stator endfaces**

Patent Assignee: POTENTIAL OIL BORE (POTE-R)  
Inventor: EISTRACH L A; SHISHORIN S A; TOKAR B I  
Number of Countries: 001 Number of Patents: 001  
Patent Family:

Patent No	Kind	Date	Applicat No	Kind	Date	Week
SU 1494148	A	19890715	SU 4298293	A	19870819	199019 B

Priority Applications (No Type Date): SU 4298293 A 19870819

Abstract (Basic): SU 1494148 A

The encapsulation of stator windings includes mounting air-tight plugs with rotating (3) and non-rotating (4) parts on the stator's (1) end-faces carrying the encapsulated winding (2). An air-tight entrance is provided in the plugs coaxially with the stator, the entrance being fitted with connectors for evacuation (5) and for supply of compound. The stator (1) is mounted on a device (8) for rotating the stator with heater (9).

USE - Electrical engineering. Bul.26/15.7.89. (3pp Dwg.No.1/1)

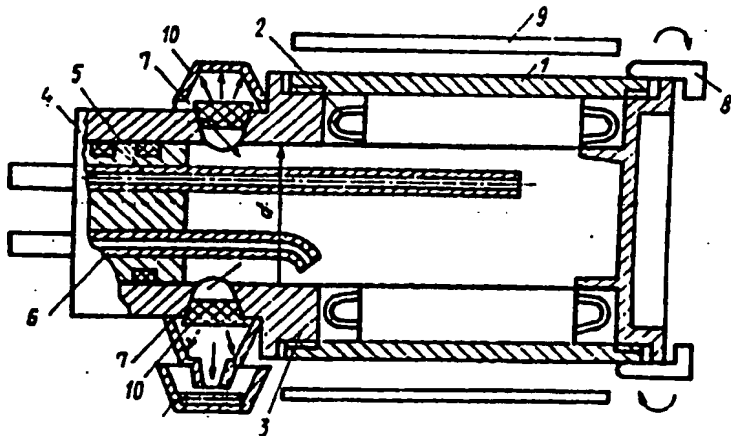

Title Terms: IMMERSE; ELECTRIC; MOTOR; STATOR; WIND; ENCAPSULATE; AIR;  
TIGHT; ENTER; PLUG; STATOR; ENDFACE  
Derwent Class: V06; X11  
International Patent Class (Additional): H02K-015/12  
File Segment: EPI  
Manual Codes (EPI/S-X): V06-M11C; X11-J08C  
?





ГОСУДАРСТВЕННЫЙ КОМИТЕТ  
ПО ИЗОБРЕТЕНИЯМ И ОТКРЫТИЯМ  
ПРИ ГНТ СССР

(51) 4 Н 02 К 15/12

# ОПИСАНИЕ ИЗОБРЕТЕНИЯ

## К АВТОРСКОМУ СВИДЕТЕЛЬСТВУ

(21) 4298293/24-07

(22) 19.08.87

(46) 15.07.89. Бюл. № 26

(71) Специальное проектно-конструкторское и технологическое бюро по погружному электрооборудованию для бурения скважин и добычи нефти Всесоюзного научно-производственного объединения "Потенциал"

(72) Л.А.Эйстрах, С.А.Шнорин, Б.И.Токарь, М.Л.Плавник и Л.Х.Надель

(53) 621.315 (088.8)

(56) Авторское свидетельство СССР № 1334297 А1, кл. Н 02 К 15/12, 1984.

2

(54) СПОСОБ КАПУЛИРОВАНИЯ ОБМОТКИ СТАТОРА ПОГРУЖНОГО ЭЛЕКТРОДВИГАТЕЛЯ  
(57) Изобретение относится к электротехнике, в частности к технологии капсулирования обмоток статоров электрических машин. Цель изобретения - повышение производительности и упрощение процесса капсулирования. На торцах статора 1 с капсулируемой обмоткой 2 устанавливают герметизирующие заглушки с вращающимися 3 и неподвижными 4 частями, в которых соосно со статором устанавливают герметичный ввод. Герметичный ввод снабжен патрубками для вакуумирования 5 и для подачи компаунда. Статор

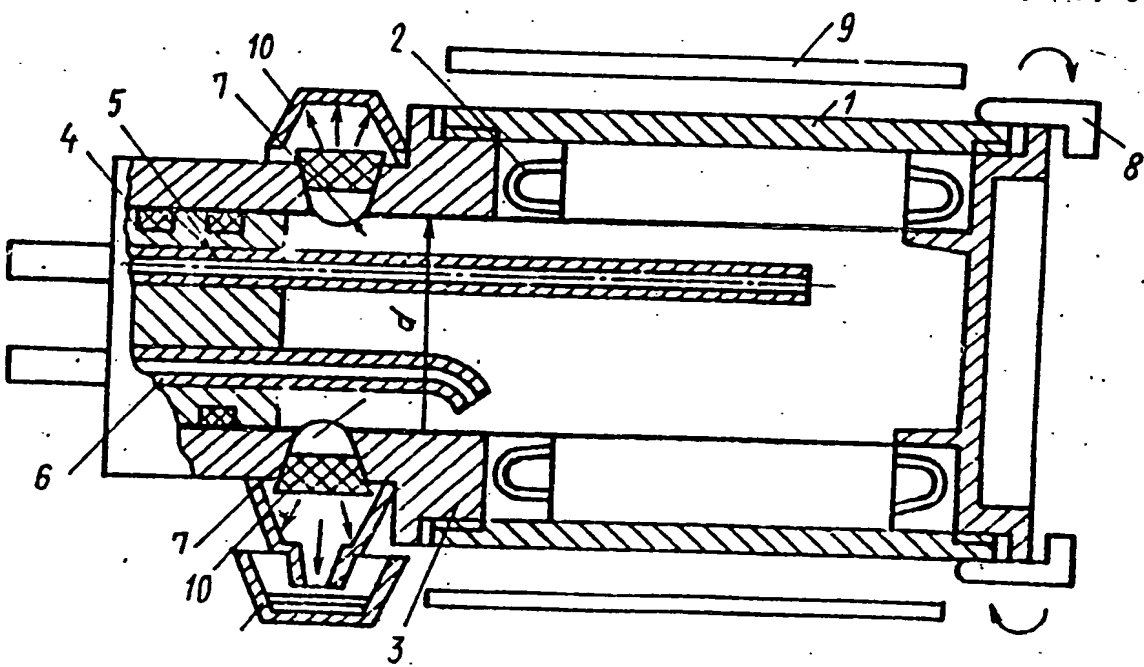

1494148 A1

1 устанавливают в устройство 8 для вращения статора и включают нагреватель 9. В каналы 7 устанавливают уплотняющие пробки 10, одновременно начиная вакуумировать полость статора. Включают вращение статора и подают компаунд через патрубок в полость вращающегося статора. Заливку обмотки статора компаундом производят при вращении статора, не снимая вакуума при повышенной температуре.

5 После заливки производят разгерметизацию статора путем прекращения вакуумирования, при этом под действием центробежных сил пробки 10 выталкиваются и излишки компаунда вытекают из полости статора. Повышают температуру нагрева статора и производят термообработку, не прекращая вращения статора до полного или частичного отверждения компаунда. 1 э.п. ф-лы.  
1 ил.

Изобретение относится к области электротехники, в частности к технологии капсулирования обмоток статоров электрических машин.

Цель изобретения - повышение производительности, упрощение процесса капсулирования и уменьшение расхода компаунда.

На чертеже изображен статор в процессе его заливки.

Капсулирование обмотки по предлагаемому способу осуществляют следующим образом.

На торцах статора 1 с капсулируемой обмоткой 2 устанавливают герметизирующие заглушки, в которых соосно со статором с одной или двух сторон установлены герметичные вводы. На чертеже показан герметичный ввод, установленный в одной из сторон статора в заглушке, включающей вращающуюся 3 и неподвижную 4 части. Герметичный ввод снабжен патрубками для вакуумирования 5, подачи компаунда 6, расположенными в неподвижной части 4 герметизирующей заглушки.

В качестве патрубка для слива излишков компаунда используют внутреннюю цилиндрическую полость во вращающейся части 3 герметизирующей заглушки, минимальный диаметр (d) полости по крайней мере на границе капсулирования равен заданному диаметру заливки. Эта полость сообщается с радиальными каналами 7, расположенными под углом до 90° к оси статора с вершиной, обращенной к полости статора, и имеющими форму конуса, меньшее основание которого направлено к оси статора.

20 Статор 1 устанавливают в устройство 8 для вращения статора и включают нагреватель 9 для предварительного нагрева статора 1.

25 В выходные отверстия каналов 7 для слива компаунда устанавливают уплотняющие пробки 10, одновременно начиная вакуумировать полость статора 1. При этом за счет наружного атмосферного давления пробки 10 уплотняют каналы 7, обеспечивая требуемый вакуум внутри статора 1.

30 Затем начинают вращать статор вместе с установленной герметизирующей заглушкой. При этом патрубки для вакуумирования 5 и подачи компаунда 6 связаны через краны либо устройства их заменяющие соответственно с системами вакуумирования и емкостью с компаундом. Одновременно на статоре при помощи нагревателя 9 поддерживается температура, требуемая для обеспечения качественной заливки компаунда.  
35 Эту температуру выбирают из условия достижения оптимальной вязкости компаунда при заливке.

40 Производят подачу компаунда в вакуумированную полость вращающегося статора непосредственно к пазам статора через патрубок 6, установленный в неподвижной (невращающейся) части 4 герметичного ввода и продолжают вакуумировать вращающийся  
50 статор.

55 Обмотку вращающегося статора заполняют жидким компаундом в количестве, несколько превышающем расчетное. После этого производят разгерметизацию статора путем прекращения вакуумирования полости статора и одновременный слив излишков компаунда. Эта одновременность дос-

тигается тем, что при прекращении вакуумирования под действием центробежных сил выталкиваются пробки 10, уплотнявшие каналы для слива излишков компаунда.

Излишки компаунда под действием центробежных сил вытекают из полости статора до уровня, определяемого минимальным диаметром цилиндрической полости подвижной части герметизирующей заглушки. Затем повышают температуру нагрева статора и производят термообработку статора в процессе его вращения до полного или частично 15 его отверждения компаунда.

**П р и м е р.** Заливку статора погружного электродвигателя ПЭДД2,5-117/4 производят эпоксидным наполненным компаундом марки ЭЗК8/4. Число 20 оборотов, необходимое для создания давления в компаунде в процессе вращения, определенное по размерам статора и удельному весу компаунда 150 об/мин. Температура статора при заливке, необходимая для поддержания компаунда в жидком состоянии, 70°С. Полость статора вакуумируют до остаточного давления 40 мм рт.ст.

В качестве материала для изготовления пробок использована резина марки 3826 на основе бутадиен-нитрильного каучука с плотностью 1350-1400 кг/м<sup>3</sup>.

После заполнения статора компаундом в количестве, превышающем расчетное на 0,3-0,5 кг его выдерживают в процессе вращения при остаточном давлении не выше 40 мм рт.ст. в течение 3-5 мин, при 70-80°С, после чего прекращают вакуумирование, что одновременно вызывает выпадение пробок из каналов во вращающейся части герметичных вводов и слив излишков компаунда до уровня, определяемого минимальным диаметром цилиндрической полости используемого в качестве патрубка для слива 46 мм. Время слива компаунда 10-12 мин. Затем статор нагревают до 120-130°С во вращении (в течение 0,5-0,7 ч) и термообработывают, поддерживая эту температуру в течение 3 ч. Затем вращение прекращают. Статор помещают в печь с 150-160°С, где производят оконча-

тельную термообработку в течение 10 ч.

Способ может быть использован для 5 капсулирования обмоток статоров электрических машин.

Изобретение позволит уменьшить трудоемкость капсулирования ввиду 10 отсутствия сложной и требующей периодической очистки (мойка, выключенные) системы кранов, повысить производительность благодаря сокращению времени капсулирования за счет 15 уменьшения времени слива компаунда и совмещения операций слива и разгерметизации. Кроме того, способ обеспечивает экономию компаунда, излишки которого не остаются в трубке в процессе слива.

#### Ф о р м у л а и з о б р е т е н и я

1. Способ капсулирования обмотки 25 статора погружного электродвигателя при котором производят установку на торцах статора вращающихся заглушек, одна из которых имеет герметизирующий ввод, вращение статора относительно его оси, вакуумирование 30 полости статора, подачу жидкого компаунда к обмоткам статора, разгерметизацию полости статора, слив излишков компаунда и термообработку не 35 прекращая вращения, отличающийся тем, что, с целью повышения производительности и упрощения процесса капсулирования одну из заглушек и ввод выполняют с разной 40 высотой для образования внутренней цилиндрической полости, в которой выполняют радиальные каналы для установки уплотняющих пробок, слив излишков компаунда производят при разгерметизации полости статора через 45 цилиндрическую полость и каналы, освобожденные от пробок при снятии вакуума под действием центробежных сил.

2. Способ по п.1, отличающийся 50 тем, что, с целью уменьшения расхода компаунда, диаметр цилиндрической полости на границе капсулирования выполняют равным уровню 55 заливки.

Редактор О.Спесивых

Составитель С.Монсеев  
Техред А.Кравчук

Корректор М.Васильева

Заказ 4124/52

Тираж 646

Подписное

ВНИИПИ Государственного комитета по изобретениям и открытиям при ГКНТ СССР  
113035, Москва, Ж-35, Раушская наб., д. 4/5

Производственно-издательский комбинат "Патент", г. Ужгород, ул. Гагарина, 101

?s pn=su 1334297  
S3 1 PN=SU 1334297  
?t s3/19/

3/19/1

DIALOG(R)File 351:DERWENT WPI  
(c) 2000 Derwent Info Ltd. All rts. reserv.

007456961 \*\*Image available\*\*  
WPI Acc No: 1988-090895/198813  
XRPX Acc No: N88-068569

**Submersion type electric motor stator windings encapsulation - by feeding liquid compound into stator cavity and plugging stator end faces**

Patent Assignee: POTENTIAL BOREHOLE (POTE-R)  
Inventor: EISTRACH L A; REZNIKOV V D; SHAGALOV S B  
Number of Countries: 001 Number of Patents: 001  
Patent Family:

Patent No	Kind	Date	Applicat No	Kind	Date	Week
SU 1334297	A	19870830	SU 3833308	A	19841230	198813 B

Priority Applications (No Type Date): SU 3833308 A 19841230

Patent Details:

Patent No	Kind	Lan	Pg	Main IPC	Filing Notes
SU 1334297	A		2		

Abstract (Basic): SU 1334297 A

Stator windings encapsulation method includes rotating the stator about its mounting axis, and feeding a liq. compd. into the inner cavity of the stator and draining off the residual compd. with subsequent heat-treatment of the compound in situ.. Better quality of encapsulation is claimed by providing impermeability and accurate dimensioning of the stator potting, with the stators mounting means for positioning hermetising elements on their end faces. The stator (1) end faces thus mount hermetising plugs (3) having internal hermetising inlets (4) coaxial with the stator, and fitted with pipe ways for evacuation.

USE - Mfr. of submersible type electric motors. Bul.32/ 30.8.87  
Dwg.1/1

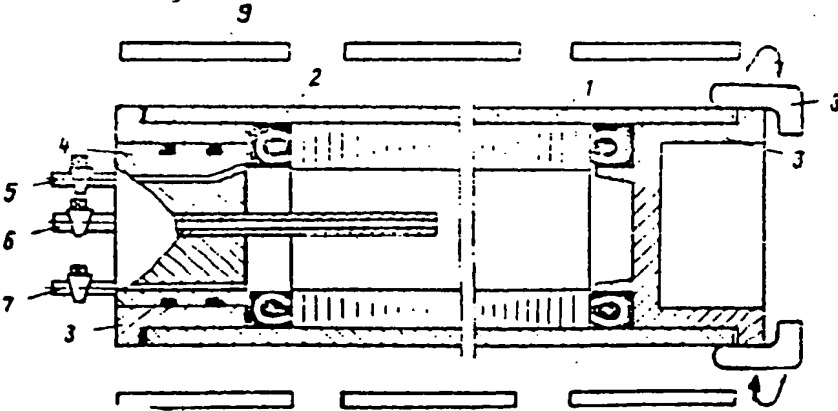

Title Terms: SUBMERGED; TYPE; ELECTRIC; MOTOR; STATOR; WIND; ENCAPSULATE;  
FEED; LIQUID; COMPOUND; STATOR; CAVITY; PLUG; STATOR; END; FACE

Derwent Class: X11

International Patent Class (Additional): H02K-015/12

File Segment: EPI

Manual Codes (EPI/S-X): X11-J08C

?



ГОСУДАРСТВЕННЫЙ КОМИТЕТ СССР  
ПО ДЕЛАМ ИЗОБРЕТЕНИЙ И ОТКРЫТИЙ

# ОПИСАНИЕ ИЗОБРЕТЕНИЯ

## К АВТОРСКОМУ СВИДЕТЕЛЬСТВУ

(21) 3833308/24-07

(22) 30.12.84

(46) 30.08.87. Бюл. № 32

(71) Специальное проектно-конструкторское и технологическое бюро по погружному электрооборудованию для бурения скважин и добычи нефти Всесоюзного научно-производственного объединения "Потенциал"

(72) В.Д. Резников, Л.А. Эйстрах и С.Б. Шагалов

(53) 621. 315(088.8)

(56) Заявка Японии № 55-23017, кл. Н 02 К 15/10, 1973.

Заявка Японии № 55-33126, кл. 55 А 01, 1971.

(54) СПОСОБ КАПСУЛИРОВАНИЯ ОБМОТКИ СТАТОРА ПОГРУЖНОГО ЭЛЕКТРОДВИГАТЕЛЯ

(57) Изобретение относится к электротехнике, в частности к электромашиностроению. Цель изобретения - повышение

качества капсулирования путем обеспечения монолитности и точности размеров заливки статоров. Статор после установки в зажимах 8 и установки заглушек 3, герметизирующего ввода 4, патрубков 5, 6 и 7 и подсоединения их к соответствующим системам питания приводят во вращение. Открывают патрубок 6 и вакуумируют полость статора. Открывают патрубок 5 и подают жидкий компаунд к лобовым частям обмотки 2. Компаунд растекается по пазам обмотки, заполняя пустоты. Открывают патрубок 7, вследствие чего излишек компаунда выдавливается из полости. Отсоединяют патрубок 6 от вакуум-системы и разгерметизируют полость статора. Включают нагреватели 9 и производят термообработку статора в процессе его вращения до отверждения компаунда. 1 ил.

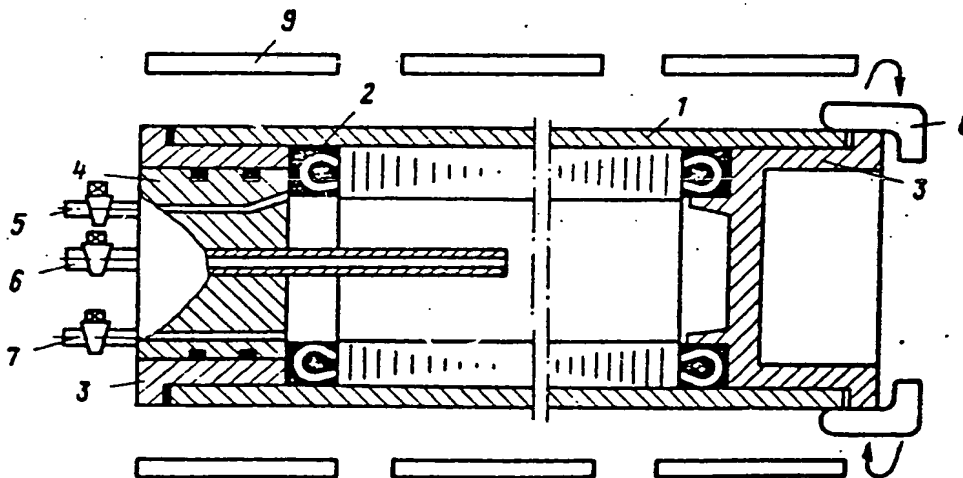

(19) **SU** (11) **1334297** **A 1**

Изобретение относится к электро-технике, в частности к технологии изготовления погружных электродвигателей.

Цель изобретения - повышение качества капсулирования путем обеспечения монолитности и точности размеров заливки статоров, снабженных на торцах средствами для установки герметизирующих элементов.

На чертеже представлен статор с герметизированной полостью в процессе его заливки.

В корпусе статора 1 закреплена расположенная в пазах обмотка с лобовыми частями 2. На торцах корпуса, на резьбе, предназначенной для крепления герметизирующих полость статора уплотнений, имеются заглушки 3, в которых с возможностью вращения относительно заглушки 3 установлен герметизирующий полость статора ввод 4, на котором расположены патрубок 5 для подачи жидкого компаунда к лобовым частям обмотки 2, патрубок 6 для подсоединения к вакуум-системе и патрубок 17 для слива излишков компаунда. Статор закреплен в зажимах 8 привода. Вокруг статора установлены нагреватели 9.

Статор после установки в зажимах 8 и установки заглушек 3, герметизирующего ввода 4, патрубков 5 - 7 и подсоединения их к соответствующим системам питания, приводят во вращение. Скорость вращения выбирают исходя из условия обеспечения давления в жидком компаунде не менее 0,05 МПа. Открывают патрубок 6 и вакуумируют полость статора. Открывают патрубок 5 и подают жидкий компаунд к лобовым частям обмоток 2. Под действием центробежной силы внутри вакуумированной полости статора компаунд растекается по пазам обмотки и в лобовых частях, заполняя пустоты. Отсоединяют патрубок 6 от вакуум-системы и разгерметизируют полость статора, не прекращая вращения статора. Открывают патрубок 7, вследствие чего излишек компаунда под действием центробежной силы выдавливается из полости статора до уровня установки патрубка 7. Включают нагреватели 9 и производят термообработку статора в про-

цессе его вращения до отверждения компаунда.

5        П р и м е р. Заливку статора погружного электродвигателя ПЭД 32-103ВВ5 проводят наполненным компаундом ЭЗК 8/4. Число оборотов, необходимое для создания давления в компаунде в процессе вращения, определенное по размерам статора и удельному весу компаунда, составляет 182 об/м. Температура статора при заливке, необходимая для поддержания компаунда в жидком состоянии, равна 70°C. Полость статора вакуумируют до остаточного давления 40 мм рт.ст. После заливки компаунда статор выдерживают при вращении в течение 3 ч при 100-120°C, после чего его помещают в печь для нормализации при 160-180°C.

#### Ф о р м у л а   и з о б р е т е н и я

25        Способ капсулирования обмотки статора погружного электродвигателя, включающий вращение статора относительно его оси, подачу жидкого компаунда во внутреннюю полость статора, слив излишков и последующую термообработку компаунда до его отверждения, отличающийся тем, что, с целью повышения качества капсулирования путем обеспечения монолитности и точности размеров заливки статоров, снабженных размещенными на торцах средствами для установки герметизирующих элементов, на торцах статора устанавливают герметизирующие заглушки, в которых совместно со статором устанавливают герметичные вводы, снабженные патрубками для вакуумирования, для подачи компаунда к лобовым частям обмоток 45 вращающегося статора и для слива излишков компаунда, установленным в герметичном вводе на уровне, соответствующем заданному уровню заливки, после чего вакуумируют вращающийся статор, подают жидкий компаунд по патрубку подачи компаунда, разгерметизируют вращающийся статор, осуществляют слив излишков компаунда из полости вращающегося статора через 50 патрубок слива и после слива излишков подвергают вращающийся статор термообработке.

ВНИИПИ    Заказ 3975/53    Тираж 659    Подписное

Пронзв. полигр. пр-тие, г. Ужгород, ул. Проектная, 4

August 2, 2000

?s pn=be 891258  
S7 1 PN=BE 891258  
?t s7/19/

7/19/1

DIALOG(R)File 351:DERWENT WPI  
(c) 2000 Derwent Info Ltd. All rts. reserv.

003289178

WPI Acc No: 1982-D7189E/198214

**Moulded integrated circuit encapsulation - has conductors and support formed from single sheet adaptable to different chips with spool to spool mfg. process**

Patent Assignee: WESTERN ELECTRIC CO INC (AMTT )

Number of Countries: 010 Number of Patents: 011

Patent Family:

Patent No	Kind	Date	Applicat No	Kind	Date	Week
BE 891258	A	19820316				198214 B
[REDACTED]		1982Q609	GB 8135721	A	19811126	198223
US 4331831	A	19820525				198223
DE 3146796	A	19820616				198225
NL 8105387	A	19820616				198228
SE 8106859	A	19820628				198228
FR 2495377	A	19820604				198229
JP 57117264	A	19820721				198235
CA 1168764	A	19840605				198427
[REDACTED]		19840815				198433
IT 1139839	B	19860924				198824

Priority Applications (No Type Date): US 80210776 A 19801128

Patent Details:

Patent No	Kind	Lan Pg	Main IPC	Filing Notes
BE 891258	A	16		

Abstract (Basic): BE 891258 A

The encapsulation consists of a moulded body which encloses the chip, the front face of the chip carrying the electrodes. The conductive elements forming the external contacts and the connections to the chip are produced from a single piece. A second single piece conductor forms large area tongues of metal which are in contact with the rear face of the chip and are brought out to at least one external contact per tongue. The encapsulation is rectangular with extended corners which protect the external contact parts of the conductors.

The two contacts either side of each corner are connected to the metal tongues which serve as heat sinks and mechanical support. The connectors and support can be produced from a single band of metal, connected to the chip and then moulded with a subsequent spool to spool trimming, cleaning, cropping and lead-forming operation and stacking in dispensers. The connector pattern is formed by a mask and chemical attack which can be easily changed to adapt to different chips.

Abstract (Equivalent): GB 2088635 B

An encapsulation for a semiconductor integrated circuit chip, the chip having a front and a back side, the front side having electrodes thereon, the encapsulation comprising a moulded body member enclosing the chip, first unitary lead members connected to respective ones of the said electrodes and having integral contact portions external to the body member and second unitary lead members integral with large-area tab members in contact with the back side of the chip.

Title Terms: MOULD; INTEGRATE; CIRCUIT; ENCAPSULATE; CONDUCTOR; SUPPORT; FORMING; SINGLE; SHEET; ADAPT; CHIP; SPOOL; SPOOL; MANUFACTURE; PROCESS

Derwent Class: U11

International Patent Class (Additional): H01L-021/68; H01L-023/50; H05K-001/06; H05K-005/06





N° 891.258

Classif. Internat.: **H05K**Mis en lecture le: **16 -03- 1982**

Le Ministre des Affaires Économiques,

*Vu la loi du 24 mai 1854 sur les brevets d'invention;**Vu la Convention d'Union pour la Protection de la Propriété Industrielle;**Vu le procès-verbal dressé le 26 novembre 1981 à 14 h. 55**au Service de la Propriété industrielle;***ARRÊTE :**

Article 1. — Il est délivré à la Sté dite : WESTERN ELECTRIC COMPANY  
INCORPORATED  
222 Broadway, New York, N.Y. (Etats-Unis d'Amérique),  
repr. par les Bureaux Vander Haeghen à Bruxelles,

un brevet d'invention pour : Encapsulation pour un circuit intégré,

qu'elle déclare avoir fait l'objet d'une demande de brevet  
déposée aux Etats-Unis d'Amérique le 28 novembre 1980,  
n° 210.776 au nom de A.J. Ingram et I. Weingrod dont elle  
est l'ayant cause.

Article 2. — Ce brevet lui est délivré sans examen préalable, à ses risques et  
périls, sans garantie soit de la réalité, de la nouveauté ou du mérite de l'invention, soit  
de l'exactitude de la description, et sans préjudice au droit des tiers.

Au présent arrêté demeurera joint un des doubles de la spécification de l'invention  
(mémoire descriptif et éventuellement dessins) signés par l'intéressé et déposés à l'appui  
de sa demande de brevet.

Bruxelles, le 15 décembre 19 81

PAR DELEGATION SPÉCIALE :

Le Directeur

L. SALPETEUR

0158

A.J.Ingram 1-2 Belgium  
B. 74 846 DS

DESCRIPTION

jointe à une demande de

## BREVET BELGE

déposée par la société dite:

WESTERN ELECTRIC COMPANY, INCORPORATED

ayant pour objet: Encapsulation pour un circuit intégré

---

Qualification proposée: BREVET D'INVENTION

Priorité d'une demande de brevet déposée aux Etats-Unis  
d'Amérique le 28 novembre 1980 sous le n° 210.776 aux noms  
de Arthur J. INGRAM et Irving WEINGROD



La présente invention concerne l'encapsulation des puces de circuits intégrés à semiconducteurs.

On encapsule les puces de semiconducteurs à la fois pour la protection et pour la commodité de l'interconnexion des circuits des puces avec des bornes situées sur des supports de montage tels que des cartes de circuit imprimé. L'encapsulation facilite également le test et le montage automatique de puces dans un dispositif. Il existe une très grande variété de boîtiers de puces de circuits intégrés, mais les types en matière plastique post-moulée, non hermétiques, tels que le boîtier à double rangée de connexions et le boîtier du type porte-puce, présentent un intérêt majeur. Des normes existent ou sont en cours d'élaboration pour les boîtiers de ces types, et ces normes prescrivent les dimensions générales, les types de contacts externes et l'écartement entre contacts.

L'encapsulation de dispositifs à semiconducteurs constitue cependant une proportion considérable du coût total d'un dispositif terminé. Des efforts permanents sont donc consacrés au développement de boîtiers et de techniques d'encapsulation qui réduisent le coût, assurent une fiabilité élevée et conduisent à une taille réduite. Les techniques automatisées de fabrication, de test et de montage contribuent à diminuer le coût et à augmenter la fiabilité. Il est également souhaitable qu'une structure de boîtier particulière puisse recevoir, avec peu ou pas de changement, diverses puces de semiconducteurs différentes. Ceci a pour conséquence de réduire au minimum le nombre total de tailles de boîtier nécessaires pour toutes les tailles de puces.

Le brevet U.S. 4 132 856 décrit une encapsulation d'une puce de circuit intégré à semiconducteurs dans laquelle des conducteurs formés d'une seule pièce sont connectés à des électrodes du côté avant de la puce et se terminent par des contacts extérieurs au corps d'encapsulation en matière plastique moulée. Un élément métallique séparé est nécessaire pour établir un contact thermique avec le côté arrière de la puce et pour établir un support mécanique

avant la formation du corps en matière plastique moulée. Les éléments conducteurs peuvent être formés à partir d'un seul morceau de feuille métallique, comme une bande à éléments poutres, mais la nécessité d'employer l'élément métallique 5 séparé complique l'opération d'encapsulation.

Conformément à l'invention, le contact thermique et, si on le désire, électrique avec la face arrière de la puce et le support mécanique pendant la fabrication sont établis par des éléments conducteurs en une seule pièce réalisée 10 sés d'un seul tenant avec des languettes d'aire élevée qui sont en contact avec la face arrière de la puce.

Cette forme d'encapsulation se prête particulièrement bien à l'utilisation d'une bande à éléments poutres passant d'une bobine à une autre, du fait que tous les éléments 15 conducteurs et toutes les languettes peuvent être formés à partir d'une seule feuille de métal.

L'invention sera mieux comprise à la lecture de la description qui va suivre de modes de réalisation et en se référant aux dessins annexés sur lesquels :

20 La figure 1 est une représentation en perspective, partiellement arrachée et en coupe, d'une encapsulation conforme à l'invention ;

La figure 2 est une vue en plan d'un cadre de montage unique formé dans une partie d'une bande à éléments 25 poutres au cours de la fabrication de l'encapsulation de la figure 1 ;

La figure 3 est une vue de détail en perspective de l'extrémité intérieure de l'un des éléments poutres du côté avant de l'encapsulation de la figure 1 ;

30 La figure 4 montre une variante du détail de la figure 3 ; et

La figure 5 est une vue en perspective, partiellement arrachée et en coupe, montrant plusieurs encapsulations conformes à l'invention à l'intérieur d'un magasin du type 35 réglette.

La figure 1 montre, en perspective, un porte-puce qui consiste en un corps en matière plastique post-moulée 10 qui maintient en association les divers éléments de l'encap-

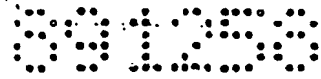

sulation et qui définit un profil de boîtier convenant pour un équipement de manipulation du type à réglette. Le porte-puce est représenté sous une forme partiellement arrachée et en coupe pour montrer la configuration des divers éléments à l'intérieur du corps en matière plastique moulée 10.

La puce de semiconducteur 11 est placée à l'intérieur du corps 10. Sur le dessin, la face avant ou active de la puce se trouve du côté supérieur et elle porte un ensemble d'électrodes 15 consistant en zones de métal destinées à l'établissement de connexions avec le circuit intégré à semiconducteur .

L'interconnexion entre les électrodes 15 qui se trouvent sur la puce de semiconducteur 11 et les contacts externes 13 s'effectue au moyen d'éléments conducteurs 12. Sur la face avant de la puce, à l'intérieur du boîtier, les éléments conducteurs 12 se terminent par des doigts 14 dont les bouts comprennent une zone destinée à la fixation sur une électrode de puce 15, le terme "fixation" étant pris dans un sens qui englobe tous les moyens connus pour réaliser une liaison conductrice, ces moyens comprenant, de façon non limitative, la fixation par thermocompression, la fixation thermosonore et ultrasonore, la fixation par un adhésif conducteur et eutectique, le soudage avec une matière fusible, le brasage, et diverses formes de soudage par fusion. A l'extérieur du corps 10, les éléments conducteurs 12 se terminent par des contacts externes 13, conçus de façon à venir en contact avec des zones de bornes sur un circuit d'interconnexion, qui peut comprendre des éléments céramiques à couches épaisses et à couches minces et des cartes de circuit imprimé rigides et flexibles. De tels contacts peuvent utiliser la pression d'un ressort ou un certain mode de fixation, de soudage par fusion ou de soudage par une matière fusible. Bien qu'ils soient représentés dans ce mode de réalisation sous la forme de pieds en L destinés à être montés sur une surface, les conducteurs 12 et les contacts 13 pourraient tout aussi bien être adaptés à un autre type de connexion, comme par exemple par insertion dans des trous dans une pièce de montage. Selon une variante, les conduc-



teurs 12 et les contacts externes 13 peuvent être courbés dans la direction opposée par rapport à l'orientation de la puce de semiconducteur. Ceci conduit à une connexion des électrodes 15 de la puce de semiconducteur 11 aux zones de bornes du circuit d'interconnexion qui est l'image dans un miroir de la connexion précédente, sans changements pour la puce de semiconducteur. Il est important de noter que chaque élément conducteur 12 est un élément continu unique s'étendant depuis le doigt 14 de la face avant jusqu'au contact externe 13. Il n'y a pas de connexions intermédiaires qui tendraient à augmenter le coût et à réduire la fiabilité.

Quatre languettes 16, relativement grandes et en forme de palettes, viennent en contact avec la face inférieure ou arrière de la puce de semiconducteur 11, et ces languettes sont formées de façon similaire dans la bande à éléments poutres. A son tour, chaque languette 16 est connectée à une paire d'éléments conducteurs 17 se terminant par des contacts externes 18, et elle est réalisée d'un seul tenant avec ces éléments. Les éléments conducteurs 17 sont placés aux extrémités des rangées d'éléments conducteurs 12. Les languettes 16 procurent un support mécanique d'aire élevée pour la puce de semiconducteur 11, ainsi qu'un contact thermique et un contact électrique avec celle-ci, si on le désire. De façon caractéristique, les languettes 16 sont fixées de manière conductrice à la face arrière de la puce 11 et assurent la dissipation thermique à la fois par convection et conduction, et par l'étalement de la chaleur à l'intérieur de la puce de semiconducteur en silicium.

On peut également concevoir d'autres configurations de contacts de face arrière formées d'un seul tenant à partir du cadre de montage. Le nombre, la forme et la disposition des languettes 16 peuvent différer de ceux représentés. A titre d'exemple, une autre configuration peut comporter deux languettes disposées de façon centrale sur des côtés opposés de la puce, au lieu de se trouver dans les coins. On peut employer de façon similaire des configurations très diverses d'éléments conducteurs pour les languettes.

Des caractéristiques supplémentaires de la structure

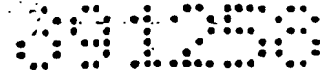

porte-puce de la figure 1 ressortiront de la manière selon laquelle l'encapsulation est réalisée. En particulier, la structure unitaire de chaque conducteur de contact 12 pour les contacts de la face avant et de chaque conducteur de contact 17 pour les contacts de la face arrière découle de la manière selon laquelle le cadre de montage est fabriqué et assemblé. La figure 2 montre une partie 20 d'une bande à éléments poutres, d'un type conçu de façon à être déplacé entre deux bobines, avec un positionnement précis à des postes de travail. Dans ce but, la bande est munie de trous d'entraînement 22. Le trou triangulaire 31 est une marque d'identification et d'orientation. La bande 21 consiste de façon caractéristique en une feuille de cuivre dorée ayant une épaisseur caractéristique d'environ 0,1 mm.

Selon une variante, la feuille de cuivre peut avoir une autre épaisseur et elle peut être revêtue avec d'autres métaux, comme l'étain, ou elle peut ne pas être revêtue. De façon similaire, on peut utiliser d'autres métaux conducteurs, comme l'aluminium et des alliages ferreux appropriés, à la place de la feuille de cuivre.

La figure 2 montre la partie 20 de la bande à laquelle on a donné une forme définissant le cadre de montage, et qui a été assemblée, par fixation, à une puce de semiconducteur 23. Plusieurs étapes de fabrication sont intercalées entre la réalisation de la bande à éléments poutres et l'obtention de la structure représentée sur la figure 2. On forme tout d'abord sur la bande un masque résistant à l'attaque pour définir une configuration particulière du cadre de montage. Le masque définit les divers éléments conducteurs de contact 24 de la face avant et les éléments conducteurs de contact 26 qui sont reliés aux languettes de contact 27 de la face arrière. Les languettes de contact 27 de la face arrière sont également définies dans la bande, dans les vides 30 qui se trouvent dans les coins de la configuration du cadre de montage. Ainsi, le cadre de montage est défini dans la bande dans un seul plan et il comprend le réseau d'éléments conducteurs 24 qui se terminent par les contacts de la face avant, les éléments conduc-

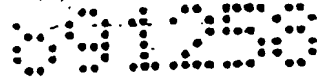

teurs 25 qui sont inutilisés et les éléments conducteurs 26 qui se terminent par les languettes 27 de la face arrière.

Comme le montre la figure 2, l'aire de contact entre chacune des languettes de la face arrière, 27, et la face arrière de la puce 23 représente environ 20% de l'aire de la face arrière, soit 80% pour l'ensemble des quatre languettes 27.

On va maintenant passer à la figure 3 sur laquelle la partie d'extrémité 41 d'un conducteur de contact de face avant, 24, de la figure 2 est représentée retournée pour montrer le plot de fixation 43 au bout du conducteur, et la partie adjacente 42 de section transversale réduite. Cette configuration de la zone de fixation et de la partie de section transversale réduite est également formée au moyen d'une opération spécialisée de masquage et d'attaque. La partie adjacente 42 de section transversale réduite assure la libération des contraintes induites par voie thermique afin d'éviter des ruptures de fixation au niveau du contact sur la puce de semiconducteur.

La figure 4 représente une autre configuration pour la partie d'extrémité 51 du conducteur de contact de face avant. Dans cette configuration, il est avantageux de former sur la puce de semiconducteur une électrode surélevée sur laquelle la zone 53 du conducteur est fixée. La libération des contraintes est assurée par une partie 52 adjacente à la zone de fixation 53, avec une section transversale réduite pour la partie 52 comme pour la zone de fixation 53.

Une fois que le cadre de montage est formé dans la bande à éléments poutres, il peut être revêtu en totalité ou en partie avec une ou plusieurs couches minces de métal. On positionne ensuite le cadre de montage en contact avec une puce de semiconducteur 23, avec les bouts des éléments conducteurs de contact de la face avant, 24, sur les électrodes 28 de la puce de semiconducteur. On applique ensuite un outil pour fixer les plots de fixation 43 aux électrodes 28 de la puce. Le cadre de montage représenté sur la figure 2 comprend un réseau standard de quatorze éléments conducteurs sur chacun des quatre côtés, ce qui fait un total de 56.



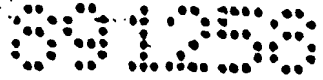

Ceci correspond à une configuration particulière dans une famille de cadres de montage de taille et de forme similaires. Comme il est représenté, les éléments conducteurs d'extrémité 26, au nombre de huit au total, sont utilisés pour réaliser des contacts externes pour les languettes de contact de la face arrière, 27. Les conducteurs de contact restants de la face avant sont disponibles pour connecter des électrodes de la puce de semiconducteur à des circuits externes. Cependant, tous les conducteurs ne sont pas nécessairement utilisés dans une structure particulière de puce de semiconducteur, et c'est par exemple le cas du conducteur 25. Toutes les parties de conducteur formant les contacts externes sont fabriquées et conservées à l'intérieur du corps moulé afin d'améliorer la résistance mécanique et l'uniformité du boîtier. Les éléments inutilisés, comme le conducteur 25, peuvent être supprimés ultérieurement, en fonction de nécessités particulières de la conception. La languette 32 formée sur un conducteur 24 particulier assure l'identification.

On voit que c'est ici que réside la souplesse de conception de cette configuration de cadre de montage. De simples changements de la conception du masque d'attaque permettent de produire une variété de configurations d'éléments conducteurs, ce qui permet d'accepter une grande variété de configurations d'électrodes sur la face avant de la puce de semiconducteur 23. Les éléments conducteurs 24 des contacts de la face avant peuvent avoir diverses configurations aux extrémités des conducteurs de la face avant et diverses extrémités de conducteurs peuvent être supprimées pour s'adapter à diverses configurations d'électrodes 28 sur la surface avant de la puce. Si on le désire, on peut également modifier la forme ou l'emplacement des languettes de contact 27 de la face arrière, ou les supprimer partiellement, comme décrit précédemment. Selon une variante, on peut supprimer certaines des languettes de contact 27 de la face arrière, et on peut utiliser leurs conducteurs respectifs 26 pour la connexion à des électrodes 28 de la puce de semiconducteur.

Une fois que les conducteurs de contact de la face

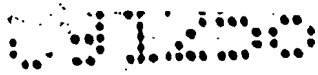

avant, 24, ont été fixés aux électrodes 28 sur la puce de semiconducteur 23, on bobine la bande, en employant avantageusement une pièce intercalaire qui fait en sorte que les puces de semiconducteur soient suspendues par les conducteurs fixés et soient donc disponibles pour le nettoyage ou un autre traitement. Ainsi, par exemple, on peut soumettre la bobine complète à un traitement d'ensemble consistant en une immersion dans un bain de nettoyage ou un traitement dans un four d'étuvage.

10 La bande est ensuite amenée à un autre poste de travail et les languettes 27 de la face arrière sont pliées à 180° pour les placer dans l'orientation indiquée par des traits partiellement en pointillés sur la figure 2. On accomplit cette opération à l'aide d'un outillage destiné à plier les languettes dans la zone 29, de manière à établir un dégagement qui est de façon générale égal à l'épaisseur de la puce de semiconducteur 23. Ainsi, les languettes de contact 27 de la face arrière établissent un contact pratiquement plan avec la surface arrière de la puce de semiconducteur.

20 Les languettes de contact 27 de la face arrière peuvent être fixées de manière conductrice par l'un quelconque des divers moyens désignés précédemment par le terme "fixation", pour établir un contact électrique ou thermique entre les languettes et la puce. Si on utilise de la matière époxyle conductrice, on la fait habituellement durcir dans un four. Comme on l'a indiqué précédemment, l'interconnexion de type thermique ou électrique, ou des deux types, avec les languettes de contact 27 de la face arrière est réalisée finalement au moyen des éléments conducteurs 26.

30 Ensuite, la partie de bande 20 qui demeure un élément d'une bobine, avec des contacts établis sur l'avant comme sur l'arrière de la puce de semiconducteur, de la manière décrite ci-dessus, est introduite dans un moule dans lequel on forme le corps en matière plastique moulée, 10, représenté sur la figure 1. Dans certains cas, il peut être avantageux d'appliquer un revêtement protecteur sur la surface active de la puce de semiconducteur, avant l'opération

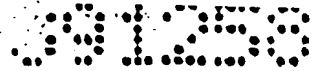

de moulage. Ce revêtement peut consister en une matière épousant la forme de son substrat, comme un caoutchouc aux silicones approprié qui se vulcanise à la température ambiante.

5 Dans un exemple particulier, le corps 10 est moulé par injection en utilisant une matière thermoplastique telle que le Ryton BRO6-A. Le Ryton est une marque de la firme Phillips Petroleum Corp. Une matière thermoplastique ne nécessite généralement pas une période de durcissement après  
10 moulage, et l'opération de moulage peut être accomplie en une durée de l'ordre de quelques secondes, soit de façon caractéristique d'environ six à vingt secondes.

Le corps 10 moulé par injection peut être formé simultanément à plusieurs emplacements de la bande et l'appareil de moulage peut recevoir plus d'une bande. Ensuite, dans  
15 un autre traitement de bobine à bobine, on ébavure les boîtiers pour enlever la matière de moulage en excès et on les nettoie. Enfin, dans un autre traitement de bobine à bobine, on sectionne la bande pour en séparer chaque boîtier moulé, et on effectue  
20 la mise en forme et la finition des conducteurs externes. On introduit ensuite automatiquement les boîtiers individuels, avec une orientation uniforme, dans un magasin du type réglette. Une caractéristique des opérations de sectionnement, de finition et de pliage consiste en ce qu'elles sont accom-  
25 plies après l'opération de moulage du boîtier. Il existe donc automatiquement un support mécanique pour la structure de cadre de montage pendant ces opérations. On évite ainsi l'utilisation de dispositifs de maintien spéciaux ou d'autres supports pour éviter le gauchissement ou la déformation de la  
30 structure de cadre de montage pendant les opérations de travail du métal.

En se reportant à la figure 5, on voit une partie  
61 d'un magasin du type réglette qui contient plusieurs boîtiers 62, 63, 64. Les corps en matière plastique de chacun  
35 des boîtiers 62, 63, 64 portent sur les rails internes 66-67, 72-73, 74-75. Ces rails assurent la suspension des boîtiers dans la réglette de telle manière que les conducteurs externes 71 ne viennent en contact avec aucune des surfaces inter-

e

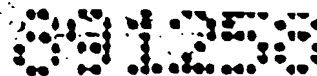

nes de la réglette. La configuration de suspension par rails établit également un dégagement tout autour du boîtier de façon que les débris présents à l'intérieur de la réglette ne gênent pas le mouvement des boîtiers. Les coins 69 des 5 boîtiers moulés s'étendent au-delà des conducteurs externes 71 et font en sorte que les conducteurs d'un boîtier ne viennent pas en contact avec ceux d'un boîtier adjacent ou avec les rails latéraux 72-73.

Il est très avantageux de manipuler les boîtiers 10 lorsqu'ils sont chargés dans des réglottes à partir desquelles ils peuvent être distribués et dans lesquelles ils peuvent être réintroduits au cours de diverses opérations de test, de vieillissement, ou autres.

Il va de soi que de nombreuses modifications 15 peuvent être apportées au dispositif décrit et représenté, sans sortir du cadre de l'invention.

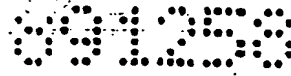

REVENDEICATIONS

1. Encapsulation pour une puce de circuit intégré à semiconducteur (11, 23), la puce comportant une face avant et une face arrière, la face avant portant des électrodes (15, 28), et l'encapsulation comprenant un corps moulé (10) qui enferme la puce, et des premiers éléments conducteurs en une seule pièce (12, 24) qui sont connectés à des électrodes (14, 28) respectives et qui comportent des parties de contact (13) d'un seul tenant, à l'extérieur du corps (10), caractérisée en ce qu'elle comporte des seconds éléments conducteurs en une seule pièce (17, 26), réalisés d'un seul tenant avec des languettes (16, 27) d'aire élevée qui sont en contact avec la face arrière de la puce (11, 23).
2. Encapsulation selon la revendication 1, caractérisée en ce que les seconds éléments conducteurs en une seule pièce (17) comportent au moins une partie de contact (18) réalisée d'un seul tenant à l'extérieur du corps (10), pour chacune des languettes (16, 23).
3. Encapsulation selon l'une quelconque des revendications 1 ou 2, dans laquelle le corps (10) a un contour de forme générale rectangulaire, lorsqu'il est vu en plan, caractérisée en ce que les coins (19, 69) du corps (10) font saillie à partir du corps de façon à protéger les parties de contact externes (13, 18) des éléments conducteurs.
4. Encapsulation selon la revendication 3, caractérisée en ce que la paire de parties de contact externes (18) qui est adjacente à chaque coin est formée d'un seul tenant avec l'une respective des languettes (16, 27).
5. Encapsulation selon l'une quelconque des revendications 1 à 4, caractérisée en ce que les premier et second éléments conducteurs (12, 17, 24, 26) et les languettes (16, 27) sont tous formés à partir d'une seule feuille de métal (20).
6. Encapsulation pour un circuit intégré, telle que décrite ci-dessus et représentée aux dessins annexés.

BRUXELLES, le 26 NOV. 1981

P. Pon \_\_\_\_\_

WESTERN ELECTRIC COMPANY, INCORPORATED

P. Pon BIRFALL: AUDIT: HAFOLTA

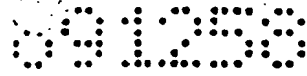
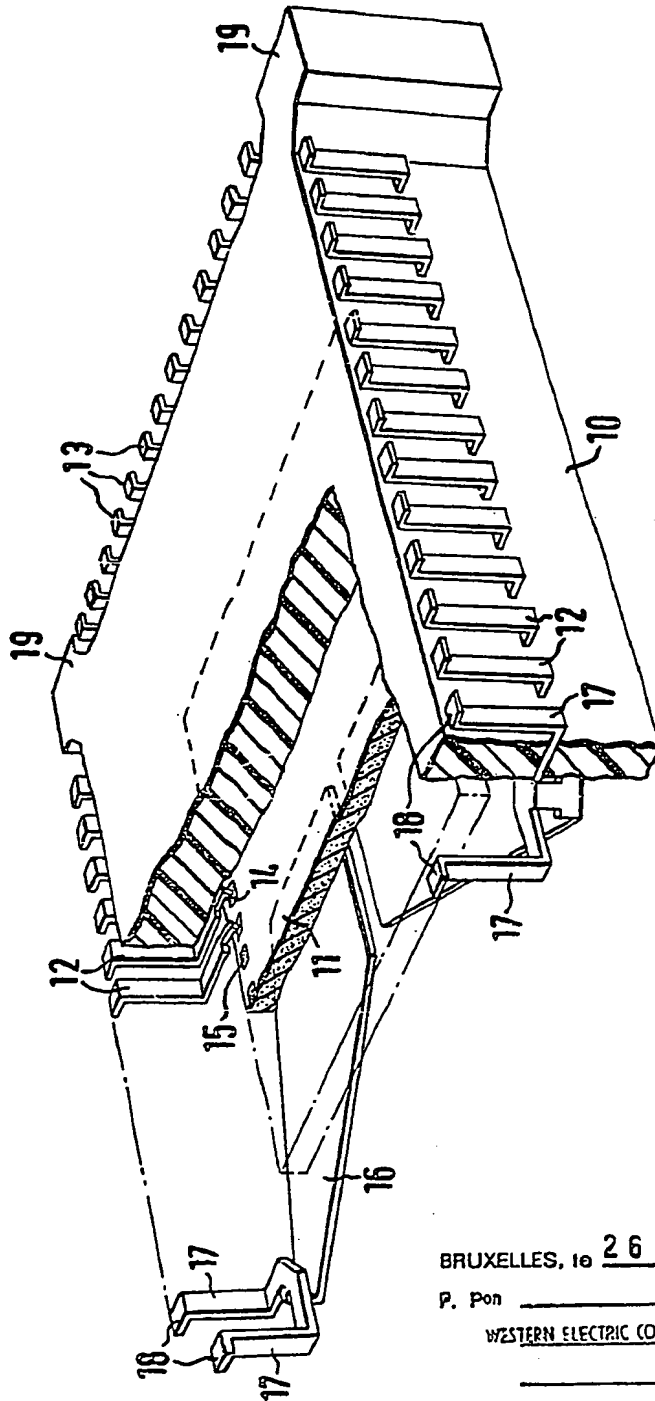

FIG. 1



BRUXELLES, le 26 NOV. 1981

P. Pon

WESTERN ELECTRIC COMPANY, INCORPORATED

P. Pon PATENT AN DER HAEGHEN



FIG. 2

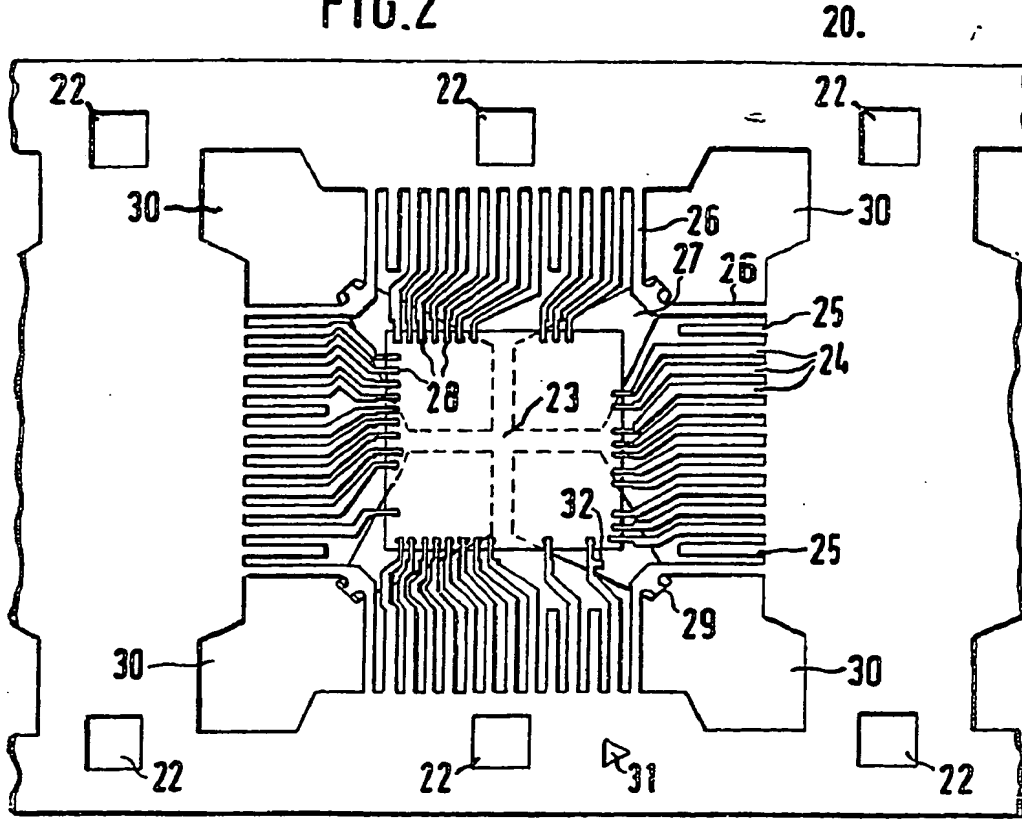

FIG. 3

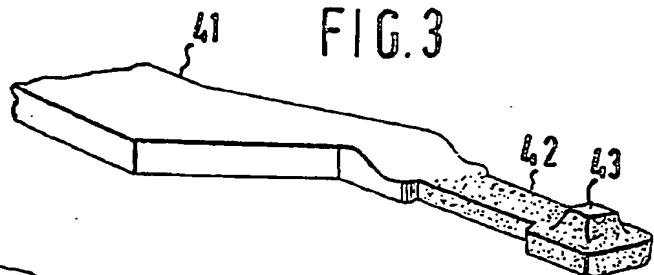
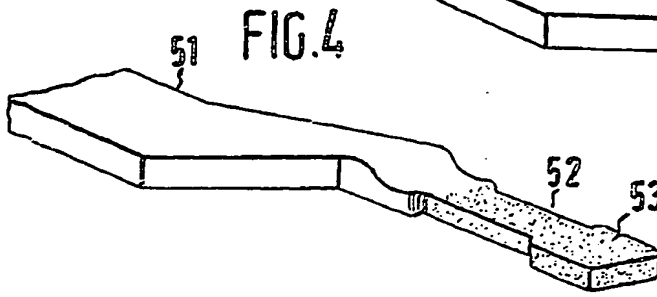

FIG. 4



BRUXELLES, le 26 NOV. 1931

P. Pen

WESTERN ELECTRIC COMPANY, INCORPORATED

P. Pen PHILADELPHIE ANDER WASHINGTON

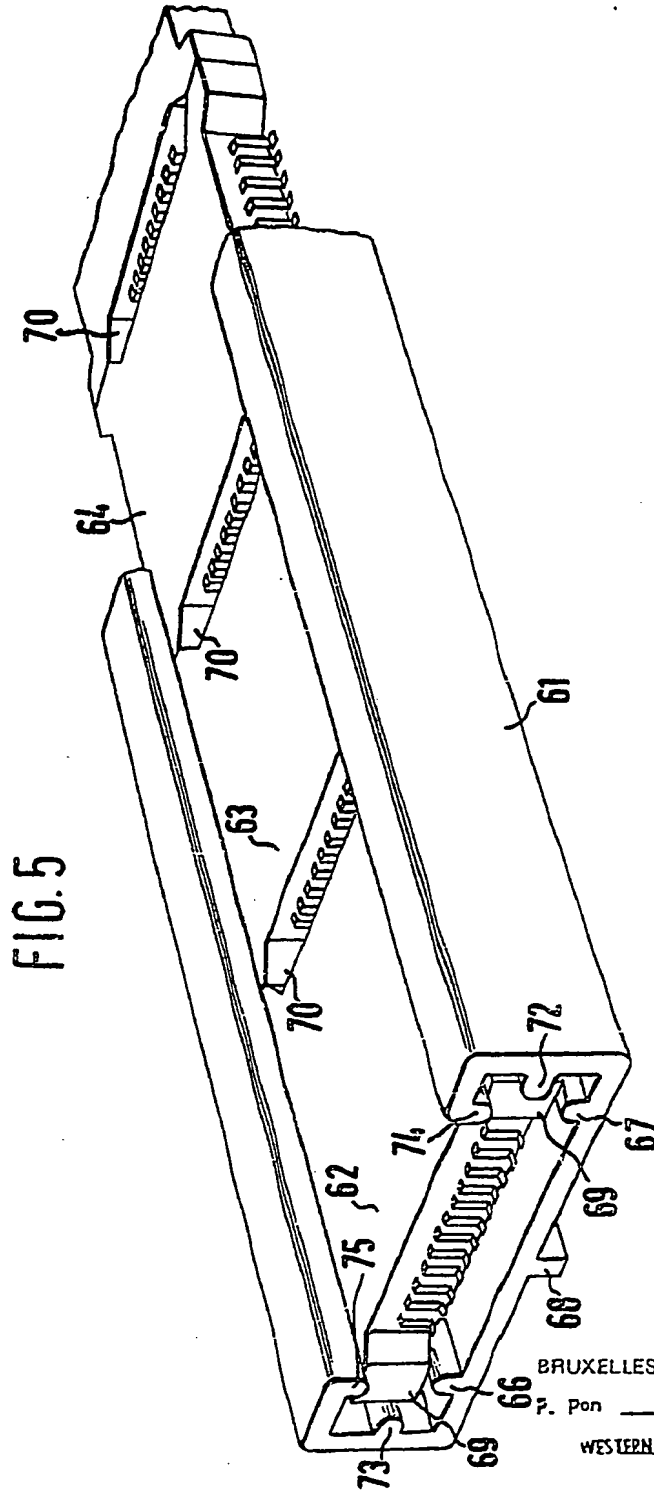

FIG. 5

BRUXELLES, le 26 NOV. 1981

P. Pon

WESTERN ELECTRIC COMPANY, INCORPORATED

P. Pon DIRECTEUR GÉNÉRAL



**This Page is Inserted by IFW Indexing and Scanning  
Operations and is not part of the Official Record**

**BEST AVAILABLE IMAGES**

Defective images within this document are accurate representations of the original documents submitted by the applicant.

Defects in the images include but are not limited to the items checked:

- BLACK BORDERS**
- IMAGE CUT OFF AT TOP, BOTTOM OR SIDES**
- FADED TEXT OR DRAWING**
- BLURRED OR ILLEGIBLE TEXT OR DRAWING**
- SKEWED/SLANTED IMAGES**
- COLOR OR BLACK AND WHITE PHOTOGRAPHS**
- GRAY SCALE DOCUMENTS**
- LINES OR MARKS ON ORIGINAL DOCUMENT**
- REFERENCE(S) OR EXHIBIT(S) SUBMITTED ARE POOR QUALITY**
- OTHER:** \_\_\_\_\_

**IMAGES ARE BEST AVAILABLE COPY.**

**As rescanning these documents will not correct the image problems checked, please do not report these problems to the IFW Image Problem Mailbox.**

August 2, 2000

?s pn=be 870878  
S8 1 PN=BE 870878  
?t s8/19/

8/19/1  
DIALOG(R)File 351:DERWENT WPI  
(c) 2000 Derwent Info Ltd. All rts. reserv.

002215047  
WPI Acc No: 1979-14195B/197908

**Integrated circuit chip encapsulation method - comprises covering active surface only, then connecting chips to substrate and encapsulating in a different resin**

Patent Assignee: CII-HONEYWELL BULL (SELA )  
Number of Countries: 007 Number of Patents: 008  
Patent Family:

Patent No	Kind	Date	Applicat No	Kind	Date	Week
BE 870878	A	19790115				197908 B
NL 7809979	A	19790405				197916
DE 2843133	A	19790419				197917
SE 7810315	A	19790514				197922
<del>GB 2005500</del>		19790613				197924
FR 2404992	A	19790601				197927
<del>FR 2404992</del>		19820512				198219
IT 1098983	B	19850918				198701

Priority Applications (No Type Date): FR 7729686 A 19771003

Abstract (Basic): BE 870878 A

Integrated circuit chip is claimed, of the type including an active surface provided with circuit elements connected to leads at the periphery of the surface. The active surface is entirely covered with a layer of insulating resin which may be flexible or in the form of a solidified gel. At the edge of the chip, the resin covering makes an angle of 25-45 degrees with the active surface. The resin is pref. a flexible silicone resin.

The connecting leads pass out through the sides of the insulating resin to be attached to the substrate wafer, hence individual chips can be attached to or removed from the substrate during service allowing repairs to be effected. The resin comprises having high resistivities combined with good thermal flock-resistance values and will accept a wide range of working temps. By use of a suitable solvent it is possible to remove the external layer of resin, without altering or removing the layer covering the active surface, when the whole interconnection substrate is encapsulated.

Title Terms: INTEGRATE; CIRCUIT; CHIP; ENCAPSULATE; METHOD; COMPRISE; COVER ; ACTIVE; SURFACE; CONNECT; CHIP; SUBSTRATE; ENCAPSULATE; RESIN

Index Terms/Additional Words: SILICONE

Derwent Class: A85; L03; U11; U12; V04

International Patent Class (Additional): H01L-021/94; H01L-023/28; H05K-003/28; H05K-007/02

File Segment: CPI; EPI

Manual Codes (CPI/A-N): A06-A00E2; A12-E07A; L03-D03; L03-D04; L03-H02

Plasdoc Codes (KS): 0231 1306 2382 2437 2439 2440 2483 2500 2512 2551 2600 2608 2628 2728 2738 2740

Polymer Fragment Codes (PF):

\*001\* 011 04- 05- 229 331 38- 402 405 431 443 445 466 47& 470 477 501 506  
509 52- 541 548 551 560 566 623 627 628

?



N° 870.878

Classif. Internat. : H 01 L

Mis en lecture le : 15 -01- 1979

Le Ministre des Affaires Économiques,

*Vu la loi du 24 mai 1854 sur les brevets d'invention ;*

*Vu la Convention d'Union pour la Protection de la Propriété Industrielle ;*

*Vu le procès-verbal dressé le 29 septembre 1978 à 11 h. 30*

*au Service de la Propriété industrielle ;*

## ARRÊTE :

Article 1. — Il est délivré à la Sté dite : COMPAGNIE INTERNATIONALE  
POUR L'INFORMATIQUE CII-HONEYWELL BULL,  
94 Avenue Gambetta à Paris (20ème) (France),

repr. par Mr Gauthier c/o Honeywell Bull S.A., 28,  
avenue Marnix à Bruxelles 1050,

un brevet d'invention pour : Circuits électriques intégrés protégés,  
substrats d'interconnexion protégés comportant de tels  
circuits et procédé d'obtention desdits circuits et  
substrats,

qu'elle déclare avoir fait l'objet d'une demande de brevet  
déposée en France le 3 octobre 1977, n° 77 29 686.

Article 2. — Ce brevet lui est délivré sans examen préalable, à ses risques et  
périls, sans garantie soit de la réalité, de la nouveauté ou du mérite de l'invention, soit  
de l'exactitude de la description, et sans préjudice du droit des tiers.

Au présent arrêté demeurera joint un des doubles de la spécification de l'invention  
(mémoire descriptif et éventuellement dessins) signés par l'intéressé et déposés à l'appui  
de sa demande de brevet.

Bruxelles, le 13 octobre 1978.

PAR DÉLÉGATION SPÉCIALE :

Le Directeur

A. SCHURMANS

070878

2109

BREVET D'INVENTION

"Circuits électriques intégrés protégés, substrats  
d'interconnexion protégés comportant de tels circuits  
et procédé d'obtention desdits circuits et substrats"

Invention de : Patrick COURANT

COMPAGNIE INTERNATIONALE POUR L'INFORMATIQUE  
CII - HONEYWELL BULL

D.

07070

La présente invention concerne, d'une manière générale, la protection mécanique et/ou chimique des circuits électriques intégrés et des substrats d'interconnexion équipés de tels circuits

5 Plus spécifiquement, elle a pour objet une pastille formant circuit électrique intégré, protégée par une résine isolante, et des substrats d'interconnexion équipés d'une pastille ou d'une pluralité de pastilles formant chacune un circuit électrique intégré, ces substrats équipés étant protégés et comportant application de la pastille précitée.

10 En outre, l'invention est relative à des procédés pour l'obtention desdits substrats ou pastilles.

Les techniques modernes mises actuellement en oeuvre pour réaliser des équipements électroniques, et plus particulièrement des ensembles de traitement de l'information, font de plus en plus appel à l'emploi de dispositifs semi-conducteurs à circuits intégrés non enfermés dans des boîtiers. Ces dispositifs sans boîtier sont désignés le plus souvent sous le nom de pastilles de circuits intégrés ("chips" en langue anglo-saxonne).

20 De telles pastilles formant circuits intégrés et se présentant par exemple sous la forme de plaquettes rectangulaires ou carrées de quelques millimètres de côté et d'une épaisseur de l'ordre du demi-millimètre, possèdent une face inactive pourvue d'une couche isolante de support et une face active pourvue d'éléments de circuit tels que résistances, condensateurs, transistors, diodes, reliés à des bornes situées à la périphérie de ladite surface active.

30 On connaît bien par ailleurs l'emploi des substrats d'interconnexion, qui se présentent communément sous la forme d'une plaquette faite généralement d'un matériau isolant pourvu de conducteurs réalisés sous forme de circuits imprimés sur la plaquette. Ces conducteurs se répartissent habituellement en plusieurs couches séparées par des couches d'isolation et reliées entre elles par des traversées, qui sont des ouvertures pratiquées dans les couches isolantes et remplies d'un matériau conducteur  
35 pour réaliser les connexions entre couches conductrices superposées. La couche conductrice extérieure du substrat d'interconnexion multicouche est pourvue de séries de plots de connexion, chaque série bordant un domaine du substrat qui est réservé à la mise en place d'un composant électronique tel qu'une pastille

20070

de circuits intégrés. On trouvera des exemples de montage de pastilles, formant circuits intégrés, sur un substrat d'interconnexion dans les demandes de brevet déposées en France par la demanderesse le 20 Septembre 1976, sous le n° 76-28170 intitulée "Procédé pour le montage de microplaquettes de circuits intégrés sur un substrat et installation pour sa mise en oeuvre" et le 4 Février 1977, n° 77-03271 intitulée : "Procédé et appareil de montage de dispositifs sur un substrat".

Ces pastilles sont généralement collées sur la face active du substrat en des emplacements prédéterminés et chacune d'entre elles est reliée électriquement au circuit d'interconnexion porté par la face active dudit substrat par des conducteurs de liaison joignant les bornes de la pastille aux plots du domaine correspondant dudit circuit d'interconnexion.

Une structure de ce type est rappelée sur les figures 1 et 2 des dessins ci-joints, lesquelles figures montrent respectivement une vue en coupe longitudinale et une vue de dessus d'un substrat d'interconnexion 1 équipé de pastilles formant circuits intégrés 2a, 2b, 2c, 2d, etc. La face active 1a de ce substrat comporte des plots tels que 3 reliés, par des conducteurs de liaison tels que 4, aux bornes telles que 5 des faces actives telles que 2'a des pastilles telles que 2a ; les références 1b d'une part et 2"a, 2"b, 2"c, 2"d, etc. d'autre part représentent les faces inactives, formées chacune d'une couche isolante de support, respectivement du substrat d'interconnexion et des différentes pastilles.

On a représenté sur la figure 1, pour la pastille 2d seulement, les moyens de protection classiques d'une pastille formant circuit intégré, ces moyens étant constitués par une résine isolante 6 recouvrant la pastille 2d, ses bornes 5, les plots 3, la zone avoisinante de la face active du substrat 1, et enrobant les conducteurs de liaison 4.

Ce type de moyens de protection présente les inconvénients suivants :

a) la résine isolante utilisée étant choisie parmi

03030

celles présentant une bonne résistance aux chocs thermiques et aux basses températures, ne présente pas une bonne résistance mécanique, car il est pratiquement impossible de disposer d'une résine possédant simultanément un  
5 aussi grand nombre de propriétés distinctes ; il en résulte une mauvaise protection mécanique des pastilles entraînant une mauvaise protection vis-à-vis des substances agressives, des poussières, etc. ;

10 b) le simple remplacement d'une pastille défectueuse n'est plus possible après l'application de la résine isolante, puisque cette dernière recouvre aussi les plots du substrat d'interconnexion et au moins les zones du circuit d'interconnexion qui avoisinent ces plots ;

15 c) la réparation des parties du circuit d'interconnexion qui sont recouvertes par la résine isolante n'est pas possible, à moins de dissoudre au préalable la résine dans un agent approprié tel qu'un solvant organique.

La présente invention permet de remédier aux inconvénients précités.

20 La pastille formant circuit intégré selon l'invention est du type comportant une face active pourvue d'éléments de circuit reliés à des bornes situées à la périphérie de ladite face active, et est caractérisée en ce que sa face active est recouverte d'une couche  
25 superficielle de résine isolante, souple ou sous forme de gel solidifié, cette couche s'étendant seulement sur ladite face active.

30 Le substrat d'interconnexion équipé, conforme à l'invention, du type comportant (a) une plaquette de forme quelconque qui constitue ledit substrat d'interconnexion et qui comprend une face active portant un circuit d'interconnexion des différentes pastilles, (b) lesdites pastilles qui sont collées, par celles de leurs faces qui sont opposées à leurs faces actives,  
35 sur ledit substrat d'interconnexion, en des emplacements

040070

prédéterminés de celui-ci, et (c) des conducteurs de liaison  
reliant les bornes précitées des pastilles à des séries de plots  
appartenant audit circuit d'interconnexion, chaque série de  
plots entourant une pastille déterminée, est caractérisé en ce  
5 que la face active de chaque pastille est recouverte d'une cou-  
che superficielle de résine isolante souple ou sous forme de gel  
solidifié.

10 Selon un mode de réalisation préféré de l'invention, le  
substrat d'interconnexion précité est revêtu d'une couche exter-  
ne, de préférence continue, d'une seconde résine isolante,  
rigide et résistante mécaniquement, cette couche externe recou-  
vrant au moins la couche superficielle de résine isolante et les  
plots précités et enrobant les conducteurs qui relient lesdits  
plots aux bornes précitées.

15 Conformément à la présente invention, les résines isolan-  
tes précitées sont de préférence choisies dans le groupe des  
silicones.

20 La résine isolante souple précitée utilisée pour recouvrir  
la face active des pastilles formant circuits intégrés est avan-  
tageusement celle connue sous la dénomination commerciale  
"XR 90714" (Dow Corning) qui présente une résistance volumique  
de l'ordre de  $2 \cdot 10^{15}$  ohm.cm et une résistivité superficielle  
d'environ  $7 \cdot 10^6$  ohms (mesurées selon la norme américaine ASTM-  
D 257), cette résine résistant bien aux chocs thermiques et pou-  
25 vant supporter de basses températures pouvant aller jusqu'à  
environ  $-60^{\circ}\text{C}$ .

30 Au lieu d'utiliser une résine de ce type, la résine de  
silicone recouvrant les pastilles précitées peut aussi, selon  
une variante conforme à l'invention, se présenter sous la forme  
d'un gel solidifié. Par l'expression "gel solidifié", on entend  
un produit dont la structure est celle d'un gel, mais qui possè-  
de, au moins aux températures d'utilisation, une consistance  
suffisamment ferme pour assurer la protection des pastilles,  
étant bien entendu qu'une telle substance peut avoir la consis-  
35 tance habituelle d'une gelée à des températures plus élevées que  
la température d'utilisation, notamment à la température ambian-  
te. Ce gel solidifié peut éventuellement être recouvert d'une  
fine capsule métallique permettant d'éviter l'écoulement ou la  
détérioration accidentelle dudit gel lors d'un éventuel maintien

7



auxdites températures plus élevées. Comme exemple d'un tel gel isolant électriquement, on peut citer le gel de silicone connu sous la dénomination commerciale "Q3-6527" (Dow Corning) qui présente une consistance appropriée à basses températures et qui peut être utilisé jusqu'à des températures de l'ordre de -60°C (résistivité volumique de  $1,42 \cdot 10^{15}$  ohm.cm).

La résine isolante rigide et mécaniquement résistante formant la couche externe précitée est avantageusement celle connue sous la dénomination commerciale "XR 648" (Dow Corning) et elle est avantageusement utilisée en association avec une couche superficielle en la résine "XR 90714" précitée. L'analogie de structure de ces deux résines entraîne une bonne compatibilité entre lesdites résines et une bonne adhérence entre lesdites deux couches.

Cette résine "XR 648" possède une résistivité volumique de  $26 \cdot 10^5$  ohm.cm, une très bonne résistance mécanique et une grande dureté et elle résiste également à des températures pouvant aller jusqu'à -30°C, ce qui lui permet de jouer un rôle de protection efficace des pastilles formant circuits intégrés, en renforçant considérablement le rôle protecteur de la résine "XR 90714". Si elle était utilisée seule, en recouvrement direct de la face active d'une pastille, cette résine "XR 648" serait trop rigide, insuffisamment résistante aux chocs thermiques et elle ne pourrait pas jouer un rôle protecteur adéquat.

Il résulte de ce qui précède que l'inconvénient a) exposé plus haut est précisément éliminé par la présente invention.

D'autre part, il est facile de remplacer une pastille d'un substrat d'interconnexion par une autre, dans un but quelconque (réparation ou modification de circuit électrique) même après avoir partiellement protégé ladite pastille par la couche superficielle de résine isolante souple précitée, à condition que la couche externe de résine isolante, rigide et résistante mécaniquement, n'ait pas encore été appliquée sur ladite couche superficielle et ce, soit avant soudage des conducteurs de liaison aux plots du substrat d'interconnexion, soit après un tel soudage ; il est en effet beaucoup plus aisé et rapide de rompre les points de soudure, de changer de pastille et d'effectuer le soudage des conducteurs de liaison de la nouvelle pastille auxdits plots qu'il est de procéder à la dissolution d'une résine qui enroberait

les conducteurs et plots, d'effectuer ensuite les opérations de déssoudage, remplacement de pastille et ressoudage, et de protéger enfin la nouvelle pastille par de la résine.

L'inconvénient b) exposé plus haut est donc également  
 5 éliminé par la présente invention.

En outre, on peut procéder à la réparation ou modification éventuelle de n'importe quelle partie du circuit d'interconnexion appartenant au substrat d'interconnexion, même après avoir muni  
 10 les pastilles formant circuits intégrés de la couche superficielle de résine isolante souple et disposé et/ou fixé et/ou relié électriquement ces pastilles sur le ou au substrat d'intercon-  
 15nexion, ce qui élimine l'inconvénient c) mentionné plus haut.

L'invention présente aussi un avantage supplémentaire exposé ci-après. Par le choix judicieux des deux résines et d'un  
 15 agent de solubilisation ou d'enlèvement sélectif vis-à-vis de calles-ci, par exemple un solvant organique agissant sélective-  
 20ment vis-à-vis desdites résines, il est possible d'éliminer la couche externe sans enlever, voire sans altérer d'aucune  
 25manière, la couche superficielle sous-jacente recouvrant la face active de chaque pastille, de façon à permettre les réparations  
 30sélectives du circuit d'interconnexion, des plots ou des conduc-  
 35teurs de liaison précités.

Bien entendu, on peut aussi procéder à l'enlèvement éven-  
 25tuel de la couche superficielle d'une pastille isolée protégée conformément à l'invention ou bien à l'enlèvement des deux cou-  
 30ches de protection d'un substrat d'interconnexion équipé de ces pastilles, soit à l'aide d'un seul agent de solubilisation  
 35agissant sur lesdites deux couches, soit à l'aide, successive-  
 40ment, de deux agents agissant sélectivement et successivement sur chacune desdites couches et ce, afin de réparer éventuelle-  
 45ment certains circuits intégrés ou d'en modifier les caractéris-  
 50tiques électriques.

Selon un mode de réalisation préféré de la présente inven-  
 35tion, la quantité de résine de la couche superficielle de chaque pastille est telle que la surface externe de cette couche fait,  
 40au niveau des bords de la face active de la pastille, un angle de l'ordre de 25 à 45 degrés, ces valeurs étant liées au procédé  
 45préférentiellement mis en oeuvre pour former ladite couche super-  
 50ficielle ainsi qu'il apparaîtra plus loin.

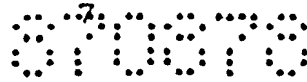

Un procédé d'obtention d'une pastille formant circuit intégré selon l'invention est caractérisé en ce qu'il consiste à recouvrir la face active de ladite pastille d'une résine isolante, à l'état fluide ou pâteux, et à provoquer la prise en masse de celle-ci par polymérisation (par exemple par chauffage et/ou séchage), de façon à obtenir une résine isolante, souple ou sous forme de gel, et à refroidir ensuite ce gel pour obtenir un gel solidifié.

Selon un mode de réalisation particulier de ce procédé, permettant le garnissage, par la résine isolante de la couche superficielle, de l'espace compris entre la face active de la pastille et les départs des conducteurs de liaison au voisinage des bornes de la pastille, un tel espace pouvant par exemple être d'une hauteur aussi faible qu'une dizaine de microns, on applique tout d'abord une première sous-couche de la résine isolante précitée dans un état suffisamment fluide pour qu'elle s'écoule dans l'espace précité et le garnisse, on prend cette résine en masse par polymérisation, et on applique ensuite, sur ladite première sous-couche, une deuxième sous-couche de la même résine, mais dans un état plus visqueux, obtenu de préférence par prépolymérisation, cette seconde sous-couche étant sous une épaisseur plus grande que la première sous-couche, à la suite de quoi on prend en masse ladite seconde sous-couche, par poursuite de la polymérisation.

Pour obtenir un substrat d'interconnexion protégé, comportant une pastille formant circuit intégré protégé, on peut procéder avantageusement de la façon suivante : on effectue, pour les différentes pastilles portées par le substrat, l'application de la couche superficielle dans les conditions indiquées ci-dessus, à la suite de quoi on réalise l'application, sur la surface active du substrat, de la résine constitutive de la couche externe précitée, de telle sorte que celle-ci puisse acquérir son état final isolant électriquement, rigide et mécaniquement résistant.

La résine isolante de la couche superficielle et/ou celle de la couche externe peuvent être appliquées, sous forme prépolymérisée ou non-polymérisée, éventuellement en l'absence de tout solvant ou agent de dispersion, comme cela est possible dans le cas de la résine de silicone "XR 90714".

La demanderesse a déterminé les conditions optimales de mouillabilité de la résine de la couche superficielle précitée, lors de son application sur la face active d'une pastille, vis-à-vis de cette face active ; l'angle de raccordement  $\theta$  du film ou goutte de résine placé sur ladite face active doit être de préférence de l'ordre de 22 à 45 degrés ; pour une valeur de l'angle  $\theta$  inférieure à 22 degrés, la mouillabilité est trop grande et la faiblesse de cet angle de raccordement est telle que l'épaisseur moyenne de la couche superficielle est trop faible pour assurer une protection efficace de ladite face active ; une épaisseur appropriée est d'environ 2 mm au centre de la pastille formant circuit intégré ; d'autre part, la résine risque de couler au-delà du contour de ladite face active ; pour un angle de raccordement  $\theta$  supérieur à environ 45 degrés, l'adhérence entre la couche superficielle de résine et ladite face active est trop faible et cette couche risque de se détacher spontanément ou d'être accidentellement arrachée, ce qui détériore la pastille ou au moins nuit à la qualité ou efficacité de sa protection.

D'autres caractéristiques, buts ou avantages de la présente invention apparaîtront au cours de la description ci-après, en référence aux figures 3 à 11 ci-annexées dans lesquelles :

- la figure 3 représente, en coupe transversale, une pastille formant circuit électrique intégré protégé conforme à la présente invention ;
- la figure 4 est une vue de dessus de cette même pastille ;
- la figure 5 représente une vue en coupe transversale d'un circuit d'interconnexion équipé de pastilles, formant circuits électriques intégrés protégés, tant ces pastilles que l'ensemble du substrat d'interconnexion équipé desdites pastilles étant conformes à la présente invention ;
- la figure 6 représente une vue en coupe transversale du même substrat d'interconnexion que sur la figure 5, après réalisation d'une protection complémentaire de l'ensemble de la face active de ce substrat, ce mode de réalisation étant également conforme à l'invention ;
- la figure 7 représente une vue en coupe transversale d'une pastille formant circuit intégré protégé selon l'invention, au cours de son processus d'obtention ;

070370

- la figure 8 représente une vue en coupe transversale d'un fragment de substrat d'interconnexion, d'une pastille formant circuit électrique intégré protégé selon la présente invention et d'un film de positionnement de cette pastille, cette figure illustrant la localisation de l'étape d'obtention de la pastille formant circuit intégré protégé, dans le cadre d'un processus connu d'adaptation d'une telle pastille sur un substrat d'interconnexion ;

- la figure 9 représente une vue de dessus de l'ensemble représenté sur la figure 8, à échelle réduite par rapport à la figure 8 ;

- la figure 10 est une vue en coupe transversale d'une pastille formant circuit électrique intégré protégé selon l'invention, où l'on montre l'angle de raccordement  $\theta$  entre la résine et la couche superficielle, à l'état fluide, et la face active de la pastille ;

- la figure 11 est un abaque représentant le cosinus de l'angle de raccordement  $\theta$  en fonction de la tension superficielle de la résine à l'état fluide, en dynes.cm<sup>-1</sup> ; et

- la figure 12 est une vue en perspective représentant une pastille formant circuit électrique intégré protégé conforme à l'invention et du fragment du substrat d'interconnexion qui la porte.

On voit sur les figures 3 et 4, une pastille formant circuit électrique intégré protégé comportant un corps de pastille 6 avec sa face active 6a portant des éléments de circuit (non représentés) reliés aux bornes 7 et sa face inactive 6b formée d'une couche isolante de support, les conducteurs de liaison 8 dont l'une des extrémités est soudée auxdites bornes 7, et la couche superficielle protectrice 9 en résine isolante électriquement et souple ; cette dernière, dans une variante conforme à la présente invention peut être remplacée par une résine isolante sous forme d'un gel solidifié du type indiqué plus haut.

On remarque que la couche superficielle isolante 9 ne s'étend pas au-delà du contour 10 de la face active 6a.

Les figures 5 et 6 montrent un substrat d'interconnexion désigné par la référence générale 11, qui comporte, de manière connue en soi une couche isolante de support 11b qui forme la face inactive du dit substrat et, au-dessus de cette couche 11b, une pluralité de couches isolantes comportant des traversées

conductrices telles que 12 ainsi que, aux interfaces entre ces couches et sur le dessus de la couche supérieure, des conducteurs tous désignés par la référence générale 13 et formant, dans la face active 11a du substrat un circuit d'interconnexion comportant des plots tels que 14. De manière connue en soi, des pastilles formant circuits intégrés ont été collées sur la face active 11a dudit substrat d'interconnexion et les conducteurs de liaison 8 desdites pastilles ont été soudés sur les plots 14. Conformément à la présente invention, la face active 6a des pastilles est recouverte d'une couche superficielle de résine isolante souple 9, comme indiqué précédemment à propos des figures 3 et 4.

Dans le mode de réalisation de la figure 5, les conducteurs de liaison 8, les plots 14 et le circuit d'interconnexion porté par la face active 11a du substrat d'interconnexion 11 ne sont pas recouverts d'une résine isolante, ce qui permet le remplacement éventuel des pastilles formant circuits intégrés par d'autres pastilles du même type, pouvant former des circuits intégrés ayant une autre structure électrique, sans qu'il soit nécessaire de procéder à une dissolution quelconque de résine comme dans les circuits électriques intégrés protégés par résine de l'art antérieur.

Dans le mode de réalisation de la figure 6, les couches superficielles 9 de résine isolante électriquement et souple des différentes pastilles 6a sont recouvertes, de même que toute la face active libre du substrat d'interconnexion 11, d'une couche externe 15 en une résine isolante électriquement, rigide et douée d'une résistance mécanique élevée ainsi que, de préférence, d'une dureté élevée, ce qui permet d'accroître la protection de l'ensemble du circuit vis-à-vis des agents mécaniques et chimiques y compris les plus usuels tels que l'humidité, l'action de l'air, les vapeurs agressives, les poussières, etc.

La résine de la couche superficielle 9 est notamment la résine de silicone connue sous la dénomination commerciale "XR 90714" tandis que celle de la couche externe 15 est notamment la résine de silicone connue sous la dénomination commerciale "XR 648", ou la résine "XR 90714" ou le gel de silicone "93-6527".

# BREVET

La figure 7 montre comment peut être obtenue une pastille formant circuit électrique intégré protégé, conforme à l'invention. Cette pastille, sur les bornes 7 de la surface active 6a de laquelle on a soudé des tronçons de conducteurs 8 (dont les extrémités opposées aux bornes 7 restent ici provisoirement libres), est placée sur un support approprié 16, à la suite de quoi on applique la couche superficielle de résine 9, soit en procédant en une seule application, soit en procédant en deux applications de la manière indiquée ci-après dans le cas de l'utilisation de la résine de silicone "XR 90714".

On modifie tout d'abord les caractéristiques d'écoulement de la résine XR 90714 disponible dans le commerce en augmentant sa viscosité par polymérisation partielle ou prépolymérisation, sous l'action d'un chauffage ; celui-ci est effectué pendant 2 minutes à 125°C, ce qui donne un produit dont la viscosité est de 6000 centipoises à 20°C (temps de montée à 125°C : 3 minutes ; temps de descente à 20°C : 2 minutes) ; dans ces conditions l'étalement de la résine sur la face active de la pastille, à 20°C, est régulier et l'angle de raccordement  $\theta$  est compris entre 25 et 45°, ce qui donne une épaisseur moyenne suffisante à la couche superficielle.

Le tableau ci-après montre l'influence de la durée du chauffage à 125°C sur la qualité du dépôt de résine sur la face active de la pastille formant circuit intégré.

	Temps de maintien à 125°C			
	0 mn	2 mn	3 mn	5 mn
Viscosité à 20°C	4 000 cps fluide	6.000 cps sirop	9.000 cps pâte	25.000 cps graisse
Forme du dépôt de résine après polymérisation complète	étalement trop important $\theta < 25^\circ$	dépôt correct $25^\circ < \theta < 45^\circ$	dépôt correct $25^\circ < \theta < 45^\circ$	dépôt irrégulier

Pour l'application proprement dite de la résine XR 90714 précitée on procède alors comme il suit :

5 - on étend tout d'abord, à l'aide d'un fin pinceau, une couche de résine non-prépolymérisée sur la face active de la pastille ; cette résine non-prépolymérisée est suffisamment fluide pour s'étaler parfaitement sur toute la surface active et notamment dans l'espace de faible épaisseur situé sous les départs des conducteurs de liaison, au voisinage des bornes de la pastille ; on effectue ensuite la polymérisation pendant 10 heure à 125°C (la résine ayant été auparavant additionnée de 10% d'un catalyseur approprié) ;

15 - on utilise ensuite la résine XR 90714 ayant été prépolymérisée pendant 2 minutes à 125°C, de la manière indiquée ci-dessus, et contenant également la proportion précitée de catalyseur ; l'application de cette seconde sous-couche de résine XR 90714 s'effectue à l'aide d'un fin pinceau ; toutefois, en raison de la plus grande viscosité de la résine, on obtient une couche superficielle 9 d'une épaisseur suffisante, qui n'aurait pu être obtenue avec la seule résine fluide non-prépolymérisée 20 (l'angle de raccordement  $\theta$  aurait alors été trop faible) ; on effectue la polymérisation de cette seconde sous-couche par chauffage à 125°C pendant 2 heures.

25 Dans le mode de réalisation des figures 8 et 9, on a procédé à l'application de la couche superficielle 9 des pastilles formant circuits intégrés 6 après avoir, de manière connue en soi, rendu lesdites pastilles solidaires d'un film de support 17 permettant le pré-positionnement des pastilles 6 par rapport au substrat d'interconnexion 11.

30 Ce film de support 17 est pourvu de fenêtres telles que 17a dans lesquelles sont logées les pastilles 6 ; à cet effet, le film 17 comprend des bandes conductrices, telles que 18, obtenues par métallisation de la surface du film 17, lesdites bandes se prolongeant, en 18a, au-dessus des fenêtres telles que 17a, ces prolongements 18a étant destinés à former les conducteurs de liaison 9 reliant les bornes 7 des pastilles aux plots 14 de la 35 face active 11a du substrat d'interconnexion 11.

De manière connue en soi, on a centré les pastilles 6 dans les fenêtres telles que 17a, elles-mêmes centrées au-dessus des emplacements de la face active du substrat d'interconnexion 11



# ANOTE

qui sont destinés à recevoir lesdites pastilles.

On procède alors, conformément à la présente invention, à l'application de la couche superficielle 9 de résine isolante et à sa polymérisation (dans la position représentée en traits  
5 continus sur la figure 8).

De manière en soi connue, on découpe ensuite, suivant le contour 19, les bandes conductrices 18 et, la face inactive 6b des pastilles 6 étant revêtue d'une composition adhésive, on applique lesdites pastilles aux emplacements correspondants de  
10 la face active 11a du substrat d'interconnexion 11, de manière à fixer lesdites pastilles sur ce substrat ; on procède alors au séchage de la composition adhésive et au soudage des prolongements 18a, devenus les conducteurs de liaison 8, sur les plots 14 portés par la face active du substrat d'interconnexion 11.

15 Lorsque cette opération est terminée, et après toutes les vérifications souhaitables, on procède à l'application de la couche externe 15 de résine rigide et résistante mécaniquement, non représentée sur la figure 8, mais visible sur la figure 6.

On retrouve sur la figure 10 la pastille formant circuit  
20 intégré 6, munie de la couche superficielle de résine isolante souple 9 dont l'angle de raccordement avec la face active 6a de la pastille 6 est désigné par l'angle  $\theta$ . La courbe de la figure 11 donne le cosinus de l'angle  $\theta$  en fonction de la tension superficielle à l'état non-polymérisé de la résine (l'angle  $\theta$  n'est  
25 substantiellement pas modifié lors de la polymérisation de la résine sur la face active de la pastille). Pour les raisons indiquées plus haut, l'angle de raccordement  $\theta$  est de préférence compris entre  $25^\circ$  et  $45^\circ$ , ce qui correspond à  $\cos \theta$  compris entre environ 0,9 et 0,7 et par conséquent, à une tension super-  
30 ficieuse comprise entre environ 30 et 36 dynes/cm. C'est donc cette tension superficielle de la résine utilisée, relativement à la face active de la pastille, que doit posséder la résine au moment de son application.

Il convient d'ajouter que, pour obtenir une couche super-  
35 ficieuse présentant les meilleures caractéristiques possibles, il convient de dégazer la résine, ce qui est par exemple obtenu par maintien pendant 20 minutes sous une pression de 2 mmHg, et de mettre en oeuvre un appareillage automatique pour appliquer la résine, de manière à obtenir des conditions précises et

reproductibles d'application ; à titre d'exemple non limitatif, on peut utiliser un dispositif de délivrance de gouttes liquides fabriqué par la firme Laurier Associates Inc., Modèle M101, les gouttes étant de préférence délivrées à une distance de l'ordre de 2 mm au-dessus de la face active des pastilles.

On retrouve sur la figure 12 le substrat d'interconnexion 11, les plots 14, les conducteurs de liaison 8, la pastille formant circuit intégré 6 munie de sa couche superficielle 9 de résine isolante souple ; on remarque que l'angle de raccordement  $\theta$  présente ici une valeur de l'ordre de 40 à 45°.

La viscosité de la résine "XR 648" au moment de son application doit être de préférence comprise entre 80 et 140 centipoises ; elle est alors en mélange avec une quantité sensiblement égale de xylène (49 à 52% de solides dans la résine fluidifiée) ; une épaisseur de 1,5 mm de la couche externe, au-dessus de la couche superficielle, est suffisante. La polymérisation de cette résine s'effectue par chauffage à 150°C pendant 2 heures.

Au lieu d'utiliser la résine "XR 90714" pour former la couche superficielle, on peut former un gel de silicone de la manière suivante : on mélange, au moment de constituer cette couche, la résine de silicone A et le durcisseur B du produit connu sous la dénomination commerciale Q3-6527 (Dow Corning) ; on obtient un mélange de densité 0,97 dont la viscosité est de 510 centistokes ; l'extrait sec est de 98,2% . après application du mélange du mélange ainsi obtenu, on polymérise la résine pour obtenir un gel, dans les conditions suivantes : chauffage à 65°C pendant 4 heures, puis à 100°C pendant 1 heure, puis à 150°C pendant 15 minutes.

La réparation d'un substrat revêtu de la couche superficielle 15 constitue de l'une des résines isolantes précitées peut être effectuée par dissolution de ladite couche dans divers solvants organiques ; l'un de ceux qui sont les plus faciles à mettre en oeuvre et celui connu sous la dénomination commerciale "WEHA-SOLVE SI" (S. C. P. C.) qui permet l'élimination de ladite couche superficielle par digestion à la suite de l'immersion de ladite pastille ou de l'immersion d'une partie du circuit d'interconnexion pendant par exemple 6 mn à 110°C dans ce solvant ; les parties métalliques et les couches

070070

5 de matière isolante ne sont pas attaquées (aucune corrosion) tandis que l'adhésion de la pastille au substrat n'est pas altérée à condition de bien rincer le solvant après digestion et d'avoir choisi une colle ou composition adhésive appropriée pour la fixation de la pastille sur le substrat.

10 Bien entendu, l'invention n'est nullement limitée aux modes d'exécution décrits et représentés qui n'ont été donnés qu'à titre d'exemple. En particulier, elle comprend tous les moyens constituant des équivalents techniques des moyens décrits ainsi que leurs combinaisons, si celles-ci sont exécutées suivant son esprit et mises en oeuvre dans le cadre des revendications qui suivent.

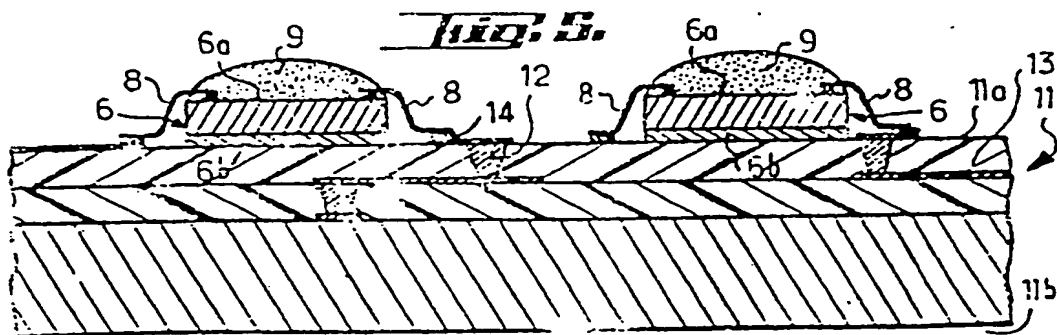
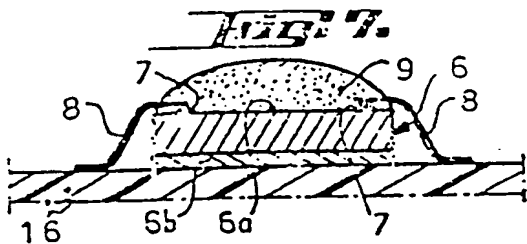
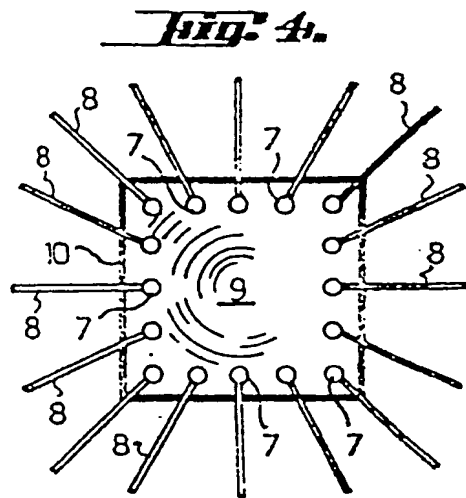
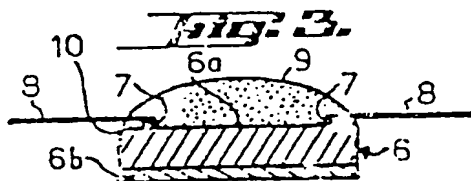
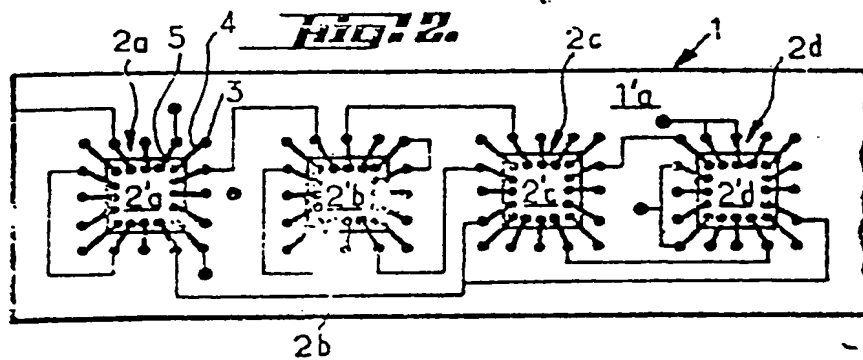
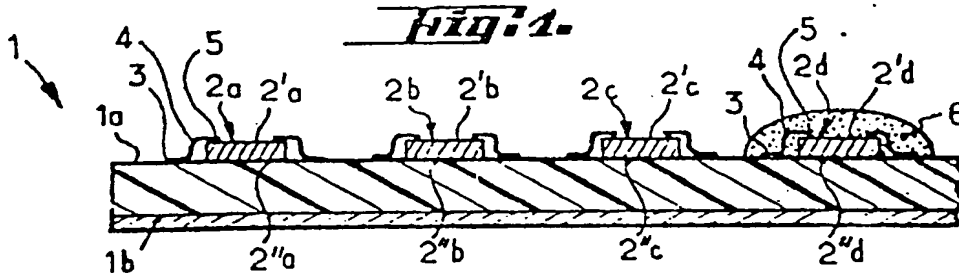

28000000, Ce 1-7 of 1/7/6  
 Figure 16

07070

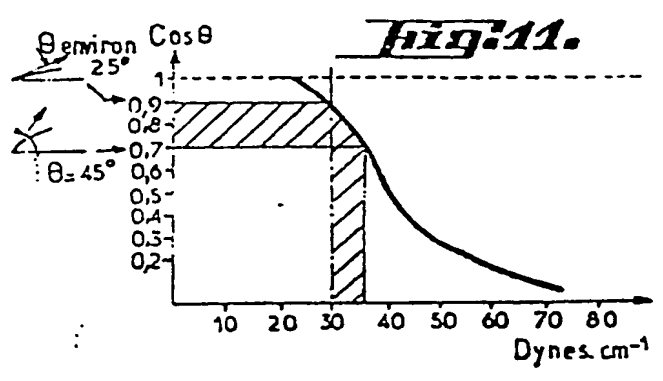
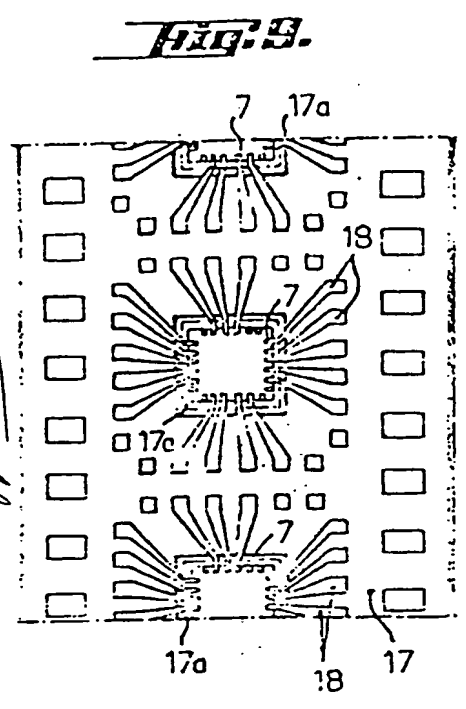
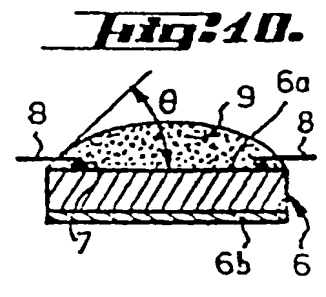
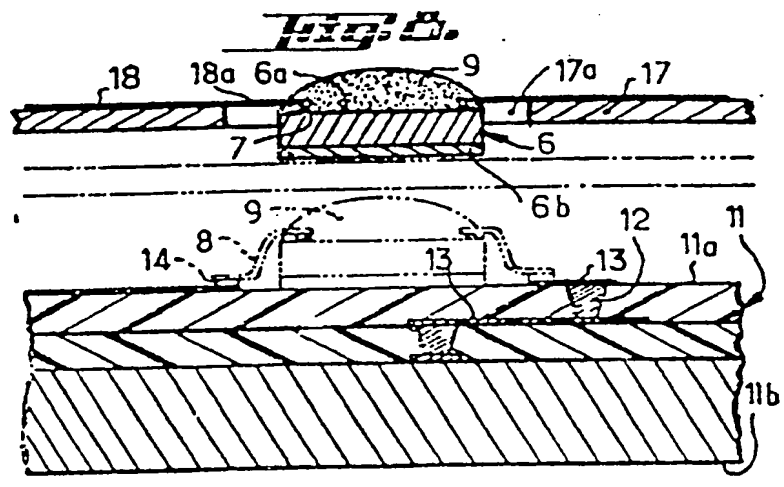
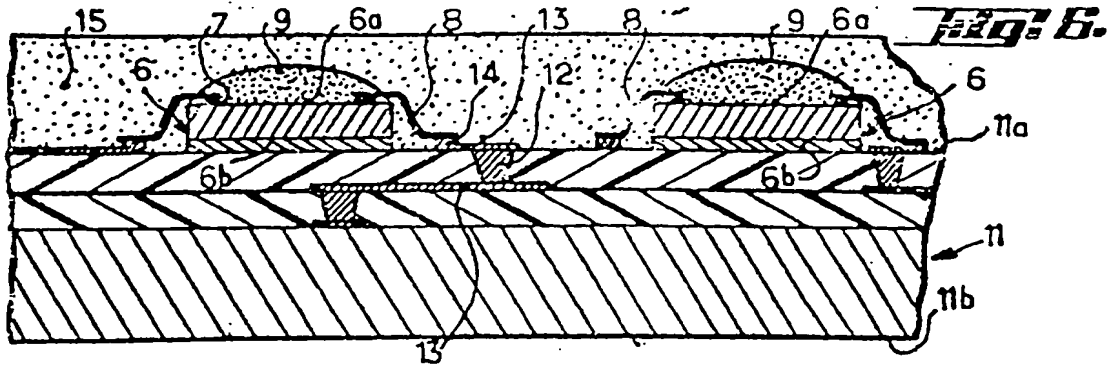

*Handwritten signature*

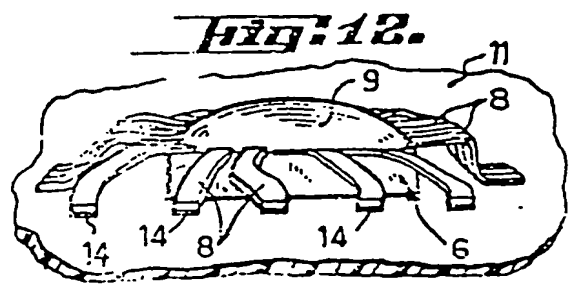

**This Page is Inserted by IFW Indexing and Scanning  
Operations and is not part of the Official Record**

**BEST AVAILABLE IMAGES**

Defective images within this document are accurate representations of the original documents submitted by the applicant.

Defects in the images include but are not limited to the items checked:

- BLACK BORDERS**
- IMAGE CUT OFF AT TOP, BOTTOM OR SIDES**
- FADED TEXT OR DRAWING**
- BLURRED OR ILLEGIBLE TEXT OR DRAWING**
- SKEWED/SLANTED IMAGES**
- COLOR OR BLACK AND WHITE PHOTOGRAPHS**
- GRAY SCALE DOCUMENTS**
- LINES OR MARKS ON ORIGINAL DOCUMENT**
- REFERENCE(S) OR EXHIBIT(S) SUBMITTED ARE POOR QUALITY**
- OTHER:** \_\_\_\_\_

**IMAGES ARE BEST AVAILABLE COPY.**

**As rescanning these documents will not correct the image problems checked, please do not report these problems to the IFW Image Problem Mailbox.**

August 2, 2000

?s pn=de 2539492  
S6 1 PN=DE 2539492  
?t s6/19/

6/19/1

DIALOG(R)File 351:DERWENT WPI  
(c) 2000 Derwent Info Ltd. All rts. reserv.

001685022

WPI Acc No: 1977-C1499Y/197711

**Encapsulated driving motor for pump - is fitted with combined bearing carrier and adaptor plate between pump and motor**

Patent Assignee: HALM R (HALM-I)

Number of Countries: 001 Number of Patents: 001

Patent Family:

Patent No	Kind	Date	Applicat No	Kind	Date	Week
DE 2539492	A	19770310				197711 B

Priority Applications (No Type Date): DE 2539492 A 19750905

Abstract (Basic): DE 2539492 A

The design is particularly applicable to small motors driving circulating pumps in heating systems. A standardised motor encapsulation is employed in conjunction with a specialised a adaptor plate (7) which carries the motor drive end bearing and also joins the motor to the driven component.

The motor core and windings are cast into a housing (14) which also carries the outboard bearing. An endplate (7) is designed to fit the standardised drive end of the motor stator and to form an integral part of the pump housing (1). It is spigoted (8, 9) to both thus joining them together. A standardised motor construction can be employed for a variety of drives by the addition of a special bearings carrying adaptor plate.

Title Terms: ENCAPSULATE; DRIVE; MOTOR; PUMP; FIT; COMBINATION; BEARING; CARRY; ADAPT; PLATE; PUMP; MOTOR

Derwent Class: V06; X11

International Patent Class (Additional): H02K-007/14

File Segment: EPI

?

51

Int. Cl. 2:

H 02 K 7/14

19 BUNDESREPUBLIK DEUTSCHLAND

DEUTSCHES PATENTAMT



Behördenamt

DT 25 39 492 A 1

11

# Offenlegungsschrift 25 39 492

21

Aktenzeichen: P 25 39 492.7

22

Anmeldetag: 5. 9. 75

43

Offenlegungstag: 10. 3. 77

30

Unionspriorität:

32 33 31

54

Bezeichnung: Vorrichtung zum Verbinden eines Elektromotors mit einem Arbeitsgerät

71

Anmelder: Halm, Richard, 7061 Baltmannsweiler

72

Erfinder: gleich Anmelder

DT 25 39 492 A 1



2539492

DIPL.-ING. H. FINK PATENTANWALT · D 7300 ESSLINGEN BEI STUTTGART · HINDENBURGSTRASSE 44

Patentanwalt FINK - D 7300 Esslingen (Neckar), Hindenburgstraße 44

21. August 1975 Z  
P 6294

Richard Halm, 7061 Baltmannsweiler, Silcherstraße 54

"Vorrichtung zum Verbinden eines Elektromotors mit einem Arbeits-  
gerät"

Die Erfindung betrifft eine Vorrichtung entsprechend dem Oberbegriff des Anspruches 1.

Bei einer bekannten Vorrichtung dieser Art sind die gegenseitig angepaßten Gehäuse des Elektromotors und des Arbeitsgerätes unmittelbar miteinander verbunden und der Lagerträger ist innerhalb des Motorgehäuses untergebracht. Der durch die Form des Arbeitsgeräts bedingte Anschlußflansch des Motorgehäuses hat meist einen verhältnismäßig großen Durchmesser, was einen verhältnismäßig hohen Werkstoffaufwand zur Folge hat. Bei der Ausbildung des Arbeitsgerätes als Pumpe ist die Verbindung zwischen den Gehäusen einem hohen Druck unterworfen, der sich insbesondere bei Motorgehäusen aus Kunststoff wegen dessen begrenzter Temperaturbeständigkeit bei hoher Flüssigkeitstemperatur und hoher Wicklungstemperatur nachteilig auswirkt. Eine mechanische Verstärkung des Flansches ist oft aus technischen und wirtschaftlichen Gründen nicht möglich. Das Motorgehäuse muß der jeweiligen Form des Arbeitsgerätes angepaßt werden, was bei der Verschiedenartigkeit der Gehäuse der Arbeitsgeräte auch andere Gehäuseformen des Motors bedingt. Hier-

709810/0208

-2-

durch entstehen hohe Herstellungs- und Formkosten für ein Kunststoffgehäuse. Häufig ist das Ein- und Ausformen der Gießlinge des Motorgehäuses schwierig (DT-OS 2 135 433).

Der Erfindung liegt die Aufgabe zugrunde, die Form des Motorgehäuses weitgehend zu standardisieren. Diese Aufgabe wird durch die Merkmale im Kennzeichnungsteil des Anspruches 1 erfindungsgemäß gelöst. Durch die Zwischenschaltung des Lagerträgers zwischen die Gehäuse des Arbeitsgerätes und des Elektromotors ist es möglich, die Form des Motorgehäuses zu vereinheitlichen und an einer einzigen Art von Motorgehäuse bei entsprechender Ausbildung des jeweiligen Lagerträgers jeweils eine andere Gehäuseform des Arbeitsgerätes anzubringen. Hierdurch wird die Anzahl der zur Anbringung an unterschiedliche Gehäuse der Arbeitsgeräte notwendigen Bauformen des Motorgehäuses wesentlich verringert. Es muß zwar jeweils der Lagerträger an die Form des Gehäuses des Arbeitsgerätes angepaßt werden. Diese Maßnahme ist jedoch weniger aufwendig und weniger schwierig als die jeweilige Anpassung des Motorgehäuses. Dieses läßt sich in einfacher Weise derart ausbilden, daß ein geringer Materialverbrauch vorhanden ist, daß sich nur geringe Formkosten ergeben und daß sich der Gießling des Motorgehäuses in einfacher Weise ein- und ausformen läßt. Der Lagerträger kann außerdem in der Weise ausgebildet werden, daß er einen Teil des statischen Druckes auf seiten des Motors aufnimmt und der Motor nur noch einen geringen Restdruck, wenn das Arbeitsgerät eine Pumpe, insbesondere eine Heizungsumwälzpumpe, ist.

Weitere Vorteile ergeben sich aus den übrigen Ansprüchen, der Beschreibung und der Zeichnung. In dieser ist eine mit einem Motor versehene Heizungsumwälzpumpe als Ausführungsbeispiel des Gegenstandes der Erfindung im Teillängsschnitt schematisch dargestellt.

Eine Heizungsumwälzpumpe 1 hat ein Pumpengehäuse 2, dessen Saugseite mit 3 und dessen Druckseite mit 4 bezeichnet sind. Innerhalb des Gehäuses befindet sich ein Laufrad 5. Das Pumpengehäuse 2 sitzt mit seinem Pumpenflansch 6 in einer Ringnut eines Lagerträgers 7, der mit seinem pumpenseitigen zylindrischen Vorsprung 8 in das Pumpengehäuse 2 hineinragt. Der Lagerträger 7 hat auf der andern Seite einen motorseitigen zylindrischen Vorsprung 9 kleineren Durchmessers, der in eine Statorbohrung 10 eines Elektromotors 11 hineinragt und dort zentriert ist. Zwischen dem Pumpenflansch 6 einerseits und dem Vorsprung 8 andererseits ist ein Dichtring 12 vorgesehen und zwischen dem Außenumfang des Vorsprungs 9 und dem Innenumfang der Statorbohrung 10 ein Dichtring 13.

Der Motor 11 hat ein aus Gießharz bestehendes Motorgehäuse 14, in dem die von einer Isolierkappe 15 teilweise umgebenen Wicklungen 16 eingebettet sind. Das Motorgehäuse 14 umgibt auch ein Statorpaket 17. An dem Motorgehäuse 14 ist ein Anschlußkasten 18 befestigt.

In dem Motorgehäuse 14 ist eine einen Rotor 19 tragende Motorwelle 20 drehbar gelagert, die auf ihrem in das Pumpengehäuse 2 hineinragenden und den Lagerträger 7 durchsetzenden Ende das Laufrad 5 trägt.

Das Motorgehäuse 14 hat auf seiner der Heizungsumwälzpumpe 1 benachbarten Seite einen kreisförmigen Ringflansch 21, der geringfügig übersteht und auf seiten der Heizungsumwälzpumpe 1 eine Stützstelle für die Anlage der Stützstelle des Lagerträgers 7 hat. Dieser umgibt mit seinem Flanschteil 22 den Ringflansch 21 mit Spiel.

Der Flanschteil 22 weist radiale Vorsprünge auf, von denen nur ein Vorsprung 23 dargestellt ist. Der Vorsprung 23 ist durch eine Befestigungsschraube 24 durchsetzt, die in eine Gewindebohrung im Pumpengehäuse 2 eingeschraubt ist. Zwischen dem Kopf

P a t e n t a n s p r ü c h e

1. Vorrichtung zum Verbinden eines ein Gehäuse und einen Lagerträger aufweisenden Elektromotors und eines ein Gehäuse aufweisenden Arbeitsgerätes, insbesondere einer Pumpe, wobei der Lagerträger zwischen dem Rotor des Elektromotors und dem Arbeitsgerät angeordnet ist, dadurch gekennzeichnet, daß der Lagerträger (7) als zwischen den gegenseitig nicht angepaßten Gehäusen (2, 14) angeordnetes und diesen jeweils angepaßtes Verbindungsstück ausgebildet ist, an das auf der einen Seite das Motorgehäuse (14) und auf der anderen Seite das Gehäuse (2) des Arbeitsgerätes angegeschlossen sind.
2. Vorrichtung nach Anspruch 1, dadurch gekennzeichnet, daß der die Gehäuse (2, 14) voneinander trennende Lagerträger (7) auf der einen Seite einen in das Motorgehäuse (14) eingreifenden Vorsprung (9) und auf der anderen Seite einen in das Gehäuse (2) des Arbeitsgerätes eingreifenden Vorsprung (8) aufweist.
3. Vorrichtung nach Anspruch 1 oder 2, dadurch gekennzeichnet, daß der Lagerträger (7) einen Flansch aufweist, an dem auf der einen Seite der in das Gehäuse (2) des Arbeitsgerätes eingreifende Vorsprung (8) und auf der anderen Seite ein einen Flansch (21) am Motorgehäuse (14) mit Spiel übergreifender Flanschteil (22) und eine Stützstelle für den Lagerträger am Motorgehäuse vorgesehen sind.

4. Vorrichtung nach einem der vorhergehenden Ansprüche, dadurch gekennzeichnet, daß mindestens ein am Lagerträger (7) angreifendes Befestigungsglied (24) zum Befestigen der Gehäuse (2, 14) von Elektromotor (11) und Arbeitsgerät (1) an dem Lagerträger dient.
5. Vorrichtung nach Anspruch 4, dadurch gekennzeichnet, daß dem im Lagerträger (7) und in einem der Gehäuse (2, 14) angebrachten Befestigungsglied (24) eine Lasche (26) zugeordnet ist, die an einem Vorsprung (21) am andern Gehäuse (14, 2) ansteht.
6. Vorrichtung nach einem der Ansprüche 2 bis 5, dadurch gekennzeichnet, daß der in das Motorgehäuse (14) eingreifende Vorsprung (9) in dessen Statorbohrung (10) zentriert ist und daß der in das Gehäuse (2) des Arbeitsgerätes (1) eingreifende Vorsprung (8) sich am Außenumfang des Lagerträgers (7) im Bereich von dessen das Motorgehäuse übergreifenden Flanschteil (22) befindet.

709810/0208

7

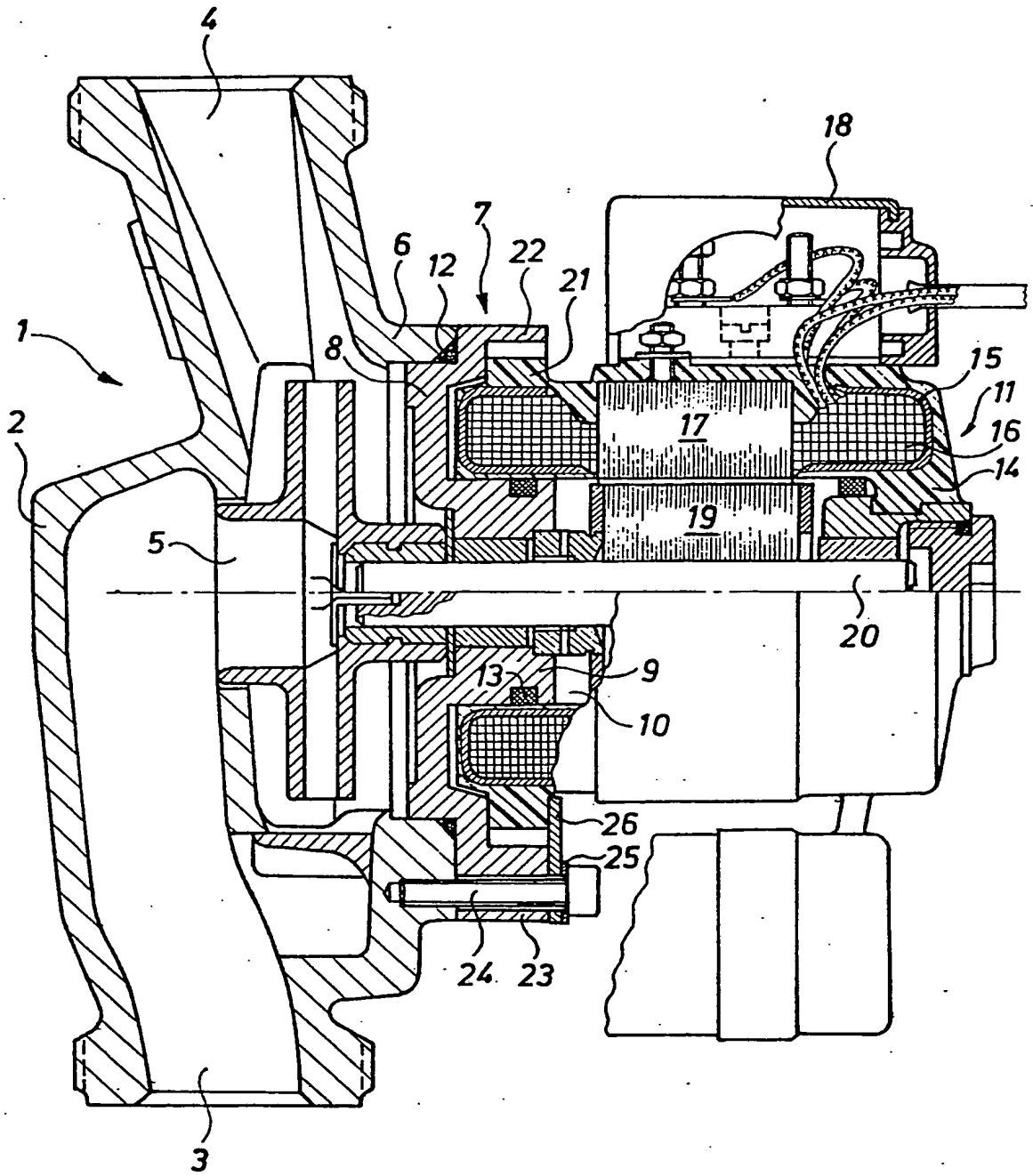

709810/0208

H02K

7-14

AT:05.09.1975 OT:10.03.1977

# EUROPEAN PATENT OFFICE

## Patent Abstracts of Japan

PUBLICATION NUMBER : 05336722  
PUBLICATION DATE : 17-12-93

APPLICATION DATE : 28-07-92  
APPLICATION NUMBER : 04201114

APPLICANT : FUJI ELECTRIC CO LTD;

INVENTOR : FURUKAWA MASA HARU;

INT.CL. : H02K 29/00 H02K 5/08 H02K 5/24  
H02K 21/22

TITLE : SPINDLE MOTOR FOR DRIVING  
MAGNETIC DISC

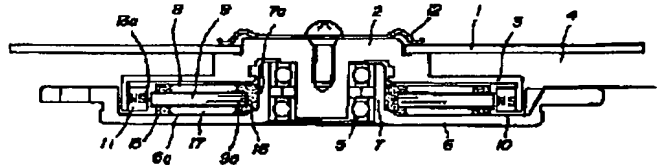

ABSTRACT : PURPOSE: To suppress noise by lessening at least one side of a stator and a rotor.

CONSTITUTION: The vibration and the noise mainly in a stator are suppressed while lessening the influence of dust by injection-molding or cast-molding a stator core 9 and its winding 8, or the stator core 9, its winding 8 and a printed board 10 for letting a current to this winding 8 each integrally, with plastic resin 15, and similarly the vibration on rotor side can be suppressed by paying attention to the structure, too, on rotor side 3, and further the vibration of both the stator and the rotor can be suppressed.

COPYRIGHT: (C)1993,JPO&Japio

**THIS PAGE BLANK (USPTO)**



(19) 日本国特許庁 ( J P )

(12) 公開特許公報 ( A )

(11) 特許出願公開番号

特開平5-336722

(43) 公開日 平成5年(1993)12月17日

(51) Int.Cl. <sup>5</sup>	識別記号	庁内整理番号	F I	技術表示箇所
H 0 2 K 29/00		Z 9180-5H		
5/08		A 7254-5H		
5/24		Z 7254-5H		
21/22		M 7429-5H		

審査請求 未請求 請求項の数7(全 8 頁)

(21) 出願番号	特願平4-201114	(71) 出願人	00005234 富士電機株式会社 神奈川県川崎市川崎区田辺新田1番1号
(22) 出願日	平成4年(1992)7月28日	(72) 発明者	大澤 正弘 神奈川県川崎市川崎区田辺新田1番1号 富士電機株式会社内
(31) 優先権主張番号	特願平4-80125	(72) 発明者	曳田 博 神奈川県川崎市川崎区田辺新田1番1号 富士電機株式会社内
(32) 優先日	平4(1992)4月2日	(72) 発明者	古川 雅晴 神奈川県川崎市川崎区田辺新田1番1号 富士電機株式会社内
(33) 優先権主張国	日本 ( J P )	(74) 代理人	弁理士 松崎 清

(54) 【発明の名称】 磁気ディスク駆動用スピンドルモータ

(57) 【要約】

【目的】 ステータ、ロータの少なくとも一方の振動を少なくして騒音を抑制する。

【構成】 ステータコア9とその巻線8、またはステータコア9、その巻線8およびこの巻線8に電流を流通するためのプリント板10をそれぞれ一体的にプラスチック樹脂15で射出成形または注型成形することにより、塵埃の影響を少なくしながら主としてステータにおける振動および騒音を抑制し、同様に、ロータ3側の構造にも留意することによりロータ側の振動を抑制可能とし、さらにはステータ、ロータ双方の振動を抑制可能とする。

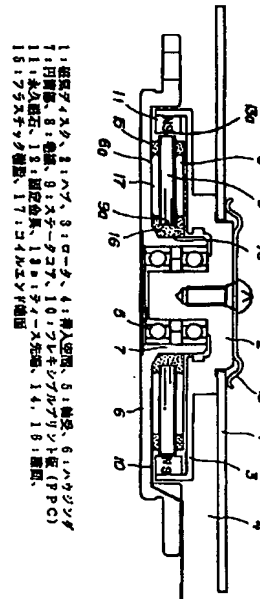

## 【特許請求の範囲】

【請求項1】 界磁用永久磁石を備え、ハウジングの円筒内部に固定された軸受を介して回転自在に支持され、磁気ディスクが搭載されるハブと、ハウジングの円筒外周部に装着され前記界磁用永久磁石に対し僅かな空隙を以て対向するように配置されたステータコアと、このステータコアに巻回されプリント板に電気的に接続される巻線とを有してなる磁気ディスク駆動用スピンドルモータにおいて、前記ステータコアとその巻線、またはステータコア、その巻線およびこの巻線に接続されたプリント板をそれぞれ一括してプラスチック樹脂で射出成形または注型成形することを特徴とする磁気ディスク駆動用スピンドルモータ。

【請求項2】 ハウジングの内筒部に固定された軸受を介して回転自在に支持された磁気ディスクを搭載するハブと、このハブと一体的に形成され界磁用永久磁石を有するロータと、巻線が巻装されハウジングの外筒部に装着され前記界磁用永久磁石と僅かな空隙を以て対向するように配置されるステータとを有してなる磁気ディスク駆動用スピンドルモータにおいて、前記ロータと界磁用永久磁石との間に、プラスチックまたはゴム性のリング状弾性体を介在させて、界磁用永久磁石をロータに固定支持することを特徴とする磁気ディスク駆動用スピンドルモータ。

【請求項3】 ハウジングの内筒部に固定された軸受を介して回転自在に支持された磁気ディスクを搭載するハブと、このハブと一体的に形成され界磁用永久磁石を有するロータと、ハウジングの円筒外周部に装着され前記界磁用永久磁石に対し僅かな空隙を以て対向するように配置されたステータコアと、このステータコアに巻回されプリント板に電気的に接続される巻線とを有してなる磁気ディスク駆動用スピンドルモータにおいて、前記ステータコアとその巻線、またはステータコア、その巻線およびこの巻線に接続されたプリント板をそれぞれ一括してプラスチック樹脂で射出成形または注型成形する一方、前記ロータと界磁用永久磁石との間にプラスチック樹脂またはゴム性のリング状弾性体を介在させて、界磁用永久磁石をロータに固定支持することを特徴とする磁気ディスク駆動用スピンドルモータ。

【請求項4】 前記ステータコアの内径部と、ステータコアが嵌合されるハウジングの円筒外周部との間に隙間を設け、この隙間内にプラスチック樹脂を介在させることを特徴とする請求項1または3に記載の磁気ディスク駆動用スピンドルモータ。

【請求項5】 前記ステータコアの内径部と、ステータコアが嵌合されるハウジングの円筒外周部との間に隙間を設け、この隙間内に比較的低弾性の材料からなるブッシュを嵌合し、このブッシュにステータコアを支持することを特徴とする請求項1または3に記載の磁気ディス

ク駆動用スピンドルモータ。

【請求項6】 前記プラスチック樹脂またはゴム性のリング状弾性体に鉄粉を含む磁性体を混合することにより磁性を持たせることを特徴とする請求項2または3に記載の磁気ディスク駆動用スピンドルモータ。

【請求項7】 前記界磁用永久磁石の一側面と、これに対向するロータの側面との間に隙間を設け、その間に非磁性のプラスチック樹脂またはゴム性の中空円板状弾性体を挿入することを特徴とする請求項2または3に記載の磁気ディスク駆動用スピンドルモータ。

【発明の詳細な説明】

【0001】

【産業上の利用分野】 この発明は、比較的小型の磁気ディスク装置に用いられる、磁気ディスク駆動用DCブラシレススピンドルモータ（以下、単にスピンドルモータともいう）に関する。

【0002】

【従来の技術】 近年、コンピュータのダウンサイジングに伴い、磁気ディスク装置も3.5インチ→2.5インチ→1.8インチと小型化、薄型化が進められており、特にノートパソコンと呼ばれる携帯用パソコンに使用される小型の磁気ディスク装置は、高さ1/2インチ以下で設計されることが殆どである。これに伴い、かかる装置で使用されるスピンドルモータは、例えば軸方向全高寸法が7mm以下と非常に薄型を要求される場合が多い。また、携帯に伴う耐衝撃性の確保、起動トルクなどモータ性能の確保も併せて要求されることになる。

【0003】 図8はこの種のスピンドルモータの従来例を示す断面図である。すなわち、磁気ディスク1を装着されるハブ2に対し、これと一体的に作られたロータ3が磁気ヘッド（図示なし）の挿入空間4を確保して、磁気ディスク1の下方に設けられている。また、ロータ3は軸受5で回転自在に支持されてハウジング6に固定されている。一方、軸受5が挿入されているハウジング6の円筒部7の外筒部7aには、巻線8が巻装されたステータコア9の内径部9aが接着剤で接着または圧入され、ロータ3と同軸的に固定されている。ここで、図示されない駆動回路より予め定められた順序で、巻線8に接続されたフレキシブルプリント板（以下、FPCともいう）10を介して巻線8に電流が通流制御されることにより、ロータ3はステータコア9とロータ3に装着された永久磁石11との間に発生する電磁気力によって、一方向に回転させられる。なお、磁気ディスク1は固定金具12により、ハブ2に対し同軸かつ一体的に固定されて回転するようになっている。

【0004】 以上の説明からも明らかなように、モータ部の厚さは非常に薄く、かつ起動トルクなどのモータ性能を確保するためにモータ部の直径は大きくなっている。例えばハウジング6の下面からロータ3の上面までの高さとして約4mm、ロータ3の外径として約30φ

3

の如き値が要求される。その他、低騒音であること（例えば40dBA以下：Aはoverallの略で、全周波数領域にわたってという意味を表わす）、塵埃の発生は皆無であること、耐衝撃性が大きいことなどが要求される。ここで、ステータコアの寸法について考える。図8におけるステータコア9の厚さ $t_s$ は、ロータ3の厚さ $t_r$ 、ハウジング6の厚さ $t_h$ 、巻線8のコイルエンド厚さ $t_w$ などを差し引くと非常に薄く、例えばハウジング6の下面からロータ3の上面までの高さを約4mmとすると、1mmの寸法も取り得ない。一方、モータ性能を確保するためにはロータ3の外径が大きく、ステータコア9の半径方向の寸法 $L_s$ は長くなる。

【0005】次に、ステータコアの振動について考える。図9は図8のステータコアと永久磁石との関係を示すモータの上面図、図10は図9におけるティースのA-A断面図、図11はステータコアの永久磁石の高さ方向の位置ずれを説明するための概要図である。すなわち、上述のようにステータコア9のティース部(13)は図8に示すように厚さ $t_s$ が非常に薄く、かつ半径方向の長さ $L_s$ が比較的長いので、図9のように半径方向に放射状に延びた薄板の形を成しており、しかもステータコア9の内径部9aは図9、図10には図示していない円筒部7の外筒部7aに固定されているため、ティース13の先端部13aは図10にV1、V2で示す方向に非常に振れ易い構造となっている。そして、各ティース13に装着された巻線8(図8参照)に電流が通流制御されることにより、永久磁石11と各ティース13との間に働く電磁力によって、ティース先端部13aがカンチレバー的に、図10にV1、V2で示す方向に振動することになる。

【0006】上記のような振動は、図11に示すように、ステータコア9と永久磁石11との相対位置がモータ高さ方向(軸方向)に位置ずれを起こした場合に特に生じやすいことが指摘されている。つまり、ステータコア9と永久磁石11との磁気的中心ずれ $L_x$ は、これが僅かでもであると振動が発生し、 $L_x$ が大きくなる程振動も大きくなる傾向にある。この磁気的中心ずれ $L_x$ は、ステータコア9の製造工程や巻線工程の取扱いによるソリや曲がりが発生し、かつ各ティース毎にその大きさも異なる。また、ステータコア9をハウジング6に取り付ける際にも、取り付け誤差や傾きによっても発生する。したがって、全てのティースについて磁気的中心ずれ $L_x$ を無くすことは殆ど不可能であるということになる。

【0007】

【発明が解決しようとする課題】ところで、上記のような振動が生じると、磁気ディスク上のデータを誤読するおそれがあるだけでなく、これが巻線に流れる電流の転流周波数と一致すると、非常に耳障りな電磁騒音を発生する。また、ステータコア9の内径部9aから図8の円筒部7に振動が伝わり、ハウジング6全体を振動させて

4

さらに騒音が増大することになる。図12に図8の構成によるスピンドルモータの騒音分析スペクトラムの1例を示す。同図の $f_1$ は巻線に流れる電流の通電制御周波数(転流周波数)に一致し、 $f_2$ 、 $f_3$ はその整数倍の周波数を示す。これは、要求される騒音値を満足できないばかりでなく、騒音値では表わせない非常に耳障りな特異な音であり、またモータ全体および磁気ディスク装置全体を振動させる原因ともなっている。

【0008】ここで、塵埃について考える。すなわち、ステータコアおよび巻線の製造、組立工程等においては、何らかの原因で塵埃が付着することが考えられる。各部品は空調された清浄な室内で製造されることにも、各製造工程毎に清浄されて塵埃は殆ど除去されているが、例えば巻線工程において巻線に付着している僅かな塵埃などが巻線時に一緒に巻き込まれると、清浄によってもこれを取り去ることは困難である。この塵埃は、モータの使用中に図8に示すロータ3とハウジング6の隙間14を通して磁気ディスク1に付着し、図示されない磁気ヘッドや磁気ディスク1を損傷することになる。したがって、この発明の課題は振動を抑制して騒音を減らすこと、さらには塵埃の影響を極力少なくすることにある。

【0009】

【課題を解決するための手段】このような課題を解決するため、第1の発明では、界磁用永久磁石を備え、ハウジングの円筒内部に固定された軸受を介して回転自在に支持され、磁気ディスクが搭載されるハブと、ハウジングの円筒外周部に装着され前記界磁用永久磁石に対し僅かな空隙を以て対向するように配置されたステータコアと、このステータコアに巻回されプリント板に電気的に接続される巻線とを有してなる磁気ディスク駆動用スピンドルモータにおいて、前記ステータコアとその巻線、またはステータコア、その巻線およびこの巻線に接続されたプリント板をそれぞれ一括してプラスチック樹脂で射出成形または注型成形することを特徴としている。

【0010】第2の発明では、ハウジングの内筒部に固定された軸受を介して回転自在に支持された磁気ディスクを搭載するハブと、このハブと一体的に形成され界磁用永久磁石を有するロータと、巻線が巻装されハウジングの外筒部に装着され前記界磁用永久磁石と僅かな空隙を以て対向するように配置されるステータとを有してなる磁気ディスク駆動用スピンドルモータにおいて、前記ロータと界磁用永久磁石との間に、プラスチックまたはゴム性のリング状弾性体を介在させて、界磁用永久磁石をロータに固定支持することを特徴としている。

【0011】第3の発明では、ハウジングの内筒部に固定された軸受を介して回転自在に支持された磁気ディスクを搭載するハブと、このハブと一体的に形成され界磁用永久磁石を有するロータと、ハウジングの円筒外周部に装着され前記界磁用永久磁石に対し僅かな空隙を以て

対向するように配置されたステータコアと、このステータコアに巻回されプリント板に電気的に接続される巻線とを有してなる磁気ディスク駆動用スピンドルモータにおいて、前記ステータコアとその巻線、またはステータコア、その巻線およびこの巻線に接続されたプリント板をそれぞれ一括してプラスチック樹脂で射出成形または注型成形する一方、前記ロータと界磁用永久磁石との間にプラスチック樹脂またはゴム性のリング状弾性体を介在させて、界磁用永久磁石をロータに固定支持することを特徴としている。

【0012】なお、上記第1または第3の発明では、前記ステータコアの内径部と、ステータコアが嵌合されるハウジングの円筒外周部との間に隙間を設け、この隙間内にプラスチック樹脂を介在させるか、比較的低弾性の材料からなるプッシュを嵌合し、このプッシュにステータコアを支持することができる。また、上記第2または第3の発明では、前記プラスチック樹脂またはゴム性のリング状弾性体に鉄粉を含む磁性体を混合することにより磁性を持たせるか、前記界磁用永久磁石の側面と、これに対向するロータの側面との間に隙間を設け、その間に非磁性のプラスチック樹脂またはゴム性の中空円板状弾性体を挿入することができる。

【0013】

【作用】ステータコアとその巻線、またはステータコア、その巻線およびこの巻線に接続されたプリント板をそれぞれ一括してプラスチック樹脂で射出成形または注型することにより、振動を抑制し塵埃の影響を少なくする。また、ステータコアの内径部と、ステータコアが嵌合されるハウジングの円筒外周部との間に隙間を設け、この隙間内にプラスチック樹脂を介在させるか、または比較的低弾性の材料からなるプッシュを嵌合し、このプッシュにステータコアを支持することによりその振動がハウジングに伝達されないようにする。さらには、上記界磁用永久磁石の外周部とロータ内周部との間にプラスチック樹脂またはゴムを介在させるか、これらの手法を組み合わせることに、振動の抑制を図る。

【0014】

【実施例】図1はこの発明の実施例を示す構成図で、スピンドルモータの断面図を示す。これは、巻線8とステータコア9、あるいは巻線8、ステータコア9およびFPC10をプラスチック樹脂15により一体的に射出成形し、ハウジング6の円筒部7に圧入または接着固定して構成したものである。また、ステータコア9の内径部9aと円筒部7との隙間16にプラスチック樹脂15を埋め込むことにより、ステータコア9の内径部9aが円筒部7の外筒部7aとは直接接触しないようにし、ステータコア9の振動がハウジング6に伝わらないようにしている。一方、ハウジング6のモータ内部側の面6aはプラスチック樹脂15で一体化された巻線8のコイルエンド端面17に当接しており、これにより永久磁石11

とステータコア9の磁気中心が一致するように、プラスチック樹脂の成形寸法が予め定められている。また、モータ内部側の面6aとコイルエンド端面17とが当接していることから、ステータコア9の取り付け時の傾きも無くすることができる。なお、その他の点は従来例と同じである。

【0015】いま、巻線8にFPC10を介して図示していない駆動回路から電流が通電制御されると、従来例の場合と同じく永久磁石11とステータコア9との間に電磁力が発生し、これによって図示されないティースの先端部に振れが生じるが、ここでは、プラスチック樹脂15によってステータコア9全体が一体的に覆われかつ固められているため、その動きが抑制されることになる。また、ステータコア9は隙間16によってハウジング6の円筒部7とは直接接触していないため、振動がハウジング6に直接伝わることもない。ここで、プラスチック樹脂15としては適当な弾性を持ち、かつ磁気ディスク1に悪影響を与えない材料、例えばポリブチレンテレフタレート(PBT)樹脂などを用いるようにする。

【0016】図2、図3はスピンドルモータの騒音特性を示す周波数スペクトル図で、図12と同様の条件で測定したものである。図2は巻線8、ステータコア9およびFPC10をプラスチック樹脂15により一体的に射出成形したスピンドルモータであるが、ステータコア9の内径部9aを円筒部7の外筒部7aと直接接触させて接着した場合の騒音スペクトルである。この図からも明らかのように、巻線8に流れる通電制御周波数(転流周波数) $f_1$ 、 $f_2$ 、 $f_3$ が図12の場合に比して低減していることが分かる。ただ、図12に示す第1次、2次の転流周波数 $f_1$ 、 $f_2$ 付近のスペクトルの盛り上がりは、ステータコア9の振動が直接ハウジング6に伝達されているので、図2では小さくなってはいるものの、完全に無くなっているわけではない。

【0017】一方、図3はステータコア9の内径部9aと円筒部7との隙間16にプラスチック樹脂15を埋め込むことにより、ステータコア9の内径部9aが円筒部7の外筒部7aとは直接接触しないようにした場合の騒音スペクトルである。この図によれば、転流周波数 $f_1$ 、 $f_2$ 、 $f_3$ のレベルが図2の場合よりも更に低減されるばかりでなく、第2次の転流周波数 $f_2$ 付近のスペクトルの盛り上がりも無くなっている。これは、隙間16をプラスチック樹脂15で埋めたことにより、振動のハウジング6への伝達が抑制されるためと考えられる。なお、騒音測定結果の1例を示すと、図12の場合の騒音は約40dBA、図2では36dBA、図3では33dBAであり、この発明によるものが騒音抑制効果が1番優れていることが分かる。

【0018】図4は巻線8、ステータコア9およびFPC10を一体的に射出成形する方法の1例を説明するための説明図で、成形金型18に挿入した状態を示す断面

7

図である。すなわち、ステータコア9に巻線8を巻装し、FPC10に巻線8のリード線8aをハンダ付けした状態で成形金型18に装着する。成形金型18の溝面18a, 18bの対向寸法はステータコア9の積層寸法と同じであり、溝面18cはステータコア9の外径と嵌合する直径寸法とし、成形金型18のボス19の直径寸法はハウジング6の円筒部7の外筒部7aの直径寸法と同じで、かつ溝面18cと同軸に形成されている。また、成形金型18の溝面18dから溝面18bまでの寸法Lyは、樹脂成形されたステータコア9をハウジング6に取り付けたとき、永久磁石11との磁気的中心位置が一致する寸法にしている。

【0019】すなわち、

(1) ティース13の先端部13aを溝面18a, 18bで挟み、複数のティース13の積層方向(高さ方向)のばらつきを無くし、正確な位置決めができるようにする。

(2) 溝面18cによりステータコア9の直径方向の位置決めを行ない、ボス19を同軸に配置することにより、全円周方向にわたって均一な隙間16が形成されるようにする。

の如く成形金型の形状、寸法を定めた状態で、成形金型18の樹脂注入口20を通してプラスチック樹脂15を射出成形することにより、ステータコア9と巻線8、またはステータコア9、巻線8およびFPC10を一括して一体的に成形する。なお、射出成形する代わりに、液状の樹脂を成形金型に流し込んで注型成形することもできる。

【0020】図5は図1の成形方法の他の例を説明するための断面図である。これは、ステータコア9の内径部9aと円筒部7の外筒部7aとの間の隙間16に、プラスチック樹脂15とは別の材料で形成したプッシュ21を配置して構成したものである。ここで、プラスチック樹脂15としては比較的固い樹脂、例えばエポキシ系樹脂(PBTを含む)を使用し、ステータコア9のティース13の振動を積極的に抑制するようにする。また、プッシュ21の材料としては比較的柔らかい樹脂、例えばブチルゴムなどを用いて製作し、これによりステータコア9の振動がハウジング6に伝わるのを抑止するようにする。

【0021】以上では、主としてステータ側の振動を抑制する場合について説明したが、振動の抑制についてはロータ側についても同様に考慮する必要がある。図6はかかる観点にもとづくこの発明の他の実施例を示す部分断面図である。図6(イ)はロータ3の円筒部の内径面3aと界磁用永久磁石11の外周側11aとの間に隙間を設け、そこにリング状弾性体22を挿入したものである。リング状弾性体22は磁性または非磁性のプラスチック樹脂若しくはゴムで、隙間寸法に合わせて射出成形または注型で作成し、隙間に挿入して接着剤23で固定

8

する。この他、図示されない治具で界磁用永久磁石11とロータ3を同軸上に位置決め固定し、隙間にプラスチック樹脂を射出成形してリング状弾性体22を一体的に製作する方法を採ることもできる。この方法によれば、接着剤を使用せずに済み、また治具で軸偏心がないように同軸上に置くことにより、界磁用永久磁石11やロータ3の製作寸法誤差を吸収して回転アンバランスを僅少にすることができる。

【0022】ところで、ロータ3は磁性体で作られており、その円筒部は界磁用永久磁石11の継鉄(ヨーク)の役目も果たしている。したがって、この円筒部と界磁用永久磁石11との間に隙間を開けリング状弾性体22を挿入すると、そのヨークとしての効果が減少して界磁用永久磁石11の磁束量が減少することがある。この場合は、リング状弾性体22の材料として鉄粉などを混入した磁性プラスチック樹脂、または磁性ゴムを使用することにより、磁束量が減少しないようにすることができる。

【0023】図6(ロ)に(イ)の変形例を示す。これは、界磁用永久磁石11の一側面11bと対向するロータ3の一側面3bとの間に、中空円板状弾性体24を挿入したものである。つまり、界磁用永久磁石11の側面からロータ3に伝わる振動をも減衰させる目的で構成したものであり、中空円板状弾性体24の材質を非磁性とすることにより、界磁用永久磁石11の側面からロータ3に漏洩する磁束を低減する効果もある。その組み立て、製作方法はリング状弾性体22を磁性体、中空円板状弾性体24を非磁性体とする場合は別々に作って接着剤で固定し、磁性または非磁性の同材料とする場合は、(イ)の場合と同様に治具を用いて一体的に射出成形することもできる。

【0024】図6(ハ)にさらに別の変形例を示す。これは、界磁用永久磁石11をプラスチック樹脂による射出成形でその全体を覆ったものである。すなわち、図示されない治具でロータ3と界磁用永久磁石11を同軸上になるように位置決めしつつ接着剤23により、界磁用永久磁石11の一側面11bをロータ3の一側面3bに仮り止めしておく。その後、図示されない別の治具を用い、界磁用永久磁石11全体を覆うようにプラスチック樹脂25を射出成形して製作する。このようにすれば、図6(イ)と同様の効果を持たせることができるだけでなく、モータ組み立て時の接触衝撃による界磁用永久磁石11の割れや欠けが発生し難くなり、さらには発生した微小な磁石片が飛び散らないため、その磁気ディスクへの付着を無くすることができる。この場合、プラスチック樹脂25は非磁性とするのが良い。

【0025】図7にこの発明のさらに他の実施例を示す。同図からも明らかなように、この実施例はステータとロータの双方に工夫をこらしたもので、ステータ側については図1に示すものと構造、作用も同じなのでその

説明は省略し、図1との相違点について以下に説明する。すなわち、界磁用永久磁石11とロータ3の円筒部との間に、図6で説明した如きプラスチック樹脂またはゴムで作られたリング状弾性体22を設ける。こうすれば、界磁用永久磁石11とステータコア9との間に働く電磁力によって生じる界磁用永久磁石11の振動が、このリング状弾性体22によって減衰され、ロータ3には殆ど伝わらないようになる。このリング状弾性体22としては、ステータコア9などを射出成形したプラスチック15と同様の適度な弾性力を持つ材料、例えばPBT樹脂を用いることができ、さらに減衰効果を持たせる場合はゴムを使用することができる。

【0026】

【発明の効果】この発明によれば、以下のような効果を期待することができる。

(1) ステータコアなどをプラスチック樹脂にて一体的に成形するようにしているので、転流時の電磁加振力にもとづく振動が抑制され、モータ騒音が低減される。

(2) ステータコア内径とハウジングとの間に、適当な弾性を持つプラスチック樹脂を介在させるようにしたので、ステータコアの振動がハウジングに伝達されず、その結果、モータ騒音や振動が著しく低減される。

(3) ステータコア、巻線およびFPCをプラスチック樹脂で一体的に成形するようにしたので、巻線などに付着し洗浄などによっても除去されない塵埃を封止して外部に出さないようにし得るので、磁気ディスク装置に悪い影響を及ぼすことがなく、その結果、信頼性が大幅に向上する。

(4) 上記封止をプラスチック樹脂で行なうようにしたので、巻線工程後やFPCリード線ハンダ付け後のフラックス(溶剤)除去などの洗浄作業が簡略化、または省略可能となり、コストの低減を図ることができる。

(5) 界磁用永久磁石とロータとの間にリング状弾性体または中空円板状弾性体を設けることにより、ロータ側に伝わる電磁力が減衰され、モータ騒音や振動が低減する。

(6) 上記界磁用永久磁石の割れや欠けによる、磁石片の磁気ディスクへの付着を無くすことができる。

(7) 上記リング状弾性体に磁性を持たせることによ

り、界磁用永久磁石による磁束の低減を抑制することができる。

なお、上記(1)～(3)のいずれかと、(4)～(7)のいずれかをと適宜に組み合わせることにより、さらに振動抑制効果を上げることができる。

【図面の簡単な説明】

【図1】この発明の実施例を示す断面図である。

【図2】ステータコアをハウジング円筒部に直接固着した場合の騒音分析スペクトルを示す特性図である。

【図3】ステータコア内径とハウジングとの間にプラスチック樹脂を介在させた場合の騒音分析スペクトルを示す特性図である。

【図4】図1の成形方法を説明するための説明図である。

【図5】図1の成形方法の他の例を示す断面図である。

【図6】この発明の他の実施例を示す断面図である。

【図7】この発明のさらに他の実施例を示す断面図である。

【図8】スピンドルモータの従来例を示す断面図である。

【図9】図8のステータコアと永久磁石の関係を示す上面図である。

【図10】ステータコアのティースを図9のA-A面で切断した断面図である。

【図11】図8におけるステータコアの永久磁石に対する高さ方向のずれを説明するための説明図である。

【図12】図8に示すスピンドルモータの騒音分析スペクトルを示す特性図である。

【符号の説明】

- 1…磁気ディスク、2…ハブ、3…ロータ、4…挿入空間、5…軸受、6…ハウジング、7…円筒部、7a…外筒部、8…巻線、9…ステータコア、9a…内径部、10…フレキシブルプリント板(FPC)、11…永久磁石、12…固定金具、13…ティース、13a…ティース先端部、14、16…隙間、15、25…プラスチック樹脂、17…コイルエンド端面、18…成形金具、18a～18d…溝面、19…ボス、20…樹脂注入口、21…プッシュ、22…リング状弾性体、23…接着剤、24…中空円板状弾性体。

【図2】



【図3】

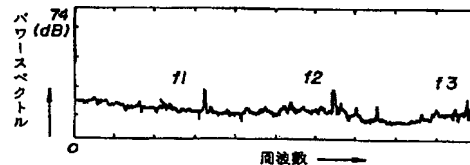

【図1】

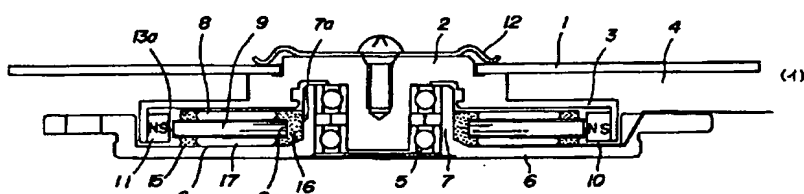

1: 磁気ディスク、2: ハブ、3: ロータ、4: 挿入空間、5: 軸受、6: ハウジング  
 7: 円筒部、8: 巻線、9: ステータコア、10: フレキシブルプリント板 (FPC)  
 11: 永久磁石、12: 固定金具、13a: ティース先端、14、16: 隙間、  
 15: フラスチック樹脂、17: コイルエンド端面

【図6】

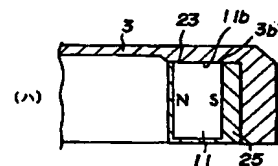
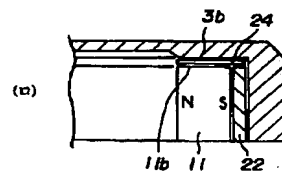
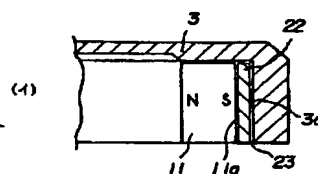

【図4】

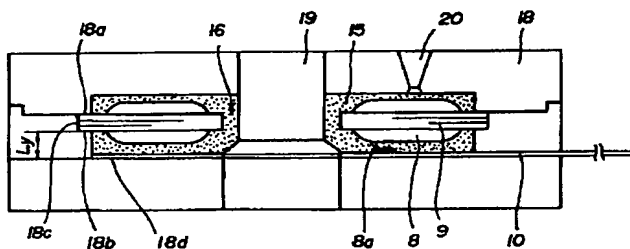

【図5】

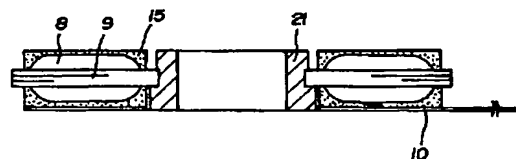

【図10】

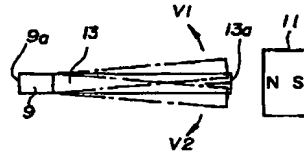

【図7】

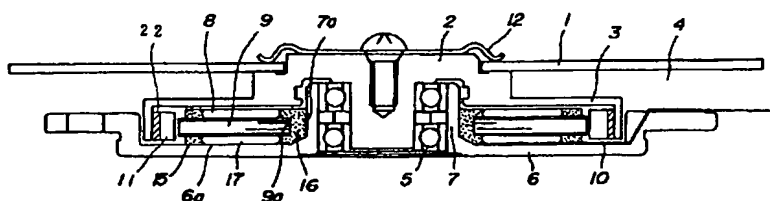

(8)

特開平5-336722

【図8】

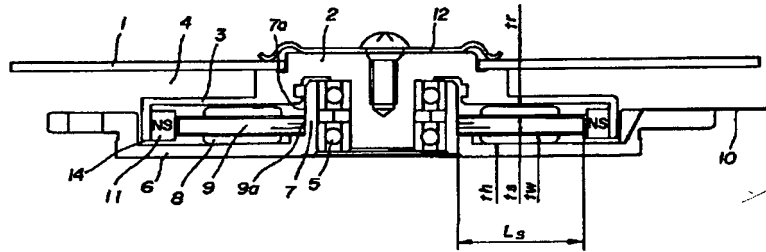

【図9】

【図11】

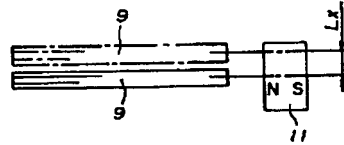
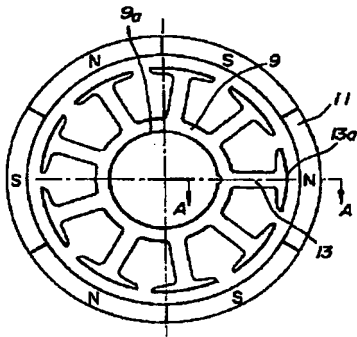

【図12】







**THIS PAGE BLANK (USPTO)**

(51)Int.Cl. <sup>6</sup>	識別記号	F I	
F 1 6 C 32/00		F 1 6 C 32/00	C
35/10		35/10	
G 1 1 B 19/20		G 1 1 B 19/20	E
H 0 2 K 7/09		H 0 2 K 7/09	
21/12		21/12	M
		審査請求 有	請求項の数5 OL (全 6 頁)

(21)出願番号 特願平9-244393  
 (22)出願日 平成9年(1997) 9月9日

(71)出願人 000002325  
 セイコーインスツルメンツ株式会社  
 千葉県千葉市美浜区中瀬1丁目8番地  
 (72)発明者 大塚 校市  
 千葉県千葉市美浜区中瀬1丁目8番地 セ  
 イコーインスツルメンツ株式会社内  
 (72)発明者 石田 隆  
 千葉県千葉市美浜区中瀬1丁目8番地 セ  
 イコーインスツルメンツ株式会社内  
 (74)代理人 弁理士 林 敬之助

(54)【発明の名称】 スピンドル装置、スピンドルモータ及びスピンドルモータを採用した回転体装置

(57)【要約】

【課題】 気体スラスト軸受が不要でありスピンドルが気体ラジアル軸受のギャップ寸法の範囲で偏芯して回転し軸の振れ回りを防止できるスピンドル装置、及び前記スピンドル装置にモータを備えたスピンドルモータ、及び前記スピンドルモータを採用した回転体装置。

【解決手段】 ラジアル軸受固定部材7Aが微小寸法偏芯し、リング磁石9A<sub>1</sub>、9A<sub>2</sub>の磁力とリング磁石10Aの磁力が反発し合ってスピンドル2Aをスピンドル支持部材1Aに対して浮かせてリング磁石9A<sub>1</sub>、9A<sub>2</sub>の中心にリング磁石10Aの中心を合わせようとする自動調芯作用を生起し、回転すると、ラジアル軸受固定部材7Aとラジアル軸受可動部材8Aのギャップ内にエア動圧が発生し、ラジアル軸受固定部材7Aとラジアル軸受可動部材8Aの間に動圧発生ギャップが生じて片当たりが解消するが引き続き偏芯状態が確保され、もってスピンドル2Aの振れ回りを回避でき非繰り返し回転振れ(NRRO)が減少する。

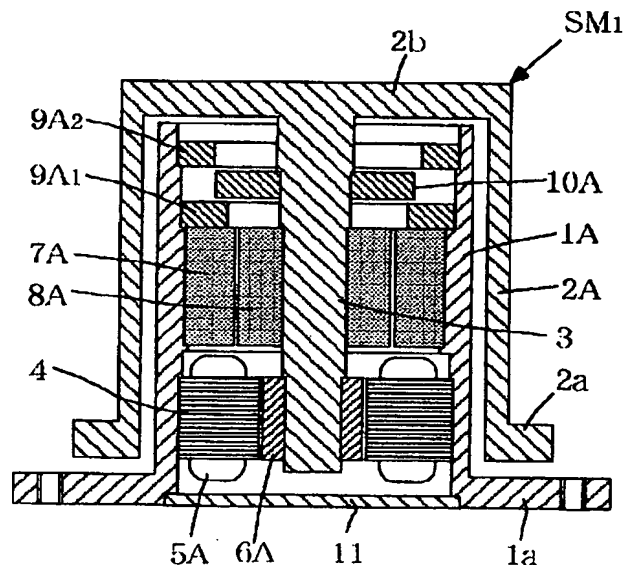

## 【特許請求の範囲】

【請求項1】 スピンドルが気体ラジアル軸受を介してスピンドル支持部材に支持されたスピンドル装置において、

N極とS極が両端面に分極された三つのリング磁石の中、二つのリング磁石がスピンドルまたはスピンドル支持部材のいずれか一方に間隔をあけて取り付けられているとともに、残り一つのリング磁石が前記二つのリング磁石の中間に位置されてスピンドルまたはスピンドル支持部材のいずれか他方に取り付られ、スピンドルに取り付られたリング磁石とスピンドル支持部材に取り付られたリング磁石の反発により、スピンドルが浮く構成であることを特徴とするスピンドル装置。

【請求項2】 スピンドル支持部材に取り付けられているリング磁石がスピンドル支持部材に取り付けられているラジアル軸受固定部材に対して微小寸法偏芯していることを特徴とする「請求項1」記載のスピンドル装置。

【請求項3】 「請求項1」または「請求項2」に記載のスピンドル装置にモータが備えられていることを特徴とするスピンドルモータ。

【請求項4】 スピンドルの回転中心にスピンドルに取り付けられたラジアル軸受可動部材の中心が一致していることを特徴とする「請求項3」に記載のスピンドルモータ。

【請求項5】 「請求項3」または「請求項4」のスピンドルモータのスピンドルに磁気ディスクあるいは光ディスク等の被回転体に取り付けられていることを特徴とするスピンドルモータを採用した回転体装置。

## 【発明の詳細な説明】

## 【0001】

【発明の属する技術分野】本願発明は、気体ラジアル軸受を備え気体スラスト軸受は不要なスピンドル装置、及びスピンドルが気体ラジアル軸受のギャップ寸法の範囲で片側に微小寸法偏芯して回転して軸の振れ回り（ホワール）を防止でき安定した回転を確保できるスピンドル装置、及び前記スピンドル装置にモータを備えたスピンドルモータ、及び前記スピンドルモータを採用した回転体装置に関する。

## 【0002】

【従来の技術】従来、気体動圧軸受式スピンドルモータを採用したレーザースキャナーやハードディスク駆動装置のテスト装置等において、スピンドルモータのスピンドルが固定軸に対して振れ回り（ホワール）を生じることにより非繰り返し回転振れ（NRR O）が生じることが知られている。他方、スピンドル支持部材のスピンドルの支持中心に対してスピンドルの回転中心を微小寸法偏芯させると、気体ラジアル軸受のラジアル軸受固定部材とラジアル軸受可動部材との間の偏芯側に最小ギャップが生じかつそこに動圧が有効に発生し、偏芯の確保と動圧の発生によってスピンドルが固定軸に対して振れ回

り（ホワール）を回避でき非繰り返し回転振れ（NRR O）が減少することが研究レベルにおいて知られている。

## 【0003】

【発明が解決しようとする課題】しかしながら、気体ラジアル軸受は、ラジアル軸受固定部材とラジアル軸受可動部材のいずれか一方に動圧発生溝を形成して空気の粘性を利用して空気を動圧発生溝内に誘導し昇圧することによりラジアル軸受固定部材でラジアル軸受可動部材を非接触で支持するものであり、このため、ラジアル軸受可動部材をラジアル軸受固定部材に対して微小寸法偏芯させる方法・手段は未だ提案されていない。

## 【0004】

【課題を解決するための手段】本願発明は、気体ラジアル軸受を備え気体スラスト軸受は不要なスピンドル装置を提供することにある。本願発明は、気体ラジアル軸受を備え気体スラスト軸受は不要でありスピンドルが気体ラジアル軸受のギャップ寸法の範囲で片側に微小寸法偏芯して回転して軸の振れ回り（ホワール）を防止でき安定した回転を確保できるスピンドル装置を提供することにある。本願発明は、前記スピンドル装置にモータを備えたスピンドルモータを提供することにある。本願発明は、前記スピンドルモータを採用した回転体装置を提供することにある。

## 【0005】

【課題を解決するための手段】本願第一の発明は、スピンドルが気体ラジアル軸受を介してスピンドル支持部材に支持されたスピンドル装置において、N極とS極が両端面に分極された三つのリング磁石の中、二つのリング磁石がスピンドルまたはスピンドル支持部材のいずれか一方に間隔をあけて取り付けられているとともに、残り一つのリング磁石が前記二つのリング磁石の中間に位置されてスピンドルまたはスピンドル支持部材のいずれか他方に取り付られ、スピンドルに取り付られたリング磁石とスピンドル支持部材に取り付られたリング磁石の反発により、スピンドルが浮く構成であることを特徴とするスピンドル装置を提供するものである。本願第二の発明は、スピンドル支持部材に取り付けられているリング磁石がスピンドル支持部材に取り付けられているラジアル軸受固定部材に対して微小寸法偏芯していることを特徴とするスピンドル装置を提供するものである。本願第三の発明は、前記第一または第二の発明のスピンドル装置にモータが備えられていることを特徴とするスピンドルモータを提供するものである。本願第四の発明は、スピンドルの中心にスピンドルに取り付けられているラジアル軸受可動部材の回転中心が一致していることを特徴とするスピンドルモータを提供するものである。本願第五の発明は、前記第三または第四の発明のスピンドルモータのスピンドルに磁気ディスクあるいは光ディスク等の被回転体に取り付けられていることを特徴とするスピンドルモ

ータを採用した回転体装置を提供するものである。

【0006】

【発明の実施の形態】図1は本願第三の発明のスピンドルモータの第一の実施の形態を示しているとともに、本願第一及び第二の発明のスピンドル装置の第一の実施の形態を示している。このスピンドルモータSM<sub>1</sub>は、下端に鏝部1aを有する概略円筒状のスピンドル支持部材1Aに、下端に鏝部2aを有しかつ上面が閉じている概略キャップ形状に形成されたスピンドル2Aが被さっており、さらにスピンドル2Aの上面部2bの中央に設けられた回転軸3が前記スピンドル支持部材1Aの内部に垂下しており、さらに、スピンドル支持部材1Aの内面下部にステータ4が嵌着されかつステータ4のスロットにモータコイル5Aが設けられている一方、ステータ4の磁極歯に対応するように、回転軸3の下端にモータ用永久磁石6Aが設けられモータ要素が備えられており、さらに、スピンドル支持部材1Aの内面中部にセラミック、その他の高耐摩耗材料からなるラジアル軸受固定部材7Aが嵌着されている一方、これに対応するように、回転軸3の中部にセラミック、その他の高耐摩耗材料からなるラジアル軸受可動部材8Aが設けられ、ラジアル軸受固定部材7Aの内周面とラジアル軸受可動部材8Aの外周面のいずれか一方に図示しない動圧発生溝が刻設され、もって気体ラジアル軸受が備えられており、さらに、スピンドル支持部材1Aの内面上部にN極とS極が両端面に分極されたリング磁石9A<sub>1</sub>、9A<sub>2</sub>が間隔をあけて嵌着されている一方、リング磁石9A<sub>1</sub>、9A<sub>2</sub>の間に対応するように、回転軸3の上部にリング磁石10Aが嵌着され、リング磁石9A<sub>1</sub>または9A<sub>2</sub>のN極とリング磁石10AのN極が対向して磁力が反発し合っているとともにリング磁石9A<sub>1</sub>または9A<sub>2</sub>のS極とリング磁石10AのS極が対向して磁力が反発し合っていて、もってスピンドル2Aがスピンドル支持部材1Aに対して浮くようになっており、そうして、スピンドル支持部材1Aの内空間の下端が蓋板11で閉じられている。

【0007】このスピンドルモータSM<sub>1</sub>は、上記のようにスピンドル支持部材1Aに取り付けられたリング磁石9A<sub>1</sub>、9A<sub>2</sub>の磁力と、回転軸3に取り付けられたリング磁石10Aの磁力が反発し合ってスピンドル2Aがスピンドル支持部材1Aに対して浮いて安定するので、気体スラスト軸受は設けられていない。リング磁石10Aの外径がリング磁石9A<sub>1</sub>の内径よりも大きくリング磁石9A<sub>1</sub>の上にリング磁石10Aがオーバーラップしているのは、磁石同士の反発力を大きくしてスピンドル2Aの浮上力を確保するためである。また、リング磁石9A<sub>2</sub>の内径がリング磁石10Aの外径よりも僅かに大きくなっているのは、モータ用永久磁石6Aとラジアル軸受可動部材8Aとリング磁石10Aを組み付けたスピンドル2Aを、ステータ4とモータコイル5Aとリ

ング磁石9A<sub>1</sub>、9A<sub>2</sub>とラジアル軸受、組み付けたスピンドル支持部材1Aに組付けにするためである。

【0008】このスピンドルモータSM<sub>1</sub>は、スピンドル2Aと完全に同芯の回転軸3に対し、モータ用永久磁石6Aとラジアル軸受可動部材8Aとリング磁石10Aが完全に同芯に設けられている。また、スピンドル支持部材1Aの円筒部の外径に対し、ラジアル軸受固定部材7Aが完全に同芯状態に組付けられている。他方、スピンドル支持部材1Aの円筒部の外径に対し、ラジアル軸受固定部材7Aが同芯状態に、またステータ4とリング磁石9A<sub>1</sub>、9A<sub>2</sub>が偏芯して設けられている。リング磁石9A<sub>1</sub>と9A<sub>2</sub>は互いに同芯状態に設けられている。リング磁石9A<sub>1</sub>と9A<sub>2</sub>が偏芯して設けられている構成とは、リング磁石9A<sub>1</sub>と9A<sub>2</sub>の内径が外径に対して偏心しているか、スピンドル支持部材1Aのリング磁石9A<sub>1</sub>と9A<sub>2</sub>が被嵌している箇所の孔径がスピンドル支持部材1Aの円筒部の外径の中心線に対して50～100ミクロンmm偏心しているかのどちらでも良い。リング磁石9A<sub>1</sub>と9A<sub>2</sub>が偏芯して設けられていると、組付けられた状態では、モータ停止時とモータ回転時のいかにかわからず、リング磁石10Aの磁力とリング磁石9A<sub>1</sub>と9A<sub>2</sub>の磁力が反発して自動調芯作用力を生起し、この自動調芯作用力が固定側のリング磁石9A<sub>1</sub>と9A<sub>2</sub>の偏芯方向にスピンドル2Aを偏心する。

【0009】図2(a)に誇張して示すように、モータ停止時には、ラジアル軸受固定部材7A(円は内径を示す)の中心aに対して、ステータ4(円は外径を示す)の中心bとラジアル軸受可動部材8A(円は外径を示す)の中心cとリング磁石9A<sub>1</sub>、9A<sub>2</sub>(円は内径を示す)の中心dが片側に一軸線上に偏心している。中心a, b, c, dの位置関係を参照して説明する。ラジアル軸受固定部材7Aの中心aに対してリング磁石9A<sub>1</sub>、9A<sub>2</sub>の中心dが50～100ミクロンmmと最も大きく偏心している。この偏芯量は、リング磁石9A<sub>1</sub>、9A<sub>2</sub>の磁力とリング磁石10Aの磁力が反発し合ってスピンドル2Aをスピンドル支持部材1Aに対して浮かせて固定側のリング磁石9A<sub>1</sub>、9A<sub>2</sub>の中心dに可動側のリング磁石10Aの中心を合わせようとする自動調芯作用力を生起し、スピンドル2Aがリング磁石9A<sub>1</sub>、9A<sub>2</sub>の偏芯方向に偏心する。従って、モータ停止時には、ラジアル軸受可動部材8Aがラジアル軸受固定部材7Aに対して偏芯移動してラジアル軸受可動部材8Aの外径がラジアル軸受固定部材7Aの内径に片側で接してラジアル軸受可動部材8Aの中心cがラジアル軸受固定部材7Aの中心aに対して微小寸法、例えば約5～10ミクロンmmずれる。

【0010】好ましい実施の態様では、ステータ4の中心bは中心a-c間の略中間に位置している。図2

示して示すように、モータ回転時には、ラジアル軸受可動部材8Aの中心cが移動してステータ4の中心bに一致する。これは、ラジアル軸受固定部材7Aとラジアル軸受可動部材8Aのいずれかに設けられた動圧発生溝に取り込まれ昇圧する空気がラジアル軸受固定部材7Aとラジアル軸受可動部材8Aの片当たりを解消するギャップ(例えば0.01mm)を生ぜしめて、該ギャップが生じる分だけラジアル軸受可動部材8Aが移動してその中心cがステータ4の中心bに一致するからである。従って、モータ回転時には、スピンドル2Aの回転中心がステータ4の中心bに対して同芯状態に維持され、かつラジアル軸受可動部材8Aが片側に偏芯してラジアル軸受固定部材7Aとの間に有効な空気動圧を発生し、もってスピンドル2Aの振れ回りを回避でき非線り返し回転振れ(NRRO)が減少する。

【0011】スピンドル支持部材1Aのステータ収容孔をラジアル軸受固定部材収容孔に対して微小寸法(例えば5~10ミクロンmm)偏芯させ、さらにスピンドル支持部材1Aのリング磁石収容孔をラジアル軸受固定部材収容孔に対して微小寸法(例えば50~100ミクロンmm)偏芯させることは高度の加工技術を必要とし製作コストは高く付くので、スピンドル支持部材1Aのステータ収容孔をラジアル軸受固定部材収容孔に対して同芯として、スピンドル支持部材1Aのリング磁石収容孔をラジアル軸受固定部材収容孔に対して微小寸法偏芯させても実用上差し支えない。

【0012】図3は本願第三の発明のスピンドルモータの第二の実施の形態を示しているとともに、本願第一及び第二の発明のスピンドル装置の第二の実施の形態を示している。このスピンドルモータSM<sub>2</sub>は、円板状のスピンドル支持部材1Bに、下端に鏝部2aを有しかつ上面が閉じている概略キャップ形状に形成されたスピンドル2Bが被さっており、さらにスピンドル支持部材1Bの中央に立設された固定軸12が前記スピンドル2Bの中心を通過しており、さらに、スピンドル支持部材1Bの上面にモータコイル5Bが設けられている一方、モータコイル5Bに対向してスピンドル2Bの鏝部2aの下面にモータ用永久磁石6Bが設けられており、さらに、スピンドル2Bの内面上部にセラミック、その他の高耐摩耗材料からなるラジアル軸受可動部材8Bが嵌着されている一方、これに対応するように、固定軸12の上部にセラミック、その他の高耐摩耗材料からなるラジアル軸受固定部材7Bが設けられ、かつラジアル軸受固定部材7Bの外周面とラジアル軸受可動部材8Bの内周面のいずれか一方に図示しない動圧発生溝が刻設され、もって気体ラジアル軸受が備えられており、さらに、スピンドル2Bの内面下部にN極とS極が両端面に分極されたリング磁石10B<sub>1</sub>、10B<sub>2</sub>が間隔をあけて嵌着されている一方、リング磁石10B<sub>1</sub>、10B<sub>2</sub>の間に対応するように、固定軸12の下部にリング磁石9Bが嵌着さ

れ、リング磁石10B<sub>1</sub>または10B<sub>2</sub>のN極とリング磁石9BのN極が対向して磁力が反発し合っていると同時にリング磁石10B<sub>1</sub>または10B<sub>2</sub>のS極とリング磁石9BのS極が対向して磁力が反発し合っていて、もってスピンドル2Bがスピンドル支持部材1Bに対して浮くようになっている。

【0013】このスピンドルモータSM<sub>2</sub>は、上記のようにスピンドル2Bに取り付けられたリング磁石10B<sub>1</sub>、10B<sub>2</sub>の磁力と、固定軸12に取り付けられたリング磁石9Bの磁力が反発し合ってスピンドル2Bがスピンドル支持部材1Bに対して浮いて安定するので、気体スラスト軸受は設けられていない。リング磁石9Bの外径がリング磁石10B<sub>1</sub>の内径よりも大きくリング磁石9Bの上にリング磁石10B<sub>1</sub>がオーバーラップしているのは、磁石同士の反発力を大きくしてスピンドル2Bの浮上力を確保するためである。また、リング磁石10B<sub>2</sub>の内径がリング磁石9Bの外径よりも僅かに小さくなっているのは、モータ用永久磁石6Bとラジアル軸受可動部材8Bとリング磁石10B<sub>1</sub>、10B<sub>2</sub>を組み付けたスピンドル2Bを、モータコイル5Bとリング磁石9Bとラジアル軸受固定部材7Bを組み付けたスピンドル支持部材1Bに組付けられるようにするためである。

【0014】このスピンドルモータSM<sub>2</sub>は、スピンドル2Bに対し、モータ用永久磁石6Bとラジアル軸受可動部材8Bとリング磁石10B<sub>1</sub>、10B<sub>2</sub>が完全に同芯状態に組付けられ、また、固定軸12に対し、ラジアル軸受固定部材7Bが完全に同芯状態に組付けられている。固定軸12に対し、モータコイル5Bとリング磁石9Bは偏芯状態に設けられている。リング磁石9Bが偏芯状態に設けられる構成とは、リング磁石9Bの内径が外径に対して偏心しているか、固定軸12のリング磁石9Bが被嵌している箇所の軸径が固定軸12の中心線に対して50~100ミクロンmm偏心しているかのどちらでも良い。固定軸12に対しリング磁石9Bが偏芯状態に設けられていると、組付けられた状態では、モータ停止時とモータ回転時のいかにかわらず、リング磁石10B<sub>1</sub>、10B<sub>2</sub>の磁力とリング磁石9Bの磁力が反発して自動調芯作用を生起することにより、リング磁石9Bの偏芯側にスピンドル2Bが偏心する。

【0015】図4(a)に誇張して示すように、モータ停止時には、ラジアル軸受固定部材7B(円は外径を示す)の中心eに対して、モータコイル5B(円はコイルの内径の中間の径を示す)の中心fとラジアル軸受可動部材8B(円は内径を示す)の中心gとリング磁石9Bの中心hが片側に一軸線上に偏心している。中心e、f、g、hの位置関係を参照して説明する。ラジアル軸受固定部材7Bの中心eに対してリング磁石9Bの中心hが50~100ミクロンmmと最も大きく偏心している。この偏芯量は、リング磁石10B<sub>1</sub>、10B<sub>2</sub>の磁

力とリング磁石9Bの磁力が反発し合ってスピンドル2Bをスピンドル支持部材1Bに対して浮かせてリング磁石10B<sub>1</sub>、10B<sub>2</sub>の中心をリング磁石9Bの中心に合わせようとする自動調芯作用力を生起し、この自動調芯作用力がスピンドル2Bを偏心し、ラジアル軸受可動部材8Bとリング磁石10B<sub>1</sub>、10B<sub>2</sub>が一体に偏芯する。従って、図4(a)に示すように、モータ停止時には、ラジアル軸受可動部材8Bがラジアル軸受固定部材7Bに対して偏芯移動してラジアル軸受可動部材8Bの内径がラジアル軸受固定部材7Bの外径に片側で接してラジアル軸受可動部材8Bの中心gがラジアル軸受固定部材7Bの中心eに対して微小寸法、例えば約5~10ミクロンmmずれている。

【0016】好ましい実施の態様では、モータコイル5Bの中心fは中心e-g間の略中間に位置している。図4(b)に誇張して示すように、モータ回転時には、ラジアル軸受可動部材8Bの中心gが移動してモータコイル5Bの中心fに一致する。これは、ラジアル軸受固定部材7Bとラジアル軸受可動部材8Bのいずれかに設けられた動圧発生溝に取り込まれ昇圧する空気がラジアル軸受固定部材7Bとラジアル軸受可動部材8Bの片当たりを解消するギャップ(例えば0.01mm)を生ぜしめて、該ギャップが生じる分だけラジアル軸受可動部材8Bが移動してその中心gがモータコイル5Bの中心fに一致するからである。従って、モータ回転時には、スピンドル2Bの回転中心がモータコイル5Bに対して同芯状態に維持され、かつラジアル軸受可動部材8Bが片側に偏芯してラジアル軸受固定部材7Bとの間に有効な空気動圧を発生し、もってスピンドル2Bの振れ回りを回避でき非繰り返し回転振れ(NRRO)が減少する。

【0017】固定軸12に対して、ラジアル軸受固定部材7Bを同芯とし、モータコイル5Bを微小寸法(例えば5~10ミクロンmm)偏芯させ、さらにリング磁石9Bを同一方向に異なる微小寸法(例えば50~100ミクロンmm)偏芯させることは高度の加工技術を必要とし製作コストは高く付くので、固定軸12に対して、ラジアル軸受固定部材7Bとモータコイル5Bを同芯としても実用上差し支えない。

【0018】図5は、図3のスピンドルモータを採用した回転体装置を示す。この回転体装置は、図3のスピンドルモータSM<sub>2</sub>のスピンドル2Bにポリゴンミラー13が被着され、ミラーケース14がスピンドルモータSM<sub>2</sub>のスピンドル支持部材1Bに支持されている構成である。図6は、図1のスピンドルモータSM<sub>1</sub>を採用した回転体装置を示す。この回転体装置は、ディスク装置であり、本願第一の発明のスピンドルモータSMのスピンドルに、磁気ディスクまたは光ディスク等の被回転円

盤15を複数枚被着してなる。

【0019】

【発明の効果】以上説明してきたように、本願発明のスピンドル装置、及びスピンドルモータ、及びスピンドルモータを採用した回転体装置によれば、気体スラスト軸受が不要でありスピンドルが気体ラジアル軸受のギャップ寸法の範囲で偏芯して回転し軸の振れ回り(ホワール)を回避でき非繰り返し回転振れ(NRRO)が減少し安定した回転を確保できる。

【図面の簡単な説明】

【図1】本願第一の発明の第一の実施の態様に係るスピンドルモータの縦断面図。

【図2】(a)はモータ停止時の偏芯状態を示す説明図であり、(b)はモータ回転時の偏芯状態を示す説明図である。

【図3】本願第一の発明の第一の実施の態様に係るスピンドルモータの要部であるステータの形状と永久磁石とスピンドルの関係を示す水平断面図。

【図4】(a)はモータ停止時の偏芯状態を示す説明図であり、(b)はモータ回転時の偏芯状態を示す説明図である。

【図5】図3のスピンドルモータを採用した回転体装置の断面図。

【図6】図1のスピンドルモータを採用した回転体装置の断面図。

【符号の説明】

SM <sub>1</sub>	スピンドルモータ
1A	スピンドル支持部材
2A	スピンドル
4	ステータ
5A	モータコイル
6A	モータ用永久磁石
7A	ラジアル軸受固定部材
8A	ラジアル軸受可動部材
9A <sub>1</sub> 、9A <sub>2</sub>	リング磁石
10A	リング磁石
SM <sub>2</sub>	スピンドルモータ
1B	スピンドル支持部材
2B	スピンドル
5B	モータコイル
6B	モータ用永久磁石
7B	ラジアル軸受固定部材
8B	ラジアル軸受可動部材
9B	リング磁石
10B <sub>1</sub> 、10B <sub>2</sub>	リング磁石
13	ポリゴンミラー
15	被回転円盤

【図1】

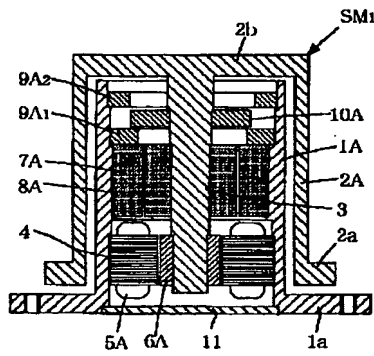

【図2】

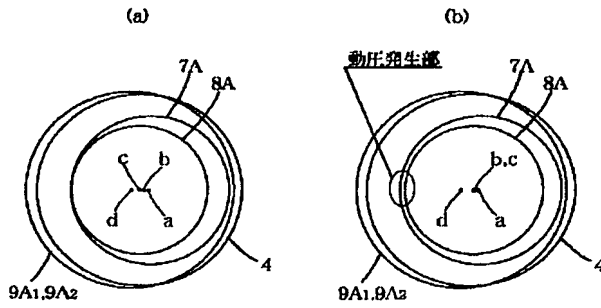

【図4】

【図3】

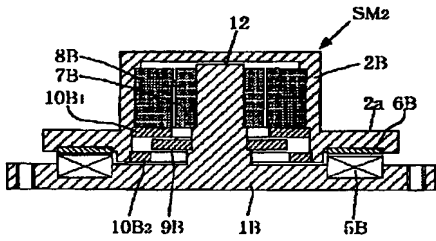

(a)

(b)

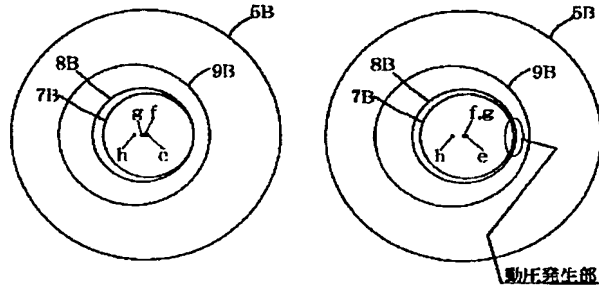

【図5】

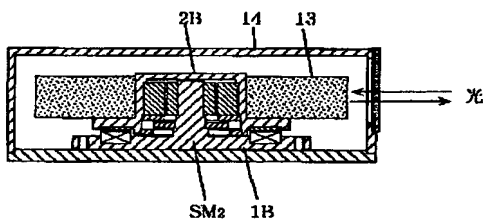

【図6】

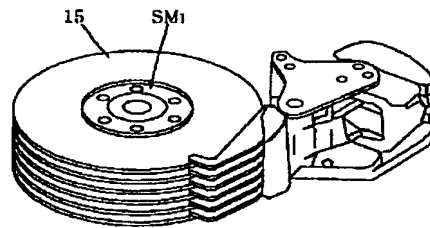



Under the Paperwork Reduction Act of 1995, no persons are required to respond to a collection of information unless it displays a valid OMB control number.

**PATENT APPLICATION FEE DETERMINATION RECORD**

Substitute for Form PTO-875 Effective December 8, 2004

Application of Office Number

12 388 219

**APPLICATION AS FILED - PART I**

(Column 1) (Column 2)

FOR	NUMBER FILED	NUMBER EXTRA
BASIC FEE (37 CFR 1.16(a) (b) or (c))	N/A	N/A
SEARCH FEE (37 CFR 1.16(h), (i), or (m))	N/A	N/A
EXAMINATION FEE (37 CFR 1.16(a), (b), or (q))	N/A	N/A
TOTAL CLAIMS (37 CFR 1.16(i))	minus 20 =	.
INDEPENDENT CLAIMS (37 CFR 1.16(h))	minus 3 =	.
APPLICATION SIZE FEE (37 CFR 1.16(s))	If the specification and drawings exceed 100 sheets of paper, the application size fee due is \$250 (\$125 for small entity) for each additional 50 sheets or fraction thereof. See 35 U.S.C. 41(a)(1)(G) and 37 CFR 1.16(s).	
MULTIPLE DEPENDENT CLAIM PRESENT (37 CFR 1.16(j))		

**SMALL ENTITY**

OR

**OTHER THAN SMALL ENTITY**

RATE (\$)	FEE (\$)
N/A	150.00
N/A	\$250
N/A	\$100
X\$ 25 .	
X100 .	
+180=	
TOTAL	

OR

RATE (\$)	FEE (\$)
N/A	300.00
N/A	\$500
N/A	\$200
X\$50 .	
X200 .	
+360=	
TOTAL	

\* If the difference in column 1 is less than zero, enter "0" in column 2.

**APPLICATION AS AMENDED - PART II**

(Column 1) (Column 2) (Column 3)

AMENDMENT A	CLAIMS REMAINING AFTER AMENDMENT	MINUS	HIGHEST NUMBER PREVIOUSLY PAID FOR	PRESENT EXTRA
	Total (37 CFR 1.16(i))	15	Minus	20
Independent (37 CFR 1.16(h))	1	Minus	3	"
Application Size Fee (37 CFR 1.16(s))				
FIRST PRESENTATION OF MULTIPLE DEPENDENT CLAIM (37 CFR 1.16(j))				

**SMALL ENTITY**

OR

**OTHER THAN SMALL ENTITY**

RATE (\$)	ADDITIONAL FEE (\$)
X\$ 25 .	
X100 .	
+180=	
TOTAL ADD'L FEE	

OR

RATE (\$)	ADDITIONAL FEE (\$)
X\$50 .	
X200 .	
+360=	
TOTAL ADD'L FEE	

AMENDMENT B	CLAIMS REMAINING AFTER AMENDMENT	MINUS	HIGHEST NUMBER PREVIOUSLY PAID FOR	PRESENT EXTRA
	Total (37 CFR 1.16(i))	15	Minus	20
Independent (37 CFR 1.16(h))	1	Minus	3	"
Application Size Fee (37 CFR 1.16(s))				
FIRST PRESENTATION OF MULTIPLE DEPENDENT CLAIM (37 CFR 1.16(j))				

RATE (\$)	ADDITIONAL FEE (\$)
X\$ 25 .	
X100 .	
+180=	
TOTAL ADD'L FEE	

OR

RATE (\$)	ADDITIONAL FEE (\$)
X\$50 .	
X200 .	
+360=	
TOTAL ADD'L FEE	

- \* If the entry in column 1 is less than the entry in column 2, write "0" in column 3.
- \*\* If the "Highest Number Previously Paid For" IN THIS SPACE is less than 20, enter "20".
- \*\*\* If the "Highest Number Previously Paid For" IN THIS SPACE is less than 3, enter "3".

The "Highest Number Previously Paid For" (Total or Independent) is the highest number found in the appropriate box in column 1.

This collection of information is required by 37 CFR 1.16. The information is required to obtain or retain a benefit by the public which is to file (and by the PTO to process) an application. Confidentiality is governed by 35 U.S.C. 122 and 37 CFR 1.14. This collection is estimated to take 12 minutes to complete, including gathering, preparing, and submitting the completed application form to the USPTO. Time will vary depending upon the individual case. Any comments the amount of time you require to complete this form and/or suggestions for reducing this burden, should be sent to the Chief Information Officer, U.S. Patent and Trademark Office, U.S. Department of Commerce, P.O. Box 1450, Alexandria, VA 22313-1450. DO NOT SEND FEES OR COMPLETED FORMS TO THIS ADDRESS. SEND TO: Commissioner for Patents, P.O. Box 1460, Alexandria, VA 22313-1460.

If you need assistance in completing the form, call 1-800-PTO-9199 and select option 2.

CLAIMS ONLY

Application Number  
**10383219**  
 Applicant(s)

Filing Date

\* May be used for additional claims or amendments

CLAIMS	AS FILED		AFTER FIRST AMENDMENT		AFTER SECOND AMENDMENT							
	Indep	Depend	Indep	Depend	Indep	Depend	Indep	Depend	Indep	Depend	Indep	Depend
1												
2												
3												
4												
5												
6												
7												
8												
9												
10												
11												
12												
13												
14												
15												
16												
17												
18												
19												
20												
21												
22												
23												
24												
25												
26												
27												
28												
29												
30												
31												
32												
33												
34												
35												
36												
37												
38												
39												
40												
41												
42												
43												
44												
45												
46												
47												
48												
49												
50												
Total Indep												
Total Depend												
Total Claims												
51												
52												
53												
54												
55												
56												
57												
58												
59												
60												
61												
62												
63												
64												
65												
66												
67												
68												
69												
70												
71												
72												
73												
74												
75												
76												
77												
78												
79												
80												
81												
82												
83												
84												
85												
86												
87												
88												
89												
90												
91												
92												
93												
94												
95												
96												
97												
98												
99												
100												
Total Indep												
Total Depend												
Total Claims												

Ref #	Hits	Search Query	DBs	Default Operator	Plurals	Time Stamp
L1	35	(("3,590,328") or ("3,638,055") or ("3,802,066") or ("3,874,073") or ("3,908,138") or ("3,942,054") or ("3,979,530") or ("4,128,527") or ("4,173,822") or ("4,352,897") or ("4,365,180") or ("4,372,035") or ("4,387,311") or ("4,492,889") or ("4,572,979") or ("4,643,346") or ("4,679,313") or ("4,712,035") or ("4,760,299") or ("4,801,833") or ("4,853,576") or ("4,858,073") or ("4,868,970") or ("4,954,739") or ("4,990,809") or ("5,008,572") or ("5,036,580") or ("5,073,735") or ("5,075,585") or ("5,121,021") or ("5,134,327") or ("5,142,103") or ("5,147,982") or ("5,191,698") or ("5,206,554") or ("5,268,607")). PN.	USPAT	OR	OFF	2005/10/14 17:11
L2	39	(("5,334,897") or ("5,345,129") or ("5,382,852") or ("5,396,210") or ("5,400,218") or ("5,414,317") or ("5,459,190") or ("5,461,772") or ("5,500,780") or ("5,506,458") or ("5,541,787") or ("5,548,458") or ("5,558,445") or ("5,579,188") or ("5,587,617") or ("5,592,731") or ("5,598,048") or ("5,610,463") or ("5,619,083") or ("5,619,389") or ("5,621,372") or ("5,633,545") or ("5,666,242") or ("5,668,427") or ("5,672,927") or ("5,675,196") or ("5,694,268") or ("5,698,919") or ("5,728,600") or ("5,729,072") or ("5,729,404") or ("5,742,450") or ("5,751,085") or ("5,751,514") or ("5,766,535") or ("5,783,888") or ("5,806,169") or ("5,814,412") or ("5,850,318") or ("5,859,486")). PN.	USPAT	OR	OFF	2005/10/14 17:13

L3	36	((("3,590,328") or ("3,638,055") or ("3,802,066") or ("3,874,073") or ("3,908,138") or ("3,942,054") or ("3,979,530") or ("4,128,527") or ("4,173,822") or ("4,352,897") or ("4,365,180") or ("4,372,035") or ("4,387,311") or ("4,492,889") or ("4,572,979") or ("4,643,346") or ("4,679,313") or ("4,712,035") or ("4,760,299") or ("4,801,833") or ("4,853,576") or ("4,858,073") or ("4,868,970") or ("4,954,739") or ("4,990,809") or ("5,008,572") or ("5,036,580") or ("5,073,735") or ("5,075,585") or ("5,121,021") or ("5,134,327") or ("5,142,103") or ("5,147,982") or ("5,191,698") or ("5,206,554") or ("5,268,607"))). PN.	USPAT	OR	OFF	2005/10/14 17:11
L4	40	((("5,334,897") or ("5,345,129") or ("5,382,852") or ("5,396,210") or ("5,400,218") or ("5,414,317") or ("5,459,190") or ("5,461,772") or ("5,500,780") or ("5,506,458") or ("5,541,787") or ("5,548,458") or ("5,558,445") or ("5,579,188") or ("5,587,617") or ("5,592,731") or ("5,598,048") or ("5,610,463") or ("5,619,083") or ("5,619,389") or ("5,621,372") or ("5,633,545") or ("5,666,242") or ("5,668,427") or ("5,672,927") or ("5,675,196") or ("5,694,268") or ("5,698,919") or ("5,728,600") or ("5,729,072") or ("5,729,404") or ("5,742,450") or ("5,751,085") or ("5,751,514") or ("5,766,535") or ("5,783,888") or ("5,806,169") or ("5,814,412") or ("5,850,318") or ("5,859,486"))). PN.	USPAT	OR	OFF	2005/10/14 17:13
L5	23	((("5,875,540") or ("5,880,179") or ("5,881,447") or ("5,898,252") or ("5,918,360") or ("5,942,824") or ("5,949,172") or ("5,958,466") or ("5,973,424") or ("5,982,057") or ("5,986,365") or ("5,986,377") or ("5,990,247") or ("6,002,185") or ("6,019,516") or ("6,020,661") or ("6,034,841") or ("6,043,583") or ("6,049,153") or ("6,071,014") or ("6,075,304") or ("6,153,959") or ("6,163,952"))).PN.	USPAT	OR	OFF	2005/10/14 17:14

L6	6	((("5,875,540") or ("5,880,179") or ("5,881,447") or ("5,898,252") or ("5,918,360") or ("5,942,824") or ("US6,167,610B1") or ("US6,201,334B1") or ("US6,265,800B1") or ("US6,265,804B1") or ("US6,300,695B1") or ("US6,362,554B1") or ("US6,437,464B1") or ("US6,501,616B1") or ("US6,617,721B1") or ("US6,753,628B1") or ("US6,844,636B2") or ("US6,892,439B1") or ("US6,911,166B2") or ("US9,941,640B2")).PN. or ((US2003/0081347A1) or (US2005/0134124A1)).CCLS.	US-PGPUB; USPAT	OR	OFF	2005/10/14 17:14
L7	22	((("5,875,540") or ("5,880,179") or ("5,881,447") or ("5,898,252") or ("5,918,360") or ("5,942,824") or ("6,167,610") or ("6,201,334") or ("6,265,800") or ("6,265,804") or ("6,300,695") or ("6,362,554") or ("6,437,464") or ("6,501,616") or ("20030081347") or ("6,617,721") or ("6,753,628") or ("6,844,636") or ("6,892,439") or ("6,911,166") or ("20050134124") or ("6,941,640")).PN.	US-PGPUB; USPAT	OR	OFF	2005/10/14 17:16
L8	20	((("5,875,540") or ("5,880,179") or ("5,881,447") or ("5,898,252") or ("5,918,360") or ("5,942,824") or ("6,167,610") or ("6,201,334") or ("6,265,800") or ("6,265,804") or ("6,300,695") or ("6,362,554") or ("6,437,464") or ("6,501,616") or ("6,617,721") or ("6,753,628") or ("6,844,636") or ("6,892,439") or ("6,911,166") or ("6,941,640")).PN.	US-PGPUB; USPAT	OR	OFF	2005/10/14 17:16
L9	115	3 4 5 6 7	US-PGPUB; USPAT; USOCR; EPO; JPO; DERWENT; IBM_TDB	OR	OFF	2005/10/14 19:30
L10	4883	(310/42,43,45,216,217,218). CCLS.	US-PGPUB; USPAT	OR	OFF	2005/10/14 17:27
L11	0	(244/432,433).CCLS.	US-PGPUB; USPAT	OR	OFF	2005/10/14 17:28
L12	0	(244/433.4).CCLS.	US-PGPUB; USPAT	OR	OFF	2005/10/14 17:28
L13	2083	(29/596).CCLS.	US-PGPUB; USPAT	OR	OFF	2005/10/14 17:27

L14	114	(242/432,433).CCLS.	US-PGPUB; USPAT	OR	OFF	2005/10/14 17:28
L15	141	(242/433.4).CCLS.	US-PGPUB; USPAT	OR	OFF	2005/10/14 17:28
L16	6471	10 13 14 15	US-PGPUB; USPAT; USOCR; EPO; JPO; DERWENT; IBM_TDB	OR	OFF	2005/10/14 17:28
L17	615727	@pd>"20050601"	US-PGPUB; USPAT; USOCR; EPO; JPO; DERWENT; IBM_TDB	OR	OFF	2005/10/14 17:29
L18	176	16 and 17	US-PGPUB; USPAT; USOCR; EPO; JPO; DERWENT; IBM_TDB	OR	OFF	2005/10/14 17:38
L19	660	(310/254,259,42,43,216,217,218). CCLS.	US-PGPUB	OR	OFF	2005/10/14 17:40
L20	0	19 and pole\$1.cims. and stator. cims.	US-PGPUB	OR	OFF	2005/10/14 17:41
L21	218	19 and pole\$1.cim. and stator.cim.	US-PGPUB	OR	OFF	2005/10/14 17:43
L22	2	(("6081859") or ("5774974")).PN.	USPAT	OR	OFF	2005/10/14 17:44
L23	2	(("6081059") or ("5774974")).PN.	USPAT	OR	OFF	2005/10/14 18:12
L24	1	("6081059").PN.	USPAT	OR	OFF	2005/10/14 18:12
L25	0	24 and plastic\$1	US-PGPUB; USPAT; USOCR; EPO; JPO; DERWENT; IBM_TDB	OR	OFF	2005/10/14 18:12
L26	1	24 and resin\$1	US-PGPUB; USPAT; USOCR; EPO; JPO; DERWENT; IBM_TDB	OR	OFF	2005/10/14 18:13
L27	0	24 and polyamide\$1	US-PGPUB; USPAT; USOCR; EPO; JPO; DERWENT; IBM_TDB	OR	OFF	2005/10/14 19:00
L28	1	("5,494,190").PN.	USPAT	OR	OFF	2005/10/14 19:01

L29	1	("5,459,190").PN.	USPAT	OR	OFF	2005/10/14 19:05
L30	15	polyamide near bobbin\$1	US-PGPUB; USPAT; USOCR; EPO; JPO; DERWENT; IBM_TDB	OR	OFF	2005/10/14 19:24
L31	8	"5774974"	US-PGPUB; USPAT; USOCR; EPO; JPO; DERWENT; IBM_TDB	OR	OFF	2005/10/14 19:24
L32	1	("6043583").PN.	USPAT	OR	OFF	2005/10/14 19:30
L33	0	32 and thermoplastic	US-PGPUB; USPAT; USOCR; EPO; JPO; DERWENT; IBM_TDB	OR	OFF	2005/10/14 19:31
L34	1	("6002185").PN.	USPAT	OR	OFF	2005/10/14 19:31
L35	0	34 and thermoplastic	US-PGPUB; USPAT; USOCR; EPO; JPO; DERWENT; IBM_TDB	OR	OFF	2005/10/14 19:31
L36	1	("5990247").PN.	USPAT	OR	OFF	2005/10/14 19:31
L37	1	36 and thermoplastic	US-PGPUB; USPAT; USOCR; EPO; JPO; DERWENT; IBM_TDB	OR	OFF	2005/10/14 19:43
L38	3	stator near molded near thermoplastic	US-PGPUB; USPAT; USOCR; EPO; JPO; DERWENT; IBM_TDB	OR	OFF	2005/10/14 19:45
L39	1	("5982057").PN.	USPAT	OR	OFF	2005/10/14 19:45
L40	0	39 and thermoplastic	US-PGPUB; USPAT; USOCR; EPO; JPO; DERWENT; IBM_TDB	OR	OFF	2005/10/14 19:45
L41	1	("5783888").PN.	USPAT	OR	OFF	2005/10/14 19:45

L42	0	41 and thermoplastic	US-PGPUB; USPAT; USOCR; EPO; JPO; DERWENT; IBM_TDB	OR	OFF	2005/10/14 19:45
L43	7	stator near thermoplastic	US-PGPUB; USPAT; USOCR; EPO; JPO; DERWENT; IBM_TDB	OR	OFF	2005/10/14 19:46
L44	767	stator same thermoplastic	US-PGPUB; USPAT; USOCR; EPO; JPO; DERWENT; IBM_TDB	OR	OFF	2005/10/14 19:46
L45	123532	"310"/\$.ccls.	US-PGPUB; USPAT; USOCR; EPO; JPO; DERWENT; IBM_TDB	OR	OFF	2005/10/14 19:46
L46	255	44 and 45	US-PGPUB; USPAT; USOCR; EPO; JPO; DERWENT; IBM_TDB	OR	OFF	2005/10/14 19:46





UNITED STATES PATENT AND TRADEMARK OFFICE

UNITED STATES DEPARTMENT OF COMMERCE  
United States Patent and Trademark Office  
Address: COMMISSIONER FOR PATENTS  
P.O. Box 1450  
Alexandria, Virginia 22313-1450  
www.uspto.gov

APPLICATION NO.	FILING DATE	FIRST NAMED INVENTOR	ATTORNEY DOCKET NO.	CONFIRMATION NO.
10/383,219	03/05/2003	Griffith D. Neal	8864/33	9248
757	7590	10/19/2005	EXAMINER MULLINS, BURTON S	
BRINKS HOFER GILSON & LIONE P.O. BOX 10395 CHICAGO, IL 60610			ART UNIT 2834	PAPER NUMBER

DATE MAILED: 10/19/2005

Please find below and/or attached an Office communication concerning this application or proceeding.

98

<b>Office Action Summary</b>	<b>Application No.</b> 10/383,219	<b>Applicant(s)</b> NEAL, GRIFFITH D.	
	<b>Examiner</b> Burton S. Mullins	<b>Art Unit</b> 2834	

-- The MAILING DATE of this communication appears on the cover sheet with the correspondence address --

**Period for Reply**

A SHORTENED STATUTORY PERIOD FOR REPLY IS SET TO EXPIRE 3 MONTH(S) OR THIRTY (30) DAYS, WHICHEVER IS LONGER, FROM THE MAILING DATE OF THIS COMMUNICATION.

- Extensions of time may be available under the provisions of 37 CFR 1.136(a). In no event, however, may a reply be timely filed after SIX (6) MONTHS from the mailing date of this communication.
- If NO period for reply is specified above, the maximum statutory period will apply and will expire SIX (6) MONTHS from the mailing date of this communication.
- Failure to reply within the set or extended period for reply will, by statute, cause the application to become ABANDONED (35 U.S.C. § 133). Any reply received by the Office later than three months after the mailing date of this communication, even if timely filed, may reduce any earned patent term adjustment. See 37 CFR 1.704(b).

**Status**

- 1)  Responsive to communication(s) filed on 19 September 2005.
- 2a)  This action is FINAL.
- 2b)  This action is non-final.
- 3)  Since this application is in condition for allowance except for formal matters, prosecution as to the merits is closed in accordance with the practice under *Ex parte Quayle*, 1935 C.D. 11, 453 O.G. 213.

**Disposition of Claims**

- 4)  Claim(s) 1-10, 25, 29, 30, 33 and 34 is/are pending in the application.
  - 4a) Of the above claim(s) \_\_\_\_\_ is/are withdrawn from consideration.
- 5)  Claim(s) 34 is/are allowed.
- 6)  Claim(s) 1-8, 10, 25, 29 and 30 is/are rejected.
- 7)  Claim(s) 9 and 33 is/are objected to.
- 8)  Claim(s) \_\_\_\_\_ are subject to restriction and/or election requirement.

**Application Papers**

- 9)  The specification is objected to by the Examiner.
- 10)  The drawing(s) filed on \_\_\_\_\_ is/are: a)  accepted or b)  objected to by the Examiner.
  - Applicant may not request that any objection to the drawing(s) be held in abeyance. See 37 CFR 1.85(a).
  - Replacement drawing sheet(s) including the correction is required if the drawing(s) is objected to. See 37 CFR 1.121(d).
- 11)  The oath or declaration is objected to by the Examiner. Note the attached Office Action or form PTO-152.

**Priority under 35 U.S.C. § 119**

- 12)  Acknowledgment is made of a claim for foreign priority under 35 U.S.C. § 119(a)-(d) or (f).
  - a)  All    b)  Some \*    c)  None of:
    - 1.  Certified copies of the priority documents have been received.
    - 2.  Certified copies of the priority documents have been received in Application No. \_\_\_\_\_.
    - 3.  Copies of the certified copies of the priority documents have been received in this National Stage application from the International Bureau (PCT Rule 17.2(a)).

\* See the attached detailed Office action for a list of the certified copies not received.

**Attachment(s)**

- 1)  Notice of References Cited (PTO-892)
- 2)  Notice of Draftsperson's Patent Drawing Review (PTO-948)
- 3)  Information Disclosure Statement(s) (PTO-1449 or PTO/SB/08)  
Paper No(s)/Mail Date 9/05.
- 4)  Interview Summary (PTO-413)  
Paper No(s)/Mail Date. \_\_\_\_\_.
- 5)  Notice of Informal Patent Application (PTO-152)
- 6)  Other: \_\_\_\_\_.

**DETAILED ACTION**

*Response to Arguments*

1. The indicated allowability of claim 1 is withdrawn in view of the newly discovered reference to Hsu (US 6,081,059). Rejections based on the newly cited reference follow.

*Claim Rejections - 35 USC § 102*

2. The following is a quotation of the appropriate paragraphs of 35 U.S.C. 102 that form the basis for the rejections under this section made in this Office action:

A person shall be entitled to a patent unless –

(b) the invention was patented or described in a printed publication in this or a foreign country or in public use or on sale in this country, more than one year prior to the date of application for patent in the United States.

3. Claims 1-4, 6, 8, 25 and 29 are rejected under 35 U.S.C. 102(b) as being anticipated by Hsu (US 6,081,059). Hsu teaches a stator assembly, comprising: a) a plurality of discrete stator segments (fin arrays) 110 each at least partially encased with a phase change material (bobbin 14 made of insulating material, i.e., plastic, c.5, lines 51-53), wherein the phase change material also comprises a bridge (hinge) 144 between adjacent segments to link adjacent segments into a continuous strip (Figs.3&4); and b) the linked stator segments being arranged and secured together to form the stator assembly 11 (c.4, lines 13-29; Fig.6).

Regarding claim 2, the coil bobbins may be either pre-wound or wound after the bobbins engage the stator segments or fins (c.4, lines 46-50). In either case, the bridges 144 inherently “produce such a continuous linkage between segments that the bridges may be used to orient and manipulate the segments during wire winding” because the stator segments are linked by the bridges, thus allowing the segments to be “manipulated”.

Art Unit: 2834

Regarding claim 3, the limitation that the packing density of the wire be in a range greater than 80 percent is inherent to Hsu since the coil windings 12, after the segments are bent to form the stator, completely fill the slots (Fig.6), thus fulfilling Hsu's intent of a higher winding capacity and output torque (c.5, lines 60-64).

Regarding claim 4, Hsu's bridges 144 between adjoining segments 110 inherently "...orient and position wire relative to the poles" since the bridges contact the coils 12 at their inner periphery (Fig.6).

Regarding claim 6, the stator segments comprise discrete steel laminations 11 (c.4, lines 63-65).

Regarding claim 8, the stator segments 110 are held in a toroidal shape by a retaining member comprising the core 100 with recesses 102 (Figs.8&14).

Regarding claim 29, Hsu's linked bobbins 14 comprise the "flexible carrier used to link said stator arc segments" 110 formed by steel laminations 11, which are insulated from the wires 12 by the bobbins 14. The limitation that the bobbins 14 are "adhered" to the segments is met by Hsu because it is a product-by-process limitation, and the claimed product is no different than Hsu's product which includes bobbins of phase-change material contacting the segments 110.

### ***Claim Rejections - 35 USC § 103***

4. The following is a quotation of 35 U.S.C. 103(a) which forms the basis for all obviousness rejections set forth in this Office action:

(a) A patent may not be obtained though the invention is not identically disclosed or described as set forth in section 102 of this title, if the differences between the subject matter sought to be patented and the prior art are such that the subject matter as a whole would have been obvious at the time the invention was made to a person having ordinary skill in the art to which said subject matter pertains. Patentability shall not be negated by the manner in which the invention was made.

Art Unit: 2834

5. Claim 5 is rejected under 35 U.S.C. 103(a) as being unpatentable over Hsu in view of Nakamura (US 5,459,190). Hsu discloses the claimed invention except for phase change material with a thermal conductivity of at least 0.4 watts/meter<sup>°K</sup> at 23° C.

Nakamura discloses a polymer phase change material useful for insulating a motor and motor windings (Fig.1). The material has a thermal conductivity of 0.188-0.7 Watts/meter<sup>°K</sup> for the purpose of assuring a good electrical insulation of the stator core, thus insuring high reliability of the machine.

It would have been obvious to modify Hsu's phase change, insulating material and provide one with a thermal conductivity of at least 0.4 watts/meter<sup>°K</sup> at 23° C per Nakamura to assure good electrical insulation of the stator core and high machine reliability.

6. Claims 7 and 30 are rejected under 35 U.S.C. 103(a) as being unpatentable over Hsu in view of Foerster (US 3,348,302). Hsu discloses the claimed invention except for a phase change material of polyamide (claim 7) or a dielectric strength of at least 250 volts per one thousandth of an inch of thickness (claim 30).

Foerster teaches a coil and bobbin structure wherein the bobbin comprises a cylindrical tube formed of an aromatic polyamide having temperature and dielectric properties that enable it to meet high thermal standards and maintain long periods of mechanical and electrical strength (c.1, lines 41-66). Further, Foerster's bobbin meets the NEMA requirement that the bobbin be able to withstand an electrical stress between the winding and ground of twice the rated voltage plus 1000 volts meets the claimed dielectric strength.

It would have been obvious to modify Hsu's phase change material and provide one made of polyamide or with a dielectric strength of at least 250 volts per one thousandth of an

Art Unit: 2834

inch of thickness per Foerster to enable it to meet high thermal standards and maintain long periods of mechanical and electrical strength.

7. Claim 10 is rejected under 35 U.S.C. 103(a) as being unpatentable over Hsu in view of Tanaka et al. (US 4,015,154). Hsu discloses the claimed invention except for overmolding the toroidal stator segments in thermoplastic material.

Tanaka teaches injecting molding of a stator core with plural teeth 14 using a thermosetting and thermoplastic resin mixture, the latter of which can be polystyrene (c.4, lines 64-66), which encapsulates the stator accurately due to its fluidity (c.4, lines 30-55).

It would have been obvious to modify Hsu and provide a thermoplastic overmolded on the stator per Tanaka to encapsulate the stator with a material providing accurate, fluid molding, thus improving manufacture.

***Allowable Subject Matter***

8. Claims 9 and 33 are objected to as being dependent upon a rejected base claim, but would be allowable if rewritten in independent form including all of the limitations of the base claim and any intervening claims. Regarding claim 9, the prior art does not teach that the retaining member comprises a metal band. Regarding claim 33, the prior art does not teach or suggest that the bridge is formed by interconnecting two mating sections formed from the phase change material. In particular, Hsu's bridges 144 do not comprise two mating sections interconnected.

9. Claim 34 is allowed. The prior art does not teach, inter alia, the claimed stator arc segments and flexible carrier of phase change material "wherein the flexible carrier links said segments by connecting two mating sections formed in said carrier".

Art Unit: 2834

**Conclusion**

10. Any inquiry concerning this communication or earlier communications from the examiner should be directed to Burton S. Mullins whose telephone number is 571-272-2029. The examiner can normally be reached on Monday-Friday, 9 am to 5 pm. If attempts to reach the examiner by telephone are unsuccessful, the examiner's supervisor, Darren Schuberg can be reached on 571-272-2044. The fax phone number for the organization where this application or proceeding is assigned is 571-273-8300. Information regarding the status of an application may be obtained from the Patent Application Information Retrieval (PAIR) system. Status information for published applications may be obtained from either Private PAIR or Public PAIR. Status information for unpublished applications is available through Private PAIR only. For more information about the PAIR system, see <http://pair-direct.uspto.gov>. Should you have questions on access to the Private PAIR system, contact the Electronic Business Center (EBC) at 866-217-9197 (toll-free).

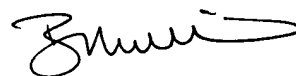

Burton S. Mullins  
Primary Examiner  
Art Unit 2834

bsm  
14 October 2005



FORM PTO-1449	SERIAL NO. 10/383,219	CASE NO. 8864/33
<b>LIST OF PATENTS AND PUBLICATIONS FOR APPLICANT'S INFORMATION DISCLOSURE STATEMENT</b>	FILING DATE March 5, 2003	GROUP ART UNIT 2834
(use several sheets if necessary)		APPLICANT: Griffith D. Neal

**REFERENCE DESIGNATION U.S. PATENT DOCUMENTS**

EXAMINER INITIAL		DOCUMENT NUMBER <small>Number-Kind Code (if known)</small>	DATE	NAME	CLASS/SUBCLASS	FILING DATE
JM	A1	3,590,328	06/29/1971	Bert L. Frescura		
	A2	3,638,055	01/25/1972	Zimmermann		
	A3	3,802,066	4/09/1974	Barrett		
	A4	3,874,073	04/01/1975	Dochterman et al.		
	A5	3,908,138	9/23/1975	Shieh		
	A6	3,942,054	03/02/1976	Kristen et al.		
	A7	3,979,530	09/07/1976	Schwider et al.		
	A8	4,128,527	12/05/1978	Kinjo et al.		
	A9	4,173,822	11/13/1979	Futterer et al.		
	A10	4,352,897	10/05/1982	Ogata et al.		
	A11	4,365,180	12/21/1982	Licata et al.		
	A12	4,372,035	2/08/1983	McMillen		
	A13	4,387,311	06/07/1983	Kobayashi et al.		
	A14	4,492,889	01/08/1985	Fukushi et al.		
	A15	4,572,979	02/25/1986	Haar et al.		
	A16	4,643,346	2/17/1987	Gotoh		
	A17	4,679,313	07/14/1987	Schultz et al.		
	A18	4,712,035	12/08/1987	Forbes et al.		
	A19	4,760,299	07/26/1988	Dickie et al.		
	A20	4,801,833	01/31/1989	Dye		
	A21	4,853,576	08/01/1989	Mayumi et al.		
	A22	4,858,073	08/15/1989	Gregory		
	A23	4,868,970	09/26/1989	Schultz et al.		
	A24	4,954,739	09/04/1990	Schultz et al.		
	A25	4,990,809	2/05/1991	Artus et al.		
	A26	5,008,572	04/16/1991	Marshall et al.		
	A27	5,036,580	08/06/1991	Fox et al.		
	A28	5,073,735	12/17/1991	Takagi		
	A29	5,075,585	12/24/1991	Teruyama et al.		
	A30	5,121,021	06/09/1992	Ward		
	A31	5,134,327	07/28/1992	Sumi et al.		
	A32	5,142,103	08/25/1992	Stine		
	A33	5,147,982	09/15/1992	Steffen		
	A34	5,191,698	03/09/1003	Sumi et al.		
	A35	5,206,554	04/27/1993	Perrot		
	A36	5,268,607	12/07/1993	McManus		

EXAMINER <i>JM</i>	DATE CONSIDERED 10/14/05
-----------------------	-----------------------------

EXAMINER: Initial if reference considered, whether or not citation is in conformance with MPEP 609; Draw line through citation if not in conformance and not considered. Include copy of this form with next communication to applicant.



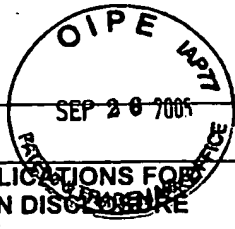

FORM PTO-1449	SERIAL NO. 10/383219 -09798,511	CASE NO. 8864/33 8864/20
LIST OF PATENTS AND PUBLICATIONS FOR APPLICANT'S INFORMATION DISCLOSURE STATEMENT	FILING DATE March 2, 2001 March 5, 2005	GROUP ART UNIT 2834
(use several sheets if necessary)		APPLICANT(S): Griffith D. Neal

Bm

Bm

REFERENCE DESIGNATION U.S. PATENT DOCUMENTS

EXAMINER INITIAL	DOCUMENT NUMBER <small>Number-Kind Code (if known)</small>	DATE	NAME	CLASS/ SUBCLASS	FILING DATE
Bm	A37	5,334,897	08/02/1994	Ineson et al.	
	A38	5,345,129	09/06/1994	Molnar	
	A39	5,382,852	01/17/1995	Yuhi et al.	
	A40	5,396,210	03/07/1995	Purohit et al.	
	A41	5,400,218	03/21/1995	Val	
	A42	5,414,317	05/09/1995	Reid et al.	
	A43	5,459,190	10/17/1995	Nakamura et al.	
	A44	5,461,772	10/31/1995	Puri	
	A45	5,500,780	03/19/1996	Boutaghou et al.	
	A46	5,506,458	04/09/1996	Pace et al.	
	A47	5,541,787	07/30/1996	Jabbari et al.	
	A48	5,548,458	08/20/1996	Pelstring et al.	
	A49	5,558,445	09/24/1996	Chen et al.	
	A50	5,579,188	11/26/1996	Dunfield et al.	
	A51	5,587,617	12/24/1996	Dunfield et al.	
	A52	5,592,731	1/14/1997	Huang et al.	
	A53	5,598,048	01/28/1997	Dunfield et al.	
	A54	5,610,463	03/11/1997	Dunfield et al.	
	A55	5,619,083	04/08/1997	Dunfield et al.	
	A56	5,619,389	04/08/1997	Dunfield et al.	
	A57	5,621,372	04/15/1997	Purohit	
	A58	5,633,545	05/27/1997	Albrecht et al.	
	A59	5,666,242	09/09/1997	Edwards et al.	
	A60	5,668,427	09/16/1997	Morita	
	A61	5,672,927	09/30/1997	Viskochil	
	A62	5,675,196	10/07/1997	Huang et al.	
	A63	5,694,268	12/02/1997	Dunfield et al.	
	A64	5,698,919	12/16/1998	Obara	
	A65	5,728,600	03/17/1998	Saxelby, Jr. et al.	
	A66	5,729,072	3/17/1998	Hirano et al.	
	A67	5,729,404	03/17/1998	Dunfield et al.	
	A68	5,742,450	04/21/1998	Moser	
	A69	5,751,085	05/12/1998	Hayashi	
	A70	5,751,514	05/12/1998	Hyde et al.	
	A71	5,766,535	06/16/1998	Ong	
	A72	5,783,888	07/21/1998	Yamano	
	A73	5,806,169	09/15/1998	Trago et al.	
	A74	5,814,412	09/29/1998	Terada et al.	
	A75	5,850,318	12/15/1998	Dunfield	
	A76	5,859,486	1/12/1999	Nakahara et al.	

EXAMINER <i>Bm</i>	DATE CONSIDERED 10/14/05
-----------------------	-----------------------------

EXAMINER: Initial if reference considered, whether or not citation is in conformance with MPEP 609; Draw line through citation if not in conformance and not considered. Include copy of this form with next communication to applicant.



FORM PTO-1449	SERIAL NO. <i>10/383,219</i> <i>-091798,544</i>	CASE NO. <i>8864/33</i> <i>-8864/20</i>
LIST OF PATENTS AND PUBLICATIONS FOR APPLICANT'S INFORMATION DISCLOSURE STATEMENT (use several sheets if necessary)	FILING DATE <i>-March 2, 2004</i> <i>March 5, 2003</i>	GROUP ART UNIT <i>2834</i>
APPLICANT(S): Griffith D. Neal		

REFERENCE DESIGNATION U.S. PATENT DOCUMENTS

EXAMINER INITIAL	DOCUMENT NUMBER <small>Number-Kind Code (if known)</small>	DATE	NAME	CLASS/SUBCLASS	FILING DATE
<i>gm</i>	A77	5,875,540	3/02/1999	Sargent et al.	
	A78	5,880,179	03/09/1999	Ito et al.	
	A79	5,881,447	03/16/1999	Molnar	
	A80	5,898,252	3/27/1999	Tanaka et al.	
	A81	5,918,360	7/06/1999	Fornes et al.	
	A82	5,942,824	08/24/1999	Shioya et al.	
	A83	5,949,172	9/07/1999	Katagiri	
	A84	5,958,466	09/28/1999	Ong	
	A85	5,973,424	10/26/1999	Engelberger et al.	
	A86	5,982,057	11/09/1999	Imada et al.	
	A87	5,986,365	11/16/1999	Kuwert et al.	
	A88	5,986,377	11/16/1999	Yamada et al.	
	A89	5,990,247	11/23/1999	Terada et al.	
	A90	6,002,185	12/14/1999	Nakao et al.	
	A91	6,019,516	02/01/2000	Leuthold et al.	
A92	6,020,661	02/01/2000	Trago et al.		
A93	6,034,841	03/07/2000	Albrecht et al.		
A94	6,043,583	03/28/2000	Kurosawa et al.		
A95	6,049,153	4/11/2000	Nishiyama et al.		
A96	6,071,014	06/06/2000	Lee et al.		
A97	6,075,304	06/13/2000	Nakatsuka		
A98	6,153,959	11/28/2000	Lorenzo		
A99	6,163,952	12/26/2000	Takehara		
A100	US 6,167,610 B1	01/02/2001	Nakahara et al.		
A101	US 6,201,334 B1	03/13/2001	Sargeant et al.		
A102	US 6,265,800 B1	07/24/2001	Kimura et al.		
A103	US 6,265,804 B1	07/24/2001	Nitta et al.		
A104	US 6,300,695 B1	10/09/2001	Neal		
A105	US 6,362,554 B1	03/26/2002	Neal		
A106	US 6,437,464 B1	08/20/2002	Neal		
A107	US 6,501,616 B1	12/31/2002	Neal		
A108	US 2003/0081347 A1	05/01/2003	Neal		
A109	US 6,617,721 B1	09/09/2003	Neal		
A110	US 6,753,628 B1	06/22/2004	Neal		
A111	US 6,844,636 B2	01/18/2005	Neal		
A112	US 6,892,439 B1	05/17/2005	Neal		
A113	US 6,911,166 B2	06/28/2005	Neal		
A114	US 2005/0134124 A1	06/23/2005	Lieu		
A115	US 6,941,640 B2	09/13/2005	Neal		

EXAMINER <i>gm</i>	DATE CONSIDERED <i>10/14/05</i>
--------------------	---------------------------------

EXAMINER: Initial if reference considered, whether or not citation is in conformance with MPEP 609; Draw line through citation if not in conformance and not considered. Include copy of this form with next communication to applicant.

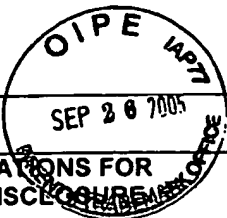

FORM PTO-1449	SERIAL NO. <u>10/383219</u> <del>097798,511</del>	CASE NO. <u>8864/33</u> <del>8864/20</del>
LIST OF PATENTS AND PUBLICATIONS FOR APPLICANT'S INFORMATION DISCLOSURE STATEMENT (use several sheets if necessary)	FILING DATE <del>March 2, 2001</del> <u>March 5, 2003</u>	GROUP ART UNIT <u>2834</u>
APPLICANT(S): Griffith D. Neal		

FOREIGN PATENT DOCUMENTS

EXAMINER INITIAL		DOCUMENT NUMBER <small>Number-Kind Code (if known)</small>	DATE	COUNTRY	CLASS/ SUBCLASS	TRANSLATION	
						YES	NO
BM	A116	DT 25 39 492 A1	03/10/77	Germany		Abstract	
	A117	870.878	01/15/79	Belgium		Abstract	
	A118	891.258	03/16/82	Belgium		Abstract	
	A119	SU 1334297	08/30/87	Soviet Union		Abstract	
	A120	SU 1494148	07/15/89	Soviet Union		Abstract	
	A121	2 647 958	12/07/90	France		Abstract	
	A122	WO 92/06532	04/16/92	PCT			
	A123	05336722	12/17/93	Japan		Abstract	
	A124	WO 96/20501	07/04/96	PCT			
	A125	WO 96/33533	10/24/96	PCT			
	A126	WO 97/39870	10/30/97	PCT			
	A127	EP 0 747 943 A2	12/11/96	EPO			
	A128	10070870	03/10/98	Japan		Abstract	
A129	410271719	10/09/98	Japan		Abstract		
V	A130	EP 0 883 171 A1	12/09/98	EPO		Abstract	
	A131	11082508	03/26/99	Japan		Abstract	

EXAMINER INITIAL	OTHER ART (Including Author, Title, Date, Pertinent Pages, etc.)	
BM	A132	LNP Engineering Plastics, Advertisement entitled "Konduit™ Thermally Conductive Composites," undated (2 pages)
	A133	Product Information from Dupont Engineering Polymers entitled "Electrical/Electronic Thermoplastic Encapsulation," undated, Publ. Reorder No.: H-58633 (R, 96.7), 20 pages.
	A134	LNP Engineering Plastics, Press Release entitled "LNP Introduces First-Ever Line of Thermally Conductive Compounds," January 28, 1999 (2 pages)
	A135	Buchanan Motor Works, Inc., article from the Internet entitled "Epoxy Seal - Prevents Down Time and Keeps Equipment Running Longer," 07/14/99, < <a href="http://www.bmwworks.com/VIP.htm">http://www.bmwworks.com/VIP.htm</a> >, 1 page.
	A136	The Epoxylite Corporation, article from the Internet entitled "Vacuum Pressure Impregnation (VPI) Systems", 11/19/99, < <a href="http://www.epoxylite.com/EpoxyliteEquipment.htm">http://www.epoxylite.com/EpoxyliteEquipment.htm</a> >, 3 pages.
	A137	Neeltran Inc., article from the Internet entitled "Vacuum Pressure Impregnation (VPI)", 11/19/99, < <a href="http://www.neeltran.thomasregister.com/olc/neeltran/nee19.htm">http://www.neeltran.thomasregister.com/olc/neeltran/nee19.htm</a> > 2 pages.
	V	

EXAMINER <u>B Mull</u>	DATE CONSIDERED <u>10/14/05</u>
------------------------	---------------------------------

EXAMINER: Initial if reference considered, whether or not citation is in conformance with MPEP 609; Draw line through citation if not in conformance and not considered. Include copy of this form with next communication to applicant.

<b>Notice of References Cited</b>	Application/Control No. 10/383,219	Applicant(s)/Patent Under Reexamination NEAL, GRIFFITH D.	
	Examiner Burton S. Mullins	Art Unit 2834	Page 1 of 1

**U.S. PATENT DOCUMENTS**

*	Document Number Country Code-Number-Kind Code	Date MM-YYYY	Name	Classification
A	US-6,081,059	06-2000	Hsu, Chun-Pu	310/179
B	US-3,348,302	10-1967	FOERSTER JAMES A	29/605
C	US-			
D	US-			
E	US-			
F	US-			
G	US-			
H	US-			
I	US-			
J	US-			
K	US-			
L	US-			
M	US-			

**FOREIGN PATENT DOCUMENTS**

*	Document Number Country Code-Number-Kind Code	Date MM-YYYY	Country	Name	Classification
N					
O					
P					
Q					
R					
S					
T					

**NON-PATENT DOCUMENTS**

*	Include as applicable: Author, Title Date, Publisher, Edition or Volume, Pertinent Pages)
U	
V	
W	
X	

\*A copy of this reference is not being furnished with this Office action. (See MPEP § 707.05(a).)  
Dates in MM-YYYY format are publication dates. Classifications may be US or foreign.



2834 IFW

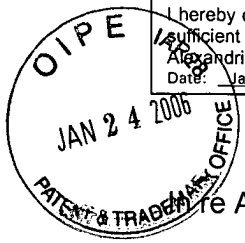

CERTIFICATE OF MAILING UNDER 37 C.F.R. §1.8

I hereby certify that this correspondence is being deposited with the United States Postal Service as first class mail, with sufficient postage, in an envelope addressed to: Mail Stop Amendment, Commissioner for Patents, P. O. Box 1450, Alexandria, VA 22313-1450, on the below date:  
 Date: January 19, 2006 Name: Steven P. Shurtz, Reg. No. 31,424 Signature: /Steven P. Shurtz/

**BRINKS  
 HOFER  
 GILSON  
 & LIONE**

**IN THE UNITED STATES PATENT AND TRADEMARK OFFICE**

Re Appln. of: **Griffith D. Neal**  
 Appln. No.: **10/383,219**  
 Filed: **March 5, 2003**  
 For: **STATOR ASSEMBLY MADE FROM A  
 MOLDED WEB OF CORE SEGMENTS AND  
 MOTOR USING SAME**  
 Attorney Docket No: **8864-33**

Examiner: **Burton S. Mullins**  
 Group Art Unit: **2834**

Mail Stop Amendment  
 Commissioner for Patents  
 P. O. Box 1450  
 Alexandria, VA 22313-1450

**TRANSMITTAL**

Sir:

**Attached is/are:**

- Transmittal Letter (in duplicate); Amendment.
- Return Receipt Postcard

**Fee calculation:**

- No additional fee is required.
- An extension fee in an amount of \$\_\_\_ for a \_\_\_-month extension of time under 37 C.F.R. § 1.136(a).
- A petition or processing fee in an amount of \$\_\_\_ under 37 C.F.R. § 1.17(\_\_\_\_).
- An additional filing fee has been calculated as shown below:

					Small Entity		Not a Small Entity		
	Claims Remaining After Amendment		Highest No. Previously Paid For	Present Extra	Rate	Add'l Fee	or	Rate	Add'l Fee
Total	14	Minus	34	0	x \$25=			x \$50=	0
Indep.	2	Minus	6	0	x 100=			x \$200=	0
First Presentation of Multiple Dep. Claim									
					+\$180=			+\$360=	
					Total			Total	\$0

**Fee payment:**

- A credit card authorization in the amount of \$\_\_\_ to cover the above-identified fee(s) is enclosed.
  - Please charge Deposit Account No. 23-1925 in the amount of \$\_\_\_\_. A copy of this Transmittal is enclosed for this purpose.
  - The Director is hereby authorized to charge payment of any additional filing fees required under 37 CFR § 1.16 and any patent application processing fees under 37 CFR § 1.17 associated with this paper (including any extension fee required to ensure that this paper is timely filed), or to credit any overpayment, to Deposit Account No. 23-1925.
- Respectfully submitted,

January 19, 2006  
 Date

/Steven P. Shurtz/  
 Steven P. Shurtz  
 (Registration No. 31,424)  
 Brinks Hofer Gilson Lione  
 P.O. Box 10395  
 Chicago, IL. 60610



I hereby certify that this correspondence is being deposited with the United States Postal Service, with sufficient postage, as first class mail in an envelope addressed to:

Commissioner for Patents  
P.O. Box 1450  
Alexandria, VA 22313  
on January 19, 2006

\_\_\_\_\_  
Date of Deposit

\_\_\_\_\_  
Steven P. Shurtz, Reg. No. 31,424

\_\_\_\_\_  
Name of applicant, assignee or  
Registered Representative

\_\_\_\_\_  
/Steven P. Shurtz/

\_\_\_\_\_  
Signature

\_\_\_\_\_  
January 19, 2006

\_\_\_\_\_  
Date of Signature

Case No. 8864/33

**IN THE UNITED STATES PATENT AND TRADEMARK OFFICE**

In re Application of:

Griffith D. Neal

Serial No.: 10/383,219

Filed: March 5, 2003

For: STATOR ASSEMBLY  
MADE FROM A  
MOLDED WEB OF  
CORE SEGMENTS AND  
MOTOR USING SAME

Examiner: Burton S. Mullins  
Group Art Unit: 2834

**AMENDMENT**

Mail Stop Amendment  
Commissioner for Patents  
P.O. Box 1450  
Alexandria, VA 22313-1450

Dear Sir:

In response to the Office Action mailed October 19, 2005, please enter the following amendment and consider the following remarks.

Amendments to the claims are reflected in the listing of claims which begins on page 2 of this paper.

Remarks begin on page 5 of the paper.

2834 IFW

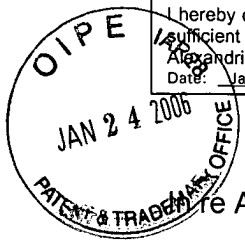

CERTIFICATE OF MAILING UNDER 37 C.F.R. §1.8

I hereby certify that this correspondence is being deposited with the United States Postal Service as first class mail, with sufficient postage, in an envelope addressed to: Mail Stop Amendment, Commissioner for Patents, P. O. Box 1450, Alexandria, VA 22313-1450, on the below date:  
 Date: January 19, 2006 Name: Steven P. Shurtz, Reg. No. 31,424 Signature: /Steven P. Shurtz/

**BRINKS  
 HOFER  
 GILSON  
 & LIONE**

**IN THE UNITED STATES PATENT AND TRADEMARK OFFICE**

Applicant: Griffith D. Neal  
 Appln. No.: 10/383,219  
 Filed: March 5, 2003  
 For: STATOR ASSEMBLY MADE FROM A  
 MOLDED WEB OF CORE SEGMENTS AND  
 MOTOR USING SAME

Examiner: Burton S. Mullins  
 Group Art Unit: 2834

Attorney Docket No: 8864-33

Mail Stop Amendment  
 Commissioner for Patents  
 P. O. Box 1450  
 Alexandria, VA 22313-1450

**TRANSMITTAL**

Sir:

**Attached is/are:**

- Transmittal Letter (in duplicate); Amendment.
- Return Receipt Postcard

**Fee calculation:**

- No additional fee is required.
- An extension fee in an amount of \$\_\_\_ for a \_\_\_-month extension of time under 37 C.F.R. § 1.136(a).
- A petition or processing fee in an amount of \$\_\_\_ under 37 C.F.R. § 1.17(\_\_\_\_).
- An additional filing fee has been calculated as shown below:

					Small Entity		Not a Small Entity		
	Claims Remaining After Amendment		Highest No. Previously Paid For	Present Extra	Rate	Add'l Fee	or	Rate	Add'l Fee
Total	14	Minus	34	0	x \$25=			x \$50=	0
Indep.	2	Minus	6	0	x 100=			x \$200=	0
First Presentation of Multiple Dep. Claim									
					+\$180=			+\$360=	
					Total			Total	\$0

**Fee payment:**

- A credit card authorization in the amount of \$\_\_\_ to cover the above-identified fee(s) is enclosed.
  - Please charge Deposit Account No. 23-1925 in the amount of \$ . A copy of this Transmittal is enclosed for this purpose.
  - The Director is hereby authorized to charge payment of any additional filing fees required under 37 CFR § 1.16 and any patent application processing fees under 37 CFR § 1.17 associated with this paper (including any extension fee required to ensure that this paper is timely filed), or to credit any overpayment, to Deposit Account No. 23-1925.
- Respectfully submitted,

January 19, 2006  
 Date

/Steven P. Shurtz/  
 Steven P. Shurtz  
 (Registration No. 31,424)  
 Brinks Hofer Gilson Lione  
 P.O. Box 10395  
 Chicago, IL. 60610





I hereby certify that this correspondence is being deposited with the United States Postal Service, with sufficient postage, as first class mail in an envelope addressed to:

Commissioner for Patents  
P.O. Box 1450  
Alexandria, VA 22313  
on January 19, 2006

\_\_\_\_\_  
Date of Deposit

\_\_\_\_\_  
Steven P. Shurtz, Reg. No. 31,424

Name of applicant, assignee or  
Registered Representative

\_\_\_\_\_  
/Steven P. Shurtz/

Signature

\_\_\_\_\_  
January 19, 2006

Date of Signature

Case No. 8864/33

**IN THE UNITED STATES PATENT AND TRADEMARK OFFICE**

In re Application of:

Griffith D. Neal

Serial No.: 10/383,219

Filed: March 5, 2003

For: STATOR ASSEMBLY  
MADE FROM A  
MOLDED WEB OF  
CORE SEGMENTS AND  
MOTOR USING SAME

Examiner: Burton S. Mullins  
Group Art Unit: 2834

**AMENDMENT**

Mail Stop Amendment  
Commissioner for Patents  
P.O. Box 1450  
Alexandria, VA 22313-1450

Dear Sir:

In response to the Office Action mailed October 19, 2005, please enter the following amendment and consider the following remarks.

Amendments to the claims are reflected in the listing of claims which begins on page 2 of this paper.

Remarks begin on page 5 of the paper.

## Amendments to the Claims

Please cancel claims 8-9 and 29-30 without prejudice to filing the claims in a continuing application. Please amend claims 1, 10 and 33 as follows, again without prejudice to presenting the unamended claims in a continuing application. Also, add claim 35-37 as follows. A complete listing of the claims with proper claim identifiers follows.

### Listing of Claims

1. (Currently amended) A stator assembly, comprising:
  - a) a plurality of discrete stator segments each at least partially encased with a phase change material, wherein the phase change material also comprises a bridge between adjacent segments to link adjacent segments into a continuous strip; and
  - b) the linked stator segments being arranged and secured together to form the stator assembly, wherein the stator segments are held in a toroidal shape by a retaining member which comprises a metal band.
2. (Original) The stator assembly of claim 1 wherein the bridges produce such a continuous linkage between segments that the bridges may be used to orient and manipulate the segments during wire winding.
3. (Original) The stator assembly of claim 1 wherein wire having a packing density of greater than 80 percent is wound around the poles.
4. (Original) The stator assembly of claim 1 wherein the bridges between adjoining segments can be used to orient and position wire relative to the poles.
5. (Original) The stator assembly of claim 1 wherein the phase change material has a thermal conductivity of at least 0.4 watts/meter<sup>°K</sup> at 23°C.
6. (Original) The stator assembly of claim 1 wherein the discrete stator segments are each made from a plurality of steel laminations.
7. (Original) The stator assembly of claim 1 wherein the phase change material comprises polyamide.

8-9. (Canceled)

10. (Currently amended) The stator assembly of claim ~~[[1]]~~ 33 wherein the stator segments are held in a toroidal shape by an overmolded thermoplastic material.

11-24. (Canceled)

25. (Original) A motor made from the stator assembly of claim 1.

26-32. (Canceled)

33. (Currently amended) ~~The stator assembly of claim 1~~ A stator assembly, comprising:

a) a plurality of discrete stator segments each at least partially encased with a phase change material, wherein the phase change material also comprises a bridge between adjacent segments to link adjacent segments into a continuous strip, wherein the bridge is formed by interconnecting two mating sections formed from the phase change material; and

b) the linked stator segments being arranged and secured together to form the stator assembly.

34. (Previously presented) A combination of stator arc segments and a flexible carrier used to link said stator arc segments during a winding operation comprising:

a) a plurality of stator arc segments; and

b) a phase change material constituting said flexible carrier adhered to the stator arc segments which links said segments in a uniform and predetermined position with respect to one another; wherein the flexible carrier links said segments by connecting two mating sections formed in said carrier.

35. (New) The stator assembly of claim 1 wherein the bridge is formed by interconnecting two mating sections formed from the phase change material.

36. (New) The stator assembly of claim 33 wherein the stator segments are held in a toroidal shape by a retaining member.

37. (New) The stator assembly of claim 36 wherein retaining member comprises a metal band.

### Remarks

In the outstanding Office Action, claim 34 was allowed, and claims 9 and 33 were indicated as allowable if rewritten in independent form. Claim 1 has been amended to include the limitations of claims 8 and 9. Claim 33 has been rewritten to include the limitations of claim 1. New claims 35-37 are based on former claims 33, 8 and 9 respectively.

The rejections of claims 1-8, 10, 25, and 29-30 in the outstanding Office Action is traversed. However, since those claims are amended or canceled, the rejection is moot.

Since all of the remaining claims have been indicated as being allowable, or are dependent on an allowable claim, the case is believed to be in condition for allowance.

Respectfully submitted,

/Steven P. Shurtz/

Steven P. Shurtz  
Registration No. 31,424  
Attorney for Applicant

Dated: January 19, 2006  
BRINKS HOFER GILSON & LIONE  
P.O. Box 10395  
Chicago, IL 60610  
(312) 321-4200  
Direct Dial: (801) 444-3933

**PATENT APPLICATION FEE DETERMINATION RECORD**

Substitute for Form PTO-875

Application or Docket Number

10 | 383,219

**CLAIMS AS FILED - PART I**

FOR	NUMBER FILED	NUMBER EXTRA
BASIC FEE (37 CFR 1.16(a))		
TOTAL CLAIMS (37 CFR 1.16(c))	minus 20 =	
INDEPENDENT CLAIMS (37 CFR 1.16(b))	minus 3 =	
MULTIPLE DEPENDENT CLAIM PRESENT (37 CFR 1.16(d))		

SMALL ENTITY	
RATE	FEE
	\$
x \$ 25 =	
x \$ 100 =	
+ \$ 180 =	
TOTAL	

OTHER THAN SMALL ENTITY	
RATE	FEE
	\$
x \$ 50 =	
x \$ 200 =	
+ \$ 360 =	
TOTAL	

\* If the difference in column 1 is less than zero, enter "0" in column 2.

**CLAIMS AS AMENDED - PART II**

AMENDMENT A	(Column 1)	(Column 2)	(Column 3)	PRESENT EXTRA
	CLAIMS REMAINING AFTER AMENDMENT	HIGHEST NUMBER PREVIOUSLY PAID FOR		
Total (37 CFR 1.16(c))	14	Minus ** 20	=	/
Independent (37 CFR 1.16(b))	3	Minus *** 3	=	/
FIRST PRESENTATION OF MULTIPLE DEPENDENT CLAIM (37 CFR 1.16(d))				

SMALL ENTITY	
RATE	ADDITIONAL FEE
x \$ 25 =	
x \$ 100 =	
+ \$ 180 =	
TOTAL ADD'L FEE	

OTHER THAN SMALL ENTITY	
RATE	ADDITIONAL FEE
x \$ 50 =	
x \$ 200 =	
+ \$ 360 =	
TOTAL ADD'L FEE	

AMENDMENT B	(Column 1)	(Column 2)	(Column 3)	PRESENT EXTRA
	CLAIMS REMAINING AFTER AMENDMENT	HIGHEST NUMBER PREVIOUSLY PAID FOR		
Total (37 CFR 1.16(c))		Minus **	=	
Independent (37 CFR 1.16(b))		Minus ***	=	
FIRST PRESENTATION OF MULTIPLE DEPENDENT CLAIM (37 CFR 1.16(d))				

SMALL ENTITY	
RATE	ADDITIONAL FEE
x \$ 25 =	
x \$ 100 =	
+ \$ 180 =	
TOTAL ADD'L FEE	

OTHER THAN SMALL ENTITY	
RATE	ADDITIONAL FEE
x \$ 50 =	
x \$ 200 =	
+ \$ 360 =	
TOTAL ADD'L FEE	

AMENDMENT C	(Column 1)	(Column 2)	(Column 3)	PRESENT EXTRA
	CLAIMS REMAINING AFTER AMENDMENT	HIGHEST NUMBER PREVIOUSLY PAID FOR		
Total (37 CFR 1.16(c))		Minus **	=	
Independent (37 CFR 1.16(b))		Minus ***	=	
FIRST PRESENTATION OF MULTIPLE DEPENDENT CLAIM (37 CFR 1.16(d))				

SMALL ENTITY	
RATE	ADDITIONAL FEE
x \$ 25 =	
x \$ 100 =	
+ \$ 180 =	
TOTAL ADD'L FEE	

OTHER THAN SMALL ENTITY	
RATE	ADDITIONAL FEE
x \$ 50 =	
x \$ 200 =	
+ \$ 360 =	
TOTAL ADD'L FEE	

- \* If the entry in column 1 is less than the entry in column 2, write "0" in column 3.
- \*\* If the "Highest Number Previously Paid For" IN THIS SPACE is less than 20, enter "20".
- \*\*\* If the "Highest Number Previously Paid For" IN THIS SPACE is less than 3, enter "3".

The "Highest Number Previously Paid For" (Total or Independent) is the highest number found in the appropriate box in column 1.

This collection of information is required by 37 CFR 1.16. The information is required to obtain or retain a benefit by the public which is to file (and by the USPTO to process) an application. Confidentiality is governed by 35 U.S.C. 122 and 37 CFR 1.14. This collection is estimated to take 12 minutes to complete, including gathering, preparing, and submitting the completed application form to the USPTO. Time will vary depending upon the individual case. Any comments on the amount of time you require to complete this form and/or suggestions for reducing this burden, should be sent to the Chief Information Officer, U.S. Patent and Trademark Office, U.S. Department of Commerce, P.O. Box 1450, Alexandria, VA 22313-1450. DO NOT SEND FEES OR COMPLETED FORMS TO THIS ADDRESS. SEND TO: Commissioner for Patents, P.O. Box 1450, Alexandria, VA 22313-1450.

If you need assistance in completing the form, call 1-800-PTO-9199 and select option 2

**Index of Claims**



Application No.

10/383,219

Examiner

Tim Phan

Applicant(s)

NEAL, GRIFFITH D.

Art Unit

3729

✓	Rejected
=	Allowed

-	(Through numeral) Cancelled
+	Restricted

N	Non-Elected
I	Interference

A	Appeal
O	Objected

Claim		Date	
Final	Original		
	3/22/06		
1	+		
2			
3			
4			
5			
6			
7			
8			
9			
10			
11			
12			
13			
14			
15			
16			
17			
18			
19			
20			
21			
22			
23			
24			
25			
26			
27			
28			
29			
30			
31			
32			
33			
34			
35			
36			
37			
38			
39			
40			
41			
42			
43			
44			
45			
46			
47			
48			
49			
50			

Claim		Date	
Final	Original		
51			
52			
53			
54			
55			
56			
57			
58			
59			
60			
61			
62			
63			
64			
65			
66			
67			
68			
69			
70			
71			
72			
73			
74			
75			
76			
77			
78			
79			
80			
81			
82			
83			
84			
85			
86			
87			
88			
89			
90			
91			
92			
93			
94			
95			
96			
97			
98			
99			
100			

Claim		Date	
Final	Original		
101			
102			
103			
104			
105			
106			
107			
108			
109			
110			
111			
112			
113			
114			
115			
116			
117			
118			
119			
120			
121			
122			
123			
124			
125			
126			
127			
128			
129			
130			
131			
132			
133			
134			
135			
136			
137			
138			
139			
140			
141			
142			
143			
144			
145			
146			
147			
148			
149			
150			

## EAST Search History

Ref #	Hits	Search Query	DBs	Default Operator	Plurals	Time Stamp
L1	9859	(310/259,42,43,45,216,217,218,254).CCLS.	US-PGPUB; USPAT; USOCR; EPO; JPO	OR	OFF	2006/03/15 16:57
L2	747789	@pd>"20051001"	US-PGPUB; USPAT; USOCR; EPO; JPO; DERWENT; IBM_TDB	OR	OFF	2006/03/15 16:46
L3	169	1 and 2	US-PGPUB; USPAT; USOCR; EPO; JPO; DERWENT; IBM_TDB	OR	OFF	2006/03/15 16:55
L4	754	(310/259,42,43,45,216,217,218,254).CCLS.	US-PGPUB	OR	OFF	2006/03/15 16:57
L5	51	4 and (stator and plastic\$1).clm.	US-PGPUB; USPAT; USOCR; EPO; JPO; DERWENT; IBM_TDB	OR	OFF	2006/03/15 16:59
L6	29	4 and (bridge\$1).clm.	US-PGPUB; USPAT; USOCR; EPO; JPO; DERWENT; IBM_TDB	OR	OFF	2006/03/15 17:00





UNITED STATES PATENT AND TRADEMARK OFFICE

UNITED STATES DEPARTMENT OF COMMERCE
United States Patent and Trademark Office
Address: COMMISSIONER FOR PATENTS
P.O. Box 1450
Alexandria, Virginia 22313-1450
www.uspto.gov

NOTICE OF ALLOWANCE AND FEE(S) DUE

00757 7590 03/21/2006
BRINKS HOFER GILSON & LIONE
P.O. BOX 10395
CHICAGO, IL 60610

EXAMINER

MULLINS, BURTON S

ART UNIT PAPER NUMBER

2834

DATE MAILED: 03/21/2006

Table with 5 columns: APPLICATION NO., FILING DATE, FIRST NAMED INVENTOR, ATTORNEY DOCKET NO., CONFIRMATION NO.
10/383,219 03/05/2003 Griffith D. Neal 8864/33 9248

TITLE OF INVENTION: STATOR ASSEMBLY MADE FROM A MOLDED WEB OF CORE SEGMENTS AND MOTOR USING SAME

Table with 6 columns: APPLN. TYPE, SMALL ENTITY, ISSUE FEE, PUBLICATION FEE, TOTAL FEE(S) DUE, DATE DUE
nonprovisional YES \$700 \$300 \$1000 06/21/2006

THE APPLICATION IDENTIFIED ABOVE HAS BEEN EXAMINED AND IS ALLOWED FOR ISSUANCE AS A PATENT. PROSECUTION ON THE MERITS IS CLOSED. THIS NOTICE OF ALLOWANCE IS NOT A GRANT OF PATENT RIGHTS. THIS APPLICATION IS SUBJECT TO WITHDRAWAL FROM ISSUE AT THE INITIATIVE OF THE OFFICE OR UPON PETITION BY THE APPLICANT. SEE 37 CFR 1.313 AND MPEP 1308.

THE ISSUE FEE AND PUBLICATION FEE (IF REQUIRED) MUST BE PAID WITHIN THREE MONTHS FROM THE MAILING DATE OF THIS NOTICE OR THIS APPLICATION SHALL BE REGARDED AS ABANDONED. THIS STATUTORY PERIOD CANNOT BE EXTENDED. SEE 35 U.S.C. 151. THE ISSUE FEE DUE INDICATED ABOVE REFLECTS A CREDIT FOR ANY PREVIOUSLY PAID ISSUE FEE APPLIED IN THIS APPLICATION. THE PTOL-85B (OR AN EQUIVALENT) MUST BE RETURNED WITHIN THIS PERIOD EVEN IF NO FEE IS DUE OR THE APPLICATION WILL BE REGARDED AS ABANDONED.

HOW TO REPLY TO THIS NOTICE:

I. Review the SMALL ENTITY status shown above.

If the SMALL ENTITY is shown as YES, verify your current SMALL ENTITY status:

A. If the status is the same, pay the TOTAL FEE(S) DUE shown above.

B. If the status above is to be removed, check box 5b on Part B - Fee(s) Transmittal and pay the PUBLICATION FEE (if required) and twice the amount of the ISSUE FEE shown above, or

If the SMALL ENTITY is shown as NO:

A. Pay TOTAL FEE(S) DUE shown above, or

B. If applicant claimed SMALL ENTITY status before, or is now claiming SMALL ENTITY status, check box 5a on Part B - Fee(s) Transmittal and pay the PUBLICATION FEE (if required) and 1/2 the ISSUE FEE shown above.

II. PART B - FEE(S) TRANSMITTAL should be completed and returned to the United States Patent and Trademark Office (USPTO) with your ISSUE FEE and PUBLICATION FEE (if required). Even if the fee(s) have already been paid, Part B - Fee(s) Transmittal should be completed and returned. If you are charging the fee(s) to your deposit account, section "4b" of Part B - Fee(s) Transmittal should be completed and an extra copy of the form should be submitted.

III. All communications regarding this application must give the application number. Please direct all communications prior to issuance to Mail Stop ISSUE FEE unless advised to the contrary.

IMPORTANT REMINDER: Utility patents issuing on applications filed on or after Dec. 12, 1980 may require payment of maintenance fees. It is patentee's responsibility to ensure timely payment of maintenance fees when due.

**PART B - FEE(S) TRANSMITTAL**

Complete and send this form, together with applicable fee(s), to: **Mail** Mail Stop ISSUE FEE  
 Commissioner for Patents  
 P.O. Box 1450  
 Alexandria, Virginia 22313-1450  
 or **Fax** (571)-273-2885

**INSTRUCTIONS:** This form should be used for transmitting the ISSUE FEE and PUBLICATION FEE (if required). Blocks 1 through 5 should be completed where appropriate. All further correspondence including the Patent, advance orders and notification of maintenance fees will be mailed to the current correspondence address as indicated unless corrected below or directed otherwise in Block 1, by (a) specifying a new correspondence address; and/or (b) indicating a separate "FEE ADDRESS" for maintenance fee notifications.

CURRENT CORRESPONDENCE ADDRESS (Note: Use Block 1 for any change of address)

Note: A certificate of mailing can only be used for domestic mailings of the Fee(s) Transmittal. This certificate cannot be used for any other accompanying papers. Each additional paper, such as an assignment or formal drawing, must have its own certificate of mailing or transmission.

00757                      7590                      03/21/2006  
**BRINKS HOFER GILSON & LIONE**  
 P.O. BOX 10395  
 CHICAGO, IL 60610

**Certificate of Mailing or Transmission**  
 I hereby certify that this Fee(s) Transmittal is being deposited with the United States Postal Service with sufficient postage for first class mail in an envelope addressed to the Mail Stop ISSUE FEE address above, or being facsimile transmitted to the USPTO (571) 273-2885, on the date indicated below.

(Depositor's name)
(Signature)
(Date)

APPLICATION NO.	FILING DATE	FIRST NAMED INVENTOR	ATTORNEY DOCKET NO.	CONFIRMATION NO.
-----------------	-------------	----------------------	---------------------	------------------

10/383,219                      03/05/2003                      Griffith D. Neal                      8864/33                      9248

TITLE OF INVENTION: STATOR ASSEMBLY MADE FROM A MOLDED WEB OF CORE SEGMENTS AND MOTOR USING SAME

APPLN. TYPE	SMALL ENTITY	ISSUE FEE	PUBLICATION FEE	TOTAL FEE(S) DUE	DATE DUE
-------------	--------------	-----------	-----------------	------------------	----------

nonprovisional                      YES                      \$700                      \$300                      \$1000                      06/21/2006

EXAMINER	ART UNIT	CLASS-SUBCLASS
----------	----------	----------------

MULLINS, BURTON S                      2834                      310-259000

<p>1. Change of correspondence address or indication of "Fee Address" (37 CFR 1.363).</p> <p><input type="checkbox"/> Change of correspondence address (or Change of Correspondence Address form PTO/SB/122) attached.</p> <p><input type="checkbox"/> "Fee Address" indication (or "Fee Address" Indication form PTO/SB/47; Rev 03-02 or more recent) attached. Use of a Customer Number is required.</p>	<p>2. For printing on the patent front page, list</p> <p>(1) the names of up to 3 registered patent attorneys or agents OR, alternatively, 1 _____</p> <p>(2) the name of a single firm (having as a member a registered attorney or agent) and the names of up to 2 registered patent attorneys or agents. If no name is listed, no name will be printed. 2 _____</p> <p>3 _____</p>
------------------------------------------------------------------------------------------------------------------------------------------------------------------------------------------------------------------------------------------------------------------------------------------------------------------------------------------------------------------------------------------------------------	---------------------------------------------------------------------------------------------------------------------------------------------------------------------------------------------------------------------------------------------------------------------------------------------------------------------------------------------------------------------------------------

3. ASSIGNEE NAME AND RESIDENCE DATA TO BE PRINTED ON THE PATENT (print or type)

PLEASE NOTE: Unless an assignee is identified below, no assignee data will appear on the patent. If an assignee is identified below, the document has been filed for recordation as set forth in 37 CFR 3.11. Completion of this form is NOT a substitute for filing an assignment.

(A) NAME OF ASSIGNEE \_\_\_\_\_ (B) RESIDENCE: (CITY and STATE OR COUNTRY) \_\_\_\_\_

Please check the appropriate assignee category or categories (will not be printed on the patent) :  Individual  Corporation or other private group entity  Government

<p>4a. The following fee(s) are enclosed:</p> <p><input type="checkbox"/> Issue Fee</p> <p><input type="checkbox"/> Publication Fee (No small entity discount permitted)</p> <p><input type="checkbox"/> Advance Order - # of Copies _____</p>	<p>4b. Payment of Fee(s):</p> <p><input type="checkbox"/> A check in the amount of the fee(s) is enclosed.</p> <p><input type="checkbox"/> Payment by credit card. Form PTO-2038 is attached.</p> <p><input type="checkbox"/> The Director is hereby authorized by charge the required fee(s), or credit any overpayment, to Deposit Account Number _____ (enclose an extra copy of this form).</p>
------------------------------------------------------------------------------------------------------------------------------------------------------------------------------------------------------------------------------------------------	-----------------------------------------------------------------------------------------------------------------------------------------------------------------------------------------------------------------------------------------------------------------------------------------------------------------------------------------------------------------------------------------------------

5. Change in Entity Status (from status indicated above)

a. Applicant claims SMALL ENTITY status. See 37 CFR 1.27.                       b. Applicant is no longer claiming SMALL ENTITY status. See 37 CFR 1.27(g)(2).

The Director of the USPTO is requested to apply the Issue Fee and Publication Fee (if any) or to re-apply any previously paid issue fee to the application identified above. NOTE: The Issue Fee and Publication Fee (if required) will not be accepted from anyone other than the applicant; a registered attorney or agent; or the assignee or other party in interest as shown by the records of the United States Patent and Trademark Office.

Authorized Signature \_\_\_\_\_ Date \_\_\_\_\_

Typed or printed name \_\_\_\_\_ Registration No. \_\_\_\_\_

This collection of information is required by 37 CFR 1.311. The information is required to obtain or retain a benefit by the public which is to file (and by the USPTO to process) an application. Confidentiality is governed by 35 U.S.C. 122 and 37 CFR 1.14. This collection is estimated to take 12 minutes to complete, including gathering, preparing, and submitting the completed application form to the USPTO. Time will vary depending upon the individual case. Any comments on the amount of time you require to complete this form and/or suggestions for reducing this burden, should be sent to the Chief Information Officer, U.S. Patent and Trademark Office, U.S. Department of Commerce, P.O. Box 1450, Alexandria, Virginia 22313-1450. DO NOT SEND FEES OR COMPLETED FORMS TO THIS ADDRESS. SEND TO: Commissioner for Patents, P.O. Box 1450, Alexandria, Virginia 22313-1450.

Under the Paperwork Reduction Act of 1995, no persons are required to respond to a collection of information unless it displays a valid OMB control number.



UNITED STATES PATENT AND TRADEMARK OFFICE

UNITED STATES DEPARTMENT OF COMMERCE
United States Patent and Trademark Office
Address: COMMISSIONER FOR PATENTS
P.O. Box 1450
Alexandria, Virginia 22313-1450
www.uspto.gov

Table with 5 columns: APPLICATION NO., FILING DATE, FIRST NAMED INVENTOR, ATTORNEY DOCKET NO., CONFIRMATION NO.
10/383,219 03/05/2003 Griffith D. Neal 8864/33 9248

00757 7590 03/21/2006
BRINKS HOFER GILSON & LIONE
P.O. BOX 10395
CHICAGO, IL 60610

EXAMINER

MULLINS, BURTON S

ART UNIT PAPER NUMBER

2834

DATE MAILED: 03/21/2006

Determination of Patent Term Adjustment under 35 U.S.C. 154 (b)
(application filed on or after May 29, 2000)

The Patent Term Adjustment to date is 248 day(s). If the issue fee is paid on the date that is three months after the mailing date of this notice and the patent issues on the Tuesday before the date that is 28 weeks (six and a half months) after the mailing date of this notice, the Patent Term Adjustment will be 248 day(s).

If a Continued Prosecution Application (CPA) was filed in the above-identified application, the filing date that determines Patent Term Adjustment is the filing date of the most recent CPA.

Applicant will be able to obtain more detailed information by accessing the Patent Application Information Retrieval (PAIR) WEB site (http://pair.uspto.gov).

Any questions regarding the Patent Term Extension or Adjustment determination should be directed to the Office of Patent Legal Administration at (571)-272-7702. Questions relating to issue and publication fee payments should be directed to the Customer Service Center of the Office of Patent Publication at 1-(888)-786-0101 or (571)-272-4200.

5

<b>Notice of Allowability</b>	<b>Application No.</b>	<b>Applicant(s)</b>	
	10/383,219	NEAL, GRIFFITH D.	
	<b>Examiner</b>	<b>Art Unit</b>	
	Burton S. Mullins	2834	

**-- The MAILING DATE of this communication appears on the cover sheet with the correspondence address--**

All claims being allowable, PROSECUTION ON THE MERITS IS (OR REMAINS) CLOSED in this application. If not included herewith (or previously mailed), a Notice of Allowance (PTOL-85) or other appropriate communication will be mailed in due course. **THIS NOTICE OF ALLOWABILITY IS NOT A GRANT OF PATENT RIGHTS.** This application is subject to withdrawal from issue at the initiative of the Office or upon petition by the applicant. See 37 CFR 1.313 and MPEP 1308.

- 1.  This communication is responsive to amendment filed 24 January 2006.
- 2.  The allowed claim(s) is/are 1-7, 10, 25 and 33-37.
- 3.  Acknowledgment is made of a claim for foreign priority under 35 U.S.C. § 119(a)-(d) or (f).
  - a)  All    b)  Some\*    c)  None    of the:
    - 1.  Certified copies of the priority documents have been received.
    - 2.  Certified copies of the priority documents have been received in Application No. \_\_\_\_\_.
    - 3.  Copies of the certified copies of the priority documents have been received in this national stage application from the International Bureau (PCT Rule 17.2(a)).

\* Certified copies not received: \_\_\_\_\_.

Applicant has THREE MONTHS FROM THE "MAILING DATE" of this communication to file a reply complying with the requirements noted below. Failure to timely comply will result in ABANDONMENT of this application. **THIS THREE-MONTH PERIOD IS NOT EXTENDABLE.**

- 4.  A SUBSTITUTE OATH OR DECLARATION must be submitted. Note the attached EXAMINER'S AMENDMENT or NOTICE OF INFORMAL PATENT APPLICATION (PTO-152) which gives reason(s) why the oath or declaration is deficient.
  - 5.  CORRECTED DRAWINGS ( as "replacement sheets") must be submitted.
    - (a)  including changes required by the Notice of Draftsperson's Patent Drawing Review ( PTO-948) attached
      - 1)  hereto or 2)  to Paper No./Mail Date \_\_\_\_\_.
    - (b)  including changes required by the attached Examiner's Amendment / Comment or in the Office action of Paper No./Mail Date \_\_\_\_\_.
- Identifying indicia such as the application number (see 37 CFR 1.84(c)) should be written on the drawings in the front (not the back) of each sheet. Replacement sheet(s) should be labeled as such in the header according to 37 CFR 1.121(d).
- 6.  DEPOSIT OF and/or INFORMATION about the deposit of BIOLOGICAL MATERIAL must be submitted. Note the attached Examiner's comment regarding REQUIREMENT FOR THE DEPOSIT OF BIOLOGICAL MATERIAL.

**Attachment(s)**

- 1.  Notice of References Cited (PTO-892)
- 2.  Notice of Draftsperson's Patent Drawing Review (PTO-948)
- 3.  Information Disclosure Statements (PTO-1449 or PTO/SB/08), Paper No./Mail Date \_\_\_\_\_
- 4.  Examiner's Comment Regarding Requirement for Deposit of Biological Material
- 5.  Notice of Informal Patent Application (PTO-152)
- 6.  Interview Summary (PTO-413), Paper No./Mail Date \_\_\_\_\_
- 7.  Examiner's Amendment/Comment
- 8.  Examiner's Statement of Reasons for Allowance
- 9.  Other \_\_\_\_\_

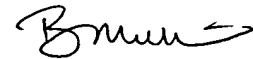

Burton S. Mullins  
Primary Examiner  
Art Unit: 2834



UNITED STATES PATENT AND TRADEMARK OFFICE

UNITED STATES DEPARTMENT OF COMMERCE
United States Patent and Trademark Office
Address: COMMISSIONER FOR PATENTS
P.O. Box 1450
Alexandria, Virginia 22313-1450
www.uspto.gov

\*BIBDATASHEET\*

CONFIRMATION NO. 9248

Bib Data Sheet

Table with 5 columns: SERIAL NUMBER (10/383,219), FILING OR 371(c) DATE (03/05/2003), CLASS (310), GROUP ART UNIT (2834), ATTORNEY DOCKET NO. (8864/33)

APPLICANTS
Griffith D. Neal, Alameda, CA;
\*\* CONTINUING DATA \*\*\*\*\*
This application is a CIP of 09/798,511 03/02/2001
\*\* FOREIGN APPLICATIONS \*\*\*\*\*
IF REQUIRED, FOREIGN FILING LICENSE GRANTED\*\* SMALL ENTITY \*\*
\*\* 05/06/2003

Table with 5 columns: Foreign Priority claimed (no), 35 USC 119 (a-d) conditions met (no), STATE OR COUNTRY (CA), SHEETS DRAWING (5), TOTAL CLAIMS (32), INDEPENDENT CLAIMS (6). Includes Examiner's Signature and Initials.

ADDRESS
00757

TITLE
Stator assembly made from a molded web of core segments and motor using same

Table with 2 main columns: FILING FEE RECEIVED (737) and FEES: Authority has been given in Paper. Includes a list of fee checkboxes: All Fees, 1.16 Fees ( Filing ), 1.17 Fees ( Processing Ext. of time ), 1.18 Fees ( Issue ), Other, Credit.

<b>Issue Classification</b> 	<b>Application/Control No.</b> 10/383,219	<b>Applicant(s)/Patent under Reexamination</b> NEAL, GRIFFITH D.	
	<b>Examiner</b> Burton S. Mullins	<b>Art Unit</b> 2834	

ISSUE CLASSIFICATION										
ORIGINAL					CROSS REFERENCE(S)					
CLASS	SUBCLASS				CLASS	SUBCLASS (ONE SUBCLASS PER BLOCK)				
310	259				310	42	45	218		
INTERNATIONAL CLASSIFICATION										
H	0	2	K	1/18						
H	0	2	K	15/02						
H	0	2	K	15/10						
				/						
				/						

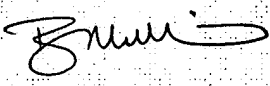
_____ (Assistant Examiner) (Date)	 <b>Burton Mullins</b> 15 March 2006 (Primary Examiner) (Date)	<b>Total Claims Allowed: 14</b>  <table border="1" style="width: 100%;"> <tr> <td>O.G. Print Claim(s)</td> <td>O.G. Print Fig.</td> </tr> <tr> <td style="text-align: center;">1</td> <td style="text-align: center;">3&amp;5</td> </tr> </table>	O.G. Print Claim(s)	O.G. Print Fig.	1	3&5
O.G. Print Claim(s)	O.G. Print Fig.					
1	3&5					
Hawkins 3/16/06 (Legal Instruments Examiner) (Date)						

<input type="checkbox"/> Claims renumbered in the same order as presented by applicant		<input type="checkbox"/> CPA		<input type="checkbox"/> T.D.		<input type="checkbox"/> R.1.47	
Final	Original	Final	Original	Final	Original	Final	Original
1	1		31		61		91
2	2		32		62		92
3	3	10	33		63		93
4	4	14	34		64		94
5	5	9	35		65		95
6	6	12	36		66		96
7	7	13	37		67		97
	8		38		68		98
	9		39		69		99
11	10		40		70		100
	11		41		71		101
	12		42		72		102
	13		43		73		103
	14		44		74		104
	15		45		75		105
	16		46		76		106
	17		47		77		107
	18		48		78		108
	19		49		79		109
	20		50		80		110
	21		51		81		111
	22		52		82		112
	23		53		83		113
	24		54		84		114
8	25		55		85		115
	26		56		86		116
	27		57		87		117
	28		58		88		118
	29		59		89		119
	30		60		90		120
							121
							122
							123
							124
							125
							126
							127
							128
							129
							130
							131
							132
							133
							134
							135
							136
							137
							138
							139
							140
							141
							142
							143
							144
							145
							146
							147
							148
							149
							150
							151
							152
							153
							154
							155
							156
							157
							158
							159
							160
							161
							162
							163
							164
							165
							166
							167
							168
							169
							170
							171
							172
							173
							174
							175
							176
							177
							178
							179
							180
							181
							182
							183
							184
							185
							186
							187
							188
							189
							190
							191
							192
							193
							194
							195
							196
							197
							198
							199
							200
							201
							202
							203
							204
							205
							206
							207
							208
							209
							210



PART B - FEE(S) TRANSMITTAL

Complete and send this form, together with applicable fee(s), to: Mail

Mail Stop ISSUE FEE  
Commissioner for Patents  
P.O. Box 1450  
Alexandria, Virginia 22313-1450  
or Fax (571)-273-2885

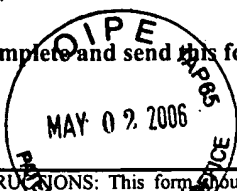

INSTRUCTIONS: This form should be used for transmitting the ISSUE FEE and PUBLICATION FEE (if required). Blocks 1 through 5 should be completed where appropriate. All further correspondence including the Patent, advance orders and notification of maintenance fees will be mailed to the current correspondence address as indicated unless stated below or directed otherwise in Block 1, by (a) specifying a new correspondence address; and/or (b) indicating a separate "FEE ADDRESS" for maintenance fee notifications.

CURRENT CORRESPONDENCE ADDRESS (Note: Use Block 1 for any change of address)

Note: A certificate of mailing can only be used for domestic mailings of the Fee(s) Transmittal. This certificate cannot be used for any other accompanying papers. Each additional paper, such as an assignment or formal drawing, must have its own certificate of mailing or transmission.

00757 7590 03/21/2006

BRINKS HOFER GILSON & LIONE  
P.O. BOX 10395  
CHICAGO, IL 60610

**Certificate of Mailing or Transmission**  
I hereby certify that this Fee(s) Transmittal is being deposited with the United States Postal Service with sufficient postage for first class mail in an envelope addressed to the Mail Stop ISSUE FEE address above, or being facsimile transmitted to the USPTO (571) 273-2885, on the date indicated below.

05/03/2006 HBERHE1 00000048 10383219

**Steven P. Shurtz (Reg. No. 31,424)**  
*Steven P. Shurtz* (Signature)  
4/27/2006 (Date)

01 FC:1501 1400.00 OP  
02 FC:1504 300.00 OP

APPLICATION NO.	FILING DATE	FIRST NAMED INVENTOR	ATTORNEY DOCKET NO.	CONFIRMATION NO.
10/383,219	03/05/2003	Griffith D. Neal	8864/33	9248

TITLE OF INVENTION: STATOR ASSEMBLY MADE FROM A MOLDED WEB OF CORE SEGMENTS AND MOTOR USING SAME

APPLN. TYPE	SMALL ENTITY	ISSUE FEE	PUBLICATION FEE	TOTAL FEE(S) DUE	DATE DUE
nonprovisional	YES	<del>\$700</del> 1400	\$300	\$1000	06/21/2006

EXAMINER	ART UNIT	CLASS-SUBCLASS
MULLINS, BURTON S	2834	310-259000

1. Change of correspondence address or indication of "Fee Address" (37 CFR 1.363).  
 Change of correspondence address (or Change of Correspondence Address form PTO/SB/122) attached.  
 "Fee Address" indication (or "Fee Address" Indication form PTO/SB/47; Rev 03-02 or more recent) attached. Use of a Customer Number is required.

2. For printing on the patent front page, list  
 (1) the names of up to 3 registered patent attorneys or agents OR, alternatively,  
 (2) the name of a single firm (having as a member a registered attorney or agent) and the names of up to 2 registered patent attorneys or agents. If no name is listed, no name will be printed.

1 Steven P. Shurtz  
 2 Brinks Hofer Gilson  
 3 & Lione

3. ASSIGNEE NAME AND RESIDENCE DATA TO BE PRINTED ON THE PATENT (print or type)  
 PLEASE NOTE: Unless an assignee is identified below, no assignee data will appear on the patent. If an assignee is identified below, the document has been filed for recordation as set forth in 37 CFR 3.11. Completion of this form is NOT a substitute for filing an assignment.

(A) NAME OF ASSIGNEE (B) RESIDENCE: (CITY and STATE OR COUNTRY)

**Encap Motor Corporation Alameda, CA 94501**

Please check the appropriate assignee category or categories (will not be printed on the patent):  Individual  Corporation or other private group entity  Government

4a. The following fee(s) are enclosed:

- Issue Fee
- Publication Fee (No small entity discount permitted)
- Advance Order - # of Copies \_\_\_\_\_

4b. Payment of Fee(s):

- A check in the amount of the fee(s) is enclosed.
- Payment by credit card. Form PTO-2038 is attached.
- The Director is hereby authorized to charge the required fee(s), or credit any overpayment, to Deposit Account Number 31923 (enclose an extra copy of this form).

5. Change in Entity Status (from status indicated above)

- a. Applicant claims SMALL ENTITY status. See 37 CFR 1.27.
- b. Applicant is no longer claiming SMALL ENTITY status. See 37 CFR 1.27(g)(2).

The Director of the USPTO is requested to apply the Issue Fee and Publication Fee (if any) or to re-apply any previously paid issue fee to the application identified above. NOTE: The Issue Fee and Publication Fee (if required) will not be accepted from anyone other than the applicant; a registered attorney or agent; or the assignee or other party in interest as shown by the records of the United States Patent and Trademark Office.

Authorized Signature Steven P. Shurtz  
 Typed or printed name **Steven P. Shurtz**

Date 4/27/06  
 Registration No. 31,424

This collection of information is required by 37 CFR 1.311. The information is required to obtain or retain a benefit by the public which is to file (and by the USPTO to process) an application. Confidentiality is governed by 35 U.S.C. 122 and 37 CFR 1.14. This collection is estimated to take 12 minutes to complete, including gathering, preparing, and submitting the completed application form to the USPTO. Time will vary depending upon the individual case. Any comments on the amount of time you require to complete this form and/or suggestions for reducing this burden, should be sent to the Chief Information Officer, U.S. Patent and Trademark Office, U.S. Department of Commerce, P.O. Box 1450, Alexandria, Virginia 22313-1450. DO NOT SEND FEES OR COMPLETED FORMS TO THIS ADDRESS. SEND TO: Commissioner for Patents, P.O. Box 1450, Alexandria, Virginia 22313-1450.

Under the Paperwork Reduction Act of 1995, no persons are required to respond to a collection of information unless it displays a valid OMB control number.



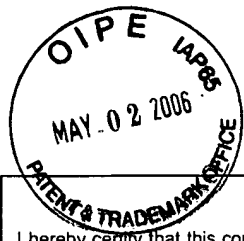

CERTIFICATE OF MAILING UNDER 37 C.F.R. §1.8

I hereby certify that this correspondence is being deposited with the United States Postal Service as first class mail, with sufficient postage, in an envelope addressed to: Commissioner for Patents, P. O. Box 1450, Alexandria, VA 22313-1450, on the below date:

Date: April 27, 2006 Name: Steven P. Shurtz Signature: /Steven P. Shurtz/

**BRINKS  
HOFER  
GILSON  
& LIONE**

**IN THE UNITED STATES PATENT AND TRADEMARK OFFICE**

In re Appln. of: Griffith D. Neal

Appln. No.: 10/383,219

Filed: March 5, 2003

For: STATOR ASSEMBLY MADE FROM A  
MOLDED WEB OF CORE SEGMENTS  
AND MOTOR USING SAME

Examiner: Burton S. Mullins

Art Unit: 2834

Attorney Docket No: 8864/33

Mail Stop Issue Fee  
Commissioner for Patents  
P. O. Box 1450  
Alexandria, VA 22313-1450

**TRANSMITTAL**

Sir:

**Attached is/are:**

- Issue Fee Transmittal (in dup); Request for Removal of Small Entity Status.
- Return Receipt Postcard

**Fee calculation:**

- No additional fee is required.
- Small Entity.
- An extension fee in an amount of \$ \_\_\_\_\_ for a \_\_\_\_\_-month extension of time under 37 C.F.R. § 1.136(a).
- A petition or processing fee in an amount of \$ \_\_\_\_\_ under 37 C.F.R. § 1.17(\_\_\_\_\_).
- An additional filing fee has been calculated as shown below:

					Small Entity		Not a Small Entity		
	Claims Remaining After Amendment		Highest No. Previously Paid For	Present Extra	Rate	Add'l Fee	or	Rate	Add'l Fee
Total		Minus			x \$25=			x \$50=	
Indep.		Minus			x 100=			x \$200=	
First Presentation of Multiple Dep. Claim					+\$180=			+\$360=	
					Total	\$		Total	\$

**Fee payment:**

- A check in the amount of \$ \_\_\_\_\_ is enclosed.
- Please charge Deposit Account No. 23-1925 in the amount of \$ \_\_\_\_\_ . A copy of this Transmittal is enclosed for this purpose.
- Payment by credit card in the amount of \$1,700.00 (Form PTO-2038 is attached).
- The Director is hereby authorized to charge payment of any additional filing fees required under 37 CFR § 1.16 and any patent application processing fees under 37 CFR § 1.17 associated with this paper (including any extension fee required to ensure that this paper is timely filed), or to credit any overpayment, to Deposit Account No. 23-1925.

Respectfully submitted,

April 27, 2006  
Date

/Steven P. Shurtz/  
Steven P. Shurtz (Reg. No. 31,424)

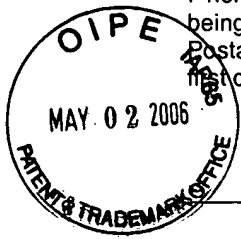

I hereby certify that this correspondence is being deposited with the United States Postal Service, with sufficient postage, as first class mail in an envelope addressed to:

Commissioner for Patents  
P.O. Box 1450  
Alexandria, VA 22313  
on April 27, 2006

Date of Deposit

Steven P. Shurtz, Reg. No. 31,424

Name of applicant, assignee or  
Registered Representative

/Steven P. Shurtz/

Signature

April 27, 2006

Date of Signature

Case No. 8864/33

**IN THE UNITED STATES PATENT AND TRADEMARK OFFICE**

In re Application of:

Griffith D. Neal

Serial No.: 10/383,219

Filed: March 5, 2003

For: STATOR ASSEMBLY  
MADE FROM A  
MOLDED WEB OF  
CORE SEGMENTS AND  
MOTOR USING SAME

Examiner: Burton S. Mullins  
Group Art Unit: 2834

**REQUEST FOR REMOVAL OF SMALL ENTITY  
STATUS PURSUANT TO 37 C.F.R. § 1.27(g)(2)**

Commissioner for Patents  
P.O. Box 1450  
Alexandria, Virginia 22313-1450

Dear Sir:

A small entity statement or assertion of entitlement to claim small entity status was previously filed in this application. Such status is no longer desired.

Respectfully submitted,

/Steven P. Shurtz/

Steven P. Shurtz  
Registration No. 31,424  
Attorney for Applicants

BRINKS HOFER GILSON & LIONE  
P.O. BOX 10395  
CHICAGO, IL 60610  
(312)321-4200  
Direct Dial (801)444-3933



UNITED STATES PATENT AND TRADEMARK OFFICE

UNITED STATES DEPARTMENT OF COMMERCE
United States Patent and Trademark Office
Address: COMMISSIONER FOR PATENTS
P.O. Box 1450
Alexandria, Virginia 22313-1450
www.uspto.gov

\*BIBDATASHEET\*

CONFIRMATION NO. 9248

Bib Data Sheet

Table with 5 columns: SERIAL NUMBER (10/383,219), FILING DATE (03/05/2003), CLASS (310), GROUP ART UNIT (2834), ATTORNEY DOCKET NO. (8864/33)

APPLICANTS

Griffith D. Neal, Alameda, CA;

\*\* CONTINUING DATA \*\*\*\*\*

This application is a CIP of 09/798,511 03/02/2001 PAT 7,036,207

\*\* FOREIGN APPLICATIONS \*\*\*\*\*

IF REQUIRED, FOREIGN FILING LICENSE GRANTED

\*\* 05/06/2003

Table with 5 columns: Foreign Priority claimed, 35 USC 119 (a-d) conditions met, STATE OR COUNTRY (CA), SHEETS DRAWING (5), TOTAL CLAIMS (32), INDEPENDENT CLAIMS (6)

ADDRESS

00757
BRINKS HOFER GILSON & LIONE
P.O. BOX 10395
CHICAGO , IL
60610

TITLE

STATOR ASSEMBLY MADE FROM A MOLDED WEB OF CORE SEGMENTS AND MOTOR USING SAME

Table with 2 columns: FILING FEE RECEIVED (1037), FEES: Authority has been given in Paper No. \_\_\_\_\_ to charge/credit DEPOSIT ACCOUNT No. \_\_\_\_\_ for following: (List of fee boxes: All Fees, 1.16 Fees ( Filing ), 1.17 Fees ( Processing Ext. of time ), 1.18 Fees ( Issue ), Other)

Applicant or Patentee: Griffith D. Neal  
 Serial or Patent No: 7,067,952 Case No.: 8864-33  
 Filed or Issued: June 27, 2006  
 For: STATOR ASSEMBLY MADE FROM A MOLDED WEB OF CORE SEGMENTS AND MOTOR USING SAME

**VERIFIED STATEMENT (DECLARATION) CLAIMING SMALL ENTITY STATUS  
 (37 CFR 1.9(f) and 1.27(c)) - SMALL BUSINESS CONCERN**

I hereby declare that I am

- the owner of the small business concern identified below:
- an official of the small business concern empowered to act on behalf of the concern identified below:

NAME OF CONCERN: ENCAP TECHNOLOGIES, INC.  
 ADDRESS OF CONCERN: 1334 Bay Street, Alameda, California 94501

I hereby declare that the above identified small business concern qualifies as a small business concern as defined in 13 CFR 121.3-18, and reproduced in 37 CFR 1.9(d), for purposes of paying reduced fees under Section 41(a) and (b) of Title 35, United States Code, in that the number of employees of the concern, including those of its affiliates, does not exceed 500 persons. For purposes of this statement, (1) the number of employees of the business concern is the average over the previous fiscal year of the concern of the persons employed on a full-time, part-time or temporary basis during each of the pay periods of the fiscal year, and (2) concerns are affiliates of each other when either, directly or indirectly, one concern controls or has the power to control the other, or a third party or parties controls or has the power to control both.

I hereby declare that rights under contract or law have been conveyed to and remain with the small business concern identified above with regard to the invention, entitled STATOR ASSEMBLY MADE FROM A MOLDED WEB OF CORE SEGMENTS AND MOTOR USING SAME by inventor(s) Griffith D. Neal described in:

- the specification filed herewith.
- application serial no. \_\_\_\_\_, filed \_\_\_\_\_.
- patent no. 7,067,952, issued June 27, 2006.

If the rights held by the above identified small business concern are not exclusive, each individual, concern or organization having rights to the invention is listed below\* and no rights to the invention are held by any person, other than the inventor, who would not qualify as an independent inventor under 37 CFR 1.9(c) if that person made the invention, or by any concern which would not qualify as a small business concern under 37 CFR 1.9(d), or a nonprofit organization under 37 CFR 1.9(e). \*NOTE: Separate verified statements are required from each named person, concern or organization having rights to the invention averring to their status as small entities. (37 CFR 1.27)

NAME \_\_\_\_\_  
 ADDRESS \_\_\_\_\_  
 INDIVIDUAL     SMALL BUSINESS CONCERN     NONPROFIT ORGANIZATION

NAME \_\_\_\_\_  
 ADDRESS \_\_\_\_\_  
 INDIVIDUAL     SMALL BUSINESS CONCERN     NONPROFIT ORGANIZATION

I acknowledge the duty to file, in this application or patent, notification of any change in status resulting in loss of entitlement to small entity status prior to paying, or at the time of paying, the earliest of the issue fee or any maintenance fee due after the date on which status as a small entity is no longer appropriate. (37 CFR 1.28(b))

I hereby declare that all statements made herein of my own knowledge are true and that all statements made on information and belief are believed to be true; and further that these statements were made with the knowledge that willful false statements and the like so made are punishable by fine or imprisonment, or both, under Section 1001 of Title 18 of the United States Code, and that such willful false statements may jeopardize the validity of the application, any patent issuing thereon, or any patent to which this verified statement is directed.

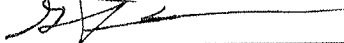
SIGNATURE  DATE 11-22-11  
 NAME OF PERSON SIGNING Griffith D. Neal  
 TITLE OF PERSON OTHER THAN OWNER CEO  
 ADDRESS OF PERSON SIGNING 1334 Bay Street, Alameda, California 94501

**BRINKS HOFER GILSON & LIONE**  
 P.O. BOX 10395  
 Chicago, Illinois 60610  
 (312) 321-4200

## Electronic Acknowledgement Receipt

<b>EFS ID:</b>	11703255
<b>Application Number:</b>	10383219
<b>International Application Number:</b>	
<b>Confirmation Number:</b>	9248
<b>Title of Invention:</b>	STATOR ASSEMBLY MADE FROM A MOLDED WEB OF CORE SEGMENTS AND MOTOR USING SAME
<b>First Named Inventor/Applicant Name:</b>	Griffith D. Neal
<b>Customer Number:</b>	757
<b>Filer:</b>	Steven P. Shurtz/Kristin Hooper
<b>Filer Authorized By:</b>	Steven P. Shurtz
<b>Attorney Docket Number:</b>	8864/33
<b>Receipt Date:</b>	23-DEC-2011
<b>Filing Date:</b>	05-MAR-2003
<b>Time Stamp:</b>	16:14:32
<b>Application Type:</b>	Utility under 35 USC 111(a)

### Payment information:

Submitted with Payment	no
------------------------	----

### File Listing:

Document Number	Document Description	File Name	File Size(Bytes)/ Message Digest	Multi Part /.zip	Pages (if appl.)
1	Petition for review by the Office of Petitions.	8864-33_Verified_Statement_C laiming_Small-Entity.pdf	90926 <small>2e6d8ec0fdbf90cf7e4e64de76016eee252c11e1</small>	no	1

### Warnings:

### Information:

Am. Honda v. IV II - IPR2018-00619  
PET\_HONDA\_1003-0394

This Acknowledgement Receipt evidences receipt on the noted date by the USPTO of the indicated documents, characterized by the applicant, and including page counts, where applicable. It serves as evidence of receipt similar to a Post Card, as described in MPEP 503.

**New Applications Under 35 U.S.C. 111**

If a new application is being filed and the application includes the necessary components for a filing date (see 37 CFR 1.53(b)-(d) and MPEP 506), a Filing Receipt (37 CFR 1.54) will be issued in due course and the date shown on this Acknowledgement Receipt will establish the filing date of the application.

**National Stage of an International Application under 35 U.S.C. 371**

If a timely submission to enter the national stage of an international application is compliant with the conditions of 35 U.S.C. 371 and other applicable requirements a Form PCT/DO/EO/903 indicating acceptance of the application as a national stage submission under 35 U.S.C. 371 will be issued in addition to the Filing Receipt, in due course.

**New International Application Filed with the USPTO as a Receiving Office**

If a new international application is being filed and the international application includes the necessary components for an international filing date (see PCT Article 11 and MPEP 1810), a Notification of the International Application Number and of the International Filing Date (Form PCT/RO/105) will be issued in due course, subject to prescriptions concerning national security, and the date shown on this Acknowledgement Receipt will establish the international filing date of the application.

Under the Paperwork Reduction Act of 1995, no persons are required to respond to a collection of information unless it displays a valid OMB control number.

## POWER OF ATTORNEY TO PROSECUTE APPLICATIONS BEFORE THE USPTO

I hereby revoke all previous powers of attorney given in the application identified in the attached statement under 37 CFR 3.73(b).

I hereby appoint:

Practitioners associated with the Customer Number:

35690

OR

Practitioner(s) named below (if more than ten patent practitioners are to be named, then a customer number must be used):

Name	Registration Number	Name	Registration Number

as attorney(s) or agent(s) to represent the undersigned before the United States Patent and Trademark Office (USPTO) in connection with any and all patent applications assigned only to the undersigned according to the USPTO assignment records or assignment documents attached to this form in accordance with 37 CFR 3.73(b).

Please change the correspondence address for the application identified in the attached statement under 37 CFR 3.73(b) to:

The address associated with Customer Number:

35690

OR

Firm or Individual Name

Address

City

State

Zip

Country

Telephone

Email

Assignee Name and Address:

Intellectual Ventures Holding 88 LLC  
7251 W Lake Mead Blvd  
Ste 300  
Las Vegas, Nevada 89128

A copy of this form, together with a statement under 37 CFR 3.73(b) (Form PTO/SB/98 or equivalent) is required to be filed in each application in which this form is used. The statement under 37 CFR 3.73(b) may be completed by one of the practitioners appointed in this form if the appointed practitioner is authorized to act on behalf of the assignee, and must identify the application in which this Power of Attorney is to be filed.

### SIGNATURE of Assignee of Record

*The individual whose signature and title is supplied below is authorized to act on behalf of the assignee*

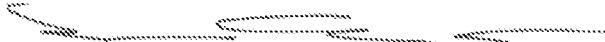
Signature		Date	29 OCT 2012
Name	Jeanne Suchodolski	Telephone	
Title	Authorized Person for Intellectual Ventures Holding 88 LLC		

This collection of information is required by 37 CFR 1.31, 1.32 and 1.33. The information is required to obtain or retain a benefit by the public which is to file (and by the USPTO to process) an application. Confidentiality is governed by 35 U.S.C. 122 and 37 CFR 1.11 and 1.14. This collection is estimated to take 3 minutes to complete, including gathering, preparing, and submitting the completed application form to the USPTO. Time will vary depending upon the individual case. Any comments on the amount of time you require to complete this form and/or suggestions for reducing this burden, should be sent to the Chief Information Officer, U.S. Patent and Trademark Office, U.S. Department of Commerce, P.O. Box 1450, Alexandria, VA 22313-1450. DO NOT SEND FEES OR COMPLETED FORMS TO THIS ADDRESS. SEND TO: Commissioner for Patents, P.O. Box 1450, Alexandria, VA 22313-1450.

*If you need assistance in completing the form, call 1-800-PTO-9199 and select option 2.*



DECLARATION REGARDING AUTHORITY TO SIGN  
ON BEHALF OF A LEGAL ENTITY  
37 C.F.R. 3.73(b)(2)(i)

I, Jeanne Suchodolski (whose title is supplied below), hereby declare that I am authorized to sign documents on behalf of Intellectual Ventures Holding 88 LLC.

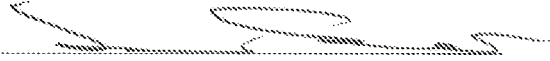

Jeanne Suchodolski  
Authorized Person for Intellectual Ventures Holding 88 LLC

29 OCT 2012

Date

## Electronic Acknowledgement Receipt

<b>EFS ID:</b>	14373028
<b>Application Number:</b>	10383219
<b>International Application Number:</b>	
<b>Confirmation Number:</b>	9248
<b>Title of Invention:</b>	STATOR ASSEMBLY MADE FROM A MOLDED WEB OF CORE SEGMENTS AND MOTOR USING SAME
<b>First Named Inventor/Applicant Name:</b>	Griffith D. Neal
<b>Customer Number:</b>	757
<b>Filer:</b>	Dean M. Munyon/Dawn DeLuca
<b>Filer Authorized By:</b>	Dean M. Munyon
<b>Attorney Docket Number:</b>	8864/33
<b>Receipt Date:</b>	03-DEC-2012
<b>Filing Date:</b>	05-MAR-2003
<b>Time Stamp:</b>	20:37:16
<b>Application Type:</b>	Utility under 35 USC 111(a)

### Payment information:

Submitted with Payment	no
------------------------	----

### File Listing:

Document Number	Document Description	File Name	File Size(Bytes)/ Message Digest	Multi Part /.zip	Pages (if appl.)
1	Assignee showing of ownership per 37 CFR 3.73.	373b.pdf	39796 <small>6002f647dde4796837247c85582a685597f20d4e</small>	no	3

### Warnings:

### Information:

Am. Honda v. IV II - IPR2018-00619  
PET\_HONDA\_1003-0398

2	Power of Attorney	POA.pdf	967342	no	2
			875449c23023d37e5da46803aa55a6ac615df8c8		

**Warnings:**

**Information:**

<b>Total Files Size (in bytes):</b>	1007138
-------------------------------------	---------

**This Acknowledgement Receipt evidences receipt on the noted date by the USPTO of the indicated documents, characterized by the applicant, and including page counts, where applicable. It serves as evidence of receipt similar to a Post Card, as described in MPEP 503.**

**New Applications Under 35 U.S.C. 111**

**If a new application is being filed and the application includes the necessary components for a filing date (see 37 CFR 1.53(b)-(d) and MPEP 506), a Filing Receipt (37 CFR 1.54) will be issued in due course and the date shown on this Acknowledgement Receipt will establish the filing date of the application.**

**National Stage of an International Application under 35 U.S.C. 371**

**If a timely submission to enter the national stage of an international application is compliant with the conditions of 35 U.S.C. 371 and other applicable requirements a Form PCT/DO/EO/903 indicating acceptance of the application as a national stage submission under 35 U.S.C. 371 will be issued in addition to the Filing Receipt, in due course.**

**New International Application Filed with the USPTO as a Receiving Office**

**If a new international application is being filed and the international application includes the necessary components for an international filing date (see PCT Article 11 and MPEP 1810), a Notification of the International Application Number and of the International Filing Date (Form PCT/RO/105) will be issued in due course, subject to prescriptions concerning national security, and the date shown on this Acknowledgement Receipt will establish the international filing date of the application.**

Under the Paperwork Reduction Act of 1995, no persons are required to respond to a collection of information unless it displays a valid OMB control number.

**STATEMENT UNDER 37 CFR 3.73(b)**

Applicant/Patent Owner: Intellectual Ventures Holding 88 LLC

Application No./Patent No.: 7067952 Filed/Issue Date: 06/27/2006

Titled: STATOR ASSEMBLY MADE FROM A MOLDED WEB OF CORE SEGMENTS AND MOTOR USING SAME

Intellectual Ventures Holding 88 LLC, a LIMITED LIABILITY COMPANY  
(Name of Assignee) (Type of Assignee, e.g., corporation, partnership, university, government agency, etc.)

states that it is:

- 1.  the assignee of the entire right, title, and interest in;
  - 2.  an assignee of less than the entire right, title, and interest in  
(The extent (by percentage) of its ownership interest is \_\_\_\_\_ %); or
  - 3.  the assignee of an undivided interest in the entirety of (a complete assignment from one of the joint inventors was made)
- the patent application/patent identified above, by virtue of either:

A.  An assignment from the inventor(s) of the patent application/patent identified above. The assignment was recorded in the United States Patent and Trademark Office at Reel \_\_\_\_\_, Frame \_\_\_\_\_, or for which a copy therefore is attached.

**OR**

B.  A chain of title from the inventor(s), of the patent application/patent identified above, to the current assignee as follows:

1. From: Griffith D. Neal To: Encap Motor Corporation

The document was recorded in the United States Patent and Trademark Office at  
Reel 014596, Frame 0432, or for which a copy thereof is attached.

2. From: Encap Motor Corporation To: Encap Merger Co., Inc.

The document was recorded in the United States Patent and Trademark Office at  
Reel 018524, Frame 0001, or for which a copy thereof is attached.

3. From: Encap Merger Co., Inc. To: Encap Technologies, Inc.

The document was recorded in the United States Patent and Trademark Office at  
Reel 018524, Frame 0039, or for which a copy thereof is attached.

Additional documents in the chain of title are listed on a supplemental sheet(s).

As required by 37 CFR 3.73(b)(1)(i), the documentary evidence of the chain of title from the original owner to the assignee was, or concurrently is being, submitted for recordation pursuant to 37 CFR 3.11.

[NOTE: A separate copy (i.e., a true copy of the original assignment document(s)) must be submitted to Assignment Division in accordance with 37 CFR Part 3, to record the assignment in the records of the USPTO. See MPEP 302.08]

The undersigned (whose title is supplied below) is authorized to act on behalf of the assignee.

/Dean M. Munyon/  
Signature

12/3/2012  
Date

Dean M. Munyon  
Printed or Typed Name

Reg. No. 42,914  
Title

This collection of information is required by 37 CFR 3.73(b). The information is required to obtain or retain a benefit by the public which is to file (and by the USPTO to process) an application. Confidentiality is governed by 35 U.S.C. 122 and 37 CFR 1.11 and 1.14. This collection is estimated to take 12 minutes to complete, including gathering, preparing, and submitting the completed application form to the USPTO. Time will vary depending upon the individual case. Any comments on the amount of time you require to complete this form and/or suggestions for reducing this burden, should be sent to the Chief Information Officer, U.S. Patent and Trademark Office, U.S. Department of Commerce, P.O. Box 1450, Alexandria, VA 22313-1450. DO NOT SEND FEES OR COMPLETED FORMS TO THIS ADDRESS. SEND TO: Commissioner for Patents, P.O. Box 1450, Alexandria, VA 22313-1450.

Am. Honda v. IV II - IPR2018-00619

## Privacy Act Statement

The **Privacy Act of 1974 (P.L. 93-579)** requires that you be given certain information in connection with your submission of the attached form related to a patent application or patent. Accordingly, pursuant to the requirements of the Act, please be advised that: (1) the general authority for the collection of this information is 35 U.S.C. 2(b)(2); (2) furnishing of the information solicited is voluntary; and (3) the principal purpose for which the information is used by the U.S. Patent and Trademark Office is to process and/or examine your submission related to a patent application or patent. If you do not furnish the requested information, the U.S. Patent and Trademark Office may not be able to process and/or examine your submission, which may result in termination of proceedings or abandonment of the application or expiration of the patent.

The information provided by you in this form will be subject to the following routine uses:

1. The information on this form will be treated confidentially to the extent allowed under the Freedom of Information Act (5 U.S.C. 552) and the Privacy Act (5 U.S.C. 552a). Records from this system of records may be disclosed to the Department of Justice to determine whether disclosure of these records is required by the Freedom of Information Act.
2. A record from this system of records may be disclosed, as a routine use, in the course of presenting evidence to a court, magistrate, or administrative tribunal, including disclosures to opposing counsel in the course of settlement negotiations.
3. A record in this system of records may be disclosed, as a routine use, to a Member of Congress submitting a request involving an individual, to whom the record pertains, when the individual has requested assistance from the Member with respect to the subject matter of the record.
4. A record in this system of records may be disclosed, as a routine use, to a contractor of the Agency having need for the information in order to perform a contract. Recipients of information shall be required to comply with the requirements of the Privacy Act of 1974, as amended, pursuant to 5 U.S.C. 552a(m).
5. A record related to an International Application filed under the Patent Cooperation Treaty in this system of records may be disclosed, as a routine use, to the International Bureau of the World Intellectual Property Organization, pursuant to the Patent Cooperation Treaty.
6. A record in this system of records may be disclosed, as a routine use, to another federal agency for purposes of National Security review (35 U.S.C. 181) and for review pursuant to the Atomic Energy Act (42 U.S.C. 218(c)).
7. A record from this system of records may be disclosed, as a routine use, to the Administrator, General Services, or his/her designee, during an inspection of records conducted by GSA as part of that agency's responsibility to recommend improvements in records management practices and programs, under authority of 44 U.S.C. 2904 and 2906. Such disclosure shall be made in accordance with the GSA regulations governing inspection of records for this purpose, and any other relevant (*i.e.*, GSA or Commerce) directive. Such disclosure shall not be used to make determinations about individuals.
8. A record from this system of records may be disclosed, as a routine use, to the public after either publication of the application pursuant to 35 U.S.C. 122(b) or issuance of a patent pursuant to 35 U.S.C. 151. Further, a record may be disclosed, subject to the limitations of 37 CFR 1.14, as a routine use, to the public if the record was filed in an application which became abandoned or in which the proceedings were terminated and which application is referenced by either a published application, an application open to public inspection or an issued patent.
9. A record from this system of records may be disclosed, as a routine use, to a Federal, State, or local law enforcement agency, if the USPTO becomes aware of a violation or potential violation of law or regulation.

Supplemental Sheet

A chain of title from the inventor(s), of the patent application/patent identified above, to the current assignee continues as follows:

4. From: Encap Technologies Inc. To: Intellectual Ventures Holding 88 LLC  
The document was recorded in the United States Patent and Trademark Office at  
Reel 029228 , Frame 0379 , or for which a copy thereof is attached.
5. From: \_\_\_\_\_ To: \_\_\_\_\_  
The document was recorded in the United States Patent and Trademark Office at  
Reel \_\_\_\_\_ , Frame \_\_\_\_\_ , or for which a copy thereof is attached.
6. From: \_\_\_\_\_ To: \_\_\_\_\_  
The document was recorded in the United States Patent and Trademark Office at  
Reel \_\_\_\_\_ , Frame \_\_\_\_\_ , or for which a copy thereof is attached.  
\_\_\_\_\_  
\_\_\_\_\_
7. From: \_\_\_\_\_ To: \_\_\_\_\_  
The document was recorded in the United States Patent and Trademark Office at  
Reel \_\_\_\_\_ , Frame \_\_\_\_\_ , or for which a copy thereof is attached.  
\_\_\_\_\_  
\_\_\_\_\_
8. From: \_\_\_\_\_ To: \_\_\_\_\_  
The document was recorded in the United States Patent and Trademark Office at  
Reel \_\_\_\_\_ , Frame \_\_\_\_\_ , or for which a copy thereof is attached.  
\_\_\_\_\_  
\_\_\_\_\_



UNITED STATES PATENT AND TRADEMARK OFFICE

UNITED STATES DEPARTMENT OF COMMERCE  
United States Patent and Trademark Office  
Address: COMMISSIONER FOR PATENTS  
P.O. Box 1450  
Alexandria, Virginia 22313-1450  
www.uspto.gov

APPLICATION NUMBER	FILING OR 371(C) DATE	FIRST NAMED APPLICANT	ATTY. DOCKET NO./TITLE
10/383,219	03/05/2003	Griffith D. Neal	8864/33

**CONFIRMATION NO. 9248**

**POA ACCEPTANCE LETTER**

35690  
MEYERTONS, HOOD, KIVLIN, KOWERT & GOETZEL, P.C.  
P.O. BOX 398  
AUSTIN, TX 78767-0398



Date Mailed: 12/24/2012

**NOTICE OF ACCEPTANCE OF POWER OF ATTORNEY**

This is in response to the Power of Attorney filed 12/03/2012.

The Power of Attorney in this application is accepted. Correspondence in this application will be mailed to the above address as provided by 37 CFR 1.33.

/sharris/

Office of Data Management, Application Assistance Unit (571) 272-4000, or (571) 272-4200, or 1-888-786-0101



UNITED STATES PATENT AND TRADEMARK OFFICE

UNITED STATES DEPARTMENT OF COMMERCE  
United States Patent and Trademark Office  
Address: COMMISSIONER FOR PATENTS  
P.O. Box 1450  
Alexandria, Virginia 22313-1450  
www.uspto.gov

APPLICATION NUMBER	FILING OR 371(C) DATE	FIRST NAMED APPLICANT	ATTY. DOCKET NO./TITLE
10/383,219	03/05/2003	Griffith D. Neal	8864/33

**CONFIRMATION NO. 9248**

**POWER OF ATTORNEY NOTICE**

757  
BRINKS HOFER GILSON & LIONE  
P.O. BOX 10395  
CHICAGO, IL 60610



Date Mailed: 12/24/2012

**NOTICE REGARDING CHANGE OF POWER OF ATTORNEY**

This is in response to the Power of Attorney filed 12/03/2012.

- The Power of Attorney to you in this application has been revoked by the assignee who has intervened as provided by 37 CFR 3.71. Future correspondence will be mailed to the new address of record(37 CFR 1.33).

/sharris/

Office of Data Management, Application Assistance Unit (571) 272-4000, or (571) 272-4200, or 1-888-786-0101



**IN THE UNITED STATES PATENT AND TRADEMARK OFFICE**

Atty. Dkt. No:	6757-35502	§	Title: STATOR ASSEMBLY MADE
Application No:	10/383219	§	FROM A MOLDED WEB OF CORE
Patent No:	7,067,952	§	SEGMENTS AND MOTOR USING
Filing Date:	03/05/2003	§	SAME
Inventor(s):	Griffith D. Neal	§	Examiner: Mullins, Burton S.
		§	Group/Art Unit: 2834
		§	
		§	
		§	
		§	

**STATEMENT REGARDING CHANGE FROM SMALL ENTITY STATUS**

Patentee is no longer entitled to small entity status in the above-referenced patent.

No fees are believed necessary; however if any fees are required, the Commissioner is hereby authorized to immediately charge the fees or credit any overpayment to Meyertons, Hood, Kivlin, Kowert & Goetzel, P.C. Deposit Account No. 501505/6757-35502/DMM.

Respectfully submitted,

Date: January 7, 2013

By: /Dean M. Munyon/  
Dean M. Munyon  
Reg. No. 42,914

Meyertons, Hood, Kivlin, Kowert & Goetzel, P.C.  
P. O. Box 398  
Austin, Texas 78767  
(512) 853-8800

## Electronic Acknowledgement Receipt

<b>EFS ID:</b>	14628362
<b>Application Number:</b>	10383219
<b>International Application Number:</b>	
<b>Confirmation Number:</b>	9248
<b>Title of Invention:</b>	STATOR ASSEMBLY MADE FROM A MOLDED WEB OF CORE SEGMENTS AND MOTOR USING SAME
<b>First Named Inventor/Applicant Name:</b>	Griffith D. Neal
<b>Customer Number:</b>	35690
<b>Filer:</b>	Dean M. Munyon/Danielle Kramer
<b>Filer Authorized By:</b>	Dean M. Munyon
<b>Attorney Docket Number:</b>	6757-35502
<b>Receipt Date:</b>	07-JAN-2013
<b>Filing Date:</b>	05-MAR-2003
<b>Time Stamp:</b>	13:05:28
<b>Application Type:</b>	Utility under 35 USC 111(a)

### Payment information:

Submitted with Payment	no
------------------------	----

### File Listing:

Document Number	Document Description	File Name	File Size(Bytes)/ Message Digest	Multi Part /.zip	Pages (if appl.)
1	Miscellaneous Incoming Letter	small-entity-change-form.pdf	16962 <small>961cf0e3c98350485ddb61aa516b24913c253ae5</small>	no	1

### Warnings:

### Information:

Am. Honda v. IV II - IPR2018-00619  
PET\_HONDA\_1003-0406

**This Acknowledgement Receipt evidences receipt on the noted date by the USPTO of the indicated documents, characterized by the applicant, and including page counts, where applicable. It serves as evidence of receipt similar to a Post Card, as described in MPEP 503.**

**New Applications Under 35 U.S.C. 111**

**If a new application is being filed and the application includes the necessary components for a filing date (see 37 CFR 1.53(b)-(d) and MPEP 506), a Filing Receipt (37 CFR 1.54) will be issued in due course and the date shown on this Acknowledgement Receipt will establish the filing date of the application.**

**National Stage of an International Application under 35 U.S.C. 371**

**If a timely submission to enter the national stage of an international application is compliant with the conditions of 35 U.S.C. 371 and other applicable requirements a Form PCT/DO/EO/903 indicating acceptance of the application as a national stage submission under 35 U.S.C. 371 will be issued in addition to the Filing Receipt, in due course.**

**New International Application Filed with the USPTO as a Receiving Office**

**If a new international application is being filed and the international application includes the necessary components for an international filing date (see PCT Article 11 and MPEP 1810), a Notification of the International Application Number and of the International Filing Date (Form PCT/RO/105) will be issued in due course, subject to prescriptions concerning national security, and the date shown on this Acknowledgement Receipt will establish the international filing date of the application.**

AO 120 (Rev. 08/10)

TO: <b>Mail Stop 8</b> <b>Director of the U.S. Patent and Trademark Office</b> <b>P.O. Box 1450</b> <b>Alexandria, VA 22313-1450</b>	<b>REPORT ON THE</b> <b>FILING OR DETERMINATION OF AN</b> <b>ACTION REGARDING A PATENT OR</b> <b>TRADEMARK</b>
-----------------------------------------------------------------------------------------------------------------------------------------------	-------------------------------------------------------------------------------------------------------------------------

In Compliance with 35 U.S.C. § 290 and/or 15 U.S.C. § 1116 you are hereby advised that a court action has been filed in the U.S. District Court District of Delaware on the following

Trademarks or  Patents. (  the patent action involves 35 U.S.C. § 292.):

DOCKET NO.	DATE FILED 3/20/2017	U.S. DISTRICT COURT District of Delaware
PLAINTIFF Intellectual Ventures II LLC		DEFENDANT Honda Motor Co., Ltd., Honda North America, Inc., American Honda Motor Co., Inc., Honda of America Mfg., Inc., Honda Manufacturing of Alabama, LLC, and Honda R&D Americas, Inc.
PATENT OR TRADEMARK NO.	DATE OF PATENT OR TRADEMARK	HOLDER OF PATENT OR TRADEMARK
1 US 7,067,944 B2	6/27/2006	Intellectual Ventures II LLC
2 US 7,067,952 B2	6/27/2006	Intellectual Ventures II LLC
3 US 7,154,200 B2	12/26/2006	Intellectual Ventures II LLC
4 US 7,683,509 B2	3/23/2010	Intellectual Ventures II LLC
5 US 7,928,348 B2	4/19/2011	Intellectual Ventures II LLC

In the above—entitled case, the following patent(s)/ trademark(s) have been included:

DATE INCLUDED	INCLUDED BY	<input type="checkbox"/> Amendment <input type="checkbox"/> Answer <input type="checkbox"/> Cross Bill <input type="checkbox"/> Other Pleading
PATENT OR TRADEMARK NO.	DATE OF PATENT OR TRADEMARK	HOLDER OF PATENT OR TRADEMARK
1		
2		
3		
4		
5		

In the above—entitled case, the following decision has been rendered or judgement issued:

DECISION/JUDGEMENT
--------------------

CLERK	(BY) DEPUTY CLERK	DATE
-------	-------------------	------

Copy 1—Upon initiation of action, mail this copy to Director    Copy 3—Upon termination of action, mail this copy to Director  
 Copy 2—Upon filing document adding patent(s), mail this copy to Director    Copy 4—Case file copy

AO 120 (Rev. 08/10)

TO: <b>Mail Stop 8</b> <b>Director of the U.S. Patent and Trademark Office</b> <b>P.O. Box 1450</b> <b>Alexandria, VA 22313-1450</b>	<b>REPORT ON THE</b> <b>FILING OR DETERMINATION OF AN</b> <b>ACTION REGARDING A PATENT OR</b> <b>TRADEMARK</b>
-----------------------------------------------------------------------------------------------------------------------------------------------	-------------------------------------------------------------------------------------------------------------------------

In Compliance with 35 U.S.C. § 290 and/or 15 U.S.C. § 1116 you are hereby advised that a court action has been filed in the U.S. District Court District of Delaware on the following

Trademarks or  Patents. (  the patent action involves 35 U.S.C. § 292.):

DOCKET NO.	DATE FILED 3/20/2017	U.S. DISTRICT COURT District of Delaware
PLAINTIFF Intellectual Ventures II LLC		DEFENDANT Denso Corporation and Denso International America, Inc.
PATENT OR TRADEMARK NO.	DATE OF PATENT OR TRADEMARK	HOLDER OF PATENT OR TRADEMARK
1 US 7,067,952 B2	6/27/2006	Intellectual Ventures II LLC
2		
3		
4		
5		

In the above—entitled case, the following patent(s)/ trademark(s) have been included:

DATE INCLUDED	INCLUDED BY <input type="checkbox"/> Amendment <input type="checkbox"/> Answer <input type="checkbox"/> Cross Bill <input type="checkbox"/> Other Pleading	
PATENT OR TRADEMARK NO.	DATE OF PATENT OR TRADEMARK	HOLDER OF PATENT OR TRADEMARK
1		
2		
3		
4		
5		

In the above—entitled case, the following decision has been rendered or judgement issued:

DECISION/JUDGEMENT
--------------------

CLERK	(BY) DEPUTY CLERK	DATE
-------	-------------------	------

Copy 1—Upon initiation of action, mail this copy to Director Copy 3—Upon termination of action, mail this copy to Director  
 Copy 2—Upon filing document adding patent(s), mail this copy to Director Copy 4—Case file copy

AO 120 (Rev. 08/10)

TO: <b>Mail Stop 8</b> <b>Director of the U.S. Patent and Trademark Office</b> <b>P.O. Box 1450</b> <b>Alexandria, VA 22313-1450</b>	<b>REPORT ON THE</b> <b>FILING OR DETERMINATION OF AN</b> <b>ACTION REGARDING A PATENT OR</b> <b>TRADEMARK</b>
-----------------------------------------------------------------------------------------------------------------------------------------------	-------------------------------------------------------------------------------------------------------------------------

In Compliance with 35 U.S.C. § 290 and/or 15 U.S.C. § 1116 you are hereby advised that a court action has been filed in the U.S. District Court District of Delaware on the following

Trademarks or  Patents. (  the patent action involves 35 U.S.C. § 292.):

DOCKET NO.	DATE FILED 3/20/2017	U.S. DISTRICT COURT District of Delaware
PLAINTIFF Intellectual Ventures II LLC		DEFENDANT Mitsuba Corporation and American Mitsuba Corporation
PATENT OR TRADEMARK NO.	DATE OF PATENT OR TRADEMARK	HOLDER OF PATENT OR TRADEMARK
1 US 7,067,952 B2	6/27/2006	Intellectual Ventures II LLC
2		
3		
4		
5		

In the above—entitled case, the following patent(s)/ trademark(s) have been included:

DATE INCLUDED	INCLUDED BY	
		<input type="checkbox"/> Amendment <input type="checkbox"/> Answer <input type="checkbox"/> Cross Bill <input type="checkbox"/> Other Pleading
PATENT OR TRADEMARK NO.	DATE OF PATENT OR TRADEMARK	HOLDER OF PATENT OR TRADEMARK
1		
2		
3		
4		
5		

In the above—entitled case, the following decision has been rendered or judgement issued:

DECISION/JUDGEMENT
--------------------

CLERK	(BY) DEPUTY CLERK	DATE
-------	-------------------	------

Copy 1—Upon initiation of action, mail this copy to Director    Copy 3—Upon termination of action, mail this copy to Director  
 Copy 2—Upon filing document adding patent(s), mail this copy to Director    Copy 4—Case file copy

AO 120 (Rev. 08/10)

TO: <b>Mail Stop 8</b> <b>Director of the U.S. Patent and Trademark Office</b> <b>P.O. Box 1450</b> <b>Alexandria, VA 22313-1450</b>	<b>REPORT ON THE</b> <b>FILING OR DETERMINATION OF AN</b> <b>ACTION REGARDING A PATENT OR</b> <b>TRADEMARK</b>
-----------------------------------------------------------------------------------------------------------------------------------------------	-------------------------------------------------------------------------------------------------------------------------

In Compliance with 35 U.S.C. § 290 and/or 15 U.S.C. § 1116 you are hereby advised that a court action has been filed in the U.S. District Court District of Delaware on the following

Trademarks or  Patents. (  the patent action involves 35 U.S.C. § 292.):

DOCKET NO.	DATE FILED 3/20/2017	U.S. DISTRICT COURT District of Delaware
PLAINTIFF Intellectual Ventures II LLC		DEFENDANT Toyota Motor Corporation, Toyota Motor North America, Inc., Toyota Motor Sales, U.S.A., Inc., Toyota Motor Engineering & Manufacturing North America, Inc., Toyota Motor Manufacturing, Indiana, Inc., and Toyota Motor Manufacturing, Kentucky, Inc.
PATENT OR TRADEMARK NO.	DATE OF PATENT OR TRADEMARK	HOLDER OF PATENT OR TRADEMARK
1 US 7,067,944 B2	6/27/2006	Intellectual Ventures II LLC
2 US 7,067,952 B2	6/27/2006	Intellectual Ventures II LLC
3 US 7,154,200 B2	12/26/2006	Intellectual Ventures II LLC
4 US 7,683,509 B2	3/23/2010	Intellectual Ventures II LLC
5 US 7,928,348 B2	4/19/2011	Intellectual Ventures II LLC

In the above—entitled case, the following patent(s)/ trademark(s) have been included:

DATE INCLUDED	INCLUDED BY <input type="checkbox"/> Amendment <input type="checkbox"/> Answer <input type="checkbox"/> Cross Bill <input type="checkbox"/> Other Pleading	
PATENT OR TRADEMARK NO.	DATE OF PATENT OR TRADEMARK	HOLDER OF PATENT OR TRADEMARK
1		
2		
3		
4		
5		

In the above—entitled case, the following decision has been rendered or judgement issued:

DECISION/JUDGEMENT
--------------------

CLERK	(BY) DEPUTY CLERK	DATE
-------	-------------------	------

Copy 1—Upon initiation of action, mail this copy to Director Copy 3—Upon termination of action, mail this copy to Director  
 Copy 2—Upon filing document adding patent(s), mail this copy to Director Copy 4—Case file copy

AO 120 (Rev. 08/10)

TO: <b>Mail Stop 8</b> <b>Director of the U.S. Patent and Trademark Office</b> <b>P.O. Box 1450</b> <b>Alexandria, VA 22313-1450</b>	<b>REPORT ON THE</b> <b>FILING OR DETERMINATION OF AN</b> <b>ACTION REGARDING A PATENT OR</b> <b>TRADEMARK</b>
-----------------------------------------------------------------------------------------------------------------------------------------------	-------------------------------------------------------------------------------------------------------------------------

In Compliance with 35 U.S.C. § 290 and/or 15 U.S.C. § 1116 you are hereby advised that a court action has been filed in the U.S. District Court District of Delaware on the following

Trademarks or  Patents. (  the patent action involves 35 U.S.C. § 292.);

DOCKET NO.	DATE FILED 3/20/2017	U.S. DISTRICT COURT District of Delaware
PLAINTIFF Intellectual Ventures II LLC		DEFENDANT Nidec Corporation and Nidec Automotive Motor Americas, LLC
PATENT OR TRADEMARK NO.	DATE OF PATENT OR TRADEMARK	HOLDER OF PATENT OR TRADEMARK
1 US 7,067,952 B2	6/27/2006	Intellectual Ventures II LLC
2		
3		
4		
5		

In the above—entitled case, the following patent(s)/ trademark(s) have been included:

DATE INCLUDED	INCLUDED BY <input type="checkbox"/> Amendment <input type="checkbox"/> Answer <input type="checkbox"/> Cross Bill <input type="checkbox"/> Other Pleading	
PATENT OR TRADEMARK NO.	DATE OF PATENT OR TRADEMARK	HOLDER OF PATENT OR TRADEMARK
1		
2		
3		
4		
5		

In the above—entitled case, the following decision has been rendered or judgement issued:

DECISION/JUDGEMENT
--------------------

CLERK	(BY) DEPUTY CLERK	DATE
-------	-------------------	------

Copy 1—Upon initiation of action, mail this copy to Director Copy 3—Upon termination of action, mail this copy to Director  
 Copy 2—Upon filing document adding patent(s), mail this copy to Director Copy 4—Case file copy



Under the Paperwork Reduction Act of 1995, no persons are required to respond to a collection of information unless it displays a valid OMB control number.

**POWER OF ATTORNEY TO PROSECUTE APPLICATIONS BEFORE THE USPTO**

I hereby revoke all previous powers of attorney given in the application identified in the attached statement under 37 CFR 3.73(b).

I hereby appoint:

 Practitioners associated with the Customer Number:**20995**

OR

 Practitioner(s) named below (if more than ten patent practitioners are to be named, then a customer number must be used):

Name	Registration Number	Name	Registration Number

as attorney(s) or agent(s) to represent the undersigned before the United States Patent and Trademark Office (USPTO) in connection with any and all patent applications assigned only to the undersigned according to the USPTO assignment records or assignment documents attached to this form in accordance with 37 CFR 3.73(b).

Please change the correspondence address for the application identified in the attached statement under 37 CFR 3.73(b) to:

 The address associated with Customer Number:**20995**

OR

 Firm or Individual Name

Address

City

State

Zip

Country

Telephone

Email

Assignee Name and Address:

Intellectual Ventures II LLC  
2711 Centerville Road  
Suite 400  
Wilmington, DE 19808

A copy of this form, together with a statement under 37 CFR 3.73(b) (Form PTO/SB/96 or equivalent) is required to be filed in each application in which this form is used. The statement under 37 CFR 3.73(b) may be completed by one of the practitioners appointed in this form if the appointed practitioner is authorized to act on behalf of the assignee, and must identify the application in which this Power of Attorney is to be filed.

**SIGNATURE of Assignee of Record**

The individual whose signature and title is supplied below is authorized to act on behalf of the assignee

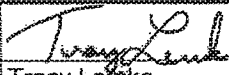
Signature		Date	3/27/14
Name	Tracy Lemke	Telephone	
Title	Authorized Person for Intellectual Ventures II LLC		

This collection of information is required by 37 CFR 1.31, 1.32 and 1.33. The information is required to obtain or retain a benefit by the public which is to file (and by the USPTO to process) an application. Confidentiality is governed by 35 U.S.C. 122 and 37 CFR 1.11 and 1.14. This collection is estimated to take 3 minutes to complete, including gathering, preparing, and submitting the completed application form to the USPTO. Time will vary depending upon the individual case. Any comments on the amount of time you require to complete this form and/or suggestions for reducing this burden, should be sent to the Chief Information Officer, U.S. Patent and Trademark Office, U.S. Department of Commerce, P.O. Box 1450, Alexandria, VA 22313-1450. DO NOT SEND FEES OR COMPLETED FORMS TO THIS ADDRESS. SEND TO: Commissioner for Patents, P.O. Box 1450, Alexandria, VA 22313-1450.

If you need assistance in completing the form, call 1-800-PTO-9199 and select option 2.

DECLARATION REGARDING AUTHORITY TO SIGN  
ON BEHALF OF A LEGAL ENTITY  
37 C.F.R. 3.73(b)(2)(i)

I, Tracy Lemke (whose title is supplied below), hereby declare that I am authorized to sign documents on behalf of Intellectual Ventures II LLC.

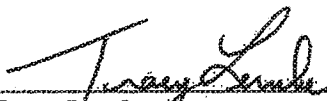
  
\_\_\_\_\_  
Tracy Lemke  
Authorized Person for Intellectual Ventures II LLC

2/17/14  
\_\_\_\_\_  
Date

---

**STATEMENT UNDER 37 CFR § 3.73  
ESTABLISHMENT OF ASSIGNEE**

First Inventor	:	Griffith D. Neal
App. No.	:	10/383219
Filed	:	March 5, 2003
For	:	STATOR ASSEMBLY MADE FROM A MOLDED WEB OF CORE SEGMENTS AND MOTOR USING SAME
Examiner	:	Mullins, Burton S.
Group Art Unit	:	2834
Conf No.	:	9248

---

Commissioner for Patents  
P.O. Box 1450  
Alexandria, VA 22313-1450

Dear Sir:

This document is being filed with a copy of a Power of Attorney signed by the Assignee. This Statement sets forth the chain of title of the above-identified application.

Intellectual Ventures II LLC, a Limited Liability Corporation, is the Assignee of the entire right, title, and interest of the above-referenced application by virtue of:

A chain of title, in reverse order, from the inventor(s) to the current Assignee as shown by the following recorded assignments:

1. Assignment from Inventor to Encap Motor Corporation recorded in the United States Patent and Trademark Office on 12/22/1999, at Reel 010508, and Frame 0837.
2. Assignment from Encap Motor Corporation to Encap Merger Co., Inc. recorded in the United States Patent and Trademark Office on 11/15/2006, at Reel 018524, and Frame 0001.
3. Assignment from Encap Merger Co., Inc. to Encap Technologies, Inc. recorded in the United States Patent and Trademark Office on 11/15/2006, at Reel 018524, and Frame 0039.
4. Assignment from Encap Technologies, Inc. to Intellectual Ventures Holding 88 LLC recorded in the United States Patent and Trademark Office on 11/01/2012, at Reel 029228, and Frame 0379.

5. Assignment from Intellectual Ventures Holding 88 LLC to Nytell Software LLC recorded in the United States Patent and Trademark Office on 01/13/2016, at Reel 037482, and Frame 0814.
6. Assignment from Nytell Software LLC to Intellectual Ventures II LLC recorded in the United States Patent and Trademark Office on 12/21/2016, at Reel 041115, and Frame 0818.

The undersigned is an agent of Customer No. 20995 and is authorized to act on behalf of the Assignee. Please recognize or change the correspondence address for the above-identified application to **Customer No. 20995**.

Respectfully submitted,  
KNOBBE, MARTENS, OLSON & BEAR, LLP

Dated: August 7, 2017

By: Vladislav Z. Teplitskiy  
Vladislav Z. Teplitskiy  
Registration No. 68,069  
Attorney of Record  
Customer No. 20995  
(949) 760-0404

STMNT373

26449959

Under the Paperwork Reduction Act of 1995, no persons are required to respond to a collection of information unless it displays a valid OMB control number.

**"FEE ADDRESS" INDICATION FORM**

**Address to:**  
**Mail Stop M Correspondence**  
**Commissioner for Patents**  
**P.O. Box 1450**  
**Alexandria, VA 22313-1450**

**Fax to:**  
**571-273-6500**

- OR -

**INSTRUCTIONS:** The issue fee must have been paid for application(s) listed on this form. In addition, only an address represented by a Customer Number can be established as the fee address for maintenance fee purposes (hereafter, fee address). A fee address should be established when correspondence related to maintenance fees should be mailed to a different address than the correspondence address for the application. **When to check the first box below:** If you have a Customer Number to represent the fee address. **When to check the second box below:** If you have no Customer Number representing the desired fee address, in which case a completed Request for Customer Number (PTO/SB/125) must be attached to this form. For more information on Customer Numbers, see the Manual of Patent Examining Procedure (MPEP) § 403.

For the following listed application(s), please recognize as the "Fee Address" under the provisions of 37 CFR 1.363 the address associated with:

Customer Number:

OR

The attached Request for Customer Number (PTO/SB/125) form.

PATENT NUMBER (if known)	APPLICATION NUMBER
7067952	10/383219

Completed by (check one):

Applicant/Inventor /Vladislav Z. Teplitkiy/  
Signature

Attorney or Agent of record 68,069 Vladislav Z. Teplitkiy  
(Reg. No.) Typed or printed name

Assignee of record of the entire interest. See 37 CFR 3.71. 949-760-0404  
Statement under 37 CFR 3.73(b) is enclosed. Requester's telephone number  
(Form PTO/SB/96)

Assignee recorded at Reel \_\_\_\_\_ Frame \_\_\_\_\_ 08/07/17  
Date

NOTE: Signatures of all the inventors or assignees of record of the entire interest or their representative(s) are required. Submit multiple forms if more than one signature is required, see below\*.

\* Total of \_\_\_\_\_ forms are submitted.

This collection of information is required by 37 CFR 1.363. The information is required to obtain or retain a benefit by the public which is to file (and by the USPTO to process) an application. Confidentiality is governed by 35 U.S.C. 122 and 37 CFR 1.11 and 1.14. This collection is estimated to take 5 minutes to complete, including gathering, preparing, and submitting the completed application form to the USPTO. Time will vary depending upon the individual case. Any comments on the amount of time you require to complete this form and/or suggestions for reducing this burden, should be sent to the Chief Information Officer, U.S. Patent and Trademark Office, U.S. Department of Commerce, P.O. Box 1450, Alexandria, VA 22313-1450. DO NOT SEND COMPLETE D FORMS TO THIS ADDRESS. SEND TO: Mail Stop M Correspondence, Commissioner for Patents, P.O. Box 1450, Alexandria, VA 22313-1450.

If you need assistance in completing the form, call 1-800-PTO-9199 and select option 2.

Am. Honda v. IV II - IPR2018-00619  
 PET\_HONDA\_1003-0417

## Privacy Act Statement

The **Privacy Act of 1974 (P.L. 93-579)** requires that you be given certain information in connection with your submission of the attached form related to a patent application or patent. Accordingly, pursuant to the requirements of the Act, please be advised that: (1) the general authority for the collection of this information is 35 U.S.C. 2(b)(2); (2) furnishing of the information solicited is voluntary; and (3) the principal purpose for which the information is used by the U.S. Patent and Trademark Office is to process and/or examine your submission related to a patent application or patent. If you do not furnish the requested information, the U.S. Patent and Trademark Office may not be able to process and/or examine your submission, which may result in termination of proceedings or abandonment of the application or expiration of the patent.

The information provided by you in this form will be subject to the following routine uses:

1. The information on this form will be treated confidentially to the extent allowed under the Freedom of Information Act (5 U.S.C. 552) and the Privacy Act (5 U.S.C. 552a). Records from this system of records may be disclosed to the Department of Justice to determine whether disclosure of these records is required by the Freedom of Information Act.
2. A record from this system of records may be disclosed, as a routine use, in the course of presenting evidence to a court, magistrate, or administrative tribunal, including disclosures to opposing counsel in the course of settlement negotiations.
3. A record in this system of records may be disclosed, as a routine use, to a Member of Congress submitting a request involving an individual, to whom the record pertains, when the individual has requested assistance from the Member with respect to the subject matter of the record.
4. A record in this system of records may be disclosed, as a routine use, to a contractor of the Agency having need for the information in order to perform a contract. Recipients of information shall be required to comply with the requirements of the Privacy Act of 1974, as amended, pursuant to 5 U.S.C. 552a(m).
5. A record related to an International Application filed under the Patent Cooperation Treaty in this system of records may be disclosed, as a routine use, to the International Bureau of the World Intellectual Property Organization, pursuant to the Patent Cooperation Treaty.
6. A record in this system of records may be disclosed, as a routine use, to another federal agency for purposes of National Security review (35 U.S.C. 181) and for review pursuant to the Atomic Energy Act (42 U.S.C. 218(c)).
7. A record from this system of records may be disclosed, as a routine use, to the Administrator, General Services, or his/her designee, during an inspection of records conducted by GSA as part of that agency's responsibility to recommend improvements in records management practices and programs, under authority of 44 U.S.C. 2904 and 2906. Such disclosure shall be made in accordance with the GSA regulations governing inspection of records for this purpose, and any other relevant (*i.e.*, GSA or Commerce) directive. Such disclosure shall not be used to make determinations about individuals.
8. A record from this system of records may be disclosed, as a routine use, to the public after either publication of the application pursuant to 35 U.S.C. 122(b) or issuance of a patent pursuant to 35 U.S.C. 151. Further, a record may be disclosed, subject to the limitations of 37 CFR 1.14, as a routine use, to the public if the record was filed in an application which became abandoned or in which the proceedings were terminated and which application is referenced by either a published application, an application open to public inspection or an issued patent.
9. A record from this system of records may be disclosed, as a routine use, to a Federal, State, or local law enforcement agency, if the USPTO becomes aware of a violation or potential violation of law or regulation.

## Electronic Acknowledgement Receipt

<b>EFS ID:</b>	30009426
<b>Application Number:</b>	10383219
<b>International Application Number:</b>	
<b>Confirmation Number:</b>	9248
<b>Title of Invention:</b>	STATOR ASSEMBLY MADE FROM A MOLDED WEB OF CORE SEGMENTS AND MOTOR USING SAME
<b>First Named Inventor/Applicant Name:</b>	Griffith D. Neal
<b>Customer Number:</b>	35690
<b>Filer:</b>	Vladislav Z. Teplitskiy/Leah Ford
<b>Filer Authorized By:</b>	Vladislav Z. Teplitskiy
<b>Attorney Docket Number:</b>	6757-35502
<b>Receipt Date:</b>	07-AUG-2017
<b>Filing Date:</b>	05-MAR-2003
<b>Time Stamp:</b>	19:33:30
<b>Application Type:</b>	Utility under 35 USC 111(a)

### Payment information:

Submitted with Payment	no
------------------------	----

### File Listing:

Document Number	Document Description	File Name	File Size(Bytes)/ Message Digest	Multi Part /.zip	Pages (if appl.)
1	Power of Attorney	2017-08-07_General_POA_KM2 702_001A.PDF	1585333  4b5b5f2f7fc881dbcccc3ef5483bb73949d4 2e64	no	2

### Warnings:

Am. Honda v. IV II - IPR2018-00619  
PET\_HONDA\_1003-0419

Information:					
2	Assignee showing of ownership per 37 CFR 3.73	2017-08-07_statement_373_KM2956003P1.pdf	123525	no	2
			14161ee3ceb8d1d6e41156ffeb0d2c4abe80078		
Warnings:					
Information:					
3	Maintenance Fee Address Change	2017-08-07_Fee_Address_Indication_KM2956_003P1.pdf	204336	no	2
			0c7a333bf0228836610f579e3e250f82d6917477		
Warnings:					
Information:					
<b>Total Files Size (in bytes):</b>			1913194		
<p><b>This Acknowledgement Receipt evidences receipt on the noted date by the USPTO of the indicated documents, characterized by the applicant, and including page counts, where applicable. It serves as evidence of receipt similar to a Post Card, as described in MPEP 503.</b></p> <p><b><u>New Applications Under 35 U.S.C. 111</u></b>  <b>If a new application is being filed and the application includes the necessary components for a filing date (see 37 CFR 1.53(b)-(d) and MPEP 506), a Filing Receipt (37 CFR 1.54) will be issued in due course and the date shown on this Acknowledgement Receipt will establish the filing date of the application.</b></p> <p><b><u>National Stage of an International Application under 35 U.S.C. 371</u></b>  <b>If a timely submission to enter the national stage of an international application is compliant with the conditions of 35 U.S.C. 371 and other applicable requirements a Form PCT/DO/EO/903 indicating acceptance of the application as a national stage submission under 35 U.S.C. 371 will be issued in addition to the Filing Receipt, in due course.</b></p> <p><b><u>New International Application Filed with the USPTO as a Receiving Office</u></b>  <b>If a new international application is being filed and the international application includes the necessary components for an international filing date (see PCT Article 11 and MPEP 1810), a Notification of the International Application Number and of the International Filing Date (Form PCT/RO/105) will be issued in due course, subject to prescriptions concerning national security, and the date shown on this Acknowledgement Receipt will establish the international filing date of the application.</b></p>					





UNITED STATES PATENT AND TRADEMARK OFFICE

UNITED STATES DEPARTMENT OF COMMERCE  
United States Patent and Trademark Office  
Address: COMMISSIONER FOR PATENTS  
P.O. Box 1450  
Alexandria, Virginia 22313-1450  
www.uspto.gov

APPLICATION NUMBER	FILING OR 371(C) DATE	FIRST NAMED APPLICANT	ATTY. DOCKET NO./TITLE
10/383,219	03/05/2003	Griffith D. Neal	KM2956.003P1

**CONFIRMATION NO. 9248**

**POA ACCEPTANCE LETTER**

20995  
KNOBBE MARTENS OLSON & BEAR LLP  
2040 MAIN STREET  
FOURTEENTH FLOOR  
IRVINE, CA 92614



Date Mailed: 08/14/2017

**NOTICE OF ACCEPTANCE OF POWER OF ATTORNEY**

This is in response to the Power of Attorney filed 08/07/2017.

The Power of Attorney in this application is accepted. Correspondence in this application will be mailed to the above address as provided by 37 CFR 1.33.

Questions about the contents of this notice and the requirements it sets forth should be directed to the Office of Data Management, Application Assistance Unit, at (571) 272-4000 or (571) 272-4200 or 1-888-786-0101.

/nrhayden/



UNITED STATES PATENT AND TRADEMARK OFFICE

UNITED STATES DEPARTMENT OF COMMERCE  
United States Patent and Trademark Office  
Address: COMMISSIONER FOR PATENTS  
P.O. Box 1450  
Alexandria, Virginia 22313-1450  
www.uspto.gov

APPLICATION NUMBER	FILING OR 371(C) DATE	FIRST NAMED APPLICANT	ATTY. DOCKET NO./TITLE
10/383,219	03/05/2003	Griffith D. Neal	6757-35502

**CONFIRMATION NO. 9248**

**POWER OF ATTORNEY NOTICE**

35690  
MEYERTONS, HOOD, KIVLIN, KOWERT & GOETZEL, P.C.  
P.O. BOX 398  
AUSTIN, TX 78767-0398



Date Mailed: 08/14/2017

**NOTICE REGARDING CHANGE OF POWER OF ATTORNEY**

This is in response to the Power of Attorney filed 08/07/2017.

- The Power of Attorney to you in this application has been revoked by the assignee who has intervened as provided by 37 CFR 3.71. Future correspondence will be mailed to the new address of record(37 CFR 1.33).

Questions about the contents of this notice and the requirements it sets forth should be directed to the Office of Data Management, Application Assistance Unit, at (571) 272-4000 or (571) 272-4200 or 1-888-786-0101.

/nrhayden/

UNITED STATES PATENT AND TRADEMARK OFFICE

---

BEFORE THE PATENT TRIAL AND APPEAL BOARD

---

DENSO CORPORATION,  
DENSO INTERNATIONAL AMERICA, INC., AMSO CO. LTD., and  
TOYOTA MOTOR CORPORATION,  
Petitioner,

v.

INTELLECTUAL VENTURES II LLC,  
Patent Owner.

---

Case IPR2017-01631  
Patent 7,067,952 B2

---

Before KRISTEN L. DROESCH, JOHN A. HUDALLA, and  
AMANDA F. WIEKER, *Administrative Patent Judges*.

DROESCH, *Administrative Patent Judge*.

DECISION  
Institution of *Inter Partes* Review  
37 C.F.R. § 42.108

## I. INTRODUCTION

### *A. Background*

DENSO Corporation, DENSO International America, Inc., AMSO Co. Ltd., and Toyota Motor Corporation (collectively, “Petitioner”) filed a Petition requesting an *inter partes* review of claims 1–6 and 8–14 (“the challenged claims”) of U.S. Patent No. 7,067,952 B2 (Ex. 1001, “the ’952 Patent”). Paper 1 (“Pet”). Intellectual Ventures II LLC (“Patent Owner”) timely filed a Preliminary Response. Paper 10 (“Prelim. Resp.”).

We have authority under 35 U.S.C. § 314 and 37 C.F.R. § 42.4. An *inter partes* review may not be instituted unless it is determined that “the information presented in the petition filed under section 311 and any response filed under section 313 shows that there is a reasonable likelihood that the petitioner would prevail with respect to at least 1 of the claims challenged in the petition.” 35 U.S.C. § 314(a).

For the reasons provided below, we determine, based on the record before us, there is a reasonable likelihood Petitioner would prevail in showing at least one of the challenged claims are unpatentable.

### *B. Related Proceedings*

The parties represent that the ’952 Patent is at issue in the following proceedings: *In the Matter of Certain Thermoplastic-Encapsulated Electric Motors, Components Thereof, and Products and Vehicles Containing Same*, ITC Inv. No. 337-TA-1052; *Intellectual Ventures II LLC v. Honda Motor Co., Ltd.*, Case No. 1:17-cv-00294 (D. Del.); *Intellectual Ventures II LLC v. Aisin Seiki Co., Ltd.*, Case No. 1:17-cv-00295 (D. Del.); *Intellectual Ventures II LLC v. Bayerische Motoren Werke, AG*, Case No. 1:17-cv-00296 (D. Del.); *Intellectual Ventures II LLC v. DENSO Corp.*, Case No. 1:17-cv-

Case IPR2017-01631  
Patent 7,067,952 B2

00297 (D. Del.); *Intellectual Ventures II LLC v. Mitsuba Corporation*, Case No. 1:17-cv-00298 (D. Del.); *Intellectual Ventures II LLC v. Nidec Corporation*, Case No. 1:17-cv-00299 (D. Del.); and *Intellectual Ventures II LLC v. Toyota Motor Corp.*, Case No. 1:17-cv-00300 (D. Del.). Pet. 51; Paper 7, 1–2; Paper 9, 2.

According to Patent Owner, the '952 Patent is also at issue in Case IPR2017-01497. Pet. 2; Paper 7, 2.

### C. The '952 Patent (Ex. 1001)

The '952 Patent issued from an application filed on March 5, 2003, as a continuation-in part of Application No. 09/798,511, filed on March 2, 2001, now U.S. Patent No 7,036,207 (“the '207 Patent”). Ex. 1001, (22), (63). The '952 Patent discloses a motor stator assembly comprising a plurality of stator segments. *See id.*, Abstract, 5:43–54.

Figures 3 and 5 of the '952 Patent are reproduced below.

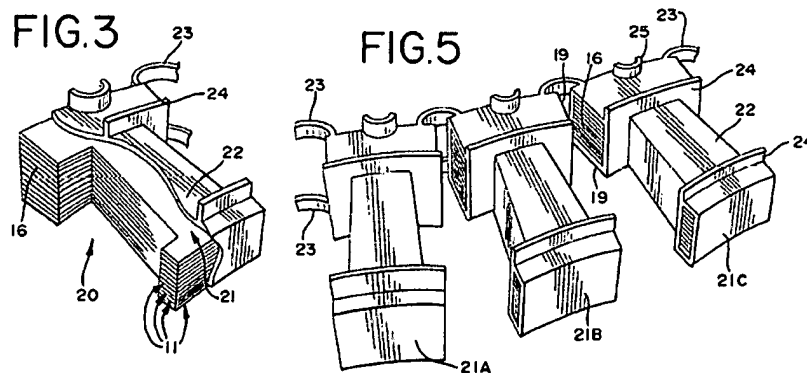

Figure 3 depicts stator arc segment 20 encapsulated in phase change material 22, which may be linked via webbing 23 into a series of stator arc segments 20, as depicted in Figure 5. *See Ex. 1001*, 5:17–19, 5:61–6:5. Steel laminations 11 are placed in a multi-cavity mold and coated with phase change encapsulating material 22 to form arc segments 20 and link them into

a continuous strip via webbing 23. *See id.* at 5:61–6:9, 6:29–33, 6:36–39, 6:48–50. The most useful phase change materials are thermoplastic materials and thermosetting materials. *See id.* at 6:6–28. Webbing 23 allows deflection to increase the gap between adjoining poles 21 to allow wire 15 to be wound around poles 21 of stator arc segments 20. *See id.* at 6:61–65, Fig. 6. A length of connected stator segments 20 are cut from the continuous strip and rolled into a toroidal core. *See id.* at 7:6–11.

Figure 7 of the '952 Patent is reproduced below.

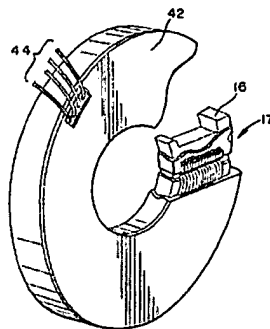

Figure 7 depicts toroidal core 17 encapsulated in monolithic body 42. *See Ex. 1001, 7:23–36.*

Figure 10 of the '952 Patent is reproduced below.

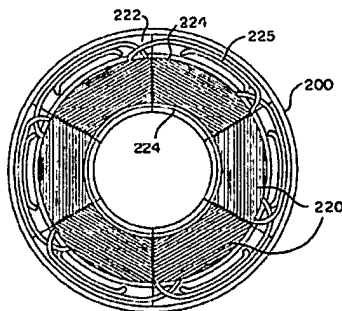

Figure 10 depicts steel collar 200 fixing stator segments together. *See Ex. 1001, 10:40–55.*

*D. Illustrative Claims*

Of the challenged claims, claims 1, 10, and 14 are independent, with claims 2–6, 8, and 9 dependent from claim 1, and claims 11–13 dependent from claim 10. Claims 10 and 14 are illustrative and reproduced below:

10. A stator assembly, comprising:

- a) a plurality of discrete stator segments each at least partially encased with a phase change material, wherein the phase change material also comprises a bridge between adjacent segments to link adjacent segments into a continuous strip, wherein the bridge is formed by interconnecting two mating sections formed from the phase change material; and
- b) the linked stator segments being arranged and secured together to form the stator assembly.

14. A combination of stator arc segments and a flexible carrier used to link said stator arc segments during a winding operation comprising:

- a) a plurality of stator arc segments; and
- b) a phase change material constituting said flexible carrier adhered to the stator arc segments which links said segments in a uniform and predetermined position with respect to one another; wherein the flexible carrier links said segments by connecting two mating sections formed in said carrier.

Ex. 1001, 14:1–9, 14:21–31.

*E. Asserted Grounds of Unpatentability*

Petitioner challenges the patentability of the following claims of the '952 Patent on the following grounds and prior art (Pet. 5–6, 17–78):

<b>Claim(s)</b>	<b>Statutory Basis</b>	<b>Reference(s)</b>
10 and 14	§ 102	Calsonic <sup>1</sup>
11	§ 103	Calsonic and Dunfield <sup>2</sup>
10, 12, and 14	§ 103	DENSO <sup>3</sup> and Calsonic
1, 2, 4, 6, 8, 9, 12, and 13	§ 103	Calsonic and Matsushita <sup>4</sup>
3 and 5	§ 103	Calsonic, Matsushita, and knowledge of a person of ordinary skill in the art

The Petition also relies on the Declaration of Dr. Thomas R. Brinner. Ex. 1013.

**II. ANALYSIS**

*A. Claim Construction*

Claims of an unexpired patent that will not expire before issuance of a final written decision are interpreted using the broadest reasonable interpretation in light of the specification. *See* 37 C.F.R. § 42.100(b); *Cuozzo Speed Techs., LLC v. Lee*, 136 S. Ct. 2131, 2144–46 (2016). Under the broadest reasonable interpretation standard, claim terms are given their

---

<sup>1</sup> Ex. 1003, JP 2000-184635 A, published June 30, 2000 (“Calsonic”), filed with an English translation (Ex. 1004 (corrected, filed Sept. 9, 2017)). Our citations herein are to the English translation.

<sup>2</sup> Ex. 1010, U.S. Patent No. 5,694,268, issued Dec. 2, 1997 (“Dunfield”).

<sup>3</sup> Ex. 1005, JP S60-278563, published June 20, 1987 (“DENSO”), filed with an English translation (Ex. 1006 (corrected, filed Sept. 9, 2017)). Our citations herein are to the English translation.

<sup>4</sup> Ex. 1008, JP H11-341717 A, published Dec. 10, 1999 (“Matsushita”), filed with an English translation (Ex. 1009 (corrected, filed Sept. 9, 2017)). Our citations herein are to the English translation.



ordinary and customary meaning as would be understood by one of ordinary skill in the art in the context of the entire disclosure. *See In re Translogic Tech., Inc.*, 504 F.3d 1249, 1257 (Fed. Cir. 2007). Any special definitions for claim terms must be set forth with reasonable clarity, deliberateness, and precision. *See In re Paulsen*, 30 F.3d 1475, 1480 (Fed. Cir. 1994).

1. “*phase change material*” (Claims 1, 10, and 14)

Petitioner asserts a person of ordinary skill in the art “would understand a ‘phase change material,’ under the broadest reasonable interpretation, to mean “a material that can be used in a liquid phase to envelop[] the stator, but which later changes to a solid phase.”” Pet. 16 (citing Ex. 1013 ¶ 49); *see id.* at 15 (quoting e.g., Ex. 1001, 6:6–9). Petitioner contends a “‘phase change material’ broadly encompasses at least thermosetting materials, thermoplastics, polypropylene, polybutylene terephthalate, and polyethylene terephthalate.” *Id.* at 16 (citing Ex. 1013 ¶ 49). In support of its assertions, Petitioner contends that the ’952 Patent Specification describes temperature activated and chemically activated phase change materials as two types of phase change materials most useful in practicing the invention, with the most preferred temperature activated phase change materials being thermoplastics that will become molten at a temperature at which it can be injection molded and then solid at motor operating temperatures. *See id.* at 15 (quoting Ex. 1001, 6:9–11, 20–24; citing Ex. 1013 ¶ 47). Petitioner further asserts the ’952 Patent specifically identifies numerous suitable thermoplastic resins including polybutylene terephthalate, polyethylene terephthalate, polypropylene, etc. *See id.* at 15–16 (quoting Ex. 1001, 9:2–19; citing Ex. 1013 ¶ 48).

Patent Owner contends, “[t]he broadest reasonable interpretation of ‘phase change material’ is simply its plain and ordinary meaning, e.g., a material that is capable of changing phases.” Prelim. Resp. 7. Patent Owner asserts, “[n]either the ’952 Patent claims nor the specification explicitly restrict the scope of [‘phase change material’] to a particular material or configuration using a special definition or disclaimer language.” *Id.* Patent Owner argues that Petitioner’s construction is based on mistaking disclosures of a preferred embodiment in the ’952 Patent for inventor lexicography. *See id.* at 8 (quoting Ex. 1001, 6:6–9). Patent Owner further points out that, in addition to the disclosure of the phase change material enveloping the stator, the ’952 Patent Specification discloses the phase change material partially encases stator segments. *See id.* (citing Ex. 1001, 5:61–6:4, 7:6–11, 13:4–5, 14:2–3). Patent Owner argues that Petitioner’s construction requiring envelopment of the complete stator contradicts the language of claims 1, 10, and 14. *See id.* at 8–9.

We agree with Patent Owner that the ’952 Patent Specification does not provide a special definition for “phase change material,” and does not require the phase change material to envelop the complete stator. The mere description of a preferred embodiment is not a limiting definition for a claim term. *See E-Pass Techs, Inc. v. 3Com Corp*, 343 F.3d 1364, 1369 (Fed Circ. 2003), *Liebel-Flarsheim Co. v. Medrad, Inc.*, 358 F.3d 898, 908–09 (Fed. Cir. 2004). Patent Owner’s proposed construction of “phase change material” as “a material that is capable of changing phases” is consistent with the ’952 Patent Specification. *See Ex. 1001, 6:6–28, 7:37–9:45.*

Accordingly, for purposes of this Decision and based on this record, we adopt Patent Owner’s construction and construe the broadest reasonable

interpretation of “phase change material” as “a material that is capable of changing phases.”

2. “*the bridge is formed by interconnecting two mating sections formed from the phase change material*” (Claims 9 and 10)

Petitioner contends “the bridge is formed by interconnecting two mating sections formed from the phase change material” is a product-by-process limitation, for which patentability does not depend on its method of production. *See* Pet. at 16–17 (citing *In re Thorpe*, 777 F.2d 695, 698 (Fed. Cir. 1985)). Petitioner asserts “the prior art will satisfy the limitation of a ‘bridge [that] is formed by interconnecting two mating sections formed from the phase change material’ so long as the bridge comprises two mating sections, interconnected, formed from phase change material. No particular step of ‘form[ing] by interconnecting’ is required.” *Id.* at 17. Petitioner argues this construction is consistent with the Examiner’s construction during prosecution. *See id.* (citing Ex. 1002, 45).

Patent Owner does not dispute that the limitation is a product-by-process limitation. *See* Prelim. Resp. 9. For purposes of this Decision, we accept Petitioner’s contention that the limitation is a product-by-process limitation.

Patent Owner, however, contends that Petitioner’s construction is incorrect and inconsistent with the claim language because claim 10 recites “the phase change material,” not just “phase change material. *See* Prelim. Resp. 9–10. Patent Owner contends that the correct construction for the claim phrase is “two mating sections that are interconnected and formed from the phase change material.” *See id.* at 10. We agree with Patent Owner that Petitioner’s construction omits “formed from *the* phase change

material.” Accordingly, our construction will include a reference to “*the* phase change material” such that it refers to the antecedent “a phase change material” recited in claim 10.

Patent Owner also implicitly argues that “two mating sections” must include additional structure. *See* Prelim. Resp. 13–16. Patent Owner argues that, during prosecution of the application that issued as the ’952 Patent, the disclosure of a hinge portion in Hsu (Ex. 2002) was distinguished from the claims. *See id.* at 14–15 (reproducing Ex. 1002, 359, 362; citing Ex. 2002, 4:8–9). In support of its position, Patent Owner provides an annotated version of Hsu’s Figure 4 (*see id.* at 14), which is reproduced below:

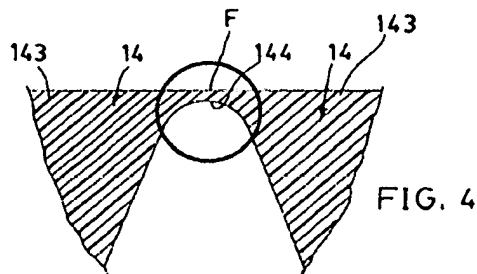

Figure 4 depicts an annotated sectional drawing of hinge portion 144 of two linked bobbins 14, with Patent Owner’s annotation encircling hinge portion 144. *See* Ex. 2002, 2:1–2.

The claim phrases “two mating sections” or “interconnecting two mating sections” do not appear in the written description of the ’952 Patent Specification. *See generally* Ex. 1001. These phrases appear only in claim 9 (dependent from claim 1) and independent claim 10. *See* Ex. 1001, 13:31–33, 14:7–9. These phrases were first added to the claims by an amendment filed May 3, 2005. *See* Ex. 1002, 68 (claim 33); *see also id.* at 375 (amendment filed Jan. 24, 2006 incorporating limitations of independent claim 1 into claim 33 and adding new dependent claim 35). Figures 3



segments 20. The '952 Patent further discloses forming a continuous strip of stator arc segments “by linking the webbing from successive molding operation[s].” *Id.* at 6:36–38. The tool can be designed such that a section of the plastic webbing of the outermost stator segment molded in the prior cycle can be inserted with the new laminations to be molded. *See id.* at 6:38–41. “When the plastic encapsulates the new segments, it can mechanically lock with or, depending on the design, re-melt the webbing from the prior cycle.” *Id.* at 6:41–44. In view of the '952 Patent Specification disclosure, we construe the broadest reasonable interpretation of “two mating sections” as “two sections mated to the stator segments” without any requirement of additional structure, as suggested by Patent Owner.

For these reasons, we construe the broadest reasonable interpretation of the claim phrase as “the bridge comprises two sections mated to the stator segments that are interconnected and formed from the phase change material.”

### 3. *Other Claim Terms and Phrases*

Aside from the terms and phrases discussed above, for purposes of this Decision, we also need not construe explicitly any other claim terms or phrases. *See Vivid Techs., Inc. v. Am. Sci. & Eng'g, Inc.*, 200 F.3d 795, 803 (Fed. Cir. 1999) (“[O]nly those terms need be construed that are in controversy, and only to the extent necessary to resolve the controversy.”).

#### *B. Entitlement of Challenged Claims to Earlier Effective Filing Date*

Petitioner asserts the '952 Patent is not entitled to the benefit of the May 2, 2001, filing date of the parent '207 Patent because it does not

provide adequate support for the '952 Patent claims in accordance with 35 U.S.C. § 112. *See* Pet. 12–13 (citing Ex. 1013 ¶¶ 40–41) (case law citations omitted); *New Railhead Mfg., LLC v. Vermeer Mfg. Co.*, 298 F.3d 1295 (Fed. Cir. 2002)). Specifically, Petitioner contends there is not adequate support for “a bridge between adjacent segments to link adjacent segments into a continuous strip, wherein the bridge is formed by interconnecting two mating sections,” as recited in claim 10. *See id.* at 13. Petitioner contends the file history of the application that issued as the '207 Patent does not disclose any interconnection between stator segments nor a bridge interconnecting stator segments, and does not contain the terms “bridge,” “interconnect,” “link,” and “connect” with respect to stator segments. *See id.* (citing Ex. 1013 ¶ 42). Petitioner contends that these features were first introduced in the March 5, 2003, continuation-in-part application that issued as the '952 Patent. *See id.* at 13 (citing Ex. 1013 ¶ 43). On this basis, Petitioner argues that the '952 Patent only is entitled to its March 5, 2003, filing date. *See id.* Patent Owner does not address whether the '952 Patent is entitled to an earlier effective filing date. *See generally* Prelim. Resp.

For a claim in a later-filed application to be entitled to the filing date of an earlier application, the earlier application must provide written description support for the claimed subject matter. *Anascape, Ltd. v. Nintendo of America Inc.*, 601 F.3d 1333, 1337 (Fed. Cir. 2010). We agree with Petitioner’s contentions. The '207 Patent does not disclose or depict “a bridge between adjacent [stator] segments to link adjacent [stator] segments into a continuous strip, wherein the bridge is formed by interconnecting two mating sections.” *See generally* Ex. 1007.

Accordingly, for purposes of this Decision, the '952 Patent is not entitled to an earlier March 2, 2001, effective filing date, but is entitled to its March 5, 2003, actual filing date.

*C. Petitioner's Asserted Grounds Unpatentability*

*1. Anticipation of Claims 10 and 14 by Calsonic*

*a. Overview of Calsonic (Ex. 1004)*

Calsonic discloses a motor including a stator core with wound coils, and a rotor. *See* Ex. 1004, Abstract.

Figures 4 and 5 of Calsonic are reproduced below.

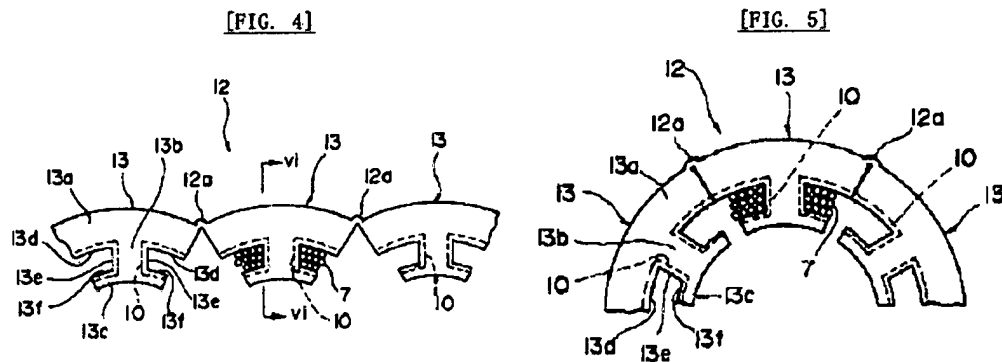

Figure 4 depicts main part of the stator core before being formed into an annular ring, and Figure 5 depicts main part of the stator core after being formed into an annular ring. *See* Ex. 1004 ¶ 18. Stator core includes a plurality of divided core blocks 10 and divided core holding members 12. *See id.* ¶¶ 22–23. Divided core blocks 10 are formed by stacking and integrating a plurality of divided core plates, each plate having a divided yoke portion having an arch shape, a salient pole protruding inward in the radial direction from the divided yoke portion, and an arch portion at the distal end portion of the salient pole. *See id.* ¶ 24. “[D]ivided core holding member 12 includes a plurality of holding portions 13 for holding the



divided core block 10 that . . . are coupled to each other in series via thin deformable portions 12a.” *Id.* ¶ 27. “The holding portions 13 of divided core holding member 12 . . . [are] integrally formed by molding an insulating thermoset resin material, such as polybutylene terephthalate (PBT) and polyethylene terephthalate (PET).” Ex. 1004 ¶ 28. Holding portions 13 of divided core holding member 12 each include a yoke end surface covering portion 13a, salient pole end surface covering portion 13b, arch end surface covering portion 13c, yoke side surface covering portions 13d, salient pole side surface covering portions 13e, and a pair of arch side surface covering portions 13f. *See id.* “The holding portions 13 of the divided core holding member 12 are integrally formed with the thin deformable portions 12a to be coupled to each other.” *Id.* ¶ 44. “[A]djacent holding portions 13 can pivot with each other with the deformable portion 12a deformed.” *Id.* ¶ 27. Figure 4, in particular, depicts “the holding portions 13 . . . substantially arranged on a single line by being pivoted with the deformable portions 12a deformed as illustrated in Fig. 4 for the sake of workability.” *Id.* ¶ 30. In the state illustrated in Figure 4, coil 7 is wound around salient pole covered by covering portions 13b and 13e. *See id.* ¶ 30.

*b. Analysis of Independent Claim 10*

For the purposes of this Decision and based on Petitioner’s citations to Calsonic and Petitioner’s declarant testimony (Ex. 1013), we are persuaded that Petitioner establishes sufficiently that Calsonic discloses each of the limitations recited in claim 10. For example, Petitioner asserts that Calsonic discloses “a plurality of discrete stator segments each at least partially encased with a phase change material” based on Calsonic’s disclosure of divided core blocks 10 and divided core holding member 12 including a

plurality of holding portions 13 for holding the divided core block 10 that is integrally formed by molding using an insulating thermoset resin material. *See* Pet. 19–22 (reproducing Ex. 1004, Figs. 2, 8, 9; citing Ex. 1004 ¶¶ 5, 23, 27, 28; Ex. 1013 ¶¶ 58–61).

As another example, Petitioner contends that Calsonic discloses “wherein the phase change material also comprises a bridge between adjacent segments to link adjacent segments into a continuous strip” based on Calsonic’s disclosure of divided core holding member 12 including a plurality of holding portions 13 for holding core block 10 that are arranged on a single line and coupled to each other in series via thin deformable portions 12a. *See* Pet. 22–24 (reproducing Ex. 1004, Fig. 4; citing Ex. 1004 ¶¶ 9, 10, 27, 28, 30; Ex. 1013 ¶¶ 62–65). As yet another example, Petitioner contends that Calsonic discloses “wherein the bridge is formed by interconnecting two mating sections formed from the phase change material” based on Calsonic’s disclosure of deformable portions 12a interconnecting divided core blocks 10 via mating sections of holding portions 13 formed of phase change material. *See id.* at 24–25 (reproducing Ex. 1004, Fig. 4; citing Ex. 1004 ¶ 30; Ex. 1013 ¶¶ 66–67). Petitioner also points out that Calsonic discloses that the deformable portions 12a alternately may be formed independently from the adjacent holding portion 13 and interconnecting by using a rotatable member such as hinge. *See id.* at 25 (citing Ex. 1004 ¶ 44; Ex. 1013 ¶ 68). As a final example, Petitioner contends that Calsonic discloses “the linked stator segments being arranged and secured together to form the stator assembly” based on Calsonic’s disclosure that both end portions of a pair of divided core holding members are joined and fixed to each other in an annular form as illustrated in

Figures 2 and 5. *See id.* at 25–27 (reproducing Ex. 1004, Figs. 2, 5; citing Ex. 1004 ¶ 32; Ex. 1013 ¶ 70).

Patent Owner argues that Petitioner’s contention addressing “a bridge linking mating sections of adjacent divided cores’ as phrased and argued by Petitioners has no basis in the claim language.” Prelim. Resp. 13. Patent Owner’s argument is misplaced and not persuasive because claim 10 recites “a bridge between adjacent segments to *link* adjacent segments into a continuous strip; wherein the bridge is formed by *interconnecting two mating sections* formed from the phase change material; and *the linked stator segments . . .*” Ex. 1001, 14:4–11 (emphases added).

Patent Owner further contends that, according to Petitioner’s proposed construction of “bridge,” as discussed above in Section II.A.2., Calsonic does not depict two mating sections, interconnected, formed from phase change material. *See* Prelim. Resp. 13 (reproducing Ex. 1004, Fig. 4). Patent Owner contends that Calsonic’s Figure 4 discloses a configuration akin to the prior art reference Hsu (Ex. 2002) disclosing a hinge portion that was distinguished during prosecution of the application that issued as the ’952 Patent. *See id.* at 14–15 (reproducing Ex. 2002, Fig. 4; reproducing Ex. 1002, 359, 362; citing Ex. 2002, 4:8–9). Patent Owner further argues, “Calsonic does not disclose holding portions 13 as having mating sections, nor that such (undisclosed) mating sections form deformable portions 12a.” *Id.* at 16. Patent Owner contends that the Petition does not point to a mating section illustrated in Calsonic’s Figures or described in the written description. *See id.*

For purposes of this Decision and based on this record, we are persuaded by Petitioner’s contentions regarding Calsonic’s disclosures. As

explained above in Section IIA.2, we construe the broadest reasonable interpretation of “the bridge is formed by interconnecting two mating sections formed from the phase change material” as “the bridge comprises two sections mated to the stator segments that are interconnected and formed from the phase change material.” For purposes of this Decision, we do not agree with Patent Owner that Calsonic’s disclosure of deformable portions 12a that include sections mated to divided core holding portions 13 that are interconnected (*see* Ex. 1004, Figs. 4, 5) fails to disclose the disputed limitation commensurate with its broadest reasonable construction.

Patent Owner also contends that Calsonic is silent as to the type of material that constitutes deformable portions 12a, and never identifies deformable portions 12a as part of the holding portions 13. *See id.* at 16–17. For purposes of this Decision and based on this record, we do not agree with Patent Owner’s arguments because Calsonic discloses: (1) “[t]he holding portions 13 of the divided core holding member 12 . . . [are] integrally formed by molding using an insulating thermoset resin material” (Ex. 1004 ¶ 28); and (2) “[t]he holding portions 13 of divided core holding member 12 are integrally formed with the thin deformable portions 12a to be coupled to each other” (*id.* at ¶ 44). Stated in other terms, Calsonic discloses the divided core holding portions 13 and thin deformable portions 12a are formed integrally by molding using an insulating thermoset resin material. *See id.* ¶¶ 28, 44; *see also id.* ¶ 41 (disclosing the deformable portion may be integrally formed along the yoke outer surface covering portion).

Accordingly, for purposes of this Decision and based on the current record before us, there is a reasonable likelihood Petitioner would prevail in showing claim 10 is anticipated by Calsonic.

*c. Analysis of Independent Claim 14*

For the purposes of this Decision and based on Petitioner's citations to Calsonic and Petitioner's declarant testimony (Ex. 1013), we are persuaded that Petitioner establishes sufficiently that Calsonic discloses each of the limitations recited in claim 14. For example, Petitioner asserts that Calsonic discloses "[a] combination of stator arc segments and a flexible carrier used to link said stator arc segments during a winding operation" based on Calsonic's disclosure of eight divided core blocks 10, the pair of divided core holding members 12, holding portions 13, and deformable portions 12a. *See* Pet. 27–31 (reproducing Ex. 1004, Figs. 2, 4, 8, 9; citing Ex. 1004 ¶¶ 10, 13, 23, 27; Ex. 1013 ¶¶ 71–76).

As another example, Petitioner contends that Calsonic discloses "a phase change material constituting said flexible carrier adhered to the stator arc segments which links said segments in a uniform and predetermined position with respect to one another" based on Calsonic's disclosures of: (1) divided core holding member 12 including a plurality of holding portions 13 for holding core block 10 that are arranged on a single line and coupled to each other in series via thin deformable portions 12a; (2) holding portions 13 and divided holding members 12 are formed integrally by molding insulating thermoset resin; (3) Figure 4 depicting divided core holding member 12 with deformable portions 12a in a uniform and predetermined position with respect to one another; and (4) the plurality of divided core blocks are held by being clamped between the pair of divided core holding members 12, and substantially arranged on a single line by being pivoted with deformable portions 12a. *See id.* at 31–33 (reproducing Ex. 1004, Fig. 4; citing Ex. 1004 ¶¶ 27, 28, 30; Ex. 1001, 9:3–19; Ex. 1013 ¶¶ 78–80).

As a final example, Petitioner contends that Calsonic discloses “wherein the flexible carrier links said segments by connecting two mating sections formed in said carriers” based on Calsonic’s aforementioned disclosures. *See id.* at 33 (citing Ex. 1013 ¶ 81).

Patent Owner argues, “Petitioner’s analogous arguments with respect to ‘the flexible carrier [that] links said segments by connecting two mating sections’ suffer similar deficiencies” as Calsonic’s “fail[ure] to teach a ‘bridge [] formed by interconnecting two mating sections formed from the phase change material’ as recited in . . . claim 10.” Prelim. Resp. 19. For the same reasons as those discussed immediately above in Section II.C.1.b, for purposes of this Decision we are persuaded by Petitioner’s contentions and do not agree with Patent Owner’s.

Accordingly, for purposes of this Decision and based on the current record before us, there is a reasonable likelihood Petitioner would prevail in showing claim 14 is anticipated by Calsonic.

## 2. *Unpatentability of Dependent Claim 11 over Calsonic and Dunfield*

### *a. Overview of Dunfield (Ex. 1010)*

Dunfield discloses a spindle motor having an overmold that encapsulates the stator and provides the stator with a smooth external surface. *See* Ex. 1010, Abstract, 2:34–40. “The overmold mechanically isolates the stator from the base and damps sympathetic vibrations in the stator structure to reduce the generation of acoustic noise in the storage device.” *Id.* at Ex. 1010, 2:40–43. The overmold material includes a 70 durometer rubber-like material that flows over the stator to form the desired overmolding features and then is hardened. *See id.* at 8:28–35; *see also id.* at 6:3–8 (disclosing 70 durometer Viton® polymer product).

*b. Analysis of Dependent Claim 11*

For the purposes of this Decision and based on Petitioner's citations to Calsonic, Dunfield, and Petitioner's declarant testimony (Ex. 1013), we are persuaded that Petitioner establishes sufficiently that the combination of Calsonic and Dunfield teach or suggest "the stator segments are held in a toroidal shape by an overmolded thermoplastic material." For example, Petitioner asserts that that Calsonic teaches stator segments of the divided core block are encapsulated by thermoplastic material and Calsonic's Figure 1 depicts the stator assembly held in a toroidal shape by an overmolded material. *See* Pet. 71–72 (reproducing Ex. 1004, Fig. 1; citing Ex. 1013 ¶ 149; Ex. 1004 ¶ 6). Petitioner acknowledges that Calsonic does not state explicitly the encapsulating material illustrated in Figure 1 is the same thermoplastic material used to encapsulate the stator segments or another type of thermoplastic material. *See id.* at 72. Petitioner contends that Dunfield discloses an overmold that encapsulates at least a portion of the stator and provides the stator with a smooth external surface, which isolates the stator from the base to damp vibrations and reduce acoustic noise. *See id.* (quoting Ex. 1010, Abstract). Petitioner further asserts that Dunfield's overmold is a thermoplastic because Dunfield discloses that the overmold is a "rubber-like" or "plastic-like" material, which flows over the stator to form the desired overmolding feature and is hardened at a selected temperature and pressure. *See id.* at 73 (quoting Ex. 1010, 8:31–36; Ex. 1013 ¶ 151).

For purposes of this Decision and based on Petitioner's citations to specific prior art disclosures and supporting evidence, we are persuaded Petitioner sets forth sufficient articulated reasoning with rational

underpinning to support the conclusion that it would have been obvious to one with ordinary skill in the art to modify Calsonic's stator arrangement consisting of divided core blocks in a toroidal shape in view of Dunfield's teachings of overmolding the stator for damping vibrations in the stator structure. *See* Pet. 73 (citing Ex. 1013 ¶ 152); *KSR Int'l Co. v. Teleflex Inc.*, 550 U.S. 398, 418 (2007) (quoting *In re Kahn*, 441 F.3d 977, 988 (Fed. Cir. 2006)). For example, Petitioner asserts that a person of ordinary skill in the art "would have found it obvious to encapsulate Calsonic's divided core blocks based on the express motivation provided by Dunfield . . . that the overmolding helps isolate the stator and 'damp[en] sympathetic vibrations in the stator structure to reduce the generation of acoustic noise . . .'" *Id.* (quoting Ex. 1010, 2:39–44). Petitioner also asserts overmolding stator assemblies was known in the art. *See id.* at 74 (citing Ex. 1013 ¶ 154, incorporating by reference Pet. 7–8 (citing Ex. 1001, 3:12–19)). As a final example, Petitioner contends that combining the teachings of Calsonic and Dunfield would amount to an application of a known technique to a known device that was ready for improvement to yield a predictable result. *See id.* at 73 (citing Ex. 1013 ¶ 153). Patent Owner does not provide substantive arguments addressing the limitations of claim 11. *See* Prelim. Resp. 23.

Accordingly, for purposes of this Decision and based on the record before us, there is a reasonable likelihood Petitioner would prevail in showing claim 11 is unpatentable over Calsonic and Dunfield.

### 3. Unpatentability of Claims 10, 12, and 14 over DENSO and Calsonic

#### a. Overview of DENSO (Ex. 1006)

DENSO discloses arranging a plurality of magnetic pole cores in an outer circumference of a support member such that the plurality of magnetic



cores are projected radially. *See Ex. 1006, p. 2* (“Means for Solving the Problem”).

Figures 1 and 3 of DENSO are reproduced below.

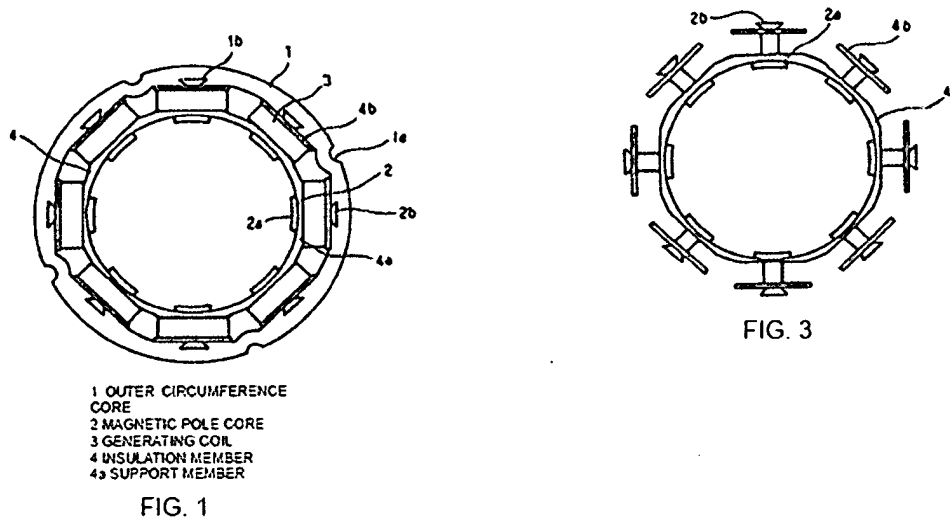

Figures 1 and 3 depict insulation material 4 fixedly attached to outer circumference of magnetic pole cores 2, support member 4a having a ring-shape designed to make magnetic pole cores 2 continuous and formed of a resin so as to be integrated with the inner circumference portion of insulation material 4. *See Ex. 1006, 3.* Magnetic pole cores 2 have magnetic pole portions 2a and wedge shaped projections 2b formed on outer circumference portions of magnetic pole cores 2 that are projected radially. *See id.* Wedge shaped projections of magnetic pole cores 2 are driven into wedge-shaped grooves 1b of ring-shaped outer circumference core 1. *See id.* at 3–4. Generator coils 3 are wound around each magnetic pole core 2. *See id.* at 3. “[I]nner circumference sides of magnetic pole cores 2 are made continuous by the ring-shaped support member 4a of the insulation material 4, so that the magnetic pole cores 2 are integrated together in advance.” *Id.*

Figure 4 of DENSO is reproduced below.

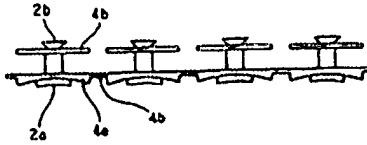

Figure 4 depicts an embodiment including a support member 4a of insulation material 4 formed of resin linearly in advance. *See* Ex. 1006, 4. Magnetic pole cores 2 are segmented by thin-walled portions 4b of continuous support member 4a into pieces corresponding to a desired number of poles. *See id.* “The resin pieces, which are continuous for the necessary number of poles, are bent into a ring shape.” *Id.* “[P]arts of the thin-walled portions 4b in the resin pieces, which are formed of a resin so as to be continuous, has a reduced thickness to facilitate the bending at the continued portions.” *Id.*

*b. Analysis of Independent Claim 10*

For the purposes of this Decision and based on Petitioner’s citations to DENSO, Calsonic, and Petitioner’s declarant testimony (Ex. 1013), we are persuaded that Petitioner establishes sufficiently that DENSO and Calsonic teach or suggest each of the limitations recited in claims 10. For example, Petitioner asserts that DENSO teaches “a plurality of discrete stator segments each at least partially encased with a . . . material” based on DENSO’s disclosure of magnetic pole cores 2 with insulation material 4 fixedly attached to the outer circumference of the magnetic pole cores 2, where insulation material 4 is formed of a resin. *See* Pet. 55–56 (reproducing Ex. 1006, Figs. 3–4; citing Ex. 1006, 2–3; Ex. 1013 ¶¶ 120–123). As another example, Petitioner contends that DENSO teaches “wherein the . . . material also comprises a bridge between adjacent

segments to link adjacent segments into a continuous strip,” and “the linked stator segments being arranged and secured together to form the stator assembly” based on DENSO’s following disclosures: (1) “a support member 4a of an insulation material 4 is formed of a resin linearly in advance, so that the magnetic pole cores 2 are made continuous;” (2) segmenting magnetic pole cores 2 by thin walled portions 4b of continuous support member 4a into pieces corresponding to the desired number of poles; (3) “[t]he resin pieces, which are continuous for the necessary number of poles, are bent into a ring shape;” and (4) “parts of the thin-walled portions 4b in the resin pieces, which are formed of resin so as to be continuous, has a reduced thickness to facilitate bending at the continued portions.” *See id.* at 59–60 (reproducing Ex. 1006, Fig. 4; quoting Ex. 1006, 4; citing Ex. 1013 ¶¶ 128–129); *id.* at 62–63 (quoting Ex. 1006, 4; reproducing Ex. 1006, Figs. 1, 3; citing Ex. 1013 ¶ 134).

Petitioner asserts, “DENSO discloses that the interconnecting bridge is formed by mating sections formed from the resin . . . but does not explicitly disclose interconnecting two mating sections.” *Id.* at 60. In other words, Petitioner implicitly construes the claim phrase as requiring some unarticulated additional structure. As explained above in Section II.A.2, we construe the broadest reasonable interpretation of “the bridge is formed by interconnecting two mating sections formed from the phase change material” as “the bridge comprises two sections mated to the stator segments that are interconnected and formed from the phase change material.” For purposes of this Decision, DENSO’s continuous support member 4a including thin walled portions 4b made of resin teaches the disputed limitation commensurate in scope with its broadest reasonable construction.

Petitioner acknowledges that DENSO's insulating resin material is not disclosed expressly as a phase change material or thermoplastic material. *See* Pet. 57. Petitioner asserts that Calsonic teaches divided core blocks 10 each at least partially encased with a phase change material, including a plurality of holding portions 13 coupled to each other in series via thin deformable portions 12a. *See id.* (citing Ex. 1004 ¶ 27). Petitioner further contends that Calsonic teaches holding portions 13 of the divided core holding member are formed integrally using an insulating thermoset resin material, for example, polybutylene terephthalate (PBT) and polyethylene terephthalate (PET). *See id.* (citing Ex. 1004 ¶ 28). Petitioner contends that PBT and PET are thermoplastic resins identified in the '952 Patent as being phase change materials. *See id.* (citing Ex. 1001, 9:3–19; Ex. 1013 ¶ 124).

For purposes of this Decision and based on Petitioner's citations to specific prior art disclosures and supporting evidence, we are persuaded Petitioner sets forth sufficient articulated reasoning with rational underpinning to support the conclusion that it would have been obvious to one with ordinary skill in the art to combine the Calsonic's teachings of phase changing thermoplastic materials with DENSO's stator arrangement, which calls for being covered in an insulating material that is a resin. *See* Pet. 58 (citing Ex. 1013 ¶ 125), 62 (citing Ex. 1013 ¶ 133); *KSR*, 550 U.S. at 418 (2007) (quoting *Kahn*, 441 F.3d at 988). For example, Petitioner asserts that a person of ordinary skill in the art would have found it obvious to adopt Calsonic's phase change thermoplastic materials or resins based on Calsonic's disclosures of particular insulating resins as being suitable for coating the electric motor stators for the purposes of flexibility and insulation. *See* Pet. 58 (citing Ex. 1013 ¶ 125). Petitioner further contends,

“the use of the specific materials disclosed in Calsonic for the same purpose in DENSO, especially where both describe the material as a ‘resin,’ would be a natural substitution.” *Id.* at 58 (citing Ex. 1013 ¶ 125). As another example, Petitioner asserts that a person of ordinary skill in the art would have been motivated to combine the teachings of DENSO and Calsonic because it would have amounted to applying Calsonic’s thermoplastic insulating resins to DENSO’s known resin-coated flexible stator core device that was ready for improvement to yield the predictable results of providing flexibility and insulation. *See id.* (citing Ex. 1013 ¶ 126). As yet another example, Petitioner contends that this combination of DENSO and Calsonic would have been obvious to try because it amounts to merely choosing from a finite number of identified, predictable solutions for useful insulating resins, and with a reasonable expectation of success. *See id.* (citing Ex. 1013 ¶ 126). As a last example, Petitioner contends that assembling stators from discrete segments and partially encasing with insulating material was known in the art. *See id.* at 59 (citing Ex. 1013 ¶ 127, *id.* at 7 (addressing ’952 Patent disclosure of prior art teachings of partially encasing stator segments with insulating materials)).

Patent Owner repeats its argument that Calsonic does not disclose the “bridge between adjacent segments to link adjacent segments into a continuous strip, wherein the bridge is formed by interconnecting two mating sections formed from the phase change material.” *See* Prelim. Resp. 22. For the same reasons as those discussed above in Section II.C.1.b addressing anticipation by Calsonic, for purposes of this Decision we are persuaded by Petitioner’s contentions and do not agree with Patent Owner’s arguments.

Patent Owner also contends that Petitioner does not sufficiently articulate why a person of ordinary skill in the art at the time of the invention would have combined the teachings of Calsonic and DENSO because neither reference discloses covering or coating the stator, and DENSO's magnetic pole cores are themselves made of an insulating material such as nylon resin. *See* Prelim. Resp. 22–23 (citing Pet. 58; Ex. 1006, 3). Patent Owner argues there is no factual basis in evidence and no merit for Petitioner's conclusion that the use of Calsonic's specific disclosed materials for the same purpose in DENSO would be a natural substitution. *See id.* at 23.

For purposes of this Decision and based on this record, we are persuaded by Petitioner's contentions and do not agree with Patent Owner's arguments. Contrary to Patent Owner's arguments, Petitioner establishes that DENSO teaches “[t]he reference numeral ‘4’ indicates an insulation material fixedly attached to the outer circumferences of the magnetic pole cores 2 so that the generating coils 3 and the magnetic pole cores 2 are insulated from each other.” *See* Pet. 56 (quoting Ex. 1006, 4). Petitioner also establishes that the use of Calsonic's phase change material would provide not only insulation, but also flexibility, which further supports Petitioner's proposed combination. *See* Pet. 58 (citing Ex. 1013 ¶ 125).

Accordingly, for purposes of this Decision and based on the current record before us, there is a reasonable likelihood Petitioner would prevail in showing claim 10 is unpatentable over DENSO and Calsonic.

*c. Analysis of Dependent Claim 12*

Claim 12 depends from claim 10. For purposes of this Decision and based on this record, we are persuaded by Petitioner's additional citations to

DENSO and Petitioner's declarant testimony (Ex. 1013) that DENSO teaches "the stator segments are held in a toroidal shape by a retaining member," based on DENSO's teaching of outer circumference core 1. *See* Pet. 63–64 (reproducing Ex. 1006, Fig. 1; quoting Ex. 1006, 2, 4; citing Ex. 1013 ¶ 135). Patent Owner does not present substantive arguments addressing claim 12. *See* Prelim. Resp. 22–23.

Accordingly, for purposes of this Decision and based on the current record before us, there is a reasonable likelihood that Petitioner would prevail in showing claim 12 is unpatentable over DENSO and Calsonic.

*d. Analysis of Independent Claim 14*

For the purposes of this Decision and based on Petitioner's citations to Calsonic and Petitioner's declarant testimony (Ex. 1013), we are persuaded that Petitioner establishes sufficiently that Calsonic discloses each of the limitations recited in claim 14. For example, Petitioner asserts that DENSO teaches "[a] combination of stator arc segments and a flexible carrier used to link said stator arc segments during a winding operation" based on DENSO's disclosures of: (1) magnetic pole cores 2 and support member 4a of insulating material formed of a resin linearly in advance so that magnetic pole cores are made continuous; and (2) thin-walled portions 4b of continuous support member 4a enabling the pieces of continuous support member 4a to be bent into a ring shape. *See* Pet. 64–65 (reproducing Ex. 1006, Fig. 4; citing Ex. 1006, 4; Ex. 1013 ¶¶ 136–138).

As another example, Petitioner contends that DENSO teaches a "material constituting said flexible carrier adhered to the stator arc segments which links said segments in a uniform and predetermined position with respect to on another" based on DENSO's teachings that: (1) insulating

material 4 is fixedly attached to the outer circumferences of the magnetic pole cores 2; (2) support member 4a of insulation material 4 is formed of a resin linearly in advance so that the magnetic pole cores are made continuous; and (3) thin-walled portions 4b of continuous support member 4a enable the pieces of continuous support member 4a to be bent into a ring shape. *See id.* at 67–69 (reproducing Ex. 1006, Figs. 3, 4; quoting Ex. 1006, 4; citing Ex. 1013 ¶ 143). Petitioner further contends that DENSO teaches “wherein the flexible carrier links said segments by connecting two mating section formed in said carriers” based on DENSO’s same aforementioned disclosures. *See* Pet. 69–70 (reproducing Ex. 1006, Fig. 4; quoting Ex. 1006, 4; citing Ex. 1013 ¶¶ 144–145).

In addressing the “phase change material” limitation, Petitioner incorporates by reference its arguments addressing unpatentability of claim 10 over DENSO and Calsonic. *See* Pet. 69 (incorporating by reference Pet. 55–59). For the same reasons as those discussed above in Section II.C.5.b., we are persuaded Petitioner sets forth sufficient articulated reasoning with rational underpinning to support the conclusion that it would have been obvious to one with ordinary skill in the art to combine Calsonic’s teachings of phase changing thermoplastic materials with DENSO’s stator arrangement. Patent Owner does not present substantive arguments addressing claim 14. *See* Prelim. Resp. 22–23.

Accordingly, for purposes of this Decision and based on the current record before us, there is a reasonable likelihood that Petitioner would prevail in showing claim 14 is unpatentable over DENSO and Calsonic.



4. Unpatentability of Claims 1, 2, 4, 6, 8, 9, 12, and 13 over  
Calsonic and Matsushita

a. Overview of Matsushita (Ex. 1009)

Matsushita discloses a method of forming a motor stator including annularly arranging unit cores. See Ex. 1009 ¶ 1.

Figures 28 and 29 of Matsushita are reproduced below:

[Fig. 28]

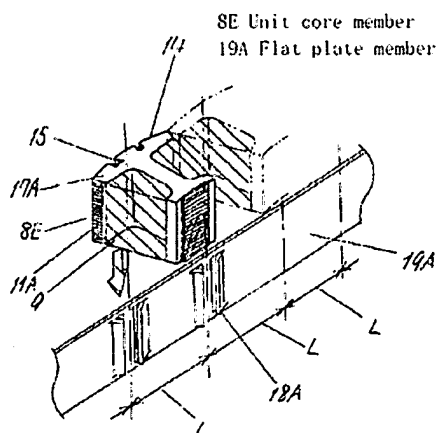

[Fig. 29]

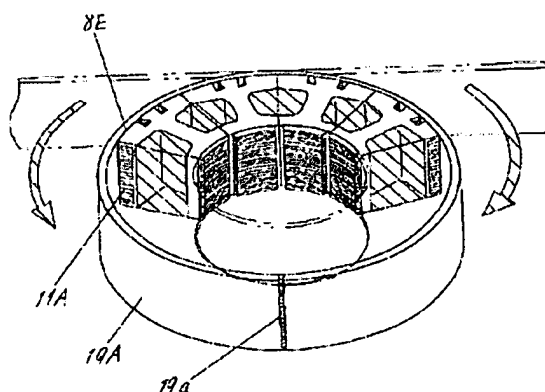

Figure 28 depicts unit core member 8E and a flat plate member 19A that may be made of a metal material, and Figure 29 depicts an annular arrangement of unit core members 8E rigidly held by flat plate member 19A. See Ex. 1009 ¶¶ 55–57; see also Ex. 1009 ¶ 26 (describing the plate member holding the unit core members “whereby the stator can be rigidly held to be prevented from deforming.”).

b. Analysis of Claim 1 and Claims 12 and 13 (Dependent from Claim 10)

For the purposes of this Decision and based on Petitioner’s citations to Calsonic, Matsushita, and Petitioner’s declarant testimony (Ex. 1013), we are persuaded that Petitioner establishes sufficiently that Calsonic and Matsushita teach or suggest each of the limitations recited in claims 1, 12, and 13. Petitioner relies on the same arguments regarding Calsonic from

claim 10, which we discussed above in Section II.C.1.b. *See* Pet. 34–35, 37 (citing Ex. 1013 ¶¶ 84, 86, 91, 92), 50 (citing Ex. 1013 ¶ 111). Petitioner also contends that Matsushita teaches “a plurality of discrete stator segments each at least partially encased with a phase change material.” *See* Pet. 35–37 (reproducing Ex. 1009, Figs. 10, 28, 29; quoting Ex. 1009 ¶¶ 24, 55, 56; Ex. 1013 ¶¶ 87–90).

Petitioner acknowledges that Calsonic does not disclose “wherein the stator segments are held in a toroidal shape by a retaining member which comprises a metal band,” as recited in claims 1, 12, and 13. *See* Pet. 38, 50. Petitioner asserts, “Calsonic, however, discloses that ‘both end portions of the pair of divided core holding members 12 are joined and fixed to each other, whereby the stator core 6 (stator 3) in an annular form as illustrated in Fig. 2 and Fig. 5 is manufactured.’” *Id.* at 38, 50 (quoting Ex. 1004 ¶ 32 (Petitioner’s emphasis omitted)). Petitioner further contends that Calsonic states:

How both end portions of the divided core holding members 12 are joined is not particularly limited, and fixing using an adhesive 14 (see Fig. 2) may be employed for example. Alternatively, engagement portions that engage with each other may be formed in advance on both end portions of the divided core holding members 12, and the fixing may be achieved with the engagement portions. Furthermore, the joined portions may be welded to each other.

Pet. 38 (quoting Ex. 1004 ¶ 32; citing Ex. 1013 ¶ 112); 50 (quoting Ex. 1004 ¶ 32; citing Ex. 1013 ¶ 93). Petitioner asserts that Matsushita discloses stator segments held in a toroidal shape by a metal band retaining member based on Matsushita’s disclosure of a metal flat plate member holding unit core members in an annular arrangement forming the stator.

*See* Pet. 38–40 (reproducing Ex. 1009, Figs. 28, 29, 33; citing Ex. 1009 ¶¶ 26, 29, 33, 55, 56; Ex. 1013 ¶¶ 94–95), 50–52 ((reproducing Ex. 1009, Figs. 28, 29, 33; citing Ex. 1009 ¶¶ 26, 29, 33, 55, 56, 65, Ex. 1013 ¶¶ 113–114).

For purposes of this Decision and based on Petitioner’s citations to specific prior art disclosures and supporting evidence, we are persuaded Petitioner sets forth sufficient articulated reasoning with rational underpinning to support the conclusion that it would have been obvious to one with ordinary skill in the art to combine Matsushita’s teachings for maintaining a stator core in a toroidal/annular shape with Calsonic’s stator arrangement, which also requires maintaining its stator core in a toroidal/annular shape. *See* Pet. 40–41 (citing Ex. 1013 ¶ 96); *KSR*, 550 U.S. at 418 (2007) (quoting *Kahn*, 441 F.3d at 988); *see also* Pet. 52–53 (citing Ex. 1013 ¶ 115, incorporating by reference Pet. 38–42). For example, Petitioner asserts that a person of ordinary skill in the art would have found it obvious to use Matsushita’s flat plate member with Calsonic’s stator core because: (1) both references pertain to analogous art (citing Ex. 1004 ¶¶ 1, 23; Ex. 1009 ¶¶ 1, 55; Ex. 1013 ¶ 96); (2) Calsonic states that how both end portions of the divided core holding members are joined is not limited; (3) Matsushita provides express motivation for using a metal band as a retaining member to hold stator segments of a divided stator core because Matsushita teaches the flat plate member rigidly holds the stator to prevent deformation (quoting Ex. 1009 ¶ 26; citing Ex. 1013 ¶ 97). *See* Pet. 41–42. As another example, Petitioner contends a person of ordinary skill in the art would have been motivated to combine the teachings of Calsonic and Matsushita as it would amount to the application of

Matsushita's known technique to Calsonic's known device that was ready for improvement to yield the predictable result of providing a stator less susceptible to deforming. *See id.* at 42 (citing Ex. 1013 ¶ 98). As a final example, Petitioner argues that the proposed combination of the teachings of Calsonic and Matsushita would have been obvious to try because it amounts to choosing from a finite number of identified, predictable solutions for maintaining a divided stator core in a toroidal/annular shape and reducing stator deformities, with a reasonable expectation of success that would have been within the skill of a person of ordinary skill in the art. *See id.* (citing Ex. 1013 ¶ 98).

Patent Owner argues that neither Calsonic nor Matsushita provide any reason or motivation for incorporating Matsushita's plate member into Calsonic. *See Prelim. Resp.* 19–20. Patent Owner contends that Calsonic already achieves a configuration for holding the stator segments together adjacent to one another using upper and lower holding members 12. *See id.* at 20. Patent Owner also points out that Calsonic teaches that an adhesive may be employed to fix both end portions of the divided core holding members to each other to be integrated to form the stator. *See id.* at 20–21 (reproducing Ex. 1004, with Petitioner's annotations; quoting Ex. 1004 ¶¶ 32–33). Patent Owner argues a person of ordinary skill in the art would have no reason to add Matsushita's additional component to accomplish the configuration for holding stator segments together already provided in Calsonic and would have understood the proposed modification to add manufacturing time and cost. *See id.* at 20–21.

For purposes of this Decision and based on this record, we are persuaded by Petitioner's contentions and do not agree with Patent Owner's

arguments. Contrary to Patent Owner's arguments, Petitioner establishes that one with ordinary skill in the art would have modified Calsonic to include Matsushita's flat metal plate member to yield the predictable result of providing a stator that is less susceptible to deforming. *See* Pet. 41–42.

Accordingly, for purposes of this Decision and based on the current record before us, there is a reasonable likelihood Petitioner would prevail in showing claims 1, 12, and 13 are unpatentable over Calsonic and Matsushita.

*c. Analysis of Dependent Claims 2, 4, 6, 8, and 9*

Claims 2, 4, 6, 8, and 9 depend from claim 1. For purposes of this Decision and based on this record, we are persuaded by Petitioner's citations to Calsonic and Petitioner's declarant testimony (Ex. 1013) that Calsonic teaches each of the additional limitations recited in claims 2, 4, 6, 8, and 9. *See* Pet. 43–49. Patent Owner does not present substantive arguments addressing claims 2, 4, 6, and 8. *See* Prelim. Resp. 19–22.

With respect to claim 9, Patent Owner argues, "Matsushita, like Calsonic, also fails to disclose at least the 'two mating sections' and 'phase change material' limitations recited in claim 9. Nor do[es] Petitioner[] claim that Matsushita discloses these elements. (Pet. 33–53)." *Id.* at 21–22. Claim 9, similar to independent claim 10 discussed above in Section II.C.1.b., recites "wherein the bridge is formed by interconnecting two mating sections formed from phase change material." For the same reasons addressing the identical limitation recited in claim 10, discussed above in Section II.C.1.b, we are persuaded by Petitioner's contentions and do not agree with Patent Owner's arguments.

Accordingly, for purposes of this Decision and based on the current record before us, there is a reasonable likelihood that Petitioner would prevail in showing claims 2, 4, 6, 8, and 9 are unpatentable over Calsonic and Matsushita.

*5. Unpatentability of Claims 3 and 5 over Calsonic, Matsushita, and the Knowledge of a Person of Ordinary Skill in the Art*

*a. Analysis of Dependent Claims 3 and 5*

Claims 3 and 5 depend from claim 1. For purposes of this Decision and based on this record, we are persuaded by Petitioner's additional citations to Calsonic and Petitioner's declarant testimony (Ex. 1013) that the combined teachings of Calsonic, Matsushita, and the knowledge of one with ordinary skill in the art would have rendered obvious "wherein wire having a packing density of greater than 80 percent is wound around the poles," as recited in claim 3. *See* Pet. 74–77 (citing Ex. 1004 ¶¶ 10, 13; Ex. 1013 ¶¶ 156–157; Ex. 1001, 7:1–5; *In re Woodruff*, 919 F.2d 1575, 1578 (Fed. Cir. 1990)). For purposes of this Decision and based on this record, we are persuaded by Petitioner's additional citations to Calsonic and Petitioner's declarant testimony (Ex. 1013) that the combined teachings of Calsonic, Matsushita, and the knowledge of one with ordinary skill in the art would have rendered obvious "wherein the phase change material has a thermal conductivity of at least 0.4 watts/meter° K at 23° C," as recited in claim 5. *See* Pet. 77–78 (citing Ex. 1004 ¶¶ 28; Ex. 1013 ¶¶ 161–162; Ex. 1011, 350). Patent Owner does not present substantive arguments addressing the limitations of claims 3 and 5. *See* Prelim. Resp. 23–24.

Accordingly, for purposes of this Decision and based on the current record before us, there is a reasonable likelihood that Petitioner would

Case IPR2017-01631  
Patent 7,067,952 B2

prevail in showing claims 3 and 5 are unpatentable over Calsonic, Matsushita, and the knowledge of one with ordinary skill in the art.

*D. Discretion to Deny “Redundant” Grounds*

Patent Owner contends that we should exercise our discretion to limit the grounds at issue in this case. *See* Prelim. Resp. 24–32. Patent Owner argues that “Petitioner[] challenge[s] claims 10 of the ’952 Patent on five grounds across two petitions, claims 11 and 12 on four grounds across two petitions, claims 11 and 12 on four grounds across two petitions with overlapping and similar references and claim 14 of the ’952 Patent on two grounds in this petition with overlapping and similar references” *Id.* at 24 (citing *Liberty Mut. Ins. Co. v. Progressive Cas. Ins. Co.*, Case CBM2013-00003, 2012 WL 9494791, at \*1 (PTAB Oct. 25, 2012)). Patent Owner contends that Petitioner fails to explain the differences or relative strengths of these duplicative grounds. *See id.* at 29–31.

We have considered Patent Owner’s argument, but decline to exercise our discretion to deny institution of the grounds presented in this Petition. In determining whether to institute an *inter partes* review, the Board may “deny some or all grounds for unpatentability for some or all of the challenged claims.” *See* 37 C.F.R. § 42.108(b); *see also* 35 U.S.C. § 314(a) (authorizing, but not mandating, institution). Our discretionary determination of whether to institute review is guided by 35 U.S.C. § 325(d), which states, in relevant part, that “[i]n determining whether to institute or order a proceeding under . . . chapter 31 [applicable to *inter partes* review proceedings], the Director may take into account whether, and reject the petition or request because, the same or substantially the same prior art or arguments previously were presented to the Office.” The statutory language

gives the Director the authority not to institute review on the basis that the same or substantially the same prior art or arguments were presented previously to the Office, but does not require that result.

Here, we do not exercise our discretion to deny the Petition under § 325(d). As discussed above, Petitioner has shown a reasonable likelihood that it will prevail in showing unpatentability on all asserted grounds in this Petition. Calsonic, DENSO, and Mastushita were not considered during prosecution of the '952 Patent. *See* Ex. 1001, (56). Additionally, the primary references applied here—Calsonic and DENSO—are not at issue as primary references in IPR2017-01497, which was filed concurrently with this Petition. Thus, we are not persuaded that the analysis in this Petition is substantially the same as that presented previously to the Office, either during prosecution or in IPR2017-01497. Although we are mindful of the burden on Patent Owner and the Office in hearing two challenges to the '952 Patent, based on the particular facts of these Petitions, we determine that conducting trial in this case and in IPR2017-01497 does not implicate the policy considerations reflected in 35 U.S.C. §§ 315(d), 325(d), or 315(e)(1), and does not persuade us to exercise discretion to deny institution in either proceeding. *See* Prelim. Resp. 24–32. Furthermore, the Board retains discretion to coordinate multiple proceedings, where it deems it appropriate. *See* 35 U.S.C. § 315(d).

Patent Owner also argues that Petitioner here and the petitioner in IPR2017-01497 have collectively exceeded the word limit for petitions (*see* 37 C.F.R. § 42.24(a)(1)(i)) and therefore “must now convince the Board that exceeding the word limit is in the interests of justice.” Prelim. Resp. 31–32. We do not agree that two different petitioners submitting two different



petitions are collectively subject to the same word limit, and Patent Owner does not cite any persuasive authority supporting its word limit theory. We, therefore, decline to apply the word limit in the manner suggested by Patent Owner.

### III. CONCLUSION

For the foregoing reasons, we determine Petitioner has demonstrated a reasonable likelihood it would prevail in establishing the unpatentability of challenged claims 1–6 and 8–14 of the '952 Patent. At this stage of the proceeding, we have not made a final determination as to the patentability of any challenged claim or as to the construction of any claim term.

### IV. ORDER

Accordingly, it is

ORDERED that, pursuant to 35 U.S.C. § 314(a), an *inter partes* review of the '952 Patent is hereby instituted on the following asserted grounds:

Claims 10 and 14 under 35 U.S.C. § 102 as anticipated by Calsonic;

Claim 11 under 35 U.S.C. § 103 as unpatentable over Calsonic and Dunfield;

Claims 10, 12, and 14 under 35 U.S.C. § 103 as unpatentable over DENSO and Calsonic;

Claims 1, 2, 4, 6, 8, 9, 12, and 13 under 35 U.S.C. § 103 as unpatentable over Calsonic and Matsushita; and

Claims 3 and 5 under 35 U.S.C. § 103 as unpatentable over Calsonic, Matsushita, and knowledge of a person of ordinary skill in the art;

FURTHER ORDERED that the trial is limited to the grounds identified above, and no other grounds are authorized; and

Case IPR2017-01631  
Patent 7,067,952 B2

FURTHER ORDERED that pursuant to 35 U.S.C. § 314(c) and 37 C.F.R. § 42.4, notice is given hereby of the institution of a trial, the trial commencing on the entry date of this Decision.

Case IPR2017-01631  
Patent 7,067,952 B2

PETITIONER:

Paul R. Steadman  
Matthew D. Satchwell  
Gianni Minutoli  
Harpreet Singh  
DLA PIPER LLP (US)  
[paul.steadman@dlapiper.com](mailto:paul.steadman@dlapiper.com)  
[matthew.satchwell@dlapiper.com](mailto:matthew.satchwell@dlapiper.com)  
[gianni.minutoli@dlapiper.com](mailto:gianni.minutoli@dlapiper.com)  
[harpreet.singh@dlapiper.com](mailto:harpreet.singh@dlapiper.com)

Joshua L. Goldberg  
James R. Barney  
Thomas W. Winland  
Tyler M. Akagi  
FINNEGAN, HENDERSON, FARABOW, GARRETT & DUNNER, L.L.P.  
[joshua.goldberg@finnegan.com](mailto:joshua.goldberg@finnegan.com)  
[james.barney@finnegan.com](mailto:james.barney@finnegan.com)  
[tom.winland@finnegan.com](mailto:tom.winland@finnegan.com)  
[tyler.akagi@finnegan.com](mailto:tyler.akagi@finnegan.com)

PATENT OWNER:

William Meunier  
Michael T. Renaud  
MINTZ, LEVIN, COHEN, FERRIS, GLOVSKY AND POPEO, P.C.  
[wameunier@mintz.com](mailto:wameunier@mintz.com)  
[mtrenaud@mintz.com](mailto:mtrenaud@mintz.com)

Tim R. Seeley  
James R. Hietala  
INTELLECTUAL VENTURES  
[tim@intven.com](mailto:tim@intven.com)  
[jhietala@intven.com](mailto:jhietala@intven.com)

UNITED STATES PATENT AND TRADEMARK OFFICE

---

BEFORE THE PATENT TRIAL AND APPEAL BOARD

---

TOYOTA MOTOR CORPORATION and DENSO CORPORATION,  
Petitioner,

v.

INTELLECTUAL VENTURES II LLC,  
Patent Owner.

---

Case IPR2017-01497  
Patent 7,067,952 B2

---

Before KRISTEN L. DROESCH, JOHN A. HUDALLA, and  
AMANDA F. WIEKER, *Administrative Patent Judges*.

DROESCH, *Administrative Patent Judge*.

DECISION  
Institution of *Inter Partes* Review  
37 C.F.R. § 42.108

## I. INTRODUCTION

### *A. Background*

Toyota Motor Corporation and Denso Corporation (collectively, “Petitioner”) filed a Petition requesting an *inter partes* review of claims 10–12 (“the challenged claims”) of U.S. Patent No. 7,067,952 B2 (Ex. 1001, “the ’952 Patent”). Paper 3 (“Pet”). Intellectual Ventures II LLC (“Patent Owner”) timely filed a Preliminary Response. Paper 8 (“Prelim. Resp.”).

We have authority under 35 U.S.C. § 314 and 37 C.F.R. § 42.4. An *inter partes* review may not be instituted unless it is determined that “the information presented in the petition filed under section 311 and any response filed under section 313 shows that there is a reasonable likelihood that the petitioner would prevail with respect to at least 1 of the claims challenged in the petition.” 35 U.S.C. § 314(a).

For the reasons provided below, we determine, based on the record before us, there is a reasonable likelihood Petitioner would prevail in showing at least one of the challenged claims are unpatentable.

### *B. Related Proceedings*

The parties represent that the ’952 Patent is at issue in the following proceedings: *In the Matter of Certain Thermoplastic-Encapsulated Electric Motors, Components Thereof, and Products and Vehicles Containing Same*, ITC Inv. No. 337-TA-1052; *Intellectual Ventures II LLC v. Honda Motor Co., Ltd.*, Case No. 1:17-cv-00294 (D. Del.); *Intellectual Ventures II LLC v. DENSO Corp.*, Case No. 1:17-cv-00297 (D. Del.); *Intellectual Ventures II LLC v. Mitsuba Corporation*, Case No. 1:17-cv-00298 (D. Del.); *Intellectual Ventures II LLC v. Nidec Corporation*, Case No. 1:17-cv-00299 (D. Del.);

and *Intellectual Ventures II LLC v. Toyota Motor Corp.*, Case No. 1:17-cv-00300 (D. Del.). Pet. 71–72; Paper 5, 1–2; Paper 7, 1–2; Paper 9, 2.

According to Patent Owner, the '952 Patent is also at issue in Case IPR2017-01631. Paper 5, 2.

*C. The '952 Patent (Ex. 1001)*

The '952 Patent issued from an application filed on March 5, 2003, as a continuation-in part of Application No. 09/798,511, filed on March 2, 2001, now U.S. Patent No 7,036,207 (“the '207 Patent”). Ex. 1001, (22), (63). The '952 Patent discloses a motor stator assembly comprising a plurality of stator segments. *See id.*, Abstract, 5:43–54.

Figures 3 and 5 of the '952 Patent are reproduced below.

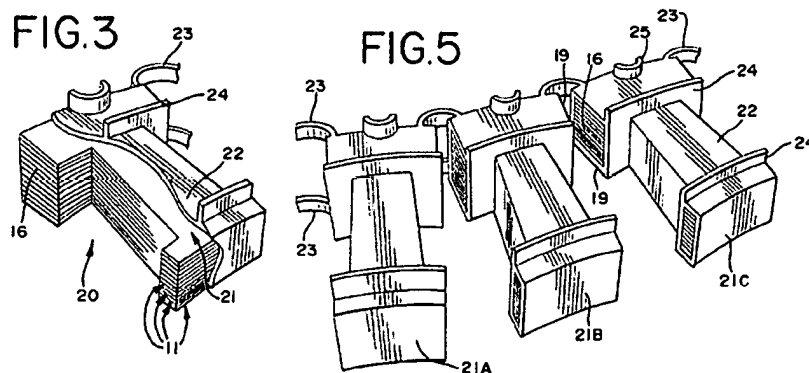

Figure 3 depicts stator arc segment 20 encapsulated in phase change material 22, which may be linked via webbing 23 into a series of stator arc segments 20, as depicted in Figure 5. *See Ex. 1001*, 5:17–19, 5:61–6:5. Steel laminations 11 are placed in a multi-cavity mold and coated with phase change encapsulating material 22 to form arc segments 20 and link them into a continuous strip via webbing 23. *See id.* at 5:61–6:9, 6:29–33, 6:36–38, 6:48–50. The most useful phase change materials are thermoplastic materials and thermosetting materials. *See id.* at 6:6–28. Webbing 23

allows deflection to increase the gap between adjoining poles 21 to allow wire 15 to be wound around poles 21 of stator arc segments 20. *See id.* at 6:61–65, Fig. 6. A length of connected stator segments 20 is cut from the continuous strip and rolled into a toroidal core. *See id.* at 7:6–11.

Figure 7 of the '952 Patent is reproduced below.

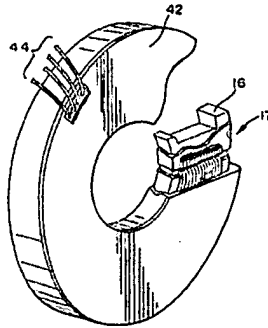

Figure 7 depicts toroidal core 17 encapsulated in monolithic body 42. *See Ex. 1001, 7:23–36.*

Figure 10 of the '952 Patent is reproduced below.

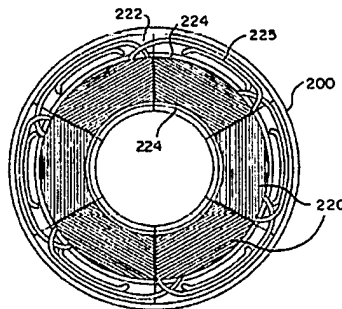

Figure 10 depicts steel collar 200 fixing stator segments together. *See Ex. 1001, 10:40–55.*

#### *D. Illustrative Claim*

Of the challenged claims, claim 10 is independent, with claims 11 and 12 dependent from claim 10. Claim 10 is illustrative and reproduced below:

10. A stator assembly, comprising:
- a plurality of discrete stator segments each at least partially encased with a phase change material, wherein

- the phase change material also comprises a bridge between adjacent segments to link adjacent segments into a continuous strip, wherein the bridge is formed by interconnecting two mating sections formed from the phase change material; and
- b) the linked stator segments being arranged and secured together to form the stator assembly.

Ex. 1001, 14:1-9.

*E. Asserted Grounds of Unpatentability*

Petitioner challenges the patentability of the following claims of the '952 Patent on the following grounds and prior art (Pet. 23-71, 74):

Claim(s)	Statutory Basis	References
10, 12	§ 103	Nakahara <sup>1</sup> and Ishihara <sup>2</sup>
11	§ 103	Nakahara, Ishihara, and Lieu <sup>3</sup>
10, 12	§ 103	Sheeran <sup>4</sup> and Nakahara
11	§ 103	Sheeran, Nakahara, and Lieu
10	§ 103	Iikuma <sup>5</sup> and Nakahara
11	§ 103	Iikuma, Nakahara and Lieu
12	§ 103	Iikuma, Nakahara, and Stridsberg <sup>6</sup>

<sup>1</sup> Ex. 1006, JP 7-245895 A, published Sept. 19, 1995 ("Nakahara"), filed with an English translation. Our citations herein are to the English translation.

<sup>2</sup> Ex. 1007, JP 11-89128 A, published March 30, 1999 ("Ishihara"), filed with an English translation. Our citations herein are to the English translation.

<sup>3</sup> Ex. 1008, WO 01/45233 A, published June 21, 2001 ("Lieu").

<sup>4</sup> Ex. 1010, U.S. Pat. No. 7,471,025 B2 ("'025 Patent"), issued Dec. 30, 2008, filed Feb. 12, 2008 ("Sheeran"), and claiming priority through a chain of applications to the Oct. 31, 2002, filing date of provisional application. Ex. 1010 (60); *see also* Pet. 21-23.

<sup>5</sup> Ex. 1009, JP 9-308163 A, published Nov. 28, 1997 ("Ikuma"), filed with an English translation. Our citations herein are to the English translation.

<sup>6</sup> Ex. 1017, WO 95/12912 A, published May 11, 1995 ("Stridsberg").



The Petition also relies on the Declaration of Gerald John Micklow, Ph.D. Ex. 1024.

## II. ANALYSIS

### A. Claim Construction

Claims of an unexpired patent that will not expire before issuance of a final written decision are interpreted using the broadest reasonable interpretation in light of the specification. *See* 37 C.F.R. § 42.100(b); *Cuozzo Speed Techs., LLC v. Lee*, 136 S. Ct. 2131, 2144–46 (2016). Under the broadest reasonable interpretation standard, claim terms are given their ordinary and customary meaning as would be understood by one of ordinary skill in the art in the context of the entire disclosure. *See In re Translogic Tech., Inc.*, 504 F.3d 1249, 1257 (Fed. Cir. 2007). Any special definitions for claim terms must be set forth with reasonable clarity, deliberateness, and precision. *See In re Paulsen*, 30 F.3d 1475, 1480 (Fed. Cir. 1994).

#### 1. “phase change material” (Claim 10)

Petitioner asserts a person of ordinary skill in the art “would understand a ‘phase change material,’ under the broadest reasonable interpretation, to mean ‘a material that can be used in a liquid phase to envelop[] the stator, but which later changes to a solid phase.’” Pet. 12 (citing Ex. 1024 ¶ 49); *see id.* at 11 (quoting, e.g., Ex. 1001, 6:6–9). Petitioner contends a “‘phase change’ material broadly encompasses at least thermosetting materials, epoxies, thermoplastics, polypropylene, polybutylene terephthalate, and polyethylene terephthalate.” *Id.* at 12 (citing Ex. 1024 ¶ 49). In support of its assertions, Petitioner contends that the ’952 Patent Specification describes temperature activated and chemically activated phase change materials as two types most useful in practicing the

invention, with the most preferred temperature activated phase change materials being thermoplastics that will become molten at a temperature at which it can be injection molded and then solid at normal motor operating temperatures. *See id.* at 11 (quoting Ex. 1001, 6:9–11, 20–24, 9:2–19; citing Ex. 1024 ¶ 49). Petitioner further asserts the '952 Patent specifically identifies numerous suitable thermoplastic resins including polybutylene terephthalate, polyethylene terephthalate, polypropylene, etc. *See id.* at 11–12 (quoting Ex. 1001, 9:2–19). Petitioner also contends the '952 Patent identifies epoxy as a chemically activated phase change material, and states “[o]ther suitable phase change materials may be classified as thermosetting materials.” *See id.* at 12 (quoting Ex. 1001, 6:24–28)

Patent Owner contends, “[t]he broadest reasonable interpretation of ‘phase change material’ is simply its plain and ordinary meaning, e.g., a material that is capable of changing phases.” Prelim. Resp. 6. Patent Owner asserts, “[n]either the '952 Patent claims nor the specification explicitly restrict the scope of [‘phase change material’] to a particular material or configuration using a special definition or disclaimer language.” *Id.* Patent Owner argues that Petitioner’s construction is based on mistaking disclosures of a preferred embodiment in the '952 Patent for inventor lexicography. *See id.* at 7 (quoting Ex. 1001, 6:6–9). Patent Owner further points out that, in addition to the disclosure of the phase change material enveloping the stator, the '952 Patent Specification discloses the phase change material partially encases stator segments. *See id.* (citing Ex. 1001, 5:61–6:4, 7:6–11, 13:4–5, 14:2–3). Patent Owner argues that Petitioner’s construction requiring envelopment of the complete stator contradicts the language of claim 10. *See id.* at 8.

We agree with Patent Owner that the '952 Patent Specification does not provide a special definition for “phase change material,” and does not require the phase change material to envelop the complete stator. The mere description of a preferred embodiment is not a limiting definition for a claim term. *See E-Pass Techs., Inc. v. 3Com Corp*, 343 F.3d 1364, 1369 (Fed. Cir. 2003), *Liebel-Flarsheim Co. v. Medrad, Inc.*, 358 F.3d 898, 908–09 (Fed. Cir. 2004). Patent Owner’s proposed construction of “phase change material” as “a material that is capable of changing phases” is consistent with the '952 Patent Specification. *See Ex. 1001*, 6:6–28, 7:37–9:45.

Accordingly, for purposes of this Decision and based on this record, we adopt Patent Owner’s construction and construe the broadest reasonable interpretation of “phase change material” as “a material that is capable of changing phases.”

2. *“a bridge between adjacent segments to link adjacent segments into a continuous strip” (Claim 10)*

Petitioner asserts a person of ordinary skill in the art would understand “a bridge between adjacent segments to link adjacent segments into a continuous strip,” as recited in claim 10, “to encompass a configuration in which a bridge links two adjacent stator segments into a strip that is continuous in a *lengthwise* direction (i.e., peripherally around the stator in the direction of the stator segments), in contrast to a *width* direction (i.e., in the direction of the motor axis).” Pet. 12–13 (reproducing Ex. 1001, Fig. 5 with annotations; citing Ex. 1024 ¶ 50). Petitioner further asserts that a person of ordinary skill in the art would understand from the claim language and context of surrounding claim language that the claimed strip may be continuous in the same direction as the line of stator segments. *See*

*id.* at 13 (citing *Phillips v. AWH Corp.*, 415 F.3d 1303, 1314 (Fed. Cir. 2005; Ex. 1024 ¶ 51). Petitioner further contends this interpretation is confirmed by the '952 Patent Specification and drawings, which consistently describes webbing 23 in a continuous strip in a lengthwise direction as the preferred embodiment, while webbing 23 is consistently illustrated as discontinuous in the width direction with a gap between the webbing elements. *See id.* at 14–15 (reproducing Ex. 1001, Fig. 5 with annotations; quoting Ex. 1001, 6:48–50; citing Ex. 1001, 5:43–45, 6:1–5, 37, 7:6–8, Figs. 2–7, 9; Ex. 1024 ¶¶ 52–53; *Phillips*, 415 F.3d at 1313). In sum, Petitioner concludes that the according to the proper construction, “the prior art will satisfy the ‘continuous strip’ limitation of claim 10 so long as the strip is continuous in a lengthwise direction i.e., in the direction of the line of adjacent stator segments.” *Id.* at 15 (citing Ex. 1024 ¶ 55). Petitioner also argues that the claim cannot be construed in a manner that would exclude a strip that is continuous in the lengthwise direction. *See id.* (citing *Vitrionics Corp. v. Conceptoronic, Inc.*, 90 F.3d 1576, 1583 (Fed. Cir. 1996).

Patent Owner asserts that the broadest reasonable interpretation of “a bridge between adjacent segments to link adjacent segments into a continuous strip,” is its plain and ordinary meaning. *See* Prelim. Resp. 8. Patent Owner asserts that the phrase “lengthwise direction” is not used in the '952 Patent Specification. *See id.* at 9. Patent Owner argues that Petitioner’s use of the phrases “lengthwise direction” and “width direction” are vague and confusing. *See id.* (citing Pet. 13, 15). Patent Owner also argues that Petitioner’s assertion that bridge cannot include a strip that is continuous in the width direction is improper because negative limitations are rarely appropriate in a claim construction. *See id.* at 10.

For purposes of this Decision, we are not persuaded by Petitioner’s assertions that the broadest reasonable interpretation should require a strip that is continuous in a particular direction. Petitioner does not direct us to an explicit definition for the claim phrase. Petitioner’s reliance on certain disclosures of webbing 23 (i.e., bridge) depicted in Figures 2–7 and 9 of the ’952 Patent (*see* Pet. 13–15) is not sufficient to limit the broadest reasonable interpretation of the claim phrase. The mere description of a preferred embodiment is not a limiting definition for a claim term. *See E-Pass Techs.*, 343 F.3d at 1369, *Liebel-Flarsheim Co.*, 358 F.3d at 908–09.

Aside from not adopting Petitioner’s proposed construction, for purposes of this Decision, we need not construe explicitly “a bridge between adjacent segments to link adjacent segments into a continuous strip.”

3. “*the bridge is formed by interconnecting two mating sections formed from the phase change material*” (Claim 10)

Petitioner contends “the bridge is formed by interconnecting two mating sections formed from the phase change material” is a product-by-process limitation, for which patentability does not depend on its method of production. *See* Pet. 15–16 (citing *In re Thorpe*, 777 F.2d 695, 698 (Fed. Cir. 1985)). Petitioner asserts “the prior art will satisfy the limitation of a ‘bridge [that] is formed by interconnecting two mating sections formed from the phase change material’ so long as the bridge comprises two mating sections, interconnected, formed from phase change material. No particular step of ‘form[ing] by interconnecting’ is required.” *Id.* at 16. Petitioner argues this construction is consistent with the Examiner’s construction during prosecution. *See id.* (citing Ex. 1002, 45).

Patent Owner does not dispute that the limitation is a product-by-process limitation. *See* Prelim. Resp. 10. For purposes of this Decision, we accept Petitioner’s contention that the limitation is a product-by-process limitation.

Patent Owner, however, contends that Petitioner’s construction is incorrect and inconsistent with the claim language because claim 10 recites “*the* phase change material,” not just “phase change material.” *See* Prelim. Resp. 10–11. Patent Owner contends that the correct construction for the claim phrase is “two mating sections that are interconnected and formed from the phase change material.” *See id.* at 11. We agree with Patent Owner that Petitioner’s construction omits “formed from *the* phase change material.” Accordingly, our construction will include a reference to “*the* phase change material” such that it refers to the antecedent “a phase change material” recited in claim 10.

Petitioner also implicitly argues that “two mating sections” must include additional structure. *See* Pet. 28. Specifically, Petitioner argues that Nakahara’s thin parts 15a of coil bobbin coupling body 15 do not teach two interconnected mating sections. *See id.* (reproducing Ex. 1001, Figs. 5, 6 and Ex. 1006, Fig. 6 with annotations).

The claim phrases “two mating sections” or “interconnecting two mating sections” do not appear in the written description of the ’952 Patent Specification. *See generally* Ex. 1001. These phrases appear only in claim 9 (dependent from claim 1) and independent claim 10. *See* Ex. 1001, 13:31–33, 14:7–9. These phrases were first added to the claims by an amendment filed May 3, 2005. *See* Ex. 1002, 344 (claim 33); *see also id.* at 35 (amendment filed Jan. 24, 2006 incorporating limitations of independent

claim 1 into claim 33 and adding new dependent claim 35). Figures 3 through 6 of the '952 Patent provide illumination as to the meaning of the claim phrases.

Figures 3 and 4 of the '952 Patent are reproduced below.

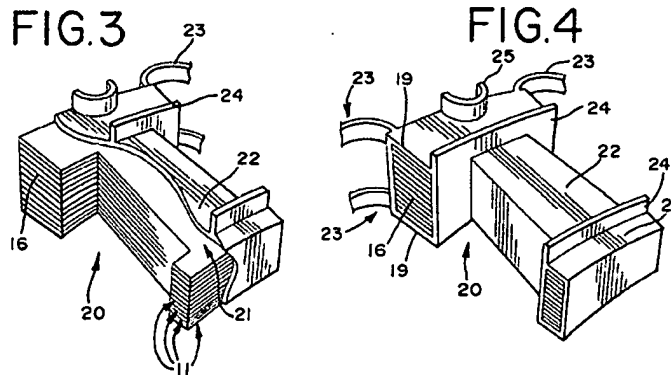

Figures 3 and 4 depict encapsulated stator arc segments 20 and webbing 23. *See Ex. 1001, 5:13–16, 5:61–6:5, 6:36–45, 6:48–50.*

Figure 5 with annotations and Figure 6 of the '952 Patent are reproduced below.

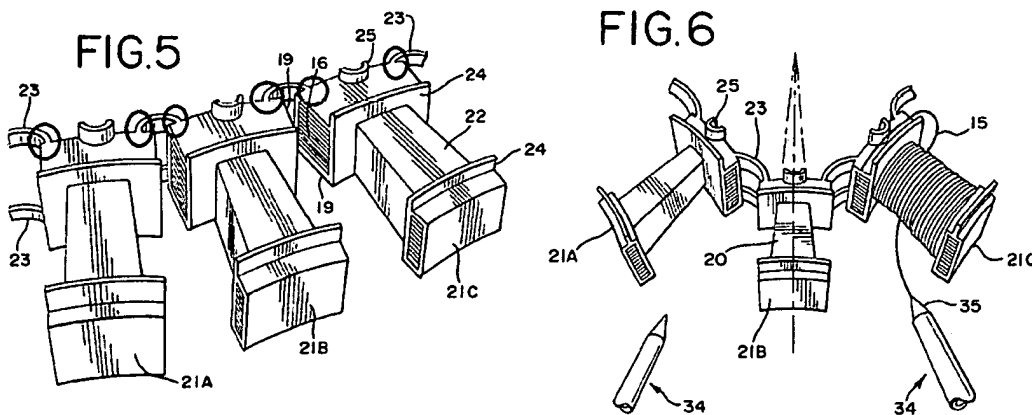

Figure 5 depicts encapsulated stator arc segments 20 linked together by thermoplastic webbing 23, and Figure 6 depicts deflection of webbing 23 during wire winding. *See Ex. 1001, 5:17–21, 6:61–62.* As illustrated in Figures 3 through 6, no additional structure apart from webbing 23 is disclosed for linking stator segments 20. The annotations to Figure 5

encircle the locations where webbing 23 is mated to encapsulated stator arc segments 20. The '952 Patent further discloses forming a continuous strip of stator arc segments “by linking the webbing from successive molding operation[s].” *Id.* at 6:36–38. The tool can be designed such that a section of the plastic webbing of the outermost stator segment molded in the prior cycle can be inserted with the new laminations to be molded. *See id.* at 6:38–41. “When the plastic encapsulates the new segments, it can mechanically lock with or, depending on the design, re-melt the webbing from the prior cycle.” *Id.* at 6:41–44. In view of the '952 Patent Specification disclosure, we construe the broadest reasonable interpretation of “two mating sections” as “two sections mated to the stator segments” without any requirement of additional structure, as suggested by Petitioner.

For these reasons, we construe the broadest reasonable interpretation of the claim phrase as “the bridge comprises two sections mated to the stator segments that are interconnected and formed from the phase change material.”

4. “toroidal shape” (*Claims 11 and 12*)

An explicit definition for the term “toroidal shape” is not provided in the '952 Patent. Therefore, we turn to the ordinary and customary meaning of “toroid,” which is: “a surface generated by a closed plane curve rotated about a line that lies in the same plane as the curve but does not intersect it.” MERRIAM WEBSTER ONLINE DICTIONARY, <http://www.merriam-webster.com/dictionary/toroid> (last accessed December 20, 2017). The toroidal stator core depicted in Figures 7 and 10 of the '952 Patent, reproduced above, is consistent with the ordinary and customary meaning.



Accordingly, for purposes of this Decision, we construe the broadest reasonable interpretation of “toroidal shape” as “shape having a surface generated by a closed plane curve rotated about a line that lies in the same plane as the curve but does not intersect it.”

#### 5. *Other Claim Terms and Phrases*

Aside from the terms and phrases discussed above, for purposes of this Decision, we also need not construe explicitly any other claim terms or phrases. *See Vivid Techs., Inc. v. Am. Sci. & Eng'g, Inc.*, 200 F.3d 795, 803 (Fed. Cir. 1999) (“[O]nly those terms need be construed that are in controversy, and only to the extent necessary to resolve the controversy.”).

#### *B. Entitlement of Challenged Claims to Earlier Effective Filing Date*

Petitioner asserts the '952 Patent is not entitled to the benefit of the May 2, 2001, filing date of the parent '207 Patent because it does not provide adequate support for the '952 Patent claims in accordance with 35 U.S.C. § 112. *See* Pet. 9–10 (citing Ex. 1024 ¶¶ 60–61; *Go Med. Indus. Pty., Ltd. v. Inmed Corp.*, 471 F.3d 1264, 1270 (Fed. Cir. 2006)). Specifically, Petitioner contends there is not adequate support for “a bridge between adjacent [stator] segments to link adjacent segments into a continuous strip, wherein the bridge is formed by interconnecting two mating sections,” as recited in claim 1. *See id.* at 9. Petitioner contends the file history of the application that issued as the '207 Patent omits any mention of a strip of stator segments linked together, whether by webbing, a bridge, or any other mechanism, and does not include any of the figures utilized in the '952 Patent to depict those features. *See id.* at 10 (citing Ex. 1024 ¶ 61; Ex. 1001, 5:61–7:5, Figs. 2–7; Ex. 1021, 266–297). Petitioner contends that

these features were described and illustrated for the first time in the March 5, 2003, continuation-in-part application that issued as the '952 Patent. *See id.* (citing Ex. 1002, 381, 399–404). On this basis, Petitioner argues that the '952 Patent only is entitled to its March 5, 2003, filing date. *See id.* at 9. Patent Owner does not address whether the '952 Patent is entitled to an earlier effective filing date. *See generally* Prelim. Resp.

For a claim in a later-filed application to be entitled to the filing date of an earlier application, the earlier application must provide written description support for the claimed subject matter. *Anascape, Ltd. v. Nintendo of Am. Inc.*, 601 F.3d 1333, 1337 (Fed. Cir. 2010). For purposes of this Decision, we agree with Petitioner's contentions. The application that issued as the '207 Patent does not disclose or depict "a bridge between adjacent segments to link adjacent segments into a continuous strip, wherein the bridge is formed by interconnecting two mating sections," as recited in claim 10. *See* Ex. 1021, 267–272, 274–290, 293–297.

Accordingly, for purposes of this Decision, the '952 Patent is not entitled to an earlier March 2, 2001, effective filing date, but is entitled to its March 5, 2003, actual filing date.

*C. Petitioner's Asserted Grounds Unpatentability*

*1. Unpatentability of Claims 10 and 12 over Nakahara and Ishihara*

*a. Overview of Nakahara (Ex. 1006)*

Nakahara discloses a rotary motor including a stator. *See* Ex. 1006, 20 [Claim 1].

Figure 1 of Nakahara is reproduced below.

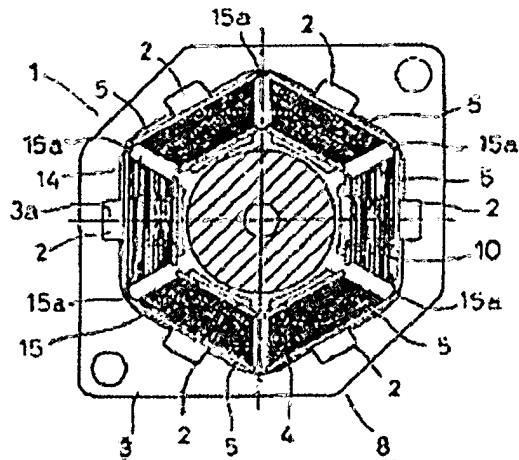

Figure 1 depicts a front view of rotary motor including rotor 10 and stator 8 comprising stator core 1, coil bobbins 5 made of resin, and coil 4. *See Ex. 1006, 23 ¶ 32.* “The coil bobbins 5 should be made of insulating material, but they need not be made of resin.” *Id.* Stator core 1 is divided into magnetic pole teeth 2, and a ring-shaped outer yoke 3 is situated on the outer-diameter side of the magnetic pole teeth 2. *See id.* at 23 ¶ 33. The outer yoke 3 is constructed from a regular hexagonal hole 3a in the center with mating concave portions 3b along the inner edge of the inner circumference of hexagonal hole 3a. *See id.* Mating concave portions 3b engage outer edges of each of the magnetic pole teeth 2.

Figure 3 of Nakahara is reproduced below.

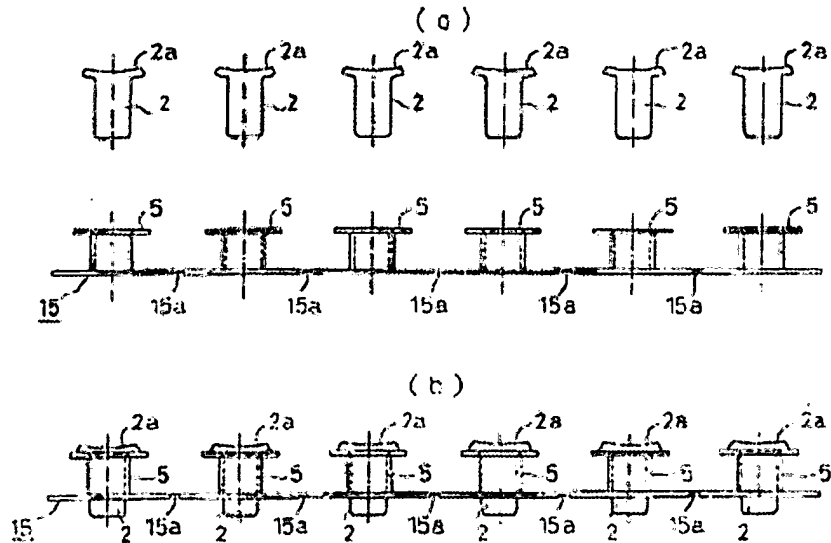
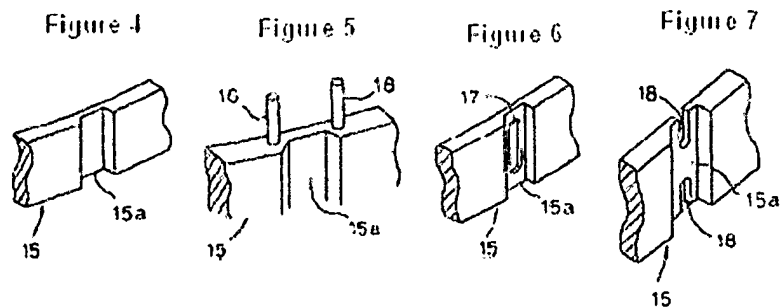

Figure 3a depicts “a correspondence relationship between the coil bobbin connector 15 formed from resin and the individual magnetic pole teeth 2. The coil bobbin coupling body 15 has six coil bobbins 5 serially coupled that are fitted respectively to the six magnetic pole teeth 2 . . . .” Ex. 1006, 24 ¶ 34. Figure 3b depicts “a state in which magnetic pole teeth 2 are fitted to the individual coil bobbins 5 of the coil bobbin coupling body 15.” *Id.* Coil bobbin coupling body 15 is formed to a size such that it fits perfectly into hexagonal hole 3a of outer yoke 3 at the time of assembly. *See id.* “If the resin material, for example, is polypropylene resin, nylon resin, or ABS resin, good moldability and sufficient suppleness to withstand flexing several times can be obtained.” *Id.* Thin parts 15a are created at the coupling sections of the coil bobbin 5, and are thinly formed to be sufficiently flexible to bend. *See id.*

Figures 4 through 7 of Nakahara are reproduced below.



Figures 4 through 7 depict several embodiments of thin parts 15a of coil bobbin coupling body 15. In Figure 4, each thin part 15a is formed to a length from one end to the other in the transverse direction. *See* Ex. 1006, 24 ¶ 34. In Figure 5, projections are installed on both sides of thin part 15a in order to hook crossover wires. *See id.* at 24 ¶ 35. In Figure 6, thin part 15a includes a hole 17 in the center of the thin part 15a. *See id.* In Figure 7, thin part 15a includes notches 18 on both edges of thin part 15a. *See id.*

*b. Overview of Ishihara (Ex. 1007)*

Ishihara discusses the teachings of Nakahara as related art. *See* Ex. 1007 ¶¶ 2–5, Figs. 10, 11. Specifically, Ishihara discloses that in manufacturing Nakahara’s stator, “a plurality of coil bobbins are integrated as a band shaped continuous coil bobbin unit with discrete coil bobbins held at uniform separations by thin parts. Consequently, large molding dies are required in the manufacturing of the coil bobbin units and the manufacturing properties are quite poor.” *Id.* ¶ 5. Ishihara discloses, “[t]he objective [of its invention] is to provide a method of manufacture that does not necessitate a large molding die in the manufacture of coil bobbin units.” *Id.* ¶ 7.

Figure 1 of Ishihara is reproduced below.

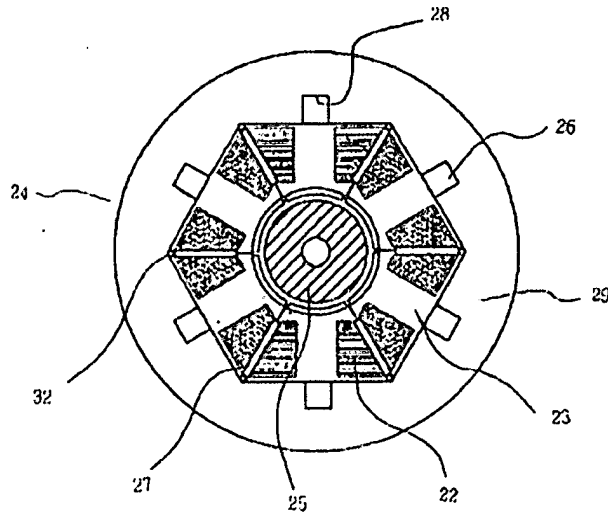

Figure 1 depicts electric motor including rotor 25 and stator 24. *See* Ex. 1007 ¶ 22. Stator 24 is constructed from a coil bobbin unit 20 and a plurality of coupled coil bobbins 23 and magnetic pole teeth 26 are fitted to each of the coil bobbins 23. *See id.* Coils 22 are wound around each of the coil bobbins 23. *See id.* ¶ 23. Ring-shaped stator core 29 is formed with recesses 28 for mating and fitting of magnetic pole teeth 26. *See id.* ¶ 22.

Figure 3 of Ishihara is reproduced below.

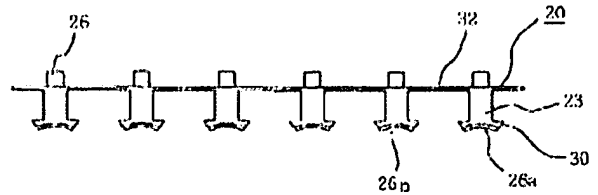

Figure 3 depicts the structure of each coil bobbin unit 20 fitted to magnetic pole teeth 26. *See* Ex. 1007 ¶ 23. A predetermined number of coil bobbins are 23 are connected by connecting member 32 to form an integrated strip. *See id.* In the alternative, a plurality of coil bobbins 23 connected by bendable thin parts are connected by a connecting member to form an integrated strip. *See id.*

Figure 5(a) and 5(b) of Ishihara is reproduced below.

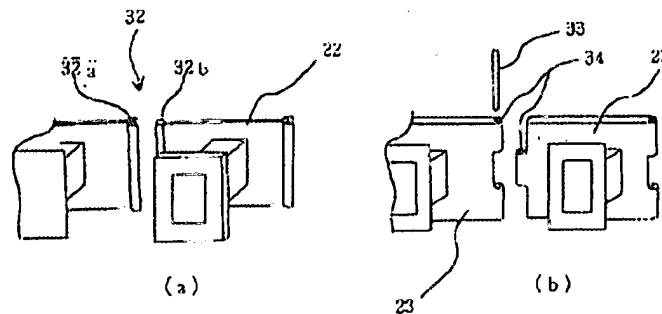

Figure 5(a) depicts connecting member 32 including connecting portion 32a with a recessed profile at one end and connecting portion 32b with a convex shape at the other end to enable mating and free rotation. *See* Ex. 1007 ¶ 23. Figure 5(b) depicts a structure in which coil bobbins 23 are rotatably connected using engaging pin 33 and holes 34. *See id.*

*c. Analysis of Claim 10*

For the purposes of this Decision and based on Petitioner’s citations to Nakahara, Ishihara, and Petitioner’s declarant testimony (Ex. 1024), we are persuaded that Petitioner establishes sufficiently that Nakahara and Ishihara teach or suggest each of the limitations recited in claim 10. For example, Petitioner asserts that Nakahara teaches “a plurality of discrete stator segments each at least partially encased with a phase change material” based on Nakahara’s disclosure of magnetic pole teeth 2 encased by insulating coil bobbins 5. *See* Pet. 25 (reproducing Ex. 1001, Figs. 3, 5 and Ex. 1006, Fig. 3b with annotations, citing Ex. 1006 ¶¶ 32–34; Ex. 1024 ¶ 68). Petitioner notes that Nakahara teaches that coil bobbins should be made of insulating material, but need not be made of resin. *Id.* (citing Ex. 1006 ¶ 32). Petitioner asserts that Nakahara teaches that resins such as polypropylene resin, nylon resin, and acrylonitrile butadiene styrene (ABS)

resin may be particularly suitable because they provide good moldability and suppleness. *See id.* 25–26 (citing Ex. 1006 ¶ 34). Petitioner asserts that ABS, nylon, and polypropylene are thermoplastic materials, and that the '952 Patent identifies thermoplastics as a phase change material. *See id.* at 26 (citing Ex. 1019, 1:8–14, 7:57–61; Ex. 1001, 6:20–21, 9:3–16; Ex. 1024 ¶ 69).

As another example, Petitioner contends that Nakahara teaches “wherein the phase change material also comprises a bridge between adjacent segments to link adjacent segments into a continuous strip” based on Nakahara’s coil bobbins 5 being part of a longer coil bobbin coupling body 15. *See Pet.* 26 (citing Ex. 1006 ¶ 34). Petitioner asserts that Nakahara teaches thin parts 15a of coil bobbin coupling body 15 are created at the coupling section of the coil bobbin 5, and are formed thinly to be sufficiently flexible to bend. *See id.* at 26–27 (citing Ex. 1006 ¶ 34). Petitioner contends that Nakahara teaches the thin parts 15a as being formed from the same thermoplastic materials as the bobbins. *See id.* at 27 (reproducing Ex. 1006, Figs. 3(b) and 6 with annotations; citing Ex. 1024 ¶ 71). Petitioner also asserts that Nakahara’s teachings of utilizing hole 17 in the center of thin parts 15a allows thin parts 15a to bend more readily. *See id.* at 27–28 (quoting Ex. 1006 ¶ 35; comparing Ex. 1006, Fig. 6 with Ex. 1001, Figs. 5–6; citing Ex. 1024 ¶ 72). As another example, Petitioner contends that Nakahara’s thin parts 15 teach “a bridge between adjacent segments to link adjacent segments into a continuous strip.” *See id.* at 27 (citing Ex. 1024 ¶ 73). As a final example, Petitioner asserts that Nakahara teaches “the linked stator segments being arranged and secured together to form the stator assembly” based on Nakahara’s teachings of the coil bobbin connector



being rounded to the normal state, mated to magnetic pole teeth 2 and fixed to outer yoke 3 to complete the structure of stator 8. *See id.* at 33–34 (reproducing Ex. 1006, Fig. 1 with annotations; citing Ex. 1006 ¶ 41; Ex. 1007 ¶ 27; Ex. 1024 ¶¶ 84, 86).

Petitioner, however, contends that Nakahara’s bridge (i.e., thin parts 15a) does not comprise two interconnected mating sections. *See* Pet. 28. In other words, Petitioner implicitly construes the claim phrase as requiring some unarticulated additional structure. As explained above in Section II.A.3., we construe the broadest reasonable interpretation of the claim phrase as “the bridge comprises two sections mated to the stator segments that are interconnected and formed from the phase change material.” For purposes of this Decision, Nakahara’s thin parts 15a of coil bobbin coupling body 15 that are located between and interconnected with coil bobbins 5 teaches the disputed limitation commensurate in scope with its broadest reasonable interpretation.

For purposes of this Decision and based on Petitioner’s citations to specific prior art disclosures and supporting evidence, we are persuaded Petitioner sets forth sufficient articulated reasoning with rational underpinning to support the conclusion that it would have been obvious to one with ordinary skill in the art to modify Nakahara’s coil bobbin arrangement to include Ishihara’s interconnected mated coil bobbins. *See* Pet. 29–32; *KSR Int’l Co. v. Teleflex Inc.*, 550 U.S. 398, 418 (2007) (quoting *In re Kahn*, 441 F.3d 977, 988 (Fed. Cir. 2006)). For example, Petitioner asserts that Ishihara expressly teaches to modify Nakahara and provides a reason why one would be motivated to modify Nakahara—Ishihara’s invention was devised in light of Nakahara’s drawbacks with the objective to

provide a method of manufacture that does not necessitate a large die to manufacture coil bobbin units. *See id.* at 29 (citing Ex. 1007 ¶¶ 2–7), 31–32 (citing Ex. 1007 ¶¶ 2, 5–10); Ex. 1024 ¶ 79; *Allergan, Inc. v. Sandoz Inc.*, 726 F.3d 1286, 1291–92 (Fed. Cir. 2013)). As another example, Petitioner asserts that modifying Nakahara to include the interconnecting, mated coil bobbins of Ishihara would have amounted to the use of a known technique to improve a similar device in a known manner yielding a predictable result. *See id.* at 32 (citing Ex. 1024 ¶ 80). As yet another example, Petitioner asserts that a person of ordinary skill in the art would have had a reasonable expectation of success in making the combination because the disclosures of Nakahara and Ishihara are remarkably similar. *See id.* (comparing Ex. 1006, Fig. 1, with Ex. 1007, Fig. 1; comparing Ex. 1006, Fig. 3, with Ex. 1007, Fig. 3). Petitioner further contends that, in the combination of Nakahara and Ishihara, it would have been obvious to form the interconnecting mated coiled bobbin sections from the same thermoplastic or phase change materials as Nakahara’s bobbins. *See* Pet. 33–34 (citing Ex. 1007 ¶ 30; Ex. 1024 ¶ 82; *KSR*, 550 U.S. at 421).

Patent Owner argues that Nakahara does not teach using the same phase change material to partially encase and link the stator segments. *See* Prelim. Resp. 12–16; *see id.* at 15–16. More specifically, Patent Owner argues that Nakahara does not teach that coil bobbin coupling body 15 is comprised of the same phase change material as coil bobbins 5. *See id.* at 13–14 (reproducing Ex. 1006, Figs. 3b and 6). Patent Owner asserts the Petition admits that Nakahara teaches that the coil bobbin 5 need not be made of resin. *See id.* at 14–15 (citing Pet. 25). Patent Owner contends that although Nakahara describes coil bobbins 5 as being part of coil bobbin

coupling body 15, they are not necessarily made of resin and therefore coil bobbins 5 and coil bobbin coupling body 15 need not be the same material. *See id.* at 15.

For purposes of this Decision and based on this record, we do not agree with Patent Owner’s arguments. Although Nakahara teaches, “coil bobbins 5 should be made of insulating material, but they need not be made of resin,” (Ex. 1006 ¶ 32), Nakahara otherwise teaches or suggests that coil bobbins 5 are made of resin. For example, Nakahara teaches: (1) “5 denotes coil bobbins made of resin” (*id.*); and (2) “[t]he coil bobbins made of resin are reversed after wire winding of the coils . . .” (*id.* ¶ 27).

Patent Owner further argues that Nakahara and Ishihara do not teach “the linked stator segments being arranged and secured together to form the stator assembly” based on comparisons with the ’952 Patent disclosure. *See* Prelim. Resp. 16–17 (reproducing Ex. 1001, Figs. 5, 7, and 8a; citing Ex. 1001, 4:34–37; 5:17–19, 5:22–28, 14:1–11). Patent Owner contends that Nakahara’s and Ishihara’s stator assemblies are not formed by the stator segments, but require an additional component such as Nakahara’s yoke element 3 or Ishihara’s stator iron core 29. *See id.* at 18–19 (reproducing Ex. 1006, Fig. 1 and Ex. 1007, Fig. 2 with annotations; quoting Ex. 1006 ¶¶ 38, 41, 50; Pet. 24; Ex. 1007, 7).

For purposes of this Decision, we do not agree with Patent Owner’s arguments because they are not commensurate in scope with the claim limitations. Claim 10 does not recite or require that the linked stator segments must be arranged and secured together by the stator segments alone, nor does the scope of claim 10 exclude additional structure for arranging and securing together the linked stator segments.

Accordingly, for purposes of this Decision and based on the current record before us, there is a reasonable likelihood Petitioner would prevail in showing claim 10 is unpatentable over Nakahara and Ishihara.

*d. Analysis of Dependent Claim 12*

Claim 12 recites, “the stator segments are held in a toroidal shape by a retaining member.” Petitioner contends that Nakahara teaches this limitation based on its assertion that Nakahara’s outer yoke 3 holds Nakahara’s magnetic pole teeth 2 in a similar fashion to the ’952 Patent disclosure of collar 200 positioned around the circumference of stator core to hold the core segments in shape. *See* Pet. 40–41 (reproducing Ex. 1006, Fig. 1 and Ex. 1001, Fig. 10 with annotations; citing Ex. 1006 ¶¶ 33, 34, 36; Ex. 1001, 10:40–55; Ex. 1024 ¶¶ 98–99). Petitioner notes that Nakahara teaches, “[t]he outer edges of the magnetic pole teeth 2 are mated and fixed to the outer yoke 3 so as to be housed in the hexagonal hole 3a of the outer yoke 3. They are held in place by the magnetic pole teeth 2 to thereby complete the stator 8.” *See id.* at 40 (quoting Ex. 1006 ¶ 38).

Patent Owner contends that Nakahara’s hexagonal hole 3a housed in outer yoke 3 holds the stator segments (i.e., magnetic pole teeth 2) in a hexagonal shape, not a toroidal shape as required by claim 12. *See* Prelim. Resp. 20–21 (citing, *inter alia*, Ex. 1006, Fig. 1). We agree with Patent Owner that Nakahara’s outer yoke 3 that holds magnetic pole teeth 2 in hexagonal hole 3a does not teach or suggest “the stator segments are held in a toroidal shape by a retaining member.” As explained above in Section II.A.4., we construe the broadest reasonable interpretation of “toroidal shape” as a “shape having a surface generated by a closed plane curve rotated about a line that lies in the same plane as the curve but does not

intersect it.” Petitioner does not explain sufficiently how Nakahara’s hexagonal hole 3a of outer yoke 3 holds the magnetic pole teeth 2 in a toroidal shape consistent with its broadest reasonable construction.

Accordingly, for purposes of this Decision and based on the current record before us, there is not a reasonable likelihood that Petitioner would prevail in showing claim 12 is unpatentable over Nakahara and Ishihara.

2. *Unpatentability of Dependent Claim 11 over Nakahara, Ishihara, and Lieu*

Claim 11 recites, “wherein the stator segments are held in a toroidal shape by an overmolded thermoplastic material.” Petitioner contends that Nakahara teaches molding the outer contour of stator 8 using molded resin 30. *See* Pet. 35 (citing Ex. 1006 ¶ 45). Petitioner contends that a person of ordinary skill in the art would understand that Nakahara’s stator segments would be held in a toroidal shape by Nakahara’s resin. *See id.* (citing Ex. 1024 ¶ 89). Petitioner does not rely on the teachings of Ishihara or Lieu for teaching “the stator segments are held in a toroidal shape.” *See id.* at 35–40.

For the same reasons as those addressing claim 12 immediately above in Section II.C.1.d., we agree with Patent Owner that Nakahara’s outer yoke 3 that holds magnetic pole teeth 2 in hexagonal hole 3a does not teach or suggest “the stator segments are held in a toroidal shape.” Accordingly, for purposes of this Decision and based on the current record before us, there is not a reasonable likelihood that Petitioner would prevail in showing claim 11 is unpatentable over Nakahara, Ishihara, and Lieu.

3. *Unpatentability of Claims 10 and 12 over Sheeran and Nakahara*

a. *Effective Filing Date of Sheeran (Ex. 1010)*

Sheeran issued on December 30, 2008, but claims entitlement to an earlier October 31, 2002, effective filing date of Provisional Application No. 60/422,676 (“the ’642 Provisional,” Ex. 1018). *See* Ex. 1010 (45), (60), (61). Petitioner asserts that Sheeran is entitled to the October 31, 2002, effective filing date and is prior art under pre-AIA 35 U.S.C. § 102(e). *See* Pet. 21. In support of its assertion, Petitioner provides a chart to demonstrate that the ’642 Provisional discloses the invention recited in claim 1 of Sheeran. *See id.* at 22–23. Patent Owner does not present arguments addressing the effective filing date of Sheeran. *See* Prelim. Resp. 21.

For purposes of this Decision, we agree that Sheeran is entitled to an earlier October 31, 2002, effective filing date on the basis that the ’642 Provisional provides adequate written description support for claim 1. We also note that the Sheeran’s Figures and written description appear to be substantially identical to the Figures and written description of the ’642 Provisional. *Compare* Ex. 1010, *with* Ex. 1018. Thus, for purposes of this Decision, Sheeran qualifies as prior art under pre-AIA 35 U.S.C. § 102(e).

b. *Overview of Sheeran (Ex. 1010)*

Sheeran discloses a segmented stator assembly including a plurality of discrete, non-interconnected stator segments. *See* Ex. 1010, 3:10–12, 3:40–42.

Figures 1B and 1C of Sheeran are reproduced below.

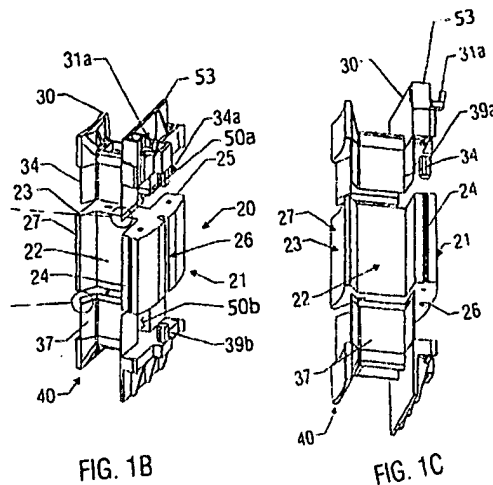

Figures 1B and 1C depict stator segment 20 sandwiched between two containment structures 30 and 40. *See Ex. 1010, 3:40–42.* Stator segments 20 include main yoke portion 21 and extending tooth portion 22 that terminates in T shaped portion 23. *See id.* at 4:2–4. Yoke portion 21 of each stator segment 20 defines engagement projection 24 on one side of yoke 21 and engagement notch 25 on the opposing side of yoke 21, each sized such that when adjacent stator segments are brought together, engagement projection 24 will be received in engagement notch 25. *See id.* at 4:5–11. Stator segments 20 are positioned within and held in place by pockets or recesses 50a and 50b in flexible plastic containment structures 30 and 40 designed and shaped to receive stator segments 20. *See id.* at 3:46–49, 4:48–52. Containment structures 30 and 40 insulate a winding coil from the metal forming stator segments 20. *See id.* at 6:6–9, 6:13–14, 11:9–14. Pockets or recesses 50a and 50b are held together by integral flexible hinges. *See id.* at 4:53, 6:33–52, Figs. 3A–3B. Upon completion of winding, the stator assembly will be rounded into an annular form for use. *See id.* at 9:66–10:7; Fig. 2. Sheeran discloses that there are several approaches that may be used

to maintain the rounded stator assembly in its annular form, including, for example, insertion into a motor housing or shell in a press fit relationship, some form of band or other external retaining structure, and providing one or more of the containment structures with engagement or locking elements. *See id.* at 10:8–21.

Figures 7A and 7B of Sheeran are reproduced below.

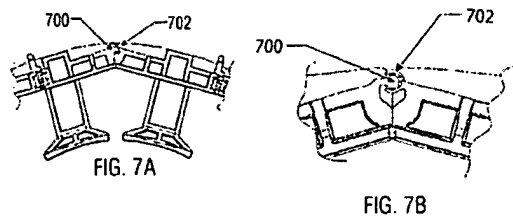

Figures 7A and 7B depict alternate engagement/locking structures 700, 702 that may be provided on containment structures 30, 40 to hold the stator assembly in annular form. *See Ex. 1010, 10:22–43.*

*c. Analysis of Claim 10*

For purposes of this Decision and based on Petitioner’s citations to Sheeran, Nakahara, and Petitioner’s declarant testimony (Ex. 1024), we are persuaded that Petitioner establishes sufficiently that Sheeran and Nakahara teach or suggest each of the limitations recited in claim 10. For example, Petitioner asserts that Sheeran teaches “a plurality of discrete stator segments each at least partially encased with a . . . material” based on Sheeran’s disclosure of each stator segment 20 sandwiched between and positioned within pockets in flexible plastic insulating containment structures 30 and 40. *See Pet. 61–62 (reproducing Ex. 1010, Figs. 1B and 1C with annotations; citing Ex. 1010, 1:17–22, 3:40–49, 4:49–52, 6:6–16; Ex. 1024 ¶ 150).*



As another example, Petitioner contends that Sheeran teaches “wherein the . . . material also comprises a bridge between adjacent segments to link adjacent segments into a continuous strip, wherein the bridge is formed by interconnecting two mating sections formed from the . . . material” based on Sheeran’s containment structures 30 and 40 including flexible members that serve as hinges, and in particular Sheeran’s disclosure of projections 700 and receptive element 702 of engagement/locking structures. *See* Pet. 65–67 (reproducing Ex. 1010, Figs. 7A and 7B with annotations; citing Ex. 1010, 4:41–49, 10:16–35, Figs. 1A, 2; Ex. 1024 ¶¶ 160–162). As yet another example, Petitioner asserts that Sheeran teaches “the linked stator segments being arranged and secured together to form the stator assembly,” based on Sheeran’s aforementioned disclosure of engagement/locking structures. *See id.* at 67–68 (citing Ex. 1010, 10:8–35; Ex. 1024 ¶ 165).

Petitioner acknowledges that Sheeran does not specify precisely the type of plastic or insulating barrier used for containment structures 30 and 40. *See* Pet. 62. Petitioner asserts that it was known to use a phase change material to encase a stator segment, as evidenced by Nakahara’s teaching to encase stator segment with coil bobbins of phase change material, such as polypropylene resin, nylon resin, or ABS resin. *See id.* at 62–63 (incorporating by reference Pet. 42–47; citing Ex. 1024 ¶¶ 151–152)

For purposes of this Decision and based on Petitioner’s citations to specific prior art disclosures and supporting evidence, we are persuaded Petitioner sets forth sufficient articulated reasoning with rational underpinning to support the conclusion that it would have been obvious to one with ordinary skill in the art to make Sheeran’s insulating containment

structures out of the same materials as Nakahara's insulators. *See* Pet. 63–65; *KSR*, 550 U.S. at 418 (quoting *Kahn*, 441 F.3d at 988). For example, Petitioner asserts: (1) because Sheeran does not prescribe a particular insulator material, a person of ordinary skill in the art would have been motivated to consult literature to determine suitable types of materials for stator insulation applications; and (2) a person of ordinary skill in the art would have turned to publications such as Nakahara because it is directed to segmented stator cores like Sheeran. *See id.* at 63–64 (reproducing an excerpt of Ex. 1006, Fig. 3(b) and Ex. 1010, Fig. 1B with annotations; citing Ex. 1024 ¶¶ 154–155). Petitioner further contends that because of the similarities between Sheeran and Nakamara, the modification would have required no more than substituting a known material for the known purpose of insulating segments of a stator, and a person of ordinary skill in the art would have had a reasonable expectation of success for this substitution. *See id.* at 64–65 (citing Ex. 1024 ¶¶ 155–157; *In re Leshin*, 277 F.2d 197, 199 (CCPA 1960)).

Patent Owner argues that the Petition fails to demonstrate that Nakahara teaches the same phase change material partially encases the plurality of discrete stator segments, forms a bridge that links adjacent stator segments into a continuous strip, and forms the two mating sections that comprise the bridge. For purposes of this Decision, we do not agree with Patent Owner's arguments because they address the teachings of Nakahara alone, instead of addressing the combined teachings of Sheeran and Nakahara. One cannot show non-obviousness by analyzing a reference individually, as Patent Owner has, where the asserted ground of unpatentability is based on a combination of references. *See In re Merck &*

*Co., Inc.*, 800 F.2d 1091, 1097 (Fed. Cir. 1986). Contrary to Patent Owner's arguments, Petitioner relies on Sheeran for teaching the use of the same material to partially encase the plurality of discrete stator segments, to form a bridge that links adjacent stator segments into a continuous strip, and to form the two mating sections that comprise the bridge, as modified in view of Nakahara's teachings of using particular phase change materials.

Accordingly, for purposes of this Decision and based on the current record before us, there is a reasonable likelihood Petitioner would prevail in showing claim 10 is unpatentable over Sheeran and Nakahara.

*d. Analysis of Dependent Claim 12*

For purposes of this Decision and based on this record, we are persuaded by Petitioner's additional citations to Sheeran and Petitioner's declarant testimony (Ex. 1024) that Sheeran teaches or suggests "the stator segments are held in a toroidal shape by a retaining member" based on Sheeran's teaching that some form of band or other external retaining structure may be used to circle the annularized stator assembly to hold it in the desired configuration. *See* Pet. 70–71 (citing Ex. 1010, 10:13–16; Ex. 1001, 10:40–55, Fig. 10; Ex. 1024 ¶ 176). Patent Owner does not present substantive arguments addressing claim 12. *See* Prelim. Resp. 21.

Therefore, for purposes of this Decision and based on the current record before us, there is a reasonable likelihood Petitioner would prevail in showing claim 12 is unpatentable over Sheeran and Nakahara

4. Unpatentability of Dependent Claim 11 over  
Sheeran, Nakahara, and Lieu

a. Overview of Lieu (Ex. 1008)

Lieu has a June 21, 2001, publication date. Ex. 1008, (43). As explained above in Section II.B., for purposes of this Decision, the '952 Patent is entitled to its March 5, 2003, actual filing date. Thus, for purposes of this Decision, Lieu qualifies as prior art under pre-AIA 35 U.S.C. § 102(b).

Lieu discloses a high-speed spindle motor including a stator assembly. *See id.* at 9:10–18.

Figures 2 and 3 of Lieu are reproduced below.

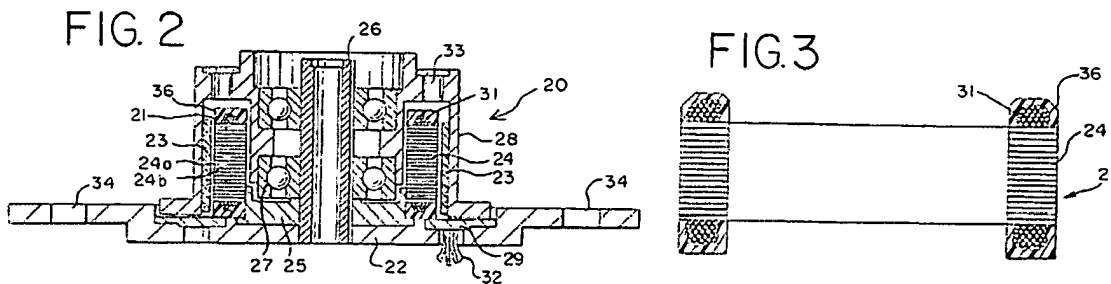

Figure 2 depicts spindle motor 20 and Figure 3 depicts stator assembly 21 of spindle motor 20. *See Ex. 1008, 9:10–18.* Stator assembly 21 includes steel laminated magnetically inducible core 24, and wire windings 31. *See id.* at 9:15–18. “Once the windings are in place, the wire 31 is encapsulated with a thermoplastic material 36 . . . and the core 24 is substantially encapsulated by the material 36 (FIG. 3).” *Id.* at 9:21–23; *see also id.* at 10:13–33 (disclosing preferred example thermoplastic materials). Lieu discloses advantages of using thermoplastic encapsulation include: reduced motor vibration, reduced acoustic emissions, facilitated heat dissipation/reduced overall motor temperature, and reduced manufacturing costs. *See id.* at 13:10–14:5.

*b. Analysis of Claim 11*

Claim 11 recites, “wherein the stator segments are held in a toroidal shape by an overmolded thermoplastic material.” Petitioner contends that Sheeran teaches the stator segments are held in a toroidal shape using a retaining member, motor housing, shell, or other form of retention, and relies on Lieu for teaching overmolding a stator with thermoplastic materials. *See* Pet. 68–69 (quoting Ex. 1010, 10:8–9, 10:41–43; citing Ex. 1008, 2:4–6, 2:19–4:15, 9:21–23, 12:8–18, Fig. 2). Petitioner also notes that Sheeran teaches alternate embodiments of containment structures may be filled with thermally conductive resin or thermally conductive materials to aid in the removal of heat from the stator assembly during operation of the motor. *See id.* at 69 (citing Ex. 1010, 11:22–27). Petitioner contends that a person of ordinary skill in the art would have recognized one alternate form of retention that would be suitable for use with Sheeran would have been the thermoplastic overmold of Lieu. *See id.* at 69 (citing Ex. 1024 ¶ 169).

For purposes of this Decision and based on Petitioner’s citations to specific prior art disclosures and supporting evidence, we are persuaded Petitioner sets forth sufficient articulated reasoning with rational underpinning to support the conclusion that it would have been obvious to one with ordinary skill in the art to modify the teachings of Sheeran to include the overmolded thermoplastic materials of Lieu. *See* Pet. 69–70; *KSR*, 550 U.S. at 418 (quoting *Kahn*, 441 F.3d at 988). For example, Petitioner asserts a person of ordinary skill in the art would have understood from Lieu that overmolding with a thermoplastic material could provide a motor stator with the benefit of heat dissipation, and would be particularly motivated to use Lieu’s thermoplastic overmold with Sheeran’s stator to

achieve heat dissipation. *See id.* at 69–70 (citing Ex. 1008, 13:4–14:5; Ex. 1010, 11:22–27; Ex. 1024 ¶¶ 171–172). Petitioner also contends: (1) the art had long understood the benefits of thermoplastic molding; (2) Lieu teaches the need for overmolding a stator with thermoplastic materials and teaches the overmolding process; (3) Lieu teaches several advantages achieved by overmolding a stator with thermoplastic materials including improved heat dissipation. *See id.* at 69 (incorporating by reference Pet. 35–40; citing Ex. 1008, 2:4–6, 2:19–4:15, 9:21–23, 12:8–18, 13:4–14:5, Fig. 2). Lastly, Petitioner contends that modifying Sheeran to include the overmolded thermoplastic materials of Lieu would have required no more than the use of a known technique to improve a similar device to yield a predictable result. *See id.* (citing Ex. 1024 ¶ 171). Petitioner does not present arguments addressing dependent claim 12. *See Prelim. Resp.* 21.

Accordingly, for purposes of this Decision and based on the current record before us, there is a reasonable likelihood Petitioner would prevail in showing claim 11 is unpatentable over Sheeran, Nakahara, and Lieu.

*5. Unpatentability of Claim 10 over Ikuma and Nakahara*

*a. Overview of Ikuma (Ex. 1009)*

Ikuma discloses an electric motor including a divided stator core. *See Ex. 1009*, 5.

Figures 2 and 3 of Ikuma are reproduced below:

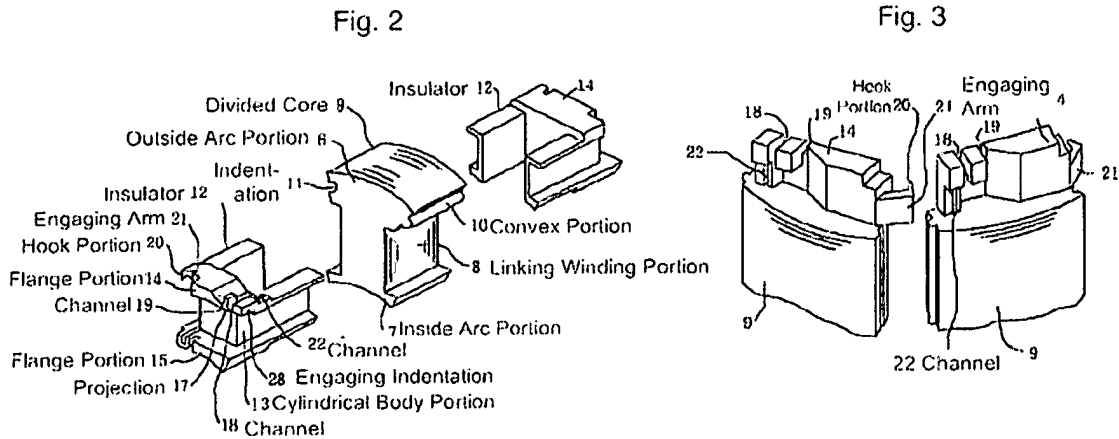

Figure 2 depicts a perspective view of divided iron core 9 and insulator 12, and Figure 3 depicts a perspective view of main portions of stator core and attached insulator 12. *See Ex. 1009, 8.* Divided iron core 9 includes outside arc portion 6, inside arc portion 7, and linking winding portion 8. *See id.* Convex portion 10 projecting in the circumferential direction on the end surface of one side of outside arc portion 6 can engage with indentation 11 provided on the other end surface of outside arc portion 6. *See id.* Insulator 12 includes cylindrical body portion 13 and flange portions 14 and 15 formed at the two ends of cylindrical body portion 13. *See id.* at 8–9. Engaging arm 21 having hook portion 20 is provided on the side surface in the circumferential direction of flange portion 14. *See id.* at 9. Channel 22 engaged by hook portion 20 is also provided on the side surface of flange portion 14. *See id.* Divided iron cores 9 are arrayed in the circumferential direction. *See id.*

Figure 4 of Ikuma is reproduced below.

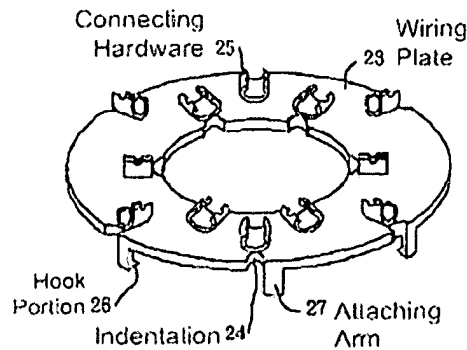

Figure 4 depicts a perspective view of disk-shaped wiring plate 23. *See* Ex. 1009, 8–9. Wiring plate 23 is mounted on the axial-direction end portion of stator winding for connecting winding ends. *See id.* at 9. Attaching arm 27 with hook portion 26 is disposed on the lower surface of wiring plate and engages indentation 28 disposed on the insulator flange portion 14 of insulation 12. *See id.* at 9, Fig. 5.

*b. Analysis of Claim 10*

For purposes of this Decision and based on Petitioner’s citations to Ikuma, Nakahara, and Petitioner’s declarant testimony (Ex. 1024), we are persuaded that Petitioner establishes sufficiently that Ikuma and Nakahara teach or suggest each of the limitations recited in claim 10. For example, Petitioner asserts that Ikuma teaches “a plurality of discrete stator segments each at least partially encased with a . . . material” based on Ikuma’s disclosure of divided iron cores 9 and body portion 13 of insulator 12 that at least partially encases the linking winding portion 8 of divided iron core 9. *See* Pet. 41–42 (reproducing Ex. 1009, Figs. 2 and 3 with annotations; citing Ex. 1009 ¶ 5; Ex. 1024 ¶¶ 105–106). As another example, Petitioner contends that Ikuma teaches “wherein the . . . material also comprises a bridge between adjacent segments to link adjacent segments into a



continuous strip, wherein the bridge is formed by interconnecting two mating sections formed from the . . . material,” based on Ikuma’s insulator 12 flange portion 14 including engaging arm 21 having hook portion 20 to be engaged by channel 22 on an adjacent insulator 12 flange portion 14. *See id.* at 47–48 (reproducing Ex. 1009, Fig. 2 with annotations; citing Ex. 1009 ¶ 5; Ex. 1024 ¶¶ 116–117). As yet another example, Petitioner asserts that Ikuma teaches “the linked stator segments being arranged and secured together to form the stator assembly,” based on Ikuma’s disclosure that each divided iron core 9 includes convex portion 10 to engage with indented portion provided on the other end of divided iron core segment 9. *See id.* at 49 (citing Ex. 1009 ¶ 5, Fig. 2; Ex. 1024 ¶¶ 119–120).

Petitioner acknowledges that Ikuma does not describe a specific type of material used to form insulator 12. *See* Pet. 43. Petitioner asserts that it was known to use a phase change material to encase a stator segment, as evidenced by Nakahara’s teaching to encase stator segments with coil bobbins in phase change material, such as, polypropylene resin, nylon resin, or ABS resin. *See id.* at 44 (incorporating by reference Pet. 25–26; citing Ex. 1024 ¶ 108; Ex. 1006 ¶ 34; Ex. 1001, 6:20–21).

For purposes of this Decision and based on Petitioner’s citations to specific prior art disclosures and supporting evidence, we are persuaded Petitioner sets forth sufficient articulated reasoning with rational underpinning to support the conclusion that it would have been obvious to one with ordinary skill in the art to make Ikuma’s insulator out of the same materials as Nakahara’s insulators. *See* Pet. 44–45; *KSR*, 550 U.S. at 418 (quoting *Kahn*, 441 F.3d at 988). For example, Petitioner asserts:

- (1) because Ikuma does not prescribe a particular insulator material, a person

of ordinary skill in the art would have been motivated to consult literature to determine suitable types of materials for stator insulation applications; and (2) a person of ordinary skill in the art would have turned to publications such as Nakahara because it is directed to segmented stator cores like Ikuma. *See id.* at 45–46 (reproducing Ex. 1009, Fig. 2 and Ex. 1006, Fig. 11 with annotations; citing Ex. 1024 ¶ 110). Petitioner further contends that because of the similarities between Ikuma and Nakamara, the modification would have required no more than substituting a known material for the known purpose of insulating segments of a stator, and a person of ordinary skill in the art would have had a reasonable expectation of success for this substitution. *See id.* at 46–47 (citing Ex. 1024 ¶¶ 111–112; *Leshin*, 277 F.2d at 199).

Patent Owner repeats its argument, discussed above in Section II.C.3.c., that the Petition fails to demonstrate that Nakahara teaches the same phase change material partially encases the plurality of discrete stator segments, forms a bridge that links adjacent stator segments into a continuous strip, and forms the two mating sections that comprise the bridge. *See Prelim. Resp.* 21. For the same reasons as discussed above in Section II.C.3.c., we are persuaded by Petitioner’s contentions.

Accordingly, for purposes of this Decision and based on the current record before us, there is a reasonable likelihood Petitioner would prevail in showing claim 10 is unpatentable over Ikuma and Nakahara.

*6. Unpatentability of Dependent Claim 11 over Ikuma, Nakahara, and Lieu*

Claim 11 recites, “wherein the stator segments are held in a toroidal shape by an overmolded thermoplastic material.” Petitioner contends that Ikuma teaches the stator segments are held in a toroidal shape by an

overmolded material, and relies on the Lieu for teaching overmolded thermoplastic material. *See* Pet. 50–54. Specifically, Petitioner contends that Ikuma teaches “[o]nce the segmented stator . . . is assembled, a wiring plate is ‘affixed to the insulator 12,’ after which ‘[t]he stator winding 16 is then covered by an insulating resin 35 to insulate the stator winding 16, and a stator core 5 thus constituted is inserted and *affixed* in a frame 2.’” *Id.* at 50 (quoting Ex. 1009 ¶ 5). In support of its contentions, Petitioner reproduces Figure 1 of Ikuma with annotations. *See id.* at 50–51.

Figure 1 of Ikuma with Petitioner’s annotations is reproduced below.

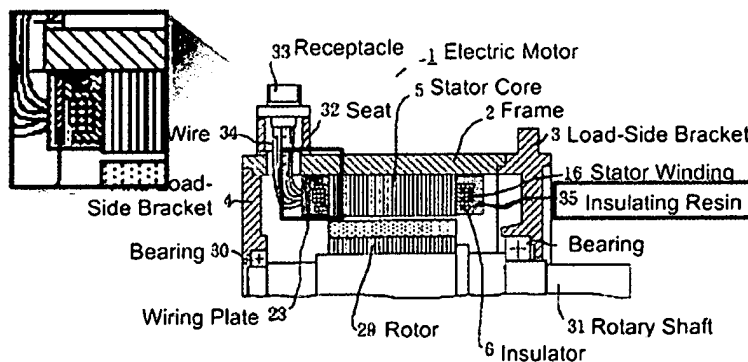

Figure 1 depicts a cross section of the upper portion of electric motor. Ex. 1009 ¶ 5. Petitioner contends Figure 1 illustrates “[t]he insulating resin 35 and the frame 2 (pink) to which it embeds and affixes the stator.” Pet. 50. Petitioner contends that a person of ordinary skill in the art “would understand from Ikuma’s description—i.e., ‘the stator winding 16 is *covered by*’ the insulating resin causing the stator to be ‘inserted and affixed in [the] frame 2’—that the stator segments are ‘overmolded’ with and ‘held in a toroidal shape’ by the insulating resin. *Id.* at 51 (citing Ex. 1024 ¶ 124).

Petitioner acknowledges that Ikuma does not describe the precise materials used as an insulating resin to overmold the stator segments. *See* Pet. 51. Petitioner asserts that Lieu specifically teaches using a

thermoplastic material to overmold a stator. *See id.* at 52 (incorporating by reference Pet. 25–26)

For purposes of this Decision and based on Petitioner’s citations to specific prior art disclosures and supporting evidence, we are persuaded Petitioner sets forth sufficient articulated reasoning with rational underpinning to support the conclusion that it would have been obvious to one with ordinary skill in the art to modify the teachings of Ikuma to include the overmolded thermoplastic materials of Lieu. *See* Pet. 52–54; *KSR*, 550 U.S. at 418 (quoting *Kahn*, 441 F.3d at 988). For example, Petitioner asserts a person of ordinary skill in the art would have understood from Lieu that overmolding with a thermoplastic material could provide a motor stator with the benefit of heat dissipation, and would have been motivated to modify Ikuma with Lieu’s overmolded thermoplastic material to achieve heat dissipation. *See id.* at 52 (citing Ex. 1008, 13:4–14:5; Ex. 1024 ¶ 128). As another example, Petitioner contends that because Ikuma and Lieu teach overmolding a stator with a resin, it would have been obvious for a person of ordinary skill in the art to simply substitute Lieu’s thermoplastic resin for Ikuma’s insulating resin. *See id.* at 53 (citing Ex. 1024 ¶ 130). As a final example, Petitioner asserts that modifying Ikuma to include the overmolded thermoplastic materials of Lieu would have required no more than the use of a known technique to improve a similar device to yield a predictable result. *See id.* at 53–54 (citing Ex. 1024 ¶ 130). Patent Owner does not present arguments addressing dependent claim 12. *See* Prelim. Resp. 21.

Accordingly, for purposes of this Decision and based on the current record before us, there is a reasonable likelihood Petitioner would prevail in showing claim 11 is unpatentable over Ikuma, Nakahara, and Lieu.

7. *Unpatentability of Dependent Claim 12 over  
Ikuma, Nakahara, and Stridsberg*

a. *Overview of Stridsberg (Ex. 1017)*

Stridesberg discloses a brushless electric motor comprising poles and arch segments as separate parts that constitute a part of the whole circumference of the yoke. *See Ex. 1017, 4–5.*

Figures 12a and 12b of Stridesberg are reproduced below.

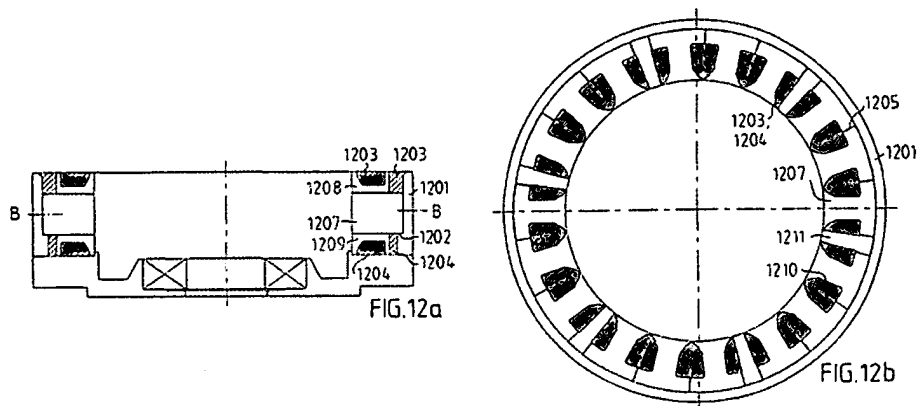

Figures 12a and 12b depict an assembled stator assembly in axial and radial sections. *See Ex. 1017, 7–8.* Stator poles 1207 are positioned against outer ring 1201 during assembly. *See id.* at 12–14.

b. *Analysis of Claim 12*

For purposes of this Decision and based on this record, we are persuaded by Petitioner’s additional citations to Ikuma and Petitioner’s declarant testimony (Ex. 1024) that Ikuma teaches “the stator segments are held in a toroidal shape by a retaining member.” *See Pet. 54–56.* For example, Petitioner contends that Ikuma teaches this limitation based on wiring plate 23 affixed to insulator 12 by way of attaching arm 27 hook portion 26 and engaging indentation 28 on insulator flange 14. *See Pet. 54–*

56 (reproducing Ex. 1009, Figs. 4–6 with annotations; citing Ex. 1006 ¶ 5; Ex. 1024 ¶¶ 133–136).

Petitioner also asserts that “[t]o the extent that ‘retaining member’ is construed more narrowly to require the specific structure described in the ’952 patent for holding stator segments in a toroidal shape—which is not the ‘broadest reasonable interpretation’—it nonetheless would have been obvious to modify Iikuma to include that structure in view of Stridsberg.” Pet. 56–57; *see id.* at 57–61 (citations omitted). Patent Owner does not present arguments addressing the limitations of claim 12, nor does Patent Owner propose a narrow construction of “retaining member.” *See* Pet. 5–11, 21.

In any event, for purposes of this Decision and based on this record, we are persuaded by Petitioner’s additional citations to Ikuma, Stridesberg, and Petitioner’s declarant testimony (Ex. 1024) that Stridesberg also teaches “the stator segments are held in a toroidal shape by a retaining member,” based on Stridesberg’s outer ring 1201 retaining poles 1207. *See* Pet. 57–58 (reproducing Ex. 1017, Figs 12a and 12b with annotations; Ex. 1001, Fig. 10 with annotations; quoting Ex. 1017, 7, 14–16; comparing Ex. 1001, with Ex. 1017).

For purposes of this Decision and based on Petitioner’s citations to specific prior art disclosures and supporting evidence, we are persuaded Petitioner sets forth sufficient articulated reasoning with rational underpinning to support the conclusion that it would have been obvious to one with ordinary skill in the art to modify the teachings of Ikuma and Nakahara to include Stridesberg’s outer ring in order to reduce magnetic losses by causing the stator segments to align more precisely. *See* Pet. 59–

60 (citing Ex. 1024 ¶¶ 141–144; Ex. 1017, 14–15); *KSR*, 550 U.S. at 418 (quoting *Kahn*, 441 F.3d at 988).

Accordingly, for purposes of this Decision and based on the current record before us, there is a reasonable likelihood that Petitioner would prevail in showing claim 12 is unpatentable over Ikuma, Nakahara, and Stridesberg.

*D. Discretion to Deny “Redundant” Grounds*

Patent Owner contends that we should exercise our discretion to limit the grounds at issue in this case. *See* Prelim. Resp. 22–29. Patent Owner argues that “Petitioner[] challenge[s] claim[s] 10 of the ’952 Patent on five grounds across two petitions, claims 11 and 12 on four grounds across two petitions with overlapping and similar references.” *Id.* at 22 (citing *Liberty Mut. Ins. Co. v. Progressive Cas. Ins. Co.*, Case CBM2013-00003, 2012 WL 9494791, at \*1 (PTAB Oct. 25, 2012)). Patent Owner contends that Petitioner fails to explain the differences or relative strengths of these duplicative grounds. *See id.* at 25–29.

We have considered Patent Owner’s argument, but decline to exercise our discretion to deny institution of the grounds presented in this Petition. In determining whether to institute an *inter partes* review, the Board may “deny some or all grounds for unpatentability for some or all of the challenged claims.” *See* 37 C.F.R. § 42.108(b); *see also* 35 U.S.C. § 314(a) (authorizing, but not mandating, institution). Our discretionary determination of whether to institute review is guided by 35 U.S.C. § 325(d), which states, in relevant part, that “[i]n determining whether to institute or order a proceeding under . . . chapter 31 [applicable to *inter partes* review proceedings], the Director may take into account whether, and reject the

petition or request because, the same or substantially the same prior art or arguments previously were presented to the Office.” The statutory language gives the Director the authority not to institute review on the basis that the same or substantially the same prior art or arguments were presented previously to the Office, but does not require that result.

Here, we do not exercise our discretion to deny the Petition under § 325(d). As discussed above, Petitioner has shown a reasonable likelihood that it will prevail in showing unpatentability on most asserted grounds in this Petition. Nakahara, Ikuma, and Sheeran were not considered during prosecution of the '952 Patent. *See* Ex. 1001, (56). Additionally, the primary references applied here—Nakahara, Sheeran, and Ikuma—are not at issue as primary references in IPR2017-01631, which was filed concurrently with this Petition. Thus, we are not persuaded that the analysis in this Petition is substantially the same as that presented previously to the Office, either during prosecution or in IPR2017-01631. Although we are mindful of the burden on Patent Owner and the Office in hearing two challenges to the '952 Patent, based on the particular facts of these Petitions, we determine that conducting trial in this case and in IPR2017-01631 does not implicate the policy considerations reflected in 35 U.S.C. §§ 315(d), 325(d), or 315(e)(1), and does not persuade us to exercise discretion to deny institution in either proceeding. *See* Prelim. Resp. 24–32. Furthermore, the Board retains discretion to coordinate multiple proceedings where it deems it appropriate. *See* 35 U.S.C. § 315(d).

Patent Owner also argues that Petitioner here and the petitioner in IPR2017-01631 have collectively exceeded the word limit for petitions (*see* 37 C.F.R. § 42.24(a)(1)(i)) and therefore “must now convince the Board that



exceeding the word limit is in the interests of justice.” Prelim. Resp. 29–31. We do not agree that two different petitioners submitting two different petitions are collectively subject to the same word limit, and Patent Owner does not cite any persuasive authority supporting its word limit theory. We, therefore, decline to apply the word limit in the manner suggested by Patent Owner.

### III. CONCLUSION

For the foregoing reasons, we determine Petitioner has demonstrated a reasonable likelihood it would prevail in establishing the unpatentability of claims 10–12 of the ’952 Patent. At this stage of the proceeding, we have not made a final determination as to the patentability of any challenged claim or as to the construction of any claim term.

### IV. ORDER

Accordingly, it is

ORDERED that, pursuant to 35 U.S.C. § 314(a), an *inter partes* review of the ’952 Patent is hereby instituted on the following asserted grounds:

Claim 10 under 35 U.S.C. § 103 as unpatentable over Nakahara and Ishihara;

Claims 10 and 12 under 35 U.S.C. § 103 as unpatentable over Sheeran and Nakahara;

Claim 11 under 35 U.S.C. § 103 as unpatentable over Sheeran, Nakahara, and Lien;

Claim 10 under 35 U.S.C. § 103 as unpatentable over Ikuma and Nakahara;

Case IPR2017-01497  
Patent 7,067,952 B2

Claim 11 under 35 U.S.C. § 103 as unpatentable over Ikuma, Nakahara, and Lieu; and

Claim 12 under 35 U.S.C. § 103 as unpatentable over Ikuma, Nakahara, and Stridesberg;

FURTHER ORDERED that the trial is limited to the grounds identified above, and no other grounds are authorized; and

FURTHER ORDERED that pursuant to 35 U.S.C. § 314(c) and 37 C.F.R. § 42.4, notice is given hereby of the institution of a trial, the trial commencing on the entry date of this Decision.

Case IPR2017-01497

Patent 7,067,952 B2

PETITIONER:

Joshua L. Goldberg

James R. Barney

Thomas W. Winland

Tyler M. Akagi

FINNEGAN, HENDERSON, FARABOW, GARRETT & DUNNER, L.L.P.

[joshua.goldberg@finnegan.com](mailto:joshua.goldberg@finnegan.com)

[james.barney@finnegan.com](mailto:james.barney@finnegan.com)

[tom.winland@finnegan.com](mailto:tom.winland@finnegan.com)

[tyler.akagi@finnegan.com](mailto:tyler.akagi@finnegan.com)

Paul R. Steadman

Matthew D. Satchwell

DLA PIPER LLP (US)

[paul.steadman@dlapiper.com](mailto:paul.steadman@dlapiper.com)

[matthew.satchwell@dlapiper.com](mailto:matthew.satchwell@dlapiper.com)

PATENT OWNER:

William Meunier

Michael T. Renaud

Daniel B. Weinger

Serge Subach

Brad M. Scheller

MINTZ, LEVIN, COHEN, FERRIS, GLOVSKY AND POPEO, P.C.

[wameunier@mintz.com](mailto:wameunier@mintz.com)

[mtrenaud@mintz.com](mailto:mtrenaud@mintz.com)

[dbweinger@mintz.com](mailto:dbweinger@mintz.com)

[ssubach@mintz.com](mailto:ssubach@mintz.com)

[bmscheller@mintz.com](mailto:bmscheller@mintz.com)

Tim R. Seeley

James R. Hietala

INTELLECTUAL VENTURES

[tim@intven.com](mailto:tim@intven.com)

[jhietala@intven.com](mailto:jhietala@intven.com)