



US 20080073662A1

(19) **United States**

(12) **Patent Application Publication**

**Wang et al.**

(10) **Pub. No.: US 2008/0073662 A1**

(43) **Pub. Date: Mar. 27, 2008**

(54) **METHOD OF MANUFACTURING HIGH POWER LIGHT-EMITTING DEVICE PACKAGE AND STRUCTURE THEREOF**

(52) **U.S. Cl. .... 257/99; 438/26; 438/28; 257/100**

(76) **Inventors:** **Bily Wang**, Hsin Chu City (TW); **Jonnie Chuang**, Pan Chiao City (TW); **Shih-Yu Wu**, Pan Chiao City (TW)

(57) **ABSTRACT**

A method of manufacturing high power light-emitting device packages and structure thereof, wherein the method thereof includes the steps of: (a) forming a plurality of lead frames, each of the lead frames includes a heat-dissipating element and a plurality of leads; (b) electroplating an outer surface of the lead frames each; (c) coating conductive gel on a surface of the heat-dissipating element each; (d) arranging at least one light-emitting chip on the conductive gel; (e) forming an encapsulant on each of the lead frames; (f) connecting at least one top electrode of the light-emitting chip with one of the leads; (g) coating silicon gel for covering the at one light-emitting chip, and forming integrally a focusing light convex surface on a top surface of the silicon gel; and (h) cutting off the tie-bars to separate the lead frames from one another, whereby forming a plurality of high power light-emitting device packages.

Correspondence Address:  
**ROSENBERG, KLEIN & LEE**  
**3458 ELLICOTT CENTER DRIVE-SUITE 101**  
**ELLICOTT CITY, MD 21043**

(21) **Appl. No.: 11/524,462**

(22) **Filed: Sep. 21, 2006**

**Publication Classification**

(51) **Int. Cl.**  
**H01L 33/00** (2006.01)  
**H01L 21/50** (2006.01)

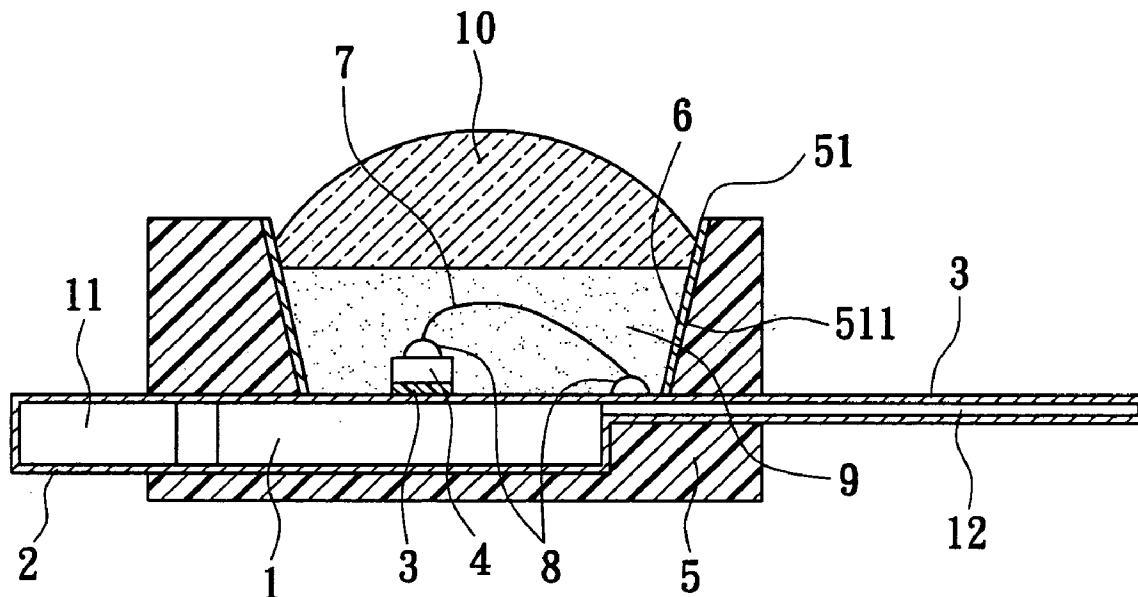

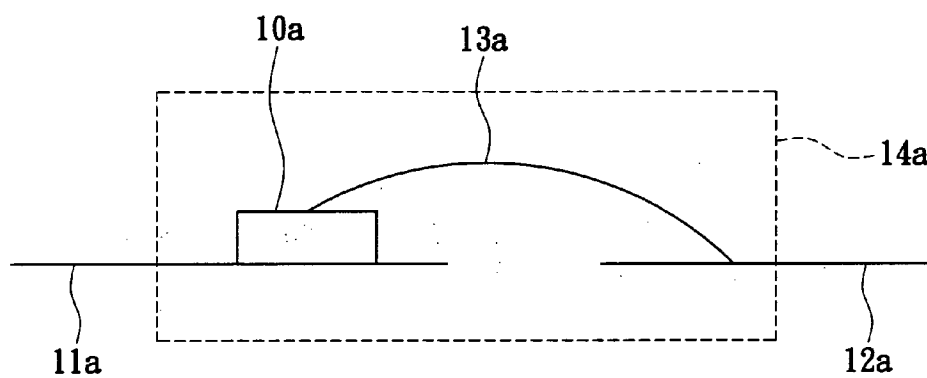

FIG. 1  
PRIOR ART

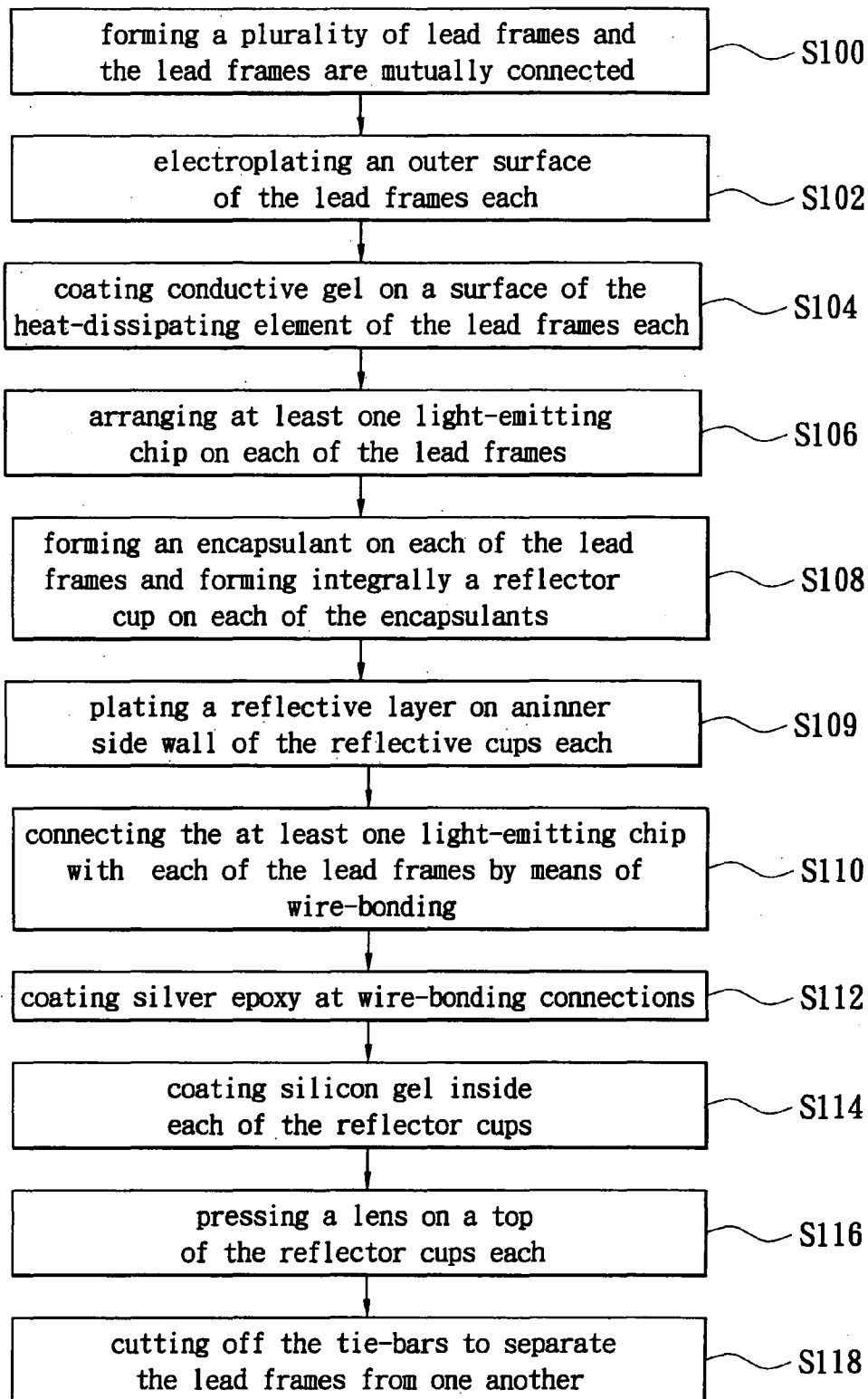

FIG. 2

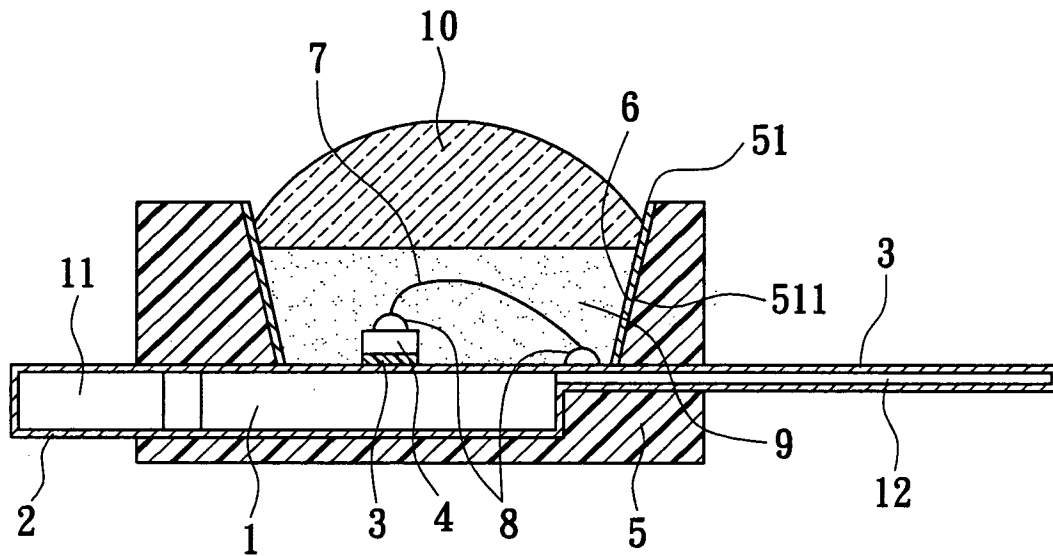

FIG. 3

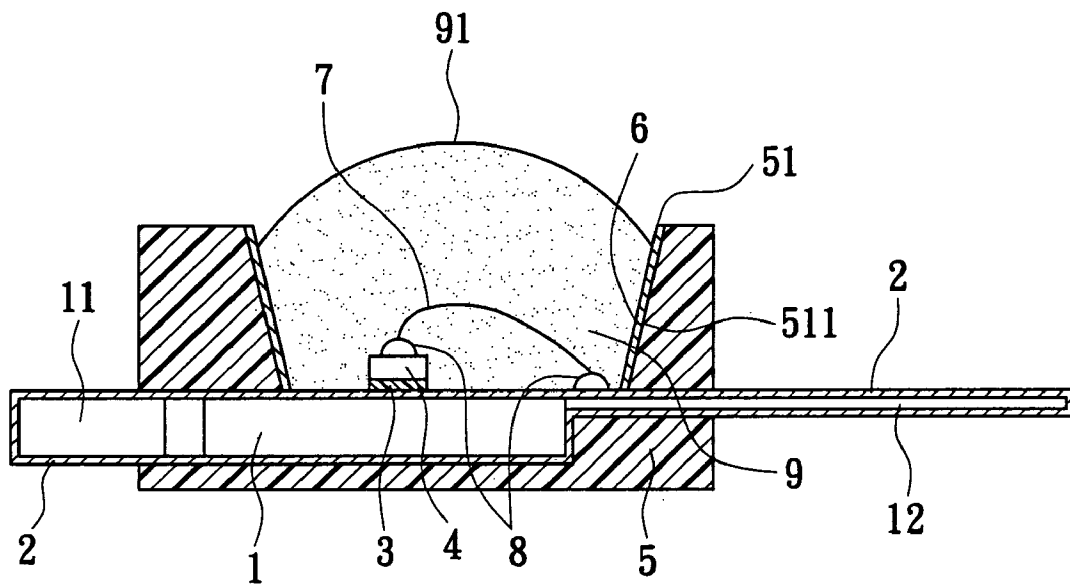

FIG. 4

# Explore Litigation Insights

Docket Alarm provides insights to develop a more informed litigation strategy and the peace of mind of knowing you're on top of things.

## Real-Time Litigation Alerts



Keep your litigation team up-to-date with **real-time alerts** and advanced team management tools built for the enterprise, all while greatly reducing PACER spend.

Our comprehensive service means we can handle Federal, State, and Administrative courts across the country.

## Advanced Docket Research



With over 230 million records, Docket Alarm's cloud-native docket research platform finds what other services can't. Coverage includes Federal, State, plus PTAB, TTAB, ITC and NLRB decisions, all in one place.

Identify arguments that have been successful in the past with full text, pinpoint searching. Link to case law cited within any court document via Fastcase.

## Analytics At Your Fingertips



Learn what happened the last time a particular judge, opposing counsel or company faced cases similar to yours.

Advanced out-of-the-box PTAB and TTAB analytics are always at your fingertips.

## API

Docket Alarm offers a powerful API (application programming interface) to developers that want to integrate case filings into their apps.

## LAW FIRMS

Build custom dashboards for your attorneys and clients with live data direct from the court.

Automate many repetitive legal tasks like conflict checks, document management, and marketing.

## FINANCIAL INSTITUTIONS

Litigation and bankruptcy checks for companies and debtors.

## E-DISCOVERY AND LEGAL VENDORS

Sync your system to PACER to automate legal marketing.