



(19) **United States**

(12) **Patent Application Publication** (10) **Pub. No.: US 2007/0126020 A1**

Lin et al.

(43) **Pub. Date: Jun. 7, 2007**

(54) **HIGH-POWER LED CHIP PACKAGING STRUCTURE AND FABRICATION METHOD THEREOF**

(57) **ABSTRACT**

(76) Inventors: **Cheng Lin**, Zhonghe City (TW);
Hua-Hsin Su, Ping-Chen City (TW);
Masami Nei, Zhonghe City (TW)

Correspondence Address:
LIN & ASSOCIATES INTELLECTUAL PROPERTY
P.O. BOX 2339
SARATOGA, CA 95070-0339 (US)

A packaging structure and a related fabrication method for high-power LED chip are provided herein, which mainly contains a base made of a metallic material and an electrically insulating material integrated into a single object. The metallic material forms a heat sinking seat in the middle of the base, which is exposed from the top surface of the base, and from the bottom surface or a side surface of the base. The metallic material also forms a plurality of electrodes surrounding the heat sinking seat, which are exposed from the top surface of the base, and from the bottom surface or a side surface of the base, respectively. The electrically insulating material is interposed between the electrodes and the heat sinking seat so that they are adhere together, and so that the heat sinking seat and any one of the electrodes, and any two electrodes are electrically insulated. The packaging structure achieves superior heat dissipation efficiency by separating the electricity and heat dissipation channels and, in another way, is applicable in mass production for a significantly reduced production cost.

(21) Appl. No.: **11/294,135**

(22) Filed: **Dec. 3, 2005**

Publication Classification

(51) **Int. Cl.**
H01L 33/00 (2006.01)

(52) **U.S. Cl.** **257/100**

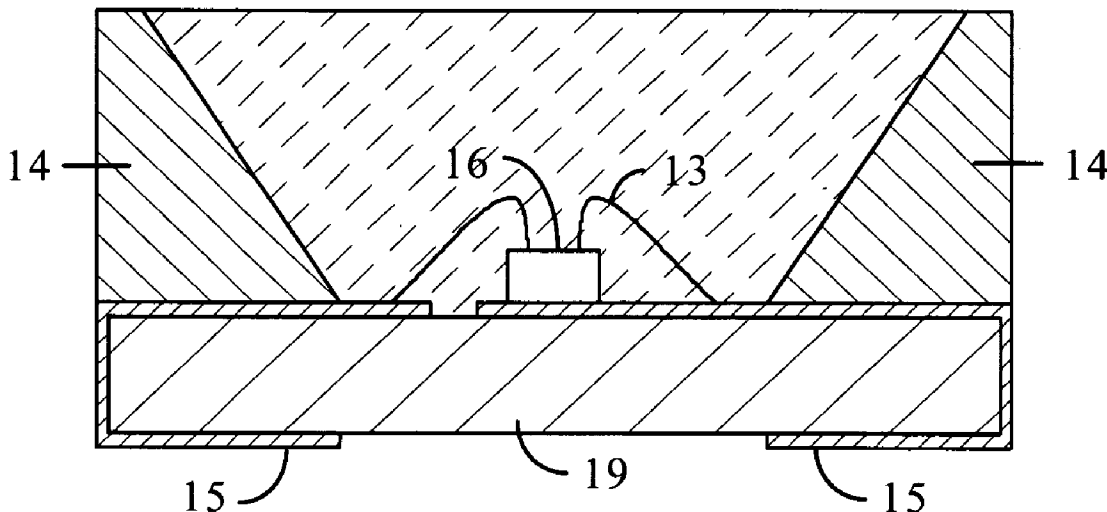

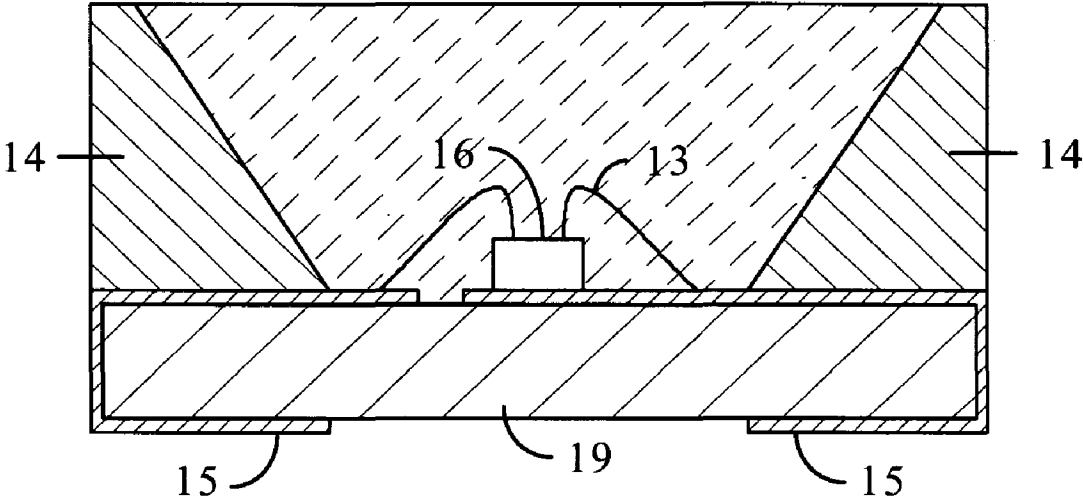

FIG. 1a

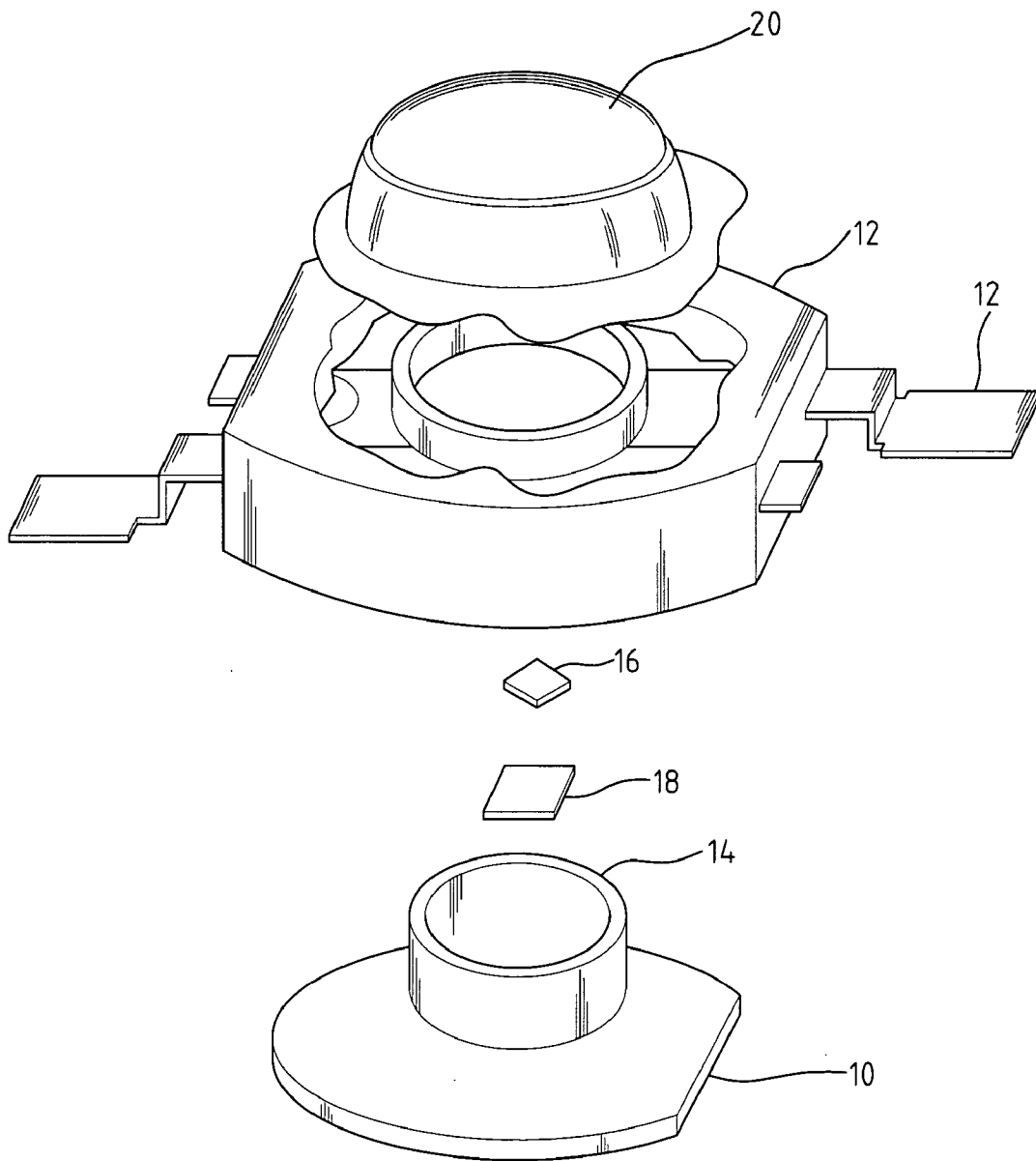

FIG. 1b

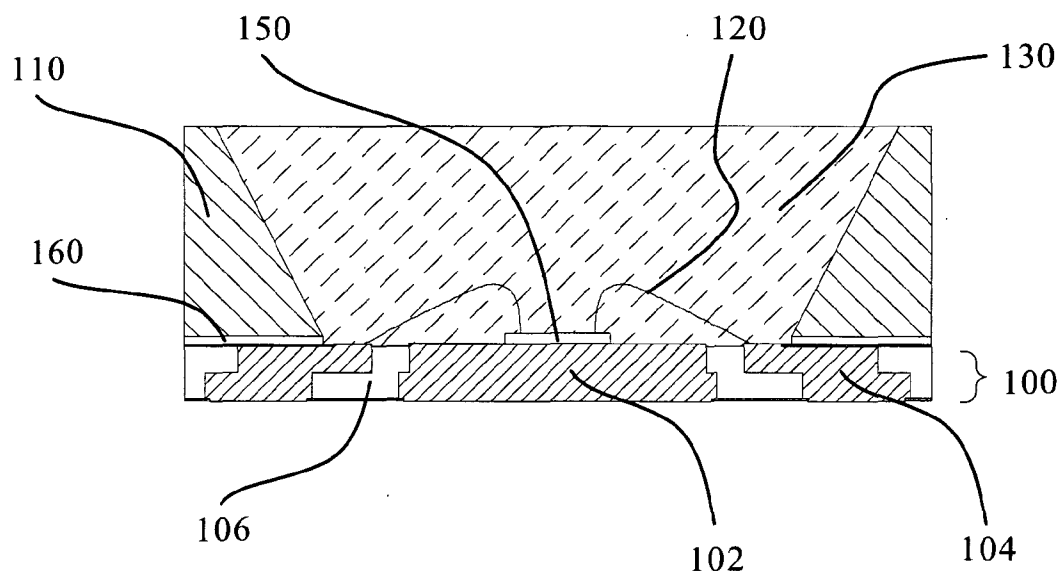

FIG. 2a

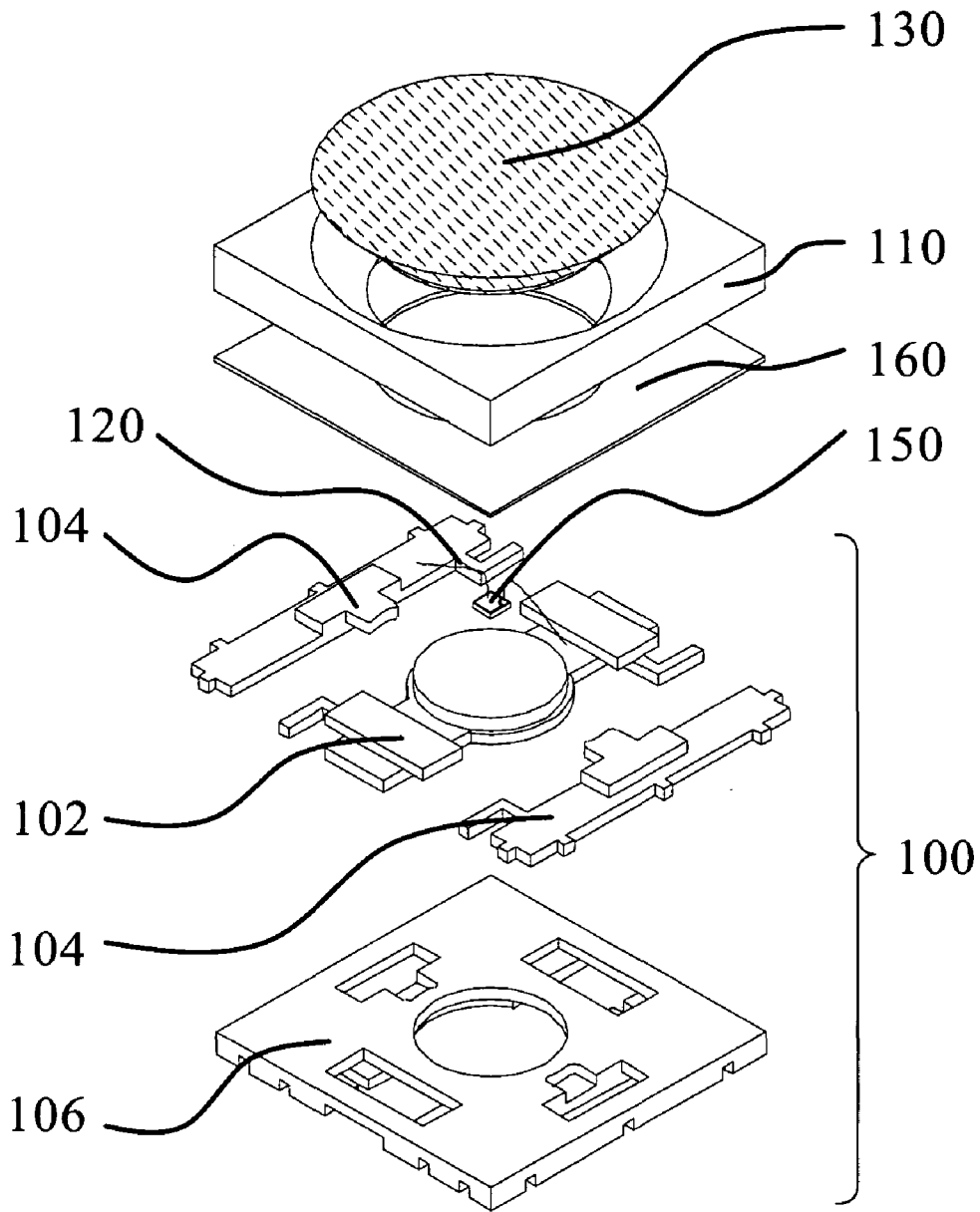

FIG. 2b

Explore Litigation Insights

Docket Alarm provides insights to develop a more informed litigation strategy and the peace of mind of knowing you're on top of things.

Real-Time Litigation Alerts



Keep your litigation team up-to-date with **real-time alerts** and advanced team management tools built for the enterprise, all while greatly reducing PACER spend.

Our comprehensive service means we can handle Federal, State, and Administrative courts across the country.

Advanced Docket Research



With over 230 million records, Docket Alarm's cloud-native docket research platform finds what other services can't. Coverage includes Federal, State, plus PTAB, TTAB, ITC and NLRB decisions, all in one place.

Identify arguments that have been successful in the past with full text, pinpoint searching. Link to case law cited within any court document via Fastcase.

Analytics At Your Fingertips



Learn what happened the last time a particular judge, opposing counsel or company faced cases similar to yours.

Advanced out-of-the-box PTAB and TTAB analytics are always at your fingertips.

API

Docket Alarm offers a powerful API (application programming interface) to developers that want to integrate case filings into their apps.

LAW FIRMS

Build custom dashboards for your attorneys and clients with live data direct from the court.

Automate many repetitive legal tasks like conflict checks, document management, and marketing.

FINANCIAL INSTITUTIONS

Litigation and bankruptcy checks for companies and debtors.

E-DISCOVERY AND LEGAL VENDORS

Sync your system to PACER to automate legal marketing.