



US 20080261339A1

(19) **United States**

(12) **Patent Application Publication**
KOUNG et al.

(10) **Pub. No.: US 2008/0261339 A1**

(43) **Pub. Date: Oct. 23, 2008**

(54) **PACKAGING METHOD TO MANUFACTURE PACKAGE FOR A HIGH-POWER LIGHT EMITTING DIODE**

Publication Classification

(51) **Int. Cl.**
H01L 21/60 (2006.01)
(52) **U.S. Cl.** 438/27; 257/E31.117; 257/E21.512

(76) **Inventors:** Chia-Yin KOUNG, Xindian City (TW); Wen LIN, Fuzhou City (CN)

(57) **ABSTRACT**

Correspondence Address:
PATENTTM.US
P. O. BOX 82788
PORTLAND, OR 97282-0788 (US)

A packaging method to manufacture a package for a high-power light emitting diode (LED) has steps of (a) obtaining a metal board, (b) treating the metal board, (c) molding a cell matrix with multiple reflective bases, (d) attaching LED chips onto the dissipating boards and bonding conductive wires in each corresponding reflective base of the cell matrix, (e) encapsulating the LED chips and conductive wires in the reflective base of the cell matrix to form an after-packaging board and (f) cutting off the after-packaging board to form multiple individual high-power LED packages. Most heat from the LED chips is conducted via the dissipating board thereby improving thermal conduction efficiency and allowing more powerful and numerous LED chips to operate per package so increasing applications of LEDs. Therefore, the present invention provides different pass ways for conducting heat and electricity to improve heat conduction of the LED.

(21) **Appl. No.: 12/062,406**

(22) **Filed: Apr. 3, 2008**

(30) **Foreign Application Priority Data**

Apr. 17, 2007 (TW) 096113537

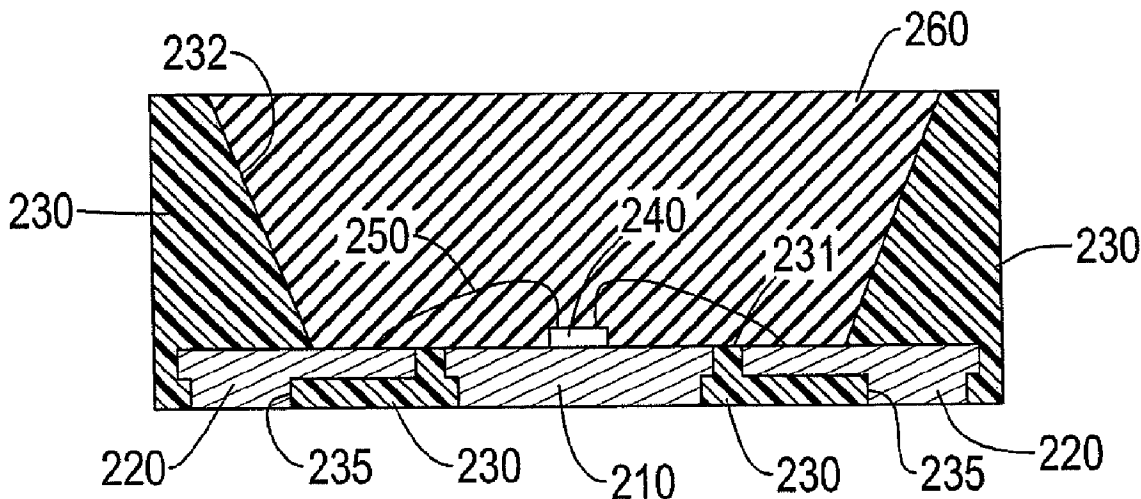

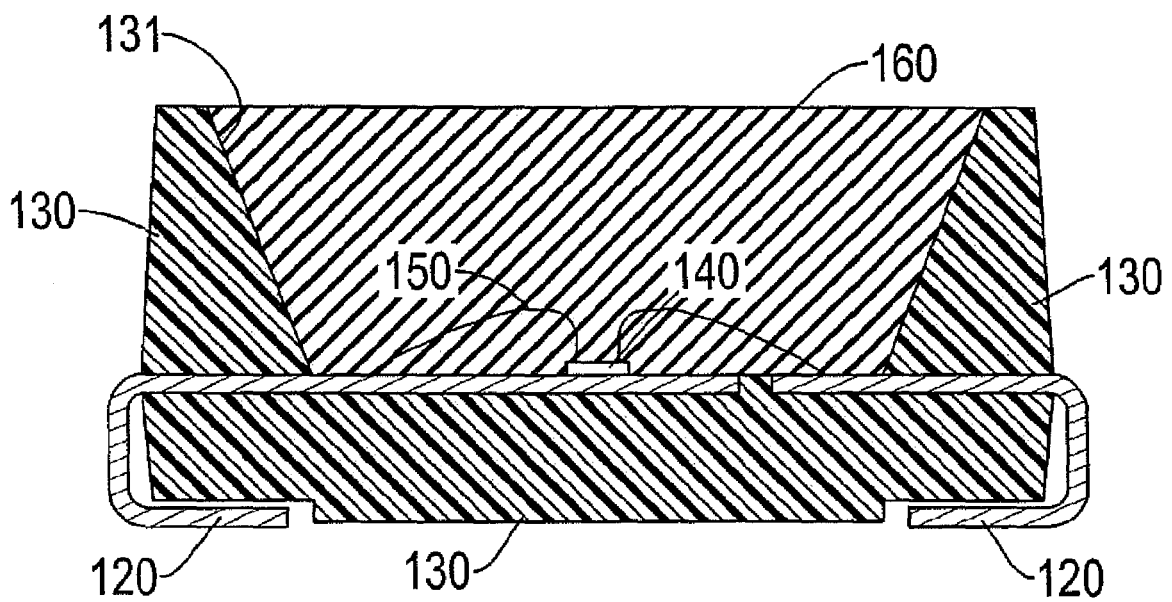

FIG.1
PRIOR ART

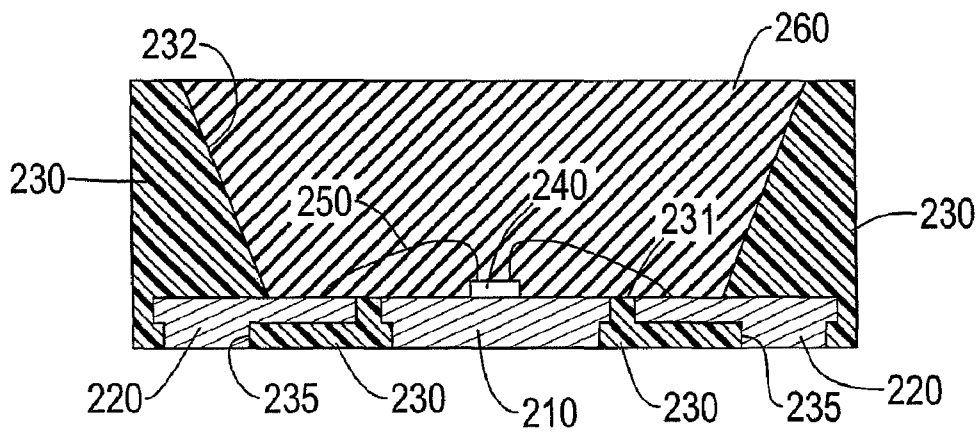

FIG.2A

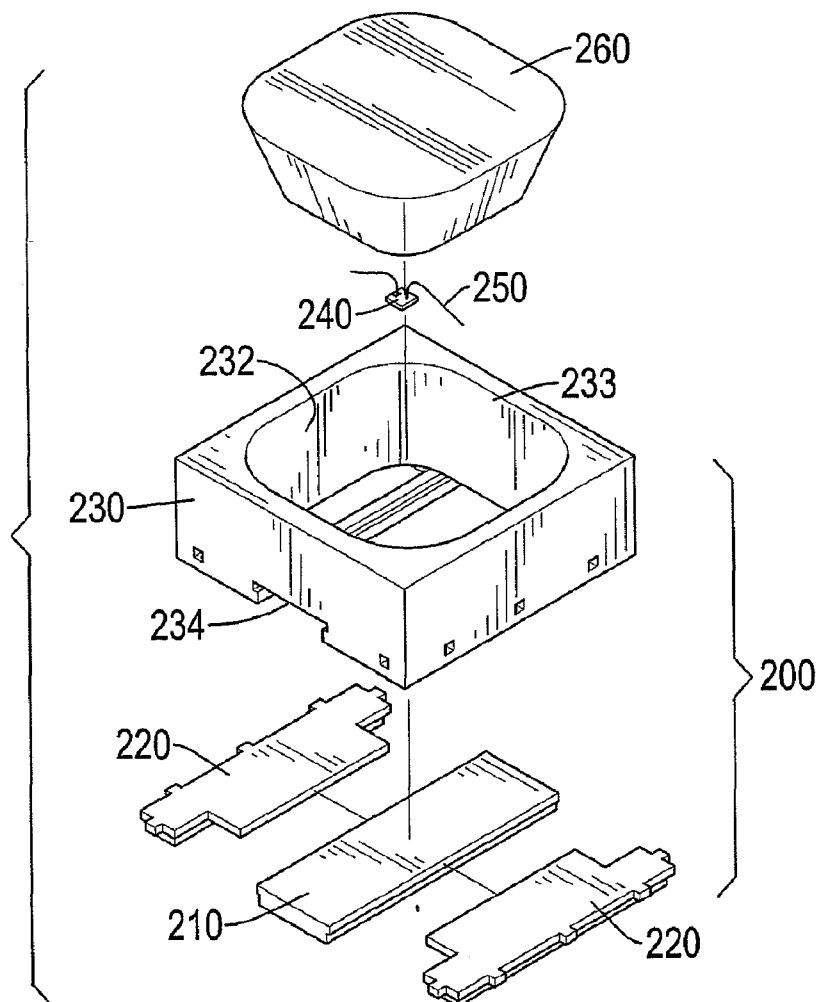

FIG.2B

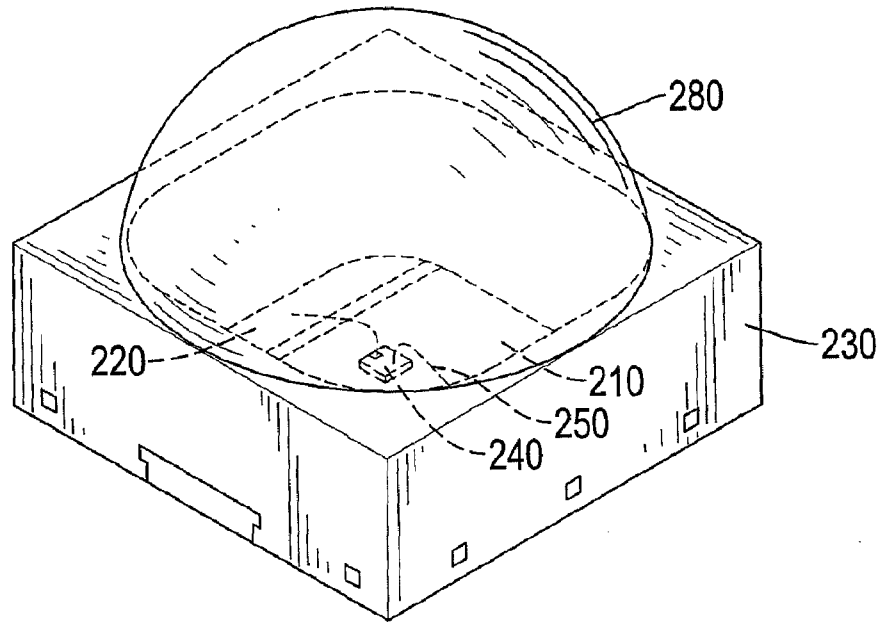

FIG. 2C

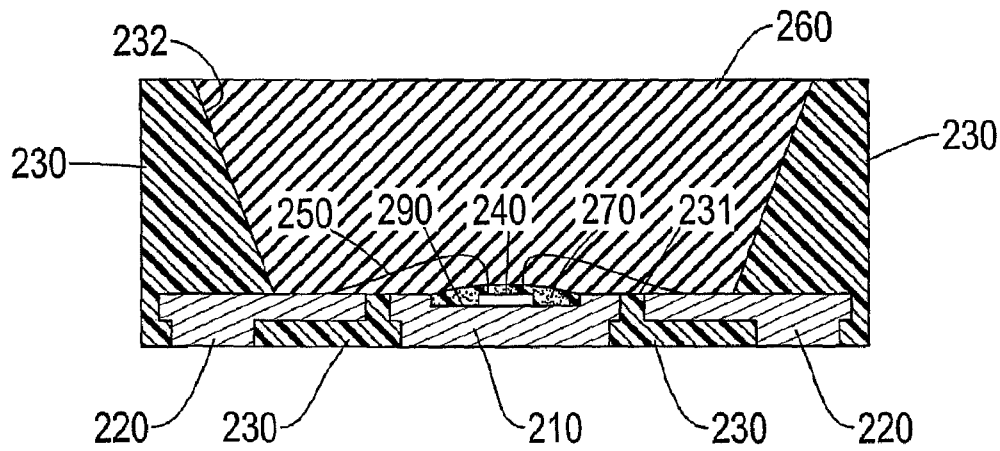

FIG. 2D

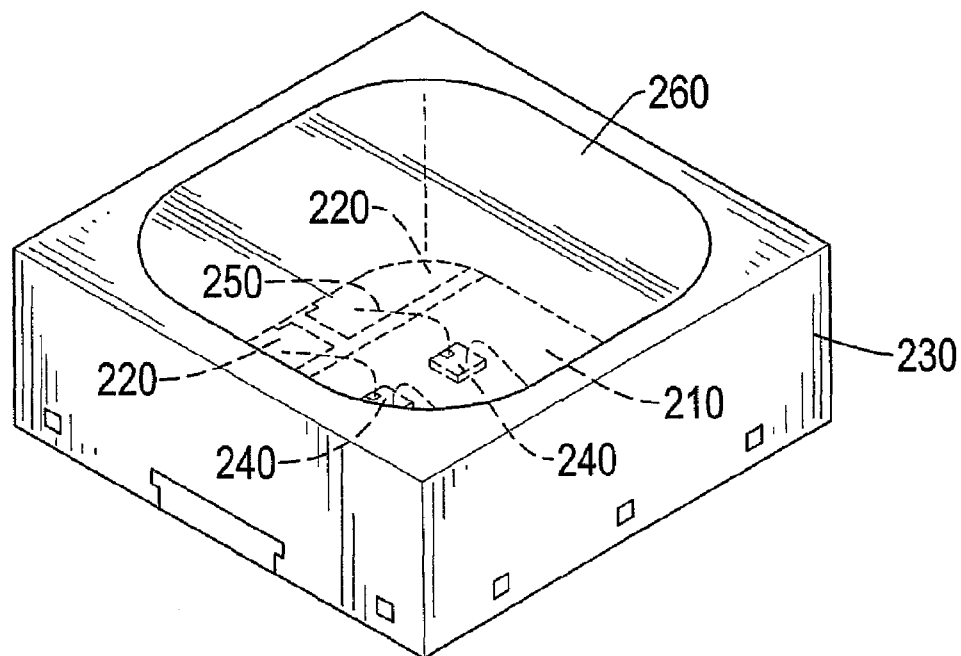

FIG. 3A

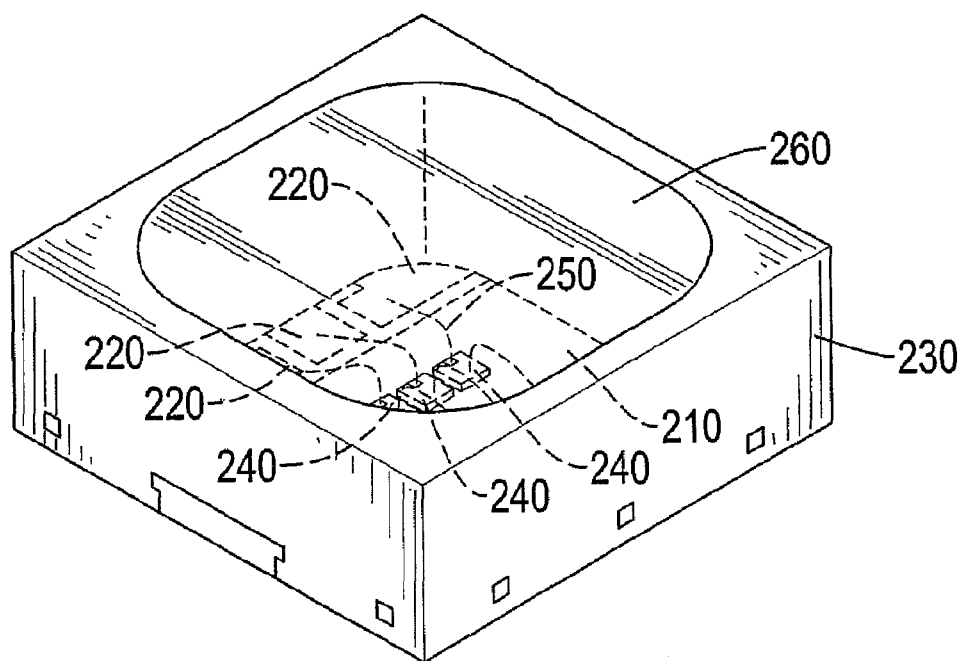

FIG. 3B

Explore Litigation Insights

Docket Alarm provides insights to develop a more informed litigation strategy and the peace of mind of knowing you're on top of things.

Real-Time Litigation Alerts



Keep your litigation team up-to-date with **real-time alerts** and advanced team management tools built for the enterprise, all while greatly reducing PACER spend.

Our comprehensive service means we can handle Federal, State, and Administrative courts across the country.

Advanced Docket Research



With over 230 million records, Docket Alarm's cloud-native docket research platform finds what other services can't. Coverage includes Federal, State, plus PTAB, TTAB, ITC and NLRB decisions, all in one place.

Identify arguments that have been successful in the past with full text, pinpoint searching. Link to case law cited within any court document via Fastcase.

Analytics At Your Fingertips



Learn what happened the last time a particular judge, opposing counsel or company faced cases similar to yours.

Advanced out-of-the-box PTAB and TTAB analytics are always at your fingertips.

API

Docket Alarm offers a powerful API (application programming interface) to developers that want to integrate case filings into their apps.

LAW FIRMS

Build custom dashboards for your attorneys and clients with live data direct from the court.

Automate many repetitive legal tasks like conflict checks, document management, and marketing.

FINANCIAL INSTITUTIONS

Litigation and bankruptcy checks for companies and debtors.

E-DISCOVERY AND LEGAL VENDORS

Sync your system to PACER to automate legal marketing.