

United States Patent [19]

[11] **Patent Number:** **5,474,083**

Church et al.

[45] **Date of Patent:** **Dec. 12, 1995**

[54] **LIFTING MONITORING AND EXERCISE TRAINING SYSTEM**

4,667,513 5/1987 Konno 128/774
4,667,685 5/1987 Fine 128/782

[75] Inventors: **John Church**, Miami; **William R. Hassel**, Davie; **Fred Naghdi**, Boca Raton, all of Fla.

Primary Examiner—Kyle L. Howell
Assistant Examiner—John P. Lacyk
Attorney, Agent, or Firm—Kinney & Lange

[73] Assignee: **Empi, Inc.**, St. Paul, Minn.

[57] **ABSTRACT**

[21] Appl. No.: **152,082**

The invention is directed to a microprocessor based system utilizing electromyographic sensor to monitor muscle force for lift training and exercise training. In the lift training embodiment the electrodes of the electromyographic sensor are secured to a belt so that they are located adjacent to the lower back of the user when wearing the belt. The lift training embodiment is also provided with a goniometer to measure lifting angle during training, which together with muscle force generated by the lower back is compared in the microprocessor to a programmed lifting parameters and if these parameters are exceeded the user is warned by and audible indicator. The lift trainer embodiment also periodically measures interelectrode impedance to insure actual usage. The exercise training embodiment has a bar graph display displaying muscle intensity and two light emitting diodes alerting a user when to contract or relax a monitored muscle group. The microprocessor is programmed with a exercise routine and alerts a user when the routine is to begin, the duration of muscle contraction and relaxation, and the repetitions required. During exercise the user can monitor muscle intensity from the bar graph display and or auditory feedback element. An alternate lift training systems comprises a belt mounted goniometer which is operatively coupled to a microprocessor having an electronic memory for time logging a lifting session. To insure actual usage the belt is also provided with temperature and/or motion sensors.

[22] Filed: **Nov. 15, 1993**

Related U.S. Application Data

[63] Continuation of Ser. No. 657,954, Feb. 21, 1991, abandoned, which is a continuation of Ser. No. 319,850, Mar. 6, 1989, abandoned, which is a continuation of Ser. No. 938,830, Dec. 8, 1986, abandoned.

[51] **Int. Cl.⁶** **A61B 5/04**
[52] **U.S. Cl.** **128/733; 128/782**
[58] **Field of Search** 128/733, 736,
128/774, 775, 781, 782; 340/573; 33/571,
512; 73/865.1

[56] **References Cited**

U.S. PATENT DOCUMENTS

3,875,929	3/1975	Grant	340/573
3,991,745	11/1976	Yoslow et al.	33/512
4,108,164	8/1978	Hall, Sr.	33/512
4,331,161	5/1982	Patel	128/736
4,367,752	1/1983	Jimenez et al.	128/782
4,399,824	8/1983	Davidson	128/736
4,418,337	11/1983	Bader	340/573
4,450,437	5/1984	Ho	340/573
4,655,227	4/1987	Gracovetsky	128/781
4,665,928	5/1987	Linial et al.	128/782

18 Claims, 11 Drawing Sheets

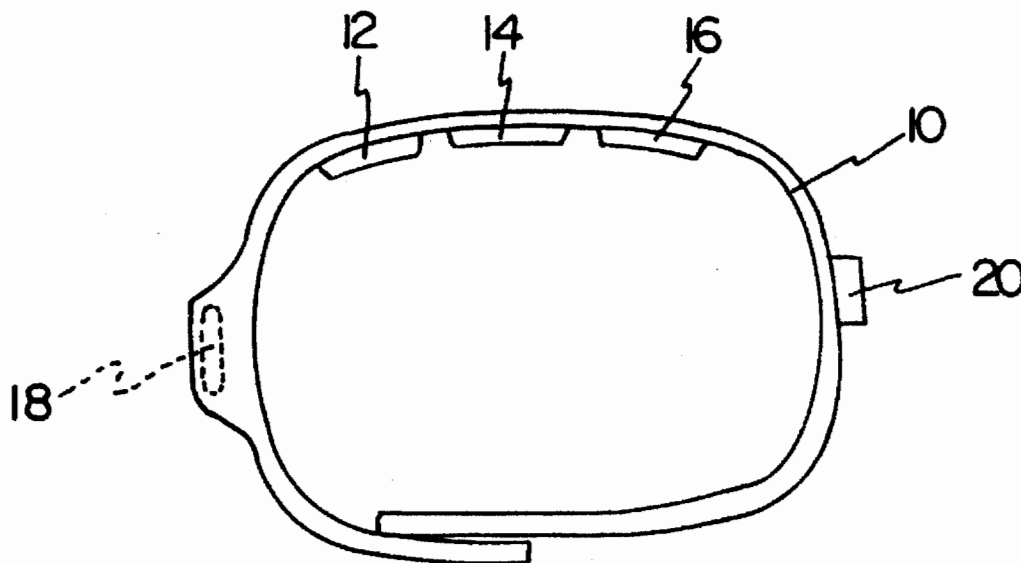

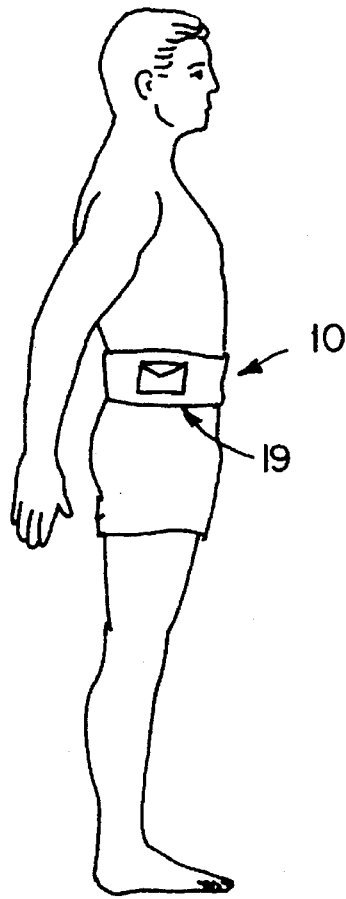

Fig. 1

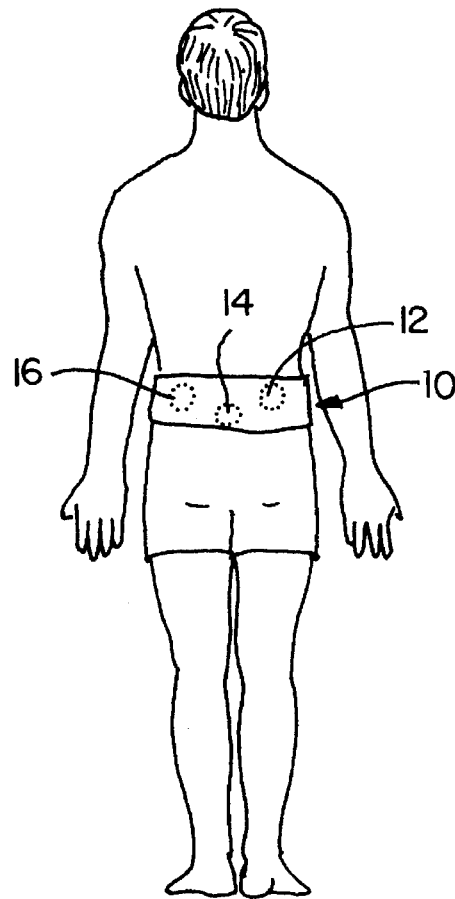

Fig. 2

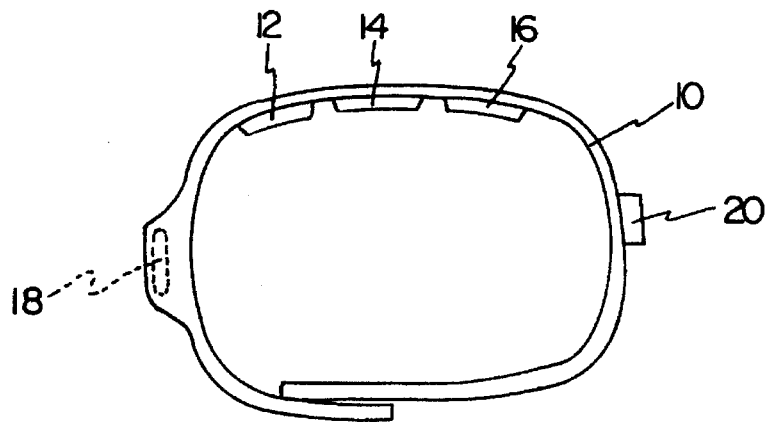

Fig. 3

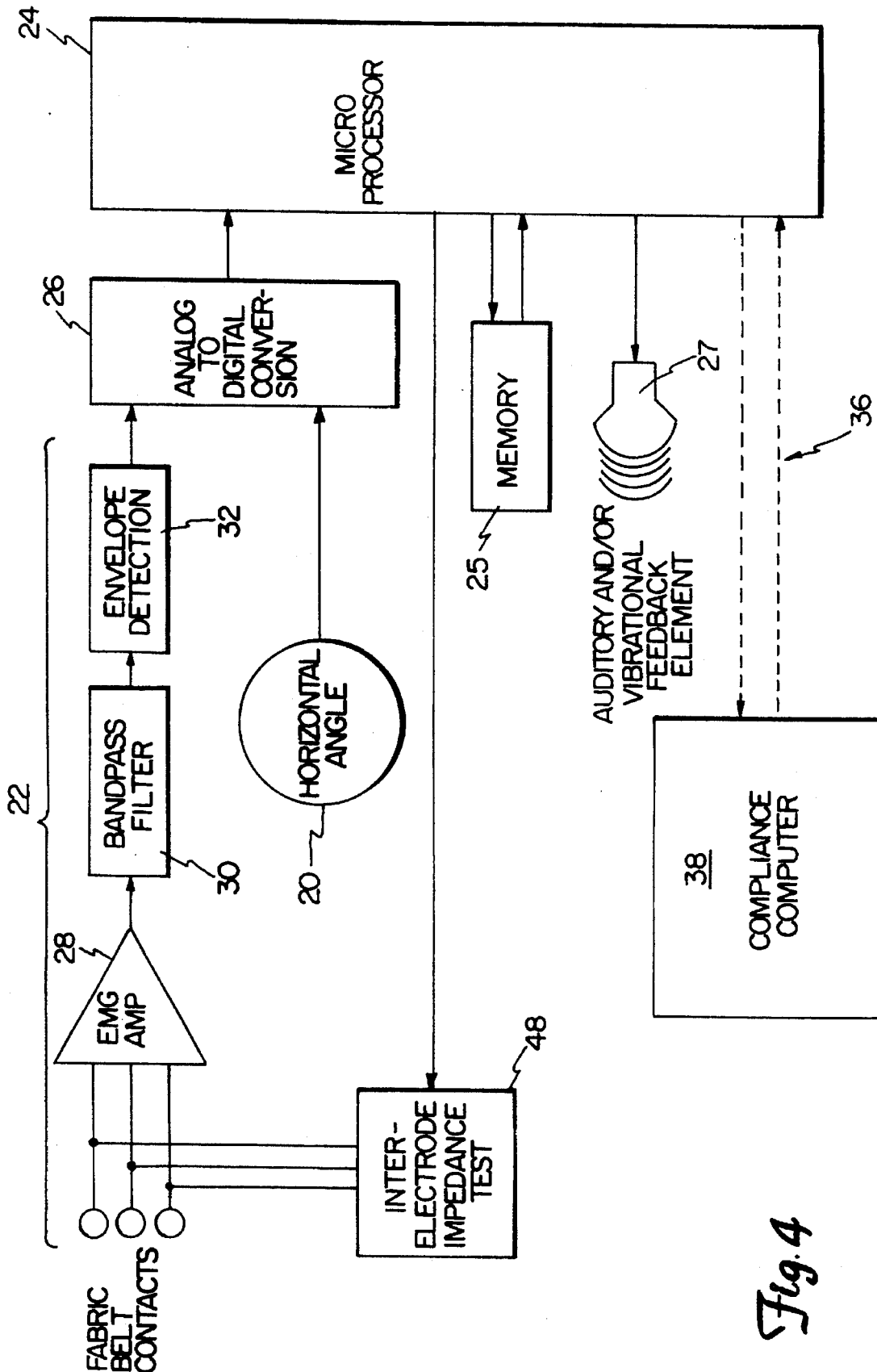

Fig. 4

Fig. 5 A

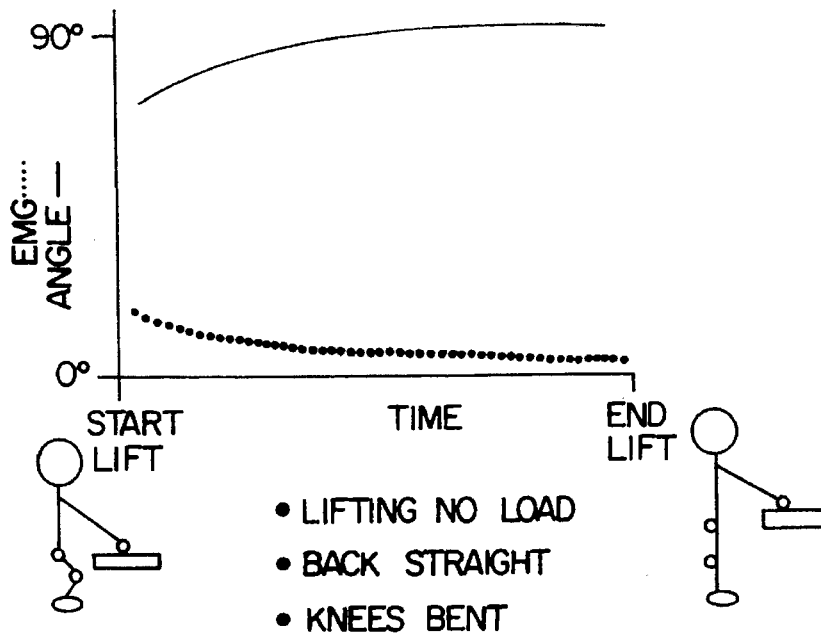
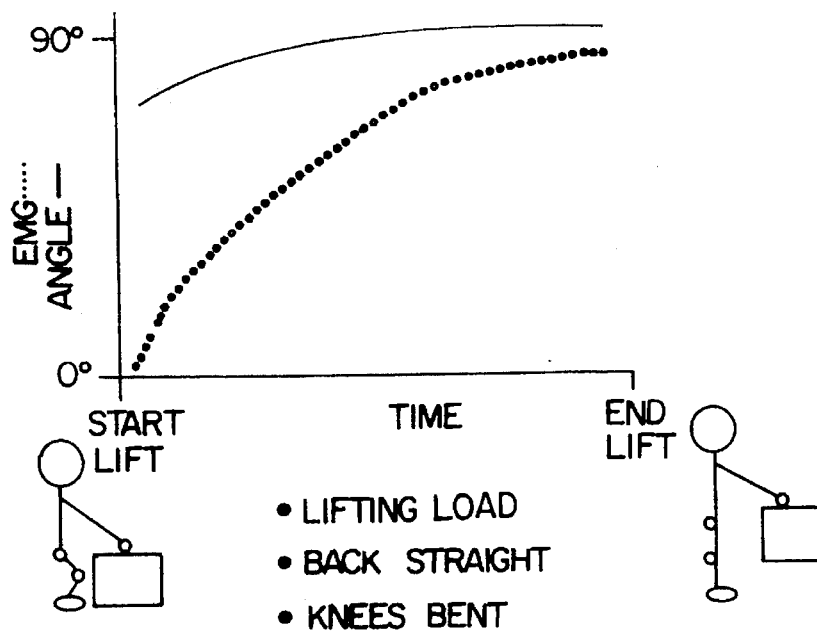

Fig. 5 B



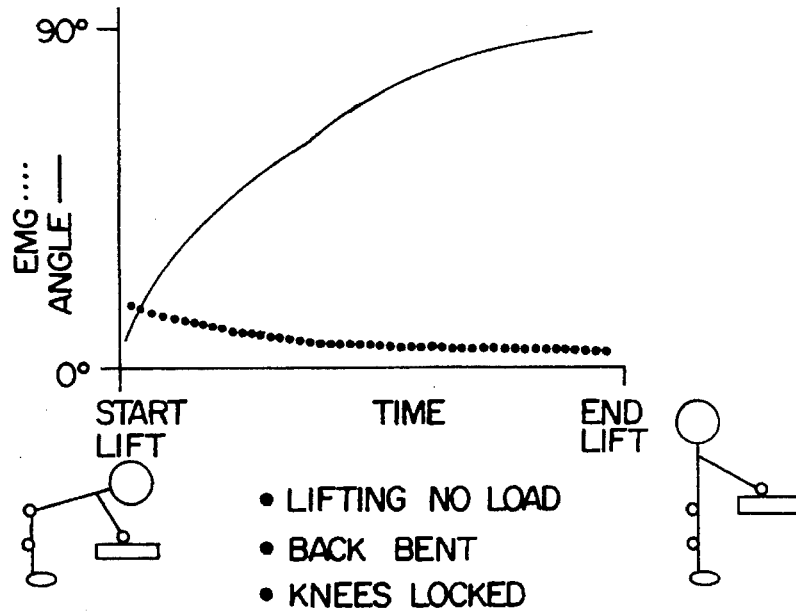

Fig. 5C

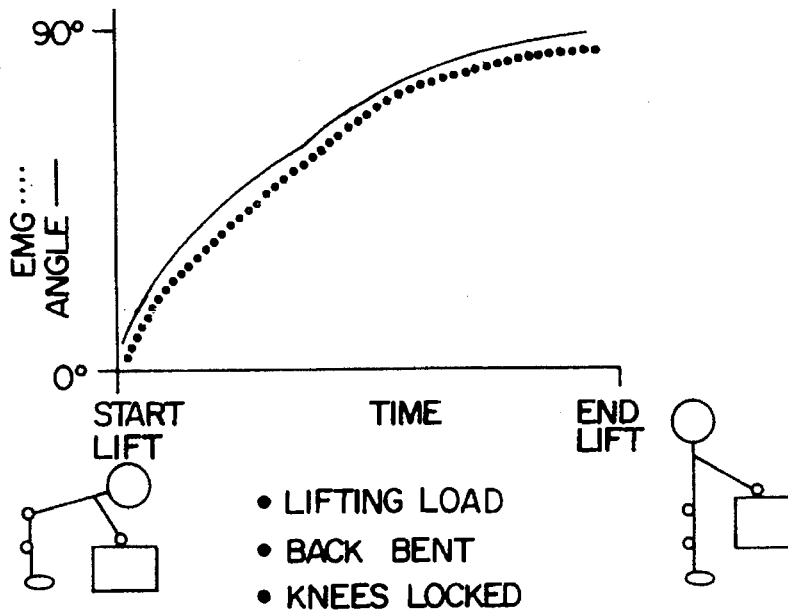

Fig. 5D

Explore Litigation Insights

Docket Alarm provides insights to develop a more informed litigation strategy and the peace of mind of knowing you're on top of things.

Real-Time Litigation Alerts



Keep your litigation team up-to-date with **real-time alerts** and advanced team management tools built for the enterprise, all while greatly reducing PACER spend.

Our comprehensive service means we can handle Federal, State, and Administrative courts across the country.

Advanced Docket Research



With over 230 million records, Docket Alarm's cloud-native docket research platform finds what other services can't. Coverage includes Federal, State, plus PTAB, TTAB, ITC and NLRB decisions, all in one place.

Identify arguments that have been successful in the past with full text, pinpoint searching. Link to case law cited within any court document via Fastcase.

Analytics At Your Fingertips



Learn what happened the last time a particular judge, opposing counsel or company faced cases similar to yours.

Advanced out-of-the-box PTAB and TTAB analytics are always at your fingertips.

API

Docket Alarm offers a powerful API (application programming interface) to developers that want to integrate case filings into their apps.

LAW FIRMS

Build custom dashboards for your attorneys and clients with live data direct from the court.

Automate many repetitive legal tasks like conflict checks, document management, and marketing.

FINANCIAL INSTITUTIONS

Litigation and bankruptcy checks for companies and debtors.

E-DISCOVERY AND LEGAL VENDORS

Sync your system to PACER to automate legal marketing.