

[54] SELF-INJURIOUS BEHAVIOR INHIBITING SYSTEM

[75] Inventors: Robert E. Fischell; Glen H. Fountain; Charles M. Blackburn, all of Silver Spring, Md.

[73] Assignee: The Johns Hopkins University, Baltimore, Md.

[21] Appl. No.: 340,753

[22] Filed: Jan. 19, 1982

[51] Int. Cl.³ A61N 1/38

[52] U.S. Cl. 128/132 R; 128/419 S

[58] Field of Search 128/419 R, 419 S, 791, 128/802, 903, 731-733, 138 A, 782, 82.1, 132 R, 774; 340/407, 573; 361/232

[56] References Cited

U.S. PATENT DOCUMENTS

3,460,123	8/1969	Bass	128/138 A
3,508,235	4/1970	Baisden	128/138 A
3,834,379	9/1974	Grant	128/419 S X
3,850,161	11/1974	Liss	128/419 S X
3,885,576	5/1975	Symmes	128/802 X
3,998,209	12/1976	MacVaugh	361/232 X
4,048,986	9/1977	Ott	128/653
4,163,449	8/1979	Regal	340/573 X
4,203,098	5/1980	Muncheryan	340/407 X
4,292,630	9/1981	Dumont	340/573
4,359,724	11/1982	Zimmerman et al.	128/733 X

FOREIGN PATENT DOCUMENTS

8101506	6/1981	Sweden	128/782
---------	--------	--------	---------

OTHER PUBLICATIONS

Friauf; "An Aversive Stimulator for Autistic Children;" *Medical and Biological Engineering*; vol. 11, No. 5, 9-1973, pp. 609-612.

Primary Examiner—Lee S. Cohen
Assistant Examiner—Angela D. Sykes
Attorney, Agent, or Firm—Robert E. Archibald;
Howard W. Califano

[57] ABSTRACT

An apparatus for preventing self-injurious behavior in patients is disclosed. The apparatus generally contains one or more sensor modules, which detect self-injurious blows, and a separate stimulation module, which produces an aversive electric stimulation. The sensor module and stimulation module are mounted directly on a patient's body members, e.g., a sensor module can be mounted on a headband worn around the patient's head and the stimulation module can be mounted on an arm band worn around the patient's arm. The sensor module communicates with the stimulation module by either: (1) transmitting radio waves, which are received by the stimulation module or (2) sending a small alternating electrical signal through the patient's body, which is detected by electrodes in the stimulation module. In operation, a sensor module detects a blow to the sensed body member and sends a signal to the stimulation module which in turn generates a controlled electrical current for aversive stimulation.

8 Claims, 5 Drawing Figures

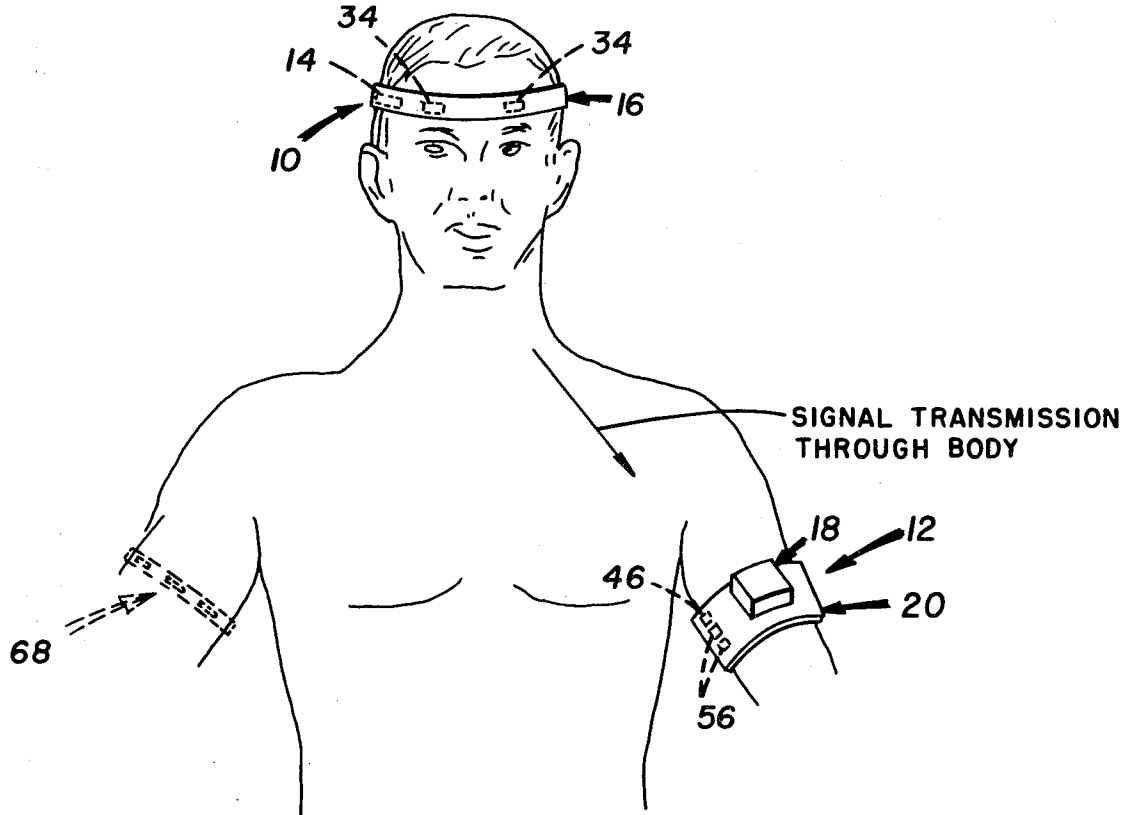

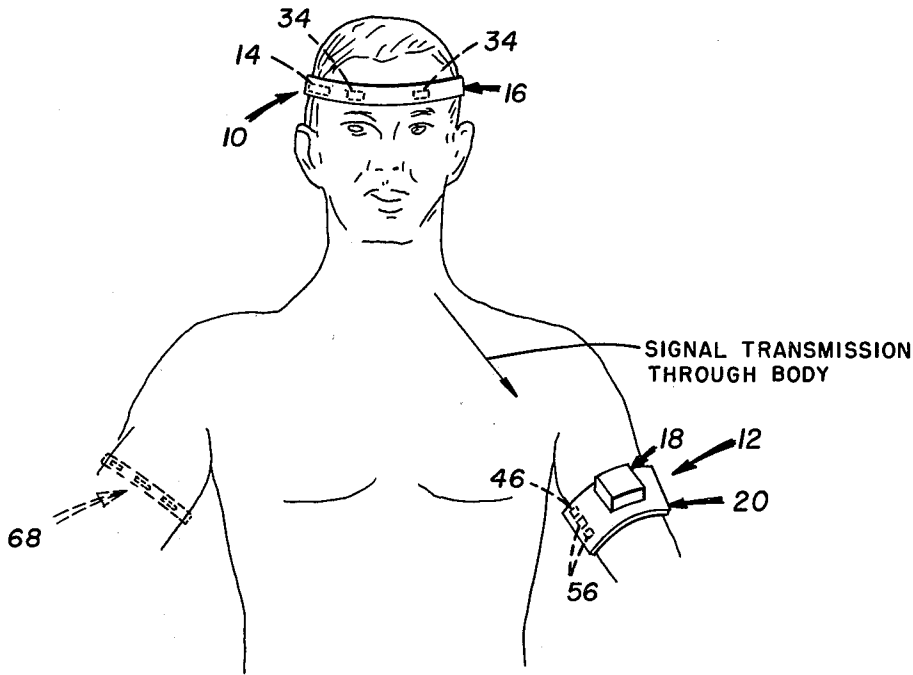

FIG. 1

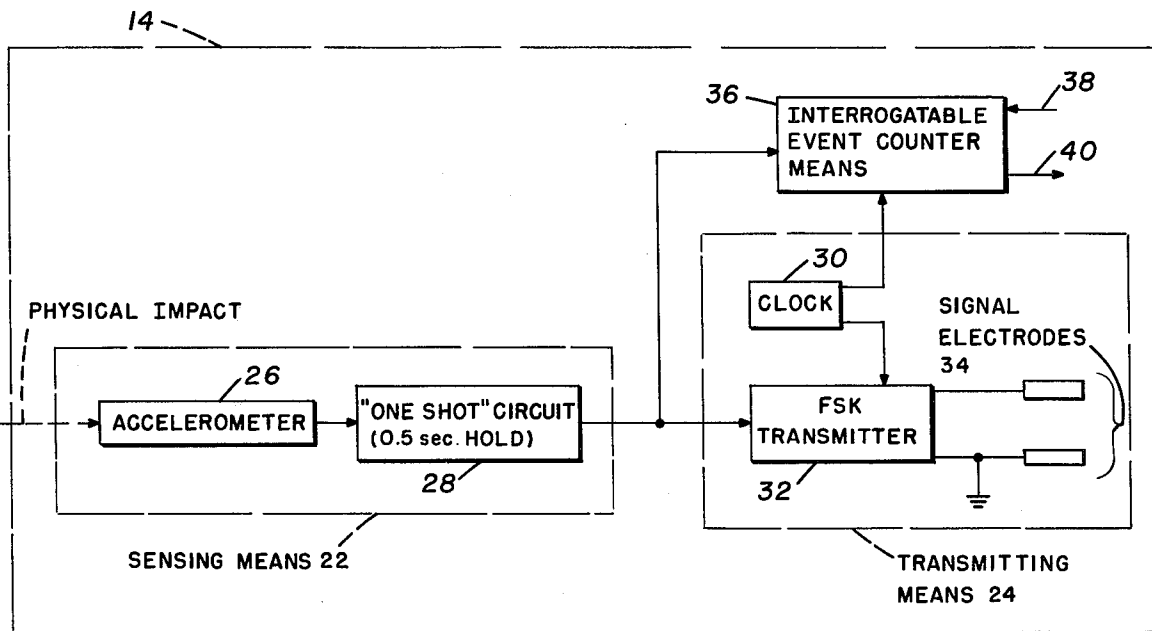

FIG. 2

ACCELERATION AT THE FOREHEAD FROM A MILD IMPULSE TO THE HEAD

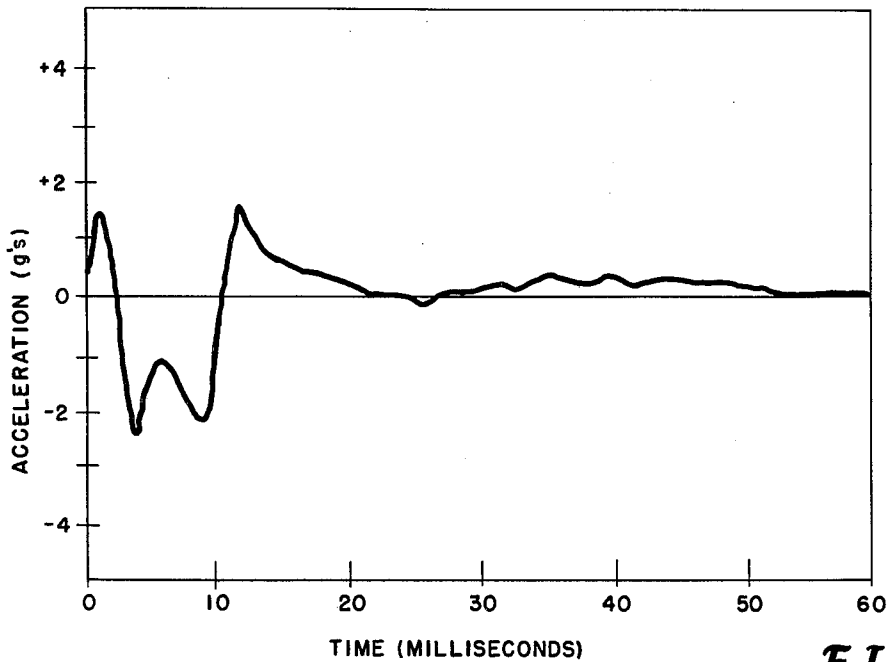

FIG. 3

ACCELERATION

SUBWAY	0.14g
AUTO	0.2-45g
MOTORCYCLE	0.6g
COMMERCIAL JET	0.5

FIG. 4

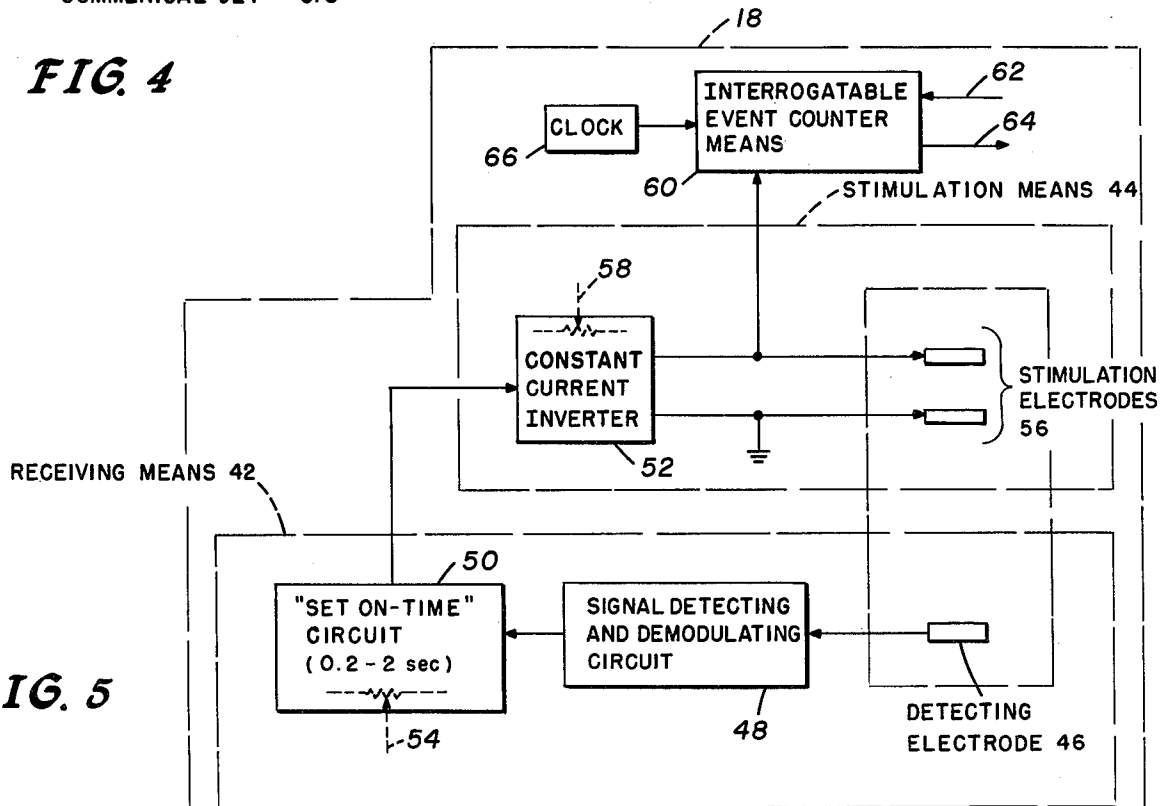

FIG. 5

SELF-INJURIOUS BEHAVIOR INHIBITING SYSTEM

BACKGROUND OF THE INVENTION

1. Field of the Invention

The invention relates to an apparatus for preventing self-injurious behavior in patients. More particularly, the invention teaches an improved apparatus for sensing self-injurious behavior and for transmitting a signal to a separate stimulation module which then supplies aversive electrical stimulation to the patient's skin.

2. Description of the Prior Art

The use of aversive stimulation to prevent certain types of behavior is known in the art. U.S. Pat. No. 3,998,209, issued to Gilbert Macvaugh on Dec. 21, 1976, teaches the application of electric shock pulses, generated by a charged capacitor circuit, for deconditioning snoring. U.S. Pat. No. 3,885,576, issued to Elliott Symmes, on May 27, 1975, teaches the use of electric shock as a means to deter smoking. In that patent a mercury switch is mounted on a wristband so that when the user moves his arm (e.g., to place a cigarette to his lips), the mercury switch closes and allows an electric current to flow to electrodes mounted on the user's wristband.

The use of aversive stimulation to inhibit self-injurious behavior was first described by Mooza Grant in U.S. Pat. No. 3,834,379, issued Sept. 10, 1974. Mooza Grant describes an apparatus which conditions psychotic self-destructive patients against self-injurious blows to the head. The apparatus contains a helmet which is mounted on the patient's head to absorb self-injurious blows. The helmet contains a metallic cylinder and a movable pin disposed centrally therein. When the patient strikes the helmet, the pin contacts with the cylinder and establishes an electrical contact which activates an electronic package (described as being disposed within a packet in patient's clothes.) An electrical pulse generated in the electronic package is sent to the electrodes contained in an arm band and provides an aversive electric shock to the patient's arm. The helmet, electronic package, and stimulation electrodes are all connected by electrical wires.

SUMMARY OF THE INVENTION

The prior art apparatus required bulky equipment and connecting cables which run between the sensing transducer, and the stimulation circuitry and electrodes. Observations of patients indicated that the connecting wires restricted the patient's activities. The invented apparatus contains a sensor module that is separate from the stimulation module and provides a wireless communication link between the sensor and stimulation modules.

The prior art aversive stimulation apparatus required a bulky helmet to support the sensing switch and also to protect the head. For the sensor module, the proposed apparatus of the present invention uses a miniature accelerometer and electrical circuitry which is contained in a single miniaturized hybrid circuit, all of which can be mounted on an elastic headband. The invented apparatus enables the patient to be conditioned against self-injurious behavior without requiring the patient to wear a bulky helmet which inhibits his or her activities, which can be uncomfortable when worn for extended

time periods, and which causes the patient to have an abnormal appearance.

The inventors also observed that patients exhibiting such self-injurious behavior frequently injure body members other than the head. The present invention thus discloses a sensor module which can be attached to an elastic band and worn on any body member. Moreover, several of the invented sensor modules can be worn on different body members and can simultaneously communicate with a single stimulation module, and report an injurious blow to any of the sensed body members. Not only does the prior art not teach the use of multiple sensors but, the interconnection cables used in the prior art would entangle the patient in a web of wires if such sensing from multiple locations was attempted. Typical of other body members where sensing might be useful are elbows and knees.

The present invention uses a separate sensor and stimulation module, each made from a hybrid circuit containing (CMOS) integrated circuits. The sensor module detects a rapid acceleration or blow and transmits a signal to a remote stimulation module. The sensor module might be mounted on the body member that is being struck or on the body member that is doing the striking. In either case, it is to be understood that a body member is being struck. The transmission made by the sensor module can be by means of radio emissions (i.e., electromagnetic waves) or by a unique method of transmitting an electrical signal through the patient's body. The stimulation module detects and demodulates the transmitter signal and provides aversive stimulation in response to each detected self-injurious action. Aversive stimulation is provided by means of stimulation electrodes which are placed in contact with the patient's skin. In operation, each sensor module can detect self-injurious blows to a particular body member and communicate this information to the stimulation module which then provides an aversive electrical shock.

One novel feature of the invented apparatus is the use of a sensor module which is remote from and not connected by wires to the stimulation module.

The second novel feature of the invented apparatus is the use of a wireless communication link between the sensor and stimulation modules.

A third novel feature of the invented apparatus is the ability of the sensor module to transmit an electrical signal containing event information through the patient's body, and to have the transmitted signal be detected and be demodulated by the stimulation module.

A fourth novel feature of the invented apparatus is to mount the sensor module on an elastic band. As such, the sensor module can be worn as a headband (not a bulky helmet) to detect self-injurious blows to the head, and it can be worn on an arm or knee band to detect self-injurious behavior to the arm or leg respectively.

A fifth novel feature of the invented apparatus is that one or more sensor modules can simultaneously communicate with a single stimulation module. This feature allows the invented apparatus to be successfully used for patients who exhibit self-injurious behavior to more than one body member.

A sixth novel feature of the invented apparatus is the incorporation of a recording means in both the stimulation and sensor modules. This feature allows the invented apparatus to be a more useful diagnostic tool.

A seventh novel feature of the invented apparatus is an aversive stimulation system where the level of the

electrical shock is adjustable to provide a minimum shock level that will accomplish the intended purpose.

BRIEF DESCRIPTION OF THE DRAWINGS

FIG. 1 is an illustration of a person wearing the invented self-injurious behavior inhibiting system.

FIG. 2 is a block diagram of the sensor module.

FIG. 3 is a graph showing acceleration versus time for acceleration at the forehead caused by a mild blow to the head.

FIG. 4 is a table showing various accelerations a patient will experience during normal activities.

FIG. 5 is a block diagram of the stimulation module.

DETAILED DESCRIPTION OF THE PREFERRED EMBODIMENT

The proposed apparatus for inhibiting self-injurious behavior is illustrated in FIG. 1. The apparatus is generally composed of a sensor module subsystem 10 and a separate stimulation module subsystem 12. The sensor module subsystem 10 contains a sensor module 14 which is mounted on a headband 16 and detects blows to the patient's head. Although not illustrated in FIG. 1, the sensor module 14 could also be mounted on any other body member and detect blows to that body member (e.g., sensor modules could be mounted on an elastic elbow band, knee band, ankle band, wristband, etc.). For patients who exhibit injurious behavior to several different body members, it is within the scope of this invention to place sensor modules on several body members simultaneously, and to detect self-injurious blows to each of those body members. Furthermore, if the patient always uses his hand to strike a variety of body parts, then a sensor module mounted on his wrist could detect any body part being hit by his hand and this would cause an appropriate signal to be sent to the stimulation module. The stimulation module subsystem 12 is mounted on the patient's body at a position remote from the sensor module subsystem 10. The stimulation module subsystem 12 consists of a stimulation module 18 mounted on an elastic band 20. FIG. 2 shows the stimulation module subsystem 12 mounted on the patient's arm, although the stimulation module subsystem 12 could be mounted on other body members depending on its effectiveness for a particular patient.

Unlike the prior art, the invented apparatus contains no wires or cables connecting the sensor module 14 to the stimulation module 18. As will be described in greater detail, the sensor module 14 transmits a signal either through the body or by propagated radio waves to the stimulation module 18. The signal transmitted by the sensor module 14 carries event information which indicates when a blow has been sustained. The stimulation module 18 applies aversive stimulation to the patient in response to this event information. It is contemplated that several sensor modules mounted on different body members can transmit event information to a single stimulation module.

FIG. 2 is a block diagram of the sensor module 14. The sensor module would generally consist of a single hybrid circuit typically consisting of (CMOS) integrated circuit components chosen for their low voltage requirements, and particularly because of their low electrical power drain. The sensor module 14 contains a sensing means 22 for sensing a blow to a body member, and a transmitting means 24 for transmitting a signal to the stimulation module 18. The sensing means 14 further contains: a miniaturized two-axis or three-axis accel-

ometer 26; a small single cell battery (not shown), such as a Li So₂Cl battery; and, a "one-shot" circuit 28. The accelerometer 26 behaves as a switch and is closed momentarily when an accelerating impulse, above a set threshold level, is detected, and automatically resets after the acceleration impulse subsides. FIG. 3 contains a graph showing acceleration detected at the forehead of a person experiencing a mild blow to the head. A 2 g acceleration level is attained with a slight, non-damaging impulse to the head. A typical self-injurious blow might produce a 20 g acceleration to the head or other body member. A threshold level between 2 g's and 5 g's can be selected as values large enough to avoid aversive stimulation as a result of accelerations experienced in normal activity, and yet small enough to detect even a non-damaging impulse to the head. FIG. 4 contains a table showing some accelerations experienced in normal activities particularly in various types of transportation—the threshold value is chosen so that acceleration experienced during transportation would not activate the invented apparatus.)

Although the use of an accelerometer switch is described herein, the sensor module could also use the actual blow to cause electrical contact between two surfaces or the blow might be detected by a change in capacitance caused by the proximity of two body members coming in contact.

Returning now to FIG. 2, a "one-shot" circuit 28, or its equivalent, is connected to the accelerometer 26 and will be activated when the accelerometer output exceeds a threshold level for a period longer than 10 milliseconds. (NOTE: A range of threshold values, other than those specified above, is contemplated by the inventors—any threshold value is acceptable which would be large enough to avoid stimulation during normal activity but sensitive enough to detect mild non-injurious blows.) The "one-shot" circuit 28 shall not accept another input from the accelerometer for the duration of a hold period (a hold period of 0.5 seconds is suggested). The "one-shot" circuit 28 sustains a level output during the hold period enabling the "one-shot" circuit 28 to "stretch" the electrical impulse received from the accelerometer 26 thus allowing the transmitting means 24 time to (1) be powered, (2) to be stabilized, and (3) to transmit a signal indicating the occurrence of the self-injurious blow.

The transmitting means 24 has two embodiments. In the first embodiment, the transmitter means 24, as shown in FIG. 2, contains a crystal oscillator clock 30 and an FSK transmitter 32, which generates FSK frequencies of 48 kHz (a logical "0") and 52 kHz (a logical "1"). The FSK transmitter 32 is of a design known in the communication art and will produce a [coded] signal at a 5-millisecond bit rate. The transmitter 32 is activated by the "one-shot" circuit 28 and, after it stabilizes, transmits a signal for the remainder of the 0.5 second hold period. The output signal from the transmitter 32 runs to signal electrodes 34 (also see FIG. 1) which are in contact with the patient's skin and electrically couple the transmitter 32 output to the patient's body. The electrical signal, generated by the FSK transmitter 32, is conducted by electrodes 34 to the patient's skin and travels through the patient's body to be received by a remotely located stimulation module 18. It should be noted that any type of alternating electrical signal can be conducted through the human body in the manner disclosed above. This technique is more fully described in co-pending U.S. application entitled "In-

Explore Litigation Insights

Docket Alarm provides insights to develop a more informed litigation strategy and the peace of mind of knowing you're on top of things.

Real-Time Litigation Alerts



Keep your litigation team up-to-date with **real-time alerts** and advanced team management tools built for the enterprise, all while greatly reducing PACER spend.

Our comprehensive service means we can handle Federal, State, and Administrative courts across the country.

Advanced Docket Research



With over 230 million records, Docket Alarm's cloud-native docket research platform finds what other services can't. Coverage includes Federal, State, plus PTAB, TTAB, ITC and NLRB decisions, all in one place.

Identify arguments that have been successful in the past with full text, pinpoint searching. Link to case law cited within any court document via Fastcase.

Analytics At Your Fingertips



Learn what happened the last time a particular judge, opposing counsel or company faced cases similar to yours.

Advanced out-of-the-box PTAB and TTAB analytics are always at your fingertips.

API

Docket Alarm offers a powerful API (application programming interface) to developers that want to integrate case filings into their apps.

LAW FIRMS

Build custom dashboards for your attorneys and clients with live data direct from the court.

Automate many repetitive legal tasks like conflict checks, document management, and marketing.

FINANCIAL INSTITUTIONS

Litigation and bankruptcy checks for companies and debtors.

E-DISCOVERY AND LEGAL VENDORS

Sync your system to PACER to automate legal marketing.