

Put the Right Bus in Your Car

The amazing array of features available in today's cars has spawned new in-vehicle bus standards.



by Karen Parnell
Automotive Product Manager
Xilinx, Inc.
karen.parnell@xilinx.com

The next few years will be a rocky road for automobile electronics designers. No single in-car data bus can adequately handle the entertainment, safety, and intelligent-control requirements of the cars that will roll off assembly lines in North America, Europe, and Asia.

Choosing the right data bus can lead to a competitive advantage, but the selection is increasingly difficult, as carmakers around the globe adopt different solutions.

Electronics Drives Innovation

In-car electronics have grown tremendously in recent years. Traditional body-control and engine-management functions, plus new driver-assistance and telematics sys-

tems, have spurred annual growth rates as high as 16%, according to the Institute of Electrical and Electronics Engineers (IEEE). The IEEE forecasts that electronics will account for 25% of the cost of a mid-size car by 2005.

One high-growth area is telematics systems – the convergence of mobile telecommunications and information processing in cars. Significantly, telematics applications exhibit market characteristics similar to those of consumer products: short time to market, short time in market, and changing standards and protocols. These market characteristics are just the opposite of the relatively long design cycles of traditional in-car electronics, which are often dictated by safety and tooling-cost considerations.

Traditional systems such as CAN (controller area network) and J1850 have been used in body control for many years. But

bandwidth and speed restrictions make it difficult for these serial, event-driven buses to handle newer real-time applications.

A number of new bus standards have emerged featuring time-triggered protocols and optical data buses. These in-car bus networks can be divided into four categories:

- Body control – dashboard/instrument panel clusters, mirrors, seat belts, door locks, and passive airbags
- Entertainment and driver-information systems – radios, Web browsers, CD/DVD players, telematics, and infotainment systems
- Under the hood – antilock brakes, emission control, power train, and transmission systems
- Advanced safety systems – brake-by-wire, steer-by-wire, and driver assistance systems (active safety).

Figure 1 shows the relative speeds of the various bus systems, which range from kilobits per second to gigabits per second.

“Under-the-Hood” Buses

Two networks found under the hood serve functions ranging from seat adjustment to antilock brakes.

Controller Area Network

One of the first and most enduring control networks, the CAN bus, is the most widely used, with more than 100 million nodes installed worldwide.

A typical vehicle integrates two or three CAN buses operating at different speeds. A low-speed CAN bus runs at less than 125 Kbps and manages body-control electronics, such as seat and window movement controls and other simple user interfaces. A high-speed (up to 1 Mbps) CAN bus runs real-time critical functions such as engine management, antilock brakes, and cruise control.

CAN protocols are becoming standard for under-the-hood connectivity in cars, trucks, and off-road vehicles. One outstanding feature of the CAN protocol is its high transmission reliability.

Local Interconnect Network

The local interconnect network (LIN) was developed to supplement the CAN bus in applications where cost is critical and data transfer rates are low. The LIN bus is an inexpensive serial bus used for distributed body control electronic systems. It enables effective communication for smart sensors and actuators where the bandwidth and versatility of the CAN bus are not required. Typical applications are door control (windows, door locks, and mirrors), seats, climate regulation, lighting, and rain sensors.

The LIN bus is a UART-based, single-master, multiple-slave networking architecture originally developed for automotive sensor and actuator networking applications. The LIN master node connects the

LIN network with higher-level networks such as a CAN bus, extending the benefits of networking all the way to the individual sensors and actuators.

Entertainment and Driver Information Systems

Car infotainment and telematics devices, especially car navigation systems, require highly functional operating systems and connectivity. Until now, both open-standard and proprietary standalone buses have

Media Oriented System Transport

MOST networks connect multiple devices, including car navigation, digital radios, displays, cellular phones, and CD/DVDs. MOST technology is optimized for use with plastic optical fiber. It supports data rates as high as 24.8 Mbps and is highly reliable and scalable at the device level.

MOST offers full support for real-time audio and compressed video. It is vigorously supported by German automakers and suppliers. The MOST bus is endorsed by

BMW, DaimlerChrysler, Harman/Becker, and OASIS Silicon Systems. A recent notable example of a MOST implementation is its use by Harman/Becker in the latest BMW 7 series.

Intelligent Transport System Data Bus

The IDB Forum manages the IDB-C and IDB-1394 buses and standard interfaces for OEMs that develop aftermarket and portable devices. Based on the CAN bus, IDB-C is geared toward devices with data rates of 250 Kbps.

IDB-1394 (based on the IEEE-1394 FireWire™ standard) is designed for high-

speed multimedia applications. IDB-1394 is a 400 Mbps network using fiber-optic technology. Applications include DVD and CD changers, displays, and audio/video systems.

IDB-1394 also allows 1394-portable consumer electronic devices to connect and interoperate with an in-vehicle network. Zayante Inc., for example, supplies 1394 physical layer devices for the consumer market. A recent joint demonstration with the Ford Motor Company included plug-and-play connections of a digital video camera and a Sony PlayStation™ 2 game console, as well as two video displays and a DVD player.

Digital Data Bus

The Digital Data Bus (D2B) is a networking protocol for multimedia data commu-

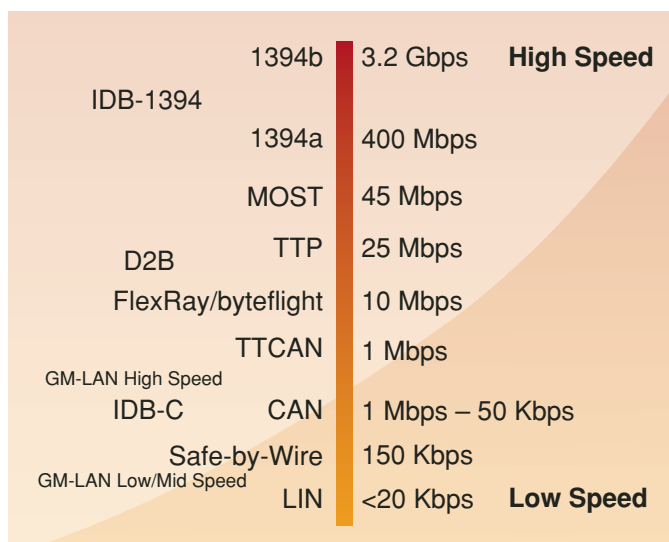

Figure 1 – In-car network data-transfer speeds

coexisted independently and peacefully. But because of the pressures of convergence, future systems will require integrated electronic subsystems.

By relying on open industry standards, all key players – from manufacturers to service centers to retailers – can focus on delivering core expertise to the customer. Open standards will save the duplication of time and effort it would take to develop separate, incompatible designs for specific vehicles or proprietary computing platforms.

Several organizations and consortia are leading standardization efforts, including the MOST (Media Oriented System Transport) Cooperation, the IDB (Intelligent Transport System Data Bus) Forum, and the Bluetooth™ Special Interest Group (SIG).

nication that integrates digital audio, video, and other high-data-rate synchronous or asynchronous signals. It can run as fast as 11.2 Mbps and be built around either SmartWire™ unshielded twisted pair cable or a single optical fiber.

This communication network is being driven by C&C Electronics in the UK and has industry acceptance from Jaguar and Mercedes-Benz. The integrated multimedia communication systems deployed in the Jaguar X-Type, S-Type, and new XJ Saloon, for example, use D2B.

The D2B optical multimedia system is designed to evolve in line with new technologies while remaining backwards compatible. D2B optical is based on an open architecture that simplifies expansion, because changes to the cable harness are not required when adding a new device or function to the optical ring. The bus uses just one polymer optical fiber to handle the in-car multimedia data and control information. This gives better reliability, fewer external components and connectors, and a significant reduction in overall system weight.

Bluetooth and ZigBee

Bluetooth wireless technology is a low-cost, low-power, short-range radio protocol for mobile devices and WAN/LAN access points. Its specification describes how mobile phones, computers, and PDAs can easily interconnect with each other, with home and business phones, and with computers.

The Bluetooth SIG includes such members as AMIC, BMW, DaimlerChrysler, Ford, General Motors, Toyota, and Volkswagen. An example of Bluetooth deployment in cars is Johnson Controls' BlueConnect™ technology, a hands-free system that allows drivers to keep their hands on the wheel while staying connected through a Bluetooth-enabled cellular phone.

There is, however, some concern about long-term support of Bluetooth devices. The problem centers on how the electromagnetically noisy in-car environment will affect Bluetooth operation. The lifecycle of cars and other vehicles is much longer than

that for consumer products or mobile phones, so silicon manufacturers must address this mismatch between support and service timescales. On the other hand, Chrysler showed Bluetooth connectivity in its vehicles at Convergence 2002.

Some feel Bluetooth technology may be overkill in the car environment, however. So, an emerging standard for low data rate wireless data transfer and control has entered the scene. The ZigBee™ wireless networking solution is a low-data-rate (868 MHz to 2.4 GHz), low-power, low-cost system pioneered by Philips. The ZigBee range is up to 75 meters and is equally at home in industrial control, home automation, consumer, and possibly automotive applications.

Advanced Safety Systems

Safety equipment has evolved from the physical to the electronic domain, starting with advancements in tire and braking technology, through side impact protection and airbags, and on to today's driver-assistance systems.

The latest vehicles are electronics-rich and sensor-based to continuously evaluate the surroundings, display relevant information to the driver, and, in some instances, even take control of the vehicle.

Advanced safety systems include by-wire (for example, drive-by-wire and brake-by-wire), which will replace traditional hydraulic and mechanical linkages with safer, lighter electronic systems.

Other examples of advanced, real-time safety systems include distance control, self-adjusting and sensing airbag systems, radar parking, reversing aids, and back guide monitors (cameras set in the car's bumpers to aid parking).

FlexRay

The FlexRay™ network communication system is aimed at the next generation of by-wire automotive applications. These applications demand high-speed buses that are deterministic, fault-tolerant, and capable of supporting distributed control systems.

BMW, DaimlerChrysler, Philips Semiconductors, Motorola, and the newest member, Bosch, are developing the

FlexRay standard for next-generation applications.

The FlexRay system is more than a communications protocol. It also includes a specially designed high-speed transceiver and the definition of hardware and software interfaces between various components of a FlexRay "node." The FlexRay protocol defines the format and function of the communication process within a networked automotive system. It is designed to complement CAN, LIN, and MOST networks.

As a scalable system, FlexRay technology supports both synchronous and asynchronous data transmission. The synchronous data transmission enables time-triggered communication to meet the requirement of dependable systems. FlexRay's synchronous data transmission is deterministic, with guaranteed minimum message latency and message jitter. It supports redundancy and fault-tolerant distributed clock synchronization to keep the schedule of all network nodes within a tight, predefined, precision window.

The asynchronous transmission, based on the fundamentals of the byteflight™ protocol, allows each node to use the full bandwidth for event-driven communications.

Time-Triggered Protocol

Designed for fault-tolerant, real-time distributed systems, the time-triggered protocol (TTP) ensures that there is no single point of failure.

TTP is a mature, low-cost solution that can handle safety-critical applications. Second-generation silicon supporting communication speeds as high as 25 Mbps is available today. The TTA Group, the governing body for TTP, includes Audi, SA, Renault, NEC, TTChip, Delphi, and Visteon among its members.

Time-Triggered CAN

The time-triggered CAN (TTCAN) standard is an extension of the CAN protocol. It adds a session layer on top of the existing data link layer and physical layers to ensure that all transmission deadlines are met, even at peak bus loads. The protocol implements a hybrid, time-triggered, TDMA

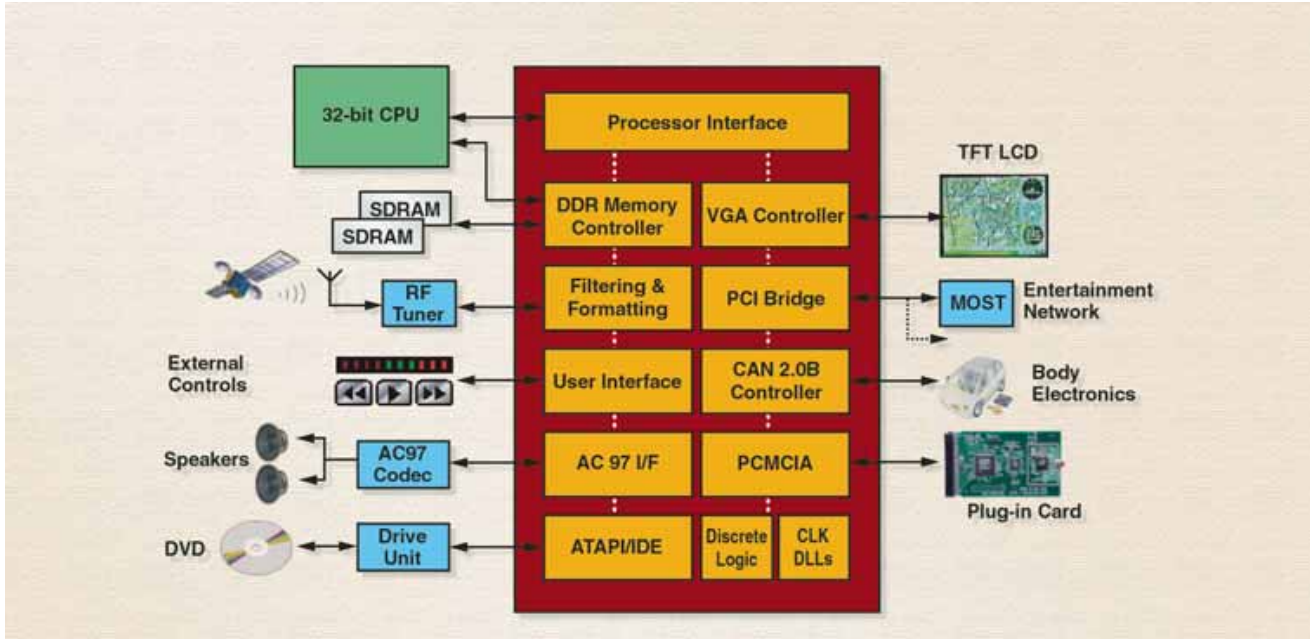

Figure 2 – In-car multimedia functions embedded in an FPGA

(time-division multiplexed access) schedule that also accommodates event-triggered communications. Some of the intended TTCAN uses include engine management systems and transmission and chassis controls, with scope for by-wire applications.

The Programmable Logic Solution

As we have seen from the proliferating number of in-car bus standards, the next few years will become a minefield for automotive electronics designers. Choosing the right data bus will be crucial to success – now measured not simply during integration and testing of units for production, but long after the car has rolled off the assembly line.

The problem is amplified for Tier 1 suppliers and aftermarket companies that supply units to many OEMs, because these customers are likely to opt for different data buses and protocols. The industry has seen a huge shift away from designing a different unit for every OEM – indeed for every car model. Taking its place is a design philosophy that emphasizes reconfigurable platforms.

Design platforms that are cleverly partitioned between software and reprogrammable hardware let manufacturers change system buses and interfaces late in the

design process – and even in production. The reconfigurable system concept supports try-outs of different standards and protocols. Programmable logic devices (PLDs) in the form of FPGAs and CPLDs enable modification during all phases of design – from prototype through pre-production and into production.

PLDs can also alleviate over-stocking and inventory issues, because generic FPGAs can be used across many projects and are not application-specific. Once the programmable logic-based unit is on the road, it can even be reconfigured remotely via a wireless communication link to allow for system upgrades or extra functions.

Drop-In IP Cores

The reconfigurable hardware platform can be brought to market quickly by utilizing drop-in intellectual property (IP) core blocks. Memec Design, for example, recently announced the availability of a cost-optimized CAN core interface that includes the complete data link layer, including the framer, transmit-and-receive control, error core design, and flexible interface. Bit rate and sub-bit segments can be configured to meet the timing specification of the connected CAN bus.

The Memec core is designed to provide a bus bit rate of up to 1 Mbps, with a minimum core clock frequency of 8 MHz. It can provide an interface between the message filter, the message priority mechanism, and various system functions such as sensor/activator controls.

Alternatively, the Memec CAN bus can be embedded into a system application interfacing with the microprocessor and various peripheral functions. Another example is Intelliga's iLIN™ core, which is supplied as a LIN bus controller IP core. It uses a synchronous 8-bit general-purpose microcontroller interface with minimal buffering to transport message data. In addition, the reference design includes a single slave message response filter and a software interface that allows the connected microcontroller to perform address filtration.

This emerging LIN body control protocol can be easily tried and tested using the Intelliga iDEV prototyping board, which can demonstrate not only LIN but also CAN and TTCAN buses – all implemented in a Xilinx Spartan™-IIE FPGA.

Figure 2 shows a generic in-car multimedia system design with a CAN core supplying communications for a PCMCIA

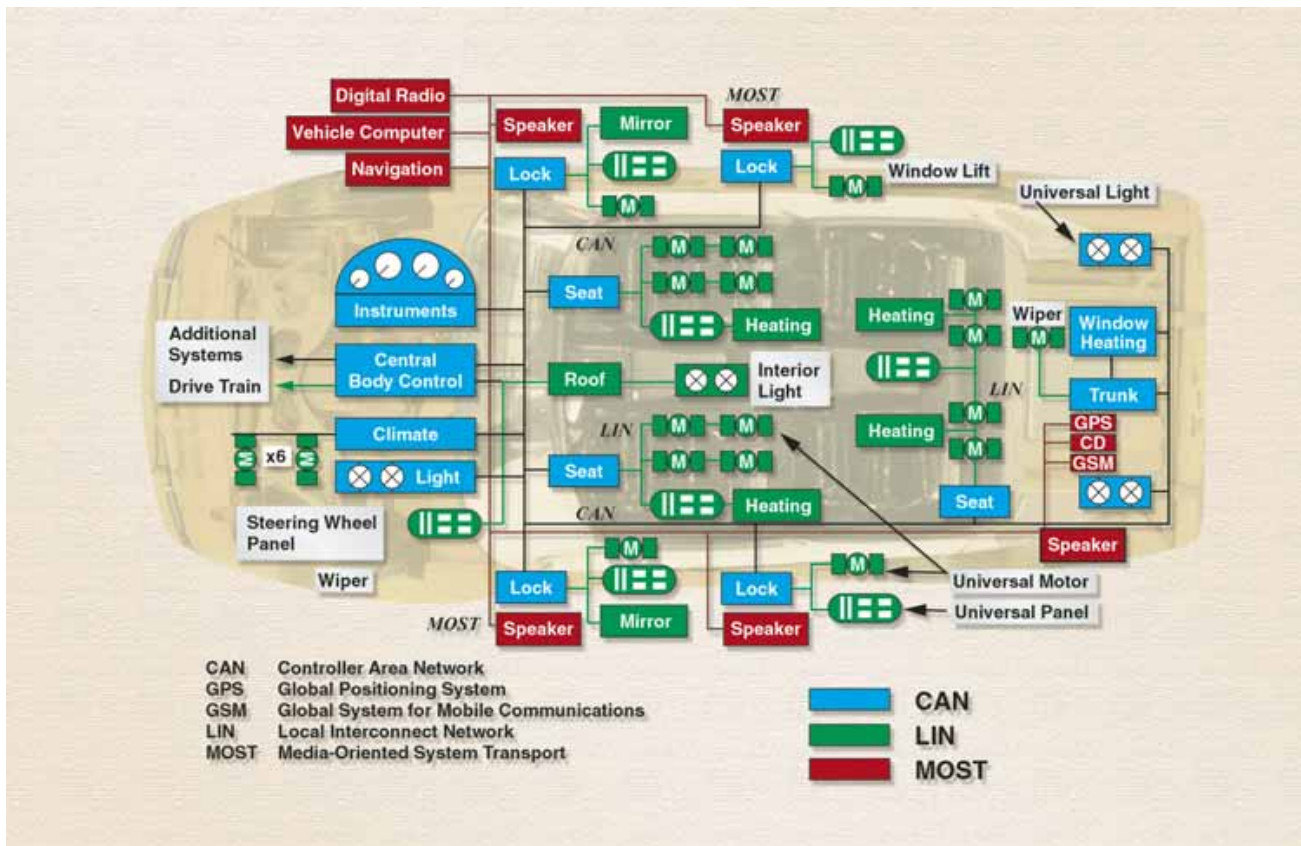

Figure 3 – In-car complementary networks

interface, PCI bridging, an IDE interface, and other functions. One printed circuit board can be used for many customers with customization in the FPGA instead of the board. The model can be extended to include modification or upgrades in the field via wireless connection to reconfigure the FPGA in-system.

Bus Coexistence

Several in-car bus networks can coexist to deliver the right combination of data rates, robustness, and cost.

Figure 3 shows the LIN bus handling low-cost, low-speed connections between the motors for the mirrors, roof, windows, and so forth. A CAN bus handles data communication and control between the instrument cluster, body controllers, door locks, and climate control. Finally, the high-speed MOST optical bus connects the entertainment, navigation, and communication devices.

This model can be extended to include

a FlexRay bus (or other real-time safety bus) to handle the high-speed, real-time data required by advanced safety systems.

Conclusion

The delicate engineering balance between cost, reliability, and performance has created a variety of emerging in-car bus systems that will complicate design decisions for years to come. Therefore, automotive OEMs are backing more than one standard due to uncertainties over which one will eventually prevail.

There is an elegant solution to this dilemma. Reconfigurable platforms based on Xilinx programmable logic and IP cores are the best way out of this design predicament. Without sacrificing performance or cost advantages, reconfigurable hardware and software systems from Xilinx allow manufacturers to quickly accommodate changing standards and protocols late in the design process, in production, and even on the road. ⌘

Website resources	
CAN	www.can.bosch.com
GM LAN	www.gmtny.com/lan.htm
MOST	www.mostnet.de
TTTech (TTP)	www.ttgroup.org , www.ttchip.com
FlexRay	www.flexray.com
D2B	www.candc.co.uk
LIN	www.lin-subbus.org
Intelliga (LIN)	www.intelliga.co.uk
Bluetooth	www.bluetooth.com
IDB	www.idbforum.org
ZigBee	www.zigbee.org
Xilinx Automotive	www.xilinx.com/automotive/