

IN THE UNITED STATES PATENT AND TRADEMARK OFFICE

Applicant : Niall R. Lynam
For : EXTERIOR REARVIEW MIRROR ASSEMBLY

Commissioner for Patents
P.O. Box 1450
Alexandria, VA 22313-1450

Dear Sir:

REQUEST FOR FILING CONTINUATION APPLICATION
UNDER 37 CFR 1.53(b)

This is a request for filing a continuation of U.S. patent application Serial No. 12/911,274, filed October 25, 2010, which is a continuation of U.S. patent application Serial No. 12/851,045, filed August 5, 2010, now U.S. Patent No. 7,934,843, which is a continuation of U.S. patent application Serial No. 12/197,666, filed August 25, 2008, now U.S. Patent No. 7,842,154, which is a division of U.S. patent application Serial No. 10/709,434, filed May 5, 2004, now U.S. Patent No. 7,420,756, which claims the benefit of U.S. provisional application, Serial No. 60/471,872, filed May 20, 2003.

1. Copy of Prior Application as Filed Which is Attached

I hereby verify that the attached papers are a copy of what is shown in my records to be the above-identified prior application, including the Declaration as originally filed (37 CFR 1.53). No amendments referred to in any Declaration filed to complete the prior application introduced new matter in that application.

The attached copy of the papers of the parent application includes 36 pages of specification, 3 pages of claims (18 claims), 1 page of Abstract, 16 sheets of drawings, and signed Declaration and Power of Attorney (1 page). The attached drawings are copies of the

Applicant : Niall R. Lynam
For : EXTERIOR REARVIEW MIRROR ASSEMBLY
Page : 2

formal drawings filed in the parent applications and correspond to the drawings originally filed with the parent applications and as amended and/or approved during prosecution of the parent applications.

2. Amendments

The copy of the application includes any amendments made during prosecution of the parent application and includes updates to any references to incorporated patent applications that have issued as patents and includes a revised/updated Cross Reference to Related Applications and a new Abstract.

The attached copy includes new claims 1-18, which replace the claims of the parent patent application.

New claims 1-18 have been substantially copied from U.S. Patent No. 7,857,469, which issued December 28, 2010, and claims 1-18 correspond to claims 1-18 of U.S. Patent No. 7,857,469. Claims 1-18 have been added herein to preserve Applicant's right to request an interference with U.S. Patent No. 7,857,469. Claims 1-18 are fully supported in the specification and drawings as originally filed in the present application and its priority applications. No new matter has been added.

3. Notice Regarding Prosecution relative to Parent Application

This application is a continuation of U.S. patent application Serial No. 12/911,274, filed October 25, 2010, which is part of the continuation chain noted above. Applicants note from controlling case law that disclaimer of subject matter made during an earlier prosecution can be rescinded, permitting recapture of the disclaimed scope, so long as

Applicant : Niall R. Lynam
For : EXTERIOR REARVIEW MIRROR ASSEMBLY
Page : 4

Number of claims in excess of twenty, -0- times \$60.00	\$0.00
Filing multiple dependent claims per application \$450.00	\$0.00
Application size fee for each additional 50 sheets that exceeds 100 sheets (-0- times \$310.00)	\$0.00
<u>Additional Fees:</u>	
Search Fee - \$620	\$620.00
Examination Fee - \$250	<u>\$250.00</u>
Total Filing Fee	\$1,250.00

The above fees will be paid by credit card. The Commissioner is hereby authorized to charge any additional fees which may be required, or credit any overpayment, to Deposit Account No. 50-5553.

The Commissioner is hereby authorized to charge the following fees during the pendency of this application, or credit any overpayment to Deposit Account 50-5553.

- a) Any filing fees under 37 CFR 1.16 for presentation of extra claims for which full payment has not been tendered.
- b) Any patent application processing fees under 37 CFR 1.17 for which full payment has not been tendered.

6. Drawings

Sixteen (16) sheets of formal drawings are enclosed and are copies of those filed in the parent application. The formal drawings correspond to the drawings originally filed with

Applicant : Niall R. Lynam
For : EXTERIOR REARVIEW MIRROR ASSEMBLY
Page : 5

the parent application and include any revisions made and approved during prosecution of the parent application.

7. Disclosure Statement

Applicants respectfully request that information cited in the prior parent application, Serial No. 12/911,274, be considered in the present application. An Information Disclosure Statement will be submitted that lists the cited references.

8. Inventorship Statement

With respect to the prior U.S. application from which this application claims benefit under 35 USC 120, the inventor in this application is the same, namely, Niall R. Lynam.

9. Assignment

The prior application was originally assigned to Donnelly Corporation, a corporation of the State of Michigan, located and doing business at 49 W. Third Street, Holland, Michigan 49423. That Assignment was recorded in the United States Patent and Trademark Office on August 23, 2004, at Reel 015715, Frame 0476.

10. Power of Attorney

The Power of Attorney in the parent applications is to the individual patent attorneys listed thereon. The attached Power of Attorney includes the original declaration signed by the inventors and confirms that the undersigned attorney is an attorney of record for this application.

Applicant : Niall R. Lynam
For : EXTERIOR REARVIEW MIRROR ASSEMBLY
Page : 6

Please address all future correspondence to:

Timothy A. Flory
Gardner, Linn, Burkhart & Flory, LLP
2851 Charlevoix Drive, S.E.
P.O. Box 888695
Grand Rapids, MI 49588-8695
Ph: (616) 975-5500
Fax: (616) 975-5505

11. Verification

I hereby declare further that all statements made herein of my own knowledge are true and that all statements made on information and belief are believed to be true; and further that these statements are made with the knowledge that willful false statements and the like so made are punishable by fine or imprisonment, or both, under Section 1001 of Title 18 of the United States Code, and that such willful false statements may jeopardize the validity of the application or any patent issuing thereon.

Respectfully submitted,

NIALL R. LYNAM

By: Gardner, Linn, Burkhart & Flory, LLP

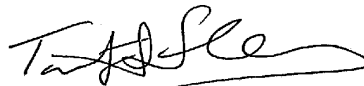

Date: December 23, 2011

Timothy A. Flory
Registration No. 42 540
2851 Charlevoix Drive, S.E.
P.O. Box 888695
Grand Rapids, MI 49588-8695
(616) 975-5500

TAF/ars
DON09 P-1800

Under the Paperwork Reduction Act of 1995, no persons are required to respond to a collection of information unless it contains a valid OMB control number.

Application Data Sheet 37 CFR 1.76		Attorney Docket Number	DON09 P-1800
		Application Number	
Title of Invention	EXTERIOR REARVIEW MIRROR ASSEMBLY		
The application data sheet is part of the provisional or nonprovisional application for which it is being submitted. The following form contains the bibliographic data arranged in a format specified by the United States Patent and Trademark Office as outlined in 37 CFR 1.76. This document may be completed electronically and submitted to the Office in electronic format using the Electronic Filing System (EFS) or the document may be printed and included in a paper filed application.			

Secrecy Order 37 CFR 5.2

Portions or all of the application associated with this Application Data Sheet may fall under a Secrecy Order pursuant to 37 CFR 5.2 (Paper filers only. Applications that fall under Secrecy Order may not be filed electronically.)

Applicant Information:

Applicant 1					<input type="button" value="Remove"/>
Applicant Authority		<input checked="" type="radio"/> Inventor		<input type="radio"/> Legal Representative under 35 U.S.C. 117	
				<input type="radio"/> Party of Interest under 35 U.S.C. 118	
Prefix	Given Name	Middle Name	Family Name	Suffix	
	Niall	R.	Lynam		
Residence Information (Select One)					
		<input checked="" type="radio"/> US Residency		<input type="radio"/> Non US Residency	
				<input type="radio"/> Active US Military Service	
City	Holland	State/Province	MI	Country of Residence i	US
Citizenship under 37 CFR 1.41(b) i		US			
Mailing Address of Applicant:					
Address 1	281 Norwood Avenue				
Address 2					
City	Holland	State/Province	MI		
Postal Code	49424	Countryi	US		
All Inventors Must Be Listed - Additional Inventor Information blocks may be generated within this form by selecting the Add button.					
<input type="button" value="Add"/>					

Correspondence Information:

Enter either Customer Number or complete the Correspondence Information section below. For further information see 37 CFR 1.33(a).			
<input type="checkbox"/> An Address is being provided for the correspondence information of this application.			
Customer Number	15671		
Email Address	flory@glbf.com	<input type="button" value="Add Email"/>	<input type="button" value="Remove Email"/>

Application Information:

Title of the Invention	EXTERIOR REARVIEW MIRROR ASSEMBLY		
Attorney Docket Number	DON09 P-1800	Small Entity Status Claimed <input type="checkbox"/>	
Application Type	Nonprovisional		
Subject Matter	Utility		
Suggested Class (if any)		Sub Class (if any)	
Suggested Technology Center (if any)			
Total Number of Drawing Sheets (if any)	16	Suggested Figure for Publication (if any)	

Application Data Sheet 37 CFR 1.76		Attorney Docket Number	DON09 P-1800
		Application Number	
Title of Invention	EXTERIOR REARVIEW MIRROR ASSEMBLY		

Publication Information:

Request Early Publication (Fee required at time of Request 37 CFR 1.219)

Request Not to Publish. I hereby request that the attached application not be published under 35 U.S.C. 122(b) and certify that the invention disclosed in the attached application **has not and will not** be the subject of an application filed in another country, or under a multilateral international agreement, that requires publication at eighteen months after filing.

Representative Information:

Representative information should be provided for all practitioners having a power of attorney in the application. Providing this information in the Application Data Sheet does not constitute a power of attorney in the application (see 37 CFR 1.32). Enter either Customer Number or complete the Representative Name section below. If both sections are completed the Customer Number will be used for the Representative Information during processing.

Please Select One:	<input checked="" type="radio"/> Customer Number	<input type="radio"/> US Patent Practitioner	<input type="radio"/> Limited Recognition (37 CFR 11.9)
Customer Number	15671		

Domestic Benefit/National Stage Information:

This section allows for the applicant to either claim benefit under 35 U.S.C. 119(e), 120, 121, or 365(c) or indicate National Stage entry from a PCT application. Providing this information in the application data sheet constitutes the specific reference required by 35 U.S.C. 119(e) or 120, and 37 CFR 1.78(a)(2) or CFR 1.78(a)(4), and need not otherwise be made part of the specification.

Prior Application Status	Pending		Remove		
Application Number	Continuity Type	Prior Application Number	Filing Date (YYYY-MM-DD)		
	Continuation of	12911274	2010-10-25		
Prior Application Status	Patented		Remove		
Application Number	Continuity Type	Prior Application Number	Filing Date (YYYY-MM-DD)	Patent Number	Issue Date (YYYY-MM-DD)
12911274	Continuation of	12851045	2010-08-05	7934843	2011-05-03
Prior Application Status	Patented		Remove		
Application Number	Continuity Type	Prior Application Number	Filing Date (YYYY-MM-DD)	Patent Number	Issue Date (YYYY-MM-DD)
12851045	Continuation of	12197666	2008-08-25	7842154	2010-11-30
Prior Application Status	Patented		Remove		
Application Number	Continuity Type	Prior Application Number	Filing Date (YYYY-MM-DD)	Patent Number	Issue Date (YYYY-MM-DD)
12197666	Division of	10709434	2004-05-05	7420756	2008-09-02
Prior Application Status	Expired		Remove		
Application Number	Continuity Type	Prior Application Number	Filing Date (YYYY-MM-DD)		
10709434	non provisional of	60471872	2003-05-20		

Under the Paperwork Reduction Act of 1995, no persons are required to respond to a collection of information unless it contains a valid OMB control number.

Application Data Sheet 37 CFR 1.76		Attorney Docket Number	DON09 P-1800
		Application Number	
Title of Invention	EXTERIOR REARVIEW MIRROR ASSEMBLY		

Additional Domestic Benefit/National Stage Data may be generated within this form by selecting the **Add** button.

Foreign Priority Information:

This section allows for the applicant to claim benefit of foreign priority and to identify any prior foreign application for which priority is not claimed. Providing this information in the application data sheet constitutes the claim for priority as required by 35 U.S.C. 119(b) and 37 CFR 1.55(a).

<input type="button" value="Remove"/>			
Application Number	Country ⁱ	Parent Filing Date (YYYY-MM-DD)	Priority Claimed
			<input type="radio"/> Yes <input checked="" type="radio"/> No
Additional Foreign Priority Data may be generated within this form by selecting the Add button.			<input type="button" value="Add"/>

Assignee Information:

Providing this information in the application data sheet does not substitute for compliance with any requirement of part 3 of Title 37 of the CFR to have an assignment recorded in the Office.

<input type="button" value="Remove"/>			
Assignee 1			
If the Assignee is an Organization check here. <input checked="" type="checkbox"/>			
Organization Name	Donnelly Corporation		
Mailing Address Information:			
Address 1	49 W. Third Street		
Address 2			
City	Holland	State/Province	MI
Country ⁱ	US	Postal Code	49424
Phone Number		Fax Number	
Email Address			
Additional Assignee Data may be generated within this form by selecting the Add button.			<input type="button" value="Add"/>

Signature:

A signature of the applicant or representative is required in accordance with 37 CFR 1.33 and 10.18. Please see 37 CFR 1.4(d) for the form of the signature.			
Signature	/taf/	Date (YYYY-MM-DD)	2011-12-23
First Name	Timothy	Last Name	Flory
		Registration Number	42540

Under the Paperwork Reduction Act of 1995, no persons are required to respond to a collection of information unless it contains a valid OMB control number.

Application Data Sheet 37 CFR 1.76		Attorney Docket Number	DON09 P-1800
		Application Number	
Title of Invention	EXTERIOR REARVIEW MIRROR ASSEMBLY		

This collection of information is required by 37 CFR 1.76. The information is required to obtain or retain a benefit by the public which is to file (and by the USPTO to process) an application. Confidentiality is governed by 35 U.S.C. 122 and 37 CFR 1.14. This collection is estimated to take 23 minutes to complete, including gathering, preparing, and submitting the completed application data sheet form to the USPTO. Time will vary depending upon the individual case. Any comments on the amount of time you require to complete this form and/or suggestions for reducing this burden, should be sent to the Chief Information Officer, U.S. Patent and Trademark Office, U.S. Department of Commerce, P.O. Box 1450, Alexandria, VA 22313-1450. DO NOT SEND FEES OR COMPLETED FORMS TO THIS ADDRESS. **SEND TO: Commissioner for Patents, P.O. Box 1450, Alexandria, VA 22313-1450.**

Privacy Act Statement

The Privacy Act of 1974 (P.L. 93-579) requires that you be given certain information in connection with your submission of the attached form related to a patent application or patent. Accordingly, pursuant to the requirements of the Act, please be advised that: (1) the general authority for the collection of this information is 35 U.S.C. 2(b)(2); (2) furnishing of the information solicited is voluntary; and (3) the principal purpose for which the information is used by the U.S. Patent and Trademark Office is to process and/or examine your submission related to a patent application or patent. If you do not furnish the requested information, the U.S. Patent and Trademark Office may not be able to process and/or examine your submission, which may result in termination of proceedings or abandonment of the application or expiration of the patent.

The information provided by you in this form will be subject to the following routine uses:

1. The information on this form will be treated confidentially to the extent allowed under the Freedom of Information Act (5 U.S.C. 552) and the Privacy Act (5 U.S.C. 552a). Records from this system of records may be disclosed to the Department of Justice to determine whether the Freedom of Information Act requires disclosure of these records.
2. A record from this system of records may be disclosed, as a routine use, in the course of presenting evidence to a court, magistrate, or administrative tribunal, including disclosures to opposing counsel in the course of settlement negotiations.
3. A record in this system of records may be disclosed, as a routine use, to a Member of Congress submitting a request involving an individual, to whom the record pertains, when the individual has requested assistance from the Member with respect to the subject matter of the record.
4. A record in this system of records may be disclosed, as a routine use, to a contractor of the Agency having need for the information in order to perform a contract. Recipients of information shall be required to comply with the requirements of the Privacy Act of 1974, as amended, pursuant to 5 U.S.C. 552a(m).
5. A record related to an International Application filed under the Patent Cooperation Treaty in this system of records may be disclosed, as a routine use, to the International Bureau of the World Intellectual Property Organization, pursuant to the Patent Cooperation Treaty.
6. A record in this system of records may be disclosed, as a routine use, to another federal agency for purposes of National Security review (35 U.S.C. 181) and for review pursuant to the Atomic Energy Act (42 U.S.C. 218(c)).
7. A record from this system of records may be disclosed, as a routine use, to the Administrator, General Services, or his/her designee, during an inspection of records conducted by GSA as part of that agency's responsibility to recommend improvements in records management practices and programs, under authority of 44 U.S.C. 2904 and 2906. Such disclosure shall be made in accordance with the GSA regulations governing inspection of records for this purpose, and any other relevant (i.e., GSA or Commerce) directive. Such disclosure shall not be used to make determinations about individuals.
8. A record from this system of records may be disclosed, as a routine use, to the public after either publication of the application pursuant to 35 U.S.C. 122(b) or issuance of a patent pursuant to 35 U.S.C. 151. Further, a record may be disclosed, subject to the limitations of 37 CFR 1.14, as a routine use, to the public if the record was filed in an application which became abandoned or in which the proceedings were terminated and which application is referenced by either a published application, an application open to public inspections or an issued patent.
9. A record from this system of records may be disclosed, as a routine use, to a Federal, State, or local law enforcement agency, if the USPTO becomes aware of a violation or potential violation of law or regulation.

DECLARATION AND POWER OF ATTORNEY

As a below named inventor, I hereby declare:

My residence, post office address and citizenship are as stated below next to my name.

I believe I am the original, first and sole inventor, if only one name is listed below, or an original, first and joint inventor, if plural names are listed below, of the subject matter which is claimed and for which a patent is sought on the invention entitled MIRROR REFLECTIVE ELEMENT, the specification of which was filed on May 5, 2004 as application Serial No. 10/709,434.

I have reviewed and understand the contents of the above-identified specification, including the claims, as amended by any amendment referred to above.

I acknowledge the duty to disclose to the United States Patent and Trademark Office (the Office), all information which is known by me to be material to patentability as defined in Title 37, Code of Federal Regulations (C.F.R.), Section 1.56.

CLAIM OF PRIORITY

I hereby claim the benefit under Title 35, United States Code, § 119(e) of any United States provisional application(s) listed below:

U.S. Serial No. 60/471,872, filed on May 20, 2003.

POWER OF ATTORNEY

I hereby appoint the patent law firm of Van Dyke, Gardner, Linn & Burkhart, LLP, 2851 Charlevoix Drive, S.E., Suite 207, Grand Rapids, Michigan 49546, telephone number 616/975-5500, facsimile number 616/975-5505, and the individual patent attorneys and patent agents at such patent law firm, namely, Daniel Van Dyke, Reg. No. 25 046; Donald S. Gardner, Reg. No. 25 975; Terence J. Linn, Reg. No. 30 283; Frederick S. Burkhart, Reg. No. 29 288; Catherine S. Collins, Reg. No. 37 599; Timothy A. Flory, Reg. No. 42 540; and Karl T. Ondersma, Reg. No. 55 894 my attorney(s) or agent(s) with full power of substitution and revocation, to prosecute this application and to transact all business in and to receive all correspondence from the Patent and Trademark Office connected therewith.

All statements made herein of my own knowledge are true and all statements made on information and belief are believed to be true, and further, these statements are made with the knowledge that willful false statements and the like are punishable by fine or imprisonment, or both, under 18 U.S.C. § 1001, and that such willful false statements may jeopardize the validity of this application or any patent issued thereon.

Sole inventor:

Niall R. Lynam _____ Date 8/12/04

Citizenship: U.S.A.

Residence: 248 Foxdown
Holland, Michigan 49424
United States of America

Post Office Address: Same as above.

EXTERIOR REARVIEW MIRROR ASSEMBLY
CROSS REFERENCE TO RELATED APPLICATIONS

[0001] The present application is a continuation of U.S. patent application Ser. No. 12/911,274, filed Oct. 25, 2010 (Attorney Docket DON09 P-1651), which is a continuation of U.S. patent application Ser. No. 12/851,045, filed Aug. 5, 2010, now U.S. Pat. No. 7,934,843, which is a continuation of U.S. patent application Ser. No. 12/197,666, filed Aug. 25, 2008, now U.S. Pat. No. 7,842,154, which is a division of U.S. patent application Ser. No. 10/709,434, filed May 5, 2004, now U.S. Pat. No. 7,420,756, which claims the benefit of U.S. provisional application, Ser. No. 60/471,872, filed May 20, 2003, which are hereby incorporated herein by reference in their entireties.

FIELD OF THE INVENTION

[0002] The present invention relates generally to rearview mirror elements for a rearview mirror assembly of a vehicle and, more particularly, to exterior rearview mirror elements comprising multi-radius reflective elements.

BACKGROUND OF THE INVENTION

[0003] Typically, mirror reflective elements are formed of glass and have a reflective coating deposited thereon, such as via vacuum deposition or wet chemical silvering or the like, such as on a silver line, such as described in U.S. Pat. No. 4,737,188, which is hereby incorporated herein by reference. Polymeric reflective elements are also known, such as are described in U.S. Pat. Nos. 6,601,960; 6,409,354; 4,944,581; 4,385,804; 4,193,668; 4,666,264; and 5,483,386, which are hereby incorporated herein by reference. For such polymeric mirror reflective elements, the need exists for a hard coat or surface on the first or outer or exterior surface of the element which is contacted by the exterior elements, such as rain, road debris, or the like, or contacted, for example, by a person scraping ice or wiping snow or condensation off the mirror element outer surface, such as during winter. A variety of hard coats have been proposed in the art, typically applied by dip coating or vacuum deposition techniques. However, a need exists for an automotive mirror reflective element which has the properties of plastic (i.e., a specific gravity roughly half that of glass), and which has a glass-like exterior surface.

[0004] Also, exterior rearview mirror reflective elements may be aspheric or multi-radius, and may typically have a less curved or substantially flat (around 2000 mm radius or thereabouts) inboard

portion or surface at the inboard side of the reflective element (i.e., closer to the side body of the vehicle when the mirror assembly is mounted to the vehicle), and a more curved multi-radius portion or surface at the outboard side of the reflective element (i.e., further from the side body of the vehicle when the mirror assembly is mounted to the vehicle), in order to provide an extended field of view. It is typically desirable to have the reflective elements or substrates of such exterior mirror elements to be formed of a glass material because glass material typically provides an enhanced scratch resistance over conventional optical resins and the like.

[0005] Therefore, there is a need in the art for a mirror reflective element that overcomes the shortcomings of the prior art elements and substrates.

SUMMARY OF THE INVENTION

[0006] The present invention provides a molded wide angle or multi-radius substrate for a reflective element. The molded substrate comprises a polymeric optical resin transparent material and has a curved exterior surface, which may have a less curved/flatter or substantially flat inboard portion or surface and a more curved outboard portion or surface. The molded substrate may have an anti-abrasion film or layer, such as an ultrathin glass film, applied over the exterior surface or first surface to provide substantial protection against scratches occurring to the molded substrate. The inner surface or second surface of the reflective element substrate may have a reflective coating or layer, such as a polymeric reflective film, laminated or adhered or otherwise applied thereto.

[0007] According to an aspect of the present invention, a wide angle reflective element for a mirror assembly for a vehicle includes a wide angle substrate having an exterior surface and a glass film disposed at the exterior surface. The exterior surface of the substrate has a less curved inboard portion or surface and a more curved outboard portion or surface. The substrate comprises a polymeric resin material. The glass film is adapted to substantially conform to the exterior surface of the wide angle substrate. The glass film comprises a glass material and has a thickness of less than approximately 0.8 mm.

[0008] According to another aspect of the present invention, a reflective element for a mirror assembly for a vehicle comprises a substrate having an exterior surface, and an anti-abrasion film applied to the exterior surface. The substrate comprises a polymeric resin material, such as a transparent optical polymeric resin material. The anti-abrasion film preferably comprises a glass material (such as a soda lime glass or a borosilicate or the like) and has a thickness of less than approximately 0.8 mm, and is flexible to conform to the exterior surface.

- [0009] The substrate may be cut from a strip or sheet of molded or extruded or cast substrate material (or less preferably, may be cut from an injected molded strip or sheet). The flexible glass film may be unrolled from a reel or roll and applied to the exterior surface of the elongated strip or sheet of substrate material. The substrate, including the glass film or layer, may then be cut or otherwise formed from the elongated strip or sheet.
- [0010] The substrate may comprise a wide angle substrate and/or may comprise a multi-radius exterior surface having a less curved inboard portion or surface and a more curved outboard portion or surface.
- [0011] A reflective film or layer may be applied to the inner surface or side of the substrate or strip opposite the exterior surface. The reflective film may comprise a polymeric reflective film laminated or otherwise adhered or applied to the inner side of the substrate or strip. The reflective film may comprise an all polymer-thin-film multilayer, high reflective mirror film comprising multiple coextrusion of many plastic layers to form a highly reflective mirror film.
- [0012] Optionally, a reflective film or layer may be applied to the exterior surface of the substrate or sheet or strip, and the glass film or layer or sheet may be applied over the reflective film layer. In such an application, the substrate acts as a support or backing plate for the reflective film or layer and the glass film or layer, whereby optical clarity / transparency of the substrate material is not necessary.
- [0013] According to another aspect of the present invention, a method for forming a reflective element substrate for a mirror assembly of a vehicle comprises generally continuously forming an elongated strip or sheet of substrate material and applying a substantially transparent functional film, such as an anti-abrasion film or a hydrophilic film or a hydrophobic film or the like, to a surface of the elongated strip sheet. The substrate material may comprise a transparent optical polymeric resin. The functional film is preferably unrolled from a reel or roll of film and applied to the surface of the elongated strip or sheet generally continuously as the strip or sheet is formed or extruded or cast or molded. Preferably, multiple mirror element shapes or mirror element substrates may be cut or otherwise formed from the elongated sheet after the functional film is applied to the surface of the strip or sheet.
- [0014] The functional or anti-abrasion film may comprise an ultrathin glass material which is sufficiently flexible to be provided in a reel or roll (or in a sheet that is flexible and conformable to a bent substrate). The substrates may be formed with a wide angle exterior surface or a multi-radius

exterior surface. The anti-abrasion film may be sufficiently flexible to conform to the wide angle or multi-radius or curved exterior surface.

[0015] A reflective film, such as a polymeric reflective film or the like, may be applied to the opposite surface of the substrate or sheet or strip. The reflective film may be sufficiently flexible to be provided in a reel or roll form (or in a sheet that is flexible and conformable to a bent substrate) for unrolling the reflective film as the film is generally continuously applied to the surface of the generally continuously formed sheet or strip.

[0016] Therefore, the present invention provides a molded wide angle or multi-radius single substrate for a rearview mirror assembly which has an anti-abrasion or anti-scratch film or layer applied to the curved, wide angle or multi-radius exterior surface of the substrate. The anti-abrasion film preferably comprises an ultrathin glass film or sheet to provide enhanced scratch resistance. The molded substrate may have a reflective film or layer laminated or applied to the inner surface opposite the exterior surface.

[0017] These and other objects, advantages, purposes and features of the present invention will become apparent upon review of the following specification in conjunction with the drawings.

BRIEF DESCRIPTION OF THE DRAWINGS

[0018] FIG. 1 is a perspective view of an exterior rearview mirror assembly in accordance with the present invention;

[0019] FIG. 2 is a perspective view of a wide angle or multi-radius reflective element in accordance with the present invention;

[0020] FIG. 3 is a sectional view of the wide angle or multi-radius reflective element taken along the line III-III in FIG. 2;

[0021] FIG. 4 is a sectional view similar to FIG. 3, showing a wide angle or multi-radius reflective element in accordance with the present invention with a reflective film or layer applied to the exterior surface of the element and an anti-abrasion film or layer applied over the reflective film or layer;

[0022] FIG. 5 is a diagram showing the extruding, coating and cutting processes for manufacturing a prismatic mirror reflective element in accordance with the present invention;

[0023] FIG. 5A is an elevation of the extruder of FIG. 5, showing the wedge shape of the extruded strip and reflective element substrate;

[0024] FIG. 6 is a plan view of the extruded strip showing the cut out shapes of the reflective element cut from the extruded strip;

- [0025] FIG. 7 is a sectional view of the reflective element formed by the process shown in FIG. 5;
- [0026] FIG. 8 is a diagram showing an alternate process for manufacturing a prismatic mirror reflective element in accordance with the present invention, where a strip of substrate material is cast and formed via a caster and float section;
- [0027] FIG. 9 is a perspective view of an automobile equipped with exterior sideview mirror assemblies according to this present invention;
- [0028] FIG. 10 is a top plan partial fragmentary view of the driver's side exterior rearview mirror assembly of FIG. 9;
- [0029] FIG. 11 is an enlarged sectional view of a plano-multiradius reflective element assembly of the mirror assembly in FIG. 10;
- [0030] FIG. 12 is an enlarged sectional view of a demarcation element of the plano-multiradius reflective element assembly of FIG. 11;
- [0031] FIGS. 13A-13H illustrate views of various locations for a plano reflective element and an auxiliary reflective element according to this present invention;
- [0032] FIG. 14 is a sectional view of a second embodiment of a plano reflective element assembly according to the present invention including a demarcation element formed as a dividing wall in a backing plate element;
- [0033] FIG. 14A is a cross-section taken along line XX of FIG. 14;
- [0034] FIG. 14B is a cross-sectional view taken along line YY of FIG. 14;
- [0035] FIG. 15 is a schematic of a third embodiment of a plano-auxiliary reflective element assembly according to this present invention;
- [0036] FIG. 16 is a front elevation view of another embodiment of a plano reflective element assembly according to the present invention;
- [0037] FIG. 17 is an exploded perspective view of the plano reflective element assembly of FIG. 16;
- [0038] FIG. 18 is an end view of the plano reflective element assembly of FIG. 16 as viewed from line XVIII--XVIII of FIG. 16;
- [0039] FIG. 19 is a top view of the plano reflective element assembly of FIG. 16 as viewed from line XIX--XIX of FIG. 16;
- [0040] FIG. 20 is a schematic representation of the plano reflective element assembly of FIG. 16 illustrating the orientation of the reflective element;

[0041] FIG. 21 is another schematic representation of the orientation of the reflective elements of the plano reflective element in FIG. 16;

[0042] FIG. 22 is a diagram illustrating the range of viewing of the reflective elements of the plano reflective element assembly of FIG. 16; and

[0043] FIG. 23 is a perspective view of another embodiment of an exterior rearview mirror system of the present invention.

DESCRIPTION OF THE PREFERRED EMBODIMENTS

[0044] Referring now to the drawings and the illustrative embodiments depicted therein, an exterior rearview mirror assembly 10 includes a reflective element 12 mounted at a casing 14, which is mounted at an exterior portion of a vehicle 16 (FIG. 1). Reflective element 12 may provide an enhanced field of view or wide angle field of view to a driver or occupant of the vehicle and may comprise a single reflective element substrate 18 having an inner surface 18a and an opposite exterior surface 18b (FIGS. 2 and 3). The exterior surface 18b comprises a less curved or substantially flat inboard portion or surface 18c and a more curved outboard portion or surface 18d, as discussed below. The substrate 18 may have an anti-abrasion coating or layer or film 20, such as an ultrathin glass coating or layer or film, laminated or deposited or otherwise applied to the exterior surface 18b, and may have a reflective coating or layer 22 laminated or applied to the inner surface 18a, as also discussed below. Aspects of the reflective element of the present invention may be suitable for use in a reflective element for an exterior rearview mirror assembly (as shown in FIG. 1) and/or a reflective element for an interior rearview mirror assembly (not shown).

[0045] Reflective element 12 may comprise an aspheric or multi-radius or wide angle single element reflective element substrate. The reflective element 12 may provide a field of view similar to the plano-auxiliary reflective element assembly disclosed in U.S. Pat. Nos. 6,522,451 and 6,717,712, which are hereby incorporated herein by reference.

[0046] As illustrated in FIG. 9 from U.S. Pat. No. 6,717,712, incorporated above, passenger automobile 110 (which may be a sedan, a station-wagon, a sports car, a convertible, a minivan, a sports utility vehicle, a pick-up truck or a similar passenger carrying non-commercial, personal transportation automobile) includes an interior rearview mirror assembly 127 positioned within interior vehicle cabin 125. Interior vehicle cabin 125 further includes a steering wheel 116, a driver seat 129 positioned at steering wheel 116, a front passenger seat 121 adjacent to driver seat 129 in the front portion of cabin 125, and a rear passenger seat 123 in the rear portion of cabin 125. Automobile 110 further includes a driver-side exterior sideview mirror assembly 112 and a

passenger-side exterior sideview mirror assembly 114, each adapted for attachment to opposing sides of automobile body 111, most preferably adjacent to the seating position of the driver seated in driver seat 129 for driver-side assembly 112 and adjacent to the front passenger seat 121 for passenger-side assembly 114. Exterior sideview mirrors, mounted as shown in FIG. 9 close to the driver seating location, are commonly referred to as door-mounted exterior sideview mirror assemblies. Driver-side exterior sideview mirror assembly 112 includes, as illustrated in FIG. 10, a plano-multiradius exterior sideview reflective element assembly 130. Plano-multiradius reflective element assembly 130 is mounted to a reflective element positioning actuator 136. The orientation of plano-multiradius reflective element assembly 130, and hence its rearward field of view, is adjustable by actuator 136 in response to control 137. Control 137 can comprise a handset control that allows the driver manually move the orientation of plano-multiradius reflective element assembly 130 within exterior mirror housing 140 (such as by a lever control or by a cable control) and hence reposition the rearward field of view of plano-multiradius reflective element assembly 130. Alternately, when actuator 136 comprises an electrically actuated actuator that is electrically operable incorporating at least one motor, control 137 can comprise a switch (which, preferably, is operable under control of the driver seated in cabin 125) or control 137 can comprise a memory controller, as known in the automotive mirror art, that controls actuator 136 to move the position of plano-multiradius reflective element assembly 130 to a pre-set orientation that suits the rearward field of view preference of an individual driver. Actuator 136 is mounted to bracket 138 which attaches to vehicle body side 111. Plano-multiradius reflective element assembly 130 is positionable by actuator 136 within exterior mirror housing 140.

[0047] Plano-multiradius reflective element assembly 130, as shown in FIG. 11, comprises a plano element 150 and a separate multiradius element 155. Preferably, plano element 150 is adjacent to multiradius element at a joint. At their joint, plano element 150 and separate multiradius element 155 can touch leaving substantially no gap or space therebetween, or plano element 150 and separate multiradius element 155 can be spaced apart at their joint by a space or gap, as in FIG. 11. Plano element 150 and multiradius element 155 are both mounted to surface 159 of, and are both supported by, a single backing plate element 160. Plano element 150 and multiradius element 155 are demarcated apart by demarcation element 165. Surface 161 of backing plate element 160 is preferably adapted to attach, such as by attachment member 164, to actuator 136 when plano-multiradius reflective element assembly 130 is mounted in driver-side exterior sideview mirror assembly 112 (and/or in passenger-side exterior side view mirror assembly 114) such that plano.

element 150 and multiradius element 155 are adjusted and positioned in tandem and simultaneously when the driver (or alternatively, when a mirror memory system, as is conventional in the rearview mirror arts) activates actuator 136 to reposition the rearward field of view of plano-multiradius reflective element assembly 130. Thus, since elements 150, 155 are part of plano-multiradius reflective element assembly 130, movement of plano-multiradius reflective element assembly 130 by actuator 136 simultaneously and similarly moves plano element 150 and multiradius element 155.

[0048] Plano element 150 preferably comprises a flat reflector-coated glass substrate having unit magnification, and comprises a reflective surface through which the angular height and width of the image of an object is equal to the angular height and width of the object when viewed at the same distance (except for flaws that do not exceed normal manufacturing tolerances). Plano element 150 may comprise a conventional fixed reflectance mirror reflector or it may comprise a variable reflectance mirror reflector whose reflectivity is electrically adjustable. For example, plano element 150 may comprise a flat glass substrate coated with a metallic reflector coating such as a chromium coating, a titanium coating, a rhodium coating, a metal alloy coating, a nickel-alloy coating, a silver coating, an aluminum coating (or any alloy or combination of these metal reflectors). The metal reflector coating of plano element 150 may be a first surface coating (such as on surface 166) or a second surface coating (such as on surface 167), as such terms are known in the mirror art. The reflector coating on plano element 150 may also comprise a dielectric coating, or a multilayer of dielectric coatings, or a combination of a metal layer and a dielectric layer to form automotive mirror reflectors as known in the automotive mirror art. If a variable reflectance reflector element, plano element 150 preferably comprises an electro-optic reflector element and, most preferably, an electrochromic reflector element.

[0049] When mounted into exterior side view mirror assembly 112 and/or 114, plano-multiradius reflective element assembly 130 is preferably orientated so that at least a portion of (more preferably a substantial portion of) the reflector surface of plano element 150 is positioned closer to the vehicle body (and hence to the driver) than any portion of the reflector surface of multiradius element 155. Thus, and referring to FIG. 11, side A of plano element 150 of plano-multiradius reflective element assembly 130 is positioned closer to the driver than side D of multiradius element 155 when plano-multiradius reflective element assembly 130 is mounted on an automobile. Also, when mounted into exterior side view mirror assembly 112 and/or 114, surfaces 166, 168 of plano-

multiradius reflective element assembly 130 face rearwardly in terms of the direction of vehicle travel.

[0050] Multiradius element 155 of plano-multiradius reflective element assembly 130 preferably comprises a curved/bent mirrored glass substrate. The degree of curvature preferably increases (and hence the local radius of curvature decreases) across the surface of multiradius element 155 with the least curvature (largest radius of curvature) occurring at the side of multiradius element 155 (side C in FIG. 11) positioned adjacent its joint to plano element 150 when both are mounted on backing plate element 160. Thus, and referring to FIG. 11, the local radius of curvature at side C of multiradius element 155, when mounted on backing plate element 160, is larger than at side D. Also, the local radius of curvature preferably progressively decreases across multiradius element 155 from side C to side D. Preferably, the local radius of curvature at side C of multiradius element 155 is at least about 1000 mm; more preferably is at least about 2000 mm and most preferably is at least about 3000 mm whereas the local radius of curvature at side D of multiradius element 155 is, preferably, less than about 750 mm, more preferably less than about 350 mm; most preferably less than about 150 mm. Preferably, multiradius element 155 comprises a bent glass substrate with radii of curvature in the range of from about 4000 mm to about 50 mm. The multiradius prescription for the multiradius element to be used in a particular exterior mirror assembly can vary according to the specific field of view needs on a specific automobile model.

[0051] The total field of view rearwardly of the automobile of the plano-auxiliary reflective element assembly (which is a combination of the field of view of the plano reflective element and of the auxiliary reflective element) preferably generally subtends an angle of at least about 20 degrees (and more preferably, generally subtends an angle of at least about 25 degrees and most preferably, generally subtends an angle of at least about 30 degrees) with respect to the side of an automobile to which is attached an exterior sideview mirror assembly equipped with the plano-auxiliary reflective element assembly.

[0052] Multiradius element 155 may comprise a conventional fixed reflectance mirror reflector or it may comprise a variable reflectance mirror reflector whose reflectivity is electrically adjustable. For example, multiradius element 155 may comprise a flat glass substrate coated with a metallic reflector coating such as a chromium coating, a titanium coating, a rhodium coating, a metal alloy coating, a nickel-alloy coating, a silver coating, an aluminum coating (or any alloy or combination of these metal reflectors). The metal reflector coating of multiradius element 155 may be a first surface coating (such as on surface 168) or a second surface coating (such as on surface 169), as

such terms are known in the mirror art. The reflector coating on multiradius element 155 may also comprise a dielectric coating, or a multilayer of dielectric coatings, or a combination of a metal layer and a dielectric layer to form automotive mirror reflectors as known in the automotive mirror art. If a variable reflectance reflector element, multiradius element 155 preferably comprises an electro-optic reflector element and, most preferably, an electrochromic reflector element.

[0053] Also, it is preferable that the thickness of plano element 150 and multiradius element 155 be substantially the same in dimension so that their respective outer surfaces, 166 and 168, are substantially coplanar so that a driver can readily view images in either or both elements. The thickness dimension of elements 150, 155 is determined by the thickness of the substrate (or in the case of laminate-type electrochromic reflective elements, the thickness of the two substrates between which the electrochromic medium is disposed). For example, plano element 150 and/or multiradius element 155 can comprise a reflector coated glass substrate or panel of thickness preferably equal to or less than about 2.3 mm, more preferably equal to or less than about 1.6 mm, most preferably equal to or less than about 1.1 mm. Use of a thinner substrate is beneficial in terms of improving the overall stability/vibration performance of the image seen in plano-multiradius reflective element assembly 130 when mounted to an automobile.

[0054] The reflector area of plano element 150 is preferably larger than that of multiradius element 155. Preferably, the width dimension of plano element 150 is larger than the width dimension of multiradius element 155 (both width dimensions measured at their respective widest dimension and with the width of the respective element being gauged with the respective element oriented as it would be orientated when mounted on the automobile). Thus, and referring to FIG. 11, the distance from side A to side B of plano element 150 is larger than the distance from side C to side D of multiradius element 155. Thus, the ratio of the width of plano element 150 to the width of multiradius element 155 is preferably greater than 1; more preferably greater than 1.5; most preferably greater than 2.5 in order to provide a large, unit magnification plano element 150 as the principal rear viewing portion of plano-multiradius reflective element assembly 130 and providing multiradius element 155 as a smaller, auxiliary, separate, wide-angle viewing portion of plano-multiradius reflective element assembly 130. For plano-multiradius reflective element assemblies to be mounted to the exterior sideview assemblies of passenger automobiles used non-commercially and for non-towing purpose, the width of plano element 150 (at its widest dimension) is preferably in the range of from about 50 mm to about 225 mm; more preferably in the range of from about 75 mm to about 175 mm; most preferably in the range of from about 100 mm to about 150 mm.

[0055] Backing plate element 160 is preferably a rigid polymeric substrate capable of supporting plano element 50 and multiradius element 155. Backing plate element 160 comprises a flat portion (generally between E and F as shown in FIG. 11) that corresponds to and is aligned with plano element 150. Backing plate element 60 also comprises a curved portion (generally between G and H as shown in FIG. 11) that corresponds to and is aligned with multiradius element 155. Preferably, curved portion G-H of multiradius element 155 is fabricated with a multiradius prescription that is substantially the same as the multiradius prescription of multiradius element 155. Backing plate element 160 is formed as a single element to which elements 150 and 155 are separately attached. Preferably, backing plate element 160 is formed by injection molding of a thermoplastic or a thermosetting polymer resin. Materials suitable to use for backing plate element 160 include unfilled or filled polymeric materials such as glass and/or mineral filled nylon or glass and/or mineral filled polypropylene, ABS, polyurethane and similar polymeric materials. For example, backing plate element 160 can be formed of ABS in an injection molding operation. Plano element 150 can be cut from a stock lite of flat chromium mirror-coated 1.6 mm thick glass. Multiradius element 155 can be cut from a stock lite of multiradiusly-bent chromium mirror-coated 1.6 mm thick glass. Plano element 150 and multiradius element 155 can then be attached (such as by an adhesive attachment such as an adhesive pad or by mechanical attachment such by clips, fasteners or the like) to the already molded backing plate element 160. Alternatively, plano element 150 and multiradius element 155 can each be individually loaded into an injection molding tool. Once loaded, a polymeric resin (or the monomers to form a polymeric resin) can be injected into the mold in order to integrally form backing plate element 160 with elements 150, 155 integrally molded thereto. Integral molding of the backing plate element to plano element 150 and multiradius element 155 (along with any other elements such as the demarcation element 165) in a single integral molding operation, is a preferred fabrication process for plano-multiradius reflective element assembly 130.

[0056] Plano-multiradius reflective element assembly 130 further preferably includes demarcation element 165 that functions to delineate and demarcate the plano region of the assembly from the wide-angle, multiradius region and also preferably functions to prevent ingress of debris, dirt, water and similar contaminants (such as road splash, car wash spray, rain, snow, ice, leaves, bugs and similar items that plano-multiradius reflective element assembly 130 would be subject to when mounted and used on an automobile) into any gap between plano element 150 and multiradius element 155 when both are attached to backing plate element 160. Optionally, at least a portion of

demarcation element 165 can be disposed in any gap between plano element 150 and multiradius element 155 at their joint on backing plate element 160. Preferably, demarcation element 165 is formed of a polymeric material that is dark colored (such as black or dark blue or dark brown or dark grey or a similar dark color) such as a dark colored polypropylene resin or a dark colored nylon resin or a dark colored polyurethane resin or a dark colored polyvinyl chloride resin or a dark colored silicone material. Most preferably demarcation element 165 is formed of an at least partially elastomeric material (such as silicone, or EPDM, or plasticized PVC or the like) in order to provide a degree of vibration dampening for elements 150, 155. As shown in FIG. 12, demarcation element 165 optionally includes a crown portion 170 that includes wing portions 173, 173' and a stem portion 171. Stem portion 171 preferably has a cross-sectional width CCC of less than about 4 mm, more preferably less than about 3 mm and, most preferably less than about 2 mm. Crown portion 170 preferably is dimensioned to not protrude substantially beyond surfaces 166, 168 of elements 150, 155 when demarcation element 165 is installed between elements 150 and 155. Also, wings 173, 173' are preferably dimensioned to protrude (most preferably slightly) onto surfaces 166, 168 of elements 150, 155 when demarcation element 165 is installed between elements 150 and 155 in order to provide a weather barrier seal and/or to at least partially accommodate any dimensional tolerances of elements 150, 155 that could lead to variation in the inter-element gap between sides C and B. While the demarcation element shown in FIG. 12 is one embodiment, other constructions are possible including a demarcation element that has minimal or no crown portion. Likewise, a demarcation element can have little or no stem portion, especially when the joint between plano element 150 and multiradius element 155 includes no gap to receive a stem. Also, where a gap at the plano to multiradius joint exists, any stem of the demarcation element can at least partially be disposed in such gap so as to at least partially fill the gap (or it can optionally substantially fill the gap). Optionally, demarcation element 165 is fabricated by injection molding of a polymeric resin. After plano element 150 and multiradius element 155 have been attached to backing plate element 160, a separately formed demarcation element 165 can then be inserted (and secured such as by an adhesive or by a mechanical attachment such as by a fastener) into a space between elements 150 and 155. Note that, optionally, side B of plano element 150 and side C of multiradius element 155 can touch (leaving substantially no gap or space therebetween). In such a situation, demarcation element 165 can comprise a dark colored strip such as of a tape or of a plastic film that covers the joint between elements 150 and 155. Alternatively, demarcation element 165 can comprise a preferably dark-colored paint, lacquer, caulk or similar material that can be applied to, and that can

preferably fill into, the joint between elements 150 and 155. The width of the portion of demarcation element 165 that is visible to the driver is preferably less than about 4 mm, more preferably less than about 3 mm and most preferably less than about 2 mm, but is equal to or greater than about 0.5 mm, more preferably is equal to or greater than about 0.75 mm, most preferably is equal to or greater than about 1 mm in order to provide adequate demarcation of the plano region from the multiradius radius region without unduly obscuring the rearward field of view of the respective elements. Optionally, demarcation element 165 can be formed as part of backing plate element 160 such as by forming demarcation element 165 as a wall structure of the backing plate element that partitions backing plate element 160 into two regions: A first region adapted to receive plano reflective element 150 and a separate and adjacent second region adapted to receive multiradius reflective element 155.

[0057] Thus, and referring to FIG. 14, a second embodiment of plano-multiradius reflective element assembly 130' may include a backing plate element 160' which comprises a plate molded from a polymer resin (such as a polyolefin such as polypropylene or such as ABS or nylon) with a demarcation element 165' that is molded as a wall structure that partitions backing plate element 165' into a first region (from CC to BB) adapted to receive and accommodate plano reflective element 150' and into a second region (from BB to AA) adapted to receive and accommodate wide-angle optic multiradius reflective element 155'. Note that section AA to BB of backing plate element 160' is angled to section BB to CC. Such angling of the auxiliary reflective element relative to the plano element can be advantageous in allowing the auxiliary reflective element view a portion of the road adjacent the automobile that is in a blind spot of the plano reflective element. In this regard, it is preferable that the multiradius element be angled away from the plane of the plano element, as shown in FIG. 14 by the angling of section AA to BB to section BB to CC.

[0058] Preferably, demarcation element 165 is formed in an integral molding operation, along with formation of backing plate element 160, and attachment of elements 150, 155 thereto. For example, plano element 150 and multiradius element 155 can each be individually loaded into an injection molding tool. Once loaded, a polymeric resin (or the monomers to form a polymeric resin) can be injected into the mold in order to integrally form backing plate element 160 with elements 150, 155 integrally molded thereto and, in the same molding operation and in the same tool, also form by molding the demarcation element. Integral molding of the backing plate element to plano element 150 and multiradius element 155 along with creation in the single molding operation of demarcation element 165, (along with any other elements such as attachment member 164) in a single integral

molding operation, is a preferred fabrication process for plano-multiradius reflective element assembly 130. By loading all the sub components of plano-multiradius reflective element assembly 130 into a molding tool, and then injecting polymeric resin to form the backing plate, demarcation member and any attachment member, a substantially complete or fully complete plano-multiradius reflective element assembly can be unloaded from the tool at the completion of the integral molding operation (as known in the molding art), thus enabling economy in manufacturing and accommodation of any dimensional tolerances in the sub components. Where integral molding is so used, it is preferable to use a reactive molding operation such as reactive injection molding of a urethane as such reactive injection molding operations occur at relatively modest temperatures.

[0059] Plano element 150 and/or multiradius element 155 can comprise a heater element, as known in the automotive mirror art, that is operable to deice/demist surfaces 166, 168. Such heater elements are conventional and can comprise a positive temperature coefficient heater pad, a resistive heater element and/or a conductive coating. Plano element 150 and/or multiradius element 155 can also optionally comprise a scatterproofing member, as known in the automotive mirror art, such as an adhesive tape, to enhance safety in an accident.

[0060] Also, plano element 150 and/or multiradius element 155 can comprise a variable reflectance electro-optic element such as an electrochromic mirror reflector. Thus, both element 150 and element 155 can comprise an electrochromic mirror element or either of element 150 and element 155 can comprise an electrochromic mirror element and the other can comprise a fixed reflectance non-variable reflectance mirror element such as a metal reflector coated glass panel such as a chromium coated glass substrate. Also, if both plano element 150 and multiradius element 155 comprise an electro-optic element such as an electrochromic mirror element capable of electrically dimmable reflectivity, both elements 150, 155 can dim together and in tandem under control of a common dimming control signal (typically provided by an electro-optic automatic dimming interior mirror assembly mounted in the cabin of the automobile and equipped with photosensors to detect incident glare and ambient light). Alternately, if both plano element 150 and multiradius element 155 comprise an electrooptic element such as an electrochromic mirror element capable of electrically dimmable reflectivity, element 150 can dim independently of element 155 (such as is disclosed in U.S. Pat. No. 5,550,677, the entire disclosure of which is incorporated by reference in U.S. Pat. No. 6,717,712, incorporated herein above). If either or both of elements 150, 155 comprise an electrochromic element, preferably, the electrochromic reflective element comprises a front substrate and a rear substrate with an electrochromic medium disposed between, such as a

solid polymer matrix electrochromic medium such as is disclosed in U.S. patent application Ser. No. 09/350,930, filed Jul. 12, 1999, entitled "ELECTROCHROMIC POLYMERIC SOLID FILMS, MANUFACTURING ELECTROCHROMIC DEVICES USING SUCH FILMS, AND PROCESSES FOR MAKING SUCH SOLID FILMS AND DEVICES" to Desaraju V. Varaprasad et al., now U.S. Pat. No. 6,154,306, or such as is disclosed in U.S. Pat. Nos. 5,668,663; 5,724,187; 5,910,854; and 5,239,405, the entire disclosures of which are incorporated by reference in U.S. Pat. No. 6,717,712, incorporated herein above. Most preferably, in such laminate-type electrochromic mirror reflective elements, the front substrate comprises a glass plate of thickness less than about 1.6 mm, most preferably about 1.1 mm thickness or lower, and the rear substrate comprises a glass plate of thickness equal to or greater than about 1.6 mm, more preferably greater than about 1.8 mm thickness, most preferably equal to or greater than about 2.0 mm thickness. The rearmost surface of the rear substrate (the fourth surface as known in the mirror art) is reflector coated with a high reflecting metal film such as of aluminum or silver, or an alloy of aluminum or silver. Most preferably, the front-most surface of the rear substrate (the third surface as known in the mirror art) is reflector coated with a high reflecting metal film such as of aluminum or silver, or an alloy of aluminum or silver.

[0061] Backing plate element 165 of plano-multiradius reflective element assembly 130 is optionally equipped on its rearmost surface with attachment member 164 to facilitate attachment to the reflector-positioning actuator of the exterior sideview mirror assembly that plano-multiradius reflective element assembly 130 is mounted to. Attachment of plano-multiradius reflective element assembly 130 to the actuator can be by mechanical attachment such as by a tab, clip or fastener, or may be by adhesive attachment such as by a silicone adhesive, a urethane adhesive or a similar adhesive material such as a tape coated on both surfaces with a pressure sensitive adhesive to form a "double-sticky" tape. The exterior sideview mirror assembly, on whose mirror reflector-positioning actuator the plano-multiradius reflective element assembly is mounted, can be a fixedly attached exterior sideview mirror assembly, a break-away exterior sideview mirror assembly and a powerfold exterior sideview mirror assembly, as known in the automotive mirror art.

[0062] FIGS. 13A-13H shows various arrangements of multiradius reflective element 155 relative to its adjacent plano reflective element 150 (with demarcation element 165 disposed at their joint). In FIGS. 13A, 13B, 13C, 13E and 13F, plano element 150 is mounted wholly inboard of multiradius element 155. Thus, in FIGS. 13A, 13B, 13C, 13E and 13F, plano element 150 would be disposed closer to the vehicle body (and hence to the driver) than multiradius element 155 when plano-

multiradius reflective element assembly 130 was mounted in an exterior sideview mirror attached to a side of an automobile. Therefore, in FIGS. 13A, 13B, 13C, 13E and 13F, plano element 150 would be mounted inboard relative to the side of the automobile and multiradius element 155 would be mounted outboard relative to the side of the automobile. In general, the location of the multiradius reflective element in the outboard, upper portion of the plano-multiradius reflective element assembly, as in FIGS. 13B and 13E, is preferred as this allows the plano portion provide a desired rearward field of view along the side of the vehicle. The configuration as shown in FIG. 13G (where the multiradius reflective element is along the inboard side of the assembly) is also desirable as this allows the driver view the side of the vehicle (something many drivers desire in order to have a frame of reference for their rearward field of view) while facilitating having a wide field of view for the plano portion.

[0063]

Unlike trucks, busses and commercial vehicles the size of an exterior sideview mirror assembly suitable for use on an automobile (and especially when the automobile is not towing a trailer or the like) is restricted. Automobiles generally are non-commercial vehicles intended for personal transportation. Automobiles typically carry 5 passengers or less, although minivans and large sports utility vehicles (which are classified herein as automobiles) can have seat accommodation for up to 10 passengers (although accommodation for 7 passengers or less is more common). The tandem mounting of a plano element of unit magnification and a separate auxiliary element onto a common, single backing plate element, and the mounting of this backing plate element onto an actuator of an exterior sideview mirror assembly so that a driver can simultaneously and similarly move the auxiliary element and the plano element so as to position their respective rearward fields of view, and to achieve this within the relatively restricted space available in a standard automobile-sized exterior sideview mirror assembly is an important element of this present invention. By utilizing a plano element of unit magnification in the plano-multiradius reflective element assembly, and by sizing the reflector area of the plano element larger than the reflector area of the multiradius element and, preferably, by sizing the reflector area of the plano element at a sufficiently large size that the rearward field of view provided by the plano element alone meets and satisfies the minimum field of view requirement mandated by an automaker specification and/or a government regulation, the need to provide a safety warning indicia such as "OBJECTS IN MIRROR ARE CLOSER THAN THEY APPEAR" in the plano element and/or in the multiradius element can be obviated. Preferably, the plano element comprises a reflector surface area of a size sufficient, when mounted as part of a plano-multiradius reflective

element assembly in a driver-side exterior sideview mirror assembly on an automobile, to provide the driver of the automobile a view of a level road surface extending to the horizon from a line, perpendicular to a longitudinal plane tangent to the driver's side of the automobile at the widest point, extending 8 feet out from the tangent plane 35 feet behind the driver's eyes (at a nominal location appropriate for any 95th percentile male driver or at the driver's eye reference points established in Federal Motor Vehicle Standard No. 104), with the driver seated in the driver's seat and with the driver's seat in the rearmost position. Also, preferably, the aspect ratio of the plano-multiradius reflective element assembly (defined as the ratio of its largest vertical dimension to its largest horizontal dimension, measured with the plano-multiradius reflective element assembly oriented as it would be oriented when mounted in an exterior sideview mirror assembly on an automobile, and with "horizontal" being generally parallel with the road surface the automobile travels on and "vertical" being generally perpendicular to the road surface the automobile travels on) is preferably less than 1, more preferably less than 0.8, most preferably less than 0.6. Further, it is preferable that the multiradius element be disposed outboard (relative to the side of the vehicle and with the plano-multiradius reflective element assembly oriented as it would be when mounted in an exterior sideview mirror assembly on an automobile) on the plano-multiradius reflective element assembly so that the multiradius element is positioned to provide an auxiliary, wide-angle view of a "blind-spot" region in an adjacent sidelane while the more inboard-disposed plano element with unit magnification provides the principal sideview image to the driver.

[0064] Also, it is preferable that the principal axis of the rearward field of view of the multiradius element be different from and angled to the principal axis of the rearward field of view of the plano element when both are attached to the backing plate element of the plano-multiradius reflective element assembly and when the plano-multiradius reflective element assembly is mounted and operated in an exterior sideview mirror assembly on an automobile. Preferably, the principal axis of the rearward field of view of the plano element is directed generally parallel to the road that the automobile equipped with the plano-multiradius reflective element assembly is travelling on (i.e. generally parallel to the longitudinal axis of the automobile) so as to provide the driver with a long-distance view of approaching vehicles in the side lane that the plano element views). However, preferably the principal axis of the rearward field of view of the multiradius element of, for example, a door-mounted driver-side (or passenger-side) exterior sideview mirror assembly in which the plano-multiradius reflective element assembly is mounted is directed generally downwardly towards the road surface adjacent to the driver seating location and/or several feet

(such as about 1 foot to about 24 feet; more preferably, about 1 foot to about 12 feet; most preferably about 1 foot to about 8 feet in distance) to its rear (in order to capture a field of view of a rear approaching vehicle that is approaching to overtake, or is about to overtake, or is overtaking the automobile equipped with the plano-multiradius reflective element assembly). Thus, preferably, the principal axis of the rearward field of view of the multiradius element is angled and directed generally downwardly with respect to the longitudinal axis of the automobile and thus is at an angle to the principal axis of the rearward field of view of the plano element. For example, multiradius element 155' when attached to surface 173" of backing plate 160' (see FIG. 14B) would have its principal axis of rearward view as indicated by 180' as in FIG. 14B, and as such would be canted towards the road surface when mounted in an exterior sideview mirror assembly attached to the side of an automobile. By contrast, plano element 150' when attached to surface 174' of backing plate 160' (see FIG. 14A) would have a principal axis as indicated by 185' as in FIG. 14A and, as such, would be generally parallel to the road surface when mounted in an exterior sideview mirror assembly attached to the side of an automobile. Having the multiradius element canted somewhat downwards towards the road surface assists visual detection by the driver of overtaking vehicles in the traditional "blind-spot" in the adjacent side lane. The angle that the multiradius element is angled on the backing plate element of the plano-multiradius reflective element assembly relative to the plane of the plano reflective element will vary from automobile model to model, but generally is preferred to be in the about 1 degree to about 10 degrees range; about 2 degrees to about 8 degrees range more preferred; and about 3 degrees to about 6 degrees range most preferred. In order to conveniently achieve an angling of the multiradius portion with respect to the plano portion (and preferably a downward angling), the portion of the backing plate element that the multiradius reflective element is attached to can be angled relative to the adjacent portion of the backing plate element that the plano reflective portion is attached to. Thus, and referring to FIG. 14, plano-multiradius reflective element assembly 130' includes a molded polymeric backing plate element 160' comprising a generally flat portion 162' (between BB and CC in FIG. 14) and an adjacent curved portion 161' (between AA and BB). As indicated by 190' and 195', portion AA to BB of backing plate element 160' is generally angled to portion BB to CC of backing plate 160'. Preferably, the portion of backing plate element 160' to which the auxiliary reflective element attaches is angled towards the front (compared to the angling of plano reflective element) of an automobile equipped with the plano-auxiliary reflective element assembly of the present invention. FIG. 14 is a view of plano-multiradius reflective element assembly 130' as it would appear from

above the vehicle as it would be orientated in use (with portion 162' closer to the driver than portion 161'). The wall section, section XX in FIG. 14, taken through section 162' of backing plate element 160' is of substantially constant dimension (as illustrated in FIG. 14A) whereas the wall section, section YY in FIG. 14B, taken through section 161' of backing plate element 160' is of varying dimension and is angled. Plano reflective element 150' and multiradius reflective element 155' (for example, plano element 150' can comprise an electrochromic mirror element and multiradius element 155' can comprise a chrome coated glass reflector) are attached to portions 162' and 161', respectively. By being supported on the angled face 173" (see FIG. 14B) of portion 161', the principal viewing axis of multiradius reflector element 155' is angled downwards towards the road surface, as compared to the more horizontal-viewing principal viewing axis of plano element 150', when plano-multiradius reflective element 130' is mounted in an exterior sideview mirror assembly on an automobile. Demarcation element 165' is preferably molded in the same molding tool as is used to mold backing plate element 160', and so demarcation element 165' is formed as an integral part of backing plate element 160', forming a wall thereof that partitions the surface of backing plate element 160' into a region for receiving the plano reflective element 150' and a region for receiving the auxiliary reflective element 155'. Also, end-caps 170' and 171' are optionally provided. Plano reflective element 150' can attach into the cavity formed between demarcation element 165' and end-cap 171'; multiradius reflective element 155' can attach into the cavity formed between demarcation element 165' and end-cap 170'. Note that the portion of the backing plate element where the wide-angle optic multiradius element attaches can have a thicker wall thickness than that of the portion of the backing plate element where the unit magnification optic element attaches in order to allow for the angling of the multiradius element downwardly relative to the angle of the plano element, as illustrated in FIGS. 14A-B. As illustrated in FIGS. 14A-B, the angle downwards to the longitudinal axis of the vehicle of the multiradius element can generally be set by an angling of a surface of the backing plate element in order to ensure that the principal axis of the rearward field of view of the plano element is directed generally parallel to the longitudinal axis of an automobile equipped with the plano-multiradius reflective element assembly and that the principal axis of the rearward field of view of the multiradius element is directed generally at an angle downwards to the longitudinal axis of the automobile.

[0065] Note that the provision of the plano-multiradius reflective element assembly of this invention as a unitary module has manufacturing advantages, particularly for exterior sideview mirror assembly manufacturers who can procure a plano-multiradius reflective element assembly

module from a mirror reflector supplier and then mount the plano-multiradius reflective element assembly module onto an actuator.

[0066] Referring to FIG. 15, a third embodiment 230 of a plano-multiradius reflective element assembly is illustrated. Plano-multiradius reflective element assembly 230 includes a plano reflective element 250 and a separate multiradius reflective element assembly 255, both individually attached to a backing plate element, and with demarcation element 265 disposed at their joint. Plano-multiradius reflective element assembly 230 is about 8.5 inches wide and about 4.25 inches tall (aspect ratio of 0.5), at their largest dimension. Shown as the shaded triangle 240 in plano reflective element 250 is the image of a triangular target object set about 35 feet rearward and of width about 8 feet and of height of about 4.1 feet as would be seen were plano-multiradius reflective element assembly 230 mounted in a driver-side exterior sideview mirror assembly in an automobile such as a sports utility vehicle. In general, it is desirable that the plano reflective element be dimensioned and configured so as to have its rearward field of view capture an image (that is visible, by reflection in the plano reflective element, to a driver seated in the driver's seat in an automobile to which is attached an exterior sideview mirror assembly equipped with the plano-auxiliary reflective element assembly according to this present invention) of a triangular shaped target located about 35 feet rearward of the driver seating location, extending about 8 feet out from the plane defined by the side of the automobile and reaching a height of between about 4 feet and about 5 feet from the road surface at that location 35 feet rearward of the automobile. The total field of view rearwardly of the vehicle of plano-multiradius reflective element assembly 230 (which is a combination of the field of view of plano reflective element 250 and of the auxiliary multiradius reflective element 255) preferably generally subtends an angle of at least about 30 degrees (and more preferably, generally subtends an angle of at least about 35 degrees and most preferably, generally subtends an angle of at least about 40 degrees) with respect to the side of an automobile to which is attached an exterior sideview mirror assembly equipped with plano-multiradius reflective element assembly 230.

[0067] Referring to FIG. 16, another embodiment 310 of the plano-auxiliary reflective element assembly of the present invention is illustrated. Plano-auxiliary reflective element assembly 310 includes a first reflective element 312 and a second or auxiliary, separate reflective element 314 which are together supported in a frame element assembly 316. As will be more fully described below, frame element assembly 316 is adapted such that when reflective elements 312 and 314 are placed, or otherwise positioned, in frame element assembly 316, the angular orientation of each

reflective element is pre-established such that during assembly, the assembler need simply place the reflective elements in frame element assembly 316.

[0068] In the illustrated embodiment, frame element assembly 316 includes a frame 318 with a forward facing open portion 318a (FIG. 17) (and thus when frame element assembly 316 is mounted in a vehicle-mounted exterior sideview mirror assembly, the forward facing open portion (318a) is facing to the front of the vehicle) through which a reflective element subassembly 317a, which includes reflective element 312, is positioned in frame element assembly 316 and a rearward facing open portion 318b (FIG. 16) (which faces the rear of the vehicle when frame element assembly 316 is mounted in a vehicle mounted exterior sideview mirror assembly) in which a second reflective element subassembly 317b, which includes reflective element 314, is positioned in frame element assembly 316. Frame 318 preferably comprises a molded member formed from a plastic material, such as a reinforced nylon.

[0069] In preferred form, first reflective element 312 comprises a plano reflective element 350, such as a flat reflector coated glass substrate, with a reflective surface through which the angular height and width of an image of an object is equal to the angular height and width of the object when viewed to the same distance (except for flaws that do not exceed normal manufacturing tolerances) so as to have a unit magnification. Similar to the previous embodiment, plano reflective element 350 may comprise a conventional fixed reflectance reflective element or may comprise a variable reflectance reflective element whose reflectivity is electrically adjustable, as is known in the art. For example, plano reflective element 350 may comprise a flat glass substrate coated with metallic reflector coating, such as a chromium coating, titanium coating, rhodium coating, metal alloy coating, nickel alloy coating, silver coating, aluminum coating, or any alloy or composition of these metal reflectors. For further details of plano reflective element 350, reference is made to the previous embodiments.

[0070] In the illustrated embodiment, reflective element 312 comprises an electrochromic reflective element and includes a first substrate 312a and a second substrate 312b with an electrochromic medium 312c disposed between first and second substrates 312a, 312b. Such suitable electrochromic media include, for example, a solid polymer matrix electrochromic medium as noted in reference to the previous embodiments. Electrical connectors 320a and 320b are coupled to the electrochromic medium 312c to provide a potential across the electrochromic medium which induces the electrochromic medium to darken, as is known in the art. In the illustrated embodiment, reflective element subassembly 317a also includes an optional heater pad 322, which is disposed

behind reflective element 312, and a vibration reducing element, such as a foam pad 326, positioned behind heater pad 322, which absorbs vibration of reflective element 312.

[0071] Referring again to FIG. 17, frame 318 is adapted to receive and support reflective element subassembly 317a, which is mounted to frame 318 by a backing plate 324, such as a plastic backing plate. In the illustrated embodiment, backing plate 324 mounts to the inner perimeter portion of frame 318 using conventional techniques, such as by adhesive bonding, heatstaking, snap-fit coupling, welding, or the like, to form part of frame element assembly 316. Alternatively, backing plate 324 may mount onto foam pad 326, for example, by an adhesive attachment, such as double sided sticky tape. In which case, reflective element 312 may be mounted to an inner surface of frame 318, such as by an adhesive attachment, including for example a silicone adhesive, with heater pad 322 mounted to reflective element 312, such as by an adhesive attachment, and foam pad 326 mounted to heater pad 322, such as by an adhesive attachment including, for example, double-sided sticky tape.

[0072] Frame element assembly 316 mounts reflective element assembly 310 in the mirror casing and preferably on an actuator, such as an electric actuator, which permits adjustment to the orientation of reflective element assembly 310 about one or more axis. Examples of suitable actuators are described in U.S. Pat. Nos. 5,900,999; 5,986,364; 6,132,052; 6,037,689; and 6,094,027 and applications Ser. No. 09/277,632, filed Mar. 26, 1999, now U.S. Pat. No. 6,229,226, and Ser. No. 09/408,867, filed Sep. 29, 1999, now U.S. Pat. No. 6,243,218, which are incorporated by reference in their entireties in U.S. Pat. No. 6,717,712 (incorporated herein above). Optionally and preferably, backing plate 324 is adapted to engage or be engaged by the actuator for repositioning of plano-auxiliary reflective element assembly 310 about one or more axes. In this manner, the orientation of both reflective element 312 and reflective element 314 are simultaneously adjusted by the actuator. As best seen in FIG. 17, forward facing side 324a of backing plate 324 includes mounting structures 324b which are engaged by the actuator to thereby mount reflective element assembly 310 in the mirror casing.

[0073] Referring again to FIG. 16, frame 318 is a unitary frame and includes a first bezel portion 330 which extends around reflective element 312 and a second bezel portion 332 which extends around reflective element 314 to provide styling utility as well as functional utility. In this manner, a portion of forward facing side of frame 318 forms a support surface for reflective element 312, while a portion of rearward facing side of frame 318 forms first bezel portion 330. Similarly, another portion of the rearward facing side of frame provides support for reflective element 314 and

also provides bezel portion 332. In addition, a portion of frame 318 forms a demarcation element at the juncture of reflective elements 312 and 314. In the illustrated embodiment, the demarcation element is formed by a section or portion of bezel portion 330, which will be described in greater detail in reference to bezel portion 330. Thus, frame element assembly 316 provides a support function, a positioning function, including an angling function, while also serving to provide styling utility and a demarcation function.

[0074] Second reflective element 314 comprises a radiused reflective element and, more preferably, a multiradiused reflective element 355 having a multiradiused curvature. For example, the radii of curvature of reflective element 314 may range from about 4000 mm to about 100 mm and, preferably, range from about 3000 mm to about 150 mm, and, most preferably, range from about 2000 mm to about 200 mm. In addition, reflective element 314 may comprise a fixed reflectance reflective element or may comprise a variable reflectance reflective element whose reflectivity is electrically adjustable. Preferably, reflective elements 312 and 314 include glass substrates, with at least the outer surface of each reflective element comprising glass. However, metalized plastic reflectors may also be used which is especially suitable for reflective element 314. In which case, the reflective element (314) would be especially suitable for molding in or along with frame 318, with the preformed metalized substrate forming reflective element 314 being placed into the mold forming frame 318. For further details of other suitable reflective elements, reference is made to the previous embodiments. In addition to reflective element 314, reflective element subassembly 317b includes a vibration reducing element, such as a foam pad 314a, which is positioned behind reflective element 314. Similar to reflective element 312, foam pad 314a is attached to reflective element 314 by an adhesive attachment, such as a double-sided sticky tape and, similarly, is attached to frame 318 as will be more fully described below.

[0075] As noted above, frame 318 includes a first bezel portion 330 and a second bezel portion 332. In addition, frame 318 includes an auxiliary support element 320 that provides a mounting surface or support surface for reflective element subassembly 317b. As best seen in FIGS. 17 and 18, support element 320 includes a recessed support surface 328 which is angled to provide an angled support surface for reflective element subassembly 317b. Thus, when reflective subassembly 317b is positioned on and mounted on support surface 328, such as by an adhesive attachment between foam pad 314a and support surface 328, the orientation of reflective element 314 is established by the angle of the support surface. Optionally, support element 320 includes gussets 321a and 321b

which project forwardly from the forward facing side of frame 318 to thereby reinforce support surface 328.

[0076] Referring to FIG. 16, first bezel portion 330 includes an upper portion 330a, two side portions 330b and 330c, and a lower portion 330d. Side portion 330b forms an acute angle with respect to the lower portion 330d and an obtuse angle with respect to upper portion 330a and together with upper portion 330a, side portion 330c, and lower portion 330d form a perimeter around reflective element 312 to thereby form a styling feature. Second bezel portion 332 extends outwardly from upper portion 330a and downwardly to lower portion 330d of first perimeter portion 330 and together with side portion 330b forms a perimeter around second reflective element 314. Support element 320 extends behind and between side portion 330b and second bezel portion 332 so that reflective element 314 is recessed behind side portion 330b and bezel portion 332.

[0077] As best seen in FIG. 18, upper portion 330a, side portions 330b and 330c, and lower portion 330d are substantially coplanar and together define an outer surface below which reflective element 312 is recessed when reflective element 312 is mounted in frame 318. In contrast, perimeter portion 332 is angled forwardly with respect to the plane in which upper portion 330a, side portions 330b and 330c, and lower portion 330d lie. It should be understood that the terms "forwardly", "rearwardly" and "downwardly", are used in reference to when the mirror system is mounted in an automobile. Therefore, "forwardly" is a direction heading toward the front of the automobile, "rearwardly" is a direction heading to the rear of the automobile, "outwardly" is a direction away from the side of the vehicle on which the mirror assembly is mounted, and "downwardly" is a direction heading toward the surface on which the vehicle is positioned (such as a ground or road surface). Similarly as noted above, reflective element 314 is recessed below an outer surface of perimeter portion 332 and also below the outer surface of side portion 330b when mounted in frame 318.

[0078] As would be understood from FIGS. 17-19, support surface 328 is also angled forwardly with respect to back plate 324 and/or reflective element 312 when frame element assembly 316 is mounted in an automobile mounted exterior sideview mirror system. In addition, support surface 328 is also angled or tilted downwardly with respect to reflective element 312 and/or backing plate 324 such that when reflective element 314 is supported on support surface 328, reflective element 314 provides an increased field of view extending laterally or outwardly from the longitudinal axis of the automobile and also downwardly of the longitudinal axis of the automobile.

[0079] Referring to FIGS. 21 and 22, support surface 328 is configured such that reflective element 314 is tilted forwardly at an angle α with respect to the X-axis of reflective element 312. In one form, angle α is in a range of about 0.75 degrees to about 5 degrees. In another form, angle α is in a range of about 1 degree to about 3 degrees. In yet another form, angle α is in a range of about 1.25 degrees to about 2.5 degrees. Reflective element 314 is also tilted downwardly with respect to the Y-axis of reflective element 312 at an angle β . In one form, angle β is in a range of about 0.75 degrees to about 5 degrees. In another form, angle β is in a range of about 1.5 degrees to about 3.5. In yet another form, angle β is in a range of about 2 degrees to about 3 degrees. With the tilted orientation of reflective element 314, reflective element 314 provides a field of view with a principal axis that sweeps outwardly and downwardly with respect to the principal axis of the field of view of reflective element 312.

[0080] In the illustrated embodiment, support surface 328 is provided by a plate member 321. Plate member 321 may comprise a solid plate member or a foraminous plate member. In the illustrated embodiment, plate member 321 is integrally formed with perimeter portions 330 and 332 during the molding process of frame 318. As previously noted, frame 318 includes a rearwardly facing opening 318b through which reflective element 314 is inserted for placement on support surface 328. For example, reflective element 314 may be positioned in frame 318 on support surface 328 during the molding process of frame 318, such as by insert molding, or may be inserted into frame 318 before the plastic material forming frame 318 is fully cured and is still pliable. In which case, reflective element subassembly 317b is mounted to auxiliary support 320 by an adhesive attachment or a mechanical attachment. Alternatively, support surface 328 may be formed by peripheral flange or a frame. In this manner, reflective element subassembly 317b may be placed in frame 318 from its forward facing side.

[0081] Referring to FIG. 22, when reflective element assembly 310 is mounted in a vehicle reflective element 312 has a field of view 360 which forms an angle A with respect to the longitudinal center line of the vehicle in a range of about 8 degrees to about 20 degrees. In another form, angle A is in a range of about 10 degrees to about 18 degrees. In yet another form, angle A is in a range of about 12 degrees to about 16 degrees. Similarly, reflective element 314 has a field of view 362 which forms an angle C in range of about 15 degrees to about 50 degrees. In another form, angle C is in a range of about 15 degrees to about 35 degrees. In yet another form, angle C is in a range of about 15 degrees to about 25 degrees. Consequently, the overall field of view of

reflective elements 312 and 314 extends over an angle B, which ranges from about 8 degrees to about 50 degrees in one form, about 10 degrees to about 35 degrees in another form, and about 12 degrees to about 25 degrees in yet another form. Furthermore, field of views 360 and 362 overlap over a range having angle D in a range of about 20 degrees to about 2 degrees, or in a range of about 15 degrees to about 5 degrees. In another form, angle D is in a range of about 10 degrees to about 8 degrees.

[0082] From the foregoing, it can be appreciated that reflective elements 312 and 314 provide a wider field of view than a wholly planar rearview mirror element that fully accommodates an equivalent frame having similar dimensions. In addition, because reflective elements 312 and 314 have overlapping field of views, an image in the field of view of reflective element 314 will transition or move between the reflective elements and appear in both reflective elements during the transition to thereby enable the driver of the automobile to view or be conscious of the object continuously. In the illustrated embodiment, reflective element 314 is positioned in an outboard position relative to reflective element 312; therefore, when a vehicle or object that is approaching the automobile from the rear and to some extent from the side, the image of the approaching object will first appear in reflective element 312, then appear in both reflective elements 314 and 312, and then move to reflective element 314 so that the driver will be initially aware of the approaching object when its image first appears in reflective element 312 and continue to be aware of the object as it moves closer to the automobile, thus increasing the range of viewing of the driver. Since the image transitions smoothly from reflective element 312 to reflective element 314, the driver's awareness of the object is continuous and, further, the driver is not distracted from sudden transitions that often occur with conventional spotter mirrors. Typically, when an object "falls" or "drops" out, a driver's consciousness of the object reduces significantly, if not ceases, which is one of the causes of many automobile blind spot accidents. Hence, when combined with the field of view of an interior rearview mirror system, the present invention reduces, if not eliminates, an automobile's blind spot. For further discussion of blind spots in vehicle rearview mirror systems, reference is made to U.S. provisional application entitled VEHICULAR REARVIEW MIRROR SYSTEM, Ser. No. 60/252,149, filed Nov. 20, 2000 by Robert E. Schnell, David K. Willmore, and Richard J. Weber, which is incorporated by reference in its entirety in U.S. Pat. No. 6,717,712 (incorporated herein above). Thus, the plano-auxiliary reflective element assembly provides a seamless rearvision function whereby the image of a side approaching/side overtaking other vehicle is substantially seamlessly maintained as the image of the overtaking or approaching vehicle

transitions from being principally and substantially viewed by the driver of the vehicle (the vehicle mounted with the mirror system of the present invention) in the plano reflective element to be seen in the auxiliary reflective element.

[0083] Referring to FIG. 23, the numeral 410 generally designates yet another embodiment of an automobile exterior sideview mirror system of the present invention. Exterior sideview mirror system 410 includes a housing 412, a first reflective element 414, and a second or auxiliary, separate reflective element 416, which together provide an increase field of view over conventional planar reflectors mounted in a frame of equivalent dimensions to the combined lateral dimensions of reflective element 414 and 416.

[0084] Housing 412 includes a mirror casing 417 and a sail 418, which mounts casing 412 to a side of an automobile. Though illustrated as a fixed mounting arrangement, it should be understood that mirror system 410, like the previous embodiments, may comprise a break-away mirror system or a powerfold mirror system.

[0085] In the illustrated embodiment, reflective element 414 comprises a plano reflective element having a unit magnification, similar to the plano reflective elements described in reference to the previous embodiments. Reflective element 416 preferably comprises a wide-angle reflector, such as a convex or aspheric reflector, and may include a multiradiused curvature. For further description of suitable reflectors, reference is made to the previous embodiment.

[0086] In the illustrated embodiment, reflective element 416 is mounted in an outboard position relative to reflective element 414 and is fixedly mounted to bezel 420 of mirror casing 417. In addition, reflective element 416 is preferably angled downwardly and forwardly relative to first reflective element 414 when mirror system 410 is mounted to an automobile to thereby increase the field of view of mirror system 410. Optionally and preferably, reflective element 416 is detachably mounted to bezel 420, such as by mechanical fasteners, including clips, so that reflective element 416 can be removed, such as for replacement.

[0087] Reflective element 414 preferably comprises an independently positionable reflective element and is mounted by a backing member, such as a backing plate, to an actuator, which provides multi-axis positioning of reflective element 414. In this manner, reflective element 414 and reflective element 416 are separately and independently mounted in housing 412. In addition, reflective element 414 optionally extends behind reflective element 416 in order to maintain the overlap of the field of views of reflective elements 414 and 416 even when reflective element 414 is moved by the actuator. Similar to the previous embodiment, when an object moves toward the

automobile, in which mirror system 410 is mounted, from the rear of the automobile or laterally with respect to the automobile, the image of the object will appear initially in reflective element 414. As the object moves closer to the automobile, the image of the object will move from reflective element 414 to reflective element 416 such that when the image transitions between reflective element 414 and reflective element 416, the image will appear in both reflective elements.

[0088] Also, although it is preferable to utilize a multiradius or compound curvature reflective element, such as an aspherical element or a compound curvature element, for the second or auxiliary mirror element adjacent the plano or first reflective element (as this enables least discontinuity in image at the joint between the adjacent elements of the assembly), a spherical reflective element (that has substantially only one radius of curvature and, as such, is a section from a sphere) can optionally be used adjacent the plano reflective element instead of, or in addition to, the multiradius reflective element. Also, a plano auxiliary mirror such as a flat mirrored substrate can be used, less preferably, as a substitute for a multiradius reflective element in those embodiments where the auxiliary reflective element is angled relative to the plane of the principal, plano reflective element so as to view a blind spot region of the principal plano element. Also, the plano-multiradius reflective element assembly can optionally be fixedly attached to an exterior sideview mirror assembly housing that is not movable, or, alternately, the exterior sideview mirror assembly housing to which the plano-multiradius reflective element assembly is fixedly attached can itself be actuated to move, such as by motor action, so that by moving the exterior sideview mirror assembly housing, the field of rearward view of the plano-multiradius reflective element assembly fixedly attached thereto can correspondingly move and be repositioned to suit the field of view need of a particular driver seated in the automobile cabin.

[0089] The substrate 18 of the reflective element 12 of the present invention may be formed (such as by casting, extrusion or injection molding) of a polymeric optical resin material, such as an acrylic or polycarbonate resin, a polyolefin, a cyclic olefin copolymer, such as a COC resin known as "TOPAS" and available from Ticona of Summit, NJ (such as a resin of the type described in U.S. pat. application, Ser. No. 09/946,228, filed Sep. 5, 2001 for IMPROVED PLASTIC SUBSTRATE FOR INFORMATION DEVICE AND METHOD FOR MAKING SAME, which is hereby incorporated herein by reference) or the like. Because the substrate can be, for example, injection molded from an optical resin, the substrate may be molded or formed to a desired shape having a wide angle or multi-radius surface, which is typically challenging to accomplish with glass sheets. This is because any prescription or form for the substrate can be established in an injection mold by

machining, such that when the injection mold is filled with molten injected optical resin material, the optical resin material takes the shape of the mold. Thus, for example, a substrate having a substantially or fully flat inboard region for a multi-radius (often referred to as an aspheric) exterior mirror element is fully practical.

[0090] As shown in FIGS. 1-3, inboard portion or surface 18c of exterior surface 18b is positioned at or toward the side of the reflective element that is toward the side body of the vehicle when the mirror assembly is mounted to or attached to the vehicle. The inboard portion 18c of surface 18b of substrate 18 may comprise a substantially flat or slightly curved or less curved surface, such as a surface having a radius of curvature of preferably greater than at least approximately 4000 mm, more preferably greater than at least approximately 9000 mm, and most preferably greater than at least approximately 12000 mm. The inboard surface 18c may provide a field of view of up to approximately 10 degrees, preferably up to approximately 15 degrees, and more preferably up to approximately 20 degrees.

[0091] Outboard portion or surface 18d of exterior surface 18b of substrate 18 is positioned outward from inboard portion and is thus further away from the side body of the vehicle when the mirror assembly is mounted to or attached to the vehicle. Outboard portion 18d of exterior surface 18b may be a more convex or curved surface, such that the substrate comprises a wide angle or multi-radius exterior surface substrate. The more curved outboard surface 18d of the substrate may have radii of curvature in the range of less than about 4000 mm to about 100 mm or lower. The more curved outboard portion or surface 18d may provide an extended field of view when combined with the less curved inboard portion or surface 18c. For example, the combined field of view of the mirror reflective element 12 may be preferably greater than at least approximately 25 degrees, more preferably greater than at least approximately 35 degrees, and most preferably greater than at least approximately 45 degrees. The substrate may be formed to have curves or shapes or to provide other field of views, without affecting the scope of the present invention.

[0092] The exterior surface 18b of substrate 18 may be coated or covered with a substantially transparent functional film or layer 20, such as an anti-abrasion film or layer, such as an ultrathin glass film or layer or sheet having a thickness of preferably less than or equal to approximately 0.8 mm, more preferably less than or equal to approximately 0.5 mm, and most preferably less than or equal to approximately 0.3 mm. The ultrathin glass film or layer or sheet 20 provides a flexible glass film which can be conformed to the exterior surface of the molded substrate (for example, such as described in U.S. Pat. No. 5,085,907, which is hereby incorporated herein by reference)

after the substrate is molded. The ultrathin glass film or layer may provide substantial protection against scratches on the outboard surface, such as may occur due to impact by debris at the outside of the vehicle (for exterior mirror assembly applications) or by use of ice scrapers and the like on the glass surface and the like. The ultrathin glass film or layer may be applied to a molded or extruded strip (such as described below with respect to FIGS. 5-8) or may be applied to the surface or surfaces of a formed or cut substrate, without affecting the scope of the present invention. The flexible ultrathin glass film or layer of the present invention allows the wide angle or multi-radius substrate to be molded in the desired shape out of a transparent acrylic resin material, yet may conform to the curved or multi-radius or aspheric shape and provide enhanced protection or scratch resistance to the substrate.

[0093] It is envisioned that other functional films or hard coats or anti-abrasion films or the like may be applied to the exterior surface of the molded substrate, such as via adhering or applying a film to the exterior surface or via dip coating or vacuum deposition or the like. Optionally, a hydrophobic film or hydrophilic film or element or property may also or otherwise be applied to the exterior surface 18b of the substrate. Optionally, the functional film may comprise a non-glass or polymeric film, such as a polymeric material that is a harder and/or different property material than the substrate itself. Optionally, the anti-abrasion film may be formed of the same resin material as the substrate to match the coefficients of thermal expansion and thus reduce thermal expansion/contraction mismatches between the materials.

[0094] Optionally, the inner or rear surface 18a of the substrate 18 may have a reflective layer or coating or film or sheet 22 laminated or otherwise applied thereto. For example, the reflective layer or film 22 may comprise a polymeric reflective film 22 laminated or otherwise adhered or applied to the rear or inner surface 18a of a molded or extruded or cast strip (such as described below with respect to FIGS. 5-8) or of the molded or formed substrate 18. Reflective film 22 may comprise a polymeric reflective film, such as an all polymer-thin-film multilayer, high reflective mirror film, such as a multilayer, non-metallic reflective film which may comprise multiple coextrusion of many plastic layers to form a highly reflective mirror film, such as described in U.S. Pat. Nos. 3,773,882; 3,884,606; and 3,759,647, which are hereby incorporated herein by reference. Such a reflective film thus may comprise multilayers of polymer materials to form a highly reflective mirror film, such as a Radiant Light Film, a Radiant Mirror Film or a Radiant Color Film, such as commercially available from 3M of St. Paul, Minn., such as a Radiant Color Film CM590 or CM500. Also, a

durable metallized polymeric mirror layer can be used, such as described in U.S. Pat. No. 5,361,172, which is hereby incorporated herein by reference.

[0095] As shown in FIG. 4, it is envisioned that a substrate or substrate shape or sheet or strip of substrate material 118 may have a reflective film or layer 122 adhered or laminated or otherwise applied to the exterior surface 118b of the substrate material. An anti-abrasion film or layer 120 (which may comprise an ultrathin glass film or layer as described above) may be adhered or laminated or otherwise applied to the reflective film or layer 122. In such an application, with the reflective layer on the front or exterior surface of the substrate, the substrate material may be molded or formed of a polymeric material that does not provide optical clarity and need not be transparent. The substrate material may act only as a support or backing plate for the reflective film or layer and the anti-abrasion film or layer and thus may be opaque or non-transparent. The exterior surface 118b of substrate material 118 may comprise a wide angle exterior surface or a multi-radius exterior surface having a less curved inboard portion or surface 118c and a more curved outboard portion or surface 118d, such as discussed above with respect to substrate 18.

[0096] Optionally, and such as shown in FIGS. 5, 6 and 8, the optical resin material may be molded or extruded or cast into a generally continuous strip 19 having the desired curved or multi-radius surfaces, and may be cut to form the substrates. The substrates may be cut from the strip via any known cutting process, such as via a laser cutting process or a water-jet cutting process or the like, without affecting the scope of the present invention.

[0097] As shown in FIGS. 5-8, the molding processes and film or layer application processes of the present invention may be used to form a prismatic or wedge-shaped strip for forming prismatic or wedge-shaped substrates 18' (FIG. 7) for use in an interior rearview mirror assembly of a vehicle.

[0098] As also shown in FIGS. 5-8, the substrate material or optical resin material may be extruded or cast to form the continuous strip or sheet 19. For example, and as shown in FIGS. 5 and 5A, the strip 19 may be extruded by an extruder 24, which, preferably continuously, extrudes the optical resin material through an extrusion nozzle 26. The extruded material may be moved through an annealing Lehr 28 to reduce or substantially eliminate birefringence, striation, stress and/or distortion in the strip or substrates. The coatings or layers or films 20 and/or 22 may be applied to one or both surfaces of the strip or substrate after the annealing process. The strip 19 may then be cut, such as via laser cutting or water-jet cutting devices or processes 30, or via other forming processes, to form the substrates 18' after the films or coatings have been applied thereto.

[0099] Optionally, and as shown in FIG. 8, the strip 19 of optical polymeric resin material may be cast by a caster 32, which deposits the molten polymer or resin material onto a float section 34, such as a heated plate or heated melt. The float section 34 may be angled to form the wedge-shaped strip as the strip or ribbon of cast molten polymer solidifies as it passes across the hot float section (it is also envisioned that the float may provide a curved surface to form the curved outboard surface of the substrate). The coatings or layers or films 20, 22 may be applied to the solidified strip and the strip may be cut to form the substrates after the coatings or layers or films have been applied thereto.

[00100] Because the films or layers are flexible, it is envisioned that the anti-abrasion film or ultrathin glass film and/or the reflective polymeric film may be unwound or unrolled and applied along the generally continuously extruded or cast substrate material or strip 19. For example, and as shown in FIGS. 5-8, the ultrathin glass film (or other outer layer anti-abrasion coating or film) 20 may be provided in a reel or roll form or strip 20a and may be unwound or unrolled and laminated or otherwise adhered or applied along the exterior surface 19b of the extruded or cast strip 19 of substrate material. Likewise, the reflective polymeric film 22 may be provided in a reel or roll form or strip 22a and may be attached or applied to the inner surface 19a of the substrate material strip 19, such as via laminating or adhering or otherwise applying the film to the substrate material, such as by using optical adhesive and/or via rolling or ironing the film or sheet (preferably at an elevated temperature and with vacuum assist) onto the substrate or strip surface, to secure the reflective film to the substrate or extruded or cast strip or sheet.

[00101] Optionally, the glass film or layer or sheet (or reel or roll of glass sheet or strip) may be coated with a highly reflective metallic layer, such as silver or aluminum or the like, deposited on or applied to its inner surface (i.e., the surface which is adhered to or otherwise applied to the substrate or substrate sheet or strip). The reflective layer or coating may be applied to the glass film or layer with or without transparent overcoats. The glass film thus may provide the reflective layer at the exterior surface of the substrate, such that the reflective layer provides the second layer or surface, with the substrate behind the reflective layer. The glass sheet or film may thus be provided with the reflective mirror coating already applied thereto. The glass layer with reflective layer or coating applied thereto may be provided in a reel or roll form for applying both the reflective layer and the anti-abrasion layer to the exterior surface of the substrate or substrate strip or sheet in one application process. In such an application, the substrate material need not comprise a transparent

optical resin material, and a separate reflective layer or film or coating would not be necessary at the inner or rear surface of the substrate.

[00102] It is envisioned that other hard coats or films or the like may be applied to one or more surfaces of the molded substrate strip or to the molded and cut substrates, such as via dip coating or vacuum deposition or the like, without affecting the scope of the present invention. The other hard coats or films may be substantially flexible and may be applied via unrolling of a reel of an anti-abrasion film or sheet and applying the film or sheet to a surface of an extruded or cast strip of transparent acrylic resin or the like, as discussed above. Optionally, a hydrophobic film or hydrophilic film or element or property may also or otherwise be applied to (or sprayed on) one or both surfaces 18a, 18b of the substrate or strip or sheet. Optionally, one or both of the reflective polymeric film 22 and the anti-abrasion film 20 may be formed of the same resin material as the substrate 18, 18' or substrate strip 19 to match the coefficients of thermal expansion and thus reduce thermal expansion/contraction mismatches between the materials.

[00103] Optionally, it is envisioned that such ultrathin glass films, anti-abrasion films, reflective films or reflective systems may be used for electrochromic mirror reflective elements or cells as well. For example, the interior or exterior rearview mirror assembly of the present invention may comprise an electrochromic mirror, such as an electrochromic mirror assembly and electrochromic element utilizing principles disclosed in commonly assigned U.S. Pat. Nos. 5,140,455; 5,151,816; 6,690,268; 6,178,034; 6,154,306; 6,002,544; 5,567,360; 5,525,264; 5,610,756; 5,406,414; 5,253,109; 5,076,673; 5,073,012; 5,117,346; 5,724,187; 5,668,663; 5,910,854; 5,142,407 and/or 4,712,879, which are hereby incorporated herein by reference, and/or as disclosed in the following publications: N. R. Lynam, "Electrochromic Automotive Day/Night Mirrors", SAE Technical Paper Series 870636 (1987); N. R. Lynam, "Smart Windows for Automobiles", SAE Technical Paper Series 900419 (1990); N. R. Lynam and A. Agrawal, "Automotive Applications of Chromogenic Materials", Large Area Chromogenics: Materials and Devices for Transmittance Control, C.M. Lampert and C.G. Granquist, EDS., Optical Engineering Press, Wash. (1990), which are hereby incorporated by reference herein. The mirror assembly may comprise an interior rearview mirror assembly, and may include an accessory module or may be mounted to an accessory module, such as an accessory module of the types disclosed in U.S. pat. application, Ser. No. 10/355,454, filed Jan. 31, 2003 for VEHICLE ACCESSORY MODULE, now U.S. Pat. No. 6,824,281, which is hereby incorporated herein by reference.

[00104] Optionally, the mirror assembly may include one or more displays for displaying information to a driver of the vehicle at or through the reflective element of the mirror assembly. For example, the mirror assembly may include one or more displays of the types described in U.S. Pat. Nos. 6,329,925; 6,501,387; 6,690,268; 5,910,854; 6,420,036; 5,668,663; and 5,724,187, and/or in U.S. pat. applications, Ser. No. 10/054,633, filed Jan. 22, 2002 by Lynam et al. for VEHICULAR LIGHTING SYSTEM, now U.S. Pat. No. 7,195,381; and Ser. No. 10/456,599, filed Jun. 6, 2003 by Weller et al. for INTERIOR REARVIEW MIRROR SYSTEM WITH COMPASS, now U.S. Pat. No. 7,004,593, and/or in PCT Application No. PCT/US03/29776, filed Sep. 19, 2003 by Donnelly Corporation et al. for ELECTROCHROMIC MIRROR ASSEMBLY; PCT Application No. PCT/US03/35381, filed Nov. 5, 2003 by Donnelly Corporation et al. for ELECTRO-OPTIC REFLECTIVE ELEMENT ASSEMBLY; and/or PCT Application No. PCT/US03/40611, filed Dec. 19, 2003 by Donnelly Corporation et al. for ACCESSORY SYSTEM FOR VEHICLE, and/or in U.S. provisional applications, Ser. No. 60/508,086, filed Oct. 2, 2003 by Schofield for MIRROR REFLECTIVE ELEMENT ASSEMBLY INCLUDING ELECTRONIC COMPONENT; Ser. No. 60/525,952, filed Nov. 26, 2003 by Lynam for MIRROR REFLECTIVE ELEMENT FOR A VEHICLE; Ser. No. 60/471,546, filed May 19, 2003; Ser. No. 60/525,537, filed Nov. 26, 2003; and Ser. No. 60/556,259, filed Mar. 25, 2004, which are all hereby incorporated herein by reference, without affecting the scope of the present invention.

[00105] Optionally, the mirror assembly may include or be associated with electronic accessories, such as, for example, antennas, including global positioning system (GPS) or cellular phone antennas, such as disclosed in U.S. Pat. No. 5,971,552, a communication module, such as disclosed in U.S. Pat. No. 5,798,688, a blind spot detection system, such as disclosed in U.S. Pat. Nos. 5,929,786 and/or 5,786,772, a high/low headlamp controller, such as disclosed in U.S. Pat. Nos. 5,796,094 and/or 5,715,093, transmitters and/or receivers, such as a garage door opener or the like, a digital network, such as described in U.S. Pat. No. 5,798,575, a memory mirror system, such as disclosed in U.S. Pat. No. 5,796,176, a hands-free phone attachment, a video device for internal cabin surveillance and/or video telephone function, such as disclosed in U.S. Pat. Nos. 5,760,962 and/or 5,877,897, a remote keyless entry receiver or system or circuitry and/or a universal garage door opening system or circuitry (such as the types disclosed in U.S. Pat. Nos. 6,396,408; 6,362,771; 5,798,688 and 5,479,155, and/or U.S. pat. application, Ser. No. 10/770,736, filed Feb. 3, 2004 by Baumgardner et al. for GARAGE DOOR OPENING SYSTEM FOR VEHICLE, now U.S. Pat. No. 7,023,322), lights, such as map reading lights or one or more other lights or illumination

sources, such as disclosed in U.S. Pat. Nos. 6,690,268; 5,938,321; 5,813,745; 5,820,245; 5,673,994; 5,649,756; 5,178,448; 5,671,996; 4,646,210; 4,733,336; 4,807,096; 6,042,253; and/or 5,669,698, and/or U.S. pat. application, Ser. No. 10/054,633, filed Jan. 22, 2002 by Lynam et al. for VEHICULAR LIGHTING SYSTEM, now U.S. Pat. No. 7,195,381, microphones, such as disclosed in U.S. Pat. Nos. 6,243,003; 6,278,377; and/or 6,420,975, and/or PCT Application No. PCT/US03/30877, filed Oct. 1, 2003, speakers, a compass or compass system, such as disclosed in U.S. Pat. Nos. 5,924,212; 4,862,594; 4,937,945; 5,131,154; 5,255,442; and/or 5,632,092; and/or U.S. pat. application, Ser. No. 10/456,599, filed Jun. 6, 2003 by Weller et al. for INTERIOR REARVIEW MIRROR SYSTEM WITH COMPASS, now U.S. Pat. No. 7,004,593, a navigation system, such as described in U.S. Pat. No. 6,477,464, and U.S. pat. applications, Ser. No. 10/456,599, filed Jun. 6, 2003 by Weller et al. for INTERIOR REARVIEW MIRROR SYSTEM WITH COMPASS, now U.S. Pat. No. 7,004,593; Ser. No. 10/287,178, filed Nov. 4, 2002 by McCarthy et al. for NAVIGATION SYSTEM FOR A VEHICLE, now U.S. Pat. No. 6,678,614; Ser. No. 10/645,762, filed Aug. 20, 2003 by Taylor et al. for VEHICLE NAVIGATION SYSTEM FOR USE WITH A TELEMATICS SYSTEM, now U.S. Pat. No. 7,167,796; and Ser. No. 10/422,378, filed Apr. 24, 2003, now U.S. Pat. No. 6,946,978; and/or PCT Application No. PCT/US03/40611, filed Dec. 19, 2003 by Donnelly Corporation et al. for ACCESSORY SYSTEM FOR VEHICLE, a tire pressure monitoring system, such as the types disclosed in U.S. Pat. Nos. 6,294,989; 6,445,287; and/or 6,472,979, and/or in U.S. pat. application, Ser. No. 10/206,495, filed Jul. 26, 2002 by Schofield et al. for SELF TRAINING TIRE PRESSURE MONITORING SYSTEM, now U.S. Pat. No. 6,731,205, a seat occupancy detector, a trip computer, a telematics system, such as an ONSTAR[®] system or the like, and/or any other desired accessory or system or the like (with all of the above-referenced patents and patent applications and PCT applications being commonly assigned to Donnelly Corporation, and with the disclosures of all of the above referenced patents and patent applications and PCT applications being hereby incorporated herein by reference in their entirety).

[00106] Optionally, a vehicle compass or compass system may comprise a printed circuit board and may be positioned within a pod or the like that may be fixedly mounted in the vehicle. The compass may be initially calibrated (such as at the assembly plant or the like) via a small Helmholtz coil that may accommodate the small circuit board or pod. The coil induces a field to calibrate the compass, such as described in U.S. provisional application, Ser. No. 60/467,899, filed May 5, 2003, which is hereby incorporated herein by reference in its entirety. The induced field in the miniature

Helmholtz coil may be controlled via the use of a highly permeable magnetic shielding material that may enclose the miniature Helmholtz coil with only a small slot for the circuit board or compass pod to enter through. Such a set up may allow the compass pod manufacturer to automate and magnetically shield the calibration and test stage of a microprocessor-based compass. The calibration process may utilize an indexing rotary table that may rotate to move a compass pod from a loading bay to a calibration bay. The shielded Helmholtz coil may be adjacent to the rotary table and may be shuttled back and forth to align with the rotary table to receive a compass pod therefrom. The rotary table may rotate to move a calibrated compass pod (after it leaves the miniature Helmholtz coil) from the calibration bay to a final functional test station to test the calibrated compass pod.

[00107] Therefore, the present invention provides a wide angle or multi-radius single substrate or reflective element which may provide an enhanced field of view for an interior or exterior rearview mirror assembly. The wide angle or multi-radius single element reflector may have an anti-abrasion coating or ultrathin glass film conformed to and applied to the exterior curved surface of the substrate. The substrate may be molded or extruded into the desired shape and may be formed into an elongated strip or sheet, whereby the anti-abrasion coating or film may be applied along the strip before the strip is cut into the desired substrates. The present invention thus provides a single element wide angle or multi-radius substrate which has enhanced scratch resistance. A polymeric reflective film may be laminated, adhered or otherwise applied to the opposite inner surface of the substrate or extruded strip while the anti-abrasion coating or film is applied to the exterior surface. Optionally, a reflective film or layer may be applied to the exterior surface of the substrate and an anti-abrasion film or layer may be applied to the reflective film or layer.

[00108] Changes and modifications in the specifically described embodiments can be carried out without departing from the principles of the present invention, which is intended to be limited only by the scope of the appended claims, as interpreted according to the principles of patent law.

The embodiments of the invention in which an exclusive property or privilege is claimed are defined as follows:

1. An exterior rearview mirror assembly for a motor vehicle, said exterior rearview mirror assembly comprising:

a bracket fixedly secured to the motor vehicle;

a mirror casing secured to said bracket, said mirror casing defining a primary opening;

a single mirror support movably secured within said mirror casing disposed adjacent said primary opening;

a primary mirror fixedly secured to said single mirror support and disposed within said primary opening for providing a view rearward of the motor vehicle through a primary field of view; and

a spotting mirror fixedly secured to said single mirror support and disposed adjacent said primary mirror, said spotting mirror defined by a single radius of curvature differing from said primary mirror such that said spotting mirror provides a second field of view rearward of the motor vehicle, such that said first field of view of said primary mirror overlaps said second field of view of said spotting mirror.

2. An exterior rearview mirror assembly as set forth in claim 1 wherein said single mirror support defines a primary portion for having said primary mirror fixedly secured thereto and a spotting portion for having said spotting mirror fixedly secured thereto.

3. An exterior rearview mirror assembly as set forth in claim 2 wherein said primary portion of said single mirror support defines a primary plane that is substantially flat.

4. An exterior rearview mirror assembly as set forth in claim 3 wherein said spotting portion of said single mirror support defines a spotting mirror support radius of curvature substantially equal to said single radius of curvature.

5. An exterior rearview mirror assembly as set forth in claim 4 wherein said spotting portion is forward of said primary plane.

6. An exterior rearview mirror assembly as set forth in claim 4 wherein said spotting portion is substantially rearward of said primary plane.
7. An exterior rearview mirror assembly for a motor vehicle, said exterior rearview mirror assembly comprising:
 - a bracket fixedly secured to the motor vehicle;
 - a mirror casing secured to said bracket, said mirror casing defining a primary opening;
 - a primary mirror disposed within said primary mirror for providing a view rearward of the motor vehicle through a primary field of view;
 - a spotting mirror disposed adjacent said primary mirror, said spotting mirror defining a periphery and including a rim flange extending thereabout; and
 - a single mirror support for supporting said primary mirror and said spotting mirror with respect to each other and within said primary opening, said single mirror support including a flange channel for receiving a portion of said rim flange therein.
8. An exterior rearview mirror assembly as set forth in claim 7 wherein a portion of said rim flange extends between said primary mirror and said single mirror support to accurately position said spotting mirror with respect to said primary mirror.
9. An exterior rearview mirror assembly as set forth in claim 8 wherein a portion of said rim flange includes a rim extension extending perpendicularly to said rim flange.
10. An exterior rearview mirror assembly as set forth in claim 9 wherein said spotting mirror defines an outer reflective surface having a single radius of curvature.
11. An exterior rearview mirror assembly as set forth in claim 9 wherein said spotting mirror defines an inner reflective surface.
12. An exterior rearview mirror assembly as set forth in claim 11 wherein said inner reflective surface defines a single radius of curvature.

13. An exterior rearview mirror assembly as set forth in claim 12 wherein said spotting mirror is fabricated from a translucent polymer resin.
14. An exterior rearview mirror assembly as set forth in claim 13 wherein said inner reflective surface is coated with a reflective material.
15. An exterior rearview mirror assembly as set forth in claim 14 wherein said reflective material is chrome.
16. An exterior rearview mirror assembly for a motor vehicle, said exterior rearview mirror assembly comprising:
 - a bracket fixedly secured to the motor vehicle;
 - a mirror casing secured to said bracket, said mirror casing defining a primary opening;
 - a primary mirror disposed within said primary opening for providing a view rearward of the motor vehicle through a primary field of view, said primary mirror defining a primary plane;
 - a spotting mirror spaced apart from said primary mirror, said spotting mirror extending through a secondary plane different from said primary plane; and
 - a divider extending between said primary mirror and said spotting mirror to separate said primary and secondary mirrors visually.
17. An exterior rearview mirror assembly as set forth in claim 16 wherein said spotting mirror is forward of said primary plane.
18. An exterior rearview mirror assembly as set forth in claim 16 wherein said spotting mirror is rearward of said primary plane.

EXTERIOR REARVIEW MIRROR ASSEMBLY

ABSTRACT

An exterior rearview mirror assembly for a vehicle includes a bracket fixedly secured to the vehicle, a mirror casing secured to the bracket and defining a primary opening, and a single mirror support movably secured within the mirror casing disposed adjacent the primary opening. A primary mirror is fixedly secured to the single mirror support and disposed within the primary opening for providing a view rearward of the vehicle through a primary field of view, and a spotting mirror is fixedly secured to the single mirror support and disposed adjacent the primary mirror. The spotting mirror is defined by a single radius of curvature differing from the primary mirror such that the spotting mirror provides a second field of view rearward of the vehicle, such that the first field of view of the primary mirror overlaps the second field of view of the spotting mirror.

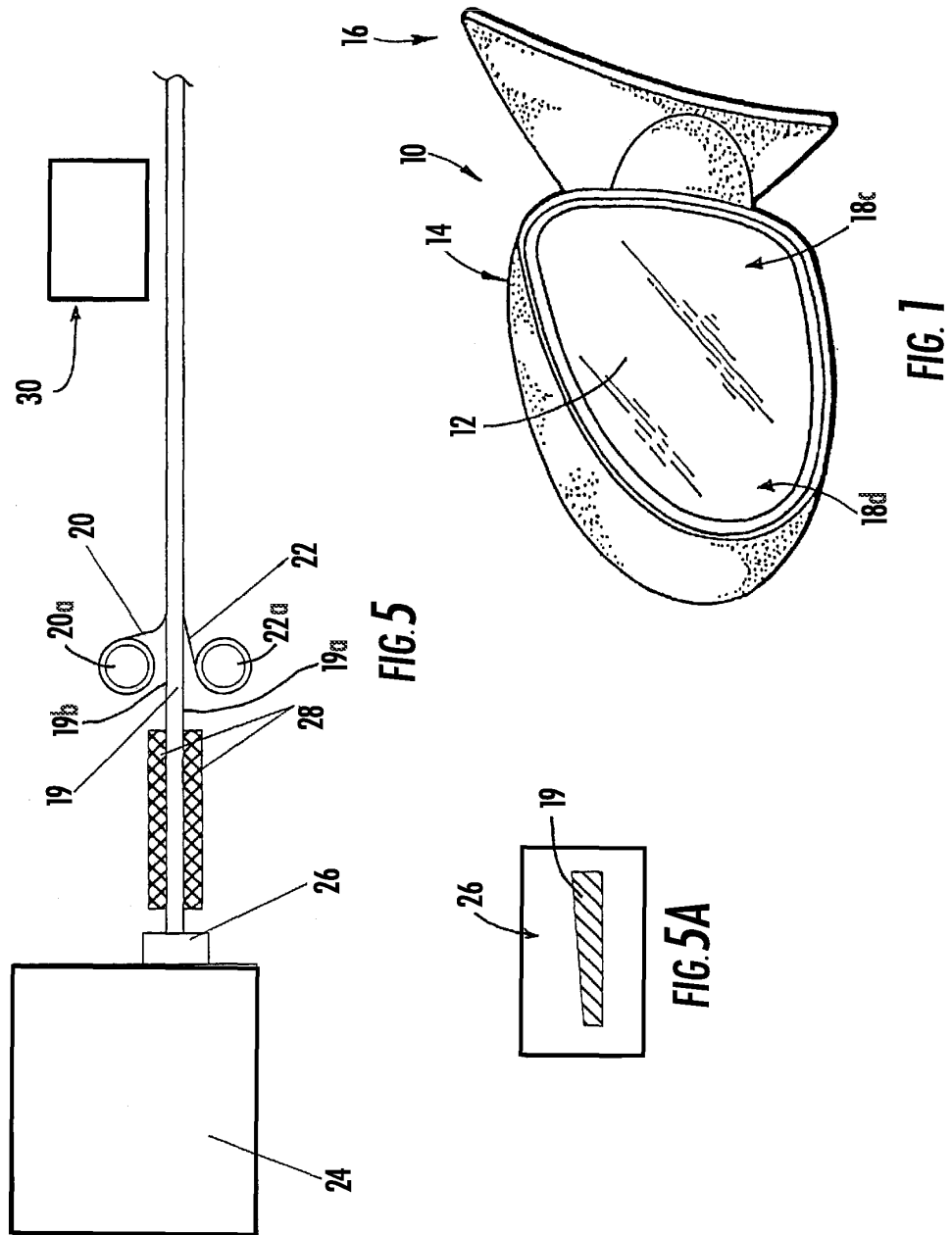

FIG. 3

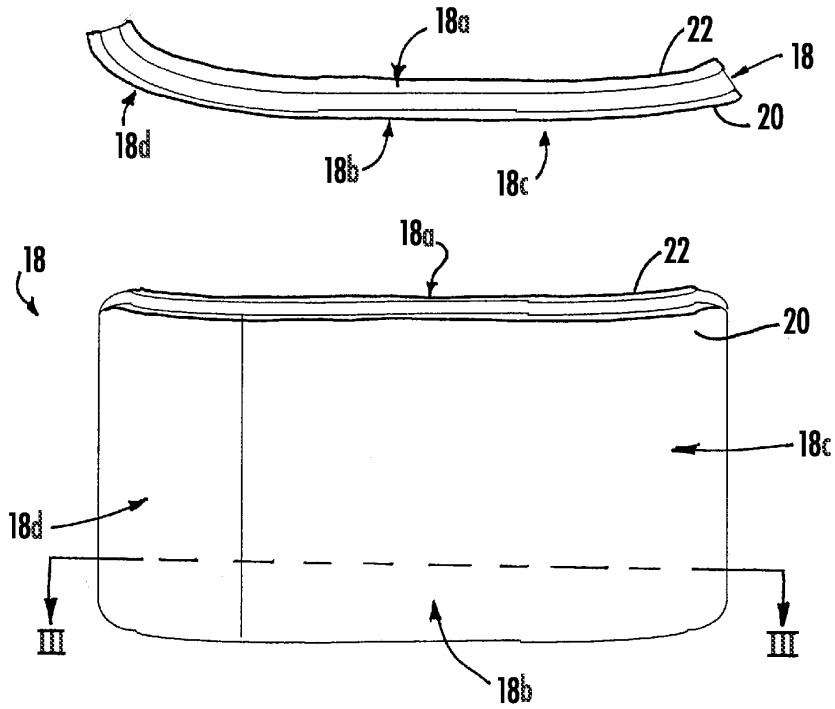
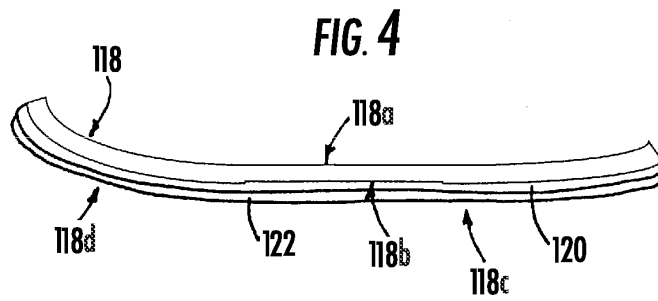
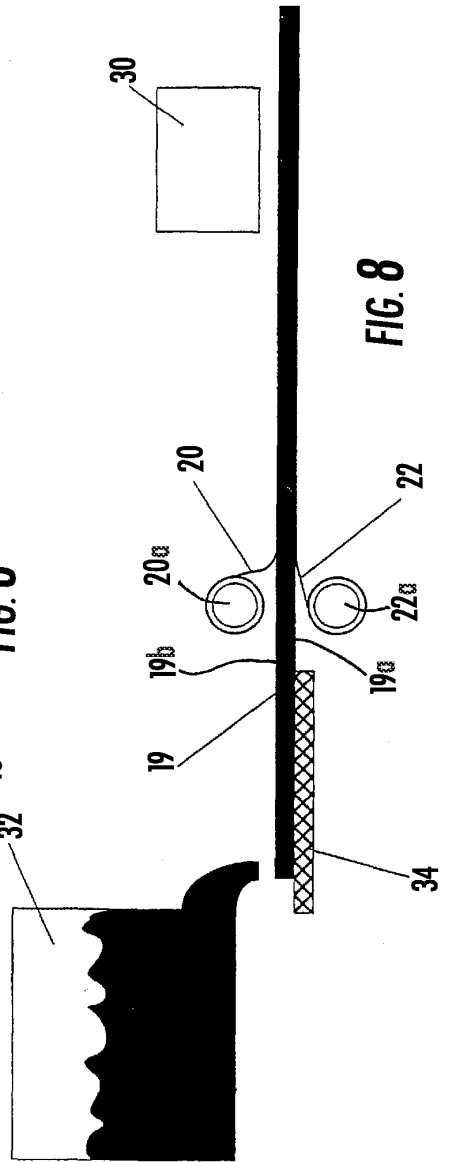
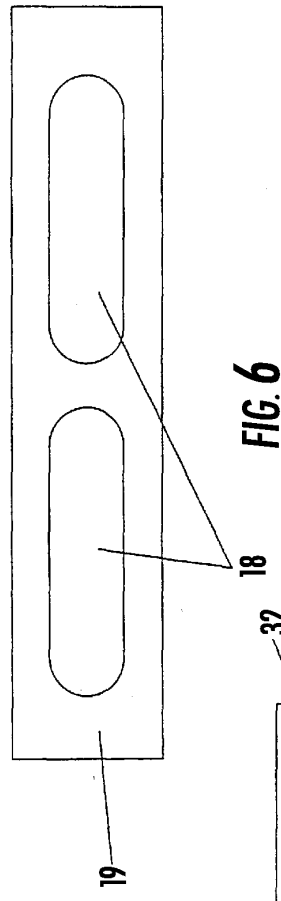
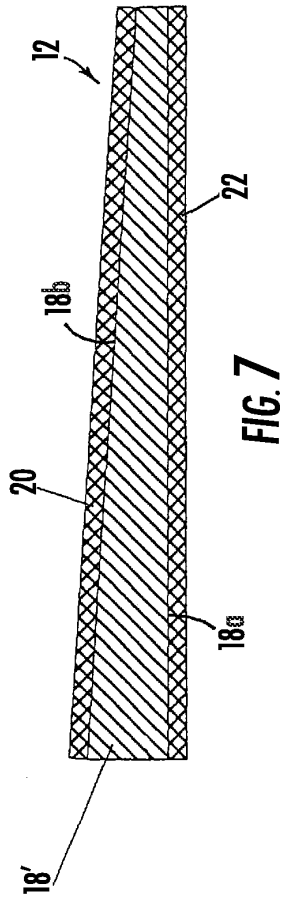

FIG. 2





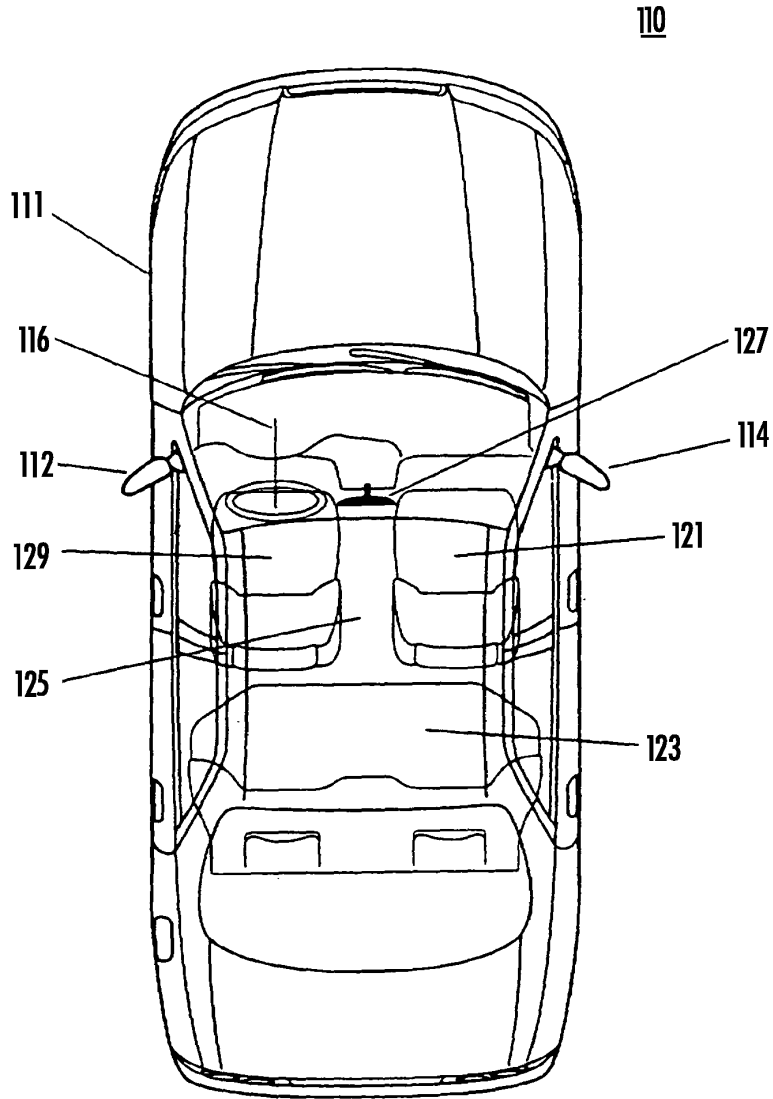
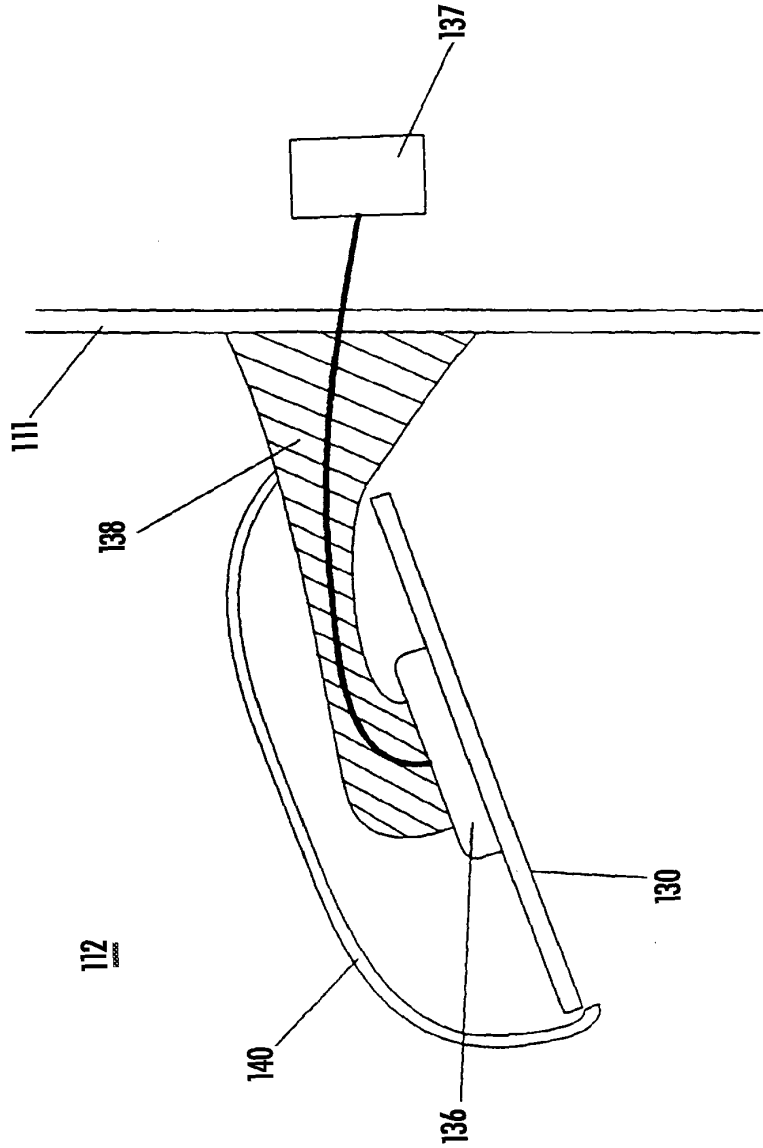

FIG. 9



130

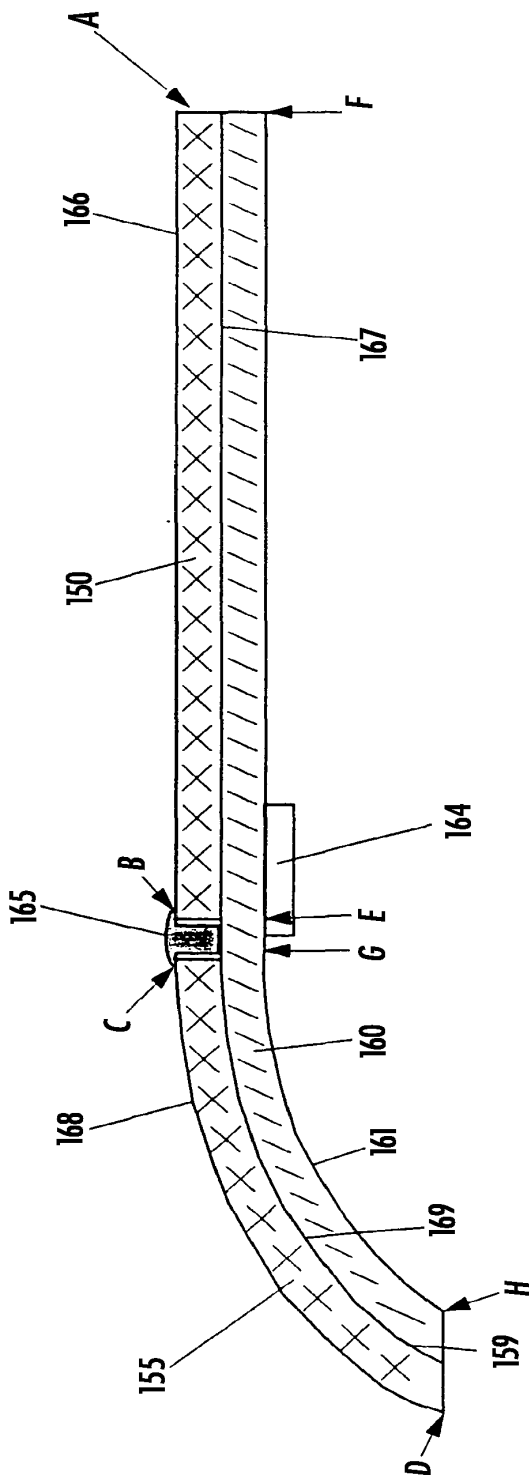

FIG. 11

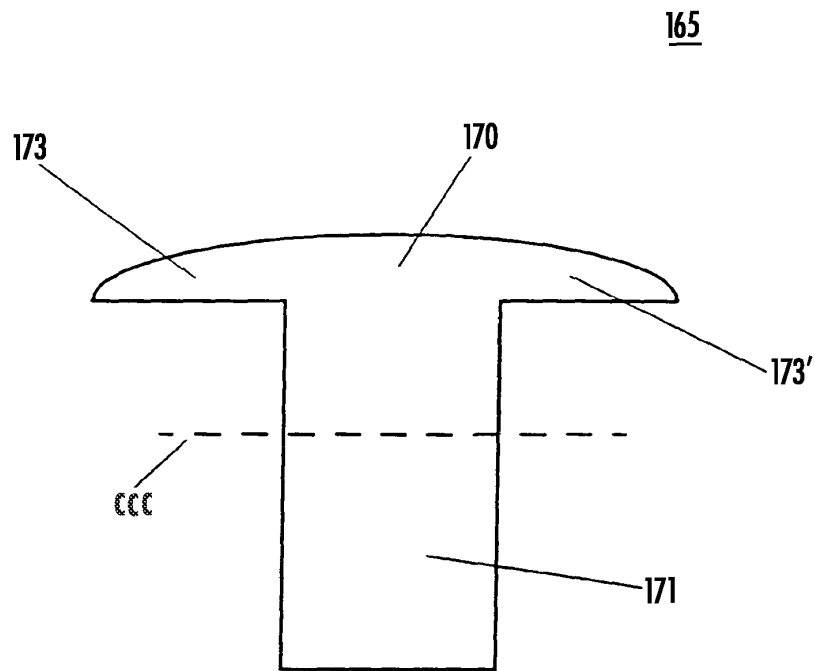
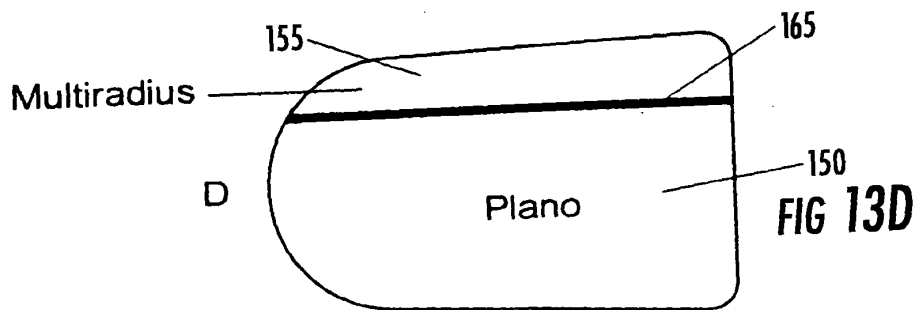
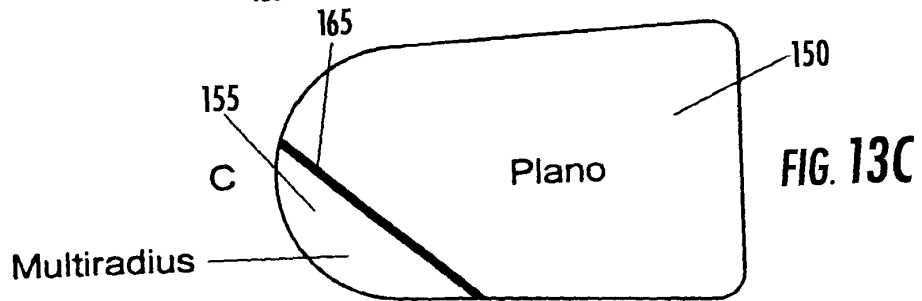
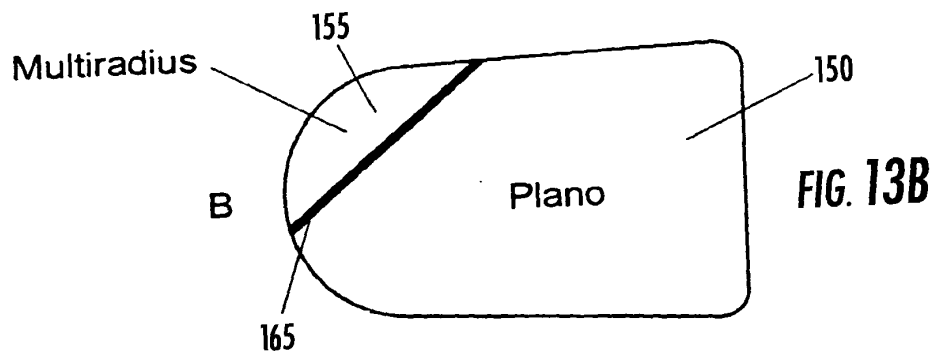
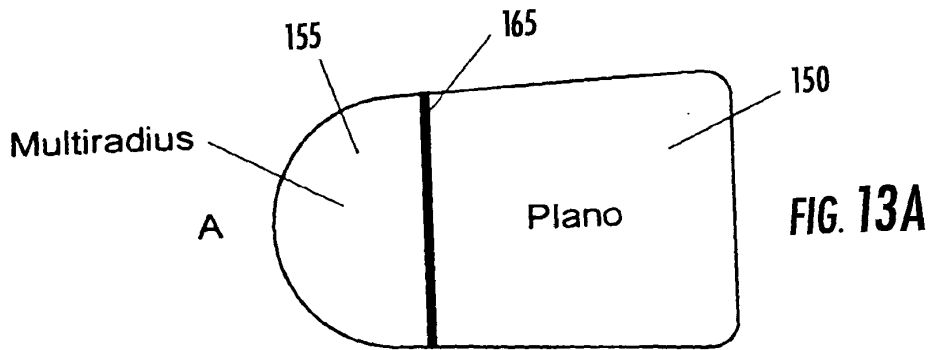
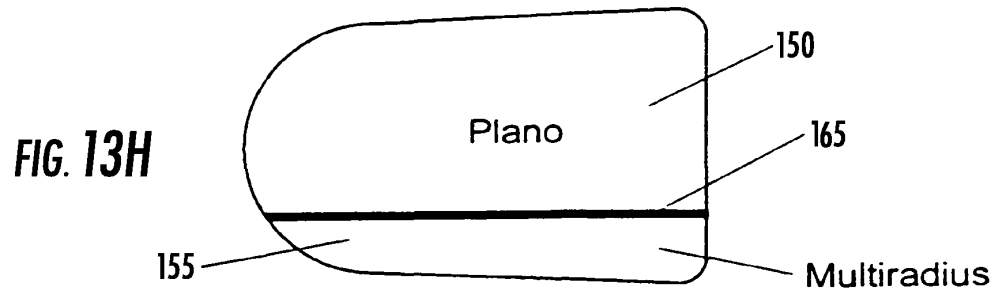
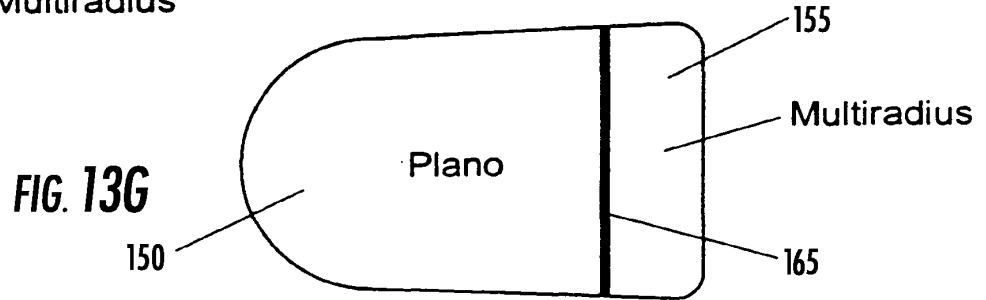
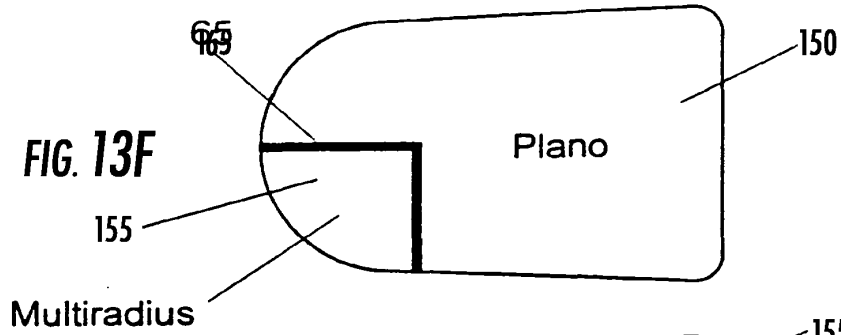
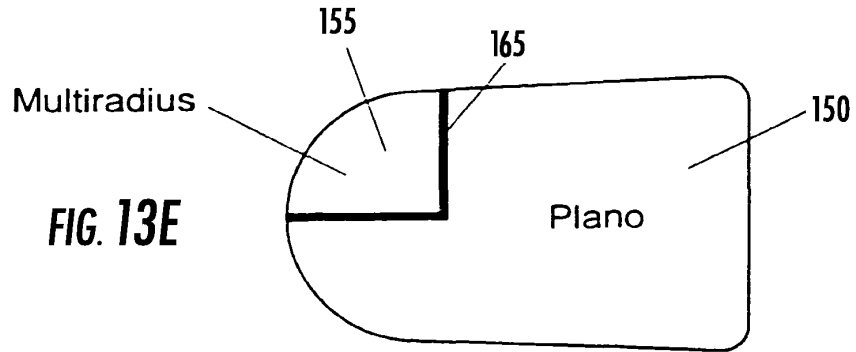

FIG. 12





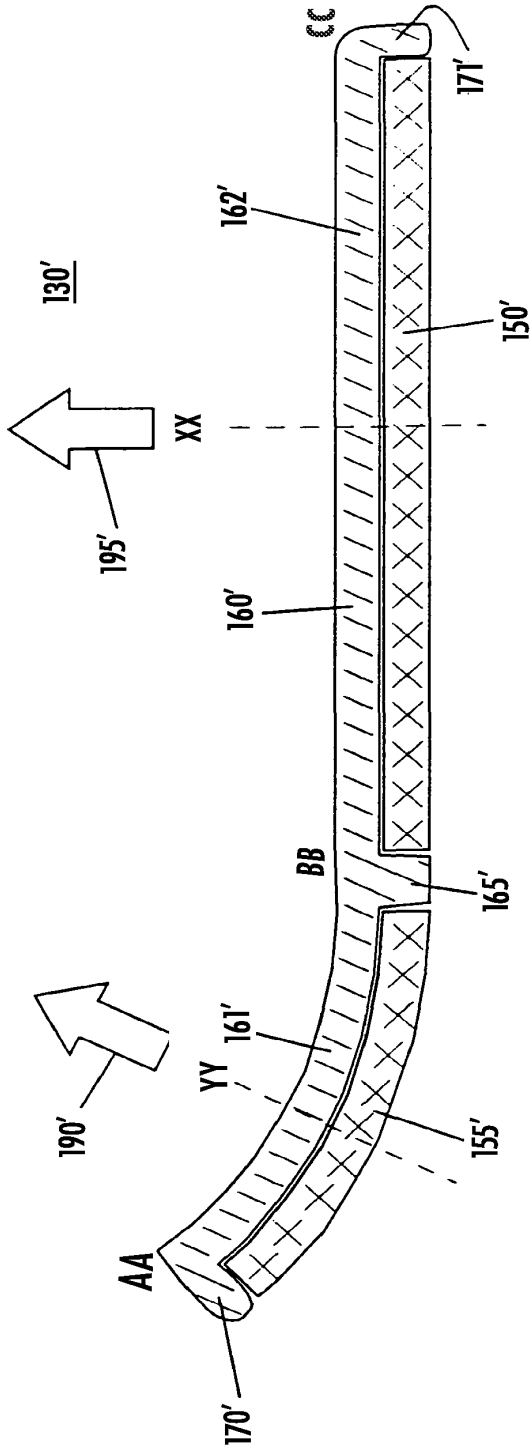

FIG. 14

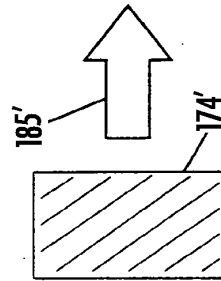

FIG. 14A

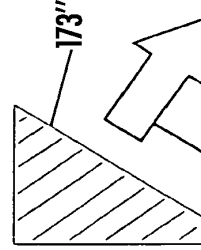
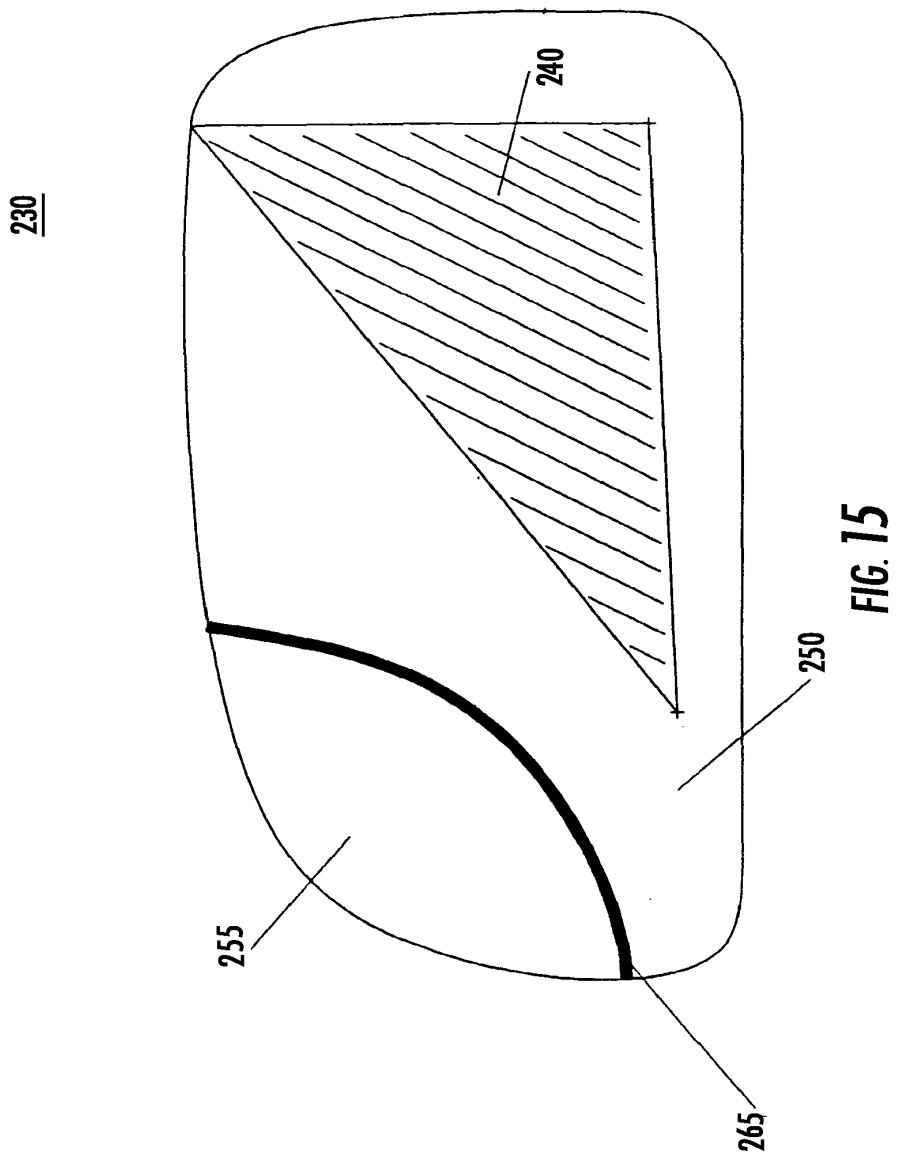

FIG. 14B



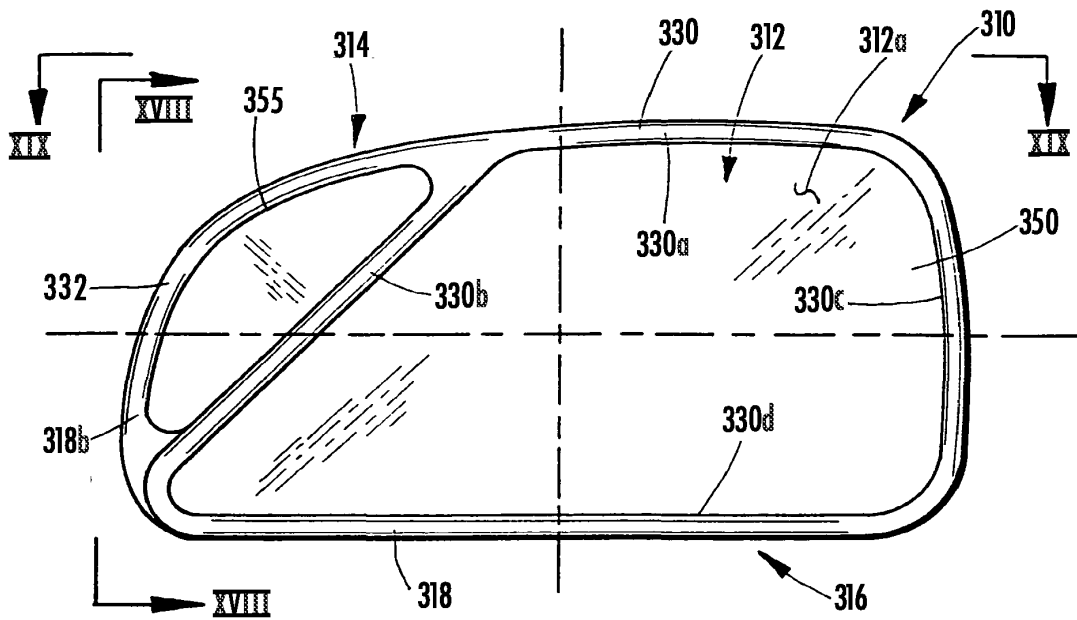

FIG. 16

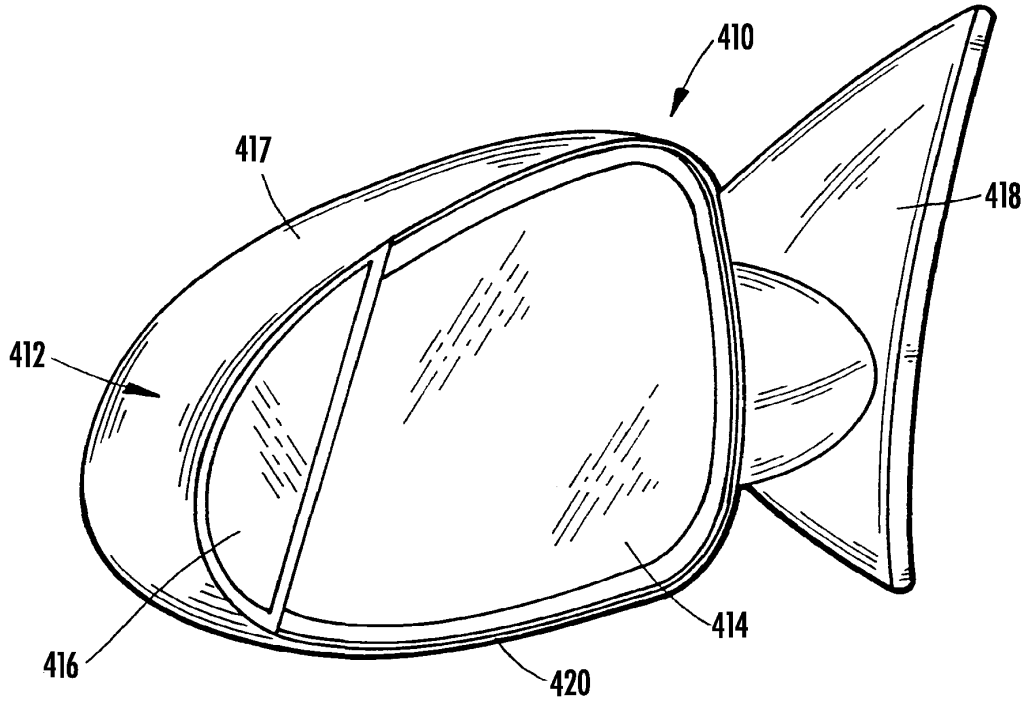

FIG. 23

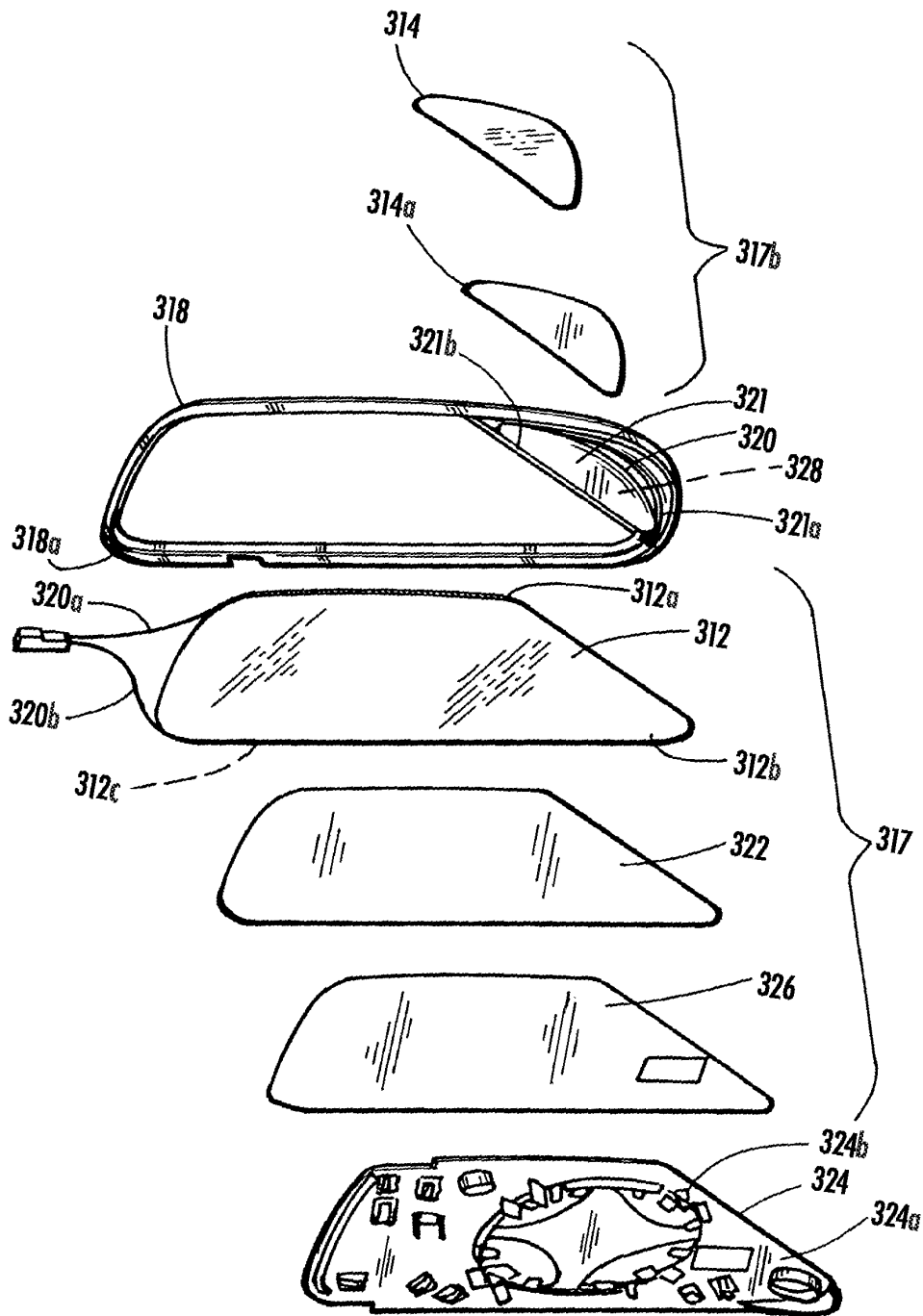

FIG. 17

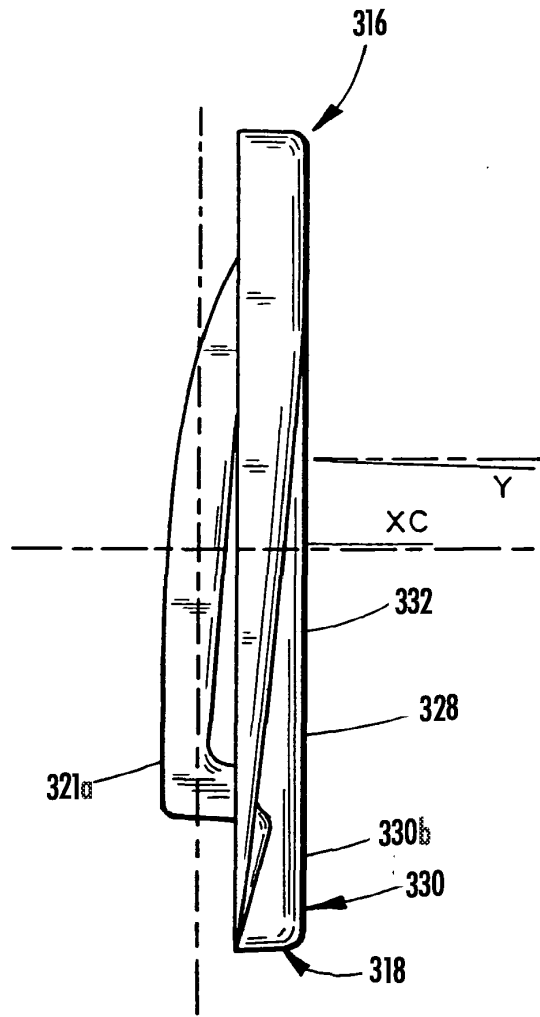

FIG. 18

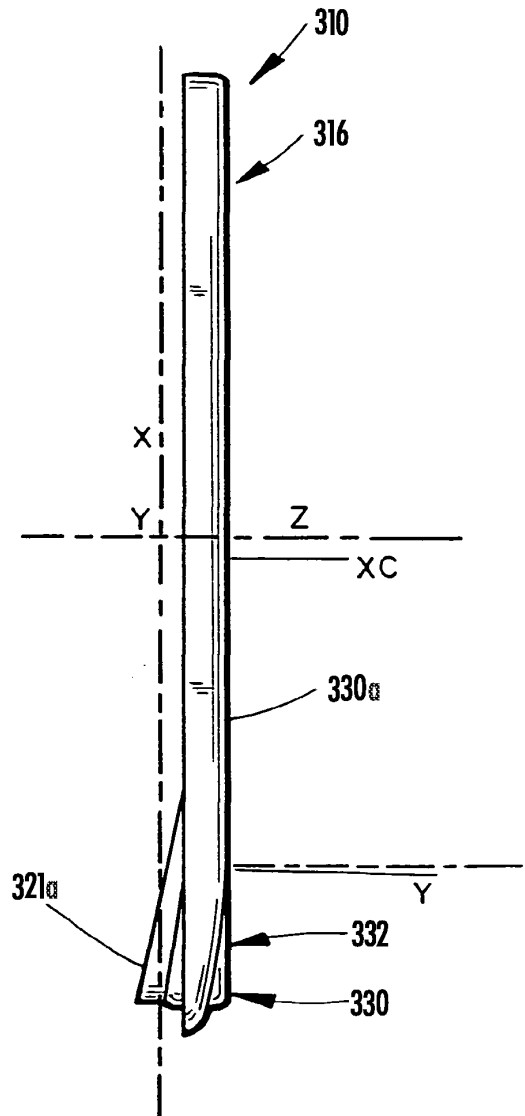

FIG. 19

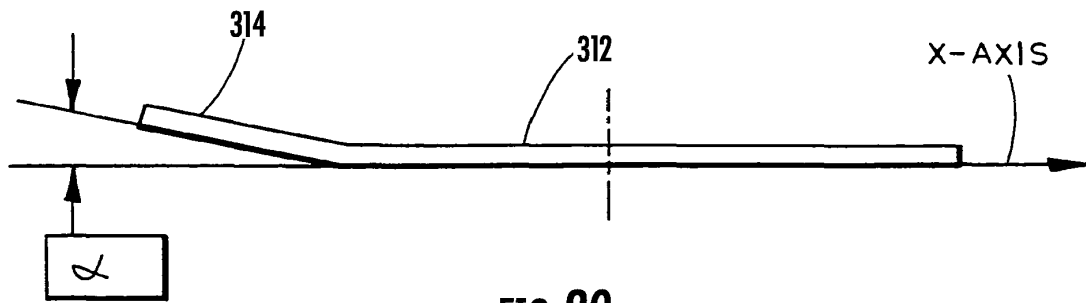

FIG. 20

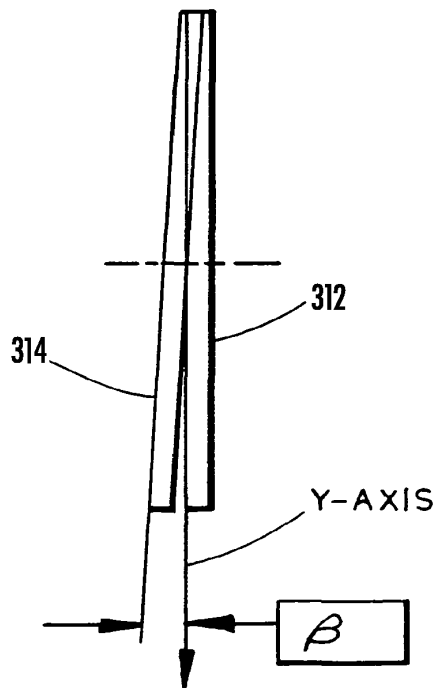

FIG. 21

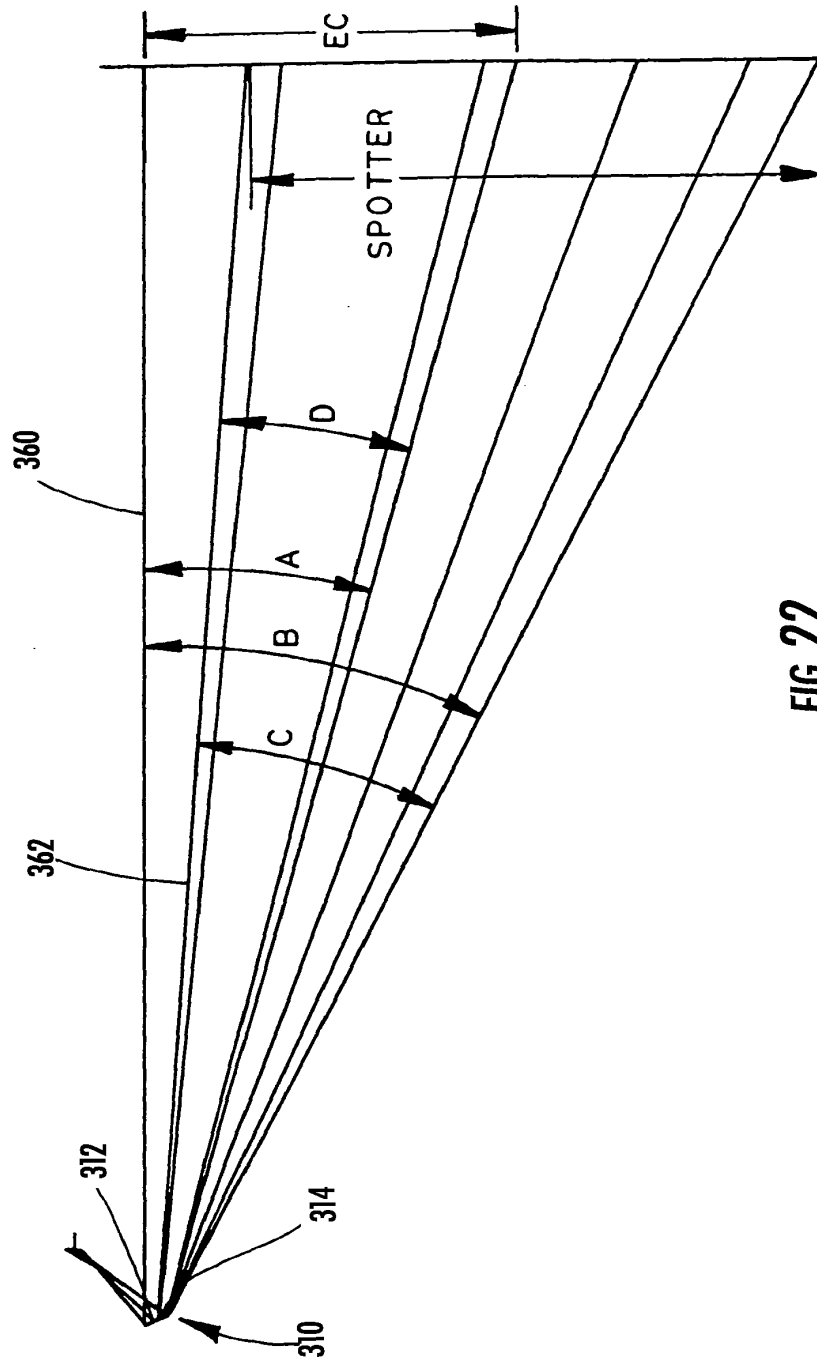

FIG. 22

Electronic Patent Application Fee Transmittal

Application Number:					
Filing Date:					
Title of Invention:	EXTERIOR REARVIEW MIRROR ASSEMBLY				
First Named Inventor/Applicant Name:	Niall R. Lynam				
Filer:	Timothy A. Flory/Amanda Sytsma				
Attorney Docket Number:	DON09 P-1800				
Filed as Large Entity					
Utility under 35 USC 111 (a) Filing Fees					
Description	Fee Code	Quantity	Amount	Sub-Total in USD(\$)	
Basic Filing:					
Utility application filing	1011	1	380	380	
Utility Search Fee	1111	1	620	620	
Utility Examination Fee	1311	1	250	250	
Pages:					
Claims:					
Miscellaneous-Filing:					
Petition:					
Patent-Appeals-and-Interference:					

Description	Fee Code	Quantity	Amount	Sub-Total in USD(\$)
Post-Allowance-and-Post-Issuance:				
Extension-of-Time:				
Miscellaneous:				
Total in USD (\$)				1250

Electronic Acknowledgement Receipt

EFS ID:	11697678
Application Number:	13336018
International Application Number:	
Confirmation Number:	7833
Title of Invention:	EXTERIOR REARVIEW MIRROR ASSEMBLY
First Named Inventor/Applicant Name:	Niall R. Lynam
Customer Number:	15671
Filer:	Timothy A. Flory/Amanda Sytsma
Filer Authorized By:	Timothy A. Flory
Attorney Docket Number:	DON09 P-1800
Receipt Date:	23-DEC-2011
Filing Date:	
Time Stamp:	09:27:33
Application Type:	Utility under 35 USC 111(a)

Payment information:

Submitted with Payment	yes
Payment Type	Credit Card
Payment was successfully received in RAM	\$ 1250
RAM confirmation Number	11040
Deposit Account	
Authorized User	

File Listing:

Document Number	Document Description	File Name	File Size(Bytes)/ Message Digest	Multi Part /.zip	Pages (if appl.)
-----------------	----------------------	-----------	-------------------------------------	------------------	------------------

1	Transmittal of New Application	Transmittal.pdf	273978 fcf3b8eda1be8a1efec36d793a1e0ee7a807b41	no	1
Warnings:					
Information:					
2	Miscellaneous Incoming Letter	RequestforContinuation.pdf	281005 209c9ca1cb4305fcd70191bf889f938d7ef010b	no	6
Warnings:					
Information:					
3	Application Data Sheet	ApplicationDataSheet.pdf	967836 41264572781af8462b151114c238de38f563e85	no	5
Warnings:					
Information:					
4	Oath or Declaration filed	Declaration.pdf	80692 35ca2148ca4eaf900a2daf7ba8e8921e81d1bbfb	no	1
Warnings:					
Information:					
5		Specification.pdf	3616952 75c188976793be9af37fd4319acd0d31708a6e3	yes	40
	Multipart Description/PDF files in .zip description				
	Document Description		Start	End	
	Specification		1	36	
	Claims		37	39	
Abstract		40	40		
Warnings:					
Information:					
6	Drawings-only black and white line drawings	P1800Drawings.pdf	4065886 8f07605a9cb17d9b4c28b0f6dbdec298d786913e	no	16
Warnings:					
Information:					
7	Fee Worksheet (SB06)	fee-info.pdf	33009 4ab5d8dd7d92d4e5451de146cb2b433f44401650	no	2
Warnings:					
Information:					
Total Files Size (in bytes):			9319358		

This Acknowledgement Receipt evidences receipt on the noted date by the USPTO of the indicated documents, characterized by the applicant, and including page counts, where applicable. It serves as evidence of receipt similar to a Post Card, as described in MPEP 503.

New Applications Under 35 U.S.C. 111

If a new application is being filed and the application includes the necessary components for a filing date (see 37 CFR 1.53(b)-(d) and MPEP 506), a Filing Receipt (37 CFR 1.54) will be issued in due course and the date shown on this Acknowledgement Receipt will establish the filing date of the application.

National Stage of an International Application under 35 U.S.C. 371

If a timely submission to enter the national stage of an international application is compliant with the conditions of 35 U.S.C. 371 and other applicable requirements a Form PCT/DO/EO/903 indicating acceptance of the application as a national stage submission under 35 U.S.C. 371 will be issued in addition to the Filing Receipt, in due course.

New International Application Filed with the USPTO as a Receiving Office

If a new international application is being filed and the international application includes the necessary components for an international filing date (see PCT Article 11 and MPEP 1810), a Notification of the International Application Number and of the International Filing Date (Form PCT/RO/105) will be issued in due course, subject to prescriptions concerning national security, and the date shown on this Acknowledgement Receipt will establish the international filing date of the application.

PATENT APPLICATION FEE DETERMINATION RECORD

Substitute for Form PTO-875

Application or Docket Number
13/336,018

APPLICATION AS FILED - PART I

(Column 1)		(Column 2)	SMALL ENTITY		OR	OTHER THAN SMALL ENTITY	
FOR	NUMBER FILED	NUMBER EXTRA	RATE(\$)	FEE(\$)		RATE(\$)	FEE(\$)
BASIC FEE (37 CFR 1.16(a), (b), or (c))	N/A	N/A	N/A			N/A	380
SEARCH FEE (37 CFR 1.16(k), (l), or (m))	N/A	N/A	N/A			N/A	620
EXAMINATION FEE (37 CFR 1.16(o), (p), or (q))	N/A	N/A	N/A			N/A	250
TOTAL CLAIMS (37 CFR 1.16(j))	18	minus 20 = *			OR	x 60 =	0.00
INDEPENDENT CLAIMS (37 CFR 1.16(h))	3	minus 3 = *			OR	x 250 =	0.00
APPLICATION SIZE FEE (37 CFR 1.16(s))	If the specification and drawings exceed 100 sheets of paper, the application size fee due is \$310 (\$155 for small entity) for each additional 50 sheets or fraction thereof. See 35 U.S.C. 41(a)(1)(G) and 37 CFR 1.16(s).						0.00
MULTIPLE DEPENDENT CLAIM PRESENT (37 CFR 1.16(j))							0.00
* If the difference in column 1 is less than zero, enter "0" in column 2.			TOTAL			TOTAL	1250

APPLICATION AS AMENDED - PART II

AMENDMENT A	(Column 1)	(Column 2)	(Column 3)	SMALL ENTITY		OR	OTHER THAN SMALL ENTITY	
	CLAIMS REMAINING AFTER AMENDMENT	HIGHEST NUMBER PREVIOUSLY PAID FOR	PRESENT EXTRA	RATE(\$)	ADDITIONAL FEE(\$)		RATE(\$)	ADDITIONAL FEE(\$)
Total (37 CFR 1.16(i))	*	Minus **	=	x	=	OR	x	=
Independent (37 CFR 1.16(h))	*	Minus ***	=	x	=	OR	x	=
Application Size Fee (37 CFR 1.16(s))						OR		
FIRST PRESENTATION OF MULTIPLE DEPENDENT CLAIM (37 CFR 1.16(j))						OR		
			TOTAL ADD'L FEE			OR	TOTAL ADD'L FEE	
AMENDMENT B	(Column 1)	(Column 2)	(Column 3)	SMALL ENTITY		OR	OTHER THAN SMALL ENTITY	
	CLAIMS REMAINING AFTER AMENDMENT	HIGHEST NUMBER PREVIOUSLY PAID FOR	PRESENT EXTRA	RATE(\$)	ADDITIONAL FEE(\$)		RATE(\$)	ADDITIONAL FEE(\$)
Total (37 CFR 1.16(i))	*	Minus **	=	x	=	OR	x	=
Independent (37 CFR 1.16(h))	*	Minus ***	=	x	=	OR	x	=
Application Size Fee (37 CFR 1.16(s))						OR		
FIRST PRESENTATION OF MULTIPLE DEPENDENT CLAIM (37 CFR 1.16(j))						OR		
			TOTAL ADD'L FEE			OR	TOTAL ADD'L FEE	

* If the entry in column 1 is less than the entry in column 2, write "0" in column 3.
 ** If the "Highest Number Previously Paid For" IN THIS SPACE is less than 20, enter "20".
 *** If the "Highest Number Previously Paid For" IN THIS SPACE is less than 3, enter "3".
 The "Highest Number Previously Paid For" (Total or Independent) is the highest found in the appropriate box in column 1.



UNITED STATES PATENT AND TRADEMARK OFFICE

UNITED STATES DEPARTMENT OF COMMERCE
United States Patent and Trademark Office
Address: COMMISSIONER FOR PATENTS
P.O. Box 1450
Alexandria, Virginia 22313-1450
www.uspto.gov

Table with 6 columns: APPLICATION NUMBER, FILING or 371(c) DATE, GRP ART UNIT, FIL FEE REC'D, ATTY.DOCKET.NO, TOT CLAIMS, IND CLAIMS. Row 1: 13/336,018, 12/23/2011, 2872, 1250, DON09 P-1800, 18, 3

CONFIRMATION NO. 7833

FILING RECEIPT



15671
Gardner, Linn, Burkhardt & Flory, LLP
2851 Charlevoix Dr.
SE, Suite 207
Grand Rapids, MI 49546

Date Mailed: 01/10/2012

Receipt is acknowledged of this non-provisional patent application. The application will be taken up for examination in due course. Applicant will be notified as to the results of the examination. Any correspondence concerning the application must include the following identification information: the U.S. APPLICATION NUMBER, FILING DATE, NAME OF APPLICANT, and TITLE OF INVENTION. Fees transmitted by check or draft are subject to collection. Please verify the accuracy of the data presented on this receipt. If an error is noted on this Filing Receipt, please submit a written request for a Filing Receipt Correction. Please provide a copy of this Filing Receipt with the changes noted thereon. If you received a "Notice to File Missing Parts" for this application, please submit any corrections to this Filing Receipt with your reply to the Notice. When the USPTO processes the reply to the Notice, the USPTO will generate another Filing Receipt incorporating the requested corrections

Applicant(s)

Niall R. Lynam, Holland, MI;

Assignment For Published Patent Application

DONNELLY CORPORATION, Holland, MI

Power of Attorney:

Daniel Van Dyke--25046 Timothy Flory--42540
Donald Gardner--25975 Karl Ondersma--55894
Frederick Burkhardt--29288
Terence Linn--30283
Catherine Collins--37599

Domestic Priority data as claimed by applicant

This application is a CON of 12/911,274 10/25/2010
which is a CON of 12/851,045 08/05/2010 PAT 7934843
which is a CON of 12/197,666 08/25/2008 PAT 7842154
which is a DIV of 10/709,434 05/05/2004 PAT 7420756
which claims benefit of 60/471,872 05/20/2003

Foreign Applications (You may be eligible to benefit from the Patent Prosecution Highway program at the USPTO. Please see http://www.uspto.gov for more information.)

If Required, Foreign Filing License Granted: 01/09/2012

The country code and number of your priority application, to be used for filing abroad under the Paris Convention, is US 13/336,018

Projected Publication Date: 04/19/2012

Non-Publication Request: No

Early Publication Request: No

Title

EXTERIOR REARVIEW MIRROR ASSEMBLY

Preliminary Class

359

PROTECTING YOUR INVENTION OUTSIDE THE UNITED STATES

Since the rights granted by a U.S. patent extend only throughout the territory of the United States and have no effect in a foreign country, an inventor who wishes patent protection in another country must apply for a patent in a specific country or in regional patent offices. Applicants may wish to consider the filing of an international application under the Patent Cooperation Treaty (PCT). An international (PCT) application generally has the same effect as a regular national patent application in each PCT-member country. The PCT process **simplifies** the filing of patent applications on the same invention in member countries, but **does not result** in a grant of "an international patent" and does not eliminate the need of applicants to file additional documents and fees in countries where patent protection is desired.

Almost every country has its own patent law, and a person desiring a patent in a particular country must make an application for patent in that country in accordance with its particular laws. Since the laws of many countries differ in various respects from the patent law of the United States, applicants are advised to seek guidance from specific foreign countries to ensure that patent rights are not lost prematurely.

Applicants also are advised that in the case of inventions made in the United States, the Director of the USPTO must issue a license before applicants can apply for a patent in a foreign country. The filing of a U.S. patent application serves as a request for a foreign filing license. The application's filing receipt contains further information and guidance as to the status of applicant's license for foreign filing.

Applicants may wish to consult the USPTO booklet, "General Information Concerning Patents" (specifically, the section entitled "Treaties and Foreign Patents") for more information on timeframes and deadlines for filing foreign patent applications. The guide is available either by contacting the USPTO Contact Center at 800-786-9199, or it can be viewed on the USPTO website at <http://www.uspto.gov/web/offices/pac/doc/general/index.html>.

For information on preventing theft of your intellectual property (patents, trademarks and copyrights), you may wish to consult the U.S. Government website, <http://www.stopfakes.gov>. Part of a Department of Commerce initiative, this website includes self-help "toolkits" giving innovators guidance on how to protect intellectual property in specific countries such as China, Korea and Mexico. For questions regarding patent enforcement issues, applicants may call the U.S. Government hotline at 1-866-999-HALT (1-866-999-4158).

**LICENSE FOR FOREIGN FILING UNDER
Title 35, United States Code, Section 184
Title 37, Code of Federal Regulations, 5.11 & 5.15**

GRANTED

The applicant has been granted a license under 35 U.S.C. 184, if the phrase "IF REQUIRED, FOREIGN FILING LICENSE GRANTED" followed by a date appears on this form. Such licenses are issued in all applications where the conditions for issuance of a license have been met, regardless of whether or not a license may be required as set forth in 37 CFR 5.15. The scope and limitations of this license are set forth in 37 CFR 5.15(a) unless an earlier license has been issued under 37 CFR 5.15(b). The license is subject to revocation upon written notification. The date indicated is the effective date of the license, unless an earlier license of similar scope has been granted under 37 CFR 5.13 or 5.14.

This license is to be retained by the licensee and may be used at any time on or after the effective date thereof unless it is revoked. This license is automatically transferred to any related applications(s) filed under 37 CFR 1.53(d). This license is not retroactive.

The grant of a license does not in any way lessen the responsibility of a licensee for the security of the subject matter as imposed by any Government contract or the provisions of existing laws relating to espionage and the national security or the export of technical data. Licensees should apprise themselves of current regulations especially with respect to certain countries, of other agencies, particularly the Office of Defense Trade Controls, Department of State (with respect to Arms, Munitions and Implements of War (22 CFR 121-128)); the Bureau of Industry and Security, Department of Commerce (15 CFR parts 730-774); the Office of Foreign Assets Control, Department of Treasury (31 CFR Parts 500+) and the Department of Energy.

NOT GRANTED

No license under 35 U.S.C. 184 has been granted at this time, if the phrase "IF REQUIRED, FOREIGN FILING LICENSE GRANTED" DOES NOT appear on this form. Applicant may still petition for a license under 37 CFR 5.12, if a license is desired before the expiration of 6 months from the filing date of the application. If 6 months has lapsed from the filing date of this application and the licensee has not received any indication of a secrecy order under 35 U.S.C. 181, the licensee may foreign file the application pursuant to 37 CFR 5.15(b).

SelectUSA

The United States represents the largest, most dynamic marketplace in the world and is an unparalleled location for business investment, innovation and commercialization of new technologies. The USA offers tremendous resources and advantages for those who invest and manufacture goods here. Through SelectUSA, our nation works to encourage, facilitate, and accelerate business investment. To learn more about why the USA is the best country in the world to develop technology, manufacture products, and grow your business, visit SelectUSA.gov.

IN THE UNITED STATES PATENT AND TRADEMARK OFFICE

Group Art Unit : 2872
Applicant : Niall R. Lynam
Serial No. : 13/336,018
Filed : December 23, 2011
For : EXTERIOR REARVIEW MIRROR ASSEMBLY

Mail Stop Amendment
Commissioner for Patents
P.O. Box 1450
Alexandria, VA 22313-1450

Dear Sir:

PRELIMINARY AMENDMENT

Prior to the examination of this application, Applicant requests amendment of the application as follows:

Amendments to the Claims are reflected in the listing of claims which begins on page 2 of this paper.

Remarks are on page 9 of this paper.

Applicant : Niall R. Lynam
Serial No. : 13/336,018
Page : 2

Amendments to the Claims:

This listing of claims will replace all prior versions and listings of claims in the present application:

1 (original): An exterior rearview mirror assembly for a motor vehicle, said exterior rearview mirror assembly comprising:

a bracket fixedly secured to the motor vehicle;

a mirror casing secured to said bracket, said mirror casing defining a primary opening;

a single mirror support movably secured within said mirror casing disposed adjacent said primary opening;

a primary mirror fixedly secured to said single mirror support and disposed within said primary opening for providing a view rearward of the motor vehicle through a primary field of view; and

a spotting mirror fixedly secured to said single mirror support and disposed adjacent said primary mirror, said spotting mirror defined by a single radius of curvature differing from said primary mirror such that said spotting mirror provides a second field of view rearward of the motor vehicle, such that said first field of view of said primary mirror overlaps said second field of view of said spotting mirror.

2 (original): An exterior rearview mirror assembly as set forth in claim 1 wherein said single mirror support defines a primary portion for having said primary mirror fixedly secured thereto and a spotting portion for having said spotting mirror fixedly secured thereto.

3 (original): An exterior rearview mirror assembly as set forth in claim 2 wherein said primary portion of said single mirror support defines a primary plane that is substantially flat.

Applicant : Niall R. Lynam
Serial No. : 13/336,018
Page : 3

4 (original): An exterior rearview mirror assembly as set forth in claim 3 wherein said spotting portion of said single mirror support defines a spotting mirror support radius of curvature substantially equal to said single radius of curvature.

5 (original): An exterior rearview mirror assembly as set forth in claim 4 wherein said spotting portion is forward of said primary plane.

6 (original): An exterior rearview mirror assembly as set forth in claim 4 wherein said spotting portion is substantially rearward of said primary plane.

7-15 (canceled).

16 (original): An exterior rearview mirror assembly for a motor vehicle, said exterior rearview mirror assembly comprising:

- a bracket fixedly secured to the motor vehicle;
- a mirror casing secured to said bracket, said mirror casing defining a primary opening;
- a primary mirror disposed within said primary opening for providing a view rearward of the motor vehicle through a primary field of view, said primary mirror defining a primary plane;
- a spotting mirror spaced apart from said primary mirror, said spotting mirror extending through a secondary plane different from said primary plane; and
- a divider extending between said primary mirror and said spotting mirror to separate said primary and secondary mirrors visually.

17 (original): An exterior rearview mirror assembly as set forth in claim 16 wherein said spotting mirror is forward of said primary plane.

18 (original): An exterior rearview mirror assembly as set forth in claim 16 wherein said spotting mirror is rearward of said primary plane.

Applicant : Niall R. Lynam
Serial No. : 13/336,018
Page : 4

19 (new): An exterior rearview mirror assembly for a motor vehicle, said exterior rearview mirror assembly comprising:

a bracket fixedly secured to the motor vehicle;

a mirror casing secured to said bracket, said mirror casing defining a primary opening;

a single mirror support movably secured within said mirror casing disposed adjacent said primary opening;

a primary mirror fixedly secured to said single mirror support and disposed within said primary opening for providing a view rearward of the motor vehicle through a primary field of view;

a spotting mirror fixedly secured to said single mirror support and disposed adjacent said primary mirror, said spotting mirror defined by a single radius of curvature differing from said primary mirror such that said spotting mirror provides a second field of view rearward of the motor vehicle, such that said primary field of view of said primary mirror overlaps said second field of view of said spotting mirror; and

wherein said primary mirror comprises one of (a) a generally flat glass substrate having a surface coated with a metallic reflector coating and (b) a generally flat polymeric substrate having a thin glass element applied to a surface thereof and with an opposing surface thereof having a reflecting layer applied thereto.

20 (new): An exterior rearview mirror assembly as set forth in claim 19 wherein said single mirror support defines a primary portion for having said primary mirror fixedly secured thereto and a spotting portion for having said spotting mirror fixedly secured thereto.

21 (new): An exterior rearview mirror assembly as set forth in claim 20 wherein said primary portion of said single mirror support defines a primary plane that is substantially flat.

Applicant : Niall R. Lynam
Serial No. : 13/336,018
Page : 5

22 (new): An exterior rearview mirror assembly as set forth in claim 21 wherein said spotting portion of said single mirror support defines a spotting mirror support radius of curvature substantially equal to said single radius of curvature.

23 (new): An exterior rearview mirror assembly as set forth in claim 22 wherein said spotting portion is forward of said primary plane.

24 (new): An exterior rearview mirror assembly as set forth in claim 22 wherein said spotting portion is substantially rearward of said primary plane.

25 (new): An exterior rearview mirror assembly for a motor vehicle, said exterior rearview mirror assembly comprising:

- a bracket fixedly secured to the motor vehicle;

- a mirror casing secured to said bracket, said mirror casing defining a primary opening;

- a primary mirror disposed within said primary opening for providing a view rearward of the motor vehicle through a primary field of view, said primary mirror defining a primary plane;

- a spotting mirror spaced apart from said primary mirror, said spotting mirror extending through a secondary plane different from said primary plane;

- a divider extending between said primary mirror and said spotting mirror to separate said primary and secondary mirrors visually; and

wherein said primary mirror comprises one of (a) a generally flat glass substrate having a surface coated with a metallic reflector coating and (b) a generally flat polymeric substrate having a thin glass element applied to a surface thereof and with an opposing surface thereof having a reflecting layer applied thereto.

26 (new): An exterior rearview mirror assembly as set forth in claim 25 wherein said spotting mirror is forward of said primary plane.

Applicant : Niall R. Lynam
Serial No. : 13/336,018
Page : 6

27 (new): An exterior rearview mirror assembly as set forth in claim 25 wherein said spotting mirror is rearward of said primary plane.

28 (new): An exterior rearview mirror assembly for a motor vehicle, said exterior rearview mirror assembly comprising:

a bracket fixedly secured to the motor vehicle;

a mirror casing secured to said bracket, said mirror casing defining a primary opening;

a single mirror support movably secured within said mirror casing disposed adjacent said primary opening;

a primary mirror fixedly secured to said single mirror support and disposed within said primary opening for providing a view rearward of the motor vehicle through a primary field of view;

a spotting mirror fixedly secured to said single mirror support and disposed adjacent said primary mirror, said spotting mirror defined by a single radius of curvature differing from said primary mirror such that said spotting mirror provides a second field of view rearward of the motor vehicle, such that said primary field of view of said primary mirror overlaps said second field of view of said spotting mirror;

wherein said spotting mirror is at an angle relative to said primary mirror; and

wherein said primary mirror comprises one of (a) a generally flat glass substrate having a surface coated with a metallic reflector coating and (b) a generally flat polymeric substrate having a thin glass element applied to a surface thereof and with an opposing surface thereof having a reflecting layer applied thereto.

29 (new): An exterior rearview mirror assembly as set forth in claim 28 wherein said single mirror support defines a primary portion for having said primary mirror fixedly secured thereto and a spotting portion for having said spotting mirror fixedly secured thereto.

Applicant : Niall R. Lynam
Serial No. : 13/336,018
Page : 7

30 (new): An exterior rearview mirror assembly as set forth in claim 29 wherein said primary portion of said single mirror support defines a primary plane that is substantially flat.

31 (new): An exterior rearview mirror assembly as set forth in claim 30 wherein said spotting portion of said single mirror support defines a spotting mirror support radius of curvature substantially equal to said single radius of curvature.

32 (new): An exterior rearview mirror assembly as set forth in claim 31 wherein said spotting portion is forward of said primary plane.

33 (new): An exterior rearview mirror assembly as set forth in claim 31 wherein said spotting portion is substantially rearward of said primary plane.

34 (new): An exterior rearview mirror assembly as set forth in claim 28, wherein the second field of view of said spotting mirror is generally directed at least one of outwardly and downwardly with respect to the longitudinal axis of the motor vehicle when said exterior rearview mirror assembly is attached to the motor vehicle.

35 (new): An exterior rearview mirror assembly as set forth in claim 28, wherein said spotting mirror is at an angle of at least about three degrees relative to said primary mirror.

36 (new): An exterior rearview mirror assembly for a motor vehicle, said exterior rearview mirror assembly comprising:

- a bracket fixedly secured to the motor vehicle;
- a mirror casing secured to said bracket, said mirror casing defining a primary opening;
- a primary mirror disposed within said primary opening for providing a view rearward of the motor vehicle through a primary field of view, said primary mirror defining a primary plane;

Applicant : Niall R. Lynam
Serial No. : 13/336,018
Page : 8

a spotting mirror spaced apart from said primary mirror, said spotting mirror extending through a secondary plane different from said primary plane;

wherein said spotting mirror is at an angle relative to said primary mirror;

a divider extending between said primary mirror and said spotting mirror to separate said primary and secondary mirrors visually; and

wherein said primary mirror comprises one of (a) a generally flat glass substrate having a surface coated with a metallic reflector coating and (b) a generally flat polymeric substrate having a thin glass element applied to a surface thereof and with an opposing surface thereof having a reflecting layer applied thereto.

37 (new): An exterior rearview mirror assembly as set forth in claim 36 wherein said spotting mirror is forward of said primary plane.

38 (new): An exterior rearview mirror assembly as set forth in claim 36 wherein said spotting mirror is rearward of said primary plane.

39 (new): An exterior rearview mirror assembly as set forth in claim 36, wherein the second field of view of said spotting mirror is generally directed at least one of outwardly and downwardly with respect to the longitudinal axis of the motor vehicle when said exterior rearview mirror assembly is attached to the motor vehicle.

40 (new): An exterior rearview mirror assembly as set forth in claim 36, wherein said spotting mirror is at an angle of at least about three degrees relative to said primary mirror.

Applicant : Niall R. Lynam
Serial No. : 13/336,018
Page : 9

Remarks:

Claims 1-6 and 16-40 are pending in the application. Claims 7-15 have been canceled herein without prejudice, and new claims 19-40 have been added. New claims 19-40 are fully supported in the specification and drawings as originally filed in the present application and its priority applications. No new matter has been added.

Claims 1-18 were substantially copied from U.S. Patent No. 7,857,469, which issued December 28, 2010. Claims 1-6 and 16-18 correspond to claims 1-6 and 16-18 of U.S. Patent No. 7,857,469. Claims 1-18 were added to preserve Applicant's right to request an interference with U.S. Patent No. 7,857,469. New independent claims 19, 25, 28 and 36 are derived from independent claims 1 and 16 of U.S. Patent No. 7,857,469.

Examination of claims 1-6 and 16-40 and an early and favorable action on the merits is respectfully requested.

Respectfully submitted,

NIALL R. LYNAM

By: Gardner, Linn, Burkhardt & Flory, LLP

Date: January 19, 2012

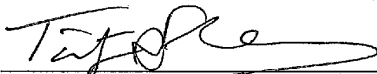

Timothy A. Flory
Registration No. 42 540
2851 Charlevoix Drive, S.E.
P.O. Box 888695
Grand Rapids, Michigan 49588-8695
(616) 975-5500

Electronic Patent Application Fee Transmittal

Application Number:	13336018			
Filing Date:	23-Dec-2011			
Title of Invention:	EXTERIOR REARVIEW MIRROR ASSEMBLY			
First Named Inventor/Applicant Name:	Niall R. Lynam			
Filer:	Timothy A. Flory/Amanda Sytsma			
Attorney Docket Number:	DON09 P-1800			
Filed as Large Entity				
Utility under 35 USC 111 (a) Filing Fees				
Description	Fee Code	Quantity	Amount	Sub-Total in USD(\$)
Basic Filing:				
Pages:				
Claims:				
Claims in excess of 20	1202	11	60	660
Independent claims in excess of 3	1201	3	250	750
Miscellaneous-Filing:				
Petition:				
Patent-Appeals-and-Interference:				
Post-Allowance-and-Post-Issuance:				

Description	Fee Code	Quantity	Amount	Sub-Total in USD(\$)
Extension-of-Time:				
Miscellaneous:				
Total in USD (\$)				1410

Electronic Acknowledgement Receipt

EFS ID:	11869368
Application Number:	13336018
International Application Number:	
Confirmation Number:	7833
Title of Invention:	EXTERIOR REARVIEW MIRROR ASSEMBLY
First Named Inventor/Applicant Name:	Niall R. Lynam
Customer Number:	15671
Filer:	Timothy A. Flory/Amanda Sytsma
Filer Authorized By:	Timothy A. Flory
Attorney Docket Number:	DON09 P-1800
Receipt Date:	19-JAN-2012
Filing Date:	23-DEC-2011
Time Stamp:	12:23:10
Application Type:	Utility under 35 USC 111(a)

Payment information:

Submitted with Payment	yes
Payment Type	Credit Card
Payment was successfully received in RAM	\$ 1410
RAM confirmation Number	11530
Deposit Account	
Authorized User	

File Listing:

Document Number	Document Description	File Name	File Size(Bytes)/ Message Digest	Multi Part /.zip	Pages (if appl.)
-----------------	----------------------	-----------	-------------------------------------	------------------	------------------

1	Transmittal Letter	TransmittalForm.pdf	87476	no	1
			d204239f7328757c3b6219168dd45a1a63067c4		
Warnings:					
Information:					
2	Preliminary Amendment	PreliminaryAmendment.pdf	474757	no	9
			6ae3397a3efb1e02877d2656cd2f8ab2e47d6d24		
Warnings:					
Information:					
3	Fee Worksheet (SB06)	fee-info.pdf	31815	no	2
			0c0ba656f9724146320f9e44ec57f70b8455253b		
Warnings:					
Information:					
Total Files Size (in bytes):				594048	
<p>This Acknowledgement Receipt evidences receipt on the noted date by the USPTO of the indicated documents, characterized by the applicant, and including page counts, where applicable. It serves as evidence of receipt similar to a Post Card, as described in MPEP 503.</p> <p><u>New Applications Under 35 U.S.C. 111</u> If a new application is being filed and the application includes the necessary components for a filing date (see 37 CFR 1.53(b)-(d) and MPEP 506), a Filing Receipt (37 CFR 1.54) will be issued in due course and the date shown on this Acknowledgement Receipt will establish the filing date of the application.</p> <p><u>National Stage of an International Application under 35 U.S.C. 371</u> If a timely submission to enter the national stage of an international application is compliant with the conditions of 35 U.S.C. 371 and other applicable requirements a Form PCT/DO/EO/903 indicating acceptance of the application as a national stage submission under 35 U.S.C. 371 will be issued in addition to the Filing Receipt, in due course.</p> <p><u>New International Application Filed with the USPTO as a Receiving Office</u> If a new international application is being filed and the international application includes the necessary components for an international filing date (see PCT Article 11 and MPEP 1810), a Notification of the International Application Number and of the International Filing Date (Form PCT/RO/105) will be issued in due course, subject to prescriptions concerning national security, and the date shown on this Acknowledgement Receipt will establish the international filing date of the application.</p>					

Under the Paperwork Reduction Act of 1995, no persons are required to respond to a collection of information unless it displays a valid OMB control number.

TRANSMITTAL FORM <small>(to be used for all correspondence after initial filing)</small>	Application Number	13/336,018
	Filing Date	December 23, 2011
	First Named Inventor	Niall R. Lynam
	Art Unit	2872
	Examiner Name	
Total Number of Pages in This Submission	Attorney Docket Number	DON09 P-1800

ENCLOSURES (Check all that apply)		
<input type="checkbox"/> Fee Transmittal Form	<input type="checkbox"/> Drawing(s)	<input type="checkbox"/> After Allowance Communication to TC
<input type="checkbox"/> Fee Attached	<input type="checkbox"/> Licensing-related Papers	<input type="checkbox"/> Appeal Communication to Board of Appeals and Interferences
<input type="checkbox"/> Amendment/Reply	<input type="checkbox"/> Petition	<input type="checkbox"/> Appeal Communication to TC (Appeal Notice, Brief, Reply Brief)
<input type="checkbox"/> After Final	<input type="checkbox"/> Petition to Convert to a Provisional Application	<input type="checkbox"/> Proprietary Information
<input type="checkbox"/> Affidavits/declaration(s)	<input type="checkbox"/> Power of Attorney, Revocation	<input type="checkbox"/> Status Letter
<input type="checkbox"/> Extension of Time Request	<input type="checkbox"/> Change of Correspondence Address	<input checked="" type="checkbox"/> Other Enclosure(s) (please identify below):
<input type="checkbox"/> Express Abandonment Request	<input type="checkbox"/> Terminal Disclaimer	-Preliminary Amendment
<input type="checkbox"/> Information Disclosure Statement	<input type="checkbox"/> Request for Refund	
<input type="checkbox"/> Certified Copy of Priority Document(s)	<input type="checkbox"/> CD, Number of CD(s) _____	
<input type="checkbox"/> Reply to Missing Parts/ Incomplete Application	<input type="checkbox"/> Landscape Table on CD	
<input type="checkbox"/> Reply to Missing Parts under 37 CFR 1.52 or 1.53	Remarks	

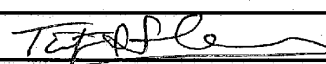
SIGNATURE OF APPLICANT, ATTORNEY, OR AGENT	
Firm Name	GARDNER, LINN, BURKHART & FLORY, LLP
Signature	
Printed name	Timothy A. Flory
Date	January 19, 2012
Reg. No.	42540

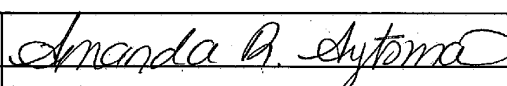
CERTIFICATE OF TRANSMISSION/MAILING	
I hereby certify that this correspondence is being facsimile transmitted to the USPTO or deposited with the United States Postal Service with sufficient postage as first class mail in an envelope addressed to: Commissioner for Patents, P.O. Box 1450, Alexandria, VA 22313-1450 on the date shown below:	
Signature	
Typed or printed name	Amanda R. Sytsma
Date	January 19, 2012

This collection of information is required by 37 CFR 1.5. The information is required to obtain or retain a benefit by the public which is to file (and by the USPTO to process) an application. Confidentiality is governed by 35 U.S.C. 122 and 37 CFR 1.11 and 1.14. This collection is estimated to 2 hours to complete, including gathering, preparing, and submitting the completed application form to the USPTO. Time will vary depending upon the individual case. Any comments on the amount of time you require to complete this form and/or suggestions for reducing this burden, should be sent to the Chief Information Officer, U.S. Patent and Trademark Office, U.S. Department of Commerce, P.O. Box 1450, Alexandria, VA 22313-1450. DO NOT SEND FEES OR COMPLETED FORMS TO THIS ADDRESS. SEND TO: Commissioner for Patents, P.O. Box 1450, Alexandria, VA 22313-1450.

If you need assistance in completing the form, call 1-800-PTO-9199 and select option 2.

Under the Paperwork Reduction Act of 1995, no persons are required to respond to a collection of information unless it displays a valid OMB control number.

PATENT APPLICATION FEE DETERMINATION RECORD Substitute for Form PTO-875					Application or Docket Number 13/336,018		Filing Date 12/23/2011		<input type="checkbox"/> To be Mailed
APPLICATION AS FILED – PART I					SMALL ENTITY <input type="checkbox"/> OR		OTHER THAN SMALL ENTITY		
(Column 1)		(Column 2)							
FOR	NUMBER FILED	NUMBER EXTRA	RATE (\$)	FEE (\$)	OR	RATE (\$)	FEE (\$)		
<input checked="" type="checkbox"/> BASIC FEE <small>(37 CFR 1.16(a), (b), or (c))</small>	N/A	N/A	N/A			N/A	380		
<input type="checkbox"/> SEARCH FEE <small>(37 CFR 1.16(k), (l), or (m))</small>	N/A	N/A	N/A			N/A			
<input type="checkbox"/> EXAMINATION FEE <small>(37 CFR 1.16(o), (p), or (q))</small>	N/A	N/A	N/A			N/A			
TOTAL CLAIMS <small>(37 CFR 1.16(i))</small>	20 minus 20 =	* 0	X \$ =		OR	X \$60 =	0		
INDEPENDENT CLAIMS <small>(37 CFR 1.16(h))</small>	3 minus 3 =	* 0	X \$ =			X \$250 =	0		
<input type="checkbox"/> APPLICATION SIZE FEE <small>(37 CFR 1.16(s))</small>	If the specification and drawings exceed 100 sheets of paper, the application size fee due is \$250 (\$125 for small entity) for each additional 50 sheets or fraction thereof. See 35 U.S.C. 41(a)(1)(G) and 37 CFR 1.16(s).								
<input type="checkbox"/> MULTIPLE DEPENDENT CLAIM PRESENT <small>(37 CFR 1.16(j))</small>									
* If the difference in column 1 is less than zero, enter "0" in column 2.					TOTAL		TOTAL	380	
APPLICATION AS AMENDED – PART II					SMALL ENTITY OR		OTHER THAN SMALL ENTITY		
(Column 1)		(Column 2)		(Column 3)					
AMENDMENT	01/19/2012	CLAIMS REMAINING AFTER AMENDMENT	HIGHEST NUMBER PREVIOUSLY PAID FOR	PRESENT EXTRA	RATE (\$)	ADDITIONAL FEE (\$)	OR	RATE (\$)	ADDITIONAL FEE (\$)
	Total (37 CFR 1.16(i))	* 31	Minus	** 20	=	11		X \$60=	660
	Independent (37 CFR 1.16(h))	* 6	Minus	***3	=	3		X \$250=	750
	<input type="checkbox"/> Application Size Fee (37 CFR 1.16(s))								
	<input type="checkbox"/> FIRST PRESENTATION OF MULTIPLE DEPENDENT CLAIM (37 CFR 1.16(j))								
					TOTAL ADD'L FEE		OR	TOTAL ADD'L FEE	1410
(Column 1)		(Column 2)		(Column 3)					
AMENDMENT		CLAIMS REMAINING AFTER AMENDMENT	HIGHEST NUMBER PREVIOUSLY PAID FOR	PRESENT EXTRA	RATE (\$)	ADDITIONAL FEE (\$)	OR	RATE (\$)	ADDITIONAL FEE (\$)
	Total (37 CFR 1.16(i))	*	Minus	**	=			X \$ =	
	Independent (37 CFR 1.16(h))	*	Minus	***	=			X \$ =	
	<input type="checkbox"/> Application Size Fee (37 CFR 1.16(s))								
	<input type="checkbox"/> FIRST PRESENTATION OF MULTIPLE DEPENDENT CLAIM (37 CFR 1.16(j))								
					TOTAL ADD'L FEE		OR	TOTAL ADD'L FEE	

* If the entry in column 1 is less than the entry in column 2, write "0" in column 3.

** If the "Highest Number Previously Paid For" IN THIS SPACE is less than 20, enter "20".

*** If the "Highest Number Previously Paid For" IN THIS SPACE is less than 3, enter "3".

The "Highest Number Previously Paid For" (Total or Independent) is the highest number found in the appropriate box in column 1.

Legal Instrument Examiner:
/JESSICA GAYNOR/

This collection of information is required by 37 CFR 1.16. The information is required to obtain or retain a benefit by the public which is to file (and by the USPTO to process) an application. Confidentiality is governed by 35 U.S.C. 122 and 37 CFR 1.14. This collection is estimated to take 12 minutes to complete, including gathering, preparing, and submitting the completed application form to the USPTO. Time will vary depending upon the individual case. Any comments on the amount of time you require to complete this form and/or suggestions for reducing this burden, should be sent to the Chief Information Officer, U.S. Patent and Trademark Office, U.S. Department of Commerce, P.O. Box 1450, Alexandria, VA 22313-1450. DO NOT SEND FEES OR COMPLETED FORMS TO THIS ADDRESS. **SEND TO: Commissioner for Patents, P.O. Box 1450, Alexandria, VA 22313-1450.**

If you need assistance in completing the form, call 1-800-PTO-9199 and select option 2.

IN THE UNITED STATES PATENT AND TRADEMARK OFFICE

Group Art Unit : 2872
Applicant : Niall R. Lynam
Serial No. : 13/336,018
Filed : December 23, 2011
For : EXTERIOR REARVIEW MIRROR ASSEMBLY

Mail Stop Amendment
Commissioner for Patents
P.O. Box 1450
Alexandria, VA 22313-1450

Dear Sir:

TRANSMITTAL OF REPLACEMENT DRAWINGS

Enclosed is one (1) sheet of replacement formal drawings to be entered in the above-identified application. The enclosed replacement drawings correspond to the drawings now on file and corrects an error in reference number 165 in Figure 13F. No new matter has been added. Applicant requests that the enclosed one (1) sheet of replacement formal drawings be entered in the above-identified application.

Respectfully submitted,

NIALL R. LYNAM

By: Gardner, Linn, Burkhardt & Flory, LLP

Date: February 1, 2012



Timothy A. Flory
Registration No. 42 540
2851 Charlevoix Drive, S.E.
P.O. Box 888695
Grand Rapids, Michigan 49588-8695
(616) 975-5500

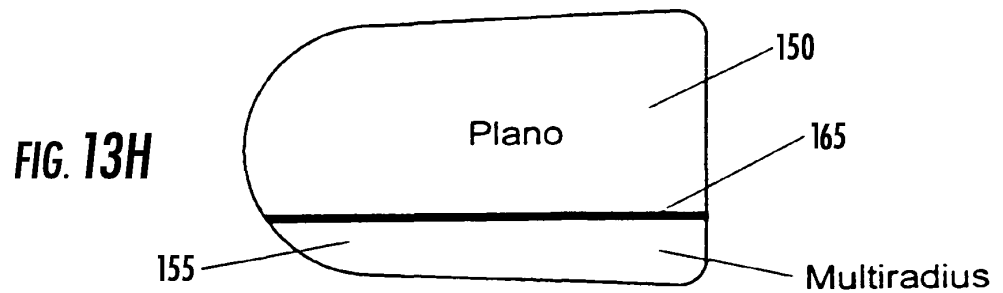
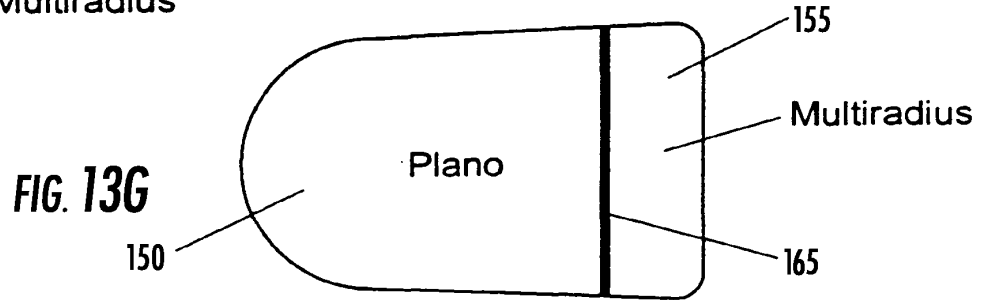
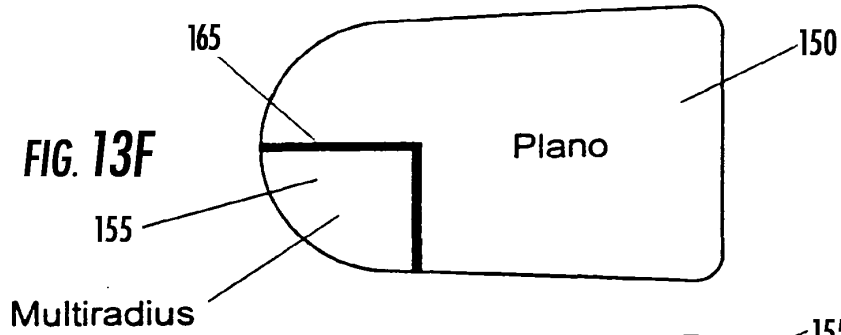
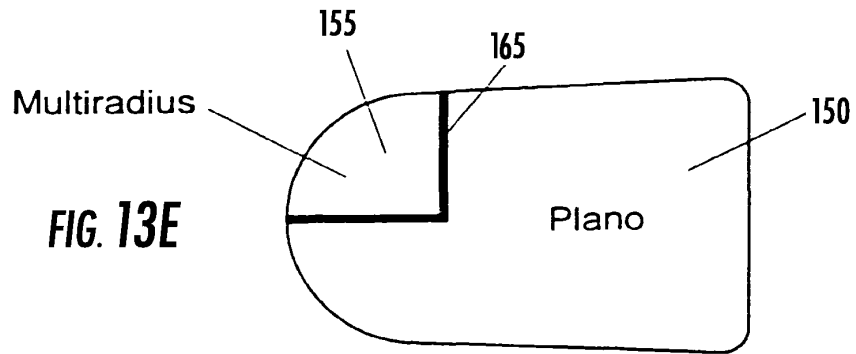

Electronic Acknowledgement Receipt

EFS ID:	11974503
Application Number:	13336018
International Application Number:	
Confirmation Number:	7833
Title of Invention:	EXTERIOR REARVIEW MIRROR ASSEMBLY
First Named Inventor/Applicant Name:	Niall R. Lynam
Customer Number:	15671
Filer:	Timothy A. Flory/Amanda Sytsma
Filer Authorized By:	Timothy A. Flory
Attorney Docket Number:	DON09 P-1800
Receipt Date:	01-FEB-2012
Filing Date:	23-DEC-2011
Time Stamp:	14:58:46
Application Type:	Utility under 35 USC 111(a)

Payment information:

Submitted with Payment	no
------------------------	----

File Listing:

Document Number	Document Description	File Name	File Size(Bytes)/ Message Digest	Multi Part /.zip	Pages (if appl.)
1	Transmittal Letter	TransmittalForm.pdf	83988 afb91ea5f2d393212f3fc66b84300377334d62b0	no	1

Warnings:

Information:

2	Miscellaneous Incoming Letter	TransmittalofReplacementDrawing.pdf	41189 09077a48a391cb474d68f5e5d16a847b4289f44e	no	1
Warnings:					
Information:					
3	Drawings-only black and white line drawings	ReplacementDrawings.pdf	461325 e539e874bd07ef58218b8d9d0ebcc6e364737381	no	1
Warnings:					
Information:					
Total Files Size (in bytes):			586502		
<p>This Acknowledgement Receipt evidences receipt on the noted date by the USPTO of the indicated documents, characterized by the applicant, and including page counts, where applicable. It serves as evidence of receipt similar to a Post Card, as described in MPEP 503.</p> <p><u>New Applications Under 35 U.S.C. 111</u> If a new application is being filed and the application includes the necessary components for a filing date (see 37 CFR 1.53(b)-(d) and MPEP 506), a Filing Receipt (37 CFR 1.54) will be issued in due course and the date shown on this Acknowledgement Receipt will establish the filing date of the application.</p> <p><u>National Stage of an International Application under 35 U.S.C. 371</u> If a timely submission to enter the national stage of an international application is compliant with the conditions of 35 U.S.C. 371 and other applicable requirements a Form PCT/DO/EO/903 indicating acceptance of the application as a national stage submission under 35 U.S.C. 371 will be issued in addition to the Filing Receipt, in due course.</p> <p><u>New International Application Filed with the USPTO as a Receiving Office</u> If a new international application is being filed and the international application includes the necessary components for an international filing date (see PCT Article 11 and MPEP 1810), a Notification of the International Application Number and of the International Filing Date (Form PCT/RO/105) will be issued in due course, subject to prescriptions concerning national security, and the date shown on this Acknowledgement Receipt will establish the international filing date of the application.</p>					

Under the Paperwork Reduction Act of 1995, no persons are required to respond to a collection of information unless it displays a valid OMB control number.

TRANSMITTAL FORM <i>(to be used for all correspondence after initial filing)</i>	Application Number	13/336,018
	Filing Date	December 23, 2011
	First Named Inventor	Niall R. Lynam
	Art Unit	2872
	Examiner Name	
Total Number of Pages In This Submission	Attorney Docket Number	DON09 P-1600

ENCLOSURES (Check all that apply)		
<input type="checkbox"/> Fee Transmittal Form	<input checked="" type="checkbox"/> Drawing(s)	<input type="checkbox"/> After Allowance Communication to TC
<input type="checkbox"/> Fee Attached	<input type="checkbox"/> Licensing-related Papers	<input type="checkbox"/> Appeal Communication to Board of Appeals and Interferences
<input type="checkbox"/> Amendment/Reply	<input type="checkbox"/> Petition	<input type="checkbox"/> Appeal Communication to TC (Appeal Notice, Brief, Reply Brief)
<input type="checkbox"/> After Final	<input type="checkbox"/> Petition to Convert to a Provisional Application	<input type="checkbox"/> Proprietary Information
<input type="checkbox"/> Affidavits/declaration(s)	<input type="checkbox"/> Power of Attorney, Revocation	<input type="checkbox"/> Status Letter
<input type="checkbox"/> Extension of Time Request	<input type="checkbox"/> Change of Correspondence Address	<input checked="" type="checkbox"/> Other Enclosure(s) (please identify below):
<input type="checkbox"/> Express Abandonment Request	<input type="checkbox"/> Terminal Disclaimer	-Transmittal of Replacement Drawings
<input type="checkbox"/> Information Disclosure Statement	<input type="checkbox"/> Request for Refund	
<input type="checkbox"/> Certified Copy of Priority Document(s)	<input type="checkbox"/> CD, Number of CD(s) _____	
<input type="checkbox"/> Reply to Missing Parts/ Incomplete Application	<input type="checkbox"/> Landscape Table on CD	
<input type="checkbox"/> Reply to Missing Parts under 37 CFR 1.52 or 1.53	Remarks	

SIGNATURE OF APPLICANT, ATTORNEY, OR AGENT			
Firm Name	GARDNER, LINN, BURKHART & FLORY, LLP		
Signature			
Printed name	Timothy A. Flory		
Date	February 1, 2012	Reg. No.	42540

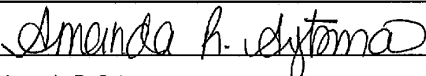
CERTIFICATE OF TRANSMISSION/MAILING			
I hereby certify that this correspondence is being facsimile transmitted to the USPTO or deposited with the United States Postal Service with sufficient postage as first class mail in an envelope addressed to: Commissioner for Patents, P.O. Box 1450, Alexandria, VA 22313-1450 on the date shown below:			
Signature			
Typed or printed name	Amanda R. Sytsma	Date	February 1, 2012

This collection of information is required by 37 CFR 1.5. The information is required to obtain or retain a benefit by the public which is to file (and by the USPTO to process) an application. Confidentiality is governed by 35 U.S.C. 122 and 37 CFR 1.11 and 1.14. This collection is estimated to 2 hours to complete, including gathering, preparing, and submitting the completed application form to the USPTO. Time will vary depending upon the individual case. Any comments on the amount of time you require to complete this form and/or suggestions for reducing this burden, should be sent to the Chief Information Officer, U.S. Patent and Trademark Office, U.S. Department of Commerce, P.O. Box 1450, Alexandria, VA 22313-1450. DO NOT SEND FEES OR COMPLETED FORMS TO THIS ADDRESS. SEND TO: Commissioner for Patents, P.O. Box 1450, Alexandria, VA 22313-1450.

If you need assistance in completing the form, call 1-800-PTO-9199 and select option 2.

Under the Paperwork Reduction Act of 1995, no persons are required to respond to a collection of information unless it contains a valid OMB control number.

Substitute for form 1449/PTO INFORMATION DISCLOSURE STATEMENT BY APPLICANT <i>(Use as many sheets as necessary)</i>		Complete if Known	
		Application Number	13/336,018
		Filing Date	December 23, 2011
		First Named Inventor	Niall R. Lynam
		Art Unit	2872
		Examiner Name	Alessandro V. Amari
Sheet 1	of 11	Attorney Docket Number	DON09 P-1800

U. S. PATENT DOCUMENTS					
Examiner Initials*	Cite No. ¹	Document Number	Publication Date	Name of Patentee or Applicant of Cited Document	Pages, Columns, Lines, Where Relevant Passages or Relevant Figures Appear
		Number-Kind Code ^{2 (if known)}	MM-DD-YYYY		

		7,934,843	2011-05-03	Lynam	
		7,857,469	2010-12-28	Sinelli et al.	
		7,636,188	2009-12-22	Baur et al.	
		7,626,749	2009-12-01	Baur et al.	
		7,581,859	2009-09-01	Lynam	
		7,526,103	2009-04-28	Schofield et al.	
		7,492,281	2009-02-17	Lynam et al.	
		7,423,522	2008-09-09	O'Brien et al.	
		7,420,756	2008-09-02	Lynam	
		7,400,435	2008-07-15	Byers et al.	
		7,391,563	2008-06-24	McCabe et al.	
		7,377,675	2008-05-27	Pastrick et al.	
		7,370,983	2008-05-13	DeWind et al.	
		7,345,680	2008-03-18	David	
		7,339,149	2008-03-04	Schofield et al.	
		7,338,177	2008-03-04	Lynam	
		7,289,037	2007-10-30	Uken et al.	
		7,274,501	2007-09-25	McCabe et al.	
		7,267,448	2007-09-11	Schmidt et al.	
		7,255,451	2007-08-14	McCabe et al.	
		7,249,860	2007-07-31	Kulas et al.	
		7,195,381	2007-03-27	Lynam et al.	
		7,184,190	2007-02-27	McCabe et al.	
		7,168,830	2007-01-30	Pastrick et al.	
		7,167,294	2007-01-23	Lynam et al.	
		7,126,456	2006-10-24	Boddy et al.	
		7,106,392	2006-09-12	You	
		7,097,312	2006-08-29	Platzer, Jr.	
		7,038,577	2006-05-02	Pawlicki et al.	
		7,025,469	2006-04-11	Manfre' et al.	
		7,005,974	2006-02-28	McMahon et al.	
		7,001,032	2006-02-21	Lo	
		6,979,090	2005-12-27	Wnuk	
		6,932,483	2005-08-23	Strumolo et al.	
		6,919,796	2005-07-19	Boddy et al.	
		6,882,287	2005-04-19	Schofield	
		6,831,268	2004-12-14	Bechtel et al.	
		6,824,281	2004-11-30	Schofield et al.	

Examiner Signature	Date Considered
--------------------	-----------------

*EXAMINER: Initial if reference considered, whether or not citation is in conformance with MPEP 609. Draw line through citation if not in conformance and not considered. Include copy of this form with next communication to applicant. ¹ Applicant's unique citation designation number (optional). ² See Kinds Codes of USPTO Patent Documents at www.uspto.gov or MPEP 901.04. ³ Enter Office that issued the document, by the two-letter code (WIPO Standard ST.3). ⁴ For Japanese patent documents, the indication of the year of the reign of the Emperor must precede the serial number of the patent document. ⁵ Kind of document by the appropriate symbols as indicated on the document under WIPO Standard ST.16 if possible. ⁶ Applicant is to place a check mark here if English language Translation is attached.

This collection of information is required by 37 CFR 1.97 and 1.98. The information is required to obtain or retain a benefit by the public which is to file (and by the USPTO to process) an application. Confidentiality is governed by 35 U.S.C. 122 and 37 CFR 1.14. This collection is estimated to take 2 hours to complete, including gathering, preparing, and submitting the completed application form to the USPTO. Time will vary depending upon the individual case. Any comments on the amount of time you require to complete this form and/or suggestions for reducing this burden, should be sent to the Chief Information Officer, U.S. Patent and Trademark Office, P.O. Box 1450, Alexandria, VA 22313-1450. DO NOT SEND FEES OR COMPLETED FORMS TO THIS ADDRESS. SEND TO:

Under the Paperwork Reduction Act of 1995, no persons are required to respond to a collection of information unless it contains a valid OMB control number.

Substitute for form 1449/PTO		Complete if Known	
INFORMATION DISCLOSURE STATEMENT BY APPLICANT <i>(Use as many sheets as necessary)</i>		Application Number	13/336,018
		Filing Date	December 23, 2011
		First Named Inventor	Niall R. Lynam
		Art Unit	2872
		Examiner Name	Alessandro V. Amari
		Attorney Docket Number	DON09 P-1800
Sheet	2	of	11

U. S. PATENT DOCUMENTS					
Examiner Initials*	Cite No. ¹	Document Number	Publication Date MM-DD-YYYY	Name of Patentee or Applicant of Cited Document	Pages, Columns, Lines, Where Relevant Passages or Relevant Figures Appear
		Number-Kind Code ^{2 (if known)}			

		6,757,109	2004-06-29	Bos	
		6,742,904	2004-06-01	Bechtel et al.	
		6,737,629	2004-05-18	Nixon et al.	
		6,731,205	2004-05-04	Schofield et al.	
		6,719,215	2004-04-13	Drouillard	
		6,717,712	2004-04-06	Lynam et al.	
		6,717,610	2004-04-06	Bos et al.	
		6,709,119	2004-03-23	Gillich et al.	
		6,690,268	2004-02-10	Schofield et al.	
		6,669,109	2003-12-30	Ivanov et al.	
		6,648,477	2003-11-18	Hutzel et al.	
		6,642,851	2003-11-04	DeLine et al.	
		6,627,918	2003-09-30	Getz et al.	
		6,615,438	2003-09-09	Franco	
		6,595,649	2003-07-22	Hoekstra et al.	
		6,582,109	2003-06-24	Miller	
		6,537,138	2003-03-25	Ohmori et al.	
		6,522,451	2003-02-18	Lynam	
		6,512,624	2003-01-28	Tonar et al.	
		6,511,192	2003-01-28	Henion et al.	
		6,501,387	2002-12-31	Skiver et al.	
		6,498,620	2002-12-24	Schofield et al.	
		6,472,979	2002-10-29	Schofield et al.	
		6,449,082	2002-09-10	Agrawal et al.	
		6,445,287	2002-09-03	Schofield et al.	
		6,441,964	2002-08-27	Chu et al.	
		6,428,172	2002-08-06	Hutzel et al.	
		6,420,036	2002-07-16	Varaprasad et al.	
		6,409,354	2002-06-25	Richard	
		6,398,377	2002-06-04	Chou	
		6,396,397	2002-05-28	Bos et al.	
		6,390,632	2002-05-21	Palathingal	
		6,356,376	2002-03-12	Tonar et al.	
		6,343,402	2002-02-05	Smith et al.	
		6,341,523	2002-01-29	Lynam	
		6,329,925	2001-12-11	Skiver et al.	
		6,320,282	2001-11-20	Caldwell	
		6,318,870	2001-11-20	Spooner et al.	

Examiner Signature	Date Considered
--------------------	-----------------

*EXAMINER: Initial if reference considered, whether or not citation is in conformance with MPEP 609. Draw line through citation if not in conformance and not considered. Include copy of this form with next communication to applicant. ¹ Applicant's unique citation designation number (optional). ² See Kinds Codes of USPTO Patent Documents at www.uspto.gov or MPEP 901.04. ³ Enter Office that issued the document, by the two-letter code (WIPO Standard ST.3). ⁴ For Japanese patent documents, the indication of the year of the reign of the Emperor must precede the serial number of the patent document. ⁵ Kind of document by the appropriate symbols as indicated on the document under WIPO Standard ST.16 if possible. ⁶ Applicant is to place a check mark here if English language Translation is attached. This collection of information is required by 37 CFR 1.97 and 1.98. The information is required to obtain or retain a benefit by the public which is to file (and by the USPTO to process) an application. Confidentiality is governed by 35 U.S.C. 122 and 37 CFR 1.14. This collection is estimated to take 2 hours to complete, including gathering, preparing, and submitting the completed application form to the USPTO. Time will vary depending upon the individual case. Any comments on the amount of time you require to complete this form and/or suggestions for reducing this burden, should be sent to the Chief Information Officer, U.S. Patent and Trademark Office, P.O. Box 1450, Alexandria, VA 22313-1450. DO NOT SEND FEES OR COMPLETED FORMS TO THIS ADDRESS. SEND TO:

Under the Paperwork Reduction Act of 1995, no persons are required to respond to a collection of information unless it contains a valid OMB control number.

Substitute for form 1449/PTO		Complete if Known	
INFORMATION DISCLOSURE STATEMENT BY APPLICANT <i>(Use as many sheets as necessary)</i>		Application Number	13/336,018
		Filing Date	December 23, 2011
		First Named Inventor	Niall R. Lynam
		Art Unit	2872
		Examiner Name	Alessandro V. Amari
Sheet	3	of	11
		Attorney Docket Number	DON09 P-1800

U. S. PATENT DOCUMENTS					
Examiner Initials*	Cite No. ¹	Document Number	Publication Date	Name of Patentee or Applicant of Cited Document	Pages, Columns, Lines, Where Relevant Passages or Relevant Figures Appear
		Number-Kind Code ^{2 (if known)}	MM-DD-YYYY		

		6,315,419	2001-11-13	Platzer, Jr.	
		6,310,611	2001-10-30	Caldwell	
		6,294,989	2001-09-25	Schofield et al.	
		6,286,965	2001-09-11	Caskey et al.	
		6,276,821	2001-08-21	Pastrick et al.	
		6,270,225	2001-08-07	Goolsby	
		6,260,608	2001-07-17	Kim	
		6,257,746	2001-07-10	Todd et al.	
		6,250,148	2001-06-26	Lynam	
		6,245,262	2001-06-12	Varaprasad et al.	
		6,227,689	2001-05-08	Miller	
		6,207,083	2001-03-27	Varaprasad et al.	
		6,201,642	2001-03-13	Bos	
		6,199,993	2001-03-13	Mou	
		6,198,409	2001-03-06	Schofield et al.	
		6,196,688	2001-03-06	Caskey et al.	
		6,178,034	2001-01-23	Allemand et al.	
		6,176,602	2001-01-23	Pastrick et al.	
		6,172,613	2001-01-09	DeLine et al.	
		6,164,564	2000-12-26	Franco et al.	
		6,154,306	2000-11-28	Varaprasad et al.	
		6,135,419	2001-11-13	Platzer, Jr.	
		6,128,860	2000-10-10	Varaprasad et al.	
		6,124,647	2000-09-26	Marcus et al.	
		6,116,743	2000-09-12	Hoek	
		6,111,684	2000-08-29	Forgette et al.	
		6,109,586	2000-08-29	Hoek	
		6,097,023	2000-08-01	Schofield et al.	
		6,074,068	2000-06-13	Palathingal	
		6,065,840	2000-05-23	Caskey et al.	
		6,033,078	2000-03-07	Su et al.	
		6,032,323	2000-03-07	Smith et al.	
		6,030,084	2002-02-29	Schmidt	
		6,022,511	1999-12-14	Varaprasad et al.	
		6,011,486	1999-12-14	Varaprasad et al.	
		6,007,207	1999-12-28	Liu	
		6,005,724	1999-12-21	Todd	
		6,002,544	1999-12-14	Yatsu	

Examiner Signature	Date Considered
--------------------	-----------------

*EXAMINER: Initial if reference considered, whether or not citation is in conformance with MPBP 609. Draw line through citation if not in conformance and not considered. Include copy of this form with next communication to applicant. ¹ Applicant's unique citation designation number (optional). ² See Kinds Codes of USPTO Patent Documents at www.uspto.gov or MPBP 901.04. ³ Enter Office that issued the document, by the two-letter code (WIPO Standard ST.3). ⁴ For Japanese patent documents, the indication of the year of the reign of the Emperor must precede the serial number of the patent document. ⁵ Kind of document by the appropriate symbols as indicated on the document under WIPO Standard ST.16 if possible. ⁶ Applicant is to place a check mark here if English language Translation is attached.

This collection of information is required by 37 CFR 1.97 and 1.98. The information is required to obtain or retain a benefit by the public which is to file (and by the USPTO to process) an application. Confidentiality is governed by 35 U.S.C. 122 and 37 CFR 1.14. This collection is estimated to take 2 hours to complete, including gathering, preparing, and submitting the completed application form to the USPTO. Time will vary depending upon the individual case. Any comments on the amount of time you require to complete this form and/or suggestions for reducing this burden, should be sent to the Chief Information Officer, U.S. Patent and Trademark Office, P.O. Box 1450, Alexandria, VA 22313-1450. DO NOT SEND FEES OR COMPLETED FORMS TO THIS ADDRESS. SEND TO:

Under the Paperwork Reduction Act of 1995, no persons are required to respond to a collection of information unless it contains a valid OMB control number.

Substitute for form 1449/PTO		Complete if Known	
		Application Number	13/336,018
INFORMATION DISCLOSURE STATEMENT BY APPLICANT <i>(Use as many sheets as necessary)</i>		Filing Date	December 23, 2011
		First Named Inventor	Niall R. Lynam
		Art Unit	2872
		Examiner Name	Alessandro V. Amari
		Attorney Docket Number	DON09 P-1800
Sheet	4	of	11

U. S. PATENT DOCUMENTS					
Examiner Initials*	Cite No. ¹	Document Number	Publication Date MM-DD-YYYY	Name of Patentee or Applicant of Cited Document	Pages, Columns, Lines, Where Relevant Passages or Relevant Figures Appear
		Number-Kind Code ^{2 (if known)}			

		5,980,050	1999-11-09	McCord	
		5,938,320	1999-08-17	Crandall	
		5,929,786	1999-07-27	Schofield et al.	
		5,922,176	1999-07-13	Caskey	
		5,910,854	1999-06-08	Varaprasad et al.	
		5,877,897	1999-03-02	Schofield et al.	
		5,864,434	1999-01-26	Taylor	
		5,863,116	1999-01-26	Pastrick et al.	
		5,847,889	1998-12-08	Komiyama et al.	
		5,838,505	1998-11-17	Palathingal	
		5,835,294	1998-11-10	Minegishi	
		5,825,527	1998-10-20	Forgette et al.	
		5,823,654	1998-10-20	Pastrick et al.	
		5,808,777	1998-09-15	Lynam et al.	
		5,805,367	1998-09-08	Kanazawa	
		5,796,532	1998-08-18	Kanazawa	
		5,796,094	1998-08-18	Schofield et al.	
		5,793,542	1998-08-11	Kondo et al.	
		5,790,327	1998-08-04	Lee et al.	
		5,790,298	1998-08-04	Tonar	
		5,788,357	1998-08-04	Muth et al.	
		5,786,772	1998-07-28	Schofield et al.	
		5,784,211	1998-07-21	Mingledorff	
		5,760,962	1998-06-02	Schofield et al.	
		5,751,489	1998-05-12	Caskey et al.	
		5,724,187	1998-03-03	Varaprasad et al.	
		5,722,836	1998-03-03	Yunker	
		5,715,093	1998-02-03	Schierbeek et al.	
		5,691,855	1997-11-25	Lupkas	
		5,689,370	1997-11-18	Tonar et al.	
		5,670,935	1997-09-23	Schofield et al.	
		5,669,705	1997-09-23	Pastrick et al.	
		5,669,704	1997-09-23	Pastrick	
		5,669,699	1997-09-23	Pastrick et al.	
		5,669,698	1997-09-23	Veldman et al.	
		5,668,663	1997-09-16	Varaprasad et al.	
		5,649,756	1997-07-22	Adams et al.	
		5,644,442	1997-07-01	Lemere	

Examiner Signature		Date Considered	
--------------------	--	-----------------	--

*EXAMINER: Initial if reference considered, whether or not citation is in conformance with MPEP 609. Draw line through citation if not in conformance and not considered. Include copy of this form with next communication to applicant. ¹ Applicant's unique citation designation number (optional). ² See Kinds Codes of USPTO Patent Documents at www.uspto.gov or MPEP 901.04. ³ Enter Office that issued the document, by the two-letter code (WIPO Standard ST.3). ⁴ For Japanese patent documents, the indication of the year of the reign of the Emperor must precede the serial number of the patent document. ⁵ Kind of document by the appropriate symbols as indicated on the document under WIPO Standard ST.16 if possible. ⁶ Applicant is to place a check mark here if English language Translation is attached.

This collection of information is required by 37 CFR 1.97 and 1.98. The information is required to obtain or retain a benefit by the public which is to file (and by the USPTO to process) an application. Confidentiality is governed by 35 U.S.C. 122 and 37 CFR 1.14. This collection is estimated to take 2 hours to complete, including gathering, preparing, and submitting the completed application form to the USPTO. Time will vary depending upon the individual case. Any comments on the amount of time you require to complete this form and/or suggestions for reducing this burden, should be sent to the Chief Information Officer, U.S. Patent and Trademark Office, P.O. Box 1450, Alexandria, VA 22313-1450. DO NOT SEND FEES OR COMPLETED FORMS TO THIS ADDRESS. SEND TO:

Under the Paperwork Reduction Act of 1995, no persons are required to respond to a collection of information unless it contains a valid OMB control number.

Substitute for form 1449/PTO		Complete if Known	
INFORMATION DISCLOSURE STATEMENT BY APPLICANT <i>(Use as many sheets as necessary)</i>		Application Number	13/336,018
		Filing Date	December 23, 2011
		First Named Inventor	Niall R. Lynam
		Art Unit	2872
		Examiner Name	Alessandro V. Amari
		Attorney Docket Number	DON09 P-1800
Sheet	5	of	11

U. S. PATENT DOCUMENTS					
Examiner Initials*	Cite No. ¹	Document Number	Publication Date MM-DD-YYYY	Name of Patentee or Applicant of Cited Document	Pages, Columns, Lines, Where Relevant Passages or Relevant Figures Appear
		Number-Kind Code ² (if known)			

		5,621,577	1997-04-15	Lang et al.	
		5,621,569	1997-04-15	Schlenke	
		5,610,756	1997-03-11	Lynam et al.	
		5,594,593	1997-01-14	Milner	
		5,594,222	1997-01-14	Caldwell	
		5,587,699	1996-12-24	Faloon et al.	
		5,587,236	1996-12-24	Agrawal et al.	
		5,579,133	1996-11-26	Black et al.	
		5,575,552	1996-11-19	Faloon et al.	
		5,567,360	1996-10-22	Varaprasad et al.	
		5,563,744	1996-10-08	Matsumiya	
		5,559,640	1996-09-24	Vachss et al.	
		5,557,467	1996-09-17	McColgan et al.	
		5,550,677	1996-08-27	Schofield et al.	
		5,535,056	1996-07-09	Caskey et al.	
		5,530,588	1996-06-25	Vivier	
		5,526,195	1996-06-11	Thomas	
		5,525,264	1996-06-11	Cronin et al.	
		5,523,877	1996-06-04	Lynam	
		5,517,367	1996-05-14	Kim et al.	
		5,509,606	1996-04-23	Breithaupt et al.	
		5,497,306	1996-03-05	Pastrick	
		5,497,305	1996-03-05	Pastrick et al.	
		5,483,386	1996-01-09	Carson	
		5,481,409	1996-01-02	Roberts	
		5,446,576	1995-08-29	Lynam et al.	
		5,437,931	2003-08-01	Tsai et al.	
		5,432,643	1995-07-11	Huang	
		5,424,875	1995-06-13	Davis, II	
		5,412,512	1995-05-02	Zebold et al.	
		5,406,414	1995-04-11	O'Farrell et al.	
		5,371,659	1994-12-06	Pastrick et al.	
		5,361,172	1994-11-01	Schissel et al.	
		5,355,245	1994-10-11	Lynam	
		5,354,965	1994-10-11	Lee	
		5,327,288	1994-07-05	Wellington et al.	
		5,313,335	1994-05-17	Gray et al.	
		5,296,973	1994-03-22	Burke	

Examiner Signature		Date Considered	
--------------------	--	-----------------	--

*EXAMINER: Initial if reference considered, whether or not citation is in conformance with MPEP 609. Draw line through citation if not in conformance and not considered. Include copy of this form with next communication to applicant. ¹ Applicant's unique citation designation number (optional). ² See Kinds Codes of USPTO Patent Documents at www.uspto.gov or MPEP 901.04. ³ Enter Office that issued the document, by the two-letter code (WIPO Standard ST.3). ⁴ For Japanese patent documents, the indication of the year of the reign of the Emperor must precede the serial number of the patent document. ⁵ Kind of document by the appropriate symbols as indicated on the document under WIPO Standard ST.16 if possible. ⁶ Applicant is to place a check mark here if English language Translation is attached.

This collection of information is required by 37 CFR 1.97 and 1.98. The information is required to obtain or retain a benefit by the public which is to file (and by the USPTO to process) an application. Confidentiality is governed by 35 U.S.C. 122 and 37 CFR 1.14. This collection is estimated to take 2 hours to complete, including gathering, preparing, and submitting the completed application form to the USPTO. Time will vary depending upon the individual case. Any comments on the amount of time you require to complete this form and/or suggestions for reducing this burden, should be sent to the Chief Information Officer, U.S. Patent and Trademark Office, P.O. Box 1450, Alexandria, VA 22313-1450. DO NOT SEND FEES OR COMPLETED FORMS TO THIS ADDRESS. SEND TO:

Under the Paperwork Reduction Act of 1995, no persons are required to respond to a collection of information unless it contains a valid OMB control number.

Substitute for form 1449/PTO				Complete if Known	
INFORMATION DISCLOSURE STATEMENT BY APPLICANT <i>(Use as many sheets as necessary)</i>				Application Number	13/336,018
				Filing Date	December 23, 2011
				First Named Inventor	Niall R. Lynam
				Art Unit	2872
				Examiner Name	Alessandro V. Amari
Sheet	6	of	11	Attorney Docket Number	DON09 P-1800

U. S. PATENT DOCUMENTS

Examiner Initials*	Cite No. ¹	Document Number	Publication Date MM-DD-YYYY	Name of Patentee or Applicant of Cited Document	Pages, Columns, Lines, Where Relevant Passages or Relevant Figures Appear
		Number-Kind Code ^{2 (if known)}			
		5,295,021	1994-03-15	Swanson	
		5,285,060	1994-02-08	Larson et al.	
		5,262,894	1993-11-16	Wheatley et al.	
		5,253,109	1993-10-12	O'Farrell et al.	
		5,247,395	1993-09-21	Martinez	
		5,239,405	1993-08-24	Varaprasad et al.	
		5,237,459	1993-08-17	Strauss	
		5,237,458	1993-08-17	Polanyi et al.	
		5,233,461	1993-08-03	Dornan et al.	
		5,225,943	1993-07-06	Lupo	
		5,207,492	1993-05-04	Roberts	
		5,193,029	1993-03-09	Schofield et al.	
		5,189,537	1993-02-23	O'Farrell	
		5,183,099	1993-02-02	Bechu	
		5,179,471	1993-01-12	Caskey et al.	
		5,178,448	1993-01-12	Adams et al.	
		5,166,833	1992-11-24	Shyu	
		5,151,824	1992-09-29	O'Farrell	
		5,151,816	1992-09-29	Varaprasad et al.	
		5,142,407	1992-08-25	Varaprasad et al.	
		5,140,455	1992-08-18	Varaprasad et al.	
		5,118,540	1992-06-02	Hutchison	
		5,117,346	1992-05-26	Gard	
		5,115,352	1992-05-19	do Espirito Santo	
		5,115,346	1992-05-19	Lynam	
		5,107,374	1992-04-21	Lupo et al.	
		5,085,907	1992-02-04	Smith	
		5,080,492	1992-01-14	Platzer, Jr.	
		5,078,480	1992-01-07	Warszawski	
		5,076,673	1991-12-31	Lynam et al.	
		5,073,012	1991-12-17	Lynam	
		5,066,112	1991-11-19	Lynam et al.	
		5,052,792	1991-10-01	McDonough	
		5,050,977	1991-09-24	Platzer, Jr.	
		5,044,739	1991-09-03	do Espirito Santo	
		5,033,835	1991-07-23	Platzer, Jr.	
		5,022,747	1991-06-11	Polanyi et al.	
		5,014,167	1991-05-07	Roberts	

Examiner Signature		Date Considered	
-----------------------	--	--------------------	--

*EXAMINER: Initial if reference considered, whether or not citation is in conformance with MPEP 609. Draw line through citation if not in conformance and not considered. Include copy of this form with next communication to applicant. ¹ Applicant's unique citation designation number (optional). ² See Kinds Codes of USPTO Patent Documents at www.uspto.gov or MPEP 901.04. ³ Enter Office that issued the document, by the two-letter code (WIPO Standard ST.3). ⁴ For Japanese patent documents, the indication of the year of the reign of the Emperor must precede the serial number of the patent document. ⁵ Kind of document by the appropriate symbols as indicated on the document under WIPO Standard ST.16 if possible. ⁶ Applicant is to place a check mark here if English Language Translation is attached.

This collection of information is required by 37 CFR 1.97 and 1.98. The information is required to obtain or retain a benefit by the public which is to file (and by the USPTO to process) an application. Confidentiality is governed by 35 U.S.C. 122 and 37 CFR 1.14. This collection is estimated to take 2 hours to complete, including gathering, preparing, and submitting the completed application form to the USPTO. Time will vary depending upon the individual case. Any comments on the amount of time you require to complete this form and/or suggestions for reducing this burden, should be sent to the Chief Information Officer, U.S. Patent and Trademark Office, P.O. Box 1450, Alexandria, VA 22313-1450. DO NOT SEND FEES OR COMPLETED FORMS TO THIS ADDRESS. SEND TO:

Under the Paperwork Reduction Act of 1995, no persons are required to respond to a collection of information unless it contains a valid OMB control number.

Substitute for form 1449/PTO		Complete if Known	
INFORMATION DISCLOSURE STATEMENT BY APPLICANT (Use as many sheets as necessary)		Application Number	13/336,018
		Filing Date	December 23, 2011
		First Named Inventor	Niall R. Lynam
		Art Unit	2872
		Examiner Name	Alessandro V. Amari
		Attorney Docket Number	DON09 P-1800
Sheet	7	of	11

U. S. PATENT DOCUMENTS					
Examiner Initials*	Cite No. ¹	Document Number	Publication Date	Name of Patentee or Applicant of Cited Document	Pages, Columns, Lines, Where Relevant Passages or Relevant Figures Appear
		Number-Kind Code ^{2 (if known)}	MM-DD-YYYY		

		5,005,962	1991-04-09	Edelman	
		4,989,964	1991-02-05	Meise	
		4,948,242	1990-08-14	Desmond et al.	
		4,944,581	1990-07-31	Ichikawa	
		4,932,770	1990-06-12	Caravaty	
		4,932,769	1990-06-12	Goosen	
		4,929,074	1990-05-29	Urban	
		4,917,485	1990-04-17	Baldwin, Sr.	
		4,913,542	1990-04-03	Adolfsson	
		4,906,085	1990-03-06	Sugihara et al.	
		4,906,075	1990-03-06	Majsumiya	
		4,882,565	1989-11-21	Gallmeyer	
		4,882,466	1989-11-21	Friel	
		4,859,046	1989-08-22	Traynor et al.	
		4,853,283	1989-08-01	Skolnick	
		4,828,379	1989-05-09	Parsons et al.	
		4,826,289	1989-05-02	Vandenbrink et al.	
		4,824,231	1989-04-25	Quintana	
		4,799,768	1989-01-24	Gahan	
		4,793,690	1988-12-27	Gahan et al.	
		4,773,740	1988-09-27	Kawakami et al.	
		4,770,522	1988-09-13	Alten	
		4,737,188	1988-04-12	Bahls	
		4,733,336	1988-03-22	Skogler et al.	
		4,727,302	1988-02-23	Mizuta et al.	
		4,721,364	1988-01-26	Itoh et al.	
		4,715,701	1987-12-29	Urban	
		4,712,879	1987-12-15	Lynam et al.	
		4,679,906	1987-07-14	Brandenburg	
		4,678,294	1987-07-01	Van Nostrand	
		4,674,850	1987-06-23	Blom	
		4,674,849	1987-06-23	Stewart	
		4,666,264	1987-05-19	Yamabe	
		4,630,904	1986-12-23	Pastore	
		4,629,296	1986-12-16	White	
		4,623,222	1986-11-18	Itoh et al.	
		4,609,266	1986-09-02	Blom	
		4,588,267	1986-05-13	Pastore	

Examiner Signature	Date Considered
--------------------	-----------------

*EXAMINER: Initial if reference considered, whether or not citation is in conformance with MPEP 609. Draw line through citation if not in conformance and not considered. Include copy of this form with next communication to applicant. ¹ Applicant's unique citation designation number (optional). ² See Kinds Codes of USPTO Patent Documents at www.uspto.gov or MPEP 901.04. ³ Enter Office that issued the document, by the two-letter code (WIPO Standard ST.3). ⁴ For Japanese patent documents, the indication of the year of the reign of the Emperor must precede the serial number of the patent document. ⁵ Kind of document by the appropriate symbols as indicated on the document under WIPO Standard ST.16 if possible. ⁶ Applicant is to place a check mark here if English language Translation is attached. This collection of information is required by 37 CFR 1.97 and 1.98. The information is required to obtain or retain a benefit by the public which is to file (and by the USPTO to process) an application. Confidentiality is governed by 35 U.S.C. 122 and 37 CFR 1.14. This collection is estimated to take 2 hours to complete, including gathering, preparing, and submitting the completed application form to the USPTO. Time will vary depending upon the individual case. Any comments on the amount of time you require to complete this form and/or suggestions for reducing this burden, should be sent to the Chief Information Officer, U.S. Patent and Trademark Office, P.O. Box 1450, Alexandria, VA 22313-1450. DO NOT SEND FEES OR COMPLETED FORMS TO THIS ADDRESS. SEND TO:

Under the Paperwork Reduction Act of 1995, no persons are required to respond to a collection of information unless it contains a valid OMB control number.

Substitute for form 1449/PTO		Complete if Known	
INFORMATION DISCLOSURE STATEMENT BY APPLICANT <i>(Use as many sheets as necessary)</i>		Application Number	13/336,018
		Filing Date	December 23, 2011
		First Named Inventor	Niall R. Lynam
		Art Unit	2872
		Examiner Name	Alessandro V. Amari
		Attorney Docket Number	DON09 P-1800
Sheet	8	of	11

U. S. PATENT DOCUMENTS					
Examiner Initials*	Cite No. ¹	Document Number	Publication Date MM-DD-YYYY	Name of Patentee or Applicant of Cited Document	Pages, Columns, Lines, Where Relevant Passages or Relevant Figures Appear
		Number-Kind Code ² (if known)			

		4,575,202	1986-03-11	McGuire	
		4,555,166	1985-11-26	Enomoto	
		4,549,786	1985-10-29	Albers et al.	
		4,526,446	1985-07-02	Adams	
		4,499,451	1985-02-12	Suzuki et al.	
		4,470,665	1984-09-11	Blom	
		4,449,786	1984-05-22	McCord	
		4,439,013	1984-03-27	Hagn et al.	
		4,436,372	1984-03-13	Schmidt et al.	
		4,436,371	1984-03-13	Wood et al.	
		4,435,042	1984-06-03	Wood et al.	
		4,385,804	1983-05-31	Tamura et al.	
		4,350,412	1982-09-21	Steenblik et al.	
		4,331,382	1982-05-25	Graff	
		4,325,609	1982-04-20	Alford	
		4,311,363	1982-01-19	Marsalka et al.	
		4,311,362	1982-01-19	LaPorte	
		4,306,770	1981-12-22	Marhauer	
		4,303,308	1981-12-01	Kobrin	
		4,293,191	1981-10-06	Kim	
		4,281,899	1981-08-04	Oskam	
		4,268,120	1981-05-19	Jitsumori	
		4,264,144	1981-04-28	McCord	
		4,258,979	1981-03-31	Mahin	
		4,223,983	1980-09-23	Bloom	
		4,200,359	1980-04-29	Lawson	
		4,193,668	1980-03-18	Skinner	
		3,909,117	1975-09-30	Takahashi et al.	
		3,884,606	1975-05-20	Schrenk	
		3,881,811	1975-05-06	French	
		3,826,563	1974-07-30	Davis	
		3,806,232	1974-04-23	Gray	
		3,773,882	1973-11-20	Schrenk	
		3,764,201	1973-10-09	Haile	
		3,759,647	1973-09-18	Schrenk et al.	
		3,708,222	1973-01-02	Stern	
		3,667,833	1972-06-06	Baldwin, Sr.	
		3,610,739	1971-10-05	Seashore	

Examiner Signature		Date Considered	
--------------------	--	-----------------	--

*EXAMINER: Initial if reference considered, whether or not citation is in conformance with MPEP 609. Draw line through citation if not in conformance and not considered. Include copy of this form with next communication to applicant. ¹ Applicant's unique citation designation number (optional). ² See Kinds Codes of USPTO Patent Documents at www.uspto.gov or MPEP 901.04. ³ Enter Office that issued the document, by the two-letter code (WIPO Standard ST.3). ⁴ For Japanese patent documents, the indication of the year of the reign of the Emperor must precede the serial number of the patent document. ⁵ Kind of document by the appropriate symbols as indicated on the document under WIPO Standard ST.16 if possible. ⁶ Applicant is to place a check mark here if English language Translation is attached.

This collection of information is required by 37 CFR 1.97 and 1.98. The information is required to obtain or retain a benefit by the public which is to file (and by the USPTO to process) an application. Confidentiality is governed by 35 U.S.C. 122 and 37 CFR 1.14. This collection is estimated to take 2 hours to complete, including gathering, preparing, and submitting the completed application form to the USPTO. Time will vary depending upon the individual case. Any comments on the amount of time you require to complete this form and/or suggestions for reducing this burden, should be sent to the Chief Information Officer, U.S. Patent and Trademark Office, P.O. Box 1450, Alexandria, VA 22313-1450. DO NOT SEND FEES OR COMPLETED FORMS TO THIS ADDRESS. SEND TO:

Under the Paperwork Reduction Act of 1995, no persons are required to respond to a collection of information unless it contains a valid OMB control number.

Substitute for form 1449/PTO		Complete if Known	
INFORMATION DISCLOSURE STATEMENT BY APPLICANT <i>(Use as many sheets as necessary)</i>		Application Number	13/336,018
		Filing Date	December 23, 2011
		First Named Inventor	Niall R. Lynam
		Art Unit	2872
		Examiner Name	Alessandro V. Amari
Sheet 9	of 11	Attorney Docket Number	DON09 P-1800

U. S. PATENT DOCUMENTS

Examiner Initials*	Cite No. ¹	Document Number	Publication Date	Name of Patentee or Applicant of Cited Document	Pages, Columns, Lines, Where Relevant Passages or Relevant Figures Appear
		Number-Kind Code ^{2 (if known)}	MM-DD-YYYY		
		3,601,614	1971-08-24	Platzer, Jr.	
		3,563,638	1971-02-16	Panozzo	
		3,424,517	1969-01-28	Budreck	
		3,408,136	1968-10-29	Travis	
		3,404,935	1968-10-08	Creager	
		3,389,952	1968-06-25	Tobin, Jr.	
		3,375,053	1968-03-26	Ward	
		3,338,655	1967-08-29	Young	
		3,337,285	1967-08-22	Travis	
		3,280,701	1966-10-25	Donnelly et al.	
		3,267,806	1966-08-23	Azegami	
		3,266,016	1966-08-09	Maruyama et al.	
		3,175,463	1965-03-30	Seashore	
		3,170,985	1965-02-23	Katulich	
		3,146,296	1964-08-25	Fischer	
		3,131,250	1964-04-28	Ely	
		3,104,274	1963-09-17	King	
		2,911,177	1959-11-03	West	
		2,890,539	1959-06-16	Holt	
		2,778,273	1957-01-22	Fellmeth	
		2,636,419	1953-04-28	Kerr	
		2,580,014	1951-12-25	Gazda	
		2,514,989	1950-07-11	Buren	
		2,263,382	1941-11-18	Gotzinger	
		2,135,262	1938-11-01	Schumacher	
		1,672,559	1928-06-05	Doble	
		1,114,559	1914-10-20	Weed	
		D297,926	1988-10-04	Kesler	
		D493,394	2004-07-27	Lawlor et al.	
		D493,131	2004-07-20	Lawlor et al.	
		2002/0036828	2002-03-28	Wong	
		2002/0105741	2002-08-08	Platzer, Jr.	
		2002/0159169	2002-10-31	McCord	
		2002/0159270	2002-10-31	Lynam et al.	
		2003/0043589	2003-03-06	Blank	
		2003/0117731	2003-06-26	Platzer, Jr.	
		2004/0032675	2004-02-19	Weller et al.	
		2004/0032676	2004-02-19	Drummond et al.	

Examiner Signature	Date Considered
--------------------	-----------------

*EXAMINER: Initial if reference considered, whether or not citation is in conformance with MPEP 609. Draw line through citation if not in conformance and not considered. Include copy of this form with next communication to applicant. ¹ Applicant's unique citation designation number (optional). ² See Kinds Codes of USPTO Patent Documents at www.uspto.gov or MPEP 901.04. ³ Enter Office that issued the document, by the two-letter code (WIPO Standard ST.3). ⁴ For Japanese patent documents, the indication of the year of the reign of the Emperor must precede the serial number of the patent document. ⁵ Kind of document by the appropriate symbols as indicated on the document under WIPO Standard ST.16 if possible. ⁶ Applicant is to place a check mark here if English language Translation is attached.

This collection of information is required by 37 CFR 1.97 and 1.98. The information is required to obtain or retain a benefit by the public which is to file (and by the USPTO to process) an application. Confidentiality is governed by 35 U.S.C. 122 and 37 CFR 1.14. This collection is estimated to take 2 hours to complete, including gathering, preparing, and submitting the completed application form to the USPTO. Time will vary depending upon the individual case. Any comments on the amount of time you require to complete this form and/or suggestions for reducing this burden, should be sent to the Chief Information Officer, U.S. Patent and Trademark Office, P.O. Box 1450, Alexandria, VA 22313-1450. DO NOT SEND FEES OR COMPLETED FORMS TO THIS ADDRESS. SEND TO:

Under the Paperwork Reduction Act of 1995, no persons are required to respond to a collection of information unless it contains a valid OMB control number.

Substitute for form 1449/PTO INFORMATION DISCLOSURE STATEMENT BY APPLICANT (Use as many sheets as necessary)				Complete if Known		
				Application Number	13/336,018	
Sheet		10	of	11	Attorney Docket Number	DON09 P-1800

U. S. PATENT DOCUMENTS					
Examiner Initials*	Cite No. ¹	Document Number	Publication Date MM-DD-YYYY	Name of Patentee or Applicant of Cited Document	Pages, Columns, Lines, Where Relevant Passages or Relevant Figures Appear
		Number-Kind Code ^{2 (if known)}			

		2004/0114260	2004-06-17	Bartnick	
		2004/0165291	2004-08-26	Platzer, Jr.	
		2004/0257685	2004-12-23	Minor et al.	
		2004/0264011	2004-12-30	Lynam	
		2005/0078389	2005-04-14	Kulas et al.	
		2005/0083577	2005-04-21	Varaprasad et al.	
		2005/0099693	2005-05-12	Schofield et al.	
		2005/0134983	2005-06-23	Lynam	
		2005/0232469	2005-10-20	Schofield et al.	
		2005/0248859	2005-11-10	Platzer, Jr.	
		2006/0050018	2006-03-09	Hutzel et al.	
		2006/0061008	2006-03-23	Karner et al.	
		2006/0125919	2006-06-15	Camilleri et al.	
		2006/0126150	2006-06-15	Tonar et al.	
		2006/0171704	2006-08-03	Bingle et al.	
		2006/0184297	2006-08-17	Higgins-Luthman	
		2006/0268440	2006-11-30	Platzer, Jr.	
		2006/0279863	2006-12-14	Starbuck	
		2007/0032638	2004-02-19	Tonar et al.	
		2007/0058257	2007-03-15	Lynam	
		2007/0285789	2007-12-13	Lindahl et al.	
		2008/0212189	2008-09-04	Baur et al.	
		2008/0225421	2008-09-18	Platzer	
		2008/0304170	2008-12-11	Zhao	
		2008/0308219	2008-12-18	Lynam	
		2009/0040306	2009-02-12	Foote et al.	
		2009/0115631	2009-05-07	Foote et al.	
		2009/0237820	2009-09-24	McCabe et al.	
		2009/0268321	2009-10-29	Wilson	
		2010/0195228	2010-08-05	Sinelli et al.	
		2010/0296187	2010-11-25	Lynam	
		2011/0157732	2011-06-30	Henion et al.	
		2011/0170207	2011-07-14	Lynam	
		RE17274	1929-04-16	Porter	

Examiner Signature		Date Considered	
--------------------	--	-----------------	--

*EXAMINER: Initial if reference considered, whether or not citation is in conformance with MPEP 609. Draw line through citation if not in conformance and not considered. Include copy of this form with next communication to applicant. ¹ Applicant's unique citation designation number (optional). ² See Kinds Codes of USPTO Patent Documents at www.uspto.gov or MPEP 901.04. ³ Enter Office that issued the document, by the two-letter code (WIPO Standard ST.3). ⁴ For Japanese patent documents, the indication of the year of the reign of the Emperor must precede the serial number of the patent document. ⁵ Kind of document by the appropriate symbols as indicated on the document under WIPO Standard ST.16 if possible. ⁶ Applicant is to place a check mark here if English language Translation is attached. This collection of information is required by 37 CFR 1.97 and 1.98. The information is required to obtain or retain a benefit by the public which is to file (and by the USPTO to process) an application. Confidentiality is governed by 35 U.S.C. 122 and 37 CFR 1.14. This collection is estimated to take 2 hours to complete, including gathering, preparing, and submitting the completed application form to the USPTO. Time will vary depending upon the individual case. Any comments on the amount of time you require to complete this form and/or suggestions for reducing this burden, should be sent to the Chief Information Officer, U.S. Patent and Trademark Office, P.O. Box 1450, Alexandria, VA 22313-1450. DO NOT SEND FEES OR COMPLETED FORMS TO THIS ADDRESS, SEND TO:

Under the Paperwork Reduction Act of 1995, no persons are required to respond to a collection of information unless it contains a valid OMB control number.

Substitute for form 1449/PTO		Complete if Known	
INFORMATION DISCLOSURE STATEMENT BY APPLICANT <i>(Use as many sheets as necessary)</i>		Application Number	13/336,018
		Filing Date	December 23, 2011
		First Named Inventor	Niall R. Lynam
		Art Unit	2872
		Examiner Name	Alessandro V. Amari
		Attorney Docket Number	DON09 P-1800
Sheet	11	of	11

FOREIGN PATENT DOCUMENTS						
Examiner initials*	Cite No. ¹	Foreign Patent Document	Publication Date MM-DD-YYYY	Name of Patentee or Applicant of Cited Document	Pages, Columns, Lines, Where Relevant Passages Or Relevant Figures Appear	T ⁶
		Country Code ² Number ³ Kind Code ⁵ <i>(if known)</i>				

		DE 2409748	1975-09-04	Leitz		
		DE 2550095	1976-05-20	Schiff et al.		
		DE 2647592	1978-04-27	Uta		
		DE 2915521	1980-10-30	Docie		
		DE 3302735	1984-08-02	Schulze		X
		DE 3329998	1985-03-07	Horn		X
		DE 3620228	1987-12-17	Thomen		X
		DE 4026578	1992-04-30	Kramer		X
		EP 0210757	1987-02-04	Von Seidel		X
		EP 0310261	1989-04-05	Britax Wingard Limited		X
		EP 0551802	1992-01-15	Jonsson		X
		EP 0791503	1997-08-27	Gentex Corporation		X
		EP 0917987	1999-05-26	Magneti Marelli France		X
		EP 0356099	1990-02-28	Yamada et al.		X
		EP 0728618	08-28-1996	Gentex Corporation		X
		EP 0729864	09-04-1996	Gentex Corporation		X
		FR 2628042	1988-03-01	Racel		X
		GB 1279158	1972-06-28	Hacker		X
		GB 2048189	1980-12-10	Mirrocraft Inc.		X
		GB 2092534	1982-08-18	Hagiri		X
		JP 0051637	1980-04-15	Katsumata Giken KK		X
		JP 55076721	1980-10-06	Nikken Kogyo KK		X
		JP 1186443	1989-07-25	Kitsumoto Norihiko		X
		JP 1208245	1989-08-22	Moriwake		X
		JP 362075619	1987-04-07	Tomita		X
		JP 62105103	1987-05-15	Miyake Shinya		X
		KR 2002092059	2002-12-11	Jung		X
		NL 7908257	1981-06-01	Bartholomeus		
		TW424057	2001-03-01	Lin		X
		WO 2001081956	11-01-2001	Platzer, Jr.		X
		WO 2004026633	04-01-2004	Donnelly Corporation		X
		WO 2004047421	06-03-2004	Donnelly Corporation		X
		WO 2004103772	12-02-2004	Donnelly Corporation		X
		WO 2006124682	11-23-2006	Donnelly Corporation		X
		WO 2007005942	01-11-2007	Donnelly Corporation		X
		WO 2008051910	05-02-2008	Donnelly Corporation		X

Examiner Signature		Date Considered	
--------------------	--	-----------------	--

*EXAMINER: Initial if reference considered, whether or not citation is in conformance with MPEP 609. Draw line through citation if not in conformance and not considered. Include copy of this form with next communication to applicant. ¹ Applicant's unique citation designation number (optional). ² See Kinds Codes of USPTO Patent Documents at www.uspto.gov or MPEP 901.04. ³ Enter Office that issued the document, by the two-letter code (WIPO Standard ST.3). ⁴ For Japanese patent documents, the indication of the year of the reign of the Emperor must precede the serial number of the patent document. ⁵ Kind of document by the appropriate symbols as indicated on the document under WIPO Standard ST.16 if possible. ⁶ Applicant is to place a check mark here if English language Translation is attached. This collection of information is required by 37 CFR 1.97 and 1.98. The information is required to obtain or retain a benefit by the public which is to file (and by the USPTO to process) an application. Confidentiality is governed by 35 U.S.C. 122 and 37 CFR 1.14. This collection is estimated to take 2 hours to complete, including gathering, preparing, and submitting the completed application form to the USPTO. Time will vary depending upon the individual case. Any comments on the amount of time you require to complete this form and/or suggestions for reducing this burden, should be sent to the Chief Information Officer, U.S. Patent and Trademark Office, P.O. Box 1450, Alexandria, VA 22313-1450. DO NOT SEND FEES OR COMPLETED FORMS TO THIS ADDRESS. SEND TO:



Espacenet

Bibliographic data: TW 424057 (B)

A method of manufacturing integrally formed outside mirror with plane and wide-angle reflective function for vehicle

Publication date: 2001-03-01
Inventor(s): LIN JUNG-MOU [TW]; HUANG DAU-NENG [TW] +
Applicant(s): LIN JUNG MOU [TW]; HUANG DAU NENG [TW] +
Classification:
 - **international:** **B60R1/08**; (IPC1-7): B60R1/08
 - **European:**
Application number: TW19990118774 19991029
Priority number(s): TW19990118774 19991029

Abstract of TW 424057 (B)

A method of manufacturing integrally formed outside mirror with plane and wide-angle mirror function for vehicle is a manufacturing method to have a plane glass with uniform thickness integrally manufactured and formed as a mirror with plane mirror and convex wide-angle mirror. The method is to polish a concave surface with a specific diameter and radius of curvature at a specific position of the bottom side of plane glass to be formed as a convex mirror thereon, and a predetermined circle with the same diameter is provided at the position relative to the formed concave surface on the upper surface of plane glass, then polishing and grinding the outer periphery of the circle out to a predetermined thickness. Furthermore, the predetermined circle is polished and formed as a convex with the same radius of curvature as that of the concave and with the thickness equal to that of the plane mirror glass so that the convex glass part is protruded to the plane glass. Thus the identical glass material can be used to form an outside mirror integrally for vehicle including both plane reflection and convex wide-angle optical characteristics so as to improve mirror lens to have reliability and convenience effects.

Last updated: 12.10.2011 Worldwide Database 5.7.23.1; 93p

Taiwanese Patent 424057 -- Patent Information

Published Serial No. 424057

Title **A method of manufacturing integrally formed outside mirror with plane and wide-angle reflective function for vehicle provides an identical glass material that can be integrally formed as mirror including both plane reflection and convex wide-angle optical characteristics so as to improve mirror lens to have reliability and convenience effects**

Patent type B

Date of Grant 2001/3/1

Application Number 088118774

Filing Date 1999/10/29

IPC B60R1/08

Inventor **LIN, JUNG-MOU(TW)**
HUANG, DAU-NENG(TW)

	Name	Country	Individual/Company
Applicant	LIN, JUNG-MOU	TW	Individual
	HUANG, DAU-NENG	TW	Individual

Abstract A method of manufacturing integrally formed outside mirror with plane and wide-angle mirror function for vehicle is a manufacturing method to have a plane glass with uniform thickness integrally manufactured and formed as a mirror with plane mirror and convex wide-angle mirror. The method is to polish a concave surface with a specific diameter and radius of curvature at a specific position of the bottom side of plane glass to be formed as a convex mirror thereon, and a predetermined circle with the same diameter is provided at the position relative to the formed concave surface on the upper surface of plane glass, then polishing and grinding the outer periphery of the circle out to a predetermined thickness. Furthermore, the predetermined circle is polished and formed as a convex with the same radius of curvature as that of the concave and with the thickness equal to that of the plane mirror glass so that the convex glass part is protruded to the plane glass. Thus the identical glass material can be used to form an outside mirror integrally for vehicle including both plane reflection and convex wide-angle optical characteristics so as to improve mirror lens to have reliability and convenience effects.

公告本

申請日期	88.10.29
案 號	68118774
類 別	B60R1/02

A4
C4

424057

(以上各欄由本局填註)

發 明 專 利 說 明 書 新 型		
一、發明 名稱	中 文	具平面與廣角功能之汽車反射鏡一體成形之製作法
	英 文	
二、發明人 創作	姓 名	1. 林 仲 謀 2. 黃 道 能
	國 籍	中華民國
	住、居所	1. 台北市濟南路一段7號8樓 2. 苗栗縣苗栗市北苗里北苗29-1號
三、申請人	姓 名 (名稱)	1. 林 仲 謀 2. 黃 道 能
	國 籍	中華民國
	住、居所 (事務所)	1. 台北市濟南路一段7號8樓 2. 苗栗縣苗栗市北苗里北苗29-1號
	代 表 人 姓 名	

經濟部智慧財產局員工消費合作社印製

裝 訂 線

本紙張尺度適用中國國家標準 (CNS) A4規格 (210×297公釐)

五、發明說明()

本發明係應用於一般汽車反射鏡之製作方法，使利用本方法產製之汽車反射鏡具有平面鏡與廣角鏡一體成形之功效者。

以一般之汽車反射鏡而言，單純平面式之反射鏡由於其製作容易，且反射之景物因其比例固定，對於駕駛者來說，較不會因此而誤判距離與大小，所以應用也最為普遍，但平面反射鏡之缺點乃視野過小，容易產生視覺上的死角，因此駕駛人常因平面反射鏡的一些不可見的死角，而造成交通事故乃時有所聞；為改善此種狀況的發生，一般之作法則是在平面反射鏡上再加上一小片之輔助凸面廣角反射鏡，由於凸面廣角反射鏡具有廣角之作用，單一鏡片內較平面鏡能容納較大範圍之景物，故能彌補平面反射鏡之不足，消弭視覺上不可見之死角產生，然通常凸面廣角鏡係以一雙面背膠黏接於平面反射鏡之上，此種作法雖簡單，但實際使用效果並不佳，除了其係以黏接方式結合而易受外界冷熱雨水之環鏡影響造成脫落，並常因平面反射鏡與廣角反射鏡係分別獨立之鏡面，其鏡面材質、反射率、濾光效果等等不盡相同，因而會有兩者無法搭配之狀況產生；再者，若其平面反射鏡具有加熱除霧之功能，以黏貼方式接合之廣角鏡則將不可能具有相同之除霧功能，因此應用上反而是弊大於利。

因此，其最佳之解決方法乃需將平面反射鏡與廣角之凸面反射鏡製作成為一體，方能解決此一問題，但利用現有之光學研磨機械並不能達成此一目的，其中技術上之限

五、發明說明()

制可歸納如以下之要點：

A、研磨具有較大厚度玻璃素材所產生之振動問題。由於欲使平面反射鏡與廣角之凸面反射鏡製作成為一體，其所取之原始平板玻璃素材之厚度勢必需包含凸面反射鏡突出於平面反射鏡之高度，因此其厚度乃遠大於一般之光學玻璃厚度，在研磨切削之後保留凸面反射鏡之位置，才能達到一體之目的，故可知其所需要研磨之材料厚度相當大，有可能高達 5mm 以上之厚度，此種厚度對一般之光學鏡片研磨機具而言，一般皆無法順利達到，主要之限制在於研磨愈厚之鏡片其機具所產生之振動愈加劇烈，而振動所造成之後果將使所研磨產出之鏡片表面失去平整性，造成不實鏡面之產生，所形成之影像將成為如波浪一般，完全無法使用。

B、研磨具有較大厚度玻璃素材所產生之發熱問題。眾所周知地，研磨作業必定產生熱量，尤其必須將厚度大於 5mm 之玻璃材料研磨去除，其所產生之熱量乃相當可觀，而習用之技術與機具因無法控制熱量的產生，常導致過度發熱，造成玻璃材料強度降低，加上上述振動之產生，故往往尚未研磨至特定厚度即會使玻璃發生破裂之現象而形成廢品者。

C、平面鏡與凸面鏡交界處所產生之不實鏡面問題。由於其係產製平面鏡與凸面鏡一體成形之鏡片，而並非單純之平面鏡或凸面鏡者，因此以一般之習用技術加工，將難以控制交界處之平整度，一旦交界處失去平整，將使交

五、發明說明()

界處周圍皆產生不實鏡面，其結果亦是讓所生產之鏡片無法使用，且其研磨之鑽石磨刀非經特殊之設計亦難達到既定之效果者。

有鑑於上述所言，發明人即亟思改進之方法，經多次之構思與反覆試驗之下，終使本發明「具平面與廣角功能之汽車反射鏡一體成形之製作法」付諸實施，使用本方法磨製出之鏡面，不但兼具平面鏡與廣角鏡之功用，大大增加視野範圍，消弭行車不可見之死角，確保行車安全，更不虞會有脫落或兩者無法搭配等狀況產生。

為俾 審查委員能對本發明之製作方法有一完整之了解，以下即配合圖示作一詳細說明。

圖式之簡要說明：

第一圖：係本發明之一實施例圖。

第二圖：係本發明之實施過程示意圖。

第三圖：係應用本發明製成之後視鏡於小客車上應用例。

圖式中之引用數號：

(10) 平面鏡 (20) 廣角鏡

請參考第一圖所示，為一利用本發明所製作出之右後視鏡之成品實施例。圖上之廣角鏡(20)係位於平面鏡(10)

五、發明說明()

之右下方處，而呈一圓形並凸出於紙面之凸面鏡者。以下即以厚度 8 mm 之平板玻璃而於其上製作出一圓直徑為 60 mm、曲率半徑為 116 mm 之凸面為例並利用第二圖說明本發明之製作方法，本發明之製程大略可分為四步驟，分述如后：

製程一：首先，取一厚度 8 mm 之平板玻璃，切削成所需之反射鏡大小，在欲形成凸面鏡之特定位置處底面，以研磨凹面用之菌形磨具，研磨出直徑為 60 mm、曲率半徑為 116 mm 之凹面，如圖上 A 之斜線部份乃應研磨去除之部份。至於曲率半徑之決定，係取決於所使用玻璃之折射率、表面鏡曲度(D)，以查表或公式計算之方式而求得表面加工磨具與量具之曲率半徑。

製程二：在平板玻璃之上表面與製程一所形成之凹面對應位置處預留直徑 60 mm 之圓，於圓之外側分別以粗、中、細之車刀分三次切削完成，並經平面研磨、磨光等程序，將如圖斜線 B 之部份去除，使其圓外側部份厚度減至 3 mm。

製程三：於直徑 60 mm 之圓平面上，以研磨凸面用之空心磨具，將其切削、研磨及磨光後，去除圖上斜線 C 之部份，而形成與製程一所形成之凹面相同曲率半徑之凸面，其凸面之厚度亦維持在 3 mm 之大小。

製程四：沿已完成之圓凸面周緣處，切削出寬 2 mm 之凹槽，如圖上 E 之部份。此凹槽之作用在於將平面鏡與凸面鏡之交接處去除，以避免交接處玻璃鏡面因形狀

五、發明說明()

不同 所造成光線折射、反射不同所引起之干擾現象，在後方 有來車車燈或陽光之光線照射下，可減少光線之閃爍，防止駕駛者目光受到干擾；此外，凹槽位於凸面鏡之周 緣，亦有一種增加美觀之作用存在。

由以上四個製程所產製出之後視鏡即可形成一厚度維持於 3 mm大小而具有平面與部份凸面一體成形之結構，使其在相同玻璃材質當中，同時具有兩部份不同之光學特性，而不必再如習用以黏貼之方式達到此目的，使用上更加可靠。而為解決前述有關習用技術所產生之研磨機振動問題，其克服之方法乃在於直立式切削機之軸心使用直徑 160mm、利度 30#之鑽石切削刀配合一高轉速專用之滾珠軸承，並於機台周緣位置裝置有 7mm之鐵板以形成一體之結構，利用此鐵板遠高於一般研磨機台之質量慣性，將可有效抵消研磨時所產生之振動問題；此外，在切削或研磨之過程中，添加以一 PH 值 8.7、常溫比重 1.098 之切削液，即可順利保持溫度於可接受之範圍內，而不致造成過熱；而為避免研磨時產生不實鏡面，經過長久試驗後之結果，以採用聚氨脂材料為主之拋光輪、硬度指數在 70~90 度為最佳，可完全避免鏡面研磨時所產生之不平現象，再搭配以氧化鈾材質之研磨劑，可達到最完美之拋光作業。再者，利用本發明之方法所生產之後視反射鏡，其後續作業（如於玻璃上電鍍一反射層、於鏡面上覆上一層防雨滴駐留之薄膜、或於鏡面背後加上一除霧功能之電熱線等）均能獲致一致的效果，因此不會如習用結構產生平面

(請先閱讀背面之注意事項再填寫本頁)

裝

訂

線

經濟部中央標準局員工消費合作社印製

五、發明說明()

鏡與廣角凸面鏡無法搭配之現象產生，使用上效果更佳乃無庸置疑。此外，本發明之製作方法將凸面鏡部份凸出於平面鏡之上目的在於其凸面廣角鏡之效果較佳，理論上可達到 180° 之廣角功能及 3.2 至 3.5 倍視角之能力，相較於單純在平面玻璃背面研磨出一凹面所構成之廣角鏡，本發明所得到之效果不但具有較寬廣的視野，亦具有較為清晰而不受干擾之影像，這也正是本發明如此用心製作之主要原因。如第三圖所示，乃應用本發明製作方法之後視鏡於小客車上之實施示意圖，由於此種一體成形之平面廣角鏡其弧面反射鏡面具有寬廣之視野及抑制平面鏡折射、反射、遮擋干擾或光源重疊所產生之成像不清，因此其視野所含蓋之範圍如圖上虛線所包含之扇形區域，對於車體下方以至於後方之後輪附近之景物皆能清楚地一覽無遺，乃任何一種習用後視鏡所無法比擬，對於駕駛者超車、倒車或於彎路行駛時之安全，提供莫大之助益，而不虞會有視線不及之處以致造成意外之情形發生。

綜合以上所述，本發明「具平面與廣角功能之汽車反射鏡一體成形之製作法」乃一前所未見之製作方法，具有高度之創作性，而本發明於說明中所引以例證之數據，如平板玻璃之厚度、凸面廣角鏡之圓直徑與凸面之曲率半徑等，均可依所使用之車型不同或應用所需而調整其數據值之大小，而能依本發明之製程產製出符合所需之反射後視鏡，故並不限定本發明所能產製之反射鏡大小，因此，本發明亦具有高度之產業利用性，實符合專利之申請要件，

424057

A7
B7

五、發明說明()

爰依法申請專利之，如蒙核准，實感德便。

(請先閱讀背面之注意事項再填寫本頁)

裝

訂

線

經濟部中央標準局員工消費合作社印製

424057

A5
B5

四、中文發明摘要 (發明之名稱：具平面與廣角功能之汽車反射鏡一體成形之製作法)

一種「具平面與廣角功能之汽車反射鏡一體成形之製作法」係一種能於單一厚度之平板玻璃上製作出平面鏡與凸面廣角鏡一體成形之製造方法，主要在於平板玻璃上欲形成凸面鏡之特定位置處底面，研磨出特定直徑、曲率半徑之凹面，在於平板玻璃上表面與凹面相對位置處預留相同直徑之圓，而將圓之外側研磨、磨光至特定厚度，於預留之圓平面上，研磨出與凹面相同曲率半徑之凸面，使其凸面之厚度平面鏡玻璃厚度相同之大小，而形成凸面玻璃部份凸出於平面玻璃之外觀者，而能利用相同之玻璃材質製作出具有平面反射與凸面廣角兩種光學特性於一體，並可提高鏡片使用之可靠性與方便性之功用者。

英文發明摘要 (發明之名稱：)

(請先閱讀背面之注意事項再填寫本頁各欄)

裝

訂

線

經濟部中央標準局員工消費合作社印製

六、申請專利範圍

一種「具平面與廣角功能之汽車反射鏡一體成形之製作法」係一種能於單一厚度之平板玻璃上製作出平面鏡與凸面廣角鏡一體成形之製造方法者，機台周緣位置裝置有厚鐵板以形成一體之結構，利用機台之質量慣性，以抵消研磨時所產生之振動；在切削或研磨之過程中，添加以一PH值 8.7、常溫比重 1.098 之切削液，使玻璃素材不致過熱；另採用聚氨脂材料為主之拋光輪、硬度指數 70~90 度，再搭配以氧化鈾材質之研磨劑，可避免鏡面研磨時所產生之不平現象者，其特徵在於：

取單一厚度之平板玻璃，先切割成所需後視鏡大小，在欲形成凸面鏡之特定位置處底面，以研磨凹面用之菌形磨具，研磨出特定直徑、曲率半徑之凹面；

在平板玻璃之上表面與先前所形成之凹面相對位置處預留相同直徑之圓，於圓之外側分別以粗、中、細之車刀分三次切削完成，並經平面研磨、磨光等程序，使圓之外側部份厚度減少至特定厚度；

於預留之圓平面上，以研磨凸面用之空心磨具，將其切削、研磨及磨光後，而形成與先前形成之凹面相同曲率半徑之凸面，使其凸面之厚度亦維持與平面鏡玻璃厚度相同之大小，而形成凸面玻璃部份凸出於平面玻璃之外觀者；

沿已完成之圓凸面周緣處，切削出特定寬度之凹槽，用以將平面鏡與凸面鏡之交接處去除，以避免交接處玻璃鏡面因形狀不同所造成光線之干擾現象，減少光線之閃

(請先閱讀背面之注意事項再填寫本頁)

裝

訂

線

424057

A8
B8
C8
D8

六、申請專利範圍

燦，亦有增加美觀之作用者。

(請先閱讀背面之注意事項再填寫本頁)

裝

訂

線

經濟部智慧財產局員工消費合作社印製

10

本紙張尺度適用中國國家標準 (CNS) A4規格 (210×297公釐)

424057

88118174

第一圖

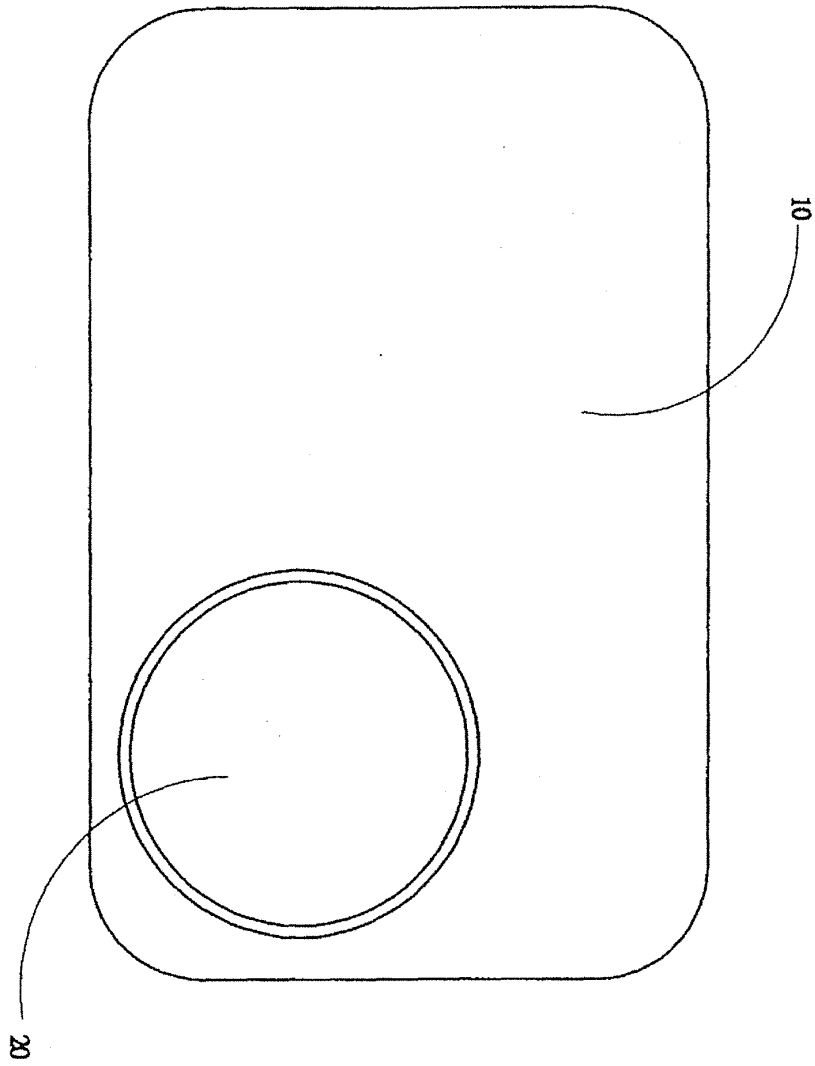

424057

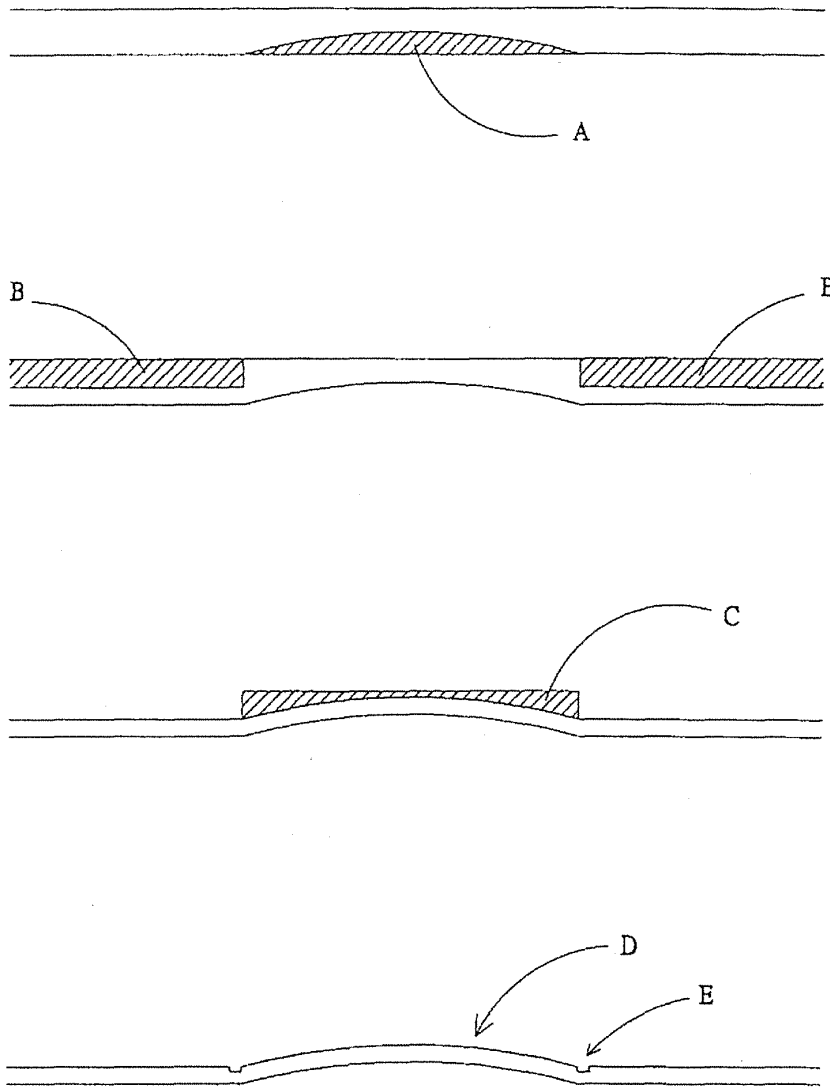

第二圖

424057

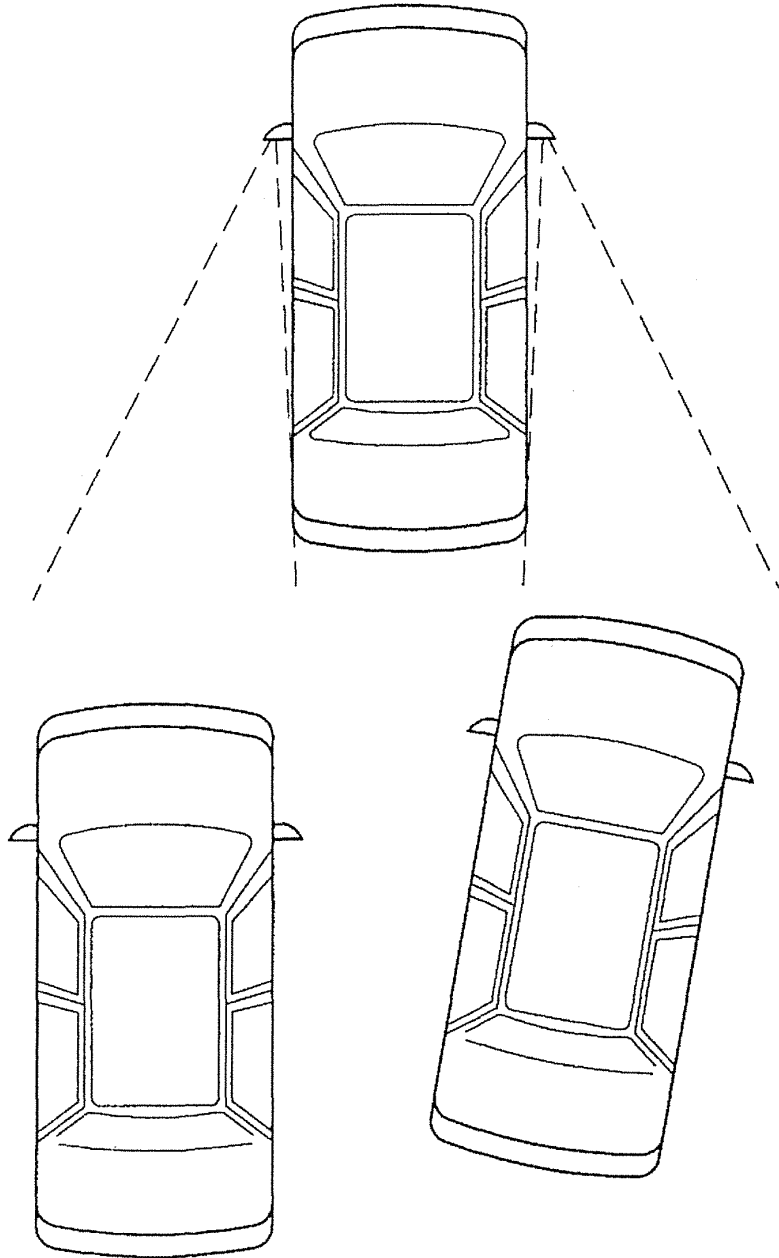

第三圖

Electronic Acknowledgement Receipt

EFS ID:	12037574
Application Number:	13336018
International Application Number:	
Confirmation Number:	7833
Title of Invention:	EXTERIOR REARVIEW MIRROR ASSEMBLY
First Named Inventor/Applicant Name:	Niall R. Lynam
Customer Number:	15671
Filer:	Timothy A. Flory/Amanda Sytsma
Filer Authorized By:	Timothy A. Flory
Attorney Docket Number:	DON09 P-1800
Receipt Date:	09-FEB-2012
Filing Date:	23-DEC-2011
Time Stamp:	13:18:12
Application Type:	Utility under 35 USC 111(a)

Payment information:

Submitted with Payment	no
------------------------	----

File Listing:

Document Number	Document Description	File Name	File Size(Bytes)/ Message Digest	Multi Part /.zip	Pages (if appl.)
1	Transmittal Letter	TransmittalForm.pdf	84548 44d23be324869ec3f8b78b4f371918c21490e652	no	1

Warnings:

Information:

2	Transmittal Letter	IDSLetter.pdf	63365 a405445cefa18559bb1ce3685923f101997b8941	no	1
Warnings:					
Information:					
3	Information Disclosure Statement (IDS) Form (SB08)	IDSForms.pdf	1178994 20209abfe886cce6f10acd382fc502e4fb5a844a	no	11
Warnings:					
Information:					
This is not an USPTO supplied IDS fillable form					
4	Foreign Reference	TW424057.pdf	790580 3554fb5b3bb0a9245f248dfa11395e2a74fb5d1c	no	16
Warnings:					
Information:					
			Total Files Size (in bytes):	2117487	
<p>This Acknowledgement Receipt evidences receipt on the noted date by the USPTO of the indicated documents, characterized by the applicant, and including page counts, where applicable. It serves as evidence of receipt similar to a Post Card, as described in MPEP 503.</p> <p><u>New Applications Under 35 U.S.C. 111</u> If a new application is being filed and the application includes the necessary components for a filing date (see 37 CFR 1.53(b)-(d) and MPEP 506), a Filing Receipt (37 CFR 1.54) will be issued in due course and the date shown on this Acknowledgement Receipt will establish the filing date of the application.</p> <p><u>National Stage of an International Application under 35 U.S.C. 371</u> If a timely submission to enter the national stage of an international application is compliant with the conditions of 35 U.S.C. 371 and other applicable requirements a Form PCT/DO/EO/903 indicating acceptance of the application as a national stage submission under 35 U.S.C. 371 will be issued in addition to the Filing Receipt, in due course.</p> <p><u>New International Application Filed with the USPTO as a Receiving Office</u> If a new international application is being filed and the international application includes the necessary components for an international filing date (see PCT Article 11 and MPEP 1810), a Notification of the International Application Number and of the International Filing Date (Form PCT/RO/105) will be issued in due course, subject to prescriptions concerning national security, and the date shown on this Acknowledgement Receipt will establish the international filing date of the application.</p>					

Under the Paperwork Reduction Act of 1995, no persons are required to respond to a collection of information unless it displays a valid OMB control number.

TRANSMITTAL FORM <i>(to be used for all correspondence after initial filing)</i>	Application Number	13/336,018
	Filing Date	December 23, 2011
	First Named Inventor	Niall R. Lynam
	Art Unit	2872
	Examiner Name	Alessandro V. Amari
Total Number of Pages in This Submission	Attorney Docket Number	DON09 P-1800

ENCLOSURES (Check all that apply)		
<input type="checkbox"/> Fee Transmittal Form	<input type="checkbox"/> Drawing(s)	<input type="checkbox"/> After Allowance Communication to TC
<input type="checkbox"/> Fee Attached	<input type="checkbox"/> Licensing-related Papers	<input type="checkbox"/> Appeal Communication to Board of Appeals and Interferences
<input type="checkbox"/> Amendment/Reply	<input type="checkbox"/> Petition	<input type="checkbox"/> Appeal Communication to TC (Appeal Notice, Brief, Reply Brief)
<input type="checkbox"/> After Final	<input type="checkbox"/> Petition to Convert to a Provisional Application	<input type="checkbox"/> Proprietary Information
<input type="checkbox"/> Affidavits/declaration(s)	<input type="checkbox"/> Power of Attorney, Revocation	<input type="checkbox"/> Status Letter
<input type="checkbox"/> Extension of Time Request	<input type="checkbox"/> Change of Correspondence Address	<input type="checkbox"/> Other Enclosure(s) (please identify below):
<input type="checkbox"/> Express Abandonment Request	<input type="checkbox"/> Terminal Disclaimer	
<input checked="" type="checkbox"/> Information Disclosure Statement	<input type="checkbox"/> Request for Refund	
<input type="checkbox"/> Certified Copy of Priority Document(s)	<input type="checkbox"/> CD, Number of CD(s) _____	
<input type="checkbox"/> Reply to Missing Parts/Incomplete Application	<input type="checkbox"/> Landscape Table on CD	
<input type="checkbox"/> Reply to Missing Parts under 37 CFR 1.52 or 1.53	Remarks	

SIGNATURE OF APPLICANT, ATTORNEY, OR AGENT		
Firm Name	GARDNER, LINN, BURKHART & FLORY, LLP	
Signature		
Printed name	Timothy A. Flory	
Date	February 9, 2012	Reg. No. 42540

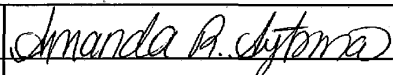
CERTIFICATE OF TRANSMISSION/MAILING		
I hereby certify that this correspondence is being facsimile transmitted to the USPTO or deposited with the United States Postal Service with sufficient postage as first class mail in an envelope addressed to: Commissioner for Patents, P.O. Box 1450, Alexandria, VA 22313-1450 on the date shown below:		
Signature		
Typed or printed name	Amanda R. Sytsma	Date February 9, 2012

This collection of information is required by 37 CFR 1.5. The information is required to obtain or retain a benefit by the public which is to file (and by the USPTO to process) an application. Confidentiality is governed by 35 U.S.C. 122 and 37 CFR 1.11 and 1.14. This collection is estimated to 2 hours to complete, including gathering, preparing, and submitting the completed application form to the USPTO. Time will vary depending upon the individual case. Any comments on the amount of time you require to complete this form and/or suggestions for reducing this burden, should be sent to the Chief Information Officer, U.S. Patent and Trademark Office, U.S. Department of Commerce, P.O. Box 1450, Alexandria, VA 22313-1450. DO NOT SEND FEES OR COMPLETED FORMS TO THIS ADDRESS. SEND TO: Commissioner for Patents, P.O. Box 1450, Alexandria, VA 22313-1450.

If you need assistance in completing the form, call 1-800-PTO-9199 and select option 2.

IN THE UNITED STATES PATENT AND TRADEMARK OFFICE

Group : 2872
Examiner : Alessandro V. Amari
Applicant : Niall R. Lynam
Serial No. : 13/336,018
Filing Date : December 23, 2011
For : EXTERIOR SIDEVIEW MIRROR SYSTEM

Mail Stop Amendment
Commissioner for Patents
P.O. Box 1450
Alexandria, VA 22313-1450

Dear Sir:

INFORMATION DISCLOSURE STATEMENT

In accordance with 37 CFR 1.51, 1.56, 1.97 and 1.98, Applicants submit herewith patents, publications or other information listed on the attached PTO/SB/08A forms for consideration by the Examiner in connection with examination of the present application. Copies of some of the cited non-U.S. patent/publication references are not provided herewith, since these references were previously made of record during prosecution of the parent application Serial No. 12/911,274. The Examiner is invited to contact the undersigned attorney if an additional copy of any of these references is desired.

This Information Disclosure Statement is not intended to constitute an admission that any patent, publication or other information referred to herein is "prior art" for this invention unless specifically designated as such.

Under 37 CFR 1.97, the filing of this Information Disclosure Statement shall not be construed to mean that a search has been made or that no other material information as defined in 37 CFR 1.56(a) exists.

An early and favorable action on the merits is respectfully requested.

Respectfully submitted,

NIALL R. LYNAM

By: Gardner, Linn, Burkhart & Flory, LLP

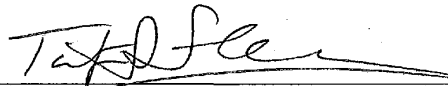

Timothy A. Flory
Registration No. 42 540
2851 Charlevoix Drive, S.E., Suite 207
P.O. Box 888695
Grand Rapids, Michigan 49588-8695
(616) 975-5500

Date: February 9, 2012

TAF/ars



UNITED STATES PATENT AND TRADEMARK OFFICE

UNITED STATES DEPARTMENT OF COMMERCE
United States Patent and Trademark Office
Address: COMMISSIONER FOR PATENTS
P.O. Box 1450
Alexandria, Virginia 22313-1450
www.uspto.gov

APPLICATION NO.	FILING DATE	FIRST NAMED INVENTOR	ATTORNEY DOCKET NO.	CONFIRMATION NO.
13/336,018	12/23/2011	Niall R. Lynam	DON09 P-1800	7833
15671 7590 03/13/2012 Gardner, Linn, Burkhart & Flory, LLP 2851 Charlevoix Dr. SE, Suite 207 Grand Rapids, MI 49546			EXAMINER AMARI, ALESSANDRO V	
			ART UNIT	PAPER NUMBER
			2872	
			MAIL DATE	DELIVERY MODE
			03/13/2012	PAPER

Please find below and/or attached an Office communication concerning this application or proceeding.

The time period for reply, if any, is set in the attached communication.

DETAILED ACTION

Election/Restrictions

Restriction to one of the following inventions is required under 35 U.S.C. 121:

- I. Claims 1-6, 19-24 and 28-35, drawn to an exterior rearview mirror assembly with single mirror support specifics, classified in class 359, subclass 883.
- II. Claims 16-18, 25-27 and 36-40, drawn to an exterior rearview mirror assembly with divider specifics, classified in class 359, subclass 872.

The inventions are distinct, each from the other because of the following reasons:

Inventions I and II are directed to related products. The related inventions are distinct if:

(1) the inventions as claimed are either not capable of use together or can have a materially different design, mode of operation, function, or effect; (2) the inventions do not overlap in scope, i.e., are mutually exclusive; and (3) the inventions as claimed are not obvious variants. See MPEP § 806.05(j). In the instant case, claims 1-6, 19-24 and 28-35 evidence that the combination does not rely on the details of Invention II and claims 16-18, 25-27 and 36-40 evidence that the combination does not rely on the details of Invention I. Furthermore, the inventions as claimed do not encompass overlapping subject matter and there is nothing of record to show them to be obvious variants.

Restriction for examination purposes as indicated is proper because all these inventions listed in this action are independent or distinct for the reasons given above

and there would be a serious search and/or examination burden if restriction were not required because at least the following reason(s) apply:

- (a) the inventions have acquired a separate status in the art in view of their different classification;
- (b) the inventions have acquired a separate status in the art due to their recognized divergent subject matter;
- (c) the inventions require a different field of search (for example, searching different classes/subclasses or electronic resources, or employing different search queries)

Applicant is advised that the reply to this requirement to be complete must include (i) an election of a invention to be examined even though the requirement may be traversed (37 CFR 1.143) and (ii) identification of the claims encompassing the elected invention.

The election of an invention may be made with or without traverse. To reserve a right to petition, the election must be made with traverse. If the reply does not distinctly and specifically point out supposed errors in the restriction requirement, the election shall be treated as an election without traverse. Traversal must be presented at the time of election in order to be considered timely. Failure to timely traverse the requirement will result in the loss of right to petition under 37 CFR 1.144. If claims are added after the election, applicant must indicate which of these claims are readable upon the elected invention.

Should applicant traverse on the ground that the inventions are not patentably distinct, applicant should submit evidence or identify such evidence now of record showing the inventions to be obvious variants or clearly admit on the record that this is the case. In either instance, if the examiner finds one of the inventions unpatentable over the prior art, the evidence or admission may be used in a rejection under 35 U.S.C. 103(a) of the other invention.

Any inquiry concerning this communication or earlier communications from the examiner should be directed to ALESSANDRO AMARI whose telephone number is (571)272-2306. The examiner can normally be reached on Monday-Friday 8:00 AM to 5:30 PM.

If attempts to reach the examiner by telephone are unsuccessful, the examiner's supervisor, Stephone B. Allen can be reached on (571) 272-2434. The fax phone number for the organization where this application or proceeding is assigned is 571-273-8300.

Information regarding the status of an application may be obtained from the Patent Application Information Retrieval (PAIR) system. Status information for published applications may be obtained from either Private PAIR or Public PAIR. Status information for unpublished applications is available through Private PAIR only. For more information about the PAIR system, see <http://pair-direct.uspto.gov>. Should you have questions on access to the Private PAIR system, contact the Electronic Business Center (EBC) at 866-217-9197 (toll-free). If you would like assistance from a USPTO Customer Service Representative or access to the automated information system, call 800-786-9199 (IN USA OR CANADA) or 571-272-1000.

/Alessandro Amari/
Primary Examiner, Art Unit 2872

Index of Claims 	Application/Control No. 13336018	Applicant(s)/Patent Under Reexamination LYNAM, NIAL R.
	Examiner ALESSANDRO AMARI	Art Unit 2872

✓	Rejected
=	Allowed

-	Cancelled
÷	Restricted

N	Non-Elected
I	Interference

A	Appeal
O	Objected

Claims renumbered in the same order as presented by applicant
 CPA
 T.D.
 R.1.47

CLAIM		DATE							
Final	Original	03/08/2012							
	1	+							
	2	+							
	3	+							
	4	+							
	5	+							
	6	+							
	7	-							
	8	-							
	9	-							
	10	-							
	11	-							
	12	-							
	13	-							
	14	-							
	15	-							
	16	+							
	17	+							
	18	+							
	19	+							
	20	+							
	21	+							
	22	+							
	23	+							
	24	+							
	25	+							
	26	+							
	27	+							
	28	+							
	29	+							
	30	+							
	31	+							
	32	+							
	33	+							
	34	+							
	35	+							
	36	+							

<i>Index of Claims</i> 	Application/Control No. 13336018	Applicant(s)/Patent Under Reexamination LYNAM, NIAL R.
	Examiner ALESSANDRO AMARI	Art Unit 2872

✓	Rejected
=	Allowed

-	Cancelled
÷	Restricted

N	Non-Elected
I	Interference

A	Appeal
O	Objected

Claims renumbered in the same order as presented by applicant
 CPA
 T.D.
 R.1.47

CLAIM		DATE							
Final	Original	03/08/2012							
	37	+							
	38	+							
	39	+							
	40	+							

IN THE UNITED STATES PATENT AND TRADEMARK OFFICE

Group Art : 2872
Examiner : Alessandro V. Amari
Applicant : Niall R. Lynam
Serial No. : 13/336,018
Filing Date : December 23, 2011
For : EXTERIOR SIDEVIEW MIRROR SYSTEM

Mail Stop Amendment
Commissioner for Patents
P.O. Box 1450
Alexandria, VA 22313-1450

Dear Sir:

INVENTION ELECTION

This is in response to the Office Action mailed March 13, 2012. The Office Action requires that Applicant elects a single disclosed invention for prosecution on the merits. Applicant provisionally elects Invention I, which corresponds to claims 1-6, 19-24 and 28-35 of the application. An early and favorable action on the merits is respectfully requested.

Respectfully submitted,

NIALL R. LYNAM

By: Gardner, Linn, Burkhardt & Flory, LLP



Dated: March 21, 2012

Timothy A. Flory
Registration No. 42 540
2851 Charlevoix Drive, S.E., Suite 207
P.O. Box 888695
Grand Rapids, Michigan 49588-8695
(616) 975-5500

Electronic Acknowledgement Receipt

EFS ID:	12356236
Application Number:	13336018
International Application Number:	
Confirmation Number:	7833
Title of Invention:	EXTERIOR REARVIEW MIRROR ASSEMBLY
First Named Inventor/Applicant Name:	Niall R. Lynam
Customer Number:	15671
Filer:	Timothy A. Flory/Amanda Sytsma
Filer Authorized By:	Timothy A. Flory
Attorney Docket Number:	DON09 P-1800
Receipt Date:	21-MAR-2012
Filing Date:	23-DEC-2011
Time Stamp:	15:26:50
Application Type:	Utility under 35 USC 111(a)

Payment information:

Submitted with Payment	no
------------------------	----

File Listing:

Document Number	Document Description	File Name	File Size(Bytes)/ Message Digest	Multi Part /.zip	Pages (if appl.)
1	Transmittal Letter	TransmittalForm.pdf	79204 <small>c0028842237dba17010c2971afdd6897e3369f31</small>	no	1

Warnings:

Information:

2	Response to Election / Restriction Filed	InventionElection.pdf	39237 aa13d404be1db756de95f47746727880521f60ec	no	1
Warnings:					
Information:					
Total Files Size (in bytes):				118441	
<p>This Acknowledgement Receipt evidences receipt on the noted date by the USPTO of the indicated documents, characterized by the applicant, and including page counts, where applicable. It serves as evidence of receipt similar to a Post Card, as described in MPEP 503.</p> <p><u>New Applications Under 35 U.S.C. 111</u> If a new application is being filed and the application includes the necessary components for a filing date (see 37 CFR 1.53(b)-(d) and MPEP 506), a Filing Receipt (37 CFR 1.54) will be issued in due course and the date shown on this Acknowledgement Receipt will establish the filing date of the application.</p> <p><u>National Stage of an International Application under 35 U.S.C. 371</u> If a timely submission to enter the national stage of an international application is compliant with the conditions of 35 U.S.C. 371 and other applicable requirements a Form PCT/DO/EO/903 indicating acceptance of the application as a national stage submission under 35 U.S.C. 371 will be issued in addition to the Filing Receipt, in due course.</p> <p><u>New International Application Filed with the USPTO as a Receiving Office</u> If a new international application is being filed and the international application includes the necessary components for an international filing date (see PCT Article 11 and MPEP 1810), a Notification of the International Application Number and of the International Filing Date (Form PCT/RO/105) will be issued in due course, subject to prescriptions concerning national security, and the date shown on this Acknowledgement Receipt will establish the international filing date of the application.</p>					

Doc Code: TRAN.LET

Document Description: Transmittal Letter

Approved for use through 07/31/2012. OMB 0651-0031
U.S. Patent and Trademark Office; U.S. DEPARTMENT OF COMMERCE

Under the Paperwork Reduction Act of 1995, no persons are required to respond to a collection of information unless it displays a valid OMB control number.

TRANSMITTAL FORM <i>(to be used for all correspondence after initial filing)</i>	Application Number	13/336,018
	Filing Date	December 23, 2011
	First Named Inventor	Niall R. Lynam
	Art Unit	2872
	Examiner Name	Alessandro V. Amari
Total Number of Pages in This Submission	Attorney Docket Number	DON09 P-1800

ENCLOSURES (Check all that apply)		
<input type="checkbox"/> Fee Transmittal Form	<input type="checkbox"/> Drawing(s)	<input type="checkbox"/> After Allowance Communication to TC
<input type="checkbox"/> Fee Attached	<input type="checkbox"/> Licensing-related Papers	<input type="checkbox"/> Appeal Communication to Board of Appeals and Interferences
<input checked="" type="checkbox"/> Amendment/Reply	<input type="checkbox"/> Petition	<input type="checkbox"/> Appeal Communication to TC (Appeal Notice, Brief, Reply Brief)
<input type="checkbox"/> After Final	<input type="checkbox"/> Petition to Convert to a Provisional Application	<input type="checkbox"/> Proprietary Information
<input type="checkbox"/> Affidavits/declaration(s)	<input type="checkbox"/> Power of Attorney, Revocation Change of Correspondence Address	<input type="checkbox"/> Status Letter
<input type="checkbox"/> Extension of Time Request	<input type="checkbox"/> Terminal Disclaimer	<input type="checkbox"/> Other Enclosure(s) (please identify below):
<input type="checkbox"/> Express Abandonment Request	<input type="checkbox"/> Request for Refund	
<input type="checkbox"/> Information Disclosure Statement	<input type="checkbox"/> CD, Number of CD(s) _____	
<input type="checkbox"/> Certified Copy of Priority Document(s)	<input type="checkbox"/> Landscape Table on CD	
<input type="checkbox"/> Reply to Missing Parts/ Incomplete Application	Remarks	
<input type="checkbox"/> Reply to Missing Parts under 37 CFR 1.52 or 1.53		

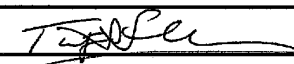
SIGNATURE OF APPLICANT, ATTORNEY, OR AGENT		
Firm Name	GARDNER, LINN, BURKHART & FLORY, LLP	
Signature		
Printed name	Timothy A. Flory	
Date	March 21, 2012	Reg. No. 42540

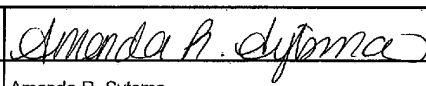
CERTIFICATE OF TRANSMISSION/MAILING		
I hereby certify that this correspondence is being facsimile transmitted to the USPTO or deposited with the United States Postal Service with sufficient postage as first class mail in an envelope addressed to: Commissioner for Patents, P.O. Box 1450, Alexandria, VA 22313-1450 on the date shown below:		
Signature		
Typed or printed name	Amanda R. Sytsma	Date March 21, 2012

This collection of information is required by 37 CFR 1.5. The information is required to obtain or retain a benefit by the public which is to file (and by the USPTO to process) an application. Confidentiality is governed by 35 U.S.C. 122 and 37 CFR 1.11 and 1.14. This collection is estimated to 2 hours to complete, including gathering, preparing, and submitting the completed application form to the USPTO. Time will vary depending upon the individual case. Any comments on the amount of time you require to complete this form and/or suggestions for reducing this burden, should be sent to the Chief Information Officer, U.S. Patent and Trademark Office, U.S. Department of Commerce, P.O. Box 1450, Alexandria, VA 22313-1450. DO NOT SEND FEES OR COMPLETED FORMS TO THIS ADDRESS. SEND TO: Commissioner for Patents, P.O. Box 1450, Alexandria, VA 22313-1450.

If you need assistance in completing the form, call 1-800-PTO-9199 and select option 2.



UNITED STATES PATENT AND TRADEMARK OFFICE

UNITED STATES DEPARTMENT OF COMMERCE
United States Patent and Trademark Office
Address: COMMISSIONER FOR PATENTS
P.O. Box 1450
Alexandria, Virginia 22313-1450
www.uspto.gov

Table with 4 columns: APPLICATION NUMBER (13/336,018), FILING OR 371(C) DATE (12/23/2011), FIRST NAMED APPLICANT (Niall R. Lynam), ATTY. DOCKET NO./TITLE (DON09 P-1800)

CONFIRMATION NO. 7833

PUBLICATION NOTICE



15671
Gardner, Linn, Burkhardt & Flory, LLP
2851 Charlevoix Dr.
SE, Suite 207
Grand Rapids, MI 49546

Title: EXTERIOR REARVIEW MIRROR ASSEMBLY

Publication No. US-2012-0092783-A1

Publication Date: 04/19/2012

NOTICE OF PUBLICATION OF APPLICATION

The above-identified application will be electronically published as a patent application publication pursuant to 37 CFR 1.211, et seq. The patent application publication number and publication date are set forth above.

The publication may be accessed through the USPTO's publically available Searchable Databases via the Internet at www.uspto.gov. The direct link to access the publication is currently http://www.uspto.gov/patft/.

The publication process established by the Office does not provide for mailing a copy of the publication to applicant. A copy of the publication may be obtained from the Office upon payment of the appropriate fee set forth in 37 CFR 1.19(a)(1). Orders for copies of patent application publications are handled by the USPTO's Office of Public Records. The Office of Public Records can be reached by telephone at (703) 308-9726 or (800) 972-6382, by facsimile at (703) 305-8759, by mail addressed to the United States Patent and Trademark Office, Office of Public Records, Alexandria, VA 22313-1450 or via the Internet.

In addition, information on the status of the application, including the mailing date of Office actions and the dates of receipt of correspondence filed in the Office, may also be accessed via the Internet through the Patent Electronic Business Center at www.uspto.gov using the public side of the Patent Application Information and Retrieval (PAIR) system. The direct link to access this status information is currently http://pair.uspto.gov/. Prior to publication, such status information is confidential and may only be obtained by applicant using the private side of PAIR.

Further assistance in electronically accessing the publication, or about PAIR, is available by calling the Patent Electronic Business Center at 1-866-217-9197.

Office of Data Management, Application Assistance Unit (571) 272-4000, or (571) 272-4200, or 1-888-786-0101



UNITED STATES PATENT AND TRADEMARK OFFICE

UNITED STATES DEPARTMENT OF COMMERCE
United States Patent and Trademark Office
Address: COMMISSIONER FOR PATENTS
P.O. Box 1450
Alexandria, Virginia 22313-1450
www.uspto.gov

APPLICATION NO.	FILING DATE	FIRST NAMED INVENTOR	ATTORNEY DOCKET NO.	CONFIRMATION NO.
13/336,018	12/23/2011	Niall R. Lynam	DON09 P-1800	7833
15671	7590	05/17/2012	EXAMINER	
Gardner, Linn, Burkhart & Flory, LLP			AMARI, ALESSANDRO V	
2851 Charlevoix Dr.			ART UNIT	PAPER NUMBER
SE, Suite 207			2872	
Grand Rapids, MI 49546			MAIL DATE	DELIVERY MODE
			05/17/2012	PAPER

Please find below and/or attached an Office communication concerning this application or proceeding.

The time period for reply, if any, is set in the attached communication.

Office Action Summary	Application No. 13/336,018	Applicant(s) LYNAM, NIALL R.	
	Examiner ALESSANDRO AMARI	Art Unit 2872	

-- The MAILING DATE of this communication appears on the cover sheet with the correspondence address --
Period for Reply

A SHORTENED STATUTORY PERIOD FOR REPLY IS SET TO EXPIRE 3 MONTH(S) OR THIRTY (30) DAYS, WHICHEVER IS LONGER, FROM THE MAILING DATE OF THIS COMMUNICATION.

- Extensions of time may be available under the provisions of 37 CFR 1.136(a). In no event, however, may a reply be timely filed after SIX (6) MONTHS from the mailing date of this communication.
- If NO period for reply is specified above, the maximum statutory period will apply and will expire SIX (6) MONTHS from the mailing date of this communication.
- Failure to reply within the set or extended period for reply will, by statute, cause the application to become ABANDONED (35 U.S.C. § 133). Any reply received by the Office later than three months after the mailing date of this communication, even if timely filed, may reduce any earned patent term adjustment. See 37 CFR 1.704(b).

Status

- 1) Responsive to communication(s) filed on 21 March 2012.
- 2a) This action is **FINAL**.
- 2b) This action is non-final.
- 3) An election was made by the applicant in response to a restriction requirement set forth during the interview on _____; the restriction requirement and election have been incorporated into this action.
- 4) Since this application is in condition for allowance except for formal matters, prosecution as to the merits is closed in accordance with the practice under *Ex parte Quayle*, 1935 C.D. 11, 453 O.G. 213.

Disposition of Claims

- 5) Claim(s) 1-6,16-40 is/are pending in the application.
 - 5a) Of the above claim(s) 16-18,25-27 and 36-40 is/are withdrawn from consideration.
- 6) Claim(s) _____ is/are allowed.
- 7) Claim(s) 1-6,19-24 and 28-35 is/are rejected.
- 8) Claim(s) _____ is/are objected to.
- 9) Claim(s) _____ are subject to restriction and/or election requirement.

Application Papers

- 10) The specification is objected to by the Examiner.
- 11) The drawing(s) filed on 01 February 2012 is/are: a) accepted or b) objected to by the Examiner.
 - Applicant may not request that any objection to the drawing(s) be held in abeyance. See 37 CFR 1.85(a).
 - Replacement drawing sheet(s) including the correction is required if the drawing(s) is objected to. See 37 CFR 1.121(d).
- 12) The oath or declaration is objected to by the Examiner. Note the attached Office Action or form PTO-152.

Priority under 35 U.S.C. § 119

- 13) Acknowledgment is made of a claim for foreign priority under 35 U.S.C. § 119(a)-(d) or (f).
 - a) All b) Some * c) None of:
 - 1. Certified copies of the priority documents have been received.
 - 2. Certified copies of the priority documents have been received in Application No. _____.
 - 3. Copies of the certified copies of the priority documents have been received in this National Stage application from the International Bureau (PCT Rule 17.2(a)).
- * See the attached detailed Office action for a list of the certified copies not received.

Attachment(s)

- 1) Notice of References Cited (PTO-892)
- 2) Notice of Draftsperson's Patent Drawing Review (PTO-948)
- 3) Information Disclosure Statement(s) (PTO/SB/08)
Paper No(s)/Mail Date 2/9/2012
- 4) Interview Summary (PTO-413)
Paper No(s)/Mail Date. _____
- 5) Notice of Informal Patent Application
- 6) Other: _____

DETAILED ACTION

Election/Restrictions

Applicant's election of Invention I (claims 1-6, 19-24 and 28-35) in the reply filed on 21 March 2012 is acknowledged. Because applicant did not distinctly and specifically point out the supposed errors in the restriction requirement, the election has been treated as an election without traverse (MPEP § 818.03(a)). Claims 16-18, 25-27 and 36-40 are withdrawn from further consideration pursuant to 37 CFR 1.142(b), as being drawn to a nonelected Invention, there being no allowable generic or linking claim.

Double Patenting

The nonstatutory double patenting rejection is based on a judicially created doctrine grounded in public policy (a policy reflected in the statute) so as to prevent the unjustified or improper timewise extension of the "right to exclude" granted by a patent and to prevent possible harassment by multiple assignees. A nonstatutory obviousness-type double patenting rejection is appropriate where the conflicting claims are not identical, but at least one examined application claim is not patentably distinct from the reference claim(s) because the examined application claim is either anticipated by, or would have been obvious over, the reference claim(s). See, e.g., *In re Berg*, 140 F.3d 1428, 46 USPQ2d 1226 (Fed. Cir. 1998); *In re Goodman*, 11 F.3d 1046, 29 USPQ2d 2010 (Fed. Cir. 1993); *In re Longi*, 759 F.2d 887, 225 USPQ 645 (Fed. Cir. 1985); *In re Van Ornum*, 686 F.2d 937, 214 USPQ 761 (CCPA 1982); *In re Vogel*, 422

F.2d 438, 164 USPQ 619 (CCPA 1970); and *In re Thorington*, 418 F.2d 528, 163 USPQ 644 (CCPA 1969).

A timely filed terminal disclaimer in compliance with 37 CFR 1.321(c) or 1.321(d) may be used to overcome an actual or provisional rejection based on a nonstatutory double patenting ground provided the conflicting application or patent either is shown to be commonly owned with this application, or claims an invention made as a result of activities undertaken within the scope of a joint research agreement.

Effective January 1, 1994, a registered attorney or agent of record may sign a terminal disclaimer. A terminal disclaimer signed by the assignee must fully comply with 37 CFR 3.73(b).

Claims 1-6, 19-24 and 28-34 are rejected on the ground of nonstatutory obviousness-type double patenting as being unpatentable over claims 1, 6, 10, 13, 15, 16 and 24 of U.S. Patent No. 8,128,243. Although the conflicting claims are not identical, they are not patentably distinct from each other because the claims of the instant invention are broader and claim essentially the same subject matter as that of US 8,128,243.

Claim Rejections - 35 USC § 102

The following is a quotation of the appropriate paragraphs of 35 U.S.C. 102 that form the basis for the rejections under this section made in this Office action:

A person shall be entitled to a patent unless –

(e) the invention was described in (1) an application for patent, published under section 122(b), by another filed in the United States before the invention by the applicant for patent or (2) a patent granted on an application for patent by another filed in the United States before the invention by the

Art Unit: 2872

applicant for patent, except that an international application filed under the treaty defined in section 351(a) shall have the effects for purposes of this subsection of an application filed in the United States only if the international application designated the United States and was published under Article 21(2) of such treaty in the English language.

Claims 1-6, 19-24 and 28-35 are rejected under 35 U.S.C. 102(e) as being anticipated by Lynam et al (hereafter "Lynam") US 2002/0072026.

The applied reference has a common inventor with the instant application. Based upon the earlier effective U.S. filing date of the reference, it constitutes prior art under 35 U.S.C. 102(e). This rejection under 35 U.S.C. 102(e) might be overcome either by a showing under 37 CFR 1.132 that any invention disclosed but not claimed in the reference was derived from the inventor of this application and is thus not the invention "by another," or by an appropriate showing under 37 CFR 1.131.

In regard to claims 1, 19 and 28, Lynam discloses (see Fig. 2, 3) an exterior rearview mirror assembly for a motor vehicle, said exterior rearview mirror assembly comprising: a bracket (38) fixedly secured to the motor vehicle as described in paragraph [0041]; a mirror casing (40) secured to said bracket, said mirror casing defining a primary opening; a single mirror support (60) movably secured within said mirror casing disposed adjacent said primary opening; a primary mirror (50) fixedly secured to said single mirror support and disposed within said primary opening for providing a view rearward of the motor vehicle through a primary field of view as described in [0046]; a spotting mirror (55) fixedly secured to said single mirror support and disposed adjacent said primary mirror, said spotting mirror defined by a single radius of curvature differing from said primary mirror such that said spotting mirror provides a second field of view rearward of the motor vehicle as described in [0083],

such that said primary field of view of said primary mirror overlaps said second field of view of said spotting mirror as described in [0076] and [0082]; wherein said spotting mirror is at an angle relative to said primary mirror as shown in Figures 3 and 14; and wherein said primary mirror comprises one of (a) a generally flat glass substrate having a surface coated with a metallic reflector coating as described in [0043] and (b) a generally flat polymeric substrate having a thin glass element applied to a surface thereof and with an opposing surface thereof having a reflecting layer applied thereto as described in [0050].

Regarding claims 2, 20 and 29, Lynam discloses said single mirror support defines a primary portion for having said primary mirror fixedly secured thereto and a spotting portion for having said spotting mirror fixedly secured thereto as shown in Figure 3 and as described in [0042].

Regarding claims 3, 21 and 30, Lynam discloses that said primary portion of said single mirror support defines a primary plane that is substantially flat as shown in Figure 3 and as described in [0042].

Regarding claims 4, 22 and 31, Lynam discloses that said spotting portion of said single mirror support defines a spotting mirror support radius of curvature substantially equal to said single radius of curvature as described in [0005], [0045], [0069] and [0083].

Regarding claims 5, 23 and 32, Lynam discloses said spotting portion is forward of said primary plane as described in [0072] and as shown in Figure 10.

Regarding claims 6, 24 and 33, Lynam discloses said spotting portion is substantially rearward of said primary plane as shown in Figure 3.

Regarding claim 34, Lynam discloses the second field of view of said spotting mirror is generally directed at least one of outwardly and downwardly with respect to the longitudinal axis of the motor vehicle when said exterior rearview mirror assembly is attached to the motor vehicle as shown in Figure 6 and as described in [0052].

Regarding claim 35, Lynam discloses that said spotting mirror is at an angle of at least about three degrees relative to said primary mirror as described in [0059].

Claim Rejections - 35 USC § 103

The following is a quotation of 35 U.S.C. 103(a) which forms the basis for all obviousness rejections set forth in this Office action:

(a) A patent may not be obtained though the invention is not identically disclosed or described as set forth in section 102 of this title, if the differences between the subject matter sought to be patented and the prior art are such that the subject matter as a whole would have been obvious at the time the invention was made to a person having ordinary skill in the art to which said subject matter pertains. Patentability shall not be negated by the manner in which the invention was made.

Claims 1-6 are rejected under 35 U.S.C. 103(a) as being unpatentable over Platzer, Jr. (hereafter "Platzer") US 7097312 in view of Black et al (hereafter "Black") US 5579133.

In regard to claim 1, Platzer discloses (see Figures 20-22) an exterior rearview mirror assembly for a motor vehicle, said exterior rearview mirror assembly comprising: a single mirror support (92) disposed adjacent said primary opening; a primary mirror (88) fixedly secured to said single mirror support and disposed within said primary opening for providing a view rearward of the motor vehicle through a primary field of

view; a spotting mirror (90) fixedly secured to said single mirror support and disposed adjacent said primary mirror, said spotting mirror defined by a single radius of curvature differing from said primary mirror such that said spotting mirror provides a second field of view rearward of the motor vehicle as described in col. 7, lines 60-67 and col. 8, lines 1-25, such that said primary field of view of said primary mirror overlaps said second field of view of said spotting mirror as shown in Figure 1 and as described in col. 8, lines 26-51;

However, in regard to claim 1, Platzer does not teach a bracket fixedly secured to the motor vehicle; a mirror casing secured to said bracket, said mirror casing defining a primary opening; and the mirror support moveable secured within mirror casing

In regard to claim 1, Black teaches (see Fig. 12) a bracket (60) fixedly secured to the motor vehicle; a mirror casing (61) secured to said bracket, said mirror casing defining a primary opening; and the mirror support moveable secured within mirror casing (via 62, 63) as described in col. 6, lines 11-51.

It would have been obvious to one having ordinary skill in the art at the time the invention was made to incorporate the bracket, casing wherein the mirror support is moveably secured within casing as taught by Black in the mirror assembly of Platzer in order to provide for attaching the mirror to the motor vehicle, protection of mirror from hazards and for adjustability of the mirror so that motorist can change angle of mirror in response to road conditions or changes in driver configuration (e.g., seat height).

Regarding claim 2, the Platzer-Black combination teaches that said single mirror support defines a primary portion for having said primary mirror fixedly secured thereto

and a spotting portion for having said spotting mirror fixedly secured thereto as shown in Figures 20 and 21 of Platzer and Figure 12 of Black.

Regarding claim 3, the Platzer-Black combination teaches that said primary portion of said single mirror support defines a primary plane that is substantially flat as shown in Figures 20 and 21 of Platzer and Figure 12 of Black.

Regarding claim 4, the Platzer-Black combination teaches that said spotting portion of said single mirror support defines a spotting mirror support radius of curvature (44) substantially equal to said single radius of curvature as shown in Figure 8 of Platzer.

Regarding claim 5, the Platzer-Black combination teaches that said spotting portion is forward of said primary plane as shown in Figure 21 of Platzer and Figure 12 of Black.

Regarding claim 6, the Platzer-Black combination teaches that said spotting portion is substantially rearward of said primary plane as shown in Figure 22 and as described in col. 11, lines 58-62.

Claims 19-24, 28-33 and 35 are rejected under 35 U.S.C. 103(a) as being unpatentable over Platzer US 7097312 in view of Black US 5579133 and further in view of Richard US 6409354.

In regard to claims 19 and 28, Platzer discloses (see Figures 20-22) an exterior rearview mirror assembly for a motor vehicle, said exterior rearview mirror assembly comprising: a single mirror support (92) disposed adjacent said primary opening; a

primary mirror (88) fixedly secured to said single mirror support and disposed within said primary opening for providing a view rearward of the motor vehicle through a primary field of view; a spotting mirror (90) fixedly secured to said single mirror support and disposed adjacent said primary mirror, said spotting mirror defined by a single radius of curvature differing from said primary mirror such that said spotting mirror provides a second field of view rearward of the motor vehicle as described in col. 7, lines 60-67 and col. 8, lines 1-25, such that said primary field of view of said primary mirror overlaps said second field of view of said spotting mirror as shown in Figure 1 and as described in col. 8, lines 26-51; wherein said spotting mirror is at an angle relative to said primary mirror as shown in Figure 21.

However, in regard to claims 19 and 28, Platzer does not teach a bracket fixedly secured to the motor vehicle; a mirror casing secured to said bracket, said mirror casing defining a primary opening; and the mirror support moveable secured within mirror casing

In regard to claims 19 and 28, Black teaches (see Fig. 12) a bracket (60) fixedly secured to the motor vehicle; a mirror casing (61) secured to said bracket, said mirror casing defining a primary opening; and the mirror support moveable secured within mirror casing (via 62, 63) as described in col. 6, lines 11-51.

It would have been obvious to one having ordinary skill in the art at the time the invention was made to incorporate the bracket, casing wherein the mirror support is moveably secured within casing as taught by Black in the mirror assembly of Platzer in order to provide for attaching the mirror to the motor vehicle, protection of mirror from

hazards and for adjustability of the mirror so that motorist can change angle of mirror in response to road conditions or changes in driver configuration (e.g., seat height).

However, in further regard to claims 19 and 28, the Platzer-Black combination while teaching the invention as set forth above does not teach that said primary mirror comprises one of (a) a generally flat glass substrate having a surface coated with a metallic reflector coating and (b) a generally flat polymeric substrate having a thin glass element applied to a surface thereof and with an opposing surface thereof having a reflecting layer applied thereto.

In regard to claims 19 and 28, Richard teaches teach that said primary mirror comprises one of (a) a generally flat glass substrate having a surface coated with a metallic reflector coating and (b) a generally flat polymeric substrate having a thin glass element applied to a surface thereof and with an opposing surface thereof having a reflecting layer applied thereto as described in col. 1, lines 18-39.

It would have been obvious to one having ordinary skill in the art at the time the invention was made to have the generally flat glass substrate having a surface coated with a metallic reflector coating as taught by Richard for the Platzer-Black combination in order to provide for high reflectivity, low cost and to provide for a durable mirror.

Regarding claims 20 and 29, the combination teaches that said single mirror support defines a primary portion for having said primary mirror fixedly secured thereto and a spotting portion for having said spotting mirror fixedly secured thereto as shown in Figures 20 and 21 of Platzer and Figure 12 of Black.

Regarding claims 21 and 30, the combination teaches that said primary portion of said single mirror support defines a primary plane that is substantially flat as shown in Figures 20 and 21 of Platzer and Figure 12 of Black.

Regarding claims 22 and 31, the combination teaches that said spotting portion of said single mirror support defines a spotting mirror support radius of curvature (44) substantially equal to said single radius of curvature as shown in Figure 8 of Platzer.

Regarding claims 23 and 32, the combination teaches that said spotting portion is forward of said primary plane as shown in Figure 21 of Platzer and Figure 12 of Black.

Regarding claims 24 and 33, the combination teaches that said spotting portion is substantially rearward of said primary plane as shown in Figure 22 of Platzer and as described in col. 11, lines 58-62 of Platzer.

Regarding claim 35, the combination teaches that said spotting mirror is at an angle of at least about three degrees relative to said primary mirror as described in col. 5, lines 48-50 of Black.

Claim 34 is rejected under 35 U.S.C. 103(a) as being unpatentable over Platzer US 7097312 in view of Black US 5579133 and further in view of Richard US 6409354 and further in view of Hensley US 2279751.

Regarding claim 34, the Platzer-Black-Richard combination teaches the invention as set forth above but does not teach wherein the second field of view of said spotting mirror is generally directed at least one of outwardly and downwardly with respect to the

longitudinal axis of the motor vehicle when said exterior rearview mirror assembly is attached to the motor vehicle.

Regarding claim 34, Hensley teaches that the second field of view of said spotting mirror is generally directed at least one of outwardly and downwardly with respect to the longitudinal axis of the motor vehicle when said exterior rearview mirror assembly is attached to the motor vehicle as described in page 3, left column, lines 42-70.

It would have been obvious to one having ordinary skill in the art at the time the invention was made to have the spotting mirror be generally directed at least one of outwardly and downwardly with respect to the longitudinal axis of the motor vehicle as taught by Hensley in the Platzer-Black-Richard combination mirror assembly so as to increase the field of view and further eliminate blind spots so that the driver is provided with a clearer view of a wide extent of the road.

Conclusion

Any inquiry concerning this communication or earlier communications from the examiner should be directed to ALESSANDRO AMARI whose telephone number is (571)272-2306. The examiner can normally be reached on Monday-Friday 8:00 AM to 5:30 PM.

If attempts to reach the examiner by telephone are unsuccessful, the examiner's supervisor, Thomas Pham can be reached on (571) 272-3689. The fax phone number for the organization where this application or proceeding is assigned is 571-273-8300.

Information regarding the status of an application may be obtained from the Patent Application Information Retrieval (PAIR) system. Status information for published applications may be obtained from either Private PAIR or Public PAIR. Status information for unpublished applications is available through Private PAIR only. For more information about the PAIR system, see <http://pair-direct.uspto.gov>. Should you have questions on access to the Private PAIR system, contact the Electronic Business Center (EBC) at 866-217-9197 (toll-free). If you would like assistance from a USPTO Customer Service Representative or access to the automated information system, call 800-786-9199 (IN USA OR CANADA) or 571-272-1000.

/Alessandro Amari/
Primary Examiner, Art Unit 2872

Notice of References Cited	Application/Control No. 13/336,018	Applicant(s)/Patent Under Reexamination LYNAM, NIAL R.	
	Examiner ALESSANDRO AMARI	Art Unit 2872	Page 1 of 1

U.S. PATENT DOCUMENTS

*	Document Number Country Code-Number-Kind Code	Date MM-YYYY	Name	Classification
*	A US-2002/0072026	06-2002	Lynam et al.	432/77
*	B US-2,279,751	04-1942	ELWOOD HENSLEY ERNEST	359/866
C	US-			
D	US-			
E	US-			
F	US-			
G	US-			
H	US-			
I	US-			
J	US-			
K	US-			
L	US-			
M	US-			

FOREIGN PATENT DOCUMENTS

*	Document Number Country Code-Number-Kind Code	Date MM-YYYY	Country	Name	Classification
N					
O					
P					
Q					
R					
S					
T					

NON-PATENT DOCUMENTS

*	Document Number Country Code-Number-Kind Code	Date MM-YYYY	Country	Name	Classification
		Include as applicable: Author, Title Date, Publisher, Edition or Volume, Pertinent Pages)			
U					
V					
W					
X					

*A copy of this reference is not being furnished with this Office action. (See MPEP § 707.05(a).)
Dates in MM-YYYY format are publication dates. Classifications may be US or foreign.

Search Notes 	Application/Control No. 13336018	Applicant(s)/Patent Under Reexamination LYNAM, NIALL R.
	Examiner ALESSANDRO AMARI	Art Unit 2872

SEARCHED			
Class	Subclass	Date	Examiner
359	871, 872, 877, 866	5/14/2012	AA

SEARCH NOTES			
Search Notes		Date	Examiner
EAST search		5/14/2012	AA

INTERFERENCE SEARCH			
Class	Subclass	Date	Examiner

--	--

Receipt date: 02/09/2012

Approved for use through 07/2009 PTO/SB/08A (07-05)
 U.S. Patent and Trademark Office, U.S. DEPARTMENT OF COMMERCE
 P-0931: 2872

Under the Paperwork Reduction Act of 1995, no persons are required to respond to a collection of information unless it contains a valid OMB control number.

Substitute for form 1449/PTO INFORMATION DISCLOSURE STATEMENT BY APPLICANT <i>(Use as many sheets as necessary)</i>		Complete if Known	
		Application Number	13/336,018
		Filing Date	December 23, 2011
		First Named Inventor	Niall R. Lynam
		Art Unit	2872
		Examiner Name	Alessandro V. Amari
Sheet 1	of 11	Attorney Docket Number	DON09 P-1800

U. S. PATENT DOCUMENTS					
Examiner Initials*	Cite No. ¹	Document Number	Publication Date MM-DD-YYYY	Name of Patentee or Applicant of Cited Document	Pages, Columns, Lines, Where Relevant Passages or Relevant Figures Appear
		Number-Kind Code ^{2 (if known)}			

		7,934,843	2011-05-03	Lynam	
		7,857,469	2010-12-28	Sinelli et al.	
		7,636,188	2009-12-22	Baur et al.	
		7,626,749	2009-12-01	Baur et al.	
		7,581,859	2009-09-01	Lynam	
		7,526,103	2009-04-28	Schofield et al.	
		7,492,281	2009-02-17	Lynam et al.	
		7,423,522	2008-09-09	O'Brien et al.	
		7,420,756	2008-09-02	Lynam	
		7,400,435	2008-07-15	Byers et al.	
		7,391,563	2008-06-24	McCabe et al.	
		7,377,675	2008-05-27	Pastrick et al.	
		7,370,983	2008-05-13	DeWind et al.	
		7,345,680	2008-03-18	David	
		7,339,149	2008-03-04	Schofield et al.	
		7,338,177	2008-03-04	Lynam	
		7,289,037	2007-10-30	Uken et al.	
		7,274,501	2007-09-25	McCabe et al.	
		7,267,448	2007-09-11	Schmidt et al.	
		7,255,451	2007-08-14	McCabe et al.	
		7,249,860	2007-07-31	Kulas et al.	
		7,195,381	2007-03-27	Lynam et al.	
		7,184,190	2007-02-27	McCabe et al.	
		7,168,830	2007-01-30	Pastrick et al.	
		7,167,294	2007-01-23	Lynam et al.	
		7,126,456	2006-10-24	Boddy et al.	
		7,106,392	2006-09-12	You	
		7,097,312	2006-08-29	Platzer, Jr.	
		7,038,577	2006-05-02	Pawlicki et al.	
		7,025,469	2006-04-11	Manfre' et al.	
		7,005,974	2006-02-28	McMahon et al.	
		7,001,032	2006-02-21	Lo	
		6,979,090	2005-12-27	Wnuk	
		6,932,483	2005-08-23	Strumolo et al.	
		6,919,796	2005-07-19	Boddy et al.	
		6,882,287	2005-04-19	Schofield	
		6,831,268	2004-12-14	Bechtel et al.	
		6,824,281	2004-11-30	Schofield et al.	

Examiner Signature	/Alessandro Amari/	Date Considered	05/14/2012
--------------------	--------------------	-----------------	------------

*EXAMINER: Initial if reference considered, whether or not citation is in conformance with MPEP 609. Draw line through citation if not in conformance and not considered. Include copy of this form with next communication to applicant. ¹ Applicant's unique citation designation number (optional). ² See Kinds Codes of USPTO Patent Documents at www.uspto.gov or MPEP 901.04. ³ Enter Office that issued the document, by the two-letter code (WIPO Standard ST.3). ⁴ For Japanese patent documents, the indication of the year of the reign of the Emperor must precede the serial number of the patent document. ⁵ Kind of document by the appropriate symbols as indicated on the document under WIPO Standard ST.16 if possible. ⁶ Applicant is to place a check mark here if English language Translation is attached.

This collection of information is required by 37 CFR 1.97 and 1.98. The information is required to obtain or retain a benefit by the public which is to file (and by the USPTO to process) an application. Confidentiality is governed by 37 CFR 1.96 and 1.97. This collection is estimated to take 2 hours to complete, including gathering, preparing, and submitting the completed application form to the USPTO. Time will vary depending upon the individual case. Only complete this form with the USPTO forms for filing the burden of proof on the Chief Information Officer, U.S. Patent and Trademark Office, P.O. Box 1450, Alexandria, VA 22313-1450. DO NOT SEND FEES OR COMPLETED FORMS TO THIS ADDRESS. SEND TO:

Receipt date: 02/09/2012

Approved for use through 07/27/2009 - OMB 0651-0031
 U.S. Patent and Trademark Office; U.S. DEPARTMENT OF COMMERCE
 PTO/SB/08A (07-05)
 2872

Under the Paperwork Reduction Act of 1995, no persons are required to respond to a collection of information unless it contains a valid OMB control number.

Substitute for form 1449/PTO		Complete if Known	
INFORMATION DISCLOSURE STATEMENT BY APPLICANT <i>(Use as many sheets as necessary)</i>		Application Number	13/336,018
		Filing Date	December 23, 2011
		First Named Inventor	Niall R. Lynam
		Art Unit	2872
		Examiner Name	Alessandro V. Amari
		Attorney Docket Number	DON09 P-1800
Sheet	2	of	11

U. S. PATENT DOCUMENTS					
Examiner Initials*	Cite No. ¹	Document Number	Publication Date MM-DD-YYYY	Name of Patentee or Applicant of Cited Document	Pages, Columns, Lines, Where Relevant Passages or Relevant Figures Appear
		Number-Kind Code ² (if known)			

		6,757,109	2004-06-29	Bos	
		6,742,904	2004-06-01	Bechtel et al.	
		6,737,629	2004-05-18	Nixon et al.	
		6,731,205	2004-05-04	Schofield et al.	
		6,719,215	2004-04-13	Drouillard	
		6,717,712	2004-04-06	Lynam et al.	
		6,717,610	2004-04-06	Bos et al.	
		6,709,119	2004-03-23	Gillich et al.	
		6,690,268	2004-02-10	Schofield et al.	
		6,669,109	2003-12-30	Ivanov et al.	
		6,648,477	2003-11-18	Hutzel et al.	
		6,642,851	2003-11-04	DeLine et al.	
		6,627,918	2003-09-30	Getz et al.	
		6,615,438	2003-09-09	Franco	
		6,595,649	2003-07-22	Hoekstra et al.	
		6,582,109	2003-06-24	Miller	
		6,537,138	2003-03-25	Ohmori et al.	
		6,522,451	2003-02-18	Lynam	
		6,512,624	2003-01-28	Tonar et al.	
		6,511,192	2003-01-28	Henion et al.	
		6,501,387	2002-12-31	Skiver et al.	
		6,498,620	2002-12-24	Schofield et al.	
		6,472,979	2002-10-29	Schofield et al.	
		6,449,082	2002-09-10	Agrawal et al.	
		6,445,287	2002-09-03	Schofield et al.	
		6,441,964	2002-08-27	Chu et al.	
		6,428,172	2002-08-06	Hutzel et al.	
		6,420,036	2002-07-16	Varaprasad et al.	
		6,409,354	2002-06-25	Richard	
		6,398,377	2002-06-04	Chou	
		6,396,397	2002-05-28	Bos et al.	
		6,390,632	2002-05-21	Palathingal	
		6,356,376	2002-03-12	Tonar et al.	
		6,343,402	2002-02-05	Smith et al.	
		6,341,523	2002-01-29	Lynam	
		6,329,925	2001-12-11	Skiver et al.	
		6,320,282	2001-11-20	Caldwell	
		6,318,870	2001-11-20	Spooner et al.	

Examiner Signature	/Alessandro Amari/	Date Considered	05/14/2012
--------------------	--------------------	-----------------	------------

*EXAMINER: Initial if reference considered, whether or not citation is in conformance with MPEP 609. Draw line through citation if not in conformance and not considered. Include copy of this form with next communication to applicant. ¹ Applicant's unique citation designation number (optional). ² See Kinds Codes of USPTO Patent Documents at www.uspto.gov or MPEP 901.04. ³ Enter Office that issued the document, by the two-letter code (WIPO Standard ST.3). ⁴ For Japanese patent documents, the indication of the year of the reign of the Emperor must precede the serial number of the patent document. ⁵ Kind of document by the appropriate symbols as indicated on the document under WIPO Standard ST.16 if possible. ⁶ Applicant is to place a check mark here if English language Translation is attached.

This collection of information is required by 37 CFR 1.97 and 1.98. The information is required to obtain or retain a benefit by the public which is to file (and by the USPTO to process) an application. Confidentiality is governed by 35 U.S.C. 122 and 37 CFR 1.14. This collection is estimated to take 2 hours to complete, including gathering, preparing, and submitting the completed application form to the USPTO. There will be no charge for this information. Any comments and suggestions should be directed to the Office of Management and Enterprise Services, U.S. Patent and Trademark Office, P.O. Box 1450, Alexandria, VA 22313-1450. DO NOT SEND FEES OR COMPLETED FORMS TO THIS ADDRESS. SEND TO: **Alessandro Amari**

Receipt date: 02/09/2012

Under the Paperwork Reduction Act of 1995, no persons are required to respond to a collection of information unless it contains a valid OMB control number.

Substitute for form 1449/PTO		Complete if Known	
INFORMATION DISCLOSURE STATEMENT BY APPLICANT <i>(Use as many sheets as necessary)</i>		Application Number	13/336,018
		Filing Date	December 23, 2011
		First Named Inventor	Niall R. Lynam
		Art Unit	2872
		Examiner Name	Alessandro V. Amari
		Attorney Docket Number	DON09 P-1800
Sheet	3	of	11

U. S. PATENT DOCUMENTS					
Examiner Initials*	Cite No. ¹	Document Number	Publication Date	Name of Patentee or Applicant of Cited Document	Pages, Columns, Lines, Where Relevant Passages or Relevant Figures Appear
		Number-Kind Code ^{2 (if known)}	MM-DD-YYYY		

		6,315,419	2001-11-13	Platzer, Jr.	
		6,310,611	2001-10-30	Caldwell	
		6,294,989	2001-09-25	Schofield et al.	
		6,286,965	2001-09-11	Caskey et al.	
		6,276,821	2001-08-21	Pastrick et al.	
		6,270,225	2001-08-07	Goolsby	
		6,260,608	2001-07-17	Kim	
		6,257,746	2001-07-10	Todd et al.	
		6,250,148	2001-06-26	Lynam	
		6,245,262	2001-06-12	Varaprasad et al.	
		6,227,689	2001-05-08	Miller	
		6,207,083	2001-03-27	Varaprasad et al.	
		6,201,642	2001-03-13	Bos	
		6,199,993	2001-03-13	Mou	
		6,198,409	2001-03-06	Schofield et al.	
		6,196,688	2001-03-06	Caskey et al.	
		6,178,034	2001-01-23	Allemand et al.	
		6,176,602	2001-01-23	Pastrick et al.	
		6,172,613	2001-01-09	DeLine et al.	
		6,164,564	2000-12-26	Franco et al.	
		6,154,306	2000-11-28	Varaprasad et al.	
		6,135,419	2001-11-13	Platzer, Jr.	
		6,128,860	2000-10-10	Varaprasad et al.	
		6,124,647	2000-09-26	Marcus et al.	
		6,116,743	2000-09-12	Hoek	
		6,111,684	2000-08-29	Forgette et al.	
		6,109,586	2000-08-29	Hoek	
		6,097,023	2000-08-01	Schofield et al.	
		6,074,068	2000-06-13	Palathingal	
		6,065,840	2000-05-23	Caskey et al.	
		6,033,078	2000-03-07	Su et al.	
		6,032,323	2000-03-07	Smith et al.	
		6,030,084	2002-02-29	Schmidt	
		6,022,511	1999-12-14	Varaprasad et al.	
		6,011,486	1999-12-14	Varaprasad et al.	
		6,007,207	1999-12-28	Liu	
		6,005,724	1999-12-21	Todd	
		6,002,544	1999-12-14	Yatsu	

Examiner Signature	/Alessandro Amari/	Date Considered	05/14/2012
--------------------	--------------------	-----------------	------------

*EXAMINER: Initial if reference considered, whether or not citation is in conformance with MPBP 609. Draw line through citation if not in conformance and not considered. Include copy of this form with next communication to applicant. ¹ Applicant's unique citation designation number (optional). ² See Kinds Codes of USPTO Patent Documents at www.uspto.gov or MPBP 901.04. ³ Enter Office that issued the document, by the two-letter code (WIPO Standard ST.3). ⁴ For Japanese patent documents, the indication of the year of the reign of the Emperor must precede the serial number of the patent document. ⁵ Kind of document by the appropriate symbols as indicated on the document under WIPO Standard ST.16 if possible. ⁶ Applicant is to place a check mark here if English language Translation is attached. This collection of information is required by 37 CFR 1.97 and 1.98. The information is required to obtain or retain a benefit by the public which is to file (and by the USPTO to process) an application. Confidentiality is governed by 35 U.S.C. 122 and 37 CFR 1.14. This collection is estimated to take 2 hours to complete, including gathering, preparing, and submitting the completed application form to the USPTO. There will vary depending upon the filing fees. Any comments on the amount of time you require to complete this form and/or suggestions for reducing this burden should be sent to the Chief Information Officer, U.S. Patent and Trademark Office, P.O. Box 1450, Alexandria, VA 22313-1450. DO NOT SEND FEES OR COMPLETED FORMS TO THIS ADDRESS. SEND TO: /AA/

Receipt date: 02/09/2012

Approved for use through 07/2009 P.O. Box 063-011: 2872
 U.S. Patent and Trademark Office; U.S. DEPARTMENT OF COMMERCE

Under the Paperwork Reduction Act of 1995, no persons are required to respond to a collection of information unless it contains a valid OMB control number.

Substitute for form 1449/PTO INFORMATION DISCLOSURE STATEMENT BY APPLICANT (Use as many sheets as necessary)		Complete if Known	
		Application Number	13/336,018
		Filing Date	December 23, 2011
		First Named Inventor	Niall R. Lynam
		Art Unit	2872
		Examiner Name	Alessandro V. Amari
Sheet	4	of	11
		Attorney Docket Number	DON09 P-1800

U. S. PATENT DOCUMENTS					
Examiner Initials*	Cite No. ¹	Document Number	Publication Date MM-DD-YYYY	Name of Patentee or Applicant of Cited Document	Pages, Columns, Lines, Where Relevant Passages or Relevant Figures Appear
		Number-Kind Code ^{2 (if known)}			

		5,980,050	1999-11-09	McCord	
		5,938,320	1999-08-17	Crandall	
		5,929,786	1999-07-27	Schofield et al.	
		5,922,176	1999-07-13	Caskey	
		5,910,854	1999-06-08	Varaprasad et al.	
		5,877,897	1999-03-02	Schofield et al.	
		5,864,434	1999-01-26	Taylor	
		5,863,116	1999-01-26	Pastrick et al.	
		5,847,889	1998-12-08	Komiyama et al.	
		5,838,505	1998-11-17	Palathingal	
		5,835,294	1998-11-10	Minegishi	
		5,825,527	1998-10-20	Forgette et al.	
		5,823,654	1998-10-20	Pastrick et al.	
		5,808,777	1998-09-15	Lynam et al.	
		5,805,367	1998-09-08	Kanazawa	
		5,796,532	1998-08-18	Kanazawa	
		5,796,094	1998-08-18	Schofield et al.	
		5,793,542	1998-08-11	Kondo et al.	
		5,790,327	1998-08-04	Lee et al.	
		5,790,298	1998-08-04	Tonar	
		5,788,357	1998-08-04	Muth et al.	
		5,786,772	1998-07-28	Schofield et al.	
		5,784,211	1998-07-21	Mingledorff	
		5,760,962	1998-06-02	Schofield et al.	
		5,751,489	1998-05-12	Caskey et al.	
		5,724,187	1998-03-03	Varaprasad et al.	
		5,722,836	1998-03-03	Yunker	
		5,715,093	1998-02-03	Schierbeek et al.	
		5,691,855	1997-11-25	Lupkas	
		5,689,370	1997-11-18	Tonar et al.	
		5,670,935	1997-09-23	Schofield et al.	
		5,669,705	1997-09-23	Pastrick et al.	
		5,669,704	1997-09-23	Pastrick	
		5,669,699	1997-09-23	Pastrick et al.	
		5,669,698	1997-09-23	Veldman et al.	
		5,668,663	1997-09-16	Varaprasad et al.	
		5,649,756	1997-07-22	Adams et al.	
		5,644,442	1997-07-01	Lemere	

Examiner Signature	/Alessandro Amari/	Date Considered	05/14/2012
--------------------	--------------------	-----------------	------------

*EXAMINER: Initial if reference considered, whether or not citation is in conformance with MPEP 609. Draw line through citation if not in conformance and not considered. Include copy of this form with next communication to applicant. ¹ Applicant's unique citation designation number (optional). ² See Kinds Codes of USPTO Patent Documents at www.uspto.gov or MPEP 901.04. ³ Enter Office that issued the document, by the two-letter code (WIPO Standard ST.3). ⁴ For Japanese patent documents, the indication of the year of the reign of the Emperor must precede the serial number of the patent document. ⁵ Kind of document by the appropriate symbols as indicated on the document under WIPO Standard ST.16 if possible. ⁶ Applicant is to place a check mark here if English language Translation is attached. This collection of information is required by 37 CFR 1.97 and 1.98. The information is required to obtain or retain a benefit by the public which is to file (and by the USPTO to process) an application. Confidentiality is governed by 37 CFR 1.92 and 37 CFR 1.14. This collection is intended to assist you in completing, preparing, prosecuting, and submitting the multiple applications form to the USPTO. There will be a fee for this form. Do not send this form to the Chief Information Officer, U.S. Patent and Trademark Office, P.O. Box 1450, Alexandria, VA 22313-1450. DO NOT SEND FEES OR COMPLETED FORMS TO THIS ADDRESS. SEND TO: H. /A.A./

Receipt date: 02/09/2012

PTO/SB/08A (07-05)
 Approved for use through 07/31/2009, OMB 0651-0031
 U.S. Patent and Trademark Office; U.S. DEPARTMENT OF COMMERCE
 Application Number: 2872

Under the Paperwork Reduction Act of 1995, no persons are required to respond to a collection of information unless it contains a valid OMB control number.

Substitute for form 1449/PTO		Complete if Known	
INFORMATION DISCLOSURE STATEMENT BY APPLICANT <i>(Use as many sheets as necessary)</i>		Filing Date	December 23, 2011
		First Named Inventor	Niall R. Lynam
		Art Unit	2872
		Examiner Name	Alessandro V. Amari
		Attorney Docket Number	DON09 P-1800
Sheet	5	of	11

U. S. PATENT DOCUMENTS					
Examiner Initials*	Cite No. ¹	Document Number	Publication Date MM-DD-YYYY	Name of Patentee or Applicant of Cited Document	Pages, Columns, Lines, Where Relevant Passages or Relevant Figures Appear
		Number-Kind Code ² (if known)			

		5,621,577	1997-04-15	Lang et al.	
		5,621,569	1997-04-15	Schlenke	
		5,610,756	1997-03-11	Lynam et al.	
		5,594,593	1997-01-14	Milner	
		5,594,222	1997-01-14	Caldwell	
		5,587,699	1996-12-24	Faloon et al.	
		5,587,236	1996-12-24	Agrawal et al.	
		5,579,133	1996-11-26	Black et al.	
		5,575,552	1996-11-19	Faloon et al.	
		5,567,360	1996-10-22	Varaprasad et al.	
		5,563,744	1996-10-08	Matsumiya	
		5,559,640	1996-09-24	Vachss et al.	
		5,557,467	1996-09-17	McColgan et al.	
		5,550,677	1996-08-27	Schofield et al.	
		5,535,056	1996-07-09	Caskey et al.	
		5,530,588	1996-06-25	Vivier	
		5,526,195	1996-06-11	Thomas	
		5,525,264	1996-06-11	Cronin et al.	
		5,523,877	1996-06-04	Lynam	
		5,517,367	1996-05-14	Kim et al.	
		5,509,606	1996-04-23	Breithaupt et al.	
		5,497,306	1996-03-05	Pastrick	
		5,497,305	1996-03-05	Pastrick et al.	
		5,483,386	1996-01-09	Carson	
		5,481,409	1996-01-02	Roberts	
		5,446,576	1995-08-29	Lynam et al.	
		5,437,931	2003-08-01	Tsai et al.	
		5,432,643	1995-07-11	Huang	
		5,424,875	1995-06-13	Davis, II	
		5,412,512	1995-05-02	Zebold et al.	
		5,406,414	1995-04-11	O'Farrell et al.	
		5,371,659	1994-12-06	Pastrick et al.	
		5,361,172	1994-11-01	Schissel et al.	
		5,355,245	1994-10-11	Lynam	
		5,354,965	1994-10-11	Lee	
		5,327,288	1994-07-05	Wellington et al.	
		5,313,335	1994-05-17	Gray et al.	
		5,296,973	1994-03-22	Burke	

Examiner Signature	/Alessandro Amari/	Date Considered	05/14/2012
--------------------	--------------------	-----------------	------------

*EXAMINER: Initial if reference considered, whether or not citation is in conformance with MPEP 609. Draw line through citation if not in conformance and not considered. Include copy of this form with next communication to applicant. ¹ Applicant's unique citation designation number (optional). ² See Kinds Codes of USPTO Patent Documents at www.uspto.gov or MPBP 901.04. ³ Enter Office that issued the document, by the two-letter code (WIPO Standard ST.3). ⁴ For Japanese patent documents, the indication of the year of the reign of the Emperor must precede the serial number of the patent document. ⁵ Kind of document by the appropriate symbols as indicated on the document under WIPO Standard ST.16 if possible. ⁶ Applicant is to place a check mark here if English language Translation is attached.

This collection of information is required by 37 CFR 1.97 and 1.98. The information is required to obtain or retain a benefit by the public which is to file (and by the USPTO to process) an application. Confidentiality is governed by 35 U.S.C. 122 and 37 CFR 1.14. This collection is estimated to take 2 hours to complete, including gathering, preparing, and submitting the completed application form to the USPTO. The information will be used for the purposes of the USPTO. Any comments on this collection should be sent to the Chief Information Officer, U.S. Patent and Trademark Office, P.O. Box 1450, Alexandria, VA 22311-1450. DO NOT SEND FEES OR COMPLETED FORMS TO THIS ADDRESS! SEND TO: IAA@USPTO

Receipt date: 02/09/2012

Approved for use through 12/31/2009. PTO/SB/08A (07-05)
 U.S. Patent and Trademark Office; U.S. DEPARTMENT OF COMMERCE
 2872

Under the Paperwork Reduction Act of 1995, no persons are required to respond to a collection of information unless it contains a valid OMB control number.

Substitute for form 1449/PTO		Complete if Known	
INFORMATION DISCLOSURE STATEMENT BY APPLICANT <i>(Use as many sheets as necessary)</i>		Application Number	13/336,018
		Filing Date	December 23, 2011
		First Named Inventor	Niall R. Lynam
		Art Unit	2872
		Examiner Name	Alessandro V. Amari
Sheet 6	of 11	Attorney Docket Number	DON09 P-1800

U. S. PATENT DOCUMENTS					
Examiner Initials*	Cite No. ¹	Document Number	Publication Date MM-DD-YYYY	Name of Patentee or Applicant of Cited Document	Pages, Columns, Lines, Where Relevant Passages or Relevant Figures Appear
		Number-Kind Code ^{2 (if known)}			

		5,295,021	1994-03-15	Swanson	
		5,285,060	1994-02-08	Larson et al.	
		5,262,894	1993-11-16	Wheatley et al.	
		5,253,109	1993-10-12	O'Farrell et al.	
		5,247,395	1993-09-21	Martinez	
		5,239,405	1993-08-24	Varaprasad et al.	
		5,237,459	1993-08-17	Strauss	
		5,237,458	1993-08-17	Polanyi et al.	
		5,233,461	1993-08-03	Dornan et al.	
		5,225,943	1993-07-06	Lupo	
		5,207,492	1993-05-04	Roberts	
		5,193,029	1993-03-09	Schofield et al.	
		5,189,537	1993-02-23	O'Farrell	
		5,183,099	1993-02-02	Bechu	
		5,179,471	1993-01-12	Caskey et al.	
		5,178,448	1993-01-12	Adams et al.	
		5,166,833	1992-11-24	Shyu	
		5,151,824	1992-09-29	O'Farrell	
		5,151,816	1992-09-29	Varaprasad et al.	
		5,142,407	1992-08-25	Varaprasad et al.	
		5,140,455	1992-08-18	Varaprasad et al.	
		5,118,540	1992-06-02	Hutchison	
		5,117,346	1992-05-26	Gard	
		5,115,352	1992-05-19	do Espirito Santo	
		5,115,346	1992-05-19	Lynam	
		5,107,374	1992-04-21	Lupo et al.	
		5,085,907	1992-02-04	Smith	
		5,080,492	1992-01-14	Platzer, Jr.	
		5,078,480	1992-01-07	Warszawski	
		5,076,673	1991-12-31	Lynam et al.	
		5,073,012	1991-12-17	Lynam	
		5,066,112	1991-11-19	Lynam et al.	
		5,052,792	1991-10-01	McDonough	
		5,050,977	1991-09-24	Platzer, Jr.	
		5,044,739	1991-09-03	do Espirito Santo	
		5,033,835	1991-07-23	Platzer, Jr.	
		5,022,747	1991-06-11	Polanyi et al.	
		5,014,167	1991-05-07	Roberts	

Examiner Signature	/Alessandro Amari/	Date Considered	05/14/2012
--------------------	--------------------	-----------------	------------

*EXAMINER: Initial if reference considered, whether or not citation is in conformance with MPEP 609. Draw line through citation if not in conformance and not considered. Include copy of this form with next communication to applicant. ¹ Applicant's unique citation designation number (optional). ² See Kinds Codes of USPTO Patent Documents at www.uspto.gov or MPEP 901.04. ³ Enter Office that issued the document, by the two-letter code (WIPO Standard ST.3). ⁴ For Japanese patent documents, the indication of the year of the reign of the Emperor must precede the serial number of the patent document. ⁵ Kind of document by the appropriate symbols as indicated on the document under WIPO Standard ST.16 if possible. ⁶ Applicant is to place a check mark here if English language Translation is attached. This collection of information is required by 37 CFR 1.97 and 1.98. The information is required to obtain or retain a benefit by the public which is to file (and by the USPTO to process) an application. Confidentiality is governed by 37 CFR 1.92 and 1.97. This collection is estimated to take 1 hour to complete, including gathering, preparing, and submitting the complete application form to the USPTO. This will save the funding upon the initial release. Any comments and suggestions should be sent to the Chief Information Officer, U.S. Patent and Trademark Office, P.O. Box 1450, Alexandria, VA 22313-1450. DO NOT SEND FEES OR COMPLETED FORMS TO THIS ADDRESS. SEND TO: **AMARI/A.A./**

Receipt date: 02/09/2012

Under the Paperwork Reduction Act of 1995, no persons are required to respond to a collection of information unless it contains a valid OMB control number.

Substitute for form 1449/PTO		Complete if Known	
INFORMATION DISCLOSURE STATEMENT BY APPLICANT (Use as many sheets as necessary)		Application Number	13/336,018
		Filing Date	December 23, 2011
		First Named Inventor	Niall R. Lynam
		Art Unit	2872
		Examiner Name	Alessandro V. Amari
		Attorney Docket Number	DON09 P-1800
Sheet	7	of	11

U. S. PATENT DOCUMENTS					
Examiner Initials*	Cite No. ¹	Document Number	Publication Date	Name of Patentee or Applicant of Cited Document	Pages, Columns, Lines, Where Relevant Passages or Relevant Figures Appear
		Number-Kind Code ^{2 (if known)}	MM-DD-YYYY		

		5,005,962	1991-04-09	Edelman	
		4,989,964	1991-02-05	Meise	
		4,948,242	1990-08-14	Desmond et al.	
		4,944,581	1990-07-31	Ichikawa	
		4,932,770	1990-06-12	Caravaty	
		4,932,769	1990-06-12	Goosen	
		4,929,074	1990-05-29	Urban	
		4,917,485	1990-04-17	Baldwin, Sr.	
		4,913,542	1990-04-03	Adolfsson	
		4,906,085	1990-03-06	Sugihara et al.	
		4,906,075	1990-03-06	Majsumiya	
		4,882,565	1989-11-21	Gallmeyer	
		4,882,466	1989-11-21	Friel	
		4,859,046	1989-08-22	Traynor et al.	
		4,853,283	1989-08-01	Skolnick	
		4,828,379	1989-05-09	Parsons et al.	
		4,826,289	1989-05-02	Vandenbrink et al.	
		4,824,231	1989-04-25	Quintana	
		4,799,768	1989-01-24	Gahan	
		4,793,690	1988-12-27	Gahan et al.	
		4,773,740	1988-09-27	Kawakami et al.	
		4,770,522	1988-09-13	Alten	
		4,737,188	1988-04-12	Bahls	
		4,733,336	1988-03-22	Skogler et al.	
		4,727,302	1988-02-23	Mizuta et al.	
		4,721,364	1988-01-26	Itoh et al.	
		4,715,701	1987-12-29	Urban	
		4,712,879	1987-12-15	Lynam et al.	
		4,679,906	1987-07-14	Brandenburg	
		4,678,294	1987-07-01	Van Nostrand	
		4,674,850	1987-06-23	Blom	
		4,674,849	1987-06-23	Stewart	
		4,666,264	1987-05-19	Yamabe	
		4,630,904	1986-12-23	Pastore	
		4,629,296	1986-12-16	White	
		4,623,222	1986-11-18	Itoh et al.	
		4,609,266	1986-09-02	Blom	
		4,588,267	1986-05-13	Pastore	

Examiner Signature	/Alessandro Amari/	Date Considered	05/14/2012
--------------------	--------------------	-----------------	------------

*EXAMINER: Initial if reference considered, whether or not citation is in conformance with MPEP 609. Draw line through citation if not in conformance and not considered. Include copy of this form with next communication to applicant. ¹ Applicant's unique citation designation number (optional). ² See Kinds Codes of USPTO Patent Documents at www.uspto.gov or MPEP 901.04. ³ Enter Office that issued the document, by the two-letter code (WIPO Standard ST.3). ⁴ For Japanese patent documents, the indication of the year of the reign of the Emperor must precede the serial number of the patent document. ⁵ Kind of document by the appropriate symbols as indicated on the document under WIPO Standard ST.16 if possible. ⁶ Applicant is to place a check mark here if English language Translation is attached. This collection of information is required by 37 CFR 1.97 and 1.98. The information is required to obtain or retain a benefit by the public which is to file (and by the USPTO to process) an application. Confidentiality is governed by 35 U.S.C. 122 and 37 CFR 1.14. This collection is estimated to take 2 hours to complete, including gathering, preparing, and submitting the completed application form to the USPTO. Time will vary depending upon the individual case. Any comments on the amount of time you require to complete this form and suggestions for reducing the burden should be sent to the Chief Information Officer, U.S. Patent and Trademark Office, P.O. Box 1450, Alexandria, VA 22313-1450. DO NOT SEND FEES OR COMPLETED FORMS TO THIS ADDRESS. SEND TO: /AA/

Receipt date: 02/09/2012

Under the Paperwork Reduction Act of 1995, no persons are required to respond to a collection of information unless it contains a valid OMB control number.

Substitute for form 1449/PTO		Complete if Known	
INFORMATION DISCLOSURE STATEMENT BY APPLICANT <i>(Use as many sheets as necessary)</i>		Application Number	13/336,018
		Filing Date	December 23, 2011
		First Named Inventor	Niall R. Lynam
		Art Unit	2872
		Examiner Name	Alessandro V. Amari
		Attorney Docket Number	DON09 P-1800
Sheet	8	of	11

U. S. PATENT DOCUMENTS					
Examiner Initials*	Cite No. ¹	Document Number	Publication Date MM-DD-YYYY	Name of Patentee or Applicant of Cited Document	Pages, Columns, Lines, Where Relevant Passages or Relevant Figures Appear
		Number-Kind Code ² (if known)			

		4,575,202	1986-03-11	McGuire	
		4,555,166	1985-11-26	Enomoto	
		4,549,786	1985-10-29	Albers et al.	
		4,526,446	1985-07-02	Adams	
		4,499,451	1985-02-12	Suzuki et al.	
		4,470,665	1984-09-11	Blom	
		4,449,786	1984-05-22	McCord	
		4,439,013	1984-03-27	Hagn et al.	
		4,436,372	1984-03-13	Schmidt et al.	
		4,436,371	1984-03-13	Wood et al.	
		4,435,042	1984-06-03	Wood et al.	
		4,385,804	1983-05-31	Tamura et al.	
		4,350,412	1982-09-21	Steenblik et al.	
		4,331,382	1982-05-25	Graff	
		4,325,609	1982-04-20	Alford	
		4,311,363	1982-01-19	Marsalka et al.	
		4,311,362	1982-01-19	LaPorte	
		4,306,770	1981-12-22	Marhauer	
		4,303,308	1981-12-01	Kobrin	
		4,293,191	1981-10-06	Kim	
		4,281,899	1981-08-04	Oskam	
		4,268,120	1981-05-19	Jitsumori	
		4,264,144	1981-04-28	McCord	
		4,258,979	1981-03-31	Mahin	
		4,223,983	1980-09-23	Bloom	
		4,200,359	1980-04-29	Lawson	
		4,193,668	1980-03-18	Skinner	
		3,909,117	1975-09-30	Takahashi et al.	
		3,884,606	1975-05-20	Schrenk	
		3,881,811	1975-05-06	French	
		3,826,563	1974-07-30	Davis	
		3,806,232	1974-04-23	Gray	
		3,773,882	1973-11-20	Schrenk	
		3,764,201	1973-10-09	Haile	
		3,759,647	1973-09-18	Schrenk et al.	
		3,708,222	1973-01-02	Stern	
		3,667,833	1972-06-06	Baldwin, Sr.	
		3,610,739	1971-10-05	Seashore	

Examiner Signature	/Alessandro Amari/	Date Considered	05/14/2012
--------------------	--------------------	-----------------	------------

*EXAMINER: Initial if reference considered, whether or not citation is in conformance with MPEP 609. Draw line through citation if not in conformance and not considered. Include copy of this form with next communication to applicant. ¹ Applicant's unique citation designation number (optional). ² See Kinds Codes of USPTO Patent Documents at www.uspto.gov or MPEP 901.04. ³ Enter Office that issued the document, by the two-letter code (WIPO Standard ST.3). ⁴ For Japanese patent documents, the indication of the year of the reign of the Emperor must precede the serial number of the patent document. ⁵ Kind of document by the appropriate symbols as indicated on the document under WIPO Standard ST.16 if possible. ⁶ Applicant is to place a check mark here if English language Translation is attached.

This collection of information is required by 37 CFR 1.97 and 1.98. The information is required to obtain or retain a benefit by the public which is to file (and by the USPTO to process) an application. Confidentiality is governed by 35 USC 122 and 37 CFR 2.14. This collection is estimated to take 2 hours to complete, including gathering, preparing, and submitting the completed application form to the USPTO. There will be no charge for this information. If you have any questions, please contact the USPTO Customer Service Center at 1-800-351-5041 or visit the USPTO website at www.uspto.gov. Send this form to the Chief Information Officer, U.S. Patent and Trademark Office, P.O. Box 1450, Alexandria, VA 22313-1450. DO NOT SEND FEES OR COMPLETED FORMS TO THIS ADDRESS. SEND TO: **AA/AA/**

Receipt date: 02/09/2012

Approved for use through 07/2009 OMB 0667-0031
 U.S. Patent and Trademark Office; U.S. DEPARTMENT OF COMMERCE
 PTO/SB/08A (07-05)
 1573-1000 PATENT: 2872

Under the Paperwork Reduction Act of 1995, no persons are required to respond to a collection of information unless it contains a valid OMB control number.

Substitute for form 1449/PTO INFORMATION DISCLOSURE STATEMENT BY APPLICANT (Use as many sheets as necessary)		Complete if Known	
		Application Number	13/336,018
		Filing Date	December 23, 2011
		First Named Inventor	Niall R. Lynam
		Art Unit	2872
		Examiner Name	Alessandro V. Amari
Sheet 9	of 11	Attorney Docket Number	DON09 P-1800

U. S. PATENT DOCUMENTS					
Examiner Initials*	Cite No. ¹	Document Number	Publication Date	Name of Patentee or Applicant of Cited Document	Pages, Columns, Lines, Where Relevant Passages or Relevant Figures Appear
		Number-Kind Code ^{2 (if known)}	MM-DD-YYYY		

		3,601,614	1971-08-24	Platzer, Jr.	
		3,563,638	1971-02-16	Panozzo	
		3,424,517	1969-01-28	Budreck	
		3,408,136	1968-10-29	Travis	
		3,404,935	1968-10-08	Creager	
		3,389,952	1968-06-25	Tobin, Jr.	
		3,375,053	1968-03-26	Ward	
		3,338,655	1967-08-29	Young	
		3,337,285	1967-08-22	Travis	
		3,280,701	1966-10-25	Donnelly et al.	
		3,267,806	1966-08-23	Azegami	
		3,266,016	1966-08-09	Maruyama et al.	
		3,175,463	1965-03-30	Seashore	
		3,170,985	1965-02-23	Katulich	
		3,146,296	1964-08-25	Fischer	
		3,131,250	1964-04-28	Ely	
		3,104,274	1963-09-17	King	
		2,911,177	1959-11-03	West	
		2,890,539	1959-06-16	Holt	
		2,778,273	1957-01-22	Fellmeth	
		2,636,419	1953-04-28	Kerr	
		2,580,014	1951-12-25	Gazda	
		2,514,989	1950-07-11	Buren	
		2,263,382	1941-11-18	Gotzinger	
		2,135,262	1938-11-01	Schumacher	
		1,672,559	1928-06-05	Doble	
		1,114,559	1914-10-20	Weed	
		D297,926	1988-10-04	Kesler	
		D493,394	2004-07-27	Lawlor et al.	
		D493,131	2004-07-20	Lawlor et al.	
		2002/0036828	2002-03-28	Wong	
		2002/0105741	2002-08-08	Platzer, Jr.	
		2002/0159169	2002-10-31	McCord	
		2002/0159270	2002-10-31	Lynam et al.	
		2003/0043589	2003-03-06	Blank	
		2003/0117731	2003-06-26	Platzer, Jr.	
		2004/0032675	2004-02-19	Weller et al.	
		2004/0032676	2004-02-19	Drummond et al.	

Examiner Signature	/Alessandro Amari/	Date Considered	05/14/2012
--------------------	--------------------	-----------------	------------

*EXAMINER: Initial if reference considered, whether or not citation is in conformance with MPEP 609. Draw line through citation if not in conformance and not considered. Include copy of this form with next communication to applicant. ¹ Applicant's unique citation designation number (optional). ² See Kinds Codes of USPTO Patent Documents at www.uspto.gov or MPEP 901.04. ³ Enter Office that issued the document, by the two-letter code (WIPO Standard ST.3). ⁴ For Japanese patent documents, the indication of the year of the reign of the Emperor must precede the serial number of the patent document. ⁵ Kind of document by the appropriate symbols as indicated on the document under WIPO Standard ST.16 if possible. ⁶ Applicant is to place a check mark here if English language Translation is attached.

This collection of information is required by 37 CFR 1.97 and 1.98. The information is required to obtain or retain a benefit by the public which is to file (and by the USPTO to process) an application. Confidentiality is governed by 35 USC 6-12 and 37 CFR 1.97. This collection is estimated to take 2 hours to complete, including gathering, processing, and submitting the completed application form to the USPTO. This will vary depending upon the individual case. Any comments and the burden of time and resources to complete this form and suggestions for reducing this burden should be sent to the Chief Information Officer, U.S. Patent and Trademark Office, P.O. Box 1450, Alexandria, VA 22313-1450. DO NOT SEND FEES OR COMPLETED FORMS TO THIS ADDRESS. SEND TO:

Receipt date: 02/09/2012

PTO/SB/08A (07-05)
Approved for use through 07/27/2009, OMB 0667-0031
U.S. Patent and Trademark Office; U.S. DEPARTMENT OF COMMERCE
CLASSIFICATION: G01J: 2872

Under the Paperwork Reduction Act of 1995, no persons are required to respond to a collection of information unless it contains a valid OMB control number.

Substitute for form 1449/PTO		Complete if Known	
INFORMATION DISCLOSURE STATEMENT BY APPLICANT <i>(Use as many sheets as necessary)</i>		Application Number	13/336,018
		Filing Date	December 23, 2011
		First Named Inventor	Niall R. Lynam
		Art Unit	2872
		Examiner Name	Alessandro V. Amari
		Attorney Docket Number	DON09 P-1800
Sheet	10	of	11

U. S. PATENT DOCUMENTS					
Examiner Initials*	Cite No. ¹	Document Number	Publication Date MM-DD-YYYY	Name of Patentee or Applicant of Cited Document	Pages, Columns, Lines, Where Relevant Passages or Relevant Figures Appear
		Number-Kind Code ^{2 (if known)}			

		2004/0114260	2004-06-17	Bartnick	
		2004/0165291	2004-08-26	Platzer, Jr.	
		2004/0257685	2004-12-23	Minor et al.	
		2004/0264011	2004-12-30	Lynam	
		2005/0078389	2005-04-14	Kulas et al.	
		2005/0083577	2005-04-21	Varaprasad et al.	
		2005/0099693	2005-05-12	Schofield et al.	
		2005/0134983	2005-06-23	Lynam	
		2005/0232469	2005-10-20	Schofield et al.	
		2005/0248859	2005-11-10	Platzer, Jr.	
		2006/0050018	2006-03-09	Hutzel et al.	
		2006/0061008	2006-03-23	Karner et al.	
		2006/0125919	2006-06-15	Camilleri et al.	
		2006/0126150	2006-06-15	Tonar et al.	
		2006/0171704	2006-08-03	Bingle et al.	
		2006/0184297	2006-08-17	Higgins-Luthman	
		2006/0268440	2006-11-30	Platzer, Jr.	
		2006/0279863	2006-12-14	Starbuck	
		2007/0032638	2004-02-19	Tonar et al.	
		2007/0058257	2007-03-15	Lynam	
		2007/0285789	2007-12-13	Lindahl et al.	
		2008/0212189	2008-09-04	Baur et al.	
		2008/0225421	2008-09-18	Platzer	
		2008/0304170	2008-12-11	Zhao	
		2008/0308219	2008-12-18	Lynam	
		2009/0040306	2009-02-12	Foote et al.	
		2009/0115631	2009-05-07	Foote et al.	
		2009/0237820	2009-09-24	McCabe et al.	
		2009/0268321	2009-10-29	Wilson	
		2010/0195228	2010-08-05	Sinelli et al.	
		2010/0296187	2010-11-25	Lynam	
		2011/0157732	2011-06-30	Henion et al.	
		2011/0170207	2011-07-14	Lynam	
		RE17274	1929-04-16	Porter	

Examiner Signature	/Alessandro Amari/	Date Considered	05/14/2012
--------------------	--------------------	-----------------	------------

*EXAMINER: Initial if reference considered, whether or not citation is in conformance with MPEP 609. Draw line through citation if not in conformance and not considered. Include copy of this form with next communication to applicant. ¹ Applicant's unique citation designation number (optional). ² See Kinds Codes of USPTO Patent Documents at www.uspto.gov or MPEP 901.04. ³ Enter Office that issued the document, by the two-letter code (WIPO Standard ST.3). ⁴ For Japanese patent documents, the indication of the year of the reign of the Emperor must precede the serial number of the patent document. ⁵ Kind of document by the appropriate symbols as indicated on the document under WIPO Standard ST.16 if possible. ⁶ Applicant is to place a check mark here if English language Translation is attached.

This collection of information is required by 37 CFR 1.97 and 1.98. The information is required to obtain or retain a benefit by the public which is to file (and by the USPTO to process) an application. Confidentiality is governed by 35 U.S.C. 122 and 37 CFR 1.4. This collection is estimated to take 2 hours to complete, including gathering, preparing, and submitting the completed application form to the USPTO. This will vary from time to time. If you have any comments or suggestions for improvement, please contact the form administrator for the form at usptoforms@uspto.gov or call the Chief Information Officer, U.S. Patent and Trademark Office, P.O. Box 1450, Alexandria, VA 22313-1450. DO NOT SEND FEES OR COMPLETED FORMS TO THIS ADDRESS. SEND TO:

Receipt date: 02/09/2012

Approved for use through 07/01/2006, OMB 0901-0001
 U.S. Patent and Trademark Office; U.S. DEPARTMENT OF COMMERCE
 CLASSIFICATION: 2872

Under the Paperwork Reduction Act of 1995, no persons are required to respond to a collection of information unless it contains a valid OMB control number.

Substitute for form 1449/PTO		Complete if Known	
INFORMATION DISCLOSURE STATEMENT BY APPLICANT <i>(Use as many sheets as necessary)</i>		Application Number	13/336,018
		Filing Date	December 23, 2011
		First Named Inventor	Niall R. Lynam
		Art Unit	2872
		Examiner Name	Alessandro V. Amari
		Attorney Docket Number	DON09 P-1800
Sheet	11	of	11

FOREIGN PATENT DOCUMENTS							
Examiner initials*	Cite No. ¹	Foreign Patent Document		Publication Date MM-DD-YYYY	Name of Patentee or Applicant of Cited Document	Pages, Columns, Lines, Where Relevant Passages Or Relevant Figures Appear	T ⁶
		Country Code ²	Number ³ -Kind Code ⁵ <i>(if known)</i>				

		DE	2409748	1975-09-04	Leitz		
		DE	2550095	1976-05-20	Schiff et al.		
		DE	2647592	1978-04-27	Uta		
		DE	2915521	1980-10-30	Docie		
		DE	3302735	1984-08-02	Schulze		X
		DE	3329998	1985-03-07	Horn		X
		DE	3620228	1987-12-17	Thomen		X
		DE	4026578	1992-04-30	Kramer		X
		EP	0210757	1987-02-04	Von Seidel		X
		EP	0310261	1989-04-05	Britax Wingard Limited		X
		EP	0551802	1992-01-15	Jonsson		X
		EP	0791503	1997-08-27	Gentex Corporation		X
		EP	0917987	1999-05-26	Magneti Marelli France		X
		EP	0356099	1990-02-28	Yamada et al.		X
		EP	0728618	08-28-1996	Gentex Corporation		X
		EP	0729864	09-04-1996	Gentex Corporation		X
		FR	2628042	1988-03-01	Racel		X
		GB	1279158	1972-06-28	Hacker		X
		GB	2048189	1980-12-10	Mirrocraft Inc.		X
		GB	2092534	1982-08-18	Hagiri		X
		JP	0051637	1980-04-15	Katsumata Giken KK		X
		JP	55076721	1980-10-06	Nikken Kogyo KK		X
		JP	1186443	1989-07-25	Kitsumoto Norihiko		X
		JP	1208245	1989-08-22	Moriwake		X
		JP	362075619	1987-04-07	Tomita		X
		JP	62105103	1987-05-15	Miyake Shinya		X
		KR	2002092059	2002-12-11	Jung		X
		NL	7908257	1981-06-01	Bartholomeus		
		TW	424057	2001-03-01	Lin		X
		WO	2001081956	11-01-2001	Platzer, Jr.		X
		WO	2004026633	04-01-2004	Donnelly Corporation		X
		WO	2004047421	06-03-2004	Donnelly Corporation		X
		WO	2004103772	12-02-2004	Donnelly Corporation		X
		WO	2006124682	11-23-2006	Donnelly Corporation		X
		WO	2007005942	01-11-2007	Donnelly Corporation		X
		WO	2008051910	05-02-2008	Donnelly Corporation		X

Examiner Signature	/Alessandro Amari/	Date Considered	05/14/2012
--------------------	--------------------	-----------------	------------

*EXAMINER: Initial if reference considered, whether or not citation is in conformance with MPEP 609. Draw line through citation if not in conformance and not considered. Include copy of this form with next communication to applicant. ¹ Applicant's unique citation designation number (optional). ² See Kinds Codes of USPTO Patent Documents at www.uspto.gov or MPEP 901.04. ³ Enter Office that issued the document, by the two-letter code (WIPO Standard ST.3). ⁴ For Japanese patent documents, the indication of the year of the reign of the Emperor must precede the serial number of the patent document. ⁵ Kind of document by the appropriate symbols as indicated on the document under WIPO Standard ST.16 if possible. ⁶ Applicant is to place a check mark here if English language Translation is attached. This collection of information is required by 37 CFR 1.97 and 1.98. The information is required to obtain or retain a benefit by the public which is to file (and by the USPTO to process) an application. Confidentiality is governed by 35 U.S.C. 122 and 37 CFR 1.14. This collection is estimated to take 2 hours to complete, including gathering, preparing, and submitting the completed application form to the USPTO. There will be no charge for this collection. Any comments on the amount of time you require to complete this form and/or suggestions for reducing this burden should be sent to the Chief Information Officer, U.S. Patent and Trademark Office, P.O. Box 1450, Alexandria, VA 22313-1450. DO NOT SEND FEES OR COMPLETED FORMS TO THIS ADDRESS. SEND TO: **AA/**

EAST Search History

EAST Search History (Prior Art)

Ref #	Hits	Search Query	DBs	Default Operator	Plurals	Time Stamp
S1	3511	(359/866,871,872).CCLS.	US-PGPUB; USPAT; USOCR; EPO; JPO; DERWENT	OR	OFF	2012/05/08 10:18
S2	217	(blind spot or spotting) mirror	US-PGPUB; USPAT; USOCR; EPO; JPO; DERWENT	ADJ	ON	2012/05/08 10:18
S3	3638	(blind spot or spotting or auxiliary) near2 mirror	US-PGPUB; USPAT; USOCR; EPO; JPO; DERWENT	ADJ	ON	2012/05/08 10:20
S4	3511	(359/866,871,872).CCLS.	US-PGPUB; USPAT; USOCR; EPO; JPO; DERWENT	OR	OFF	2012/05/08 10:20
S6	228	S3 and S4	US-PGPUB; USPAT; USOCR; EPO; JPO; DERWENT	ADJ	ON	2012/05/08 10:20
S8	4	((("8128243") or ("7934843") or ("7842154") or ("7420756"))).PN.	USPAT	OR	OFF	2012/05/08 10:22
S9	6483668	bracket or support	US-PGPUB; USPAT; USOCR; EPO; JPO; DERWENT	ADJ	ON	2012/05/08 10:22
S10	4	S8 and S9	US-PGPUB; USPAT; USOCR; EPO; JPO; DERWENT	ADJ	ON	2012/05/08 10:22
S11	193087	radius near1 curvature	US-PGPUB; USPAT; USOCR; EPO; JPO; DERWENT	ADJ	ON	2012/05/08 10:41

EAST Search History

S12	4	S8 and S11	US-PGPUB; USPAT; USOCR; EPO; JPO; DERWENT	ADJ	ON	2012/05/08 10:41
S13	2	("20020072026").PN.	US-PGPUB; USPAT; USOCR; EPO; JPO; DERWENT	OR	OFF	2012/05/14 11:28
S14	1270106	bracket	US-PGPUB; USPAT; USOCR; EPO; JPO; DERWENT	ADJ	ON	2012/05/14 11:28
S15	193226	radius near1 curvature	US-PGPUB; USPAT; USOCR; EPO; JPO; DERWENT	ADJ	ON	2012/05/14 11:28
S16	133491	field near1 view	US-PGPUB; USPAT; USOCR; EPO; JPO; DERWENT	ADJ	ON	2012/05/14 11:29
S17	1	S13 and S14	US-PGPUB; USPAT; USOCR; EPO; JPO; DERWENT	ADJ	ON	2012/05/14 11:29
S18	1	S13 and S15	US-PGPUB; USPAT; USOCR; EPO; JPO; DERWENT	ADJ	ON	2012/05/14 11:29
S19	2	S13 and S16	US-PGPUB; USPAT; USOCR; EPO; JPO; DERWENT	ADJ	ON	2012/05/14 11:31
S20	1910	field near1 view near3 overlap	US-PGPUB; USPAT; USOCR; EPO; JPO; DERWENT	ADJ	ON	2012/05/14 11:32
S21	1	S13 and S20	US-PGPUB; USPAT; USOCR; EPO; JPO; DERWENT	ADJ	ON	2012/05/14 11:32

EAST Search History

S22	238652	glass substrate	US-PGPUB; USPAT; USOCR; EPO; JPO; DERWENT	ADJ	ON	2012/05/14 11:38
S23	1	S13 and S22	US-PGPUB; USPAT; USOCR; EPO; JPO; DERWENT	ADJ	ON	2012/05/14 11:38
S24	14604	polymeric substrate	US-PGPUB; USPAT; USOCR; EPO; JPO; DERWENT	ADJ	ON	2012/05/14 11:38
S25	1	S13 and S24	US-PGPUB; USPAT; USOCR; EPO; JPO; DERWENT	ADJ	ON	2012/05/14 11:38
S26	7129	mirror support	US-PGPUB; USPAT; USOCR; EPO; JPO; DERWENT	ADJ	ON	2012/05/14 11:39
S27	0	S13 and S26	US-PGPUB; USPAT; USOCR; EPO; JPO; DERWENT	ADJ	ON	2012/05/14 11:39
S28	41148	backing plate	US-PGPUB; USPAT; USOCR; EPO; JPO; DERWENT	ADJ	ON	2012/05/14 11:39
S29	1	S13 and S28	US-PGPUB; USPAT; USOCR; EPO; JPO; DERWENT	ADJ	ON	2012/05/14 11:39
S30	3512	(359/866,871,872).OCLS.	US-PGPUB; USPAT; USOCR; EPO; JPO; DERWENT	OR	OFF	2012/05/14 11:42
S31	3639	(blind spot or spotting or auxiliary) near2 mirror	US-PGPUB; USPAT; USOCR; EPO; JPO; DERWENT	ADJ	ON	2012/05/14 11:43

EAST Search History

S32	228	S30 and S31	US-PGPUB; USPAT; USOCR; EPO; JPO; DERWENT	ADJ	ON	2012/05/14 11:43
S33	104	S16 and S32	US-PGPUB; USPAT; USOCR; EPO; JPO; DERWENT	ADJ	ON	2012/05/14 11:43
S34	8	S20 and S32	US-PGPUB; USPAT; USOCR; EPO; JPO; DERWENT	ADJ	ON	2012/05/14 11:43
S35	4	(US-20020072026-\$ or US-20040169942-\$).did. or (US-6522451-\$ or US-7097312-\$).did.	US-PGPUB; USPAT	ADJ	ON	2012/05/14 12:03
S36	3	S15 and S35	US-PGPUB; USPAT; USOCR; EPO; JPO; DERWENT	ADJ	ON	2012/05/14 12:04
S37	4543	(359/866,871,872,877).CCLS.	US-PGPUB; USPAT; USOCR; EPO; JPO; DERWENT	OR	OFF	2012/05/14 12:11
S38	262	S31 and S37	US-PGPUB; USPAT; USOCR; EPO; JPO; DERWENT	ADJ	ON	2012/05/14 12:12
S39	730057	radius near1 curvature or convex	US-PGPUB; USPAT; USOCR; EPO; JPO; DERWENT	ADJ	ON	2012/05/14 12:42
S40	8	(US-20020072026-\$ or US-20040169942-\$ or US-20020067557-\$).did. or (US-6522451-\$ or US-7097312-\$ or US-6270225-\$ or US-5579133-\$ or US-5153781-\$).did.	US-PGPUB; USPAT	ADJ	ON	2012/05/14 12:42
S41	7	S39 and S40	US-PGPUB; USPAT; USOCR; EPO; JPO; DERWENT	ADJ	ON	2012/05/14 12:42
S42	128	("1114559" "1672559" "2135262" "2514989" "2636419" "2778273" "2911177" "3131250" "3146296" "3170985" "3175463" "3267806"	US-PGPUB; USPAT; USOCR	ADJ	ON	2012/05/14 14:39

		"3337285" "3338655" "3375053" "3389952" "3404935" "3408136" "3424517" "3563638" "3601614" "3610739" "3667833" "3708222" "3764201" "3806232" "3826563" "3881811" "3909117" "4200359" "4223983" "4264144" "4268120" "4293191" "4303308" "4306770" "4311363" "4325609" "4350412" "4436372" "4439013" "4470665" "4526446" "4549786" "4575202" "4609266" "4629296" "4674849" "4674850" "4715701" "4733336" "4824231" "4828379" "4859046" "4906075" "4913542" "4917485" "4929074" "4932770" "4989964" "5005962" "5022747" "5033835" "5044739" "5050977" "5080492" "5115352" "5166833" "5237458" "5237459" "5295021" "5296973" "5424875" "5432643" "5517367" "5526195" "5557467" "5559640" "5563744" "5579133" "5594593" "5621569" "5644442" "5691855" "5784211" "5790327" "5793542" "5796532" "5805367" "5835294" "5838505" "5847889" "5980050" "6007207" "6030084" "6033078" "6074068" "6116743" "6199993" "6270225" "6315419" "6390632" "6522451" "6919796" "D297926" "RE17274").PN.				
S43	409	boddy.in.	US- PGPUB; USPAT; USOCR; EPO; JPO; DERWENT	ADJ	ON	2012/05/14 14:47
S44	1026404	mirror	US- PGPUB; USPAT; USOCR; EPO; JPO; DERWENT	ADJ	ON	2012/05/14 14:47
S45	125	S43 and S44	US- PGPUB; USPAT; USOCR; EPO; JPO; DERWENT	ADJ	ON	2012/05/14 14:47
S46	1053726	blind spot or blind zone or auxiliary	US- PGPUB; USPAT; USOCR; EPO; JPO; DERWENT	ADJ	ON	2012/05/14 14:48
S47	13	S45 and S46	US- PGPUB; USPAT; USOCR; EPO; JPO; DERWENT	ADJ	ON	2012/05/14 14:48

EAST Search History

S48	193226	radius near1 curvature	US-PGPUB; USPAT; USOCR; EPO; JPO; DERWENT	ADJ	ON	2012/05/14 14:49
S49	10	(US-20020072026-\$ or US-20040169942-\$ or US-20020067557-\$ or US-20040114262-\$).did. or (US-6522451-\$ or US-7097312-\$ or US-6270225-\$ or US-5579133-\$ or US-5153781-\$ or US-6919796-\$).did.	US-PGPUB; USPAT	ADJ	ON	2012/05/14 14:50
S50	3	S48 and S49	US-PGPUB; USPAT; USOCR; EPO; JPO; DERWENT	ADJ	ON	2012/05/14 14:50
S51	2	("8128243").PN.	US-PGPUB; USPAT; USOCR; EPO; JPO; DERWENT	OR	OFF	2012/05/14 15:07
S52	18405	forward near3 plane	US-PGPUB; USPAT; USOCR; EPO; JPO; DERWENT	ADJ	ON	2012/05/14 15:51
S53	0	S49 and S52	US-PGPUB; USPAT; USOCR; EPO; JPO; DERWENT	ADJ	ON	2012/05/14 15:51
S54	28443	forward near5 plane	US-PGPUB; USPAT; USOCR; EPO; JPO; DERWENT	ADJ	ON	2012/05/14 15:51
S55	0	S49 and S54	US-PGPUB; USPAT; USOCR; EPO; JPO; DERWENT	ADJ	ON	2012/05/14 15:51
S56	3082445	plane	US-PGPUB; USPAT; USOCR; EPO; JPO; DERWENT	ADJ	ON	2012/05/14 15:53
S57	4	S49 and S56	US-PGPUB; USPAT; USOCR; EPO; JPO; DERWENT	ADJ	ON	2012/05/14 15:53

EAST Search History

S58	1294947	downwardly	US-PGPUB; USPAT; USOCR; EPO; JPO; DERWENT	ADJ	ON	2012/05/14 15:58
S59	2	S49 and S58	US-PGPUB; USPAT; USOCR; EPO; JPO; DERWENT	ADJ	ON	2012/05/14 15:59
S60	2	("7097312").PN.	US-PGPUB; USPAT; USOCR; EPO; JPO; DERWENT	OR	OFF	2012/05/14 17:35
S61	238652	glass substrate	US-PGPUB; USPAT; USOCR; EPO; JPO; DERWENT	ADJ	ON	2012/05/14 17:35
S62	0	S60 and S61	US-PGPUB; USPAT; USOCR; EPO; JPO; DERWENT	ADJ	ON	2012/05/14 17:36
S63	2642848	glass	US-PGPUB; USPAT; USOCR; EPO; JPO; DERWENT	ADJ	ON	2012/05/14 17:36
S64	1	S60 and S63	US-PGPUB; USPAT; USOCR; EPO; JPO; DERWENT	ADJ	ON	2012/05/14 17:36
S65	4	((("7097312") or ("5579133")).PN.	US-PGPUB; USPAT; USOCR; EPO; JPO; DERWENT	OR	OFF	2012/05/14 17:39
S66	0	S61 and S65	US-PGPUB; USPAT; USOCR; EPO; JPO; DERWENT	ADJ	ON	2012/05/14 17:39
S67	2	S63 and S65	US-PGPUB; USPAT; USOCR; EPO; JPO; DERWENT	ADJ	ON	2012/05/14 17:39

EAST Search History

S68	2364388	reflect\$3	US-PGPUB; USPAT; USOCR; EPO; JPO; DERWENT	ADJ	ON	2012/05/14 17:40
S69	4	S65 and S68	US-PGPUB; USPAT; USOCR; EPO; JPO; DERWENT	ADJ	ON	2012/05/14 17:40
S70	2593099	coating	US-PGPUB; USPAT; USOCR; EPO; JPO; DERWENT	ADJ	ON	2012/05/14 17:41
S71	1	S65 and S70	US-PGPUB; USPAT; USOCR; EPO; JPO; DERWENT	ADJ	ON	2012/05/14 17:41
S72	4003375	polymer\$2	US-PGPUB; USPAT; USOCR; EPO; JPO; DERWENT	ADJ	ON	2012/05/14 17:43
S73	0	S65 and S72	US-PGPUB; USPAT; USOCR; EPO; JPO; DERWENT	ADJ	ON	2012/05/14 17:43
S74	2419160	downward\$2	US-PGPUB; USPAT; USOCR; EPO; JPO; DERWENT	ADJ	ON	2012/05/15 09:29
S75	217	(blind spot or spotting) mirror	US-PGPUB; USPAT; USOCR; EPO; JPO; DERWENT	ADJ	ON	2012/05/15 09:29
S76	4543	(359/866,871,872,877).CCLS.	US-PGPUB; USPAT; USOCR; EPO; JPO; DERWENT	OR	OFF	2012/05/15 09:29
S77	10	S74 and S75 and S76	US-PGPUB; USPAT; USOCR; EPO; JPO; DERWENT	ADJ	ON	2012/05/15 09:29

S78	188	polymer\$2 substrate with (reflect\$3 (layer or coating))	US-PGPUB; USPAT; USOCR; EPO; JPO; DERWENT	ADJ	ON	2012/05/15 09:36
S79	1	S75 and S78	US-PGPUB; USPAT; USOCR; EPO; JPO; DERWENT	ADJ	ON	2012/05/15 09:36
S80	5	S76 and S78	US-PGPUB; USPAT; USOCR; EPO; JPO; DERWENT	ADJ	ON	2012/05/15 09:36
S81	9372	rearview mirror	US-PGPUB; USPAT; USOCR; EPO; JPO; DERWENT	ADJ	ON	2012/05/15 09:37
S82	17	S78 and S81	US-PGPUB; USPAT; USOCR; EPO; JPO; DERWENT	ADJ	ON	2012/05/15 09:37
S83	5631	polymer\$2 with (reflect\$3 (layer or coating))	US-PGPUB; USPAT; USOCR; EPO; JPO; DERWENT	ADJ	ON	2012/05/15 09:38
S84	15	S75 and S83	US-PGPUB; USPAT; USOCR; EPO; JPO; DERWENT	ADJ	ON	2012/05/15 09:38
S85	15	S76 and S83	US-PGPUB; USPAT; USOCR; EPO; JPO; DERWENT	ADJ	ON	2012/05/15 09:39
S86	96	S81 and S83	US-PGPUB; USPAT; USOCR; EPO; JPO; DERWENT	ADJ	ON	2012/05/15 09:40

EAST Search History (Interference)

<This search history is empty>

5/ 15/ 2012 10:31:41 AM**C:\Users\ aamari\ Documents\ EAST\ Workspaces\ 13336018.wsp**

Index of Claims 	Application/Control No. 13336018	Applicant(s)/Patent Under Reexamination LYNAM, NIAL R.
	Examiner ALESSANDRO AMARI	Art Unit 2872

✓	Rejected
=	Allowed

-	Cancelled
÷	Restricted

N	Non-Elected
I	Interference

A	Appeal
O	Objected

Claims renumbered in the same order as presented by applicant
 CPA
 T.D.
 R.1.47

CLAIM		DATE							
Final	Original	03/08/2012	05/15/2012						
	1	+	✓						
	2	+	✓						
	3	+	✓						
	4	+	✓						
	5	+	✓						
	6	+	✓						
	7	-	-						
	8	-	-						
	9	-	-						
	10	-	-						
	11	-	-						
	12	-	-						
	13	-	-						
	14	-	-						
	15	-	-						
	16	+	N						
	17	+	N						
	18	+	N						
	19	+	✓						
	20	+	✓						
	21	+	✓						
	22	+	✓						
	23	+	✓						
	24	+	✓						
	25	+	N						
	26	+	N						
	27	+	N						
	28	+	✓						
	29	+	✓						
	30	+	✓						
	31	+	✓						
	32	+	✓						
	33	+	✓						
	34	+	✓						
	35	+	✓						
	36	+	N						

<i>Index of Claims</i> 	Application/Control No. 13336018	Applicant(s)/Patent Under Reexamination LYNAM, NIAL R.
	Examiner ALESSANDRO AMARI	Art Unit 2872

✓	Rejected
=	Allowed

-	Cancelled
÷	Restricted

N	Non-Elected
I	Interference

A	Appeal
O	Objected

Claims renumbered in the same order as presented by applicant
 CPA
 T.D.
 R.1.47

CLAIM		DATE							
Final	Original	03/08/2012	05/15/2012						
	37	+	N						
	38	+	N						
	39	+	N						
	40	+	N						

UNITED STATES PATENT AND TRADEMARK OFFICE

UNITED STATES DEPARTMENT OF COMMERCE
United States Patent and Trademark Office
 Address: COMMISSIONER FOR PATENTS
 P.O. Box 1450
 Alexandria, Virginia 22313-1450
 www.uspto.gov

BIB DATA SHEET
CONFIRMATION NO. 7833

SERIAL NUMBER	FILING or 371(c) DATE	CLASS	GROUP ART UNIT	ATTORNEY DOCKET NO.		
13/336,018	12/23/2011	359	2872	DON09 P-1800		
APPLICANTS Niall R. Lynam, Holland, MI;						
** CONTINUING DATA ***** This application is a CON of 12/911,274 10/25/2010 PAT 8,128,243 which is a CON of 12/851,045 08/05/2010 PAT 7,934,843 which is a CON of 12/197,666 08/25/2008 PAT 7,842,154 which is a DIV of 10/709,434 05/05/2004 PAT 7,420,756 which claims benefit of 60/471,872 05/20/2003						
** FOREIGN APPLICATIONS *****						
** IF REQUIRED, FOREIGN FILING LICENSE GRANTED ** 01/09/2012						
Foreign Priority claimed	<input type="checkbox"/> Yes <input checked="" type="checkbox"/> No	<input type="checkbox"/> Met after Allowance	STATE OR COUNTRY	SHEETS DRAWINGS	TOTAL CLAIMS	INDEPENDENT CLAIMS
35 USC 119(a-d) conditions met	<input type="checkbox"/> Yes <input type="checkbox"/> No		MI	16	18	3
Verified and	/ALESSANDRO V AMARI/ Examiner's Signature	Initials				
Acknowledged						
ADDRESS Gardner, Linn, Burkhart & Flory, LLP 2851 Charlevoix Dr. SE, Suite 207 Grand Rapids, MI 49546 UNITED STATES						
TITLE EXTERIOR REARVIEW MIRROR ASSEMBLY						
FILING FEE RECEIVED 2660	FEES: Authority has been given in Paper No. _____ to charge/credit DEPOSIT ACCOUNT No. _____ for following:			<input type="checkbox"/> All Fees <input type="checkbox"/> 1.16 Fees (Filing) <input type="checkbox"/> 1.17 Fees (Processing Ext. of time) <input type="checkbox"/> 1.18 Fees (Issue) <input type="checkbox"/> Other _____ <input type="checkbox"/> Credit		

IN THE UNITED STATES PATENT AND TRADEMARK OFFICE

Group Art : 2872
Examiner : Alessandro V. Amari
Applicant : Niall R. Lynam
Serial No. : 13/336,018
Filing Date : December 23, 2011
For : EXTERIOR SIDEVIEW MIRROR SYSTEM

Mail Stop Amendment
Commissioner for Patents
P.O. Box 1450
Alexandria, VA 22313-1450

Dear Sir:

REQUEST FOR RECONSIDERATION

Responsive to the Office Action mailed May 17, 2012, Applicant wishes to submit the following:

Amendments to the Specification begin on page 2 of this paper.

Amendments to the Claims are reflected in the listing of claims which begins on page 3 of this paper.

Remarks begin on page 8 of this paper.

A **Terminal Disclaimer** is attached.

A **Declaration** under Rule 131(a) is attached.

Applicant : Niall R. Lynam
Serial No. : 13/336,018
Page : 2

Amendments to the Specification:

Please amend paragraph [0001] on page 1 as follows:

[0045] The present application is a continuation of U.S. patent application Ser. No. 12/911,274, filed Oct. 25, 2010, now U.S. Pat. No. 8,128,243 (~~Attorney Docket DON09-P-1651~~), which is a continuation of U.S. patent application Ser. No. 12/851,045, filed Aug. 5, 2010, now U.S. Pat. No. 7,934,843, which is a continuation of U.S. patent application Ser. No. 12/197,666, filed Aug. 25, 2008, now U.S. Pat. No. 7,842,154, which is a division of U.S. patent application Ser. No. 10/709,434, filed May 5, 2004, now U.S. Pat. No. 7,420,756, which claims the benefit of U.S. provisional application, Ser. No. 60/471,872, filed May 20, 2003, which are hereby incorporated herein by reference in their entireties.

Applicant : Niall R. Lynam
Serial No. : 13/336,018
Page : 3

Amendments to the Claims:

This listing of claims will replace all prior versions and listings of claims in the present application:

1 (original): An exterior rearview mirror assembly for a motor vehicle, said exterior rearview mirror assembly comprising:

a bracket fixedly secured to the motor vehicle;

a mirror casing secured to said bracket, said mirror casing defining a primary opening;

a single mirror support movably secured within said mirror casing disposed adjacent said primary opening;

a primary mirror fixedly secured to said single mirror support and disposed within said primary opening for providing a view rearward of the motor vehicle through a primary field of view; and

a spotting mirror fixedly secured to said single mirror support and disposed adjacent said primary mirror, said spotting mirror defined by a single radius of curvature differing from said primary mirror such that said spotting mirror provides a second field of view rearward of the motor vehicle, such that said first field of view of said primary mirror overlaps said second field of view of said spotting mirror.

2 (original): An exterior rearview mirror assembly as set forth in claim 1 wherein said single mirror support defines a primary portion for having said primary mirror fixedly secured thereto and a spotting portion for having said spotting mirror fixedly secured thereto.

3 (original): An exterior rearview mirror assembly as set forth in claim 2 wherein said primary portion of said single mirror support defines a primary plane that is substantially flat.

Applicant : Niall R. Lynam
Serial No. : 13/336,018
Page : 4

4 (original): An exterior rearview mirror assembly as set forth in claim 3 wherein said spotting portion of said single mirror support defines a spotting mirror support radius of curvature substantially equal to said single radius of curvature.

5 (original): An exterior rearview mirror assembly as set forth in claim 4 wherein said spotting portion is forward of said primary plane.

6 (original): An exterior rearview mirror assembly as set forth in claim 4 wherein said spotting portion is substantially rearward of said primary plane.

7-18 (canceled).

19 (previously presented): An exterior rearview mirror assembly for a motor vehicle, said exterior rearview mirror assembly comprising:

- a bracket fixedly secured to the motor vehicle;

- a mirror casing secured to said bracket, said mirror casing defining a primary opening;

- a single mirror support movably secured within said mirror casing disposed adjacent said primary opening;

- a primary mirror fixedly secured to said single mirror support and disposed within said primary opening for providing a view rearward of the motor vehicle through a primary field of view;

- a spotting mirror fixedly secured to said single mirror support and disposed adjacent said primary mirror, said spotting mirror defined by a single radius of curvature differing from said primary mirror such that said spotting mirror provides a second field of view rearward of the motor vehicle, such that said primary field of view of said primary mirror overlaps said second field of view of said spotting mirror; and

- wherein said primary mirror comprises one of (a) a generally flat glass substrate having a surface coated with a metallic reflector coating and (b) a generally flat polymeric substrate

Applicant : Niall R. Lynam
Serial No. : 13/336,018
Page : 5

having a thin glass element applied to a surface thereof and with an opposing surface thereof having a reflecting layer applied thereto.

20 (previously presented): An exterior rearview mirror assembly as set forth in claim 19 wherein said single mirror support defines a primary portion for having said primary mirror fixedly secured thereto and a spotting portion for having said spotting mirror fixedly secured thereto.

21 (previously presented): An exterior rearview mirror assembly as set forth in claim 20 wherein said primary portion of said single mirror support defines a primary plane that is substantially flat.

22 (previously presented): An exterior rearview mirror assembly as set forth in claim 21 wherein said spotting portion of said single mirror support defines a spotting mirror support radius of curvature substantially equal to said single radius of curvature.

23 (previously presented): An exterior rearview mirror assembly as set forth in claim 22 wherein said spotting portion is forward of said primary plane.

24 (previously presented): An exterior rearview mirror assembly as set forth in claim 22 wherein said spotting portion is substantially rearward of said primary plane.

25-27 (canceled).

28 (previously presented): An exterior rearview mirror assembly for a motor vehicle, said exterior rearview mirror assembly comprising:

a bracket fixedly secured to the motor vehicle;

a mirror casing secured to said bracket, said mirror casing defining a primary opening;

Applicant : Niall R. Lynam
Serial No. : 13/336,018
Page : 6

a single mirror support movably secured within said mirror casing disposed adjacent said primary opening;

a primary mirror fixedly secured to said single mirror support and disposed within said primary opening for providing a view rearward of the motor vehicle through a primary field of view;

a spotting mirror fixedly secured to said single mirror support and disposed adjacent said primary mirror, said spotting mirror defined by a single radius of curvature differing from said primary mirror such that said spotting mirror provides a second field of view rearward of the motor vehicle, such that said primary field of view of said primary mirror overlaps said second field of view of said spotting mirror;

wherein said spotting mirror is at an angle relative to said primary mirror; and

wherein said primary mirror comprises one of (a) a generally flat glass substrate having a surface coated with a metallic reflector coating and (b) a generally flat polymeric substrate having a thin glass element applied to a surface thereof and with an opposing surface thereof having a reflecting layer applied thereto.

29 (previously presented): An exterior rearview mirror assembly as set forth in claim 28 wherein said single mirror support defines a primary portion for having said primary mirror fixedly secured thereto and a spotting portion for having said spotting mirror fixedly secured thereto.

30 (previously presented): An exterior rearview mirror assembly as set forth in claim 29 wherein said primary portion of said single mirror support defines a primary plane that is substantially flat.

31 (previously presented): An exterior rearview mirror assembly as set forth in claim 30 wherein said spotting portion of said single mirror support defines a spotting mirror support radius of curvature substantially equal to said single radius of curvature.

Applicant : Niall R. Lynam
Serial No. : 13/336,018
Page : 7

32 (previously presented): An exterior rearview mirror assembly as set forth in claim 31 wherein said spotting portion is forward of said primary plane.

33 (previously presented): An exterior rearview mirror assembly as set forth in claim 31 wherein said spotting portion is substantially rearward of said primary plane.

34 (previously presented): An exterior rearview mirror assembly as set forth in claim 28, wherein the second field of view of said spotting mirror is generally directed at least one of outwardly and downwardly with respect to the longitudinal axis of the motor vehicle when said exterior rearview mirror assembly is attached to the motor vehicle.

35 (previously presented): An exterior rearview mirror assembly as set forth in claim 28, wherein said spotting mirror is at an angle of at least about three degrees relative to said primary mirror.

36-40 (canceled).

Applicant : Niall R. Lynam
Serial No. : 13/336,018
Page : 8

Remarks:

The amendments and remarks presented herein are believed to be fully responsive to the Office Action dated May 17, 2012.

Claims 1-6, 19-24 and 28-35 are pending in the application. Claims 16-18, 25-27 and 36-40 were withdrawn from consideration as being directed towards a non-elected invention. Applicants have canceled claims 16-18, 25-27 and 36-40 without prejudice so the subject matter of those claims can be pursued in a divisional application in the future. The specification has been amended to update an incorporated parent patent application which has now issued as a United States patent. No new matter has been added.

Claim Rejections Under 35 U.S.C. §102:

Claims 1-6, 19-24 and 28-35 were rejected under 35 U.S.C. §102(e) as being anticipated by Lynam, U.S. Publication No. US 2002/0072026 ("Lynam '026"). Applicant respectfully traverses. Claims 1-6 were also rejected under 35 U.S.C. §103(a) as being unpatentable over Platzer, Jr., U.S. Patent No. 7,097,312, in view of Black et al., U.S. Patent No. 5,579,133, while claims 19-24, 28-33 and 35 were also rejected under 35 U.S.C. §103(a) as being unpatentable over Platzer, in view of Black and further in view of Richard, U.S. Patent No. 6,409,354, and claim 34 was also rejected under 35 U.S.C. §103(a) as being unpatentable over Platzer, in view of Black and further in view of Richard, and further in view of Hensley, U.S. Patent No. 2,279,751.

Lynam '026 is not prior art to the present claims:

Applicant submits that Lynam '026 is not prior art to the present claims under 35 U.S.C. §102(e). Lynam '026 published June 13, 2002, and, as discussed below, the present application has an effective filing date of May 20, 2003 (the filing date of U.S. provisional application 60/471,872). Thus, Lynam '026 published prior to the priority date of the presently claimed invention and Lynam '026 cannot be cited as prior art under 35 U.S.C. §102(e).

Applicant : Niall R. Lynam
Serial No. : 13/336,018
Page : 9

Also, because the present application has a priority date of May 20, 2003 that is less than one year after the publication date of Lynam '026 (June 13, 2002), and because (as discussed below) Applicant conceived and reduced to practice the invention claimed in at least the independent claims prior to the effective date of Lynam '026, Applicant respectfully submits that Lynam '026 is also not prior art under 35 U.S.C. §102(a).

The present application is a continuation of U.S. patent application Ser. No. 12/911,274, filed October 25, 2010, now U.S. Patent No. 8,128,243, which is a continuation of U.S. patent application Ser. No. 12/851,045, filed August 5, 2010, now U.S. Patent No. 7,934,843, which is a continuation of U.S. patent application Serial No. 12/197,666, filed August 25, 2008, now U.S. Patent No. 7,842,154, which is a division of U.S. patent application Serial No. 10/709,434, filed May 5, 2004, now U.S. Patent No. 7,420,756, which claims the benefit of U.S. provisional application, Serial No. 60/471,872, filed May 20, 2003.

The present application incorporates by reference U.S. Patent Nos. 6,522,451 and 6,717,712. See, for example, paragraph [0045] on page 6 of the present application (reproduced below).

[0045] Reflective element 12 may comprise an aspheric or multi-radius or wide angle single element reflective element substrate. The reflective element 12 may provide a field of view similar to the plano-auxiliary reflective element assembly disclosed in U.S. Pat. Nos. 6,522,451 and 6,717,712, which are hereby incorporated herein by reference.

With respect to the priority provisional application Serial No. 60/471,872, this application similarly incorporates by reference U.S. Patent No. 6,522,451 and U.S. patent application Serial No. 09/745,172, filed December 20, 2000. U.S. patent application Serial No. 09/745,172 issued as U.S. Patent No. 6,717,712. Thus, the present application and each of the priority applications incorporate by reference the same disclosures.

With respect to the rejection in view of Lynam '026, and in accordance with 37 CFR 1.131, Applicant submits herewith a Declaration which declares that the invention claimed in at

Applicant : Niall R. Lynam
Serial No. : 13/336,018
Page : 10

least independent claims 1, 19 and 28 was invented by Applicant prior to the publication date of Lynam '026, namely, June 13, 2002. The specification and drawings (Exhibit A) of U.S. patent application Serial No. 09/478,315, which was filed on January 6, 2000 by Niall R. Lynam (the sole named inventor of the present application), along with U.S. Patent No. 6,522,451 (Exhibit B), which issued to Lynam from U.S. patent application Serial No. 09/478,315, are submitted with the Declaration as corroborative evidence that the present invention was reduced to practice prior to the Lynam '026 publication date of June 13, 2002 (and prior to the December 20, 2000 filing date of the application that published as Lynam '026). The Declaration is signed by the named inventor (Niall R. Lynam) for the present application. The attached specification and drawings of Exhibits A and B clearly corroborate that the inventions claimed in at least independent claims 1, 19 and 28 were reduced to practice well prior to June 13, 2002, the publication date of Lynam '026, and prior to December 20, 2000, the filing date of the application that published as Lynam '026.

Accordingly, the rejection of claims 1-6, 19-24 and 28-34 under §102(e) in view of Lynam '026 is obviated, and reconsideration and withdrawal of this rejection is respectfully requested.

Platzer is not prior art to the present claims:

Applicant also submits that Platzer is not prior art to the present claims. Platzer was filed February 23, 2004, and has a priority claim to U.S. provisional application Serial No. 60/449,370, filed on February 21, 2003. Because the May 20, 2003 priority date of the present application is within one year of the February 21, 2003 priority date of Platzer, and because (as discussed above) Applicant conceived and reduced to practice the invention claimed in at least the independent claims prior to the February 21, 2003 priority date of Platzer, Applicant respectfully submits that Platzer is not prior art to the present claims under 35 U.S.C. §102 or §103.

Applicant : Niall R. Lynam
Serial No. : 13/336,018
Page : 11

The specification and drawings (Exhibit A) of U.S. patent application Serial No. 09/478,315, which was filed on January 6, 2000 by Niall R. Lynam (the sole named inventor of the present application), along with U.S. Patent No. 6,522,451 (Exhibit B), which issued to Lynam from U.S. patent application Serial No. 09/478,315, are submitted with the Declaration as corroborative evidence that the present invention was reduced to practice prior to the Platzer priority date of February 21, 2003. The attached Declaration and the attached specification and drawings of Exhibits A and B clearly corroborate that the inventions claimed in at least independent claims 1, 19 and 28 were reduced to practice well prior to February 21, 2003, the earliest priority date of the application that issued as Platzer. Applicant notes that, because Applicant's prior invention predates the February 21, 2003 priority date of Platzer, Applicant need not address whether or not Platzer's priority provisional application discloses the same or similar subject matter as the cited Platzer patent.

Accordingly, the rejections of claims 1-6, 19-24 and 28-34 under §103(a) in view of Platzer (either alone or in combination with Black and/or any other prior art of record) are obviated, and reconsideration and withdrawal of these rejections is respectfully requested.

Double Patenting Rejection:

Claims 1-6, 19-24 and 28-34 were rejected under the judicially created doctrine of obviousness-type double patenting as being unpatentable over claims 1, 6, 10, 13, 15, 16 and 24 of U.S. Patent No. 8,128,243. Enclosed herewith is a Terminal Disclaimer with respect to U.S. Patent No. 8,128,243. The basis for the double-patenting rejection is obviated. Accordingly, withdrawal of the rejection of claims 1-6, 19-24 and 28-34 is respectfully requested.

Please charge Account No. 50-5553 for the \$160 terminal disclaimer fee due and for any additional fees which may be due.

Applicant : Niall R. Lynam
Serial No. : 13/336,018
Page : 12

Claims 1-6, 19-24 and 28-35 are pending in the application. Applicant respectfully submits that claims 1-6, 19-24 and 28-35 are in condition for allowance and a notice to that effect is earnestly and respectfully requested.

Respectfully submitted,

NIALL R. LYNAM

By: Gardner, Linn, Burkhart & Flory, LLP

Date: May 21, 2012.

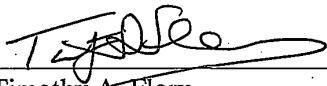

Timothy A. Flory
Registration No. 42 540
2851 Charlevoix Drive, S.E., Suite 207
P.O. Box 888695
Grand Rapids, Michigan 49588-8695
(616) 975-5500

IN THE UNITED STATES PATENT AND TRADEMARK OFFICE

Group Art : 2872
Examiner : Alessandro V. Amari
Applicant : Niall R. Lynam
Serial No. : 13/336,018
Filing Date : December 23, 2011
For : EXTERIOR SIDEVIEW MIRROR SYSTEM

Mail Stop Amendment
Commissioner for Patents
Washington, D.C. 20231

DECLARATION UNDER RULE 131(a)

Niall R. Lynam, the inventor and Applicant in the above referenced patent application,
declares as follows:

1. Prior to June 13, 2002, the inventor and Applicant conceived of the claimed invention of at least the independent claims as filed in the present application. For example, and with reference to claim 1 of the present application, the inventor and Applicant conceived of an exterior rearview mirror assembly comprising:
 - a. a bracket fixedly secured to the motor vehicle;
 - b. a mirror casing secured to said bracket, said mirror casing defining a primary opening;
 - c. a single mirror support movably secured within said mirror casing disposed adjacent said primary opening;
 - d. a primary mirror fixedly secured to said single mirror support and disposed within said primary opening for providing a view rearward of the motor vehicle through a primary field of view; and
 - e. a spotting mirror fixedly secured to said single mirror support and disposed adjacent said primary mirror, said spotting mirror defined by a single radius of curvature differing from said primary mirror such that said spotting mirror provides a second field of view rearward of the motor vehicle, such

Applicant : Niall R. Lynam
Serial No. : 13/336,018
Page : 2

that said first field of view of said primary mirror overlaps said second field of view of said spotting mirror.

2. The invention of at least the independent claims of the present application was reduced to practice sometime prior to June 13, 2002, as evidenced by the attached specification and drawings (Exhibit A), which were filed with the United States Patent and Trademark Office on January 6, 2000 by Niall R. Lynam, and assigned Serial No. 09/478,315, as evidenced by the attached U.S. Patent No. 6,522,451 (Exhibit B), which issued February 18, 2003 from the 09/478,315 application.
3. I am the sole named inventor of U.S. patent application Serial No. 13/336,018 (the present application) and I am the sole named inventor of U.S. patent application Serial No. 09/478,315 (Exhibit A), which issued as U.S. Patent No. 6,522,451 (Exhibit B).

I hereby declare that all activities relating to the conception and reduction to practice of the above invention occurred in the United States.

I hereby declare that all statements made herein of my own knowledge are true and that all statements made on information and belief are believed to be true; and further, that the statements are made with the knowledge that willful false statements and the like so made are punishable by fine or imprisonment or both, as set forth under section 1001, title 18, of the United States Code, and that such willful false statements may jeopardize the validity of the application or any patent issuing thereon.

Inventor:

Date:



Niall R. Lynam

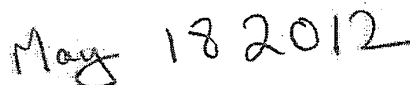

May 18 2012

Under the Paperwork Reduction Act of 1995, no persons are required to respond to a collection of information unless it displays a valid OMB control number.

TERMINAL DISCLAIMER TO OBTAIN A DOUBLE PATENTING REJECTION OVER A "PRIOR" PATENT	Docket Number (Optional) DON09 P-1800
---	--

In re Application of: Niall R. Lynam
Application No.: 13/336,018
Filed: December 23, 2011
For: EXTERIOR SIDEVIEW MIRROR SYSTEM

The owner*, Donnelly Corporation, of 100 percent interest in the instant application hereby disclaims, except as provided below, the terminal part of the statutory term of any patent granted on the instant application which would extend beyond the expiration date of the full statutory term of **prior patent** No. 8,128,243 as the term of said **prior patent** is presently shortened by any terminal disclaimer. The owner hereby agrees that any patent so granted on the instant application shall be enforceable only for and during such period that it and the **prior patent** are commonly owned. This agreement runs with any patent granted on the instant application and is binding upon the grantee, its successors or assigns.

In making the above disclaimer, the owner does not disclaim the terminal part of the term of any patent granted on the instant application that would extend to the expiration date of the full statutory term of the **prior patent**, "as the term of said **prior patent** is presently shortened by any terminal disclaimer," in the event that said **prior patent** later:
expires for failure to pay a maintenance fee;
is held unenforceable;
is found invalid by a court of competent jurisdiction;
is statutorily disclaimed in whole or terminally disclaimed under 37 CFR 1.321;
has all claims canceled by a reexamination certificate;
is reissued; or
is in any manner terminated prior to the expiration of its full statutory term as presently shortened by any terminal disclaimer.

Check either box 1 or 2 below, if appropriate.

1. For submissions on behalf of a business/organization (e.g., corporation, partnership, university, government agency, etc.), the undersigned is empowered to act on behalf of the business/organization.

I hereby declare that all statements made herein of my own knowledge are true and that all statements made on information and belief are believed to be true; and further that these statements were made with the knowledge that willful false statements and the like so made are punishable by fine or imprisonment, or both, under Section 1001 of Title 18 of the United States Code and that such willful false statements may jeopardize the validity of the application or any patent issued thereon.

2. The undersigned is an attorney or agent of record. Reg. No. 42540

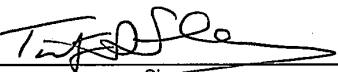

Signature

May 21, 2012
Date

Timothy A. Flory
Typed or printed name

616-975-5500
Telephone Number

- Terminal disclaimer fee under 37 CFR 1.20(d) included.

WARNING: Information on this form may become public. Credit card information should not be included on this form. Provide credit card information and authorization on PTO-2038.

*Statement under 37 CFR 3.73(b) is required if terminal disclaimer is signed by the assignee (owner).
Form PTO/SB/96 may be used for making this certification. See MPEP § 324.

This collection of information is required by 37 CFR 1.321. The information is required to obtain or retain a benefit by the public which is to file (and by the USPTO to process) an application. Confidentiality is governed by 35 U.S.C. 122 and 37 CFR 1.11 and 1.14. This collection is estimated to take 12 minutes to complete, including gathering, preparing, and submitting the completed application form to the USPTO. Time will vary depending upon the individual case. Any comments on the amount of time you require to complete this form and/or suggestions for reducing this burden, should be sent to the Chief Information Officer, U.S. Patent and Trademark Office, U.S. Department of Commerce, P.O. Box 1450, Alexandria, VA 22313-1450. DO NOT SEND FEES OR COMPLETED FORMS TO THIS ADDRESS. SEND TO: Commissioner for Patents, P.O. Box 1450, Alexandria, VA 22313-1450.

If you need assistance in completing the form, call 1-800-PTO-9199 and select option 2.

Electronic Patent Application Fee Transmittal				
Application Number:	13336018			
Filing Date:	23-Dec-2011			
Title of Invention:	EXTERIOR REARVIEW MIRROR ASSEMBLY			
First Named Inventor/Applicant Name:	Niall R. Lynam			
Filer:	Timothy A. Flory/Amanda Sytsma			
Attorney Docket Number:	DON09 P-1800			
Filed as Large Entity				
Utility under 35 USC 111 (a) Filing Fees				
Description	Fee Code	Quantity	Amount	Sub-Total in USD(\$)
Basic Filing:				
Pages:				
Claims:				
Miscellaneous-Filing:				
Petition:				
Patent-Appeals-and-Interference:				
Post-Allowance-and-Post-Issuance:				
Extension-of-Time:				

Description	Fee Code	Quantity	Amount	Sub-Total in USD(\$)
Miscellaneous:				
Statutory or terminal disclaimer	1814	1	160	160
Total in USD (\$)				160

Electronic Acknowledgement Receipt

EFS ID:	12823484
Application Number:	13336018
International Application Number:	
Confirmation Number:	7833
Title of Invention:	EXTERIOR REARVIEW MIRROR ASSEMBLY
First Named Inventor/Applicant Name:	Niall R. Lynam
Customer Number:	15671
Filer:	Timothy A. Flory/Amanda Sytsma
Filer Authorized By:	Timothy A. Flory
Attorney Docket Number:	DON09 P-1800
Receipt Date:	21-MAY-2012
Filing Date:	23-DEC-2011
Time Stamp:	14:28:05
Application Type:	Utility under 35 USC 111(a)

Payment information:

Submitted with Payment	yes
Payment Type	Credit Card
Payment was successfully received in RAM	\$ 160
RAM confirmation Number	806
Deposit Account	
Authorized User	

File Listing:

Document Number	Document Description	File Name	File Size(Bytes)/ Message Digest	Multi Part /.zip	Pages (if appl.)
-----------------	----------------------	-----------	-------------------------------------	------------------	------------------

1	Transmittal Letter	TransmittalForm.pdf	63637 eca6ac5c0f6016693882d5921f675536306c42a1	no	1
Warnings:					
Information:					
2	Amendment/Req. Reconsideration-After Non-Final Reject	ResponseA.pdf	469045 1f347653b75683a4c0c976c75e91d00b1a3ea9a3	no	12
Warnings:					
Information:					
3	Rule 130, 131 or 132 Affidavits	DeclarationunderRule131a.pdf	86177 b0bb94d2a463beddf46dd23d3c3d47af2991564b	no	2
Warnings:					
Information:					
4	Terminal Disclaimer Filed	TerminalDisclaimer.pdf	74452 3112915c4516fb00945967710b013e60f1e7948	no	1
Warnings:					
Information:					
5	Fee Worksheet (SB06)	fee-info.pdf	30101 b59ea757ab1cc08252f53cc3403635309f2655e	no	2
Warnings:					
Information:					
Total Files Size (in bytes):			723412		
<p>This Acknowledgement Receipt evidences receipt on the noted date by the USPTO of the indicated documents, characterized by the applicant, and including page counts, where applicable. It serves as evidence of receipt similar to a Post Card, as described in MPEP 503.</p> <p><u>New Applications Under 35 U.S.C. 111</u> If a new application is being filed and the application includes the necessary components for a filing date (see 37 CFR 1.53(b)-(d) and MPEP 506), a Filing Receipt (37 CFR 1.54) will be issued in due course and the date shown on this Acknowledgement Receipt will establish the filing date of the application.</p> <p><u>National Stage of an International Application under 35 U.S.C. 371</u> If a timely submission to enter the national stage of an international application is compliant with the conditions of 35 U.S.C. 371 and other applicable requirements a Form PCT/DO/EO/903 indicating acceptance of the application as a national stage submission under 35 U.S.C. 371 will be issued in addition to the Filing Receipt, in due course.</p> <p><u>New International Application Filed with the USPTO as a Receiving Office</u> If a new international application is being filed and the international application includes the necessary components for an international filing date (see PCT Article 11 and MPEP 1810), a Notification of the International Application Number and of the International Filing Date (Form PCT/RO/105) will be issued in due course, subject to prescriptions concerning national security, and the date shown on this Acknowledgement Receipt will establish the international filing date of the application.</p>					

Doc Code: TRAN.LET

Document Description: Transmittal Letter

PTO/SB/21 (07-09)
Approved for use through 07/31/2012. OMB 0651-0031
U.S. Patent and Trademark Office; U.S. DEPARTMENT OF COMMERCE

Under the Paperwork Reduction Act of 1995, no persons are required to respond to a collection of information unless it displays a valid OMB control number.

TRANSMITTAL FORM <i>(to be used for all correspondence after initial filing)</i>	Application Number	13/336,018
	Filing Date	December 23, 2011
	First Named Inventor	Niall R. Lynam
	Art Unit	2872
	Examiner Name	Alessandro V. Amari
Total Number of Pages in This Submission	Attorney Docket Number	DON09 P-1800

ENCLOSURES (Check all that apply)		
<input type="checkbox"/> Fee Transmittal Form	<input type="checkbox"/> Drawing(s)	<input type="checkbox"/> After Allowance Communication to TC
<input type="checkbox"/> Fee Attached	<input type="checkbox"/> Licensing-related Papers	<input type="checkbox"/> Appeal Communication to Board of Appeals and Interferences
<input checked="" type="checkbox"/> Amendment/Reply	<input type="checkbox"/> Petition	<input type="checkbox"/> Appeal Communication to TC (Appeal Notice, Brief, Reply Brief)
<input type="checkbox"/> After Final	<input type="checkbox"/> Petition to Convert to a Provisional Application	<input type="checkbox"/> Proprietary Information
<input type="checkbox"/> Affidavits/declaration(s)	<input type="checkbox"/> Power of Attorney, Revocation Change of Correspondence Address	<input type="checkbox"/> Status Letter
<input type="checkbox"/> Extension of Time Request	<input checked="" type="checkbox"/> Terminal Disclaimer	<input checked="" type="checkbox"/> Other Enclosure(s) (please identify below): -Declaration under Rule 131(a)
<input type="checkbox"/> Express Abandonment Request	<input type="checkbox"/> Request for Refund	
<input type="checkbox"/> Information Disclosure Statement	<input type="checkbox"/> CD, Number of CD(s) _____	
<input type="checkbox"/> Certified Copy of Priority Document(s)	<input type="checkbox"/> Landscape Table on CD	
<input type="checkbox"/> Reply to Missing Parts/ Incomplete Application	Remarks	
<input type="checkbox"/> Reply to Missing Parts under 37 CFR 1.52 or 1.53		

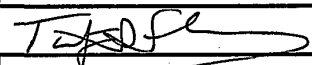
SIGNATURE OF APPLICANT, ATTORNEY, OR AGENT			
Firm Name	GARDNER, LINN, BURKHART & FLORY, LLP		
Signature			
Printed name	Timothy A. Flory		
Date	May 21, 2012	Reg. No.	42540

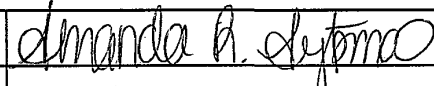
CERTIFICATE OF TRANSMISSION/MAILING			
I hereby certify that this correspondence is being facsimile transmitted to the USPTO or deposited with the United States Postal Service with sufficient postage as first class mail in an envelope addressed to: Commissioner for Patents, P.O. Box 1450, Alexandria, VA 22313-1450 on the date shown below:			
Signature			
Typed or printed name	Amanda R. Sytsma	Date	May 21, 2012

This collection of information is required by 37 CFR 1.5. The information is required to obtain or retain a benefit by the public which is to file (and by the USPTO to process) an application. Confidentiality is governed by 35 U.S.C. 122 and 37 CFR 1.11 and 1.14. This collection is estimated to 2 hours to complete, including gathering, preparing, and submitting the completed application form to the USPTO. Time will vary depending upon the individual case. Any comments on the amount of time you require to complete this form and/or suggestions for reducing this burden, should be sent to the Chief Information Officer, U.S. Patent and Trademark Office, U.S. Department of Commerce, P.O. Box 1450, Alexandria, VA 22313-1450. DO NOT SEND FEES OR COMPLETED FORMS TO THIS ADDRESS. SEND TO: Commissioner for Patents, P.O. Box 1450, Alexandria, VA 22313-1450.

If you need assistance in completing the form, call 1-800-PTO-9199 and select option 2.

Under the Paperwork Reduction Act of 1995, no persons are required to respond to a collection of information unless it displays a valid OMB control number.

PATENT APPLICATION FEE DETERMINATION RECORD Substitute for Form PTO-875					Application or Docket Number 13/336,018		Filing Date 12/23/2011		<input type="checkbox"/> To be Mailed		
APPLICATION AS FILED – PART I					SMALL ENTITY <input type="checkbox"/>		OR OTHER THAN SMALL ENTITY				
(Column 1)		(Column 2)									
FOR	NUMBER FILED	NUMBER EXTRA	RATE (\$)	FEE (\$)	OR	RATE (\$)	FEE (\$)				
<input type="checkbox"/> BASIC FEE <small>(37 CFR 1.16(a), (b), or (c))</small>	N/A	N/A	N/A			N/A					
<input type="checkbox"/> SEARCH FEE <small>(37 CFR 1.16(k), (l), or (m))</small>	N/A	N/A	N/A			N/A					
<input type="checkbox"/> EXAMINATION FEE <small>(37 CFR 1.16(o), (p), or (q))</small>	N/A	N/A	N/A			N/A					
TOTAL CLAIMS <small>(37 CFR 1.16(i))</small>	minus 20 =	*	X \$ =		OR	X \$ =					
INDEPENDENT CLAIMS <small>(37 CFR 1.16(h))</small>	minus 3 =	*	X \$ =			X \$ =					
<input type="checkbox"/> APPLICATION SIZE FEE <small>(37 CFR 1.16(s))</small>	If the specification and drawings exceed 100 sheets of paper, the application size fee due is \$250 (\$125 for small entity) for each additional 50 sheets or fraction thereof. See 35 U.S.C. 41(a)(1)(G) and 37 CFR 1.16(s).										
<input type="checkbox"/> MULTIPLE DEPENDENT CLAIM PRESENT <small>(37 CFR 1.16(j))</small>											
* If the difference in column 1 is less than zero, enter "0" in column 2.					TOTAL		TOTAL				
APPLICATION AS AMENDED – PART II					SMALL ENTITY		OR OTHER THAN SMALL ENTITY				
(Column 1)		(Column 2)		(Column 3)							
AMENDMENT	05/21/2012	CLAIMS REMAINING AFTER AMENDMENT		HIGHEST NUMBER PREVIOUSLY PAID FOR	PRESENT EXTRA	RATE (\$)	ADDITIONAL FEE (\$)	OR	RATE (\$)	ADDITIONAL FEE (\$)	
	Total (37 CFR 1.16(i))	* 20	Minus	** 31	= 0	X \$ =		OR	X \$60=	0	
	Independent (37 CFR 1.16(h))	* 3	Minus	***6	= 0	X \$ =		OR	X \$250=	0	
	<input type="checkbox"/> Application Size Fee (37 CFR 1.16(s))								OR		
	<input type="checkbox"/> FIRST PRESENTATION OF MULTIPLE DEPENDENT CLAIM (37 CFR 1.16(j))								OR		
					TOTAL ADD'L FEE		TOTAL ADD'L FEE	0			
(Column 1)		(Column 2)		(Column 3)							
AMENDMENT		CLAIMS REMAINING AFTER AMENDMENT		HIGHEST NUMBER PREVIOUSLY PAID FOR	PRESENT EXTRA	RATE (\$)	ADDITIONAL FEE (\$)	OR	RATE (\$)	ADDITIONAL FEE (\$)	
	Total (37 CFR 1.16(i))	*	Minus	**	=	X \$ =		OR	X \$ =		
	Independent (37 CFR 1.16(h))	*	Minus	***	=	X \$ =		OR	X \$ =		
	<input type="checkbox"/> Application Size Fee (37 CFR 1.16(s))								OR		
	<input type="checkbox"/> FIRST PRESENTATION OF MULTIPLE DEPENDENT CLAIM (37 CFR 1.16(j))								OR		
					TOTAL ADD'L FEE		TOTAL ADD'L FEE				
* If the entry in column 1 is less than the entry in column 2, write "0" in column 3.					Legal Instrument Examiner: /BRENDA HARRISON/						
** If the "Highest Number Previously Paid For" IN THIS SPACE is less than 20, enter "20".											
*** If the "Highest Number Previously Paid For" IN THIS SPACE is less than 3, enter "3".											
The "Highest Number Previously Paid For" (Total or Independent) is the highest number found in the appropriate box in column 1.											

This collection of information is required by 37 CFR 1.16. The information is required to obtain or retain a benefit by the public which is to file (and by the USPTO to process) an application. Confidentiality is governed by 35 U.S.C. 122 and 37 CFR 1.14. This collection is estimated to take 12 minutes to complete, including gathering, preparing, and submitting the completed application form to the USPTO. Time will vary depending upon the individual case. Any comments on the amount of time you require to complete this form and/or suggestions for reducing this burden, should be sent to the Chief Information Officer, U.S. Patent and Trademark Office, U.S. Department of Commerce, P.O. Box 1450, Alexandria, VA 22313-1450. DO NOT SEND FEES OR COMPLETED FORMS TO THIS ADDRESS. **SEND TO: Commissioner for Patents, P.O. Box 1450, Alexandria, VA 22313-1450.**

If you need assistance in completing the form, call 1-800-PTO-9199 and select option 2.

Application Number 	Application/Control No. 13/336,018	Applicant(s)/Patent under Reexamination LYNAM, NIALL R.	

Document Code - DISQ	Internal Document – DO NOT MAIL
-----------------------------	--

TERMINAL DISCLAIMER	<input checked="" type="checkbox"/> APPROVED	<input type="checkbox"/> DISAPPROVED
Date Filed : 5/21/12	This patent is subject to a Terminal Disclaimer	

Approved/Disapproved by:

jean proctor

U.S. Patent and Trademark Office

IN THE UNITED STATES PATENT AND TRADEMARK OFFICE

Group Art : 2872
Examiner : Alessandro V. Amari
Applicant : Niall R. Lynam
Serial No. : 13/336,018
Filing Date : December 23, 2011
For : EXTERIOR SIDEVIEW MIRROR SYSTEM

Mail Stop Amendment
Commissioner for Patents
P.O. Box 1450
Alexandria, VA 22313-1450

Dear Sir:

SUBMISSION OF EXHIBITS A & B OF 131(a) DECLARATION

The Request for Reconsideration filed May 21, 2012 was filed with a Declaration Under Rule 131(a), which referenced Exhibits A and B. The documents filed with the Patent Office are missing Exhibits A and B. As requested by the Examiner, attached are Exhibits A and B of the Declaration. Applicant respectfully submits that the claims are in condition for allowance and a notice to that effect is earnestly and respectfully requested.

Respectfully submitted,

NIALL R. LYNAM

By: Gardner, Linn, Burkhardt & Flory, LLP

Date: July 24, 2012.



Timothy A. Flory
Registration No. 42 540
2851 Charlevoix Drive, S.E., Suite 207
P.O. Box 888695
Grand Rapids, Michigan 49588-8695
(616) 975-5500

PATENT
DON01 P-793
Express Mail No. EL399135945US

IN THE UNITED STATES PATENT AND TRADEMARK OFFICE

Applicant : Niall R. Lynam
For : EXTERIOR MIRROR PLANO-AUXILIARY
REFLECTIVE ELEMENT ASSEMBLY

Box Patent Application
Assistant Commissioner for Patents
Washington, D.C. 20231

Dear Sir:

CERTIFICATE OF EXPRESS MAIL

I certify that the attached return postcard, Transmittal Letter (in duplicate), Form PTO-1619 Recordation Form Cover Sheet, Assignment, a check in the amount of \$40.00 for the recordal fee, 23 pages of Specification, 12 pages of claims (83 claims), 1 page of Abstract, 7 sheets of drawings (in duplicate), Declaration and Power of Attorney, and a check in the amount of \$1,824.00 for the filing fee are being deposited with the United States Postal Service as Express Mail in an envelope having Express Mail Label Number EL

US addressed to:

Box Patent Application
Assistant Commissioner for Patents
Washington, D.C. 20231

on January 6, 2000.

Lynette M. S. Clark
Lynette M. S. Clark
Van Dyke, Gardner, Linn & Burkhart, LLP
P.O. Box 888695
Grand Rapids, MI 49588-8695
(616) 975-5500

CSC:lmse
Enclosures

EXHIBIT A

PATENT
DON01 P-793
Express Mail No. EL399135945US

IN THE UNITED STATES PATENT AND TRADEMARK OFFICE

Applicant : Niall R. Lynam
For : EXTERIOR MIRROR PLANO-AUXILIARY
REFLECTIVE ELEMENT ASSEMBLY

BOX PATENT APPLICATION
Assistant Commissioner for Patents
Washington, D.C. 20231

Dear Sir:

Enclosed herewith is the above identified patent application comprising the following parts:

- 1) Postcard
- 2) Assignment, Form PTO-1619 Recordation Form Cover Sheet, and Assignment Recording Fee of \$40.00
- 3) 23 Pages of Specification
- 4) 12 Pages of Claims (83 claims)
- 5) 1 Page of Abstract
- 6) 7 Sheets of Drawings (in duplicate)
- 7) Declaration and Power of Attorney

Filing Fee:

Basic Fee \$690.00	\$690.00
Additional Fees	
Each independent claim in excess of three, times \$78.00	\$
Number of claims in excess of twenty, times \$18.00	\$1,134.00
Filing multiple dependent claims per application \$260.00	\$
Total Filing Fee	<u>\$1,824.00</u>

Checks in the amount of \$1,824.00 and \$40.00 are enclosed to cover the fees noted above.

The Commissioner is hereby authorized to charge payment of the following fees associated with this communication, and during the pendency of this application, or to credit any overpayment, to Deposit Account No. 22-0190. A duplicate copy of this sheet is enclosed.

- 1) Any additional filing fees required under 37 CFR 1.16 for which full payment has not been tendered.
- 2) Any patent application processing fees under 37 CFR 1.17 for which full payment has not been tendered.

Respectfully submitted,

NIALL R. LYNAM

By: Van Dyke, Gardner, Linn & Burkhart, LLP

Date January 6, 2000

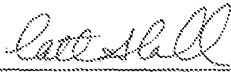
Catherine S. Collins
Registration No. 37 599
P.O. Box 888695
2851 Charlevoix Drive, S.E.
Grand Rapids, MI 49588-8695
(616) 975-5500

CSC:lmsc

**RECORDATION FORM COVER SHEET
PATENTS ONLY**

TO: The Commissioner of Patents and Trademarks: Please record the attached original document(s) or copy(ies).

Submission Type

New
 Resubmission (Non-Recordation)
Document ID#
 Correction of PTO Error
Reel # Frame #
 Corrective Document
Reel # Frame #

Conveyance Type

Assignment Security Agreement
 License Change of Name
 Merger Other
U.S. Government
(For Use ONLY by U.S. Government Agencies)
 Departmental File Secret File

Conveying Party(ies)

Mark if additional names of conveying parties attached
Execution Date
Month Day Year

Name (line 1)

Name (line 2)

Second Party

Name (line 1)

Execution Date
Month Day Year

Name (line 2)

Receiving Party

Mark if additional names of receiving parties attached

Name (line 1)

If document to be recorded is an assignment and the receiving party is not domiciled in the United States, an appointment of a domestic representative is attached. (Designation must be a separate document from Assignment.)

Name (line 2)

Address (line 1)

Address (line 2)

Address (line 3)

City

State/Country

Zip Code

Domestic Representative Name and Address

Enter for the first Receiving Party only.

Name

Address (line 1)

Address (line 2)

Address (line 3)

Address (line 4)

FOR OFFICE USE ONLY

Public burden reporting for this collection of information is estimated to average approximately 30 minutes per Cover Sheet to be recorded, including time for reviewing the document and gathering the data needed to complete the Cover Sheet. Send comments regarding this burden estimate to the U.S. Patent and Trademark Office, Chief Information Officer, Washington, D.C. 20231 and to the Office of Information and Regulatory Affairs, Office of Management and Budget, Paperwork Reduction Project (0651-0027), Washington, D.C. 20503. See OMB Information Collection Budget Package 0651-0027, Patent and Trademark Assignment Practice. DO NOT SEND REQUESTS TO RECORD ASSIGNMENT DOCUMENTS TO THIS ADDRESS.

Mail documents to be recorded with required cover sheet(s) information to:
Commissioner of Patents and Trademarks, Box Assignments, Washington, D.C. 20231

Correspondent Name and Address Area Code and Telephone Number (616) 975-5500

Name Catherine S. Collins

Address (line 1) Van Dyke, Gardner, Linn & Burkhardt, LLP

Address (line 2) 2851 Charlevoix Drive, S.E., Suite 207

Address (line 3) P.O. Box 888695

Address (line 4) Grand Rapids, Michigan 49588-8695

Pages Enter the total number of pages of the attached conveyance document including any attachments. # 1

Application Number(s) or Patent Number(s) Mark if additional numbers attached
Enter either the Patent Application Number or the Patent Number (DO NOT ENTER BOTH numbers for the same property).

Patent Application Number(s)			Patent Number(s)		
<input type="text"/>	<input type="text"/>	<input type="text"/>	<input type="text"/>	<input type="text"/>	<input type="text"/>
<input type="text"/>	<input type="text"/>	<input type="text"/>	<input type="text"/>	<input type="text"/>	<input type="text"/>
<input type="text"/>	<input type="text"/>	<input type="text"/>	<input type="text"/>	<input type="text"/>	<input type="text"/>

If this document is being filed together with a new Patent Application, enter the date the patent application was signed by the first named executing inventor. Month Day Year 01/06/2000

Patent Cooperation Treaty (PCT)
Enter PCT application number only if a U.S. Application Number has not been assigned.
PCT PCT PCT
PCT PCT PCT

Number of Properties Enter the total number of properties involved. # 1

Fee Amount Fee Amount for Properties Listed (37 CFR 3.41): \$ 40.00

Method of Payment: Enclosed Deposit Account

Deposit Account (Enter for payment by deposit account or if additional fees can be charged to the account.) Deposit Account Number: # 22-0190

Authorization to charge additional fees: Yes No

Statement and Signature
To the best of my knowledge and belief, the foregoing information is true and correct and any attached copy is a true copy of the original document. Charges to deposit account are authorized, as indicated herein.

Catherine S. Collins 37 599
Name of Person Signing

Signature

January 6, 2000
Date

Express Mail No. EL399135945US
DON01 P-793

ASSIGNMENT

WHEREAS, Niall R. Lynam residing at 248 Foxdown, Holland, Michigan 49424, (hereinafter referred to as Assignor), have invented certain new and useful improvements in EXTERIOR MIRROR PLANO-AUXILIARY REFLECTIVE ELEMENT ASSEMBLY for which an application for United States Letters Patent was executed on even date herewith.

WHEREAS, Donnelly Corporation, a corporation of the State of Michigan, having a place of business at 414 East Fortieth Street, Holland, Michigan 49423 (hereinafter referred to as Assignee), is desirous of acquiring the entire right, title and interest in and to said invention and in and to any Letters Patent that may be granted therefor in the United States and in any and all foreign countries.

NOW, THEREFORE, in consideration of the sum of one dollar (\$1.00), the receipt of which is hereby acknowledged, and for other good and valuable considerations, Assignor hereby sells, assigns and transfers unto said Assignee the full and exclusive right, title and interest to the said invention in the United States and in all foreign countries and the entire right, title and interest in and to any and all Letters Patent which may be granted therefor in the United States and in any and all foreign countries and in and to any and all divisions, reissues, continuations, continuation-in-part, and extensions thereof including the full right to claim for any such applications the benefits of the International Convention.

Assignor hereby authorizes and requests the Patent Office Officials in the United States and in any and all foreign countries to issue any and all of said Letters Patent, when granted, to said Assignee as the owner of the entire right, title and interest in and to the same, for the sole use and behoof of said Assignee, its successors and assigns.

FURTHER, Assignor agrees to communicate to said Assignee or its representatives any facts known to Assignor respecting said invention, and testify in any legal proceeding, sign all lawful papers, execute all divisional, continuation, continuation-in-part, substitution, renewal, and reissue applications, execute all necessary assignment papers to cause any and all of said Letters Patent to be issued to said Assignee, make all rightful oaths and generally do everything possible to aid said Assignee, its successors and assigns, to obtain and enforce proper protection for said invention in the United States and in any and all foreign countries.

IN TESTIMONY WHEREOF, I have hereunto set my hand on the date appearing next to my signature.

Witness:

Donetta D. Vandyke

Inventor:

Niall R. Lynam
Niall R. Lynam

Date:

JAN 6 2000

EXTERIOR MIRROR PLANO-AUXILIARY REFLECTIVE ELEMENT ASSEMBLY

TECHNICAL FIELD AND BACKGROUND OF THE INVENTION

The present invention relates to exterior sideview mirror assemblies suitable for use on an automobile, and more specifically, to plano-auxiliary reflective element assemblies
5 for use in automobile exterior sideview mirror assemblies.

Automobiles are typically equipped with an interior rearview mirror assembly (adapted for providing a rearward field of view immediately rearward of the vehicle, typically principally in the road lane the vehicle is traveling in) and at least one exterior sideview mirror assembly attached to the side of the vehicle (typically adjacent a front side
10 window portion). The exterior side view mirror assembly typically comprises a reflective element adapted to provide a rearward field of view of the side lane adjacent the vehicle so as to allow the driver see whether a side approaching vehicle is present when the driver is contemplating a lane change. Conventionally, automobiles are equipped with a driver-side exterior mirror assembly and, very often, with a passenger-side exterior sideview mirror
15 assembly mounted to the side of the automobile body opposite to that of the driver-side assembly. While the combination of an interior rearview mirror with a driver-side exterior mirror (and especially in a three-mirror system comprising an interior rearview mirror with a driver-side exterior mirror and a passenger-side exterior mirror) works well in many driving situations, rear vision blind spots present a potential safety hazard while driving. A rear
20 vision blind spot is an area adjacent the side of an automobile where a view of another vehicle (overtaking on that side) is not captured in the rearward field of view of the exterior mirror reflector on that side. This presents a potential safety hazard as the driver, upon checking the view in the exterior sideview mirror and seeing no overtaking vehicle therein, may deem it safe to initiate a lane change, unaware that there is a vehicle immediately
25 adjacent in a blind-spot of the exterior mirror reflector.

Various attempts have been made conventionally to minimize and/or eliminate exterior mirror blind-spots on vehicles. One approach is to make the exterior mirror reflector larger, and particularly wider with respect to the vehicle body. By increasing the width of the exterior mirror reflector, it has a wider field of view rearwards, and hence the reflector blind-

spot is reduced. While use of a wide exterior mirror reflector is an option for trucks, buses and commercial vehicles, increasing the width of the reflector used in an exterior sideview mirror assembly mounted on automobiles (such as sedans, station wagons, sports cars, convertibles, minivans, sports utility vehicles, pick-up trucks and similar passenger carrying automobiles) is often not an option. In such domestic automobiles, increasing the width of the exterior mirror reflector increases the size of the exterior sideview mirror assembly with a concomitant increase in aerodynamic drag, increase in fuel consumption, increased difficulty in parking in tight parking spaces, and increased reflector vibration. Use of a non-flat, curved exterior mirror reflector is commonly used to increase rearward field of view without increasing reflector size.

While working well to increase field of view, use of a curved reflector (such as a convex, spherically-curved reflector) has disadvantages. The field of view rearward increases as the degree of curvature of the bent substrate increases (i.e., the field of view rearward increases as the radius of curvature of the bent substrate decreases). However, such wide-angle mirrors have non-unit magnification and distance perception rearward is distorted. For this reason, convex (spherically-bent) exterior mirror reflectors are required in some countries (such as the United States) to carry a safety warning "OBJECTS IN MIRROR ARE CLOSER THAN THEY APPEAR". Distance perception is particularly important for a driver-side exterior mirror. Indeed, Federal Vehicle Safety Standard No: 111 in the United States (the entire disclosure of which is hereby incorporated by reference herein) requires that the driver-side exterior mirror reflector exhibit unit magnification, and places restrictions on the radius of curvature allowed for any bent passenger-side mirror as well as requiring a safety warning be placed thereon. As an improvement over spherically bent/convex mirror reflectors, aspherical or multiradius mirror reflectors (such as are disclosed in U.S. Patents 4,449,786 and 5,724,187, the entire disclosures of which are hereby incorporated by reference herein) have been developed. Such mirrors are widely used in Europe and Asia for both driver-side exterior mirror reflectors and for passenger-side exterior mirror reflectors. The aspherical or multiradius mirror reflectors typically have a less curved (larger radius of curvature) reflective region that is inboard or closest to the driver when mounted on a vehicle and, usually separated by a demarcation line or the like, have a more curved (smaller radius of curvature) region that is outboard or farthest from the driver when mounted on a vehicle. However, such aspherical or multiradius reflectors do not have unit

magnification and so cannot be used when unit magnification is mandated (such as by FMVSS 111, referenced above).

To supplement a flat driver-side exterior mirror reflector, an auxiliary and separate bent reflector is sometimes incorporated into the driver-side exterior sideview mirror assembly. However, this is often not suitable for passenger automobiles because of the extra space required in the sideview mirror assembly to accommodate an auxiliary reflector element. Also, in most passenger automobiles, the position of the side view mirror reflector is adjustable by the driver (such as by a hand-adjust, or by a manually adjustable cable such as a Bowden cable or by an electrically operable actuator, as known in the art) in order to provide to that driver his or her desired rearward field of view, which ill-suits use of a separate, auxiliary reflector. Likewise, addition of stick-on blind-spot mirror reflectors (such as are commonly sold in automotive parts stores and the like) onto an automobile exterior sideview mirror reflector has disadvantages, including obscuring field of view of the automobile mirror reflector and adding to mirror element vibration.

There is thus a need to provide an automobile exterior sideview reflective element, and particularly a driver-side automobile exterior sideview reflective element, that overcomes the disadvantages above and that provides the driver of the automobile with a distortion-free field of view with unit magnification that is supplemented with a wide-angle view of a side lane blind spot, and there is a need that this be provided in a unitary reflective element assembly module suitable to mount onto, and be adjusted by, the mirror reflector adjustment mechanism (such as an electrically operated, motorized actuator) provided in the exterior sideview mirror assembly.

BRIEF DESCRIPTION OF THE DRAWINGS

Fig. 1 is a perspective view of an automobile equipped with exterior sideview mirror assemblies according to this present invention;

Fig. 2 is a top plan partial fragmentary view of the driver's side exterior rearview mirror assembly of Fig. 1;

Fig. 3 is an enlarged sectional view of a plano-multiradius reflective element assembly of the mirror assembly in Fig. 2;

Fig. 4 is an enlarged sectional view of a demarcation element of the plano-multiradius reflective element assembly of Fig. 3;

Fig. 5A-5H illustrate views of various locations for a plano reflective element and an auxiliary reflective element according to this present invention;

Fig. 6 is a sectional view of a second embodiment of a plano reflective element assembly according to the present invention including a demarcation element formed as a dividing wall in a backing plate element;

Fig. 6A is a cross-section taken along line XX of Fig.6;

Fig. 6B is a cross-sectional view taken along line YY of Fig.6; and

Fig. 7 is a schematic of a third embodiment of a plano-auxiliary reflective element assembly according to this present invention.

10

SUMMARY OF THE INVENTION

This invention provides a plano reflective element with unit magnification and an auxiliary reflector element for use in an exterior sideview mirror assembly on an automobile. More specifically, this invention provides a plano-multiradius reflective element assembly suitable for use in an exterior sideview mirror assembly mounted to the side body of an automobile. The plano-multiradius reflective element assembly of this invention is especially suitable for mounting in a driver-side exterior sideview mirror assembly that is mounted to the side of the automobile body adjacent to the seating position of the driver in the front of the interior vehicular cabin. The plano-multiradius reflective element assembly of this invention comprises a plano portion which has a rearward field of view, when mounted in an exterior sideview mirror assembly mounted to the side body of an automobile, with unit magnification. This plano portion comprises a flat substrate, typically a flat glass substrate, provided with a reflective surface. The plano-multiradius reflective element assembly of this invention also includes a multiradius portion with a rearward field of view, when mounted in an exterior sideview mirror assembly mounted to the side body of an automobile, that has non-unit magnification. The plano portion provides a distortion-free rearward field of view and serves as the principal rearward-viewing portion of the plano-multiradius reflective element. The multiradius portion provides a wide angle rearward field of view, and typically supplements the rearward field of view of the plano portion. This multiradius portion comprises a curved substrate, typically a bent glass substrate, provided with a reflective surface. The plano portion and the multiradius portion are demarcated apart by a demarcation element. The demarcation element enables the driver of a vehicle equipped with the plano-multiradius reflective element of this invention to readily delineate a rearward

view in the plano portion from a rearward view in the multiradius portion. The plano portion comprises a flat reflective element and the multiradius portion comprises a bent reflective element. The flat, plano reflective element and the curved, multiradius reflective element are individually and separately manufactured, and are adjacently attached to a single backing plate (which typically comprises a polymeric substrate, most typically a molded polymeric substrate), and with the demarcation element disposed at the joint of the plano, flat reflective element and the multiradius, bent reflective element. The backing plate is fabricated (typically by polymeric molding) to have a flat portion that corresponds to the plano, flat reflective element, and a curved surface that corresponds to the multiradius, curved reflective element. The attachment of the plano reflective element and an auxiliary reflective element to a single backing plate produces a unitary plano-auxiliary reflective element assembly module suitable for mounting in an exterior sideview mirror assembly. By adjusting the position of the backing plate within the exterior sideview mirror assembly, the rearward fields of view of both the plano reflective element and the auxiliary reflective element are simultaneously and similarly aligned.

One embodiment of the invention includes an exterior sideview mirror system suitable for use in an automobile comprising an exterior sideview mirror assembly adapted for attachment to a side of the automobile. The exterior sideview mirror assembly includes a reflective element having a rearward field of view when attached to said side of the automobile. The reflective element is attached to an actuator and is movable by the actuator in order to position the reflective element's rearward field of view in response to a control. The reflective element comprises a plano-multiradius reflective element assembly which comprises a plano reflective element having unit magnification and a separate multiradius reflective element having a multiradius curvature. The plano element and the separate multiradius element of the plano-multiradius reflective element assembly are attached to a backing plate element. The backing plate element is mounted to the actuator such that movement of the backing plate element (and hence the plano-multiradius reflective element assembly) by the actuator simultaneously and similarly moves the plano element and the multiradius element. The plano element and the multiradius element are separately and, preferably, adjacently attached to the backing plate element at a joint.

In a further embodiment, a demarcation element is disposed at this joint to form a demarcation between the plano element and the multiradius element; this demarcation

element having a portion visible to a driver of the automobile. Preferably, the demarcation element is dark colored, such as with a color selected from the group consisting of black, grey, blue and brown. Optionally, there is a space at the joint of the plano element and the multiradius element and the demarcation element is at least partially disposed in said space
5 between said plano element and said multiradius element. The demarcation element can comprise at least one of a polymer material, a tape, a plastic film, a paint, a lacquer and a caulk.

In a further embodiment, the demarcation element comprises a wall on the backing plate element; this wall being located on the backing plate element at the joint of the
10 plano element and the multiradius element, this wall separating the respective elements apart.

In preferred embodiments, the portion of the demarcation element visible to a driver of an automobile equipped with the plano-multiradius reflective element assembly of this invention has a width from about 0.5 mm to about 4 mm.

In preferred embodiments, the plano element is attached to the backing plate
15 element by at least one of an adhesive attachment and a mechanical attachment.

In preferred embodiments, the multiradius element is attached to the backing plate element at a location such that, when the exterior mirror assembly is attached to a side of an automobile, at least portion, and preferably at least a substantial portion, of the plano element is disposed closer to the side of the vehicle than any portion of the multiradius
20 element element.

In preferred embodiments, the multiradius element comprises a bent glass substrate with radii of curvature in the range of from about 4000 mm to about 50 mm, and the ratio of the width of the plano element to the width of the multiradius element is greater than
25 1.

In preferred embodiments, the principal axis of the rearward field of view of the auxiliary, multiradius element is different from and angled to the principal axis of the rearward field of view of the plano element when both are attached to the backing plate element of the plano-multiradius reflective element assembly and when the plano-multiradius reflective element assembly is mounted in an exterior sideview mirror assembly on an
30 automobile. The principal axis of the rearward field of view of the plano element is directed generally parallel to the longitudinal axis of an automobile equipped with the plano-multiradius reflective element assembly and the principal axis of the rearward field of view

of the multiradius element is directed generally at an angle downwards to the longitudinal axis of the vehicle.

In a preferred embodiment, the exterior sideview mirror assembly equipped with the plano-multiradius reflective element assembly comprises a fixedly attached exterior sideview mirror assembly. In another preferred embodiment, the exterior sideview mirror assembly equipped with the plano-multiradius reflective element assembly comprises a break-away exterior sideview mirror assembly. In another preferred embodiment, the exterior sideview mirror assembly equipped with the plano-multiradius reflective element assembly comprises a powerfold exterior sideview mirror assembly. In another preferred embodiment, the actuator of the exterior sideview mirror assembly to which the plano-multiradius reflective element assembly is mounted comprises an electrically operable actuator. In another preferred embodiment, the actuator of the exterior sideview mirror assembly to which the plano-multiradius reflective element assembly is mounted is controlled by a switch or by a memory controller. In another preferred embodiment, the plano element and/or the multiradius element of the plano-multiradius reflective element assembly comprises an electro-optic reflective element, preferably an electrochromic reflective element. In another preferred embodiment, the plano element of the plano-multiradius reflective element assembly comprises an electro-optic reflective element, preferably an electrochromic reflective element, and the multiradius element comprises a fixed reflectance mirror reflector, such as a fixed reflectance mirror reflector comprises a bent glass substrate coated with a metallic reflector coating.

In a preferred embodiment, the plano-auxiliary reflective element assembly is formed in an integral molding operation.

These and other advantages, features, and modifications will become more apparent when reviewed in conjunction with the drawings and the detailed description which follows.

DETAILED DESCRIPTION OF THE PREFERRED EMBODIMENTS

As illustrated in Fig. 1, passenger automobile 10 (which may be a sedan, a station-wagon, a sports car, a convertible, a minivan, a sports utility vehicle, a pick-up truck or a similar passenger carrying non-commercial, personal transportation automobile) includes an interior rearview mirror assembly 18 positioned within interior vehicle cabin 25. Interior vehicle cabin 25 further includes a steering wheel 16, a driver seat 20 positioned at

steering wheel 16, a front passenger seat 21 adjacent to driver seat 20 in the front portion of cabin 25, and a rear passenger seat 23 in the rear portion of cabin 25. Automobile 10 further includes a driver-side exterior sideview mirror assembly 12 and a passenger-side exterior sideview mirror assembly 14, each adapted for attachment to opposing sides of automobile body 11, most preferably adjacent to the seating position of the driver seated in driver seat 20 for driver-side assembly 12 and adjacent to the front passenger seat 21 for passenger-side assembly 14. Exterior sideview mirrors, mounted as shown in Fig. 1 close to the driver seating location, are commonly referred to as door-mounted exterior sideview mirror assemblies. Driver-side exterior sideview mirror assembly 12 includes, as illustrated in Fig. 2, a plano-multiradius exterior sideview reflective element assembly 30. Plano-multiradius reflective element assembly 30 is mounted to a reflective element positioning actuator 36. The orientation of plano-multiradius reflective element assembly 30, and hence its rearward field of view, is adjustable by actuator 36 in response to control 37. Control 37 can comprise a handset control that allows the driver manually move the orientation of plano-multiradius reflective element assembly 30 within exterior mirror housing 40 (such as by a lever control or by a cable control) and hence reposition the rearward field of view of plano-multiradius reflective element assembly 30. Alternately, when actuator 36 comprises an electrically actuated actuator that is electrically operable incorporating at least one motor, control 37 can comprise a switch (which, preferably, is operable under control of the driver seated in cabin 25) or control 37 can comprise a memory controller, as known in the automotive mirror art, that controls actuator 36 to move the position of plano-multiradius reflective element assembly 30 to a pre-set orientation that suits the rearward field of view preference of an individual driver. Actuator 36 is mounted to bracket 38 which attaches to vehicle body side 11. Plano-multiradius reflective element assembly 30 is positionable by actuator 36 within exterior mirror housing 40.

Plano-multiradius reflective element assembly 30, as shown in Fig. 3, comprises a plano element 50 and a separate multiradius element 55. Preferably, plano element 50 is adjacent to multiradius element at a joint. At their joint, plano element 50 and separate multiradius element 55 can touch leaving substantially no gap or space therebetween, or plano element 50 and separate multiradius element 55 can be spaced apart at their joint by a space or gap, as in Fig. 3. Plano element 50 and multiradius element 55 are both mounted to surface 59 of, and are both supported by, a single backing plate element 60.

Plano element 50 and multiradius element 55 are demarcated apart by demarcation element 65. Surface 61 of backing plate element 60 is preferably adapted to attach, such as by attachment member 64, to actuator 36 when plano-multiradius reflective element assembly 30 is mounted in driver-side exterior sideview mirror assembly 12 (and/or in passenger-side exterior side view mirror assembly 14) such that plano element 50 and multiradius element 55 are adjusted and positioned in tandem and simultaneously when the driver (or alternatively, when a mirror memory system, as is conventional in the rearview mirror arts) activates actuator 36 to reposition the rearward field of view of plano-multiradius reflective element assembly 30. Thus, since elements 50, 55 are part of plano-multiradius reflective element assembly 30, movement of plano-multiradius reflective element assembly 30 by actuator 36 simultaneously and similarly moves plano element 50 and multiradius element 55.

Plano element 50 preferably comprises a flat reflector-coated glass substrate having unit magnification, and comprises a reflective surface through which the angular height and width of the image of an object is equal to the angular height and width of the object when viewed at the same distance (except for flaws that do not exceed normal manufacturing tolerances). Plano element 50 may comprise a conventional fixed reflectance mirror reflector or it may comprise a variable reflectance mirror reflector whose reflectivity is electrically adjustable. For example, plano element 50 may comprise a flat glass substrate coated with a metallic reflector coating such as a chromium coating, a titanium coating, a rhodium coating, a metal alloy coating, a nickel-alloy coating, a silver coating, an aluminum coating (or any alloy or combination of these metal reflectors). The metal reflector coating of plano element 50 may be a first surface coating (such as on surface 66) or a second surface coating (such as on surface 67), as such terms are known in the mirror art. The reflector coating on plano element 50 may also comprise a dielectric coating, or a multilayer of dielectric coatings, or a combination of a metal layer and a dielectric layer to form automotive mirror reflectors as known in the automotive mirror art. If a variable reflectance reflector element, plano element 50 preferably comprises an electro-optic reflector element and, most preferably, an electrochromic reflector element.

When mounted into exterior side view mirror assembly 12 and/or 14, plano-multiradius reflective element assembly 30 is preferably orientated so that at least a portion of (more preferably a substantial portion of) the reflector surface of plano element 50 is

positioned closer to the vehicle body (and hence to the driver) than any portion of the reflector surface of multiradius element 55. Thus, and referring to Figure 3, side A of plano element 50 of plano-multiradius reflective element assembly 30 is positioned closer to the driver than side D of multiradius element 55 when plano-multiradius reflective element
5 assembly 30 is mounted on an automobile. Also, when mounted into exterior side view mirror assembly 12 and/or 14, surfaces 66, 68 of plano-multiradius reflective element assembly 30 face rearwardly in terms of the direction of vehicle travel.

Multiradius element 55 of plano-multiradius reflective element assembly 30 preferably comprises a curved/bent mirrored glass substrate. The degree of curvature
10 preferably increases (and hence the local radius of curvature decreases) across the surface of multiradius element 55 with the least curvature (largest radius of curvature) occurring at the side of multiradius element 55 (side C in Fig. 3) positioned adjacent its joint to plano element 50 when both are mounted on backing plate element 60. Thus, and referring to Figure 3, the local radius of curvature at side C of multiradius element 55, when mounted on backing plate
15 element 60, is larger than at side D. Also, the local radius of curvature preferably progressively decreases across multiradius element 55 from side C to side D. Preferably, the local radius of curvature at side C of multiradius element 55 is at least about 1000 mm; more preferably is at least about 2000 mm and most preferably is at least about 3000 mm whereas the local radius of curvature at side D of multiradius element 55 is, preferably, less than about
20 750 mm, more preferably less than about 350 mm; most preferably less than about 150 mm. Preferably, multiradius element 55 comprises a bent glass substrate with radii of curvature in the range of from about 4000 mm to about 50 mm. The multiradius prescription for the multiradius element to be used in a particular exterior mirror assembly can vary according to the specific field of view needs on a specific automobile model.

25 The total field of view rearwardly of the automobile of the plano-auxiliary reflective element assembly (which is a combination of the field of view of the plano reflective element and of the auxiliary reflective element) preferably generally subtends an angle of at least about 20 degrees (and more preferably, generally subtends an angle of at least about 25 degrees and most preferably, generally subtends an angle of at least about 30
30 degrees) with respect to the side of an automobile to which is attached an exterior sideview mirror assembly equipped with the plano-auxiliary reflective element assembly.

Multiradius element 55 may comprise a conventional fixed reflectance mirror reflector or it may comprise a variable reflectance mirror reflector whose reflectivity is electrically adjustable. For example, multiradius element 55 may comprise a flat glass substrate coated with a metallic reflector coating such as a chromium coating, a titanium coating, a rhodium coating, a metal alloy coating, a nickel-alloy coating, a silver coating, an aluminum coating (or any alloy or combination of these metal reflectors). The metal reflector coating of multiradius element 55 may be a first surface coating (such as on surface 68) or a second surface coating (such as on surface 69), as such terms are known in the mirror art. The reflector coating on multiradius element 55 may also comprise a dielectric coating, or a multilayer of dielectric coatings, or a combination of a metal layer and a dielectric layer to form automotive mirror reflectors as known in the automotive mirror art. If a variable reflectance reflector element, multiradius element 55 preferably comprises an electro-optic reflector element and, most preferably, an electrochromic reflector element.

Also, it is preferable that the thickness of plano element 50 and multiradius element 55 be substantially the same in dimension so that their respective outer surfaces, 66 and 68, are substantially coplanar so that a driver can readily view images in either or both elements. The thickness dimension of elements 50,55 is determined by the thickness of the substrate (or in the case of laminate-type electrochromic reflective elements, the thickness of the two substrates between which the electrochromic medium is disposed). For example, plano element 50 and/or multiradius element 55 can comprise a reflector coated glass substrate or panel of thickness preferably equal to or less than about 2.3 mm, more preferably equal to or less than about 1.6 mm, most preferably equal to or less than about 1.1 mm. Use of a thinner substrate is beneficial in terms of improving the overall stability/vibration performance of the image seen in plano-multiradius reflective element assembly 30 when mounted to an automobile.

The reflector area of plano element 50 is preferably larger than that of multiradius element 55. Preferably, the width dimension of plano element 50 is larger than the width dimension of multiradius element 55 (both width dimensions measured at their respective widest dimension and with the width of the respective element being gauged with the respective element oriented as it would be orientated when mounted on the automobile). Thus, and referring to Figure 3, the distance from side A to side B of plano element 50 is larger than the distance from side C to side D of multiradius element 55. Thus, the ratio of

the width of plano element 50 to the width of multiradius element 55 is preferably greater than 1; more preferably greater than 1.5; most preferably greater than 2.5 in order to provide a large, unit magnification plano element 50 as the principal rear viewing portion of plano-multiradius reflective element assembly 30 and providing multiradius element 55 as a smaller, auxiliary, separate, wide-angle viewing portion of plano-multiradius reflective element assembly 30. For plano-multiradius reflective element assemblies to be mounted to the exterior sideview assemblies of passenger automobiles used non-commercially and for non-towing purpose, the width of plano element 50 (at its widest dimension) is preferably in the range of from about 50 mm to about 225 mm; more preferably in the range of from about 75 mm to about 175 mm; most preferably in the range of from about 100 mm to about 150 mm.

Backing plate element 60 is preferably a rigid polymeric substrate capable of supporting plano element 50 and multiradius element 55. Backing plate element 60 comprises a flat portion (generally between E and F as shown in Fig. 3) that corresponds to and is aligned with plano element 50. Backing plate element 60 also comprises a curved portion (generally between G and H as shown in Fig. 3) that corresponds to and is aligned with multiradius element 55. Preferably, curved portion G-H of multiradius element 55 is fabricated with a multiradius prescription that is substantially the same as the multiradius prescription of multiradius element 55. Backing plate element 60 is formed as a single element to which elements 50 and 55 are separately attached. Preferably, backing plate element 60 is formed by injection molding of a thermoplastic or a thermosetting polymer resin. Materials suitable to use for backing plate element 60 include unfilled or filled polymeric materials such as glass and/or mineral filled nylon or glass and/or mineral filled polypropylene, ABS, polyurethane and similar polymeric materials. For example, backing plate element 60 can be formed of ABS in an injection molding operation. Plano element 50 can be cut from a stock lite of flat chromium mirror-coated 1.6 mm thick glass. Multiradius element 55 can be cut from a stock lite of multiradiusly-bent chromium mirror-coated 1.6 mm thick glass. Plano element 50 and multiradius element 55 can then be attached (such as by an adhesive attachment such as an adhesive pad or by mechanical attachment such by clips, fasteners or the like) to the already molded backing plate element 60. Alternatively, plano element 50 and multiradius element 55 can each be individually loaded into an injection molding tool. Once loaded, a polymeric resin (or the monomers to form a

polymeric resin) can be injected into the mold in order to integrally form backing plate element 60 with elements 50, 55 integrally molded thereto. Integral molding of the backing plate element to plano element 50 and multiradius element 55 (along with any other elements such as the demarcation element 65) in a single integral molding operation, is a preferred
5 fabrication process for plano-multiradius reflective element assembly 30.

Plano-multiradius reflective element assembly 30 further preferably includes demarcation element 65 that functions to delineate and demarcate the plano region of the assembly from the wide-angle, multiradius region and also preferably functions to prevent ingress of debris, dirt, water and similar contaminants (such as road splash, car wash spray,
10 rain, snow, ice, leaves, bugs and similar items that plano-multiradius reflective element assembly 30 would be subject to when mounted and used on an automobile) into any gap between plano element 50 and multiradius element 55 when both are attached to backing plate element 60. Optionally, at least a portion of demarcation element 65 can be disposed in any gap between plano element 50 and multiradius element 55 at their joint on backing plate
15 element 60. Preferably, demarcation element 65 is formed of a polymeric material that is dark colored (such as black or dark blue or dark brown or dark grey or a similar dark color) such as a dark colored polypropylene resin or a dark colored nylon resin or a dark colored polyurethane resin or a dark colored polyvinyl chloride resin or a dark colored silicone material. Most preferably demarcation element 65 is formed of an at least partially
20 elastomeric material (such as silicone, or EPDM, or plasticized PVC or the like) in order to provide a degree of vibration dampening for elements 50, 55. As shown in Fig. 4, demarcation element 65 optionally includes a crown portion 70 that includes wing portions 73, 73' and a stem portion 71. Stem portion 71 preferably has a cross-sectional width CCC of less than about 4 mm, more preferably less than about 3 mm and, most preferably less than
25 about 2 mm. Crown portion 70 preferably is dimensioned to not protrude substantially beyond surfaces 66, 68 of elements 50, 55 when demarcation element 65 is installed between elements 50 and 55. Also, wings 73, 73' are preferably dimensioned to protrude (most preferably slightly) onto surfaces 66, 68 of elements 50, 55 when demarcation element 65 is installed between elements 50 and 55 in order to provide a weather barrier seal and/or to at
30 least partially accommodate any dimensional tolerances of elements 50, 55 that could lead to variation in the inter-element gap between sides C and B. While the demarcation element shown in Fig. 4 is one embodiment, other constructions are possible including a demarcation

element that has minimal or no crown portion. Likewise, a demarcation element can have little or no stem portion, especially when the joint between plano element 50 and multiradius element 55 includes no gap to receive a stem. Also, where a gap at the plano to multiradius joint exists, any stem of the demarcation element can at least partially be disposed in such gap so as to at least partially fill the gap (or it can optionally substantially fill the gap).
5 Optionally, demarcation element 65 is fabricated by injection molding of a polymeric resin. After plano element 50 and multiradius element 55 have been attached to backing plate element 60, a separately formed demarcation element 65 can then be inserted (and secured such as by an adhesive or by a mechanical attachment such as by a fastener) into a space
10 between elements 50 and 55. Note that, optionally, side B of plano element 50 and side C of multiradius element 55 can touch (leaving substantially no gap or space therebetween). In such a situation, demarcation element 65 can comprise a dark colored strip such as of a tape or of a plastic film that covers the joint between elements 50 and 55. Alternatively, demarcation element 65 can comprise a preferably dark-colored paint, lacquer, caulk or
15 similar material that can be applied to, and that can preferably fill into, the joint between elements 50 and 55. The width of the portion of demarcation element 65 that is visible to the driver is preferably less than about 4 mm, more preferably less than about 3 mm and most preferably less than about 2 mm, but is equal to or greater than about 0.5 mm, more preferably is equal to or greater than about 0.75 mm, most preferably is equal to or greater
20 than about 1 mm in order to provide adequate demarcation of the plano region from the multiradius radius region without unduly obscuring the rearward field of view of the respective elements. Optionally, demarcation element 65 can be formed as part of backing plate element 60 such as by forming demarcation element 65 as a wall structure of the backing plate element that partitions backing plate element 60 into two regions: A first
25 region adapted to receive plano reflective element 50 and a separate and adjacent second region adapted to receive multiradius reflective element 55.

Thus, and referring to Fig. 6, a second embodiment of plano-multiradius reflective element assembly 130 may include a backing plate element 160 which comprises a plate molded from a polymer resin (such as a polyolefin such as polypropylene or such as
30 ABS or nylon) with a demarcation element 165 that is molded as a wall structure that partitions backing plate element 165 into a first region (from CC to BB) adapted to receive and accommodate plano reflective element 150 and into a second region (from BB to AA)

adapted to receive and accommodate wide-angle optic multiradius reflective element 155. Note that section AA to BB of backing plate element 160 is angled to section BB to CC. Such angling of the auxiliary reflective element relative to the plano element can be advantageous in allowing the auxiliary reflective element view a portion of the road adjacent the automobile that is in a blind spot of the plano reflective element. In this regard, it is preferable that the multiradius element be angled away from the plane of the plano element, as shown in Fig. 6 by the angling of section AA to BB to section BB to CC.

Preferably, demarcation element 65 is formed in an integral molding operation, along with formation of backing plate element 60, and attachment of elements 50, 55 thereto. For example, plano element 50 and multiradius element 55 can each be individually loaded into an injection molding tool. Once loaded, a polymeric resin (or the monomers to form a polymeric resin) can be injected into the mold in order to integrally form backing plate element 60 with elements 50, 55 integrally molded thereto and, in the same molding operation and in the same tool, also form by molding the demarcation element. Integral molding of the backing plate element to plano element 50 and multiradius element 55 along with creation in the single molding operation of demarcation element 65 (along with any other elements such as attachment member 64) in a single integral molding operation, is a preferred fabrication process for plano-multiradius reflective element assembly 30. By loading all the sub components of plano-multiradius reflective element assembly 30 into a molding tool, and then injecting polymeric resin to form the backing plate, demarcation member and any attachment member, a substantially complete or fully complete plano-multiradius reflective element assembly can be unloaded from the tool at the completion of the integral molding operation (as known in the molding art), thus enabling economy in manufacturing and accommodation of any dimensional tolerances in the sub components. Where integral molding is so used, it is preferable to use a reactive molding operation such as reactive injection molding of a urethane as such reactive injection molding operations occur at relatively modest temperatures.

Plano element 50 and/or multiradius element 55 can comprise a heater element, as known in the automotive mirror art, that is operable to deice/demist surfaces 66, 68. Such heater elements are conventional and can comprise a positive temperature coefficient heater pad, a resistive heater element and/or a conductive coating. Plano element 50 and/or multiradius element 55 can also optionally comprise a scatterproofing member, as

known in the automotive mirror art, such as an adhesive tape, to enhance safety in an accident.

Also, plano element 50 and/or multiradius element 55 can comprise a variable reflectance electro-optic element such as an electrochromic mirror reflector. Thus, both
5 element 50 and element 55 can comprise an electrochromic mirror element or either of
element 50 and element 55 can comprise an electrochromic mirror element and the other can
comprise a fixed reflectance non-variable reflectance mirror element such as a metal reflector
coated glass panel such as a chromium coated glass substrate. Also, if both plano element 50
and multiradius element 55 comprise an electro-optic element such as an electrochromic
10 mirror element capable of electrically dimmable reflectivity, both elements 50, 55 can dim
together and in tandem under control of a common dimming control signal (typically
provided by an electro-optic automatic dimming interior mirror assembly mounted in the
cabin of the automobile and equipped with photosensors to detect incident glare and ambient
light). Alternately, if both plano element 50 and multiradius element 55 comprise an electro-
15 optic element such as an electrochromic mirror element capable of electrically dimmable
reflectivity, element 50 can dim independently of element 55 (such as is disclosed in U.S.
Patent No. 5,550,677, the entire disclosure of which is hereby incorporated by reference
herein). If either or both of elements 50, 55 comprise an electrochromic element, preferably,
the electrochromic reflective element comprises a front substrate and a rear substrate with an
20 electrochromic medium disposed between, such as a solid polymer matrix electrochromic
medium such as is disclosed in U.S. patent application Serial No. 09/350,930, filed July 12,
1999, entitled "ELECTROCHROMIC POLYMERIC SOLID FILMS, MANUFACTURING
ELECTROCHROMIC DEVICES USING SUCH FILMS, AND PROCESSES FOR
MAKING SUCH SOLID FILMS AND DEVICES" to Desaraju V. Varaprasad et al., or such
25 as is disclosed in U.S. Patent Nos. 5,668,663; 5,724,187; 5,910,854; and 5,239,405, the entire
disclosures of which are hereby incorporated by reference herein. Most preferably, in such
laminated-type electrochromic mirror reflective elements, the front substrate comprises a glass
plate of thickness less than about 1.6 mm, most preferably about 1.1 mm thickness or lower,
and the rear substrate comprises a glass plate of thickness equal to or greater than about
30 1.6mm, more preferably greater than about 1.8 mm thickness, most preferably equal to or
greater than about 2.0 mm thickness. The rearmost surface of the rear substrate (the fourth
surface as known in the mirror art) is reflector coated with a high reflecting metal film such

as of aluminum or silver, or an alloy of aluminum or silver. Most preferably, the front-most surface of the rear substrate (the third surface as known in the mirror art) is reflector coated with a high reflecting metal film such as of aluminum or silver, or an alloy of aluminum or silver.

5 Backing plate element 65 of plano-multiradius reflective element assembly 30 is optionally equipped on its rearmost surface with attachment member 64 to facilitate attachment to the reflector-positioning actuator of the exterior sideview mirror assembly that plano-multiradius reflective element assembly 30 is mounted to. Attachment of plano-multiradius reflective element assembly 30 to the actuator can be by mechanical attachment
10 such as by a tab, clip or fastener, or may be by adhesive attachment such as by a silicone adhesive, a urethane adhesive or a similar adhesive material such as a tape coated on both surfaces with a pressure sensitive adhesive to form a "double-sticky" tape. The exterior sideview mirror assembly, on whose mirror reflector-positioning actuator the plano-multiradius reflective element assembly is mounted, can be a fixedly attached exterior
15 sideview mirror assembly, a break-away exterior sideview mirror assembly and a powerfold exterior sideview mirror assembly, as known in the automotive mirror art.

 Figs. 5A-5H shows various arrangements of multiradius reflective element 55 relative to its adjacent plano reflective element 50 (with demarcation element 65 disposed at their joint). In Figs. 5A, 5B, 5C, 5E and 5F, plano element 50 is mounted wholly inboard of
20 multiradius element 55. Thus, in Figs. 5A, 5B, 5C, 5E and 5F, plano element 50 would be disposed closer to the vehicle body (and hence to the driver) than multiradius element 55 when plano-multiradius reflective element assembly 30 was mounted in an exterior sideview mirror attached to a side of an automobile. Therefore, in Figs. 5A, 5B, 5C, 5E and 5F, plano element 50 would be mounted inboard relative to the side of the automobile and multiradius
25 element 55 would be mounted outboard relative to the side of the automobile. In general, the location of the multiradius reflective element in the outboard, upper portion of the plano-multiradius reflective element assembly, as in Figs. 5B and 5E, is preferred as this allows the plano portion provide a desired rearward field of view along the side of the vehicle. The configuration as shown in Fig. 5G (where the multiradius reflective element is along the
30 inboard side of the assembly) is also desirable as this allows the driver view the side of the vehicle (something many drivers desire in order to have a frame of reference for their rearward field of view) while facilitating having a wide field of view for the plano portion.

Unlike trucks, busses and commercial vehicles the size of an exterior sideview mirror assembly suitable for use on an automobile (and especially when the automobile is not towing a trailer or the like) is restricted. Automobiles generally are non-commercial vehicles intended for personal transportation. Automobiles typically carry 5 passengers or less,
5 although minivans and large sports utility vehicles (which are classified herein as automobiles) can have seat accommodation for up to 10 passengers (although accommodation for 7 passengers or less is more common). The tandem mounting of a plano element of unit magnification and a separate auxiliary element onto a common, single backing plate element, and the mounting of this backing plate element onto an actuator of an
10 exterior sideview mirror assembly so that a driver can simultaneously and similarly move the auxiliary element and the plano element so as to position their respective rearward fields of view, and to achieve this within the relatively restricted space available in a standard automobile-sized exterior sideview mirror assembly is an important element of this present invention. By utilizing a plano element of unit magnification in the plano-multiradius
15 reflective element assembly, and by sizing the reflector area of the plano element larger than the reflector area of the multiradius element and, preferably, by sizing the reflector area of the plano element at a sufficiently large size that the rearward field of view provided by the plano element alone meets and satisfies the minimum field of view requirement mandated by an automaker specification and/or a government regulation, the need to provide a safety warning
20 indicia such as "OBJECTS IN MIRROR ARE CLOSER THAN THEY APPEAR" in the plano element and/or in the multiradius element can be obviated. Preferably, the plano element comprises a reflector surface area of a size sufficient, when mounted as part of a plano-multiradius reflective element assembly in a driver-side exterior sideview mirror assembly on an automobile, to provide the driver of the automobile a view of a level road
25 surface extending to the horizon from a line, perpendicular to a longitudinal plane tangent to the driver's side of the automobile at the widest point, extending 8 feet out from the tangent plane 35 feet behind the driver's eyes (at a nominal location appropriate for any 95th percentile male driver or at the driver's eye reference points established in Federal Motor Vehicle Standard No. 104), with the driver seated in the driver's seat and with the driver's
30 seat in the rearmost position. Also, preferably, the aspect ratio of the plano-multiradius reflective element assembly (defined as the ratio of its largest vertical dimension to its largest horizontal dimension, measured with the plano-multiradius reflective element assembly

oriented as it would be oriented when mounted in an exterior sideview mirror assembly on an automobile, and with "horizontal" being generally parallel with the road surface the automobile travels on and "vertical" being generally perpendicular to the road surface the automobile travels on) is preferably less than 1, more preferably less than 0.8, most preferably less than 0.6. Further, it is preferable that the multiradius element be disposed outboard (relative to the side of the vehicle and with the plano-multiradius reflective element assembly oriented as it would be when mounted in an exterior sideview mirror assembly on an automobile) on the plano-multiradius reflective element assembly so that the multiradius element is positioned to provide an auxiliary, wide-angle view of a "blind-spot" region in an adjacent sidelane while the more inboard-disposed plano element with unit magnification provides the principal sideview image to the driver.

Also, it is preferable that the principal axis of the rearward field of view of the multiradius element be different from and angled to the principal axis of the rearward field of view of the plano element when both are attached to the backing plate element of the plano-multiradius reflective element assembly and when the plano-multiradius reflective element assembly is mounted and operated in an exterior sideview mirror assembly on an automobile. Preferably, the principal axis of the rearward field of view of the plano element is directed generally parallel to the road that the automobile equipped with the plano-multiradius reflective element assembly is travelling on (i.e. generally parallel to the longitudinal axis of the automobile) so as to provide the driver with a long-distance view of approaching vehicles in the side lane that the plano element views). However, preferably the principal axis of the rearward field of view of the multiradius element of, for example, a door-mounted driver-side (or passenger-side) exterior sideview mirror assembly in which the plano-multiradius reflective element assembly is mounted is directed generally downwardly towards the road surface adjacent to the driver seating location and/or several feet (such as about 1 foot to about 24 feet; more preferably, about 1 foot to about 12 feet; most preferably about 1 foot to about 8 feet in distance) to its rear (in order to capture a field of view of a rear approaching vehicle that is approaching to overtake, or is about to overtake, or is overtaking the automobile equipped with the plano-multiradius reflective element assembly). Thus, preferably, the principal axis of the rearward field of view of the multiradius element is angled and directed generally downwardly with respect to the longitudinal axis of the automobile and thus is at an angle to the principal axis of the rearward field of view of the

plano element. For example, multiradius element 155 when attached to surface 173 of backing plate 160 (see Fig. 6B) would have its principal axis of rearward view as indicated by 180 as in Fig. 6B, and as such would be canted towards the road surface when mounted in an exterior sideview mirror assembly attached to the side of an automobile. By contrast, 5 plano element 150 when attached to surface 174 of backing plate 160 (see Fig. 6A) would have a principal axis as indicated by 185 as in Fig. 6A and, as such, would be generally parallel to the road surface when mounted in an exterior sideview mirror assembly attached to the side of an automobile. Having the multiradius element canted somewhat downwards towards the road surface assists visual detection by the driver of overtaking vehicles in the traditional "blind-spot" in the adjacent side lane. The angle that the multiradius element is 10 angled on the backing plate element of the plano-multiradius reflective element assembly relative to the plane of the plano reflective element will vary from automobile model to model, but generally is preferred to be in the about 1 degree to about 10 degree range; about 2 degree to about 8 degree range more preferred; and about 3 degree to about 6 degree range 15 most preferred. In order to conveniently achieve an angling of the multiradius portion with respect to the plano portion (and preferably a downward angling), the portion of the backing plate element that the multiradius reflective element is attached to can be angled relative to the adjacent portion of the backing plate element that the plano reflective portion is attached to. Thus, and referring to Fig. 6, plano-multiradius reflective element assembly 130 includes 20 a molded polymeric backing plate element 160 comprising a generally flat portion 162 (between BB and CC in Fig. 6) and an adjacent curved portion 161 (between AA and BB). As indicated by 190 and 195, portion AA to BB of backing plate element 160 is generally angled to portion BB to CC of backing plate 160. Preferably, the portion of backing plate element 160 to which the auxiliary reflective element attaches is angled towards the front 25 (compared to the angling of plano reflective element) of an automobile equipped with the plano-auxiliary reflective element assembly of the present invention. Fig. 6 is a view of plano-multiradius reflective element assembly 130 as it would appear from above the vehicle as it would be orientated in use (with portion 162 closer to the driver than portion 161). The wall section, section XX in Fig. 6, taken through section 162 of backing plate element 160 is 30 of substantially constant dimension (as illustrated in Fig. 6A) whereas the wall section, section YY in Fig. 6B, taken through section 161 of backing plate element 160 is of varying dimension and is angled. Plano reflective element 150 and multiradius reflective element

155 (for example, plano element 150 can comprise an electrochromic mirror element and
multiradius element 155 can comprise a chrome coated glass reflector) are attached to
portions 162 and 161, respectively. By being supported on the angled face 173 (see Fig. 6B)
of portion 161, the principal viewing axis of multiradius reflector element 155 is angled
5 downwards towards the road surface, as compared to the more horizontal-viewing principal
viewing axis of plano element 150, when plano-multiradius reflective element 130 is
mounted in an exterior sideview mirror assembly on an automobile. Demarcation element
165 is preferably molded in the same molding tool as is used to mold backing plate element
160, and so demarcation element 165 is formed as an integral part of backing plate element
10 160, forming a wall thereof that partitions the surface of backing plate element 160 into a
region for receiving the plano reflective element 150 and a region for receiving the auxiliary
reflective element 155. Also, end-caps 170 and 171 are optionally provided. Plano reflective
element 150 can attach into the cavity formed between demarcation element 165 and end-cap
171; multiradius reflective element 155 can attach into the cavity formed between
15 demarcation element 165 and end-cap 170. Note that the portion of the backing plate element
where the wide-angle optic multiradius element attaches can have a thicker wall thickness
than that of the portion of the backing plate element where the unit magnification optic
element attaches in order to allow for the angling of the multiradius element downwardly
relative to the angle of the plano element, as illustrated in Figs. 6A-B. As illustrated in Figs.
20 6A-B, the angle downwards to the longitudinal axis of the vehicle of the multiradius element
can generally be set by an angling of a surface of the backing plate element in order to ensure
that the principal axis of the rearward field of view of the plano element is directed generally
parallel to the longitudinal axis of an automobile equipped with the plano-multiradius
reflective element assembly and that the principal axis of the rearward field of view of the
25 multiradius element is directed generally at an angle downwards to the longitudinal axis of
the automobile.

Note that the provision of the plano-multiradius reflective element assembly
of this invention as a unitary module has manufacturing advantages, particularly for exterior
sideview mirror assembly manufacturers who can procure a plano-multiradius reflective
30 element assembly module from a mirror reflector supplier and then mount the plano-
multiradius reflective element assembly module onto an actuator.

Referring to Fig. 7, a third embodiment 230 of a plano-multiradius reflective element assembly is illustrated. Plano-multiradius reflective element assembly 230 includes a plano reflective element 250 and a separate multiradius reflective element assembly 255, both individually attached to a backing plate element, and with demarcation element 265
5 disposed at their joint. Plano-multiradius reflective element assembly 230 is about 8.5 inches wide and about 4.25 inches tall (aspect ratio of 0.5), at their largest dimension. Shown as the shaded triangle 240 in plano reflective element 250 is the image of a triangular target object set about 35 feet rearward and of width about 8 feet and of height of about 4.1 feet as would be seen were plano-multiradius reflective element assembly 230 mounted in a driver-side
10 exterior sideview mirror assembly in an automobile such as a sports utility vehicle. In general, it is desirable that the plano reflective element be dimensioned and configured so as to have its rearward field of view capture an image (that is visible, by reflection in the plano reflective element, to a driver seated in the driver's seat in an automobile to which is attached an exterior sideview mirror assembly equipped with the plano-auxiliary reflective element
15 assembly according to this present invention) of a triangular shaped target located about 35 feet rearward of the driver seating location, extending about 8 feet out from the plane defined by the side of the automobile and reaching a height of between about 4 feet and about 5 feet from the road surface at that location 35 feet rearward of the automobile. The total field of view rearwardly of the vehicle of plano-multiradius reflective element assembly 230 (which
20 is a combination of the field of view of plano reflective element 250 and of the auxiliary multiradius reflective element 255) preferably generally subtends an angle of at least about 30 degrees (and more preferably, generally subtends an angle of at least about 35 degrees and most preferably, generally subtends an angle of at least about 40 degrees) with respect to the side of an automobile to which is attached an exterior sideview mirror assembly equipped
25 with plano-multiradius reflective element assembly 230.

Also, although it is preferable to utilize a multiradius or compound curvature reflective element such as an aspherical element or a compound curvature element for the auxiliary mirror element adjacent the plano reflective element (as this enables least
30 discontinuity in image at the joint between the adjacent elements of the assembly), a spherical reflective element (that has substantially only one radius of curvature and, as such, is a section from a sphere) can optionally be used adjacent the plano reflective element instead of, or in addition to, the multiradius reflective element. Also, a plano auxiliary mirror

such as a flat mirrored substrate can be used, less preferably, as a substitute for a multiradius reflective element in those embodiments where the auxiliary reflective element is angled relative to the plane of the principal, plano reflective element so as to view a blind spot region of the principal plano element. Also, the plano-multiradius reflective element
5 assembly can optionally be fixedly attached to an exterior sideview mirror assembly housing that is not movable, or, alternately, the exterior sideview mirror assembly housing to which the plano-multiradius reflective element assembly is fixedly attached can itself be actuated to move, such as by motor action, so that by moving the exterior sideview mirror assembly housing, the field of rearward view of the plano-multiradius reflective element assembly
10 fixedly attached thereto can correspondingly move and be repositioned to suit the field of view need of a particular driver seated in the automobile cabin.

The above description is considered that of the preferred embodiments only. Modification of the invention will occur to those skilled in the art and to those who make or use the invention. Therefore, it is understood that the embodiments shown in the drawings
15 and described above are merely for illustrative purposes and are not intended to limit the scope of the invention, which is defined in the following claims as interpreted according to the principles of patent law, including the doctrine of equivalents.

I claim:

1. An exterior sideview mirror system suitable for use in an automobile, said exterior sideview mirror system comprising:

an exterior sideview mirror assembly adapted for attachment to a side of an automobile;

5 said exterior sideview mirror assembly including a reflective element having a rearward field of view when attached to said side of the automobile;

said reflective element attached to an actuator and movable by said actuator in order to position said rearward field of view in response to a control;

10 wherein said reflective element comprises a plano-multiradius reflective element assembly, said plano-multiradius reflective element assembly comprising a plano reflective element having unit magnification and a separate multiradius reflective element having a multiradius curvature; and

15 said plano reflective element and said multiradius reflective element of said plano-multiradius reflective element assembly attached to a backing plate element, said backing plate element mounting to said actuator such that movement of said backing plate element of said plano-multiradius reflective element assembly by said actuator simultaneously and similarly moves said plano reflective element and said multiradius reflective element.

2. The exterior sideview mirror system of Claim 1, wherein said plano reflective element and said multiradius reflective element are adjacently attached to said backing plate element at a joint, and wherein said plano-multiradius reflective element assembly includes a demarcation element, said demarcation element disposed at said joint to form a demarcation
5 between said plano reflective element and said multiradius reflective element, said demarcation element having a portion visible to a driver of the automobile.

3. The exterior sideview mirror system of Claim 2, wherein said demarcation element is dark colored.

4. The exterior sideview mirror system of Claim 3, wherein said demarcation element is dark colored with a color selected from the group consisting of black, grey, blue and brown.
5. The exterior sideview mirror system of Claim 2, wherein said joint comprises a space between said plano reflective element and said multiradius reflective element.
6. The exterior sideview mirror system of Claim 5, wherein said demarcation element is at least partially disposed in said space between said plano reflective element and said multiradius reflective element.
7. The exterior sideview mirror system of Claim 3, wherein said demarcation element comprises at least one of a polymer material, a tape, a plastic film, a paint, a lacquer and a caulk.
8. The exterior sideview mirror system of Claim 7, wherein said demarcation element comprises a polymer material.
9. The exterior sideview mirror system of Claim 2, wherein said demarcation element comprises a wall on said backing plate element, said wall located on said backing plate element at said joint, said wall separating said plano reflective element from said multiradius reflective element.
10. The exterior sideview mirror system of Claim 2, wherein said portion visible to a driver of the automobile has a width less than about 4 mm.
11. The exterior sideview mirror system of Claim 2, wherein said portion visible to a driver of the automobile has a width less than about 3 mm.
12. The exterior sideview mirror system of Claim 2, wherein said portion visible to a driver of the automobile has a width less than about 2 mm.

13. The exterior sideview mirror system of Claim 2, wherein said portion visible to a driver of the automobile has a width greater than about 0.5 mm.

14. The exterior sideview mirror system of Claim 2, wherein said portion visible to a driver of the automobile has a width greater than about 0.75 mm.

15. The exterior sideview mirror system of Claim 2, wherein said portion visible to a driver of the automobile has a width greater than about 1 mm.

16. The exterior sideview mirror system of Claim 1, wherein said plano reflective element is attached to said backing plate element by at least one of an adhesive attachment and a mechanical attachment.

17. The exterior sideview mirror system of Claim 1, wherein said multiradius reflective element is attached to said backing plate element by at least one of an adhesive attachment and a mechanical attachment.

18. The exterior sideview mirror system of Claim 1, wherein said multiradius reflective element is attached to said backing plate element at a location such that, when said exterior mirror assembly is attached to a side of an automobile, at least a portion of said plano reflective element is disposed closer to said side of the automobile than any portion of said
5 multiradius reflective element.

19. The exterior sideview mirror system of Claim 1, wherein said multiradius reflective element comprises a bent glass substrate with radii of curvature in the range of from about 4000 mm to about 50 mm.

20. The exterior sideview mirror system of Claim 1, wherein the ratio of the width of said plano reflective element to the width of said multiradius reflective element is greater than 1.

21. The exterior sideview mirror system of Claim 1, wherein the ratio of the width of said plano reflective element to the width of said multiradius reflective element is greater than 1.5.

22. The exterior sideview mirror system of Claim 1, wherein the ratio of the width of said plano reflective element to the width of said multiradius reflective element is greater than 2.5.

23. The exterior sideview mirror system of Claim 1, wherein the principal axis of the rearward field of view of said multiradius reflective element is different from and angled to the principal axis of the rearward field of view of said plano reflective element when both are attached to said backing plate element of said plano-multiradius reflective element
5 assembly and when said plano-multiradius reflective element assembly is mounted in said exterior sideview mirror assembly on an automobile.

24. The exterior sideview mirror system of Claim 23, wherein the principal axis of the rearward field of view of said plano reflective element is directed generally parallel to the longitudinal axis of an automobile equipped with the plano-multiradius reflective element assembly and wherein the principal axis of the rearward field of view of said multiradius
5 reflective element is directed generally at an angle downwards to the longitudinal axis of the automobile.

25. The exterior sideview mirror system of Claim 24, wherein said angle downwards to the longitudinal axis of the automobile is in the range from about 1 degree to about 10 degrees.

26. The exterior sideview mirror system of Claim 24, wherein said angle downwards to the longitudinal axis of the automobile is in the range from about 2 degrees to about 8 degrees.

27. The exterior sideview mirror system of Claim 24, wherein said angle downwards to the longitudinal axis of the automobile is in the range from about 3 degrees to about 6 degrees.

28. The exterior sideview mirror system of Claim 24, wherein said angle downwards to the longitudinal axis of the automobile is generally set by an angling of a surface of said backing plate element.

29. The exterior sideview mirror system of Claim 24, wherein said exterior sideview mirror assembly comprises a door-mounted exterior sideview mirror assembly adapted for attachment to a side of the automobile adjacent a driver seating location of a driver of the automobile and wherein the principal axis of the rearward field of view of said
5 multiradius reflective element is directed generally downwardly towards the road surface adjacent to the driver seating location at a distance in the range of about 1 foot to about 24 feet to the rear of the driver seating location.

30. The exterior sideview mirror system of Claim 24, wherein said exterior sideview mirror assembly comprises a door-mounted exterior sideview mirror assembly adapted for attachment to a side of the automobile adjacent a driver seating location of a driver of the automobile and wherein the principal axis of the rearward field of view of said
5 multiradius reflective element is directed generally downwardly towards the road surface adjacent to the driver seating location at a distance in the range of about 1 foot to about 12 feet to the rear of the driver seating location.

31. The exterior sideview mirror system of Claim 24, wherein said exterior sideview mirror assembly comprises a door-mounted exterior sideview mirror assembly adapted for attachment to a side of the automobile adjacent a driver seating location of a driver of the automobile and wherein the principal axis of the rearward field of view of said
5 multiradius reflective element is directed generally downwardly towards the road surface adjacent to the driver seating location at a distance in the range of about 1 foot to about 8 feet to the rear of the driver seating location.

32. The exterior sideview mirror system of Claim 1, wherein said exterior sideview mirror assembly comprises a fixedly attached exterior sideview mirror assembly.
33. The exterior sideview mirror system of Claim 1, wherein said exterior sideview mirror assembly comprises a break-away exterior sideview mirror assembly.
34. The exterior sideview mirror system of Claim 1, wherein said exterior sideview mirror assembly comprises a powerfold exterior sideview mirror assembly.
35. The exterior sideview mirror system of Claim 1, wherein said actuator comprises an electrically operable actuator.
36. The exterior sideview mirror system of Claim 1, wherein said control comprises a memory controller.
37. The exterior sideview mirror system of Claim 1, wherein at least one of said plano reflective element and said multiradius reflective element comprises an electro-optic reflective element.
38. The exterior sideview mirror system of Claim 1, wherein both said plano reflective element and said multiradius reflective element comprise an electro-optic reflective element.
39. The exterior sideview mirror system of Claim 1, wherein said plano reflective element comprises an electro-optical reflective element.
40. The exterior sideview mirror system of Claim 39, wherein said electro-optical reflective element comprises an electrochromic reflective element.
41. The exterior sideview mirror system of Claim 40, wherein said multiradius reflective element comprises a fixed reflectance mirror reflector.

42. The exterior sideview mirror system of Claim 41, wherein said fixed reflectance mirror reflector comprises a bent glass substrate coated with a metallic reflector coating.

43. The exterior sideview mirror system of Claim 1, wherein said plano-multiradius reflective element assembly is formed in an integral molding operation.

44. An exterior sideview mirror system suitable for use in an automobile, said exterior sideview mirror system comprising:

an exterior sideview mirror assembly adapted for attachment to a side of an automobile;

5 said exterior sideview mirror assembly including a reflective element having a rearward field of view when attached to said side of the automobile;

said reflective element attached to an electrically operable actuator and movable by said actuator in order to position said rearward field of view in response to a control;

10 wherein said reflective element comprises a plano reflective element having unit magnification and a separate auxiliary reflective element;

said plano reflective element and said auxiliary reflective element attached to a backing plate element, said backing plate element mounting to said actuator such that movement of said backing plate element by said actuator simultaneously and similarly moves said plano reflective element and said auxiliary reflective element; and

15 wherein said plano reflective element and said auxiliary reflective element are adjacently attached to said backing plate element at a joint, and wherein a demarcation element is disposed at said joint to form a demarcation between said plano reflective element and said auxiliary reflective element, said demarcation element having a portion visible to a driver of the automobile.

20 45. The exterior sideview mirror system of Claim 44, wherein demarcation element is dark colored.

46. The exterior sideview mirror system of Claim 44, wherein said demarcation element is dark colored with a color selected from the group consisting of black, grey, blue and brown.
47. The exterior sideview mirror system of Claim 44, wherein said joint comprises a space between said plano reflective element and said auxiliary reflective element.
48. The exterior sideview mirror system of Claim 47, wherein said demarcation element is at least partially disposed in said space between said plano reflective element and said auxiliary reflective element.
49. The exterior sideview mirror system of Claim 44, wherein said demarcation element comprises at least one of a polymer material, a tape, a plastic film, a paint, a lacquer and a caulk.
50. The exterior sideview mirror system of Claim 44, wherein said demarcation element comprises a polymer material.
51. The exterior sideview mirror system of Claim 44, wherein said demarcation element comprises a wall on said backing plate element, said wall located on said backing plate element at said joint, said wall separating said plano reflective element from said auxiliary reflective element.
52. The exterior sideview mirror system of Claim 44, wherein said portion visible to a driver of the automobile has a width less than about 4 mm.
53. The exterior sideview mirror system of Claim 44, wherein said portion visible to a driver of the automobile has a width less than about 3 mm.
54. The exterior sideview mirror system of Claim 44, wherein said portion visible to a driver of the automobile has a width less than about 2 mm.

55. The exterior sideview mirror system of Claim 44, wherein said portion visible to a driver of the automobile has a width greater than about 0.5 mm.

56. The exterior sideview mirror system of Claim 44, wherein said portion visible to a driver of the automobile has a width greater than about 0.75 mm.

57. The exterior sideview mirror system of Claim 44, wherein said portion visible to a driver of the automobile has a width greater than about 1 mm.

58. The exterior sideview mirror system of Claim 44, wherein said plano reflective element is attached to said backing plate element by at least one of an adhesive attachment and a mechanical attachment.

59. The exterior sideview mirror system of Claim 44, wherein said auxiliary reflective element is attached to said backing plate element by at least one of an adhesive attachment and a mechanical attachment.

60. The exterior sideview mirror system of Claim 44, wherein said auxiliary reflective element is attached to said backing plate element at a location such that, when said exterior mirror assembly is attached to a side of an automobile, at least a portion of said plano reflective element is disposed closer to said side of the automobile than any portion of said
5 auxiliary reflective element.

61. The exterior sideview mirror system of Claim 44, wherein said auxiliary reflective element comprises one of a flat glass substrate and a bent glass substrate

62. The exterior sideview mirror system of Claim 44, wherein the ratio of the width of said plano reflective element to the width of said auxiliary reflective element is greater than 1.

63. The exterior sideview mirror system of Claim 44, wherein the ratio of the width of said plano reflective element to the width of said auxiliary reflective element is greater than 1.5.

64. The exterior sideview mirror system of Claim 44, wherein the ratio of the width of said plano reflective element to the width of said auxiliary reflective element is greater than 2.5.

65. The exterior sideview mirror system of Claim 44, wherein the principal axis of the rearward field of view of said auxiliary reflective element is different from and angled to the principal axis of the rearward field of view of said plano reflective element when both are attached to said backing plate element and are mounted in said exterior sideview mirror
5 assembly on an automobile.

66. The exterior sideview mirror system of Claim 65, wherein the principal axis of the rearward field of view of said plano reflective element is directed generally parallel to the longitudinal axis of an automobile equipped with said reflective element and wherein the principal axis of the rearward field of view of said auxiliary reflective element is directed
5 generally at an angle downwards to the longitudinal axis of an automobile equipped with said reflective element.

67. The exterior sideview mirror system of Claim 66, wherein said angle downwards to the longitudinal axis of the automobile is in the range from about 1 degree to about 10 degrees.

68. The exterior sideview mirror system of Claim 66, wherein said angle downwards to the longitudinal axis of the automobile is in the range from about 2 degrees to about 8 degrees.

69. The exterior sideview mirror system of Claim 66, wherein said angle downwards to the longitudinal axis of the automobile is in the range from about 3 degrees to about 6 degrees.

70. The exterior sideview mirror system of Claim 66, wherein said angle downwards to the longitudinal axis of the automobile is generally set by an angling of a surface of said backing plate element.

71. The exterior sideview mirror system of Claim 66, wherein said exterior sideview mirror assembly comprises a door-mounted exterior sideview mirror assembly adapted for attachment to a side of the automobile adjacent a driver seating location of a driver of the automobile and wherein the principal axis of the rearward field of view of said auxiliary reflective element is directed generally downwardly towards the road surface adjacent to the driver seating location at a distance in the range of about 1 foot to about 24 feet to the rear of the driver seating location.

72. The exterior sideview mirror system of Claim 66, wherein said exterior sideview mirror assembly comprises a door-mounted exterior sideview mirror assembly adapted for attachment to a side of the automobile adjacent a driver seating location of a driver of the automobile and wherein the principal axis of the rearward field of view of said auxiliary reflective element is directed generally downwardly towards the road surface adjacent to the driver seating location at a distance in the range of about 1 foot to about 12 feet to the rear of the driver seating location.

73. The exterior sideview mirror system of Claim 66, wherein said exterior sideview mirror assembly comprises a door-mounted exterior sideview mirror assembly adapted for attachment to a side of the automobile adjacent a driver seating location of a driver of the automobile and wherein the principal axis of the rearward field of view of said auxiliary reflective element is directed generally downwardly towards the road surface adjacent to the driver seating location at a distance in the range of about 1 foot to about 8 feet to the rear of the driver seating location.

74. The exterior sideview mirror system of Claim 44, wherein said exterior sideview mirror assembly comprises a fixedly attached exterior sideview mirror assembly.

75. The exterior sideview mirror system of Claim 44, wherein said exterior sideview mirror assembly comprises a break-away exterior sideview mirror assembly.
76. The exterior sideview mirror system of Claim 44, wherein said exterior sideview mirror assembly comprises a powerfold exterior sideview mirror assembly.
77. The exterior sideview mirror system of Claim 44, wherein said control comprises a memory controller.
78. The exterior sideview mirror system of Claim 44, wherein at least one of said plano reflective element and said auxiliary reflective element comprises an electro-optic reflective element.
79. The exterior sideview mirror system of Claim 44, wherein both said plano reflective element and said auxiliary reflective element comprise an electro-optic reflective element.
80. The exterior sideview mirror system of Claim 44, wherein said plano reflective element comprises an electro-optical reflective element.
81. The exterior sideview mirror system of Claim 80, wherein said electro-optical reflective element comprises an electrochromic reflective element.
82. The exterior sideview mirror system of Claim 81, wherein said auxiliary reflective element comprises a fixed reflectance mirror reflector.
83. The exterior sideview mirror system of Claim 82, wherein said fixed reflectance mirror reflector comprises a bent glass substrate coated with a metallic reflector coating.

EXTERIOR MIRROR PLANO-AUXILIARY REFLECTIVE ELEMENT ASSEMBLY

ABSTRACT

This invention provides a plano-multiradius reflective element assembly suitable for use in an exterior sideview mirror assembly mounted to the side body of an automobile. The plano-multiradius reflective element assembly includes a plano reflective
5 element which has a rearward field of view, when mounted in an exterior sideview mirror assembly mounted to the side body of an automobile, with unit magnification. The plano-multiradius reflective element assembly also includes an auxiliary reflective element including a multiradius portion with a rearward field of view. The plano reflective element
10 provides a distortion-free rearward field of view and serves as the principal rearward-viewing portion of the plano-multiradius reflective element assembly. The multiradius portion provides a wide angle rearward field of view, and typically supplements the rearward field of view of the plano portion. The plano reflective element and the multiradius portion are separated by a demarcation element which enables the driver to readily delineate a rearward
15 view in the plano portion from a rearward view in the multiradius portion. The plano reflective element and the multiradius reflective element are individually, separately, and adjacently attached to a single backing plate which is mounted to an actuator of the exterior sideview mirror assembly. By adjusting the position of the backing plate within the housing of the exterior sideview mirror assembly via the actuator, the rearward field of view of both
20 the plano reflective element and the multiradius reflective element are simultaneously and similarly aligned.

DON01 P-793

Express Mail No. EL399135945US

DECLARATION AND POWER OF ATTORNEY

As a below named inventor, I hereby declare:

My residence, post office address and citizenship are as stated below next to my name.

I believe I am the original, first and sole inventor, if only one name is listed below, or an original, first and joint inventor, if plural names are listed below, of the subject matter which is claimed and for which a patent is sought on the invention entitled EXTERIOR MIRROR PLANO-AUXILIARY REFLECTIVE ELEMENT ASSEMBLY, the specification of which is attached hereto.

I have reviewed and understand the contents of the above-identified specification, including the claims, as amended by any amendment referred to above.

I acknowledge the duty to disclose to the United States Patent and Trademark Office (the Office), all information which is known by me to be material to patentability as defined in Title 37, Code of Federal Regulations (C.F.R.), Section 1.56.

CLAIM OF PRIORITY

I hereby claim foreign benefits under Title 35, United States Code (U.S.C.), Section 119, of any foreign application(s) for patent or inventor's certificate listed below and have also identified below any foreign application for patent or inventor's certificate having a filing date before that of the application on which priority is claimed.

Application Ser. No. None, filed in (country) _____ on _____.

I hereby claim the benefit under 35 U.S.C. § 120, of any United States application(s) listed below and, insofar as the above-identified specification, including claims, discloses and claims subject matter in addition to that disclosed in the prior copending application(s), listed below, I acknowledge the duty to disclose to the Office, all information which is known by me to be material to patentability as defined in 37 C.F.R. § 1.56, which became available between the filing date of the prior application and the national or PCT international filing date of this application.

U.S. Serial No. None, filed on _____, and now (status) _____.

I hereby claim the benefit under Title 35, United States Code, § 119(e) of any United States provisional application(s) listed below:

U.S. Serial No. None, filed on _____.

POWER OF ATTORNEY

I hereby appoint the patent law firm of Van Dyke, Gardner, Linn & Burkhart, LLP, 2851 Charlevoix Drive, S.E., Suite 207, Grand Rapids, Michigan 49546, telephone number 616/975-5500, facsimile number 616/975-5505, and the individual patent attorneys and patent agents at such patent law firm, namely, Daniel Van Dyke, Reg. No. 25 046; Donald S. Gardner, Reg. No. 25 975; Terence J. Linn, Reg. No. 30 283; Frederick S. Burkhart, Reg. No. 29 288; Catherine S. Collins, Reg. No. 37 599; Matthew L. Goska, Reg. No. 42 594; Anthony A. Bisulca, Reg. No. 40 913; and Timothy A. Flory, Reg. No. 42 540, my attorney(s) or agent(s) with full power of substitution and revocation, to prosecute this application and to transact all business in and to receive all correspondence from the Patent and Trademark Office connected therewith.

All statements made herein of my own knowledge are true and all statements made on information and belief are believed to be true, and further, these statements are made with the knowledge that willful false statements and the like are punishable by fine or imprisonment, or both, under 18 U.S.C. § 1001, and that such willful false statements may jeopardize the validity of this application or any patent issued thereon.

Sole inventor:

Niall R. Lynam JAN 6 2000
Niall R. Lynam Date

Citizenship: USA

Residence: 248 Foxdown

Holland, Michigan 49424

Post Office Address: Same as above.

10

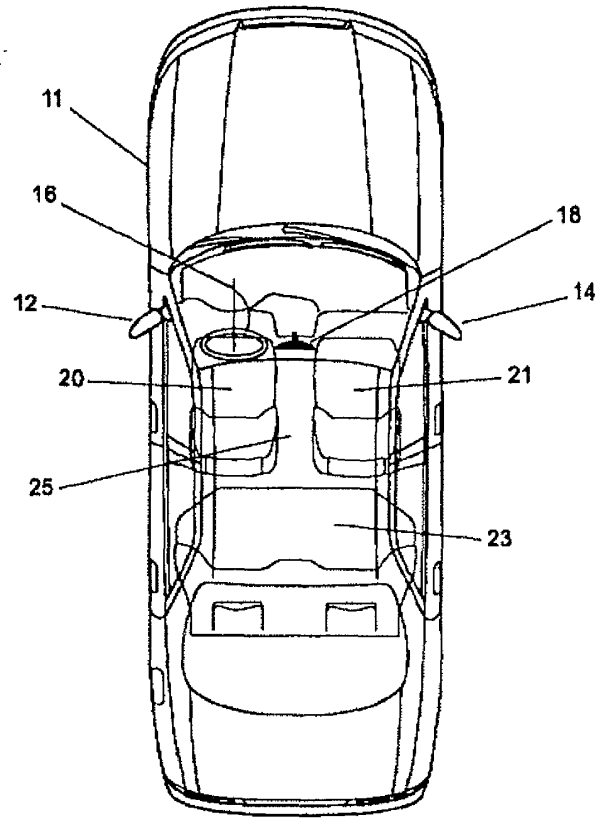

Figure 1

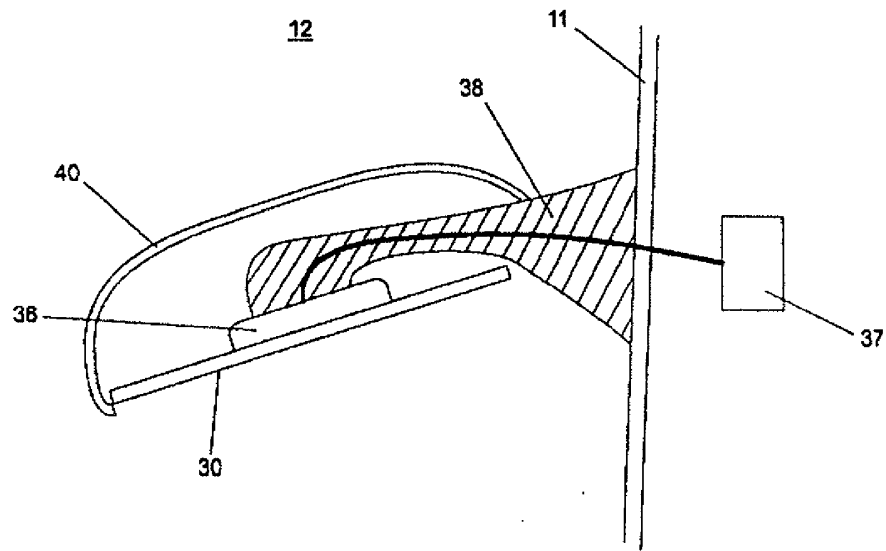

Figure 2

30

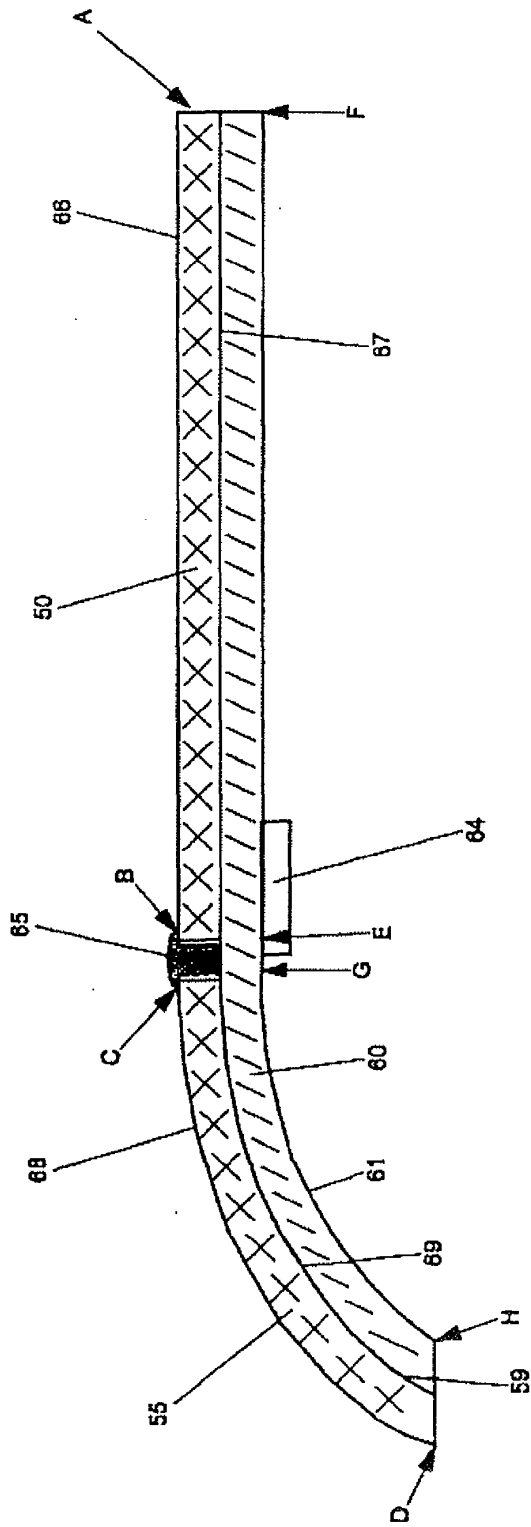

Figure 3

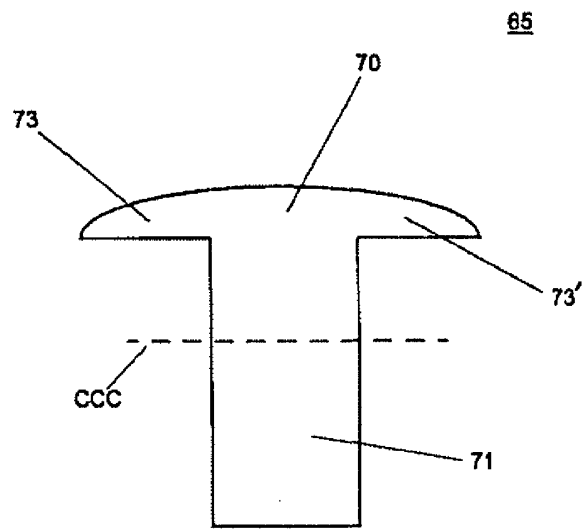

Figure 4

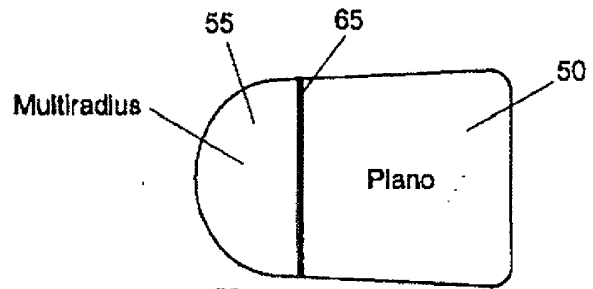

FIG. 5A

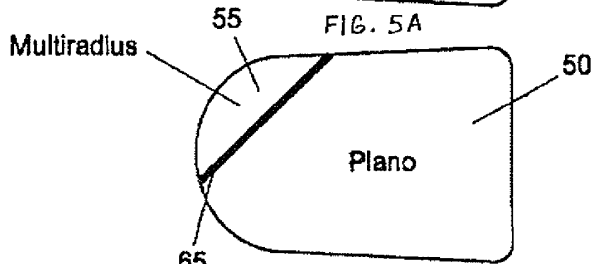

FIG. 5B

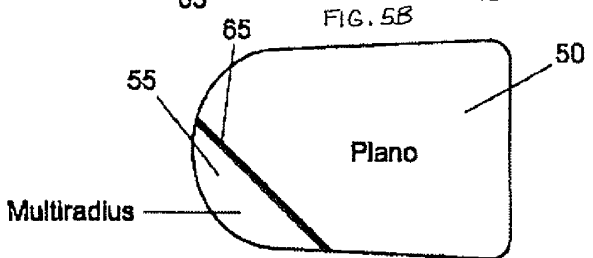

FIG. 5C

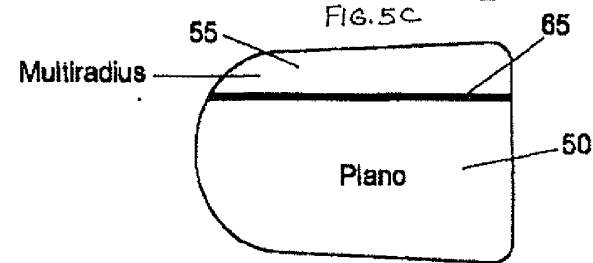

FIG. 5D

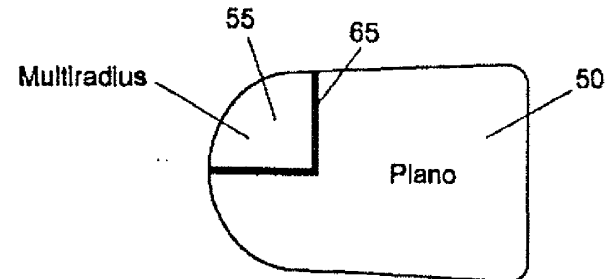

FIG. 5E

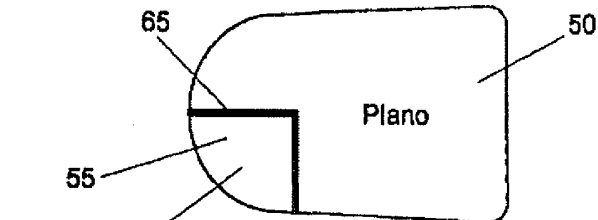

FIG. 5F

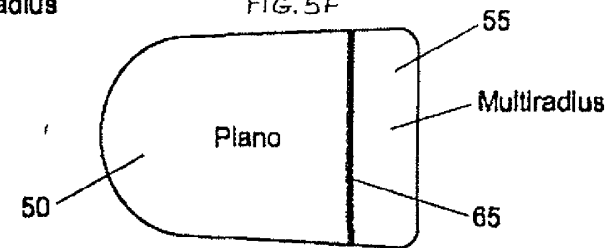

FIG. 5G

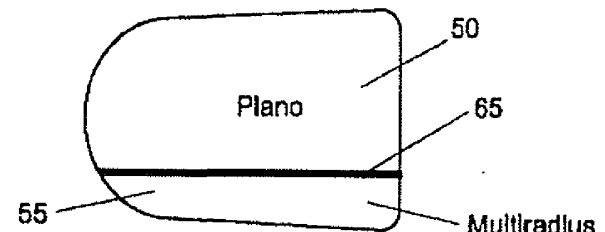

FIG. 5H

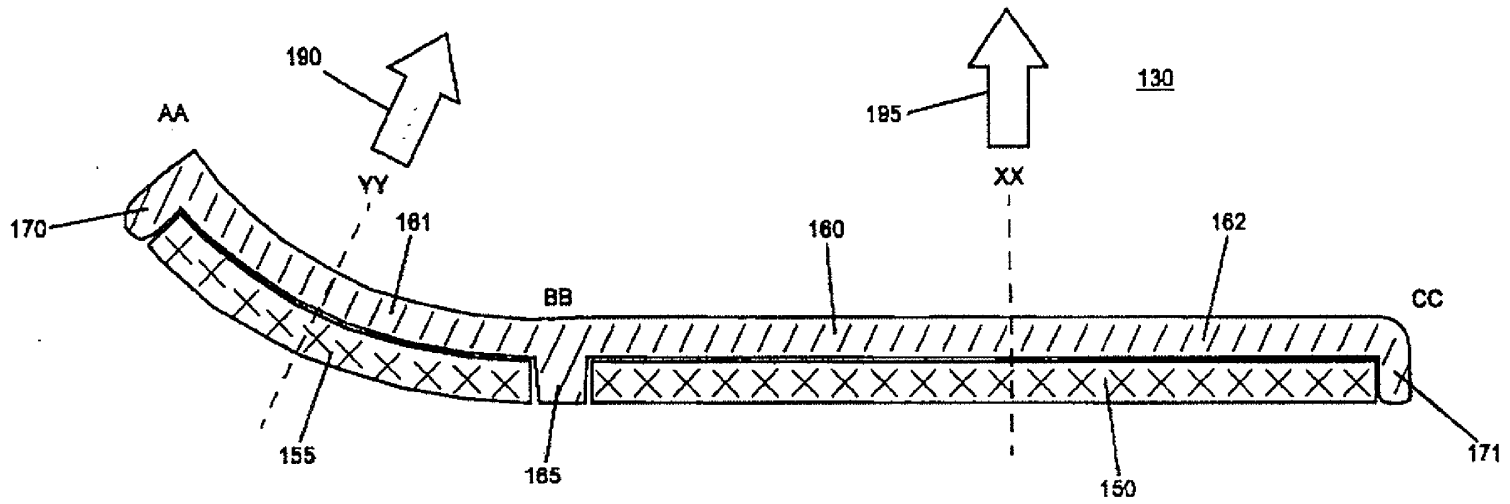

Figure 6

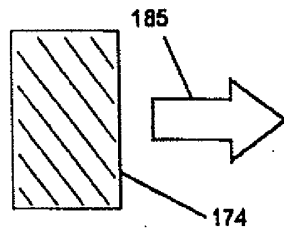

Figure 6A

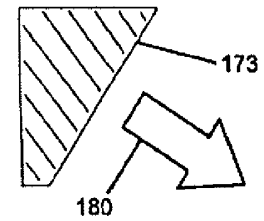

Figure 6B

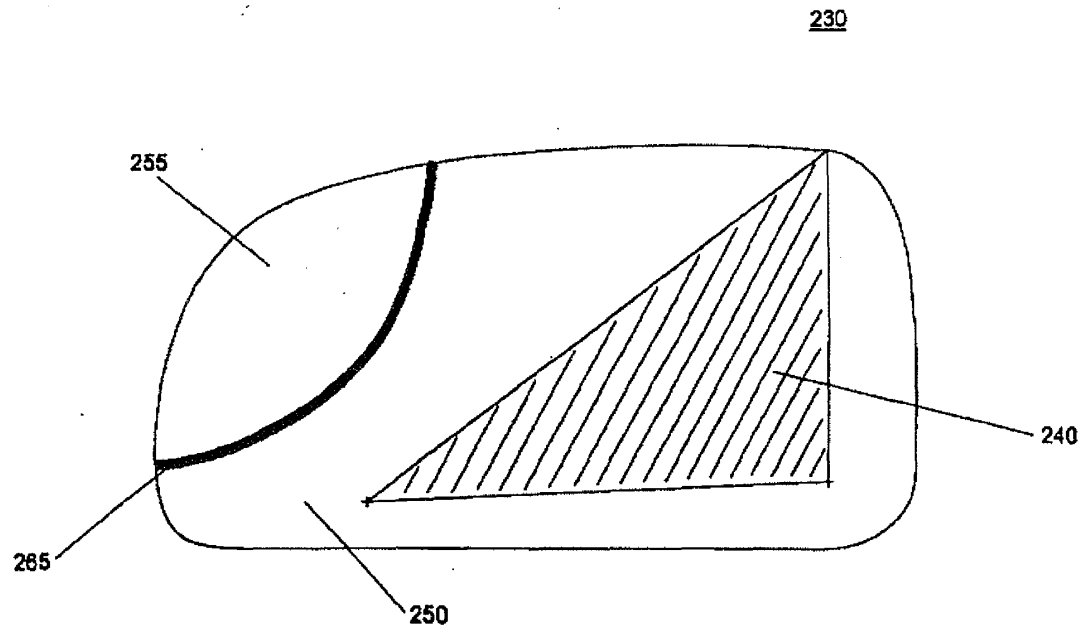

Figure 7



US006522451B1

(12) **United States Patent**
Lynam

(10) **Patent No.:** **US 6,522,451 B1**
(45) **Date of Patent:** **Feb. 18, 2003**

(54) **EXTERIOR MIRROR PLANO-AUXILIARY REFLECTIVE ELEMENT ASSEMBLY**

(75) Inventor: **Niall R. Lynam**, Holland, MI (US)

(73) Assignee: **Donnelly Corporation**, Holland, MI (US)

(*) Notice: Subject to any disclaimer, the term of this patent is extended or adjusted under 35 U.S.C. 154(b) by 0 days.

(21) Appl. No.: **09/478,315**

(22) Filed: **Jan. 6, 2000**

(51) **Int. Cl.**⁷ **G02F 1/15**; G02B 5/08; G02B 5/10; G02B 7/182; B60R 1/06

(52) **U.S. Cl.** **359/265**; 359/267; 359/841; 359/850; 359/864; 359/866; 359/868; 359/872; 359/877; 248/549; 248/900

(58) **Field of Search** 359/841, 850, 359/851, 855, 864, 865, 866, 868, 872, 877, 265, 267; 248/549, 900

(56) **References Cited**

U.S. PATENT DOCUMENTS

2,911,177	A	*	11/1959	West	
3,104,274	A	*	9/1963	King	359/864
3,170,985	A	*	2/1965	Katulich	
3,375,053	A		5/1968	Ward	350/293
3,389,952	A	*	6/1968	Tobin, Jr.	359/864
3,764,201	A	*	10/1973	Haile	

(List continued on next page.)

FOREIGN PATENT DOCUMENTS

DE	2409748		9/1975		
DE	3302735	*	8/1984		359/866
DE	4026578	*	4/1992		359/850
EP	0210757	*	2/1987		359/864
EP	0310261	A1	4/1989		
EP	0551802	*	1/1992		359/864

(List continued on next page.)

OTHER PUBLICATIONS

U.S. Pat. Ser. No. 09/350,930, filed Jul. 12, 1999, entitled Electrochromic Polymer Solid Films, Manufacturing Electrochromic Devices Using Such Films, and Processes for Making Such Solid Films and Devices, by Applicants Desraj V. Varaprasad et al.

Primary Examiner—Ricky D. Shafer

(74) *Attorney, Agent, or Firm*—Van Dyke, Gardner, Linn & Burkhart, LLP

(57) **ABSTRACT**

This invention provides a plano-multiradius reflective element assembly suitable for use in an exterior sideview mirror assembly mounted to the side body of an automobile. The plano-multiradius reflective element assembly includes a plano reflective element which has a rearward field of view, when mounted in an exterior sideview mirror assembly mounted to the side body of an automobile, with unit magnification. The plano-multiradius reflective element assembly also includes an auxiliary reflective element including a multiradius portion with a rearward field of view. The plano reflective element provides a distortion-free rearward field of view and serves as the principal rearward-viewing portion of the plano-multiradius reflective element assembly. The multiradius portion provides a wide angle rearward field of view, and typically supplements the rearward field of view of the plano portion. The plano reflective element and the multiradius portion are separated by a demarcation element which enables the driver to readily delineate a rearward view in the plano portion from a rearward view in the multiradius portion. The plano reflective element and the multiradius reflective element are individually, separately, and adjacently attached to a single backing plate which is mounted to an actuator of the exterior sideview mirror assembly. By adjusting the position of the backing plate within the housing of the exterior sideview mirror assembly via the actuator, the rearward field of view of both the plano reflective element and the multiradius reflective element are simultaneously and similarly aligned.

40 Claims, 8 Drawing Sheets

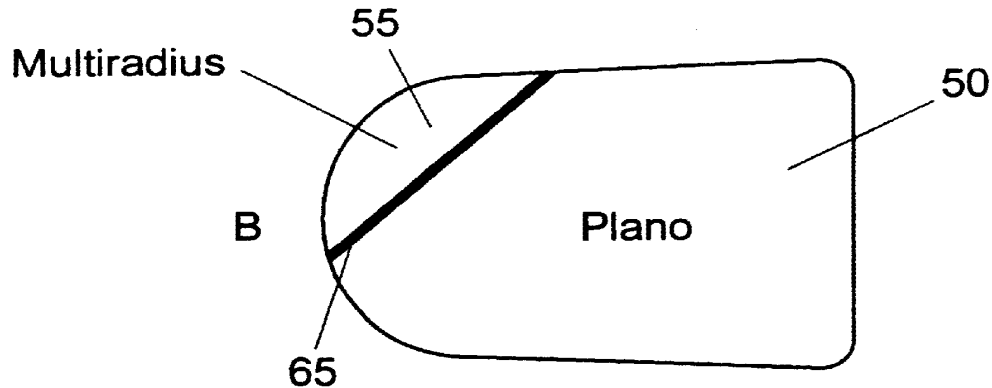

EXHIBIT B

US 6,522,451 B1

Page 2

U.S. PATENT DOCUMENTS

4,258,979	A	*	3/1981	Mahin	359/868
4,268,120	A		5/1981	Jitsumori	350/302
4,281,899	A	*	8/1981	Oskam		
4,306,770	A	*	12/1981	Marhauer	359/866
4,311,362	A	*	1/1982	LaPorte	359/864
4,331,382	A	*	5/1982	Graff	359/868
4,449,786	A		5/1984	McCord	350/293
4,555,166	A	*	11/1985	Enomoto	359/877
4,678,294	A	*	7/1987	Van Nostrand	359/864
4,727,302	A	*	2/1988	Mizuta et al.	359/877
4,770,522	A	*	9/1988	Alten	359/877
4,859,046	A	*	8/1989	Traynor et al.	359/866
4,917,485	A	*	4/1990	Baldwin, Sr.		
5,005,962	A	*	4/1991	Edelman	359/864
5,052,792	A	*	10/1991	McDonough	359/866
5,107,374	A	*	4/1992	Lupo et al.	359/841
5,115,352	A	*	5/1992	Do Espirito Santo	359/864
5,166,833	A	*	11/1992	Shyu		
5,225,943	A	*	7/1993	Lupo	359/841
5,239,405	A		8/1993	Varaprasad et al.	359/272
5,432,643	A	*	7/1995	Huang	359/864
5,550,677	A		8/1996	Schofield et al.	359/604

5,579,133	A	*	11/1996	Black et al.	359/866
5,621,569	A	*	4/1997	Schlenke	359/868
5,668,663	A		9/1997	Varaprasad et al.	359/608
5,724,187	A		3/1998	Varaprasad et al.	359/608
5,751,489	A		5/1998	Caskey et al.	359/603
5,793,542	A	*	8/1998	Kondo et al.	359/866
5,796,532	A	*	8/1998	Kanazawa	359/864
5,910,854	A		6/1999	Varaprasad et al.	359/273
6,032,323	A	*	3/2000	Smith et al.	359/877
6,199,993	B1	*	3/2001	Mou	359/864

FOREIGN PATENT DOCUMENTS

FR	2628042		9/1929			
GB	1279158	*	6/1972	359/868	
GB	2048189	*	12/1980	359/868	
GB	2092534	*	8/1982	359/868	
JP	0051637	*	4/1980	359/866	
JP	62-105103	*	5/1987			
JP	1186443		7/1989			
JP	1-208245	*	8/1989	359/871	
NL	7908257	*	6/1981	359/864	

* cited by examiner

10

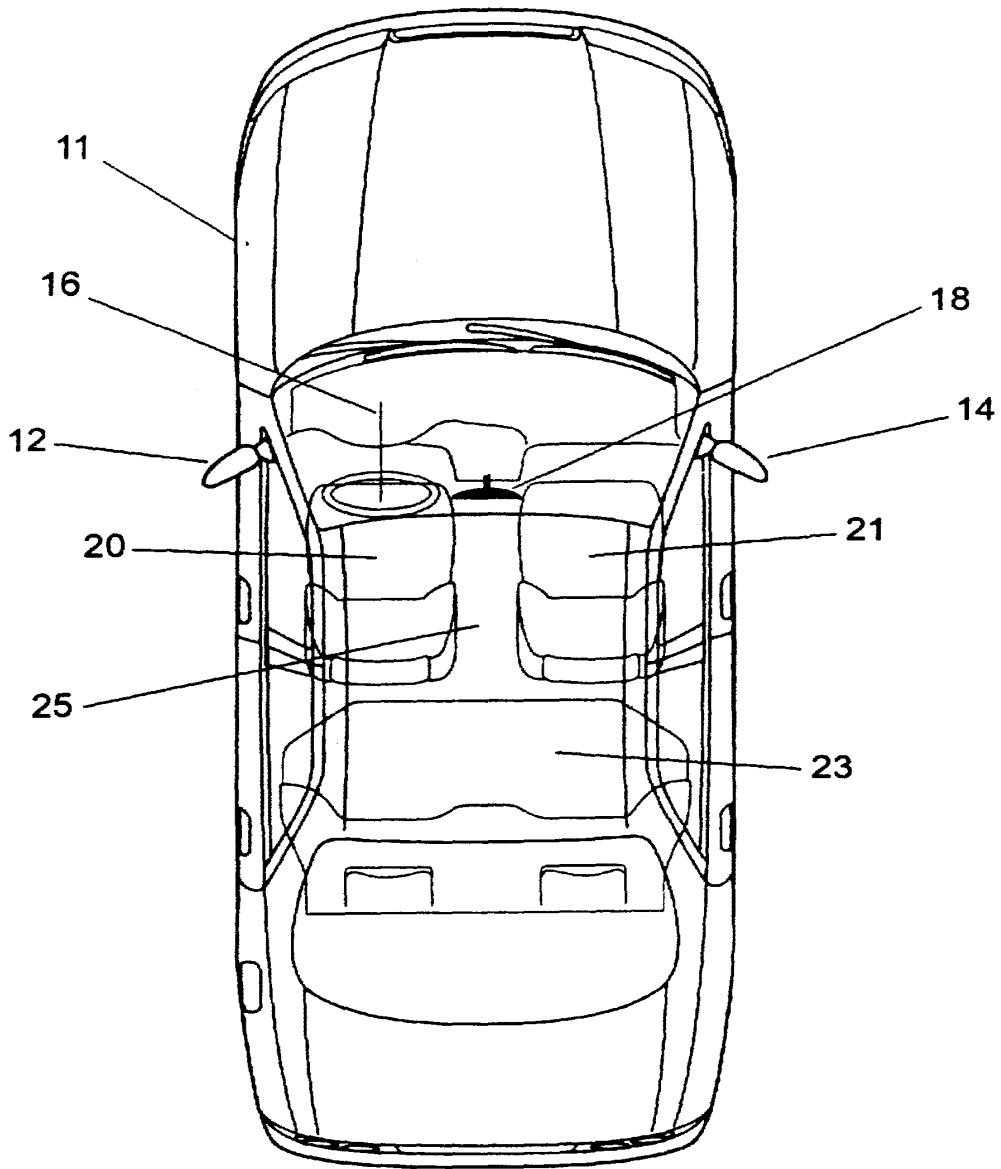

Figure 1

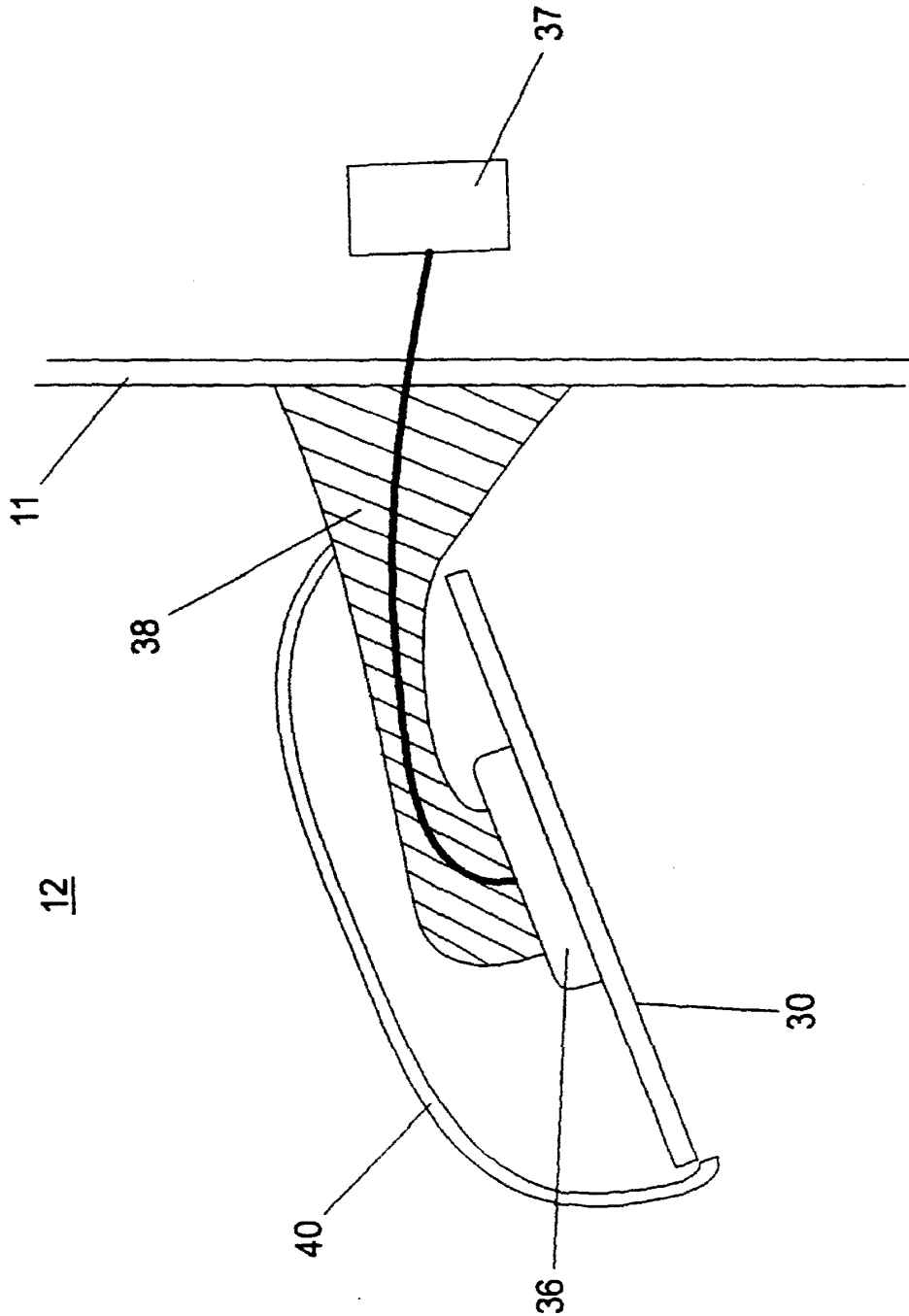

Figure 2

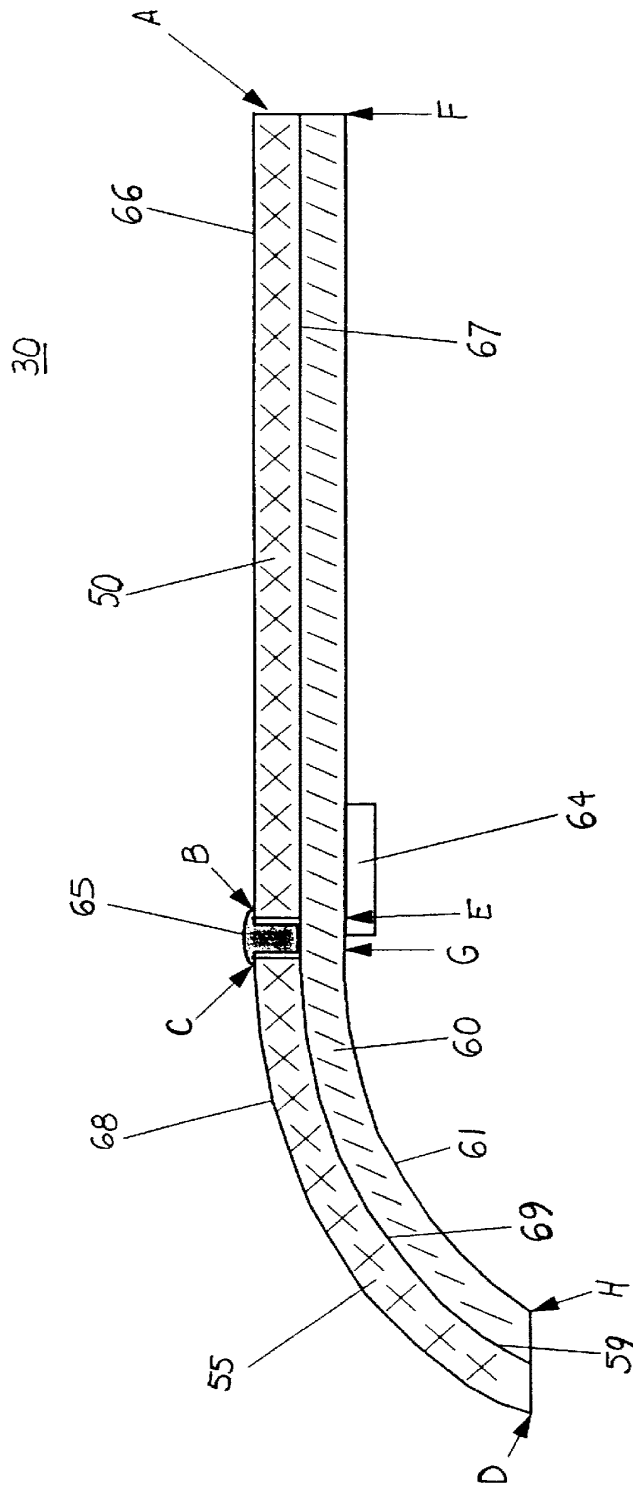

Figure 3

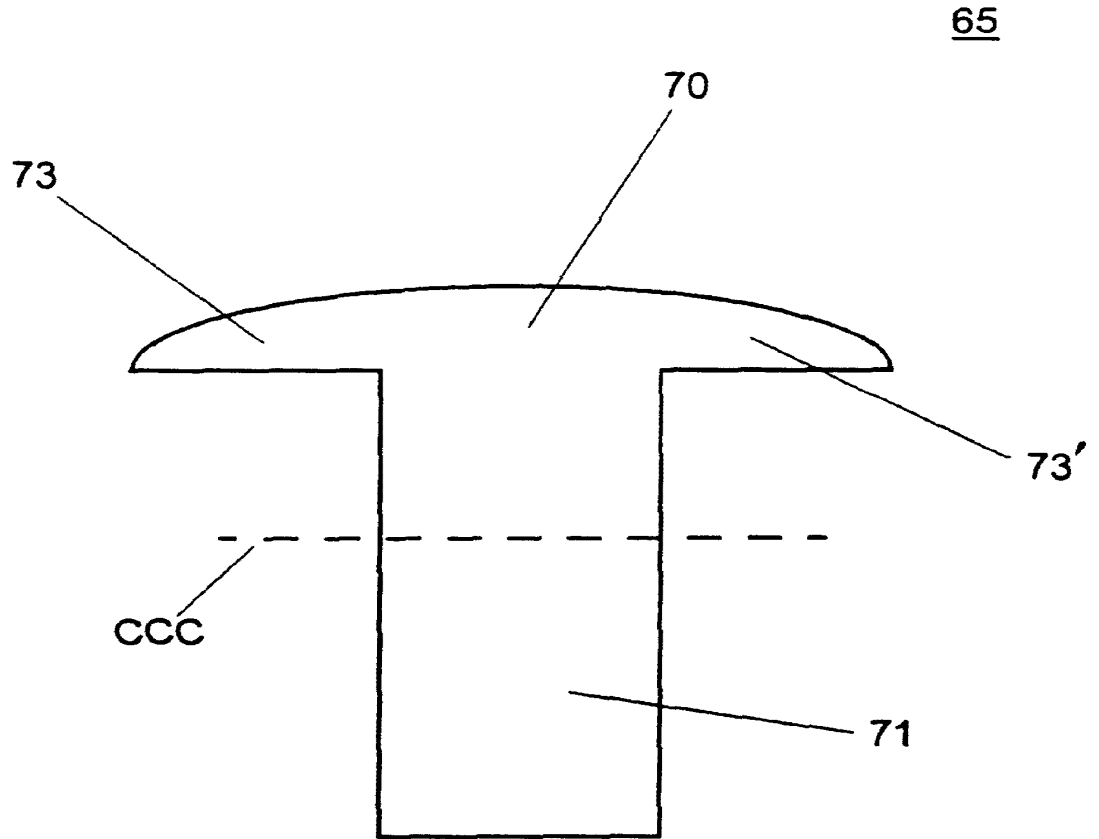
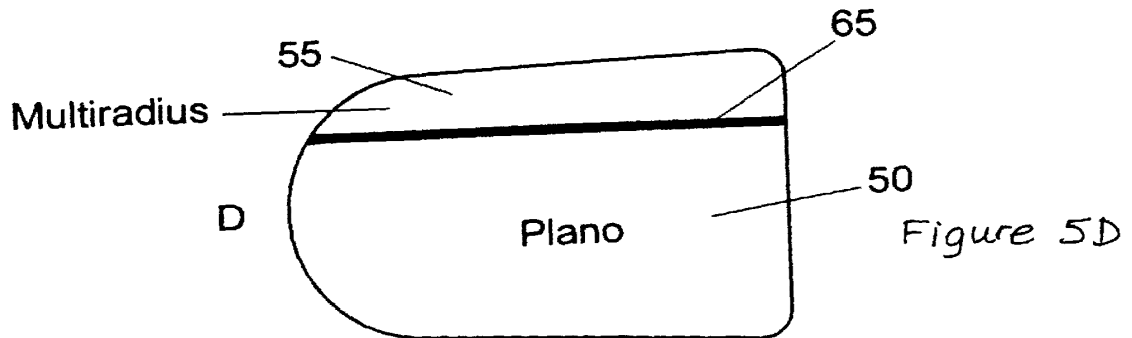
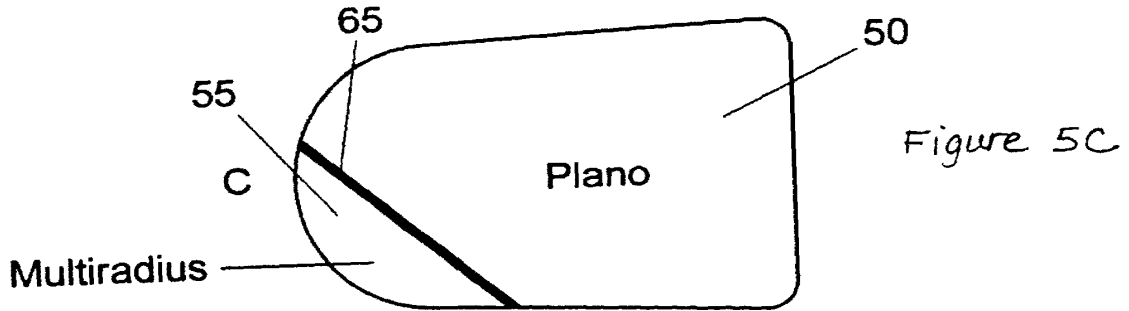
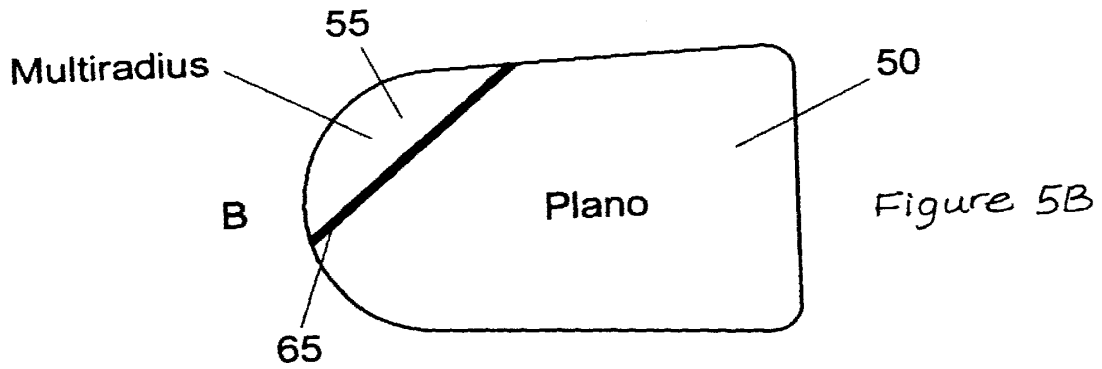
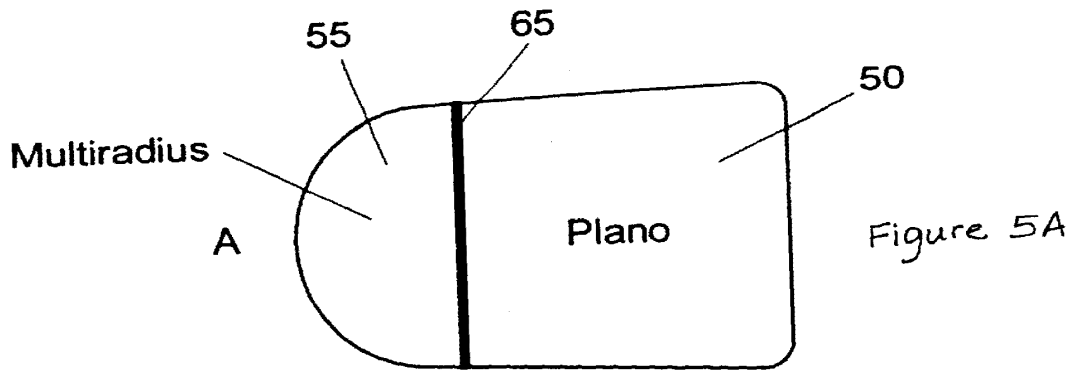
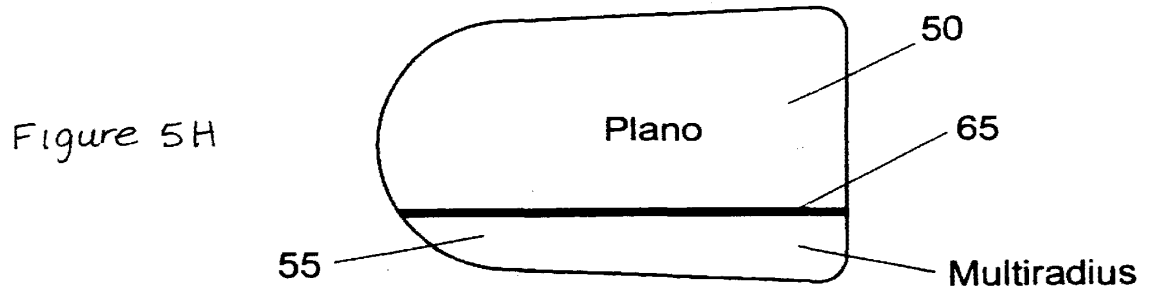
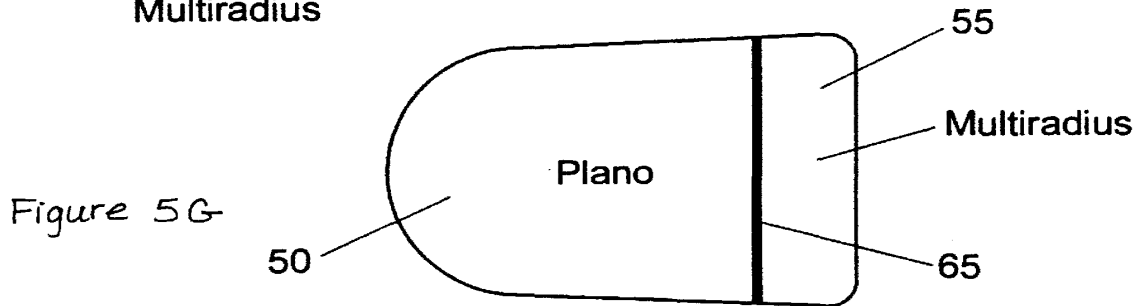
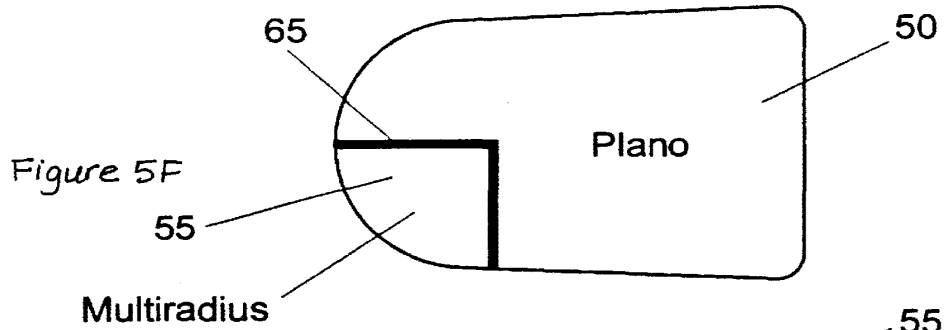
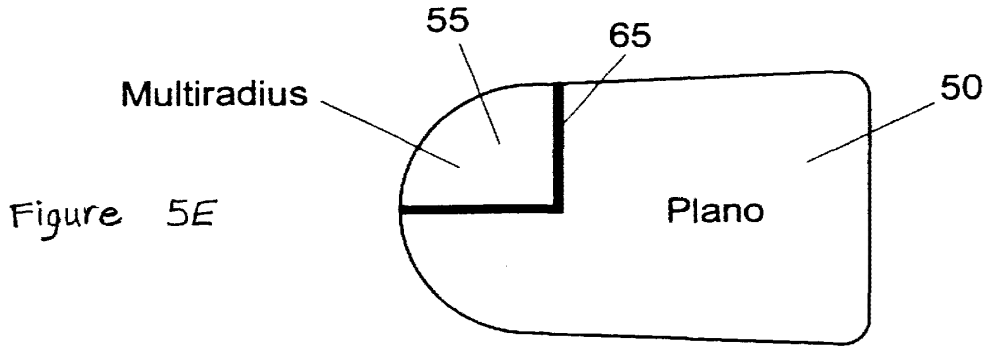

Figure 4





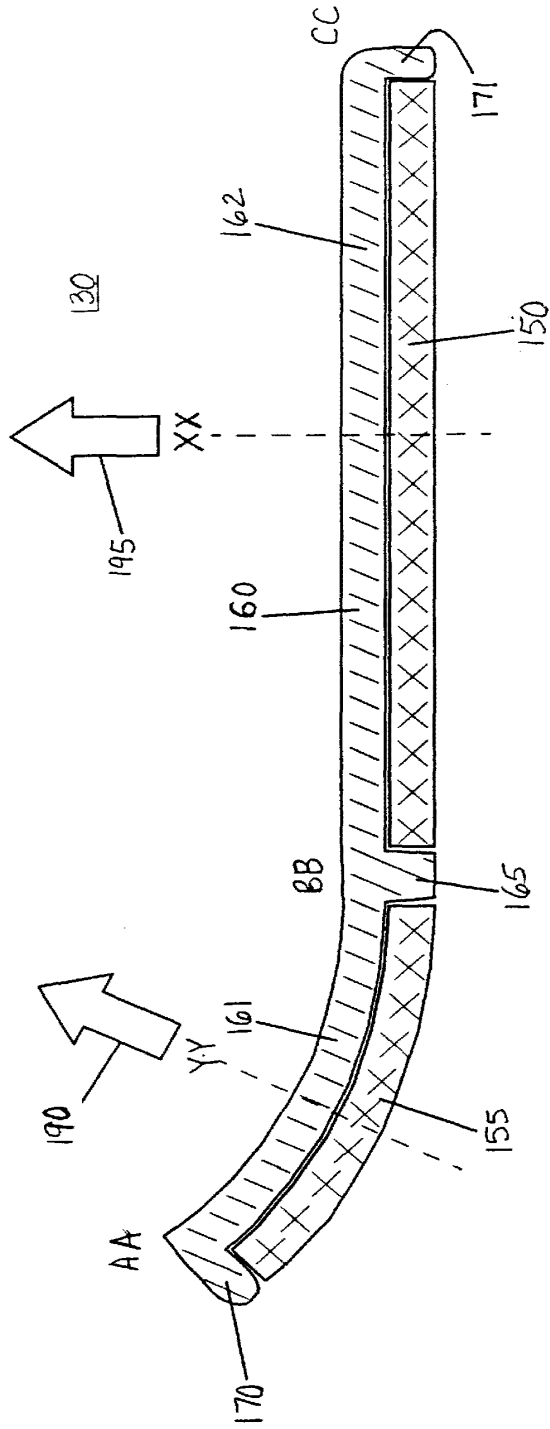

Figure 6

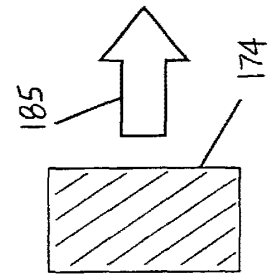

Figure 6A

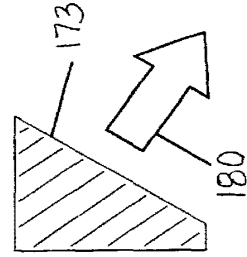

Figure 6B

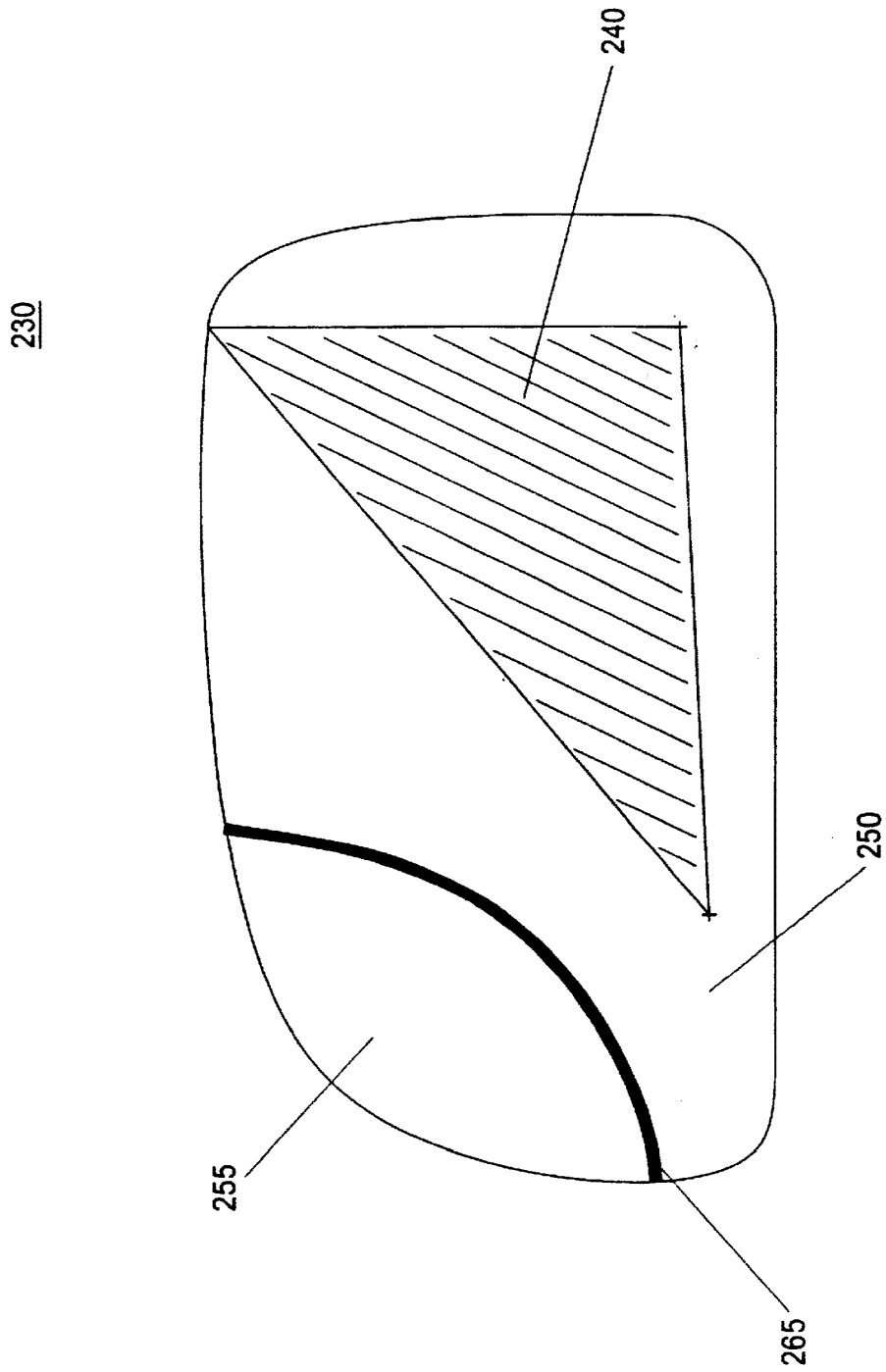

Figure 7

1

EXTERIOR MIRROR PLANO-AUXILIARY REFLECTIVE ELEMENT ASSEMBLY

TECHNICAL FIELD AND BACKGROUND OF THE INVENTION

The present invention relates to exterior sideview mirror assemblies suitable for use on an automobile, and more specifically, to plano-auxiliary reflective element assemblies for use in automobile exterior sideview mirror assemblies.

Automobiles are typically equipped with an interior rearview mirror assembly (adapted for providing a rearward field of view immediately rearward of the vehicle, typically principally in the road lane the vehicle is traveling in) and at least one exterior sideview mirror assembly attached to the side of the vehicle (typically adjacent a front side window portion). The exterior side view mirror assembly typically comprises a reflective element adapted to provide a rearward field of view of the side lane adjacent the vehicle so as to allow the driver see whether a side approaching vehicle is present when the driver is contemplating a lane change. Conventionally, automobiles are equipped with a driver-side exterior mirror assembly and, very often, with a passenger-side exterior sideview mirror assembly mounted to the side of the automobile body opposite to that of the driver-side assembly. While the combination of an interior rearview mirror with a driver-side exterior mirror (and especially in a three-mirror system comprising an interior rearview mirror with a driver-side exterior mirror and a passenger-side exterior mirror) works well in many driving situations, rear vision blind spots present a potential safety hazard while driving. A rear vision blind spot is an area adjacent the side of an automobile where a view of another vehicle (overtaking on that side) is not captured in the rearward field of view of the exterior mirror reflector on that side. This presents a potential safety hazard as the driver, upon checking the view in the exterior sideview mirror and seeing no overtaking vehicle therein, may deem it safe to initiate a lane change, unaware that there is a vehicle immediately adjacent in a blind-spot of the exterior mirror reflector.

Various attempts have been made conventionally to minimize and/or eliminate exterior mirror blind-spots on vehicles. One approach is to make the exterior mirror reflector larger, and particularly wider with respect to the vehicle body. By increasing the width of the exterior mirror reflector, it has a wider field of view rearwards, and hence the reflector blind-spot is reduced. While use of a wide exterior mirror reflector is an option for trucks, buses and commercial vehicles, increasing the width of the reflector used in an exterior sideview mirror assembly mounted on automobiles (such as sedans, station wagons, sports cars, convertibles, minivans, sports utility vehicles, pick-up trucks and similar passenger carrying automobiles) is often not an option. In such domestic automobiles, increasing the width of the exterior mirror reflector increases the size of the exterior sideview mirror assembly with a concomitant increase in aerodynamic drag, increase in fuel consumption, increased difficulty in parking in tight parking spaces, and increased reflector vibration. Use of a non-flat, curved exterior mirror reflector is commonly used to increase rearward field of view without increasing reflector size.

While working well to increase field of view, use of a curved reflector (such as a convex, spherically-curved reflector) has disadvantages. The field of view rearward increases as the degree of curvature of the bent substrate increases (i.e., the field of view rearward increases as the

2

radius of curvature of the bent substrate decreases). However, such wide-angle mirrors have non-unit magnification and distance perception rearward is distorted. For this reason, convex (spherically-bent) exterior mirror reflectors are required in some countries (such as the United States) to carry a safety warning "OBJECTS IN MIRROR ARE CLOSER THAN THEY APPEAR". Distance perception is particularly important for a driver-side exterior mirror. Indeed, Federal Vehicle Safety Standard No: 111 in the United States (the entire disclosure of which is hereby incorporated by reference herein) requires that the driver-side exterior mirror reflector exhibit unit magnification, and places restrictions on the radius of curvature allowed for any bent passenger-side mirror as well as requiring a safety warning be placed thereon. As an improvement over spherically bent/convex mirror reflectors, aspherical or multiradius mirror reflectors (such as are disclosed in U.S. Pat. Nos. 4,449,786 and 5,724,187, the entire disclosures of which are hereby incorporated by reference herein) have been developed. Such mirrors are widely used in Europe and Asia for both driver-side exterior mirror reflectors and for passenger-side exterior mirror reflectors. The aspherical or multiradius mirror reflectors typically have a less curved (larger radius of curvature) reflective region that is inboard or closest to the driver when mounted on a vehicle and, usually separated by a demarcation line or the like, have a more curved (smaller radius of curvature) region that is outboard or farthest from the driver when mounted on a vehicle. However, such aspherical or multiradius reflectors do not have unit magnification and so cannot be used when unit magnification is mandated (such as by FMVSS 111, referenced above).

To supplement a flat driver-side exterior mirror reflector, an auxiliary and separate bent reflector is sometimes incorporated into the driver-side exterior sideview mirror assembly. However, this is often not suitable for passenger automobiles because of the extra space required in the sideview mirror assembly to accommodate an auxiliary reflector element. Also, in most passenger automobiles, the position of the side view mirror reflector is adjustable by the driver (such as by a hand-adjust, or by a manually adjustable cable such as a Bowden cable or by an electrically operable actuator, as known in the art) in order to provide to that driver his or her desired rearward field of view, which ill-suits use of a separate, auxiliary reflector. Likewise, addition of stick-on blind-spot mirror reflectors (such as are commonly sold in automotive parts stores and the like) onto an automobile exterior sideview mirror reflector has disadvantages, including obscuring field of view of the automobile mirror reflector and adding to mirror element vibration.

There is thus a need to provide an automobile exterior sideview reflective element, and particularly a driver-side automobile exterior sideview reflective element, that overcomes the disadvantages above and that provides the driver of the automobile with a distortion-free field of view with unit magnification that is supplemented with a wide-angle view of a side lane blind spot, and there is a need that this be provided in a unitary reflective element assembly module suitable to mount onto, and be adjusted by, the mirror reflector adjustment mechanism (such as an electrically operated, motorized actuator) provided in the exterior sideview mirror assembly.

BRIEF DESCRIPTION OF THE DRAWINGS

FIG. 1 is a perspective view of an automobile equipped with exterior sideview mirror assemblies according to this present invention;

3

FIG. 2 is a top plan partial fragmentary view of the driver's side exterior rearview mirror assembly of FIG. 1;

FIG. 3 is an enlarged sectional view of a plano-multiradius reflective element assembly of the mirror assembly in FIG. 2;

FIG. 4 is an enlarged sectional view of a demarcation element of the plano-multiradius reflective element assembly of FIG. 3;

FIGS. 5A-5H illustrate views of various locations for a plano reflective element and an auxiliary reflective element according to this present invention;

FIG. 6 is a sectional view of a second embodiment of a plano reflective element assembly according to the present invention including a demarcation element formed as a dividing wall in a backing plate element;

FIG. 6A is a cross-section taken along line XX of FIG. 6;

FIG. 6B is a cross-sectional view taken along line YY of FIG. 6; and

FIG. 7 is a schematic of a third embodiment of a plano-auxiliary reflective element assembly according to this present invention.

SUMMARY OF THE INVENTION

This invention provides a plano reflective element with unit magnification and an auxiliary reflector element for use in an exterior sideview mirror assembly on an automobile. More specifically, this invention provides a plano-multiradius reflective element assembly suitable for use in an exterior sideview mirror assembly mounted to the side body of an automobile. The plano-multiradius reflective element assembly of this invention is especially suitable for mounting in a driver-side exterior sideview mirror assembly that is mounted to the side of the automobile body adjacent to the seating position of the driver in the front of the interior vehicular cabin. The plano-multiradius reflective element assembly of this invention comprises a plano portion which has a rearward field of view, when mounted in an exterior sideview mirror assembly mounted to the side body of an automobile, with unit magnification. This plano portion comprises a flat substrate, typically a flat glass substrate, provided with a reflective surface. The plano-multiradius reflective element assembly of this invention also includes a multiradius portion with a rearward field of view, when mounted in an exterior sideview mirror assembly mounted to the side body of an automobile, that has non-unit magnification. The plano portion provides a distortion-free rearward field of view and serves as the principal rearward-viewing portion of the plano-multiradius reflective element. The multiradius portion provides a wide angle rearward field of view, and typically supplements the rearward field of view of the plano portion. This multiradius portion comprises a curved substrate, typically a bent glass substrate, provided with a reflective surface. The plano portion and the multiradius portion are demarcated apart by a demarcation element. The demarcation element enables the driver of a vehicle equipped with the plano-multiradius reflective element of this invention to readily delineate a rearward view in the plano portion from a rearward view in the multiradius portion. The plano portion comprises a flat reflective element and the multiradius portion comprises a bent reflective element. The flat, plano reflective element and the curved, multiradius reflective element are individually and separately manufactured, and are adjacently attached to a single backing plate (which typically comprises a polymeric substrate, most typically a molded polymeric substrate), and with the demarcation element disposed at the joint of the

4

plano, flat reflective element and the multiradius, bent reflective element. The backing plate is fabricated (typically by polymeric molding) to have a flat portion that corresponds to the plano, flat reflective element, and a curved surface that corresponds to the multiradius, curved reflective element. The attachment of the plano reflective element and an auxiliary reflective element to a single backing plate produces a unitary plano-auxiliary reflective element assembly module suitable for mounting in an exterior sideview mirror assembly. By adjusting the position of the backing plate within the exterior sideview mirror assembly, the rearward fields of view of both the plano reflective element and the auxiliary reflective element are simultaneously and similarly aligned.

One embodiment of the invention includes an exterior sideview mirror system suitable for use in an automobile comprising an exterior sideview mirror assembly adapted for attachment to a side of the automobile. The exterior sideview mirror assembly includes a reflective element having a rearward field of view when attached to said side of the automobile. The reflective element is attached to an actuator and is movable by the actuator in order to position the reflective element's rearward field of view in response to a control. The reflective element comprises a plano-multiradius reflective element assembly which comprises a plano reflective element having unit magnification and a separate multiradius reflective element having a multiradius curvature. The plano element and the separate multiradius element of the plano-multiradius reflective element assembly are attached to a backing plate element. The backing plate element is mounted to the actuator such that movement of the backing plate element (and hence the plano-multiradius reflective element assembly) by the actuator simultaneously and similarly moves the plano element and the multiradius element. The plano element and the multiradius element are separately and, preferably, adjacently attached to the backing plate element at a joint.

In a further embodiment, a demarcation element is disposed at this joint to form a demarcation between the plano element and the multiradius element; this demarcation element having a portion visible to a driver of the automobile. Preferably, the demarcation element is dark colored, such as with a color selected from the group consisting of black, grey, blue and brown. Optionally, there is a space at the joint of the plano element and the multiradius element and the demarcation element is at least partially disposed in said space between said plano element and said multiradius element. The demarcation element can comprise at least one of a polymer material, a tape, a plastic film, a paint, a lacquer and a caulk.

In a further embodiment, the demarcation element comprises a wall on the backing plate element; this wall being located on the backing plate element at the joint of the plano element and the multiradius element, this wall separating the respective elements apart.

In preferred embodiments, the portion of the demarcation element visible to a driver of an automobile equipped with the plano-multiradius reflective element assembly of this invention has a width from about 0.5 mm to about 4 mm.

In preferred embodiments, the plano element is attached to the backing plate element by at least one of an adhesive attachment and a mechanical attachment.

In preferred embodiments, the multiradius element is attached to the backing plate element at a location such that, when the exterior mirror assembly is attached to a side of an automobile, at least portion, and preferably at least a sub-

5

stantial portion, of the plano element is disposed closer to the side of the vehicle than any portion of the multiradius element element.

In preferred embodiments, the multiradius element comprises a bent glass substrate with radii of curvature in the range of from about 4000 mm to about 50 mm, and the ratio of the width of the plano element to the width of the multiradius element is greater than 1.

In preferred embodiments, the principal axis of the rearward field of view of the auxiliary, multiradius element is different from and angled to the principal axis of the rearward field of view of the plano element when both are attached to the backing plate element of the plano-multiradius reflective element assembly and when the plano-multiradius reflective element assembly is mounted in an exterior sideview mirror assembly on an automobile. The principal axis of the rearward field of view of the plano element is directed generally parallel to the longitudinal axis of an automobile equipped with the plano-multiradius reflective element assembly and the principal axis of the rearward field of view of the multiradius element is directed generally at an angle downwards to the longitudinal axis of the vehicle.

In a preferred embodiment, the exterior sideview mirror assembly equipped with the plano-multiradius reflective element assembly comprises a fixedly attached exterior sideview mirror assembly. In another preferred embodiment, the exterior sideview mirror assembly equipped with the plano-multiradius reflective element assembly comprises a break-away exterior sideview mirror assembly. In another preferred embodiment, the exterior sideview mirror assembly equipped with the plano-multiradius reflective element assembly comprises a powerfold exterior sideview mirror assembly. In another preferred embodiment, the actuator of the exterior sideview mirror assembly to which the plano-multiradius reflective element assembly is mounted comprises an electrically operable actuator. In another preferred embodiment, the actuator of the exterior sideview mirror assembly to which the plano-multiradius reflective element assembly is mounted is controlled by a switch or by a memory controller. In another preferred embodiment, the plano element and/or the multiradius element of the plano-multiradius reflective element assembly comprises an electro-optic reflective element, preferably an electrochromic reflective element. In another preferred embodiment, the plano element of the plano-multiradius reflective element assembly comprises an electro-optic reflective element, preferably an electrochromic reflective element, and the multiradius element comprises a fixed reflectance mirror reflector, such as a fixed reflectance mirror reflector comprises a bent glass substrate coated with a metallic reflector coating.

In a preferred embodiment, the plano-auxiliary reflective element assembly is assembly is formed in an integral molding operation.

These and other advantages, features, and modifications will become more apparent when reviewed in conjunction with the drawings and the detailed description which follows.

DETAILED DESCRIPTION OF THE PREFERRED EMBODIMENTS

As illustrated in FIG. 1, passenger automobile 10 (which may be a sedan, a station-wagon, a sports car, a convertible, a minivan, a sports utility vehicle, a pick-up truck or a similar passenger carrying non-commercial, personal trans-

6

portation automobile) includes an interior rearview mirror assembly 18 positioned within interior vehicle cabin 25. Interior vehicle cabin 25 further includes a steering wheel 16, a driver seat 20 positioned at steering wheel 16, a front passenger seat 21 adjacent to driver seat 20 in the front portion of cabin 25, and a rear passenger seat 23 in the rear portion of cabin 25. Automobile 10 further includes a driver-side exterior sideview mirror assembly 12 and a passenger-side exterior sideview mirror assembly 14, each adapted for attachment to opposing sides of automobile body 11, most preferably adjacent to the seating position of the driver seated in driver seat 20 for driver-side assembly 12 and adjacent to the front passenger seat 21 for passenger-side assembly 14. Exterior sideview mirrors, mounted as shown in FIG. 1 close to the driver seating location, are commonly referred to as door-mounted exterior sideview mirror assemblies. Driver-side exterior sideview mirror assembly 12 includes, as illustrated in FIG. 2, a plano-multiradius exterior sideview reflective element assembly 30. Plano-multiradius reflective element assembly 30 is mounted to a reflective element positioning actuator 36. The orientation of plano-multiradius reflective element assembly 30, and hence its rearward field of view, is adjustable by actuator 36 in response to control 37. Control 37 can comprise a handset control that allows the driver manually move the orientation of plano-multiradius reflective element assembly 30 within exterior mirror housing 40 (such as by a lever control or by a cable control) and hence reposition the rearward field of view of plano-multiradius reflective element assembly 30. Alternately, when actuator 36 comprises an electrically actuated actuator that is electrically operable incorporating at least one motor, control 37 can comprise a switch (which, preferably, is operable under control of the driver seated in cabin 25) or control 37 can comprise a memory controller, as known in the automotive mirror art, that controls actuator 36 to move the position of plano-multiradius reflective element assembly 30 to a pre-set orientation that suits the rearward field of view preference of an individual driver. Actuator 36 is mounted to bracket 38 which attaches to vehicle body side 11. Plano-multiradius reflective element assembly 30 is positionable by actuator 36 within exterior mirror housing 40.

Plano-multiradius reflective element assembly 30, as shown in FIG. 3, comprises a plano element 50 and a separate multiradius element 55. Preferably, plano element 50 is adjacent to multiradius element at a joint. At their joint, plano element 50 and separate multiradius element 55 can touch leaving substantially no gap or space therebetween, or plano element 50 and separate multiradius element 55 can be spaced apart at their joint by a space or gap, as in FIG. 3. Plano element 50 and multiradius element 55 are both mounted to surface 59 of, and are both supported by, a single backing plate element 60. Plano element 50 and multiradius element 55 are demarcated apart by demarcation element 65. Surface 61 of backing plate element 60 is preferably adapted to attach, such as by attachment member 64, to actuator 36 when plano-multiradius reflective element assembly 30 is mounted in driver-side exterior sideview mirror assembly 12 (and/or in passenger-side exterior side view mirror assembly 14) such that plano element 50 and multiradius element 55 are adjusted and positioned in tandem and simultaneously when the driver (or alternatively, when a mirror memory system, as is conventional in the rearview mirror arts) activates actuator 36 to reposition the rearward field of view of plano-multiradius reflective element assembly 30. Thus, since elements 50, 55 are part of plano-multiradius reflective element assembly 30, movement of plano-multiradius

reflective element assembly **30** by actuator **36** simultaneously and similarly moves plano element **50** and multiradius element **55**.

Plano element **50** preferably comprises a flat reflector-coated glass substrate having unit magnification, and comprises a reflective surface through which the angular height and width of the image of an object is equal to the angular height and width of the object when viewed at the same distance (except for flaws that do not exceed normal manufacturing tolerances). Plano element **50** may comprise a conventional fixed reflectance mirror reflector or it may comprise a variable reflectance mirror reflector whose reflectivity is electrically adjustable. For example, plano element **50** may comprise a flat glass substrate coated with a metallic reflector coating such as a chromium coating, a titanium coating, a rhodium coating, a metal alloy coating, a nickel-alloy coating, a silver coating, an aluminum coating (or any alloy or combination of these metal reflectors). The metal reflector coating of plano element **50** may be a first surface coating (such as on surface **66**) or a second surface coating (such as on surface **67**), as such terms are known in the mirror art. The reflector coating on plano element **50** may also comprise a dielectric coating, or a multilayer of dielectric coatings, or a combination of a metal layer and a dielectric layer to form automotive mirror reflectors as known in the automotive mirror art. If a variable reflectance reflector element, plano element **50** preferably comprises an electro-optic reflector element and, most preferably, an electrochromic reflector element.

When mounted into exterior side view mirror assembly **12** and/or **14**, plano-multiradius reflective element assembly **30** is preferably orientated so that at least a portion of (more preferably a substantial portion of) the reflector surface of plano element **50** is positioned closer to the vehicle body (and hence to the driver) than any portion of the reflector surface of multiradius element **55**. Thus, and referring to FIG. 3, side A of plano element **50** of plano-multiradius reflective element assembly **30** is positioned closer to the driver than side D of multiradius element **55** when plano-multiradius reflective element assembly **30** is mounted on an automobile. Also, when mounted into exterior side view mirror assembly **12** and/or **14**, surfaces **66**, **68** of plano-multiradius reflective element assembly **30** face rearwardly in terms of the direction of vehicle travel.

Multiradius element **55** of plano-multiradius reflective element assembly **30** preferably comprises a curved/bent mirrored glass substrate. The degree of curvature preferably increases (and hence the local radius of curvature decreases) across the surface of multiradius element **55** with the least curvature (largest radius of curvature) occurring at the side of multiradius element **55** (side C in FIG. 3) positioned adjacent its joint to plano element **50** when both are mounted on backing plate element **60**. Thus, and referring to FIG. 3, the local radius of curvature at side C of multiradius element **55**, when mounted on backing plate element **60**, is larger than at side D. Also, the local radius of curvature preferably progressively decreases across multiradius element **55** from side C to side D. Preferably, the local radius of curvature at side C of multiradius element **55** is at least about 1000 mm; more preferably is at least about 2000 mm and most preferably is at least about 3000 mm whereas the local radius of curvature at side D of multiradius element **55** is, preferably, less than about 750 mm, more preferably less than about 350 mm; most preferably less than about 150 mm. Preferably, multiradius element **55** comprises a bent glass substrate with radii of curvature in the range of from about 4000 mm to about 50 mm. The multiradius prescription for the multira-

dius element to be used in a particular exterior mirror assembly can vary according to the specific field of view needs on a specific automobile model.

The total field of view rearwardly of the automobile of the plano-auxiliary reflective element assembly (which is a combination of the field of view of the plano reflective element and of the auxiliary reflective element) preferably generally subtends an angle of at least about 20 degrees (and more preferably, generally subtends an angle of at least about 25 degrees and most preferably, generally subtends an angle of at least about 30 degrees) with respect to the side of an automobile to which is attached an exterior sideview mirror assembly equipped with the plano-auxiliary reflective element assembly.

Multiradius element **55** may comprise a conventional fixed reflectance mirror reflector or it may comprise a variable reflectance mirror reflector whose reflectivity is electrically adjustable. For example, multiradius element **55** may comprise a flat glass substrate coated with a metallic reflector coating such as a chromium coating, a titanium coating, a rhodium coating, a metal alloy coating, a nickel-alloy coating, a silver coating, an aluminum coating (or any alloy or combination of these metal reflectors). The metal reflector coating of multiradius element **55** may be a first surface coating (such as on surface **68**) or a second surface coating (such as on surface **69**), as such terms are known in the mirror art. The reflector coating on multiradius element **55** may also comprise a dielectric coating, or a multilayer of dielectric coatings, or a combination of a metal layer and a dielectric layer to form automotive mirror reflectors as known in the automotive mirror art. If a variable reflectance reflector element, multiradius element **55** preferably comprises an electro-optic reflector element and, most preferably, an electrochromic reflector element.

Also, it is preferable that the thickness of plano element **50** and multiradius element **55** be substantially the same in dimension so that their respective outer surfaces, **66** and **68**, are substantially coplanar so that a driver can readily view images in either or both elements. The thickness dimension of elements **50,55** is determined by the thickness of the substrate (or in the case of laminate-type electrochromic reflective elements, the thickness of the two substrates between which the electrochromic medium is disposed). For example, plano element **50** and/or multiradius element **55** can comprise a reflector coated glass substrate or panel of thickness preferably equal to or less than about 2.3 mm, more preferably equal to or less than about 1.6 mm, most preferably equal to or less than about 1.1 mm. Use of a thinner substrate is beneficial in terms of improving the overall stability/vibration performance of the image seen in plano-multiradius reflective element assembly **30** when mounted to an automobile.

The reflector area of plano element **50** is preferably larger than that of multiradius element **55**. Preferably, the width dimension of plano element **50** is larger than the width dimension of multiradius element **55** (both width dimensions measured at their respective widest dimension and with the width of the respective element being gauged with the respective element oriented as it would be orientated when mounted on the automobile). Thus, and referring to FIG. 3, the distance from side A to side B of plano element **50** is larger than the distance from side C to side D of multiradius element **55**. Thus, the ratio of the width of plano element **50** to the width of multiradius element **55** is preferably greater than 1; more preferably greater than 1.5; most preferably greater than 2.5 in order to provide a large, unit magnification plano element **50** as the principal rear

9

viewing portion of plano-multiradius reflective element assembly **30** and providing multiradius element **55** as a smaller, auxiliary, separate, wide-angle viewing portion of plano-multiradius reflective element assembly **30**. For plano-multiradius reflective element assemblies to be mounted to the exterior sideview assemblies of passenger automobiles used non-commercially and for non-towing purpose, the width of plano element **50** (at its widest dimension) is preferably in the range of from about 50 mm to about 225 mm; more preferably in the range of from about 75 mm to about 175 mm; most preferably in the range of from about 100 mm to about 150 mm.

Backing plate element **60** is preferably a rigid polymeric substrate capable of supporting plano element **50** and multiradius element **55**. Backing plate element **60** comprises a flat portion (generally between E and F as shown in FIG. 3) that corresponds to and is aligned with plano element **50**. Backing plate element **60** also comprises a curved portion (generally between G and H as shown in FIG. 3) that corresponds to and is aligned with multiradius element **55**. Preferably, curved portion G-H of multiradius element **55** is fabricated with a multiradius prescription that is substantially the same as the multiradius prescription of multiradius element **55**. Backing plate element **60** is formed as a single element to which elements **50** and **55** are separately attached. Preferably, backing plate element **60** is formed by injection molding of a thermoplastic or a thermosetting polymer resin. Materials suitable to use for backing plate element **60** include unfilled or filled polymeric materials such as glass and/or mineral filled nylon or glass and/or mineral filled polypropylene, ABS, polyurethane and similar polymeric materials. For example, backing plate element **60** can be formed of ABS in an injection molding operation. Plano element **50** can be cut from a stock lite of flat chromium mirror-coated 1.6 mm thick glass. Multiradius element **55** can be cut from a stock lite of multiradiusly-bent chromium mirror-coated 1.6 mm thick glass. Plano element **50** and multiradius element **55** can then be attached (such as by an adhesive attachment such as an adhesive pad or by mechanical attachment such by clips, fasteners or the like) to the already molded backing plate element **60**. Alternatively, plano element **50** and multiradius element **55** can each be individually loaded into an injection molding tool. Once loaded, a polymeric resin (or the monomers to form a polymeric resin) can be injected into the mold in order to integrally form backing plate element **60** with elements **50**, **55** integrally molded thereto. Integral molding of the backing plate element to plano element **50** and multiradius element **55** (along with any other elements such as the demarcation element **65**) in a single integral molding operation, is a preferred fabrication process for plano-multiradius reflective element assembly **30**.

Plano-multiradius reflective element assembly **30** further preferably includes demarcation element **65** that functions to delineate and demarcate the plano region of the assembly from the wide-angle, multiradius region and also preferably functions to prevent ingress of debris, dirt, water and similar contaminants (such as road splash, car wash spray, rain, snow, ice, leaves, bugs and similar items that plano-multiradius reflective element assembly **30** would be subject to when mounted and used on an automobile) into any gap between plano element **50** and multiradius element **55** when both are attached to backing plate element **60**. Optionally, at least a portion of demarcation element **65** can be disposed in any gap between plano element **50** and multiradius element **55** at their joint on backing plate element **60**. Preferably, demarcation element **65** is formed of a polymeric material

10

that is dark colored (such as black or dark blue or dark brown or dark grey or a similar dark color) such as a dark colored polypropylene resin or a dark colored nylon resin or a dark colored polyurethane resin or a dark colored polyvinyl chloride resin or a dark colored silicone material. Most preferably demarcation element **65** is formed of an at least partially elastomeric material (such as silicone, or EPDM, or plasticized PVC or the like) in order to provide a degree of vibration dampening for elements **50**, **55**. As shown in FIG. 4, demarcation element **65** optionally includes a crown portion **70** that includes wing portions **73**, **73'** and a stem portion **71**. Stem portion **71** preferably has a cross-sectional width CCC of less than about 4 mm, more preferably less than about 3 mm and, most preferably less than about 2 mm. Crown portion **70** preferably is dimensioned to not protrude substantially beyond surfaces **66**, **68** of elements **50**, **55** when demarcation element **65** is installed between elements **50** and **55**. Also, wings **73**, **73'** are preferably dimensioned to protrude (most preferably slightly) onto surfaces **66**, **68** of elements **50**, **55** when demarcation element **65** is installed between elements **50** and **55** in order to provide a weather barrier seal and/or to at least partially accommodate any dimensional tolerances of elements **50**, **55** that could lead to variation in the inter-element gap between sides C and B. While the demarcation element shown in FIG. 4 is one embodiment, other constructions are possible including a demarcation element that has minimal or no crown portion. Likewise, a demarcation element can have little or no stem portion, especially when the joint between plano element **50** and multiradius element **55** includes no gap to receive a stem. Also, where a gap at the plano to multiradius joint exists, any stem of the demarcation element can at least partially be disposed in such gap so as to at least partially fill the gap (or it can optionally substantially fill the gap). Optionally, demarcation element **65** is fabricated by injection molding of a polymeric resin. After plano element **50** and multiradius element **55** have been attached to backing plate element **60**, a separately formed demarcation element **65** can then be inserted (and secured such as by an adhesive or by a mechanical attachment such as by a fastener) into a space between elements **50** and **55**. Note that, optionally, side B of plano element **50** and side C of multiradius element **55** can touch (leaving substantially no gap or space therebetween). In such a situation, demarcation element **65** can comprise a dark colored strip such as of a tape or of a plastic film that covers the joint between elements **50** and **55**. Alternatively, demarcation element **65** can comprise a preferably dark-colored paint, lacquer, caulk or similar material that can be applied to, and that can preferably fill into, the joint between elements **50** and **55**. The width of the portion of demarcation element **65** that is visible to the driver is preferably less than about 4 mm, more preferably less than about 3 mm and most preferably less than about 2 mm, but is equal to or greater than about 0.5 mm, more preferably is equal to or greater than about 0.75 mm, most preferably is equal to or greater than about 1 mm in order to provide adequate demarcation of the plano region from the multiradius radius region without unduly obscuring the rearward field of view of the respective elements. Optionally, demarcation element **65** can be formed as part of backing plate element **60** such as by forming demarcation element **65** as a wall structure of the backing plate element that partitions backing plate element **60** into two regions: A first region adapted to receive plano reflective element **50** and a separate and adjacent second region adapted to receive multiradius reflective element **55**.

Thus, and referring to FIG. 6, a second embodiment of plano-multiradius reflective element assembly **130** may

11

include a backing plate element **160** which comprises a plate molded from a polymer resin (such as a polyolefin such as polypropylene or such as ABS or nylon) with a demarcation element **165** that is molded as a wall structure that partitions backing plate element **165** into a first region (from CC to BB) adapted to receive and accommodate plano reflective element **150** and into a second region (from BB to AA) adapted to receive and accommodate wide-angle optic multiradius reflective element **155**. Note that section AA to BB of backing plate element **160** is angled to section BB to CC. Such angling of the auxiliary reflective element relative to the plano element can be advantageous in allowing the auxiliary reflective element view a portion of the road adjacent the automobile that is in a blind spot of the plano reflective element. In this regard, it is preferable that the multiradius element be angled away from the plane of the plano element, as shown in FIG. 6 by the angling of section AA to BB to section BB to CC.

Preferably, demarcation element **65** is formed in an integral molding operation, along with formation of backing plate element **60**, and attachment of elements **50**, **55** thereto. For example, plano element **50** and multiradius element **55** can each be individually loaded into an injection molding tool. Once loaded, a polymeric resin (or the monomers to form a polymeric resin) can be injected into the mold in order to integrally form backing plate element **60** with elements **50**, **55** integrally molded thereto and, in the same molding operation and in the same tool, also form by molding the demarcation element. Integral molding of the backing plate element to plano element **50** and multiradius element **55** along with creation in the single molding operation of demarcation element **65** (along with any other elements such as attachment member **64**) in a single integral molding operation, is a preferred fabrication process for plano-multiradius reflective element assembly **30**. By loading all the sub components of plano-multiradius reflective element assembly **30** into a molding tool, and then injecting polymeric resin to form the backing plate, demarcation member and any attachment member, a substantially complete or fully complete plano-multiradius reflective element assembly can be unloaded from the tool at the completion of the integral molding operation (as known in the molding art), thus enabling economy in manufacturing and accommodation of any dimensional tolerances in the sub components. Where integral molding is so used, it is preferable to use a reactive molding operation such as reactive injection molding of a urethane as such reactive injection molding operations occur at relatively modest temperatures.

Plano element **50** and/or multiradius element **55** can comprise a heater element, as known in the automotive mirror art, that is operable to deice/demist surfaces **66**, **68**. Such heater elements are conventional and can comprise a positive temperature coefficient heater pad, a resistive heater element and/or a conductive coating. Plano element **50** and/or multiradius element **55** can also optionally comprise a scatterproofing member, as known in the automotive mirror art, such as an adhesive tape, to enhance safety in an accident.

Also, plano element **50** and/or multiradius element **55** can comprise a variable reflectance electro-optic element such as an electrochromic mirror reflector. Thus, both element **50** and element **55** can comprise an electrochromic mirror element or either of element **50** and element **55** can comprise an electrochromic mirror element and the other can comprise a fixed reflectance non-variable reflectance mirror element such as a metal reflector coated glass panel such as a chromium coated glass substrate. Also, if both plano

12

element **50** and multiradius element **55** comprise an electro-optic element such as an electrochromic mirror element capable of electrically dimmable reflectivity, both elements **50**, **55** can dim together and in tandem under control of a common dimming control signal (typically provided by an electro-optic automatic dimming interior mirror assembly mounted in the cabin of the automobile and equipped with photosensors to detect incident glare and ambient light). Alternately, if both plano element **50** and multiradius element **55** comprise an electro-optic element such as an electrochromic mirror element capable of electrically dimmable reflectivity, element **50** can dim independently of element **55** (such as is disclosed in U.S. Pat. No. 5,550,677, the entire disclosure of which is hereby incorporated by reference herein). If either or both of elements **50**, **55** comprise an electrochromic element, preferably, the electrochromic reflective element comprises a front substrate and a rear substrate with an electrochromic medium disposed between, such as a solid polymer matrix electrochromic medium such as is disclosed in U.S. patent application Ser. No. 09/350,930, filed Jul. 12, 1999, entitled "ELECTROCHROMIC POLYMERIC SOLID FILMS, MANUFACTURING ELECTROCHROMIC DEVICES USING SUCH FILMS, AND PROCESSES FOR MAKING SUCH SOLID FILMS AND DEVICES" to Desraj V. Varaprasad et al., now U.S. Pat. No. 6,154,306, or such as is disclosed in U.S. Pat. Nos. 5,668,663; 5,724,187; 5,910,854; and 5,239,405, the entire disclosures of which are hereby incorporated by reference herein. Most preferably, in such laminate-type electrochromic mirror reflective elements, the front substrate comprises a glass plate of thickness less than about 1.6 mm, most preferably about 1.1 mm thickness or lower, and the rear substrate comprises a glass plate of thickness equal to or greater than about 1.6 mm, more preferably greater than about 1.8 mm thickness, most preferably equal to or greater than about 2.0 mm thickness. The rearmost surface of the rear substrate (the fourth surface as known in the mirror art) is reflector coated with a high reflecting metal film such as of aluminum or silver, or an alloy of aluminum or silver. Most preferably, the front-most surface of the rear substrate (the third surface as known in the mirror art) is reflector coated with a high reflecting metal film such as of aluminum or silver, or an alloy of aluminum or silver.

Backing plate element **65** of plano-multiradius reflective element assembly **30** is optionally equipped on its rearmost surface with attachment member **64** to facilitate attachment to the reflector-positioning actuator of the exterior sideview mirror assembly that plano-multiradius reflective element assembly **30** is mounted to. Attachment of plano-multiradius reflective element assembly **30** to the actuator can be by mechanical attachment such as by a tab, clip or fastener, or may be by adhesive attachment such as by a silicone adhesive, a urethane adhesive or a similar adhesive material such as a tape coated on both surfaces with a pressure sensitive adhesive to form a "double-sticky" tape. Exterior sideview mirror assembly **12** and/or **14**, on whose mirror reflector-positioning actuator the plano-multiradius reflective element assembly is mounted, can be a fixedly attached exterior sideview mirror assembly, a break-away exterior sideview mirror assembly and a powerfold exterior sideview mirror assembly, as known in the automotive mirror art.

FIGS. 5A–5H shows various arrangements of multiradius reflective element **55** relative to its adjacent plano reflective element **50** (with demarcation element **65** disposed at their joint). In FIGS. 5A, 5B, 5C, 5E and 5F, plano element **50** is mounted wholly inboard of multiradius element **55**. Thus, in

13

FIGS. 5A, 5B, 5C, 5E and 5F, plano element **50** would be disposed closer to the vehicle body (and hence to the driver) than multiradius element **55** when plano-multiradius reflective element assembly **30** was mounted in an exterior sideview mirror attached to a side of an automobile. Therefore, in FIGS. 5A, 5B, 5C, 5E and 5F, plano element **50** would be mounted inboard relative to the side of the automobile and multiradius element **55** would be mounted outboard relative to the side of the automobile. In general, the location of the multiradius reflective element in the outboard, upper portion of the plano-multiradius reflective element assembly, as in FIGS. 5B and 5E, is preferred as this allows the plano portion provide a desired rearward field of view along the side of the vehicle. The configuration as shown in FIG. 5G (where the multiradius reflective element is along the inboard side of the assembly) is also desirable as this allows the driver view the side of the vehicle (something many drivers desire in order to have a frame of reference for their rearward field of view) while facilitating having a wide field of view for the plano portion.

Unlike trucks, busses and commercial vehicles the size of an exterior sideview mirror assembly suitable for use on an automobile (and especially when the automobile is not towing a trailer or the like) is restricted. Automobiles generally are non-commercial vehicles intended for personal transportation. Automobiles typically carry 5 passengers or less, although minivans and large sports utility vehicles (which are classified herein as automobiles) can have seat accommodation for up to 10 passengers (although accommodation for 7 passengers or less is more common). The tandem mounting of a plano element of unit magnification and a separate auxiliary element onto a common, single backing plate element, and the mounting of this backing plate element onto an actuator of an exterior sideview mirror assembly so that a driver can simultaneously and similarly move the auxiliary element and the plano element so as to position their respective rearward fields of view, and to achieve this within the relatively restricted space available in a standard automobile-sized exterior sideview mirror assembly is an important element of this present invention. By utilizing a plano element of unit magnification in the plano-multiradius reflective element assembly, and by sizing the reflector area of the plano element larger than the reflector area of the multiradius element and, preferably, by sizing the reflector area of the plano element at a sufficiently large size that the rearward field of view provided by the plano element alone meets and satisfies the minimum field of view requirement mandated by an automaker specification and/or a government regulation, the need to provide a safety warning indicia such as "OBJECTS IN MIRROR ARE CLOSER THAN THEY APPEAR" in the plano element and/or in the multiradius element can be obviated. Preferably, the plano element comprises a reflector surface area of a size sufficient, when mounted as part of a plano-multiradius reflective element assembly in a driver-side exterior sideview mirror assembly on an automobile, to provide the driver of the automobile a view of a level road surface extending to the horizon from a line, perpendicular to a longitudinal plane tangent to the driver's side of the automobile at the widest point, extending 8 feet out from the tangent plane 35 feet behind the driver's eyes (at a nominal location appropriate for any 95th percentile male driver or at the driver's eye reference points established in Federal Motor Vehicle Standard No. 104), with the driver seated in the driver's seat and with the driver's seat in the rearmost position. Also, preferably, the aspect ratio of the plano-multiradius reflective element assembly (defined as the ratio

14

of its largest vertical dimension to its largest horizontal dimension, measured with the plano-multiradius reflective element assembly oriented as it would be oriented when mounted in an exterior sideview mirror assembly on an automobile, and with "horizontal" being generally parallel with the road surface the automobile travels on and "vertical" being generally perpendicular to the road surface the automobile travels on) is preferably less than 1, more preferably less than 0.8, most preferably less than 0.6. Further, it is preferable that the multiradius element be disposed outboard (relative to the side of the vehicle and with the plano-multiradius reflective element assembly oriented as it would be when mounted in an exterior sideview mirror assembly on an automobile) on the plano-multiradius reflective element assembly so that the multiradius element is positioned to provide an auxiliary, wide-angle view of a "blind-spot" region in an adjacent sidelane while the more inboard-disposed plano element with unit magnification provides the principal sideview image to the driver.

Also, it is preferable that the principal axis of the rearward field of view of the multiradius element be different from and angled to the principal axis of the rearward field of view of the plano element when both are attached to the backing plate element of the plano-multiradius reflective element assembly and when the plano-multiradius reflective element assembly is mounted and operated in an exterior sideview mirror assembly on an automobile. Preferably, the principal axis of the rearward field of view of the plano element is directed generally parallel to the road that the automobile equipped with the plano-multiradius reflective element assembly is travelling on (i.e. generally parallel to the longitudinal axis of the automobile) so as to provide the driver with a long-distance view of approaching vehicles in the side lane that the plano element views). However, preferably the principal axis of the rearward field of view of the multiradius element of, for example, a door-mounted driver-side (or passenger-side) exterior sideview mirror assembly in which the plano-multiradius reflective element assembly is mounted is directed generally downwardly towards the road surface adjacent to the driver seating location and/or several feet (such as about 1 foot to about 24 feet; more preferably, about 1 foot to about 12 feet; most preferably about 1 foot to about 8 feet in distance) to its rear (in order to capture a field of view of a rear approaching vehicle that is approaching to overtake, or is about to overtake, or is overtaking the automobile equipped with the plano-multiradius reflective element assembly). Thus, preferably, the principal axis of the rearward field of view of the multiradius element is angled and directed generally downwardly with respect to the longitudinal axis of the automobile and thus is at an angle to the principal axis of the rearward field of view of the plano element. For example, multiradius element **155** when attached to surface **173** of backing plate **160** (see FIG. 6B) would have its principal axis of rearward view as indicated by **180** as in FIG. 6B, and as such would be canted towards the road surface when mounted in an exterior sideview mirror assembly attached to the side of an automobile. By contrast, plano element **150** when attached to surface **174** of backing plate **160** (see FIG. 6A) would have a principal axis as indicated by **185** as in FIG. 6A and, as such, would be generally parallel to the road surface when mounted in an exterior sideview mirror assembly attached to the side of an automobile. Having the multiradius element canted somewhat downwards towards the road surface assists visual detection by the driver of overtaking vehicles in the traditional "blind-spot" in the adjacent side lane. The angle that the multiradius element is

15

angled on the backing plate element of the plano-multiradius reflective element assembly relative to the plane of the plano reflective element will vary from automobile model to model, but generally is preferred to be in the about 1 degree to about 10 degree range; about 2 degree to about 8 degree range more preferred; and about 3 degree to about 6 degree range most preferred. In order to conveniently achieve an angling of the multiradius portion with respect to the plano portion (and preferably a downward angling), the portion of the backing plate element that the multiradius reflective element is attached to can be angled relative to the adjacent portion of the backing plate element that the plano reflective element is attached to. Thus, and referring to FIG. 6, plano-multiradius reflective element assembly 130 includes a molded polymeric backing plate element 160 comprising a generally flat portion 162 (between BB and CC in FIG. 6) and an adjacent curved portion 161 (between AA and BB). As indicated by 190 and 195, portion AA to BB of backing plate element 160 is generally angled to portion BB to CC of backing plate 160. Preferably, the portion of backing plate element 160 to which the auxiliary reflective element attaches is angled towards the front (compared to the angling of plano reflective element) of an automobile equipped with the plano-auxiliary reflective element assembly of the present invention. FIG. 6 is a view of plano-multiradius reflective element assembly 130 as it would appear from above the vehicle as it would be orientated in use (with portion 162 closer to the driver than portion 161). The wall section, section XX in FIG. 6, taken through section 162 of backing plate element 160 is of substantially constant dimension (as illustrated in FIG. 6A) whereas the wall section, section YY in FIG. 6B, taken through section 161 of backing plate element 160 is of varying dimension and is angled. Plano reflective element 150 and multiradius reflective element 155 (for example, plano element 150 can comprise an electrochromic mirror element and multiradius element 155 can comprise a chrome coated glass reflector) are attached to portions 162 and 161, respectively. By being supported on the angled face 173 (see FIG. 6B) of portion 161, the principal viewing axis of multiradius reflector element 155 is angled downwards towards the road surface, as compared to the more horizontal-viewing principal viewing axis of plano element 150, when plano-multiradius reflective element 130 is mounted in an exterior sideview mirror assembly on an automobile. Demarcation element 165 is preferably molded in the same molding tool as is used to mold backing plate element 160, and so demarcation element 165 is formed as an integral part of backing plate element 160, forming a wall thereof that partitions the surface of backing plate element 160 into a region for receiving the plano reflective element 150 and a region for receiving the auxiliary reflective element 155. Also, end-caps 170 and 171 are optionally provided. Plano reflective element 150 can attach into the cavity formed between demarcation element 165 and end-cap 171; multiradius reflective element 155 can attach into the cavity formed between demarcation element 165 and end-cap 170. Note that the portion of the backing plate element where the wide-angle optic multiradius element attaches can have a thicker wall thickness than that of the portion of the backing plate element where the unit magnification optic element attaches in order to allow for the angling of the multiradius element downwardly relative to the angle of the plano element, as illustrated in FIGS. 6A-B. As illustrated in FIGS. 6A-B, the angle downwards to the longitudinal axis of the vehicle of the multiradius element can generally be set by an angling of a surface of the backing plate element in

16

order to ensure that the principal axis of the rearward field of view of the plano element is directed generally parallel to the longitudinal axis of an automobile equipped with the plano-multiradius reflective element assembly and that the principal axis of the rearward field of view of the multiradius element is directed generally at an angle downwards to the longitudinal axis of the automobile.

Note that the provision of the plano-multiradius reflective element assembly of this invention as a unitary module has manufacturing advantages, particularly for exterior sideview mirror assembly manufacturers who can procure a plano-multiradius reflective element assembly module from a mirror reflector supplier and then mount the plano-multiradius reflective element assembly module onto an actuator.

Referring to FIG. 7, a third embodiment 230 of a plano-multiradius reflective element assembly is illustrated. Plano-multiradius reflective element assembly 230 includes a plano reflective element 250 and a separate multiradius reflective element assembly 255, both individually attached to a backing plate element, and with demarcation element 265 disposed at their joint. Plano-multiradius reflective element assembly 230 is about 8.5 inches wide and about 4.25 inches tall (aspect ratio of 0.5), at their largest dimension. Shown as the shaded triangle 240 in plano reflective element 250 is the image of a triangular target object set about 35 feet rearward and of width about 8 feet and of height of about 4.1 feet as would be seen were plano-multiradius reflective element assembly 230 mounted in a driver-side exterior sideview mirror assembly in an automobile such as a sports utility vehicle. In general, it is desirable that the plano reflective element be dimensioned and configured so as to have its rearward field of view capture an image (that is visible, by reflection in the plano reflective element, to a driver seated in the driver's seat in an automobile to which is attached an exterior sideview mirror assembly equipped with the plano-auxiliary reflective element assembly according to this present invention) of a triangular shaped target located about 35 feet rearward of the driver seating location, extending about 8 feet out from the plane defined by the side of the automobile and reaching a height of between about 4 feet and about 5 feet from the road surface at that location 35 feet rearward of the automobile. The total field of view rearwardly of the vehicle of plano-multiradius reflective element assembly 230 (which is a combination of the field of view of plano reflective element 250 and of the auxiliary multiradius reflective element 255) preferably generally subtends an angle of at least about 30 degrees (and more preferably, generally subtends an angle of at least about 35 degrees and most preferably, generally subtends an angle of at least about 40 degrees) with respect to the side of an automobile to which is attached an exterior sideview mirror assembly equipped with plano-multiradius reflective element assembly 230.

Also, although it is preferable to utilize a multiradius or compound curvature reflective element such as an aspherical element or a compound curvature element for the auxiliary mirror element adjacent the plano reflective element (as this enables least discontinuity in image at the joint between the adjacent elements of the assembly), a spherical reflective element (that has substantially only one radius of curvature and, as such, is a section from a sphere) can optionally be used adjacent the plano reflective element instead of, or in addition to, the multiradius reflective element. Also, a plano auxiliary mirror such as a flat mirrored substrate can be used, less preferably, as a substitute for a multiradius reflective element in those embodiments where the auxiliary reflective

17

element is angled relative to the plane of the principal, plano reflective element so as to view a blind spot region of the principal plano element. Also, the plano-multiradius reflective element assembly can optionally be fixedly attached to an exterior sideview mirror assembly housing that is not movable, or, alternately, the exterior sideview mirror assembly housing to which the plano-multiradius reflective element assembly is fixedly attached can itself be actuated to move, such as by motor action, so that by moving the exterior sideview mirror assembly housing, the field of rearward view of the plano-multiradius reflective element assembly fixedly attached thereto can correspondingly move and be repositioned to suit the field of view need of a particular driver seated in the automobile cabin.

The above description is considered that of the preferred embodiments only. Modification of the invention will occur to those skilled in the art and to those who make or use the invention. Therefore, it is understood that the embodiments shown in the drawings and described above are merely for illustrative purposes and are not intended to limit the scope of the invention, which is defined in the following claims as interpreted according to the principles of patent law, including the doctrine of equivalents.

I claim:

1. An exterior sideview mirror system suitable for use on an automobile, said exterior sideview mirror system comprising:

an exterior sideview mirror assembly adapted for attachment to a side of an automobile;

said exterior sideview mirror assembly including a reflective element having a rearward field of view when attached to the side of the automobile;

said reflective element attached to an electrically-operated actuator and movable by said actuator in order to position said rearward field of view in response to a control;

wherein said reflective element comprises a plano-multiradius reflective element assembly, said plano-multiradius reflective element assembly comprising a plano reflective element having unit magnification and a separate multiradius reflective element having a multiradius curvature, said plano reflective element having a rearward field of view with a principal axis;

said plano reflective element and said multiradius reflective element of said plano-multiradius reflective element assembly mounted adjacently in said plano-multiradius reflective element assembly in a side-by-side relationship and not superimposed with one reflective element on top of the other reflective element, and supported by a backing plate element, said backing plate element mounting to said actuator such that movement of said backing plate element of said plano-multiradius reflective element assembly by said actuator simultaneously and similarly moves said plano reflective element and said multiradius reflective element, said multiradius reflective element having a rearward field of view with a principal axis, said backing plate element have a first support portion supporting said plano-reflective element and a second support portion supporting said multiradius reflective element, said second support portion tilted forward with respect to said first support portion whereby said principal axis of said rearward field of view of said multiradius reflective element is angled downwardly and outwardly with respect to said principal axis of said rearward field of view of said plano reflective element

18

when said multiradius reflective element and said plano reflective element are supported by said backing plate element of said plano-multiradius reflective element assembly and when said plano-multiradius reflective element assembly is mounted in said exterior sideview mirror assembly on the automobile, and said principal axis of said rearward field of view of said plano reflective element being directed generally parallel to the longitudinal axis of the automobile equipped with the plano-multiradius reflective element assembly and wherein said principal axis of said rearward field of view of said multiradius reflective element is directed generally at an angle downwards to the longitudinal axis of the automobile; and

said multiradius reflective element being positioned diagonally at an outboard upper portion of said plano-multiradius reflective element assembly when said exterior sideview mirror assembly is mounted to the side of the automobile.

2. The exterior sideview mirror system of claim 1, wherein said plano reflective element and said multiradius reflective element are adjacently attached to said backing plate element at a joint, and wherein said plano-multiradius reflective element assembly includes a demarcation element, said demarcation element disposed at said joint to form a demarcation between said plano reflective element and said multiradius reflective element, said demarcation element having a portion visible to a driver of the automobile.

3. The exterior sideview mirror system of claim 2, wherein said demarcation element is dark colored.

4. The exterior sideview mirror system of claim 3, wherein said demarcation element is dark colored with a color selected from the group consisting of black, grey, blue and brown.

5. The exterior sideview mirror system of claim 3, wherein said demarcation element comprises at least one of a polymer material, a tape, a plastic film, a paint, a lacquer and a caulk.

6. The exterior sideview mirror system of claim 5, wherein said demarcation element comprises a polymer material.

7. The exterior sideview mirror system of claim 2, wherein said joint comprises a space between said plano reflective element and said multiradius reflective element.

8. The exterior sideview mirror system of claim 7, wherein said demarcation element is at least partially disposed in said space between said plano reflective element and said multiradius reflective element.

9. The exterior sideview mirror system of claim 2, wherein said demarcation element comprises a wall on said backing plate element, said wall located on said backing plate element at said joint, said wall separating said plano reflective element from said multiradius reflective element.

10. The exterior sideview mirror system of claim 2, wherein said portion visible to a driver of the automobile has a width less than about 4 mm.

11. The exterior sideview mirror system of claim 2, wherein said portion visible to a driver of the automobile has a width less than about 3 mm.

12. The exterior sideview mirror system of claim 2, wherein said portion visible to a driver of the automobile has a width less than about 2 mm.

13. The exterior sideview mirror system of claim 2, wherein said portion visible to a driver of the automobile has a width greater than about 0.5 mm.

14. The exterior sideview mirror system of claim 2, wherein said portion visible to a driver of the automobile has a width greater than about 0.75 mm.

19

20

15. The exterior sideview mirror system of claim 2, wherein said portion visible to a driver of the automobile has a width greater than about 1 mm.

16. The exterior sideview mirror system of claim 1, wherein said plano reflective element is supported by said backing plate element by at least one of an adhesive attachment and a mechanical attachment.

17. The exterior sideview mirror system of claim 1, wherein said multiradius reflective element is supported by said backing plate element by at least one of an adhesive attachment and a mechanical attachment.

18. The exterior sideview mirror system of claim 1, wherein said multiradius reflective element is supported by said backing plate element at a location such that, when said exterior mirror assembly is attached to a side of an automobile, at least a portion of said plano reflective element is disposed closer to said side of the automobile than any portion of said multiradius reflective element.

19. The exterior sideview mirror system of claim 1, wherein said multiradius reflective element comprises a bent glass substrate with radii of curvature in the range of from about 4.000 mm to about 50 mm.

20. The exterior sideview mirror system of claim 1, wherein the ratio of the width of said plano reflective element to the width of said multiradius reflective element is greater than 1.

21. The exterior sideview mirror system of claim 1, wherein the ratio of the width of said plano reflective element to the width of said multiradius reflective element is greater than 1.5.

22. The exterior sideview mirror system of claim 1, wherein the ratio of the width of said plano reflective element to the width of said multiradius reflective element is greater than 2.5.

23. The exterior sideview mirror system of claim 1, wherein said angle downwards to the longitudinal axis of the automobile is in the range from about 1 degree to about 10 degrees.

24. The exterior sideview mirror system of claim 1, wherein said angle downwards to the longitudinal axis of the automobile is in the range from about 2 degrees to about 8 degrees.

25. The exterior sideview mirror system of claim 1, wherein said angle downwards to the longitudinal axis of the automobile is in the range from about 3 degrees to about 6 degrees.

26. The exterior sideview mirror system of claim 1, wherein said angle downwards to the longitudinal axis of the automobile is generally set by an angling of a surface of said backing plate element.

27. The exterior sideview mirror system of claim 1, wherein said exterior sideview mirror assembly comprises a door-mounted exterior sideview mirror assembly adapted for attachment to a side of the automobile adjacent a driver seating location of a driver of the automobile and wherein the principal axis of the rearward field of view of said multiradius reflective element is directed generally downwardly towards the road surface adjacent to the driver

seating location at a distance in the range of about 1 foot to about 24 feet to the rear of the driver seating location.

28. The exterior sideview mirror system of claim 1, wherein said exterior sideview mirror assembly comprises a door-mounted exterior sideview mirror assembly adapted for attachment to a side of the automobile adjacent a driver seating location of a driver of the automobile and wherein the principal axis of the rearward field of view of said multiradius reflective element is directed generally downwardly towards the road surface adjacent to the driver seating location at a distance in the range of about 1 foot to about 12 feet to the rear of the driver seating location.

29. The exterior sideview mirror system of claim 1, wherein said exterior sideview mirror assembly comprises a door-mounted exterior sideview mirror assembly adapted for attachment to a side of the automobile adjacent a driver seating location of a driver of the automobile and wherein the principal axis of the rearward field of view of said multiradius reflective element is directed generally downwardly towards the road surface adjacent to the driver seating location at a distance in the range of about 1 foot to about 8 feet to the rear of the driver seating location.

30. The exterior sideview mirror system of claim 1, wherein said exterior sideview mirror assembly comprises a fixedly attached exterior sideview mirror assembly.

31. The exterior sideview mirror system of claim 1, wherein said exterior sideview mirror assembly comprises a break-away exterior sideview mirror assembly.

32. The exterior sideview mirror system of claim 1, wherein said exterior sideview mirror assembly comprises a powerfold exterior sideview mirror assembly.

33. The exterior sideview mirror system of claim 1, wherein said control comprises a memory controller.

34. The exterior sideview mirror system of claim 1, wherein at least one of said plano reflective element and said multiradius reflective element comprises an electro-optic reflective element.

35. The exterior sideview mirror system of claim 1, wherein both said plano reflective element and said multiradius reflective element comprise an electro-optic reflective element.

36. The exterior sideview mirror system of claim 1, wherein said plano reflective element comprises an electro-optical reflective element.

37. The exterior sideview mirror system of claim 36, wherein said electro-optical reflective element comprises an electrochromic reflective element.

38. The exterior sideview mirror system of claim 37, wherein said multiradius reflective element comprises a fixed reflectance mirror reflector.

39. The exterior sideview mirror system of claim 38, wherein said fixed reflectance mirror reflector comprises a bent glass substrate coated with a metallic reflector coating.

40. The exterior sideview mirror system of claim 1, wherein said plano-multiradius reflective element assembly is formed in an integral molding operation.

* * * * *

Electronic Acknowledgement Receipt

EFS ID:	13320737
Application Number:	13336018
International Application Number:	
Confirmation Number:	7833
Title of Invention:	EXTERIOR REARVIEW MIRROR ASSEMBLY
First Named Inventor/Applicant Name:	Niall R. Lynam
Customer Number:	15671
Filer:	Timothy A. Flory/Amanda Sytsma
Filer Authorized By:	Timothy A. Flory
Attorney Docket Number:	DON09 P-1800
Receipt Date:	24-JUL-2012
Filing Date:	23-DEC-2011
Time Stamp:	10:13:53
Application Type:	Utility under 35 USC 111(a)

Payment information:

Submitted with Payment	no
------------------------	----

File Listing:

Document Number	Document Description	File Name	File Size(Bytes)/ Message Digest	Multi Part /.zip	Pages (if appl.)
1	Transmittal Letter	TransmittalForm.pdf	81828 <small>5fc1f02b2687cd4df6a11a1093056c540e1d2 9274</small>	no	1

Warnings:

Information:

2	Supplemental Response or Supplemental Amendment	SubmissionofExhibits.pdf	45621 9a1a38ce001d54ba1b1750fd26fdc32c29aa ffdc	no	1
Warnings:					
Information:					
3	Miscellaneous Incoming Letter	ExhibitA.pdf	3408214 1628f35b1c151125d957f5e1676c80c72228 00c9	no	50
Warnings:					
Information:					
4	Miscellaneous Incoming Letter	ExhibitB.pdf	1906636 9c238ca34bca5cf693a4333584819e043db 3f6f1	no	20
Warnings:					
Information:					
Total Files Size (in bytes):				5442299	
<p>This Acknowledgement Receipt evidences receipt on the noted date by the USPTO of the indicated documents, characterized by the applicant, and including page counts, where applicable. It serves as evidence of receipt similar to a Post Card, as described in MPEP 503.</p> <p><u>New Applications Under 35 U.S.C. 111</u> If a new application is being filed and the application includes the necessary components for a filing date (see 37 CFR 1.53(b)-(d) and MPEP 506), a Filing Receipt (37 CFR 1.54) will be issued in due course and the date shown on this Acknowledgement Receipt will establish the filing date of the application.</p> <p><u>National Stage of an International Application under 35 U.S.C. 371</u> If a timely submission to enter the national stage of an international application is compliant with the conditions of 35 U.S.C. 371 and other applicable requirements a Form PCT/DO/EO/903 indicating acceptance of the application as a national stage submission under 35 U.S.C. 371 will be issued in addition to the Filing Receipt, in due course.</p> <p><u>New International Application Filed with the USPTO as a Receiving Office</u> If a new international application is being filed and the international application includes the necessary components for an international filing date (see PCT Article 11 and MPEP 1810), a Notification of the International Application Number and of the International Filing Date (Form PCT/RO/105) will be issued in due course, subject to prescriptions concerning national security, and the date shown on this Acknowledgement Receipt will establish the international filing date of the application.</p>					

Under the Paperwork Reduction Act of 1995, no persons are required to respond to a collection of information unless it displays a valid OMB control number.

TRANSMITTAL FORM (to be used for all correspondence after initial filing)	Application Number	13/336,018
	Filing Date	December 23, 2011
	First Named Inventor	Niall R. Lynam
	Art Unit	2872
	Examiner Name	Alessandro V. Amari
	Attorney Docket Number	DON09 P-1800
Total Number of Pages In This Submission		

ENCLOSURES (Check all that apply)		
<input type="checkbox"/> Fee Transmittal Form	<input type="checkbox"/> Drawing(s)	<input type="checkbox"/> After Allowance Communication to TC
<input type="checkbox"/> Fee Attached	<input type="checkbox"/> Licensing-related Papers	<input type="checkbox"/> Appeal Communication to Board of Appeals and Interferences
<input type="checkbox"/> Amendment/Reply	<input type="checkbox"/> Petition	<input type="checkbox"/> Appeal Communication to TC (Appeal Notice, Brief, Reply Brief)
<input type="checkbox"/> After Final	<input type="checkbox"/> Petition to Convert to a Provisional Application	<input type="checkbox"/> Proprietary Information
<input type="checkbox"/> Affidavits/declaration(s)	<input type="checkbox"/> Power of Attorney, Revocation	<input type="checkbox"/> Status Letter
<input type="checkbox"/> Extension of Time Request	<input type="checkbox"/> Change of Correspondence Address	<input type="checkbox"/> Other Enclosure(s) (please identify below):
<input type="checkbox"/> Express Abandonment Request	<input type="checkbox"/> Terminal Disclaimer	-Submission of Exhibits A & B of 131(a) Declaration
<input type="checkbox"/> Information Disclosure Statement	<input type="checkbox"/> Request for Refund	-Exhibits A & B
<input type="checkbox"/> Certified Copy of Priority Document(s)	<input type="checkbox"/> CD, Number of CD(s) _____	
<input type="checkbox"/> Reply to Missing Parts/Incomplete Application	<input type="checkbox"/> Landscape Table on CD	
<input type="checkbox"/> Reply to Missing Parts under 37 CFR 1.52 or 1.53	<input type="text"/> Remarks	

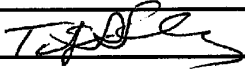
SIGNATURE OF APPLICANT, ATTORNEY, OR AGENT			
Firm Name	GARDNER, LINN, BURKHART & FLORY, LLP		
Signature			
Printed name	Timothy A. Flory		
Date	July 24, 2012	Reg. No.	42540

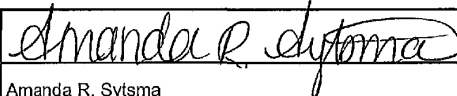
CERTIFICATE OF TRANSMISSION/MAILING		
I hereby certify that this correspondence is being facsimile transmitted to the USPTO or deposited with the United States Postal Service with sufficient postage as first class mail in an envelope addressed to: Commissioner for Patents, P.O. Box 1450, Alexandria, VA 22313-1450 on the date shown below:		
Signature		
Typed or printed name	Amanda R. Sytsma	Date July 24, 2012

This collection of information is required by 37 CFR 1.5. The information is required to obtain or retain a benefit by the public which is to file (and by the USPTO to process) an application. Confidentiality is governed by 35 U.S.C. 122 and 37 CFR 1.11 and 1.14. This collection is estimated to 2 hours to complete, including gathering, preparing, and submitting the completed application form to the USPTO. Time will vary depending upon the individual case. Any comments on the amount of time you require to complete this form and/or suggestions for reducing this burden, should be sent to the Chief Information Officer, U.S. Patent and Trademark Office, U.S. Department of Commerce, P.O. Box 1450, Alexandria, VA 22313-1450. DO NOT SEND FEES OR COMPLETED FORMS TO THIS ADDRESS. SEND TO: Commissioner for Patents, P.O. Box 1450, Alexandria, VA 22313-1450.

If you need assistance in completing the form, call 1-800-PTO-9199 and select option 2.



UNITED STATES PATENT AND TRADEMARK OFFICE

UNITED STATES DEPARTMENT OF COMMERCE
United States Patent and Trademark Office
Address: COMMISSIONER FOR PATENTS
P.O. Box 1450
Alexandria, Virginia 22313-1450
www.uspto.gov

NOTICE OF ALLOWANCE AND FEE(S) DUE

15671 7590 08/06/2012
Gardner, Linn, Burkhardt & Flory, LLP
2851 Charlevoix Dr.
SE, Suite 207
Grand Rapids, MI 49546

EXAMINER

AMARI, ALESSANDRO V

ART UNIT PAPER NUMBER

2872

DATE MAILED: 08/06/2012

Table with 5 columns: APPLICATION NO., FILING DATE, FIRST NAMED INVENTOR, ATTORNEY DOCKET NO., CONFIRMATION NO.
13/336,018 12/23/2011 Niall R. Lynam DON09 P-1800 7833

TITLE OF INVENTION: EXTERIOR REARVIEW MIRROR ASSEMBLY

Table with 7 columns: APPLN. TYPE, SMALL ENTITY, ISSUE FEE DUE, PUBLICATION FEE DUE, PREV. PAID ISSUE FEE, TOTAL FEE(S) DUE, DATE DUE
nonprovisional NO \$1740 \$300 \$0 \$2040 11/06/2012

THE APPLICATION IDENTIFIED ABOVE HAS BEEN EXAMINED AND IS ALLOWED FOR ISSUANCE AS A PATENT. PROSECUTION ON THE MERITS IS CLOSED. THIS NOTICE OF ALLOWANCE IS NOT A GRANT OF PATENT RIGHTS. THIS APPLICATION IS SUBJECT TO WITHDRAWAL FROM ISSUE AT THE INITIATIVE OF THE OFFICE OR UPON PETITION BY THE APPLICANT. SEE 37 CFR 1.313 AND MPEP 1308.

THE ISSUE FEE AND PUBLICATION FEE (IF REQUIRED) MUST BE PAID WITHIN THREE MONTHS FROM THE MAILING DATE OF THIS NOTICE OR THIS APPLICATION SHALL BE REGARDED AS ABANDONED. THIS STATUTORY PERIOD CANNOT BE EXTENDED. SEE 35 U.S.C. 151. THE ISSUE FEE DUE INDICATED ABOVE DOES NOT REFLECT A CREDIT FOR ANY PREVIOUSLY PAID ISSUE FEE IN THIS APPLICATION. IF AN ISSUE FEE HAS PREVIOUSLY BEEN PAID IN THIS APPLICATION (AS SHOWN ABOVE), THE RETURN OF PART B OF THIS FORM WILL BE CONSIDERED A REQUEST TO REAPPLY THE PREVIOUSLY PAID ISSUE FEE TOWARD THE ISSUE FEE NOW DUE.

HOW TO REPLY TO THIS NOTICE:

I. Review the SMALL ENTITY status shown above.

If the SMALL ENTITY is shown as YES, verify your current SMALL ENTITY status:

A. If the status is the same, pay the TOTAL FEE(S) DUE shown above.

B. If the status above is to be removed, check box 5b on Part B - Fee(s) Transmittal and pay the PUBLICATION FEE (if required) and twice the amount of the ISSUE FEE shown above, or

If the SMALL ENTITY is shown as NO:

A. Pay TOTAL FEE(S) DUE shown above, or

B. If applicant claimed SMALL ENTITY status before, or is now claiming SMALL ENTITY status, check box 5a on Part B - Fee(s) Transmittal and pay the PUBLICATION FEE (if required) and 1/2 the ISSUE FEE shown above.

II. PART B - FEE(S) TRANSMITTAL, or its equivalent, must be completed and returned to the United States Patent and Trademark Office (USPTO) with your ISSUE FEE and PUBLICATION FEE (if required). If you are charging the fee(s) to your deposit account, section "4b" of Part B - Fee(s) Transmittal should be completed and an extra copy of the form should be submitted. If an equivalent of Part B is filed, a request to reapply a previously paid issue fee must be clearly made, and delays in processing may occur due to the difficulty in recognizing the paper as an equivalent of Part B.

III. All communications regarding this application must give the application number. Please direct all communications prior to issuance to Mail Stop ISSUE FEE unless advised to the contrary.

IMPORTANT REMINDER: Utility patents issuing on applications filed on or after Dec. 12, 1980 may require payment of maintenance fees. It is patentee's responsibility to ensure timely payment of maintenance fees when due.

PART B - FEE(S) TRANSMITTAL

**Complete and send this form, together with applicable fee(s), to: Mail Mail Stop ISSUE FEE
 Commissioner for Patents
 P.O. Box 1450
 Alexandria, Virginia 22313-1450
 or Fax (571)-273-2885**

INSTRUCTIONS: This form should be used for transmitting the ISSUE FEE and PUBLICATION FEE (if required). Blocks 1 through 5 should be completed where appropriate. All further correspondence including the Patent, advance orders and notification of maintenance fees will be mailed to the current correspondence address as indicated unless corrected below or directed otherwise in Block 1, by (a) specifying a new correspondence address; and/or (b) indicating a separate "FEE ADDRESS" for maintenance fee notifications.

CURRENT CORRESPONDENCE ADDRESS (Note: Use Block 1 for any change of address)

15671 7590 08/06/2012
 Gardner, Linn, Burkhart & Flory, LLP
 2851 Charlevoix Dr.
 SE, Suite 207
 Grand Rapids, MI 49546

Note: A certificate of mailing can only be used for domestic mailings of the Fee(s) Transmittal. This certificate cannot be used for any other accompanying papers. Each additional paper, such as an assignment or formal drawing, must have its own certificate of mailing or transmission.

Certificate of Mailing or Transmission

I hereby certify that this Fee(s) Transmittal is being deposited with the United States Postal Service with sufficient postage for first class mail in an envelope addressed to the Mail Stop ISSUE FEE address above, or being facsimile transmitted to the USPTO (571) 273-2885, on the date indicated below.

_____ (Depositor's name)
_____ (Signature)
_____ (Date)

APPLICATION NO.	FILING DATE	FIRST NAMED INVENTOR	ATTORNEY DOCKET NO.	CONFIRMATION NO.
13/336,018	12/23/2011	Niall R. Lynam	DON09 P-1800	7833

TITLE OF INVENTION: EXTERIOR REARVIEW MIRROR ASSEMBLY

APPLN. TYPE	SMALL ENTITY	ISSUE FEE DUE	PUBLICATION FEE DUE	PREV. PAID ISSUE FEE	TOTAL FEE(S) DUE	DATE DUE
nonprovisional	NO	\$1740	\$300	\$0	\$2040	11/06/2012

EXAMINER	ART UNIT	CLASS-SUBCLASS
AMARI, ALESSANDRO V	2872	359-866000

<p>1. Change of correspondence address or indication of "Fee Address" (37 CFR 1.363).</p> <p><input type="checkbox"/> Change of correspondence address (or Change of Correspondence Address form PTO/SB/122) attached.</p> <p><input type="checkbox"/> "Fee Address" indication (or "Fee Address" Indication form PTO/SB/47; Rev 03-02 or more recent) attached. Use of a Customer Number is required.</p>	<p>2. For printing on the patent front page, list</p> <p>(1) the names of up to 3 registered patent attorneys or agents OR, alternatively, _____ 1</p> <p>(2) the name of a single firm (having as a member a registered attorney or agent) and the names of up to 2 registered patent attorneys or agents. If no name is listed, no name will be printed. _____ 2</p> <p>_____ 3</p>
---	---

3. ASSIGNEE NAME AND RESIDENCE DATA TO BE PRINTED ON THE PATENT (print or type)

PLEASE NOTE: Unless an assignee is identified below, no assignee data will appear on the patent. If an assignee is identified below, the document has been filed for recordation as set forth in 37 CFR 3.11. Completion of this form is NOT a substitute for filing an assignment.

(A) NAME OF ASSIGNEE _____ (B) RESIDENCE: (CITY and STATE OR COUNTRY) _____

Please check the appropriate assignee category or categories (will not be printed on the patent) : Individual Corporation or other private group entity Government

<p>4a. The following fee(s) are submitted:</p> <p><input type="checkbox"/> Issue Fee</p> <p><input type="checkbox"/> Publication Fee (No small entity discount permitted)</p> <p><input type="checkbox"/> Advance Order - # of Copies _____</p>	<p>4b. Payment of Fee(s): (Please first reapply any previously paid issue fee shown above)</p> <p><input type="checkbox"/> A check is enclosed.</p> <p><input type="checkbox"/> Payment by credit card. Form PTO-2038 is attached.</p> <p><input type="checkbox"/> The Director is hereby authorized to charge the required fee(s), any deficiency, or credit any overpayment, to Deposit Account Number _____ (enclose an extra copy of this form).</p>
---	---

5. **Change in Entity Status** (from status indicated above)

a. Applicant claims SMALL ENTITY status. See 37 CFR 1.27. b. Applicant is no longer claiming SMALL ENTITY status. See 37 CFR 1.27(g)(2).

NOTE: The Issue Fee and Publication Fee (if required) will not be accepted from anyone other than the applicant; a registered attorney or agent; or the assignee or other party in interest as shown by the records of the United States Patent and Trademark Office.

Authorized Signature _____ Date _____

Typed or printed name _____ Registration No. _____

This collection of information is required by 37 CFR 1.311. The information is required to obtain or retain a benefit by the public which is to file (and by the USPTO to process) an application. Confidentiality is governed by 35 U.S.C. 122 and 37 CFR 1.14. This collection is estimated to take 12 minutes to complete, including gathering, preparing, and submitting the completed application form to the USPTO. Time will vary depending upon the individual case. Any comments on the amount of time you require to complete this form and/or suggestions for reducing this burden, should be sent to the Chief Information Officer, U.S. Patent and Trademark Office, U.S. Department of Commerce, P.O. Box 1450, Alexandria, Virginia 22313-1450. DO NOT SEND FEES OR COMPLETED FORMS TO THIS ADDRESS. SEND TO: Commissioner for Patents, P.O. Box 1450, Alexandria, Virginia 22313-1450.

Under the Paperwork Reduction Act of 1995, no persons are required to respond to a collection of information unless it displays a valid OMB control number.



UNITED STATES PATENT AND TRADEMARK OFFICE

UNITED STATES DEPARTMENT OF COMMERCE
United States Patent and Trademark Office
Address: COMMISSIONER FOR PATENTS
P.O. Box 1450
Alexandria, Virginia 22313-1450
www.uspto.gov

Table with 5 columns: APPLICATION NO., FILING DATE, FIRST NAMED INVENTOR, ATTORNEY DOCKET NO., CONFIRMATION NO. Includes details for application 13/336,018 filed 12/23/2011 by Niall R. Lynam, attorney DON09 P-1800, examiner AMARI, ALESSANDRO V, art unit 2872, and paper number 7833.

DATE MAILED: 08/06/2012

Determination of Patent Term Adjustment under 35 U.S.C. 154 (b)
(application filed on or after May 29, 2000)

The Patent Term Adjustment to date is 0 day(s). If the issue fee is paid on the date that is three months after the mailing date of this notice and the patent issues on the Tuesday before the date that is 28 weeks (six and a half months) after the mailing date of this notice, the Patent Term Adjustment will be 0 day(s).

If a Continued Prosecution Application (CPA) was filed in the above-identified application, the filing date that determines Patent Term Adjustment is the filing date of the most recent CPA.

Applicant will be able to obtain more detailed information by accessing the Patent Application Information Retrieval (PAIR) WEB site (http://pair.uspto.gov).

Any questions regarding the Patent Term Extension or Adjustment determination should be directed to the Office of Patent Legal Administration at (571)-272-7702. Questions relating to issue and publication fee payments should be directed to the Customer Service Center of the Office of Patent Publication at 1-(888)-786-0101 or (571)-272-4200.

Privacy Act Statement

The Privacy Act of 1974 (P.L. 93-579) requires that you be given certain information in connection with your submission of the attached form related to a patent application or patent. Accordingly, pursuant to the requirements of the Act, please be advised that: (1) the general authority for the collection of this information is 35 U.S.C. 2(b)(2); (2) furnishing of the information solicited is voluntary; and (3) the principal purpose for which the information is used by the U.S. Patent and Trademark Office is to process and/or examine your submission related to a patent application or patent. If you do not furnish the requested information, the U.S. Patent and Trademark Office may not be able to process and/or examine your submission, which may result in termination of proceedings or abandonment of the application or expiration of the patent.

The information provided by you in this form will be subject to the following routine uses:

1. The information on this form will be treated confidentially to the extent allowed under the Freedom of Information Act (5 U.S.C. 552) and the Privacy Act (5 U.S.C. 552a). Records from this system of records may be disclosed to the Department of Justice to determine whether disclosure of these records is required by the Freedom of Information Act.
2. A record from this system of records may be disclosed, as a routine use, in the course of presenting evidence to a court, magistrate, or administrative tribunal, including disclosures to opposing counsel in the course of settlement negotiations.
3. A record in this system of records may be disclosed, as a routine use, to a Member of Congress submitting a request involving an individual, to whom the record pertains, when the individual has requested assistance from the Member with respect to the subject matter of the record.
4. A record in this system of records may be disclosed, as a routine use, to a contractor of the Agency having need for the information in order to perform a contract. Recipients of information shall be required to comply with the requirements of the Privacy Act of 1974, as amended, pursuant to 5 U.S.C. 552a(m).
5. A record related to an International Application filed under the Patent Cooperation Treaty in this system of records may be disclosed, as a routine use, to the International Bureau of the World Intellectual Property Organization, pursuant to the Patent Cooperation Treaty.
6. A record in this system of records may be disclosed, as a routine use, to another federal agency for purposes of National Security review (35 U.S.C. 181) and for review pursuant to the Atomic Energy Act (42 U.S.C. 218(c)).
7. A record from this system of records may be disclosed, as a routine use, to the Administrator, General Services, or his/her designee, during an inspection of records conducted by GSA as part of that agency's responsibility to recommend improvements in records management practices and programs, under authority of 44 U.S.C. 2904 and 2906. Such disclosure shall be made in accordance with the GSA regulations governing inspection of records for this purpose, and any other relevant (i.e., GSA or Commerce) directive. Such disclosure shall not be used to make determinations about individuals.
8. A record from this system of records may be disclosed, as a routine use, to the public after either publication of the application pursuant to 35 U.S.C. 122(b) or issuance of a patent pursuant to 35 U.S.C. 151. Further, a record may be disclosed, subject to the limitations of 37 CFR 1.14, as a routine use, to the public if the record was filed in an application which became abandoned or in which the proceedings were terminated and which application is referenced by either a published application, an application open to public inspection or an issued patent.
9. A record from this system of records may be disclosed, as a routine use, to a Federal, State, or local law enforcement agency, if the USPTO becomes aware of a violation or potential violation of law or regulation.

Notice of Allowability	Application No.	Applicant(s)	
	13/336,018	LYNAM, NIALL R.	
	Examiner	Art Unit	
	ALESSANDRO AMARI	2872	

-- The MAILING DATE of this communication appears on the cover sheet with the correspondence address--

All claims being allowable, PROSECUTION ON THE MERITS IS (OR REMAINS) CLOSED in this application. If not included herewith (or previously mailed), a Notice of Allowance (PTOL-85) or other appropriate communication will be mailed in due course. **THIS NOTICE OF ALLOWABILITY IS NOT A GRANT OF PATENT RIGHTS.** This application is subject to withdrawal from issue at the initiative of the Office or upon petition by the applicant. See 37 CFR 1.313 and MPEP 1308.

1. This communication is responsive to amendment of 5/21/2012.
2. An election was made by the applicant in response to a restriction requirement set forth during the interview on ____; the restriction requirement and election have been incorporated into this action.
3. The allowed claim(s) is/are 1-6, 19-24 and 28-35.
4. Acknowledgment is made of a claim for foreign priority under 35 U.S.C. § 119(a)-(d) or (f).
 - a) All b) Some* c) None of the:
 1. Certified copies of the priority documents have been received.
 2. Certified copies of the priority documents have been received in Application No. ____.
 3. Copies of the certified copies of the priority documents have been received in this national stage application from the International Bureau (PCT Rule 17.2(a)).

* Certified copies not received: ____.

Applicant has THREE MONTHS FROM THE "MAILING DATE" of this communication to file a reply complying with the requirements noted below. Failure to timely comply will result in ABANDONMENT of this application.

THIS THREE-MONTH PERIOD IS NOT EXTENDABLE.

5. A SUBSTITUTE OATH OR DECLARATION must be submitted. Note the attached EXAMINER'S AMENDMENT or NOTICE OF INFORMAL PATENT APPLICATION (PTO-152) which gives reason(s) why the oath or declaration is deficient.
 6. CORRECTED DRAWINGS (as "replacement sheets") must be submitted.
 - (a) including changes required by the Notice of Draftsperson's Patent Drawing Review (PTO-948) attached
 - 1) hereto or 2) to Paper No./Mail Date ____.
 - (b) including changes required by the attached Examiner's Amendment / Comment or in the Office action of Paper No./Mail Date ____.
- Identifying indicia such as the application number (see 37 CFR 1.84(c)) should be written on the drawings in the front (not the back) of each sheet. Replacement sheet(s) should be labeled as such in the header according to 37 CFR 1.121(d).**
7. DEPOSIT OF and/or INFORMATION about the deposit of BIOLOGICAL MATERIAL must be submitted. Note the attached Examiner's comment regarding REQUIREMENT FOR THE DEPOSIT OF BIOLOGICAL MATERIAL.

Attachment(s)

- | | |
|--|--|
| <ol style="list-style-type: none"> 1. <input type="checkbox"/> Notice of References Cited (PTO-892) 2. <input type="checkbox"/> Notice of Draftsperson's Patent Drawing Review (PTO-948) 3. <input type="checkbox"/> Information Disclosure Statements (PTO/SB/08),
Paper No./Mail Date ____ 4. <input type="checkbox"/> Examiner's Comment Regarding Requirement for Deposit of Biological Material | <ol style="list-style-type: none"> 5. <input type="checkbox"/> Notice of Informal Patent Application 6. <input type="checkbox"/> Interview Summary (PTO-413),
Paper No./Mail Date ____. 7. <input type="checkbox"/> Examiner's Amendment/Comment 8. <input checked="" type="checkbox"/> Examiner's Statement of Reasons for Allowance 9. <input type="checkbox"/> Other ____. |
|--|--|

REASONS FOR ALLOWANCE

Terminal Disclaimer

The terminal disclaimer filed on 21 May 2012 disclaiming the terminal portion of any patent granted on this application which would extend beyond the expiration date of US 8,128,243 has been reviewed and is accepted. The terminal disclaimer has been recorded.

Affidavit/Declaration

The declaration filed on 21 May 2012 under 37 CFR 1.131 is sufficient to overcome the Lynam US 2002/0072026 and Black US 5579133 references.

Allowable Subject Matter

Claims 1-6, 19-24 and 28-35 are allowed.

The following is an examiner's statement of reasons for allowance:

Claim 1, 19 and 28 are allowable for at least the reason, "a spotting mirror fixedly secured to said single mirror support and disposed adjacent said primary mirror, said spotting mirror defined by a single radius of curvature differing from said primary mirror such that said spotting mirror provides a second field of view rearward of the motor vehicle, such that said first field of view of said primary, mirror overlaps said second field of view of said spotting mirror" as set forth in the claimed combination. Claims 2-6 are allowable due to their dependence on claim 1, claims 20-24 are allowable due to

their dependence on claim 19 and claims 29-35 are allowable due to their dependence on claim 28.

Any comments considered necessary by applicant must be submitted no later than the payment of the issue fee and, to avoid processing delays, should preferably accompany the issue fee. Such submissions should be clearly labeled "Comments on Statement of Reasons for Allowance."

Any inquiry concerning this communication or earlier communications from the examiner should be directed to ALESSANDRO AMARI whose telephone number is (571)272-2306. The examiner can normally be reached on Monday-Friday 8:00 AM to 5:30 PM.

If attempts to reach the examiner by telephone are unsuccessful, the examiner's supervisor, Thomas Pham can be reached on (571) 272-3689. The fax phone number for the organization where this application or proceeding is assigned is 571-273-8300.

Information regarding the status of an application may be obtained from the Patent Application Information Retrieval (PAIR) system. Status information for published applications may be obtained from either Private PAIR or Public PAIR. Status information for unpublished applications is available through Private PAIR only. For more information about the PAIR system, see <http://pair-direct.uspto.gov>. Should you have questions on access to the Private PAIR system, contact the Electronic Business Center (EBC) at 866-217-9197 (toll-free). If you would like assistance from a USPTO Customer Service Representative or access to the automated information system, call 800-786-9199 (IN USA OR CANADA) or 571-272-1000.

/Alessandro Amari/
Primary Examiner, Art Unit 2872

Search Notes 	Application/Control No. 13336018	Applicant(s)/Patent Under Reexamination LYNAM, NIALL R.
	Examiner ALESSANDRO AMARI	Art Unit 2872

SEARCHED			
Class	Subclass	Date	Examiner
359	871, 872, 877, 866	5/14/2012	AA
Update	above	7/23/2012	AA

SEARCH NOTES		
Search Notes	Date	Examiner
EAST search	5/14/2012	AA

INTERFERENCE SEARCH			
Class	Subclass	Date	Examiner
	PG-Pub/USPAT/UPAD text search	7/23/2012	AA

--	--

EAST Search History**EAST Search History (Prior Art)**

Ref #	Hits	Search Query	DBs	Default Operator	Plurals	Time Stamp
L2	3537	(359/866,871,872).CCLS.	US-PGPUB; USPAT; USOCR; EPO; JPO; DERWENT	OR	OFF	2012/07/23 17:21

EAST Search History (Interference)

Ref #	Hits	Search Query	DBs	Default Operator	Plurals	Time Stamp
L3	5	single mirror support.clm.	US-PGPUB; USPAT; UPAD	ADJ	ON	2012/07/23 17:25
L4	31	(spotting or blind spot) mirror.clm.	US-PGPUB; USPAT; UPAD	ADJ	ON	2012/07/23 17:25
L5	5028	(single mirror support or backing plate).clm.	US-PGPUB; USPAT; UPAD	ADJ	ON	2012/07/23 17:26
L6	7	4 and 5	US-PGPUB; USPAT; UPAD	ADJ	ON	2012/07/23 17:26
L7	37540	radius near1 curvature.clm.	US-PGPUB; USPAT; UPAD	ADJ	ON	2012/07/23 17:28
L8	7	6 and 7	US-PGPUB; USPAT; UPAD	ADJ	ON	2012/07/23 17:28

7/ 23/ 2012 5:34:15 PM

C:\Users\ aamari\ Documents\ EAST\ Workspaces\ 13336018.wsp

Issue Classification 	Application/Control No. 13336018	Applicant(s)/Patent Under Reexamination LYNAM, NIALL R.
	Examiner ALESSANDRO AMARI	Art Unit 2872

ORIGINAL						INTERNATIONAL CLASSIFICATION												
CLASS			SUBCLASS			CLAIMED					NON-CLAIMED							
359			866			G	0	2	B	5 / 08 (2006.0)								
CROSS REFERENCE(S)						G	0	2	B	7 / 182 (2006.0)								
CLASS	SUBCLASS (ONE SUBCLASS PER BLOCK)																	
359	871																	

Claims renumbered in the same order as presented by applicant
 CPA
 T.D.
 R.1.47

Final	Original	Final	Original	Final	Original	Final	Original	Final	Original	Final	Original	Final	Original	Final	Original
1	1		17	18	33										
2	2		18	19	34										
3	3	7	19	20	35										
4	4	8	20												
5	5	9	21												
6	6	10	22												
	7	11	23												
	8	12	24												
	9		25												
	10		26												
	11		27												
	12	13	28												
	13	14	29												
	14	15	30												
	15	16	31												
	16	17	32												

NONE		Total Claims Allowed:	
		20	
(Assistant Examiner)	(Date)	O.G. Print Claim(s)	O.G. Print Figure
/ALESSANDRO AMARI/ Primary Examiner.Art Unit 2872	07/23/2012	1	13E, 14
(Primary Examiner)	(Date)		

PART B - FEE(S) TRANSMITTAL

Complete and send this form, together with applicable fee(s), to: **Mail** Mail Stop ISSUE FEE
Commissioner for Patents
P.O. Box 1450
Alexandria, Virginia 22313-1450
or Fax (571)-273-2885

INSTRUCTIONS: This form should be used for transmitting the ISSUE FEE and PUBLICATION FEE (if required). Blocks 1 through 5 should be completed where appropriate. All further correspondence including the Patent, advance orders and notification of maintenance fees will be mailed to the current correspondence address as indicated unless corrected below or directed otherwise in Block 1, by (a) specifying a new correspondence address; and/or (b) indicating a separate "FEE ADDRESS" for maintenance fee notifications.

CURRENT CORRESPONDENCE ADDRESS (Note: Use Block 1 for any change of address)

15671 7590 08/06/2012
 Gardner, Linn, Burkhardt & Flory, LLP
 2851 Charlevoix Dr.
 SE, Suite 207
 Grand Rapids, MI 49546

Note: A certificate of mailing can only be used for domestic mailings of the Fee(s) Transmittal. This certificate cannot be used for any other accompanying papers. Each additional paper, such as an assignment or formal drawing, must have its own certificate of mailing or transmission.

Certificate of Mailing or Transmission

I hereby certify that this Fee(s) Transmittal is being deposited with the United States Postal Service with sufficient postage for first class mail in an envelope addressed to the Mail Stop ISSUE FEE address above, or being facsimile transmitted to the USPTO (571) 273-2885, on the date indicated below.

Amanda R. Sytsma	(Depositor's name)
<i>Amanda R. Sytsma</i>	(Signature)
August 7, 2012	(Date)

APPLICATION NO.	FILING DATE	FIRST NAMED INVENTOR	ATTORNEY DOCKET NO.	CONFIRMATION NO.
13/336,018	12/23/2011	Niall R. Lynam	DON09 P-1800	7833

TITLE OF INVENTION: EXTERIOR REARVIEW MIRROR ASSEMBLY

APPLN. TYPE	SMALL ENTITY	ISSUE FEE DUE	PUBLICATION FEE DUE	PREV. PAID ISSUE FEE	TOTAL FEE(S) DUE	DATE DUE
nonprovisional	NO	\$1740	\$300	\$0	\$2040	11/06/2012

EXAMINER	ART UNIT	CLASS-SUBCLASS
AMARI, ALESSANDRO V	2872	359-866000

1. Change of correspondence address or indication of "Fee Address" (37 CFR 1.363). <input type="checkbox"/> Change of correspondence address (or Change of Correspondence Address form PTO/SB/122) attached. <input type="checkbox"/> "Fee Address" indication (or "Fee Address" Indication form PTO/SB/47; Rev 03-02 or more recent) attached. Use of a Customer Number is required.	2. For printing on the patent front page, list (1) the names of up to 3 registered patent attorneys or agents OR, alternatively, (2) the name of a single firm (having as a member a registered attorney or agent) and the names of up to 2 registered patent attorneys or agents. If no name is listed, no name will be printed.	GARDNER, LINN, BURKHART 1. & FLORY, LLP 2. _____ 3. _____
---	---	--

3. ASSIGNEE NAME AND RESIDENCE DATA TO BE PRINTED ON THE PATENT (print or type)
 PLEASE NOTE: Unless an assignee is identified below, no assignee data will appear on the patent. If an assignee is identified below, the document has been filed for recordation as set forth in 37 CFR 3.11. Completion of this form is NOT a substitute for filing an assignment.

(A) NAME OF ASSIGNEE: **DONNELLY CORPORATION**
 (B) RESIDENCE: (CITY AND STATE OR COUNTRY) **HOLLAND, MI**

Please check the appropriate assignee category or categories (will not be printed on the patent): Individual Corporation or other private group entity Government

4a. The following fee(s) are submitted:
 Issue Fee
 Publication Fee (No small entity discount permitted)
 Advance Order - # of Copies _____

4b. Payment of Fee(s): (Please first reapply any previously paid issue fee shown above)
 A check is enclosed.
 Payment by credit card. Form PTO-2038 is attached.
 The Director is hereby authorized to charge the required fee(s), any deficiency, or credit any overpayment, to Deposit Account Number 50-5553 (enclose an extra copy of this form).

5. Change in Entity Status (from status indicated above)
 a. Applicant claims SMALL ENTITY status. See 37 CFR 1.27. b. Applicant is no longer claiming SMALL ENTITY status. See 37 CFR 1.27(g)(2).

NOTE: The Issue Fee and Publication Fee (if required) will not be accepted from anyone other than the applicant; a registered attorney or agent; or the assignee or other party in interest as shown by the records of the United States Patent and Trademark Office.

Authorized Signature *Timothy A. Flory* Date August 7, 2012
 Typed or printed name Timothy A. Flory Registration No. 42540

This collection of information is required by 37 CFR 1.311. The information is required to obtain or retain a benefit by the public which is to file (and by the USPTO to process) an application. Confidentiality is governed by 35 U.S.C. 122 and 37 CFR 1.14. This collection is estimated to take 12 minutes to complete, including gathering, preparing, and submitting the completed application form to the USPTO. Time will vary depending upon the individual case. Any comments on the amount of time you require to complete this form and/or suggestions for reducing this burden, should be sent to the Chief Information Officer, U.S. Patent and Trademark Office, U.S. Department of Commerce, P.O. Box 1450, Alexandria, Virginia 22313-1450. DO NOT SEND FEES OR COMPLETED FORMS TO THIS ADDRESS. SEND TO: Commissioner for Patents, P.O. Box 1450, Alexandria, Virginia 22313-1450.

Under the Paperwork Reduction Act of 1995, no persons are required to respond to a collection of information unless it displays a valid OMB control number.

Electronic Patent Application Fee Transmittal

Application Number:	13336018			
Filing Date:	23-Dec-2011			
Title of Invention:	EXTERIOR REARVIEW MIRROR ASSEMBLY			
First Named Inventor/Applicant Name:	Niall R. Lynam			
Filer:	Timothy A. Flory/Amanda Sytsma			
Attorney Docket Number:	DON09 P-1800			
Filed as Large Entity				
Utility under 35 USC 111 (a) Filing Fees				
Description	Fee Code	Quantity	Amount	Sub-Total in USD(\$)
Basic Filing:				
Pages:				
Claims:				
Miscellaneous-Filing:				
Petition:				
Patent-Appeals-and-Interference:				
Post-Allowance-and-Post-Issuance:				
Utility Appl issue fee	1501	1	1740	1740
Publ. Fee- early, voluntary, or normal	1504	1	300	300

Description	Fee Code	Quantity	Amount	Sub-Total in USD(\$)
Extension-of-Time:				
Miscellaneous:				
Total in USD (\$)				2040

Electronic Acknowledgement Receipt

EFS ID:	13436942
Application Number:	13336018
International Application Number:	
Confirmation Number:	7833
Title of Invention:	EXTERIOR REARVIEW MIRROR ASSEMBLY
First Named Inventor/Applicant Name:	Niall R. Lynam
Customer Number:	15671
Filer:	Timothy A. Flory/Amanda Sytsma
Filer Authorized By:	Timothy A. Flory
Attorney Docket Number:	DON09 P-1800
Receipt Date:	07-AUG-2012
Filing Date:	23-DEC-2011
Time Stamp:	15:36:56
Application Type:	Utility under 35 USC 111(a)

Payment information:

Submitted with Payment	yes
Payment Type	Credit Card
Payment was successfully received in RAM	\$ 2040
RAM confirmation Number	2297
Deposit Account	
Authorized User	

File Listing:

Document Number	Document Description	File Name	File Size(Bytes)/ Message Digest	Multi Part /.zip	Pages (if appl.)
-----------------	----------------------	-----------	-------------------------------------	------------------	------------------

1	Issue Fee Payment (PTO-85B)	IssueFeeTransmittal.pdf	128422 c97082ec79034a4d5de14edc0ce0a8a2100310b	no	1
Warnings:					
Information:					
2	Fee Worksheet (SB06)	fee-info.pdf	32111 645c8fd9a390bb5b3896eef12a97aa37e99c553	no	2
Warnings:					
Information:					
Total Files Size (in bytes):				160533	
<p>This Acknowledgement Receipt evidences receipt on the noted date by the USPTO of the indicated documents, characterized by the applicant, and including page counts, where applicable. It serves as evidence of receipt similar to a Post Card, as described in MPEP 503.</p> <p><u>New Applications Under 35 U.S.C. 111</u> If a new application is being filed and the application includes the necessary components for a filing date (see 37 CFR 1.53(b)-(d) and MPEP 506), a Filing Receipt (37 CFR 1.54) will be issued in due course and the date shown on this Acknowledgement Receipt will establish the filing date of the application.</p> <p><u>National Stage of an International Application under 35 U.S.C. 371</u> If a timely submission to enter the national stage of an international application is compliant with the conditions of 35 U.S.C. 371 and other applicable requirements a Form PCT/DO/EO/903 indicating acceptance of the application as a national stage submission under 35 U.S.C. 371 will be issued in addition to the Filing Receipt, in due course.</p> <p><u>New International Application Filed with the USPTO as a Receiving Office</u> If a new international application is being filed and the international application includes the necessary components for an international filing date (see PCT Article 11 and MPEP 1810), a Notification of the International Application Number and of the International Filing Date (Form PCT/RO/105) will be issued in due course, subject to prescriptions concerning national security, and the date shown on this Acknowledgement Receipt will establish the international filing date of the application.</p>					

Receipt date: 02/09/2012

Under the Paperwork Reduction Act of 1995, no persons are required to respond to a collection of information unless it contains a valid OMB control number.

Substitute for form 1449/PTO		Complete if Known	
INFORMATION DISCLOSURE STATEMENT BY APPLICANT <i>(Use as many sheets as necessary)</i>		Application Number	13/336,018
		Filing Date	December 23, 2011
		First Named Inventor	Niall R. Lynam
		Art Unit	2872
		Examiner Name	Alessandro V. Amari
		Attorney Docket Number	DON09 P-1800
Sheet	8	of	11

U. S. PATENT DOCUMENTS					
Examiner Initials*	Cite No. ¹	Document Number	Publication Date MM-DD-YYYY	Name of Patentee or Applicant of Cited Document	Pages, Columns, Lines, Where Relevant Passages or Relevant Figures Appear
		Number-Kind Code ² (if known)			

		4,575,202	1986-03-11	McGuire	
		4,555,166	1985-11-26	Enomoto	
		4,549,786	1985-10-29	Albers et al.	
		4,526,446	1985-07-02	Adams	
		4,499,451	1985-02-12	Suzuki et al.	
		4,470,665	1984-09-11	Blom	
		4,449,786	1984-05-22	McCord	
		4,439,013	1984-03-27	Hagn et al.	
		4,436,372	1984-03-13	Schmidt et al.	
		4,436,371	1984-03-13	Wood et al.	
Change(s) applied to document, /C.L.V./ 8/14/2012		4,435,042	1984-03-06	1984-06-03	Wood et al.
		4,385,804	1983-05-31	Tamura et al.	
		4,350,412	1982-09-21	Steenblik et al.	
		4,331,382	1982-05-25	Graff	
		4,325,609	1982-04-20	Alford	
		4,311,363	1982-01-19	Marsalka et al.	
		4,311,362	1982-01-19	LaPorte	
		4,306,770	1981-12-22	Marhauer	
		4,303,308	1981-12-01	Kobrin	
		4,293,191	1981-10-06	Kim	
		4,281,899	1981-08-04	Oskam	
		4,268,120	1981-05-19	Jitsumori	
		4,264,144	1981-04-28	McCord	
		4,258,979	1981-03-31	Mahin	
		4,223,983	1980-09-23	Bloom	
		4,200,359	1980-04-29	Lawson	
		4,193,668	1980-03-18	Skinner	
		3,909,117	1975-09-30	Takahashi et al.	
		3,884,606	1975-05-20	Schrenk	
		3,881,811	1975-05-06	French	
		3,826,563	1974-07-30	Davis	
		3,806,232	1974-04-23	Gray	
		3,773,882	1973-11-20	Schrenk	
		3,764,201	1973-10-09	Haile	
		3,759,647	1973-09-18	Schrenk et al.	
		3,708,222	1973-01-02	Stern	
		3,667,833	1972-06-06	Baldwin, Sr.	
		3,610,739	1971-10-05	Seashore	

Examiner Signature	/Alessandro Amari/	Date Considered	05/14/2012
--------------------	--------------------	-----------------	------------

*EXAMINER: Initial if reference considered, whether or not citation is in conformance with MPEP 609. Draw line through citation if not in conformance and not considered. Include copy of this form with next communication to applicant. ¹ Applicant's unique citation designation number (optional). ² See Kinds Codes of USPTO Patent Documents at www.uspto.gov or MPEP 901.04. ³ Enter Office that issued the document, by the two-letter code (WIPO Standard ST.3). ⁴ For Japanese patent documents, the indication of the year of the reign of the Emperor must precede the serial number of the patent document. ⁵ Kind of document by the appropriate symbols as indicated on the document under WIPO Standard ST.16 if possible. ⁶ Applicant is to place a check mark here if English language Translation is attached.

This collection of information is required by 37 CFR 1.97 and 1.98. The information is required to obtain or retain a benefit by the public which is to file (and by the USPTO to process) an application. Confidentiality is governed by 35 USC 122 and 37 CFR 2.14. This collection is estimated to take 2 hours to complete, including gathering, preparing, and submitting the completed application form to the USPTO. There will be no charge for this collection of information. If you have any questions, please contact the U.S. Patent and Trademark Office, U.S. Department of Commerce, U.S. Patent and Trademark Office, P.O. Box 1450, Alexandria, VA 22313-1450. DO NOT SEND FEES OR COMPLETED FORMS TO THIS ADDRESS. SEND TO: **ATTORNEYS CONSULATED WITH THROUGH /A.A./**

Receipt date: 02/09/2012

PTO/SB/08A (07-05)
Approved for use through 07/31/2008, OMB 0651-0031
U.S. Patent and Trademark Office; U.S. DEPARTMENT OF COMMERCE
CLASSIFICATION: 2872

Under the Paperwork Reduction Act of 1995, no persons are required to respond to a collection of information unless it contains a valid OMB control number.

Substitute for form 1449/PTO		Complete if Known	
INFORMATION DISCLOSURE STATEMENT BY APPLICANT <i>(Use as many sheets as necessary)</i>		Filing Date	December 23, 2011
		First Named Inventor	Niall R. Lynam
		Art Unit	2872
		Examiner Name	Alessandro V. Amari
		Attorney Docket Number	DON09 P-1800
Sheet	5	of	11

U. S. PATENT DOCUMENTS					
Examiner Initials*	Cite No. ¹	Document Number	Publication Date MM-DD-YYYY	Name of Patentee or Applicant of Cited Document	Pages, Columns, Lines, Where Relevant Passages or Relevant Figures Appear
		Number-Kind Code ² (if known)			

		5,621,577	1997-04-15	Lang et al.	
		5,621,569	1997-04-15	Schlenke	
		5,610,756	1997-03-11	Lynam et al.	
		5,594,593	1997-01-14	Milner	
		5,594,222	1997-01-14	Caldwell	
		5,587,699	1996-12-24	Faloon et al.	
		5,587,236	1996-12-24	Agrawal et al.	
		5,579,133	1996-11-26	Black et al.	
		5,575,552	1996-11-19	Faloon et al.	
		5,567,360	1996-10-22	Varaprasad et al.	
		5,563,744	1996-10-08	Matsumiya	
		5,559,640	1996-09-24	Vachss et al.	
		5,557,467	1996-09-17	McColgan et al.	
		5,550,677	1996-08-27	Schofield et al.	
		5,535,056	1996-07-09	Caskey et al.	
		5,530,588	1996-06-25	Vivier	
		5,526,195	1996-06-11	Thomas	
		5,525,264	1996-06-11	Cronin et al.	
		5,523,877	1996-06-04	Lynam	
		5,517,367	1996-05-14	Kim et al.	
		5,509,606	1996-04-23	Breithaupt et al.	
		5,497,306	1996-03-05	Pastrick	
		5,497,305	1996-03-05	Pastrick et al.	
		5,483,386	1996-01-09	Carson	
		5,481,409	1996-01-02	Roberts	
Change(s) applied to document,		5,446,576	1995-08-29	Lynam et al.	
8/14/2012	LV	5,437,931	1995-08-01	Tsai et al.	
		5,432,643	1995-07-11	Huang	
		5,424,875	1995-06-13	Davis, II	
		5,412,512	1995-05-02	Zebold et al.	
		5,406,414	1995-04-11	O'Farrell et al.	
		5,371,659	1994-12-06	Pastrick et al.	
		5,361,172	1994-11-01	Schissel et al.	
		5,355,245	1994-10-11	Lynam	
		5,354,965	1994-10-11	Lee	
		5,327,288	1994-07-05	Wellington et al.	
		5,313,335	1994-05-17	Gray et al.	
		5,296,973	1994-03-22	Burke	

Examiner Signature	/Alessandro Amari/	Date Considered	05/14/2012
--------------------	--------------------	-----------------	------------

*EXAMINER: Initial if reference considered, whether or not citation is in conformance with MPEP 609. Draw line through citation if not in conformance and not considered. Include copy of this form with next communication to applicant. ¹ Applicant's unique citation designation number (optional). ² See Kinds Codes of USPTO Patent Documents at www.uspto.gov or MPBP 901.04. ³ Enter Office that issued the document, by the two-letter code (WIPO Standard ST.3). ⁴ For Japanese patent documents, the indication of the year of the reign of the Emperor must precede the serial number of the patent document. ⁵ Kind of document by the appropriate symbols as indicated on the document under WIPO Standard ST.16 if possible. ⁶ Applicant is to place a check mark here if English language Translation is attached.

This collection of information is required by 37 CFR 1.97 and 1.98. The information is required to obtain or retain a benefit by the public which is to file (and by the USPTO to process) an application. Confidentiality is governed by 35 U.S.C. 122 and 37 CFR 1.14. This collection is estimated to take 2 hours to complete, including gathering, preparing, and submitting the completed application form to the USPTO. The information will be used for the purposes of the USPTO. Any comments on this collection should be sent to the Chief Information Officer, U.S. Patent and Trademark Office, P.O. Box 1450, Alexandria, VA 22311-1450. DO NOT SEND FEES OR COMPLETED FORMS TO THIS ADDRESS! SEND TO:

Receipt date: 02/09/2012

Under the Paperwork Reduction Act of 1995, no persons are required to respond to a collection of information unless it contains a valid OMB control number.

Substitute for form 1449/PTO		Complete if Known	
INFORMATION DISCLOSURE STATEMENT BY APPLICANT <i>(Use as many sheets as necessary)</i>		Application Number	13/336,018
		Filing Date	December 23, 2011
		First Named Inventor	Niall R. Lynam
		Art Unit	2872
		Examiner Name	Alessandro V. Amari
Sheet	3	of	11
		Attorney Docket Number	DON09 P-1800

U. S. PATENT DOCUMENTS					
Examiner Initials*	Cite No. ¹	Document Number	Publication Date	Name of Patentee or Applicant of Cited Document	Pages, Columns, Lines, Where Relevant Passages or Relevant Figures Appear
		Number-Kind Code ^{2 (if known)}	MM-DD-YYYY		

		6,315,419	2001-11-13	Platzer, Jr.	
		6,310,611	2001-10-30	Caldwell	
		6,294,989	2001-09-25	Schofield et al.	
		6,286,965	2001-09-11	Caskey et al.	
		6,276,821	2001-08-21	Pastrick et al.	
		6,270,225	2001-08-07	Goolsby	
		6,260,608	2001-07-17	Kim	
		6,257,746	2001-07-10	Todd et al.	
		6,250,148	2001-06-26	Lynam	
		6,245,262	2001-06-12	Varaprasad et al.	
		6,227,689	2001-05-08	Miller	
		6,207,083	2001-03-27	Varaprasad et al.	
		6,201,642	2001-03-13	Bos	
		6,199,993	2001-03-13	Mou	
		6,198,409	2001-03-06	Schofield et al.	
		6,196,688	2001-03-06	Caskey et al.	
		6,178,034	2001-01-23	Allemand et al.	
		6,176,602	2001-01-23	Pastrick et al.	
		6,172,613	2001-01-09	DeLine et al.	
		6,164,564	2000-12-26	Franco et al.	
		6,154,306	2000-11-28	Varaprasad et al.	
		6,135,419 6315419	2001-11-13	Platzer, Jr.	
		6,128,860	2000-10-10	Varaprasad et al.	
		6,124,647	2000-09-26	Marcus et al.	
		6,116,743	2000-09-12	Hoek	
		6,111,684	2000-08-29	Forgette et al.	
		6,109,586	2000-08-29	Hoek	
		6,097,023	2000-08-01	Schofield et al.	
		6,074,068	2000-06-13	Palathingal	
		6,065,840	2000-05-23	Caskey et al.	
		6,033,078	2000-03-07	Su et al.	
		6,032,323	2000-03-07	Smith et al.	
		6,030,084	2000-02-29	Schmidt	
		6,022,511 6002511	1999-12-14	Varaprasad et al.	
		6,011,486 6001486	1999-12-14	Varaprasad et al.	
		6,007,207	1999-12-28	Liu	
		6,005,724	1999-12-21	Todd	
		6,002,544	1999-12-14	Yatsu	

Change(s) applied to document, /CLV/ 8/14/2012

Change(s) applied to document, /CLV/ 8/13/2012

Examiner Signature	/Alessandro Amari/	Date Considered	05/14/2012
--------------------	--------------------	-----------------	------------

*EXAMINER: Initial if reference considered, whether or not citation is in conformance with MPBP 609. Draw line through citation if not in conformance and not considered. Include copy of this form with next communication to applicant. ¹ Applicant's unique citation designation number (optional). ² See Kinds Codes of USPTO Patent Documents at www.uspto.gov or MPEP 901.04. ³ Enter Office that issued the document, by the two-letter code (WIPO Standard ST.3). ⁴ For Japanese patent documents, the indication of the year of the reign of the Emperor must precede the serial number of the patent document. ⁵ Kind of document by the appropriate symbols as indicated on the document under WIPO Standard ST.16 if possible. ⁶ Applicant is to place a check mark here if English language Translation is attached. This collection of information is required by 37 CFR 1.97 and 1.98. The information is required to obtain or retain a benefit by the public which is to file (and by the USPTO to process) an application. Confidentiality is governed by 35 U.S.C. 122 and 37 CFR 1.14. This collection is estimated to take 2 hours to complete, including gathering, preparing, and submitting the completed application form to the USPTO. This will vary depending upon the individual case. Any comments on the amount of time you require to complete this form and/or suggestions for reducing this burden should be sent to the Chief Information Officer, U.S. Patent and Trademark Office, P.O. Box 1450, Alexandria, VA 22313-1450. DO NOT SEND FEES OR COMPLETED FORMS TO THIS ADDRESS. SEND TO: /AA/



UNITED STATES PATENT AND TRADEMARK OFFICE

UNITED STATES DEPARTMENT OF COMMERCE
United States Patent and Trademark Office
Address: COMMISSIONER FOR PATENTS
P.O. Box 1450
Alexandria, Virginia 22313-1450
www.uspto.gov

APPLICATION NO.	ISSUE DATE	PATENT NO.	ATTORNEY DOCKET NO.	CONFIRMATION NO.
13/336,018	09/18/2012	8267534	DON09 P-1800	7833

15671 7590 08/29/2012
Gardner, Linn, Burkhart & Flory, LLP
2851 Charlevoix Dr.
SE, Suite 207
Grand Rapids, MI 49546

ISSUE NOTIFICATION

The projected patent number and issue date are specified above.

Determination of Patent Term Adjustment under 35 U.S.C. 154 (b)
(application filed on or after May 29, 2000)

The Patent Term Adjustment is 0 day(s). Any patent to issue from the above-identified application will include an indication of the adjustment on the front page.

If a Continued Prosecution Application (CPA) was filed in the above-identified application, the filing date that determines Patent Term Adjustment is the filing date of the most recent CPA.

Applicant will be able to obtain more detailed information by accessing the Patent Application Information Retrieval (PAIR) WEB site (<http://pair.uspto.gov>).

Any questions regarding the Patent Term Extension or Adjustment determination should be directed to the Office of Patent Legal Administration at (571)-272-7702. Questions relating to issue and publication fee payments should be directed to the Application Assistance Unit (AAU) of the Office of Data Management (ODM) at (571)-272-4200.

APPLICANT(s) (Please see PAIR WEB site <http://pair.uspto.gov> for additional applicants):

Niall R. Lynam, Holland, MI;

The United States represents the largest, most dynamic marketplace in the world and is an unparalleled location for business investment, innovation, and commercialization of new technologies. The USA offers tremendous resources and advantages for those who invest and manufacture goods here. Through SelectUSA, our nation works to encourage and facilitate business investment. To learn more about why the USA is the best country in the world to develop technology, manufacture products, and grow your business, visit SelectUSA.gov.

**UNITED STATES PATENT AND TRADEMARK OFFICE
CERTIFICATE OF CORRECTION**

Page 1 of 1

PATENT NO. : 8,267,534
APPLICATION NO.: 13/336,018
ISSUE DATE : September 18, 2012
INVENTOR(S) : Niall R. Lynam

It is certified that an error appears or errors appear in the above-identified patent and that said Letters Patent is hereby corrected as shown below:

Column 3

Line 43, Insert --III-III-- after "line"

Column 14

Line 25, "Delete "," after "indicated"

Column 17

Line 19, "plan-auxiliary" should be --plano-auxiliary--

Column 22

Line 6, "18e" should be --18c--

Column 26

Line 12, Delete "," after "positioning"

MAILING ADDRESS OF SENDER (Please do not use customer number below):

GARDNER, LINN, BURKHART & FLORY, LLP
2851 Charlevoix Dr., S.E., Suite 207
Grand Rapids, MI 49546

This collection of information is required by 37 CFR 1.322, 1.323, and 1.324. The information is required to obtain or retain a benefit by the public which is to file (and by the USPTO to process) an application. Confidentiality is governed by 35 U.S.C. 122 and 37 CFR 1.14. This collection is estimated to take 1.0 hour to complete, including gathering, preparing, and submitting the completed application form to the USPTO. Time will vary depending upon the individual case. Any comments on the amount of time you require to complete this form and/or suggestions for reducing this burden, should be sent to the Chief Information Officer, U.S. Patent and Trademark Office, U.S. Department of Commerce, P.O. Box 1450, Alexandria, VA 22313-1450. DO NOT SEND FEES OR COMPLETED FORMS TO THIS ADDRESS. **SEND TO: Attention Certificate of Corrections Branch, Commissioner for Patents, P.O. Box 1450, Alexandria, VA 22313-1450.**

If you need assistance in completing the form, call 1-800-PTO-9199 and select option 2.

Electronic Acknowledgement Receipt

EFS ID:	14148127
Application Number:	13336018
International Application Number:	
Confirmation Number:	7833
Title of Invention:	EXTERIOR REARVIEW MIRROR ASSEMBLY
First Named Inventor/Applicant Name:	Niall R. Lynam
Customer Number:	15671
Filer:	Timothy A. Flory/Amanda Sytsma
Filer Authorized By:	Timothy A. Flory
Attorney Docket Number:	DON09 P-1800
Receipt Date:	05-NOV-2012
Filing Date:	23-DEC-2011
Time Stamp:	14:16:16
Application Type:	Utility under 35 USC 111(a)

Payment information:

Submitted with Payment	no
------------------------	----

File Listing:

Document Number	Document Description	File Name	File Size(Bytes)/ Message Digest	Multi Part /.zip	Pages (if appl.)
1	Transmittal Letter	TransmittalForm.pdf	47101 <small>569dfec8f32885a6c91772094c2015b5358f741e</small>	no	1

Warnings:

Information:

2	Request for Certificate of Correction	RequestforCorrection.pdf	99765 9a3d9f78909c9368d4a3161f539325e0a11b7cd3	no	1
Warnings:					
Information:					
Total Files Size (in bytes):				146866	
<p>This Acknowledgement Receipt evidences receipt on the noted date by the USPTO of the indicated documents, characterized by the applicant, and including page counts, where applicable. It serves as evidence of receipt similar to a Post Card, as described in MPEP 503.</p> <p><u>New Applications Under 35 U.S.C. 111</u> If a new application is being filed and the application includes the necessary components for a filing date (see 37 CFR 1.53(b)-(d) and MPEP 506), a Filing Receipt (37 CFR 1.54) will be issued in due course and the date shown on this Acknowledgement Receipt will establish the filing date of the application.</p> <p><u>National Stage of an International Application under 35 U.S.C. 371</u> If a timely submission to enter the national stage of an international application is compliant with the conditions of 35 U.S.C. 371 and other applicable requirements a Form PCT/DO/EO/903 indicating acceptance of the application as a national stage submission under 35 U.S.C. 371 will be issued in addition to the Filing Receipt, in due course.</p> <p><u>New International Application Filed with the USPTO as a Receiving Office</u> If a new international application is being filed and the international application includes the necessary components for an international filing date (see PCT Article 11 and MPEP 1810), a Notification of the International Application Number and of the International Filing Date (Form PCT/RO/105) will be issued in due course, subject to prescriptions concerning national security, and the date shown on this Acknowledgement Receipt will establish the international filing date of the application.</p>					

Under the Paperwork Reduction Act of 1995, no persons are required to respond to a collection of information unless it displays a valid OMB control number.

TRANSMITTAL FORM (to be used for all correspondence after initial filing)	Application Number	13/336,018
	Filing Date	December 23, 2011
	First Named Inventor	Niail R. Lynam
	Art Unit	2872
	Examiner Name	Alessandro V. Amari
	Attorney Docket Number	DON09 P-1800
Total Number of Pages in This Submission		

ENCLOSURES (Check all that apply)		
<input type="checkbox"/> Fee Transmittal Form	<input type="checkbox"/> Drawing(s)	<input type="checkbox"/> After Allowance Communication to TC
<input type="checkbox"/> Fee Attached	<input type="checkbox"/> Licensing-related Papers	<input type="checkbox"/> Appeal Communication to Board of Appeals and Interferences
<input type="checkbox"/> Amendment/Reply	<input type="checkbox"/> Petition	<input type="checkbox"/> Appeal Communication to TC (Appeal Notice, Brief, Reply Brief)
<input type="checkbox"/> After Final	<input type="checkbox"/> Petition to Convert to a Provisional Application	<input type="checkbox"/> Proprietary Information
<input type="checkbox"/> Affidavits/declaration(s)	<input type="checkbox"/> Power of Attorney, Revocation	<input type="checkbox"/> Status Letter
<input type="checkbox"/> Extension of Time Request	<input type="checkbox"/> Change of Correspondence Address	<input type="checkbox"/> Other Enclosure(s) (please identify below):
<input type="checkbox"/> Express Abandonment Request	<input type="checkbox"/> Terminal Disclaimer	<input type="checkbox"/> -Request for Certificate of Correction
<input type="checkbox"/> Information Disclosure Statement	<input type="checkbox"/> Request for Refund	
<input type="checkbox"/> Certified Copy of Priority Document(s)	<input type="checkbox"/> CD, Number of CD(s) _____	
<input type="checkbox"/> Reply to Missing Parts/Incomplete Application	<input type="checkbox"/> Landscape Table on CD	
<input type="checkbox"/> Reply to Missing Parts under 37 CFR 1.52 or 1.53	<input type="text"/> Remarks	

SIGNATURE OF APPLICANT, ATTORNEY, OR AGENT			
Firm Name	GARDNER, LINN, BURKHART & FLORY, LLP		
Signature	/taf/		
Printed name	Timothy A. Flory		
Date	November 5, 2012	Reg. No.	42540

CERTIFICATE OF TRANSMISSION/MAILING			
I hereby certify that this correspondence is being facsimile transmitted to the USPTO or deposited with the United States Postal Service with sufficient postage as first class mail in an envelope addressed to: Commissioner for Patents, P.O. Box 1450, Alexandria, VA 22313-1450 on the date shown below:			
Signature	/ars/		
Typed or printed name	Amanda R. Sytsma	Date	November 5, 2012

This collection of information is required by 37 CFR 1.5. The information is required to obtain or retain a benefit by the public which is to file (and by the USPTO to process) an application. Confidentiality is governed by 35 U.S.C. 122 and 37 CFR 1.11 and 1.14. This collection is estimated to 2 hours to complete, including gathering, preparing, and submitting the completed application form to the USPTO. Time will vary depending upon the individual case. Any comments on the amount of time you require to complete this form and/or suggestions for reducing this burden, should be sent to the Chief Information Officer, U.S. Patent and Trademark Office, U.S. Department of Commerce, P.O. Box 1450, Alexandria, VA 22313-1450. DO NOT SEND FEES OR COMPLETED FORMS TO THIS ADDRESS. SEND TO: Commissioner for Patents, P.O. Box 1450, Alexandria, VA 22313-1450.

If you need assistance in completing the form, call 1-800-PTO-9199 and select option 2.

UNITED STATES PATENT AND TRADEMARK OFFICE
CERTIFICATE OF CORRECTION

PATENT NO. : 8,267,534 B2
APPLICATION NO. : 13/336018
DATED : September 18, 2012
INVENTOR(S) : Niall R. Lynam

Page 1 of 1

It is certified that error appears in the above-identified patent and that said Letters Patent is hereby corrected as shown below:

Column 3

Line 43, Insert --III-III-- after "line"

Column 14

Line 25, Delete "," after "indicated"

Column 17

Line 19, "plan-auxiliary" should be --plano-auxiliary--

Column 22

Line 6, "18e" should be --18c--

Column 26

Line 12, Delete "," after "positioning"

Signed and Sealed this
Eighteenth Day of December, 2012

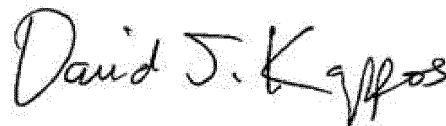

David J. Kappos
Director of the United States Patent and Trademark Office

AO 120 (Rev. 08/10)

TO: Mail Stop 8 Director of the U.S. Patent and Trademark Office P.O. Box 1450 Alexandria, VA 22313-1450	REPORT ON THE FILING OR DETERMINATION OF AN ACTION REGARDING A PATENT OR TRADEMARK
---	---

In Compliance with 35 U.S.C. § 290 and/or 15 U.S.C. § 1116 you are hereby advised that a court action has been filed in the U.S. District Court Western District of Michigan on the following
 Trademarks or Patents. (the patent action involves 35 U.S.C. § 292.);

DOCKET NO. 1:15-cv-183	DATE FILED 2/19/2015	U.S. DISTRICT COURT Western District of Michigan
PLAINTIFF Magna Mirrors of America, Inc.		DEFENDANT Ficosa International S.A.; Ficosa North America Corporation; Ficosa North America S.A. de C.V.; and Fico Mirrors, S.A.
PATENT OR TRADEMARK NO.	DATE OF PATENT OR TRADEMARK	HOLDER OF PATENT OR TRADEMARK
1		SEE ATTCHED LIST
2		
3		
4		
5		

In the above—entitled case, the following patent(s)/ trademark(s) have been included:

DATE INCLUDED	INCLUDED BY <input type="checkbox"/> Amendment <input type="checkbox"/> Answer <input type="checkbox"/> Cross Bill <input type="checkbox"/> Other Pleading	
PATENT OR TRADEMARK NO.	DATE OF PATENT OR TRADEMARK	HOLDER OF PATENT OR TRADEMARK
1		
2		
3		
4		
5		

In the above—entitled case, the following decision has been rendered or judgement issued:

DECISION/JUDGEMENT

CLERK TRACEY CORDES, CLERK OF COURT	(BY) DEPUTY CLERK /s/ Paula J. Woods	DATE 2/20/1015
--	---	-------------------

Copy 1—Upon initiation of action, mail this copy to Director Copy 3—Upon termination of action, mail this copy to Director
 Copy 2—Upon filing document adding patent(s), mail this copy to Director Copy 4—Case file copy

Patent No.	Date of Patent	Holder
U.S. Patent 7,934,843	May 3, 2011	Magna Mirrors of America, Inc.
U.S. Patent 8,128,243	March 6, 2012	Magna Mirrors of America, Inc.
U.S. Patent 8,128,244	March 6, 2012	Magna Mirrors of America, Inc.
U.S. Patent 8,147,077	April 3, 2012	Magna Mirrors of America, Inc.
U.S. Patent 8,267,534	September 18, 2012	Magna Mirrors of America, Inc.
U.S. Patent 8,550,642	October 8, 2013	Magna Mirrors of America, Inc.
U.S. Patent 8,591,047	November 26, 2013	Magna Mirrors of America, Inc.
U.S. Patent 8,783,882	July 22, 2014	Magna Mirrors of America, Inc.
U.S. Patent 8,899,762	December 2, 2014	Magna Mirrors of America, Inc.

AO 120 (Rev. 08/10)

TO: Mail Stop 8 Director of the U.S. Patent and Trademark Office P.O. Box 1450 Alexandria, VA 22313-1450	REPORT ON THE FILING OR DETERMINATION OF AN ACTION REGARDING A PATENT OR TRADEMARK
---	--

In Compliance with 35 U.S.C. § 290 and/or 15 U.S.C. § 1116 you are hereby advised that a court action has been filed in the U.S. District Court Western District of Michigan on the following
 Trademarks or Patents. (the patent action involves 35 U.S.C. § 292.);

DOCKET NO. 1:15-cv-183	DATE FILED 2/19/2015	U.S. DISTRICT COURT Western District of Michigan
PLAINTIFF Magna Mirrors of America, Inc.		DEFENDANT Ficosa International S.A., et al
PATENT OR TRADEMARK NO.	DATE OF PATENT OR TRADEMARK	HOLDER OF PATENT OR TRADEMARK
1		SEE ATTACHED LIST
2		
3		
4		
5		

In the above—entitled case, the following patent(s)/ trademark(s) have been included:

DATE INCLUDED	INCLUDED BY <input type="checkbox"/> Amendment <input type="checkbox"/> Answer <input type="checkbox"/> Cross Bill <input type="checkbox"/> Other Pleading	
PATENT OR TRADEMARK NO.	DATE OF PATENT OR TRADEMARK	HOLDER OF PATENT OR TRADEMARK
1		
2		
3		
4		
5		

In the above—entitled case, the following decision has been rendered or judgement issued:

DECISION/JUDGEMENT Voluntarily Dismissed on 3/23/2016
--

CLERK Clerk of Court	(BY) DEPUTY CLERK /s/ Paula J. Woods	DATE 3/24/2016
-------------------------	---	-------------------

Copy 1—Upon initiation of action, mail this copy to Director Copy 3—Upon termination of action, mail this copy to Director
 Copy 2—Upon filing document adding patent(s), mail this copy to Director Copy 4—Case file copy

Patent No.	Date of Patent	Holder
U.S. Patent 7,934,843	May 3, 2011	Magna Mirrors of America, Inc.
U.S. Patent 8,128,243	March 6, 2012	Magna Mirrors of America, Inc.
U.S. Patent 8,128,244	March 6, 2012	Magna Mirrors of America, Inc.
U.S. Patent 8,147,077	April 3, 2012	Magna Mirrors of America, Inc.
U.S. Patent 8,267,534	September 18, 2012	Magna Mirrors of America, Inc.
U.S. Patent 8,550,642	October 8, 2013	Magna Mirrors of America, Inc.
U.S. Patent 8,591,047	November 26, 2013	Magna Mirrors of America, Inc.
U.S. Patent 8,783,882	July 22, 2014	Magna Mirrors of America, Inc.
U.S. Patent 8,899,762	December 2, 2014	Magna Mirrors of America, Inc.

AO 120 (Rev. 08/10)

TO: Mail Stop 8 Director of the U.S. Patent and Trademark Office P.O. Box 1450 Alexandria, VA 22313-1450	REPORT ON THE FILING OR DETERMINATION OF AN ACTION REGARDING A PATENT OR TRADEMARK
---	--

In Compliance with 35 U.S.C. § 290 and/or 15 U.S.C. § 1116 you are hereby advised that a court action has been filed in the U.S. District Court Western District of Michigan on the following

Trademarks or Patents. (the patent action involves 35 U.S.C. § 292.);

DOCKET NO. 1:17-cv-77	DATE FILED 1/23/2017	U.S. DISTRICT COURT Western District of Michigan
PLAINTIFF MAGNA MIRRORS OF AMERICA, INC.		DEPENDANT SAMVARDHANA MOTHERSON REFLECTEC GROUP HOLDINGS LIMITED, et al.
PATENT OR TRADEMARK NO.	DATE OF PATENT OR TRADEMARK	HOLDER OF PATENT OR TRADEMARK
1		SEE ATTACHED
2		
3		
4		
5		

In the above—entitled case, the following patent(s)/ trademark(s) have been included:

DATE INCLUDED	INCLUDED BY	<input type="checkbox"/> Amendment <input type="checkbox"/> Answer <input type="checkbox"/> Cross Bill <input type="checkbox"/> Other Pleading
PATENT OR TRADEMARK NO.	DATE OF PATENT OR TRADEMARK	HOLDER OF PATENT OR TRADEMARK
1		
2		
3		
4		
5		

In the above—entitled case, the following decision has been rendered or judgement issued:

DECISION/JUDGEMENT

CLERK Thomas L. Dorwin, Clerk of Court	(BY) DEPUTY CLERK /s/ P. Woods	DATE 1/25/2017
---	-----------------------------------	-------------------

Copy 1—Upon initiation of action, mail this copy to Director Copy 3—Upon termination of action, mail this copy to Director
 Copy 2—Upon filing document adding patent(s), mail this copy to Director Copy 4—Case file copy

Patent No.	Date of Patent	Holder
U.S. Patent 7,934,843	May 3, 2011	Magna Mirrors of America, Inc.
U.S. Patent 8,128,243	March 6, 2012	Magna Mirrors of America, Inc.
U.S. Patent 8,128,244	March 6, 2012	Magna Mirrors of America, Inc.
U.S. Patent 8,147,077	April 3, 2012	Magna Mirrors of America, Inc.
U.S. Patent 8,267,534	September 18, 2012	Magna Mirrors of America, Inc.
U.S. Patent 8,550,642	October 8, 2013	Magna Mirrors of America, Inc.
U.S. Patent 8,591,047	November 26, 2013	Magna Mirrors of America, Inc.
U.S. Patent 8,783,882	July 22, 2014	Magna Mirrors of America, Inc.
U.S. Patent 8,899,762	December 2, 2014	Magna Mirrors of America, Inc.