

United States Patent [19]
Graff

[11] **4,331,382**
[45] **May 25, 1982**

- [54] **WIDE-ANGLE MIRROR FOR AUTOMOBILES AND THE LIKE**
- [75] **Inventor: Henry W. Graff, Elgin, Ill.**
- [73] **Assignee: Pathfinder Auto Lamp Company, Niles, Ill.**
- [21] **Appl. No.: 130,077**
- [22] **Filed: Mar. 13, 1980**
- [51] **Int. Cl.³ G02B 5/10**
- [52] **U.S. Cl. 350/303; 350/293**
- [58] **Field of Search 350/293, 303**

[56] **References Cited**
U.S. PATENT DOCUMENTS

2,279,751	4/1942	Hensley	350/303
3,389,952	6/1968	Tobin, Jr.	350/303
3,501,227	3/1970	Landen	350/303
3,628,851	12/1971	Robertson	350/293
3,764,201	10/1973	Haile	350/303
4,012,125	3/1977	Hart	350/296
4,029,399	6/1977	Haile	350/293
4,223,983	9/1980	Bloom	350/303

FOREIGN PATENT DOCUMENTS

1921076	11/1970	Fed. Rep. of Germany	350/293
1941895	3/1971	Fed. Rep. of Germany	350/303
2415270	10/1975	Fed. Rep. of Germany	350/293
2725952	12/1978	Fed. Rep. of Germany	350/293

Primary Examiner—F. L. Evans
Attorney, Agent, or Firm—Lockwood, Dewey, Alex & Cummings

[57] **ABSTRACT**

Provided is an improved rear view or rear vision mirror for passenger automobiles, vans and like vehicles, exclusive of buses or trucks larger than pick-up trucks, which mirror affords a wide-angle view well beyond the statutory requirement that outside mirrors give a view of the side of the vehicle through a 10° angle beyond such side of the vehicle to the extent that the image covers the so-called "blind spot" beyond the 10° view path. The improved mirror avoids the use of spherical reflective surfaces and consists essentially of a single substantially planar reflective surface and a single contoured reflective surface that is a generally convex cylindrically contoured surface having a radius of curvature within a critical range of values.

4 Claims, 5 Drawing Figures

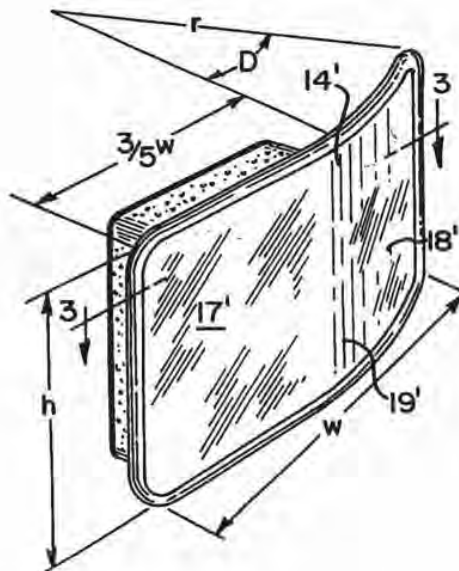

350-303
CCC46

AU 257 EX
XP 4,258,979

UNITED STATES PATENT AND TRADEMARK OFFICE
CERTIFICATE OF CORRECTION

PATENT NO. : 4,258,979

Page 1 of 2

DATED : March 31, 1981

INVENTOR(S) : William E. Mahin

It is certified that error appears in the above-identified patent and that said Letters Patent are hereby corrected as shown below:

In Column 13, TABLE I, the fifth column heading, please change "Degrees*" to --Degrees*--.

In Column 14, in TABLE I-Continued, the fifth column heading, please change "Degrees*" to --Degrees*--; also in TABLE I-Continued, the last line of the first column, please change "00" to --∞--. Also in Column 14, in TABLE II, the third column heading, change "Degrees" to --Degrees*-- and in the fifth column heading, change "Degrees*" to --Degrees*--.

In Column 15, TABLE III, third column heading, delete "Ratio" and insert --Degrees--; and in the fourth column heading, delete "Mag*" and insert therefor --Mag Ratio--.

In Column 18, line 19, delete "no" and insert therefor --not--; and in line 57, delete "24" and insert therefor --34--.

In Column 19, TABLE VI, fifth column heading, delete "Degrees" and insert --Degrees*--.

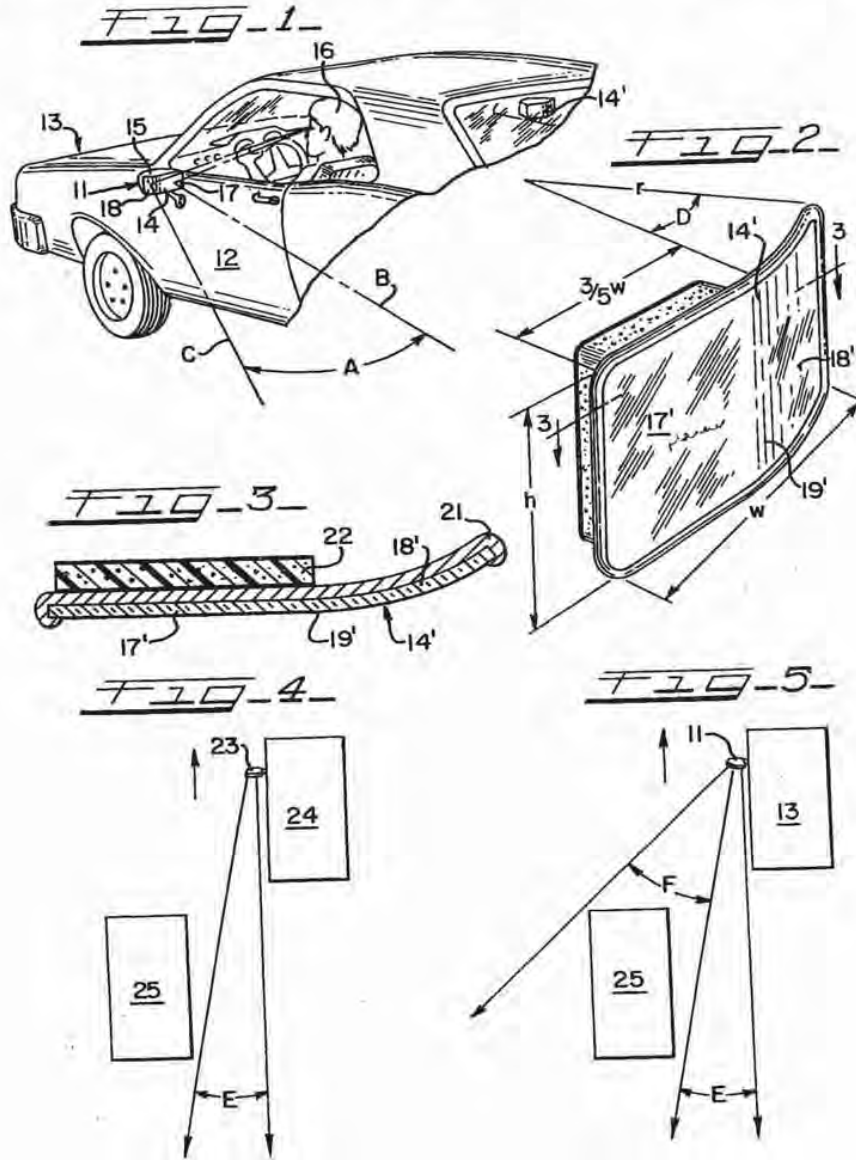

UNITED STATES PATENT AND TRADEMARK OFFICE
CERTIFICATE OF CORRECTION

PATENT NO. : 4,258,979

Page 2 of 2

DATED : March 31, 1981

INVENTOR(S) : William E. Mahin

It is certified that error appears in the above-identified patent and that said Letters Patent are hereby corrected as shown below:

Claim 18, line 63 (Column 22), delete "distance" and insert therefor --distances--.

Signed and Sealed this

Seventeenth Day of November 1981

[SEAL]

Attest:

Attesting Officer

GERALD J. MOSSINGHOFF

Commissioner of Patents and Trademarks

WIDE-ANGLE MIRROR FOR AUTOMOBILES AND THE LIKE

BACKGROUND AND DESCRIPTION OF THE INVENTION

This invention relates generally to mirrors for vehicles, more particularly to rear vision mirrors providing a wide-angle view from either outer side of the vehicle and through the blind spot that is not imaged by conventional rear view mirrors, the mirror itself consisting essentially of a single generally planar reflective surface and a single contoured reflective surface while avoiding the use of any generally spherically shaped reflective surfaces.

Rear vision mirrors that include generally convex reflective areas for providing a reflective view intended to be more extensive than that which can be provided by a flat reflective area are shown for example in U.S. Letters Pat. No. 3,764,201, which discloses a rear vision mirror expressly designed and adapted for large trucks and buses. This patent includes the use of spherical reflective surfaces. The presence of spherical surfaces necessitates, by statute, that a rear view mirror spherical reflective surface have a radius of at least 20 inches in order to preclude image distortion and vehicle operator confusion brought about by a spherical reflective surface having a radius less than 20 inches. Mirrors in compliance with this statutory requirement are exceedingly large and unsuitable for use in smaller vehicles such as passenger automobiles, vans and pick-up trucks having limited side window height and practical limits of how far an outside-mounted mirror can reasonably project beyond the width of these smaller vehicles.

Additionally, U.S. Pat. No. 3,764,201 specifies convex generally cylindrical reflecting zones or areas that curve rearwardly and that have a radius of 5 inches. With the present invention, it has been discovered that a generally convex cylindrical reflecting surface having a radius as small as on the order of 5 inches is not satisfactory because such a small radius creates an unsafe amount of image distortion that all too often leads to driver confusion, especially for non-professional drivers who typically operate passenger automobiles and the like. A radius as small as about 5 inches or less causes a deceiving and very abrupt change in the image seen in the reflective surface, particularly at the junction of the curved reflective surface and an adjacent flat reflective surface.

By the present invention, the disadvantages attendant to using spherically contoured reflective surfaces are avoided, as is the need to use exceptionally large reflective surfaces or the practice of utilizing reflective surfaces having curvature radii smaller than that now found to enhance the safe use of combined curved and planar reflective surfaces, particularly by non-professional drivers. The present invention avoids distortions brought about by spherical surfaces and by curved reflective surfaces having small radii, while at the same time avoiding the need to provide rear vision mirrors having a size that is prohibitive for smaller vehicles such as passenger automobiles and the like.

The present invention provides a wide-angle rear vision mirror that has a single contoured surface which is not spherically contoured and which is integral with and outwardly extending from a single substantially planar reflective surface, wherein the single contoured surface is a convex cylindrically contoured surface

having a radius of curvature of approximately 8 inches, plus or minus about 12½ percent.

It is accordingly a general object of the present invention to provide an improved rear vision mirror.

Another object of this invention is an improved rear vision mirror especially structured for mounting outside of either the left side window or the right side window of a vehicle.

Another object of the present invention is an improved rear view or rear vision mirror having a structure that avoids significant image distortion brought about by spherical reflective surfaces and/or contoured surfaces having radii outside of a critical range of radii values.

Another object of the present invention is an improved rear vision mirror for use on relatively small vehicles such as passenger automobiles in order to provide an image at the blind spot area without substantially distorting such image.

Another object of the present invention is an improved rear vision mirror having a single generally planar reflective surface and a single generally cylindrically contoured reflective surface, which surfaces have area measurements related to each other in a predetermined manner.

These and other objects of this invention will become apparent from the following detailed description, taken in conjunction with the accompanying drawings, wherein:

FIG. 1 is a perspective view of a portion of a passenger automobile having a mirror embodying the present invention mounted on both the left-handed side and the right hand-side thereof;

FIG. 2 is a perspective view of the mirror of this invention, shown oriented for mounting on the right-hand side of a vehicle and illustrating the critical dimensional relationships of this invention;

FIG. 3 is a cross-sectional view of the mirrored surface of FIG. 2, shown as adapted for mounting over the planar mirrored surface of a conventional vehicle rear view mirror so as to convert same into a wide-angle rear view mirror;

FIG. 4 is a schematic drawing illustrating the reflected line of sight of a traditional rear view mirror; and

FIG. 5 is a schematic drawing illustrating the wide-angle reflecting line of sight achieved by the present invention.

The preferred rear vision mirror in accordance with this invention is illustrated in FIG. 1, being generally designated as 11, shown mounted in known manner on the door 12 of a vehicle 13. Rear vision mirror 11 is depicted in this view as including a composite reflective surface 14 mounted within a streamlined frame 15. When seated within vehicle 13, a driver 16 has a field of vision extending through an angle "A" running from an inner line of sight "B" reflected from a generally planar reflective surface 17 and through an outer line of sight "C" reflected from a contoured reflective surface 18 whereby the field of vision "A" includes a field of sight generally overlapping into the peripheral vision of the driver 16.

Further details of the composite reflective surface are shown in FIG. 2 illustrating composite reflective surface 14' in which generally planar reflective surface 17' is shown oriented to the left of contoured reflective surface 18' as should be the case when mounted to the

right side of the vehicle 13, while in the embodiment shown in FIG. 1 the generally planar reflective surface 17 is illustrated as being oriented to the left of contoured reflective surface 18. Composite reflective surface 14 or 14' has a width "w" and also a height "h" which is substantially less than the width "w". It has been discovered that certain optimum dimensions provide an especially advantageous and safe field of vision, that having a field of vision angle "A" large enough to include the blind spot area and extend into the driver's peripheral vision while minimizing image distortion upon reflectance from contoured reflecting surface 18 or 18' and the unseamed location 19 or 19' where the generally planar reflective surface 17 or 17'; integrally joins the contoured reflective surface 18 or 18'.

Such optimum dimensions call for the width of the generally planar reflective surface 17 to be about 60 percent of the width of composite reflective surface 14, i.e. " $3/5 w$," while the width of the contoured reflective surface 18 is approximately 40 percent of the composite reflective surface width, i.e. " $2/5 w$ ". Additionally, in order to maintain the usefulness of mirror 11 for relatively small vehicles 13 such as passenger automobiles, but while still providing adequate, substantially distortion-free rear vision reflection, the height "h" of the composite reflective surface 14 is approximately the same as the width of the generally planar reflective surface 17, i.e. on the order of about " $3/5 w$ ", although height "h" could be as great as " $3/2 w$ ", if needed to fit within a conventional frame such as the streamlined automobile frame 15.

With more particular reference to the contoured reflective surface 18, such is a generally convex cylindrically contoured surface having a contour angle "D" of a radius "r". In order to minimize distortion of images while maximizing image size within the confines of an automobile-sized composite reflective surface 14, radius "r" must be about 8 inches in length, plus or minus about 12 1/2 percent of "r".

FIG. 3 is a cross-section through the wide-angle rear vision mirror of FIG. 2 further illustrating the composite reflective surface 14' mounted within a backing frame 21 crimped around the composite reflective surface 14', with an adhesive spacer 22 secured to the backing frame 21 directly behind at least a portion of the generally planar reflective surface 17'. The adhesive spacer 22 and backing frame 21 are provided to enable composite reflective surface 14 to be readily mounted over the flat reflective surface of a conventional rear view mirror when it is not desired to replace the conventional mirror with the entire mirror assembly 11 shown in FIG. 1.

With reference to FIG. 4, this illustrates the line of sight field of vision "E" afforded by a conventional flat surfaced outside rear view mirror 23 mounted upon a moving vehicle 24, such angle being about 10° in size to provide a field of view that excludes a "blind spot" in which another vehicle 25 can be positioned, unknown to the driver of vehicle 24. FIG. 5 illustrates a rear vision mirror 11 in accordance with this invention, such having a reflected line of sight including substantially the same field of vision "E" provided by mirror 23, onto which is added a wide-angle field of vision "F" that is provided by contoured reflective surface 18 (FIGS. 1 and 3), such field of vision "F" including within its

angular extent the second vehicle 25, thereby eliminating the "blind spot".

As an example of the preferred interrelationship among the dimensions of the mirror 11, the composite reflective surface would have a width "w" of about 5 1/2 inches and a height "h" of about 3 1/2 inches, whereby the width of the generally planar reflective surface 17 is about 3.3 inches, and the width of the contoured reflective surface 18 is about 2.2 inches.

It will be apparent to those skilled in this art that the present invention can be embodied in various forms; accordingly, this invention is to be construed and limited only by the scope of the appended claims.

I claim:

1. A wide-angle rear vision mirror that has a single contoured surface which is not spherically contoured and that is expressly designed and adapted for use on the right side or left side of passenger automobiles, vans and the like vehicles, comprising a composite reflective surface including:

a single substantially planar reflective surface having

a width and a height, said planar surface width being generally equal to said planar surface height;

a single contoured reflective surface having a con-

toured surface height and a contoured surface

width, said single contoured reflective surface

being continuous with said planar surface, said

single contoured surface being an integral exten-

sion of said planar surface in a direction away from

the vehicle, said contoured reflective surface being

a single generally convex cylindrically contoured

surface, said cylindrical contour being that of a

right cylinder having a radius of curvature of 8

inches plus or minus about 12 1/2 percent;

said composite reflective surface has a composite

width that is substantially identical to the planar

surface width plus the contoured surface width;

said composite reflective surface is straight-lined

throughout its vertical extent;

said planar surface width is about 3/5 of said compos-

ite reflective surface width, and said contoured

surface width is about 2/5 of said total reflective

surface width;

said composite reflective surface has a composite

height identical to said planar surface height and

also to said contoured surface height;

said composite reflective surface is unseamed

throughout its composite width; and

said composite reflective surface has a composite

height and a composite width such that the wide

angle rear vision mirror overlies substantially the

entire surface area of an external automobile rear

view mirror.

2. The wide-angle rear vision mirror of claim 1,

wherein said composite surface height is between about

3/5 and about 3/4 of said composite reflective surface

width.

3. The wide-angle rear vision mirror of claim 1,

wherein said composite reflective surface has a back

face, and an adhesive-backed spacer is secured to said

back face.

4. The wide-angle rear vision mirror of claim 3,

wherein said spacer is secured to a location on said back

face that is behind at least a portion of the substantially

planar-reflective surface.

* * * * *

359-864
03-13-2001

AU 2872
OR

EX
6,199,993



US006199993B1

(12) **United States Patent**
Mou

(10) **Patent No.:** US 6,199,993 B1
(45) **Date of Patent:** Mar. 13, 2001

(54) **STRUCTURE OF AUTOMOBILE EXTERIOR REARVIEW MIRROR**

(76) Inventor: **Lin Chung Mou**, 4th Fl., No. 524, Chiang Rd., Taipei (TW)

(*) Notice: Subject to any disclaimer, the term of this patent is extended or adjusted under 35 U.S.C. 154(b) by 1192 days.

(21) Appl. No.: **08/510,921**

(22) Filed: **Aug. 3, 1995**

Related U.S. Application Data

(63) Continuation of application No. 09/248,915, filed on May 25, 1994, now abandoned.

(51) Int. Cl.⁷ **G02B 5/10; B60R 1/08**

(52) U.S. Cl. **359/864; 359/850; 359/838**

(58) Field of Search **359/838, 844, 359/850, 864, 866, 868, 871**

(56) **References Cited**

U.S. PATENT DOCUMENTS

1,771,061	*	7/1930	Rice	359/844
3,104,274	*	9/1963	King	359/864
3,267,806	*	8/1966	Azegami	359/864
3,338,655	*	8/1967	Young	359/864
3,389,952	*	6/1968	Tobin, Jr.	359/864

4,325,609	*	4/1982	Alford	359/864
5,005,962	*	4/1991	Edelman	359/864

FOREIGN PATENT DOCUMENTS

1017082	*	1/1966	(GB)	359/864
2048189	*	12/1980	(GB)	359/868
7908257	*	6/1981	(NL)	359/864

* cited by examiner

Primary Examiner—Ricky D. Shafer

(74) *Attorney, Agent, or Firm*—Donald C. Casey, Esq.

(57) **ABSTRACT**

A new structure of automobile exterior rearview mirror which integrates an arc-surface wide-angle mirror and a plane mirror together to form a one-piece design. This design overcomes the drawbacks of the existing exterior rearview mirror, in which a driver use a stick-on type wide-angle mirror. In addition, the present invention also provides a blank surface area with parabolized image coating. The blank surface area is formed between the wide-angle mirror and the plane mirror and its function is to prevent the refraction and reflection interferences caused by the wide-angle mirror and the plane mirror. The exterior rearview mirror of the present invention is economical, will not fall off and has no blind spot. It is a full view safety mirror for backing up the car, making turns and changing lanes in the roadway.

3 Claims, 8 Drawing Sheets

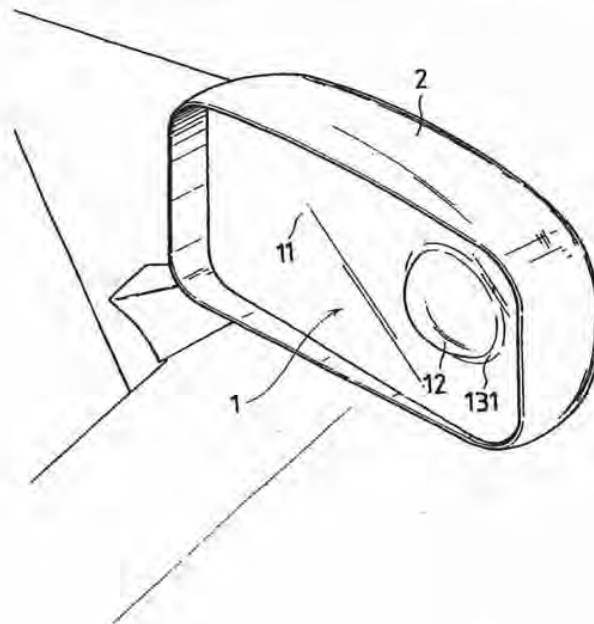

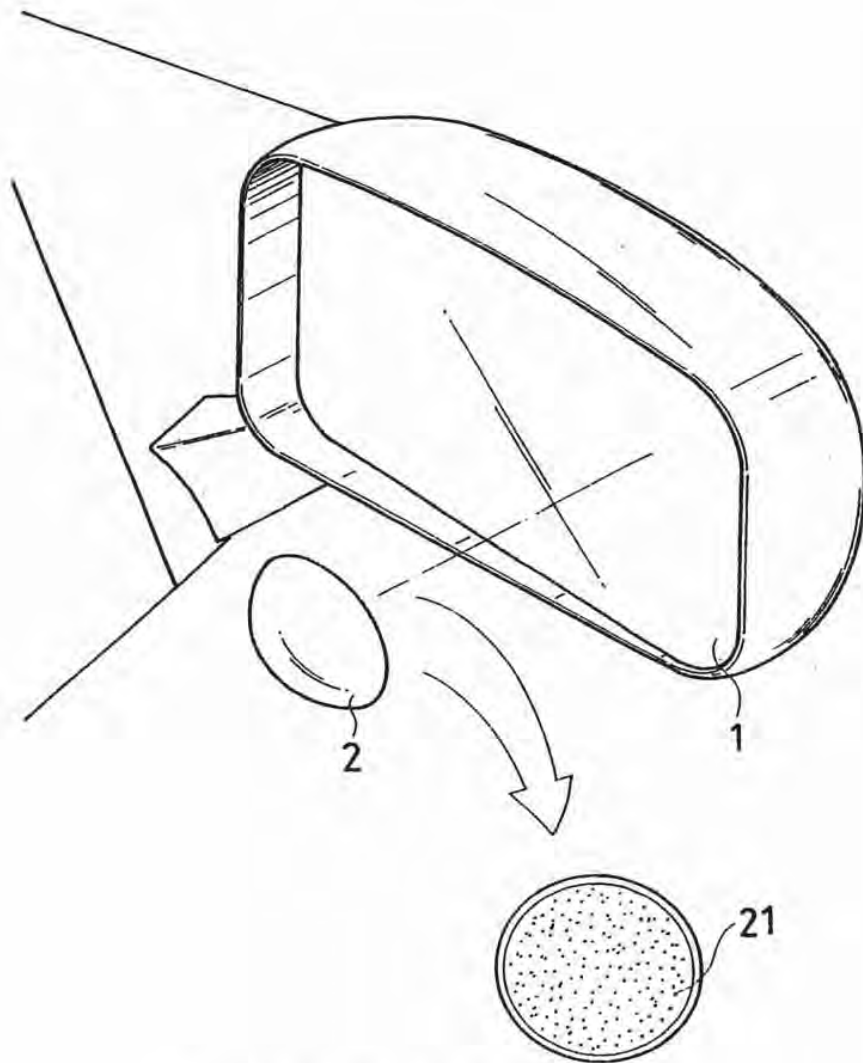

FIG. 1 PRIOR ART

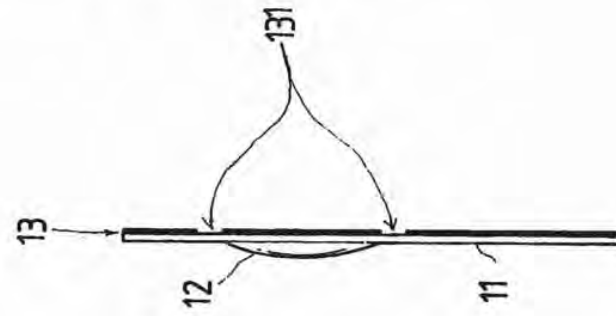

FIG. 2(B)

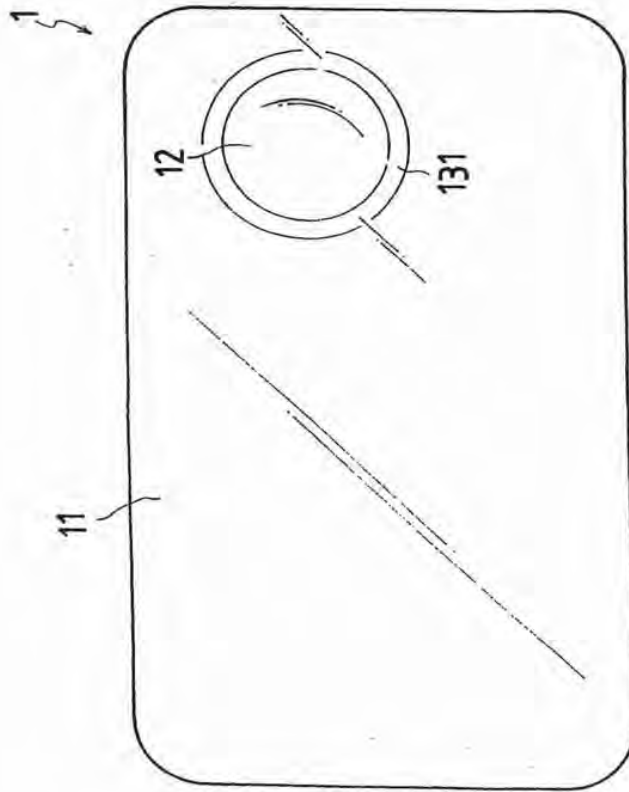

FIG. 2(A)

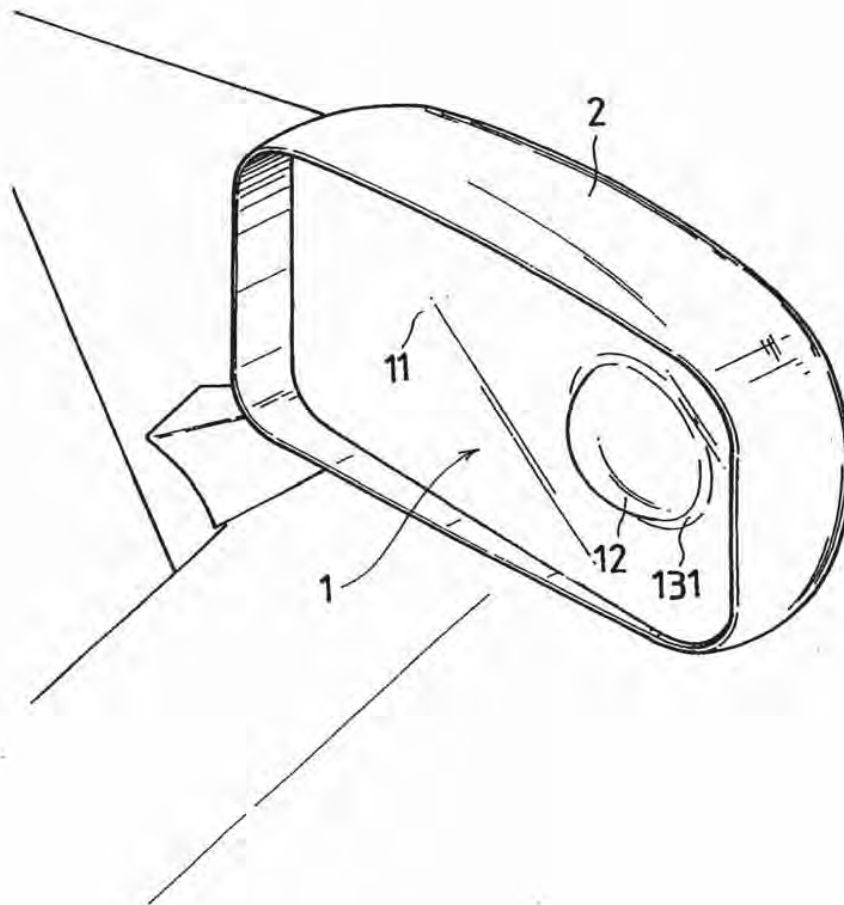

FIG. 3

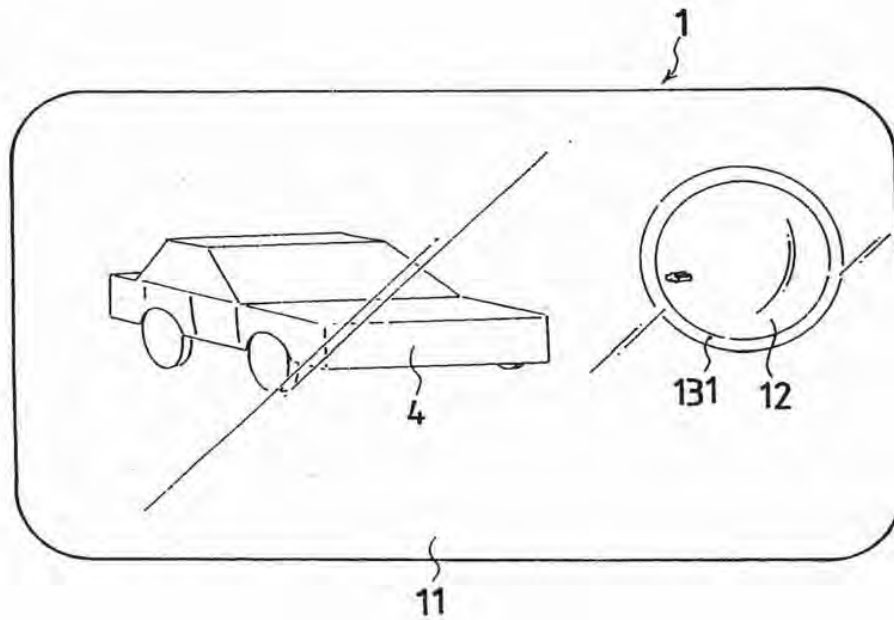

FIG. 4(A)

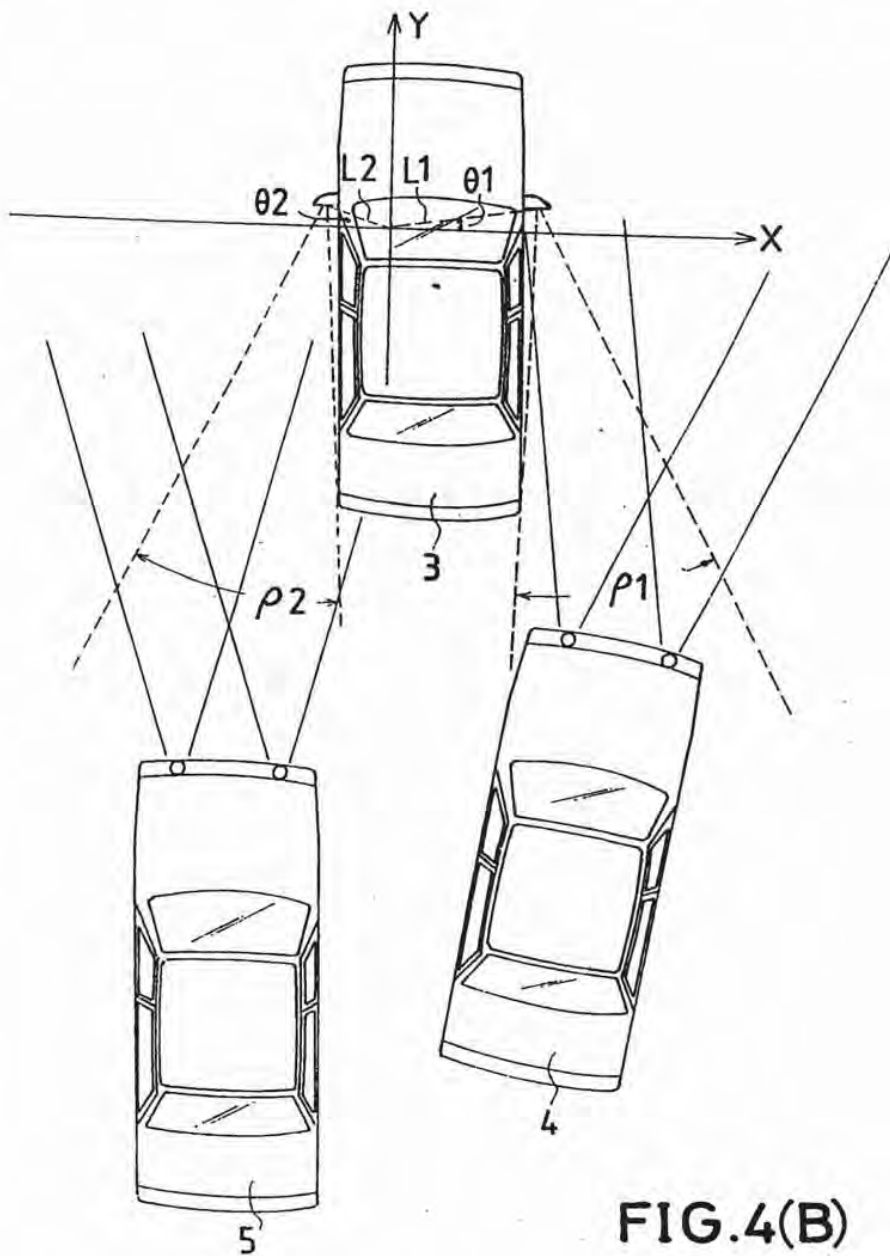

FIG.4(B)

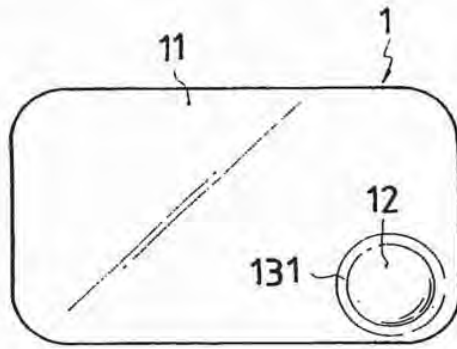

FIG. 5(A)

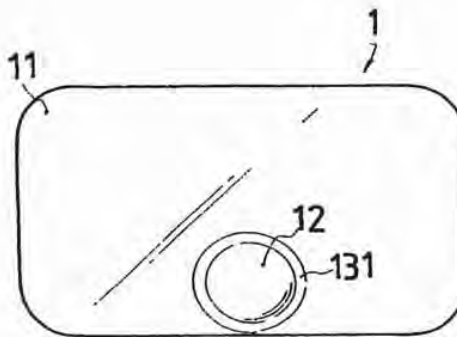

FIG. 5(B)

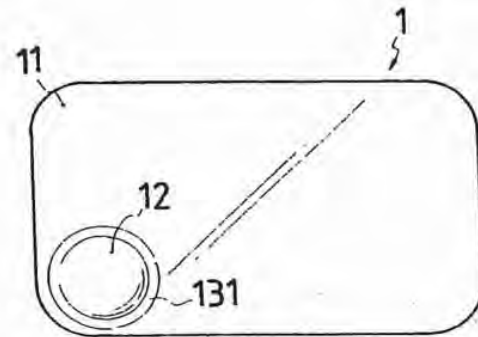

FIG. 5(C)

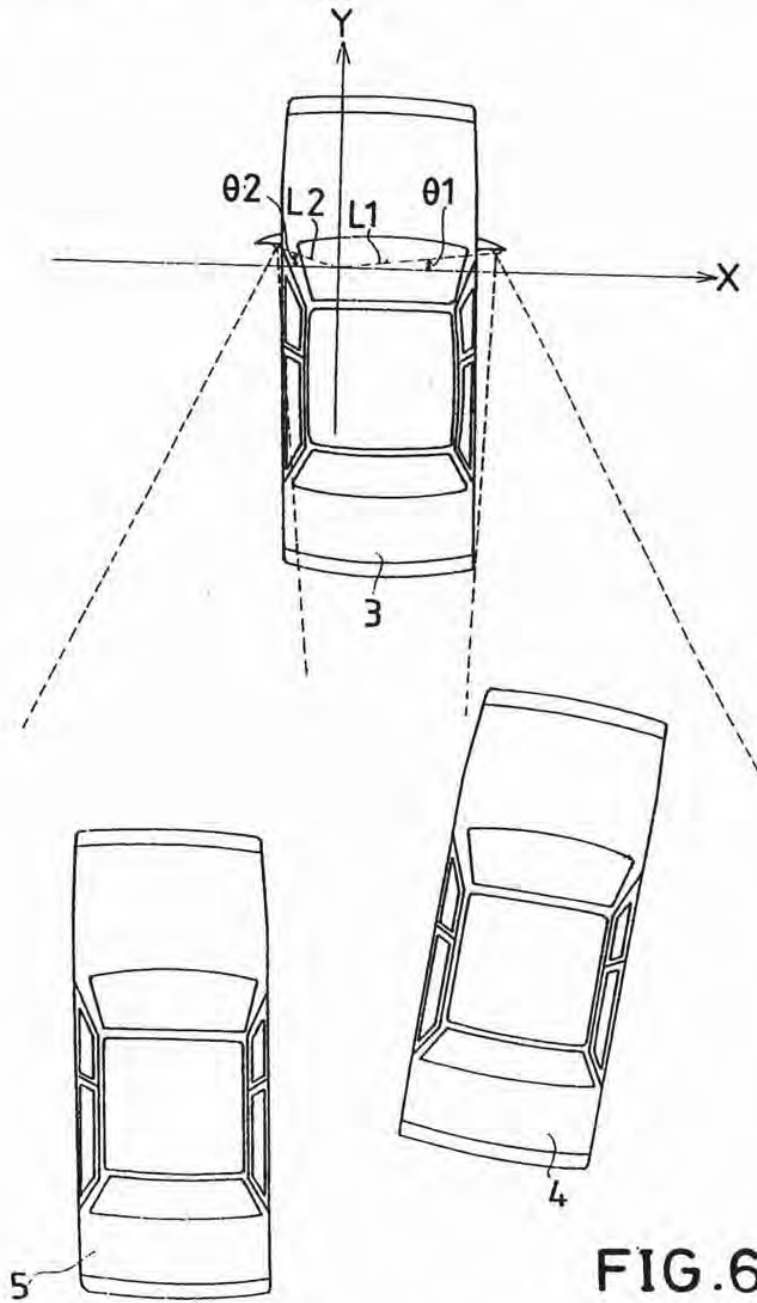

FIG. 6

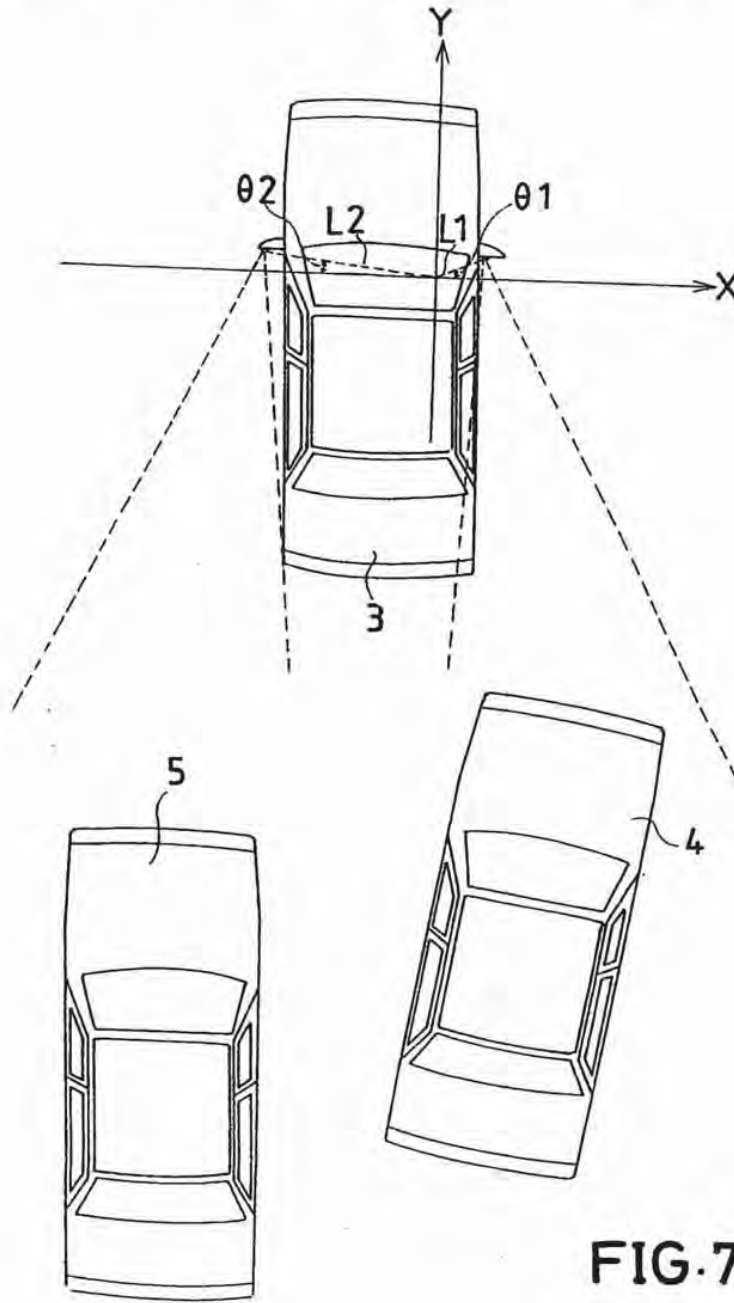

FIG. 7

STRUCTURE OF AUTOMOBILE EXTERIOR REARVIEW MIRROR

This application is a continuation of application Ser. No. 08/248,915 filed May 25, 1994 now abandoned.

BACKGROUND OF THE INVENTION

(a) Field of the Invention

The present invention relates to a new structure of an automobile exterior rearview mirror, more specifically, to the exterior rearview mirror having an arc-surface wide-angle mirror and a plane mirror integrated together to provide a fullview mirror that reduces blind spots and interferences.

(b) Description of the Prior Art

With reference to FIG. 1, when driving on a curved roadway or in an alley, a driver often encounters conditions wherein he cannot fully visualize the rearview from the exterior rearview mirror (1). In such cases the driver has to use the arc-surface mirror provided on the side of the roadway or someone has to direct the driver to go through. It is apparent that the design of the existing exterior rearview mirror for automobiles has blind spots. Because of this a stick-on type arc-surface wide-angle mirror (2) is available for the driver to adhere it to the plane exterior rearview mirror (1) in the automobile, as shown in FIG. 1. The attachment of the arc-surface mirror (2) to the exterior rearview mirror in the automobile makes use of a double-sided tape (21). This type of attachment is not secure and moisture and vibration can cause the arc-surface mirror (2) to fall off. In addition, it is not easy to position the wide-angle mirror (2). A helper is needed for the car owner to properly position the stick-on arc-surface mirror (2). Any displacement of the stick-on arc-surface mirror will only give a partial rearview to the driver.

Even though the arc-surface wide-angle mirror (2) can be attached in the right position, the image from the plane rearview mirror can be interfered by the attached arc-surface mirror (2). This can cause some trouble in driving, such as the rearview interferences in backing up the car, changing lanes or making turns. All these factors create some safety concern for the driver.

Therefore, it is an object of the present invention to provide a new structure for the automobile exterior rearview mirror to overcome the disadvantages of the stick-on type arc-surface mirror so that a full rearview of the road condition can be seen from the driver's seat.

SUMMARY OF THE INVENTION

The main object according to the present invention is to provide a new structure of an automobile exterior rearview mirror in which the arc-surface wide-angle mirror and the plane rearview mirror are integrally fabricated together so that a driver does not have to use the stick-on type and he does not have to worry about the accurate positioning of the stick-on.

Another object according to the present invention is to provide a new structure of an automobile exterior rearview mirror in which a circular surface of blank zone is parabolized with a coating during the stage of grinding, so that the interferences caused by the arc-surface wide-angle mirror and the plane mirror can be eliminated.

A further object according to the present invention is to provide a series of different models of the said automobile exterior rearview mirror for different applications.

BRIEF DESCRIPTION OF THE DRAWINGS

The drawings disclose an illustrative embodiment of the present invention which serves to exemplify the various advantages and objects hereof, and are as follows:

FIG. 1 is a diagrammatic view showing the conventional exterior rearview mirror with the stick-on type wide-angle mirror used in automobiles.

FIG. 2A is a plane view showing a new structure of the automobile exterior rearview mirror according to the present invention.

FIG. 2B is a side view of the plane view in FIG. 2A.

FIG. 3 shows the assembly of the exterior rearview mirror framed inside a frame.

FIG. 4A is an illustrative view showing the assembly in FIG. 3 installed in automobile on the road.

FIG. 4B is a diagrammatic view showing the relationship of the driver's view and the image from the exterior rearview mirror.

FIGS. 5A, 5B and 5C are respectively the plane views showing the different locations of the wide-angle mirror in the exterior rearview mirror according to the present invention.

FIG. 6 is an illustrative view showing the relationship of the driver's view and the image from the exterior rearview mirror. (The driver's seat is located on the left hand side of the car).

FIG. 7 is an illustrative view showing the relationship of the driver's view and the image from the exterior rearview mirror. (The driver's seat is located on the right hand side of the car)

DETAILED DESCRIPTION OF THE PREFERRED EMBODIMENT

The new structure of the automobile exterior rearview mirror is a device that combines the functions of a plane mirror and a wide-angle mirror. The new structure mainly consists of a plane mirror zone (11), an arc-surface wide-angle zone (12), as are shown in FIGS. 2A and 2B. In between the plane mirror zone (11) and the arc-surface wide-angle zone (12) is a circular blank surface (131) with an image coating (13) by parabolizing or grinding.

Referring to FIG. 3 for an embodiment of the new structure of the automobile exterior rearview mirror (1) as it is framed by a frame (2). The unique design of the exterior rearview mirror has the following features:

The wide-angle zone (12) and the plane mirror zone (11) are fabricated into an integral device, therefore, there is no need to concern about the falling off and the accurate positioning of the stick-on. In addition, since the device is fabricated professionally, a series of versatile, good quality and well designed products can be provided to allow a driver to replace the mirror. Moreover, the device is available at a reasonable price.

The color of the parabolized image coating and the size of the exterior rearview mirror (1) can be adjusted accordingly based on the districts (country or area), the weather and the requirement of the consumers. This makes it more practical to be used by the car driver anywhere in the world.

The circular blank surface (131) with the parabolized image coating (13) is provided to prevent the refraction and reflection interferences caused by the arc-surface wide-angle zone (12) and the plane zone (11). With the circular blank surface (131) the interferences from the two mirrors can be prevented so that the driver can have a complete control of

3

his driving based on the visibility from the plane mirror zone (11) and the wide-angle mirror zone (12) (there will be no blind spot). Thus the chances of having accidents from backing up the car and making a turn can be avoided.

Please refer to FIGS. 4A and 4B. As shown in FIG. 4B, let's assume that car (3) is the car at the front with the exterior rearview mirror (1) installed, and cars (4) and (5) are approaching from the back of car (3), then the view of the driver and the exterior rearview mirror (1) are connected by lines (L1) and (L2). The visibility from the exterior rearview mirror (1), (i.e. the horizontal axis X and the vicinity of the wide-angle mirror (12)). Let's further assume that the angles θ_1 and θ_2 can be ignored, and the image zone formed by cars (4) and (5) with the wide-angle zone (12) is expressed by the dotted lines ρ_1 and σ_2 , then the circular blank surface (131) with the parabolized coating (13) can prevent the interference of images overlapping and blocking from the plane zone (11) and the wide-angle zone (12). The visual disturbance from natural light source, reflection from the roadway and the light sources from the cars in the back can all be eliminated. Please refer to FIG. 4A.

The above circular blank surface (131) is formed based on the refraction, reflection and the blocking area of the wide-angle zone (12) and the plane zone (11). (The area of the circular blank surface can be calculated based on the refraction and reflection principles in optical physics, it is a complicated issue and therefore is not listed here). The exterior rearview mirror (1) formed with the circular blank surface area (131) will show a clear and correct positioning of the image, and the visibility will not be disturbed and blocked.

In addition, a series of different models can be fabricated based on the above configuration of the automobile exterior rearview mirror, some of these models include the placement of the wide-angle zone (12) to be in a different location. Please refer to FIGS. 5A, 5B and 5C, it can be seen that there are three kinds of exterior rearview mirror (1) that are practical to be used. The difference between the three exterior rearview mirrors are on the locations of the wide-angle zone (12). As shown in FIG. 5A, the arc-surface wide-angle mirror zone (12) is located on the right hand lower corner in the plane mirror zone (11), the wide-angle mirror (12) is located in the lower center portion of the plane mirror (11) in FIG. 5B, and the wide-angle mirror (12) is located in the left hand lower corner of the plane mirror (11) in FIG. 5C. Based on the principle of symmetry, six different models of exterior rearview mirror (1) will be available for use in different countries and different models of cars. A driver can have his own choice of selecting the right exterior rearview mirror based on his height, his driving style and habit, therefore maximizing the application and function of the arc-surface wide-angle mirror (12).

As shown in FIG. 6, the driver seat is located on the left hand side of the car. Since the driver is far away from the right-side mirror, he can choose the new device of the present invention with the wide-angle mirror located in the lower right hand corner, as shown in FIG. 5A. This selection allows the driver to have a full view on the right hand side of the car, so that he can change lane easily and have better visibility on the right side of his car. The full view from the exterior rearview mirror (1) prevents any blind spot which

4

can cause automobile accident. The related principle can be seen from FIGS. 4A and 4B. Similarly, the exterior rearview mirror (1) on the left hand side can also be selected so as to assure the safety when the car is about to take off. This is because a proper image can be displayed on the plane zone (11), and the lower image on the wide-angle zone provides the view below the body of the car and the condition at the front of the rear wheel.

Similarly, if the driver seat is located on the right hand side of the car, then the exterior rearview mirror (1) on the right hand side of the car shall be selected such that the arc-surface wide-angle zone (12) is located on the lower left hand corner of the plane mirror zone (11). Thus the driver can have a view below the body of the car. On the other hand, the left side exterior rearview mirror (1) shall be chosen to be the same type of exterior rearview mirror, so that the wide-angle zone (12) can provide a safe and wider visibility area for lane changing, backing up and making turns. Please refer to the related drawings for the above description as shown in FIG. 7. In addition, the above selection of the exterior rearview mirror shall be changed, if necessary, to meet the practical needs. This includes the use of the wide-angle mirror zone (12) located in the lower center of the exterior rearview mirror so that the road condition behind the rear wheel can be seen.

In summary, it is believed that the present invention would improve the drawbacks of the conventional product and it would also enhance the safety in driving. Therefore, a claim is made in compliance with the law.

Although the invention has been described in its preferred form with a certain degree of particularity it is understood that the present disclosure of the preferred form has been made only by way of example and numerous changes in the details of construction and the combination and arrangement of parts may be resorted to without departing from the spirit and the scope of the invention as hereinafter claimed. It is intended that the patent shall cover, by suitable expression in the appended claims, whatever features of patentable novelty exists in the invention disclosed.

What is claimed is:

1. An automobile exterior rearview mirror comprising:
a plane mirror zone;

an integral circular, convex or concave, wide-angle mirror zone disposed at a predetermined position within said plane mirror zone,

a circular blank zone surrounding said wide-angle zone and located between said plane mirror zone and said wide-angle mirror zone and integral therewith, said blank zone defining a surface separating said wide-angle and plane zones, so that said exterior rearview mirror provides a wider image without a blind spot or any interference between zones.

2. The automobile exterior rearview mirror as recited in claim 1 wherein said wide-angle mirror zone is disposed at the lower center of said plane mirror zone.

3. The automobile exterior rearview mirror as recited in claim 1 wherein said plane mirror zone is rectangular and wherein said wide angle mirror zone is disposed at a lower corner of said plane mirror zone.

* * * * *

JP A 0051637
APR 1980

JPA-1980-04

(54) REAR-VIEW MIRROR FOR AUTOMOBILE

(11) 55-51637 (A) (43) 15.4.1980 (19) JP
(21) Appl. No. 53-124495 (22) 9.10.1978
(71) KATSUMATA GIKEN K.K. (72) ISAMU KATSUMATA
(51) Int. Cl. B60R1/08, B60R1/06

PURPOSE: To prevent the images on a rear view confirmation mirror and a front side view confirmation mirror from being confused with each other, by partitioning the mirrors from each other by a holding plate.

CONSTITUTION: A rear view confirmation mirror 3, which is shaped as a vertical oblong and has a large radius of curvature, and a vehicle front side view confirmation mirror 4, which is hemispherical and has a small radius of curvature, are attached to a support frame 2, which is provided on a support rod 1 so that support frame can be fixed or adjusted. The mirror 4 is located just under the other mirror 3. The boundary edges of the mirrors 3, 4 are fixed in the fitting grooves of a holding frame 5. The images on the mirrors 3, 4 are prevented by the presence of the holding frame 5 from being confused with each other.

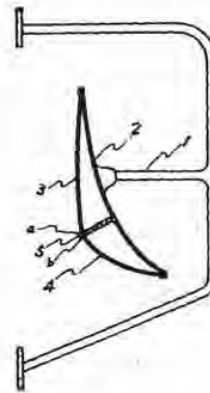

354/3-12

⑬ 日本国特許庁 (JP)
⑭ 公開特許公報 (A)

⑮ 特許出願公開
昭55-51637

⑯ Int. Cl.³
B 60 R 1/08
1/06

識別記号
庁内整理番号
7191-3D
7191-3D

⑰ 公開 昭和55年(1980)4月15日

発明の数 1
審査請求 未請求

(全 2 頁)

⑱ 自動車用バックミラー装置

沼津市足高554-3番地

⑲ 出 願 人 有限会社勝又技研

沼津市足高554-3番地

⑳ 特 願 昭53-124495

㉑ 出 願 昭53(1978)10月9日

㉒ 代 理 人 弁理士 松岡宏

㉓ 発 明 者 勝又勇

明 細 書

1. 発明の名称

自動車用バックミラー装置

2. 特許請求の範囲

(1) 支持枠(1)に調節固定を可能せしめた支承枠(2)に上部を大なる曲率半径を有する縦長で長方形状の鏡体(3)と、該鏡体(3)の直下に小なる曲率半径を有する半球状の鏡体(4)を装着させ、各々鏡体(3)、(4)の境界部接合端面(5)、(6)を嵌り溝を有する保持枠(7)に嵌挿定着させ、全体を該支承枠(2)で支承させて構成せしめたことを特徴とする自動車用バックミラー装置。

3. 発明の詳細な説明

本発明は特にバス、トラック等に装着し後方視界と共に車体前側面周辺の視界確認が容易に出来るように為させた自動車用バックミラー装置に関する。

従来のこの種の自動車用バックミラーの構成ではバス、トラック等の大型車で運転席からの左右前側面及びその直下の視界確認が非常に困難

であり広い死角を生み暫々事故発生の原因となり、特に大型車の左折時においては運転席が右にあるため左側周辺の視界確認が非常に困難となっていた。このような死角を解消するため別途にアンダーミラーを付設したり、複雑な光学装置を組込んだもの等があるがいずれも一長一短を有し、運転者に分りにくく実用性に乏しいものが多く事故防止の役割を果たさず単に煩雑なものが必要とされた。

本発明は前記に鑑み、上記欠点を削除し、後方確認と共に車体前側面周辺の視界の確認を確実に出来るようにし、且つ調整することが無い自動車用バックミラー装置を提供するものである。

以下図面について実施例を説明する。

第1図及び第2図において、車体左右前側に装着させた支持 (1)に調節固定を可能せしめた縦長で上方を長方形状とし、下方部を半円形状に形成せしめた支承枠(2)を装着させ、該支承枠(2)内の上部に大なる曲率半径を有し縦方向に長く

した長方形状の鏡体(3)と、該鏡体(3)の直下に小なる曲率半径を有する半球状の鏡体(4)を挿入せしめ、各々鏡体(3)、(4)の境界部接合端面(a)、(b)を投入側を有する適宜な巾で支承枠内に装着させた保持枠(5)に嵌挿定着させ境界を設け、全体を該支承枠(2)で支承させた構成を成している。本発明は以上のような構成であるから上部の鏡体(3)で後方確認をし、下部の曲率半径小なる半球状の鏡体(4)でもつて車体における左右前側周辺部に視界が確実に確認される。

特にバス、トラック等の大型車において、道巾の狭い道路では壁や欄干等の障害物が道の縁まで迫っているが鏡体(4)により車体前側周辺部の視界は確実に確認でき車輪を側溝に落としたり人や自転車を巻き込む等の事故も未然に防止され安全運転が確保される。又、後部確認用の鏡体(3)と前側周辺確認用の鏡体(4)との境界部を保持枠(5)で仕切つてあるため視界映像の誤認を防止している。

この発明の装置は以上に説明したような構成と

特開 昭55-51637(2)

作用をもつているので、発明所期の目的を確実に達成出来る。

4. 図面の簡単な説明

第1図は本発明による装置の全体正面図。

第2図は本発明による装置の全体側面図。

- (1)--- 支持
- (2)--- 支承枠
- (3)--- 鏡体
- (4)--- 鏡体
- (5)--- 保持枠
- (a),(b)--- 接合端面

以上

特許出願代理人

弁理士 松 岡

実

第1図

第2図

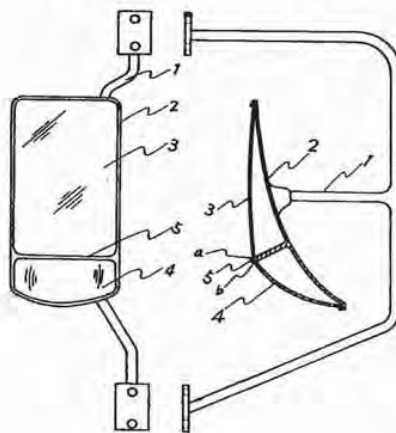



UNITED STATES DEPARTMENT OF COMMERCE
 Patent and Trademark Office
 Address: COMMISSIONER OF PATENTS AND TRADEMARKS
 Washington, D.C. 20231

SERIAL NUMBER	FILING DATE	FIRST NAMED APPLICANT	ATTORNEY DOCKET NO.
---------------	-------------	-----------------------	---------------------

09/478,315

EXAMINER

ART UNIT	PAPER NUMBER
----------	--------------

10

DATE MAILED:

EXAMINER INTERVIEW SUMMARY RECORD

All participants (applicant, applicant's representative, PTO personnel):

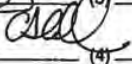
- (1) MR. NIALL R. LYNAM  (3)
- (2) MS. CATHERINE S. COLLINS  (4)

Date of Interview 6/21/01

Type: Telephonic Personal (copy is given to applicant applicant's representative).

Exhibit shown or demonstration conducted: Yes No. If yes, brief description: _____

Agreement was reached with respect to some or all of the claims in question. was not reached.

Claims discussed: PROPOSED AMENDMENT TO CLAIM 1.

Identification of prior art discussed: VAN NOSTRAND

Description of the general nature of what was agreed to if an agreement was reached, or any other comments: DURING THE PERSONAL INTERVIEW, THE PRIOR ART TO VAN NOSTRAND WAS DISCUSSED. THE EXAMINER STATED THAT THE PROPOSED AMENDMENT TO CLAIM 1 WOULD APPEAR TO REQUIRE FURTHER CLARIFICATION IN ORDER TO BE DISTINGUISHABLE OVER THE VAN NOSTRAND REFERENCE. MR. LYNAM AND MS. COLLINS, INFORMED THE EXAMINER THAT THEY WOULD CONSIDER AMENDING/CLARIFYING THE CLAIM 1 ADDRESSING THE EXAMINER'S ISSUES RAISED IN THE PERSONAL INTERVIEW.

(A fuller description, if necessary, and a copy of the amendments, if available, which the examiner agreed would render the claims allowable must be attached. Also, where no copy of the amendments which would render the claims allowable is available, a summary thereof must be attached.)

1. It is not necessary for applicant to provide a separate record of the substance of the interview.

Unless the paragraph below has been checked to indicate to the contrary, A FORMAL WRITTEN RESPONSE TO THE LAST OFFICE ACTION IS NOT WAIVED AND MUST INCLUDE THE SUBSTANCE OF THE INTERVIEW (e.g., items 1-7 on the reverse side of this form). If a response to the last Office action has already been filed, then applicant is given one month from this interview date to provide a statement of the substance of the interview.

2. Since the examiner's interview summary above (including any attachments) reflects a complete response to each of the objections, rejections and requirements that may be present in the last Office action, and since the claims are now allowable, this completed form is considered to fulfill the response requirements of the last Office action. Applicant is not relieved from providing a separate record of the substance of the interview unless box 1 above is also checked.

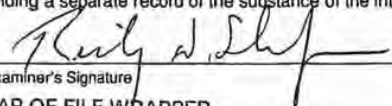
 Examiner's Signature

PTOL-413 (REV. 2-93)

ORIGINAL FOR INSERTION IN RIGHT HAND FLAP OF FILE WRAPPER



2872

PATENT
DON01 P-793

\$

IN THE UNITED STATES PATENT AND TRADEMARK OFFICE

Examiner	:	R. Shafer
Applicant	:	Niall R. Lynam
Serial No.	:	09/478,315
Filed	:	January 6, 2000
Group	:	2872
For	:	EXTERIOR MIRROR PLANO-AUXILIARY REFLECTIVE ELEMENT ASSEMBLY

TECHNOLOGY CENTER 2800

AUG - 2 2001

RECEIVED

#11/a
Amend
J. Mainella
8/6/01

Commissioner for Patents
Washington, D.C. 20231

Dear Sir:

RESPONSE

*Do not
over.*

In response to the Office Action mailed April 24, 2001, having a three month period of response ending July 24, 2001, and personal interview with Dr. Niall R. Lynam, Senior Vice President and Chief Technical Officer of Donnelly Corp and the undersigned Applicant wishes to amend his application as follows:

IN THE SPECIFICATION:

On page 17, lines 5-16, please replace with the following new paragraph:

Backing plate element 65 of plano-multiradius reflective element assembly 30 is optionally equipped on its rearmost surface with attachment member 64 to facilitate attachment to the reflector-positioning actuator of the exterior sideview mirror assembly that plano-multiradius reflective element assembly 30 is mounted to. Attachment of plano-multiradius reflective element assembly 30 to the actuator can be by mechanical attachment such as by a tab, clip or fastener, or may be by adhesive attachment such as by a silicone adhesive, a urethane adhesive or a similar adhesive material such as a tape coated on both surfaces with a pressure sensitive adhesive to form a "double-sticky" tape. [The exterior] Exterior sideview mirror assembly 12 and/or 14, on whose mirror reflector-positioning

Applicant : Niall R. Lynam
Serial No. : 09/478,315
Page : 2

actuator the plano-multiradius reflective element assembly is mounted, can be a fixedly attached exterior sideview mirror assembly, a break-away exterior sideview mirror assembly and a powerfold exterior sideview mirror assembly, as known in the automotive mirror art.

IN THE CLAIMS:

Please cancel Claims 23 and 24. Please amend Claims 1, 16, 17, and 18 as follows:

1. (Amended)

An exterior sideview mirror system suitable for use on an automobile, said exterior sideview mirror system comprising:

an exterior sideview mirror assembly adapted for attachment to a side of an automobile;

said exterior sideview mirror assembly including a reflective element having a rearward field of view when attached to the side of the automobile;

said reflective element attached to an electrically-operated actuator and movable by said actuator in order to position said rearward field of view in response to a control;

wherein said reflective element comprises a plano-multiradius reflective element assembly, said plano-multiradius reflective element assembly comprising a plano reflective element having unit magnification and a separate multiradius reflective element having a multiradius curvature, said plano reflective element having a rearward field of view with a principal axis;

said plano reflective element and said multiradius reflective element of said plano-multiradius reflective element assembly mounted adjacently in said plano-multiradius reflective element assembly in a side-by-side relationship and not superimposed with one reflective element on top of the other reflective element, and supported by a backing plate element, said backing plate element mounting to said actuator such that movement of said backing plate element of said plano-multiradius reflective element assembly by said actuator simultaneously and similarly moves said plano reflective element and said multiradius

Applicant : Niall R. Lynam
Serial No. : 09/478,315
Page : 3

reflective element, said multiradius reflective element having a rearward field of view with a principal axis, said principal axis of said rearward field of view of said multiradius element being different from and angled with respect to said principal axis of said rearward field of view of said plano reflective element when said multiradius reflective element and said plano reflective element are supported by said backing plate element of said plano-multiradius reflective element assembly and when said plano-multiradius reflective element assembly is mounted in said exterior sideview mirror assembly on the automobile, and said principal axis of said rearward field of view of said plano reflective element being directed generally parallel to the longitudinal axis of the automobile equipped with the plano-multiradius reflective element assembly and wherein said principal axis of said rearward field of view of said multiradius reflective element is directed generally at an angle downwards to the longitudinal axis of the automobile; and

said multiradius reflective element being positioned at an outboard portion of said plano-multiradius reflective element assembly when said exterior sideview mirror assembly is mounted to the side of the automobile.

16. (Amended)

The exterior sideview mirror system of Claim 1, wherein said plano reflective element is supported by said backing plate element by at least one of an adhesive attachment and a mechanical attachment.

17. (Amended)

The exterior sideview mirror system of Claim 1, wherein said multiradius reflective element is supported by said backing plate element by at least one of an adhesive attachment and a mechanical attachment.

18. (Amended)

The exterior sideview mirror system of Claim 1, wherein said multiradius reflective element is supported by said backing plate element at a location such that, when said exterior mirror assembly is attached to a side of an automobile, at least a portion of said plano reflective element is disposed closer to said side of the automobile than any portion of said multiradius reflective element.

Applicant : Niall R. Lynam
Serial No. : 09/478,315
Page : 4

Please enter the following new claims:

84. (New)

An automobile exterior sideview mirror system comprising:

an exterior sideview mirror assembly adapted for attachment to a side of an automobile;

said exterior sideview mirror assembly including a plano-auxiliary reflective element assembly having a rearward field of view when attached to the side of the automobile;

an electrically-operated actuator adapted for adjusting the rearward field of view of said plano-auxiliary reflective element assembly in response to a control;

wherein said plano-auxiliary reflective element assembly comprises a plano reflective element having unit magnification and a separate auxiliary reflective element having a curvature, said plano reflective element and said auxiliary reflective element mounted adjacently in said plano-auxiliary reflective element assembly in a side-by-side relationship and not superimposed with one reflective element on top of the other reflective element, said auxiliary reflective element having a rearward field of view with a principal axis, said principal axis of said rearward field of view of said auxiliary element being different from and angled with respect to said principal axis of said rearward field of view of said plano reflective element when said exterior sideview mirror assembly is mounted to the side of the automobile, and said principal axis of said rearward field of view of said plano reflective element being directed generally parallel to the longitudinal axis of the automobile equipped with the plano-auxiliary reflective element assembly and wherein said principal axis of said rearward field of view of said auxiliary reflective element is directed generally at an angle downwards to the longitudinal axis of the automobile; and

said auxiliary reflective element being positioned at an outboard portion of said plano-auxiliary reflective element assembly when said exterior sideview mirror assembly is mounted to the side of the automobile.

Applicant : Niall R. Lynam
Serial No. : 09/478,315
Page : 5

85. (New)

The automobile exterior sideview mirror system according to Claim 84, wherein said auxiliary reflective element is located at an upper outboard portion of said plano-auxiliary reflective element assembly.

86. (New)

The automobile exterior sideview mirror system according to Claim 84, wherein said curvature of said auxiliary reflective element comprises a convex curvature.

87. (New)

The automobile exterior sideview mirror system according to Claim 84, wherein said curvature of said auxiliary reflective element comprises a multiradius curvature.

88. (New)

The automobile exterior sideview mirror system according to Claim 84, wherein said principal axis of said rearward field of view of said auxiliary reflective element is angled downwardly in a range from about 1° to about 10°.

89. (New)

The automobile exterior sideview mirror system according to Claim 84, wherein said plano reflective element and said auxiliary reflective element are supported on a backing plate.

90. (New)

The automobile exterior sideview mirror system according to Claim 84, wherein at least one of said plano reflective element and said auxiliary reflective element comprises an electro-optic reflective element.

REMARKS

Applicants acknowledge the Examiner's review of the specification, claims, and drawings. In light of the above amendments and following remarks, Applicants respectfully request reconsideration of the present application. The amendments presented

Applicant : Niall R. Lynam
Serial No. : 09/478,315
Page : 6

herein are fully supported by the application as originally filed. No new matter has been entered.

STATUS OF THE CLAIMS:

Claims 1-22, 25-83 are pending in the application. Claims 2-15, 32, 34, and 36-83 have been withdrawn from consideration as being drawn to a non-elected species. Claims 23 and 24 have been cancelled by this amendment.

CLAIM REJECTIONS UNDER 35 U.S.C. § 112, SECOND PARAGRAPH:

The Examiner rejects Claims 1, 16-31, 33, and 35 under 35 U.S.C. § 112, second paragraph, as being indefinite. Specifically, the Examiner states that "the use of the language "in an automobile" is vague, indefinite and/or confusing." In response, Applicant has amended Claim 1 to call for "an exterior side mirror system suitable for use on an automobile". Accordingly, Applicant respectfully requests reconsideration and withdrawal of the 35 U.S.C. § 112, second paragraph, rejection.

CLAIM REJECTIONS UNDER 35 U.S.C. § 102:

The Examiner rejects Claims 1, 16-18, 20, 21, and 23 under 35 U.S.C. § 102(a) as being anticipated by U.S. Patent No. 4,678,294 to Van Nostrand. Applicant has amended Claim 1 to clarify Applicant's invention, which calls for:

An exterior sideview mirror system suitable for use [in] on an automobile, said exterior sideview mirror system comprising:
an exterior sideview mirror assembly adapted for attachment to a side of an automobile;
said exterior sideview mirror assembly including a reflective element having a rearward field of view when attached to [said] the side of the automobile;

Applicant : Niall R. Lynam
Serial No. : 09/478,315
Page : 7

said reflective element attached to an electrically-operated actuator and movable by said actuator in order to position said rearward field of view in response to a control;

wherein said reflective element comprises a plano-multiradius reflective element assembly, said plano-multiradius reflective element assembly comprising a plano reflective element having unit magnification and a separate multiradius reflective element having a multiradius curvature, said plano reflective element having a rearward field of view with a principal axis;

said plano reflective element and said multiradius reflective element of said plano-multiradius reflective element assembly mounted adjacently in said plano-multiradius reflective element assembly in a side-by-side relationship and not superimposed with one reflective element on top of the other reflective element, and supported by [attached to] a backing plate element, said backing plate element mounting to said actuator such that movement of said backing plate element of said plano-multiradius reflective element assembly by said actuator simultaneously and similarly moves said plano reflective element and said multiradius reflective element, said multiradius reflective element having a rearward field of view with a principal axis, said principal axis of said rearward field of view of said multiradius element being different from and angled with respect to said principal axis of said rearward field of view of said plano reflective element when said multiradius reflective element and said plano reflective element are supported by said backing plate element of said plano-multiradius reflective element assembly and when said plano-multiradius reflective element assembly is mounted in said exterior sideview mirror assembly on the automobile, and said principal axis of said rearward field of view of said plano reflective element being directed generally parallel to the longitudinal axis of the automobile equipped with the plano-multiradius reflective element assembly and wherein said principal axis of said rearward field of view of said multiradius reflective element is directed generally at an angle downwards to the longitudinal axis of the automobile; and

said multiradius reflective element being positioned at an outboard portion of said plano-multiradius reflective element assembly when said exterior sideview mirror assembly is mounted to the side of the automobile.

Applicant : Niall R. Lynam
Serial No. : 09/478,315
Page : 8

Applicant respectfully urges that Van Nostrand or any other reference of record does not disclose or suggest the claimed combination. For example, neither Van Nostrand nor any other reference of record, alone or in combination, discloses or suggests, for example, an exterior rearview mirror assembly which includes a plano reflective element and a multiradius reflective element of a plano-multiradius reflective element assembly which are mounted adjacent in a side-by-side relationship but not superimposed with one reflective element on top the other reflective element and supported by a backing plate element, with the backing plate element having an outboard portion, with the multiradius reflective element located at the outboard portion and, further, with the backing plate element mounted to an actuator. In addition, neither Van Nostrand nor any other reference of record discloses or suggests an exterior sideview mirror system includes a plano reflective element and a multiradius reflective element, which are mounted in a side-by-side relationship noted above, with the principal axis of the rearward field of view of the plano reflective element being directed generally parallel to the longitudinal axis of an automobile equipped with the plano-multiradius reflective element assembly and a principal axis of the rearward field of view of the multiradius reflective element being directed generally in an angle downwards to the longitudinal axis of the automobile.

Applicant, therefore, respectfully urge that Claim 1 and its dependent claims, namely Claims 16-31, 33, and 35 are patentably distinguishable over Van Nostrand alone or in combination with any other reference of record.

Applicant : Niall R. Lynam
Serial No. : 09/478,315
Page : 9

CLAIM REJECTIONS UNDER 35 U.S.C. § 102 (a) and/or 103(a):

The Examiner rejects Claims 24-31 under 35 U.S.C. § 102(a) as being anticipated or in the alternative under U.S.C. § 103(a) as being obvious over Van Nostrand '294.

Claims 24-31 depend from amended Claim 1 and, therefore, incorporate the same amendments as amended Claim 1. Therefore, for at least the reasons set forth in reference to Claim 1, Claims 24-31 are patentably distinguishable over Van Nostrand alone or in combination with any other reference of record.

With respect to Claim 24, Claim 24 has been cancelled in light of the amendments to Claim 21.

With respect to Claim 25, Claims 25 further calls for the downward angle to be in a range of about 1° to about 10°. The Examiner states that the assembly of Van Nostrand is inherently capable of obtaining a selected range since the multiradius reflective element of Van Nostrand is adjustable. However, if the Van Nostrand multiradius reflective element is adjusted to a downward angle, the principal axis of the flat reflective element would no longer be parallel to the longitudinal axis of the vehicle. In contrast to the claimed invention, the principal axis of the flat reflective element would also be angled downwardly. Therefore, Applicant submits that Van Nostrand alone or in combination with any other reference record does not disclose or suggest the claimed combination.

With respect to Claim 26, the Examiner is referred to the reasons set forth above in reference to Claim 25.

Applicant : Niall R. Lynam
Serial No. : 09/478,315
Page : 10

Therefore, Applicant respectfully urges that Claims 25-31 are also patentably distinguishable over Van Nostrand alone or in combination with any other reference of record.

The Examiner rejects Claims 19, 22, 24-32, 33, and 35 as being unpatentable over Van Nostrand '294 in view of European Patent Document 0551802 to Jonsson.

Claims 19, 22, 24-33, and 35 are dependent upon amended Claim 1 and are, therefore, similarly patentably distinguishable over Van Nostrand in view of Jonsson or any other reference of record. As noted in reference to Claim 1, Van Nostrand alone or in combination with any of the prior art does not disclose or suggest the claimed combination. For example, Van Nostrand does not disclose or suggest an exterior rearview mirror assembly which includes a plano reflective element and a multiradius reflective element of a plano-multiradius reflective element assembly which are mounted adjacent in a side-by-side relationship but not superimposed with one reflective element on top the other reflective element and supported by a backing plate element, with the backing plate element having an outboard portion, with the multiradius reflective element located at the outboard portion and, further, with the backing plate element mounted to an actuator.

Nor does Jonsson remedy the deficiencies of Van Nostrand. Like Van Nostrand, Jonsson is directed to a spotter mirror which is superimposedly mounted on flat reflective element (2)—not in a side-by-side relationship. Furthermore, neither Jonsson nor Van Nostrand discloses or suggests the further combination of the multiradius reflective element having a principal axis, which is directed downwardly with respect to the longitudinal axis of the vehicle as called for in the claims, while the principal axis of the plano reflective element is generally parallel to the longitudinal axis of a vehicle.

Applicant : Niall R. Lynam
Serial No. : 09/478,315
Page : 11

Accordingly, at least for these reasons, Claims 19, 22, 24-32, 33, and 35 are patentably distinguishable over Van Nostrand in view of Jonsson or any other reference of record.

With respect to new claims, namely, Claims 84-90, Applicant respectfully urges that neither Van Nostrand alone or in combination with any other reference of record discloses or suggests the combinations called for in Claims 84-90 either.

DRAWINGS:

The Examiner objects to the drawings as failing to illustrate the break-away exterior sideview mirror assembly. Applicant has amended the specification, specifically on page 17, with the paragraph starting with line 5, to clarify that the numeral 12 and/or 14 designates a sideview mirror, including for example a fixedly attached exterior sideview mirror assembly, a break-away exterior sideview mirror assembly, and/or a power-fold exterior sideview mirror assembly. Therefore, the feature is generally shown in the drawings. Applicant respectfully requests reconsideration and withdrawal of objection to the drawings.

Applicant : Niall R. Lynam
Serial No. : 09/478,315
Page : 12



Accordingly, in view of the above amendments and remarks, Applicant respectfully requests reconsideration of the present application and a Notice of Allowance of Claims 1, 16-31, 33, and 35 and, further, of Claims 2-15, 32, 34, 36-43, which are dependent upon allowable generic claims, at least with respect to the species called for in those claims. Should the Examiner have any questions or comments, he is invited to contact the undersigned at (616) 975-5506.

Respectfully submitted,

NIALL R. LYNAM

By: Van Dyke, Gardner, Linn & Burkhart, LLP

Date: July 24, 2001.

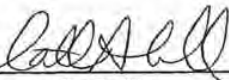
Catherine S. Collins
Registration No. 37 599
2851 Charlevoix Drive, S.E.
Suite 207
P.O. Box 888695
Grand Rapids, MI 49588-8695
(616) 975-5500

CSC:lmisc

RECEIVED
JUL 27 2001
TECHNOLOGY CENTER 2800

Applicant : Niall R. Lynam
Serial No. : 09/478,315
Page : 13

PATENT
DON01 P-793

APPENDIX TO SPECIFICATION AND CLAIMS

1. (Amended)

An exterior sideview mirror system suitable for use [in] on an automobile,
said exterior sideview mirror system comprising:

an exterior sideview mirror assembly adapted for attachment to a side of an
automobile;

said exterior sideview mirror assembly including a reflective element having a
rearward field of view when attached to [said] the side of the automobile;

said reflective element attached to an electrically-operated actuator and
movable by said actuator in order to position said rearward field of view in response to a
control;

wherein said reflective element comprises a plano-multiradius reflective
element assembly, said plano-multiradius reflective element assembly comprising a plano
reflective element having unit magnification and a separate multiradius reflective element
having a multiradius curvature, said plano reflective element having a rearward field of view
with a principal axis;

said plano reflective element and said multiradius reflective element of said
plano-multiradius reflective element assembly mounted adjacently in said plano-multiradius
reflective element assembly in a side-by-side relationship and not superimposed with one
reflective element on top of the other reflective element, and supported by [attached to] a
backing plate element, said backing plate element mounting to said actuator such that
movement of said backing plate element of said plano-multiradius reflective element
assembly by said actuator simultaneously and similarly moves said plano reflective element
and said multiradius reflective element, said multiradius reflective element having a rearward
field of view with a principal axis, said principal axis of said rearward field of view of said
multiradius element being different from and angled with respect to said principal axis of said
rearward field of view of said plano reflective element when said multiradius reflective

Applicant : Niall R. Lynam
Serial No. : 09/478,315
Page : 14

element and said plano reflective element are supported by said backing plate element of said plano-multiradius reflective element assembly and when said plano-multiradius reflective element assembly is mounted in said exterior sideview mirror assembly on the automobile, and said principal axis of said rearward field of view of said plano reflective element being directed generally parallel to the longitudinal axis of the automobile equipped with the plano-multiradius reflective element assembly and wherein said principal axis of said rearward field of view of said multiradius reflective element is directed generally at an angle downwards to the longitudinal axis of the automobile; and

said multiradius reflective element being positioned at an outboard portion of said plano-multiradius reflective element assembly when said exterior sideview mirror assembly is mounted to the side of the automobile.

16. (Amended)

The exterior sideview mirror system of Claim 1, wherein said plano reflective element is [attached to] supported by said backing plate element by at least one of an adhesive attachment and a mechanical attachment.

17. (Amended)

The exterior sideview mirror system of Claim 1, wherein said multiradius reflective element is [attached to] supported by said backing plate element by at least one of an adhesive attachment and a mechanical attachment.

18. (Amended)

The exterior sideview mirror system of Claim 1, wherein said multiradius reflective element is [attached to] supported by said backing plate element at a location such that, when said exterior mirror assembly is attached to a side of an automobile, at least a portion of said plano reflective element is disposed closer to said side of the automobile than any portion of said multiradius reflective element.

Respectfully submitted,

NIALL R. LYNAM

Applicant : Niall R. Lynam
Serial No. : 09/478,315
Page : 15

By: Van Dyke, Gardner, Linn & Burkhart, LLP

Date: July 24, 2001.



CSC:lmsc

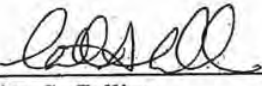

Catherine S. Collins
Registration No. 37 599
2851 Charlevoix Drive, S.E.
Suite 207
P.O. Box 888695
Grand Rapids, MI 49588-8695
(616) 975-5500

RECEIVED
AUG - 2 2001
TECHNOLOGY CENTER 2800



PATENT
DON01 P-793

IN THE UNITED STATES PATENT AND TRADEMARK OFFICE

Examiner : R. Shafer
Applicant : Niall R. Lynam
Serial No. : 09/478,315
Filed : January 6, 2000
Group : 2872
For : EXTERIOR MIRROR PLANO-AUXILIARY
REFLECTIVE ELEMENT ASSEMBLY

RECEIVED
AUG - 2 2001
TECHNOLOGY CENTER 2800

Commissioner for Patents
Washington, D.C. 20231

Dear Sir:

CERTIFICATE OF MAIL

I certify that the attached return postcard, Response, and Claims as Amended form (in duplicate) are being deposited with the United States Postal Service as first class mail an envelope addressed to:

Commissioner for Patents
Washington, D.C. 20231

on July 24, 2001.

Catherine S. Collins
Van Dyke, Gardner, Linn & Burkhart, LLP
P.O. Box 888695
Grand Rapids, MI 49588-8695
(616) 975-5500

CSC:lmsc
Enclosures



PATENT
DON01 P-793

THE UNITED STATES PATENT AND TRADEMARK OFFICE

Applicant : Niall R. Lynan Examiner : R. Shafer
Serial No. : 09/478,315 Group : 2872
Filed : January 6, 2000
For : EXTERIOR MIRROR PLANO-AUXILIARY
REFLECTIVE ELEMENT ASSEMBLY

RECEIVED
AUG -2 2001
TECHNOLOGY CENTER 2800

Commissioner for Patents
Washington, D.C. 20231

Dear Sir:

Transmitted herewith is an amendment in the above identified application.

The fee has been calculated as shown below:

CLAIMS AS AMENDED

	Col. 1		Col. 2	Col. 3	Small Entity		Other Than A Small Entity	
	Claims Remaining After Amendment		Highest No. Previously Paid For	Present Extra	Rate	Add'l Fee	Rate	Add'l Fee
Total Claims	* 88	Minus	** 83	= 5	x \$9	\$.00	x \$18	\$ 90
Independent Claims	* 3	Minus	*** 3	= 0	x \$40	\$.00	x \$80	\$
First Presentation of Multiple Dependent Claims					\$135	\$	x \$270	\$.00
TOTAL ADDITIONAL FEE FOR THIS AMENDMENT						\$.00		\$ 90.00

- * If the entry in Col. 1 is less than the entry in Col. 2, write "0" in Col. 3
- ** If the "Highest No. Previously Paid For" IN THIS SPACE is less than 20, write "20" in this space.
- *** If the "Highest No. Previously Paid For" IN THIS SPACE is less than 3, write "3" in this space.

The "Highest No. Previously Paid For" (Total or Independent) is the highest number found from the equivalent box in Col. 1 of a prior amendment or the number of claims originally filed.

1. Small entity status of this application 37 CFR 1.9 and 1.27 has been established by a verified statement previously submitted or is enclosed.
2. No additional Fee is required.
3. A check in the amount of \$ _____ is attached.
4. Please charge the amount of \$ 90.00 and any additional fees or credit overpayment to Deposit Account No. 22-0190. A duplicate copy of this sheet is attached.

By: VAN DYKE, GARDNER, LINN & BURKHART, LLP

Date: July 24, 2001

Catherine S. Collins
Registration No. 37 599
P.O. Box 888695
Grand Rapids, MI 49588-8695
(616) 975-5500

CSC:lmsc



UNITED STATES PATENT AND TRADEMARK OFFICE

COMMISSIONER FOR PATENTS
UNITED STATES PATENT AND TRADEMARK OFFICE
WASHINGTON, D.C. 20231
www.uspto.gov

APPLICATION NO.	FILING DATE	FIRST NAMED INVENTOR	ATTORNEY DOCKET NO.
-----------------	-------------	----------------------	---------------------

09/478,315 01/06/00 LYNAM

MM21-0807 DON01-P-793

EXAMINER

VAN DYKE GARDNER LINN & BURKHART LLP
2851 CHARLEVOIX DRIVE SE
SUITE 207
GRAND RAPIDS MI 49546

ART UNIT/ART. PAPER NUMBER

12

DATE MAILED: 2

08/07/01

Notice of Non-Compliant Amendment (37 CFR 1.121)

The amendment filed on 7/27/01 is considered non-compliant because it has not been submitted in the format required under 37 CFR 1.121, as amended on September 8, 2000 (see 65 Fed. Reg. 54603, Sept. 8, 2000, and 1238 O.G. 77, Sept. 19, 2000).

- 1. The amendment does not include a clean version of the replacement paragraph(s)/section(s). 37 CFR 1.121(b)(1)(ii).
- 2. The amendment does not include a marked-up version of the replacement paragraph(s)/section(s). 37 CFR 1.121(b)(1)(iii)
- 3. The amendment does not include a clean version of the amended claim(s). 37 CFR 1.121(c)(1)(i)
- 4. The amendment does not include a marked-up version of the amended claim(s). 37 CFR 1.121(c)(1)(ii)
- 5. Other _____

PRELIMINARY AMENDMENT: Unless applicant re-submits the preliminary amendment in compliance with revised 37 CFR 1.121 within ONE MONTH of the mail date of this letter, examination on the merits may commence without entry of the originally proposed preliminary amendment. This notice is not an action under 35 U.S.C. 132, and this ONE MONTH time limit is not extendable.

AMENDMENT AFTER NON-FINAL ACTION: Since the above mentioned reply appears to be *bona fide*, applicant is given a TIME PERIOD of ONE (1) MONTH or THIRTY (30) DAYS from the mailing date of this notice, whichever is longer, within which to supply the omission or correction in order to avoid abandonment. EXTENSIONS OF THIS TIME PERIOD MAY BE GRANTED UNDER 37 CFR 1.136(a).

For your convenience, attached to this correspondence is a copy of an informational flyer (MPEP Bookmark Bulletin on "Simplified Amendment Practice").

MS. McMillan
Legal Instruments Examiner



#13 B
9/13/01
amr

RECEIVED
DON01 P-793
SEP-7 2001

IN THE UNITED STATES PATENT AND TRADEMARK OFFICE TECHNOLOGY CENTER 2800

Examiner : R. Shafer
Applicant : Niall R. Lynam
Serial No. : 09/478,315
Filed : January 6, 2000
Group : 2872
For : EXTERIOR MIRROR PLANO-AUXILIARY
REFLECTIVE ELEMENT ASSEMBLY

Commissioner for Patents
Washington, D.C. 20231

Dear Sir:

CORRECTED RESPONSE

In response to the Office Action mailed April 24, 2001, having a three month period of response ending July 24, 2001, and personal interview with Dr. Niall R. Lynam, Senior Vice President and Chief Technical Officer of Donnelly Corp and the undersigned Applicant wishes to amend his application as follows:

IN THE SPECIFICATION:

On page 17, lines 5-16, please replace with the following new paragraph:

Backing plate element 65 of plano-multiradius reflective element assembly 30 is optionally equipped on its rearmost surface with attachment member 64 to facilitate attachment to the reflector-positioning actuator of the exterior sideview mirror assembly that plano-multiradius reflective element assembly 30 is mounted to. Attachment of plano-multiradius reflective element assembly 30 to the actuator can be by mechanical attachment such as by a tab, clip or fastener, or may be by adhesive attachment such as by a silicone adhesive, a urethane adhesive or a similar adhesive material such as a tape coated on both surfaces with a pressure sensitive adhesive to form a "double-sticky" tape. Exterior sideview mirror assembly 12 and/or 14, on whose mirror reflector-positioning actuator the plano-

1
B

B

31

Applicant : Niall R. Lynam
Serial No. : 09/478,315
Page : 2

multiradius reflective element assembly is mounted, can be a fixedly attached exterior sideview mirror assembly, a break-away exterior sideview mirror assembly and a powerfold exterior sideview mirror assembly, as known in the automotive mirror art.

IN THE CLAIMS:

Please cancel Claims 23 and 24. Please amend Claims 1, 16, 17, and 18 as follows:

1. (Amended)

An exterior sideview mirror system suitable for use on an automobile, said exterior sideview mirror system comprising:

an exterior sideview mirror assembly adapted for attachment to a side of an automobile;

said exterior sideview mirror assembly including a reflective element having a rearward field of view when attached to the side of the automobile;

said reflective element attached to an electrically-operated actuator and movable by said actuator in order to position said rearward field of view in response to a control;

wherein said reflective element comprises a plano-multiradius reflective element assembly, said plano-multiradius reflective element assembly comprising a plano reflective element having unit magnification and a separate multiradius reflective element having a multiradius curvature, said plano reflective element having a rearward field of view with a principal axis;

said plano reflective element and said multiradius reflective element of said plano-multiradius reflective element assembly mounted adjacently in said plano-multiradius reflective element assembly in a side-by-side relationship and not superimposed with one reflective element on top of the other reflective element, and supported by a backing plate element, said backing plate element mounting to said actuator such that movement of said backing plate element of said plano-multiradius reflective element assembly by said actuator simultaneously and similarly moves said plano reflective element and said multiradius

Bent

Sub 7
C17

B 2

72

13

Applicant : Niall R. Lynam
Serial No. : 09/478,315
Page : 3

reflective element, said multiradius reflective element having a rearward field of view with a principal axis, said principal axis of said rearward field of view of said multiradius element being different from and angled with respect to said principal axis of said rearward field of view of said plano reflective element when said multiradius reflective element and said plano reflective element are supported by said backing plate element of said plano-multiradius reflective element assembly and when said plano-multiradius reflective element assembly is mounted in said exterior sideview mirror assembly on the automobile, and said principal axis of said rearward field of view of said plano reflective element being directed generally parallel to the longitudinal axis of the automobile equipped with the plano-multiradius reflective element assembly and wherein said principal axis of said rearward field of view of said multiradius reflective element is directed generally at an angle downwards to the longitudinal axis of the automobile; and

said multiradius reflective element being positioned at an outboard portion of said plano-multiradius reflective element assembly when said exterior sideview mirror assembly is mounted to the side of the automobile.

16. (Amended)

The exterior sideview mirror system of Claim 1, wherein said plano reflective element is supported by said backing plate element by at least one of an adhesive attachment and a mechanical attachment.

17. (Amended)

The exterior sideview mirror system of Claim 1, wherein said multiradius reflective element is supported by said backing plate element by at least one of an adhesive attachment and a mechanical attachment.

18. (Amended)

The exterior sideview mirror system of Claim 1, wherein said multiradius reflective element is supported by said backing plate element at a location such that, when said exterior mirror assembly is attached to a side of an automobile, at least a portion of said plano reflective element is disposed closer to said side of the automobile than any portion of said multiradius reflective element.

Applicant : Niall R. Lynam
Serial No. : 09/478,315
Page : 4

Please enter the following new claims:

84. (New)

Sub C3
B4

An automobile exterior sideview mirror system comprising:
an exterior sideview mirror assembly adapted for attachment to a side of an automobile;
said exterior sideview mirror assembly including a plano-auxiliary reflective element assembly having a rearward field of view when attached to the side of the automobile;
an electrically-operated actuator adapted for adjusting the rearward field of view of said plano-auxiliary reflective element assembly in response to a control;
wherein said plano-auxiliary reflective element assembly comprises a plano reflective element having unit magnification and a separate auxiliary reflective element having a curvature, said plano reflective element and said auxiliary reflective element mounted adjacently in said plano-auxiliary reflective element assembly in a side-by-side relationship and not superimposed with one reflective element on top of the other reflective element, said auxiliary reflective element having a rearward field of view with a principal axis, said principal axis of said rearward field of view of said auxiliary element being different from and angled with respect to said principal axis of said rearward field of view of said plano reflective element when said exterior sideview mirror assembly is mounted to the side of the automobile, and said principal axis of said rearward field of view of said plano reflective element being directed generally parallel to the longitudinal axis of the automobile equipped with the plano-auxiliary reflective element assembly and wherein said principal axis of said rearward field of view of said auxiliary reflective element is directed generally at an angle downwards to the longitudinal axis of the automobile; and
said auxiliary reflective element being positioned at an outboard portion of said plano-auxiliary reflective element assembly when said exterior sideview mirror assembly is mounted to the side of the automobile.

B

Applicant : Niall R. Lynam
Serial No. : 09/478,315
Page : 5

85. (New)

The automobile exterior sideview mirror system according to Claim 84, wherein said auxiliary reflective element is located at an upper outboard portion of said plano-auxiliary reflective element assembly.

86. (New)

The automobile exterior sideview mirror system according to Claim 84, wherein said curvature of said auxiliary reflective element comprises a convex curvature.

87. (New)

The automobile exterior sideview mirror system according to Claim 84, wherein said curvature of said auxiliary reflective element comprises a multiradius curvature.

88. (New)

The automobile exterior sideview mirror system according to Claim 84, wherein said principal axis of said rearward field of view of said auxiliary reflective element is angled downwardly in a range from about 1° to about 10°.

89. (New)

The automobile exterior sideview mirror system according to Claim 84, wherein said plano reflective element and said auxiliary reflective element are supported on a backing plate.

90. (New)

The automobile exterior sideview mirror system according to Claim 84, wherein at least one of said plano reflective element and said auxiliary reflective element comprises an electro-optic reflective element.

REMARKS

Applicants acknowledge the Examiner's review of the specification, claims, and drawings. In light of the above amendments and following remarks, Applicants respectfully request reconsideration of the present application. The amendments presented

Applicant : Niall R. Lynam
Serial No. : 09/478,315
Page : 6

herein are fully supported by the application as originally filed. No new matter has been entered.

STATUS OF THE CLAIMS:

Claims 1-22, 25-83 are pending in the application. Claims 2-15, 32, 34, and 36-83 have been withdrawn from consideration as being drawn to a non-elected species. Claims 23 and 24 have been cancelled by this amendment.

CLAIM REJECTIONS UNDER 35 U.S.C. § 112, SECOND PARAGRAPH:

The Examiner rejects Claims 1, 16-31, 33, and 35 under 35 U.S.C. § 112, second paragraph, as being indefinite. Specifically, the Examiner states that "the use of the language "in an automobile" is vague, indefinite and/or confusing." In response, Applicant has amended Claim 1 to call for "an exterior side mirror system suitable for use on an automobile". Accordingly, Applicant respectfully requests reconsideration and withdrawal of the 35 U.S.C. § 112, second paragraph, rejection.

CLAIM REJECTIONS UNDER 35 U.S.C. § 102:

The Examiner rejects Claims 1, 16-18, 20, 21, and 23 under 35 U.S.C. § 102(a) as being anticipated by U.S. Patent No. 4,678,294 to Van Nostrand. Applicant has amended Claim 1 to clarify Applicant's invention, which calls for:

An exterior sideview mirror system suitable for use on an automobile, said exterior sideview mirror system comprising:
an exterior sideview mirror assembly adapted for attachment to a side of an automobile;
said exterior sideview mirror assembly including a reflective element having a rearward field of view when attached to the side of the automobile;
said reflective element attached to an electrically-operated actuator and movable by said actuator in order to position said rearward field of view in response to a control;

Applicant : Niall R. Lynam
Serial No. : 09/478,315
Page : 7

wherein said reflective element comprises a plano-multiradius reflective element assembly, said plano-multiradius reflective element assembly comprising a plano reflective element having unit magnification and a separate multiradius reflective element having a multiradius curvature, said plano reflective element having a rearward field of view with a principal axis;

said plano reflective element and said multiradius reflective element of said plano-multiradius reflective element assembly mounted adjacently in said plano-multiradius reflective element assembly in a side-by-side relationship and not superimposed with one reflective element on top of the other reflective element, and supported by a backing plate element, said backing plate element mounting to said actuator such that movement of said backing plate element of said plano-multiradius reflective element assembly by said actuator simultaneously and similarly moves said plano reflective element and said multiradius reflective element, said multiradius reflective element having a rearward field of view with a principal axis, said principal axis of said rearward field of view of said multiradius element being different from and angled with respect to said principal axis of said rearward field of view of said plano reflective element when said multiradius reflective element and said plano reflective element are supported by said backing plate element of said plano-multiradius reflective element assembly and when said plano-multiradius reflective element assembly is mounted in said exterior sideview mirror assembly on the automobile, and said principal axis of said rearward field of view of said plano reflective element being directed generally parallel to the longitudinal axis of the automobile equipped with the plano-multiradius reflective element assembly and wherein said principal axis of said rearward field of view of said multiradius reflective element is directed generally at an angle downwards to the longitudinal axis of the automobile; and

said multiradius reflective element being positioned at an outboard portion of said plano-multiradius reflective element assembly when said exterior sideview mirror assembly is mounted to the side of the automobile.

Applicant respectfully urges that Van Nostrand or any other reference of record does not disclose or suggest the claimed combination. For example, neither Van Nostrand nor any other reference of record, alone or in combination, discloses or suggests, for example, an exterior rearview mirror assembly which includes a plano reflective element and

Applicant : Niall R. Lynam
Serial No. : 09/478,315
Page : 8

a multiradius reflective element of a plano-multiradius reflective element assembly which are mounted adjacent in a side-by-side relationship but not superimposed with one reflective element on top the other reflective element and supported by a backing plate element, with the backing plate element having an outboard portion, with the multiradius reflective element located at the outboard portion and, further, with the backing plate element mounted to an actuator. In addition, neither Van Nostrand nor any other reference of record discloses or suggests an exterior sideview mirror system includes a plano reflective element and a multiradius reflective element, which are mounted in a side-by-side relationship noted above, with the principal axis of the rearward field of view of the plano reflective element being directed generally parallel to the longitudinal axis of an automobile equipped with the plano-multiradius reflective element assembly and a principal axis of the rearward field of view of the multiradius reflective element being directed generally in an angle downwards to the longitudinal axis of the automobile.

Applicant, therefore, respectfully urge that Claim 1 and its dependent claims, namely Claims 16-31, 33, and 35 are patentably distinguishable over Van Nostrand alone or in combination with any other reference of record.

CLAIM REJECTIONS UNDER 35 U.S.C. § 102 (a) and/or 103(a):

The Examiner rejects Claims 24-31 under 35 U.S.C. § 102(a) as being anticipated or in the alternative under U.S.C. § 103(a) as being obvious over Van Nostrand '294.

Claims 24-31 depend from amended Claim 1 and, therefore, incorporate the same amendments as amended Claim 1. Therefore, for at least the reasons set forth in

Applicant : Niall R. Lynam
Serial No. : 09/478,315
Page : 9

reference to Claim 1, Claims 24-31 are patentably distinguishable over Van Nostrand alone or in combination with any other reference of record.

With respect to Claim 24, Claim 24 has been cancelled in light of the amendments to Claim 21.

With respect to Claim 25, Claims 25 further calls for the downward angle to be in a range of about 1° to about 10°. The Examiner states that the assembly of Van Nostrand is inherently capable of obtaining a selected range since the multiradius reflective element of Van Nostrand is adjustable. However, if the Van Nostrand multiradius reflective element is adjusted to a downward angle, the principal axis of the flat reflective element would no longer be parallel to the longitudinal axis of the vehicle. In contrast to the claimed invention, the principal axis of the flat reflective element would also be angled downwardly. Therefore, Applicant submits that Van Nostrand alone or in combination with any other reference record does not disclose or suggest the claimed combination.

With respect to Claim 26, the Examiner is referred to the reasons set forth above in reference to Claim 25.

Therefore, Applicant respectfully urges that Claims 25-31 are also patentably distinguishable over Van Nostrand alone or in combination with any other reference of record.

The Examiner rejects Claims 19, 22, 24-32, 33, and 35 as being unpatentable over Van Nostrand '294 in view of European Patent Document 0551802 to Jonsson.

Claims 19, 22, 24-33, and 35 are dependent upon amended Claim 1 and are, therefore, similarly patentably distinguishable over Van Nostrand in view of Jonsson or any other reference of record. As noted in reference to Claim 1, Van Nostrand alone or in

Applicant : Niall R. Lynam
Serial No. : 09/478,315
Page : 10

combination with any of the prior art does not disclose or suggest the claimed combination. For example, Van Nostrand does not disclose or suggest an exterior rearview mirror assembly which includes a plano reflective element and a multiradius reflective element of a plano-multiradius reflective element assembly which are mounted adjacent in a side-by-side relationship but not superimposed with one reflective element on top the other reflective element and supported by a backing plate element, with the backing plate element having an outboard portion, with the multiradius reflective element located at the outboard portion and, further, with the backing plate element mounted to an actuator.

Nor does Jonsson remedy the deficiencies of Van Nostrand. Like Van Nostrand, Jonsson is directed to a spotter mirror which is superimposedly mounted on flat reflective element (2)—not in a side-by-side relationship. Furthermore, neither Jonsson nor Van Nostrand discloses or suggests the further combination of the multiradius reflective element having a principal axis, which is directed downwardly with respect to the longitudinal axis of the vehicle as called for in the claims, while the principal axis of the plano reflective element is generally parallel to the longitudinal axis of a vehicle.

Accordingly, at least for these reasons, Claims 19, 22, 24-32, 33, and 35 are patentably distinguishable over Van Nostrand in view of Jonsson or any other reference of record.

With respect to new claims, namely, Claims 84-90, Applicant respectfully urges that neither Van Nostrand alone or in combination with any other reference of record discloses or suggests the combinations called for in Claims 84-90 either.

Applicant : Niall R. Lynam
Serial No. : 09/478,315
Page : 11

DRAWINGS:

The Examiner objects to the drawings as failing to illustrate the break-away exterior sideview mirror assembly. Applicant has amended the specification, specifically on page 17, with the paragraph starting with line 5, to clarify that the numeral 12 and/or 14 designates a sideview mirror, including for example a fixedly attached exterior sideview mirror assembly, a break-away exterior sideview mirror assembly, and/or a power-fold exterior sideview mirror assembly. Therefore, the feature is generally shown in the drawings. Applicant respectfully requests reconsideration and withdrawal of objection to the drawings.

Accordingly, in view of the above amendments and remarks, Applicant respectfully requests reconsideration of the present application and a Notice of Allowance of Claims 1, 16-31, 33, and 35 and, further, of Claims 2-15, 32, 34, 36-43, which are dependent upon allowable generic claims, at least with respect to the species called for in those claims. Should the Examiner have any questions or comments, he is invited to contact the undersigned at (616) 975-5506.

Respectfully submitted,

NIALL R. LYNAM

By: Van Dyke, Gardner, Linn & Burkhart, LLP

Date: August 30, 2001.

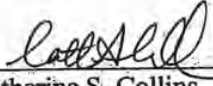
Catherine S. Collins
Registration No. 37 599
2851 Charlevoix Drive, S.E.
Suite 207
P.O. Box 888695
Grand Rapids, MI 49588-8695
(616) 975-5500

CSC:lmsc

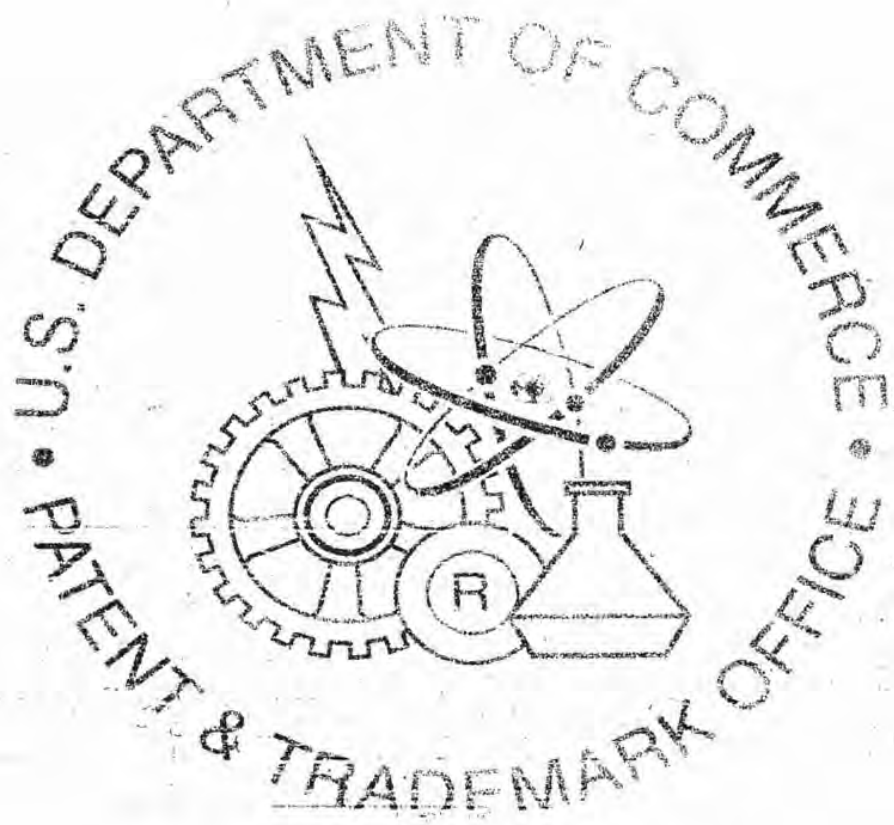

TW 7655477



THE UNITED STATES OF AMERICA

TO ALL TO WHOM THESE PRESENTS SHALL COME:

UNITED STATES DEPARTMENT OF COMMERCE
United States Patent and Trademark Office

November 29, 2017

THIS IS TO CERTIFY THAT ANNEXED IS A TRUE COPY FROM THE
RECORDS OF THIS OFFICE OF THE FILE WRAPPER AND CONTENTS
OF:

APPLICATION NUMBER: *09/478,315*

FILING DATE: *January 06, 2000*

PATENT NUMBER: *6,522,451*

ISSUE DATE: *February 18, 2003*

By Authority of the
Under Secretary of Commerce for Intellectual Property
and Director of the United States Patent and Trademark Office



SYLVIA HOLLEY
Certifying Officer

PART (3) OF (3) PARTS



Applicant : Niall R. Lynam
Serial No. : 09/478,315
Page : 12

RECEIVED

SEP -7 2001

TECHNOLOGY CENTER 2800 PATENT
DON01 P-793

APPENDIX TO SPECIFICATION AND CLAIMS

On page 17, lines 5-16, please replace with the following new paragraph:

Backing plate element 65 of plano-multiradius reflective element assembly 30 is optionally equipped on its rearmost surface with attachment member 64 to facilitate attachment to the reflector-positioning actuator of the exterior sideview mirror assembly that plano-multiradius reflective element assembly 30 is mounted to. Attachment of plano-multiradius reflective element assembly 30 to the actuator can be by mechanical attachment such as by a tab, clip or fastener, or may be by adhesive attachment such as by a silicone adhesive, a urethane adhesive or a similar adhesive material such as a tape coated on both surfaces with a pressure sensitive adhesive to form a "double-sticky" tape. [The exterior] Exterior sideview mirror assembly 12 and/or 14, on whose mirror reflector-positioning actuator the plano-multiradius reflective element assembly is mounted, can be a fixedly attached exterior sideview mirror assembly, a break-away exterior sideview mirror assembly and a powerfold exterior sideview mirror assembly, as known in the automotive mirror art.

1. (Amended)

An exterior sideview mirror system suitable for use [in] on an automobile, said exterior sideview mirror system comprising:

an exterior sideview mirror assembly adapted for attachment to a side of an automobile;

said exterior sideview mirror assembly including a reflective element having a rearward field of view when attached to [said] the side of the automobile;

Applicant : Niall R. Lynam
Serial No. : 09/478,315
Page : 13

said reflective element attached to an electrically-operated actuator and movable by said actuator in order to position said rearward field of view in response to a control;

wherein said reflective element comprises a plano-multiradius reflective element assembly, said plano-multiradius reflective element assembly comprising a plano reflective element having unit magnification and a separate multiradius reflective element having a multiradius curvature, said plano reflective element having a rearward field of view with a principal axis;

said plano reflective element and said multiradius reflective element of said plano-multiradius reflective element assembly mounted adjacently in said plano-multiradius reflective element assembly in a side-by-side relationship and not superimposed with one reflective element on top of the other reflective element, and supported by [attached to] a backing plate element, said backing plate element mounting to said actuator such that movement of said backing plate element of said plano-multiradius reflective element assembly by said actuator simultaneously and similarly moves said plano reflective element and said multiradius reflective element, said multiradius reflective element having a rearward field of view with a principal axis, said principal axis of said rearward field of view of said multiradius element being different from and angled with respect to said principal axis of said rearward field of view of said plano reflective element when said multiradius reflective element and said plano reflective element are supported by said backing plate element of said plano-multiradius reflective element assembly and when said plano-multiradius reflective element assembly is mounted in said exterior sideview mirror assembly on the automobile, and said principal axis of said rearward field of view of said plano reflective element being directed generally parallel to the longitudinal axis of the automobile equipped with the plano-multiradius reflective element assembly and wherein said principal axis of said rearward field of view of said multiradius reflective element is directed generally at an angle downwards to the longitudinal axis of the automobile; and

said multiradius reflective element being positioned at an outboard portion of said plano-multiradius reflective element assembly when said exterior sideview mirror assembly is mounted to the side of the automobile.

Applicant : Niall R. Lynam
Serial No. : 09/478,315
Page : 14

16. (Amended)

The exterior sideview mirror system of Claim 1, wherein said plano reflective element is [attached to] supported by said backing plate element by at least one of an adhesive attachment and a mechanical attachment.

17. (Amended)

The exterior sideview mirror system of Claim 1, wherein said multiradius reflective element is [attached to] supported by said backing plate element by at least one of an adhesive attachment and a mechanical attachment.

18. (Amended)

The exterior sideview mirror system of Claim 1, wherein said multiradius reflective element is [attached to] supported by said backing plate element at a location such that, when said exterior mirror assembly is attached to a side of an automobile, at least a portion of said plano reflective element is disposed closer to said side of the automobile than any portion of said multiradius reflective element.

Respectfully submitted,

NIALL R. LYNAM

By: Van Dyke, Gardner, Linn & Burkhart, LLP

Date: August 30, 2001.

Catherine S. Collins
Registration No. 37 599
2851 Charlevoix Drive, S.E.
Suite 207
P.O. Box 888695
Grand Rapids, MI 49588-8695
(616) 975-5500

CSC:lmsc



RECEIVED PATENT
DON01 P-793
SEP - 7 2001
TECHNOLOGY CENTER 2800

IN THE UNITED STATES PATENT AND TRADEMARK OFFICE

Examiner : R. Shafer
Applicant : Niall R. Lynam
Serial No. : 09/478,315
Filed : January 6, 2000
Group : 2872
For : EXTERIOR MIRROR PLANO-AUXILIARY
REFLECTIVE ELEMENT ASSEMBLY

Commissioner for Patents
Washington, D.C. 20231

Dear Sir:

RESPONSE TO NOTICE OF NON-COMPLIANT AMENDMENT
(37 CFR 1.21)

Responsive to the Notice of Non-Compliant Amendment (37 CFR 1.21)
mailed August 7, 2001, having a one-month period of response ending September 7, 2001,
Applicants submit herewith the enclosed required Corrected Response with a clean version of
the replacement paragraph(s)/section(s).

Respectfully submitted,

NIALL R. LYNAM

By: Van-Dyke, Gardner, Linn & Burkhardt, LLP

August 30, 2001
Date

Catherine S. Collins
Catherine S. Collins
Registration No. 37 599
P.O. Box 888695
2851 Charlevoix Drive, S.E.
Grand Rapids, MI 49588-8695
(616) 975-5500

CSC:lmsc



MP-2872

PATENT RECEIVED

SEP - 7 2001 TECHNOLOGY CENTER 2800

6

IN THE UNITED STATES PATENT AND TRADEMARK OFFICE

Examiner : R. Shafer
 Applicant : Niall R. Lynam
 Serial No. : 09/478,315
 Filed : January 6, 2000
 Group : 2872
 For : EXTERIOR MIRROR PLANO-AUXILIARY REFLECTIVE ELEMENT ASSEMBLY

Commissioner for Patents
Washington, D.C. 20231

Dear Sir:

CERTIFICATE OF MAIL

I certify that the attached return postcard, Response to Notice of Non-Compliant Amendment, and Corrected Response are being deposited with the United States Postal Service as first class mail an envelope addressed to:

Commissioner for Patents
 Washington, D.C. 20231

on August 30, 2001.

Catherine S. Collins
 Van Dyke, Gardner, Linn & Burkhart, LLP
 P.O. Box 888695
 Grand Rapids, MI 49588-8695
 (616) 975-5500

CSC:lmasc
Enclosures

B

13

PROPOSED RESPONSE ONLY
DO NOT ENTER

VIA FACSIMILE NO. (703) 308-7724

PATENT
DON01 P-793

IN THE UNITED STATES PATENT AND TRADEMARK OFFICE

Examiner : R. Shafer
Applicant : Niall R. Lynam
Serial No. : 09/478,315
Filed : January 6, 2000
Group : 2872
For : EXTERIOR MIRROR PLANO-AUXILIARY
REFLECTIVE ELEMENT ASSEMBLY

Commissioner for Patents
Washington, D.C. 20231

Dear Sir:

*Do not
enter
RDS*

CERTIFICATE OF FACSIMILE TRANSMISSION

I certify that the following papers are being facsimile transmitted to the Patent
and Trademark Office on the date shown below:

Corrected Proposed Amendment

YOU SHOULD RECEIVE A TOTAL OF 3 PAGES

INCLUDING THIS TRANSMITTAL.

Dated: June 20, 2001.

Lynette M.S. Clark
Lynette M.S. Clark
Van Dyke, Gardner, Linn & Burkhardt, LLP
P.O. Box 888695
Grand Rapids, MI 49588-8695
(616) 975-5500

CSC:imsc
Enclosures

FAX COPY RECEIVED

JUN 20 2001

TECHNOLOGY CENTER 2300

PROPOSED RESPONSE ONLY
DO NOT ENTER

VIA FACSIMILE NO. (703) 308-7724

PATENT
DON01 P-793

IN THE UNITED STATES PATENT AND TRADEMARK OFFICE

Examiner : R. Shafer
Applicant : Niall R. Lynam
Serial No. : 09/478,315
Filed : January 6, 2000
Group : 2872
For : EXTERIOR MIRROR PLANO-AUXILIARY
REFLECTIVE ELEMENT ASSEMBLY

Commissioner for Patents
Washington, D.C. 20231

Dear Sir:

CORRECTED
PROPOSED RESPONSE

In response to the Office Action mailed April 24, 2001, having a three month period of response ending July 24, 2001, Applicant wishes to amend his application as follows:

IN THE CLAIMS:

Please cancel Claims 23 and 24. Please amend Claim 1 as follows:

1. (Amended)

An exterior sideview mirror system suitable for use in an automobile, said exterior sideview mirror system comprising:
an exterior sideview mirror assembly adapted for attachment to a side of an automobile;
said exterior sideview mirror assembly including a reflective element having a rearward field of view when attached to said side of the automobile;
said reflective element attached to an actuator and movable by said actuator in order to position said rearward field of view in response to a control;
wherein said reflective element comprises a plano-multiradius reflective element assembly, said plano-multiradius reflective element assembly comprising a plano reflective element having unit magnification and a separate multiradius reflective element having a multiradius curvature, said plano reflective element having a rearward field of view with a principal axis; and

Applicant : Niall R. Lynam
 Serial No. : 09/478,315
 Page : 2

said plano reflective element and said multiradius reflective element of said plano-multiradius reflective element assembly mounted adjacently in said assembly and supported by [attached to] a backing plate element, said backing plate element mounting to said actuator such that movement of said backing plate element of said plano-multiradius reflective element assembly by said actuator simultaneously and similarly moves said plano reflective element and said multiradius reflective element, said multiradius reflective element having a rearward field of view with a principal axis, said principal axis of said rearward field of view of said multiradius element being different from and angled with respect to said principal axis of said rearward field of view of said plano reflective element when said multiradius reflective element and said plano reflective element are attached to said backing plate element of said plano-multiradius reflective element assembly and when said plano-multiradius reflective element assembly is mounted in said exterior sideview mirror assembly on an automobile, and said principal axis of said rearward field of view of said plano reflective element being directed generally parallel to the longitudinal axis of an automobile equipped with the plano-multiradius reflective element assembly and wherein said principal axis of said rearward field of view of said multiradius reflective element is directed generally at an angle downwards to the longitudinal axis of the automobile.

REMARKS

The Proposed Amendment is submitted in preparation for the upcoming interview on June 21, 2001, with Examiner Shafer.

Respectfully submitted,

NIALL R. LYNAM

By: Van Dyke, Gardner, Linn & Burkhart, LLP

Date: _____, 2001.

 Catherine S. Collins
 Registration No. 37 599
 2851 Charlevoix Drive, S.E.
 Suite 207
 P.O. Box 888695
 Grand Rapids, MI 49588-8695
 (616) 975-5500

CSC:lmsc

FAX COPY RECEIVED

JUN 20 2001

TECHNOLOGY CENTER 288A

PROPOSED RESPONSE ONLY
DO NOT ENTER

VIA FACSIMILE NO. (703) 308-7724

6

**PATENT
DON01 P-793**

IN THE UNITED STATES PATENT AND TRADEMARK OFFICE

Examiner : R. Shafer
Applicant : Niall R. Lynam
Serial No. : 09/478,315
Filed : January 6, 2000
Group : 2872
For : EXTERIOR MIRROR PLANO-AUXILIARY
REFLECTIVE ELEMENT ASSEMBLY

Commissioner for Patents
Washington, D.C. 20231

Dear Sir:

CERTIFICATE OF FACSIMILE TRANSMISSION

I certify that the following papers are being facsimile transmitted to the Patent
and Trademark Office on the date shown below:

Proposed Amendment

YOU SHOULD RECEIVE A TOTAL OF 3 PAGES

INCLUDING THIS TRANSMITTAL.

FAX COPY RECEIVED
JUN 19 2001
TECHNOLOGY CENTER 28011

Dated: June 19, 2001.

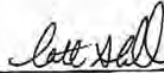

Catherine S. Collins
Van Dyke, Gardner, Linn & Burkhart, LLP
P.O. Box 888695
Grand Rapids, MI 49588-8695
(616) 975-5500

CSC:lmisc
Enclosures

PROPOSED RESPONSE ONLY
DO NOT ENTER

VIA FACSIMILE NO. (703) 308-7724

PATENT
DON01 P-793

IN THE UNITED STATES PATENT AND TRADEMARK OFFICE

Examiner : R. Shafer
Applicant : Niall R. Lynam
Serial No. : 09/478,315
Filed : January 6, 2000
Group : 2872
For : EXTERIOR MIRROR PLANO-AUXILIARY
REFLECTIVE ELEMENT ASSEMBLY

Commissioner for Patents
Washington, D.C. 20231

Dear Sir:

PROPOSED RESPONSE

In response to the Office Action mailed April 24, 2001, having a three month period of response ending July 24, 2001, Applicant wishes to amend his application as follows:

IN THE CLAIMS:

Please cancel Claims 23 and 24. Please amend Claim 1 as follows:

1. (Amended)

An exterior sideview mirror system suitable for use in an automobile, said exterior sideview mirror system comprising:
an exterior sideview mirror assembly adapted for attachment to a side of an automobile;
said exterior sideview mirror assembly including a reflective element having a rearward field of view when attached to said side of the automobile;
said reflective element attached to an actuator and movable by said actuator in order to position said rearward field of view in response to a control;
wherein said reflective element comprises a plano-multiradius reflective element assembly, said plano-multiradius reflective element assembly comprising a plano reflective element having unit magnification and a separate multiradius reflective element having a multiradius curvature, said plano reflective element having a rearward field of view with a principal axis; and

FAX COPY RECEIVED

JUN 19 2001

TECHNOLOGY CENTER (2001)

Applicant : Niall K. Lynam
Serial No. : 09/478,315
Page : 2

said plano reflective element and said multiradius reflective element of said plano-multiradius reflective element assembly attached to a backing plate element, said backing plate element mounting to said actuator such that movement of said backing plate element of said plano-multiradius reflective element assembly by said actuator simultaneously and similarly moves said plano reflective element and said multiradius reflective element, said multiradius reflective element having a rearward field of view with a principal axis, said principal axis of said rearward field of view of said multiradius element being different from and angled with respect to said principal axis of said rearward field of view of said plano reflective element when said multiradius reflective element and said plano reflective element are attached to said backing plate element of said plano-multiradius reflective element assembly and when said plano-multiradius reflective element assembly is mounted in said exterior sideview mirror assembly on an automobile, and said principal axis of said rearward field of view of said plano reflective element being directed generally parallel to the longitudinal axis of an automobile equipped with the plano-multiradius reflective element assembly and wherein said principal axis of said rearward field of view of said multiradius reflective element is directed generally at an angle downwards to the longitudinal axis of the automobile.

REMARKS

The Proposed Amendment is submitted in preparation for the upcoming interview on June 21, 2001, with Examiner Shafer.

Respectfully submitted,

NIALL R. LYNAM

By: Van Dyke, Gardner, Linn & Burkhart, LLP

Date: _____, 2001.

Catherine S. Collins
Registration No. 37 599
2851 Charlevoix Drive, S.E.
Suite 207
P.O. Box 888695
Grand Rapids, MI 49588-8695
(616) 975-5500

CSC:lmsc

FAX COPY RECEIVED

JUN 19 2001

TECHNOLOGY CENTER 2800



UNITED STATES PATENT AND TRADEMARK OFFICE

42
UNITED STATES DEPARTMENT OF COMMERCE
United States Patent and Trademark Office
Address: COMMISSIONER OF PATENTS AND TRADEMARKS
Washington, D.C. 20231
www.uspto.gov

APPLICATION NO.	FILING DATE	FIRST NAMED INVENTOR	ATTORNEY DOCKET NO.	CONFIRMATION NO.
09/478,315	01/06/2000	NIALL R. LYNAM	DON01-P-793	1526

28101 7590 12/05/2001
VAN DYKE, GARDNER, LINN AND BURKHART, LLP
2851 CHARLEVOIX DRIVE, S.E.
P.O. BOX 888695
GRAND RAPIDS, MI 49588-8695

EXAMINER

SHAFER, RICKY D

ART UNIT	PAPER NUMBER
2872	161

2872

DATE MAILED: 12/05/2001

Please find below and/or attached an Office communication concerning this application or proceeding.

P.S.

Office Action Summary

Application No. <u>09/478,315</u>	Applicant(s) <u>LYNAM</u>
Examiner <u>R.D. SHAFER</u>	Group Art Unit <u>2872</u>

— The MAILING DATE of this communication appears on the cover sheet beneath the correspondence address —

Period for Reply

A SHORTENED STATUTORY PERIOD FOR REPLY IS SET TO EXPIRE 3 months MONTH(S) FROM THE MAILING DATE OF THIS COMMUNICATION.

- Extensions of time may be available under the provisions of 37 CFR 1.136(a). In no event, however, may a reply be timely filed after SIX (6) MONTHS from the mailing date of this communication.
- If the period for reply specified above is less than thirty (30) days, a reply within the statutory minimum of thirty (30) days will be considered timely.
- If NO period for reply is specified above, such period shall, by default, expire SIX (6) MONTHS from the mailing date of this communication.
- Failure to reply within the set or extended period for reply will, by statute, cause the application to become ABANDONED (35 U.S.C. § 133).
- Any reply received by the Office later than three months after the mailing date of this communication, even if timely, may reduce any earned patent term adjustment. See 37 CFR 1.704(b).

Status

- Responsive to communication(s) filed on 9/04/01
- This action is FINAL
- Since this application is in condition for allowance except for formal matters, prosecution as to the merits is closed in accordance with the practice under *Ex parte Quayle*, 1935 C.D. 11; 453 O.G. 213.

Disposition of Claims

- Claim(s) 1-22 AND 25-90 is/are pending in the application.
- Of the above claim(s) 2-15, 32, 34 AND 36-90 is/are withdrawn from consideration.
- Claim(s) _____ is/are allowed.
- Claim(s) 1, 16-22, 25-31, 33 AND 35 is/are rejected.
- Claim(s) _____ is/are objected to.
- Claim(s) _____ are subject to restriction or election requirement

Application Papers

- The proposed drawing correction, filed on _____ is approved disapproved.
- The drawing(s) filed on _____ is/are objected to by the Examiner
- The specification is objected to by the Examiner.
- The oath or declaration is objected to by the Examiner.

Priority under 35 U.S.C. § 119 (a)-(d)

- Acknowledgement is made of a claim for foreign priority under 35 U.S.C. § 119 (a)-(d).
- All Some* None of the:
 - Certified copies of the priority documents have been received.
 - Certified copies of the priority documents have been received in Application No. _____
 - Copies of the certified copies of the priority documents have been received in this national stage application from the International Bureau (PCT Rule 17.2(a))

*Certified copies not received: _____

Attachment(s)

- Information Disclosure Statement(s), PTO-1449, Paper No(s). _____
- Notice of Reference(s) Cited, PTO-892
- Notice of Draftsperson's Patent Drawing Review, PTO-948
- Interview Summary, PTO-413
- Notice of Informal Patent Application, PTO-152
- Other _____

Office Action Summary

Art Unit: 2872

1. Newly submitted claims 84-90 are directed to an invention that is independent or distinct from the elected invention for the following reasons. Newly submitted claims 84-90 are not readable on the elected invention because the newly submitted claims fail to include the separate details of a backing plate element mounted to said actuator such that movement of the backing plate element of the plano-multiradius reflective element assembly by said actuator simultaneously and similarly moves the plano reflective element and the multiradius reflective element; and adds separate details of a plano reflective element and an auxiliary reflective element being adjacently mounted in a plano-auxiliary reflective assembly in a side by side relationship and not superimposed with one reflective element on top of an other reflective element and the auxiliary reflective element being positioned at an outboard portion of said plano-auxiliary reflective assembly.

The elected and newly submitted inventions are related as combination and subcombination. Inventions in this relationship are distinct if it can be shown that (1) the combination as claimed does not require the particulars of the subcombination as claimed for patentability, and (2) that the subcombination has utility by itself or in other combinations (MPEP 806.05(c)). In the instant case, the combination as claimed does not require the particulars of the subcombination as claimed because of the omission of the details of a backing plate element mounted to said actuator such that movement of the backing plate element of a plano-multiradius reflective element assembly by said actuator simultaneously and similarly moves a plano reflective element and a multiradius reflective element, as clearly evidenced by claim 84 or the details of a

Application/Control Number: 09/478,315

Page 3

Art Unit: 2872

plano reflective element and an auxiliary reflective element being adjacently mounted in a plano-auxiliary reflective assembly in a side by side relationship and not superimposed with one reflective element on top of an other reflective element, as evidenced by original claims 16-36. The subcombination has separate utility such as an exterior sideview mirror system without a backing plate, a multiradius reflective element or a backing plate element mounted to said actuator such that movement of the backing plate element of a plano-multiradius reflective element assembly by said actuator simultaneously and similarly moves a plano reflective element and a multiradius reflective element, as evidenced by claim 84, which would required a search in class 359 subclass 865 which would not be required for the elected invention.

Since applicant has received an action on the merits for the originally presented invention, this invention has been constructively elected by original presentation for prosecution on the merits. Accordingly, claims 84-90 are withdrawn from consideration as being directed to a non-elected invention. See 37 CFR 1.142(b) and MPEP § 821.03.

2. Claims 25-31 and 35 are rejected under 35 U.S.C. 112, second paragraph, as being indefinite for failing to particularly point out and distinctly claim the subject matter which applicant regards as the invention.

Claims 25-31 are vague and indefinite due to the fact that the above mentioned claims depend from a canceled claim.

Claim 35 is vague, indefinite and/or confusing due to the fact that the above mentioned would appear to fail to further limit the subject matter of claim 1, line 7.

Art Unit: 2872

3. The following is a quotation of 35 U.S.C. 103(a) which forms the basis for all obviousness rejections set forth in this Office action:

(a) A patent may not be obtained though the invention is not identically disclosed or described as set forth in section 102 of this title, if the differences between the subject matter sought to be patented and the prior art are such that the subject matter as a whole would have been obvious at the time the invention was made to a person having ordinary skill in the art to which said subject matter pertains. Patentability shall not be negated by the manner in which the invention was made.

4. Claims 1, 16-22, 25-31, 33 and 35 are rejected under 35 U.S.C. 103(a) as being unpatentable over Kondo et al ('542) or Hagiri ('534) in view of Oskam ('899) or Enomoto ('166) and further in view of Tobin, Jr. ('952) or Hacker et al ('158).

To the extent the claims are definite, Kondo et al and Hagiri each disclose an exterior side view mirror system comprising an exterior side view mirror assembly (1, 11) including a plano-multiradius reflective element assembly having a plano reflective portion (9, 13a) and a multiradius reflective portion (11, 13c) and an actuator (not shown) for adjustably positioning said plano-multiradius reflective assembly, note figures [(1,2,4 and 9) and (1-8)], respectively, except for explicitly stating that the actuator comprises an electrically-operated actuator and the plano and multiradius reflective portions are separated.

Oskam and Enomoto each teaches it well know to use electrically-operated actuator(s) in the same field of endeavor for the purpose of adjusting the position and/or orientation of a reflective element.

Therefore, it would have been obvious and/or within the level of one ordinary skill in the art at the time the invention was made to modify the plano-multiradius reflective assembly of Kondo et al or Hagiri to include electrically operable actuator(s) as is well known and commonly

Art Unit: 2872

used and/or employed in the mirror art, as taught by Oskam or Enomoto, in order to adjust the position and/or orientation of the plano-multiradius reflective assembly.

Moreover, it has been held that providing automatic means to replace manual activity which accomplishes the same result involves only routine skill in the art. Note In Re Venner, 120 USPQ 192.

Tobin, Jr. and Hacker et al each teaches it well know to use separate plano and multiradius reflective elements in the same field of endeavor for the purpose of providing a side by side arrangement, wherein one reflective element is not superimposed on top of another reflective element.

Therefore, it would have been obvious and/or within the level of one ordinary skill in the art at the time the invention was made to modify the plano-multiradius reflective assembly of Kondo et al or Hagiri to include separate plano and multiradius reflective elements as is well known and commonly used and/or employed in the mirror art, as taught by Tobin, Jr. or Hacker et al in order to reduce manufacturing costs, by replacing one of said reflective elements without having to replace the other one of said reflective elements, should one of the elements become defective and/or damaged during assembly.

Moreover, it has been held that constructing a formerly integral structure in various elements involves only routine skill in the art. Note Nerwin v. Erlichman, 168 USPQ 177, 179.

As to the limitations of claim 22, it would have been obvious and/or within the level of one of ordinary skill in the art at the time the invention was made to modify the size of the multiradius

Application/Control Number: 09/478,315

Page 6

Art Unit: 2872

and/or plano reflective elements of Kondo et al or Hagiri in order to obtain a desirable ratio of interest, since such a modification would have involved a mere change in the size of a component. A change in size is generally recognized as being within the level of one of ordinary skill in the art. Note In re Rose, 105 USPQ 237 (CCPA 1955).

As to the limitations of claims 19 and 25-31, it is well known to use an auxiliary (multiradius) reflective element having the radii of curvature and downward angle range recited by applicant in order to optimize and/or view a particular rearward field of view of interest.

Therefore, it would have been obvious and/or within the level of one of ordinary skill in the art at the time the invention was made to modify the auxiliary multiradius reflective element of Kondo et al or Hagiri to include the radii of curvature and downward angle range recited by applicant in order to optimize and/or view a particular rearward field of view of interest, based on user specifications.

Moreover, it would have been obvious and/or within the level of one of ordinary skill in the art at the time the invention was made to angle the multiradius reflective element of Kondo et al or Hagiri to the selected range(s) recited by applicant in order to view of particular rearward field of view of interest, since it has been held that where the general conditions of a claim are disclosed in the prior art or discovering an optimum or workable ranges involves only routine skill in the art. Note In re Aller, 105 USPQ 233 and In re Boesch, 617 F.2d 272, 205 USPQ 215 (CCPA 1980).

Art Unit: 2872

As to the limitations of claim 33, it is well known to use break-away exterior side view mirror assemblies in the same field of endeavor for the purpose of folding the position and/or orientation of a mirror. Therefore, it would have been obvious and/or within the level of one ordinary skill in the art at the time the invention was made to modify the exterior side view mirror assembly of Kondo et al or Hagiri to include a break-away exterior side view mirror assembly, as is well known and commonly used and/or employed in the mirror art, in order to fold the position and/or orientation of the reflective element(s).

5. Applicant's amendment necessitated the new ground(s) of rejection presented in this Office action. Accordingly, **THIS ACTION IS MADE FINAL**. See MPEP § 706.07(a). Applicant is reminded of the extension of time policy as set forth in 37 CFR 1.136(a).

A shortened statutory period for reply to this final action is set to expire **THREE MONTHS** from the mailing date of this action. In the event a first reply is filed within **TWO MONTHS** of the mailing date of this final action and the advisory action is not mailed until after the end of the **THREE-MONTH** shortened statutory period, then the shortened statutory period will expire on the date the advisory action is mailed, and any extension fee pursuant to 37 CFR 1.136(a) will be calculated from the mailing date of the advisory action. In no event, however, will the statutory period for reply expire later than **SIX MONTHS** from the date of this final action.

Application/Control Number: 09/478,315

Page 8

Art Unit: 2872

6. Any inquiry concerning this communication should be directed to R. D. Shafer at telephone number (703) 308-4813.

Shafer/RDS

11/18/01

R. D. Shafer
R. D. SHAFER
ART UNIT 2872

Notice of References Cited		Application No.	09/478,315		Applicant(s)	LYNAM	
		Examiner	R. OSMAIER		Group Art Unit	2872	
					Page	1 of 1	
U.S. PATENT DOCUMENTS							
*	DOCUMENT NO.	DATE	NAME	CLASS	SUBCLASS		
A	4,281,899	8-1981	OSICAM				
B	4,311,362	1-1982	LA PORTE	359	864		
C	4,555,166	11-1985	ENOMOTO	359	877		
D	4,770,522	9-1988	ALTEN	359	877		
E	5,005,962	4-1991	EDELMAN	359	864		
F	5,052,792	10-1991	MC DONOUGH	359	866		
G	5,115,352	5-1992	DO ESPIRITO SANTO	359	864		
H	5,432,643	7-1995	HUANG	359	864		
I	5,621,569	4-1997	SCHLUNICE	359	868		
J	5,793,542	8-1998	KONDO ET AL	359	866		
K	6,032,323	3-2000	SMITH ET AL	359	877		
L	6,199,993	3-2001	MOU	359	864		
M							
FOREIGN PATENT DOCUMENTS							
*	DOCUMENT NO.	DATE	COUNTRY	NAME	CLASS	SUBCLASS	
N	1,279,158	6-1972	UNITED KINGDOM	HACKER ET AL	359	868	
O	2,028,189	12-1980	UNITED KINGDOM	DOCIE	359	868	
P	7,908,257	6-1981	NETHERLANDS	—————	359	864	
Q	0210757	2-1987	EPO	VON SEIDEL	359	864	
R	1-208245	8-1989	JAPAN	MORIWAKE	359	871	
S	4026578	4-1992	WEST GERMANY	KRAMER	359	850	
T							
NON-PATENT DOCUMENTS							
*	DOCUMENT (Including Author, Title, Source, and Pertinent Pages)					DATE	
U							
V							
W							
X							

* A copy of this reference is not being furnished with this Office action.
(See Manual of Patent Examining Procedure, Section 707.05(a).)

359-864

EX

E 0137

OR

4,311,362

United States Patent [19]

[11] **4,311,362**

LaPorte

[45] **Jan. 19, 1982**

[54] **TWO-POSITION AERODYNAMIC MIRROR**

Attorney, Agent, or Firm—Remy J. VanOphem

[76] Inventor: **Thomas A. LaPorte**, 10705 Nadine,
Huntington Woods, Mich. 48070

[57] **ABSTRACT**

[21] Appl. No.: **146,035**

A two-position contoured, externally mounted rear view mirror for automotive vehicles as disclosed. The mirror housing is rotatable between two fixed positions. The mirror housing contains a first relatively large mirror providing a relatively large rearward viewing area for city driving and a second relatively smaller mirror having a reduced rearward viewing area for highway driving. In a first fixed position of the mirror housing, the first mirror is viewable by the operator and in a second fixed position, the second mirror is viewable by the operator. The mirror housing is shaped such that in the second position, the aerodynamic drag of the mirror housing is minimized to improve the high speed efficiency of the vehicle. Alternate embodiments of the invention include convex portions for the mirror to increase the rearward field of view.

[22] Filed: **May 2, 1980**

[51] Int. Cl.³ **G02B 5/10**

[52] U.S. Cl. **350/293; 350/299;**

..... **350/304**

[58] Field of Search **350/279-282,**

..... **350/289, 293, 303, 304, 299**

[56] **References Cited**

U.S. PATENT DOCUMENTS

2,330,444 9/1943 Park 350/304

4,031,772 6/1977 De Castri 350/280

FOREIGN PATENT DOCUMENTS

2605956 8/1977 Fed. Rep. of Germany 350/280

Primary Examiner—F. L. Evans

9 Claims, 9 Drawing Figures

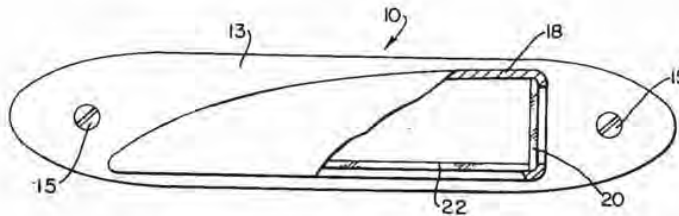

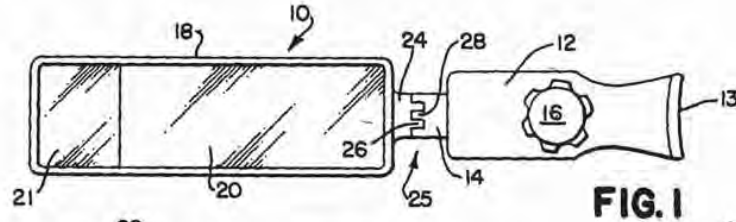

FIG. 1

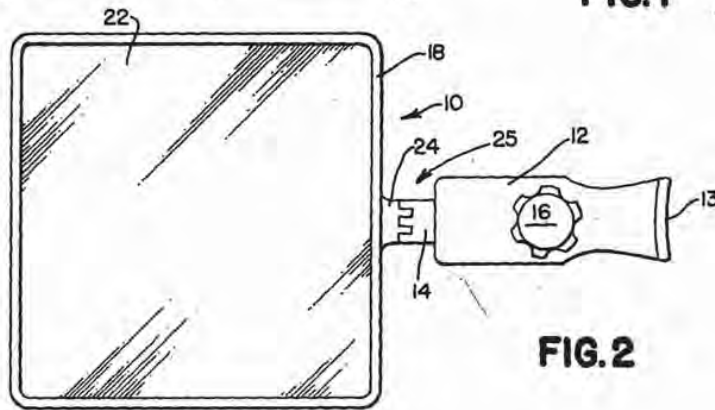

FIG. 2

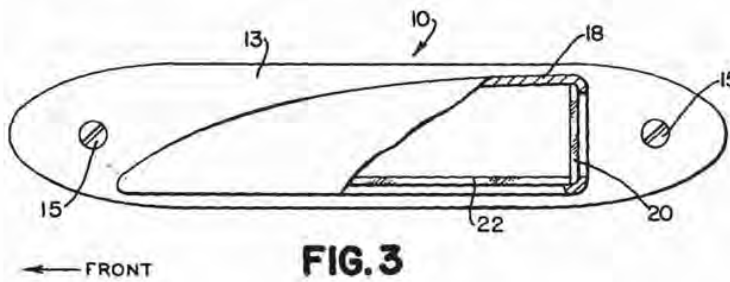

FIG. 3

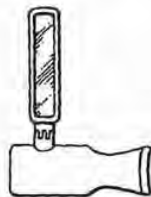

FIG. 8

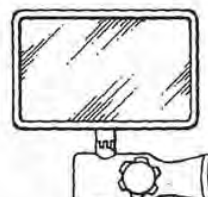

FIG. 9

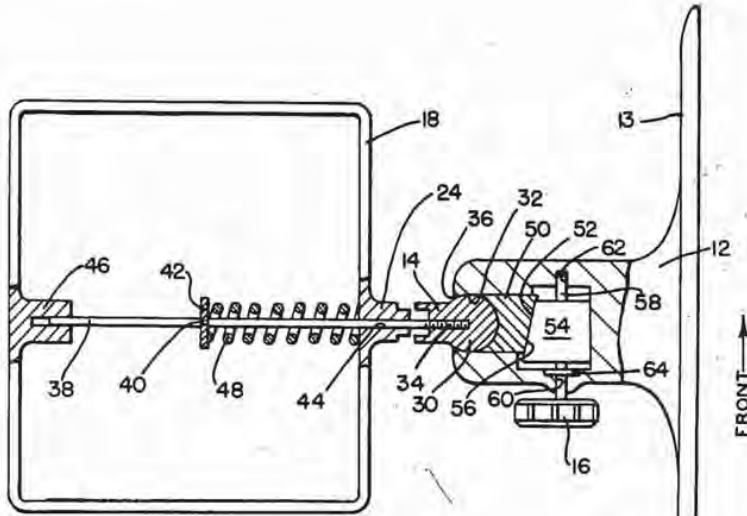

FIG. 4

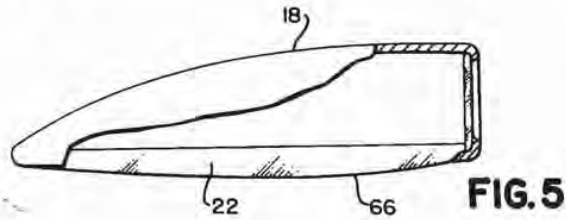

FIG. 5

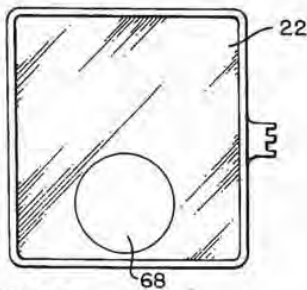

FIG. 6

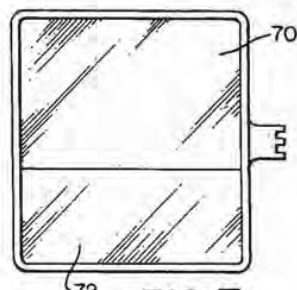

FIG. 7

TWO-POSITION AERODYNAMIC MIRROR

BACKGROUND OF THE INVENTION

1. Field of the Invention

The invention is related to the field of rear view mirrors for automotive vehicles, and in particular, to a rear view mirror rotatable between a first position for highway use and a second position for city use.

2. Description of the Prior Art

Modern day automotive vehicles are aerodynamically designed to reduce their high speed wind drag as much as possible. This not only improves the handling of the vehicle at high speeds, but also reduces the power required to sustain high speed operation of the vehicle. In these days of fuel shortages and the attendant increased fuel costs, serious efforts are being made to keep the vehicles as aerodynamically clean as possible. In addition to the overall configuration of the vehicle, additional attention is being directed to external protruberances, such as hood ornaments, door handles, luggage racks, side mounted rear view mirrors, and even the use of vinyl roof tops. These are being eliminated wherever possible, and if they cannot be eliminated, made as small and streamlined as possible.

For safety purposes, it is desirable to give the operator the widest possible rearward field of view, particularly in the city. The operator's rearward field of view may be increased by making the side mounted rearview mirror large, as exemplified by Mosby in U.S. Pat. No. 2,969,715, or using a small mirror with a convex surface as exemplified by West in U.S. Pat. No. 2,911,177. The U.S. patents to King, U.S. Pat. Nos. 3,104,274, Katulich 3,170,985 and Tobin, Jr., 3,389,952 are examples of convex rear view mirrors being used in combination with larger flat mirrors to enhance the rearward vision of the operator.

The use of large external mirrors by themselves or in combination with convex mirrors offer the best rearward view; however, at high speeds the aerodynamic drag of these large mirrors produce sufficient air drag to degrade the efficiency of the vehicle. A comparable rearward field of view can be obtained with a much smaller convex mirror; however, the images produced by the convex mirror are reduced in size and distort the operator's perspective as to distances between his vehicle and the other vehicle or object being observed. Therefore, a convex mirror by itself is unacceptable from a safety point of view.

Generally, a larger rearward field of view is desired in city driving where the streets are congested and vehicles change lanes quite rapidly. At the lower city driving speeds, aerodynamic drag caused by a large external rear view mirror is relatively small, since the drag is a function of the fourth power of the vehicle speed. On the highway where vehicles are moving at a much higher speed, the vehicles are spaced further apart, rapid lane changing is less prevalent therefore a smaller rear view mirror, with a reduced field of view, is acceptable. The smaller external rear view mirror creates less aerodynamic drag and improves the efficiency of the vehicle.

SUMMARY OF THE INVENTION

The invention is a city-highway external rear view mirror having a mirror housing rotatable between two fixed positions. The mirror housing contains a first mirror having a relatively large viewing area providing the

vehicle operator with a relatively wide angle rearward field of view for city driving and a second smaller mirror having a reduced rearward field of view for highway driving. In the first fixed position of the mirror housing, the first mirror is viewable by the operator, and in the second fixed position, the second or smaller mirror is viewable by the operator. The mirror housing is shaped such that in the second position the aerodynamic drag of the mirror housing is minimized.

In alternate embodiments of the disclosed external rearview mirrors, the first and second mirrors may include a convex portion to increase the rearward field of view.

BRIEF DESCRIPTION OF THE DRAWINGS

FIG. 1 is a frontal view of the external rear view mirror with the mirror assembly in the highway position.

FIG. 2 is a frontal view of the external rear view mirror with the mirror assembly in the city position.

FIG. 3 is a side view of the external rear view mirror showing the relative position of the two mirrors.

FIG. 4 is a cross sectional view of the external rear view mirror showing the details of pivotal member and locking mechanism.

FIG. 5 is a side view of the mirror assembly showing an alternate arrangement between the two mirrors.

FIGS. 6 and 7 are frontal views of the rear view mirror in the city position showing alternate mirror configurations having convex portions.

FIGS. 8 and 9 are frontal views of an alternate version of the rear view mirror rotatable about a vertical axis.

DESCRIPTION OF THE PREFERRED EMBODIMENT

The details of the city-highway rear view mirror are exemplified in FIGS. 1 and 2. FIG. 1 shows the rear view mirror in the highway position, while FIG. 2 shows the rear view mirror in the city position. FIG. 3 is a side view of the rear view mirror in the highway position of FIG. 1, looking from the left-hand side.

Referring first to FIGS. 1 and 2, the city-highway rear view mirror comprises a mirror assembly 10, a support housing 12, a pivotal member 14, an indexing mechanism 25, and a locking knob 16. The support housing 12 has a flange 13 adapted to be rigidly mounted to the body of the vehicle with a pair of screws 15. In the mounted position, the mirror assembly 10 is in full view of the operator through a window of the vehicle.

The mirror assembly 10 includes a mirror housing 18, a first mirror 20, a second mirror 22, and a boss 24. The second mirror 22 is mounted in the housing 18 at an angle to the first mirror 20. This angle may be 90 degrees, as shown in FIG. 3 or less than 90 degrees as shown in FIG. 5. The face of the boss 24 has a first portion of the indexing mechanism 25 comprising four equally spaced dogs 26 which mate with the second portion of the indexing mechanism comprising four corresponding dogs 28 on the face of the pivotal member 14 as shown. When the angle between the mirrors is less than 90 degrees, the indexing mechanism will permit the mirror assembly to be reindexed to a second position greater than 90 degrees such that the surface of mirror 22 will be locked in a plane parallel to the plan of mirror 20 in the first position. The first mirror 20 may or

may not have a convex portion 21. As is known in the art, the convex portion 21 would give the operator a wider field of view.

The locking knob 16 activates a locking mechanism in the support housing 12 which locks the pivotal member 14 in a fixed position with respect to the support housing 12 as illustrated in FIG. 4. This permits the operator to adjust the position of the mirror assembly 10 affording him the desired rearward view, then lock the pivotal member 14. The mirror assembly 10, which is supported by the pivotal member, is thereby locked in the desired position.

Referring now to FIG. 3, there is shown a side view of the mirror assembly 10. The mirror housing 18 has a generally triangular, streamlined shape such that when disposed in the highway position it offers a low resistance to the air flow. The first mirror 20 is disposed in the mirror housing 18 at the base of the triangular configuration, and is viewable by the operator in the highway position. The second mirror 22 is disposed generally parallel to one leg of the triangular configuration at a right angle to mirror 20.

Further details of the city-highway rear view mirror are shown in the cross sectional view of FIG. 4. The pivotal member has a spherically shaped end 30 captivated in a mating internal hemispherical surface 32 of the support housing 12. A cylindrical section 34 of the pivotal member 14 protrudes through a clearance hole 36 of the support housing. The cylindrical section 34 has, on its end, the four corresponding dogs 28 comprising the second portion of the indexing mechanism 25. A shaft 38 is fixedly attached to the pivotal member 14 concentric with the cylindrical section 34. The shaft 38 may be an integral part of the pivotal member 14 or may be pressed into a mating bore or threaded into the pivotal member 14, as shown. The shaft 38 has a groove 40 intermediate its two ends which retains spring retainer member 42 such as a "C" washer. The shaft 38 passes through a first bore 44 formed through boss 24 and is slidably received in a second bore 46 on the opposite side of the mirror housing 18. A resilient member such as spring 48 is disposed about shaft 38 between the spring retainer member 42 and the inner surface of the housing 18 adjacent to boss 24. The spring 48 urges the dogs 26 in engagement with dogs 28 locking the position of the housing 18 with respect to the pivotal member 14.

The locking mechanism disposed in the support housing comprises a locking wedge 50 having a first wedge surface 52 slidably disposed in the support housing 14 adjacent to the spherical end 30 of the pivotal member, and a driven wedge 54 having a second wedge surface 56 adjacent to the first wedge surface 52 movably disposed in the support housing. The driven wedge has a threaded bore receiving a threaded shaft 58 which passes through a bore 60 in the support housing on one side and received in a guide bore 62 on the opposite side. A retainer 64 restrains the threaded shaft 58 from lateral movement within the support housing 12. The locking knob 16 is fixedly attached to the end of the threaded shaft 58 protruding from the support housing.

Rotating the locking knob 16 in one direction displaces the driven wedge 54 forward, urging the locking wedge 50 towards the spherical end of the pivotal member 14 thereby clamping the spherical end of the pivotal member 14 between the locking wedge 50 and the internal hemispherical surface 32 of the support housing. To

adjust the mirror assembly 10, the locking knob is rotated in the opposite direction relieving the clamping force on the spherical end of the pivotal member 14.

To rotate the mirror assembly from the city position to the highway position or vice versa, the operator pushes the mirror assembly outwardly to the left as shown in FIGS. 1 and 2 against the force of spring 48 until the dogs 26 on boss 24 disengage from the dogs 28 on the pivotal member as shown in FIG. 4. The mirror assembly is then rotated 90 degrees and released by the operator. Spring 48 displaces the mirror assembly 10 to the right towards the support housing 12 and the dogs 26 and 28 re-engage locking the mirror assembly in the rotated position. Because the first and second mirrors 20 and 22 are disposed at a right angle to each other and the configuration of the dogs only permits engagement at 90 degree intervals, the mirror assembly 10 need not be readjusted as a result of the rotation.

In city driving, the mirror assembly 10 is rotated such that the larger or second mirror 22 is viewed by the operator giving him a wide angle rearward view. For highway driving, the mirror assembly 10 is rotated such that the smaller or first mirror 20 is viewed by the operator. In this position, the mirror assembly 10 has a smaller cross section and the streamlined configuration has reduced aerodynamic drag at high speeds.

As shown in FIG. 5, the large mirror 22 may have a slightly convex reflective surface 66, affording the operator a wide angle rearward view for city driving. Alternatively, as shown on FIG. 6, the large mirror 22 may be flat as shown in FIG. 3 and include thereon a circular convex section 68, providing an enlarged rearward view when observed. In another version illustrated in FIG. 7, mirror 22 may have an upper flat section 70 and a slightly convex lower section 72 to give a wide rearward field of view. Obviously, the sections 70 and 72 may be reversed with the convex section 72 on top, and the flat section 70 on the bottom.

As illustrated on FIG. 8, the pivotal arm 14 may extend from the support housing 12 in a generally vertical direction rather than horizontally as shown in FIGS. 1 and 2. This configuration may be more advantageous in larger vehicles such as light trucks and vans. The 90 degree indexing means and locking mechanism would be similar to that shown with respect to FIGS. 4 and 5. Although specific 90 degree indexing and locking mechanisms are shown in the disclosed embodiments, it is not intended that the invention be limited to the embodiments shown. Those skilled in the art are well aware of other types of 90 degree indexing and locking mechanisms which are functionally equivalent to the mechanisms shown which may be used without departing from the spirit of the invention.

What is claimed is:

1. A city-highway rear view mirror having reduced aerodynamic drag for high speed highway operation of a vehicle comprising:

support means adapted to be rigidly mounted to an external surface of a vehicle;

a mirror assembly having a first mirror, a second mirror disposed at an angle to said first mirror, and an axis of rotation parallel to the surfaces of said first and second mirrors, said first mirror having a surface area substantially larger than the surface area of said second mirror; and

indexing means rigidly supporting said mirror assembly from said support means for permitting said mirror assembly to be rotated about said axis be-

5

6

tween a city position with said first mirror disposed substantially normal to the vehicle's direction of motion and a highway position with said second mirror substantially normal to the vehicle's direction of motion to reduce the aerodynamic drag of the mirror during high speed highway operation of the vehicle.

2. The city-highway rear view mirror of claim 1 wherein said support means further includes:
 a pivotal member connected to said indexing means providing a 4 degree freedom of movement between said indexing means and said support means; and
 means for restraining the movement of said pivotal member with respect to said support means.

3. The city-highway rear view mirror of claim 2 wherein said means for restraining is a locking mechanism for locking said pivotal member in a fixed position with respect to said support means.

4. The city-highway rear view mirror of claim 3 wherein said axis of rotation is generally horizontal with respect to the vehicle.

5. The city-highway rear view mirror of claim 3 wherein said axis of rotation is generally vertical with respect to the vehicle.

6. The city-highway rear view mirror of claim 1 wherein said second mirror has a convex reflective surface.

7. The city-highway rear view mirror of claim 1 wherein said second mirror has a first portion having a flat reflective surface and a second portion having a convex reflective surface.

8. The city-highway rear view mirror of claim 1 wherein said first mirror has a first portion having a flat reflective surface and a second portion having a convex reflective surface.

9. The city-highway rear view mirror of claim 1 wherein said mirror assembly includes a housing having a streamlined configuration to further reduce the aerodynamic drag of said mirror in said highway position.

* * * * *

25
 30
 35
 40
 45
 50
 55
 60
 65

359-877

EX

E0137

XR

4,555,166

United States Patent [19]

Enomoto

[11] Patent Number: 4,555,166

[45] Date of Patent: Nov. 26, 1985

[54] ELECTRIC REMOTE CONTROL MIRROR WITH HALF-BALL PORTION

[75] Inventor: Masao Enomoto, Isehara, Japan
[73] Assignee: Ichikoh Industries Limited, Tokyo, Japan

[21] Appl. No.: 373,783
[22] Filed: Apr. 30, 1982

[30] Foreign Application Priority Data
Feb. 8, 1982 [JP] Japan 57-17604

[51] Int. Cl.⁴ G02B 5/08; G02B 5/12; A47G 1/24
[52] U.S. Cl. 350/634; 248/479
[58] Field of Search 350/289; 74/501 M, 625; 248/900, 479, 481, 483; 403/90, 124, 125, 140

[56] References Cited U.S. PATENT DOCUMENTS

3,609,014	9/1971	Kurz	350/289
4,076,392	2/1978	Suzuki et al.	350/289
4,202,603	5/1980	Miyauchi	350/289
4,324,454	4/1982	Kumai	350/289

FOREIGN PATENT DOCUMENTS

3039343 4/1981 Fed. Rep. of Germany 350/289

Primary Examiner—John K. Corbin
Assistant Examiner—David Lewis
Attorney, Agent, or Firm—Cushman, Darby & Cushman

[57] ABSTRACT

An electric remote control mirror apparatus comprising boss portion mounted on a mirror body fixing the mirror, a concave surface formed at the portion integrally formed with the mirror housing for receiving the mirror body, a pivot connection being composed of the boss portion and the concave surface, a pressure applying member having the surface to be connected to the inner surface of the boss portion and the end portion to be connected to the portion of the mirror housing by passing through the boss portion, a coil spring for pressing the member to the boss portion, thereby to surely support the mirror body within the mirror housing, wherein the rotating resistance of the pivot connection can be easily and precisely adjustable, the rotation of the mirror body around the pivot axis is prevented thereby to avoid vibration and change of inclination of the mirror body.

8 Claims, 24 Drawing Figures

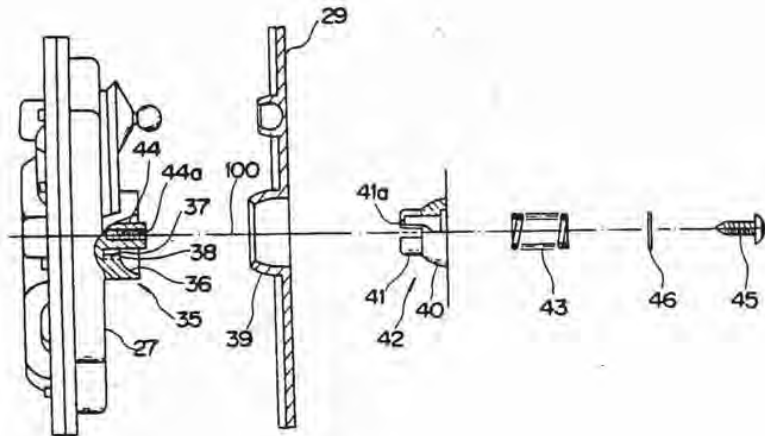

2

Fig. 1 (PRIOR ART)

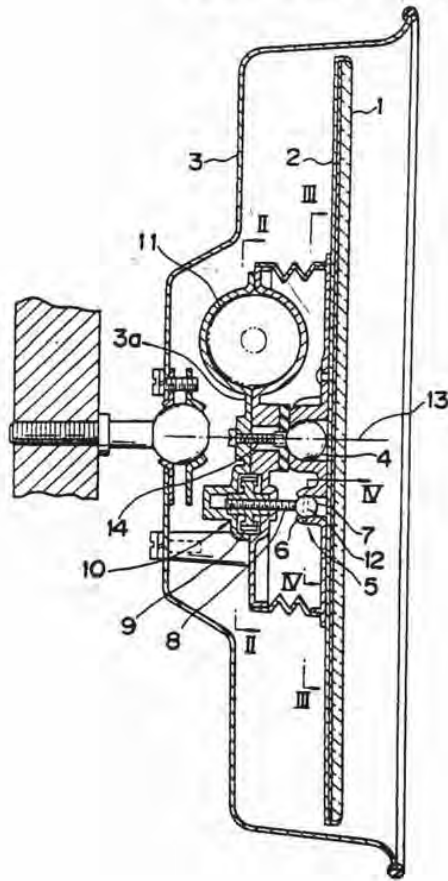

Fig. 2 (PRIOR ART)

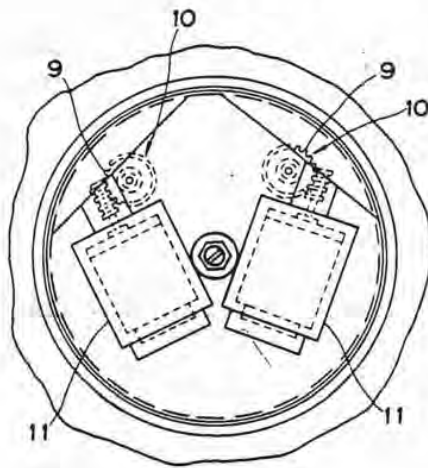

Fig. 3 (PRIOR ART)

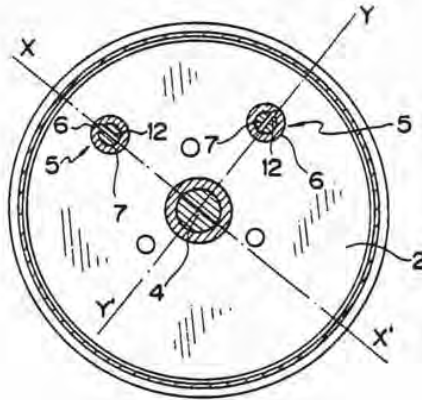

Fig. 4 (PRIOR ART)

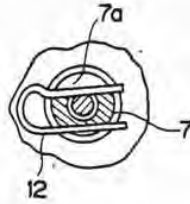

Fig. 5

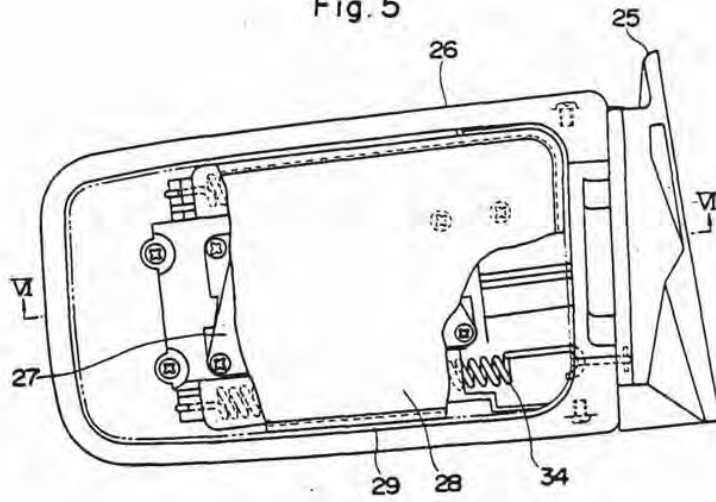

Fig. 6

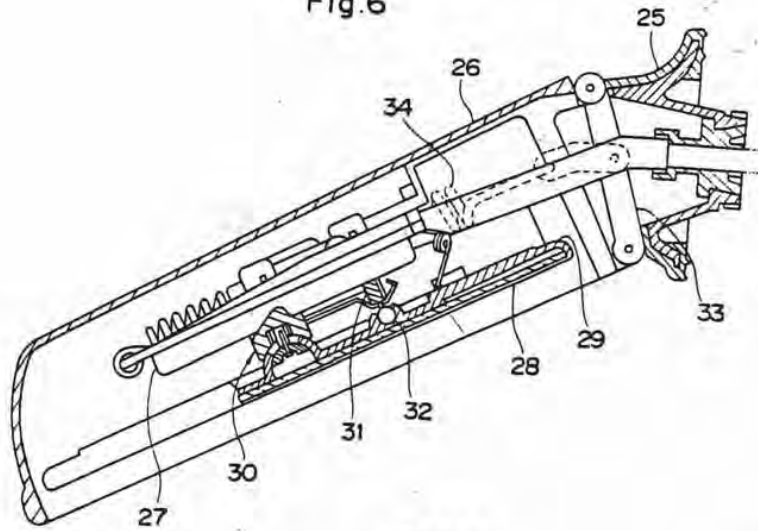

Fig. 7

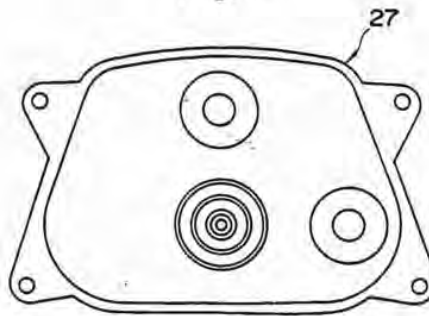

Fig. 8

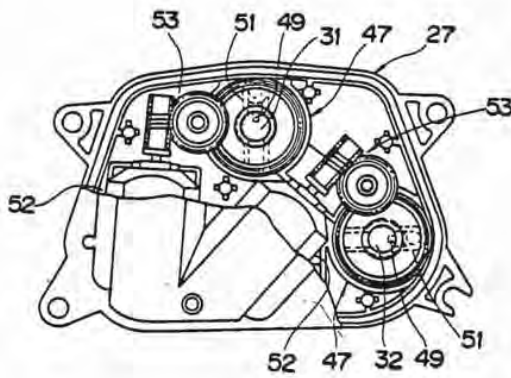

Fig. 9

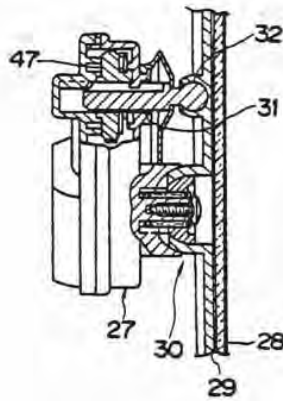

Fig. 10

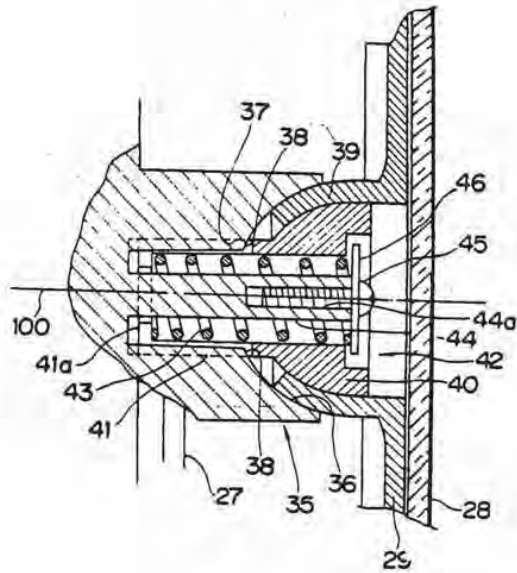

Fig. 11

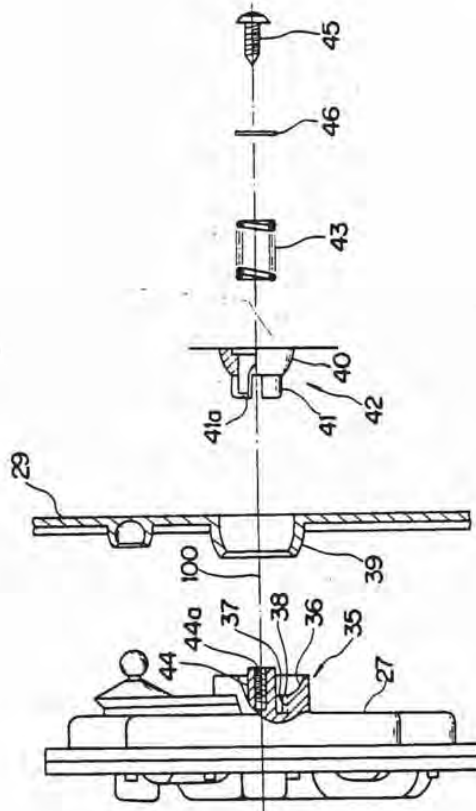

Fig. 12

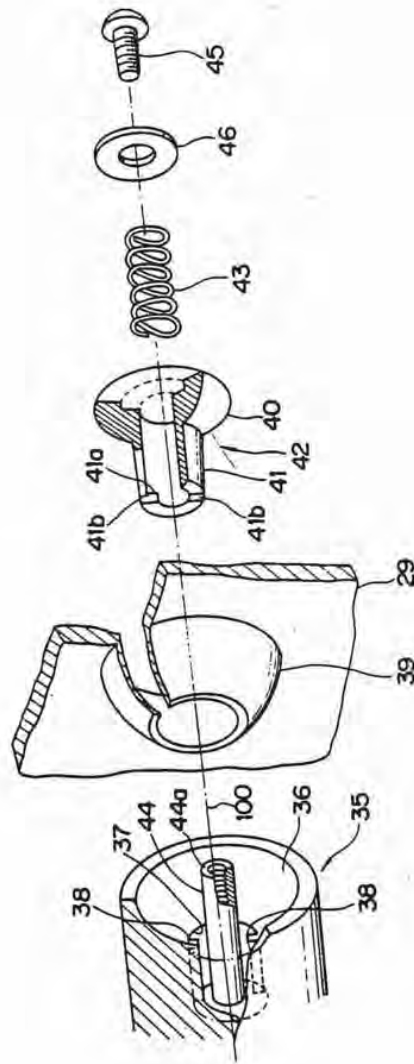

Fig. 13

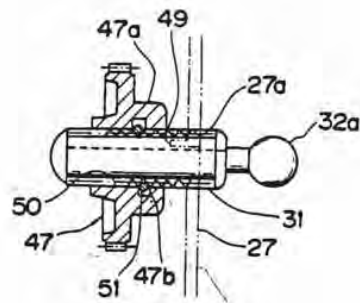

Fig. 14

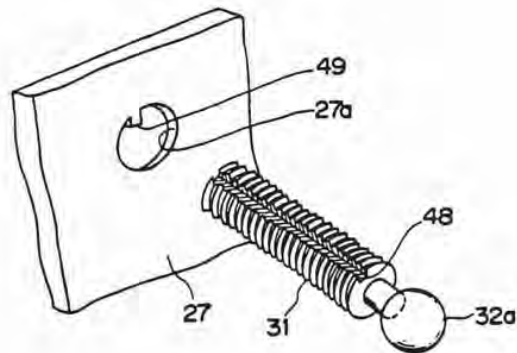

Fig. 15

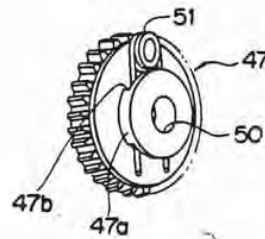

Fig. 16A



Fig. 16B



Fig. 17

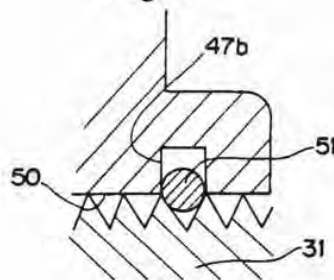

Fig. 18

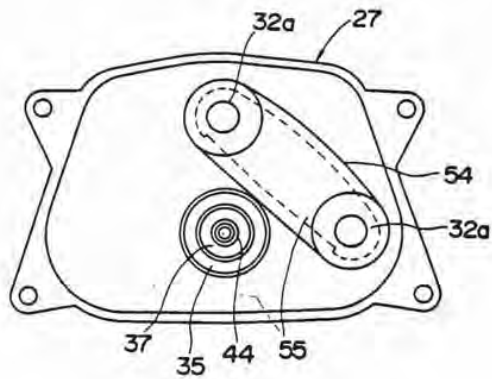

Fig. 19

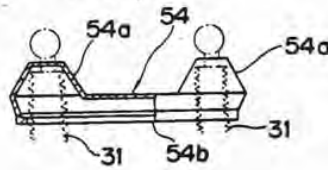

Fig. 20

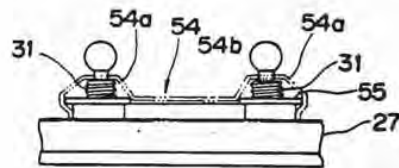

Fig. 21

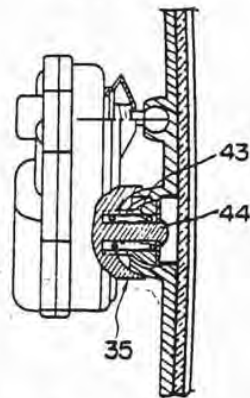

Fig. 22

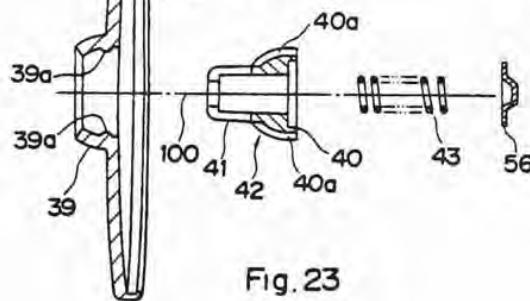

Fig. 23



ELECTRIC REMOTE CONTROL MIRROR WITH HALF-BALL PORTION

BACKGROUND OF THE INVENTION

(a) Field of the Invention

The present invention relates to an electric remote control mirror apparatus for motor vehicles.

(b) Description of the Prior Art

Conventional electric remote control mirror apparatuses are widely used as an outside mirror, one of such the mirror apparatuses is disclosed in detail in the specification of U.S. Pat. No. 3,609,014.

Referring to FIGS. 1 to 4 a conventional electric remote control mirror apparatus is shown. FIG. 1 is a longitudinal cross sectional view, FIG. 2 a cross sectional view as seen in the direction of the arrow II—II in FIG. 1, FIG. 3 a cross sectional view as seen in the direction of the arrow III—III in FIG. 1, FIG. 4 a cross sectional view as seen in the direction of the arrow IV—IV in FIG. 1.

As seen from FIGS. 1 to 3, a mirror body 2 fixing a mirror 1 is pivotably supported through a pivot connection 4 with respect to a mirror housing 3. The line X—X' passing the center of the pivot connection 4 perpendicularly crosses the line Y—Y' passing the center. Boss portion 6 for a ball joint 5 is integrally formed on the mirror body 2 on each of the above two lines. The boss portion 6 is rearwardly extended to hold the ball joint 5 as shown in FIG. 1. The threaded rod 8 having a ball 7 for the ball joint 5 has a male screw on the peripheral surface thereof, and the threaded rod 8 can be screwed into a female screw provided on a gear 9, the gear 9 being rotatably mounted in a screw member 10. Upon actuation of motors 11 the screw members 10 are rotated to move the threaded rod 8 forwardly or backwardly thereby to incline the mirror body 2. Thus, by the movement of the threaded rod 8 connected to the ball joint 5 on the line X—X' of FIG. 3, the mirror body 2 is rotatably moved around the line Y—Y', and similarly the mirror body 2 is rotatably moved around the line X—X' by the movement of the threaded rod 8 connected to the ball joint 5 on the line X—X' of FIG. 3.

Therefore since the threaded rod 8 is moved forwardly or backwardly by the rotation of the screw member 10, it is inevitably necessary to stop the rotating motion of the threaded rod 8 per se. To this end the ball 7 of the ball joint 5 is held by a hair pin like spring 12 to avoid the rotating motion of the ball 7 i.e. the threaded rod 8. FIG. 4 is a cross sectional view as seen in the direction of the arrow IV—IV of FIG. 1, and the holding states of the spring 12 and the ball 7 are shown, wherein numeral 7a designates a slot formed on the ball 7.

According to the conventional electric remote control mirror apparatus mentioned above, the mirror body 2 to which the mirror 1 is fixed can be rotatably moved around the lines X—X' and Y—Y' respectively by respective and independent actuation of the two motors 11 and 11, thereby to remotely control the angle of the mirror 1. Therefore the apparatus is preferable as an outside mirror i.e. a rear view mirror for motor vehicles.

However, as is apparent from FIG. 1, since the pivot connection 4 is composed of a driving case 3a secured on the fixed mirror housing 3, having the projected ball, and a boss portion provided on the movable mirror

body 2 for holding the projected ball provided on the driving-section case 3a, the dimension in the direction of pivot axis 13 becomes inevitably large, resulting in a heavy thickness of the mirror apparatus per se in the direction of the pivot axis 13. Further since the pivot connection 4 is constructed such that the rotating resistance of the pivot connection 4 is provided by the pressing force due to an adjusting screw 14, effected between the ball and the boss portion of the mirror body 2, the rotating resistance can be directly controlled by the adjusting screw 14. Therefore, it is actually difficult to delicately adjust the rotating resistance and further even after a correct adjustment thereof has been established a deviation of the adjustment due to looseness, wear and deformation of the screw 14 can undesirably occur. In order to overcome the above-mentioned disadvantages, if a spring (not shown) is provided to obtain a stable rotating resistance by the spring force due to the spring, the dimension of the pivot connection in the direction of the pivot axis 13 is further undesirably increased.

As is apparent from the arrangement mentioned above, the rotation of the mirror body 2 around the pivot axis 13 is not restricted, resulting in unstable support for the mirror such that the mirror is not smoothly moved when operating the mirror and the inclination of the mirror undesirably changes when not operating the mirror. Furthermore, according to the arrangement of the hair pin-like spring 12 holding the slot 7a provided on the ball 7, the rotation of the threaded rod 8 per se is insufficiently stopped, especially when the threaded rod 8 is moved forwardly in the right hand direction in FIG. 1 where the rotation of the threaded rod 8 is not sufficiently stopped. The results in unstable support of the mirror body 2 and allows change in the mirror's inclination.

SUMMARY OF THE INVENTION

The object of the present invention is to overcome the disadvantages of the above-mentioned conventional electric remote control mirror, and to provide an electric remote control mirror apparatus in which the dimension of the apparatus in thickness is reduced, a rotating resistance of a pivot connection being easily and precisely adjustable, a correctly adjusted state of the rotating resistance being maintained without any change in use, and a mirror body being supported stably thereby to especially cause no rotation of the mirror body around a pivot axis and no change of an adjusted inclination of the mirror body.

To achieve the above-mentioned object, the conventional electric remote control mirror is improved by the present invention. The features of the present invention resided in an electric remote control mirror apparatus mainly including a pivot connection for supporting a mirror body and a mirror inclining means for adjusting mirror's inclination. First, the pivot connection is composed of a ball base having a concave surface integrally formed with the member fixed to the mirror housing as a fixed body, and a cylindrical hole provided at the central portion of the concave surface coaxially with the pivot axis, together with elongated projections formed along the inner wall of the cylindrical hole which extend in the direction of the pivot axis. A boss portion is integrally formed with the mirror body as a movable body, for fitting to the concave surface of the ball base. The pivot connection also includes a pressure

3
 applying member having a half-ball like portion adapted to be fitted to the inner surface of the boss portion of the mirror body, a cylindrical portion to be inserted into the cylindrical hole, and slots to be connected to the elongated projections. A coil spring is received in the cylindrical portion of the pressure applying member for urging the pressure applying member against the ball base. The mirror inclining means further included a threaded rod having screw at the peripheral surface thereof and an elongated slot extending in the direction of the rod's axis for guiding the threaded rod along the rod's axis, and support means provided with a projection to be connected to the elongated slot, for supporting the threaded rod and guiding the rod along the rod's axis thereby to avoid the rotation of the threaded rod around the rod's axis.

The above and other objects, features and advantages of the present invention will be more clear from the following descriptions with reference to the accompanying drawings.

BRIEF DESCRIPTION OF THE DRAWINGS

FIGS. 1 to 4 shows a conventional electric remote control mirror apparatus, FIG. 1 is a longitudinal cross sectional view, FIG. 2 a cross sectional view taken along the line II—II in FIG. 1, FIG. 3 a cross sectional view taken along the line II—III in FIG. 1, and FIG. 4 a cross sectional view taken along the line IV—IV in FIG. 1.

FIG. 5 is a partially exploded elevational view of an embodiment of the present invention,

FIG. 6 is a cross sectional view as seen in the direction of the arrow VI—VI in FIG. 5,

FIG. 7 is a front view of a driving-section case shown in FIG. 6,

FIG. 8 is a partially exploded sectional view of the driving-section case,

FIG. 9 is a cross sectional view of other parts adjacent to the driving-section case,

FIG. 10 is an enlarged cross sectional view of a pivot connection shown in FIG. 6,

FIG. 11 is an exploded view of the pivot connection,

FIG. 12 is a perspective view of the pivot connection shown in FIG. 11,

FIG. 13 is an enlarged cross sectional view of a threaded rod shown in FIGS. 6 and 9,

FIG. 14 is an enlarged perspective view of the threaded rod and other parts adjacent thereto shown in FIG. 13,

FIG. 15 is an enlarged perspective view of a nut member shown in FIG. 13,

FIG. 16 is front and side views of a spring member shown in FIG. 15,

FIG. 17 is an enlarged partial-cross-sectional view showing a connection between the threaded rod and the spring member,

FIG. 18 is a front view of the driving-section case provided with a waterproof cover,

FIG. 19 is a cross sectional view of the waterproof cover shown in FIG. 18,

FIG. 20 is a side view of the driving-section case with the waterproof cover,

FIG. 21 is a partially exploded sectional view of a driving mechanism of another embodiment of the present invention,

FIG. 22 is an enlarged exploded view of the driving mechanism shown in FIG. 21, and

4
 FIG. 23 is an enlarged front view of a washer shown in FIG. 22.

DETAILED DESCRIPTION OF THE PREFERRED EMBODIMENT

Referring now to FIGS. 5 to 20, numeral 25 designates a base fixed on the body of a motor vehicle, 26 a mirror housing, and 27 a driving-section case fixed on the mirror housing 26, 28 a mirror, 29 a mirror body, 30 a pivot joint, 31 a threaded rod movable forwardly or backwardly, and 32 a joint formed at the end of the rod 31 for connecting the mirror body 29 to the threaded rod 31.

In this embodiment the mirror housing 26 is formed separately with the base 25, and is hinged to the base by a hinge 33 and actuated against the base 25 by means of a spring 34. This is a shock absorbing mechanism for absorbing shock occurred upon collision of an external object against the mirror housing 26. The mirror housing 26 is normally fixed on the body of the motor vehicle with respect to the remote control operation of the mirror when no shock is applied to the mirror housing 26.

Referring to FIGS. 7 to 12, numeral 35 designates a ball base integrally formed with the driving-section case 27 fixed on the mirror housing 26 as a fixed member. The ball base 35 is composed of a concave surface 36 symmetrical with respect to a pivot axis 100 in FIG. 10, a cylindrical hole 37 coaxial with the pivot axis 100 provided at the bottom portion of the concave surface 36, and a pair of elongated projections 38 provided on the inner surface of the hole 37 and extended in parallel with the pivot axis 100.

The mirror body 29 has a boss portion 39 rearwardly extended, and the outer surface of the boss portion has the same curvature as that of the concave surface 36 to allow a pivotal movement of the mirror body 29.

A pressure applying member 42 is composed of a half-ball portion 40 the outer surface of which has the same curvature as that of the inner surface of the boss portion 39, and a cylindrical portion 41 having an outer diameter approximately equal to the diameter of the hole 37. The cylindrical portion 41 has a pair of slots 41a, 41b (FIG. 12) adapted to receive the elongated projections 38.

Numerals 43 designates a coil spring adapted to be fitted to the cylindrical portion 41. The one end of the coil spring 43 is contacted to the bottom of the cylindrical portion 41.

Referring now to FIG. 10, the boss portion 39 of the mirror body 29 is fitted between the concave surface 36 of the ball base 35 and the pressure applying member 42. The cylindrical portion 41 of the pressure applying member 42 is inserted into the hole 37 of the ball base 35, and the pressure applying member 42 is inhibited to rotate around the pivot axis 100 by the connection of the elongated projection 38 and the slot 41b.

The pressure applying member 42 is urged to the ball base 35 by the spring force of the coil spring 43. To do so, the coil spring 43 is inserted into the cylindrical portion 41 such that the end of the coil spring 43 is contacted to the bottom 41a. There is provided a column 44 at the bottom of the cylindrical hole 37 extending along the pivot axis 100, and a screwed hole 44a at the upper end of the column 44. A screw 45 is screwed into the screwed hole 44a through a washer 46 to press the half-ball portion 40 against the boss portion 39.

According to the arrangement thus constructed, the boss portion 39 are urged with a predetermined and constant force to the ball base 35 by the spring force due to the coil spring 43, with regardless to a fastening torque of the screw 45. Thus the boss portion 39 is pressed to the concave surface 36 with stable and constant force, a stable rotating resistance can be obtained.

As apparent from FIG. 10, the position of the right end of the coil spring 43 is restricted in position in order not to make interference with the back surface of the mirror 28, on the other hand the left end of the coil spring 43 may be located at the deep portion of the cylindrical hole 37, therefore a coil spring having a comparatively larger dimension can be usable without increasing the dimension of the pivot connection in the direction of pivot axis 100. The boss portion 39 has a half ball-like configuration, so that the dimension of the pivot connection in the direction of the pivot axis 100 can be remarkably reduced in comparison with the conventional pivot connection usually utilizing a full-ball configuration.

Further the rotating resistance of the mirror body 29 can be freely changeable by selecting a spring constant, free length and compressed length etc. of a spring. The rotating resistance of the pivot connection can be set a predetermined constant value in regardless with skill in assembling, and the rotating resistance in no way deviated in use. By the way, the rotating resistance may be adjustable, if it is desired, by providing a spacer between the column 44 and the washer 46.

The relative rotation around the pivot axis 100 between the pressure applying member 42 and the ball base 35 is inhibited by the connection of the elongated projection 38 and the slot 41a.

Thus the boss portion 39 of the mirror body 29 is pressed with a constant pressing force by the pressure applying member 42 at the position between the pressure applying member 42 and the ball base 35, so that the boss portion 39 can be pivotably moved smoothly and stably.

Referring to FIG. 13 a screw formation is made on the peripheral surface of the threaded rod 31 to screw it into a screw member 47 described hereinafter. The driving-section case is served to guide the movement of the threaded rod 31 in the direction of the rod's axis as shown in FIG. 14, numeral 27a designates a through hole through the wall of the driving-section case 27 to insert the rod 31 therethrough. There is provided a projection 49 within the through hole 27a and an elongated slot 48 adapted to fit to the projection 49 on the portion of the peripheral surface of the threaded rod 31, in order to guide the forward and backward movement of the threaded rod 31 without rotation thereof. Numeral 32a designates a ball fixed on the end of the threaded rod 31.

According to the arrangement thus constructed, the threaded rod is allowed to move forward and backward without rotation in response to the rotation of the screw member 47 with stability and without any vibration of the mirror 28.

Referring to FIGS. 15 to 17 the screw member 47 does not have a female screw but a through hole 50 at the center portion of the screw member 47 for receiving the screw member 47. Further the screw of threaded rod 3 has a boss-like protrusion 47a having a pair of slots 47b in the surface perpendicular to the axis of the screw member 47. More precisely, one of the paired slots 47b is twisted to the other of the paired slots 47b by the

angle corresponding to one pitch of the screw of the threaded rod 31. A slightly twisted spring member 51 as shown in FIGS. 16(A) and (B) is inserted into the slots 47b to pinch the threaded rod 31 as shown in FIG. 17 if which is an enlarged cross sectional view of the rod 31 and slots 47b. According to the above arrangement thus constructed the spring member 51 is only allowed to move along the surface perpendicular to the axis of the screw member 47b, and the spring member 51 pinches the valley of the screw of the threaded rod 31, so that the whole of the screw member 47 is served as function of a nut, and further even if overtorque is occurred for moving the threaded rod 31, it is easily absorbed by resilient deformation of the spring member 51 thereby avoiding any damage of the above mechanism.

As shown in FIGS. 13 and 15 there is provided a gear at the peripheral surface of the screw member 47 in order to make simple the mechanism 53 in FIG. 8, transmission means, for transmitting driving force from the motors 52 and 52 to the screw member 47.

Referring to FIG. 18, a driving-section case which is the same as that shown in FIG. 7 is shown. At the mirror body side of the case 27 a waterproof cover 54 is mounted, the waterproof cover is composed of umbrella-like portions 54a and 54a and cover body portion 54b integrally connecting the umbrella-like portions 54a. As shown in FIG. 20 there are provided cover mounting members 55 surrounding the two threaded rods 31 and secured to the case 27, and the lower portion of the cover body portion 54b is fitted to the cover mounting members 55.

Thus a single waterproof cover 54 prevents two threaded rods 31 from water, and the cover 54 has a simple configuration and mounting of the cover 54 to the rods are very easy.

Referring now to FIGS. 21 and 22 there is shown another embodiment of the present invention being mainly different from the above-mentioned embodiment at the following two points.

One point of the two points is that there is provided no screw hole at the end portion of the column 44' mounted at the central bottom portion of the ball base 35 of the pivot connection, and a clip 56 having a plurality of tongue pieces 56a at inner portion thereof. The coil spring 43 inserted into the column 44' is held by the clip 56, namely by biting of the tongue pieces 56a against the free end portion of the column 44'. According to the arrangement thus constructed, operation steps in assembling the pivot connection can be effectively reduced.

The other point is that there are provided two small projections 39a at the inner surface of two boss portion 39 which are located in opposite positions with each other, with respect to the pivot axis 100, and further two slots 40a at the half-ball like portion 40 extending in the direction of the pivot axis 100. According to the arrangements thus constructed, the two projections 39a can be fitted into the two slots 40a respectively thereby to surely prevent the rotation of the boss portion 39 mounted on the mirror body 29 around the pivot axis 100.

Thus the rotation of the mirror body 29 around the pivot axis 100 is surely avoided by connections between the elongated projections 38 provided at the ball base 35 integrally formed with the driving-section case 27 fixed on the mirror housing 26 and the slots 41b of the cylindrical portion of the pressure applying member 42, and further by connections between the small projections

39a of the boss portion 39 and the slots 40a of the pressure applying member 42. As a result, the mirror body 29 can be stably supported without producing a small vibration and a change of inclination.

As stated above, the electric remote control mirror apparatus of the present invention is mainly composed of a pivot connection and a mirror inclining means. The pivot connection is composed of a ball base having a concave surface integrally formed with the member fixed to the mirror housing as a fixed body, and a cylindrical hole provided at the central portion of the concave surface coaxially with the pivot axis, together with elongated projections formed along the inner wall of the cylindrical hole which extend in the direction of the pivot axis. A boss portion is integrally formed with the mirror body as a movable body, for fitting to the concave surface of the ball base. The pivot connection also includes a pressure applying member having a half-ball like portion which is fitted to the inner surface of the boss portion of the mirror body, and a cylindrical portion which is inserted into the cylindrical hole, and slots to be connected to the elongated projections. It also includes a coil spring received in the cylindrical portion of the pressure applying member for urging the pressure applying member against the ball base. The mirror inclining means is secondarily composed of a threaded rod having screw at the peripheral surface thereof and an elongated slot extending in the direction of the rod's axis for guiding the threaded rod along the rod's axis, and support means are provided together with a projection to be connected to the elongated slot for supporting the threaded rod and guiding the rod along the rod's axis.

According to the above construction of the electric remote control mirror apparatus, the rotation of the threaded rod around the pivot axis is avoided, the whole thickness of the mirror apparatus being reduced, the rotating resistance being easily and precisely adjustable, the adjusted condition of the rotating resistance being not changed in use, so that vibration and change of inclination of the mirror body will not occur.

What is claimed is:

1. An electric remote control mirror apparatus comprising

a mirror,
a mirror body fixed to said mirror,
a mirror housing receiving said mirror body,
support means fixed within said mirror housing for holding said mirror body in said mirror housing,
said support means including a pivot connection for pivotally supporting said mirror body thereto,
two ball bases connected to said mirror housing and located on respective lines perpendicular to each other and crossing at said pivot connection, a pair of threaded rods each of which has a ball member at the end thereof and a threaded peripheral surface thereof, a screw member drivingly connected to each of said threaded rods, transmission means for respectively transmitting driving force to each of said screw members, electric motor means for driving said screw members through said transmission means,

said pivot connection including a ball base having a concave surface integrally formed with said support means, means defining a cylindrical hole extending inwardly away from the central portion of said concave surface coaxially with the pivot axis, at least one elongated projection formed so as to

extend along the inner wall of said cylindrical hole in the direction of the pivot axis, means defining a column at the central bottom portion of said cylindrical hole means, said column means extending toward said concave surface coaxially with said pivot axis, said column means further including means defining an elongated threaded interior opening;

a hollow convex shaped portion integrally formed with said mirror body for fitting within said concave surface of said ball base and having means defining an opening in the central portion of said hollow convex shaped portion;

a pressure applying member having a convex shaped portion to be fitted to the inner surface of said hollow convex shaped portion of said mirror body, and a cylindrical portion to be inserted into said cylindrical hole means through said opening means in said hollow convex shaped portion, said cylindrical portion having means defining at least one slot for engaging said at least one elongated projection for preventing rotation around the pivot axis, a coil spring disposed within said cylindrical portion about said column, one end thereof being in contact with a seat adjustably mounted at the top of said column and the other end thereof being positioned against the end wall of said cylindrical portion for urging said pressure applying member against said ball base; and

wherein each of said threaded rods includes an elongated slot for guiding the movement of said threaded rod housing means for receiving said threaded rods therethrough and projection means provided on said housing means to be connected to said elongated slot for supporting said threaded rod and guiding it along the rod's axis thereby prohibiting rotation of said threaded rod around the rod's axis.

2. An electric remote control mirror apparatus according to claim 1, wherein either one of said hollow convex shaped portion and said convex shaped portion having at least one projection, and the other thereof having at least one slot to be connected to said projection, thereby preventing a rotation of said hollow convex shaped portion around the pivot axis.

3. An electric remote control mirror apparatus according to claim 1, further comprising a waterproof cover which can be fitted to a cover mounting members for protectively enveloping said threaded rods.

4. An electric remote control mirror apparatus according to claim 1, wherein said screw member has a cylindrical and central through hole adapted to fit the threaded rod, and hold a spring member for adapted to be movable in the surface perpendicular to the rod's axis pinching the valleys of the screw of said threaded rod.

5. An electric remote control mirror apparatus comprising

a mirror having a backing member,
mirror housing means for receiving said mirror,
means for pivotally mounting said mirror within said mirror housing means to thereby define a pivoting axis, said pivotal mounting means including a housing member secured within said mirror housing means,

a pivot connection comprised to a partial ball base having a concave surface integrally formed with and extending outwardly from said housing member, means defining a cylindrical hole extending

9

10

inwardly away from the central portion of said concave surface coaxially with the pivot axis to a bottom portion, at least one elongated projection formed so as to extend along the inner wall of said cylindrical hole in the direction of the pivot axis, means defining a column at the central bottom portion of said cylindrical hole means, said column means extending outwardly away from said bottom portion toward said concave surface coaxially with said pivot axis, said column means further including means defining an elongated interior opening, said backing member including a hollow convex shaped partial spherical projection integrally formed therewith and dimensioned to fit within said concave surface and having means defining a centrally positioned opening therein,

a pressure applying member having integrally formed upper and lower portions, said upper portion comprising a convex shaped partial spherical member dimensioned to fit within the interior of said hollow convex shaped portion of said backing member, said lower portion comprising a cylindrical member dimensioned to fit into said cylindrical hole means and through said opening means in said hollow convex shaped projection, said cylindrical portion having an annular end wall for fitting around said column means and means defining at least one slot for engaging said at least one elongated projection for preventing rotation of said mirror around the pivot axis, and

a coil spring disposed within said cylindrical portion about said column, one end thereof being in contact

with a seat adjustably mounted at the top of said column and the other end thereof being held against said annular end wall for urging said pressure applying member toward said ball base so that said hollow convex shaped projection is retained between said ball base and said pressure applying member.

6. An electric remote control mirror as in claim 5, wherein said mirror pivoting means includes two ball bases positioned, respectively, on lines perpendicular to each other and crossing at said pivot connection, a pair of control rods having a threaded portion and being operatively connected to said backing member, drive means operatively connected to the threaded portion of said control rods for moving said control rods to pivot said mirror, wherein said threaded portion includes an elongated slot extending therealong, said housing member for said pivoting means including means defining an opening through which said threaded portion can move axially, said housing member opening including projection means for engaging said elongated slot and guiding said control rod so that rotation of said threaded portion is prohibited.

7. An electric remote control mirror as in claim 5 wherein said seat is adjustably mounted by means of a screw threadedly engaged within said elongated interior opening in said column means.

8. An electric remote control mirror as in claim 5, wherein rotation prevention means are provided between the upper portion of said pressure applying member and said backing member.

* * * * *

35
40
45
50
55
60
65

United States Patent [19]

Alten

[11] Patent Number: **4,770,522**

[45] Date of Patent: **Sep. 13, 1988**

[54] AUTOMOBILE MIRROR POSITION SENSOR AND ADJUSTER ASSEMBLY

[75] Inventor: **Ralph W. Alten, Arnold, Mo.**

[73] Assignee: **Siegel-Robert, Inc., St. Louis, Mo.**

[21] Appl. No.: **115,717**

[22] Filed: **Nov. 2, 1987**

[51] Int. Cl.⁴ **G02B 7/18; G05B 19/42**

[52] U.S. Cl. **350/633; 248/485; 350/637**

[58] Field of Search **350/279, 280, 281, 282, 350/283, 632, 633, 634, 635, 636, 637; 248/481, 482, 483, 484, 485, 486, 487**

[56] References Cited

U.S. PATENT DOCUMENTS

4,267,494	5/1981	Matsuoka et al.	350/637
4,449,788	5/1984	Suzuki	350/637
4,504,117	3/1985	Mittelhauser	350/636
4,625,329	11/1986	Ishikawa et al.	350/637
4,678,295	7/1987	Fisher	350/634

Primary Examiner—John K. Corbin
Assistant Examiner—Martin Lerner
Attorney, Agent, or Firm—Rogers, Howell, Moore & Haferkamp

[57] ABSTRACT

A sensing and adjustment assembly for a mirror on automobiles has a sensor comprising an electronic oscillator which is associated with a mirror position indicator member. Movement and position of the mirror is detected by the sensor. A driving arrangement responds to the sensor to move the mirror to a preset position which position is stored in a computer memory. The oscillator can have a winding of spiral shape and the indicator can comprise material capable of absorbing electromagnetic energy, such as steel, and can be of substantially tapered shape such as substantially conical. The member can be moved through a center passage-way for the winding. The oscillator can be a Colpitts or other type. A differential amplifier, a converter from A.C. to D.C., and another amplifier can be part of the sensor. A pair of sensors and indicators can be used in conjunction with the drive means to move the mirror in two planes. The mirror positions can be stored in computer memory in correlation with the selected seat positions of a plurality of passengers, and the computer connected with the assembly and seat system, so that when the seat is moved to a preset position, the mirror is also moved to a preset position that permits the passenger to have proper viewing through the mirror.

31 Claims, 3 Drawing Sheets

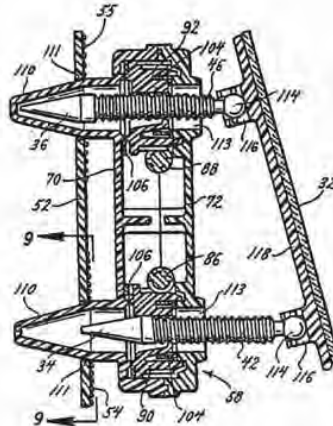

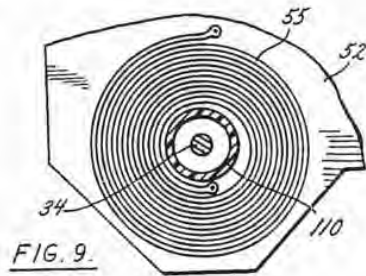
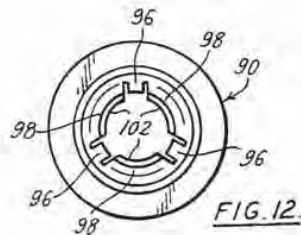
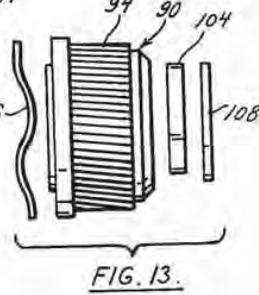
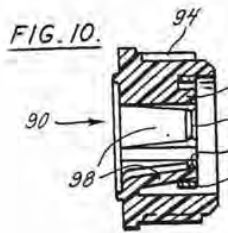
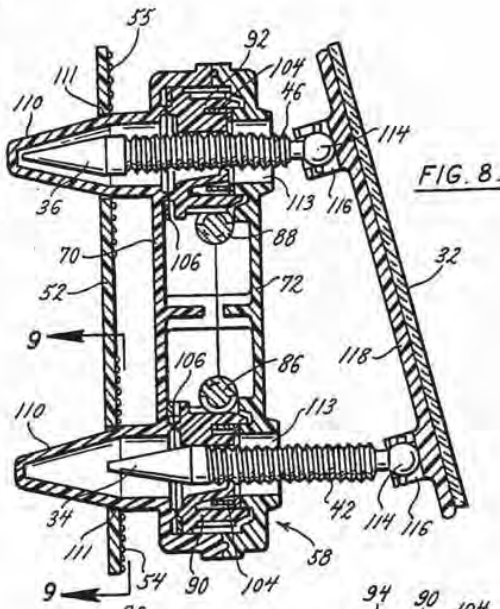
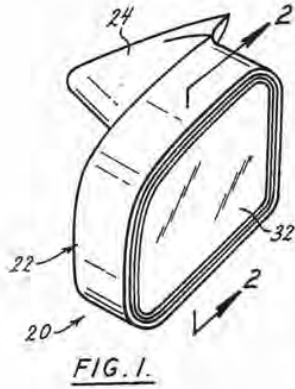

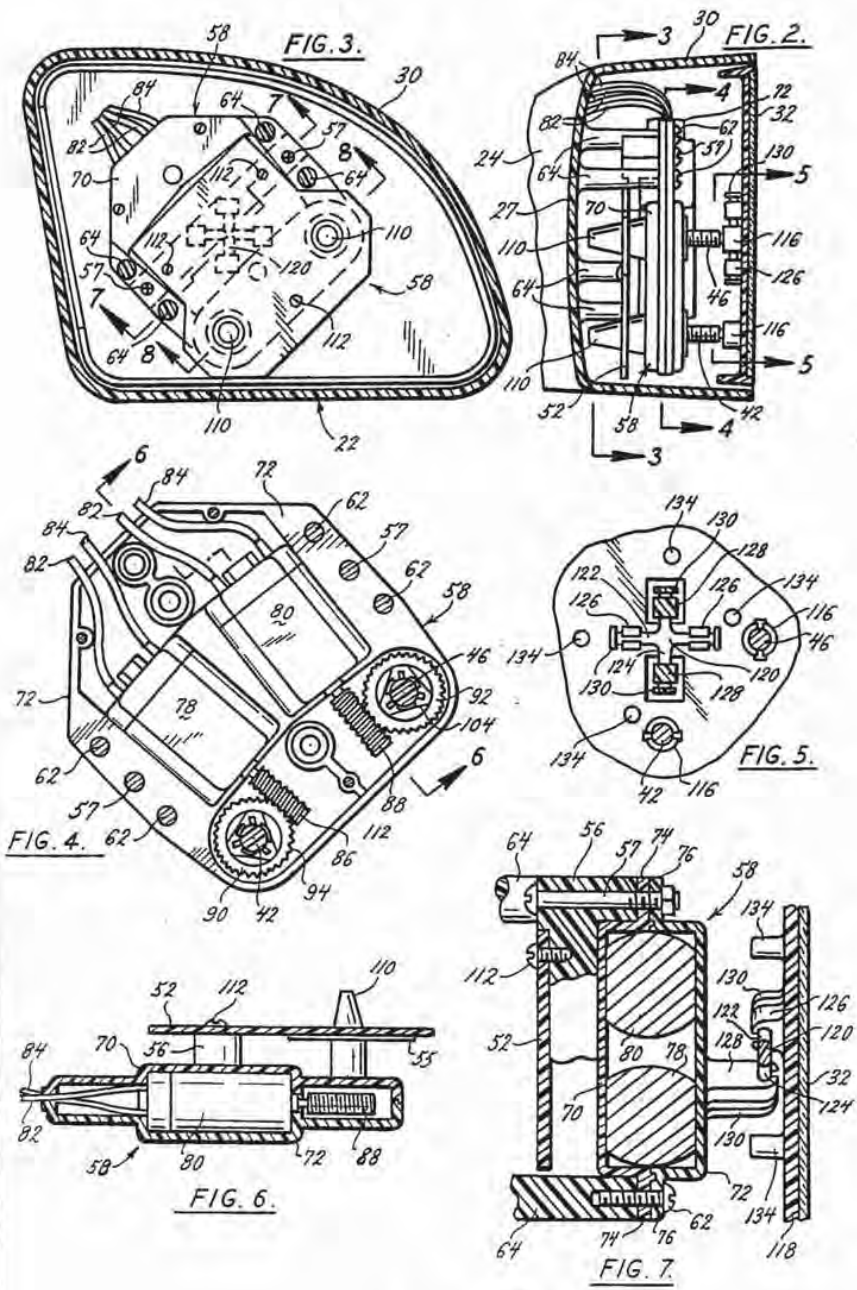

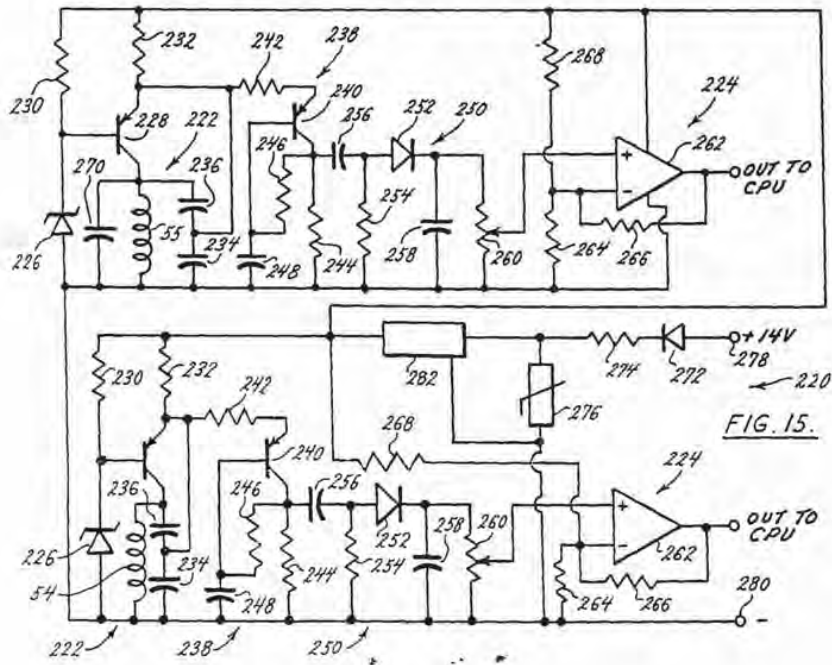
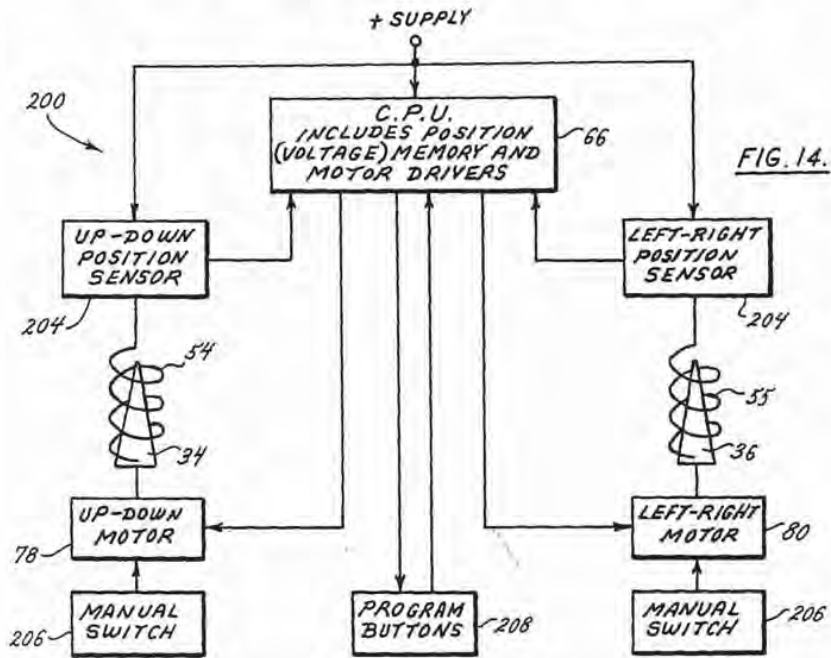

**AUTOMOBILE MIRROR POSITION SENSOR
AND ADJUSTER ASSEMBLY**

**BACKGROUND AND SUMMARY OF THE
INVENTION**

Electrically operated remote controlled rear view mirrors mounted on either the left or right side of a vehicle are an accessory found on automobiles. In the typical arrangement, a mirror is mounted on a support member which is pivotally mounted on a base member or housing. The housing is in turn mounted on either the left or right side of the automobile. The support member moves relative to the housing in the horizontal and/or vertical directions. Extending between the housing and the support member are a pair of linkages for pivoting the support member. A pair of reversible driving motors are mounted on the base member and each motor actuates one of the linkages. The motors are controlled by a switch operated by the driver. Examples of this type of remote controlled mirror are disclosed in U.S. Pat. Nos. 3,609,014 and 4,611,401.

Even though electrically operated remote controlled rear view mirrors are convenient, it is more desirable to be able to program a computer or computer module to remember a preset position of the mirror for each driver. The position sensor system for controlling the position of the mirrors is typically used in conjunction with a system for controlling the position of a driver's seat. Upon pressing a single button, a driver may automatically reposition the driver's seat as well as both the left and right outside rearview mirrors. Position information for the seat and both mirrors are programmed into the computer module.

In order to be able to program in memory the position of the mirror there must be a mechanism for sensing the position of the mirror along the horizontal and vertical axes. Presently, mirrors use linear motion potentiometers for determining the position of the mirror. The potentiometers are linearly displaced by the motion of the mirror in either the horizontal or vertical planes. A fixed voltage is impressed across the potentiometer and a portion of the voltage is tapped off by a sliding member of the linear motion potentiometer to be used as an input signal. This input signal is sent to a computer where it is processed and stored. The level of the input signal corresponds to the physical position of the mirror.

These potentiometers have been troublesome in that they are subject to mechanical wear, subject to mechanical failure of the slider contact due to contamination from salt, dirt, and dust, and are expensive to replace. Potentiometers, because of their mechanical nature, may suffer from poor resolution and backlash. This can lead to improper mirror positioning.

To solve these and other problems, the inventor herein has succeeded in replacing the linear motion potentiometers with electronic position sensors which have no moving parts in contact with one another, are not subject to mechanical wear, and are not subject to contamination due to salt, dust, or dirt. The invention includes a means for indicating the position of the mirror relative to its mount comprising a member associated with the mirror, combined with means to sense the member's position comprising an inductive winding, or an oscillator. The invention is illustrated by providing an assembly with electronic sensors each comprising an inductance coil into which is inserted a tapered steel

rod. The coil can be part of a Colpitts oscillator. When the steel rod moves through the coil it absorbs energy at a varying rate, causing the A.C. output voltage of the oscillator to change in relation to the position of the tapered rod in the oscillator coil. This output voltage is amplified, converted to a D.C. voltage signal, amplified again, and then outputted to the computer. Drive means responsive to the indicating and sensing means moves the mirror to its position.

The following set forth objects of one or more of the claims for the invention. It is an object to provide an assembly to adjust the position of a mirror of an automobile to selected preset positions relative to the mount for the mirror by a member which is associated with the mirror and is electromagnetically associated with a sensor.

It is further an object to provide a means for sensing the position of the member relative to the mirror mount. Furthermore, it is an object to provide a means for indicating and sensing the mirror position comprising an oscillator and an indicator member, with means for electromagnetically controlling the electrical output of the oscillator upon movement of the indicator member. It is further an object to provide a means for sensing the position of the member which comprises an inductive winding electrically associated with the member.

An objective as well is to provide a drive means responsive to the indicator and sensor means, which moves the mirror to the desired position.

An additional object is to provide an assembly with a position indicator comprising a member capable of absorbing electromagnetic energy. Moreover an object is to provide such a member which has a varying cross section.

Further an objective is to provide such an adjustment assembly wherein the means for indicating the position of the mirror is a rod comprising metal having a longitudinal taper, and wherein the sensing means is an inductive winding positioned so that the metal rod can be moved to be surrounded by the winding. It is an object to have the tapered part of the rod to be of a substantially conical shape.

Another object is to provide a means of generating a voltage or signal output in such a system which is a mathematical function of the position, or of the travel, of the member and which thus acts as a position sensor.

Still another objective is to provide an electromagnetic sensor using an oscillator and a differential amplifier means, and a means for converting from alternating current to direct current.

It is moreover an object to provide such an automotive position sensor which does not employ linear potentiometers.

Yet another object is to provide an automotive position or travel sensor which minimizes problems caused by frictional wear, and which resists failure caused by contamination from salt, dirt, or dust.

Another object is to provide such an adjustment and positioning assembly which eliminates inaccuracy due to noise and interference which is present with potentiometers used for such positioning and adjustment.

It is further an object to provide proper resolution of an image in a mirror which has its position adjusted on an automotive vehicle.

Yet another object is to provide a position or travel sensor comprising a self-excited electronic L-C oscillator which features a flat spiral wound inductive coil as

a component of the resonant tank circuit, into the center axis of which is inserted a steel rod, the shape of which determines the position output function.

An objective is to provide a position sensor which when used in pairs can position an automotive rear view mirror in each of two planes and provide voltage outputs that are proportional to the mirror surface position.

It is furthermore an object to provide a position sensor for an automobile mirror which can be used with a computer memory seat system to control the portion of the seats and of the mirror.

BRIEF DESCRIPTION OF THE DRAWINGS

FIG. 1 is an isometric view of the main housing, the mount, and the mirror for the assembly;

FIG. 2 is a section taken on the line 2—2 of FIG. 1, which breaks open the main housing to view the interior thereof;

FIG. 3 is a section taken on the line 3—3 of FIG. 2;

FIG. 4 is a section taken on the line 4—4 of FIG. 2;

FIG. 5 is a section taken on the line 5—5 of FIG. 2;

FIG. 6 is a section taken on the line 6—6 of FIG. 4;

FIG. 7 is a section taken on the line 7—7 of FIG. 3;

FIG. 8 is a section taken on the line 8—8 of FIG. 3 showing parts of the assembly with some parts not shown for clarity, and with the indicator rods shown in different positions relative to the sensing windings;

FIG. 9 is a plan view showing a substantially flat inductive winding taken on the line 9—9 of FIG. 8;

FIG. 10 is a section through one of the drive gears for an indicator rod;

FIG. 11 is a front plan view of such a drive gear for an indicator rod;

FIG. 12 is a rear plan view of such a drive gear for an indicator rod;

FIG. 13 is an exploded side plan view of such a drive gear for an indicator rod;

FIG. 14 is a schematic block diagram of the computer with which the assembly can be used, and certain control elements for the computer and of the adjustment assembly; and

FIG. 15 is a schematic of the circuitry for the adjustment assembly.

GENERAL DESCRIPTION OF PREFERRED EMBODIMENT

First, reference is made to FIGS. 1—13 which show the physical assembly 20 and components thereof.

Generally, FIGS. 1—13 show a housing 22 with a standard support brace 24 for attachment to an automobile door (not shown). The housing 22 has a back wall 27 and a surrounding side wall 30. A mirror 32 is mounted facing outwardly from the rear of housing 22.

The assembly 20 further includes a means for indicating the position of the mirror 32 relative to the housing mount 24 and housing 22, as well as a means for sensing the position indicated for the mirror 32. The indicating means comprises rods 34 and 36 of varying cross section, shown as substantially tapered steel rods of conical shape. Rods 34 and 36 are firmly secured to screw shafts 42 and 46, respectively. Shafts 42 and 46 may be of plastic with cylindrical projections that are press fit within conforming bores of rods 34 and 36.

The sensing means comprises a circuit board 52, with a pair of windings shown as flat spiral coils 54 and 55 mounted thereto. The board 52 is mounted in fixed position, as by a C-shaped mount block 56 held by screws and nuts 57 to a motorpack housing 58. Motor

housing 58 is in turn mounted in fixed relationship to housing 22 as by four screws 62 threaded into four sleeves 64 that are integral with the back wall 27 of mirror housing 22. The sensing means and indicating means further include circuitry shown in FIGS. 14 and 15. The indicating means and sensing means interact with other elements so that a means to adjust the mirror 32 to preset positions is provided. The mirror 32 positioning can be correlated to correspond to the position of a seat (not shown) within the automobile, by means including a computer module 66 for processing and storing the output from the sensing means shown in FIG. 14. The preset mirror 32 and seat positions stored in memory can be activated to move both the mirror 32 and seat so that the seat occupant has the mirror 32 positioned for proper selected position when the preset mirror 32 and seat positions are reached.

SPECIFIC DESCRIPTION OF PREFERRED EMBODIMENT

The motorpack housing 58 has two halves 70 and 72, each having side flanges 74 and 76 through which screws 62 pass to secure the halves together. Each half 70 and 72 has a pair of cavities which are aligned to receive motors 78 and 80, each motor having a pair of conducting wires 82 and 84 connected as known in the art. Motors 78 and 80 are connected to drive worm gears 86 and 88, respectively. Worms 86 and 88 drivingly mesh with rotary gerrs 90 and 92, which all fit within another pair of matching cavities of housing halves 70 and 72. Gears 90 and 92 are preferably of molded plastic. As seen specifically in FIGS. 10—13 for gear 90, each gear 90 and 92 has an outer teathed wall 94, spaced from an inner triad of axially extending, narrow, centering flutes 96 and wider prongs 98. Prongs 98 each have inwardly projecting flanges 102. Flanges 102 act together as threads to drivingly fit with the threads of indicator shafts 42 and 46. A metal brace 104 reinforces gear wall 94. A sinusoidal annular shock absorbing ring 106 and resilient washer 108 fit on either side of gear 90 against the housing halves 70 and 72, respectively.

Housing half 70 has integral projecting covers 110 shaped to conform to rods 34 and 36 to allow movement of those rods therein. Circuit board 52 has a pair of holes 111 sized to receive covers 110. The circuitry elements shown in FIG. 15 are mounted to board 52 by known means. Prior to mounting, the circuitry on board 52 is coated with a substance, such as polyurethane conformal coating, by dipping the circuit board assembly into such substance, to protect the circuitry from the environment, such as salt, water, dust and the like. Board 52 is firmly held to C block 56 by screws 112. On the opposite side, housing half 72 has openings 113 to receive the threaded shafts 42 and 46. Each shaft 42 and 46 terminates into a ball 114 which fits into socket sleeves 116 that are integral with the mount plate 118 to which mirror 32 is secured by known means. A cross shaped gimbal 120 has a pair of aligned arms 122 and 124 which snap-fit into slots of knobs 126 projecting from plate 118 and into slots of knobs 128 projecting from housing half 72. Stop plates 130 projecting from plate 118 and housing half 72 about the ends of arms 122 and 124. This gimbal assembly allows for stable movement of mirror 32 in two planes relative to housing 22.

There are four cylindrical stops 134 projecting integrally from the back of mount plate 118 (FIGS. 5 and 7). These stops 134 act to contact motorpack housing

half 72 to limit mirror angular travel in each of two lanes, as known in the art.

As seen in FIG. 3, motor housing 58 is mounted angularly to main housing 22 so that rod 36 and its shaft 46 and the corresponding structure about them are mounted above and to the right (viewed looking at FIG. 3) of rod 34 and shaft 46 and their surrounding structure.

As the motors 78 and 80 drive worms 86 and 88 in either direction, the gears 92 and 94 are likewise driven in the corresponding direction. As gears 92 and 94 rotate, the inner gear prongs 98 rotate, and their thread flanges 102 screw along threaded shafts 42 and 46. Thus, for example, as gear 90 is driven in a first direction, threaded shaft 42 screws toward motor housing 58, while when gear 90 is driven in the second direction, shaft 42 screws away from housing 58. The same is true for shaft 46 rotation. The flexible prongs 98 of the gears 90 and 92 allow the gears 90 and 92 to free wheel and avoid lock up and motor damage when the stops 134 contact motor housing half 72 to limit mirror 32 movement. The prongs 98 also permit manual adjustment of mirror 32 by hand pressing the mirror. The shafts 42 and 46 rotations, through the ball and socket connections 114 and 116, thus selectively move the mirror 32 in two planes. These planes, X and Y, commonly define mirror 32 movement in the up and down direction (Y plane) and the left to right direction (X plane).

As each rod 34 and 36 move through their circuit board 52 holes, the thickness of the tapered rod 34 and 36 sections which lie in the same plane as coils 54 and 55 vary. For example, in FIG. 8, the thickness of tapered rod 34 intersected by the plane of coil 54 is much smaller than the thickness of the tapered rod 36 intersected by the plane of coil 55, due to difference between the relative positions of rods 34 and 36 to board 52. The change in such rod thickness in the planes of coils 54 and 55 permits energy to be absorbed at varying rates as the tapered rods 34 and 36 move through coils 54 and 55.

This variance in energy absorption causes the A.C. output voltage of the coils 54 and 56 to change in relation to the position of the tapered rods 34 and 36 to their respective coils 54 and 55.

The rods 34 and 36 can also be of an exponential or asymptotic taper, or other taper.

Turning now to the schematic drawings, FIG. 14 shows a simplified block diagram of the mirror position sensor system 200 of the present invention is illustrated. The principal elements of the system 200 include the computer module 66 for processing and storing the output from a pair of position sensors 204. The computer module 66 is connected to the pair of motors 78 and 80. The motors 78 and 80 are controlled either by manual switches 206 or by a signal sent from the computer module 66 in response to depression of a program button 208. The screw shafts are shown by elements 42 and 46, which are driven by the motors 78 and 80, have the tapered rods 34 and 36 extending respectively from one end thereof. Rods 34 and 36 are electro-magnetically coupled to each of the position sensors 204. The position of the rods 34 and 36 within the coils 54 and 55 of the sensors 204 determines the level of the signal which is sent to the computer module 66. The coils 54 and 55 are as mentioned, preferably of substantially flat spiral shape, but for illustrative purposes, are shown differently in the FIG. 14 schematic. The value of the signal corresponds to the position of the shafts 42 and

46, and accordingly, to mirror 32. Program buttons 208 are connected to the computer module 66 to initiate the memory function of the computer module 66.

The foregoing has been a functional description of a block diagram which explains the operation of the mirror position sensor system 200 and the sensors 204 of the present invention. A detailed circuit diagram 220 of the sensors 204 is illustrated in FIG. 15, and its principal components will be explained and identified to further enable one of ordinary skill in the art to make and use the invention.

Referring to FIG. 15, there is illustrated the detailed wiring diagram 220 of the electric circuitry for sensing the position of the mirror 32 in the X and Y planes. The portion of this circuit which senses the position of the mirror 32 in the Y plane will now be described. To sense the position of the mirror, a Colpitts oscillator 222 has the tapered steel rod 34 inserted through oscillator coil 54. The Colpitts oscillator 222 is the preferred oscillator. However other oscillators such as a Hartley or Armstrong oscillator may also be used. Movement of the rod 34 through the coil 54 changes the magnitude of the A.C. output voltage from the oscillator 222. This output is amplified and converted to a D.C. signal which is applied to the input of a difference amplifier circuit 224. The output signal from the difference amplifier circuit 224 is connected to the computer module of FIG. 14 for processing and storing the signal.

The Colpitts oscillator 222 comprises an oscillator coil 54, a zener diode 226, a transistor 228 such as type number MPS 2907, a 1.5k ohm resistor 230, a 560 ohm resistor 232, a 0.1 microfarad capacitor 234, and a 0.047 microfarad capacitor 236. The oscillator 222 is connected to a grounded base amplifier circuit 238. The grounded base amplifier circuit 238 includes a transistor 240 of the same type number as transistor 228, a 47 ohm resistor 242, a 3.9k ohm resistor 244, a 330k ohm resistor 246, and a 0.01 microfarad capacitor 248. The signal from the amplifier circuit 238 is inputted into an A.C. to D.C. converter circuit 250. This converter circuit 250 has a diode 252 such as type number 1N914, a 22k ohm resistor 254, a 0.01 microfarad capacitor 256, a 0.001 microfarad capacitor 258, and a 20k ohm adjustable potentiometer 260 as its components. The difference amplifier circuit 224 receives the D.C. signal from the converter circuit 250. The difference amplifier circuit 224 comprises an operational amplifier 262 such as type number TL092, a 10k ohm resistor 264, a 240k ohm resistor 266, and a 390k ohm resistor 268.

The same numerals used to describe the circuitry for the y plane are used to reference components of the x plane circuitry except the oscillator coil of the x plane circuitry is numbered 55. The electronic circuitry for sensing the position of the mirror in the x plane includes the same components as the aforesaid circuitry for the y plane, except the x plane circuitry further includes a 0.005 microfarad capacitor 270 in parallel with the oscillator coil 55 of the Colpitts oscillator 222. This capacitor 270 shifts one oscillator frequency relative to the other oscillator to prevent the two oscillators 222 from locking together at the same frequency. If the two oscillators 222 were able to oscillate at the same frequency, they would interfere with each other, which is not desired. This capacitor 270 can be connected in parallel with either of the oscillator coils 54 or 55.

There are some components which are common to both the x plane and the y plane sensor circuits. A diode 272 such as type number 1N4004 and a 47 ohm half watt

resistor 274 in series with the diode 272, protect against reverse polarity. A varistor 276 such as type number V22ZA05 is connected across the plus 278 and minus 280 terminals of the circuit 220 to protect against transient voltages. A voltage regulator 282 such as type number MC78L08 is also included in the circuit 220 to insure that the correct voltage is applied to the circuit 220, and to stabilize the oscillator 222 output.

Programming the computer module 66 to store the desired positions of the seat and the mirror 32 is accomplished in the following manner. The user first moves the seat and the mirror 32 to the desired position by using a manual seat control to move the seat and a manual mirror control to move the mirrors. At this point the user will depress a SET button which is located near the manual controls. Pressing the SET button will initiate the program mode of the computer module. The position of the seat and the mirror 32 will now be placed in the memory of the computer module 66. A pair of buttons marked MEM 1 and MEM 2 correspond to two memory locations in the computer module 66 for storing two different positions of the seat and the mirror 32. By pressing either the MEM 1 or MEM 2 button the positions at which the seat and the mirror 32 are at that particular time will be stored in the memory of the computer module 66. A second set of seat and mirror 32 positions may be programmed in the computer module 66 for use by another driver. To reposition the seat and the mirror 32 to the position stored in the first memory location the user only needs to press the MEM 1 button and the seat and mirror 32 will automatically adjust to that position unless they are already there. The assembly can be used with the mirrors of various automobile vehicles including cars, trucks and vans.

There are various changes and modifications which may be made to the invention as would be apparent to those skilled in the art. However, these changes or modifications are included in the teaching of the disclosure, and it is intended that the invention be limited only by the scope of the claims appended hereto.

What is claimed is:

1. An assembly for adjusting the position of a mirror of an automobile to selected preset positions relative to a mount for the mirror, comprising:
 - (a) means for indicating the position of the mirror relative to the mount, comprising a member associated with the mirror; and
 - (b) means for sensing the position of the member relative to the mount, comprising an inductive winding electromagnetically associated with the member.
2. The assembly of claim 1 further comprising means for providing a computer having memory means, and wherein the indicating means indicates the position of the mirror to the computer memory means.
3. The assembly of claim 2 wherein in the preamble the assembly is further for use with a computer memory for sensing the position of an automobile seat; and wherein the indication means is correlated to the seat position stored in the computer memory.
4. The assembly of claim 1 wherein the member is capable of absorbing electromagnetic energy and comprises a part of varying cross-section.
5. The assembly of claim 4 wherein the part of varying cross-section is of a substantially tapered shape.
6. The assembly of claim 5 wherein the substantially tapered shape is a substantially conical shape.

7. The assembly of claim 4 wherein the member comprises metal.

8. The assembly of claim 1 wherein the inductive winding is comprised of a substantially flat spiral coil.

9. The assembly of claim 1 wherein the member is connected to the mirror, wherein the inductive winding is in fixed position relative to the mount, and wherein the winding has a passageway extending through the winding sized to permit the member to be moved through the passageway of the winding.

10. The assembly of claim 1 wherein the sensing means comprises a Colpitts oscillator.

11. The assembly of claim 10 wherein the sensing means comprises differential amplifier means, and means for converting from alternating current to direct current.

12. The assembly of claim 1 further comprising means for adjusting the position of the mirror relative to the mirror mount according to a selection of a preset mirror position relative to the mount, comprising drive means responsive to the indicating and sensing means to move the mirror relative to the mount to a preset mirror position.

13. An assembly for adjusting the position of a mirror of an automobile to selected preset positions relative to a mount for the mirror, which positions are stored in the memory of a computer, comprising:

- (a) means for indicating to the memory the position of the mirror relevant to the mount, comprising a rod mounted to move with the mirror, the rod comprising material capable of absorbing electromagnetic energy and having a part thereof which is of substantially tapered shape; and
 - (b) means for sensing the position of the rod relative to the mount, comprising an oscillator having a substantially flat spiral coil, means for amplifying, means for converting alternating current to direct current; and
 - (c) means for adjusting the position of the mirror relative to the mirror mount according to a selection of a preset mirror position relative to the mount, comprising drive means responsive to the indicating and sensing means to move the mirror relative to the mount to a preset mirror position.
14. An assembly for adjusting the position of a mirror of an automobile to selected preset positions relative to a mount for the mirror, comprising:

- (a) means for indicating the position of the mirror relative to the mount, comprising a pair of members associated with the mirror to move with mirror movement relative to the mount, each member having means for absorbing electromagnetic energy; and
- (b) means for sensing the position of each of the members relative to the mount comprising two inductive windings, one each of said windings being electromagnetically associated with a corresponding indicator member, each winding having a passageway extending through the winding sized to permit the indicator member to be moved through the winding passageway, and each winding comprising a substantially flat spiral coil; and
- (c) means for connecting the members to the mirror, and to the mount for the mirror, so that the movement of the members relative to the mirror mount permits movement of the mirror relative to the mount in two planes.

15. The assembly of claim 14 wherein each of the members is a rod comprising steel having a substantially tapered shape, and wherein the indicating means further comprises a drive shaft connected to each of the rods.

16. The assembly of claim 15 wherein the preamble of the assembly is further for use with a computer memory for sensing the position of an automobile seat and wherein the indication means is correlated to the seat position stored in the computer memory, and further comprising means for adjusting the position of the mirror relative to the mirror mount according to preset mirror positions which correspond to preset seat positions.

17. An assembly for adjusting the position of a mirror of an automobile to selected preset positions relative to a mount for the mirror, comprising:

- (a) means for indicating the position of the mirror relative to the mount, comprising a member associated with the mirror;
- (b) means for sensing the position of the member relative to the mount, comprising an oscillator; and
- (c) means for electromagnetically controlling the electrical output of the oscillator upon movement of the member.

18. The assembly of claim 17 wherein the member is capable of absorbing electromagnetic energy.

19. The assembly of claim 17 wherein the preamble of the assembly is further for use with a computer memory for sensing the position of an automobile seat; and wherein the indication means is correlated to the seat position stored in the computer memory.

20. An assembly for adjusting the position of a mirror of an automobile to selected preset positions relative to a mount for the mirror, comprising:

- (a) means for indicating the position of the mirror relative to the mount, comprising a member connected to the mirror, the member being capable of absorbing electromagnetic energy;
- (b) means for sensing the position of the member relative to the mount, comprising an inductive winding electromagnetically associated with the member, the winding having a passageway extending through it to permit the member to be moved through the passageway.

21. The assembly of claim 20 wherein the member has a part of varying cross-section, wherein the inductive winding is in fixed position relative to the mount; means for adjusting the position of the mirror relative to the mirror mount according to the selection of a preset mirror position relative to the mount, comprising drive means responsive to the indicating and sensing means to move the mirror relative to the mount to a preset mirror position.

22. The assembly of claim 20 wherein the preamble of the assembly is further for use with a computer memory for sensing the position of an automobile seat; and wherein the indication means is correlated to the seat position stored in the computer memory.

23. An assembly for adjusting the position of a mirror of an automobile to selected preset positions relative to a mount for the mirror, comprising:

- (a) means for indicating the position of the mirror relative to the mount, comprising a first member associated with the mirror; and
- (b) means for sensing the position of the first member relative to the mount, comprising a second member having a magnetic field, so that different positions of the first member relative to the second member causes a variation in the strength of the magnetic field of the second member.

24. The assembly of claim 23 further comprising means for providing a computer having memory means, and wherein the indicating means indicates the position of the mirror to the computer memory means.

25. The assembly of claim 23 wherein the sensing means further comprises an amplifier, and means to provide a direct current output signal.

26. The assembly of claim 23 wherein the member comprises a part of varying cross-section.

27. The assembly of claim 26 wherein the part of varying cross-section is of substantially tapered shape.

28. The assembly of claim 27:

- (a) further comprising means for adjusting the position of the mirror relative to the mirror mount according to the selection of a preset mirror position relative to the mount, comprising drive means responsive to the indicating and sensing means to move the mirror relative to the mount to a preset mirror position; and
- (b) wherein the first member comprises steel.

29. The assembly of claim 23 wherein the preamble of the assembly is further for use with a computer memory for sensing the position of an automobile seat; and wherein the indication means is correlated to the seat position stored in the computer memory.

30. An assembly for adjusting the position of a mirror of an automobile to selected preset positions relative to a mount for the mirror, comprising:

- (a) means for indicating the position of the mirror relative to the mount, comprising a first pair of members associated with the mirror to move with the mirror movement relative to the mount, each member having means for absorbing electromagnetic energy and having a substantially tapered shape; and
- (b) means for sensing the position of the first members comprising a second pair of members each having a magnetic field and correlated to interact with each of the respective first pair of members so that different positions of each of the first members relative to its corresponding second member causes a variation in the strength of the magnetic field of each corresponding second member.

31. The assembly of claim 30 wherein the means for sensing comprises each of the second pair of members including an inductive winding electromagnetically associated with its corresponding first member, each winding having a passageway extending through it to permit the corresponding first member to be moved through the corresponding passageway.

* * * * *

359-204 Au 2507 EX
 5/19/92 XR 5,115,352



US005115352A

United States Patent [19]
do Espirito Santo

[11] **Patent Number:** 5,115,352
 [45] **Date of Patent:** May 19, 1992

[54] **DOUBLE EXTERNAL REAR VIEW MIRROR ASSEMBLY FOR VEHICLES**

[76] **Inventor:** Antonio Ferreira do Espirito Santo,
 Almirante Tamandare Street 85, Sao
 Bernardo do Campo, Sao Paulo,
 Brazil

[21] **Appl. No.:** 462,796

[22] **Filed:** Jan. 10, 1990

[30] **Foreign Application Priority Data**

Jan. 10, 1989 [BR] Brazil 8900142

[51] **Int. Cl.³** G02B 5/08; B60R 1/06

[52] **U.S. Cl.** 359/855; 359/864;
 359/865; 359/874; 359/877

[58] **Field of Search** 350/612, 616, 623, 624,
 350/625, 626, 627, 633, 634, 636, 637

[56] **References Cited**

U.S. PATENT DOCUMENTS

4,022,520 10/1977 Scifres 350/616
 4,190,326 2/1980 Brodbeck 350/636
 4,268,120 5/1981 Jitsumori 350/624
 4,283,117 8/1981 Ellis 350/625

FOREIGN PATENT DOCUMENTS

0287181 10/1988 European Pat. Off. 350/637
 2409748 9/1975 Fed. Rep. of Germany 350/627
 2628042 9/1989 France 350/634
 0186443 7/1989 Japan 350/612

Primary Examiner—Bruce Y. Arnold
Assistant Examiner—R. D. Shafer
Attorney, Agent, or Firm—Michael J. Striker

[57] **ABSTRACT**

A double external rear view mirror assembly for motor vehicles and comprising a frame that supports a comparatively large flat mirror and a comparatively small convex mirror, and two actuators for pivoting the two mirrors, respectively, about their respective longitudinal and transverse axes with each of the actuators including two electric motors mounted on the frame base, a support for supporting a respective mirror in the frame, and a transmission element that connects the two motors with the support for the respective mirror to pivot the same about its longitudinal and transverse axes.

3 Claims, 1 Drawing Sheet

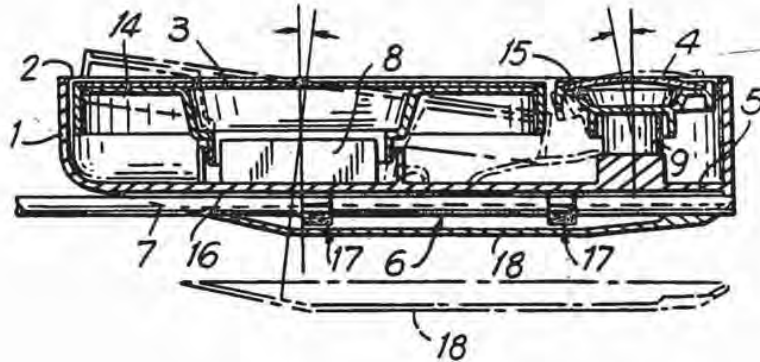

FIG. 1

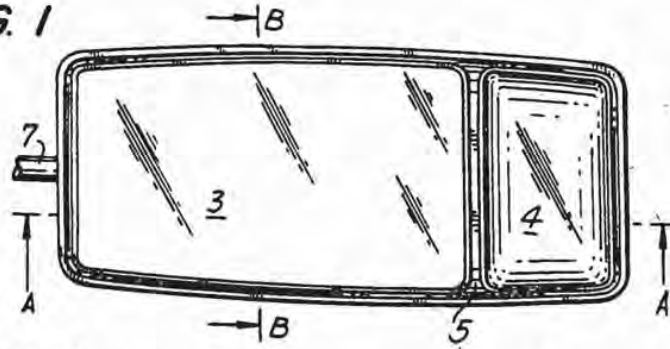

FIG. 2

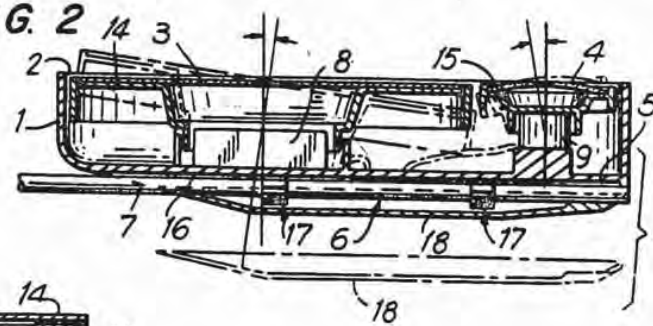

FIG. 3

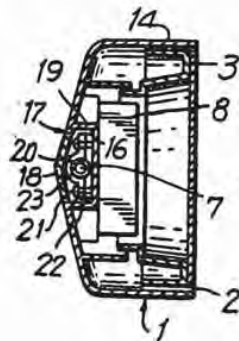
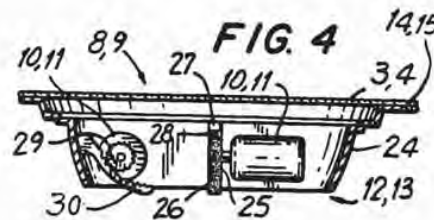

FIG. 4



DOUBLE EXTERNAL REAR VIEW MIRROR ASSEMBLY FOR VEHICLES

BACKGROUND OF THE INVENTION

The invention relates to a double external rear view mirror assembly for vehicles. Double external rear view mirror assemblies which mostly are used in buses, trucks and the like, are known. These double external rear view mirror assemblies include assemblies in which a comparatively large mirror is movable and a comparatively small mirror is fixed, and assemblies in which both mirrors are movable, generally by hand. However, in both types of double external rear view mirror assemblies, the adjustment range is small, and the adjustment itself is inconvenient for a vehicle operator to execute. Besides, these double rear view mirror assemblies are very unstable.

SUMMARY OF THE INVENTION

The object of the invention is to provide a double external hand-adjustable rear view mirror assembly for a vehicle which can be easily adjusted by a vehicle operator.

Another object of the invention is a vehicle double external rear view mirror assembly that has a relatively wide range of regulation for both mirrors.

A further object of the invention is a vehicle double external rear view mirror assembly that is stable during vehicle movement.

The object of the invention is achieved by providing a double rear view mirror assembly that comprises a comparatively large flat mirror and a comparatively small convex mirror which are mounted in a common frame and are movable by electric motors controlled by a vehicle operator from inside of the vehicle cabin.

The present invention both as to its construction so to its mode of operation, together with additional objects and advantages thereof, will be best understood from the following detailed description of the preferred embodiment with reference to the the accompanying drawings.

BRIEF DESCRIPTION OF THE DRAWINGS

FIG. 1 shows a front view of a double external rear view mirror assembly according to the invention;

FIG. 2 shows a cross-sectional view of the assembly shown in FIG. 1 along line A—A;

FIG. 3 shows a cross-sectional view of the assembly shown in FIG. 1 along line B—B;

FIG. 4 shows a cross-sectional view of a portion of a mirror actuating mechanism; and

FIGS. 5 and 6 are cross-sectional views showing further details of the inventive double external rear view mirror.

DESCRIPTION OF THE PREFERRED EMBODIMENT

FIG. 1 shows a double external rear view mirror assembly comprising a substantially prismatic and rectangular frame 1 having a front opening 2 in which a comparatively large flat mirror 3 and a comparatively small convex mirror 4 are mounted. Both mirrors are pivotable about their respective horizontal and vertical axes. The base 5 of the frame 1 is connected to a bracket 6 of a support assembly 7 by which the mirror assembly is mounted on a vehicle body. The double external rear view mirror assembly further comprises actuators 8 and

9 for adjusting the mirrors 3 and 4, respectively. Each of the actuators 8 and 9 comprises a pair of electric motors 10 and 11 mounted on the frame base 5. The electric motors 10 and 11 are connected by transmission elements 12 and 13 with support 14 for the comparatively large flat mirror 3 and support 15 for the comparatively small convex mirror 4, respectively.

The bracket 6 for the support assembly 7 has a bottom portion 16 arranged centrally at the bottom of the base 5 and in which connection elements 17 of the support 7 are engaged. The bottom portion 16 is closed by a removable cover 18. Each connection element 17 comprises a fixed base 19 having a central clip 20. The base 19 supports a locking bar 22. The locking bar 22 is connected to the base 19 by screws 21. A second clip 23 is mounted on the base 19 in spaced relationship relative to clip 20. A portion of the support assembly 7 is received and fastened in the space between the two clips.

The frame 1 and mirrors 3 and 4 generally have a shape that is best harmonized with the vehicle model.

The transmission elements 12 and 13 that connect the motors 10 and 11 with supports 14 and 15, respectively, may generally include a ring 24 having an upper edge on which a respective support 14 or 15 for the comparatively large flat mirror 3 or comparatively small and convex mirror 4, respectively, is mounted. The ring 24 is pivotally supported in the frame by support means 28. Motors of a respective pair of motors are mounted on the bottom of the base 5 with their respective axes extending transverse to each other. One of the respective pair of motors whose axis extends parallel to the longitudinal axis of the respective mirror, has at an end of the output shaft thereof a pinion 25 that engages an arched rack 26 extending transverse to the axis of the one of the motors. One of the end portions of the arched rack 26 is connected with the upper portions 27 of the respective ring 24. The other of the respective pair of motors, whose axis extends transverse to the axis of the one motor, and parallel to the transverse axis of the mirror, has at an end of the output shaft thereof a gear 29. The gear 29 engages a second arched rack 30 that is mounted transverse relative to the rack 26 and is connected at an end thereof to the ring 24 at a point displaced by 90° with respect to the point at which the rack 26 is connected with the ring 24.

The control of actuators 8 and 9 can be effected from inside of the cabin of the vehicle.

While the invention has been illustrated and described as embodied in a double external rear view mirror, it is not intended to be limited to the details shown, since various modifications and structural changes may be made without departing in any way from the spirit of the present invention.

What is claimed as new and desired to be protected by Letters Patent is set forth in the appended claims.

What is claimed is:

1. A double external rear view mirror assembly for motor vehicles, comprising a substantially prismatic frame including a base having inner and outer surfaces; a comparatively large flat mirror and a comparatively small convex mirror supported in said frame, each mirror having longitudinal and transverse axes; and two actuators arranged in said frame for moving said large and small mirrors, respectively, about their respective longitudinal and transverse axes, each of said two actuators including a pair of electric motors for moving a respective mirror about its longitudinal and transverse

3

4

axes, respectively, and mounted on the inner surface of said base, a support for supporting said respective mirror in said frame, and transmission means for connecting said pair of electric motors with said support to move said support with said respective mirror about the longitudinal and transverse axes of said respective mirror, said pair of electric motors including a first motor having an axis and a first output shaft, and mounted on said inner surface of said base such that the axis of said first motor extends parallel to the longitudinal axis of said respective mirror, and a second motor having an axis and a second output shaft, and mounted on said inner surface of said base such that the axis of said second motor extends parallel to the transverse axis of said respective mirror, said transmission means comprising a ring member having an upper edge for fixedly supporting said support for said respective mirror and surrounding said first and second motors, first and second arched racks extending substantially perpendicular to the longitudinal and transverse axes of said respective mirror, respectively, and fixedly connected to said ring

member, and first and second gears mounted on said first and second output shafts of said first and second motors, respectively, and engaging said first and second arched racks, respectively, for pivoting said ring member together with said support for said respective mirror about the longitudinal and transverse axes of said respective mirror, respectively.

2. A double external rear view mirror assembly as set forth in claim 1, further comprising means for attaching said frame to a vehicle body, said attaching means including a mounting assembly for attaching said frame to the vehicle body and a bracket attached to said outer surface of said base for connecting said frame with said mounting assembly.

3. A double external rear view mirror assembly as set forth in claim 2, wherein said bracket includes a bottom extending centrally along said outer surface of said base and connection means for connecting said mounting assembly to said bottom of said bracket.

25

30

35

40

45

50

55

60

65

359-864 AU 2507 EX
07/11/95 OR 5,432,643



US005432643A

United States Patent [19]
Huang

[11] **Patent Number:** 5,432,643
[45] **Date of Patent:** Jul. 11, 1995

- [54] **AUXILIARY MIRROR ASSEMBLY FOR REAR VIEW MIRROR**
- [76] **Inventor:** Chi S. Huang, P.O. Box 1032, Tainan, Taiwan
- [21] **Appl. No.:** 287,518
- [22] **Filed:** Aug. 8, 1994
- [51] **Int. Cl.⁶** G02B 5/08; G02B 7/182; B60R 1/06; B60R 1/08
- [52] **U.S. Cl.** 359/864; 359/865; 359/872; 248/477
- [58] **Field of Search** 359/862, 864, 865, 866, 359/872; 248/467, 476, 477
- [56] **References Cited**

U.S. PATENT DOCUMENTS

2,764,913 10/1956 Green 359/855
4,526,446 7/1985 Adams 359/865
4,629,296 12/1986 White 359/865

4,932,769 6/1990 Goosen 359/865
5,044,739 9/1991 do Espirito Santo 359/866

FOREIGN PATENT DOCUMENTS

320231 10/1929 United Kingdom 248/477

Primary Examiner—Ricky D. Shafer

[57] **ABSTRACT**

An auxiliary mirror device is for securing to a rear view mirror of a vehicle, and includes a base secured to the rear view mirror and a housing rotatable relative to the base. The housing includes a tapered portion for engaging with an optical reflecting member which includes an angular position that may be adjusted relative to the base when the housing is rotated relative to the base. The housing includes a tooth for engaging with a number of teeth formed in the base so as to position the housing relative to the base.

3 Claims, 8 Drawing Sheets

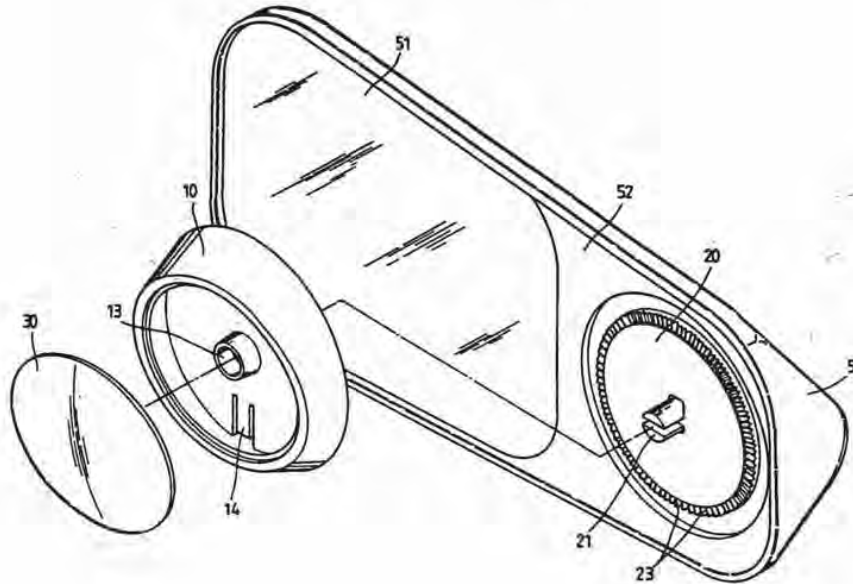

AUXILIARY MIRROR ASSEMBLY FOR REAR VIEW MIRROR

BACKGROUND OF THE INVENTION

1. Field of the Invention

The present invention relates to an auxiliary mirror, and more particularly to an auxiliary mirror assembly for rear view mirror.

2. Description of the Prior Art

A typical auxiliary mirror for rear view mirror is disclosed in U.S. Pat. No. 4,311,363 to Marsalka et al. and comprises an optical reflecting element assembled in a support housing. However, the auxiliary mirror is simply attached to the rear view mirror. The angular position of the auxiliary mirror may not be adjusted.

The present invention has arisen to mitigate and/or obviate the afore-described disadvantages of the conventional auxiliary mirrors.

SUMMARY OF THE INVENTION

The primary objective of the present invention is to provide an auxiliary mirror assembly for a rear view mirror in which the auxiliary mirror may be adjusted relative to the rear view mirror.

In accordance with one aspect of the invention, there is provided an auxiliary mirror assembly comprising a base for securing to a rear view mirror, the base including a plurality of first teeth formed therein; a housing rotatably secured to the base and including at least one second tooth formed thereon for engaging with the first teeth so as to position the housing relative to the base, the housing including a tapered portion distal to the base; and an optical reflecting member secured to the tapered portion of the housing, and the optical reflecting member being adjusted relative to the base when the housing is rotated relative to the base.

The housing includes a bottom surface having a hub formed therein, the base includes a pair of shafts extended therefrom for engaging with the hub of the housing so as to be secured to the housing. The shafts include a stop means for engaging with the hub so as to retain the shafts to the hub. The bottom surface includes at least one positioning arm formed therein, the second tooth is formed on the positioning arm for engaging with the first teeth of the base.

Further objectives and advantages of the present invention will become apparent from a careful reading of a detailed description provided hereinbelow, with appropriate reference to accompanying drawings.

BRIEF DESCRIPTION OF THE DRAWINGS

FIG. 1 is an exploded view of an auxiliary mirror assembly in accordance with the present invention;

FIG. 2 is a perspective view of the auxiliary mirror assembly;

FIGS. 3 and 4 are cross sectional views taken along lines 3-3' and 4-4' of FIG. 2;

FIG. 5 is an exploded view illustrating the attachment of the auxiliary mirror assembly to a rear view mirror;

FIG. 6 is a perspective view illustrating the attachment of the auxiliary mirror assembly to a rear view mirror;

FIG. 7 is an exploded view showing another application of the auxiliary mirror assembly in accordance with the present invention;

FIGS. 8 and 9 are perspective views illustrating the attachment of the auxiliary mirror assembly to the rear view mirror; and

FIGS. 10 and 11 are cross sectional views taken along lines 10-10' and 11-11' of FIGS. 3 and 4 respectively.

DETAILED DESCRIPTION OF THE PREFERRED EMBODIMENT

Referring to the drawings, and initially to FIGS. 1 to 3, an auxiliary mirror assembly in accordance with the present invention is generally designated with reference numeral "1" and comprises a housing 10 defined by a peripheral wall 11 which includes a tapered upper portion having an annular shoulder 110 formed therein for engaging with an optical reflecting member 30, best shown in FIGS. 3 and 4. The housing 10 includes a bottom surface 12 having a hub 13 formed in the center and having a pair of positioning arms 14 oppositely formed therein. Each of the positioning arms 14 includes a free end having a tooth 140 formed thereon.

A base 20 includes a bifurcated axle or a pair of shafts 21 for engaging in the hub 13 of the housing 10. The shafts 21 each includes a stop means 22 formed in the free end for engaging with the hub 13 so as to secure the base 20 to the housing 10. The base 20 includes a plurality of teeth 23 formed in the peripheral portion for engaging with the teeth 140 of the positioning arm 14.

In operation, as shown in FIGS. 3, 4 and 10, 11, when the housing 10 is rotated relative to the base 20, the teeth 140 of the positioning arms 14 may engage with the teeth 23 of the base 20 so as to position the housing 10 relative to the base 20. It is to be noted that the optical reflecting member 30 is inclined relative to the base 20 such that the angular position of the optical reflecting member 30 may be adjusted relative to the base 20 when the housing 10 is rotated relative to the base 20.

Referring next to FIGS. 5 and 6, the auxiliary mirror assembly 1 may be secured to the optical reflecting member 51 of a rear view mirror 50 with adhesive material 40. The housing 10 may also be rotated relative to the base 20.

Alternatively, please refer to FIGS. 7-9, the rear view mirror 50 may include a board 52 provided therein and the base 20 may be directly provided or formed in the board 52. The angular position of the optical reflecting member 30 may also be adjusted by rotating the housing 10 relative to the base 20.

Accordingly, the auxiliary mirror assembly in accordance with the present invention includes an optical reflecting member 30 having an angular position that may be adjusted.

Although this invention has been described with a certain degree of particularity, it is to be understood that the present disclosure has been made by way of example only and that numerous changes in the detailed construction and the combination and arrangement of parts may be resorted to without departing from the spirit and scope of the invention as hereinafter claimed.

I claim:

1. An auxiliary mirror comprising:
 - a base for securing to a rear view mirror, said base including a plurality of first teeth formed therein and a pair of shafts;
 - a housing rotatably secured to said base and including at least one second tooth formed thereon for engaging with said first teeth so as to position said housing relative to said base, said housing including

5,432,643

3

4

a bottom surface having a hub formed therein, said pair of shafts being engaged with said hub of said housing so as to be secured to said housing, and a tapered portion distal to said base; and
an optical reflecting member secured to said tapered portion of said housing, and said optical reflecting member being adjusted relative to said base when said housing is rotated relative to said base.

2. An auxiliary mirror according to claim 1, wherein said shafts include a stop means for engaging with said hub so as to retain said shafts to said hub.

3. An auxiliary mirror according to claim 1, wherein said bottom surface of said housing includes at least one positioning arm formed therein, said second tooth is formed on said positioning arm for engaging with said first teeth of said base.

* * * * *

10

15

20

25

30

35

40

45

50

55

60

65

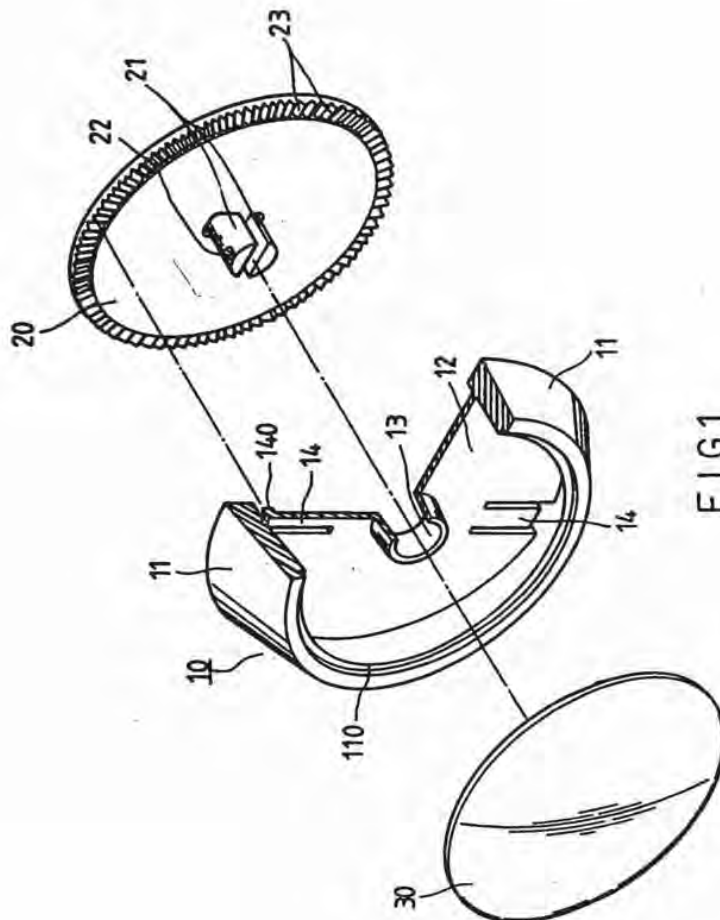
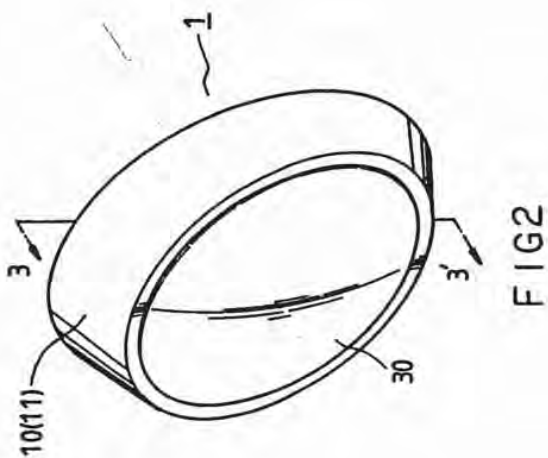

FIG 1



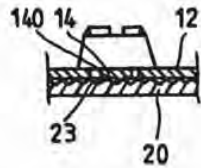

FIG 10

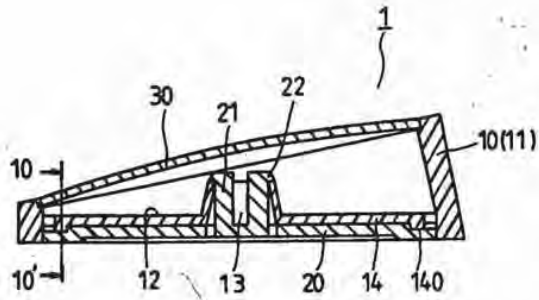

FIG 3

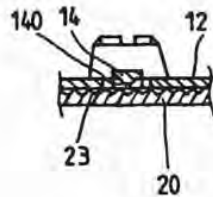

FIG 11

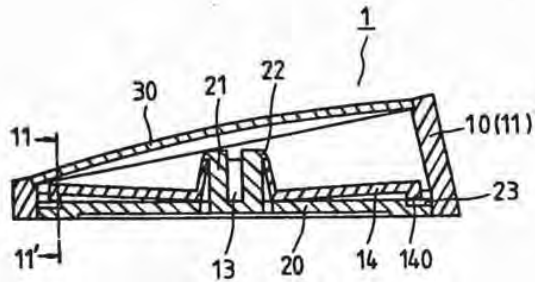

FIG 4

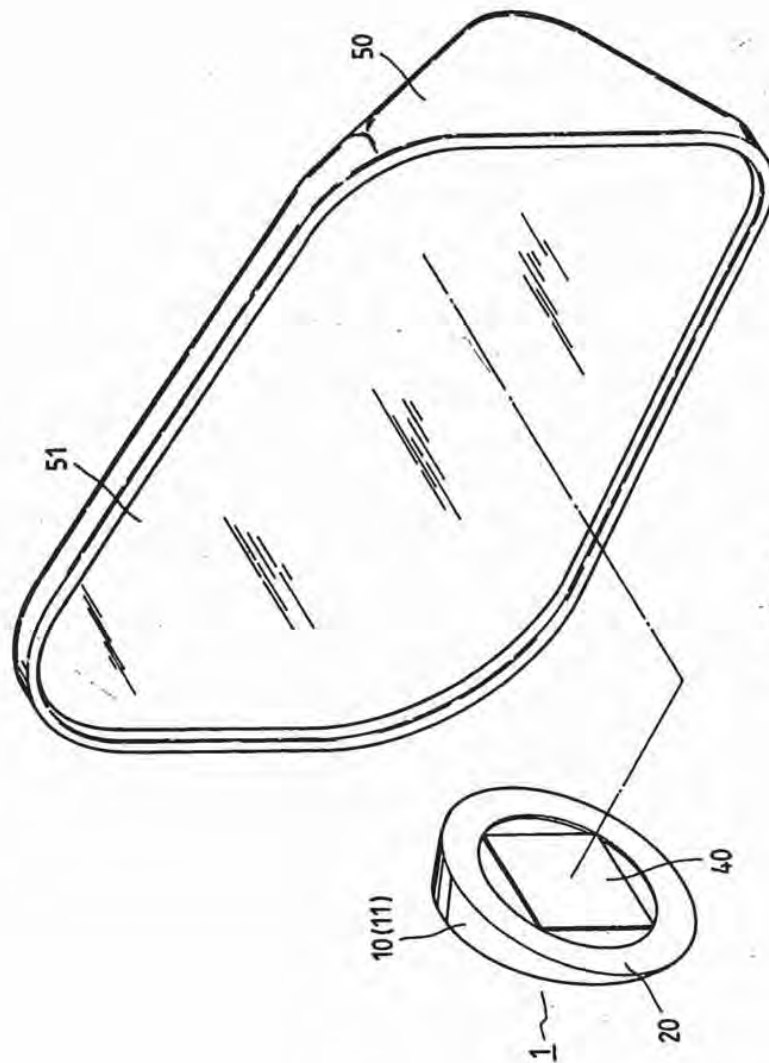

FIG 5

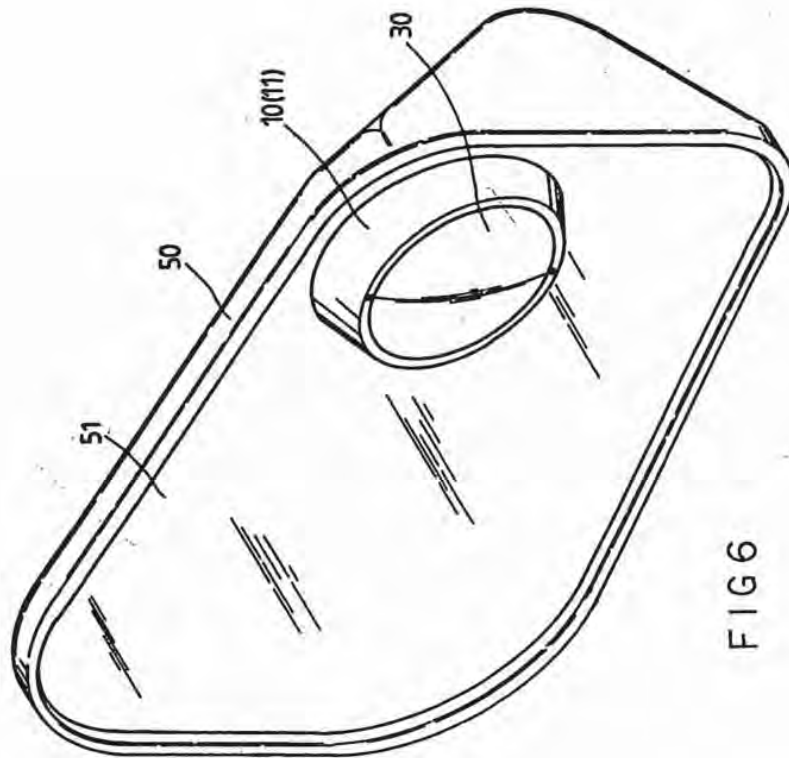

FIG 6

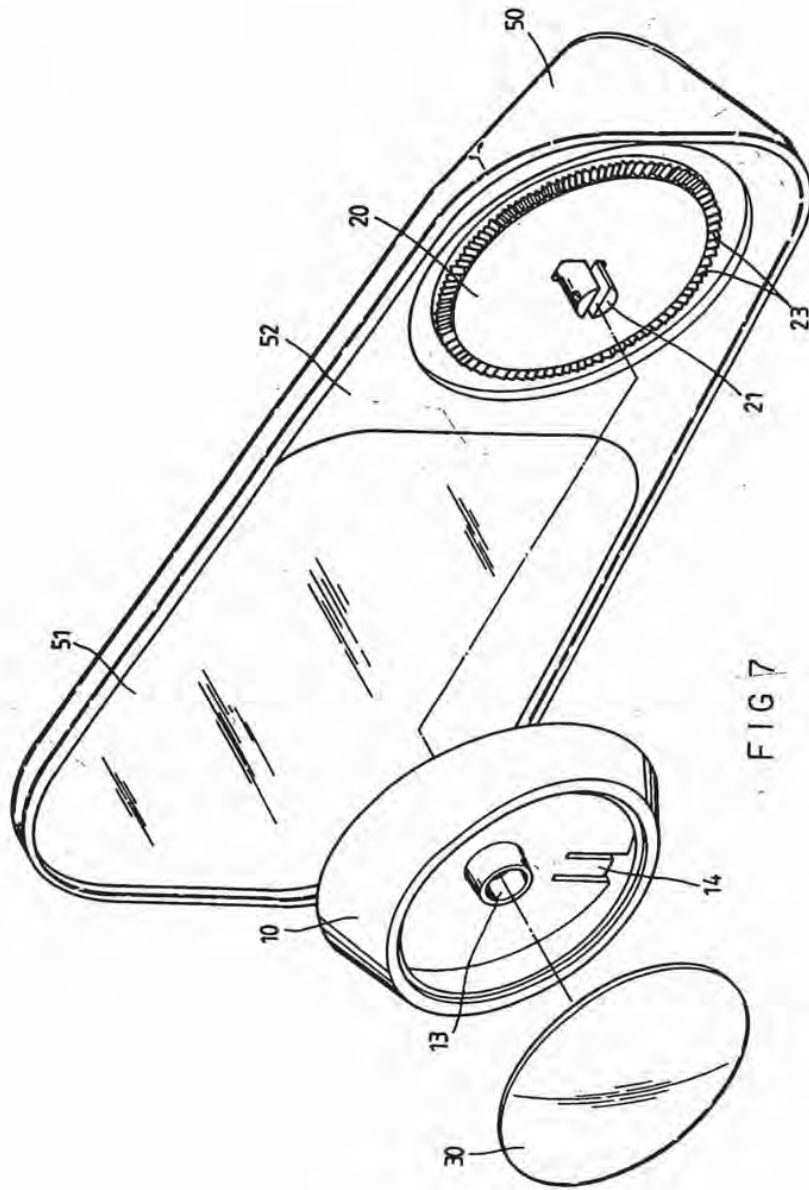
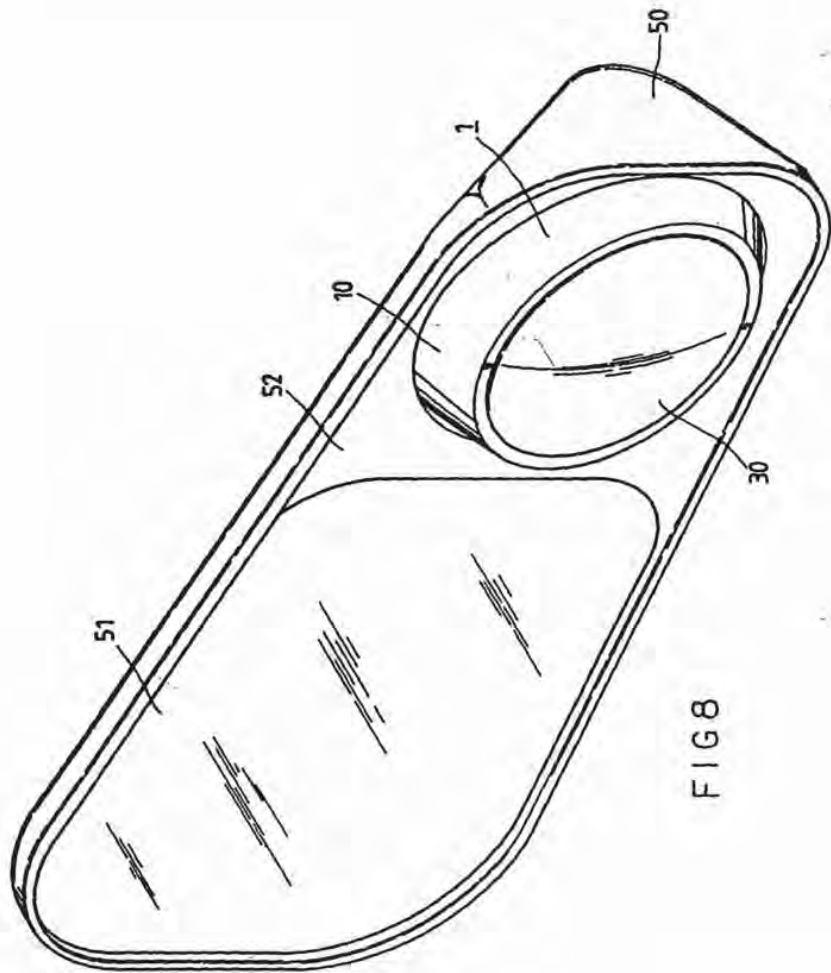

FIG 7



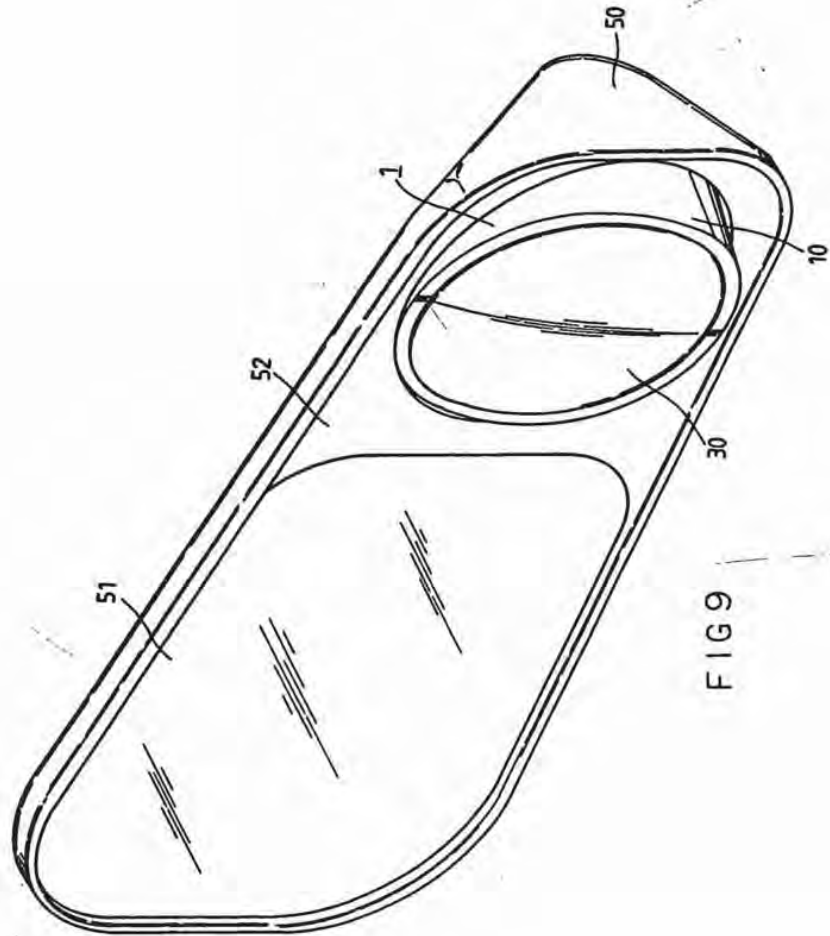

FIG 9

359-666 AL 0907 83
 04/15/97 XP 3 5621569



US005621569A

United States Patent (19)
Schlenke

(11) **Patent Number:** 5,621,569
 (45) **Date of Patent:** Apr. 15, 1997

- (54) **REAR-VIEW MIRROR FOR VEHICLES**
- (76) **Inventor:** Hubert Schlenke, Hasenwinkel 13, D-5778 Meschede, Germany
- (21) **Appl. No.:** 78,240
- (22) **PCT Filed:** Sep. 17, 1991
- (86) **PCT No.:** PCT/EP91/01764
 § 371 Date: Oct. 24, 1994
 § 102(e) Date: Oct. 24, 1994
- (87) **PCT Pub. No.:** WO92/11147
 PCT Pub. Date: Jul. 9, 1992
- (30) **Foreign Application Priority Data**
 Dec. 20, 1990 [DE] Germany 40 40 839.6
- (51) **Int. Cl.⁶** G02B 5/08; G02B 5/10; B60R 1/04; B60R 1/08
- (52) **U.S. Cl.** 359/603; 359/604; 359/864; 359/866; 359/868
- (58) **Field of Search** 359/603, 604, 359/605, 854, 855, 864, 865, 866, 868
- (56) **References Cited**
U.S. PATENT DOCUMENTS
 3,764,201 10/1973 Haile 359/868

4,258,979	3/1981	Mahin	359/868
4,264,144	4/1981	McCord	359/868
4,331,382	5/1982	Graff	359/868
4,449,786	5/1984	McCord	359/868
5,005,962	4/1991	Edelman	359/866

FOREIGN PATENT DOCUMENTS

1941895	3/1971	Germany	359/868
2054396	5/1972	Germany	359/868
1279158	6/1972	United Kingdom	359/868

Primary Examiner—Ricky D. Shafer
Attorney, Agent, or Firm—Browdy and Neimark

(57) **ABSTRACT**

The invention concerns a vehicle rear-view mirror (1) comprising a plane-mirror section (2) and at least one convex section (3, 11) contiguous with the sides of the plane section. The curvature of the convex side sections is zero at the transition line (4, 12) with the plane-mirror section (2), and increases progressively with increasing arc length (L) from the transition line, the cur of vertical orthogonal lines of intersection being equal to the curvature of a horizontal reference line (6, 6A) at their point of intersection. The rear-view mirror (1) proposed enables the driver to view both behind and to the side. The mirror (1) is easy to produce since the curvature of the convex side sections (3, 11) only departs by a small amount from the plane of the plane-mirror section (2).

20 Claims, 3 Drawing Sheets

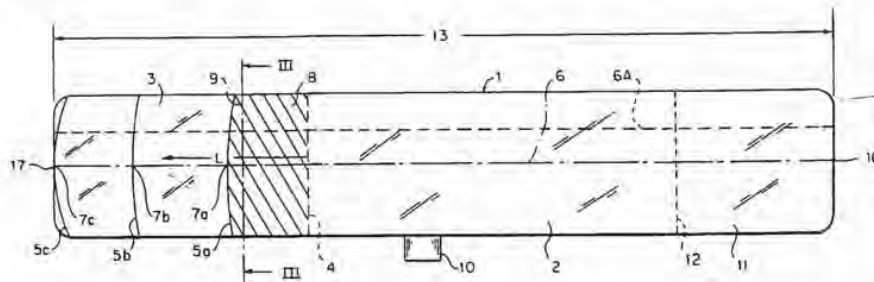

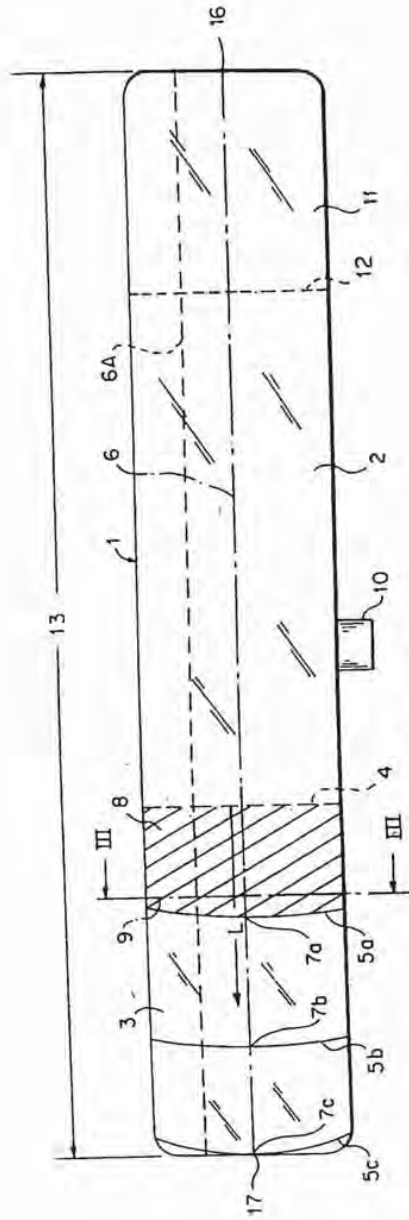

FIG. 1

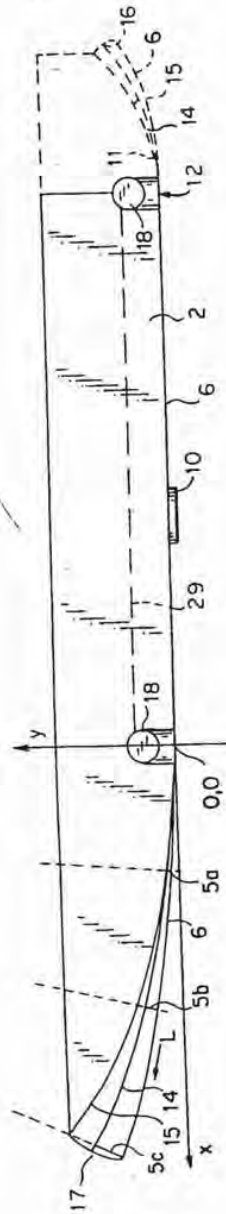

FIG. 2

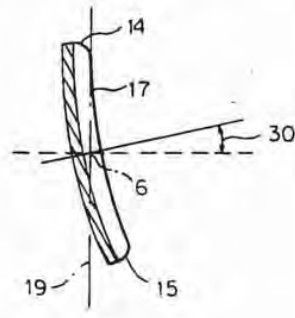

FIG. 3

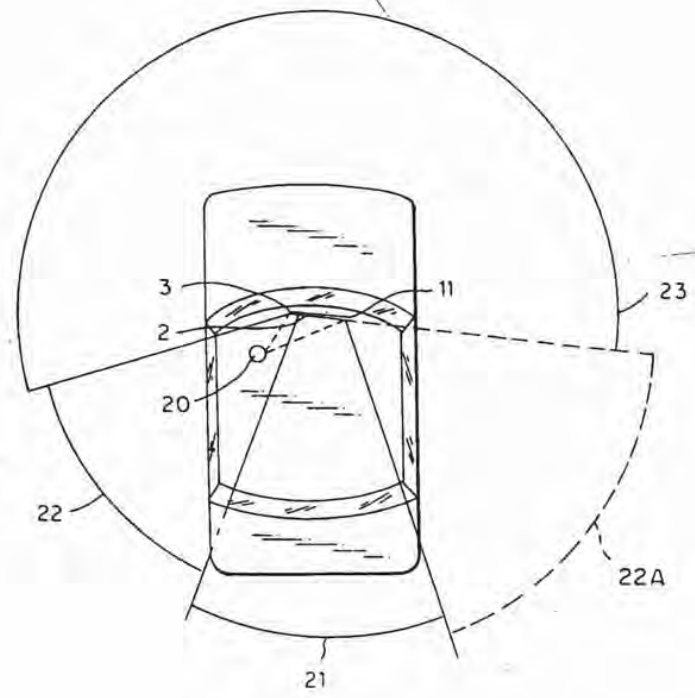

FIG. 4

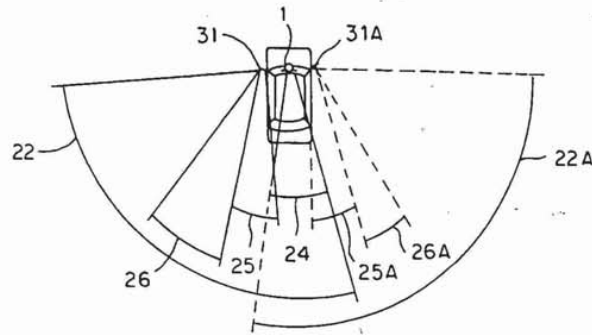

FIG. 5

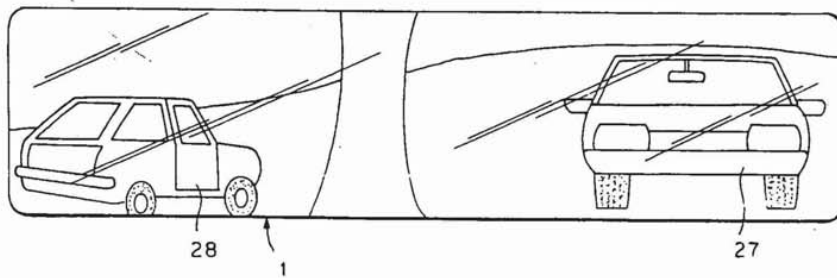

FIG. 6

1

REAR-VIEW MIRROR FOR VEHICLES

The invention relates to a rear-view mirror for motor vehicles, comprising a plane-mirror section and at least one convexly curved side section contiguous with the sides of the plane-mirror section and sloping steadily, and having a curvature of zero at the transition line to the plane-mirror section, the curvature of the side section increasing progressively with increasing distance from the plane-mirror section.

A rear-view mirror of this type is known from Netherlands Patent Document NL-A-6 400 067 as an outside mirror for a vehicle. In this case the flat mirror makes a continuous changeover into a spherical mirror with a decreasing curvature radius. Because the outside mirror is disposed under the eye level of the driver and only the lateral space is perceived from the vehicle, the visual distortions of the horizontal line that result in the transitional area into the spherical mirror are tolerable. For an inside mirror disposed above the eye level of the driver and offset from it toward the vehicle center, and which also encompasses at least the viewing area behind the vehicle, double images and a severe distortion of the horizontal line result with a dimensioning of this type, leading to visual errors.

A further rear-view mirror is already known from European Patent Document 0 210 757 A 2. In this mirror it is provided that the flat mirror section changes over tangentially into the curved section, whose curvature increases suddenly at the transition line and is further increased in spiral fashion. The sudden change in curvature is disadvantageous not only for recognizability of a reflected image due to resulting double images, but also for production.

Further, inside rear-view mirrors are known from German Patent Document DE 17 55 828 A1 in which a horizontally and vertically curved side-mirror section is contiguous with a plane-mirror section. The curvature radii of the side-mirror section are intended to become smaller with increasing distance from the mirror center. Although the curvature of this side-mirror section increases outwardly, this increase in curvature takes place in steps, not in a steady manner. This steplike increase in curvature causes a transition that is noticeable as a kink, not merely at the transition line from the plane-mirror section into the side-mirror section, but at each changeover of curvature radius, thus preventing a side view adequate to fulfill safety requirements, because as the number of radius changeovers increases, an equal number of kinks that distort the reflected image and cause double images is present on the side-mirror section. An embodiment of the side mirror curvature may permit a virtually distortion-free side view for the driver if the respective difference of the curvature radii is set to be appropriately low; however, even with this determination of curvature, no seamless changeover of curvature is provided from the plane-mirror section into the curved side-mirror section, so that the rear view is impaired at least at the transition line, which has a negative overall effect on the performance capability of this rear-view mirror.

Further, inside rear-view mirrors are known from German Patent Document DE 28 49 468 A 1 in which the plane-mirror section changes over, with respect to its horizontal axis, to a convexly curved side-mirror section shaped uniformly in the manner of a shell of a cylinder, by means of which the viewing angle is enlarged by the convex curvature of the side-mirror section in comparison to the plane-mirror section. This mirror permits a side view from the vehicle, but has the disadvantage of a distorted reflection of the side viewing field because of the cylinder shell-shaped

2

curvature. An assessment of the position of overtaking vehicles is exceedingly difficult. Moreover, there is no seamless changeover from the plane-mirror section into the curved side-mirror section, because the curvature of the side-mirror section changes suddenly at the transition line. For this reason the transition line is always perceived by the driver as a kink that causes an irregular reflected image, particularly double images. Because of the distortion of the reflected image and the kink at the transition line, the driver particularly cannot judge the position of overtaking vehicles, either sufficiently or at all, the consequence of which is a considerable reduction in safety.

Further, inside rear-view mirrors are known from German Patent Document DE 34 01 033 A 1 that permit an undistorted view through the side window by means of a combination of one main mirror and two side mirrors, which can be adjusted independently of each other to different viewing angles.

The design-related spacing between the respective individual mirrors does not permit an error-free side view, however, because the driver perceives only double images when one eye looks into the main mirror and the other eye looks into the offset side mirrors. The two eyes receive two different image signals from the angled side mirrors that can only be imprecisely assembled by the human brain into one complete image. Because of this, considerable visual perceptual errors occur that reduce safety in traffic. This rear-view mirror also causes an early onset of the decline in the seeing ability of the driver due to fatigue, because in the use of the three-part rear-view mirror he must view not only one inside mirror, but three at once.

In summary, the variations of a rear-view mirror known up to now do not adequately include the "blind spot" that lies between the direct viewing area and the side view from the curved mirror area; they only permit an unsatisfactory side view that does not meet safety requirements because of distortion or double images.

The object of the invention is to modify a mirror of the type mentioned for use as an inside rear-view mirror, wherein it is intended to be ensured that the area of the front side window on the driver side is also included visually without leaving a "blind spot," and that the spatially curved area of the rear-view mirror offers an assessable reflection, free from double images, of vehicles to the side with respect to the position of the driver's own vehicle.

The object is attained in that the rear-view mirror is an inside rear-view mirror, that the lines of intersection of orthogonal planes of the side-mirror section are circles whose curvature corresponds respectively to the curvature of a horizontal line of reference on the side-mirror section in their point of intersection with the circles, that the curvature of the side-mirror section increases in the manner of a clothoid spiral in linear fashion with the arc length on the horizontal line of reference on the side-mirror section, that the curvature of the clothoid spiral defining the curvature of the side-mirror section on the driver's side has a clothoid parameter A between 100 mm and 200 mm, and that the horizontal line of reference extends in the center or above the center of the mirror center, approximately at the height of an apparent horizontal line for the normal viewer.

The arc of the curve in accordance with the invention is distinguished in that the convex curvature of orthogonal lines of intersection of the side-mirror section surface corresponds to the curvature of a horizontal line of reference on the side-mirror section at the respective points of intersection.

A reflection of the objects to the side of the driver's own vehicle, particularly overtaking vehicles, that overcomes the previous "blind spot" and is for the most part free from distortion, is attained by means of the progressively increasing arc of the curve of the side-mirror section of the invention. Because of the reducing effect that occurs due to the steady, progressive decrease of the curvature radii toward the mirror end, the enlargement due to the approach of an overtaking vehicle is nearly compensated. By means of this compensation, a vehicle passing to the side can be visually discerned in the best possible manner, compared with conventional plane mirrors, because the apparent speed at which the vehicle in the reflected image passes is reduced to a more discernible rate. The continuous change in the curvature from the plane-mirror section to the side-mirror section permits a spatial detection by both eyes of viewed objects.

It has proven to be particularly advantageous to set the horizontal line of reference approximately at the height of a horizontal line visible to the normal viewer, that is, above the horizontal center of the mirror, because the normal viewer always selected the basic position in such a way that the road is reflected by the largest part of the mirror surface.

The arc of the curve of the horizontal curvature of the mirror surface is embodied as a clothoid spiral. The curvature law $1/R=C \times L$, where $C=A^2$, is a result of the requirement that the curvature of the mirror surface is to increase in linear fashion with the arc length. In this equation A is the so-called clothoid parameter.

The transition from the plane-mirror section into the curved side-mirror section is likewise effected according to the law of clothoid spirals. The result is a continuous transition from $R=\infty$ to $R=x$, the radius that extends over the arc length. It has proven to be sufficient to bridge the previous "blind spot" on the driver's side when the clothoid spiral progress has a parameter of $A=100$ mm to 200 mm and is embodied as extending to an end radius of $R=100$ mm to $R=300$ mm.

Special features of the rear-view mirror are characterized in the dependent claims.

The lengths of the plane-mirror section and the side-mirror section are at a ratio of approximately 2:1, and the side-mirror section has a length of 8 to 15 cm, preferably 12 cm.

It has proven to be particularly advantageous that the progress of the clothoid has a clothoid parameter A of 130 mm. The curved surface that normally results from this departs only slightly in the back from the plane of the planar mirror section. This slight divergence is not only visually advantageous, but also greatly simplifies the manufacturing process of the rear-view mirror. Because of the stepless transition in curvature, the curved area can be produced simply and without optical errors through hot bending of flat glass. The mathematical definition of the curved surface allows the curved shape to be produced very simply by means of a program-controlled, automated machine.

The inside rear mirror with the side-mirror section curvature of the invention is also suited for eliminating the previous "blind spot" on the passenger side if an appropriately sized, curved side-mirror section is also contiguous with the plane-mirror section on this side.

With proper sizing, the plane-mirror section on the passenger side can be correspondingly shortened so that a curved side-mirror section can also be received on this side of the plane-mirror section. The result of this is an enlargement of the rear-view angle toward the passenger side as well, without it being necessary to enlarge the rear-view mirror overall.

In an advantageous embodiment, the area contiguous with the plane-mirror section is torqued such that the upper mirror edge is drawn further into the vehicle interior than the lower mirror edge. The torsion begins at the transition line of the plane-mirror section to the side-mirror section and extends over approximately $\frac{1}{4}$ of the side-mirror section. The resulting tilt angle of 3° to 9° is maintained from the end of the torsion to the outer edge of the mirror.

The side-mirror section rotated downwardly around the horizontal line of reference reflects the left side of the road at approximately the height of the line of reference. Because of this, the basic position of the rear-view mirror inside the vehicle can be adjusted for optimum viewing to the side and rear. Because of the torsion, the adjusting tilt-lever dimming device provided for the plane mirror can be operated when the plane-mirror section and respective side-mirror section are connected in one piece; this does not impede the function of the respective side-mirror section.

It has proven to be particularly advantageous to set the horizontal line of reference approximately at the height of a horizontal line visible to the normal viewer, that is, above the horizontal center of the mirror, because the normal viewer always selects the basic position in such a way that the road is reflected by the largest part of the mirror surface. Torsion can be omitted with this embodiment.

It is proposed as a particular embodiment of the invention that a hinge be provided between the plane-mirror section and the side-mirror section, by means of which the plane-mirror section is dimmed by the known tilt-lever device and the side-mirror section is dimmed by means of an anti-glare coating. The plane mirror adjusted for dimming is also contiguous directly and without changes in curvature or slope with the curved side-mirror section.

The invention is explained in detail below by means of an exemplary embodiment. The drawings show in:

FIG. 1: a schematic front view of the rear-view mirror;

FIG. 2: the rear-view mirror surface in a view from above;

FIG. 3: a cross-section of the side-mirror section (III—III), seen from the torsion end line in the direction toward the left end of the mirror;

FIG. 4: a schematic view of the sight angle seen by a normal driver through the rear-view mirror;

FIG. 5: a schematic view of the view of the driver through the rear-view mirror of a vehicle to the rear and a vehicle in the previous "blind spot" to the left, next to the driver; and

FIG. 6: a schematic view of the sight angle seen in the rear-view mirror, in comparison to commercial rear-view mirrors.

FIG. 1 shows the rear-view mirror (1) schematically in a front view. The mirror comprises a plane-mirror section (2) extending from the right end of the rear-view mirror (16) to the transition line (4) and a convexly curved side-mirror section (3) contiguous with it and extending from the transition line (4) to the left end of the mirror (17). The plane-mirror section (2) comprises approximately $\frac{2}{3}$ of the total length of the mirror (13), and the side-mirror section (3) comprises approximately $\frac{1}{3}$ of the total mirror length.

The horizontal line of reference (6) in the exemplary embodiment extends through the center of the rear-view mirror (1) in the form of a clothoid spiral with the parameter $A=130$ mm. The convex curvature of the horizontal line of reference (6) increases progressively with an increasing arc length (L) toward the left end of the rear-view mirror (17).

5

In the side-mirror section (3), lines of intersection of planes of intersection (5a-5c) that are orthogonal to the line of reference (6) are drawn by way of example; their curvature corresponds to the curvature of the horizontal line of reference (6) at their points of intersection (7a-7c). The horizontal and vertical curvature radii of these points of intersection (7a-7c) chosen by way of example can be seen from the following table, according to the formula $R=A^2:L$ with a clothoid parameter of $A=130$ mm.

Point of Intersection	Arc Length (L) (in mm)	Curvature Radius (R) (in mm)
(7a)	40	338
(7b)	80	211.25
(7c)	120	140.833

The coordinates (x, y) of the horizontal line of reference (6) are determined for the clothoid parameter $A=1$, i.e., in normal form, by the respective arc length (L) according to the following equations:

$$x = \int_0^L \cos L^2/2 \cdot dL; \quad y = \int_0^L \sin L^2/2 \cdot dL.$$

A torsion section, for instance, is embodied between the transition line (4) and a vertical torsion end line (9).

Instead of the arrangement of the horizontal clothoid line of reference (6) in the center of the mirror, in another embodiment the clothoid line of reference (6A) is provided approximately at the height of the apparent horizontal image in the rear-view mirror (1), that is, above the center. This permits a better downward view to the side, and two-wheeled vehicles being driven very closely to the vehicle can be well seen. The torsion section (8) can thus be omitted, because it has a similar effect.

Further, a dimming tilt-lever (10) is shown schematically with which at least the plane-mirror section (2) can be adjusted to be free from glare.

In the right area of the rear-view mirror, a further side-mirror section (11) can optionally be provided that is curved in the manner of a clothoid spiral and extending from the vertical transition line (12) such that the right side window area can be seen. The clothoid parameter A is larger than on the curved side-mirror section (3) on the driver's side because of the different viewing angles.

FIG. 2 shows the mirror surface of the exemplary embodiment in a top view. The side-mirror section (3), which becomes more sharply curved with increasing arc length (L), is contiguous at the transition line (4) with the plane-mirror section (2). At the transition line (4) the coordinates (x, y) of the horizontal line of reference (6, 6A) equal zero. The upper mirror edge (14) of the side-mirror section (3) points away from the viewer to a lesser extent than the lower mirror edge (15) because of the torsion or upward displacement of the horizontal line of reference (6).

The optional right side-mirror section (11) shown in dashed lines has a smaller lateral extension and more severe curvature than the left side-mirror section (3).

Hinges (18, 18A) are shown on the back side of the mirror, at the transition lines (4, 12), by means of which the dimming of the plane-mirror section (2) around the dimming tilt axis (29) is possible without an effect of the adjustment angle of the side-mirror sections (3, 11).

6

FIG. 3 shows a cross-section of the side-mirror section (3), seen from the torsion end line (9) in the direction toward the left mirror end (17). The upper mirror edge (14) is rotated toward the vehicle interior around the horizontal line of reference (6), while the lower mirror edge (15) is rotated away from the vehicle interior around the horizontal line of reference (6). The torsion is illustrated in comparison to a vertical line of reference (19). The angle of torsion (30) of the exemplary embodiment is $3^\circ-9^\circ$ with respect to the vertical line of reference (19).

FIG. 4 shows the viewing angle (21) perceived through the plane-mirror section (2) from the position of a normal driver (20) and the viewing angle (22) perceived through the side-mirror section (3, 11). It can be seen that the viewing angle (22) perceived from the side-mirror section (3) directly adjoins the direct viewing angle (23), thus eliminating the previous "blind spot."

The right side viewing angle (22A) shown in dashed lines results when the right curved side-mirror section (3) is provided. This section also allows detection of two-wheeled vehicles, in particular, that are driving closely next to the vehicle.

FIG. 5 clearly shows the viewing angle (22, 22A) of a normal driver that is expanded by the rear-view mirror (1), in comparison to the inside plane-mirror viewing angle (24), and the outside mirror viewing angle (25, 25A) and outside side-angle view (26, 26A) that can be perceived through standard outside mirrors (31, 31A). The wide-angle mirror encompasses a smaller area than the part of the inside mirror curved in accordance with the invention because of its disadvantageous position with respect to the viewer.

FIG. 6 shows how the normal driver sees a vehicle (27) behind him and a vehicle (28) next to him in the rear-view mirror (1). An approximately parallel course of perspective lines and a nearly constant size of the apparent images result from the progressively increasing reduction of approaching objects.

I claim:

1. A rear-view mirror (1) for vehicles, comprising a plane-mirror section (2) and at least one convexly curved side section (3, 11) contiguous with the sides of the plane-mirror section and sloping steadily, and having a curvature of zero at the transition line (4, 12) into the plane-mirror section (2), the curvature of the side section continuously increasing progressively with increasing distance from the plane-mirror section (2), characterized in that the rear-view mirror (1) is an inside rear-view mirror, that the lines of intersection of orthogonal planes of the side-mirror section (3, 11) are circles whose curvature corresponds respectively to the curvature of a horizontal line of reference (6, 6A) on the side-mirror section in their point of intersection with the circles, that the curvature of the side-mirror section (3, 11) increases in the manner of a clothoid spiral in linear fashion with the arc length (L) on the horizontal line of reference (6, 6A) on the side-mirror section (3, 11), that the curvature of the clothoid spiral defining the curvature of the side-mirror section (3) on a driver's side has a clothoid parameter A between 100 mm and 200 mm, and that the horizontal line of reference (6, 6A) extends in the center or above the center of the mirror center, approximately at the height of an apparent horizontal line (6A) for a normal viewer.

2. The rear-view mirror as defined by claim 1, characterized in that the clothoid spiral has a clothoid parameter of $A=130$ mm.

3. The rear-view mirror as defined by claim 2, characterized in that a torsion section (8) of the curved side-mirror section (3) that is defined by the transition line (4) and a

7

vertical torsion end line (9) is oriented downward by approximately 3° to 9° around the horizontal line of reference (6) extending through the torsion section, and that the torsion section (8) is disposed to extend over approximately 1/4 of the curved side-mirror section (3).

4. The rear-view mirror as defined by claim 1, characterized in that a torsion section (8) of the curved side-mirror section (3) that is defined by the transition line (4) and a vertical torsion end line (9) is oriented downward by approximately 3° to 9° around the horizontal line of reference (6) extending through the torsion section, and that the torsion section (8) is disposed to extend over approximately 1/4 of the curved side-mirror section (3).

5. The rear-view mirror as defined by claim 4, characterized in that the lengths of the plane mirror section (2) and the side-mirror section (3) are in a ratio of approximately 2:1, and that the length of the side-mirror section (3) is approximately 8 to 15 cm.

6. The rear-view mirror as defined by claim 5, characterized in that the length of the side-mirror section (3) is approximately 12 cm.

7. The rear-view mirror as defined by claim 4, characterized in that the rear-view mirror (1) is embodied in one piece.

8. The rear-view mirror as defined by claim 7, characterized in that at least the plane-mirror section (2) is adjustable by means of dimming tilt-lever (10).

9. The rear-view mirror as defined by claim 8, characterized in that a hinge (18) is disposed between the plane-mirror section (2) and the side-mirror section (3, 11).

10. The rear-view mirror as defined by claim 9, characterized in that the side-mirror section (23, 11) is provided with an anti-glare coating.

11. The rear-view mirror as defined by claim 9, characterized in that the clothoid spiral defining the curvature of the side-mirror section (11) disposed on a passenger's side has a larger clothoid parameter A than the clothoid spiral

8

defining the curvature of the side-mirror section (3) on the driver's side.

12. The rear-view mirror as defined by claim 9, characterized in that the side-mirror section (3, 11) is produced by means of hot bending of a flat glass plate.

13. The rear-view mirror as defined by claim 1, characterized in that the lengths of the plane-mirror section (2) and the side-mirror section (3) are in a ratio of approximately 2:1, and that the length of the side-mirror section (3) is approximately 8 to 15 cm.

14. The rear-view mirror as defined by claim 13, characterized in that the length of the side-mirror section (3) is approximately 12 cm.

15. The rear-view mirror as defined by claim 1, characterized in that the rear-view mirror (1) is embodied in one piece.

16. The rear-view mirror as defined by claim 1, characterized in that at least the plane-mirror section (2) is adjustable by means of a dimming tilt-lever (10).

17. The rear-view mirror as defined by claim 1, characterized in that a hinge (18) is disposed between the plane-mirror section (2) and the side-mirror section (3, 11).

18. The rear-view mirror as defined by claim 1, characterized in that the side-mirror section (3, 11) is provided with an anti-glare coating.

19. The rear-view mirror as defined by claim 1, characterized in that the clothoid spiral defining the curvature of the side-mirror section (11) disposed on a passenger's side has a larger clothoid parameter A than the clothoid spiral defining the curvature of the side-mirror section (3) on the driver's side.

20. The rear-view mirror as defined by claim 1, characterized in that the side-mirror section (3, 11) is produced by means of hot bending of a flat glass plate.

* * * * *

Octroiraad



10 A Terinzagelegging 11 7908257

Nederland

19 NL

- 54 **Achteruitkijkspiegel.**
- 51 **Int.Cl⁹: B60R1/08.**
- 71 **Aanvrager: Nicolaas Bartholomeus de Jongh te Rotterdam.**
- 74 **Gem.: Ir. A. Siedsma c.s.
Octroobureau Arnold & Siedsma
Sweelinckplein 1
2517 GK 's-Gravenhage.**

-
- 21 **Aanvraag Nr. 7908257.**
 - 22 **Ingediend 12 november 1979.**
 - 32 **--**
 - 33 **--**
 - 31 **--**
 - 23 **--**
 - 61 **--**
 - 62 **--**

-
- 43 **Ter inzage gelegd 1 juni 1981.**

De aan dit blad gehechte stukken zijn een afdruk van de oorspronkelijk ingediende beschrijving met conclusie(s) en eventuele tekening(en).

"Achteruitkijkspiegel"

De uitvinding heeft betrekking op een achteruitkijkspiegel, in het bijzonder voor motorvoertuigen, omvattende een vlak hoofdspiegeldeel en een hulpspiegeldeel voor het vergroten van het gezichtsveld van de gebruiker.

5 Een dergelijke achteruitkijkspiegel is bekend uit de Nederlandse ter inzage gelegde octrooiaanvraag No. 77.11500. Bij deze bekende achteruitkijkspiegel is het hulpspiegeldeel uitgevoerd als vlakke spiegel. Dit brengt een aantal problemen en beperkingen met zich mee, die de
10 uitvinding beoogt op te lossen resp. op te heffen. Bij juiste instelling van de bekende spiegel kan inderdaad worden bereikt, dat het gezichtsveld van de gebruiker zodanig wordt vergroot, dat de "dode hoek" door het hulpspiegeldeel wordt bestreken, hetgeen de verkeersveiligheid ten goede komt.
15 Bij deze bekende spiegel is evenwel een juiste instelling van het uiterste belang, aangezien bij zelfs geringe verstellingen het gevaar bestaat, dat de gebruiker misleid wordt door de door hem in de spiegel waargenomen beelden. Bovendien is het hulpspiegeldeel bij de bekende achteruitkijkspiegel
20 relatief klein uitgevoerd, zodat slechts zeer beperkte informatie over de verkeerssituatie in de dode hoek wordt verkregen. Zoals verder blijkt uit de beschrijving van de bekende spiegel, is deze spiegel beperkt tot toepassing bij een buitenspiegel aan de zijde van de bestuurder, en wel in
25 het bijzonder voor het bestrijken van de dode hoek.

De uitvinding stelt zich ten doel, een achteruitkijkspiegel te verschaffen, die de gebruiker meer uitgebreide informatie over de verkeerssituatie achter hem verschaft en zich bovendien leent voor toepassingen, waarbij de
30 gebruiker gebaat kan zijn bij extra visuele informatie.

Met het oog daarop stelt de uitvinding een achteruitkijkspiegel van het in de aanhef vermelde type voor, die volgens de uitvinding het kenmerk vertoont, dat het hulpspiegeldeel bol is.

7908257

Van voordeel is die uitvoeringsvorm, waarbij het hulpspiegeldeel is uitgevoerd als op het hoofdspiegeldeel aanbrengbaar, los element. Op deze wijze kan een bezitter van een reeds van een achteruitkijkspiegel voorzien voertuig
5 een hulpspiegeldeel aanbrengen, zodat hij een samengestelde achteruitkijkspiegel verkrijgt met een hoofdspiegeldeel en een hulpspiegeldeel.

Praktisch is die uitvoeringsvorm van een los hulpspiegeldeel, waarbij dit hulpspiegeldeel is voorzien
10 van een vlakke achterplaat, waarop een klevend element is aangebracht. Bij voorkeur is dit klevende element uitgevoerd als dubbelzijdig klevende, veerkrachtige plaat. Dit heeft het voordeel dat, indien door een ongeval het hoofdspiegel-
deel beschadigd raakt, het hulpspiegeldeel met redelijke
15 waarschijnlijkheid intact blijft, zodat de gebruiker zijn reis zonder gevaar kan voortzetten.

Verder geniet de voorkeur die uitvoeringsvorm, waarbij het hulpspiegeldeel rond is en zijn rand ten minste enigszins vloeiend aan het oppervlak van het hoofdspiegeldeel
20 aansluit. Deze uitvoeringsvorm is van voordeel aangezien daarbij, anders dan bij de constructie van de bekende spiegel volgens de Nederlandse octrooiaanvraag No. 77.11500, geen kans bestaat, dat bijvoorbeeld bij het wassen van het voertuig de hulpspiegel losraakt.

25 In een verdere variant is het hulpspiegeldeel als één geheel met het hoofdspiegeldeel uitgevoerd.

Bijvoorbeeld kan de spiegel een draagplaat met een vlak en een bol deel omvatten, op welke draagplaat een spiegelende laag is aangebracht. Deze spiegelende laag kan
30 op de achterzijde van de draagplaat zijn aangebracht, waarbij de draagplaat transparant is. In dit geval dient de draagplaat tevens als beschermlaag voor de spiegelende laag. Ook kan de spiegelende laag aan de voorzijde van de draagplaat zijn aangebracht. In dat geval kan de draagplaat zijn
35 uitgevoerd als geheel vlakke plaat, met een bolvormig, verdikt deel, hetgeen de stevigheid van de plaat ten goede komt, maar de spiegelende laag onbeschermd laat.

7908257

Een verdere variant is die, waarbij het hoofd-
spiegeldeel en het hulpspiegeldeel zijn uitgevoerd als een
plaat met een vlak en een bol deel, het oppervlak van welke
plaat glad is. Bijvoorbeeld kan deze plaat van gepolijst
5 aluminium zijn.

Zoals reeds is opgemerkt, biedt de spiegel
volgens de uitvinding nog verder gaande toepassingsmogelijk-
heden. Niet alleen de horizontale gezichtshoek van de ge-
bruiker wordt namelijk vergroot, maar ook de verticale.
10 Hiervan kan gebruik worden gemaakt door bijvoorbeeld een
spiegel volgens de uitvinding aan de van de gebruiker
afgewende zijde van de auto aan te brengen, waardoor hij
bijvoorbeeld bij achteruit parkeren ook lager geplaatste
obstakels, bijvoorbeeld kilometerpalen of dergelijke,
15 kan waarnemen. Verder kan een spiegel volgens de uitvinding
als binnenspiegel in een voertuig worden geplaatst. Op deze
wijze heeft de chauffeur steeds een goed zicht op de in het
voertuig achter hem plaatsvindende gebeurtenissen, bijvoor-
beeld spelende kinderen.

20 De uitvinding zal nu worden toegelicht aan de
hand van de bijgaande tekening. Hierin tonen:
fig. 1 een aanzicht van een uitvoeringsvoorbeeld
van een spiegel volgens de uitvinding;
fig. 2 een dwarsdoorsnede langs de lijn II-II
25 in fig. 1;
fig. 3 een tweede uitvoeringsvorm van de spiegel
volgens de uitvinding;
fig. 4 een derde uitvoeringsvorm van de spiegel
volgens de uitvinding;
30 fig. 5 een schematisch bovenaanzicht van een
auto met een spiegel volgens de uitvinding, waarbij de
horizontale gezichtshoek van de chauffeur is weergegeven; en
fig. 6 een schematisch zijaanzicht van een auto,
waarbij de verticale gezichtshoek van de chauffeur is
35 weergegeven.

Fig. 1 toont een aanzicht van een eerste uit-
voeringsvorm van een achteruitkijkspiegel volgens de uit-
vinding. Deze spiegel omvat een vlak hoofdspiegeldeel 1 en

7908257

een bol hulpspiegeldeel 2, welk hoofdspiegeldeel 1 is ingebed in een huis 3, waarvan de rand 4 in fig. 1 zichtbaar is. Het hulpspiegeldeel 2 beslaat slechts een relatief klein gedeelte van het spiegeloppervlak van het hoofdspiegeldeel 1, waardoor de normaal met een vlakke spiegel verkregen informatie praktisch geheel behouden blijft. Door de bolle vorm van de spiegel 2 wordt een grotere gezichtshoek verkregen, een en ander zoals schematisch in fig. 1 is weergegeven in de vorm van het in de achteruitkijkspiegel door de gebruiker waargenomen beeld.

Fig. 2 toont een dwarsdoorsnede door de spiegel volgens fig. 1 langs de lijn II-II. In dit uitvoeringsvoorbeeld is de hulpspiegel 2 uitgevoerd als los op het hoofdspiegeldeel 1 aangebracht element, omvattende het eigenlijke hulpspiegeldeel 2, een hulpspiegeldeelhuis 5, bijvoorbeeld uit aluminium, met een vlak achteroppervlak, waarop een tweezijdig klevend, veerkrachtig element 6 is aangebracht. Zoals uit deze figuur blijkt, is de omtreksrand van het hulpspiegeldeelhuis 5 zodanig gevormd, dat, te zamen met het tweezijdige klefelement een enigszins vloeiende aansluiting op het oppervlak van het hoofdspiegeldeel 1 wordt verkregen.

Fig. 3 toont een tweede uitvoeringsvoorbeeld van de spiegel volgens de uitvinding, waarin het spiegelhuis niet is weergegeven. In deze uitvoeringsvorm omvat de spiegel een draagplaat 7, aan de achterzijde waarvan een spiegelende laag 8 is aangebracht. De draagplaat 7 moet in dit geval uit transparant materiaal bestaan; de spiegelende laag 8 kan zijn uitgevoerd als reflecterende kunststof, aluminiumfolie, spiegelende kunststof of door een opdamptechniek op de draagplaat 7 zijn aangebracht.

Fig. 4 toont een derde variant van de spiegel volgens de uitvinding, waarbij een draagplaat 9, waarvan het achteroppervlak geheel vlak is en het voorvlak ten dele vlak en ten dele bol, aan zijn voorzijde is voorzien van een spiegelende laag 10. Deze spiegelende laag 10 kan in principe op dezelfde wijze zijn uitgevoerd als reeds aan de hand van fig. 3 is besproken.

7908257

Opgemerkt wordt, dat in het uitvoeringsvoorbeeld volgens fig. 3 de spiegelende laag 8 door de draagplaat 7 tegen beschadiging is beschermd. In het uitvoeringsvoorbeeld volgens fig. 4 is dat niet het geval; de spiegelende laag 10 is derhalve bij voorkeur een weinig steviger, dikker, uitgevoerd dan de spiegelende laag 8.

Ten overvloede wordt opgemerkt, dat het uitvoeringsvoorbeeld volgens de fig. 1 en 2 in die zin van de uitvoeringsvoorbeelden volgens de fig. 3 en 4 verschilt, dat bij de fig. 1 en 2 sprake is van een hoofdspiegeldeel met een daarop aanbrengbaar los hulp Spiegeldeel, terwijl in de fig. 3 en 4 sprake is van een achteruitkijkspiegel, waarbij het hoofdspiegeldeel en het hulp Spiegeldeel geïntegreerd zijn uitgevoerd.

Fig. 5 toont, hoe de horizontale gezichtshoek van een gebruiker vergroot door toepassing van een spiegel volgens de uitvinding. Met getrokken lijnen zijn de grenzen van het gezichtsveld in horizontale richting van de gebruiker bij gebruik van het hoofdspiegeldeel weergegeven; de onderbroken lijnen tonen de grenzen van het gezichtsveld van de gebruiker, indien hij in het hulp Spiegeldeel kijkt. Duidelijk is, dat geen enkele wezenlijke informatie voor de gebruiker verloren gaat, terwijl, zelfs bij een aanzienlijke verstelling van de gehele achteruitkijkspiegel, een voldoende groot gezichtsveld overblijft. Het behoeft geen betoog, dat dit een zeer belangrijke eigenschap is, die is verkregen door toepassing van een bol hulp Spiegeldeel volgens de uitvinding.

De in fig. 6 getekende situatie heeft betrekking op het geval, waarin de chauffeur gebruik maakt van de achteruitkijkspiegel volgens de uitvinding om bijvoorbeeld in achterwaartse richting te parkeren. Behalve de reeds aan de hand van fig. 5 beschreven horizontale vergroting van zijn gezichtshoek blijkt uit fig. 6 de aanzienlijke vergroting van de verticale gezichtshoek, die in het bijzonder van belang is voor het waarnemen van laag geplaatste obstakels, overstekende kinderen, of dergelijke. De getrokken lijnen duiden, evenals in fig. 5, het gezichtsveld met het hoofdspiegeldeel aan, terwijl de onderbroken lijnen het gezichtsveld van het hulp Spiegeldeel weergeven.

7908257

De uitvinding beperkt zich niet tot de beschreven uitvoeringsvoorbeelden. Diverse wijzigingen in de onderdelen en in hun onderlinge samenhang kunnen worden aangebracht, zonder dat daardoor het kader van de uitvinding wordt
5 overschreden.

Bijvoorbeeld is in de tekening slechts het geval aangeduid, waarbij het hulpspiegeldeel rond is uitgevoerd. Het zal evenwel duidelijk zijn, dat elke andere gewenste vorm ook kan worden toegepast.

10 Tevens is een variant denkbaar, waarbij het hulpspiegeldeel vloeiend, met een geleidelijke overgang aansluit op het hoofdspiegeldeel, zodat in het hoofdspiegel-
deel en het hulpspiegeldeel geen van elkaar gescheiden
15 beelden worden waargenomen, maar slechts één beeld, dat evenwel aan de vloeiend verlopende omtreksrand van het hulpspiegeldeel vervormd is.

7908257

CONCLUSIES

1. Achteruitkijkspiegel, in het bijzonder voor motorvoertuigen, omvattende een vlak hoofdspiegeldeel en een hulpspiegeldeel voor het vergroten van het gezichtsveld van de gebruiker, met het kenmerk, dat het hulpspiegeldeel
5 bol is.

2. Achteruitkijkspiegel volgens conclusie 1, met het kenmerk, dat het hulpspiegeldeel is uitgevoerd als op het hoofdspiegeldeel aanbrengbaar, los element.

3. Achteruitkijkspiegel volgens conclusie 2,
10 met het kenmerk, dat het hulpspiegeldeel is voorzien van een vlakke achterplaat, waarop een klevend element is aangebracht.

4. Achteruitkijkspiegel volgens conclusie 3, met het kenmerk, dat het klevende element is uitgevoerd
15 als dubbelzijdig klevende, veerkrachtige plaat.

5. Achteruitkijkspiegel volgens conclusie 3 of 4, met het kenmerk, dat het hulpspiegeldeel rond is en zijn rand ten minste enigszins vloeiend aan het oppervlak van het hoofdspiegeldeel aansluit.

6. Achteruitkijkspiegel volgens conclusie 1, met het kenmerk, dat het hulpspiegeldeel is uitgevoerd als één geheel met het hoofdspiegeldeel.
20

7. Achteruitkijkspiegel volgens conclusie 6, gekenmerkt door een draagplaat met een vlak en een bol deel,
25 waarop een spiegelende laag is aangebracht.

8. Achteruitkijkspiegel volgens conclusie 7, met het kenmerk, dat de draagplaat transparant is en de spiegelende laag op de achterzijde daarvan is aangebracht.

9. Achteruitkijkspiegel volgens conclusie 7,
30 met het kenmerk, dat de spiegelende laag op de voorzijde van de draagplaat is aangebracht.

10. Achteruitkijkspiegel volgens conclusie 6, met het kenmerk, dat het hoofdspiegeldeel en het hulpspiegel-
deel zijn uitgevoerd als plaat met een vlak en een bol deel,
35 het oppervlak van welke plaat glad is.

7908257

11. Hulpspiegeldeel als omschreven in één der conclusies 2, 3, 4 of 5.

7908257

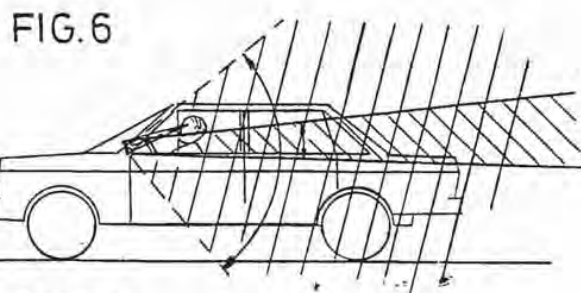
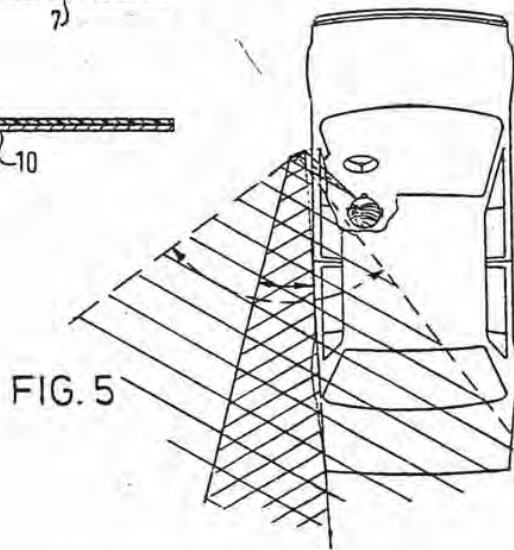
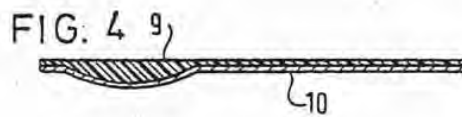
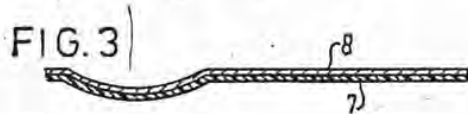
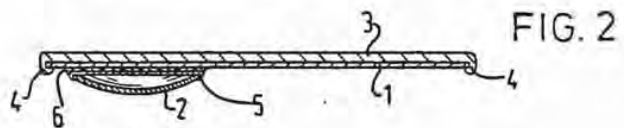
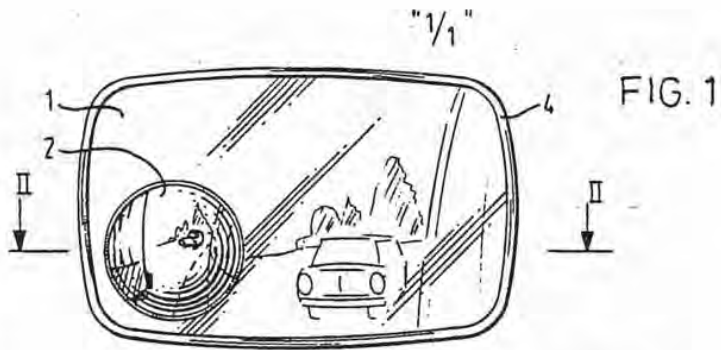

7908257



PATENT
DON01 P-793

IN THE UNITED STATES PATENT AND TRADEMARK OFFICE

Examiner : R. Shafer
Group : 2872
Applicant : Niall R. Lynam
Serial No. : 09/478,315
Filed : January 6, 2000
For : EXTERIOR MIRROR PLANO-AUXILIARY
REFLECTIVE ELEMENT ASSEMBLY

*Ext. 15
Ext. 1 mo.
J. McCallister
4/23/02*

Box RCE
Commissioner for Patents
Washington, D.C. 20231

Date of this Paper: April 5, 2002.

Dear Sir:

PETITION AND FEE FOR
EXTENSION OF TIME (37 C.F.R. 1.136(a))

1. This is a petition for an extension of time to respond to the Office Action mailed December 5, 2001, for a period of one month.

2. Applicant is:

a small entity

verified statement attached
verified statement filed

other than small entity

3. Extension (months)	Fee for other than small entity	Fee for small entity
<input checked="" type="checkbox"/> one month	\$110.00	\$55.00
two months	\$400.00	\$200.00
three months	\$920.00	\$460.00
four months	\$1,440.00	\$720.00

RECEIVED
APR 19 2002
TECHNOLOGY CENTER 2800

4. An amendment:

is filed herewith has been filed

5. Fee Payment:

Attached is a check in the amount of \$110.

Please charge any additional fees required or credit any excess fee paid to Deposit Account No. 22-0190. A duplicate of this Petition is attached.

VAN DYKE, GARDNER, LINN & BURKHART, LLP

Catherine S. Collins
Registration No. 37 599
2851 Charlevoix Drive, S.E.
P.O. Box 888695
Grand Rapids, MI 49588-8695
(616) 975-5500

04/17/2002 TBESHANI 00000055 09478315

02 FC:115

110.00 DP

CSC:lmsc



PTO/SB/30 (10-01)

Approved for use through 10/31/2002. OMB 0651-0031
U.S. Patent and Trademark Office: U.S. DEPARTMENT OF COMMERCE

Under the Paperwork Reduction Act of 1995, no persons are required to respond to a collection of information unless it displays a valid OMB control number.

REQUEST FOR CONTINUED EXAMINATION (RCE) TRANSMITTAL

Address to:
Commissioner for Patents
Box RCE
Washington, DC 20231

Application Number	09/478,315
Filing Date	January 6, 2000
First Named Inventor	Niall R. Lynam
Art Unit	2872
Examiner Name	R. Shafer
Attorney Docket Number	DON01 P-793

#16
RCE
J. M. Miller
4/23/02

This is a Request for Continued Examination (RCE) under 37 CFR 1.114 of the above-identified application. Request for Continued Examination (RCE) practice under 37 CFR 1.114 does not apply to any utility or plant application filed prior to June 8, 1995, or to any design application. See Instruction Sheet for RCEs (not to be submitted to the USPTO) on page 2.

1. **Submission required under 37 CFR 1.114**

a. Previously submitted

i. Consider the amendment(s)/reply under 37 CFR 1.116 previously filed on _____
(Any unentered amendment(s) referred to above will be entered).

ii. Consider the arguments in the Appeal Brief or Reply Brief previously filed on _____

iii. Other _____

b. Enclosed

i. Amendment/Reply

ii. Affidavit(s)/Declaration(s)

iii. Information Disclosure Statement (IDS)

iv. Other _____

2. **Miscellaneous**

a. Suspension of action on the above-identified application is requested under 37 CFR 1.103(c) for a period of _____ months. (Period of suspension shall not exceed 3 months; Fee under 37 CFR 1.17(i) required)

b. Other _____

3. **Fees** The RCE fee under 37 CFR 1.17(e) is required by 37 CFR 1.114 when the RCE is filed.

a. The Director is hereby authorized to charge ^{any additional} the following fees, or credit any overpayments, to Deposit Account No. 22-0190

i. RCE fee required under 37 CFR 1.17(e)

ii. Extension of time fee (37 CFR 1.136 and 1.17)

iii. Other _____

b. Check in the amount of \$740 and \$110 are enclosed

c. Payment by credit card (Form PTO-2038 enclosed)

WARNING: Information on this form may become public. Credit card information should not be included on this form. Provide credit card information and authorization on PTO-2038.

RECEIVED
APR 19 2002
TECHNOLOGY CENTER 2800

SIGNATURE OF APPLICANT, ATTORNEY, OR AGENT REQUIRED

Name (Print/Type)	Catherine S. Collins	Registration No. (Attorney/Agent)	37 599
Signature	<i>C. Collins</i>	Date	April 5, 2002

CERTIFICATE OF MAILING OR TRANSMISSION

I hereby certify that this correspondence is being deposited with the United States Postal Service with sufficient postage as first class mail in an envelope addressed to: Commissioner For Patents, Box RCE, Washington, DC 20231, or facsimile transmitted to the U.S. Patent and Trademark Office on the date shown below.

Name (Print/Type)	Catherine S. Collins	Date	April 5, 2002
Signature	<i>C. Collins</i>		

Burden Hour Statement: This form is estimated to take 0.2 hours to complete. Time will vary depending upon the needs of the individual case. Any comments on the amount of time you are required to complete this form should be sent to the Chief Information Officer, U.S. Patent and Trademark Office, Washington, DC 20231. DO NOT SEND FEES OR COMPLETED FORMS TO THIS ADDRESS. SEND Fees and Completed Forms to the following address: Assistant Commissioner for Patents, Box RCE, Washington, DC 20231.

04/17/2002 TBESHAI1 00000055 03478315

01 FC:179 740.00 0P



PATENT
DON01 P-793

IN THE UNITED STATES PATENT AND TRADEMARK OFFICE

Examiner : R. Shafer
Applicant : Niall R. Lynam
Serial No. : 09/478,315
Filed : January 6, 2000
Group : 2872
For : EXTERIOR MIRROR PLANO-AUXILIARY
REFLECTIVE ELEMENT ASSEMBLY

#177/c
Amend
RECEIVED
4/23/02
APR 19 2002
TECHNOLOGY CENTER 2800

Commissioner for Patents
Washington, D.C. 20231

Dear Sir:

RESPONSE

In response to the Office Action mailed December 5, 2001, having a three month period of response ending March 5, 2002, Applicant submit herewith a Petition and Fee for a One Month Extension of Time and amends his application as follows:

IN THE CLAIMS:

Please cancel Claims 35 and 44-83. Please amend Claims 1, 25-31, 84, and 85 as follows:

1. (Twice Amended)

Sub
DI
①

An exterior sideview mirror system suitable for use on an automobile, said exterior sideview mirror system comprising:
an exterior sideview mirror assembly adapted for attachment to a side of an automobile;
said exterior sideview mirror assembly including a reflective element having a rearward field of view when attached to the side of the automobile;
said reflective element attached to an electrically-operated actuator and movable by said actuator in order to position said rearward field of view in response to a control;
wherein said reflective element comprises a plano-multiradius reflective element assembly, said plano-multiradius reflective element assembly comprising a plano

①

Applicant : Niall R. Lynam
Serial No. : 09/478,315
Page : 2

reflective element having unit magnification and a separate multiradius reflective element having a multiradius curvature, said plano reflective element having a rearward field of view with a principal axis;

said plano reflective element and said multiradius reflective element of said plano-multiradius reflective element assembly mounted adjacently in said plano-multiradius reflective element assembly in a side-by-side relationship and not superimposed with one reflective element on top of the other reflective element, and supported by a backing plate element, said backing plate element mounting to said actuator such that movement of said backing plate element of said plano-multiradius reflective element assembly by said actuator simultaneously and similarly moves said plano reflective element and said multiradius reflective element, said multiradius reflective element having a rearward field of view with a principal axis, said backing plate element have a first support portion supporting said plano-reflective element and a second support portion supporting said multiradius reflective element, said second support portion tilted with respect to said first support portion whereby said principal axis of said rearward field of view of said multiradius element being different from and angled with respect to said principal axis of said rearward field of view of said plano reflective element when said multiradius reflective element and said plano reflective element are supported by said backing plate element of said plano-multiradius reflective element assembly and when said plano-multiradius reflective element assembly is mounted in said exterior sideview mirror assembly on the automobile, and said principal axis of said rearward field of view of said plano reflective element being directed generally parallel to the longitudinal axis of the automobile equipped with the plano-multiradius reflective element assembly, and wherein said principal axis of said rearward field of view of said multiradius reflective element is directed generally at an angle downwards to the longitudinal axis of the automobile; and

said multiradius reflective element being positioned at an outboard portion of said plano-multiradius reflective element assembly when said exterior sideview mirror assembly is mounted to the side of the automobile.

Applicant : Niall R. Lynam
Serial No. : 09/478,315
Page : 3

²³
25. (Amended)

The exterior sideview mirror system of Claim 1, wherein said angle downwards to the longitudinal axis of the automobile is in the range from about 1 degree to about 10 degrees.

²⁴
26. (Amended)

The exterior sideview mirror system of Claim 1, wherein said angle downwards to the longitudinal axis of the automobile is in the range from about 2 degrees to about 8 degrees.

²⁵
27. (Amended)

The exterior sideview mirror system of Claim 1, wherein said angle downwards to the longitudinal axis of the automobile is in the range from about 3 degrees to about 6 degrees.

²⁶
28. (Amended)

The exterior sideview mirror system of Claim 1, wherein said angle downwards to the longitudinal axis of the automobile is generally set by an angling of a surface of said backing plate element.

²⁷
29. (Amended)

The exterior sideview mirror system of Claim 1, wherein said exterior sideview mirror assembly comprises a door-mounted exterior sideview mirror assembly adapted for attachment to a side of the automobile adjacent a driver seating location of a driver of the automobile and wherein the principal axis of the rearward field of view of said multiradius reflective element is directed generally downwardly towards the road surface adjacent to the driver seating location at a distance in the range of about 1 foot to about 24 feet to the rear of the driver seating location.

²⁸
30. (Amended)

The exterior sideview mirror system of Claim 1, wherein said exterior sideview mirror assembly comprises a door-mounted exterior sideview mirror assembly adapted for attachment to a side of the automobile adjacent a driver seating location of a driver of the automobile and wherein the principal axis of the rearward field of view of said multiradius reflective element is directed generally downwardly towards the road surface

34

Applicant : Niall R. Lynam
Serial No. : 09/478,315
Page : 4

adjacent to the driver seating location at a distance in the range of about 1 foot to about 12 feet to the rear of the driver seating location.

31. (Amended)

noted C2
The exterior sideview mirror system of Claim 1, wherein said exterior sideview mirror assembly comprises a door-mounted exterior sideview mirror assembly adapted for attachment to a side of the automobile adjacent a driver seating location of a driver of the automobile and wherein the principal axis of the rearward field of view of said multiradius reflective element is directed generally downwardly towards the road surface adjacent to the driver seating location at a distance in the range of about 1 foot to about 8 feet to the rear of the driver seating location.

84. (Amended)

C3
An automobile exterior sideview mirror system comprising:
an exterior sideview mirror assembly adapted for attachment to a side of an automobile;
said exterior sideview mirror assembly including a plano-auxiliary reflective element assembly having a rearward field of view when attached to the side of the automobile;
an electrically-operated actuator adapted for adjusting the rearward field of view of said plano-auxiliary reflective element assembly in response to a control;
wherein said plano-auxiliary reflective element assembly comprises a plano reflective element having unit magnification and a separate auxiliary reflective element having a curvature, said plano reflective element and said auxiliary reflective element mounted adjacently in said plano-auxiliary reflective element assembly in a side-by-side relationship and not superimposed with one reflective element on top of the other reflective element, and supported by a backing plate element, said backing plate element mounting to said actuator such that movement of said backing plate element of said plano-auxiliary reflective element assembly by said actuator simultaneously and similarly moves said plano reflective element and said auxiliary reflective element, said auxiliary reflective element having a rearward field of view with a principal axis, said principal axis of said rearward field of view of said auxiliary element being different from and angled with respect to said

C

Applicant : Niall R. Lynam
Serial No. : 09/478,315
Page : 5

principal axis of said rearward field of view of said plano reflective element when said exterior sideview mirror assembly is mounted to the side of the automobile, and said principal axis of said rearward field of view of said plano reflective element being directed generally parallel to the longitudinal axis of the automobile equipped with the plano-auxiliary reflective element assembly and wherein said principal axis of said rearward field of view of said auxiliary reflective element is directed generally at an angle downwards to the longitudinal axis of the automobile; and

said auxiliary reflective element being positioned at an outboard portion of said plano-auxiliary reflective element assembly when said exterior sideview mirror assembly is mounted to the side of the automobile, and said auxiliary reflective element being located at one of:

(a) an upper portion of said outboard portion of said plano-auxiliary reflective element assembly thereby providing an auxiliary wide-angled view of a blind spot region of the vehicle, and a portion of said plano reflective element extending below said auxiliary reflective element; and

(b) a lower portion of said outboard portion of said plano-auxiliary reflective element assembly thereby providing an auxiliary wide-angled view of a blind spot region of the vehicle, and a portion of said plano reflective element extending above said plano-auxiliary reflective element.

85. (Amended)

The automobile exterior sideview mirror system according to Claim 84, wherein said auxiliary reflective element is located at said upper outboard portion of said plano-auxiliary reflective element assembly.

REMARKS

Applicant has reviewed the Office Action and cited references therein.

Applicant acknowledges the Examiner's review of the specification, claims, and drawings.

In light of the above amendments and following remarks, Applicant respectfully requests reconsideration of the present application. The amendments and remarks presented herein

Applicant : Niall R. Lynam
Serial No. : 09/478,315
Page : 6

are believed to be fully responsive to the Office Action and are fully supported by the application as originally filed. No new matter has been entered.

STATUS OF THE CLAIMS:

Claims 1-22, 25-34, 36-43, and 84-90 are pending in the application. Claims 23 and 24 were previously cancelled. Claims 44-83 have been cancelled as being drawn to a non-elected invention. Claim 35 has been cancelled by this amendment.

The Examiner has withdrawn Claims 84-90 as being directed to a non-elected invention. Applicant has amended Claim 84 to now include the separate details of "the backing plate element mounted to the actuator such that movement of the backing plate element of the plano-auxiliary reflective element assembly by the actuator simultaneously and similarly moves the plano reflective element and the auxiliary reflective element." Applicant now believes that Claims 84-90 are directed to the elected invention and, therefore, respectfully requests consideration of Claims 84-90 along with Claims 1, 16-22, 25-31, 33, and 35.

CLAIM REJECTIONS UNDER 35 U.S.C. § 112, SECOND PARAGRAPH:

The Examiner rejects Claims 25-31 and 35 as being indefinite. Specifically, the Examiner states that Claims 25-31 are vague and indefinite since they depend from a cancelled claim. With reference to Claim 35, the Examiner states that Claim 35 is vague due to the fact that the claim would appear to fail to further limit the subject matter of Claim 1, line 7. Claims 25-31 have been amended to depend from Claim 1. Claim 35 has been cancelled.

CLAIM REJECTIONS UNDER 35 U.S.C. § 103(a):

Applicant : Niall R. Lynam
Serial No. : 09/478,315
Page : 7

The Examiner rejects Claims 1, 16-22, 25-31, 33, and 35 under 35 U.S.C. § 103(a) as being unpatentable over Kondo et al. '542 or Hagiri '534 in view of Oskam '899 or Enomoto '166 and further in view of Tobin, Jr. '952 or Hacker et al. '158. The Applicant respectfully traverses. Applicant respectfully urges that none of the references, namely Kondo, Hagiri, Oskam, Enomoto, Tobin, Hacker, individually or when combined discloses or suggests the claimed combination. For example, none of the references discloses or suggests a plano-multiradius reflective element assembly that includes a plano reflective element of a unit magnification and a separate multiradius reflective element having a multiradius curvature, where the principal axis of the rearward field of view of the multiradius element is different from and angled with respect to the principal axis of the rearward field of view of the plano reflective element when the multiradius element and the plano reflective element are supported by a backing plate element of the plano-multiradius reflective element assembly and when the plano-multiradius reflective element assembly is mounted to an exterior rearview mirror assembly on an automobile, and with the principal axis of the rearward field of view of the plano reflective element being generally directed parallel to the longitudinal axis of the automobile and equipped with the plano multiradius reflective element assembly and the principal axis of the rearward field of view of the multiradius reflective element is directed generally at an angle downwards to a longitudinal axis of the automobile. This combination is neither taught nor suggested by the prior art. Notwithstanding, Applicant has amended Claim 1 to more clearly define Applicant's invention which now calls for:

An exterior sideview mirror system suitable for use on an automobile, said exterior sideview mirror system comprising:

Applicant : Niall R. Lynam
Serial No. : 09/478,315
Page : 8

an exterior sideview mirror assembly adapted for attachment to a side of an automobile;

said exterior sideview mirror assembly including a reflective element having a rearward field of view when attached to the side of the automobile;

said reflective element attached to an electrically-operated actuator and movable by said actuator in order to position said rearward field of view in response to a control;

wherein said reflective element comprises a plano-multiradius reflective element assembly, said plano-multiradius reflective element assembly comprising a plano reflective element having unit magnification and a separate multiradius reflective element having a multiradius curvature, said plano reflective element having a rearward field of view with a principal axis;

said plano reflective element and said multiradius reflective element of said plano-multiradius reflective element assembly mounted adjacently in said plano-multiradius reflective element assembly in a side-by-side relationship and not superimposed with one reflective element on top of the other reflective element, and supported by a backing plate element, said backing plate element mounting to said actuator such that movement of said backing plate element of said plano-multiradius reflective element assembly by said actuator simultaneously and similarly moves said plano reflective element and said multiradius reflective element, said multiradius reflective element having a rearward field of view with a principal axis, said backing plate element have a first support portion supporting said plano-reflective element and a second support portion supporting said multiradius reflective element, said second support portion tilted with respect to said first support portion whereby said principal axis of said rearward field of view of said multiradius element being different from and angled with respect to said principal axis of said rearward field of view of said plano reflective element when said multiradius reflective element and said plano reflective element are supported by said backing plate element of said plano-multiradius reflective element assembly and when said plano-multiradius reflective element assembly is mounted in said exterior sideview mirror assembly on the automobile, and said principal axis of said rearward field of view of said plano reflective element being directed generally parallel to the longitudinal axis of the automobile equipped with the plano-multiradius reflective element assembly and wherein said principal axis of said rearward field of view of said multiradius reflective element is directed generally at an angle downwards to the longitudinal axis of the automobile; and

Applicant : Niall R. Lynam
Serial No. : 09/478,315
Page : 9

said multiradius reflective element being positioned at an outboard portion of said plano-multiradius reflective element assembly when said exterior sideview mirror assembly is mounted to the side of the automobile.

Applicant respectfully urges that neither Kondo nor Hagiri in view of Oskam or Enomoto or Tobin or Hacker discloses or suggests the claimed combination. For example, neither Kondo nor Hagiri in view of Oskam or Enomoto or Tobin or Hacker discloses or suggests a backing plate element having a first support portion supporting the plano reflective element and a second support portion supporting the multiradius reflective element, with the second support portion tilted with respect to the first support portion whereby the principal axis of the rearward field of view of the multiradius element is different from an angle with respect to the principal axis of the rearward field of view with the plano reflective element, for example. Therefore, Applicant respectfully urges that Claim 1 and its dependent claims, namely Claims 16-22, 25-31, 33, and 35 are patentably distinguishable over Kondo or Hagiri in view of Oskam or Enomoto and further in view of Tobin, Jr. or Hacker or any other reference of record.

With respect to Claim 84, Claim 84 has been amended to call for:

An automobile exterior sideview mirror system comprising:
an exterior sideview mirror assembly adapted for attachment to a side of an automobile;
said exterior sideview mirror assembly including a plano-auxiliary reflective element assembly having a rearward field of view when attached to the side of the automobile;
an electrically-operated actuator adapted for adjusting the rearward field of view of said plano-auxiliary reflective element assembly in response to a control;
wherein said plano-auxiliary reflective element assembly comprises a plano reflective element having unit magnification and a separate auxiliary reflective element having a curvature, said plano reflective element and said auxiliary

Applicant : Niall R. Lynam
Serial No. : 09/478,315
Page : 10

reflective element mounted adjacently in said plano-auxiliary reflective element assembly in a side-by-side relationship and not superimposed with one reflective element on top of the other reflective element, and supported by a backing plate element, said backing plate element mounting to said actuator such that movement of said backing plate element of said plano-auxiliary reflective element assembly by said actuator simultaneously and similarly moves said plano reflective element and said auxiliary reflective element, said auxiliary reflective element having a rearward field of view with a principal axis, said principal axis of said rearward field of view of said auxiliary element being different from and angled with respect to said principal axis of said rearward field of view of said plano reflective element when said exterior sideview mirror assembly is mounted to the side of the automobile, and said principal axis of said rearward field of view of said plano reflective element being directed generally parallel to the longitudinal axis of the automobile equipped with the plano-auxiliary reflective element assembly and wherein said principal axis of said rearward field of view of said auxiliary reflective element is directed generally at an angle downwards to the longitudinal axis of the automobile; and

said auxiliary reflective element being positioned at an outboard portion of said plano-auxiliary reflective element assembly when said exterior sideview mirror assembly is mounted to the side of the automobile, and said auxiliary reflective element being located at one of:

(a) an upper portion of said outboard portion of said plano-auxiliary reflective element assembly thereby providing an auxiliary wide-angled view of a blind spot region of the vehicle, and a portion of said plano reflective element extending below said auxiliary reflective element; and

(b) a lower portion of said outboard portion of said plano-auxiliary reflective element assembly thereby providing an auxiliary wide-angled view of a blind spot region of the vehicle, and a portion of said plano reflective element extending above said plano-auxiliary reflective element.

Applicant respectfully urges that Claim 84 is similarly patentable distinguishable over the prior art of record.

Accordingly, in light of the above amendments and above remarks, Applicant respectfully requests reconsideration of the present application and a Notice of Allowance of

Applicant : Niall R. Lynam
Serial No. : 09/478,315
Page : 11

all claims, namely Claims 1, 16-22, 25-32, 33, 35, and 84-90. In addition, Applicant respectfully requests that since Claims 2-15, 32, 34, and 36 depend from an allowable claim, that they be reentered in the case and allowed with allowable Claim 1.

Should the Examiner have any questions or comments, he is invited to contact the undersigned at (616) 975-5506.

Respectfully submitted,

NIALL R. LYNAM

By: Van Dyke, Gardner, Linn & Burkhart, LLP

Date: April 5, 2002.

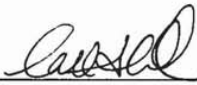

Catherine S. Collins
Registration No. 37 599
2851 Charlevoix Drive, S.E.
Suite 207
P.O. Box 888695
Grand Rapids, MI 49588-8695
(616) 975-5500

CSC:lmasc

Applicant : Niall R. Lynam
Serial No. : 09/478,315
Page : 12

PATENT
DON01 P-793

APPENDIX TO CLAIMS

1. (Twice Amended)

An exterior sideview mirror system suitable for use on an automobile, said exterior sideview mirror system comprising:

an exterior sideview mirror assembly adapted for attachment to a side of an automobile;

said exterior sideview mirror assembly including a reflective element having a rearward field of view when attached to the side of the automobile;

said reflective element attached to an electrically-operated actuator and movable by said actuator in order to position said rearward field of view in response to a control;

wherein said reflective element comprises a plano-multiradius reflective element assembly, said plano-multiradius reflective element assembly comprising a plano reflective element having unit magnification and a separate multiradius reflective element having a multiradius curvature, said plano reflective element having a rearward field of view with a principal axis;

said plano reflective element and said multiradius reflective element of said plano-multiradius reflective element assembly mounted adjacently in said plano-multiradius reflective element assembly in a side-by-side relationship and not superimposed with one reflective element on top of the other reflective element, and supported by a backing plate element, said backing plate element mounting to said actuator such that movement of said backing plate element of said plano-multiradius reflective element assembly by said actuator simultaneously and similarly moves said plano reflective element and said multiradius reflective element, said multiradius reflective element having a rearward field of view with a principal axis, said backing plate element have a first support portion supporting said plano-reflective element and a second support portion supporting said multiradius reflective element, said second support portion tilted with respect to said first support portion whereby said principal axis of said rearward field of view of said multiradius element being different



Applicant : Niall R. Lynam
Serial No. : 09/478,315
Page : 13

from and angled with respect to said principal axis of said rearward field of view of said plano reflective element when said multiradius reflective element and said plano reflective element are supported by said backing plate element of said plano-multiradius reflective element assembly and when said plano-multiradius reflective element assembly is mounted in said exterior sideview mirror assembly on the automobile, and said principal axis of said rearward field of view of said plano reflective element being directed generally parallel to the longitudinal axis of the automobile equipped with the plano-multiradius reflective element assembly and wherein said principal axis of said rearward field of view of said multiradius reflective element is directed generally at an angle downwards to the longitudinal axis of the automobile; and

said multiradius reflective element being positioned at an outboard portion of said plano-multiradius reflective element assembly when said exterior sideview mirror assembly is mounted to the side of the automobile.

25. (Amended)

The exterior sideview mirror system of Claim [24] 1, wherein said angle downwards to the longitudinal axis of the automobile is in the range from about 1 degree to about 10 degrees.

26. (Amended)

The exterior sideview mirror system of Claim [24] 1, wherein said angle downwards to the longitudinal axis of the automobile is in the range from about 2 degrees to about 8 degrees.

27. (Amended)

The exterior sideview mirror system of Claim [24] 1, wherein said angle downwards to the longitudinal axis of the automobile is in the range from about 3 degrees to about 6 degrees.

28. (Amended)

Applicant : Niall R. Lynam
Serial No. : 09/478,315
Page : 14

The exterior sideview mirror system of Claim [24] 1, wherein said angle downwards to the longitudinal axis of the automobile is generally set by an angling of a surface of said backing plate element.

29. (Amended)

The exterior sideview mirror system of Claim [24] 1, wherein said exterior sideview mirror assembly comprises a door-mounted exterior sideview mirror assembly adapted for attachment to a side of the automobile adjacent a driver seating location of a driver of the automobile and wherein the principal axis of the rearward field of view of said multiradius reflective element is directed generally downwardly towards the road surface adjacent to the driver seating location at a distance in the range of about 1 foot to about 24 feet to the rear of the driver seating location.

30. (Amended)

The exterior sideview mirror system of Claim [24] 1, wherein said exterior sideview mirror assembly comprises a door-mounted exterior sideview mirror assembly adapted for attachment to a side of the automobile adjacent a driver seating location of a driver of the automobile and wherein the principal axis of the rearward field of view of said multiradius reflective element is directed generally downwardly towards the road surface adjacent to the driver seating location at a distance in the range of about 1 foot to about 12 feet to the rear of the driver seating location.

31. (Amended)

The exterior sideview mirror system of Claim [24] 1, wherein said exterior sideview mirror assembly comprises a door-mounted exterior sideview mirror assembly adapted for attachment to a side of the automobile adjacent a driver seating location of a driver of the automobile and wherein the principal axis of the rearward field of view of said multiradius reflective element is directed generally downwardly towards the road surface adjacent to the driver seating location at a distance in the range of about 1 foot to about 8 feet to the rear of the driver seating location.

84. (Amended)

An automobile exterior sideview mirror system comprising:



Applicant : Niall R. Lynam
Serial No. : 09/478,315
Page : 15

an exterior sideview mirror assembly adapted for attachment to a side of an automobile;

said exterior sideview mirror assembly including a plano-auxiliary reflective element assembly having a rearward field of view when attached to the side of the automobile;

an electrically-operated actuator adapted for adjusting the rearward field of view of said plano-auxiliary reflective element assembly in response to a control;

wherein said plano-auxiliary reflective element assembly comprises a plano reflective element having unit magnification and a separate auxiliary reflective element having a curvature, said plano reflective element and said auxiliary reflective element mounted adjacently in said plano-auxiliary reflective element assembly in a side-by-side relationship and not superimposed with one reflective element on top of the other reflective element, and supported by a backing plate element, said backing plate element mounting to said actuator such that movement of said backing plate element of said plano-auxiliary reflective element assembly by said actuator simultaneously and similarly moves said plano reflective element and said auxiliary reflective element, said auxiliary reflective element having a rearward field of view with a principal axis, said principal axis of said rearward field of view of said auxiliary element being different from and angled with respect to said principal axis of said rearward field of view of said plano reflective element when said exterior sideview mirror assembly is mounted to the side of the automobile, and said principal axis of said rearward field of view of said plano reflective element being directed generally parallel to the longitudinal axis of the automobile equipped with the plano-auxiliary reflective element assembly and wherein said principal axis of said rearward field of view of said auxiliary reflective element is directed generally at an angle downwards to the longitudinal axis of the automobile; and

said auxiliary reflective element being positioned at an outboard portion of said plano-auxiliary reflective element assembly when said exterior sideview mirror assembly is mounted to the side of the automobile, and said auxiliary reflective element being located at one of:

Applicant : Niall R. Lynam
Serial No. : 09/478,315
Page : 16

(a) an upper portion of said outboard portion of said plano-auxiliary reflective element assembly thereby providing an auxiliary wide-angled view of a blind spot region of the vehicle, and a portion of said plano reflective element extending below said auxiliary reflective element; and

(b) a lower portion of said outboard portion of said plano-auxiliary reflective element assembly thereby providing an auxiliary wide-angled view of a blind spot region of the vehicle, and a portion of said plano reflective element extending above said plano-auxiliary reflective element.

85. (Amended)

The automobile exterior sideview mirror system according to Claim 84, wherein said auxiliary reflective element is located at said [an] upper outboard portion of said plano-auxiliary reflective element assembly.

Respectfully submitted,

NIALL R. LYNAM

By: Van Dyke, Gardner, Linn & Burkhart, LLP

Date: April 5, 2001.



Catherine S. Collins
Registration No. 37 599
2851 Charlevoix Drive, S.E.
Suite 207
P.O. Box 888695
Grand Rapids, MI 49588-8695
(616) 975-5500

CSC:lmsc

Applicant : Niall R. Lynam
Serial No. : 09/478,315
Page : 17

Respectfully submitted,

NIALL R. LYNAM

By: Van Dyke, Gardner, Linn & Burkhart, LLP

Date: April 5, 2001.



Catherine S. Collins
Registration No. 37 599
2851 Charlevoix Drive, S.E.
Suite 207
P.O. Box 888695
Grand Rapids, MI 49588-8695
(616) 975-5500

CSC:lmsc



RCE/2800

PATENT
DON01 P-793

IN THE UNITED STATES PATENT AND TRADEMARK OFFICE

Examiner : R. Shafer
Applicant : Niall R. Lynam
Serial No. : 09/478,315
Filed : January 6, 2000
Group : 2872
For : EXTERIOR MIRROR PLANO-AUXILIARY
REFLECTIVE ELEMENT ASSEMBLY

RECEIVED
APR 19 2002
TECHNOLOGY CENTER 28000

Box RCE
Commissioner for Patents
Washington, D.C. 20231

Dear Sir:

CERTIFICATE OF MAIL

I certify that the attached return postcard, Request for Continued Examination (RCE) Transmittal (in duplicate), Petition and Fee for Extension of Time (in duplicate), Response, a check in the amount of \$740 for the RCE filing fee, and a check in the amount of \$110.00 for the extension fee are being deposited with the United States Postal Service as first class mail an envelope addressed to:

Commissioner for Patents
Washington, D.C. 20231

on April 5, 2002.

Catherine S. Collins
Van Dyke, Gardner, Linn & Burkhart, LLP
P.O. Box 888695
Grand Rapids, MI 49588-8695
(616) 975-5500

CSC:lmsc
Enclosures



UNITED STATES PATENT AND TRADEMARK OFFICE

UNITED STATES DEPARTMENT OF COMMERCE
United States Patent and Trademark Office
Address: COMMISSIONER OF PATENTS AND TRADEMARKS
Washington, D.C. 20231
www.uspto.gov

APPLICATION NO.	FILING DATE	FIRST NAMED INVENTOR	ATTORNEY DOCKET NO.	CONFIRMATION NO.
09/478,315	01/06/2000	NIAL R. LYNAM	DON01-P-793	1526

28101 7590 05/08/2002
 VAN DYKE, GARDNER, LINN AND BURKHART, LLP
 2851 CHARLEVOIX DRIVE, S.E.
 P.O. BOX 888695
 GRAND RAPIDS, MI 49588-8695

EXAMINER

SHAFAER, RICKY D

ART UNIT	PAPER NUMBER
2872	18

DATE MAILED: 05/08/2002

Please find below and/or attached an Office communication concerning this application or proceeding.

Office Action Summary

Application No. <u>09/478,315</u>	Applicant(s) <u>LYNAM</u>
Examiner <u>R D SHAFER</u>	Group Art Unit <u>2872</u>

— The MAILING DATE of this communication appears on the cover sheet beneath the correspondence address —

Period for Reply

A SHORTENED STATUTORY PERIOD FOR REPLY IS SET TO EXPIRE 3 MONTHS MONTH(S) FROM THE MAILING DATE OF THIS COMMUNICATION.

- Extensions of time may be available under the provisions of 37 CFR 1.136(a). In no event, however, may a reply be timely filed after SIX (6) MONTHS from the mailing date of this communication.
- If the period for reply specified above is less than thirty (30) days, a reply within the statutory minimum of thirty (30) days will be considered timely.
- If NO period for reply is specified above, such period shall, by default, expire SIX (6) MONTHS from the mailing date of this communication.
- Failure to reply within the set or extended period for reply will, by statute, cause the application to become ABANDONED (35 U.S.C. § 133).
- Any reply received by the Office later than three months after the mailing date of this communication, even if timely, may reduce any earned patent term adjustment. See 37 CFR 1.704(b).

Status

- Responsive to communication(s) filed on 4/16/02
- This action is FINAL
- Since this application is in condition for allowance except for formal matters, prosecution as to the merits is closed in accordance with the practice under *Ex parte Quayle*, 1935 C.D. 111; 453 O.G. 213.

Disposition of Claims

- Claim(s) 1-22, 25-34, 36-43 AND 84-90 is/are pending in the application.
- Of the above claim(s) 2-15, 32, 34, 36-43 AND 84-90 is/are withdrawn from consideration.
- Claim(s) _____ is/are allowed.
- Claim(s) 1, 16-22, 25-31 AND 33 is/are rejected.
- Claim(s) _____ is/are objected to.
- Claim(s) _____ are subject to restriction or election requirement

Application Papers

- The proposed drawing correction, filed on _____ is approved disapproved.
- The drawing(s) filed on _____ is/are objected to by the Examiner
- The specification is objected to by the Examiner.
- The oath or declaration is objected to by the Examiner.

Priority under 35 U.S.C. § 119 (a)-(d)

- Acknowledgement is made of a claim for foreign priority under 35 U.S.C. § 119 (a)-(d).
- All Some* None of the:
 - Certified copies of the priority documents have been received.
 - Certified copies of the priority documents have been received in Application No. _____
 - Copies of the certified copies of the priority documents have been received in this national stage application from the International Bureau (PCT Rule 17.2(a))
- *Certified copies not received: _____

Attachment(s)

- Information Disclosure Statement(s), PTO-1449, Paper No(s). _____
- Notice of Reference(s) Cited, PTO-892
- Notice of Draftsperson's Patent Drawing Review, PTO-948
- Interview Summary, PTO-413
- Notice of Informal Patent Application, PTO-152
- Other _____

Office Action Summary

Art Unit: 2872

1. A request for continued examination (RCE) under 37 CFR 1.114, including the fee set forth in 37 CFR 1.17(e), was filed in this application after final rejection. Since this application is eligible for continued examination under 37 CFR 1.114, and the fee set forth in 37 CFR 1.17(e) has been timely paid, the finality of the previous Office action has been withdrawn pursuant to 37 CFR 1.114. Applicant's submission filed on 04/16/02 has been entered.

2. Newly submitted claims 84-90 are directed to an invention that is independent or distinct from the elected invention for the following reasons. Newly submitted claims 84-86 and 88-90 are not readable on the elected invention because the newly submitted claims fail to include the separate details of the auxiliary reflective element having a multiradius curvature; and adds separate details of the plano reflective element being positioned above or below the auxiliary reflective element.

3. The newly submitted and elected inventions are related as combination and subcombination. Inventions in this relationship are distinct if it can be shown that (1) the combination as claimed does not require the particulars of the subcombination as claimed for patentability, and (2) that the subcombination has utility by itself or in other combinations (MPEP 806.05(c)). In the instant case, the combination as claimed does not require the particulars of the subcombination as claimed because of the omission of the details of the auxiliary reflective element having a multiradius curvature, as clearly evidenced by claim 84. The subcombination has separate utility such as an exterior sideview mirror system with the plano reflective element being positioned right or left of the auxiliary reflective element, without the plano reflective element

Art Unit: 2872

being positioned above or below of the auxiliary reflective element, which would required a search in class 359 subclass 850 which would not be required for the elected invention.

Moreover, newly submitted claim 90 is directed to invention III (see Paper No. 5).

Since applicant has received an action on the merits for the originally presented invention, this invention has been constructively elected by original presentation for prosecution on the merits. Accordingly, claims 84-90 are withdrawn from consideration as being directed to a non-elected invention. See 37 CFR 1.142(b) and MPEP § 821.03.

4. The following is a quotation of 35 U.S.C. 103(a) which forms the basis for all obviousness rejections set forth in this Office action:

(a) A patent may not be obtained though the invention is not identically disclosed or described as set forth in section 102 of this title, if the differences between the subject matter sought to be patented and the prior art are such that the subject matter as a whole would have been obvious at the time the invention was made to a person having ordinary skill in the art to which said subject matter pertains. Patentability shall not be negated by the manner in which the invention was made.

5. Claims 1, 16-22, 25-31 and 33 are rejected under 35 U.S.C. 103(a) as being unpatentable over Kondo et al ('542) or Hagiri ('534) in view of Tobin, Jr. ('952) or Hacker et al ('158) and further in view of Oskam ('899) or Enomoto ('166).

Kondo et al and Hagiri each disclose an exterior side view mirror system comprising an exterior side view mirror assembly (1, 11) including a plano-multiradius reflective element assembly having a plano reflective portion (9, 13a) and a multiradius reflective portion (11, 13c) and an actuator (not shown) for adjustably positioning said plano-multiradius reflective assembly, note figures [(1,2,4 and 9) and (1-8)] and the associated description thereof, respectively, except

Art Unit: 2872

for explicitly stating that the actuator comprises an electrically-operated actuator and the plano and multiradius reflective portions are separated.

Tobin, Jr. and Hacker et al each teaches it well know to use separate plano and multiradius reflective elements supported by a common backing plate, wherein said backing plate is configured to follow the contour of the separate plano and multiradius reflective elements in the same field of endeavor for the purpose of providing a side by side arrangement, wherein one reflective element is not superimposed on top of another reflective element.

Therefore, it would have been obvious and/or within the level of one ordinary skill in the art at the time the invention was made to modify the plano-multiradius reflective assembly of Kondo et al or Hagiri to include separate plano and multiradius reflective elements having a common backing plate as is well known and commonly used and/or employed in the mirror art, as taught by Tobin, Jr. or Hacker et al in order to reduce manufacturing costs, by replacing one of said reflective elements without having to replace the other one of said reflective elements, should one of the elements become defective and/or damaged during assembly.

Moreover, it has been held that constructing a formerly integral structure in various elements involves only routine skill in the art. Note Nerwin v. Erlichman, 168 USPQ 177, 179.

Oskam and Enomoto each teaches it well know to use electrically-operated actuator(s) attached to a backing plate in the same field of endeavor for the purpose of adjusting the position and/or orientation of a reflective element.

Art Unit: 2872

Therefore, it would have been obvious and/or within the level of one ordinary skill in the art at the time the invention was made to modify the plano-multiradius reflective assembly of Kondo et al or Hagiri in view of Tobin, Jr. or Hacker et al to include electrically operable actuator(s) as is well known and commonly used and/or employed in the mirror art, as taught by Oskam or Enomoto, in order to adjust the position and/or orientation of the plano-multiradius reflective assembly.

Moreover, it has been held that providing automatic means to replace manual activity which accomplishes the same result involves only routine skill in the art. Note In Re Verner, 120 USPQ 192.

As to the limitations of claim 22, it would have been obvious and/or within the level of one of ordinary skill in the art at the time the invention was made to modify the size of the multiradius and/or plano reflective elements of Kondo et al or Hagiri in order to obtain a desirable ratio of interest, since such a modification would have involved a mere change in the size of a component. A change in size is generally recognized as being within the level of one of ordinary skill in the art. Note In re Rose, 105 USPQ 237 (CCPA 1955).

As to the limitations of claims 19 and 25-31, it is well known to use an auxiliary (multiradius) reflective element having the radii of curvature and downward angle range recited by applicant in order to optimize and/or view a particular rearward field of view of interest.

Therefore, it would have been obvious and/or within the level of one of ordinary skill in the art at the time the invention was made to modify the auxiliary multiradius reflective element of

Art Unit: 2872

Kondo et al or Hagiri to include the radii of curvature and downward angle range recited by applicant in order to optimize and/or view a particular rearward field of view of interest, based on user specifications.

Moreover, it would have been obvious and/or within the level of one of ordinary skill in the art at the time the invention was made to angle the multiradius reflective element of Kondo et al or Hagiri to the selected range(s) recited by applicant in order to view of particular rearward field of view of interest, since it has been held that where the general conditions of a claim are disclosed in the prior art or discovering an optimum or workable ranges involves only routine skill in the art. Note In re Aller, 105 USPQ 233 and In re Boesch, 617 F.2d 272, 205 USPQ 215 (CCPA 1980).

As to the limitations of claim 33, it is well known to use break-away exterior side view mirror assemblies in the same field of endeavor for the purpose of folding the position and/or orientation of a mirror. Therefore, it would have been obvious and/or within the level of one ordinary skill in the art at the time the invention was made to modify the exterior side view mirror assembly of Kondo et al or Hagiri to include a break-away exterior side view mirror assembly, as is well known and commonly used and/or employed in the mirror art, in order to fold the position and/or orientation of the reflective element(s).

6. All claims are drawn to the same invention claimed in the application prior to the entry of the submission under 37 CFR 1.114 and could have been finally rejected on the grounds and art of record in the next Office action if they had been entered in the application prior to entry under 37

Application/Control Number: 09/478,315

Page 7

Art Unit: 2872

CFR 1.114. Accordingly, THIS ACTION IS MADE FINAL even though it is a first action after the filing of a request for continued examination and the submission under 37 CFR 1.114. See MPEP § 706.07(b). Applicant is reminded of the extension of time policy as set forth in 37 CFR 1.136(a).

A shortened statutory period for reply to this final action is set to expire THREE MONTHS from the mailing date of this action. In the event a first reply is filed within TWO MONTHS of the mailing date of this final action and the advisory action is not mailed until after the end of the THREE-MONTH shortened statutory period, then the shortened statutory period will expire on the date the advisory action is mailed, and any extension fee pursuant to 37 CFR 1.136(a) will be calculated from the mailing date of the advisory action. In no event, however, will the statutory period for reply expire later than SIX MONTHS from the mailing date of this final action.

7. Any inquiry concerning this communication should be directed to R. D. Shafer at telephone number (703) 308-4819.

RDS

May 2, 2002

RICHARD D. SHAFER
PATENT EXAMINER
ART UNIT 2872

Notice of References Cited		Application No.	Applicant(s)			
		09/478,315	LYNAM			
		Examiner	Group Art Unit	Page		
		RO SHAFER	2872	1 of 1		
U.S. PATENT DOCUMENTS						
*	DOCUMENT NO.	DATE	NAME	CLASS	SUBCLASS	
A	2,911,177	11-1959	WEST	—	—	
B	3,170,985	12-1965	KATULICH	—	—	
C	3,764,201	10-1973	HAILE	—	—	
D	4,917,485	4-1990	BALDWIN, SR.	—	—	
E	5,166,833	11-1992	SHYU	—	—	
F						
G						
H						
I						
J						
K						
L						
M						
FOREIGN PATENT DOCUMENTS						
*	DOCUMENT NO.	DATE	COUNTRY	NAME	CLASS	SUBCLASS
N	62-105103	5-1987	JAPAN	MIYAIKE	—	—
O						
P						
Q						
R						
S						
T						
NON-PATENT DOCUMENTS						
*	DOCUMENT (Including Author, Title, Source, and Pertinent Pages)				DATE	
U						
V						
W						
X						

* A copy of this reference is not being furnished with this Office action.
(See Manual of Patent Examining Procedure, Section 707.05(a).)

359-864 AU 25/7 EX
 11/24/92 09 2/10/92



US005166833A

United States Patent [19]
Shyu

[11] **Patent Number:** 5,166,833
 [45] **Date of Patent:** Nov. 24, 1992

[54] **REAR SIDE MIRROR FOR VEHICLES**

[76] **Inventor:** Tian T. Shyu, P.O. Box 82-144,
 Taipei, Taiwan

[21] **Appl. No.:** 743,921

[22] **Filed:** Aug. 12, 1991

[51] **Int. Cl.:** G02B 5/10

[52] **U.S. Cl.:** 359/864; 359/869

[58] **Field of Search:** 359/864, 868, 869

5,005,962 4/1991 Edelman 359/864

Primary Examiner—Bruce Y. Arnold
Assistant Examiner—J. P. Ryan
Attorney, Agent, or Firm—Alfred Lei

[57] **ABSTRACT**

This invention relates to a rear side mirror for vehicles and in particular to one including a front side with a flat surface and a rear side having a first planar surface gradually decreased in width from an inner edge to a vertical lateral edge, a second surface concaving from a vertical outer edge towards the first planar surface, and a third surface concaving from a lower edge towards the first planar surface.

[56] **References Cited**

U.S. PATENT DOCUMENTS

3,764,201	10/1973	Haile	359/864
4,264,144	4/1981	McCord	359/868
4,331,382	5/1982	Graff	359/868
4,620,777	11/1986	Nu	359/869

1 Claim, 4 Drawing Sheets

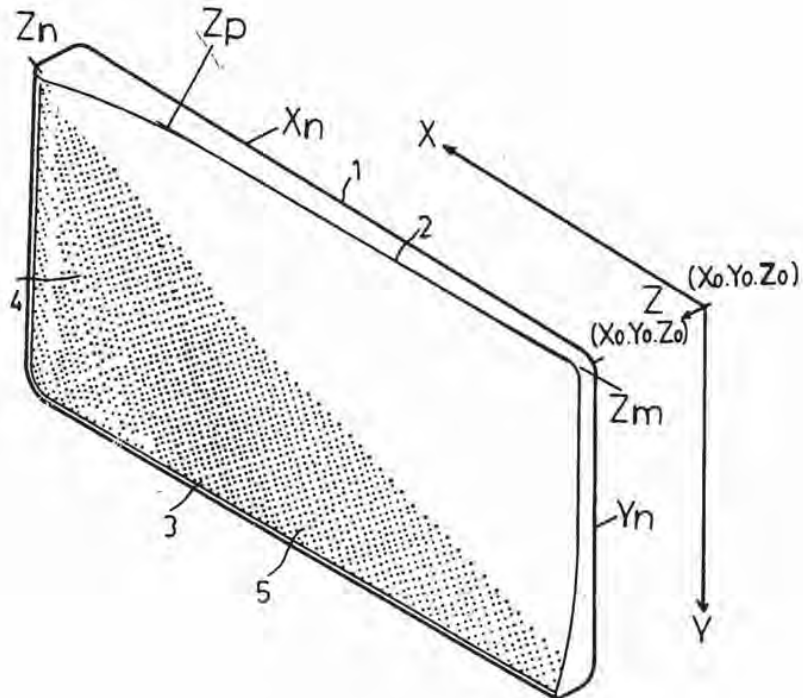

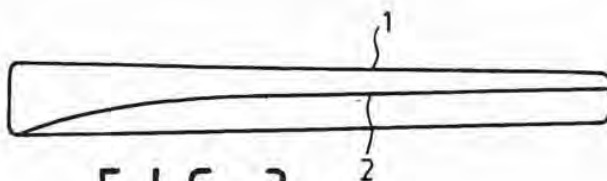

FIG. 3

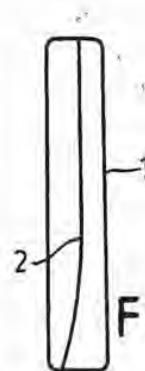

FIG. 2

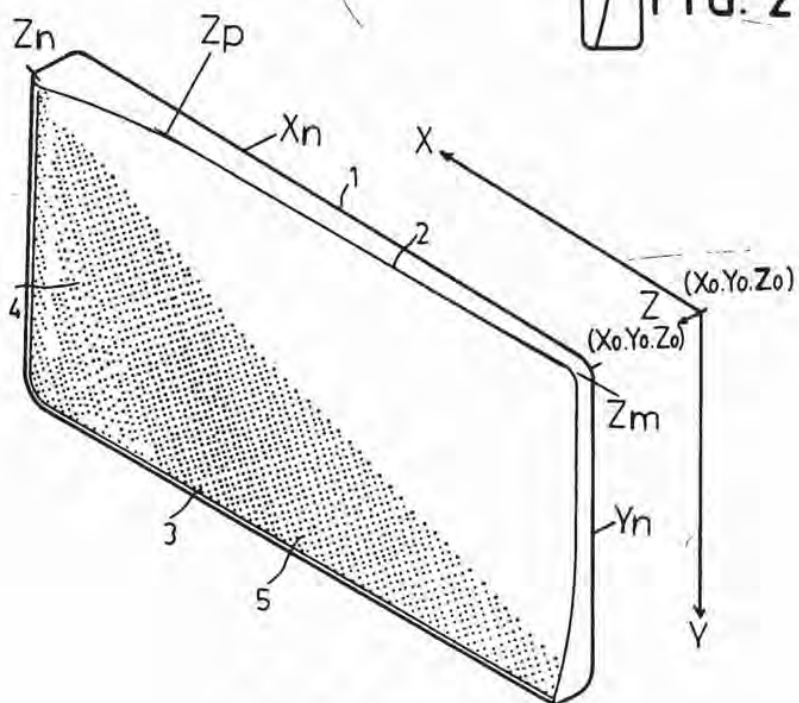

FIG. 1

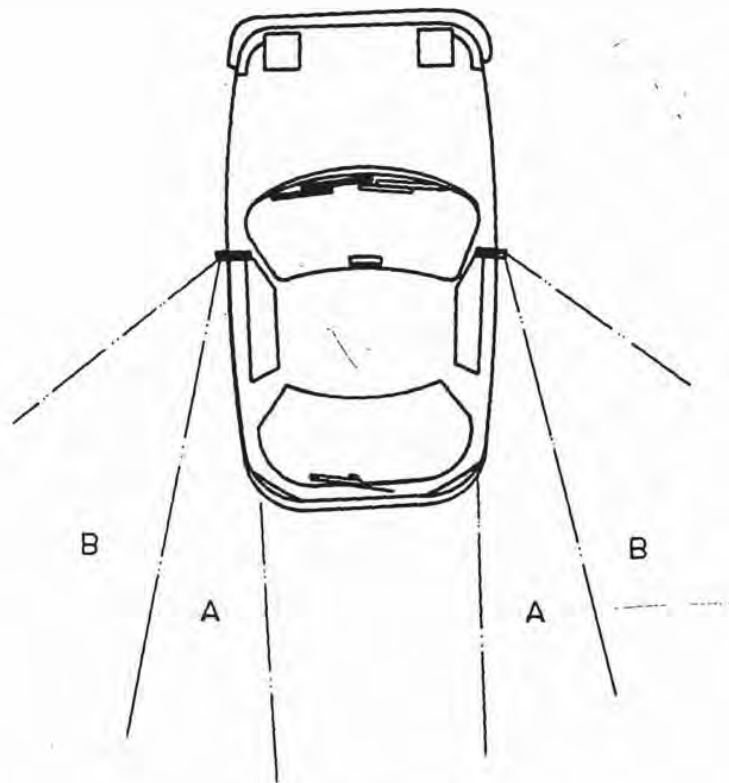

FIG. 4

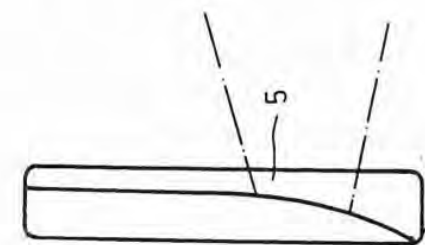

FIG. 6

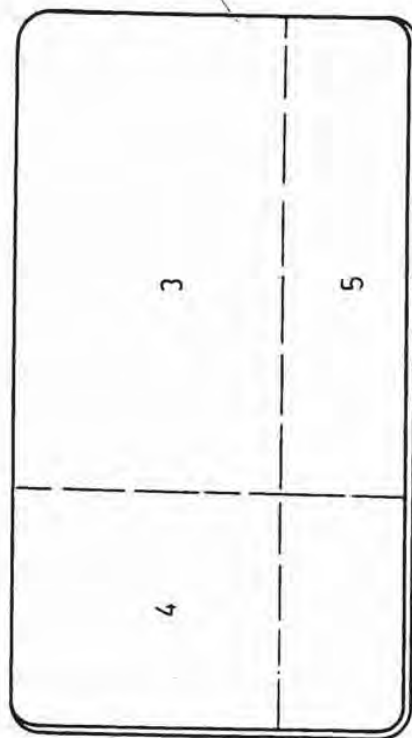

FIG. 5

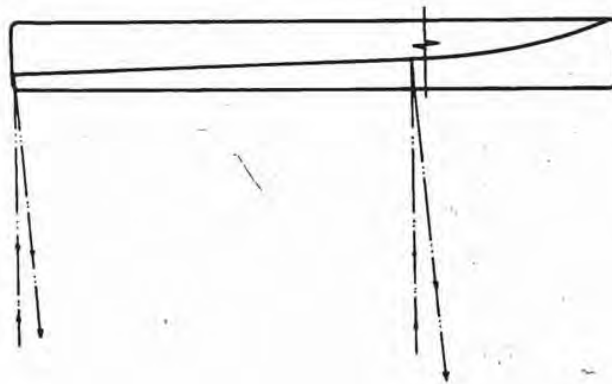

FIG. 7

REAR SIDE MIRROR FOR VEHICLES

BACKGROUND OF THE INVENTION

It is found that attempts have been made to improve the performance of rear side mirrors by providing auxiliary mirror structures that may either be independently mounted on the vehicle or attached to the conventional side mounted mirrors. The usual type of auxiliary mirror heretofore provided comprises a circular segment of a spherical surfaced shell that may be adhesively bonded onto a surface of the primary mirror if the primary mirror is sufficiently large as in the case of truck mirror. Alternatively, a spherical segment mirror may be mounted exteriorly on the vehicle in independent relationship to any of the other mirrors.

However, such mirrors are not satisfactory in use and it is therefore an object of the present invention to provide an improved rear side mirror which may obviate and mitigate the above-mentioned drawbacks.

SUMMARY OF THE INVENTION

This invention relates to an improved rear side mirror.

It is the primary object of the present invention to provide a rear side mirror which may widen the vision angle of the driver.

It is another object of the present invention to provide a rear side mirror which may prevent the driver from being irritated by the light beam from the rear.

It is still another object of the present invention to provide a rear side mirror which is simple in construction.

It is still another object of the present invention to provide a rear side mirror which is economic to produce.

It is still another object of the present invention to provide a rear side mirror which is fit for mass production.

Other objects and merits and a fuller understanding of the present invention will be obtained by those having ordinary skill in the art when the following detailed description of the preferred embodiment is read in conjunction with the accompanying drawings.

BRIEF DESCRIPTION OF THE DRAWINGS

FIG. 1 is a perspective view of a rear side mirror according to the present invention;

FIG. 2 is a side view of the rear side mirror;

FIG. 3 is a top view of the rear side mirror;

FIG. 4 is a working view of the rear side mirror;

FIG. 5 shows another preferred embodiment of the rear side mirror;

FIG. 6 is a side view of FIG. 5; and

FIG. 7 shows a third preferred embodiment of the rear side mirror.

DETAILED DESCRIPTION OF THE PREFERRED EMBODIMENT

Before explaining the present invention in detail, it is to be understood that the invention is not limited in its application to the details of construction and arrangement of parts illustrated in the accompanying drawings, since the invention is capable of other embodiments and of being practiced or carried out in various ways. Also it is to be understood that the phraseology or terminology employed herein is for the purpose of description and not of limitation.

With reference to the drawings and in particular to FIGS. 1, 2, and 3, the rear side mirror according to the present invention comprises a front side 1 with a flat surface and a reflective rear side 2 with a partially curved surface. The rear side 2 includes a first surface 3 which extends from a lateral inner edge 3A to a lateral top edge 3B, and a second surface 4 concaving from a vertical outer edge 4A towards a vertical inner edge 3C of the first surface, and a third surface 5 concaving from a lateral bottom edge 5A towards the lateral inner edge 3A.

As mentioned above, the present invention is composed of a first surface 3, a second surface 4 and a third surface 5. The first surface 3 is planar in structure and extends downwards from Yo to Yn, leftwards from Xo to Xn and outwards from Zm to Zp. The second surface 4 is arcuated in structure and concaves outwards from Zp to Zn. The third surface 5 is also arcuated in structure and concaves inwards from Zn to Zp and Zm.

Hence, the rear side mirror according to the present invention mainly comprises a first surface 3, a second surface 4 and a third surface 5. The first surface 3 is designed for the driver to observe the region A, while the second surface 4 is designed to observe the region B (see FIG. 4). As to the third surface 5, it is used to reflect downward to the condition of the road surface (see FIG. 6).

Further, the light beam from the rear will be reflected away from the eye of the driver (see FIG. 7) thereby preventing the driver from being irritated by the light and therefore, making the drive safer.

The application of the present invention is too wide to be mentioned and cannot be all enumerated here in detail. It is understood that the present disclosure is made by way of example only and that numerous changes in the detail of construction and the combination of parts may be resorted to without departing from the spirit and scope of the invention as hereinafter claimed.

I claim:

- 1. A rear side mirror comprising: a front side with a flat surface; and a reflective rear side including a first planar surface which extends from a lateral inner edge to a lateral top edge, a second surface concaving from a vertical outer edge towards a vertical inner edge of said first planar surface, and a third surface concaving from a lateral bottom edge towards said lateral inner edge.

• • • • •

359/868

CLIPPEDIMAGE= JP362105103A
PAT-NO: JP362105103A
DOCUMENT-IDENTIFIER: JP 62105103 A
TITLE: CONVEX REFLECTION MIRROR

PUBN-DATE: May 15, 1987

INVENTOR-INFORMATION:

NAME
MIYAKE, SHINYA

ASSIGNEE-INFORMATION:

NAME	COUNTRY
MIYAKE SHINYA	N/A
YAMADA MASAHIRO	N/A
KUNO KOICHI	N/A

APPL-NO: JP60246703
APPL-DATE: October 31, 1985

INT-CL (IPC): G02B005/10; B60R001/06
US-CL-CURRENT: 359/868

ABSTRACT:

PURPOSE: To obtain a natural reflected image without generating a distortion by constituting a surface area of a mirror body by dividing it into plural spherical areas consisting of a radius of curvature which has been set optionally in accordance with a use purpose, and forming a discontinuous area as a gradated area for continuing smoothly mutual spherical areas.

CONSTITUTION: Radiuses of curvature Ra, Rb... of spherical areas 3, 3a... of a surface area 2 of a mirror body 1 are set optionally in accordance with a use purpose. For instance, when it is desired to catch as a larger image than an expanse of a visible area in the center part, and to secure a visible area of a wide range in the end part, the radius of curvature Rb of the center part, and the radiuses of curvature Ra, Rb of the end are set to as to become large and small, respectively. Also, the spherical area 3 of the radius of curvature Ra

is set extending over a wide range, and in an optional interval position in the remaining area, the spherical areas 3a, 3b... of the radiuses of curvature R_b , $R_c...$ are set as points, and between the points of each spherical area 3a, 3b..., it is migrated by gradated areas 5, 5a... whose radius of curvature is varied continuously. In this way, an image is not distorted excessively and a natural reflected image can be obtained, and also a distance sense can easily be grasped.

COPYRIGHT: (C)1987, JPO&Japio

11/18/2001, EAST Version: 1.02.0008

⑨ 日本国特許庁(JP)

⑩ 特許出願公開

⑫ 公開特許公報(A) 昭62-105103

⑬ Int. Cl.⁴ 識別記号 庁内整理番号 ⑭ 公開 昭和62年(1987)5月15日
 G 02 B 5/10 A-7036-2H
 B 60 R 1/06 G-7443-3D
 G 02 B 5/10 J-7036-2H 審査請求 未請求 発明の数 1 (全3頁)

⑮ 発明の名称 凸面反射鏡

⑯ 特 願 昭60-246703

⑰ 出 願 昭60(1985)10月31日

⑱ 発 明 者 三 宅 信 也 名古屋市千種区香流橋1-4-36
 ⑲ 出 願 人 三 宅 信 也 名古屋市千種区香流橋1-4-36
 ⑳ 出 願 人 山 田 正 弘 愛知県知多郡南知多町大字豊浜字会下坪26
 ㉑ 出 願 人 久 野 孝 一 名古屋市南区御替地町東2丁目31
 ㉒ 代 理 人 弁 理 士 西 山 閑 一

明 細 書

1. 発明の名称
凸面反射鏡
2. 特許請求の範囲
- (1) 鏡本体の表面領域を、使用目的に応じて任意に設定された曲率半径より成る複数の球面領域にて区割構成し、隣接する球面領域間に生じる不連続領域を相互の球面領域間に渉り順次連続的に曲率半径が変化する曲面にて移行せしめ、かかる不連続領域を相互の球面領域を円滑に連続せしめる量し領域と成したことを特徴とする凸面反射鏡。
- (2) 球面領域は一端方から他端方へ向かうに従い順次曲率半径を小ならしめる様に配置したことを特徴とする特許請求の範囲第1項記載の凸面反射鏡。
- (3) 任意の球面領域間には平面領域が介在されていることを特徴とする特許請求の範囲第1項記載の凸面反射鏡。
3. 発明の詳細な説明

〔発明の目的〕

産業上の利用分野

本発明は車輦用バックミラー、防犯ミラー、路上に設置されるカーブミラー等の広視界反射鏡として利用される凸面反射鏡に関するものである。

従来の技術

従来車輦用バックミラー、防犯ミラー、路上に設置されるカーブミラー等の各種用途に供されている凸面反射鏡は、全面に渉り同一の曲率半径にて成形されたものであるため、充分なる視認領域の確保を得る目的で曲率半径を小さく設定した場合は、全体に像の歪が大きく距離感の把握が困難となり、又凸面反射鏡の用途によっては特定の方向は視認範囲の広がりが必要されるも、他の方向は歪の少ない像の視認が要求される場合があり、かかる要求に対しては全面に渉り同一の曲率半径にて成形された従来の凸面反射鏡では、視認領域の拡張に伴って不要範囲の像も必然的に視認されることとなるため

、用途によっては却って目的とする像の認識の妨げとなる等の不都合を生じていた。

発明が解決しようとする問題点

本発明は用途に応じて任意の方向に視認範囲の広がりを得られ、像の倍率も目的とする視認領域に応じて任意の倍率が得られ、且つ全面に渉り像の曇りがり自然で歪の少ない凸面反射鏡を提供せんとするものである。

(発明の構成)

問題点を解決するための手段

本発明はかかる点に鑑み、鏡本体の表面領域を、使用目的に応じて任意に設定された曲率半径より成る複数の球面領域にて区割構成し、隣接する球面領域間に生じる不連続領域を相互の球面領域間に渉り順次連続的に曲率半径が変化する曲面にて移行せしめ、かかる不連続領域を相互の球面領域を円滑に連続せしめる重し領域と成した凸面反射鏡を提供して上記欠点を解消せんとしたものである。

作用

部分を相互の球面領域3、3a…間の移行部分としての重し領域5、5a…と成している。

上記球面領域3、3a…の曲率半径 R_a 、 R_b 、 R_c …は、車輪用バックミラー、防犯ミラー、路上に設置されるカーブミラー等の使用用途に応じて任意に設定されるもので、如何なる組み合わせも可能であり、例えば中央部においては視認領域の広がりより大きな像として捉え、端方部分においては広範囲の視認領域の確保を希望する場合には、中央部の曲率半径 R_b を大、端方の曲率半径 R_a 、 R_c を小に設定せしめることにより、かかる要請に対応可能である。

又、各球面領域3、3a…の設定範囲は第3図に図示する様に、曲率半径 R_a の球面領域3を広い範囲に渉り設定し、残りの領域中の任意の間隔位置には曲率半径 R_b 、 R_c …の球面領域3a、3b…をポイントとして設定せしめ、各球面領域3a、3b…のポイント間を曲率半径が連続的に変化する重し領域5、5a…にて移行せしめたもの等球面領域3、3a…の設定範囲の広狭は任意であ

本発明に係る凸面反射鏡は、複数の球面領域が配置されているため、鏡本体内の場所によりその視認範囲、倍率は設定された曲率半径に応じて変化し、又隣接する球面領域間の不連続領域は重し領域にて円滑に連続されているため、像に極端な歪を生じることなく自然な反射像が得られるのである。

実施例

以下本発明の一実施例を図面に基づいて説明すると、

1は無鏡ガラスにて型成形せしめた後、表面を鏡面蒸着処理せしめた凸面反射鏡の鏡本体であり、該鏡本体1の表面領域2を所定の曲率半径 R_a 、 R_b 、 R_c …より成る複数の球面領域3、3a…に区割せしめ、該球面領域3、3a…において隣接する相互の球面領域3、3a…間に生じる曲面の不連続領域4、4a…は、相互の球面領域3、3a…の接線間に渉り順次連続的に曲率半径が変化すると共に、相互間を段差を生じることなく円滑に連続せしめる曲面にて構成し、かかる

る。

又、第4図は第2の実施例を示し、球面領域3、3a…を一端方から他端方へ向かうに従い順次曲率半径を小ならしめる様に配置したもので、一端側の視認領域を充分に確保したい場合に適し、例えば大型車輪用のバックミラーとして下方へ至るに従い順次曲率半径を小ならしめる様に配置したもの(一例として $R_a = 600$ mm、 $R_b = 500$ mm、 $R_c = 400$ mm)を使用すれば、通常死角とされている前輪側方の視認が可能となり、前輪による巻き込み事故の防止に役立つものである。

又、第5図に第3の実施例を示し、任意の球面領域3、3a…間に平面領域6を介在せしめたものであり、これは特定の部分に写る像を等倍に近い状態で視認させることにより、特に距離感の正確な把握が要求される場合に適する。

尚、何れの実施例においても球面領域3、3a…の中心は、鏡本体1に対し中央軸上に整列配置されなければならないものではなく、例えば第6

図に図示する様に傾斜する軸上に配置することも可能であり、球面領域3、3a…の中心位置は何ら限定するものではない。

(発明の効果)

要するに本発明は、鏡本体1の表面領域2を、使用目的に応じて任意に設定された曲率半径より成る複数の球面領域3、3a…にて区割構成したので、距離感の正確なる把握を希望する領域、視認範囲の広がり希望する領域を、用途に応じて鏡本体1中の上下、左右任意の位置に自由に設定出来、又隣接する球面領域3、3a…間に生じる不連続領域4、4a…を相互の球面領域3、3a…間に沿り順次連続的に曲率半径が変化する曲面にて移行せしめ、かかる不連続領域4、4a…を相互の球面領域3、3a…を円滑に連続せしめる畳し領域5、5a…と成したので、鏡本体1に複数の曲率半径の異なる球面領域3、3a…が存在しているにも拘らず像が極端に歪むことなく自然な反射像を得ることが出来ると共に、距離感の把握も容易ならしめることが出来

、よって車輻用バックミラー、防犯ミラー、路上に設置されるカーブミラー等の広視界反射鏡として広範囲に活用することが出来る等その実用的効果甚だ大なるものである。

4. 図面の簡単な説明

図は本発明の一実施例を示すものにして、第1図は本発明に係る凸面反射鏡の正面図、第2図は同上断面図、第3図乃至第6図は他の実施例を示す図である。

1 鏡本体 2 表面領域 3、3a… 球面領域
4、4a… 不連続領域 5、5a… 畳し領域

以上

出願人 三宅信也
山田正弘
久野孝一
代理人 弁理士 西山 野一



第1図

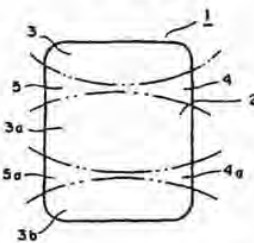

第4図

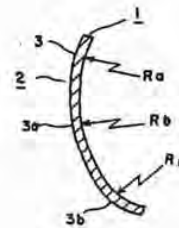

第5図

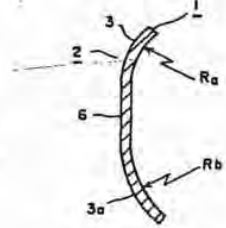

第2図

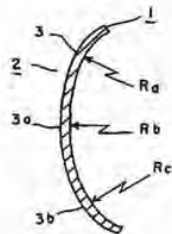

第3図

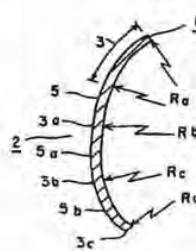

第6図

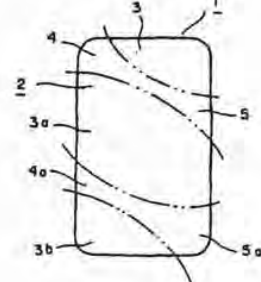

IN THE UNITED STATES PATENT AND TRADEMARK OFFICE

Examiner : R. Shafer
Group : 2872
Applicant : Niall R. Lynam
Serial No. : 09/478,315
Filed : January 6, 2000
For : EXTERIOR MIRROR PLANO-AUXILIARY
REFLECTIVE ELEMENT ASSEMBLY

#19
2
9/12/02

Box AF
Commissioner for Patents
Washington, D.C. 20231

Date of this Paper: 9/9, 2002

Dear Sir:

PETITION AND FEE FOR
EXTENSION OF TIME (37 C.F.R. 1.136(a))

1. This is a petition for an extension of time to respond to the Office Action mailed May 8, 2002, for a period of one month.

2. Applicant is:

a small entity

verified statement attached
verified statement filed

x other than small entity

3. Extension (months)	Fee for other than small entity	Fee for small entity
x one month	\$110.00	\$55.00
two months	\$400.00	\$200.00
three months	\$920.00	\$460.00
four months	\$1,440.00	\$720.00

FAX COPY RECEIVED
SEP 09 2002

4. An amendment:

x is filed herewith

has been filed TECHNOLOGY CENTER 2800

5. Fee Payment:

x Please charge the petition fee of \$110 and any additional fees required or credit any excess fee paid to Deposit Account No. 22-0190. A duplicate of this Petition is attached.

VAN DYKE, GARDNER, LINN & BURKHART, LLP

Catherine S. Collins
Registration No. 37 599
2851 Charlevoix Drive, S.E.
P.O. Box 888695
Grand Rapids, MI 49588-8695
(616) 975-5500

09/12/2002 PBRITTON-00000001 EP0190 09478315
Sale Ref: 09930001 DAN: EP0190 09478315
01 FC:115 110.00 CH

CSC:lmcc

Received from < 6169755505 > at 9/9/02 9:52:30 PM [Eastern Daylight Time]

#20/p n/e

9/12/02

VIA FACSIMILE NO. (703)0872-9319

AMENDMENT AFTER FINAL
(37 C.F.R. 1.116)
EXPEDITED HANDLING

PATENT
DON01 P-793

IN THE UNITED STATES PATENT AND TRADEMARK OFFICE

Examiner : R. Shafer
Applicant : Niall R. Lynam
Serial No. : 09/478,315
Filed : January 6, 2000
Group : 2872
For : EXTERIOR MIRROR PLANO-AUXILIARY
REFLECTIVE ELEMENT ASSEMBLY

Box AF
Commissioner for Patents
Washington, D.C. 20231

Dear Sir:

AMENDMENT AFTER FINAL REJECTION (37 C.F.R. 1.116)

In response to the final Office Action mailed May 8, 2002, having a three-month period of response ending August 8, 2002, Applicant submits a petition and fee for a one month extension of time, request that the finality of the Office Action be withdrawn and, further, amends his application as follows:

IN THE CLAIMS:

Please cancel Claims 84-90.

Please amend Claim 1 as follows:

1. (Thrice Amended)

An exterior sideview mirror system suitable for use on an automobile, said exterior sideview mirror system comprising:

an exterior sideview mirror assembly adapted for attachment to a side of an automobile;

said exterior sideview mirror assembly including a reflective element having a rearward field of view when attached to the side of the automobile;

OK
To enter
KAS

Di

D

SEP-09-02 21:58 FROM: VANDYKE-GARDNER-LINN-BURK ID: 6169755505 PAGE 2/18

36

Applicant : Niall R. Lynam
Serial No. : 09/478,315
Page : 2

said reflective element attached to an electrically-operated actuator and movable by said actuator in order to position said rearward field of view in response to a control;

wherein said reflective element comprises a plano-multiradius reflective element assembly, said plano-multiradius reflective element assembly comprising a plano reflective element having unit magnification and a separate multiradius reflective element having a multiradius curvature, said plano reflective element having a rearward field of view with a principal axis;

said plano reflective element and said multiradius reflective element of said plano-multiradius reflective element assembly mounted adjacently in said plano-multiradius reflective element assembly in a side-by-side relationship and not superimposed with one reflective element on top of the other reflective element, and supported by a backing plate element, said backing plate element mounting to said actuator such that movement of said backing plate element of said plano-multiradius reflective element assembly by said actuator simultaneously and similarly moves said plano reflective element and said multiradius reflective element, said multiradius reflective element having a rearward field of view with a principal axis, said backing plate element have a first support portion supporting said plano-reflective element and a second support portion supporting said multiradius reflective element, said second support portion tilted forward with respect to said first support portion whereby said principal axis of said rearward field of view of said multiradius reflective element is angled downwardly and outwardly with respect to said principal axis of said rearward field of view of said plano reflective element when said multiradius reflective element and said plano reflective element are supported by said backing plate element of said plano-multiradius reflective element assembly and when said plano-multiradius reflective element assembly is mounted in said exterior sideview mirror assembly on the automobile, and said principal axis of said rearward field of view of said plano reflective element being directed generally parallel to the longitudinal axis of the automobile equipped with the plano-multiradius reflective element assembly and wherein said principal axis of said rearward field of view of said multiradius reflective element is directed generally at an angle downwards to the longitudinal axis of the automobile; and

Cont'd
Di

E

D

31

Applicant : Niall R. Lynam
Serial No. : 09/478,315
Page : 3

Cont'd
01 E

said multiradius reflective element being positioned ^{diagonally} at an outboard upper portion of said plano-multiradius reflective element assembly when said exterior sideview mirror assembly is mounted to the side of the automobile.

REMARKS

Applicant has reviewed the final Office Action mailed May 8, 2002, and cited references therein. In light of the above amendments and following remarks, Applicant respectfully requests reconsideration of the present application.

Furthermore, Applicant respectfully requests the withdrawal of the finality of this Office Action since not all the claims presented in the RCE were drawn to the same invention claimed in the application prior to the entry of the RCE submission. For example, Claim 1 as presented in the submission added the further limitation of "said backing plate element having a first support portion supporting said plano reflective element and a second support portion supporting said multiradius reflective element, said second support portion tilted with respect to said first support portion." These limitations were presented for the first time in the RCE submission and did not appear in the claims prior to entry of that submission. Therefore, Applicant respectfully submits that the finality of the Office Action is improper and respectfully requests withdrawal of the finality of this Office Action.

STATUS OF THE CLAIMS:

Claims 1-22, 25-34, and 36-43 are pending in the application. Claims 84-90 have been canceled as being drawn to a non-elected invention. Claims 2-15, 32, 34, and 36-43 have been withdrawn from consideration as drawn to a non-elected invention. Claims 1, 16-22, 25-31, 33, and 35 have been examined on the merits.

CLAIM REJECTIONS UNDER 35 U.S.C. § 103(a):

28

D

Applicant : Niall R. Lynam
Serial No. : 09/478,315
Page : 4

The Examiner rejects Claims 1, 16-22, 25-31, 33, and 35 under 35 U.S.C. § 103(a) as being unpatentable over Kondo et al. '542 or Hagiri '534 in view of Tobin '952 or Hacker '158 and, further, in view of Oskam '899 or Enomoto '166.

The Examiner states "Kondo et al and Hagiri each disclose an exterior side view-mirror system comprising an exterior side view mirror assembly (1, 11) including a plano-multiradius reflective element assembly having a plano reflective (9, 13a) portion and a multiradius reflective portion (11, 13c) and an actuator (not shown) for adjustably positioning the plano-multiradius reflective element assembly, note FIGURES 2, 4 and 9, and (1-8) and the associated description thereof, respectively, except for explicitly stating that the actuator comprises an electrically-operated actuator and the plano multiradius reflective portions was separated." Furthermore, the Examiner states that "it would have been obvious and/or within the level of one ordinary skill in the art at the time the invention was made to modify the plano-multiradius reflective element assembly of Kondo et al or Hagiri to include separate plano and multiradius reflective elements having a common backing plate as is well known and commonly used and/or employed in the mirror art, as taught by Tobin, Jr. or Hacker et al. in order to reduce manufacturing costs, by replacing one of the reflective elements without having to replace the other one of the reflective elements, should one of the elements become defective and/or damaged during assembly."

Applicant respectfully traverses. One of the purposes addressed in Kondo et al. is to provide a mirror that has a gradually changing mirror section. To achieve this, Kondo utilizes a single substrate mirror element with a gradually changing mirror section. By contrast, the present invention combines a plano mirror section that is flat, i.e. not gradually changing, with a separate multiradius auxiliary reflective element. At best, Kondo teaches a form for a multiradius reflective element. But Kondō egregiously teaches away

Applicant : Niall R. Lynam
Serial No. : 09/478,315
Page : 5

from the present invention that combines a multiradius reflective element and a separate plano, i.e. flat, reflective element for the intent and purposes described throughout the specification.

Nor can Tobin alone or in combination with Kondo cure the deficiencies of Kondo. Tobin is directed to a mirror assembly that includes a planar mirror section and a convex section with an indicia strip to provide a visual means for the driver to distinguish between the images. Tobin totally lacks the features of the claimed invention. For example, Tobin does not disclose or suggest a backing plate element, the backing plate element mounting to the actuator such that movement of the backing plate element of the plano-multiradius reflective element assembly by the actuator simultaneously and similarly moves the plano reflective element and the multiradius reflective element, the multiradius reflective element having a rearward field of view with a principal axis, the backing plate element have a first support portion supporting the plano-reflective element and a second support portion supporting the multiradius reflective element, the second support portion tilted forward with respect to the first support portion whereby the principal axis of the rearward field of view of the multiradius element is angled downwardly and outwardly with respect to the principal axis of the rearward field of view of the plano reflective element when the multiradius reflective element and the plano reflective element are supported by the backing plate element, as called for in the claims. Nor does Tobin disclose or suggest a multiradius reflective element being positioned at an outboard upper portion of a plano-multiradius reflective element assembly.

Therefore, Applicant respectfully urges that even when combined with the other cited references the Tobin reference does not teach or suggest all of the claimed limitations. In addition, Applicant respectfully urges that it would not be obvious to modify

Applicant : Niall R. Lynam
Serial No. : 09/478,315
Page : 6

Kondo in view of Tobin, as suggested by the Examiner, since such a modification would change the principal operation of Kondo and would in fact destroy the principal operation of the Kondo mirror. A prior art reference must be considered in its entirety, i.e., as a whole, including portions that would lead away from the claimed invention. W.L. Gore & Associates, Inc. v. Garlock, Inc., 721 F.2d 1540, 220 U.S.P.Q. 303 (Fed. Cir. 1983), cert. denied, 469 U.S. 851 (1984). Where the proposed modification or combination of the prior art would change the principle of operation of the prior art invention being modified, then the teachings of the references are not sufficient to render the claims prima facie obvious. In re Ratti, 270 F.2d 810, 123 U.S.P.Q. 349 (CCPA 1959).

Applicant respectfully also submits that it would not be obvious to modify Kondo in view of Hacker. Hacker does not disclose, for example, a backing plate element, the backing plate element mounting to the actuator such that movement of the backing plate element of the plano-multiradius reflective element assembly by the actuator simultaneously and similarly moves the plano reflective element and the multiradius reflective element, the multiradius reflective element having a rearward field of view with a principal axis, the backing plate element have a first support portion supporting the plano-reflective element and a second support portion supporting the multiradius reflective element, the second support portion tilted forward with respect to the first support portion whereby the principal axis of the rearward field of view of the multiradius element is angled downwardly and outwardly with respect to the principal axis of the rearward field of view of the plano reflective element when the multiradius reflective element and the plano reflective element are supported by the backing plate element, as called for in the claims. Nor does Hagiri disclose or suggest a multiradius reflective element being positioned at an outboard upper portion of a plano-multiradius reflective element assembly. Applicant respectfully submits

Applicant : Niall R. Lynam
Serial No. : 09/478,315
Page : 7

that the modification of Kondo in view of Hacker, as proposed by the Examiner, would change the principle operation of the Kondo mirror in that the separate reflective elements will change the expressed principal operation of the Kondo reflective element.

With respect to Hagiri '534, Hagiri is again directed to a single reflective element that has contiguously curved reflective faces in order to maintain images on these reflective surfaces contiguous to each other so that the drive will be able to make a correct judgment as to the location of the object viewed in the reflective element. Hagiri does not disclose or suggest a plano-multiradius reflective element assembly comprising a plano reflective element having unit magnification and a separate multiradius reflective element having a multiradius curvature. Nor does Hagiri disclose or suggest a backing plate element, the backing plate element mounting to the actuator such that movement of the backing plate element of the plano-multiradius reflective element assembly by the actuator simultaneously and similarly moves the plano reflective element and the multiradius reflective element, the multiradius reflective element having a rearward field of view with a principal axis, the backing plate element have a first support portion supporting the plano-reflective element and a second support portion supporting the multiradius reflective element, the second support portion tilted forward with respect to the first support portion whereby the principal axis of the rearward field of view of the multiradius element is angled downwardly and outwardly with respect to the principal axis of the rearward field of view of the plano reflective element when the multiradius reflective and the plano reflective element are supported by the backing plate element, as called for in the claims. Nor does Hagiri disclose or suggest a multiradius reflective element being positioned at an outboard upper portion of a plano-multiradius reflective element assembly.

Applicant : Niall R. Lynam
Serial No. : 09/478,315
Page : 8

Applicant respectfully urges that, for the at least the reasons set forth above in reference to Kondo, it would not be obvious to modify Hagiri in view of Tobin or Hacker either, since such a modification would change the principle operation of the Hagiri mirror. As such, such a modification is not obvious.

Nor do Oskam or Enomoto cure the deficiencies of Kondo, Hagiri, Tobin or Hacker.

As noted above, the Examiner has failed to establish that the references when combined teach or suggest all the limitations of the claims. For example, even when combined the references do not teach or suggest a backing plate element having a first support portion supporting a plano-reflective element and a second support portion supporting a multiradius reflective element, with a second support portion tilted with respect to the first support portion whereby the principal axis of the rearward field of view of the multiradius element is different from and angled with respect of the principal axis of the rearward field of view of the plano-reflective element. Nor do the references disclose or suggest disclose or suggest a multiradius reflective element being positioned at an outboard upper portion of a plano-multiradius reflective element assembly.

To establish a prima facie case of obviousness, three basic criteria must be met. First, there must be some suggestion or motivation either in the references themselves or in the knowledge generally available to one of ordinary skill in the art to modify the reference or combine the reference teachings. Second, there must be a reasonable expectation of success. Finally, the prior art reference or references when combined must teach or suggest all the claimed limitations. The teaching or suggestion to make the claim combination and reasonable expectation of success must both be found in the prior art and not based on Applicant's disclosure. In re Vaeck, 947 F.2d 488, 20 U.S.P.Q.2d 1438 (Fed.

Applicant : Niall R. Lynam
Serial No. : 09/478,315
Page : 9

Cir. 1991). See MPEP § 2143. In addition, all words in a claim must be considered in judging patentability of a claim against prior art. In re Fine, 873 F.2d 1071, 5 U.S.P.Q.2d 1596 (Fed. Cir. 1988); In re Wilson, 424 F.2d 1382, 165 U.S.P.Q. 494 (CCPA 1970).

Applicant respectfully urges that the Examiner has not established a prima facie case of obviousness and, further, that Claim 1 and its dependant claims, namely Claims 16-22, 25-31, 33 and 35, are patentably distinguishable over Kondo or Hagiri in view of Tobin or Hacker or Oskam or Enomoto or any reference of record.

Therefore, Applicant respectfully solicits a Notice of Allowance of all claims, namely Claims 1, 16-22, 25-31, 33 and 35 and Claims 2- 15, 32, 34, 36-43, which depend from allowable Claim 1.

Should the Examiner have any questions or comments, he is invited to contact the undersigned at (616) 975-5506.

Respectfully submitted,

NIALL R. LYNAM

By: Van Dyke, Gardner, Linn & Burkhardt, LLP

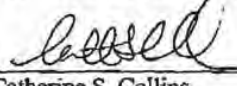

Catherine S. Collins
Registration No. 37 599
2851 Charlevoix Drive, S.E.
Suite 207
P.O. Box 888695
Grand Rapids, MI 49588-8695
(616) 975-5500

Date 9/9/2002

CSC:lmsc

Applicant : Niall R. Lynam
Serial No. : 09/478,315
Page : 10

AMENDMENT AFTER FINAL
(37 C.F.R. 1.116)
EXPEDITED HANDLING

PATENT
DON01 P-793

APPENDIX TO CLAIMS

1. (Thrice Amended)

An exterior sideview mirror system suitable for use on an automobile, said exterior sideview mirror system comprising:

an exterior sideview mirror assembly adapted for attachment to a side of an automobile;

said exterior sideview mirror assembly including a reflective element having a rearward field of view when attached to the side of the automobile;

said reflective element attached to an electrically-operated actuator and movable by said actuator in order to position said rearward field of view in response to a control;

wherein said reflective element comprises a plano-multiradius reflective element assembly, said plano-multiradius reflective element assembly comprising a plano reflective element having unit magnification and a separate multiradius reflective element having a multiradius curvature, said plano reflective element having a rearward field of view with a principal axis;

said plano reflective element and said multiradius reflective element of said plano-multiradius reflective element assembly mounted adjacently in said plano-multiradius reflective element assembly in a side-by-side relationship and not superimposed with one reflective element on top of the other reflective element, and supported by a backing plate element, said backing plate element mounting to said actuator such that movement of said backing plate element of said plano-multiradius reflective element assembly by said actuator simultaneously and similarly moves said plano reflective element and said multiradius reflective element, said multiradius reflective element having a rearward field of view with a principal axis, said backing plate element have a first support portion supporting said plano-reflective element and a second support portion supporting said multiradius reflective element, said second support portion tilted forward with respect to said first support portion

Applicant : Niall R. Lynam
Serial No. : 09/478,315
Page : 11

whereby said principal axis of said rearward field of view of said multiradius element [being] is [different from and] angled downwardly and outwardly with respect to said principal axis of said rearward field of view of said plano reflective element when said multiradius reflective element and said plano reflective element are supported by said backing plate element of said plano-multiradius reflective element assembly and when said plano-multiradius reflective element assembly is mounted in said exterior sideview mirror assembly on the automobile, and said principal axis of said rearward field of view of said plano reflective element being directed generally parallel to the longitudinal axis of the automobile equipped with the plano-multiradius reflective element assembly and wherein said principal axis of said rearward field of view of said multiradius reflective element is directed generally at an angle downwards to the longitudinal axis of the automobile; and

said multiradius reflective element being positioned at an outboard upper portion of said plano-multiradius reflective element assembly when said exterior sideview mirror assembly is mounted to the side of the automobile.

Respectfully submitted,

NIALL R. LYNAM

By: Van Dyke, Gardner, Linn & Burkhart, LLP

Date:

9/9/2002

Catherine S. Collins
Catherine S. Collins
Registration No. 37 599
2851 Charlevoix Drive, S.E.
Suite 207
P.O. Box 888695
Grand Rapids, MI 49588-8695
(616) 975-5500

CSC:lmsc

PATENT
DON01 P-793

IN THE UNITED STATES PATENT AND TRADEMARK OFFICE

Examiner : R. Shafer
Applicant : Niall R. Lynam
Serial No. : 09/478,315
Filed : January 6, 2000
Group : 2872
For : EXTERIOR MIRROR PLANO-AUXILIARY
REFLECTIVE ELEMENT ASSEMBLY

Commissioner for Patents
Washington, D.C. 20231

Dear Sir:

PETITION TO WITHDRAW FINALITY

In response to the final Office Action mailed May 9, 2002, having a three-month period of response ending August 8, 2002, Applicant petitions that the finality of the Office Action be withdrawn.

REMARKS

FINALITY OF REJECTION:

The Examiner states that all claims are drawn to the same invention claimed in the application prior to the entry of the submission under 37 C.F.R. 1.114 and could have been finally rejected on the grounds at art-of-record in the next Office Action if they had been entered in the application prior to entry under 37 C.F.R. 1.114. Accordingly, this action is made final even though it is a first Office Action after the filing of a Request for Continued Examination and the submission under 37 C.F.R. 1.114.

Applicant respectfully traverses. Specifically, Applicant respectfully urges that not all the claims are drawn to the same invention claimed in the application prior to the entry of the RCE. For example, Claim 1 as presented in the RCE submission added the further limitation of "said backing element having a first support portion supporting said

Applicant : Niall R. Lynam
Serial No. : 09/478,315
Page : 2

plano reflective element and a second support portion supporting said multi-radius reflective element and said support portion tilted with respect to said first support portion." These limitations were presented for the first time in the RCE submission and did not appear in the claims prior to the entry of the RCE submission. Therefore, Applicant respectfully submits that the finality of the Office Action is improper and respectfully request withdrawal of the finality of this Office Action.

The Commissioner is hereby authorized to charge Deposit Account No. 22-0190 for a Petition fee of \$130.00, if required. Should the Commissioner grant the Petition, Applicant respectfully requests a refund by crediting the deposit account the amount of the fee. A duplicate copy of this Petition is enclosed.

Should the Examiner have any questions or comments, the Examiner is invited to contact the undersigned attorney at (616) 975-5506.

Respectfully submitted,

NIALL R. LYNAM

By: Van Dyke, Gardner, Linn & Burkhardt, LLP

Catherine S. Collins

Catherine S. Collins
Registration No. 37 599
P.O. Box 888695
2851 Charlevoix Drive, S.E.
Grand Rapids, MI 49588-8695
(616) 975-5500

FAX COPY RECEIVED

SEP 09 2002

TECHNOLOGY CENTER 2800

Date

9/9/2002

CSC:imsc

VIA FACSIMILE NO. (703)872-9319

AMENDMENT AFTER FINAL

(37 C.F.R. 1.116)
EXPEDITED HANDLING

PATENT
DON01 P-793

IN THE UNITED STATES PATENT AND TRADEMARK OFFICE

Examiner : R. Shafer
Applicant : Niall R. Lynam
Serial No. : 09/478,315
Filed : January 6, 2000
Group : 2872
For : EXTERIOR MIRROR PLANO-AUXILIARY
REFLECTIVE ELEMENT ASSEMBLY

FAX COPY RECEIVED

SEP 09 2002

TECHNOLOGY CENTER 2800

Box AF
Commissioner for Patents
Washington, D.C. 20231

Dear Sir:

CERTIFICATE OF FACSIMILE TRANSMISSION

I certify that the following papers are being facsimile transmitted to the Patent and Trademark Office on the date shown below:

Amendment After Final;

Petition to Withdraw Finality (in duplicate); and

Petition and Authorization to Charge Fee for a One-Month Extension of Time (in duplicate)

YOU SHOULD RECEIVE A TOTAL OF ___ PAGES

INCLUDING THIS TRANSMITTAL.

Dated: September 9, 2002.



Catherine S. Collins
Van Dyke, Gardner, Linn & Burkhart, LLP
P.O. Box 888695
Grand Rapids, MI 49588-8695
(616) 975-5500

CSC:lmse
Enclosures



UNITED STATES DEPARTMENT OF COMMERCE
United States Patent and Trademark Office
 Address: COMMISSIONER OF PATENTS AND TRADEMARKS
 Washington, D.C. 20231

091/478,315

APPLICATION NUMBER	FILING DATE	FIRST NAMED APPLICANT	ATTORNEY DOCKET NO.
--------------------	-------------	-----------------------	---------------------

EXAMINER

ART UNIT	PAPER NUMBER
----------	--------------

21/E

DATE MAILED:

This is a communication from the examiner in charge of this application.
 COMMISSIONER OF PATENTS AND TRADEMARKS

NOTICE OF ALLOWABILITY

All claims being allowable, PROSECUTION ON THE MERITS IS (OR REMAINS) CLOSED in this application. If not included herewith (or previously mailed), a Notice of Allowance and Issue Fee Due or other appropriate communication will be mailed in due course. THIS NOTICE OF ALLOWABILITY IS NOT A GRANT OF PATENT RIGHTS. This application is subject to withdrawal from issue at the initiative of the Office or upon petition by the applicant. See 37 CFR 1.313 and MPEP 1308.

This communication is responsive to THE AMENDMENT FILED ON 9/9/02

The allowed claim(s) is/are 1-22, 25-34 AND 36-43

The drawings filed on _____ are acceptable as formal drawings.

Acknowledgement is made of a claim for foreign priority under 35 U.S.C. § 119(a)-(d) or (f).

- All Some* None of the:
- Certified copies of the priority documents have been received.
 - Certified copies of the priority documents have been received in Application No. _____
 - Copies of the certified copies of the priority documents have been received in this national stage application from the International Bureau (PCT Rule 17.2(a)).

*Certified copies not received: _____

Acknowledgement is made of a claim for domestic priority under 35 U.S.C. § 119(e).

Applicant has THREE MONTHS FROM THE "MAILING DATE" of this communication to file a reply complying with requirements noted below. Failure to timely comply will result in ABANDONMENT of this application. THIS THREE-MONTH PERIOD IS NOT EXTENDABLE FOR SUBMITTING NEW FORMAL DRAWINGS, OR A SUBSTITUTE OATH OR DECLARATION. This three-month period for complying with the REQUIREMENT FOR THE DEPOSIT OF BIOLOGICAL MATERIAL is extendable under 37 CFR 1.136(a).

Note the attached EXAMINER'S AMENDMENT or NOTICE OF INFORMAL APPLICATION, PTO-152, which discloses that the oath or declaration is deficient. A SUBSTITUTE OATH OR DECLARATION IS REQUIRED.

Applicant MUST submit ~~new~~ FORMAL DRAWINGS

- because the originally filed drawings were declared by applicant to be informal.
- including changes required by the Notice of Draftsperson's Patent Drawing Review, PTO-948, attached hereto or to Paper No. 9
- including changes required by the proposed drawing correction filed on _____, which has been approved by the examiner.
- including changes required by the attached Examiner's Amendment/Comment or in the Office action of Paper No. _____

Identifying indicia such as the application number (see 37 CFR 1.84(c)) should be written on the drawings.

Note the attached Examiner's comment regarding REQUIREMENT FOR THE DEPOSIT OF BIOLOGICAL MATERIAL

Any reply to this notice should include, in the upper right hand corner, the APPLICATION NUMBER (SERIES CODE/SERIAL NUMBER). If applicant has received a Notice of Allowance and Issue Fee Due, the ISSUE BATCH NUMBER and DATE of the NOTICE OF ALLOWANCE should also be included.

Attachment(s)

- Notice of References Cited, PTO-892
- Information Disclosure Statement(s), PTO-1449, Paper No(s) _____
- Notice of Draftsperson's Patent Drawing Review, PTO-948
- Notice of Informal Patent Application, PTO-152
- Interview Summary, PTO-413
- Examiner's Amendment/Comment
- Examiner's Comment Regarding Requirement for the Deposit of Biological Material
- Examiner's Statement of Reasons for Allowance

Ricky A. Shaper
 RICKY A. SHAPER
 PATENT EXAMINER
 ART UNIT 2512

Art Unit: 2872

1. Applicant's request for reconsideration of the finality of the rejection of the last Office action is persuasive and, therefore, the finality of that action is withdrawn.
2. An examiner's amendment to the record appears below. Should the changes and/or additions be unacceptable to applicant, an amendment may be filed as provided by 37 CFR 1.312. To ensure consideration of such an amendment, it MUST be submitted no later than the payment of the issue fee.
3. Authorization for this examiner's amendment was given in a telephone interview with Ms. Catherine S. Collins on 9/24/02.
4. The application has been amended as follows:
In claim 1, line 26, the language "multiradius element" has been changed to read --multiradius reflective element--.
In claim 1, line 37, the language --diagonally-- has been inserted after "positioned".
5. The following is an examiner's statement of reasons for allowance:
The prior art of record does not teach or fairly suggest an exterior sideview mirror system comprising an exterior sideview mirror assembly adapted for attachment to a side of an automobile, wherein said exterior sideview mirror assembly includes a reflective element attached to an electrically-operated actuator, wherein said reflective element comprises a plano-multiradius reflective element assembly, wherein said plano-multiradius reflective element assembly includes a plano reflective element having unit magnification and a separate multiradius reflective element

Application/Control Number: 09/478,315

Page 3

Art Unit: 2872

having a multiradius supported by a backing plate, wherein said plano reflective element and said multiradius reflective element includes the limitations and arrangement as recited in claim 1, lines 15-39.

Any comments considered necessary by applicant must be submitted no later than the payment of the issue fee and, to avoid processing delays, should preferably accompany the issue fee. Such submissions should be clearly labeled "Comments on Statement of Reasons for Allowance."

6. Any inquiry concerning this communication or earlier communications from the examiner should be directed to R.D. Shafer whose telephone number is (703) 308-4813.

RDS

September 24, 2002

RICHARD D. SHAFER
PATENT EXAMINER
ART UNIT 2872



UNITED STATES PATENT AND TRADEMARK OFFICE

UNITED STATES DEPARTMENT OF COMMERCE
United States Patent and Trademark Office
Address: COMMISSIONER OF PATENTS AND TRADEMARKS
Washington, D.C. 20231
www.uspto.gov

NOTICE OF ALLOWANCE AND FEE(S) DUE

28101 7590 09/26/2002
VAN DYKE, GARDNER, LINN AND BURKHART, LLP
2851 CHARLEVOIX DRIVE, S.E.
P.O. BOX 888695
GRAND RAPIDS, MI 49588-8695

EXAMINER	
SHAFER, RICKY D	
ART UNIT	CLASS-SUBCLASS
2872	359-874000

DATE MAILED: 09/26/2002

APPLICATION NO.	FILING DATE	FIRST NAMED INVENTOR	ATTORNEY DOCKET NO.	CONFIRMATION NO.
09/478,315	01/06/2000	NIALL R. LYNAM	DON01-P-793	1526

TITLE OF INVENTION: EXTERIOR MIRROR PLANO-AUXILIARY REFLECTIVE ELEMENT ASSEMBLY

APPLN. TYPE	SMALL ENTITY	ISSUE FEE	PUBLICATION FEE	TOTAL FEE(S) DUE	DATE DUE
nonprovisional	NO	\$1280	\$0	\$1280	12/26/2002

THE APPLICATION IDENTIFIED ABOVE HAS BEEN EXAMINED AND IS ALLOWED FOR ISSUANCE AS A PATENT. PROSECUTION ON THE MERITS IS CLOSED. THIS NOTICE OF ALLOWANCE IS NOT A GRANT OF PATENT RIGHTS. THIS APPLICATION IS SUBJECT TO WITHDRAWAL FROM ISSUE AT THE INITIATIVE OF THE OFFICE OR UPON PETITION BY THE APPLICANT. SEE 37 CFR 1.313 AND MPEP 1308.

THE ISSUE FEE AND PUBLICATION FEE (IF REQUIRED) MUST BE PAID WITHIN THREE MONTHS FROM THE MAILING DATE OF THIS NOTICE OR THIS APPLICATION SHALL BE REGARDED AS ABANDONED. THIS STATUTORY PERIOD CANNOT BE EXTENDED. SEE 35 U.S.C. 151. THE ISSUE FEE DUE INDICATED ABOVE REFLECTS A CREDIT FOR ANY PREVIOUSLY PAID ISSUE FEE APPLIED IN THIS APPLICATION. THE PTOL-85B (OR AN EQUIVALENT) MUST BE RETURNED WITHIN THIS PERIOD EVEN IF NO FEE IS DUE OR THE APPLICATION WILL BE REGARDED AS ABANDONED.

HOW TO REPLY TO THIS NOTICE:

I. Review the SMALL ENTITY status shown above.

If the SMALL ENTITY is shown as YES, verify your current SMALL ENTITY status:

- A. If the status is the same, pay the TOTAL FEE(S) DUE shown above.
- B. If the status is changed, pay the PUBLICATION FEE (if required) and twice the amount of the ISSUE FEE shown above and notify the United States Patent and Trademark Office of the change in status, or

If the SMALL ENTITY is shown as NO:

- A. Pay TOTAL FEE(S) DUE shown above, or
- B. If applicant claimed SMALL ENTITY status before, or is now claiming SMALL ENTITY status, check the box below and enclose the PUBLICATION FEE and 1/2 the ISSUE FEE shown above.
 - Applicant claims SMALL ENTITY status. See 37 CFR 1.27.

II. PART B - FEE(S) TRANSMITTAL should be completed and returned to the United States Patent and Trademark Office (USPTO) with your ISSUE FEE and PUBLICATION FEE (if required). Even if the fee(s) have already been paid, Part B - Fee(s) Transmittal should be completed and returned. If you are charging the fee(s) to your deposit account, section "4b" of Part B - Fee(s) Transmittal should be completed and an extra copy of the form should be submitted.

III. All communications regarding this application must give the application number. Please direct all communications prior to issuance to Box ISSUE FEE unless advised to the contrary.

IMPORTANT REMINDER: Utility patents issuing on applications filed on or after Dec. 12, 1980 may require payment of maintenance fees. It is patentee's responsibility to ensure timely payment of maintenance fees when due.

PART B - FEE(S) TRANSMITTAL

Complete and send this form, together with applicable fee(s), to: **Mail** **Box ISSUE FEE**
Commissioner for Patents
Washington, D.C. 20231
Fax (703)746-4000

INSTRUCTIONS: This form should be used for transmitting the ISSUE FEE and PUBLICATION FEE (if required). Blocks 1 through 4 should be completed where appropriate. All further correspondence including the Patent, advance orders and notification of maintenance fees will be mailed to the current correspondence address as indicated unless corrected below or directed otherwise in Block 1, by (a) specifying a new correspondence address; and/or (b) indicating a separate "FEE ADDRESS" for maintenance fee notifications.

CURRENT CORRESPONDENCE ADDRESS (Note: Legibly mark-up with any corrections or use Block 1)

28101 7590 09/26/2002
VAN DYKE, GARDNER, LINN AND BURKHART, LLP
 2851 CHARLEVOIX DRIVE, S.E.
 P.O. BOX 888695
 GRAND RAPIDS, MI 49588-8695

Note: A certificate of mailing can only be used for domestic mailings of the Fee(s) Transmittal. This certificate cannot be used for any other accompanying papers. Each additional paper, such as an assignment or formal drawing, must have its own certificate of mailing or transmission.

Certificate of Mailing or Transmittal
 I hereby certify that this Fee(s) Transmittal is being deposited with the United States Postal Service with sufficient postage for first class mail in an envelope addressed to the Box Issue Fee address above, or being facsimile transmitted to the USPTO, on the date indicated below.

_____ (Depositor's name)
_____ (Signature)
_____ (Date)

APPLICATION NO.	FILING DATE	FIRST NAMED INVENTOR	ATTORNEY DOCKET NO.	CONFIRMATION NO.
09/478,315	01/06/2000	NIALL R. LYNAM	DON01-P-793	1526

TITLE OF INVENTION: EXTERIOR MIRROR PLANO-AUXILIARY REFLECTIVE ELEMENT ASSEMBLY

APPLN. TYPE	SMALL ENTITY	ISSUE FEE	PUBLICATION FEE	TOTAL FEE(S) DUE	DATE DUE
nonprovisional	NO	\$1280	\$0	\$1280	12/26/2002

EXAMINER	ART UNIT	CLASS-SUBCLASS
SHAFER, RICKY D	2872	359-874000

1. Change of correspondence address or indication of "Fee Address" (37 CFR 1.363). <input type="checkbox"/> Change of correspondence address (or Change of Correspondence Address form PTO/SB/122) attached. <input type="checkbox"/> "Fee Address" indication (or "Fee Address" Indication form PTO/SB/47; Rev 03-02 or more recent) attached. Use of a Customer Number is required.	2. For printing on the patent front page, list (1) the names of up to 3 registered patent attorneys or agents OR, alternatively, (2) the name of a single firm (having as a member a registered attorney or agent) and the names of up to 2 registered patent attorneys or agents. If no name is listed, no name will be printed. 1 _____ 2 _____ 3 _____
---	--

1. ASSIGNEE NAME AND RESIDENCE DATA TO BE PRINTED ON THE PATENT (print or type)
 PLEASE NOTE: Unless an assignee is identified below, no assignee data will appear on the patent. Inclusion of assignee data is only appropriate when an assignment has been previously submitted to the USPTO or is being submitted under separate cover. Completion of this form is NOT a substitute for filing an assignment.
 (A) NAME OF ASSIGNEE _____ (B) RESIDENCE: (CITY and STATE OR COUNTRY) _____

Please check the appropriate assignee category or categories (will not be printed on the patent) individual corporation or other private group entity government

4a. The following fee(s) are enclosed: <input type="checkbox"/> Issue Fee <input type="checkbox"/> Publication Fee <input type="checkbox"/> Advance Order - # of Copies _____	4b. Payment of Fee(s): <input type="checkbox"/> A check in the amount of the fee(s) is enclosed. <input type="checkbox"/> Payment by credit card. Form PTO-2038 is attached. <input type="checkbox"/> The Commissioner is hereby authorized by charge the required fee(s), or credit any overpayment, to Deposit Account Number _____ (enclose an extra copy of this form).
--	--

Commissioner for Patents is requested to apply the Issue Fee and Publication Fee (if any) or to re-apply any previously paid issue fee to the application identified above.

(Authorized Signature) _____ (Date) _____

NOTE: The Issue Fee and Publication Fee (if required) will not be accepted from anyone other than the applicant; a registered attorney or agent; or the assignee or other party in interest as shown by the records of the United States Patent and Trademark Office.

This collection of information is required by 37 CFR 1.311. The information is required to obtain or retain a benefit by the public which is to file (and by the USPTO to process) an application. Confidentiality is governed by 35 U.S.C. 122 and 37 CFR 1.14. This collection is estimated to take 12 minutes to complete, including gathering, preparing, and submitting the completed application form to the USPTO. Time will vary depending upon the individual case. Any comments on the amount of time you require to complete this form and/or suggestions for reducing this burden, should be sent to the Chief Information Officer, U.S. Patent and Trademark Office, U.S. Department of Commerce, Washington, D.C. 20231. DO NOT SEND FEES OR COMPLETED FORMS TO THIS ADDRESS. SEND TO: Commissioner for Patents, Washington, DC 20231.

Under the Paperwork Reduction Act of 1995, no persons are required to respond to a collection of information unless it displays a valid OMB control number.

TRANSMIT THIS FORM WITH FEE(S)



UNITED STATES PATENT AND TRADEMARK OFFICE

UNITED STATES DEPARTMENT OF COMMERCE
United States Patent and Trademark Office
Address: COMMISSIONER OF PATENTS AND TRADEMARKS
Washington, D.C. 20251
www.uspto.gov

APPLICATION NO.	FILING DATE	FIRST NAMED INVENTOR	ATTORNEY DOCKET NO.	CONFIRMATION NO.
09/478,315	01/06/2000	NIALL R. LYNAM	DON01-P-793	1526
28101	7590	09/26/2002	EXAMINER	
VAN DYKE, GARDNER, LINN AND BURKHART, LLP 2851 CHARLEVOIX DRIVE, S.E. P.O. BOX 888695 GRAND RAPIDS, MI 49588-8695 UNITED STATES			SHAFER, RICKY D	
			ART UNIT	PAPER NUMBER
			2872	
DATE MAILED: 09/26/2002				

Determination of Patent Term Extension under 35 U.S.C. 154 (b)
(application filed after June 7, 1995 but prior to May 29, 2000)

The patent term extension is 0 days. Any patent to issue from the above identified application will include an indication of the 0 day extension on the front page.

If a continued prosecution application (CPA) was filed in the above-identified application, the filing date that determines patent term extension is the filing date of the most recent CPA.

Applicant will be able to obtain more detailed information by accessing the Patent Application Information Retrieval (PAIR) system. (<http://pair.uspto.gov>)



UNITED STATES PATENT AND TRADEMARK OFFICE

UNITED STATES DEPARTMENT OF COMMERCE
United States Patent and Trademark Office
Address: COMMISSIONER OF PATENTS AND TRADEMARKS
Washington, D.C. 20251
www.uspto.gov

APPLICATION NO.	FILING DATE	FIRST NAMED INVENTOR	ATTORNEY DOCKET NO.	CONFIRMATION NO.
09/478,315	01/06/2000	NIALL R. LYNAM	DON01-P-793	1526
28101	7590	09/26/2002	EXAMINER	
VAN DYKE, GARDNER, LINN AND BURKHART, LLP 2851 CHARLEVOIX DRIVE, S.E. P.O. BOX 888695 GRAND RAPIDS, MI 49588-8695 UNITED STATES			SHAFER, RICKY D	
			ART UNIT	PAPER NUMBER
			2872	
DATE MAILED: 09/26/2002				

Notice of Possible Fee Increase on October 1, 2002

If a reply to a "Notice of Allowance and Fee(s) Due" is filed in the Office on or after October 1, 2002, then the amount due may be higher than that set forth in the "Notice of Allowance and Fee(s) Due" since there may be an increase in fees effective on October 1, 2002. See Revision of Patent and Trademark Fees for Fiscal Year 2003: Notice of Proposed Rulemaking, 67 Fed. Reg. 30634, 30636 (May 7, 2002). Although a change to the amount of the publication fee is not currently proposed for October 2002, if the issue fee or publication fee is to be paid on or after October 1, 2002, applicant should check the USPTO web site for the current fees before submitting the payment. The USPTO Internet address for the fee schedule is: <http://www.uspto.gov/main/howtofees.htm>.

If the issue fee paid is the amount shown on the "Notice of Allowance and Fee(s) Due," but not the correct amount in view of any fee increase, a "Notice to Pay Balance of Issue Fee" will be mailed to applicant. In order to avoid processing delays associated with mailing of a "Notice to Pay Balance of Issue Fee," if the response to the Notice of Allowance and Fee(s) due form is to be filed on or after October 1, 2002 (or mailed with a certificate of mailing on or after October 1, 2002), the issue fee paid should be the fee that is required at the time the fee is paid. If the issue fee was previously paid, and the response to the "Notice of Allowance and Fee(s) Due" includes a request to apply a previously-paid issue fee to the issue fee now due, then the difference between the issue fee amount at the time the response is filed and the previously paid issue fee should be paid. See Manual of Patent Examining Procedure, Section 1308.01 (Eighth Edition, August 2001).

Questions relating to issue and publication fee payments should be directed to the Customer Service Center of the Office of Patent Publication at (703) 305-8283.



PATENT
DON01 P-793

#22/F
DM
11/27/02

IN THE UNITED STATES PATENT AND TRADEMARK OFFICE

Examiner : R. Shafer
Applicant : Niall R. Lynam
Serial No. : 09/478,315
Filed : January 6, 2000
Group : 2872
For : EXTERIOR MIRROR PLANO-AUXILIARY
REFLECTIVE ELEMENT ASSEMBLY
Confirmation No. : 1526
Notice of Allowance Mailing Date: September 26, 2002

Box Issue Fee
Commissioner for Patents
Washington D.C. 20231

Dear Sir:

AMENDMENT AFTER ALLOWANCE UNDER 37 CFR § 1.312

Receipt of the Notice of Allowability and the Notice of Allowance and Issue Fee Due form mailed September 26, 2002, in the above-identified application is hereby acknowledged. A review of the application post receipt of the Notice of Allowance and Issue Fee Due form has revealed the need for a further amendment in the specification as follows:

IN THE SPECIFICATION:

On page 16, please replace the paragraph starting on line 3 with the following new paragraph:

Also, plano element 50 and/or multiradius element 55 can comprise a variable reflectance electro-optic element such as an electrochromic mirror reflector. Thus, both element 50 and element 55 can comprise an electrochromic mirror element or either of element 50 and element 55 can comprise an electrochromic mirror element and the other can comprise a fixed reflectance non-variable reflectance mirror element such as a metal reflector coated glass panel such as a chromium coated glass substrate. Also, if both plano element 50 and multiradius element 55 comprise an electro-optic element such as an electrochromic mirror element capable of electrically dimmable reflectivity, both elements 50, 55 can dim together and in tandem under control of a common dimming control signal (typically

F1

Applicant : Niall R. Lynam
Serial No. : 09/478,315
Page : 2

provided by an electro-optic automatic dimming interior mirror assembly mounted in the cabin of the automobile and equipped with photosensors to detect incident glare and ambient light). Alternately, if both plano element 50 and multiradius element 55 comprise an electro-optic element such as an electrochromic mirror element capable of electrically dimmable reflectivity, element 50 can dim independently of element 55 (such as is disclosed in U.S. Patent No. 5,550,677, the entire disclosure of which is hereby incorporated by reference herein). If either or both of elements 50, 55 comprise an electrochromic element, preferably, the electrochromic reflective element comprises a front substrate and a rear substrate with an electrochromic medium disposed between, such as a solid polymer matrix electrochromic medium such as is disclosed in U.S. patent application Serial No. 09/350,930, filed July 12, 1999, entitled "ELECTROCHROMIC POLYMERIC SOLID FILMS, MANUFACTURING ELECTROCHROMIC DEVICES USING SUCH FILMS, AND PROCESSES FOR MAKING SUCH SOLID FILMS AND DEVICES" to Desraj V. Varaprasad et al., now U.S. Pat. No. 6,154,306, or such as is disclosed in U.S. Patent Nos. 5,668,663; 5,724,187; 5,910,854; and 5,239,405, the entire disclosures of which are hereby incorporated by reference herein. Most preferably, in such laminate-type electrochromic mirror reflective elements, the front substrate comprises a glass plate of thickness less than about 1.6 mm, most preferably about 1.1 mm thickness or lower, and the rear substrate comprises a glass plate of thickness equal to or greater than about 1.6mm, more preferably greater than about 1.8 mm thickness, most preferably equal to or greater than about 2.0 mm thickness. The rearmost surface of the rear substrate (the fourth surface as known in the mirror art) is reflector coated with a high reflecting metal film such as of aluminum or silver, or an alloy of aluminum or silver. Most preferably, the front-most surface of the rear substrate (the third surface as known in the mirror art) is reflector coated with a high reflecting metal film such as of aluminum or silver, or an alloy of aluminum or silver.

Fl
cont'd

REMARKS

A review of the specification and claims post receipt of the Notice of Allowance and Issue Fee Due form indicated that the specification needed updated information for a referenced application. Since the present amendment relates to matters of form only, and does not require any further search on the part of the Examiner, it is

Applicant : Niall R. Lynam
Serial No. : 09/478,315
Page : 3

respectfully submitted that it is proper for entry and such entry is requested along with a
Notice of Approval of the amendment.

Respectfully submitted,

NIALL R. LYNAM

By: Van Dyke, Gardner, Linn & Burkhart LLP

October 23, 2008
Date

Catherine S. Collins
Catherine S. Collins
Registration No. 37 599
P.O. Box 888695
Grand Rapids, MI 49588-8695
(616) 975-5500

CSC:lmsc

Applicant : Niall R. Lynam
Serial No. : 09/478,315
Page : 4

PATENT
DON01 P-793

APPENDIX OF THE SPECIFICATION

On page 16, please replace the paragraph starting on line 3 with the following new paragraph:

Also, plano element 50 and/or multiradius element 55 can comprise a variable reflectance electro-optic element such as an electrochromic mirror reflector. Thus, both element 50 and element 55 can comprise an electrochromic mirror element or either of element 50 and element 55 can comprise an electrochromic mirror element and the other can comprise a fixed reflectance non-variable reflectance mirror element such as a metal reflector coated glass panel such as a chromium coated glass substrate. Also, if both plano element 50 and multiradius element 55 comprise an electro-optic element such as an electrochromic mirror element capable of electrically dimmable reflectivity, both elements 50, 55 can dim together and in tandem under control of a common dimming control signal (typically provided by an electro-optic automatic dimming interior mirror assembly mounted in the cabin of the automobile and equipped with photosensors to detect incident glare and ambient light). Alternately, if both plano element 50 and multiradius element 55 comprise an electro-optic element such as an electrochromic mirror element capable of electrically dimmable reflectivity, element 50 can dim independently of element 55 (such as is disclosed in U.S. Patent No. 5,550,677, the entire disclosure of which is hereby incorporated by reference herein). If either or both of elements 50, 55 comprise an electrochromic element, preferably, the electrochromic reflective element comprises a front substrate and a rear substrate with an electrochromic medium disposed between, such as a solid polymer matrix electrochromic medium such as is disclosed in U.S. patent application Serial No. 09/350,930, filed July 12, 1999, entitled "ELECTROCHROMIC POLYMERIC SOLID FILMS, MANUFACTURING ELECTROCHROMIC DEVICES USING SUCH FILMS, AND PROCESSES FOR MAKING SUCH SOLID FILMS AND DEVICES" to Desaraju V. Varaprasad et al., now U.S. Pat. No. 6,154,306, or such as is disclosed in U.S. Patent Nos. 5,668,663; 5,724,187; 5,910,854; and 5,239,405, the entire disclosures of which are hereby incorporated by reference herein. Most preferably, in such laminate-type electrochromic mirror reflective

Applicant : Niall R. Lynam
Serial No. : 09/478,315
Page : 5

elements, the front substrate comprises a glass plate of thickness less than about 1.6 mm, most preferably about 1.1 mm thickness or lower, and the rear substrate comprises a glass plate of thickness equal to or greater than about 1.6mm, more preferably greater than about 1.8 mm thickness, most preferably equal to or greater than about 2.0 mm thickness. The rearmost surface of the rear substrate (the fourth surface as known in the mirror art) is reflector coated with a high reflecting metal film such as of aluminum or silver, or an alloy of aluminum or silver. Most preferably, the front-most surface of the rear substrate (the third surface as known in the mirror art) is reflector coated with a high reflecting metal film such as of aluminum or silver, or an alloy of aluminum or silver.

Respectfully submitted,

NIALL R. LYNAM

By: Van Dyke, Gardner, Linn & Burkhart LLP

October 23, 2002
Date

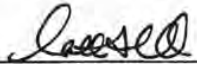
Catherine S. Collins
Registration No. 37 599
P.O. Box 888695
Grand Rapids, MI 49588-8695
(616) 975-5500

CSC:lmsc



Handwritten marks: 'e' and 'HOM'

OK to Enter

Handwritten initials: 'p/B'

**PATENT
DON01 P-793**

IN THE UNITED STATES PATENT AND TRADEMARK OFFICE

Examiner : R. Shafer
Applicant : Niall R. Lynam
Serial No. : 09/478,315
Filed : January 6, 2000
Group : 2872
For : EXTERIOR MIRROR PLANO-AUXILIARY
REFLECTIVE ELEMENT ASSEMBLY

Confirmation No. : 1526
Notice of Allowance Mailing Date: September 26, 2002

Box Issue Fee
Commissioner for Patents
Washington D.C. 20231

Dear Sir:

CERTIFICATE OF MAIL

I certify that the attached return postcard and Amendment After Allowance
Under 37 CFR § 1.312 are being deposited with the United States Postal Service as first class

mail an envelope addressed to:

Box Issue Fee
Commissioner for Patents
Washington, D.C. 20231

on October 23, 2002.

Handwritten signature of Catherine S. Collins

Catherine S. Collins
Van Dyke, Gardner, Linn & Burkhart, LLP
P.O. Box 888695
Grand Rapids, MI 49588-8695
(616) 975-5500

CSC:Imsc
Enclosures



UNITED STATES PATENT AND TRADEMARK OFFICE

UNITED STATES DEPARTMENT OF COMMERCE
United States Patent and Trademark Office
Address: COMMISSIONER OF PATENTS AND TRADEMARKS
Washington, D.C. 20231
www.uspto.gov

APPLICATION NO.	FILING DATE	FIRST NAMED INVENTOR	ATTORNEY DOCKET NO.	CONFIRMATION NO.
09/478,315	01/06/2000	NIALL R. LYNAM	DON01-P-793	1526

28101 7590 11/27/2002

VAN DYKE, GARDNER, LINN AND BURKHART, LLP
2851 CHARLEVOIX DRIVE, S.E.
P.O. BOX 888695
GRAND RAPIDS, MI 49588-8695

EXAMINER

SHAFFER, RICKY D

ART UNIT	PAPER NUMBER
2872	#23

DATE MAILED: 11/27/2002

Please find below and/or attached an Office communication concerning this application or proceeding.



UNITED STATES DEPARTMENT OF COMMERCE
 Patent and Trademark Office
 Address: COMMISSIONER OF PATENTS AND TRADEMARKS
 Washington, D.C. 20231

APPLICATION NUMBER	FILING DATE	FIRST NAMED APPLICANT	ATTORNEY DOCKET NO.
--------------------	-------------	-----------------------	---------------------

EXAMINER

ART UNIT	PAPER NUMBER
----------	--------------

#23

DATE MAILED: 11/27/02

**Response to Rule 312
 Communication**

The petition filed _____ under 37 CFR 1.312(b) is granted. The paper has been forwarded to the examiner for consideration on the merits.

 Director,
 Patent Examining Group _____

The amendment filed 10/29/02 under 37 CFR 1.312 has been considered, and has been:

- entered.
- entered as directed to matters of form not affecting the scope of the invention (Order 3311).
- disapproved. See explanation below.
- entered in part. See explanation below.

Don Marsh

Publishing Division



J. J. Con
PATENT
DON01 P-793

IN THE UNITED STATES PATENT AND TRADEMARK OFFICE.

Examiner : R. Shafer
Applicant : Niall R. Lynam
Serial No. : 09/478,315
Filed : January 6, 2000
Group : 2872
For : EXTERIOR MIRROR PLANO-AUXILIARY
REFLECTIVE ELEMENT ASSEMBLY
Confirmation No. : 1526
Notice of Allowance Mailing Date: September 26, 2002

Attention: Official Draftsman
Box Issue Fee
Commissioner for Patents
Washington D.C. 20231

Dear Sir:

TRANSMITTAL OF FORMAL DRAWINGS

In response to the Notice of Allowance and Issue Fee Due form and the Notice of Allowability dated September 26, 2002, the Applicant requests that the enclosed eight (8) sheets of formal drawings be entered in the above-identified application.

REMARKS

In response to the Notice of Allowance and Issue Fee Due form and the Notice of Allowability, enclosed please find eight (8) sheets of formal drawings for filing in the present application. The enclosed drawings correspond to the informal drawings now on file and approved as to content, and correct the informalities noted in Form PTO-948 from the Official Draftsman mailed April 24, 2001.

Respectfully submitted,

NIALL R. LYNAM

By: Van Dyke, Gardner, Linn & Burkhart, LLP

December 13, 2002
Date

Catherine S. Collins
Catherine S. Collins
Registration No. 37 599
P.O. Box 888695
2851 Charlevoix Drive, S.E.
Grand Rapids, MI 49588-8695
(616) 975-5500

CSC:lmsc



B
T

PATENT
DON01 P-793

IN THE UNITED STATES PATENT AND TRADEMARK OFFICE

Examiner : R. Shafer
Applicant : Niall R. Lynam
Serial No. : 09/478,315
Filed : January 6, 2000
Group : 2872
For : EXTERIOR MIRROR PLANO-AUXILIARY
REFLECTIVE ELEMENT ASSEMBLY

Confirmation No. : 1526
Notice of Allowance Mailing Date: September 26, 2002

Attention: Official Draftsman
Box Issue Fee
Commissioner for Patents
Washington D.C. 20231

Dear Sir:

CERTIFICATE OF MAIL

I certify that the attached return postcard, Transmittal of Formal Drawings,
and eight (8) sheets of formal drawings are being deposited with the United States Postal
Service as first class mail an envelope addressed to:

* Attention: Official Draftsperson
Box Issue Fee
Commissioner for Patents
Washington, D.C. 20231

on December 13, 2002.

Catherine S. Collins
Van Dyke, Gardner, Linn & Burkhart, LLP
P.O. Box 888695
Grand Rapids, MI 49588-8695
(616) 975-5500

CSC:lmsc
Enclosures

09/02



6522451

10

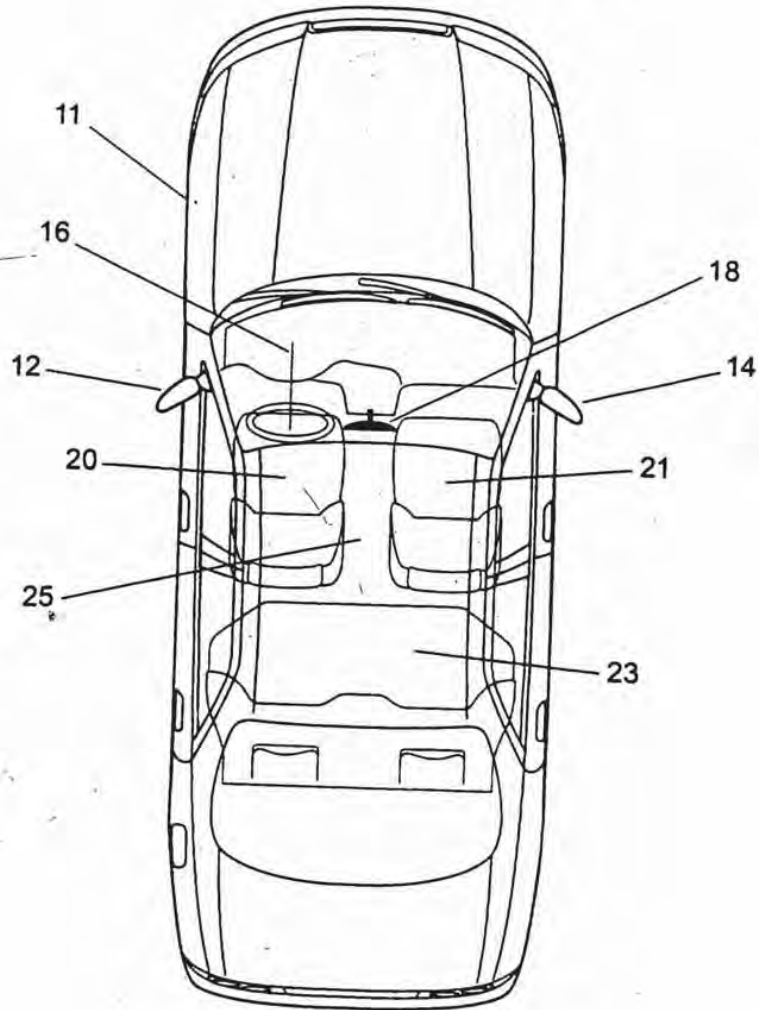

Figure 1

Examiner : R. Shafer
Applicant : Niall R. Lynam
Serial No. : 09/478,315
Filed : January 6, 2000
Group : 2872
For : EXTERIOR MIRROR PLANO-
AUXILIARY REFLECTIVE
ELEMENT ASSEMBLY
Confirmation No. : 1526
Docket No. : DON01 P-793
Attorney : Catherine S. Collins
Atty Phone : (616) 975-5506
Page : 1 of 8



H.S.
1009-478315

DEC 18 2002
PATENT & TRADEMARK OFFICE

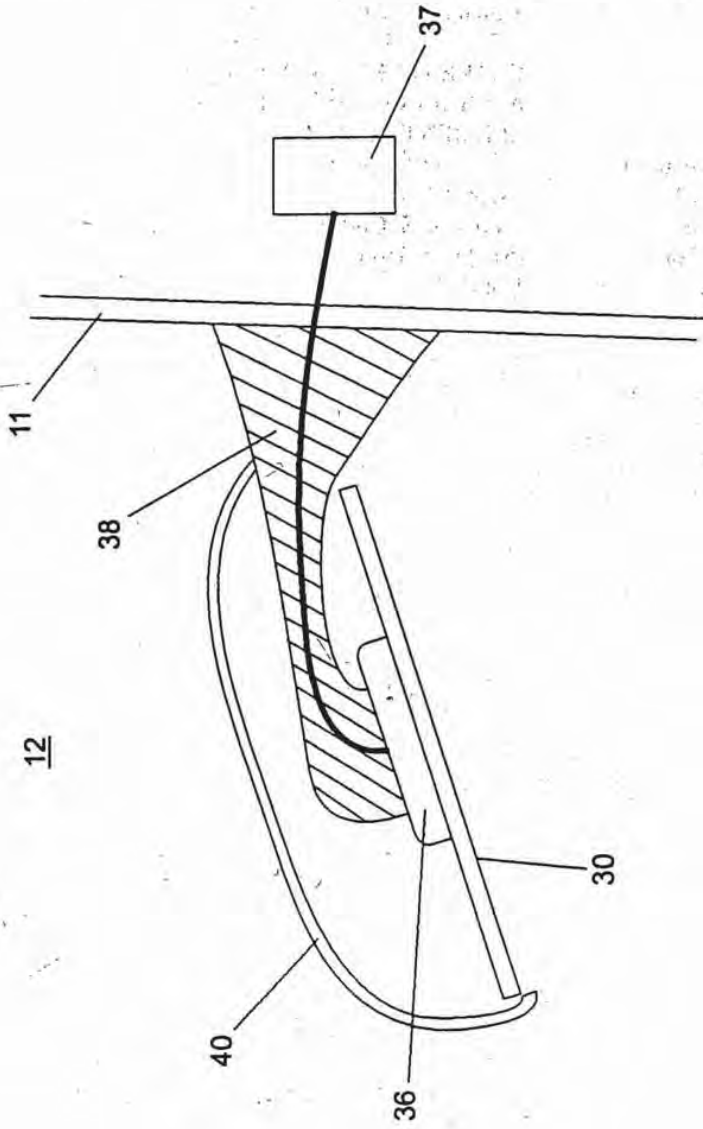

Figure 2

Examiner : R. Shafer
Applicant : Niall R. Lynam
Serial No. : 09/478,315
Filed : January 6, 2000
Group : 2872
For : EXTERIOR MIRROR PLANO-
AUXILIARY REFLECTIVE
ELEMENT ASSEMBLY
Confirmation No. : 1526
Docket No. : DON01 P-793
Attorney : Catherine S. Collins
Atty Phone : (616) 975-5506
Page : 2 of 8

O I P F JG:14
DEC 18 2007
COPYRIGHT & TRADEMARK OFFICE

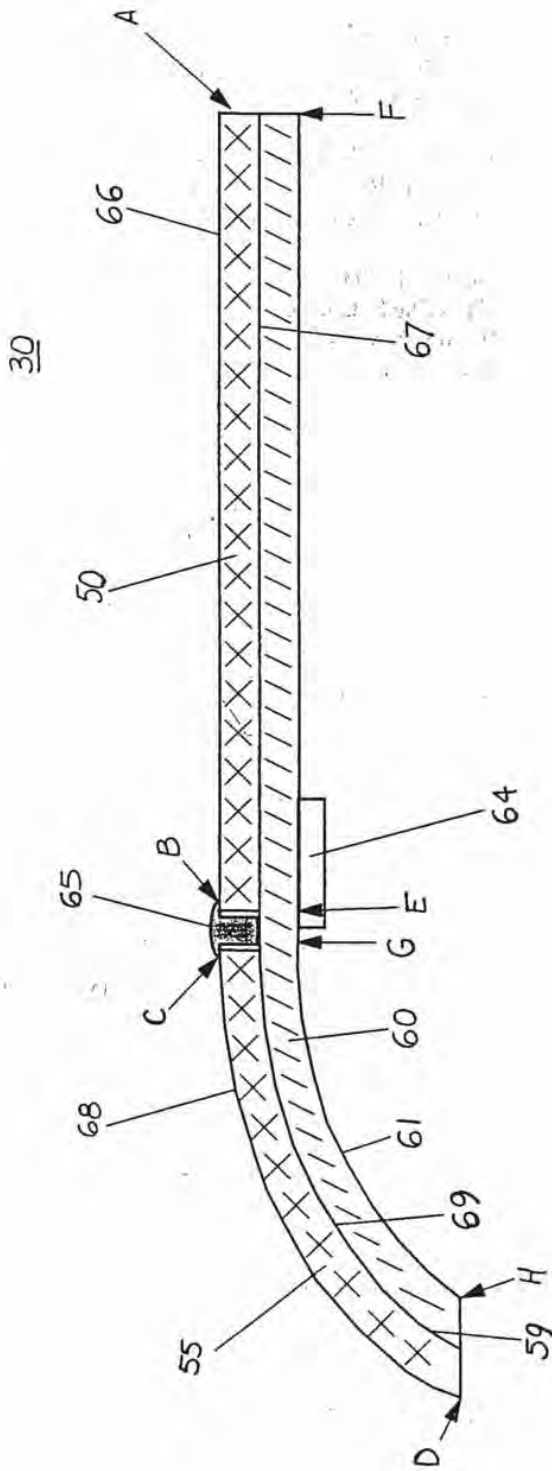

Figure 3

Examiner : R. Shafer
Applicant : Niall R. Lynam
Serial No. : 09/478,315
Filed : January 6, 2000
Group : 2872
For : EXTERIOR MIRROR PLANO-
AUXILIARY REFLECTIVE
ELEMENT ASSEMBLY
Confirmation No. : 1526
Docket No. : DON01 P-793
Attorney : Catherine S. Collins
Atty Phone : (616) 975-5506
Page : 3 of 8

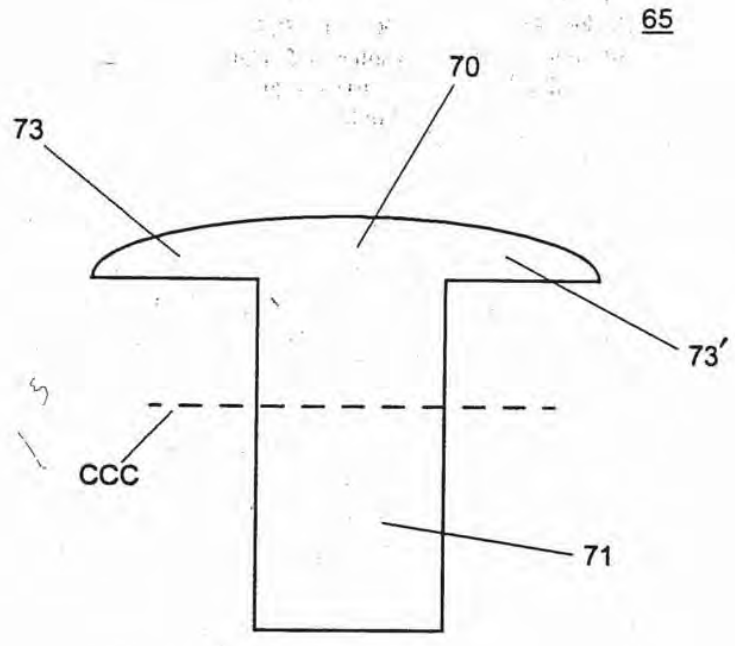
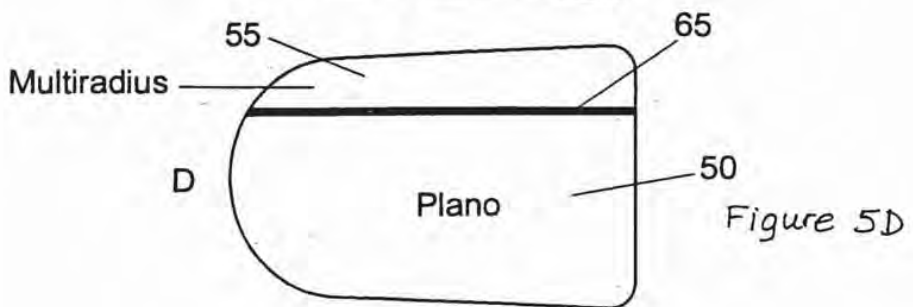
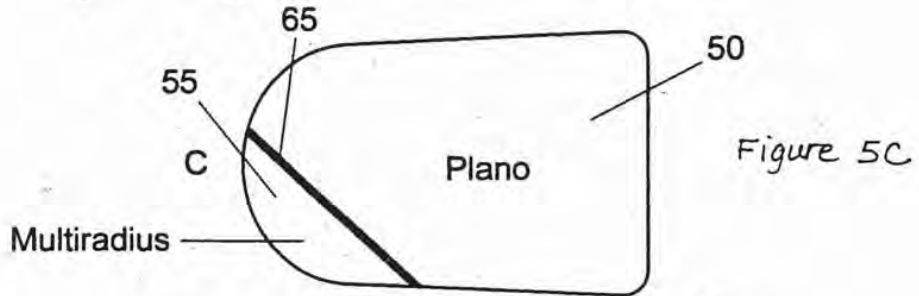
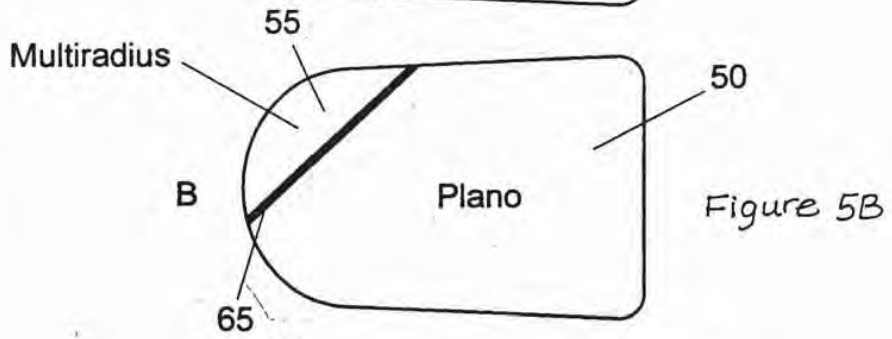
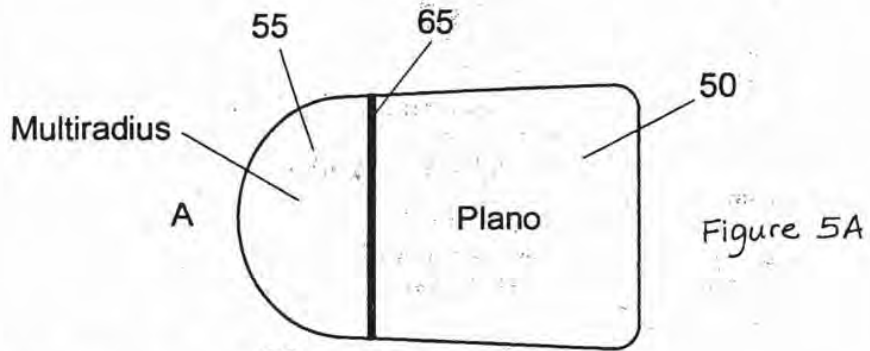

Figure 4

Examiner : R. Shafer
Applicant : Niall R. Lynam
Serial No. : 09/478,315
Filed : January 6, 2000
Group : 2872
For : EXTERIOR MIRROR PLANO-
AUXILIARY REFLECTIVE
ELEMENT ASSEMBLY
Confirmation No. : 1526
Docket No. : DON01 P-793
Attorney : Catherine S. Collins
Atty Phone : (616) 975-5506
Page : 4 of 8



Examiner : R. Shafer
Applicant : Niall R. Lynam
Serial No. : 09/478,315
Filed : January 6, 2000
Group : 2872
For : EXTERIOR MIRROR PLANO-
AUXILIARY REFLECTIVE
ELEMENT ASSEMBLY
Confirmation No. : 1526
Docket No. : DON01 P-793
Attorney : Catherine S. Collins
Atty Phone : (616) 975-5506
Page : 5 of 8

PAGE 1029

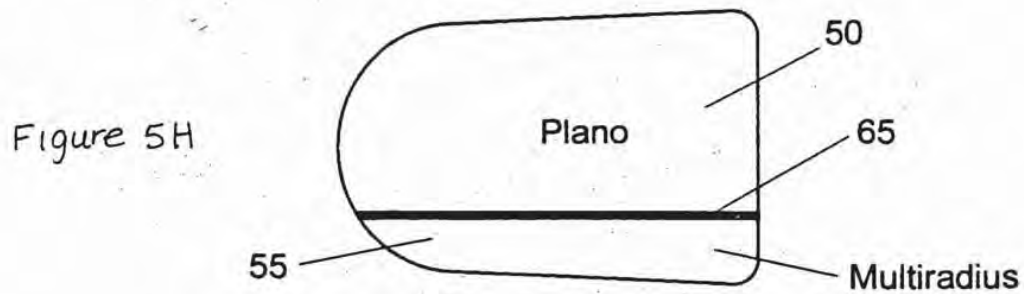
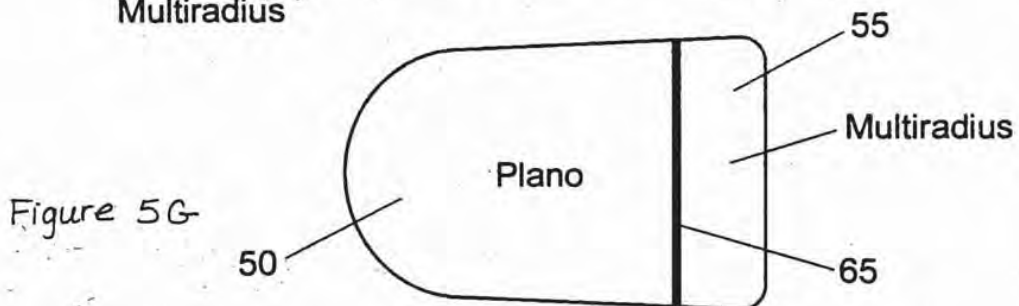
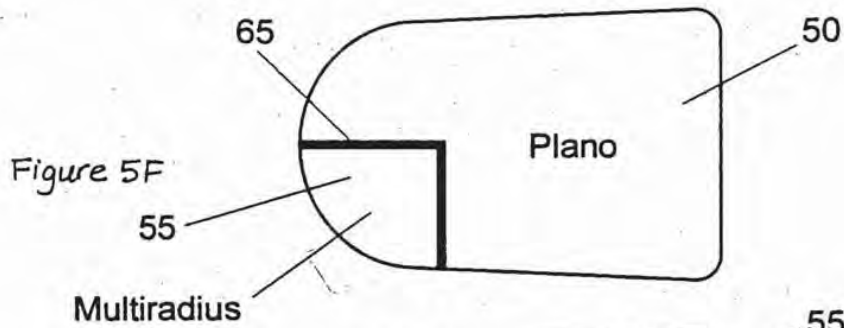
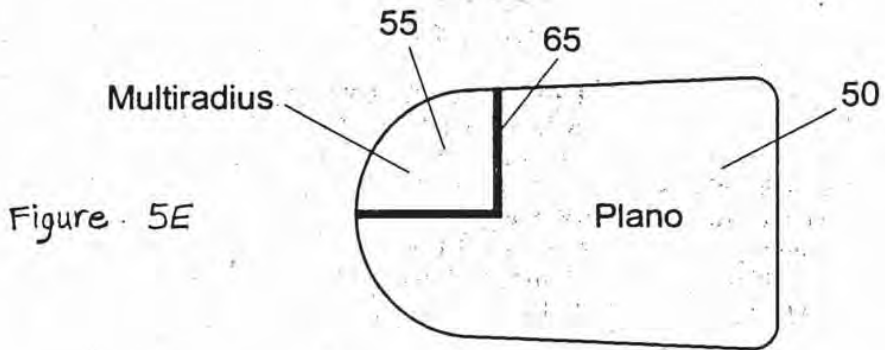

Examiner : R. Shafer
Applicant : Niall R. Lynam
Serial No. : 09/478,315
Filed : January 6, 2000
Group : 2872
For : EXTERIOR MIRROR PLANO-
AUXILIARY REFLECTIVE
ELEMENT ASSEMBLY
Confirmation No. : 1526
Docket No. : DON01 P-793
Attorney : Catherine S. Collins
Atty Phone : (616) 975-5506
Page : 6 of 8

U.S. PAT. & TRADEMARK OFFICE
DEC 18 2002

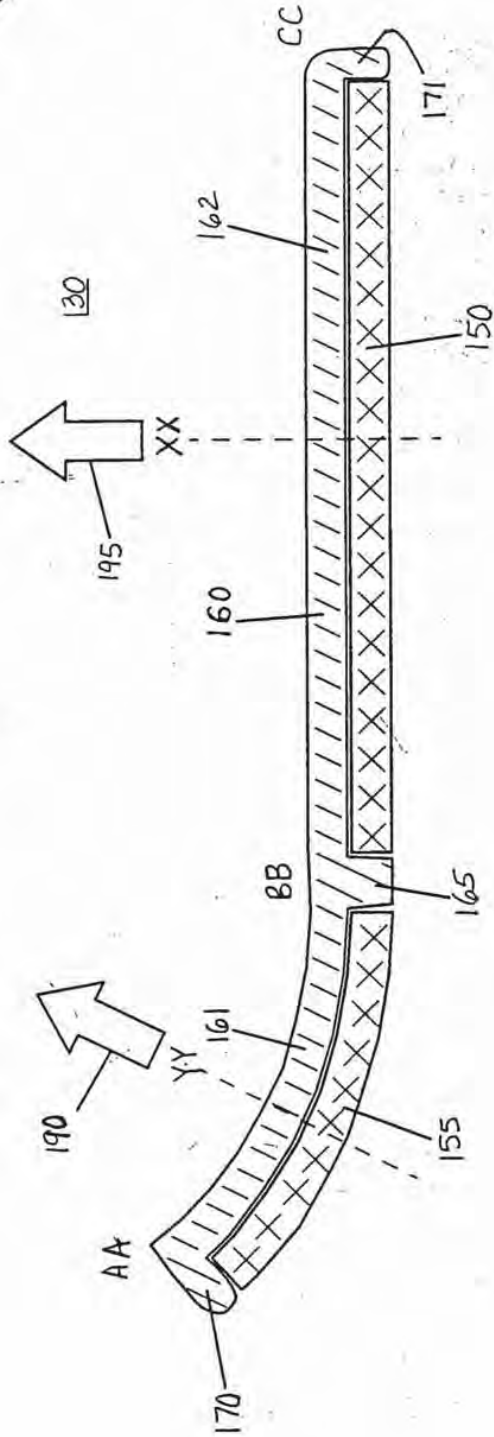

Figure 6

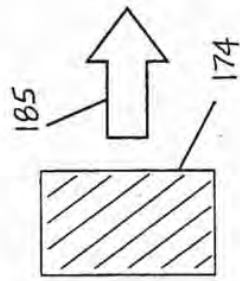

Figure 6A

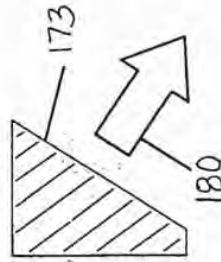

Figure 6B

Examiner : R. Shafer
Applicant : Niall R. Lynam
Serial No. : 09/478,315
Filed : January 6, 2000
Group : 2872
For : EXTERIOR MIRROR PLANO-
AUXILIARY REFLECTIVE
ELEMENT ASSEMBLY
Confirmation No. : 1526
Docket No. : DON01 P-793
Attorney : Catherine S. Collins
Atty Phone : (616) 975-5506
Page : 7 of 8



230

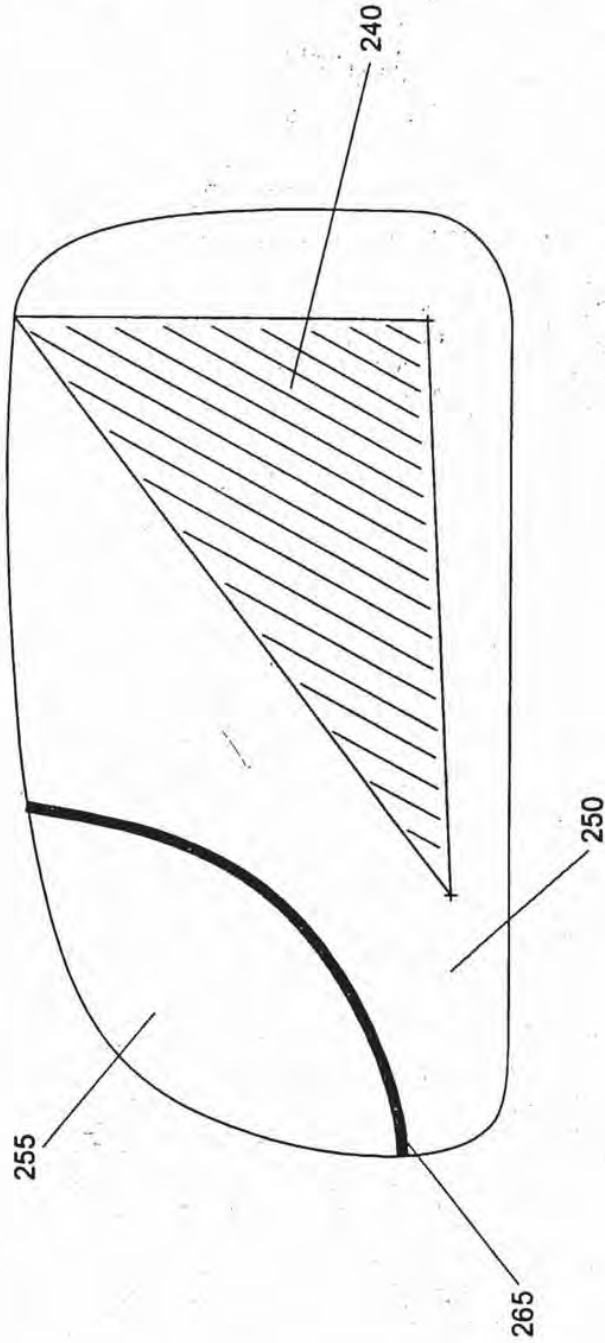

Figure 7

Examiner : R. Shafer
Applicant : Niall R. Lynam
Serial No. : 09/478,315
Filed : January 6, 2000
Group : 2872
For : EXTERIOR MIRROR PLANO-
AUXILIARY REFLECTIVE
ELEMENT ASSEMBLY
Confirmation No. : 1526
Docket No. : DON01 P-793
Attorney : Catherine S. Collins
Atty Phone : (616) 975-5506
Page : 8 of 8



R

C94

PATENT
DON01 P-793

25

IN THE UNITED STATES PATENT AND TRADEMARK OFFICE

Applicant : Niall R. Lynam
Serial No. : 09/478,315
Filing Date : January 6, 2000
Patent No. : 6,522,451
Issue Date : February 18, 2003
Entitled : EXTERIOR MIRROR PLANO-AUXILIARY REFLECTIVE ELEMENT ASSEMBLY

Commissioner for Patents
P.O. Box 1450
Alexandria, VA 22313-1450

CERTIFICATE OF MAILING

Dear Sir:

I hereby certify that the accompanying return postcard, Request for Certificate of Correction (1 page), Letter of Record (1 page), and Form PTO-1050 (1 page, in duplicate) are being deposited in the United States Postal Service as First Class Mail, in an envelope addressed to:

Commissioner for Patents
P.O. Box 1450
Alexandria, VA 22313-1450

on 11/22/06

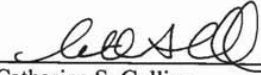
Catherine S. Collins
Registration No. 37 599
2851 Charlevoix Drive, S.E. Suite 207
P.O. Box 888695
Grand Rapids, MI 49588-8695
(616) 975-5506

CSC:clw:arr
Enclosures

Certificate
NOV 30 2006
of Correction

DEC 01 2006



PATENT
DON01 P-793

IN THE UNITED STATES PATENT AND TRADEMARK OFFICE

Applicant : Niall R. Lynam
Serial No. : 09/47,315
Filing Date : January 6, 2000
Patent No. : 6,522,451
Issue Date : February 18, 2003
Entitled : EXTERIOR MIRROR PLANO-AUXILIARY REFLECTIVE ELEMENT
ASSEMBLY

Commissioner for Patents
P.O. Box 1450
Alexandria, VA 22313-1450

REQUEST FOR CERTIFICATE OF CORRECTION

Dear Sir:

A request is being made for Certificate of Correction in the above-identified patent, which issued with the following errors identified by Column and Line from the patent.

Column 11:

Line 54, "Piano" should be --Plano--.

Column 15:

Line 53, "Piano" should be --Plano--.

Column 19:

Line 22, Claim 19, "4.000" should be --4000--.

Enclosed is the Certificate of Correction Form PTO-1050 (in duplicate) identifying errors by Column and Line from the patent which are chargeable to the Official Printer.

Respectfully submitted,

NIALL R. LYNAM

By: Van Dyke, Gardner, Linn & Burkhart, LLP

Date: 11/22/06

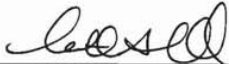
Catherine S. Collins
Registration No. 37 599
2851 Charlevoix Drive, S.E. Suite 207
P.O. Box 888695
Grand Rapids, MI 49588-8695
(616) 975-5506

CSC:clw:arr

DEC 01 2006



PATENT
DON01 P-793

IN THE UNITED STATES PATENT AND TRADEMARK OFFICE

Applicant : Niall R. Lynam
Serial No. : 09/47,315
Filing Date : January 6, 2000
Patent No. : 6,522,451
Issue Date : February 18, 2003
Entitled : EXTERIOR MIRROR PLANO-AUXILIARY REFLECTIVE ELEMENT
ASSEMBLY

Commissioner for Patents
P.O. Box 1450
Alexandria, VA 22313-1450

LETTER OF RECORD

Dear Sir:

Concerning the above-identified patent, the following error(s) was (were)
found:

Column 5:

Line 3, Delete "element" after --element--.

Column 12

Line 21, "en titled" should be --entitled--.

This letter is written to point out such error(s) and make it (them) of record in
this case.

Respectfully submitted,

NIALL R. LYNAM

By: Van Dyke, Gardner, Linn & Burkhart, LLP

Date: 11/22/06

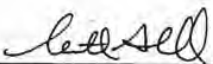
Catherine S. Collins
Registration No. 37 599
2851 Charlevoix Drive, S.E. Suite 207
P.O. Box 888695
Grand Rapids, MI 49588-8695
(616) 975-5506

CSC:clw:arr

NOV 27 2006

Staple
Here
Only

UNITED STATES PATENT AND TRADEMARK OFFICE CERTIFICATE OF CORRECTION

PATENT NO. : 6,522,451
DATED : February 18, 2003
INVENTOR(S) : Niall R. Lynam

It is certified that error appears in the above-identified patent and that said Letters Patent is hereby corrected as shown below:

Column 11:

Line 54, "Piano" should be --Plano--.

Column 15:

Line 53, "Piano" should be --Plano--.

Column 19:

Line 22, Claim 19, "4.000" should be --4000--.

MAILING ADDRESS OF SENDER:

Catherine S. Collins
Van Dyke, Gardner, Linn
& Burkhardt, LLP
2851 Charlevoix Dr., S.E., P.O. Box 888695
Grand Rapids, MI 49588-8695

PATENT NO. 6,522,451
No. of add'l copies
@ \$0.50 per page

FORM PTO. 1050

FEB 01 2006

Staple
Here
Only!

UNITED STATES PATENT AND TRADEMARK OFFICE
CERTIFICATE OF CORRECTION

PATENT NO. : 6,522,451 *B1*
DATED : February 18, 2003
INVENTOR(S) : Niall R. Lynam *09/478315*

It is certified that error appears in the above-identified patent and that said Letters Patent is hereby corrected as shown below:

Column 11:
Line 54, "Piano" should be --Plano--.

Column 15:
Line 53, "Piano" should be --Plano--.

Column 19:
Line 22, Claim 19, "4.000" should be --4000--

MAILING ADDRESS OF SENDER:

Catherine S. Collins
Van Dyke, Gardner, Linn
& Burkhart, LLP
2851 Charlevoix Dr., S.E., P.O. Box 888695
Grand Rapids, MI 49588-8695

PATENT NO. 6,522,451
No. of add'l copies
@ \$0.50 per page

FORM PTO 1050

DEC 01 2006

UNITED STATES PATENT AND TRADEMARK OFFICE
CERTIFICATE OF CORRECTION

PATENT NO. : 6,522,451 B1
APPLICATION NO. : 09/478315
DATED : February 18, 2003
INVENTOR(S) : Niall R. Lynam

Page 1 of 1

It is certified that error appears in the above-identified patent and that said Letters Patent is hereby corrected as shown below:

Column 11:

Line 54, "Piano" should be --Plano--.

Column 15:

Line 53, "Piano" should be --Plano--.

Column 19:

Line 22, Claim 19, "4.000" should be --4000--

Signed and Sealed this

Eleventh Day of March, 2008

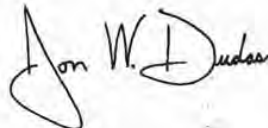

JON W. DUDAS
Director of the United States Patent and Trademark Office

PATENT APPLICATION FEE DETERMINATION RECORD
Effective October 1, 2000

Application or Docket Number

CLAIMS AS FILED - PART I

	(Column 1)	(Column 2)
TOTAL CLAIMS		
FOR	NUMBER FILED	NUMBER EXTRA
TOTAL CHARGEABLE CLAIMS	minus 20=	*
INDEPENDENT CLAIMS	minus 3 =	*
MULTIPLE DEPENDENT CLAIM PRESENT <input type="checkbox"/>		

SMALL ENTITY TYPE <input type="checkbox"/>		OR	OTHER THAN SMALL ENTITY	
RATE	FEE		RATE	FEE
BASIC FEE	355.00	OR	BASIC FEE	710.00
X\$ 9=		OR	X\$18=	
X40=		OR	X80=	
+135=		OR	+270=	
TOTAL		OR	TOTAL	

* If the difference in column 1 is less than zero, enter "0" in column 2

CLAIMS AS AMENDED - PART II

	(Column 1)	(Column 2)	(Column 3)
	CLAIMS REMAINING AFTER AMENDMENT	HIGHEST NUMBER PREVIOUSLY PAID FOR	PRESENT EXTRA
Total	88	Minus 83	= 5
Independent	3	Minus 3	=
FIRST PRESENTATION OF MULTIPLE DEPENDENT CLAIM <input type="checkbox"/>			

SMALL ENTITY		OR	OTHER THAN SMALL ENTITY	
RATE	ADDITIONAL FEE		RATE	ADDITIONAL FEE
X\$ 9=		OR	X\$18=	90
X40=		OR	X80=	
+135=		OR	+270=	
TOTAL ADDIT. FEE		OR	TOTAL ADDIT. FEE	90

	(Column 1)	(Column 2)	(Column 3)
	CLAIMS REMAINING AFTER AMENDMENT	HIGHEST NUMBER PREVIOUSLY PAID FOR	PRESENT EXTRA
Total	88	Minus 88	=
Independent	3	Minus 3	=
FIRST PRESENTATION OF MULTIPLE DEPENDENT CLAIM <input type="checkbox"/>			

SMALL ENTITY		OR	OTHER THAN SMALL ENTITY	
RATE	ADDITIONAL FEE		RATE	ADDITIONAL FEE
X\$ 9=		OR	X\$18=	
X40=		OR	X80=	
+135=		OR	+270=	
TOTAL ADDIT. FEE		OR	TOTAL ADDIT. FEE	

	(Column 1)	(Column 2)	(Column 3)
	CLAIMS REMAINING AFTER AMENDMENT	HIGHEST NUMBER PREVIOUSLY PAID FOR	PRESENT EXTRA
Total		Minus	=
Independent		Minus	=
FIRST PRESENTATION OF MULTIPLE DEPENDENT CLAIM <input type="checkbox"/>			

SMALL ENTITY		OR	OTHER THAN SMALL ENTITY	
RATE	ADDITIONAL FEE		RATE	ADDITIONAL FEE
X\$ 9=		OR	X\$18=	
X40=		OR	X80=	
+135=		OR	+270=	
TOTAL ADDIT. FEE		OR	TOTAL ADDIT. FEE	

* If the entry in column 1 is less than the entry in column 2, write "0" in column 3.
 ** If the "Highest Number Previously Paid For" IN THIS SPACE is less than 20, enter "20."
 *** If the "Highest Number Previously Paid For" IN THIS SPACE is less than 3, enter "3."
 The "Highest Number Previously Paid For" (Total or Independent) is the highest number found in the appropriate box in column 1.

PATENT APPLICATION FEE DETERMINATION RECORD
Effective October 1, 2001

Application or Docket Number

CLAIMS AS FILED - PART I

	(Column 1)	(Column 2)
TOTAL CLAIMS		
FOR	NUMBER FILED	NUMBER EXTRA
TOTAL CHARGEABLE CLAIMS	minus 20= *	
INDEPENDENT CLAIMS	minus 3 = *	
MULTIPLE DEPENDENT CLAIM PRESENT		<input type="checkbox"/>

* If the difference in column 1 is less than zero, enter "0" in column 2

SMALL ENTITY TYPE OR OTHER THAN SMALL ENTITY

RATE	FEE	OR	RATE	FEE
BASIC FEE	370.00	OR	BASIC FEE	740.00
X\$ 9=		OR	X\$18=	
X42=		OR	X84=	
+140=		OR	+280=	
TOTAL		OR	TOTAL	

CLAIMS AS AMENDED - PART II

	(Column 1)		(Column 2)		(Column 3)
	CLAIMS REMAINING AFTER AMENDMENT	Minus	HIGHEST NUMBER PREVIOUSLY PAID FOR	PRESENT EXTRA	
Total	* 47	Minus	** 88	=	
Independent	* 2	Minus	*** 3	=	
FIRST PRESENTATION OF MULTIPLE DEPENDENT CLAIM					<input type="checkbox"/>

SMALL ENTITY OR OTHER THAN SMALL ENTITY

RATE	ADDITIONAL FEE	OR	RATE	ADDITIONAL FEE
X\$ 9=		OR	X\$18=	
X42=		OR	X84=	
+140=		OR	+280=	
TOTAL ADDIT. FEE		OR	TOTAL ADDIT. FEE	

	(Column 1)		(Column 2)		(Column 3)
	CLAIMS REMAINING AFTER AMENDMENT	Minus	HIGHEST NUMBER PREVIOUSLY PAID FOR	PRESENT EXTRA	
Total	* 40	Minus	** 88	=	
Independent	* 1	Minus	*** 3	=	
FIRST PRESENTATION OF MULTIPLE DEPENDENT CLAIM					<input type="checkbox"/>

RATE	ADDITIONAL FEE	OR	RATE	ADDITIONAL FEE
X\$ 9=		OR	X\$18=	
X42=		OR	X84=	
+140=		OR	+280=	
TOTAL ADDIT. FEE		OR	TOTAL ADDIT. FEE	

	(Column 1)		(Column 2)		(Column 3)
	CLAIMS REMAINING AFTER AMENDMENT	Minus	HIGHEST NUMBER PREVIOUSLY PAID FOR	PRESENT EXTRA	
Total	*	Minus	**	=	
Independent	*	Minus	***	=	
FIRST PRESENTATION OF MULTIPLE DEPENDENT CLAIM					<input type="checkbox"/>

RATE	ADDITIONAL FEE	OR	RATE	ADDITIONAL FEE
X\$ 9=		OR	X\$18=	
X42=		OR	X84=	
+140=		OR	+280=	
TOTAL ADDIT. FEE		OR	TOTAL ADDIT. FEE	

* If the entry in column 1 is less than the entry in column 2, write "0" in column 3.
 ** If the "Highest Number Previously Paid For" IN THIS SPACE is less than 20, enter "20."
 *** If the "Highest Number Previously Paid For" IN THIS SPACE is less than 3, enter "3."
 The "Highest Number Previously Paid For" (Total or Independent) is the highest number found in the appropriate box in column 1.

$$\begin{array}{r} 40 \\ 7 \\ \hline 47 \end{array}$$

PATENT APPLICATION FEE DETERMINATION RECORD
Effective December 29, 1999

Application or Docket Number

47800

CLAIMS AS FILED - PART I

	(Column 1)	(Column 2)
FOR	NUMBER FILED	NUMBER EXTRA
BASIC FEE		
TOTAL CLAIMS	80 minus 20=	60
INDEPENDENT CLAIMS	2 minus 3 =	-
MULTIPLE DEPENDENT CLAIM PRESENT		

SMALL ENTITY TYPE **OR** **OTHER THAN SMALL ENTITY**

RATE	FEE	OR	RATE	FEE
	345.00			690.00
X\$ 9=			X\$18=	1260
X39=			X78=	
+130=			+260=	
TOTAL			TOTAL	1800

* If the difference in column 1 is less than zero, enter "0" in column 2

CLAIMS AS AMENDED - PART II

	(Column 1)	(Column 2)	(Column 3)
AMENDMENT A	CLAIMS REMAINING AFTER AMENDMENT	HIGHEST NUMBER PREVIOUSLY PAID FOR	PRESENT EXTRA
	Total	Minus	**
	Independent	Minus	***
FIRST PRESENTATION OF MULTIPLE DEPENDENT CLAIM			

SMALL ENTITY **OR** **OTHER THAN SMALL ENTITY**

RATE	ADDITIONAL FEE	OR	RATE	ADDITIONAL FEE
X\$ 9=			X\$18=	
X39=			X78=	
+130=			+260=	
TOTAL ADDIT. FEE			TOTAL ADDIT. FEE	

	(Column 1)	(Column 2)	(Column 3)
AMENDMENT B	CLAIMS REMAINING AFTER AMENDMENT	HIGHEST NUMBER PREVIOUSLY PAID FOR	PRESENT EXTRA
	Total	Minus	**
	Independent	Minus	***
FIRST PRESENTATION OF MULTIPLE DEPENDENT CLAIM			

RATE	ADDITIONAL FEE	OR	RATE	ADDITIONAL FEE
X\$ 9=			X\$18=	
X39=			X78=	
+130=			+260=	
TOTAL ADDIT. FEE			TOTAL ADDIT. FEE	

	(Column 1)	(Column 2)	(Column 3)
AMENDMENT C	CLAIMS REMAINING AFTER AMENDMENT	HIGHEST NUMBER PREVIOUSLY PAID FOR	PRESENT EXTRA
	Total	Minus	**
	Independent	Minus	***
FIRST PRESENTATION OF MULTIPLE DEPENDENT CLAIM			

RATE	ADDITIONAL FEE	OR	RATE	ADDITIONAL FEE
X\$ 9=			X\$18=	
X39=			X78=	
+130=			+260=	
TOTAL ADDIT. FEE			TOTAL ADDIT. FEE	

* If the entry in column 1 is less than the entry in column 2, write "0" in column 3.
 ** If the "Highest Number Previously Paid For" IN THIS SPACE is less than 20, enter "20."
 *** If the "Highest Number Previously Paid For" IN THIS SPACE is less than 3, enter "3."
 The "Highest Number Previously Paid For" (Total or Independent) is the highest number found in the appropriate box in column 1.

PATENT
DON01 P-793
Express Mail No. EL399135945US

IN THE UNITED STATES PATENT AND TRADEMARK OFFICE

Applicant : Niall R. Lynam
For : EXTERIOR MIRROR PLANO-AUXILIARY
REFLECTIVE ELEMENT ASSEMBLY



BOX PATENT APPLICATION
Assistant Commissioner for Patents
Washington, D.C. 20231

Dear Sir:

Enclosed herewith is the above identified patent application comprising the following parts:

- 1) Postcard
- 2) Assignment, Form PTO-1619 Recordation Form Cover Sheet, and Assignment Recording Fee of \$40.00
- 3) 23 Pages of Specification
- 4) 12 Pages of Claims (83 claims)
- 5) 1 Page of Abstract
- 6) 7 Sheets of Drawings (in duplicate)
- 7) Declaration and Power of Attorney

Filing Fee:

Basic Fee \$690.00	\$690.00
Additional Fees	
Each independent claim in excess of three, times \$78.00	\$
Number of claims in excess of twenty, times \$18.00	\$1,134.00
Filing multiple dependent claims per application \$260.00	\$
Total Filing Fee	<u>\$1,824.00</u>

Checks in the amount of \$1,824.00 and \$40.00 are enclosed to cover the fees noted above.

The Commissioner is hereby authorized to charge payment of the following fees associated with this communication, and during the pendency of this application, or to credit any overpayment, to Deposit Account No. 22-0190. A duplicate copy of this sheet is enclosed.

- 1) Any additional filing fees required under 37 CFR 1.16 for which full payment has not been tendered.
- 2) Any patent application processing fees under 37 CFR 1.17 for which full payment has not been tendered.

Respectfully submitted,

NIALL R. LYNAM

By: Van Dyke, Gardner, Linn & Burkhardt, LLP

Date

January 6, 2000

Catherine S. Collins
Catherine S. Collins
Registration No. 37 599
P.O. Box 888695
2851 Charlevoix Drive, S.E.
Grand Rapids, MI 49588-8695
(616) 975-5500

CSC:lmsc



P75M
VAN DYKE, GARDNER, LINN & BURKHART, LLP
2851 CHARLEVOIX DRIVE, S.E., SUITE 207
GRAND RAPIDS MI 49546

DATE PRINTED
03/13/15

NOTICE OF PATENT EXPIRATION

According to the records of the U.S. Patent and Trademark Office (USPTO), payment of the maintenance fee for the patent(s) listed below has not been received timely prior to the end of the six-month grace period in accordance with 37 CFR 1.362(e). THE PATENT(S) LISTED BELOW HAS THEREFORE EXPIRED AS OF THE END OF THE GRACE PERIOD. 35 U.S.C. 41(b). Notice of the expiration will be published in the USPTO Official Gazette.

Expired patents may be reinstated in accordance with 37 CFR 1.378 if upon petition, the maintenance fee and the surcharge set forth in 37 CFR 1.20(i) are paid, AND the delay in payment of the maintenance fee is shown to the satisfaction of the Director to have been unavoidable or unintentional. 35 U.S.C. 41(c)(1).

If the Director accepts payment of the maintenance fee and surcharge upon petition under 37 CFR 1.378, the patent shall be considered as not having expired but would be subject to the intervening rights and conditions set forth in 35 U.S.C. 41(c)(2).

For instructions on filing a petition under 37 CFR 1.378 to reinstate an expired patent, customers should call the Office of Petitions Help Desk at 571-272-3282 or refer to the USPTO Web site at www.uspto.gov/web/offices/pac/dapp/petitionspractice.html. The USPTO also permits reinstatement under 37 CFR 1.378(c) by electronic petition (e-petition) using EFS-Web; e-petitions may be automatically granted if all the eligibility requirements are met. For further information on filing an e-petition, please call the Electronic Business Center (EBC) at 866-217-9197 (toll-free) or 571-272-4100 or refer to the EBC's e-petition guide at www.uspto.gov/ebc/portal/efs/petition_quickstart.pdf.

PATENT NUMBER	U.S. APPLICATION NUMBER	PATENT ISSUE DATE	APPLICATION FILING DATE	EXPIRATION DATE	ATTORNEY DOCKET NUMBER
6522451	09478315	02/18/03	01/06/00	02/18/15	DON01-P-793

NOTE: This notice was automatically generated based on the amount of time that elapsed since the date a patent was granted. It is possible that the patent term may have ended or been shortened due to a terminal disclaimer that was filed in the application. Also, for any patent that issued from an application filed on or after June 8, 1995 containing a specific reference to an earlier filed application or applications under 35 U.S.C. 120, 121, or 365(c), the patent term ends 20 years from the date on which the earliest such application was filed, unless the term was adjusted or extended under 35 U.S.C. 154 or 156.



UNITED STATES PATENT AND TRADEMARK OFFICE

Commissioner for Patents
United States Patent and Trademark Office
P.O. Box 1450
Alexandria, VA 22313-1450
www.uspto.gov

P75M
VAN DYKE, GARDNER, LINN & BURKHART, LLP
2851 CHARLEVOIX DRIVE, S.E., SUITE 207
GRAND RAPIDS MI 49546

DATE PRINTED
03/13/15

NOTICE OF PATENT EXPIRATION

According to the records of the U.S. Patent and Trademark Office (USPTO), payment of the maintenance fee for the patent(s) listed below has not been received timely prior to the end of the six-month grace period in accordance with 37 CFR 1.362(e). THE PATENT(S) LISTED BELOW HAS THEREFORE EXPIRED AS OF THE END OF THE GRACE PERIOD. 35 U.S.C. 41(b). Notice of the expiration will be published in the USPTO Official Gazette.

Expired patents may be reinstated in accordance with 37 CFR 1.378 if upon petition, the maintenance fee and the surcharge set forth in 37 CFR 1.20(i) are paid, AND the delay in payment of the maintenance fee is shown to the satisfaction of the Director to have been unavoidable or unintentional. 35 U.S.C. 41(c)(1).

If the Director accepts payment of the maintenance fee and surcharge upon petition under 37 CFR 1.378, the patent shall be considered as not having expired but would be subject to the intervening rights and conditions set forth in 35 U.S.C. 41(c)(2).

For instructions on filing a petition under 37 CFR 1.378 to reinstate an expired patent, customers should call the Office of Petitions Help Desk at 571-272-3282 or refer to the USPTO Web site at www.uspto.gov/web/offices/pac/dapp/petitionspractice.html. The USPTO also permits reinstatement under 37 CFR 1.378(c) by electronic petition (e-petition) using EFS-Web; e-petitions may be automatically granted if all the eligibility requirements are met. For further information on filing an e-petition, please call the Electronic Business Center (EBC) at 866-217-9197 (toll-free) or 571-272-4100 or refer to the EBC's e-petition guide at www.uspto.gov/ebc/portal/efs/petition_quickstart.pdf.

Table with 6 columns: PATENT NUMBER, U.S. APPLICATION NUMBER, PATENT ISSUE DATE, APPLICATION FILING DATE, EXPIRATION DATE, ATTORNEY DOCKET NUMBER. Row 1: 6522451, 09478315, 02/18/03, 01/06/00, 02/18/15, DON01-P-793

NOTE: This notice was automatically generated based on the amount of time that elapsed since the date a patent was granted. It is possible that the patent term may have ended or been shortened due to a terminal disclaimer that was filed in the application. Also, for any patent that issued from an application filed on or after June 8, 1995 containing a specific reference to an earlier filed application or applications under 35 U.S.C. 120, 121, or 365(c), the patent term ends 20 years from the date on which the earliest such application was filed, unless the term was adjusted or extended under 35 U.S.C. 154 or 156.

MA441D (11/2008)

357/35+

AC 257 42106

NL 7908257
JUN 1981

NL-1981-06

DJON/ * Q17 F7442 D/25 *NL 7338-257
Motor vehicle rear view mirror - has auxiliary section with
spherical surface to increase field of vision
DE JONGH NB 12.11.79-NL-008257
(01.06.81) B60r-01/08

12.11.79 as 008257 (10pp160TJ)

The rear-view mirror is particularly for motor vehicles, having a flat main section, and an auxiliary one increasing the user's field of vision. The auxiliary section (2) has a spherical surface, and can be a separate component fitted to the main mirror, typically by means of an adhesive surface on a flat backplate, while the adhesive can be on both sides of a spring plate.

The auxiliary section can be round, its edges being flush with those of the main one, and alternatively it can be integral with the latter, with a support plate having a flat and a spherical section to which a reflective layer is applied.

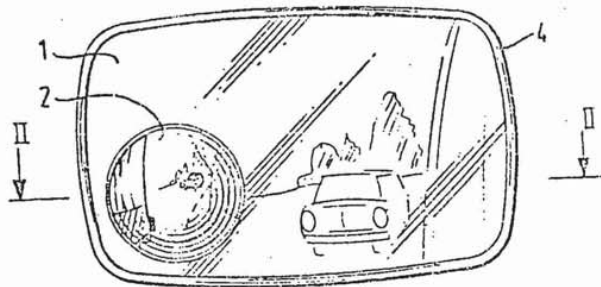



European Patent
Office

EUROPEAN SEARCH REPORT

Application Number

EP 88 30 8482

DOCUMENTS CONSIDERED TO BE RELEVANT			
Category	Citation of document with indication, where appropriate, of relevant passages	Relevant to claim	CLASSIFICATION OF THE APPLICATION (Int. Cl. 4)
X	DE-A-2 537 876 (REITTER & SCHEFENACKER KG) * Claim 1; figures 1,2 *	1,2	B 60 R 1/08
X	US-A-3 408 136 (TRAVIS) * Page 1, lines 20-29; figures 1-4 *	1	
X	US-A-3 175 463 (SEASHORE) * Column 1, line 62 - column 2, lines 1-40; figures 1-7 *	1	
			TECHNICAL FIELDS SEARCHED (Int. Cl. 4)
			B 60 R
The present search report has been drawn up for all claims			
Place of search THE HAGUE		Date of completion of the search 02-01-1989	Examiner MAUSSER, T.
CATEGORY OF CITED DOCUMENTS		T : theory or principle underlying the invention E : earlier patent document, but published on, or after the filing date D : document cited in the application L : document cited for other reasons & : member of the same patent family, corresponding document	
X : particularly relevant if taken alone Y : particularly relevant if combined with another document of the same category A : technological background O : non-written disclosure P : intermediate document			

EPO FORM 130 (01.81) (page 1)



PATENT
DON01 P-793

IN THE UNITED STATES PATENT AND TRADEMARK OFFICE

Examiner : R. Shafer
Group : 2872
Applicant : Niall R. Lynam
Serial No. : 09/478,315
Filed : January 6, 2000
For : EXTERIOR MIRROR PLANO-AUXILIARY
REFLECTIVE ELEMENT ASSEMBLY

Box RCE
Commissioner for Patents
Washington, D.C. 20231

Date of this Paper: April 5, 2002.

Dear Sir:

PETITION AND FEE FOR
EXTENSION OF TIME (37 C.F.R. 1.136[a])

1. This is a petition for an extension of time to respond to the Office Action mailed December 5, 2001, for a period of one month.

2. Applicant is:

a small entity

verified statement attached
verified statement filed

other than small entity

3. Extension (months)	Fee for other than small entity	Fee for small entity
<input checked="" type="checkbox"/> one month	\$110.00	\$55.00
two months	\$400.00	\$200.00
three months	\$920.00	\$460.00
four months	\$1,440.00	\$720.00

RECEIVED
APR 19 2002
TECHNOLOGY CENTER 2800

4. An amendment:

is filed herewith has been filed

5. Fee Payment:

Attached is a check in the amount of \$110.

Please charge any additional fees required or credit any excess fee paid to Deposit Account No. 22-0190. A duplicate of this Petition is attached.

VAN DYKE, GARDNER, LINN & BURKHART, LLP

Catherine S. Collins
Registration No. 37 599
2851 Charlevoix Drive, S.E.
P.O. Box 888695
Grand Rapids, MI 49588-8695
(616) 975-5500

CSC:lmse



Approved for use through 10/31/2002, OMB 0951-0031
 U.S. Patent and Trademark Office: U.S. DEPARTMENT OF COMMERCE

Under the Paperwork Reduction Act of 1995, no persons are required to respond to a collection of information unless it displays a valid OMB control number.

REQUEST FOR CONTINUED EXAMINATION (RCE) TRANSMITTAL Address to: Commissioner for Patents Box RCE Washington, DC 20231	Application Number	09/478,315
	Filing Date	January 6, 2000
	First Named Inventor	Niall R. Lynam
	Art Unit	2872
	Examiner Name	R. Shafer
	Attorney Docket Number	DON01 P-793

This is a Request for Continued Examination (RCE) under 37 CFR 1.114 of the above-identified application. Request for Continued Examination (RCE) practice under 37 CFR 1.114 does not apply to any utility or plant application filed prior to June 8, 1995, or to any design application. See Instruction Sheet for RCEs (not to be submitted to the USPTO) on page 2.

1. Submission required under 37 CFR 1.114

a. Previously submitted

i. Consider the amendment(s)/reply under 37 CFR 1.116 previously filed on _____
 (Any unamended amendment(s) referred to above will be entered).

ii. Consider the arguments in the Appeal Brief or Reply Brief previously filed on _____

iii. Other _____

b. Enclosed

i. Amendment/Reply

ii. Affidavit(s)/Declaration(s)

iii. Information Disclosure Statement (IDS)

iv. Other _____

2. Miscellaneous

a. Suspension of action on the above-identified application is requested under 37 CFR 1.103(c) for period of _____ months. (Period of suspension shall not exceed 3 months; Fee under 37 CFR 1.17(i) required)

b. Other _____

3. Fees The RCE fee under 37 CFR 1.17(e) is required by 37 CFR 1.114 when the RCE is filed.

a. The Director is hereby authorized to charge ~~the following~~ ^{any additional} fees, or credit any overpayments, to Deposit Account No. 22-0190

i. RCE fee required under 37 CFR 1.17(e)

ii. Extension of time fee (37 CFR 1.138 and 1.17)

iii. Other _____

b. Check in the amount of \$740 and \$110 are enclosed

c. Payment by credit card (Form PTO-2038 enclosed)

WARNING: Information on this form may become public. Credit card information should not be included on this form. Provide credit card information and authorization on PTO-2038.

RECEIVED
 APR 19 2002
 TECHNOLOGY CENTER 2800

SIGNATURE OF APPLICANT, ATTORNEY, OR AGENT REQUIRED			
Name (Print/Type)	Catherine S. Collins	Registration No. (Attorney/Agent)	37 599
Signature	<i>Catherine S. Collins</i>	Date	April 5, 2002

CERTIFICATE OF MAILING OR TRANSMISSION			
I hereby certify that this correspondence is being deposited with the United States Postal Service with sufficient postage as first class mail in an envelope addressed to: Commissioner For Patents, Box RCE, Washington, DC 20231, or facsimile transmitted to the U.S. Patent and Trademark Office on the date shown below.			
Name (Print/Type)	Catherine S. Collins	Date	April 5, 2002
Signature	<i>Catherine S. Collins</i>	Date	April 5, 2002

Burden Hour Statement: This form is estimated to take 0.2 hours to complete. Time will vary depending upon the needs of the individual case. Any comments on the amount of time you are required to complete this form should be sent to the Chief Information Officer, U.S. Patent and Trademark Office, Washington, DC 20231. DO NOT SEND FEES OR COMPLETED FORMS TO THIS ADDRESS. SEND Fees and Completed Forms to the following address: Assistant Commissioner for Patents, Box RCE, Washington, DC 20231.

COOPER'S PATENT

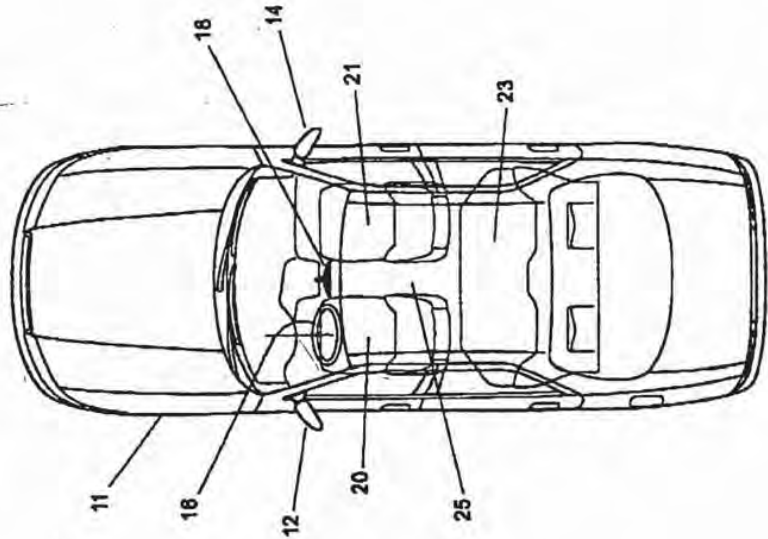

Figure 1

Apip

17

Applicant : Niall R. Lynam
For : EXTERIOR MIRROR PLANO-
AUXILIARY REFLECTIVE
ELEMENT ASSEMBLY
Docket No. : DON01 P-793
Express Mail No. EL399135945US
Sheet : 1 of 7

POST-OFF-SEASON

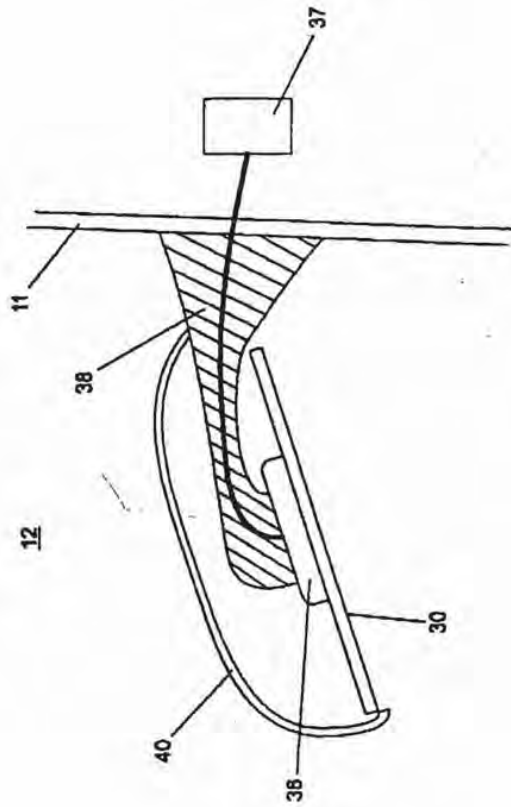



Figure 2



Applicant : Niall R. Lynam
For : EXTERIOR MIRROR PLANO-
AUXILIARY REFLECTIVE
ELEMENT ASSEMBLY
Docket No. : DON01 P-793
Express Mail No. EL399135945US
Sheet : 2 of 7

WO 2010/075620

30

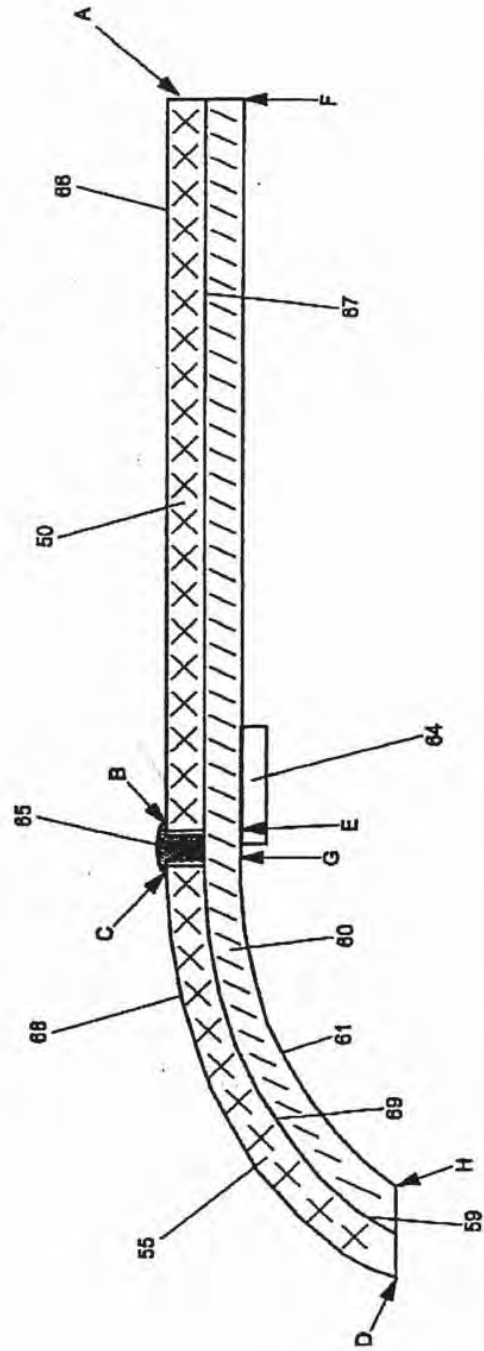

Figure 3

Applicant : Niall R. Lynam
For : EXTERIOR MIRROR PLANO-
AUXILIARY REFLECTIVE
ELEMENT ASSEMBLY
Docket No. : DON01 P-793
Express Mail No. : EL399135945US
Sheet : 3 of 7

00000000 - 51482460

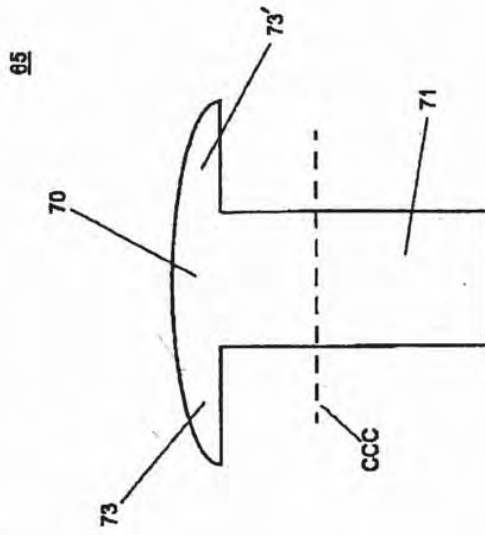
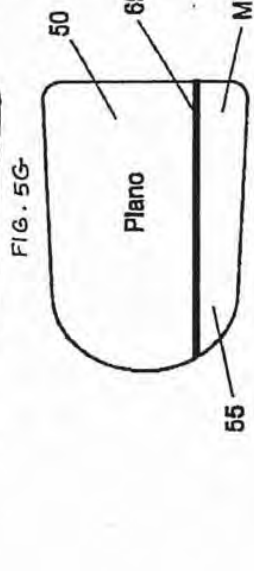
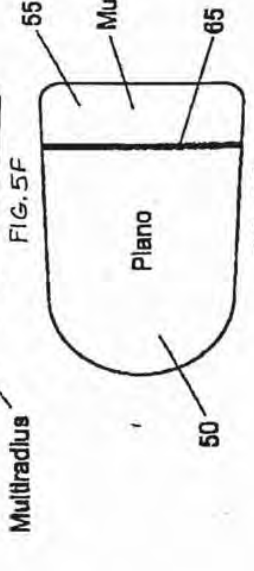
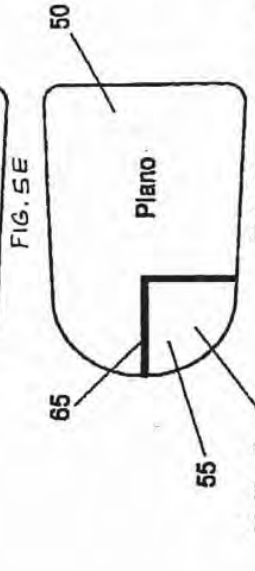
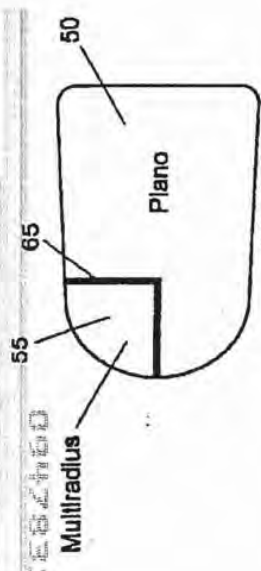
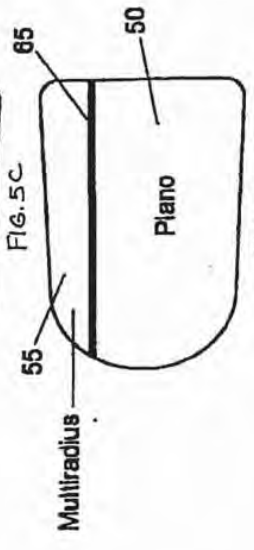
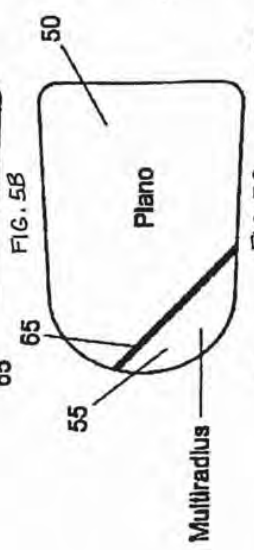
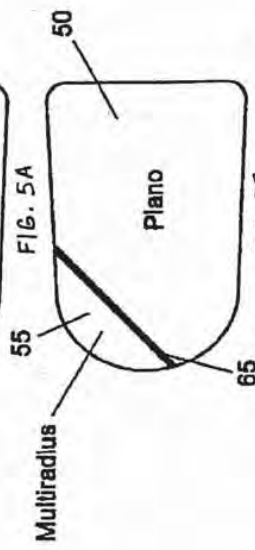
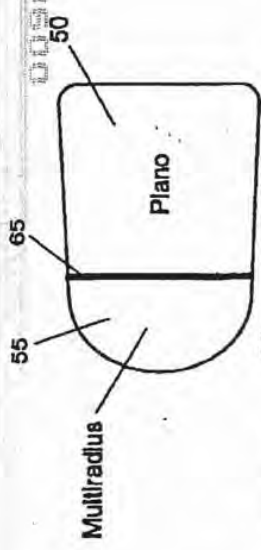

Figure 4

Applicant : Niall R. Lynam
For : EXTERIOR MIRROR PLANO-
AUXILIARY REFLECTIVE
ELEMENT ASSEMBLY
Docket No. : DON01 P-793
Express Mail No. EL399135945US
Sheet : 4 of 7

USPTO STEPHEN



Applicant : Niall R. Lynam
For : EXTERIOR MIRROR PLANO-
AUXILIARY REFLECTIVE
ELEMENT ASSEMBLY
Docket No. : DON01 P-793
Express Mail No. EL399135945US
Sheet : 5 of 7

000000-5766160

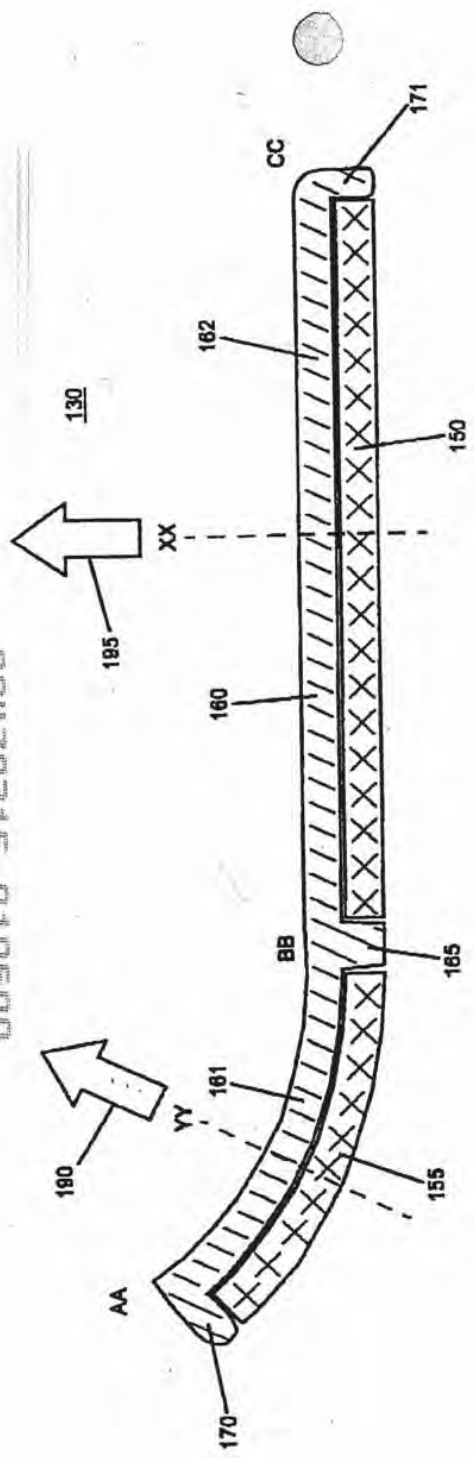

Figure 6

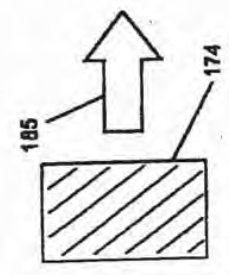

Figure 6A

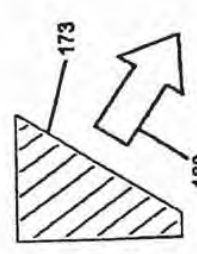

Figure 6B

Applicant : Niall R. Lynam
For : EXTERIOR MIRROR PLANO-
AUXILIARY REFLECTIVE
ELEMENT ASSEMBLY
Docket No. : DON01 P-793
Express Mail No. EL399135945US
Sheet : 6 of 7

CONFIDENTIAL

230

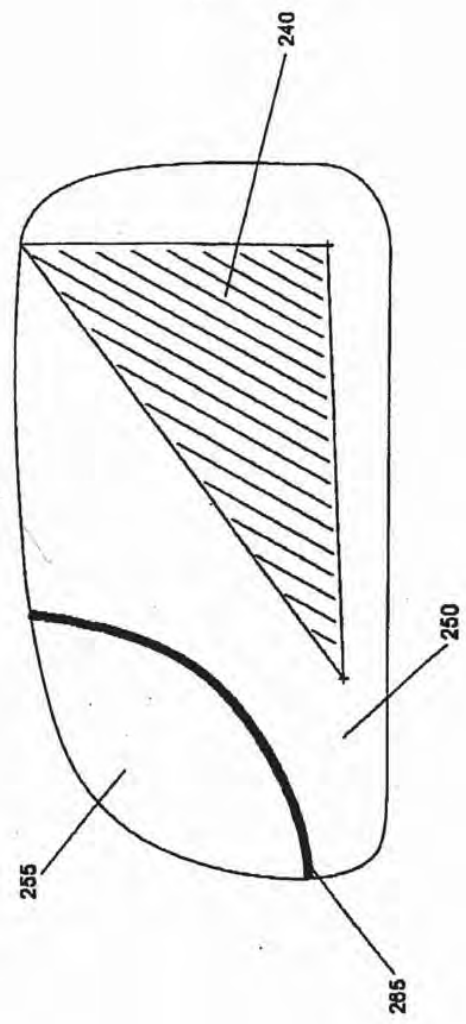

Figure 7

Applicant : Niall R. Lynam
For : EXTERIOR MIRROR PLANO-
AUXILIARY REFLECTIVE
ELEMENT ASSEMBLY
Docket No. : DON01 P-793
Express Mail No. EL399135945US
Sheet : 7 of 7

United States Patent [19]

[11] 4,281,899

Oskam

[45] Aug. 4, 1981

[54] ADJUSTING DEVICE FOR MOTORCAR MIRRORS

[75] Inventor: Aane A. Oskam, De Meern, Netherlands

[73] Assignee: Industrie Koot B.V., Montfoort, Netherlands

[21] Appl. No.: 76,953

[22] Filed: Sep. 19, 1979

[30] Foreign Application Priority Data

Jul. 26, 1979 [NL] Netherlands 7905806

[51] Int. Cl.³ B60R 1/06; G02B 7/18

[52] U.S. Cl. 350/289

[58] Field of Search 350/289; 248/476, 479, 248/487

[56] References Cited

U.S. PATENT DOCUMENTS

3,609,014	9/1971	Kurz, Jr.	350/289
4,114,988	9/1978	Enomoto	350/289
4,116,538	9/1978	Oskam	350/289
4,158,483	6/1979	Fisher et al.	350/289

Primary Examiner—F. L. Evans
Attorney, Agent, or Firm—Wendroth, Ljnd & Ponack

[57] ABSTRACT

A device for adjusting the mirror of an automotive vehicle, as disclosed in U.S. Pat. No. 4,116,538, includes drive and transmission devices consisting of two motors, each provided with a planetary transmission system mounted on a motor shaft, the two motor transmission systems being arranged mirror-symmetrically relatively to a median plane of a housing, the median plane containing the axis of a stiffening element.

6 Claims, 4 Drawing Figures

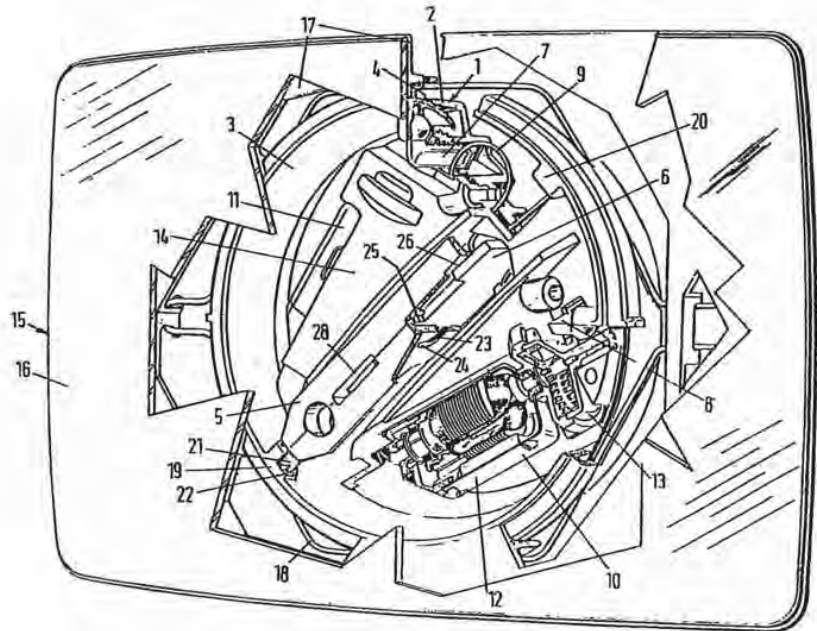

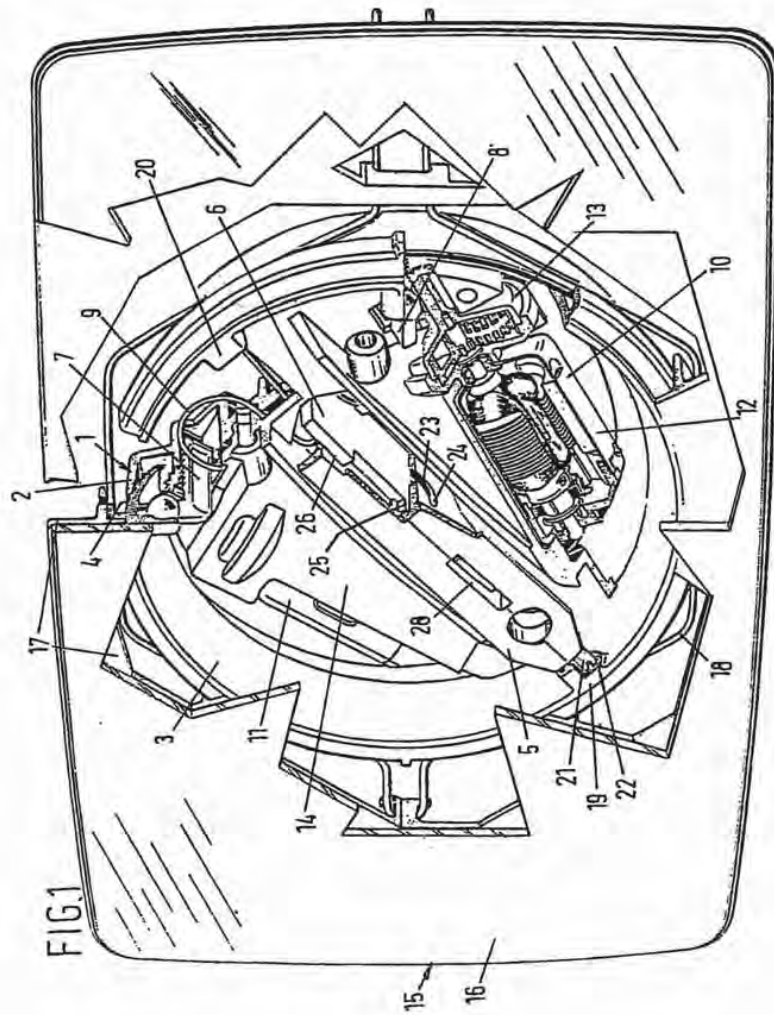

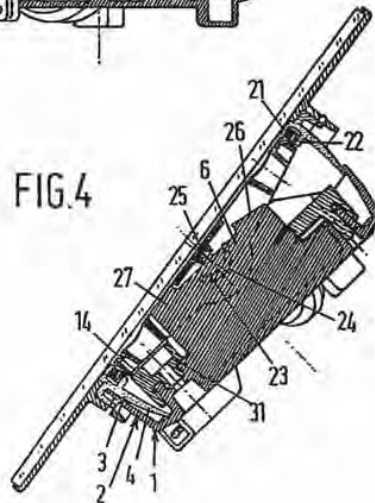
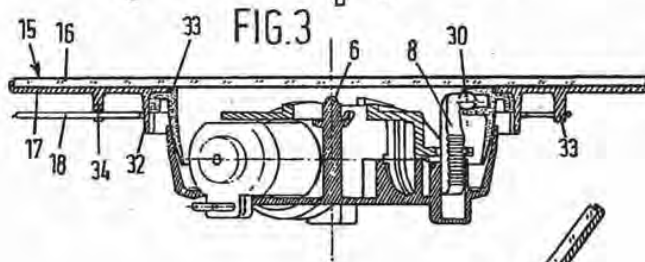
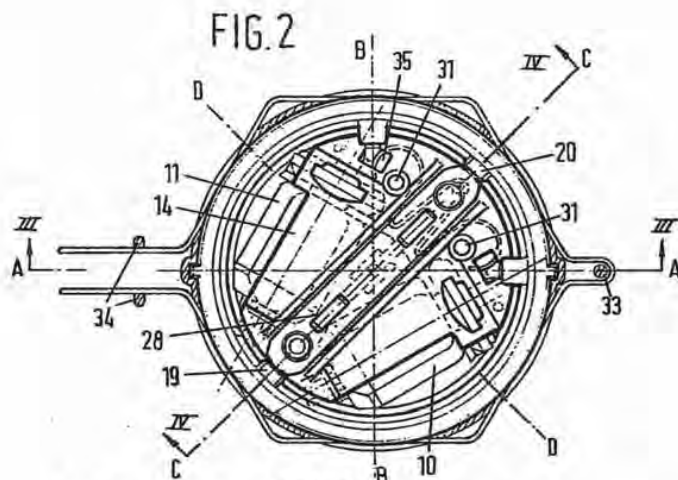

ADJUSTING DEVICE FOR MOTORCAR MIRRORS

BACKGROUND OF THE INVENTION

This invention relates to an adjusting device for motorcar mirrors.

In U.S. Pat. No. 4,116,538 there is described a device for adjusting a motorcar mirror about two perpendicular axes, which device essentially consists of a cup-shaped housing having a raised edge, an adjusting ring mounted therein for tilting movement, which ring in any position is in sealing contact with the raised edge, and is supported in its center by means of a stiffening element extending along a ring diameter, and further having two mirror adjusting members engaging with the adjusting ring and being off-set relatively to each other through 90°, and drive means and transmission means, whose output shafts are operatively associated with the mirror adjusting members.

In this prior device, the drive and transmission means are formed by one single unit consisting of a motor which is reversible with regards to the direction of rotation, a clutch and two planetary transmission systems. This combined unit can be excellently accommodated in an instrument housing of relatively large dimensions, which therefore must in turn be housed in a mirror housing, likewise of large dimensions, mounted on an automotive vehicle. In order that the mirror adjusting device may also be suitable for smaller motorcars, and hence smaller mirror housings, it is desirable for them to be constructed as compact as possible, and so to avoid a relatively large combined drive-and-transmission unit.

In addition to reducing the size of the device proper, a further saving in space can be realized by placing the mirror adjusting device eccentrically relative to the mirror center, because mirror housings on motorcars have an asymmetrical form, with the depth of the housing being less accordingly as the distance from the sidewall of the motorcar is larger. When the mirror adjusting device is placed eccentrically there is the risk that the mirror turns about an axis perpendicular to the plane of the mirror and consequently comes to hang askew in its housing. This not only meets with esthetic objections, but also increases the risk that, when subjected to jolting or bumping, an edge of the mirror comes into contact with an edge of the mirror housing, which is undesirable. In order that an eccentric location of the mirror adjusting device may be possible, the device itself should have a high torsional stiffness.

In addition to a compact construction and a high torsional stiffness at positions it is also desirable that tilting axes should be provided, spaced as closely from the actual mirror surface as possible, this to make the space between the edge of the mirror housing on the motor vehicle and the edge of the mirror as small as possible.

SUMMARY OF THE INVENTION

In order to provide a compact construction, the device according to the present invention is characterized in that the drive and transmission means consist of two motors, each provided with a planetary transmission system mounted on the motor output shaft, the two motor transmissions systems being arranged mirror-symmetrically relative to a median plane of the housing, the median plane containing the axis of the stiffening

element. Preferably, the axes of the two motor transmission systems enclose an acute angle.

Owing to the smaller drive and transmission systems and their mirror-symmetrical arrangement in the instrument housing, an optimum division of the space available in the housing is achieved, so that the instrument housing can be made considerably smaller. Furthermore, as a result of the arrangement selected, the two mirror adjusting members can act directly on the adjusting ring, this in contrast with the construction described in the above U.S. Pat. No. 4,116,538, in which one of the output shafts of the drive and transmission means acts on the mirror adjusting member indirectly through the stiffening element, which is of sector-shaped form. Moreover, the construction according to the present invention has two additional tilting axes, one of which extends according to the center line of the stiffening element and the other of which is perpendicular to this center line. The adjustment of the mirror about these additional tilting axes is effected by operating the two motors simultaneously in the same or contrary directions of rotation.

The increased torsional stiffness of the mirror adjusting device according to the present invention is realized in that the cup-shaped housing is provided with a ridge extending according to the median plane, with the stiffening element being of U-shaped cross-sectional configuration and having its legs located on opposite sides of the ridge. In this way, a rotation of a mirror plate placed eccentrically on the mirror adjusting instrument relative to the adjusting instrument is not possible, even with heavy mirror plates and large eccentricities. Owing to the combination of a ridge and a stiffening element embracing this ridge, the pivotal support of this stiffening element can be effected in a simple manner by means of a semi-cylindrical fulcrum, spaced a very short distance from the mirror plate, with crescent-shaped guide lugs being provided on the ridge below the fulcrum, which lugs can snappingly engage with correspondingly shaped recesses in the legs of the U-shaped stiffening member. In this way the stiffening member can pivot about the fulcrum and remains connected to the ridge by means of the crescent-shaped guide lugs.

In addition to this fulcrum, the adjusting ring can also tilt about pins with which the stiffening member is mounted in the adjusting ring. From considerations of strength, these pins must have a certain thickness, while on the other hand the tilting axis must be as closely behind the mirror plate as possible, which requirement leads to connecting pins as thin as possible. These contradictory requirements can be met by providing the pins mounted at the end of the stiffening member with a V-shaped recess, while the bearing holes in the adjusting ring are of anchor-shaped form with a knife edge mounted in the V-shaped recess of the pins, the arrangement being such that the adjusting ring can rock from its position of equilibrium into both directions through approximately 20°. Owing to these features, the space between the rim of the mirror housing mounted on a vehicle and the circumferential edge of the mirror plate may be minimal. Such a minimal space, however, involves the problem that a mirror plate which, in accordance with U.S. Pat. No. 4,116,538, is secured to the adjusting instrument by means of a snap connection, cannot be easily replaced after being mounted in a mirror housing, because there is no space for loosening the snap lugs engaging behind the turned-up edge of the

adjusting ring, for example with a screw-driver. In order that the mounted mirror plate may yet be readily removed from the mirror adjusting instrument, according to the present invention, a hexagonally bent mounting spring is used as a fastening means, which spring is connected on the one hand to the mirror mounting plate, and whose six straight edges can engage behind the turned-up edge of the adjusting ring. This mounting spring terminates in two parallel legs, whose ends project beyond the mirror mounted on the instrument, which legs are retained under tension between two confining pegs on the mirror mounting plate. When the ends of these two parallel legs are moved towards each other and subsequently moved backwards, the mounting spring is released from the pegs on the mirror mounting plate, and also from the turned-up edge of the adjusting ring, whereafter the mirror can easily be removed and replaced by another one.

BRIEF DESCRIPTION OF THE DRAWINGS

One embodiment of the device according to the present invention will now be described, by way of example, with reference to the accompanying drawings, in which

FIG. 1 is a front elevation, with some parts being broken away, of a mirror adjusting instrument with a mirror mounted thereon;

FIG. 2 is a front elevation of the mirror adjusting instrument without the mirror;

FIG. 3 is a cross-sectional view, taken on the line III—III of FIG. 2, with a mirror plate being mounted on the adjusting instrument; and

FIG. 4 is a cross-sectional view, taken on the line IV—IV of FIG. 2, in which the adjusting instrument is also provided with a mirror plate.

DETAILED DESCRIPTION OF THE INVENTION

As best shown in FIG. 1, the mirror adjusting instrument according to the present invention comprises a cup-shaped housing 1 having a raised edge 2, preferably made of a suitable synthetic plastics material. Mounted within housing 1 is an adjustable ring 3, also made of a synthetic plastics material, with a spherical side surface 4 resting on the raised edge 2 of housing 1, so that ring 3 can rotate in all directions without losing contact with housing 1 and hence with friction. Mounted in adjusting ring 3 is a stiffening element 5, in FIG. 1 placed diagonally at an angle of 45°, which element is coupled to a ridge 6 formed integrally with instrument housing 1. Provided on the vertical and horizontal axes of the instrument are adjusting arms 7,8, made of synthetic plastics material, which arms by means of a steel zig-zag spring 9 form the coupling between adjusting ring 3 and drive units 10,11 for the adjustment of the mirror. Each drive unit 10,11 consists of an electric motor 12 coupled to a planetary transmission system 13, the toothed output shaft of which meshes with the likewise toothed associated adjusting arm 7,8. The drive units 10,11 and spring 9 are retained in position by a confining plate 14 which is forced into instrument housing 1 by means of a snap connection. After the adjusting instrument has been mounted in a mirror housing, not shown, and secured to a motor vehicle, mirror plate 15, consisting of a mirror glass 16, a mounting plate 17 and a mounting spring 18, is snapped onto adjusting ring 3.

THE MIRROR SUPPORTING STRUCTURE

The mirror supporting structure consists of instrument housing 1, mirror adjusting ring 3 and the stiffening element or pivot member 5. During the manufacture of instrument housing 1, by injection moulding, a number of projections are formed on the bottom of this housing, the form of which is adapted to that of the combined drive-transmission systems 10,11, so that these units can be placed in housing 1 so as to be confined in two directions (see FIG. 3). Also formed on the bottom is a ridge 6, extending according to a median plane, and in the vertical direction projecting from the raised edges 2. In the center, ridge 6 is provided with a semi-cylindrical fulcrum 25, on which pivot member 5 can be supported. Provided on opposite sides of this fulcrum 25 on the upper edge of ridge 6 are two lugs 26,27, which fit slots 28 formed in pivot member 5. Lugs 26,27 are beveled at the top, which top comes to lie substantially in contact with mirror glass 16 when mirror 15 has been adjusted in the longitudinal direction of ridge 6 up to its end position. Lugs 26,27 serve to effect maximum resistance against torsion of member 5 and adjusting ring 3, connected to it, as well as mirror plate 15 relative to housing 1.

As clearly apparent from FIG. 2, drive units 10,11 are arranged in housing 1 mirror-symmetrically relative to ridge 6, and the axes of these drive units 10,11 enclose an acute angle. The output shafts of each planetary transmission 13 of drive units 10,11 terminate adjacent to the raised edge of housing 1 spaced apart an arcuate distance of 90°.

Provided below fulcrum 25 of ridge 6, and on opposite sides, are crescent-shaped guide lugs 23 with the concave side facing upwardly. These crescent-shaped lugs can engage with correspondingly shaped slots 24, provided in the side legs of member 5. In order that this member 5 can be easily moved from above over ridge 6, the crescent-shaped lugs are beveled downwardly and outwardly, so that there is a snapping connection between member 5 and ridge 6. The top sides of ridge 6, member 5, lugs 23 and slots 24 are formed so that member 5 can rock from the position of equilibrium through 20° in both directions.

Member 5 is provided at each of its two ends with a pin 21 that can be received in a hole 22 in adjusting ring 3. The two pin-and-hole connections 21,22 form the pivots 19,20 about which the adjusting ring 3 can turn relative to member 5. In order that the axis of rotation of pivots 19,20 may be as close to the back of mirror plate 15 as possible, pins 21 are provided with a V-shaped notch, with the apex of the V being located above the axis of pin 21. Holes 22 are formed in a corresponding manner. They are essentially round, but opposite the V-shaped recess in pin 21 they have a V-shaped knife edge, with the two legs of this knife edge enclosing a more acute angle than do the legs of the V-shaped recess in pin 21. The form of the hole is indicated herein as anchor-shaped.

Member 5 is mounted in adjusting ring 3 by pinching the latter into an oval shape and after member 5 has been introduced releasing it again, whereafter ring 3 re-assumes its round form and member 5 is received by its end pins 21 in holes 22 of ring 3. After ring 3 has been mounted in housing 1, the spherical surface 4 of ring 3 is in contact with the raised edge 2 of instrument housing 1 with slight friction. This friction prevents a mirror plate 15 mounted on ring 3 from being vibrated by

whirling air, while the interior of housing 1 is thus adequately sealed from dust and moisture.

THE MIRROR DRIVE AND THE CONNECTION OF THE DRIVE UNITS TO THE ADJUSTING RING

Provided in instrument housing 1 are two drive units 10,11, each consisting of a motor 12, the output shaft of which is coupled to the sun wheel of an associated planetary transmission system 13. This planetary transmission system is of the same type as described in U.S. Pat. No. 4,116,538, referred to hereinbefore, and will not, therefore, be described in more detail herein. The toothed output shaft of each planetary transmission system 13 is in mesh with an adjusting arm 7,8, which is partly formed as a rack. Arms 7 and 8 are provided at their ends with a ball 30, which is snappingly received in adjusting ring 3. The two arms 7,8 are of identical construction. The points of engagement of balls 30 of the two arms 7,8 are peripherally spaced a distance of 90°, i.e. 45° on opposite sides of a pivot 20 of member 5. The zig-zag spring 9 forces the toothed portion of the two arms 7,8 into contact with the teeth of the output shafts of the planetary drive systems 13 in order that the two toothed members may be maintained in mesh with each other. If, however, mirror plate 15 is subject to an external force, the toothed portion of arms 7,8 may be released from the teeth on the output shaft of the associated planetary transmission system against the action of spring 9, so that arms 7,8 can move over the associated gear wheel without any damage to the drive. The same effect takes place when the adjusting instrument has arrived at the end of its stroke and the associated motor continues to run. In that case the teeth of arms 7,8 and of the output shafts of the planetary transmission systems 13 slide over one another against the action of spring 9.

At their ends remote from ball 30, adjusting arms 7,8 are provided on the surface facing spring 9 with a hook-shaped projection 35, which during the outgoing stroke of arms 7,8 comes to lie in abutment with spring 9, whereby the stroke of the instrument is stopped.

When motor 12, associated with drive unit 11, is energized, adjusting ring 3 and hence mirror plate 15 mounted on it will tilt about axis A-A (see FIG. 2). The fixed points on axis A-A are the fulcrum 25 of member 5, and the ball of arm 8, snapped into ring 3. The tilting movement about axis A-A is composed of a tilting movement of member 5 about axis D-D (see FIG. 2) and a tilting movement about the pivots 19,20 of member 5. When motor 12 of drive unit 10 is energized mirror plate 15 is tilted similarly about axis B-B. When motors 12 of drive units 10,11 are simultaneously driven in the same direction, mirror plate 15 is tilted about axis D-D and when the two drive motors are turned in opposite directions of rotation, the mirror is tilted about axis C-C.

THE MOUNTING OF VARIOUS PARTS

The parts of the adjusting device are all kept in position by a retaining plate 14, the function of which is to confine drive units 10,11 and take up forces arising from the pressure of spring 9 and from the adjustment of the device. Spring 9 can be mounted in plate 14 in pre-tensioned condition, whereafter plate 14 is placed over drive units 10,11 and secured by means of three hollow snap pins 31 (see FIG. 4), which are formed integrally with plate 14, in corresponding recesses in the instru-

ment housing 1. The three snap pins 31 are hollow to receive three bolts for securing the mirror adjusting device 1 in a mirror housing, and these three bolts also serve for clamping plate 14 on the instrument housing 1.

THE MOUNTING OF THE MIRROR PLATE

Mirror plate 15 is composed of a mirror glass 16 which by means of an adhesive layer is secured to a mirror mounting plate 17. Plate 17 has a raised edge 32, which is contiguous with the outer circumferential rim of adjusting ring 3. Plate 17 further has a recess shaped to match raised edge 33 (see FIG. 3) of the adjusting ring, so that edge 33 comes to lie in direct contact with the rear surface of mirror glass 16, to which it is glued. The mirror glass 16 thus also functions as a cover for the adjusting device, and the adhesive layer on the rear surface of the mirror also serves as a sound and vibration insulating layer. Formed in the raised edge 32 of the mirror mounting plate are six slots, which fit a mounting spring 18, bent into hexagonal form. At the closed side, this spring 18 is laid around a peg 33 provided on the rear surface of mirror mounting plate 17, and subsequently through the six slots in the raised edge 32, whereafter the two spring legs at the open spring end are confined under tension between two pegs 34, which are likewise provided on the rear surface of plate 17. When plate 17 is forced onto ring 3, the six straight sides of spring 18 spring behind the outer edge of ring 3. In this way plate 15 is retained on ring 3 at six points spaced around its circumference.

When plate 15 must be removed from the adjusting instrument, the two legs of spring 18 projecting beyond plate 15 are pinched together and forced backwards so that they come to lie outside pegs 34. Spring 18 is thus released from ring 3, and plate 15 can be detached from ring 3, during which operation the narrow adhesive strip between ring 3 and the rear surface of the mirror is broken.

I claim:

1. A device for adjusting the mirror of an automotive vehicle about at least two perpendicular axes, said device comprising:

a cup-shaped housing having a raised edge and a ridge extending along a median plane of said housing;

said ridge having an upper edge having at the center of the length thereof a substantially semi-cylindrical fulcrum;

a tiltable adjusting ring mounted in said housing for relative movement with respect thereto, said ring being in sealing contact with said raised edge of said housing in all positions of said ring;

a stiffening element of U-shaped cross-sectional configuration defined by two legs, said stiffening element having opposite ends received in diametrically opposed holes in said adjusting ring, and said stiffening element being mounted in contact with said semi-cylindrical fulcrum of said ridge and with said two legs positioned on opposite sides of said ridge;

first and second mirror adjustment members mounted for engagement with said adjusting ring at positions off-set from each other by 90° with respect to said adjusting ring, each said adjustment member including a rack portion; and

first and second drive and transmission means for achieving relative movement of said ring with respect to said housing in at least two perpendicular

7

axes, said first and second drive and transmission means being arranged mirror-symmetrically relative to said median plane of said ridge of said housing and extending in directions enclosing an acute angle, each said drive and transmission means comprising a motor having an output shaft, a planetary transmission system mounted on said motor output shaft and having an output shaft, and a gear fixed to said transmission system output shaft and engaging a said rack portion of a respective said adjustment member.

2. A device as claimed in claim 1, wherein said ridge has opposite side walls, each having thereon a crescent-shaped guide lug at a position below said fulcrum, each said leg of said stiffening element has formed therein a crescent-shaped recess, and said guide lugs are snappingly engaged in said recesses.

3. A device as claimed in claim 1, wherein each said opposite end of said stiffening element comprises a pin having therein a V-shaped recess, each said hole in said adjusting ring comprises an anchor-shaped bearing hole, and each said pin is journaled into a respective

8

said bearing hole such that said adjusting ring is rockable with respect to said housing and said ridge from a position of equilibrium thereof through approximately 20° in opposite directions.

4. A device as claimed in claim 1, wherein said drive and transmission means are retained in said housing exclusively by a retaining plate having at least three pins snappingly engaging in respective recesses in said housing.

5. A device as claimed in claim 1, wherein said ring has a raised edge, and further comprising a mirror glued to a mirror mounting plate secured to said ring by fastening means comprising a hexagonally shaped mounting spring having six straight sides, said spring being connected to said mounting plate, with said six straight sides engaging behind said raised edge of said ring.

6. A device as claimed in claim 5, wherein said spring has two ends in the form of parallel legs extending outwardly and retained under tension between two pegs on said mounting plate.

* * * * *

25

30

35

40

45

50

55

60

65

PATENTED OCT 9 1973

3,764,201

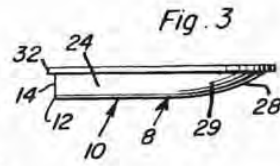
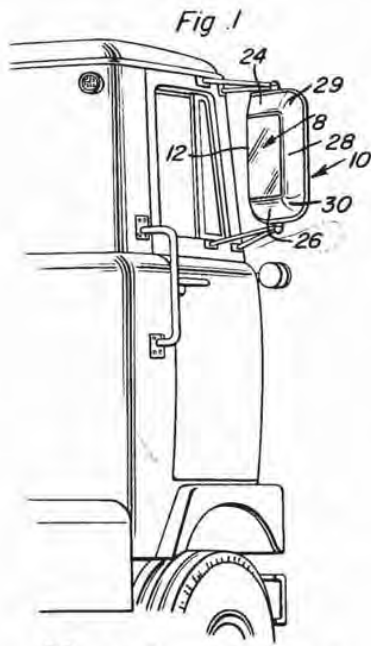
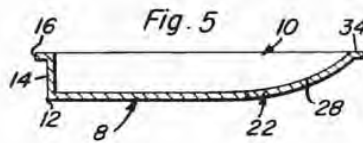
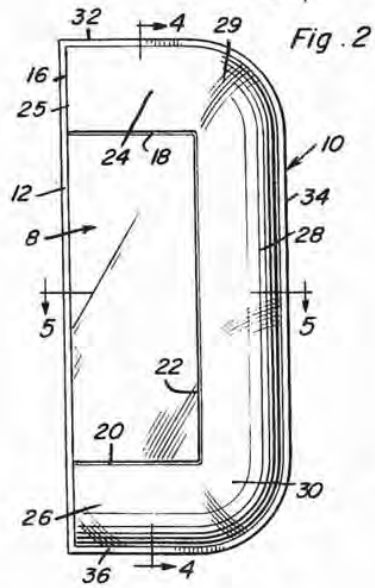
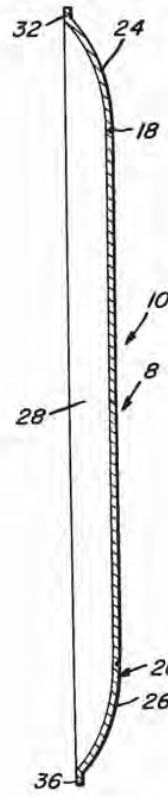

Fig. 4



REAR VISION MIRROR

The present invention relates to a rear view or vision mirror which because of its unique construction lends itself to safe and feasible use on support brackets such as are provided on trucks and buses and, more specifically stated, has to do with a simple, practical and economical mirror structure characterized by features which function individually and collectively to first and more safely serve the suspended use primarily on the right hand side remote from the driver and whose features function to reduce dangerous blind spots to a practical minimum.

In carrying out the principles of the inventive concept a mirror of reliable performance is provided, one which, for the most part, is capable of being mounted on frames and brackets which are currently in use on trucks and buses. The mirror is so mounted and adjusted in the frame that the principal or main planar or flat area or zone reflects much in the manner of currently or commonly used rear view mirrors but which has several marginal portions provided with rearwardly and properly curved horizontal and vertical areas and junctional corner portions which contribute to the function of the main mirror so as to enable the driver to see back and out at a broader angle and also enable him to see downward and further forward. In addition experience has shown that the mirror is such in construction and capability that it will enable truck and bus drivers to view the rear wheels of their vehicles which, manifestly, is helpful when called upon to back or park as the case may be. Mirrors commonly in use on trucks and buses are often such that the driver is unable to see small automobiles at the right hand side and in fact objects and signs and curbs which can and often do result in unforeseen and exasperating as well as damaging and difficult-to-cope with situations.

It is a matter of common knowledge that when a truck or bus driver is called upon to slow down at a stop sign or a yield sign on a side road merging with a main highway and often involving a sharp angle on the right hand side, he has difficulty viewing even when the highway to the right appears to be clear. From the driver's seat looking directly out the window in the right door it is quite likely that he cannot envision a safe distance to his right due to the special angle of approach. It follows that in many cases the rear view mirror commonly used does not reflect outward enough to cover the situation, presenting a blind area. It is an object of the present invention to structurally, functionally and otherwise improve upon known mirrors and to provide an adaptation which well and safety serves the purposes for which it has been evolved, produced and successfully used.

Many and varied types and styles of rear view mirrors for trucks and buses have been devised and offered for use but often without success. Take for example the patent to Robert E. Fellmeth, U.S. Pat. No. 2,778,273, which has to do with a rear view mirror for outside bracket supported use characterized by a centrally disposed and substantially flat circular reflecting area marginally encompassed by a spherical convex peripheral reflecting surface which is integral with and completely circumscribes the central area and extends rearwardly therefrom. The patentee suggests a curved marginal portion, but conceivably the curved side portions could meet as curved moldings meet on a picture frame having ridges at the corners and should this be the case

there would be obvious and dangerous blind areas at the corners notably out and up as well as down. Fellmeth will not be further discussed except as exemplary prior art. A more pertinent citation would be the Ernest E. Hensley rear view mirror shown in U.S. Pat. No. 2,279,751. Hereagain and despite the fact that the patentee Hensley shows a main rectangular planar mirror and marginal auxiliary mirrors, the latter are planar and at such angles in relation to each other and the main mirror that serious blind areas between the central portion and side apron portions are present. Under the circumstances it would appear that the apron-like marginal components have failed to comply with the requirements of widespread adoption and use.

Briefly the mirror herein revealed lends itself to use on either side of a vehicle but is primarily intended for right-hand side use remote from the observer or driver and essentially on trucks and buses. It is simple and practical and economical and is of unitary or one-piece construction and characterized in the main by a primary or main flat rectangular image and object reflecting area which corresponds to commonly used outside truck mirrors. It is improved in that a first horizontal convex reflecting zone or area borders and merges with the upper transverse marginal edge of the main reflecting area and this curves rearwardly at the predetermined 5 inch or equivalent radius. The main mirror can be some 8 inches long and perhaps three inches wide. The first horizontal convex area corresponds to the second lower horizontal rearwardly curving convex reflecting area and is, like the first area, some three inches more or less in width. Opposite the inboard or inward longitudinal straight edge of the overall mirror the outward longitudinal edge portion is provided with a third but vertical convex reflecting area which merges with the outer longitudinal marginal edge of said main reflecting area. All of these curvate areas are selectively as well as conjointly viewable in keeping with the particular locale as well as the relationship of vehicles and objects such as may be considered to be within the zone or range of usefulness of the overall mirror. Therefore there is a main planar mirror or area, upper and lower and intermediate convex auxiliary narrower mirrors and, indeed, suitably spherical or curved and coordinating corner portions which unite the ends of the longitudinal and transverse convex areas.

With a view toward providing further background for the instant concept it can be added here that on high speed super highways access lanes are provided in a manner that the informed and experienced driver may enter the high speed highway at an angle in the same general direction of the traffic already in motion in the high speed lane. But it is to be remembered that access lanes do not always approach at the same angle. Accordingly before pulling into a high speed lane especially with a slow accelerating vehicle one must necessarily have a clear back view for at least 500 feet more or less. In lanes merging at certain angles prior patented constructions could perhaps detect the traffic situation some 500 feet back. In other cases where access lanes approach at different angles, a driver relying on previously devised and patented rear view mirrors could easily check his mirror, see no vehicle coming and pull into the high speed lane and at the same time a large truck could be bearing down on him at perhaps 70 miles more or less per hour. It follows that the blind area between the central portion and the side apron

3

portion of prior patented adaptations make it extremely dangerous to rely upon which is another reason for offering the herein disclosed mirror with curvate areas at top and bottom and outside therefore on three marginal portions of the main mirror. Then, too, the inward edge is provided with a wall and all marginal edges including the rearwardly convex areas have coplanar outstanding attaching flanges for adequate mounting purposes.

These together with other objects and advantages which will become subsequently apparent reside in the details of construction and operation as more fully hereinafter described and claimed, reference being had to the accompanying drawings forming a part hereof, wherein like numerals refer to like parts throughout.

FIG. 1 is a view in perspective showing the upper right hand corner portion of a cab such as is used on a tractor trailer or the like (trucks and buses) and showing, what is more important, the bracket supported improved multi-purpose mirror as constructed in accordance with the present invention.

FIG. 2 is an enlarged rear elevation of the mirror by itself.

FIG. 3 is a view on a smaller scale which can be said to be the top edge or top plan view.

FIG. 4 is a section taken lengthwise on the longitudinal section line 4—4 of FIG. 2 looking in the direction of the indicating arrows.

And FIG. 5 is a horizontal cross section on the line 5—5 of FIG. 2.

The outside rear vision mirror for trucks and buses is designed primarily for suspended use as brought out in FIG. 1. It is of one piece construction and is characterized by a main flat rectangular image and object reflecting area which is denoted, generally stated, by the numeral 8. The overall finished and ready-to-use mirror, including the features desired is denoted by the numeral 10. The sharp straight edge which may be called the inboard or inward longitudinal edge is denoted by the numeral 12 and has an integral lateral or right angularly disposed lengthwise non-reflecting wall 14 one edge of which is provided with one of the flanges 16 of the flange means which is to be hereinafter more specifically set forth. The three marginal edges of the area or zone 8 which are emphasized here can be etched, painted, or otherwise delineated as denoted by the upper marginal edge 18 (FIG. 4), the lower horizontal marginal edge 20 and the intervening longitudinal marginal edge 22 which is opposite the edge 12 and parallel thereto and is denoted at 22. A first horizontal convex reflecting area borders and merges with the upper edge 18 and is denoted at 24 and curves rearwardly and has a straight left-hand end 25 flush with the edge 12. A second lower horizontal rearwardly curving convex reflecting area, like the upper horizontal convex area is provided and it is differentiated in FIG. 2 by the numeral 26. A complementary third but vertical convex reflecting area merges with the outer vertical marginal edge portion 22 and it is of requisite length and curvature and is differentiated by the numeral 28. It is commensurate in length with the edge 22 as perhaps best evident in FIG. 2. All of these three areas are selectively as well as conjointly viewable in keeping with the particular locale and relationship of vehicles (not shown) and objects within the zone and range of usefulness of the overall mirror. The horizontal and vertical convex areas 24, 26 and 28 are referred to as auxiliary

4

to the main area or mirror 8. The adjacent terminal ends of the first and second horizontal areas are integrally and convexly united by coordinating upper and lower convexly curved junctional and corner portions the upper one of which is denoted at 29 and the lower one at 30. Reverting to the flange means 16 it may be added that companion or complementary flanges 32, 34 and 36 are integrally provided on the outer perimeter edges and are in a common plane with each other as is best shown in FIGS. 3, 4 and 5 whereby to permit the ready-to-use mirror to be mounted on a bracket. The concept pertains in part to a rear vision mirror for mounting upon either side of an automotive vehicle comprising a centrally disposed and substantially flat rectangular reflecting area, and from a common radius, rectangular cylinder section curved convex reflecting areas at the upper, outer and lower edges and triangular sphere section convex reflecting areas at the upper outer corner and lower outer corner integral with the flat reflecting area and extending rearwardly therefrom.

The corner portions of the herein disclosed rear vision mirror serve highly significant and important safety purposes. By utilizing curved convex sphere sections at the upper outer corner and lower outer corner, blind areas between the vertical curved side portion are avoided. The driver of a vehicle equipped with the disclosed rear vision mirror, traveling up an access ramp into a highway would be able to see up, out and back by viewing the upper outer corner of the rear vision mirror or traveling down an access ramp he would be able to see down, out and back through the lower outer corner of the rear vision mirror. Likewise, a driver already on the main highway would be able to see vehicles entering on uphill ramps or downhill ramps through the lower outer and upper outer corners of the rear vision mirror.

It is submitted that a careful consideration of the views of the drawing taken in conjunction with the specification and the invention as claimed, will enable the reader to obtain a clear and comprehensive understanding of the invention. Therefore a more extended description is believed to be unnecessary.

The foregoing is considered as illustrative only of the principles of the invention. Further, since numerous modifications and changes will readily occur to those skilled in the art, it is not desired to limit the invention to the exact construction and operation shown and described, and accordingly all suitable modifications and equivalents may be resorted to, falling within the scope of the invention.

What is claimed as new is as follows:

1. An exterior rear vision mirror expressly designed and adapted for trucks, buses and the like comprising: a flat substantially rectangular main reflecting area, three substantially rectangular cylindrically contoured selectively and conjointly functioning auxiliary reflecting areas, namely, a first one situated along, coextensive and integrally united with an upper transverse marginal edge of said main reflecting area, a second one positioned along, coextensive and integrally united with an outward longitudinal marginal edge of said main reflecting area and oriented therewith, and a third one corresponding to said first one but coextensive and integrally united with a lower transverse marginal edge of said main area, a first generally triangular spherically contoured upper corner reflecting area junctionally

5

6

joining adjacent ends of said first and second auxiliary reflecting areas, and a second generally triangular spherically contoured lower corner reflecting area junctionally joining adjacent coacting ends of said second and third auxiliary areas, said auxiliary rectangular convex areas and said junctional corner areas being derived from a common radius.

2. The rear vision mirror defined in and according to claim 1, and wherein the entire inward longitudinal marginal edge of said mirror is straight from end to end and is provided with an integral elongated straight non-reflecting wall which is disposed in a plane at right angles to the plane of said main area.

3. The rear vision mirror defined in and according to claim 1, and wherein the entire inward longitudinal marginal edge of said mirror is straight from end to end and is provided with an elongated straight wall which is non-reflecting and disposed at right angles to the main area, and also wherein said wall and outer peripheral edges of all of said convexly contoured areas, including said upper and lower corners, are provided with narrow angularly projecting outstanding endless flange means defining a mounting rim for the overall ready-to-use mirror, said flange being in a plane parallel to the plane of said main flat reflecting area.

4. An outside rear vision mirror designed primarily for suspended use on the right hand side of a truck or bus comprising a main flat rectangular vertically positionable reflecting area, a first horizontal substantially rectangular cylindrically convex reflecting area bordering and merging with an upper transverse marginal edge of said main reflecting area, a second substantially rectangular but lower horizontal rearwardly corre-

spondingly curving convex reflecting area like said upper horizontal convex area merging with the transverse lower marginal edge of said main reflecting area, and a complementary third but vertical correspondingly curving convex reflecting area merging with the outer vertical longitudinal marginal edge of said main reflecting area, all of said areas being selectively as well as conjointly viewable in keeping with particular locale and relationship of vehicles and objects within the zone and range of usefulness of the overall mirror, said horizontal and vertical convex areas being auxiliary to but complementary with said main area, adjacent terminal ends of said first and second horizontal areas being integrally united by coordinating upper and lower convexly curved junctional triangular corner portions, the cylindrically contoured convex curvatures of said auxiliary upper, lower and vertical areas and also said junctional corner portions corresponding with each other and being derived from a common radius.

5. The rear vision mirror defined in and according to claim 4, and wherein the entire inward longitudinal marginal edge of said mirror is straight from end to end and is provided with an elongated straight wall which is non-reflecting and disposed at right angles to the main area, and also wherein said wall and outer peripheral edges of all of said convexly contoured areas, including said upper and lower corners, are provided with narrow angularly projecting outstanding endless flange means defining a mounting rim for the overall ready-to-use mirror, said flange being in a plane parallel to the plane of said main flat reflecting area.

* * * * *

35

40

45

50

55

60

65

United States Patent [19]

[11] 3,764,201

Haile

[45] Oct. 9, 1973

[54] REAR VISION MIRROR

[75] Inventor: Ernest Haile, Trenton, N.J.

[73] Assignee: Allen C. Haile, Carson, Calif.

[22] Filed: May 17, 1972

[21] Appl. No.: 254,244

[52] U.S. Cl. 350/303, 350/307

[51] Int. Cl. G02b 5/08

[58] Field of Search 350/293, 303, 304, 350/307, 288

[56] References Cited

UNITED STATES PATENTS

2,778,273	1/1957	Fellmeth	350/303
2,279,751	4/1942	Hensley	350/303
2,857,810	10/1958	Troendle	350/293

FOREIGN PATENTS OR APPLICATIONS

616,615	8/1969	Germany	350/293
1,420,532	11/1965	France	350/293

Primary Examiner—David Schonberg
Assistant Examiner—Michael J. Tokar
Attorney—Harvey B. Jacobson

[57] ABSTRACT

A rear vision mirror for exterior use primarily on

trucks and buses and designed for suspended use on the right-hand side of a cab remote from the driver at the left. It is of one piece construction and characterized broadly by a main flat rectangular image and object reflecting area. A first horizontally disposed convex reflecting area borders and merges with the upper transverse marginal edge of the main reflecting area or zone and is curved rearwardly. A second but lower horizontal rearwardly curving convex reflecting area basically like the upper horizontal convex area merges with the lower transverse marginal area of the main reflecting area or zone. A complementary third but vertical convex reflecting area merges with the outer vertical edge of the main reflecting area. The inward longitudinal edge has a right angularly positioned wall of requisite thickness and width. All of the areas whether flat or convexly curved are selectively as well as conjointly viewable in keeping with the particular locale and relationship of the vehicles and objects within the zone or range of usefulness. All convex areas are of corresponding convexity and adjacent terminal end portions of the third area and the first and second areas are united by spherical corner portions. The entire peripheral or marginal edge is provided with narrow flange means capable of mounting the unique mirror in a support bracket or fixture.

5 Claims, 5 Drawing Figures

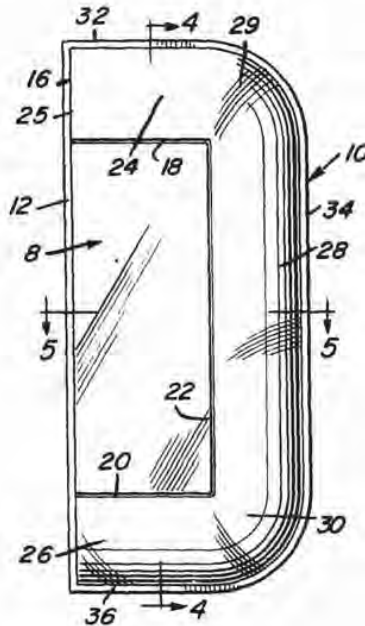



US006522451B1

(12) **United States Patent**
Lynam

(10) **Patent No.:** **US 6,522,451 B1**
(45) **Date of Patent:** **Feb. 18, 2003**

(54) **EXTERIOR MIRROR PLANO-AUXILIARY REFLECTIVE ELEMENT ASSEMBLY**

(75) Inventor: **Niall R. Lynam**, Holland, MI (US)

(73) Assignee: **Donnelly Corporation**, Holland, MI (US)

(*) Notice: Subject to any disclaimer, the term of this patent is extended or adjusted under 35 U.S.C. 154(b) by 0 days.

(21) Appl. No.: **09/478,315**

(22) Filed: **Jan. 6, 2000**

(51) **Int. Cl.**⁷ **G02F 1/15; G02B 5/08; G02B 5/10; G02B 7/182; B60R 1/06**

(52) **U.S. Cl.** **359/265; 359/267; 359/841; 359/850; 359/864; 359/866; 359/868; 359/872; 359/877; 248/549; 248/900**

(58) **Field of Search** **359/841, 850, 359/851, 855, 864, 865, 866, 868, 872, 877, 265, 267; 248/549, 900**

(56) **References Cited**

U.S. PATENT DOCUMENTS

2,911,177 A	*	11/1959	West	
3,104,274 A	*	9/1963	King	359/864
3,170,985 A	*	2/1965	Karulich	
3,375,053 A		5/1968	Ward	350/293
3,389,952 A	*	6/1968	Tobin, Jr.	359/864
3,764,201 A	*	10/1973	Haile	

(List continued on next page.)

FOREIGN PATENT DOCUMENTS

DE	2409748	9/1975		
DE	3302735	* 8/1984		359/866
DE	4026578	* 4/1992		359/850
EP	0210757	* 2/1987		359/864
EP	0310261 A1	4/1989		
EP	0551802	* 1/1992		359/864

(List continued on next page.)

OTHER PUBLICATIONS

U.S. Pat. Ser. No. 09/350,930, filed Jul. 12, 1999, entitled Electrochromic Polymer Solid Films, Manufacturing Electrochromic Devices Using Such Films, and Processes for Making Such Solid Films and Devices, by Applicants Desraj V. Varaprasad et al.

Primary Examiner—Ricky D. Shafer
(74) *Attorney, Agent, or Firm*—Van Dyke, Gardner, Linn & Burkhart, LLP

(57) **ABSTRACT**

This invention provides a plano-multiradius reflective element assembly suitable for use in an exterior sideview mirror assembly mounted to the side body of an automobile. The plano-multiradius reflective element assembly includes a plano reflective element which has a rearward field of view, when mounted in an exterior sideview mirror assembly mounted to the side body of an automobile, with unit magnification. The plano-multiradius reflective element assembly also includes an auxiliary reflective element including a multiradius portion with a rearward field of view. The plano reflective element provides a distortion-free rearward field of view and serves as the principal rearward-viewing portion of the plano-multiradius reflective element assembly. The multiradius portion provides a wide angle rearward field of view, and typically supplements the rearward field of view of the plano portion. The plano reflective element and the multiradius portion are separated by a demarcation element which enables the driver to readily delineate a rearward view in the plano portion from a rearward view in the multiradius portion. The plano reflective element and the multiradius reflective element are individually, separately, and adjacently attached to a single backing plate which is mounted to an actuator of the exterior sideview mirror assembly. By adjusting the position of the backing plate within the housing of the exterior sideview mirror assembly via the actuator, the rearward field of view of both the plano reflective element and the multiradius reflective element are simultaneously and similarly aligned.

40 Claims, 8 Drawing Sheets

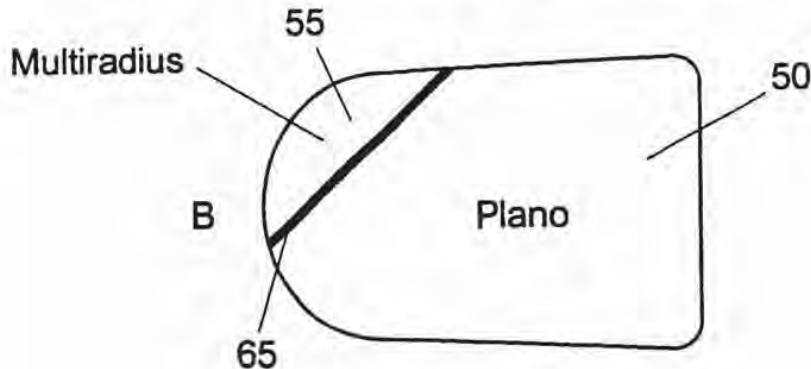

U.S. PATENT DOCUMENTS

4,258,979	A	*	3/1981	Mahin	359/868
4,268,120	A		5/1981	Jitsumori	350/302
4,281,899	A	*	8/1981	Oskam	
4,306,770	A	*	12/1981	Marhauer	359/866
4,311,362	A	*	1/1982	LaPorte	359/864
4,331,382	A	*	5/1982	Graff	359/868
4,449,786	A		5/1984	McCord	350/293
4,555,166	A	*	11/1985	Enomoto	359/877
4,678,294	A	*	7/1987	Van Nostrand	359/864
4,727,302	A	*	2/1988	Mizuta et al.	359/877
4,770,522	A	*	9/1988	Alten	359/877
4,859,046	A	*	8/1989	Traynor et al.	359/866
4,917,485	A	*	4/1990	Baldwin, Sr.	
5,005,962	A	*	4/1991	Edelman	359/864
5,052,792	A	*	10/1991	McDonough	359/866
5,107,374	A	*	4/1992	Lupo et al.	359/841
5,115,352	A	*	5/1992	Do Espirito Santo	359/864
5,166,833	A	*	11/1992	Shyu	
5,225,943	A	*	7/1993	Lupo	359/841
5,239,405	A		8/1993	Varaprasad et al.	359/272
5,432,643	A	*	7/1995	Huang	359/864
5,550,677	A		8/1996	Schofield et al.	359/604

5,579,133	A	*	11/1996	Black et al.	359/866
5,621,569	A	*	4/1997	Schlenke	359/868
5,668,663	A		9/1997	Varaprasad et al.	359/608
5,724,187	A		3/1998	Varaprasad et al.	359/608
5,751,489	A		5/1998	Caskey et al.	359/603
5,793,542	A	*	8/1998	Kondo et al.	359/866
5,796,532	A	*	8/1998	Kanazawa	359/864
5,910,854	A		6/1999	Varaprasad et al.	359/273
6,032,323	A	*	3/2000	Smith et al.	359/877
6,199,993	B1	*	3/2001	Mou	359/864

FOREIGN PATENT DOCUMENTS

FR	2628042		9/1929		
GB	1279158	*	6/1972		359/868
GB	2048189	*	12/1980		359/868
GB	2092534	*	8/1982		359/868
JP	0051637	*	4/1980		359/866
JP	62-105103	*	5/1987		
JP	1186443		7/1989		
JP	1-208245	*	8/1989		359/871
NL	7908257	*	6/1981		359/864

* cited by examiner

10

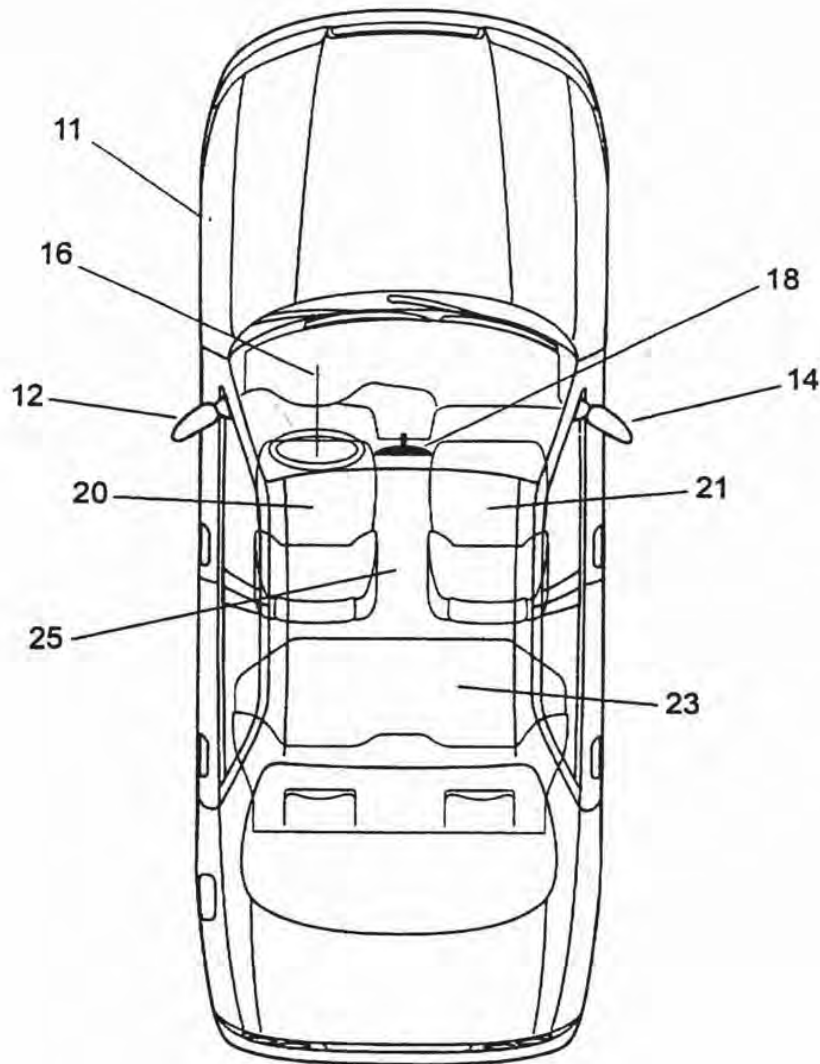

Figure 1

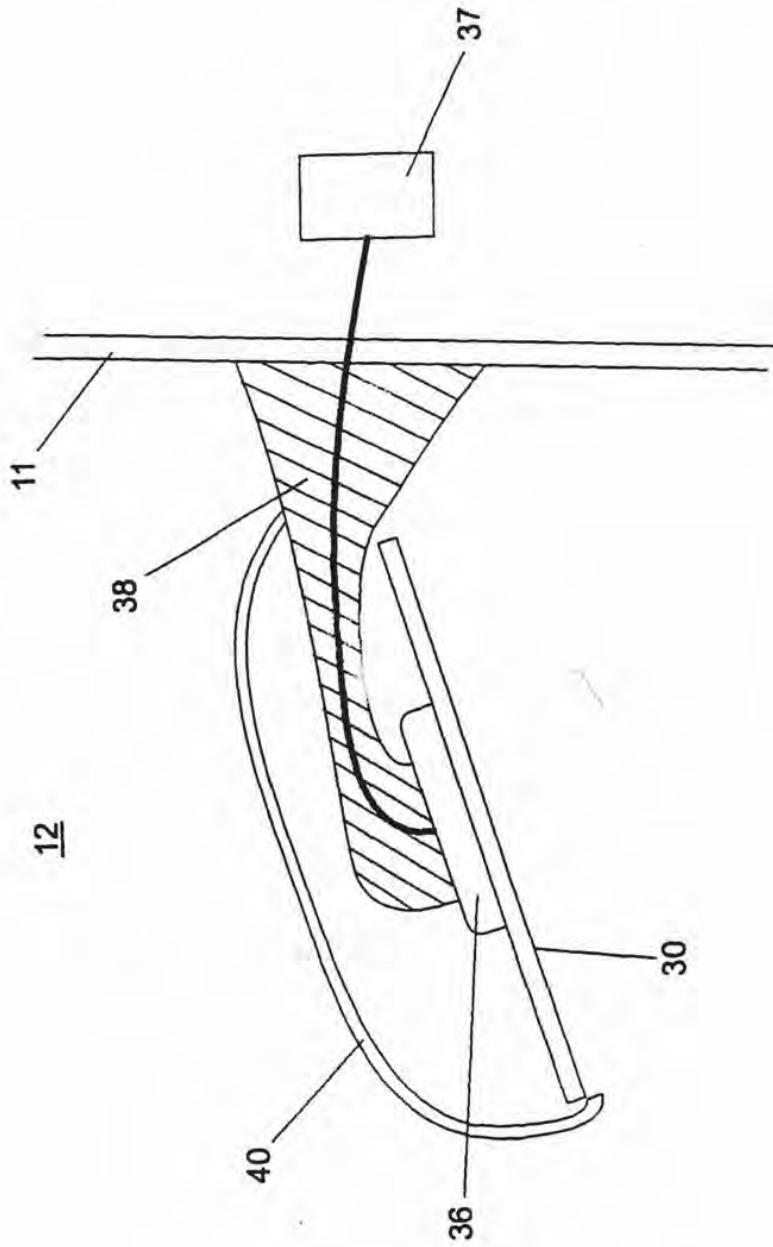

Figure 2

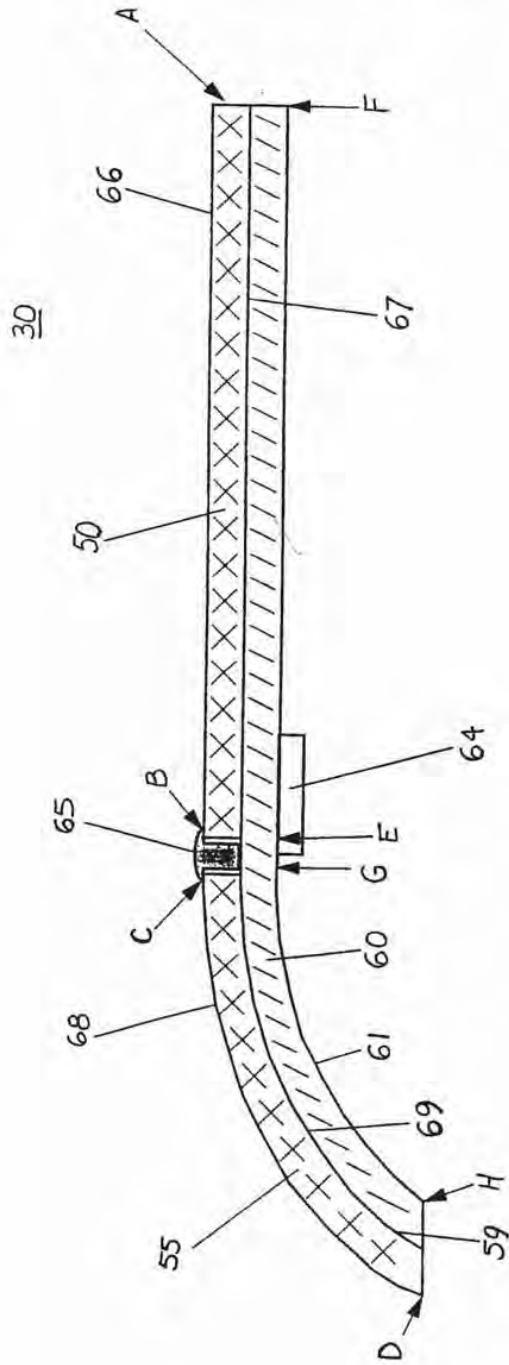

Figure 3

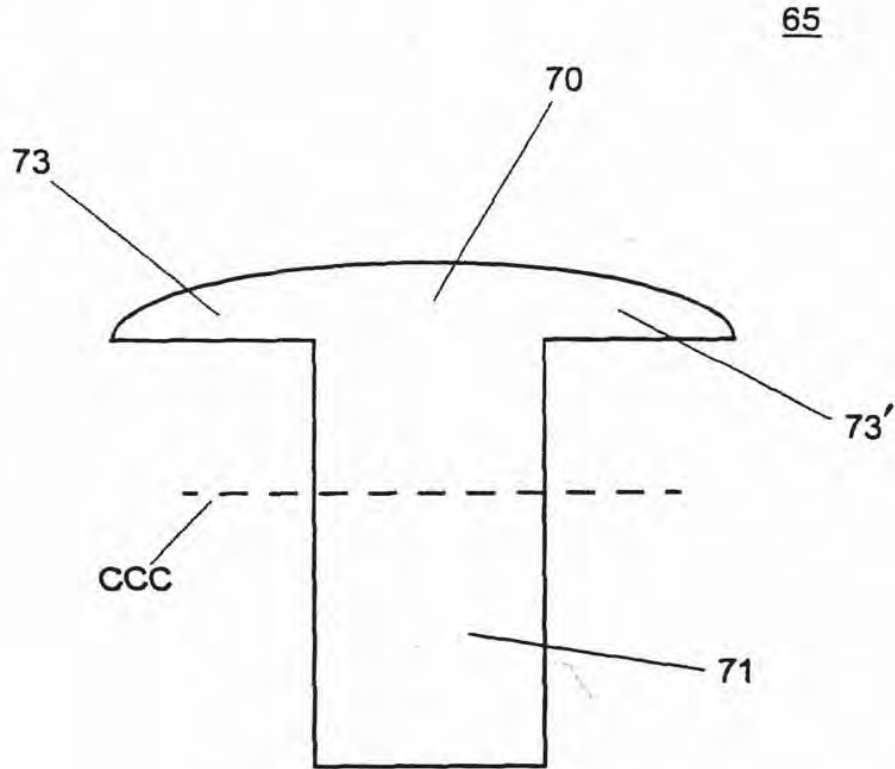
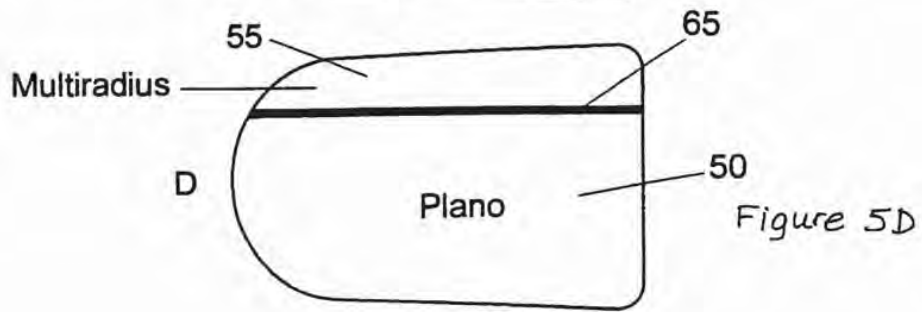
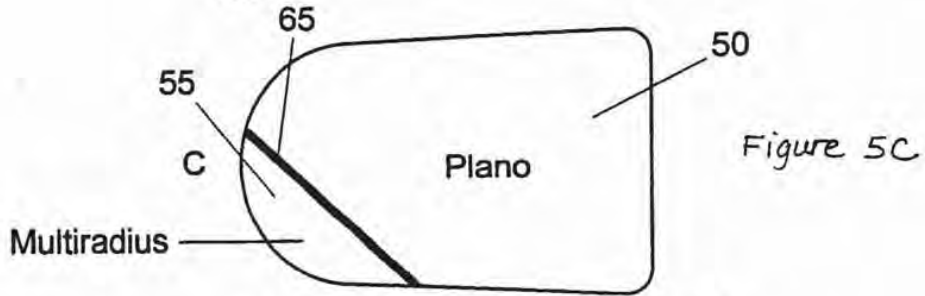
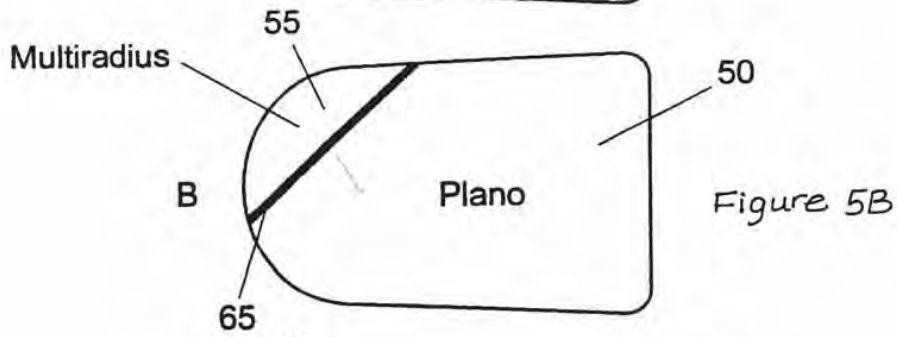
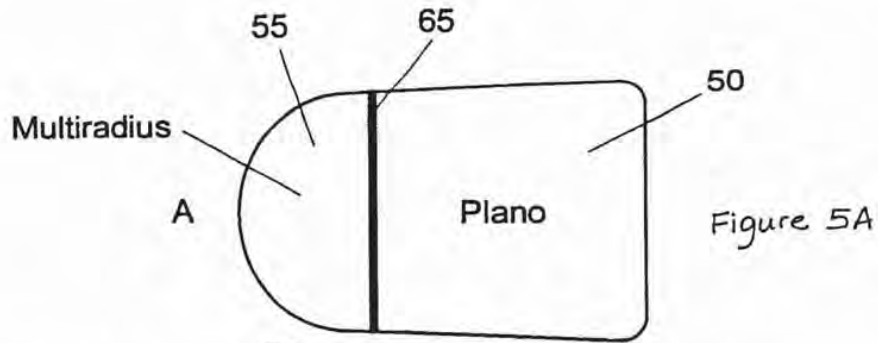
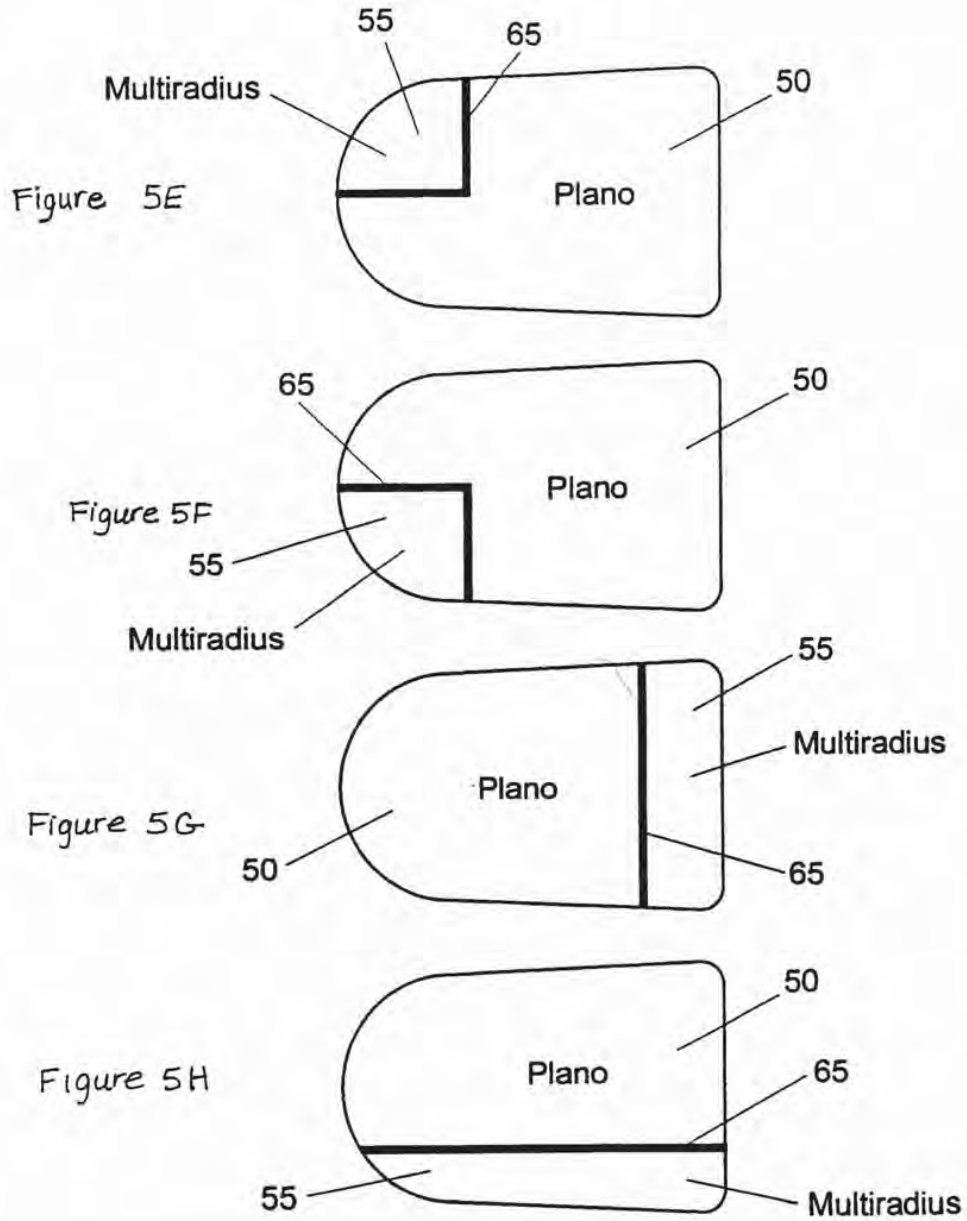

Figure 4





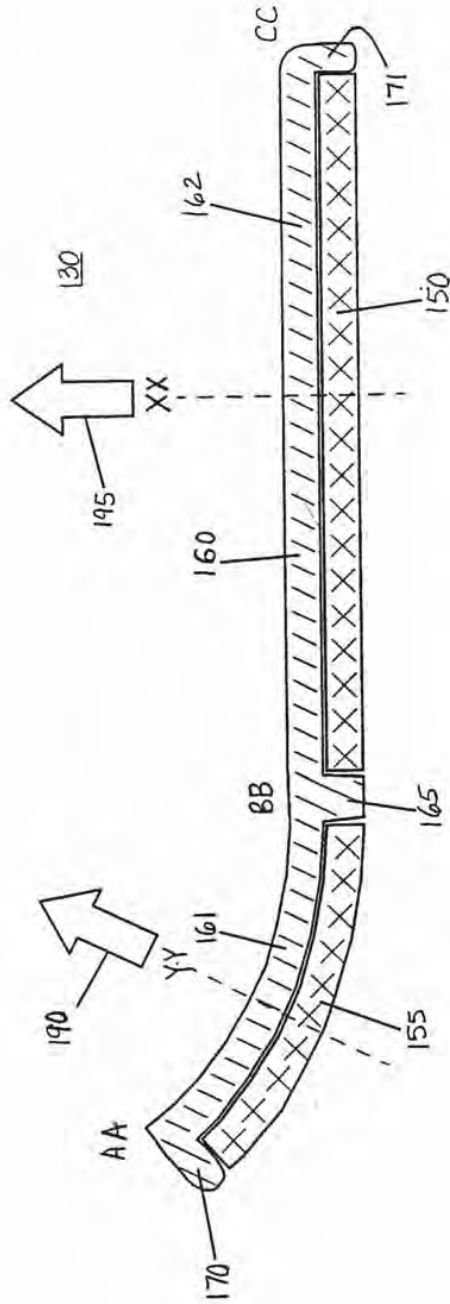

Figure 6

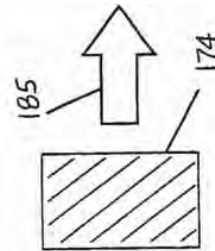

Figure 6A

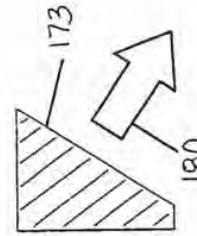

Figure 6B

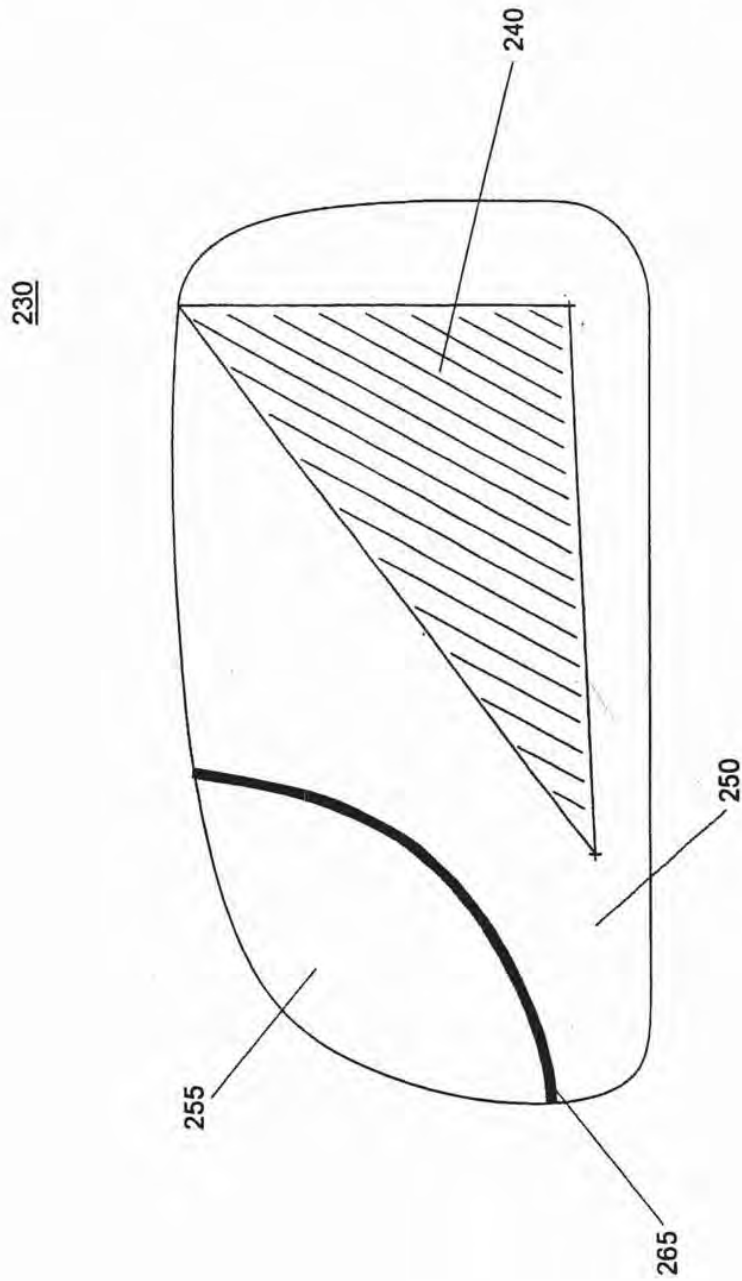

Figure 7

EXTERIOR MIRROR PLANO-AUXILIARY REFLECTIVE ELEMENT ASSEMBLY

TECHNICAL FIELD AND BACKGROUND OF THE INVENTION

The present invention relates to exterior sideview mirror assemblies suitable for use on an automobile, and more specifically, to plano-auxiliary reflective element assemblies for use in automobile exterior sideview mirror assemblies.

Automobiles are typically equipped with an interior rearview mirror assembly (adapted for providing a rearward field of view immediately rearward of the vehicle, typically principally in the road lane the vehicle is traveling in) and at least one exterior sideview mirror assembly attached to the side of the vehicle (typically adjacent a front side window portion). The exterior side view mirror assembly typically comprises a reflective element adapted to provide a rearward field of view of the side lane adjacent the vehicle so as to allow the driver see whether a side approaching vehicle is present when the driver is contemplating a lane change. Conventionally, automobiles are equipped with a driver-side exterior mirror assembly and, very often, with a passenger-side exterior sideview mirror assembly mounted to the side of the automobile body opposite to that of the driver-side assembly. While the combination of an interior rearview mirror with a driver-side exterior mirror (and especially in a three-mirror system comprising an interior rearview mirror with a driver-side exterior mirror and a passenger-side exterior mirror) works well in many driving situations, rear vision blind spots present a potential safety hazard while driving. A rear vision blind spot is an area adjacent the side of an automobile where a view of another vehicle (overtaking on that side) is not captured in the rearward field of view of the exterior mirror reflector on that side. This presents a potential safety hazard as the driver, upon checking the view in the exterior sideview mirror and seeing no overtaking vehicle therein, may deem it safe to initiate a lane change, unaware that there is a vehicle immediately adjacent in a blind-spot of the exterior mirror reflector.

Various attempts have been made conventionally to minimize and/or eliminate exterior mirror blind-spots on vehicles. One approach is to make the exterior mirror reflector larger, and particularly wider with respect to the vehicle body. By increasing the width of the exterior mirror reflector, it has a wider field of view rearwards, and hence the reflector blind-spot is reduced. While use of a wide exterior mirror reflector is an option for trucks, buses and commercial vehicles, increasing the width of the reflector used in an exterior sideview mirror assembly mounted on automobiles (such as sedans, station wagons, sports cars, convertibles, minivans, sports utility vehicles, pick-up trucks and similar passenger carrying automobiles) is often not an option. In such domestic automobiles, increasing the width of the exterior mirror reflector increases the size of the exterior sideview mirror assembly with a concomitant increase in aerodynamic drag, increase in fuel consumption, increased difficulty in parking in tight parking spaces, and increased reflector vibration. Use of a non-flat, curved exterior mirror reflector is commonly used to increase rearward field of view without increasing reflector size.

While working well to increase field of view, use of a curved reflector (such as a convex, spherically-curved reflector) has disadvantages. The field of view rearward increases as the degree of curvature of the bent substrate increases (i.e., the field of view rearward increases as the

radius of curvature of the bent substrate decreases). However, such wide-angle mirrors have non-unit magnification and distance perception rearward is distorted. For this reason, convex (spherically-bent) exterior mirror reflectors are required in some countries (such as the United States) to carry a safety warning "OBJECTS IN MIRROR ARE CLOSER THAN THEY APPEAR". Distance perception is particularly important for a driver-side exterior mirror. Indeed, Federal Vehicle Safety Standard No: 111 in the United States (the entire disclosure of which is hereby incorporated by reference herein) requires that the driver-side exterior mirror reflector exhibit unit magnification, and places restrictions on the radius of curvature allowed for any bent passenger-side mirror as well as requiring a safety warning be placed thereon. As an improvement over spherically bent/convex mirror reflectors, aspherical or multiradius mirror reflectors (such as are disclosed in U.S. Pat. Nos. 4,449,786 and 5,724,187, the entire disclosures of which are hereby incorporated by reference herein) have been developed. Such mirrors are widely used in Europe and Asia for both driver-side exterior mirror reflectors and for passenger-side exterior mirror reflectors. The aspherical or multiradius mirror reflectors typically have a less curved (larger radius of curvature) reflective region that is inboard or closest to the driver when mounted on a vehicle and, usually separated by a demarcation line or the like, have a more curved (smaller radius of curvature) region that is outboard or farthest from the driver when mounted on a vehicle. However, such aspherical or multiradius reflectors do not have unit magnification and so cannot be used when unit magnification is mandated (such as by FMVSS 111, referenced above).

To supplement a flat driver-side exterior mirror reflector, an auxiliary and separate bent reflector is sometimes incorporated into the driver-side exterior sideview mirror assembly. However, this is often not suitable for passenger automobiles because of the extra space required in the sideview mirror assembly to accommodate an auxiliary reflector element. Also, in most passenger automobiles, the position of the side view mirror reflector is adjustable by the driver (such as by a hand-adjust, or by a manually adjustable cable such as a Bowden cable or by an electrically operable actuator, as known in the art) in order to provide to that driver his or her desired rearward field of view, which ill-suits use of a separate, auxiliary reflector. Likewise, addition of stick-on blind-spot mirror reflectors (such as are commonly sold in automotive parts stores and the like) onto an automobile exterior sideview mirror reflector has disadvantages, including obscuring field of view of the automobile mirror reflector and adding to mirror element vibration.

There is thus a need to provide an automobile exterior sideview reflective element, and particularly a driver-side automobile exterior sideview reflective element, that overcomes the disadvantages above and that provides the driver of the automobile with a distortion-free field of view with unit magnification that is supplemented with a wide-angle view of a side lane blind spot, and there is a need that this be provided in a unitary reflective element assembly module suitable to mount onto, and be adjusted by, the mirror reflector adjustment mechanism (such as an electrically operated, motorized actuator) provided in the exterior sideview mirror assembly.

BRIEF DESCRIPTION OF THE DRAWINGS

FIG. 1 is a perspective view of an automobile equipped with exterior sideview mirror assemblies according to this present invention;

3

FIG. 2 is a top plan partial fragmentary view of the driver's side exterior rearview mirror assembly of FIG. 1;

FIG. 3 is an enlarged sectional view of a plano-multiradius reflective element assembly of the mirror assembly in FIG. 2;

FIG. 4 is an enlarged sectional view of a demarcation element of the plano-multiradius reflective element assembly of FIG. 3;

FIGS. 5A-5H illustrate views of various locations for a plano reflective element and an auxiliary reflective element according to this present invention;

FIG. 6 is a sectional view of a second embodiment of a plano reflective element assembly according to the present invention including a demarcation element formed as a dividing wall in a backing plate element;

FIG. 6A is a cross-section taken along line XX of FIG. 6;

FIG. 6B is a cross-sectional view taken along line YY of FIG. 6; and

FIG. 7 is a schematic of a third embodiment of a plano-auxiliary reflective element assembly according to this present invention.

SUMMARY OF THE INVENTION

This invention provides a plano reflective element with unit magnification and an auxiliary reflector element for use in an exterior sideview mirror assembly on an automobile. More specifically, this invention provides a plano-multiradius reflective element assembly suitable for use in an exterior sideview mirror assembly mounted to the side body of an automobile. The plano-multiradius reflective element assembly of this invention is especially suitable for mounting in a driver-side exterior sideview mirror assembly that is mounted to the side of the automobile body adjacent to the seating position of the driver in the front of the interior vehicular cabin. The plano-multiradius reflective element assembly of this invention comprises a plano portion which has a rearward field of view, when mounted in an exterior sideview mirror assembly mounted to the side body of an automobile, with unit magnification. This plano portion comprises a flat substrate, typically a flat glass substrate, provided with a reflective surface. The plano-multiradius reflective element assembly of this invention also includes a multiradius portion with a rearward field of view, when mounted in an exterior sideview mirror assembly mounted to the side body of an automobile, that has non-unit magnification. The plano portion provides a distortion-free rearward field of view and serves as the principal rearward-viewing portion of the plano-multiradius reflective element. The multiradius portion provides a wide angle rearward field of view, and typically supplements the rearward field of view of the plano portion. This multiradius portion comprises a curved substrate, typically a bent glass substrate, provided with a reflective surface. The plano portion and the multiradius portion are demarcated apart by a demarcation element. The demarcation element enables the driver of a vehicle equipped with the plano-multiradius reflective element of this invention to readily delineate a rearward view in the plano portion from a rearward view in the multiradius portion. The plano portion comprises a flat reflective element and the multiradius portion comprises a bent reflective element. The flat, plano reflective element and the curved, multiradius reflective element are individually and separately manufactured, and are adjacently attached to a single backing plate (which typically comprises a polymeric substrate, most typically a molded polymeric substrate), and with the demarcation element disposed at the joint of the

4

plano, flat reflective element and the multiradius, bent reflective element. The backing plate is fabricated (typically by polymeric molding) to have a flat portion that corresponds to the plano, flat reflective element, and a curved surface that corresponds to the multiradius, curved reflective element. The attachment of the plano reflective element and an auxiliary reflective element to a single backing plate produces a unitary plano-auxiliary reflective element assembly module suitable for mounting in an exterior sideview mirror assembly. By adjusting the position of the backing plate within the exterior sideview mirror assembly, the rearward fields of view of both the plano reflective element and the auxiliary reflective element are simultaneously and similarly aligned.

One embodiment of the invention includes an exterior sideview mirror system suitable for use in an automobile comprising an exterior sideview mirror assembly adapted for attachment to a side of the automobile. The exterior sideview mirror assembly includes a reflective element having a rearward field of view when attached to said side of the automobile. The reflective element is attached to an actuator and is movable by the actuator in order to position the reflective element's rearward field of view in response to a control. The reflective element comprises a plano-multiradius reflective element assembly which comprises a plano reflective element having unit magnification and a separate multiradius reflective element having a multiradius curvature. The plano element and the separate multiradius element of the plano-multiradius reflective element assembly are attached to a backing plate element. The backing plate element is mounted to the actuator such that movement of the backing plate element (and hence the plano-multiradius reflective element assembly) by the actuator simultaneously and similarly moves the plano element and the multiradius element. The plano element and the multiradius element are separately and, preferably, adjacently attached to the backing plate element at a joint.

In a further embodiment, a demarcation element is disposed at this joint to form a demarcation between the plano element and the multiradius element; this demarcation element having a portion visible to a driver of the automobile. Preferably, the demarcation element is dark colored, such as with a color selected from the group consisting of black, grey, blue and brown. Optionally, there is a space at the joint of the plano element and the multiradius element and the demarcation element is at least partially disposed in said space between said plano element and said multiradius element. The demarcation element can comprise at least one of a polymer material, a tape, a plastic film, a paint, a lacquer and a caulk.

In a further embodiment, the demarcation element comprises a wall on the backing plate element; this wall being located on the backing plate element at the joint of the plano element and the multiradius element, this wall separating the respective elements apart.

In preferred embodiments, the portion of the demarcation element visible to a driver of an automobile equipped with the plano-multiradius reflective element assembly of this invention has a width from about 0.5 mm to about 4 mm.

In preferred embodiments, the plano element is attached to the backing plate element by at least one of an adhesive attachment and a mechanical attachment.

In preferred embodiments, the multiradius element is attached to the backing plate element at a location such that, when the exterior mirror assembly is attached to a side of an automobile, at least portion, and preferably at least a sub-

5

stantial portion, of the plano element is disposed closer to the side of the vehicle than any portion of the multiradius element element.

In preferred embodiments, the multiradius element comprises a bent glass substrate with radii of curvature in the range of from about 4000 mm to about 50 mm, and the ratio of the width of the plano element to the width of the multiradius element is greater than 1.

In preferred embodiments, the principal axis of the rearward field of view of the auxiliary, multiradius element is different from and angled to the principal axis of the rearward field of view of the plano element when both are attached to the backing plate element of the plano-multiradius reflective element assembly and when the plano-multiradius reflective element assembly is mounted in an exterior sideview mirror assembly on an automobile. The principal axis of the rearward field of view of the plano element is directed generally parallel to the longitudinal axis of an automobile equipped with the plano-multiradius reflective element assembly and the principal axis of the rearward field of view of the multiradius element is directed generally at an angle downwards to the longitudinal axis of the vehicle.

In a preferred embodiment, the exterior sideview mirror assembly equipped with the plano-multiradius reflective element assembly comprises a fixedly attached exterior sideview mirror assembly. In another preferred embodiment, the exterior sideview mirror assembly equipped with the plano-multiradius reflective element assembly comprises a break-away exterior sideview mirror assembly. In another preferred embodiment, the exterior sideview mirror assembly equipped with the plano-multiradius reflective element assembly comprises a powerfold exterior sideview mirror assembly. In another preferred embodiment, the actuator of the exterior sideview mirror assembly to which the plano-multiradius reflective element assembly is mounted comprises an electrically operable actuator. In another preferred embodiment, the actuator of the exterior sideview mirror assembly to which the plano-multiradius reflective element assembly is mounted is controlled by a switch or by a memory controller. In another preferred embodiment, the plano element and/or the multiradius element of the plano-multiradius reflective element assembly comprises an electro-optic reflective element, preferably an electrochromic reflective element. In another preferred embodiment, the plano element of the plano-multiradius reflective element assembly comprises an electro-optic reflective element, preferably an electrochromic reflective element, and the multiradius element comprises a fixed reflectance mirror reflector, such as a fixed reflectance mirror reflector comprises a bent glass substrate coated with a metallic reflector coating.

In a preferred embodiment, the plano-auxiliary reflective element assembly is formed in an integral molding operation.

These and other advantages, features, and modifications will become more apparent when reviewed in conjunction with the drawings and the detailed description which follows.

DETAILED DESCRIPTION OF THE PREFERRED EMBODIMENTS

As illustrated in FIG. 1, passenger automobile 10 (which may be a sedan, a station-wagon, a sports car, a convertible, a minivan, a sports utility vehicle, a pick-up truck or a similar passenger carrying non-commercial, personal trans-

6

portation automobile) includes an interior rearview mirror assembly 18 positioned within interior vehicle cabin 25. Interior vehicle cabin 25 further includes a steering wheel 16, a driver seat 20 positioned at steering wheel 16, a front passenger seat 21 adjacent to driver seat 20 in the front portion of cabin 25, and a rear passenger seat 23 in the rear portion of cabin 25. Automobile 10 further includes a driver-side exterior sideview mirror assembly 12 and a passenger-side exterior sideview mirror assembly 14, each adapted for attachment to opposing sides of automobile body 11, most preferably adjacent to the seating position of the driver seated in driver seat 20 for driver-side assembly 12 and adjacent to the front passenger seat 21 for passenger-side assembly 14. Exterior sideview mirrors, mounted as shown in FIG. 1 close to the driver seating location, are commonly referred to as door-mounted exterior sideview mirror assemblies. Driver-side exterior sideview mirror assembly 12 includes, as illustrated in FIG. 2, a plano-multiradius exterior sideview reflective element assembly 30. Plano-multiradius reflective element assembly 30 is mounted to a reflective element positioning actuator 36. The orientation of plano-multiradius reflective element assembly 30, and hence its rearward field of view, is adjustable by actuator 36 in response to control 37. Control 37 can comprise a handset control that allows the driver manually move the orientation of plano-multiradius reflective element assembly 30 within exterior mirror housing 40 (such as by a lever control or by a cable control) and hence reposition the rearward field of view of plano-multiradius reflective element assembly 30. Alternately, when actuator 36 comprises an electrically actuated actuator that is electrically operable incorporating at least one motor, control 37 can comprise a switch (which, preferably, is operable under control of the driver seated in cabin 25) or control 37 can comprise a memory controller, as known in the automotive mirror art, that controls actuator 36 to move the position of plano-multiradius reflective element assembly 30 to a pre-set orientation that suits the rearward field of view preference of an individual driver. Actuator 36 is mounted to bracket 38 which attaches to vehicle body side 11. Plano-multiradius reflective element assembly 30 is positionable by actuator 36 within exterior mirror housing 40.

Plano-multiradius reflective element assembly 30, as shown in FIG. 3, comprises a plano element 50 and a separate multiradius element 55. Preferably, plano element 50 is adjacent to multiradius element at a joint. At their joint, plano element 50 and separate multiradius element 55 can touch leaving substantially no gap or space therebetween, or plano element 50 and separate multiradius element 55 can be spaced apart at their joint by a space or gap, as in FIG. 3. Plano element 50 and multiradius element 55 are both mounted to surface 59 of, and are both supported by, a single backing plate element 60. Plano element 50 and multiradius element 55 are demarcated apart by demarcation element 65. Surface 61 of backing plate element 60 is preferably adapted to attach, such as by attachment member 64, to actuator 36 when plano-multiradius reflective element assembly 30 is mounted in driver-side exterior sideview mirror assembly 12 (and/or in passenger-side exterior side view mirror assembly 14) such that plano element 50 and multiradius element 55 are adjusted and positioned in tandem and simultaneously when the driver (or alternatively, when a mirror memory system, as is conventional in the rearview mirror arts) activates actuator 36 to reposition the rearward field of view of plano-multiradius reflective element assembly 30. Thus, since elements 50, 55 are part of plano-multiradius reflective element assembly 30, movement of plano-multiradius

reflective element assembly 30 by actuator 36 simultaneously and similarly moves plano element 50 and multiradius element 55.

Plano element 50 preferably comprises a flat reflector-coated glass substrate having unit magnification, and comprises a reflective surface through which the angular height and width of the image of an object is equal to the angular height and width of the object when viewed at the same distance (except for flaws that do not exceed normal manufacturing tolerances). Plano element 50 may comprise a conventional fixed reflectance mirror reflector or it may comprise a variable reflectance mirror reflector whose reflectivity is electrically adjustable. For example, plano element 50 may comprise a flat glass substrate coated with a metallic reflector coating such as a chromium coating, a titanium coating, a rhodium coating, a metal alloy coating, a nickel-alloy coating, a silver coating, an aluminum coating (or any alloy or combination of these metal reflectors). The metal reflector coating of plano element 50 may be a first surface coating (such as on surface 66) or a second surface coating (such as on surface 67), as such terms are known in the mirror art. The reflector coating on plano element 50 may also comprise a dielectric coating, or a multilayer of dielectric coatings, or a combination of a metal layer and a dielectric layer to form automotive mirror reflectors as known in the automotive mirror art. If a variable reflectance reflector element, plano element 50 preferably comprises an electro-optic reflector element and, most preferably, an electrochromic reflector element.

When mounted into exterior side view mirror assembly 12 and/or 14, plano-multiradius reflective element assembly 30 is preferably orientated so that at least a portion of (more preferably a substantial portion of) the reflector surface of plano element 50 is positioned closer to the vehicle body (and hence to the driver) than any portion of the reflector surface of multiradius element 55. Thus, and referring to FIG. 3, side A of plano element 50 of plano-multiradius reflective element assembly 30 is positioned closer to the driver than side D of multiradius element 55 when plano-multiradius reflective element assembly 30 is mounted on an automobile. Also, when mounted into exterior side view mirror assembly 12 and/or 14, surfaces 66, 68 of plano-multiradius reflective element assembly 30 face rearwardly in terms of the direction of vehicle travel.

Multiradius element 55 of plano-multiradius reflective element assembly 30 preferably comprises a curved/bent mirrored glass substrate. The degree of curvature preferably increases (and hence the local radius of curvature decreases) across the surface of multiradius element 55 with the least curvature (largest radius of curvature) occurring at the side of multiradius element 55 (side C in FIG. 3) positioned adjacent its joint to plano element 50 when both are mounted on backing plate element 60. Thus, and referring to FIG. 3, the local radius of curvature at side C of multiradius element 55, when mounted on backing plate element 60, is larger than at side D. Also, the local radius of curvature preferably progressively decreases across multiradius element 55 from side C to side D. Preferably, the local radius of curvature at side C of multiradius element 55 is at least about 1000 mm; more preferably is at least about 2000 mm and most preferably is at least about 3000 mm whereas the local radius of curvature at side D of multiradius element 55 is, preferably, less than about 750 mm, more preferably less than about 350 mm; most preferably less than about 150 mm. Preferably, multiradius element 55 comprises a bent glass substrate with radii of curvature in the range of from about 4000 mm to about 50 mm. The multiradius prescription for the multira-

dus element to be used in a particular exterior mirror assembly can vary according to the specific field of view needs on a specific automobile model.

The total field of view rearwardly of the automobile of the plano-auxiliary reflective element assembly (which is a combination of the field of view of the plano reflective element and of the auxiliary reflective element) preferably generally subtends an angle of at least about 20 degrees (and more preferably, generally subtends an angle of at least about 25 degrees and most preferably, generally subtends an angle of at least about 30 degrees) with respect to the side of an automobile to which is attached an exterior sideview mirror assembly equipped with the plano-auxiliary reflective element assembly.

Multiradius element 55 may comprise a conventional fixed reflectance mirror reflector or it may comprise a variable reflectance mirror reflector whose reflectivity is electrically adjustable. For example, multiradius element 55 may comprise a flat glass substrate coated with a metallic reflector coating such as a chromium coating, a titanium coating, a rhodium coating, a metal alloy coating, a nickel-alloy coating, a silver coating, an aluminum coating (or any alloy or combination of these metal reflectors). The metal reflector coating of multiradius element 55 may be a first surface coating (such as on surface 68) or a second surface coating (such as on surface 69), as such terms are known in the mirror art. The reflector coating on multiradius element 55 may also comprise a dielectric coating, or a multilayer of dielectric coatings, or a combination of a metal layer and a dielectric layer to form automotive mirror reflectors as known in the automotive mirror art. If a variable reflectance reflector element, multiradius element 55 preferably comprises an electro-optic reflector element and, most preferably, an electrochromic reflector element.

Also, it is preferable that the thickness of plano element 50 and multiradius element 55 be substantially the same in dimension so that their respective outer surfaces, 66 and 68, are substantially coplanar so that a driver can readily view images in either or both elements. The thickness dimension of elements 50,55 is determined by the thickness of the substrate (or in the case of laminate-type electrochromic reflective elements, the thickness of the two substrates between which the electrochromic medium is disposed). For example, plano element 50 and/or multiradius element 55 can comprise a reflector coated glass substrate or panel of thickness preferably equal to or less than about 2.3 mm, more preferably equal to or less than about 1.6 mm, most preferably equal to or less than about 1.1 mm. Use of a thinner substrate is beneficial in terms of improving the overall stability/vibration performance of the image seen in plano-multiradius reflective element assembly 30 when mounted to an automobile.

The reflector area of plano element 50 is preferably larger than that of multiradius element 55. Preferably, the width dimension of plano element 50 is larger than the width dimension of multiradius element 55 (both width dimensions measured at their respective widest dimension and with the width of the respective element being gauged with the respective element oriented as it would be orientated when mounted on the automobile). Thus, and referring to FIG. 3, the distance from side A to side B of plano element 50 is larger than the distance from side C to side D of multiradius element 55. Thus, the ratio of the width of plano element 50 to the width of multiradius element 55 is preferably greater than 1; more preferably greater than 1.5; most preferably greater than 2.5 in order to provide a large, unit magnification plano element 50 as the principal rear

viewing portion of plano-multiradius reflective element assembly 30 and providing multiradius element 55 as a smaller, auxiliary, separate, wide-angle viewing portion of plano-multiradius reflective element assembly 30. For plano-multiradius reflective element assemblies to be mounted to the exterior sideview assemblies of passenger automobiles used non-commercially and for non-towing purpose, the width of plano element 50 (at its widest dimension) is preferably in the range of from about 50 mm to about 225 mm; more preferably in the range of from about 75 mm to about 175 mm; most preferably in the range of from about 100 mm to about 150 mm.

Backing plate element 60 is preferably a rigid polymeric substrate capable of supporting plano element 50 and multiradius element 55. Backing plate element 60 comprises a flat portion (generally between E and F as shown in FIG. 3) that corresponds to and is aligned with plano element 50. Backing plate element 60 also comprises a curved portion (generally between G and H as shown in FIG. 3) that corresponds to and is aligned with multiradius element 55. Preferably, curved portion G-H of multiradius element 55 is fabricated with a multiradius prescription that is substantially the same as the multiradius prescription of multiradius element 55. Backing plate element 60 is formed as a single element to which elements 50 and 55 are separately attached. Preferably, backing plate element 60 is formed by injection molding of a thermoplastic or a thermosetting polymer resin. Materials suitable to use for backing plate element 60 include unfilled or filled polymeric materials such as glass and/or mineral filled nylon or glass and/or mineral filled polypropylene, ABS, polyurethane and similar polymeric materials. For example, backing plate element 60 can be formed of ABS in an injection molding operation. Plano element 50 can be cut from a stock lite of flat chromium mirror-coated 1.6 mm thick glass. Multiradius element 55 can be cut from a stock lite of multiradiusly-bent chromium mirror-coated 1.6 mm thick glass. Plano element 50 and multiradius element 55 can then be attached (such as by an adhesive attachment such as an adhesive pad or by mechanical attachment such by clips, fasteners or the like) to the already molded backing plate element 60. Alternatively, plano element 50 and multiradius element 55 can each be individually loaded into an injection molding tool. Once loaded, a polymeric resin (or the monomers to form a polymeric resin) can be injected into the mold in order to integrally form backing plate element 60 with elements 50, 55 integrally molded thereto. Integral molding of the backing plate element to plano element 50 and multiradius element 55 (along with any other elements such as the demarcation element 65) in a single integral molding operation, is a preferred fabrication process for plano-multiradius reflective element assembly 30.

Plano-multiradius reflective element assembly 30 further preferably includes demarcation element 65 that functions to delineate and demarcate the plano region of the assembly from the wide-angle, multiradius region and also preferably functions to prevent ingress of debris, dirt, water and similar contaminants (such as road splash, car wash spray, rain, snow, ice, leaves, bugs and similar items that plano-multiradius reflective element assembly 30 would be subject to when mounted and used on an automobile) into any gap between plano element 50 and multiradius element 55 when both are attached to backing plate element 60. Optionally, at least a portion of demarcation element 65 can be disposed in any gap between plano element 50 and multiradius element 55 at their joint on backing plate element 60. Preferably, demarcation element 65 is formed of a polymeric material

that is dark colored (such as black or dark blue or dark brown or dark grey or a similar dark color) such as a dark colored polypropylene resin or a dark colored nylon resin or a dark colored polyurethane resin or a dark colored polyvinyl chloride resin or a dark colored silicone material. Most preferably demarcation element 65 is formed of an at least partially elastomeric material (such as silicone, or EPDM, or plasticized PVC or the like) in order to provide a degree of vibration dampening for elements 50, 55. As shown in FIG. 4, demarcation element 65 optionally includes a crown portion 70 that includes wing portions 73, 73' and a stem portion 71. Stem portion 71 preferably has a cross-sectional width CCC of less than about 4 mm, more preferably less than about 3 mm and, most preferably less than about 2 mm. Crown portion 70 preferably is dimensioned to not protrude substantially beyond surfaces 66, 68 of elements 50, 55 when demarcation element 65 is installed between elements 50 and 55. Also, wings 73, 73' are preferably dimensioned to protrude (most preferably slightly) onto surfaces 66, 68 of elements 50, 55 when demarcation element 65 is installed between elements 50 and 55 in order to provide a weather barrier seal and/or to at least partially accommodate any dimensional tolerances of elements 50, 55 that could lead to variation in the inter-element gap between sides C and B. While the demarcation element shown in FIG. 4 is one embodiment, other constructions are possible including a demarcation element that has minimal or no crown portion. Likewise, a demarcation element can have little or no stem portion, especially when the joint between plano element 50 and multiradius element 55 includes no gap to receive a stem. Also, where a gap at the plano to multiradius joint exists, any stem of the demarcation element can at least partially be disposed in such gap so as to at least partially fill the gap (or it can optionally substantially fill the gap). Optionally, demarcation element 65 is fabricated by injection molding of a polymeric resin. After plano element 50 and multiradius element 55 have been attached to backing plate element 60, a separately formed demarcation element 65 can then be inserted (and secured such as by an adhesive or by a mechanical attachment such as by a fastener) into a space between elements 50 and 55. Note that, optionally, side B of plano element 50 and side C of multiradius element 55 can touch (leaving substantially no gap or space therebetween). In such a situation, demarcation element 65 can comprise a dark colored strip such as of a tape or of a plastic film that covers the joint between elements 50 and 55. Alternatively, demarcation element 65 can comprise a preferably dark-colored paint, lacquer, caulk or similar material that can be applied to, and that can preferably fill into, the joint between elements 50 and 55. The width of the portion of demarcation element 65 that is visible to the driver is preferably less than about 4 mm, more preferably less than about 3 mm and most preferably less than about 2 mm, but is equal to or greater than about 0.5 mm, more preferably is equal to or greater than about 0.75 mm, most preferably is equal to or greater than about 1 mm in order to provide adequate demarcation of the plano region from the multiradius radius region without unduly obscuring the rearward field of view of the respective elements. Optionally, demarcation element 65 can be formed as part of backing plate element 60 such as by forming demarcation element 65 as a wall structure of the backing plate element that partitions backing plate element 60 into two regions: A first region adapted to receive plano reflective element 50 and a separate and adjacent second region adapted to receive multiradius reflective element 55.

Thus, and referring to FIG. 6, a second embodiment of plano-multiradius reflective element assembly 130 may

11

include a backing plate element 160 which comprises a plate molded from a polymer resin (such as a polyolefin such as polypropylene or such as ABS or nylon) with a demarcation element 165 that is molded as a wall structure that partitions backing plate element 165 into a first region (from CC to BB) adapted to receive and accommodate plano reflective element 150 and into a second region (from BB to AA) adapted to receive and accommodate wide-angle optic multiradius reflective element 155. Note that section AA to BB of backing plate element 160 is angled to section BB to CC. Such angling of the auxiliary reflective element relative to the plano element can be advantageous in allowing the auxiliary reflective element view a portion of the road adapted to receive and accommodate wide-angle optic multiradius reflective element 155. In this regard, it is preferable that the multiradius element be angled away from the plane of the plano element, as shown in FIG. 6 by the angling of section AA to BB to section BB to CC.

Preferably, demarcation element 65 is formed in an integral molding operation, along with formation of backing plate element 60, and attachment of elements 50, 55 thereto. For example, plano element 50 and multiradius element 55 can each be individually loaded into an injection molding tool. Once loaded, a polymeric resin (or the monomers to form a polymeric resin) can be injected into the mold in order to integrally form backing plate element 60 with elements 50, 55 integrally molded thereto and, in the same molding operation and in the same tool, also form by molding the demarcation element. Integral molding of the backing plate element to plano element 50 and multiradius element 55 along with creation in the single molding operation of demarcation element 65 (along with any other elements such as attachment member 64) in a single integral molding operation, is a preferred fabrication process for plano-multiradius reflective element assembly 30. By loading all the sub components of plano-multiradius reflective element assembly 30 into a molding tool, and then injecting polymeric resin to form the backing plate, demarcation member and any attachment member, a substantially complete or fully complete plano-multiradius reflective element assembly can be unloaded from the tool at the completion of the integral molding operation (as known in the molding art), thus enabling economy in manufacturing and accommodation of any dimensional tolerances in the sub components. Where integral molding is so used, it is preferable to use a reactive molding operation such as reactive injection molding of a urethane as such reactive injection molding operations occur at relatively modest temperatures.

Plano element 50 and/or multiradius element 55 can comprise a heater element, as known in the automotive mirror art, that is operable to deice/demist surfaces 66, 68. Such heater elements are conventional and can comprise a positive temperature coefficient heater pad, a resistive heater element and/or a conductive coating. Plano element 50 and/or multiradius element 55 can also optionally comprise a scatterproofing member, as known in the automotive mirror art, such as an adhesive tape, to enhance safety in an accident.

Also, plano element 50 and/or multiradius element 55 can comprise a variable reflectance electro-optic element such as an electrochromic mirror reflector. Thus, both element 50 and element 55 can comprise an electrochromic mirror element or either of element 50 and element 55 can comprise an electrochromic mirror element and the other can comprise a fixed reflectance non-variable reflectance mirror element such as a metal reflector coated glass panel such as a chromium coated glass substrate. Also, if both plano

12

element 50 and multiradius element 55 comprise an electro-optic element such as an electrochromic mirror element capable of electrically dimmable reflectivity, both elements 50, 55 can dim together and in tandem under control of a common dimming control signal (typically provided by an electro-optic automatic dimming interior mirror assembly mounted in the cabin of the automobile and equipped with photosensors to detect incident glare and ambient light). Alternately, if both plano element 50 and multiradius element 55 comprise an electro-optic element such as an electrochromic mirror element capable of electrically dimmable reflectivity, element 50 can dim independently of element 55 (such as is disclosed in U.S. Pat. No. 5,550,677, the entire disclosure of which is hereby incorporated by reference herein). If either or both of elements 50, 55 comprise an electrochromic element, preferably, the electrochromic reflective element comprises a front substrate and a rear substrate with an electrochromic medium disposed between, such as a solid polymer matrix electrochromic medium such as is disclosed in U.S. patent application Ser. No. 09/350,930, filed Jul. 12, 1999, entitled "ELECTROCHROMIC POLYMERIC SOLID FILMS, MANUFACTURING ELECTROCHROMIC DEVICES USING SUCH FILMS, AND PROCESSES FOR MAKING SUCH SOLID FILMS AND DEVICES" to Desraj V. Varaprasad et al., now U.S. Pat. No. 6,154,306, or such as is disclosed in U.S. Pat. Nos. 5,668,663; 5,724,187; 5,910,854; and 5,239,405, the entire disclosures of which are hereby incorporated by reference herein. Most preferably, in such laminate-type electrochromic mirror reflective elements, the front substrate comprises a glass plate of thickness less than about 1.6 mm, most preferably about 1.1 mm thickness or lower, and the rear substrate comprises a glass plate of thickness equal to or greater than about 1.6 mm, more preferably greater than about 1.8 mm thickness, most preferably equal to or greater than about 2.0 mm thickness. The rearmost surface of the rear substrate (the fourth surface as known in the mirror art) is reflector coated with a high reflecting metal film such as of aluminum or silver, or an alloy of aluminum or silver. Most preferably, the front-most surface of the rear substrate (the third surface as known in the mirror art) is reflector coated with a high reflecting metal film such as of aluminum or silver, or an alloy of aluminum or silver.

Backing plate element 65 of plano-multiradius reflective element assembly 30 is optionally equipped on its rearmost surface with attachment member 64 to facilitate attachment to the reflector-positioning actuator of the exterior sideview mirror assembly that plano-multiradius reflective element assembly 30 is mounted to. Attachment of plano-multiradius reflective element assembly 30 to the actuator can be by mechanical attachment such as by a tab, clip or fastener, or may be by adhesive attachment such as by a silicone adhesive, a urethane adhesive or a similar adhesive material such as a tape coated on both surfaces with a pressure sensitive adhesive to form a "double-sticky" tape. Exterior sideview mirror assembly 12 and/or 14, on whose mirror reflector-positioning actuator the plano-multiradius reflective element assembly is mounted, can be a fixedly attached exterior sideview mirror assembly, a break-away exterior sideview mirror assembly and a powerfold exterior sideview mirror assembly, as known in the automotive mirror art.

FIGS. 5A-5H shows various arrangements of multiradius reflective element 55 relative to its adjacent plano reflective element 50 (with demarcation element 65 disposed at their joint). In FIGS. 5A, 5B, 5C, 5E and 5F, plano element 50 is mounted wholly inboard of multiradius element 55. Thus, in

FIGS. 5A, 5B, 5C, 5E and 5F, plano element 50 would be disposed closer to the vehicle body (and hence to the driver) than multiradius element 55 when plano-multiradius reflective element assembly 30 was mounted in an exterior sideview mirror attached to a side of an automobile. Therefore, in FIGS. 5A, 5B, 5C, 5E and 5F, plano element 50 would be mounted inboard relative to the side of the automobile and multiradius element 55 would be mounted outboard relative to the side of the automobile. In general, the location of the multiradius reflective element in the outboard, upper portion of the plano-multiradius reflective element assembly, as in FIGS. 5B and 5E, is preferred as this allows the plano portion provide a desired rearward field of view along the side of the vehicle. The configuration as shown in FIG. 5G (where the multiradius reflective element is along the inboard side of the assembly) is also desirable as this allows the driver view the side of the vehicle (something many drivers desire in order to have a frame of reference for their rearward field of view) while facilitating having a wide field of view for the plano portion.

Unlike trucks, busses and commercial vehicles the size of an exterior sideview mirror assembly suitable for use on an automobile (and especially when the automobile is not towing a trailer or the like) is restricted. Automobiles generally are non-commercial vehicles intended for personal transportation. Automobiles typically carry 5 passengers or less, although minivans and large sports utility vehicles (which are classified herein as automobiles) can have seat accommodation for up to 10 passengers (although accommodation for 7 passengers or less is more common). The tandem mounting of a plano element of unit magnification and a separate auxiliary element onto a common, single backing plate element, and the mounting of this backing plate element onto an actuator of an exterior sideview mirror assembly so that a driver can simultaneously and similarly move the auxiliary element and the plano element so as to position their respective rearward fields of view, and to achieve this within the relatively restricted space available in a standard automobile-sized exterior sideview mirror assembly is an important element of this present invention. By utilizing a plano element of unit magnification in the plano-multiradius reflective element assembly, and by sizing the reflector area of the plano element larger than the reflector area of the multiradius element and, preferably, by sizing the reflector area of the plano element at a sufficiently large size that the rearward field of view provided by the plano element alone meets and satisfies the minimum field of view requirement mandated by an automaker specification and/or a government regulation, the need to provide a safety warning indicia such as "OBJECTS IN MIRROR ARE CLOSER THAN THEY APPEAR" in the plano element and/or in the multiradius element can be obviated. Preferably, the plano element comprises a reflector surface area of a size sufficient, when mounted as part of a plano-multiradius reflective element assembly in a driver-side exterior sideview mirror assembly on an automobile, to provide the driver of the automobile a view of a level road surface extending to the horizon from a line, perpendicular to a longitudinal plane tangent to the driver's side of the automobile at the widest point, extending 8 feet out from the tangent plane 35 feet behind the driver's eyes (at a nominal location appropriate for any 95th percentile male driver or at the driver's eye reference points established in Federal Motor Vehicle Standard No. 104), with the driver seated in the driver's seat and with the driver's seat in the rearmost position. Also, preferably, the aspect ratio of the plano-multiradius reflective element assembly (defined as the ratio

of its largest vertical dimension to its largest horizontal dimension, measured with the plano-multiradius reflective element assembly oriented as it would be oriented when mounted in an exterior sideview mirror assembly on an automobile, and with "horizontal" being generally parallel with the road surface the automobile travels on and "vertical" being generally perpendicular to the road surface the automobile travels on) is preferably less than 1, more preferably less than 0.8, most preferably less than 0.6. Further, it is preferable that the multiradius element be disposed outboard (relative to the side of the vehicle and with the plano-multiradius reflective element assembly oriented as it would be when mounted in an exterior sideview mirror assembly on an automobile) on the plano-multiradius reflective element assembly so that the multiradius element is positioned to provide an auxiliary, wide-angle view of a "blind-spot" region in an adjacent sidlane while the more inboard-disposed plano element with unit magnification provides the principal sideview image to the driver.

Also, it is preferable that the principal axis of the rearward field of view of the multiradius element be different from and angled to the principal axis of the rearward field of view of the plano element when both are attached to the backing plate element of the plano-multiradius reflective element assembly and when the plano-multiradius reflective element assembly is mounted and operated in an exterior sideview mirror assembly on an automobile. Preferably, the principal axis of the rearward field of view of the plano element is directed generally parallel to the road that the automobile equipped with the plano-multiradius reflective element assembly is travelling on (i.e. generally parallel to the longitudinal axis of the automobile) so as to provide the driver with a long-distance view of approaching vehicles in the side lane that the plano element views). However, preferably the principal axis of the rearward field of view of the multiradius element of, for example, a door-mounted driver-side (or passenger-side) exterior sideview mirror assembly in which the plano-multiradius reflective element assembly is mounted is directed generally downwardly towards the road surface adjacent to the driver seating location and/or several feet (such as about 1 foot to about 24 feet; more preferably, about 1 foot to about 12 feet; most preferably about 1 foot to about 8 feet in distance) to its rear (in order to capture a field of view of a rear approaching vehicle that is approaching to overtake, or is about to overtake, or is overtaking the automobile equipped with the plano-multiradius reflective element assembly). Thus, preferably, the principal axis of the rearward field of view of the multiradius element is angled and directed generally downwardly with respect to the longitudinal axis of the automobile and thus is at an angle to the principal axis of the rearward field of view of the plano element. For example, multiradius element 155 when attached to surface 173 of backing plate 160 (see FIG. 6B) would have its principal axis of rearward view as indicated by 180 as in FIG. 6B, and as such would be canted towards the road surface when mounted in an exterior sideview mirror assembly attached to the side of an automobile. By contrast, plano element 150 when attached to surface 174 of backing plate 160 (see FIG. 6A) would have a principal axis as indicated by 185 as in FIG. 6A and, as such, would be generally parallel to the road surface when mounted in an exterior sideview mirror assembly attached to the side of an automobile. Having the multiradius element canted somewhat downwards towards the road surface assists visual detection by the driver of overtaking vehicles in the traditional "blind-spot" in the adjacent side lane. The angle that the multiradius element is

15

angled on the backing plate element of the plano-multiradius reflective element assembly relative to the plane of the plano reflective element will vary from automobile model to model, but generally is preferred to be in the about 1 degree to about 10 degree range; about 2 degree to about 8 degree range more preferred; and about 3 degree to about 6 degree range most preferred. In order to conveniently achieve an angling of the multiradius portion with respect to the plano portion (and preferably a downward angling), the portion of the backing plate element that the multiradius reflective element is attached to can be angled relative to the adjacent portion of the backing plate element that the plano reflective portion is attached to. Thus, and referring to FIG. 6, plano-multiradius reflective element assembly 130 includes a molded polymeric backing plate element 160 comprising a generally flat portion 162 (between BB and CC in FIG. 6) and an adjacent curved portion 161 (between AA and BB). As indicated by 190 and 195, portion AA to BB of backing plate element 160 is generally angled to portion BB to CC of backing plate 160. Preferably, the portion of backing plate element 160 to which the auxiliary reflective element attaches is angled towards the front (compared to the angling of plano reflective element) of an automobile equipped with the plano-auxiliary reflective element assembly of the present invention. FIG. 6 is a view of plano-multiradius reflective element assembly 130 as it would appear from above the vehicle as it would be orientated in use (with portion 162 closer to the driver than portion 161). The wall section, section XX in FIG. 6, taken through section 162 of backing plate element 160 is of substantially constant dimension (as illustrated in FIG. 6A) whereas the wall section, section YY in FIG. 6B, taken through section 161 of backing plate element 160 is of varying dimension and is angled. Plano reflective element 150 and multiradius reflective element 155 (for example, plano element 150 can comprise an electrochromic mirror element and multiradius element 155 can comprise a chrome coated glass reflector) are attached to portions 162 and 161, respectively. By being supported on the angled face 173 (see FIG. 6B) of portion 161, the principal viewing axis of multiradius reflector element 155 is angled downwards towards the road surface, as compared to the more horizontal-viewing principal viewing axis of plano element 150, when plano-multiradius reflective element 130 is mounted in an exterior sideview mirror assembly on an automobile. Demarcation element 165 is preferably molded in the same molding tool as is used to mold backing plate element 160, and so demarcation element 165 is formed as an integral part of backing plate element 160, forming a wall thereof that partitions the surface of backing plate element 160 into a region for receiving the plano reflective element 150 and a region for receiving the auxiliary reflective element 155. Also, end-caps 170 and 171 are optionally provided. Plano reflective element 150 can attach into the cavity formed between demarcation element 165 and end-cap 171; multiradius reflective element 155 can attach into the cavity formed between demarcation element 165 and end-cap 170. Note that the portion of the backing plate element where the wide-angle optic multiradius element attaches can have a thicker wall thickness than that of the portion of the backing plate element where the unit magnification optic element attaches in order to allow for the angling of the multiradius element downwardly relative to the angle of the plano element, as illustrated in FIGS. 6A-B. As illustrated in FIGS. 6A-B, the angle downwards to the longitudinal axis of the vehicle of the multiradius element can generally be set by an angling of a surface of the backing plate element in

16

order to ensure that the principal axis of the rearward field of view of the plano element is directed generally parallel to the longitudinal axis of an automobile equipped with the plano-multiradius reflective element assembly and that the principal axis of the rearward field of view of the multiradius element is directed generally at an angle downwards to the longitudinal axis of the automobile.

Note that the provision of the plano-multiradius reflective element assembly of this invention as a unitary module has manufacturing advantages, particularly for exterior sideview mirror assembly manufacturers who can procure a plano-multiradius reflective element assembly module from a mirror reflector supplier and then mount the plano-multiradius reflective element assembly module onto an actuator.

Referring to FIG. 7, a third embodiment 230 of a plano-multiradius reflective element assembly is illustrated. Plano-multiradius reflective element assembly 230 includes a plano reflective element 250 and a separate multiradius reflective element assembly 255, both individually attached to a backing plate element, and with demarcation element 265 disposed at their joint. Plano-multiradius reflective element assembly 230 is about 8.5 inches wide and about 4.25 inches tall (aspect ratio of 0.5), at their largest dimension. Shown as the shaded triangle 240 in plano reflective element 250 is the image of a triangular target object set about 35 feet rearward and of width about 8 feet and of height of about 4.1 feet as would be seen were plano-multiradius reflective element assembly 230 mounted in a driver-side exterior sideview mirror assembly in an automobile such as a sports utility vehicle. In general, it is desirable that the plano reflective element be dimensioned and configured so as to have its rearward field of view capture an image (that is visible, by reflection in the plano reflective element, to a driver seated in the driver's seat in an automobile to which is attached an exterior sideview mirror assembly equipped with the plano-auxiliary reflective element assembly according to this present invention) of a triangular shaped target located about 35 feet rearward of the driver seating location, extending about 8 feet out from the plane defined by the side of the automobile and reaching a height of between about 4 feet and about 5 feet from the road surface at that location 35 feet rearward of the automobile. The total field of view rearwardly of the vehicle of plano-multiradius reflective element assembly 230 (which is a combination of the field of view of plano reflective element 250 and of the auxiliary multiradius reflective element 255) preferably generally subtends an angle of at least about 30 degrees (and more preferably, generally subtends an angle of at least about 35 degrees and most preferably, generally subtends an angle of at least about 40 degrees) with respect to the side of an automobile to which is attached an exterior sideview mirror assembly equipped with plano-multiradius reflective element assembly 230.

Also, although it is preferable to utilize a multiradius or compound curvature reflective element such as an aspherical element or a compound curvature element for the auxiliary mirror element adjacent the plano reflective element (as this enables least discontinuity in image at the joint between the adjacent elements of the assembly), a spherical reflective element (that has substantially only one radius of curvature and, as such, is a section from a sphere) can optionally be used adjacent the plano reflective element instead of, or in addition to, the multiradius reflective element. Also, a plano auxiliary mirror such as a flat mirrored substrate can be used, less preferably, as a substitute for a multiradius reflective element in those embodiments where the auxiliary reflective

element is angled relative to the plane of the principal, plano reflective element so as to view a blind spot region of the principal plano element. Also, the plano-multiradius reflective element assembly can optionally be fixedly attached to an exterior sideview mirror assembly housing that is not 5 movable, or, alternately, the exterior sideview mirror assembly housing to which the plano-multiradius reflective element assembly is fixedly attached can itself be actuated to move, such as by motor action, so that by moving the exterior sideview mirror assembly housing, the field of 10 rearward view of the plano-multiradius reflective element assembly fixedly attached thereto can correspondingly move and be repositioned to suit the field of view need of a particular driver seated in the automobile cabin.

The above description is considered that of the preferred 15 embodiments only. Modification of the invention will occur to those skilled in the art and to those who make or use the invention. Therefore, it is understood that the embodiments shown in the drawings and described above are merely for illustrative purposes and are not intended to limit the scope 20 of the invention, which is defined in the following claims as interpreted according to the principles of patent law, including the doctrine of equivalents.

I claim:

1. An exterior sideview mirror system suitable for use on 25 an automobile, said exterior sideview mirror system comprising:

an exterior sideview mirror assembly adapted for attachment to a side of an automobile;

said exterior sideview mirror assembly including a reflective 30 element having a rearward field of view when attached to the side of the automobile;

said reflective element attached to an electrically-operated actuator and movable by said actuator in order to 35 position said rearward field of view in response to a control;

wherein said reflective element comprises a plano-multiradius reflective element assembly, said plano-multiradius reflective element assembly comprising a 40 plano reflective element having unit magnification and a separate multiradius reflective element having a multiradius curvature, said plano reflective element having a rearward field of view with a principal axis;

said plano reflective element and said multiradius reflective 45 element of said plano-multiradius reflective element assembly mounted adjacently in said plano-multiradius reflective element assembly in a side-by-side relationship and not superimposed with one reflective element on top of the other reflective 50 element, and supported by a backing plate element, said backing plate element mounting to said actuator such that movement of said backing plate element of said plano-multiradius reflective element assembly by said actuator simultaneously and similarly moves said plano 55 reflective element and said multiradius reflective element, said multiradius reflective element having a rearward field of view with a principal axis, said backing plate element have a first support portion supporting said plano-reflective element and a second 60 support portion supporting said multiradius reflective element, said second support portion tilted forward with respect to said first support portion whereby said principal axis of said rearward field of view of said multiradius reflective element is angled downwardly 65 and outwardly with respect to said principal axis of said rearward field of view of said plano reflective element

when said multiradius reflective element and said plano reflective element are supported by said backing plate element of said plano-multiradius reflective element assembly and when said plano-multiradius reflective element assembly is mounted in said exterior sideview mirror assembly on the automobile, and said principal axis of said rearward field of view of said plano reflective element being directed generally parallel to the longitudinal axis of the automobile equipped with the plano-multiradius reflective element assembly and wherein said principal axis of said rearward field of view of said multiradius reflective element is directed generally at an angle downwards to the longitudinal axis of the automobile; and

said multiradius reflective element being positioned diagonally at an outboard upper portion of said plano-multiradius reflective element assembly when said exterior sideview mirror assembly is mounted to the side of the automobile.

2. The exterior sideview mirror system of claim 1, 20 wherein said plano reflective element and said multiradius reflective element are adjacently attached to said backing plate element at a joint, and wherein said plano-multiradius reflective element assembly includes a demarcation element, said demarcation element disposed at said joint to form a demarcation between said plano reflective element and said 25 multiradius reflective element, said demarcation element having a portion visible to a driver of the automobile.

3. The exterior sideview mirror system of claim 2, wherein said demarcation element is dark colored.

4. The exterior sideview mirror system of claim 3, 30 wherein said demarcation element is dark colored with a color selected from the group consisting of black, grey, blue and brown.

5. The exterior sideview mirror system of claim 3, wherein said demarcation element comprises at least one of a polymer material, a tape, a plastic film, a paint, a lacquer 35 and a caulk.

6. The exterior sideview mirror system of claim 5, wherein said demarcation element comprises a polymer material.

7. The exterior sideview mirror system of claim 2, wherein said joint comprises a space between said plano reflective element and said multiradius reflective element.

8. The exterior sideview mirror system of claim 7, wherein said demarcation element is at least partially disposed in said space between said plano reflective element 40 and said multiradius reflective element.

9. The exterior sideview mirror system of claim 2, wherein said demarcation element comprises a wall on said backing plate element, said wall located on said backing plate element at said joint, said wall separating said plano reflective element from said multiradius reflective element. 45

10. The exterior sideview mirror system of claim 2, wherein said portion visible to a driver of the automobile has a width less than about 4 mm.

11. The exterior sideview mirror system of claim 2, wherein said portion visible to a driver of the automobile has a width less than about 3 mm.

12. The exterior sideview mirror system of claim 2, wherein said portion visible to a driver of the automobile has a width less than about 2 mm.

13. The exterior sideview mirror system of claim 2, wherein said portion visible to a driver of the automobile has a width greater than about 0.5 mm.

14. The exterior sideview mirror system of claim 2, wherein said portion visible to a driver of the automobile has a width greater than about 0.75 mm.

19

15. The exterior sideview mirror system of claim 2, wherein said portion visible to a driver of the automobile has a width greater than about 1 mm.

16. The exterior sideview mirror system of claim 1, wherein said plano reflective element is supported by said backing plate element by at least one of an adhesive attachment and a mechanical attachment.

17. The exterior sideview mirror system of claim 1, wherein said multiradius reflective element is supported by said backing plate element by at least one of an adhesive attachment and a mechanical attachment.

18. The exterior sideview mirror system of claim 1, wherein said multiradius reflective element is supported by said backing plate element at a location such that, when said exterior mirror assembly is attached to a side of an automobile, at least a portion of said plano reflective element is disposed closer to said side of the automobile than any portion of said multiradius reflective element.

19. The exterior sideview mirror system of claim 1, wherein said multiradius reflective element comprises a bent glass substrate with radii of curvature in the range of from about 4,000 mm to about 50 mm.

20. The exterior sideview mirror system of claim 1, wherein the ratio of the width of said plano reflective element to the width of said multiradius reflective element is greater than 1.

21. The exterior sideview mirror system of claim 1, wherein the ratio of the width of said plano reflective element to the width of said multiradius reflective element is greater than 1.5.

22. The exterior sideview mirror system of claim 1, wherein the ratio of the width of said plano reflective element to the width of said multiradius reflective element is greater than 2.5.

23. The exterior sideview mirror system of claim 1, wherein said angle downwards to the longitudinal axis of the automobile is in the range from about 1 degree to about 10 degrees.

24. The exterior sideview mirror system of claim 1, wherein said angle downwards to the longitudinal axis of the automobile is in the range from about 2 degrees to about 8 degrees.

25. The exterior sideview mirror system of claim 1, wherein said angle downwards to the longitudinal axis of the automobile is in the range from about 3 degrees to about 6 degrees.

26. The exterior sideview mirror system of claim 1, wherein said angle downwards to the longitudinal axis of the automobile is generally set by an angling of a surface of said backing plate element.

27. The exterior sideview mirror system of claim 1, wherein said exterior sideview mirror assembly comprises a door-mounted exterior sideview mirror assembly adapted for attachment to a side of the automobile adjacent a driver seating location of a driver of the automobile and wherein the principal axis of the rearward field of view of said multiradius reflective element is directed generally downwards towards the road surface adjacent to the driver

20

seating location at a distance in the range of about 1 foot to about 24 feet to the rear of the driver seating location.

28. The exterior sideview mirror system of claim 1, wherein said exterior sideview mirror assembly comprises a door-mounted exterior sideview mirror assembly adapted for attachment to a side of the automobile adjacent a driver seating location of a driver of the automobile and wherein the principal axis of the rearward field of view of said multiradius reflective element is directed generally downwards towards the road surface adjacent to the driver seating location at a distance in the range of about 1 foot to about 12 feet to the rear of the driver seating location.

29. The exterior sideview mirror system of claim 1, wherein said exterior sideview mirror assembly comprises a door-mounted exterior sideview mirror assembly adapted for attachment to a side of the automobile adjacent a driver seating location of a driver of the automobile and wherein the principal axis of the rearward field of view of said multiradius reflective element is directed generally downwards towards the road surface adjacent to the driver seating location at a distance in the range of about 1 foot to about 8 feet to the rear of the driver seating location.

30. The exterior sideview mirror system of claim 1, wherein said exterior sideview mirror assembly comprises a fixedly attached exterior sideview mirror assembly.

31. The exterior sideview mirror system of claim 1, wherein said exterior sideview mirror assembly comprises a break-away exterior sideview mirror assembly.

32. The exterior sideview mirror system of claim 1, wherein said exterior sideview mirror assembly comprises a powerfold exterior sideview mirror assembly.

33. The exterior sideview mirror system of claim 1, wherein said control comprises a memory controller.

34. The exterior sideview mirror system of claim 1, wherein at least one of said plano reflective element and said multiradius reflective element comprises an electro-optic reflective element.

35. The exterior sideview mirror system of claim 1, wherein both said plano reflective element and said multiradius reflective element comprise an electro-optic reflective element.

36. The exterior sideview mirror system of claim 1, wherein said plano reflective element comprises an electro-optical reflective element.

37. The exterior sideview mirror system of claim 36, wherein said electro-optical reflective element comprises an electrochromic reflective element.

38. The exterior sideview mirror system of claim 37, wherein said multiradius reflective element comprises a fixed reflectance mirror reflector.

39. The exterior sideview mirror system of claim 38, wherein said fixed reflectance mirror reflector comprises a bent glass substrate coated with a metallic reflector coating.

40. The exterior sideview mirror system of claim 1, wherein said plano-multiradius reflective element assembly is formed in an integral molding operation.

* * * * *



JB

PART B - FEE(S) TRANSMITTAL

and send this form, together with applicable fee(s), to: **Mail** Box ISSUE FEE
Commissioner for Patents
Washington, D.C. 20231
Fax (703)746-4000

INSTRUCTIONS: This form should be used for transmitting the ISSUE FEE and PUBLICATION FEE (if required). Blocks 1 through 4 should be completed where appropriate. All further correspondence including the Patent, advance orders and notification of maintenance fees will be mailed to the current correspondence address as indicated unless corrected below or directed otherwise in Block 1, by (a) specifying a new correspondence address; and/or (b) indicating a separate "FEE ADDRESS" for maintenance fee notifications.

CURRENT CORRESPONDENCE ADDRESS (Title: Lightly mark-up with any correction or use BLOCK 1)
28101 7590 09/26/2002
VAN DYKE, GARDNER, LINN AND BURKHART, LLP
2851 CHARLEVOIX DRIVE, S.E.
P.O. BOX 888695
GRAND RAPIDS, MI 49588-8695

Note: A certificate of mailing can only be used for domestic mailings of the Fee(s) Transmittal. This certificate cannot be used for any other accompanying papers. Each additional paper, such as an assignment or formal drawing, must have its own certificate of mailing or transmission.

Certificate of Mailing or Transmission
I hereby certify that this Fee(s) Transmittal is being deposited with the United States Postal Service with sufficient postage for first class mail in an envelope addressed to the Box Issue Fee address above, or being facsimile transmitted to the USPTO, on the date indicated below.

Catherine S. Collins (Depositor's name)
Catherine S. Collins (Signature)
December 13, 2002 (Date)

APPLICATION NO.	FILING DATE	FIRST NAMED INVENTOR	ATTORNEY DOCKET NO.	CONFIRMATION NO.
09/478,315	01/06/2000	NIALL R. LYNAM	DON01-P-793	1526

TITLE OF INVENTION: EXTERIOR MIRROR PLANO-AUXILIARY REFLECTIVE ELEMENT ASSEMBLY

APPLN. TYPE	SMALL ENTITY	ISSUE FEE	PUBLICATION FEE	TOTAL FEE(S) DUE	DATE DUE
nonprovisional	NO	\$1280	\$0	\$1280	12/26/2002

EXAMINER	ART UNIT	CLASS-SUBCLASS
SHAFFER, RICKY D	2872	359-874000

1. Change of correspondence address or indication of "Fee Address" (37 CFR 1.363).
 Change of correspondence address (or Change of Correspondence Address form PTO/SB/122) attached.
 "Fee Address" indication (or "Fee Address" Indication form PTO/SB/47; Rev 03-02 or more recent) attached. Use of a Customer Number is required.

2. For printing on the patent front page, list (1) Van Dyke, Gardner, Linn & Burkhardt, LLP the names of up to 3 registered patent attorneys or agents OR, alternatively, (2) the name of a single firm (having as a member a registered attorney or agent) and the names of up to 2 registered patent attorneys or agents. If no name is listed, no name will be printed.

3. ASSIGNEE NAME AND RESIDENCE DATA TO BE PRINTED ON THE PATENT (print or type)
PLEASE NOTE: Unless an assignee is identified below, no assignee data will appear on the patent. Inclusion of assignee data is only appropriate when an assignment has been previously submitted to the USPTO or is being submitted under separate cover. Completion of this form is NOT a substitute for filing an assignment.
(A) NAME OF ASSIGNEE: Donnelly Corporation
(B) RESIDENCE: (CITY and STATE OR COUNTRY) Holland, Michigan

Please check the appropriate assignee category or categories (will not be printed on the patent) individual corporation or other private group entity government

4a. The following fee(s) are enclosed:
 Issue Fee
 Publication Fee
 Advance Order - # of Copies 10

4b. Payment of Fee(s):
 A check in the amount of the fee(s) is enclosed.
 Payment by credit card. Form PTO-2038 is attached.
 The Commissioner is hereby authorized to charge the advance additional fee(s), or credit any overpayment, to Deposit Account Number 22-0190 (enclose an extra copy of this form).

Commissioner for Patents is requested to apply the Issue Fee and Publication Fee (if any) or to re-apply any previously paid issue fee to the application identified above.

(Authorized Signature) *Catherine S. Collins* (Date) 12/13/2002
Catherine S. Collins 37 599

NOTE: The Issue Fee and Publication Fee (if required) will not be accepted from anyone other than the applicant; a registered attorney or agent; or the assignee or other party in interest as shown by the records of the United States Patent and Trademark Office.

This collection of information is required by 37 CFR 1.311. The information is required to obtain or retain a benefit by the public which is to file (and by the USPTO to process) an application. Confidentiality is governed by 35 U.S.C. 122 and 37 CFR 1.14. This collection is estimated to take 12 minutes to complete, including gathering, preparing, and submitting the completed application form to the USPTO. Time will vary depending upon the individual case. Any comments on the amount of time you require to complete this form and/or suggestions for reducing this burden, should be sent to the Chief Information Officer, U.S. Patent and Trademark Office, U.S. Department of Commerce, Washington, D.C. 20231. DO NOT SEND FEES OR COMPLETED FORMS TO THIS ADDRESS. SEND TO: Commissioner for Patents, Washington, DC 20231.

Under the Paperwork Reduction Act of 1995, no persons are required to respond to a collection of information unless it displays a valid OMB control number.

12/19/2002 180UTENR 00000217 09478315

01 FC:1501
02 FC:0001

1280.00 DP
30.00 DP

PATENT APPLICATION



09478315

09/478315

01/05/00

FEB 08 09 4

INITIALS _____

CONTENTS

	Date Received (Incl. C. of M.) or Date Mailed	Date Received (Incl. C. of M.) or Date Mailed
1. Application ^{7 sheets} papers.		
2. <u>IDS</u>	7/10/00	
3. <u>RESTRICTION (1 month)</u>	9-18-00	
4. <u>election</u>	10/16/00	
5. <u>RESTRICTION (4 months)</u>	1-3-01	
6. <u>Supp. IDS</u>	1-16-DIRTY	
7. <u>Supp. IDS</u>	1-25-DIRTY	
8. <u>election</u>	1/16/01	
9. <u>RET (3 months)</u>	4/24/01	
10. <u>EX. INT. Sum. Rec</u>	6/21/01	
11. <u>Amndt A N/E</u>	7/27/01 ^{CR 12/4/01}	
12. <u>Non-Compliant</u>	8/7/01	
13. <u>Amndt B</u>	9/4/01	
14. <u>FINAL RET (3 months)</u>	12/5/01	
15. <u>Act. 1 mo.</u>	4/16/02	
16. <u>Reg for RCE</u>	4/16/02	
17. <u>Amndt C</u>	4/16/02	
18. <u>FINAL RET (3 months)</u>	5/18/02	
19. <u>SOT 1</u>	5-09-02	
20. <u>Amndt D</u>	5-09-02	
21. <u>EX. AMEND E (=)</u>	9-26-02	
22. <u>AMDT F</u>	10/29/02	
23. <u>Formal Drawings (27 sheets) set</u>	11/27/02	
24. <u>Formal Drawings (8 sheets) set</u>	12/18/02	
25. <u>Copy C</u>	11-27-06	
26.		
27.		
28.		
29.		
30.		
31.		
32.		
33.		
34.		
35.		
36.		
37.		
38.		
39.		
40.		
41.		
42.		
43.		
44.		
45.		
46.		
47.		
48.		
49.		
50.		
51.		
52.		
53.		
54.		
55.		
56.		
57.		
58.		
59.		
60.		
61.		
62.		
63.		
64.		
65.		
66.		
67.		
68.		
69.		
70.		
71.		
72.		
73.		
74.		
75.		
76.		
77.		
78.		
79.		
80.		
81.		
82.		

(LEFT OUTSIDE)

ISSUE SLIP STAPLE AREA (for additional cross references)

POSITION	INITIALS	ID NO.	DATE
FEE DETERMINATION	J.B.	70000	2-7-00
O.I.P.E. CLASSIFIER	J.W.	37	2/8
FORMALITY REVIEW			
RESPONSE FORMALITY REVIEW	R.R.	70029	2/16/00

INDEX OF CLAIMS

- ✓ Rejected
- ✓ Allowed
- (Through numeral) ... Canceled
- ± Restricted
- N Non-elected
- I Interference
- A Appeal
- O Objected

Claim	Final	Original	Date
1			
2			
3			
4			
5			
6			
7			
8			
9			
10			
11			
12			
13			
14			
15			
16			
17			
18			
19			
20			
21			
22			
23			
24			
25			
26			
27			
28			
29			
30			
31			
32			
33			
34			
35			
36			
37			
38			
39			
40			
41			
42			
43			
44			
45			
46			
47			
48			
49			
50			

Claim	Final	Original	Date
1			
2			
3			
4			
5			
6			
7			
8			
9			
10			
11			
12			
13			
14			
15			
16			
17			
18			
19			
20			
21			
22			
23			
24			
25			
26			
27			
28			
29			
30			
31			
32			
33			
34			
35			
36			
37			
38			
39			
40			
41			
42			
43			
44			
45			
46			
47			
48			
49			
50			

Claim	Final	Original	Date
101			
102			
103			
104			
105			
106			
107			
108			
109			
110			
111			
112			
113			
114			
115			
116			
117			
118			
119			
120			
121			
122			
123			
124			
125			
126			
127			
128			
129			
130			
131			
132			
133			
134			
135			
136			
137			
138			
139			
140			
141			
142			
143			
144			
145			
146			
147			
148			
149			
150			

If more than 150 claims or 10 actions
staple additional sheet here

(LEFT INSIDE)

SEARCHED			
Class	Sub.	Date	Exmr.
359	841	4/2/01	NOS
	850	"	"
	851	"	"
	855	"	"
	864	"	"
	865	"	"
	868	"	"
	872	"	"
877	4/2/01	NOS	
SEARCH	UPON	11/18/01	NOS
SEARCH	UPON	5/2/02	NOS
359	265	9/24/02	NOS
	267	9/24/02	NOS
SEARCH	UPON	9/24/02	NOS
248	549	9/24/02	NOS
	900	9/24/02	NOS

SEARCH NOTES (INCLUDING SEARCH STRATEGY)		
Date	Exmr.	

INTERFERENCE SEARCHED			
Class	Sub.	Date	Exmr.
359	265	9/24/02	NOS
	267	"	"
	841	"	"
	850	"	"
	864	"	"
	866	"	"
	868	"	"
	872	"	"
	877	9/24/02	NOS
	248	549	9/24/02
	900	9/24/02	NOS

(RIGHT OUTSIDE)

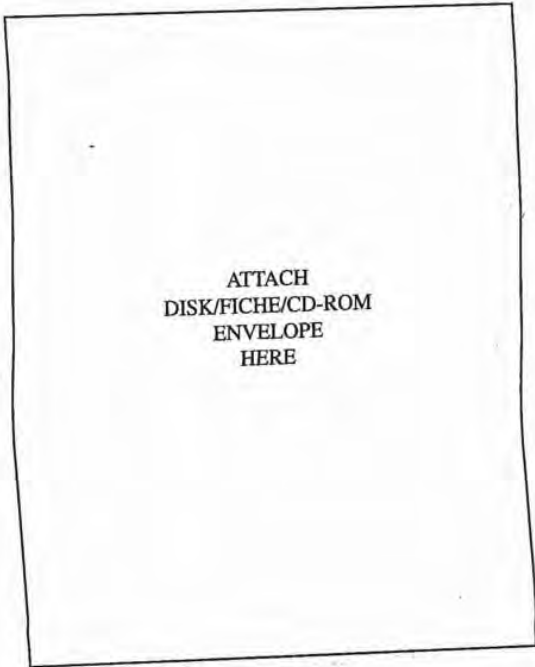
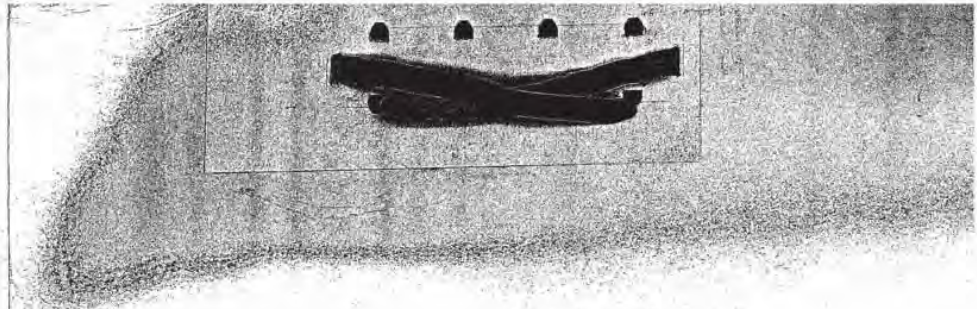

ATTACH
DISK/FICHE/CD-ROM
ENVELOPE
HERE

(RIGHT INSIDE)

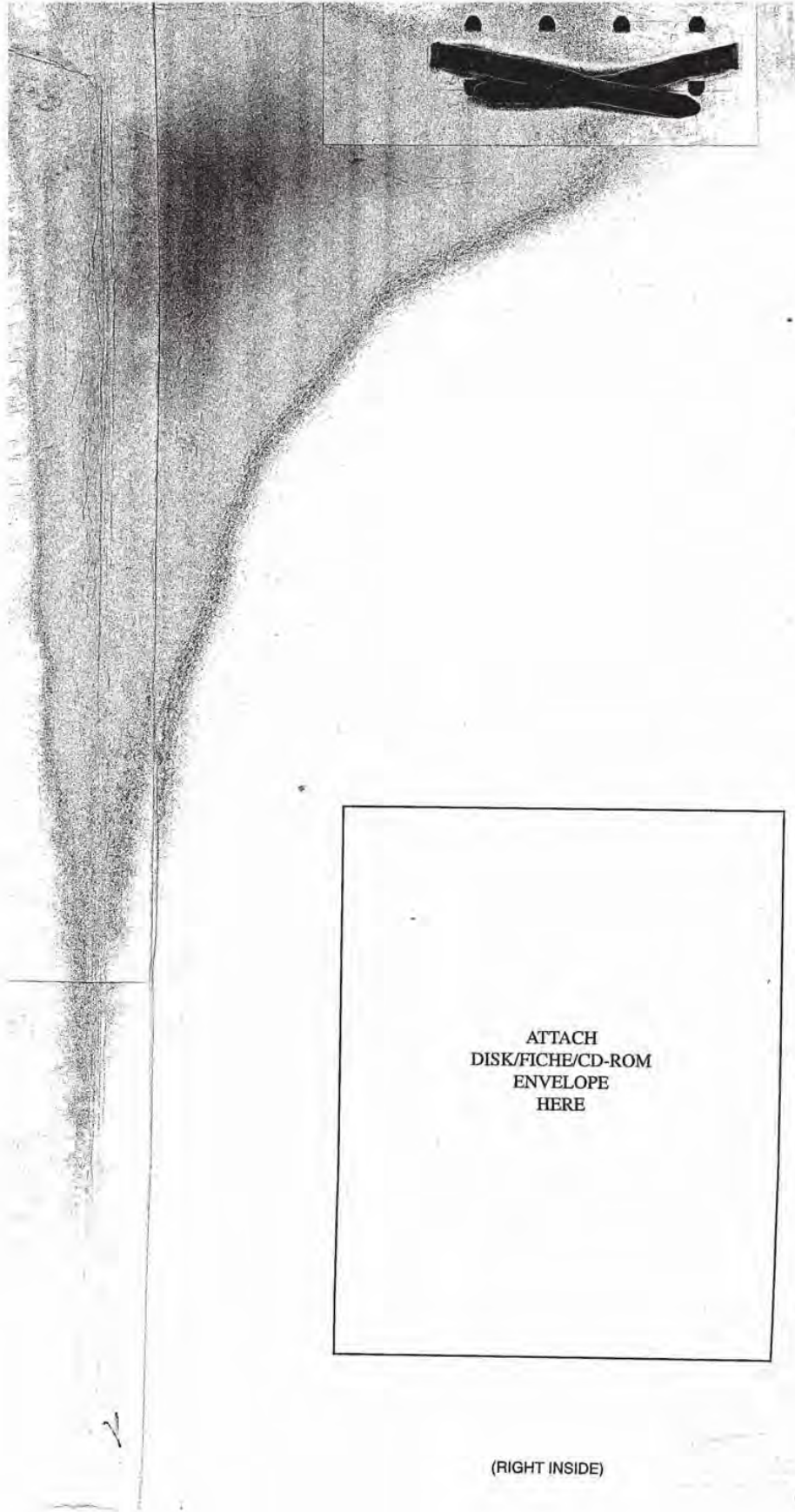

ATTACH
DISK/FICHE/CD-ROM
ENVELOPE
HERE

(RIGHT INSIDE)



PTO-1683
(Rev. 7-96)