

Fig. 24

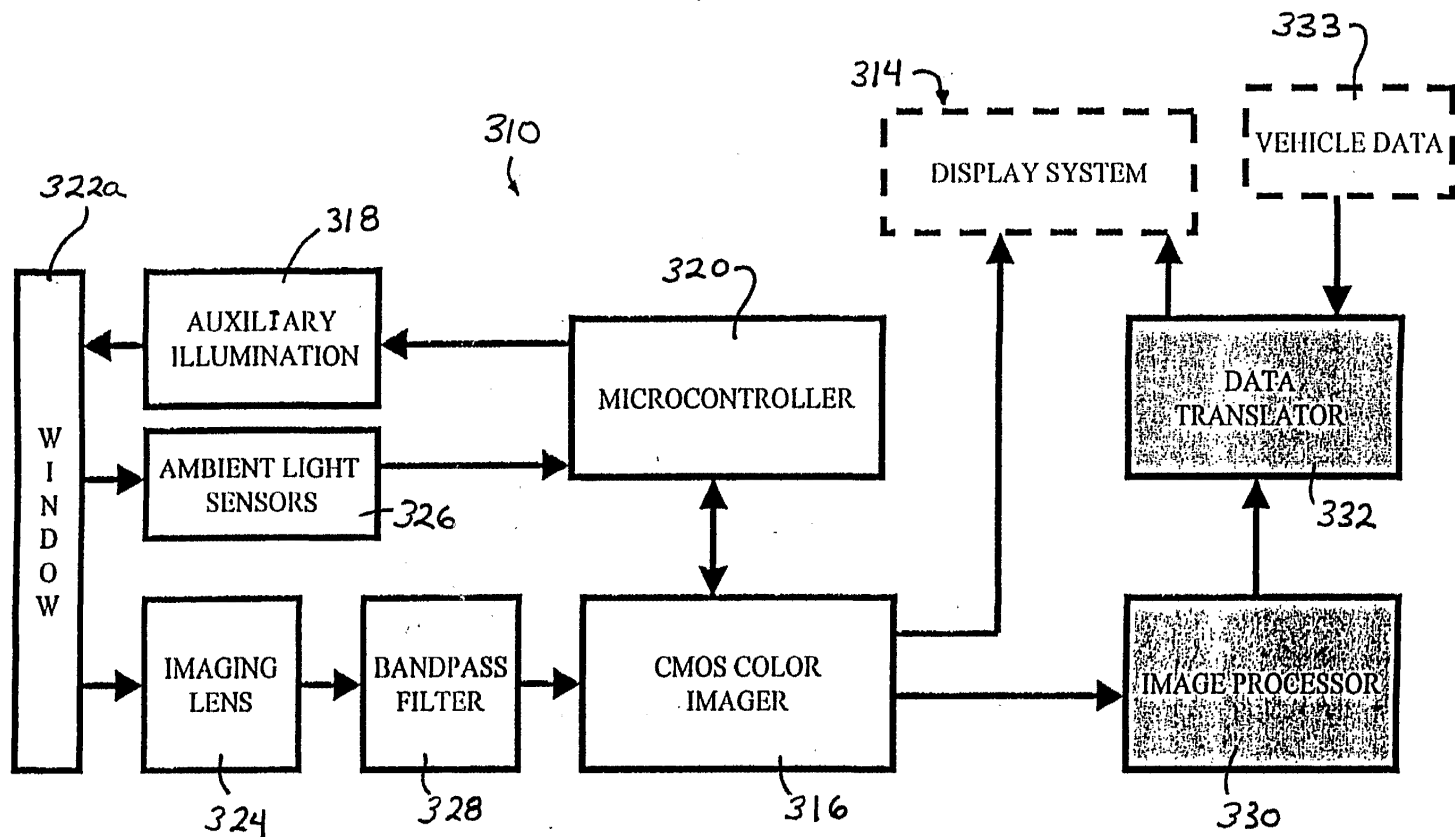

Fig. 25

WO 2004/047421

17/18

PCT/US2003/036177

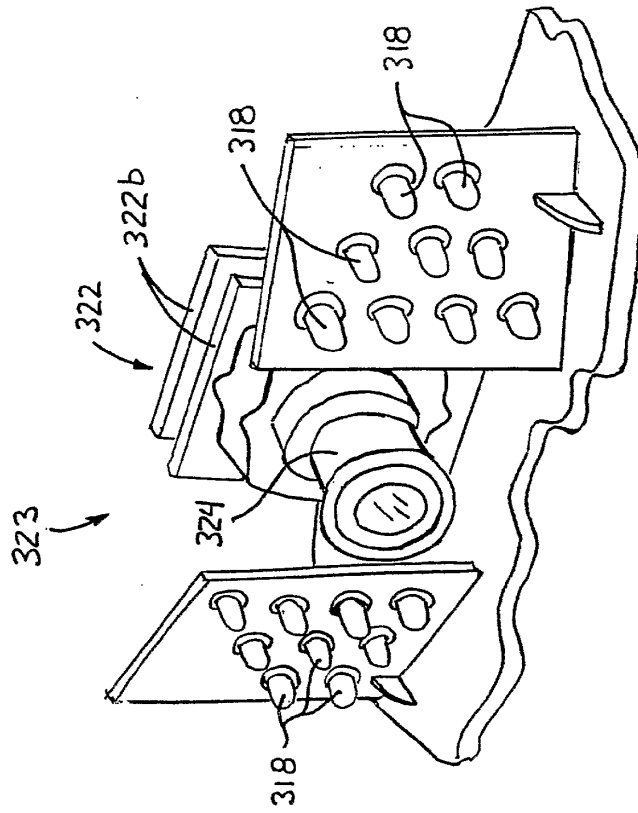

Fig. 26

(12) INTERNATIONAL APPLICATION PUBLISHED UNDER THE PATENT COOPERATION TREATY (PCT)

(19) World Intellectual Property
Organization
International Bureau



(43) International Publication Date
2 December 2004 (02.12.2004)

PCT

(10) International Publication Number
WO 2004/103772 A2

- (51) International Patent Classification⁷: **B60R**
- (21) International Application Number: PCT/US2004/015424
- (22) International Filing Date: 18 May 2004 (18.05.2004)
- (25) Filing Language: English
- (26) Publication Language: English
- (30) Priority Data:
60/471,546 19 May 2003 (19.05.2003) US
60/525,537 26 November 2003 (26.11.2003) US
60/556,259 25 March 2004 (25.03.2004) US
- (71) Applicant (for all designated States except US): **DONNELLY CORPORATION** [US/US]; 414 East Fortieth Street, Holland, Michigan 49423 (US).
- (72) Inventors; and
- (75) Inventors/Applicants (for US only): **UKEN, John, T.** [US/US]; 7730 Steele Avenue, Jenison, Michigan 49428 (US). **KARNER, Lee** [US/US]; 2974 N. 168th, Holland, Michigan 49424 (US). **HOOK, Richard, R.** [US/US]; 7035 Michael Drive, Hudsonville, Michigan 49426 (US).
- (74) Agent: **VAN DYKE, GARDNER, LINN & BURKHART, LLP**; FLORY, Timothy A., 2851 Charlevoix Drive, SE, Suite 207, P.O. Box 888695, Grand Rapids, Michigan 49588-8695 (US).
- (81) Designated States (unless otherwise indicated, for every kind of national protection available): AE, AG, AL, AM, AT, AU, AZ, BA, BB, BG, BR, BW, BY, BZ, CA, CH, CN, CO, CR, CU, CZ, DE, DK, DM, DZ, EC, EE, EG, ES, FI, GB, GD, GE, GH, GM, HR, HU, ID, IL, IN, IS, JP, KE, KG, KP, KR, KZ, LC, LK, LR, LS, LT, LU, LV, MA, MD, MG, MK, MN, MW, MX, MZ, NA, NI, NO, NZ, OM, PG, PI, PL, PT, RO, RU, SC, SD, SE, SG, SK, SL, SY, TJ, TM, TN, TR, TT, TZ, UA, UG, US, UZ, VC, VN, YU, ZA, ZM, ZW.
- (84) Designated States (unless otherwise indicated, for every kind of regional protection available): ARIPO (BW, GH, GM, KE, LS, MW, MZ, NA, SD, SL, SZ, TZ, UG, ZM, ZW), Eurasian (AM, AZ, BY, KG, KZ, MD, RU, TJ, TM), European (AT, BE, BG, CH, CY, CZ, DE, DK, EE, ES, FI,

[Continued on next page]

(54) Title: MIRROR ASSEMBLY FOR VEHICLE

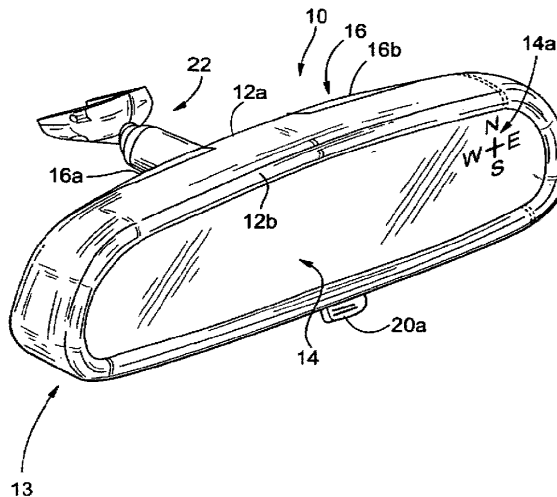

(57) Abstract: An interior rearview mirror assembly (10) for a vehicle includes a reflective element assembly portion (13) and at least one cap portion (16) adapted to attach to the reflective element assembly portion. The reflective element assembly portion includes a reflective element (14). The reflective element assembly portion comprises a first molding that encompasses at least a perimeter portion of the reflective element. The first molding is formed by molding a first resinous material having a tool shrinkage factor equal to or greater than about 1%. The cap portion comprises at least one second molding formed by molding a second resinous material having a tool shrinkage factor of less than or equal to about 1%. The cap portion preferably includes internal structure for supporting at least one accessory.

WO 2004/103772 A2



FR, GB, GR, HU, IE, IT, LU, MC, NL, PL, PT, RO, SE, SI, SK, TR), OAPI (BF, BJ, CF, CG, CI, CM, GA, GN, GQ, GW, ML, MR, NE, SN, TD, TG).

IT, LU, MC, NL, PL, PT, RO, SE, SI, SK, TR), OAPI patent (BF, BJ, CF, CG, CI, CM, GA, GN, GQ, GW, ML, MR, NE, SN, TD, TG)

Declarations under Rule 4.17:

— as to applicant's entitlement to apply for and be granted a patent (Rule 4.17(ii)) for the following designations AE, AG, AL, AM, AT, AU, AZ, BA, BB, BG, BR, BW, BY, BZ, CA, CH, CN, CO, CR, CU, CZ, DE, DK, DM, DZ, EC, EE, EG, ES, FI, GB, GD, GE, GH, GM, HR, HU, ID, IL, IN, IS, JP, KE, KG, KP, KR, KZ, LC, LK, LR, LS, LT, LU, LV, MA, MD, MG, MK, MN, MW, MX, MZ, NA, NI, NO, NZ, OM, PG, PH, PL, PT, RO, RU, SC, SD, SE, SG, SK, SL, SY, TJ, TM, TN, TR, TT, TZ, UA, UG, UZ, VC, VN, YU, ZA, ZM, ZW, ARIPO patent (BW, GH, GM, KE, LS, MW, MZ, NA, SD, SL, SZ, TZ, UG, ZM, ZW), Eurasian patent (AM, AZ, BY, KG, KZ, MD, RU, TJ, TM), European patent (AT, BE, BG, CH, CY, CZ, DE, DK, EE, ES, FI, FR, GB, GR, HU, IE,

- as to the applicant's entitlement to claim the priority of the earlier application (Rule 4.17(iii)) for all designations
- as to the applicant's entitlement to claim the priority of the earlier application (Rule 4.17(iii)) for all designations
- as to the applicant's entitlement to claim the priority of the earlier application (Rule 4.17(iii)) for all designations
- of inventorship (Rule 4.17(iv)) for US only

Published:

- without international search report and to be republished upon receipt of that report

For two-letter codes and other abbreviations, refer to the "Guidance Notes on Codes and Abbreviations" appearing at the beginning of each regular issue of the PCT Gazette.

MIRROR ASSEMBLY FOR VEHICLE

CROSS REFERENCE TO RELATED APPLICATIONS

The present application claims benefit of U.S. provisional applications, Ser. No. 60/471,546, filed May 19, 2003 (Attorney Docket DON01 P-1093); Ser. No. 60/525,537, filed Nov. 26, 2003 (Attorney Docket DON01 P-1129); and Ser. No. 60/556,259, filed Mar. 25, 2004 (Attorney Docket DON01 P-1147), which are hereby incorporated herein by reference in their entireties.

FIELD OF THE INVENTION

The present invention relates generally to the field of interior rearview mirror assemblies for vehicles and, more particularly, to interior rearview mirror assemblies which incorporate an accessory or feature, particularly an electronic accessory or feature.

BACKGROUND OF THE INVENTION

The base level mirror for a vehicle is often a prismatic mirror assembly, which may provide a low cost mirror for the vehicle. The mirror assembly is often economically assembled by snapping or inserting the toggle assembly and prismatic reflective element into the casing at the front or bezel portion of the mirror casing substantially immediately after the casing (which may be formed of a hot molded polypropylene or the like) is formed and while the casing is still hot and pliable. As the casing cools, it shrinks to secure the reflective element in place in the casing. Because the reflective element is inserted into the casing while the casing is hot (such as after being freshly molded), the timing for the insertion process may be limited. Thus, it may be difficult to install or insert other accessories or components into the casing before the casing cools and shrinks.

It is often desirable to provide an electronic feature in the mirror assembly, such as a compass sensor and/or compass display, a tire pressure monitoring system and/or display and/or the like. In order to facilitate the addition of accessories or other components in the mirror assembly, the mirror assembly may typically have a casing and a separate bezel portion, which allows the accessory or accessories or the like to be installed into the casing (via its front opening) after it has cooled, and then allows the reflective element and bezel portion to be installed at the front portion of the casing. The bezel portion may be snapped to the casing or may be otherwise attached to the casing via sonic welding or the like to secure the bezel portion to the casing and to secure the components or accessories and the reflective

element at or within the mirror casing. Although practical, this involves a less economical two-part, non-unitary casing and bezel design.

It is typically preferred to have the unitarily formed casing and bezel portion so that the reflective element is inserted into the casing while the casing is hot and pliable. However, it is also desirable to provide additional features or functions to the mirror assembly. Therefore, there is a need in the art for an improved mirror assembly which overcomes the shortcomings of the prior art.

SUMMARY OF THE INVENTION

The present invention provides an interior rearview mirror assembly which has one or more cap portions which attach or secure to a rear portion of a mirror holder. The mirror holder comprises part of a reflective element assembly portion comprising a mirror reflective element and a bezel portion or the like that preferably encompasses at least a perimeter portion of the reflective element, thereby at least partially securing the reflective element in the reflective element assembly portion. The cap portion or portions may include one or more electronic accessories or circuitry to provide additional features or functions to the mirror assembly. The additional features or functions may thus be back-loaded into the mirror holder after the mirror holder is formed and after the reflective element is attached at the bezel portion or front portion of the mirror holder.

According to an aspect of the present invention, an interior rearview mirror assembly for a vehicle comprises a mirror holder having a front portion and a rear portion, a reflective element positioned at the front portion of the mirror holder and received at least partially within the front portion of the mirror holder, and at least one cap portion. The rear portion of the mirror holder has at least one opening therethrough and the at least one cap portion is attachable to the rear portion of the mirror holder generally at the at least one opening. The at least one cap portion includes circuitry for at least one accessory. The at least one cap portion provides a rear cover for the mirror holder generally over the at least one opening.

According to another aspect of the present invention, a method of manufacturing an interior rearview mirror assembly portion includes forming a first molding by injection molding a first resinous material in a mold. The first resinous material has a tool shrinkage factor of at least approximately 1%. The first molding is at an elevated temperature when the first molding is removed from the mold. A reflective element is provided and positioned at the first molding before the first molding has cooled to approximately ambient temperature. The first molding at least partially encompasses a perimeter portion of the reflective element to form a reflective element assembly portion. The first molding is allowed to cool and

shrink to retain the reflective element at the first molding. A cap portion comprises a second resinous material, which has a tool shrinkage factor of at less than or equal to approximately 1%. The cap portion includes at least one accessory. The cap portion is attached to the reflective element assembly portion after the first molding has cooled and shrunk. The cap
5 portion is attached to the reflective element assembly portion such that the accessory is at least partially within the mirror assembly.

The accessory may comprise a compass sensor and/or display, a tire pressure monitoring system receiver/control circuitry and/or display, an antenna, a garage door opener, or any other accessory and/or accessory display and associated circuitry. For example, the
10 circuitry may comprise compass display circuitry and the reflective element may have at least one port or icon or character etched or otherwise formed thereon, and preferably with an element of the circuitry aligned with / juxtaposed with the at least one port or icon or character etched or otherwise formed on the reflective element. The display circuitry may include at least one illumination source or lighting element for projecting illumination
15 through a corresponding or appropriate port or icon or character on the mirror reflective element.

The cap portion or portions may be detachably attached to the mirror holder or first molding or bezel portion, such as via accessible detents or snaps or the like, and may be detachably removable from the mirror holder or first molding or bezel portion for service or
20 replacement. However, the cap portion may alternatively be non-detachably attached, such as by adhesive attachment or by heat staking or by ultrasonic welding or the like.

Therefore, the present invention provides an interior rearview mirror assembly which may include one or more electronic accessories or features. The accessory or feature may be installed at the rear portion of the mirror holder or bezel portion opposite the reflective
25 element, and may be installed after the reflective element is inserted into the freshly molded or hot mirror holder or bezel portion and after the mirror holder has cooled and shrunk to secure the reflective element. Preferably, the accessory or feature may be mounted or positioned at, within or on one or more cap portions (preferably also with any associated wiring, interconnects and/or connectors and the like) which may be secured to the rear
30 portion of the mirror holder and which may form a rear wall or surface of the mirror holder. The cap portion may be snapped to or attached to the mirror holder (which has the reflective element already inserted/installed therein) after the mirror holder has cooled, such that the assembly may be completed at a facility or assembly line that is remote from the facility or line at which the reflective element and mirror holder are assembled together. The present

invention thus facilitates the addition of an electronic accessory or feature into a low cost mirror assembly with minimal additional investment to add the accessory or feature. The present invention may thus easily accommodate various features which may be selected by a customer.

5 These and other objects, advantages, purposes and features of the present invention will become apparent upon review of the following specification in conjunction with the drawings.

BRIEF DESCRIPTION OF THE DRAWINGS

10 FIG. 1 is a front perspective view of an interior rearview mirror assembly in accordance with the present invention;

 FIG. 2 is an exploded perspective view of the interior rearview mirror assembly of FIG. 1;

 FIG. 3 is an exploded perspective view of another interior rearview mirror assembly in accordance with the present invention;

15 FIG. 4 is an exploded perspective view of another interior rearview mirror assembly in accordance with the present invention;

 FIG. 5 is an exploded perspective view of another interior rearview mirror assembly in accordance with the present invention;

20 FIG. 6 is a perspective view of a reflective element assembly portion of the mirror assembly of the present invention, with the reflective element removed to show additional details;

 FIG. 7 is an opposite perspective view of the reflective element assembly portion of FIG. 6;

 FIG. 8 is a perspective view of a cap portion of the mirror assembly of FIG. 5;

25 FIG. 9 is a perspective view of a cap portion and circuit boards of FIG. 5, as assembled;

 FIG. 10 is a rear perspective view of another interior rearview mirror assembly of the present invention;

30 FIG. 11 is a rear elevation of another interior rearview mirror assembly of the present invention;

 FIG. 12 is a front elevation of an interior rearview mirror assembly, having directional heading or compass display in accordance with the present invention;

 FIGS. 13A-D are enlarged elevations of customized compass displays in accordance with the present invention;

FIG. 14 is a front elevation of another interior rearview mirror assembly, showing another compass display in accordance with the present invention;

FIG. 15 is a front elevation of another interior rearview mirror assembly, showing another compass display in accordance with the present invention; and

5 FIG. 16 is a front elevation of another interior rearview mirror assembly, showing another compass display in accordance with the present invention

FIG. 17 is a front elevation of another interior rearview mirror assembly having a compass and temperature display;

10 FIG. 18 is a front elevation of another interior rearview mirror assembly, having a garage door opening system display and user inputs in accordance with the present invention;

FIG. 19 is a front elevation of another interior rearview mirror assembly, having a compass display and a tire pressure monitoring system display in accordance with the present invention;

15 FIG. 20 is a front elevation of another interior rearview mirror assembly, having a tire pressure monitoring system display in accordance with the present invention;

FIG. 21 is an enlarged front elevation of another tire pressure monitoring system display in accordance with the present invention;

FIG. 22 is a front elevation of another interior rearview mirror assembly, having a telematics module and display in accordance with the present invention;

20 FIG. 23 is a front elevation of another interior rearview mirror assembly, having a telematics module and display in accordance with the present invention;

FIG. 24 is a perspective view of a cap portion for an interior rearview mirror assembly in accordance with the present invention;

25 FIG. 25 is an enlarged perspective view of a light actuator of the cap portion of FIG. 24;

FIG. 26 is a perspective view of another cap portion of the present invention;

FIG. 27 is an upper perspective view of an interior rearview mirror assembly of the present invention, with microphones positioned along an upper cap portion;

30 FIG. 28 is a sectional view of an interior rearview mirror assembly having a battery in accordance with the present invention;

FIG. 29 is an exploded perspective view of another interior rearview mirror assembly in accordance with the present invention;

FIG. 30 is a rear perspective view of the mounting assembly of the mirror assembly of FIG. 29;

FIG. 31 is a sectional view of the mounting arm and mount of FIG. 30;

FIG. 32 is a rear perspective view of another mounting assembly of the present invention;

FIG. 33A is a sectional view of an electrochromic reflective element assembly portion
5 in accordance with the present invention;

FIG. 33B is a sectional view of another electrochromic reflective element assembly portion in accordance with the present invention;

FIG. 34 is a perspective view of another interior rearview mirror assembly and a windshield accessory module in accordance with the present invention; and

10 FIGS. 35A-D are perspective views of different accessory modules of the present invention.

DESCRIPTION OF THE PREFERRED EMBODIMENTS

Referring now to the drawings and the illustrative embodiments depicted therein, an interior rearview mirror assembly or modular prismatic rearview mirror assembly 10 for a
15 vehicle includes a reflective element assembly portion 13 including a mirror holder 12 and a reflective element 14 (FIG. 1) positioned at and at least partially within the mirror holder and/or bezel portion, that preferably is molded from a polyolefin material, such as a polypropylene material or the like. Mirror assembly 10 includes a plastic molded cap or cap
20 portion 16, preferably molded from an ABS material, an engineering resin material, such as a filled or unfilled nylon material, or the like (and may be integrally molded with metallic or ceramic materials or inserts or the like to provide mechanical bracing and enhanced structural rigidity). Cap portion 16 is mountable or attachable to a rear portion or open portion 12a of mirror holder 12, and may include an accessory or feature or the like, such as a printed circuit
25 board 18 having an electronic accessory or circuitry thereon or integrated therein or attached thereto. Cap portion 16 may be snapped or otherwise mounted to or attached to the open rear portion 12a of mirror holder 12 to install or back-load the printed circuit board and/or accessory within the mirror holder 12 of mirror assembly 10. Cap portion 16 may be detachably mounted or attached to the mirror holder, such as via accessible detents or snaps or the like, and may be removable or detachable from the rear portion of the mirror holder,
30 such as for service or replacement of the cap portion or one or more accessories of the cap portion.

Various cap portions of the present invention may be provided with different options or accessories, and may be selected to mount to or attach to a universal or common mirror holder to form different mirror assemblies having different content. The present invention

thus allows an automobile manufacturer to order or purchase common or standard mirror holders or reflective element assembly portions and different or custom cap portions and to assemble the mirror assembly with the desired cap portion and content at the vehicle assembly plant. The automobile manufacturer may even choose to purchase the mirror
5 holders (which may include the reflective element) from one source and the cap portions from another source, and may complete the mirror assembly at the vehicle assembly plant or at another facility, such as a mirror assembly plant or the like. The present invention thus allows an automobile manufacturer to order or purchase the mirror holder and reflective element (and maybe the toggle assembly and mounting assembly as well, such as shown in
10 FIGS. 6 and 7) from a mirror specialist, and the cap portions and accessories (such as shown in FIG. 9) from an electronics specialist. The cap portion may snap or otherwise attach to the mirror holder to complete the assembly of the rearview mirror assembly.

Because the cap portion or portions may be purchased separately, the present invention lends itself to aftermarket applications or to dealership or consumer
15 customizations/personalizations, where a cap portion having the desired accessories or appearance or design may be purchased and installed to a mirror holder to alter or upgrade the mirror assembly of the vehicle. It is envisioned that such an upgrade could be made to a base mirror that does not originally include any electronic accessories, whereby the cap portion could provide electrical content to the mirror assembly. In such applications, the cap
20 portion may connect to a power source or the like of the vehicle (such as via a wire or cable that extends between the mirror assembly and the headliner or an accessory module of the vehicle when the mirror assembly is installed in the vehicle) or the cap portion may include a battery or self-contained power source to provide power to the accessories and circuitry contained within the cap portion, such as discussed below with respect to FIG. 28.

25 In an aftermarket application, cap portions may be provided as aftermarket cap portions, and a consumer may purchase a desired cap portion, which may have desired content or features and/or may have a desired color or texture or appearance or the like, and may readily remove the existing cap portion from the mirror of their vehicle and replace it with the new cap portion. For example, the cap portion and/or the mirror holder may have
30 snaps or clasps that may retain the cap portion and the mirror holder together, but that may release or detach such that the cap portion may be detachable from the mirror holder by a user. The cap portion may be pulled or detached from the mirror holder and a new cap portion may be pressed or snapped into place on the mirror holder to provide the vehicle

owner with the new cap portion having the desired content or functions or features and/or the desired appearance or the like, as discussed in detail below.

Reflective element 14 may comprise a prismatic reflective element having a wedge shaped prism with a reflective coating on its rear surface, such as described in U.S. Pat. Nos. 5 6,318,870; 5,327,288; 4,948,242; 4,826,289; 4,436,371; and 4,435,042; and/or U.S. pat. application, Ser. No. 10/709,434, filed May 5, 2004 by Lynam for MIRROR REFLECTIVE ELEMENT (Attorney Docket DON01 P-1152); and/or U.S. provisional application, Ser. No. 60/525,952, filed Nov. 26, 2003 by Lynam for MIRROR REFLECTIVE ELEMENT FOR A VEHICLE (Attorney Docket DON01 P-1130), which are all hereby incorporated herein by 10 reference. Reflective element 14 may include one or more displays which may be laser-etched or otherwise formed thereon, such as via an appliqué or the like on the surface of the reflective element or such as a display on demand type of display (discussed below). The display may include one or more display elements, such as illumination sources, such as vacuum fluorescent (VF) elements, liquid crystal displays (LCDs), light emitting diodes 15 (LEDs), such as inorganic LEDs or organic light emitting diodes (OLEDs), electroluminescent (EL) elements or the like. Optionally, the prismatic reflective element may comprise a display on demand or transfective prismatic element (such as described in PCT Application No. PCT/US03/29776, filed Sep. 19, 2003 by Donnelly Corp. et al. for MIRROR REFLECTIVE ELEMENT ASSEMBLY (Attorney Docket DON01 FP- 20 1109(PCT)); and/or U.S. provisional application, Ser. No. 60/525,952, filed Nov. 26, 2003 by Lynam for MIRROR REFLECTIVE ELEMENT FOR A VEHICLE (Attorney Docket DON01 P-1130), which are all hereby incorporated herein by reference) so that the displays are viewable through the reflective element, while the display area still functions to substantially reflect light, in order to provide a generally uniform prismatic reflective element 25 even in the areas that have display elements positioned behind the reflective element.

For example, as shown in FIGS. 1-5 and 12, prismatic reflective element 14 may include a compass display 14a and/or other display, such as a passenger side inflatable restraint status display 14b (FIGS. 2-4) or the like, formed or etched on the reflective element. For example, the compass display 14a may include ports 15a, such as icons, 30 characters or directional headings (N, S, E, W), etched or formed in the reflective coating of the reflective element (such as via removing the reflective coating of the reflective element to form a desired port or icon or character and/or such as by utilizing aspects described in U.S. Pat. No. 4,882,565, issued to Gallmeyer, which is hereby incorporated herein by reference) to allow light from corresponding illumination sources or elements 19a (such as light emitting

diodes or the like) to pass through the reflective element to illuminate or back light the appropriate port or icon or heading character for viewing by the driver or occupant of the vehicle, such as similar to the compass systems disclosed in U.S. pat. application, Ser. No. 10/456,599, filed Jun. 6, 2003 by Weller et al. for INTERIOR REARVIEW MIRROR SYSTEM WITH COMPASS (Attorney Docket DON01 P-1076), which is hereby
5 incorporated herein by reference in its entirety, and as discussed below.

As shown in FIG. 5, the reflective element 14 may include an anti-scatter film or sheet or tape 14c applied over its rear surface. The tape 14c may be adhered or otherwise attached to the rear surface of the reflective element so as to limit shattering or scattering of
10 the mirror glass if the vehicle is involved in an accident. Also, the reflective element 14 may include a display appliqué 14d that may be adhered or applied to the rear surface of the reflective element in the general region of the display 14a (and/or at the region of other displays at the reflective element). The display appliqué 14d may comprise a diffusing element or material, such as a white diffusing material with a smoked front or the like, to
15 diffuse the light emitted by the display elements so that a person viewing the display 14a will not readily discern the individual lighting elements or filaments, but will view substantially uniform illumination provided by the lighting elements or filaments.

Interior rearview mirror assembly 10 may include a toggle assembly 20 and a mounting portion 22, which may be pivotally connected to toggle assembly 20 and mounted
20 to the vehicle to provide pivotal movement of the mirror holder and reflective element relative to the vehicle. Toggle assembly 20 may include a toggle member 20a, which may be actuated or moved by a user to adjust the mirror holder and reflective element relative to the vehicle. Optionally, toggle member 20a may comprise a soft touch surface or portion, such as disclosed in U.S. Pat. Nos. 6,318,870 and 6,349,450, which are hereby incorporated herein
25 by reference. Such a soft touch surface or portion preferably comprises a soft touch material (such as a thermoplastic elastomer or other similar thermoplastic materials, such as Santoprene or the like), preferably having a Shore A durometer value of less than about 110 Shore A, more preferably less than about 90 Shore A, and most preferably less than about 70 Shore A, that may be molded over a rigid or harder material or structure, such as by utilizing
30 aspects described in U.S. Pat. No. 6,349,450, which is hereby incorporated herein by reference. The toggle assembly or the mirror holder may also include a pivot joint or pivot element 20b, such as a socket and/or ball member, molded or formed thereon or attached or mounted thereto, in order to provide pivotal movement or adjustment of the mirror assembly relative to the mounting arm or portion. The mounting portion 22 may be mounted to the

vehicle, such as to an interior surface of the vehicle windshield or to a header portion of the vehicle or the like, via any mounting arm and button or any other mounting arrangement or construction, such as the types disclosed in U.S. Pat. Nos. 6,499,850; 6,318,870; 6,315,421; 6,227,675; 5,671,996; 5,813,745; 5,673,994; 5,820,097; 5,708,410; 5,680,263; 5,582,383; 5,576,687; 5,555,136; 5,521,760; 5,330,149; 5,100,095; 5,058,851; 4,930,742; 4,936,533; 4,436,371; 4,524,941; 4,435,042; and/or 4,646,210; and/or PCT Publication No. WO 03/095269 A2, published Nov. 20, 2003 for REARVIEW MIRROR ASSEMBLIES; and/or PCT Publication No. WO 03/099614 A1, published Dec. 4, 2003 for MODULAR REARVIEW MIRROR ASSEMBLY, which are hereby incorporated by reference herein, without affecting the scope of the present invention. Optionally, the mirror assembly may be mounted to the vehicle portion (such as to the windshield or headliner of the vehicle) via a substantially plastic or all plastic double ball mounting arrangement, such as described in U.S. Pat. No. 6,318,870 and/or U.S. pat. application, Ser. No. 10/032,401, filed Dec. 20, 2001 by March et al. for INTERIOR REARVIEW MIRROR ASSEMBLY WITH POLYMERIC COMPONENTS (Attorney Docket DON01 P-951), which are hereby incorporated herein by reference. The mounting arrangement may be configured to provide for wiring to the mirror assembly through the mounting arrangement and to or into the mirror assembly, without affecting the scope of the present invention.

During assembly of the reflective element assembly portion, the mounting member or arm may be inserted into the socket portion at the reflective element assembly portion (such as at the reflective element or at a backing plate of the reflective element or at a toggle assembly of the mirror assembly or the like) via an automated device or machine or by a robot. The automatic device or machine may be used to attach or snap the front end of the mounting member to the socket portion at the reflective element.

Optionally, the mirror assembly may provide or include an automatic flip prismatic reflective element, such as described in U.S. Pat. Nos. 6,717,712; 6,568,414; and/or 6,382,806, which are hereby incorporated herein by reference. Because the circuit board and any display elements positioned thereon is/are generally fixedly secured to the cap portion, which in turn is generally fixedly secured to or relative to the mirror holder and reflective element, the circuit board and display elements move with the reflective element during adjustment of the mirror, such that there is substantially no change in the juxtapositioning / alignment of the lighting or display through the prismatic reflective element.

Mirror holder 12 of interior rearview mirror assembly 10 preferably comprises a unitary or one-piece mirror holder (preferably molded from a thermoplastic resin, such as a

polyolefin, such as polypropylene or the like), which may be molded or otherwise formed with a bezel portion 12b integrally formed therewith, and which receives the prismatic reflective element therein. As shown in FIGS. 6 and 7, the toggle assembly 20 and mounting portion 22 may be attached to the mirror holder / bezel portion 12, preferably while the mirror holder is still warm and pliable. Although not shown in FIGS. 6 and 7, the reflective element 14 may be attached to or inserted into the mirror holder / bezel portion 12 at around the same time to form a mirror holder assembly that may be attached to the appropriate or desired cap portion, as discussed below. The reflective element and molded portion or bezel portion thus may define a reflective element assembly portion 13 of the mirror assembly 10. The toggle assembly 20 and the prismatic reflective element 14 thus may be secured into place (such as by snapping together) at or in the mirror holder 12 while the molded mirror holder (preferably the freshly molded mirror holder) is still warm and pliable, such as disclosed in U.S. Pat. No. 4,436,371, issued to Wood et al., which is hereby incorporated herein by reference. When the molded mirror holder (preferably the freshly molded mirror holder and thus just exiting the injection molding press, or alternately, and less desirably, a heated mirror holder having been heated, such as in an oven or the like, to make the mirror holder warm and pliable) cools and shrinks, the mirror holder grips around the toggle assembly and the prismatic reflective element to retain the toggle assembly and the reflective element in the reflective element assembly portion.

The material of the mirror holder or bezel portion, and/or of the reflective element assembly portion in totality, may be selected to have a desired linear mold shrinkage or tool shrinkage factor to provide the desired amount or degree of shrinkage as the mirror holder cools and shrinks around the reflective element to secure the reflective element at the mirror holder or bezel portion. For example, at least the bezel material, and preferably the reflective element assembly portion in totality, may have a linear mold shrinkage or tool shrinkage factor of preferably at least about 0.01 cm/cm or about 1%, and more preferably at least about 0.015 cm/cm or about 1.5%. For example, a UV stabilized, general purpose black polypropylene polymeric molding resinous material, such as is commercially available from Huntsman Corp. of Houston, Tex. under the trade name REXENE 17C9A, and having a tool shrinkage factor of 0.018 cm/cm or 1.8%, may be a suitable material for the bezel portion in that it provides a desired degree of shrinkage around the reflective element as the material cools, and after formation of the mirror holder or bezel portion by molding in an injection molding operation and/or after heating an already-molded mirror holder or bezel portion to an

elevated temperature (such as greater than 70 degrees Celsius or higher), in order to sufficiently retain the reflective element at the bezel portion.

The linear mold shrinkage or tool shrinkage factors, as known in the material science arts, are determinable by test standards, such as by test standards set by the American Society
5 for Testing and Materials (ASTM), such as the ASTM D 955 (Standard Test Method of Measuring Shrinkage from Mold Dimensions of Thermoplastics), which is hereby incorporated herein by reference, or such as by ISO 294-4, which is hereby incorporated
10 herein by reference. The test measures the shrinkage from the mold cavity to the molded dimensions of thermoplastics when molded by compression or injection molding processes with specified process conditions or parameters.

As shown in FIGS. 2 and 3, the rear portion 12a of mirror holder 12 may have openings or apertures 12c formed therethrough at either or both sides of the toggle assembly to allow for insertion of the accessory or accessories supported by the corresponding cap
15 portions, as discussed below. Optionally, and as shown in FIGS. 4-7, the mirror holder 12' may be substantially open for a unitary cap portion 16" to attach at, as also discussed below.

After the mirror holder and reflective element are assembled together, and maybe after the mirror holder has cooled and shrunk (such as in applications where the reflective element / mirror holder assembly is provided or shipped from a different location than where the cap portion and electrical circuitry or electrical content are from), the cap portion 16 may
20 be attached or secured to the rear portion 12a of mirror holder 12 to complete the assembly of rearview mirror assembly 10. In comparison to the bezel material, the material selected for the cap portion need not have such shrinkage properties as described above, because the cap portion may be fabricated at and supplied from separate operations, locations and/or facilities than the bezel portion. However, the cap portion may be fabricated at the same facility or
25 location, but could be made during a different operation and/or at a different time, without affecting the scope of the present invention. For example, the cap portion preferably is formed by injection molding of a polymeric resinous material having a tool shrinkage factor of less than and preferably substantially less than about 0.01 cm/cm or about 1% (although it may also have higher tool shrinkage factors, without affecting the scope of the present
30 invention), and preferably less than approximately 0.008 cm/cm or about 0.8%. This enables the provision in the cap portion of material properties not readily deliverable by the higher linear mold shrinkage or tool shrinkage factor materials used for the bezel portion.

For example, the cap portion material may have a higher heat stability / higher heat deflection property / higher flexural modulus compared to the reflective element assembly

portion, in order to maintain any accessories or elements mechanically attached thereto or therein. Also, the cap portion material may be selected to provide a higher structural strength if desired. For example, the cap portion material may comprise a high temperature ABS material, such as available from BASF or others under the trade name TERLURAN®

5 GRADE-HH106, which has a tool shrinkage factor of around 0.006 cm/cm or 0.6%, or other suitable materials, such as Nylon and preferably a filled Nylon material or the like. Such a material may also provide structural characteristics that are suitable for supporting accessories or the like. For example, the cap portion material may desirably have a heat deflection temperature under load of 0.45 MPa of greater than approximately 100 degrees

10 Celsius (and more desirably, greater than approximately 110 degrees Celsius and most desirably greater than approximately 115 degrees Celsius), as determined by standard testing, such as by ASTM 648 or ISO 75-1/-2 (which are hereby incorporated herein by reference) or the like. Such testing may determine the temperature at which an arbitrary deformation occurs when a specimen of the material is subjected to an arbitrary set of testing conditions or

15 parameters.

The tool shrinkage factor of the resinous material molded to form the cap portion thus is preferably less than the tool shrinkage factor of the resinous material molded to form the bezel portion of the reflective element assembly portion. Also, the flexural modulus of the material that forms the cap portion may preferably be greater than the flexural modulus of the

20 material that forms the mirror holder or bezel portion. Also, the material that forms the cap portion may preferably have a higher heat deflection temperature (such as may be determined by standard testing, such as ASTM D-790, which is hereby incorporated herein by reference) than the material that forms the bezel portion or mirror holder. Such standardized testing may determine the flexural properties or flexural strength of the material via bending or

25 breaking of specimens of the material in accordance with the appropriate test parameters. Desirably, although the polymeric resinous materials used for the bezel portion and the cap portion may be different, the portions may have similar exterior finishes and/or textures. Alternatively, however, the portions may have different finishes and/or textures or the like as discussed below, without affecting the scope of the present invention.

30 Optionally, and as described above, the mirror holder and reflective element assembly portion may be packaged and moved to another facility and/or the cap portion may be received from another facility to complete the mirror assembly. The appropriate or selected cap portion (with the appropriate associated electrical circuitry/accessory/content) may then be attached to the reflective element / mirror holder assembly, such as at the vehicle assembly

line, to assemble the mirror assembly for installation into the appropriate vehicle having the optional content of the mirror assembly, as discussed below. The modular mirror assembly of the present invention thus facilitates assembly of the reflective element assembly portion and of the cap portion at different assembly locations, whereby the two portions may be
5 joined or assembled together at a different location, such as at the vehicle assembly plant, to complete the mirror assembly. The cap portion may attach to the reflective element assembly portion via a snap together connection or other type of connection, and may removably or detachably attach, so that the cap portion may be removed from the reflective element
10 assembly portion if desired. However, the cap portion may alternatively be non-detachably attached, such as by adhesive attachment or by heat staking or by ultrasonic welding or the like, without affecting the scope of the present invention. The cap portion may attach to the reflective element assembly portion via any manner, such as, for example, utilizing aspects described in U.S. Pat. No. 6,402,331, which is hereby incorporated herein by reference. Thus, the present invention encompasses customization/selection of material properties for
15 the cap portion to be different from material properties selected for the reflective element assembly portion so that decorative finishes and/or functional properties may be customized/delivered to be the same or different for one or both of the portions.

Optionally, one or more accessory modules or blocks (such as discussed below) may be attached to or inserted or plugged into the cap portion and/or mirror assembly, such as at
20 the vehicle assembly line, to provide a desired or selected or customized optional feature or accessory to the mirror assembly. The accessory module may insert or attach to the mirror assembly or cap portion utilizing aspects described in U.S. Pat. Nos. 6,672,744; 6,402,331; 6,386,742; and 6,124,886, and/or U.S. pat. application, Ser. No. 10/739,766, filed Dec. 18, 2003 by DeLine et al. for MODULAR REARVIEW MIRROR ASSEMBLY (Attorney
25 Docket DON01 P-1119), which are hereby incorporated herein by reference. The accessory module may include circuitry and display elements and user inputs, and may plug into the cap portion or mirror assembly in a manner whereby mechanical and electrical connections are preferably simultaneously made as the module is inserted into the cap portion or mirror assembly, such as by utilizing aspects described in U.S. Pat. No. 6,669,267, and/or U.S. pat.
30 application, Ser. No. 10/727,731, filed Dec. 3, 2003 by Lynam et al. for EXTERIOR ACCESSORY MODULE FOR VEHICULAR MODULAR DOOR (Attorney Docket DON01 P-1124), which are hereby incorporated herein by reference. The mirror assemblies thus may be customized to particular work orders or selected options at the vehicle assembly

line via insertion or attachment of the appropriate accessory module, such that the cap portion and the reflective element assembly portion may comprises common or universal components for two or more options offered for the particular mirror assembly or vehicle application.

The modular mirror assembly of the present invention thus may provide fully
5 assembled mirror assemblies to a vehicle assembly plant and line, where the cap portion and selected content are attached to the reflective element assembly portion at a remote location, such that different mirror assemblies are provided for different options or applications. Optionally, the modular mirror assembly may provide a universal or common reflective element assembly portion to a vehicle assembly plant, and a selected cap portion (with the
10 appropriate or desired or selected optional content) may be attached to the reflective element assembly portion at the vehicle assembly line to customize the mirror assembly for the particular selected option or application. Optionally, the modular mirror assembly of the present invention may provide a universal reflective element assembly portion and a partially or substantially universal (at least universal as to two or more selectable options) cap portion,
15 whereby the selected accessory module may be inserted into or attached to the cap portion and/or mirror assembly at the vehicle assembly line to complete the mirror assembly and to provide the desired or selected option or feature to the mirror assembly.

As shown in FIG. 2, cap portion 16 may comprise two separate cap portions 16a, 16b, or a cap portion 16' (FIG. 3) may have two cap portions 16a', 16b' joined together by a
20 connecting portion or wire channel 16c. One or both of the cap portions 16a, 16b may have an accessory or circuit board 18a, 18b attached thereto. The circuit board or boards may snap or otherwise affix or secure to the cap portion or portions. As shown in FIG. 2, the cap portions may have retainers or pillars extending from an interior surface for retaining and supporting the circuit board or boards thereon. Optionally, the cap portion may comprise a
25 unitary cap portion 16" (FIGS. 4, 5, 8-11, 24 and 26) substantially covering the rear portion of the mirror holder (opposite the reflective element) and receiving or supporting one or more printed circuit boards thereon. The cap portion may receive the mounting portion 22 between the side portions of the cap portion 16' (FIG. 3) or through an opening 25a in the cap portion 16" (FIGS. 4, 8-11, 24 and 26) as the cap portion is attached to the mirror holder. For
30 example, the mounting portion 22 may be threaded through the opening 25a in the cap portion as the cap portion is moved toward and into engagement with the bezel portion during the mirror assembly process. The mirror assemblies 10' and 10" (with cap portions 16' and 16", respectively) may be substantially similar to and may have substantially similar components and accessories as mirror assembly 10 (with cap portions 16a, 16b), such that a

detailed description will not be repeated for the different mirror assemblies. The common or similar components of the mirror assemblies are referred to in FIGS. 2-11 with the same reference numbers.

5 The cap portion 16 or portions 16a, 16b may be positioned at openings 12c of mirror holder 12 such that the accessories or circuitry supported by the cap portions are positioned generally within mirror holder 12. The cap portions may snap onto the rear portion 12a of mirror holder 12 and generally cover the openings 12c in mirror holder 12. Optionally, the unitary cap portion 16" may snap onto or otherwise secure to the mirror holder and generally cover or define the rear portion of the mirror assembly when so assembled. The cap portion
10 or portions thus support the circuit board or circuit boards and associated circuitry and/or accessories at or within the mirror assembly.

Optionally, the circuit boards or accessories may be provided at, within or on the cap portions at a cap portion manufacturing facility or electrical accessory manufacturing facility, such that the cap portion and circuitry assemblies are provided as a unit to the mirror
15 assembly facility or plant. The cap portion and circuitry units may then be snapped or otherwise affixed to the mirror holder or reflective element assembly portion of an appropriate mirror assembly having features or components or displays corresponding to the cap portion and circuitry units, as discussed below. The assembly or back-loading of the cap portions to the mirror holder and reflective element assembly portion thus may be performed
20 remote from the molding tool for molding the mirror holder, since the cap portions may be mounted to the mirror holder after the mirror holder has cooled and shrunk.

Each cap portion may support one or more desired accessories or circuit boards for providing the desired feature to the mirror assembly. The cap portions, and corresponding accessory or feature or electrical content, may be selected and attached to a universal or
25 common mirror holder to provide different features to the mirror depending on the options selected for a particular application or vehicle. Optionally, the cap portions may be selected/configured to have accessories contained/supported therein to correspond to and be aligned with/juxtapositioned with one or more displays of a particular or respective reflective element secured in the common mirror holder and/or may correspond with a particular mirror
30 holder for applications where the accessory includes buttons or controls which may extend through openings or recesses in the mirror holder for access thereto by the driver or occupant of the vehicle, as discussed in detail below.

The cap portion or cap portions may be snapped or otherwise secured to the rear portion 12a of mirror holder 12, such as generally at and covering corresponding openings

12c through the rear portion 12a of mirror holder 12. The opening or openings 12c may be at either or both sides of the toggle assembly and mounting portion of the mirror assembly. The cap portion may snap over or otherwise interconnect with the respective opening via a plurality of hooks or snap clasps (which may extend from the cap portion or the mirror holder) engaging a plurality of corresponding slots or the like at the other of the cap portion and the mirror holder. The cap portion may be formed to provide an exterior surface which may substantially match the exterior surface of the mirror holder to provide a finished appearance to the mirror assembly when the cap portions are attached to the mirror holder and thus form the rear or back portion of the mirror holder and/or it may provide a contrast or distinctive aesthetic or functional appearance or finish. The mirror holder and the cap portions may be formed of a polypropylene material or a talc-filled polypropylene material or the like, or preferably the mirror holder is formed of a molded polyolefin, while the cap portion is formed of a molded engineering resin, such as ABS or a Nylon or the like. Optionally, the cap portion may comprise a metallic material or may comprise a polymeric molding overcoated with a metallic layer or coating, and may have ribs or ripples to provide enhanced rigidity of the cap portion, without affecting the scope of the present invention.

Optionally, the cap portion may have a different color or texture (such as a chrome or colored or textured surface or the like) than the mirror holder or bezel portion to provide a two-tone configuration to the mirror assembly. Optionally, the cap portion and/or the mirror holder may have a decorative finish, and may be painted or plated, such as electroplated or the like, or may have a film or an in mold film or coating thereon to provide the desired surface to the cap portion and/or the mirror holder. For example, the cap portion (or the mirror holder) may provide a contrast or accent color or may be chrome plated or may be brushed aluminum or the like or may provide an angle variant color (where the perceived color may change depending on the viewing angle) or may provide various colors or patterns or textures or the like as may be desired by a consumer (for example, certain colors or patterns or textures may be provided to target different demographics, such as for targeting teenagers or other age groups or genders or the like). Optionally, the cap portion or bezel portion may have a fabric cover (such as, for example, leather or cloth or denim or other cover material or the like) at and substantially over at least a portion or the entirety of its exterior surface to provide a desired appearance or texture or the like. Optionally, the cap portion and/or the mirror holder or bezel portion may have a soft touch surface, such as a soft touch surface and material similar to that described above (preferably having a Shore A

durometer value of less than about 110 Shore A, more preferably less than about 90 Shore A, and most preferably less than about 70 Shore A) with respect to the toggle tab and/or similar to the types described in U.S. Pat. Nos. 6,318,870 and/or 6,349,450, which are hereby incorporated herein by reference. For example, either the mirror holder or the cap portion
5 may have such a soft touch surface independent of the other, or both may have such a soft touch surface or neither may have a soft touch surface. Although the cap portion may be finished with a metallized reflective finish, such as a chrome or chrome-plated finish, the bezel portion desirably may not be chrome or chrome-plated or the like, in order to reduce reflections or glare at the bezel portion around the reflective element, and thus not be
10 specularly reflecting.

It is further envisioned that the cap portion or bezel of the interior or exterior mirror assembly may include a personalization element, such as a logo or text or pattern or other indicia, thereon as desired by the consumer to provide highly personalized and unique mirror assemblies for the particular consumers that purchase the vehicles or the mirror assemblies,
15 such as described in U.S. provisional applications, Ser. No. 60/553,842, filed Mar. 17, 2004 by Bareman et al. for METHOD OF MANUFACTURING ELECTRO-OPTIC MIRROR CELL (Attorney Docket DON01 P-1143); and Ser. No. 60/563,342, filed Apr. 19, 2004 by Bareman et al. for METHOD OF MANUFACTURING ELECTRO-OPTIC MIRROR CELL (Attorney Docket DON01 P-1153), which are hereby incorporated herein by reference. For
20 example, the cap portion may include a school logo and colors, such as, for example, the letters "MSU" in green and white print/background, to provide a desirable appearance to the personalized mirror assembly for a particular consumer, such as, for example, a student or graduate of Michigan State University. Optionally, the cap portion may include other text or logos or brand names or other types of identifying indicia, such as, for example, "FORD" to
25 identify the vehicle manufacturer, or "TOMMY HILFIGER" to identify the vehicle owner's clothing preference or the like, or other text or messages or images or trademarks or colors or patterns or indicia or the like to provide a desired appearance or identification or message or statement or advertisement or logo or sponsorship identification or style or brand
30 identification on the interior or exterior mirror assembly. The mirror assemblies may thus be assembled to have the desired or personalized cap portion with the desired or personalized logo or color or message or indicia thereon to provide the desired or personalized finish or appearance of the interior or exterior mirror assembly.

In an aftermarket application, various cap portions as described above may be provided as aftermarket interior or exterior mirror cap portions. A consumer may then purchase a desired cap portion, which may have desired content or features and/or may have a desired color or texture or appearance or the like, and may readily remove the existing cap portion from the interior or exterior mirror assembly of their vehicle and replace it with the new cap portion. For example, the cap portion and/or the mirror holder or reflective element assembly portion (such as the mirror support arm for an interior rearview mirror assembly or a mirror mount for an exterior rearview mirror assembly) may have snaps or clasps that may retain the cap portion and mirror holder/mount/bezel together, but that may release or detach such that the cap portion may be detachable from the mirror assembly by a user/consumer. The cap portion may be pulled or detached from the mirror assembly and a new cap portion (with the desired content therein and/or personalized text or indicia or colors or the like thereon) may be pressed or snapped into place on the mirror assembly to provide the vehicle owner with the new cap portion having the desired content or functions or features and/or the desired or personalized appearance or the like.

Optionally, the modular mirror assembly of the present invention may provide customizing of other visible or viewable portions of the mirror assembly as well. For example, the flip tab or toggle tab 20a (or a rotary knob or the like depending on the type of toggle assembly of the particular mirror assembly) may be removably attached to the toggle assembly, such that the tab may be selected or replaced as desired. The tab may threadedly attach to a threaded stud or bolt or nut or the like at the toggle assembly (or may detachably attach via other means, such as snaps, twist-on connections, a bayonet connection or the like), such that a desired tab may be readily attached to the toggle assembly to provide the desired tab for the mirror assembly. The selectable or replaceable or customized toggle tabs may provide various styles, sizes, shapes, appearances, textures, touches/feels (such as a soft touch material or the like), colors, patterns, indicia (such as logos or icons or the like as described below with respect to the center port 15c of the compass display 14a in FIGS. 13A-D). The customer/consumer thus may select the desired toggle tab for attachment to the mirror assembly (such as a tab that matches or is associated with the selected cap portion and/or bezel portion and/or reflective element ports (discussed below) or the like) to customize the mirror assembly. The customization and selection or replacement of the toggle tab may occur at the reflective element assembly portion assembly plant or at the mirror assembly plant or at the vehicle assembly plant or at the vehicle dealership or at any other aftermarket facility or the like, without affecting the scope of the present invention. The custom tab may

thus be selected and attached or replaced at the mirror assembly to provide a custom appearance without having to retool or mold a different toggle assembly.

Optionally, the bezel portion 12 may be molded of a universal or standard color, finish and/or material, such as a black plastic material or black polypropylene or the like, and an outer rim portion or perimeter trim portion element may attach to a forward edge of the bezel portion (at the viewable side of the reflective element) to provide a desired appearance and/or functionality of the bezel portion of the mirror assembly to the driver and passenger of the vehicle. The bezel portion 12 may be formed to have a recess or trough or lip or the like around its perimeter portion (such as at 12b in FIG. 2), and the desired trim portion element may be selected and snapped to or pressed into or otherwise received in / attached to the perimeter portion of the bezel portion to provide the desired appearance/functionality to the mirror assembly. The attachable trim portion element may provide various styles, appearances, textures, touches/feels (such as a rubber or elastomeric material or soft touch material or the like), colors, patterns, indicia (such as logos, icons or the like as described below with respect to the center port 15c of the compass display 14a in FIGS. 13A-D). The customer thus may select the desired trim portion element for attachment to the bezel portion of the mirror assembly (such as a trim portion element that matches or is associated with the selected cap portion and/or toggle tab and/or reflective element ports (discussed below) or the like) to customize the mirror assembly. The trim portion element may be selected to provide a soft material or an impact absorbing material, and may have a Shore A durometer hardness that is less than that of the bezel portion or mirror holder. The customization and selection or replacement of the trim portion element may occur at the reflective element assembly portion assembly plant or at the mirror assembly plant or at the vehicle assembly plant or at the vehicle dealership or at any other aftermarket facility or the like, without affecting the scope of the present invention. The bezel portion thus may be formed as a universal or common bezel portion, and the viewable rim of the bezel portion (such as around the perimeter of the reflective element and viewable by a driver of the vehicle when the mirror is installed in the vehicle) may be selected or replaced to provide the desired or customized appearance and/or feel of the mirror assembly.

Optionally, the cap portion, or one of the cap portions, such as the cap portion 16b on the side of the mirror assembly, such as the side which will be toward the passenger side of the vehicle when the mirror assembly is installed in the vehicle, may include an electrical connector for connecting the accessory or circuit board or boards 18a, 18b to a vehicle wiring harness or power source of the vehicle. Optionally, the circuit board 18b at the cap portion

may include a multi-pin connector 24 for connecting to a corresponding multi-pin connector of the vehicle wire harness. In such applications, an opening (such as opening 25b of cap portion 16" in FIGS. 4, 5 and 8-11) of sufficient size may be provided in the cap portion (or optionally in the mirror holder) to allow the connector on the wire harness to insert
5 therethrough for connection to the connector on the circuit board 18b. The circuit board 18b or connector 24 may be substantially supported at the cap portion to provide sufficient support of the connector when a corresponding connector of the wire harness is pushed into engagement with connector 24.

For example, the cap portion or mirror holder may have a connector formed therein,
10 whereby the wire harness may then connect to or plug into the connector at the rear of the mirror assembly. The connector may be formed as a selected or appropriate connector (such as a six pin or eight pin connector or the like) depending on the accessories of the cap portions. Optionally, the connector may be formed with an insert in the mold or tool for forming the cap portion, such that an appropriate insert may be placed in the mold or tool to
15 form the desired or appropriate connector on that particular cap portion. In the illustrated embodiment of FIGS. 4, 5 and 8-11, the connector 24 of the circuit board includes a plurality of pins 24a for connecting to a connector or plug, and the cap portion 16" has an opening 25b formed therethrough so that the connector or plug may readily connect to the circuit board, and may snap or otherwise be fastened or secured thereto, such as via clasps or the like at the
20 plug and/or at the cap portion 16".

In applications where both cap portions 16a, 16b support an accessory or circuit board, the circuit board 18a on the cap portion 16a (or the circuit board on one side of the unitary cap portion) opposite the connector 24 may be connected to the other circuit board 18b and/or connector 24 via one or more connecting wires 26, in order to provide power
25 and/or control to the accessory on cap portion 16a. The connecting wire or wires 26 may extend between the cap portions 16a, 16b within the mirror holder 12 or may extend along the rear surface of the mirror holder 12, without affecting the scope of the present invention. As shown in FIG. 3, cap portion 16' of an interior rearview mirror assembly 10' may
30 comprise a single cap portion having a wire channel or connector 16c extending between opposite end caps or end portions 16a', 16b'. The connecting wire (not shown in FIG. 3) may extend between the circuit boards 18a, 18b or accessories supported on the end portions 16a', 16b' and may be routed within the wire channel 16c or between the channel 16c and the rear portion 12a of the mirror holder 12. Optionally, and as shown in FIGS. 4, 5, 8-11, 24 and 26, a mirror assembly 10" may have the single or unitary cap portion 16" in accordance with the

present invention, and a connecting wire between two circuit boards or accessories may extend along the cap portion to electrically connect the circuit boards or accessories together.

As shown in FIG. 2, printed circuit board 18b may include circuitry 19 for a compass display 14a and/or other accessory display, such as a passenger side inflatable restraint display 14b or the like, at reflective element 12. More particularly, circuit board 18b may include compass display circuitry 19 having a plurality of illumination sources 19a which are individually illuminated or illuminated in combination to project illumination through respective openings in circuit board 18b to illuminate one or more of the ports or direction characters 15a etched or formed in reflective element 14, such as in the manner disclosed in U.S. pat. application, Ser. No. 10/456,599, filed Jun. 6, 2003 by Weller et al. for INTERIOR REARVIEW MIRROR SYSTEM WITH COMPASS (Attorney Docket DON01 P-1076), which is hereby incorporated herein by reference in its entirety. The compass display thus may be controlled or actuated by a microcontroller or microprocessor of the cap portion of the mirror assembly. The controller may drive or energize the illumination sources (such as light emitting diodes or the like) directly, without the need for additional display drivers. The direct energization of the illumination sources of the display thus avoids the need for other controllers or drivers within the cap portion or the mirror assembly or the vehicle.

When the cap portion 16b (or cap portion 16" or the like) and circuit board 18b are attached to or juxtaposed with the mirror holder 12, circuit board 18b may be pressed or urged toward the rear surface of reflective element 14 such that the illumination sources 19a (such as light emitting diodes or the like) at the circuit board may generally align with the appropriate ports or characters or icons formed in the reflective element 14, as discussed below. For example, and as best shown in FIGS. 8 and 9, the cap portion may include guide members or posts 25c for engaging corresponding guide members or tabs or holes or notches or recesses 18c of the circuit board for guiding the circuit board into the appropriate position and orientation on the cap portion as the circuit board is attached or snapped to the cap portion. The cap portion may then attach to the mirror holder / bezel portion via engagement and guiding of corresponding tabs and holes and the like, which function to position the cap portion in the desired location relative to the bezel portion, such that the circuit board (and any illumination devices or the like positioned thereon) is/are properly aligned with any associated display ports or switches or the like at the mirror holder / bezel portion / reflective element.

As shown in FIGS. 4 and 5, a seal or sealing member or layer 17 or the like may be applied to the rear surface of reflective element 14 or to the forward face 18d of circuit board

18b to substantially seal the interface between the circuit board 18b and the reflective element 14, in order to limit or substantially preclude light from one of the illumination sources from illuminating a port or character or icon at the reflective element other than the respective port or character or icon aligned with that illumination source and opening. The seal 17 may
5 comprise an opaque material, and may comprise a white (or other color) silicone gasket or the like, to diffuse and/or reflect light. The seal 17 may be at least partially and preferably substantially flexible or resilient to compress and seal against the reflective element and the circuit board to limit or substantially preclude light leakage from one illumination source to one of the other ports or characters of the display.

10 The circuit board may also include a connecting wire 28 which may connect to a compass pod or module 30 or other accessory or accessory module or the like for communication of compass heading or control information to the compass display circuitry 19 at the circuit board or for communication of other control information between the accessory module and the circuit board of the cap portion. For example, the connecting wire
15 28 may extend from the cap portion and the rear of the mirror assembly to the compass module 30, which may be attached to the mounting arm or mounting button of the mirror assembly or otherwise positioned or mounted at or near the mirror assembly. Compass module 30 may include the compass circuitry (which may include calibration circuitry, a microprocessor and the like) and magneto-responsive compass sensors (such as
20 magneto-resistive sensors, magneto-capacitive sensors, magnetoinductive sensors or the like or a flux gate sensor or the like), such as described in U.S. Pat. Nos. 6,513,252 and 5,802,727, and/or U.S. pat. application, Ser. No. 10/456,599, filed Jun. 6, 2003 by Weller et al. for INTERIOR REARVIEW MIRROR SYSTEM WITH COMPASS (Attorney Docket DON01 P-1076), which are hereby incorporated herein by reference in their entireties. The
25 compass pod may also include an ambient light sensor, whereby the intensity of the compass display (and other displays of the mirror assembly) may be adjusted in response to the detected ambient light levels. Optionally, the compass system may utilize principles disclosed in U.S. Pat. Nos. 5,924,212; 4,862,594; 4,937,945; 5,131,154; 5,255,442; and/or 5,632,092, which are hereby incorporated herein by reference.

30 Although shown and described as having a separate compass pod that may mount to the mirror mounting portion of the mirror assembly that in turn mounts to the likes of a mirror mounting button on the windshield (such as described in U.S. Pat. Nos. 6,648,478; 5,708,410 and/or 5,576,687, which are hereby incorporated herein by reference) to remain generally stationary, it is envisioned that a compass pod or module or compass circuitry and

sensors may be positioned in a post or arm of a single ball mounting arrangement such that the sensors and circuitry are generally fixedly positioned relative to the mounting button and the vehicle. A wire may be routed along the generally fixed mounting arm (via and through the single ball joint) and to the display elements or illumination sources, such as in a manner similar to that shown in FIG. 34, or a wire may be routed along the mounting arm and through the single ball and into the mirror casing or a wire or conductor may be routed or positioned along the arm and ball in any other manner to communicate electrical signals and the like to the circuitry and/or illumination sources of the cap portion, without affecting the scope of the present invention. The wire may provide slack to allow for the adjustment and movement of the mirror holder/cap portion about the single arm to avoid pulling at the wire during adjustment of the mirror.

The compass circuitry 19 on circuit board 18b may also include a button or switch or control or may be in communication with a button or control 23 (FIGS. 8, 10 and 11), such as at the rear of the cap portion 16" or at the rear of the mirror holder, for actuating a calibration or zone function of the compass circuitry. In the illustrated embodiment, the button 23 may include an inward protrusion 23a (FIGS. 8 and 24) that extends forwardly from the cap portion 16" or inwardly toward the button or switch or control on the circuit board when the cap portion 16" is attached to the circuit board. The button 23 may comprise a flexible tab 23b integrally formed with and extending partially along the cap portion 16". When a user presses at the button 23, the tab 23b flexes and the protrusion 23a is moved toward and urged against the button or switch on the circuit board 18b to actuate the switch to control or activate/deactivate the associated function of the compass circuitry (or other circuitry or accessory or the like that may be associated with the switch on the circuit board). Although shown and described as being integrally formed with the single cap portion 16" in FIGS. 8, 10, 11 and 24, the button/flexible tab or flip actuation tab member may be integrally formed on one of the side cap portions 16a, 16b or end portions 16a', 16b' of cap portion 16' or the like, or on other types of casings or housings or the like, without affecting the scope of the present invention.

Optionally, an additional illumination source or lighting element may be provided on the circuit board 18b for projecting illumination through a corresponding port or icon or character 15b formed on the reflective element 14 to indicate that the compass system is in the calibration mode or zone setting mode. Optionally, the calibration mode may be indicated by a light emitting diode (LED) at the center port 15c of the display. For example, a dual-color LED may be provided at the center port, where illumination in one color (such

as, for example, red) indicates that the compass system is in the calibration mode. Once the compass system is calibrated, however, illumination may be provided in the other color (such as, for example, blue). Thus, when the compass system is not in the calibration mode, the other color (such as blue) indication color may be provided. Optionally, the calibration mode could be indicated without a dedicated illumination source or light emitting diode or the like (because such an indicator would be used very rarely in the life of the part). For example, the center illumination source or LED (which may be activated to provide an anchor point or focal point for the display, as discussed below) may be flashed or otherwise modulated or adjusted when the system is in the calibration mode, or other similar types of indication may be provided to convey to the driver that the compass is in its calibration mode.

The circuit board 18b may also have an ambient light sensor or photocell (not shown) for detecting the ambient light level at the mirror assembly, whereby the circuitry may adjust the intensity of the display in response to the detected ambient light levels. A corresponding opening in the mirror holder 12 or at the rear of the cap portion 16 (such as opening 25d in cap portion 16" of FIGS. 8, 10 and 11) may allow the ambient light sensor to detect the ambient light levels through the opening. The light sensor may alternately be positioned at the compass pod or module 30, without affecting the scope of the present invention.

The compass display 14a (FIGS. 1-5 and 12) thus may include a plurality of direction indicating ports 15a (such as four such ports formed to represent the cardinal directional points or "N", "E", "S" and "W" or the like) and may include an additional port 15b for a calibration indicator or light source, such as described in U.S. pat. application, Ser. No. 10/456,599, filed Jun. 6, 2003 by Weller et al. for INTERIOR REARVIEW MIRROR SYSTEM WITH COMPASS (Attorney Docket DON01 P-1076), which is hereby incorporated herein by reference in its entirety. Compass display 14a may further include a center port 15c etched or otherwise formed at a central region of the display 14a. Center port 15c may provide an opening or port for a rearward facing photosensor positioned at the circuit board to receive light therethrough to determine the ambient light at or in the vehicle cabin (or a glare sensor for determining glare at the mirror assembly for controlling an exterior electrochromic mirror assembly or cell or the like as discussed below) when the mirror assembly is assembled and positioned in the vehicle, such as discussed below.

Optionally, center port 15c may align with an illumination source or light emitting diode at the circuit board to provide a visible center indicator or central anchor or focal point at the central region of the display 14a such that a person may readily identify the center of the compass display. For example, when one of the directional heading indicators at ports

15a are illuminated or energized, the indicator or light source at center port 15c may also be energized to provide a visible central anchor point for a person to recognize as the central region of the display. The provision of an extra illumination source or port that is central to the rosette N-E-S-W indicia thus helps to serve as a reference point for the driver, in order to aid the driver's cognitive association of the cardinal direction point that is intended to be communicated when any one (or combination of two) of the N, E, S, W icons or ports are illuminated.

Optionally, the light emitting diodes aligned with the directional indicating ports 15a may be one color, while the light emitting diodes at the central port 15c and/or at the calibration indicating port 15b may be another color or colors. For example, the directional indicating ports 15a may be illuminated or back lit via blue indicators or light emitting diodes or the like, while the central port 15c may be illuminated or back lit via a red or amber indicator or light emitting diode or the like, so that a person viewing the compass display in darkened conditions may readily discern which indicator is indicative of the central region of the display and thus where the center of the display is, such that the person may readily recognize which directional indicating port is illuminated, without having to look to see whether it is an "N" or an "E" or the like.

Optionally, the center port may be illuminated whenever the vehicle is on or powered, in order to provide substantially continuous illumination of the center port. Preferably, the center port is illuminated at a lower light output intensity than that of the respective cardinal N, E, S, W ports, so as to serve as a subtle eye point, but not to be confused with an actual directional indication. For this reason, a color contrast as well as an intensity contrast may be desirable.

In such applications where the center port is illuminated or back lit, an ambient sensor may be positioned elsewhere in the mirror assembly, such as elsewhere in the cap portion, and may be a forwardly facing sensor (i.e. toward the windshield when the interior rearview mirror assembly is normally mounted in the interior cabin of a vehicle) and may receive light through a port or opening 25d in the cap portion. Alternatively, the ambient sensor may be facing downwardly or upwardly when installed in the vehicle, without affecting the scope of the present invention. The ambient sensor may be generally aligned with or juxtaposed at the port or opening or may receive the ambient light via a light pipe or the like, without affecting the scope of the present invention.

Optionally, and with reference to FIGS. 13A-D, the center port 15c of the compass display 14a (or other port or display area of the reflective element) may provide a graphic

depiction of a desired image, such as a logo of the vehicle manufacturer or other desired image. For example, the center port 15c may be etched (such as by laser etching or ablation or by sandblasting or the like) or otherwise formed to provide the letters "FORD" or may be etched or otherwise formed in a pattern similar to the design or designs indicative of the manufacturer, such as the Chevrolet "bowtie" or the like. Optionally, other designs or patterns or text or logos or indicia or the like may be provided at the center port 15c (or elsewhere on the reflective element) to provide a desired image or logo. In the illustrated embodiments of FIGS. 13A-D, the central port is formed to be indicative of the vehicle manufacturer, such as for Dodge (FIG. 13A), Honda (FIG. 13B) or Jeep (FIG. 13C), or Subaru (FIG. 13D). However, the central port may be formed to be indicative of other vehicle manufacturers or entities or sponsors or indicia or trademarks or emblems or signature items, or representations of a certain political views, religious beliefs, tribal affiliations, community ties, collegiate affiliations, allegiances and/or advocacy (such as, for example, a "peace" sign or other symbol or text or the like) or other views, affiliations, beliefs, etc., or other custom ports or icons may be formed elsewhere on the reflective element to convey other information or logos or the like, without affecting the scope of the present invention.

The desired image or logo may be indicative of the vehicle manufacturer, or may be selected by the user or vehicle owner to provide a customized interior rearview mirror assembly, such as described above with respect to the different logos or colors or textures or appearances or touch/feel provided on the cap portion or bezel portion of the mirror assembly, without affecting the scope of the present invention. For example, a person may select the logo or mascot of their alma mater to be etched at the center of the compass display (or elsewhere on the reflective element) to customize the mirror assembly for that particular person or owner. The customized or selected port may be at the central port of the compass display or may be at or incorporated into another display at the reflective element or may be elsewhere at the reflective element and separate from any other information display, without affecting the scope of the present invention. Optionally, the light source or indicator positioned at the circuit board behind the custom port may be selected to match the color that may be typically associated with the selected logo, such as a green or red or blue indicator or light emitting diode or the like for the school color or the like. Other forms of customized logos or indicia or the like may be etched or otherwise formed at the reflective element, without affecting the scope of the present invention.

Optionally, and with reference to FIGS. 14-16, an interior rearview mirror assembly 10" may include an intuitive heading instructional icon element or display 14a' at the reflective element 14', such as the types described in U.S. provisional application, Ser. No. 60/553,517, filed Mar. 16, 2004 by Schofield for MIRROR ASSEMBLY (Attorney Docket DON01 P-1145), which is hereby incorporated herein by reference. The compass display 14a' may be associated with or controlled or adjusted by a compass system and/or a navigational system, such as a compass and/or navigational system of the types described in U.S. Pat. Nos. 6,678,614; 6,477,464; 5,924,212; 4,862,594; 4,937,945; 5,131,154; 5,255,442; and/or 5,632,092, and/or U.S. pat. applications, Ser. No. 10/456,599, filed Jun. 6, 2003 by Weller et al. for INTERIOR REARVIEW MIRROR SYSTEM WITH COMPASS (Attorney Docket DON01 P-1076); Ser. No. 10/645,762, filed Aug. 20, 2003 by Taylor et al. for VEHICLE NAVIGATION SYSTEM FOR USE WITH A TELEMATICS SYSTEM (Attorney Docket DON01 P-1103); and Ser. No. 10/422,378, filed Apr. 24, 2003 (Attorney Docket DON01 P-1074); and/or PCT Application No. PCT/US03/40611, filed Dec. 19, 2003 by Donnelly Corporation et al. for ACCESSORY SYSTEM FOR VEHICLE (Attorney Docket DON01 FP-1123(PCT)), which are all hereby incorporated herein by reference.

Display 14a' includes a plurality of characters or icons or letters 15a (such as N, E, S, W as shown in FIGS. 14-16) formed or etched in the reflective coating or layer of the reflective element 14' and includes an arrow or direction pointer 15d at each of the characters 15a. The display 14a' may also include a central port 15c through the reflective coating or layer reflective element 14' behind which may be positioned an illumination source as described above or a glare sensor, such as a photo sensor or the like, such as a glare sensor and/or an ambient light sensor and electrochromic automatic dimming circuitry described in U.S. Pat. Nos. 4,793,690 and 5,193,029, and U.S. pat. application, Ser. No. 10/456,599, filed Jun. 6, 2003 by Weller et al. for INTERIOR REARVIEW MIRROR SYSTEM WITH COMPASS (Attorney Docket DON01 P-1076), which are all hereby incorporated herein by reference. The arrows of direction pointers may point generally upward when the mirror assembly is mounted in the vehicle with the reflective element facing generally rearward and opposite to the direction of forward travel of the vehicle. The arrows or pointers thus may be representative of the direction of forward travel of the vehicle. As shown in FIGS. 14-16, the direction pointers of display 14a' may comprise generally triangular shaped icons or pointers 15d positioned outward from the characters 15a and opposite the characters from the center or port 15c of the display (such as shown in FIG. 14), or the direction pointers of the display may comprise arrows 15d' positioned next to the characters 15a (such as shown in FIG. 15),

or the direction pointers of the display may comprise arrows 15d" positioned inward of the characters 15a and between the respective characters and the center or port 15c (such as shown in FIG. 16).

5 The compass/navigation system may be operable to energize one or more illumination sources positioned at and rearward of a respective one of the characters 15a and corresponding direction pointer 15d to illuminate or back light the respective character and direction pointer. For example, the compass/ navigation system may be operable to illuminate or back light a particular character and adjacent direction pointer to indicate to an occupant of the vehicle the direction that the vehicle is currently heading. For example, if the character "W" and the arrow or direction pointer next to the "W" are illuminated, then the display indicates that the vehicle is heading west. The intuitive heading instructional icon element or display thus may provide reinforcement to a viewer that when the character (such as "W" or other character) is illuminated, it is done so to indicate that the vehicle is traveling in the direction (such as west or other direction) indicated by the character. This is reinforced by the illumination of the corresponding arrow or direction pointer that points upward so as to be representative of pointing in the direction of forward travel of the vehicle. A person viewing the display thus will not misinterpret the illumination of the characters to be indicative of a driving or turning instruction (such as an instruction to turn the vehicle right or east to follow a programmed route) in connection with the navigation system.

20 Optionally, the display may function as a display for providing both an indication of the directional heading of the vehicle and an indication of which direction the vehicle should be turned in order to follow a programmed route or path. For example, only a particular direction pointer may be illuminated or back lit to indicate that the vehicle is heading in the direction indicated by the non-lit character next to the illuminated pointer, while a different character (separate from the illuminated pointer) may be illuminated or back lit to indicate that the vehicle is to be turned in that direction to follow a programmed route to a desired destination. The compass/navigation system and display thus may clearly display to a driver of the vehicle which direction the vehicle is heading at that time via the directional arrows, while the compass/navigation system and display may also be operable to provide driving or turning instructions to a driver of the vehicle to instruct the driver as to which direction the driver is to turn to follow a particular route to a desired destination. For example, the compass/navigation system may be associated with a global positioning system and/or telematics system of the vehicle, and may generate and display driving instructions to the driver of the vehicle as the vehicle is driven along a generated route, such as by utilizing

aspects described in U.S. Pat. Nos. 6,678,614 and 6,477,464, and/or U.S. pat. application, Ser. No. 10/456,599, filed Jun. 6, 2003 by Weller et al. for INTERIOR REARVIEW MIRROR SYSTEM WITH COMPASS (Attorney Docket DON01 P-1076); Ser. No. 10/645,762, filed Aug. 20, 2003 by Taylor et al. for VEHICLE NAVIGATION SYSTEM FOR USE WITH A TELEMATICS SYSTEM (Attorney Docket DON01 P-1103); and Ser. No. 10/422,378, filed Apr. 24, 2003 (Attorney Docket DON01 P-1074); and/or PCT Application No. PCT/US03/40611, filed Dec. 19, 2003 by Donnelly Corporation et al. for ACCESSORY SYSTEM FOR VEHICLE (Attorney Docket DON01 FP-1123(PCT)), which are all hereby incorporated herein by reference.

During operation, the compass/navigation system thus may be operable to energize an illumination source positioned at and rearward of/behind a respective one of the characters to provide a driving instruction to the driver of the vehicle that is separate from the directional heading indication also provided by illumination or back lighting of the arrows or pointers of the display. For example, if the vehicle is heading generally west, the compass/ navigation system may illuminate or back light the arrow next to the "W" to indicate to the driver of the vehicle that the vehicle is traveling generally in that direction. If the programmed route for the vehicle involves an upcoming right turn onto a generally northbound road, the compass/navigation system may then illuminate or back light the letter "N" to indicate to the driver of the vehicle that the driver should turn the vehicle to head north.

It is further envisioned that the illuminated character may be altered or adjusted as the vehicle gets closer to the turning point or intersection, such as by flashing the illumination source or intensifying the illumination source or changing the color of the illumination as the vehicle approaches the desired or appropriate turning point or intersection. It is also further envisioned that arrows pointing sideways may be provided at one or more of the characters of the display (or elsewhere at the display), and the appropriate arrow may be illuminated or back lit to indicate that the driver is to turn right or left to stay on the desired course or route. In such an embodiment, illumination or back lighting of the character may be indicative of the directional heading of the vehicle, while illumination or back lighting of the arrows may be indicative of the driving instructions to the driver of the vehicle.

The intuitive display elements thus provide a clear indication as to which direction the vehicle is presently traveling by providing a directional heading arrow or pointer at each of the compass heading characters. The driver of the vehicle thus will not likely become confused as to the meaning of the illuminated characters or letters. The compass/navigation system and display of the present invention also may provide point-to-point driving

instructions and the present directional heading of the vehicle with the same display or display icons/characters.

Optionally, the compass display may include a temperature display or another type of information display with an LED array at or near the compass display ports or icons. One or
5 more control buttons or inputs (such as at the rear side of the mirror assembly) may be provided to allow the driver or occupant of the vehicle to select or actuate the calibration or zone or temperature display functions. The circuit board may be in communication with a temperature sensor or system, such as via a connecting wire or the like, to receive an electronic signal indicative of the temperature to be displayed. Optionally, the cap portions
10 and circuit boards may support or provide a compass and/or temperature display utilizing vacuum fluorescent displays and filters to display the compass heading and/or temperature via two or more characters or letters or numbers. For example, and as shown in FIG. 17, a compass heading display 32a and a temperature display 32b may be provided or formed at a display region 32c of a reflective element 14" of a mirror assembly. The displays may
15 comprise alphanumeric characters or the like to convey the directional heading information and temperature information to the driver of the vehicle.

Optionally, the circuit board may also or otherwise include circuitry for another accessory and/or display at the reflective element. The other display circuitry may illuminate or project information via illuminating ports or icons or characters or the like which are
20 etched or otherwise formed on the reflective element, such as in a similar manner as described above. The display circuitry and associated control circuitry may be positioned at the circuit board. Optionally, some of the circuitry may be positioned outside of the mirror assembly, such as at an accessory pod or module, and may be in communication with the circuitry of the circuit board via a connecting wire or the like, such as described above with
25 respect to the compass circuitry.

Optionally, the illumination sources utilized to back light or illuminate the display icons or characters may emit a desired color of light, such as a blue colored or tinted light or other color as may be desired. In many mirror applications, a blue light is typically preferred because it provides high visibility of the display during high lighting or daytime conditions,
30 but may not be as favorable during low light or nighttime conditions. Optionally, a control or multiplexer may be operable to change the color of the display in response to an ambient light sensor or the like. For example, the control may deactivate a blue illumination source and activate an amber or red illumination source (or other color) when the ambient light level drops to a threshold level. The nighttime color may be selected to provide enhanced viewing

of the displays and may be selected to generally match the lighting color scheme or signature color of the particular vehicle in which the display is implemented. Optionally, the colors may be ramped on and off, such that in intermediate lighting conditions, both colors may be provided and mixed, in order to provide a gradual change from one color to the next as the ambient light levels increase or decrease. Optionally, the control may activate a second illumination source (a nighttime illumination source that may be directed toward and through the same port as a daytime illumination source) in parallel with the daytime illumination source (such as a blue illumination source), which may remain activated so that the colors of the illumination sources are mixed during nighttime or darkened conditions.

As also shown in FIGS. 2-5, one of the circuit boards, such as circuit board 18a supported by cap portion 16a (FIG. 2) or circuit board 18a supported by cap portion 16" (FIGS. 4 and 5) or the like, may include an accessory or circuitry 21 and associated manual inputs or controls or buttons 21a for providing manual control of the circuitry or accessory 21. For example, circuitry 21 may comprise circuitry for a garage door opening device or system, such as a universal garage door opener or the like. With reference to FIG. 2, one or more buttons 21a (and/or one or more lights or illuminated buttons or controls) may extend or project from circuitry 21 and may extend at least partially through or may be accessible through corresponding openings or holes 21b in mirror holder 12. Optionally, and as shown in FIGS. 4 and 5, one or more buttons 21a' may be provided at a circuit board 18a, and may be positioned or received in a recessed area 21b' along the bezel portion or mirror holder 12 and/or in a recessed area 25e along the cap portion 16", such that the buttons may be secured in place between the mirror holder and cap portion when the cap portion is attached to or secured to the mirror holder. The buttons 21a, 21a' may be readily accessible by the driver or occupant of the vehicle to actuate or control the circuitry 21, such as to actuate a transmitting device to open or close a garage door, such as utilizing the principles disclosed in U.S. Pat. Nos. 6,396,408; 6,362,771; 5,798,688 and 5,479,155; and/or U.S. pat. application, Ser. No. 10/770,736, filed Feb. 3, 2004 by Baumgardner et al. for GARAGE DOOR OPENING SYSTEM FOR VEHICLE (Attorney Docket DON01 P-1135), which are hereby incorporated herein by reference.

Optionally, and as shown in FIG. 18, a garage door opener display 34 may be provided at the reflective element of the mirror assembly for displaying a Homelink® icon (or other icon or indicia indicative of such a system) at the buttons or inputs 21a, 21a' for the garage door opener system, such as might be useful as an indicator to assist a user when training or operating in a learning mode of a trainable garage door opener (such as by

intermittently illuminating or modulating/flashing/blinking an LED or the like behind a Homelink® icon or the like when in the learning mode) and/or as an indicator for company brand promotion/feature illustration promotion, such as by constantly illuminating the LED or the like, such as when a trainable garage door opener is not in the training or learning
5 mode. The garage door opener display 34 may have an illumination source (such as a light emitting diode or the like) that may be activated or energized to back light or otherwise illuminate the display as desired. The display elements and circuitry and user inputs may be added to or attached to the cap portion as a module so that the desired feature or content may be readily added to a corresponding cap portion to provide the desired feature or content to
10 the appropriate mirror assembly.

Because it is desirable that the mirror holder be a universal mirror holder for mirror assemblies having various accessories or no accessories, it is envisioned that the openings 21b in mirror holder 12 for the input controls 21a of accessory 21 (and/or other openings for other user inputs or buttons or switches or the like for other accessories or the like) may be
15 formed in the mirror holder via inserts positioned in the mirror holder mold or tool for mirror holders which require such openings. The inserts may be removed from the tool to provide molding of a mirror holder without such openings for applications where no such accessory and associated controls or buttons is selected. Similarly, the recessed regions 21b' in the mirror holder and/or the cap portion may be formed via inserts placed in the molds during the
20 forming of the mirror holder or cap portion. The different mirror holders may thus be molded or formed using the same tool, yet may receive different cap portions having or supporting different accessories or features.

In the illustrated embodiment, the buttons 21a are positioned at the mirror assembly so that user actuation of the buttons requires a generally vertical upward force (when the
25 mirror assembly is installed in the vehicle) to move the button or input upwardly to actuate the electronic switch. Optionally, however, the buttons or inputs may be positioned at the mirror assembly so that actuation of the button or switch or input may be accomplished by a generally horizontal force or movement, such as a generally horizontal force toward the mirror assembly or in the direction of travel of the vehicle. For example, the user inputs may
30 be positioned in a gondola or pod or attachment or extension of the cap portion that extends outwardly (such as downwardly or upwardly or sidewardly) from the cap portion so as to be viewable and readily accessible by the driver of the vehicle. The user inputs may be positioned within the gondola or pod so that pressing the user inputs generally horizontally actuates the switch (such as an electronic switch at the printed circuit board within the cap

portion of the mirror assembly). The cap portion or attachment may include mechanical elements or structure for mechanically translating the generally horizontal movement of the input to a generally vertical actuation of an electronic switch, or the electronic switch may be oriented at the circuit board to be responsive to the generally horizontal actuation movement, without affecting the scope of the present invention. Preferably, such gondola or pod may extend upward or toward the passenger side of the mirror assembly (when the mirror assembly is installed in the vehicle) to limit or reduce any interference with the forward field of view of the driver of the vehicle.

Although shown and described as having buttons such as shown in FIGS. 2-5 and 10, it is envisioned that the mirror assembly may include buttons or inputs of the types described in U.S. provisional applications, Ser. No. 60/553,517, filed Mar. 16, 2004 by Lindahl et al. for MIRROR ASSEMBLY (Attorney Docket DON01 P-1145); and Ser. No. 60/535,559, filed Jan. 9, 2004 by Lindahl for MIRROR ASSEMBLY (Attorney Docket DON01 P-1134), which are hereby incorporated herein by reference. For example, the buttons may be integrally molded in the cap portion or bezel, or the buttons may extend downward through openings in the cap portion or bezel or between the cap portion and bezel when the cap portion is attached to the bezel, without affecting the scope of the present invention.

Optionally, the cap portions and circuit boards may support one or more other accessories and/or corresponding displays at or within the mirror holder, such as a tire pressure monitoring system and display 36, 36' (FIGS. 19-21), whereby the display may indicate when a tire pressure has dropped below a set or preselected tire pressure. For example, a particular light source may be energized or activated to back light or illuminate an icon 36a indicative of one of the tires of the vehicle when the pressure in that tire drops below the threshold tire pressure. The individual light sources may be individually energized, such as in a similar manner as the directional heading indicators discussed above and/or described in U.S. pat. application, Ser. No. 10/456,599, filed Jun. 6, 2003 by Weller et al. for INTERIOR REARVIEW MIRROR SYSTEM WITH COMPASS (Attorney Docket DON01 P-1076), which is hereby incorporated herein by reference. The display may include an iconistic display that may be laser etched or otherwise formed on the reflective element (such as described above), and may provide for illumination (via one or more illumination sources at the circuit board of one of the cap portions) of one or more icons 36a representative of a particular tire of the vehicle. Optionally, and as shown in FIG. 21, the tire pressure display 36' may be printed on a screen and placed at and generally aligned with a window formed in the reflective layer of the prismatic reflective element, without affecting the scope of the

present invention. The display may further provide for illumination of an additional icon or character 36b or may provide a different color illumination when a puncture is detected at one of the tires of the vehicle. Optionally, the tire pressure monitoring display 36' may include a digital display 36c (or other type of character or alphanumeric display) for
5 indicating the tire pressure of one of the tires. The tire pressure monitoring system may utilize principles disclosed in U.S. Pat. Nos. 6,124,647; 6,294,989; 6,445,287; 6,472,979; and/or 6,731,205, which are hereby incorporated herein by reference.

The tire pressure display thus may be controlled or actuated by a microcontroller or microprocessor of the cap portion of the mirror assembly. The controller may drive or
10 energize the illumination sources (such as light emitting diodes or the like) directly, without the need for additional display drivers. The direct energization of the illumination sources of the display thus avoids the need for other controllers or drivers within the mirror assembly or the vehicle. The tire pressure monitoring system display 36, 36' may utilize aspects of the compass display disclosed in U.S. pat. application, Ser. No. 10/456,599, filed Jun. 6, 2003 by
15 Weller et al. for INTERIOR REARVIEW MIRROR SYSTEM WITH COMPASS (Attorney Docket DON01 P-1076), which is hereby incorporated herein by reference in its entirety.

Optionally, the cap portion may include circuitry and user inputs associated with a telematics system, such as ONSTAR[®] or the like. For example, a circuit board may include circuitry for the telematics system and may be attached to or mounted to a cap portion, such
20 as a circuit board similar to circuit board 18a described above. The cap portion and/or mirror holder may include a recess or opening for one or more user inputs to be positioned when the mirror assembly is assembled, so that the user inputs may be readily accessible by a driver of the vehicle when the mirror assembly is installed in the vehicle. As shown in FIG. 22, the user inputs or buttons 38 may extend along a lower portion of the mirror assembly and may
25 be readily viewable and accessible at the lower portion of the mirror assembly by a driver of the vehicle. The user inputs 38 may comprise a keypad or the like that is positioned within corresponding notches or recesses along the opposed or mating edges of the mirror holder and the cap portion, such as described above with respect to user inputs 21a' of FIGS. 4 and 5. A telematics display 40 may be etched or otherwise formed in the reflective element 14 to
30 indicate to a user the function of the user inputs 38. The display 40 may include one or more icons or images or characters 40a or the like that may be etched or formed in the reflective element and backlit by respective illumination sources. The illumination source or sources may be activated during low ambient lighting conditions (such as dusk or night, such as when ambient lighting is less than, for example, about 200 lux) to illuminate the display 40 so a

user can see the function of the user inputs (which may also be illuminated or backlit or the like) during low lighting conditions, such as at nighttime. Optionally, individual illumination sources may be provided at each icon or port 40a to independently illuminate or back light the respective icon, such as in response to actuation of a respective one of the user inputs
5 (such as in a manner as described above with respect to the individual directional icons of the compass display). Optionally, and with reference to FIG. 23, the display 40' may be positioned at a window 42 of the reflective element 14 and may be viewable through the reflective element window.

The cap portions of the present invention thus may provide a desired content, such as
10 a garage door opening system and respective user inputs or a telematics feature and respective user inputs, to a particular mirror assembly. The desired system may be provided to the cap portion as a module, such as a garage door opening system module (which may include the transmitter and circuitry and user inputs) or a telematics module (which may include the circuitry and user inputs and display elements), and the module may be attached
15 to or snapped to or mounted to the cap portion, such as at a cap portion assembly facility or at the vehicle assembly facility. Although shown as a garage door opening system module or a telematics module, clearly, the cap portion may include or incorporate other modules or displays or the like, such as, for example, a passenger side air bag status display (typically on the lower passenger side corner or area of the reflective element) or other displays, or a rear-
20 facing sensor (which may align with an opening or port or window formed in the reflective element when the cap portion is attached to the mirror holder), or other types of displays or systems or modules, without affecting the scope of the present invention. Optionally, the user inputs or buttons or switches or the like may be positioned in the cap portion or in the bezel portion (or between the cap portion and bezel portion), or the cap portion may include
25 an eyebrow portion or gondola portion or underbrow portion or chin portion or attachment (that may extend or protrude partially outward and/or partially around the bezel portion, and that may extend upwardly or downwardly or sidewardly therefrom) in which the inputs may be positioned, such that the inputs are contained at or in the cap portion and readily viewable and/or accessible at a desired location around the bezel portion.

30 The desired cap portion (with the desired features or content) may be readily attached to a common or universal mirror holder (which may include the reflective element and toggle and mounting assembly, which may be assembled at a mirror holder assembly facility) to assemble the mirror assembly, such as at a mirror assembly facility. The mirror holder may be adapted to partially receive the user inputs therein, and/or the reflective element contained

in the mirror holder may have a particular display or displays formed thereon. The display icons or ports or windows formed in the reflective layer of the reflective element may generally align with the respective display elements or illumination sources of the circuitry within the cap portion when the cap portion is attached to the mirror assembly, such as

5 described above with respect to the compass display. In applications where different modules may be provided that provide different display information at the reflective element, the reflective element may be selected to have the appropriate ports or icons or the like that correspond with the particular module, or the reflective element may have a window or windows formed in the desired or appropriate locations or may comprise a transfective

10 prismatic reflective element (such as described in PCT Application No. PCT/US03/29776, filed Sep. 19, 2003 by Donnelly Corp. et al. for MIRROR REFLECTIVE ELEMENT ASSEMBLY (Attorney Docket DON01 FP-1109(PCT)); and/or U.S. provisional application, Ser. No. 60/525,952, filed Nov. 26, 2003 by Lynam for MIRROR REFLECTIVE ELEMENT FOR A VEHICLE (Attorney Docket DON01 P-1130), which are hereby incorporated herein

15 by reference), such that the display elements (which may be illuminated alphanumeric characters or icons or indicia or the like) of the modules may be viewable through the reflective element to view the information being displayed by the display elements. The present invention thus provides for various mirror assemblies having different features or electronic content, while providing common or universal mirror holders and cap portions,

20 where different circuitry or circuit boards or modules may be attached to the cap portion to provide the desired content to the mirror assembly.

Optionally, the cap portion or portions and circuit board or boards may support one or more other accessories or features at or within the mirror holder, such as one or more electrical or electronic devices or accessories. For example, and as can be seen in FIGS. 24-

25 26, illumination sources or lights, such as map reading lights 46 or one or more other lights or illumination sources (which may be positioned at or aligned with openings formed in the bottom of the mirror holder to direct illumination generally downward to illuminate the console of the vehicle), such as illumination sources of the types disclosed in U.S. Pat. Nos. 6,690,268; 5,938,321; 5,813,745; 5,820,245; 5,673,994; 5,649,756; 5,178,448; 5,671,996;

30 4,646,210; 4,733,336; 4,807,096; 6,042,253; and/or 5,669,698, and/or U.S. pat. applications, Ser. No. 10/054,633, filed Jan. 22, 2002 (Attorney Docket DON01 P-962); and/or Ser. No. 10/745,056, filed Dec. 22, 2003 by Lynam et al. for LIGHT MODULE FOR INTERIOR REARVIEW MIRROR ASSEMBLY (Attorney Docket DON01 P-1122); and/or U.S. provisional application, Ser. No. 60/500,858, filed Sep. 5, 2003 by Kulas et al. for

INTERIOR REARVIEW MIRROR ASSEMBLY (Attorney Docket DON01 P-1112), which are hereby incorporated herein by reference, may be included with the cap portion 16". The illumination source or sources 46 may be attachable to or positionable at or molded into the cap portion and may connect to a circuit board 47 of the cap portion 16". The illumination sources and/or the circuit board may be connected to one or more buttons or inputs 48 for activating and deactivating the illumination sources.

Optionally, and with reference to FIG. 26, the circuitry 47a may comprise a stamped circuit that is molded into and/or along the cap portion, with the electrical connections between the lights and buttons and power source being made via stamped connectors or terminals molded into the cap portion (such as terminals of the type described in U.S. Pat. No. 6,227,689, which is hereby incorporated herein by reference) and extending between the lights 46 and/or inputs/buttons (not shown in FIG. 26) and/or the power source/circuit board 47. The illumination sources 46 and inputs 48 may be positioned at recesses in and along a forward edge or portion of cap portion 16" and may be partially received in corresponding recesses along the rearward edge of the corresponding mirror holder to secure the illumination sources and buttons at the mirror assembly.

As best shown in FIGS. 24 and 25, the light actuators or buttons 48 may comprise a push button actuator having a user actuating portion 48a at a lower end of a body portion 48b. The actuator 48 may comprise any known switch or button assembly, or may be of the type described in U.S. pat. application, Ser. No. 10/447,641, filed May 29, 2003 by Adams for ELECTRICAL SWITCH (Attorney Docket DON01 P-1081), which is hereby incorporated herein by reference. Body portion 48b may be slidably mounted to or positioned in or at the cap portion 16" and may slide between an activated position, where the switch closes the circuit to activate the light source, and a deactivated position, where the switch opens the circuit to deactivate the light source. The actuator 48 includes a torsional spring 49 wrapped around a shaft 48c protruding from body portion 48b. One end 49a of the spring 49 engages a stop 50a extending from the cap portion 16", while the other end 49b is movable around a detent 50b as the switch body 48b is moved between the activated and deactivated positions. For example, when the switch is in the lowered or deactivated position, the spring may bias the switch downward (which may open the circuit) via engagement with the stop 50a. When the switch is pressed upward, the end 49b may move upward around the detent 50b and may rest within a recess 50c of the detent 50b when the switch is released to retain the switch in the raised or activated position (which may close the circuit). When the switch is again pressed upward by a user, the end 49b may move upward and out from the recess 50c and

may move downward around the detent 50b as the switch is urged or moved downward in response to the biasing forces of the spring 49. The actuator 48 thus provides a low cost actuating device that only has a few components and, thus, is less costly and less complicated and more durable than many multiple component switches in use today.

5 Optionally, the cap portion may provide circuitry or power for a light or illumination source, such as a map reading light or the like, and a desired or appropriate lighting capsule or module (including the light source and user input or button or switch) may be plugged into the mirror assembly (such as described in U.S. pat. applications, Ser. No. 10/054,633, filed Jan. 22, 2002 (Attorney Docket DON01 P-962); and Ser. No. 10/745,056, filed Dec. 22, 2003
10 by Lynam et al. for LIGHT MODULE FOR INTERIOR REARVIEW MIRROR ASSEMBLY (Attorney Docket DON01 P-1122), which are hereby incorporated herein by reference). The circuit board of the cap portion may include prongs or connectors or the like at a lower portion of the circuit board, and the lighting capsule may be inserted through an opening in the cap portion and/or mirror holder and may engage and connect to the prongs or
15 connectors to electrically connect the light to the circuit board. The lights thus may be readily inserted into or connected to the circuit board of the cap portion if desired or appropriate to provide the desired feature or content to the cap portion and the mirror assembly.

 Optionally, the mirror assembly may include a white light emitting diode, or a cluster
20 of LEDs may be provided, as a map/reading light or light module. Optionally, the cap portion or bezel portion may include illumination sources, such as light emitting diodes or the like, that may be embedded in the rim of the bezel portion or the lower portion of the cap portion to emit or project illumination toward the desired area of the vehicle cabin. The illumination sources may be switched on locally, such as via user inputs or switches or
25 buttons as described above, or may be activated/deactivated/controlled by a control or system remote from the mirror assembly, such as via a vehicle electronic or communication system, and may be connected via a hard wire or via various protocols or nodes, such as Bluetooth, SCP, UBP, J1850, CAN J2284, Fire Wire 1394, MOST, LIN and/or the like, depending on the particular application.

30 Optionally, the illumination sources may comprise modular light sources, and may comprise one or more incandescent light sources or light emitting diodes or the like, such as described in U.S. pat. applications, Ser. No. 10/054,633, filed Jan. 22, 2002 (Attorney Docket DON01 P-962); and Ser. No. 10/745,056, filed Dec. 22, 2003 by Lynam et al. for LIGHT MODULE FOR INTERIOR REARVIEW MIRROR ASSEMBLY (Attorney Docket DON01

P-1122), which are hereby incorporated herein by reference. Optionally, the light emitting diodes may be operable to individually emit illumination in different colors as desired, so as to provide mood lighting or the like. The illumination sources may be controlled via a user input at the lights or a separate or remote control device, such as a vehicle electronic or communication system, and may be connected via a hard wire or via various protocols or nodes, such as Bluetooth, SCP, UBP, J1850, CAN J2284, Fire Wire 1394, MOST, LIN and/or the like (which may also control the exterior mirror or mirrors of the vehicle), and may provide ramped activation and/or deactivation to provide theater like lighting or the like if desired.

Optionally, the cap portion may include or incorporate or receive other modules as selected or desired to customize the mirror assembly. For example, the cap portion and/or reflective element assembly portion may receive a microphone array module, a garage door opening system module, a telematics user access button/input module, and/or the like. The modules may be provided at the vehicle assembly plant or at the mirror assembly plant, and may be inserted or plugged into the cap portion or mirror assembly to provide the desired content to the mirror assembly. The modules and the cap portion may include connectors that provide both electrical and mechanical connection so that the modules are electrically connected to the appropriate circuitry as they are inserted or received into or snapped to or attached to the cap portion. An operator at the vehicle assembly plant thus may readily connect the appropriate module to the cap portion or to the mirror assembly to provide the desired content for that particular mirror assembly. For a base mirror that may not include such content, a blank module or plug may be inserted into or attached to the cap portion or mirror assembly, so as to fill or conceal any opening in the mirror assembly that otherwise may receive an electronic module or accessory. The modules may also be readily removed and replaced to ease repair and replacement of the accessory or circuitry, and to ease replacement or changeover to a different accessory or module, if a different option is desired, such as an aftermarket module or the like.

Optionally, the cap portion or portions and the circuit board or boards of the present invention may also or otherwise include other accessories, such as microphones (such as shown in FIGS. 5 and/or 27). The microphones may comprise analog microphones or digital microphones or the like, and may be positioned at or aligned with one or more openings formed in the top and/or bottom of the cap portion or the mirror holder. The microphones, such as microphones of the types disclosed in U.S. Pat. Nos. 6,243,003; 6,278,377; and/or 6,420,975, and/or in PCT Application No. PCT/US03/308877, filed Oct. 1, 2003 by Donnelly

Corp. et al. for MICROPHONE SYSTEM FOR VEHICLE (Attorney Docket DON01 FP-1111(PCT)), may be provided for interfacing with a vehicle telematics system or the like. Optionally, the cap portion or portions and the circuit board or boards may also or otherwise include other accessories, such as a telematics system, speakers, antennas, including global positioning system (GPS) or cellular phone antennas, such as disclosed in U.S. Pat. No. 5,971,552, a communication module, such as disclosed in U.S. Pat. No. 5,798,688, a voice recorder, a blind spot detection system, such as disclosed in U.S. Pat. Nos. 5,929,786 and/or 5,786,772, and/or U.S. pat. applications, Ser. No. 10/427,051, filed Apr. 30, 2003 (Attorney Docket DON01 P-1075); and Ser. No. 10/209,173, filed Jul. 31, 2002 (Attorney Docket DON01 P-1016), transmitters and/or receivers, such as for a garage door opener or a vehicle door unlocking system or the like (such as a remote keyless entry system), a digital network, such as described in U.S. Pat. No. 5,798,575, a high/low headlamp controller, such as a camera-based headlamp control, such as disclosed in U.S. Pat. Nos. 5,796,094 and/or 5,715,093, a memory mirror system, such as disclosed in U.S. Pat. No. 5,796,176, a hands-free phone attachment, a video device for internal cabin surveillance (such as for sleep detection or driver drowsiness detection or the like) and/or video telephone function, such as disclosed in U.S. Pat. Nos. 5,760,962 and/or 5,877,897, a remote keyless entry receiver, a seat occupancy detector, a remote starter control, a yaw sensor, a clock, a carbon monoxide detector, status displays, such as displays that display a status of a door of the vehicle, a transmission selection (4wd/2wd or traction control (TCS) or the like), an antilock braking system, a road condition (that may warn the driver of icy road conditions) and/or the like, a trip computer, a tire pressure monitoring system (TPMS) receiver (such as described in U.S. Pat. Nos. 6,124,647; 6,294,989; 6,445,287; 6,472,979; and/or 6,731,205), an ONSTAR[®] system and/or the like (with all of the above-referenced patents and PCT and U.S. patent applications being commonly assigned to Donnelly Corporation, and with the disclosures of the referenced patents and patent applications being hereby incorporated herein by reference in their entireties). The accessory or accessories may be positioned at or on the cap portions and thus positioned at or within the mirror holder and may be included on or integrated in a printed circuit board positioned within the mirror holder.

Optionally, the cap portion or portions of the present invention may include one or more attachments, such as attachments of the types described in U.S. Pat. Nos. 6,690,268 and/or 6,428,172, which are hereby incorporated herein by reference. The attachment or attachments, such as a pen holder or display screen or the like, may be incorporated into the cap portion or may be removably attached to the cap portion and, thus, may be removable if

not desired for the particular mirror application, without affecting the scope of the present invention. The desired attachment may be selected for the particular application of the cap portion and mirror assembly, and may provide additional features to the cap portion and mirror assembly as may be desired or selected for the particular mirror application.

5 Optionally, the cap portion or portions may include a conversation mirror that may flip up or out from the cap portion to allow the driver of the vehicle to view a person in the rear seat (such as a child in the rear seat) to see and talk to the person in the rear seat without having to adjust the reflective element of the mirror assembly. The conversation mirror may be pulled out when desired or may be spring loaded to pop up or out when actuated or
10 depressed, or may be electronically controlled to extend out from the cap portion when an input is actuated, without affecting the scope of the present invention.

 Optionally, a blind spot detection or side object detection system or circuitry and corresponding display or indicator may be provided on one of the cap portions and on the reflective element for indicating to the driver or occupant of the vehicle that another vehicle
15 may be in a lane adjacent to the subject vehicle. The indicator may comprise any iconistic type of display which may indicate that another vehicle has been detected and/or that the subject vehicle is changing lanes toward the detected object or vehicle. The side object detection and warning system may utilize the principles disclosed in U.S. pat. applications, Ser. No. 10/427,051, filed Apr. 30, 2003 (Attorney Docket DON01 P-1075); and Ser. No.
20 10/209,173, filed Jul. 31, 2002 (Attorney Docket DON01 P-1016), which are hereby incorporated herein by reference.

 Optionally, the side object detection system may be operable to detect objects or other vehicles at one or both sides of the subject vehicle and to detect and identify a lane marker or lane markers at one or both sides of the vehicle, such as disclosed in U.S. pat. application,
25 Ser. No. 10/427,051, filed Apr. 30, 2003, incorporated above. The side object detection system may be further operable to provide a visible and/or audible warning to the driver of the subject vehicle in response to the detection of another object or vehicle at a side of the subject vehicle and in response to the position or movement of the subject vehicle relative to the lane markers. The use of lane marker detection integrated with such side object detection
30 systems can be used to reduce false positives (where the system detects a vehicle in the adjacent lane when there is no vehicle in the adjacent lane) significantly and enable longer distances of detection, which in turn improves response time for system warnings from high speed target vehicles. In known or conventional side object detection systems, the systems do not track lane markings. Known radar systems are incapable of lane tracking due to the

nature of the technology, and conventional vision systems do not currently include this functionality. This forces the detection zone of such known side object detection systems to be static or non-changing regardless of any curvature in the road, and does not allow for higher warning functionality based on the lane position of the subject vehicle.

5 It is envisioned that the side object detection system (which may have components and/or circuitry on a cap portion or portions of the interior rearview mirror assembly, or on or at or in the mirror assembly or on or at or in an accessory module or pod mounted to or positioned at or near the mirror assembly or positioned elsewhere in the vehicle) may utilize lane marking detection and recognition to allow the side object detection system to determine
10 or adjust a detection zone or target zone or area based on the lane markings of the adjacent lane. Such lane marking detection may accommodate a non-linear detection zone when the subject vehicle is turning or on a curve. This may provide a longer detection distance because non-linear lanes may cause false positives in a static detection zone, whereas a dynamic zone may facilitate a better area of interest at greater distances, since it may avoid
15 tracking trailing vehicles (such as in the same lane as the subject vehicle) on sharp curves. Such a side object detection system may also allow higher human/machine interface (HMI) processing.

Known side object detection systems may be specified to warn when a vehicle is in the blind spot or will be in a short amount of time. This may force the system to warn the
20 driver of a detected object even when a driver is not intending to make a lane change toward the detected object. This can be a source of annoyance to the driver, and it emphasizes the effect of false positives from detection of infrastructure, shadows, miscellaneous road clutter and the like. However, if the side object detection system requires the above condition or detection and also requires a close proximity to or movement toward the lane markers or
25 adjacent lane (i.e. the subject vehicle is moving toward the lane markers and thus toward the adjacent lane) prior to providing a warning, then the system may only provide such a warning when actual danger is present (i.e. the subject vehicle is changing lanes toward an adjacent lane which is occupied by a detected vehicle or object).

Such a side object detection system may provide a large reduction of false positives
30 over current side object detection systems, and the warning may thus represent a heightened level of risk for the current maneuver, instead of a heightened level of risk for a potential maneuver. The side object detection system thus may reduce annoyance, improve perceived reliability, and improve overall detection distances, which in turn may improve the predictive nature of the system to reduce latencies based on human response. The side object detection

system, or circuitry and/or display of the side object detection system, may be incorporated into one or more cap portions mounted at the interior rearview mirror assembly, or may be incorporated into the rearview mirror assembly or an accessory module or pod positioned at or near the rearview mirror assembly. The display may be at the reflective element of the mirror assembly and may be an iconistic display of the subject vehicle and a detected object adjacent to the subject vehicle, or any other type of display, and may provide an audible signal to the driver of the vehicle, without affecting the scope of the present invention.

Optionally, the cap portion or portions may include a display element, such as a video display element or the like, that may slide out or flip up or down from the cap portion to provide a video screen that is viewable by the driver of the vehicle, such as a video display screen of the type described in PCT Application No. PCT/US03/40611, filed Dec. 19, 2003 by Donnelly Corporation for ACCESSORY SYSTEM FOR VEHICLE (Attorney Docket DON01 FP-1123(PCT)), which is hereby incorporated herein by reference. The video display screen may be operable to display information to the driver of the vehicle, and may be incorporated into or may be in communication with a vision system or imaging system of the vehicle, such as a rearwardly directed vehicle vision system utilizing principles disclosed in U.S. Pat. Nos. 5,550,677; 5,760,962; 5,670,935; 6,201,642; and/or 6,717,610, and/or in U.S. pat. application, Ser. No. 10/010,862, filed Dec. 6, 2001 by Bos for PLASTIC LENS SYSTEM FOR VEHICLE IMAGING SYSTEM (Attorney Docket DON01 P-954), which are hereby incorporated herein by reference, a trailer hitching aid or tow check system, such as the type disclosed in U.S. pat. application, Ser. No. 10/418,486, filed Apr. 18, 2003 by McMahon et al. for VEHICLE IMAGING SYSTEM (Attorney Docket DON01 P-1070), which is hereby incorporated herein by reference, a cabin viewing device or system, such as a baby viewing or rear seat viewing camera or device or system or the like, such as disclosed in U.S. Pat. Nos. 5,877,897 and 6,690,268, which are hereby incorporated herein by reference, a video communication device or system, such as disclosed in U.S. Pat. No. 6,690,268, which is hereby incorporated herein by reference, and/or the like. Optionally, the video display screen may also or otherwise serve as a screen for a navigation system of the vehicle or the like, such as a GPS-based navigation system, such as is known in the automotive art.

Optionally, the mirror assembly may include a heating device or element for heating the display element or the area around the display element. At low temperatures, it may be desirable to heat the display element, such as a liquid crystal display (LCD) element or the like (or such as a video screen display or illuminated display or the like), in order to enhance the performance and response of the display element in such low temperatures or cold

conditions or environments. The display element may comprise any type of display element or light emitting element, such as a vacuum fluorescent (VF) display element, a light emitting diode (LED) display element (such as an inorganic LED display element or an organic light emitting diode (OLED) display element or a high intensity, high efficiency LED display element, such as disclosed in U.S. Pat. Nos. 6,690,268 and 6,428,172 and in U.S. pat. application, Ser. No. 10/054,633, filed Jan. 22, 2002 (Attorney Docket DON01 P-962), which are hereby incorporated herein by reference), a multi-pixel, dot-matrix liquid crystal display element, an electroluminescent display element, a backlit display element, such as a back lit iconistic display (such as disclosed in U.S. Pat. Nos. 6,642,851; 6,501,387 and 6,329,925, which are hereby incorporated herein by reference), a display element backlit by an incandescent light source, or a backlit liquid crystal display (LCD), a video display screen (such as the type described in PCT Application No. PCT/US03/40611, filed Dec. 19, 2003 for ACCESSORY SYSTEM FOR VEHICLE (Attorney Docket DON01 FP-1123(PCT)), which is hereby incorporated herein by reference) or the like, without affecting the scope of the present invention.

The heating device may be operable to heat the reflective element at the area of the display element or may heat the display element itself. For example, the rear surface of the reflective element may have a transparent conductive coating or layer, such as an indium tin oxide (ITO), a tin oxide (TO) or the like (such as transparent conductive layers of the types suitable for use in electrochromic cells and such as described in U.S. Pat. Nos. 6,690,268; 5,668,663; 5,724,187; 5,140,455; 5,151,816; 6,178,034; 6,154,306; 6,002,544; 5,567,360; 5,525,264; 5,610,756; 5,406,414; 5,253,109; 5,076,673; 5,073,012; 5,117,346; 5,910,854; 5,142,407 and 4,712,879, and/or in U.S. pat. application, Ser. No. 10/054,633, filed Jan. 22, 2002 (Attorney Docket DON01 P-962), and/or in PCT Application No. PCT/US03/29776, filed Sep. 19, 2003 by Donnelly Corporation et al. for MIRROR REFLECTIVE ELEMENT ASSEMBLY (Attorney Docket DON01 FP-1109(PCT)); PCT Application No. PCT/US03/35381, filed Nov. 5, 2003 by Donnelly Corporation et al. for ELECTRO-OPTIC REFLECTIVE ELEMENT ASSEMBLY (Attorney Docket DON01 FP-1116(PCT)); and/or in PCT Application No. PCT/US03/036177, filed Nov. 14, 2003 by Donnelly Corporation et al. for IMAGING SYSTEM FOR VEHICLE (Attorney Docket DON01 FP-1118(PCT)); and/or U.S. provisional applications, Ser. No. 60/531,838, filed Dec. 23, 2003 by Bareman for METHOD OF MANUFACTURING ELECTRO-OPTIC MIRROR CELL (Attorney Docket DON01 P-1132); Ser. No. 60/553,842, filed Mar. 17, 2004 by Bareman et al. for METHOD OF MANUFACTURING ELECTRO-OPTIC MIRROR CELL (Attorney Docket

DON01 P-1143); and Ser. No. 60/563,342, filed Apr. 19, 2004 by Bareman et al. for METHOD OF MANUFACTURING ELECTRO-OPTIC MIRROR CELL (Attorney Docket DON01 P-1153), which are hereby incorporated herein by reference), applied thereto or deposited thereon in at least the area at which the display element may be positioned. An
5 electrical current may then be applied to the transparent conductive layer (such as via a pair of terminals contacting opposite portions of the transparent conductive layer or the like) to energize the conductive layer and to heat the conductive layer. For example, the transparent conductive coating or layer may generate heat as electrons or electricity flow from a contact of a power terminal across the surface or coating or layer to a contact of a ground terminal.
10 The contacts may be spaced apart at generally opposite sides of the transparent conductive layer and may provide for generally uniform and thorough heating of the transparent conductive layer when electricity is applied to the heating or power terminal.

The display element may be positioned behind the reflective element and transparent conductive coating and may be next to or urged against or optically coupled to the transparent
15 conductive coating on the rear surface of the reflective element. When the electrical current is applied across the transparent conductive layer, the resistivity in the conductive layer causes the conductive layer to be heated, which functions to heat the display element to enhance the performance of the display element during low temperature conditions. Optionally, other types of heating devices may be implemented at or against the display
20 element and/or the reflective element, or may be positioned at the printed circuit board upon which the display element may be mounted, without affecting the scope of the present invention.

Optionally, for example, a heating device may be implemented at or near a display (such as a video display screen displaying, for example, driver information such as
25 navigational information or a view of an interior or exterior scene, such as a curb side view such as is now being required for certain vehicles in Japan, or a parking/reversing view or the like) to heat the display or display area at least initially upon start up of the vehicle in extremely cold conditions. When the vehicle is in a cold climate (such as, for example, in northern Minn. in the winter time where the temperature may drop to around thirty degrees
30 below zero), the heater may be activated on the first ignition cycle of the vehicle or when the vehicle is first turned on or the like and when the temperature is below a threshold temperature. The heating device may include a thermometer or thermistor or the like to determine the ambient temperature at the vehicle or at or near the display, and the heater may be activatable in response to an output of the thermometer. Optionally, if the temperature is

below a threshold temperature, the heater may be operable in a "quick heat mode" to rapidly heat the display so that it works properly very quickly after start up of the vehicle. The heater may be operable at a higher than normal power dissipation during the quick heat mode to provide rapid heating or thawing or defrosting of the display when the vehicle ignition is first
5 turned on during winter or cold conditions, but after the initial rapid heating phase is completed, the heater may operate at a lower power dissipation level more suited for ongoing heating during the driving event. This is particularly useful when the display is associated with a back up aid or reverse vision system or the like (such as those described in U.S. Pat. Nos. 5,550,677; 5,760,962; 5,670,935; 6,201,642; 6,717,610; 5,877,897 and 6,690,268,
10 and/or in U.S. pat. applications, Ser. No. 10/010,862, filed Dec. 6, 2001 by Bos for PLASTIC LENS SYSTEM FOR VEHICLE IMAGING SYSTEM (Attorney Docket DON01 P-954), and Ser. No. 10/418,486, filed Apr. 18, 2003 by McMahon et al. for VEHICLE IMAGING SYSTEM (Attorney Docket DON01 P-1070), and/or in PCT Application No. PCT/US03/40611, filed Dec. 19, 2003 for ACCESSORY SYSTEM FOR VEHICLE
15 (Attorney Docket DON01 FP-1123(PCT)), which are hereby incorporated herein by reference), where it is important for the display to be fully operational at the start up of the vehicle so it provides a proper or desired display of the rearward field of view of the camera as the vehicle is initially backed out of its parking space or driveway or the like.

The heating device and the construction of the mirror assembly thus may provide
20 heating of a display or display element (such as, for example, heating of a slide out display screen such as the type described in PCT Application No. PCT/US03/40611, filed Dec. 19, 2003 for ACCESSORY SYSTEM FOR VEHICLE (Attorney Docket DON01 FP-1123(PCT)), which is hereby incorporated herein by reference), such as for a backup aid or rear vision system or the like, during cold temperatures to enhance the performance of the
25 display during such cold temperatures. The heating device may provide intimate heating of the display medium, such as for a liquid crystal display element or the like, to enhance the performance of the display element. The heating device may provide such intimate heating of the display medium while not interfering with or heating other components or circuitry of the mirror assembly. The heating device may be included in the construction of the mirror
30 assembly itself, such as a transparent conductive layer across the display screen or element or reflective element or such as a wire grid or other heating element or the like at or near the display area, to intimately heat the display element or display medium without substantially heating other components and circuitry in the vicinity of the display element. Optionally, the heating device may be activated/deactivated/controlled in conjunction with the heating

elements for the exterior rearview mirrors of the vehicle (in such applications where the exterior rearview mirrors may be heated or defrosted, such as when a rear window defroster/defogger is actuated or the like). The heating device may utilize or incorporate aspects of heating devices used to heat and defrost exterior rearview mirror reflective elements, such as the heating means described in U.S. Pat. No. 5,446,576, issued to Lynam et al., which is hereby incorporated herein by reference, such as a positive thermal coefficient (PTC) heater element that is continuously connected to voltage ignition, but that principally only operates at low temperatures, such as less than about 10 degrees Celsius or lower. Optionally, a separate temperature controller, such as a thermistor, may be provided at or near the display in the interior rearview mirror assembly that powers the heater element at low temperatures.

Optionally, it is envisioned that the cap portion or portions may include a shielding element or sleeve or the like to provide shielding from external fields and unwanted radiation fields. The shielding may comprise a thin metal or foil member or sleeve or sheet or the like that is placed over and along an interior surface or portion of the cap portion (such that the shielding is within the mirror assembly and thus not readily visible when the mirror assembly is assembled). The shielding may be attached to the cap portion or portions so as to be retained thereto during the mirror assembly process. The shielding material/sheet preferably has a magnetic and/or electromagnetic permeability appropriate for shielding the accessories and the like within the cap portion and mirror assembly from external fields and unwanted radiation fields and the like.

Optionally, the cap portion or portions may include a hands free phone attachment to allow a driver of the vehicle to use a cellular or mobile telephone via circuitry and microphones and speakers of the mirror assembly and/or vehicle. The cap portion or portions may include a connector, such as a plug or socket type of connector or telephone docking device or the like, for a user to plug their mobile telephone into, which would connect the mobile telephone to a communication system or the like of the mirror assembly or vehicle.

Optionally, and as shown in FIG. 28, the cap portion or portions 16 may house or include a battery 52 for providing power to one or more electronic accessories or to a circuit board 58 of the cap portion or mirror assembly (such as, for example, described in U.S. Pat. No. 6,690,298, which is hereby incorporated herein by reference). The accessory or accessories of the mirror assembly thus may be powered by the battery such that the mirror assembly or circuitry of the cap portion may not have to connect to the power source of the vehicle. The battery may be contained within the cap portion and at or near an exterior or

outer portion of the cap portion and may be readily accessible by a user to facilitate changing of the battery when desired or necessary. For example, the battery 52 may be within a recess 54 of cap portion 16 and may be contained therein via a trap door or panel or door 56 that may cover battery 52 and recess 54 when closed. Panel 56 may be opened and may be
5 removable or may be hingedly attached or otherwise movably attached to cap portion 16 to facilitate access to recess 54 and battery 52. For example, panel 56 may be molded with cap portion 16 and may be hingedly attached to cap portion 16 via a living hinge 56a along an edge of panel 56. Other means for storing a battery and selectively accessing the battery may be implemented, without affecting the scope of the present invention. The various
10 accessories and electronic content and directly driven or energized displays may function via power from the battery or internal power source of the cap portion.

Optionally, and with reference to FIGS. 29-32, an interior rearview mirror assembly 60 may include a bezel portion 62 of a mirror casing, a reflective element 64 and a cap portion or rear portion 66 of the mirror casing. The mirror assembly 60 may include a
15 mounting arrangement or mounting assembly 68 for pivotally or adjustably mounting or attaching the mirror assembly to the vehicle, such as to a windshield of the vehicle or the like. The mounting assembly 68 may include a mounting arm 70 having a ball member 70a at one end and an attachment end or mounting end 70b opposite to the ball member 70a. Ball member 70a may be pivotally received within a socket 72 that may be positioned at or
20 formed with or established at or attached to an attachment plate 74 at the reflective element 64. When so positioned, attachment end 70b may extend from attachment plate 74 and may insert through an opening 66a in rear casing portion 66. The attachment end 70b may then attach or mount to a mounting portion or base portion or mounting base 76, which in turn may be attached or mounted to the vehicle or to a mounting button or the like (not shown) at
25 the windshield or headliner or overhead console of the vehicle.

In the illustrated embodiment, attachment end 70b is a threaded stud or end, and is secured to or mounted to the mounting or base portion 76 via insertion of the threaded end 70b through an opening 76a (FIG. 31) in mounting portion 76 and tightening a female fastener or nut 78 onto threaded end 70b. The mounting arm 70 thus may have a narrow end
30 for insertion through the opening 66a in rear casing portion 66, such that the opening in the rear casing portion may be smaller than is typically required (because typically the ball end of the mounting arm is inserted through the opening in the rear casing and snapped into the socket at the attachment plate). The mounting arm may be inserted into the socket of the attachment plate, which may be attached to the reflective element at the bezel portion, and

then may be inserted through the opening in the rear casing portion or cap portion as the rear casing portion or cap portion is moved toward and into engagement with the bezel portion, such that the attachment end of the mounting arm extends or protrudes from the rear casing portion or cap portion after the mirror is assembled. The attachment end may then be
5 attached or secured to the mounting portion or base portion via the nut or other type of fastener. As shown in FIG. 29, the mirror assembly may also include a circuit board 80 (with circuitry and/or accessories such as those described above), which may be attached to the attachment plate 74 or which may be attached to the cap portion for mirror assemblies of the types described above.

10 Although shown as having a threaded attachment end for securing the mounting arm to a mounting base via a nut or the like, it is envisioned that the mounting arm may have other forms of attachment ends for fixedly or pivotally or adjustably mounting the mounting arm to a mounting base or the like, without affecting the scope of the present invention. For example, the attachment end may provide a female fastener which may threadedly receive a
15 male fastener or screw or bolt or stud, or the attachment end may provide a bayonet type fastener, or the attachment end and mounting base may cooperate to provide a snap together attachment or the like, or the attachment end and mounting base may otherwise attach or secure together, such as via adhesive or welding, such as ultrasonic welding or the like. Optionally, the attachment end may attach to or receive another ball member, which may be
20 received within a socket at the mounting base, in order to provide a double ball mounting arrangement. The mounting arm, socket and/or mounting base may comprise plastic or polymeric materials, or may be die cast or otherwise formed, without affecting the scope of the present invention.

Optionally, and as shown in FIG. 32, the ball member 70a of mounting arm 70 may
25 be received in a socket 72' attached to or positioned at or formed with or established at a toggle assembly 82, such as for a prismatic reflective element. The toggle assembly may be any type of toggle assembly, such as described above, and may be attached to or mounted to the mirror holder or the mirror casing, whereby the attachment end of the mounting arm may extend or protrude from the mirror casing when the toggle assembly and mounting arm are
30 mounted therein or attached thereto. The attachment end may then connect or attach to the appropriate connector or attachment (such as to the mounting base 76 via a fastener or nut 78 as shown in FIG. 32) as described above to adapt the mirror assembly for the particular application.

The mounting arrangement of the present invention thus may provide a pre-established pivot element or member, such as a ball joint, at the attachment plate of the reflective element or at the toggle assembly or the like, whereby other attachments or mounting elements may be attached to the other end of the mounting arm to provide the
5 desired attachment or mounting arrangement for the particular application of the mirror assembly. The mounting arm and ball member may be inserted within the socket and then the backing plate or toggle assembly (at which the socket may be formed) may be attached or secured to the reflective element with the pre-established pivot joint or element. The ball
10 member of the mounting arm may already be inserted or snapped into the socket when the backing plate or toggle assembly is attached to or juxtaposed with the reflective element, such that the ball member need not be rammed into the socket when the socket is positioned at or juxtaposed with the reflective element, which avoids the impact or shock to the reflective element that typically occurs when a ball member is rammed into a socket that is at or attached to or juxtaposed with a reflective element.

15 The other end of the mounting arm may then be attached, such as via a snap together arrangement or a threaded fastener or the like, to another mounting portion or base portion or the like at the vehicle. Optionally, the other portion may have a second pivot element or member, such as a ball member, already received within a socket at a mounting base, and the end of the mounting arm may readily attach to the end of the other ball member to mount the
20 mirror assembly in the vehicle. For example, the attachment end of the mounting arm extending from the reflective element assembly may threadedly attach to a corresponding attachment end of another ball member extending from a socket at a base portion at the vehicle. The mounting arrangement thus may provide a single or double ball mounting arrangement without the need to press or ram the ball member or ball members into the
25 respective socket after the socket is attached to or positioned at the reflective element. The mounting arrangement also avoids the impact or shock of ramming the opposite ball member into the respective socket at the mounting base or button.

Because the pivot element or member, such as a ball member or ball members, is/are already inserted into their respective sockets so that the pivot joints are pre-established at the
30 reflective element and mounting base, the ball member(s) do not have to be rammed or snapped into place in their respective sockets during installation of the mirror assembly, which substantially reduces the stresses at the reflective element to substantially limit or reduce cracking of the reflective element during installation of the mirror assembly. The

mounting arrangement thus may substantially reduce the stresses at the reflective element during the installation processes.

Also, because the mounting arm may have an attachment end opposite a ball member, the ball member may be received or pre-established in any suitable or corresponding socket of a substantially universal bezel portion or reflective element assembly portion, whereby the attachment end of the mounting arm may be attached to any corresponding connector or attachment at the vehicle to complete the installation process for the respective mirror assembly. The present invention thus may provide a substantially universal and pre-established ball joint or pivot joint at the reflective element (and thus lends itself to provision of a universal reflective element assembly portion) that does not require attachment or insertion of the ball member at a later time (after the socket portion is positioned at or established at or juxtaposed with the reflective element), and may provide the capability of adapting or configuring the mounting arm to fixedly or pivotally or adjustably attach to a particular mounting base or vehicle portion or console or the like for the particular mirror application. The mounting arrangement may be suitable for applications with the cap portion and mirror holder assemblies as described above, or may be suitable for applications with other types of mirror assemblies, such as a mirror assembly of the type shown in FIG. 29, without affecting the scope of the present invention.

Optionally, and as shown in FIG. 31, the mounting arm 70 may comprise a hollow mounting arm that provides a wiring channel or passageway 70c therethrough. One or more wires or cables or the like thus may be routed through the mounting arm to provide power and/or control to the circuitry and accessories within the mirror assembly. As can be seen in FIGS. 30 and 31, the wires may route along and within the mounting base 76 and through the mounting arm and into the mirror casing or housing. Optionally, the attachment end of the mounting arm may include a connector and may plug into or connect to a corresponding connector at the mounting base or the like to establish mechanical and electrical connections (such as via utilizing aspects described in U.S. Pat. Nos. 6,672,744; 6,669,267; 6,402,331; 6,386,742; and 6,124,886, and/or U.S. pat. application, Ser. No. 10/739,766, filed Dec. 18, 2003 by DeLine et al. for MODULAR REARVIEW MIRROR ASSEMBLY (Attorney Docket DON01 P-1119), and Ser. No. 10/355,454, filed Jan. 31, 2003 by Schofield et al. for VEHICLE ACCESSORY MODULE (Attorney Docket DON01 P-1050), which are hereby incorporated herein by reference) as the mirror assembly is mounted within the vehicle. The mounting arm may include wiring therethrough to electrically connect the connector or attachment end to the circuitry within the mirror assembly.

As shown in FIGS. 29 and 30, the mounting base 76 may have a hollow body portion 76b that may extend along the interior surface of the windshield and that may extend generally downwardly from an attaching portion 76c of mounting base 76. The attaching portion 76c may attach to the mounting button or other attachment element (not shown) positioned at or attached to the interior surface of the windshield or the headliner or an overhead console of the vehicle to position the mounting base at the desired or appropriate location at the vehicle. As shown in FIG. 29, the mounting base 76 may include a cover plate 76d that may encase or enclose the body portion 76b to provide a finished appearance to the mounting base 76 along the windshield. Optionally, the body portion 76b may include or receive one or more electronic elements or accessories, such as a rain sensor or the like (such as a rain sensor of the types described in commonly assigned U.S. Pat. Nos. 6,516,664; 6,320,176; 6,353,392; 6,313,454; 6,341,523; and 6,250,148; and/or in U.S. pat. applications, Ser. No. 10/355,454, filed Jan. 31, 2003 by Schofield et al. for VEHICLE ACCESSORY MODULE (Attorney Docket DON01 P-1050); and Ser. No. 10/348,514, filed Jan. 21, 2003 by Lynam for RAIN SENSOR MOUNTING SYSTEM (Attorney Docket DON01 P-1057), which are all hereby incorporated herein by reference), that may be positioned at the windshield and that may be optically coupled to the windshield, depending on the particular application. In such embodiments, the cover plate 76d may include one or more openings or apertures at which the rain sensor camera or sensing device may be positioned.

Although the mirror assembly may include a prismatic reflective element, it is envisioned that the cap portion or portions may include controls or circuitry for controlling electro-optic or electrochromic reflective elements, such as electrochromic reflective elements of one or more exterior rearview mirror assemblies of the vehicle. The circuitry or controls may control the dimming of the exterior mirrors, such as in a known manner, such as described in commonly assigned U.S. Pat. Nos. 5,140,455; 5,151,816; 6,178,034; 6,154,306; 6,002,544; 5,567,360; 5,525,264; 5,610,756; 5,406,414; 5,253,109; 5,076,673; 5,073,012; 5,117,346; 5,724,187; 5,668,663; 5,910,854; 5,142,407 and/or 4,712,879, which are hereby incorporated herein by reference. Optionally, the cap portion or portions may include one or more photo-sensors, such as an ambient light photo-sensor and a glare sensor, and the controls or circuitry may control the exterior electro-optic or electrochromic reflective elements in response to such photo-sensors.

Optionally, the exterior rearview mirror assemblies of the vehicle may comprise electrochromic mirror reflective element assemblies, while the sensors and electronic circuitry for glare detection and ambient light detection may be positioned inside the vehicle,

such as at an interior electrochromic rearview mirror assembly. In applications where the exterior mirror assemblies comprise passenger and/or driver side electrochromic exterior rearview mirror assemblies, such as may be implemented in large vehicles, such as SUVs and the like, the electrochromic controls and circuitry may be contained within the exterior rearview mirror assemblies or the exterior electrochromic reflective element assemblies may be slaved off of the controls and circuitry of an associated electrochromic interior rearview mirror assembly of the vehicle. Optionally, it is envisioned that such sensors and electronic circuitry may be positioned at or near or incorporated into an interior prismatic rearview mirror assembly having a prismatic reflective element. The circuitry and the glare sensor and/or ambient light sensor (such as a photo sensor or the like, such as a glare sensor and/or an ambient light sensor and electrochromic automatic dimming circuitry of the types described in U.S. Pat. Nos. 4,793,690 and 5,193,029, and U.S. pat. application, Ser. No. 10/456,599, filed Jun. 6, 2003 by Weller et al. for INTERIOR REARVIEW MIRROR SYSTEM WITH COMPASS (Attorney Docket DON01 P-1076), which are all hereby incorporated herein by reference) thus may be positioned at or in or near or incorporated into the added feature prismatic interior rearview mirror assembly. The sensors may be positioned at or within the prismatic interior rearview mirror assembly such that the glare sensor is directed generally rearwardly (in the direction opposite to the forward direction of travel of the vehicle), such as through a bezel portion of the prismatic interior rearview mirror assembly, while the ambient sensor may be directed generally forwardly (in the direction of travel of the vehicle) or downwardly toward the floor of the vehicle when the mirror assembly is installed in the vehicle.

It is further envisioned that the sensors and/or control circuitry may be provided at, on or within a cap portion of the interior rearview mirror assembly and, thus, may be provided as an option for vehicles that offer the electrochromic exterior rearview mirror assemblies with a base or prismatic interior rearview mirror assembly. The appropriate cap portion (with electrochromic control circuitry and sensors and the like incorporated therein) may be selected and attached to the interior rearview mirror reflective element assembly portion to provide glare and light sensing capability and electrochromic reflective element assembly control capability to the interior rearview mirror assembly. Optionally, the cap portion may include the glare sensor in a location therein that may extend downward or outward from the cap portion so that the glare sensor may be directed generally rearward toward the rear of the vehicle when the mirror assembly is installed in the vehicle. For example, the cap portion may include a gondola or pod extending therefrom for housing the sensor or sensors and/or

control circuitry. Alternately, the cap portion may include the glare sensor at a location therein that may align with a view port or the like through the reflective element, such as for applications where, for example, the mirror assembly includes a compass/display system or other display system, such as the types described herein and/or the types disclosed in U.S. 5 pat. application, Ser. No. 10/456,599, filed Jun. 6, 2003 by Weller et al. for INTERIOR REARVIEW MIRROR SYSTEM WITH COMPASS (Attorney Docket DON01 P-1076), which is hereby incorporated herein by reference. In such applications, the ambient sensor may provide a dual function of providing an input to the control circuitry for controlling the exterior electrochromic reflective element assemblies and providing an input to the control 10 circuitry for the display element of the interior rearview mirror assembly. The cap portion may include the ambient light sensor in a location and orientation whereby the ambient light sensor is directed generally forwardly in the direction of travel of the vehicle when the mirror assembly is installed in the vehicle.

Optionally, the electrochromic controls and glare/ambient light sensors thus may be 15 provided in a cap portion (such as in a protrusion therefrom, such as a gondola or the like) and, thus, may be provided as an option for use with a common bezel and prismatic reflective element assembly. The present invention thus provides for optional controls and circuitry and sensors for optional accessories, such as electrochromic exterior rearview mirror assemblies, while providing a common bezel and prismatic reflective element and mounting 20 attachment. The desired or appropriate cap portion (with the desired or appropriate controls/sensors/circuitry) may be selected for a particular application and may be snapped onto or otherwise attached to the common bezel and prismatic reflective element assembly. The assembled mirror assembly may then be installed in the appropriate vehicle with the exterior electrochromic mirror assemblies. The present invention thus may provide added 25 feature prismatic interior rearview mirror assemblies, where the desired content of the mirror assemblies may be selected and provided on a respective optional cap portion while the rest of the mirror assemblies comprise common components.

Although shown and described as having a prismatic reflective element, the interior rearview mirror assembly of the present invention may optionally have an electro-optic or 30 electrochromic mirror assembly. The electrochromic mirror element of the electrochromic mirror assembly may utilize the principles disclosed in commonly assigned U.S. Pat. Nos. 6,690,298; 5,140,455; 5,151,816; 6,178,034; 6,154,306; 6,002,544; 5,567,360; 5,525,264; 5,610,756; 5,406,414; 5,253,109; 5,076,673; 5,073,012; 5,117,346; 5,724,187; 5,668,663; 5,910,854; 5,142,407 and/or 4,712,879, which are hereby incorporated herein by reference,

and/or as disclosed in the following publications: N. R. Lynam, "Electrochromic Automotive Day/Night Mirrors", *SAE Technical Paper Series* 870636 (1987); N. R. Lynam, "Smart Windows for Automobiles", *SAE Technical Paper Series* 900419 (1990); N. R. Lynam and A. Agrawal, "Automotive Applications of Chromogenic Materials", *Large Area Chromogenics: Materials and Devices for Transmittance Control*, C.M. Lampert and C.G. Granquist, EDS., Optical Engineering Press, Wash. (1990), which are hereby incorporated by reference herein; and/or as described in U.S. pat. application, Ser. No. 10/054,633, filed Jan. 22, 2002 (Attorney Docket DON01 P-962), which is hereby incorporated herein by reference. Optionally, the electrochromic circuitry and/or a glare sensor and circuitry and/or an ambient light sensor and circuitry may be provided on one or more circuit boards at the cap portion or portions of the mirror assembly.

Optionally, the electrochromic reflective element may include one or more displays, such as for the accessories or circuitry described above. The displays may be similar to those described above, or may be of types disclosed in U.S. Pat. Nos. 5,530,240 and/or 6,329,925, which are hereby incorporated herein by reference, and/or may be display-on-demand or transflective type displays, such as the types disclosed in U.S. Pat. Nos. 6,690,298; 5,668,663 and/or 5,724,187, and/or in U.S. pat. application, Ser. No. 10/054,633, filed Jan. 22, 2002 (Attorney Docket DON01 P-962); and/or in U.S. provisional application, Ser. No. 60/525,952, filed Nov. 26, 2003 by Lynam for MIRROR REFLECTIVE ELEMENT FOR A VEHICLE (Attorney Docket DON01 P-1130), and/or in PCT Application No. PCT/US03/29776, filed Sep. 19, 2003 by Donnelly Corp. et al. for MIRROR REFLECTIVE ELEMENT ASSEMBLY (Attorney Docket DON01 FP-1109(PCT)), which are all hereby incorporated herein by reference.

Optionally, and with reference to FIG. 33A, a reflective element assembly portion 84 may hold or receive or comprise an electrochromic reflective element assembly or cell 86, which includes a front substrate 88 and a rear substrate 90 and an electrochromic medium 92 sandwiched therebetween. In the illustrated embodiment, the reflective element assembly or cell 86 comprises a front substrate 88 that is larger than the rear substrate 90 so as to create a relief region or overhang region or ledge 93 around the perimeter of the reflective element assembly, such as described in PCT Application No. PCT/US03/35381, filed Nov. 5, 2003 by Donnelly Corporation et al. for ELECTRO-OPTIC REFLECTIVE ELEMENT ASSEMBLY (Attorney Docket DON01 FP-1116(PCT)); and/or in U.S. provisional applications, Ser. No. 60/553,842, filed Mar. 17, 2004 by Bareman et al. for METHOD OF MANUFACTURING ELECTRO-OPTIC MIRROR CELL (Attorney Docket DON01 P-1143); and Ser. No.

60/563,342, filed Apr. 19, 2004 by Bareman et al. for METHOD OF MANUFACTURING ELECTRO-OPTIC MIRROR CELL (Attorney Docket DON01 P-1153), which are hereby incorporated herein by reference.

5 The larger front substrate 88 allows the bezel portion or molding 94 to be molded around the electrochromic reflective element assembly and allows the bezel portion to shrink and directly stress the front substrate 88 without placing the interpane seal 96 under the hoop stresses and shear stresses that typically occur with conventional electrochromic cells or reflective element assemblies (where the front and rear substrates are offset one to another such that any bezel shrinkage typically places the front substrate in shear stress relative to the rear substrate, potentially leading to failure of the seal therebetween that protects the electrochromic medium from the outside environment) when the bezel portion cools and contracts around the cell. The bezel portion or molding 94 thus may be formed around the reflective element assembly or cell, and the cap portion (not shown in FIG. 33A) may be provided at a later step after the bezel portion has cooled around the reflective element
10 assembly (such as described above) to provide a modular electrochromic mirror assembly in accordance with the present invention. Optionally, the bezel portion may be formed of a soft polymer or impact absorbing material (such as a soft touch material as described above, and/or preferably having a Shore A durometer value of less than about 110 Shore A, more preferably less than about 90 Shore A, and most preferably less than about 70 Shore A) at
15 or around the perimeter of the front substrate 88 or of the front or first surface 88b of the front substrate 88, or a soft or impact absorbing trim portion or element may be provided at or around the perimeter of the front substrate 88, without affecting the scope of the present invention.

The front substrate 88 includes a transparent conductive coating or layer 89 (such as
25 an indium tin oxide (ITO), a tin oxide (TO) or the like) on its rear surface 88a (the second surface of the cell), while the rear substrate 90 includes a metallic conductive coating or layer or layers or stack of coatings or layers 91 on its front surface 90a (the third surface of the cell), such as is generally done with electrochromic reflective element assemblies, and such as by utilizing aspects described in U.S. Pat. Nos. 6,690,268; 5,668,663; 5,724,187;
30 5,140,455; 5,151,816; 6,178,034; 6,154,306; 6,002,544; 5,567,360; 5,525,264; 5,610,756; 5,406,414; 5,253,109; 5,076,673; 5,073,012; 5,117,346; 5,910,854; 5,142,407 and 4,712,879, and/or in U.S. pat. application, Ser. No. 10/054,633, filed Jan. 22, 2002 (Attorney Docket DON01 P-962), and/or in PCT Application No. PCT/US03/29776, filed Sep. 19, 2003 by

Donnelly Corporation et al. for MIRROR REFLECTIVE ELEMENT ASSEMBLY (Attorney Docket DON01 FP-1109(PCT)); PCT Application No. PCT/US03/35381, filed Nov. 5, 2003 by Donnelly Corporation et al. for ELECTRO-OPTIC REFLECTIVE ELEMENT ASSEMBLY (Attorney Docket DON01 FP-1116(PCT)); and/or in PCT Application No. 5 PCT/US03/036177, filed Nov. 14, 2003 by Donnelly Corporation et al. for IMAGING SYSTEM FOR VEHICLE (Attorney Docket DON01 FP-1118(PCT)); and/or U.S. provisional applications, Ser. No. 60/531,838, filed Dec. 23, 2003 by Bareman for METHOD OF MANUFACTURING ELECTRO-OPTIC MIRROR CELL (Attorney Docket DON01 P-1132); Ser. No. 60/553,842, filed Mar. 17, 2004 by Bareman et al. for METHOD OF 10 MANUFACTURING ELECTRO-OPTIC MIRROR CELL (Attorney Docket DON01 P-1143); and Ser. No. 60/563,342, filed Apr. 19, 2004 by Bareman et al. for METHOD OF MANUFACTURING ELECTRO-OPTIC MIRROR CELL (Attorney Docket DON01 P-1153), which are hereby incorporated herein by reference.

As shown in FIG. 33A, the metallic conductive coating or layer or layers 91 may be 15 removed from (or not disposed at) a perimeter region 90b of the front surface 90a of rear substrate 90, and the interpane seal 96 may be disposed around the masked or uncoated perimeter region, in order to electrically isolate the conductive coatings 91 from the perimeter edge of the rear substrate 90, such as described in U.S. provisional applications, Ser. No. 60/553,842, filed Mar. 17, 2004 by Bareman et al. for METHOD OF MANUFACTURING 20 ELECTRO-OPTIC MIRROR CELL (Attorney Docket DON01 P-1143); and Ser. No. 60/563,342, filed Apr. 19, 2004 by Bareman et al. for METHOD OF MANUFACTURING ELECTRO-OPTIC MIRROR CELL (Attorney Docket DON01 P-1153), which are hereby incorporated herein by reference. The conductive coatings or layers 91 may provide a tab out region (not shown in FIG. 33A) along the front surface of the rear substrate to provide for 25 electrical connection between the third surface coating 91 and the perimeter edge of the substrate (such as described in U.S. provisional applications, Ser. No. 60/553,842, filed Mar. 17, 2004 by Bareman et al. for METHOD OF MANUFACTURING ELECTRO-OPTIC MIRROR CELL (Attorney Docket DON01 P-1143); and Ser. No. 60/563,342, filed Apr. 19, 2004 by Bareman et al. for METHOD OF MANUFACTURING ELECTRO-OPTIC 30 MIRROR CELL (Attorney Docket DON01 P-1153), which are hereby incorporated herein by reference. A conductor or electrical connector 100 may connect to the conductive coating 89 via a solder or conductive strip 101 around the overhang region, while a second conductor or electrical connector (not shown in FIG. 33A) may connect to the conductive coating 91 via connection to the tab out region. The reflective element assembly may include a reflective

perimeter region around the perimeter of the reflective element assembly or may have an opaque or blackened or darkened perimeter region, such as by utilizing the principles described in U.S. Pat. No. 5,066,112, which is hereby incorporated herein by reference, in order to at least partially conceal the seal 96 from being readily viewable by the driver of the vehicle.

Optionally, and with reference to FIG. 33B, a reflective element assembly portion 84' may hold an electro-optic reflective element assembly 86, such as an electrochromic reflective element assembly or cell, and may include a mounting or attachment plate 98 positioned at the rear surface of the reflective element assembly 86 (the fourth surface of the cell). The bezel portion or molding 94' may be molded or formed around the reflective element assembly 86 and around or at the attachment plate 98 to retain the attachment plate 98 and the reflective element assembly 86 within the bezel portion or molding 94'. As can be seen in FIG. 33B, the mounting plate 98 may include protrusions or recesses or the like 98a at least partially around its perimeter edge to facilitate mechanical connection and securement of the bezel portion 94' (such as by snap on or snap in) to the mounting plate 98 when the bezel portion 94' is molded around the mounting plate 98. The attachment plate 98 may include a pivot joint or element 102 established or formed thereon. The reflective element assembly portion 84' may be otherwise substantially similar to reflective element assembly portion 84, discussed above, such that a detailed description of the reflective element assembly will not be repeated herein. The components that are common with the reflective element assemblies 84 and 84' are shown with the same reference numbers in FIGS. 33A and 33B.

Therefore, the reflective element assembly portion may be formed or molded with the molding or bezel portion molded or formed around the larger front substrate to contain the reflective element assembly or cell within or at the bezel portion. The pivot element or joint 102 may be formed or established at the rear of the reflective element assembly, such as in the manners described above, and the mounting arm 104 may extend generally rearwardly from the pivot joint. The cap portion may then receive the mounting arm through an opening or the like in the cap portion such that the mounting arm extends from the cap portion after the cap portion is attached to or snapped to the reflective element assembly portion. The electrical connectors of the reflective element assembly portion may connect to the appropriate electrical connectors or terminals or circuitry of the cap portion as the cap portion is assembled to or attached to the reflective element assembly portion, such as in the manners

described above, in order to provide electrical power and/or control to the electrochromic cell.

The electrochromic reflective element assembly portion of the present invention thus may comprise a standard or universal or common reflective element assembly or cell and mirror holder or bezel portion, which may then be attached to a customized or selected or desired cap portion, as described above. Optionally, the reflective element assembly portion may be customized as well. For example, a selected bezel material may be molded around a common reflective element assembly or cell. The reflective element assembly portion may be formed by placing an electrochromic cell into a mold cavity (such as face down into the mold cavity with the rear surface of the rear substrate facing upward), and the plastic piece or mounting plate (preferably with a pivot element or member already established therein or thereon) may be inserted into the mold or placed generally at or on the rear surface of the rear substrate of the reflective element assembly or cell (i.e. the fourth surface of the cell). The mounting plate may be generally smaller than the profile of the rear substrate and may include the pivot element or socket formed thereon (or such pivot components may be added or attached or molded later). Optionally, the mounting plate may include electronic circuitry and the like, such as for making the electrical connection to the electrical connectors of the cell and/or for providing other electronic content or features or functions as may be desired (such as display elements for displaying information through the cell to a driver of the vehicle or the like, or such as ports or aperture for aligning with display elements of the cap portion so that information may be displayed or projected through the apertures in the mounting plate and through the cell to a driver of the vehicle). The bezel portion or molding may then be molded (such as via injection molding or reaction injection molding of a desired or selected or appropriate material into the mold cavity) to form the bezel portion around the perimeter of the front substrate (such as described above).

Optionally, the electrochromic reflective element assembly portion may be readily customized by injection molding a selected material into the mold to form the bezel portion of a selected or customized material. For example, the material may be selected to be a desired color, or may be selected to have desired properties, such as, for example, a soft touch or desired feel or appearance or finish or the like. The present invention thus may provide a common cell and attachment or mounting plate (and pivot element or joint), but may readily customize the appearance and/or feel of the bezel portion or molding to provide a particular, selected and customized reflective element assembly portion, while utilizing the same molding tool or mold to form the customized molding or bezel portion. Optionally, the

reflective element assembly or cell and attachment or backing plate may comprise standard or common components for multiple mirror assemblies, and may be placed in desired or appropriate molds for molding the appropriate bezel portion for a particular mirror application. The customized reflective element assembly portion may then be attached to the
5 desired or selected or customized cap portion as described above, and the electrical connections of the electronic circuitry and the like at the plate of the reflective element assembly portion may be made to the corresponding or appropriate connectors or circuitry of the cap portion as the cap portion is attached to the reflective element assembly portion. Although shown and described as molding a bezel portion around the perimeter region of a
10 larger front substrate (which is larger than the rear substrate) of an electrochromic reflective element assembly or cell, it is envisioned that the bezel portion or molding may be molded or formed around other types of electrochromic reflective element assemblies or cells (such as flush cells or offset or staggered cells or the like), and/or may be molded or formed around prismatic reflective elements and the like, without affecting the scope of the present
15 invention.

Optionally, and such as described in PCT Publication No. WO 03/095269 A2, published Nov. 20, 2003 for REARVIEW MIRROR ASSEMBLIES, which is hereby incorporated by reference herein, an electro-optic rearview mirror assembly portion may comprise an electro-optic reflective element assembly or unit or cell, such as an
20 electrochromic reflective unit or cell (whose reflectivity is variable in response to an electrical voltage applied thereto), and an electrical circuit for controlling operation of the mirror cell in response to one or more one light sensors. The interior mirror assembly portion may also comprise at least one pivot element or member, such as a ball and socket member, which allows angular adjustment of the mirror reflective element when the mirror
25 assembly is mounted in the vehicle. Optionally, the ball member may include a plurality of electrical contacts on an exposed surface thereof for sliding engagement by respective counter-contacts over a range of angular movement of the mirror unit for supplying power to the electrical circuit from a vehicle electrical system external to the mirror assembly. Optionally, other means for providing electrical power and/or control to the
30 circuitry/accessories of the mirror assembly may be provided (such as a wire or cable along an exterior surface or portion of the mounting arm or member or the like), without affecting the scope of the present invention.

Optionally, a prismatic mirror assembly portion and cap portion of the present invention may include electrochromic drive circuitry for controlling the exterior electrochromic reflective elements of the exterior rearview mirror assemblies of the vehicle, such as described above. The cap portion may include a glare sensor and an ambient sensor to determine the glare levels and ambient light levels and the control circuitry may adjust the dimming of the exterior mirrors accordingly. The glare sensor may receive the light through an aligned port in the reflective element or may receive light via a light pipe or the like, without affecting the scope of the present invention. The cap portion thus may provide electrochromic control circuitry for applications where the vehicle may have exterior electrochromic mirror assemblies, while the interior rearview mirror assembly may comprise a base or prismatic mirror that may otherwise not include such control circuitry. The cap portion of the present invention thus may provide a low cost conversion of an interior rearview mirror to provide electrochromic mirror control for the exterior rearview mirrors of the vehicle.

Optionally, and with reference to FIGS. 34 and 35A-D, an interior rearview mirror assembly 110 may be attachable or mountable to a windshield accessory module 112, which may be attachable or mountable to an interior surface of the windshield of a vehicle, such as at a mounting button or the like. Windshield accessory module 112 may include a body portion 114 that extends generally along the windshield and may include a head portion 116 at the upper end of the body portion 114 generally above the mirror assembly 110 and viewable by a driver of the vehicle when the windshield accessory module 112 and mirror assembly 110 are mounted in a vehicle, such as in a similar manner as described in U.S. pat. application, Ser. No. 10/355,454, filed Jan. 31, 2003 by Schofield et al. for VEHICLE ACCESSORY MODULE (Attorney Docket DON01 P-1050), which is hereby incorporated herein by reference. Windshield accessory module 112 may include one or more accessories or circuitry therein, and may include one or more user interface controls or inputs and/or a display or indicator or indicators or the like at the head portion that are readily viewable and/or accessible above the mirror assembly, such as discussed below and as shown in FIGS. 35A-D and/or as described in U.S. pat. application, Ser. No. 10/355,454, filed Jan. 31, 2003 by Schofield et al. for VEHICLE ACCESSORY MODULE (Attorney Docket DON01 P-1050), which is hereby incorporated herein by reference. As shown in FIGS. 34 and 35A, a wiring or cabling conduit 118 may extend upward from the body portion 114 and along the windshield 111 to conceal and route the wiring harness between the headliner of the vehicle and the windshield accessory module 112.

Preferably, the windshield accessory module may be configured to attach to a typical mounting button or the like for an interior rearview mirror assembly, and may include a replica of the mounting button or the like for the mirror assembly to mount thereto. The accessory module thus may attach to the existing button on the windshield and the mirror assembly may be attached to the button on the accessory module in the same manner. The mirror assembly may comprise a modular mirror assembly as described above, or may comprise other types of prismatic or electro-optic or electrochromic mirror assembly, without affecting the scope of the present invention. As shown in FIG. 34, a wiring harness 119 and connector or plug 119a may extend from accessory module 112 and plug into the back of the mirror casing or cap portion, such as in a similar manner as described above. The accessory module thus may provide an aftermarket addition to add additional electronic content or accessories, without having to replace the mirror assembly. The accessory module of the present invention thus may provide the desired accessories or options, while providing the vehicle manufacturer and/or the customer the freedom to select any mirror assembly. Optionally, for aftermarket applications, the windshield accessory module may be battery-operated and may include a battery compartment for receiving and connecting to a battery or power source or the like.

As shown in FIG. 35A, windshield accessory module 112 may include or may be associated with a garage door opening system, and head portion 116 may include one or more user actuatable inputs 120a-c for controlling or actuating the garage door opening system. Head portion 116 may also include an icon or indicia 122 or the like, which may be illuminated or back lit via a light source in head portion 116 to indicate to the user of the garage door opening system that the system is activated or that the button or input was successfully actuated. The garage door opening system may comprise a trainable garage door opening system and/or may utilize principles disclosed in U.S. Pat. Nos. 6,396,408; 6,362,771; 5,798,688 and 5,479,155; and/or U.S. pat. application, Ser. No. 10/770,736, filed Feb. 3, 2004 by Baumgardner et al. for GARAGE DOOR OPENING SYSTEM FOR VEHICLE (Attorney Docket DON01 P-1135), which are hereby incorporated herein by reference.

Optionally, and with reference to FIG. 35B, the windshield accessory module 112' may also or otherwise include or be associated with a telematics system or cellular telephone system or the like. The head portion 116' thus may provide user inputs 124a, 124b, 124c for actuating the system, placing a telephone call and ending a telephone call, respectively. The head portion 116' may also include a microphone 126 for receiving voice or audio signals

from within the cabin of the vehicle, such as via a microphone system of the types described in U.S. Pat. Nos. 6,243,003; 6,278,377; and/or 6,420,975, and/or in PCT Application No. PCT/US03/308877, filed Oct. 1, 2003 by Donnelly Corp. et al. for MICROPHONE SYSTEM FOR VEHICLE (Attorney Docket DON01 FP-1111(PCT)), which are hereby incorporated
5 herein by reference. In the illustrated embodiment of FIG. 35B, the head portion 116' includes user inputs and/or indicators 120a', 120b', 120c' for controlling and actuating the garage door opening system and/or for indicating successful operation of the garage door opening system, such as described above.

Optionally, and with reference to FIG. 35C, the windshield accessory module 112"
10 may also or otherwise include or be associated with a tire pressure monitoring system. The head portion 116" may include a display 128 that includes a pressure display 128a for displaying the tire pressure of a particular tire of the vehicle and indicators or light sources 128b for indicating which tire the display 128a is showing the pressure for. Head portion 116" may also include a reset button or input 128c for resetting the tire pressure monitoring
15 system. The tire pressure monitoring system may comprise any tire pressure monitoring system, and may utilize the principles described in U.S. Pat. Nos. 6,124,647; 6,294,989; 6,445,287; 6,472,979; and/or 6,731,205, which are hereby incorporated herein by reference. The head portion 116" may also include one or more user inputs and/or indicators 120a", 120b", 120c" for controlling and actuating the garage door opening system and/or for
20 indicating successful operation of the garage door opening system, such as described above.

Optionally, and with reference to FIG. 35D, the windshield accessory module 112""
may also or otherwise include or be associated with a navigational system for providing instructions to the driver to follow to arrive at a desired or input destination. The head
portion 116"" may include a display screen or display device 130 for providing directional
25 heading or driving instructions to the driver. For example, the display device 130 may display the next step to follow and may indicate how far the vehicle has to travel until it arrives at the next turn or intersection. The head portion 116"" may also include one or more user inputs or buttons 132 for controlling the navigational display and/or for scrolling through the instructions being displayed by the display device 130. The navigational system may be
30 associated with or controlled or adjusted by a global positioning system of the vehicle and/or a telematics system of the vehicle and/or a compass system of the vehicle, and may utilize principles such as used in the compass and/or navigational systems of the types described in U.S. Pat. Nos. 6,678,614; 6,477,464; 5,924,212; 4,862,594; 4,937,945; 5,131,154; 5,255,442; and/or 5,632,092, and/or U.S. pat. application, Ser. No. 10/456,599, filed Jun. 6, 2003 by

Weller et al. for INTERIOR REARVIEW MIRROR SYSTEM WITH COMPASS (Attorney Docket DON01 P-1076); Ser. No. 10/645,762, filed Aug. 20, 2003 by Taylor et al. for VEHICLE NAVIGATION SYSTEM FOR USE WITH A TELEMATICS SYSTEM (Attorney Docket DON01 P-1103); and Ser. No. 10/422,378, filed Apr. 24, 2003 (Attorney Docket DON01 P-1074); and/or PCT Application No. PCT/US03/40611, filed Dec. 19, 2003 by Donnelly Corporation et al. for ACCESSORY SYSTEM FOR VEHICLE (Attorney Docket DON01 FP-1123(PCT)), which are all hereby incorporated herein by reference. As shown in FIG. 35D, head portion 116" may also include one or more user inputs and/or indicators 120 for controlling and actuating the garage door opening system and/or for indicating successful operation of the garage door opening system, such as described above.

The desired accessory module or content may be used with any mirror assembly and, for aftermarket applications, may be used with an existing mirror assembly in the vehicle. The existing mirror assembly may be removed from the mounting button and the windshield module may be attached to the windshield button and the mirror assembly may be attached to the button of the module. Optionally, and particularly for aftermarket applications, the accessory module may include a power source or battery for providing power to the electronic accessories contained within the module and/or within an associated mirror assembly.

Although certain examples of the controls and/or displays that may be provided at the head portion of the windshield accessory module are shown in FIGS. 35A-D and described above, clearly other displays and/or user inputs and/or accessories or functions or features may be provided within or at the windshield accessory module, without affecting the scope of the present invention. The desired features or content may be provided on a circuit board and may include display elements and/or display screens or panels or the like. The circuit board and associated display elements and circuitry and inputs (or appropriate or selected or desired display elements and the like) may be mounted to or attached to or snapped into a common or universal body or base portion to convert or form the desired windshield electronics module for the particular application. If the screen or circuitry is larger than the standard head size of the module, a larger cap portion (such as shown in FIGS. 35B and 35D) may be implemented to contain and conceal the circuitry and the like within the head portion. The windshield electronics module or accessory module of the present invention thus provides various modules with the desired features or content, while utilizing common or universal components.

The windshield electronics module of the present invention thus eases assembly of various modules having varied content, and eases disassembly and repair of the modules. Optionally, however, the module may be sealed to contain the circuit board and display elements therewithin, without affecting the scope of the present invention. The components
5 of the module, such as the telematics controls and the like, may be associated with other components and/or circuitry and/or systems of vehicle, such as a vehicle electronic or communication system, and may be connected via a hard wire or via various protocols or nodes, such as Bluetooth, SCP, UBP, J1850, CAN J2284, Fire Wire 1394, MOST, LIN and/or the like, depending on the particular application.

10 Therefore, the present invention provides a modular prismatic interior rearview mirror assembly which may have features, such as electronic accessories and/or displays or the like. The accessories or circuitry may be attached to one or more cap portions which may snap or otherwise affix or secure or mount to the rear portion of the mirror holder or bezel portion or reflective element assembly portion. The mirror holder may receive the reflective element,
15 which may be a prismatic reflective element or an electro-optic or electrochromic reflective element, soon after the mirror holder is formed or heated, such that the reflective element may be installed to the mirror holder without a separate bezel portion. The cap portions and associated accessories and/or circuitry may be mounted to the mirror holder after the reflective element is installed and after the mirror holder has cooled and shrunk. The cap
20 portion of the present invention thus avoids the increased costs associated with a two piece mirror holder having a separate bezel portion which is secured to the mirror holder to secure the reflective element at the mirror holder. The cap portions may be selected to have accessories and/or circuitry corresponding to openings in the mirror holder and/or to displays or display icons or the like at the reflective element. The cap portion may be selected to be
25 formed of a different material than the bezel portion or molding, so as to provide the desired material properties and characteristics to both the bezel portion and the cap portion.

Changes and modification in the specifically described embodiments may be carried out without departing from the principles of the present invention, which is intended to be limited only by the scope of the appended claims as interpreted according to the principles of
30 patent law.

The embodiments of the invention in which an exclusive property or privilege is claimed are defined as follows:

1. An interior rearview mirror assembly for a vehicle comprising:
a reflective element assembly portion;
at least one cap portion, said at least one cap portion adapted to attach to said reflective element assembly portion;
5 said reflective element assembly portion including a mirror reflective element, said reflective element assembly portion comprising a first molding that encompasses at least a perimeter portion of said reflective element, said first molding being formed by molding a first resinous material having a tool shrinkage factor equal to or greater than about 1%;
said reflective element assembly portion comprising at least one pivot element, said
10 pivot element providing adjustability of said reflective element when said reflective element assembly portion is mounted within the interior cabin of the vehicle; and
said at least one cap portion including at least one accessory, said at least one cap portion comprising at least one second molding formed by molding a second resinous material having a tool shrinkage factor of less than or equal to about 1%.
2. The interior rearview mirror assembly of claim 1, wherein said at least one cap portion comprises a single cap portion substantially encasing a rear portion of said mirror assembly and having an aperture therethrough, wherein a mounting member extends from said pivot element and through said aperture when said cap portion is attached to said reflective element assembly portion.
3. The interior rearview mirror assembly of claim 1, wherein said at least one cap portion comprises a pair of cap portions attachable at corresponding portions of said reflective element assembly portion.
4. The interior rearview mirror assembly of claim 3, wherein each of said cap portions supports at least one accessory having circuitry, said circuitry of said cap portions being connected via a connecting cable.
5. The interior rearview mirror assembly of claim 4, wherein said cap portions are connected via a connecting member.

6. The interior rearview mirror assembly of claim 1, wherein said reflective element is received into said first molding while said first molding is warm and pliable.
7. The interior rearview mirror assembly of claim 1, wherein said at least one accessory includes circuitry operable to control a display at said reflective element.
8. The interior rearview mirror assembly of claim 7, wherein said display comprises at least one of a compass display, a tire pressure monitoring display, a telematics display, a navigation system display, a garage door opening system display, a temperature display, a supplemental inflatable restraint system status display, and an object detection display.
9. The interior rearview mirror assembly of claim 1, wherein at least one illumination source is positioned to align with at least one port formed on said reflective element when said cap portion is attached to said reflective element assembly portion.
10. The interior rearview mirror assembly of claim 7, wherein said display comprises a compass display.
11. The interior rearview mirror assembly of claim 10, wherein said circuitry is in communication with compass circuitry.
12. The interior rearview mirror assembly of claim 11, wherein said compass circuitry is positioned at an accessory module positioned at a mounting portion of said mirror assembly.
13. The interior rearview mirror assembly of claim 1, wherein said at least one accessory comprises an accessory module insertable at least partially into said cap portion.
14. The interior rearview mirror assembly of claim 13, wherein said accessory module includes at least one user input for selectively actuating an accessory of the vehicle.
15. The interior rearview mirror assembly of claim 13, wherein insertion of said accessory module into said cap portion interconnects said accessory module to said cap portion both mechanically and electrically.

16. The interior rearview mirror assembly of claim 15, wherein said accessory module is inserted into said cap portion after said cap portion is attached to said reflective element assembly portion.
17. The interior rearview mirror assembly of claim 1, wherein said cap portion includes a connector for connecting to a vehicle wiring harness.
18. The interior rearview mirror assembly of claim 1, wherein said at least one cap portion is detachably attached to said reflective element assembly portion.
19. The interior rearview mirror assembly of claim 1, wherein said at least one cap portion is detachably attached to said reflective element assembly portion via at least one mechanical interconnect.
20. The interior rearview mirror assembly of claim 1, wherein said first molding comprises a bezel portion of said mirror assembly.
21. The interior rearview mirror assembly of claim 1, wherein said first molding comprises a backing plate at said reflective element.
22. The interior rearview mirror assembly of claim 1, wherein said first resinous material has a tool shrinkage factor equal to or greater than about 1.5%.
23. The interior rearview mirror assembly of claim 1, wherein said first resinous material comprises a polyolefin material.
24. The interior rearview mirror assembly of claim 1, wherein said second resinous material has a tool shrinkage factor of less than or equal to about 0.8%.
25. The interior rearview mirror assembly of claim 1, wherein said second resinous material has a tool shrinkage factor of less than or equal to about 0.6%.

26. The interior rearview mirror assembly of claim 1, wherein said second resinous material comprises one of an ABS material and a NYLON material.
27. The interior rearview mirror assembly of claim 1, wherein said first molding has a first color and said second molding has a second color, said first color being different than said second color.
28. The interior rearview mirror assembly of claim 1, wherein said first molding has a first exterior finish and said second molding has a second exterior finish, said first exterior finish being different than said second exterior finish.
29. The interior rearview mirror assembly of claim 1, wherein said pivot element comprises a ball joint.
30. The interior rearview mirror assembly of claim 29, wherein a mounting member connects to said reflective element assembly portion by said ball joint.
31. The interior rearview mirror assembly of claim 30, wherein said mounting member comprises a second ball joint connecting to a mirror attachment member, said mirror attachment member being adapted to attach the interior rearview mirror assembly to an interior portion of the vehicle.
32. The interior rearview mirror assembly of claim 2, wherein said pivot element comprises a ball joint.
33. The interior rearview mirror assembly of claim 1, wherein said reflective element comprises a prismatic reflective element and said pivot element is actuated by a toggle element.
34. The interior rearview mirror assembly of claim 1, wherein said reflective element comprises a prismatic reflective element.
35. The interior rearview mirror assembly of claim 1, wherein said reflective element comprises an electro-optic reflective element assembly.

36. The interior rearview mirror assembly of claim 1, wherein said reflective element assembly portion comprises a first sub-assembly and said cap portion comprises a second sub-assembly, said second sub-assembly being attached to said first sub-assembly to assemble said mirror assembly.

37. A method of manufacturing an interior rearview mirror assembly, said method comprising:

forming a first molding by injection molding a first resinous material in a mold, said first resinous material having a tool shrinkage factor of at least approximately 1%, said first molding being at an elevated temperature when said first molding is removed from the mold;
5 providing a reflective element;

positioning said reflective element at said first molding before said first molding has cooled to ambient temperature, said first molding at least partially encompassing a perimeter portion of said reflective element to form a reflective element assembly portion;

10 allowing said first molding to cool and shrink to retain said reflective element at said first molding;

providing a cap portion comprising a second resinous material, said second resinous material having a tool shrinkage factor of at less than or equal to approximately 1%, said cap portion including at least one accessory; and

15 attaching said cap portion to said reflective element assembly portion after said first molding has cooled and shrunk, said cap portion being attached to said reflective element assembly portion such that said accessory is at least partially within said mirror assembly.

38. The method of claim 37, wherein said cap portion includes a printed circuit board therein, said accessory comprising circuitry at said printed circuit board.

39. The method of claim 38 including forming a display region at said reflective element, said circuitry including at least one display element that generally aligns with at least a portion of said display region when said cap portion is attached to said reflective element assembly portion.

40. The method of claim 39, wherein at least one of said cap portion and said first molding include guide portions to guide said cap portion into engagement with and

attachment to said first molding to align said at least one display element with a display port formed in said reflective element.

41. The method of claim 37, wherein said reflective element assembly portion is fabricated as a first sub-assembly and said cap portion and at least one accessory is fabricated as a second sub-assembly.

42. The method of claim 41, wherein said first sub-assembly is fabricated at a first assembly location and said second sub-assembly is fabricated at a second assembly location.

43. The method of claim 42, wherein said first assembly location is remote from said second assembly location.

44. The method of claim 43, wherein said second sub-assembly is attached to said first sub-assembly at a third assembly location.

45. The method of claim 44, wherein said third assembly location is remote from said first and second assembly locations.

46. The method of claim 37, wherein said first resinous material has a tool shrinkage factor of at least approximately 1.5%.

47. The method of claim 37, wherein said first resinous material comprises a polyolefin material.

48. The method of claim 37, wherein said second resinous material has a tool shrinkage factor of less than or equal to approximately 0.8%.

49. The method of claim 37, wherein said second resinous material has a tool shrinkage factor of less than or equal to approximately 0.6%.

50. The method of claim 37, wherein said second resinous material comprises one of an ABS material and a NYLON material.

51. The method of claim 37, wherein said first molding has a first color and said cap portion has a second color, said first color being different than said second color.
52. The method of claim 37, wherein said first molding has a first exterior finish and said cap portion has a second exterior finish, said first exterior finish being different than said second exterior finish.
53. The method of claim 37, wherein said reflective element assembly portion includes a pivot element for providing adjustability of said reflective element when said reflective element assembly portion is mounted within the interior cabin of the vehicle.
54. The method of claim 53, wherein said pivot element comprises a ball joint, said mirror assembly including a mounting member pivotally attached to said reflective element assembly portion via said ball joint.
55. The method of claim 54, wherein said mounting member extends through said cap portion when said cap portion is attached to said reflective element assembly portion.
56. The method of claim 55, wherein said mounting member comprises a second ball joint connecting to a mirror attachment member, said mirror attachment member being adapted to attach the interior rearview mirror assembly to an interior portion of the vehicle.
57. The method of claim 37, wherein said reflective element comprises a prismatic reflective element and said pivot element is attached to a toggle assembly of said reflective element assembly portion.
58. The method of claim 37, wherein said reflective element comprises a prismatic reflective element.
59. The method of claim 37, wherein said reflective element comprises an electro-optic reflective element assembly.
60. An interior rearview mirror assembly for a vehicle comprising:
a reflective element assembly portion;

said reflective element assembly portion including an electro-optic reflective element, said reflective element assembly portion comprising a first molding that encompasses at least a perimeter portion of said reflective element, said first molding being formed by molding a
5 first resinous material having a tool shrinkage factor equal to or greater than about 1%;

at least one cap portion, said at least one cap portion adapted to attach to said reflective element assembly portion, said at least one cap portion comprises at least one second molding formed by molding a second resinous material having a tool shrinkage factor
10 of less than or equal to about 1%;

said reflective element assembly portion comprising at least one pivot element, said pivot element providing adjustability of said reflective element when said reflective element assembly portion is mounted via a mounting member within the interior cabin of the vehicle;
and

15 said at least one cap portion including electro-optic circuitry for controlling said reflective element assembly, said at least one cap portion providing electrical connection of said electro-optic circuitry to said reflective element assembly when said cap portion attaches to said reflective element assembly portion.

61. The interior rearview mirror assembly of claim 60, wherein said reflective element assembly comprises a pair of substrates with conductive coatings on opposed surfaces of substrates and an electrochromic medium disposed between said conductive coatings.

62. The interior rearview mirror assembly of claim 61 including a pair of connectors connected to respective ones of said conductive coatings, said connectors extending from said first molding for connection to said cap portion when said cap portion is attached to said reflective element assembly portion.

63. The interior rearview mirror assembly of claim 61, wherein said pair of substrates comprises a front substrate and a rear substrate, said front substrate having a first dimension thereacross and said rear substrate having a second dimension thereacross and juxtaposed with said first dimension, said first dimension of said front substrate being larger than said
5 second dimension of said rear substrate.

64. The interior rearview mirror assembly of claim 60 including a mounting plate with said pivot element established thereon, said mounting plate being positioned at a rear surface of said reflective element assembly.

65. The interior rearview mirror assembly of claim 64, wherein said first molding at least partially encompasses said mounting plate to attach to said mounting plate and to substantially secure said mounting plate relative to said reflective element assembly.

66. An interior rearview mirror assembly for a vehicle comprising:
a reflective element assembly portion;
said reflective element assembly portion including a mirror reflective element, said reflective element assembly portion comprising a first molding that encompasses at least a
5 perimeter portion of said reflective element;
at least one trim element adapted to attach to said first molding, said at least one trim element extending at least partially around a front portion of said reflective element assembly portion when attached to said first molding;
at least one cap portion, said at least one cap portion adapted to attach to said
10 reflective element assembly portion, said at least one cap portion including at least one accessory; and
said reflective element assembly portion comprising at least one pivot element, said pivot element providing adjustability of said reflective element when said reflective element assembly portion is mounted within the interior cabin of the vehicle.

67. The interior rearview mirror assembly of claim 66, wherein said first molding is formed by molding a first resinous material having a tool shrinkage factor equal to or greater than about 1%.

68. The interior rearview mirror assembly of claim 66, wherein said at least one cap portion comprises at least one second molding formed by molding a second resinous material having a tool shrinkage factor of less than or equal to about 1%.

69. The interior rearview mirror assembly of claim 66, wherein said at least one trim element comprises a material having a Shore A durometer hardness that is less than a Shore A durometer hardness of said first molding.

70. The interior rearview mirror assembly of claim 66, wherein a portion of said at least one trim element is received at least partially within a portion of said first molding.

71. The interior rearview mirror assembly of claim 66, wherein said first molding has a first exterior finish and said at least one trim element has a second exterior finish, said first exterior finish being different than said second exterior finish.

72. The interior rearview mirror assembly of claim 71, wherein said cap portion has a third exterior finish, said third exterior finish being different than at least one of said first and second exterior finishes.

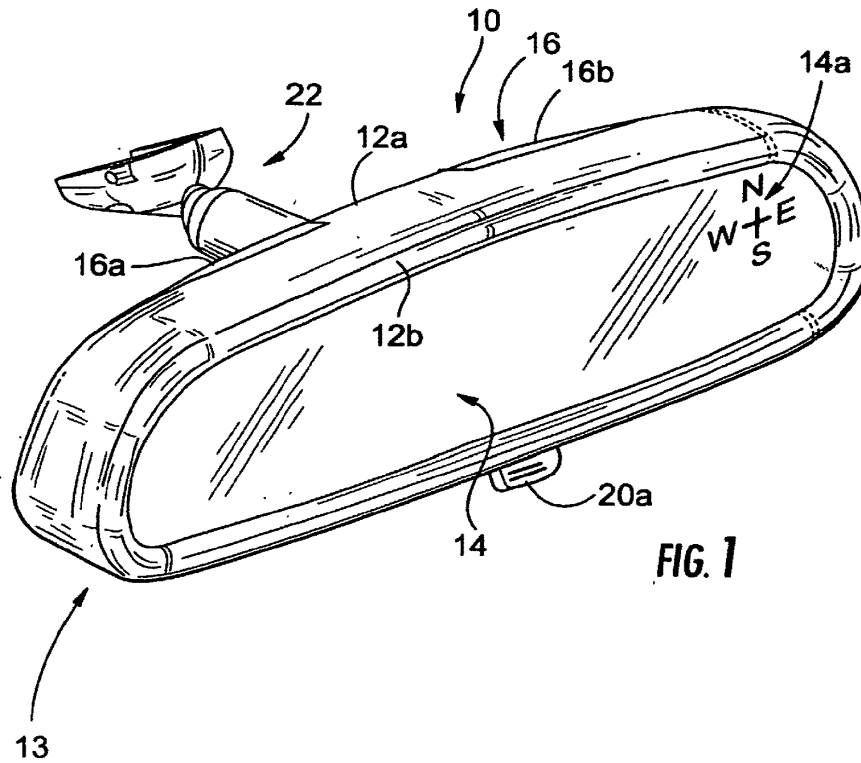

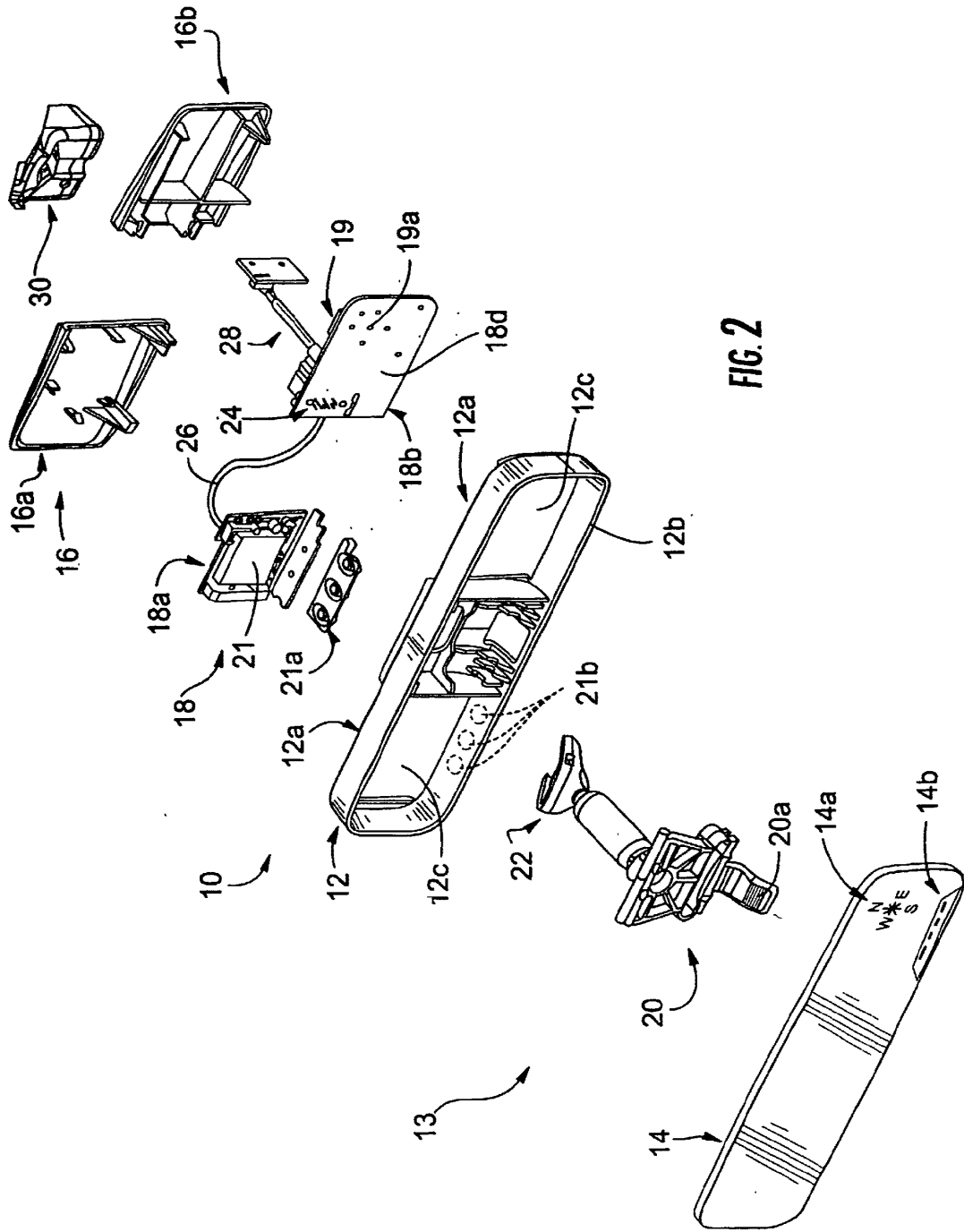

FIG. 2

SUBSTITUTE SHEET (RULE 26)

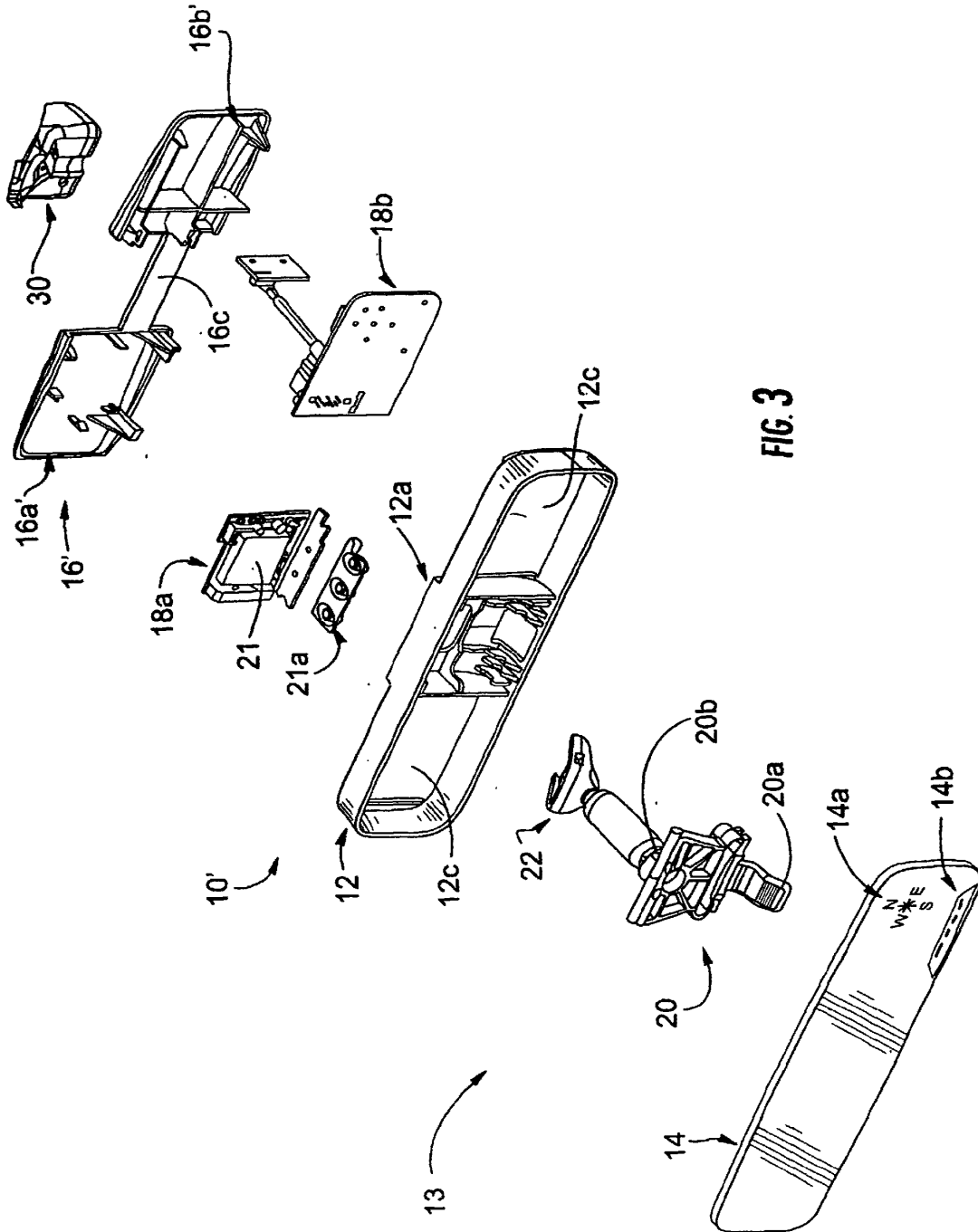

FIG. 3

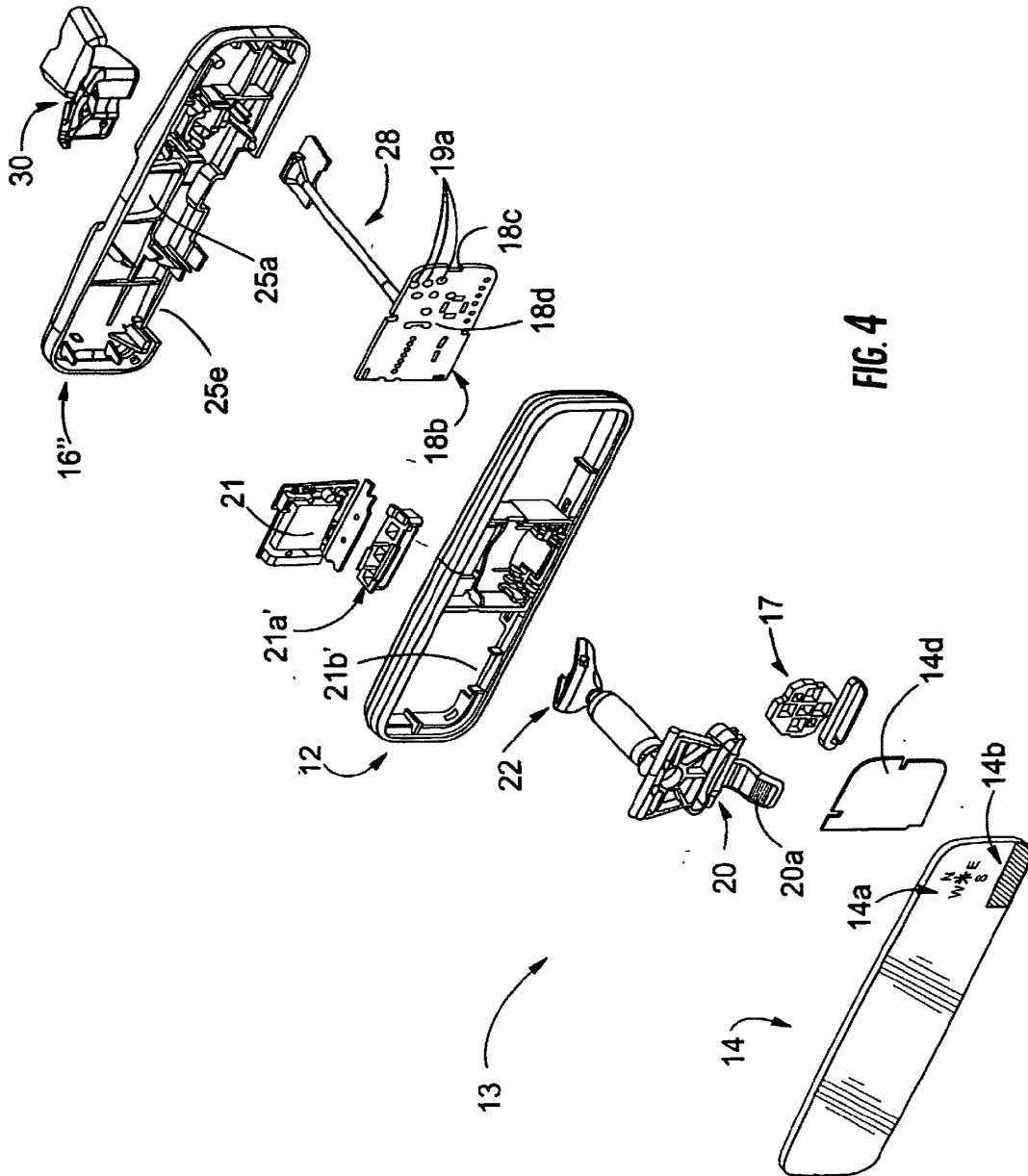

FIG. 4

SUBSTITUTE SHEET (RULE 26)

5/36

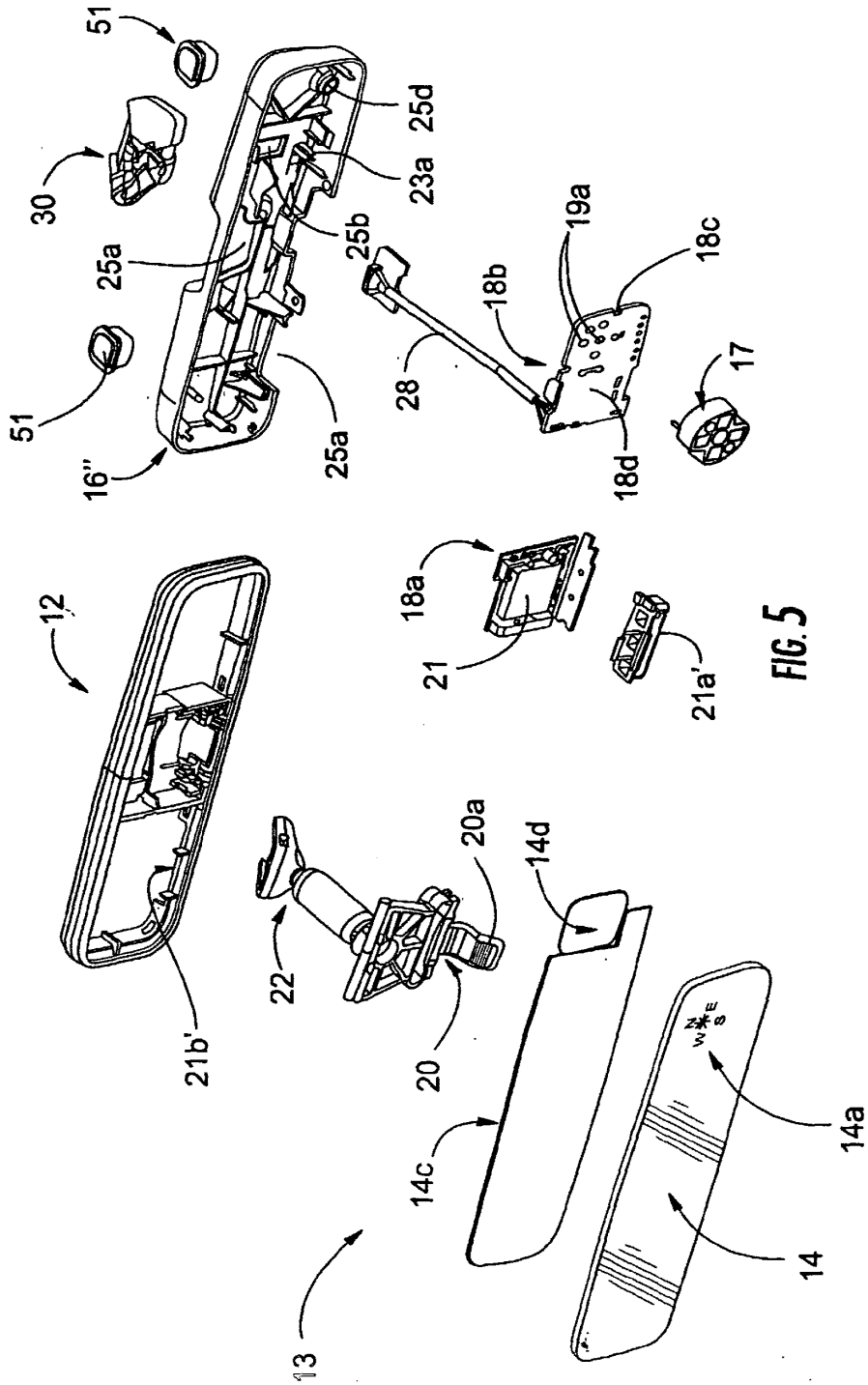

FIG. 5

SUBSTITUTE SHEET (RULE 26)

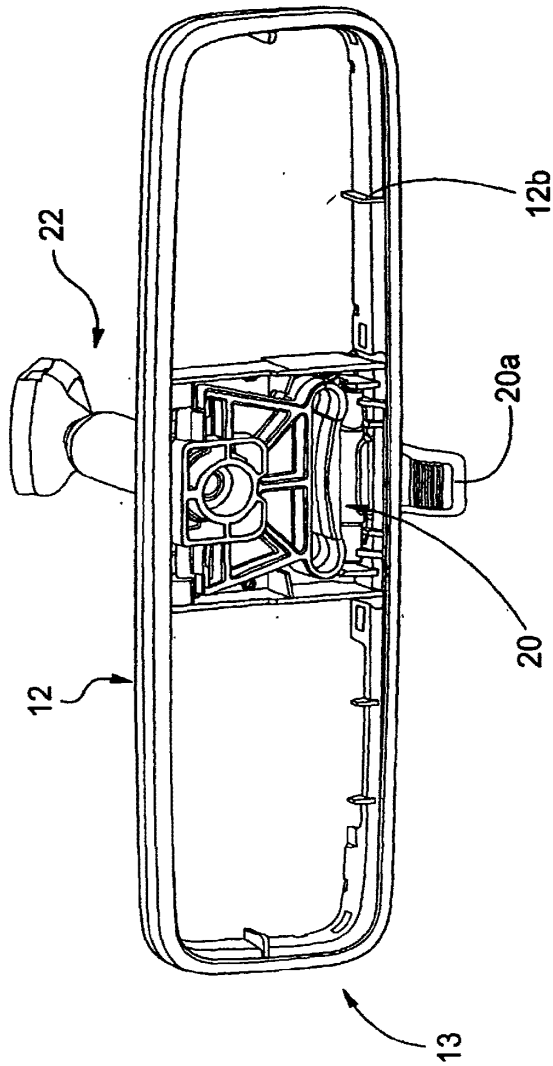

FIG. 6

SUBSTITUTE SHEET (RULE 26)

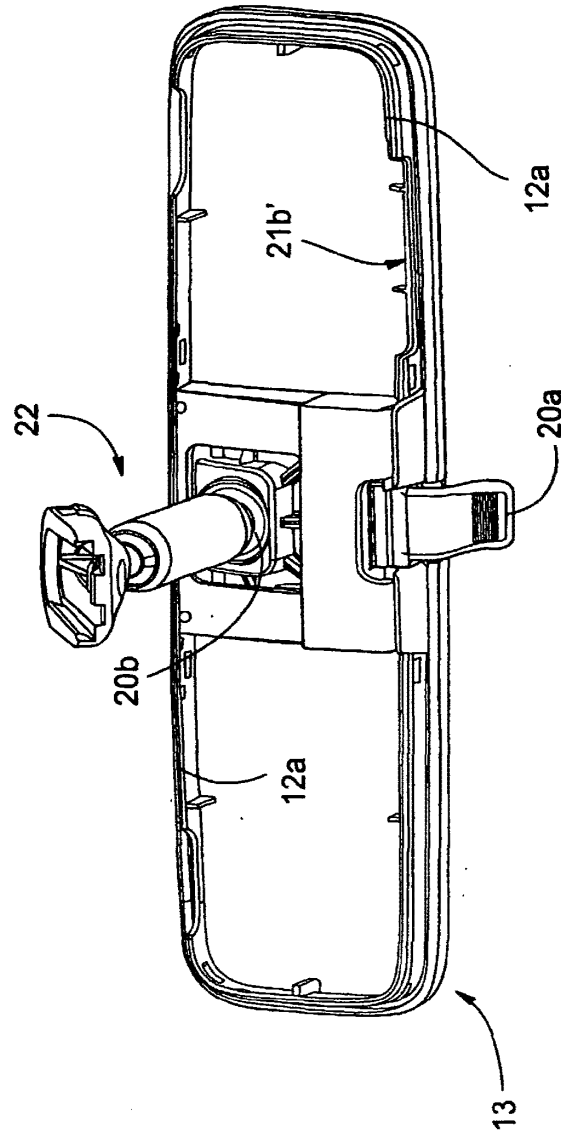

FIG. 7

8/36

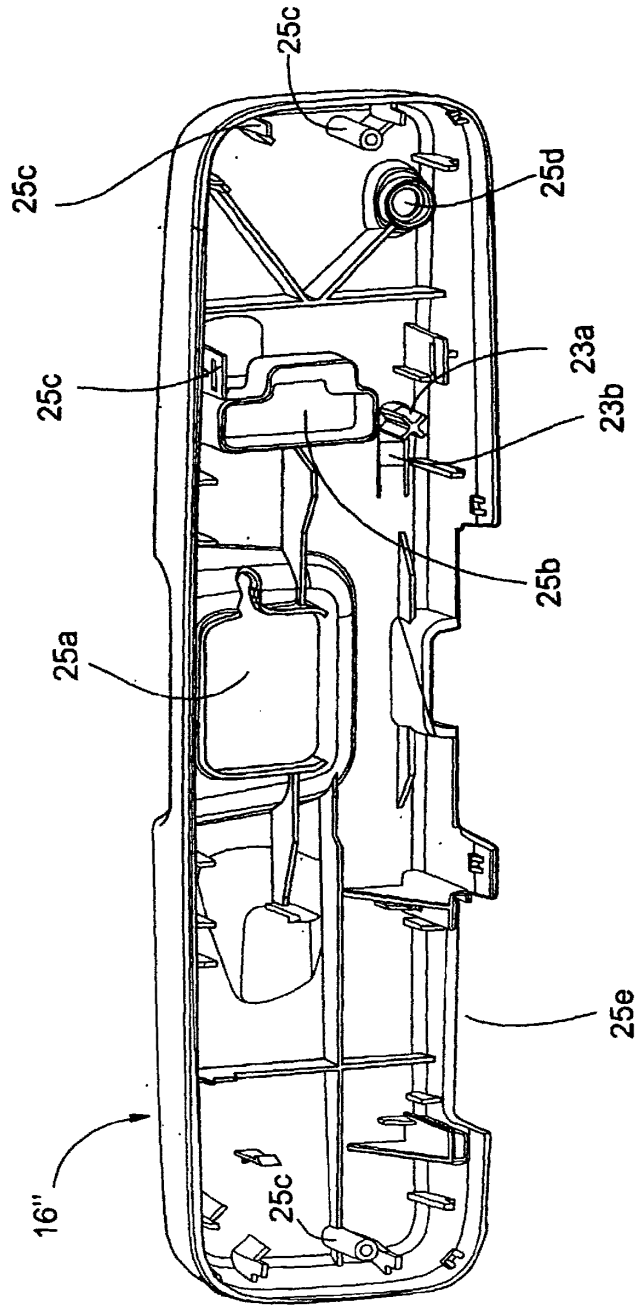

FIG. 8

SUBSTITUTE SHEET (RULE 26)

9/36

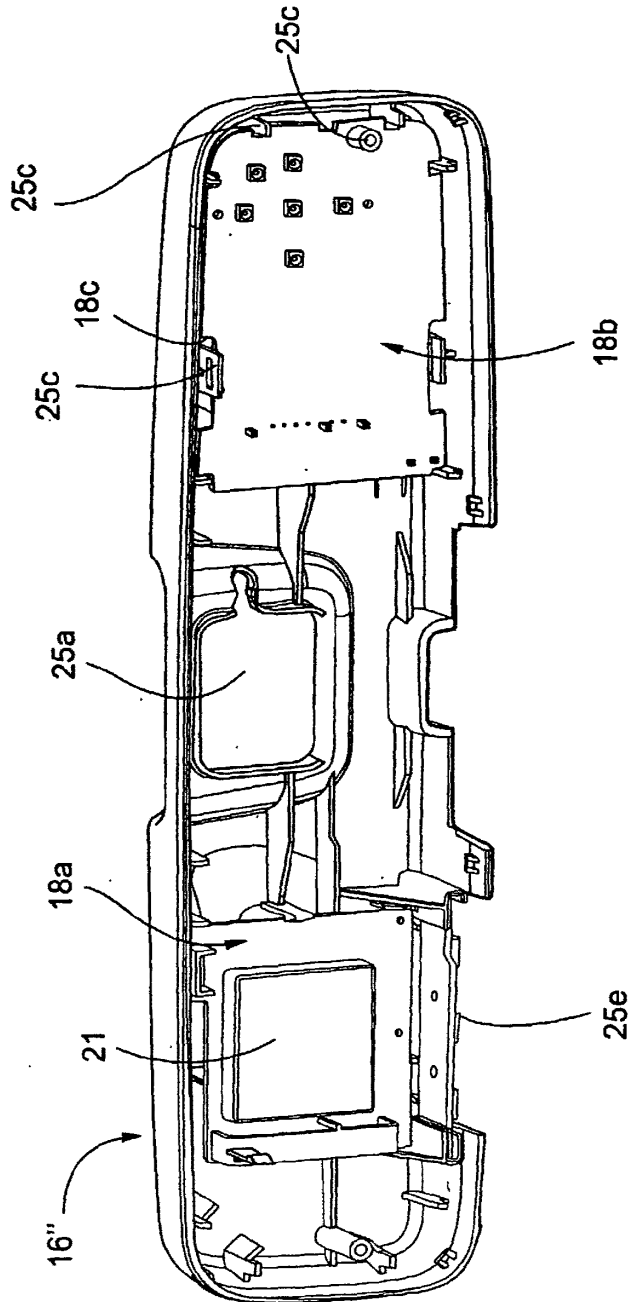
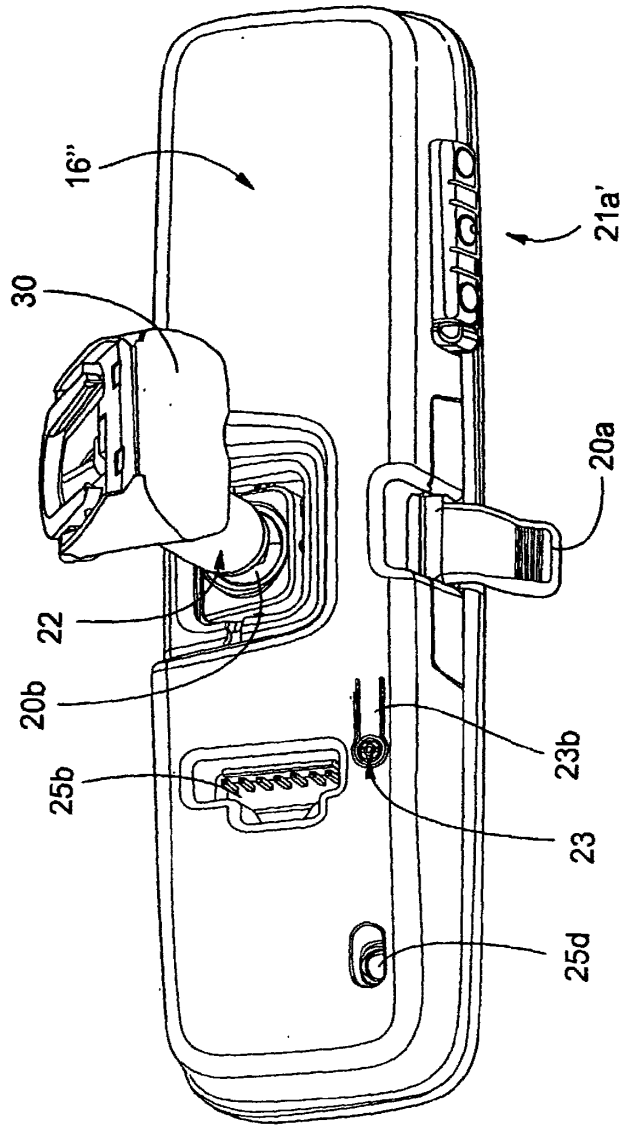

FIG. 9

SUBSTITUTE SHEET (RULE 26)

10/36



SUBSTITUTE SHEET (RULE 26)

11/36

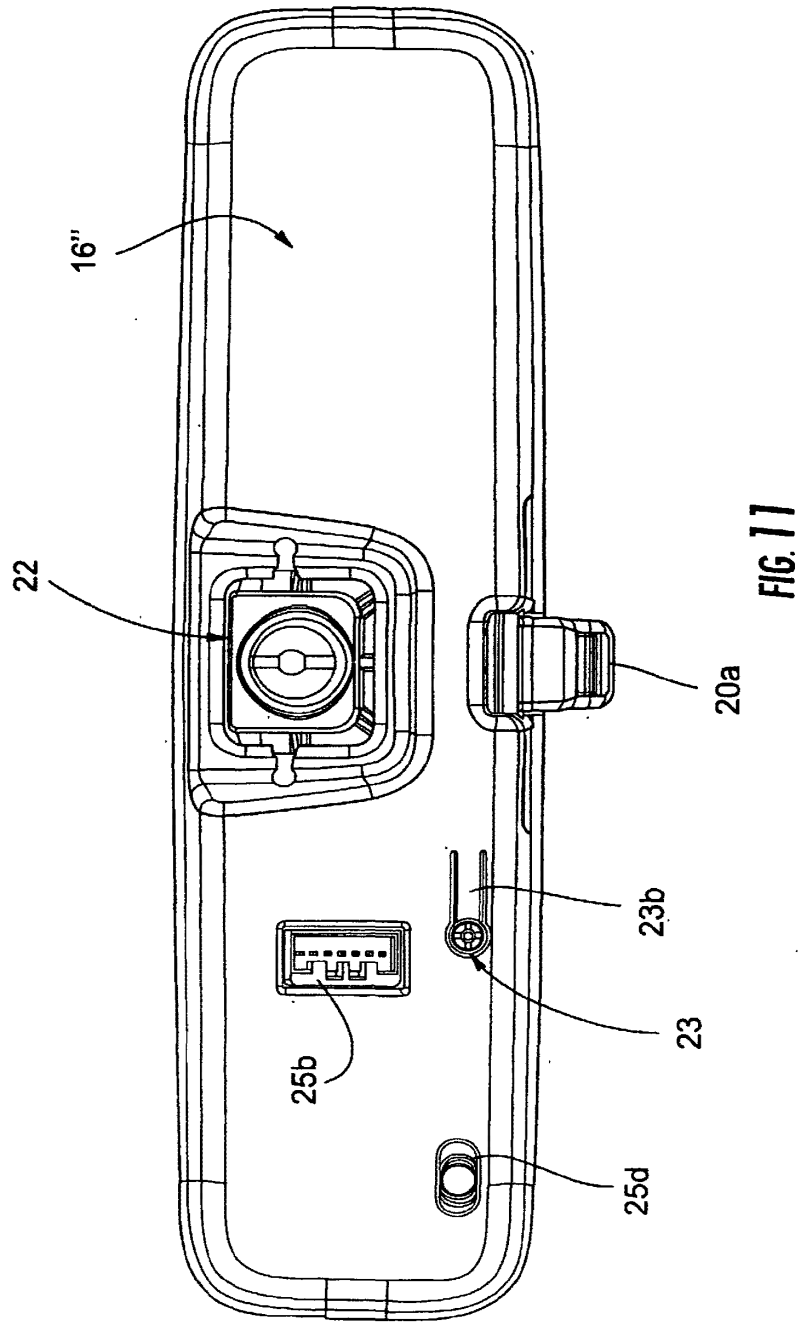

SUBSTITUTE SHEET (RULE 26)

12/36

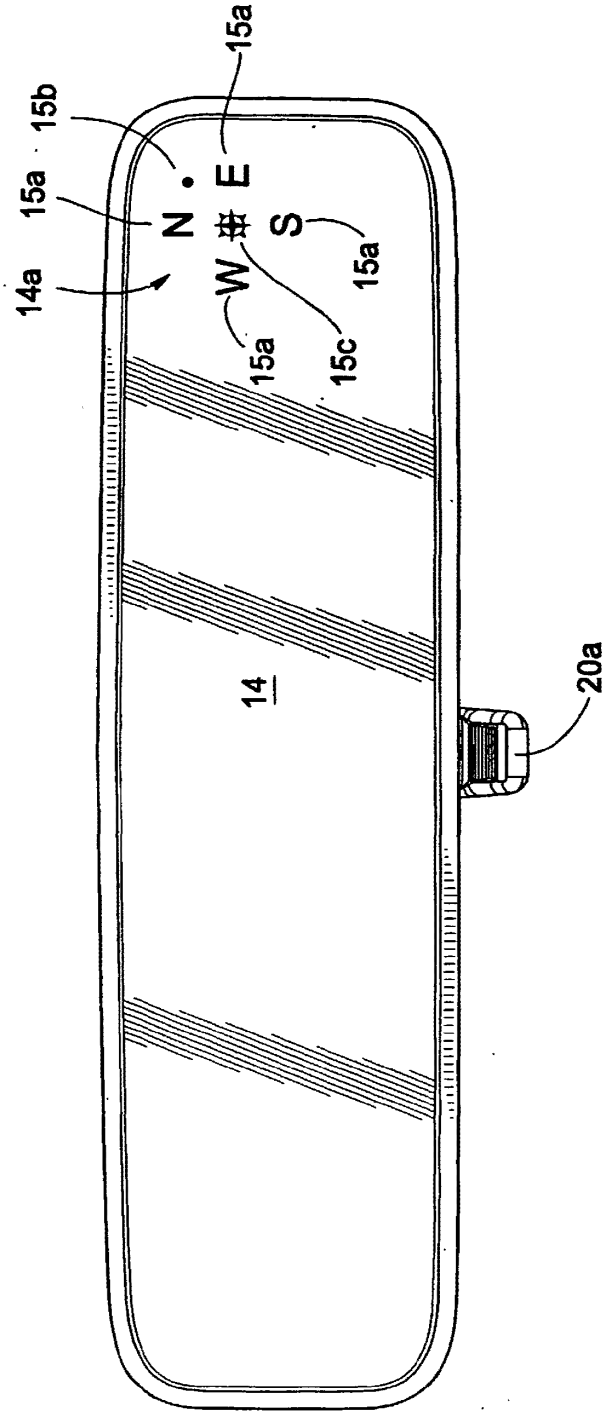

FIG. 12

SUBSTITUTE SHEET (RULE 26)

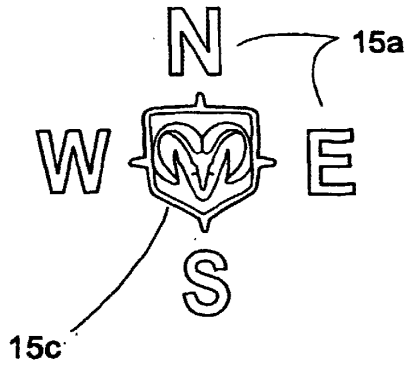

FIG. 13A

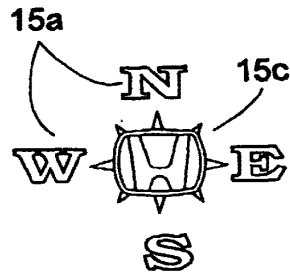

FIG. 13B

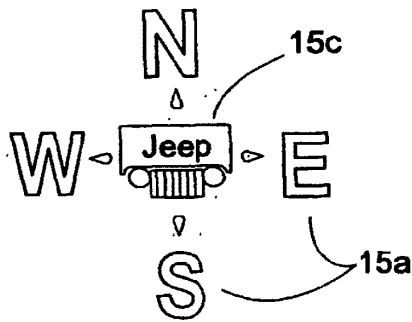

FIG. 13C

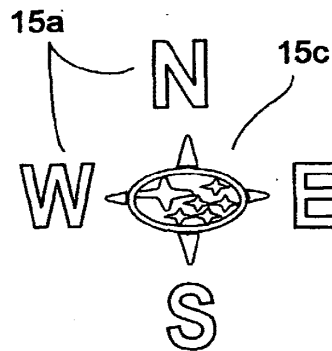

FIG. 13D

14/36

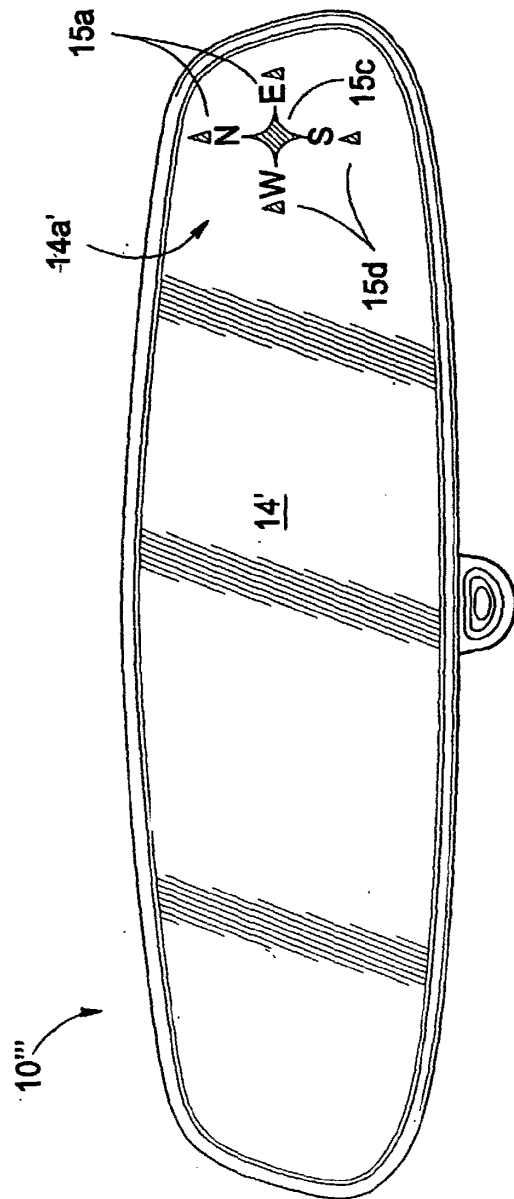

FIG. 14

SUBSTITUTE SHEET (RULE 26)

15/36

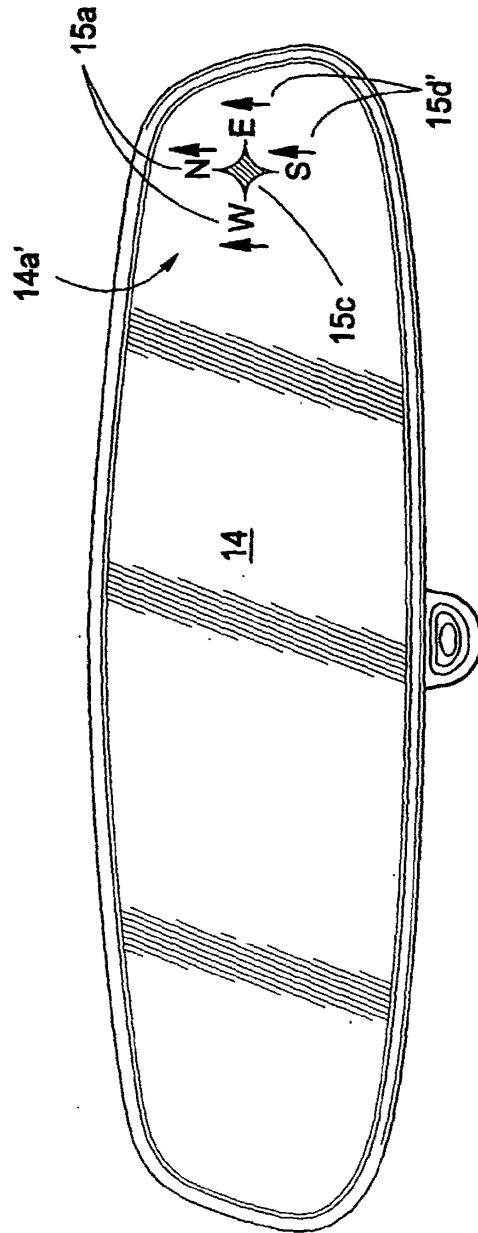

FIG. 15

SUBSTITUTE SHEET (RULE 26)

16/36

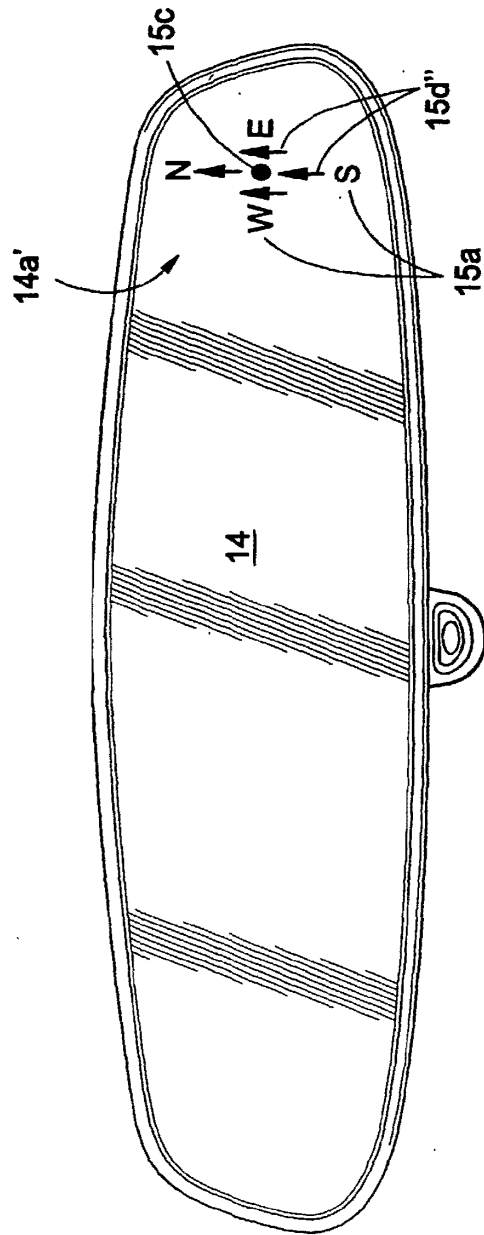

FIG. 16

SUBSTITUTE SHEET (RULE 26)

17/36

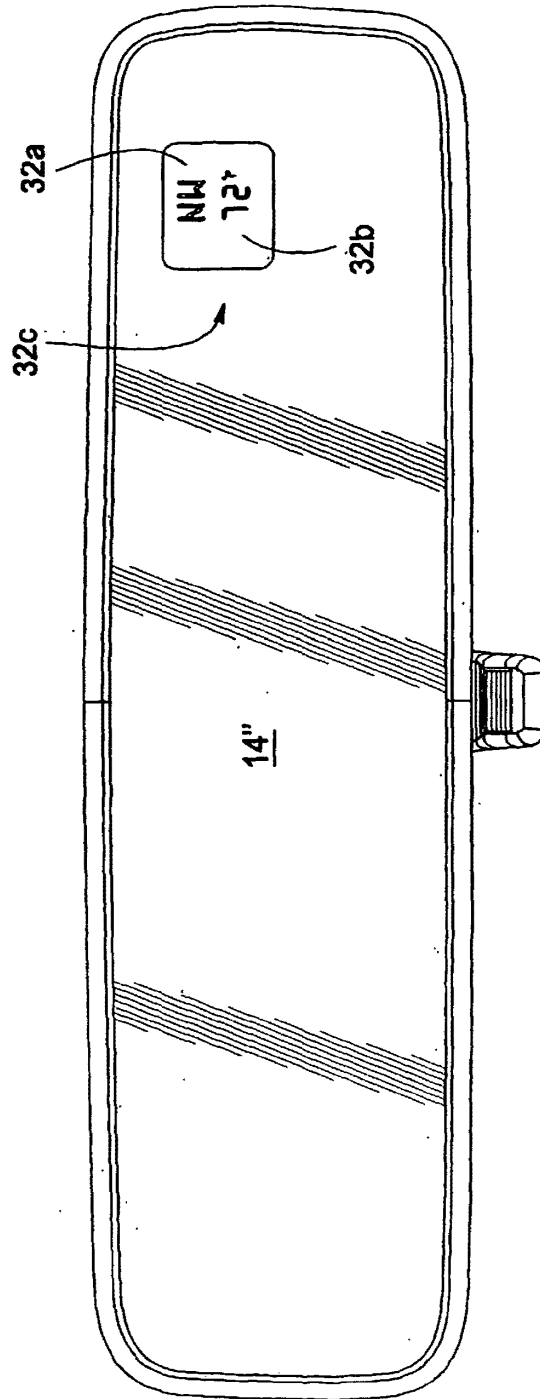

FIG. 17

SUBSTITUTE SHEET (RULE 26)

18/36

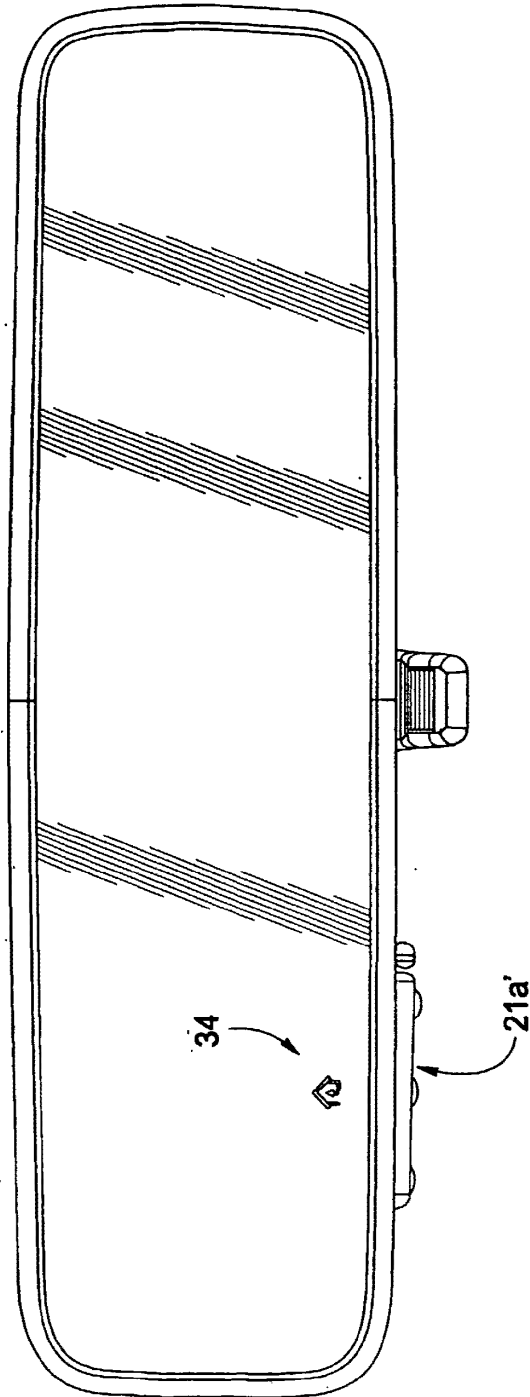

FIG. 18

SUBSTITUTE SHEET (RULE 26)

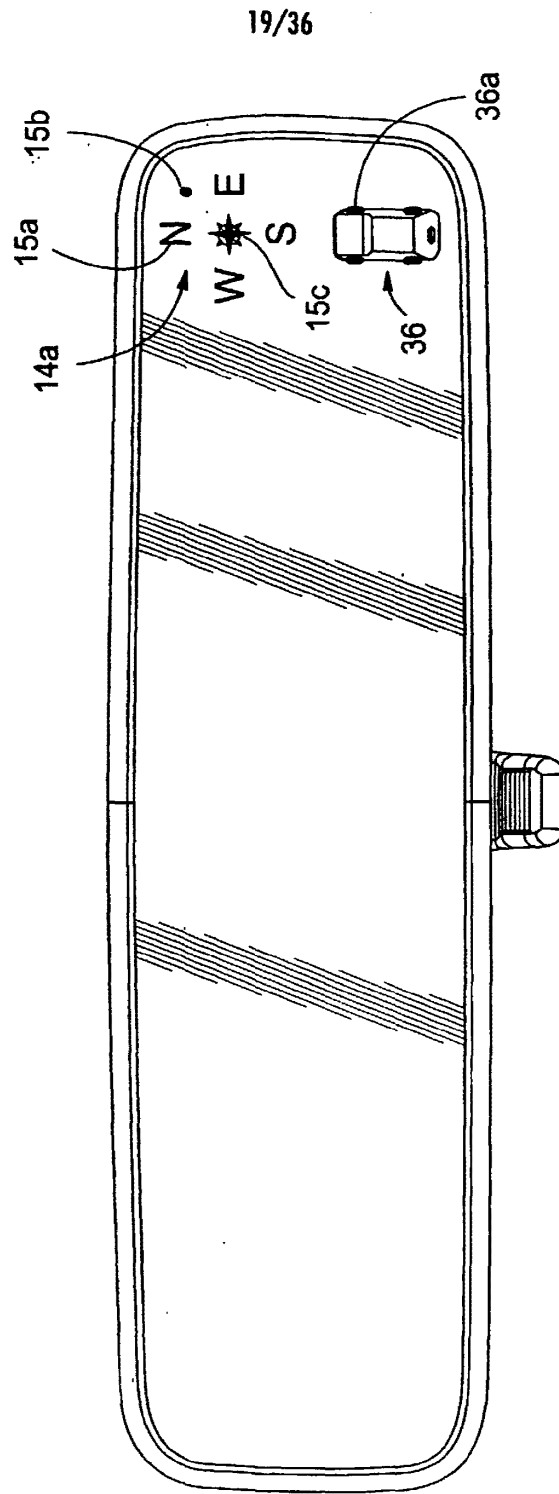

FIG. 19

SUBSTITUTE SHEET (RULE 26)

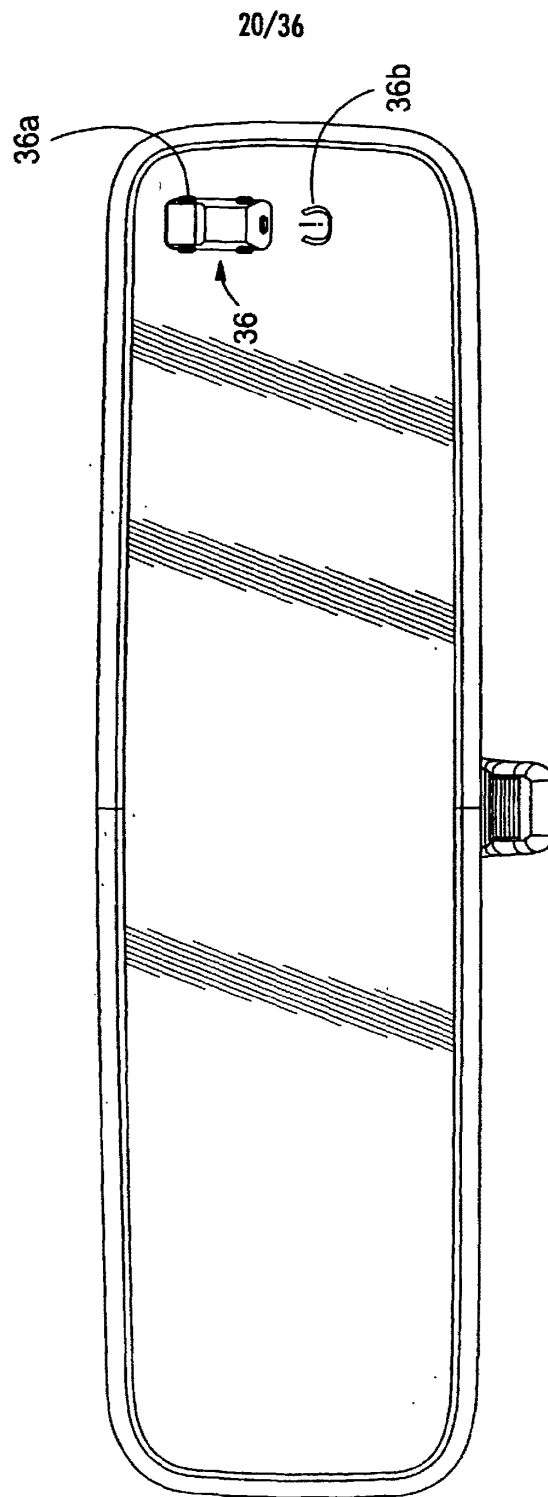

FIG. 20

SUBSTITUTE SHEET (RULE 26)

21/36

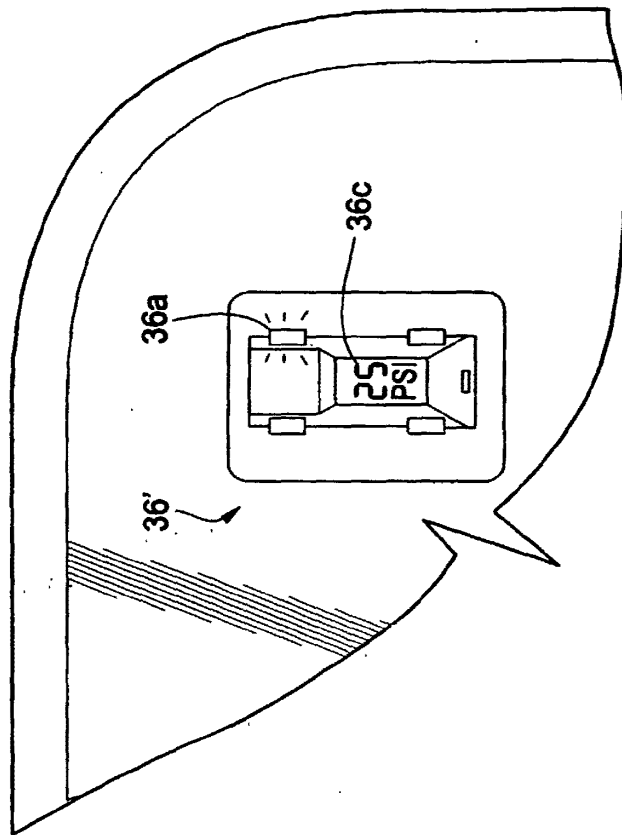

FIG. 21

SUBSTITUTE SHEET (RULE 26)

22/36

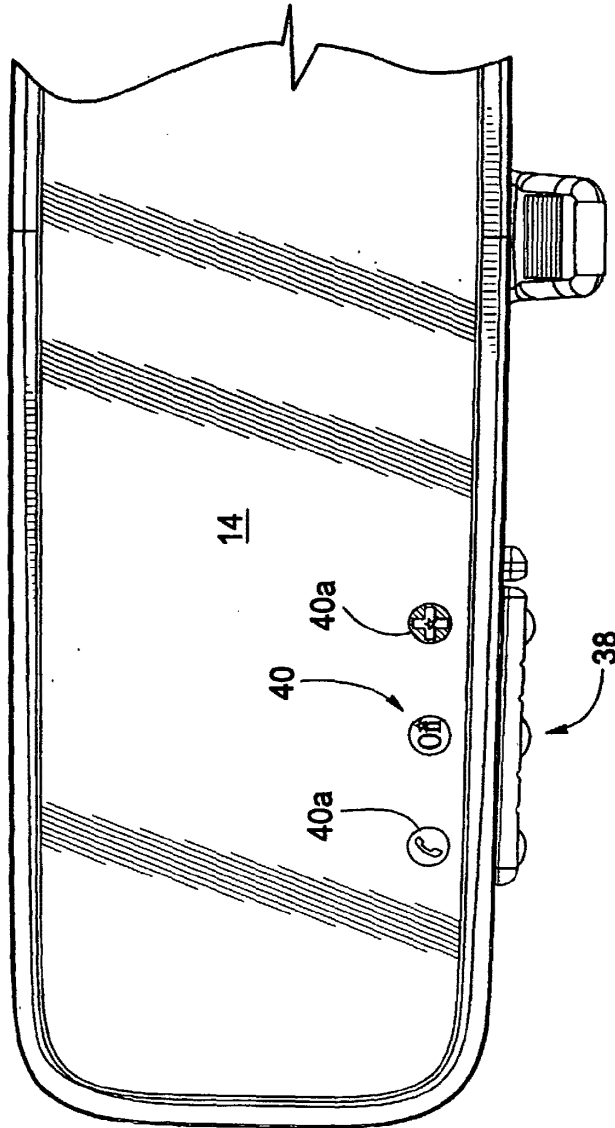

FIG. 22

SUBSTITUTE SHEET (RULE 26)

23/36

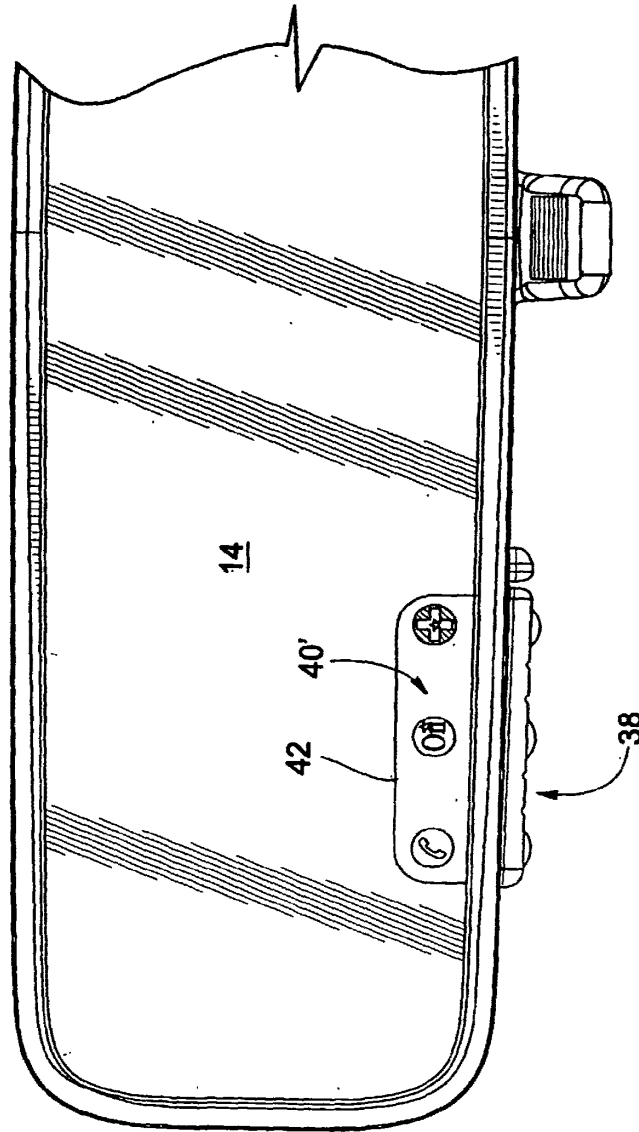

FIG. 23

SUBSTITUTE SHEET (RULE 26)

24/36

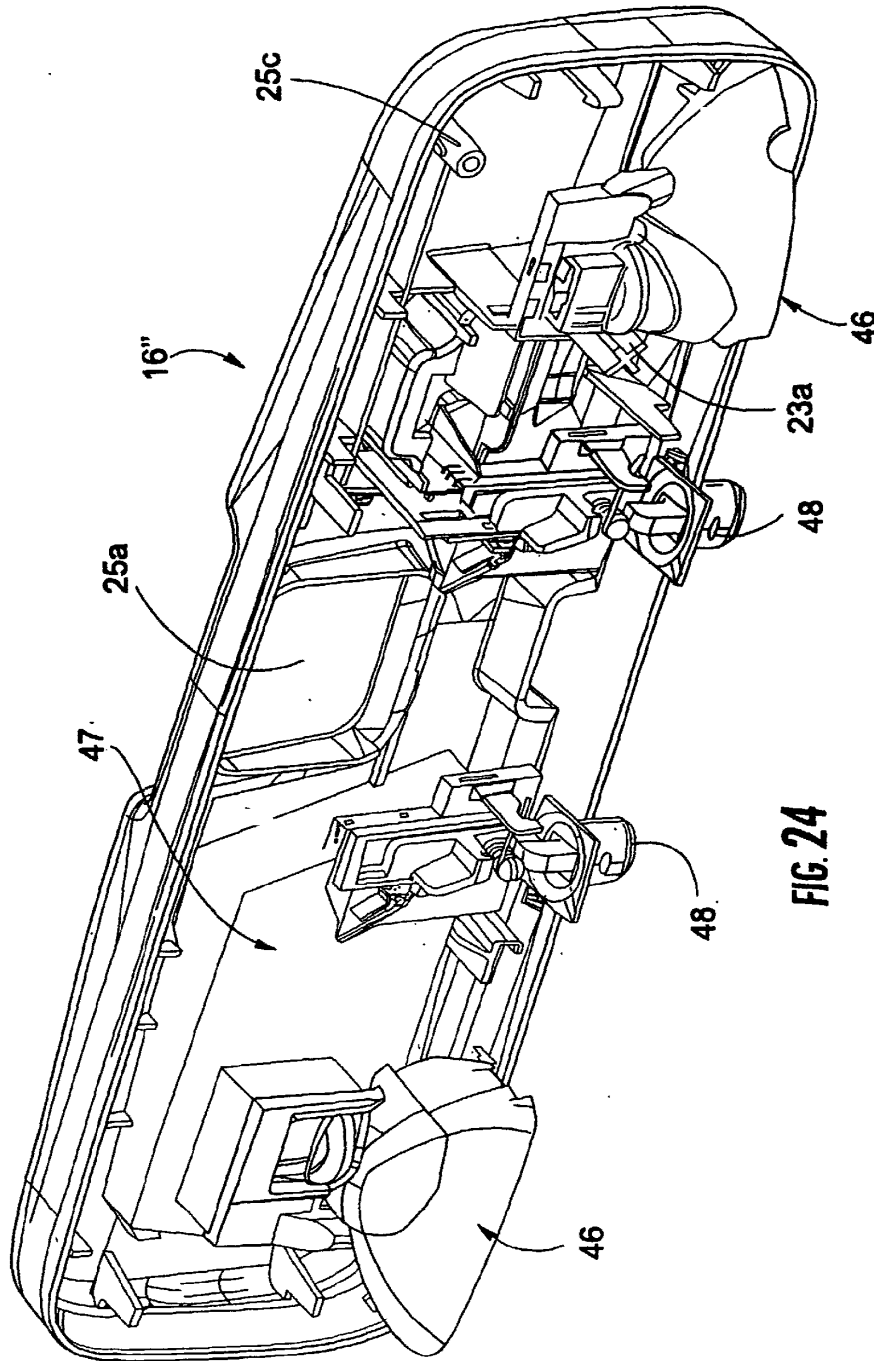
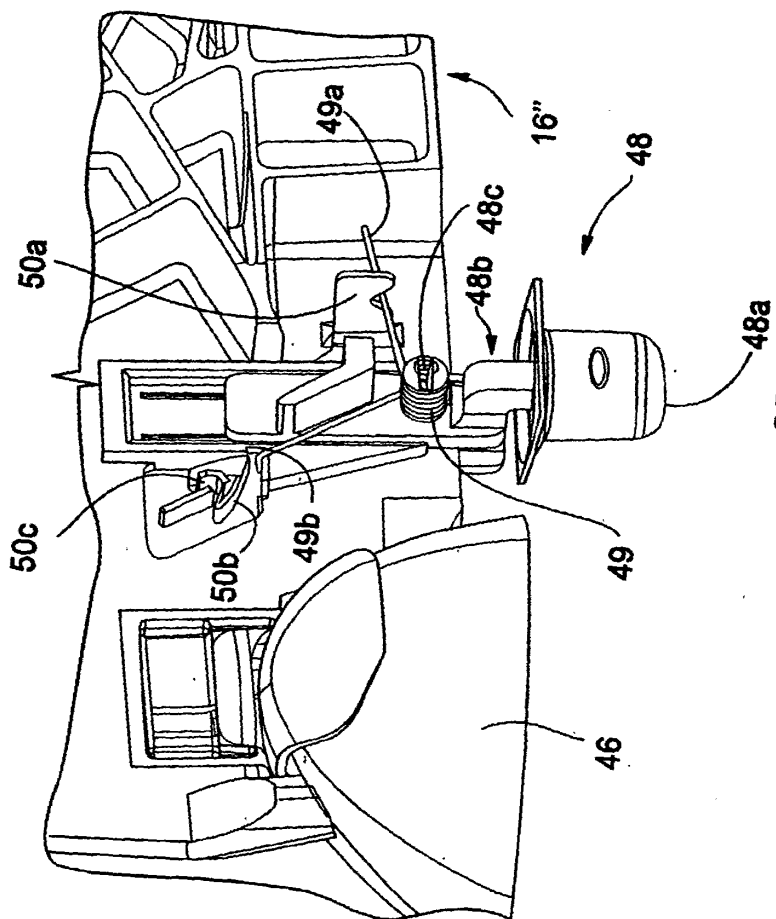

FIG. 24

SUBSTITUTE SHEET (RULE 26)



SUBSTITUTE SHEET (RULE 26)

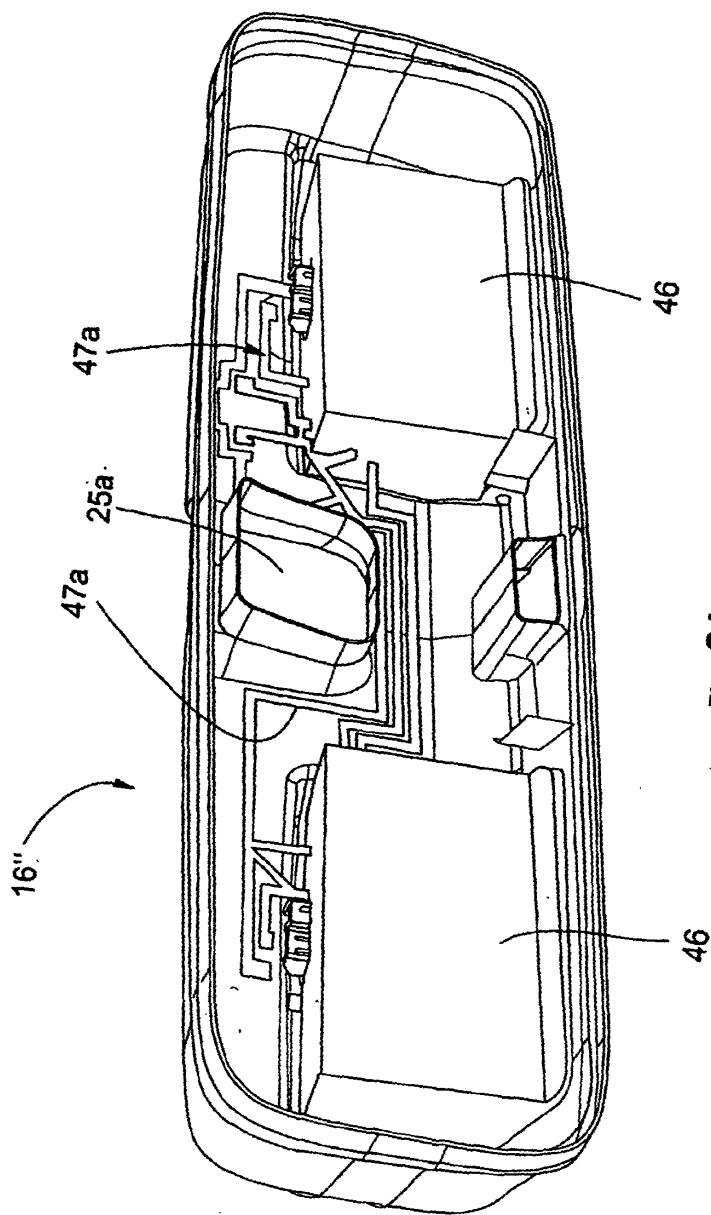

FIG. 26

SUBSTITUTE SHEET (RULE 26)

27/36

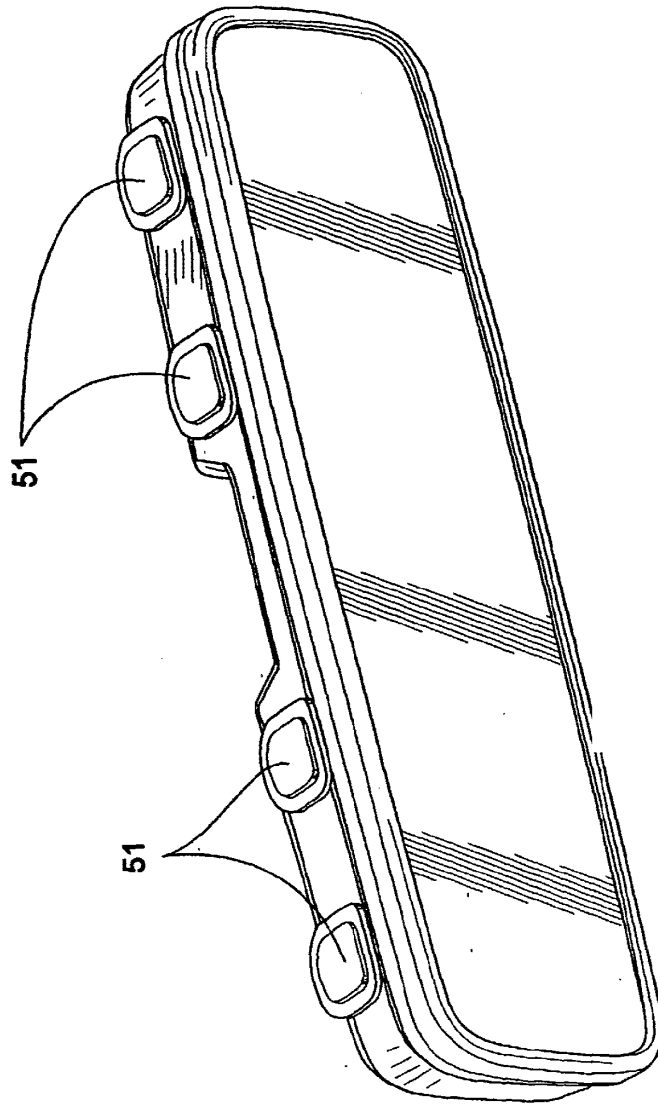

FIG. 27

SUBSTITUTE SHEET (RULE 26)

28/36

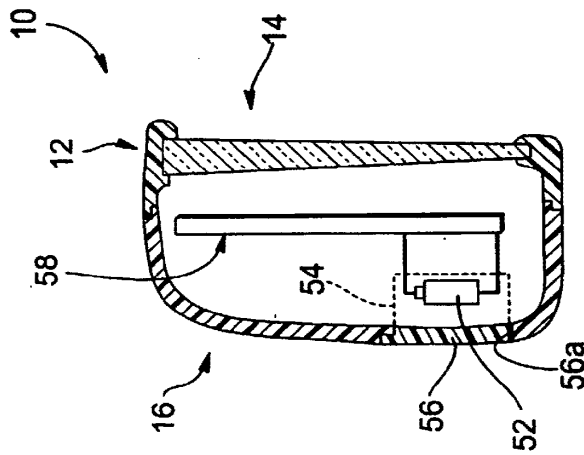

FIG. 28

SUBSTITUTE SHEET (RULE 26)

29/36

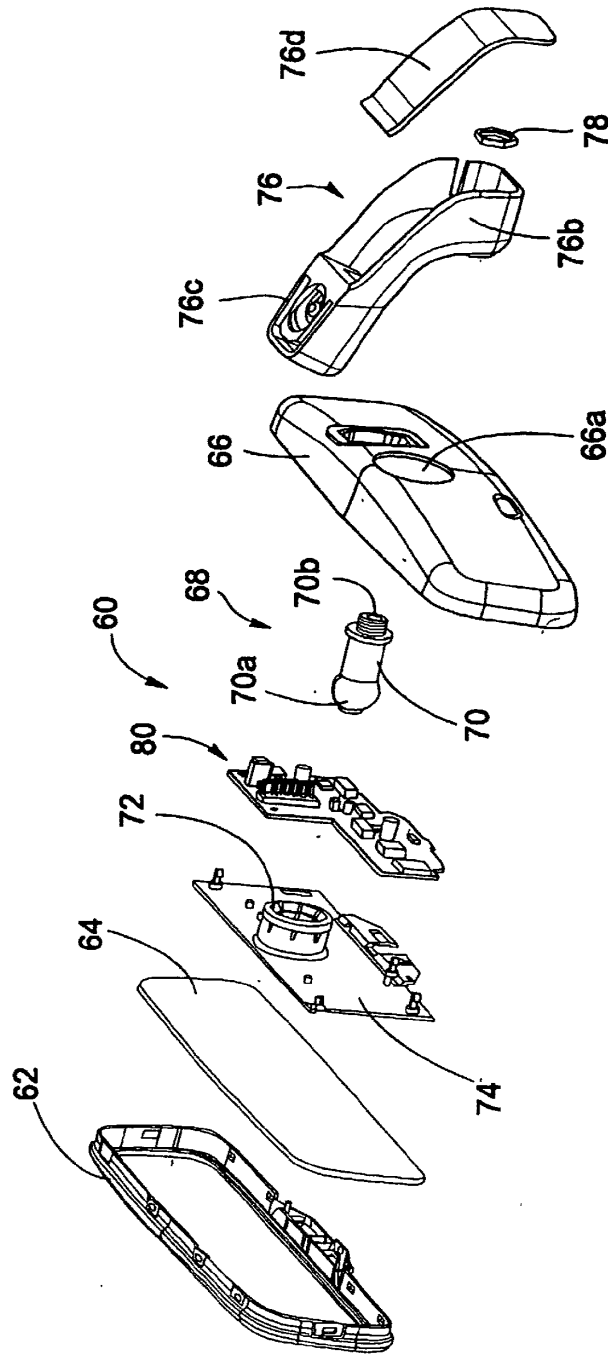

FIG. 29

SUBSTITUTE SHEET (RULE 26)

30/36

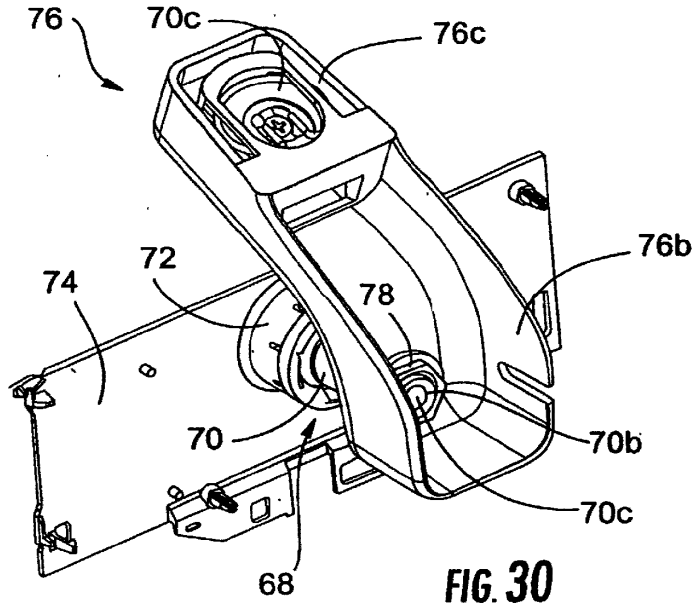

FIG. 30

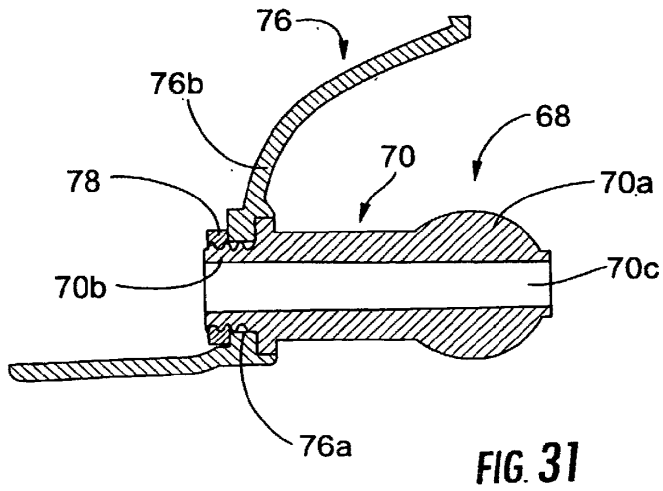

FIG. 31

SUBSTITUTE SHEET (RULE 26)

31/36

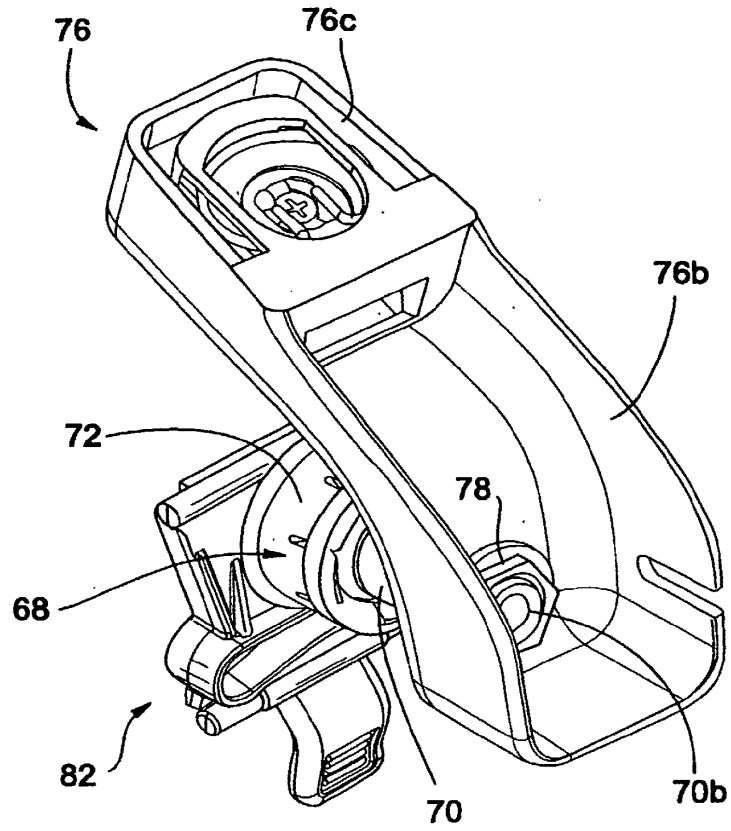
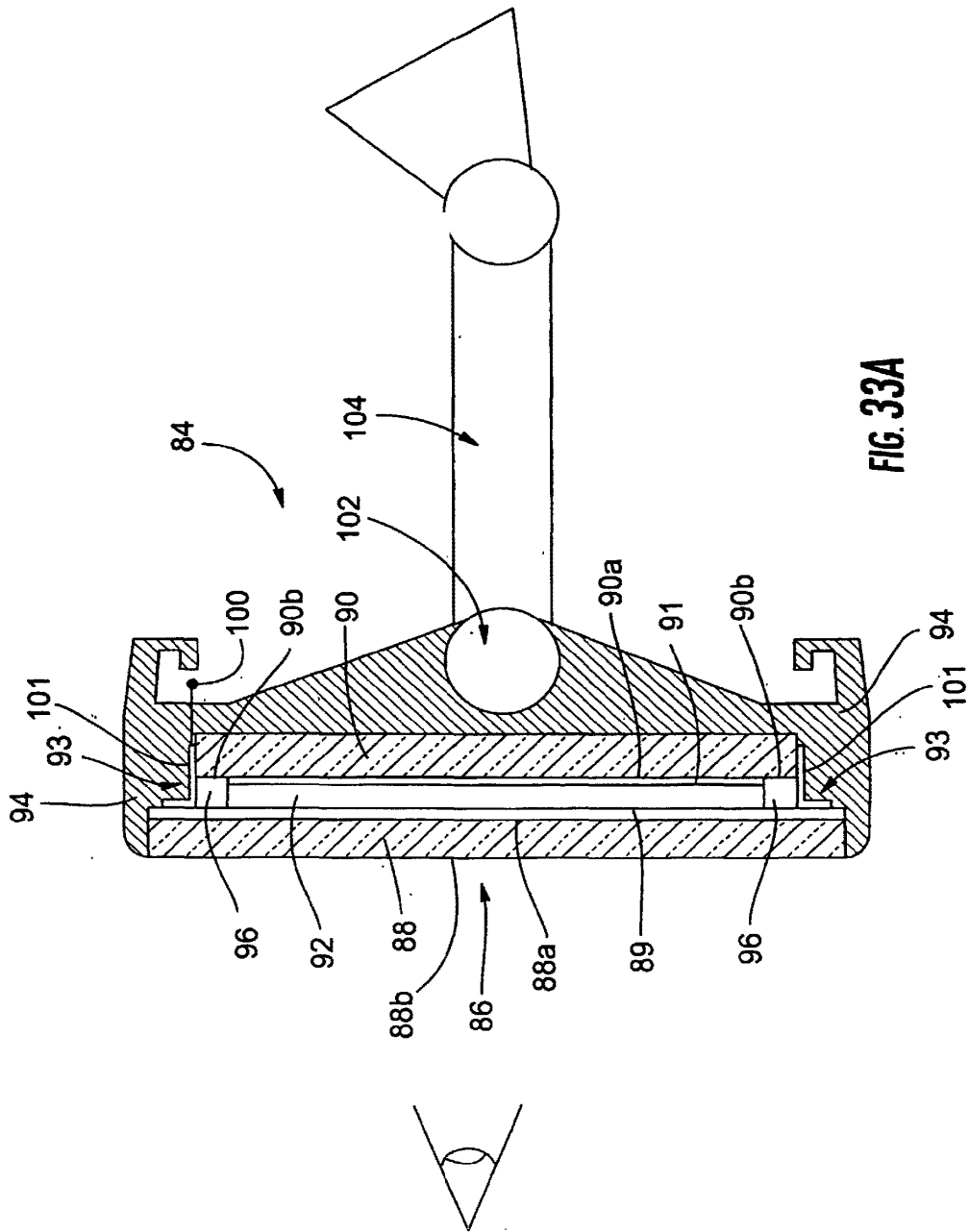

FIG. 32

SUBSTITUTE SHEET (RULE 26)

32/36



SUBSTITUTE SHEET (RULE 26)

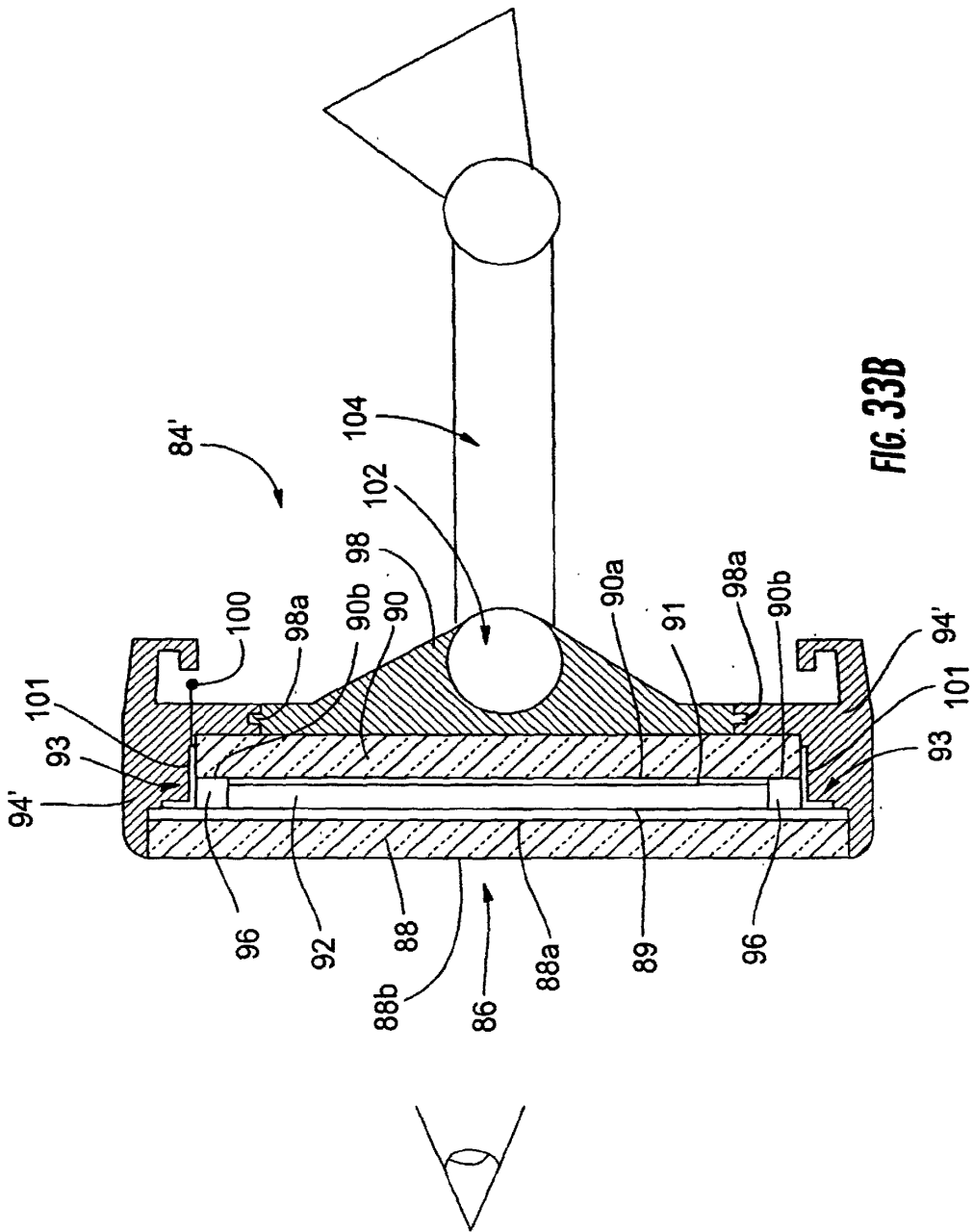

FIG. 33B

SUBSTITUTE SHEET (RULE 26)

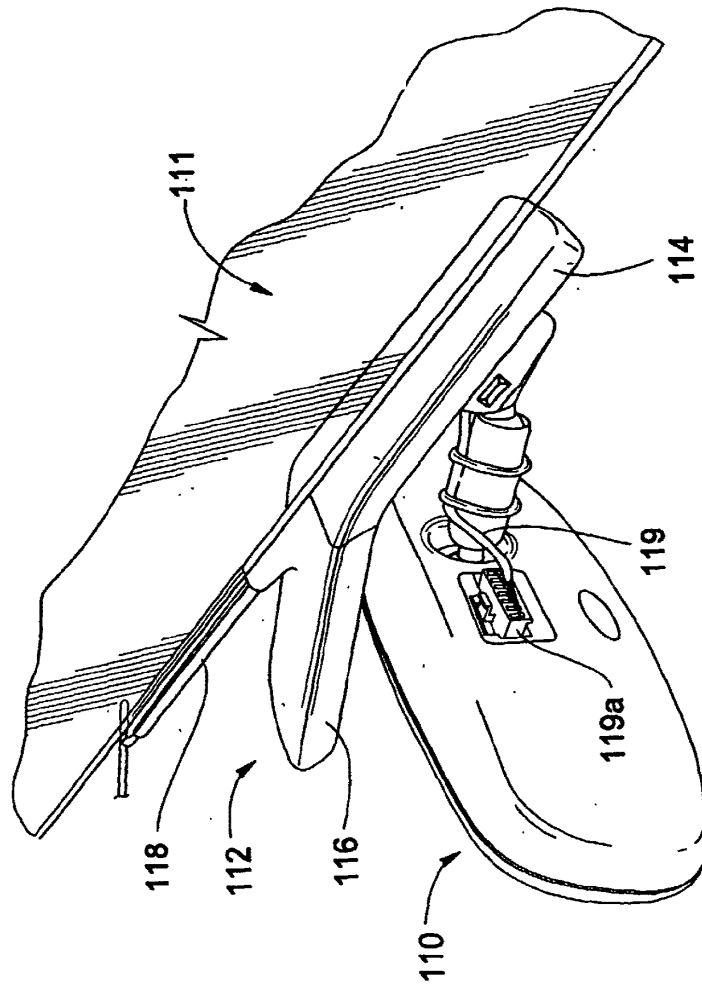

FIG. 34

SUBSTITUTE SHEET (RULE 26)

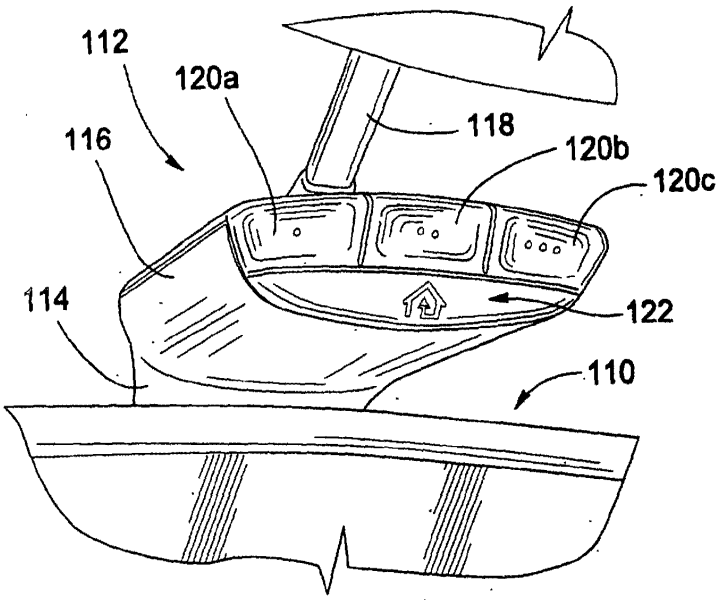

FIG. 35A

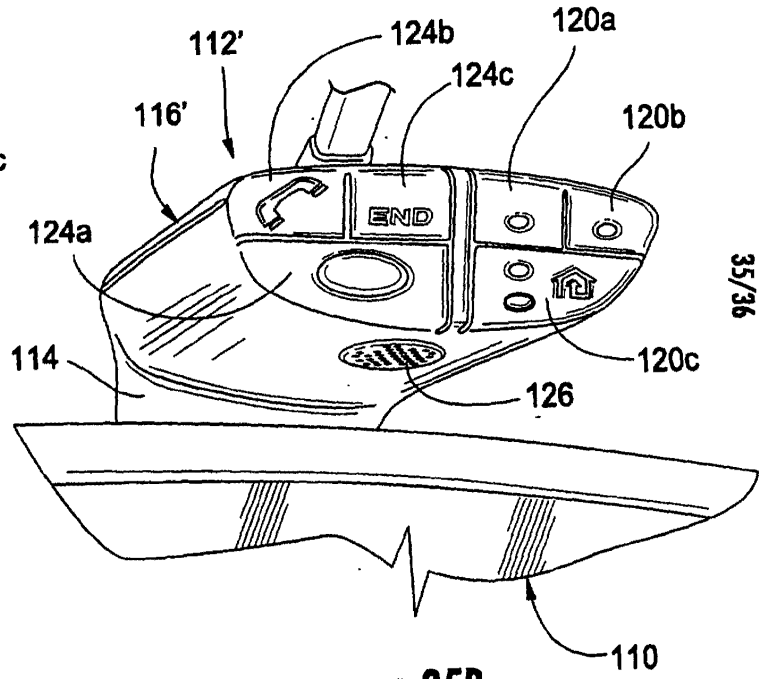

FIG 35B

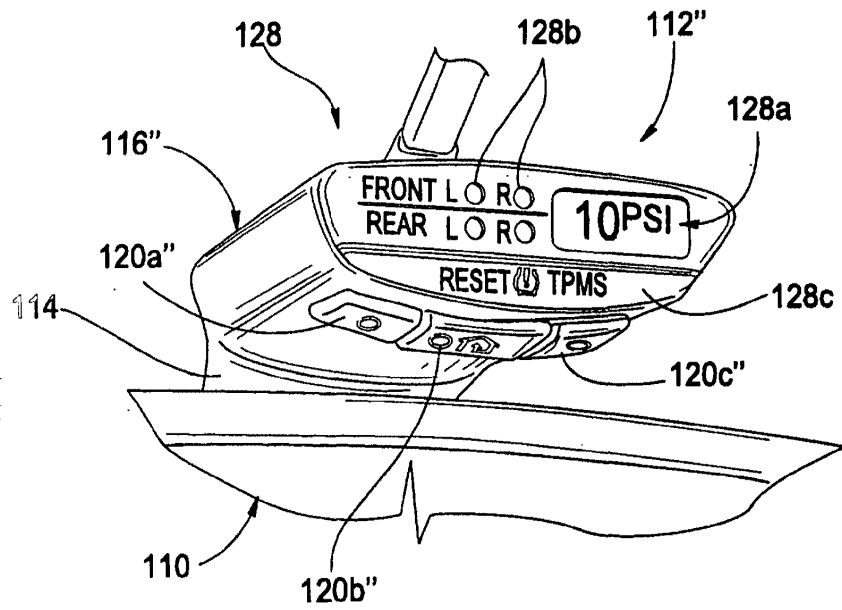

FIG. 35C

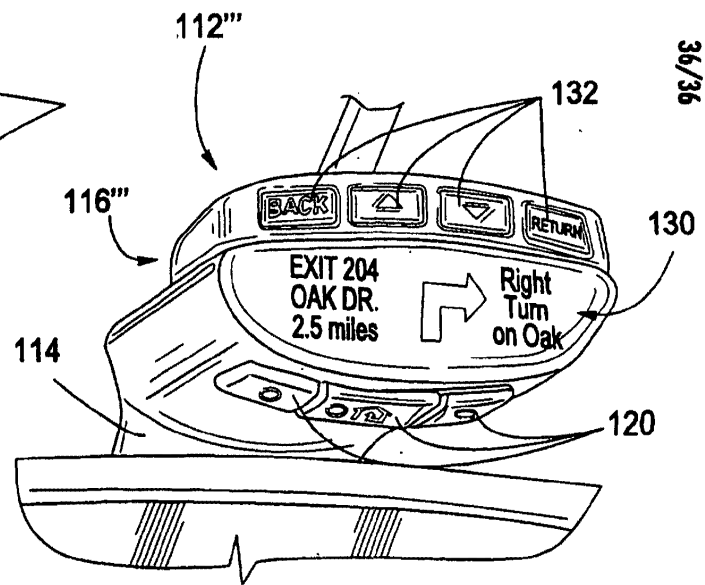

FIG. 35D

(12) INTERNATIONAL APPLICATION PUBLISHED UNDER THE PATENT COOPERATION TREATY (PCT)

(19) World Intellectual Property Organization
International Bureau



(43) International Publication Date
23 November 2006 (23.11.2006)

PCT

(10) International Publication Number
WO 2006/124682 A2

- (51) International Patent Classification: **B63H 1/20** (2006.01) LYNAM, Niall R. [US/US]; 248 Foxdown, Holland, Michigan 49424 (US).
- (21) International Application Number: PCT/US2006/018567 (74) Agent: VAN DYKE, GARDNER, LINN & BURKHART, LLP; Timothy A. Flory, 2851 Charlevoix Drive Se, P.o. Box 888695, Grand Rapids, Michigan 49588-8695 (US).
- (22) International Filing Date: 15 May 2006 (15.05.2006) (81) Designated States (unless otherwise indicated, for every kind of national protection available): AE, AG, AL, AM, AT, AU, AZ, BA, BB, BG, BR, BW, BY, BZ, CA, CH, CN, CO, CR, CU, CZ, DE, DK, DM, DZ, EC, EE, EG, ES, FI, GB, GD, GE, GH, GM, HR, HU, ID, IL, IN, IS, JP, KE, KG, KM, KN, KP, KR, KZ, LC, LK, LR, LS, LT, LU, LV, LY, MA, MD, MG, MK, MN, MW, MX, MZ, NA, NG, NI, NO, NZ, OM, PG, PH, PL, PT, RO, RU, SC, SD, SE, SG, SK, SL, SM, SY, TJ, TM, TN, TR, TT, TZ, UA, UG, US, UZ, VC, VN, YU, ZA, ZM, ZW.
- (25) Filing Language: English (84) Designated States (unless otherwise indicated, for every kind of regional protection available): ARIPO (BW, GH, GM, KE, LS, MW, MZ, NA, SD, SL, SZ, TZ, UG, ZM, ZW), Eurasian (AM, AZ, BY, KG, KZ, MD, RU, TJ, TM), European (AT, BE, BG, CH, CY, CZ, DE, DK, EE, ES, FI, FR, GB, GR, HU, IE, IS, IT, LT, LU, LV, MC, NL, PL, PT, RO, SE, SI, SK, TR), OAPI (BF, BJ, CF, CG, CI, CM, GA, GN, GQ, GW, ML, MR, NE, SN, TD, TG).
- (26) Publication Language: English
- (30) Priority Data:

60/681,250	16 May 2005 (16.05.2005)	US
60/690,400	14 June 2005 (14.06.2005)	US
60/695,149	29 June 2005 (29.06.2005)	US
60/730,334	26 October 2005 (26.10.2005)	US
60/750,199	14 December 2005 (14.12.2005)	US
60/774,449	17 February 2006 (17.02.2006)	US
60/783,496	18 March 2006 (18.03.2006)	US
- (71) Applicant (for all designated States except US): **DONNELLY CORPORATION** [US/US]; 414 East Fortieth Street, Holland, Michigan 49423-5368 (US).
- (72) Inventors; and
- (75) Inventors/Applicants (for US only): **BAUR, Michael J.** [US/US]; 5089 Reis Circle, Fayetteville, New York 13966 (US). **MCCABE, Ian A.** [IE/US]; 16092 Ransom Street, Holland, Michigan 49424 (US). **HABIBI, Hamid** [IR/US]; 4057 66th Street, Holland, Michigan 49423 (US).

Declarations under Rule 4.17:
— as to applicant's entitlement to apply for and be granted a patent (Rule 4.17(ii))

[Continued on next page]

(54) Title: VEHICLE MIRROR ASSEMBLY WITH INDICIA AT REFLECTIVE ELEMENT

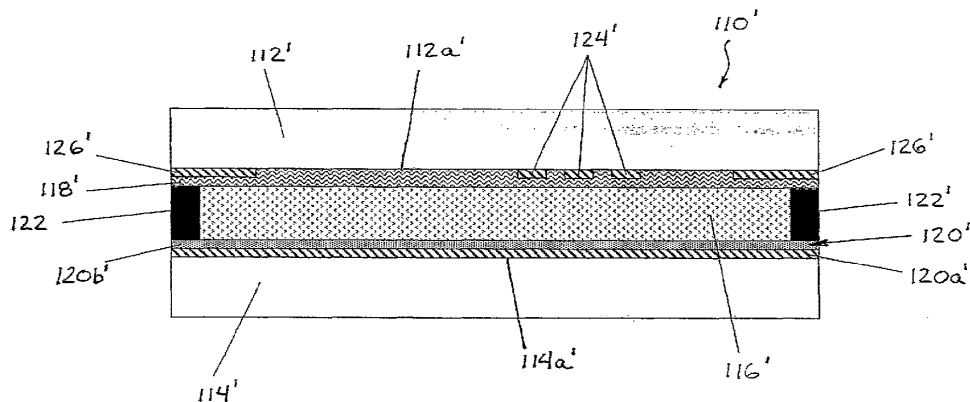

(57) Abstract: A rearview mirror assembly for a vehicle includes a reflective element (110) having at least one substrate (114) with a reflective coating (120) thereon. A specularly reflective indicia reflector (124) is established to form indicia or information at the reflective element. The indicia reflector provides a visible contrast to the main mirror reflector so that the indicia or information is subtly viewable by a person viewing the mirror assembly. The reflective element reflects light incident thereon over the surface coated by the reflective coating of the main mirror reflector, including the area at which the indicia reflector is established.

WO 2006/124682 A2



- *as to the applicant's entitlement to claim the priority of the earlier application (Rule 4.17(iii))*
- *of inventorship (Rule 4.17(iv))*

For two-letter codes and other abbreviations, refer to the "Guidance Notes on Codes and Abbreviations" appearing at the beginning of each regular issue of the PCT Gazette.

Published:

- *without international search report and to be republished upon receipt of that report*

VEHICLE MIRROR ASSEMBLY WITH INDICIA AT REFLECTIVE ELEMENT
CROSS REFERENCE TO RELATED APPLICATIONS

[0001] The present application claims the benefit of U.S. provisional applications, Ser. No. 60/681,250, filed May 16, 2005 (Attorney Docket DON01 P-1221); Ser. No. 60/690,400, filed Jun. 14, 2005 (Attorney Docket DON01 P-1225); Ser. No. 60/695,149, filed Jun. 29, 2005 (Attorney Docket DON01 P-1227); Ser. No. 60/730,334, filed Oct. 26, 2005 (Attorney Docket DON01 P-1250); Ser. No. 60/750,199, filed Dec. 14, 2005 (Attorney Docket DON01 P-1260); Ser. No. 60/774,449, filed Feb. 17, 2006 (Attorney Docket DON01 P-1269); and Ser. No. 60/783,496, filed Mar. 18, 2006 (Attorney Docket DON01 P-1272), which are all hereby incorporated herein by reference in their entireties.

FIELD OF THE INVENTION

[0002] The present invention relates to rearview mirror assemblies and, more particularly, to an interior or exterior rearview mirror assembly having information displayed at the mirror assembly.

BACKGROUND OF THE INVENTION

[0003] Interior and exterior mirrors for vehicles typically comprise a substrate having a first surface facing a viewer of the mirror and a second, reflecting surface opposite the first surface. Often, such mirrors may comprise electro-optic reflective element assemblies, which have first and second substrates, whereby the reflecting surface is typically at the third surface of the reflective element assembly (the front surface of the rear substrate) or at the fourth surface of the reflective element assembly (the rear surface of the rear substrate). It is common to include information created on the reflective element substrate, such as safety messages (for example, an exterior rearview mirror may include the message "objects in mirror are closer than they appear" or the like) or other information or indicia. Examples of such indicia are described in U.S. Pat. Nos. 5,189,537 and 5,825,527, which are hereby incorporated herein by reference in their entireties.

[0004] Such indicia or information is typically created by removal of the reflective coating or layers at the respective surface of the substrate, such as by sand blasting or laser ablating the reflective coating, or by overlaying or overcoating a material onto one of the layers or coatings, such as by screening of materials, such as ink or epoxy, onto the layers or coatings at the respective substrate surface (such as described in U.S. Pat. No. 5,189,537, which is hereby incorporated herein by reference). Such indicia or information thus provides a

marked, highly visible and definite indicia or information conveyance that is readily discernible and viewable by a person viewing the mirror assembly.

SUMMARY OF THE INVENTION

[0005] The present invention provides a display of information or indicia at a reflective element by applying or disposing or otherwise forming or establishing indicia or the like by establishing a layer of a material that is different from the reflective material that is coated on the respective substrate to define the reflective surface of the reflective element (such as a layer of reflective material that has a distinctly higher or lower reflectivity than that of the layer of reflective material it is coated over or under). The indicia or information is visible to the viewer of the mirror assembly without unduly detracting from or interfering with the functionality of the reflective element.

[0006] According to an aspect of the present invention, a rearview mirror assembly for a vehicle includes a reflective element having a substrate with a reflective coating thereon. A layer of material is established to form indicia or information at the reflective element. The layer of material provides a visible contrast between the reflective coating and the layer of material so that the indicia or information is viewable by a person viewing the mirror assembly. The reflective element reflects light incident thereon over the coated surface, including the area at which the layer of material is disposed, and the indicia so created (such as for example, a vehicle brand name or logo) is subtly visible to the viewer by contrast with the adjacent main reflector coating reflective property, so that the presence of the indicia or logo is visible but subtle and non-obtrusive.

[0007] The layer of material may comprise a reflective material or a transparent material, and may be discernible due to a contrast in color or reflectance or due to an interference effect or difference in refractive index or the like. The reflective element may comprise an electro-optic reflective element assembly or cell, such as an electrochromic reflective element or cell, and may have the reflective coating at the third or fourth surface of the cell (the front surface of the rear substrate or the rear surface of the rear substrate). The layer of material may be disposed or established over the reflective coating or under the reflective coating. The layer of material may be established to provide indicia or a logo or the like, or to provide an information message or the like at the mirror reflective element. The invention may also be applicable to non-electro optic mirrors such as conventional chromium or titanium mirror reflectors or to blue mirror reflectors (as are commonly known in the automotive mirror art).

[0008] Therefore, the present invention provides a mirror reflective element that includes an information message or indicia established at the reflective element that does not unduly

detract from or interfere with the functionality of the reflective element. The reflective element provides a desired amount of reflectance of visible light incident thereon over the reflective area of the mirror, including the area or region that includes the indicia or information, maintaining at least about 35 percent reflectivity (as measured using SAE J964a), more preferably at least about 40 percent reflectivity, and most preferably at least about 45 percent reflectivity, in the region or regions where the indicia is established. The reflective element and indicia layer thus provide a watermark-type effect at the reflective element, which allows the vehicle manufacturer or mirror manufacturer to provide a brand name or emblem or logo or the like at the reflective element without unduly affecting the reflectance of the reflective element over the viewable reflective surface of the reflective element.

[0009] These and other objects, advantages, purposes and features of the present invention will become apparent upon review of the following specification in conjunction with the drawings.

BRIEF DESCRIPTION OF THE DRAWINGS

[0010] FIG. 1 is a front elevation of a reflective element of a rearview mirror assembly in accordance with the present invention;

[0011] FIG. 2 is a rear elevation of the reflective element of FIG. 1;

[0012] FIG. 3 is a sectional view of a reflective element of the present invention;

[0013] FIG. 4 is a sectional view of a rear substrate of a reflective element of the present invention;

[0014] FIG. 5 is a sectional view of another rear substrate of a reflective element of the present invention;

[0015] FIG. 6 is a sectional view of a reflective element of the present invention;

[0016] FIG. 6A is a sectional view of another reflective element of the present invention;

[0017] FIG. 6B is a sectional view of another reflective element of the present invention;

[0018] FIG. 7 is a sectional view of another reflective element of the present invention, with a display element at a patterned element at the fourth surface of the reflective element;

[0019] FIG. 8 is a sectional view of another reflective element of the present invention, with a display element at a transfective element at the fourth surface of the reflective element;

[0020] FIG. 9 is a sectional view of another reflective element of the present invention, with a display element module at the fourth surface of the reflective element;

[0021] FIG. 10A is a sectional view of another reflective element of the present invention, with a display element at the rear of the reflective element;

- [0022] FIG. 10B is a plan view of the display element of FIG. 10A;
- [0023] FIG. 10C is a sectional view of the display element of FIGS. 10A and 10B;
- [0024] FIG. 10D is a sectional view of another reflective element of the present invention, with a display element at the rear of a transfective electro-optic reflective element;
- [0025] FIG. 10E is a sectional view of another reflective element of the present invention, with a display element at the rear of a non-electro-optic reflective element;
- [0026] FIG. 10F is a plan view of the display element of FIG. 10E;
- [0027] FIG. 10G is a sectional view of the display element of FIGS. 10E and 10F;
- [0028] FIG. 10H is a sectional view of another reflective element of the present invention, with a display element at the rear of a transfective electro-optic reflective element;
- [0029] FIG. 10I is a sectional view of another reflective element of the present invention, with a display element at the rear of a transfective reflective element;
- [0030] FIG. 11 is a plan view of another reflective element of the present invention;
- [0031] FIG. 12 is a plan view of another reflective element of the present invention, with a wide angle mirror portion;
- [0032] FIG. 13 is a sectional view of the wide angle mirror portion of the reflective element of FIG. 12;
- [0033] FIG. 14 is a sectional view of a curved non-electro-optic reflective element of the present invention;
- [0034] FIG. 15A is a plan view of a non-electro-optic reflective element having a perimeter band formed thereon in accordance with the present invention;
- [0035] FIG. 15B is a sectional view of the non-electro-optic reflective element of FIG. 15A;
- [0036] FIG. 16 is a plan view of another non-electro-optic reflective element having a perimeter band formed thereon in accordance with the present invention;
- [0037] FIG. 17 is a perspective view of a rear substrate of a mirror reflective element for an exterior rearview mirror of the present invention, as viewed from the front or third surface of the rear substrate;
- [0038] FIG. 18 is a perspective view of the rear substrate of FIG. 17, as viewed from the rear or fourth surface of the rear substrate;
- [0039] FIG. 19 is a sectional view of the rear substrate of FIGS. 17 and 18, with the third and fourth surface wrap-around coatings thereon;
- [0040] FIG. 20 is a perspective view of the rear substrate of FIGS. 17-19, as viewed from the front or third surface of the rear substrate, and showing the transfective mirror layer or layers disposed thereon;

- [0041] FIG. 21 is a sectional view of a mirror reflective element, incorporating the rear substrate of FIG. 20 in accordance with the present invention;
- [0042] FIG. 22 is a sectional view of another mirror reflective element in accordance with the present invention;
- [0043] FIG. 23 is a graph depicting optical properties of a coated rear substrate in accordance with the present invention;
- [0044] FIG. 24 is a graph depicting optical properties of a mirror cell in accordance with the present invention;
- [0045] FIG. 25 is a graph depicting optical properties of a coating of the present invention;
- [0046] FIG. 26 is a table listing the initial performance characteristics of samples of electrochromic cells in accordance with the present invention;
- [0047] FIG. 27 is a table similar to the table of FIG. 26, but listing the performance characteristics of the samples after 50,000 cycles;
- [0048] FIG. 28 is a sectional view of a reflective element assembly in accordance with the present invention;
- [0049] FIG. 29 is a sectional view of another reflective element assembly in accordance with the present invention;
- [0050] FIG. 30 is a partial sectional view of a mirror assembly in accordance with the present invention;
- [0051] FIG. 30A is another partial sectional view of the mirror assembly of FIG. 30;
- [0052] FIG. 30B is a partial sectional view of another mirror assembly in accordance with the present invention;
- [0053] FIG. 31 is a rear plan view of a reflective element assembly of the present invention;
- [0054] FIG. 32 is a perspective view of another mirror reflective element assembly in accordance with the present invention; and
- [0055] FIG. 33 is front plan view of another mirror reflective element assembly in accordance with the present invention.

DESCRIPTION OF THE PREFERRED EMBODIMENTS

- [0056] Referring now to the drawings and the illustrative embodiments depicted therein, a reflective element 10 (FIGS. 1 and 2) for a rearview mirror assembly, such as for an interior or exterior rearview mirror assembly for a vehicle, may comprise an electro-optic reflective element assembly or cell, such as an electrochromic reflective element or cell. The reflective element 10 includes a front substrate 12 and a rear substrate 14 (FIGS. 1-3). The rear reflective element substrate 14 is spaced from front reflective element substrate 12, and the

cell includes an electrolyte or monomer composition or electrochromic medium 16 and conductive or semi-conductive layers 18, 20 (described below) sandwiched therebetween. An epoxy seal material 22 or the like, is applied between the substrates to define the cavity for the electrochromic medium and to adhere the substrates together. Reflective element assembly 10 includes a reflectant indicia layer 24 disposed or otherwise formed at the rear surface 12a of the front substrate 12 or the front surface 14a of rear substrate 14, whereby the reflectant indicia layer 24 is viewable through the front substrate 12 by a driver of the vehicle, yet does not interfere with the reflectance of the reflective element assembly.

[0057] The rearview mirror assembly may comprise an electro-optic or electrochromic reflective element or cell, such as an electrochromic mirror assembly and electrochromic reflective element utilizing principles disclosed in commonly assigned U.S. Pat. Nos. 6,690,268; 5,140,455; 5,151,816; 6,178,034; 6,154,306; 6,002,544; 5,567,360; 5,525,264; 5,610,756; 5,406,414; 5,253,109; 5,076,673; 5,073,012; 5,117,346; 5,724,187; 5,668,663; 5,910,854; 5,142,407; 4,824,221; 5,818,636; 6,166,847; 6,111,685; 6,392,783; 6,710,906; 6,798,556; 6,554,843 and/or 4,712,879, and/or U.S. pat. applications, Ser. No. 10/054,633, filed Jan. 22, 2002 by Lynam et al. for VEHICULAR LIGHTING SYSTEM (Attorney Docket DON01 P-962); and/or Ser. No. 11/021,065, filed Dec. 23, 2004 (Attorney Docket DON01 P-1193), and/or International Pat. Publication Nos. WO 2004/098953, published Nov. 18, 2004; WO 2004/042457, published May 21, 2004; and WO 2003/084780, published Oct. 16, 2003, which are all hereby incorporated herein by reference in their entireties, and/or as disclosed in the following publications: N. R. Lynam, "Electrochromic Automotive Day/Night Mirrors", *SAE Technical Paper Series* 870636 (1987); N. R. Lynam, "Smart Windows for Automobiles", *SAE Technical Paper Series* 900419 (1990); N. R. Lynam and A. Agrawal, "Automotive Applications of Chromogenic Materials", *Large Area Chromogenics: Materials and Devices for Transmittance Control*, C. M. Lampert and C. G. Granquist, EDS., Optical Engineering Press, Wash. (1990), which are hereby incorporated by reference herein in their entireties. The thicknesses and materials of the coatings on the substrates of the electrochromic reflective element, such as on the third surface of the reflective element assembly, may be selected to provide a desired color or tint to the mirror reflective element, such as a blue colored reflector, such as is known in the art and/or such as described in U.S. Pat. Nos. 5,910,854 and 6,420,036, and in PCT Application No. PCT/US03/29776, filed Sep. 9, 2003 by Donnelly Corp. et al. for MIRROR REFLECTIVE ELEMENT ASSEMBLY (Attorney Docket DON01 FP-1109(PCT)), which are all hereby incorporated herein by reference in their entireties.

[0058] Optionally, use of an elemental semiconductor mirror, such as a silicon metal mirror, such as disclosed in U.S. Pat. Nos. 6,286,965; 6,196,688; 5,535,056; 5,751,489; and 6,065,840, and/or in U.S. pat. application, Ser. No. 10/993,302, filed Nov. 19, 2004 by Lynam for MIRROR REFLECTIVE ELEMENT FOR A VEHICLE (Attorney Docket DON01 P-1186), which are all hereby incorporated herein by reference in their entireties, can be advantageous because such elemental semiconductor mirrors (such as can be formed by depositing a thin film of silicon) can be greater than 50 percent reflecting in the photopic (SAE J964a measured), while being also substantially transmitting of light (up to 20 percent or even more). Such silicon mirrors also have the advantage of being able to be deposited onto a flat glass substrate and to be bent into a curved (such as a convex or aspheric) curvature, which is also advantageous since many passenger-side exterior rearview mirrors are bent or curved.

[0059] As shown in FIG. 3, the rear surface 12a of front substrate 12 may have a transparent conductive layer 18 disposed thereon. The transparent conductive layer 18 may comprise any suitable transparent conductive coating or layer, such as an indium tin oxide (ITO) or doped (antimony or fluorine doped) tin oxide or doped zinc oxide (such as aluminum-doped zinc oxide) or an ITO/thin Ag/ITO stack or an ITO/thin Al/ITO stack or a thin (preferably, less than about 200 angstroms in physical thickness; more preferably less than about 150 angstroms thick; most preferably less than about 125 angstroms thick; and greater than about 75 angstroms thick, more preferably greater than about 85 angstroms thick and most preferably greater than about 100 angstroms thick) coating of silver (or a silver alloy) sandwiched between ITO or doped zinc oxide layers or a thin coating of aluminum (or an aluminum alloy) sandwiched between ITO or doped zinc oxide layers or a thin coating of platinum or palladium (or an alloy thereof) sandwiched between ITO or doped zinc oxide layers or a thin coating of ruthenium (or a ruthenium alloy) sandwiched between ITO or doped zinc oxide layers, or such as the conductive layers described in U.S. Pat. Nos. 6,690,268; 5,668,663; 5,142,406; 5,442,478 and 5,724,187, and/or in U.S. pat. applications, Ser. No. 10/054,633, filed Jan. 22, 2002 by Lynam et al. for VEHICULAR LIGHTING SYSTEM (Attorney Docket DON01 P-962); Ser. No. 11/021,065, filed Dec. 23, 2004 by McCabe et al. for ELECTRO-OPTIC MIRROR CELL (Attorney Docket DON01 P-1193); Ser. No. 10/528,269, filed Mar. 17, 2005 (Attorney Docket DON01 P-1109); Ser. No. 10/533,762, filed May 4, 2005 (Attorney Docket DON01 P-1116), and/or in PCT Application No. PCT/US03/29776, filed Sep. 19, 2003 by Donnelly Corp. et al. for MIRROR REFLECTIVE ELEMENT ASSEMBLY (Attorney Docket DON01 FP-1109(PCT)); and/or

PCT Application No. PCT/US03/35381, filed Nov. 5, 2003 by Donnelly Corp. et al. for ELECTRO-OPTIC REFLECTIVE ELEMENT ASSEMBLY (Attorney Docket DON01 FP-1116(PCT)), which are hereby incorporated herein by reference in their entireties. Note that double-silver stacks (as such term is commonly known and used in the heat mirror-coated art) may be used as a transparent conductor layer. Transparent conductor layers useful in the present invention thus may comprise conductive material such as tin oxide (SnO_2) doped with antimony or fluorine, indium oxide, indium oxide and tin ($\text{In}_2\text{O}_3\text{Sn}$) (preferably 5-15 percent Sn), zinc oxide (ZnO), zinc oxyfluoride, zinc oxide and indium (ZnO:In), zinc oxide and aluminum (ZnO:Al), cadmium stannate (Cd_2SnO_4), cadmium stannite (CdSnO_3), cadmium oxide (CdO), copper sulfide (Cu_2S), titanium nitride (TiN), or titanium oxynitride ($\text{TiO}_x\text{N}_{1-x}$) to provide electrical contact to the electrochromic medium and/or for other layers/elements useful in the present invention.

[0060] In the illustrated embodiment, the reflective element 10 comprises a third surface reflective element, and the front surface 14a of rear substrate 14 includes a metallic reflective layer or coating or coatings 20 disposed thereon. The metallic reflective coatings 20 may comprise any suitable metallic layer or layers, such as silver or chromium or rhodium or aluminum or the like, and/or such as the layer or layers of the types described in U.S. Pat. Nos. 6,690,268; 5,668,663 and 5,724,187, and/or in U.S. pat. application, Ser. No. 10/054,633, filed Jan. 22, 2002 by Lynam et al. for VEHICULAR LIGHTING SYSTEM (Attorney Docket DON01 P-962); Ser. No. 11/021,065, filed Dec. 23, 2004 by McCabe et al. for ELECTRO-OPTIC MIRROR CELL (Attorney Docket DON01 P-1193); Ser. No. 10/528,269, filed Mar. 17, 2005 (Attorney Docket DON01 P-1109); Ser. No. 10/533,762, filed May 4, 2005 (Attorney Docket DON01 P-1116), and/or in PCT Application No. PCT/US03/29776, filed Sep. 19, 2003 by Donnelly Corp. et al. for MIRROR REFLECTIVE ELEMENT ASSEMBLY (Attorney Docket DON01 FP-1109(PCT)); and/or PCT Application No. PCT/US03/35381, filed Nov. 5, 2003 by Donnelly Corp. et al. for ELECTRO-OPTIC REFLECTIVE ELEMENT ASSEMBLY (Attorney Docket DON01 FP-1116(PCT)), which are hereby incorporated herein by reference in their entireties.

[0061] As shown in FIG. 3, the indicia reflector or indicia layer 24 may be disposed or established over a portion of the third surface metallic conductive layer 20. For example, the metallic reflective layer may comprise silver or aluminum or the like or alloys thereof, and may provide at least approximately 80 percent or more reflectivity of light incident thereon. The indicia metallic reflector 24 may comprise a metallic material that has a reduced reflectivity of light incident thereon as compared to the reflectivity of the metallic reflective

layer 20. For example, the indicia metallic reflector 24 may comprise chromium or titanium or the like or alloys thereof, and thus may provide reflectivity in the range of approximately 35 percent to approximately 65 percent. The reduced reflectivity of light incident on the indicia metallic reflector 24 provides a contrast between the indicia reflector and the reflective coating 20, such that the indicia metallic reflector is discernible by a person viewing the reflective element, yet still provides reflectivity at the indicia area so as to not unduly affect the functionality of the reflective element. Optionally, the indicia reflector may comprise a dielectric coating, such as a transparent conductive coating, such as an ITO or doped tin oxide or doped zinc oxide (such as with an aluminum dopant) or the like, whereby the interference effect caused by the ITO adds a slight but discernible color tint at the indicia reflector so that the indicia is discernible by a person viewing the reflective element, yet still provides reflectivity at the indicia area so as to not unduly affect the functionality of the reflective element. Examples of various interference effects of ITO or other transparent conductive materials are described in PCT Application No. PCT/US03/29776, filed Sep. 19, 2003 by Donnelly Corp. et al. for MIRROR REFLECTIVE ELEMENT ASSEMBLY (Attorney Docket DON01 FP-1109(PCT)); and/or PCT Application No. PCT/US03/35381, filed Nov. 5, 2003 by Donnelly Corp. et al. for ELECTRO-OPTIC REFLECTIVE ELEMENT ASSEMBLY (Attorney Docket DON01 FP-1116(PCT)); and/or PCT Application No. PCT/US2004/015424, filed May 18, 2004 by Donnelly Corp. et al. for MIRROR ASSEMBLY FOR VEHICLE (Attorney Docket DON01 FP-1150(PCT)); and/or U.S. pat. applications, Ser. No. 11/226,628, filed Sep. 14, 2005 (Attorney Docket DON01 P-1236); Ser. No. 11/021,065, filed Dec. 23, 2004 by McCabe et al. for ELECTRO-OPTIC MIRROR CELL (Attorney Docket DON01 P-1193); Ser. No. 10/528,269, filed Mar. 17, 2005 (Attorney Docket DON01 P-1109); Ser. No. 10/533,762, filed May 4, 2005 (Attorney Docket DON01 P-1116); and/or Ser. No. 11/021,065, filed Dec. 23, 2004 by McCabe et al. for ELECTRO-OPTIC MIRROR CELL (Attorney Docket DON01 P-1193); and/or U.S. provisional applications, Ser. No. 60/692,113, filed Jun. 20, 2005 (Attorney Docket DON01 P-1224); Ser. No. 60/677,990, filed May 5, 2005 (Attorney Docket DON01 P-1219); Ser. No. 60/653,787, filed Feb. 17, 2005 (Attorney Docket DON01 P-1207); Ser. No. 60/642,227, filed Jan. 7, 2005 (Attorney Docket DON01 P-1199); Ser. No. 60/638,250, filed Dec. 21, 2004 (Attorney Docket DON01 P-1198); Ser. No. 60/624,091, filed Nov. 1, 2004 (Attorney Docket DON01 P-1184), and Ser. No. 60/609,642, filed Sep. 14, 2004 (Attorney Docket DON01 P-1171), which are hereby incorporated herein by reference in their entireties.

[0062] As can be seen with reference to FIG. 4, the indicia reflector may be established over the reflective layer 20 at the front surface 14a of the rear substrate 14 so that the rear substrate with the indicia reflector established thereon may be readily assembled with the front substrate, electro-optic medium and seal in a suitable manner. Optionally, and as shown in FIG. 5, the indicia metallic reflector 24' may be applied to or established at a portion or region of the front surface 14a of the rear substrate 14, and the metallic conductive layer 20' may be disposed or established over substantially the rest of the front surface 14a and over the indicia metallic reflector 24', so that the indicia metallic reflector 24' is behind the reflective layer 20 and between at least one layer 20 and the rear substrate. For example, the indicia layer 24' may comprise a layer of chromium (such as about 2000 angstroms thick), and the reflective coating may comprise a layer of silver (such as about 600 angstroms thick). The presence of the thicker layer of chromium underneath the thin layer of silver provides a subtle viewable indicia layer at the reflective element, without adversely effecting the functionality of the reflective element. Optionally, materials for the layer may be selected to provide a difference in the reflectivity and/or color of the reflective coating or layer and the indicia layer to provide a discernible contrast so that the indicia is discernible by a person viewing the reflective element, yet still provides reflectivity at the indicia area so as to not unduly affect the functionality of the reflective element. Optionally, the indicia layer or reflector may be disposed or established at either side of a fourth surface reflective coating at the rear surface of the rear substrate in a similar manner to provide the desired discernibility of the indicia at the reflective element, without affecting the scope of the present invention.

[0063] The indicia reflector or layer may be established via any suitable means. For example, the indicia reflector may be disposed, such as by sputter coating or the like, at a masked area of the substrate surface to dispose the material at the desired location. Optionally, the indicia layer may be coated or screened onto the substrate surface or onto the reflective coating, such as by a screen/coat/strip process (where a resist pre-deposition is screened or printed onto the substrate, and the indicia layer (such as chromium or the like) is coated onto the substrate and the resist post deposition of the indicia layer material is washed away, whereby the indicia layer material remains at the screened or printed areas). Other means for applying or establishing or forming the indicia layer onto the substrate surface (or onto a reflective coating on the substrate surface) may be implemented without affecting the scope of the present invention.

[0064] Optionally, a light source or indicator may be positioned behind the indicia layer, such as at a circuit board within the mirror, to illuminate or backlight the indicia layer to

further enhance viewing of the indicia, particularly in low lighting conditions, such as at nighttime. Optionally, the illumination source or light source behind the indicia may be selected to match the color that may be typically associated with the selected logo (such as discussed below), such as a green or red or blue indicator or light emitting diode or the like for the school color or the like. Other forms of customized logos or indicia or the like and associated illumination sources and the like may be established at the reflective element, without affecting the scope of the present invention.

[0065] Although shown and described as an exterior rearview mirror assembly, the reflective element of the present invention may be suitable for use with an interior rearview mirror assembly, where the reflective element and a housing of the mirror are pivotally or adjustably mounted to an interior portion of a vehicle, such as via a double ball mounting or bracket assembly or the like.

[0066] Optionally, the indicia layer may provide a graphic depiction of a desired image, such as a logo of the vehicle manufacturer or other desired image. For example, the indicia may be established or otherwise formed to provide the letters "FORD" or may be established or otherwise formed in a pattern similar to the design or designs indicative of the manufacturer, such as the Chevrolet "bowtie" or the like. Optionally, other designs or patterns or text or logos or indicia or the like may be provided at the reflective element to provide a desired image or logo. For example, the indicia layer may be formed to be indicative of other vehicle manufacturers or entities or sponsors or indicia or trademarks or emblems or signature items, or representations of a certain political views, religious beliefs, tribal affiliations, community ties, collegiate affiliations, allegiances and/or advocacy (such as, for example, a "peace" sign or other symbol or text or the like) or other views, affiliations, beliefs, etc., or other custom ports or icons may be formed elsewhere on the reflective element to convey other information or logos or the like, without affecting the scope of the present invention (and such as described in U.S. pat. application, Ser. No. 11/021,065, filed Dec. 23, 2004 by McCabe et al. for ELECTRO-OPTIC MIRROR CELL (Attorney Docket DON01 P-1193), and/or PCT Application No. PCT/US2004/015424, filed May 18, 2004 by Donnelly Corp. et al. for MIRROR ASSEMBLY FOR VEHICLE (Attorney Docket DON01 FP-1150(PCT)), which are hereby incorporated herein by reference in their entireties).

[0067] The desired image or logo may be indicative of the vehicle manufacturer, or may be selected by the user or vehicle owner to provide a customized interior or exterior rearview mirror assembly, such as described above with respect to the different logos or colors, without affecting the scope of the present invention. For example, a person may select the

logo or mascot of their alma mater to be established at a desired location at the reflective element to customize the mirror assembly for that particular person or owner. The customized reflective element may provide the desired logo or indicia or the like, without unduly affecting the functionality of the reflective element.

[0068] Optionally, and as shown in FIGS. 1 and 2, the reflective element 10 may include a perimeter metallic band 26, such as the types described in PCT Application No. PCT/US03/29776, filed Sep. 19, 2003 by Donnelly Corp. et al. for ELECTROCHROMIC MIRROR ASSEMBLY (Attorney Docket DON01 FP-1109(PCT)); and/or PCT Application No. PCT/US03/35381, filed Nov. 5, 2003 by Donnelly Corp. et al. for ELECTRO-OPTIC REFLECTIVE ELEMENT ASSEMBLY (Attorney Docket DON01 FP-1116(PCT)); and/or U.S. pat. applications, Ser. No. 11/021,065, filed Dec. 23, 2004 by McCabe et al. for ELECTRO-OPTIC MIRROR CELL (Attorney Docket DON01 P-1193); Ser. No. 10/528,269, filed Mar. 17, 2005 (Attorney Docket DON01 P-1109); Ser. No. 10/533,762, filed May 4, 2005 (Attorney Docket DON01 P-1116); Ser. No. 11/226,628, filed Sep. 14, 2005 (Attorney Docket DON01 P-1236); and/or Ser. No. 11/021,065, filed Dec. 23, 2004 by McCabe et al. for ELECTRO-OPTIC MIRROR CELL (Attorney Docket DON01 P-1193); and/or U.S. provisional applications, Ser. No. 60/692,113, filed Jun. 20, 2005 (Attorney Docket DON01 P-1224); Ser. No. 60/677,990, filed May 5, 2005 (Attorney Docket DON01 P-1219); Ser. No. 60/653,787, filed Feb. 17, 2005 (Attorney Docket DON01 P-1207); Ser. No. 60/642,227, filed Jan. 7, 2005 (Attorney Docket DON01 P-1199); Ser. No. 60/638,250, filed Dec. 21, 2004 (Attorney Docket DON01 P-1198); Ser. No. 60/624,091, filed Nov. 1, 2004 (Attorney Docket DON01 P-1184), and Ser. No. 60/609,642, filed Sep. 14, 2004 (Attorney Docket DON01 P-1171), which are hereby incorporated herein by reference in their entireties. The perimeter band metallic material may be selected to provide a desired band color, such as due to interference effects or material colors and/or reflectances and/or refractive indices. Optionally, the material for the perimeter band may be selected so that the appearance or color of the perimeter band may substantially match or contrast the appearance or color of the indicia layer or reflector, depending on the desired appearance of the reflective element. For example, a combination or stack of oxides comprising materials having different high and low refractive indices may be stacked upon one another to provide alternating refractive indices to spectrally tune the metallic band and/or the indicia reflector or layer to the desired colors or tints or appearances (such as utilizing principles described in PCT Application No. PCT/US03/29776, filed Sep. 19, 2003 by Donnelly Corp. et al. for ELECTROCHROMIC MIRROR ASSEMBLY (Attorney Docket DON01 FP-1109(PCT)),

and/or Ser. No. 10/528,269, filed Mar. 17, 2005 (Attorney Docket DON01 P-1109), which are hereby incorporated herein by reference in their entireties).

[0069] Optionally, and with reference to FIG. 6, a reflective element assembly or cell 110 for a rearview mirror assembly, such as for an interior or exterior rearview mirror assembly for a vehicle, includes a front substrate 112 and a rear substrate 114 spaced from front reflective element substrate 112, with an electrolyte or a cured monomer composition or electrochromic medium 116 sandwiched therebetween. The front substrate 112 has a transparent conductive coating or layer 118 disposed on its rear surface 112a (typically referred to as the second surface of the reflective element assembly) and the rear substrate 114 has a metallic conductive coating or layer 120 disposed on its front surface 114a (typically referred to as the third surface of the reflective element assembly), such as described above. As can be seen in FIG. 6, the indicia 126 is locally deposited or established or disposed at the second surface of the front substrate at the desired location and/or pattern (and with the ITO coating adjacent to or over the indicia), while the metallic conductive coating 120 is deposited or established or disposed over substantially the entire third surface of the rear substrate so as to be behind and surrounding the indicia as viewed by the driver when the mirror assembly is installed at the vehicle. An epoxy seal material 122 or the like, is applied between the substrates to define the cavity for the electrochromic medium and to adhere the substrates together. Reflective element assembly 110 includes a reflective perimeter or border band 126 and a reflectant indicia layer 124 disposed or otherwise formed or established at the rear or second surface 112a of the front substrate 112.

[0070] Indicia layer 124 may be established during the same coating process as the perimeter band 126 and may be established on the rear surface of the substrate, so that the transparent conductive layer 118 is disposed or established onto the perimeter band 126 and indicia layer 124 and over the rear surface 112a of front substrate 112. For example, the rear surface of the front substrate may be masked to define the perimeter border and the desired indicia or form. The mask may be etched or cut or punched to provide the desired indicia or logo or the like (which may appear in a reverse image manner when the mask is placed on the rear surface of the front substrate). The etched mask thus may be placed at or on the rear surface of the front substrate and the desired reflective material (such as described below) may be disposed onto the rear surface of the substrate in the unmasked or uncovered areas. The reflective indicia may be formed so as to be located at the electrochromic portion of the mirror (radially inward from the seal and perimeter or border band), so as to be readily viewable by the driver of the vehicle and so as to be visibly effected by the darkening of the

electrochromic medium and the corresponding dimming of the electrochromic mirror, as discussed below.

[0071] Preferably, metallic conductive coating 120 comprises a substantially highly reflective material with a high degree of reflectivity of light incident thereon. For example, the third surface coating 120 may comprise aluminum or silver or their alloys (or other similar or suitable metallic compositions and the like), and may provide greater than about 80 percent reflectivity of light incident thereon (as measured using SAE J964a) and more preferably greater than about 90 percent reflectivity of light incident thereon. Preferably, the reflective indicia 124 (and the reflective perimeter band 126) comprises a lower or reduced reflectivity of light incident thereon than that provided by the third surface reflective coating. For example, the reflective indicia 124 may comprise chromium or titanium or nickel or molybdenum or ruthenium or their alloys or other similar or suitable metal (such as a stainless steel or a nickel based alloy, such as Hastelloy C), and may provide about 65 percent reflectivity of light incident thereon, and more preferably less than about 55 percent reflectivity of light incident thereon (such as between about 35 percent reflectivity to about 65 percent reflectivity of light incident thereon).

[0072] Indicia layer 124 may also comprise a specularly reflective layer, preferably such as a mirror-reflective thin film of chromium, ruthenium, silver, silver alloy, aluminum, aluminum alloy or other metal or metal alloy. Thus, and preferably, the indicia layer material comprises a metallic material such that is locally provides a mirror-like reflection at the second surface of the front substrate that is subtly discernible against the third surface mirror reflector at the third surface of the rear substrate of the electrochromic reflective element. Such a specular or mirror-like reflective material may be attained from a sputtered or vacuum deposited metallic thin film coated onto the substrate. The indicia coating or coatings or layer(s) may be disposed onto the substrate surface at the desired location and pattern with the transparent electrically conductive coating of the second surface of the front substrate (such as ITO or other transparent electrically conductive coatings, such as doped tin oxide or doped zinc oxide such as ZnO:Al or the like) deposited over the glass surface and over the indicia material (so that the reflection off the indicia layer(s) is unaffected by the ITO disposed therebehind and thus more metallic or "silvery" in hue and is substantially spectrally neutral rather than being spectrally reflecting/tinted), or the ITO coating may be deposited onto the second-surface surface of the front substrate with the indicia coating material disposed onto the ITO-coated surface at the desired location and pattern (so that the reflection off the indicia layer(s) is/are seen through the ITO and so an interference spectral character to such

reflectivity may be imparted), depending on the particular application and desired appearance/effect of the mirror reflective element assembly.

[0073] Although shown as a mirror reflective element having the front substrate 112 larger than the rear substrate, such as for a frameless mirror reflective element for an exterior rearview mirror assembly, the mirror reflective element with indicia may comprise other types of reflective elements, such as a flush reflective element for an interior or exterior rearview mirror assembly or an offset construction such as is known in the electro-optic mirror art, without affecting the scope of the present invention. For example, and as shown in FIG. 6A, a reflective element 110' (preferably an exterior vehicular mirror element) may have a front substrate 112' that is substantially flush with the rear substrate 114', with a reflective indicia or logo 124' (and optionally and preferably a perimeter border band 126' as well) established at the second surface 112a' of front substrate 112'. The front substrate 112' is spaced from the rear substrate 114' with an electrochromic medium 116' disposed therebetween and sealed by a perimeter seal 122'. The logo or indicia 124' (locally established inboard of the perimeter edge or border of the front substrate on its second surface) and border band 126' (at and substantially circumscribing the second-surface perimeter edge or border region of the front substrate) preferably comprise the same metallic reflecting layer, such as sputtered chromium or the like or have distinctly different reflectivity (such as chromium for indicia 124' and ruthenium for border band 126'), and are preferably established via the same coating process as described above. Reflective element 110' includes a transparent conductive coating 118' at the second surface 112a' (such as disposed or established over the perimeter border band 126' and indicia 124', such as described above), which may comprise an ITO coating or a doped zinc oxide (such as ZnO:Al) coating (such as the types discussed below) or other suitable transparent conductive coating or layer or material.

[0074] The third surface reflective coating or layers 120' at the third surface 114a' of rear substrate 114' may comprise any suitable material or materials or layers to provide the desired reflectivity and/or transreflectivity at the third surface of the mirror reflective element. For example, the third surface coatings 120' may comprise a layer of chromium 120a' at the third surface 114a' of rear substrate 114', with a layer of ruthenium 120b' disposed over the layer of chromium 120a'. In such an application, the indicia 124' may comprise chromium and the front-most layer 120b' of third surface reflector 120' may comprise ruthenium (that typically is about 5-20 percent or so more reflecting than chromium, depending on the deposition conditions employed), or both may be similar or identical materials (e.g. chromium or

ruthenium). Even with the same materials, the indicia is still discernible due to a contrast between the indicia 124' at the second surface and the coatings or layers 120' at the third surface (due to the optical properties such as refractive index and spectral absorption of the electro-optic EC medium disposed between the second and third surfaces). In the illustrated embodiment, the ITO layer 118' is disposed over the indicia 124', but optionally the ITO layer may be disposed at the second surface with the indicia disposed over the ITO at the desired location or pattern. If the ITO is established at the second surface before the indicia, the indicia may be colored or tinted due to the optical interference effect or coloring caused by the ITO (when the ITO is between the substrate and the indicia and thus the indicia is viewed through the ITO coating by a person viewing the mirror reflective element). Such an arrangement may provide a gold-tinted or blue-tinted or other color tint to the indicia, dependent principally on the thickness of the ITO (or other transparent conductive material) used, which may be preferred depending on the particular application of the mirror assembly and desired effect or appearance of the mirror assembly. Optionally, indicia layer(s) 124' may be formed of a metallic metal coating (such as of gold or a gold alloy) that is itself spectrally selective in reflectivity so as to be tinted in reflection.

[0075] Optionally, and as shown in FIG. 6B, a mirror reflective element 110" (preferably an exterior vehicular mirror element) may be substantially similar to mirror reflective element 110' as described above, and may include a third surface coating or layers 120" at a rear surface 114a" of the rear substrate 114" that comprises a layer of chromium 120a" disposed at the third surface of the rear substrate, with a layer of silver 120b" disposed over the layer of chromium 120a" and a layer of aluminum zinc oxide 120c" (ZnO:Al) disposed over the layer of silver 120b". The third surface reflector thus comprises a different material and specular reflectivity as compared to the chromium indicia 124', whereby the indicia may be more readily discernible by a person viewing the reflective element when the reflective element is in its "day" state due to the contrast between the much more highly reflecting third surface main mirror reflector (typically a silver or silver-alloy metal coating that has a specular first-surface reflectivity, as measured in accordance with SAE J964a, that is at least about 80%R and often at least about 90%R) and the less highly reflecting second-surface indicia/logo reflecting coating or layer (for example, an evaporated chromium coating that has a reflectivity of about 45-55%R or a sputtered chromium coating that has a reflectivity of about 55-65%R). Other stacks or layers of metallic conductive reflective or transfective coatings or layers may be implemented to achieve the desired reflectivity and transmissivity at the third surface of the reflective element, while providing a desired degree of discernibility of

the indicia, while remaining within the spirit and scope of the present invention. The indicia material and third surface reflector material and arrangement of the indicia and ITO coatings may be selected to achieve the desired color and reflectivity differential of the indicia relative to the third surface reflector, depending on the particular application and desired effect of the mirror assembly.

[0076] Because the reflective indicia that is locally established in a pattern on the second surface of the front substrate is desirably less reflective than the third surface reflective coating on the rear substrate (when the mirror is in its "day" or undimmed state or high reflectance state) or, less desirably, vice versa, and is surrounded by and backdropped by the third surface reflective coating (which preferably provides a higher reflectivity background to the indicia), the indicia is subtly (such as via the differences in reflectivities of the materials used) discernible by a person viewing the reflective element when the EC medium is unpowered and is in its high reflectance state. The viewability and discernibility of the indicia may be subtle when the reflective surface of the rear substrate is at its highly reflective state or when the electrochromic medium is not darkened. Thus, during the unpowered state of the electrochromic mirror, the indicia may be subtly viewable and discernible by a person viewing the mirror assembly. However, when the electrochromic mirror is powered to darken the electrochromic medium and thus to dim the mirror (such as in response to a glare sensor or the like located at the mirror assembly or elsewhere in the vehicle), the reflectivity of light provided by the third surface reflective coating is reduced (due to the darkening of the electrochromic medium in front of the third surface reflective coating), so that the indicia becomes more visible or more discernible to a person viewing the mirror. In other words, the indicia may be enhanced and more readily viewable and discernible as the mirror is darkened and the reflectivity of the third surface reflective coating is limited or reduced by the darkening of the electrochromic medium.

[0077] Optionally, the third surface metal reflector on the third surface of the rear substrate of the cell, the perimeter reflective border band around the edge border of the second surface of the front substrate, and the indicia (also on the second surface but inward of the border band) may be reflective materials, and may comprise substantially the same metallic or reflective material, so that all three have similar or closely similar reflective properties, and may all have substantially the same optical properties, such as reflectivity level and refractive index/k-value. By so choosing, the optical contrast between the third surface reflector coating and the second surface perimeter border is substantially reduced and essentially eliminated such that the viewer barely sees or notices the presence of the second surface

border band when the electrochromic cell is not powered (i.e. is undimmed and is in its bleached state), and the presence of the border reflective band is only discernable when the electrochromic medium dims when the cell is powered. Also, the presence of the indicia (such as an ANTI-GLARE indicia or AUTODIM indicia or the like) on the second surface is subtly noticeable to a viewer because its optical properties substantially match those of the third surface reflector coating (for example, chromium may be used for the indicia and ruthenium for the third surface reflector for an exterior mirror element, or chromium may be used for the indicia and silver or a silver-alloy may be used for the third surface reflector for an interior mirror element), such that the viewer subtly sees or notices or discerns the presence of the second surface indicia when the electrochromic cell is not powered (i.e. is undimmed and in its bleached state), but the presence of the indicia on the second surface becomes appreciably discernable when the electrochromic medium dims when the cell is powered, and in such circumstances provides a "surprise and delight" benefit to the consumer.

[0078]

This is particularly advantageous when an AUTODIM or similar automatic dimming indication logo/indicia is used. When the likes of an electrochromic automatic dimming interior mirror element dims in reflectivity at night when rear-approaching glaring headlights are detected, the driver is often unaware of and thus unappreciative of the anti-glare benefits of this feature. In accordance with the present invention, the AUTODIM logo/indicia on the second surface of the front substrate becomes plainly visible once the electro-optic EC medium is powered at night when the mirror element is subject to and is being illuminated by incident light from approaching headlights that are sufficiently intense to cause the automatic glare detection circuitry to power the electro-optic EC medium. And the more intense the glare detected, the darker the electro-optic EC medium dims and the more the second-surface logo/indicia stands out, and so the continuously variable reflectivity feature of such automatic electrochromic mirror assemblies is conveyed to the driver. Note that, for example, the third surface reflector coating and the second surface perimetal border reflector band (if present) and the second surface indicia may all three comprise chromium thin films or all three may comprise ruthenium thin films or all three may comprise rhodium thin films or all three may comprise Hastelloy C-276 thin films or all three may comprise molybdenum thin films or all three may comprise aluminum (or aluminum alloy) thin films or all three may comprise aluminum/palladium alloy thin films or all three may comprise silver (or silver alloy) thin films, or all three may comprise sub-sets of these or other suitable coatings or films.

[0079] Thus, the indicia may optionally be selected to provide information that may be relevant to the driver of the vehicle during night driving when the EC medium dims or darkens in response to detected incident glaring conditions. For example, the logo/indicia may provide a notice or indication to the driver that the electrochromic mirror assembly is powered and thus in an active mode or darkened or dimmed mode, in order to provide a visual reinforcement or communication to the driver that the mirror assembly is working in the desired and designed manner, and is delivering glare protection. Such an information display logo or indication is thus desirable, since customers may not otherwise readily recognize that the electrochromic mirror is properly dimming, and thus may not otherwise fully appreciate the benefits provided by the automatic mirror dimming feature. For example, the indicia can read "AUTODIM" or "ANTI-GLARE" or "EC" or "NIGHT" or may be an icon, such as a representation of a headlamp with a cross or "X" superimposed thereon, indicating that the glare or reflection of the light from the headlamps is being reduced or dimmed by the mirror. Optionally, the logo/indicia may convey other information, such as an automaker brand or personalization information, to the driver that stands out when the EC medium dims.

[0080] The indicia material of the present invention thus may provide a reflective logo that is faintly visible/discernible to the driver when the EC mirror is in its "day" state (where the EC medium is not darkened or colored), but becomes plainly or substantially visible/discernible when the EC mirror dims to its "night" state (when the EC medium is darkened or colored to reduce glare at the reflective element). For example, the reflective logo may be locally coated or established at the second surface of the front substrate and may have a reflectivity of about 55 percent of light incident thereon, while the main or primary mirror reflector established at the third surface of the rear substrate may have a reflectivity of about 70 percent of light incident thereon. Thus, in the "day" state, the driver can discern the lower reflectivity of the logo against the distinctly higher or brighter reflectivity of the main mirror reflector behind the logo; whereby the logo is subtly but distinctly visible/discernible at the mirror reflective element while the mirror reflectivity of light incident thereon is sustained across the viewing surface, even at the location where the logo is disposed or established. Because a person's eyes typically can discern a difference in reflectivity of about 5 percent, and can more readily discern a difference in reflectivity of about 10 percent or more, the difference in reflectivity between the logo and the third surface mirror reflector is readily discernible by the driver of the vehicle when the mirror is in its "day" state.

[0081] When the mirror changes to its "night" or antiglare state, the reflectivity of the primary mirror reflector is substantially reduced (due to the darkening or coloring of the EC medium), while the reflectivity of the logo (established at the second surface and thus in front of the EC medium) is substantially unaffected by the activation of the EC mirror. Thus, when the EC mirror dims, the logo "stands-out" or becomes plainly or substantially visible or discernible at the reflective element. The indicia or logo may be selected to convey the desired message or information or display to the viewer. For example, the logo may comprise the term "AUTODIM" or "ANTI-GLARE" or the like to indicate to the driver that the EC mirror has such a feature. Optionally, the logo may comprise a personalized logo, such as a sports logo or college logo or the like (which may be selected by the user or owner of the vehicle) or a vehicle logo, such as "FORD" or "GM" or the like, depending on the particular application and desired display or appearance of the mirror assembly.

[0082] The indicia material and the third surface reflector material may comprise similar materials or may comprise different reflective materials, depending on the desired appearance and effect of the reflective element. For example, the indicia material may be selected as a gold or bronze colored or tinted material (such as a gold or gold alloy or the like) to provide a desired spectral appearance. Such a colored or tinted indicia material may be more readily discernible at the reflective element since it is backdropped and surrounded by the specularly reflective mirror reflector at the third surface. The third surface mirror reflector may comprise any suitable reflective or transreflective material or materials, such as an ISI (ITO - silver - ITO) stack of layers or layers including other metallic materials, such as silver alloys and the like, such as the other materials discussed herein), and provides a specularly reflective (and optionally transreflective) mirror reflector behind and around the indicia as viewed by a driver of the vehicle.

[0083] Note that the degree of subtly that the logo/indicia is discernible to the driver when the electrochromic (EC) medium is not powered (i.e., the EC mirror element is in its high or "day" reflectance state) can be determined by the choices made for the logo/indicia metallic reflecting layer and those of the third surface reflector (or fourth surface reflector) metallic main mirror reflecting layer. For example, a chromium or similar lower reflecting (typically with a first-surface reflectivity in the about 45%R to about 65%R range) metal coating choice for the logo/indicia will be more discernible if the main mirror reflector (that preferably is on the third surface rather than on the fourth surface) is a high reflecting reflector [such as a silver mirror coating (or a silver alloy) with a first-surface reflectivity of at least about 80%R (and often greater than about 90%R)] than it would be if the main mirror reflector is a

medium reflecting reflector [such as a ruthenium mirror coating (or a ruthenium alloy or a platinum or palladium metal or alloy) with a first-surface reflectivity in the about 65%R to about 75%R range, typically]. Also, should the metallic logo/indicia overcoat the transparent conductor coating (such as ITO or AZO) of the second surface (and thus be located behind the transparent conductor coating when the mirror reflective element is viewed by a person at the vehicle), the metallic logo/indicia may be less subtly discernible than if the metallic logo/indicia undercoats the transparent conductor coating (because the metallic logo/indicia is subject to optical interference effects and has a spectrally selective reflectivity so as to be color tinted in reflectance when the metallic logo/indicia overcoats and is thus located behind the transparent conductor coating).

[0084] Particularly for an exterior mirror, a user typically cannot discern that the EC function is working, since there is no feedback to the user when the EC function is operating to dim or darken the mirror reflection. The increased viewability of the indicia when the EC medium is darkened provides a visual prompt to the user to reinforce to the consumer the value of the feature, particularly for exterior mirror applications, such that the consumer may recognize the value and functionality of the feature and may increase the use the EC feature, thereby enhancing safety. Although it is known to provide LEDs or the like to interior mirror assemblies, the indicia of the present invention provides a similar function, but with reduced costs and complexity of the mirror assembly, since no additional electronic LED or the like is needed to convey the indication that the EC mirror is powered.

[0085] Although shown and described as having a third surface reflective coating, the reflective element may have a fourth surface reflective coating, without affecting the scope of the present invention. Optionally, and as shown in FIG. 6, the third surface reflective metallic coating may be disposed over the perimeter edge or edges of the rear substrate so as to provide a wraparound portion at the perimeter edge or edges for electrical connection of electrical connectors at the fourth surface 114a of the reflective element assembly 110 to the conductive coatings 118, 120, such as by utilizing aspects described in U.S. pat. applications, Ser. No. 11/226,628, filed Sep. 14, 2005 (Attorney Docket DON01 P-1236); and/or Ser. No. 11/021,065, filed Dec. 23, 2004 by McCabe et al. for ELECTRO-OPTIC MIRROR CELL (Attorney Docket DON01 P-1193), which are hereby incorporated herein by reference in their entireties.

[0086] Also, although shown and described with the perimeter band and indicia being formed directly on the rear surface of the front (first) substrate and with the transparent conductive coating disposed over the perimeter band and indicia, the transparent conductive coating may

first be disposed over the rear surface of the front substrate with the perimeter band and indicia then being disposed onto the transparent conductive coating, without affecting the scope of the present invention. Such an arrangement may be desired if a color or tint of the perimeter band and indicia, such as due to the interference effect of the transparent conductive coating between the perimeter band / indicia and the substrate surface, such as described above and by utilizing aspects described in U.S. pat. applications, Ser. No. 11/226,628, filed Sep. 14, 2005 (Attorney Docket DON01 P-1236); and/or Ser. No. 11/021,065, filed Dec. 23, 2004 by McCabe et al. for ELECTRO-OPTIC MIRROR CELL (Attorney Docket DON01 P-1193); and/or U.S. provisional applications, Ser. No. 60/692,113, filed Jun. 20, 2005 (Attorney Docket DON01 P-1224); Ser. No. 60/677,990, filed May 5, 2005 (Attorney Docket DON01 P-1219); Ser. No. 60/653,787, filed Feb. 17, 2005 (Attorney Docket DON01 P-1207); Ser. No. 60/642,227, filed Jan. 7, 2005 (Attorney Docket DON01 P-1199); Ser. No. 60/638,250, filed Dec. 21, 2004 (Attorney Docket DON01 P-1198); Ser. No. 60/624,091, filed Nov. 1, 2004 (Attorney Docket DON01 P-1184), and Ser. No. 60/609,642, filed Sep. 14, 2004 (Attorney Docket DON01 P-1171), which are hereby incorporated herein by reference in their entireties.

[0087] The indicia and the perimeter band or coating may be established onto the substrate surface, such as onto the rear surface of the front substrate via the same coating operation and with the same material. The indicia thus may be established without additional coating processes, since the indicia is established by using the same mask and coating that normally would be utilized for establishing the perimeter coating or band. The indicia is thus established at the substrate surface in a highly economical manner. For example, a substrate may be provided and a mask (with an outer portion defining the perimeter band and with the indicia formed or cut through the mask) may be placed on the substrate surface (such as the rear surface of the front substrate). The desired metallic layer material may be disposed at the substrate surface so as to be established at the unmasked perimeter band and indicia regions via a single deposition process or the like. The perimeter band and the indicia thus may be readily established in an economical manner without multiple steps or processes and with the same material so that the indicia may substantially match the perimeter band in appearance or color or tint or discernibility.

[0088] Although shown and described as an electro-optic or electrochromic reflective element assembly or cell, the reflective element may comprise a single substrate with a reflective coating at its rear surface, without affecting the scope of the present invention. The indicia layer may be disposed or established at the rear of the reflective coating so as to be

discernible through the substrate and reflective coating, or may be disposed or established between the reflective coating and the rear surface of the substrate, such as in a similar manner as described above. The mirror assembly may comprise a prismatic mirror assembly or other mirror having a single substrate reflective element, such as a mirror assembly utilizing aspects described in U.S. Pat. Nos. 6,318,870; 6,598,980; 5,327,288; 4,948,242; 4,826,289; 4,436,371; and 4,435,042; and PCT Application No. PCT/US04/015424, filed May 18, 2004 by Donnelly Corporation et al. for MIRROR ASSEMBLY FOR VEHICLE (Attorney Docket DON01 FP-1150(PCT)); and U.S. pat. application, Ser. No. 10/933,842, filed Sep. 3, 2004 (Attorney Docket DON01 P-1166), which are hereby incorporated herein by reference in their entireties. Optionally, the prismatic reflective element may comprise a conventional prismatic or flat reflective element or prism, or may comprise a prismatic or flat reflective element of the types described in PCT Application No. PCT/US03/29776, filed Sep. 19, 2003 by Donnelly Corp. et al. for MIRROR REFLECTIVE ELEMENT ASSEMBLY (Attorney Docket DON01 FP-1109(PCT)); U.S. pat. applications, Ser. No. 10/528,269, filed Mar. 17, 2005 (Attorney Docket DON01 P-1109); Ser. No. 10/709,434, filed May 5, 2004 by Lynam for MIRROR REFLECTIVE ELEMENT (Attorney Docket DON01 P-1152); Ser. No. 10/933,842, filed Sep. 3, 2004 by Kulas et al. for INTERIOR REARVIEW MIRROR ASSEMBLY (Attorney Docket DON01 P-1166); Ser. No. 11/021,065, filed Dec. 23, 2004 by McCabe et al. for ELECTRO-OPTIC MIRROR CELL (Attorney Docket DON01 P-1193); and/or Ser. No. 10/993,302, filed Nov. 19, 2004 by Lynam for MIRROR REFLECTIVE ELEMENT FOR A VEHICLE (Attorney Docket DON01 P-1186), and/or PCT Application No. PCT/US2004/015424, filed May 18, 2004 by Donnelly Corp. et al. for MIRROR ASSEMBLY FOR VEHICLE (Attorney Docket DON01 FP-1150(PCT)), which are all hereby incorporated herein by reference in their entireties, without affecting the scope of the present invention. A variety of mirror accessories and constructions are known in the art, such as those disclosed in U.S. Pat. Nos. 5,555,136; 5,582,383; 5,680,263; 5,984,482; 6,227,675; 6,229,319; and 6,315,421 (the entire disclosures of which are hereby incorporated herein by reference in their entireties), that can benefit from the present invention. The subtle contrast indicia of the present invention may be established on any of a first, second, third or fourth surface of a laminate-type electro optic mirror cell or on any of a first or second surface of a single-substrate mirror element.

[0089] Optionally, a mirror reflective element may include a display element that emits or projects illumination through a pattern or indicia formed or established at the reflective element. For example, and with reference to FIG. 7, a mirror reflective element 210 for a

rearview mirror assembly, such as for an interior or exterior rearview mirror assembly for a vehicle, includes a front substrate 212 and a rear substrate 214 spaced from front reflective element substrate 212, with an electrolyte or a cured monomer composition or electrochromic medium 216 sandwiched therebetween. The front substrate 212 has a transparent conductive coating or layer 218 (such as an ITO layer, such as a $\frac{1}{2}$ wave ITO layer or a doped tin oxide layer or a doped zinc oxide layer or a light transmissive metal oxide/metal/metal oxide stack such as ITO/Ag/ITO or ZnAlO/Ag/ZnAlO or ZnAlO/Al/ZnAlO or ITO/Ag/ZnAlO or the like) disposed on its rear surface 212a (typically referred to as the second surface of the reflective element assembly) and the rear substrate 214 has a metallic conductive coating or layer 220 disposed on and substantially over its front surface 214a (typically referred to as the third surface of the reflective element assembly), such as described above. An epoxy seal material 222 or the like, is applied between the substrates to define the cavity for the electrochromic medium and to adhere the substrates together. In the illustrated embodiment, reflective element assembly 210 includes a reflective perimeter or border band 226 disposed or otherwise formed or established at the rear or second surface 212a of the front substrate 212, such as described above.

[0090] Reflective element 210 includes a display element 230 located rearward of the reflective element and directed at a pattern or indicia 232 formed or established at the rear surface 214b of rear substrate 214 (commonly referred to as the fourth surface of the reflective element). The pattern 232 may comprise the likes of a pattern of stars or dots, a pattern of bars or bar segments, portions of which may be connected or unconnected to each other, or other patterns or indicia or the like. The pattern or indicia 232 may comprise any suitable material (such as chromium, molybdenum or tungsten or the like) and may provide a decorative or light management effect that is viewable and discernible by the driver of the vehicle (or other person viewing the mirror) when the display element 230 (such as a light source, such as a light emitting diode (LED) or the like) is activated. For example, the pattern 232 may be formed to indicate that the turn signal of the subject vehicle is activated, such as for exterior mirror applications for indicating to a driver of an adjacent vehicle that the turn signal of the subject vehicle is activated. The indicia or pattern or structure established at the fourth surface of the reflective element thus may break up or direct light from the display element and/or may obscure or hide the presence of the display element from direct view by a person viewing the reflective element, so as to provide a desired appearance or direction of the light passing through the reflective element for viewing by the driver of the vehicle or other person within or outside of the vehicle. Optionally, the pattern

may be thin film coating or a thick film coating, such as a printed pattern or painted pattern, such as a paint or ink or lacquer, or such as an adhesively applied or "stick-on" element or appliqué or the like. For example, the pattern or indicia may be printed or painted or coated or otherwise applied or disposed at a portion of the rear surface of the reflective element, or may be coated or applied or formed or otherwise established on a Mylar shape (or other substrate or the like) that may be adhered to the rear surface of the reflective element, thereby avoiding coating the entire rear surface or substantially the entire rear surface of the reflective element.

[0091] The third surface conductive coating 220 may comprise a transflective coating or layer or other suitable third surface reflective and conductive coatings. In the illustrated embodiment, the third surface conductive coating 220 comprises a layer of a transparent conductive material 220a (such as ITO or the like) over substantially the entire front surface 214a of the rear substrate 214, and a reflective coating or layer 220b (or multiple coatings or layers), such as a layer of chromium/rhodium or chromium/ruthenium or molybdenum/chromium or an ITO/silver/ITO stack of layers or the like. A window or aperture 234 is formed or established in the reflective coating or coatings 220b (such as by laser ablating or etching the reflective coating 220b to remove the coating 220b at the window area [or by masking the metallic transflective coating 220b while it is being deposited onto the transparent conductive layer 220a], while maintaining the transparent conductive coating 220a at the window area).

[0092] As shown in FIG. 7, the reflective element 210 may include a fourth surface conductor 236a and wrap-around coating 236b that wraps around and over a perimeter edge 214c of rear substrate 214 and over a third surface conductive wraparound coating 220c at the perimeter edge 214c, in order to provide electrical conductivity between the fourth surface conductor 236a and the third surface conductive and reflective coating 220b. Preferably, the indicia or pattern 232 is formed or established during the same coating process that establishes the fourth surface conductor 236a and wrap-around coating 236b and thus may comprise the same material as the fourth surface conductor 236a and wrap-around coating 236b (such as chromium or molybdenum or tungsten or Hastelloy or ruthenium or rhodium or other suitable conductive material). Alternately, the pattern or indicia 232 may comprise a different material and may be established via a different coating or forming or establishing process.

[0093] For example, and with reference to FIG. 8, the reflective element 210' may include a transflective coating or layer or appliqué 232' established at the fourth surface 214b' of the

reflective element 214' and at the display element 230 and generally opposite the window area 234 at the third surface reflective coating 220b. The transflective coating 232' thus may provide a reflective appearance at the window area 234, while allowing light from display element 230 to pass through the transflective coating 232' and through the reflective element 210' for viewing by a person viewing the mirror reflective element assembly. The transparent conductive coating 220a may be disposed over substantially the entire front surface 214a' of rear substrate 214', while the third surface reflective coating or reflector 220b may have an aperture 234 established therein, such as described above.

[0094] Optionally, and with reference to FIG. 9, the reflective element 210" may include a display module 229 that may be attached or adhered or established at the rear surface 214b" of rear substrate 214" and generally opposite the window area 234 formed in the third surface reflective coating 220b (that is disposed on the transparent conductive layer 220a [such as a layer or coating of ITO or the like, such as a layer of 80 ohms/sq. ITO or the like] at the front surface 214a" of rear substrate 214"). The display module 229 includes a housing 229a, a light source or display element 230" (such as a light emitting diode or other suitable light source) and a transflective window element 232". The housing 229a may include electrical connectors 229b for electrically connecting the display module 229 to a power source or circuitry of the mirror assembly. Preferably, display module 229 may be attached to the rear surface 214b" of rear substrate 214" via an optical index matching adhesive 229c, such as an optical epoxy or optical acrylic (such as utilizing aspects of the reflective element described in U.S. pat. application, Ser. No. 10/993,302, filed Nov. 19, 2004 (Attorney Docket DON01 P-1186), which is hereby incorporated herein by reference in its entirety. The housing 229a may mount or receive the display element 230" such that the light is emitted at an angle through the transflective window and the reflective element (such as, for example, for a blind spot system indicator whose light output is directed into the vehicle cabin so as to be seen by the driver of the host vehicle) to enhance viewability and discernibility of the display (or to reduce the viewability or discernibility of the display, such as by directing the light output away from the cabin of the vehicle so that the light output is not readily discernible by the driver of the host vehicle) to a person viewing the reflective element at an angle. The housing 229a may have a polished or reflective or otherwise shaped or formed inner surface to enhance directing of the light toward and through the reflective element when the display module 229 is attached to the fourth surface of the reflective element. Optionally, the display module may include a pattern or indicia formed on a window element, which may or may not

comprise a transfective window element, in order to provide the desired pattern or appearance of the display.

[0095] Reflective elements 210' and 210" of FIGS. 8 and 9 may be otherwise substantially similar to the reflective element 210 and other reflective elements described above, such that a detailed discussion of the reflective elements will not be repeated herein. The common or similar elements of the reflective elements are shown in FIGS. 8 and 9 with the same reference numbers as used in FIG. 7 with respect to reflective element 210.

[0096] Optionally, and with reference to FIGS. 10A-C, a mirror reflective element 250, such as an exterior mirror reflective element, includes a glass substrate 252, a transfective mirror reflector 254 and a display element, such as a turn signal indicator 256, at the rear of the substrate 252 and behind the transfective mirror reflector 254. The mirror reflective element may comprise a single glass substrate (such as glass substrate 252 shown in FIG. 10A), or may comprise an electro-optic reflective element assembly or cell, such as an electrochromic reflective element assembly or cell (such as electro-optic reflective element assembly 250' of FIG. 10D, discussed below, which includes a front substrate 252' and a rear substrate 253' with an electro-optic medium 255' disposed therebetween). In the illustrated embodiment, the transfective mirror reflector 254 is disposed at the rear surface of the substrate 252. However, the transfective mirror reflector may be disposed at the front surface of the substrate, without affecting the scope of the present invention. Turn signal indicator 256 is disposed at the rear of the reflective element substrate and transfective reflector and is operable to emit or project light therethrough for viewing by a person viewing the reflective element, and preferably for viewing by a person viewing the reflective element at an angle with respect to the reflective element.

[0097] Turn signal indicator 256 includes a transparent or translucent optical plastic block 258 and a light control film 260. As shown in FIG. 10A, optical plastic block 258 is disposed at the rear of the substrate 252 and at the rear of the transfective mirror reflector 254, with the light control film 260 disposed between optical plastic block 258 and transfective mirror reflector 254. Optical plastic block 258 may comprise a transparent plastic material, such as, for example, an acrylic or polycarbonate or polystyrene material or the like, formed such as by injection molding, casting or the like. Turn signal indicator 256 includes a plurality of illumination sources 262, such as light emitting diodes or the like, located at the rear of optical plastic block 258 and generally at or aligned with a plurality of apertures or passageways or pipeways 259 formed through block 258 and through which light passes without passing through the optical plastic material of the block itself. However, because of

the physical laws of refraction, and because of the angles involved, some of the light generated and emitted by each individual light source or light sources 262 passes through the pipeways and some of the light enters the optical plastic material of the block and exits other points or areas of the block so that the block effectively glows.

[0098] Thus, when the light sources are activated, a person viewing the reflective element will see the five beams of relatively intense light that passes through the pipeways and a less intense but visibly appreciable illumination of the block itself around the light beams. In order to limit or substantially preclude light leaking or passing through the sidewalls of the block so as to be viewable through the reflective element outside of the block shape or footprint (such as an arrow or chevron or the like), the outer walls 258a of the block 258 may be specularly or diffusely reflective or absorbing (such as via a coating or surface finish or the like at the outer walls of the block). Optionally, the rest of the reflective element backing may have an opaque coating or paint or the like (such as an dark or otherwise substantially opaque coating or paint or tape or the like) disposed or applied over the rear of the reflective element except at the display region (the area at which the light control film is disposed).

[0099] Thus, light emitted by the light sources may pass through the pipeways in the block and through the block material itself at the rear of the reflective element, whereby the block provides a continuous shape (such as an arrow or chevron shape or footprint) around the series of illumination sources so as to provide an illuminated shape emanating from the block and through the mirror reflective element. Light control film 260 may comprise any suitable film and may function as microlouvers, so as to preferentially direct light that is received from one angle whereby the light is redirected or controlled to another direction. An example of a suitable light control film or material is disclosed in U.S. Pat. No. 5,481,409 (which is hereby incorporated herein by reference in its entirety), and may comprise a light control film manufactured by the 3M Company of Minn., such as the light control film commercially available under the trade name LCF-P (light control film - polycarbonate). Such a film comprises a thin plastic film enclosing a plurality of closely spaced, light black colored microlouvers. A preferred light control film is approximately 0.75 mm thick or thereabouts, and the angled microlouvers are spaced approximately 0.127 mm apart. The microlouvers may be in various angular positions to provide a particular viewing angle, such as from as narrow as about a 48 degree angle to as wide as about a 90 degree angle. Thus, the light control film controls or directs the light emitted by the illumination sources 262, including the light beams passing through the pipeways in the block as well as the other light emanating from the block material itself, in a desired or appropriate or predetermined angle with respect

to the mirror substrate, and helps assure that the driver of the host vehicle is largely unaware or not bothered by actuation of the through-the-mirror reflector turn signal indicating light sources.

[00100] The likes of 3M Light Control Film comprises a thin plastic film containing closely spaced dark or black or light absorbing microlouvers. When used as described herein, the film simulates a tiny Venetian blind, wherein the microlouvers allow for controlled transmission of the light emitted by the indicator light sources (that are disposed behind the transfective mirror element) along the axis of the microlouvers so that the light is seen by drivers overtaking the host vehicle in a side-lane blind spot area but the line of sight from the driver of the host vehicle to the turn signal indicator's emitted light beam is substantially blocked by the microlouvers. Examples of light directing or regulating filters or baffle assemblies can be found in U.S. Pat. Nos. 4,906,085 and 5,313,335, the entire disclosures of which are hereby incorporated by reference herein.

[00101] Although shown and described as a turn signal indicator, and with the pipeways allowing the light beams to pass through the block at an outward angle and the light control film directing the light at an outward angle away from the vehicle (so as to be principally viewable by a driver of a vehicle approaching or overtaking the subject vehicle while being substantially not viewable or discernible by the driver of the subject vehicle), the display element may comprise other types of indicators or displays or illuminated indicia, such as a blind spot detector system alert or an information display or an approach light or the like. The angle of the pipeways and of the light control film may be selected depending on the particular application of the display element. For example, for a blind spot detector alert, the block and light control film may be constructed and arranged so as to direct light toward the driver of the subject vehicle. Optionally, a display element or display elements at a rearview mirror may have a block and light directing film that direct light at different angles so as to provide two different displays or indicators at the mirror. For example, the block and light directing film may direct illumination from one or more illumination sources or LEDs outward away from the vehicle for a turn signal indicator, and may direct illumination from one or more other illumination sources or LEDs inward or toward the vehicle for a blind spot detector alert, so that two distinct displays or display types are provided at the reflective element of the mirror assembly. The two distinct displays may be provided by a single display element or module or may be provided by separate display elements at the rear of the reflective element.

[00102] As shown in FIGS. 10A and 10C, pipeways 259 are formed with recesses 259a at the rear or back of the block 258 and angled pipeways 259b between the recesses 259a and the front of the block 258. The recesses 259a are configured to receive or partially receive the illumination sources 262, which may be mounted to or established on a printed circuit board 264 or the like disposed at or attached to the optical plastic block 258. Although shown in FIG. 10A as being loosely positioned at or received in the recesses 259a, it is desirable to have the illumination sources or LEDs snugly fit in or contacting, and preferably optically coupled to, the transparent block 258 so that the illumination from the illumination sources is emitted or projected into the block when the illumination sources are activated.

[00103] Optionally, and with reference to FIG. 10D, the mirror reflective element may comprise a transfective electro-optic mirror reflective element 250', which includes a glass front substrate 252', a glass rear substrate 253', and a display element or turn signal indicator 256' at the rear of the rear substrate 253'. The mirror reflective element 250' comprises an electro-optic, such as electrochromic, reflective element assembly or cell with an electro-optic medium 255' (such as electrochromic medium) disposed between the front and rear substrates 252', 253'. Rear substrate 253' includes a transfective mirror reflector 254' disposed at its front surface (the third surface of the reflective element assembly or cell), while front substrate 252' includes a transparent conductor 257' disposed at its rear surface (the second surface of the reflective element assembly or cell). The electro-optic medium 255' is disposed between the substrates and is in contact with the transparent conductor 257' and transfective mirror reflector 254' and contained between the substrates via a perimeter seal 261'. The electro-optic mirror construction may be of an offset construction or a flush or frameless construction or design, such as utilizing aspects of various mirror constructions and designs, such as described herein.

[00104] Turn signal indicator 256' is disposed at the rear of the rear substrate 253' and is operable to emit or project light therethrough for viewing by a person viewing the reflective element, and preferably for viewing by a person viewing the reflective element at an angle with respect to the reflective element, such as in a similar manner as described above. Although shown in FIG. 10D as having a third surface transfective mirror reflector 254', the transfective mirror reflector may be disposed at the rear of the rear substrate 253' (at the fourth surface of the reflective element assembly or cell), with the turn signal indicator 256' disposed at the fourth surface transfective mirror reflector at the rear surface of the rear substrate. As described above, the turn signal indicator 256' includes a transparent or translucent optical plastic block 258', a light control film 260', and a plurality of illumination

sources 262 (preferably LEDs) on a printed circuit board 264. Turn signal indicator 256' may be substantially similar to turn signal indicator 256, described above, such that a detailed discussion of the turn signal indicators need not be repeated herein. The similar elements of the turn signal indicators not specifically addressed above with respect to turn signal indicator 250' are referenced with like numbers in FIGS. 10A and 10D.

[00105] When manufacturing a printed circuit board (PCB), it is least expensive and thus desirable to vertically or axially place the LEDs or chips. However, one could choose to have the LEDs put in and angled relative to the plane of the circuit board. The present invention allows for flat placement of the LEDs on the circuit board or substrate or chip, while still providing an angled direction of light emitted by the LEDs. The LEDs are thus substantially vertically oriented on the circuit board (so light emitted by the LEDs would be substantially vertical), but the emitted light is piped through the hollow tubes or pipeways in the block at or near the desired angle or direction for viewing of the lights by a person viewing the reflective element. Some of the emitted light would also leak into and through the transparent walls of the tubes and block to provide the substantially solid, continuous illumination or glow in the desired or appropriate shape around the illumination sources.

[00106] The angled pipeways 259b through optical plastic block 258, 258' are angled so that light from illumination sources 262 passes through the pipeways at an angle relative to the substrate 252 or substrates 252', 253', such as at an outward angle (such as for a turn signal indicator application) so as to direct or guide the light outward away from the side of the vehicle when the mirror reflective element is mounted at a vehicle, such as at a driver or passenger-side exterior rearview mirror of a vehicle, so as to be generally not viewable or discernible by the driver or occupant of the vehicle. For example, for a turn signal indicator application, the pipeways and/or light control film preferably function to angle the light emitted by the illumination sources outwardly away from the subject vehicle such that a driver of an overtaking vehicle would see the display, but the driver of the subject vehicle would not readily see or discern the display at the mirror reflective element. The pipeways and/or light control film may be constructed and/or arranged so as to be angled outward for a turn signal indicator (such as shown in FIGS. 10A and 10D and described above), but could be otherwise angled inward or downward for other applications (such as for a blind spot detector alert or an approach light or the like) or could have multiple angles, as discussed below.

[00107] Preferably, the optical plastic block 258, 258' is formed to be generally arrow-shaped with illumination sources 262 disposed therealong. As can be seen with reference to FIGS.

10A and 10D, the light control film 260, 260' may function to direct or guide the light generally along the same angle as the angled pipeways 259b (as shown in FIG. 10D), or the light control film may function to direct or guide the light at a different angle than the angle of the angled pipeways 259b (as shown in FIG. 10A), without affecting the scope of the present invention. By providing the angle of transmission of the light control film as a different angle as compared to the angle of the pipeways through the block, more of the light emitted from the illumination sources and passing through and along the pipeways may reflect back off of the light control film and/or transmit through the walls, and/or couple through the walls of the pipeways/tubes and into the block, thereby enhancing the illumination of the block when the illumination sources are activated and effectively creating a substantially solid illuminated block, such as a solid continuous illuminated chevron or arrow shape or indicia or the like, as opposed to a series of five or seven individual separated discontinuous light sources that are chevron shaped but not forming a solid continuous arrow.

[00108] Optionally, the optical plastic block may be formed without any passageways or pipeways or the plastic block may have pipeways extending only partially through the block depending on the desired appearance of the display element at the reflective element. Optionally, the illumination sources or LEDs may be located at different areas at the block, such as at a side of the block (and generally at or aligned with pipeways or at the sidewall of the block), depending on the particular application and desired appearance of the display element at the reflective element.

[00109] Optionally, and with reference to FIG. 10E, 10F and 10G, a mirror reflective element 250", such as an exterior mirror reflective element, includes a glass or optical plastic substrate 252" (such as, for example, a substrate having a thickness of about 2 mm to about 2.5 mm or thereabouts), a transfective mirror reflector 254" (such as an aluminum-doped silicon or an ISI stack, such as an ITO/silver/ITO stack or the like) and a display element, such as a turn signal indicator 256", at the rear of the substrate 252" and behind the transfective mirror reflector 254". Turn signal indicator 256" includes a light transmitting optical plastic block 258" (that may be specularly light transmitting so as to be clear or that may be rendered diffusely light transmitting should diffuse light transmission be desired) and a light control film 260" (such as a light control film as described above). Turn signal indicator 256" includes a plurality of illumination sources 262", such as light emitting diodes or diode lasers or incandescent sources or the like, located at the rear of optical plastic block 258" and generally at or aligned with a plurality of recesses or receiving portions 259" for the light

sources at an outer or rearward surface of block 258". The plurality of illumination sources 262 (preferably LEDs) may be established on a printed circuit board 264" or may be on a flexible polymeric substrate, such as an extruded plastic flat flexible cable with TPU, PVC or PBT insulation and flat copper connectors (such as is available from 3M Corporation of Minneapolis, MN as FFCe harnesses).

[00110] As shown in FIG. 10E, optical plastic block 258" is disposed at the rear of the substrate 252" and at the rear of the transfective mirror reflector 254", with the light control film 260" disposed between optical plastic block 258" and transfective mirror reflector 254". As also shown in FIG. 10E, turn signal indicator 256" may include a light absorbing wall or coating or material 257" established at and around block 258" to limit or substantially preclude light from passing through the sidewalls of block 258" to other areas of or at the rear of the reflective element. The light absorbing wall or coating or material 257" may comprise any suitable light absorbing material or layer or element, such as a dark or opaque wall or coating established around the block 258", such as a dark plastic or a black or dark-colored paint, or it may be a light reflecting but substantially non-light transmitting material or layer so that any stray light incident on such walls is reflected back into the body of block 258". The turn signal indicator 256" may be purchased by the mirror element sub-assembly manufacturer (such as from a low cost manufacturer such as in the Far East) and provided as a modular unit having the block and light control film within a light absorbing element/structure and with the printed circuit board and illumination sources at the rear surface of the block, and with any connectors/covers, etc., so that all the mirror element sub-assembly manufacturer need do is attach (either mechanically or adhesively, preferably with optical coupling) the bought-in or separately purchased/supplied module to the rear of the mirror element. One option is to use the likes of a PVB (polyvinyl butyral) laminating clear light transmitting film or a silicone laminating film or the like and to use the likes of an autoclave or a vacuum lamination technique (such as is described in U.S. provisional applications, Ser. No. 60/732,245, filed Nov. 1, 2005 (Attorney Docket DON01 P-1251); and Ser. No. 60/759,992, filed Jan. 18, 2006 (Attorney Docket DON01 P-1264), which are hereby incorporated herein by reference in their entireties) to optically attach the turn signal indicator module at the rear of the mirror element. Optionally, a light absorbing coating or material or opacifying material or coating may be established over the rear surface of the reflective element at locations other than where the turn signal indicator is located to limit or substantially preclude light transmission through the reflective element at regions surrounding the turn signal indicator. In such an application, an opacifying layer or element

may be disposed at the rear of the reflective element and may have an opening or aperture or window established at the desired or appropriate location for the turn signal indicator to be located.

[00111] As shown in FIG. 10G, optical plastic block 258" is generally wedge-shaped or angled at its outer or rearward surface (the surface opposite from the rear of the reflective element and that has the recesses or receiving portions 259" for receiving the illumination sources 262" therein), so that the principal light axis from the illumination sources is directed at an angle relative to the rear surface of the reflective element. For example, the block may preferably be formed with its rear surface (at which the light sources mount) at an angle of about 2 degrees to about 12 degrees or thereabouts (more preferably, at an angle of about 3 degrees to about 8 degrees or thereabouts and most preferably at an angle of about 3.5 degrees to about 5.5 degrees or thereabouts) relative to the front surface of the block (and hence to the rear surface of the mirror element to which the block engages/attaches). Note also that the front surface of the block may be convex contoured to generally match the local (concave) contour of the rear of the mirror element if it is a bent (such as a convex or an aspheric) exterior mirror element. Thus, when the reflective element is mounted at a vehicle as part of an exterior mirror assembly and is adjusted by a typical driver for rearward viewing at the side of the vehicle, the principal light axis of the illumination sources is directed away from the driver and principally into the overtaking area or adjacent lane or blind spot area so as to be readily viewable by a driver of an overtaking vehicle. Note that the angle for the rear surface of block 258" may generally match the light control angle of light control film 260", or may be somewhat different so that light control film 260" somewhat masks the presence of the individual light sources from view by an observer (whether lit or not lit). Note also that a heater pad (not shown) may be present and may have a chevron or other shaped cut out (or alternatively, a light transmitting, optionally light diffuser) portion that matches and juxtaposes where optical plastic block 258" is positioned to the rear of the reflective element.

[00112] Optionally, and with reference to FIG. 10H, the mirror reflective element may comprise transfective electro-optic mirror reflective element 250"', which includes a glass front substrate 252"', a glass rear substrate 253"', and a display element or turn signal indicator 256"' at the rear of the rear substrate 253 "'. The mirror reflective element 250"' comprises an electro-optic, such as electrochromic, reflective element assembly or cell with an electro-optic medium 255"' (such as electrochromic medium) disposed between the front and rear substrates 252"', 253 "'. Rear substrate 253"' includes a transfective mirror reflector 254"' (such as a thin transfective silver or silver-alloy or aluminum or aluminum-alloy or

metal oxide/metal/metal oxide transfective coating stacks such as ITO/Ag/ITO or AZO/Ag/AZO) disposed at its front, inner-facing surface (the third surface of the reflective element assembly or cell), while front substrate 252^{''} includes a transparent conductor 257^{''} (such as ITO or AZO or doped tin oxide) disposed at its rear surface (the second surface of the reflective element assembly or cell). The electro-optic medium 255^{''} is disposed between the substrates and is in contact with the transparent conductor 257^{''} and transfective mirror reflector 254^{''} and contained between the substrates via a perimeter seal 261^{''}. The electro-optic mirror construction may be of an offset construction or a flush or frameless construction or design, such as utilizing aspects of various mirror constructions and designs, such as described herein. The mirror reflective element may include a heater pad disposed at its rear surface, and the heater pad may have an aperture or window or hole established at the display area for the turn signal indicator to project or emit light therethrough.

[00113] As shown in FIG. 10H, turn signal indicator 256^{''} includes an optical plastic block 258^{''}, light control film 260^{''}, a plurality of illumination sources 262^{''} and a printed circuit board 264^{''}, such as in a similar manner as described above. Mirror reflective element 250^{''} includes a molded backplate 270^{''} attached or adhered to the rear surface of rear substrate 253^{''} with actuator mounting elements 270a^{''} for mounting the mirror reflective element to a mirror actuator of the exterior mirror assembly, such as in a known manner. Backplate 270^{''} includes a receiving pocket 270b^{''} molded or formed at a desired or appropriate location at the backplate for receiving the turn signal indicator 256^{''} therein. As can be seen in FIG. 10H, the light control film 260^{''} and optical block 258^{''} may be received within pocket 270b^{''} with illumination sources 262^{''} and printed circuit board 264^{''} established at the outer or rearward surface of block 258^{''}. Preferably, the turn signal indicator 256^{''} may be provided as a modular unit (including the block, light control film, illumination sources and printed circuit board assembled together into a unitary module) and inserted into or received in the pocket 270b^{''} at the rear of the mirror reflective element (and held therein, such as mechanically or adhesively). However, rather than being provided as a preassembled module, the block, light control film and illumination sources (preferably LEDs) on the printed circuit board may be provided individually and assembled to the mirror reflector individually. Optionally, the mirror reflective element may include a diffuser or diffusing window or layer and/or the block itself may be diffusing or slightly diffusing of the light passing therethrough.

[00114] The backplate 270^{''} thus has a pocket 270b^{''} surrounding an aperture formed through the backplate and receiving the turn signal indicator 256^{''} therein. The aperture and pocket

thus may be arrow-shaped or chevron-shaped and may receive a correspondingly shaped or formed turn signal indicator. The pocket 270b''' is defined by walls extending rearward or outward from the backplate to substantially encase or surround the optical block 258''' when inserted into the pocket 270b'''.

[00115] Thus, the backplate may be attached or adhered to the rear surface of the reflective element and the turn signal indicator may be inserted into or slid into the pocket. The turn signal indicator desirably may be provided as a modular unit (including the block, light control film, printed circuit board and illumination sources) that is readily inserted into the pocket and electrically connected to electrical circuitry of the reflective element and/or mirror assembly. The turn signal indicator module thus may be purchased and provided as a separate modular unit that is readily installed or attached at the rear of the reflective element, such as at the mirror manufacturer's assembly facility or plant.

[00116] Optionally, the light control film may be diffusing or partially diffusing, or the turn signal indicator may include a separate diffuser or the block itself may comprise a diffusing material. Optionally, a diffuser is not included, and optionally, the turn signal indicator may not include the light control film. The turn signal indicator may be mechanically attached or secured at the pocket and may include or provide optical coupling of the block and/or light control film with the rear surface of the reflective element, such as via an optical adhesive or the like. Optionally, the individual elements of the turn signal indicator may be inserted into or established in the pocket to assemble the turn signal indicator in the pocket.

[00117] Optical plastic blocks 258'', 258''' may be otherwise substantially similar to blocks 258, 258', described above, such that a detailed description of the optical blocks need not be repeated herein. Similar to optical plastic block 258, described above, optical plastic blocks 258'', 258''' may comprise a transparent plastic material, such as, for example, an acrylic or polycarbonate or polystyrene material or the like, formed such as by injection molding, casting or the like. Also, and similar to the optical blocks described above, optical block 258'', 258''' may be generally arrow-shaped to provide a substantially solid illuminated arrow at the reflective element when the illumination sources are activated. As can be seen in FIGS. 10E, 10G and 10H, blocks 258'', 258''' may be wedge-shaped, and may have narrower or thinner outer leg portions as compared to a thicker center or arrow head portion. Optionally, and as can be seen in FIGS. 10E, 10G and 10H, the illumination sources may be located at recesses 259'', 259''', without pipeways formed through the block as described above. The block may be substantially transparent and may diffuse the light passing therethrough.

[00118] Note that one advantage of the embodiments above is that light sources such as LEDs can be axially mounted onto PCBs and any angling of their orientation to the rear of the reflective element is via the angling of the rear surface of the optical block. This facilitates economy of manufacture as the PCB manufacturer may use automatic chip placement machines to axially (i.e. generally perpendicular to the surface of the PCB substrate) insert the likes of surface-mount LEDs (and without the need to insert at an angle or to angle the LEDs in a post-insertion operation). Also, though illustrated as a turn signal indicator, the advantages of the above embodiments may also be achieved with a blind spot detection system indicator (and where the angling of the rear surface of the optical block and of the light control film is towards the driver/cabin of the host vehicle when the reflective element is mounted in the exterior mirror assembly of the host vehicle). Also, a combined turn signal/blind spot indicator may be formed with portions of the optical block (and of the optical control film, if present) angled away from the cabin of the host vehicle for the turn signal function and towards the cabin of the host vehicle for the blind spot detection indicator function. Also, such angling of the rear surface of the optical block is also applicable should light transmitting channels or tubes be created at least partially through the block, such as shown in FIGS. 10A, 10C and 10D (and note that should such channels or tubes be present, the rest of the block may be formed of a light absorbing material, such as of a dark-pigmented polymeric material or of a light diffusing material).

[00119] Also, note that optionally, the optical control film may be disposed at the rear surface of the optical block (rather than disposed between the block 258, 258', 258" or 258''' and the rear surface of the mirror reflective element such as shown in FIGS. 10A, 10D, 10E and 10H), while remaining within the spirit and scope of the indicator of the present invention. For example, and as shown in FIG. 10I, the turn signal indicator 256''' includes an optical plastic block 258''', with a light control film 260''' established (such as via adhering or otherwise attaching) at its rear surface, and with a plurality of illumination sources 262''' and a printed circuit board 264''' at the rear of the block and film. Optionally, and desirably, the indicator 256''' includes an opaque wall or tape or material 257''' at and around the optical block 258''', such as described above. As can be seen in FIG. 10I, the light control film 260''' has its micro louvers 260a''' at about zero degrees (i.e., generally perpendicular to the plane of the light control film) so as to direct the principle beam axis 261''' of the light emitted by the illumination sources at the desired or appropriate angle established by the angling of the rear surface of the block relative to its front surface and so have the light beam emitted by the light sources pass through the block 258''' and through the substrate 252''' of

the reflective element 250"" to exit at an angle. Because the light control film 260"" is established at the rear surface of the block 258"" , the block may not include recesses to receive the light sources, but optionally, the light control film may be laminated (at an angle) between a lower block portion (that has an angled rear face) and an upper block portion, and with such recesses provided in the upper block portion. The block can optionally include light transmitting pipeways therethrough (such as pipeways described above with respect to blocks 258, 258', 258", 258"").

[00120] As shown in FIG. 10I, the rear surface of the block may be angled relative to the forward surface of the block at the rear of the reflective element, and may be substantially flat or planar, with the light control film established thereat, and with the illumination sources and printed circuit board located at the rear of the light control film so as to direct or emit illumination through the light control film and through the transparent block and further through the transfective reflective element at an angle set by the slanted rear face of the block. The angle of the rear surface of the block and the angle of the micro louvers thus may be selected to provide the desired angle of the principle beam axis of the light emitted by the indicator. However, and as shown in FIG 10I, it is desirable in such a configuration to use light control film with zero degree louvers. Turn signal indicator 256"" may be otherwise substantially similar to the turn signal indicators 256, 256', 256", 256"" described above, such that a detailed discussion of the turn signal indicators need not be repeated herein. Although shown in FIG. 10I as being established at a rear of a substrate 252"" of a non-electro-optic transfective reflective element, the indicator 256"" (with the light control film established at the rear of the optical block) may be implemented at the rear of an electro-optic reflective element, such as described above with respect to indicators 256' and 256"", and the indicator may be received or inserted into a pocket at a backplate or the like of the reflective element).

[00121] Placement of the light control film on the angled rear surface of the optical block is advantageous when the light control film (such as 3M's Vikuiti™ ALCF-P or LCF-P) is used where the louver angle is zero degrees and where on-axis vertically incident light from the light sources is highly transmitted but where off-axis light is cut-off by the embedded micro louvers. Such zero degree louvered light control film is used for privacy filters for laptop computer screens and ATM screens, and so is economically available. By being able to purchase and use zero angle louvered light control film as shown in FIG. 10I, but by using the likes of an angled optical block to support the light control film at an angle in front of the light sources that are similarly angled and supported, economical assembly can be enhanced [or, alternatively, by using a mechanical support to mutually support and angle the light

control film/light sources relative to the plane of the rear of the mirror reflective element, so that light emitted by the light sources is generally aligned with or on-axis with the light transmission axis between the louvers, and so that the light beam passed through the light control film impinges on the mirror reflective element and passes therethrough with its principal beam axis directed away (for a turn signal indicator) from the vehicle body side and away from direct view by a driver of the host vehicle to which the exterior mirror reflective element is attached].

[00122] Economy of assembly and supply can be achieved by utilizing the embodiment such as shown in FIG. 10H. The combination of a mirror backplate that is adapted to receive a turn signal indicator module (or a blind spot indicator module or an approach light module) in combination with a transflective mirror reflective element can optimize the cost for the mirror assembly supplier as follows. The mirror assembly supplier (which may be the Tier 1 supplier to the automaker) can make or procure the transflective mirror element. Separately, the mirror assembly supplier can make or procure the mirror backplate. Separately, the mirror assembly supplier can make or procure the turn signal module (or its sub-components). Then, the mirror assembly supplier (or a sub-assembly supplier thereto) can take the transflective mirror element and attach a heater pad to its rear (with an aperture or a light transmitting window, preferably a light diffuser and transmitter, created therein that matches, for example, the chevron shape and dimensions of the turn signal indicator module that will be used). Then the backplate (that is modified to receive the turn signal module such as is shown in FIG. 10H) can be attached (such as via a tape adhesive or the like). Then the turn signal indicator module may be inserted into the pocket at the backplate, and any cap or cover may be attached and the assembly of the mirror element with indicator feature is achieved.

[00123] There are several benefits to using a transflective mirror reflector for such a through-the-mirror-reflective element turn signal feature (or other indication or lighting feature). Currently, the likes of a General Motors GMT 800 driver-side exterior mirror assembly is equipped with an electrochromic mirror element that has a signal light area formed in its reflective coating by removing a portion of the reflective coating and aligning the signal light with this signal light area. The portion removed is laser ablated to leave lines devoid of reflective material separated by lines of the reflective material in a non-transflective mirror reflector that is deposited onto the third surface of the electrochromic mirror element used (such as is disclosed in U.S. Pat. No. 6,111,683, the entire disclosure of which is hereby incorporated by reference herein).

[00124] The embodiment illustrated in FIG. 10H and disclosed herein has several advantages and improvement over these existing through-the-mirror-reflective element turn signal electrochromic mirrors. For example, use of a third surface transflective mirror reflector instead of a third surface mirror reflector where holes/apertures/jail-bar lines/ablations/micro-ablations or the like are created has the benefit that there are no consumer viewable openings such as holes/apertures/jail-bar lines/ablations/micro-ablations present in the mirror reflector's coating(s). Thus, should the automaker or consumer elect not to use the turn signal feature, the turn signal module may be left out but the common backplate [where the receiving structure for the turn signal module/components can be economically created during the injection molding of the backplate from a polymeric resin (such as ABS or PC/ABS or the like)] and heater pad may still be used. This is because with a transflective reflector, there are no visible holes or ablations or lines of the like visible to the consumer that betray that there is now no turn signal indicator present. Thus, use of a third surface transflective mirror reflector in such an electrochromic through-the-mirror-reflective element turn signal feature allows the Tier 1 mirror maker and/or the automaker elect to supply a base or turn-signal featured electrochromic mirror assembly using a common assembly process.

[00125] As a further advantage, use of a third surface transflective mirror reflector has the advantage that there is no need to align the light sources (such as the 5 or 7 LEDs in a turn signal chevron) of the turn signal unit/module with holes or apertures in the mirror reflector. And by having the receiving structure/elements for the turn signal module be molded into the plastic backplate itself, the turn signal alignment and positioning to the rear of the mirror element is accurately established in the precise attachment of the backplate to the rear of the mirror element (an operation that the mirror element sub-assembly maker has to do in any event so that the mirror sub-assembly correctly receives the mirror element-positioning actuator).

[00126] Thus, and in accordance with embodiments above, a transparent or substantially transparent optical plastic block may be formed in the general shape of an arrow so that the arrow is viewable and discernible by a person viewing the reflective element. The light emitted through the pipeways in the block and through the light control film may be viewed (such as at or near the angle of the directed or guided light) as relatively intense points of light or light sources when the illumination sources are activated, while the transparent block (preferably in the shape of an arrow or other suitable shape or form) will be viewable as a solid shape (such as an arrow shape or the like) around the light sources to provide an image of the arrow and not just the individual points of light. When the illumination sources are

activated, light emitted by the illumination sources is guided through and along the angled pipeways through the block and may be refracted or guided or controlled by light control film so as to be directed in a desired direction, such as outwardly away from the vehicle. Thus, the illumination sources and the illuminated block are readily viewable by a driver of another vehicle adjacent or approaching the subject vehicle, while the illumination is not readily viewable or discernible by the driver of the subject vehicle.

[00127] The transflective mirror reflector (such as at the rear of the single substrate or at the front surface of the rear substrate of the electro-optic reflective element assembly or cell) may comprise any suitable transflective mirror reflector or coating or layer or layers, such as those described herein. For example, and in a preferred embodiment, the transflective mirror reflector may comprise a silicon material or a doped silicon material or the like, preferably having a refractive index (as measured at the sodium D line) of at least about 3 or thereabouts. For example, good results have been achieved by sputtering from a silicon-aluminum sputtering target (e.g. 95% / 5% Si:Al) or the like. In such an embodiment, a sputter coating of a physical thickness (sputtered in an argon atmosphere) of about 200 to 300 angstroms or thereabouts exhibits a first surface reflectivity of about 60-65 %R photopic reflectivity (as measured per SAE J964a), and a second surface reflectivity of about 50-55 %R, and a photopic transmission of around 18 to 20 %T or thereabouts. The coating may be deposited or disposed on a flat or substantially flat substrate (and optionally, subsequently bent in a glass bender thereafter), or may be deposited or disposed on a curved substrate, such as a curved substrate of the type shown in FIG. 14 and discussed below. Other transflective mirror reflectors may be implemented depending on the particular application. Optionally, the substrate may include a reflective perimeter band around its perimeter, such as described below with respect to FIG. 14, so that a single substrate mirror reflective element may be used at an opposite side of the vehicle (such as the passenger-side of the vehicle) in conjunction with an electro-optic reflective element assembly implemented at the other side of the vehicle (such as the driver-side of the vehicle) that may include such a perimeter reflective band to provide a frameless reflective element, such as described herein.

[00128] Optionally, and particularly for exterior mirror applications, the reflective element may include a broader perimeter band at the area or region where a display element is located. For example, and with reference to FIG. 11, an exterior mirror reflective element 310 may include a perimeter band 326 around the perimeter or border of the reflective element. The perimeter band 326 has a broader band portion 326a along a perimeter portion of the reflective element 310 and along an area that has one or more display elements 330.

The display elements 330 may comprise illumination sources or light sources, such as light emitting diodes (LEDs) or the like, and may be positioned behind the rear surface of the reflective element and directed to emit illumination through the reflective element and through the broader band portion 326a of perimeter band 326. The broader band portion 326a may have one or more windows or ports 327a formed or established through the band portion and generally at or aligned with the display elements 330, or the perimeter border band 326 (or at least the broader band portion 326a of perimeter band 326) may be passively transfective (such as a band formed or established by a layer of a silicon material or the like) to allow light from the display element or elements 330 to pass through the reflective element and the perimeter band (optionally, the perimeter band may have a higher transmissivity characteristic than the electro-optic area of the reflective element to enhance viewability and discernibility of the light emitted by the display elements) so as to be viewable by a person viewing the reflective element. For example, and such as is described in U.S. Pat. No. 6,065,840, which is hereby incorporated herein by reference in its entirety, a sputtered silicon thin film (with a physical thickness in a range of about 300 angstroms to about 450 angstroms) can have a photopic reflectivity greater than at least about 50 percent, and more preferably greater than at least about 55 percent of light incident thereon, and having a transmission value greater than at least about 15 percent, and more preferably greater than at least about 20 percent of light incident thereon.

[00129] Optionally, the reflective element 310 may include a photo sensor 340 for sensing light at the reflective element. In the illustrated embodiment, the photo sensor 340 is located at and behind the perimeter band 326, and at a broader region 326b of perimeter band 326. The photo sensor 340 may be directed or angled or oriented so as to be facing generally upward or skyward to detect light above the reflective element. The perimeter band portion 326b may have a window or port 327b formed therethrough to allow light to pass through the perimeter band portion 326b to the photo sensor 340.

[00130] The reflective element 310 may comprises a transfective or display on demand type of reflective element with a perimeter seal around the perimeter of the reflective element and, thus, around the perimeter of the electro-optic area of the mirror reflective element. The perimeter band may be disposed (such as on the second surface of the front substrate as described above) around the perimeter of the substrate so as to conceal the perimeter seal (such as described in PCT Application No. PCT/US03/29776, filed Sep. 19, 2003 by Donnelly Corp. et al. for ELECTROCHROMIC MIRROR ASSEMBLY (Attorney Docket DON01 FP-1109(PCT))); and/or PCT Application No. PCT/US03/35381, filed Nov. 5, 2003

by Donnelly Corp. et al. for ELECTRO-OPTIC REFLECTIVE ELEMENT ASSEMBLY (Attorney Docket DON01 FP-1116(PCT)); and/or U.S. pat. applications, Ser. No. 11/021,065, filed Dec. 23, 2004 by McCabe et al. for ELECTRO-OPTIC MIRROR CELL (Attorney Docket DON01 P-1193); Ser. No. 10/528,269, filed Mar. 17, 2005 (Attorney Docket DON01 P-1109); Ser. No. 10/533,762, filed May 4, 2005 (Attorney Docket DON01 P-1116); Ser. No. 11/226,628, filed Sep. 14, 2005 (Attorney Docket DON01 P-1236); and/or Ser. No. 11/021,065, filed Dec. 23, 2004 by McCabe et al. for ELECTRO-OPTIC MIRROR CELL (Attorney Docket DON01 P-1193); and/or U.S. provisional applications, Ser. No. 60/692,113, filed Jun. 20, 2005 (Attorney Docket DON01 P-1224); Ser. No. 60/677,990, filed May 5, 2005 (Attorney Docket DON01 P-1219); Ser. No. 60/653,787, filed Feb. 17, 2005 (Attorney Docket DON01 P-1207); Ser. No. 60/642,227, filed Jan. 7, 2005 (Attorney Docket DON01 P-1199); Ser. No. 60/638,250, filed Dec. 21, 2004 (Attorney Docket DON01 P-1198); Ser. No. 60/624,091, filed Nov. 1, 2004 (Attorney Docket DON01 P-1184), and Ser. No. 60/609,642, filed Sep. 14, 2004 (Attorney Docket DON01 P-1171), which are hereby incorporated herein by reference in their entireties. The display elements 330 and/or photo sensor 340 may be positioned outboard of the perimeter seal so that they are not located in the electro-optic area of the reflective element. Because the display elements and/or photo sensor are positioned at the perimeter band area, they are not invasive of the electro-optic function of the reflective element. Thus, the display elements may be positioned at the reflective element for emitting illumination through the reflective element, without the extra complexities of the electro-optic or electrochromic transreflective function. Also, the photo sensor may be positioned at the reflective element for receiving light external to the reflective element, without having to form a window or aperture in the reflective coatings of the transreflective reflective element.

[00131] Optionally, and with reference to FIGS. 12 and 13, a mirror reflective element 310' may include a wide angle or auxiliary mirror or reflector 350 at a perimeter region or corner region of the reflective element to provide a rearward wide angle view to the driver of the vehicle. The wide angle reflector may be established at the reflective element and behind the fourth surface of the reflective element, such as by utilizing aspects of the reflective elements described in U.S. Pat. No. 6,315,419 and/or U.S. pat. publications, Pub. No. US 2002/0105741, published Aug. 8, 2002; and/or US 2003/0117731, published Jun. 26, 2003; and/or International Pub. No. WO 01/81956, published Nov. 1, 2001, which are all hereby incorporated herein by reference in their entireties. The wide angle reflector may be positioned at a perimeter region of the reflective element so as to provide a wide angle

viewing area for viewing the blind spot area at the side and rearward of the vehicle, while the primary or central region of the reflective element provides a generally planar reflective surface for viewing rearward and sideward of the vehicle mirror.

[00132] The reflective element 310' includes a perimeter band 326' around the perimeter of the reflective element and a perimeter band portion 326a' inboard of a wide angle area or region 352 at the reflective element and around an inboard perimeter region of the wide angle reflector 350. The perimeter band thus separates and/or demarcates the wide angle reflective portion from the generally planar reflective portion of the reflective element, and may conceal or hide the edges of the wide angle reflector. As can be seen with reference to FIG. 13, the perimeter band 326' is disposed on the second surface 312a of the front substrate 312 and generally at or along the perimeter seal 322 of the reflective element 310', while the perimeter band portion 326a' is disposed on the second surface 312a and inboard of the seal 322 to generally outline/demarcate an inner perimeter of the wide angle reflector 350. The perimeter band portion 326a' may have generally the same width as the perimeter band 326', or may have a reduced width or narrow width to reduce the effect on the viewing area of the reflective element.

[00133] Wide angle reflector 350 is positioned at the rear (or fourth) surface 314b of rear substrate 314 and may be adhered to rear surface 314b and generally behind the wide angle area 352 defined by the perimeter band 326' and perimeter band portion 326a'. In the illustrated embodiment, wide angle reflector 350 comprises a substantially clear, transparent optical plastic member 354 (such as, for example, an acrylic or polycarbonate or COC or CR39 or the like) and a reflective coating or layer or adhesive or film 356. Optical plastic member 354 has a substantially flat mating surface 354a and a curved face 354b opposite to the mating face 354a. Reflective film 356 may be adhered or otherwise attached to curved face 354b so as to establish a curved reflective surface 356a. Wide angle reflector 350 may be adhered to or otherwise attached to rear surface 314b of rear substrate 314, such as via an optical adhesive 358, such as an optical epoxy or acrylic material. The optical adhesive may be substantially optically matched to the reflective element substrates, so that the refractive index of the optical adhesive is substantially similar to the refractive index of the glass substrate (such as at about 1.52 refractive index), such as by utilizing aspects of the reflective element described in U.S. pat. application, Ser. No. 10/993,302, filed Nov. 19, 2004 (Attorney Docket DON01 P-1186), which is hereby incorporated herein by reference in its entirety.

[00134] Thus, the wide angle reflector may be positioned at the rear surface of the reflective element and may reflect light from a wide angle view to the driver of the vehicle to assist the driver in viewing the blind spot area at the side of the vehicle. The reflective element may comprise an electro-optic reflective element with a transparent conductive coating or layer 318 at the rear surface 312a of the front substrate 312 and a third surface reflective coating or layer (or layers) 320b at the front surface 314a of the rear substrate 314, and with an electro-optic or electrochromic medium 316 disposed therebetween. As can be seen in FIG. 13, the third surface reflective coating or layer 320b (such as a layer of chromium or ruthenium or rhodium or ruthenium/chromium or rhodium/chromium or other suitable layer or coating) may be removed or not established at the wide angle reflector area, and a transparent conductive coating or layer 320a may be disposed over the third surface, including the wide angle reflector area, so that the electro-optic feature may function in that area. A window or port or non-reflective region 321 thus may be formed in the third surface reflector (so as to provide a window or area that is substantially devoid of the reflective coating or coatings) to enhance the light transmissivity therethrough (such as by ablating or masking the area to remove or not establish the reflective coating or coatings at the wide angle reflector area). The front surface of the rear substrate thus may have the transparent conductive coating 320a over its entire surface, with the wide angle reflector area being masked during the deposition or coating of the third surface reflective coating or coatings so that the reflective coatings are not deposited or established at the wide angle viewing area (or the reflective coatings may be removed or ablated after the coating process). The wide angle reflector thus may be disposed behind the electro-optic medium so as to provide the wide angle reflective field of view through the electro-optic medium.

[00135] Optionally, the perimeter seal may be disposed around the perimeter of the reflective element and along the wide angle perimeter band portion 326a' so that the wide angle area 352 is devoid of the electro-optic medium (and may be devoid of the third surface reflector layers or coatings in that area as well) to enhance light transmissivity through the reflective element in the wide angle viewing area. In such an application, the transparent conductive coating may also be removed from the wide angle reflector area, such that the coatings or layers in that area may be readily removed or not established, such as by laser ablating or masking or the like.

[00136] Optionally, the perimeter band (and/or any indicia or display elements or the like as described above) may be established at a rear surface of a curved or bent substrate, such as for a passenger-side exterior mirror of a vehicle. For example, and with reference to FIG. 14,

a curved reflective element 410 includes a bent or curved substrate 412 (such as a convex or aspheric substrate) and a reflective coating or layer 418 disposed or established at the rear surface 412a of substrate 412. A perimeter border or band 426 (such as chromium or other suitable material) may be disposed around the perimeter region of the reflective element, such as directly on the rear surface of the substrate 412 (as shown in FIG. 14) or over the reflective coating at the perimeter region (so that the reflective coating is between the perimeter band and the rear surface of the substrate), such as described above.

[00137] The reflective coating or layer may comprise a metallic reflective material or may comprise transfective materials, such as a silicon or indium/silver material or an interference stack, such as an SiO₂/TiO₂/SiO₂ stack of layers or the like (such as by utilizing aspects of the reflective elements described in PCT Application No. PCT/US03/29776, filed Sep. 9, 2003 by Donnelly Corp. et al. for MIRROR REFLECTIVE ELEMENT ASSEMBLY (Attorney Docket DON01 FP-1109(PCT)); and/or PCT Application No. PCT/US03/35381, filed Nov. 5, 2003 by Donnelly Corp. et al. for ELECTRO-OPTIC REFLECTIVE ELEMENT ASSEMBLY (Attorney Docket DON01 FP-1116(PCT)); and/or U.S. pat. applications, Ser. No. 11/021,065, filed Dec. 23, 2004 by McCabe et al. for ELECTRO-OPTIC MIRROR CELL (Attorney Docket DON01 P-1193); Ser. No. 10/528,269, filed Mar. 17, 2005 (Attorney Docket DON01 P-1109); Ser. No. 10/533,762, filed May 4, 2005 (Attorney Docket DON01 P-1116); Ser. No. 10/993,302, filed Nov. 19, 2004 (Attorney Docket DON01 P-1186), which are hereby incorporated herein by reference in their entireties). As shown in FIG. 13, a protective coating 438 (such as a lacquer or paint, which may be substantially transparent if the reflective element is a transfective reflective element) may be disposed over the reflective coating 418 to protect the reflective coating.

[00138] Typically, it is desired that the appearance of the mirror reflective elements of the exterior rearview mirrors of a vehicle match or substantially match between the driver-side and passenger-side rearview mirrors of a vehicle, so that, for example, for a vehicle with a driver-side electro-optic reflective element and a passenger-side non-electro-optic reflective element, the bleached (or non-colored or non-darkened) appearance of the driver-side mirror reflector matches or substantially matches the appearance of the non-electro-optic passenger-side mirror reflector. A person viewing the vehicle, such as in a vehicle showroom or at a parking lot or the like, or while the vehicle is being driven along a road, thus may view and discern that that the mirror reflector at the driver-side mirror matches or substantially matches the mirror reflector at the passenger-side mirror.

[00139] When both the driver and passenger-side rearview mirrors are selected to have the same type of reflective element (such as a frameless electro-optic reflective element using a border, non-dimming metallic reflective band, such as, for example, a frameless electrochromic reflective element as described above), such symmetry of appearance is readily achieved. However, it is not unusual, for economy purposes, to provide an electro-optic reflective element at the driver-side exterior rearview mirror and a non-electro-optic reflective mirror at the passenger-side exterior rearview mirror. When an electro-optic driver-side exterior rearview mirror is implemented on a vehicle with a non-electro-optic passenger-side exterior rearview mirror (as is often selected to reduce costs associated with the mirror assemblies of the vehicle), it is still typically desired that the reflective elements of the side rearview mirrors substantially or fully match in appearance to provide a similar appearance or style at the mirror at both sides of the vehicle, such as for aesthetic purposes. Thus, it is desired that the appearance of the non-electro-optic reflective element of the passenger-side rearview mirror substantially or fully match the appearance of the electro-optic reflective element of the driver-side rearview mirror, such as when the electro-optic reflective element is in its bleached or non-powered or non-darkened state (such as during high ambient lighting or daytime lighting conditions).

[00140] The perimeter band material thus may be selected to substantially match the appearances between the driver-side exterior mirror (which may comprise an electrochromic mirror with a perimeter band around the perimeter to conceal the perimeter seal of the reflective element) and the passenger-side exterior mirror (which may comprise a non-electrochromic mirror), so that both mirrors provide a similar appearance to the perimeter band and reflective element. For applications where the perimeter band material of the electrochromic or driver-side mirror is selected to be the same as the third surface reflector material, the optical match (as viewed by a person viewing the reflective element) between the perimeter band and the third surface reflector is sufficient so that the perimeter band is not readily discernible at the mirror reflector. Thus, in such applications, it may not be necessary to provide a perimeter band on the corresponding conventional (such as chrome or titanium or "Blue" coated), non-EC passenger-side exterior mirror reflective element.

[00141] However, even in such applications, the perimeter band at the driver-side mirror may be discernible to a person viewing the exterior mirror, even when the perimeter band is substantially optically matched with the central reflector region of the reflective element. Thus, in order to at least substantially match the passenger-side non-electro-optic reflective element with the electro-optic reflective element at the driver-side mirror, a perimeter band or

coating (for example, a layer of chromium or of rhodium or of rhodium/chromium) may be disposed around the perimeter edge or region of the non-electro-optic reflective element, such as a curved single substrate reflective element or the like. Thus, when one exterior side rearview mirror has an electro-optic reflective element (as is typically located at the driver-side of the vehicle) and the other exterior side rearview mirror has a curved reflective element or non-electro-optic reflective element (as may be provided at the passenger-side of the vehicle), a matching perimeter band may be disposed around the non-electro-optic reflective element so that the perimeter band of the passenger-side mirror matches or substantially matches the perimeter band of the driver-side mirror (such as by utilizing aspects described in U.S. patent application Ser. No. 11/226,628, filed Sep. 14, 2005 (Attorney Docket DON01 P-1236), which is hereby incorporated herein by reference in its entirety).

[00142] Such a matching appearance of the non-electro-optic reflective element with the frameless electro-optic reflective element (with perimeter band as described above) may be achieved via various processes. For example (and such as described above and shown in FIG. 14), a perimeter reflective border may comprise a first metallic reflective layer (such as a metallic border or band, such as a ruthenium metal or the like) and may be disposed around the perimeter region of the second surface of the curved glass substrate (such as by sputter deposition or the like of the border material over the second surface of the substrate while the central region or primary viewing area of the second surface of the substrate is masked). A reflective layer or coating of a second metal reflector material (such as chromium or the like) may be disposed over the second surface and over the perimeter border or band to provide the central reflective region with a reflective perimeter border or band for a frameless non-electro-optic reflective element (such as by utilizing aspects described in U.S. patent applications, Ser. No. 11/226,628, filed Sep. 14, 2005 (Attorney Docket DON01 P-1236); Ser. No. 10/533,762, filed May 4, 2005 (Attorney Docket DON01 P-1116); and/or Ser. No. 11/021,065, filed Dec. 23, 2004 (Attorney Docket DON01 P-1193), and/or U.S. provisional applications, Ser. No. 60/681,250, filed May 16, 2005 (Attorney Docket DON01 P-1221); Ser. No. 60/690,400, filed Jun. 14, 2005 (Attorney Docket DON01 P-1225); Ser. No. 60/695,149, filed Jun. 29, 2005 (Attorney Docket DON01 P-1227); Ser. No. 60/730,334, filed Oct. 26, 2005 (Attorney Docket DON01 P-1250); and Ser. No. 60/750,199, filed Dec. 14, 2005 (Attorney Docket DON01 P-1260), which are hereby incorporated herein by reference in their entireties. Optionally, and desirably, the percent reflectivity of the second metallic reflective layer is less than the percent reflectivity of the first metallic reflective layer. Optionally, the reflective material and thickness of the material layer at the perimeter or

border region of the reflective element may be selected to provide a desired spectral reflectivity so as to match or substantially match the spectral reflectivity and appearance of the central region or main reflective region or dimming region of the electro-optic reflective element when the electro-optic reflective element is in its bleached or non-powered or non-darkened/non-colored state.

[00143] Optionally, the appearance of a matching perimeter band (that matches a perimeter band of an electro-optic reflective element, such as a perimeter band that substantially matches the color or tint of the central reflective region of the electro-optic reflective element when bleached) may be achieved by establishing a demarcation line along and through the reflective coating of a single substrate, so that the demarcation line appears to be an inward perimeter edge of a reflective perimeter band or border. For example, and as shown in FIGS. 15A and 15B, a reflective element 510, such as a generally planar reflective element or a curved reflective element for an exterior rearview mirror, includes a substrate 512 (such as a glass substrate, such as a generally flat substrate or a bent or curved substrate, such as a convex or aspheric substrate) and a reflective coating or layer 518 (such as a mirror reflector coating or coatings comprising, for example, chromium or titanium or silver or aluminum or silver alloy or aluminum alloy or a stack of layers, such as an ITO/silver/ITO stack of layers, or like) disposed or established at the second or rear surface 512b of substrate 512 (opposite the first or front or viewable surface 512a of the substrate 512), such as by sputter deposition in a vacuum deposition chamber, such as is known in the coating arts. As shown in FIG. 15B, a perimeter or border reflector region 526 may be outlined or demarcated or defined by a demarcation line 526a established (such as by laser etching or the like) through the reflective coating or layer 518 at the perimeter region. The reflective element 510 thus has a central main reflector region 524 and the perimeter or border reflector region 526 separated or defined or circumscribed by demarcation line 526a.

[00144] Thus, a mirror substrate or shape (such as a glass substrate or shape) may be cut from a sheet of glass to the desired mirror shape. The mirror substrate may be uniformly coated (with no masking) over at least substantially or entirely the second or rear surface of the substrate to provide a substantially uniform reflective coating or layer at the second surface of the substrate. Optionally, a sheet of glass or the like may be substantially uniformly coated over a surface of the sheet, and one or more coated mirror substrates or shapes may be cut from the coated glass sheet to provide the mirror substrate with the reflective coating or layer at the second surface of the substrate. The demarcation line then may be established (such as via laser etching or the like) around the perimeter of the cut and coated substrate so as to

circumscribe and run around substantially or wholly the perimeter region of the cut substrate or shape. The demarcation line and perimeter or border reflector region and central main reflector region of the reflective element thus may be established via a single, unmasked coating process. The demarcation line may be established at a range of about 2 mm to about 5 mm (or more or less) inward from the perimeter cut edge of the substrate, whereby the width of the demarcation line may be selected to match or substantially match the border or perimeter band on the electro-optic reflective element at the driver-side mirror.

[00145] As shown in FIG. 15B, a coating or layer or overcoating 538 (such as a lacquer or paint or frit or tape or appliqué or coating) may be disposed over the reflective coating 518 to cover or coat the rear surface of the reflective element. The coating or layer may be painted or pad printed or screened or inked or otherwise applied or disposed or established at the rear surface of the reflective element. Optionally, the coating or layer 538 may be disposed over the entire rear surface (whereby the coating may provide environmental protection if needed or desired at and over the metallic layer materials (such as aluminum or gold or the like) of the reflective layer or coating, or may be disposed along the demarcation line 526a to substantially fill in the demarcation line 526a.

[00146] The paint or coating or layer may be selected to be any desired color or tint so as to provide the desired edge demarcation of the perimeter or border reflector region 526. For example, the coating or layer 538 may comprise a dark color, such as black or the like, or may comprise a light grey or other color or tint, depending on the particular application and, more particularly, on the color or visibility or viewability of the perimeter band on the electro-optic reflective element at the driver-side rearview mirror. For example, the darker the color of the coating or layer or paint, the more readily viewable or discernible the demarcation line 526a may be to a person viewing the exterior rearview mirror. Thus, it may be desirable to provide a light grey (or similar or selected pale color or the like) demarcation line so that the demarcation line is readily viewable/discernible, but not overly apparent or dominant at the reflective element.

[00147] The viewable width of the demarcation line (the dimension across the demarcation line when viewed at the reflective element by a person viewing the exterior rearview mirror) may be selected to provide the desired degree of viewability or discernibility of the demarcation line, so as to give the appearance of an edge of a perimeter band or border coating. Optionally, for example, the demarcation line may have a width of preferably less than approximately 350 microns (one micron being equal to one millionth of a meter), more preferably less than approximately 250 microns and more preferably less than approximately

175 microns. Also, for example, the demarcation line may have a width of preferably greater than approximately 50 microns, more preferably greater than approximately 75 microns and more preferably greater than approximately 100 microns. The demarcation line through the reflective coating at the rear surface of the reflective element thus functions to demarcate a perimeter border or band so as to provide the appearance of a perimeter band at the border region of the reflective element that substantially optically matches the central main reflector region of the reflective element.

[00148] Although shown and described as a substantially continuous or uninterrupted demarcation line that circumscribes the perimeter region of the reflective element substrate, the demarcation line may be formed to only partially circumscribe the perimeter region of the reflective element substrate, without affecting the scope of the present invention. For example, the demarcation line may be a line segment around a portion of the perimeter region of the substrate or the demarcation line may comprise a non-continuous or interrupted demarcation line (such as a plurality of line segments or dashes or the like) that extends partially or entirely around the perimeter region of the mirror substrate.

[00149] Optionally, and as shown in FIG. 16, a mirror reflective element 510' may have a mirror reflective coating or reflector 518 and a perimeter or border reflector region 526' and central main reflector region 524', and a demarcation line 526a', such as described above. Mirror reflective element 510' includes a second demarcation line 526b' established or formed (such as by laser etching or the like) in and through the reflective coating 518, such as in a similar manner as described above with respect to demarcation line 526a' of reflective element 510. In the illustrated embodiment, the second demarcation line 526b' extends along the lower perimeter region of the mirror substrate and curves downward to the perimeter edge of the reflective element 510'. Such a second demarcation line may be desirable for a passenger-side non-electro-optic mirror reflective element so that the non-electro-optic passenger-side mirror reflective element matches or substantially matches an electro-optic driver-side mirror reflective element, such as, for example, the driver-side mirror reflective element supplied by Gentex Corp. of Zeeland, MI for a model year 2006 Audi vehicle. The mirror reflective element 510' may be otherwise substantially similar to the mirror reflective element 510 described above, such that a detailed discussion of the mirror reflective elements will not be repeated herein.

[00150] Although shown and described as having the central main reflector region and the border reflector region (as either defined by a demarcation line through the reflector coating or by a separate layer or coating around a perimeter region of the reflective element) at the

same surface of the electro-optic or non-electro-optic reflective element, it is envisioned that the border reflector band may be formed or established on the second or rear surface of the substrate while the central or main reflector coating may be established on the first or front surface of the substrate (in such an application, masking may be required to form the coatings at one or both sides of the substrate). Alternately, and optionally, the border reflector band may be established on the first surface of the substrate while the central or main reflector coating may be established on the second surface of the substrate (in such an application, masking may be required to form the coatings at one or both sides of the substrate). Optionally, the border and central reflector coatings may both be on the first or front surface of the reflective element, depending on the particular application of the reflective element and mirror assembly.

[00151] The substrate or substrates of the reflective element may comprise any type of suitable substrate, such as a single glass substrate or the like. For example, the substrate may comprise a glass substrate having a thickness of at least about 1.6 mm, more preferably a thickness of at least about 1.8 mm and more preferably a thickness of at least about 2 mm, but could have a greater thickness or a reduced thickness without affecting the scope of the present invention. The substrate may comprise a substantially flat or planar substrate or may comprise a curved substrate depending on the particular application of the reflective element.

[00152] Optionally, and with reference to FIGS. 17-21, a reflective element assembly 610 for an exterior rearview mirror assembly includes a front substrate 612 (FIG. 21) and a rear substrate 614 spaced from front reflective element substrate 612, with an electro-optic medium 616 (preferably an electrochromic medium) sandwiched therebetween. The front substrate 612 has a transparent conductive coating or layer 618 (such as an ITO layer, such as a $\frac{1}{2}$ wave ITO layer or a doped tin oxide layer or a doped zinc oxide layer or the like) disposed on its rear surface 612a (typically referred to as the second surface of the laminate reflective element assembly) and the rear substrate 614 has a third surface mirror reflector 620 (FIGS. 20 and 21) coated thereon (the mirror reflector may comprise a layer or stack of layers of metals or a metal or stack of metals with at least one conductive oxide layer, such as ITO, or the like as discussed below). The third surface mirror reflector covers the central region or EC-active or viewing region of the front surface 614a (typically referred to as the third surface of the reflective element assembly) of the rear substrate 614 (but does not extend or cover fully to the perimeter edge of the substrate), and the mirror reflector coating 620 overlaps a tab-out or edge wraparound coating or coatings 636 (that extends substantially or fully to a perimeter edge of the substrate, and preferably, if in a "flush" electrochromic

mirror element construction, wraps around the cut edge of the substrate) as discussed below. An epoxy seal material 622 (FIG. 21) or the like, is applied between the substrates to define the cavity for the electrochromic medium and to adhere the substrates together. The epoxy seal 622 overlaps and seals an overlap region 621 where the third surface mirror reflector 620 overlaps the wraparound coating 636 to environmentally protect the third surface mirror reflector 620, as also discussed below.

[00153] Because an exterior rearview mirror is located at the exterior of a vehicle, the mirror reflective element is typically exposed to a hostile environment and may be exposed to humidity, rain, snow, ice, dirt, salt, debris and the like. In typical laminate electrochromic reflective element assemblies, any portion of the mirror reflector layer or layers that extend beyond the perimeter seal toward the outer edge of the rear substrate (for purposes of electrical contact) are particularly vulnerable. Thus, it is desirable to provide a robust reflective element, such as a mirror reflective element having environmentally stable coatings or layers on the surfaces of the reflective element substrates that can be exposed to the hostile environment. Although such environmentally stable or robust coatings, as discussed below, are desirable and suited for exterior mirror applications, aspects of such coatings and the constructions herein are equally suited for interior mirror applications as well.

[00154] As shown in FIG. 18, the rear substrate 614 of reflective element 610 includes a third surface conductor or coating 636 that is disposed over the uncoated glass substrate and along a portion (such as an uncoated perimeter region or perimeter glass surface) of the third surface 614a of rear substrate 614. The third surface coating 636 includes a third surface conductor portion or tab-out portion 636a (disposed at the perimeter region of the third surface 614a) and a wrap-around portion or coating 636b that wraps around and over a perimeter edge or cut edge 614c of rear substrate 614. Third surface coating 636 may comprise an environmentally stable metallic layer or material, such as chromium or rhodium or ruthenium or platinum or the like, or a stack of, for example, of chromium/ruthenium or chromium/rhodium or chromium/platinum or the like, and thus provides an environmentally stable or robust wraparound coating at the perimeter region of the front surface 614a of the rear substrate 614.

[00155] As shown in FIGS. 17 and 19, rear substrate 614 also includes a fourth surface conductor or coating 638 disposed over the glass substrate and along a portion (such as an uncoated perimeter region or perimeter glass surface) of the fourth surface 614b of rear substrate 614. Fourth surface coating 638 includes a fourth surface conductor portion or electrical contact portion 638a and a wrap-around portion or coating 638b that wraps around

and over perimeter edge or cut edge 614c of rear substrate 614 onto the cut edge of the substrate and contacting third surface conductor coating 636 (and may be disposed at or over or under wrap-around portion 636b at perimeter edge 614c, as shown in FIG. 19), in order to provide electrical conductivity between the fourth surface conductor 638a and the third surface conductor 636 and the third surface mirror reflector coating 620, as discussed below. The fourth surface conductor 638a and wrap-around coating 638b may comprise the same material as the third surface conductor 636a and wrap-around coating 636b (such as chromium or molybdenum or tungsten or Hastelloy or ruthenium or rhodium or platinum, or a stack of, for example, of chromium/ruthenium or chromium/rhodium or chromium/platinum or the like, or other suitable environmentally stable conductive material). Alternately, the fourth surface coating 638 may comprise a different material than the third surface coating 636, with both coatings or layers being selected to be substantially environmentally stable or robust.

[00156] The third and fourth surface conductors 636, 638 may be disposed onto the respective perimeter regions and edge of the rear substrate during the same or separate coating processes. For example, the rear substrate preferably has at least the third and fourth perimeter edge wraparound environmentally robust conductor coatings formed in a dual-side sputtering coating chamber (such as a sputter-up/sputter-down or a sputter-left/sputter-right coating chamber where the substrate carrier passes through opposing sputter targets so that the substrate can be coated at both sides), such as by utilizing aspects of the coating chambers and processes described in U.S. patent application Ser. No. 11/021,065, filed Dec. 23, 2004 by McCabe et al. for ELECTRO-OPTIC MIRROR CELL (Attorney Docket DON01 P-1193), which is hereby incorporated herein by reference in its entirety. In such a chamber, for example, one of the conductors (such as, for example, fourth surface conductor 638) may be sputter coated from the bottom of the substrate, while the other conductor (such as, for example, third surface conductor 636) may be sputter coated from the top of the substrate (with the central region of the respective third and fourth surface (and other perimeter portions or regions where the conductor coating is not desired) masked so that the respective conducting coatings are deposited only at an edge). The conductor coatings 636, 638 thus are disposed over the perimeter edge 614c and over a perimeter region of the respective glass surfaces 614a, 614b of the rear substrate 614. Optionally, one or both of the conductor coatings 636, 638 may be disposed around more than one perimeter region or around substantially the entire perimeter of the substrate. Optionally, one of the coatings may be disposed over the other coating at the perimeter edge 614c (if the coatings are disposed

during separate coating processes) or the coatings may be disposed together onto the perimeter edge (such as for applications where the coatings are disposed during a single coating process) so as to contact one another and establish electrical conductivity between the conductor coatings 636, 638 and, thus, between the fourth surface and the third surface of the rear substrate of the reflective element assembly.

[00157] After the conductor coatings 636, 638 are disposed at the respective perimeter regions and at the edge of the substrate, the perimeter regions 614d of the front surface 614a of rear substrate 614 may be masked, whereby the third surface mirror reflector coating or layer 620 is disposed (such as via a sputter deposition process or the like) over the unmasked or central portion or EC-active portion or viewing portion or region (which is within the perimeter seal of the reflective element assembly when the reflective element assembly or cell is assembled) of the third surface 614a, and within or encompassed or surrounded by the perimeter band or region 614d of the third surface 614a of rear substrate 614. The third surface perimeter band 614d may be established by masking the perimeter region of the third surface 614a prior to deposition of the mirror reflector coating or layer 620 onto the central region of the third surface 614a. The third surface mirror reflector coating or layer 620 may comprise a transfective coating or layer or other suitable third surface mirror reflector coating comprising reflective and conductive coatings. For example, the third surface mirror reflector coating 620 may comprise a reflective metallic coating or layer or multiple coatings or layers, such as a bi-layer or the like, such as a reflective metallic coating or layer (or multiple coatings or layers), such as a layer of chromium/rhodium or chromium/ruthenium or molybdenum/chromium, or an ITO/silver/ITO or AZO/silver/AZO stack of layers or the like, over the central region or viewing region or EC-active region of the front surface 614a of the rear substrate 614.

[00158] Optionally, the third surface mirror reflector coating may not be transfective (such as for a fourth surface reflective element), and/or may comprise a substantially non-transmissive metallic reflector coating, such as a coating or layer of silver or aluminum or their alloys or the like, or may comprise a substantially non-transmissive ITO/Ag/ITO or AZO/Ag/AZO coating or layers or the like. Optionally, the rear substrate may initially be coated with a transparent conductive coating, such as ITO or the like, disposed over its entire third or front surface (for example, a substrate having such a coating already established thereon may be purchased by the mirror manufacturer), whereby the third surface conductor 636 is disposed over the perimeter region of the ITO coated third surface and the mirror reflector coating or

coatings is/are disposed over the ITO coated central region or EC-active region of the rear substrate, without affecting the scope of the present invention.

[00159] As shown in FIGS. 20 and 21, the mirror reflector coating or layer 620 is disposed over the central region or portion of the third surface 614a that is substantially surrounded by the perimeter seal 622 and so is environmentally protected thereby. The mirror reflector coating 620 overlaps and makes conductive contact at a portion of the third surface conductor 636a of third surface coating 636, such as at overlap region 621, so as to contact the conductor 636a and establish conductivity between the mirror reflector coating 620 and the third surface conductor coating 636 and, thus, between the mirror reflector coating 620 and the fourth surface conductor 638a at the fourth surface 614b of rear substrate 614. As can be seen in FIG. 21, the overlap region 621 is positioned inward of the perimeter edge of the rear substrate and at a region that is encompassed by the perimeter seal 622 when the seal 622 is established at the rear substrate 614. Perimeter seal 622 thus overlaps a portion of the mirror reflector coating 620 and a portion of the third surface conductor 636a and limits or substantially precludes exposure of the mirror reflector coating 620 to the exterior elements. The perimeter seal overlaps and seals against a perimeter portion of the mirror reflector coating and the uncoated glass surface of the third surface of the rear substrate in other perimeter regions where the third surface conductor 636a is not established.

[00160] The fragile or less environmentally stable mirror reflector coating 620 thus terminates or stops within the area encompassed by the perimeter seal 622 and the robust or more environmentally stable third surface conductor coating 636a contacts/overlaps the fragile mirror reflector coating 620 in the area encompassed by the perimeter seal. Thus, the more environmentally stable third surface conductor coating 636a extends outward from the perimeter seal and over the third surface at the perimeter region and to the edge of the substrate. The perimeter seal 622 thus provides environmental protection for the mirror reflector coating 620, so that the mirror reflector coating 620 may comprise a less environmentally stable or robust material, such as silver or silver alloy or ISI stack (such as metal oxide/metal/metal oxide stack, such as an ITO-silver-ITO stack or a ZnAlO/Ag/ZnAlO stack or a ZnAlO/Al/ZnAlO stack or a ITO/Ag/ZnAlO stack or the like), while the third surface conductor coating 636 and the fourth surface conductor coating 638 may comprise a more environmentally stable or robust material (such as chromium or rhodium or ruthenium or the like). Thus, the exposed conductor coatings 636, 638 (i.e., the coatings that are not encompassed and sealed by the perimeter seal and thus not within the sealed EC region of the

reflective element) may be exposed to the elements and may withstand exposure to the elements at the exterior perimeter of the rear substrate and/or reflective element.

[00161] In the illustrated embodiment, and as also shown in FIG. 21, electrical connectors 640a, 640b, such as terminals or clips or pins or conductive epoxy or paste or the like, may be conductively connected to the second surface transparent conductive coating 618 and the fourth surface conductor 638a, respectively. The connectors 640a, 640b may be connected to an electrical wire or wire harness or lead or terminal or the like (not shown) to electrically connect the electrochromic reflective element to a vehicle or mirror control or power source or the like. Thus, the environmentally stable conductive wrap-around coatings 636, 638 provide electrical conductivity between the fourth surface of the reflective element to the third surface mirror reflector coating 620 at the EC-active region of the third surface of the reflective element, while the third surface mirror reflector coating 620 is substantially sealed and protected and substantially or entirely not exposed to the elements.

[00162] In a preferred embodiment, the rear substrate 614 may comprise a glass substrate having a thickness of between about 1.1 mm and about 1.6 mm or thereabouts. The third surface conduct coating 636 may comprise a layer of chromium, such as a layer of chromium that is sputtered deposited onto the glass substrate to a thickness of about 800 to about 1000 angstroms or more. The fourth surface conductor coating 638 may comprise a layer of chromium, such as a layer of chromium that is sputtered deposited onto the substrate to a thickness of about 800 to about 1000 angstroms, and the coating may be overcoated with a layer of ruthenium (such as a layer that is about 300 angstroms thick) or a layer of rhodium (such as a layer that is about 200 angstroms thick), whereby the electrical connector (typically a silver paste or epoxy or the like) contacts the overcoated layer of ruthenium or rhodium to establish the electrical connection to the conductor coating/coatings.

[00163] Optionally, and as shown in FIG. 21, reflective element 610 may include a display device 630 at the fourth surface 614b of rear substrate 614. Display device 630 may be operable to emit or project illumination through the reflective element 610, such as through a window established at the third surface mirror reflector coating 620, or through the third surface mirror reflector coating 620 for a transreflective reflective element. Display device 630 may be operable to provide a turn signal indicator or a blindspot alert indicator or the like, and may be directed to be substantially viewable to a driver of a rearwardly approaching vehicle or to be substantially viewable to the driver of the subject vehicle, depending on the particular application of the display device. The display device and reflective element may utilize aspects of the display devices described in U.S. patent application Serial No.

11/226,628, filed Sep. 14, 2005 (Attorney Docket DON01 P-1236); and/or U.S. provisional applications, Ser. No. 60/717,093, filed Sep. 14, 2005 by Lynam (Attorney Docket DON01 P-1240); Ser. No. 60/732,245, filed Nov. 1, 2005 (Attorney Docket DON01 P-1251); and/or Ser. No. 60/759,992, filed Jan. 18, 2006 by Weller et al. for INTERIOR REARVIEW MIRROR ASSEMBLY WITH DISPLAY (Attorney Docket DON01 P-1264), which are hereby incorporated herein by reference in their entireties.

[00164] The construction shown in FIG. 21 particularly suits "flush" type reflective elements having overhang regions (defined by the front substrate being larger than the rear substrate so as to provide an overhang region or regions along the upper and/or lower perimeter regions of the reflective element assembly) as shown in FIG. 21 (and such as described in U.S. patent application Ser. No. 11/226,628, filed Sep. 14, 2005 (Attorney Docket DON01 P-1236), which is hereby incorporated herein by reference in its entirety). However, for offset reflective elements, where the front and rear substrates may be similarly sized, but one is vertically offset relative to the other (such as described in U.S. patent application Ser. No. 11/021,065, filed Dec. 23, 2004 by McCabe et al. for ELECTRO-OPTIC MIRROR CELL (Attorney Docket DON01 P-1193); and/or U.S. Pat. Nos. 5,724,187 and 5,668,663, which are hereby incorporated herein by reference in their entireties), the reflective element may not include a fourth surface conductive wraparound coating or bus bar. For example, an offset reflective element may not include a fourth surface conductor coating, whereby the environmentally stable third surface conductor coating may be disposed at the perimeter region of the front or third surface of the rear substrate and may or may not wrap-around onto the cut edge of the rear substrate, whereby the electrical connection to the third surface coatings may be made by a known clip or the like at the perimeter region so as to contact the conductor coating at the perimeter region of the third surface of the rear substrate.

[00165] The third surface mirror reflector coating (established over the central or EC-active region of the glass third surface of the rear substrate) may comprise a metallic coating or layer or a metal oxide/metal/metal oxide coating, such as a stack of materials or layers, such as, for example, a layer of ITO (such as about 500 angstroms thick), a layer of metal (such as a layer of silver or aluminum that is about 300 angstroms thick), and a layer of ITO (such as about 120 angstroms thick). Optionally, the third surface mirror reflector stack may comprise an aluminum zinc oxide (AZO) stack, such as a stack comprising an AZO layer, a metallic layer, and another AZO layer (for example, an AZO/Ag/AZO stack of layers). The layer or layers of AZO may be sputtered from a sputtering target comprising zinc oxide doped with aluminum oxide. For example, a doped zinc oxide target having ZnO: 2% Al₂O₃ has

achieved desired results. Such an AZO layer may be formed via sputter deposition with such a doped zinc oxide sputtering target, such as can be made by a co-precipitation process; formed of ZnO: 2% Al₂O₃. Note that while good results have been obtained with aluminum-doped zinc oxide, other dopants such as silver or gold can be used.

[00166] Preferably, the sputtering is done by direct current (DC) sputtering, more preferably by pulsed DC sputtering, and more preferably by medium frequency (such as within a range of about 40 kHz to about 1 MHz or thereabouts) dual magnetron DC sputtering. Alternatively, radio frequency (RF) sputtering could be used or other sputtering techniques or systems may be used, depending on what is better suited for the particular chamber and chamber conditions.

[00167] Advantages found by utilizing an AZO layer or layers include that it is a lower cost material than ITO. We find that effective AZO coatings for purposes of the present invention (i.e. highly transmissive and sufficiently conductive to allow electron flow therethrough for electrical contact to the electrochromic medium when a thin layer of AZO is overcoated over the underlying metal layer (the layer of AZO that contacts the electrochromic medium when the reflective element is assembled)) can be formed or established using non-reactive DC magnetron sputtering (and hence obviating the cost/complexity of introducing and controlling an oxygen partial vapor pressure during the sputter deposition process). Although the AZO layer may not be as conductive as an ITO layer, the conductivity of the AZO layer is sufficient to allow the electron flow from the highly conductive metallic layer (that underlies the AZO layer and acts as a conductive raceway over the third surface of the rear substrate) and through the thin AZO layer to energize the electrochromic medium when electrical power is applied to the connectors or contacts of the reflective element assembly. For instance, and for the AZO layer that the electrochromic medium contacts, we find that AZO layers having a sheet resistance of greater than about 100 ohms per square, or in certain constructions greater than about 250 ohms per square, are effective.

[00168] The glass surface of the rear substrate thus may be coated with a third surface mirror reflector comprising a conductive coating or a stack of coatings or layers. For example, the glass surface may be regionally coated (such as at a perimeter region) with a conductive tab-out layer of sputtered chromium (such as a layer having a thickness of about 500 angstroms or thereabouts), and the central or EC-active or viewing portion of the front surface of the substrate, and a portion of the conductive tab-out layer, is overcoated with a third surface mirror reflector/mirror transreflector layer. For example, a mirror reflector coating may be disposed that comprises a stack of layers, such as, for example, an AZO layer (such as about

500 angstroms thick), a metallic layer (such as a highly conducting layer of silver or aluminum doped silver or doped aluminum or the like and having a thickness of about 800 angstroms to about 1000 angstroms or thereabouts), and a layer of aluminum zinc oxide or AZO (such as a layer of AZO having a thickness of about 100 angstroms to about 200 angstroms or thereabouts). Such an AZO:metal:AZO stack of layers thus provides the desired transmissivity and reflectivity at the EC-active region of the reflective element, while being sufficiently conductive for its intended purpose of selectively energizing the electrochromic medium. Other thicknesses of layers and other materials may be utilized depending on the particular application and desired characteristics of the reflective element and mirror assembly.

[00169] Optionally, and desirably, a rear substrate for a reflective element may have a mirror reflector coating that utilizes chromium (or titanium or other stable metal) for an adhesion layer at the glass surface of the front of the substrate. For example, a preferred embodiment of such a rear substrate may have a mirror reflector coating comprising a layer of chromium (such as a layer that is about 400 angstroms thick), with a layer of metal, such as silver or aluminum or alloys thereof the like, such as a layer of silver that is about 800 angstroms thick, disposed thereon. A layer of AZO (such as a layer of AZO that is about 150 angstroms thick) is then non-reactively deposited or disposed onto the metal layer. Thus, the AZO layer or overcoat (that contacts the electrochromic medium when the reflective element is assembled and protects or isolates the metal layer from the electrochromic medium) may be non-reactively deposited, and thus obviating the cost/complexity of introducing and controlling an oxygen partial vapor pressure during the sputter deposition process. Such a mirror reflector coating may be disposed at the glass third surface of the rear substrate via a multiple target sputtering process. The adhesion layer of chromium at the glass surface of such a rear substrate may also provide reduced costs of the mirror reflector coating and of the reflective element as compared to rear substrates with an ITO adhesion layer at the glass surface.

[00170] Note that a benefit of a third surface reflector that comprises a glass substrate coated first with an environmentally stable electrically conducting layer (such as chromium), which in turn is overcoated with a highly reflecting metallic mirror layer (such as a layer of silver or of a predominantly silver-silver-alloy or such as a layer of aluminum or of a predominantly aluminum-aluminum-alloy), which in turn is overcoated with a transparent electrically conductive layer (that is disposed between the highly reflecting mirror metallic layer and the electrochromic medium within the electrochromic mirror element cell), is that electrical

conductivity and contact to the electrochromic medium can be sustained by the underlying environmentally stable electrically conducting layer even if its overlaying environmentally fragile layers (such as silver or the like) degrade or deteriorate due to environmental exposure. An example of such a third surface reflector comprises a glass/chromium/metal (such as silver or aluminum or an alloy of silver or of aluminum)/aluminum doped zinc oxide [herein referred to as "CAZ"]. In such an exemplary construction, the third surface reflector coating (TSR) can be taken out to the edge (or wrap-around the edge) of the substrate beyond the seal, and the end product can be environmentally resilient without the need to use encapsulants or the like to environmentally protect tab out regions, cut-edge wraparound coatings, offset regions, overhang regions and/or the like. This is because the electrical continuity of CAZ or similar constructions is environmentally stable due to the underlying bedrock of the environmentally stable metallic electrical conductor, such as chromium. In such constructions, any environmentally fragile layers, such as AZO and silver coating portion, that extends beyond the perimeter seal of the mirror cell may be exposed to environmental conditions and so may deteriorate in severe environmental testing, such as 85C / 85%RH, salt spray, steam autoclave, etc. (or in field usage on a vehicle), while the underlying adhesion layer/base electrically conducting coating of chromium remains intact. Thus, the EC mirror element cell can still be powered even if the overlying layers of the CAZ were partially or substantially deteriorated at the likes of a tabout or edge wraparound or offset or overhang region. Thus, for example, in an offset interior mirror (or exterior mirror) electrochromic cell construction, the clips or contacts can maintain electrical contact to the chromium (and hence thereby to the third surface mirror reflector coating that is protected by the EC perimeter seal itself), even if the overlying silver or AZO layer may locally corrode.

[00171] In a flush construction, where the likes of an edge overcoat or fourth surface electrical connection, such as via a conductive epoxy or the like, may be made, the conductive epoxy itself may locally encapsulate and environmentally protect the CAZ layer or stack, but having the bedrock of environmentally stable chromium (or a similar environmentally stable metal electrically conducting thin film layer such as of a chromium-based alloy or such as of a nickel-based alloy, such as an Inconel or a Hastelloy, or such as of an iron-based alloy, such as a stainless steel or such as of titanium or a titanium-based alloy) has the advantage that the underlying chromium or similarly environmentally stable metal thin film layer remains electrically conducting and integral even should the overlying silver or AZO (or other transparent electrical conductor, such as other doped zinc oxides or a doped indium tin oxide, such as ITO or indium oxide or tin oxide or doped tin oxide) degrade or deteriorate in harsh

environmental conditions. For example, for third surface mirror reflectors, such as ITO/Ag/ITO (ISI) or the like, where the silver metal layer is environmentally vulnerable, an encapsulating or potting material (such as described in U.S. patent application Serial No. 11/021,065, filed Dec. 23, 2004 by McCabe et al. for ELECTRO-OPTIC MIRROR CELL (Attorney Docket DON01 P-1193), which is hereby incorporated herein by reference in its entirety) may be used at the tabout or edge wraparound or offset or overhang regions, and this has proven to be successful. But, with the likes of CAZ, where the underlying bedrock adhesion-enhancing and electrically-conducting metal layer comprises an environmentally stable metal material, such as chromium or titanium or nickel or metal alloys or the like, the use of any extra potting or encapsulating material, such as at a tab-out region or at a clip region or wherever electrical connection is being made to the third surface reflector coating or layer outside of its sealed portion, becomes optional.

[00172] An example of a preferred stack design for an interior rearview mirror reflective element 710 is shown in FIG. 22 and includes a rear glass substrate 714 (such as float glass) and a CAZ layer 720 disposed at the front or third surface of the rear substrate 714. The CAZ layer 720 comprises a layer of chromium 720a (having a thickness of about 800 angstroms) disposed on the front surface of the rear substrate (i.e. the third surface of the electrochromic cell), a layer of silver 720b (having a thickness of about 800 angstroms) over the chromium layer 720a, and a layer 720c of ZnO:Al (such as a layer deposited by sputtering from a sputter target of ZnO:Al₂O₃ so as to have a layer thickness of about 80 angstroms) disposed over the silver layer 720b. An electrochromic medium 716, such as an electrochromic solid polymer matrix (SPM) or other suitable electrochromic medium (such as a liquid or solid electrochromic medium), is disposed between the coated rear substrate 714 and a coated front substrate 712 (such as in a 110 μm interpane gap between the substrates and coatings/layers) and sealed within the interpane cavity via a perimeter seal 722 (such as an epoxy seal). The front glass substrate 712 (preferably float glass) has a layer of a transparent electrical conductor 718 (such as ITO, and preferably having a resistivity of about 12 ohms per square) disposed on its rear or second surface. Optionally, and as shown in FIG. 22, the reflective element 710 may include an indicia coating or layer or element 724, which preferably is disposed at the second surface of the front substrate (as shown in FIG. 22), but may be optionally disposed at the third or fourth surface of the rear substrate, such as in the manners described herein. Of course, the FIG. 22 is purely exemplary, and other constructions and materials and thicknesses may be selected and implemented depending on the particular

application and desired performance of the interior or exterior vehicular mirror reflective cell, while remaining within the spirit and scope of the present invention.

[00173] The CAZ layers may be coated on either the tin side of the float glass substrate or the air side of the float glass substrate. Other environmentally stable electrically conductive materials, such as a layer of titanium or the like, may be disposed at the substrate in place of the layer of chromium. For example, a grade 2 titanium may be used. Although AZO is typically about 1/3 the cost of ITO and thus may be desired, ITO or other transparent conductors can be used. Alternately, however, AZO or other suitable or similar transparent conductors can be used instead of the ITO. Alternately, aluminum, such as Al(6061), or an aluminum alloy or a silver alloy, which has a high reflectivity of light incident thereon, such as a reflectivity of at least about 80 percent of light incident thereon, more preferably at least about 85 percent reflective of light incident thereon, and more preferably at least about 90 percent reflective of light incident thereon, may be used instead of silver.

[00174] Preferably, the surface or surfaces of the glass substrates are cleaned and/or treated prior to deposition of the coatings. For example, the surface may be prepared or treated to prepare the surface and/or to dissolve any moisture or water vapor from the surface. For example, the substrate may be heated prior to deposition or the surface may be treated with a plasma or ion beam, such as described in U.S. patent application Serial No. 11/021,065, filed Dec. 23, 2004 by McCabe et al. for ELECTRO-OPTIC MIRROR CELL (Attorney Docket DON01 P-1193), which is hereby incorporated herein by reference in its entirety.

[00175] Preferably, the coatings or layers are deposited at the substrate in a multi-cathode (either vertical or horizontal) conveyORIZED sputter chamber. The chamber may contain an argon atmosphere at the AZO and/or other sputtering target, such as of silver or chromium, at about 3-5 mtorr, and the AZO material may be sputtered at about 300 sccm or more of argon flow. However, other chambers and/or processes may be implemented, depending on the particular coater being used and depending on the particular application. The power density applied to the AZO target (and to other targets) is preferably at least about 3 W/cm², more preferably at least about 5 W/cm², and more preferably at least about 8 W/cm². Due to the relatively inferior electrical specific conductivity of AZO, a dual magnetron sputtering system is desired for long term stable, arc-free operation within the sputter chamber. An example of a suitable AZO sputtering target is a ceramic of ZnO:Al₂O₃ (e.g., 98% / 2% weight), formed from a co-precipitation process, "hip'd" and sintered. The preferred density is greater than about 5.3 g/cc. The AZO tiles may be attached, such as soldered, such as indium soldered, to an OFHC copper backing plate.

[00176] One desirable property of AZO is that it can be deposited in a metallizer sputter chamber without the cost/complexity of introducing oxygen gas handling to the vacuum chamber at the sputter station for the AZO. Thus, advantageously, a chromium target and a silver target and an AZO target (in that sequence relative to the direction of travel of the substrates thereunder) may be disposed in the same vacuum chamber and may be commonly exposed to the same sputtering atmosphere, such as the argon atmosphere described above. Thus, the sputtering station and the sputtering of the thin films may be achieved non-reactively and without recourse to introducing additional oxygen. By contrast, but optionally, another transparent conductor, such as ITO, could be used instead of AZO. However, reactive sputtering in a oxygen rich atmosphere is desirable for ITO transparent electrical conductor thin film deposition, and in such a vacuum chamber, steps must be taken to isolate the non-reactive sputtering of the preceding silver and chromium metallic layers from the reactive sputtering of the ITO layer. We find surprisingly good results when AZO is used in the CAZ layer and when the AZO is deposited in an argon sputtering atmosphere.

[00177] Optical properties of both the coated rear substrate and of the completed CAZ interior EC mirror element are shown in FIGS. 23 and 24, respectively. FIG. 23 shows the reflectance of the stack 720 of FIG. 22 of light incident on the coated rear substrate 714. As shown, the reflectance of visible light incident on the coated rear substrate 714 is about 90 percent or more. When the coated substrate 714 is formed into a cell 710, such as a cell using an electrochromic solid polymer matrix (SPM) (such as described in U.S. Pat. Nos. 5,725,809; 5,910,854; 6,002,511; 6,154,306; 6,245,262; 6,420,036; 6,855,431; and 6,954,300, which are hereby incorporated herein by reference in their entireties), the reflectance of light incident on the cell is as shown in FIG. 24. FIG. 24 shows the reflectance of light incident on the cell when the cell is in its bleached and when the cell is in its darkened or colored state (such as with about 1.2 volts applied across the cell). As can be seen in FIG. 24, visible light reflectance is greater than about 80 percent or thereabouts in the bleached state and around 10 percent or thereabouts in the colored state.

[00178] The optical constants of the ZnO:Al layer are shown in FIG. 25. More specifically, FIG. 25 shows the optical constants, particularly the index of refraction "n" and the extinction coefficient "k", for the coated substrate. The sheet resistance of the coated rear substrate and of its individual layers was measured to be about 4-5 ohms per square for the 800 angstroms thick chromium layer and less than about 1 ohm per square for the 800 angstroms thick silver layer.

[00179] The electrochromic performance (high end/low end reflectivity and color and bleach speeds, etc.) of the CAZ interior EC mirror element is shown in the tables of FIGS. 26 and 27. The tables show the rate to color/bleach of the cells and the maximum and minimum percent reflectance of light incident thereon, and the maximum current draw and steady state current draws of the cells. FIG. 26 shows the initial performance characteristics of various samples at about 23 degrees Celsius and at 1.2 volts when powered, while FIG. 27 shows the final performance characteristics of various samples at the same temperature and voltage, but after the samples have endured about 50,000 cycles at 65 degrees Celsius and 95 percent relative humidity.

[00180] The AZO is desirably deposited in an argon sputter atmosphere and without added oxygen in the sputtering gas mix or composition. This may simplify in-line sputter coater designs, since there may be no need for "process isolation" between the chromium sputtering station/cathode, the silver sputtering station/cathode and the AZO sputtering station/cathode.

[00181] We find that the optical extinction coefficient "k" of ITO deposited under nearly identical oxygen-free sputtering in argon conditions is over ten times greater than that for AZO that is similarly non-reactively sputtered. Also, ITO exhibits an index grading, whereas AZO does not. We also find reduced formation of surface nodules using the AZO ceramic target when it is non-reactively sputtered as compared to reactive sputtering with ITO targets. Further, AZO sputtered in pure argon has a faster deposition rate than ITO in Ar/O₂; such as at least about 30 percent faster rate.

[00182] If a display on demand transfective display application is desired, the stack or layers used for the third surface reflector are correspondingly reduced and/or adjusted in thickness. For enhanced transmissivity, a transparent conductor may be used as the adhesion layer in place of the chromium. For example, a transfective TSR rear substrate may comprise: glass/AZO/Ag/AZO or glass/ITO/AZO/Ag/AZO. Due to the K value of AZO, its use in transfective third surface reflector (TSR) constructions can be desirable, given that such a DOD stack has a good T%, R% and neutral appearance.

[00183] A chromium layer has excellent adhesion to an ITO base coat and may improve the environmental robustness of the cell and may eliminate any need for surface preparation, such as ion beam cleaning.

[00184] AZO exhibits less compressive stress compared to ITO, which may enable more environmentally stable DOD stacks with thicker AZO layers.

[00185] AZO also may be used as the second surface transparent conductive coating or oxide (TCO) in the electrochromic cell if sufficiently thick so as to have a sheet resistance of at or

about 20 ohms per square or lower. AZO is less inherently conductive than ITO, which has a specific resistivity of about 2×10^{-4} ohm.cm. With appropriate deposition conditions, including use of an oxygen sputtering atmosphere and heated substrate, a specific resistivity of about 6×10^{-4} ohm.cm or better of AZO can be achieved. The AZO layer, when deposited on the glass substrate, may provide a transparent conductor having a sheet resistance of about 20 ohms per square or lower if appropriately deposited. An electrochromic cell thus may be constructed using AZO as its second surface transparent electrically conductive layer.

[00186] Therefore, the present invention provides an electrochromic mirror element with the rear glass substrate third surface reflector (TSR) coated with an environmentally stable or resilient electrically conductive metal layer, such as chromium or titanium, and with a highly specularly reflective metal layer [such as comprising silver or silver alloy (such as preferably at least 80 percent and more preferably at least 90 percent silver content) or aluminum or aluminum alloy (such as preferably at least 80 percent and more preferably at least 90 percent aluminum content) or the like] disposed over the environmentally stable underlying layer. The highly reflecting mirror reflective layer itself thus has a reflectivity of preferably at least about 80 percent reflectivity (more preferably at least about 85 percent reflectivity, and more preferably at least about 90 percent reflectivity) of light incident thereon, as measured per SAE J964a. The AZO layer or other transparent electrically conductive layer is then disposed over the highly reflecting mirror reflective metal layer and need only have a modest but finite electrical conductivity, since the underlying highly reflecting mirror reflective layer and/or the adhesion promoting environmentally stable metal layer can provide the desired high electrical conductivity across the third surface of the EC cell. The CAZ or similarly coated rear substrate thus provides substantial reflectivity at the third surface of the mirror element, while providing an environmentally stable layer for providing conductive continuity to the third surface of the mirror element and any portions of the third surface reflector such as tabouts or edge wraparounds or offset regions or overhang regions or the like.

[00187] Optionally, and as shown in FIG. 28, an electro-optic mirror assembly 710' (such as for an interior or exterior mirror assembly) includes a rear glass substrate 714' and a larger front substrate 712' so that no cross dimension of the smaller rear substrate 714' extends beyond a corresponding cross dimension of the larger front substrate 712'. An electrochromic medium 716', such as an electrochromic solid polymer matrix (SPM) or other suitable electrochromic medium (such as a liquid or solid electrochromic medium), is disposed between the coated rear substrate 714' and a coated front substrate 712' (such as in a 110 μ m

interpane gap between the substrates and coatings/layers) and sealed within the interpane cavity via a perimeter seal 722' (such as an epoxy seal). Of course other thicknesses or interpane gaps can be used without affecting the scope of the present invention.

[00188] Rear substrate 714' includes a third surface mirror reflector 720' (optionally, the third surface mirror reflector may be a third surface transfective mirror reflector) disposed at the front or third surface 714a' of the rear substrate 714'. The third surface mirror reflector 720' may be any type of suitable third surface mirror reflector, such as a third surface mirror reflector similar to the CAZ reflector described above, or a third surface reflective element consisting of glass/chromium/ruthenium or glass/ITO/silver or silver alloy/ITO or the like. For example, the third surface mirror reflector 710' may include a layer 720a' of environmentally stable metallic material, such as chromium or the like, disposed on the front surface of the rear substrate (i.e. the third surface of the electrochromic cell), and a layer or layers 720b' of metal/transparent conductive material/materials over the chromium layer 720a', such as described above. The third surface mirror reflector 720' includes a wraparound portion or tabout portion 721' that wraps around and overcoats a perimeter edge 714c' of the rear substrate 714' in order to facilitate electrical connection at the fourth surface as discussed below.

[00189] As can be seen in FIG. 28, a portion of the third surface mirror reflector 720' terminates at the third surface 714a' of the rear substrate 714' before the perimeter edge 714d' and within the seal region so that there is a gap 714e' at the third surface between the perimeter edge region 714d' and the edge of the third surface mirror reflector 720'. For example, the third surface of the rear substrate may be masked at a portion or region along the perimeter edge 714d' of the substrate during the coating or deposition of the third surface mirror reflector 720' so that a portion 714e' of the third surface 714a' is devoid of the third surface mirror reflector. The masked portion or gap portion 714e' may be only a portion or section or length along the perimeter edge 714d', and provides electrical isolation between the third surface mirror reflector and a conductive material or element 719' that provides electrical conductivity between a rear or fourth surface contact 740b' and the second surface transparent conductor 718', as discussed below. The third surface mirror reflector may be disposed over the rest of the third surface 714a' except at the gap portion, leaving an area (such as about 1 to 2 cm long along the edge 714d') along the edge region 714d' that is devoid of the third surface mirror reflector.

[00190] The gap portion 714e' electrically isolates or insulates the third surface mirror reflector 720' from the outer perimeter region or edge 714d' of rear substrate 714' at the

region or portion along the perimeter edge at which the gap portion is established. The perimeter seal 722' is disposed at and substantially fills in the gap portion 714e' to further electrically isolate or insulate the third surface mirror reflector 720' from the outer perimeter region or edge 714d' of rear substrate 714' and to obviate any electrical contact or shorting with the second surface conductive electrode. The gap 714e' may be formed or established by masking of the perimeter edge region 714d' during the coating/deposition process of the third surface mirror reflector 720', or the third surface mirror reflector may be disposed over substantially the entire third surface and the third surface mirror reflector may be removed at the gap region via deletion or ablation (or sand blasting or other suitable deletion/ablation means, such as laser ablation) of the third surface mirror reflector 720' at or near the perimeter edge region 714d', without affecting the scope of the present invention.

[00191] The front glass substrate 712' has a transparent electrical conductor 718' disposed on its rear or second surface 712a'. As shown in FIG. 28, a perimeter band 726' (which may comprise any suitable material, and preferably is a reflective perimeter band comprising a chromium reflective layer or the like) is disposed around the perimeter region of the rear surface of the front substrate 712', with the transparent electrical conductor 718' overlapping the perimeter band 726'. However, the transparent electrical conductor may be disposed over the rear surface of the front substrate and the perimeter band 726' may be disposed over the transparent electrical conductor, without affecting the scope of the present invention.

[00192] Reflective element 710' provides fourth surface electrical contacts or connectors 740a', 740b' (such as conductive epoxy or the like) at the rear surface 714b' of the rear substrate 714' for electrical connection to the third surface mirror reflector 720' and second surface transparent conductor 718', respectively. Reflective element 710' includes a fourth surface wraparound coating or coatings or layers 738' that is/are disposed over a portion of the rear surface 714b' of rear substrate 714' and that overlaps the wraparound portion 721' of the third surface mirror reflector 720'. In the illustrated embodiment, the fourth surface wraparound layer 738' comprises an environmentally stable stack of metallic conductive layers, such as a chromium layer 738a' and a ruthenium layer 738b' disposed over chromium layer 738a'. The wraparound portion 721' may extend over substantially the entire edge portion 714c' of the rear substrate 714' or may extend only partially over the edge portion 714c' (such as shown in FIG. 28), with the fourth surface wraparound portion 738' extending partially or entirely over the wraparound portion 721' so as to establish electrical conductivity between the wraparound portions 721' and 738'. The fourth surface wraparound coating 738' thus provides electrical conductivity between the fourth surface busbar or contact 740a' (such

as conductive epoxy or the like disposed at the fourth surface of the reflective element and at a portion of the wraparound coating 738' at the fourth surface of the reflective element) and the third surface mirror reflector 720' via the substantial overlap at the perimeter edge region of the rear substrate 714'.

[00193] The electrical conductivity between the electrical contact 740b' at the fourth surface of the reflective element 710' and the second surface transparent conductor 718' may be established via a conductive element or material 719' (such as a conductive epoxy) disposed over a portion of the fourth surface 714b' and over the perimeter edge 714d' of the rear substrate and between the front and rear substrates so as to contact and establish electrical conductivity to the second surface transparent conductor 718' at the rear of the front substrate 712'. The conductive element or material 719' is disposed at the reflective element at the area or region that corresponds to the gap portion 714e' at which the third surface 714a' is devoid of the third surface mirror reflector material. Because the third surface mirror reflector 720' is not present at the gap portion 714e' at the third surface 714a' of the rear substrate (and the third surface mirror reflector terminates inboard or perimetally inward of the perimeter edge 714d' at the gap region 714e' and is within the seal region of the reflective element or cell at the gap region 714e'), the third surface mirror reflector 720' is substantially electrically insulated or isolated from the conductive epoxy 719' at the perimeter edge 714d'. The conductive element or material 719' is thus disposed at the portion or region of the reflective element that corresponds to the gap portion 714e' to provide electrical conductivity between the fourth surface contact 740b' and the second surface transparent conductor 718' at that portion, which may be about 1 to 2 cm (or thereabouts or more or less) along the perimeter edge regions of the substrates of the reflective element.

[00194] Optionally, and as shown in FIGS. 29 and 30, a reflective element assembly 810 (such as for an interior or exterior mirror assembly) includes a smaller front substrate 812 and a larger rear substrate 814, so that an overhang region 815 is defined or established by the perimeter region or regions of the rear substrate overhanging or extending beyond the perimeter region or regions of the front substrate 812. Similar to rear substrate 714', discussed above, rear substrate 814 include a third surface mirror reflector 820 (which may comprise any suitable third surface mirror reflector, such as a third surface transfective mirror reflector or the like). For example, the third surface mirror reflector 820 may be similar to the CAZ reflector described above, may include a layer 820a of environmentally stable metallic material, such as chromium or the like, disposed on the front surface of the rear substrate (i.e. the third surface of the electrochromic cell), and a layer or layers 820b of

metal/transparent conductive material/materials over the chromium layer 820a. The third surface mirror reflector 820 includes a wraparound portion or tabout portion 821 that wraps around and overcoats a perimeter edge 814c of the rear substrate 814 to establish electrical conductivity between the third surface mirror reflector 820 and a fourth surface electrical contact 840a via a fourth surface wraparound portion or coating or layer 838, such as in a similar manner as discussed above (and which may comprise an environmentally stable stack of metallic conductive layers, such as a chromium layer 838a and a ruthenium layer 838b disposed over chromium layer 838a). The wraparound portion 821 may extend over substantially the entire edge portion 814c of the rear substrate 814 or may extend only partially over the edge portion 814c (such as shown in FIG. 29), with the fourth surface wraparound portion 838 extending partially or entirely over the wraparound portion 821 so as to establish electrical conductivity between the wraparound portions 821 and 838.

[00195] An electrochromic medium 816, such as an electrochromic solid polymer matrix (SPM) or other suitable electrochromic medium (such as a liquid or solid electrochromic medium), is disposed between the coated rear substrate 814 and a coated front substrate 812 (such as in a 110 μm interpane gap between the substrates and coatings/layers) and sealed within the interpane cavity via a perimeter seal 822 (such as an epoxy seal). The third surface mirror reflector 820 is disposed substantially over the entire third surface 814a except at a gap portion or isolating portion 814e at a portion of the third surface along and inboard or perimetally inward of the perimeter edge 814d (or in other words is disposed over the third surface with the perimeter portion masked during the deposition process) so as to define a gap or isolating portion 814e at the third surface 814a where the third surface mirror reflector is not disposed. The gap or isolating portion 814e may extend along the perimeter edge region about 1 to 2 cm (or thereabouts or more or less) and functions to electrically insulate or isolate the third surface mirror reflector from the perimeter edge region and overhang region 815 of the reflective element at that portion of the edge region. The perimeter seal 822 is disposed at the gap portion and may overlap an edge portion of the third surface mirror reflector to further electrically insulate or isolate the third surface mirror reflector 820 from the perimeter edge region 814d of rear substrate 814. The third surface mirror reflector 820 may extend over substantially the entire third surface 814a except at the gap portion (and thus may extend to the perimeter edge 814d at other areas at either side of the gap portion), such that the gap portion may be established by masking a relatively small portion of the third surface during the deposition of the third surface mirror reflector materials on the third surface or front surface of the rear substrate.

[00196] The front glass substrate 812 has a transparent electrical conductor 818 (such as a coating or layer of ITO or the like) disposed on its rear or second surface 812a. As shown in FIG. 29, a perimeter band 826 (which may comprise any suitable material, such as chromium or the like) may be disposed around the perimeter region of the rear surface of the front substrate 812, with the transparent electrical conductor 818 overlapping the perimeter band 826. Optionally, however, the transparent electrical conductor may be disposed over the rear surface of the front substrate and the perimeter band may be disposed over the transparent electrical conductor, without affecting the scope of the present invention. The perimeter band 826 includes a wraparound portion or tabout portion 826a disposed over a perimeter edge 812b of front substrate 812 (such as about a 1 to 2 cm length or portion along the perimeter edge 812b), while the transparent electrical conductor 818 likewise includes a wraparound portion or tabout portion 818a that is disposed over (or could be under depending on the particular application) the wraparound portion or tabout portion 826a of perimeter band 826 at the perimeter edge 812b of front substrate 812. The tabout portions 818a, 826a are formed along a portion of the perimeter edge 812b of front substrate 812 that corresponds to the location of the gap portion 814e at the third surface 814a of rear substrate 814 when the substrates 812, 814 are juxtaposed, such that the third surface reflector 820 is not coincident with or opposing the tabout portion 818a, 826a of the second surface transparent conductor of the front substrate.

[00197] Thus, the perimeter metallic band 826 may be disposed around the entire perimeter region of the rear surface of the front substrate and the second surface transparent conductor 818 may be disposed over the entire second surface and over the metallic band. The second surface transparent conductor may also be disposed at a wrap around or tab out portion of one edge, such as only about 1 to 2 cm or thereabouts (or more or less) along one of the edges of the front substrate. The third surface mirror reflector may be disposed over the third surface (the front surface of the rear substrate) except at a corresponding portion or region of the front surface of the rear substrate that corresponds with or opposes the second surface transparent conductor tabout / wraparound portion when the substrates are juxtaposed. The third surface mirror reflector thus may be disposed over the front surface of the rear substrate with a mask portion or element only at the portion of the front surface that corresponds to and opposes the second surface transparent conductor tabout / wraparound portion of the front substrate.

[00198] A wraparound element or tabout element or portion 842 is disposed at the perimeter edge 814d of rear substrate 814 and at the gap portion 814e (such as about a 1 to 2 cm length

or portion along the perimeter edge) of rear substrate 814 (and thus at a location along the perimeter edge that corresponds to the location of the tabout portion 826a, 818a at the front substrate 812 when the reflective element assembly is assembled together and the front and rear substrates are juxtaposed as shown in FIG. 29). As can be seen in FIG. 29, the tabout portion 842 may be disposed partially at the rear surface 814b of the rear substrate 814 to establish a fourth surface contact or busbar 840b, and the tabout portion 842 may be disposed partially at the front or third surface 814a of the rear substrate and at the region 814e that is devoid of the third surface reflector 820. Thus, electrical conductivity may be established between the fourth surface contact 840b at the fourth surface 814b of rear substrate 814 via a conductive element or material 819 (such as a conductive epoxy or the like) established or disposed at the overhang region 815 of the reflective element 810 (such as at the perimeter region 814d of the rear substrate 814 and the perimeter region 812b of the front substrate 812), and generally at a location along the perimeter edge region 814d that corresponds with the gap portion 814e and that corresponds with the location of the tabout portions 818a, 826a at the front substrate when the front and rear substrates are juxtapositioned next to one another. In the illustrated embodiment, the electrically conductive tab or wraparound coating or layer or element 842 is disposed over a portion of the rear surface 814b and perimeter region 814d and also partially over the perimeter gap region 814e of the front or third surface 814a of the rear substrate 814. The wraparound layer or element 842 is electrically isolated or insulated from the third surface mirror reflector 820 via the gap (or area at the third surface that is devoid of the third surface reflector 820) and the perimeter seal.

[00199] Thus, the conductive epoxy 819 disposed at the overhang region 815 contacts and establishes electrical conductivity to the second surface electrical conductor 818 via the wraparound portions 826a, 818a at perimeter edge 812b of front substrate 812, and may provide electrical conductivity to the fourth surface contact 840b via the wraparound element or tab or portion 842 at the corresponding location along the perimeter region of the third surface 814a of rear substrate 814. The wraparound portion 818a (comprising ITO or the like) is desirably disposed between the wraparound chromium portion 826a and the conductive epoxy 819 so that the conductive epoxy 819 does not directly contact the chromium perimeter band 826 and wraparound portion 826a. Optionally, the electrical conductivity between the wraparound portions 818a, 826a and the fourth surface contact 840b may be established by disposing a conductive material, such as conductive epoxy or the like, at the overhang region and further over the perimeter edge region 814d of the rear surface. Optionally, the electrical conductivity between the wraparound portions 818a, 826a

and the fourth surface contact or bus bar 840b may be established by disposing a conductive material, such as a conductive epoxy or the like, at the overhang region and providing a metallic clip or element at the corresponding portion of the perimeter region of the rear substrate. For example, the conductive material or epoxy may be disposed at the overhang region 815 and over the perimeter region 814d and a metallic clip may be slid over the perimeter region while the conductive epoxy is wet to establish electrical conductivity between the fourth surface portion of the clip and the conductive epoxy at the overhang region. Other means of establishing such electrical conductivity between the fourth surface of the larger rear substrate and the second surface wraparound portions at the smaller front substrate may be implemented without affecting the scope of the present invention.

[00200] As shown in FIGS. 30 and 30A, reflective element assembly 810 may be disposed at a mirror support or casing or housing or bezel 850 of an interior rearview mirror assembly 852. The bezel portion 850 may include a thin, substantially non-structural overlap 850a at the front surface of the front substrate 812, while the oversized rear substrate 814 is supported by a supporting portion 850b of the bezel portion 850, and thus takes substantially all of the load at the bezel portion 850. Such construction substantially reduces the stresses, such as hoop stresses, applied to the seal 822 and reflective element assembly 810 during assembly and construction of the mirror assembly, because the bezel primarily contacts the larger dimensioned rear substrate and preferably makes little or no contact to the smaller dimensioned front substrate. Further, such construction facilitates the use of a reduced reflective perimeter band 826, since the perimeter seal 822 is partially hidden or concealed by the thin overlap portion 850a of bezel portion 850. The size of the reflective band and the visibility or viewability or discernibility of the reflective band thus may be reduced. The overlap 850a may extend or overlap the front surface of the front substrate enough so as to at least partially and preferably substantially cover or conceal the perimeter seal 822. The electrical connection to the second surface transparent conductor thus may be made via an electrical connection at the fourth or rear surface of the rear substrate and outboard of the perimeter seal and thus hidden from view via the bezel portion 850.

[00201] As can be seen with reference to FIGS. 30, 30A and 30B, the smaller front substrate reflective element construction of FIGS. 30 and 30A allows the bezel to substantially or primarily or entirely engage and support the reflective element at the rear substrate, while primarily not contacting the front substrate. The smaller front substrate reflective element construction thus allows for a smaller bezel overlap portion at the front of the reflective element, as compared to an offset reflective element construction as shown at 870 in FIG.

30B. In the mirror construction of FIG. 30B, a larger bezel 872 is used to contain the cell 874 and to cover up or conceal the perimeter seal of the cell. As shown in FIG. 30B, the reflective element may include a backing plate or structural support and the bezel portion may attach to or snap to a rear casing portion or cap portion or the like to assemble the mirror assembly, such as utilizing aspects described in PCT Application No. PCT/US2004/015424, filed May 18, 2004, and published Dec. 2, 2004 as PCT Publication No. WO 2004/103772 A3 (our file DON01 FP-1150 (PCT)), which is hereby incorporated herein by reference in its entirety.

[00202] For example, and as shown in FIG. 30A, the bezel overlap portion 850a may extend only about 1 mm over the front surface of the reflective element. As shown in FIG. 30A, the bezel 850 may include the overlap portion 850a that extends about 2 mm (such as about 2.33 mm as shown in FIG. 30A) from the rear substrate contact or support portion 850b so as to extend over the front surface of the reflective element about 1 mm or thereabouts (i.e., the 2.33 mm overlap portion extends over or across the overhang region 815 of the reflective element (which is illustrated as being about 1.33 mm) and further over the front surface of the reflective element about 1 mm). Although the dimensions described above are shown in FIG. 30A as being relative to the lower chin portion of the bezel portion, similar dimensioned bezel portions may be provided at the upper portion of the bezel. A backing plate or attachment plate 854 may be provided at the rear of the rear substrate 814 and may extend to the bezel portion 850, such as for securing the reflective element to or within the mirror assembly and/or for providing user inputs, such as buttons or switches or the like, or display elements or illumination sources or the like, at the bezel portion for viewing and/or access by a user or occupant of the vehicle.

[00203] The smaller front substrate reflective element construction of the present invention thus allows for a smaller or reduced bezel portion around the perimeter of the front surface of the front substrate, while providing substantial support and retention of the reflective element at the bezel. The electrical conductive connection to the transparent conductor at the rear of the front or first substrate may be made via wraparound elements and/or conductive elements or materials (such as conductive epoxy or the like), such as described above. Thus, the reflective element may be supported at the bezel with a reduced overlap bezel portion around the front perimeter of the reflective element, and while providing for electrical connection to the reflective element or cell at the fourth surface of the reflective element or cell. Electrical connection or conductive continuity may be made to the second surface transparent conductor

on the smaller front substrate via the wraparound or tab out portion at the portion of the perimeter edge of the front substrate.

[00204] Optionally, and as shown in FIG. 31, an opaque paint or coating or layer 860 may be established or disposed at the rear surface 814b of the rear substrate 814 of the reflective element 810. In applications where the reflective element 810 is a transfective reflective element, the electrical contacts or tabs 841 at the rear of the reflective element may be viewable through the reflective element if they are positioned inboard of the perimeter seal and bezel portion. Thus, it is desirable to establish an opaque coating/layer 860, such as via printing or painting an opaque material or paint or ink or the like, onto the rear or fourth surface to substantially conceal the electrical contact or tab. The opaque coating/layer 860 may be screen printed or laser jet printed or ink jet printed or transfer printed, such as via booby printing or the like, or otherwise established across the fourth surface (or may be an opaque tape applied to the fourth surface) and partially over the fourth surface conductor or bus bar 840a (optionally, the opaque coating/layer 860 may be disposed onto the rear surface of the substrate and the fourth surface conductor 840a may be disposed partially over the opaque coating/layer). The electrical contact or tab 841 thus may be disposed at the fourth surface and partially over the opaque coating 860 and over or to or in conductive continuity with the fourth surface bus bar 840a, so that the tab 841 can extend into the viewing area for electrical connection without becoming visible through the reflective element. Optionally, the opaque layer may comprise a conductive material, whereby the tab may not be necessary.

[00205] Optionally, the mirror assembly may include a logo or message or iconistic display that is formed or established in and through (or at least partially through) the opaque layer. Optionally, the layer may be partially transmissive (so its mostly opaque (maybe 3-5%T)) at least at a portion of the opaque or substantially opaque layer, and the mirror reflective element assembly could have an icon behind the layer, such as an opaque icon or the like. Thus, an illumination source may be located at the rear of the reflective element and may be activatable or energizable to backlight the logo or message or icon so it is viewable through the reflective element. The backlit logo or message or icon thus may be readily viewable or discernible by a person viewing the mirror reflective element.

[00206] For the third surface metallic reflectors, second surface metallic reflectors, second surface metallic reflective bands, second surface indicia reflective bands/indicia and/or fourth surface wrap-around metallic conductor layers (such as are described herein and/or disclosed in U.S. pat. applications, Ser. No. 11/226,628, filed Sep. 14, 2005 (Attorney Docket DON01 P-1236); Ser. No. 11/021,065, filed Dec. 23, 2004 by McCabe et al. for ELECTRO-OPTIC

MIRROR CELL (Attorney Docket DON01 P-1193); and/or Ser. No. 11/334,139, filed Jan. 18, 2006 by Byers et al. for MIRROR ASSEMBLY WITH HEATER ELEMENT (Attorney Docket DON01 P-1259); and/or U.S. provisional applications, Ser. No. 60/644,903, filed Jan. 19, 2005 by Byers et al. for MIRROR ASSEMBLY WITH HEATER ELEMENT (Attorney Docket DON01 P-1202); Ser. No. 60/667,049, filed Mar. 31, 2005 by Byers et al. for MIRROR ASSEMBLY WITH HEATER ELEMENT (Attorney Docket DON01 P-1213); and/or Ser. No. 60/692,113, filed Jun. 20, 2005 (Attorney Docket DON01 P-1224), which are hereby incorporated herein by reference in their entireties), thin film coatings formed preferably by sputtering of nickel-alloys or iron-alloys can be used.

[00207] For example, Inconel (a nickel-based superalloy such as Inconel alloy 600 which is 72 percent nickel, 16 percent chromium, and 8 percent iron) can be used. Other forms of Inconel can be used, depending on the property required for a particular mirror construction/coating. For example, Inconel alloy 750, which has a small percentage of titanium and aluminum added for hardenability, can be used. Another example of a suitable material is Inconel 625, which contains molybdenum and columbium.

[00208] Another suitable nickel-alloy choice is HASTELLOY, which is a registered trademark name of Haynes International, Inc. The predominant alloying ingredient is typically nickel. Other alloying metals may be added to the nickel, including varying percentages of the elements molybdenum, chromium, cobalt, iron, copper, manganese, titanium, zirconium, aluminum, carbon, and tungsten. For example, for the third surface metallic reflectors, second surface metallic reflective bands and/or fourth surface wrap-around metallic conductor layers of the electrochromic mirrors described herein, thin film coatings may be deposited on the substrates involved by sputtering in a vacuum chamber from a Hastelloy C 276 or a Hastelloy X alloy planar magnetron or rotary magnetron sputtering target.

[00209] Another suitable choice is Nichrome, which is an alloy of nickel and chromium. Typically, the alloy is 80 percent nickel and 20 percent chromium. Nichrome, when sputter deposited as a conductive, metallic, reflective thin film of at least about 300 angstroms thickness has a specular reflectivity greater than about 60 percent reflectivity; and depending on the vacuum deposition conditions greater than about 65 percent reflectivity (as measured using SAE J964a). For example, good results can be achieved using a thin film of Nichrome [typically about 400-600 angstroms thick sputter-deposited onto the inward-facing surface (third surface) of the rear substrate in a laminate-type electrochromic mirror cell construction], and then overcoating this thin layer of Nichrome with a thinner layer (typically

about 100-200 angstroms thick or thereabouts) of Rhodium to form a Nichrome/Rhodium third surface reflector. If Nichrome is also used as a wrap-around fourth surface conductor [or for the perimetral reflector band around the edge perimeter of the inward-facing surface (second surface) of the front substrate of the EC cell construction], contact resistance challenges sometimes experienced when a chromium thin film conductor layer is contacted to by some silver-loaded conductive epoxies are reduced/mitigated.

[00210] Another alloy choice for these third surface metal reflector, second surface indicia reflective bands/indicia and/or fourth surface conductor layers is a coating of Nickel Silver, which is an alloy of copper with nickel and often, but not always, zinc. Nickel-silver alloys are commonly named by listing their percentages of copper and nickel, thus "Nickel Silver 55-18" would contain 55 percent copper, 18 percent nickel, and 27 percent other elements, most probably entirely zinc. For example, a NS-12 Nickel-silver alloy, which is 88 percent copper and 12 percent nickel, may be used.

[00211] Another alloy choice for these third surface metal reflector, second surface indicia reflective bands/indicia and/or fourth surface conductor layers is a coating of Cupronickel which is an alloy of copper, nickel and strengthening impurities. A typical mix is 75 percent copper, 25 percent nickel, and a trace amount of manganese. A 55 percent copper/45 percent nickel alloy may also be used.

[00212] Another alloy choice for these third surface metal reflector, second surface indicia reflective bands/indicia and/or fourth surface conductor layers is a coating of Monel metal, which is a copper-nickel alloy. Monel is a metal alloy, primarily composed of nickel and copper, with some iron and other trace elements. Also, bronze (copper alloyed with tin), brass (copper alloyed with zinc), and nickel silver (another group of copper-nickel alloys) may be used.

[00213] Another alloy choice for these third surface metal reflector, second surface indicia reflective bands/indicia and/or fourth surface conductor layers is a coating of stainless steel which is a ferrous alloy with a minimum of 10.5 percent chromium, preferably with additions of more than 12 percent (by weight) chromium. For example, a thin film coating sputtered off a AL-6XN alloy target, which is a superaustenitic stainless steel which was developed by Allegheny Ludlum Corporation (www.alleghenyludlum.com), can be used. It exhibits far greater resistance to chloride pitting, crevice corrosion and stress-corrosion cracking than exhibited by the standard 300 series stainless steels, and is less costly than traditional nickel-base corrosion resistant alloys. The UNS Designation of the AL-6XN® alloy is N08367.

- [00214] The high nickel (24 percent) and molybdenum (6.3 percent) contents of the AL-6XN® alloy give it good resistance to chloride stress-corrosion cracking. The molybdenum confers resistance to chloride pitting. The nitrogen content of AL-6XN® alloy serves to further increase pitting resistance and also gives it higher strength than typical 300 series austenitic stainless steels, and thereby often allows it to be used in thinner sections. The high levels of chromium, molybdenum and nitrogen in AL-6XN® alloy all serve to produce exceptional corrosion resistance for this formable and weldable stainless steel.
- [00215] Another alloy choice for these third surface metal reflector, second surface indicia reflective bands/indicia and/or fourth surface conductor layers is a coating of Chinese silver, which is an alloy made of silver, nickel and bronze, such as used for jewelry or a coating of a Ferroalloy that constitutes various alloys of less than 50 percent iron and one or more other element, manganese or silicon for example. The main Ferroalloys are: ferromanganese, ferrochromium, ferromolybdenum, ferrotitanium, ferrovandium, ferrosilicon, ferroboron, and ferrophosphorus.
- [00216] Another alloy choice for these third surface metal reflector, second surface indicia reflective bands/indicia and/or fourth surface conductor layer is a coating of German silver that is an alloy of 45–70 percent copper, 5–30 percent nickel, and 8–45 percent zinc - sometimes small amounts of tin or lead are added. It has a color resembling silver. Other names are Nickel silver, Pakfong (also *Paktong*) and Alpacca (originally a trademark of Berndorf AG).
- [00217] Another alloy choice for these third surface metal reflector, second surface indicia reflective bands/indicia and/or fourth surface conductor layer is a coating of a titanium alloy such as a Grade F-5 titanium alloy (6 percent aluminum, 4 percent vanadium); Grade F-6 titanium alloy (5 percent aluminum, 2.5 percent tin); a titanium/palladium alloy; Grade F-12 titanium alloy (0.3 percent molybdenum, 0.8 percent nickel).
- [00218] Another alloy choice for these third surface metal reflector, second surface indicia reflective bands/indicia and/or fourth surface conductor layer is a coating of a manganese alloy, such as a manganese-copper or a manganese-iron or a manganese-gold alloy. Another alloy choice for these metal reflector and/or conductor layers is a coating of a molybdenum alloy, such as a 52 percent molybdenum/48 percent rhenium alloy or a 99 percent Mo, 0.5 percent Ti and 0.08 percent Zr alloy (commonly known as a TZM alloy).
- [00219] Another alloy choice for these third surface metal reflector, second surface indicia reflective bands/indicia and/or fourth surface conductor layer is Sterling silver, which is an alloy of silver containing least 92.5 percent pure silver and 7.5 percent other metals, usually

copper. In Sterling silver, the silver is usually alloyed with copper to give strength. Other metals can replace the copper. For example, a thin film coating formed by sputter deposition from a Silver/Germanium alloy target can be used.

[00220] Another alloy choice for these third surface metal reflector, second surface indicia reflective bands/indicia and/or fourth surface conductor layer is an aluminum alloy, such as Duralumin which is an alloy of aluminum (about 95 percent), copper (about 4 percent), and small amounts of magnesium (0.5 percent to 1 percent) and manganese (less than 1 percent). When sputter deposited to form a thin film metallic conductor reflector/electrode layer, such aluminum alloy thin films may optionally be overcoated with a thin film of a transparent conductor (such as of indium tin oxide) that is thus disposed between the aluminum-based reflector layer and the electrochromic medium in the electrochromic cell construction (and thus protecting the aluminum-based reflector layer from direct contact with the electrochromic medium).

[00221] Another alloy choice for these third surface metal reflector, second surface indicia reflective bands/indicia and/or fourth surface conductor layer is Stellite, which is a range of cobalt-chromium alloys designed for wear resistance. It may also contain tungsten and a small but important amount of carbon.

[00222] Another alloy choice for these third surface metal reflector, second surface indicia reflective bands/indicia and/or fourth surface conductor layer is Billon, which is an alloy of silver (sometimes gold) with a high base metal content (such as copper) or a silver alloy such as a silver-palladium alloy.

[00223] Another alloy choice for these third surface metal reflector, second surface indicia reflective bands/indicia and/or fourth surface conductor layer are copper-zinc-aluminum alloys or nickel-titanium (NiTi) alloys, such as the nickel-titanium alloy available under the trade name Nitinol (an acronym for Nickel Titanium Naval Ordnance Laboratories).

[00224] Another alloy choice for these third surface metal reflector, second surface indicia reflective bands/indicia and/or fourth surface conductor layer are tungsten alloys with tungsten content ranging from 40 to 97 percent featuring varying degrees of physical and mechanical properties; examples include W-Fe, W-Cu and W-Co alloys.

[00225] Another alloy choice for these third surface metal reflector, second surface indicia reflective bands/indicia and/or fourth surface conductor layer are palladium alloys, such as palladium-rhodium alloys.

- [00226] Another alloy choice for these third surface metal reflector, second surface indicia reflective bands/indicia and/or fourth surface conductor layer are indium alloys, such as indium-bismuth-tin alloys or lead-indium alloys or tin-indium alloys.
- [00227] Another alloy choice for these third surface metal reflector, second surface indicia reflective bands/indicia and/or fourth surface conductor layer are zinc alloys, such as with copper or magnesium or nickel.
- [00228] Another alloy choice for these third surface metal reflector, second surface indicia reflective bands/indicia and/or fourth surface conductor layer is Brass, which is an alloy of copper and zinc. Some types of brass are called bronzes, despite their high zinc content. Alpha bronzes (with less than 40 percent zinc) or Beta bronzes, with a higher zinc content, can be used, depending on the circumstance involved. White brass, with more than 45 percent zinc, can also be used when it delivers the desired property.
- [00229] Another alloy choice for these third surface metal reflector, second surface indicia reflective bands/indicia and/or fourth surface conductor layer is a rhenium alloy, such as a molybdenum-rhenium or a tungsten-rhenium alloy.
- [00230] Another alloy choice for these third surface metal reflector, second surface indicia reflective bands/indicia and/or fourth surface conductor layer is a gold alloy such as an ELKONIUM® 76 gold-copper alloy or an ELKONIUM® 70 gold-silver-nickel alloy or a gold-palladium-nickel alloy or a gold-copper alloy or a gold-copper-nickel alloy or a gold-indium alloy or gold-nickel alloy or a gold-tin alloy.
- [00231] Another alloy choice for these third surface metal reflector, second surface indicia reflective bands/indicia and/or fourth surface conductor layer is a platinum alloy, such as with cobalt, or with copper or with iridium (for example, Pt70/Ir30) or with palladium or with rhodium or with gallium or with ruthenium or with tungsten or with indium.
- [00232] Another alloy choice for these third surface metal reflector, second surface indicia reflective bands/indicia and/or fourth surface conductor layer is a rhodium alloy, such as with iron or platinum (for example, Pt90/Rh10 or Pt87/Rh13).
- [00233] Another alloy choice for these third surface metal reflector, second surface indicia reflective bands/indicia and/or fourth surface conductor layer is a cobalt alloy, such as with iron or nickel.
- [00234] Another alloy choice for these third surface metal reflector, second surface indicia reflective bands/indicia and/or fourth surface conductor layer is a copper alloy, such as with tin or nickel or lead. Examples include Phosphor Bronze, Gun Metal, Tin Bronze, Leaded Bronze and Nickel Bronze.

- [00235] Another alloy choice for these third surface metal reflector, second surface indicia reflective bands/indicia and/or fourth surface conductor layer are superalloys, such as PM2000 available from Plansee AG of Reutte, Austria, and having a composition in weight percentage: 20 Cr, 5.5 Al, 0.5 Ti, 0.3 Al, 0.5 Y₂O₃, remainder Fe. The Plansee PM 2000 is a highly oxidation resistant and extremely creep resistant ferritic iron-chromium based alloy, due to its high content of aluminum and chromium.
- [00236] Another alloy choice for these third surface metal reflector layers, second surface indicia reflective bands/indicia layers and/or fourth surface conductor layers are tantalum alloys, such as tantalum-tungsten alloys and tantalum-niobium alloys. Another alloy choice for these metal reflector and/or conductor layers are niobium alloys or zirconium or iridium alloys or osmium alloys or ruthenium alloys or lead alloys or beryllium alloys or tin alloys.
- [00237] Alloys formed of tin and lead with other metal elements and non-metal elements (such as phosphorous or silicon or carbon) may be used where the coating properties suit the particular electrochromic cell structure/performance desired.
- [00238] Another alloy choice for these third surface metal reflector, second surface indicia reflective bands/indicia and/or fourth surface conductor layer is a magnesium alloy, such as Magnesium-manganese; Magnesium-aluminum-manganese; Magnesium-aluminum-zinc-manganese; Magnesium-zirconium; Magnesium-zinc-zirconium; Magnesium-rare earth metal-zirconium; Magnesium-silver-rare earth metal-zirconium; and/or Magnesium-yttrium-rare earth metal-zirconium.
- [00239] Metal reflector layers and/or indicia layers and/or conductor layers may also be sputter (or otherwise) deposited from metal targets such as from a chromium metal target, or from a nickel metal target or from a tungsten metal target or from a ruthenium metal target or from a titanium metal target or from a molybdenum metal target or from a cobalt metal target or from a manganese metal target or from a silver metal target or from an aluminum metal target or from a platinum metal target or from a palladium metal target or from a gold metal target or from a rhenium metal target or from a rhodium metal target or from a tantalum metal target or from a niobium target or from a zirconium target or from an iridium target or from an osmium target or from a lead target or from a beryllium target or from a zinc target or from a tin target or from an indium target or from a target that is a mixture of one or more of these metals (optionally with other metallic and/or non-metallic elements included). In general, improved results in terms of making contact thereto, such as via a conductive epoxy (such as lower, stabler contact resistances), are obtained for metal reflector and/or conductor layers by using metals or alloys that have a low Gibbs Energy of formation of metal oxides as

the sputter target (or evaporation material) for vacuum deposition of thin metallic layers. For example, deposited thin films of palladium or nickel or tungsten or molybdenum or rhodium have a low Gibbs Energy of formation of metal oxides compared to, for example, thin films of aluminum or chromium.

[00240] The choice of alloy or metal reflector and/or conductor layer to use is dependent on the reflectivity level and spectral content desired (for example, whether a silvery reflectivity is desired or whether a more copper-toned reflectivity is desired) and by the electrical properties (such as specific conductivity of the deposited thin film) and/or optical properties (such as the optical constants such as refractive index and k-value) desired for the deposited thin metallic film and/or by the sputtering rate/evaporation rate desired in the production process and/or by the cost bearable by the construction involved.

[00241] Also, when sputtering or otherwise vacuum depositing the metal reflector and/or conductor layers of the present invention from an alloy or mixed-metal target or source, the elemental composition/structure of the target/source is preferably substantially replicated in the deposited metallic thin film coating or layer but need not be exactly replicated.

[00242] Also, and as described previously above and optionally, the third surface metal reflector on the third surface of the rear substrate of the cell, the perimeter reflective border band around the edge border of the second surface of the front substrate and any indicia on the second surface but inward of the border band (if present) may be substantially the same material so that all three have substantially the same optical properties such as reflectivity level and refractive index /k-value. By so choosing, the optical contrast between the third surface reflector coating and the second surface perimeter border is substantially reduced and essentially eliminated such that the viewer barely sees or notices the presence of the second surface border band when the electrochromic cell is not powered (i.e. is undimmed and is in its bleached state). For example, the third surface reflector coating and the second surface perimetral border reflector band may both comprise chromium thin films or both may comprise ruthenium thin films or both may comprise rhodium thin films or both may comprise Hastelloy C-276 thin films or both may comprise molybdenum thin films or both may comprise aluminum (or aluminum alloy) thin films or both may comprise aluminum/palladium alloy thin films or both may comprise silver (or silver alloy) thin films or both may comprise an ITO/thick Ag (preferably greater than about 200 angstroms physical thickness; more preferably greater than about 250 angstroms thickness and most preferably greater than about 300 angstrom thickness)/ITO stack or a ZnAlO/thick Al/ZnAlO stack or a ZnAlO/thick Ag/ZnAlO stack or an SnO₂/Ag/SnO₂ stack or the like.

[00243] Optionally, it may be desirable to select a bezel for a mirror assembly that has a material or color or appearance or construction or reflectance character that matches or accentuates or complements the reflective surface of the interior mirror (or exterior mirror) reflector, and particularly for an interior EC mirror element that uses a reflecting perimeter border band or coating (such as disclosed in U.S. pat. applications, Ser. No. 11/021,065, filed Dec. 23, 2004 by McCabe et al. for ELECTRO-OPTIC MIRROR CELL (Attorney Docket DON01 P-1193); Ser. No. 10/528,269, filed Mar. 17, 2005 (Attorney Docket DON01 P-1109); Ser. No. 10/533,762, filed May 4, 2005 (Attorney Docket DON01 P-1116); Ser. No. 11/226,628, filed Sep. 14, 2005 (Attorney Docket DON01 P-1236); and/or Ser. No. 11/021,065, filed Dec. 23, 2004 by McCabe et al. for ELECTRO-OPTIC MIRROR CELL (Attorney Docket DON01 P-1193), which are hereby incorporated herein by reference in their entireties) in a flush or frameless EC mirror cell construction. The bezel of the mirror casing and the perimeter metal band around the perimeter of the reflective element are preferably selected so as to mutually pick up on or complement each other so as to enhance the appearance and utility of the mirror assembly. The mirror assembly thus may include the use of a metal (or metal-like or metal-coated) bezel that can pick up on or complement the frameless character of the mirror element, and give the mirror assembly a metal-look functionality. For example, and as shown in FIG. 32, a mirror assembly 910 includes a mirror reflective element 912 having a perimeter metallic band 914 (with a metallic or silvery appearance or color). The mirror assembly 910 includes a bezel portion 916 that is selected to substantially match or contrast the color or appearance or reflectance of the perimeter metallic band 914. In the illustrated embodiment, the perimeter band has a silvery appearance or color, and the bezel portion 916 is selected to have a silver or chrome appearance or color or reflectance. Thus, for reflective elements with metallic perimeter bands (or other mirror reflector types), the bezel portion may comprise a metallic material (such as a silvery or brass-like metal stamping or forming or a chromed or metal-coated plastic molding) so as to have a metallic or metal-like appearance. The bezel portion thus picks up or complements the perimeter band of the mirror reflective element (or the mirror reflector itself) so as to provide an aesthetically pleasing mirror assembly. Although shown in FIG. 32 as an interior rearview mirror assembly, the mirror assembly may comprise an exterior rearview mirror assembly utilizing similar principles. Thus, a retro-look or high-tech look can be imparted to the mirror assembly and the look to the driver or occupants of the vehicle of the bezel can blend in with the look of the mirror reflective element itself.

[00244] Optionally, the mirror assembly may include one or more displays, such as for the accessories or circuitry described herein. The display or displays may be similar to those described above, or may be of the types described in U.S. Pat. Nos. 5,530,240 and/or 6,329,925, which are hereby incorporated herein by reference in their entireties, or may be display-on-demand or transfective type displays or other displays, such as the types disclosed in U.S. Pat. Nos. 6,690,268; 5,668,663 and/or 5,724,187, and/or in U.S. pat. applications, Ser. No. 10/054,633, filed Jan. 22, 2002 by Lynam et al. for VEHICULAR LIGHTING SYSTEM (Attorney Docket DON01 P-962); Ser. No. 11/021,065, filed Dec. 23, 2004 by McCabe et al. for ELECTRO-OPTIC MIRROR CELL (Attorney Docket DON01 P-1193); Ser. No. 10/528,269, filed Mar. 17, 2005 (Attorney Docket DON01 P-1109); Ser. No. 10/533,762, filed May 4, 2005 (Attorney Docket DON01 P-1116); Ser. No. 10/538,724, filed Jun. 13, 2005 by Hutzler et al. for ACCESSORY SYSTEM FOR VEHICLE (Attorney Docket DON01 P-1123); Ser. No. 11/226,628, filed Sep. 14, 2005 by Karner et al. (Attorney Docket DON01 P-1236); Ser. No. 10/993,302, filed Nov. 19, 2004 (Attorney Docket DON01 P-1186); and/or Ser. No. 11/284,543, filed Nov. 22, 2005 (Attorney Docket DON01 P-1245), and/or PCT Application No. PCT/US03/29776, filed Sep. 9, 2003 by Donnelly Corp. et al. for MIRROR REFLECTIVE ELEMENT ASSEMBLY (Attorney Docket DON01 FP-1109(PCT)); and/or PCT Application No. PCT/US03/35381, filed Nov. 5, 2003 by Donnelly Corp. et al. for ELECTRO-OPTIC REFLECTIVE ELEMENT ASSEMBLY (Attorney Docket DON01 FP-1116(PCT)); and/or U.S. provisional applications, Ser. No. 60/630,061, filed Nov. 22, 2004 by Lynam et al. for MIRROR ASSEMBLY WITH VIDEO DISPLAY (Attorney Docket DON01 P-1189); Ser. No. 60/667,048, filed Mar. 31, 2005 by Lynam et al. for MIRROR ASSEMBLY WITH VIDEO DISPLAY (Attorney Docket DON01 P-1212); Ser. No. 60/629,926, filed Nov. 22, 2004 by McCabe et al. for METHOD OF MANUFACTURING ELECTRO-OPTIC MIRROR CELL (Attorney Docket DON01 P-1190); Ser. No. 60/531,838, filed Dec. 23, 2003 (Attorney Docket DON01 P-1132); Ser. No. 60/553,842, filed Mar. 17, 2004 (Attorney Docket DON01 P-1143); Ser. No. 60/563,342, filed Apr. 19, 2004 (Attorney Docket DON01 P-1153); Ser. No. 60/681,250, filed May 16, 2005 (Attorney Docket DON01 P-1221); Ser. No. 60/690,400, filed Jun. 14, 2005 (Attorney Docket DON01 P-1225); Ser. No. 60/695,149, filed Jun. 29, 2005 (Attorney Docket DON01 P-1227); Ser. No. 60/717,093, filed Sep. 14, 2005 by Lynam (Attorney Docket DON01 P-1240); Ser. No. 60/730,334, filed Oct. 26, 2005 by Baur for VEHICLE MIRROR ASSEMBLY WITH INDICIA AT REFLECTIVE ELEMENT (Attorney Docket DON01 P-1250); Ser. No. 60/732,245, filed Nov. 1, 2005 (Attorney Docket DON01 P-1251); and/or

Ser. No. 60/759,992, filed Jan. 18, 2006 by Weller et al. for INTERIOR REARVIEW MIRROR ASSEMBLY WITH DISPLAY (Attorney Docket DON01 P-1264), and/or PCT Application No. PCT/US03/40611, filed Dec. 19, 2003 by Donnelly Corp. et al. for ACCESSORY SYSTEM FOR VEHICLE (Attorney Docket DON01 FP-1123(PCT)), which are all hereby incorporated herein by reference in their entireties, or may include or incorporate video displays or the like, such as the types described in PCT Application No. PCT/US03/40611, filed Dec. 19, 2003 by Donnelly Corp. et al. for ACCESSORY SYSTEM FOR VEHICLE (Attorney Docket DON01 FP-1123(PCT)), U.S. patent applications, Ser. No. 10/538,724, filed Jun. 13, 2005 (Attorney Docket DON01 P-1123); and/or Ser. No. 11/284,543, filed Nov. 22, 2005 (Attorney Docket DON01 P-1245), and/or U.S. provisional applications, Ser. No. 60/630,061, filed Nov. 22, 2004 by Lynam et al. for MIRROR ASSEMBLY WITH VIDEO DISPLAY (Attorney Docket DON01 P-1189); and Ser. No. 60/667,048, filed Mar. 31, 2005 by Lynam et al. for MIRROR ASSEMBLY WITH VIDEO DISPLAY (Attorney Docket DON01 P-1212), which are hereby incorporated herein by reference in their entireties.

[00245] Optionally, the mirror assembly and/or reflective element assembly (such as a transfective electro-optic or non-electro-optic mirror reflective element) may include or may be associated with a rearwardly facing video display screen, such as a video display screen positioned at and behind the fourth surface of the reflective element and operable to emit light through the reflective element so as to be viewable to a driver of the vehicle when actuated. Typically, the intensity of the display is maximized during daytime operation (such as bright ambient light conditions) to reduce or limit washout of the display. However, at night, the intensity may be reduced, such as via photo-sensor control or by applying a reduced voltage when vehicle logic adapts an instrument panel dimmed illumination state. Accordingly, visibility of the display at night (i.e., during low or reduced ambient light conditions) is readily accomplished for such displays as the intensity of the display emission can be readily reduced by applying a reduced voltage compared to that applied when the display intensity is maximized during daytime driving. However, when an electro-optic (such as electrochromic) reflective element is dimmed or darkened at night in response to a detected glaring headlight condition, it may be desirable to re-brighten the intensity of the display (such as a navigation display or the like) to compensate for the reduced transmission through the electro-optic medium and thus enhance visibility and discernibility of the display through the darkened or dimmed reflective element, such as by utilizing aspects of the system described in U.S. Pat. Nos. 5,285,060 and 5,416,313, which are hereby incorporated herein

by reference in their entireties. Also, when the electro-optic medium is dimmed, such dimming may introduce a spectral characteristic or tint at the display and/or may impact the color rendition and/or color balance of a displayed color video image. Thus, and as described below, it may be desirable to avoid actuation and hence darkening/dimming of the electro-optic medium local to and in front of where the video display is disposed behind the reflective element.

[00246] For backup applications, such as a display that displays a rearward view at the rear of the vehicle, such as in conjunction with reverse aid or backup systems, such as a display that emits a video image of the rearward scene in response to a rearward facing video camera, the electro-optic mirror element may function in association with a reverse inhibit function (where the dimming of the electro-optic reflective element is inhibited when the reverse gear of the vehicle is engaged, such as described in U.S. Pat. Nos. 6,992,573; 6,590,193; 6,547,404; 6,305,807; 6,089,721; and 5,812,321, which are hereby incorporated herein by reference in their entireties), whereby the mirror reflective element is forced to and maintained in its day state when the vehicle is shifted into its reverse gear. In such backup or rear vision system applications, it may be desirable to locally dim the electro-optic medium in front of where the display is located behind the reflective element. Alternatively, and in particular applications, preferably, an electro-optically dimmed or darkened frame may be electro-optically created adjacent to and around where the video display is disposed (behind the reflective element) so as to frame the display for enhance viewability and discernibility of the display at and behind the reflective element. For example, and with reference to FIG. 33, a reflective element assembly 920 may be segmented into a primary reflective element viewing area or region D and a video display viewing area or region B, with the video display viewing area B at least partially surrounded or framed by a framing area or portion or region A.

[00247] Optionally, a lower frame portion or area or region C may be provided along the lower portion of the video display viewing area B, with a pair of leg portions of the video display viewing area B extending to the perimeter of the reflective element 920 at opposite sides of lower frame portion C and between lower frame portion C and frame portion A. The size or length of frame portion or region C may be selected depending on the desired or appropriate size or width of the legs of display area B, since the legs provide the conductive path to display area B and the electric flow to display area B may be reduced as the legs are made more narrow. Optionally, the reflective element may have a perimeter border band (such as described above), and the lower frame portion may not be readily viewable at the

lower perimeter band, such that the reflective element may not include such a lower frame portion.

[00248] The different portions or areas or regions A, B, C, D are defined by demarcation lines or deletion lines through at least one or some of the conductive coating or coatings of the reflective element 920 so as to electrically isolate one region from another and so as to enable electrical powering, and hence local actuation and dimming, of the electro-optic medium at each particular segment or region separate from the others. The demarcation lines are formed to electrically isolate the adjacent regions, while being sufficiently thin so as to be largely unnoticeable to the viewer of the mirror element. Preferably, the deletion lines are formed through the transparent conductive layer (such as ITO or the like) disposed on the second surface or rear surface of the front substrate of an electro-optic reflective element, such as by laser ablating or deleting thin lines along the second surface to define the desired viewing portions. Optionally, the deletion lines may be formed in and through the third surface reflector coatings or layers, but such deletion lines in the third surface reflector may be more readily visible or discernible than deletion lines formed through the second surface transparent conductive coating or layer.

[00249] Thus, during normal dimming or anti-glare operation of the reflective element 920, all of the regions A, B, C, D are powered to dim the viewable area of the reflective element. Optionally, the reflective element may be selectively dimmed, such as by dimming or darkening regions A and C (such as by powering contacts or electrodes at E and grounding or shorting contacts or electrodes at F) so as to provide a darkened frame around the video display and display area B. Such selective dimming may occur in response to the vehicle being shifted into its reverse gear. Such a frame enhances the viewability of the display by drawing the driver's eyes to the display area B when the frame is dimmed and the other viewing regions are not. Optionally, either the main or principle viewing / reflecting area D or the display area B may be dimmed while the other is un-dimmed or unpowered, in order to provide the desired reflectivity and viewability of the reflective element and display, depending on the particular application and desired appearance and function of the reflective element assembly.

[00250] In this manner, the presence and viewability of a video image displayed on such a video display/screen disposed behind a transfective electrochromic mirror element may be enhanced even during usage by day under higher ambient lighting (sunny) conditions where display wash-out can be a problem. The localized darkening of the EC medium local to and at least partially framing (preferably, substantially or wholly framing) the portion of the EC

mirror element where the video screen is disposed during daylight operation as described above helps draw the driver's attention and focus to the potentially faint/washed-out video image (such as a reversing back-up scene) and helps the driver distinguish this from the much brighter reflected image from the mirror reflector at other than where the video display is disposed.

[00251] This discrimination can be further augmented by increasing the intensity of display backlighting and or provision of additional lighting at but just beyond the border peripheral edges of the display element so that a ring or at least a partial frame of intense light can be seen by the driver that at least partially frames where the video screen is located (and so draws his/her attention and eye-focus to that location). Such an intense-light created frame or the like can be also used with a conventional fixed reflectance transfective mirror element (such as a transfective day/night prismatic mirror element)/video display as described above [with or without demarcation lines being ablated, such as by laser ablation, into the mirror reflector's coating(s)]. Such a ring or frame of intense light may be created, for example, by disposing behind the mirror element a number of intense light sources (such as LEDs or diode lasers or cold cathode tubes) that at least partially circumscribe the video display element at the rear of the mirror reflector, but that are located close to but just outside the display element itself so that the light emitted by such, for example, LEDs does not pass through (and so be attenuated by) the display element itself (typically, an LCD video display element). For example, a linear row of a plurality of LEDs, such as 3 – 6 LEDs or more, can be positioned along (but just outside) the top edge, along the bottom edge, along the right edge and/or along the left edge, so as to frame the location of the video display via emitting intense light through the transfective reflector of such a DOD transfective electrochromic or non-electrochromic (conventional) through-the-reflector video mirror.

[00252] Optionally, the likes of light pipes/light conduits and light distributors/diffusers (such as are common in the art) can be used in conjunction with an LED or a couple of LEDs or a plurality of LEDs in creating such a frame of intense light that at least partially frames the video display image so that its visibility and viewability to the driver is enhanced during daylight operation and so that the driver can better discern and focus on the video image being displayed, even under wash-out conditions. Optionally, the likes of photosensors can be used to adjust the intensity of such framing light sources (that preferably are LEDs but that alternatively can be a cold-cathode tubular light source, such as light sources of the types described in U.S. provisional applications, Ser. No. 60/732,245, filed Nov. 1, 2005 (Attorney Docket DON01 P-1251); and Ser. No. 60/759,992, filed Jan. 18, 2006 (Attorney Docket

DON01 P-1264), which are hereby incorporated herein by reference in their entireties, or can be any other suitable intense light source, such as a diode laser light source or a high-intensity incandescent light source) in accordance with prevailing ambient light conditions (and so that at night, intensity is reduced but by day, intensity is increased in accordance with an increase in ambient lighting detected). Note that it may be preferable to use a red or any other selected spectral intensity/color for the ring or frame of intense light created around the video image so that the demarcation creates both spectral demarcation and light intensity demarcation relative to the light intensity and spectral character of the video image itself.

[00253] Typically, it is desirable to substantially render unnoticeable or camouflage the presence of the video display (such as a liquid crystal display (LCD) video display or the like) that is disposed behind a transfective mirror element, such as a transfective mirror element that is at least about 10 percent transmissive of light therethrough and preferably about 20 percent transmissive. It is known to use a dark or black tape (or other suitable darkening or opacifying materials or layers, such as dark paint or ink or the like) to black out or opacify the areas where the display is not present, so that the presence of the display is not readily discernible to a person viewing the reflective element. However, this may lead to the joint lines between the tape and the display being visible or discernible, and even with such opacifying means, the outline of the display or display area may be noticeable to the driver, particularly during high ambient lighting conditions, such as during daytime driving conditions.

[00254] Optionally, a video display framing element or pocket may be provided as follows that is surprisingly effective in rendering the presence behind a transfective mirror element (and an interior prismatic transfective mirror element in particular) of the un-illuminated video screen non-noticeable. A piece of metal shim stock, such as stainless steel (such as a sheet or shim of stainless steel having a thickness of about 0.01 inches to about 0.02 inches or thereabouts) or the like, may be laser cut to match the shape of the prism or reflective element. The shim stock stainless steel substrate may have a window formed or laser cut therefrom that matches or substantially matches the size and shape of the active area of the display screen. Desirably, the color, reflectance and gloss of the shim stock substrate is selected to substantially match the OFF condition of the video display screen. The video display screen may be located at and behind the window of the shim stock substrate, and may be secured or adhered or glued or fastened in place at the window. The display element and shim stock substrate assembly may be located at or attached to the reflective element and behind the display on demand (DOD) reflective element.

[00255] The presence and location of the video display is thus substantially camouflaged or hidden or non-discernible so that it may be difficult to identify or discern the location of the video display when viewing the reflective element. The display assembly (including the shim stock plate or substrate and display element attached thereto) may be attached or adhered to the rear of the reflective element, such as to the rear of a backing plate of the reflective element or to the rear surface of a prismatic reflective element substrate or prism. Optionally, the display assembly may be attached or adhered to the rear surface of a prismatic reflective element substrate, such as an aluminum and silicon layered transfective prism, such as a prismatic substrate or element utilizing aspects of the mirrors described in U.S. Pat. Nos. 6,286,965; 6,196,688; 5,535,056; 5,751,489; and 6,065,840, and/or in U.S. pat. application, Ser. No. 10/993,302, filed Nov. 19, 2004 by Lynam for MIRROR REFLECTIVE ELEMENT FOR A VEHICLE (Attorney Docket DON01 P-1186), which are all hereby incorporated herein by reference in their entireties.

[00256] Optionally, a non-electro-optic transfective or display-on-demand (DOD) mirror element, such as a transfective prismatic mirror element, may be formed using a transfective DOD coating or coating stack on its second surface. Preferably, the coating or coating stack may comprise a coating comprising silicon or doped-silicon, such as silicon-aluminum mirror stack (with high silicon content) deposited onto the substrate surface. Such a silicon or doped-silicon coating may provide about 70 percent or more reflectivity of light incident thereon, while providing at least about 10 percent or more transmission of light therethrough, typically at least 20 percent or more transmission. The reflectivity from such a silicon-based coating may provide a silvery appearance and may provide enhanced durability to the substrate surface. Such a silicon-based mirror stack may be suitable for a transfective display on demand (DOD) prismatic substrate, such as for an interior or exterior rearview mirror assembly. Such a transfective silicon-based mirror element is suitable for use with a video display located behind the mirror so as to display video images at the mirror element for viewing by the driver of the vehicle. Alternately, similar silicon-based transfective mirror elements can be formed for exterior or outside mirror elements, such as flat, convex or aspheric elements (optionally, with the transfective layers on the front or first surface or on the rear or second surfaces, such as is known in the exterior mirror arts).

[00257] Optionally, a mirror reflective element may comprise a transfective display-on-demand (DOD) reflective element having suitable transfective coatings or layers on the third surface or fourth surface of an electro-optic reflective element, or on the first surface or second surface of a single substrate conventional fixed reflectance reflective element.

Desirably, a mirror substrate may have a silicon or doped-silicon coating or other suitable coating on its transfective surface. For example, mirror reflective elements for use in automobiles may utilize, in forming their substrates, transfective reflector-coated glass sheets having silicon-based transfective coatings or other suitable material, such as transfective reflector-coated glass sheets of the type that is commercially available from Pilkington of Toledo, Ohio and marketed under the trade name Mirropane T.M.TM Transparent Mirror Glass. Such silicon-based transfective coated glass sheets may have a reflectivity of at least about 70 percent of light incident thereon and a transmissivity, even in grey, of at least about 11 percent, and if clear glass, its transmissivity may be higher, such as up to about 20 percent or more. To manufacture an interior mirror prismatic element from such commercially available transfective reflector-coated glass sheets or substrates or panels, large, thick (such as about 6 mm to 6.6 mm thick or thereabouts) silicon-based transfective mirror glass sheets (preferably with the transfective reflector coating(s) coated onto non-tinted, highly light transmitting clear glass) may be purchased from Pilkington or another manufacturer. The transfective reflector-coated glass sheets may then be cut to interior mirror sized shapes or dimensions, which in turn may be ground to a prism wedge and edge finished to form the desired silicon-based transfective interior prismatic mirror elements suitable for use in interior automotive rearview mirror assemblies as a flip or manually-operated day/night mirror, as is known in the art. Such a process benefits from advantages such as its superior durability and chemical inertness of the silicon-based reflector during the prism manufacturing operations(s). Optionally however, a transparent tape or coating may be disposed over the reflector of the transfective reflector-coated glass as a protectorant prior to and during the prism fabrication process. Note that the silicon-based transfective mirror reflector coating is on the second surface opposite to the ground prism's slanted front surface of the mirror shape.

[00258] For a transfective interior mirror element behind which a video screen will be disposed as part of a display-through-the-mirror element video mirror/reversing camera system or the like, a clear, light transmitting layer or film may be used to environmentally and/or physically protect or encapsulate the mirror reflector coating or coatings at the second surface of the prismatic glass element. Suitable materials to use include encapsulants and conformal coatings commonly used in the electronics industry, and such as are available for CDs and DVDs, such as SK3200 and similar materials from Sony Chemicals or Shinetsu moisture cure silicone or Dymax 3095 or Loctite 3493 or Emerson & Cuming UV 7993. Such coatings can be applied by screen printing, dipping, spraying, roller coating, pad

printing, ink-jet printing and the like, and may be cured chemically or by heating or by UV exposure or the like. It is desirable to avoid any voids or bubbles or inclusions in the applied optically clear coating/film and that the applied coating/film be clear and highly light transmitting and be uniform in thickness. Optionally, a flexible sheet of plasticized PVB or of silicone or similar optically clear and transparent flexible film sheet may be laid over the second surface coating, and then vacuum-assisted/heating means (such as are described in U.S. provisional applications, Ser. No. 60/732,245, filed Nov. 1, 2005 (Attorney Docket DON01 P-1251); and Ser. No. 60/759,992, filed Jan. 18, 2006 (Attorney Docket DON01 P-1264), which are hereby incorporated herein by reference in their entireties) can be used to conform and attach to the coated second surface of the prism shape and so encapsulate/protect.

[00259] Even for the likes of a silicon-based second surface reflector, but particularly if a more environmentally fragile transfective reflector, such as of ITO/Ag/ITO, is used, it is desirable and preferred to protect well the exposed edges at the border edges around second surface of the prism part or substrate. In this regard, it is desirable either to mask close to the edges so that the reflector coating is not formed right out to the very edge and so that any encapsulant or conformal coating or sheet or means used can extend out to the very edge and/or to ensure that any encapsulant or conformal coating or sheet or means used actually wraps around the cut edge to form a wrap-around encapsulant/protectorant that mitigates or prevents edge corrosion.

[00260] If a metal oxide/metal/metal oxide transfective stack, such as ITO/Ag/ITO (ISI), is used as the mirror transfective, clear optical conformal coatings, such as acrylics or silicones or epoxies (that may be chemically cured or thermally cured or UV cured or microwave cured) or the like, can beneficially have the effect of flattening any spectral character of the thin film stack by acting as a massive layer (the physical thickness of the conformal coating or similar polymeric encapsulating layer may be many microns in thickness whereas the thin film ISI coatings are only several nanometers in thickness). For example, and for a typical ISI transfective mirror reflector coated onto the second surface of a cut glass prism shape, photopic reflection rose by about 6%R when a typical clear conformal polymeric coating was sprayed and cured thereon, and the percent transmission correspondingly decreased. Thus, if an ISI stack is to be used as a second surface reflector on a prism shape and then in turn is to be conformal coated for protection as described above, then the layer thicknesses of the ISI stack should be adjusted, as known in the optical modeling arts, to compensate for the

addition of the clear optical protecting massive film (massive relative to the thickness of the ISI stack layers).

[00261] As an alternative to directly coating the likes of a silicon-based translector or an ISI translector directly onto the second surface of a ground, clear-glass prismatic shape, the translector coating or coatings can be deposited onto a flat thin glass shape that is then adhered to/laminated to the glass second surface of the prism shape, such as is disclosed in U.S. pat. application, Ser. No. 10/993,302, filed Nov. 19, 2004 by Lynam for MIRROR REFLECTIVE ELEMENT FOR A VEHICLE (Attorney Docket DON01 P-1186), which is hereby incorporated herein by reference in its entirety (and with the translector coating(s) sandwiched between the two glass substrates). This has the advantage that the translector coating(s) are protected against physical damage and/or environmental degradation (including edge attack) by the extra glass substrate, and that large stock sheets of thin glass can be coated from which interior mirror shapes can be cut later to match the particular prism part to be laminated to.

[00262] The likes of an autoclave or a vacuum/heat-assisted technique may be used to adhere the flat translector-coated shape to the second surface of the clear prism part [such as by placing the uncoated prism shape onto a hotplate with its second surface up, placing a flexible sheet of PVB or silicone onto the second surface, juxtaposing the cut flat translector-coated glass shape onto the flexible polymeric sheet with the coated surface downward, pulling a rubber flexible cover over this sandwich (or placing the sandwich in a vacuum bag), drawing down a vacuum so as to remove air and compress the parts together, and heating to laminate and secure permanently]. Alternatively, the rear flat second translector-coated shape may be adhered to the second-surface of the front prism-shaped element via a seal as is used in EC cell constructions, and the interpane gap may be left unfilled or filled with the likes of a solvent, such as propylene carbonate or a solid film such as a plasticized urethane or the like.

[00263] Also, large sheets of, for example, about 2 mm thick or thereabouts, coated flat transfective reflector-coated mirror panes can be purchased. Such sheets or shapes can be bent or cut to the desired shape or form to suit the exterior mirror shape desired, and may be heated and bent to the desired curvature or form so that the shapes may be suitable for use in exterior mirror assemblies. The glass sheets may be purchased as coated sheets such as those described above. The mirror elements may comprise prismatic DOD substrates, and may utilize aspects described in U.S. Patent application, Ser. No. 10/993,302, filed Nov. 19, 2004 by Lynam for MIRROR REFLECTIVE ELEMENT FOR A VEHICLE (Attorney Docket DON01 P-1186), which is hereby incorporated herein by reference in its entirety. Optionally,

a transfective CAZ coating stack or a transfective ISI coating stack or the like may be used as a fourth surface transfective reflector in an electrochromic mirror element or as a first or second surface of a single substrate exterior mirror assembly.

[00264] Optionally, the transfective mirror reflector, such as for a silicon-based transfective prismatic interior mirror element or a flat or bent silicon-based exterior transfective mirror element, may be sputter coated in a vacuum deposition process using an aluminum-doped silicon target or the like (such as utilizing aspects described in U.S. Patent Application, Ser. No. 11/021,065, filed Dec. 23, 2004 (Attorney Docket DON01 P-1193, which is hereby incorporated herein by reference in its entirety). Alternatively, the mirror reflector may be formed by chemical deposition or chemical vapor deposition or pyrolytic deposition on the glass surface. Optionally, the silicon-based transfective mirror reflector may be formed by deposition onto the glass surface at the glass float-line itself when the glass ribbon is first being formed from the molten glass raw materials (where the red-hot molten glass exiting the glass furnace is floated onto a tin bath and where the coating materials or gasses or precursors are blown onto the red hot glass ribbon as it first forms while it exits the tin bath and while it is still in a very hot condition to form the transfective coatings on the glass surface).

[00265] Optionally, for example, a driver-side mirror may comprise an electro-optic mirror element (such as a driver-side flat electrochromic electrically variable reflectance mirror element, preferably a transfective, display-on-demand flat electrochromic electrically variable reflectance mirror element, and most preferably of flush or frameless construction and utilizing a reflective border band), and the passenger-side mirror may comprise a non-electro-optic mirror element (such as a passenger-side convex conventional fixed reflectance mirror element, preferably a transfective, display-on-demand fixed reflectance mirror element, and most preferably utilizing a reflective border band to match that used on the corresponding driver-side mirror element, as described herein). The driver-side electro-optic mirror element (that preferably comprises an electro-optic medium disposed between and sandwiched by a front transparent glass or plastic substrate and a rear, mirror reflector-coated transparent glass or plastic substrate) may have the second surface of its front transparent substrate coated with a transparent electrically conductive coating (such as ITO or the like) and may have its third surface (the inward surface of its rear transparent substrate) also coated with a transparent conductive coating (such as ITO or the like) so that light passes therethrough, and may have a significantly visible light reflecting (preferably at least about 60%R specularly reflecting there off; more preferably at least about 65%R there off and most preferably at least about 70%R there off) and substantially visible light transmitting

(preferably at least about 10%T there through; more preferably at least about 15%T there through and most preferably at least about 20%T there through) transflective mirror reflector on its fourth surface (the rearmost substrate of the EC cell) that, preferably, comprises a high optical refractive index elemental semiconductor mirror coating, such as of silicon or doped-silicon (or germanium or doped germanium), and most preferably comprises sputter coated silicon or doped-silicon such as silicon-aluminum or the like, such as described above. Suitable high optical refractive index elemental semiconductor mirror coatings such as of silicon or doped-silicon (or germanium or doped germanium) and preferably having an index of refraction of at least 3 and an optical thickness of at least about 275 angstroms are disclosed in U.S. Pat. Nos. 6,286,965; 5,751,489; and 5,535,056, the entire disclosures of which are hereby incorporated by reference herein. The passenger-side non-electro-optic mirror element may comprise a bent glass shape or substrate with a transflective mirror reflector on its first or second surface that, preferably, comprises a high index semiconductor coating such as of silicon or doped-silicon (or germanium or doped germanium), and more preferably comprises sputter coated silicon or doped-silicon such as silicon-aluminum or the like, and most preferably is selected to match the reflectance characteristic and visual appearance of the driver-side mirror element's reflector. Optionally, both the driver-side electro-optic mirror element and the passenger-side non-electro-optic mirror element may include a metallic specularly reflecting perimeter border band, such as a neutral reflecting perimeter band as described above, such as described above. Preferably, the driver-side mirror element has the perimeter band disposed on its second surface with the ITO coating disposed over the second surface and over the perimeter band, and the passenger-side mirror element has the perimeter band disposed on its second surface with the silicon or doped-silicon or silicon-aluminum disposed over the second surface and over the perimeter band. Thus, the reflective perimeter bands of the driver and passenger-side mirror elements may provide a generally cosmetic or visual appearance match between the two mirrors as both might be viewed, for example, at a car dealership or in use on the road or in a parking lot or the like.

[00266] Optionally, the interior mirror of the vehicle may comprise a transflective prismatic mirror element (such as with a transflective mirror reflector comprising silicon coating or doped-silicon coating, such as a silicon-aluminum coating, disposed thereon) and a display operable to emit illumination or video images through the transflective interior mirror element. The driver-side and/or passenger-side mirror element/assembly may include an independent EC controller or control circuit system (such as is disclosed in U.S. Pat. No.

5,659,423, the entire disclosure of which is hereby incorporated by reference herein) for independently controlling the driver-side (and/or passenger-side) electro-optic mirror element or, for example, the driver-side independent EC controller outboard at the exterior mirror element/assembly may also control an interior electro-optic mirror element if applicable. Optionally, the vehicle may have an interior electro-optic mirror that includes EC driver/circuitry/controllers for controlling the interior electro-optic mirror element and the driver-side electro-optic mirror element (and even a passenger-side electro-optic mirror element if applicable). Also, compass-on-a-chip circuitry as disclosed herein may be included in either or both of the exterior mirror assemblies, and the microprocessor or allied circuitry of such an exterior mirror-located compass-on-a-chip may also function to control the reflectivity of an electro-optic mirror element, such as an independent exterior electrochromic side view mirror element or an interior electrochromic rear view mirror element.

00267] Where a video display screen is disposed behind a transreflective interior prismatic mirror element (for use as, for example, the video screen in a video mirror/reversing or back-up camera application), the video screen or monitor (typically an LCD or OLED flat panel of about 2.5 inches to about 3.5 inches diagonal dimension) may attach directly to the flat second surface of the interior prism mirror element, or preferably, may be mounted at an angle thereto so as to compensate for the prism wedge angle (typically about 4 degrees to about 4.75 degrees or thereabout – about 4.5 degrees being common) so as to mitigate any potential double imaging/ghosting due to the angling of the first surface of the prism wedge from its second surface. For example, a clear optical plastic block can be attached to the second surface of the prism and with its rear surface at an about 4.5 degree angle to its front (that contacts the second surface of the prism) and slanted so that the rear surface of the optical plastic block runs generally parallel to the front, first surface of the prism shape. Then, when the flat video screen element attaches to the rear surface of the block, it is orientated generally parallel with the front, first surface of the prism element, and video images emitted by the video screen are generally incident perpendicular to the prism's first surface and so video image double-imaging and ghosting is reduced. As an alternative to a clear optical block, a slanted mount can be used to hold the video screen at an angle to the second surface of the prism in order to achieve similar benefit. Also, and optionally, a light control film such as 3M's Vikuiti™ Light Control Film can be placed in front of the video screen between it and the rear of the mirror element so as to mitigate washout in high ambient viewing conditions such as a sunny day. Such light control films or louver films comprise a

continuous matrix of parallel black louvers embedded in the likes of a polycarbonate film/thin (typically less than 0.04 inches thick) plastic sheet that limits viewing off axis of the direction of the louvers. For example, and taking an example where the louvers are at a 0.00 degrees angle to a vertical axis to the horizontal plane of the sheet (i.e., the louvers are vertical to the horizontal plane of the sheet), light transmission of light that impinges generally vertically to the horizontal plane of the sheet has an about 75%T transmission through the light control sheet, whereas light that impinges at about 15 degrees to vertical has only about a 35%T transmission due to the vertical orientation of the louvers, and light impinging or incident at an angle of about 30 degrees and above is largely cut-off by the louvers. 3M Vikuiti™ ALCF-P light control film can be used, having a louver angle of about 0 degrees (plus or minus 2 degrees), a viewing angle of about 60 degrees (plus or minus 4 degrees) and a sheet thickness of about 0.021 inches (plus or minus 0.003 inches). Alternately, 3M Vikuiti™ LCF-P light control film can be used, having a louver angle of about 0 degrees (plus or minus 8 degrees), a viewing angle of about 60 degrees (plus or minus 8 degrees) and a sheet thickness of about 0.021 inches (plus or minus 0.003 inches). Alternately, 3M Vikuiti™ LCF-P light control film can be used, having a louver angle of about 0 degrees (plus or minus 8 degrees), a viewing angle of about 60 degrees (plus or minus 8 degrees) and a sheet thickness of about 0.032 inches (plus or minus 0.005 inches). Should an angled block or mechanical angling of the video screen to the plane of the rear of the mirror element be used, then the light control film may be similarly angled if the louver angle is at about 0 degrees (such as by placing it between the video screen and the angled rear surface of the optical block attached to the rear, second surface of the prismatic mirror element). If no angling is used for the video screen with respect to the back of the transfective mirror element (such as a prismatic transfective mirror element or an electrochromic transfective mirror element), then the Vikuiti™ Light Control Film can be placed between the video screen and the second surface of the prism to which it is mounted. Note that if moiré patterns are seen with such light control films, the film may be slightly angled to mitigate this.

[00268] Optionally, an exterior mirror reflective element of the present invention may be used in a vehicle equipped with a transfective interior prismatic mirror element such as is disclosed in co-pending U.S. Patent Application Serial No. 10/993,302, filed Nov. 19, 2004 by Lynam for MIRROR REFLECTIVE ELEMENT FOR A VEHICLE, and published Jun. 23, 2005 as U.S. Publication No. US 2005/0134983 (Attorney Docket DON01 P-1186), the entire disclosure of which is hereby incorporated by reference herein. A transfective

prismatic mirror element may be made by first grinding clear glass prisms from about 6 mm to about 6.5 mm or so thick flat glass shapes, and then coating the non-ground surface of these clear glass shapes with a transflective mirror reflector, such as for example, with a sputter-coater deposited ITO/silver or silver-alloy/ITO transflective mirror reflector coating stack. Similarly, conventional transflective non-electro-optic transflective exterior mirror elements can be made by first cutting clear glass shapes from about 2 mm or so thick glass sheets, bending if desired, edge finishing and then sputter coating the second surface (or less preferably the first surface) with a transflective doped-silicon mirror reflector or with a transflective metal oxide/metal/metal oxide transflective mirror reflector (such as ITO/silver/ITO or AZO/Ag-alloy/AZO) or with a transflective silver or silver alloy coating or with a transflective aluminum or aluminum alloy coating [and optionally environmentally protecting the second surface coating with a clear, light transmitting protectorant such as a lacquer or coating (although in regions behind the second surface of the transflective prism element where display may not be likely located, a non-light transmitting protecting means may be used)].

[00269] Optionally, the mirror assembly and/or reflective element assembly (such as a transflective mirror reflective element) may include a photodiode or phototransistor or a silicon-based photosensor or the like for sensing ambient light and/or glare at the reflective element. Optionally, the photosensor may comprise a silicon-based photosensor, such as the types available from Microsemi of Irvine, CA, such as a Microsemi 1973B photosensor, such as a LX 1973A or 1973B photosensor that has a maximum dark current (at 50 degrees Centigrade) of less than about 7500 microLux, preferably less than about 5000 microLux, and more preferably less than about 4000 microLux. Preferably, such a photosensor (which is arranged so as to be looking through the transflective mirror reflector of the reflective element) operates in a closed loop control, such as is known in the art and such as is described in U.S. Pat. No. 4,917,477, which is hereby incorporated herein by reference in its entirety.

[00270] Optionally, the mirror assembly may accommodate other accessories or circuitry or the like as well, such as a rain sensor or imaging device or the like. For example, the mirror assembly may include a mounting portion (such as the types described in U.S. patent application Ser. No. 11/226,628, filed Sep. 14, 2005 (Attorney Docket DON01 P-1236); and/or U.S. provisional applications, Ser. No. 60/692,113, filed Jun. 20, 2005 (Attorney Docket DON01 P-1224); Ser. No. 60/677,990, filed May 5, 2005 (Attorney Docket DON01 P-1219); Ser. No. 60/653,787, filed Feb. 17, 2005 (Attorney Docket DON01 P-1207); Ser.

No. 60/642,227, filed Jan. 7, 2005 (Attorney Docket DON01 P-1199); Ser. No. 60/638,250, filed Dec. 21, 2004 (Attorney Docket DON01 P-1198); Ser. No. 60/624,091, filed Nov. 1, 2004 (Attorney Docket DON01 P-1184), and Ser. No. 60/609,642, filed Sep. 14, 2004 (Attorney Docket DON01 P-1171), which are all hereby incorporated herein by reference in their entireties), and may include a rain sensor or the like and may position the rain sensor against the windshield, such as described in U.S. Pat. Nos. 6,250,148; 6,341,523; 6,516,664; 6,968,736; and 6,824,281, and in U.S. pat. application Ser. No. 10/958,087, filed Oct. 4, 2004 by Schofield et al. for VEHICLE ACCESSORY MODULE (Attorney Docket DON01 P-1175), which are all hereby incorporated herein by reference in their entireties. Optionally, the mirror assembly may include an imaging device, such as an imaging array sensor for imaging systems of the types described in U.S. Pat. Nos. 6,757,109; 6,717,610; 6,396,397; 6,201,642; 6,353,392; 6,313,454; 6,396,397; 5,550,677; 5,670,935; 5,796,094; 5,877,897; 6,097,023; and 6,498,620, and U.S. pat. applications, Ser. No. 09/441,341, filed Nov. 16, 1999 by Schofield et al. for VEHICLE HEADLIGHT CONTROL USING IMAGING SENSOR (Attorney Docket DON01 P-770); Ser. No. 10/427,051, filed Apr. 30, 2003 by Pawlicki et al. for OBJECT DETECTION SYSTEM FOR VEHICLE, now U.S. Pat. No. 7,038,577 (Attorney Docket DON01 P-1075); and/or Ser. No. 11/315,675, filed Dec. 22, 2005 (Attorney Docket DON01 P-1253), and/or U.S. provisional application, Ser. No. 60/638,687, filed Dec. 23, 2004 (Attorney Docket DON01 P-1195), which are all hereby incorporated herein by reference in their entireties.

[00271] Optionally, the mirror assembly may be associated with various accessories or systems, such as, for example, a tire pressure monitoring system or a passenger air bag status or a garage door opening system or a telematics system or any other accessory or system of the mirror assembly or of the vehicle or of an accessory module or console of the vehicle, such as an accessory module or console of the types described in U.S. Pat. Nos. 6,690,268; 6,672,744; 6,386,742; and 6,124,886, and/or U.S. pat. applications, Ser. No. 10/739,766, filed Dec. 18, 2003 by DeLine et al. for MODULAR REARVIEW MIRROR ASSEMBLY, now U.S. Pat. No. 6,877,888 (Attorney Docket DON01 P-1119); and/or Ser. No. 10/355,454, filed Jan. 31, 2003 by Schofield et al. for VEHICLE ACCESSORY MODULE, now U.S. Pat. No. 6,824,281 (Attorney Docket DON01 P-1050), and/or PCT Application No. PCT/US03/03012, filed Jan. 31, 2003 by Donnelly Corporation for VEHICLE ACCESSORY MODULE (Attorney Docket DON01 FP-1050(PCT)), and/or PCT Application No. PCT/US03/40611, filed Dec. 19, 2003 by Donnelly Corporation for ACCESSORY SYSTEM FOR VEHICLE (Attorney Docket DON01 FP-1123(PCT)), and/or PCT Application No.

PCT/US04/15424, filed May 18, 2004 by Donnelly Corporation et al. for MIRROR ASSEMBLY FOR VEHICLE (Attorney Docket DON01 FP-1150(PCT)), which are hereby incorporated herein by reference in their entireties.

[00272] Optionally, the mirror assembly may support one or more other accessories or features, such as one or more electrical or electronic devices or accessories. For example, illumination sources or lights, such as map reading lights or one or more other lights or illumination sources, such as illumination sources of the types disclosed in U.S. Pat. Nos. 6,690,268; 5,938,321; 5,813,745; 5,820,245; 5,673,994; 5,649,756; 5,178,448; 5,671,996; 4,646,210; 4,733,336; 4,807,096; 6,042,253; 6,971,775; and/or 5,669,698, and/or U.S. pat. applications, Ser. No. 10/054,633, filed Jan. 22, 2002 (Attorney Docket DON01 P-962); and/or Ser. No. 10/933,842, filed Sep. 3, 2004 by Kulas et al. for INTERIOR REARVIEW MIRROR ASSEMBLY (Attorney Docket DON01 P-1166), which are hereby incorporated herein by reference in their entireties, may be included in the mirror assembly. The illumination sources and/or the circuit board may be connected to one or more buttons or inputs for activating and deactivating the illumination sources. Optionally, the mirror assembly may also or otherwise include other accessories, such as microphones, such as analog microphones or digital microphones or the like, such as microphones of the types disclosed in U.S. Pat. Nos. 6,243,003; 6,278,377; and/or 6,420,975, and/or in U.S. patent application Ser. No. 10/529,715, filed Mar. 30, 2005 (Attorney Docket DON01 P-1111), and in PCT Application No. PCT/US03/308877, filed Oct. 1, 2003 by Donnelly Corp. et al. for MICROPHONE SYSTEM FOR VEHICLE (Attorney Docket DON01 FP-1111(PCT)). Optionally, the mirror assembly may also or otherwise include other accessories, such as a telematics system, speakers, antennas, including global positioning system (GPS) or cellular phone antennas, such as disclosed in U.S. Pat. No. 5,971,552, a communication module, such as disclosed in U.S. Pat. No. 5,798,688, a voice recorder, a blind spot detection and/or indication system, such as disclosed in U.S. Pat. Nos. 5,929,786 and/or 5,786,772, and/or U.S. pat. applications, Ser. No. 10/427,051, filed Apr. 30, 2003, now U.S. Pat. No. 7,038,577 (Attorney Docket DON01 P-1075); and/or Ser. No. 11/315,675, filed Dec. 22, 2005 (Attorney Docket DON01 P-1253); and/or Ser. No. 10/209,173, filed Jul. 31, 2002, now U.S. Pat. No. 6,882,287 (Attorney Docket DON01 P-1016); and/or U.S. provisional applications, Ser. No. 60/638,687, filed Dec. 23, 2004 (Attorney Docket DON01 P-1195); Ser. No. 60/696,953, filed Jul. 6, 2006 (Attorney Docket DON01 P-1228); and/or Ser. No. 60/784,570, filed Mar. 22, 2006 (Attorney Docket DON01 P-1273), transmitters and/or receivers, such as for a garage door opener or a vehicle door unlocking system or the like (such as a remote

keyless entry system), a digital network, such as described in U.S. Pat. No. 5,798,575, a high/low headlamp controller, such as a camera-based headlamp control, such as disclosed in U.S. Pat. Nos. 5,796,094 and/or 5,715,093, a memory mirror system, such as disclosed in U.S. Pat. No. 5,796,176, a hands-free phone attachment, an imaging system or components or circuitry or display thereof, such as an imaging and/or display system of the types described in U.S. Pat. Nos. 6,690,268 and 6,847,487; and/or U.S. provisional applications, Ser. No. 60/614,644, filed Sep. 30, 2004 (Attorney Docket DON01 P-1177); Ser. No. 60/618,686, filed Oct. 14, 2004 (Attorney Docket DON01 P-1183); Ser. No. 60/628,709, filed Nov. 17, 2004 (Attorney Docket DON01 P-1188); Ser. No. 60/644,903, filed Jan. 11, 2005 (Attorney Docket DON01 P-1202); Ser. No. 60/667,049, filed Mar. 31, 2005 (Attorney Docket DON01 P-1213); and/or U.S. pat. applications, Ser. No. 11/105,757, filed Apr. 14, 2005 (Attorney Docket DON01 P-1208); and/or Ser. No. 11/239,980, filed Sep. 30, 2005 (Attorney Docket DON01 P-1238), a slide out or extendable/retractable video device or module, such as described in U.S. patent applications, Ser. No. 10/538,724, filed Jun. 13, 2005 (Attorney Docket DON01 P-1123); and/or Ser. No. 11/284,543, filed Nov. 22, 2005 (Attorney Docket DON01 P-1245), U.S. provisional applications, Ser. No. 60/630,061, filed Nov. 22, 2004 (Attorney Docket DON01 P-1189); and/or Ser. No. 60/667,048, filed Mar. 31, 2005 (Attorney Docket DON01 P-1212); and/or PCT Application No. PCT/US03/40611, filed Dec. 19, 2003 (Attorney Docket DON01 FP-1123(PCT)), a video device for internal cabin surveillance (such as for sleep detection or driver drowsiness detection or the like) and/or video telephone function, such as disclosed in U.S. Pat. Nos. 5,760,962 and/or 5,877,897, a remote keyless entry receiver, a seat occupancy detector, a remote starter control, a yaw sensor, a clock, a carbon monoxide detector, status displays, such as displays that display a status of a door of the vehicle, a transmission selection (4wd/2wd or traction control (TCS) or the like), an antilock braking system, a road condition (that may warn the driver of icy road conditions) and/or the like, a trip computer, a tire pressure monitoring system (TPMS) receiver (such as described in U.S. Pat. Nos. 6,124,647; 6,294,989; 6,445,287; 6,472,979; and/or 6,731,205; and/or U.S. patent application Ser. No. 11/232,324, filed Sep. 21, 2005 by O'Brien et al. for TIRE PRESSURE ALERT SYSTEM (Attorney Docket DON01 P-1237); and/or U.S. provisional application, Ser. No. 60/611,796, filed Sep. 21, 2004 (Attorney Docket DON01 P-1179)), and/or an ONSTAR[®] system and/or any other accessory or circuitry or the like (with all of the above-referenced patents and PCT and U.S. patent applications being commonly assigned to Donnelly Corporation, and with the disclosures of

the referenced patents and patent applications being hereby incorporated herein by reference in their entireties).

[00273] Optionally, the accessory module and/or mirror assembly may accommodate other accessories or circuitry or the like as well, such as a rain sensor or imaging device or the like. For example, the mirror assembly may include a mounting portion (such as the types described in U.S. patent application Ser. No. 11/226,628, filed Sep. 14, 2005 (Attorney Docket DON01 P-1236); and/or U.S. provisional applications, Ser. No. 60/692,113, filed Jun. 20, 2005 (Attorney Docket DON01 P-1224); Ser. No. 60/677,990, filed May 5, 2005 (Attorney Docket DON01 P-1219); Ser. No. 60/653,787, filed Feb. 17, 2005 (Attorney Docket DON01 P-1207); Ser. No. 60/642,227, filed Jan. 7, 2005 (Attorney Docket DON01 P-1199); Ser. No. 60/638,250, filed Dec. 21, 2004 (Attorney Docket DON01 P-1198); Ser. No. 60/624,091, filed Nov. 1, 2004 (Attorney Docket DON01 P-1184); Ser. No. 60/609,642, filed Sep. 14, 2004 (Attorney Docket DON01 P-1171); and/or Ser. No. 60/729,430, filed Oct. 21, 2005 (Attorney Docket DON01 P-1249), which are all hereby incorporated herein by reference in their entireties), and may include a rain sensor or the like and may position the rain sensor against the windshield, such as described in U.S. Pat. Nos. 6,250,148; 6,341,523; 6,516,664; 6,968,736; and 6,824,281, and in U.S. pat. application Ser. No. 10/958,087, filed Oct. 4, 2004 by Schofield et al. for VEHICLE ACCESSORY MODULE (Attorney Docket DON01 P-1175), which are all hereby incorporated herein by reference in their entireties. Optionally, the mirror assembly may include an imaging device, such as an imaging array sensor for imaging systems of the types described in U.S. Pat. Nos. 6,757,109; 6,717,610; 6,396,397; 6,201,642; 6,353,392; 6,313,454; 6,396,397; 5,550,677; 5,670,935; 5,796,094; 5,877,897; 6,097,023; and 6,498,620, and U.S. pat. applications, Ser. No. 09/441,341, filed Nov. 16, 1999 by Schofield et al. for VEHICLE HEADLIGHT CONTROL USING IMAGING SENSOR (Attorney Docket DON01 P-770); Ser. No. 10/427,051, filed Apr. 30, 2003 by Pawlicki et al. for OBJECT DETECTION SYSTEM FOR VEHICLE, now U.S. Pat. No. 7,038,577 (Attorney Docket DON01 P-1075); and/or Ser. No. 11/315,675, filed Dec. 22, 2005 (Attorney Docket DON01 P-1253), and/or U.S. provisional application, Ser. No. 60/638,687, filed Dec. 23, 2004 (Attorney Docket DON01 P-1195), which are all hereby incorporated herein by reference in their entireties.

[00274] Optionally, the mirror assembly may include one or more other accessories at or within the mirror casing, such as one or more electrical or electronic devices or accessories, such as antennas, including global positioning system (GPS) or cellular phone antennas, such as disclosed in U.S. Pat. No. 5,971,552, a communication module, such as disclosed in U.S.

Pat. No. 5,798,688, a blind spot detection system, such as disclosed in U.S. Pat. Nos. 5,929,786 and/or 5,786,772, transmitters and/or receivers, such as a garage door opener or the like, a digital network, such as described in U.S. Pat. No. 5,798,575, a high/low headlamp controller, such as disclosed in U.S. Pat. Nos. 5,796,094 and/or 5,715,093, a memory mirror system, such as disclosed in U.S. Pat. No. 5,796,176, a hands-free phone attachment, a video device for internal cabin surveillance and/or video telephone function, such as disclosed in U.S. Pat. Nos. 5,760,962 and/or 5,877,897, a remote keyless entry receiver, lights, such as map reading lights or one or more other lights or illumination sources, such as disclosed in U.S. Pat. Nos. 6,690,268; 5,938,321; 5,813,745; 5,820,245; 5,673,994; 5,649,756; 5,178,448; 5,671,996; 4,646,210; 4,733,336; 4,807,096; 6,042,253; and/or 5,669,698, and/or U.S. pat. applications, Ser. No. 10/054,633, filed Jan. 22, 2002 by Lynam et al. for VEHICULAR LIGHTING SYSTEM (Attorney Docket DON01 P-962); Ser. No. 10/745,056, filed Dec. 22, 2003 by Lynam et al. for LIGHT MODULE FOR INTERIOR REARVIEW MIRROR ASSEMBLY (Attorney Docket DON01 P-1122); and/or Ser. No. 10/933,842, filed Sep. 3, 2004 by Kulas et al. for INTERIOR REARVIEW MIRROR ASSEMBLY (Attorney Docket DON01 P-1166), microphones, such as disclosed in U.S. Pat. Nos. 6,243,003; 6,278,377; and/or 6,420,975; and/or U.S. patent application Ser. No. 10/529,715, filed Mar. 30, 2005 (Attorney Docket DON01 P-1111); and/or PCT Application No. PCT/US03/30877, filed Oct. 1, 2003 (Attorney Docket DON01 FP-1111(PCT)), speakers, antennas, including global positioning system (GPS) or cellular phone antennas, such as disclosed in U.S. Pat. No. 5,971,552, a communication module, such as disclosed in U.S. Pat. No. 5,798,688, a voice recorder, a blind spot detection system, such as disclosed in U.S. Pat. Nos. 5,929,786 and/or 5,786,772, and/or U.S. pat. applications, Ser. No. 10/427,051, filed Apr. 30, 2003, now U.S. Pat. No. 7,038,577 (Attorney Docket DON01 P-1075); Ser. No. 11/315,675, filed Dec. 22, 2005 (Attorney Docket DON01 P-1253); and Ser. No. 10/209,173, filed Jul. 31, 2002, now U.S. Pat. No. 6,882,287 (Attorney Docket DON01 P-1016); and/or U.S. provisional application, Ser. No. 60/638,687, filed Dec. 23, 2004 (Attorney Docket DON01 P-1195), transmitters and/or receivers, such as for a garage door opener or a vehicle door unlocking system or the like (such as a remote keyless entry system), a digital network, such as described in U.S. Pat. No. 5,798,575, a high/low headlamp controller, such as a camera-based headlamp control, such as disclosed in U.S. Pat. Nos. 5,796,094 and/or 5,715,093, a memory mirror system, such as disclosed in U.S. Pat. No. 5,796,176, a hands-free phone attachment, an imaging system or components or circuitry or display thereof, such as an imaging and/or display system of the types described in U.S. Pat. Nos. 6,690,268 and 6,847,487; and/or U.S.

provisional applications, Ser. No. 60/614,644, filed Sep. 30, 2004 (Attorney Docket DON01 P-1177); Ser. No. 60/618,686, filed Oct. 14, 2004 (Attorney Docket DON01 P-1183); Ser. No. 60/628,709, filed Nov. 17, 2004 (Attorney Docket DON01 P-1188); Ser. No. 60/644,903, filed Jan. 11, 2005 (Attorney Docket DON01 P-1202); Ser. No. 60/667,049, filed Mar. 31, 2005 (Attorney Docket DON01 P-1213); and/or U.S. patent application Ser. No. 11/105,757, filed Apr. 14, 2005 (Attorney Docket DON01 P-1208), a video device for internal cabin surveillance (such as for sleep detection or driver drowsiness detection or the like) and/or video telephone function, such as disclosed in U.S. Pat. Nos. 5,760,962 and/or 5,877,897, a remote keyless entry receiver, a seat occupancy detector, a remote starter control, a yaw sensor, a clock, a carbon monoxide detector, status displays, such as displays that display a status of a door of the vehicle, a transmission selection (4wd/2wd or traction control (TCS) or the like), an antilock braking system, a road condition (that may warn the driver of icy road conditions) and/or the like, a trip computer, a tire pressure monitoring system (TPMS) receiver (such as described in U.S. Pat. Nos. 6,124,647; 6,294,989; 6,445,287; 6,472,979; and/or 6,731,205; and/or U.S. patent application Ser. No. 11/232,324, filed Sep. 21, 2005 by O'Brien et al. for TIRE PRESSURE ALERT SYSTEM (Attorney Docket DON01 P-1237); and/or U.S. provisional application, Ser. No. 60/611,796, filed Sep. 21, 2004 (Attorney Docket DON01 P-1179)), and/or an ONSTAR[®] system, a compass, such as disclosed in U.S. Pat. Nos. 5,924,212; 4,862,594; 4,937,945; 5,131,154; 5,255,442; and/or 5,632,092, and/or U.S. pat. applications, Ser. No. 10/456,599, filed Jun. 6, 2003 by Weller et al. for INTERIOR REARVIEW MIRROR SYSTEM WITH COMPASS (Attorney Docket DON01 P-1076); and/or Ser. No. 11/305,637, filed Dec. 16, 2005 (Attorney Docket DON01 P-1254), and/or any other accessory or circuitry or the like (with all of the above-referenced patents and PCT and U.S. patent applications being commonly assigned to Donnelly Corporation, and with the disclosures of the referenced patents and patent applications being hereby incorporated herein by reference in their entireties).

[00275] Optionally, a display of driver performance or aggressiveness or the like can be included at the interior mirror assembly or at a windshield electronics module that utilizes data from the likes of the SmartCenter developed by and available from Drive Diagnostics Ltd of Tel Aviv, Israel (see www.drivediagnostics.com). DriveDiagnostics' SafetyCenter comprises sensors that monitor moves and maneuvers the vehicle makes by measuring the forces on the car and software that identifies the maneuvers and produces a 'driver behavior' report. The system also can have a GPS location device that measures the speed at which the car is being driven, rather than hooking up to the car's own speedometer. As disclosed in

U.S. Pat. Publication No. 20050131597 (published Jun. 16, 2005 based on an U.S. Patent Application Serial No. 10/894345, filed Jul. 20, 2004, the entire disclosure of which is hereby incorporated by reference herein), the system and method analyzes and evaluates the performance and attitude of a motor vehicle driver. A raw data stream from a set of vehicle sensors is filtered to eliminate extraneous noise, and then parsed to convert the stream into a string of driving event primitives. The string of driving events is then processed by a pattern-recognition system to derive a sequence of higher-level driving maneuvers.

[00276] Driving maneuvers include such familiar procedures as lane changing, passing, and turning and braking. Driving events and maneuvers are quantified by parameters developed from the sensor data. The parameters and timing of the maneuvers can be analyzed to determine skill and attitude factors for evaluating the driver's abilities and safety ratings. The rendering of the data into common driving-related concepts allows more accurate and meaningful analysis and evaluation than is possible with ordinary statistical threshold-based analysis.

[00277] As soon as aggressive or dangerous driving is detected, real time alerts are presented to the driver in the car (such as by a transfective display at the interior mirror or by another mirror-located display) and optionally, a parent can be notified via SMS messaging, mail or voice mail or a report can be sent to the car owner via a regular report (for example, for General Motors vehicles equipped with an OnStar® telematics systems, the monthly OnStar® e-mail report sent to subscribers can include a report on driver safety/"aggressiveness" and on the impact such has on fuel economy. SafetyCenter builds driver specific profiles and points directly at attitude and skill deficiencies that have to be corrected. Using user-friendly web interface, and as an example, both a parent and a young driver can get a better understanding of a driver's behavior and what has to be done in order to turn a young driver into a skilled and responsible driver.

[00278] To achieve this, a compact unit can be installed, for example, in the interior mirror housing or on a pod attaching to the interior mirror mount (so it is fixedly mounted) that may link into an in-car data logging/analysis system and/or can link into the on-board OnStar® or similar system so that GPS data and driver behavior data may be regularly broadcast to the external OnStar® or similar telematics server for recording/compilation/analysis and reporting back to the driver/owner/subscriber/insurance agency. The unit mounted at or in the interior mirror assembly/windshield electronics module may comprise its own set of sensors, GPS modem and GPS unit. The sensors in such a unit can measure the forces impacting the vehicle and provide precise information about each maneuver the driver

performs. Each maneuver can be evaluated on both attitude and skill parameters. This high resolution detection enables full visibility of driver behavior. Once aggressive or dangerous driving is detected, the information is sent real-time to an external server (such as the OnStar® server) or can be processed in-car; the data is analyzed and driver specific reports describing the driver's behavior are generated and can be reported/displayed to the driver such as via a transfective video interior mirror display. The displayed data can provide information and prescriptive guidance to driver while he/she is driving and can alert if the driving pattern suggest risky/aggressive/unsafe driving and/or a driving pattern (fast starts/heavy stops) likely to reduce fuel efficiency.

[00279] Typically, such a system utilizes a PCB or similar circuit element equipped with a 3-axis accelerometer or the like. Such a PCB could be accommodated in the interior mirror assembly (or in an attachment thereto) or in a windshield electronics module. Thus, a display may be placed at or about the interior mirror of the vehicle mirror that feeds back to the driver his/her driver "aggressiveness" performance and ties this to fuel economy and/or safety, and preferably is a thru-the-mirror-reflector "display-on-demand" mirror display. Also, information from a forward facing video sensor (such as a lane departure warning video sensor or the likes of MobilEye's EyeQ video-based object detection sensing system) or of a video camera monitoring the driver's face/eyes to detect driver drowsiness can be combined/fused with DriveDiagnostic's "see how you drive" capability, thus making the assessment of aggressiveness tie into road type/conditions and weather conditions (what might not be aggressive driving on a clear day might be hazardous if it is snowing or foggy or at night or on a crowded road compared to a road with little traffic or on a wide road versus a narrow road) and make the diagnosis dynamic to road/weather conditions, and if a driver drowsiness is included, to how alert the driver appears to be. Packaging the electronics and/or the display (preferably a dynamic display and most preferably a display that ties in fuel economy to driver aggressiveness/behavior) in a windshield electronics module (WEM) or in (or at) an interior mirror assembly has several benefits, and particularly in a vehicle equipped with a telematics system (such as OnStar®) where the likes of GPS and 3-axis accelerometers may already be on board and where the interior mirror already serves as a human-machine interface or HMI (for example, microphone and button actuation) for the telematics system. Also, the mirror-mounted or WEM-mounted display may alert the driver if his or her driving habits are being reported unfavorably to the driver's insurance company and thus possibly degrading the ranking and reduction in premium awarded by the insurer in order to entice less-aggressive and hence safer driving. For example, a "green-yellow-red"

background or indicia may be utilized on the display to convey to the driver the ranking being reported.

[00280] Optionally, the mirror assembly of the present invention comprise an interior or exterior rearview mirror assembly and may include a compass-on-a-chip with electrochromic circuitry, such as described in U.S. pat. applications, Ser. No. 11/226,628, filed Sep. 14, 2005 (Attorney Docket DON01 P-1236); and/or Ser. No. 11/201,661, filed Aug. 11, 2005 (Attorney Docket DON01 P-1233), which are hereby incorporated herein by reference in their entireties. For example, an exterior mirror assembly may include a compass-on-a-chip, preferably with electrochromic circuitry, such as for an independent outside electrochromic mirror drive, such as by utilizing aspects described in U.S. Pat. No. 5,659,423, which is hereby incorporated herein by reference in its entirety. Optionally, the driver-side exterior mirror may comprise an electro-optic mirror element (such as an electrochromic mirror element) and the passenger-side exterior mirror may comprise a non-electro-optic mirror element, with the driver-side mirror having an independent electrochromic mirror drive and a compass-on-a-chip and electrochromic circuitry. Optionally, the interior rearview mirror assembly may comprise an electro-optic mirror element and may have an independent electrochromic mirror drive or may be driven by the electrochromic mirror drive of the driver-side electro-optic mirror.

[00281] Optionally, the mirror assembly may be utilized with a video slide-out mirror, such as the types described in PCT Application No. PCT/US03/40611, filed Dec. 19, 2003 by Donnelly Corp. et al. for ACCESSORY SYSTEM FOR VEHICLE (Attorney Docket DON01 FP-1123(PCT)), and/or U.S. pat. applications, Ser. No. 10/538,724, filed Jun. 13, 2005 (Attorney Docket DON01 P-1123); and/or Ser. No. 11/284,543, filed Nov. 22, 2005 (Attorney Docket DON01 P-1245), and/or U.S. provisional applications, Ser. No. 60/630,061, filed Nov. 22, 2004 by Lynam et al. for MIRROR ASSEMBLY WITH VIDEO DISPLAY (Attorney Docket DON01 P-1189); and Ser. No. 60/667,048, filed Mar. 31, 2005 by Lynam et al. for MIRROR ASSEMBLY WITH VIDEO DISPLAY (Attorney Docket DON01 P-1212), which are hereby incorporated herein by reference in their entireties. Further, when such a vehicle equipped with such a video mirror is also equipped with a side viewing or front viewing or rear viewing sensor vision system (such as by utilizing a radar sensor or an ultrasonic sensor or a camera sensor (such as described in U.S. patent applications, Ser. No. 10/534,632, filed May 11, 2005 (Attorney Docket DON01 P-1118); Ser. No. 11/239,980, filed Sep. 30, 2005 (Attorney Docket DON01 P-1238); and/or Ser. No. 11/315,675, filed Dec. 22, 2005 (Attorney Docket DON01 P-1253), and/or U.S. provisional

applications, Ser. No. 60/628,709, filed Nov. 17, 2004 by Camilleri et al. for IMAGING AND DISPLAY SYSTEM FOR VEHICLE (Attorney Docket DON01 P-1188); Ser. No. 60/614,644, filed Sep. 30, 2004 (Attorney Docket DON01 P-1177); Ser. No. 60/618,686, filed Oct. 14, 2004 by Laubinger for VEHICLE IMAGING SYSTEM (Attorney Docket DON01 P-1183); Ser. No. 60/731,183, filed Oct. 28, 2005 (Attorney Docket DON01 P-1248); Ser. No. 60/765,797, filed Feb. 7, 2006 (Attorney Docket DON01 P-1265); and/or Ser. No. 60/638,687, filed Dec. 23, 2004 by Higgins-Luthman for OBJECT DETECTION SYSTEM FOR VEHICLE (Attorney Docket DON01 P-1195), which are hereby incorporated herein by reference in their entireties) to monitor an area adjacent the vehicle), the video screen may automatically extend when such a sensor system detects the presence of an obstacle and/or a human adjacent to the vehicle. Also, the video display screen may extend in conjunction with a trailer-hitch monitoring system (such as the types described in U.S. pat. application, Ser. No. 10/418,486, filed Apr. 18, 2003 by McMahon et al. for VEHICLE IMAGING SYSTEM (Attorney Docket DON01 P-1070), which is hereby incorporated herein by reference in their entireties) and icons and/or indicia and/or instructions may be created on the video image displayed on the extended video screen of the video mirror to assist or guide the driver to hitch a trailer to the trailer hitch of the vehicle.

00282] Optionally, the mirror assembly may include one or more user actuatable inputs or input devices or human machine interfaces. For example, the inputs or user interfaces may include buttons, such as are described in U.S. Pat. No. 6,501,387, which is hereby incorporated herein by reference in its entirety, or that include touch/proximity sensors such as are disclosed in U.S. Pat. Nos. 6,001,486; 6,310,611; 6,320,282; and 6,627,918, and U.S. pat. application, Ser. No. 09/817,874, filed Mar. 26, 2001 by Quist et al. for INTERACTIVE AUTOMOTIVE REARVISION SYSTEM (Attorney Docket DON01 P-889), and PCT Application No. PCT/US03/40611, filed Dec. 19, 2003 (Attorney Docket DON01 FP-1123(PCT)), which are hereby incorporated herein by reference in their entireties, or that include other types of buttons or switches, such as those described in U.S. pat. application, Ser. No. 11/029,695, filed Jan. 5, 2005 by Lindahl et al. for MIRROR ASSEMBLY (Attorney Docket DON01 P-1192); and/or U.S. provisional applications, Ser. No. 60/556,259, filed Mar. 25, 2004 (Attorney Docket DON01 P-1147); Ser. No. 60/553,517, filed Mar. 16, 2004 (Attorney Docket DON01 P-1145); and Ser. No. 60/535,559, filed Jan. 9, 2004 (Attorney Docket DON01 P-1134); and/or PCT Application No. PCT/US2004/015424, filed May 18, 2004 by Donnelly Corp. et al. for MIRROR ASSEMBLY FOR VEHICLE (Attorney Docket DON01 FP-1150(PCT)), which are hereby incorporated herein by

reference in their entireties, or that include fabric-made position detectors, such as are disclosed in U.S. Pat. Nos. 6,504,531; 6,501,465; 6,492,980; 6,452,479; 6,437,258; and 6,369,804, which are hereby incorporated herein by reference in their entireties. The mirror assembly may comprise any other type of switches or buttons, such as touch or proximity sensing switches, such as touch or proximity switches of the types described in U.S. patent application Ser. No. 11/021,065, filed Dec. 23, 2004 (Attorney Docket DON01 P-1193); Ser. No. 10/956,749, filed Oct. 1, 2004 by Schofield et al. for MIRROR REFLECTIVE ELEMENT ASSEMBLY INCLUDING ELECTRONIC COMPONENT (Attorney Docket DON01 P-1173); Ser. No. 10/933,842, filed Sep. 3, 2004 by Kulas et al. for INTERIOR REARVIEW MIRROR ASSEMBLY (Attorney Docket DON01 P-1166); Ser. No. 11/021,065, filed Dec. 23, 2004 (Attorney Docket DON01 P-1193); and/or Ser. No. 11/140,396, filed May 27, 2005 (Attorney Docket DON01 P-1215); and/or U.S. provisional application, Ser. No. 60/563,342, filed Apr. 19, 2004 by Bareman et al. for METHOD OF MANUFACTURING ELECTRO-OPTIC MIRROR CELL (Attorney Docket DON01 P-1153), which are hereby incorporated herein by reference in their entireties, or the inputs may comprise other types of buttons or switches, such as those described in U.S. pat. application, Ser. No. 11/029,695, filed Jan. 5, 2005 (Attorney Docket DON01 P-1192); and/or U.S. provisional applications, Ser. No. 60/553,517, filed Mar. 16, 2004 (Attorney Docket DON01 P-1145); Ser. No. 60/535,559, filed Jan. 9, 2004 (Attorney Docket DON01 P-1134); Ser. No. 60/690,401, filed Jun. 14, 2005 (Attorney Docket DON01 P-1226); Ser. No. 60/719,482, filed Sep. 22, 2005 (Attorney Docket DON01 P-1241); and Ser. No. 60/749,423, filed Dec. 12, 2005 (Attorney Docket DON01 P-1258), which are hereby incorporated herein by reference in their entireties, or such as fabric-made position detectors, such as those described in U.S. Pat. Nos. 6,504,531; 6,501,465; 6,492,980; 6,452,479; 6,437,258; and 6,369,804, which are hereby incorporated herein by reference in their entireties. Other types of switches or buttons or inputs or sensors may be incorporated to provide the desired function, without affecting the scope of the present invention. The manual inputs or user actuatable inputs or actuators may control or adjust or activate/deactivate one or more accessories or elements or features. For touch sensitive inputs or applications or switches, the mirror assembly or accessory module or input may, when activated, provide a positive feedback (such as activation of an illumination source or the like, or such as via an audible signal, such as a chime or the like, or a tactile or haptic signal, or a rumble device or signal or the like) to the user so that the user is made aware that the input was successfully activated.

[00283] Optionally, the user inputs or buttons may comprise user inputs for a garage door opening system, such as a vehicle based garage door opening system of the types described in U.S. Pat. Nos. 6,396,408; 6,362,771; and 5,798,688, and/or U.S. patent application Ser. No. 10/770,736, filed Feb. 3, 2004 (Attorney Docket DON01 P-1135); and/or U.S. provisional applications, Ser. No. 60/502,806, filed Sep. 12, 2003 by Taylor et al. for GARAGE DOOR OPENING SYSTEM FOR VEHICLE (Attorney Docket DON01 P-1114); and Ser. No. 60/444,726, filed Feb. 4, 2003 by Baumgardner et al. for GARAGE DOOR OPENING SYSTEM FOR VEHICLE (Attorney Docket DON01 P-1065), which are hereby incorporated herein by reference in their entireties. The user inputs may also or otherwise function to activate and deactivate a display or function or accessory, and/or may activate/deactivate and/or commence a calibration of a compass system of the mirror assembly and/or vehicle. The compass system may include compass sensors and circuitry within the mirror assembly or within a compass pod or module at or near or associated with the mirror assembly. Optionally, the user inputs may also or otherwise comprise user inputs for a telematics system of the vehicle, such as, for example, an ONSTAR® system as found in General Motors vehicles and/or such as described in U.S. Pat. Nos. 4,862,594; 4,937,945; 5,131,154; 5,255,442; 5,632,092; 5,798,688; 5,971,552; 5,924,212; 6,243,003; 6,278,377; 6,420,975; 6,946,978; and 6,477,464; and/or 6,678,614; and/or U.S. pat. applications, Ser. No. 10/456,599, filed Jun. 6, 2003 by Weller et al. for INTERIOR REARVIEW MIRROR SYSTEM WITH COMPASS (Attorney Docket DON01 P-1076); Ser. No. 10/645,762, filed Aug. 20, 2003 by Taylor et al. for VEHICLE NAVIGATION SYSTEM FOR USE WITH A TELEMATICS SYSTEM (Attorney Docket DON01 P-1103); and Ser. No. 10/964,512, filed Oct. 13, 2004 (Attorney Docket DON01 P-1174); and/or PCT Application No. PCT/US03/40611, filed Dec. 19, 2003 by Donnelly Corporation et al. for ACCESSORY SYSTEM FOR VEHICLE (Attorney Docket DON01 FP-1123(PCT)), and/or PCT Application No. PCT/US03/308877, filed Oct. 1, 2003 by Donnelly Corp. for MICROPHONE SYSTEM FOR VEHICLE (Attorney Docket DON01 FP-1116(PCT)), which are all hereby incorporated herein by reference in their entireties.

[00284] Optionally, the accessory module may utilize aspects of other accessory modules or windshield electronics modules or the like, such as the types described in U.S. pat. applications, Ser. No. 10/958,087, filed Oct. 4, 2004 by Schofield et al. for VEHICLE ACCESSORY MODULE (Attorney Docket DON01 P-1175); Ser. No. 10/456,599, filed Jun. 6, 2003 by Weller et al. for INTERIOR REARVIEW MIRROR SYSTEM WITH COMPASS (Attorney Docket DON01 P-1076); and/or Ser. No. 11/201,661, filed Aug. 11, 2005

(Attorney Docket DON01 P-1233), and/or U.S. Pat. Nos. 6,824,281; 6,690,268; 6,250,148; 6,341,523; 6,593,565; 6,428,172; 6,501,387; 6,329,925; and 6,326,613, and/or in PCT Application No. PCT/US03/40611, filed Dec. 19, 2003 by Donnelly Corp. et al. for ACCESSORY SYSTEM FOR VEHICLE (Attorney Docket DON01 FP-1123(PCT)), and/or Ireland pat. applications, Ser. No. S2004/0614, filed Sep. 15, 2004 (Attorney Docket P72723IE00); Ser. No. S2004/0838, filed Dec. 14, 2004 (Attorney Docket P73992IE00); and Ser. No. S2004/0840, filed Dec. 15, 2004 (Attorney Docket P73923IE00), which are all hereby incorporated herein by reference in their entireties.

[00285] Changes and modifications to the specifically described embodiments may be carried out without departing from the principles of the present invention, which is intended to be limited only by the scope of the appended claims as interpreted according to the principles of patent law.

[00286] The embodiments of the invention in which an exclusive property or privilege is claimed are defined as follows:

1. A rearview mirror system for a vehicle comprising:
 - a rearview mirror assembly comprising an electro-optic mirror reflective element having electrically variable reflectivity between a high reflectance state and a dimmed reflectance state;
 - said electro-optic mirror reflective element comprising a front substrate having a first surface and a second surface;
 - said electro-optic mirror reflective element comprising a rear substrate having a third surface and a fourth surface;
 - said second surface of said front substrate and said third surface of said rear substrate opposing each other in said electro-optic mirror reflective element and with an electro-optic medium disposed therebetween;
 - a specularly reflecting mirror reflector established at a surface of said rear substrate;
 - a specularly reflecting indicia reflector locally established at said second surface of said front substrate to form indicia at said reflective element; and
 - the indicia providing a visible contrast between light incident at said mirror reflector and light incident at said indicia reflector so that when said electro-optic mirror reflective element is in its high reflectance state, indicia information is subtly viewable by a person viewing said reflective element of said mirror assembly.
2. The rearview mirror system of claim 1, wherein said rearview mirror assembly comprises an exterior rearview mirror assembly.
3. The rearview mirror system of claim 2 including at least one of a turn signal indicator and a blind spot system alert indicator at and to the rear of said reflective element for indicating, by display through said reflective element when actuated, at least one of (a) activation of a turn signal of the vehicle and (b) detection of another vehicle in a side lane.
4. The rearview mirror system of claim 3, wherein said at least one of a turn signal indicator and a blind spot system alert indicator comprises a transparent block to the rear of said reflective element, said block having light-transmitting pipeways formed at least

partially therethrough for passage of light therethrough, and wherein said pipeways are angled relative to the rear surface of said reflective element.

5. The rearview mirror system of claim 1, wherein said rearview mirror assembly comprises an interior rearview mirror assembly.
6. The rearview mirror system of claim 1, wherein said indicia reflector comprises a reflective metal coating.
7. The rearview mirror system of claim 1, wherein said indicia reflector is overcoated by a transparent electrically conductive coating at said second surface.
8. The rearview mirror system of claim 1, wherein the indicia is discernible due to at least one of (a) a contrast in color between said indicia reflector and said mirror reflector, (b) a contrast in reflectance between said indicia reflector and said mirror reflector, and (c) an interference effect of said indicia reflector with an undercoating transparent conductor layer.
9. The rearview mirror system of claim 1, wherein said reflective element comprises an electrochromic reflective element, said electro-optic medium comprising an electrochromic medium.
10. The rearview mirror system of claim 1, wherein said mirror reflector is established at said third surface of said reflective element.
11. The rearview mirror system of claim 10, wherein said mirror reflector comprises a transfective reflector disposed at said third surface of said reflective element.
12. The rearview mirror system of claim 10, wherein said mirror reflector comprises an environmentally stable metallic electrical conductor layer disposed at said third surface and an environmentally less stable layer disposed over said environmentally stable metallic electrical conductor layer.

13. The rearview mirror system of claim 12, wherein said environmentally stable metallic electrical conductor layer comprises chromium and said environmentally less stable layer comprises one of silver and a silver-alloy.
14. The rearview mirror system of claim 1 including a transparent electrically conductive coating disposed at said second surface of said front substrate.
15. The rearview mirror system of claim 14, wherein said indicia reflector is disposed one of in front of said transparent electrically conductive coating and behind said transparent electrically conductive coating as viewed by a person viewing said reflective element through said front substrate.
16. The rearview mirror system of claim 14, wherein said indicia reflector is established behind said transparent electrically conductive coating and between said mirror reflector and said transparent electrically conductive coating.
17. The rearview mirror system of claim 14, wherein said indicia reflector is established in front of said transparent electrically conductive coating and between said transparent electrically conductive coating and said second surface.
18. The rearview mirror system of claim 1, wherein said indicia reflector comprises a reflective coating or stack of coatings having a lower reflectivity than that of a reflective coating or stack of coatings of said mirror reflector.
19. The rearview mirror system of claim 1, wherein said indicia reflector is configured to provide one of (a) an icon, (b) a logo, and (c) an information message at said reflective element.
20. The rearview mirror system of claim 1, wherein the indicia conveys information informing that said rearview mirror assembly is an automatic dimming type.
21. The rearview mirror system of claim 1, wherein said rearview mirror assembly comprises an exterior rearview mirror assembly and wherein said rearview mirror system further comprises an interior rearview mirror assembly having a transreflective mirror element.

22. The rearview mirror system of claim 21, wherein said interior rearview mirror assembly includes a video screen covertly disposed behind said transfective mirror element and operable so that when said video screen is actuated and is displaying an image, the image is viewable to a driver of the vehicle who views said transfective mirror element of said interior rearview mirror assembly when it is normally mounted in the vehicle.
23. The rearview mirror system of claim 22, wherein said transfective mirror element comprises a transfective day/night prismatic mirror element.
24. The rearview mirror system of claim 23, wherein said transfective day/night prismatic mirror element comprises a silicon-based second-surface translector.
25. The rearview mirror system of claim 23, wherein said transfective day/night prismatic mirror element comprises a metal oxide layer/a metal layer/a metal oxide layer second-surface translector.
26. The rearview mirror system of claim 25, wherein said metal layer comprises silver or a silver alloy.
27. The rearview mirror system of claim 23, wherein said transfective day/night prismatic mirror element comprises an indium tin oxide/metal/indium tin oxide second-surface translector.
28. The rearview mirror system of claim 27, wherein said metal comprises silver or a silver alloy.
29. The rearview mirror system of claim 23, wherein said transfective day/night prismatic mirror element comprises a second-surface translector that is protected by an overlying optically clear protectorant.
30. The rearview mirror system of claim 29, wherein said overlying optically clear protectorant comprises a clear polymeric coating layer.

31. The rearview mirror system of claim 30, wherein said polymeric coating layer comprises at least one of an acrylic, an acrylate, a urethane, a silicone, a poly vinyl butyral and an epoxy.
32. The rearview mirror system of claim 29, wherein said overlying optically clear protectorant comprises a flat transparent glass element adhered to the translector by at least one of an optically clear adhesive and an optically clear laminating film.
33. The rearview mirror system of claim 1, wherein at least one light source is disposed at an angle to the rear of said fourth surface and is operable to emit light when powered through said mirror reflective element with a principal beam axis that is substantially non-perpendicular to the horizontal plane of said fourth surface of said rear substrate.
34. The rearview mirror system of claim 1, including a light control film disposed to the rear of said rear substrate, said light control film comprising embedded micro louvers and said light control film having a higher light transmission for light incident thereon along an axis generally parallel to the axis of alignment of said micro louvers than for light incident thereon along an axis generally different from the axis of alignment of said micro louvers.
35. A rearview mirror system for a vehicle comprising:
a rearview mirror assembly comprising an electrochromic mirror reflective element having electrically variable reflectivity between a high reflectance state and a dimmed reflectance state;
said electrochromic mirror reflective element comprising a front substrate having a first surface and a second surface;
said electrochromic mirror reflective element comprising a rear substrate having a third surface and a fourth surface;
said second surface of said front substrate and said third surface of said rear substrate opposing each other in said electrochromic mirror reflective element and with an electrochromic medium disposed therebetween;
a specularly reflecting mirror reflector established at said third surface of said rear substrate, said specularly reflecting mirror reflector having a reflectance value of at least about 70 percent of light incident thereon;

a specularly reflecting indicia reflector locally established at said second surface of said front substrate to form indicia at said reflective element, said specularly reflecting indicia reflector having a reflectance value of light that passes through said front substrate to be incident thereon that is at least about 5 percent less than that of said specularly reflecting mirror reflector; and

the indicia providing a visible contrast between light incident at said mirror reflector and light incident at said indicia reflector so that when said electrochromic mirror reflective element is in its high reflectance state, indicia information is subtly viewable by a person viewing said reflective element of said mirror assembly.

36. The rearview mirror system of claim 35, wherein said third surface reflector comprises a ruthenium coating.

37. The rearview mirror system of claim 36, wherein said specularly reflecting indicia reflector comprises a chromium coating.

38. A rearview mirror system for a vehicle comprising:

an interior rearview mirror assembly comprising an electro-optic mirror reflective element having electrically variable reflectivity between a high reflectance state and a dimmed reflectance state;

said electro-optic mirror reflective element comprising a front substrate having a first surface and a second surface;

said electro-optic mirror reflective element comprising a rear substrate having a third surface and a fourth surface;

said second surface of said front substrate and said third surface of said rear substrate opposing each other in said electro-optic mirror reflective element and with an electro-optic medium disposed therebetween;

a specularly reflecting mirror reflector established at said third surface of said rear substrate, said specularly reflecting mirror reflector having a reflectance value of at least about 70 percent of light incident thereon;

a specularly reflecting indicia reflector locally established at said second surface of said front substrate to form indicia at said reflective element, said specularly reflecting indicia reflector having a reflectance value of light that passes through said front substrate to be incident thereon that is one of (a) higher than, (b) the same as, and (c) lower than that of said

specularly reflecting mirror reflector;

the indicia providing a visible contrast between light incident at said mirror reflector and light incident at said indicia reflector so that when said electro-optic mirror reflective element is in its high reflectance state, indicia information is subtly viewable by a person viewing said reflective element of said mirror assembly; and

wherein the indicia conveys information that least one of: (a) informs that the rearview mirror assembly is an automatic dimming type, (b) informs of a brand logo and (c) informs of a personalization logo.

36. The rearview mirror system of claim 35, wherein said third surface reflector comprises one of a silver coating and a silver alloy coating.

37. The rearview mirror system of claim 36, wherein said third surface reflector comprises a conducting metal oxide coating.

38. The rearview mirror system of claim 37, wherein said conducting metal oxide coating comprises indium tin oxide.

39. The rearview mirror system of claim 37, wherein said conducting metal oxide coating comprises doped zinc oxide.

40. The rearview mirror system of claim 39, wherein said doped zinc oxide comprises aluminum-doped zinc oxide.

41. The rearview mirror system of claim 36, wherein the indicia conveys information that informs that the rearview mirror assembly is an automatic dimming type.

42. The rearview mirror system of claim 36, wherein the indicia conveys information that informs of a brand logo.

43. The rearview mirror system of claim 36, wherein the indicia conveys information that informs of a personalization logo.

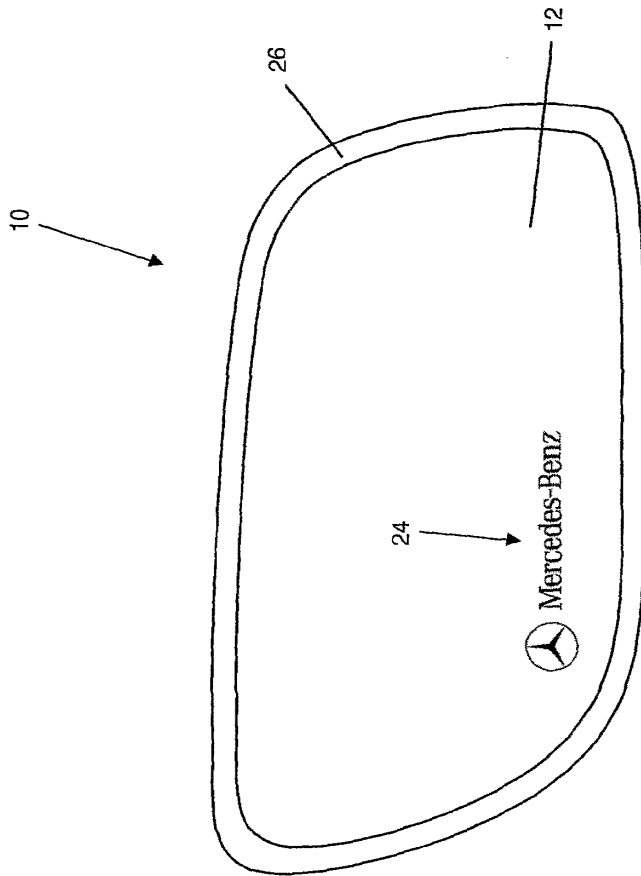

Fig. 1

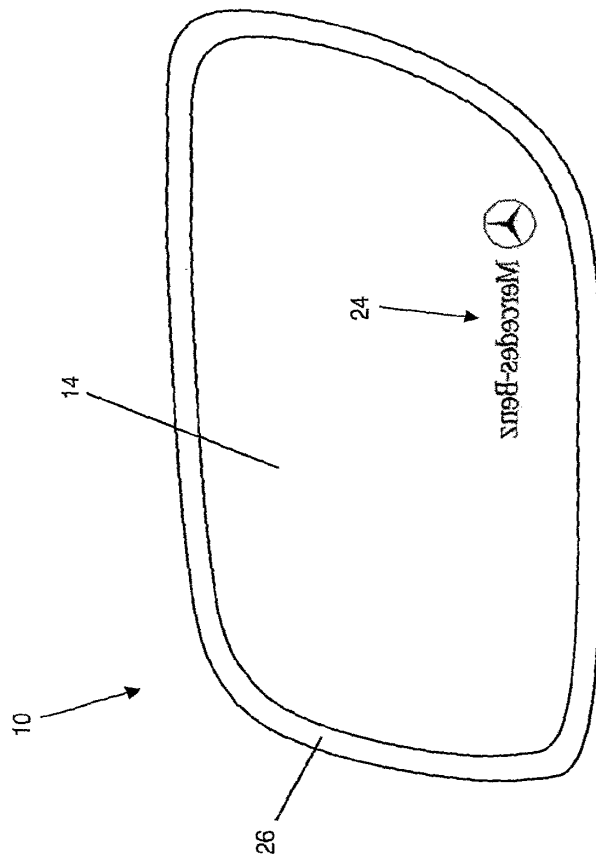

Fig. 2

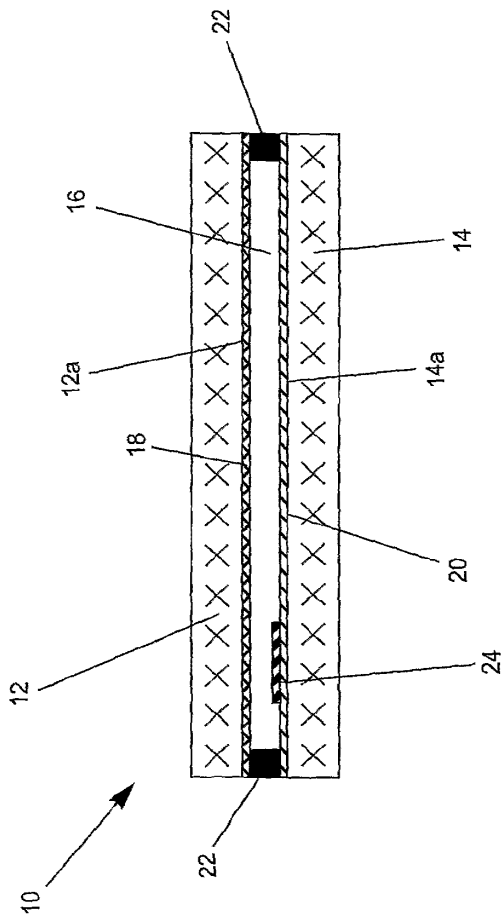

Fig. 3

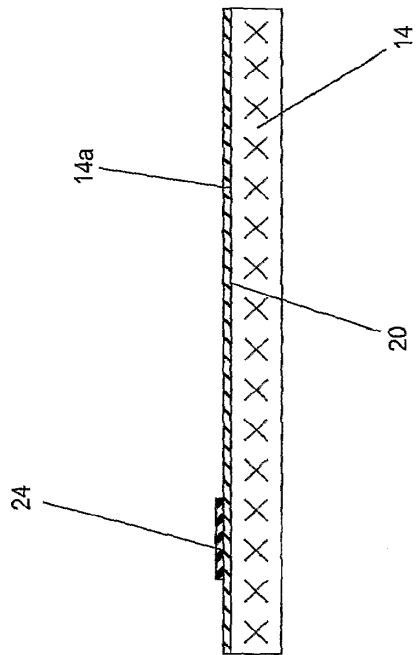

Fig. 4

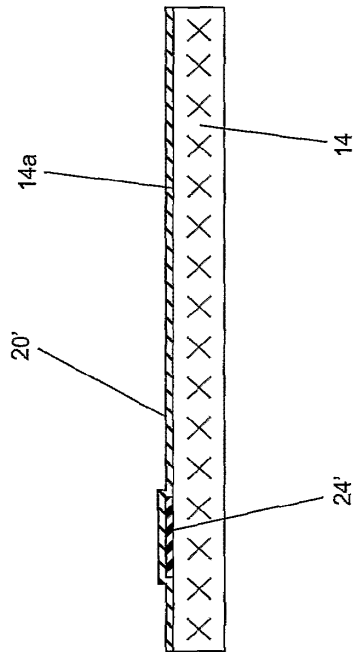

Fig. 5

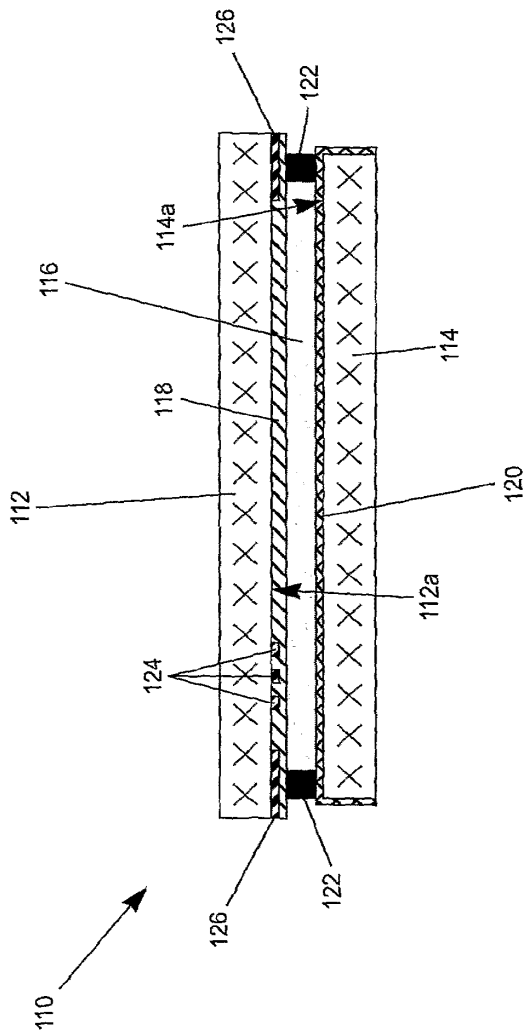

Fig. 6

7/36

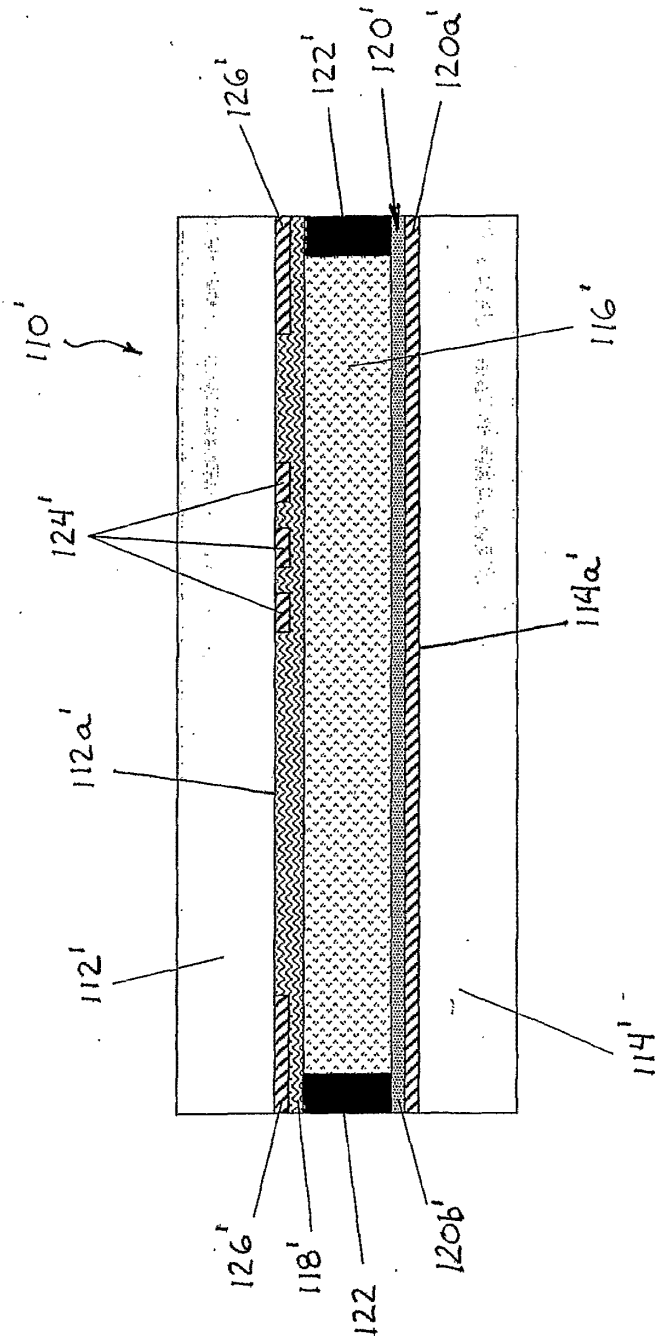

Fig. 6A

8/36

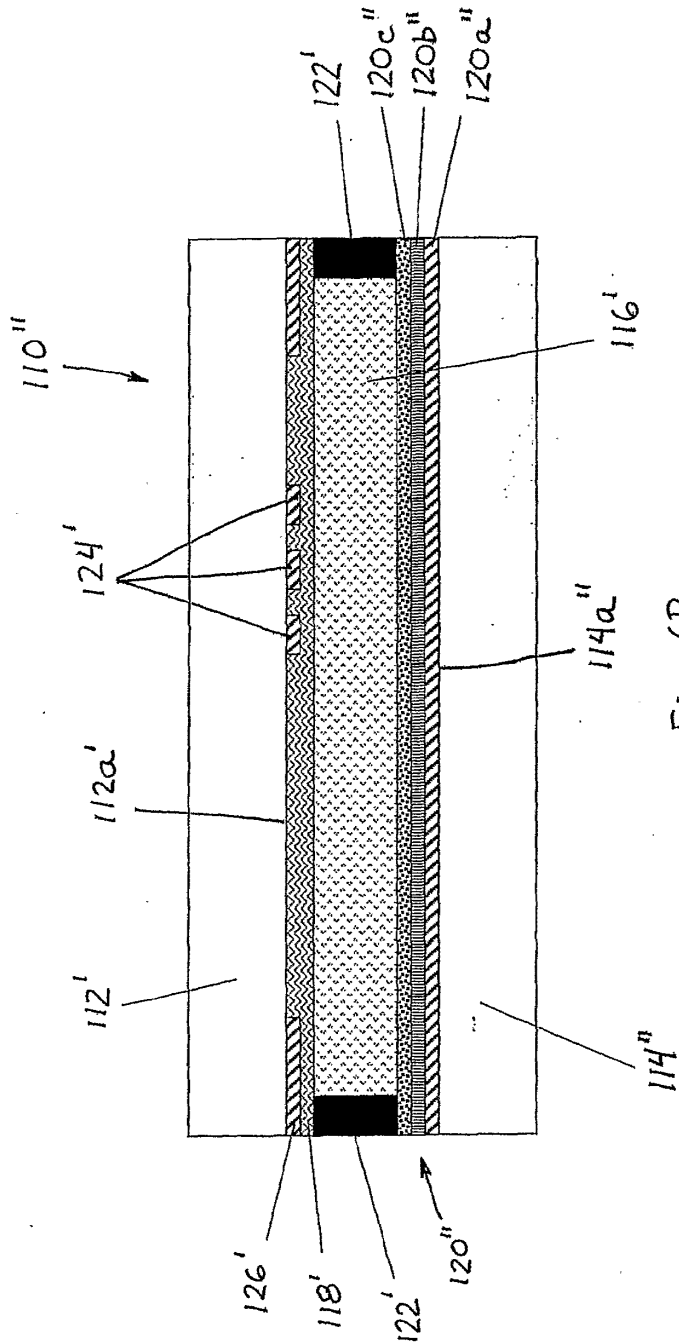

Fig. 6B

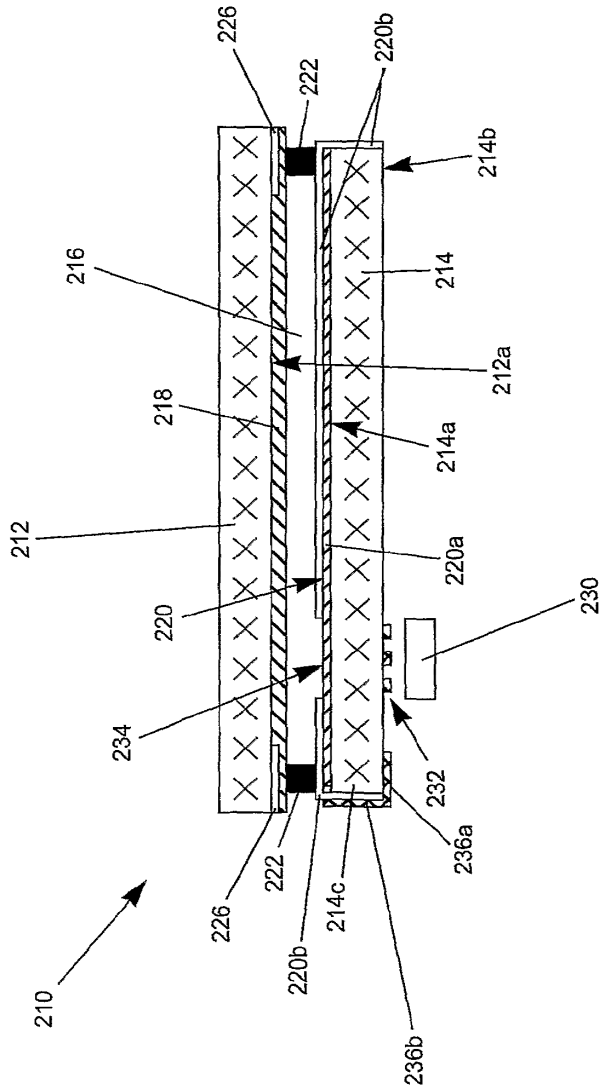

Fig. 7

10/36

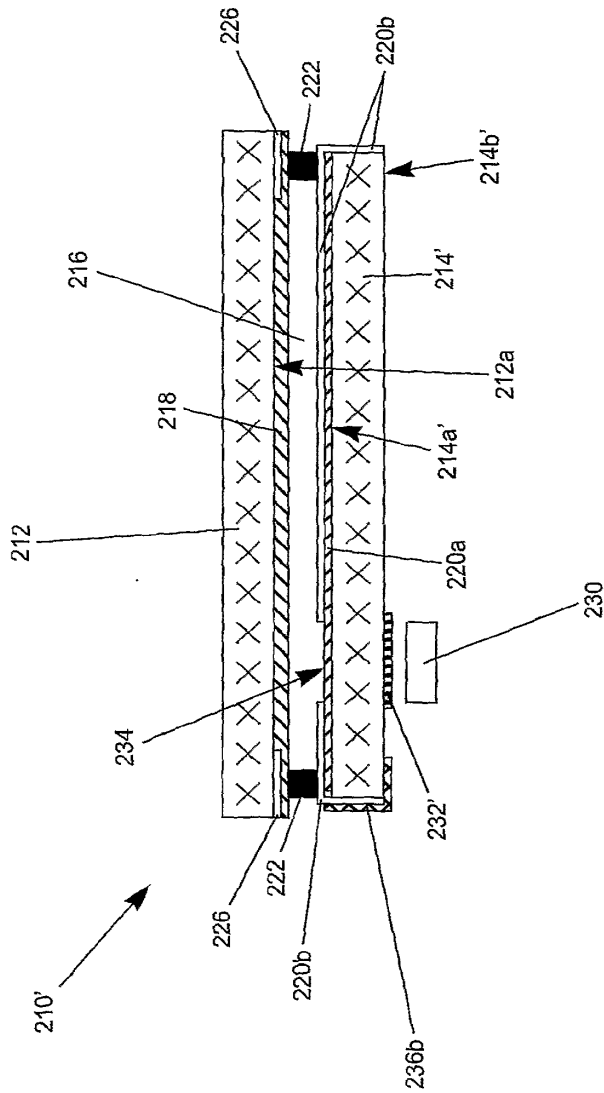

Fig. 8

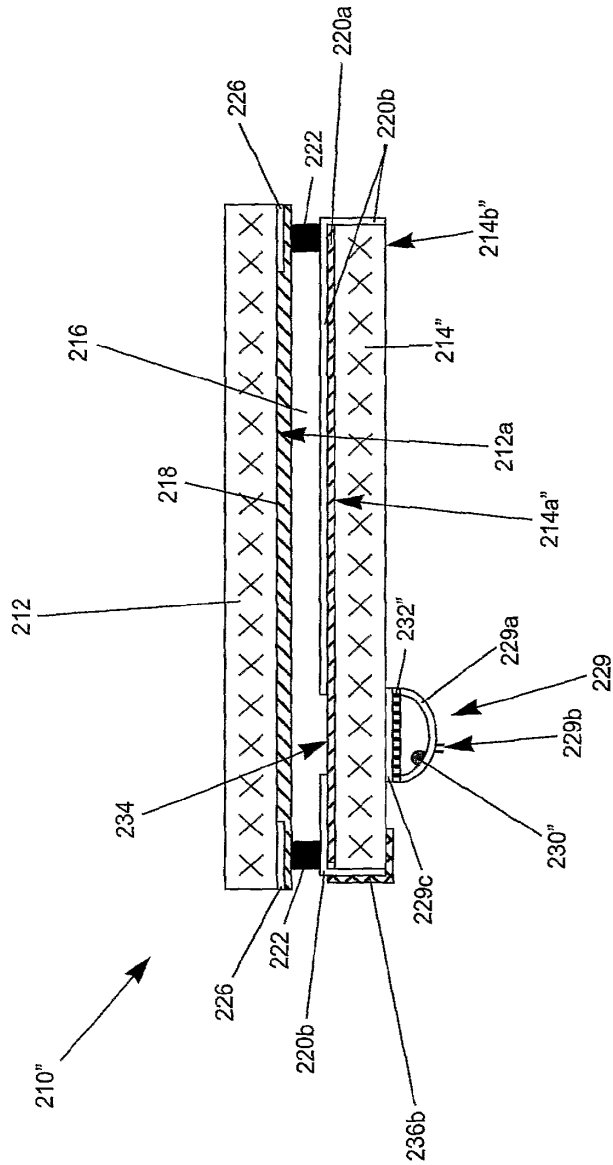

Fig. 9

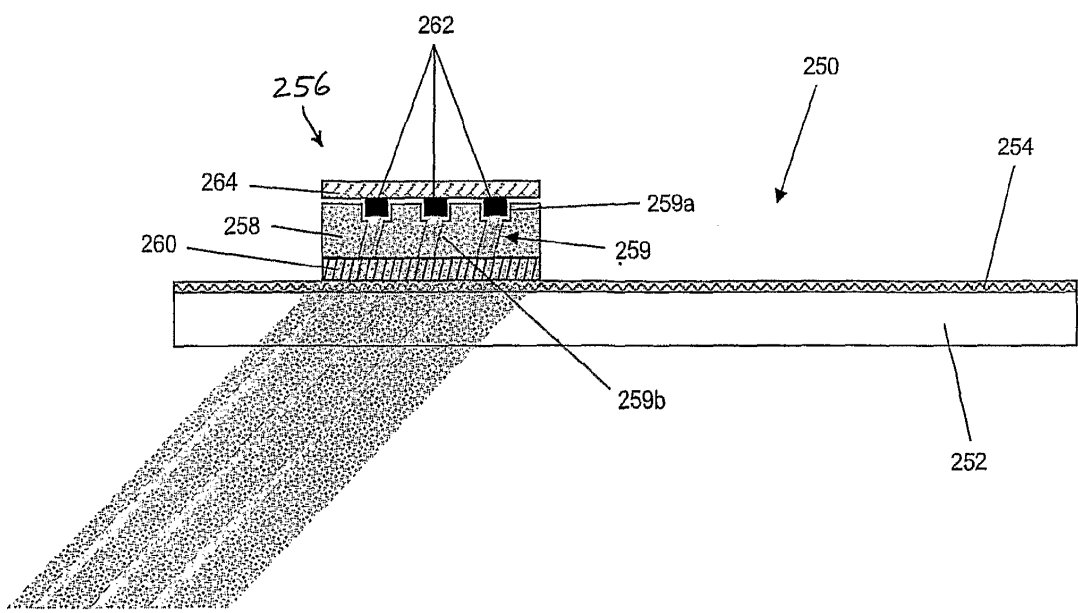

Fig. 10A

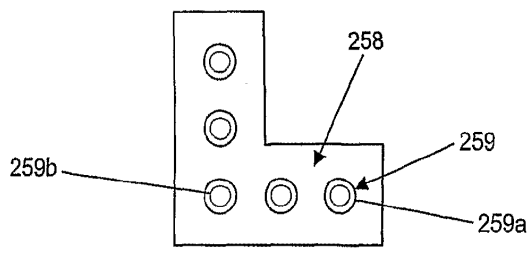

Fig. 10B

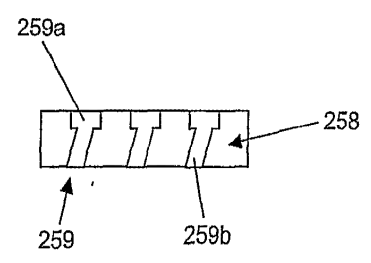

Fig. 10C

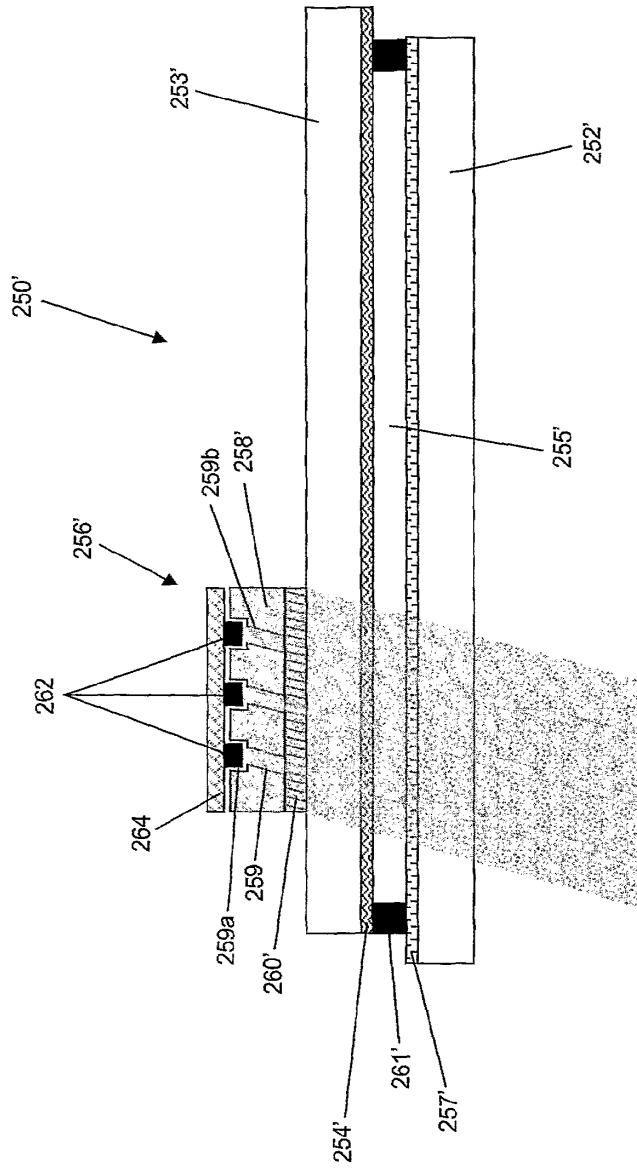

Fig. 10D

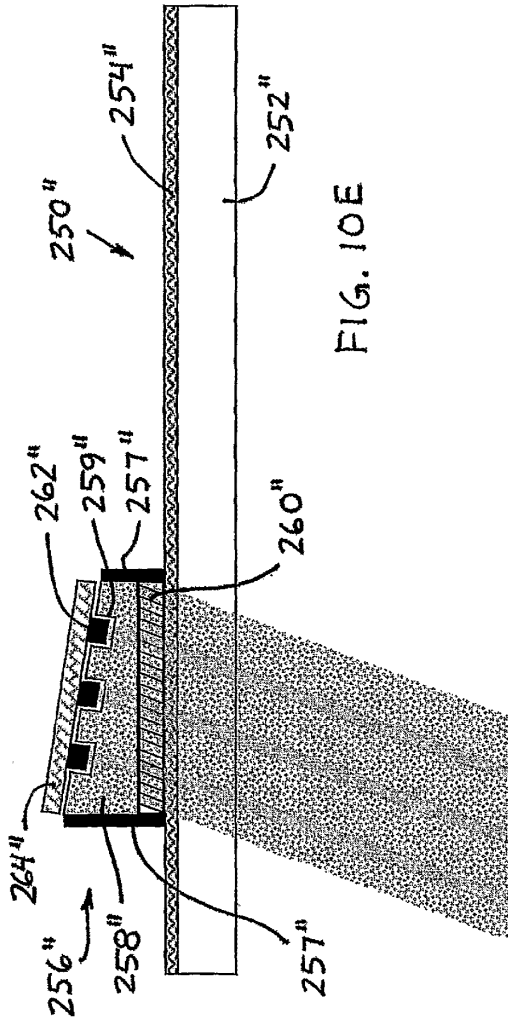

FIG. 10E

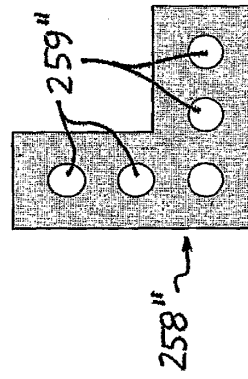

FIG. 10F



FIG. 10G

16/36

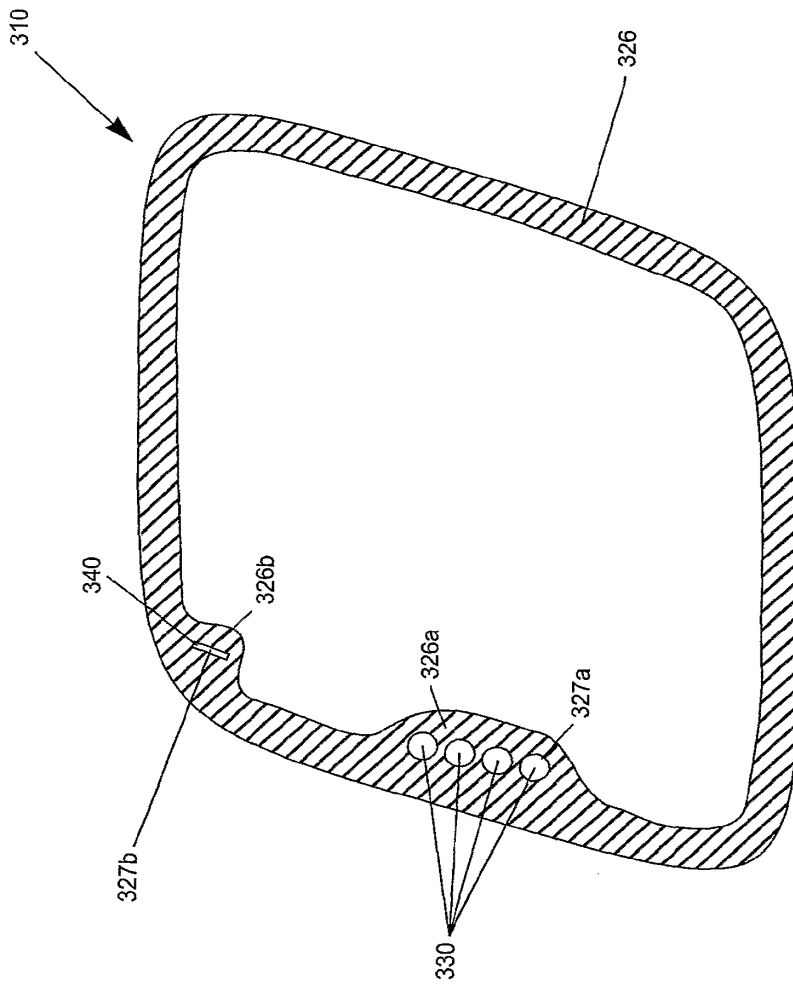

Fig. 11

17/36

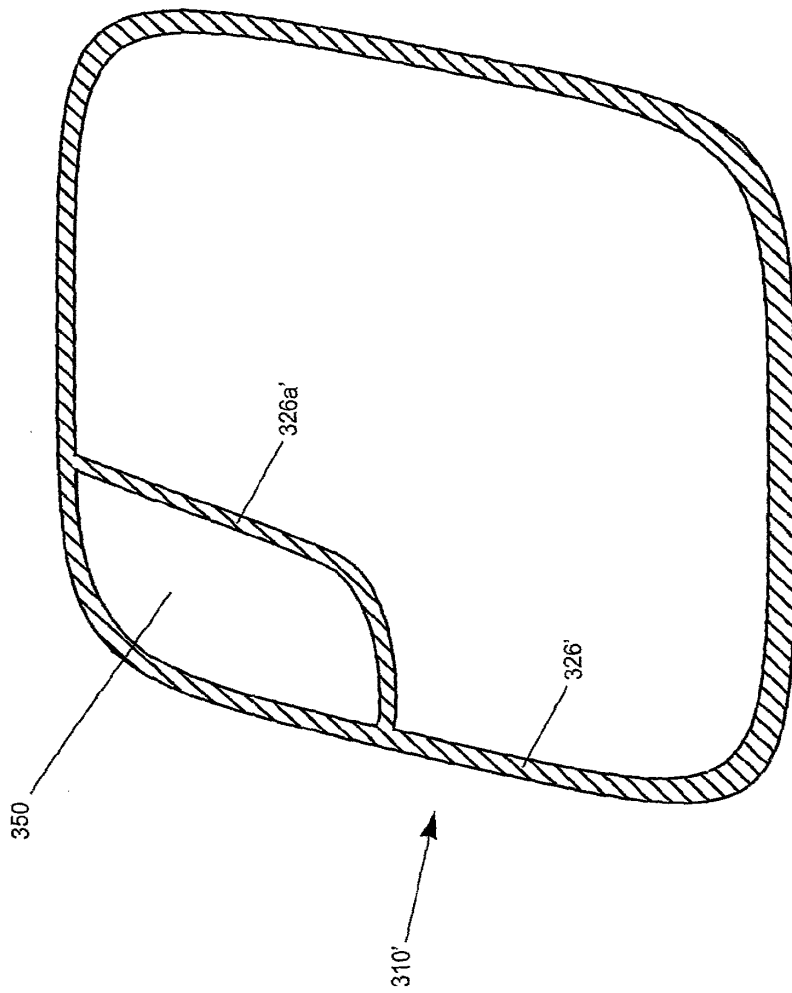

Fig. 12

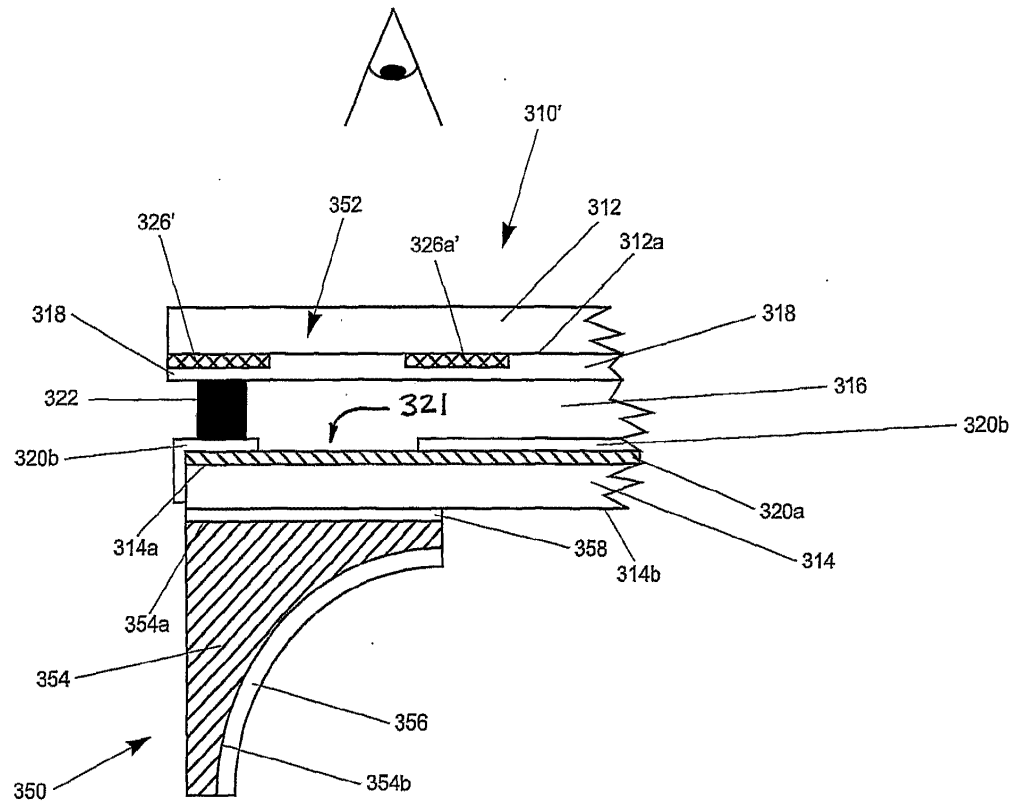

Fig. 13

19/36

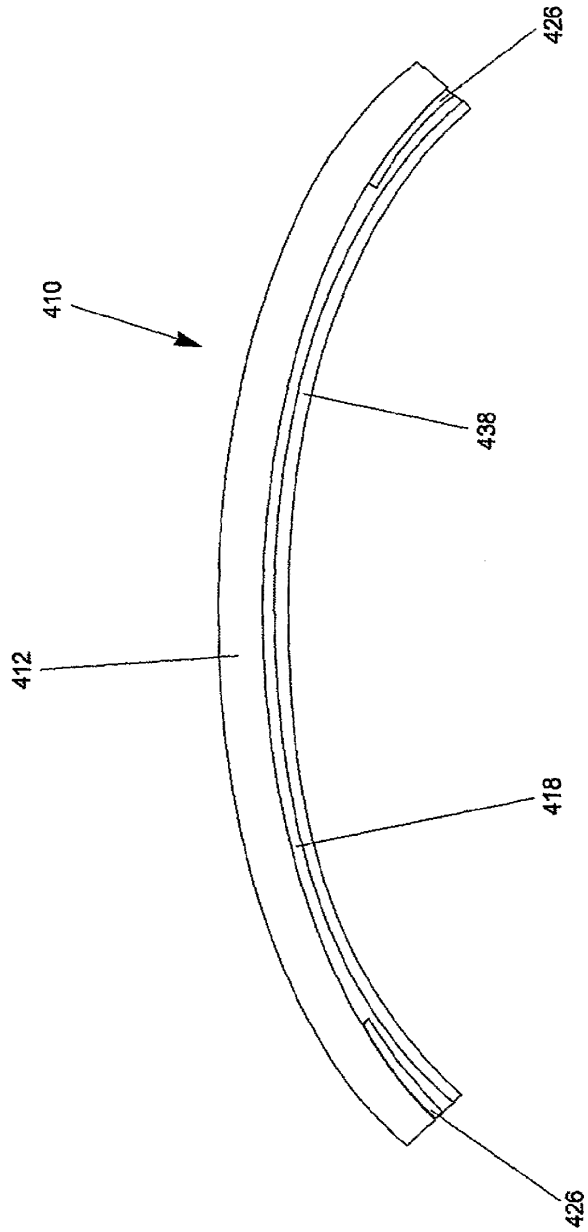

Fig. 14

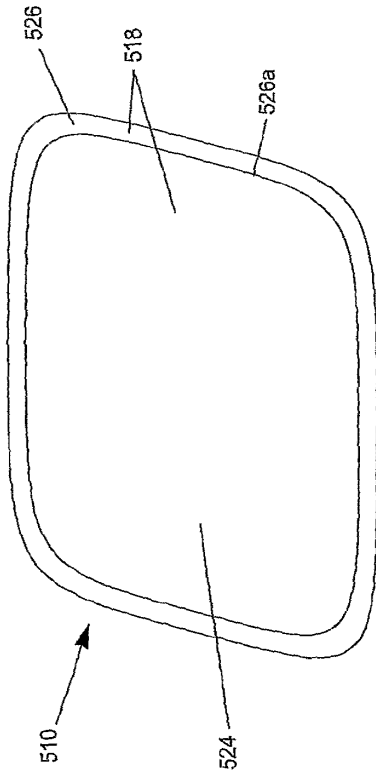

Fig. 15A

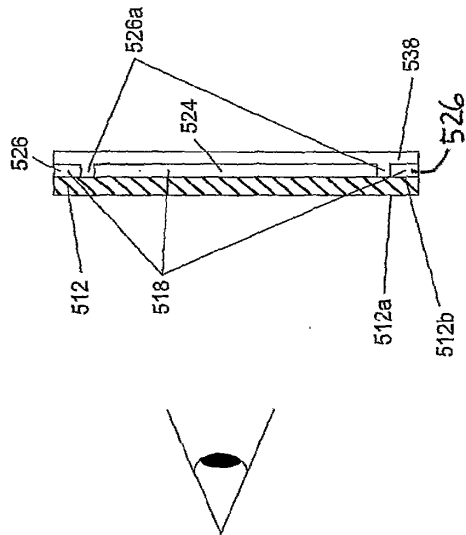

Fig. 15B

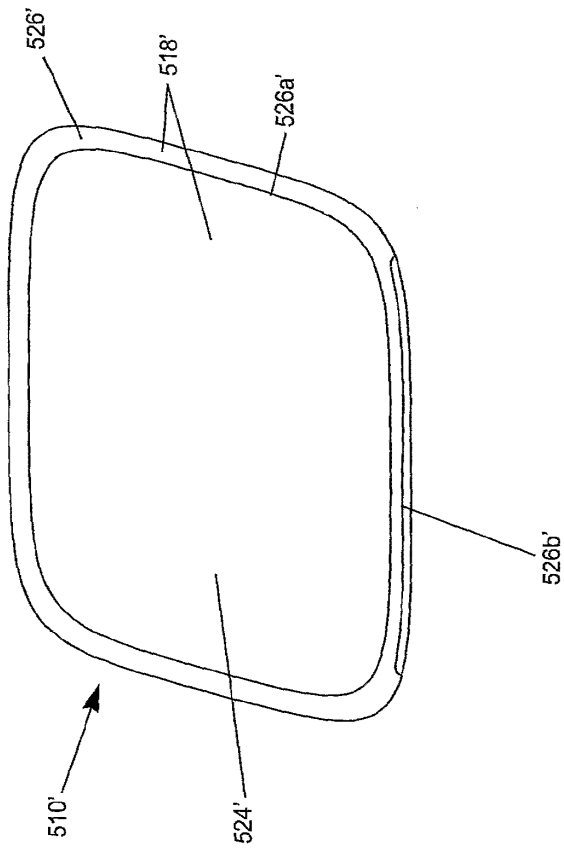

Fig. 16

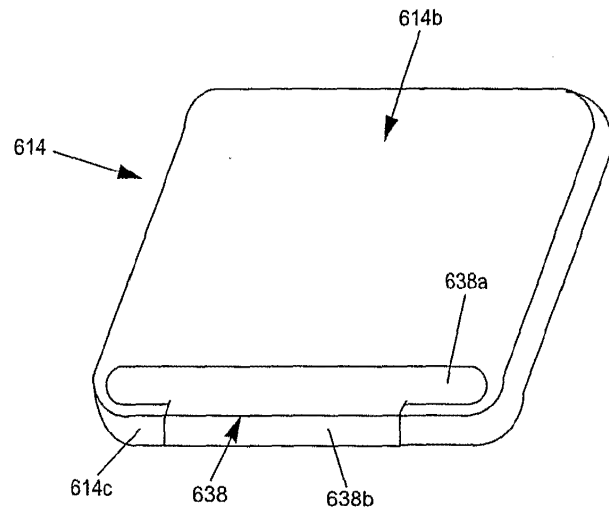

Fig. 17

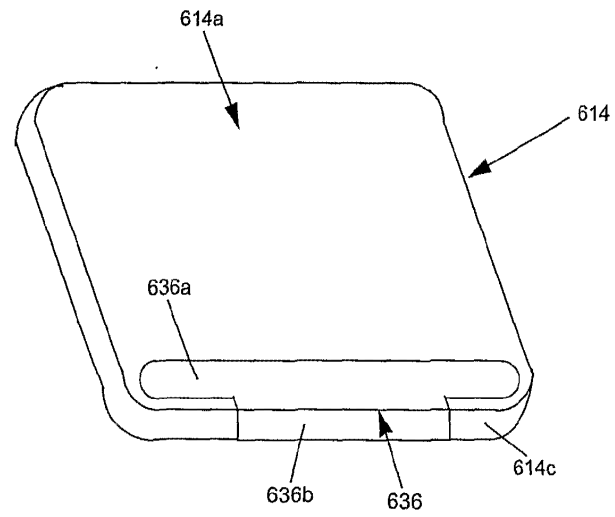

Fig. 18

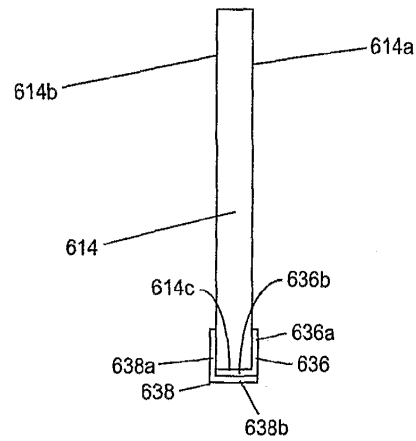

Fig. 19

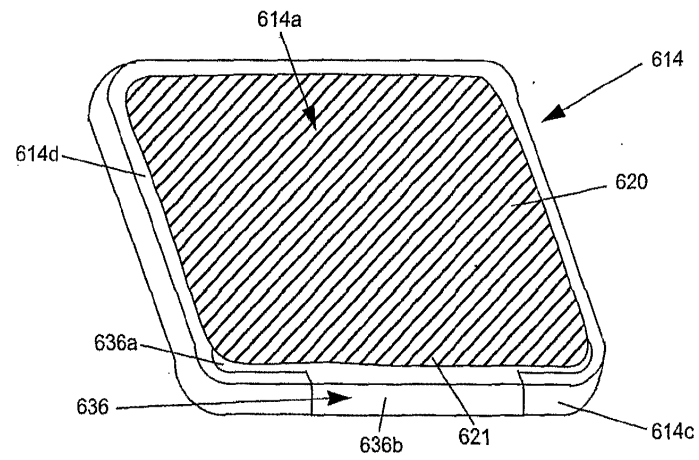

Fig. 20

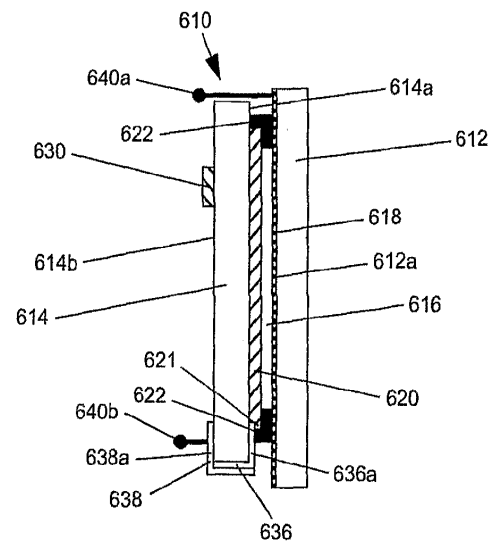

Fig. 21

25/36

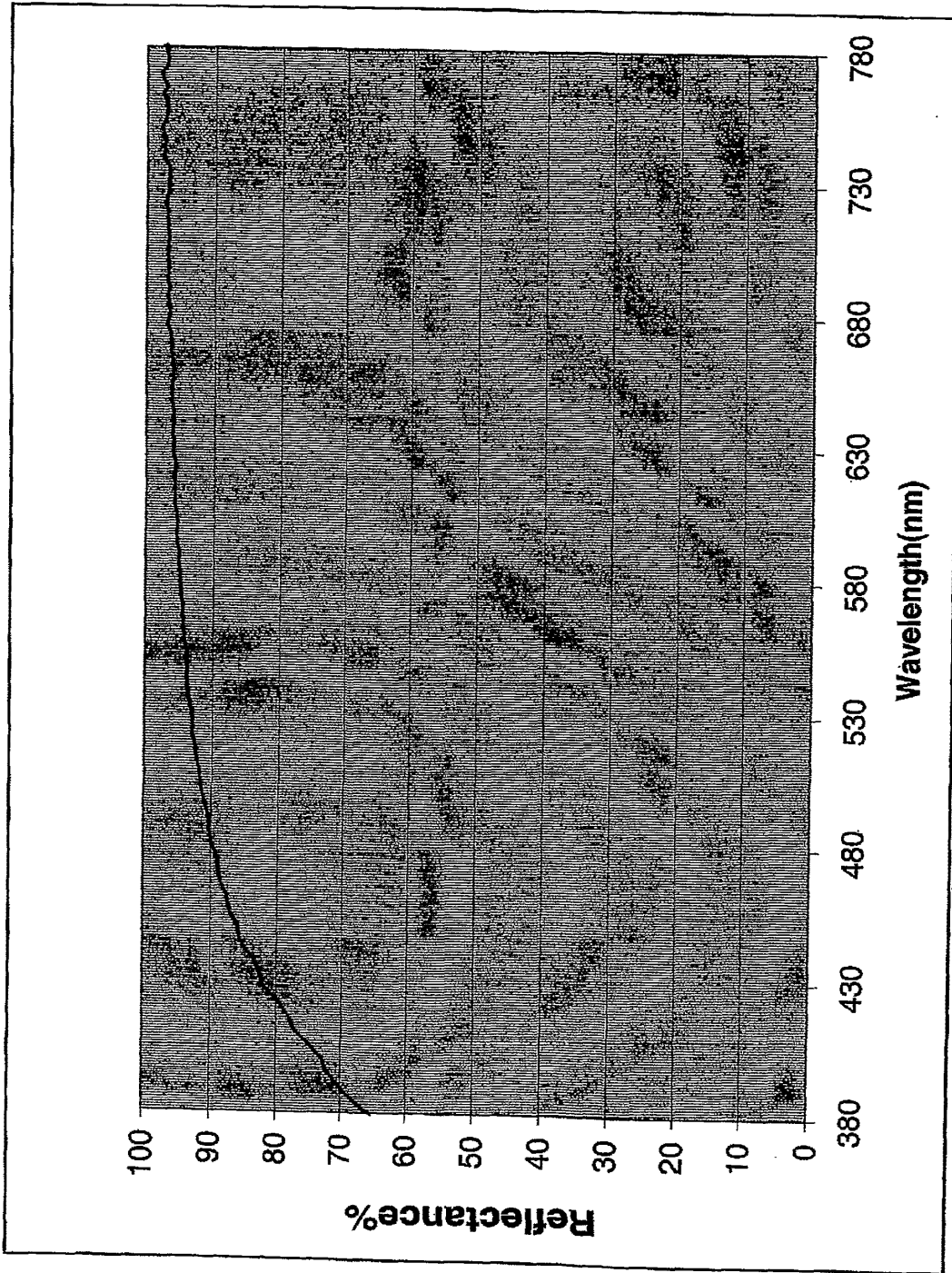

FIG. 23

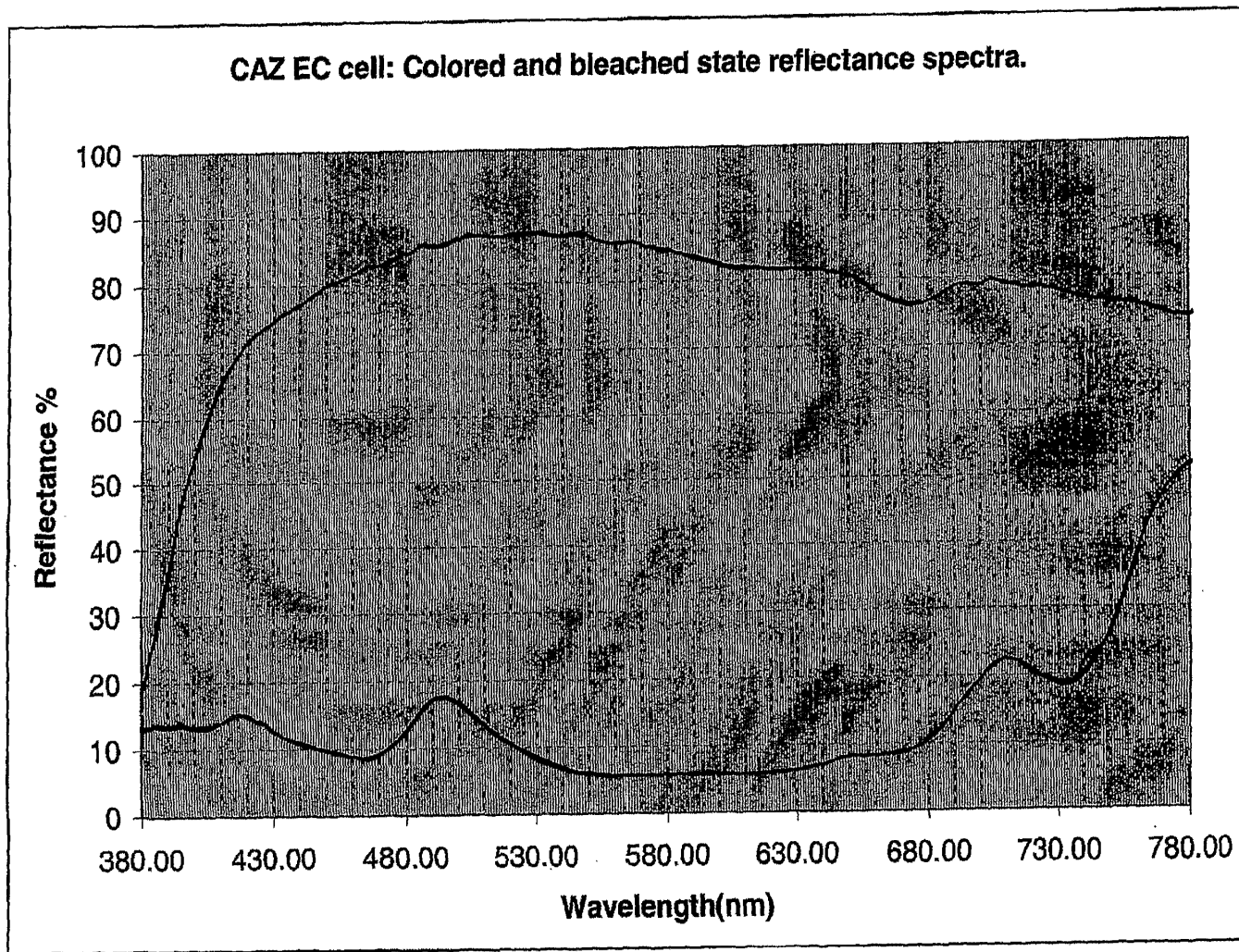
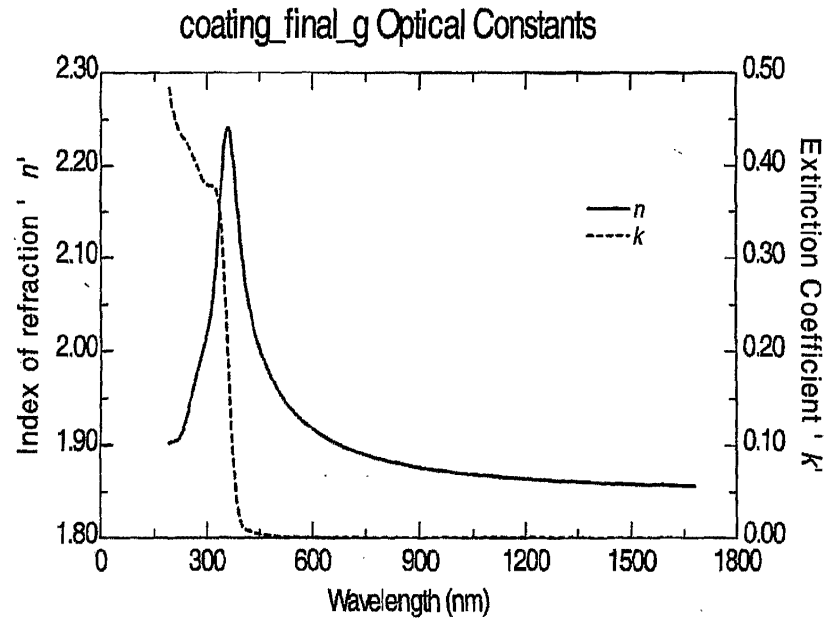

FIG. 24

WO 2006/124682

26/36

PCT/US2006/018567



n,k of 300Å of ZnO:Al₂O₃ on soda lime glass. Denton coater

FIG. 25

28/36

Initial Reflectance, Response Time and Current Draw @ 23°C, 1.2V

Sample #	50 to 10% Color (sec)	10 to 50% Bleach (sec)	Max Ref (%)	Min Ref (%)	Max Current Draw (mA)	SS Current Draw (mA)
1	3.2	4.9	86.1	6.8	287	110
2	3.2	5.1	86.6	6.6	286	106
3	3.1	5.5	87.3	6.5	282	103
4	3.5	4.9	87.9	6.9	275	106
5	2.8	5.5	85.6	6.4	319	104
6	3.4	5.2	87.4	6.8	282	108
7	3.1	5.0	85.1	6.6	291	109
8	3.1	5.0	85.7	6.8	307	108
9	3.0	5.1	84.8	6.6	310	107
10	3.1	5.1	85.1	6.7	311	107
11	2.9	5.0	84.8	6.8	315	108
12	3.0	5.5	86.4	6.3	300	103
13	3.0	4.9	86.9	6.7	311	108
14	3.1	5.2	84.4	6.5	286	106
15	3.1	5.0	85.6	6.6	300	107
16	2.9	5.1	85.2	6.6	318	107
17	3.2	5.0	86.2	6.8	276	106
18	3.1	5.3	86.5	6.6	287	107
19	3.0	5.2	84.7	6.6	300	108
20	3.1	5.2	85.2	6.7	300	107
21	3.0	5.0	85.9	6.8	300	109
22	3.0	5.1	85.4	6.6	301	108
23	3.0	5.3	86.8	6.5	312	105
24	2.9	5.2	85.9	6.6	312	107
25	3.2	5.2	86.3	6.6	284	107
26	2.9	5.1	86.3	6.6	314	108
27	3.0	4.7	87.6	6.9	309	110
28	3.1	4.8	87.1	6.9	311	108

Fig. 26

29/36

Initial Reflectance, Response Time and Current Draw @ 23°C, 1.2V
 After 50,000 cycles (30 sec, 30 sec) @ 65°C / 95% RH

Sample #	50 to 10% Color (sec)	10 to 50% Bleach (sec)	Max Ref (%)	Min Ref (%)	Max Current Draw (mA)	SS Current Draw (mA)
1	4.0	5.6	84.8	6.7	241	97
2	3.6	5.5	85.2	6.6	251	95
3	3.5	6.0	85.8	6.6	250	94
4	3.8	5.4	86.7	6.8	249	96
5	3.4	6.1	84.1	6.4	277	96
6	3.6	5.5	86.0	6.8	256	98
7	3.6	5.8	84.0	6.5	252	96
8	3.6	5.5	84.1	6.7	257	97
9	3.6	5.9	83.0	6.5	269	96
10	3.5	5.8	83.6	6.6	266	97
11	3.4	5.5	83.4	6.7	272	97
12	3.2	6.2	84.8	6.2	259	93
13	3.5	5.4	85.2	6.8	264	97
14	3.4	5.7	83.4	6.3	251	96
15	3.6	5.7	84.1	6.7	255	97
16	3.2	5.5	83.5	6.5	277	98
17	3.8	5.6	84.9	6.7	249	96
18	3.5	5.8	84.8	6.6	258	96
19	3.4	5.4	83.5	6.7	266	97
20	3.4	5.7	83.6	6.7	267	97
21	3.4	5.4	84.2	6.8	266	98
22	3.4	5.5	83.9	6.6	263	97
23	3.5	5.9	85.2	6.5	269	96
24	3.7	5.9	84.3	6.5	271	96
25	3.8	5.8	84.9	6.6	242	95
26	3.2	5.7	84.9	6.6	279	97
27	3.5	5.2	85.9	6.8	277	99
28	3.5	5.3	85.7	6.7	265	98

Fig. 27

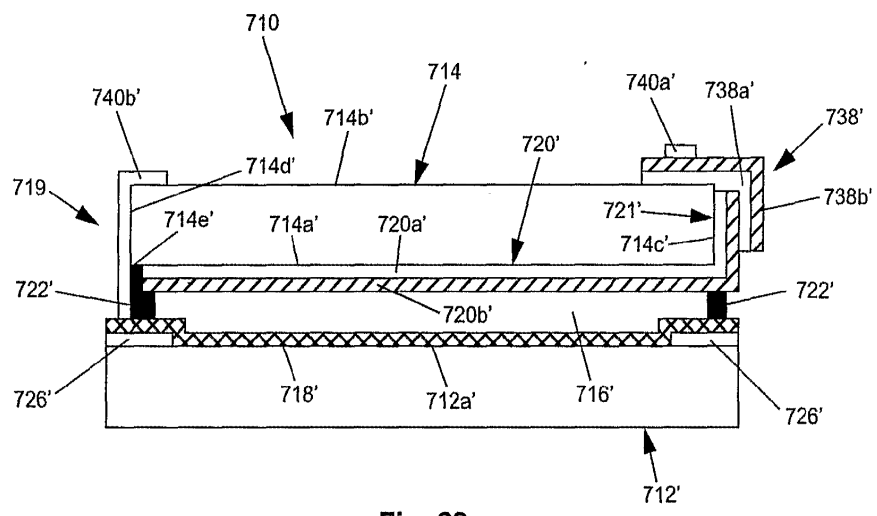

Fig. 28

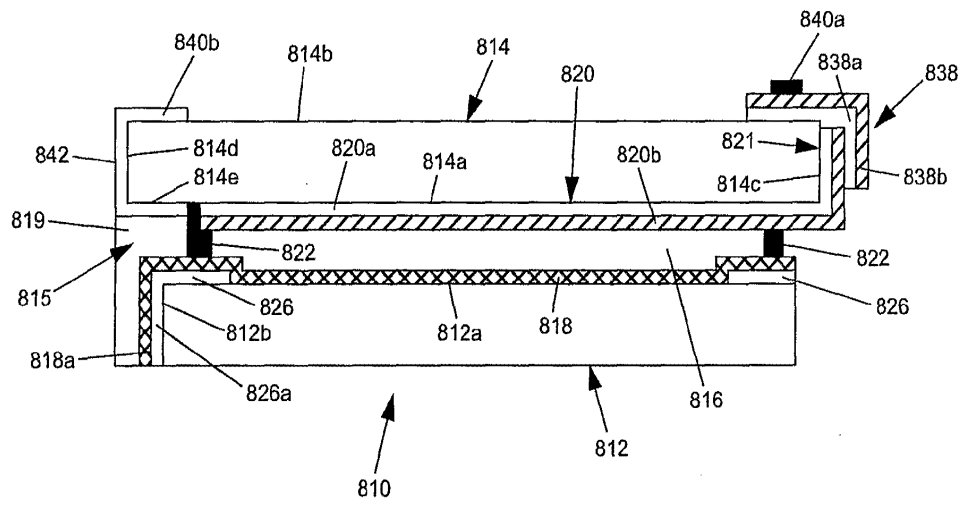

Fig. 29

31/36

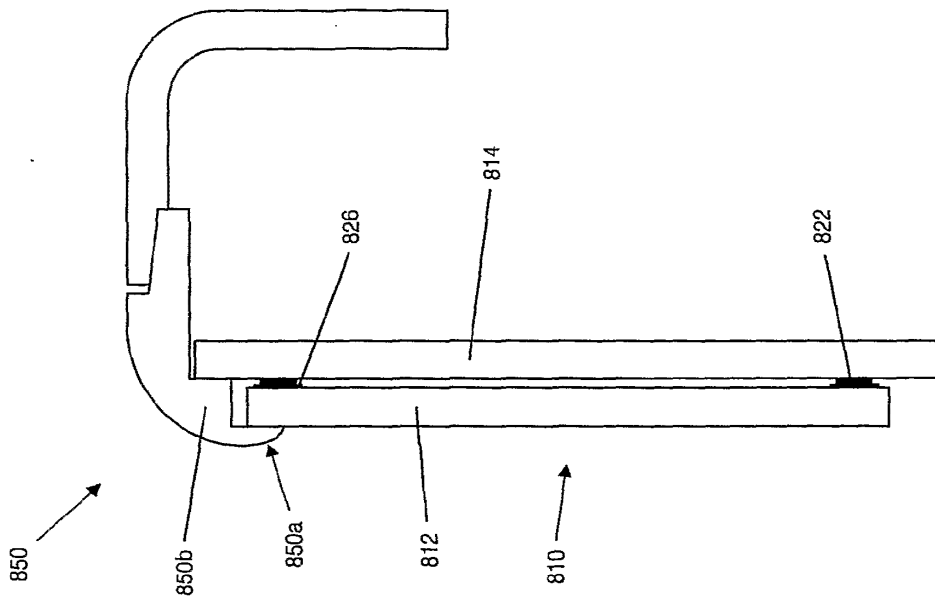

Fig. 30

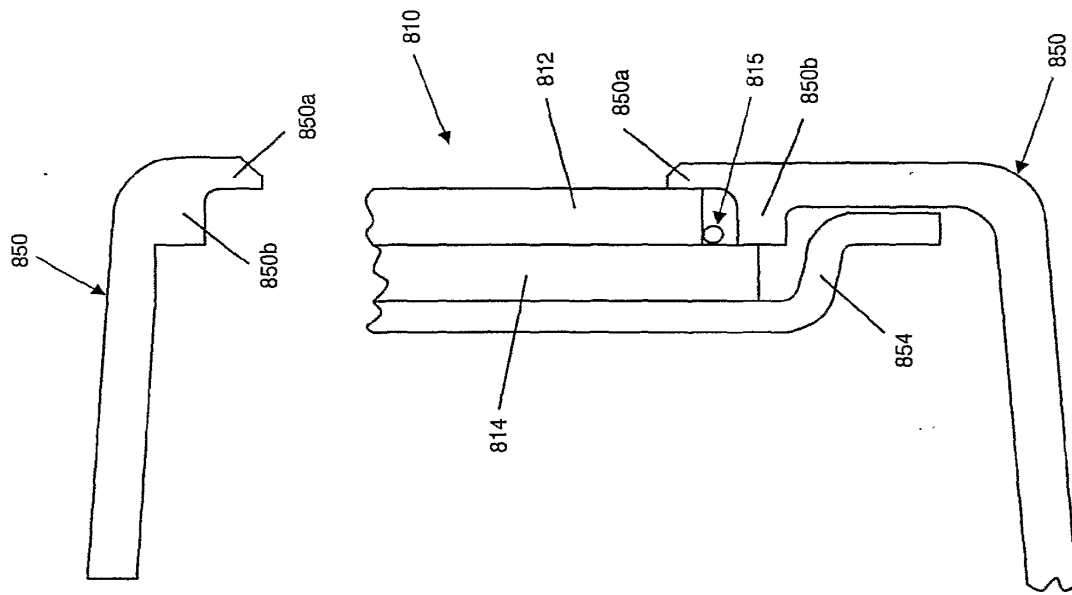

Fig. 30A

33/36

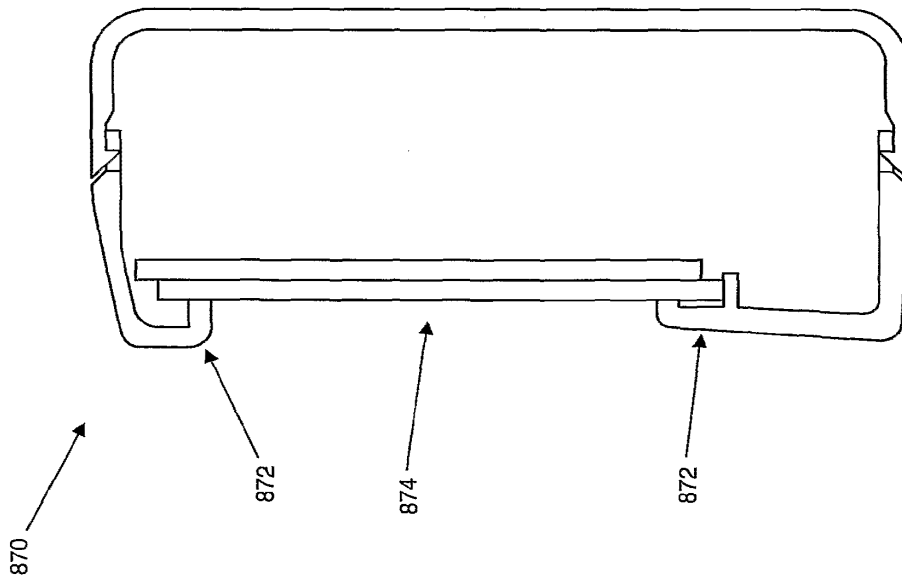

Fig. 30B

34/36

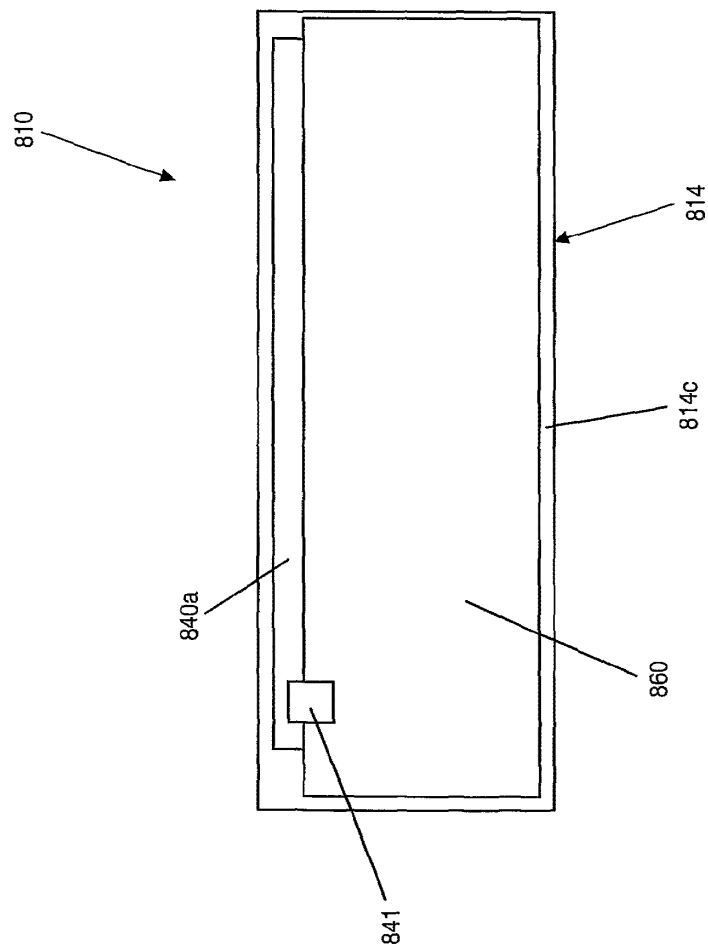

Fig. 31

35/36

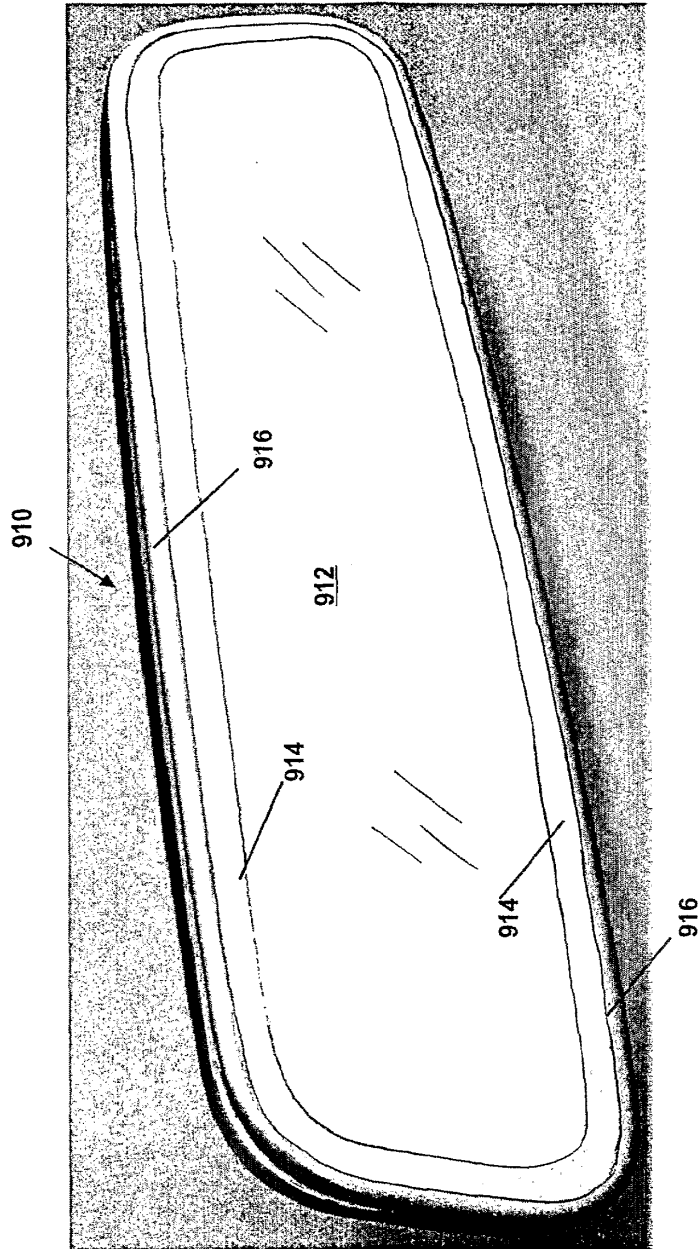

Fig. 32

36/36

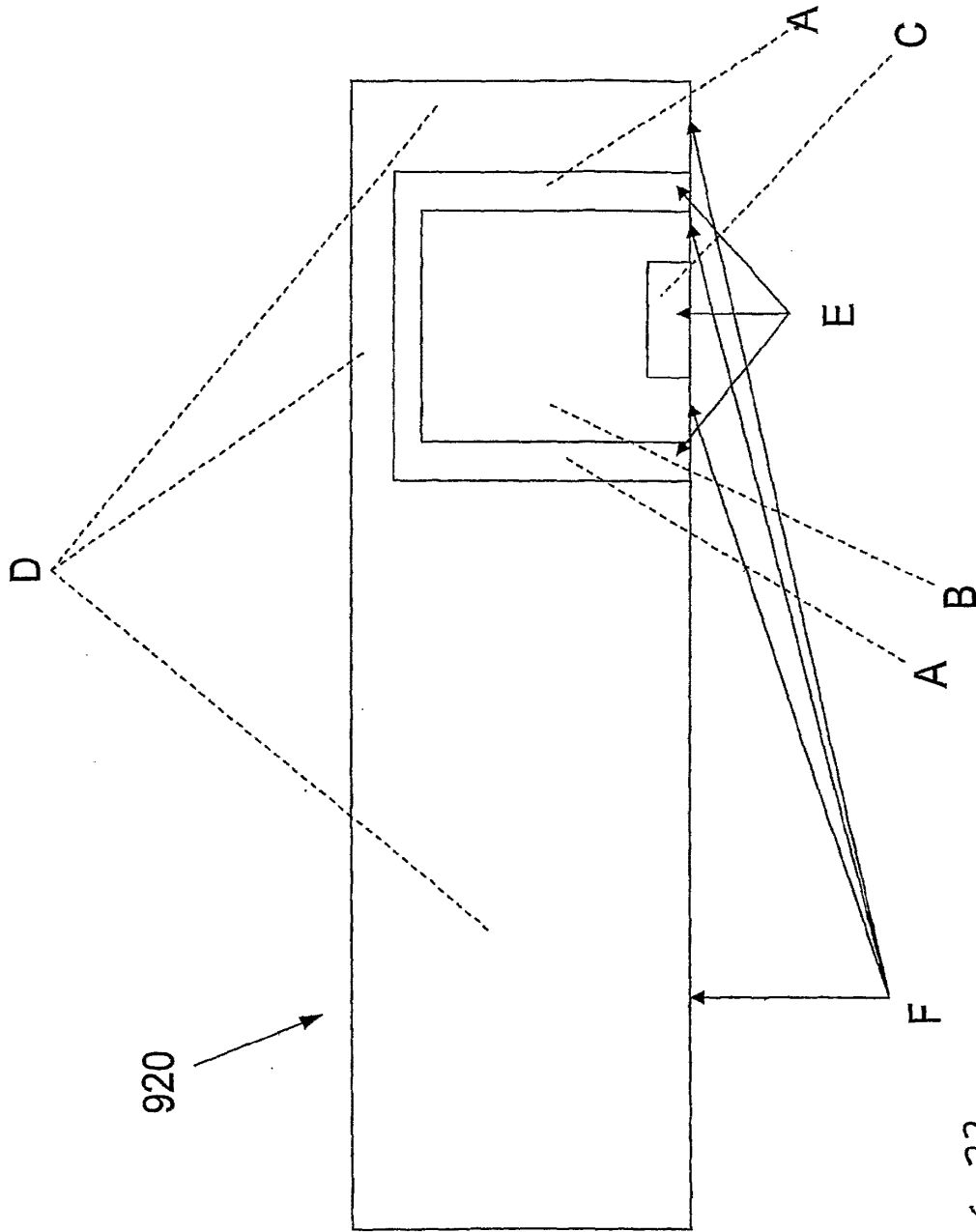

FIG. 33

(12) INTERNATIONAL APPLICATION PUBLISHED UNDER THE PATENT COOPERATION TREATY (PCT)

(19) World Intellectual Property Organization
International Bureau



(43) International Publication Date
11 January 2007 (11.01.2007)

PCT

(10) International Publication Number
WO 2007/005942 A2

(51) International Patent Classification:
G02B 7/182 (2006.01)

13805 Lake Sedge Drive, Grand Haven, Michigan 49417 (US).

(21) International Application Number:
PCT/US2006/026148

(74) Agent: Timothy A. Flory; VAN DYKE, GARDNER, LINN & BURKHART, LLP, 2851 Charlevoix Drive Se, P.o. Box 888695, Grand Rapids, Michigan 49588-8695 (US).

(22) International Filing Date: 5 July 2006 (05.07.2006)

(25) Filing Language: English

(81) Designated States (unless otherwise indicated, for every kind of national protection available): AE, AG, AL, AM, AT, AU, AZ, BA, BB, BG, BR, BW, BY, BZ, CA, CH, CN, CO, CR, CU, CZ, DE, DK, DM, DZ, EC, EE, EG, ES, FI, GB, GD, GE, GH, GM, HN, HR, HU, ID, IL, IN, IS, JP, KE, KG, KM, KN, KP, KR, KZ, LA, LC, LK, LR, LS, LT, LU, LV, LY, MA, MD, MG, MK, MN, MW, MX, MZ, NA, NG, NI, NO, NZ, OM, PG, PH, PL, PT, RO, RS, RU, SC, SD, SE, SG, SK, SL, SM, SY, TJ, TM, TN, TR, TT, TZ, UA, UG, US, UZ, VC, VN, ZA, ZM, ZW.

(26) Publication Language: English

(30) Priority Data:
60/696,953 6 July 2005 (06.07.2005) US
60/784,570 22 March 2006 (22.03.2006) US

(71) Applicant (for all designated States except US): DONNELLY CORPORATION [US/US]; 414 East Fortieth Street, Holland, Michigan 49423 (US).

(72) Inventors; and

(75) Inventors/Applicants (for US only): LYNAM, Niall R. [US/US]; 281 Norwood Avenue, Holland, Michigan 49424 (US). RUSE, James A. [US/US]; 2584 36th Street, Allegan, Michigan 49010 (US). KENDALL, Craig [GB/US];

(84) Designated States (unless otherwise indicated, for every kind of regional protection available): ARIPO (BW, GH, GM, KE, LS, MW, MZ, NA, SD, SL, SZ, TZ, UG, ZM, ZW), Eurasian (AM, AZ, BY, KG, KZ, MD, RU, TJ, TM), European (AT, BE, BG, CH, CY, CZ, DE, DK, EE, ES, FI, FR, GB, GR, HU, IE, IS, IT, LT, LU, LV, MC, NL, PL, PT,

[Continued on next page]

(54) Title: VEHICLE EXTERIOR MIRROR ASSEMBLY WITH BLIND SPOT INDICATOR

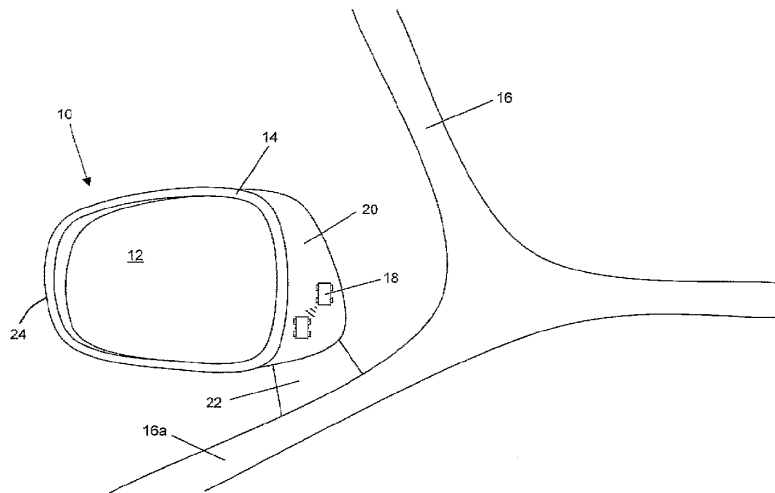

(57) Abstract: An exterior rearview mirror system for a vehicle includes an exterior mirror assembly (10) that is mountable at an exterior side (16a) of a vehicle (16) and has an inboard portion (20) that is viewable by a driver of the vehicle when the mirror assembly is mounted at the exterior side of the vehicle. A blind spot indicator (18) is disposed at the inboard portion (20) of the mirror casing (14) of the mirror assembly. The blind spot indicator comprises at least one illumination source for indicating to the driver a detected presence of an object alongside of and/or rearward of the vehicle. The indicator may comprise a unitary indicator module (518) that is mountable at the inboard portion of the mirror assembly. The indicator module includes an illumination source (546c, 546d) and circuitry (546) and is connectable to an electrical connector (548).

WO 2007/005942 A2



RO, SE, SI, SK, TR), OAPI (BF, BJ, CF, CG, CI, CM, GA, GN, GQ, GW, ML, MR, NE, SN, TD, TG).

For two-letter codes and other abbreviations, refer to the "Guidance Notes on Codes and Abbreviations" appearing at the beginning of each regular issue of the PCT Gazette.

Published:

— *without international search report and to be republished upon receipt of that report*

VEHICLE EXTERIOR MIRROR ASSEMBLY WITH BLIND SPOT INDICATOR
CROSS REFERENCE TO RELATED APPLICATIONS

[0001] The present application claims benefit of U.S. provisional applications, Ser. No. 60/696,953, filed July 6, 2005 (Attorney Docket DON01 P-1228); and Ser. No. 60/784,570, filed Mar. 22, 2006 (Attorney Docket DON01 P-1273), which are hereby incorporated herein by reference in their entireties.

FIELD OF THE INVENTION

[0002] The present invention relates to exterior rearview mirror assemblies and, more particularly, to an exterior rearview mirror assembly having a blind spot indicator and/or a lane change aid (LCA) indicator at the mirror assembly.

BACKGROUND OF THE INVENTION

[0003] It is known to provide a blind spot detection/LCA system for a vehicle that detects the presence of another vehicle or object in the lane next to the host vehicle, where it may be difficult for the driver of the host vehicle to determine whether or not there is another vehicle or object adjacent to the host vehicle. Such a blind spot detection/LCA system often includes a visual indicator that visually indicates to the driver that another vehicle or object has been detected. The visual indicator (commonly a light emitting diode or the like) is often located at the reflective mirror element of the exterior rearview mirror assembly and external of the vehicle cabin, or may be located interior to the vehicle, such as at the A-pillar of the vehicle within the interior of the vehicle cabin (such as on MY 2005 Volvo vehicle models equipped with camera-based BLIS systems). The visual blind spot/LCA indicators indicate or alert to the driver of the host vehicle the presence or impending presence of another vehicle in a blind spot in an adjacent side lane that typically cannot be readily seen within the field of view of the exterior mirror reflective element of the exterior mirror assembly mounted at that side of the vehicle and/or cannot be readily seen by the driver's peripheral vision or the like. The visual blind spot/LCA indicators typically must be viewable principally or solely by the driver of the host vehicle and not by drivers of other vehicles. If the indicator is located external to the vehicle cabin, and especially since it is now common to use turn signals on exterior mirrors, any visibility of the indicator to the driver of another vehicle (such as a trailing vehicle or an overtaking vehicle) may cause confusion to the driver of the other vehicle as to whether or not the indicator is a turn signal indicator or some other vehicle lighting or the like. This may be particularly problematic when the blind spot indicator is

located behind (and often supported by) the reflective mirror element of the vehicle exterior mirror assembly, and may be especially confusing if other indicators are also disposed behind/supported by the mirror reflective element so as to function, for example, as turn signal indicators. For example, somewhat costly and complicated blind spot indicator constructions have been contemplated that, when placed behind and supported by the mirror reflective element, attempt to have their projected beam of emitted light shielded from view by other drivers and attempt to be directed principally to be viewed by the driver of the host vehicle. This can be further complicated by the fact that the mirror reflective element (and hence any blind spot indicator supported thereon/therebehind) is adjustable via a mirror actuator (such as described in U.S. Pat. Nos. 6,755,544; 6,616,314; 6,467,920; and 6,243,218, which are hereby incorporated herein by reference in their entireties), so that the axis of principal illumination of the blind spot indicator will move with movement of the mirror reflective element.

[0004] Thus, prior art blind spot/LCA indicators are often supported by and to the rear of the movable mirror reflective element, so as to be viewable by a driver of the host vehicle through the reflective element of the mirror assembly. For example, a transmissive window may be formed in the reflective coating or coatings of the reflective element and an illumination source or indicator may be positioned so as to direct or emit illumination through the window and toward the driver of the host vehicle so as to be viewable by the driver of the host vehicle. Alternately, transflective mirror coatings (such as, for example, those described in U.S. Pat. Nos. 6,855,431; 5,724,187; 5,340,503; 6,286,965; 6,196,688; 5,535,056; 5,751,489; and 6,065,840, which are hereby incorporated herein by reference in their entireties) may be used.

[0005] Because of vehicle regulations and mirror and vehicle configurations and geometries, and because of the need to provide an uninterrupted reflective surface to satisfy the likes of the FMVSS 111 field of view regulation, blind spot/LCA indicators in the prior art are typically located towards or at the outboard edge, and typically towards or at the upper corner/quadrant, of the reflective mirror element of the exterior mirror assembly. Thus, the prior art blind spot/LCA indicators are located at a distal or furthest outboard location of the mirror reflective element, such that the driver of the host vehicle typically has to look across to the outboard dimension of the reflective element to view and discern the blind spot indicator. Also, the blind spot/LCA indicators (when located at the reflective element so as to be viewable through the reflective element and when supported thereon such that the blind spot/LCA indicator moves in tandem with the mirror reflective element when its field of view

is adjusted by the driver to his/her preferences) may be directed differently for different drivers. These prior art blind spot/LCA indicators thus are not provided at a universally controllable angle or fixed angle relative to the geometry of the vehicle and thus may not be optimally directed for viewing by some drivers, depending on the desired and set angle of the mirror reflective element for the particular driver of the host vehicle and/or may not be optimally directed for non-viewing by drivers of other vehicles, such as trailing or overtaking vehicles that are part of the traffic encountered by the host vehicle.

[0006] A variety of interior and exterior mirror assemblies with indicators are known in the art, such as U.S. Pat. Nos. 5,788,357; 6,257,746; 6,005,724; 5,481,409; 6,512,624; 6,356,376; 2,263,382; 2,580,014; 3,266,016; 4,499,451; 4,588,267; 4,630,904; 4,623,222; 4,721,364; 4,906,085; 5,313,335; 5,587,699; 5,575,552; 5,938,320; and 5,786,772, Canadian Pat. No. CA 1,063,695, Pat. Abstracts of Japan Publication No. 0917573, published Jul. 8, 1997, which are all hereby incorporated herein by reference in their entireties.

[0007] Therefore, there is a need in the art for an improved blind spot/LCA indicator that is readily viewable by a driver of the host vehicle and not visible or viewable by a driver of another vehicle.

SUMMARY OF THE INVENTION

[0008] The present invention provides a blind spot indicator or lane change assist (LCA) indicator that is fixedly located at the mirror shell or casing and/or at a support arm of an exterior rearview mirror assembly, so as not to move or adjust when the mirror reflective element is moved or adjusted to set its field of view. Preferably, the blind spot indicator is fixedly located at the inboard wall or portion of the mirror shell or casing, so as to be readily viewed by the driver of the host vehicle, while being substantially non-visible or non-viewable by a driver of another vehicle. The blind spot/LCA indicator is preferably located at an angled, outwardly extending rearward portion of the mirror assembly that is angled so as to slope or extend at an angle away from the body side of the vehicle, so that the blind spot/LCA indicator is generally facing the driver of the host vehicle and is readily viewable by the driver of the host vehicle and substantially non-visible or non-viewable by a driver of another vehicle at or approaching the host vehicle.

[0009] According to an aspect of the present invention, an exterior rearview mirror assembly for a vehicle includes a reflective element, a mirror shell or casing and a blind spot indicator. The shell or casing has an inboard portion that is inboard of the reflective element relative to the position of the reflective element with respect to the body side of the vehicle when the exterior mirror assembly is mounted thereto, and thus is between the reflective element and

the body side of the vehicle to which the mirror assembly is attached. The blind spot indicator is located at and oriented at the inboard portion of the mirror shell or casing so as to be viewable by the driver of the vehicle and so as to be substantially to totally non-viewable by the drivers of other vehicular traffic, such as other vehicular traffic rearward of, sideward of, approaching, overtaking, forward of or otherwise at or near the host vehicle.

[0010] The inboard portion of the mirror shell or casing (which at least in part defines a cavity within which the mirror reflective element is disposed and within which the mirror reflective element is adjustable) may comprise an inboard wall of the mirror shell or casing. Typically, the exterior mirror assembly comprises a stalk or support arm or member of the mirror assembly that extends from the side of the vehicle to where the mirror shell is disposed.

[0011] The blind spot indicator may include a light source or illumination source (such as one or more light emitting diodes (LEDs) or the like), and may include a lens or other optic or light directing/guiding device or element or means or a light channel, conduit or means, or a light baffle or means, or a light louver or blind or means, or a light directing element or means, preferably at the mirror shell or casing (and substantially disposed therein so as not to overly protrude to create aerodynamic drag and so as to provide an aesthetically pleasing exterior appearance) for directing the light emitted by the light source toward the driver for viewing by the driver of the host vehicle and, if required, for limiting or restricting viewing by drivers of other vehicles.

[0012] Thus, the present invention provides an exterior rearview mirror assembly for a vehicle that includes a mirror shell portion and a blind spot or lane change assist (LCA) indicator. A cavity of the mirror shell portion is formed or defined at least partially by the walls of the shell portion. A variety of suitable mirror shells are known in the exterior mirror assembly art, such as skull-cap mirror shells (such as described in U.S. Pat. Nos. 6,612,708; 6,447,130; and 6,310,738, which are hereby incorporated herein by reference in their entireties), uni-body mirror shells, and the like. A reflective element is disposed within the cavity, along with any accessories or displays and associated adjustment device or actuator associated with the reflective element or mirror assembly. The mirror shell consists of an inner or inboard wall or side or portion that, when the mirror assembly is mounted at the side of the vehicle, preferably proximate to or at the driver or passenger side front door and proximate to or at the join of the door to the front portion of the vehicle body side (often referred to as the A-pillar region of the vehicle), the inner wall portion is at or near to the vehicle side body and readily viewable by the driver of the host vehicle. The mirror shell

also includes an outer or outboard side or wall or portion that is further from the side of the vehicle and outward or outboard from the inner or inboard wall or portion. The mirror reflective element is disposed within the mirror shell and between the inner wall or portion or side and the outer wall or portion or side of the mirror shell. The blind spot or LCA indicator is located at the inboard or inner wall or side or portion of the mirror shell and, thus, is readily viewable by the driver of the host vehicle.

[0013] The mirror assembly is mounted to the body side of the vehicle (such as to a front door portion or to a vehicle body portion, depending on the particular application of the mirror assembly). The mounting portion of the mirror assembly often includes a stalk or mounting arm or member or support arm or member that extends from the mounting area of the vehicle body side to where the mirror shell is disposed. The mounting arm may extend from the vehicle body side by about an inch or more, and often about two to three inches or thereabouts, depending on the styling, type or size of the vehicle and associated exterior mirror assembly.

[0014] Note that, and as can be readily seen in FIGS. 6A and 6B, the inner portion of the driver side mirror assembly is most readily visible / viewable to the driver of the vehicle, as compared to the inner portion of the passenger side mirror assembly. The blind spot/LCA indicator of the present invention is thus highly suited for applications where the blind spot indicator is on the driver side only. However, it is envisioned that a blind spot/LCA indicator of the present invention may also or otherwise be located at the inner or inboard portion or wall or side of the passenger side exterior rearview mirror assembly, without affecting the scope of the present invention.

[0015] According to another aspect of the present invention, an exterior rearview mirror system for a vehicle includes an exterior mirror assembly having a mirror casing. The mirror casing comprises a mirror portion including a reflective element and an attachment portion configured for attaching the mirror assembly at an exterior side of a vehicle, such as via an attachment or attachment element for attaching the mirror assembly at the exterior side of the vehicle, such as via any suitable attachment element or means, such as are known in the automotive mirror art. The reflective element is adjustably supported by an actuator within the mirror portion of the mirror casing. The mirror casing has an inboard portion that faces generally toward the exterior side of the vehicle and is viewable by a driver of the vehicle when the exterior mirror assembly is attached at the exterior side of the vehicle. The mirror system includes a unitary indicator module at the inboard portion of the mirror casing. The unitary indicator module comprises an illumination source, and is responsive to a control

signal to activate the illumination source to indicate to the driver a detected presence of an object at least one of alongside the vehicle and rearward of the vehicle. The unitary indicator module is substantially sealed so as to be substantially impervious to water. The unitary indicator module is configured at the inboard portion of the mirror casing so that illumination of the illumination source is readily viewable by the driver of the vehicle and wherein the illumination of the illumination source is generally not viewed by other road users when the exterior rearview mirror assembly is mounted to the side of the vehicle and when the vehicle is operated on a road.

[0016] According to another aspect of the present invention, a method of supplying an exterior rearview mirror system for a vehicle includes providing mirror casings, with each mirror casing at least comprising a mirror portion including a reflective element. The reflective element is adjustably supportable by an actuator within the mirror portion of the mirror casing. Each of the mirror casings has an inboard portion that faces generally toward the exterior side of the vehicle and that is viewable by a driver of the vehicle when the exterior mirror assembly is mounted at the exterior side of the vehicle. At least some of the mirror casings are provided with an aperture established at the inboard portion. Blind spot indicator units are provided, with each of the blind spot indicator units comprising at least one illumination source for indicating to the driver a detected presence of an object at at least one of alongside and rearward of the vehicle. First mirror assemblies are established by disposing the blind spot indicator units at the apertures of the inboard portions of the at least some of the mirror casings. The blind spot indicator units are at least partially received at the apertures. Second mirror assemblies are established by providing mirror casings lacking an aperture established at the inboard portion. The first mirror assemblies are supplied to a vehicle manufacturing facility when inclusion of a blind spot indicator is required and the second mirror assemblies are supplied to a vehicle manufacturing facility when inclusion of a blind spot indicator is not required.

[0017] Therefore, the present invention provides a blind spot indicator at an inboard wall or portion of an exterior rearview mirror assembly. The blind spot indicator is located at an inboard wall or portion of the mirror casing or shell or at an inboard support arm or the like of the mirror assembly and, thus, is readily viewable by the driver of the host vehicle, and without the driver having to look across to the outboard dimension of the mirror reflective element to see or notice actuation or illumination of the blind spot indicator. The blind spot indicator thus may be readily viewable by the driver and may be so viewable without the driver having to look at the reflective element of the exterior mirror to see the blind spot