

dot pattern, to permit a vacuum fluorescent display, such as a compass or clock, to show through to the driver of the vehicle. Such concept is also applicable to a mirror which uses only one video chip light sensor to measure both glare and ambient light and which is further capable of determining the direction of glare. An automatic mirror on the inside of a vehicle can also control one or both outside mirrors as slaves in an automatic mirror system.

The foregoing also has application in the construction of elements for mirrors where high maximum reflectance is desired, and the electrochromic materials may be solution phase containing liquids, gels, rigid gels and/or polymers. It may also be a hybrid design where some or all of the electrochromic materials are not in solution and may be confined on the surfaces of the electrodes, and also particularly applies to electro-optic mirrors which draw more than 10 milliamps in operation at any point in their process of dimming.

The above described structure is particularly effective when used with selected low cost transparent coatings, as for example, "TEK 20", marketed by Libbey Owens-Ford Co. of Toledo, Ohio. The benefits over the most commonly used automatic mirrors in use today are as follows: mirrors embodying the multilayer combination reflector/electrode change reflectance faster, have a clearer image, have better coloration of image in the nondimmed state, eliminate the need and inconvenience of putting silver reflective coatings on the fourth surface of the mirror element, have fewer handling steps thereby creating fewer chances for scratching in the glass during processing and providing a final product with better optical quality, and having fewer surfaces through which the light must travel, and the first surface and third surface reflections are closer together with the result that there are less multiple images and less distortion in the mirror for the driver. Moreover, when used as an outside mirror, there are less reflections from raindrops and dust on the front surface of the front glass, and the reflector at the front surface of the rear glass element is protected from aging, exposure to airborne contaminants and physical abuse that often affect reflectors placed at the back surface of the rear glass element.

In the embodiment of the invention illustrated in Figures 1 through 6, the front glass element 14 of each outside mirror is formed in one continuous piece that includes an inboard main body portion 14B that may be substantially flat with an infinite radius of curvature, or slightly curved with a relatively large radius of curvature. This curvature is generally spherical with a radius of curvature in the range of 1200 to 3000 mm and more typically in the range of 1400 to 2600 mm. The main body portion 14B is integrally joined to an outboard aspherical portion 14A having a radius of curvature substantially less than the radius of curvature of the main body portion 14B. Thus, the aspherical portion 14A contributes a predetermined field of view which, when combined with the field of view of the main body portion 14B,

is substantially greater than the field of view of the main body portion 14B alone. The rear glass element 18 of each outside mirror of this embodiment of the invention is substantially the same size as the main body portion 14B of the front glass element so that the aspherical portion 14A projects laterally outwardly, i.e., outboard of both the main body portion 14B and the rear glass element 18. Since the aspheric portion 14A of the front glass element 18 projects outwardly beyond the adjacent edge of the rear glass element 18, the aspheric portion 14A of the front glass element does not dim when the electro-optic inboard portion 14B of the mirror dims. It should also be understood that a bezel structure 34, shown in dashed lines for clarity of illustration, is preferably utilized which extends around the entire periphery of the front glass element and conceals the peripheral edge portions thereof.

In this embodiment of the invention, the rear surface 36 of the front glass element 14 of each outside mirror is preferably coated with a reflective layer 38 only in the area of the outboard aspherical portion 14A. This reflective material also preferably covers the outboard section 40 of the seal 16 so that the outboard section 40 of the seal 16 is not visible to the driver of the vehicle, although, if desired, a portion of the seal may be purposely allowed to be visible to the driver to provide a demarcation to apprise the driver that there is a difference in the minor configuration. As previously mentioned, the outboard area 14A of each outside mirror can be either aspheric, cylindrical, spherical, formed with multiple radii of curvature formed of any combination of the preceding, or be of other desired configuration. It should also be understood that the reflective layer could be on the front surface of the aspherical portion 14A.

The above described construction overcomes serious cost and technical problems which are encountered when efforts are made to perfectly match two glass shapes of complex curvature. Since the rear glass element 18 and the electro-optic portion 14B of the front glass element 14 are either flat or only slightly curved, matching of the overlying portions thereof is more readily achieved, and serious mismatching, which can cause double imaging, is obviated or at least minimized. Moreover, since the aspheric portion 14A of the front element 14 projects outwardly beyond the outboard edge of the rear glass element 18, no matching whatsoever is required because there is only one layer of glass in the aspherical portion 14A of each outside mirror.

It will be understood that if a reflective layer 38, such as chromium or rhodium, is deposited on the rear surface 36 in the aspherical portion 14A of the front glass element 14, and a reflective layer such as 22 is also used as a reflector on the inner surface of the rear glass element 18, behind the electro-optic material 24, then there will be a minimum discontinuity in the reflected image since the electro-optic media layer is very thin (typically 150 microns or less). In that connection it should be understood that light from reflection in

the clear state of the electrochromic portion of the device may 10-20% less than the first surface reflectance of the layer 22 when measured with the layer 22 in contact with air.

It should also be understood that, by way of example, it is also possible to utilize indium tin oxide (ITO) as the transparent conductors on the confronting surfaces of the front and rear glass elements and a reflective layer such as silver on the back of the rear glass element. For matching purposes, it is also possible to provide a silver reflector on the back surface of the aspherical portion 14A of the front glass. In the preferred embodiment of the invention, a layer of chromium or a layer of rhodium makes up the reflective layer 38 provided on the back surface 36 of the aspherical portion 14A of the front glass element, limited to the aspheric area as illustrated in the drawings. For example, a rhodium layer 22 can be used on the front surface of the back glass element 18, deposited over a thick highly conductive chromium layer 20. By way of example, the rhodium layer may have a thickness of about 100-700 Angstroms, while the chromium layer may have a thickness of about 300 to 1500 Angstroms. In the alternative, instead of a dual layer of rhodium and chromium, a single layer of chromium may be utilized together with a single layer of chromium on surface 38. A single layer of smooth, high transmission ITO is preferred for application to the surface 36 in both areas 14A and 14B to simplify the ITO coating process and to maximize reflection of 38 and minimize haze of reflector 38. When the reflector of the outboard portion is placed on the front side of element 14 then the smoothness of the transparent conductor 36 is not critical, and it is possible to use the low cost but somewhat rough or hazy coating sold by Libbey Owens-Ford as "TEK 20" tin oxide coated glass or the Libbey Owens-Ford "TEK 15" glass or a similar type low cost tin oxide coated glass, or it is possible to remove the tin oxide transparent conductive layer prior to applying the reflector to the area 14A. Thus, if desired, the transparent conductive coating 26 on the front element 14 may be uniformly applied, selectively applied or removed from a portion of surface 36 prior to the application of the reflective layer 38 so that in the latter case the reflective layer 38 is applied directly onto the rear surface 36 of element 14. This latter configuration of the front element reflector is especially desirable if the transparent conductive coating has significant haze. It may also be desirable to lower the reflectivity at the area 14A to a value as bright as, or lower than, the reflectance range of the dimming portion by choice of reflector material or transmission properties of the layer 26, if present, in the area 14A.

From the foregoing description, it will be understood that much of the uniqueness of this embodiment of the invention resides in the fact that only the inboard main body portion 14B of the front element 14 will be dimmed utilizing electro-optic principles. This permits protection from glare and yet preserves safety, since the aspheric portion 14A is not allowed to dim and the driver can still

see nearby vehicles in adjacent lanes. Moreover, the unitary front face of the front glass element 14 can still be easily cleaned and scraped of ice in the winter. In addition, the one-piece face of the front glass element is cosmetically stylish. Also, the layers of reflective material can be made so close to the same plane that their discontinuity will not be objectionable to the driver of the vehicle. It should also be understood that for defrosting purposes, a conventional heater (not shown) can be utilized to cover either the entire back of each outside mirror assembly including both the aspherical outboard portion and the automatically dimming inboard portion of the mirror, or only the automatic dimming portion with the heat eventually spreading through thermal conduction to the outboard portion 14A.

From the foregoing description, it will be appreciated that the aspheric outboard portion of the mirror provides a greatly increased field of view, thereby virtually eliminating blind spots, and mirrors embodying the present invention can replace conventional driver's side exterior mirrors or both the driver's side and the passenger's side exterior mirrors. The outside mirrors embodying the present invention combine two types of curvature, i.e., a convex main area with a large radius of curvature or a flat main area with an infinite radius of curvature, the latter being similar to conventional United States driver side exterior mirrors, together with an aspheric section on the outboard portion of the mirror. The relatively high curvature in the aspheric area yields a greatly expanded field of view, and at the same time, since the aspheric portion does not dim, the bright outboard portion provides a danger signal in the event another vehicle is positioned immediately adjacent to the vehicle equipped with mirrors embodying the present invention. It should also be understood that if desired, the aspheric portion of the mirror assembly could be tinted or provided with less reflective capability than the undimmed electro-optic portion of the mirror.

With reference to FIG. 6, a preferred arrangement for connecting the electronic conductive layers to a power source is illustrated. In this arrangement, the two electrode-bearing front and rear glass elements 14 and 18 are displaced in opposite directions, laterally from, but parallel to, the chamber 13 in order to provide exposed areas on the front and rear glass elements. Electrically conductive spring clips 42 and 44 are provided which are placed on the coated glass sheets to make electrical contact with the exposed areas of the electrically conductive layers. Suitable electrical conductors (not shown) may be soldered or otherwise connected to the spring clips 42 and 44 so that desired voltage may be applied to the device from a suitable power source. It is preferred but not essential that the combination reflector/electrode, which may or may not be multilayer, function as and be maintained as the cathode in the circuitry.

Rearview mirrors embodying the present invention preferably include a bezel 34 which extends around the entire periphery of the assembly. The bezel 34 conceals

and protects the spring clips 42 and 44 and the peripheral edge portions of both of the front and the rear elements 14 and 18. By way of example, the bezel 34 may be of the type disclosed in the co-pending Continuation Application of William L. Tonar, Serial No. 08/142,875, filed October 29, 1993, which is a continuation of Application Serial No. 07/907,055, filed July 1, 1992, both of which applications are assigned to the assignee of the present invention and both of which applications are hereby incorporated herein by reference. The assembly may also include a conventional heater and a plastic mirror back or glass case which is adapted to snap into an outside mirror housing (not shown) that may be of any desired configuration including with and without a motor pack for remote adjustment of mirror position. The outside mirror housing is supported on the outside of an automotive vehicle in any desired or conventional manner, and the inside mirror is supported inside the vehicle in any desired or conventional manner, whereby the field of view of each mirror may be adjusted by the driver of the vehicle in a conventional manner, as for example, through manual adjustment or by mechanical or electrical means of the types conventionally provided on modern day automobiles.

Another embodiment of the invention is illustrated in Figure 7 which enables each outside mirror to implement a signaling function, and in which the reflector on the outboard section 14A is constructed to reflect most of the spectra while transmitting only a selected spectra of a cooperative signal light source located behind the mirror. In an alternate approach, the reflector can be made generally reflective, but partially light transmissive over a broad spectral range, thus requiring a signal light of sufficient intensity to be seen by passing vehicles after attenuation through the partially reflecting layer. In order to direct the light away from the driver's eyes either louvers or a sheet of plastic light directing film is placed behind the mirror surface between the signal light source and the reflector. The ambient light sensor in the automatic interior mirror can be used along with a conventional control circuit (not shown) to progressively reduce the signal light output under progressively darker night driving conditions. Areas behind the outboard portion of each outside mirror where the signal light is not expected to shine through can optionally be covered with black or dark paint to make the interior behind the mirror reflector less visible cosmetically in the daytime. In this embodiment of the invention, a dichroic reflector in area 14A may be utilized, along with a light source that is compatible with the dichroic reflector, e.g., a red light emitting diode, emitting in specific spectral wavelengths of the band pass region of the dichroic reflector. Another possibility for a light source for use with a dichroic reflector is a neon gas tube, power supplies (not shown) for the light emitting diodes or neon tube being well known in the art.

With a partially reflecting mirror, any wide band light source is acceptable provided it has sufficient light output and life to withstand the automotive environment,

and provided the color is acceptable for an automotive safety signal. Where a white or broad spectrum light source is preferably used, either a tinted lamp enclosure or separate colored filter between the light source and the reflector is sufficient to provide the proper orange or red light output. The preferred color of the light output with the partial reflector approach is orange. The most practical low cost light source is of the incandescent type with possible variations to include halogen, xenon or other life-extending, high efficiency technology. It is desired to produce the most light with the least cost using a practical, affordable light source for which replacement bulbs are readily available for service.

Whatever light source is used, it is preferred to use either a lamp reflector, lens or both for the purpose of increasing light output efficiency in the desired direction. The lamp reflector referred to in this case is distinctively separate from the mirror reflector on the outboard portion of the partially dimming aspheric mirror. As an alternate approach, this signal light concept and partial dimming concept can also be useful with a substantially uniformly curved mirror, such as a convex mirror, where only a portion of the mirror is automatically dimming and the outboard portion is non-dimming with a signal light feature behind the outboard reflector.

In order to direct light, emitting from the signal light source, away from the driver's view, a laser can be used to cut (burn) a precise controllable louver pattern in a plastic louver member effective to direct light out of the mirror so it can be seen by other vehicles on the side of the vehicle equipped with the signaling mirror, but not seen by the driver of the vehicle so equipped. The plastic louver sheet can be either extruded flat or molded flat or it can be molded in a curved shape to fit the mirror curve.

It will be understood that a laser or other suitable means can be utilized to burn slots at an angle through the plastic sheet, and that the slots can be arranged in a manner to provide the greatest practical ratio of open area with the laser cut slots being stopped at certain points to allow sufficient structural retention and support. Referring to Figure 7, a schematic simplified side elevational view of this embodiment of the invention is illustrated therein. In this embodiment of the invention, a front reflector 138 is provided on the aspherical portion 114A of the glass 114, the reflector 138 preferably being a very highly reflective but partially transparent metal coating.

It should be understood, however, that in this embodiment of the invention it is not necessary that the outboard portion of the mirror be aspheric, and that if desired the outboard portion can be flat or curved. If desired, protective coatings may also be provided upon the condition that the reflective coating be substantially transmissive thereby allowing light from behind the mirror to pass through. The higher the natural reflectance of the front layers the greater will be the ability to sacrifice reflectance to transmittance and still fall within an acceptable mirror reflectance range of about 40% to

60%. Suitable reflectors are rhodium, coated aluminum, coated silver, or other suitable different metal. The key aspect is that the natural reflectance be high enough to allow a thin controlled thickness to transmit approximately 10 to 30% or greater of the signal light and still allow approximately 40 to 60% reflectance. The glass itself is designated 114 in Figure 7, but clear plastic may be useful as an alternate.

The layer designated 115 is the louvered layer which incorporates an appropriate signal pattern which can be recognized as a turn or other signal, which when lighted is visible to vehicles on the side, but not to driver of the vehicle equipped with outside mirrors embodying the present invention.

In the embodiment of the invention illustrated in Figure 7, an optional lens 117 is provided to direct light for efficiency. A signal light source 119 is provided which may be in the form of an LED array, a filament lamp or lamps, or a gas filled lamp such as neon or xenon, and a reflector or reflector array 121 is provided to direct light emanating from the light source 119 toward the lens 117 and/or the louvers 115. If desired, a clear transparent electrode heater and black mask could be positioned between the louvers 115 and the glass 114. The louvers 115 would then be glued to the substrate with adhesive.

In the operation of this embodiment of the invention, when the signal light source is energized, the turn or other signal is thus visible only to the drivers of other vehicles. At the same time, the reflective surfaces of the mirror function in a conventional manner.

In accordance with the present invention, the signaling concept described hereinabove can be extended to include electro-optic dimming mirrors as shown in Figure 8. Referring to Figure 8, an electro-optic assembly generally designated 210 is provided which includes a sealed chamber 213 defined by a front glass element 214, an edge seal 216, and a rear glass element 218 having reflective but partially light transmitting and electrically conducting chromium and rhodium layers 220 and 222, respectively, on the front face thereof. An electro-optic medium 224 having the desired electro-optic properties fills the chamber 213, and a transparent electrically conductive layer or layers 226, such as ITO, is carried on the back face of the front glass 214. A louvered layer 215 is provided which is secured to the back surface of the rear glass 218, the louvered layer having an appropriate signal pattern, such as an arrow, which can be recognized as a turn or other signal, visible to vehicles on the side, but not to the driver of the vehicle equipped with outside mirrors embodying the invention. This embodiment of the invention includes an optional lens 217 to direct light for efficiency. A signal light source 219 is provided which may be in the form of an LED array, a filament lamp or lamps, or a gas-filled lamp such as a neon lamp or a xenon lamp, and a reflector or reflector array 221 is provided to direct light emanating from the light source 219 toward the lens 217 and/or the louvers 215. If desired, a clear transparent electrode

heater can be positioned between the louvers 215 and the rear glass 218, the louvers being fixed to the heater substrate, as with an adhesive. Thus, in the operation of this embodiment of the invention, when the signal light source is energized, the signal is visible only to drivers of other vehicles, while the electro-optic dimming features of the mirrors are visible to the driver of the vehicle equipped with the mirrors embodying the invention.

Another embodiment of the invention is illustrated in Figure 9. In this embodiment of the invention, the rear glass element is substantially the same size as the front glass element including the aspherical portion thereof so that the entire mirror including the aspheric portion thereof has the reversibly variable transmittance capabilities. Referring to Figure 9, an outside mirror, generally designated 111, is illustrated which includes a sealed chamber 113 defined by a front glass element 114, an edge seal 116, and a rear glass element 118 having reflective and electrically conductive metal layer 122 and optionally also a metal under coating 120. An electro-optic medium 124 having the desired electro-optic properties fills the chamber 113, and a transparent electrically conductive layer, such as a fluorine-doped tin oxide conductive layer 126 is carried by the front element 114. The electrically conductive layers are connected to an electrical circuit in the manner previously described, and, if desired, a color suppression coating or coatings, such as 128 may be disposed between the conductive layer 126 and the adjacent rear surface of the front element 114.

In this embodiment of the invention, the front glass element 114 is formed in one continuous piece that includes an inboard main body portion 114B that may be substantially flat with an infinite radius of curvature, or slightly curved with a relatively large radius of curvature. The main body portion 114B is integrally joined to an outboard aspherical portion 114A having a radius of curvature substantially less than the radius of curvature of the main body portion 114B. Thus, the aspherical portion 114A contributes a predetermined field of view which, when combined with the field of view of the main body portion 114B is substantially greater than the field of view of the main body portion 114B alone. The rear glass element 118 of the mirror of this embodiment of the invention is substantially the same size as the front glass element 114 and includes a main body portion 118B that is substantially the same size as the main body portion 114B of the front glass element, and an aspherical portion 118A that is substantially the same size as the aspherical portion 114A of the front glass element.

In this embodiment of the invention the reflective surface on the inside of the rear glass 118 is comprised of a single metal layer combination reflector/electrode or a series of coatings which may be the same as the multilayer combination reflector/electrode types previously described which serve as a mirror reflective layer and also form an integral electrode in contact with the electrochromic media. The other electrode on the inside sur-

face of the front glass 114 may be the same as the transparent electrode 26 previously described which contacts the electrochromic media inside the mirror element. The multilayer combination reflector/electrode in this embodiment of the invention thus functions in the same manner and obtains the same results as the multilayer combination reflector/electrode previously described, and the transparent electrode on the inside surface of the front glass 114 also functions in the manner and obtains the same results as the transparent electrodes previously described, the difference in this embodiment of the invention being that the multilayer combination reflector/electrode and the transparent electrode include the aspheric portion of the mirror, it being understood that the seal 116 encompasses the entire chamber 113 which extends to the left end of the mirror structure, as illustrated in Figure 9, including the aspheric portion of the mirror. Thus, the entire mirror 111 including the aspheric portion of the mirror has the reversibly variable transmittance capabilities, and the entire mirror functions in the same manner as the inboard main body portion 14B of the embodiment of the invention illustrated in Figures 1 through 6.

While preferred embodiments of the invention have been illustrated and described, it will be understood that various changes and modifications may be made without departing from the scope of the invention which is defined by the appended claims.

Claims

1. An electro-optically dimming exterior rearview mirror for automotive vehicles, said mirror comprising, in combination, a front element having an optically transparent inboard portion and an outboard portion projecting laterally outwardly from said inboard portion, a rear element, said outboard portion of said front element and said rear element each having reflective surfaces thereon, said inboard portion of said front element and said rear element each having front and rear surfaces and defining a space between said rear surface of said inboard portion and said front surface of said rear element, an electro-optic medium confined in said space whereby light transmittance of said medium is variable upon the application of an electrical potential thereto, said front surface of said inboard portion of said front element having a predetermined radius of curvature, said outboard portion of said front element having a front surface projecting laterally outwardly beyond said front surface of said rear element.
2. A mirror according to claim 1 and including sealing means disposed between said rear surface of said inboard portion of said front element and said front surface of said rear element, said reflective surface on said outboard portion of said front element being effective to conceal the adjacent portion of said sealing means.

3. A mirror according to claim 1 or 2, wherein said outboard portion of said front element is of aspheric configuration.
4. A mirror according to claim 1, 2 or 3, wherein said inboard portion and said outboard portion of said front element each have a predetermined field of view, said fields of view of the combination of said inboard portion and said outboard portion being greater than said field of view of said inboard portion alone.
5. A mirror according to any one of the preceding claims, including bezel means extending around the periphery of said front element.
6. A mirror according to any one of the preceding claims, wherein said rear element is substantially the same size as said inboard portion of said front element whereby said outboard portion of said front element projects laterally outwardly beyond both said inboard portion of said front element and said rear element.
7. A mirror according to any one of the preceding claims, including means disposed between said inboard portion of said front element and said rear element for suppressing colour.
8. A mirror according to any one of the preceding claims, wherein said inboard portion and said outboard portion of said front element are formed of one continuous piece of glass.
9. A mirror according to any one of the preceding claims, wherein said outboard portion of said front element has a radius of curvature less than said radius of curvature of said front surface of said inboard portion of said front element.
10. A mirror according to any one of the preceding claims, wherein said inboard portion of said front element and said rear element have confronting curved surfaces.
11. A mirror according to any one of claims 1 to 9, wherein said inboard portion of said front element and said rear element have confronting surfaces of substantially flat configuration.
12. A mirror according to any one of the preceding claims, wherein said reflective surface on said outboard portion is located on the back side of said outboard portion.
13. A mirror according to any one of claims 1 to 11, wherein said reflective surface on said outboard portion is located on the front side of said outboard portion.

14. A mirror according to any one of the preceding claims, wherein said reflective surface on said rear element is located on the front side of said rear element.
15. A mirror according to any one of the preceding claims, wherein said field of view of said light reflecting means of said rear element is less than the field of view of said light reflecting means of the combination of said rear element and said outboard portion of said front element.
16. A mirror according to any one of the preceding claims, the confronting sides of said inboard portion of said front element and said rear element each including at least one layer of electrically conductive material and said electro-optic medium is an electro-optic reversible variable transmittance medium in contact with each or said electrically conductive layers, and further comprising means for applying electrical potential to said layers of electrically conductive material to cause variation in the light transmittance of said electro-optic medium.
17. A mirror according to any one of the preceding claims, wherein said light reflecting surface of said rear element is also electrically conductive and located on the side of said rear element confronting said front element.
18. A mirror according to any one of the preceding claims, wherein said light reflecting surface of said rear element is formed of multiple layers of electrically conductive material and is located on the side of said rear element confronting said front element.
19. A mirror according to any one of the preceding claims, said light reflecting surface of said rear element includes a layer of rhodium and a layer of chromium, said layer of rhodium being on the side of said layer of chromium confronting said front element.
20. A mirror according to claim 19, wherein said layer of chromium is greater in thickness than said layer of rhodium.
21. An electrochromic rearview mirror for automotive vehicles, comprising a partially transparent and partially reflective element, a light source, means for directing light emanating from said light source through said transparent reflective element in a predetermined direction while permitting light reflected from said transparent reflective element to be viewed from a different direction.
22. A mirror according to claim 21, wherein said partially transparent and partially reflective element includes a light transmissive reflective coating.
23. A mirror according to claim 21 or 22, wherein said light directing means includes louvre means.
24. A mirror according to claim 21, 22 or 23, including lens means for directing light emanating from said light source toward said element.
25. A mirror according to any one of claims 21 to 24, wherein said light directing means includes louvre means, and lens means for directing light emanating from said light source toward said louvre means.
26. A mirror according to any one of claims 21 to 25, wherein said element has a portion thereof of aspheric configuration.
27. A mirror according to any one of claims 21 to 26, wherein said partially transparent and partially light reflective element comprises front and rear spaced elements, said front element and said rear element defining a chamber therebetween, said front element being transparent, the side of said front element confronting said rear element including transparent electrically conductive means, the side of said rear element confronting said front element including combined electrically conductive light reflecting means, said chamber containing an electro-optic reversible variable transmittance medium in contact with said transparent electrically conductive material on said front element and said combined electrically conductive light reflecting means on said rear element, said combined electrically conductive light reflecting means on said rear element being effective to reflect light through said medium and through said front element when said light reaches said combined electrically conductive light reflecting means after passing through said medium and through said front element.
28. A mirror according to any one of claims 16 to 20 or claim 27, wherein said transparent electrically conductive means on said front element has a higher electrical resistance per unit area than said combined electrically conductive light reflecting means on said rear element.
29. A mirror according to any one of claims 16 to 20, 27 or 28, wherein said transparent electrically conductive means on said front element comprises indium tin oxide.
30. A mirror according to any one of claims 16 to 20, 27, 28 or 29, wherein said transparent electrically conductive means on said rear element comprises chromium and rhodium.
31. A mirror according to any one of claims 16 to 20 or 27 to 30, wherein said electrically conductive light

reflecting means on said rear element includes a coating selected from the group consisting of rhodium, platinum, titanium, ruthenium, iridium, gold, stainless steel, silver, nicked-chromium and chromium, and alloys thereof.

5

32. A mirror according to any one of the preceding claims, including indicia means visible through said front element.

10

33. A mirror according to claim 32, when dependent on any one of claims 16 to 20 or 27 to 31, wherein said combined electrically conductive light reflecting means on said rear element defines an opening, and said indicia means are aligned with said opening and visible through said front and rear elements.

15

34. A mirror according to claim 33, wherein said indicia means comprise vacuum fluorescent display means.

20

35. A mirror according to any one of claims 16 to 20 or 27 to 34, wherein combined electrical conductive light reflecting means on said rear element includes a first high conductance coating selected from the group consisting of chromium, titanium, stainless steel, nickel-chromium, gold and silver, and alloys thereof, and a second high reflectance coating selected from the group consisting of rhodium, platinum, ruthenium, iridium, stainless steel and chromium, and alloys thereof.

25

30

35

40

45

50

55

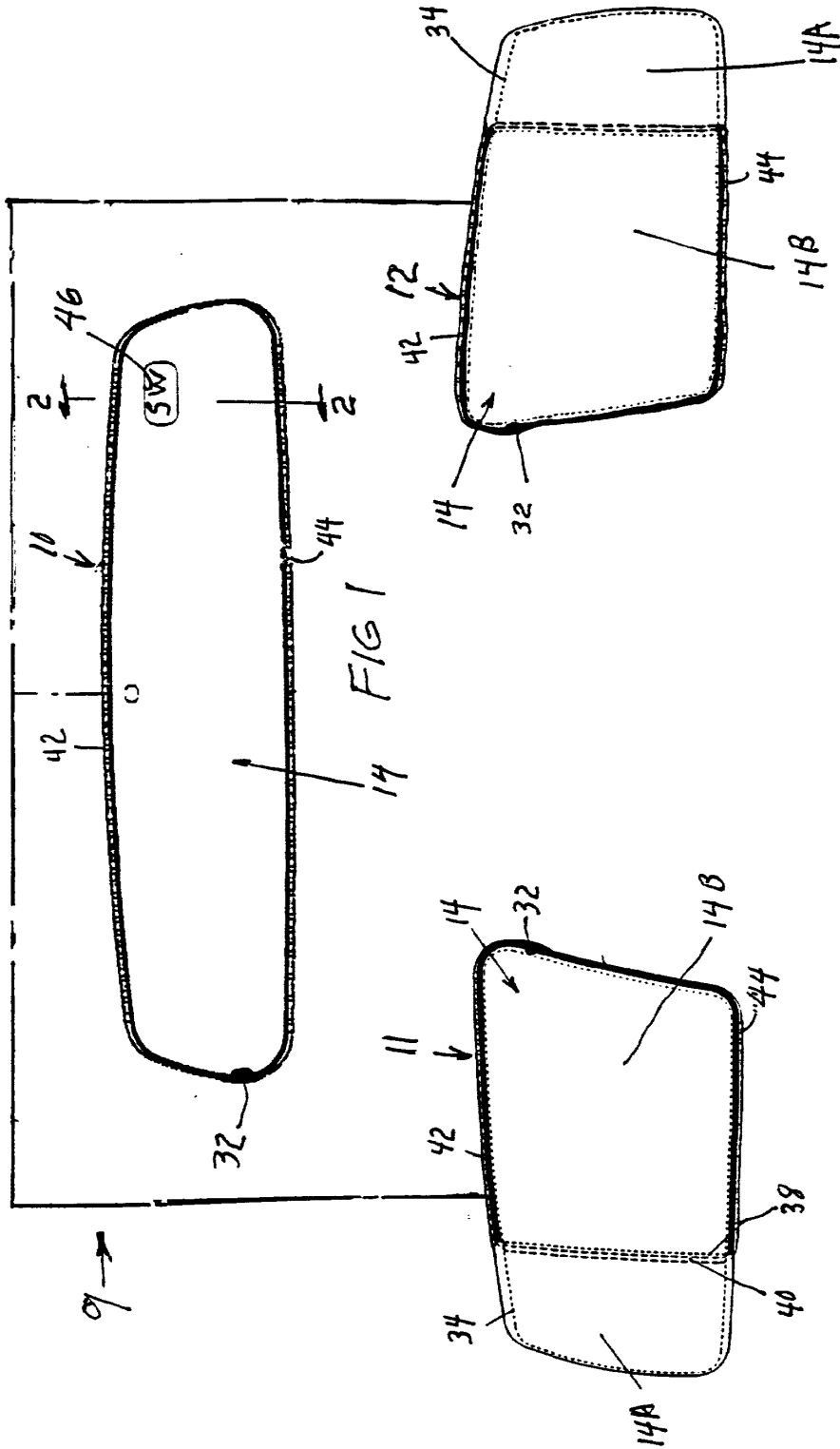

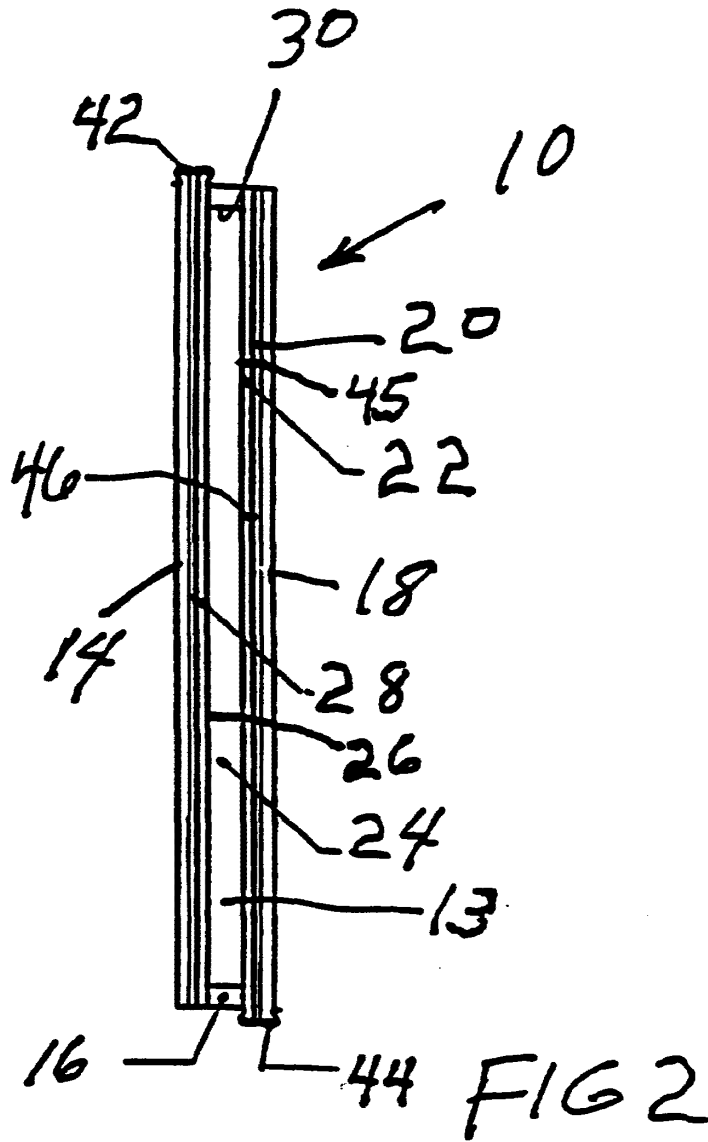

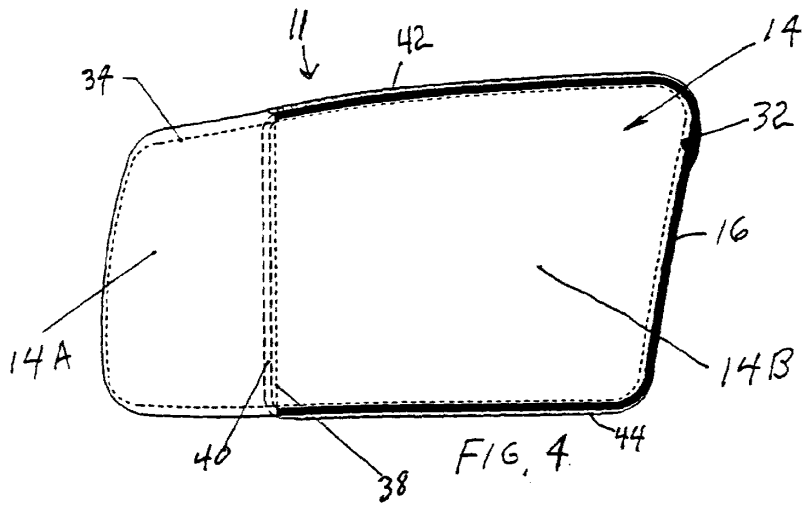
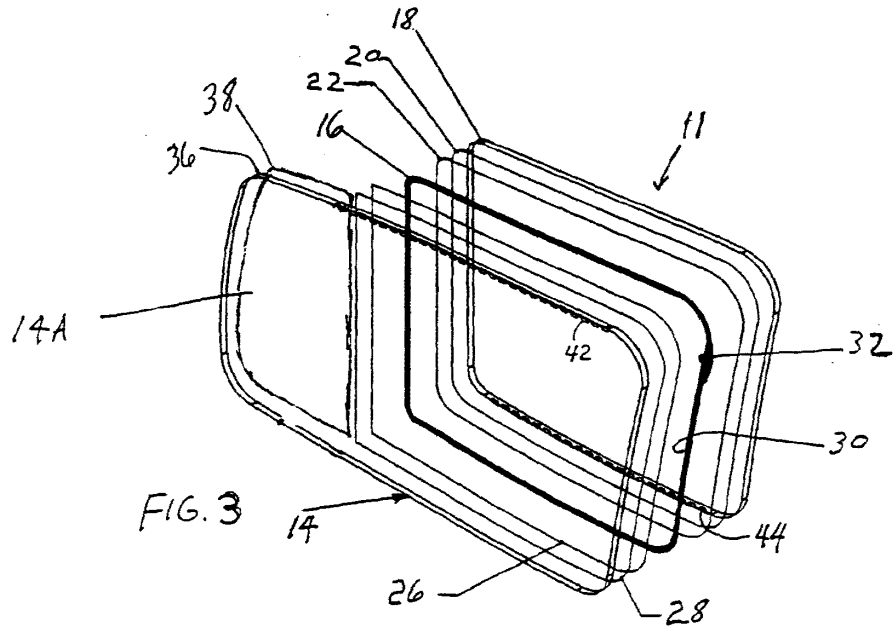

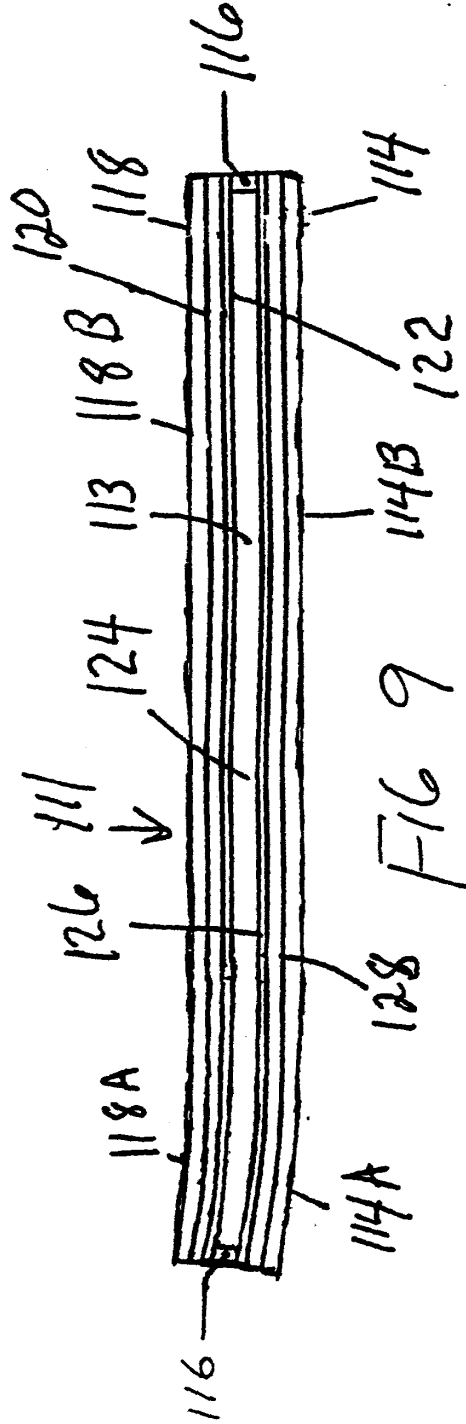
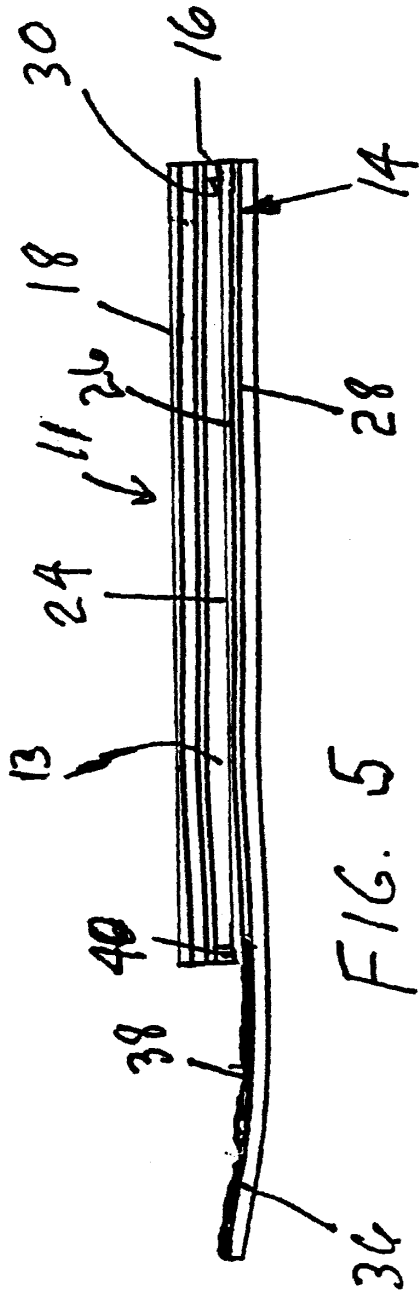

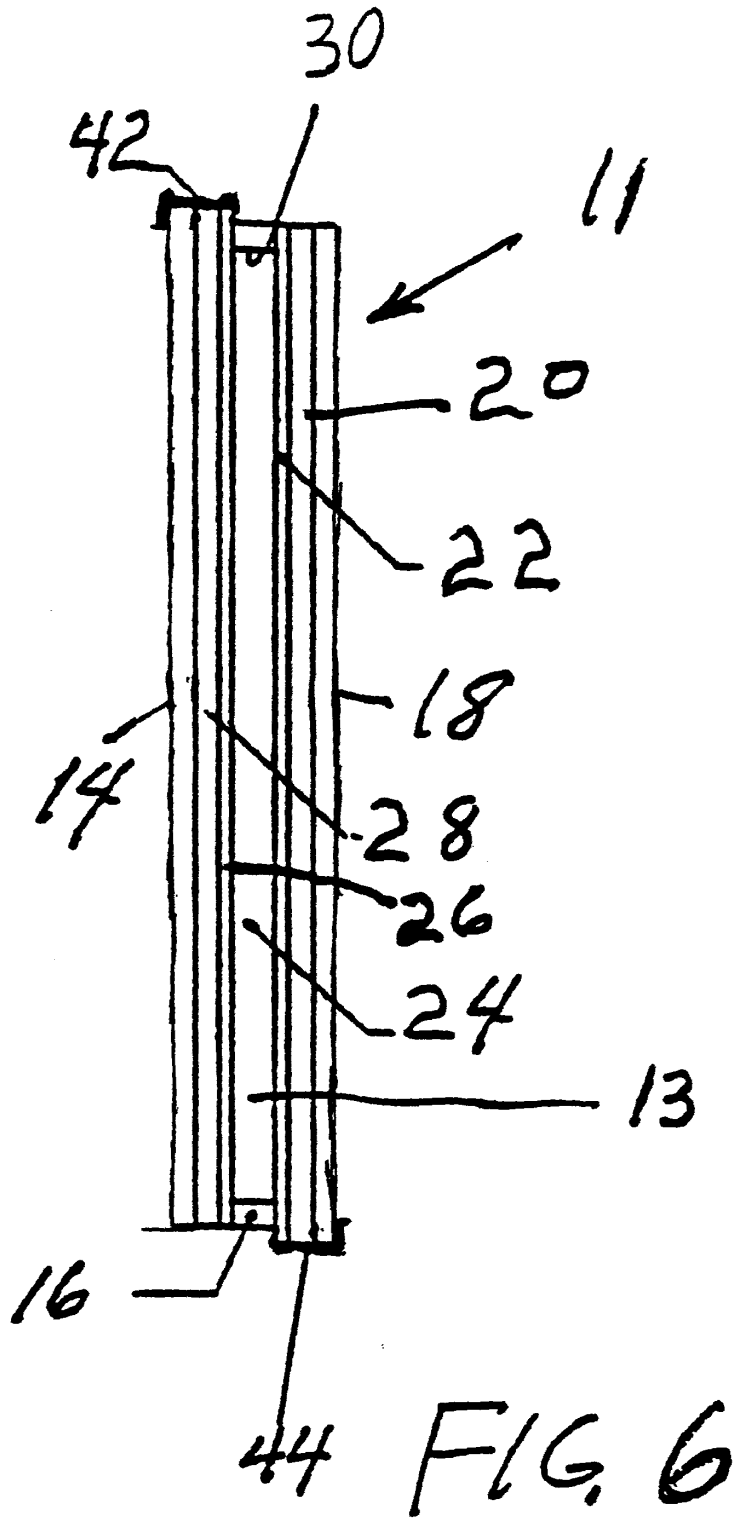

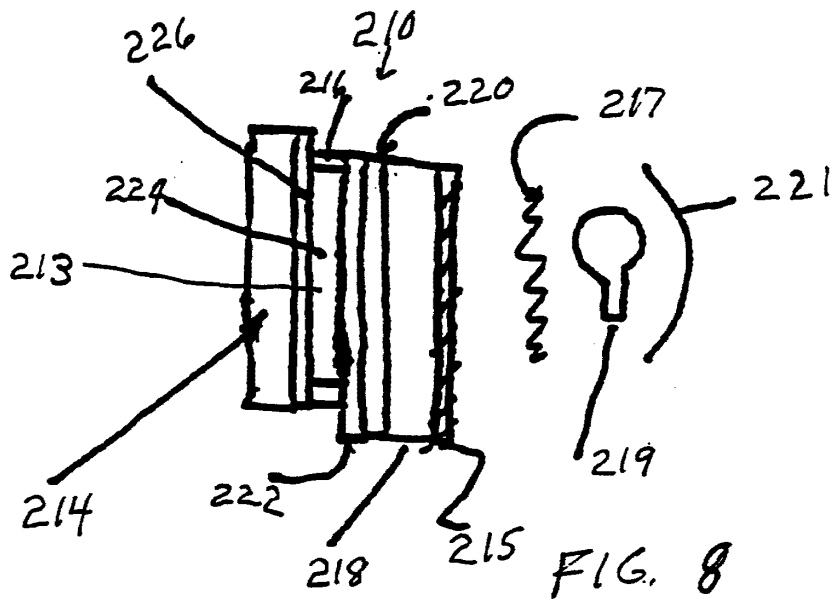
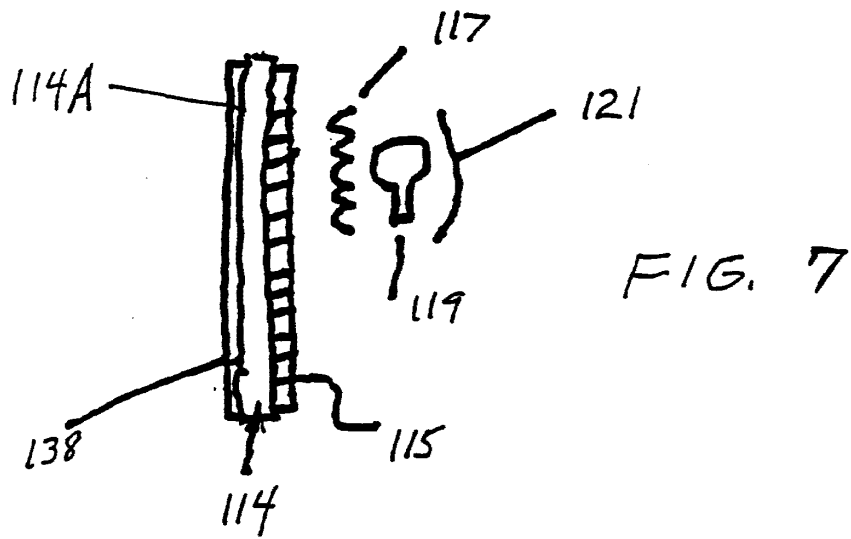



European Patent
Office

EUROPEAN SEARCH REPORT

Application Number
EP 95 30 8981

DOCUMENTS CONSIDERED TO BE RELEVANT			
Category	Citation of document with indication, where appropriate, of relevant passages	Relevant to claim	CLASSIFICATION OF THE APPLICATION (Int.Cl.6)
D,A	US-A-4 917 477 (JON H. BECHTEL ETAL) * the whole document * ---	1	B60R1/08
A	EP-A-0 152 098 (NIPPONDENSO CO., LTD) * the whole document * ---	1	
A	EP-A-0 168 497 (NIPPONDENSO CO., LTD) * the whole document * ---	1	
A	EP-A-0 210 757 (VON SEIDEL MICHAEL) * the whole document * -----	1	
The present search report has been drawn up for all claims			TECHNICAL FIELDS SEARCHED (Int.Cl.6)
			B60R
Place of search	Date of completion of the search	Examiner	
BERLIN	6 May 1996	Deprun, M	
CATEGORY OF CITED DOCUMENTS		T : theory or principle underlying the invention E : earlier patent document, but published on, or after the filing date D : document cited in the application L : document cited for other reasons ----- & : member of the same patent family, corresponding document	
X : particularly relevant if taken alone Y : particularly relevant if combined with another document of the same category A : technological background O : non-written disclosure P : intermediate document			

EPO FORM 1503 01/82 (P/MCDU)

Twin-focus electrically-driven rear-view mirror for vehicle - has outer section giving normal coverage, and inner portion covering otherwise dead zone on vehicle quarter

Publication number: FR2628042
Publication date: 1989-09-08
Inventor:
Applicant: RACLE JACQUES (FR)
Classification:
- International: *B60R1/06; B60R1/08; (IPC1-7): B60R1/06*
- European: B60R1/08D
Application number: FR19880002831 19880301
Priority number(s): FR19880002831 19880301

Report a data error here

Abstract of FR2628042

A vehicle's rear-view mirror has a broad outer section (2) which provides coverage of the usual field behind. A narrower inner section (3) does not cover this field, but is aligned upon the blind spot otherwise encountered around the vehicle's quarter. Both sections are carried on a common support (7), but can be individually orientated by manual or power control from inside the vehicle. A driver thus receives a comprehensive presentation of traffic location behind him, including those units in course of overtaking. ADVANTAGE - Two-section individually-controllable mirror concept solves basic blind spot problem encountered in most vehicles and provides driver with comprehensive view of activity behind him.

.....
Data supplied from the *esp@cnet* database - Worldwide

①9 RÉPUBLIQUE FRANÇAISE
INSTITUT NATIONAL
DE LA PROPRIÉTÉ INDUSTRIELLE
PARIS

①1 N° de publication : **2 628 042**
(à n'utiliser que pour les
commandes de reproduction)

②1 N° d'enregistrement national : **88 02831**

⑤1 Int Cl^a : B 60 R 1/06.

⑫

DEMANDE DE BREVET D'INVENTION

A1

②2 Date de dépôt : 1^{er} mars 1988.

③0 Priorité :

④3 Date de la mise à disposition du public de la
demande : BOPI « Brevets » n° 36 du 8 septembre 1989.

⑥0 Références à d'autres documents nationaux appa-
rentés :

⑦1 Demandeur(s) : *RACLE Jacques*. — FR.

⑦2 Inventeur(s) : Jacques Racle.

⑦3 Titulaire(s) :

⑦4 Mandataire(s) :

⑤4 Rétroviseur à double foyer.

⑤7 Dispositif permettant d'avoir une vision instantanée d'une zone invisible située derrière soi. L'invention concerne un « rétroviseur à double foyer » réglable et orientable.

Il est constitué d'un boîtier bloc rétroviseur 1 comportant un grand miroir 2 et un plus petit 3 situé à sa droite, séparés et orientables individuellement, articulés dans le boîtier 1 pourvu d'un support 7, muni d'un système d'orientation soit mécanique soit électrique.

Le dispositif selon l'invention est plus particulièrement destiné à tout véhicule ou engin ou autre, motorisé ou non.

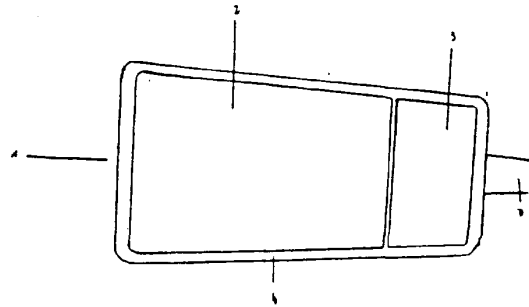

FR 2 628 042 - A1

D

Vente des fascicules à l'IMPRIMERIE NATIONALE, 27, rue de la Convention — 75732 PARIS CEDEX 15

La présente invention concerne un dispositif relatif à un "RETRO-
-VISEUR A DOUBLE Foyer ", composé d'un miroir en deux parties: ces deux par-
-ties séparées, ayant une orientation différente, permettent ainsi d'obtenir
un champ de vision différent et double, complémentaire, supprimant ainsi
"l'angle mort" existant avec un rétroviseur normal.

Ces deux miroirs sont juxtaposés et incorporés dans un "bloc" "ré-
-troviseur", mais peuvent avoir une position adaptée soit par un déplacement
latéral ou vertical, manuel ou électrique au moyen d'un moteur électrique.

La forme et la taille du rétroviseur et des miroirs seront variables
et adaptées aux besoins.

Le dispositif comporte un grand miroir (1) ayant un champ de vision
plus grand et plus large situé sur la partie gauche (5) et d'un miroir plus
petit (2) couvrant le secteur de l'ancienne "zone morte" (6).

Le dispositif peut se présenter par la juxtaposition de 2 miroirs
(2) et (3) séparés et orientables séparément.

La figure 2 représente le dispositif.

REVENDEICATIONS

1)-Dispositif comprenant un grand miroir (2) et un deuxième plus petit (3), séparés et juxtaposés, encastrés dans un "bloc rétroviseur" (1).

2)-Dispositif selon la revendication (1) caractérisé en ce que chaque miroir peut se mouvoir séparément et s'orienter de manière manuelle ou électrique, latéral ou vertical.

3)-Dispositif selon la revendication (2) caractérisé par le fait que chaque miroir permet de "couvrir" une zone différente complémentaire (5) et (6), qui vuent simultanément ensemble permet d'avoir une vision totale de la zone considérée.

4)-Dispositif selon la revendication (2) qui permet d'accroître la vision et la sécurité d'une personne qui est amenée à surveiller une zone morte" qu'il ne voit pas directement et complètement, zones situées par côté (droite et gauche) et derrière lui.

5)-Dispositif selon la revendication (1) caractérisé par son usage sur tout véhicule ou engin, motorisé ou non, se déplaçant sur terre, mer, air: auto-moto-vélo-canon....bateau...., avion....ou pour surveiller un secteur donné d'un point donné.

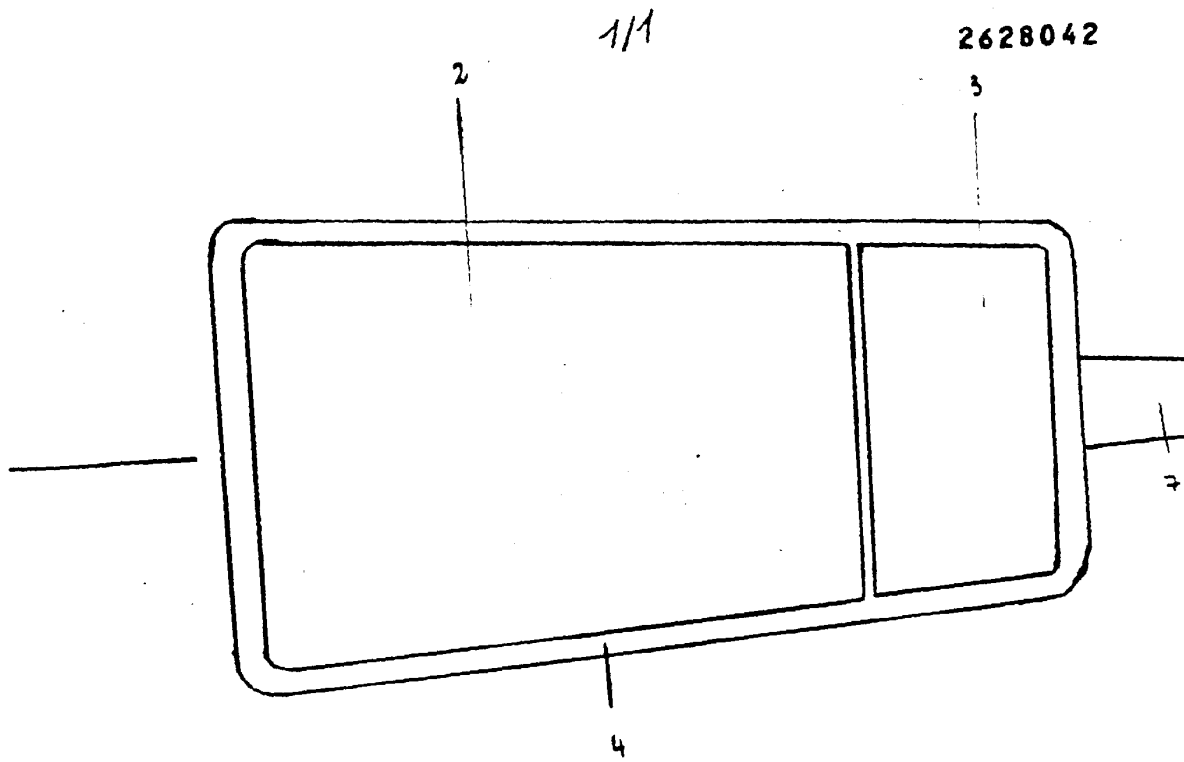

Fig 1

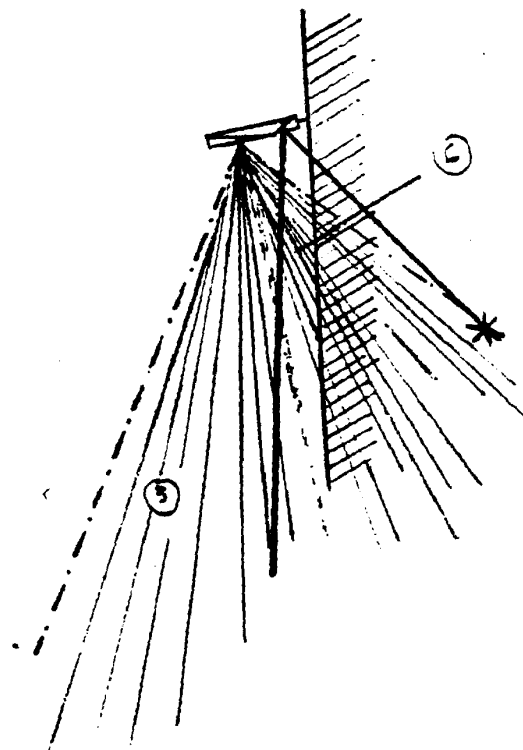

Fig 2

PATENT SPECIFICATION

(11)

1 279 158

DRAWINGS ATTACHED

1 279 158

- (21) Application No. 32282/69 (22) Filed 26 June 1969
(31) Convention Application No.
P 17 55 828-0 (32) Filed 27 June 1968 in
(33) Germany (DT)
(45) Complete Specification published 28 June 1972
(51) International Classification B60R 1/08
(52) Index at acceptance
B7J 69
G2J 11A 11B1 11B3 B7H



(54) DRIVING-MIRROR ASSEMBLY FOR A VEHICLE

(71) We, KURT HACKER of 7 Stuttgart-Zuffenhausen, Wollinstrasse 37, Germany and REINHOLD WEIGLE of 7015 Korntal, Hindenburgstrasse 52, Germany, both German citizens, do hereby declare the invention, for which we pray that a patent may be granted to us, and the method by which it is to be performed, to be particularly described in and by the following statement:—

This invention is concerned with a driving-mirror assembly for a vehicle.

It is known, from British patent specifications Nos. 827,336 and 1,133,005, to provide such a driving-mirror assembly in the form of a plane mirror alongside a convex mirror. These known arrangements are such that it is possible for the assembly when in use to give double-representation of an object viewed by means of the assembly, one such representation being given by reflection by the plane mirror and the other representation being given by reflection by the convex mirror. The existence of such double-representation is confusing to the driver, and is hence a possible source of danger, the more so because the plane mirror gives distortionless reproduction of the object at full-size, whilst the convex mirror pictures the object with at least some of its dimensions reduced in size and is a possible source of apparent distortion of the shape of the object.

According to the invention there is provided a driving-mirror assembly for a vehicle, the assembly comprising a planar first mirror reflecting surface formed upon a first member, and at least one second mirror reflecting surface which is curved so as to be convex towards the viewer and which is formed upon a second member, the first and second members being separate bodies fixedly interconnected to form a unit, the second mirror reflecting surface having, as a portion of its periphery, a line

which lies in a plane which is a tangent plane to that second mirror reflecting surface and which follows a corresponding portion of the periphery of the first mirror reflecting surface, the said tangent plane being arranged to coincide with or be parallel to the plane of the first mirror reflecting surface, whereby the assembly does not give double-representation of an object viewed by means of the assembly.

This arrangement, according to the invention, effectively provides what will be referred to herein as a "bend-free merger" between, or a "tangential transition" between, the (planar) first and the (convex) second mirror reflecting surfaces; for, with this arrangement, the first mirror reflecting surface is caused to effectively merge tangentially into the second mirror reflecting surface without the interposition of a bending line. This effective bend-free merger or tangential transition ensures that the said double-representation does not occur, and, moreover, can be so arranged that the field of view provided by the driving-mirror assembly is uninterrupted: thus, when an object (viewed by means of the assembly) passes across the field of view of the assembly, the object never appears to be duplicated and is seen as moving, without interruption, from the first to the second mirror reflecting surface (or vice versa).

The arrangement according to the invention is also convenient, in that experience has shown that whereas a plane mirror, or a convex mirror, can be manufactured in a relatively simple manner with high precision and with high surface-quality, the same does not apply to a single mirror which is required to exhibit a transition from a plane-mirror part to a convex-mirror part.

There may be two of the second mirror reflecting surfaces formed upon a single said second member and similarly arranged

respectively at relatively opposite peripheral portions of the first mirror reflecting surface.

Conveniently, the second member has a portion which extends behind the first mirror reflecting surface so as to form a rear support for the first member.

Conveniently, the said portion of the second member also affords a protective rim for a peripheral portion of the first member.

In one arrangement the assembly may be such that, in a plane which is normal to the first mirror reflecting surface and extends from that surface to intersect the second mirror reflecting surface(s) across the width thereof, the radius of curvature of the or each second mirror reflecting surface decreases with the distance from the first mirror reflecting surface.

In an alternative arrangement the assembly may be such that, in a plane which is normal to the first mirror reflecting surface and extends from that surface to intersect the second mirror reflecting surface(s) across the width thereof, the radius of curvature of the or each second mirror reflecting surface increases, at least initially, with the distance from the first mirror reflecting surface.

The invention will now be described with reference to and as illustrated in the accompanying drawings, wherein:—

Fig. 1 is a diagrammatic top view of a passenger car with an inside driving-mirror assembly according to the invention;

Fig. 1a is a partial top view similar to that of Fig. 1 but with an outside driving-mirror assembly;

Fig. 2 is an enlarged central section, in a horizontal plane, of the inside driving-mirror assembly when in position in Fig. 1;

Fig. 2a is a vertical cross-section through the driving-mirror assembly, said section being taken along the line A-A of Fig. 2;

Figs. 2b and 2c are respectively vertical cross-sections taken along the lines B-B and C-C of Fig. 2;

Figs. 3, 4, 5 and 6 are similar to Fig. 2 but relate to modified arrangements;

Fig. 7 is an explanatory drawing;

Fig. 8 is similar to Fig. 2 and relates to one structural arrangement according to the invention; and

Fig. 9 is similar to Fig. 8 but relates to an outside driving-mirror assembly.

Referring now to the drawings in detail, Fig. 1 shows a passenger car 1 with a windshield between roof posts 2 and 3 and with the driver's seat F on the left-hand side of the vehicle. The normal direct field of view n of the driver is at both sides limited by the marginal lines of vision 20 and 21 and comprises, for instance, a viewing angle of approximately 150° . In the central area of the windshield there is mounted an inside

driving-mirror assembly S which permits the viewing of an indirect field of view z by means of a central plane mirror, this indirect field of view extending behind the vehicle and being limited by a rear window 8 laterally defined by the roof posts 6 and 7.

At each side of the plane mirror there is provided a corresponding convexly curved mirror via which a lateral indirect viewing range, s or r , can be observed. The corresponding front marginal lines of vision 10 and 11 intersect the marginal lines of vision 20, 21 of the direct field of view at the points P, T at such a distance laterally of the vehicle that practically no blind lateral angle remains.

In a manner to be described, the central plane mirror merges by bend-free merger and tangential transition, into the two convexly curved mirrors.

Fig. 1a shows the corresponding arrangement of an outside driving-mirror assembly Sa the field of view of which, defined by the marginal lines 10a and 10b, deals with not only the rearward blind angle t of the inside rear-view mirror S but also the lateral blind angle behind the direct marginal line of vision 20.

In the case of Fig. 1a, the driving-mirror assembly Sa comprises a plane mirror Sa2 which (see below) merges by bend-free merger and tangential transition, into a convex mirror Sa1.

Figs. 2 and 2a-2c show one possible form of the driving-mirror assembly S of Fig. 1. A central plane mirror reflecting surface 15 merges, at each of its opposite sides, into a respective convex mirror reflecting surface 16, 17 associated with the viewing ranges s and r (Fig. 1) respectively. As indicated in Fig. 2 by the decreasing radii of curvature U, V and W, each of the convex mirror reflecting surfaces 16, 17 is progressively more curved (in the plane of the Fig. 1 drawing) with distance from the plane mirror reflecting surface 15. In addition, as indicated by Figs. 2b and 2c, which are cross-sections of a convex mirror reflecting surface (16,17) in planes which are normal to the mirror section of Fig. 2, the radius of curvature of each such convex mirror reflecting surface, in those normal planes, also decreases progressively with distance (of the said normal plane) from the plane mirror reflecting surface 15.

In Fig. 2, the chain lines 100 and 101 indicate the extent of the central plane mirror reflecting surface 15. It will thus be understood that there is, at each side of the central plane mirror reflecting surface 15, a boundary line which forms the common boundary of that surface and the convex mirror reflecting surface in question. At each such boundary line, the central

plane mirror reflecting surface 15 merges into the relevant convex mirror reflecting surface tangentially, without the interposition of a bending line; this bend-free merger or tangential transition ensures that the said double-representation does not occur and also ensures that the field of view provided by the driving-mirror assembly is uninterrupted.

10 Figs. 3-6 show other possible forms of the driving-mirror assembly. Here, in each case, there is a plane mirror reflecting surface E which merges, at one side, into a convex mirror reflecting surface; in each case, the convex mirror reflecting surface is a surface of revolution of which the generatrix is the curved horizontal section shown in the drawing and of which the axis of rotation is an axis Z which is normal to the plane mirror reflecting surface E. Moreover, in each case the generated surface of revolution (a part-annulus) is arranged to merge tangentially into the plane mirror reflecting surface E, without the interposition of a bending line: again, this bend-free merger or tangential transition ensures that the said double-representation does not occur and also ensures that the field of view provided by the driving-mirror assembly is uninterrupted.

30 In the case of Fig. 3, the generatrix of the convex mirror reflecting surface has a first portion W3a which lies adjacent to the plane mirror reflecting surface E and which has a radius of curvature R3a, this portion merging into a second portion which has a radius of curvature R3b which is less than R3a. In this case, the radius R3a is so selected that when the driver pictures an object via the first portion W3a, that picture is not greatly reduced in size as compared with the full-size picture which would be presented by the plane mirror reflecting surface E; in the case of the second portion W3b, the apparent reduction in size of the object is greater but this is unimportant for that part of the field of view of the driving-mirror assembly with which the portion W3b is concerned.

50 In the case of Fig. 4, the generatrix of the convex mirror reflecting surface has a curvature which decreases progressively with distance from the plane mirror reflecting surface E, as indicated by the increasing radii of curvature R4a and R4b.

55 In the case of Fig. 5, the generatrix of the convex mirror reflecting surface has a first portion W5a which lies adjacent to the plane mirror reflecting surface E and which has a radius of curvature R5a, this portion merging into a second portion W5b which has a radius of curvature R5b which is greater than R5a. With this arrangement, which is suitable for an inside driving-mirror assembly, the first portion W5a pro-

duces a relatively large apparent reduction in size of an object viewed by the driver via that portion which is, however, intended to correspond to a part of the field of view which is covered up by, or includes, the driver himself, the first portion being thus of lesser importance in the arrangement; the second portion W5b produces relatively less apparent reduction in size of an object viewed by the driver via that portion.

75 In the case of Fig. 6, the generatrix of the convex mirror reflecting surface has inner and outer strongly curved sections W6a and W6c and a central, less strongly and uniformly curved section W6b.

80 Experience has shown that an almost distortion-free mirroring in the curved mirror reflecting surface is obtained when the ratio between the maximum and the minimum radii of curvature at any point of the mirror reflecting surface, does not exceed a certain value. Surprisingly, relatively high values of this ratio are tolerable, without a disturbing distortion of the width-height ratio of an object mirrored by the part of the mirror reflecting surface concerned.

95 Fig. 7 shows the surface normal N at a point Q of a curved mirror reflecting surface W. There is drawn, in the tangential plane at the point Q, a polar plot of the radii of curvature of the mirror reflecting surface W at the point Q; such a polar plot indicates, for the point Q concerned, the largest radius of curvature Rmax and the smallest radius of curvature Rmin. The mirror reflecting surface W is preferably so arranged that the ratio of these radii of curvature nowhere exceeds 5:1. Experience has shown, however, that ratios of up to 7:1 are possible without disturbing distortions.

100 Fig. 8 shows a constructional arrangement of an inside driving-mirror assembly according to the invention. The plane mirror reflecting surface E is formed upon a body Fe and is flanked, at its opposite sides, by the two convex mirror reflecting surfaces Ws and Wr which are respectively formed upon curved opposite sides of the body Fa. The body Fa is shaped to receive the body Fe which is inserted into it and fixed in position. The body Fe, which provides the plane mirror reflecting surface E which is required to give true mirroring, may be made of glass so as to provide a high-grade mirror reflecting surface. The body Fa is preferably made of fracture-resistant material in case of accidents, and may be made of sheet metal, or may be cast, or may be made of synthetic plastics material. Loops K may be provided which make it possible to mount the driving-mirror assembly on to a simple rear-view mirror already installed in the vehicle concerned.

105 Fig. 9 shows a constructional arrange-

ment of an outside driving-mirror assembly according to the invention. The plane mirror reflecting surface E is formed upon a body Fe and is flanked, at one side, by the convex mirror reflecting surface W which is formed upon a curved side Fw of a body Fh. The body Fh is shaped to receive the body Fe which is inserted into it and fixed in position; thus, the body Fh has a rim Fr which forms a part-frame for the body Fe. The body Fe may be made of glass. The body Fh may be made of easily deformable and shock-absorbing material, and may be made of sheet metal.

15

WHAT WE CLAIM IS:—

1. A driving-mirror assembly for a vehicle, the assembly comprising a planar first mirror reflecting surface formed upon a first member, and at least one second mirror reflecting surface which is curved so as to be convex towards the viewer and which is formed upon a second member, the first and second members being separate bodies fixedly interconnected to form a unit, the second mirror reflecting surface having, as a portion of its periphery, a line which lies in a plane which is a tangent plane to that second mirror reflecting surface and which follows a corresponding portion of the periphery of the first mirror reflecting surface, the said tangent plane being arranged to coincide with or be parallel to the plane of the first mirror reflecting surface, whereby the assembly does not give double-representation of an object viewed by means of the assembly.

2. An assembly according to Claim 1, wherein there are two of the second mirror reflecting surfaces formed upon a single said second member and similarly arranged respectively at relatively opposite peripheral portions of the first mirror reflecting surface.

3. An assembly according to Claim 1 or Claim 2, wherein the second member has a portion which extends behind the first mirror reflecting surface so as to form a rear support for the first member.

4. An assembly according to Claim 3, wherein the said portion of the second member also affords a protective rim for a peripheral portion of the first member.

5. An assembly according to any preceding Claim, wherein the first member is made of glass and the second member is made of a material resistant to fracture.

6. An assembly according to any preceding Claim, wherein, in a plane which is normal to the first mirror reflecting surface and extends from that surface to intersect the second mirror reflecting surface(s) across the width thereof, the radius of curvature of the or each second mirror reflecting surface decreases with the distance from the first mirror reflecting surface.

7. An assembly according to Claim 6, wherein the said radius of curvature has a first constant value over an initial region adjacent to the first mirror reflecting surface and has a second constant value, less than the first constant value, over a further region more distant from the first mirror reflecting surface.

8. An assembly according to any one of Claims 1-5, wherein, in a plane which is normal to the first mirror reflecting surface and extends from that surface to intersect the second mirror reflecting surface(s) across the width thereof, the radius of curvature of the or each second mirror reflecting surface increases, at least initially, with the distance from the first mirror reflecting surface.

9. An assembly according to Claim 8, wherein the said radius of curvature has a first constant value over an initial region adjacent to the first mirror reflecting surface and has a second constant value, greater than the first constant value, over a further region more distant from the first mirror reflecting surface.

10. An assembly according to Claim 8, wherein the said radius of curvature is decreased, over a marginal region most distant from the first mirror reflecting surface.

11. An assembly according to any preceding Claim, wherein, at any point upon the or each second mirror reflecting surface, the ratio of the maximum to the minimum radius of curvature does not exceed 7:1.

12. An assembly according to Claim 11, wherein the said ratio does not exceed 5:1.

13. A driving-mirror assembly substantially as specifically described herein with reference to the accompanying drawings.

Agents for the Applicants,
 SYDNEY E. M'CAW & CO.,
 Chartered Patent Agents,
 "Saxone House",
 52-56 Market Street,
 Manchester 1.

1,279,158
4 SHEETS

COMPLETE SPECIFICATION
This drawing is a reproduction of
the Original on a reduced scale.
SHEET 1

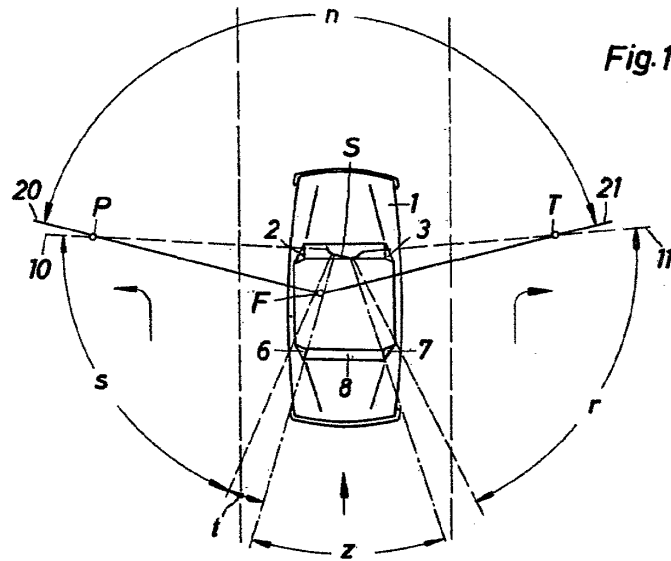

Fig. 1

Fig. 2a



Fig. 2b

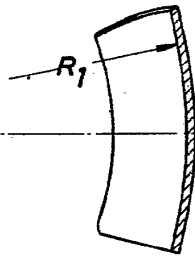

Fig. 2c

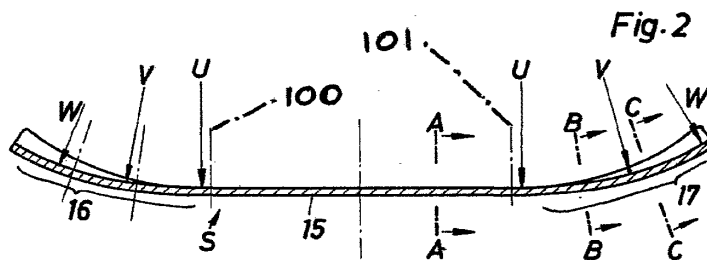
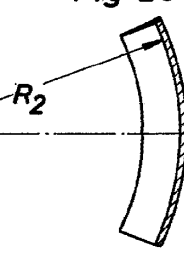
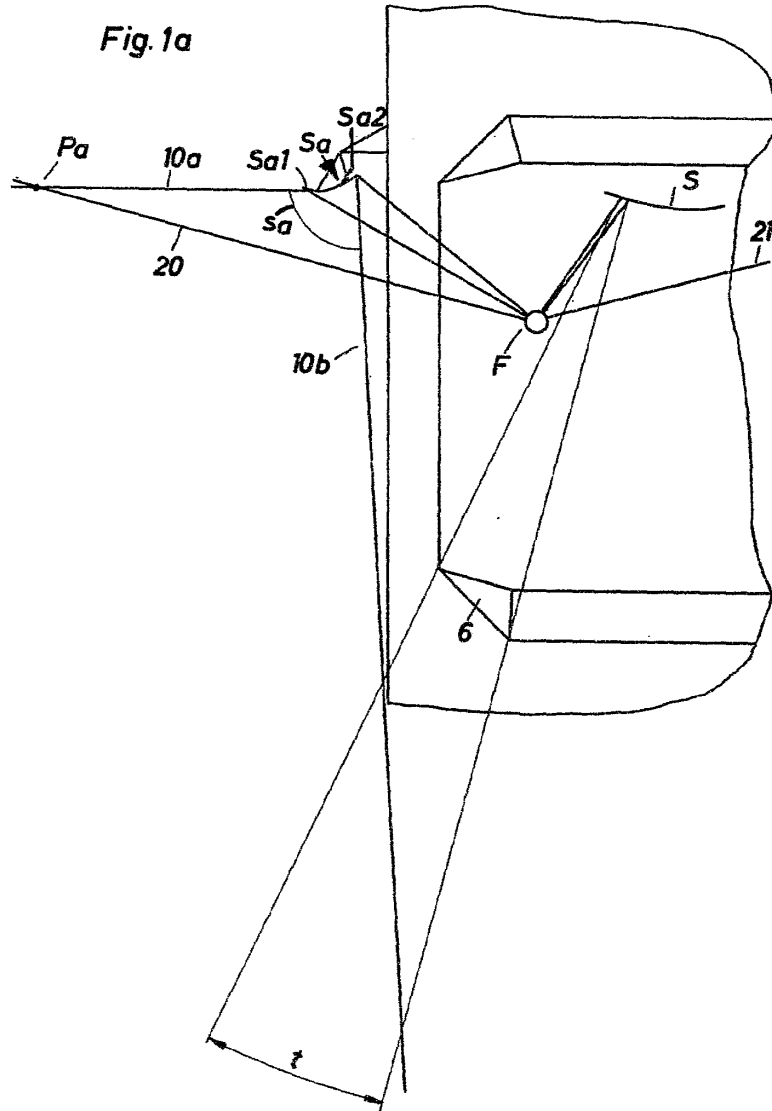

Fig. 2



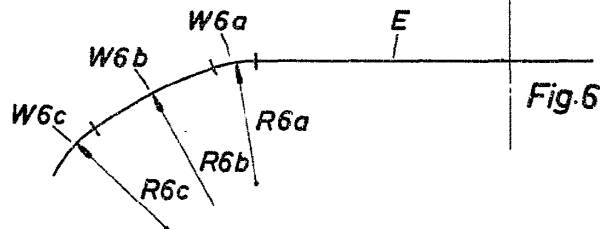
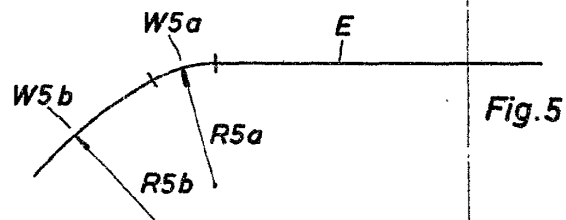
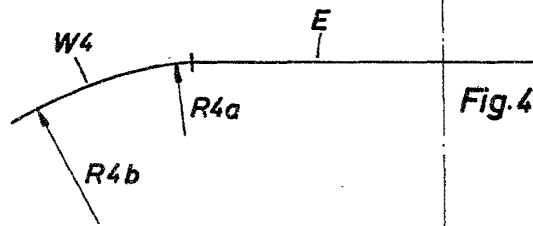
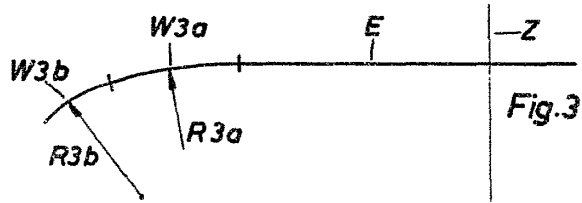

Fig. 8

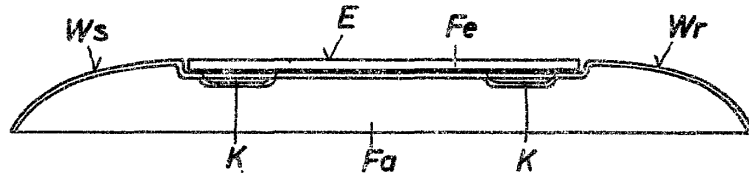

Fig. 9

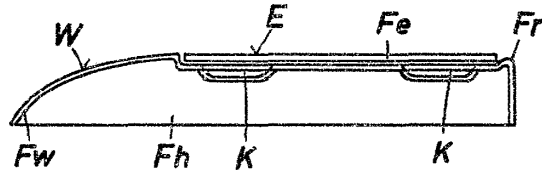
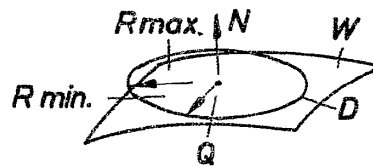

Fig. 7



Rear view mirror for vehicles

Publication number: GB2048189 (A)
Publication date: 1980-12-10
Inventor(s):
Applicant(s): MIRRORCRAFT INC
Classification:
 - **international:** *B60R1/08; B60R1/08*; (IPC1-7): B60R1/02
 - **European:** B60R1/08D2
Application number: GB19790014733 19790427
Priority number(s): GB19790014733 19790427

Abstract of GB 2048189 (A)

A vehicle rear view mirror (10) has a composite surface including a primary reflecting surface (11) which may be planar and formed therewith a secondary or auxiliary mirror section (14), that has an arcuately curved reflecting surface, in a corner area of the primary mirror so as to be effectively non-obstructing in normal use of the primary mirror, but of sufficient size and configuration as to produce a reflected image of a relatively large angular field of view in a horizontal plane with respect to that of the primary mirror. The auxiliary mirror is integrally formed with the primary mirror and may be on the front or rear thereof.

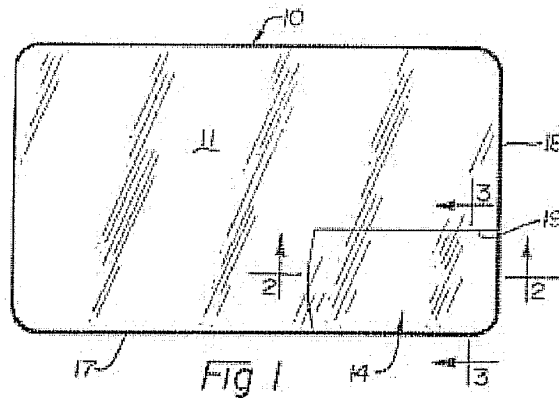

Data supplied from the *esp@cenet* database — Worldwide

(12) UK Patent Application (19) GB (11) 2 048 189 A

- (21) Application No 7914733
- (22) Date of filing 27 Apr 1979
- (43) Application published 10 Dec 1980
- (51) INT CL³ B60R 1/02
- (52) Domestic classification B7J 69
- (56) Documents cited GB 1505658 GB 1279158 GB 1133005 GB 827336
- (58) Field of search B7J
- (71) Applicants Mirrorcraft, Inc., 2074 Arlington Avenue, Columbus, Ohio 43221, United States of America
- (72) Inventor Ronald L. Docie
- (74) Agents Withers & Rogers

(54) Rear view mirror for vehicles

(57) A vehicle rear view mirror (10) has a composite surface including a primary reflecting surface (11) which may be planar and formed therewith a secondary or auxiliary mirror section (14), that has an arcuately curved reflecting surface, in a corner area of the primary mirror so as to be

effectively non-obstructing in normal use of the primary mirror, but of sufficient size and configuration as to produce a reflected image of a relatively large angular field of view in a horizontal plane with respect to that of the primary mirror. The auxiliary mirror is integrally formed with the primary mirror and may be on the front or rear thereof.

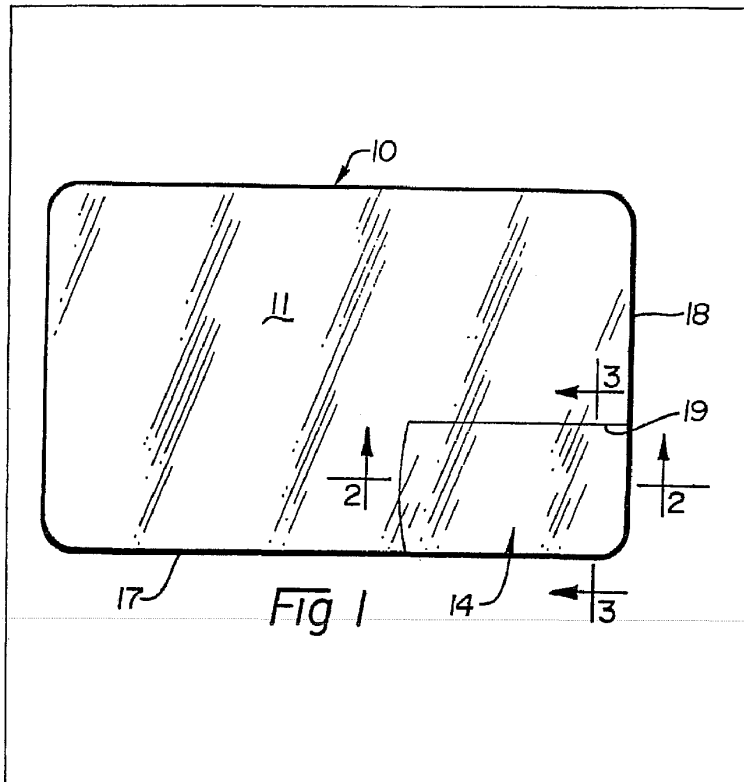

GB 2 048 189 A

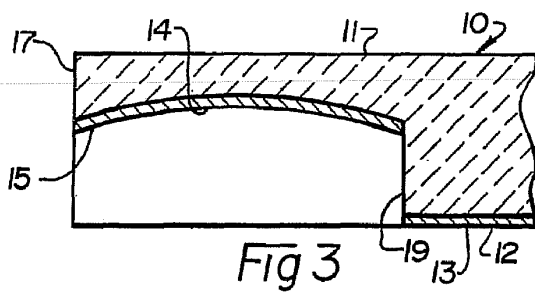
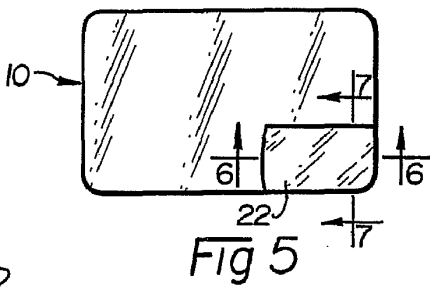
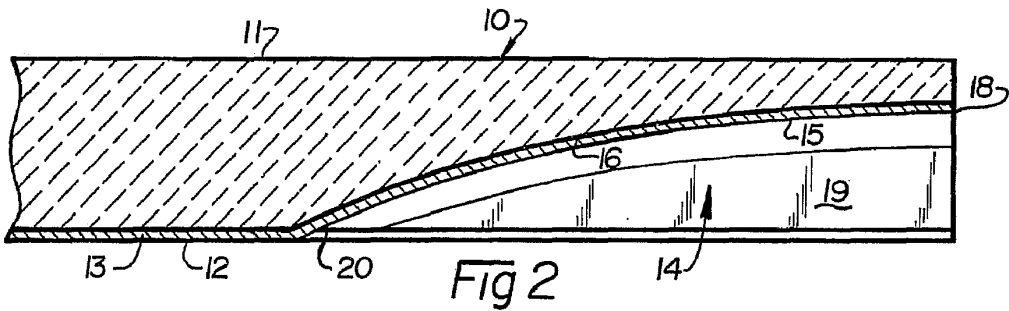
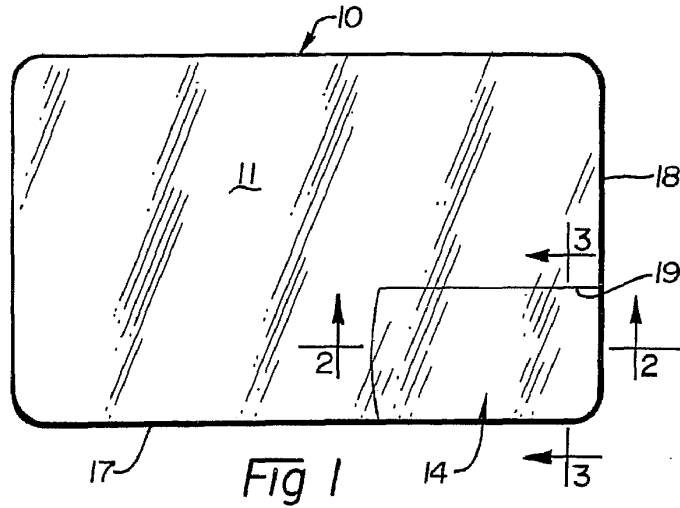

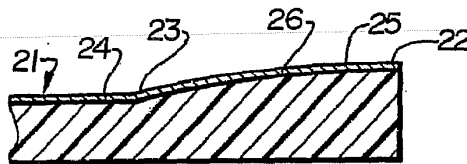
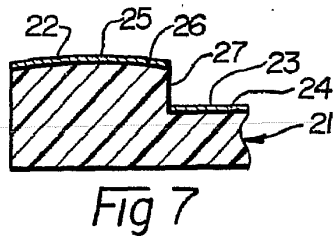
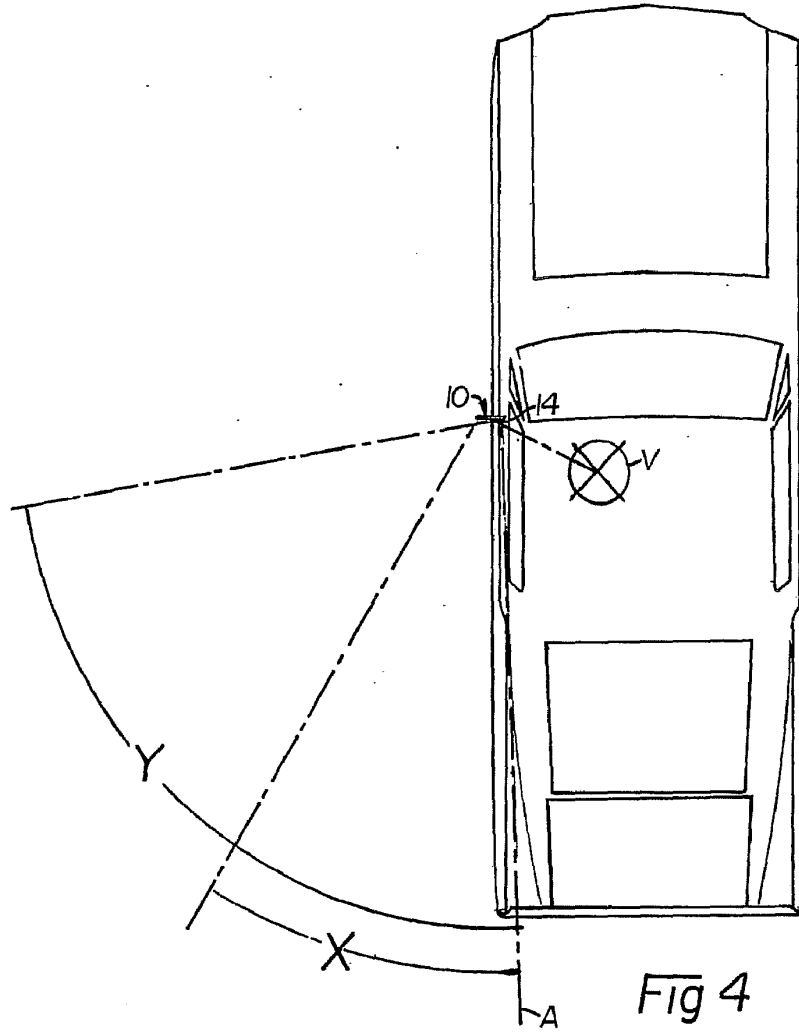

SPECIFICATION

Rear view mirror for vehicles

BACKGROUND OF THE INVENTION

5 Vehicle mirrors as conventionally provided
comprise a planar reflecting surface of sufficient
area to meet the normal requirements for
establishing a field of view with respect to the
vehicle operator. These mirrors may be either
installed in the interior of the vehicle for rearward
10 vision through a window at the back of the vehicle
or attached to the side door panels at either side
for primarily enlarging the field of view in a
sideward or lateral direction. This invention is
directed primarily to the exterior mounted side
15 view mirrors that are attached to the doors of the
vehicle or may be mounted on the front fender.
While the objective of such auxiliary mirrors in the
form of a side mounted type is to enlarge and
enhance the lateral directed field of view with
20 respect to the vehicle operator, the mirrors
presently available and on the market remain
inherently incapable of providing the optimum
field of view with a positive reference to the
vehicle itself.

25 Attempts have been made to improve the
performance of such mirrors by providing auxiliary
mirror structures that may either be independently
mounted on the vehicle or attached to the
conventional side mounted mirrors. The usual type
30 of auxiliary mirror heretofore provided comprises a
circular segment of a spherical surfaced shell that
may be adhesively bonded onto a surface of the
primary mirror if the primary mirror is sufficiently
large as in the case of truck mirrors. Alternatively,
35 a spherical segment mirror may be mounted
exteriorly on the vehicle in independent
relationship to any of the other mirrors.

40 While these spherical segment mirrors provide
a large field of view, it will be recognized that such
mirrors provide an enlarged field of view through
360 degrees of viewing angle. The disadvantage
of this enlargement of the field of view is that the
operator of the vehicle is necessarily presented
45 with a vastly distorted peripheral field of view
which includes substantial portions that are
immaterial from a safety standpoint. It will be
readily apparent that such a mirror provides a field
of view which includes an extensive and
unimportant view of the side of the vehicle and
50 which also extends substantially upwards as well
as downwards with respect to the vehicle, and
these areas are of no real interest or significance
to safe operation of the vehicle.

55 Accordingly, it will be seen that the circular
spherical segment mirrors, as well as others, such
as cylindrical convex type which have been
devised in attempts to overcome the inherent
blind spot that occurs with the standard planar
reflecting surface mirrors have not succeeded in
60 achieving this desirable objective. While such
mirrors attempt to obtain a field of view adequate
for the purposes of the driver, they inherently
incorporate and produce a substantially greater
area of viewing that tends to detract from their

65 usefulness and accordingly tend to detract and
decrease the safety features that were originally
attempted to be achieved.

SUMMARY OF THE INVENTION

70 In accordance with this invention a composite
mirror is provided in which the major portion or
primary section of the mirror conforms to the
usual standards of having a planar reflecting
surface for producing a relatively narrow angular
75 field of view in a horizontal plane immediately
adjacent to the vehicle when utilized at a side of
the vehicle. The composite mirror of this invention
has the further objective of enabling the operator
to independently view a specified area at the side
of the vehicle which includes a lateral angle of
80 substantial extent and optimally approaches a 90
degree angle to the longitudinal axis of the vehicle.
Achievement of this objective thus produces a
mirror wherein a vehicle operator may readily
ascertain the presence of a vehicle in an area
85 which would otherwise not be seen in a
conventional planar mirror properly adjusted in
accordance with specified standards to view an
area which extends angularly outward from a side
of the vehicle to only a relatively limited extent.
90 Accomplishment of this objective is achieved
through the combination of a planar mirror surface
and a segment of an arcuately curved mirror that
is incorporated in a relatively small portion of the
area of the planar mirror. This arrangement places
95 the arcuately curved segment in an area with
respect to the primary mirror such that the field of
view of the primary mirror is substantially
unobstructed by the addition of this auxiliary
mirror. Specifically, the auxiliary mirror is
100 preferably located in the lower right corner, that is,
the side edge next adjacent to the vehicle body as
to a mirror mounted on the driver's side of the
vehicle whereas a similar type of mirror on the
opposite side would have the mirror segment
105 located in the lower left corner. This location and
arrangement is for a vehicle having the driver
seated on the left side and it will be understood
that the arrangement would be appropriately
modified for a vehicle having the driver seated on
110 the right side.

115 This invention illustrates the various techniques
providing a composite mirror to effectively obtain
and achieve the two distinct and separate fields of
view regarding the side areas of a motor vehicle. A
technique for providing a mirror incorporating the
concepts of this invention is the integral formation
of an auxiliary mirror surface with the primary
mirror. This integrally formed auxiliary mirror
surface may appear either on the exterior or
120 outwardly facing surface of the primary mirror or
may be incorporated in the rear surface. The only
difference between these two techniques is that
the silvering for forming the reflecting surface in
one instance is applied to the outer surface
125 whereas in the other it would be applied to the
rear surface of the primary mirror.

These and other objects and advantages of the
invention will be readily apparent from the

following detailed description of the several embodiments thereof and the accompanying drawings.

DESCRIPTION OF THE DRAWING FIGURES

5 Figure 1 is a front view of a mirror embodying this invention.

Figure 2 is a fragmentary vertical sectional view on an enlarged scale taken along line 2—2 of Figure 1.

10 Figure 3 is a fragmentary vertical sectional view on an enlarged scale taken along line 3—3 of Figure 1.

Figure 4 is a diagrammatic plan view of the field of view of the mirror.

15 Figure 5 is a front view of a modified mirror embodying this invention.

Figure 6 is a fragmentary vertical sectional view on an enlarged scale taken along line 6—6 of Figure 5.

20 Figure 7 is a fragmentary vertical sectional view on an enlarged scale taken along line 7—7 of Figure 5.

DESCRIPTION OF THE ILLUSTRATIVE EMBODIMENT

25 Having reference to the drawings, a basic form of the invention is shown in Figures 1, 2 and 3. In Figure 1, a conventionally shaped side view mirror is shown in elevation without the auxiliary supporting or mounting frames or bracket components. Those structural components bear no relationship to this invention other than to provide the necessary support for the mirror in the attachment or mounting thereof on the side of the vehicle. However, since such mounting components are well-known, it is not deemed necessary to illustrate or describe those structures in conjunction with the illustrative embodiments.

30 The side view mirror includes a primary mirror 10 comprising a flat plate formed from glass or other optically transmissive material having planar front and rear surfaces 11 and 12, respectively. A coating of silvering material 13 is applied to the surface 12 thereof as indicated in Figures 2 and 3. The illustrated primary mirror 10 is of conventional rectangular configuration and may be of the generally conventional size of 7.6 x 12.7 centimeters and mounted with the long axis horizontally disposed. However, it will be understood that the primary mirror size may be otherwise dimensioned.

50 Integrally formed with the primary mirror 10 is a secondary or auxiliary mirror structure which is generally designated by the numeral 14 and can be best seen with references to Figures 2 and 3. In this illustrative embodiment, the secondary mirror 14 is formed in the body of the glass plate forming the primary mirror and comprises a surface 15 having a generally rectangular configuration in plan view as will be noted in Figure 1. A coating of silvering material 16 is applied to the surface 14 thereby forming the reflecting surface.

The secondary mirror 14 is most advantageously located in a corner area of the

65 primary mirror and is substantially smaller so as to minimize the loss of effective viewing area of the primary mirror. In this illustrative embodiment, the secondary mirror has the exemplary planar area dimensions of 4.8 centimeters in its longer dimension extending horizontally and 2.9 centimeters in its vertical or height dimension with respect to the vertical of the primary mirror. Also, the secondary mirror is preferably located with one of its longer sides adjacent to, or coextensive with, the bottom edge 17 of the primary mirror and its one vertical side adjacent to, or coextensive with, the one vertical side edge 18 of the primary mirror. This vertical side edge 18 is that which is intended to be positioned next adjacent the side of the vehicle on which the mirror is to be mounted. Locating the secondary mirror in this area results in the cavity formed in the body of the primary mirror by generation of the mirror surface 15 being open at both the bottom edge 17 and vertical side edge 18 of the primary mirror. A planar surface 19 defining the other longitudinal side of the secondary mirror is also generated, but the inner side edge of the secondary mirror surface 15 lies in the plane of primary mirror's rear surface 12 defining a juncture line 20.

90 It will be further noted with reference to Figures 2 and 3 that the secondary mirror surface 15 is a non-planar surface and comprises a segment of a curved surface. This surface in the illustrative embodiment is a spherical surfaced segment having a radius of curvature of the order of 12 centimeters. As previously stated, the one end of this surface segment intersects the rear surface 12 of the juncture line 20 and it will be noted with reference to Figure 2 that the opposite end, at its juncture with the vertical side edge 18, to be displaced about 0.8 centimeters from the rear surface 12 of the primary mirror. This specific dimensional configuration is considered exemplary as providing particularly useful fields of view and resulting in a composite mirror structure capable of achieving the intended objective as explained in further detail hereinafter. It will also be apparent that, while the secondary mirror surface is described as being a spherical surface segment of specific radius of curvature, this radius of curvature may be increased to the extent that it approaches infinity and the surface may effectively be planar, but disposed at an angle with respect to the front and rear surfaces 11, 12 of the primary mirror 10. However, the curved surface is deemed advantageous in that it provides a larger field of view.

115 Functional objectives achieved by the 120 aforescribed structural combination of a primary and a secondary mirror 10, 14 are diagrammatically illustrated in Figure 4. In that drawing figure, a side view mirror comprising the primary mirror and secondary mirror is shown mounted on a left side of a vehicle which is diagrammatically shown in top plan view. The respective fields of view that are provided by the reflecting surfaces of the primary mirror 10 and

secondary mirror 14 are diagrammatically shown in Figure 4. These angular fields of view are referenced to a horizontal plane with the field of view for the primary mirror designated X and includes a horizontal angular space extending laterally outward from a base or reference line A which is effectively aligned with the side of the vehicle. Preferably, this limiting line of sight overlaps portions of the side of the vehicle to better provide the vehicle operator V with a reference in determining relative locations of objects that appear within that field. The angular extent of this field of view designated X is effectively of the order of 35 degrees.

Consequently, it will be readily seen that the field of view is clearly inadequate to provide an operator, indicated to be located at a position designated V within the vehicle with reflected images of objects or vehicles that may be laterally spaced further forward with respect to the vehicle and are outside the angular field of view designated by the letter X.

It is the objective of the secondary mirror 14 to increase this lateral angular field of view to that which is designated Y in Figure 4. This substantially greater angular field of view in a horizontal plane with the mirror construction utilizing a secondary mirror surface 15 comprising a segment of a spherical segment oriented as previously described, extends from the base line A to substantially a line which will be 80-90 degrees displaced from the side of the vehicle.

An extremely important advantage of the specific structural configuration of the auxiliary mirror 14 of this invention is the presentation of a relatively wide field of view in a horizontal plane of a particularly important area whereas the field of view is limited in its vertical extent to a relatively narrow band. The effective viewing area laterally relative to the vehicle includes a nearly 90 degree horizontal field of view in the region where the operator of the vehicle will be readily able to detect the presence of other vehicles at a position where greater detail is unimportant. This display of a vehicle in the so-called-blind spot area is of substantial advantage in that the field of view does cover an area which would otherwise require the vehicle operator to physically turn his head and directly view that area. In the matter of changing lanes on multilane highways, this is a particularly important feature. Merely checking the primary planar mirror 10 only indicates whether a vehicle is in a substantially rearward position with respect to the operator's own vehicle. There is really no indication in that mirror of the presence and location of a vehicle immediately sideways of the vehicle, but still sufficiently rearward that a person's normal peripheral vision is unable to detect such a vehicle.

A further important advantage of this mirror construction is that the field of view in a vertical plane is relatively limited in its vertical extent, both upwardly and downwardly, and thus the operator is not presented with a substantial amount of extraneous information and detail that is of no

concern to his operating decisions. It is only the lateral position of a vehicle in this "blind spot" that is essential for the operator's safe performance and maneuvering of his vehicle. Furthermore, this observation can be accomplished without the disadvantageous head and eye movement that would otherwise be required and could adversely affect the proper and safe control of the vehicle.

A modified form of the mirror embodying this invention is shown in Figures 5, 6 and 7. This modified mirror structure comprises an integrally formed combination of a primary mirror 21 and a secondary mirror 22. The primary mirror 21 may be of the same dimensional configuration described with reference to Figure 1, but may be formed from a material that is not optically transmissive. The front surface 23 of the primary mirror is either formed to directly provide adequate reflectivity or, as is illustrated, is provided with a thin layer 24 of a suitable material capable of producing a high degree of reflectivity. Also, the secondary mirror 22 is formed in a lower corner area of the primary mirror and thus provides the same advantageous viewing of lateral areas as obtained with the Figure 1 embodiment. While the reflecting surfaces 23 and 25 are advantageously provided with a reflective coating, neither the peripheral edges of the primary mirror 21 nor an upper horizontally extending edge surface 27 of the secondary mirror 22 would be provided with such a coating. Preferably, the edge surface 27 would be treated or conditioned to minimize its reflectivity. This would tend to minimize extraneous reflections that could possibly be generated by the adjacent and angularly disposed edge surface 27 and primary mirror front surface 23.

The mirrors of this invention were previously described as being formed from glass. It will be understood that glass was suggested as an appropriate material, but it is also suggested that other materials may be suitable. For example, there are certain plastic materials which possess the desired structural characteristics and, in the case of the Figure 1 embodiment, have the necessary optical transmission characteristics. Plastics may enable a greater economy to be affected in manufacture as they may be better adapted to molding techniques to achieve the necessary smooth surface for purposes of reflection.

It will be readily apparent from the foregoing detailed descriptions of the embodiments of this invention that a particular novel and useful mirror is provided for automotive vehicle purposes. The mirror of this invention is specifically designed and inherently capable of providing the substantially increased field of view necessary to eliminate the present blind spot that exists in the case of conventional mirrors having a single, flat, planar surface. The mirror construction of this invention limits the field of view provided by the secondary mirror surface to a specifically defined area that is of exceptional interest to the vehicle operator in ascertaining the presence of an object or vehicle

immediately laterally positioned with respect to his own vehicle. The segment of spherical surface is of considerable advantage in this respect as it provides a slight vertically upward and downward field of view to better form reference or a relationship to the image reflected by the primary mirror for the operator. The angular disposition of the vertical segment with respect to the primary planar mirror surface results in this segment being particularly capable of illustrating the extreme lateral extent of this field of view as well as providing a line of sight in reference with respect to the side of the vehicle. It will also be apparent that a mirror embodying this invention may be constructed to be positioned on either side of a vehicle for providing the advantageous field of view.

CLAIMS

1. An optical mirror comprising
 20 a primary mirror having a reflecting surface that includes a side edge and which is adapted to be normally viewed from a position displaced in laterally outward offset relationship with respect to said side edge, said primary reflecting surface
 25 providing a primary angular field of view of predetermined extent in a first plane oriented in generally perpendicular relationship to said side edge and said primary reflecting surface, and
 30 a secondary mirror integrally formed with said primary mirror, said secondary mirror being substantially lesser in dimension than said primary mirror and disposed closely adjacent said side edge of said primary mirror and terminating in spaced relationship to an opposite side edge of
 35 said primary mirror to thereby leave a substantial primary reflecting surface area therebetween, said secondary mirror having a reflecting surface providing a secondary angular field of view of predetermined extent in said first plane oriented in
 40 generally perpendicular relationship to said side edge and said primary reflecting surface of said primary mirror with the secondary angular field of view being substantially greater than the primary angular field of view provided by the reflecting
 45 surface of said primary mirror, said secondary angular field of view being at least partially coextensive with the primary angular field of view and extending beyond the primary angular field of view of said primary mirror only in a direction
 50 away from said side edge and across the reflecting surface of said primary mirror with respect to the point of viewing.

2. An optical mirror according to claim 1 wherein said primary mirror has a front viewing surface and said secondary mirror is formed to
 55 position its reflecting surface at the front surface of said primary mirror.

3. An optical mirror according to claim 2

60 wherein each of said primary and secondary mirrors has a reflecting surface formed at a front surface thereof.

4. An optical mirror according to claim 3 wherein the front surfaces of each of said primary and secondary mirrors have a coating of reflective
 65 material applied thereto.

5. An optical mirror according to claim 1 wherein said primary mirror has a front viewing surface and is formed from an optically
 70 transmissive material, and said secondary mirror has its reflecting surface formed in rearwardly spaced relationship to the primary mirror front viewing surface.

6. An optical mirror according to claim 5 wherein said primary mirror has a rear surface
 75 forming a reflective surface.

7. An optical mirror according to claim 6 wherein each of said primary and secondary mirror reflective surfaces have a coating of reflective
 material applied thereto.

8. An optical mirror according to claim 1 wherein said secondary mirror reflecting surface is oriented with respect to the reflecting surface of
 80 said primary mirror such that said planes of the respective angular fields of view are coplanar.

9. An optical mirror according to claim 8 wherein the angular field of view of said secondary
 85 mirror includes substantially all of the angular field of view of said primary mirror in said planes.

10. An optical mirror according to claim 9 wherein the respective angular fields of view are
 90 coincident at one limiting extent.

11. An optical mirror according to claim 1 wherein the reflecting surface of said secondary
 95 mirror is arcuately curved to provide a greater angular field of view than that of said primary mirror reflecting surface in a second plane oriented substantially perpendicular to said first
 mentioned plane.

12. An optical mirror according to claim 11 wherein the angular field of view of said secondary
 100 mirror reflecting surface in said second plane includes the angular field of view of said primary mirror reflecting surface.

13. An optical mirror according to claim 12 wherein the angular field of view of said secondary
 105 mirror reflecting surface in said second plane extends beyond the field of view of said primary mirror in only one direction with respect to said first plane.

14. An optical mirror according to claim 1 wherein said secondary mirror is substantially
 110 smaller than said primary mirror and is positioned closely adjacent said side edge thereof and an edge perpendicular to said side edge.

15. An optical mirror according to claim 1 wherein said secondary mirror's reflecting surface
 115 has a dimension in said first plane that is greater than the dimension thereof in said second plane.

(12) UK Patent Application (19) GB (11) 2 092 534 A

- (21) Application No 8136435
- (22) Date of filing
3 Dec 1981
- (30) Priority data
- (31) 55/172575
- (32) 3 Dec 1980
- (33) Japan (JP)
- (43) Application published
18 Aug 1982
- (51) INT CL³ B60R 1/06
- (52) Domestic classification
B7J 69
- (56) Documents cited
GB 1279158
GB 1199344
GB 1180930
GB 1133005
GB 0895855
GB 0827336
GB A 2048189
- (58) Field of search
B7J
- (71) Applicant
Yoshikazu Hagiri
1169 Shibazakicho
Takasaki-shi
Gunma-ken 370
Japan
- (72) Inventor
Yoshikazu Hagiri
- (74) Agents
J F Williams and Co
34 Tavistock Street
London WC2E 7PB

(54) Rear-view mirror device for vehicles

(57) A rear-view mirror for vehicles comprises a plane reflective face 13a and a convex reflective face 13b contiguous to and at an angle with 13a. A further convex face 13c may also be provided. Faces 13b, 13c increase the field of view provided by the mirror.

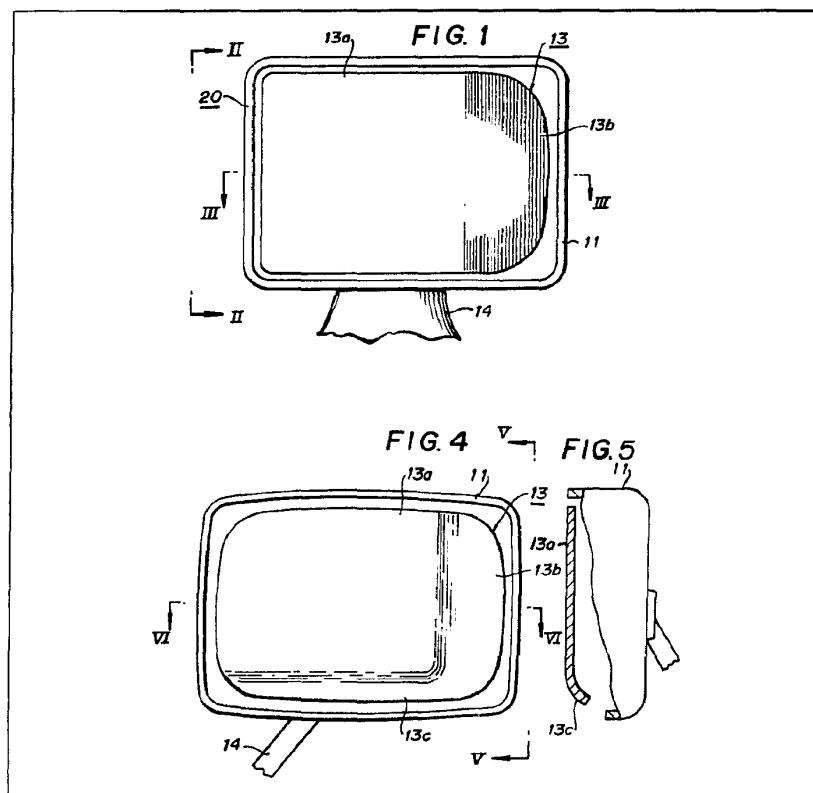

GB 2 092 534 A

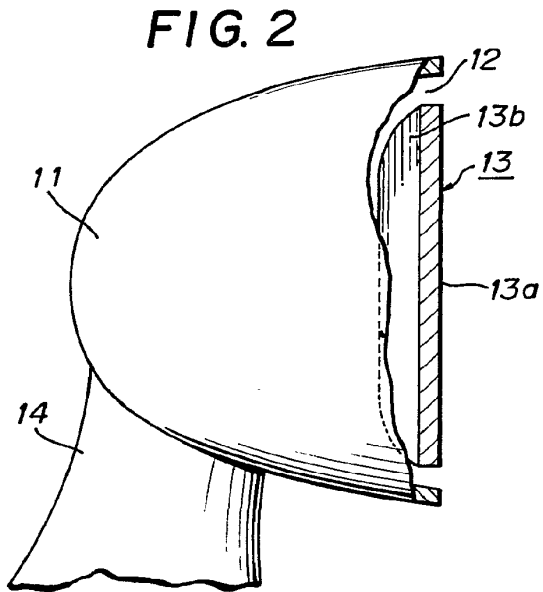
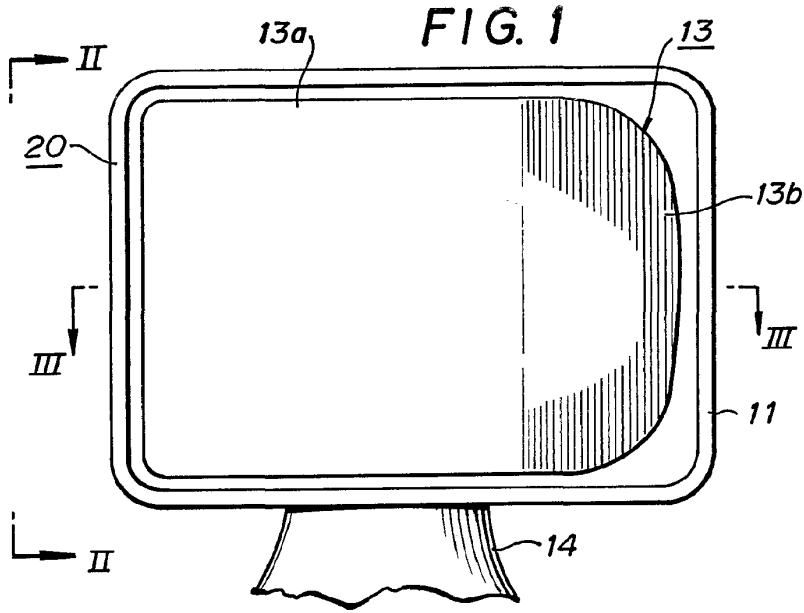

FIG. 3

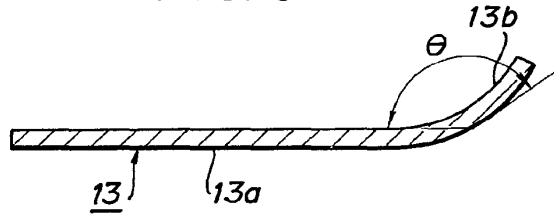

FIG. 4

FIG. 5

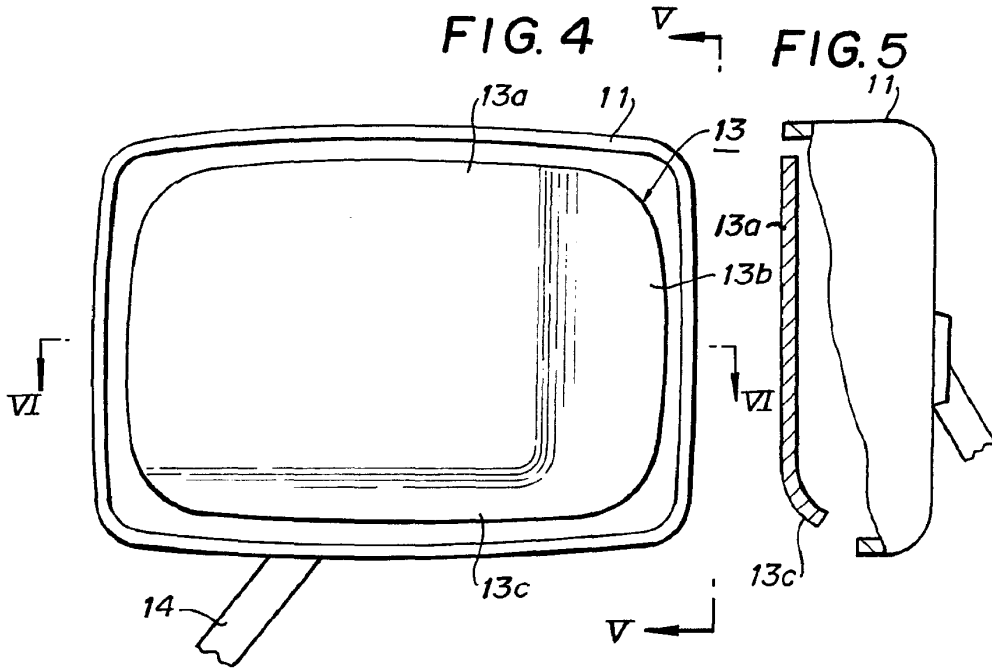

FIG. 6

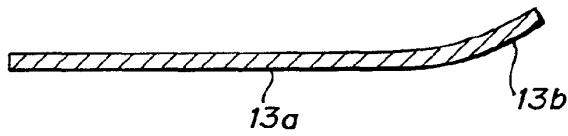

FIG. 7

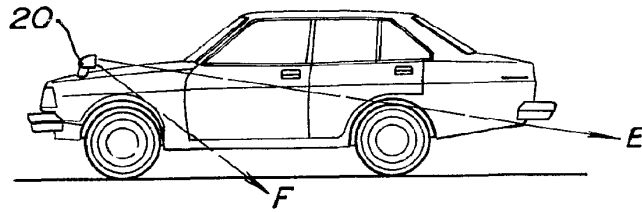
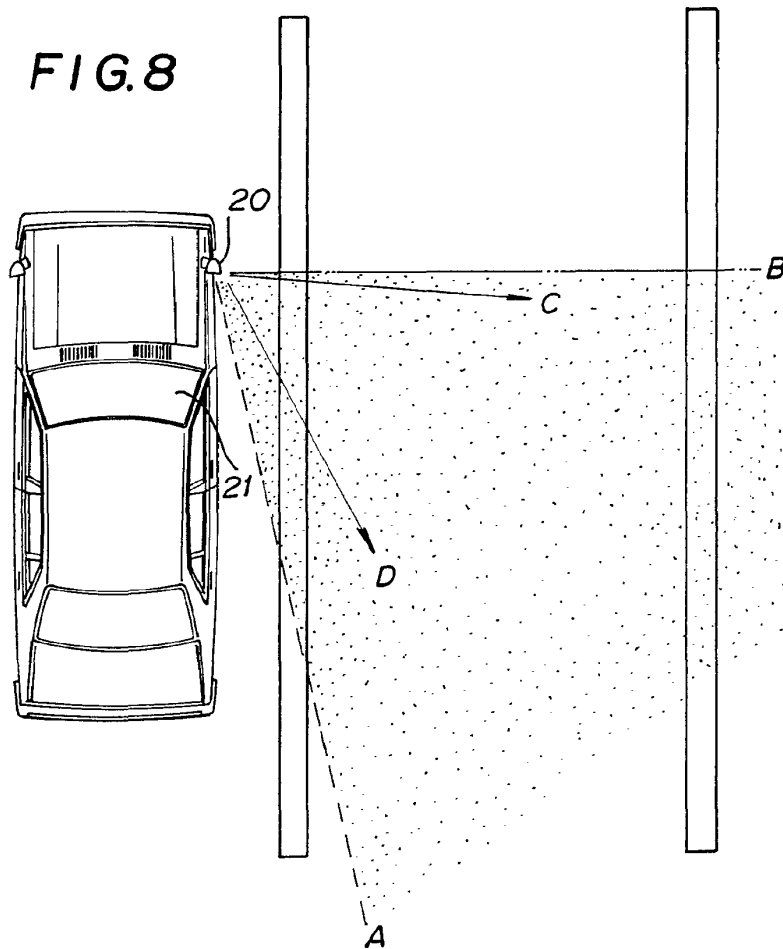

FIG. 8



SPECIFICATION

Rear-view mirror device for vehicles

5 The present invention relates to a rear-view mirror device for automotive vehicles and the like.

The well-known rear-view mirrors installed outside of automotive vehicles and the like, for example at the front wings or front fenders of automobiles have a single-plane mirror surface. With such a single-plane structure of the conventional rear-view mirror, the field of view of the driver in his seat is limited to a range from the end of the car body to a lateral position a little away from the car body. Any object existing on the lateral side or lateral rear side of the car body will not get into the field of view of the driver via the prior-art rear-view mirror device. When one is about to shift from one lane to another while driving a car along a motorway, for example, and if another car running in the latter lane is approaching your car of which you are not aware, a disastrous accident will possibly result. One reads and sees almost everyday such accidents in newspapers and television newscasts. Further, the conventional rear-view mirror device used on an automotive vehicle such as tractor trailer assures the view of the tractor rear, but not the view of the trailer rear, when the tractor trailer turns along a curve or around a corner. The range from the rear end of the tractor to the trailer's rear end cannot be covered by the driver's sight via the conventional rear-view mirror. If a person or bicycle is standing at that curve or corner when such a large automotive vehicle turns there, he or it will possibly be caught under the chassis of the vehicle because of the relatively long distance between the front and rear wheels. This is a critical problem in the field of traffic safety.

The present invention seeks to provide a rear-view mirror device for automotive vehicles and the like which assures a wider field of view.

According to the present invention there is provided a rear-view mirror device for vehicles comprising a mirror body and means for supporting said mirror body on a vehicle body, the surface of said mirror body including a first reflective face which is arranged to reflect in use substantially the vehicle body side and its neighborhood, and a second reflective face which adjoins the edge of the first reflective face and is inclined with respect to the first reflective face so as to cover a substantial range which cannot be covered by the first reflective face and extends further outwardly from the range covered by the first reflective face.

The second reflective face is preferably formed as a convex mirror contiguous to the first reflective face.

The apparatus may also comprise a third reflective face which is contiguous to the first reflective face and so arranged with respect to the first reflective face that it can cover, in use, a side lower range of the car body to produce an image thereof contiguous to the image produced by the first reflective face.

The third reflective face is also preferably formed as a convex mirror.

Preferred embodiments of the present invention will now be described, by way of example only with reference to the accompanying drawings of which:

Figure 1 shows a front view of a mirror device in accordance with a first embodiment of the present invention;

Figure 2 is a partly sectional side view taken along the line II-II of Fig. 1;

Figure 3 is a sectional view taken along the line III-III of Fig. 1 and showing only the mirror;

Figure 4 is a front view of a mirror device in accordance with a second embodiment of the present invention;

Figure 5 is a partly sectional side view taken along the line V-V of Fig. 4;

Figure 6 is a sectional view taken along the lines VI-VI of Fig. 4 and showing only the mirror;

Figure 7 illustrates the functioning of the mirror device shown in Figs. 4 to 6; and

Figure 8 illustrates the rearward field of view of the mirror devices of Figs. 1 to 6.

Referring now to the drawings, Figs. 1 to 3 show a first embodiment of the rear-view mirror device according to the present invention. In the Figures, the reference numeral 11 denotes a mirror housing which is provided therein with an opening 12. A mirror 13 is disposed within said housing 12 of the housing 11. The mirror 13 is fixed to an appropriate backing material which is supported through a universal joint (not shown) on the housing 11. A stay 14 is integrally formed with the housing 11 which is fixed at a portion (not shown) thereof to the body of a car or other automotive vehicle.

The mirror 13 consists of a transparent plate member on the one face of which a reflective layer is formed. The mirror 13 comprises a first reflective face 13a and a second reflective face 13b which forms an angle δ with the first reflective face 13a. The first reflective face 13a is formed like a plane mirror as shown in Fig. 2.

The second reflective face 13b is contiguous to the first reflective face 13a and formed like a convex mirror of an appropriate radius of curvature.

This example of rear-view mirror apparatus is to be installed on the front fender or front wing of a car at a certain distance, for example, 1 meter, from the windscreen 21, as shown in Fig. 8. In the illustration, the mirror device as a whole is indicated by reference

numeral 20. Before the car is driven, the mirror device is manually pivoted about the universal joint for the first reflective face to reflect the car body side and its surroundings (for example, a range defined by the broken line A and the body side face) as in the case of conventional rear-view mirror. The angle δ of the second reflective face 13b with respect to the first reflective face 13a is so selected that the second reflective face 13b can give the driver (sitting in the seat to the right of the driving direction in the illustration) a field of view defined by the line A and two dot-dash line B.

The first reflective face 13a of this rear-view mirror device permits the driver to visually check the range including the car body side face and its surrounding quite the same as by the conventional rear-view mirror devices. According to the present invention, the second reflective face 13b further permits the driver to visually check the lateral side and lateral rear side, indicated by C and D, respectively, of the car. In addition, the driver of a car running along a main road can visually locate, by means of the rear-view mirror of the present invention, a car coming along a road which joins the main road obliquely. Thus, the driver can view, from the position of his seat, a range which could not be covered by the conventional rear-view mirror devices. The present invention is very advantageous for traffic safety. Since the first and second reflective faces 13a and 13b are contiguous to each other, the correlation between the images on these reflective faces is clear to the driver who will judge and act quickly and correctly at the occurrence of any imminent danger.

Figs. 4 to 7 show a second embodiment of the present invention. In the first embodiment described above, one reflective face is formed as contiguous to the lateral edge of another reflective face, to permit the driver to view a range which cannot be covered by the conventional rear-view mirror. In the second embodiment, however, two reflective faces are formed as contiguous to the lateral and lower edges of a mirror 13, to cover, respectively, ranges which cannot be viewed by conventional rear-view mirrors. In Figs. 4 to 7 the elements similar to those in the first embodiment are indicated with like reference numerals and symbols. As shown in Figs. 5 and 6, the above-mentioned two reflective faces are formed as convex mirrors which are contiguous to the first reflective face 13a and are indicated at 13b and 13c. The second reflective face 13b is so formed as to permit the driver to view a range including the lateral and lateral rear sides of a car, the range being defined by the dotted line in Fig. 8, similarly to the first embodiment. The third reflective face 13c is so curved with respect to the first reflective face 13a as to provide a view of the

side lower range of the car as contiguous to the view from the first reflective face 13a, when the rear-view mirror device is installed on a car body. The bending angle and radius of curvature of the third reflective face 13c are so selected that a range from the rear tyre (indicated at E) to the rear position of the door (indicated at F) as shown in Fig. 7 can be covered.

With this embodiment of the present invention, provision of two reflective faces contiguous to the first reflective face 13a for covering the ranges which cannot be viewed by the conventional rear-view mirror minimize such range as cannot be seen when driving a car etc. It will be clear to those skilled in the art that the mirror device permits the driver to view the lower zone of a car which is not viewable to the driver by any conventional rear-view mirror.

In the foregoing, examples of rear-view mirror for use on passenger cars have been described. However, it is possible to apply the present invention to larger cars and other vehicles. When the present invention is applied to a large car, it will be apparent to those skilled in the art than an accident of the type in which a person or bicycle standing at a corner is caught in under the car around the corner because the distance between the front and rear wheels is relatively long, can be prevented.

As described in the foregoing, a rear-view mirror device according to the present invention comprises a mirror and means for supporting said mirror to the body of a car, said mirror including a first reflective face to view a substantial range including the car body side face and its surroundings, and a second reflective face so formed as contiguous to and curved with respect to the first face that an outer range compared with that covered by the first reflective face can be viewed as contiguous to the image on the first face.

Thus, the driver can view, from his seat, a range which could not be viewed by the conventional rear-view mirror. Since the first and second reflective faces are formed as contiguous to each other, also the images on these reflective faces are contiguous to each other, so the driver can easily know the relation between the image on the first reflective face and that of a range which cannot be viewed by the conventional rear-view mirror. He can act quickly and correctly at the occurrence of any imminent danger. Because of the contiguity between the first and second reflective faces, if the reflective face for viewing the range which is invisible by the conventional rear-view mirror is narrow or the image thereon is somewhat distorted, the driver will be able to make a correct judgement. Further, since a single mirror can attain the above-mentioned effects, the rear-view mirror apparatus according to the present invention has a

simple construction and can be easily manufactured.

CLAIMS

- 5 1. A rear-view mirror device for vehicles comprising a mirror body and means for supporting said mirror body on a vehicle body, the surface of said mirror body including a first reflective face which is arranged to reflect
10 in use substantially the vehicle body side and its neighborhood, and a second reflective face which adjoins the edge of the first reflective face and is inclined with respect to the first reflective face so as to cover a substantial
15 range which cannot be covered by the first reflective face and extends further outwardly from the range covered by the first reflective face.
- 20 2. A rear-view mirror device as claimed in claim 1, wherein the second reflective face is formed as a convex mirror contiguous to the first reflective face.
- 25 3. A rear-view mirror device as claimed in claim 1 or 2, further comprising a third reflective face which is contiguous to the first reflective face and so arranged with respect to the first reflective face that it can cover, in use, a side lower region of the car body to produce an image thereof contiguous to the
30 image produced by the first reflective face.
4. A rear-view mirror device as claimed in claim 3, wherein the third reflective face is formed as convex mirror together with the second reflective face.
- 35 5. A rear-view mirror device as claimed in any preceding claim wherein the first reflective face is formed as plane mirror.
- 40 6. A rear-view mirror device substantially as herein described with reference to Figs. 1,2,3 and 8, or 4,5,6,7 and 8 of the accompanying drawings.

Printed for Her Majesty's Stationery Office
by Burgess & Son (Abingdon) Ltd.—1982.
Published at The Patent Office, 25 Southampton Buildings,
London, WC2A 1AY, from which copies may be obtained.

PATENT ABSTRACTS OF JAPAN

(11)Publication number : 55-051637

(43)Date of publication of application : 15.04.1980

(51)Int.Cl.

B60R 1/08

B60R 1/06

(21)Application number : 53-124495

(71)Applicant : KATSUMATA GIKEN:KK

(22)Date of filing : 09.10.1978

(72)Inventor : KATSUMATA ISAMU

(54) REAR-VIEW MIRROR FOR AUTOMOBILE

(57)Abstract:

PURPOSE: To prevent the images on a rear view confirmation mirror and a front side view confirmation mirror from being confused with each other, by partitioning the mirrors from each other by a holding plate.

CONSTITUTION: A rear view confirmation mirror 3, which is shaped as a vertical oblong and has a large radius of curvature, and a vehicle front side view confirmation mirror 4, which is hemispherical and has a small radius of curvature, are attached to a support frame 2, which is provided on a support rod 1 so that support frame can be fixed or adjusted. The mirror 4 is located just under the other mirror 3. The boundary edges of the mirrors 3, 4 are fixed in the fitting grooves of a holding frame 5. The images on the mirrors 3, 4 are prevented by the presence of the holding frame 5 from being confused with each other.

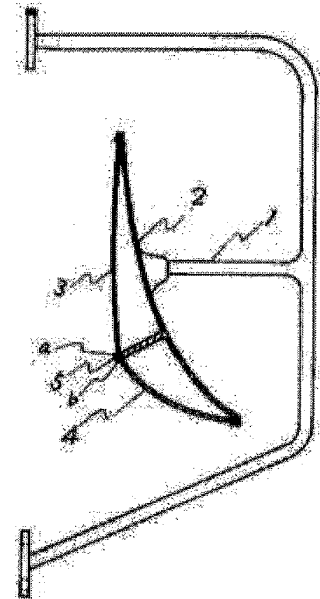

⑩ 日本国特許庁 (JP)

⑪ 特許出願公開

⑫ 公開特許公報 (A)

昭55—51637

⑬ Int. Cl.³
B 60 R 1/08
1/06

識別記号

庁内整理番号
7191—3D
7191—3D

⑭ 公開 昭和55年(1980)4月15日

発明の数 1
審査請求 未請求

(全 2 頁)

⑮ 自動車用バックミラー装置

沼津市足高554—3番地

⑯ 特 願 昭53—124495

⑰ 出 願 人 有限会社勝又技研

⑱ 出 願 昭53(1978)10月9日

沼津市足高554—3番地

⑲ 発 明 者 勝又勇

⑳ 代 理 人 弁理士 松岡宏

明 細 書

1. 発明の名称

自動車用バックミラー装置

2. 特許請求の範囲

支持杆(1)に調節固定を可能せしめた支承棒(2)に上部を大なる曲率半径を有する縦長で長方形状の鏡体(3)と、該鏡体(3)の直下に小なる曲率半径を有する半球状の鏡体(4)を装着させ、各々鏡体(3)、(4)の境界部接合端面(a)、(b)を嵌挿溝を有する保持棒(5)に嵌挿定着させ、全体を該支承棒(2)で支承させて構成せしめたことを特徴とする自動車用バックミラー装置。

3. 発明の詳細な説明

本発明は特にバス、トラック等に装着し後方視界と共に車体前側部周辺の視界確認が容易に出来るように為させた自動車用バックミラー装置に関する。

従来のこの種の自動車用バックミラーの構成ではバス、トラック等の大型車で運転席からの左右前側面及びその直下の視界確認が非常に困難

であり広い死角を生み暫々事故誘発の原因となり、特に大型車の左折時においては運転席が右にあるため左側周辺の視界確認が非常に困難となっていた。このような死角を解消するために別途にアンダーミラーを付設したり、複雑な光学装置を組み込んだもの等があるがいずれも一長一短を有し、運転者に分りにくく実用性に乏しいものが多く事故防止の役割を果たさず簡単で確実なものを必要とされた。

本発明は前記に鑑み、上記欠点を削除し、後方確認と共に車体前側部周辺の視界の確認を確実に出来るようにし、且つ誤認することが無い自動車用バックミラー装置を提供するものである。

以下図面について実施例を説明する。

第1図及び第2図において、車体左右前側に螺着させた支持(1)に調節固定を可能せしめた縦長で上方を長方形状とし、下方部を半円形状に形成せしめた支承棒(2)を装着させ、該支承棒(2)内の上部に大なる曲率半径を有し縦方向に長く

した長方形状の鏡体(3)と、該鏡体(3)の直下に小なる曲率半径を有する半球状の鏡体(4)を押し寄せしめ、各々鏡体(3)、(4)の境界部接合端面(a)、(b)を嵌り溝を有する適宜な巾で支承枠内に装着させた保持枠(5)に嵌挿定着させ境界を設け、全体を該支承枠(2)で支承させた構成を成している。本発明は以上のような構成であるから上部の鏡体(3)で後方確認をし、下部の曲率半径小なる半球状の鏡体(4)でもつて車体における左右前側周辺部に視界が確実に確認される。

特にバス、トラック等の大型車において、道中の狭い道路では壁や側溝等の障害物が道の縁まで迫っているが鏡体(4)により車体前側周辺の視界は確実に確認でき車輪を側溝に落としたり人や自転車を巻き込む等の事故も未然に防止され安全運転が確保される。又、後部確認用の鏡体(3)と前側周辺確認用の鏡体(4)との境界部を保持枠(5)で仕切つてあるため視界映像の誤認を防止している。

この発明の装置は以上に説明したような構成と

作用をもっているので、発明所期の目的を確実に達成出来る。

4. 図面の簡単な説明

第1図は本発明による装置の全体正面図。

第2図は本発明による装置の全体側面図。

- (1)..... 支持
- (2)..... 支承枠
- (3)..... 鏡体
- (4)..... 鏡体
- (5)..... 保持枠
- (a),(b)..... 接合端面

以上

特許出願代理人

弁理士 松 岡

宏

第1図

第2図

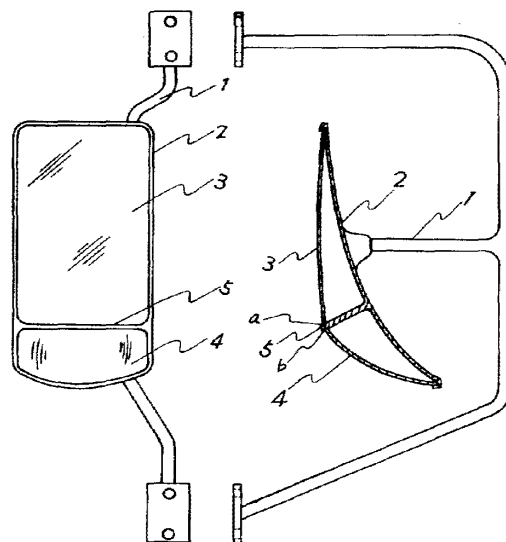

PATENT ABSTRACTS OF JAPAN

(11) Publication number: 55076721 A
(43) Date of publication of application: 10.06.1980

(51) Int. Cl. B60R 1/06

(21) Application number: 53148552
(22) Date of filing: 29.11.1978

(71) Applicant: NIKKEN KOGYO KK
(72) Inventor: YANAGIHARA TAKEO

(54) BACK MIRROR

(57) Abstract:

PURPOSE: To provide a back mirror having no blind area and rigidity with a ready fabrication by adhering a spherical inside transparent plate onto the limited area on the inside surface of a spherical outside transparent plate and then treating thin silver film adhered onto the inside surfaces of the respective transparent plates.

CONSTITUTION: The outside 5 of a spherical inside transparent plate 3 is adhered onto the lower portion of the inside recess surface 2 of a spherical outside transparent plate 1. This is adhered by a transparent adhesive so that the transparency between the outside transparent plate 1 and the inside transparent plate 3 may not be obstructed at the position of the adhered portion 6. Silver thin film is formed by vacuum evaporation process or the like on the inside surfaces of

the transparent plates 1 and 3 in thus adhered state to thereby form mirror treatment on the plates 1 and 3. The peripheral edges of the back palte 8 laminated with the back of the transparent plate 1 are fixed via edgewise member 9 to the transparent plate 1.

COPYRIGHT: (C)1980,JPO&Japic

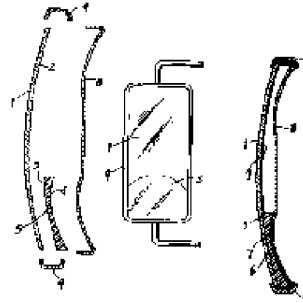

⑩ 日本国特許庁 (JP)

⑪ 特許出願公開

⑫ 公開特許公報 (A)

昭55—76721

⑬ Int. Cl.³
B 60 R 1/06

識別記号 庁内整理番号
7191—3D

⑭ 公開 昭和55年(1980)6月10日

発明の数 1
審査請求 未請求

(全 3 頁)

⑮ バックミラー

号

⑯ 特 願 昭53—148552
⑰ 出 願 昭53(1978)11月29日
⑱ 発 明 者 柳原健男
大阪市生野区巽西2丁目4番5

⑲ 出 願 人 日建工業株式会社
大阪市生野区巽西2丁目4番5
号
⑳ 代 理 人 弁理士 中島正次

明 細 書

1. 発明の名称

バックミラー

2. 特許請求の範囲

(1) 大なる曲率半径をその内側凹面に有する外側球面状透明板の内側面の限定領域に、上記外側球面状透明板の内側曲率半径より小なる曲率半径を内側凹面に有する内側球面状透明板を貼着した後、外側球面状透明板および内側球面状透明板の内面に銀面薄膜付着処理したことを特徴とするバックミラー。

(2) 内側球面状透明板は外側球面状透明板の内側面の下部領域に貼着されることを特徴とする上記実用新案登録請求の範囲第1項記載のバックミラー。

(3) 外側球面状透明板はガラス材料とすると共に、内側球面状透明板は硬質アクリル樹脂材料で形成したことを特徴とする上記実用新案登録請求の範囲第1項又は第2項記載のバックミラー。

(1)

3. 発明の詳細を説明

この発明は、自動車のバックミラーに映る可視領域を広範囲に拡げて、バックミラーに映らぬ死角領域をなくすようにした自動車用バックミラーに関する。

従来、自動車用バックミラー、特に大型自動車の走行の際、バックミラーに映る領域に死角領域があるため、該死角領域内にある人又は物を後車輪にて巻き込む事故が発生する。このような事故を予防するために、近時バックミラーに種々の改良が加えられているが、製造価格が高価にいたり、振動によりミラーがひび破れたりする等の欠点があつた。

この発明は、上記の欠点を解決するもので、その目的とするところは、大なる曲率半径をその内側凹面に有する外側球面状透明板の内側面の限定領域に、上記外側球面状透明板の内側曲率半径より小なる曲率半径を内側凹面に有する内側球面状透明板を貼着した後、外側球面状透明板および内側球面状透明板の内面に銀面薄膜処理することに

(2)

より、バックミラーの可視領域を拡げて死角をなくすと共に、製作が容易なため廉価であり、しかも頑強性を備えたバックミラーを提供することである。

以下、この発明を添付図面に示す実施例に従つて説明する。

(1)はガラス又は硬質合成樹脂等の適当な材料で形成される外側球面状透明板で、その内側凹面(2)は曲率半径500ミリメートルの球面を形成している。(3)は硬質アクリル樹脂成型された内側球面状透明板で、この内側凹面(4)は、上記外側球面状透明板の内側凹面(2)の曲率半径より小さくしてあり、曲率半径は200ミリメートル程度が望ましい。この内側球面状透明板(3)の外側(5)を上記外側球面状透明板(1)の内側凹面(2)の下部に貼着してある。この貼着は、透明性接着剤により行われ、該接着(6)位置にて、外側の透明板(1)と内側の透明板(3)の透明性が損われないようにされている。

外側球面状透明板(1)の内側凹面(2)に内側球面状透明板(3)を上記の如く接着該部にてその透過性を

(3)

この発明は、上述のように、曲率半径の大なる外側球面状透明板の内側凹面に内側球面状透明板が全面接着されるので、接着操作も簡単であり、且つその接着は非常に強固に行われ、長期の使用に耐えるバックミラーとなし得る。更に、外面透明板に内側透明板を接着した後、それらの内面に同時に銀面薄膜付着処理して均一なミラー効果を達成できる。又、内側球面状透明板は外側球面状透明板により外部から有効に保護されるため、内側球面状透明板は量産に適する比較的廉価な透明硬質アクリル樹脂材料による場合でもその表面は完全に保護される。更に、内側球面状鏡体はその外面の外側球面状鏡体よりその映像領域が広いために従来のバックミラーでは死角となる領域も他の可視領域と共にドライバーの視野に入るため、従来のバックミラーの死角によつて発生したような事故を未然に防止できる。

4. 図面の簡単な説明

図面はこの発明の実施例を示すもので、第1図は取付状態を示す正面図、第2図は縦断面図、第

(6)

3図は各構成部品を分離して示した断面図、第4図は従来のバックミラーとの比較において本発明の使用状態を示す説明図である。

この発明のバックミラーによると、曲率半径の小さな内側球面状透明板(3)による鏡体はその外面の鏡体(1)よりもその映像領域が広いために、従来のバックミラーにおいては死角であつた領域も広範囲に映像せしめるので、自動車の発進又は折曲走行、特に左折走行時において、対物又は対人事故となる対象物を予めドライバーの視野に入るためこれらの事故を未然に予防出来る。内側鏡体(3)を外側鏡体(1)の $\frac{1}{8}$ の面積を占めるようその下部に配置した場合、第3図点線で示す矢印Bの領域は既存のバックミラーで映るが、本発明のバックミラーでは鎖線で示す矢印Bの領域が可視でき大幅に可視領域が拡大する。

(4)

3図は各構成部品を分離して示した断面図、第4図は従来のバックミラーとの比較において本発明の使用状態を示す説明図である。

- (1)…外側球面状透明板
- (2)…外側透明板の凹面
- (3)…内側球面状透明板
- (4)…内側透明板の凹面
- (6)…接着部
- (7)…銀面薄膜

以上

特許出願人 日建工業株式会社
代理人 弁理士 中島正次

(6)

第 2 図

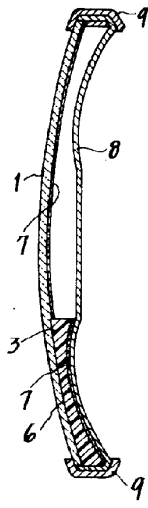

第 1 図

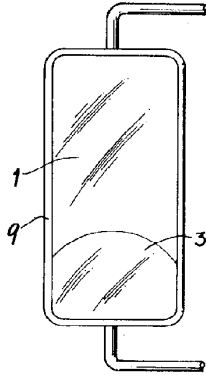

第 3 図

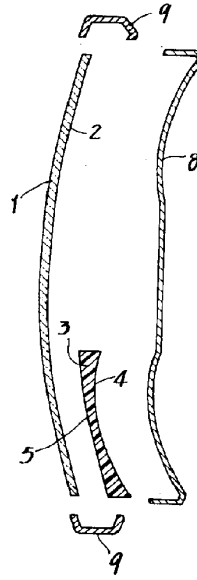

第 4 図

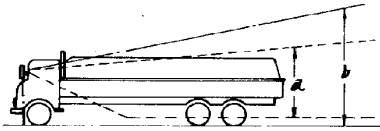

1. Name of Invention

Back Mirror

2. Scope of Patent Claim

- ① This is a back mirror characterized as after a smaller spherical inside plate is adhered to a specific area inside of the larger spherical outside transparent plate, the inner surfaces of both plates are treated with silver thin film.
- ② This back mirror is a proposal application as indicated above in scope of patent claim ①; characterized as a spherical inside transparent plate that is adhered onto the lower inner area of spherical outside transparent plate.
- ③ This back mirror is a proposal application as indicated above in scope of patent claim ① and ②; characterized by spherical outside transparent plate made of glass material and a spherical inside transparent plate made of molded rigid acrylic material.

3. Detailed explanation of Invention

This invention is an automobile back mirror which expands the visible area reflected in the mirror and minimizes blind areas that do not appear in the back mirror.

In past automobile back mirrors, especially for large vehicles, there were blind areas that did not appear in the back mirror, causing accidents where a person or object standing in this blind area gets run over. In order to prevent such accidents, various improvements have been made on recent back mirrors, but there were drawbacks such as production costs being too expensive, mirrors cracking, etc.

This invention is to solve the above issues, and the intent is to attach a smaller spherical inside plate onto a specific area inside of the larger spherical outside transparent plate. Both inner surfaces of the plate are treated with silver thin film. This expands the visible area in the back mirror while simultaneously removing blind areas. Also, this back mirror is low in cost, is simple to manufacture and is also a robust structure.

Below is the explanation of the invention along with its pictures.

- ① is a spherical outside transparent plate made of glass or synthetic resin etc. or equivalent material. Its inner recess surface ② has a curvature radius of 500mm.
- ③ is a spherical inside transparent plate molded from rigid acrylic material. The inner recess surface ④ has a smaller curvature radius than the spherical outside transparent plate ②, where the ideal curvature radius is about 200mm. The outer surface ⑤ of spherical inside transparent plate ③ is adhered to the lower inside

surface ② of spherical inside transparent plate ①. This is adhered by a transparent adhesive so that the transparency between the outside transparent plate ① and the inside transparent plate ③ may not be obstructed at the position of the adhered portion ⑥.

With the spherical inside transparent plate ③ adhered to the inner surface ② of spherical outside transparent plate ① as mentioned above so that the transparency is not obstructed, a silver thin film is formed by vacuum evaporation process or the like on the inner surfaces of spherical outside transparent surface ① and spherical inside transparent surface ③ and both transparent plates ① and ③ are mirror treated. ⑧ is a back plate layered behind the spherical inside transparent surface, and the peripheral edges of the back plate ⑧ and spherical outer transparent plate ① are fixed via edgewise member ⑨.

According to the invention of this back mirror, the mirror of the spherical inside transparent plate ③ with a smaller curvature radius has a greater imaging area than that of the outside mirror ①. Therefore, areas that would be blind areas in previous back mirrors are now reflected on this new mirror. Thus, when the vehicle is in motion or turning, especially when turning left, those objects or persons in this blind area that would cause accidents in the past will already be in the field of vision of the driver, preventing accidents from occurring. When the inside mirror ③ is located on the lower portion of outside mirror ① so that it takes up 1/3 of its area, previous back mirrors would only reflect within span of dotted area (arrow A) but this invention of the back mirror would greatly expand this visible area to (arrow B) (See picture 4).

This invention adheres the entire surface on the spherical inside transparent plate to the inside surface of the spherical outer transparent plate, so adhesion process is simple and extremely robust, making it a back mirror with long term durability. Furthermore, after adhesion of the inside transparent plate to the outside transparent plate, both inside surfaces are simultaneously treated with silver thin film, resulting in an even-surface mirror effect. Also, since the spherical inside transparent plate is effectively protected by the spherical outside transparent plate, its surface is completely protected even if the spherical inside transparent plate is made of transparent rigid acrylic material which is a relatively low cost material fit for mass production. Furthermore, since the spherical inside mirror has a greater image field than that of the spherical outside mirror, areas which would have remained blind areas in previous back mirrors will now be visible to the driver, thus, allowing prevention of accidents that in the past would occur due to these

blind areas in the back mirror.

4. Simple Explanation of Pictures

The pictures show examples of this invention. Picture 1 shows the front view as it is installed, picture 2 shows the vertical section, Picture 3 shows the section of component parts, and picture 4 shows comparison of the field of vision to current back mirrors.

- Spherical outside transparent plate
- Inside recess surface of outside transparent plate
- Spherical inside transparent plate
- Inside recess surface of inside transparent plate
-
- Adhesion area
- Silver thin film

DOUBLE SIDE MIRROR FOR AUTOMOBILE

Publication number: JP1186443
 Publication date: 1989-07-25
 Inventor: KITSUMOTO NORIHIKO
 Applicant: KITSUMOTO NORIHIKO
 Classification:
 - International: **B60R1/06; B60R1/08; B60R1/06; B60R1/08; (IPC1-7): B60R1/06**
 - European: B60R1/08D
 Application number: JP19880012348 19880121
 Priority number(s): JP19880012348 19880121

Report a data error here

Abstract of JP1186443

PURPOSE:To contribute to traffic safety by constituting side mirrors to be arranged at the opposite sides of an automobile with master and slave mirrors thereby limiting dead angle of driver. **CONSTITUTION:**The side mirror comprises a master mirror 2 and a slave mirror 3, suitable for confirmation of rear and side views of an automobile, fixed to a side mirror frame 1 which is fixed to the body at a base fixing section 4. Since conditions at immediately rear section or side section, which conventionally come within dead angle, can be confirmed reliably, the side mirror contributes to safe driving.

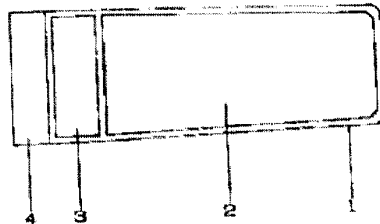
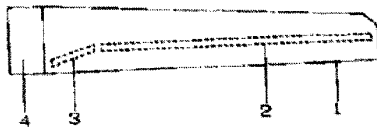

Data supplied from the esp@cenet database - Worldwide

⑩ 日本国特許庁(JP)

⑪ 特許出願公開

⑫ 公開特許公報(A)

平1-186443

⑬ Int.Cl.⁴

識別記号

庁内整理番号

⑭ 公開 平成1年(1989)7月25日

B 60 R 1/06

G-7812-3D

審査請求 未請求 請求項の数 1 (全2頁)

⑮ 発明の名称 自動車用二面式サイドミラー

⑯ 特 願 昭63-12348

⑰ 出 願 昭63(1988)1月21日

⑱ 発 明 者 橋 本 紀 彦 山口県吉敷郡小郡町大字下郷2410番地

⑲ 出 願 人 橋 本 紀 彦 山口県吉敷郡小郡町大字下郷2410番地

明 細 書

1. 発明の名称 自動車用二面式サイドミラー
2. 特許請求の範囲
自動車の両側に取付けるサイドミラーを親子二面の鏡で構成した装置。
3. 発明の詳細な説明
(A) 産業上の利用分野
この発明は、自動車に取付けるサイドミラーを、親子二面にする事により、運転者の死角を少なくする装置に関するものです。
(B) 従来技術
これまでのサイドミラーは、一面であるため、運転者の後方視野が狭い。
(C) 発明が解決しようとする問題点
道路の形状によっては、支線から本線へ合流する時や、高速道路及び複線を併走する場合に、現在のサイドミラーでは、後方の確認は出来るが、自車の最近かな後方や、側方が確認できず死角となって居り非常に危険である。

(D) 問題点を解決するための手段
サイドミラーの形状を親子二面の鏡にする事により後方のみならず側方の確認が容易に出来る事になる。

(E) 発明の効果
本発明の効果は、運転者が走行中に道路の合流点や高速道路、及び複線での車線変更をする場合、最近かな後方や側方の確認が出来るため、安全運転の確保になります。

4. 図面の簡単な説明
第一図は本発明の平面図
1. サイドミラーフレーム 3. 子ミラー
2. 親ミラー 4. 取付部
第二図は本発明の正面図

特許出願人 橋本紀彦

第一図

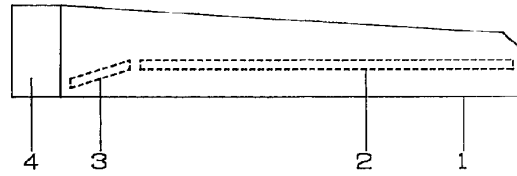

第二図

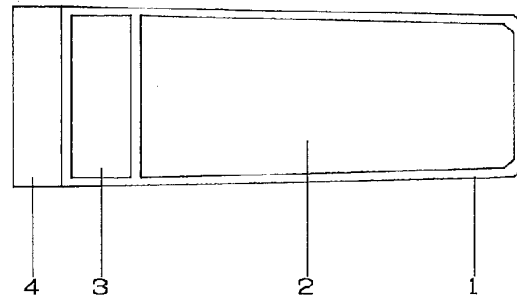

VISION MIRROR OF VEHICLE

Publication number: JP1208245 (A)

Publication date: 1989-08-22

Inventor(s): MORIWAKE TAKUMI +

Applicant(s): MORIWAKE TAKUMI +

Classification:

- **international:** B60R1/06; B60R1/08; B60R1/06; B60R1/08; (IPC1-7): B60R1/06

- **European:** B60R1/08D2

Application number: JP19880034760 19880217

Priority number(s): JP19880034760 19880217

Abstract of JP 1208245 (A)

PURPOSE:To allow safe checking of a wide field of sight covering side fields by equipping a back vision mirror at its side edges with a side vision mirror.

CONSTITUTION:A mirror 1 is equipped with a side vision mirror, which is bent in the direction of widening the mirror surface to the right edge of a smaller back vision mirror 2 in a plane or with a radius of curvature near plane. The mirror surface of this side vision mirror 3 may be flat, curved, or hyperbolic. This widens the field of sight greatly to the side view ranges 6, compared with the conventional arrangement which permits checking merely the back view range 5 from the point of sight 7 of the maneuverer, that accomplishes safe maneuvering of a vehicle.

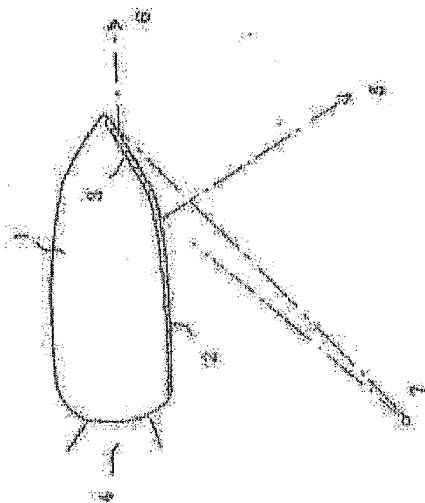

Data supplied from the *espacenet* database — Worldwide

⑯ 日本国特許庁(JP)

⑰ 特許出願公開

⑫ 公開特許公報(A) 平1-208245

⑤ Int. Cl.⁴
B 60 R 1/06

識別記号 庁内整理番号
G-7812-3D

⑬ 公開 平成1年(1989)8月22日

審査請求 未請求 請求項の数 1 (全3頁)

⑭ 発明の名称 乗り物用後写鏡

⑱ 特 願 昭63-34760

⑲ 出 願 昭63(1988)2月17日

⑳ 発 明 者 守 分 巧 岡山県岡山市津高1444-24

㉑ 出 願 人 守 分 巧 岡山県岡山市津高1444-24

明 細 書

1、発明の名称

乗り物用後写鏡

2、特許請求の範囲

乗り物用後写鏡において後写鏡の側縁部に側写鏡を設けたことを特徴とする後写鏡。

3、発明の詳細な説明

(産業上の利用分野)

本発明は、乗り物用後写鏡に関するものである。

(従来技術)

従来の後写鏡は、後方視野は確認出来ても側方視野は確認出来なく視野範囲が狭いと言う問題があった。また平面鏡もしくはそれに近い曲面率の小さい曲面鏡では視野が狭く、曲面率の大きい広視野の曲面鏡では距離感がつかみにくいと言う問題があった。

(発明の目的)

本発明は、これら従来方法の欠点を除去することを目的とするものであって、乗り物における後方視野の距離感をつかむと共に、運転者の視点を

大きく動かすことなく側写鏡により側方視野までの広範囲な視野を安全に確認できるようにした。

(実施例)

以下図面に示した実施例に基づいて本発明を説明する。

第1図の実施例では右側の自動車用後写鏡について示している。第2図は第1図のX-Y方向の断面図で鏡体1に平面もしくはそれに近い曲面率の小さい後写鏡2の右側縁部を鏡面を広げる方向に彎曲させ側写鏡3としたものである。側写鏡3の鏡面は平面、曲面または双曲線でも良い。第3図は第1図と同じ形状の他の実施例のX-Y方向の断面図で後写鏡2、側写鏡3を分割して作成した後、合わせて一鏡体に取り付けたものである。また側写鏡3は後写鏡2との合わせ部を可動支点として矢符に示す様に任意の角度に動かす事も出来、また側写鏡の背面に可動支点を設ければあらゆる角度に動かすことも出来る。また後写鏡に現在広く使われているような遠隔操作により運転席よりこれを動かすことも可能である。

第4図は他の実施例を示すものである。説明を簡単にするために以下第1図と同じ記号で説明する。本実施例は自動車用の室内後写鏡についての実施例で平面もしくはそれに近い曲面率の小さい後写鏡2の両側の側縁部を鏡面を広げる方向に彎曲させ側写鏡3とした実施例である。

第5図は本発明の更にその他の実施例を示すものである。本実施例は大型自動車用の右側の後写鏡についての実施例で後写鏡2の右側縁部と下方の側縁部を彎曲させそれぞれを側写鏡3、下方鏡10として取り付けた実施例である。

第6図は自動車の後写鏡のフェンダー取り付け部8とドア取り付け部9に本発明を取り付けた取り付け状態の実施例である。なを実施例ではすべて右側の後写鏡について述べたが左側の後写鏡については左側縁部を鏡面を広げる方向に彎曲させ側写鏡としたり、第3図のように別の鏡を合わせて側写鏡とすれば良いことは言うまでもない。

(発明の効果)

本発明は、実施例に示すように乗り物用後写鏡

の側縁部に側写鏡を設けたもので、その効果を第2図について説明すると運転者の視点7に対して現在広く使用されているものでは後方視野範囲5までしか確認出来なかったものが側方視野範囲6まで視野の大幅な拡大が出来る。この効果を第6図によって詳しく説明すると後写鏡のドア取り付け部9に取り付けた場合は運転者の視点7に対してその後方視野範囲は現在一般に使われているものでは5Aまでであるが本発明では側方視野範囲6Aまでの連続した広視野を持つことが出来る。さらにこのような広視野でありながら視野範囲については距離感をつかむことが出来、側写鏡により側方視野が確認出来ることにより車線変更時、道路の合流点等において運転者の視点を大きく動かすことなく安全に運転出来る。同じく第6図のフェンダー取り付け部8に取り付けた場合は未通視の悪い交差点、車庫の出し入れ時等においての側方道路の状況を運転者が直接確認出来るまで自動車を前進させなくても側写鏡により側方視野範囲6Bまでの視野を確認することが出来、なをか

つ後方視野範囲5についても同じく距離感をつかむことが出来る。以上のとおり本発明を使用することにより従来の技術で述べた問題点を解決することが出来、乗り物をより安全に運転することが出来る。

4、図面の簡単な説明

図は本発明の実施例を示すもので、第1図は右側後写鏡の斜視図。第2図は第1図のX-Y方向の断面図。第3図は同じく第1図の他の実施例のX-Y方向の断面図。第4図は室内後写鏡の平面図。第5図はその他の実施例の平面図。第6図は自動車に本発明を取り付けた取り付け状態の平面図である。

図中の符号を説明すれば次のとおりである。

- (1) は鏡体
- (2) は後写鏡
- (3) は側写鏡
- (4) は鏡体取り付け部
- (5) は後方視野範囲
- (6) は側方視野範囲

- (7) は運転者の視点
- (8) はフェンダー取り付け部
- (9) はドア取り付け部
- (10) は下方鏡

特許出願人

守 分 巧



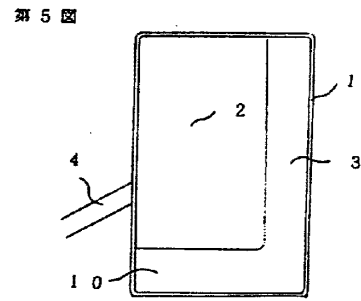
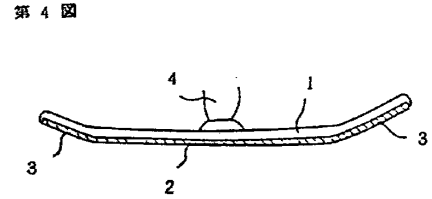
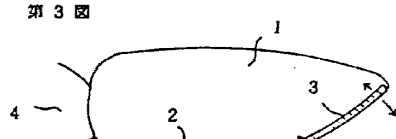
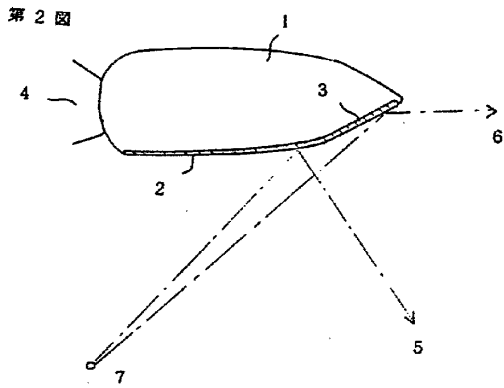
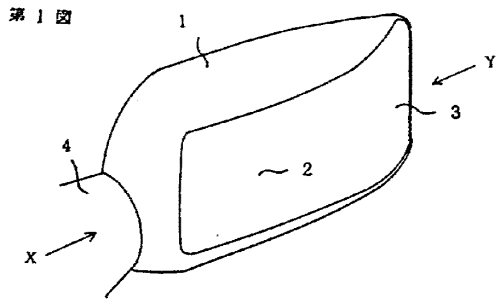

第6圖

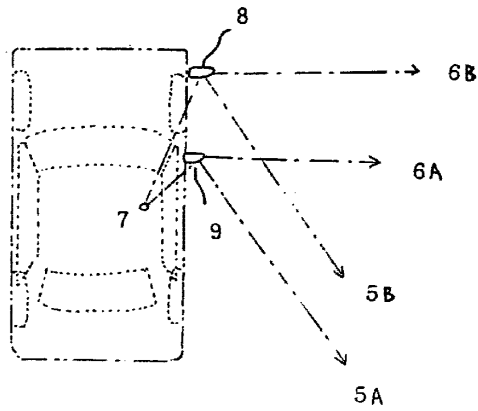

DONOI FP-1116 (PCT)

PAT-NO: JP362075619A
DOCUMENT-IDENTIFIER: JP 62075619 A
TITLE: GLARE-PROOF MIRROR
PUBN-DATE: April 7, 1987

INVENTOR-INFORMATION:
NAME
TOMITA, MASA AKI

ASSIGNEE-INFORMATION:
NAME COUNTRY
NIFCO INC N/A

APPL-NO: JP60217718

APPL-DATE: September 30, 1985

INT-CL (IPC): G02F001/133, B60R001/04, G02B005/08, G02F001/133

US-CL-CURRENT: 359/603

ABSTRACT:

PURPOSE: To improve the uniformity of thickness of a liquid crystal of a curved dazzleproof mirror by forming one electrode substrate with a curved hard material and using a flexible plate-shaped body to curve the other electrode substrate along the curved hard material.

CONSTITUTION: Since an electrode substrate 11 consisting of a flexible plate material is curved along a curved hard electrode substrate 10 and has both ends held, the gap between two electrode substrates 10 and 11 is kept approximately uniform, and as the result, the thickness of a liquid crystal layer 14 is approximately uniform throughout. Plural ball-shaped spacers 15 which consist of a glass material and have the same particle size are scattered in the liquid crystal to form the liquid crystal 14 with a uniform thickness throughout more surely.

COPYRIGHT: (C)1987,JPO&Japi

⑨ 日本国特許庁 (JP)

⑩ 特許出願公開

⑫ 公開特許公報 (A)

昭62-75619

⑮ Int. Cl. 4	識別記号	庁内整理番号	⑬ 公開	昭和62年(1987)4月7日
G 02 F 1/133	3 0 1	8205-2H		
B 60 R 1/04		A-7443-3D		
G 02 B 5/08		P-7036-2H		
G 02 F 1/133	3 0 9	8205-2H	審査請求	未請求
			発明の数	1 (全4頁)

⑭ 発明の名称 防眩ミラー

⑰ 特 願 昭60-217718

⑱ 出 願 昭60(1985)9月30日

⑲ 発 明 者 富 田 正 明 横浜市戸塚区舞岡町184番地1 株式会社ニフコ内
 ⑳ 出 願 人 株式会社 ニフコ 横浜市戸塚区舞岡町184番地1
 ㉑ 代 理 人 弁理士 早川 誠志

明 細 書

1. 発明の名称

防眩ミラー

2. 特許請求の範囲

光を反射するための反射層を有する第1の電極基板と第2の電極基板との間に液晶が保持され、前記第1の電極基板と前記第2の電極基板との間に電界を与えることによって前記液晶の光透過率を可変するようにした防眩ミラーにおいて;

前記第1の電極基板と前記第2の電極基板のいずれか一方の電極基板を硬質材で湾曲状に形成し、他方の電極基板を可撓性材で形成して、前記一方の電極基板に沿って湾曲状に配置して、前記湾曲状に形成された電極基板と前記可撓性材で形成された他方の電極基板との間に湾曲形状に前記液晶を保持したことを特徴とする防眩ミラー。

3. 発明の詳細な説明

<本発明の産業上の利用分野>

本発明は、液晶を用いて反射率を可変する防眩

ミラーに関する。

<従来の技術> (第3図)

例えば自動車のバックミラーなどは、表面に、防眩膜として、金属酸化物等の着色被膜を施したり、偏光膜を重ねたりして反射鏡への光の透過率を低下させて、眩しさを防いでいる。しかし、このような防眩ミラーを自動車のバックミラーなどに用いる場合は、視界を広くするために凸面に湾曲させている。

ところで、近年、光透過率可変という液晶の性質を利用して、外光の強度に応じて反射率を調整して眩しさを防ぐように、上記の防眩膜の代わりに液晶を利用した防眩ミラーが開発されている。

第3図は、このように液晶を防眩膜の代りとして用いた従来の防眩ミラーを示している。

第3図において、1は平板状の透明なガラス材よりなり、上方側からの光を反射するために、その下面側に、金属膜などから成る反射層1aが形成され、また上面側に透明電極層1bが形成された透明な第1の電極基板である。

2は、シール材3、3を介して第1の電極基板1と平行に対向して配置された透明な第2の電極基板である。第2の電極基板2は、第1の電極基板1と同様に、平板上のガラス材よりなり、その下面側には透明電極層2aがまた、シール材3を挟んで透明電極層2bが形成されている。

4は、第1の電極基板1と第2の電極基板2および、シール材3、3とによって形成された空間に封入された液晶である。

液晶4としては、二色性染料を含む液晶組成物を使用し、透明電極1b、2a間に電界が印加されると、光透過率が変化する。5は導電材である。

6は、液晶駆動回路であり、第1の電極基板1の透明電極層1bと第2の電極基板2の透明電極層2aとの間との間に所定の電位差を与え、これによって液晶層4の液晶を駆動して光透過率を変化させるものである。

この防眩ミラーでは、入射光は、矢印Aで示すように、透明な電極基板2、透明電極層2a、液晶4、透明電極層1b、透明な電極基板1を透過

して反射層1aで反射されるが、液晶駆動回路6によって液晶4の光透過率を変えることによって、防眩ミラーの反射率を変えることができる。

<本発明が解決しようとする問題点>

しかしながら、このような従来の液晶を用いた防眩ミラーは、平板状であって湾曲されていないため、自動車のバックミラーなどに用いる場合、視界が狭く、運転の安全上、極めて不都合であった。

このため、第3図に示した液晶による防眩ミラーにおいて、電極基板1及び2として所定曲率に湾曲した硬質の透明板を作成し、この2枚の湾曲透明板間に液晶を保持させることが試みられている。

しかし、2枚の湾曲板間に保持される液晶層の厚みを全面にわたり均一にするには、両湾曲板の曲面精度を高くすることが必要となる。しかし、現実には、液晶層の厚みは極めて薄い(10μ程度)ので、いかに湾曲板の曲面精度を高くしても、液晶層の厚さを全面にわたっての10μ±1μ程

度の均一さに達成することは全く困難であった。

このため、液晶を用いた防眩ミラーを凸面にしようとしても、液晶層の厚さの不均一が避けられず、反射像のゆがみ、明るさの不均一が生じていた。

<本発明の目的>

本発明は、上記の欠点を改め、極めて容易に液晶層の厚さを均一にした湾曲形状の、液晶を用いた防眩ミラーを提供することを目的としている。

<本発明の一実施例>(第1図)

以下、図面に基づいて本発明の一実施例を説明する。

第1図は、本発明の一実施例の防眩ミラーを示す断面図である。

図において、10は所望の視界をもつために、所定の曲率で長さ方向に湾曲された板状の透明な硬材質(例えばガラス材)よりなる第1の電極基板であり、その下面側には、上方側からの光を反射するために、アルミニウム等の金属が蒸着されて、鏡面状に処理された反射層10aが下面側全

面に形成されている。

また、第1の電極基板10の上面側には、金属酸化物(例えば酸化インジウム)などの透明で電気伝導度の高い透明電極層10bが、また、シール材12aを挟んで透明電極層10cが、絶縁された状態でほぼ全面にわたって形成されている。

11は、可撓性をもつ透明材(例えばプラスチックフィルムなど)によって板状に形成された第2の電極基板であり、第2の電極基板11の下面側には、第1の電極基板10と同様に全面にわたって透明電極層11aが形成されていて、シール材12a、12bを介して第1の電極基板10に拾って湾曲させて取付けられている。

13は第1の電極基板10の透明電極層10cと第2の電極基板11の透明電極層11aとを電気的に接続するための導電材(例えば導電性ゴム)である。

14は、第1の電極基板10の透明電極層10b、第2の電極基板11の透明電極層11aおよび、シール材12a、12bによって形成された

湾曲した空間に保持された液晶層である。

16は液晶14を駆動して光透過率を変化させる液晶駆動回路である。

このように、可撓性板材から成る電極基板11を硬質の湾曲した電極基板10に沿って湾曲させて両端を保持するため、2つの電極基板10、11間の間隔はほぼ均一に保たれ、この結果、液晶層14の厚さが全面にわたって、ほぼ均一となる。

<本発明の他の実施例> (第2図)

第2図は本発明の他の実施例による防眩ミラーの要部を拡大して示している。

即ち、この実施例では、第1図の実施例における液晶14内に例えばガラス材などからなる複数の球状の同一粒径のスペーサ15が散布されている。

このスペーサ15は、目標とする液晶層の厚みと同一寸法の粒径をもち、液晶層14の全面にほぼ均一に配置されている。このため、可撓性をもち第2の電極基板11を第1の電極基板10に沿ってシール材12a、12bを介して取付けると、

液晶14a内に散布された同一径のスペーサ15、15、…に第2の電極基板11下面の透明電極11aが当接するため、液晶層14の厚さは、一層確実に全面にわたって均一に形成される。

<本発明の効果>

以上の説明のように本発明の防眩ミラーでは、一方の電極基板を湾曲した硬質材で形成し、他方の電極基板を可撓性のある板状体を用いて、湾曲した硬質材に沿って湾曲させているので、2つの電極基板は全面にわたって同一間隔で対向する。このため、2つの電極基板間の液晶層は全面にわたって均一な厚さとなる。

従って、極めて薄い液晶層が全面にわたって均一な厚さとなった湾曲した防眩ミラーを、簡単な構造でありながら精度良く容易に実現できる。このため、バックミラーなどとして用いると視界が広くなり安全となり、また反射像のゆがみ、明るさの不均一もなくなる。

4. 図面の簡単な説明

第1図は本発明の一実施例を示す断面図、第2

図は本発明の他の実施例の要部を示す拡大断面図、第3図は従来の液晶を用いた防眩ミラーを示す断面図である。

- 10 …… 第1の電極基板、10a …… 反射層、
- 10b …… 透明電極層、10c …… 透明電極層、
- 11 …… 第2の電極基板、11a …… 透明電極層、
- 12a …… シール材、12b …… シール材、13
- …… 導電材、14 …… 液晶層、14a …… 液晶、
- 15 …… スペーサ、16 …… 液晶駆動回路。

第 1 図

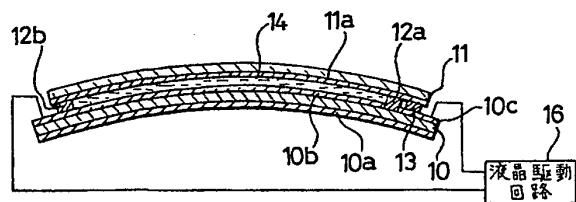

第 2 図

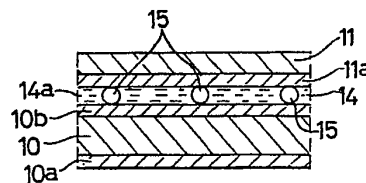

特許出願人 株式会社ニフコ

代理人 弁理士 早川 誠 志

第 3 圖

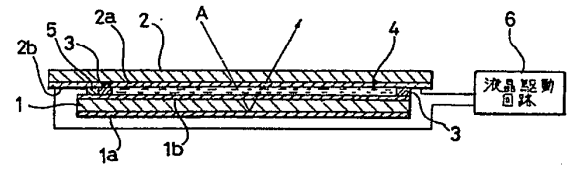

CONVEX REFLECTION MIRROR

Publication number: JP62105103 (A)

Publication date: 1987-05-15

Inventor(s): MIYAKE SHINYA +

Applicant(s): MIYAKE SHINYA; YAMADA MASAHIRO; KUNO KOICHI +

Classification:

- international: **B60R1/06; G02B5/10; B60R1/06; G02B5/10;** (IPC1-7): B60R1/06; G02B5/10

- European:

Application number: JP19850246703 19851031

Priority number(s): JP19850246703 19851031

Abstract of JP 62105103 (A)

PURPOSE:To obtain a natural reflected image without generating a distortion by constituting a surface area of a mirror body by dividing it into plural spherical areas consisting of a radius of curvature which has been set optionally in accordance with a use purpose, and forming a discontinuous area as a graded area for continuing smoothly mutual spherical areas.

CONSTITUTION:Radiuses of curvature Ra, Rb... of spherical areas 3, 3a... of a surface area 2 of a mirror body 1 are set optionally in accordance with a use purpose. For instance, when it is desired to catch as a larger image than an expanse of a visible area in the center part, and to secure a visible area of a wide range in the end part, the radius of curvature Rb of the center part, and the radiuses of curvature Ra, Rb of the end are set to as to become large and small, respectively. Also, the spherical area 3 of the radius of curvature Ra is set extending over a wide range, and in an optional interval position in the remaining area, the spherical areas 3a, 3b... of the radiuses of curvature Rb, Rc... are set as points, and between the points of each spherical area 3a, 3b..., it is migrated by graded areas 5, 5a... whose radius of curvature is varied continuously. In this way, an image is not distorted excessively and a natural reflected image can be obtained, and also a distance sense can easily be grasped.

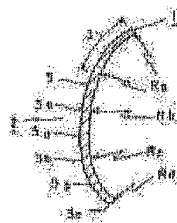
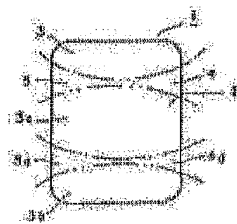

Data supplied from the *espacenet* database — Worldwide

⑨ 日本国特許庁(JP)

⑩ 特許出願公開

⑫ 公開特許公報(A)

昭62-105103

⑮ Int.Cl.⁴

識別記号

庁内整理番号

⑬ 公開 昭和62年(1987)5月15日

G 02 B 5/10

A-7036-2H

B 60 R 1/06

G-7443-3D

G 02 B 5/10

J-7036-2H

審査請求 未請求 発明の数 1 (全3頁)

⑭ 発明の名称 凸面反射鏡

⑯ 特 願 昭60-246703

⑰ 出 願 昭60(1985)10月31日

⑱ 発 明 者	三 宅	信 也	名古屋市千種区香流橋1-4-36
⑲ 出 願 人	三 宅	信 也	名古屋市千種区香流橋1-4-36
⑲ 出 願 人	山 田	正 弘	愛知県知多郡南知多町大字豊浜字会下坪26
⑲ 出 願 人	久 野	孝 一	名古屋市南区御替地町東2丁目31
⑳ 代 理 人	弁 理 士	西 山 聞 一	

明 細 書

1. 発明の名称

凸面反射鏡

2. 特許請求の範囲

- (1) 鏡本体の表面領域を、使用目的に応じて任意に設定された曲率半径より成る複数の球面領域にて区割構成し、隣接する球面領域間に生じる不連続領域を相互の球面領域間に涉り順次連続的に曲率半径が変化する曲面にて移行せしめ、かかる不連続領域を相互の球面領域を円滑に連続せしめる曇し領域と成したことを特徴とする凸面反射鏡。
 - (2) 球面領域は一端方から他端方へ向かうに従い順次曲率半径を小ならしめる様に配置したことを特徴とする特許請求の範囲第1項記載の凸面反射鏡。
 - (3) 任意の球面領域間には平面領域が介在されていることを特徴とする特許請求の範囲第1項記載の凸面反射鏡。
3. 発明の詳細な説明

(発明の目的)

産業上の利用分野

本発明は車輛用バックミラー、防犯ミラー、路上に設置されるカーブミラー等の広視界反射鏡として利用される凸面反射鏡に関するものである。

従来の技術

従来車輛用バックミラー、防犯ミラー、路上に設置されるカーブミラー等の各種用途に供されている凸面反射鏡は、全面に涉り同一の曲率半径にて成形されたものであるため、充分なる視認領域の確保を得る目的で曲率半径を小さく設定した場合は、全体に像の歪が大きく距離感の把握が困難となり、又凸面反射鏡の用途によっては特定の方向は視認範囲の拡がりが必要されるも、他の方向は歪の少ない像の視認が要求される場合があり、かかる要求に対しては全面に涉り同一の曲率半径にて成形された従来の凸面反射鏡では、視認領域の拡張化に伴って不要範囲の像も必然的に視認されることとなるため

、用途によっては却って目的とする像の認識の妨げとなる等の不都合を生じていた。

発明が解決しようとする問題点

本発明は用途に応じて任意の方向に視認範囲の広がりを得られ、像の倍率も目的とする視認領域に応じて任意の倍率が得られ、且つ全面に渉り像の繋がり自然で歪の少ない凸面反射鏡を提供せんとするものである。

(発明の構成)

問題点を解決するための手段

本発明はかかる点に鑑み、鏡本体の表面領域を、使用目的に応じて任意に設定された曲率半径より成る複数の球面領域にて区割構成し、隣接する球面領域間に生じる不連続領域を相互の球面領域間に渉り順次連続的に曲率半径が変化する曲面にて移行せしめ、かかる不連続領域を相互の球面領域を円滑に連続せしめる量し領域と成した凸面反射鏡を提供して上記欠点を解消せんとしたものである。

作用

部分を相互の球面領域3、3a…間の移行部分としての量し領域5、5a…と成している。

上記球面領域3、3a…の曲率半径Ra、Rb、Rc…は、車輛用バックミラー、防犯ミラー、路上に設置されるカーブミラー等の使用用途に応じて任意に設定されるもので、如何なる組み合わせも可能であり、例えば中央部においては視認領域の広がりより大きな像として捉え、端方部分においては広範囲の視認領域の確保を希望する場合には、中央部の曲率半径Rbを大、端方の曲率半径Ra、Rcを小に設定せしめることにより、かかる要請に対応可能である。

又、各球面領域3、3a…の設定範囲は第3図に図示する様に、曲率半径Raの球面領域3を広い範囲に渉り設定し、残りの領域中の任意の間隔位置には曲率半径Rb、Rc…の球面領域3a、3b…をポイントとして設定せしめ、各球面領域3a、3b…のポイント間を曲率半径が連続的に変化する量し領域5、5a…にて移行せしめたもの等球面領域3、3a…の設定範囲の広狭は任意であ

本発明に係る凸面反射鏡は、複数の球面領域が配置されているため、鏡本体内の場所によりその視認範囲、倍率は設定された曲率半径に応じて変化する、又隣接する球面領域間の不連続領域は量し領域にて円滑に連続されているため、像に極端な歪を生じることなく自然な反射像が得られるのである。

実施例

以下本発明の一実施例を図面に基づいて説明すると、

1は無機ガラスにて型成形せしめた後、表面を鏡面蒸着処理せしめた凸面反射鏡の鏡本体であり、該鏡本体1の表面領域2を所定の曲率半径Ra、Rb、Rc…より成る複数の球面領域3、3a…にて区割せしめ、該球面領域3、3a…において隣接する相互の球面領域3、3a…間に生じる曲面の不連続領域4、4a…は、相互の球面領域3、3a…の接線間に渉り順次連続的に曲率半径が変化すると共に、相互間を段差を生じることなく円滑に連続せしめる曲面にて構成し、かかる

る。

又、第4図は第2の実施例を示し、球面領域3、3a…を一端方から他端方へ向かうに従い順次曲率半径を小ならしめる様に配置したもので、一側端の視認領域を充分に確保したい場合に適し、例えば大型車輛用のバックミラーとして下方へ至るに従い順次曲率半径を小ならしめる様に配置したもの(一例としてRa=600mm、Rb=500mm、Rc=400mm)を使用すれば、通常死角とされている前輪側方の視認が可能となり、前輪による巻き込み事故の防止に役立つものである。

又、第5図は第3の実施例を示し、任意の球面領域3、3a…間に平面領域6を介在せしめたものであり、これは特定の部分に写る像を等倍に近い状態で視認させることにより、特に距離感の正確な把握が要求される場合に適する。

尚、何れの実施例においても球面領域3、3a…の中心は、鏡本体1に対し中央軸上に整列配置されねばならないものではなく、例えば第6

図に図示する様に傾斜する軸上に配置することも可能であり、球面領域3、3a…の中心位置は何ら限定するものではない。

〔発明の効果〕

要するに本発明は、鏡本体1の表面領域2を、使用目的に応じて任意に設定された曲率半径より成る複数の球面領域3、3a…にて区割構成したので、距離感の正確なる把握を希望する領域、視認範囲の拡がりを希望する領域を、用途に応じて鏡本体1中の上下、左右任意の位置に自由に設定出来、又隣接する球面領域3、3a…間に生じる不連続領域4、4a…を相互の球面領域3、3a…間に涉り順次連続的に曲率半径が変化する曲面にて移行せしめ、かかる不連続領域4、4a…を相互の球面領域3、3a…を円滑に連続せしめる疊し領域5、5a…と成したので、鏡本体1に複数の曲率半径の異なる球面領域3、3a…が存在しているにも拘らず像が極端に歪むことなく自然な反射像を得ることが出来ると共に、距離感の把握も容易ならしめることが出来

、よって車輛用バックミラー、防犯ミラー、路上に設置されるカーブミラー等の広視界反射鏡として広範囲に活用することが出来る等その実用的効果甚だ大なるものである。

4. 図面の簡単な説明

図は本発明の一実施例を示すものにして、第1図は本発明に係る凸面反射鏡の正面図、第2図は同上断面図、第3図乃至第6図は他の実施例を示す図である。

- 1 鏡本体 2 表面領域 3、3a… 球面領域
- 4、4a… 不連続領域 5、5a… 疊し領域

以上

出願人 三宅信也
 “ 山田正弘
 “ 久野孝一
 代理人 弁理士 西山 啓

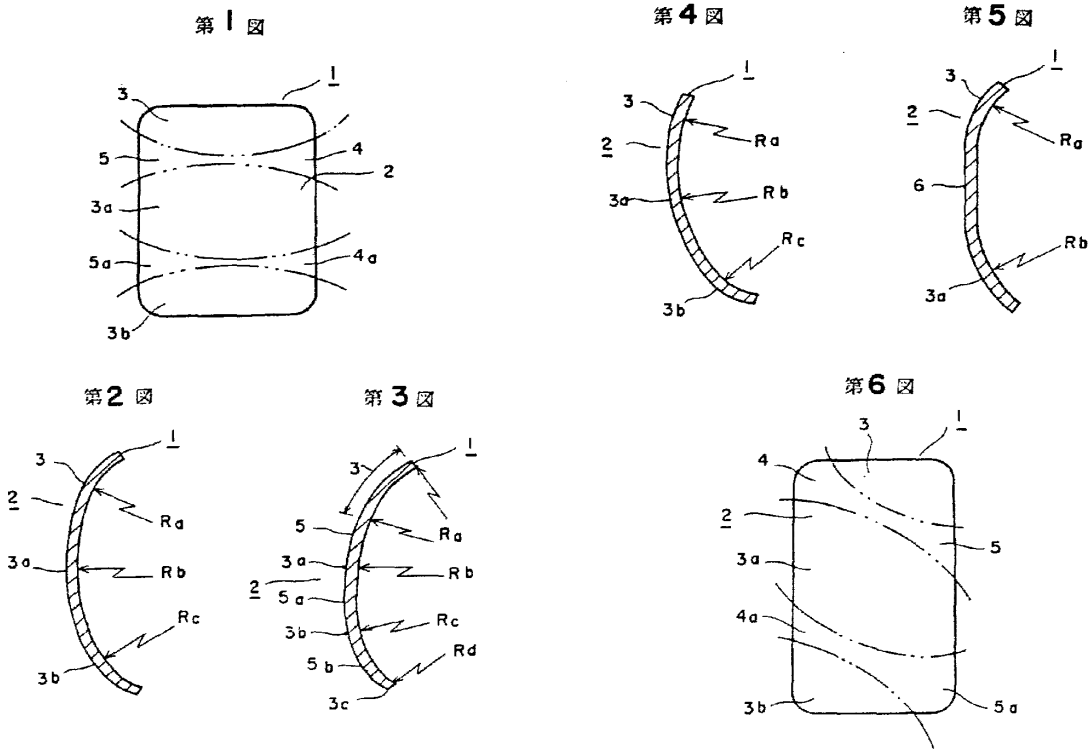

DERWENT-ACC-NO: 2003-296969

DERWENT-WEEK: 200329

COPYRIGHT 1999 DERWENT INFORMATION LTD

TITLE: Manufacture of vehicle mirror integrally
formed with
convex mirror

INVENTOR: JUNG, G Y

PATENT-ASSIGNEE: JUNG G Y[JUNGI]

PRIORITY-DATA: 2001KR-0030916 (June 1, 2001)

PATENT-FAMILY:

PUB-NO	PUB-DATE	LANGUAGE	PAGES
MAIN-IPC			
KR 2002092059 A	December 11, 2002	N/A	001
B60R 001/08			

APPLICATION-DATA:

PUB-NO	APPL-DESCRIPTOR	APPL-NO
APPL-DATE		
KR2002092059A	N/A	2001KR-0030916
June 1, 2001		

INT-CL (IPC): B60R001/08

ABSTRACTED-PUB-NO: KR2002092059A

BASIC-ABSTRACT:

NOVELTY - The production of a vehicle mirror allows a driver to view a hidden area without installing an auxiliary mirror and manufactures the vehicle mirror inexpensively.

DETAILED DESCRIPTION - A flat glass plate (2) is cut to a predetermined size. After processing the edges of the flat glass plate, mercury is applied to a rear surface of the flat glass plate. The flat glass plate is placed in a mold frame (3). The mold frame is formed with a molding slot (3b) having a diameter of 30-50 mm and a thickness of 3-4 mm. Heat is applied to the flat glass plate from an upper portion by a heating device (4). At this time, the flat glass plate is heated to 1200-1400 deg. C to form a convex part (5). The flat glass plate is rapidly cooled and mercury is applied to a rear side of the flat glass plate.

CHOSEN-DRAWING: Dwg.1/10

TITLE-TERMS: MANUFACTURE VEHICLE MIRROR INTEGRAL
FORMING CONVEX MIRROR

DERWENT-CLASS: L01 Q17

CPI-CODES: L01-E05; L01-G04C; L01-G07; L01-L02;

SECONDARY-ACC-NO:

CPI Secondary Accession Numbers: C2003-077129

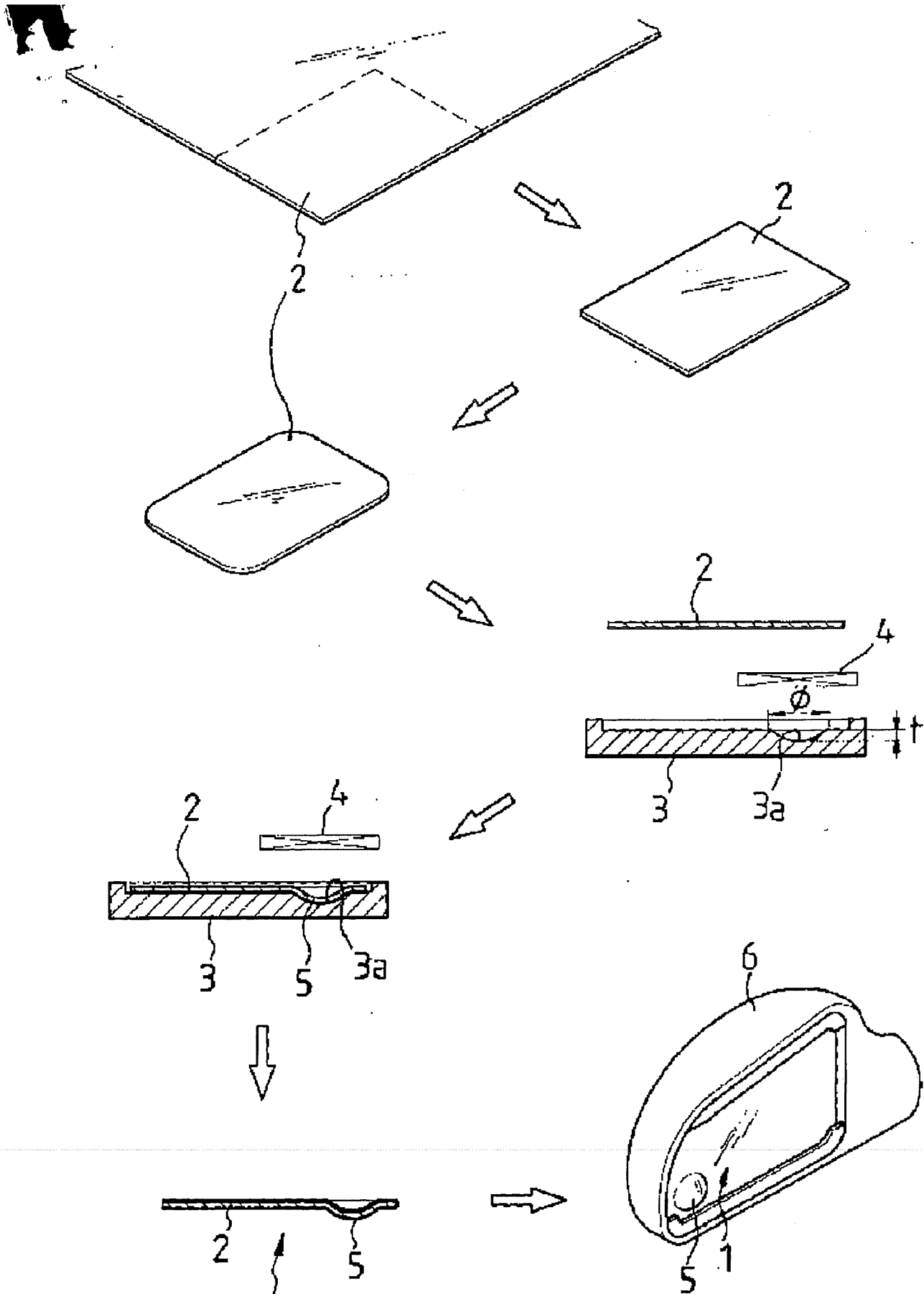

11/11/2004, EAST Version: 1.4.1

Octrooiraad



⑩ **A Terinzagelegging** ⑪ **7908257**

Nederland

⑲ **NL**

- ⑤④ **Achteruitkijkspiegel.**
- ⑤① Int.Cl³: B60R1/08.
- ⑦① Aanvrager: Nicolaas Bartholomeus de Jongh te Rotterdam.
- ⑦④ Gem.: Ir. A. Siedsma c.s.
Octroobureau Arnold & Siedsma
Sweelinckplein 1
2517 GK 's-Gravenhage.

-
- ②① Aanvraag Nr. 7908257.
- ②② Ingediend 12 november 1979.
- ③② --
- ③③ --
- ③① --
- ②③ --
- ⑥① --
- ⑥② --

-
- ④③ Ter inzage gelegd 1 juni 1981.

De aan dit blad gehechte stukken zijn een afdruk van de oorspronkelijk ingediende beschrijving met conclusie(s) en eventuele tekening(en).

"Achteruitkijkspiegel"

De uitvinding heeft betrekking op een achteruitkijkspiegel, in het bijzonder voor motorvoertuigen, omvattende een vlak hoofdspiegeldeel en een hulpspiegeldeel voor het vergroten van het gezichtsveld van de gebruiker.

- 5 Een dergelijke achteruitkijkspiegel is bekend uit de Nederlandse ter inzage gelegde octrooiaanvraag No. 77.11500. Bij deze bekende achteruitkijkspiegel is het hulpspiegeldeel uitgevoerd als vlakke spiegel. Dit brengt een aantal problemen en beperkingen met zich mee, die de
- 10 uitvinding beoogt op te lossen resp. op te heffen. Bij juiste instelling van de bekende spiegel kan inderdaad worden bereikt, dat het gezichtsveld van de gebruiker zodanig wordt vergroot, dat de "dode hoek" door het hulpspiegeldeel wordt bestreken, hetgeen de verkeersveiligheid ten goede komt.
- 15 Bij deze bekende spiegel is evenwel een juiste instelling van het uiterste belang, aangezien bij zelfs geringe verstellingen het gevaar bestaat, dat de gebruiker misleid wordt door de door hem in de spiegel waargenomen beelden. Bovendien is het hulpspiegeldeel bij de bekende achteruitkijkspiegel
- 20 relatief klein uitgevoerd, zodat slechts zeer beperkte informatie over de verkeerssituatie in de dode hoek wordt verkregen. Zoals verder blijkt uit de beschrijving van de bekende spiegel, is deze spiegel beperkt tot toepassing bij een buitenspiegel aan de zijde van de bestuurder, en wel in
- 25 het bijzonder voor het bestrijken van de dode hoek.

De uitvinding stelt zich ten doel, een achteruitkijkspiegel te verschaffen, die de gebruiker meer uitgebreide informatie over de verkeerssituatie achter hem verschaft en zich bovendien leent voor toepassingen, waarbij de

30 gebruiker gebaat kan zijn bij extra visuele informatie.

Met het oog daarop stelt de uitvinding een achteruitkijkspiegel van het in de aanhef vermelde type voor, die volgens de uitvinding het kenmerk vertoont, dat het hulpspiegeldeel bol is.

7908257

Van voordeel is die uitvoeringsvorm, waarbij het hulpspiegeldeel is uitgevoerd als op het hoofdspiegeldeel aanbrengbaar, los element. Op deze wijze kan een bezitter van een reeds van een achteruitkijkspiegel voorzien voertuig
5 een hulpspiegeldeel aanbrengen, zodat hij een samengestelde achteruitkijkspiegel verkrijgt met een hoofdspiegeldeel en een hulpspiegeldeel.

Praktisch is die uitvoeringsvorm van een los hulpspiegeldeel, waarbij dit hulpspiegeldeel is voorzien
10 van een vlakke achterplaat, waarop een klevend element is aangebracht. Bij voorkeur is dit klevende element uitgevoerd als dubbelzijdig klevende, veerkrachtige plaat. Dit heeft het voordeel dat, indien door een ongeval het hoofdspiegel-
deel beschadigd raakt, het hulpspiegeldeel met redelijke
15 waarschijnlijkheid intact blijft, zodat de gebruiker zijn reis zonder gevaar kan voortzetten.

Verder geniet de voorkeur die uitvoeringsvorm, waarbij het hulpspiegeldeel rond is en zijn rand ten minste enigszins vloeiend aan het oppervlak van het hoofdspiegeldeel
20 aansluit. Deze uitvoeringsvorm is van voordeel aangezien daarbij, anders dan bij de constructie van de bekende spiegel volgens de Nederlandse octrooiaanvraag No. 77.11500, geen kans bestaat, dat bijvoorbeeld bij het wassen van het voertuig de hulpspiegel losraakt.

25 In een verdere variant is het hulpspiegeldeel als één geheel met het hoofdspiegeldeel uitgevoerd.

Bijvoorbeeld kan de spiegel een draagplaat met een vlak en een bol deel omvatten, op welke draagplaat een spiegelende laag is aangebracht. Deze spiegelende laag kan
30 op de achterzijde van de draagplaat zijn aangebracht, waarbij de draagplaat transparant is. In dit geval dient de draagplaat tevens als beschermlaag voor de spiegelende laag. Ook kan de spiegelende laag aan de voorzijde van de draagplaat zijn aangebracht. In dat geval kan de draagplaat zijn
35 uitgevoerd als geheel vlakke plaat, met een bolvormig, verdikt deel, hetgeen de stevigheid van de plaat ten goede komt, maar de spiegelende laag onbeschermd laat.

7908257

Een verdere variant is die, waarbij het hoofdspiegeldeel en het hulpspiegeldeel zijn uitgevoerd als een plaat met een vlak en een bol deel, het oppervlak van welke plaat glad is. Bijvoorbeeld kan deze plaat van gepolijst
5 aluminium zijn.

Zoals reeds is opgemerkt, biedt de spiegel volgens de uitvinding nog verder gaande toepassingsmogelijkheden. Niet alleen de horizontale gezichtshoek van de gebruiker wordt namelijk vergroot, maar ook de verticale.
10 Hiervan kan gebruik worden gemaakt door bijvoorbeeld een spiegel volgens de uitvinding aan de van de gebruiker afgewende zijde van de auto aan te brengen, waardoor hij bijvoorbeeld bij achteruit parkeren ook lager geplaatste obstakels, bijvoorbeeld kilometerpalen of dergelijke,
15 kan waarnemen. Verder kan een spiegel volgens de uitvinding als binnenspiegel in een voertuig worden geplaatst. Op deze wijze heeft de chauffeur steeds een goed zicht op 'de in het voertuig achter hem plaatsvindende gebeurtenissen, bijvoorbeeld spelende kinderen.

20 De uitvinding zal nu worden toegelicht aan de hand van de bijgaande tekening. Hierin tonen:
fig. 1 een aanzicht van een uitvoeringsvoorbeeld van een spiegel volgens de uitvinding;
fig. 2 een dwarsdoorsnede langs de lijn II-II
25 in fig. 1;
fig. 3 een tweede uitvoeringsvorm van de spiegel volgens de uitvinding;
fig. 4 een derde uitvoeringsvorm van de spiegel volgens de uitvinding;
30 fig. 5 een schematisch bovenaanzicht van een auto met een spiegel volgens de uitvinding, waarbij de horizontale gezichtshoek van de chauffeur is weergegeven; en
fig. 6 een schematisch zijaanzicht van een auto, waarbij de verticale gezichtshoek van de chauffeur is
35 weergegeven.

Fig. 1 toont een aanzicht van een eerste uitvoeringsvorm van een achteruitkijkspiegel volgens de uitvinding. Deze spiegel omvat een vlak hoofdspiegeldeel 1 en

7908257

een bol hulpspiegeldeel 2, welk hoofdspiegeldeel 1 is inge-
bed in een huis 3, waarvan de rand 4 in fig. 1 zichtbaar is.
Het hulpspiegeldeel 2 beslaat slechts een relatief klein
gedeelte van het spiegeloppervlak van het hoofdspiegeldeel
5 1, waardoor de normaal met een vlakke spiegel verkregen
informatie praktisch geheel behouden blijft. Door de bolle
vorm van de spiegel 2 wordt een grotere gezichtshoek verkre-
gen, een en ander zoals schematisch in fig. 1 is weergegeven
in de vorm van het in de achteruitkijkspiegel door de gebrui-
10 ker waargenomen beeld.

Fig. 2 toont een dwarsdoorsnede door de spiegel
volgens fig. 1 langs de lijn II-II. In dit uitvoeringsvoor-
beeld is de hulpspiegel 2 uitgevoerd als los op het hoofd-
spiegeldeel 1 aangebracht element, omvattende het eigenlijke
15 hulpspiegeldeel 2, een hulpspiegeldeelhuis 5, bijvoorbeeld
uit aluminium, met een vlak achteroppervlak, waarop een
tweezijdig klevend, veerkrachtig element 6 is aangebracht.
Zoals uit deze figuur blijkt, is de omtreksrand van het
hulpspiegeldeelhuis 5 zodanig gevormd, dat, te zamen met het
20 tweezijdige klefelement een enigszins vloeiende aansluiting
op het oppervlak van het hoofdspiegeldeel 1 wordt verkregen.

Fig. 3 toont een tweede uitvoeringsvoorbeeld van
de spiegel volgens de uitvinding, waarin het spiegelhuis niet
is weergegeven. In deze uitvoeringsvorm omvat de spiegel een
25 draagplaat 7, aan de achterzijde waarvan een spiegelende
laag 8 is aangebracht. De draagplaat 7 moet in dit geval
uit transparant materiaal bestaan; de spiegelende laag 8
kan zijn uitgevoerd als reflecterende kunststof, aluminium-
folie, spiegelende kunststof of door een opdamptechniek op
30 de draagplaat 7 zijn aangebracht.

Fig. 4 toont een derde variant van de spiegel
volgens de uitvinding, waarbij een draagplaat 9, waarvan
het achteroppervlak geheel vlak is en het voorvlak ten dele
vlak en ten dele bol, aan zijn voorzijde is voorzien van
35 een spiegelende laag 10. Deze spiegelende laag 10 kan in
principe op dezelfde wijze zijn uitgevoerd als reeds aan
de hand van fig. 3 is besproken.

7908257

Opgemerkt wordt, dat in het uitvoeringsvoorbeeld volgens fig. 3 de spiegelende laag 8 door de draagplaat 7 tegen beschadiging is beschermd. In het uitvoeringsvoorbeeld volgens fig. 4 is dat niet het geval; de spiegelende laag 5 10 is derhalve bij voorkeur een weinig steviger, dikker, uitgevoerd dan de spiegelende laag 8.

Ten overvloede wordt opgemerkt, dat het uitvoeringsvoorbeeld volgens de fig. 1 en 2 in die zin van de uitvoeringsvoorbeelden volgens de fig. 3 en 4 verschilt, dat 10 bij de fig. 1 en 2 sprake is van een hoofdspiegeldeel met een daarop aanbrengbaar los hulpspiegeldeel, terwijl in de fig. 3 en 4 sprake is van een achteruitkijkspiegel, waarbij het hoofdspiegeldeel en het hulpspiegeldeel geïntegreerd zijn uitgevoerd.

15 Fig. 5 toont, hoe de horizontale gezichtshoek van een gebruiker vergroot door toepassing van een spiegel volgens de uitvinding. Met getrokken lijnen zijn de grenzen van het gezichtsveld in horizontale richting van de gebruiker bij gebruik van het hoofdspiegeldeel weergegeven; de onder- 20 broken lijnen tonen de grenzen van het gezichtsveld van de gebruiker, indien hij in het hulpspiegeldeel kijkt. Duidelijk is, dat geen enkele wezenlijke informatie voor de gebruiker verloren gaat, terwijl, zelfs bij een aanzienlijke verstelling van de gehele achteruitkijkspiegel, een voldoende groot 25 gezichtsveld overblijft. Het behoeft geen betoog, dat dit een zeer belangrijke eigenschap is, die is verkregen door toepassing van een bol hulpspiegeldeel volgens de uitvinding.

De in fig. 6 getekende situatie heeft betrekking op het geval, waarin de chauffeur gebruik maakt van de 30 achteruitkijkspiegel volgens de uitvinding om bijvoorbeeld in achterwaartse richting te parkeren. Behalve de reeds aan de hand van fig. 5 beschreven horizontale vergroting van zijn gezichtshoek blijkt uit fig. 6 de aanzienlijke vergroting van de verticale gezichtshoek, die in het bijzonder van 35 belang is voor het waarnemen van laag geplaatste obstakels, overstekende kinderen, of dergelijke. De getrokken lijnen duiden, evenals in fig. 5, het gezichtsveld met het hoofdspiegeldeel aan, terwijl de onderbroken lijnen het gezichtsveld van het hulpspiegeldeel weergeven.

7908257

De uitvinding beperkt zich niet tot de beschreven uitvoeringsvoorbeelden. Diverse wijzigingen in de onderdelen en in hun onderlinge samenhang kunnen worden aangebracht, zonder dat daardoor het kader van de uitvinding wordt
5 overschreden.

Bijvoorbeeld is in de tekening slechts het geval aangeduid, waarbij het hulpspiegeldeel rond is uitgevoerd. Het zal evenwel duidelijk zijn, dat elke andere gewenste vorm ook kan worden toegepast.

10 Tevens is een variant denkbaar, waarbij het hulpspiegeldeel vloeiend, met een geleidelijke overgang aansluit op het hoofdspiegeldeel, zodat in het hoofdspiegel-
deel en het hulpspiegeldeel geen van elkaar gescheiden
15 beelden worden waargenomen, maar slechts één beeld, dat evenwel aan de vloeiend verlopende omtreksrand van het hulpspiegeldeel vervormd is.

7908257

CONCLUSIES

1. Achteruitkijkspiegel, in het bijzonder voor motorvoertuigen, omvattende een vlak hoofdspiegeldeel en een hulpspiegeldeel voor het vergroten van het gezichtsveld van de gebruiker, met het kenmerk, dat het hulpspiegeldeel
5 bol is.

2. Achteruitkijkspiegel volgens conclusie 1, met het kenmerk, dat het hulpspiegeldeel is uitgevoerd als op het hoofdspiegeldeel aanbrengbaar, los element.

3. Achteruitkijkspiegel volgens conclusie 2,
10 met het kenmerk, dat het hulpspiegeldeel is voorzien van een vlakke achterplaat, waarop een klevend element is
aangebracht.

4. Achteruitkijkspiegel volgens conclusie 3,
15 met het kenmerk, dat het klevende element is uitgevoerd als dubbelzijdig klevende, veerkrachtige plaat.

5. Achteruitkijkspiegel volgens conclusie 3 of 4,
met het kenmerk, dat het hulpspiegeldeel rond is en zijn rand ten minste enigszins vloeiend aan het oppervlak van het hoofdspiegeldeel aansluit.

20 6. Achteruitkijkspiegel volgens conclusie 1, met het kenmerk, dat het hulpspiegeldeel is uitgevoerd als één geheel met het hoofdspiegeldeel.

7. Achteruitkijkspiegel volgens conclusie 6,
25 gekenmerkt door een draagplaat met een vlak en een bol deel, waarop een spiegelende laag is aangebracht.

8. Achteruitkijkspiegel volgens conclusie 7,
met het kenmerk, dat de draagplaat transparant is en de spiegelende laag op de achterzijde daarvan is aangebracht.

9. Achteruitkijkspiegel volgens conclusie 7,
30 met het kenmerk, dat de spiegelende laag op de voorzijde van de draagplaat is aangebracht.

10. Achteruitkijkspiegel volgens conclusie 6,
met het kenmerk, dat het hoofdspiegeldeel en het hulpspiegel-
deel zijn uitgevoerd als plaat met een vlak en een bol deel,
35 het oppervlak van welke plaat glad is.

7908257

11. Hulpspiegeldeel als omschreven in één der conclusies 2, 3, 4 of 5.

7908257

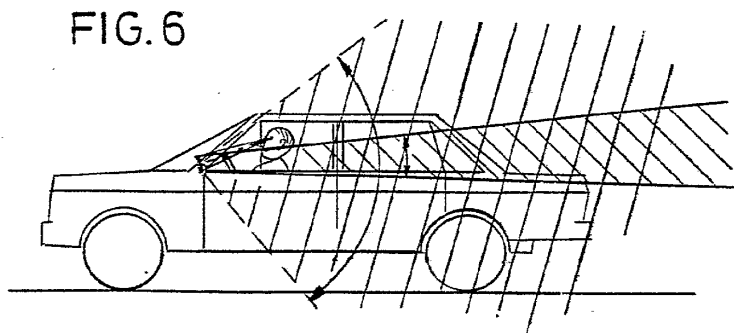
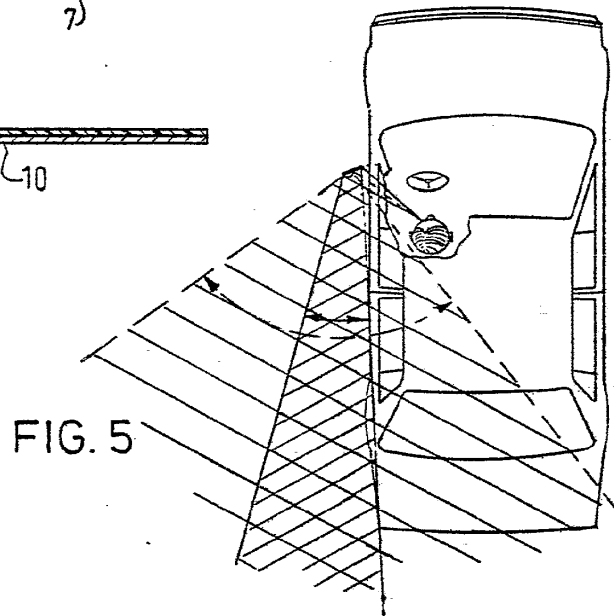
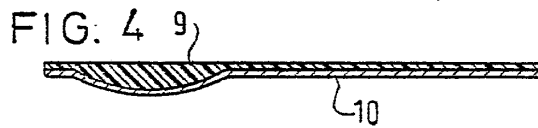
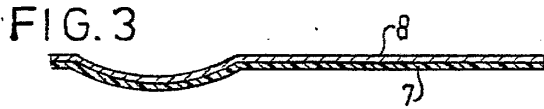
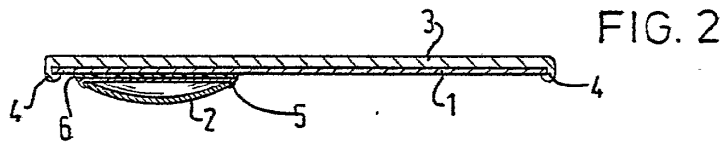
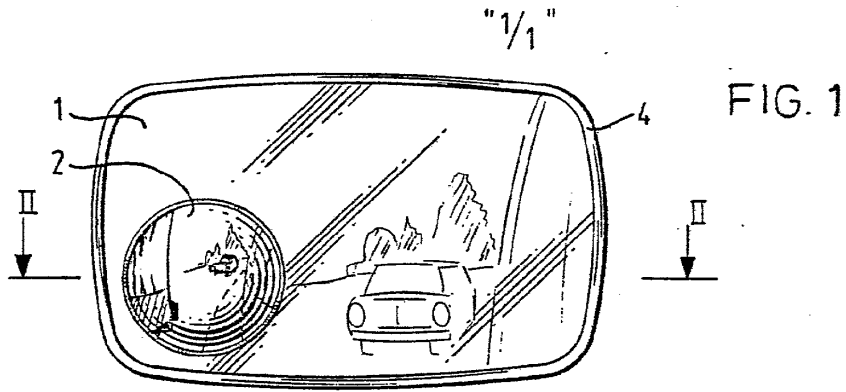

7908257

(12) INTERNATIONAL APPLICATION PUBLISHED UNDER THE PATENT COOPERATION TREATY (PCT)

(19) World Intellectual Property Organization
International Bureau



(43) International Publication Date
1 November 2001 (01.11.2001)

PCT

(10) International Publication Number
WO 01/81956 A1

- (51) International Patent Classification⁷: **G02B 5/08**
- (21) International Application Number: PCT/US01/13283
- (22) International Filing Date: 24 April 2001 (24.04.2001)
- (25) Filing Language: English
- (26) Publication Language: English
- (30) Priority Data:
09/551,676 24 April 2000 (24.04.2000) US
09/733,410 11 December 2000 (11.12.2000) US
- (71) Applicant and
(72) Inventor: **PLATZER, George, E., Jr.** [US/US]; 424 Cypress Road, Rochester Hills, MI 48309 (US).
- (74) Agents: **NEMAZI, John, E.** et al.; Brooks & Kushman, 1000 Town Center, 22nd floor, Southfield, MI 48075 (US).
- (81) Designated States (*national*): AE, AG, AL, AM, AT, AU, AZ, BA, BB, BG, BR, BY, BZ, CA, CH, CN, CO, CR, CU, CZ, DE, DK, DM, DZ, EE, ES, FI, GB, GD, GE, GH, GM, HR, HU, ID, IL, IN, IS, JP, KE, KG, KP, KR, KZ, LC, LK, LR, LS, LT, LU, LV, MA, MD, MG, MK, MN, MW, MX, MZ, NO, NZ, PL, PT, RO, RU, SD, SE, SG, SI, SK, SL, TJ, TM, TR, TT, TZ, UA, UG, US, UZ, VN, YU, ZA, ZW.
- (84) Designated States (*regional*): ARIPO patent (GH, GM, KE, LS, MW, MZ, SD, SL, SZ, TZ, UG, ZW), Eurasian patent (AM, AZ, BY, KG, KZ, MD, RU, TJ, TM), European patent (AT, BE, CH, CY, DE, DK, ES, FI, FR, GB, GR, IE, IT, LU, MC, NL, PT, SE, TR), OAPI patent (BF, BJ, CF, CG, CI, CM, GA, GN, GW, ML, MR, NE, SN, TD, TG).
- Published:**
— with international search report
- For two-letter codes and other abbreviations, refer to the "Guidance Notes on Codes and Abbreviations" appearing at the beginning of each regular issue of the PCT Gazette.*



(54) Title: COMPOUND AUTOMOTIVE REARVIEW MIRROR

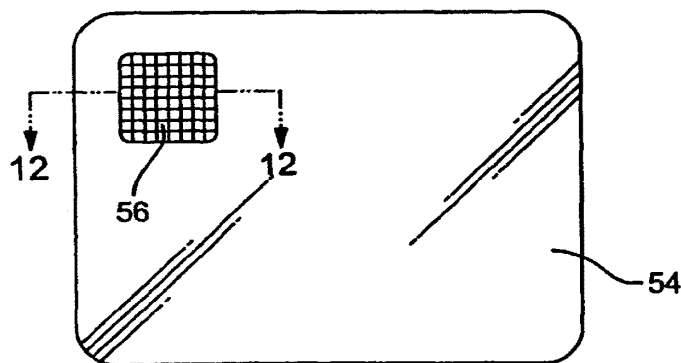

(57) Abstract: A composite mirror includes a main viewing mirror (40) and an auxiliary blindzone viewing mirror (36) juxtaposed to expose the vehicle blindzone to the operator.

WO 01/81956 A1

with the seat in the rear most position.” FMVSS 111 thus effectively determines the size of the mirror, which a manufacturer must provide. The size will vary among different manufacture’s vehicles because of the placement of the mirror on the vehicle with regard to the driver’s seat location.

5

Unfortunately, outside mirrors meeting FMVSS 111 still do not provide adequate adjacent lane visibility to view cars that are in the range of one car length to the rear. That is, a blindzone exists where a vehicle is not visible in either the inside mirror or the outside mirror. Even a glance over the shoulder may not be adequate to observe a vehicle in the blindzone. For many vehicles, the door pillar between the front and rear doors obscures the view to the blindzone. Furthermore, this obstruction is not obvious to most drivers, and they may assume that the “over the shoulder glance” has allowed them to see the blindzone when in reality it has not.

10
15

Rearward vision in automobiles is mathematically described in a paper published by the Society of Automotive Engineers (SAE) in 1995. That paper is designated as SAE Technical Paper 950601. It is entitled, The Geometry of Automotive Rearview Mirrors – Why Blindzones Exist and Strategies to Overcome Them, by George Platzer, the inventor of the present invention. That paper is hereby incorporated by reference.

20

A common method of overcoming the blindzone is to add a spherically convex blindzone-viewing mirror to the required plane main mirror. Spherically convex mirrors provide a wide field of view, but at the penalty of a reduced image size. However, this may be acceptable if the mirror is only used to indicate the presence of a vehicle in the blindzone and it is not used to judge the distance or approach speed of vehicles to the rear. Simply placing a round segment of a convex mirror on the main mirror surface, as is commonly done with stick-on convex mirrors, does not solve the problem. Doing so can provide a view to the rear which includes the blindzone, but it will also show much of the side of the car, the sky and the road surface, which are distracting and extraneous to the safe operation of the vehicle. What is required is a convex blindzone-viewing mirror that shows the driver primarily

25
30

only the blindzone. In this way, if the driver sees a vehicle in the blindzone-viewing mirror, he knows it is unsafe to move into the adjacent lane. All extraneous and distracting information should be removed from the blindzone-viewing mirror. Furthermore, by eliminating the irrelevant portions of the
5 bull's-eye mirror, the remaining portion can have a larger radius of curvature, thereby increasing the image size for the given amount of area that is to be allocated to the convex mirror.

Other problems with add-on mirrors are that they:

- 10 ▪ may interfere with the requirements of FMVSS 111;
- may substantially decrease the plane main mirror viewing angle;
- interfere with cleaning, especially when there is ice on it; and
- appear as an unsightly excrescence on the main mirror. A blindzone-viewing mirror that is provided by a car manufacturer must not appear
15 to be an afterthought, but rather an integral part of the mirror.

Summary of the Invention

One object of the present invention is to provide a unit magnification
20 main mirror, which meets the requirements of FMVSS 111 and simultaneously provides a blindzone-viewing mirror having a magnification of less than unity that is in application able to show an automobile driver's side blindzone.

Another object of the invention is to provide a less than unit
25 magnification mirror that meets the requirements of FMVSS 111 on the passenger's side and simultaneously provides a blindzone-viewing mirror having a magnification of less than unity that is able to show the driver the blindzone on the passenger's side.

30 Yet another object of the invention is to provide a mirror having a combination of two surfaces of different magnification that is not objectionable in appearance.

Still another object of the invention is to provide a mirror having a combination of two surfaces of different magnification that is inexpensive and easy to manufacture.

5 In a preferred embodiment of the invention, a less than unit magnification mirror is located in the upper and outer region of a unit magnification mirror, and it is optimized in size and orientation to provide primarily only a view of the blindzone while leaving the region surrounding it available to meet the requirements of FMVSS 111. The less than unit
10 magnification mirror is integral with the unit magnification mirror. In yet another preferred embodiment of the invention, the unit magnification main mirror includes means operative to selectively vary the intensity of the reflection from the main mirror while maintaining a relatively fixed reflection intensity characteristic of the auxiliary mirror.

15

Brief Description of the Drawings

In the drawings, wherein for clarity certain details may be omitted from one or more views:

20 Figure 1, is a plan view of an automobile on a three-lane highway depicting the field of view of the outside mirrors and the blindzones;

 Figure 2, is a diagram showing the requirements of FMVSS 111 for the horizontal field of view of the driver's outside mirror;

25 Figure 3, is a diagram showing the requirements of FMVSS 111 for the vertical field of view of the driver's outside mirror;

 Figure 4, is an image of the road as seen in the driver's outside mirror showing the effect of the requirements of FMVSS 111 on the horizontal width and the vertical height of the mirror;

30 Figure 5, is a perspective drawing showing how a less than unit magnification mirror can be placed on the driver's outside mirror to avoid conflicting with the requirements of FMVSS 111 and yet provide a wide angle mirror to observe the blindzone;

 Figure 6, is a front view of the mirror of Figure 5;

Figure 7, is side sectional view of the mirror of Figure 6 in the plane along line 7-7 in the direction of the arrows showing the proper location of the center of the sphere on which the surface of the blindzone mirror lies, so as to produce vertical centering of the image of a vehicle that is in the blindzone;

Figure 8, is a top sectional view of the mirror of Figure 6 in the plane along line 8-8 looking in the direction of the arrows showing the proper location of the center of the sphere on which the surface of the blindzone mirror lies, so as to produce horizontal centering of the image of a vehicle that is in the blindzone;

Figure 9, is a plan view of a two-lane highway showing a vehicle in the right lane equipped with the mirror of Figure 5 and four positions of an overtaking vehicle in the left lane;

Figure 10a, shows the image of an overtaking vehicle in Figure 9, in a mirror like that of Figure 5;

Figure 10b, is like Figure 10a except that the overtaking vehicle is farther to the rear; Figure 10c, is like Figure 10b except that the overtaking vehicle is farther to the rear;

Figure 10d, is like Figure 10c except that the overtaking vehicle is farther to the rear;

Figure 11, is a front view of a driver's side mirror embodying the teachings of this invention;

Figure 12, is an enlarged top sectional view of the mirror of Figure 11 taken in the plane along line 12-12 in the direction of the arrows.

Figure 13, is a top view of a circular segment of a spherical mirror;

Figure 14, is a side view of the mirror of Figure 13;

Figure 15, is a top view of the mirror of Figure 13 wherein the mirror has been cut into square elements;

Figure 16, is a side sectional view of the mirror of Figure 15 taken in the plane along line 16-16 looking in the direction of the arrows;

Figure 17, depicts how the mirror of Figures 15 and 16 can be rearranged into a planar array of reflecting facets;

Figure 18, shows how light is reflected from the mirror of Figure 14;

Figure 19, shows how light reflected from the mirror of Figure 17 simulates the reflections from the mirror of Figure 14;

Figure 20, shows a mirror alternatively embodying the teachings of the invention;

5 Figure 21, is an enlarged side sectional view of the mirror of Figure 20 taken in the plane along line 21-21 and looking in the direction of the arrows;

Figure 22, is a diagram comparing a directly reflected ray from a front surface mirror to a refracted ray from a second surface mirror;

10 Figure 23, is a diagram comparing the radius of curvature of a front surface mirror to the radius of curvature of a second surface mirror;

Figure 24, shows another embodiment of a mirror using the teachings of the invention;

Figure 25, shows an enlarged top sectional view of the mirror of Figure 24 in the plane along line 25-25 looking in the direction of the arrows;

15 Figure 26, shows yet another embodiment of a mirror employing the teachings of the invention;

Figure 27, is an enlarged top sectional view of the mirror of Figure 26 in the plane along line 27-27 looking in the direction of the arrows;

20 Figure 28, shows still another embodiment of a mirror employing the teachings of the invention;

Figure 29, is an enlarged top sectional view of the mirror of Figure 28 in the plane along line 29-29 and looking in the direction of the arrows;

Figure 30, shows another embodiment of a mirror using the teachings of the invention;

25 Figure 31, is an enlarged top sectional view of the mirror of Figure 30 taken in the plane along line 31-31 looking in the direction of the arrows;

Figure 32, shows yet another mirror embodying the teachings of this invention;

30 Figure 33, is an enlarged top sectional view of the mirror of Figure 32 taken in the plane along line 33-33 and looking in the direction of the arrows;

Figure 34, shows another mirror incorporating the teachings of the invention;

Figure 35, shows still another mirror incorporating the teachings of the invention;

Figure 36, is a front view of a prior art mirror having variable reflectivity;

Figure 37, is a top sectional view of the mirror of Figure 36 in the plane along line 37-37 looking in the direction of the arrows;

5 Figure 38, is a front view of a variable reflectivity mirror embodying the present invention;

Figure 39a, is a top sectional view of the mirror of Figure 38 in the plane along line 39-39 looking in the direction of the arrows;

10 Figure 39b, shows another embodiment of a variable reflectivity mirror employing the teachings of the present invention similar in a number of respects to the embodiment of Figure 39a;

Figure 40, is a front view of an alternative embodiment variable reflectivity mirror;

Figure 41, is a top sectional view of the mirror of Figure 40 in the plane along line 41-41 looking in the direction of the arrows;

15 Figure 42, is a front view of another alternative embodiment variable reflectivity mirror;

Figure 43, is a top sectional view of the mirror of Figure 42 in the plane along line 43-43 looking in the direction of the arrows;

20 Figure 44, is a front view of another alternative embodiment variable reflectivity mirror similar in a number of respects to the embodiment of Figures 42 and 43;

Figure 45, is a top sectional view of the mirror of Figure 44 in the plane along line 45-45 looking in the direction of the arrows;

25 Figure 46, is a front view of another alternative embodiment variable reflectivity mirror;

Figure 47a, is a broken, top sectional view of the mirror of Figure 46 on an enlarged scale in the plane along line 47-47 looking in the direction of the arrows;

30 Figure 47b, shows another embodiment of a variable reflectivity mirror similar in a number of respects to the embodiment of Figure 47a;

Figure 47c, shows yet another embodiment of the variable reflectivity mirror similar in a number of respects to the embodiment of Figure 47a;

Figure 48, is a front view of another alternative embodiment variable reflectivity mirror similar in a number of respects to the embodiment of Figures 46 and 47a;

5 Figure 49, is a top sectional view of the mirror of Figure 48 in the plane along line 49-49 looking in the direction of the arrows;

Figure 50, is a front view of another alternative embodiment variable reflectivity mirror similar in a number of respects to the embodiment of Figure 46 and 47c;

10 Figure 51, is a top sectional view of the mirror of Figure 50 in the plane along line 51-51 looking in the directions of the arrows;

Figure 52, is a front view of yet another alternative embodiment variable reflectivity mirror;

Figure 53, is a top sectional view of the mirror of Figure 52, in the plane along line 53-53 looking in the direction of the arrows;

15 Figure 54, is an exploded perspective view of the mirror of Figure 52;

Figure 55 is a front view of another embodiment of a mirror employing the teachings of this invention;

Figure 56 is an enlarged sectional view of the mirror of Figure 55 taken along section line 56-56 in the direction of the arrows;

20 Figure 57 is an exploded view of a mirror assembly of the present invention; and

Figure 58 is a cross-sectional side view of a mirror and bezel.

Detailed Description of the Preferred and Alternative Embodiments

25

Referring now in greater detail to the drawings, Figure 1 shows a mid-sized passenger car 10 in the middle lane of a three-lane highway with 12-foot wide lanes. The vehicle 10 is equipped with a driver's side outside mirror 12. The driver's eyes are shown centered at point 14, from which the driver has a field of view to the rear in the horizontal plane encompassing the acute angle formed by lines 16 and 18. Line 20 defines the rearward limit of the driver's peripheral vision when looking at mirror 12. Thus, the area bounded by lines 18 and 20 is a blindzone, shown crosshatched, which cannot be observed in either the driver's direct forward vision or indirectly in the mirror.

30

SAE Technical Paper 950601 describes the horizontal field of view of a plane mirror in a mathematical equation as a function of the mirror's dimensions and the position of the eyes relative to the mirror. Typically, the angle θ subtended by lines 16 and 18 is in the order of 15° to 20° . Angle θ is given by Eq. 1, and it is,

$$\theta = 2 \tan^{-1} \left[\frac{w \cos \lambda + D}{2 \sqrt{s_L^2 + s_T^2}} \right], \quad \text{Eq. 1}$$

where: w = mirror width;

D = interpupillary distance;

10 S_L = the longitudinal distance along the axis of the vehicle from the driver's eyes to the center of the mirror;

S_T = the transverse distance perpendicular to the longitudinal axis from the driver's eyes to the center of the mirror; and

$\lambda = \frac{1}{2} \tan^{-1} (s_T/s_L)$.

15

As described in SAE Technical Paper 950601, the peripheral vision line 20 cannot be precisely located. It depends on the location of the drivers' eyes relative to the mirror 12 and several other factors. For example, Burg (Journal of Applied Psychology, Vol.5, No. 12, 1968) has shown that the angular extent of peripheral vision is a function of age. At age 20 it extends 88° from straight-ahead to the side. At 70 years, this angle has dropped to 75° .

Angle ϕ in Figure 1 is the angle of the peripheral vision line 20 relative to line 22, which is perpendicular to the longitudinal axis of vehicle 10.

25 Typically this angle will be in the range of 40 degrees.

Figure 2 shows the requirement imposed on the width of mirror 12 by FMVSS 111. As previously stated, the mirror 12 must be able to show a point, as 24, which is 244 cm (8 feet) out from a plane 26 tangent to the side of the vehicle and 1067 cm (35 feet) behind the driver's eyes with the seat in the rear most position. Point 28 is 1067 cm behind the driver's eyes and in

30

plane 26. Points 24 and 28 are on the road surface. Angle θ in Figure 2 is obviously,

$$\theta = \tan^{-1}\left(\frac{244}{S_L + 1067}\right). \quad \text{Eq.2}$$

Angle θ has a value of about 11.5° for almost any passenger car, and the variation in θ produced by variations in s_L is a second order effect. Hence, the width of the mirror required by FMVSS 111 can be calculated by solving Equation 1 for w . Then,

$$w = \frac{2\sqrt{s_L^2 + s_T^2}\left(\tan\frac{\theta}{2}\right) - D}{\cos\lambda}. \quad \text{Eq.3}$$

Angle θ in this case is equal to 11.5° . Using values of $S_L = 45.7\text{cm}$, $S_T = 70\text{cm}$, and $D = 6.4\text{cm}$, w is found to be 9.4cm . This value can vary significantly among vehicles, since in Eq.3, S_L and S_T variations no longer produce only second order effects as in Eq. 2. In practice, vehicle manufactures will specify mirror widths in excess of the FMVSS 111 requirements to further reduce the blindzone size.

Figure 3 shows the requirements imposed on the vertical dimension of mirror 12 by FMVSS 111. In the vertical plane, vision is monocular since the eyes are not separated as they are in the horizontal plane. SAE Technical Paper 950601 shows that for monocular vision, the interpupillary distance D drops out of Equation 1, so that it becomes,

$$\theta = 2 \tan^{-1}\left[\frac{w \cos \lambda}{2\sqrt{s_L^2 + s_T^2}}\right]. \quad \text{Eq.4}$$

Then,

$$w = \frac{2\sqrt{s_L^2 + s_T^2} \tan \frac{\theta}{2}}{\cos \lambda}. \quad \text{Eq.5}$$

In Figure 3, h is the height in cm of mirror 12 above the ground, and it can vary significantly from a sports car to a sedan to a van. Angle θ_v is the angle that determines what the vertical dimension, w_v , of mirror 12 must be, in conjunction with the distance of the eye from the mirror. Angle θ_v replaces angle θ in Equation 5 when calculating the vertical dimension of the mirror. Applying Equation 5 to the required vertical dimension of the mirror, w_v ,

$$w_v = \frac{2\sqrt{s_L^2 + s_v^2} \tan \frac{\theta_v}{2}}{\cos \lambda_v}, \quad \text{Eq.6}$$

10 where: S_v = vertical distance in the vertical plane from the eye to the mirror;

$$\lambda_v = \frac{1}{2} \tan^{-1}(S_v/S_L); \text{ and}$$

$$\theta_v = \tan^{-1}\left(\frac{h}{S_v + 1067}\right).$$

15 Substituting measured values of h, S_L , and S_v from one mid-size passenger car gave a value for w_v of 6.4cm.

The FMVSS 111 requirement for the vertical dimension of the mirror is only a minimum, and it does not provide a satisfactory mirror. Drivers usually set their mirrors so that if the car is on a straight and level road, the horizon will be in about the center of the mirror. This means that if point 24 is to be visible with the horizon centered, the mirror should be about 12.7cm high. Most passenger car mirrors are not this large vertically, and are closer to 10.2cm to 11.4cm. However, the requirements of the standard are met.

25 Figure 4 shows mirror 12 adjusted so that the horizon 30 lies at its center. Point 24 is shown in the lower left-hand corner. Also shown is point 28 in the right-hand corner. Line 32 represents the dashed yellow lane marker between the two left lanes. Line 34 represents the left edge of the left lane. Lines 32 and 34 converge at infinity on the horizon. The mirror has

been adjusted so that point 28 is just visible, i.e. rotating the mirror farther outward would make point 28 disappear from view.

As previously mentioned, a mirror constructed to just meet the
 5 requirement in its horizontal field of view would have an excessively large
 blindzone. This could be remedied by providing an auxiliary blindzone-
 viewing mirror of less than unit magnification with a wide field of view, located
 such that it does not interfere with line 34. Such an auxiliary mirror 36 is
 shown in Figure 5 attached to a plane main viewing mirror 40. Mirror 36 is a
 10 spherically convex mirror having dimensions and an orientation such that its
 field of view encompasses the region in Figure 1 between lines 18 and 38.
 Mirror 36 can be made small enough so that it does not excessively encroach
 on the plane area of the main viewing mirror 40 above line 34. For example, if
 mirror 40 is 10 cm wide, mirror 36 could easily be 4.4 X 4.4 cm square. Using
 15 4.4 cm as the horizontal dimension for mirror 36, the radius of curvature
 required to encompass the blindzone can be calculated from another equation
 in SAE Technical Paper 950601. There it is shown that the field of view of a
 convex mirror is,

$$20 \quad \theta = 2 \left[2 \tan^{-1} \frac{w}{2r} + \tan^{-1} \frac{w \cos \lambda + D}{2\sqrt{s_L^2 + s_T^2}} \right]. \quad \text{Eq.7}$$

All of the variables in Equation 7 are the same as Equation 1 except for r ,
 which is the radius of curvature of the convex mirror. Angle θ in Equation 7 is
 to be taken as the angle between lines 18 and 38 in Figure 1. Line 38 is seen
 25 to extend from mirror 12 and intersect the peripheral vision line 20 in the
 center of the adjacent lane. The angle between lines 18 and 38 is about 25° .
 Using $w = 4.5\text{cm}$, $S_L = 46.0\text{cm}$, $S_T = 61.0\text{cm}$ and $D = 6.4\text{cm}$, r calculates out
 to be 29.9cm. Selection of 25° as the blindzone width is partially subjective.
 It involves the choice of the peripheral vision angle, the positioning of the
 30 mirror and an estimate of how much of the geometrically defined blindzone
 must be included to assure that a driver is able to see a vehicle in the

blindzone. In general a radius of curvature in the range of 20cm to 35cm will be satisfactory depending upon the vehicle.

5 A key factor in the shaping and positioning of the blindzone-viewing mirror is the required location of the center of the sphere from which the segment is taken. A vehicle in the blindzone should appear centered in the auxiliary blindzone-viewing mirror. Figures 6, 7 and 8 comprise a geometric orthographic projection showing the proper orientation of a spherically convex mirror segment 36 relative to a plane mirror 40. A radius 10 42 and an arc 44 of the sphere from which segment 36 is taken, must pass through the center 46 of the face of segment 36. The location of the center of the sphere must be specified so that centering of the image of a vehicle in the blindzone will occur.

15 As previously stated, most drivers adjust their mirrors so that if they were on a straight and level road, the horizon would be approximately centered in the mirror. Vertical centering of an image in the blindzone-viewing mirror 36 then requires that the image of the horizon pass through center 46 of mirror 36. This simply requires that radius 42 lie in a plane perpendicular to 20 plane mirror 40, and that the plane also pass through center point 46, as shown in Figure 7.

Horizontal centering of the view of the blindzone in mirror 36 requires that radius 42 be located such that it passes through center 46 of 25 mirror 36 and also falls along line 48 in Figure 1 which bisects the acute angle formed by lines 18 and 38. The actual position of radius line 42 in Figure 8 relative to the vehicle is dependent upon how the driver has positioned the mirror relative to the vehicle. However, the position of line 42 relative to line 50 in Figure 8 is constant. If the driver is instructed to position the plane 30 mirror so that the side of the car is just visible, the position of line 42 is then effectively constant relative to the side of the vehicle, and the blindzone view is effectively centered about line 48 in Figure 1.

The field of view in the plane main viewing mirror is θ degrees wide as shown in Figure 1. If the driver so chooses, he or she could readjust the main viewing mirror so angle θ straddles line 48. Then, the plane mirror view would be centered on the blindzone. Many drivers actually set their mirrors
5 this way to view the blindzone. Since the angle of reflection is equal to the angle of incidence, rotating the field of view outward by say 30° , would require rotating the mirror outward by 15° . Hence, to make the plane mirror look into the center of the blindzone requires that it be rotated by $1/2$ of the angle between line 48 and line 52, where line 52 bisects angle θ . Again selecting
10 the blindzone width as 25° , and using a value of 15° for θ , the field of view would have to be rotated $\frac{1}{2} (25^\circ + 15^\circ) = 20^\circ$. This would require rotating the mirror 10° to look into the center of the blindzone with the plane mirror.

The same reasoning applies to the convex blindzone-viewing mirror.
15 If radius 42 were perpendicular to the surface of plane mirror 40, the field of view of the convex mirror would be centered about line 52 in Figure 1. But we want the spherical mirror's field of view to be centered about line 48 when the plane mirror is adjusted to just see the side of the vehicle. Therefore in Figure 8, line 42 should be at an angle of 10° to line 50. The exact angle chosen will
20 be dependent upon the vehicle and the assumptions made for the position of line 48 in Figure 1.

The criteria required to size, place and orient the less than unit magnification auxiliary blindzone-viewing mirror have now been established.
25 Using these criteria will provide a mirror which conforms with FMVSS 111, centers the image of a vehicle in the blindzone in the less than unit magnification mirror, and optimizes the image size for the space allocated to the less than unit magnification mirror. Mirror 36 in Figure 5 may be visualized as a spherically convex bull's-eye mirror wherein all extraneous
30 portions of the bull's-eye have been removed, leaving only that portion which will show a vehicle in the blindzone. When driving with a mirror so configured, a vehicle overtaking on the driver's side will be seen in the main viewing mirror when the vehicle is to the rear of the blindzone. As the vehicle

approaches, it appears to slide outwardly off of main viewing mirror 40 and onto blindzone-viewing mirror 36. Figure 9 shows an overtaking vehicle at various distances behind vehicle 10 of Figure 1. Figures 10a, 10b, 10c and 10d show the position of the image of the overtaking vehicle on mirror 12 in Figure 9. Note that a small portion of the left rear fender of vehicle 10 is seen in the lower right-hand corner of the plane main mirror. Figure 10d shows the image of the overtaking vehicle at a position 11d in Figure 9 about 12 car lengths to the rear of vehicle 10. Figure 10c shows the image of the vehicle at a position 11c about 3.5 car lengths to the rear. Figure 10b shows the image of the vehicle at position 11b about 1.25 car length back, and it is seen mostly in the plane main viewing portion of the mirror, but partially in the auxiliary blindzone-viewing portion. Figure 10a shows the image of the overtaking vehicle in position 11a, which is entirely in the blindzone, and it is seen that the image is entirely in the blindzone-viewing mirror. Thus, the image of the approaching vehicle moves from inside to outside across the mirror, and this is one reason why the auxiliary mirror is placed in the upper and outer quadrant of the rearview mirror. Placing it on the inner quadrant would disturb the apparent flow of the image of the overtaking vehicle as it moves across the main mirror from inside to outside.

20

Next, various ways of implementing the combination of the main viewing mirror and the blindzone-viewing mirror will be shown. One simple way is to adhere a glass or plastic segment of a spherically convex mirror to the plane mirror as shown in Figure 5. However, the stick-on mirror is objectionable in its appearance, its vulnerability to damage, and its interference with cleaning the mirror. It would be highly desirable to reduce its protrusion above the surface of the main mirror. One way of doing this is shown in Figures 11 and 12. Figure 11 is a front view of a plane mirror 54 to which an auxiliary blindzone-viewing mirror 56 has been adhered. Mirror 56 is a planar array of small square reflecting facets that simulate the reflection from a segment of a spherically convex mirror such as the auxiliary blindzone-viewing mirror 36 in Figure 5. As will be shown, the planar array of reflecting facets provides a very thin mirror compared to the spherically convex mirror it simulates. Figure 12 is an enlarged top sectional view of mirrors 54 and 56

30

taken along section line 12-12 in Figure 11. Figure 12 shows that the facets are progressively more canted relative to the plane surface of mirror 54 in moving from right to left across mirror 56. For clarity, the facets in Figures 11 and 12 are shown larger than they really are. While sixty-four facets are shown, a practical mirror will have several hundred facets, and with that many facets the mirror may be as thin as 0.5 mm.

Figures 13 to 17 show the concept of creating a planar array of reflecting facets, which will perform the function of a spherically convex mirror. Figure 13 is plan view of a spherically convex mirror 58 of the familiar bull's-eye type having a radius r . Figure 14 is a side view of mirror 58 showing how it is a solid segment of a sphere of radius R . The surface of mirror 58 is highly polished and has a reflective coating. In Figure 15, the mirror of Figure 13 is cut into an array of squares by an imaginary infinitely thin knife. All of the cuts are perpendicular to the base 60 of mirror 58, as shown in Figure 16, which is a sectional side view of Figure 15 taken along section line 16-16. Only one material is present in the cross-section, so crosshatching is not used since this would make the drawing confusing.

Next, imagine that we take the mirror of Figure 15, which is now cut up into an array of square rods, turn it upside down, and let the reflecting ends all drop to the same plane surface. Then the rods are adhered together in some manner at the end opposite the polished end so that the reflecting facets stay in the same plane. Now the array may be turned back over to give the planar array of facets of Figure 17. In this array of facets, the highest point of each facet is located on a reference plane 62. Notice that the slope of each facet in Figure 17 has the slope of each corresponding segment in Figure 16. Figures 18 and 19 correspond with Figures 14 and 17 redrawn to show that the convex mirror and the planar array of facets reflect light in the same way. Parallel light rays reflecting off of corresponding points on the two mirrors reflect in the same direction. For example, ray 64 reflects off of point 66 as ray 68, and ray 70 reflects off of point 72 on the facet as ray 74, which is parallel to ray 68. Likewise, rays 76 and 82 reflect off of points 78 and 84 as parallel rays 80 and 86.

The planar array shown in Figure 17 is derived from convex mirror 15 that was cut up into squares. However, the facets do not all need to be squares of the same size, or for that matter, even be square. A factor in
 5 determining the size of a square is the depth of the facet below line 62 in Fig.17. This depth determines the practical thickness of an array that can be formed in a thin sheet of plastic. For example, if the maximum depth of a facet at the perimeter of the convex mirror is say 1.0mm, an injection molding incorporating the facet should be at least 2.0mm thick. Thus, the planar array
 10 shown in Figure 19 could be 2.0mm thick with a facet depth of 1.0mm. Noting in Fig.17 that the depth of a facet when the squares are all the same size, varies directly with the distance from the center of the mirror, it is obvious that a square starting at the center of the mirror can be much larger before its depth equals that of a square farther away from the center. In fact, it is seen
 15 that about three squares in Fig. 19 are required to produce the depth of the outer square if the individual depths of the first three are added up. While the square size depicted in Fig.15 is not intended to be a practical size, the fact that the squares closer to the center can be larger than the squares farther from the center is verified.

20

The advantage of using larger squares where possible is that the image quality is better with fewer squares, i.e., the mirror does not have to be divided up into as many pieces to simulate the convex mirror. Also, larger squares have less ability to produce discernable diffraction effects. Finally,
 25 the fewer the number of squares required to simulate the convex mirror, the easier it is to build the mold to form the mirror.

The depth of any given facet below line 16 in Fig.17 is easily determined. Line 60 in Fig.16 is the chord of arc 58. The distance, d, along
 30 the convex mirror axis from the center of the mirror to the chord is:

$$d = R \left[1 - \cos \left(\sin^{-1} \frac{c}{R} \right) \right], \quad \text{Eq. 8}$$

where R = radius of curvature of the convex mirror(see Fig.14)

c = the distance along the chord from the mirror axis to the point where the facet depth is to be determined.

5 Or, solving Eq.8 for c :

$$c = R \sin \left[\cos^{-1} \left(1 - \frac{d}{R} \right) \right]. \quad \text{Eq.8'}$$

10 Now let's construct a mirror having different sized squares, but formed so that they all have the same depth. Let's select the depth of the facets as 1.0mm and the radius of curvature of the mirror as 180mm. We will calculate the distance along the chord, starting at the center of the mirror, and going out from the center in both directions, for successive squares, each having a depth of 1.0mm. The table below shows the result of this calculation, and
 15 Figures 16a and 17a, which are like Figures 16 and 17, pictorially show the size of the required

d,mm	C,mm	($c_n - c_{n-1}$),mm
1	19	19
2	27	8
3	33	6
4	38	5
5	42	4
6	46	4

20 squares along a diameter. Off of the horizontal or vertical axis, the squares cannot be placed precisely to maintain a depth of 1.0mm. A slight variation of the depth will not matter. Figure 15a shows an array of squares comprised of elements that differ from each other in steps of $\frac{1}{2}$ of the previous square's dimension, e.g., the largest square is 20mm square, the next is 10mm, then 5mm and finally 2.5mm. This dimensioning is desirable to allow the elements

to fit together. Again, the depth of the elements will not all be 1.0mm, but exactness is not required.

5 The array of Fig. 15a is made by the process described for making the array of Figure 17. Square metal rods are assembled in a frame, and the ends are machined and polished as group to a convex shape. Then, the frame is slightly loosened and the machined rod ends are all pushed to the same plane, and the frame is tightened. This array can be used in several ways to make a tool to duplicate the array in a transparent material.

10

Figure 15a also shows another way to make a planar array, but with circular array elements. First, a solid cylinder is machined for the center element. Then, a group of hollow cylinders are machined to overlap each other with a slight clearance. These cylinders are then pinned at one end and machined and polished on the other end to form a convex surface. The cylinders are then unpinned, the machined end is pushed to the same plane and the cylinders are repinned. Again, this array becomes the basis of a forming tool.

20

Mirror 58 in Figure 18 and the planar array of Figure 19 would correspond exactly if the number of facets could be made infinite. With finite dimensions, there will be some distortion, and the array pattern will be discernible. However, a very good approximation is produced with facets that are in the order of 0.5mm to 1.5mm square.

25

The planar array of facets shown in Figure 19 simulates the convex bull's-eye mirror of Figure 14. Any portion of convex bull's-eye mirror 58 may be simulated by a planar array of facets. For example, the convex mirror 36 of Figure 5, which is actually a portion of a bull's-eye mirror, is easily represented by a planar array.

30

To show the principal of the planar array of reflecting facets, a convex mirror was imagined being cut up into square elements with an infinitely thin knife. Of course this cannot be done in the real world, but there

are practical ways of fabricating such an array. One way is to assemble a group of square steel wires held together by a frame. The wires may be, for example, 3cm or so long and .75mm square. One end of the assembly is machined to the desired convex shape and then polished to a mirror finish.

5 Next, the pressure on the frame is released just enough to be able to push the machined and polished ends to same plane. The assembly may be re-secured by a variety of methods. Such an assembly can be used in a plastic injection mold to replicate the surface, or it might be used to press the pattern into a plastic or glass surface. The surface of the replica is then coated with a

10 reflective metal by one of several common methods such as sputtering, vacuum deposition or chemical deposition.

The choice of material used for the square wires depends upon the application. For short run injection molding, aluminum wire could be used.

15 For greater durability in an injection mold, hard steel or nickel is required.

The assembly just described was machined to a convex shape. Any replication in another surface formed by the assembly is the negative of the machined surface. That is, looking directly at the pressed or molded

20 surface produced by a convex surface would appear as a concave surface. However, if the pattern is pressed into a thin sheet of transparent plastic or glass and the pattern is viewed through the glass or plastic, it appears as a convex mirror.

25 Depending upon whether a first surface convex mirror (the reflective coating is on the front or first surface) is desired, or if a second surface convex mirror (the reflective coating is on the back or second surface) is desired, determines if the rod assembly is machined convex or concave. Obviously, a tool used to form a convex mirror on a first surface mirror should

30 be machined concave. Likewise, a tool used to form a mirror appearing convex in a second surface mirror should be machined convex.

While the planar array just described used square facets, other arrays of facets may be used. For example, the facets may be rectangles,

parallelepipeds, rings and even irregular random shapes as described by Blom in U.S. Patent 4,674,850. Part of the method used to make a Fresnel lens could be used to make a convex mirror. Fresnel lenses are made by machining very narrow concentric rings in a soft metal with a special diamond
5 tool. The surface of each ring is slightly canted relative to the plane of the lens. As the rings progress outward from the center, the cant angle increases. At the center the cant angle is zero, and at the outer edge of the lens the cant angle may be for example 30° . A section through the center of a Fresnel lens will look like the section of Figure 17. The machined rings are
10 used to press the ring pattern into a transparent plastic. The surface can then be converted to a mirror by applying a reflective coating to it. As with the planar array of square facets, the mirror 36 which is a portion of a bull's-eye mirror, may be simulated by using a portion of a Fresnel bull's-eye pattern. That is, the mirror 36 could be simulated by segments of concentric circular
15 rings.

While the rings of a Fresnel lens are evenly spaced and a fraction of a millimeter apart, the rings do not have to be evenly spaced or close together. A circular array of rings can be made by the process just described
20 for making an array of square facets, but instead of using a bundle of square rods, a bundle of concentric cylinders is used.

Having developed the concept of the planar array of reflecting facets, various ways of using such an array will be shown. While arrays of
25 squares are shown in these examples, it should be understood that any suitable type of array might be used. Figure 11 has already shown a planar array 56 adhered to mirror 54. The array in this case is molded or pressed into a thin plate of a thermoplastic material. The thermoplastic plate can be quite thin. The thickness depends on the number of facets per square
30 centimeter. Referring to Figure 19, it is obvious that if more facets are used to simulate the convex mirror of Figure 16, the depth of the facets will decrease. For example, with facets that are 0.75mm square, the maximum depth of the edge facets will be in the range of .05mm. Thus, array mirror element 56 in

Figure 12 can have a thickness in the range of 0.5mm thick and still provide adequate material in which to form the .05mm deep facets.

Figure 20 is a front view of a plane main viewing mirror 88 to which
5 an auxiliary blindzone-viewing mirror 90 has been adhered. Mirror 90 in this
embodiment is a thin second surface planar array of reflecting facets as
opposed to the first surface planar array of Figure 11. Figure 21 is an
enlarged top sectional view of mirrors 88 and 90 taken along the section line
indicated by 21-21 in Figure 20. Here, the material of array mirror 90 must be
10 transparent, being glass or plastic. If a plastic is used, it should be one of the
optical grades plastics, e.g.: an acrylic such as Lucite manufactured by E.I. du
Pont; a polycarbonate such as Lexan manufactured by General Electric; or a
cyclic olefin copolymer such as Topas manufactured by the Ticona division of
Hoechst. The facets formed in the thin plate of mirror 90 have a reflective
15 metal coating 92 applied to them. Also, if mirror 90 is implemented in a plastic
material, its plane first surface may be protected by an optically transparent
abrasion resistant coating such as a siloxane. Several companies including
G. E. Silicones (Waterford, NY) and Dow Chemical Co (Midland, MI)
manufacture siloxanes used as transparent hardcoats on plastics. This
20 embodiment has the advantage of protecting the faceted surface and its
reflective coating.

Any second surface faceted mirror will produce additional deviation
of an incident ray of light due to the fact that the front surface of the glass or
25 plastic and the reflecting second surface of the material are not parallel. In
fact, the glass or plastic between the front and back surfaces form a prism.
As is well known, a prism produces a deviation of an incident ray which is
proportional to the prism angle and the index of refraction of the material of
which the prism is composed. Thus, the deviation of a ray caused by a
30 second surface faceted mirror varies from facet to facet, and it is necessary
compensate the mirror for this deviation by changing the prism angles relative
to the flat front surface.

If the faceted second surface mirror of Figure 21 is to have the same field of view as the first surface mirrors of Figures 5,6,7,8 and 12, it can be shown that to a first approximation, its element's angles should correspond to those of a convex mirror similar to that of Figure 5, except that radius 42 in Figures 7 and 8 should be greater by a factor of μ , the index of refraction of the glass or plastic, and the angle β between lines 42 and 50 in Figure 8 should be less by a factor of $1/\mu$. This results from the fact that the angle of a second surface facet mirror element relative to the plane of the front surface of the thin plate in which the faceted mirror has been formed must be less than the angle of a corresponding element on a first surface faceted mirror due to refraction. Figure 22 shows why this is so. Here, a line 94 represents the edge a plane parallel to the plane of the unity gain mirror to which the faceted mirror is adhered. Line 96 is a first surface mirror element at an angle α to line 94, and line 98 is a second surface mirror element at an angle α' to line 94. Line 100 represents a ray of light that reflects off of surface 96, becoming ray 102 going to an observer's eye. Line 100 is at an angle γ to the perpendicular to line 94. Line 102 is at an angle ϕ to the perpendicular to line 94. Knowing that the sum of the angles in a triangle is 180° , it is seen that for the first surface mirror,

20

$$\alpha = \frac{\gamma - \phi}{2}. \quad \text{Eq.9}$$

For the second surface mirror, the region between lines 94 and 98 is a refracting medium having an index of refraction μ . Ray 100 is refracted at line 94 such that the angle of refraction, γ' , is related to incident angle γ by the familiar equation,

25

$$\frac{\sin \gamma}{\sin \gamma'} = \mu. \quad \text{Eq.10}$$

Solving for γ' ,

$$\gamma' = \sin^{-1} \left(\frac{\sin \gamma}{\mu} \right). \quad \text{Eq.11}$$

30

The refracted ray reflects off of surface 98, and at line 94 again undergoes refraction, emerging along line 102. In leaving the refractive medium at line 94, the ray bends away from the perpendicular to line 94, so that,

5
$$\varphi' = \sin^{-1}\left(\frac{\sin \varphi}{\mu}\right). \quad \text{Eq.12}$$

Again using the geometry of triangles, it can be shown that

$$\alpha' = \frac{\gamma' - \varphi'}{2}. \quad \text{Eq.13}$$

10 Substituting Eq. 11 and 12 into Eq. 13,

$$\alpha' = \frac{1}{2} \left[\sin^{-1}\left(\frac{\sin \gamma}{\mu}\right) - \sin^{-1}\left(\frac{\sin \varphi}{\mu}\right) \right]. \quad \text{Eq.14}$$

15 Using the power series expansion for the arcsine and sine, and assuming γ and φ are small,

$$\alpha' \cong \frac{1}{2} \left(\frac{\gamma}{\mu} - \frac{\varphi}{\mu} \right) \cong \frac{1}{\mu} \left(\frac{\gamma - \varphi}{2} \right) \cong \frac{\alpha}{\mu}. \quad \text{Eq.15}$$

Hence, to a first approximation, the angle of a given facet on a second surface mirror is reduced by a factor of $1/\mu$ compared to a corresponding facet on a first surface mirror.

20

Since the angle of each facet on a second surface mirror is reduced by a factor of $1/\mu$, this obviously increases the spherical radius of the second surface mirror as compared to the first surface mirror. In fact, we can guess that the radius is increased by a factor of μ , but to verify this, let's return to Figure 8 and examine the top view of mirror 36 repeated in Figure 23. Arc 44 includes the surface of the front surface spherical mirror 36 in Figure 8. That sphere is centered at point 104 and it has a radius indicated by line 42. Line 42 is at an angle β to line 50, which is perpendicular to mirror 40. If a second

25

surface mirror is to produce the same view as mirror 36, β must be reduced by a factor of $1/\mu$ since radii 42 and 110 are respectively perpendicular to arcs 44 and 112 at point 46, and the lines tangent to arcs 44 and 112 at point 46 are related by Eq. 15. Hence, the radius 110 of the sphere generating the second surface mirror must be at an angle β/μ to line 50, and its center 108 must lie on line 114 for arc 112 to pass through point 46 in the direction of line 110. Second surface 106 must be interpreted in view of second surface 134 in Figure 31. In Figure 23, a refracting medium is not shown in front of surface 106 since the drawing would then become confusing. Since spherical arcs 44 and 112 both pass through point 46, and both spheres are symmetrical about axis 114, then

$$d = R \sin \beta = R' \sin \frac{\beta}{\mu}, \quad \text{Eq.18}$$

where: d = the distance between line 50 and line 114;
 R = radius 42 of first surface mirror 36; and
 R' = radius 110 of second surface mirror 106.

Solving for R' ,

$$R' = R \frac{\sin \beta}{\sin \frac{\beta}{\mu}}. \quad \text{Eq.19}$$

Again using the power series approximation,

$$R' \cong \mu R. \quad \text{Eq.20}$$

Equation 17 and Equation 20 are approximations. Accurate values of α' and R' are obtained using a computer solution.

Figures 24 and 25 show another embodiment of this invention wherein a faceted mirror 116 is adhered to the back of a first surface plane mirror 118. Figure 24 is a front view of mirror 118. Figure 25 is an enlarged top sectional view of mirrors 116 and 118 taken along section line 25-25 in Figure 24. Since mirror 118 is a first surface mirror having a reflective coating 120 on the front surface, the metallization in front of mirror 116 must be removed for mirror 116 to be visible from the front. Thus, a window 122 in the

metallization is provided for this purpose. The faceted mirror 116 is a second surface mirror, and it is adhered to mirror 118 with a clear adhesive, preferably having an index of refraction near that of the glass to avoid reflections at the adhesive interface. An example of such an adhesive is an ultraviolet cured acrylic adhesive manufactured by the Loctite Corporation of Rocky Hill, Connecticut. This particular product is designated as their 3494 adhesive, and it has an index of refraction of 1.48. The embodiment shown in Figures 24 and 25 provides protection for the faceted mirror and keeps the plane mirror a first surface mirror, which is the common type of mirror in use. The arrangement shown in Figures 24 and 25 could also be implemented with mirror 118 being a second surface mirror.

Figures 26 and 27 are like Figures 24 and 25, and like elements are identified with like reference numbers. The difference lies in the fact that the adhered faceted mirror 124 has the facets formed on the inner face. Here, care must be taken to assure that the clear adhesive is applied so that no air is trapped between the main mirror 118 and auxiliary blindzone-viewing mirror 124 since air bubbles would interfere with the reflections seen. This arrangement provides additional protection for the facets. It should be noted that with this arrangement of using a clear adhesive uniformly applied between the facets and the back surface of mirror 118, mirror 124 becomes a second surface mirror. Additional care must be taken when designing this mirror since the glass and the adhesive may have different indices of refraction. Mirror 124 could also be adhered only along its perimeter, in which case it is optically a first surface mirror in the sense that the angle of a reflected ray is not influenced by the refraction that occurs as the ray passes through 118.

Figures 28 and 29 are also like Figures 24 and 25, and again like elements are denoted by like reference numbers. The difference here is that the faceted blindzone-viewing mirror has been replaced by solid clear plastic element 126 having a spherically concave rear face with a reflective coating 128. It is also adhered to the main viewing mirror 118 with a transparent adhesive, again having an index of refraction near that of the glass and the

plastic to minimize reflections at the plane of the adhesive. Mirror surface 128 is viewed through window 122 where it is seen as a spherically convex mirror. The advantage of this embodiment is that use of the planar array can be avoided in those applications where there is adequate space behind the main viewing mirror 118 to accommodate the volume of element 126 without interfering with the mirror positioning mechanism.

Figures 30 and 31 show a rearview mirror 130 formed in a transparent material wherein a concave portion is molded integrally with a plane portion. The entire back surface of mirror 130 is coated with reflective material so that mirror 130 is a second surface mirror. Figure 30 is a front view of mirror 130. Area 132 is the region in which concave portion 134 is visible. Figure 31 is an enlarged top sectional view of mirror 130 taken along section line 31-31 in Figure 30. In Figure 30, concave surface 134 appears as a segment of a spherical convex mirror lying in region 132 when viewed from the front. Second surface 136 appears as a plane mirror when mirror 130 is viewed from the front. The advantage of this embodiment is that the use of adhesives is avoided, and it is a single component.

Figures 32 and 33 depict a mirror 138 having a faceted blindzone-viewing portion 140 formed integrally with a plane main viewing portion. The entire back surface of mirror 138 has a reflective coating 142, making it a second surface mirror. Figure 32 is a front view of mirror 138, showing faceted portion 140 and plane portion 144. Figure 33 is an enlarged top sectional view of mirror 138 taken along the section line indicated by 33-33. Faceted portion 140 is formed in the material of which mirror 138 is made. Mirror 138 may be plastic or glass. It may be a molding, or the facets may be pressed into sheet stock. If the material of 138 is a plastic, the front surface may be protected with a hardcoat as previously described. The advantage of this embodiment is that it requires no additional space, and the current mirror glass can be directly replaced with mirror 138.

Preferably, the faceted portion 140 in Figure 32 should have as high a reflectivity as possible, being coated with aluminum or silver. Since the

blindzone-viewing portion is a second surface mirror, the first surface will have a reflection of about 4%, which will be faintly visible over the reflection from the blindzone-viewing portion. The two reflections are in different directions, and are of different magnifications. By keeping the reflection from the less
5 than unit magnification mirror as high as possible, the reflection from the first surface is less noticeable. This applies to any of the embodiments utilizing a second surface blindzone-viewing mirror.

Figure 34 shows a truck type of mirror incorporating some of the
10 principles described above. Most truck mirrors are taller than they are wide as indicated in Figure 34. Many of these mirrors use a large bull's-eye convex mirror attached at the lower end to increase the horizontal field of view so that the blindzone may be seen. Figure 34 shows a convex faceted mirror 146 on the lower end of a main unit magnification mirror 148. Mirror 146 has been
15 optimized to view primarily the blindzone. Any of the methods described above may be used to form the mirror of Figure 34.

The passenger's side outside mirror is also subject to restrictions imposed by FMVSS 111. Because that mirror is so far away from the driver,
20 the field of view of a unit magnification mirror of the same size as the mirror on the driver's side would be only about 10°. This would result in a very large blindzone on the passenger's side. For this reason, FMVSS 111 allows a convex mirror having a wider field of view to be used. This of course reduces the size of the images seen in the mirror. FMVSS 111 says that the radius of
25 curvature used on passenger's side mirrors "shall be not less than 34 inches and not more than 65 inches." It also requires that the mirror be inscribed with the statement, "Objects in Mirror are Closer Than They Appear." At a radius of curvature of 1651 mm (65 inches), the magnification is about 0.30, and the field of view is about 27°. A radius of curvature of 1016 mm (40
30 inches) is in common use. Using the largest possible radius of curvature increases the image size, but it also increases the size of the blindzone.

Returning to Figure 1, lines 150 and 152 define the viewing angle of a 1651 mm radius convex mirror 154. When the driver is looking at mirror 154, the peripheral vision line is approximately shown by line 156. However, because passengers and the vehicle structure block the driver's peripheral vision to the road, the peripheral vision line cannot be used to define the blindzone as on the driver's side. A line 158 extending from the driver's eyes through the right rear door window is about the limit of the driver's vision to the rear. A blindzone then exists between lines 152 and 158, and it is shown crosshatched. This blindzone may be removed by providing an auxiliary blindzone-viewing mirror as in Figure 5, except that such an auxiliary mirror must be placed in the upper right hand corner, as shown in Figure 35.

In Figure 35, a passenger's side mirror 160 has a surface 162 that is a spherically convex mirror having a radius of curvature falling within the requirements of FMVSS 111, and mirror 164 is a less than unit magnification mirror designed to view generally only the blindzone. Mirror 164 should have a field of view encompassing the region between lines 152 and 158, and that will require a field of view in the range of 25 to 30 degrees. If the width for mirror 164 is to be 4.5cm with a viewing angle of 30 degrees and $S_T = 140\text{cm}$, its required radius of curvature calculated from Eq. 7 is 20cm.

While being able to use the largest possible radius of curvature for mirror 164 is an advantage, the main advantage of having a right side blindzone-viewing mirror is that such a mirror unambiguously tells you that you cannot change lanes if a vehicle is visible in that mirror. Without the blindzone viewing mirror, it is necessary to try to judge the position of a vehicle seen in a mirror which has an image size 1/3 of that in direct vision. Mirror 160 can be implemented by any of the arrangements used on the driver's side mirror. And obviously, main viewing mirror 162 which is also a less than unit magnification mirror, may be implemented as a planar array of reflecting facets, with or without the blindzone-viewing mirror.

Figures 55 and 56 show an arrangement similar to that shown in Figures 26 and 27, both of which show a discrete first surface planar array of

reflecting facets adhered to the second surface of a first surface plane mirror having a window in the first surface reflective coating through which the planar array is viewed. Figure 55 is a front view of a first surface plane mirror 310 having a faceted mirror 312 adhered to its back surface. The faceted mirror 5 312 is viewed through a window 314 in the first surface reflective coating 316 on mirror 310. Figure 56 is an enlarged partial sectional view of the mirror of Figure 55 taken along section line 56-56 in the direction of the arrows. Here it is seen that a recess 318 is ground in the back surface of mirror 310, and faceted mirror 312 is adhered in the recess. Again, an adhesive having an 10 index of refraction near that of the glass and the plastic of the discrete mirror is used to prevent reflections at the interface of the glass and the faceted mirror. Having the index of refraction near that of the glass also allows the recess to be rough ground and not polished, since the adhesive will fill all of the surface asperity making the grind marks invisible. The ground recess is 15 shown starting at the left edge and proceeding only far enough to accept the size of the planar array. If the array fills the whole upper corner, the recess is obviously ground accordingly. The advantage of providing the recess is that it allows the faceted discrete mirror to be flush with the back surface of the mirror. Remembering that the discrete mirror can be as thin as 0.5 mm, 20 removing this much from the back of a 2mm thick glass is quite feasible. Hence, the mirror of Figures 55 and 56 can directly replace a standard mirror without requiring any modification to the outside mirror assembly. While a thin first surface faceted mirror is shown in Figures 55 and 56, obviously, a thin second surface faceted mirror may also be used.

25

So far, all of the mirrors shown have had a constant reflectivity. It is also possible to use the blindzone viewing technology herein disclosed in conjunction with the technology used to provide variable reflectivity mirrors. Various unique combinations of the two technologies combine to provide a 30 new and novel category of mirrors.

Figures 36 and 37 show the generic structure of prior art variable reflectivity mirrors. In general, such mirrors are comprised of a transparent front plate, a rear plate which may or may not be transparent, and a chamber

between the two plates which is sealed at their perimeter. Not shown is the manner in which the two plates are held together and their spacing maintained. The chamber is filled with a material that is able to effect a change in the intensity of the reflection from such a mirror. The material may be liquid, gel or solid. Figure 36 is a front view of such a prior art mirror 165 showing a front plate 166 and a perimeter seal 168. Figure 37 is the section indicated by section line 37-37 in Figure 36 in the direction of the arrows. In addition to front plate 166, a rear plate 170 is shown that has a reflective coating 172 applied to its second surface. Perimeter seal 168 is also seen. A chamber 174 exists between the plates. Several materials can be used to fill chamber 174. At present the most extensively used filling is a so-called electrochromic material. This material changes its ionization state when an electric current is passed through it, and in this state it changes its color to a deep bluish green. The material in this state absorbs visible light photons. They are absorbed as light passes through the front plate and into the electrochromic layer and again as the light passes through the rear plate, reflects at coating 172 and exits through the electrochromic material and the front plate 166. The density of the ionized material, and hence the intensity of the light reflected from reflective coating 172, is controlled by the current. Electrically conductive transparent coatings 176 and 178 are applied to the second surface of the front plate 166 and to the first surface of the rear plate 170, respectively. Coatings 176 and 178 are required to obtain uniform current flow through the electrochromic material. A commonly used material for transparent electrically conductive coatings is indium tin oxide, known as ITO. Also indicated in Figures 36 and 37 are wires 180 and 182 connected to the ITO by methodologies not shown, but which are well known in the art.

In Figure 36, mirror 165 is connected electrically in-circuit with a reflectivity control circuit 300 typically comprised of a series interconnected activation switch 302, an electronic control circuit 304, a rear facing light sensor 306 and an ambient light sensor 308. Control circuit 300 is in circuit with mirror 165 via wires 180 and 182 to establish an electric current therein and thus selectively vary the ionization state of the electrochromic material. As the illumination from the rear and the ambient illumination vary, electronic

control circuit 304 produces a variation in the current to the electrochromic material thereby altering the reflectivity of the mirror in such a way as to keep the illumination reaching the driver's eyes below the annoyance level. A discussion of the relationship between illumination from the rear and ambient illumination in automatic control of rearview mirrors is found in U. S. Patent 5 3,601,614 Aug. 24,1971; G.E.Platzer, Jr.

In addition to electrochromics, liquid crystals have been used. Liquid crystals change their ability to polarize light under the influence of an electric field, and when used with a polarizer, the intensity of light passing 10 through such a cell can be controlled by the electric field strength. The liquid crystal mirror controller suffers from a low maximum reflectivity due to an immediate 50% loss due to a polarizer. Furthermore, a loss of power puts it in the minimum reflectivity state.

15

Another method for controlling reflectivity uses an electroplating process. Here, the chamber is filled with an electrolyte containing ions such as silver which when plated out on either inside surface of the cell produces a reflective surface. The reflectivity is controlled by controlling the amount of 20 silver plated out of the electrolyte. The process is reversible, so the reflectivity can be reduced by removing silver from the surface of the plate chosen to be the mirror.

In the future, additional materials that change their optical transmission in response to an applied electric field or current will probably be 25 discovered, and the teachings of this invention apply to any variable reflectivity mirror.

As with the generic variable reflectivity mirror just described, none of 30 the following mirror configurations will show the manner in which the front and rear plates are held together or how the spacing is maintained. The intent is to delineate the types of mirrors that can be used in a variable reflectivity mirror having a main viewing mirror and an auxiliary blindzone viewing mirror and the unique relationship of the reflective surfaces used in such mirrors.

Figures 38, 39a and 39b show two different configurations, but in a front view they both look the same. Like elements have been given like identification numbers. Figure 38 is a front view of a variable reflectivity mirror 184 that has a plane mirror region 186 and an auxiliary blindzone viewing mirror 187 at the outer end (generally indicated at 189) formed by a planar array of reflecting facets 188 simulating a convex mirror. The advantage of this configuration is that many European and Asian drivers have become accustomed to a mirror with an aspheric mirror at the outer end of the mirror 184, and an aspheric mirror is easily simulated by the planar array.

Figure 39a is a sectional view of Figure 38 taken along line 39-39 in the direction indicated by the arrows showing one way of implementing mirror 184. Here, a planar array of reflecting facets 190 is integral with and on the first surface of rear plate 192. Reflective coatings 194 and 195 are applied to the second surface of the rear plate 192 and to the surface of planar array 190 respectively. Transparent electrically conductive coatings 196 and 198 are applied to the second surface of front plate 186 and to the first surface of rear plate 192, respectively. A seal 200 between the front and rear plates 186 and 192 provide a chamber 202 which is filled with one of the electrically active materials capable of changing the intensity of the light reflected from mirror surface 194. Note that in Figure 39a the transparent electrically conductive coatings 196 and 198 do not extend in front of planar array 190. While the region between the plates 186 and 192 in front of auxiliary mirror 187 is filled with an electrically active material, a current cannot flow nor can a field exist in that region, and for that reason the reflection from mirror 187 remains unaffected. This is desirable since a convex mirror already has a reduced reflectivity in comparison to a plane mirror, and as shown in SAE Paper 950601, the relative illuminance of a convex mirror is equal to the square of the relative magnification. For example, if the relative magnification of a convex mirror is 0.2, the relative illuminance is 0.04. Dimming such a low magnification mirror is undesirable. If mirror 184 is very large, it is possible that the radius of curvature simulated by planar array 188 may be large enough to produce a relative illuminance which would make it desirable to dim

the light reflected from planar array 188. In this case the ITO layers would be extended to the area in front of array 190.

Figure 39b shows mirror 185 which is a variation of the mirror of
5 Figure 39a wherein the planar array of reflecting facets 204 is a second
surface mirror on a discrete element 206 whose first surface is adhered to the
second surface of a rear plate 208. A reflective coating 210 has been applied
to the second surface of rear plate 208 which is similar to coating 194 in
Figure 39a. Again, the reflectivity from planar array 204 may be controlled or
10 uncontrolled depending upon the placement of the ITO coating.

A non-dimming mirror in the configuration of Figure 38 is shown
generally at 211 in Figures 40 and 41. As in Figure 38, the planar array of
reflecting facets 220 is shown at the outer end of this mirror. A plane main
15 viewing mirror 212 is provided by means of second surface reflective coating
214 applied to plane plate 216. An auxiliary blindzone viewing mirror is
provided by a discrete element 218 carrying a second surface planar array of
reflecting facets 220. The first surface of element 218 is adhered to the
second surface of plate 216. Planar array 220 may simulate either a spherical
20 or aspherical convex mirror. The advantage of this non-dimming configuration
is that it may be desirable to retain some features of the European and Asian
mirrors as described in the discussion of Figure 38. The vast majority of
European and Asian mirrors are non-dimming, so it is desirable to be able to
provide the mirror of Figures 40 and 41. While a discrete adhered mirror is
25 shown in Figure 41, any of the previously described methods of providing a
planar array may be used.

For the US market, use of the blindzone mirror in the upper and
outer quadrant of a mirror is preferred for reasons previously described.
30 Therefore, various ways of modifying the variable reflectivity mirror to accept
an auxiliary blindzone viewing mirror in this configuration will be shown.
Figure 42 shows a variable reflectivity mirror 221 with a plane main viewing
portion 222 and a blindzone viewing portion 224 comprised of a planar array
of reflecting facets. Figure 43 is a sectional view of the mirror of Figure 42

taken along section line 43-43 and in the direction of the arrows. A front plate 226 covers the entire area defined by the perimeter of the mirror shown in Figure 42. A rear plate 228 is notched out to accept blindzone viewing mirror 224 which is a second surface planar array mirror formed in transparent discrete element 230. The first surface of mirror element 230 is planar, and it is adhered to the second surface of front plate 226. A seal 232 must now cover the perimeter of plate 228, so it will be seen as shown in Figure 42 with a jog around mirror element 230. A reflective coating 234 is applied to the second surface of rear plate 228, and ITO coatings 236 and 238 are applied to the inside surfaces of plates 226 and 228, respectively. Since mirror element 230 is adhered to the second surface of front plate 236, there is no electrically active material in front of the planar array, so the reflection from the planar array does not dim. Conductive leads (not shown), such as in Figures 36 and 37 could be used to place mirror 221 in circuit with a power supply and control circuit.

Figures 44 and 45 show a modification of the mirror of Figures 42 and 43 wherein a variable reflectivity mirror 239 has the planar array mirror element 230 replaced with a solid clear element 240 having a spherically concave rear surface with a reflective coating 242. Like elements in these Figures are identified with like numbers. From the front, element 240 appears as a spherically convex mirror, and as such it performs the function of providing a wide angle view of the blindzone, as does the planar array of Figures 42 and 43.

Figures 47a, 47b and 47c show three alternative configurations 243a, 243b and 243c of a mirror depicted generically in Figure 46 and identified as 243. All of the alternative configurations 243a, 243b and 243c use a planar array and appear the same from the front. In Figure 46, region 244 has a magnification of unity, providing a reflection from a plane mirror. Region 246 has a magnification of less than unity, providing a reflection from a planar array of facets simulating a convex mirror. Also seen in Figure 46 is seal 248 that seals in the electrically active material which dims the reflection from the mirror. In Figures 46 through 47c, like elements will be identified by

like numbers. Figures 47a, 47b and 47c are enlarged sectional views taken along section line 47-47 in the direction indicated by the arrows. All three drawings show a front plate 250, a seal 248, a chamber 252 retaining the electrically active dimming material and ITO coatings 254 and 256 on the inside surfaces of the chamber. Figure 47a has a rear plate 258 with an integrally formed planar array 260 having a reflective coating. Planar array 260 may be made dimming or non-dimming depending upon whether or not the ITO coating is used in the region in front of array 260.

Variable reflectivity in both region 244 and 246 of mirror 243 can be accomplished by providing a second seal (not illustrated) around the periphery of region 246 to define two separate chambers (such as chamber 252), each filled with electrochromic material. In addition, separate electrically isolated ITO coatings would be provided in the front and rear plate surfaces within the chamber co-extensively with region 246. Lastly, a separate set of wires would interconnect the additional ITO coatings with a second reflectivity control circuit. Thus arranged, the primary mirror and the auxiliary blindzone viewing mirror could each have a characteristic reflectivity independent of one another.

Figure 47b has a planar array mirror 262 formed in the second surface of rear plate 264. Again, the array may be dimming or non-dimming.

Figure 47c uses a separate element 266 having a planar array mirror 268 formed in its second surface. Its first surface is adhered to the second surface of rear plate 270. This configuration has the advantage of allowing the use of a standard variable reflectivity mirror. However, if dimming of the blindzone mirror is not desired, the ITO coating must not extend in front of mirror 268. Planar arrays 260, 262 and 268 are coated with a reflective surface as described earlier in conjunction with aforementioned embodiments of the invention.

The mirror 271 of Figures 48 and 49 is very similar to the mirror of Figures 46 and 47a. Again, like numbers will be used to identify like

elements. The only difference between these mirrors is that the planar array of reflecting facets 272 is integrally formed in the second surface of front plate 274 rather than in the first surface of the rear plate 276. In this configuration, the planar array is non-dimming since the array is in front of the electrically
5 conductive material. Also, since the array is in front of the chamber, the seal 248 does not show behind the array 272 which has its second surface coated with a reflective material. Alternatively, rear plate 276 can be provided by a thin reflective layer deposited directly upon the rear surface of the electrochromic layer.

10

Figures 50 and 51 show a mirror 275 similar to Figures 46 and 47c, and again like numbers will be used to identify like elements. The difference is that element 266 carrying planar array 268 has been replaced with the concave mirror element 240 of Figure 45 which is now adhered to the second
15 surface of rear plate 270. This configuration is an alternate method to using the planar array of Figure 47c.

Figures 52, 53 and 54 show yet another alternative to producing a blindzone viewing mirror 276 with a flat front face, and in this case it is
20 incorporated with a variable reflectivity mirror. Figure 52 is a front view of the mirror. It has a unity magnification region 278 and a less than unity magnification mirror 280 for viewing primarily only the blindzone. Figure 53 is a sectional view of the mirror 276 of Figure 52 taken along section line 53-53 in the direction of the arrows. A customarily constructed variable reflectivity
25 mirror is indicated by front plate 282, rear plate 284, chamber 286 containing an electrically active material and a chamber seal 288. The upper and outer corner of the variable reflectivity mirror is notched out to provide space for the blindzone viewing mirror 280. Like mirror 240 of Figures 45 and 51, mirror 280 is a segment of a second surface concave mirror. A plastic or metal case
30 290 supports the variable reflectivity mirror and the concave mirror in such a manner that the first surface of mirror 280 is coplanar with the first surface of front plate 282. Figure 54 is an exploded view of Figure 53 showing the construction of case 290 and how the components fit into it. Case 290 has a sidewall 292 extending around its perimeter, a back wall 294 and a shelf 296

which matches the concave surface of mirror 280. The height of shelf 296 is such that when the variable reflectivity mirror and mirror 280 are in place in the case, the first surfaces of the mirrors are coplanar. These first surfaces may be contiguous or they may be separated by a thin additional wall that
5 may be molded into case 290. Thus, a variable reflectivity mirror and a blindzone viewing mirror are combined to produce a mirror with a flat front face. This same type of structure may be used to combine an ordinary plane non-dimming mirror and a second surface plano-concave blindzone viewing mirror to also have a flat front face.

10

If any of the mirrors shown which utilize a second surface blindzone viewing mirror are to be used in conjunction with a passenger's side mirror, the first surface of the blindzone viewing mirror must be changed to a spherical surface to match the curvature of the main viewing mirror.

15

The invention in its broader aspects is not limited to the specific details shown and described, and departures may be made from such details without departing from the principles of the invention and without sacrificing its advantages. For example, the present invention can be applied in other
20 applications such as heavy off-road vehicles and the like where a clear unobstructed wide field of view is required for safe operation, and yet the size of the mirror must be limited.

A mirror assembly 300 utilizing a two zone mirror element 302 of the
25 type previously described as shown in Figure 57. Mirror assembly 300 is made up of a mirror housing 304, a mirror position motor 306 which can be remotely actuated by the vehicle occupant using an electrical switch within the vehicle to position face plate 308. Face plate 308 is provided with a series of posts 310 and a lock on lock lever 312. Posts 310 are adapted to cooperate
30 with a series of apertures 314 and mirror bezel 316. Mirror bezel 316 is a plastic molding adapted to securely retain two zone mirror 302 as illustrated in the Figure a cross-section. Bezel 316 is provided with a series of clips 318 adjacent apertures 314 and bezel 316 for engaging posts 310 on face plate 308. With clips 318 cooperating with posts 310, the lock unlock lever is

moved to the lock or unlock position as desired to retain or release the bezel relative to the face plate. In instances when mirror 302 is of the electrochromic or heated variety, an electrical connector not shown in the mirror will be coupled to electrical connector 320 within housing 304.

5

What is claimed is:

1. A mirror for automotive rearview application comprising a main viewing outside mirror and an auxiliary blindzone viewing mirror, said auxiliary blindzone viewing mirror defining a reflective surface comprised of a planar array of reflecting facets simulating a convex mirror and having a radius of curvature and a magnification less than that of said main viewing outside mirror, wherein said auxiliary blindzone viewing mirror is located generally in an upper and outer quadrant of said main viewing outside mirror, and said radius of curvature of said auxiliary blindzone viewing mirror lies in a plane generally perpendicular to said main viewing outside mirror, and said plane passes through the center point of said auxiliary blindzone viewing mirror so that its viewing angle primarily encompasses the region between the outer limit of the viewing angle of said main viewing outside mirror and the rearward limit of the driver's peripheral vision when said driver is looking at said mirror.

2. The mirror of claim 1 wherein said main viewing mirror having a first surface and a second surface, said second surface incorporating a recess in which said blindzone viewing mirror is adhered such that said blindzone viewing mirror is flush with the second surface of said main viewing mirror.

3. The mirror of claim 2, wherein said auxiliary blindzone viewing mirror is located generally in an upper and outer quadrant of said mirror.

4. The mirror of claim 1 further comprising a reflective layer and an electrochromic layer oriented forward of the reflective layer for selectively varying the intensity of the reflection from at least a portion of said mirror.

5. The mirror of claim 3, wherein said main viewing outside mirror and said auxiliary blindzone-viewing mirror are both first surface mirrors.

6. The mirror of claim 3, wherein said main viewing outside mirror is a first surface mirror and said auxiliary blindzone-viewing mirror is a second surface mirror.

5 7. The mirror of claim 3, wherein said main viewing outside mirror and said auxiliary blindzone-viewing mirror are both second surface mirrors.

8. The mirror of claim 3, wherein said auxiliary blindzone-viewing mirror is a separate element attached to said main viewing outside mirror.

10

9. The mirror of claim 3, wherein said main viewing outside mirror and said auxiliary blindzone-viewing mirror are an integral structure.

10. The mirror of claim 9 wherein said mirror is protected with an
15 optically transparent hardcoat.

11. The mirror of claim 3, wherein said reflecting facets are formed in an optically transparent material.

20 12. The mirror of claim 3, wherein said reflecting facets are squares lying in a plane generally parallel the main viewing outside mirror and each square being a segment of convex mirror.

13. The mirror of claim 12, wherein the facet squares have sides
25 dimensioned in the range of 1.5 mm to 0.5 mm.

14. The mirror of claim 3, wherein said reflecting facets are segments of concentric circular rings.

15. The mirror of claim 14, wherein the width of said rings is in the range 1.5 mm to 0.2mm.

16. The mirror of claim 3, wherein the characteristic reflectivity of said
5 auxiliary blindzone-viewing mirror is greater than the characteristic reflectivity of said main viewing outside mirror.

17. The mirror of claim 3, wherein said main viewing outside mirror is a
10 first surface mirror and said auxiliary blindzone-viewing mirror is attached to a back surface of said main viewing outside mirror, said auxiliary blindzone-viewing mirror, in application, being viewed through a region of said main viewing outside mirror which is devoid of reflective material.

18. A mirror for automotive rearview application comprising:
15 a main viewing outside mirror and an auxiliary blindzone-viewing mirror, said auxiliary blindzone viewing mirror, said auxiliary blindzone-viewing mirror defining a segment of a convex mirror having a radius of a curvature and a magnification less than that of said main viewing mirror and located behind a first surface of said main viewing outside mirror, wherein said auxiliary
20 blindzone viewing mirror is located generally in an upper and outer quadrant of said main viewing outside mirror, and said radius of curvature of said auxiliary blindzone viewing mirror lies in a plane generally perpendicular to said main viewing outside mirror, and said plane passes through the center point of said auxiliary blindzone viewing mirror so that its viewing angle
25 primarily encompasses the region between the outer limit of the viewing angle of said main viewing outside mirror and the rearward limit of the driver's peripheral vision when said driver is looking at said mirror.

19. The mirror of claim 18, wherein said main viewing mirror is a first
30 surface mirror and said auxiliary blindzone viewing mirror is attached to a back surface of said main viewing mirror and, in application, viewed through a

region of said main viewing outside mirror which is devoid of reflective material.

20. The mirror of claim 18, wherein said auxiliary blindzone-viewing
5 mirror is a second surface mirror.

21. The mirror of claim 18, wherein said main viewing outside mirror and said auxiliary blindzone-viewing mirror are an integral structure.

10 22. The mirror of claim 18, wherein said main viewing outside mirror and said auxiliary blindzone-viewing mirror are both second surface mirrors.

15 23. The mirror of claim 18, wherein the characteristic reflectivity of said auxiliary blindzone-viewing mirror is greater than the characteristic reflectivity of said main viewing outside mirror.

20 24. An auxiliary blindzone-viewing mirror for attachment to an automotive outside rearview mirror wherein said blindzone viewing mirror is comprised of a thin plate in which a planar array of reflecting facets has been formed, said planar array of reflecting facets simulating a convex mirror wherein said auxiliary blindzone viewing mirror is located generally in an upper and outer quadrant of said main viewing outside mirror, and said radius of curvature of said auxiliary blindzone viewing mirror lies in a plane generally perpendicular to said main viewing outside mirror, and said plane passes
25 through the center point of said auxiliary blindzone viewing mirror so that its viewing angle primarily encompasses the region between the outer limit of the viewing angle of said main viewing outside mirror and the rearward limit of the driver's peripheral vision when said driver is looking at said mirror.

25. The mirror of claim 24, wherein said thin plate is optically transparent and said planar array is formed in the second surface of said thin plate, and said thin plate is adhesively attached to said outside rearview mirror.

5

26. The mirror of claim 24, wherein said thin plate comprises a thermoplastic material.

27. The mirror of claim 25, wherein the front surface of said thin plate is protected with an optically transparent abrasion resistant coating.

10

28. A mirror adapted for automotive rearview application comprising a main viewing mirror and an auxiliary mirror, said auxiliary mirror defining a reflective surface comprised of a planar array of reflecting facets simulating a convex mirror and having a characteristic magnification less than that of said main viewing mirror, said auxiliary mirror being shaped and positioned for viewing primarily a vehicle in the vehicle blindzone, said mirror having means for selectively varying the intensity of the reflection from at least a portion of said mirror, and said means for selectively varying the intensity of the reflection comprising an electrically modifiable medium intermediate a transparent front plate and a rear plate such that the intensity of the reflection from said mirror varies in response to an electrical signal applied to conductive coatings on said front plate and said rear plate.

15

20

29. The mirror of claim 28, wherein said planar array of reflecting facets is defined by the second surface of said front plate.

25

30. The mirror of claim 28, wherein said planar array of reflecting facets is defined by the first surface of said rear plate.

30

31. The mirror of claim 28, wherein said planar array of reflecting facets is defined by the second surface of said rear plate.

32. The mirror of claim 28, wherein said planar array of reflecting facets comprises a discrete second surface mirror, and the first surface of said discrete second surface mirror is adhered to the second surface of said front plate.
5

33. The mirror of claim 28, wherein said planar array of reflecting facets comprises a thin discrete mirror, and the second surface of said front plate incorporates a recess in which said thin discrete mirror is adhered such that the second surface of said thin discrete mirror is flush with the second surface of said front plate.
10

34. The mirror of claim 28, wherein said planar array of reflecting facets is a discrete second surface mirror adhered to the first surface of said second plate and the first surface of said discrete second surface mirror is coplanar with the first surface of said front plate.
15

35. The mirror of claim 28, wherein said planar array of reflecting facets comprises a thin discrete mirror, and the first surface of said rear plate incorporates a recess in which said thin discrete mirror is adhered such that the first surface of said thin discrete mirror is approximately flush with the first surface of said rear plate.
20

36. The mirror of claim 28, wherein said planar array of reflecting facets comprises a discrete second surface mirror adhered to the second surface of said rear plate.
25

37. The mirror of claim 28, wherein said planar array of reflecting facets comprises a discrete first surface mirror adhered to the second surface of said rear plate.
30

38. The mirror of claim 28, wherein said electrically conductive coating is selectively deposited to avoid changing the intensity of the reflected light from said planar array of reflecting facets.

39. A mirror adapted for automotive rearview application comprising a main viewing mirror and an auxiliary mirror, said auxiliary mirror defining a transparent solid element having a first surface and a concave reflective second surface appearing as a segment of a convex mirror when viewed from the first surface and having a characteristic magnification less than that of said main viewing mirror, said auxiliary mirror being shaped and positioned for viewing primarily a vehicle in the vehicle blindzone, and said mirror having means for selectively varying the intensity of the reflection from at least a portion of said mirror.

40. The mirror of claim 39, wherein said auxiliary mirror is located generally in the upper and outer quadrant of said mirror.

41. The mirror of claim 39, wherein said main viewing mirror and said auxiliary mirror are both retained in a retaining frame such that the first surface of said auxiliary mirror is retained coplanar with the first surface of said front plate.

42. The mirror of claim 39, wherein the first surface of said main viewing mirror and the first surface of said auxiliary mirror both have the same radius of curvature and are retained in a retaining frame such that the first surface of said auxiliary mirror is tangent to the first surface of said main viewing mirror.

43. A mirror adapted for automotive rearview application comprising a main viewing mirror and an auxiliary mirror, said auxiliary mirror defining a transparent solid element having a first surface and a concave reflective second surface appearing as a segment of convex mirror when viewed from the first surface and having a characteristic magnification less than that of said main viewing mirror, said auxiliary mirror being shaped and positioned for viewing primarily a vehicle in the vehicle blindzone, said mirror having means for selectively varying the intensity of the reflection from at least a portion of said mirror, and said means for selectively varying the intensity of the

reflection is comprised of an electrically modifiable medium intermediate a transparent front plate and a rear plate such that the intensity of the reflection from said mirror varies in response to an electrical signal applied to electrically conductive coatings on said front plate and said rear plate.

5

44. The mirror of claim 43, wherein the first surface of said auxiliary mirror is adhered to the second surface of said front plate.

45. The mirror of claim 43, wherein the first surface of said auxiliary mirror segment is adhered to the second surface of said rear plate.

10

46. The mirror of claim 43, wherein said electrically conductive coating is selectively deposited to avoid changing the intensity of the reflected light from said auxiliary mirror.

15

47. A mirror adapted for automotive rearview application comprising a main viewing mirror and an auxiliary blindzone viewing mirror having a magnification less than that of said main viewing mirror wherein said auxiliary blindzone viewing mirror is located at an outer end of said mirror, said auxiliary blindzone viewing mirror being comprised of a planar array of reflecting facets.

20

48. The mirror of claim 47, wherein said planar array of reflecting facets simulates a convex mirror.

25

49. The mirror of claim 47, wherein said planar array of reflecting facets simulates an aspheric convex mirror.

50. A mirror adapted for automotive rearview application comprising a main viewing mirror and an auxiliary mirror, said auxiliary mirror defining a transparent solid element having a first surface and a concave reflective second surface appearing as a segment of a convex mirror when viewed from the first surface and having a characteristic magnification less than that of said main viewing mirror, said auxiliary mirror being shaped and positioned for

30

viewing primarily a vehicle in the vehicle blindzone, and said main viewing mirror and said auxiliary mirror are both retained in a retaining frame such that the first surface of said auxiliary mirror is retained tangent with the first surface of said main viewing mirror.

5

51. A mirror adapted for automotive rearview application comprising a first exterior viewing portion characterized by a first reflectivity characteristic and a second exterior viewing surface portion characterized by a second reflectivity characteristic.

10

52. The mirror of claim 51 wherein said viewing surface portions have different magnification characteristics.

15

53. The mirror of claim 51, wherein said first reflectivity characteristic is relatively fixed and said second reflectivity characteristic is selectively variable.

20

54. The mirror of claim 51, wherein both of said reflectivity characteristics are variable, independently of one another.

25

55. An automotive outside rearview mirror assembly comprising;
a housing adapted to be affixed to the exterior of a vehicle having an enclosed chamber with a rearwardly facing opening;
a mirror adjustment mechanism mounted within the housing enclosed chamber and provided with a remotely positionable face plate; and

30

a mirror element affixed to the face plate, said mirror element comprising a main viewing outside mirror and an auxiliary blindzone viewing mirror, said auxiliary blindzone viewing mirror defining a reflective surface comprised of a planar array of reflecting facets simulating a convex mirror and having a radius of curvature and a magnification less than that of said main viewing outside mirror, wherein said auxiliary blindzone viewing mirror is located generally in

an upper and outer quadrant of said main viewing outside mirror, and
said radius of curvature of said auxiliary blindzone viewing mirror lies in
a plane generally perpendicular to said main viewing outside mirror,
and said plane passes through the center point of said auxiliary
5 blindzone viewing mirror so that its viewing angle primarily
encompasses the region between the outer limit of the viewing angle of
said main viewing outside mirror and the rearward limit of the driver's
peripheral vision when said driver is looking at said mirror.

10

1/20

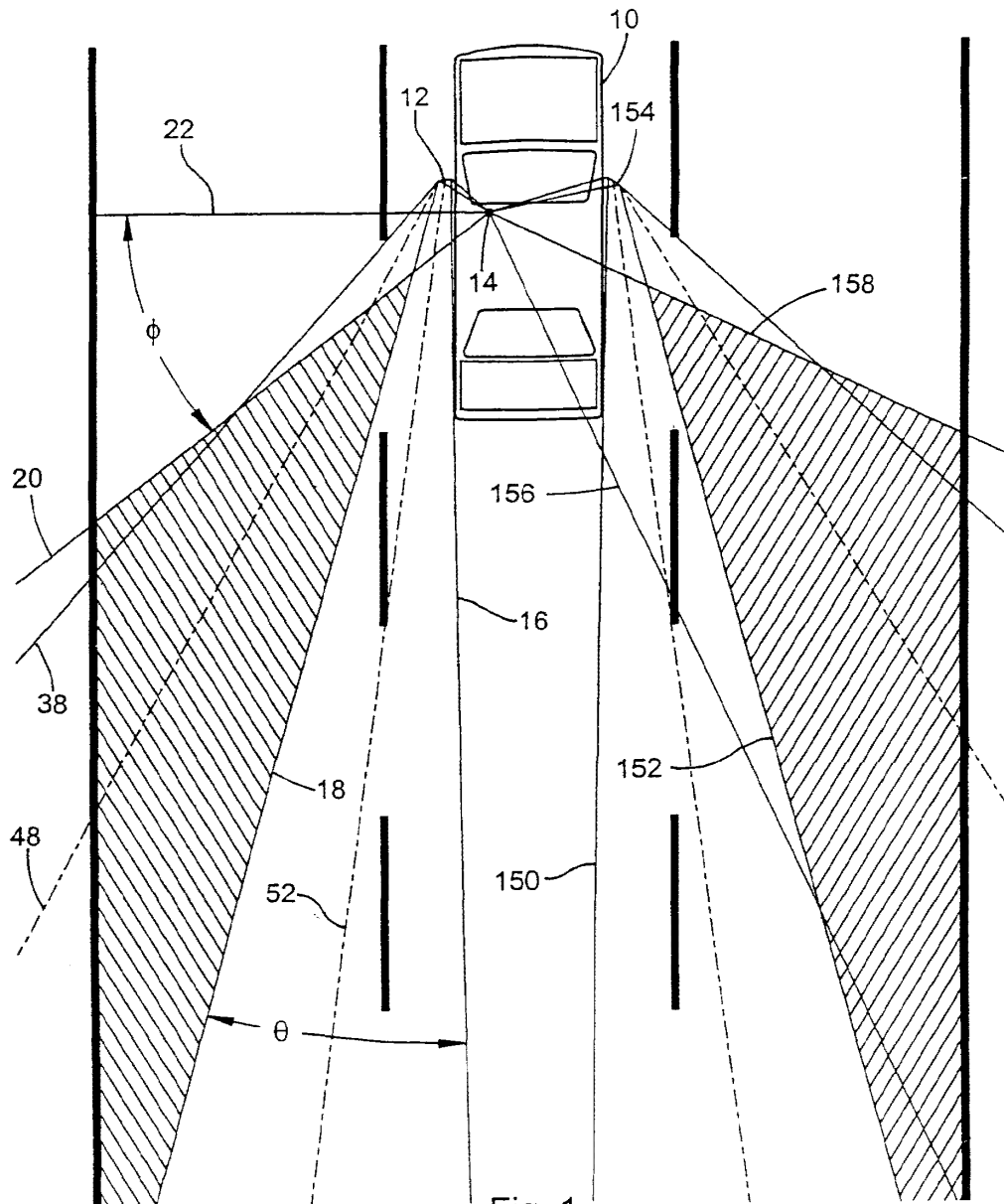
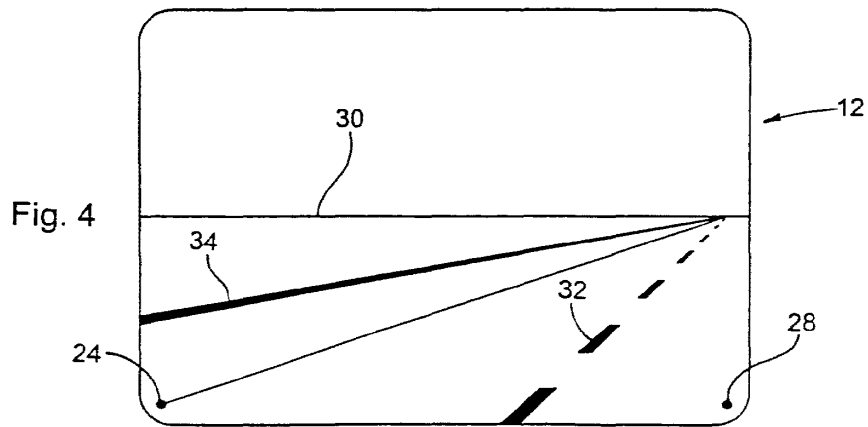
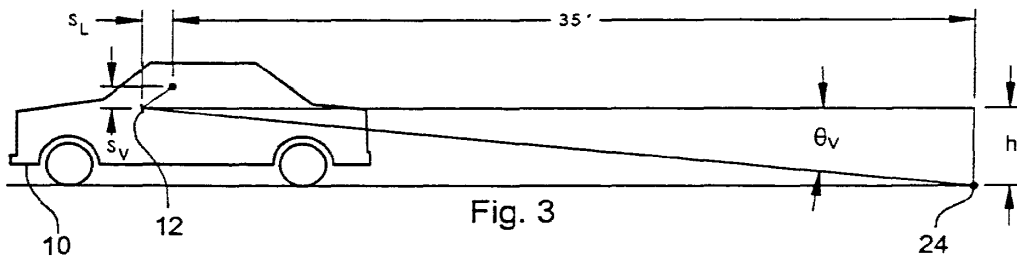
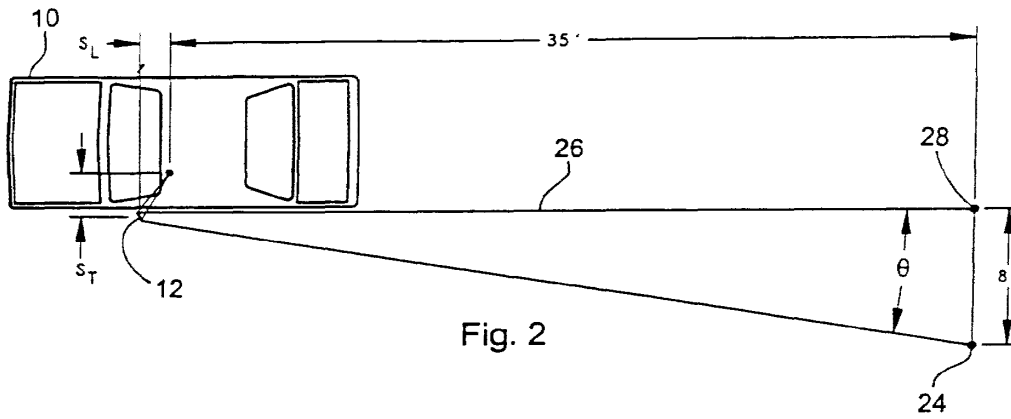
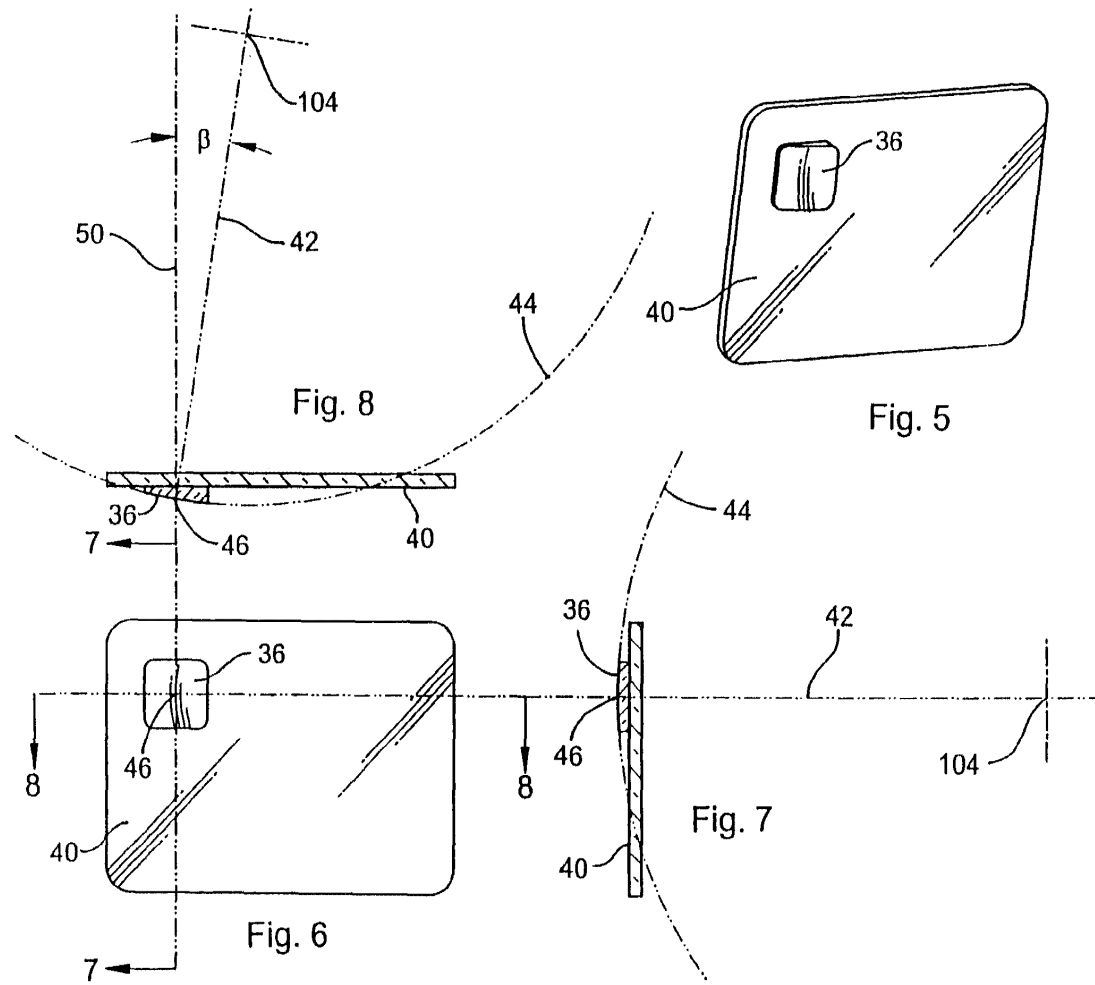

Fig. 1

2 / 20





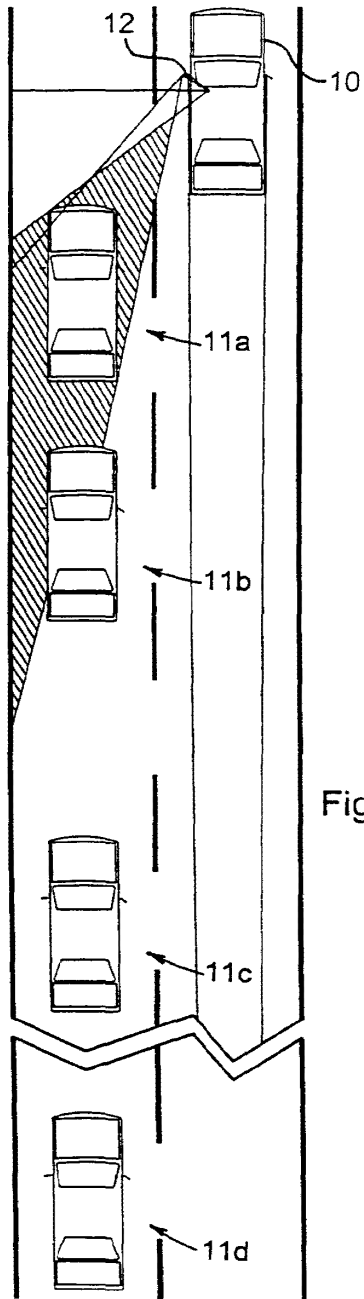

Fig. 9

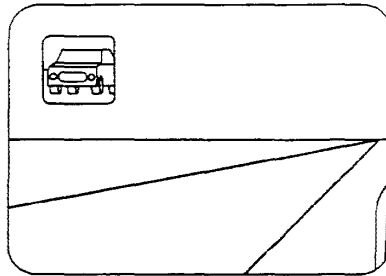

Fig. 10a

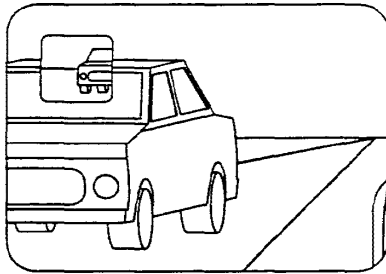

Fig. 10b

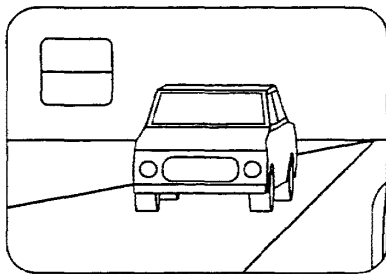

Fig. 10c

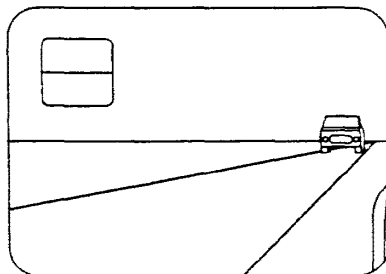

Fig. 10d

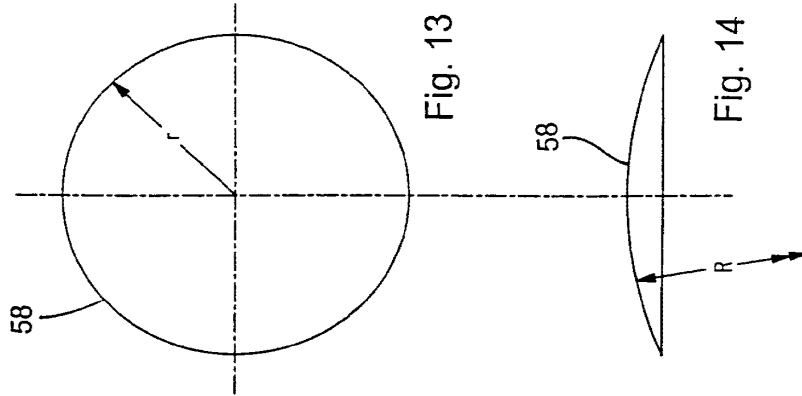

Fig. 12

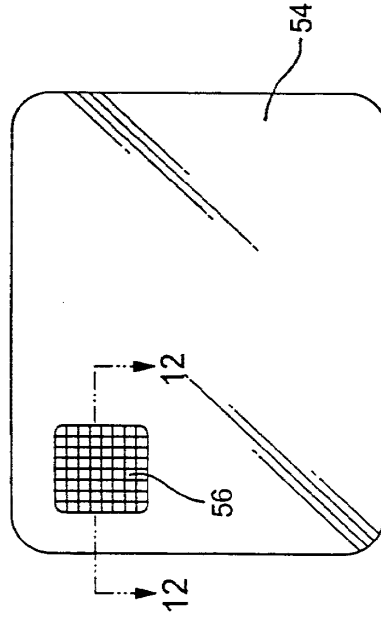
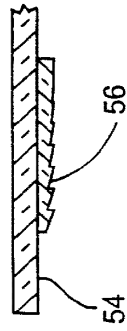
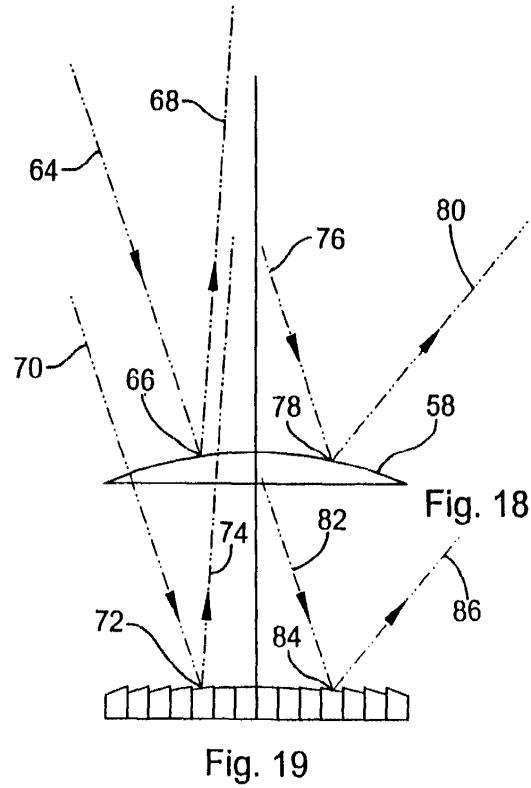
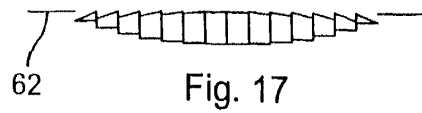
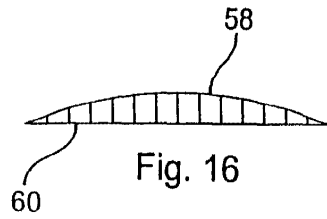
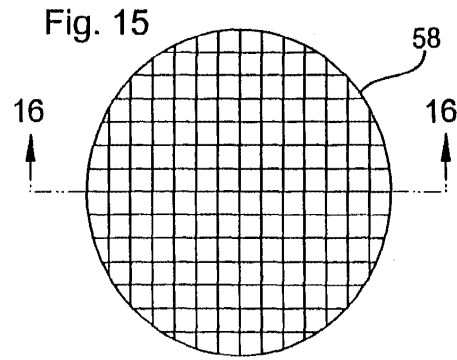
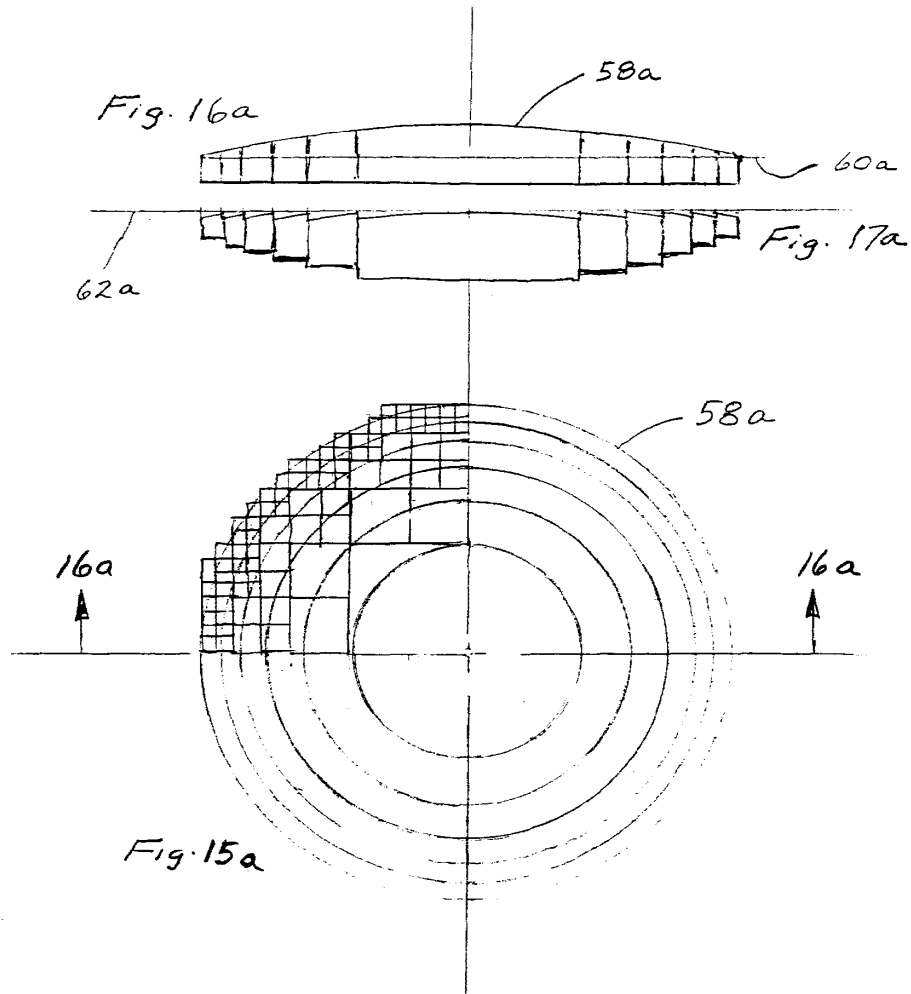

Fig. 11



6/20

7/20



8/20

Fig. 21

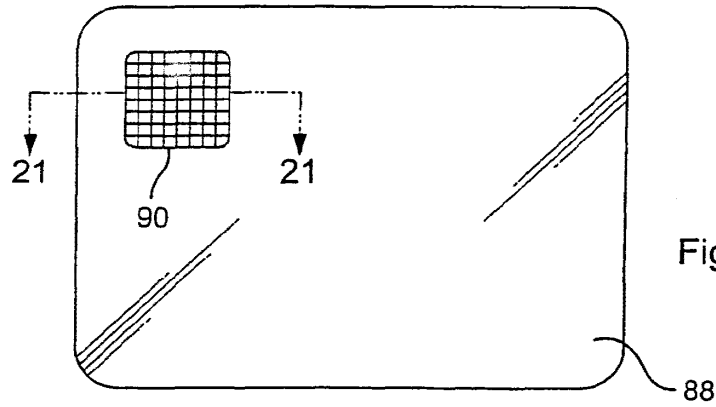
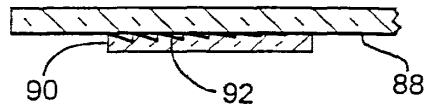

Fig. 20

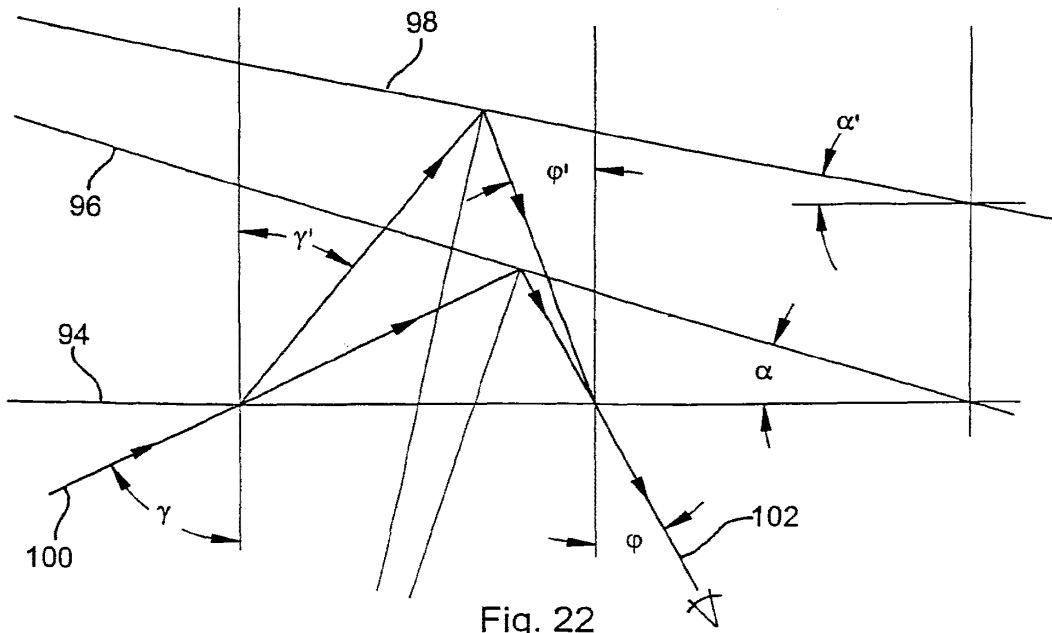

Fig. 22

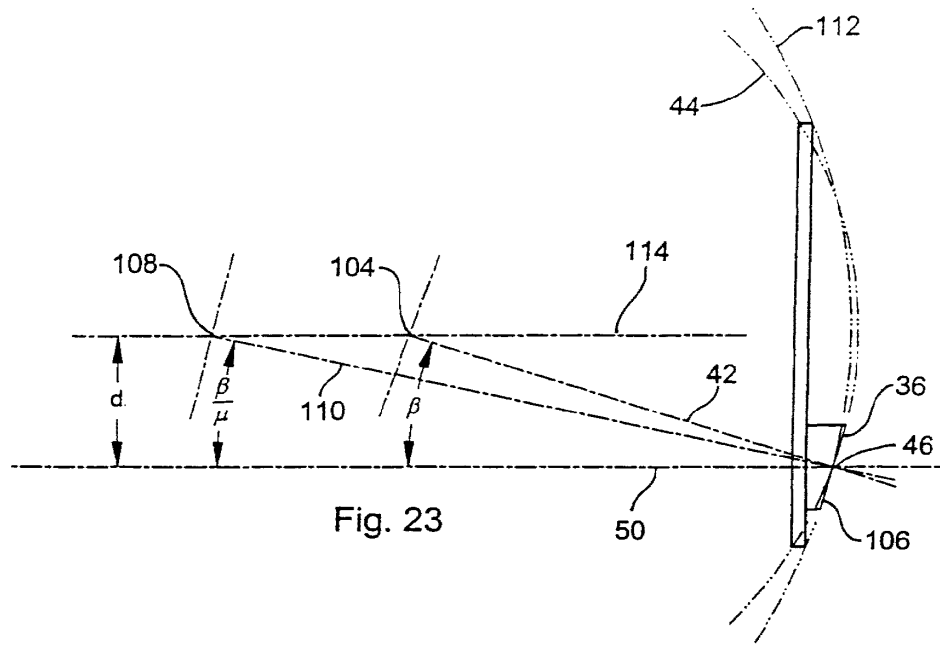

Fig. 23

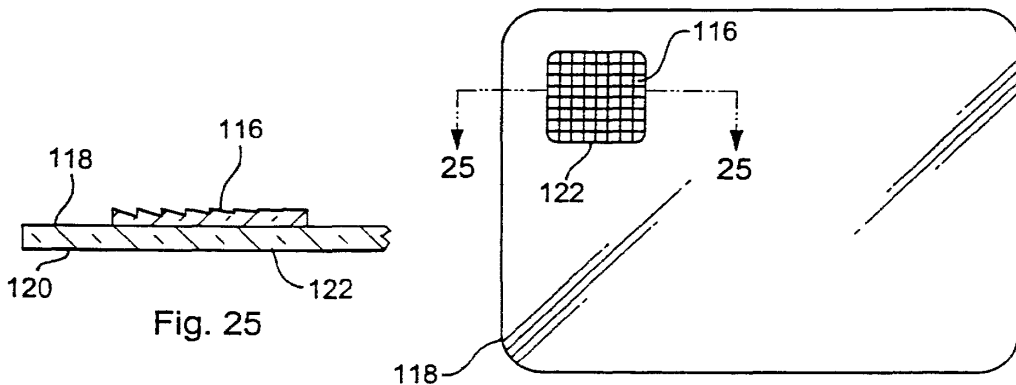
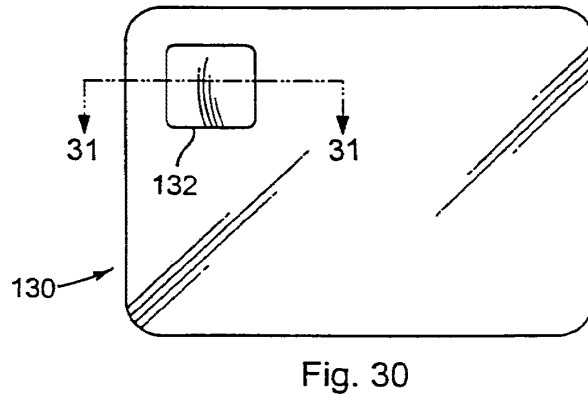
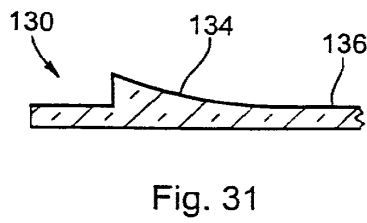
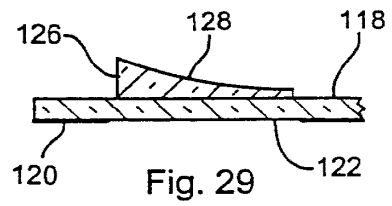
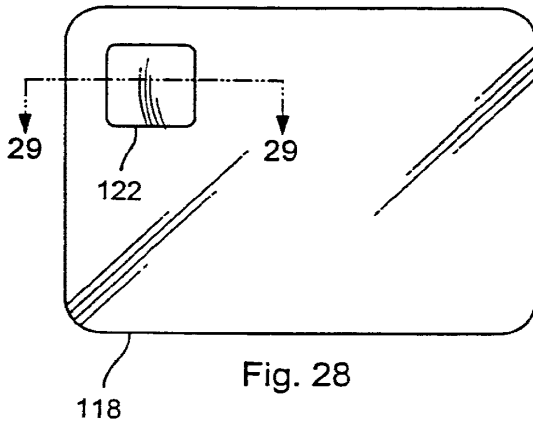
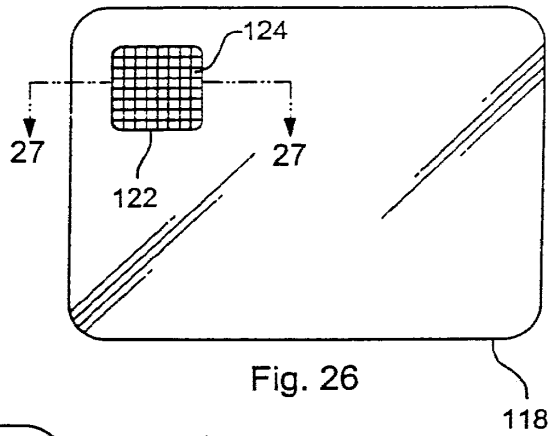
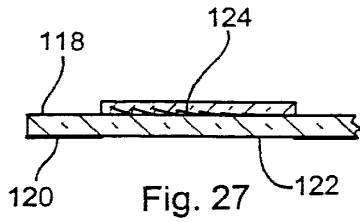

Fig. 25

Fig. 24



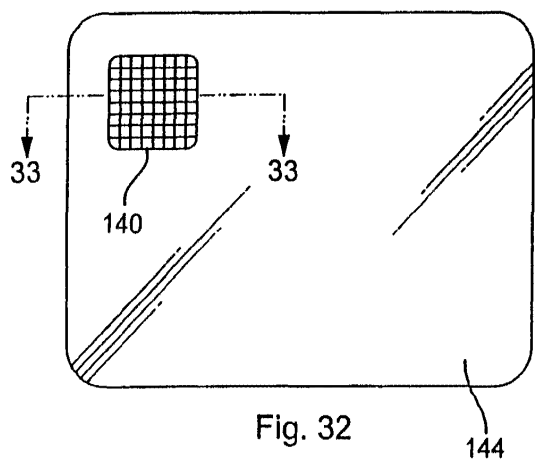

Fig. 32

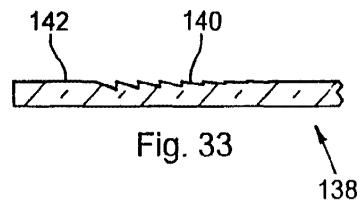

Fig. 33

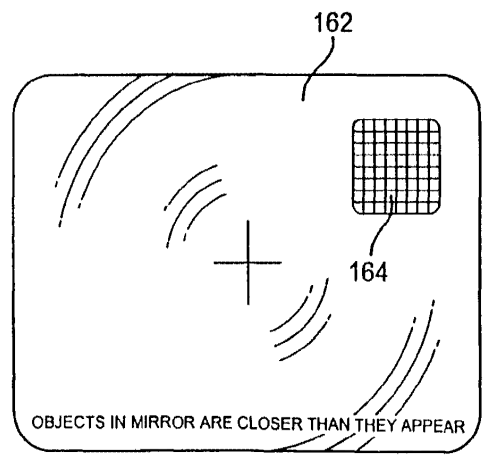

Fig. 35

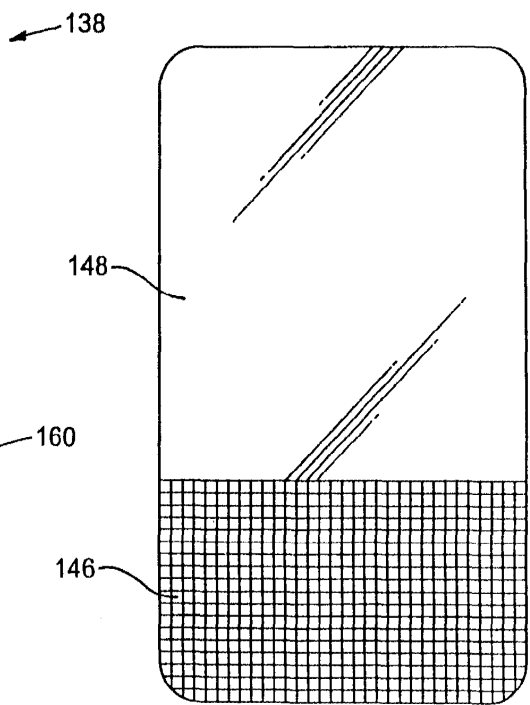
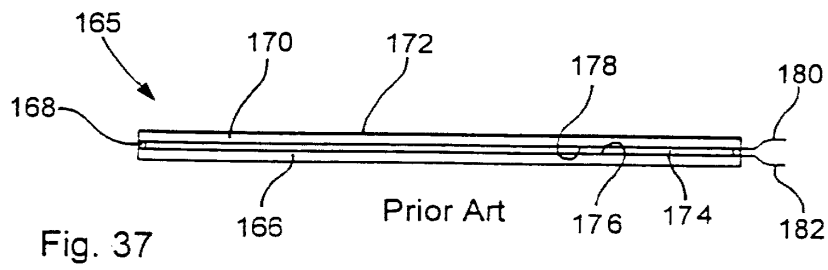
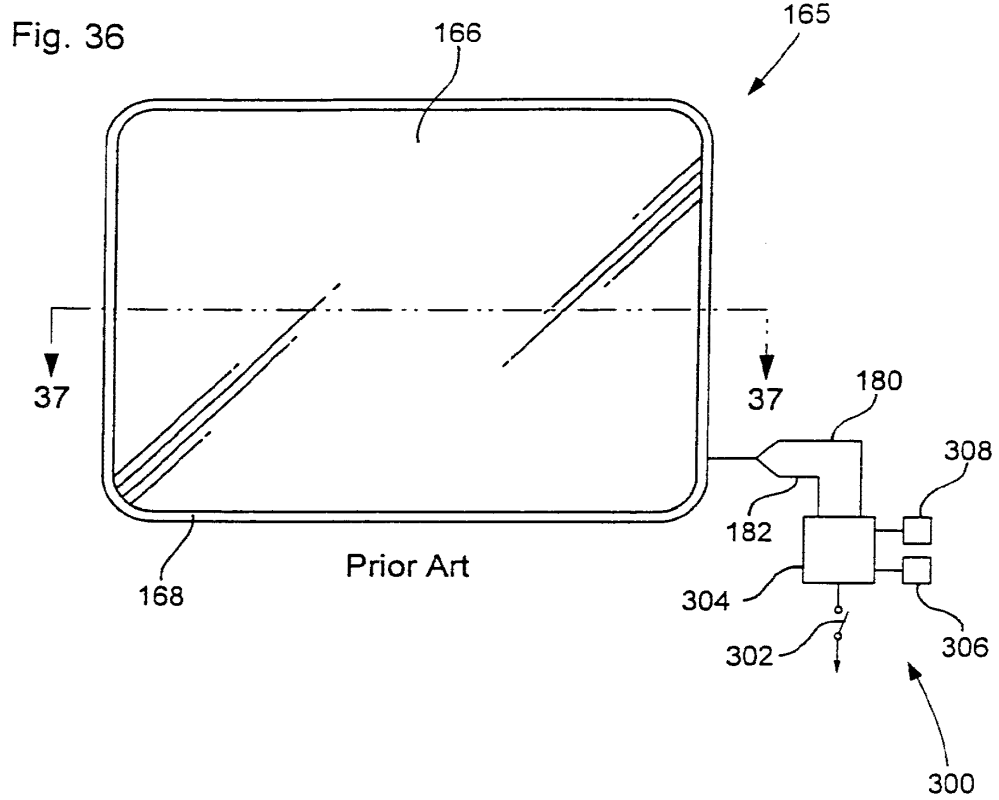
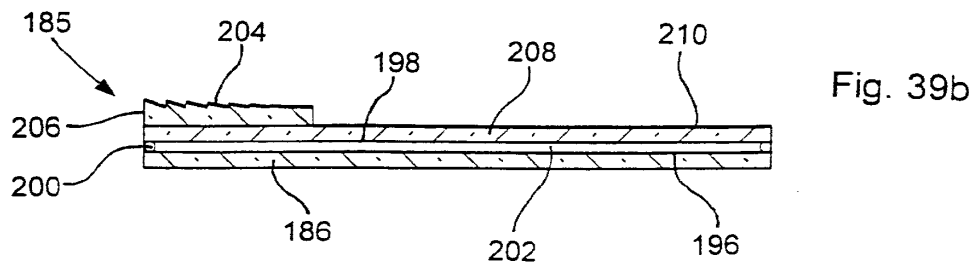
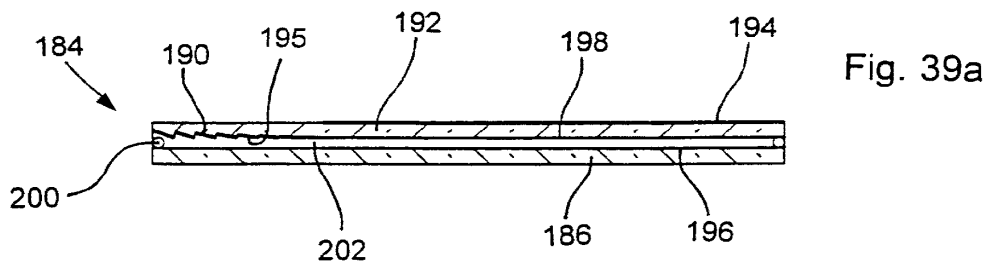
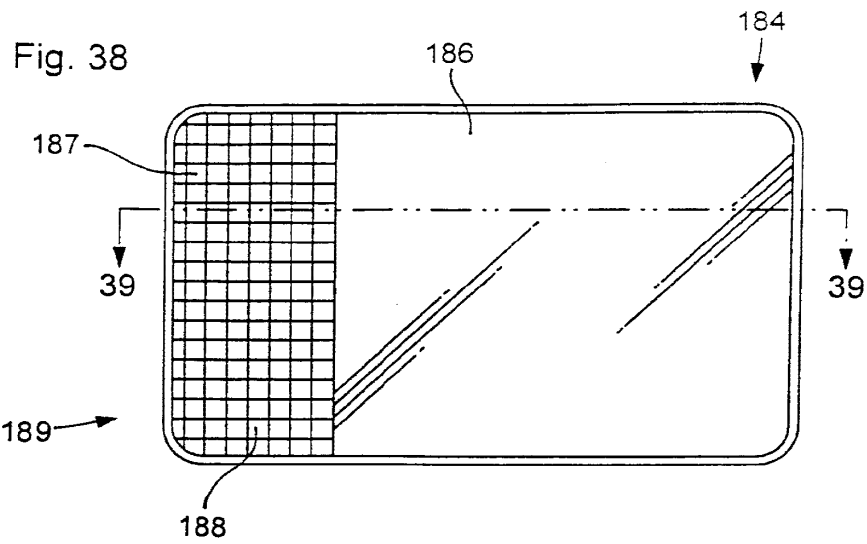

Fig. 34





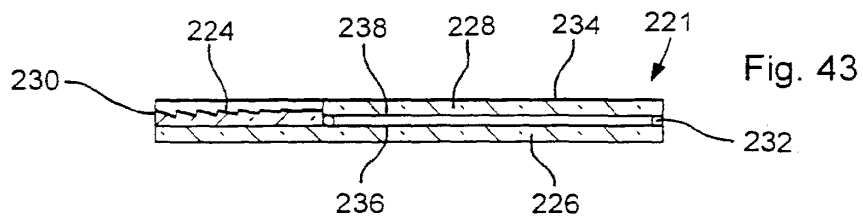
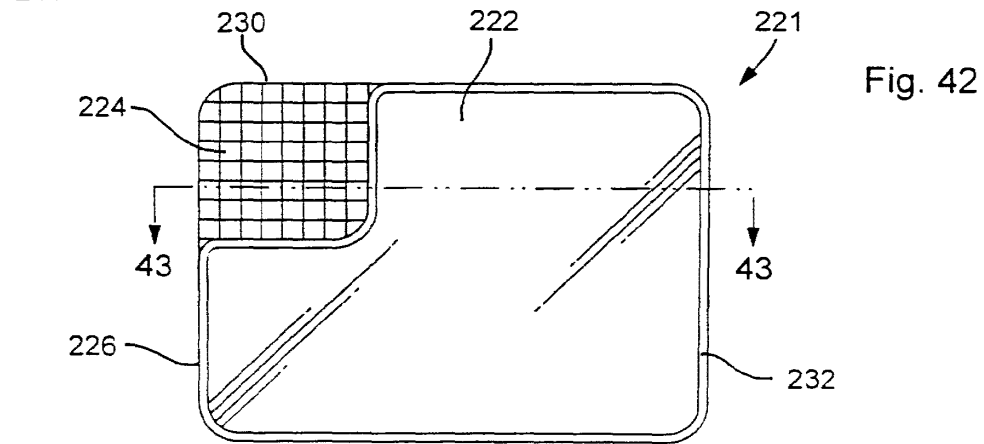
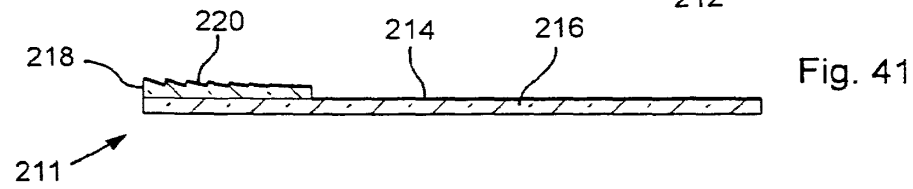
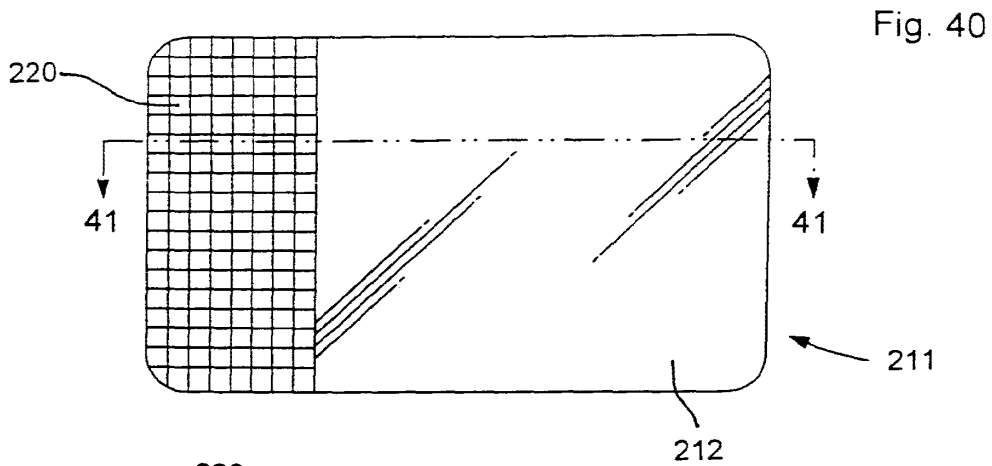

Fig. 44

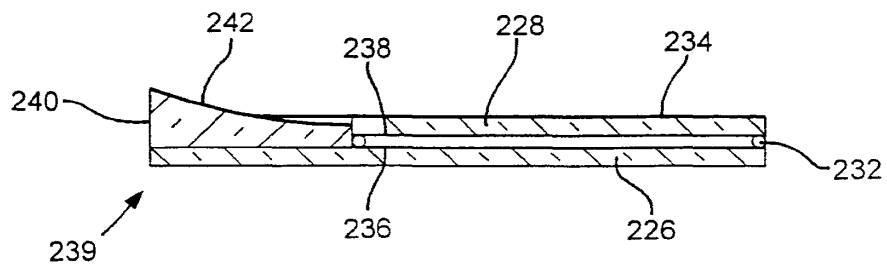
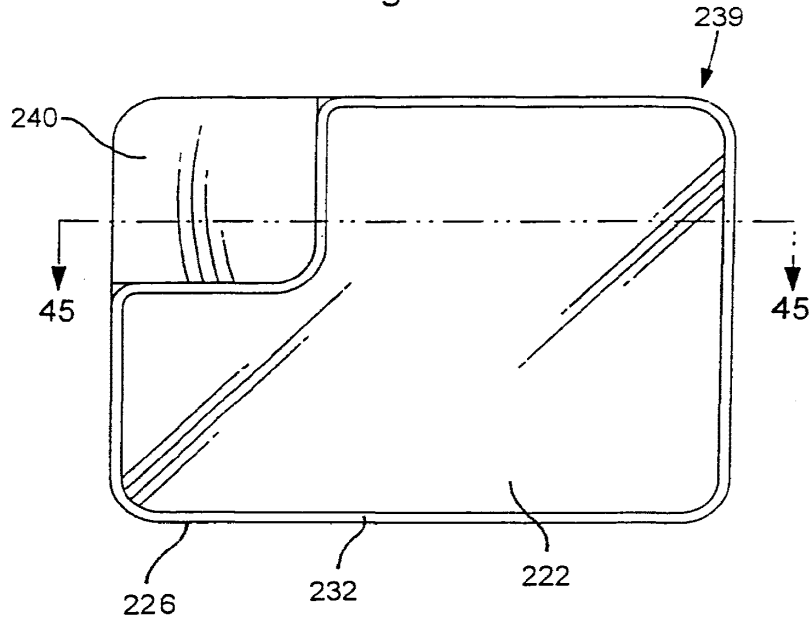

Fig. 45

16/20

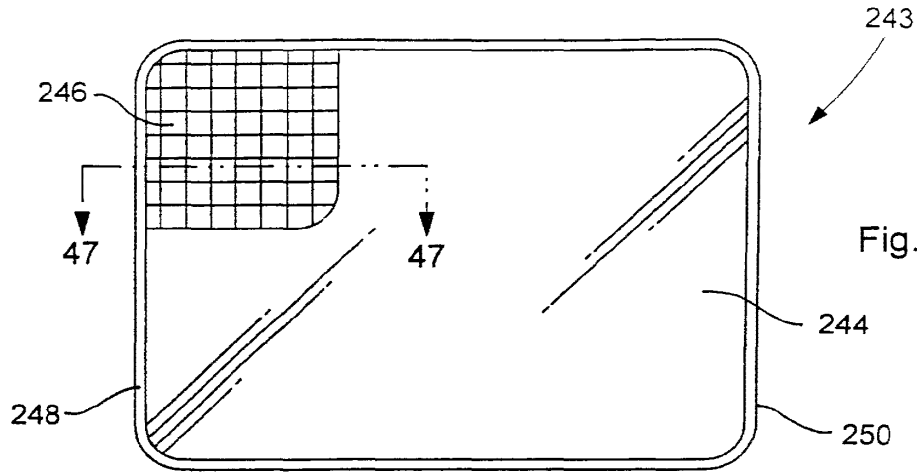

Fig. 46

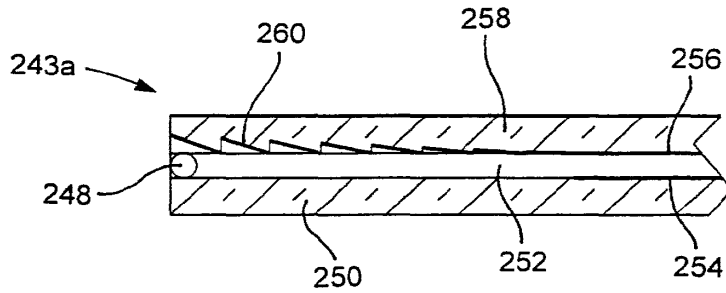

Fig. 47a

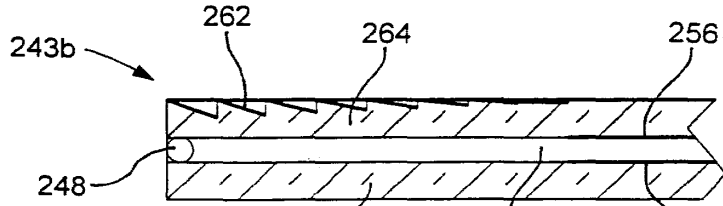

Fig. 47b

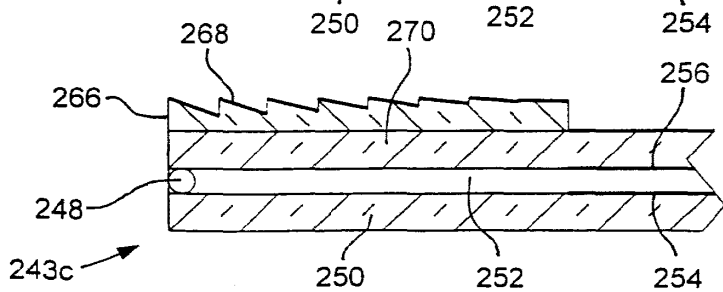
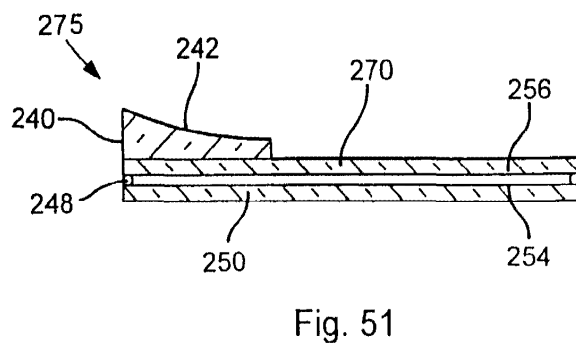
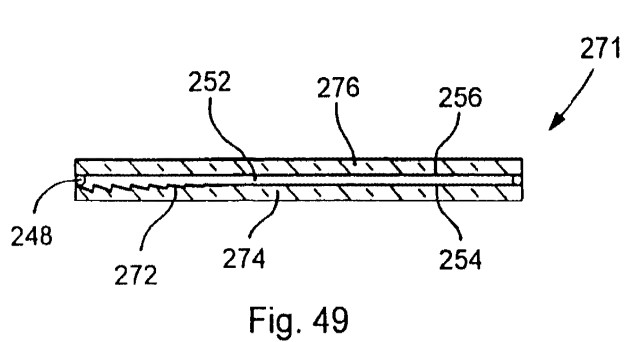
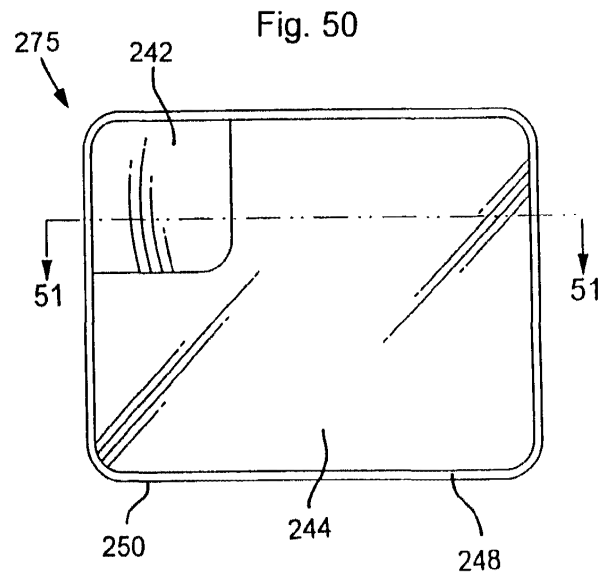
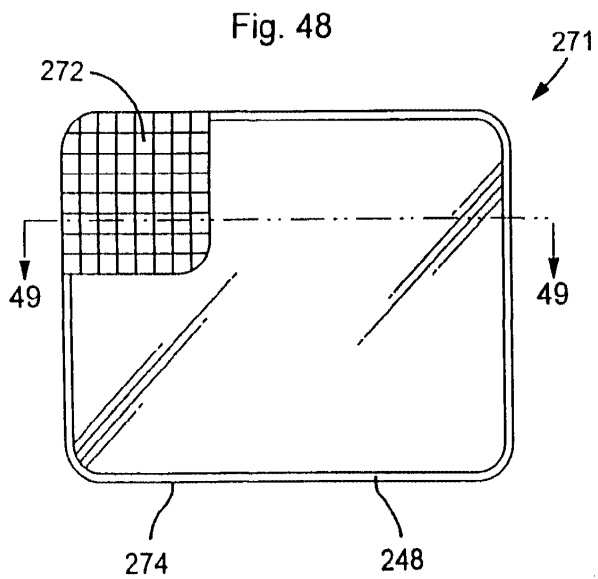

Fig. 47c



17/20

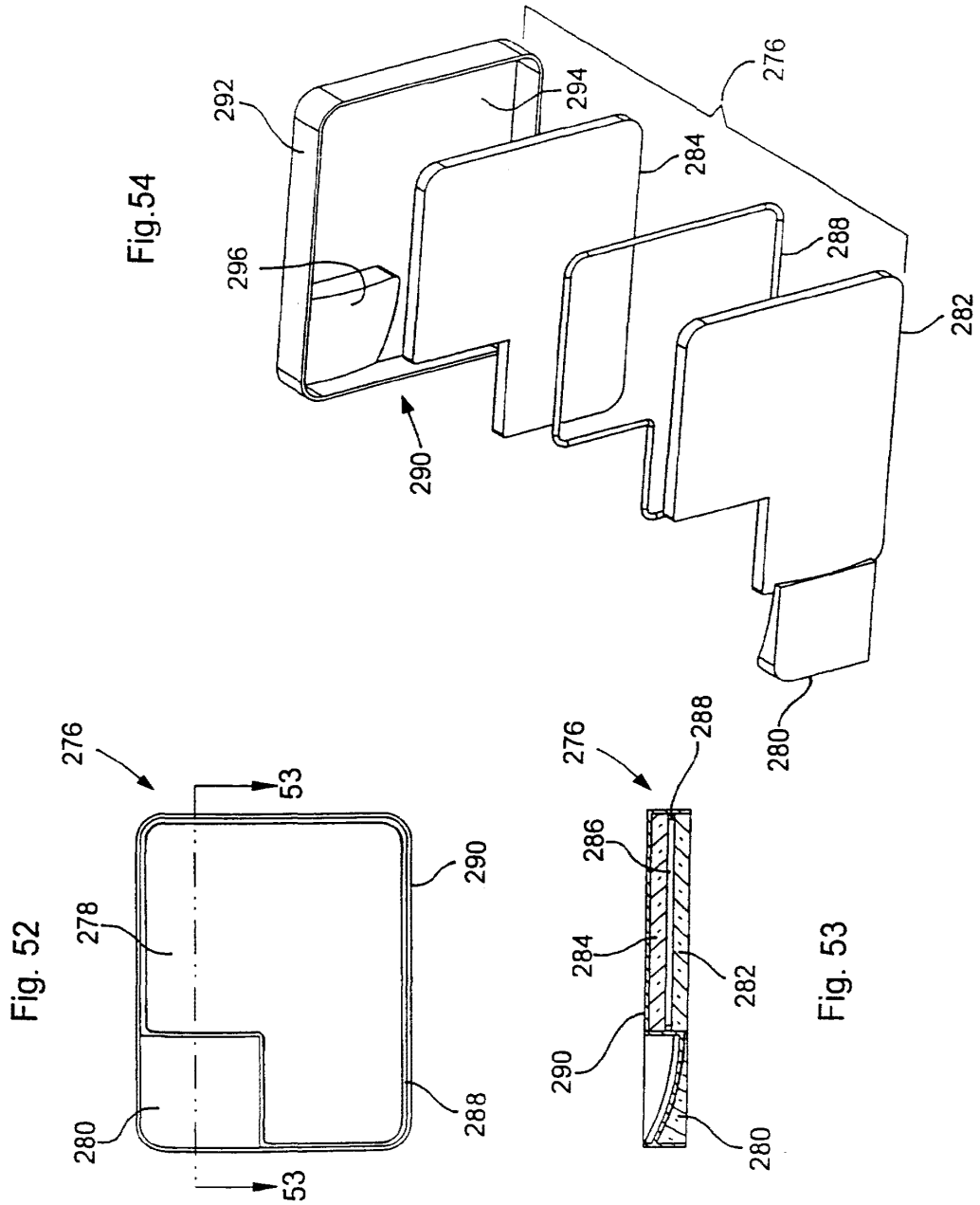

Fig. 55

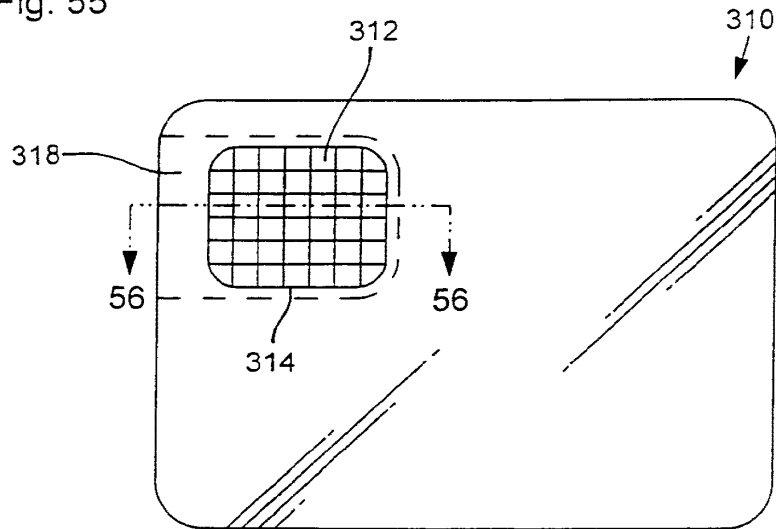
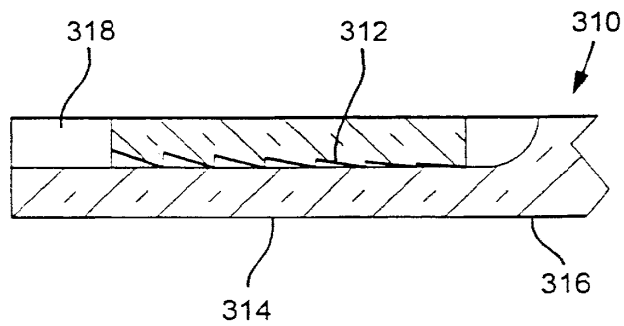

Fig. 56



20/20

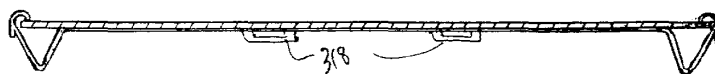
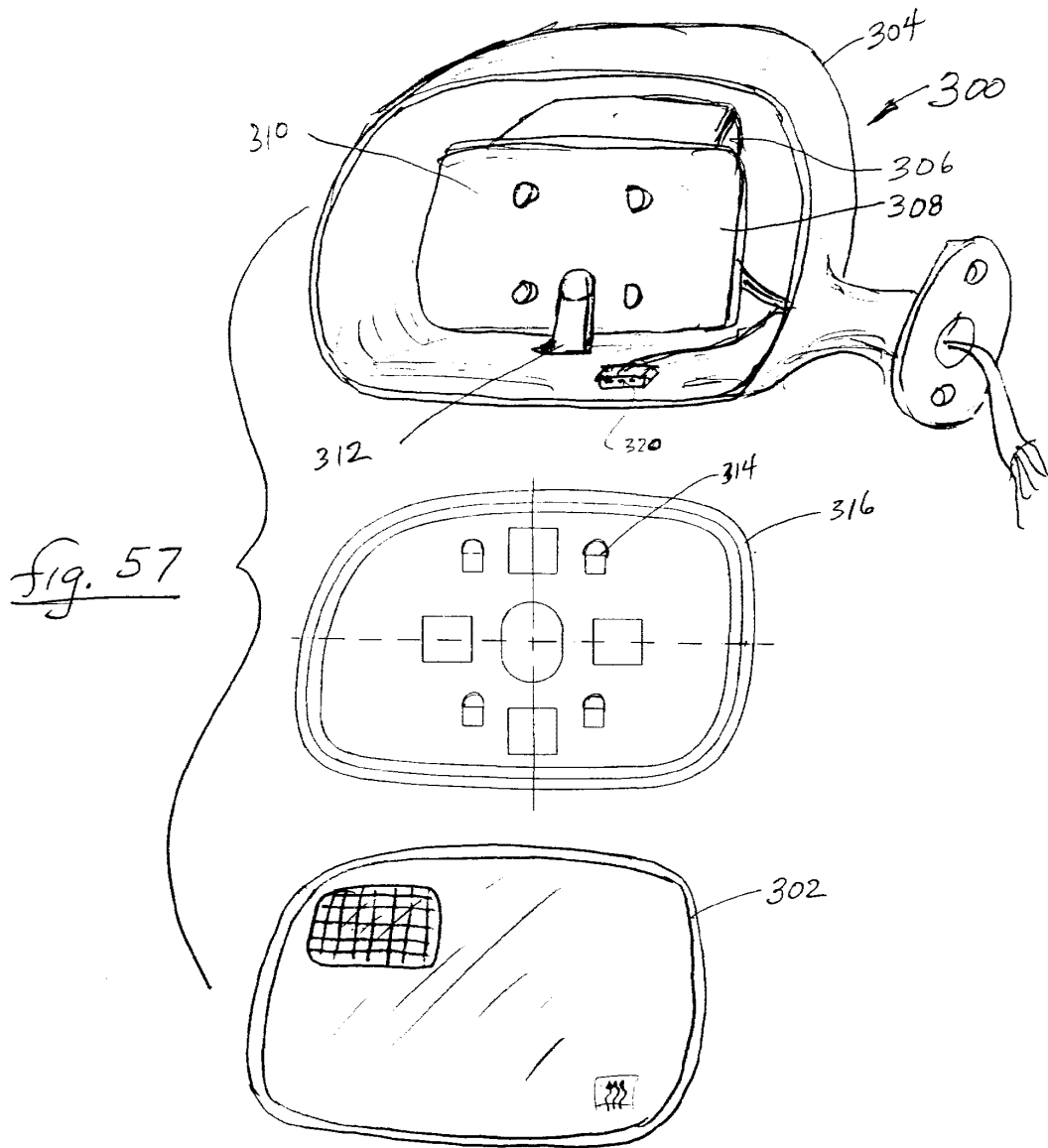

fig. 58

INTERNATIONAL SEARCH REPORT

International application No.

PCT/US01/13283

A. CLASSIFICATION OF SUBJECT MATTER				
IPC(7) : G02B 5/08				
US CL : 359/856, 857, 871, 872				
According to International Patent Classification (IPC) or to both national classification and IPC				
B. FIELDS SEARCHED				
Minimum documentation searched (classification system followed by classification symbols) U.S. : 359/856, 857, 871, 872				
Documentation searched other than minimum documentation to the extent that such documents are included in the fields searched NONE				
Electronic data base consulted during the international search (name of data base and, where practicable, search terms used) NONE				
C. DOCUMENTS CONSIDERED TO BE RELEVANT				
Category *	Citation of document, with indication, where appropriate, of the relevant passages	Relevant to claim No.		
Y	US 4,436,372 A (SCHMIDT et al.) 13 March 1984 (13.03.1984), whole document.	1-55		
Y	US 5,847,889 A (KOMIYAMA et al.) 08 December 1998 (08.12.1998), whole document.	1-55		
<input type="checkbox"/> Further documents are listed in the continuation of Box C. <input type="checkbox"/> See patent family annex.				
* Special categories of cited documents: <table border="0" style="width: 100%;"> <tr> <td style="width: 50%;"> "A" document defining the general state of the art which is not considered to be of particular relevance "E" earlier application or patent published on or after the international filing date "L" document which may throw doubts on priority claim(s) or which is cited to establish the publication date of another citation or other special reason (as specified) "O" document referring to an oral disclosure, use, exhibition or other means "P" document published prior to the international filing date but later than the priority date claimed </td> <td style="width: 50%;"> "T" later document published after the international filing date or priority date and not in conflict with the application but cited to understand the principle or theory underlying the invention "X" document of particular relevance; the claimed invention cannot be considered novel or cannot be considered to involve an inventive step when the document is taken alone "Y" document of particular relevance; the claimed invention cannot be considered to involve an inventive step when the document is combined with one or more other such documents, such combination being obvious to a person skilled in the art "&" document member of the same patent family </td> </tr> </table>			"A" document defining the general state of the art which is not considered to be of particular relevance "E" earlier application or patent published on or after the international filing date "L" document which may throw doubts on priority claim(s) or which is cited to establish the publication date of another citation or other special reason (as specified) "O" document referring to an oral disclosure, use, exhibition or other means "P" document published prior to the international filing date but later than the priority date claimed	"T" later document published after the international filing date or priority date and not in conflict with the application but cited to understand the principle or theory underlying the invention "X" document of particular relevance; the claimed invention cannot be considered novel or cannot be considered to involve an inventive step when the document is taken alone "Y" document of particular relevance; the claimed invention cannot be considered to involve an inventive step when the document is combined with one or more other such documents, such combination being obvious to a person skilled in the art "&" document member of the same patent family
"A" document defining the general state of the art which is not considered to be of particular relevance "E" earlier application or patent published on or after the international filing date "L" document which may throw doubts on priority claim(s) or which is cited to establish the publication date of another citation or other special reason (as specified) "O" document referring to an oral disclosure, use, exhibition or other means "P" document published prior to the international filing date but later than the priority date claimed	"T" later document published after the international filing date or priority date and not in conflict with the application but cited to understand the principle or theory underlying the invention "X" document of particular relevance; the claimed invention cannot be considered novel or cannot be considered to involve an inventive step when the document is taken alone "Y" document of particular relevance; the claimed invention cannot be considered to involve an inventive step when the document is combined with one or more other such documents, such combination being obvious to a person skilled in the art "&" document member of the same patent family			
Date of the actual completion of the international search 04 June 2001 (04.06.2001)		Date of mailing of the international search report 03 JUL 2001		
Name and mailing address of the ISA/US Commissioner of Patents and Trademarks Box PCT Washington, D.C. 20231 Facsimile No. (703)305-3230		Authorized officer <i>Shawn S. Noppe</i> MOHAMMAD Y SIKDER Telephone No. 703-308-0530		

Form PCT/ISA/210 (second sheet) (July 1998)

(12) INTERNATIONAL APPLICATION PUBLISHED UNDER THE PATENT COOPERATION TREATY (PCT)

(19) World Intellectual Property
Organization
International Bureau



(43) International Publication Date
1 April 2004 (01.04.2004)

PCT

(10) International Publication Number
WO 2004/026633 A2

(51) International Patent Classification⁷: **B60R**

1281 Innisbrook Court, Holland, MI 49423 (US). **LY-NAM, Niall, R.** [US/US]; 248 Foxdown, Holland, MI 49424 (US).

(21) International Application Number:
PCT/US2003/029776

(22) International Filing Date:
19 September 2003 (19.09.2003)

(74) Agent: **FLORY, Timothy**; Van Dyke, Gardner, Linn & Burkhart, LLP, 2851 Charlevoix Drive SE, Suite 207, P.O. Box 888695, Grand Rapids, MI 49588-8695 (US).

(25) Filing Language: English

(26) Publication Language: English

(30) Priority Data:
60/412,275 20 September 2002 (20.09.2002) US
60/424,116 5 November 2002 (05.11.2002) US
60/489,816 24 July 2003 (24.07.2003) US

(81) Designated States (*national*): AE, AG, AL, AM, AT, AU, AZ, BA, BB, BG, BR, BY, BZ, CA, CH, CN, CO, CR, CU, CZ, DE, DK, DM, DZ, EC, EE, EG, ES, FI, GB, GD, GE, GH, GM, HR, HU, ID, IL, IN, IS, JP, KE, KG, KP, KR, KZ, LC, LK, LR, LS, LT, LU, LV, MA, MD, MG, MK, MN, MW, MX, MZ, NI, NO, NZ, OM, PG, PH, PL, PT, RO, RU, SC, SD, SE, SG, SK, SL, SY, TJ, TM, TN, TR, TT, TZ, UA, UG, US, UZ, VC, VN, YU, ZA, ZM, ZW.

(71) Applicant (*for all designated States except US*): **DONNELLY CORPORATION** [US/US]; 414 East Fortieth Street, Holland, MI 49423 (US).

(84) Designated States (*regional*): ARIPO patent (GH, GM, KE, LS, MW, MZ, SD, SL, SZ, TZ, UG, ZM, ZW), Eurasian patent (AM, AZ, BY, KG, KZ, MD, RU, TJ, TM), European patent (AT, BE, BG, CH, CY, CZ, DE, DK, EE, ES, FI, FR, GB, GR, HU, IE, IT, LU, MC, NL, PT, RO, SE, SI, SK, TR), OAPI patent (BF, BJ, CF, CG, CI, CM, GA, GN, GQ, GW, ML, MR, NE, SN, TD, TG).

(72) Inventors; and
(75) Inventors/Applicants (*for US only*): **MCCABE, Ian, A.** [IE/US]; 16092 Ransom Street, Holland, MI 49424 (US). **HABIBI, Hamid** [IR/US]; 4057 66th Street, Holland, MI 49423 (US). **VARAPRASAD, Desaraju, V.** [US/US];

[Continued on next page]

(54) Title: MIRROR REFLECTIVE ELEMENT ASSEMBLY

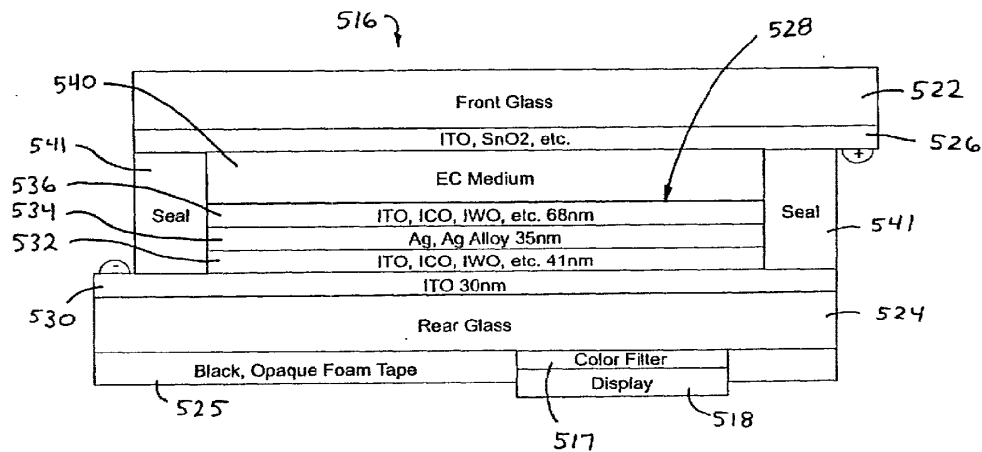

(57) Abstract: A mirror assembly for a vehicle includes a mirror element having at least one substrate that has a forward surface and a rearward surface. The mirror element comprises at least one substantially reflective metallic layer sandwiched between a respective pair of substantially transparent non-metallic layers. Each of the substantially transparent non-metallic layers and the substantially reflective metallic layer have a selected refractive index and a selected physical thickness such that the reflective element is selectively spectrally tuned to substantially transmit at least one preselected spectral band of radiant energy therethrough while substantially reflecting other radiant energy. A radiant energy emitting element is disposed at or near the rearward surface of the at least one substrate. The radiant energy emitting element is configured to emit radiant energy with a peak intensity within the at least one preselected spectral band.

WO 2004/026633 A2



Published:

— without international search report and to be republished upon receipt of that report

For two-letter codes and other abbreviations, refer to the "Guidance Notes on Codes and Abbreviations" appearing at the beginning of each regular issue of the PCT Gazette.

PATENT
DON01 FP-1109 (PCT)
Express Mail No. EV327021890US

MIRROR REFLECTIVE ELEMENT ASSEMBLY

CROSS REFERENCE TO RELATED APPLICATIONS

The present application claims priority of U.S. provisional applications, Ser. No. 60/412,275, filed Sep. 20, 2002 by McCabe for ELECTROCHROMIC MIRROR ASSEMBLY (Attorney Docket DON01 P-1011); Ser. No. 60/424,116, filed Nov. 5, 2002 by McCabe for ELECTROCHROMIC MIRROR ASSEMBLY (Attorney Docket DON01 P-1045); and Ser. No. 60/489,816, filed Jul. 24, 2003 by McCabe for ELECTROCHROMIC MIRROR ASSEMBLY (Attorney Docket DON01 P-1099), which are all hereby incorporated herein by reference in their entireties.

10

FIELD OF THE INVENTION

The present invention relates to a mirror reflective element assembly for a vehicle, such as an electro-optic mirror reflective element assembly, such as an electrochromic interior or exterior rearview mirror reflective element assembly, and, more particularly, to a rearview mirror reflective element assembly which provides transmission of display information or illumination or radiant energy through the reflective element of the mirror reflective element assembly, while providing sufficient reflectance of the reflective element. Aspects of the present invention are equally applicable to interior and exterior mirror reflective element assemblies, as well as to prismatic mirror reflective element assemblies or other mirror reflective element assemblies having a single glass substrate.

15

BACKGROUND OF THE INVENTION

Variable reflectivity mirror assemblies, such as electrochromic mirror assemblies are known and are widely implemented in vehicles. The reflective element of the mirror assemblies often include two substrates or glass elements. The back or outer surface of the second substrate (commonly referred to as the "fourth surface" of the reflective element) may include a silvered coating to provide reflectance of an image. In embodiments where the mirror assembly may include a display, a window may be formed, such as by sand blasting, laser etching or the like, through the silvered coating, such that display information may be transmitted through the window for viewing by the driver. The window provides a highly transmissive, generally spectrally neutral window for the display. However, the window defines an area of the reflective element that no longer has the reflective coating,

20

such that reflectivity is lost in the window area. Therefore, the size and the quantity of displays that can be provided at the mirror reflective element is limited.

It is known to provide a metallic reflective layer on an inward surface of the second substrate of the electrochromic reflective element (commonly known in the art as a "third surface" of the reflective element), such as disclosed in U.S. Pat. No. 3,280,701, which is hereby incorporated herein by reference. An electrochromic medium may be positioned between the metallic layer and a transparent electrically conductive layer on the inward surface of the first substrate (i.e., the "second surface" of the reflective element). However, there are concerns with the electrochromic medium of such mirror assemblies contacting the metallic layer, since chemical and/or electro-chemical attack on the metallic layer may result in corrosion of the metallic layer.

As disclosed in U.S. Pat. No. 5,724,187, which is hereby incorporated herein by reference, a metallic conductive layer may be disposed on the third surface, with a protective layer, such as a transparent semi-conductive layer of indium tin oxide, disposed on the metallic layer. The electrochromic medium is then positioned between the protective layer and a conductive layer on the inward surface of the first substrate. It is preferable for such designs to include an adhesion layer, such as a second transparent semi-conductive layer, such as indium tin oxide, or another metallic layer, between the metallic layer and the inward surface of the second substrate, in order to enhance adhesion of the metallic layer to the second substrate.

In electrochromic mirror assemblies which include a display that may transmit through the substrates of the reflective element, the metallic layer or coating must be thin enough to be transmissive to allow viewing of the display through the metallic coating. It is known to provide a thinner metallic coating in a display area to provide increased transmissivity (but with a consequently reduced reflectivity) only in the display area or areas of the reflective element, such as disclosed in U.S. Pat. No. 6,356,376, which is hereby incorporated herein by reference. However, such designs have layers or coatings that are relatively thin (often less than 150Å or thereabouts in thickness) and so any variation in metallic layer thickness may lead to a significant variation in light transmission through such thin metallic coatings. Thus, such significantly thin metallic coatings or layers may have a substantially low variability tolerance for the thickness and may require a substantially uniform thickness coating, in order to provide the desired results. Such tolerances and uniformity may be difficult to achieve through sputter coating or other coating processes

typically used in the manufacture of such reflective elements. Therefore, such significantly thin metallic coatings may be difficult and costly to manufacture.

An example of a known electrochromic reflective element is shown in FIG. 1. The reflective element includes an electrochromic (EC) medium layer and a metallic reflective layer sandwiched between conductive layers at the front and rear glass substrates. A display is positioned at a rear surface of the rear substrate (the fourth surface of the reflective element). The display emits light through the substrates and layers therebetween so as to be viewable by a person viewing the first surface of the reflective element. Such known reflective elements provide little or no spectrally selective transmission characteristics of visible light, as can be seen with reference to FIG. 1A (which shows the transmissivity of the ITO and silver layers at the rear substrate versus the wavelength of the radiant energy), and may be subject to chemical/electrochemical corrosion through contact with the EC medium.

Sometimes it is desired to have an illumination source and/or a camera or imaging device or sensor at an interior rearview mirror assembly for illuminating and/or capturing images of the interior cabin of the vehicle, such as part of a cabin monitoring system, a driver alertness/drowsiness detection system, an intrusion detection system, a seat occupancy detection system and/or the like. The illumination sources and imaging device, if provided at the interior rearview mirror assembly, are typically positioned around the bezel, chin or eyebrow portion of the mirror casing or at a pod or module associated with the mirror assembly or elsewhere in the vehicle. The illumination sources and imaging device cannot typically be positioned within the mirror casing due to the difficulties encountered in projecting light or illumination through the reflective element to the cabin and allowing light from within the cabin to pass through the reflective element to the imaging device. Typically, such transmissivity of light, even of infrared or near infrared light, through the reflective element may not be achieved utilizing reflective coatings that comprise a metallic layer, such as a thin silver or silver alloy or aluminum or aluminum alloy layer or the like. In such applications, the infrared or near infrared light emitted by the illumination source may reflect back into the cavity of the mirror casing, such that a desired amount of light may not reach the cabin and such that the imaging device may be adversely affected by the reflectant light.

Therefore, there is a need in the art for an electrochromic mirror assembly which provides sufficient reflectivity and sufficient transmissivity to allow for transmission

of display information or illumination through the reflective element, and which overcomes the above disadvantages and shortcomings of the prior art.

SUMMARY OF THE INVENTION

The present invention provides an interior or exterior rearview mirror
5 assembly that has a mirror reflective element that may be spectrally tuned to substantially transmit light having a particular wavelength or range of wavelengths, while substantially reflecting other light. The mirror reflective element may comprise a third surface reflective element having a particular combination or stack of at least partially conductive layers (such as semi-conductive layers formed of at least partially conducting inorganic oxides, such as
10 doped or undoped indium oxide, doped or undoped tin oxide, doped or undoped zinc oxide, doped or undoped nickel oxide, and/or doped or undoped tungsten oxide or the like) and metallic layer(s) at the third surface. The mirror assembly is suitable for including a display element which emits and transmits viewable information through the reflective element of the mirror assembly. More particularly, the mirror assembly of the present invention is suitable
15 for including a display on demand (DOD) type of display. The mirror assembly of the present invention provides a particular combination of reflector design or designs suitable for a display on demand type of display which are economical and which match and/or make most beneficial use of a particular light emitting display element and color thereof. The present invention thus provides a spectrally selective transmission of visible light
20 characteristic to the reflective element of the mirror assembly, while maintaining a substantially non-spectrally selective, substantially untinted reflectant characteristic, and while maintaining a relatively high photopic reflectance, such as greater than approximately 60% photopic reflectivity, more preferably greater than approximately 70% photopic reflectivity, and most preferably greater than approximately 80% photopic reflectivity. The
25 spectrally selective transmissivity of the reflective element may thus be selected or tuned to optimize transmission of a particular spectral band or range of light wavelengths at least primarily emitted by the display element.

According to an aspect of the present invention, a mirror assembly for a vehicle comprises a mirror element including at least one substrate having a forward surface
30 facing towards a viewer of the mirror assembly and a rearward surface facing away from a viewer of the mirror assembly. The mirror element comprises at least one substantially reflective metallic layer sandwiched between a respective pair of substantially transparent non-metallic layers. Each of the substantially transparent non-metallic layers and the

substantially reflective metallic layer have a selected refractive index and a selected physical thickness such that the reflective element is selectively spectrally tuned to substantially transmit at least one preselected spectral band of radiant energy therethrough while substantially reflecting other radiant energy. A radiant energy emitting element is disposed at
5 or near the rearward surface of the at least one substrate. The radiant energy emitting element is operable to emit radiant energy towards the rearward surface and through the mirror element. The radiant energy emitting element is operable to emit radiant energy with a peak intensity within the at least one preselected spectral band.

Optionally, the at least one preselected spectral band may comprise a
10 preselected band of visible light, while the radiant energy emitting element may be operable to emit visible radiant energy or light with a peak intensity within the preselected spectral band of visible light. The radiant energy emitting element thus may provide a display on demand type of display for viewing of displayed or emitted information through the reflective element.

15 Optionally, the at least one preselected spectral band may comprise first and second preselected bands of radiant energy, while the radiant energy emitting element comprises first and second radiant energy emitting elements. The first radiant energy emitting element may be operable to emit radiant energy with a peak intensity within the first preselected spectral band of radiant energy and the second radiant energy emitting element
20 may be operable to emit visible radiant energy with a peak intensity within the second preselected spectral band of radiant energy.

Optionally, the at least one preselected spectral band may comprise a
preselected band of near infrared radiant energy, while the radiant energy emitting element may be operable to emit near infrared radiant energy with a peak intensity within the
25 preselected spectral band of near infrared radiant energy. The mirror assembly may include an imaging sensor at or near the rear surface that may be sensitive to near infrared radiant energy.

Optionally, the mirror reflective element may comprise an electro-optic or electrochromic mirror element, and may comprise an electrochromic medium sandwiched
30 between a pair of substrates. The non-metallic and metallic layers may be disposed on a third surface (the surface of the rear substrate that opposes electrochromic medium and the front substrate).

Optionally, the mirror reflective element may comprise a prismatic mirror element. The alternating non-metallic and metallic layers may be disposed on a rear surface of the prismatic element or substrate. The radiant energy emitting element may be positioned at a rear layer of the alternating layers and operable to emit radiant energy or light through
5 the layers and the prismatic substrate, such that the information displayed or emitted by the radiant energy emitting element is viewable through the prismatic reflective element by a driver or occupant of the vehicle, while the prismatic reflective element substantially reflects light having other wavelengths or spectral bands. The radiant energy emitting element thus may provide a display on demand type of display to the prismatic mirror element.

10 According to another aspect of the present invention, an electrochromic mirror assembly for a vehicle comprises an electrochromic mirror element comprising a first substrate having first and second surfaces and a second substrate having third and fourth surfaces. The first and second substrates are arranged so that the second surface opposes the third surface with an electrochromic medium disposed therebetween. The third surface of the
15 second substrate comprises a transflective reflector comprising a first substantially transparent semi-conductive non-metallic layer contacting the electrochromic medium, a second substantially transparent semi-conductive non-metallic layer, and a substantially reflective metallic conductive layer sandwiched between (and electrically in contact/
20 connection with) the first and second substantially transparent semi-conductive non-metallic layers. When the mirror element is viewed from outside the first surface (such as by a driver or passenger within the vehicle), the mirror element is substantially spectrally untinted (i.e., is substantially spectrally unselective in photopic reflectivity) when no voltage is applied across the electrochromic medium. The mirror element is at least partially spectrally selective in
25 transmission (i.e., is at least partially tinted for transmittant light) and exhibits a spectrally selective transmission characteristic, which is established by the refractive indices and physical thicknesses of the first and second substantially transparent semi-conductive non-metallic layers and the substantially reflective metallic conductive layer. The mirror assembly includes a light emitting or display element disposed at the fourth surface of the second substrate which is operable to emit light having an emitted spectral characteristic
30 through the mirror element. The transflective reflector is configured to exhibit a spectrally selective transmission characteristic so as to substantially transmit light having a spectral band in regions at or near the emitted spectral characteristic and to substantially reflect other light.

Optionally, the second substantially transparent semi-conductive non-metallic layer may contact the third surface of the second substrate. Optionally, the transflective reflector may comprise two or more substantially reflective metallic conductive layers. Each of the two or more substantially reflective metallic conductive layers may be sandwiched
5 between a respective pair of substantially transparent semi-conductive non-metallic layers disposed between the electrochromic medium and the second substrate.

Optionally, the transflective reflector may substantially transmit light or radiant energy having a spectral band in the near infrared region of the spectrum, while the light emitting or display element may emit near infrared light or radiant energy through the
10 transflective reflector. The mirror assembly may include an imaging sensor at the fourth surface that is operable to sense near infrared light.

Optionally, the transflective reflector may substantially transmit light having a first spectral band at a first visible region of the spectrum, and may also substantially transmit light having a second spectral band at a second visible region of the spectrum. The light
15 emitting or display element may emit light that has a peak intensity at or near the first visible region, while the mirror assembly may include a second light emitting element at the fourth surface that may emit light that has a peak intensity at or near the second visible region.

According to another aspect of the present invention, an electro-optic mirror assembly, such as an electrochromic mirror assembly, for a vehicle comprises an
20 electrochromic mirror element comprising a first substrate having first and second surfaces and a second substrate having third and fourth surfaces. The first and second substrates are arranged so that the second surface opposes the third surface, with an electrochromic medium disposed between the second substrate and the first substrate. The mirror element comprises a transflective reflector at the third surface, which comprises at least one conductive metallic
25 reflective layer sandwiched between first and second substantially transparent semi-conductive non-metallic layers. The first substantially transparent semi-conductive non-metallic layer contacts the electrochromic medium. The mirror assembly includes a display element at the fourth surface of the second substrate. A refractive index and a physical thickness of each of the first and second substantially transparent semi-conductive non-
30 metallic layers and the substantially reflective metallic conductive layer are selected such that the transflective reflector is selectively spectrally tuned to substantially transmit at least one preselected spectral band of visible light therethrough while substantially reflecting other

visible light. The display element is configured to emit visible light with a peak intensity within the preselected spectral band.

According to another aspect of the present invention, a mirror assembly for a vehicle includes a mirror element and a radiant energy emitting element. The mirror element includes a substrate having a forward surface facing towards a viewer of the mirror assembly and a rearward surface facing away from a viewer of the mirror assembly. The mirror element includes at least one substantially reflective metallic layer sandwiched between a respective pair of substantially transparent non-metallic layers disposed at the rearward surface of the substrate. Each of the substantially transparent non-metallic layers and the substantially reflective metallic layer having a selected refractive index and a selected physical thickness such that the mirror element is selectively spectrally tuned to substantially transmit at least one preselected spectral band of radiant energy therethrough while substantially reflecting other radiant energy. The radiant energy emitting element is operable to emit radiant energy towards the rearward surface and through the mirror element. The radiant energy emitting element is operable to emit radiant energy with a peak intensity within the at least one preselected spectral band.

The substrate may comprise a single substrate. The single substrate may comprise a prismatic or wedge-shaped substrate. The radiant energy emitting element and alternating layers thus may provide for a display on demand type of display for a prismatic (or flat or curved) mirror assembly.

According to other aspects of the present invention, an electrochromic mirror assembly for a vehicle includes an electrically variable mirror element. The mirror element includes a first substrate having first and second surfaces and a second substrate having third and fourth surfaces. The first and second substrates are arranged so that the second surface opposes the third surface. The second substrate includes a conductive stack on the third surface. The conductive stack may comprise a first electrically conductive or semi-conductive layer deposited on the third surface, a reflective or metallic layer of reflective or metallic material on the first electrically semi-conductive layer, and a second electrically conductive or semi-conductive layer on the reflective layer. The mirror element includes an electrochromic medium disposed between the second electrically semi-conductive layer of the second substrate and the electrically semi-conductive coating on the second surface of the first substrate. The thicknesses and materials of the layers are selected to provide or exhibit a spectrally selective visible light transmission characteristic for a particular spectral band or

range of wavelengths to provide enhanced transmissivity of the spectral band of light through the reflective element while providing sufficient reflectivity of other light.

In one form, the electrochromic mirror assembly may include a display element positioned at the fourth surface, wherein the display element is operable to emit light through the mirror element for viewing by a driver of the vehicle. The thicknesses of the particular layers of the conductive stack are selected such that the mirror element is spectrally tuned to transmit a predetermined spectral band of light therethrough. The spectral band that is transmittable through the mirror element may be selected to match a spectral band or range of light wavelengths emitted by the display element, such that the mirror element is spectrally tuned for the particular display element positioned at the fourth surface of the mirror element. The mirror element thus may be spectrally tuned to match at least a portion of the transmissive band or range of wavelengths of the mirror element to a particular band or range of wavelengths of the light being emitted by the display element. In one form, the peak transmissivity of the transmissive band of the mirror element is selected to match the peak intensity of the spectral band emitted by the display element. The conductive stack preferably provides at least approximately 60 percent photopic reflectance (preferably as measured in accordance with Society of Automotive Engineers test procedure SAE J964a, which is hereby incorporated herein by reference in its entirety), more preferably at least approximately 70 percent photopic reflectance, and most preferably at least approximately 80 percent photopic reflectance, while providing at least approximately 10 percent transmission, preferably at least approximately 15 percent transmission, more preferably at least approximately 20 percent transmission, and most preferably at least approximately 30 percent transmission, of at least a particular spectral band of light. Preferably, the physical thicknesses of the layers are selected to limit tinting and/or color interference affects as seen in the mirror element (i.e. to provide a neutral reflector) and to spectrally tune the mirror element for a transmission characteristic for providing enhanced transmissivity through the mirror element for a particular spectral band or range of wavelengths, in order to match the transmissivity of the mirror element to the spectral band of emission of light from the display element.

The semi-conductive layers and metallic layer of the conductive stack may be deposited at the third surface via a sputter coating process. The present invention thus may provide a low cost reflective element which provides for sufficient transmission of a particular spectral band or bands of visible light and sufficient reflectance at the third surface

of the mirror assembly (with at least 60% photopic reflectance preferred, more preferably, with at least 70% photopic reflectance, and most preferably, with at least 75% photopic reflectance). Preferably, the semi-conductive layers, such as indium tin oxide or the like, sandwiching the metallic layer are formed of the same material. Thus, for example, a
5 conductive stack of alternating layers may comprise a metallic layer of silver sandwiched between two semi-conductive layers of indium tin oxide.

According to another aspect of the present invention, an electro-optic or electrochromic interior rearview mirror assembly comprises an electro-optic or electrochromic mirror reflective element. The electro-optic mirror element provides a
10 substantially reflective mirror element having a first region having a first reflectivity and a first transmissivity and a second region having a second reflectivity and a second transmissivity. The electro-optic mirror element includes a display element positioned at or behind the second region and operable to transmit light through the second region. The first reflectivity is greater than the second reflectivity. Preferably, the second region provides at
15 least approximately 25% transmissivity of light from the display.

Therefore, the present invention provides a mirror reflective element, such as a third surface reflective element or mirror element or a fourth surface reflective element or a prismatic reflective element or the like, which is sufficiently and spectrally selectively transmissive or spectrally tuned to allow a particular spectral range or band of light to pass
20 therethrough from a display at the rear surface of the mirror reflective element. The layers of the reflective element are selected or spectrally tuned to match one or more predetermined or selected spectral bands or ranges of wavelengths and to thus pass the predetermined spectral bands of light therethrough, while being substantially reflective to other spectral bands or wavelengths of light, and do not require windows or apertures formed in the reflective
25 metallic layer of the reflective element.

These and other objects, advantages, purposes, and features of the present invention will become more apparent from the study of the following description taken in conjunction with the drawings.

BRIEF DESCRIPTION OF THE DRAWINGS

30 FIG. 1 is a sectional view of a conventional electrochromic mirror reflective element;

FIG. 1A is a graphical depiction of the transmissivity of visible light of the conventional electrochromic mirror reflective element of FIG. 1;

FIG. 2 is a perspective view of an interior rearview mirror assembly in accordance with the present invention;

FIG. 3 is a sectional view of the mirror assembly taken along the line III-III in FIG. 2;

5 FIG. 4 is a sectional view of a second substrate and opaque conductive and reflective layers suitable for use in the mirror assembly of FIG. 2;

FIG. 5 is a front elevation of a second substrate of a reflective element in accordance with the present invention, with a tab-out portion to facilitate electrical connection with the conductive layers;

10 FIG. 6 is a sectional view of the second substrate taken along the line VI-VI in FIG. 5;

FIG. 7 is a perspective view of another interior rearview mirror assembly in accordance with the present invention, with a display;

15 FIG. 8 is a sectional view of a reflective element of the mirror assembly taken along the line VIII-VIII in FIG. 7;

FIG. 9 is a sectional view similar to FIG. 6 of a second substrate in accordance with the present invention, which is suitable for use in the mirror assembly of FIG. 7, and includes a tab-out portion to facilitate electrical connection with the conductive layers;

20 FIG. 10 is a sectional view of another second substrate and transmissive conductive and reflective layer or stack in accordance with the present invention suitable for use in a mirror assembly having a display;

FIG. 11 is another sectional view of a particular embodiment of a reflective element of the present invention;

25 FIG. 11A is a graphical depiction of the transmissivity of the reflective element of FIG. 11;

FIG. 11B is a graphical depiction of the emission spectrum of the display element for the reflective element of FIG. 11;

FIG. 12 is a sectional view of another particular embodiment of a reflective element of the present invention;

30 FIG. 12A is a graphical depiction of the transmissivity of the reflective element of FIG. 12;

FIG. 12B is a graphical depiction of the emission spectrum of the display element for the reflective element of FIG. 12;

FIG. 13 is a sectional view of another particular embodiment of a reflective element of the present invention;

FIG. 13A is a graphical depiction of the transmissivity of the reflective element of FIG. 13;

5 FIG. 14 a sectional view of a particular embodiment of a double stack reflective element of the present invention;

FIG. 14A is a graphical depiction of the transmissivity of the double stack reflective element of FIG. 14;

10 FIG. 14B is a graphical depiction of the emission spectrum of the display element for the double stack reflective element of FIG. 14;

FIG. 15 a sectional view of another particular embodiment of a double stack reflective element of the present invention;

FIG. 15A is a graphical depiction of the transmissivity of the double stack reflective element of FIG. 15;

15 FIG. 16 a sectional view of a particular embodiment of a multiple stack reflective element of the present invention;

FIG. 16A is a graphical depiction of the transmissivity of the multiple stack reflective element of FIG. 16;

20 FIG. 17 a sectional view of another particular embodiment of a multiple stack reflective element of the present invention;

FIG. 17A is a graphical depiction of the transmissivity of the multiple stack reflective element of FIG. 17;

FIG. 18 is a forward facing view of another electro-optic mirror reflective element in accordance with of the present invention;

25 FIG. 19 is a sectional view of another reflective element in accordance with the present invention, which is capable of transmitting near infrared illumination therethrough;

FIG. 20 is a sectional view of another reflective element in accordance with the present invention;

30 FIG. 21 is a sectional view of another reflective element in accordance with the present invention;

FIG. 22 is a graphical depiction of the transmissivity of light through the cover and rear substrate of the reflective elements of FIGS. 19-21;

FIG. 23 is a sectional view of another reflective element in accordance with the present invention, which is capable of transmitting near infrared illumination therethrough;

FIG. 24 is a sectional view of another reflective element in accordance with the present invention;

FIG. 25 is a sectional view of another reflective element in accordance with the present invention;

FIG. 26 is a graphical depiction of the transmissivity of light through the rear substrate and IRT stack of the reflective elements of FIGS. 23-25;

FIG. 27 is a graphical depiction of the transmissivity of light through the front substrate and enhanced semi-conductive layers of the reflective element of FIG. 24;

FIG. 28 is a graphical depiction of the transmissivity of light through the front substrate and enhanced semi-conductive layers of the reflective element of FIG. 25;

FIG. 29 is a sectional view of a reflective element similar to the reflective element of FIG. 25, with an anti-reflective stack or layers on a rear surface of the rear substrate in accordance with the present invention;

FIG. 30 is a sectional view of another reflective element in accordance with the present invention; and

FIG. 31 is a graphical depiction of the transmissivity of light through the rear substrate and IRT-DOD stack of the reflective element of FIG. 30; and

FIG. 32 is a sectional view of a prismatic reflective element in accordance with the present invention.

DESCRIPTION OF THE PREFERRED EMBODIMENTS

Referring now to the drawings and the illustrative embodiments depicted therein, an electrochromic interior rearview mirror assembly 10 is mounted to a mounting button 12 mounted at an interior surface of a windshield 14 of a vehicle (FIG. 2). Mirror assembly 10 includes a housing or casing 15 and an electrochromic reflective element or mirror element or cell 16 which has electrically variable reflectivity. Reflective element 16 includes first and second glass substrates 22, 24, and provides a third surface reflective element, whereby the reflective coating of the reflective element 16 is deposited on the third surface 24a of the substrates (FIG. 3). An electrochromic medium 40 and a plurality of metallic and non-metallic conductive or semi-conductive layers 28 are disposed between the electrochromic medium 40 and the second substrate 24. The refractive indices and physical

thicknesses of the layers are selected to maximize transmission of a particular spectral band of light while substantially reflecting other light to provide a desired degree of photopic reflectance, while also providing the desired degree of conductivity across the layers.

Although shown and described herein as being implemented in an interior
5 rearview mirror assembly of a vehicle, the reflective element or mirror element of the present invention is equally suitable for or applicable to other electro-optic reflective elements, or reflective elements for exterior rearview mirror assemblies for vehicles or for other mirror assemblies, without affecting the scope of the present invention. Also, although shown and described as an electrochromic reflective element, aspects of the present invention may be
10 equally applicable to prismatic reflective elements (such as described below with respect to FIG. 32) or to exterior reflective elements, without affecting the scope of the present invention. Also, the mirror element of the present invention may comprise a substantially flat element or substrate or may comprise a curved element or substrate, such as a convex element or aspheric element or the like, without affecting the scope of the present invention.

15 Electrochromic reflective element 16 comprises a first or front substantially transparent substrate 22 and a second or rear substantially transparent substrate 24 (which may be glass substrates or the like). The first substrate 22 includes an electrically conductive or semi-conductive layer 26, such as a tin oxide (doped or undoped) or indium tin oxide (ITO) or any other transparent electrically semi-conductive layer or coating or the like (such
20 as indium cerium oxide (ICO), indium tungsten oxide (IWO), or indium oxide (IO) layers or the like or a zinc oxide layer or coating, or a zinc oxide coating or the like doped with aluminum or other metallic materials, such as silver or gold or the like, or other oxides doped with a suitable metallic material or the like), deposited on an inward surface 22a of first substrate 22 (i.e., the second surface 22a of the reflective element 16).

25 Also, the first (or forward or outermost) surface 22b of front substrate 22 (exposed to the atmosphere exterior of the mirror assembly) may be optionally coated with an anti-wetting property such as via a hydrophilic coating (or stack of coatings), such as is disclosed in U.S. Pat. Nos. 6,193,378; 5,854,708; 6,071,606; and 6,013,372, the entire disclosures of which are hereby incorporated by reference herein. Also, or otherwise, the
30 first (outermost) surface 22b of front substrate 22 may be optionally coated with an anti-wetting property such as via a hydrophobic coating (or stack of coatings), such as is disclosed in U.S. Pat. No. 5,724,187, the entire disclosure of which is hereby incorporated by reference herein. Such hydrophobic property on the first/outermost surface of electrochromic mirror

reflective elements (and on the first/outermost surface of non-electrochromic mirror, non-electro-optical conventional reflective elements) can be achieved by a variety of means, such as by use of organic and inorganic coatings utilizing a silicone moiety (for example, a urethane incorporating silicone moieties) or by utilizing diamond-like carbon coatings. For example, long-term stable water-repellent and oil-repellent ultra-hydrophobic coatings, such as described in PCT Application Nos. WO0192179 and WO0162682, the entire disclosures of which are hereby incorporated by reference herein, can be disposed on the first (outermost) surface 22b of front substrate 22. Such ultra-hydrophobic layers comprise a nano structured surface covered with a hydrophobic agent which is supplied by an underlying replenishment layer (such as is described in Classen et al., "Towards a True 'Non-Clean' Property: Highly Durable Ultra-Hydrophobic Coating for Optical Applications", ECC 2002 "Smart Coatings" Proceedings, 2002, 181-190, the entire disclosure of which is hereby incorporated by reference herein).

Second or rear substrate 24 includes at least three layers or coatings defining a reflective and conductive layer or stack or ISI layer or stack 28 (i.e., the combination or stack of a layer of: a semi-conducting coating, such as an ITO layer or the like; a metallic layer, such as a layer of silver, aluminum or an alloy of silver or an alloy of aluminum or other metal or metal alloy; and another layer of a semi-conducting coating, such as an ITO layer or the like, as discussed below, is referred to herein as an ISI stack or layer) on an inward surface 24a of second substrate 24 (or the third surface of the reflective element). Thus, an ISI stack 28 comprises a metallic layer sandwiched between two semi-conducting layers (both of which preferably are the same material, but either of which can be different from the other). In the illustrated embodiment of FIG. 4, ISI layer 28 comprises a first semi-conductive layer 30 disposed on inward surface 24a of second substrate 24, a second semi-conductive layer or adhesion layer 32 disposed on semi-conductive layer 30, a metallic layer or coating 34 disposed on semi-conductive layer 32, and a transparent semi-conductive layer or passivation layer 36 disposed on metallic layer 34. As shown in FIGS. 3 and 4, first semi-conductive layer 30 extends outwardly from the other ISI layers 32, 34 and 36, in order to provide for electrical connection with bus bars 38 of mirror assembly 10. Although referred to herein as an "ISI layer" or an "ISI stack", the conductive and reflective stack or layers of the present invention may comprise materials or coatings other than ITO, ICO, IO, IWO layers or coatings or the like and silver or silver alloy layers or coatings, without affecting the scope of the present invention. For example, a semi-conducting layer of doped zinc oxide, or

a semi-conducting layer of cadmium stannate, or a semi-conducting layer of titanium nitride or other titanium compound or the like may be used in the stack, without affecting the scope of the present invention.

As shown in FIG. 3, the first and second substrates 22, 24 are positioned in
5 spaced-apart relationship with one another with an electrochromic medium 40 disposed
between semi-conductive layer 26 and semi-conductive layer 36. The electrochromic
medium 40 changes color or darkens in response to electricity or voltage applied to or
through the semi-conductive layers 26 and 30 at either side of the electrochromic medium.
The electrochromic medium 40 disposed between the front and rear substrates 22, 24 may be
10 a solid polymer matrix electrochromic medium, such as is disclosed in U.S. Pat. No.
6,154,306, which is hereby incorporated by reference herein, or other suitable medium, such
as a liquid or solid medium or thin film or the like, such as the types disclosed in U.S. pat.
application, Ser. No. 09/793,002, entitled VIDEO MIRROR SYSTEMS INCORPORATING
AN ACCESSORY MODULE, filed Feb. 26, 2001 (Attorney Docket DON01 P-869), and in
15 U.S. Pat. Nos. 5,668,663 and 5,724,187, the entire disclosures of which are hereby
incorporated by reference herein, without affecting the scope of the present invention. The
electrochromic mirror element may utilize the principles disclosed in commonly assigned
U.S. Pat. Nos. 5,140,455; 5,151,816; 6,178,034; 6,154,306; 6,002,544; 5,567,360; 5,525,264;
5,610,756; 5,406,414; 5,253,109; 5,076,673; 5,073,012; 5,117,346; 5,724,187; 5,668,663;
20 5,910,854; 5,142,407 or 4,712,879, which are hereby incorporated herein by reference, or as
disclosed in the following publications: N. R. Lynam, "Electrochromic Automotive
Day/Night Mirrors", *SAE Technical Paper Series* 870636 (1987); N. R. Lynam, "Smart
Windows for Automobiles", *SAE Technical Paper Series* 900419 (1990); N. R. Lynam and
A. Agrawal, "Automotive Applications of Chromogenic Materials", *Large Area*
25 *Chromogenics: Materials and Devices for Transmittance Control*, C.M. Lampert and C.G.
Grandquist, EDS., Optical Engineering Press, Wash. (1990), which are hereby incorporated
by reference herein, and in U.S. pat. application, Ser. No. 09/793,002, filed Feb. 26, 2001 by
Schofield et al. for VIDEO MIRROR SYSTEMS INCORPORATING AN ACCESSORY
MODULE (Attorney Docket DON01 P-869), which is hereby incorporated herein by
30 reference. Reflective element 16 may also include a seal 41 positioned around the outer
portions of the layers 32, 34, 36 and the electrochromic medium 40 to seal the layers and
avoid corrosion of the metallic layer 34.

During operation, a voltage may be applied to reflective element 16 via bus bars 38 positioned around and engaging the outer edges of the semi-conductive layers 26, 30 (FIG. 3). The voltage applied by bus bars 38 is bled from semi-conductive layer 30 and through the layers 32, 34, 36 to the electrochromic medium 40. The ISI layer 28 of the present invention preferably provides for reduced resistance through the layers, which provides for faster, more uniform coloration of the electrochromic medium 40, since the electrons applied via bus bars 38 at semi-conductive layer 30 may bleed through the semi-conductive layers 32, 36 faster due to the enhanced conductivity in the conductive layers 32, 36. Preferably, the ISI layer or stack 28 provides a sheet resistance of less than approximately 10 ohms per square, more preferably less than approximately 5 ohms per square, and most preferably less than approximately 2 ohms per square. Desirably, and particularly for larger area mirrors, the sheet resistance is less than approximately 1 ohm per square, such as in the range of approximately 0.1 to 0.7 ohms per square.

In order to provide enhanced performance of the electrochromic element, each of the layers of the ISI layer or stack has substantial conductivity and none of the layers significantly retard electron/electrical conductivity from one layer to the other throughout the stack, and, thus, do not impede the flow of electrons into the electrochromic (EC) medium. In this regard, it is desirable that one or more of the metallic layers comprises a metallic material (which is preferably a highly reflective material, such as silver or silver alloys or the like) having a specific resistivity of preferably less than approximately 5×10^{-5} ohm.cm, more preferably less than approximately 1×10^{-5} ohm.cm, and most preferably less than approximately 5×10^{-6} ohm.cm. Preferably, such a highly conductive metallic layer or layers is/are sandwiched between two non-metallic, partially conducting layers, preferably formed of a non-metallic material (such as a semi-conducting oxide, such as indium oxide, tungsten oxide, tin oxide, doped tin oxide or the like) having a specific resistivity of less than approximately 1×10^{-2} ohm.cm, more preferably less than approximately 1×10^{-3} ohm.cm, and most preferably less than approximately 5×10^{-4} ohm.cm.

In the illustrated embodiment of FIGS. 3 and 4, first semi-conductive layer 30 is deposited on inward surface 24a of second substrate 24. The semi-conductive layer 30 may be deposited on the glass or substrate 24 via any suitable process. The particular thickness of the conductive layer may vary depending on the particular application of reflective element 16, as discussed below. In the illustrated embodiments of FIGS. 2-4, the semi-conductive layer 30 need not be transparent and may comprise a chromium layer or the

like. However, the semi-conductive layer 30 may comprise a generally transparent semi-conductive layer of coating, such as a tin oxide layer, an indium tin oxide (ITO) layer or the like, without affecting the scope of the present invention. In a preferred embodiment, semi-conductive layer 30 may comprise a chromium layer on surface 24a of second substrate 24.

5 The transparent semi-conductive layers 32 and 36 of ISI layer 28 on second substrate 24 may comprise non-metallic transparent electrically conducting or semi-conducting materials, such as tin oxide, indium oxide, indium cerium oxide, indium tungsten oxide, nickel oxide, tungsten oxide, indium tin oxide, half-wave indium tin oxide, full wave indium tin oxide, doped tin oxides, such as antimony-doped tin oxide and fluorine-doped tin
10 oxide, doped zinc oxides, such as antimony-doped zinc oxide and aluminum-doped zinc oxide, and/or the like. Both of the semi-conductive layers 32, 36 may comprise the same type of material for ease of manufacturing, as discussed below.

 Metallic layer or coating 34 comprises a thin film or layer of metal, such as silver, aluminum, or alloys thereof, or the like, with a selected thickness to provide sufficient
15 reflectivity and/or transmissivity, as discussed below. The selected metallic material may comprise silver, but may otherwise comprise a material selected from aluminum, silver alloys, aluminum alloys (such as 6061 or 1100 aluminum alloys or the like), manganese, chromium or rhodium, or any other metallic material which is sufficiently reflective and/or
20 transmissive at a selected thickness. The thickness of metallic layer 34 is preferably selected to be thick enough (such as approximately 60-100 nm or 600-1000Å) to be substantially reflective and not transmissive, such that the ISI layer 28 is substantially opaque or non-transparent.

 In a preferred embodiment, the semi-conductive layer 30 comprises indium tin oxide (ITO) and is deposited onto surface 24a of substrate 24 via a hot deposition process,
25 involving, for example, sputter deposition onto a heated substrate, with the heated substrate often being heated to a temperature of greater than about 200°C, sometimes greater than 300°C, as is known in the art. The combination of the semi-conductive layer 30 on the substrate 24 defines a conductive substrate which may be used for various embodiments of the present invention, as discussed below.

30 The semi-conductive layer 32 of ISI layer 28 may be deposited onto semi-conductive layer 30 via a cold deposition process, such as sputter coating or the like onto an unheated substrate. Preferably, each of the layers 32, 34, 36 of ISI layer 28 is deposited on second substrate 24 by a sputter deposition process. More particularly, the substrate 24

(including the semi-conductive layer 30 already deposited thereon) may be positioned in one or more sputter deposition chambers with either planar or rotary magnetron targets, and with deposition of the layers being achieved by either reactive deposition of an oxide coating by sputtering from a metal target (or from a conductive, pressed oxide target) in an oxygen-rich atmosphere, or by DC sputtering from an oxide target, such as an IO, IWO, ITO or ICO target or the like. For example, the substrate 24 may be sputter coated with two targets in a single chamber, such as by depositing the ITO layer 32 on semi-conductive layer 30, turning or flipping the targets for sputter coating of the metallic layer 34, and then turning the targets back to deposit the second ITO layer or passivation layer 36 on the metallic layer 34. With such a process, it is important that the two ITO layers 30, 34 comprise the same conductive material. Alternately, two targets may be positioned in a row, such that the substrate 24 is moved from one target (for the first ITO coating) to the other (for the metallic coating) and then back to the first (for the second ITO coating). It is further envisioned that three targets may be positioned in a row, with each target depositing the layer in order on the substrate (in which case it would not be as important to have the semi-conductive or ITO layers 32, 36 comprise the same material). Other processes for applying or depositing layers of conductive material or layers and metallic material or layers may be implemented, without affecting the scope of the present invention. In the illustrated embodiment of FIGS. 2 and 3, semi-conductive layer 30 may be deposited or applied to substantially the entire surface 24a of substrate 24, while the outer region or edge of semi-conductive layer 30 and substrate 24 may be masked during the deposition process so that layers 32, 34, 36 do not cover the outer edge of substrate 24 and semi-conductive layer 30.

Because the embodiment of the reflective element of the present invention illustrated in FIG. 4 does not include a display on demand or other type of display transmitting or projecting through the electrochromic reflective element, it is desirable to have a thick metallic or silver layer 34, such as in a range of approximately 60-100 nm (600-1000Å), because the metallic layer does not have to be transmissive of any light therethrough. It is also unnecessary for the second substrate to be transparent. However, it is desirable to avoid tinting or color interference affects as seen in reflection from the reflector (which may arise when stacking layers of conductive coatings and/or metallic coatings on top of one another), because it is desirable to have a neutral or non-colored/non-tinted reflector when no voltage is applied across the electrochromic medium.

Optionally, the metallic layer may be absent or removed at portions, such as to create a local window for placement therebehind of a light emitting display, such as a compass display or PSIR display or other informational display or the like, such as a display of the type disclosed in commonly assigned U.S. Pat. Nos. 6,222,460 and 6,326,900, which
5 are hereby incorporated herein by reference in their entireties, but while maintaining at least the underlying semi-conducting ITO layer at the local window region so that electrical connection through the electrochromic medium at that local region is sustained. In this regard, it is preferable to have an ITO underlayer with a sheet resistance of less than approximately 80 ohms per square, more preferably less than approximately 25 ohms per
10 square, and most preferably less than approximately 15 ohms per square.

In order to avoid such undesirable tinting or color interference affects, such as yellow tinting or other color tinting of the compound or stacked reflective element, as seen in the reflection when the electrochromic reflective element is unpowered, the physical thicknesses of the conductive layers and the metallic layer are selected to provide a desired
15 combination of layer thicknesses to achieve the desired results. For example, the ISI layer 28 may include an adhesion layer or undercoating semi-conductive layer 32 of approximately 100Å +/- 50Å of ITO or the like, a silver layer 34 of approximately 800Å +/- 200Å and a passivation semi-conductive layer 36 of approximately 120Å +/- 25Å of ITO or the like, which provides a desired result with minimal yellow tinting or other color tinting or color
20 interference affects as seen in the reflection.

The range of thicknesses of the layers may be selected to provide a desired untinted affect in the reflection, such that the reflective element may be spectrally tuned to provide a desired reflectant untinted appearance. Testing of various embodiments has shown that the thicknesses of the layers may vary by approximately 25 percent or more from a
25 desired or targeted dimension, yet will still provide the desired results. Such tolerances significantly ease the processing of the ISI layer, since this is well within the capability of typical sputter coating equipment. The layers of the reflective element and ISI stack may be selected such that the reflective element provides a substantially spectrally untinted reflection when viewed by a driver or passenger in the vehicle when no voltage is applied across the
30 electrochromic medium. Also, the layers may be selected and combined to exhibit a spectrally selective transmissive characteristic, which is established by the refractive indices and physical thicknesses of the layers disposed between the electrochromic medium and the third surface of the second substrate.

Although the above embodiment provides a desired neutral color/tint for the reflector, if the passivation layer 36 is increased in thickness, the reflector may become tinted or yellowed. However, if the passivation layer is further increased in thickness to approximately 680Å, then the non-tinting is approximately the same as when the passivation layer has a thickness of approximately 120Å. This periodic change in tinting affect in response to the thicknesses of the layers or coatings of the ISI layer of the present invention allows for selection of different thicknesses of the layers depending on the particular application and desired result of the electrochromic reflective element of the present invention.

Referring now to FIGS. 5 and 6, a reflective element 116 may have alternating layers or an ISI stack or layer 128 comprising a first semi-conductive layer or adhesion layer 132 deposited or sputter coated directly onto surface 24a of second substrate 24, a metallic layer 134 deposited on semi-conductive layer 132, and a second semi-conductive layer or passivation layer 136 deposited on metallic layer 134. The second or rear substrate 24 is masked around substantially the entire outer region 24c of surface 24a during the deposition process, such that the ISI layer 128 is not deposited in the masked region 24c. However, the substrate is not masked over the entire outer edge or region of substrate 24, in order to allow deposition of the ISI layer at a particular area, such that a tab-out portion or area 131 is formed in the ISI layer 128. The tab out area 131 facilitates electrical connection with the conductive coatings 132, 134, 136, such that the first semi-conductive layer 30 of reflective element 16 is not required. In a preferred embodiment of the present invention, the reflective element 116 may include a semi-conductive layer 132 of an ITO coating which has a thickness of approximately 100Å +/- 25Å, a silver layer 134 having a thickness of approximately 900Å +/- 100Å, and a second semi-conductive layer 136 of ITO or the like having a thickness of approximately 120Å +/- 25Å. Such an arrangement of semi-conductive layers and a sandwiched metallic layer provides a neutral reflectance with minimal tinting or color interference affects as seen in reflectance and with the electrochromic medium unpowered.

The opaque ISI layer 28, 128 and the third surface reflective element of the present invention therefore provides an economical, low cost electrochromic reflective element, which provides a neutral color reflection. Typically, for a sputter coating operation, a range of within +/- 5% of a nominal target for uniformity of coating is desired. However, in the present invention, the uniformity tolerance is approximately +/- 25% for each of the

coatings or layers from cell to cell. The ISI layer on the second substrate thus may be easy and fast to manufacture due to the thicknesses and the tolerances for the thickness of each particular coating.

Referring now to FIGS. 7 and 8, a mirror assembly 210 in accordance with the present invention (shown as an interior rearview mirror assembly in FIG. 7; however, the reflective element 216 may be implemented at an exterior mirror assembly or other mirror assembly, without affecting the scope of the present invention) may include a display system or element 218 which is operable to provide, emit or display information or light through a mirror element or reflective element 216 of the mirror assembly. The light is emitted through the reflective element 216 at a display area 220 of mirror assembly 210, such that the display information or light is viewable by a driver of the vehicle. The reflective element 216 includes first (or front) and second (or rear) substrates 222, 224, and a conductive and transmissive ISI stack or layer or DOD stack or layer 228 disposed on the inward surface 224a of the second substrate (or the third surface of the reflective element). The second substrate 224 and ISI layer 228 comprise a transflective one way mirror, such as disclosed in commonly assigned U.S. pat. application, Ser. No. 10/054,633, filed Jan. 22, 2002 by Lynam et al. for VEHICULAR LIGHTING SYSTEM (Attorney Docket DON01 P-962), which is hereby incorporated herein by reference. Preferably, the mirror reflective element (behind which the display is disposed so that the information displayed is visible by viewing through the mirror reflective element) of the mirror assembly comprises a transflective mirror reflector, such that the mirror reflective element is significantly transmitting to visible light incident from its rear (i.e., the portion furthest from the driver in the vehicle), while simultaneously the mirror reflective element is substantially reflective to visible light incident from its front (i.e. the position closest to the driver when the interior mirror assembly is mounted in the vehicle). The transflective electrochromic reflective mirror element (such as is disclosed in U.S. pat. application, Ser. No. 09/793,002, entitled VIDEO MIRROR SYSTEMS INCORPORATING AN ACCESSORY MODULE, filed Feb. 26, 2001 (Attorney Docket DON01 P-869) and in U.S. Pat. Nos. 5,668,663 and 5,724,187, the entire disclosures of which are hereby incorporated by reference herein) comprises an electrochromic medium sandwiched between the first and second substrates.

The ISI stack or layer 228 includes a conductive metallic layer 234, which is thin enough to be sufficiently transparent or transmissive to allow the display information to be transmitted through the ISI or DOD layer 228 and through reflective element 216 for

viewing by the driver of the vehicle. As the thickness of the metallic layer 234 decreases, the transmissivity increases, but the reflectivity decreases. Therefore, a desired thickness of the metallic layer (along with a desired thickness of the other layers of the ISI stack or layer) must be selected to provide sufficient reflectivity and transmissivity, as discussed below.

5 Because the metallic layer 234 is at least partially transmissive, it is desirable to provide an opaque coating or tape or the like 225 on an outer surface 224b of second substrate 224 (or the fourth surface of the reflective element 216). The coating or tape 225 may be a black tape or other color tape or coating.

Display system 218 preferably comprises a display on demand type of display
10 and includes a display element or light emitting device 218a positioned at the back surface 224b of second substrate 224. Display element 218a is operable to emit light, such as in the form of indicia, alphanumeric characters, images, or the like, in response to a control or input.

Display element 218a may be a vacuum fluorescent (VF) display element, a light emitting diode (LED) display element, an organic light emitting diode (OLED) display element, a gas
15 discharge display element, a plasma display element, a cathode ray tube display element, a backlit active matrix LCD screen, an electroluminescent display element, a field emission display element or the like, without affecting the scope of the present invention. The particular display element may be selected to provide a desired color to the display. For example, a VF display element may provide a blue-green color or other colors to the
20 information displayed (depending on the phosphor selected for the display), while a light emitting diode display element may provide other colors, such as reds, ambers, or other colors to the information displayed.

Preferably, the display is a display-on-demand type of display, such as of the type disclosed in commonly assigned U.S. Pat. Nos. 5,668,663 and 5,724,187, and/or in U.S.
25 pat. applications, Ser. No. 10/054,633, filed Jan. 22, 2002 by Lynam et al. for VEHICULAR LIGHTING SYSTEM (Attorney Docket DON01 P-962); and Ser. No. 09/793,002, filed Feb. 26, 2001 by Schofield et al. for VIDEO MIRROR SYSTEMS INCORPORATING AN ACCESSORY MODULE (Attorney Docket DON01 P-869), which are all hereby incorporated herein by reference. With such a display, it is not only desirable to adjust the
30 display brightness according to ambient lighting conditions, but it is also desirable to adjust the display brightness such that a sufficient contrast ratio is maintained against the variable background brightness of the reflected scene. Also, it may be desirable to compensate for

changes in transmission of the electrochromic device effected to control rearward glare sources, so that the display brightness appears to be maintained at a generally constant level.

It is envisioned that the display 218 may include a filter or spectral element 217 positioned between the illumination source or display element 218a of the display 218 and the outer or fourth surface 224b of second substrate 224. The filter 217 may function to filter out light having a wavelength outside of the desired band of light being emitted by the display element or, in other words, the filter or spectral element 217 may transmit a band width of light that substantially matches the particular spectral output of the display or that substantially matches a desired color for the display information. By transmitting only the spectral band which at least generally matches the spectral output of the display device, the filter functions to filter out ghost images of the display, where ambient light may enter the display, such that the display characters may be visible through the reflective element when the display is off.

Because the reflectivity of the metallic layer 234 provides sufficient reflectance over its entire surface (i.e., there are no "windows" formed in or through the metallic layer), mirror assembly 210 may include other displays or multiple display on demand type displays, or other types of displays, such as one or more "display on need" type displays or the like. For example, one or more display on need type displays 213 (FIG. 7) may be provided, such as to indicate to the driver of the vehicle that a door of the vehicle is ajar, or that the driver's seat belt is not fastened, or any other condition or status that may be important to the driver or occupant of the vehicle. The display on need type display or displays may provide indicia, alphanumeric characters, symbols, or the like via one or more light emitting sources (not shown) behind the second substrate in a similar manner as display system 218 discussed above, and may include a filter (also not shown) for filtering out light that is not within the desired spectral band of the particular display system.

In the illustrated embodiment of FIG. 8, ISI or DOD layer or stack 228 includes a first semi-conductive layer 230, a second semi-conductive layer or adhesion layer 232, a reflective and transmissive metallic layer 234 and a semi-conductive or passivation layer 236. Similar to ISI layer 28, discussed above, semi-conductive layer 230 may be deposited or applied to substantially the entire surface 224a of substrate 224, while the outer region or edge of semi-conductive layer 230 and substrate 224 may be masked during the deposition process so that the layers 232, 234, 236 do not cover the outer edge of substrate 224 and semi-conductive layer 230.

Preferably, the physical thicknesses and materials of the metallic layer 234 and the semi-conductive layers 230, 232 and 236 are selected to provide sufficient transmissivity of at least a particular spectral band or range of wavelengths of light which generally matches the peak intensity spectral band of light being emitted by the display. Such spectral tuning or matching of the layers to the display allows the display information to transmit through the reflective element for viewing of the display information by the driver of the vehicle, while also providing sufficient reflectivity over the entire reflective element, and while minimizing the tinting or color interference affects on the reflected image (or targeting such tinting affects toward a desired color). Preferably, the light transmission of the particular spectral band through the reflective element is greater than approximately 15 percent and the reflectivity of the reflective element to other wavelengths of light is greater than approximately 80 percent. More preferably, the light transmission of the particular spectral band is greater than approximately 20 percent, and most preferably greater than approximately 25 percent.

The reflective element 216 is spectrally tuned to maximize transmissivity of a particular desired or targeted range or ranges of wavelengths or spectral bands and to substantially reflect or not transmit other wavelengths of light. The particular choices or thicknesses/materials of the layers is influenced by the spectral emission of the display being used in the mirror assembly. In one exemplary embodiment of the present invention, a transmissive ISI or DOD layer or stack 228 includes a metallic layer 234 of approximately 350Å sandwiched between a semi-conductive passivation layer 236 of approximately 68 nm (680Å) and a semi-conductive adhesion layer 232 of approximately 41 nm (410Å). The adhesion layer 232 is deposited on a semi-conductive layer 230 having a thickness of approximately 30 nm (300Å). In this embodiment, the ISI layer 228 is spectrally tuned for transmission of an orange light (having a peak intensity wavelength in the range of approximately 600 nm) emitting from display device 218a.

In certain conditions, the ambient light intensity within the cabin of the vehicle may be sufficiently high so that reflected light from the mirror reflective element and, in particular, from the display region 220, tends to "wash-out" the display. It is envisioned that this glare may be reduced by taking advantage of the electrochromic function of the mirror assembly. More particularly, the electrochromic medium 240 of the electrochromic mirror reflective element 216 may be colored or darkened in the area of the display by constructing a locally addressable region across the display (as shown at 220, 220a of FIG. 7). This may be

achieved by creating a deletion line in the second surface semi-conductive layer 226 at the second surface of the first or front substrate 222 (FIG. 8) and/or in the third surface semi-conductive layer 230 (or a third surface semi-conductive layer of the type shown in FIG. 9 and described below at 332), hence breaking electrical continuity from the rest of the electrochromic cell. An ambient light sensor (not shown) may be used to detect the critical ambient light levels at which "wash-out" is a problem. The addressable region may then be separately colored or darkened to the appropriate level to reduce the glare from the display area in response to the ambient light sensor. Although such a glare problem could be solved by coloring the entire mirror, by localizing the region of coloration to only the display area, the electrochromic mirror assembly of the present invention allows the rest of the mirror reflective area, which does not incorporate the display, to retain full reflectivity while the display area is colored or darkened (such as may be useful when driving by day).

In another exemplary embodiment of the present invention, a transmissive ISI or DOD layer includes a metallic layer 234 of approximately 40 nm (400Å) sandwiched between a semi-conductive passivation layer 236 of approximately 43 nm (430Å) and a semi-conductive adhesion layer 232 of approximately 10 nm (100Å). The semi-conductive adhesion layer 232 is deposited on an adhesion or semi-conductive layer 230 having a thickness of approximately 30 nm (300Å). In this embodiment, the ISI or DOD layer 228 is spectrally tuned for spectrally selective transmission of a blue-green light (having a peak intensity wavelength of approximately 505 nm) emitting from display device 218a.

The thickness of the first semi-conductive layer 230 may be the same for each embodiment described above (and for the particular embodiments discussed below, such as with respect to FIGS. 10-17), in order to provide a common conductive substrate (including the semi-conductive layer 230 already deposited or coated on the surface of the substrate) for the different particular applications of the substrate and ISI layers of the present invention. This may ease the manufacturing of the reflective elements, since the same hot ITO coating or the like may be applied to common substrates for various applications, and then the conductive substrates may be coated with different thickness layers of conductive and metallic coatings for different applications of the reflective element (such as for mirrors having different colored displays).

As discussed above with respect to ISI layer 128, and with reference now to FIG. 9, a second substrate 324 may have an ISI or DOD layer 328 on its inward or forward surface 324a which may include layers 332, 334, 336 which may have a tab-out portion 331

for electrical connections, so as to not require the first conductive layer, without affecting the scope of the present invention. Because the metallic layer 334 is thin and not as conductive as the metallic layer 134, discussed above, the tab-out portion 331 of ISI layer 328 is preferably substantially larger in size or width than the tab-out portion 131 may have been for
5 ISI layer 128. In a particular exemplary embodiment of the substrate 324 and ISI layer 328 of a reflective element as shown in FIG. 9, where the conductive layer 332 is deposited directly on the surface 324a of substrate 324, the ISI layer 328 may include a metallic layer 334 of approximately 35 nm (350Å) sandwiched between a passivation layer 336 of approximately 70 nm (700Å) and an adhesion layer 332 of approximately 70 nm (700Å).
10 This combination or stack of layers on the glass or substrate 324 provides a transflective reflective element which is at least approximately 20 percent transmissive and which is spectrally tuned to pass a particular band of light being emitted by display device 218a of display system 218. In this particular embodiment, the transflective reflective element is spectrally tuned to pass light having a peak intensity wavelength of approximately 605
15 nanometers, while substantially reflecting other light.

Other thicknesses and materials of the layers may be selected for different displays having different colors or wavelengths of emitted light, without affecting the scope of the present invention. The thicknesses and particular materials of the layers of the ISI or DOD stack and transflective reflector are selected such that their combination provides
20 enhanced or substantial transmissivity of the spectral band or bands corresponding to the spectral band of light emitted by the particular display implemented in the reflective element, while providing substantial reflectance of other visible light.

Referring now to FIG. 10, a second substrate 424 of a reflective element may have multiple layers or a double ISI or DOD layer or stack 428 applied to inward surface
25 424a. Double ISI layer 428 includes a first semi-conductive layer 430 applied to or deposited on inward surface 424a, a second semi-conductive or adhesion layer 432a deposited on semi-conductive layer 430, a first metallic layer 434a deposited on semi-conductive layer 432 and another semi-conductive layer 436a deposited on metallic layer 434a. Double ISI layer 428 further includes a second metallic layer 434b deposited on semi-conductive layer 436a with
30 another semi-conductive layer 436b deposited on second metallic layer 434b. Therefore, the ISI stack or layer 428 is an alternating stack or combination of dielectric or transparent semi-conductive layers and metallic layers, whereby each metallic layer is sandwiched between a respective pair of conductive or semi-conductive non-metallic layers.

Such an arrangement may be used to provide a desired amount or increased amount of spectrally selective transmission of one or more particular spectral bands of light through the ISI or DOD layers, while increasing the reflectivity or maintaining the reflectivity of the ISI or DOD layers with respect to other spectral bands of light over the single ISI or DOD stack designs discussed above. More particularly, the double stack arrangement (or more layers if desired) provides for increased transmission of a narrower spectral band of light, which allows the reflective element to transmit a high percentage (such as greater than approximately 50 percent transmissivity) of a selected narrow spectral band of light. The narrow spectral band is selected so as to be substantially pinpointed or targeted at the particular peak intensity wavelength or wavelengths of light being emitted by the display device. Such an arrangement is particularly suitable for use with display devices incorporating light emitting diodes, which may emit light within a particular, narrow spectral band. The particular thickness and material for each layer or coating may be selected depending on the particular application and desired results.

For example, in a single ISI or DOD stack design which provides approximately 20-25 percent transmissivity of a particular spectral band or range, the reflectance of the ISI layer may be approximately 60-70 percent with respect to other light. If it is desired that the mirror have approximately 70 percent photopic reflectance or higher and increased transmissivity of a desired spectral band of light, a double ISI or DOD stack may be implemented. One particular embodiment of such a double ISI stack provides a semi-conductive layer (430 and/or 432) of approximately 71 nm (such as a layer 430 of approximately 30 nm (300 Å) and a layer 432a of approximately 41 nm (410 Å) or other combinations) of ITO or the like, a first metallic layer 434a of approximately 41 nm (410Å), a semi-conductive layer 436a of approximately 101 nm (1010Å) of ITO or the like, a second metallic layer 434b of approximately 36 nm (360Å) and a semi-conductive layer 436b of approximately 10 nm (100Å) of ITO or the like. This embodiment provides increased reflectivity of the reflective element to most wavelengths of light, while achieving the desired amount of transmissivity of the particular, targeted spectral band or bands. This is because the two metallic layers 434a, 434b, which are generally planar and parallel to each other, are separated by a distance of the order of approximately 100 nm (1000Å), which gives rise to multiple beam interference of the incident light, resulting in constructive interference at certain wavelengths and destructive interference at other wavelengths. This particular example provides a reflective element which is spectrally tuned to substantially transmit light

with a wavelength of approximately 602 nanometers, while substantially reflecting other visible light.

Other materials (with other refractive indices) and other physical thicknesses for the layers may be selected to transmit other desired wavelengths or ranges of wavelengths, without affecting the scope of the present invention. Also, additional repeating layers may be added to form a multiple stack, such as an additional metallic conducting layer and an additional semi-conductive ITO layer (or the like), in order to achieve the desired affect. The repeating and alternating layers form a narrow band ISI stack (which may have seven or nine or more layers of conductive layers and metallic layers), which functions to pass or transmit only such light which corresponds to one or more particular, substantially narrow spectral bands or ranges of wavelengths. The additional layers may provide enhanced performance of the reflective element with only an incremental increase in cost, since the additional layers are preferably deposited onto the other layers as part of the sputter coating process. With each additional set or stack of layers, each of the reflective, metallic layers may be reduced in thickness, which may provide increased transmissivity through the stack for a targeted spectral band, while still providing the desired amount of reflectivity over the reflective element. For example, a nine layer ISI or DOD stack (such as shown in FIG. 17 and discussed below) may provide a reflective element that has a greater than approximately 60 percent transmissivity of one or more particular, narrow spectral bands, and which is tuned or substantially pinpointed to match the emission spectrum from a particular display device (such as a display device including a light emitting diode).

Referring now to FIGS. 11-17, several particular examples of a reflective element or mirror element in accordance with the present invention are shown. The reflective elements of FIGS. 11-17 incorporate the design and functional aspects of the reflective elements discussed above, and are provided as specific examples or embodiments of the present invention. The materials and physical thicknesses of the layers are selected to provide different refractive indices and thicknesses to provide different beam interference of the incident light, thereby resulting in the desired transmissive range for a particular display element. In each embodiment of FIGS. 11-17, the various layers and substrates are given similar reference numbers as shown with respect to the reflective elements shown in FIGS. 2-10, but with each embodiment adding 100 to the reference numbers of the previous embodiment. Clearly, the scope of the present invention includes other combinations of

layers that may be implemented to provide for enhanced transmissivity of one or more particular spectral bands of light, while providing substantial reflectance of other light.

With reference to FIG. 11, a reflective element 516 has a front substrate 522 and a rear substrate 524 and a display element 518 at a rear or fourth surface of rear substrate 524. A semi-conductive ITO layer (or the like) 530 of approximately 30 nm is deposited on the forward or third surface of rear substrate 524, while a semi-conductive layer 526 (such as ITO, tin oxide or the like) is deposited on the rear or second surface of front substrate 522. An ISI or DOD stack or layer 528 and an electrochromic (EC) medium 540 and seal 541 are provided between the semi-conductive layers 526, 530. ISI layer 528 comprises a substantially transparent semi-conducting non-metallic adhesion layer 532 of approximately 41 nm of ITO, ICO, IWO or the like, a metallic conducting layer 534 of approximately 35 nm of silver or silver alloy or the like, and a substantially transparent semi-conducting non-metallic passivation layer 536 of approximately 68 nm of ITO, ICO, IWO or the like. As shown in FIG. 11A, such a configuration provides a transmissivity of light through reflective element 516 with a peak transmissivity of light having a wavelength of approximately 580 nm. The transflective reflector of the reflective element 516 is thus spectrally tuned to transmit orange light, such as light emitted from an orange vacuum fluorescent display 518, which emits light having a peak intensity of approximately 580 nm, as shown in FIG. 11B. The display 518 may also include a color filter 517, such as discussed above with respect to display 218.

In another particular embodiment similar to that of FIG. 11, an automotive DOD electrochromic mirror cell may include a transparent conductive layer, such as an ITO layer or the like (having, for example, approximately 12 ohms per square resistivity, which is commercially available as an ITO coated substrate), at the innermost, second surface of the front substrate, and a three layer coating or stack deposited on a transparent conductive layer, such as an ITO layer, at the rear substrate, itself deposited on the inner facing third surface of the rear substrate in a front / rear twin substrate laminate cell construction. The ITO layer at the rear substrate layer may have, for example, approximately 80 ohms per square resistivity, and the rear substrate may be a commercially available ITO coated substrate. The three layer stack or layers may be applied to the appropriate ITO coated surface of the rear substrate, such as via sputter coating or the like. For example, the rear glass element or substrate may be placed in a coating mask fixture to mask the perimeter and may be placed in a vacuum deposition system. The transflective third surface reflector/conductor may be made on or

applied to the intended surface of the rear substrate (or to the ITO layer on the "third surface") by sequentially depositing first approximately 41 nm of ITO, second approximately 40 nm of silver metal and third approximately 65 nm of ITO onto the ITO layer at the third surface of the rear substrate.

5 The front and rear substrates are spaced apart using an epoxy perimeter seal (as is known and practiced in the electrochromic mirror art) with the conductive surfaces facing each other and preferably with an offset for the purpose of attaching an electrode clip or busbar. The spacing between the conductive planar surfaces is, for example, approximately 90 μm . After curing of the epoxy seal, the reflective element may be vacuum
10 filled with an electrochromic medium, such as an electrochromic monomer material or the like. After filling the reflective element with the electrochromic monomer, the filling port of the reflective element or cell may be plugged with a UV curable adhesive which may then be cured by exposure to UV radiation. The reflective element or cell may then be cured in an oven to form a solid polymer matrix electrochromic medium.

15 When such an embodiment was formed and tested, a voltage of approximately 1.2 volts was applied to the reflective element and it was observed to color rapidly and uniformly. The photopic reflectance of the reflective element was initially approximately 67%, with a neutral silvery appearance, and decreased to approximately 7% in less than approximately 8 seconds with the voltage applied. The transmittance of the reflective
20 element in its bleached state was approximately 19% for light having wavelengths between approximately 600 nm and 620 nm. When the voltage was disconnected or stopped, the reflectance of the reflective element substantially uniformly returned to its original value of approximately 67% within about 10 seconds. The DOD stack of the present invention thus may provide for enhanced transmittance of light having a preselected wavelength or range or
25 band of wavelengths, even when in the bleached or colored or darkened state.

 It is further envisioned that one or more adhesion enhancement layers or passivation layers, such as a layer or layers of nichrome (NiCr), palladium (Pd), platinum (Pt) or the like, may be applied or disposed at one or both sides of the metallic or silver layer 534, in order to increase the corrosion resistance of the metallic layer and to enhance the adhesion
30 and the mechanical stability of the metallic layer. For example, an adhesion or passivation layer may be applied or disposed between metallic layer 534 and semi-conductive layer 532, and another adhesion or passivation layer may be applied or disposed between metallic layer 534 and semi-conductive layer 536. The adhesion or passivation layer or layers may have a

thickness of approximately 0.5 nm to approximately 10 nm or thereabouts. The adhesion or passivation layers may be disposed at one or both sides or surfaces of the metallic layer or layers of any of the reflective element embodiments described herein or of other types of electrochromic reflective elements, without affecting the scope of the present invention.

5 Such adhesion or passivation layers may be applied at the metallic layer or layers of other stacks or layers of the present invention described herein.

With reference to FIG. 12, a reflective element 616 has a front substrate 622 and a rear substrate 624 and a display element 618 at a rear or fourth surface of rear substrate 624. A semi-conductive ITO layer (or the like) 630 of approximately 30 nm is deposited on
10 the forward or third surface of rear substrate 624, while a semi-conductive layer 626 (such as ITO, tin oxide or the like) is deposited on the rear or second surface of front substrate 622. An ISI or DOD stack or layer 628 and EC medium 640 and seal 641 are provided between the semi-conductive layers 626, 630. ISI layer 628 comprises an adhesion layer 632 of approximately 10 nm of ITO, ICO, IWO or the like, a metallic layer 634 of approximately 40
15 nm of silver or silver alloy or the like, and a passivation layer 636 of approximately 43 nm of ITO, ICO, IWO or the like. As shown in FIG. 12A, such a configuration provides a transmissivity of light through the reflective element with a peak transmissivity of light having a wavelength of approximately 500 nm. The reflective element 616 is thus spectrally tuned to transmit light emitted from a blue-green vacuum fluorescent display 618, which may
20 emit light having a peak intensity of approximately 500 nm, as shown in FIG. 12B.

With reference to FIG. 13, a reflective element 616' provides a substantially spectrally neutral transmission characteristic and has a front substrate 622' and a rear substrate 624' and a display element 618' at a rear or fourth surface of rear substrate 624'. A semi-conductive ITO layer (or the like) 630' of approximately 30 nm is deposited on the
25 forward or third surface of rear substrate 624', while a semi-conductive layer 626' (such as ITO, tin oxide or the like) is deposited on the rear or second surface of front substrate 622'. An ISI or DOD stack or layer 628' and EC medium 640' and seal 641' are provided between the semi-conductive layers 626', 630'. ISI layer 628' comprises an adhesion layer 632' of approximately 78 nm of ITO, ICO, IWO or the like, a metallic layer 634' of approximately 31
30 nm of silver or silver alloy or the like, and a passivation layer 636' of approximately 63 nm of ITO, ICO, IWO or the like. As shown in FIG. 13A, such a configuration provides a generally neutral transmission of light through the transfective reflective element for most wavelengths of visible light.

With reference to FIG. 14, a reflective element 716 has a front substrate 722 and a rear substrate 724 and a display element 718 at a rear or fourth surface of rear substrate 724. A semi-conductive ITO layer (or the like) 730 of approximately 30 nm is deposited on the forward or third surface of rear substrate 724, while a semi-conductive layer 726 (such as ITO, tin oxide or the like) is deposited on the rear or second surface of front substrate 722. A double stack ISI or DOD stack or layer 728 and EC medium 740 and seal 741 are provided between the semi-conductive layers 726, 730. Double stack ISI layer 728 comprises a semi-conductive adhesion layer 732 of approximately 60 nm of ITO, ICO, IWO or the like, a first metallic layer 734a of approximately 33 nm of silver or silver alloy or the like, a semi-conductive layer 736a of approximately 117 nm of ITO, ICO, IWO or the like, a second metallic layer 734b of approximately 33 nm of silver, silver alloy or the like, and a semi-conductive layer 736b of approximately 86 nm of ITO, ICO, IWO or the like. As shown in FIG. 14A, such a configuration provides a transmissivity of light through the reflective element with a peak transmissivity of light having a wavelength of approximately 650 nm. The reflective element 716 is thus spectrally tuned to transmit red light, such as light emitted from a red light emitting diode display 718, which may emit light having a peak intensity of approximately 650 nm, as shown in FIG. 14B. As can be seen with reference to FIGS. 14A and 11A, the transflective reflector and double stack ISI or DOD layer 728 provide a narrower band of transmissivity for the desired spectral band or range of wavelengths being emitted by the display. Such a configuration thus may provide enhanced reflectivity of light outside of the targeted spectral band.

With reference to FIG. 15, a reflective element 816 has a front substrate 822 and a rear substrate 824 and a display element 818 at a rear or fourth surface of rear substrate 824. A semi-conductive ITO layer (or the like) 830 of approximately 30 nm is deposited on the forward or third surface of rear substrate 824, while a semi-conductive layer 826 (such as ITO, tin oxide or the like) is deposited on the rear or second surface of front substrate 822. A double stack ISI or DOD stack or layer 828 and EC medium 840 and seal 841 are provided between the semi-conductive layers 826, 830. Double stack ISI layer 828 comprises a semi-conductive adhesion layer 832 of approximately 23 nm of ITO, ICO, IWO or the like, a first metallic layer 834a of approximately 30 nm of silver or silver alloy or the like, a semi-conductive layer 836a of approximately 204 nm of ITO, ICO, IWO or the like, a second metallic layer 834b of approximately 34 nm of silver, silver alloy or the like, and a semi-conductive layer 836b of approximately 47 nm of ITO, ICO, IWO or the like. As shown in

FIG. 15A, such a configuration provides a transmissivity of light through the reflective element with a peak transmissivity of light having a wavelength of approximately 500 nm. The reflective element 816 is thus spectrally tuned to transmit blue-green light, such as light emitted from a blue-green light emitting diode display 818, which may emit light having a peak intensity of approximately 500 nm. Similar to double stack ISI layer 728 discussed above, the transflective reflector and double stack ISI layer 828 provide a narrower band of transmissivity for the desired spectral band or range of wavelengths being emitted by the display. Such a configuration thus may provide enhanced transmissivity of the preselected or targeted spectral band and enhanced reflectivity of light outside of the targeted spectral band.

With reference to FIG. 16, a reflective element 916 has a front substrate 922 and a rear substrate 924 and a display element 918 at a rear or fourth surface of rear substrate 924. A semi-conductive ITO layer (or the like) 930 of approximately 30 nm is deposited on the forward or third surface of rear substrate 924, while a semi-conductive layer 926 (such as ITO, tin oxide or the like) is deposited on the rear or second surface of front substrate 922. A multiple stack ISI or DOD stack or layer 928, EC medium 940, seal 941 and encapsulant 943 are provided between the semi-conductive layers 926, 930. The ISI or DOD stack or layer 928 may be provided on ITO layer 930 so as to have a tab out portion as discussed above with respect to ISI layer 328. The encapsulant 943 is provided along the edges of the tab out portion of reflective element 916, and the seal 941 is provided between the tab out portion and the ITO layer 926 on front substrate 922 and between the ITO layers 924, 926 around ISI layer 928 where there is no tab out portion.

Multiple ISI or DOD stack or layer 928 comprises an adhesion layer 932 of approximately 80 nm of ITO, ICO, IWO or the like, a first metallic layer 934a of approximately 30 nm of silver or silver alloy or the like, a layer 936a of approximately 101 nm of silicon oxide or the like, a layer 934b of approximately 60 nm of titanium oxide or the like, a layer 936b of approximately 95 nm of silicon oxide or the like, a layer 934c of approximately 161 nm of titanium oxide or the like, a layer 936c of approximately 53 nm of silicon oxide or the like, a metallic layer 934d of approximately 50 nm of silver or silver alloy or the like, and a layer 936d of approximately 72 nm of ITO, ICO or the like. As shown in FIG. 16A, such a configuration provides a transmissivity of light through the reflective element with a peak transmissivity of light having a wavelength of approximately 650 nm. The reflective element 916 is thus spectrally tuned to transmit red light, such as light emitted from a red light emitting diode display 918, which may emit light having a peak intensity of

approximately 650 nm. The transflective reflector and multiple stack ISI layer 928 provide an extra narrow band of transmissivity for the desired spectral band or range of wavelengths being emitted by the display. Such a configuration thus may provide enhanced reflectivity of light outside of the targeted spectral band. As can be seen in FIG. 16A, reflective element
5 916 may also transmit spectral bands of light at certain other wavelengths or ranges of wavelengths as well, such as at approximately 410 nm and 470 nm.

With reference to FIG. 17, a reflective element 1016 has a front substrate 1022 and a rear substrate 1024 and a display element 1018 at a rear or fourth surface of rear substrate 1024. A semi-conductive ITO layer (or the like) 1030 of approximately 30 nm is
10 deposited on the forward or third surface of rear substrate 1024, while a semi-conductive layer 1026 (such as ITO, tin oxide or the like) is deposited on the rear or second surface of front substrate 1022. A multiple stack ISI or DOD stack or layer 1028, EC medium 1040, seal 1041 and encapsulant 1043 (around a tab out portion of the ISI layer, as discussed above) are provided between the semi-conductive layers 1026, 1030.

Multiple stack ISI or DOD layer 1028 comprises an adhesion layer 1032 of
15 approximately 80 nm of ITO, ICO, IWO or the like, a first metallic layer 1034a of approximately 46 nm of silver or silver alloy or the like, a layer 1034b of approximately 80 nm of titanium oxide or the like, a layer 1036a of approximately 85 nm of silicon oxide or the like, a layer 1034c of approximately 188 nm of titanium oxide or the like, a layer 1036b of
20 approximately 48 nm of silicon oxide or the like, a metallic layer 1034d of approximately 42 nm of silver or silver alloy or the like, and a layer 1036c of approximately 77 nm of ITO, ICO or the like. As shown in FIG. 17A, such a configuration provides a transmissivity of light through the reflective element with two peak transmission bands, namely, a first spectral band having a peak transmissivity of light having a wavelength of approximately 465 nm and
25 a second spectral band having a peak transmissivity of light having a wavelength of approximately 645 nm. The reflective element 1016 is thus spectrally tuned to substantially transmit both blue light, such as light emitted from a blue light emitting diode display 1018a, which may emit light having a peak intensity of approximately 465 nm, and red light, such as light emitted from a red light emitting diode display 1018b, which may emit light having a
30 peak intensity of approximately 645 nm. The transflective reflector and multiple stack ISI layer 1028 provide an extra narrow band of transmissivity for each of the desired spectral bands or ranges of wavelengths being emitted by the displays. Such a configuration thus may

facilitate the implementation of different colored display elements, while providing enhanced reflectivity of light outside of the targeted spectral bands.

Referring now to FIG. 18, an electro-optic or electrochromic mirror element 1116 comprises a pair of substrates (a front substrate 1122 is shown in FIG. 18), with an electrochromic medium (not shown in FIG. 18) sandwiched therebetween. Electrochromic mirror element 1116 may comprise a reflective metallic layer or layers and transparent, at least partially conductive layers, such as discussed above, to provide a transflective mirror element. The electrochromic mirror element 1116 includes one or more display elements, such as the three display elements 1118a, 1118b, 1118c shown in FIG. 18, positioned behind the rear substrate and operable to emit or transmit light through the substrates and layers and electrochromic medium for viewing at the front substrate 1122.

The electrochromic mirror element 1116 comprises at least two regions, such as the three regions 1116a, 1116b, 1116c shown in FIG. 18. A central or principle viewing region 1116a provides a respective reflectivity and transmissivity, such as via layers or coatings as described above. One or both side regions 1116b, 1116c also provide a respective reflectivity and transmissivity. In the illustrated embodiment, the display element or elements 1118a, 1118b, 1118c are positioned at the side or display regions 1116b, 1116c. The conductive metallic and semiconductive non-metallic layers may be selected and adjusted so that the transmissivity in the side regions 1116b, 1116c may be greater than the transmissivity in the central region 1116a, while the reflectivity in the central region 1116a may be greater than the reflectivity in the side or display regions 1116b, 1116c. The present invention thus provides greater transmissivity in the display regions to enhance viewing of the displays, while providing greater reflectivity in the central or main region of the mirror element to provide enhanced reflectivity in the principle viewing area.

In the illustrated embodiment, the transmissivity at the display regions may be approximately 25%, while the transmissivity in the central or principle viewing region may be approximately 20%. Likewise, the reflectivity in the central or principle viewing region may be approximately 65%, while the reflectivity in the display regions may be approximately 60%. Other reflective and transmissive characteristics may be achieved without affecting the scope of the present invention.

The difference in the reflectivity and transmissivity between the regions is achieved by selecting different combinations of vapor source and masking of the regions to achieve the desired effect. For example, the thicknesses of different layers of the conductive

metallic layer or layers and of the transparent, at least partially conductive layers may be selected or adjusted across the mirror element to achieve a desired amount of transmissivity at the display regions, while maintaining sufficient reflectivity in these regions, and to achieve a desired or optimum or maximum reflectivity at the central or principle viewing area
5 or region of the mirror element. For example, a reflective metallic coating or layer may be thicker at the principle viewing region than at the display region or regions, while a transparent layer or coating may be thinner at the principle viewing region than at the display region or regions. Although shown as having display regions at the side regions of the mirror element, clearly displays and associated display regions providing enhanced transmissivity
10 may be positioned elsewhere around the mirror element, without affecting the scope of the present invention.

Therefore, the reflective element or mirror element of the present invention allows for a display element to be positioned behind the reflective layer and transmits light from the display element through the mirror element, while providing sufficient reflectivity
15 across the entire mirror element and not requiring any windows or thinned areas of reduced reflectivity in the display region. The present invention thus provides a mirror assembly which may include multiple display-on-demand type displays or display-on-need type displays, without adversely affecting the reflective nature of the reflective element. Furthermore, the transmissivity of the ISI or DOD stack or layer or the multiple stack ISI or
20 DOD layers of the transflective reflector of the present invention may match or pinpoint the particular spectral band corresponding to the light emitted by the display element or device, in order to provide improved transmission of the display information or light through the stack (and thus through the reflective element), while providing a desired neutral reflectance over the entire surface of the reflector. The present invention thus may provide a reflective
25 element which has a transmissivity level of greater than at least approximately 20 percent, more preferably at least approximately 30 percent, and most preferably at least approximately 50 percent, for light within a particular narrow spectral band or range of wavelengths, while providing substantial reflectance of light outside of the particular, selected spectral band or range of wavelengths. The reflective element of the present invention also provides for
30 generally uniform thickness of the ISI or DOD layers, since none of the layers have to be etched or masked or reduced in thicknesses to allow for the display to transmit therethrough, thereby enhancing the manufacturing processing of the reflective element.

Optionally, the mirror assembly may include an illumination source for providing illumination, such as near infrared and/or infrared illumination, within the cabin of the vehicle. For example, the illumination source may be directed toward the head of the driver of the vehicle (or the area or location where a typical driver's head would be), and may
5 be used in conjunction with a camera device or imaging device or the like. The imaging device or imaging system may comprise a cabin monitoring system, such as a monitoring system utilizing the principles disclosed in U.S. Pat. Nos. 6,523,964; and 6,302,545, and U.S. pat. applications, Ser. No. 10/372,873, filed Feb. 24, 2003 (Attorney Docket DON01 P-1077); Ser. No. 09/793,002, entitled VIDEO MIRROR SYSTEMS INCORPORATING AN
10 ACCESSORY MODULE, filed Feb. 26, 2001 (Attorney Docket DON01 P-869); and Ser. No. 10/054,633, filed Jan. 22, 2002 by Lynam et al. for VEHICULAR LIGHTING SYSTEM (Attorney Docket DON01 P-962), which are hereby incorporated by reference herein.

Optionally, the illumination source may be operable to illuminate the head of the driver while the imaging device is operable to capture images of the driver's head, such as for a video
15 conferencing function, a driver alertness detection function (which may detect drowsiness issues, such as unorthodox head movement, nodding, glazed eyes, dilating eyes or other characteristics which may be indicative of driver fatigue or reduced alertness), a seat occupancy detection function, an intrusion detection function or any other desired functions. The illumination source or sources may comprise infrared or near infrared emitting sources,
20 such as light emitting diodes (LEDs) or the like, to minimize the affect on or visibility to the driver of the vehicle, such as disclosed in U.S. Pat. Nos. 6,523,964; and 6,302,545, and U.S. pat. application, Ser. No. 10/372,873, filed Feb. 24, 2003 (Attorney Docket DON01 P-1077), which are hereby incorporated herein by reference. The imaging device thus may be capable of sensing infrared light, and may be particularly sensitive to infrared or near infrared light,
25 and may comprise a CMOS imaging array or the like, such as disclosed in U.S. Pat. Nos. 5,550,677; 5,670,935; 5,760,962; 5,796,094 and 5,877,897, which are hereby incorporated herein by reference.

The interior rearview mirror assembly may provide the illumination source or sources at the bezel or chin or eyebrow of the mirror assembly, or at a module or pod or the
30 like associated with the mirror assembly. Optionally, the mirror assembly may include the illumination source or sources within the mirror casing and behind the electrochromic cell of the mirror assembly, whereby the illumination source may emit near infrared light or radiant energy and project the light through a transflective electrochromic element, which may have

sufficient transmissivity in the near infrared range of the spectrum, while limiting transmissivity of light in the visible range and providing a desired amount of untinted photopic reflectance, as discussed below. The illumination source thus may be positioned behind the rear substrate of the electrochromic cell and may project the near infrared illumination through both substrates of the reflective element or cell to sufficiently illuminate or bathe or flood the targeted area with near infrared illumination. The imaging device may also be positioned within the mirror casing and behind the transflective electrochromic element to capture images of the scene illuminated by the near infrared illumination source or sources.

10 The transflective display on demand type reflective element preferably maintains an untinted, high photopic reflectance of visible light, while also providing sufficient transmissivity of near infrared light or radiant energy (such as within the range of approximately 750 nm to approximately 1100 nm). Preferably, the transflective display on demand element provides at least approximately 30% transmissivity of near infrared light, 15 preferably at least approximately 40%, more preferably at least approximately 60% and most preferably at least approximately 80% transmissivity of near infrared light. Typically, such near infrared transmissivity may not be achieved utilizing reflective coatings or stacks of coatings that comprise or include a metallic layer, such as a thin silver or silver alloy or aluminum or aluminum alloy layer or the like. In such applications, the infrared or near 20 infrared light emitted by the illumination source may reflect back into the cavity of the mirror casing. The present invention overcomes this by providing an infrared or near infrared transmitting stack of dielectric layers or coatings which substantially transmit near infrared light while the transflective element also provides high photopic reflectance of visible light. The transflective element may provide high photopic reflectance and may meet the 25 specifications set forth in SAE J964A, which is hereby incorporated herein by reference. Preferably, the transflective element provides greater than approximately 55%, more preferably greater than approximately 65% and most preferably greater than approximately 75%, of such photopic reflectance.

Referring now to FIGS. 19-22, a transflective electrochromic element or cell 30 1216 includes a front substrate 1222 and a rear substrate 1224, and an illumination source 1244 and an imaging device 1246 at a rear or fourth surface of rear substrate 1224. A semi-conductive layer or coating (such as ITO, tin oxide or the like) 1230 is deposited on the forward or third surface of rear substrate 1224, while a semi-conductive layer 1226 (such as

ITO, tin oxide or the like) is deposited on the rear or second surface of front substrate 1222. An electrochromic medium 1240 and seal 1241 are provided or sandwiched between the semi-conductive layers 1226, 1230, with an electrical connector 1248 positioned at least partially along at least one edge of each of the semi-conductive layers 1226, 1230. The transfective cell 1216 further includes an infrared or near infrared transmitting (IRT) stack or layers 1228, which, in the illustrated embodiment of FIG. 19, is positioned or stacked on the rear surface of the rear substrate 1224. A protective cover or glass sheet 1225 is adhered or secured to the rear surface of the IRT stack 1228, such as via an adhesive layer 1225a, which preferably is an index matching adhesive that matches the index of the protective cover or sheet. The protective cover may comprise glass, or may comprise other transparent or substantially clear materials, such as plastic, polycarbonate, acrylic or the like, without affecting the scope of the present invention.

IRT stack 1228 comprises multiple layers of dielectric layers or coatings across the rear surface of rear substrate 1224 which function as a cold mirror stack that allows near infrared and infrared light or radiant energy to pass therethrough while substantially reflecting visible light. The IRT stack 1228 may comprise layers of titanium oxide alternating with silicon oxide layers. The titanium oxide layers provide a higher refractive index while the silicon oxide layers provide a lower refractive index. The alternating combination of the lower and higher refracting indices of alternating layers provides enhanced near infrared transmissivity, while providing reflectivity of visible light.

In an exemplary embodiment, IRT stack 1228 comprises nineteen such alternating layers having: a first titanium oxide layer approximately 72 nm thick on the rear surface of substrate 1224, a first silicon oxide layer approximately 32 nm thick on the first titanium oxide layer, a second titanium oxide layer approximately 94 nm thick on the first silicon oxide layer, a second silicon oxide layer approximately 110 nm thick on the second titanium oxide layer, a third titanium oxide layer approximately 64 nm thick on the second silicon oxide layer, a third silicon oxide layer approximately 85 nm thick on the third titanium oxide layer, a fourth titanium oxide layer approximately 62 nm thick on the third silicon oxide layer, a fourth silicon oxide layer approximately 128 nm thick on the fourth titanium oxide layer, a fifth titanium oxide layer approximately 60 nm thick on the fourth silicon oxide layer, a fifth silicon oxide layer approximately 98 nm thick on the fifth titanium oxide layer, a sixth titanium oxide layer approximately 57 nm thick on the fifth silicon oxide layer, a sixth silicon oxide layer approximately 94 nm thick on the sixth titanium oxide layer, a seventh

titanium oxide layer approximately 54 nm thick on the sixth silicon oxide layer, a seventh silicon oxide layer approximately 77 nm thick on the seventh titanium oxide layer, an eighth titanium oxide layer approximately 36 nm thick on the seventh silicon oxide layer, an eighth silicon oxide layer approximately 83 nm thick on the eighth titanium oxide layer, a ninth titanium oxide layer approximately 58 nm thick on the eighth silicon oxide layer, a ninth silicon oxide layer approximately 97 nm thick on the ninth titanium oxide layer, and a tenth titanium oxide layer approximately 28 nm thick on the ninth silicon oxide layer. Clearly, other thicknesses and combinations of layers may be implemented to achieve the desired levels of transmissivity and reflectivity, without affecting the scope of the present invention. The transflective element thus provides a fourth surface transflective mirror element, with multiple alternating layers of silicon oxide and titanium oxide to enhance the near infrared transmissivity through the ITO layers and substrates.

The transmissivity percentage of such a substrate versus the light wavelength is shown in FIG. 22. As can be seen in FIG. 22, the substrate 1224 and IRT stack 1228 transmit more than 90% of near infrared light, while substantially not transmitting light in the visible range of the spectrum. The transflective element 1216 is thus spectrally tuned to transmit near infrared light emitted from illumination source 1244, and may transmit the near infrared light from the scene back to the imaging sensor 1246. As can be seen in FIG. 22, the transmission is generally constant or flat for the desired wavelengths at an angle of incidence of the light source relative to the substrate between approximately 0 degrees and approximately 50 degrees.

The arrangement shown in FIG. 19 may allow the mirror manufacturer to purchase the rear substrate sheet or material, which may be purchased from a glass or substrate supplier or vendor with the front ITO layer or coating and the cold mirror stack or IRT stack already applied thereto or deposited thereon. The ITO layers and alternating silicon oxide and titanium oxide layers may be deposited on the respective surfaces or layers via any known manner, such as vacuum deposition or the like, and such as disclosed in U.S. Pat. Nos. 5,668,663; 5,724,187; and 6,002,511, which are hereby incorporated herein by reference. This allows the mirror manufacturer to select an appropriate rear substrate, depending on the desired function or application of the mirror assembly, and to assemble the transflective element with the selected substrate. The mirror manufacturer may purchase the substrates, cut out the desired shape for the mirror reflective element and glue or adhere or otherwise join the substrates (with coatings thereon) together (and sandwich the

electrochromic medium between the front and rear substrate) to form the desired transfective element.

Prior to deposition, it is desirable / beneficial to clean the substrate using a plasma source or an ion source, such as a linear ion source or the like, which may result in enhanced adhesion of the thin films to the substrate. It is preferable that the substrate
5 cleaning is accomplished in one single pump down cycle of the vacuum coating process. For example, glass substrates can enter a vacuum chamber via a load-lock, and pass under a plasma source, such as a linear ion source or the like, where the surface-to-be-coated is activated/cleaned by exposure to a plasma and/or by ion bombardment or the like. The now
10 plasma activated/ion-bombardment cleaned surface is then coated with an ITO layer, followed by a metallic layer (such as silver), followed by an ITO layer such as described herein. Optionally, and preferably, a three-sided target assembly is used, for example, one side may be a linear ion source, another side may be an ITO target, and the third side may be a silver target. The three-sided target assembly can, for example, rotate (such as clockwise)
15 to first ion clean the substrate, then rotate clockwise again to deposit ITO, then rotate clockwise again to deposit silver, and then rotate counterclockwise to deposit ITO again. Suitable ion sources for such a cleaning purpose include Anode Layer Sources (ALS), Kaufmann sources, gridded sources, non-gridded sources, RF sources and DC glow discharge sources and the like. The most preferred are the linear ion sources of the ALS type, such as
20 are available from Veeco Instruments, Inc. of Colorado and Advanced Energy (AE) of Colorado.

Optionally, and desirably, the substrates 1222, 1224 may have a low absorption characteristic in the near infrared range or band of the energy spectrum, whereby the substrates provide low absorption of near infrared radiant energy, such as at wavelengths
25 of around 880 nm or thereabouts. The substrates thus may provide enhanced transmissivity of such near infrared radiant energy through the transfective electrochromic element or cell. Such low absorption characteristics may be accomplished by selecting a material for the substrates that provides the desired results. For example, the substrates may comprise a borosilicate material, such as the type that is commercially available from Schott Glass Corp.
30 under the name BOROFLOAT™, or may comprise a B270 material or SUPERWHITE™, also commercially available from Schott Glass Corp., or may comprise other materials, such as fused silica or quartz materials or the like, that may also or otherwise provide the desired degree of low absorption of near infrared radiant energy. Other materials may be selected for

the substrates of the transfective electrochromic cell, without affecting the scope of the present invention.

Optionally, and with reference to FIG. 20, a transfective element 1216' may provide the IRT stack 1228' on a front surface of the protective cover or glass substrate or sheet 1225. In such an embodiment, the IRT stack 1228' and cover 1225 are adhered or secured to the rear surface of rear substrate 1224' via the index matching adhesive 1225a or the like. The arrangement shown in FIG. 20 allows the IRT stack to be manufactured on a separate glass sheet or protective cover, whereby the mirror manufacturer may purchase the front and rear substrates or sheets (with the ITO layers already applied thereto or deposited thereon) and the third glass sheet or protective cover with the IRT stack already deposited thereon. The protective cover may comprise glass, or may comprise other transparent or substantially clear materials, such as plastic, polycarbonate, acrylic or the like, without affecting the scope of the present invention. The IRT stack and other components of transfective element 1216' may be substantially similar to the IRT stack and components of transfective element 1216 discussed above, such that a detailed discussion of these elements will not be repeated herein.

Optionally, and with reference to FIG. 21, a transfective element 1216" may be substantially similar to transfective element 1216 of FIG. 19, discussed above, and may include a titanium oxide layer or coating 1227 on the rear surface of the front substrate 1222' and between the front substrate 1222' and the ITO layer or coating 1226'. The titanium oxide layer 1227 may function to partially cancel out or compensate for any near infrared reflectivity by the ITO layers of the cell or element to further enhance the performance of the transfective element.

Referring now to FIG. 23, a transfective electrochromic element or cell 1316 includes a front substrate 1322 and a rear substrate 1324, and an illumination source 1344 and an imaging device 1346 at a rear or fourth surface of rear substrate 1324. A semi-conductive layer or coating 1326 (such as ITO, tin oxide or the like) is deposited on the rear or second surface of front substrate 1322. An IRT stack 1328 is applied to or deposited on the front surface of rear substrate 1324, and a semi-conductive layer or coating 1330 (such as ITO, tin oxide or the like) is deposited on IRT stack 1328. An electrochromic medium 1340 and seal 1341 are provided or sandwiched between the semi-conductive layers 1326, 1330, with an electrical connector 1348 positioned at least partially along at least one edge of each of the semi-conductive layers 1326, 1330.

Similar to IRT stack 1228 discussed above, IRT stack 1328 comprises multiple layers of dielectric layers or coatings. IRT stack or cold mirror stack 1328 is deposited on the front surface of rear substrate 1324 and may comprise alternating layers of titanium oxide alternating with silicon oxide layers. The titanium oxide layers provide a higher refractive index while the silicon oxides provide a lower refractive index. The combination of the lower and higher refractive indices of the alternating layers provides enhanced near infrared transmissivity, while providing reflectivity of visible light.

In an exemplary embodiment, IRT stack 1328 comprises nineteen such alternating layers with a twentieth layer of ITO deposited on the outermost IRT stack layer. For example, the IRT stack may comprise a first titanium oxide layer approximately 53 nm thick on the rear surface of substrate 1324, a first silicon oxide layer approximately 57 nm thick on the first titanium oxide layer, a second titanium oxide layer approximately 84 nm thick on the first silicon oxide layer, a second silicon oxide layer approximately 103 nm thick on the second titanium oxide layer, a third titanium oxide layer approximately 58 nm thick on the second silicon oxide layer, a third silicon oxide layer approximately 96 nm thick on the third titanium oxide layer, a fourth titanium oxide layer approximately 64 nm thick on the third silicon oxide layer, a fourth silicon oxide layer approximately 108 nm thick on the fourth titanium oxide layer, a fifth titanium oxide layer approximately 63 nm thick on the fourth silicon oxide layer, a fifth silicon oxide layer approximately 93 nm thick on the fifth titanium oxide layer, a sixth titanium oxide layer approximately 44 nm thick on the fifth silicon oxide layer, a sixth silicon oxide layer approximately 70 nm thick on the sixth titanium oxide layer, a seventh titanium oxide layer approximately 37 nm thick on the sixth silicon oxide layer, a seventh silicon oxide layer approximately 61 nm thick on the seventh titanium oxide layer, an eighth titanium oxide layer approximately 58 nm thick on the seventh silicon oxide layer, an eighth silicon oxide layer approximately 102 nm thick on the eighth titanium oxide layer, a ninth titanium oxide layer approximately 31 nm thick on the eighth silicon oxide layer, a ninth silicon oxide layer approximately 55 nm thick on the ninth titanium oxide layer, and a tenth titanium oxide layer approximately 49 nm thick on the ninth silicon oxide layer. The semi-conductive layer 1330 may comprise an ITO layer approximately 130 nm thick. Clearly, other thicknesses and combinations of layers may be implemented to achieve the desired levels of transmissivity and reflectivity, without affecting the scope of the present invention. The transfective element thus provides a third surface

transflective mirror element, with multiple layers of silicon oxide and titanium oxide to enhance the near infrared transmissivity through the ITO layers and substrates.

The transmissivity percentage of such a substrate versus the light wavelength is shown in FIG. 26. As can be seen in FIG. 26, such a rear substrate transmits more than approximately 90% of near infrared light, while substantially not transmitting light in the visible range of the spectrum. The transflective element 1316 is thus spectrally tuned to transmit near infrared light emitted from illumination source 1344, and may transmit the near infrared light from the scene back to the imaging sensor 1346. As can be seen in FIG. 26, the transmission is generally constant or flat for the desired wavelengths at an angle of incidence of the light source relative to the substrate between approximately 0 degrees and approximately 50 degrees.

The arrangement shown in FIG. 23 may allow the mirror manufacturer to purchase the rear substrate sheet or material, which may be purchased from a glass or substrate supplier or vendor with the IRT or cold mirror stack and the front ITO layer or coating already applied thereto or deposited thereon. The ITO layers and silicon oxide and titanium oxide layers may be deposited on the front surface or other layers via any known manner, such as vacuum deposition or the like, and such as disclosed in U.S. Pat. Nos. 5,668,663; 5,724,187; and 6,002,511, which are hereby incorporated herein by reference. This allows the mirror manufacturer to select an appropriate rear substrate, depending on the desired function or application of the mirror assembly, and to assemble the transflective element with the selected substrate. The mirror manufacturer may purchase the substrates, cut out the desired shape for the mirror reflective element and glue, adhere or otherwise join the substrates (with coatings thereon) together (and sandwich the electrochromic medium between the front and rear substrate) to form the desired transflective element.

Optionally, and with reference to FIG. 24, a transflective element 1316' in accordance with the present invention may be substantially similar to transflective element 1316 discussed above, and may include a titanium oxide layer or coating 1327 on the rear surface of the front substrate 1322' and between the front substrate 1322' and the ITO layer or coating 1326'. In an exemplary embodiment, the titanium oxide layer 1327 may be approximately 250 nm thick, while the ITO layer 1326' may be approximately 130 nm thick, but other thicknesses may be implemented to achieve the desired result, without affecting the scope of the present invention. The titanium oxide layer 1327 may function to partially cancel out or compensate for any near infrared reflectivity by the ITO layers of the cell or

element. This arrangement provides an enhanced semi-conductive layer or coating on the rear surface of the front substrate. A graphical depiction of the transmissivity of front substrate 1322' versus wavelength of light is shown in FIG. 27. In the illustrated embodiment, the peak transmissivity wavelength is approximately 880 nm. Such a reflective element or cell thus may be particularly suited for use with an imaging device or camera that has a peak sensitivity or response to light having a wavelength of approximately 880 nm.

Optionally, and with reference to FIG. 25, another transflective element 1316" in accordance with the present invention may be substantially similar to transflective element 1316 of FIG. 23, discussed above, and may include an enhanced semi-conductive layer on the rear surface of the front substrate 1322". The enhanced semi-conductive layer includes a titanium oxide layer or coating 1329 deposited on the rear surface of the front substrate 1322", a silicon oxide layer 1327' deposited on titanium oxide layer 1329, and an ITO layer 1326" deposited on silicon oxide layer 1327'. In an exemplary embodiment, the titanium oxide layer 1329 may be approximately 109 nm thick, while the silicon oxide layer 1327' may be approximately 277 nm thick and the ITO layer 1326' may be approximately 130 nm thick. Other thicknesses may be implemented to achieve the desired result, without affecting the scope of the present invention. The titanium oxide layer 1329 and silicon oxide layer 1227' may function to partially cancel out or compensate for any near infrared reflectivity by the ITO layers of the cell or element to enhance the near infrared transmissivity of the front substrate and semi-conductive layers. A graphical depiction of the transmissivity of front substrate 1322" versus wavelengths of light is shown in FIG. 28. In the illustrated embodiment, the peak transmissivity wavelength is approximately 880 nm. Such a reflective element or cell thus may be particularly suited for use with an imaging device or camera that has a peak sensitivity or response to light having a wavelength of approximately 880 nm.

Optionally, and as shown in FIG. 29, a transflective element 1316'" may include the substrates 1322", 1324' and coatings or layers such as described above with respect to transflective element 1316" (FIG. 25), and may further include an anti-reflective (AR) stack or layers 1352 at the rear surface of the rear substrate 1324'. The anti-reflective stack or layers 1352 may be selected to minimize the reflectance of light at a desired or targeted wavelength or range of wavelengths or spectral band to enhance the overall transmissivity at the desired or targeted spectral band. For example, the anti-reflective stack 1352 may be selected to minimize the reflectance of near infrared radiant energy, such as radiant energy having a wavelength of approximately 880 nm or thereabouts, such that the

transmission of such radiant energy may be enhanced. In an exemplary embodiment, anti-reflective stack or layers 1352 comprises a layer of titanium oxide 1352a deposited on or disposed at the rear surface of the rear substrate 1324 and a layer of silicon oxide 1352b deposited on or disposed at the titanium oxide layer 1352a. In one embodiment, titanium
5 oxide layer 1352a may have a thickness of approximately 25 nm, while silicon oxide layer 1352b may have a thickness of approximately 205 nm, such that the anti-reflective stack or layers 1352 reduces the reflectance of near infrared radiant energy having a wavelength of approximately 880 nm or thereabouts. Other layers or thicknesses may be selected to achieve other desired results, and may be selected depending on the particular reflective element
10 design and the particular application of the reflective element, without affecting the scope of the present invention. Such anti-reflective surfaces may be applied to or disposed on the rearward surface of other mirror elements of the present invention described herein.

Therefore, the present invention provides a transflective electrochromic element or cell which may allow transmittance of near infrared light through the substrates
15 while providing a desired amount of untinted photopic reflectance, and while also providing the desired degree of conductivity at the conductive or semi-conductive layers. The transflective element may include multiple dielectric layers or coatings on one of the substrates or on a rear cover or glass sheet of the transflective element. The dielectric layers cooperate to enhance transmissivity of infrared or near infrared light through the substrates,
20 while providing the desired level of untinted photopic reflectance. The transflective element thus may allow the mirror assembly to include a near infrared light emitting diode or other near infrared emitting light source to be positioned behind the transflective element and within the mirror casing, whereby the light source may emit or project near infrared light through the transflective element toward and into the cabin of the vehicle. The mirror
25 assembly may also include an imaging device which may be positioned behind the transflective element and may receive or capture images of the interior cabin of the vehicle which is covered by the near infrared light of the light source.

Optionally, and with reference to FIG. 30, it is envisioned that a transflective element 1416 in accordance with the present invention may provide high transmissivity of
30 near infrared radiant energy, while also providing high transmissivity of a particular wavelength or range of wavelengths or spectral band or region of visible light, yet still providing high photopic reflectance of the other visible light and sufficient conductivity. Transflective element 1416 may be substantially similar to the transflective elements 1316,

1316', 1316", discussed above, but may include an infrared transmitting and display on demand stack 1428 (IRT-DOD stack) of alternating titanium oxide layers (or the like) and silicon oxide layers (or the like) that may provide for high transmissivity of near infrared radiant energy and high transmissivity of a desired visible light color, such as, for example, 5 visible light having a wavelength of approximately 430 nm (blue). Different combinations of alternating layers may be selected to provide sufficient transmissivity of near infrared radiant energy and of other desired spectral bands, without affecting the scope of the present invention.

The titanium oxide layers provide a higher refractive index while the silicon 10 oxides provide a lower refractive index. The combination of the lower and higher refractive indices of the alternating layers provides enhanced near infrared transmissivity, while providing high photopic reflectivity of most of the visible light, except the visible light in the desired spectral region or having the desired or selected or targeted wavelength. The transfective element thus may be used with a near infrared light emitting source 1444, which 15 may be used in conjunction with an imaging source or camera 1446, and a display on demand element 1450 that may emit light at the desired or selected wavelength or color (such as, for example, blue light having a wavelength of 430 nm) so that it is viewable through the reflective element by a driver or occupant of the vehicle.

The other elements of the transfective element 1416 may be substantially 20 similar to the transfective elements 1316, 1316', 1316", discussed above, such that a detailed discussion of these elements will not be repeated herein. The similar or common elements are shown in FIG. 30 with similar reference numbers to those of FIG. 24, but with one hundred added to each number. In the illustrated embodiment of FIG. 29, the transfective element 1416 is shown with a titanium oxide (TiO₂) layer or coating 1427 on the rear surface 25 of the front substrate 1422 and between the front substrate 1422 and the ITO layer or coating 1426, similar to transfective element 1316' of FIG. 24. However, other coatings or layers may be deposited on or applied to the front substrate of the transfective element, such as, for example, the other layers discussed above, without affecting the scope of the present invention.

30 In an exemplary embodiment of the infrared transmitting and visible light transmitting transfective element 1416, the IRT-DOD stack 1428 comprises nineteen such alternating layers with a twentieth layer of ITO 1430 deposited on the outermost IRT-DOD stack or layers. For example, the IRT-DOD stack may comprise a first titanium oxide layer

approximately 50 nm thick on the surface of the substrate, a first silicon oxide layer approximately 83 nm thick on the first titanium oxide layer, a second titanium oxide layer approximately 48 nm thick on the first silicon oxide layer, a second silicon oxide layer approximately 159 nm thick on the second titanium oxide layer, a third titanium oxide layer
5 approximately 50 nm thick on the second silicon oxide layer, a third silicon oxide layer approximately 97 nm thick on the third titanium oxide layer, a fourth titanium oxide layer approximately 61 nm thick on the third silicon oxide layer, a fourth silicon oxide layer approximately 104 nm thick on the fourth titanium oxide layer, a fifth titanium oxide layer approximately 59 nm thick on the fourth silicon oxide layer, a fifth silicon oxide layer
10 approximately 84 nm thick on the fifth titanium oxide layer, a sixth titanium oxide layer approximately 35 nm thick on the fifth silicon oxide layer, a sixth silicon oxide layer approximately 65 nm thick on the sixth titanium oxide layer, a seventh titanium oxide layer approximately 46 nm thick on the sixth silicon oxide layer, a seventh silicon oxide layer approximately 76 nm thick on the seventh titanium oxide layer, an eighth titanium oxide
15 layer approximately 48 nm thick on the seventh silicon oxide layer, an eighth silicon oxide layer approximately 175 nm thick on the eighth titanium oxide layer, a ninth titanium oxide layer approximately 19 nm thick on the eighth silicon oxide layer, a ninth silicon oxide layer approximately 61 nm thick on the ninth titanium oxide layer, and a tenth titanium oxide layer approximately 37 nm thick on the ninth silicon oxide layer. The semi-conductive layer 1430
20 may comprise an ITO layer or the like of approximately 130 nm thick. Clearly, other thicknesses and combinations of layers may be implemented to achieve the desired levels of transmissivity and reflectivity, such as high transmissivity of other colors or spectral regions of the spectrum, without affecting the scope of the present invention. The transflective element thus provides a third surface transflective mirror element, with multiple layers of
25 silicon oxide and titanium oxide to enhance the near infrared transmissivity and particular visible light wavelength or wavelengths through the ITO layers and substrates.

The transmissivity percentage of such a substrate versus the light wavelength is shown in FIG. 31. As can be seen in FIG. 31, such a substrate transmits more than approximately 90% of near infrared light, while substantially reflecting or not transmitting
30 light in the visible range of the spectrum, except for light having a wavelength of approximately 430 nm, which is also highly transmitted (such as at greater than approximately 90% transmissivity) by the substrate and alternating layers of the IRT-DOD stack. The transflective element is thus spectrally tuned to transmit near infrared light that

may be emitted from an illumination source 1444, and may transmit the near infrared light from the scene back to an imaging sensor 1446. The transflective element may also transmit light having a desired or targeted wavelength to allow for a colored display element or illumination source or indicator 1450 to be viewed through the transflective element.

5 Although shown and described as being implemented on a third surface of an electrochromic mirror element, it is envisioned that the layers or stacks of the present invention may be implemented at a fourth surface of the electrochromic reflective element, such as for a fourth surface reflective element, without affecting the scope of the present invention. In such an application, a radiant energy emitting device or element and/or an
10 imaging sensor may be positioned rearward of the stack or layers for emitting or receiving radiant energy through the reflective element. Also, a protective layer or cover may be provided over the rearwardmost layer of the alternating layers and over or around the display element or sensor to protect the layers at the rear of the reflective element.

 Also, although shown and described as being implemented in an
15 electrochromic reflective element or cell, the alternating layers or stacks of the present invention may be implemented at a rear surface (second surface) of a prismatic reflective element, without affecting the scope of the present invention. For example, and with reference to FIG. 32, a prismatic reflective element 1516 may comprise a prismatic or wedge-shaped substrate 1522 having a forward or outwardly facing surface 1522a and a rearward
20 surface 1522b opposite the forward surface 1522a. Prismatic reflective element 1522 includes alternating layers or a stack 1528 disposed at rear surface 1522b of prismatic substrate 1522. As shown in FIG. 32, a protective layer or coating 1525 may be applied over the stack 1528. The layers of stack 1528 may comprise alternating layers of metallic and
25 non-metallic layers or coatings, such as layers or stacks similar to the ISI stacks or DOD stacks or IRT stacks or IRT-DOD stacks of the present invention, as discussed above, depending on the particular application of the prismatic reflective element. The particular materials and thicknesses of the layers may be selected to provide the desired transmissivity of a particular selected spectral band or bands of radiant energy through the prismatic
30 reflective element, while providing sufficient reflectivity of other spectral bands of radiant energy.

 Prismatic reflective element 1516 may include a display element or radiant energy emitting device or illumination source 1544 positioned at a rear surface of the rearward most layer of stack 1528 and operable to emit radiant energy, such as visible light,

near infrared radiant energy or infrared radiant energy through stack 1528 and prismatic substrate 1522. The thicknesses and materials of the layers of stack 1528 may be selected to provide enhanced transmissivity of radiant energy or light within a particular spectral band through stack 1528 and prismatic substrate 1522, while providing sufficient reflectivity of
5 light having wavelengths outside of the selected particular spectral band. The particular spectral band may be selected to match the spectral band of light or radiant energy emitted by radiant energy emitting device 1544, such as in the manners discussed above. Optionally, the prismatic reflective element may include an imaging sensor or the like, such as discussed above with respect to electrochromic reflective element 1316 or 1416, without affecting the
10 scope of the present invention.

The radiant energy emitting element or display element thus may be viewable through the prismatic substrate without requiring windows or the like formed in the reflective layer at the rear of the prismatic substrate. The layers or stacks of the present invention thus may provide an improved display on demand or display on need type of display element for a
15 prismatic reflective element. Although shown as a prismatic or wedge-shaped substrate, the substrate may comprise a substantially flat substrate or may comprise a curved substrate having one or more curved surfaces, without affecting the scope of the present invention.

Although described as being implemented with interior rearview mirror assemblies, it is further envisioned that the layers or stacks of the present invention may be
20 implemented with reflective elements for exterior rearview mirror assemblies, such as exterior electrochromic rearview mirror assemblies or other exterior rearview mirror assemblies, such as exterior rearview mirror assemblies having a single flat substrate or having a curved outer surface or substrate or the like, without affecting the scope of the present invention. For example, an exterior reflective element may have a stack of
25 alternating layers (such as the types discussed above) that may have enhanced transmissivity of visible light that has a spectral band that matches a color output of a turn signal indicator or other indicator or light emitting device positioned behind the reflective element, such as within the casing of the exterior rearview mirror assembly. The indicator may thus be viewable through the reflective element when the indicator is activated, while the reflective
30 element substantially reflects other light over its entire viewing surface. The exterior rearview mirror assembly of the present invention thus may provide an indicator for viewing through the reflective element without requiring a window to be formed in the reflective layer or surface of the exterior reflective element. The present invention thus may provide a

display on demand or display on need type of display to an exterior rearview mirror assembly. Optionally, the alternating layers may comprise an IRT stack or IRT-DOD stack, such as described above, and the exterior rearview mirror assembly may include an infrared or near infrared emitting element, and may include an imaging sensor or device or camera, such as for a side or rearward imaging system of the vehicle (such as for a viewing system such as the types disclosed in U.S. Pat. Nos. 5,550,677; 5,670,935 and 6,201,642, which are hereby incorporated herein by reference, or such as for a lane change assist system or side objection detection system or the like, such as the types disclosed in U.S. pat. applications, Ser. No. 10/209,173, filed Jul. 31, 2002 by Schofield for AUTOMOTIVE LANE CHANGE AID (Attorney Docket DON01 P-1016), Ser. No. 10/427,051, filed Apr. 30, 2003 by Pawlicki et al. for OBJECT DETECTION SYSTEM FOR VEHICLE (Attorney Docket DON01 P-1075), which are hereby incorporated herein by reference). The near infrared emitting element or elements may be positioned within the exterior rearview mirror assembly and behind the reflective element and may provide illumination at the side of the vehicle without distracting or adversely affecting the view or vision of drivers of other vehicles at the side of the subject vehicle.

The present invention thus provides mirror reflective elements that provide substantial visible reflectivity, and that may provide substantial transmissivity of near infrared light, and that may also or otherwise provide substantial transmissivity of visible light within a selected spectral band or region or range of wavelengths. The mirror reflective elements of the present invention thus may be spectrally tuned for the desired application, while still providing the desired degree of photopic reflectivity and the desired conductivity on the conductive or semi-conductive layers, such that the electrochromic medium of the mirror cell colors or darkens in a desired manner.

The electrical connectors for the transflective electrochromic cells or elements of the present invention may comprise clip connectors, electrical busbars or the like, such as disclosed in U.S. Pat. Nos. 5,066,112 and 6,449,082, which are hereby incorporated herein by reference. Although shown as having the substrates and connectors offset, clearly the transflective element may comprise a flush element, such as described in U.S. Pat. No. 5,066,112, or such as described in U.S. provisional applications, Ser. No. 60/490,111, filed Jul. 25, 2003 by McCabe et al. for FLUSH ELECTROCHROMIC CELL (Attorney Docket DON01 P-1102); and Ser. No. 60/423,903, filed Nov. 5, 2002 by McCabe for ONE SIDED FLUSH ELECTROCHROMIC CELL (Attorney Docket DON01 P-1032), which are all

hereby incorporated herein by reference. Such a flush transfective element may facilitate a no-bezel or bezelless or low bezel mirror casing or assembly, with minimal or no offset between the substrates of the mirror assembly.

As discussed above, the mirror assembly of the present invention may include
5 a display for providing information for viewing by the driver of the vehicle on the reflective element so that the driver can easily see the display. In order to maintain easy viewing of the display, it is desirable to adjust the display intensity in response to ambient light levels (in order to avoid washout during daytime driving conditions and glare during nighttime driving conditions) and in response to the degree of transmissivity of the electrochromic reflective
10 element. For example, in low lighting conditions, such as during the nighttime, the intensity of the display may be dimmed to avoid glare, while in higher lighting conditions, such as during the daytime, the intensity of the display may be increased to provide sufficient visibility of the display to the driver of the vehicle. The mirror assembly may include light sensors for sensing the ambient light in the cabin of the vehicle or at the mirror assembly and
15 may include a control which is operable to automatically adjust the display intensity and/or the transmissivity of the electrochromic medium in response to the ambient light sensors.

Further, automatic dimming circuitry used in electrochromic mirror assemblies utilizing the reflective elements of the current invention may utilize one or more (typically two) photo sensors to detect glaring and/or ambient lighting. For example, a
20 silicon photo sensor such as a TSL235R Light-to-Frequency converter (available from Texas Advanced Optoelectronic Solutions Inc. of Plano, TX) can be used as such photo sensors. Such light-to-frequency converters comprise the combination of a silicon photodiode and a current-to-frequency converter on a single monolithic CMOS integrated circuit.

The mirror assembly or assemblies of the present invention may also include
25 or house a plurality of electrical or electronic devices, such as antennas, including global positioning system (GPS) or cellular phone antennas, such as disclosed in U.S. Pat. No. 5,971,552, a communication module, such as disclosed in U.S. Pat. No. 5,798,688, displays, such as shown in U.S. Pat. Nos. 5,530,240 and 6,329,925, blind spot detection systems, such as disclosed in U.S. Pat. Nos. 5,929,786 or 5,786,772, transmitters and/or receivers, such as
30 garage door openers, a digital network, such as described in U.S. Pat. No. 5,798,575, a high/low head lamp controller, such as disclosed in U.S. Pat. No. 5,715,093, a memory mirror system, such as disclosed in U.S. Pat. No. 5,796,176, a hands-free phone attachment, a video device for internal cabin surveillance and/or video telephone function, such as disclosed in

U.S. Pat. Nos. 5,760,962 and 5,877,897, a remote keyless entry receiver, map lights, such as disclosed in U.S. Pat. Nos. 5,938,321; 5,813,745; 5,820,245; 5,673,994; 5,649,756; or 5,178,448, microphones, such as disclosed in U.S. Pat. Nos. 6,243,003 and 6,278,377, speakers, a compass, such as disclosed in U.S. Pat. No. 5,924,212 or U.S. pat. application, 5 Ser. No. 10/456,599, filed Jun. 6, 2003 by Weller et al. for INTERIOR REARVIEW MIRROR SYSTEM WITH COMPASS (Attorney Docket DON01 P-1076), seat occupancy detector, a trip computer, an ONSTAR[®] system or the like (with all of the above-referenced patents and applications being commonly assigned to Donnelly Corporation, and with the disclosures of the referenced patents and applications being hereby incorporated herein by 10 reference in their entireties).

The mirror assembly and/or reflective element of the present invention may include a printed circuit board (PCB) which may be attached to its rear surface (e.g. the fourth surface) by, for example, a suitable adhesive or the like. An example of such an arrangement is disclosed in commonly assigned U.S. Pat. No. 5,820,245, which is 15 incorporated in its entirety by reference herein. The PCB optionally may include glare sensing and ambient photo sensors and electrochromic circuitry that automatically dims the reflectivity of the electrochromic mirror element when glare conditions are detected, such as at nighttime or the like. Alternately, the PCB may be snap connected, by a clip or otherwise attached, to a plastic plate that itself is adhered to the electrochromic element.

The printed circuit board may include electronic or electrical circuitry for 20 actuating the variable reflectance of the reflective element and for operating other electrical or electronic functions supported in the rearview mirror assembly. The circuit board may support, for example, light emitting diodes (LEDs) for illuminating indicia on display elements provided on the chin of the bezel of the mirror assembly or display devices provided 25 on the reflective element, or map or dash board lights or the like. The circuit board may be independently supported from the reflective element or in the casing or may be mounted to the reflective element's rear or fourth surface on a separate plate or may be directly adhered to the rear surface by a suitable adhesive. Reference is made to U.S. Pat. Nos. 5,671,996 and 5,820,245, the disclosures of which are hereby incorporated herein by reference in their 30 entireties.

Therefore, the present invention provides a reflective element which provides a combination of substantially transparent, conductive or semi-conductive layers and substantially reflective, conductive metallic layer or layers on one of the surfaces of the

reflective element, such as the inward surface (or third surface) of a second substrate of an electrochromic reflective element or a rear surface (or fourth surface) of an electrochromic reflective element or a rear surface of a prismatic reflective element or the like. The reflective element of the present invention provides enhanced manufacturing processing of
5 the reflective element, since the thicknesses of the layers and tolerances associated therewith are sufficiently large enough to be sputter coated or otherwise deposited via a low cost process. The reflective element of the present invention also provides for a reflective and transmissive element which allows transmission of display information through the reflective element, while still providing sufficient reflectance over the entire surface of the reflective
10 element, even in the display area. Accordingly, multiple displays may be positioned on, at or around the reflective element, without loss of reflectivity of the element. The materials and thicknesses of the layers of the reflective element may be selected to spectrally tune the reflective element to allow transmission of one or more particular spectral bands or range of wavelengths, in order to tune the reflective element for use with a particular spectral band of
15 light being emitted by a particular display. The materials and thicknesses of the layers may also be selected to spectrally tune the reflective element to enhance transmissivity of near infrared radiant energy. Also, the thicknesses of one or more layers may be varied across the mirror element to provide regions or areas of increased transmissivity for a display, while maintaining a desired level of reflectivity at the principle viewing area of the mirror element.
20 The mirror element may comprise an electrochromic element or a prismatic element and may be implemented at an interior rearview mirror assembly or an exterior rearview mirror assembly. Optionally, the mirror element may comprise a substantially flat element or may comprise a curved element, such as a convex element or aspheric element or the like.

Changes and modifications in the specifically described embodiments can be
25 carried out without departing from the principles of the invention, which is intended to be limited only by the scope of the appended claims, as interpreted according to the principles of patent law.

The embodiments of the invention in which an exclusive property or privilege is claimed are defined as follows:

1. A mirror assembly for a vehicle, said mirror assembly comprising:
a mirror element comprising at least one substrate having a forward surface facing towards a viewer of the mirror assembly and a rearward surface facing away from a viewer of the mirror assembly, said mirror element comprising at least one substantially reflective
5 metallic layer sandwiched between a respective pair of substantially transparent non-metallic layers, each of said substantially transparent non-metallic layers and said substantially reflective metallic layer having a selected refractive index and a selected physical thickness such that said mirror element is selectively spectrally tuned to substantially transmit at least one preselected spectral band of radiant energy therethrough while substantially reflecting
10 other radiant energy; and
a radiant energy emitting element at or near said rearward surface of said at least one substrate, said radiant energy emitting element being operable to emit radiant energy towards said rearward surface and through said mirror element, said radiant energy emitting element being operable to emit radiant energy with a peak intensity within said at least one
15 preselected spectral band.
2. The mirror assembly of claim 1, wherein said at least one preselected spectral band comprises a preselected band of visible light, said radiant energy emitting element being operable to emit visible radiant energy with a peak intensity within said preselected spectral band of visible light.
3. The mirror assembly of claim 1, wherein said at least one preselected spectral band comprises a preselected band of near infrared radiant energy, said radiant energy emitting element being operable to emit near infrared radiant energy with a peak intensity within said preselected spectral band of near infrared radiant energy.
4. The mirror assembly of claim 3 including an imaging sensor at or near said rearward surface, said imaging sensor being sensitive to near infrared radiant energy.

5. The mirror assembly of claim 1, wherein said at least one preselected spectral band comprises first and second preselected bands of radiant energy, said radiant energy emitting element comprises first and second radiant energy emitting elements, said first radiant energy emitting element being operable to emit radiant energy with a peak intensity within said first preselected spectral band of radiant energy and said second radiant energy emitting element being operable to emit radiant energy with a peak intensity within said second preselected spectral band of radiant energy.
6. The mirror assembly of claim 5, wherein said first and second preselected bands of radiant energy comprise first and second preselected bands of visible light, said first band being a different band than said second band.
7. The mirror assembly of claim 5, wherein said first preselected band of radiant energy comprises a band of near infrared radiant energy and said second preselected band of radiant energy comprises a band of visible light.
8. The mirror assembly of claim 1, wherein said reflective element comprises at least two substantially reflective metallic layers, each of said at least two substantially reflective metallic conductive layers being sandwiched between a respective pair of substantially transparent non-metallic layers.
9. The mirror assembly of claim 1 including an anti-reflective stack of layers at said rearward surface, said anti-reflective stack being spectrally tuned to minimize reflectance of radiant energy at said preselected spectral band.
10. The mirror assembly of claim 1, wherein said at least one substrate comprises first and second substrates, said first substrate having said forward surface and a second surface opposite said forward surface, said second substrate having said rearward surface and a third surface opposite said rearward surface, said first and second substrates being arranged so that said second surface opposes said third surface, said mirror element comprising an electrochromic medium disposed between said first and second substrates.

11. The mirror assembly of claim 10, wherein said substantially transparent non-metallic layers and said substantially reflective metallic layer are disposed between said electrochromic medium and said third surface, wherein said mirror element comprises a transfective reflector at said third surface.

12. The mirror assembly of claim 10, wherein said substantially transparent non-metallic layers and said substantially reflective metallic layer are disposed at said rearward surface of said second substrate, wherein said mirror element comprises a fourth surface reflective element.

13. The mirror assembly of claim 10, wherein said substantially transparent non-metallic layers comprise substantially transparent semi-conductive non-metallic layers and said substantially reflective metallic layer comprises a substantially reflective conductive metallic layer.

14. The mirror assembly of claim 13, wherein said substantially transparent semi-conductive non-metallic layers and said substantially reflective conductive metallic layer conduct electricity to darken or color said electrochromic medium in response to a voltage being applied to said layers.

15. The mirror assembly of claim 1, wherein said at least one substrate comprises a single substrate, said substantially transparent non-metallic layers and said substantially reflective metallic layer being disposed at said rearward surface of said single substrate.

16. The mirror assembly of claim 15, wherein said single substrate comprises a prismatic substrate.

17. The mirror assembly of claim 1 including at least one adhesion enhancement and passivation layer disposed between said reflective metallic layer and at least one of said transparent non-metallic layers to increase the corrosion resistance of said reflective metallic layer and to enhance the adhesion and the mechanical stability of said reflective metallic

5 layer.

18. An electrochromic mirror assembly for a vehicle, said mirror assembly comprising:
an electrochromic mirror element comprising a first substrate having first and second
surfaces and a second substrate having third and fourth surfaces, said first and second
substrates being arranged so that said second surface opposes said third surface with an
5 electrochromic medium disposed therebetween;
said third surface of said second substrate comprising a transflective reflector
comprising a first substantially transparent semi-conductive non-metallic layer contacting the
electrochromic medium, a second substantially transparent semi-conductive non-metallic
layer, and a substantially reflecting metallic conductive layer sandwiched between said first
10 and second substantially transparent semi-conductive non-metallic layers, wherein when said
mirror element is viewed from outside said first surface, said mirror element is substantially
spectrally untinted when no voltage is applied across said electrochromic medium, said
mirror element being at least partially spectrally selective in transmission and exhibiting a
spectrally selective transmission characteristic, said spectrally selective transmission
15 characteristic being established by the refractive indices and physical thicknesses of said first
and second substantially transparent semi-conductive non-metallic layers and said
substantially reflective metallic conductive layer; and
a light emitting element disposed at said fourth surface of said second substrate and
operable to emit light having an emitted spectral characteristic through said mirror element,
20 wherein said transflective reflector is configured to exhibit a spectrally selective transmission
characteristic so as to substantially transmit light having a spectral band in regions at or near
said emitted spectral characteristic and to substantially reflect other light having a spectral
band outside of said regions.
19. The electrochromic mirror assembly of claim 18, wherein said transflective reflector
provides at least 20 percent transmissivity of light at or near said emitted spectral
characteristic.
20. The electrochromic mirror assembly of claim 18, wherein said transflective reflector
provides at least 10 percent transmissivity of light at or near said emitted spectral
characteristic.

21. The electrochromic mirror assembly of claim 20, wherein said transflective reflector provides at least 60 percent photopic reflectance of other light.
22. The electrochromic mirror assembly of claim 20, wherein said transflective reflector provides at least 70 percent photopic reflectance of other light.
23. The electrochromic mirror assembly of claim 20, wherein said transflective reflector provides at least 80 percent photopic reflectance of other light.
24. The electrochromic mirror assembly of claim 18, wherein said transflective reflector provides at least 15 percent transmissivity of light at or near said emitted spectral characteristic and provides at least 60 percent photopic reflectance of other light.
25. The electrochromic mirror assembly of claim 18, wherein said transflective reflector provides at least 30 percent transmissivity of light at or near said emitted spectral characteristic and provides at least 60 percent photopic reflectance of other light.
26. The electrochromic mirror assembly of claim 18, wherein said second substantially transparent semi-conductive non-metallic layer contacts said third surface of said second substrate.
27. The electrochromic mirror assembly of claim 18, wherein said transflective reflector comprises at least two substantially reflective metallic conductive layers, each of said at least two substantially reflective metallic conductive layers being sandwiched between a respective pair of substantially transparent semi-conductive non-metallic layers disposed between said
5 electrochromic medium and said second substrate.
28. The electrochromic mirror assembly of claim 27, wherein said transflective reflector substantially transmits light having said spectral band in the near infrared region of the spectrum, said light emitting element being operable to emit near infrared light through said transflective reflector.

29. The electrochromic mirror assembly of claim 28 including an imaging sensor at said fourth surface that is operable to sense near infrared light.

30. The electrochromic mirror assembly of claim 28, wherein said transflective reflector substantially transmits light having a second spectral band in a visible region of the spectrum, said mirror assembly including a second light emitting element at said fourth surface, said second light emitting element being operable to emit light that has a peak intensity at or near
5 said second spectral band through said transflective reflector.

31. The electrochromic mirror assembly of claim 27, wherein said transflective reflector substantially transmits light having said spectral band at a first visible region of the spectrum.

32. The electrochromic mirror assembly of claim 31, wherein said transflective reflector substantially transmits light having a second spectral band in a second visible region of the spectrum, said mirror assembly including a second light emitting element at said fourth surface, said second light emitting element being operable to emit light that has a peak
5 intensity at or near said second spectral band through said transflective reflector.

33. An electrochromic mirror assembly for a vehicle, said mirror assembly comprising:
an electrochromic mirror element comprising a first substrate having first and second surfaces and a second substrate having third and fourth surfaces, said first and second substrates being arranged so that said second surface opposes said third surface with an
5 electrochromic medium disposed therebetween;
said third surface of said second substrate comprising at least one conductive metallic layer and at least one transparent, at least partially conductive layer, wherein said layers define first and second regions of said transflective reflector, said first region having a first reflectivity and a first transmissivity and said second region having a second reflectivity and a
10 second transmissivity, said second transmissivity being greater than said first transmissivity;
and
a display element positioned at said fourth surface of said second substrate and operable to transmit light through said second region of said transflective reflector.

34. The electrochromic mirror assembly of claim 33, wherein said first reflectivity is greater than said second reflectivity.

35. The electrochromic mirror assembly of claim 34, wherein said first reflectivity comprises at least approximately 60%.

36. The electrochromic mirror assembly of claim 33, wherein said first region comprises a generally central region of said electrochromic mirror element and said second region comprises at least one side region of said electrochromic mirror element.

37. The electrochromic mirror assembly of claim 33, wherein said transflective reflector comprises a first substantially transparent semi-conductive layer contacting the electrochromic medium, a second substantially transparent semi-conductive layer, and a substantially reflecting metallic conductive layer sandwiched between said first and second
5 substantially transparent semi-conductive layers.

38. The electrochromic mirror assembly of claim 37, wherein a thickness of at least one of said layers is varied between said first and second regions.

39. The electrochromic mirror assembly of claim 38, wherein each of said first and second transparent semi-conductive layers and said substantially reflective metallic conductive layer of said second region have a selected refractive index and a selected physical thickness such that said transflective reflector is selectively spectrally tuned to
5 substantially transmit at least one preselected spectral band of light therethrough while substantially reflecting other light, said display element being operable to transmit light with a peak intensity within said preselected spectral band through said second region of said transflective reflector.

40. A mirror assembly for a vehicle, said mirror assembly comprising:
a mirror element comprising a substrate having a forward surface facing towards a viewer of the mirror assembly and a rearward surface facing away from a viewer of the mirror assembly, said mirror element comprising at least one substantially reflective metallic
5 layer sandwiched between a respective pair of substantially transparent non-metallic layers

disposed at said rearward surface of said substrate, each of said substantially transparent non-metallic layers and said substantially reflective metallic layer having a selected refractive index and a selected physical thickness such that said mirror element is selectively spectrally tuned to substantially transmit at least one preselected spectral band of radiant energy therethrough while substantially reflecting other radiant energy; and

10 a radiant energy emitting element at or near said rearward surface of said substrate, , said radiant energy emitting element being operable to emit radiant energy towards said rearward surface and through said mirror element, said radiant energy emitting element being operable to emit radiant energy with a peak intensity within said at least one preselected
15 spectral band.

41. The mirror assembly of claim 40, wherein said at least one preselected spectral band comprises a preselected band of visible light, said radiant energy emitting element being operable to emit visible radiant energy with a peak intensity within said preselected spectral band of visible light.

42. The mirror assembly of claim 41, wherein said radiant energy emitting element comprises a display on demand element.

43. The mirror assembly of claim 40, wherein said at least one preselected spectral band comprises a preselected band of near infrared radiant energy, said radiant energy emitting element being operable to emit near infrared radiant energy with a peak intensity within said preselected spectral band of near infrared radiant energy.

44. The mirror assembly of claim 43 including an imaging sensor at or near said rearward surface, said imaging sensor being sensitive to near infrared radiant energy.

45. The mirror assembly of claim 40, wherein said at least one preselected spectral band comprises first and second preselected bands of radiant energy, said radiant energy emitting element comprises first and second radiant energy emitting elements, said first radiant energy emitting element being operable to emit radiant energy with a peak intensity within said first
5 preselected spectral band of radiant energy and said second radiant energy emitting element

being operable to emit radiant energy with a peak intensity within said second preselected spectral band of radiant energy.

46. The mirror assembly of claim 45, wherein said first and second preselected bands of radiant energy comprise first and second preselected bands of visible light, said first band being a different band than said second band.

47. The mirror assembly of claim 45, wherein said first preselected band of radiant energy comprises a band of near infrared radiant energy and said second preselected band of radiant energy comprises a band of visible light.

48. The mirror assembly of claim 40, wherein said reflective element comprises at least two substantially reflective metallic layers, each of said at least two substantially reflective metallic conductive layers being sandwiched between a respective pair of substantially transparent non-metallic layers.

49. The mirror assembly of claim 40 including an anti-reflective stack of layers at said rearward surface, said anti-reflective stack being spectrally tuned to minimize reflectance of radiant energy at said preselected spectral band.

50. The mirror assembly of claim 40, wherein said single substrate comprises a prismatic substrate.

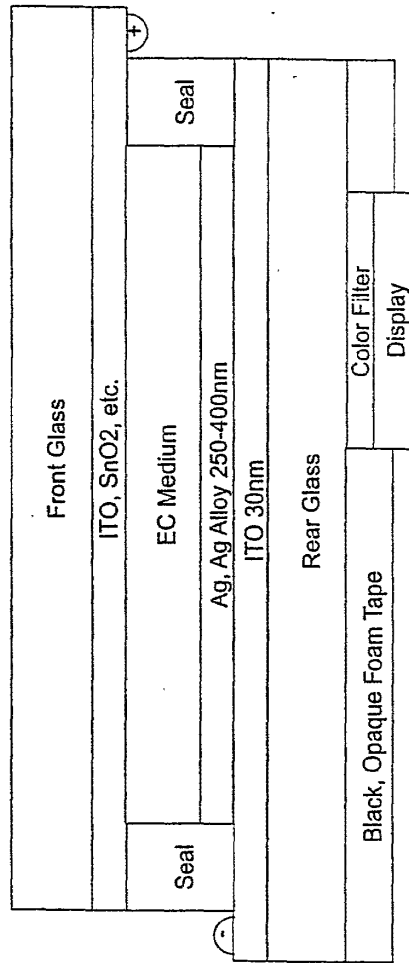

PRIOR ART

Figure 1

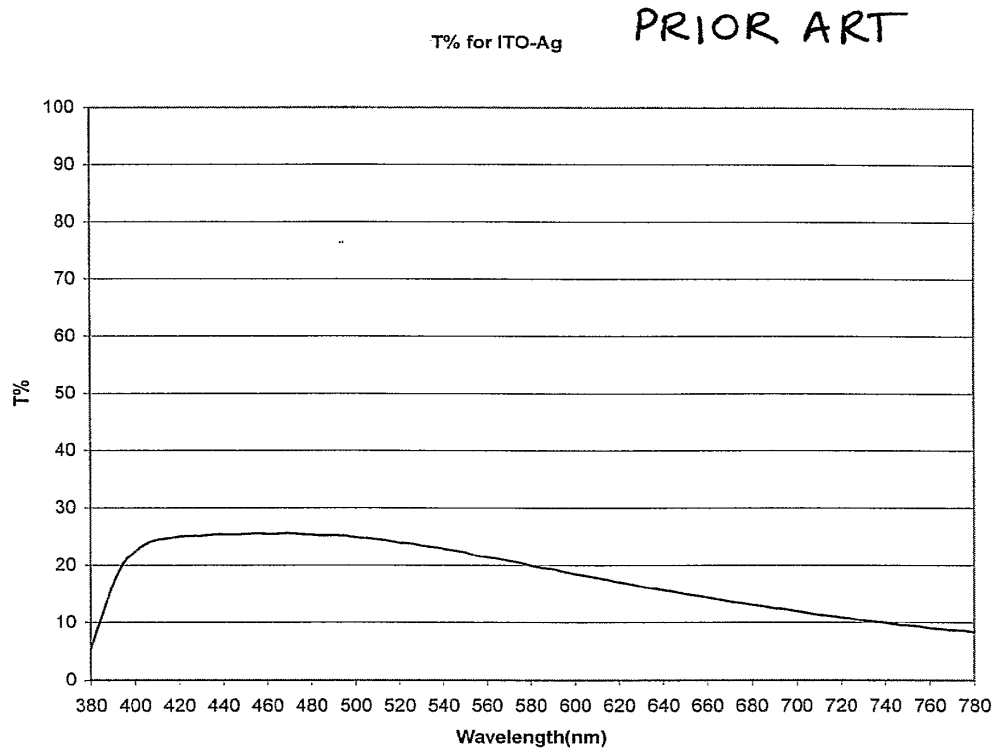

FIG. 1A

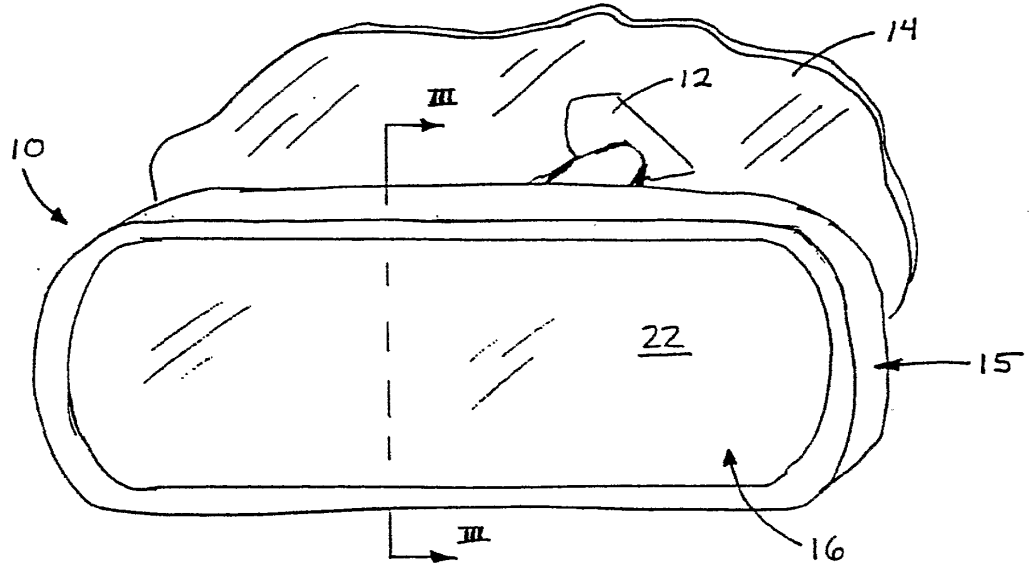

FIG. 2

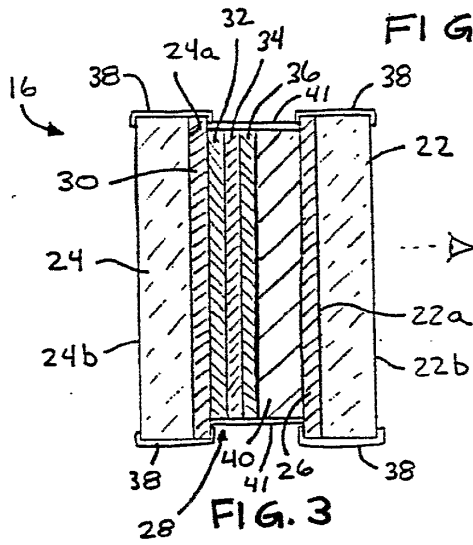

FIG. 3

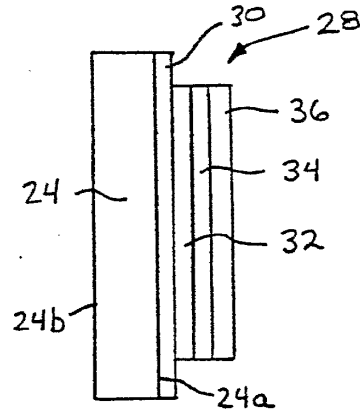

FIG. 4

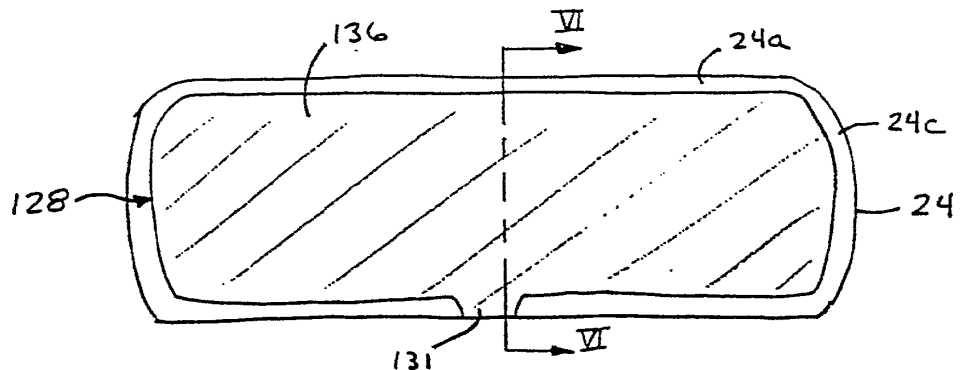
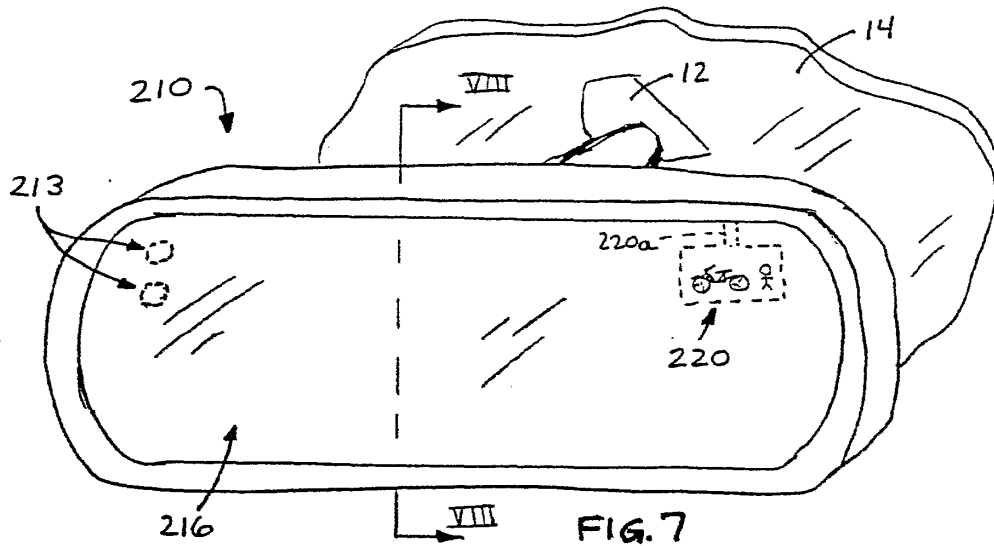
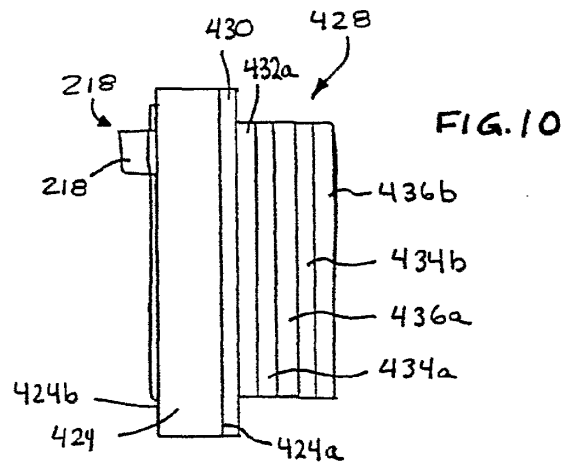
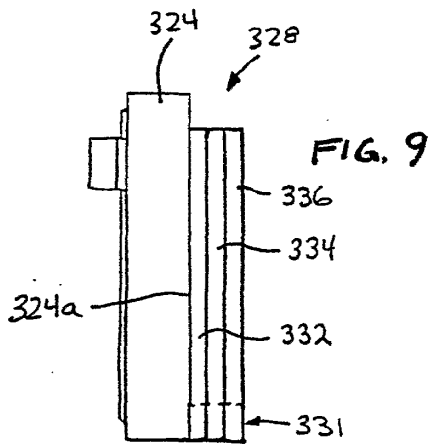
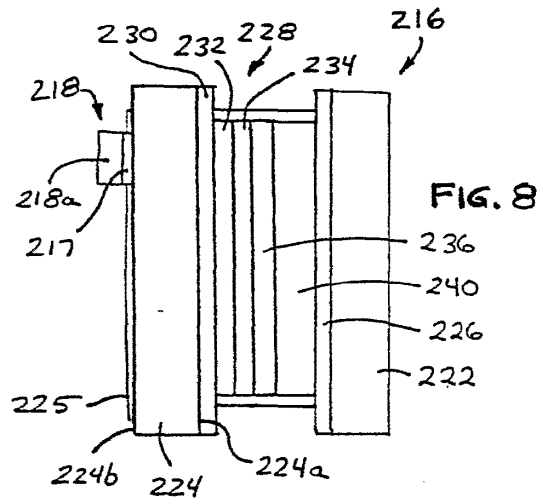
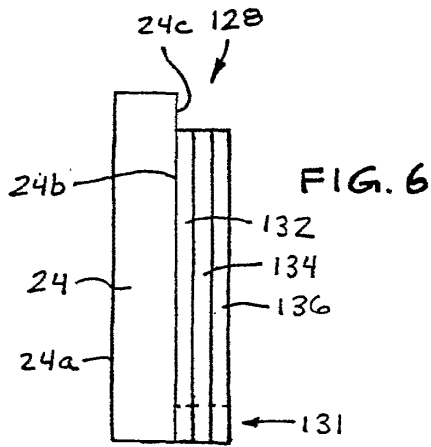

FIG. 5



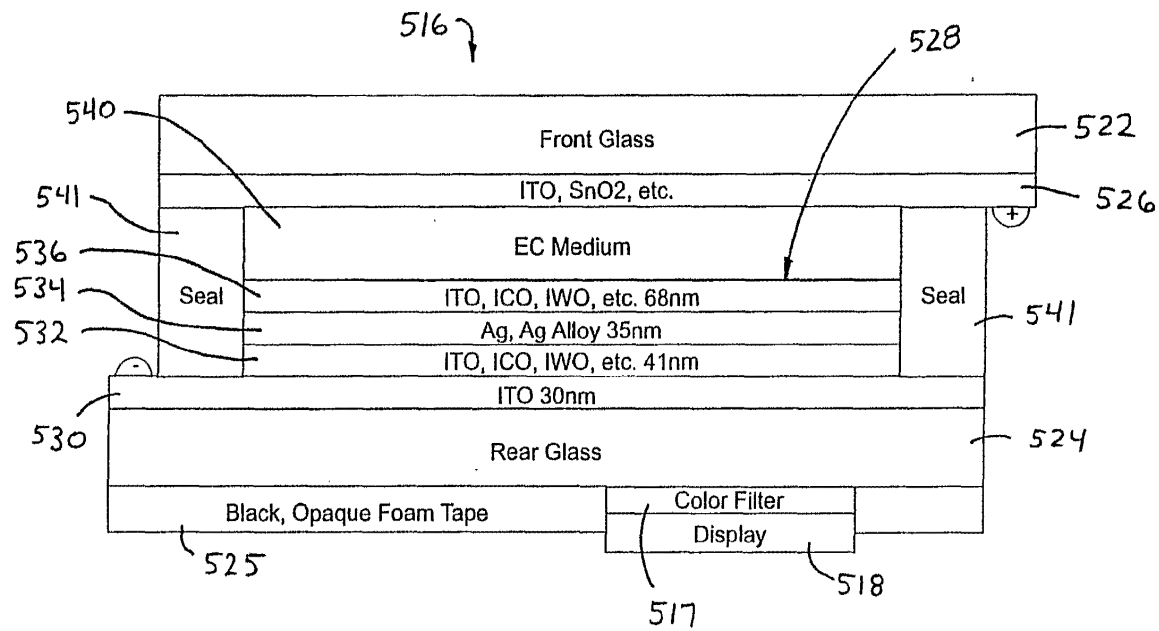

Figure 11

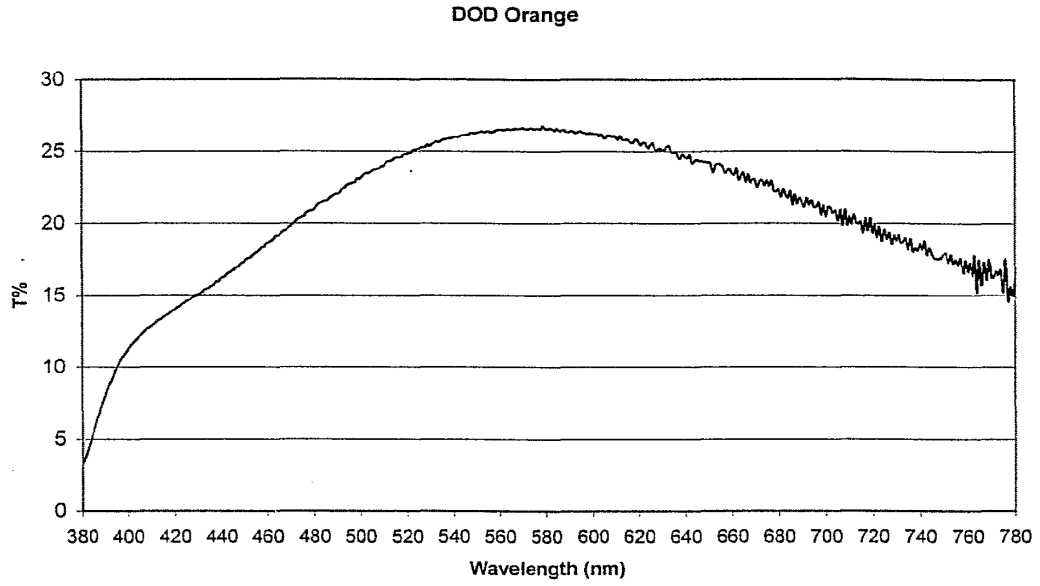
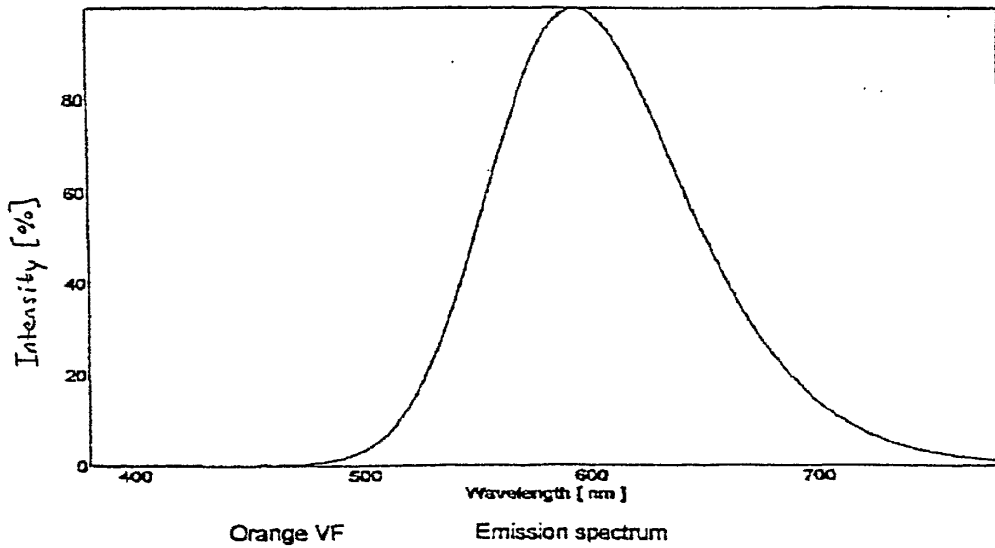

FIG. 11A



Orange VF

Emission spectrum

Improved DOD, tuned to Orange VF display

FIG. 11B

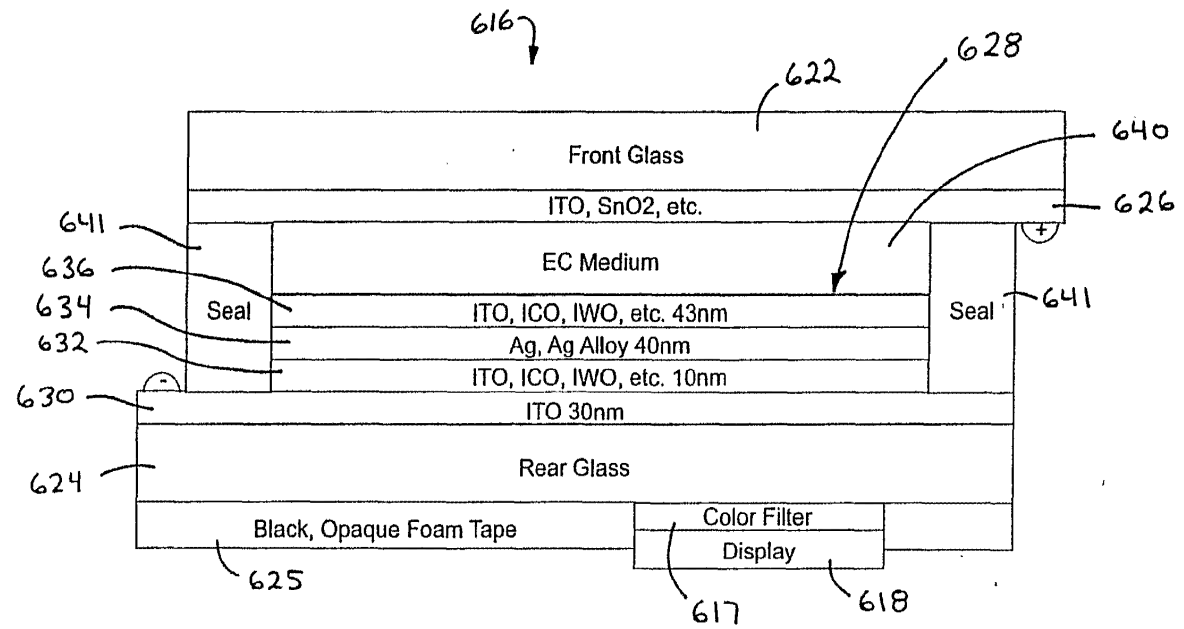

Figure 12

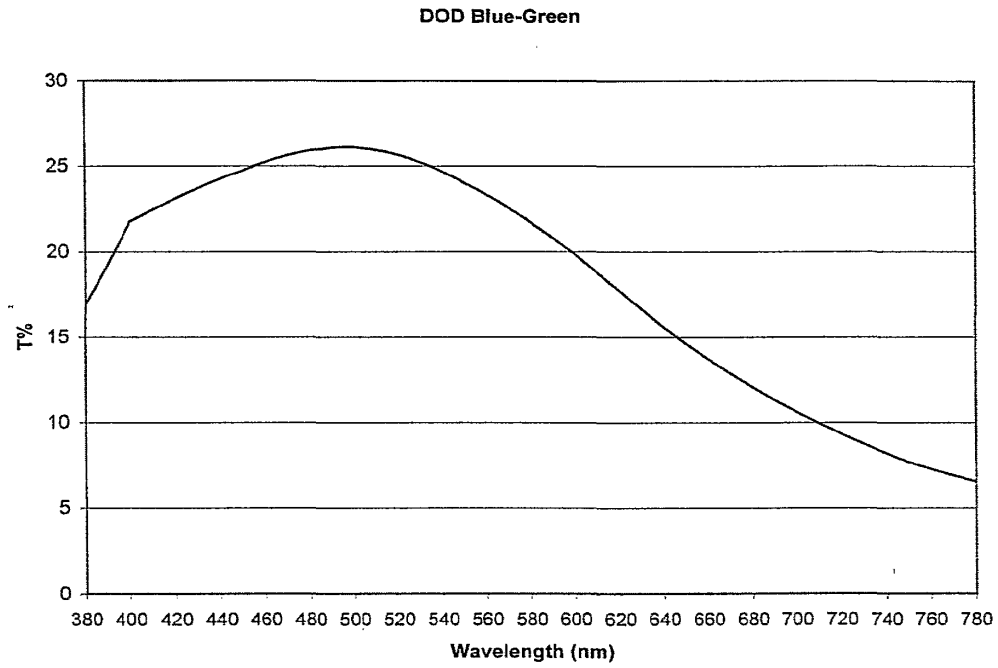
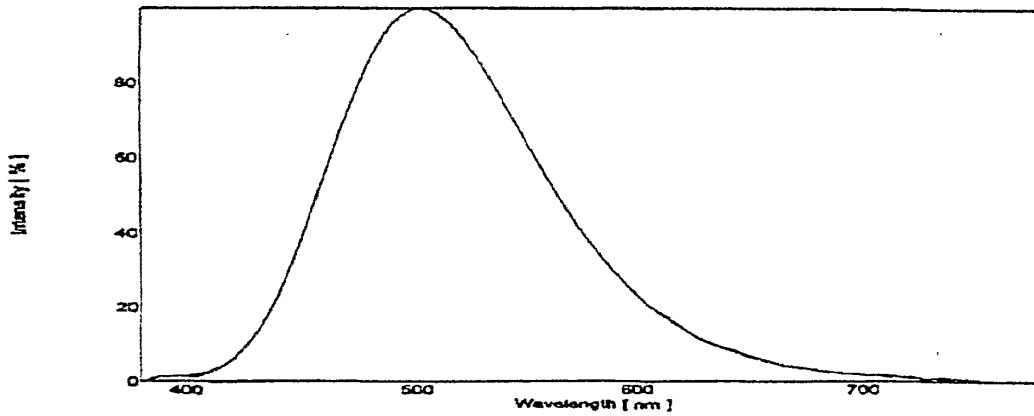

FIG. 12A



Blue-Green VF display: Emission spectrum
Improved DOD tuned to Blue-Green VF display

FIG. 12B

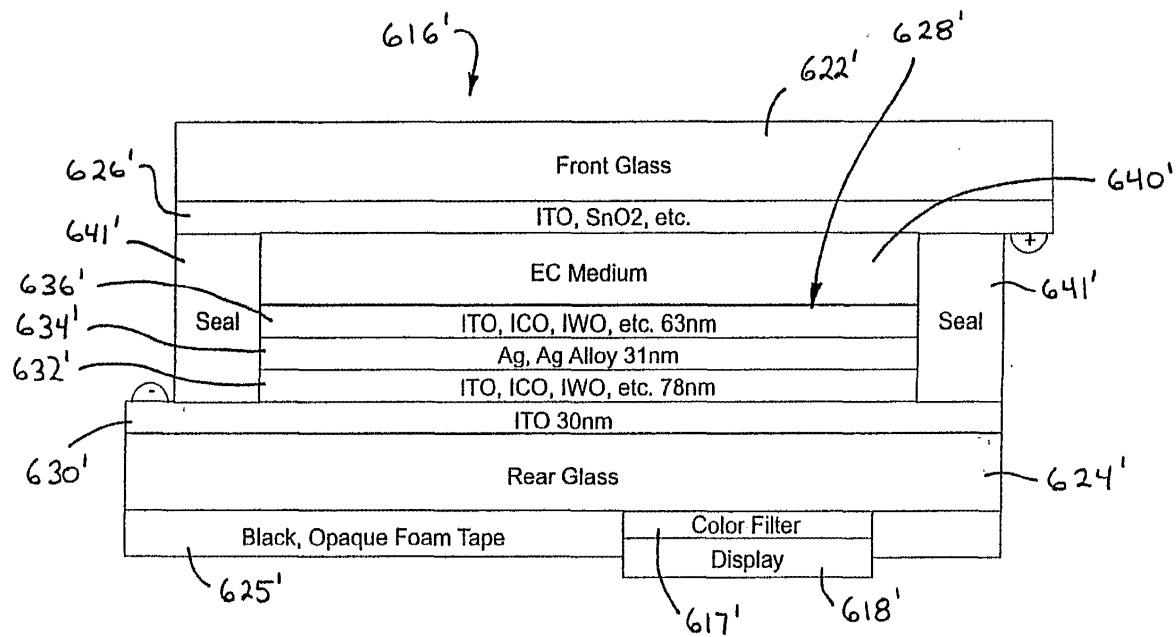

Figure 13

DOD Neutral

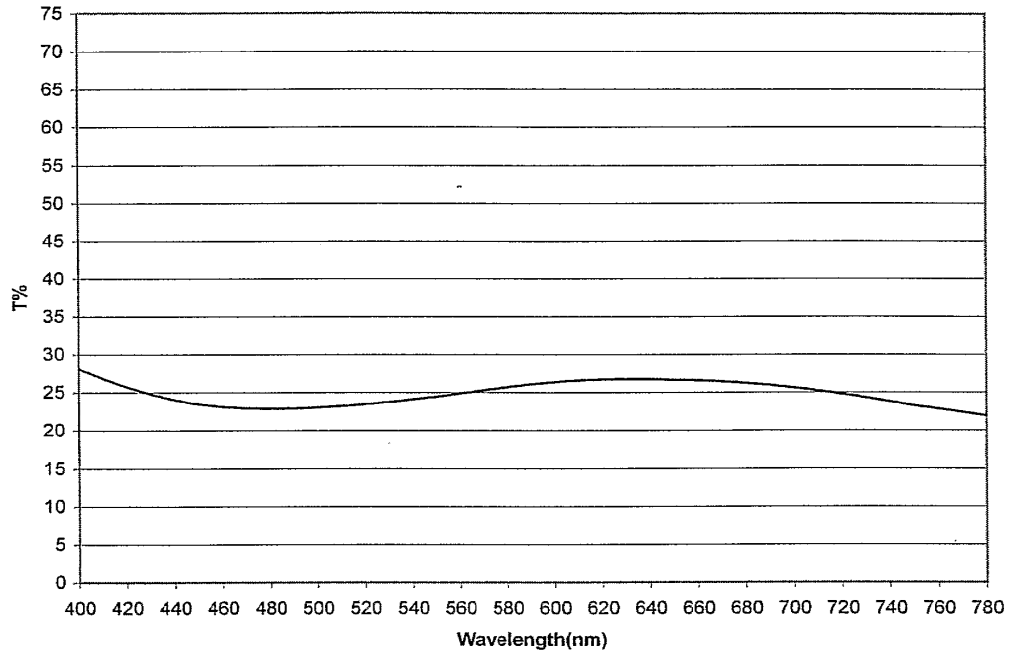

FIG. 13A

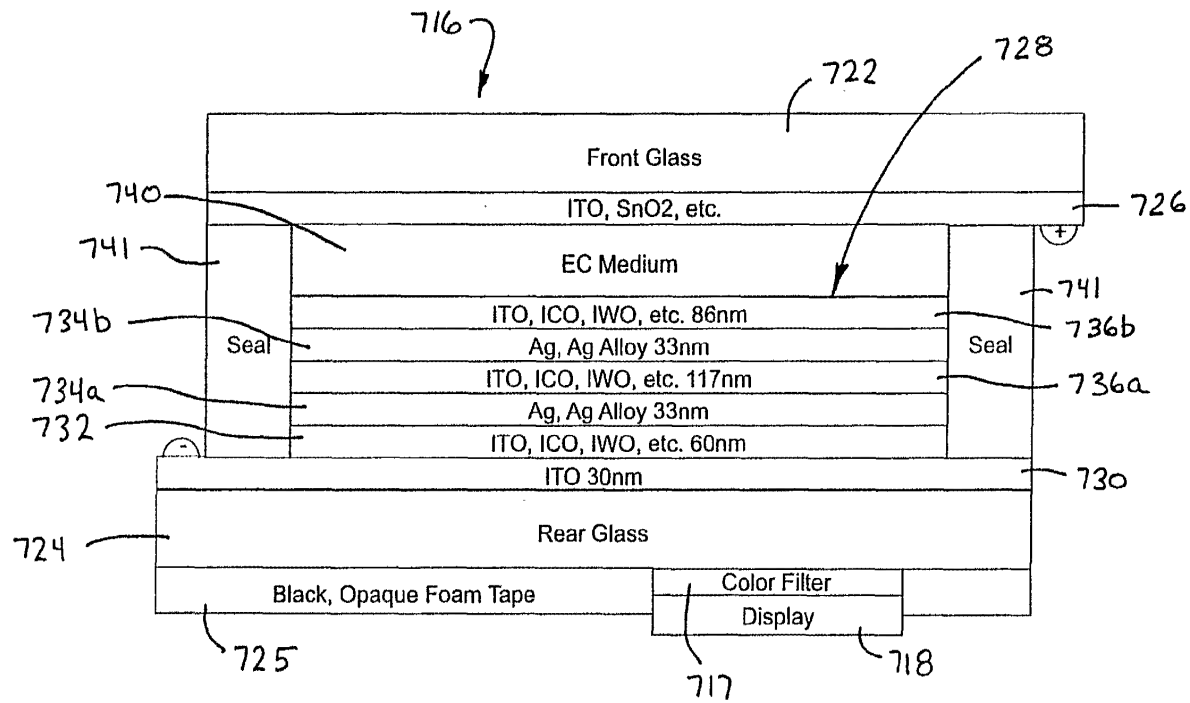

Figure 14

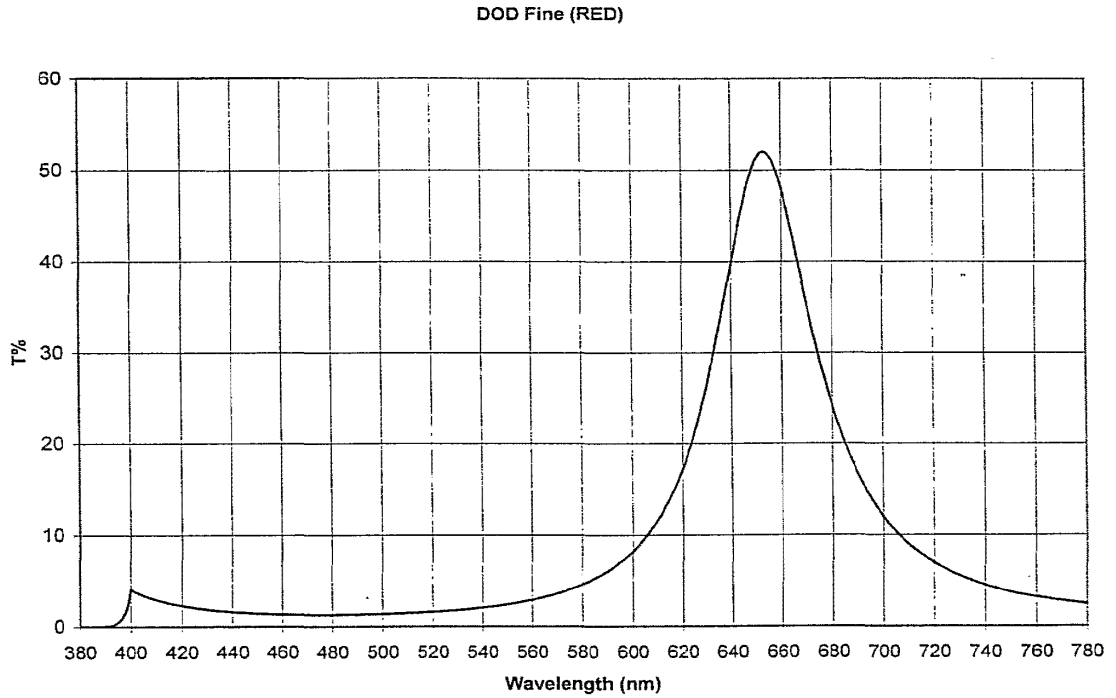

FIG. 14A

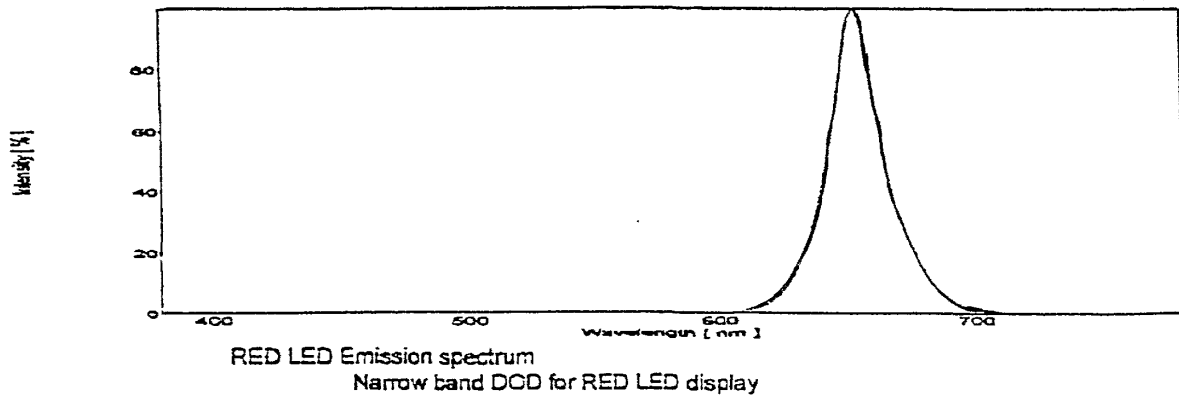

FIG. 14B

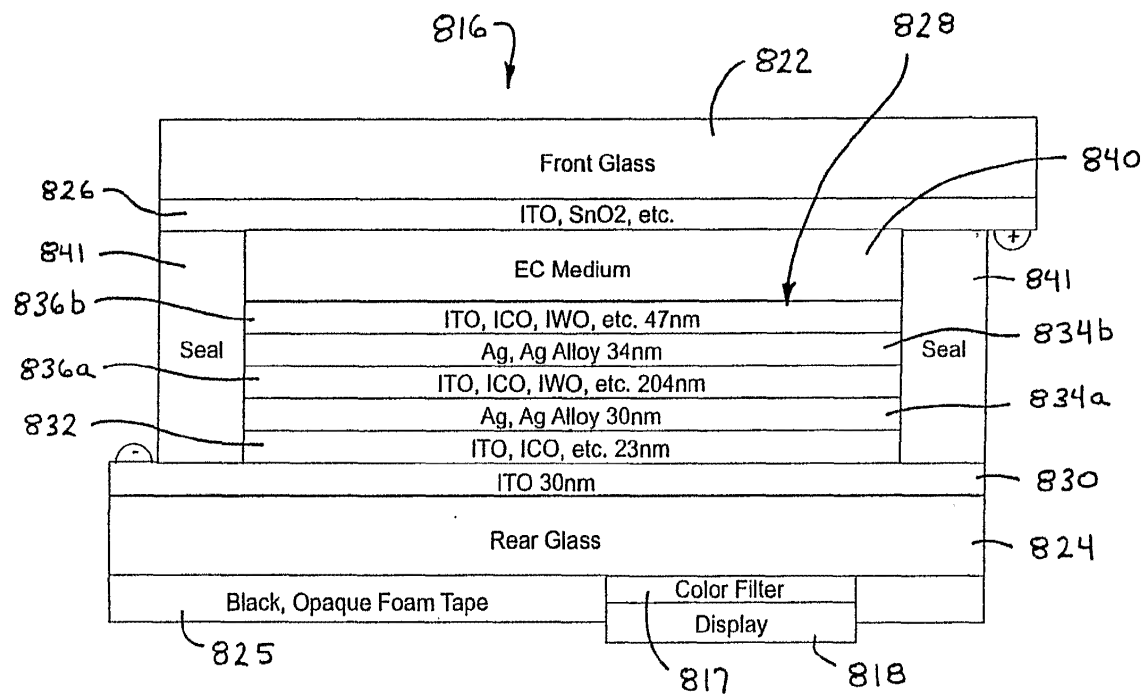

Figure 15

DOD BLUE-GREEN 502nm

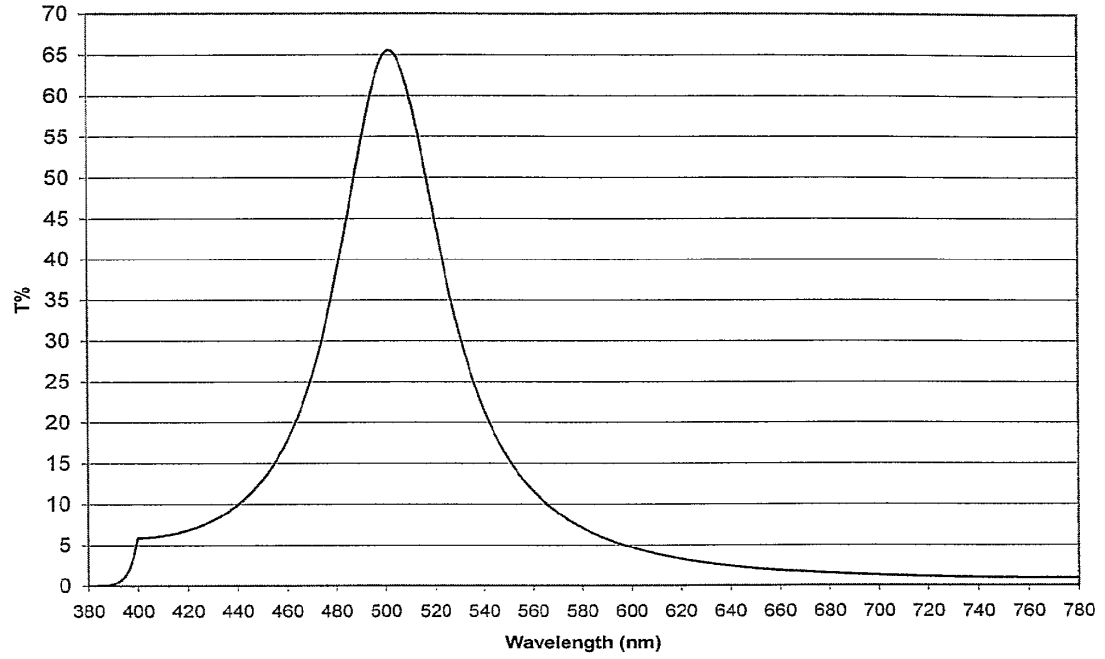

FIG. 15A

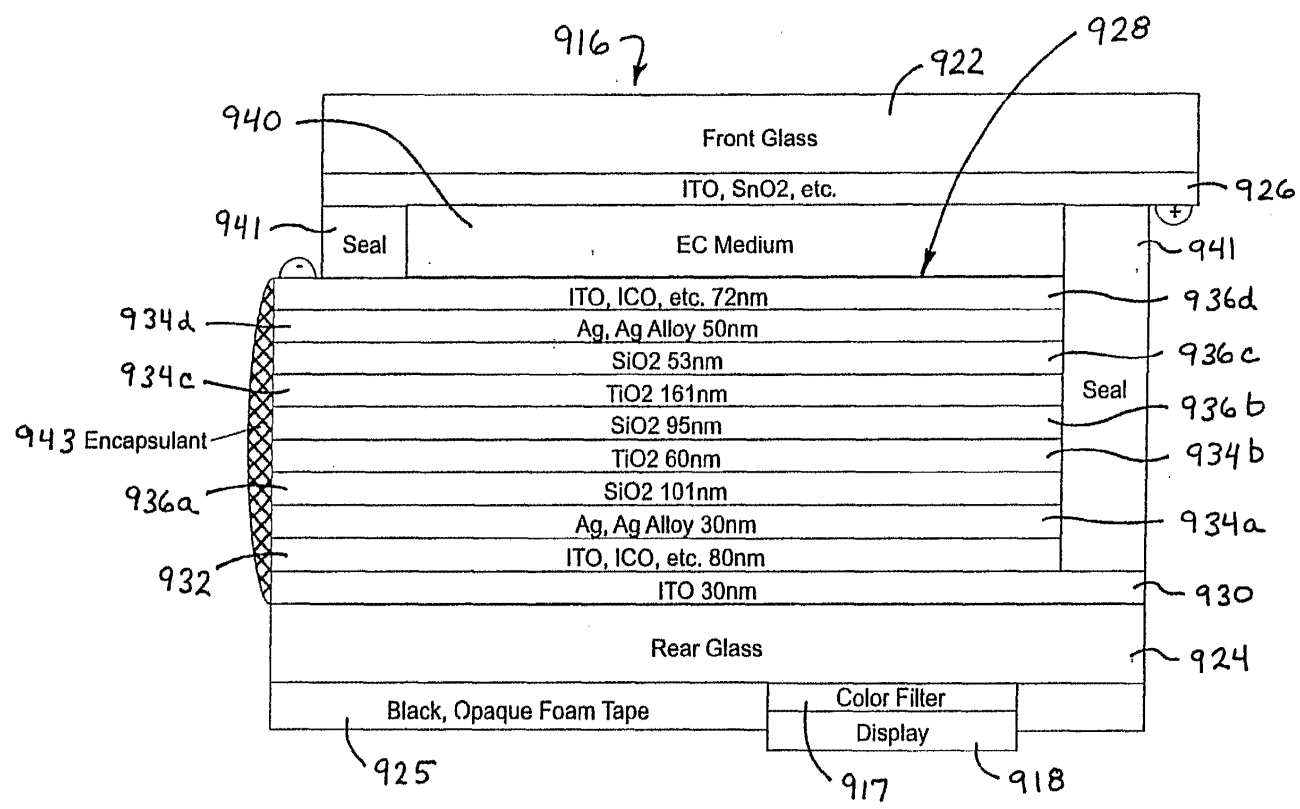

Figure 16

DOD LED 2

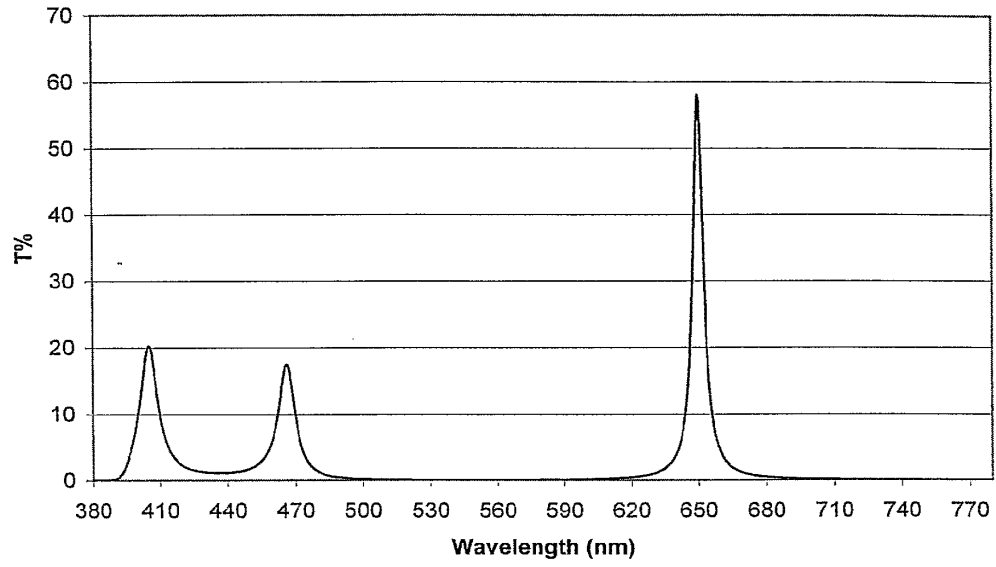

FIG. 16A

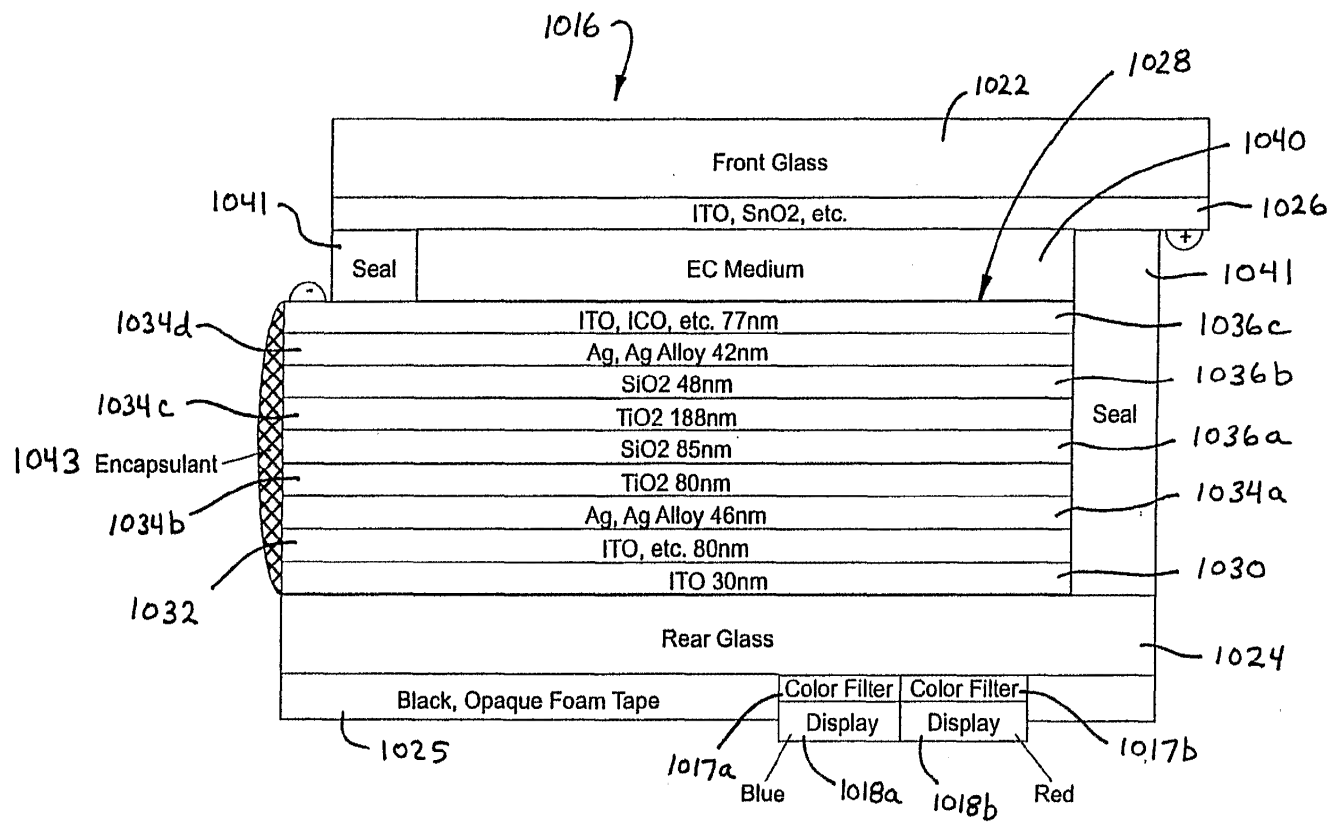

Figure 17

DOD for TWO LED DISPLAY

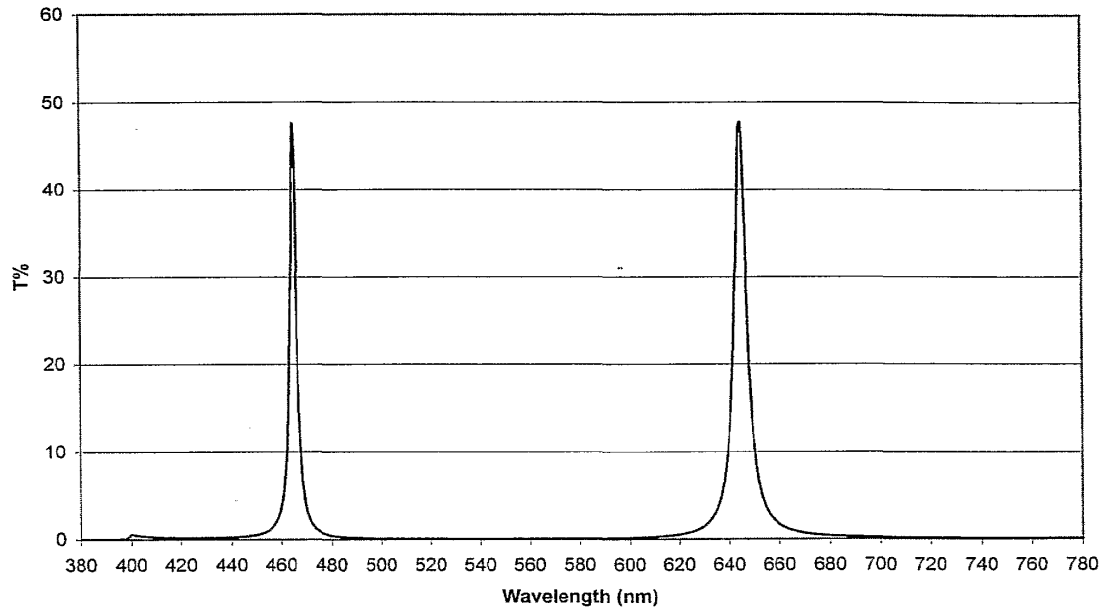

FIG. 17A

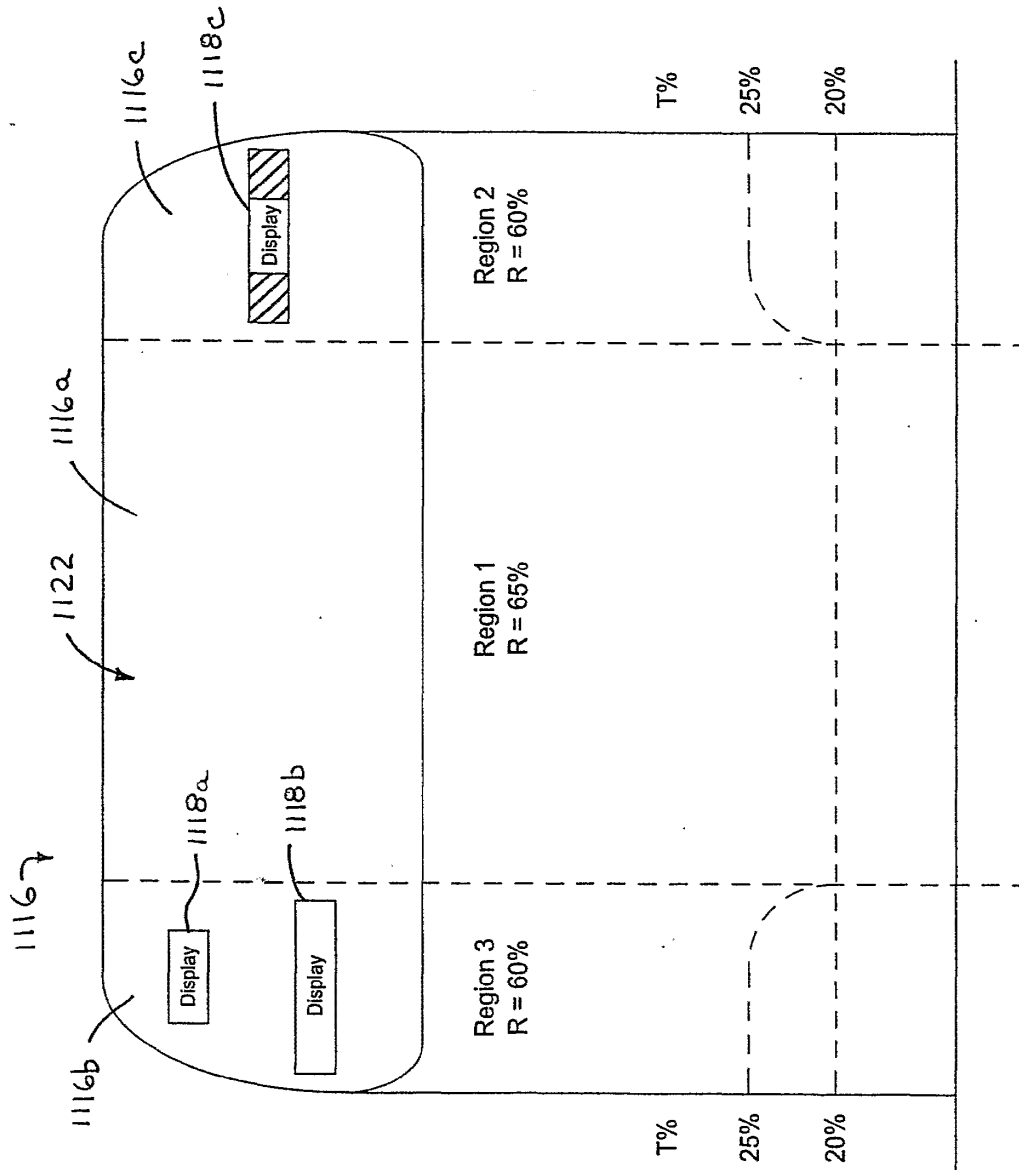

FIG. 18

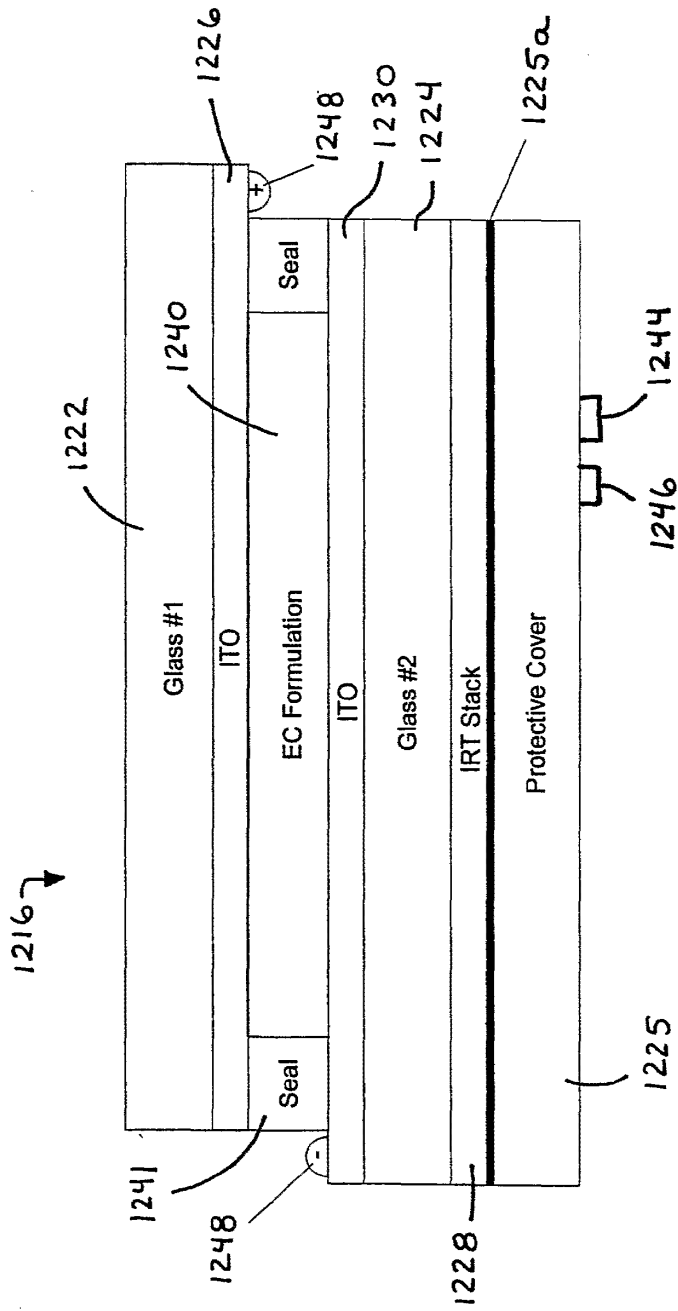

Figure 19

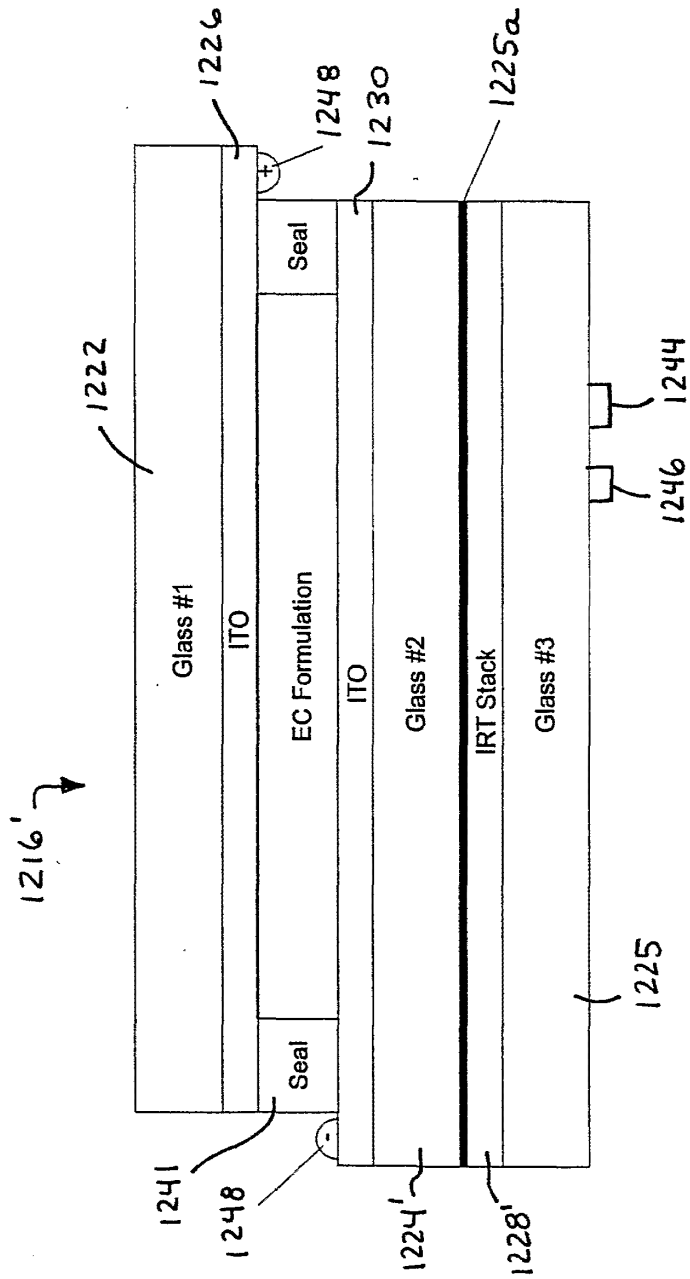

Figure 20

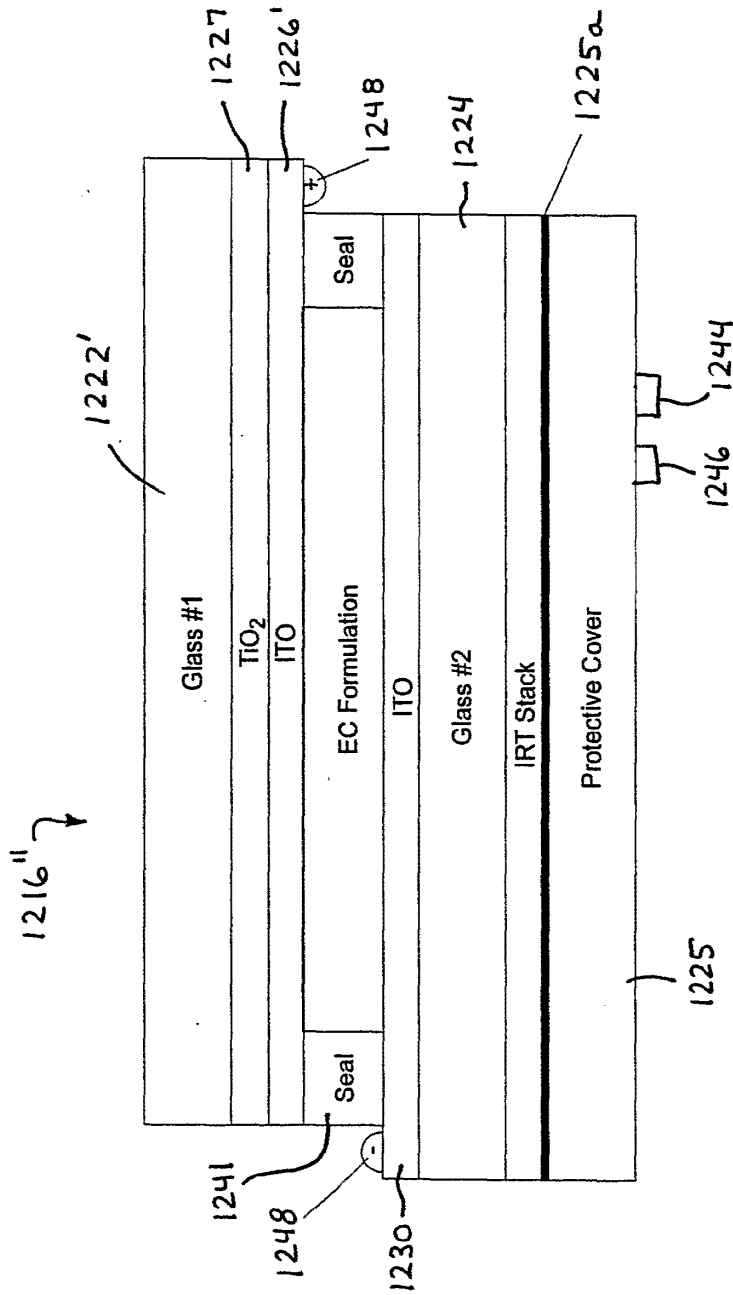

Figure 21

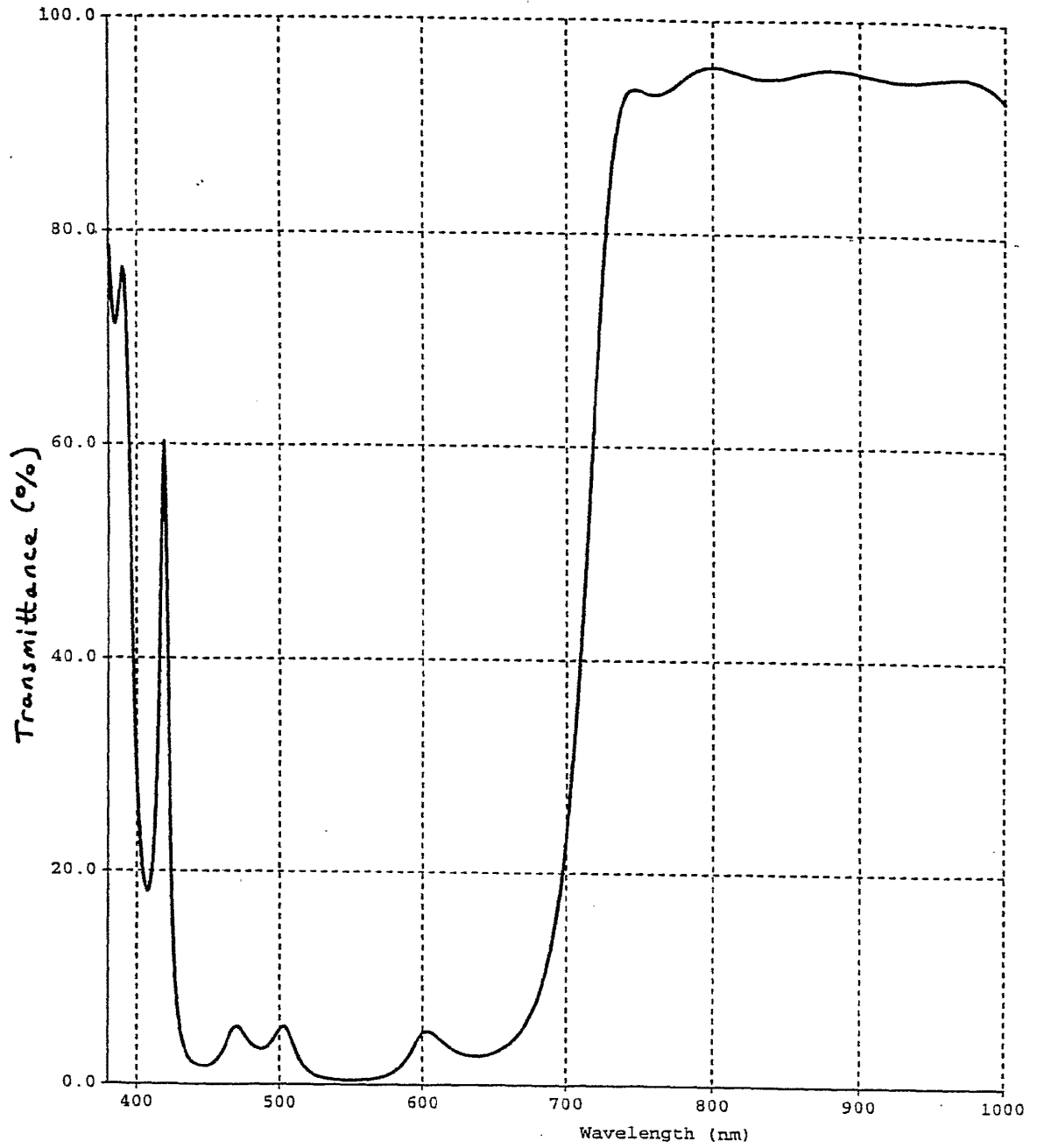

Figure 22

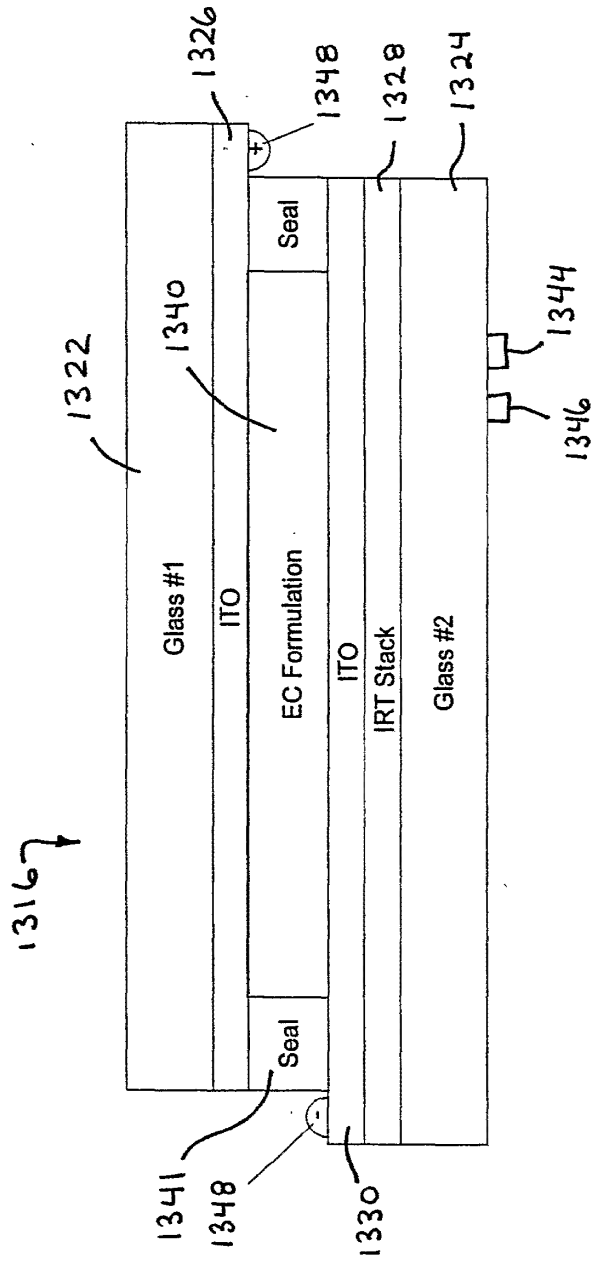

Figure 23

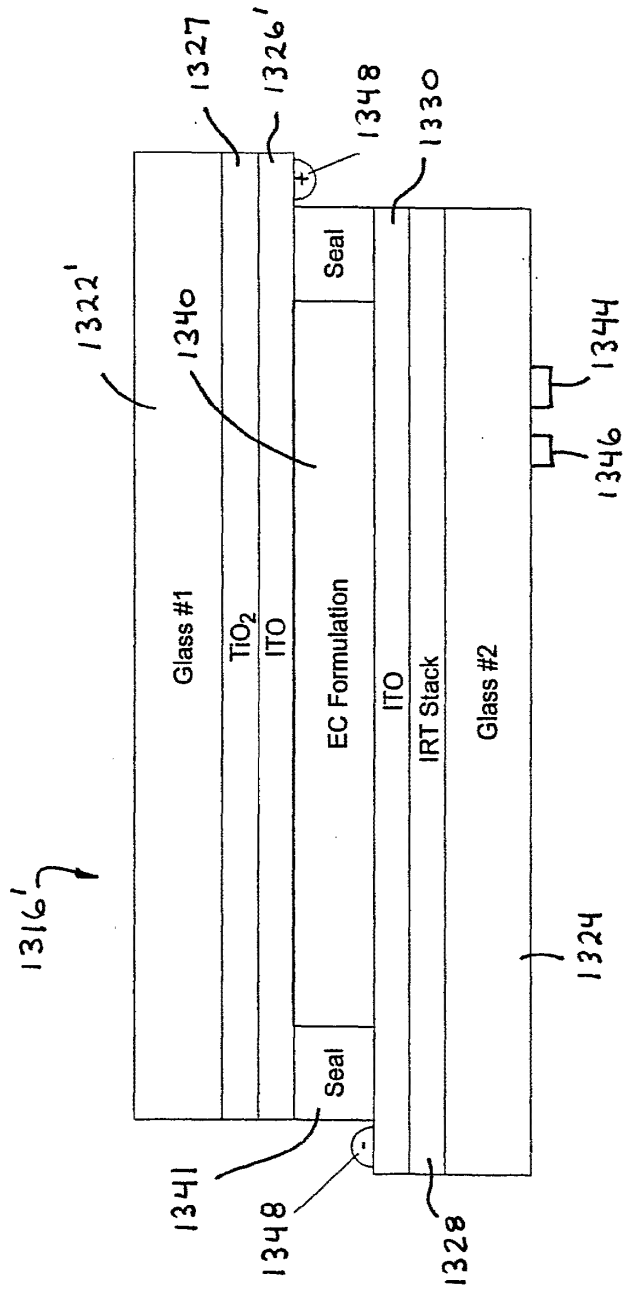

Figure 24

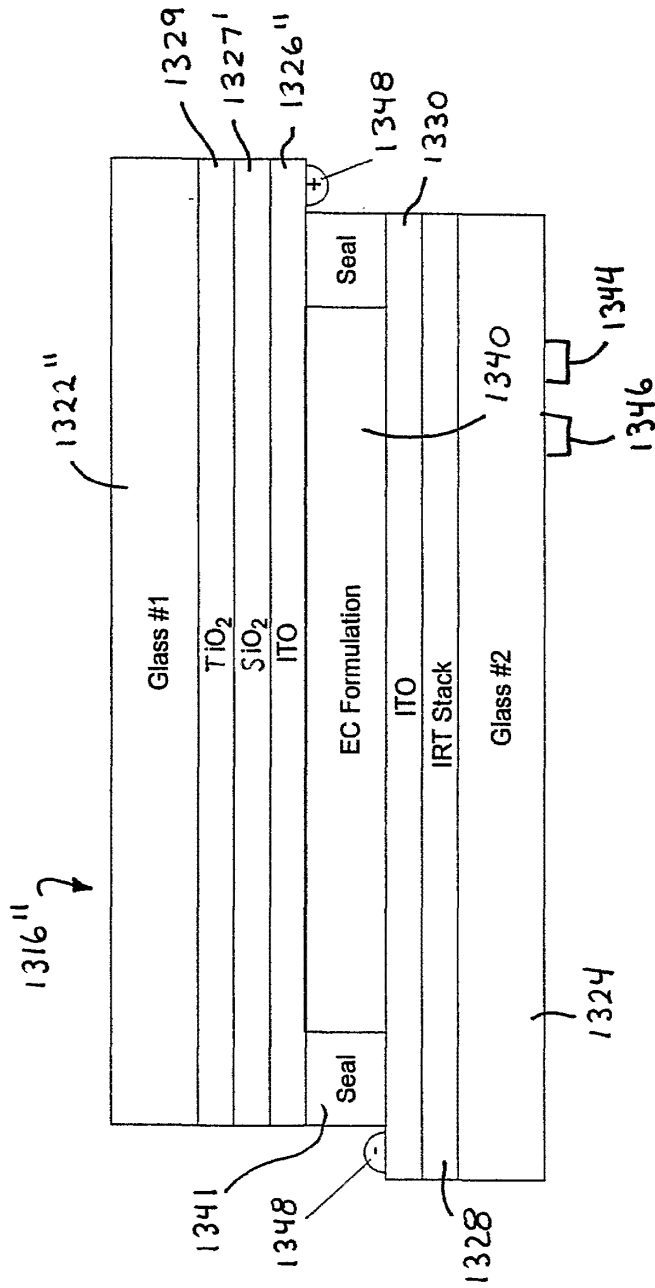

Figure 25

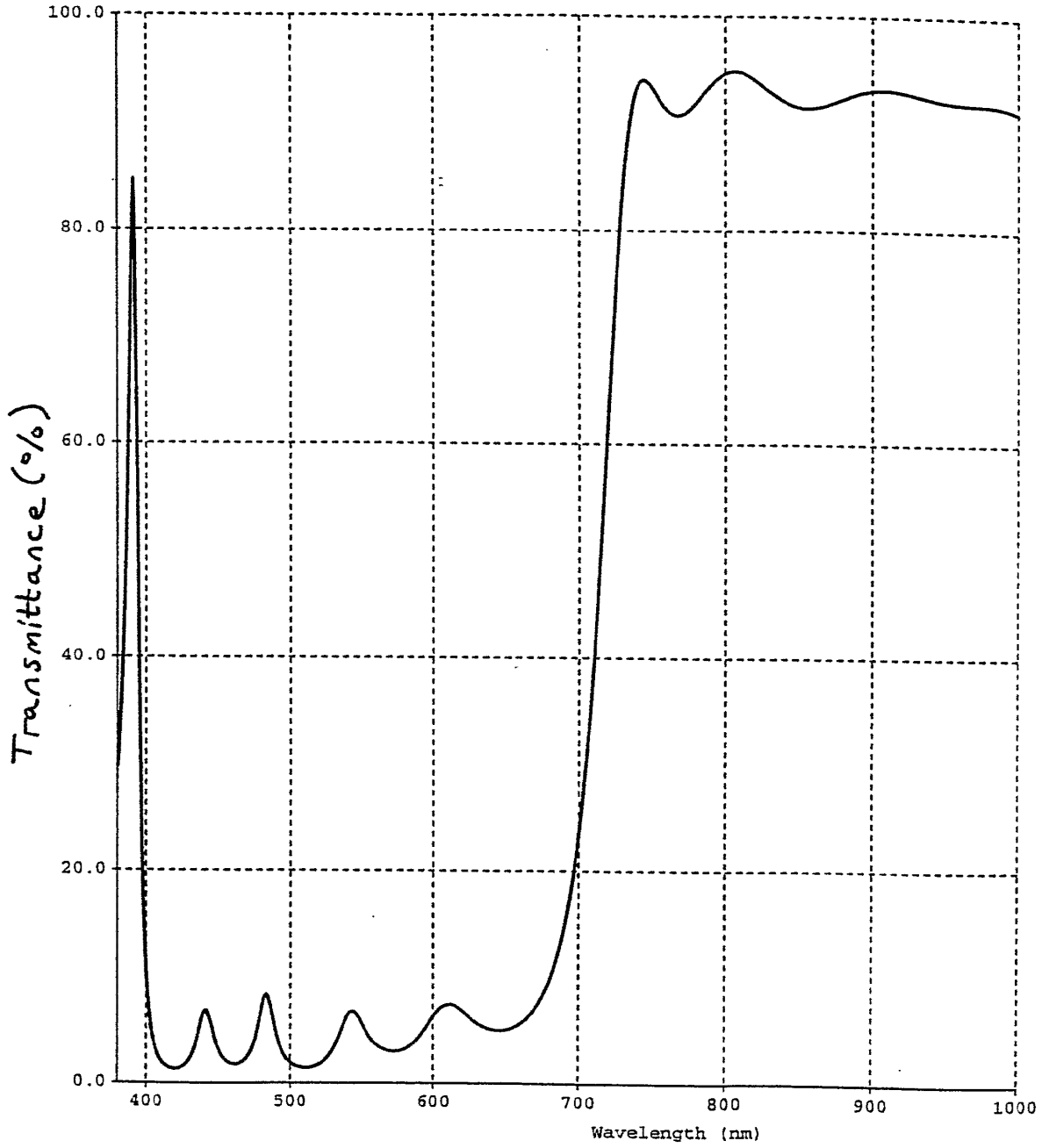

Figure 26

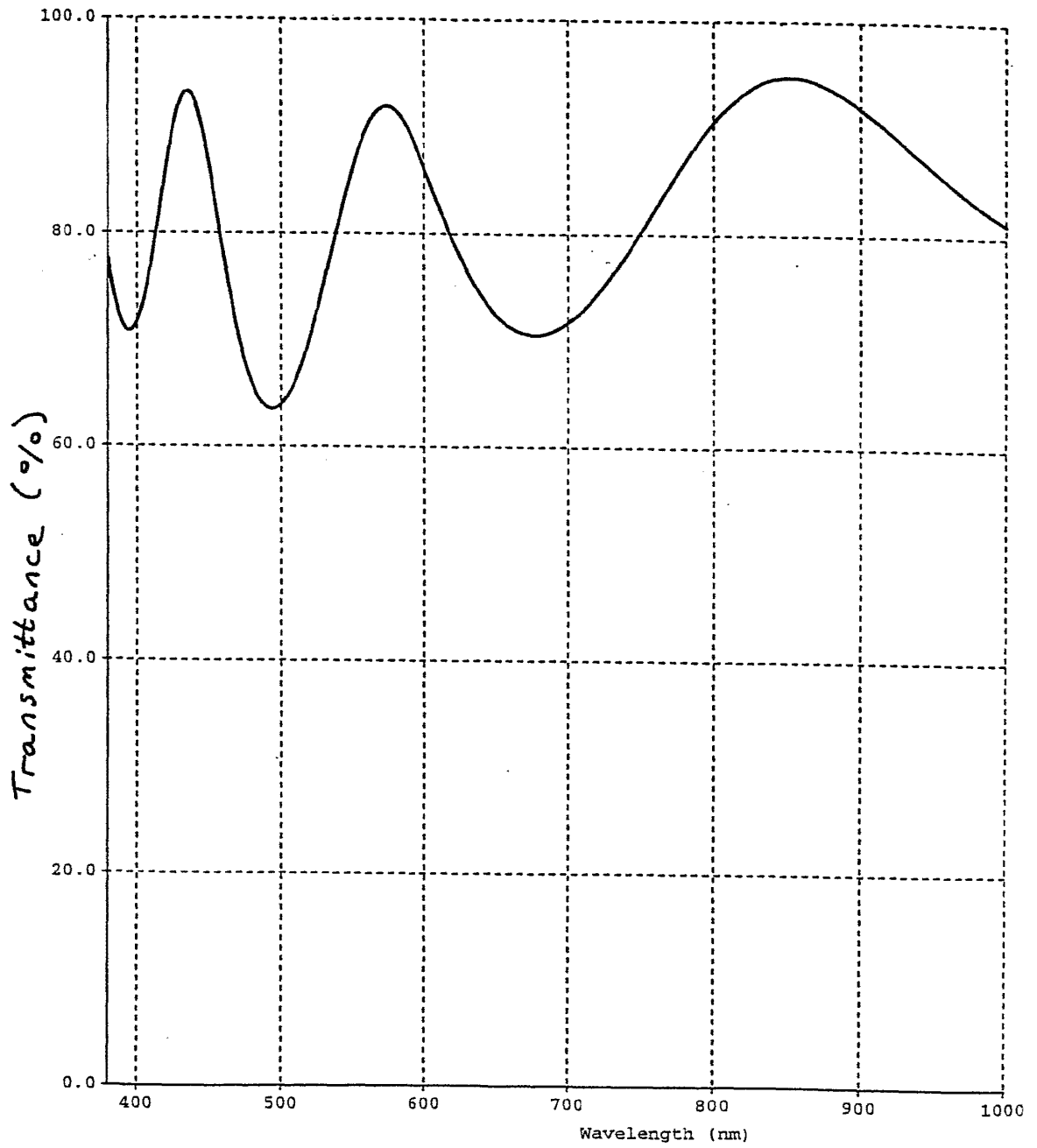

Figure 27

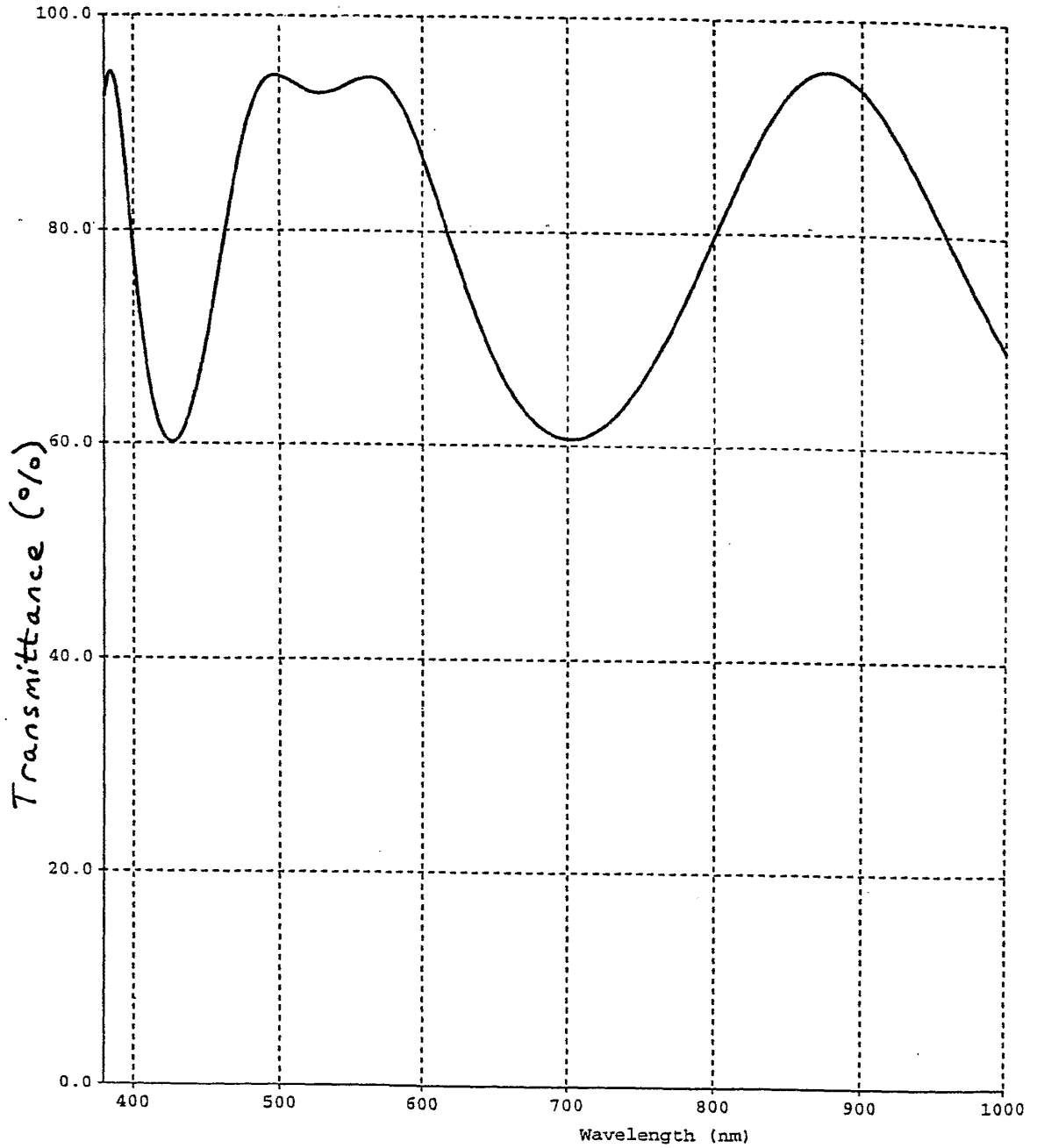

Figure 28

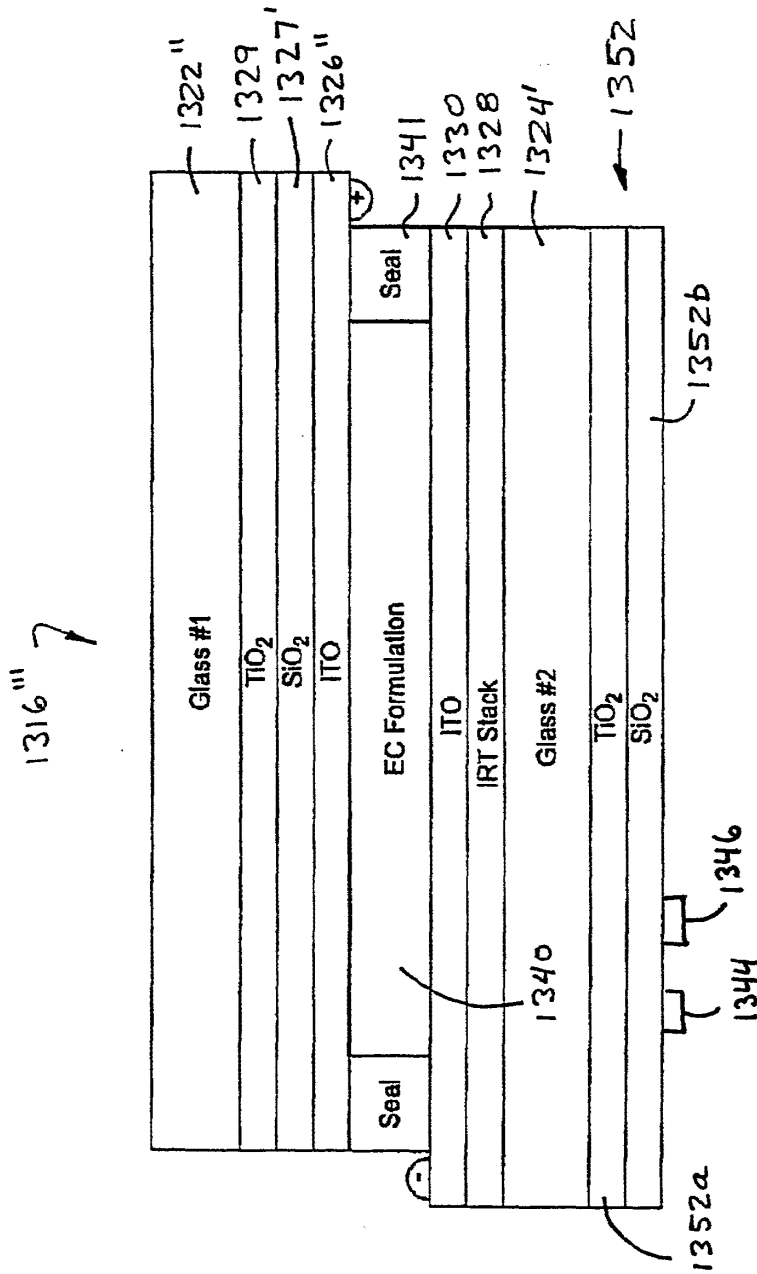

Figure 29

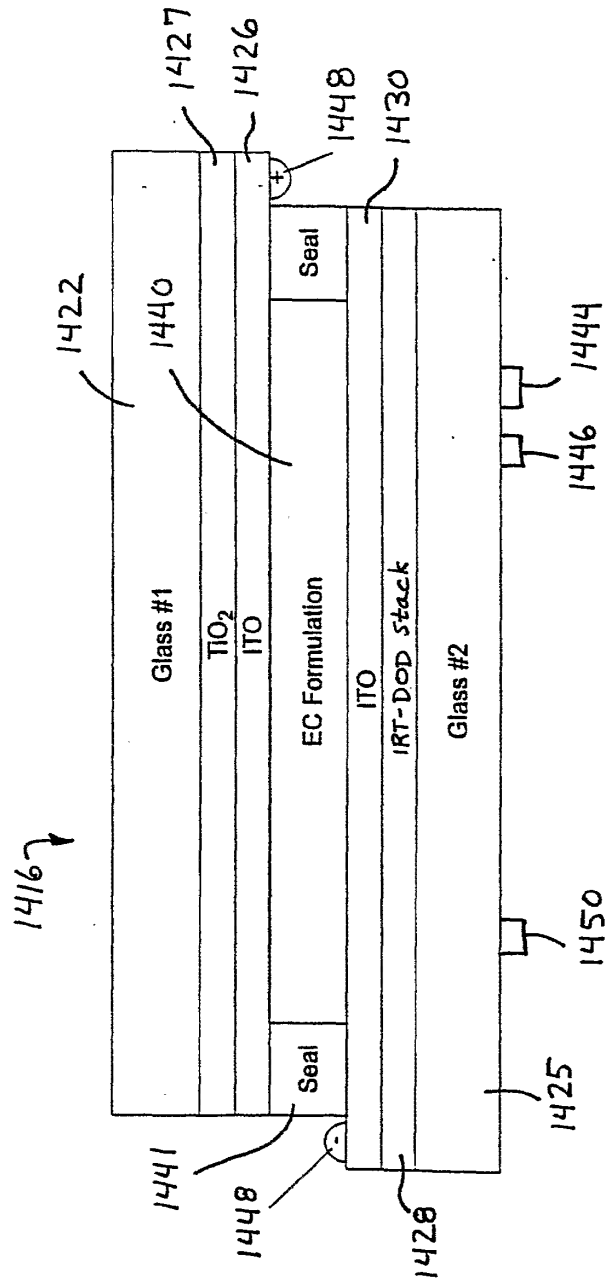
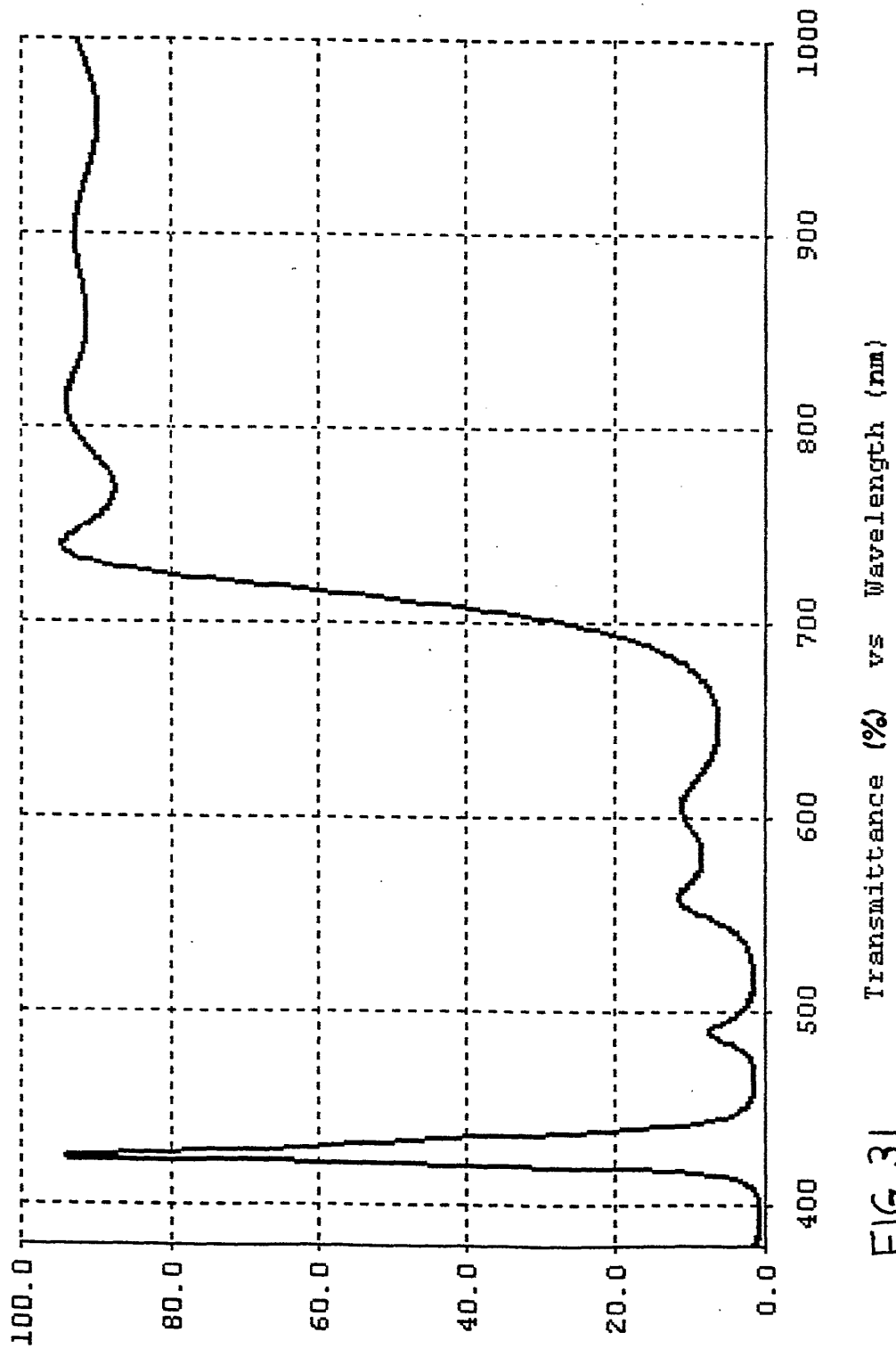

Figure 30



Transmittance (%) vs Wavelength (nm)

FIG. 31

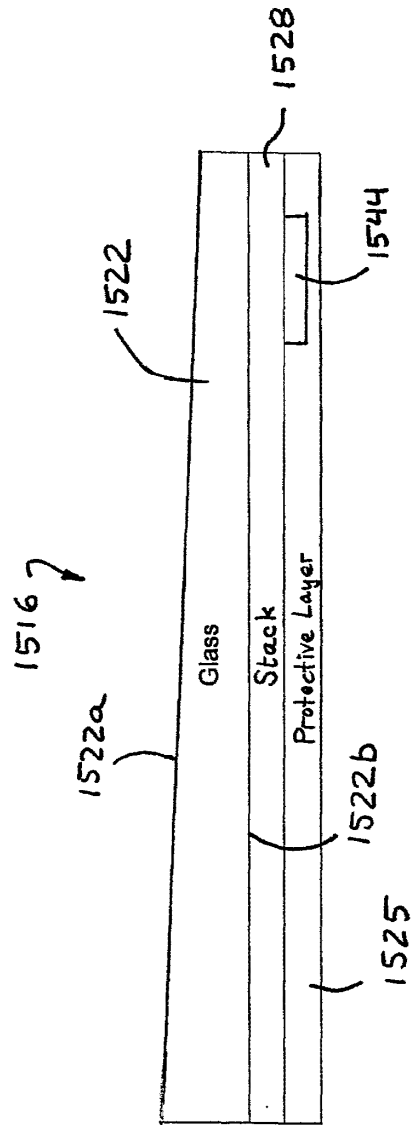

Figure 32

(12) INTERNATIONAL APPLICATION PUBLISHED UNDER THE PATENT COOPERATION TREATY (PCT)

(19) World Intellectual Property
Organization
International Bureau



(43) International Publication Date
3 June 2004 (03.06.2004)

PCT

(10) International Publication Number
WO 2004/047421 A2

(51) International Patent Classification⁷: **H04N**
(21) International Application Number:
PCT/US2003/036177
(22) International Filing Date:
14 November 2003 (14.11.2003)
(25) Filing Language: English
(26) Publication Language: English
(30) Priority Data:
60/426,239 14 November 2002 (14.11.2002) US
60/477,416 10 June 2003 (10.06.2003) US
60/492,544 5 August 2003 (05.08.2003) US

L. [US/US]; 3102 Crestbrooke Drive, Holland, MI 49424 (US). **CAMILLERI, Joseph** [US/US]; 11537 Eagle Way, Brighton, MI 48114 (US). **WHITEHEAD, Peter, J.** [GB/US]; 345 Sandcastle Drive, Holland, MI 49424 (US). **SCHOFIELD, Kenneth** [GB/US]; 4793 Crestridge Court, Holland, MI 49423 (US).

(74) Agents: **VAN DYKE, GARDNER, LINN & BURKHART, LLP** et al.; 2851 Charlevoix Drive, SE, Ste. 207, P.O. Box 888695, Grands Rapids, MI 49588-8695 (US).

(81) Designated States (*national*): AE, AG, AL, AM, AT, AU, AZ, BA, BB, BG, BR, BY, BZ, CA, CH, CN, CO, CR, CU, CZ, DE, DK, DM, DZ, EC, EE, EG, ES, FI, GB, GD, GE, GH, GM, HR, HU, ID, IL, IN, IS, JP, KE, KG, KP, KR, KZ, LC, LK, LR, LS, LT, LU, LV, MA, MD, MG, MK, MN, MW, MX, MZ, NI, NO, NZ, OM, PG, PH, PL, PT, RO, RU, SC, SD, SE, SG, SK, SL, SY, TJ, TM, TN, TR, TT, TZ, UA, UG, US, UZ, VC, VN, YU, ZA, ZM, ZW.

(84) Designated States (*regional*): ARIPO patent (GH, GM, KE, LS, MW, MZ, SD, SL, SZ, TZ, UG, ZM, ZW), Eurasian patent (AM, AZ, BY, KG, KZ, MD, RU, TJ, TM),

[Continued on next page]

(71) Applicant (*for all designated States except US*): **DONNELLY CORPORATION** [US/US]; 414 East Fortieth Street, Holland, MI 49423 (US).
(72) Inventors; and
(75) Inventors/Applicants (*for US only*): **BINGLE, Robert,**

(54) Title: IMAGING SYSTEM FOR VEHICLE

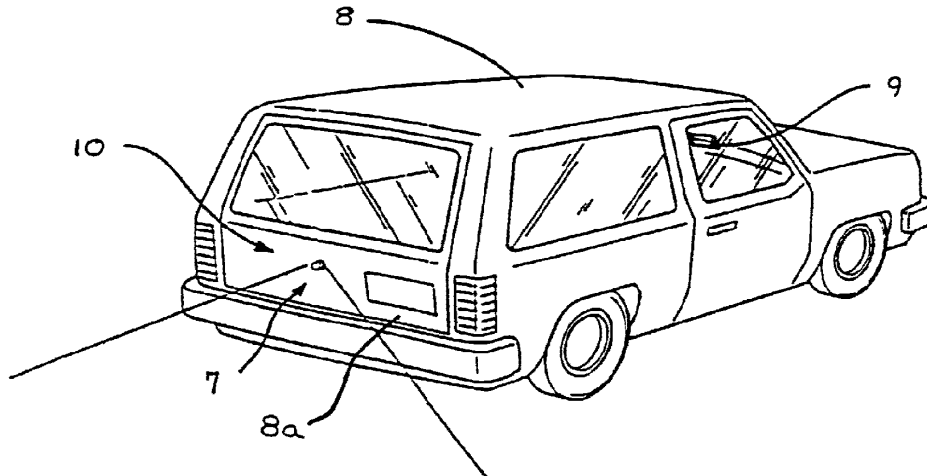

(57) Abstract: An imaging system (7) for a vehicle (8) includes a camera module (10) positionable at the vehicle and a control (9b). The camera module includes a plastic housing (16) that houses an image sensor (18), which is operable to capture images of a scene occurring exteriorly of the vehicle. The control is operable to process images captured by the image sensor. The portions of the housing may be laser welded or sonic welded together to substantially seal the image sensor and associated components within the plastic housing. The housing may include a ventilation portion (15) that is at least partially permeable to water vapor to allow water vapor to pass therethrough while substantially precluding passage of water droplets and/or other contaminants. The housing (110) may be movable at the vehicle between a stored position and an operational position, where the image sensor may be directed toward the exterior scene.

WO 2004/047421 A2



European patent (AT, BE, BG, CH, CY, CZ, DE, DK, EE, ES, FI, FR, GB, GR, HU, IE, IT, LU, MC, NL, PT, RO, SE, SI, SK, TR), OAPI patent (BF, BJ, CF, CG, CI, CM, GA, GN, GQ, GW, ML, MR, NE, SN, TD, TG).

For two-letter codes and other abbreviations, refer to the "Guidance Notes on Codes and Abbreviations" appearing at the beginning of each regular issue of the PCT Gazette.

Published:

- *without international search report and to be republished upon receipt of that report*

IMAGING SYSTEM FOR VEHICLECROSS REFERENCE TO RELATED APPLICATIONS

The present application claims priority of U.S. provisional applications, Ser. No. 60/426,239, filed Nov. 14, 2002 by Bingle for CAMERA MODULE FOR VEHICLE
5 (DON01 P-1031); Ser. No. 60/477,416, filed Jun. 10, 2003 by Camilleri for IMAGING SYSTEM FOR VEHICLE (DON01 P-1097); and Ser. No. 60/492,544, filed Aug. 5, 2003 by Whitehead et al. for CAMERA HOUSING FOR VEHICLE IMAGING SYSTEM (DON01 P-1108), which are all hereby incorporated herein by reference in their entireties.

FIELD OF THE INVENTION

10 The present invention relates to an imaging system for a vehicle and, more particularly, to a camera which may be mounted at an exterior portion of a vehicle for providing an image of a scene exteriorly of the vehicle. The present invention also relates to an imaging system for a vehicle which provides color imaging and a low light imaging capability.

BACKGROUND OF THE INVENTION

15 The advent of low cost, reliable imaging devices, based on a variety of silicon technologies, and in particular CMOS technology, combined with an improved cost/performance ratio for displays capable of meeting automotive specifications, and an increasing application rate of video monitor displays for automotive navigation systems or as
20 part of the driver interface to a wide variety of vehicle systems, has lead to an increasing use of cameras or imaging sensors designed to give the driver a view of those areas around the vehicle which are not in the normal direct field of view of the driver, typically referred to as "blind spots". These areas include the region close to the front of the vehicle, typically obscured by the forward structure of the vehicle, the region along the passenger side of the
25 vehicle, the region along the driver's side of the vehicle rearward of the driver, and the area or region immediately rearward of the vehicle which cannot be seen directly or indirectly through the rear view mirror system. The camera or imaging sensor may capture an image of the rearward (or sideward or other blind spot area) field of view, and the image may be displayed to the driver of the vehicle to assist the driver in backing up or reversing or
30 otherwise driving or maneuvering the vehicle. The use of electronic cameras in these applications significantly increases the driver's knowledge of the space immediately

surrounding the vehicle, which may be of importance prior to and during low speed maneuvers, and thus contributes to the safe completion of such maneuvers.

It is thus known to provide a camera or imaging sensor on a vehicle for providing an image of a scene occurring exteriorly or interiorly of the vehicle to a driver of the vehicle.

5 Such a camera may be positioned within a protective housing, which may be closed about the camera or sensor and secured together via fasteners or screws or the like. For example, a metallic protective housing may be provided, such as a die cast housing of aluminum or zinc or the like. In particular, for camera sensors mounted on the exterior of a vehicle, protection against environmental effects, such as rain, snow, road splash and/or the like, and physical
10 protection, such as against road debris, dirt, dust, and/or the like, is important. Thus, for example, in known exterior camera sensor mounts, a butyl seal, such as a hot dispensed butyl seal, or an O-ring or other sealing member or material or the like, has been provided between the parts of the housing to assist in sealing the housing to prevent water or other contaminants from entering the housing and damaging the camera or sensor positioned therein. However,
15 such housings typically do not provide a substantially water tight seal, and water droplets thus may enter the housing. Furthermore, any excessive vibration of the camera sensor, due to its placement (such as at the exterior of the vehicle), may lead to an undesirable instability of the image displayed to the driver of the vehicle. Also, such cameras or sensors are costly to manufacture and to implement on the vehicles.

20 Such vehicle vision systems often position a camera or imaging sensor at an exterior portion of a vehicle to capture an image of a scene occurring exteriorly of the vehicle. The cameras, particularly the cameras for rearward vision systems, are thus typically placed or mounted in a location that tends to get a high dirt buildup on the camera and/or lens of the camera, with no easy way of cleaning the camera and/or lens. In order to reduce the dirt or
25 moisture buildup on the lenses of such cameras, it has been proposed to use hydrophilic or hydrophobic coatings on the lenses. However, the use of such a hydrophilic or hydrophobic coating on the lens is not typically effective due to the lack of air flow across the lens. It has also been proposed to use heating devices or elements to reduce moisture on the lenses. However, the use of a heated lens in such applications, while reducing condensation and
30 misting on the lens, may promote the forming of a film on the lens due to contamination that may be present in the moisture or water. Also, the appearance of such cameras on the rearward portion of vehicles is often a problem for styling of the vehicle.

Typically, based on consumer preference and at least a perceived improved ability to extract information from the image, it is desired to present a color image to the driver that is

representative of the exterior scene as perceived by normal human vision. It is also desirable that such imaging devices or systems be useful in all conditions, and particularly in all lighting conditions. However, it is often difficult to provide a color imaging sensor which is capable of providing a clear image in low light conditions. This is because conventional
5 imaging systems typically have difficulty resolving scene information from background noise in low light conditions.

Silicon-based cameras may be responsive to light in the visible and near infrared portions of the spectrum. It is known to filter out the infrared portion of the energy available to the camera in order to maintain an appropriate color balance. When this is done, the
10 camera sensitivity may be less than if the near infrared and infrared light was received and used by the camera. Depending on the imaging technology used, the minimum sensitivities currently economically available for automotive cameras are typically in the range of 1 to 2 lux and may maintain a reasonable image quality at light levels at or above such levels. However, the conditions on a dark cloudy night where moonlight is obscured, and/or in rural
15 situations in which there is no source of artificial lighting, may result in a scene illumination as low as about 0.01 lux. While the technology continues to improve the low light sensitivity of silicon based cameras, it is not expected that 0.01 lux capability will become available in the foreseeable future. Other technologies may be capable of such sensitivity, but are not sufficiently cost effective for general application in the automotive industry.

20 Therefore, there is a need in the art for a camera housing that overcomes the shortcomings of the prior art, and a need in the art for an imaging system that may provide clear, satisfactory images during all driving or lighting conditions, and thus overcomes the shortcomings of the prior art imaging systems.

SUMMARY OF THE INVENTION

25 The present invention is intended to provide a camera module which includes a camera or image sensor and a circuit board positioned within a housing, which may be laser welded or sonic welded or the like to substantially seal the camera and circuit board within the housing. The housing, preferably molded of a plastic material, may include a plastic molded connector extending therefrom, such that the camera housing and connector are
30 configured as a single unitary module. The camera module may include a heating element for heating a transparent cover at the lens (or for heating the lens itself) of the camera to assist in defogging or defrosting the transparent cover in cold weather conditions. The transparent cover may have a transparent conductive coating (such as an indium tin oxide (ITO) coating or doped tin oxide or a metal grid or the like), preferably on its inner surface, such that

contact of a power terminal (connected to or in communication with or powered by a battery or other power source of the vehicle) and a ground terminal of the heating elements at the conductive coating causes heating of the coating to defrost or defog the cover. The heating elements or terminals may be actuated in response to a control or thermostat, which functions to activate and deactivate the heating element at predetermined temperatures sensed by a temperature sensor at or in the camera module or elsewhere at, in or on the vehicle. The present invention thus provides a camera module that maintains the camera or imaging sensor and is substantially impervious to environmental elements, such as rain, snow, dirt, dust, road splash, road debris and the like. The present invention also provides at least partial, and preferably substantial, reduced vibration affects of the camera or image sensor.

According to an aspect of the present invention, a substantially sealed camera module for an imaging system of a vehicle includes a plastic housing, which preferably includes first and second portions. The first and second portions are preferably laser welded or sonic welded together to substantially seal the camera or sensor and associated components within the plastic housing. The laser welded or sonic welded plastic housing provides a substantially hermetic seal to prevent water intrusion or the like into the housing. Alternately, and less preferably, the first and second portions may be adhesively sealed or joined.

The camera module may be incorporated into an imaging system that includes the sensor and a control for processing images captured by the imaging sensor. The camera module may be positioned within a movable housing that is movable relative to the vehicle to move the imaging sensor between an in use or operational position, where the imaging sensor is directed toward the exterior scene, and a storage position, where the housing and the imaging sensor are positioned within a portion of the vehicle.

According to another aspect of the present invention, a vented camera module for a vehicle includes a plastic housing which is configured to receive a camera or sensor therein. The housing of the vented camera module includes a semi-permeable ventilation area, such as a Gore-Tex assembly or area or patch or the like, which is at least partially permeable to water vapor and/or is porous enough to allow transfer of water vapor into and out from the housing, while substantially precluding entry of water droplets, dirt or the like into the housing.

According to another aspect of the present invention, a camera module for a vehicle includes a housing and a transparent cover at a portion of the housing. The transparent cover provides a transparent wall of the housing for the lens and sensor or camera to receive an

image therethrough. The cover may be heated to defrost or defog the cover in cold weather conditions or the like. The cover includes a surface (such as an inner surface within the housing) which has a conductive coating, such as a coating of indium tin oxide (ITO), doped tin oxide or the like. The module includes a pair of heater terminals or elements which
5 contact the coating, whereby heating of the cover or coating on the cover (such as the inner surface of the cover) is accomplished by generating a flow of electricity or electrons or current across the coating on the cover via the heater terminals or elements.

In one form, one of the heater terminals may be energized or charged with electricity and the other terminal may be grounded to the vehicle, such that the electrical current travels
10 from the energized or powered terminal across the conductive coating to the grounded terminal, thereby heating the conductive coating and, thus, the transparent cover. Preferably, the heater terminals are spaced apart at generally opposite sides or portions of the transparent cover.

Actuation of the heater terminals may defrost or defog the transparent cover and/or
15 may heat the module housing and interior compartment of the camera module to dry out any moisture within the housing or compartment. In applications where the module includes a ventilation area, such as a vented semi-permeable membrane, such as a Gore-Tex assembly or the like, heating of the compartment may be especially suited for driving moisture out of the compartment or module through the ventilation area to limit or substantially preclude
20 moisture condensing within the module. Optionally, the heater terminals may be actuated or energized in response to a control, which is operable to energize the heater terminals or elements in response to a thermostat and/or temperature sensor positioned at or within the camera module or elsewhere at, in or on the vehicle. Optionally, desiccant material, such as silica gel or the like, may be included in the housing to absorb moisture which may be present
25 within the housing.

According to yet another aspect of the present invention, a camera module for a vehicle comprises a housing, a transparent cover at a portion of the housing, an image sensor, at least one heating element and a control. The image sensor is positioned within the housing and is operable to receive an image of a scene exteriorly of the housing through the
30 transparent cover. The heating element is operable to heat the transparent cover. The control is operable to activate the heating element in response to a temperature sensor. The heating element is activatable to heat the transparent cover to reduce fog and/or ice on the transparent cover.

The present invention also provides a camera housing that is movably positioned at an exterior portion of a vehicle such that the camera may be moved from a stored position to an in-use or exterior or operational position. The camera housing may include a transparent window or panel and may further include a window wiper that functions to wipe dirt and/or moisture or the like from the window or panel as the housing moves the camera between the stored position and the operational position.

According to an aspect of the present invention, a holding device for movably holding an imaging device of a vehicle includes a housing, a transparent panel and a panel cleaning device. The imaging device is operable to capture an image of a scene occurring exteriorly of the vehicle. The housing is movably mountable at an exterior portion of the vehicle and is configured to receive an imaging device therein. The housing is movable relative to the exterior portion of the vehicle to move the imaging device between a stored position, where the imaging device is positioned generally within the portion of the vehicle, and an operational position, where the imaging device is positioned to have a field of view exteriorly of the vehicle. The transparent panel is positioned at least partially across an opening of the housing and generally in the field of view of the imaging device. The panel cleaning device is positionable at the exterior portion of the vehicle and configured to engage the transparent panel to clean the transparent panel as the housing moves the imaging device between the stored position and the operational position.

According to another aspect of the present invention, an imaging system for a vehicle includes an imaging device operable to capture an image of a scene occurring exteriorly of a vehicle, a control operable to process the image captured by the imaging device, and a camera housing device. The housing device includes a housing portion defining a compartment, a transparent panel substantially closing an opening of the compartment, and a panel cleaning device. The housing device is movably mountable on an exterior portion of the vehicle. The imaging device is positioned within the compartment and directed toward the transparent panel. The housing device is movable between a stored position, where the imaging device and the transparent panel are positioned at least substantially within the exterior portion of the vehicle, and an operational position, where the imaging device is directed exteriorly of the vehicle and has a field of view directed through the transparent panel and toward the exterior scene. The panel cleaning device is positionable at the exterior portion of the vehicle and configured to engage the transparent panel to clean the transparent panel as the housing device moves between the stored position and the operational position.

The imaging system may include a display operable to display the image captured by the imaging device. The housing device may be pivotably mountable at the exterior portion of the vehicle, or the housing device may be slidably or otherwise movably mountable at the exterior portion of the vehicle. An outer panel of the housing device may define an exterior cover portion at the exterior portion of the vehicle when the housing device is moved or pivoted to the stored position.

Optionally, the imaging system may comprise a color imaging sensor operable to capture color images of the exterior scene and an infrared imaging sensor operable to capture infrared images of the exterior scene. The control may selectively activate one of the color imaging sensor and the infrared imaging sensor in response to the ambient light intensity present in the exterior scene.

Optionally, the imaging system may include an illumination source positioned within the compartment and directed toward the exterior scene when the housing device is moved to the operational position. The transparent panel and the compartment are positioned generally within the exterior portion of the vehicle when the housing device is moved to the stored position. Optionally, the control may be operable to selectively activate the illumination source and the imaging device when the housing device is moved to the stored position to determine if moisture is present on the transparent panel. The housing device may include a heater element that is selectively operable to heat the transparent panel to reduce moisture present on the transparent panel.

Optionally, the housing device may be movable to selectively position the imaging device in first and second operational positions. The control may be operable to determine a distance to at least one object in the exterior scene in response to processing of images captured by the imaging device when the imaging device is in the first and second operational positions. For example, the control may be operable to selectively move the housing device to position the imaging device at the first operational position in response to the vehicle making an initial approach to a target zone and to position the imaging device at the second operational position in response to the vehicle moving further into the target zone. The imaging device may be directed more downward when in the second operational position relative to the first operational position.

According to another aspect of the present invention, an imaging system of a vehicle includes an imaging device, a holding device and a control. The imaging device is operable to capture images of a scene occurring exteriorly of the vehicle. The holding device is pivotally mountable at a portion of a vehicle and includes a housing having an exterior panel

and a transparent panel. The imaging device is positioned within the housing. The transparent panel is positioned at least partially across an opening of the housing and generally in the field of view of the imaging device. The holding device is pivotable relative to the portion of the vehicle to move the imaging device between a stored position, where the imaging device is positioned generally within the portion of the vehicle, and an operational position, where the imaging device is positioned to have a field of view exteriorly of the vehicle. The exterior panel is generally aligned with an exterior surface of the portion of the vehicle and the transparent panel is generally within the portion of the vehicle when the imaging device is in the stored position. The control is operable to process images captured by the imaging device.

The present invention also provides a vehicular imaging system or image capture system which is operable to capture an image of an exterior scene and to display the images at a display of the vehicle. The imaging system is operable to control illumination sources operable to illuminate the exterior scene and/or to control the color processing of the captured images and/or to control the color/monochromatic status or mode of the image capture device or camera of the system, in order to provide or display an optimum color or black and white image at the display which has optimum color representation of the scene or has optimum illumination or visibility or clarity or contrast ratio in the image displayed.

For example, the imaging system may selectively activate visible or infrared or near infrared illumination sources or light emitting diodes (LEDs) in response to a detected ambient light level dropping or decreasing or lowering to a threshold level. The imaging system may also or otherwise selectively switch the imaging sensor from a color mode to a black and white mode in response to the reduced ambient light level. Optionally, the imaging system may apply an infrared contribution correction to the detected levels for each color (such as red, green, blue) detected by the imaging sensor to adjust the color balance of the imaging sensor for better color rendition in the captured images. Optionally, the imaging system may provide visible illumination to the exterior scene and may limit or block infrared and near infrared light present in the illuminated scene to reduce processing requirements to obtain the appropriate color balance in the captured images.

Therefore, the present invention provides a camera module for a vehicle which may be substantially hermetically sealed to limit or substantially preclude water intrusion or the like into the housing of the module, or which may be vented to allow for water vapor to enter or exit the module. The camera housing may also include a heating element which is operable to defrost or defog the transparent cover of the module and/or to heat the

compartment of the camera housing to limit or substantially preclude condensation from forming within the module. The heating element may be activated and deactivated at predetermined temperatures in response to a temperature sensor and/or thermostat. The transparent cover of the housing may include a conductive coating on a surface thereof, such that applying an electrical current or flow through or across the coating on the surface of the transparent cover functions to heat the surface of the cover to defrost or defog the transparent cover. The present invention thus provides an environmentally resilient, protected, economical camera module which may be mounted to a vehicle and connected or plugged into a wiring connector of the vehicle.

The present invention thus also provides a camera housing device that is movable or adjustable to move a camera or imaging sensor between an operational position and a stored position. The camera thus may be positioned in a stored position within an exterior portion of the vehicle when not in use. The exterior panel of the camera housing device may provide an exterior cover at the exterior portion of the vehicle to protect the camera and lens from the elements when they are not in use. The housing device may include a transparent panel that substantially encloses the camera and lens within the housing. The housing device may also include a panel cleaning device that may clean the transparent panel to limit or substantially preclude dirt buildup or debris on the panel that may adversely effect the performance of the camera and thus of the imaging system.

The present invention also provides an imaging system that is capable of providing a color image during daytime conditions, and that may provide a black and white image, with or without additional infrared or near infrared illumination provided to the scene, during darkened or nighttime conditions. The imaging system may correct the color image to account for infrared and near infrared illumination that may be present in the exterior scene, in order to provide an image with proper or desired color balance. The present invention thus may provide optimal images to the driver of the vehicle during substantially all types of lighting conditions.

These and other objects, purposes, advantages and features of the present invention will become apparent upon review of the following specification in conjunction with the drawings.

BRIEF DESCRIPTION OF THE DRAWINGS

FIG. 1 is a rear perspective view of a vehicle having an imaging system thereon in accordance with the present invention;

FIG. 2 is a plan view of the vehicle of FIG. 1;

FIG. 3 is a perspective view of a camera module in accordance with the present invention;

FIG. 4 is a side elevation of the camera module of FIG. 3;

FIG. 5 is another side elevation of the camera module of FIGS. 3 and 4;

5 FIG. 6 is an end elevation of the camera module of FIGS. 3-5;

FIG. 7 is a sectional view of the camera module taken along the line VII-VII in FIG. 6;

FIG. 8 is an opposite end elevation of FIG. 6 of the camera module of FIGS. 3-7;

FIG. 9 is a sectional view of the camera module taken along the line IX-IX in FIG. 5;

10 FIG. 10 is a sectional view of the camera module taken along the line X-X in FIG. 8;

FIG. 11 is another sectional view of the camera module taken along the line XI-XI in FIG. 8;

FIG. 12A is a side elevation of a camera housing portion of the camera module of the present invention;

15 FIG. 12B is an end elevation of the camera housing portion of FIG. 12A;

FIG. 12C is an opposite end elevation of FIG. 12B of the camera housing portion of FIGS. 12A and 12B;

FIG. 12D is a sectional view of the camera housing portion taken along the line D-D in FIG. 12C;

20 FIG. 13A is a top plan view of a circuit board useful with the camera module of the present invention;

FIG. 13B is a side elevation of the circuit board of FIG. 13A;

FIG. 14A is another plan view of the circuit board of FIGS. 13A and 13B, with the circuit board folded over itself;

25 FIG. 14B is a side elevation of the circuit board of FIG. 14A;

FIG. 15A is a side elevation of a connector portion of the camera module of the present invention;

FIG. 15B is an end elevation of the connector portion of FIG. 15A;

30 FIG. 15C is a sectional view of the connector portion taken along the line C-C in FIG. 15B;

FIG. 15D is another sectional view of the connector portion taken along the line D-D in FIG. 15B;

FIG. 15E is an opposite end elevation of FIG. 15B of the connector portion of FIGS. 15A-D;

FIGS. 16A-D are various views of one side or portion of a metallic protective shield for the camera module of the present invention;

FIG. 16E is a sectional view of the protective shield taken along the line E-E in FIG. 16D;

5 FIG. 17A and 17B are side elevations of an alternate embodiment of another camera module and/or components thereof in accordance with the present invention, with the connector portion being angled;

FIG. 17C is a perspective view of the connector portion of the camera module of FIGS. 17A and 17B;

10 FIG. 17D is a sectional view of the camera module taken along the line D-D in FIG. 17B;

FIG. 17E is a sectional view of the camera module taken along the line E-E in FIG. 17A;

15 FIG. 18 is a rear perspective view of a vehicle with a camera housing device in accordance with the present invention positioned thereon and positioned in its in-use or operational position;

FIG. 19 is a side elevation and sectional view of a camera housing device in accordance with the present invention, with the camera housing device positioned so the camera is in its stored position;

20 FIG. 20 is a side elevation and sectional view similar to FIG. 19, with the camera housing device positioned so the camera is in its operational position;

FIG. 21 is a side elevation and sectional view of another camera housing device in accordance with the present invention, with an illumination source positioned within the camera housing device and movable with the housing device and camera;

25 FIG. 22 is a side elevation and sectional view of another camera housing device in accordance with the present invention, with the camera housing device being slidable to move the camera between its stored position and operational position, and with the camera housing device shown in the stored position;

30 FIG. 23 is a side elevation and sectional view of the camera housing device of FIG. 22, with the camera housing device shown in the extended or operational position;

FIG. 24 is a schematic of an image capture device in accordance with the present invention;

FIG. 25 is a block diagram of an imaging system in accordance with the present invention; and

FIG. 26 is a perspective view of an imaging system module in accordance with the present invention, having auxiliary illumination sources.

DESCRIPTION OF THE PREFERRED EMBODIMENTS

Referring now to the drawings and the illustrative embodiments depicted therein, an image capture system or imaging or vision system 7 is positioned at a vehicle 8, such as at a rearward exterior portion 8a of the vehicle 8, and is operable to capture an image of a scene occurring interiorly or exteriorly of the vehicle, such as rearwardly of the vehicle, and to display the image at a display or display system 9a of the vehicle which is viewable by a driver or occupant of the vehicle (FIGS. 1 and 2). Imaging system 7 includes a camera module 10, which is mountable on, at or in the vehicle to receive an image of a scene occurring exteriorly or interiorly of the vehicle, and a control 9b that is operable to process images captured by an image sensor 18 of camera module 10. Camera module 10 includes a plastic camera housing 11 and a metallic protective shield or casing 16 (FIGS. 3-12). Camera housing 11 includes a camera housing portion 12 and a connector portion 14, which mate or join together and are preferably laser welded or sonic welded together to substantially seal the housing 11 to substantially limit or prevent water intrusion or other contaminants from entering the housing, as discussed below.

Housing 11 of camera module 10 substantially encases a camera or image sensor or sensing device 18 (FIGS. 7, 9-11, 13A, 13B, 14A and 14B), which is operable to capture an image of the scene occurring exteriorly or interiorly of the vehicle, depending on the particular application of camera module 10. Housing 11 also includes a cover portion 20 at an end of camera housing portion 12. Cover portion 20 provides a transparent cover plate 22 which allows the image of the scene exteriorly or interiorly of the vehicle to pass therethrough and into housing 11 to camera 18, and which may be heated to defrost or defog the cover, as discussed below. Camera module 10 may include the protective shield 16, which substantially encases camera housing portion 12 and a portion of connector portion 14, thereby substantially limiting or reducing electronic noise going into or out of the camera module and/or protecting the plastic housing 11 from damage due to impact or the like with various items or debris that may be encountered at the exterior of the vehicle.

Camera module 10 provides a camera or image capture device 18 for capturing an image of a scene occurring exteriorly or interiorly of a vehicle. The captured image may be communicated to a display or display system 9a which is operable to display the image to a driver of the vehicle. The camera or imaging sensor 18 useful with the present invention may comprise an imaging array sensor, such as a CMOS sensor or a CCD sensor or the like, such

as disclosed in commonly assigned U.S. Pat. Nos. 5,550,677; 5,670,935; 5,796,094; and 6,097,023, and U.S. pat. application, Ser. No. 09/441,341, filed Nov. 16, 1999 by Schofield et al. for VEHICLE HEADLIGHT CONTROL USING IMAGING SENSOR (Attorney Docket DON01 P-770), which are hereby incorporated herein by reference. Camera module 10 and
5 imaging sensor 18 may be implemented and operated in connection with various vehicular vision systems, and/or may be operable utilizing the principles of such other vehicular systems, such as a vehicle headlamp control system, such as the type disclosed in U.S. Pat. Nos. 5,796,094; 6,097,023; 6,320,176; and 6,559,435, and U.S. pat. applications, Ser. No. 09/441,341, filed Nov. 16, 1999 by Schofield et al. for VEHICLE HEADLIGHT CONTROL
10 USING IMAGING SENSOR (Attorney Docket DON01 P-770); and Ser. No. 10/427,146, filed Apr. 30, 2003 by Schofield et al. for VEHICLE HEADLIGHT CONTROL USING IMAGING SENSOR (Attorney Docket DON01 P-1091), which are all hereby incorporated herein by reference, a rain sensor, such as the types disclosed in commonly assigned U.S. Pat. Nos. 6,353,392; 6,313,454; and/or 6,320,176, which are hereby incorporated herein by
15 reference, a vehicle vision system, such as a forwardly, sidewardly or rearwardly directed vehicle vision system utilizing principles disclosed in U.S. Pat. Nos. 5,550,677; 5,670,935; 5,760,962; 5,877,897; 5,949,331; 6,222,447; 6,302,545; 6,396,397; 6,498,620; 6,523,964; 6,611,202; and 6,201,642, and/or in U.S. pat. applications, Ser. No. 09/199,907, filed Nov. 25, 1998 by Bos et al. for WIDE ANGLE IMAGE CAPTURE SYSTEM FOR VEHICLE
20 (Attorney Docket DON01 P-676); Ser. No. 10/372,873, filed Feb. 24, 2003 by Schofield et al. for VEHICLE IMAGE CAPTURE SYSTEM (Attorney Docket DON01 P-1077); Ser. No. 10/011,517, filed Nov. 5, 2001 by Bos et al. for INTERIOR REARVIEW MIRROR SYSTEM INCLUDING A FORWARD FACING VIDEO DEVICE (Attorney Docket DON01 P-934); Ser. No. 10/324,679, filed Dec. 20, 2002 by Schofield et al. for
25 VEHICULAR VISION SYSTEM (Attorney Docket DON01 P-1059); Ser. No. 10/047,901, filed Jan. 14, 2002 by Bos et al. for VEHICLE IMAGING SYSTEM WITH ACCESSORY CONTROL (Attorney Docket DON08 P-949); Ser. No. 10/643,602, filed Aug. 19, 2003 by Schofield et al. for VISION SYSTEM FOR A VEHICLE INCLUDING IMAGING PROCESSOR (Attorney Docket DON01 P-1087); and Ser. No. 10/010,862, filed Dec. 6,
30 2001 by Bos for PLASTIC LENS SYSTEM FOR VEHICLE IMAGING SYSTEM (Attorney Docket DON01 P-954), which are all hereby incorporated herein by reference, a trailer hitching aid or tow check system, such as the type disclosed in U.S. pat. application, Ser. No. 10/418,486, filed Apr. 18, 2003 by McMahon et al. for VEHICLE IMAGING SYSTEM (Attorney Docket DON01 P-1070), which is hereby incorporated herein by reference, a

reverse or sideward imaging system, such as for a lane change assistance system or lane departure warning system, such as the type disclosed in U.S. pat. application, Ser. No. 10/427,051, filed Apr. 30, 2003 by Pawlicki et al. for OBJECT DETECTION SYSTEM FOR VEHICLE (Attorney Docket DON01 P-1075), which is hereby incorporated herein by
5 reference, a traffic sign recognition system, a system for determining a distance to a leading or trailing vehicle or object, such as a system utilizing the principles disclosed in U.S. Pat. No. 6,396,397, which is hereby incorporated herein by reference, and/or the like.

Typically, cameras are best suited for uniform lighting conditions, and typically have a dynamic range of approximately 60 to 70 dB. The lighting extremes which are encountered
10 in automotive applications create challenges for these cameras. For example, a single frame captured by the camera may include sunlight reflecting off concrete pavement and a dark shadow cast by the vehicle or other object. In such a situation, standard dynamic range cameras are limited in their ability to display usable images in both portions of the frame. Either the light area may be washed out, or the shadowed area may be black or darkened.

15 . Optionally, and preferably, camera 18 may comprise an extended dynamic range camera, which may have a dynamic range of greater than approximately 100 dB, and preferably approximately 100 to 120 dB. The linear dynamic range of the camera or sensor may be extended to above 100 dB by programming a non-linear response curve that generally matches the response of the human eye. By providing such an extended dynamic range
20 camera, the camera module may provide an image which is readable and not washed out or darkened in both the highly lighted areas and the dark areas of each frame of the image captured by the camera. Such a camera thus may provide an image to the display or display system which is readable in both the light and dark regions of each frame.

In a preferred embodiment, the extended dynamic range camera may provide a
25 dynamic range of approximately 62 dB in a linear mode and approximately 110 dB in a non-linear mode. The camera or sensor may have a sensitivity of approximately 5 V/lux.s (if the sensor comprises a monochrome sensor) or approximately 2.7 V/lux.s (if the sensor comprises a color sensor), and may be operable at a frame rate of approximately 30 frames per second. For example, the camera or sensor may comprise a LM9618 Monochrome
30 CMOS Image Sensor or a LM9628 Color CMOS Image Sensor, both of which are commercially available from National Semiconductor. Other suitable cameras or sensors may otherwise be implemented with the camera module, without affecting the scope of the present invention.

Although shown at a rear portion of a vehicle, camera 18 and camera module 10 may be positioned at any suitable location on the vehicle, such as within a rear panel or portion of the vehicle, a side panel or portion of the vehicle, a license plate mounting area of the vehicle, an exterior mirror assembly of the vehicle, an interior rearview mirror assembly of the vehicle or any other location where the camera may be positioned and oriented to provide the desired view of the scene occurring exteriorly or interiorly of the vehicle. The camera module of the present invention is particularly suited for use as an exterior camera module. However, the camera module may be positioned at an interior portion of the vehicle, such as at or in an interior rearview mirror assembly or accessory module at or near an interior rearview mirror assembly, to provide an image of an interior scene or of an exterior scene through a window or windshield of the vehicle, without affecting the scope of the present invention. The image captured by the camera may be displayed at a display screen or the like positioned within the cabin of the vehicle, such as at an interior rearview mirror assembly (such as disclosed in U.S. pat. application, Ser. No. 09/793,002, filed Feb. 26, 2001 by Schofield et al. for VIDEO MIRROR SYSTEMS INCORPORATING AN ACCESSORY MODULE (Attorney Docket DON01 P-869), which is hereby incorporated herein by reference), or elsewhere at or within the vehicle cabin, such as by using the principles disclosed in U.S. Pat. Nos. 5,550,677; 5,670,935; 5,796,094; 6,097,023 and 6,201,642, and/or in U.S. pat. application, Ser. No. 09/199,907, filed Nov. 25, 1998 by Bos et al. for WIDE ANGLE IMAGE CAPTURE SYSTEM FOR VEHICLE (Attorney Docket DON01 P-676), which are hereby incorporated herein by reference.

As best shown in FIGS. 7 and 9-12, camera housing portion 12 includes a generally cylindrical portion 12a extending outwardly from a base portion 12b. Camera portion 12 comprises a molded plastic component and may include a pair of heater terminals or elements 30a, 30b insert molded within and/or along the walls of cylindrical portion 12a, as discussed below. Cylindrical portion 12a receives a lens or optic system 24 therein, which functions to focus the image onto camera or sensor 18, which is positioned at a circuit board 26 mounted within the base portion 12b of camera housing portion 12.

Lens system 24 is positioned within cylindrical portion 12a of camera portion 12 so as to receive light from the exterior or interior scene through cover 22 at end 12c of camera portion 12. Lens system 24 is mounted to, such as via threaded engagement with, camera cover or housing 28, which functions to substantially cover or encase camera or sensor 18 to substantially prevent or limit incident light from being received by camera 18 and interfering with the image received by camera 18 through cover 22 and lens system 24. The lens system

24 may be any small lens or lens system which may focus an image of the scene exteriorly of the camera module onto the camera or image sensor 18, such as, for example, the types disclosed in U.S. Pat. No. 6,201,642; and/or in U.S. pat. application, Ser. No. 10/010,862, filed Dec. 6, 2001 by Bos for PLASTIC LENS SYSTEM FOR VEHICLE IMAGING SYSTEM (Attorney Docket DON01 P-954), which are hereby incorporated herein by reference. The lens system 24 may provide a wide-angle field of view, such as approximately 120 degrees or more.

Cover portion 20 is mounted at an outer end 12c of camera housing portion 12 opposite from base portion 12b, as shown in FIGS. 7 and 9-11. Cover portion 20 includes an outer circumferential ring or cover retainer 20a, which engages an outer surface of transparent cover 22 and functions to retain transparent cover 22 in position at the end 12c of the cylindrical portion 12a of camera receiving portion 12. Preferably, circumferential ring 20a is laser welded or sonic welded or otherwise joined or bonded to outer end 12c of cylindrical portion 12a of camera receiving portion 12, as discussed below. The laser or sonic welding of the seam substantially seals and secures cover portion 20 onto camera receiving portion 12, and may limit or substantially preclude any water intrusion or contaminant intrusion into the camera receiving portion at the outer end 12c. Preferably, an inner surface 22a of transparent cover 22 includes a transparent conductive coating for heating the cover, as also discussed below.

In the illustrated embodiment, base portion 12b is generally square and defines a generally square mating edge 12e around the base portion 12b for mating and securing to a corresponding edge 14g of connector portion 14, as discussed below. Base portion 12b receives circuit board 26 and camera 18 therein, while a camera housing or shield 28 and lens or lens system 24 extend into cylindrical portion 12a of camera portion 12 to receive the image through transparent cover 22.

Connector portion 14 of housing 11 is a molded plastic component and includes a connector terminal or connector 14a, such as a multi-pin snap-on connector or the like, extending from a base portion 14b. Base portion 14b is formed (such as in a square shape as shown in the illustrated embodiment) to substantially and uniformly mate or connect to base portion 12b of camera housing 12, as can be seen with reference to FIGS. 7 and 9-11. The base portions 12b and 14b mate together and define a pocket or space for receiving and securing circuit board 26 therein. Base portions 14b and 12b may be laser welded or sonic welded together at their mating joint or connection 13. Laser or sonic welding of the joint melts the plastic edges or seams together to substantially hermetically seal housing 11 to

prevent water intrusion or other contaminant intrusion into housing 11 of camera module 10. Optionally, and less desirably, the base portions may be otherwise joined or substantially sealed together (such as via suitable adhesives and/or sealants). The module may optionally include a vented portion or semi-permeable membrane to vent the module, as discussed
5 below. The base portions 12b and 14b may further include mounting tabs or flanges 12d, 14f, which extend outwardly from base portion 12b, 14b. Mounting tabs 12d, 14f are generally aligned with one another when the base portions are secured together and include an aperture therethrough for mounting the camera module 10 at or to the vehicle via suitable fasteners or the like (not shown). Although shown as having generally square-shaped mating
10 portions, connector portion 14 and camera portion 12 may have other shaped mating portions or surfaces, without affecting the scope of the present invention.

Multi-pin connector 14a extends from base portion 14b and includes a plurality of pins or terminals 14c for electrically connecting camera module 10 with a connector (not shown) of the vehicle. For example, one end 14d of terminals 14c may connect to circuit
15 board 26, while the other end 14e of terminals 14c connects to the corresponding connector of the vehicle. The corresponding connector may partially receive the ends 14e of pins or terminals 14c at multi-pin connector 14a and may snap together with multi-pin connector 14a via a snap connection or the like. As best shown in FIGS. 15A, 15C and 15D, ends 14d of terminals 14c protrude or extend from connector portion 14, such that the ends 14d may be
20 received within corresponding openings or apertures 26c in circuit board 26 when housing portion 11 is assembled, as discussed below.

As shown in FIGS. 3-11, connector portion 14 may provide a generally straight multi-pin connector extending longitudinally from the base portion of the housing 11. However, other shapes of connectors, such as angled connectors or bent connectors or the like, such as a
25 90 degree angle connector portion 14' of a camera module 10' (FIGS. 17A-E), discussed below, may be implemented, depending on the particular application of the camera module, without affecting the scope of the present invention.

Optionally, camera module 10 may comprise a substantially hermetically sealed module, such that water intrusion into the module is limited or substantially precluded. Base
30 portion 12b of camera housing portion 12 and base portion 14b of connector portion 14 are correspondingly formed so as to substantially mate or join together at their mating seam 13, whereby the portions may be laser welded or sonic welded together or otherwise joined, while cover portion 20 is also laser welded or sonic welded or otherwise secured and substantially sealed at the opposite end 12c of camera portion 12, in order to substantially

seal the camera housing. Laser or sonic welding techniques are preferred so as to join the materials at a state where they are able to re-flow, either via heat, vibration or other means, such that the materials re-flow and cross-link and become a unitary part. Such joining results in a substantially hermetically sealed camera module. Additionally, the pores in the plastic as well as any voids around the insert molded pins and stampings may be sealed with a Loctite material or other suitable sealing material, to further limit or substantially preclude entry of water droplets and/or water vapor into the housing of the substantially sealed module.

Optionally, or alternately, the camera module of the present invention may comprise a vented module, which allows for water vapor to enter and/or exit the housing, while substantially precluding water droplets and the like from entering the housing. The camera portion 12 or connector portion 14 may include a semi-permeable ventilation portion or membrane 15 (FIG. 10), which preferably comprises a material or membrane which is at least partially permeable to water vapor and/or is porous enough to allow for ventilation of water vapor, but does not allow water droplets to pass therethrough, such that water vapor may enter and exit the housing 11, while water droplets and the like are kept outside the housing 11. For example, the ventilation portion 15 may comprise a Gore-Tex material or the like. In such applications where the module comprises a vented module and includes a ventilation portion, it is not necessary that the seams of the housing be laser welded or sonic welded, since the substantially hermetic sealing of the seams of the module would not be critical when the module is vented. Optionally, desiccant material, such as silica gel or the like, may be included in the housing to absorb moisture which may be present within the housing.

Camera housing portion 12 also includes a pair of heating terminals 30a, 30b which extend from within base portion 12b to outer end 12c substantially along/or within the walls of cylindrical portion 12a. Preferably, the terminals 30a, 30b are insert molded within the cylindrical wall of camera portion 12a. As shown in FIGS. 7 and 12D, the ends 30c of terminal portions 30a, 30b extend downward into base portion 12b of camera receiving portion 12, for connection to circuit board 26, as discussed below. The opposite ends 30d of terminals 30a, 30b extend radially inward at outer end 12c of cylindrical portion 12a and may provide arcuate or semicircular contacts at inner surface 22a of transparent cover 22 (FIGS. 7, 12B and 12C). A power or positive terminal 30a may be insert molded along and at least partially within the cylindrical portion 12a and positioned generally along an interior portion of the cylindrical portion 12a, while a ground or negative terminal 30b is insert molded along and partially within cylindrical portion 12a and positioned along an exterior wall or surface of the cylindrical portion 12a (as can be seen in FIGS. 7 and 12D). The exteriorly positioned

ground terminal 30b may contact the metallic protective shield 16, discussed below, to ground the shield to the heating device and/or camera module.

Heating device 30 functions to heat inner surface 22a of transparent cover 22, in order to defrost or defog the cover 22. Heating device 30 may also function to heat the inside or interior compartment of housing 11, in order to maintain the temperature within the housing above a threshold temperature to further limit or substantially preclude moisture from condensing within the camera housing. This is especially useful when implemented in a vented module having a semi-permeable membrane or portion, whereby the heater may generate heat to dry out and drive out any moisture within the camera body compartment. The heated camera module thus may substantially preclude moisture from condensing within the module, since the water vapor would otherwise condense on the coldest surface available within the module.

The power heater terminal 30a may be connected to or in communication with the vehicle battery or other power source and may be energizable to provide electrical current to inner surface 22a of transparent cover 22, while the ground terminal 30b provides a ground connection for the heating device. Energization of terminal 30a thus causes electrical current or electrons to flow across the inner surface 22a of cover 22 to ground terminal 30b. Preferably, inner surface 22a of transparent cover 22 includes a transparent conductive coating or layer, such as an indium tin oxide (ITO) coating or a doped tin oxide coating or the like, such as the types of layers or coatings used in electro-optic or electrochromic mirror technology and as disclosed in U.S. Pat. Nos. 5,140,455; 5,151,816; 6,178,034; 6,154,306; 6,002,544; 5,567,360; 5,525,264; 5,610,756; 5,406,414; 5,253,109; 5,076,673; 5,073,012; 5,117,346; 5,724,187; 5,668,663; 5,910,854; 5,142,407 and 4,712,879, which are hereby incorporated herein by reference. Preferably, the conductive coating or layer provides a resistance of less than approximately 80 ohms per square, and more preferably less than approximately 20 ohms per square. The conductive coating generates heat as electrons or electricity flow from contact 30d of power terminal 30a across surface 22a to contact 30d of ground terminal 30b. The contacts 30d are spaced apart at generally opposite sides of the transparent cover 22 and provide for generally uniform and thorough heating of inner surface 22a when electricity is applied to heating terminal 30a. As can be seen in FIGS. 12B and 12C, contacts 30d of terminals 30a, 30b are preferably semicircular or half moon shaped contacts to extend substantially across each side of the cover 22, without interfering with the central region of the cover through which the scene may be viewed by the camera and lens.

Preferably, circuit board 26 of camera module 10 also includes a heater circuit for controlling the heater device 30 and heater terminals 30a, 30b in response to a temperature sensor (not shown). The heater circuit may be operable to actuate the heater device 30, such as via energizing heater terminal 30a, when the temperature at, within or near the camera
5 module (or elsewhere at, in or on the vehicle) drops to a threshold temperature. The control or circuit is also operable to deactivate the heating device at a second predetermined threshold temperature. The heating device thus is operable via a thermostatic circuit which may activate and deactivate the heating device to heat the transparent cover 22 and/or the interior compartment of the housing when the temperature is detected to be low enough to
10 warrant such activation. Such a thermostatic circuit may be operable to activate the heater elements when it is most desirable to heat the transparent cover and/or the interior of the housing and, thus, may limit or substantially preclude fogging or freezing of cover 22 and/or moisture condensing within the housing, while limiting or substantially precluding operation of the heating device in circumstances or situations when heat is not required on the
15 transparent cover or in the housing.

As best shown in FIGS. 13A, 13B, 14A and 14B, circuit board 26 includes a camera mounting circuit board 26a, which is connected to a connector receiving circuit board 26b via a multi-wire ribbon wire 27 or the like. Camera mounting circuit board 26a is mounted or secured to the base portion 12b of camera portion 12, while connector circuit board 26b is
20 mounted or secured to the base portion 14b of connector portion 14. Camera or image sensor 18 is mounted at a surface of camera circuit board 26a, and is substantially encased at circuit board 26a by camera cover 28 and lens 24 (FIGS. 7 and 9-11). As shown in FIGS. 7, 13A and 14A, camera circuit board 26a includes a pair of apertures 26c for receiving ends 30c of heating terminals 30a, 30b. Likewise, connector circuit board 26b includes a plurality of
25 openings or apertures 26d for receiving ends 14d of connector terminals 14c therethrough (FIGS. 7, 10, 11 and 13A). The ends of the pins or terminals may be soldered in place in their respective openings. As shown in FIGS. 9, 11 and 14B, circuit board 26 is folded at ribbon wire 27, such that circuit board 26a generally overlaps circuit board 26b when they are positioned within the base portions 12b, 14b of the camera housing. The circuit board 26
30 may thus fold to an open position after the separate boards 26a, 26b are secured within their respective base portions of the housing to facilitate soldering of the connector terminals or heater terminals at the respective circuit boards. After all of the connections are made, the housing may be folded to its closed position and laser welded or sonic welded together or otherwise joined or bonded together to substantially seal the circuit board within the housing.

Optionally, the exterior surface 22b of cover 22 (which may be exposed to the atmosphere exterior of the camera module) may be coated with an anti-wetting property such as via a hydrophilic coating (or stack of coatings), such as is disclosed in U.S. Pat. Nos. 6,193,378; 5,854,708; 6,071,606; and 6,013,372, the entire disclosures of which are hereby
5 incorporated by reference herein. Also, or otherwise, the exterior or outermost surface 22b of cover 22 may optionally be coated with an anti-wetting property such as via a hydrophobic coating (or stack of coatings), such as is disclosed in U.S. Pat. No. 5,724,187, the entire disclosure of which is hereby incorporated by reference herein. Such hydrophobic property on the outermost surface of the cover can be achieved by a variety of means, such as by use
10 of organic and inorganic coatings utilizing a silicone moiety (for example, a urethane incorporating silicone moieties) or by utilizing diamond-like carbon coatings. For example, long-term stable water-repellent and oil-repellent ultra-hydrophobic coatings, such as described in PCT Application Nos. WO0192179 and WO0162682, the entire disclosures of which are hereby incorporated by reference herein, can be disposed on the exterior surface of
15 the cover. Such ultra-hydrophobic layers comprise a nano structured surface covered with a hydrophobic agent which is supplied by an underlying replenishment layer (such as is described in Classen et al., "Towards a True 'Non-Clean' Property: Highly Durable Ultra-Hydrophobic Coating for Optical Applications", ECC 2002 "Smart Coatings" Proceedings, 2002, 181-190, the entire disclosure of which is hereby incorporated by reference herein).

20 In the illustrated embodiment, camera module 10 includes a protective shield or casing 16 which partially encases the plastic housing 11 and functions to limit or reduce electronic noise which may enter or exit camera module 10 and may protect the plastic housing from damage from impact of various items or debris which the camera module may encounter at the exterior portion of the vehicle. The protective shield or casing 16 includes a
25 pair of casing portions 16a (one of which is shown in FIGS. 16A-16E). Each of the casing portions 16a partially encases about half of the plastic housing 11 of camera module 10 and partially overlaps the other of the casing portion 16a, to substantially encase the plastic housing within protective shield 16. Each of the portions 16a includes a slot 16b for receiving the mounting tabs 12d, 14f therethrough for mounting the camera module at the
30 desired location at the vehicle. Each casing portion 16a includes overlapping portions 16c which overlap an edge of the other casing portion 16a to assemble the casing 16 around the plastic housing. The casing portions 16a may be welded, crimped, adhered, banded, or otherwise joined or secured together about the plastic housing 11, in order to encase the housing 11. Preferably, protective shield 16 comprises a metallic shield and contacts ground

terminal 30b of heating device 30 at the exterior surface of the cylindrical portion 12a of camera receiving portion 12 and, thus, may be grounded to the heating device and/or the camera module or unit via the ground terminal 30b, as can be seen with reference to FIG. 7. Protective shield 16 may comprise a stamped metal shielding or may be formed by vacuum
5 metalizing a shield layer over the plastic housing 11, or may comprise a foil or the like, without affecting the scope of the present invention.

With reference to FIGS. 17A-17E, a camera module 10' is shown which includes a connector portion 14' of a housing 11' which provides for a 90 degree bend in the connector pins or terminals 14c' to accommodate different mounts or connections to a connector of the
10 vehicle. Other bends or shapes of the molded connector portion may be implemented without affecting the scope of the present invention. The other components of camera module 10' are substantially similar to the respective components of camera module 10, discussed above, such that a detailed discussion of those components will not be repeated herein. The common components are shown in FIGS. 17A-17E with the same reference numbers as assigned to the
15 respective components of camera module 10 of FIGS. 1-16.

Therefore, the present invention provides a sealed camera module which may provide a substantially watertight and substantially hermetically sealed housing about a camera or image sensor of the camera module. The housing components may be laser welded or sonic welded together which substantially seals the plastic housing and substantially precludes
20 water intrusion or the like into the housing at the seams or mating portions of the housing. Because the plastic housing of the camera module of the present invention may be laser welded or sonic welded together to substantially seal the housing, the housing may provide an economical and rugged, environmentally resilient and protective housing for the camera or sensor and circuit board. The unitary housing and connector also makes it easy to install and
25 connect the camera module to a vehicle connector.

Alternately, the camera module of the present invention may comprise a vented camera module, where the housing includes a semi-permeable ventilation or venting portion, such as a Gore-Tex assembly, area or patch or the like, which allows for ventilation of water vapor into and out from the housing, while substantially precluding entry of water droplets or
30 dirt or other contaminants or the like into the housing. The plastic vented module of the present invention thus may also provide an economical and rugged, environmentally resilient and protective housing for the camera or sensor and circuit board.

Additionally, the camera module of the present invention may include a heating device which functions to heat a transparent conductive coating on a transparent cover of the

housing, so as to provide heat to the cover to defrost or defog the cover. The heater elements may be insert molded within the plastic housing of the camera module and may plug into a circuit board received within the housing as the camera module is assembled. Preferably, the heating device may be operable in response to a temperature sensor, such that the heating
5 device may be activated when the temperature drops to a threshold temperature and then deactivated after the temperature has been elevated to a second higher threshold temperature. The heating device is thus automatically operable in low temperature levels when it may be desirable to activate the heating device. The heating device may be activated to defrost or defog the transparent cover of the camera module and/or to heat the interior chamber of the
10 camera module to limit or substantially preclude moisture condensing therein. Heating the interior compartment of the camera module may dry out any moisture within the module and may limit or substantially preclude condensation from forming within the module. In applications where the camera module comprises a vented camera module, the heat generated within the vented camera module may also drive out water vapor through the semi-permeable
15 ventilation area to further limit or substantially preclude water vapor from condensing within the camera module.

Referring now to FIGS. 18-20, a camera housing device 110 may house or contain a camera or imaging device 116 and protect the camera from exposure to the elements in applications where the camera may be positioned at a vehicle 8 (FIG. 18) for viewing an area
20 or scene exterior of the vehicle. The camera housing device 110 may be positioned at least partially within an opening 8b at an exterior portion 8a of a vehicle 8 (such as a rearward portion or side portion or elsewhere on the vehicle) . The housing device 110 defines a compartment or cavity 114 for receiving camera or imaging device 116 therein and is operable or movable to move the camera or imaging device 116 between a stored position
25 (FIG. 19) and an operational or extended or in-use position (FIG. 20). The camera 116 and compartment 114 are positioned generally inwardly of an outer panel or flap 118 of housing device 110 at the exterior portion 8a of the vehicle 8 when the housing device and camera are in the stored position. As shown in FIG. 19, the outer panel or flap 118 is positioned generally along the exterior portion 8a of the vehicle a and serves as a cover or flap over the
30 opening 8b when housing device 110 is in its stored position.

Imaging device 116 may be operable in conjunction with a vision or imaging system of the vehicle, such as a reverse or backup aid system, such as a rearwardly directed vehicle vision system utilizing principles disclosed in U.S. Pat. Nos. 5,550,677; 5,760,962; 5,670,935; 5,760,962; 5,877,897; 5,949,331; 6,222,447; 6,302,545; 6,396,397; 6,498,620;

6,523,964; 6,611,202; and/or 6,201,642, and/or in U.S. pat. applications, Ser. No. 09/199,907, filed Nov. 25, 1998 by Bos et al. for WIDE ANGLE IMAGE CAPTURE SYSTEM FOR VEHICLE (Attorney Docket DON01 P-676); Ser. No. 10/372,873, filed Feb. 24, 2003 by Schofield et al. for VEHICLE IMAGE CAPTURE SYSTEM (Attorney Docket DON01 P-1077); Ser. No. 10/011,517, filed Nov. 5, 2001 by Bos et al. for INTERIOR REARVIEW MIRROR SYSTEM INCLUDING A FORWARD FACING VIDEO DEVICE (Attorney Docket DON01 P-934); Ser. No. 10/324,679, filed Dec. 20, 2002 by Schofield et al. for VEHICULAR VISION SYSTEM (Attorney Docket DON01 P-1059); Ser. No. 10/047,901, filed Jan. 14, 2002 by Bos et al. for VEHICLE IMAGING SYSTEM WITH ACCESSORY CONTROL (Attorney Docket DON08 P-949); and Ser. No. 10/643,602, filed Aug. 19, 2003 by Schofield et al. for VISION SYSTEM FOR A VEHICLE INCLUDING IMAGING PROCESSOR (Attorney Docket DON01 P-1087); and Ser. No. 10/010,862, filed Dec. 6, 2001 by Bos for PLASTIC LENS SYSTEM FOR VEHICLE IMAGING SYSTEM (Attorney Docket DON01 P-954), which are hereby incorporated herein by reference, a trailer hitching aid or tow check system, such as the type disclosed in U.S. pat. application, Ser. No. 10/418,486, filed Apr. 18, 2003 by McMahon et al. for VEHICLE IMAGING SYSTEM (Attorney Docket DON01 P-1070), which is hereby incorporated herein by reference, or an imaging system that may utilize aspects of other imaging or vision systems, such as the types disclosed in U.S. pat. applications, Ser. No. 10/054,633, filed Jan. 22, 2002 by Lynam et al. for VEHICULAR LIGHTING SYSTEM (Attorney Docket DON01 P-962); and Ser. No. 09/793,002, filed Feb. 26, 2001, entitled VIDEO MIRROR SYSTEMS INCORPORATING AN ACCESSORY MODULE (Attorney Docket DON01 P-869), which are hereby incorporated herein by reference. The imaging system includes a control or control system or device that is operable to process images captured by the imaging device 116 and a display 115 (FIG. 1) for displaying the captured images to a driver or occupant of the vehicle. The display may be positioned at an interior portion of the vehicle, such as at an interior rearview mirror assembly of the vehicle or accessory module of the vehicle or the like. The display may comprise a video display screen at a mirror assembly, such as the type disclosed in U.S. provisional applications, Ser. No. 60/439,626, filed Jan. 13, 2003 by Hutzet et al. for MIRROR WITH VIDEO DISPLAY SCREEN (Attorney Docket DON01 P-1061); Ser. No. 60/489,812, filed Jul. 24, 2003 by Hutzet et al. for ACCESSORY SYSTEM FOR VEHICLE (Attorney Docket DON01 P-1100); and Ser. No. 60/492,225, filed Aug. 1, 2003 by Hutzet et al. for ACCESSORY SYSTEM FOR VEHICLE (Attorney Docket DON01 P-1107), which are hereby incorporated herein by reference, or may comprise other types of displays or

display systems, such as, for example, a display on demand type of display, such as the types disclosed in commonly assigned U.S. Pat. Nos. 5,668,663 and 5,724,187, and U.S. pat. applications, Ser. No. 10/054,633, filed Jan. 22, 2002 by Lynam et al. for VEHICULAR LIGHTING SYSTEM (Attorney Docket DON01 P-962); and Ser. No. 09/793,002, filed Feb. 26, 2001, entitled VIDEO MIRROR SYSTEMS INCORPORATING AN ACCESSORY MODULE (Attorney Docket DON01 P-869), which are hereby incorporated by reference
5 herein, without affecting the scope of the present invention.

The control may also be operable to move the camera housing device between the operational and stored positions. The method of actuation of the housing to move the
10 housing and camera may be accomplished by a motor, such as via a gear or screw mechanism, or by vacuum compressed air or by magnetic or electromagnetic means, such as in the form of a solenoid or the like. Optionally, the camera housing device 110 may be movable to the operational position in response to an engagement of the reverse gear of the vehicle, or in response to an actuation of a backup aid or other reverse viewing system of the
15 vehicle. Optionally, the camera housing may be moved to the operational position in response to a user input or the like, without affecting the scope of the present invention. The camera housing thus allows for occasional use of the camera and may store and protect the camera when the camera is not in use.

Imaging device or camera 116 may comprise a camera device or other image
20 capturing device, such as a video camera or sensor, such as a CMOS imaging array sensor, a CCD sensor or the like, such as the types disclosed in commonly assigned, U.S. Pat. Nos. 5,550,677; 5,760,962; 6,097,023 and 5,796,094, which are hereby incorporated herein by reference. Such imaging array sensors comprise an array of photo-sensing pixels to sense light present in the field of view of the sensor. The imaging device 116 may comprise a color
25 sensing imaging device, which includes color filters such that the photo-sensing pixels of the imaging device sense particular colors of light from the scene. Optionally, the imaging device may or may not include an infrared filter to filter or attenuate infrared or near infrared light present in the exterior scene. Optionally, the imaging device may provide an infrared sensing capability to provide enhanced performance of the imaging device during nighttime
30 and/or darkened conditions where the visible light intensity is reduced. Optionally, the housing device may include two separate imaging devices, one for sensing color light for daytime lighting conditions and one for sensing infrared light for nighttime or darkened lighting conditions, as discussed below. Alternately, the control may be operable to selectively switch the imaging sensor between a color mode and a monochromatic mode,

such as via utilization of principles described below with respect to imaging system 310. The imaging device may have a lens 117 positioned in front of the sensor, and may utilize aspects of an imaging module of the types described above with respect to the camera modules 10, 10' of FIGS. 1-17.

5 Housing device 110 mounts or attaches the camera 116 generally at the external flap 118, such that the movement of the external flap between its opened position (FIG. 20) and its closed position (FIG. 19) moves the camera between its operational position and its stored position. The reverse aid camera or imaging device 116 is thus mounted behind the flap 118 such that when the camera is not in use it may be retracted into the vehicle exterior portion or
10 body portion 8a, thereby protecting it from the elements, such as dirt or debris or the like, and keeping the lens 117 relatively clean. The outer flap 118 may partially overlap the edges of the opening 8b in exterior portion 8a of vehicle 8 and may be generally aligned with an outer or exterior surface of the exterior portion to provide a generally flush, finished appearance to the exterior portion 8a when the housing device 110 is in the stored or closed position.

15 As shown in FIGS. 19 and 20, the camera 116 may be mounted in a housing or box or container 119 attached to the flap 118, such that the camera 116 is substantially contained or encased within the compartment 114 defined within the housing 119. The housing device 110 may define compartment or cavity 114 within and between an inner wall or flap 120 and external flap 118, and opposite side walls or flaps 122 (only one side wall shown in FIGS. 19
20 and 20). The housing 119 of camera housing device 110 may be pivotable about a generally horizontal pivot axis or pin 111 at the exterior portion 8a of the vehicle 8. In the illustrated embodiment, housing device 110 includes a pivot arm or extension 111a extending from inner wall 120. The pivot arm 111a pivotally mounts to a pivot pin 111 and may pivotally move or swing the housing 119 between the stored position and the operational position. The
25 pivot pin or axis 111 may be positioned within the exterior portion 8a of the vehicle 8 and generally adjacent to the edge of the opening 8b in the exterior portion 8a.

 Optionally, the housing device may be positioned at a side portion of the vehicle (such that the housing may pivot about a generally vertical pivot axis or the like) or at a generally horizontal portion of the vehicle (such that the housing may pivot about a generally
30 horizontal pivot axis and may have an outer flap that is generally horizontal when in its closed orientation, with the camera and housing positioned generally above or below the closed flap, depending on the particular application) or elsewhere on or in the vehicle, without affecting the scope of the present invention.

Housing 119 may include a clear or transparent glass or plastic window or panel 124 that at least partially closes the compartment 114 and that is positioned generally in front of the camera or imaging device 116 and covers or generally encases the lens 117 of the camera or imaging device 116. The transparent panel 124 may comprise a visible light transmitting panel that may substantially transmit visible light present in the scene to the imaging sensor 116 within housing 119 and behind transparent panel 124. The transparent panel 124 may comprise a substantially clear or transparent panel to provide protection to the lens and imaging sensor within the housing. Optionally, the transparent panel may comprise or provide an optical lens or may have optical qualities or characteristics or properties, whereby the transparent panel may function to serve or augment the lens of the imaging sensor.

Optionally, a wiper blade or wiping or cleaning device 126 may be positioned at the opening 8b of the exterior portion 8a of the vehicle 8 and may engage or wipe the outer surface 124a of the transparent panel 124 as the housing device 110 moves between the stored position and the operational position, in order to brush or clean or wipe debris or dirt or the like from the transparent panel 124. The wiper blade or device 126 may be spring loaded or biased (such as via a flexible spring clip 126a or the like) into engagement or contact with the surface 124a of the window or panel 124 such that as the housing device 110 opens and closes, the wiper 126 engages and wipes and cleans the window 124.

The transparent panel 124 thus may comprise a curved or arcuate panel such that the wiping device 126 generally uniformly engages the outer surface of the transparent panel as the housing device is opened and closed. However, the transparent panel may comprise other forms (and may be a generally flat panel), whereby the wiping device may engage only a desired portion of the panel or may be biased more toward the panel to maintain engagement of the wiping device with the panel during movement of the housing device. Optionally, a washer jet 128 may also be positioned at or near the opening 8b and may be operable to spray washer fluid or the like toward the panel or window 124 to clear dirt from the panel or window and to limit or prevent scratching of the window by the wiper.

Optionally, the housing device 110 may include a heating element that is operable to heat the transparent panel or window 124 to reduce moisture that may be present on the window. For example, window 124 may be heated by conductive strips embedded in the window, or surface mounted conductive strips, or ITO coatings or similar conductive or semi-conductive coatings or the like, such as described above with respect to camera module 10, 10'. The heater thus may heat the window to limit or substantially avoid condensation obscuring the field of view of the camera. Optionally, condensation may be limited by the

use of a desiccant substance or by venting the enclosure or the like, without affecting the scope of the present invention.

Optionally, the exterior surface 124a of window 124 may be coated with an anti-wetting property such as via a hydrophilic coating (or stack of coatings), such as is disclosed
5 in U.S. Pat. Nos. 6,193,378; 5,854,708; 6,071,606; and 6,013,372, the entire disclosures of which are hereby incorporated by reference herein. Also, or otherwise, the exterior surface 124a of window 124 may optionally be coated with an anti-wetting property such as via a hydrophobic coating (or stack of coatings), such as is disclosed in U.S. Pat. No. 5,724,187, the entire disclosure of which is hereby incorporated by reference herein. Such hydrophobic
10 property on the outermost surface of the window or panel can be achieved by a variety of means, such as by use of organic and inorganic coatings utilizing a silicone moiety (for example, a urethane incorporating silicone moieties) or by utilizing diamond-like carbon coatings. For example, long-term stable water-repellent and oil-repellent ultra-hydrophobic coatings, such as described in PCT Application Nos. WO0192179 and WO0162682, the
15 entire disclosures of which are hereby incorporated by reference herein, can be disposed on the exterior surface of the window. Such ultra-hydrophobic layers comprise a nano structured surface covered with a hydrophobic agent which is supplied by an underlying replenishment layer (such as is described in Classen et al., "Towards a True 'Non-Clean' Property: Highly Durable Ultra-Hydrophobic Coating for Optical Applications", ECC 2002
20 "Smart Coatings" Proceedings, 2002, 181-190, the entire disclosure of which is hereby incorporated by reference herein).

In some applications, it may be advantageous and desirable to add additional illumination to the exterior scene being captured by the camera. Accordingly, a camera housing device 110' may house or contain an imaging device or camera 116 and an
25 illumination source or auxiliary light 130 (FIG. 21) that is operable to direct illumination toward the field of view of the camera 116. The illumination source 130 may provide visible light, infrared or near infrared light or may be pulsed to provide pulsed infrared or near infrared light. The auxiliary light 130 may be fixedly positioned on the external bezel portion of the camera housing or of the exterior portion of the vehicle, or optionally, and preferably,
30 may be positioned within the housing and as part of the camera housing device or assembly (such as shown in FIG. 21). In this way, the panel 125 in front of the illumination device 130 may also be cleaned by the same operation or wiper 126 that cleans the transparent panel 124' in front of the camera 116.

Under some conditions, the light from the auxiliary illumination source 130 may be reflected, piped or refracted in or along the compartment and/or transparent panel in such a way that it may interfere with the image captured by the camera. Such interference may be avoided by splitting the clear window (as shown in FIG. 21) such that there is a window or panel 124' in front of the camera and a second window or panel or section 125 in front of the illumination source 130. Optionally, a divider or separating wall or panel or baffle 132 may be positioned between the compartments 114a, 114b that contain the camera 116 and illumination source 130, respectively. In the illustrated embodiment, the camera transparent panel 124' is substantially flat or planar, while the light transparent panel 125 is curved or arcuate. However, the transparent panels 124', 125 may be other shapes, without affecting the scope of the present invention. The separate panels and baffle provide a non-continuous path for the light to travel, so that the light will not have an adverse affect on the images being captured, while still providing for the external surface or surfaces of the panel or panels to be cleaned by the same wiper device. Optionally, by splitting the window into two panels 124', 125, the panel 125 covering the auxiliary light may be colored, such as red, to improve the appearance of the product on the vehicle. The camera housing device 110' is otherwise substantially similar to camera housing device 110, discussed above, such that a detailed discussion of the camera housing device will not be repeated herein.

Optionally, to improve the performance of the camera, the light level or intensity of the light emitted by the auxiliary light may be monitored by a sensor or device or control, and a control circuit may be used to adjust the camera for different light levels. Such a camera adjustment system would enhance the performance of the camera over a wide range of light conditions, and may also be used to control the auxiliary light if desired.

Optionally, when the camera housing is in the closed position, the camera and the auxiliary light may be at least occasionally turned on to illuminate the enclosed cavity and to capture an image of the illuminated enclosed cavity and transparent window. The enclosed cavity provides a known image, and the images captured by the camera in this orientation may be used to examine the window for condensation, dirt or other abnormalities. If condensation is detected on the window, a heater or heating mechanism may be activated to dry or evaporate the moisture from the window. The camera thus may be used to control the heaters that are used to remove condensation from the window. Optionally, if heating the window or cleaning the window does not alleviate a detected abnormality (such as if the same abnormality is detected after two or more openings and closings of the housing device), the control may provide an indication to a user of the imaging system that the transparent

window may need to be checked or replaced (in case the abnormality detected is a chip or scratch or crack or the like that may adversely effect the performance of the imaging system).

Because the camera housing device is adjustable and may move the camera, the camera housing device of the present invention may provide the ability to change the field of view. For example, the camera can be moved to the furthest out or fully extended position for an initial approach to a parking zone or target zone or area. As the vehicle further enters the parking zone, the camera can be adjusted or moved to a more vertical angle (by pivoting or moving the housing device partially toward the closed position) to display the proximity of the bumper to any obstacle in the exterior scene. Such an adjustment of the camera position or orientation may also be combined with a change or adjustment of the lens configuration, such as by using a longer focal length for the initial approach (which may provide a less distorted view or image) and a wider angle configuration for the close range viewing to provide a wider field of view to the driver of the vehicle during the back up or reverse driving or maneuvering of the vehicle.

Also, by using the folding adjustment of the camera housing device to adjust the position of the camera, the housing device and camera may be adjustable to provide a different view of the area behind the vehicle. The control of the imaging system may then be operable to process images captured in each of the views and may compare the images to determine distances to objects detected in the exterior scene (such as by utilizing principles disclosed in U.S. Pat. No. 6,396,397; and/or in U.S. pat. application, Ser. No. 10/427,051, filed Apr. 30, 2003 by Pawlicki et al. for OBJECT DETECTION SYSTEM FOR VEHICLE (Attorney Docket DON01 P-1075), which are hereby incorporated herein by reference). By electronic comparison of the images captured between two positions of the camera (capturing at least one image in each of the two views), a distance map can be produced. Such a distance map may then be used to provide additional information about the exterior scene to the driver of the vehicle.

Optionally, the housing may not be restricted to one camera and may instead house or include two cameras for different imaging situations. For example, a standard color camera could be used for daylight conditions, while an infrared camera may be used for night or darkened conditions. The infrared or night camera may comprise a CMOS camera or the like without color or infrared filtering, such that it may be highly sensitive to infrared light that is present in the visibly darkened scene. The control may selectively activate the appropriate camera or imaging sensor in response to the ambient light level or intensity present at the exterior scene, such as in response to an ambient light sensor or in response to a light

detection by one or both of the imaging sensors or the like. When the night camera is operated or used, the control may also activate (such as continuously activate or pulse) an infrared or near infrared illumination source at the exterior portion of the vehicle (such as within the compartment of the housing device, as discussed above). Optionally, a single
5 camera or imaging sensor may be switched between a color mode and a monochromatic mode (such as described below with respect to imaging system 310), and an infrared illumination source may be activated when in the monochromatic mode, to enhance the performance of the camera or imaging sensor in various lighting conditions.

Although shown as being positioned at a rearward portion of a vehicle, the camera
10 housing device of the present invention may be positioned elsewhere on the vehicle, such as a forward portion of the vehicle or a sideward portion of the vehicle or a roof portion of the vehicle or the like, without affecting the scope of the present invention. Also, although the camera housing device is shown as being mounted on a nearly vertical body portion of the vehicle, the camera housing device may be mounted or positioned at a nearly horizontal
15 surface (such as may be found in the top of a number plate appliqué or the like), without affecting the scope of the present invention. In such a horizontal mounting application, the flap of the housing device may drop down to expose the clear window and to move the camera into its operational position.

Referring now to FIGS. 22 and 23, a camera housing device 210 holds or contains a
20 camera or imaging device 216 and is movably mounted to an exterior portion 8a of a vehicle. The housing device 210 is movable to move the camera 216 (and associated lens 217) between a stored position (FIG. 22) and an operational position (FIG. 23). Housing device 210 includes a housing portion 219 that defines the cavity or compartment 214 within an outer panel or flap 218, an inner panel 220 and side panels 222 (one side panel is shown in
25 FIGS. 22 and 23). A transparent cover 224 may close a portion of the cavity and may be positioned generally in front of the imaging device, such that imaging device has a field of view through the transparent window or panel and toward the exterior scene, as discussed above. Housing device 210 is generally linearly slidable relative to the exterior portion 8a of the vehicle (such as via a linear motor, an electromagnetic device or solenoid, a pneumatic
30 device and/or the like) to extend outward from the exterior portion of the vehicle when in the operational position, as shown in FIG. 23.

The housing device 210 thus may be generally linearly moved outward and inward relative to the vehicle portion 8a. Accordingly, the transparent panel 224 may be a substantially flat or planar panel, such that the wiper device 226 (such as a wiper blade or the

like on a spring or biasing member or the like 226a) may engage and wipe the surface 224a of the panel 224 as the panel is moved along adjacent to the wiper device 226. Optionally, the housing device 210 may be generally tubular or even generally cylindrical in shape, such that the transparent panel is curved, while the wiper device is correspondingly curved to

5 substantially uniformly engage the curved or tubular transparent panel as the housing device is moved between the stored and operational positions. The wiping motion of the wiper on the transparent window or panel may thus be achieved by making the camera housing device a generally tubular construction that slides in and out in a generally linear motion, whereby the wiper can then clean the transparent window as the housing device moves in and out. The

10 housing device 210 may otherwise be substantially similar to the housing device 110, 110', discussed above, such that a detailed discussion of the housing device will not be repeated herein.

Therefore, the present invention provides a camera housing device that contains a camera and lens of an imaging system at or partially within an exterior portion of a vehicle.

15 The camera housing device is movable or adjustable to move the camera between an operational position and a stored position. The camera thus may be positioned in a stored position within an exterior portion of the vehicle when not in use. The exterior panel of the camera housing may provide an exterior cover at the exterior portion of the vehicle to protect the camera and lens from the elements when they are not in use. The housing device may

20 include a transparent panel that substantially encloses the camera and lens within the housing. The housing device may also include a panel cleaning device that may clean the transparent panel to limit or substantially preclude dirt buildup or debris on the panel that may adversely effect the performance of the camera and thus of the imaging system.

Referring now to FIGS. 24-26, an image capture system or imaging or vision system

25 310 is positioned at an exterior portion of a vehicle, such as at a rearward portion 8a of the vehicle 8 (FIGS. 1 and 2), and is operable to capture an image of a scene occurring exteriorly of the vehicle, such as rearwardly of the vehicle, and to display the image at a display or display system 314 of the vehicle which is viewable by a driver of the vehicle. Image capture system 310 includes an image capture device or camera 316 (such as a camera or camera

30 module of the types described above), which is directed exteriorly of the vehicle and has an exterior field of view which at least partially encompasses a "blind spot" area exteriorly of the vehicle. The images or frames captured by image capture device 316 are displayed at display 314 to assist the driver in viewing the blind spot areas, such as the rearward area immediately behind the vehicle for backing up or otherwise driving or maneuvering the vehicle. The

image capture system 310 may include one or more auxiliary illumination sources 318 (FIG. 26), which may be selectively operable to provide illumination within the field of view of the image capture device 316 to enhance the illumination of the exterior scene. The image capture system 310 may also include a control or control system or microcontroller or microprocessor 320 for controlling or adjusting the image capture device and/or the illumination sources in response to the light levels in the general vicinity of the imaging system or in response to the contrast ratio in the captured image. For example, the microcontroller may selectively activate one or more illumination sources or LEDs 318, or may selectively switch the imaging sensor 316 from a color mode to a monochromatic or black and white mode, or may apply an infrared or near infrared contribution correction to the color levels of the pixels of the imaging sensor to adjust the color balance for better color rendition in the captured images, in response to the ambient light levels or contrast ratio, as discussed below.

Image capture system 310 may be positioned at the exterior portion of the vehicle and directed generally exteriorly of the vehicle for capturing images of the exterior scene to assist the driver in maneuvering or driving the vehicle. Image capture system 310 may utilize principles of other vehicle vision or imaging systems, such as a forwardly, sidewardly or rearwardly directed vehicle vision system or imaging system or the like utilizing principles of the systems disclosed in U.S. Pat. Nos. 5,550,677; 5,670,935; 5,760,962; 5,796,094; 5,877,897; 5,949,331; 6,097,023; 6,201,642; 6,222,447; 6,302,545; 6,313,454; 6,320,176; 6,353,392; 6,396,397; 6,498,620; 6,523,964; 6,559,435; and 6,611,202, and U.S. pat. applications, Ser. No. 09/441,341, filed Nov. 16, 1999 by Schofield et al. for VEHICLE HEADLIGHT CONTROL USING IMAGING SENSOR (Attorney Docket DON01 P-770); Ser. No. 10/427,146, filed Apr. 30, 2003 by Schofield et al. for VEHICLE HEADLIGHT CONTROL USING IMAGING SENSOR (Attorney Docket DON01 P-1091); Ser. No. 09/199,907, filed Nov. 25, 1998 by Bos et al. for WIDE ANGLE IMAGE CAPTURE SYSTEM FOR VEHICLE (Attorney Docket DON01 P-676); Ser. No. 10/372,873, filed Feb. 24, 2003 by Schofield et al. for VEHICLE IMAGE CAPTURE SYSTEM (Attorney Docket DON01 P-1077); Ser. No. 10/011,517, filed Nov. 5, 2001 by Bos et al. for INTERIOR REARVIEW MIRROR SYSTEM INCLUDING A FORWARD FACING VIDEO DEVICE (Attorney Docket DON01 P-934); Ser. No. 10/324,679, filed Dec. 20, 2002 by Schofield et al. for VEHICULAR VISION SYSTEM (Attorney Docket DON01 P-1059); Ser. No. 10/047,901, filed Jan. 14, 2002 by Bos et al. for VEHICLE IMAGING SYSTEM WITH ACCESSORY CONTROL (Attorney Docket DON08 P-949); Ser. No. 10/643,602, filed

Aug. 19, 2003 by Schofield et al. for VISION SYSTEM FOR A VEHICLE INCLUDING IMAGE PROCESSOR (Attorney Docket DON01 P-1087); and Ser. No. 10/010,862, filed Dec. 6, 2001 by Bos for PLASTIC LENS SYSTEM FOR VEHICLE IMAGING SYSTEM (Attorney Docket DON01 P-954), which are hereby incorporated herein by reference. The
5 imaging system may be operable to captures images of the scene immediately rearward of the vehicle to assist the driver of the vehicle in backing up or maneuvering the vehicle in reverse. The back up assist system may be operable in response to the reverse gear of the vehicle being selected.

Image capture device or camera or imaging sensor 316 may comprise an imaging
10 array sensor or a pixelated imaging array, such as a multi-pixel array such as a CMOS sensor or a CCD sensor or the like, such as the types disclosed in commonly assigned U.S. Pat. Nos. 5,550,677; 5,670,935; 5,796,094; 6,097,023; and 6,498,620, and U.S. pat. applications, Ser. No. 09/441,341, filed Nov. 16, 1999 by Schofield et al. for VEHICLE HEADLIGHT CONTROL USING IMAGING SENSOR (Attorney Docket DON01 P-770); and Ser. No.
15 09/793,002, filed Feb. 26, 2001 by Schofield et al. for VIDEO MIRROR SYSTEMS INCORPORATING AN ACCESSORY MODULE (Attorney Docket DON01 P-869), which are hereby incorporated herein by reference, or such as an extended dynamic range camera, such as the types described above. For example, the imaging sensor may comprise a CMOS camera, such as the OV7930 single chip CMOS color NTSC camera available from
20 OmniVision Technologies Inc. of Sunnyvale, CA. Such color cameras may have the performance characteristics identified above and may additionally provide RGB and/or YCrCb video signals. Preferably, the color video camera operates at a minimum illumination (3000 K) of less than about 5 lux at f1.2, more preferably of less than about 3 lux at f1.2, and most preferably less than about of less than about 2 lux at f1.2. Such CMOS imaging sensors
25 typically may have a peak sensitivity in the near infrared range, such as at approximately 850 nm to 900 nm.

Such pixelated imaging sensors may include a plurality of pixels, with at least some of the pixels masked or covered with a particular color filter, such that the individual pixels function to capture a particular color, such as red, green and blue colors or the like, such as
30 disclosed in U.S. Pat. Nos. 5,550,677; 5,670,935; 5,796,094; 6,097,023; and 6,498,620, referenced above. For example, the imaging sensor 16 may comprise an individual blue or a green or a red color filter over each pixel element of the CMOS multi-pixel element array. The imaging sensor is thus operable to provide color images to the display. Such RGB filters enable the capture of a color image by the CMOS detector, but necessarily result in a reduced

or decreased low light level sensitivity for a color camera compared to a monochromatic or black and white camera. Optionally, and preferably, the imaging sensor may be capable of selectively operating in either a color mode, in which a color image may be displayed on display 314, or a monochromatic or black and white mode, in which a monochromatic or black and white image may be displayed on display 314, such as by utilizing aspects of the imaging sensor disclosed in U.S. Pat. No. 6,498,620, which is hereby incorporated herein by reference.

In the illustrated embodiment of FIGS. 26, the image capture device 316 is at least partially contained within an imaging module or camera module 322, which includes imaging sensor or camera 316 and a lens 324 positioned within a housing (such as similar to housing 11 of camera module 10, discussed above) which defines a transparent window 322a (which may comprise an at least substantially transparent glass or polycarbonate or acrylic (or other suitable material) window or panel) at the end of lens 324 (such as described above with respect to camera module 10, 10'). The imaging module 322 may include the circuitry and controls for imaging sensor 316, such as on one or more printed circuit boards 322b (FIG. 26) contained within the housing. The imaging module 322 is shown in FIG. 26 without the housing for purposes of clarity.

As shown in FIG. 26, imaging module 322 may be positioned at or adjacent to a plurality of illumination sources 318 to define an imaging system module 323. The illumination sources 318 may be operable to emit or project illumination in the general direction that the imaging sensor 316 and lens 324 are directed. Preferably, the illumination sources project or emit substantially uniform illumination directly behind the vehicle where the vehicle back up lights do not typically provide adequate illumination. The illumination sources may be selected to provide sufficient intensity over the targeted area to maintain the minimum acceptable contrast ratio (such as about 18 dB) in the displayed images.

The illumination sources 318 may comprise infrared or near infrared emitting light emitting diodes (LEDs) or the like and thus may emit light or energy in the infrared or near infrared range (such as energy having a wavelength of approximately 750 nm or greater). The infrared illumination may be provided via pulsing the illumination sources or generally continuously activating the illumination sources. An exemplary near-infrared emitting LED to use in conjunction with the imaging system of the present invention is available from Lumex Inc. of Palatine, Ill. under the trade name OED-EL-1L2. This is a T-5mm, leaded, clear epoxy - 60 degree LED that emits essentially no visible light but that has a peak spectral emission of about 940 nm. Forward current through such infrared LEDs is typically less than

about 150 mA, more preferably less than about 100 mA, and most preferably less than about 80 mA. Power consumption by such infrared LEDs is typically less than about 350 mW, more preferably less than about 250 mW, and most preferably is less than about 150 mW. Such LEDs can be powered by duty cycling, such as by pulse width modulation or by direct
5 current drive (typically via a load dropping resistor in series with the vehicle ignition supply). Other near-infrared light emitting diodes or the like can be used, such as LEDs with a peak light emission intensity at about 730 nm, at about 780 nm, at about 875 nm, and at about 880 nm. Spectral output for such near-infrared LEDs is preferably in the 5 mW/sr to about 35 mW/sr range. Such near-infrared light emitting diodes emit little or no visible light.

10 The infrared or near infrared illumination thus may provide improved camera pixel responsivity in low light levels, and the projected infrared or near infrared illumination is not readily visible directly behind the vehicle when the illumination sources are activated. The wavelength of the illumination emitted by the illumination sources may be selected to best balance the camera spectral response and to minimize ambient lighting affects in the captured
15 image. Optionally, auxiliary illumination sources may be selected that emit visible light, as discussed below. Optionally, additional visible light sources (such as visible light emitting LEDs or an incandescent source or a neon source or the like) can illuminate on occasions at night when the driver wants to have visible light illumination of the area immediately exteriorly of the vehicle. Optionally, the auxiliary illumination may be provided via
20 activation of modified back up lights, which may provide visible or infrared or near infrared illumination at the area immediately rearward of the vehicle, such as when the vehicle is shifted to the reverse gear.

With reference to FIG. 25, imaging system 310 includes microcontroller 320, which is operable to control imaging sensor 316 and auxiliary illumination sources 318. The
25 microcontroller 320 may receive an input signal from one or more ambient light sensors 326, which are operable to detect the ambient light levels within the exterior scene. The microcontroller may provide an active camera control and may be operable to adjust or control the imaging sensor and/or the illumination sources in response to the ambient light levels present in the exterior scene. Optionally, the microcontroller may process the captured
30 image to determine the contrast ratio in the images. The microcontroller may then adjust or control the imaging sensor and/or the illumination sources in response to the contrast ratio in order to maintain the image display contrast ratio at a minimum acceptable viewing contrast ratio. For example, the microcontroller may activate or increase the illumination output of

the illumination sources to increase the contrast ratio in the captured images to a desired or threshold minimum ratio or level, such as approximately 18 dB.

The imaging sensor 316 may receive or capture images via imaging lens 324 and a bandpass filter 328, all of which may be positioned behind the transparent window of camera module 322. The images captured by imaging sensor 316 may be received by an image processor 330 and data translator 332, which may process the images or pixel outputs as desired. For example, the image processor 330 and data translator 332 may be operable to process the images to determine if an object is present in the detected image, such as by utilizing the principles disclosed in U.S. pat. application, Ser. No. 10/427,051, filed Apr. 30, 2003 (Attorney Docket DON01 P-1075), which is hereby incorporated herein by reference, or may process the captured images to extract other information therefrom, without affecting the scope of the present invention. The data translator 332 may also receive inputs 333 pertaining to vehicle data or vehicle status data or the like. The images captured may be displayed at the display or display system 314, and/or the processed images or information derived or extracted from the processed images may be displayed at the display or display system 314.

During normal day time conditions or high ambient light conditions (for example, when the ambient light sensor or sensors 326 detect an ambient light level which is greater than a threshold light level or when the microcontroller determines that the contrast ratio of the captured images is greater than the minimum acceptable viewing contrast ratio), imaging sensor 316 may provide color images which provide a color rendition consistent with the driver's expectations (in other words, consistent with real world colors). The imaging sensor or camera may be switched or set to a color mode when ambient light levels are at or increase to a sufficient level at or above a minimum or threshold level, and thus may capture color images and may provide color images to the display system during such lighting conditions. The camera or system may also include an automatic color balance algorithm which may function to adjust or optimize the colors in the captured image to the visible spectrum of light, as discussed below.

As disclosed in U.S. Pat. Nos. 5,550,677; 5,670,935; 5,796,094; 6,097,023; and 6,498,620, and U.S. pat. applications, Ser. No. 09/441,341, filed Nov. 16, 1999 by Schofield et al. for VEHICLE HEADLIGHT CONTROL USING IMAGING SENSOR (Attorney Docket DON01 P-770); and Ser. No. 09/793,002, filed Feb. 26, 2001 by Schofield et al. for VIDEO MIRROR SYSTEMS INCORPORATING AN ACCESSORY MODULE (Attorney Docket DON01 P-869), which are hereby incorporated herein by reference, the pixels of the

imaging array sensor 316 may be individually operable to measure a particular color or range of color (such as red, green and blue) in the visible spectrum to determine the color image. Any near infrared radiation or infrared radiation that is received by the pixels may add to the measured value of the particular color that the particular pixel senses or accumulates. This results in a shift in the representation in the color of the captured image and may result in an image having unsatisfactory or unrepresentative color. Optionally, and as discussed below, the band pass filter 328 of the imaging system may comprise an infrared or near infrared filter, which may filter out or substantially block light in the infrared and/or near infrared range of the spectrum, such as light having wavelengths in the approximately 750 to 900 nm, and preferably blocking or reducing transmission of some light in the visible region of the electromagnetic spectrum so that band pass filter 328 passes (i.e. is highly transmitting to) visible wavelengths up to about 650 nm or thereabouts, but has reduced transmission above about 650 nm and, in particular, has substantially reduced transmission in the near infrared region.

In order to correct the color balance in the captured images, the image capture system of the present invention may subtract fixed values from the particular color values (e.g., red, green, blue) of each pixel, such that the imaging system may provide an infrared or near infrared contribution correction in situations where the infrared or near infrared light present in the scene (such as from solar radiation) may otherwise washout or distort or otherwise adversely affect the color balance of the captured images. The offset or subtracted values may be a generally fixed intensity offset or value or may be based on the ambient light levels detected by the ambient light sensor or by a combination of pixels of the imaging sensor or the like.

Optionally, the infrared radiation present in the exterior scene may be measured, such as via an infrared sensor positioned at the lens 324, imaging sensor 316 or window 322a of camera module 322. The measured infrared radiation may be factored into the infrared contribution correction amount to provide an improved and dynamic correction for the pixels. It is further envisioned that the offset for the particular colors (e.g., red, green, blue) may be different between the colors (for example, in certain lighting conditions, there may be more of an offset for one color, such as, for example, red, than the other color or colors, such as green and blue). The imaging system may thus provide a detection of the infrared radiation and may provide a dynamic correction of each pixel color. The imaging system thus may provide a sensor driven offset or correction. The sensor or sensors may comprise an infrared sensor (with a visible light filter) by itself or in combination with a second sensor which

senses visible light (with an infrared filter), to determine the infrared level or intensity in the exterior scene.

Optionally, some of the pixels of the imaging array sensor 316 may be unmasked or unfiltered, such that they capture or accumulate the entire spectrum of light (or at least substantially the entire spectrum of light) present in the scene. The unmasked pixels thus are
5 dedicated to sensing the visible and infrared light present in the exterior scene and may provide a basis for determining the offset that is to be applied to the color value of the masked pixels. In such an embodiment, the image capture device would not include an infrared filter, or at least not an infrared filter over the entire pixelated array (however, an
10 infrared filter at the pixel level may be provided, such as an infrared filter at each of the individual color pixels, which also include a mask or filter associated with the particular color that the individual pixel is to capture).

The imaging sensor 316, which may comprise a CCD or CMOS camera or the like, may thus operate sufficiently well with its factory settings at illumination levels between a
15 few lux and several thousand lux (such as may be present in normal indoor lighting conditions). When the available ambient illumination is below these levels, however, the camera may have a difficult time distinguishing features in the captured image as compared to the background noise of the camera, and thus may not be able to maintain the minimum contrast ratio during such low light levels. To address this deficiency, the auxiliary
20 illumination sources 318 may be selectively activated to project auxiliary illumination throughout the field of view of the camera, in order to provide sufficient illumination levels for the camera to operate properly. The illumination sources may be selectively activated or controlled by the microcontroller in response to the ambient light levels detected by ambient light sensor or sensors 326 or by imaging sensor 316 (such as in response to a detection that
25 the ambient light level has dropped or reduced to a threshold reduced light level), or in response to the contrast ratio in the captured image (such as in response to the contrast ratio being less than a desired or threshold amount, such as approximately 18 dB).

Optionally, the auxiliary illumination sources 318 may emit or project or provide visible light to the exterior scene. In such applications where visible light is provided by the
30 auxiliary illumination sources (or where sufficient visible light may be provided by the backup lights or other lights or illumination sources of the vehicle), the band pass filter 328 may comprise an infrared or near infrared filter (or visible light pass filter) and may provide a cutoff or block at approximately 650 nm, such that the near infrared and infrared spectral regions (and preferably a portion of the visible light region of the spectrum) are limited or

blocked from the imaging sensor or camera 316. Because greater visible illumination may thus be provided via the illumination sources in low ambient light conditions, while the infrared and near infrared illumination present in the exterior scene may be filtered or substantially blocked, the imaging system may be capable of capturing images during such lighting conditions which may have acceptable color balance, or which may require a reduced amount of processing or color adjustment to achieve the appropriate or acceptable color balance and contrast ratio. The filter pass or cutoff wavelength range may be selected to tailor the filter cutoff wavelength to the particular application (depending on the illumination provided to the exterior scene and the capabilities of the imaging sensor). The imaging system thus may provide improved imaging capabilities in low light conditions, while providing an appropriate color balance and contrast ratio for the images captured in all ambient lighting conditions.

In applications where the auxiliary illumination source or sources comprise infrared or near infrared illumination sources or LEDs, the microcontroller may switch the color camera from the color mode (where the camera captures color images and the display displays color images) to a monochromatic or black and white mode (where the camera captures monochromatic images). The microcontroller may switch the imaging sensor to the black and white mode in response to the ambient light level dropping to the threshold level or in response to the illumination sources being activated. Such a monochromatic mode is preferred in reduced visible lighting conditions and/or when the infrared emitting illumination sources are activated because the automatic color balance algorithm of the imaging system functions to optimize the color in the captured image to the visible spectrum, and may not function as well in such infrared or non-visible lighting conditions. Once the infrared or near infrared illumination is introduced by the illumination sources, the color balance control may be insufficient, which may result in a washed out or distorted image. The black and white image provided by the black and white mode may thus be more pleasing for viewing by the driver of the vehicle during such lighting conditions. The image sensor may quickly switch between the color mode and black and white mode and may provide a smooth transition from one mode to the other.

With reference to FIG. 25, the following illustrates the sequence of events that may trigger or initiate the low-light mode of the imaging system of the present invention. The microcontroller 320 may read or receive an output from one or more ambient light sensors 326, which may be positioned at or near imaging sensor 316 and which may be operable to detect or sense the ambient light present in the exterior scene. The microcontroller may also

determine the contrast ratio of the images being captured by the imaging sensor. When the ambient light levels are determined to be below a low-light mode calibrated value or threshold value (or when the contrast ratio drops below the threshold level), the microcontroller may then initiate new commands to the imaging sensor or camera 316, such as via an I2C serial link or the like. The new register commands may consist of defeating the automatic gain, exposure and color modes of the imaging sensor 316. The exposure may be set to maximum frame integration time and the amplifier gain may, for example, be set to ½ maximum. This combination provides an enhanced or optimal signal to noise ratio for such lighting conditions.

10 The microcontroller may enter the monochromatic or color defeat mode, whereby the microcontroller may select either a single color kill register or a combination of modifying the color matrix registers to negate the color balance of the imaging sensor. The microcontroller may also enable the infrared LEDs via a logic control signal or the like, so that infrared or near infrared illumination is provided to the exterior scene. The low light mode camera settings may then be maintained until one or more of the ambient light sensors returns values or signals to the microcontroller which are above or outside the calibrated or threshold low-light mode range. Once this occurs, the imaging sensor may be set to the color mode and the above mentioned registers may be again updated with new values, and the illumination sources or LEDs may be disabled. The imaging sensor, such as a CMOS camera or the like, may implement the register updates within approximately two frame times (i.e., the time it takes to capture two consecutive frames or images), which may be within approximately 66 ms, depending on the particular imaging sensor used with the imaging system of the present invention.

25 Because the imaging system of the present invention may correct for washout or distortion in the color values to account for infrared and near infrared illumination in the exterior scene, and because the imaging system may switch to a monochromatic mode when conditions darken and/or when the illumination sources are activated, the present invention may obviate the need or desirability of providing an infrared filter at the imaging sensor, since such a filter may filter out some of the infrared or near infrared illumination provided by the illumination sources when the imaging system is in the low light mode. However, it is envisioned that such a band pass filter or infrared filter element may optionally be provided at the imaging sensor to attenuate at least some of the infrared radiation that may be present in the exterior scene. For example, an infrared filter may be provided that is highly transmitting (such as an integrated photopic visible transmission of at least about 75% transmitting, more

preferably at least about 80% transmitting, and most preferably at least about 85% transmitting) in the visible light region between about 300 nm and 800 nm (where the eye's photopic response is sensitive), and more preferably in the 400 nm to 700 nm spectral range, and that has a lower or reduced transmissivity or is lowly transmitting in the 800 nm to 1100 nm region (at least) with a spectral transmission in the 750 nm to 1100 nm of less than about 5% transmission preferred, less than about 3% more preferred, and less than about 1% most preferred. Such infrared filter elements typically consist of a transparent substrate (typically glass) coated with a multilayer stack (typically at least three layers, more preferably at least five layers, most preferably at least seven layers, and typically deposited by vacuum deposition such as by sputtering or evaporation) of metal oxides and similar dielectric thin film layers that form a broad band visible band pass filter with a sharp spectral cut off around 700 nm or so. Such infrared filters typically operate by light interference, and preferably act as cold mirrors reflecting away near-infrared radiation while being highly transmitting to visible light. An example of an infrared filter element suitable for use with the imaging system of the present invention is available from Maier Photonics, Inc. of Manchester Center, VT under the part designation "p/n SP730/14s". This filter element has a 50% cut-off at +/- 10 nm at normal incidence, and comprises a 1 mm thick soda-lime glass substrate. Alternately, a WBHM infrared filter element available from OCLI of Santa Rosa, CA can be used (which has an average transmission equal to or greater than 80% from approximately 400 nm to 700 nm and an average transmission less than or equal to 2% from approximately 750 nm to 1100 nm). Also, an infrared filter element from Evaporated Coatings, Inc. of Willow Grove, PA comprising a Corning Micro-Sheet Glass 0211 coated with ECI#1010 can be used. This filter element has an average transmission equal to or greater than 85% at 400 nm to 700 nm; a partial transmission of about 80% at 740 nm (+/- 10 nm); a partial transmission of about 50% at 750 nm (+/- 10 nm); and an average transmission of less than about 3% at 780 nm to 1100 nm. Such infrared filter elements are abrasion resistant per MIL-C-675A, which is hereby incorporated by reference herein. Such infrared filters may be disposed in the camera assembly in front of the CMOS or CCD imaging array sensor (either in front of the camera lens or between the camera lens and the video detector array).

However, a problem can arise when a camera equipped with an infrared element as described above is used in conjunction with near infrared light emitting sources such as those also described above. The near infrared cut off of the camera filter may also severely attenuate and/or block the near infrared radiation emitted by the near infrared LEDs (or similar near-infrared emitting sources) such that nighttime illumination may be inadequate to

be useful/valued by the driver. In order to avoid such concerns, while still providing such an infrared filter, the infrared filter and illumination sources may be selected such that at least some of the infrared illumination emitted by the illumination sources is not filtered or blocked by the infrared filter. For example, the filter may be selected that may cut out or substantially block radiation having wavelengths above approximately 950 nm, while the illumination source may emit light having wavelengths of approximately 800 nm to 900 nm. Optionally, and as discussed above, the auxiliary illumination sources may be operable to emit or project visible light to provide adequate visible illumination to the exterior scene, whereby the infrared and near infrared light may not be required by the imaging sensor (and thus may be filtered or blocked, such as at a wavelength of approximately 650 nm and above) in order to provide appropriate clarity and color balance in the images captured by the imaging sensor.

Optionally, it is further envisioned that the imaging system may function to remove the infrared filter from in front of the imaging sensor when the infrared illumination sources are activated, such as described in U.S. pat. application, Ser. No. 09/793,002, filed Feb. 26, 2001 by Schofield et al. for VIDEO MIRROR SYSTEMS INCORPORATING AN ACCESSORY MODULE (Attorney Docket DON01 P-869), which is hereby incorporated herein by reference. For example, at nighttime when ambient lighting is low and the infrared emitting illumination sources are activated, the infrared filter element may be moved out of the field of view of the lens so that the detector or camera can view unattenuated infrared radiation from the infrared emitting illumination sources so that the output image in the video display is discernable by the driver. Various means can be used to remove the infrared filter element from the camera field of view during nighttime. For example, an electromechanical mechanism, preferably operated by the microcontroller in response to a photo sensor or ambient light sensor, can automatically move the infrared filter element, such as by electrical command, out of the line of sight or field of view of the imaging sensor when the ambient lighting conditions are low.

Optionally, electro-optic means can be used to prevent color wash out by day while maximizing low light sensitivity by night. For example, an electrochromic infrared filter can be used, such as a filter utilizing the principles disclosed in U.S. Pat. No. 6,426,492, and U.S. pat. application, Ser. No. 10/206,558, filed Jul. 26, 2002 by Bos for ELECTRO-OPTIC FILTER FOR VEHICLE IMAGING SYSTEM (Attorney Docket DON01 P-1013), which are hereby incorporated herein by reference. The filter may include a tungsten oxide electrochromic layer that changes from being substantially visible light transmitting and

substantially near-infrared transmitting when uncharged (bleached) and transforms to being significantly near-infrared absorbing/reflecting as well as being significantly visible light attenuating when cathodically charged. The degree of near-infrared attenuation and visible light attenuation is proportional to the negative voltage applied to the electrochromic tungsten oxide metal oxide layer, with applied voltages in the 0.1V to about 2.5V range typical. The higher the cathodic voltage applied, the more the near-infrared/visible light attenuation.

Optionally, the imaging system of the present invention may additionally include a plurality of infrared shutters which are in the optical path the imaging array sensor, such as disclosed in U.S. Pat. No. 6,498,620, which is hereby incorporated herein by reference. Each infrared shutter has at least one state in which infrared energy is generally not attenuated to the imaging sensor. In another state, the infrared shutter generally blocks infrared radiation from the array. The state of the infrared shutters may be controlled by the microcontroller, which may control the shutters in response to the ambient light levels in the exterior scene, such as detected by the ambient light sensor or sensors. During periods of high image luminance, the infrared shutters may switch to a state in which the shutters block near infrared radiation from the imaging sensor. However, during low image luminance conditions, the infrared shutters may switch to a state in which the shutters allow the near infrared energy to be transmitted to the imaging sensor. The addition of the near infrared radiation at low luminance levels enhances the image luminance sensed by the imaging sensor. The imaging sensor may also be switched to the monochromatic or black and white mode during such low luminance levels. The infrared shutters may be either electrochromic shutters or liquid crystal shutters, both of which are known in the art.

Although many aspects of the present invention are particularly suitable for applications having a CMOS type image sensor or camera (due to the high infrared sensitivity of CMOS cameras), other types of cameras or sensors may be implemented, such as CCDs, etc., without affecting the scope of the present invention.

Therefore, the present invention provides an imaging system which may provide enhanced imaging during nighttime conditions, while providing optimal color imaging during daytime conditions. The imaging system may determine the ambient light levels at the exterior scene, such as via ambient light sensors or photosensors, which may be associated with the camera or imaging array sensor, or which may be separate ambient light sensors. When the ambient light levels drop below a threshold level, the color mode of the imaging sensor may be turned off, such that the imaging sensor operates in a monochromatic or black and white mode in such low light conditions, thereby providing an enhanced image to the

display for viewing by the driver of the vehicle. Also, the illumination sources (which are preferably infrared or near infrared illumination sources or LEDs) may be activated when the ambient light levels are low, so as to provide additional, substantially non-visible light to the exterior scene. Optionally, the illumination sources may be activated to illuminate the
5 targeted area to increase the contrast ratio in the displayed images to a desired amount in response to the contrast ratio falling below a minimum acceptable viewing contrast ratio. Because the imaging sensors may then be operating in a black and white mode, the infrared illumination emitted by the illumination sources will not result in washed out or saturated or distorted color images. Also, because the imaging sensor may have a peak sensitivity in the
10 infrared or near infrared range, and because the illumination sources may be infrared emitting sources, the imaging sensor may be capable of capturing images in very low lighting conditions, whereby the illumination for the imaging sensor is provided by the infrared illumination sources.

Optionally, when the imaging sensor is operating in the color mode, the
15 microcontroller may adjust or correct the color balance via an adjustment of the pixel output for each of the color sensing pixels of the pixelated imaging array sensor. The present invention thus may provide a dynamic color balance adjustment function for a vehicular color exterior-viewing camera, such as one viewing rearward of the vehicle or forward of the vehicle or sideways of the vehicle, such as may be achieved by placing the camera module
20 with integrated auxiliary illumination into an exterior rearview mirror assembly with its field of view directed toward and onto a ground surface adjacent the side body of the vehicle (in this regard, and when auxiliary illumination is required, and when the camera-equipped exterior mirror assembly includes a visible light emitting ground illumination/security light, such as are disclosed in 6,276,821; 6,176,602; 5,823,654; 5,669,699; 5,497,306; and
25 5,371,659, which are hereby incorporated herein by reference, the ground illumination/security light may optionally be selectively actuated to add additional auxiliary illumination in certain circumstances, such as when about to or first starting to drive the vehicle from a parked position). Preferably, such dynamic adjustment of color balance is achieved by determination of the level of near-infrared radiation incident the camera module
30 and by using this determined level (via a closed-loop or an open-loop control algorithm) to adjust the color balance and/or other characteristics (such as selection of the monochrome or black and white mode) of the video camera system employed. Other camera functions, such as iris function or exposure function, may optionally be similarly dynamically adjusted

commensurate with a detected ambient near-infrared or other light level at the camera module. The present invention also finds applicability to interior cabin monitoring systems.

Changes and modifications to the specifically described embodiments may be carried out without departing from the principles of the present invention, which is intended to be
5 limited only by the scope of appended claims, as interpreted according to the principles of patent law.

The embodiments of the invention in which an exclusive property or privilege is claimed are defined as follows:

1. An imaging system for a vehicle, said imaging system comprising:
a camera module positionable at the vehicle, said camera module comprising a plastic housing and an imaging sensor, said plastic housing including a first portion and a second portion, said first portion and said second portion being one of laser welded and sonic welded
5 together to substantially seal said image sensor and associated components within said plastic housing; and
a control operable to process images captured by said image sensor.
2. The imaging system of claim 1 including a sealing material at said plastic housing to seal the pores of said plastic housing.
3. The imaging system of claim 1 including a heating element operable to heat at least one of a transparent cover of said housing and an interior chamber of said housing.
4. The imaging system of claim 1, wherein said first portion comprises a connector portion and includes a connector at an end thereof and said second portion comprises a camera portion and includes a transparent cover portion for receiving an image therethrough.
5. The imaging system of claim 4, wherein said transparent cover is one of laser welded and sonic welded to said camera portion.
6. The imaging system of claim 1, wherein said camera module is positioned in a movable housing that is movable relative to an exterior portion of the vehicle to move said image sensor between a stored position generally within the portion of the vehicle and an operational position where said image sensor is positioned to have a field of view exteriorly
5 of the vehicle.
7. The imaging system of claim 6, wherein said movable housing comprises a transparent panel, said transparent panel being positioned at least partially across an opening of said housing and generally in the field of view of said image sensor.

8. The imaging system of claim 7, wherein said movable housing comprises a panel cleaning device positionable at the exterior portion of the vehicle and configured to engage an exterior surface of said transparent panel to clean said transparent panel as said housing moves said image sensor between said stored position and said operational position.
9. The imaging system of claim 7, wherein said housing is configured to receive an illumination source, said illumination source being directable toward the exterior scene when said housing moves said image sensor to said operational position.
10. The imaging system of claim 9, wherein said transparent panel is positioned in front of said illumination source.
11. The imaging system of claim 9, wherein said transparent panel comprises a first transparent panel positioned in the field of view of said image sensor and a second transparent panel positioned in front of said illumination source.
12. The imaging system of claim 1 including at least one illumination source, said control being operable to selectively activate said at least one illumination source in response to a detected ambient light level decreasing to a threshold level.
13. The imaging system of claim 12, wherein said control is operable to apply an infrared contribution correction to the detected levels for at least some of the colors detected by said image sensor to adjust a color balance of said image sensor.
14. The imaging system of claim 12, wherein said at least one illumination source comprises a visible light source, said control being operable to limit or block infrared and near infrared light present in the illuminated scene to reduce processing requirements.
15. The imaging system of claim 12, wherein said control is operable to selectively switch said image sensor from a color mode to a black and white mode in response to the reduced ambient light level.
16. The imaging system of claim 1, wherein said housing includes a ventilation portion, said ventilation portion being at least partially permeable to water vapor to allow water vapor

to pass therethrough while substantially precluding passage of at least one of water droplets and contaminants.

17. An imaging system for a vehicle, said imaging system comprising:
 - a vented camera module, said vented camera module comprising a housing and an image sensor, said housing including a ventilation portion, said housing being configured to receive said image sensor therein, said ventilation portion being at least partially permeable to
 - 5 water vapor to allow water vapor to pass therethrough while substantially precluding passage of at least one of water droplets and contaminants; and
 - a control for processing images captured by said image sensor.
18. The imaging system of claim 17, wherein said ventilation portion comprises a Gore-Tex area.
19. The imaging system of claim 17 including a heating element operable to heat the interior of said housing to limit condensation from forming within said housing.
20. The imaging system of claim 19, wherein said heating element is selectively activatable in response to a signal from a temperature sensor of said imaging system, said signal being indicative of a threshold temperature within said housing.
21. The imaging system of claim 20, wherein said heating element is selectively deactivatable in response to a second signal from said temperature sensor, said second signal being indicative of a second threshold temperature within said housing.
22. The imaging system of claim 19, wherein said heating element is operable to at least one of (a) dry out moisture within said housing and (b) drive out moisture through said ventilation portion.
23. The imaging system of claim 17, wherein said camera module comprises a movable housing that is movable relative to an exterior portion of the vehicle to move said image sensor between a stored position, where said image sensor is positioned generally within the portion of the vehicle, and an operational position, where said image sensor is positioned to
- 5 have a field of view exteriorly of the vehicle.

24. The imaging system of claim 23, wherein said movable housing comprises a transparent panel, said transparent panel being positioned at least partially across an opening of said housing and generally in the field of view of said image sensor.
25. The imaging system of claim 24, wherein said movable housing comprises a panel cleaning device positionable at the exterior portion of the vehicle and configured to engage an exterior surface of said transparent panel to clean said transparent panel as said housing moves said image sensor between said stored position and said operational position.
26. The imaging system of claim 17 including at least one illumination source, said control being operable to selectively activate said at least one illumination source in response to a detected ambient light level decreasing to a threshold level.
27. The imaging system of claim 26, wherein said control is operable to apply an infrared contribution correction to the detected levels for at least some of the colors detected by said image sensor to adjust a color balance of said image sensor.
28. The imaging system of claim 26, wherein said at least one illumination source comprises a visible light source, said control being operable to limit or block infrared and near infrared light present in the illuminated scene to reduce processing requirements.
29. The imaging system of claim 26, wherein said control is operable to selectively switch said image sensor from a color mode to a black and white mode in response to the reduced ambient light level.
30. The imaging system of claim 17, wherein said housing comprises a first plastic portion and a second plastic portion, said first plastic portion being one of laser welded and sonic welded to said second plastic portion to substantially seal said image sensor and associated components within said housing.
31. An imaging system of a vehicle, said imaging system comprising:
an imaging device operable to capture images of a scene occurring exteriorly of the vehicle;

a holding device for movably holding said imaging device, said holding device
5 comprising a housing, a transparent panel and a panel cleaning device, said housing being
movably mountable at an exterior portion of a vehicle, said imaging device being positioned
within said housing, said transparent panel being positioned at least partially across an
opening of said housing and generally in the field of view of said imaging device, said
housing being movable relative to the exterior portion of the vehicle to move said imaging
10 device between a stored position, where said imaging device is positioned generally within
the portion of the vehicle, and an operational position, where said imaging device is
positioned to have a field of view exteriorly of the vehicle, said panel cleaning device being
positionable at the exterior portion of the vehicle and configured to engage an exterior surface
of said transparent panel to clean said transparent panel as said housing moves said imaging
15 device between said stored position and said operational position; and
a control operable to process images captured by said imaging device.

32. The imaging system of claim 31, wherein said housing is pivotably mountable at the exterior portion of the vehicle.

33. The imaging system of claim 31, wherein said housing is slidably mountable at the exterior portion of the vehicle.

34. The imaging system of claim 31, wherein said housing moves said imaging device to said operational position in response to engagement of a reverse gear of the vehicle.

35. The imaging system of claim 31 including a spraying device operable to spray fluid onto said transparent panel.

36. The imaging system of claim 31 including an illumination source that is selectively operable to illuminate the exterior scene.

37. The imaging system of claim 36, wherein said housing is configured to receive said illumination source, said illumination source being directable toward the exterior scene when said housing moves said imaging device to said operational position.

38. The imaging system of claim 37, wherein said transparent panel is positioned in front of said illumination source.
39. The imaging system of claim 38, wherein said transparent panel comprises a first transparent panel positioned in the field of view of said imaging device and a second transparent panel positioned in front of said illumination source.
40. The imaging system of claim 38, wherein said control is operable to selectively activate said illumination source and said imaging device when said imaging device is moved to said stored position to determine if moisture is present on said transparent panel.
41. The imaging system of claim 36, wherein said control is operable to selectively activate said illumination source in response to at least one of (a) said imaging device being in said operational position and (b) a detected ambient light level decreasing to a threshold level.
42. The imaging system of claim 36, wherein said illumination source comprises a visible light source, said control being operable to limit or block infrared and near infrared light present in the illuminated scene to reduce processing requirements.
43. The imaging system of claim 36, wherein said control is operable to apply an infrared contribution correction to the detected levels for at least some of the colors detected by said imaging device to adjust a color balance of said imaging device.
44. The imaging system of claim 31, wherein an outer panel of said housing defines an exterior cover portion at an exterior surface of said exterior portion of the vehicle when said imaging device is moved to said stored position.
45. The imaging system of claim 31 including a display operable to display the image captured by said imaging device.
46. The imaging system of claim 31, wherein said imaging device comprises a color imaging sensor operable to capture color images of the exterior scene and an infrared imaging sensor operable to capture infrared images of the exterior scene, said control selectively

activating one of said color imaging sensor and said infrared imaging sensor in response to
5 the ambient light intensity present in the exterior scene.

47. The imaging system of claim 31, wherein said housing is movable to selectively
position said imaging device in first and second operational positions.

48. The imaging system of claim 47, wherein said control is operable to determine a
distance to at least one object in response to processing of images captured by said imaging
device when in said first and second operational positions.

49. The imaging system of claim 47, wherein said control is operable to selectively move
said housing to position said imaging device at said first operational position in response to
the vehicle making an initial approach to a target zone and to position said imaging device at
said second operational position in response to the vehicle moving further into the target
5 zone, said imaging device being directed more downward when in said second operational
position relative to said first operational position.

50. An imaging system of a vehicle, said imaging system comprising:

an imaging device operable to capture images of a scene occurring exteriorly of the
vehicle;

a holding device pivotally mountable at a portion of a vehicle, said holding device
5 comprising a housing having an exterior panel and a transparent panel, said imaging device
being positioned within said housing, said transparent panel being positioned at least partially
across an opening of said housing and generally in the field of view of said imaging device,
said holding device being pivotable relative to the portion of the vehicle to move said
imaging device between a stored position, where said imaging device is positioned generally
10 within the portion of the vehicle, and an operational position, where said imaging device is
positioned to have a field of view exteriorly of the vehicle, said exterior panel being generally
aligned with an exterior surface of the portion of the vehicle and said transparent panel being
generally within the portion of the vehicle when said imaging device is in said stored
position; and

15 a control operable to process images captured by said imaging device.

51. The imaging system of claim 50, wherein said holding device includes an interior panel that is pivotally mounted at the portion of the vehicle, said interior panel and said exterior panel defining a cavity of said housing for receiving said imaging device.

52. The imaging system of claim 51, wherein said interior panel includes a pivot member that is pivotally attachable to a corresponding pivot portion of the portion of the vehicle.

53. The imaging system of claim 52, wherein said pivot member is pivotally attachable to a corresponding pivot portion of the vehicle that is positioned interiorly of the exterior surface of the portion of the vehicle.

54. The imaging system of claim 50, wherein said holding device includes a cleaning device for cleaning said transparent panel, said cleaning device being positionable at the portion of the vehicle and configured to engage an exterior surface of said transparent panel to clean said transparent panel as said holding device moves said imaging device between
5 said stored position and said operational position.

55. The imaging system of claim 50, wherein said holding device moves said imaging device to said operational position in response to engagement of a reverse gear of the vehicle.

56. The imaging system of claim 50 including an illumination source that is selectively operable to illuminate the exterior scene.

57. The imaging system of claim 56, wherein said holding device is configured to receive said illumination source, said illumination source being directable toward the exterior scene when said holding device pivots said imaging device to said operational position.

58. The imaging system of claim 57, wherein said control is operable to selectively activate said illumination source in response to at least one of (a) said imaging device being in said operational position and (b) a detected ambient light level decreasing to a threshold level.

59. The imaging system of claim 57, wherein said control is operable to selectively activate said illumination source and said imaging device when said imaging device is moved to said stored position to determine if moisture is present on said transparent panel.

60. The imaging system of claim 56, wherein said illumination source comprises a visible light source, said control being operable to limit or block infrared and near infrared light present in the illuminated scene to reduce processing requirements.

61. The imaging system of claim 56, wherein said control is operable to apply an infrared contribution correction to the detected levels for at least some of the colors detected by said imaging device to adjust a color balance of said imaging device.

62. The imaging system of claim 50, wherein said imaging device comprises a color imaging sensor operable to capture color images of the exterior scene and an infrared imaging sensor operable to capture infrared images of the exterior scene, said control selectively activating one of said color imaging sensor and said infrared imaging sensor in response to an
5 ambient light intensity present in the exterior scene.

63. The imaging system of claim 50, wherein said housing is pivotable to selectively position said imaging device in first and second operational positions.

64. The imaging system of claim 63, wherein said control is operable to determine a distance to at least one object in response to processing of images captured by said imaging device when in said first and second operational positions.

65. The imaging system of claim 63, wherein said control is operable to selectively move said housing to position said imaging device at said first operational position in response to the vehicle making an initial approach to a target zone and to position said imaging device at said second operational position in response to the vehicle moving further into the target
5 zone, said imaging device being directed more downward when in said second operational position relative to said first operational position.

1/18

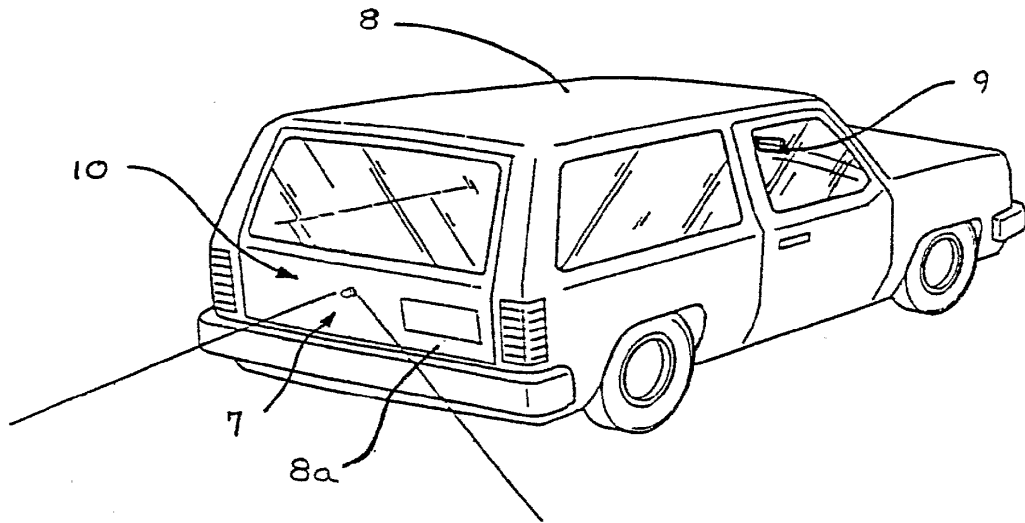

Fig. 1

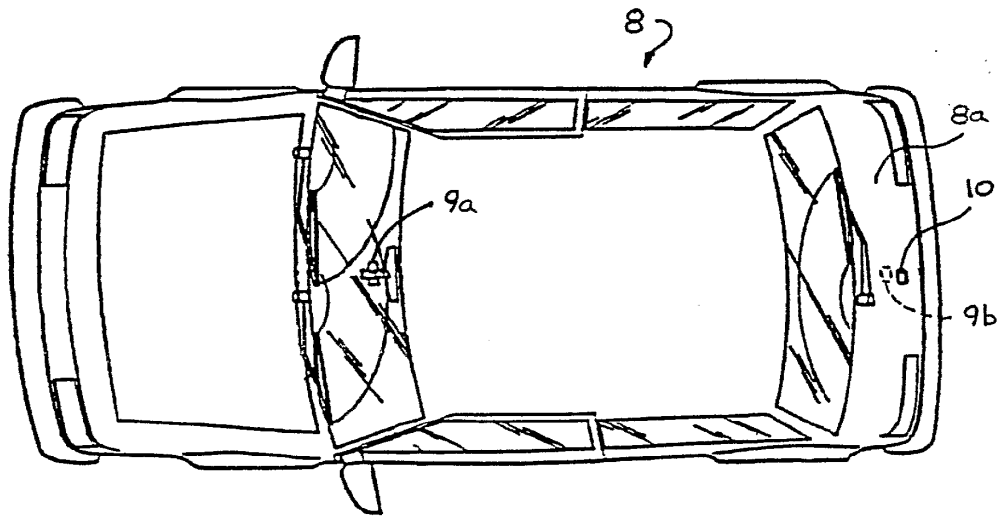

Fig. 2

3/18

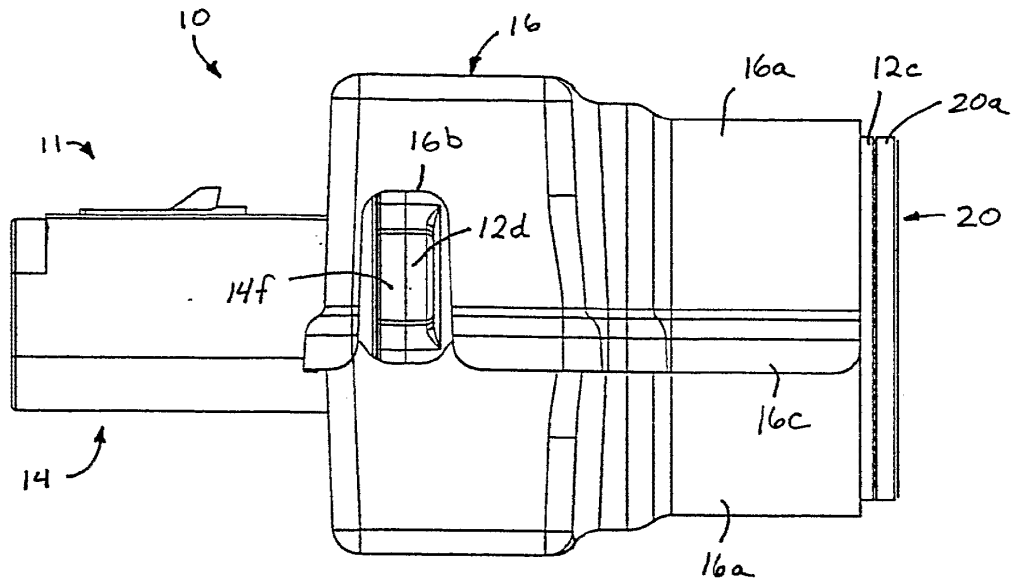

Fig. 4

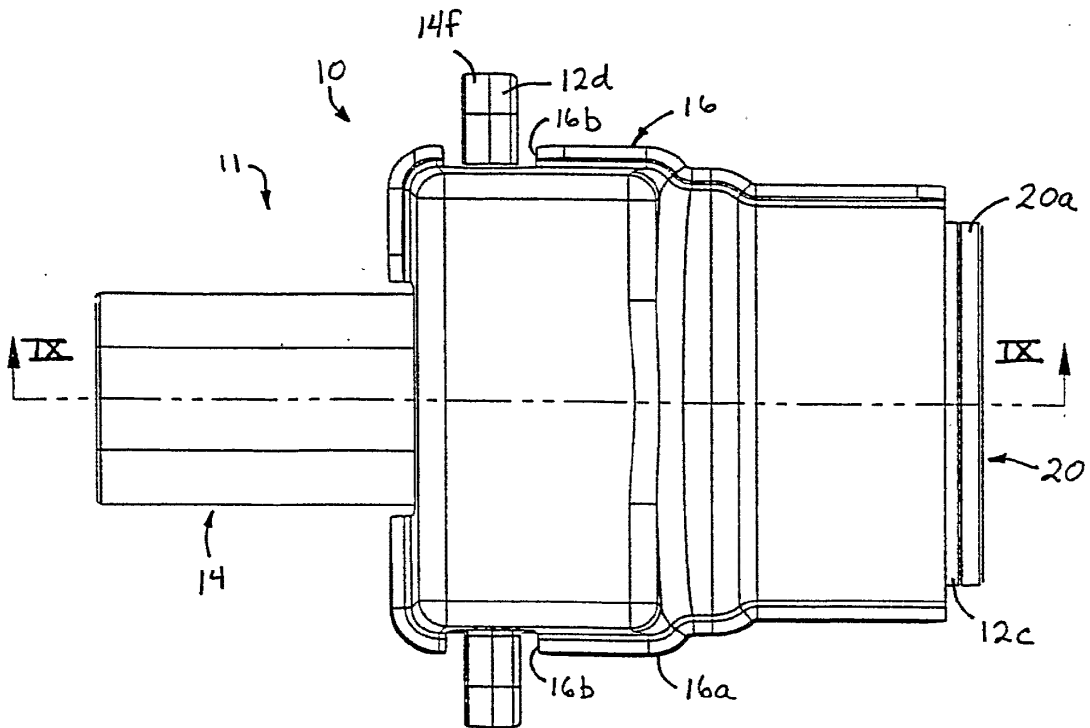
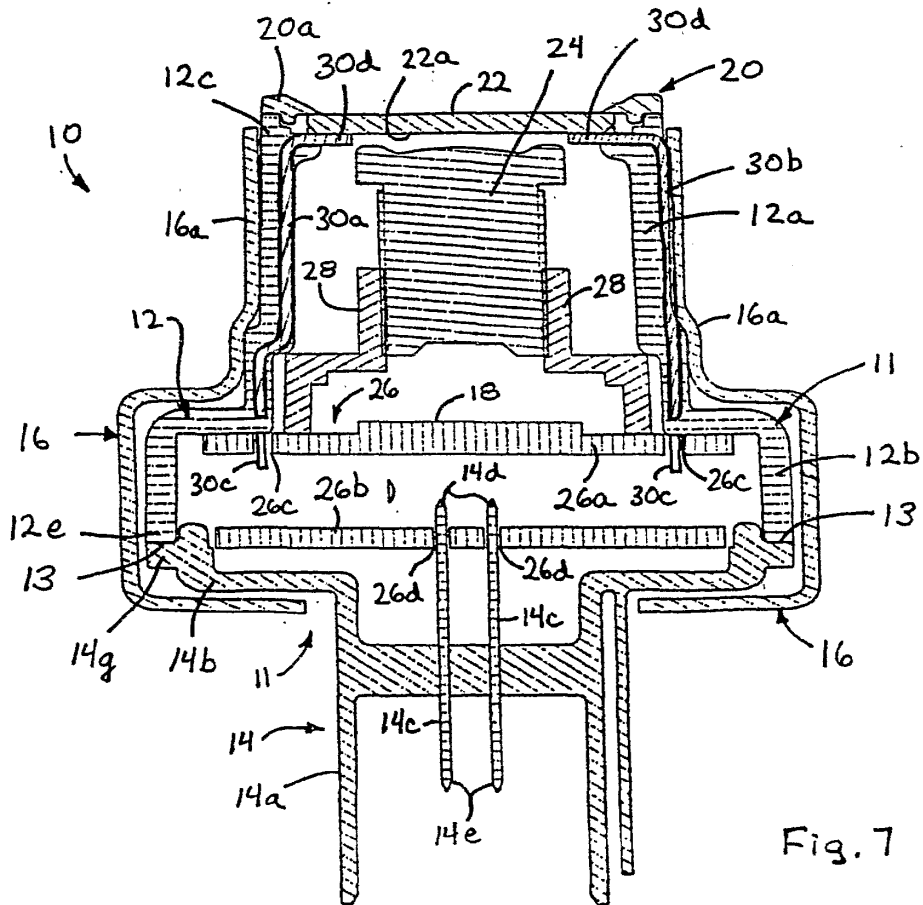
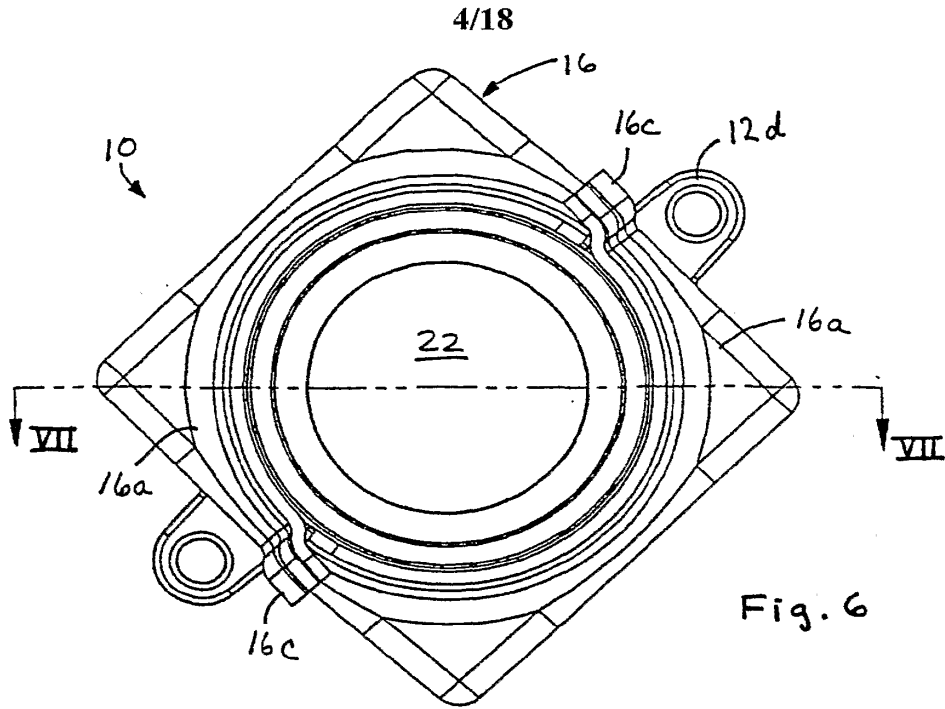

Fig. 5



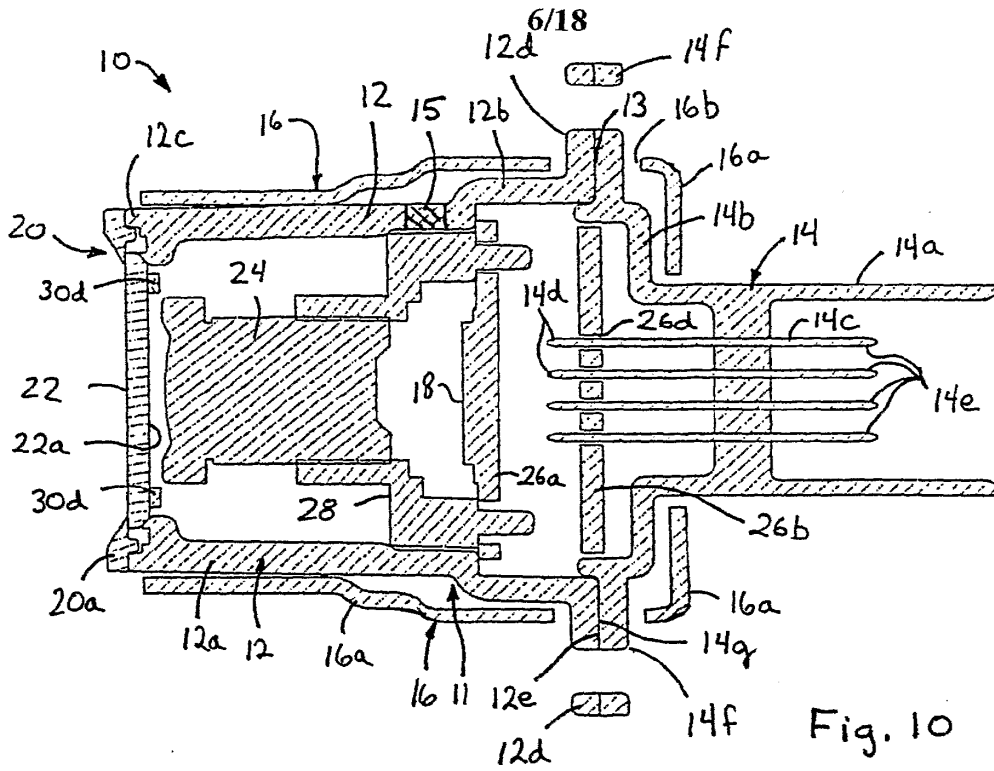

Fig. 10

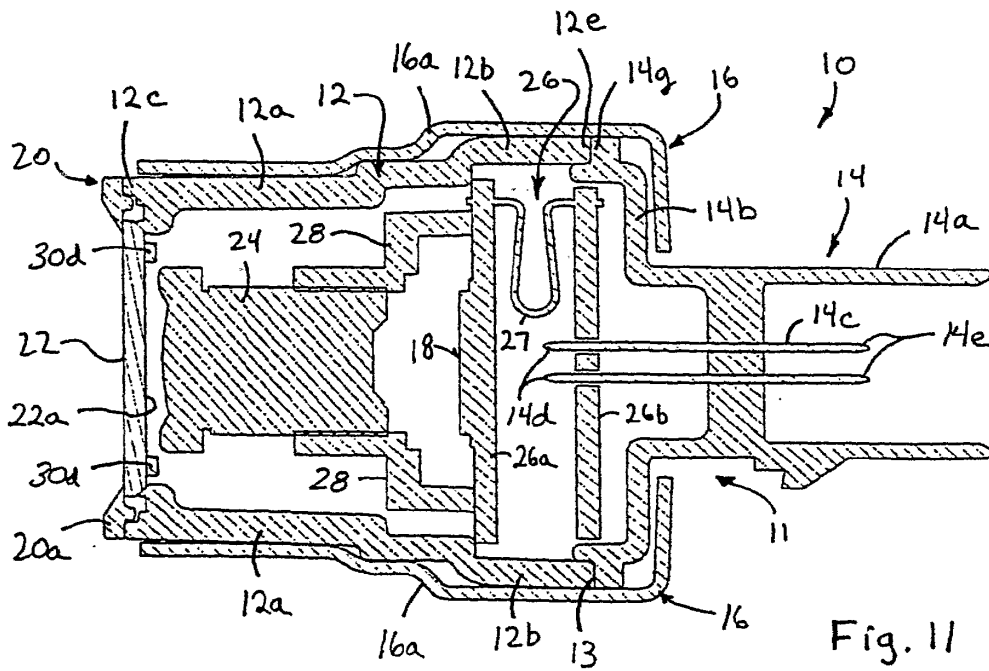

Fig. 11

7/18

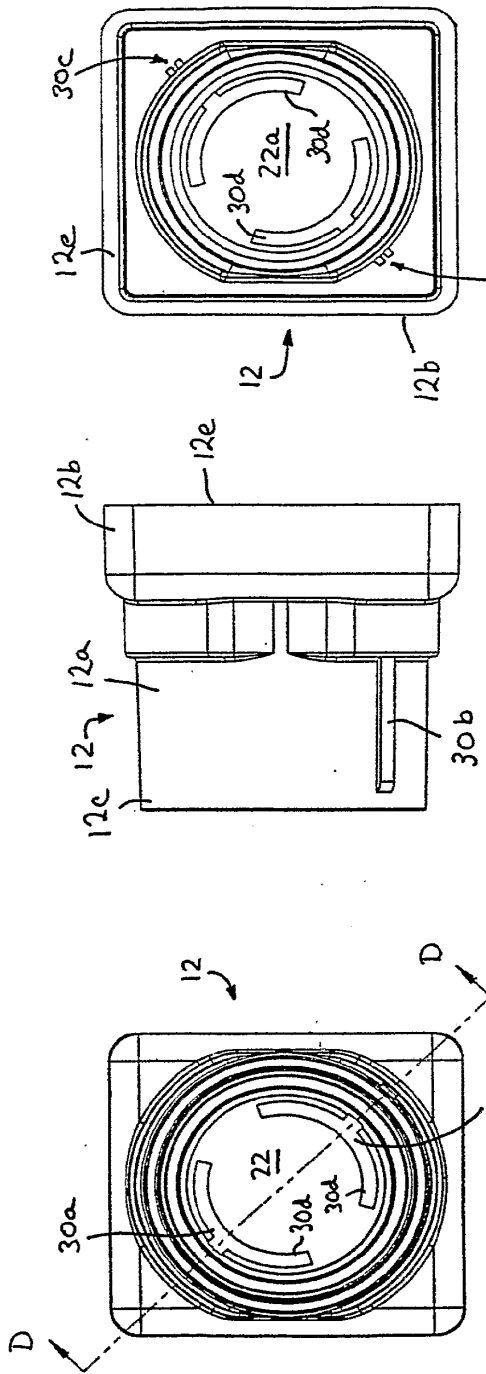

Fig. 12B

Fig. 12A

Fig. 12C

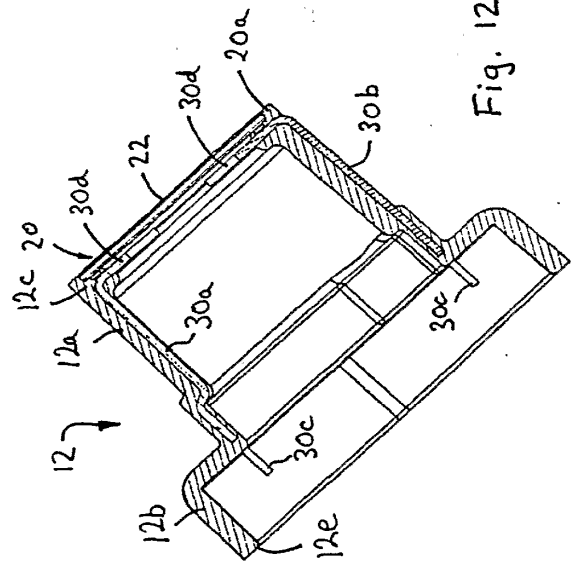
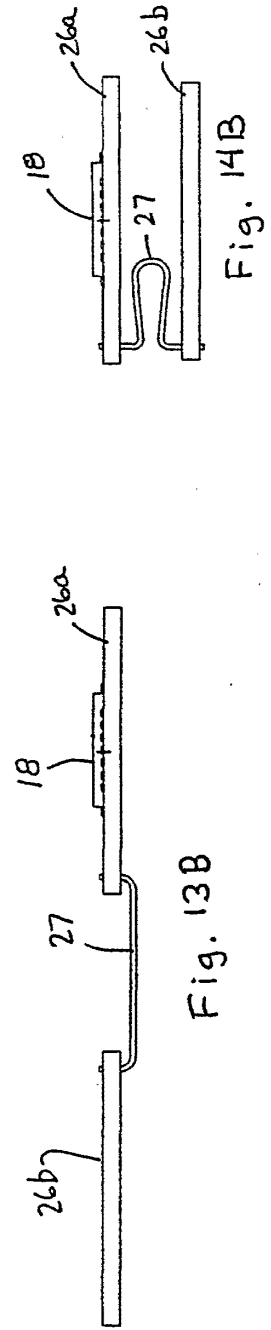
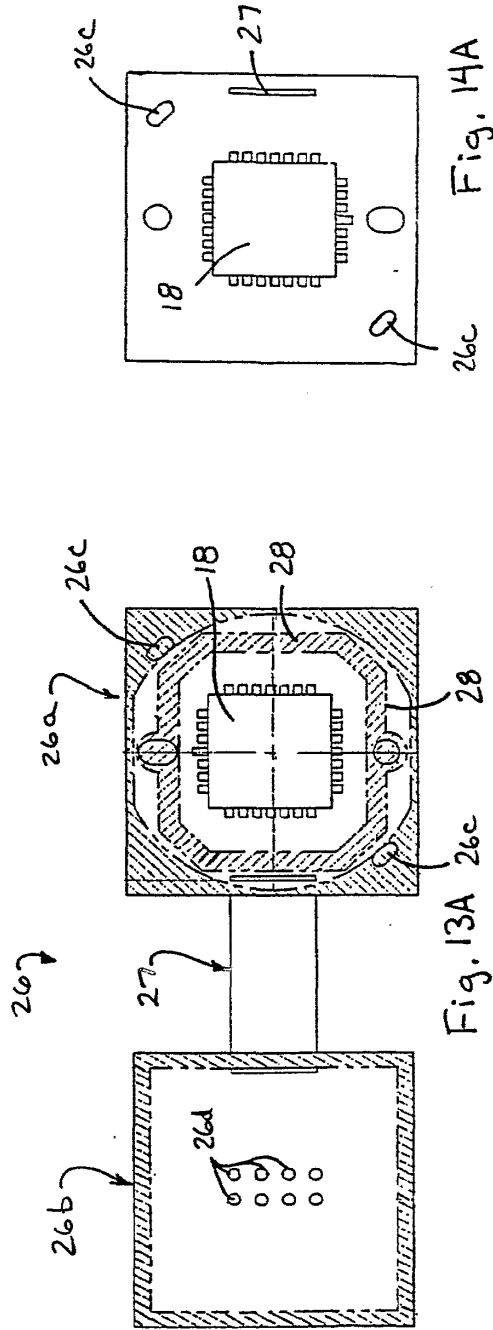

Fig. 12D



9/18

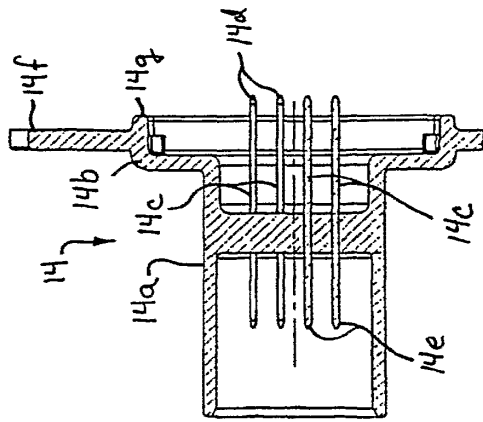

Fig. 15C

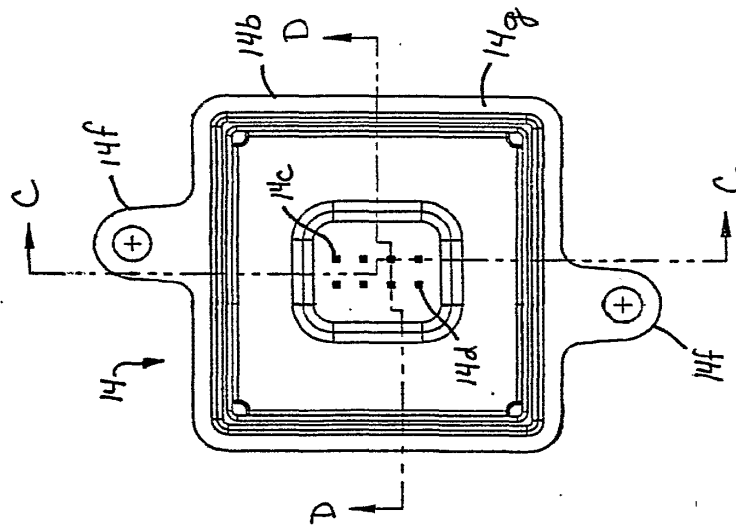

Fig. 15B

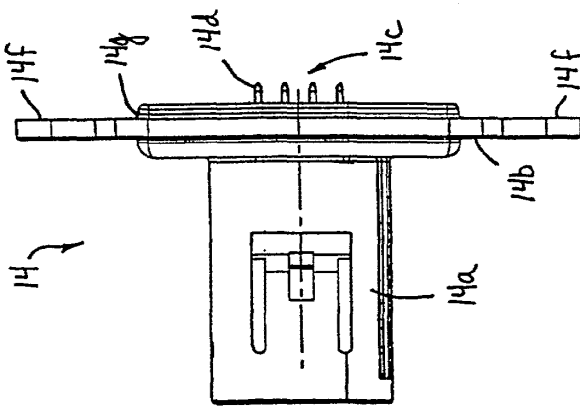

Fig. 15A

10/18

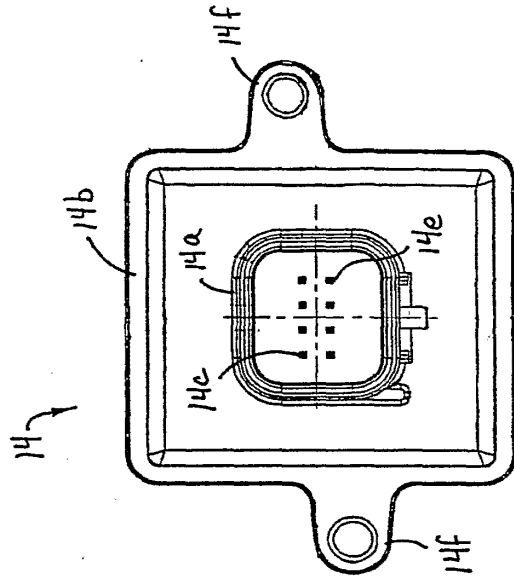

Fig. 15E

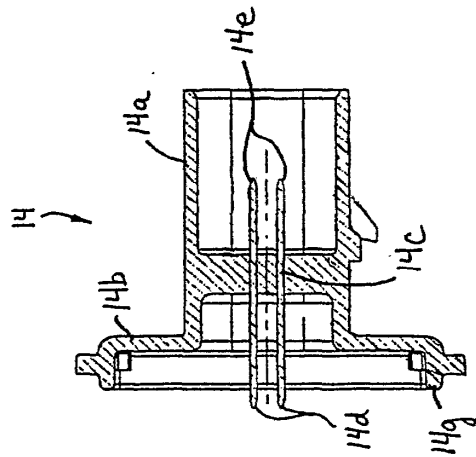

Fig. 15D

11/18

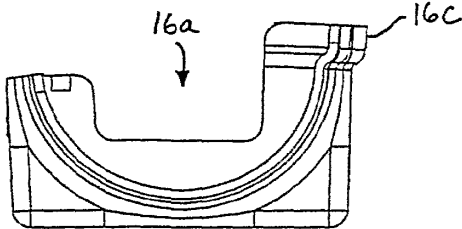

Fig. 16B

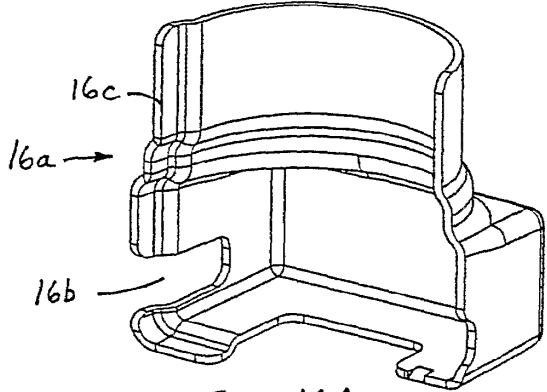

Fig. 16A

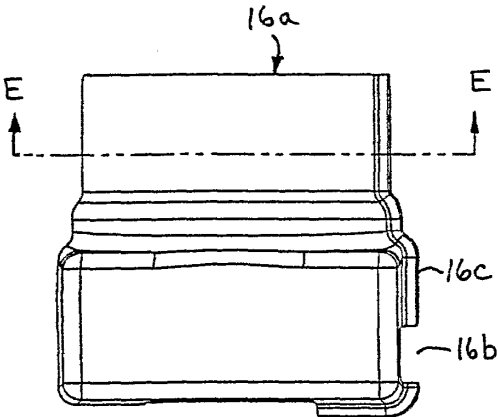

Fig. 16D

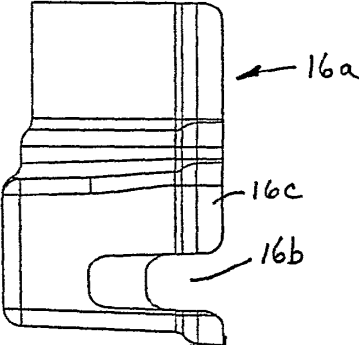

Fig. 16C

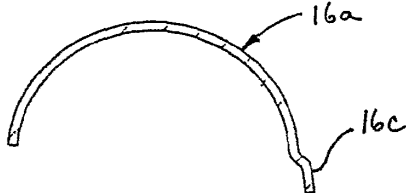

Fig. 16E

12/18

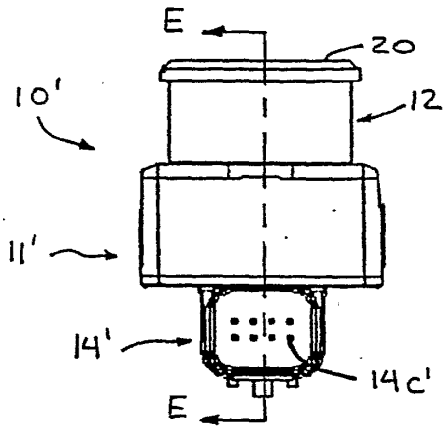

Fig. 17A

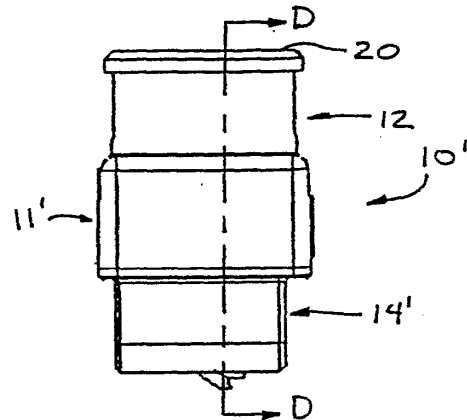

Fig. 17B

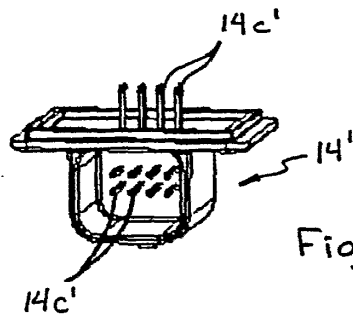

Fig. 17C

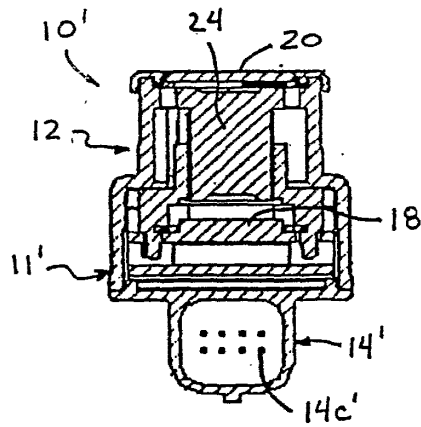

Fig. 17D

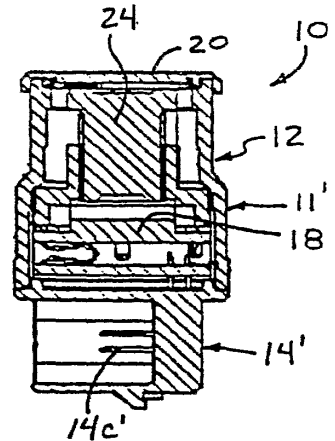

Fig. 17E

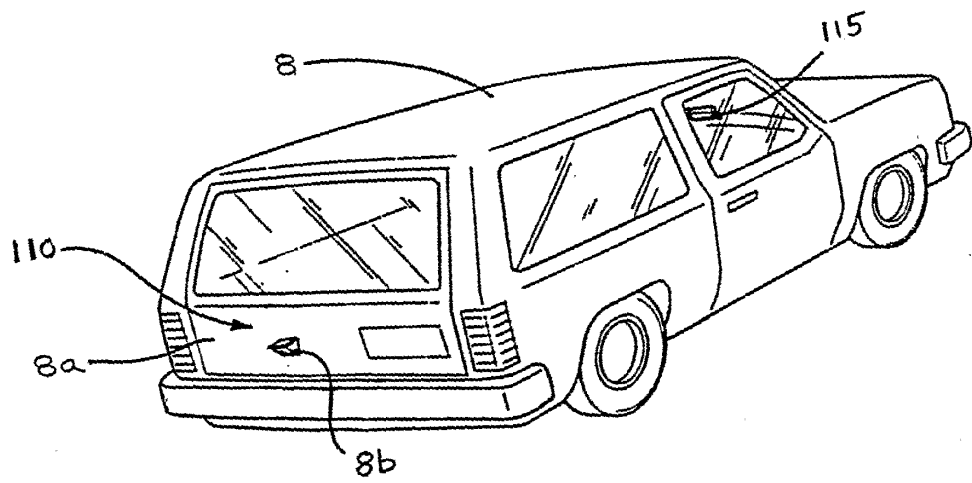

Fig. 18

