

Gzj kdkv'2005"

American
National
Standard



ANSI/AAMI/
ISO 5840-3:
2013

Cardiovascular implants —
Cardiac valve prostheses —
Part 3: Heart valve substitutes
implanted by transcatheter
techniques

Objectives and uses of AAMI standards and recommended practices

It is most important that the objectives and potential uses of an AAMI product standard or recommended practice are clearly understood. The objectives of AAMI's technical development program derive from AAMI's overall mission: the advancement of medical instrumentation. Essential to such advancement are (1) a continued increase in the safe and effective application of current technologies to patient care, and (2) the encouragement of new technologies. It is AAMI's view that standards and recommended practices can contribute significantly to the advancement of medical instrumentation, provided that they are drafted with attention to these objectives and provided that arbitrary and restrictive uses are avoided.

A voluntary *standard* for a *medical device* recommends to the manufacturer the information that should be provided with or on the product, basic safety and performance criteria that should be considered in qualifying the device for clinical use, and the measurement techniques that can be used to determine whether the device conforms with the safety and performance criteria and/or to compare the performance characteristics of different products. Some standards emphasize the information that should be provided with the device, including performance characteristics, instructions for use, warnings and precautions, and other data considered important in ensuring the safe and effective use of the device in the clinical environment. Recommending the disclosure of performance characteristics often necessitates the development of specialized test methods to facilitate uniformity in reporting; reaching consensus on these tests can represent a considerable part of committee work. When a drafting committee determines that clinical concerns warrant the establishment of *minimum* safety and performance criteria, referee tests must be provided and the reasons for establishing the criteria must be documented in the rationale.

A *recommended practice* provides guidelines for the use, care, and/or processing of a medical device or system. A recommended practice does not address device performance *per se*, but rather procedures and practices that will help ensure that a device is used safely and effectively and that its performance will be maintained.

Although a device standard is primarily directed to the manufacturer, it may also be of value to the potential purchaser or user of the device as a frame of reference for device evaluation. Similarly, even though a recommended practice is usually oriented towards healthcare professionals, it may be useful to the manufacturer in better understanding the environment in which a medical device will be used. Also, some recommended practices, while not addressing device performance criteria, provide guidelines to industrial personnel on such subjects as sterilization processing, methods of collecting data to establish safety and efficacy, human engineering, and other processing or evaluation techniques; such guidelines may be useful to health care professionals in understanding industrial practices.

In determining whether an AAMI standard or recommended practice is relevant to the specific needs of a potential user of the document, several important concepts must be recognized:

All AAMI standards and recommended practices are *voluntary* (unless, of course, they are adopted by government regulatory or procurement authorities). The application of a standard or recommended practice is solely within the discretion and professional judgment of the user of the document.

AAMI
Single user license provided to AAMI standards committee members.

Each AAMI standard or recommended practice reflects the collective expertise of a committee of health care professionals and industrial representatives, whose work has been reviewed nationally (and sometimes internationally). As such, the consensus recommendations embodied in a standard or recommended practice are intended to respond to clinical needs and, ultimately, to help ensure patient safety. A standard or recommended practice is limited, however, in the sense that it responds generally to perceived risks and conditions that may not always be relevant to specific situations. A standard or recommended practice is an important *reference* in responsible decision-making, but it should never *replace* responsible decision-making.

Despite periodic review and revision (at least once every five years), a standard or recommended practice is necessarily a static document applied to a dynamic technology. Therefore, a standards user must carefully review the reasons why the document was initially developed and the specific rationale for each of its provisions. This review will reveal whether the document remains relevant to the specific needs of the user.

Particular care should be taken in applying a product standard to existing devices and equipment, and in applying a recommended practice to current procedures and practices. While observed or potential risks with existing equipment typically form the basis for the safety and performance criteria defined in a standard, professional judgment must be used in applying these criteria to existing equipment. No single source of information will serve to identify a particular product as "unsafe". A voluntary standard can be used as one resource, but the ultimate decision as to product safety and efficacy must take into account the specifics of its utilization and, of course, cost-benefit considerations. Similarly, a recommended practice should be analyzed in the context of the specific needs and resources of the individual institution or firm. Again, the rationale accompanying each AAMI standard and recommended practice is an excellent guide to the reasoning and data underlying its provision.

In summary, a standard or recommended practice is truly useful only when it is used in conjunction with other sources of information and policy guidance and in the context of professional experience and judgment.

INTERPRETATIONS OF AAMI STANDARDS AND RECOMMENDED PRACTICES

Requests for interpretations of AAMI standards and recommended practices must be made in writing, to the AAMI Vice President, Standards Policy and Programs. An official interpretation must be approved by letter ballot of the originating committee and subsequently reviewed and approved by the AAMI Standards Board. The interpretation will become official and representation of the Association only upon exhaustion of any appeals and upon publication of notice of interpretation in the "Standards Monitor" section of the *AAMI News*. The Association for the Advancement of Medical Instrumentation disclaims responsibility for any characterization or explanation of a standard or recommended practice which has not been developed and communicated in accordance with this procedure and which is not published, by appropriate notice, as an *official interpretation* in the *AAMI News*.

Cardiovascular implants — Cardiac valve prostheses — Part 3: Heart valve substitutes implanted by transcatheter techniques

Approved 23 November 2012 by
Association for the Advancement of Medical Instrumentation

Approved 4 December 2012 by
American National Standards Institute

Abstract: Outlines an approach for verifying/validating the design and manufacture of a transcatheter heart valve substitute through risk management. The selection of appropriate verification/validation tests and methods are to be derived from the risk assessment. The tests may include those to assess the physical, chemical, biological and mechanical properties of heart valve substitutes and of their materials and components. The tests can also include those for preclinical in vivo evaluation and clinical evaluation of the finished heart valve substitute.

Keywords: design, hydrodynamic, material, performance, preclinical, risk, verification, structural

AAMI Standard

This Association for the Advancement of Medical Instrumentation (AAMI) standard implies a consensus of those substantially concerned with its scope and provisions. The existence of an AAMI standard does not in any respect preclude anyone, whether they have approved the standard or not, from manufacturing, marketing, purchasing, or using products, processes, or procedures not conforming to the standard. AAMI standards are subject to periodic review, and users are cautioned to obtain the latest editions.

CAUTION NOTICE: This AAMI standard may be revised or withdrawn at any time. AAMI procedures require that action be taken to reaffirm, revise, or withdraw this standard no later than 5 years from the date of publication. Interested parties may obtain current information on all AAMI standards by calling or writing AAMI, or by visiting the AAMI website at www.aami.org.

All AAMI standards, recommended practices, technical information reports, and other types of technical documents developed by AAMI are *voluntary*, and their application is solely within the discretion and professional judgment of the user of the document. Occasionally, voluntary technical documents are adopted by government regulatory agencies or procurement authorities, in which case the adopting agency is responsible for enforcement of its rules and regulations.

Published by

Association for the Advancement of Medical Instrumentation
4301 N. Fairfax Drive, Suite 301
Arlington, VA 22203-1633
www.aami.org

© 2013 by the Association for the Advancement of Medical Instrumentation

All Rights Reserved

This publication is subject to copyright claims of ISO, ANSI, and AAMI. No part of this publication may be reproduced or distributed in any form, including an electronic retrieval system, without the prior written permission of AAMI. All requests pertaining to this document should be submitted to AAMI. It is illegal under federal law (17 U.S.C. § 101, et seq.) to make copies of all or any part of this document (whether internally or externally) without the prior written permission of the Association for the Advancement of Medical Instrumentation. Violators risk legal action, including civil and criminal penalties, and damages of \$100,000 per offense. For permission regarding the use of all or any part of this document, complete the reprint request form at www.aami.org or contact AAMI at 4301 N. Fairfax Drive, Suite 301, Arlington, VA 22203-1633. Phone: +1-703-525-4890; Fax: +1-703-525-1067.

Printed in the United States of America

ISBN 1-57020-492-6

Contents

Page

Glossary of equivalent standards	vi
Committee representation.....	vii
Background	vii
Foreword.....	ix
Introduction	x
1 Scope.....	1
2 Normative references	1
3 Terms and definitions.....	3
4 Abbreviations	11
5 Fundamental requirements.....	11
6 Device description	11
6.1 Intended use.....	11
6.2 Design inputs	12
6.2.1 Operational specifications	12
6.2.2 Performance specifications	13
6.2.3 Implant procedure.....	15
6.2.4 Packaging, labeling and sterilization.....	15
6.3 Design outputs.....	15
6.4 Design transfer (manufacturing verification/validation).....	15
6.5 Risk management	15
7 Design verification testing and analysis/design validation.....	16
7.1 General requirements	16
7.2 <i>In vitro</i> assessment.....	16
7.2.1 Test conditions, sample selection and reporting requirements	16
7.2.2 Material property assessment	17
7.2.3 Device hydrodynamic performance assessment	18
7.2.4 Structural performance assessment.....	20
7.2.5 Additional implant design evaluation requirements	22
7.2.6 Delivery system design evaluation requirements	23
7.2.7 Design-specific testing.....	24
7.2.8 Visibility	25
7.2.9 Simulated use.....	25
7.2.10 Human factors/usability assessment.....	25
7.3 Preclinical <i>in vivo</i> evaluation.....	25
7.3.1 Overall requirements	25
7.3.2 Methods	27
7.3.3 Test report	28
7.4 Clinical investigations	29
7.4.1 General.....	29
7.4.2 Statistical considerations	29
7.4.3 Distribution of subjects and investigators	30
7.4.4 Sample size.....	30
7.4.5 Entry criteria	30
7.4.6 Duration of the study	30

7.4.7	Clinical data requirements	31
7.4.8	Clinical investigation report.....	33

Annexes

Annex A (informative)	Rationale for the provisions of this part of ISO 5840	35
Annex B (informative)	Examples of transcatheter heart valve substitutes, components and delivery systems	38
Annex C (normative)	Packaging.....	44
Annex D (normative)	Product labels, instructions for use and training	45
Annex E (normative)	Sterilization.....	49
Annex F (informative)	Valve description	50
Annex G (informative)	Transcatheter heart valve substitute hazards, associated failure modes and evaluation methods	52
Annex H (informative)	<i>In vitro</i> test guidelines for paediatric devices	57
Annex I (informative)	Statistical procedures when using performance criteria.....	62
Annex J (informative)	Examples and definitions of some physical and material properties of transcatheter heart valve substitutes and their components	63
Annex K (informative)	Examples of standards applicable to testing of materials and components of transcatheter heart valve substitutes	78
Annex L (informative)	Raw and post-conditioning mechanical properties for support structure materials	85
Annex M (informative)	Corrosion assessment	87
Annex N (informative)	Guidelines for verification of hydrodynamic performance	90
Annex O (informative)	Durability testing	94
Annex P (informative)	Fatigue assessment	96
Annex Q (informative)	Preclinical <i>in vivo</i> evaluation	103
Annex R (normative)	Adverse event classification during clinical investigation	106
Annex S (informative)	Echocardiographic protocol.....	112
Bibliography	115

Figures

Figure 1	— Schematic representation of flow waveform and regurgitant volumes for one cycle	4
Figure 2	— Schematic representation of the positive pressure period of an aortic forward flow interval	9
Figure B.1	— Example A.....	38
Figure B.2	— Example B.....	39
Figure B.3	— Example C.....	39
Figure B.4	— Example D.....	40
Figure B.5	— Example E.....	40

Figure B.6 — Example F	41
Figure B.7 — Example G	41
Figure B.8 — Example H.....	42
Figure B.9 — Example I	42
Figure B.10 — Example J	43
Figure B.11 — Example K.....	43
Figure J.1 — Example DSC graph for single-stage transformation nickel-titanium alloy.....	72
Figure J.2 — Typical stress-strain curve of superelastic (SE) nitinol indicating various reportable parameters	74
Figure J.3 — Force-diameter curve of a superelastic (SE) nitinol support structure demonstrating chronic outward force (COF) and radial resistive force (RRF).....	76
Figure P.1 — Example schematic of a structural component fatigue assessment using a stress-or strain-life approach	96
 Tables	
Table 1 — Heart valve substitute operational environment for left side of heart — Adult population	12
Table 2 — Heart valve substitute operational environment for right side of heart — Adult population.....	13
Table 3 — Minimum device performance requirements, aortic	18
Table 4—Minimum device performance requirements, mitral	19
Table G.1 — Transcatheter heart valve substitute hazards, associated failure modes and evaluation methods	52
Table H.1 — Pediatric definitions	57
Table H.2 — Pulsatile flow test conditions: left side.....	58
Table H.3 — Pulsatile flow test conditions: right side	58
Table H.4 — Steady back pressure and forward flow conditions: left side	59
Table H.5 — Steady back pressure and forward flow conditions: right side	59
Table H.6 — AWT test conditions: left side.....	60
Table H.7 — AWT test conditions: right side	60
Table H.8 — FEA/life analysis conditions: left side.....	61
Table H.9 — FEA/life analysis conditions: right side	61
Table Q.1—Examples of evaluations	104
Table R.1—Examples of adverse events clinical outcome severity ranking	110

Glossary of equivalent standards

International Standards adopted in the United States may include normative references to other International Standards. AAMI maintains a current list of each International Standard that has been adopted by AAMI (and ANSI). Available on the AAMI website at the address below, this list gives the corresponding U.S. designation and level of equivalency to the International Standard.

www.aami.org/standards/glossary.pdf

Committee representation

Association for the Advancement of Medical Instrumentation

Cardiac Valve Committee

The adoption of ISO 5840-3:2013 as an American National Standard was initiated by the AAMI Cardiac Valve Committee. The AAMI Cardiac Valve Committee also functions as a U.S. Technical Advisory Group to the relevant work in the International Organization for Standardization (ISO). U.S. representatives from the AAMI Cardiac Valve Committee (U.S. Sub-TAG for ISO/TC 150/SC 2/WG 1, Cardiac valves) played an active part in developing the ISO standard.

At the time this document was published, the **AAMI Cardiac Valve Committee** had the following members:

Cochairs: Ann M. Graves
Ajit Yoganathan, PhD

Members: Richard W. Bianco, University of Minnesota
Jeffrey Borer, MD, Weill Cornell Medical College of Cornell University
Lawrence Burr, MD, Vancouver, BC, Canada
Robert Chang, Sadra Medical
James C. Conti, PhD, Dynatek Labs
Robert W.M. Frater, MD, Bronxville, NY
Ann M. Graves St. Jude Medical
Stephen Hilbert, PhD MD, Children's Mercy Hospital
Timothy A. Kelley, Medtronic, Inc.
Salvador Marquez, Edwards LifeSciences
David Mester, W.L. Gore & Associates
Keith Morel, DEKRA
Stanton P. Nolan, MD, University of Virginia Health Sciences Center
Jonas Runquist, HLT Inc.
Hartzell Schaff, MD, Mayo Clinic
Julie Selstrom, Direct Flow Medical, Inc.
Sandy F. Stewart, PhD, Center for Devices and Radiological Health, U.S. Food and Drug Administration
Craig Weinberg, PhD, Biomedical Device Consultants & Laboratories
Julie Zaha, RN Southeastern Regional Medical Center
Ajit Yoganathan, PhD, Georgia Institute of Technology

Alternates: Lori Adels, BA PhD, Edwards LifeSciences
Fernando Aguel, Center for Devices and Radiological Health, U.S. Food and Drug Administration
Aaron Chalekian, St. Jude Medical Cardiovascular Division, Inc.
Carol E. Eberhart, Medtronic, Inc.
Helen Lavin, Sadra Medical
Elaine, Strobe, PhD, Dynatek Labs
Steven L. Weinberg, PhD, Biomedical Device Consultants & Laboratories
David Williams, RN MSN, W.L. Gore & Associates

NOTE—Participation by federal agency representatives in the development of this standard does not constitute endorsement by the federal government or any of its agencies.

Background of ANSI/AAMI adoption of ISO 5840-3:2013

As indicated in the foreword to the main body of this document (page ix), the International Organization for Standardization (ISO) is a worldwide federation of national standards bodies. The United States is one of the ISO members that took an active role in the development of this standard, which was developed by ISO Technical Subcommittee 150/SC 2, *Cardiovascular implants and extracorporeal systems*, to fill a need for standardization in the field of transcatheter heart valve substitutes.

U.S. participation in this ISO SC is organized through the U.S. Technical Advisory Group for ISO/TC 150/SC 2, administered by the Association for the Advancement of Medical Instrumentation (AAMI). The U.S. TAG for ISO/TC 150/SC 2 supports the guidance provided in this document to select appropriate verification/validation tests and methods that are to be derived from risk assessment and define operational conditions and performance requirements where adequate scientific and/or clinical evidence exists for their justification.

The U.S. adoption of ANSI/AAMI/ISO 5840-3:2013 was approved by the American National Standards Institute (ANSI) on 4 December 2012. The AAMI Cardiac Valve Committee (U.S. Sub-TAG for ISO/TC 150/SC 2/WG 1, *Cardiac valves*) initiated the U.S. adoption of ISO 5840-3:2013.

AAMI and ANSI procedures require that standards be reviewed and, if necessary, revised every five years to reflect technological advances that may have occurred since publication.

AAMI (and ANSI) have adopted other ISO standards. See the Glossary of Equivalent Standards for a list of ISO standards adopted by AAMI which gives the corresponding U.S. designation and the level of equivalency with the ISO standard.

As used within the context of this document, "shall" indicates requirements strictly to be followed to conform to the standard. "Should" indicates that among several possibilities, one is recommended as particularly suitable, without mentioning or excluding others, or that a certain course of action is preferred but not necessarily required, or that (in the negative form) a certain possibility or course of action should be avoided but is not prohibited. "May" is used to indicate that a course of action is permissible within the limits of the standard. "Can" is used as a statement of possibility and capability. Finally, "must" is used only to describe "unavoidable" situations, including those mandated by government regulation.

The concepts incorporated in this document should not be considered inflexible or static. This standard, like any other, must be reviewed and updated periodically to assimilate progressive technological developments. To remain relevant, it must be modified as technological advances are made and as new data come to light.

Suggestions for improving this document are invited. Comments and suggested revisions should be sent to Standards Department, AAMI, 4301 N. Fairfax Drive, Suite 301, Arlington, VA 22203-1633.

NOTE—Beginning with the ISO foreword on page ix, this American National Standard is identical to ISO 5840-3:2013.

Foreword

ISO (the International Organization for Standardization) is a worldwide federation of national standards bodies (ISO member bodies). The work of preparing International Standards is normally carried out through ISO technical committees. Each member body interested in a subject for which a technical committee has been established has the right to be represented on that committee. International organizations, governmental and non-governmental, in liaison with ISO, also take part in the work. ISO collaborates closely with the International Electrotechnical Commission (IEC) on all matters of electrotechnical standardization.

International Standards are drafted in accordance with the rules given in the ISO/IEC Directives, Part 2.

The main task of technical committees is to prepare International Standards. Draft International Standards adopted by the technical committees are circulated to the member bodies for voting. Publication as an International Standard requires approval by at least 75 % of the member bodies casting a vote.

Attention is drawn to the possibility that some of the elements of this document may be the subject of patent rights. ISO shall not be held responsible for identifying any or all such patent rights.

ISO 5840-3 was prepared by Technical Committee ISO/TC 150, *Implants for surgery*, Subcommittee SC 2, *Cardiovascular implants and extracorporeal systems*.

ISO 5840 consists of the following parts, under the general title *Cardiovascular implants — Cardiac valve prostheses*:

— *Part 3: Heart valve substitutes implanted by minimally invasive techniques*

Introduction

No heart valve substitute is ideal. Therefore, a group of engineers, scientists and clinicians well aware of the problems associated with heart valve substitutes and their development has prepared this part of ISO 5840. In several areas, the provisions of this part of ISO 5840 have been deliberately left partially defined so as not to inhibit development and innovation. This part of ISO 5840 specifies types of tests, test methods and requirements for test apparatus. It requires documentation of test methods and results. This part of ISO 5840 deals with those areas that will ensure adequate mitigation of device-associated risks for patients and other users of the device, facilitate quality assurance, aid the cardiac surgeon and cardiologist in choosing a heart valve substitute, and ensure that the device will be presented in a convenient form. This part of ISO 5840 emphasizes the need to specify types of *in vitro* testing, preclinical *in vivo* and clinical evaluations as well as to report all *in vitro*, preclinical *in vivo* and clinical evaluations. It describes the labels and packaging of the device. Such a process involving *in vitro*, preclinical *in vivo* and clinical evaluations is intended to clarify the required procedures prior to market release and to enable prompt identification and management of any subsequent problems.

With regard to *in vitro* testing and reporting, apart from basic material testing for mechanical, physical, chemical and biocompatibility characteristics, this part of ISO 5840 also covers important hydrodynamic and durability characteristics of transcatheter heart valve substitutes and their delivery systems. This part of ISO 5840 does not specify exact test methods for hydrodynamic and durability testing but it offers guidelines for the test apparatus.

This part of ISO 5840 should be revised, updated and amended as knowledge and techniques in heart valve substitute technology improve.

This part of ISO 5840 is to be used in conjunction with ISO 5840:2005, which will be replaced by ISO 5840-1 in future.

Cardiovascular implants — Cardiac valve prostheses — Part 3: Heart valve substitutes implanted by transcatheter techniques

1 Scope

This part of ISO 5840 outlines an approach for verifying/validating the design and manufacture of a transcatheter heart valve substitute through risk management. The selection of appropriate verification/validation tests and methods are to be derived from the risk assessment. The tests may include those to assess the physical, chemical, biological and mechanical properties of heart valve substitutes and of their materials and components. The tests can also include those for preclinical *in vivo* evaluation and clinical evaluation of the finished heart valve substitute.

This part of ISO 5840 defines operational conditions and performance requirements for transcatheter heart valve substitutes where adequate scientific and/or clinical evidence exists for their justification.

This part of ISO 5840 is applicable to all devices intended for implantation in human hearts as a transcatheter heart valve substitute.

This part of ISO 5840 is applicable to both newly developed and modified transcatheter heart valve substitutes and to the accessory devices, packaging and labeling required for their implantation and for determining the appropriate size of heart valve substitute to be implanted.

This part of ISO 5840 excludes heart valve substitutes designed for implantation in artificial hearts or heart assist devices.

This part of ISO 5840 excludes valve-in-valve configurations and homografts.

This part of ISO 5840 does not specifically address non-traditional surgically implanted heart valve substitutes (e.g. sutureless). For these devices, the requirements of both this part of ISO 5840 and ISO 5840:2005 might be relevant and can be considered.

NOTE A rationale for the provisions of this part of ISO 5840 is given in Annex A.

2 Normative references

The following referenced documents are indispensable for the application of this document. For dated references, only the edition cited applies. For undated references, the latest edition of the referenced document (including any amendments) applies.

ISO 10993-1, *Biological evaluation of medical devices — Part 1: Evaluation and testing within a risk management process*

ISO 10993-2, *Biological evaluation of medical devices — Part 2: Animal welfare requirements*

ISO 11135-1, *Sterilization of health care products — Ethylene oxide — Part 1: Requirements for development, validation and routine control of a sterilization process for medical devices*

ISO/TS 11135-2, *Sterilization of health care products — Ethylene oxide — Part 2: Guidance on the application of ISO 11135-1*

ISO 11137-1, *Sterilization of health care products — Radiation — Part 1: Requirements for development, validation and routine control of a sterilization process for medical devices*

ISO 11137-2, *Sterilization of health care products — Radiation — Part 2: Establishing the sterilization dose*

ISO 11137-3, *Sterilization of health care products — Radiation — Part 3: Guidance on dosimetric aspects*

ISO 11607-1, *Packaging for terminally sterilized medical devices — Part 1: Requirements for materials, sterile barrier systems and packaging systems*

ISO 11607-2, *Packaging for terminally sterilized medical devices — Part 2: Validation requirements for forming, sealing and assembly processes*

ISO 14155, *Clinical investigation of medical devices for human subjects — Good clinical practice*

ISO 14160, *Sterilization of health care products — Liquid chemical sterilizing agents for single-use medical devices utilizing animal tissues and their derivatives — Requirements for characterization, development, validation and routine control of a sterilization process for medical devices*

ISO 14630:2012, *Non-active surgical implants — General requirements*

ISO 14937, *Sterilization of health care products — General requirements for characterization of a sterilizing agent and the development, validation and routine control of a sterilization process for medical devices*

ISO 14971, *Medical devices — Application of risk management to medical devices*

ISO 17665-1, *Sterilization of health care products — Moist heat — Part 1: Requirements for the development, validation and routine control of a sterilization process for medical devices*

ISO 22442-1, *Medical devices utilizing animal tissues and their derivatives — Part 1: Application of risk management*

ISO 22442-2, *Medical devices utilizing animal tissues and their derivatives — Part 2: Controls on sourcing, collection and handling*

ISO 22442-3, *Medical devices utilizing animal tissues and their derivatives — Part 3: Validation of the elimination and/or inactivation of viruses and transmissible spongiform encephalopathy (TSE) agents*

ISO/IEC 17025, *General requirements for the competence of testing and calibration laboratories*

IEC 62366, *Medical devices — Application of usability engineering to medical devices*

ASTM F2052, *Standard test method for measurement of magnetically induced displacement force on medical devices in the magnetic resonance environment*

ASTM F2503, *Standard practice for marking medical devices and other items for safety in the magnetic resonance environment*

ASTM F2213, *Standard test method for measurement of magnetically induced torque on medical devices in the magnetic resonance environment*

ASTM F2182, *Standard test method for measurement of radio frequency induced heating near passive implants during magnetic resonance imaging*

ASTM F2119, *Standard test method for evaluation of MR image artifacts from passive implants*

3 Terms and definitions

For the purposes of this document, the following terms and definitions apply.

NOTE Additional definitions can be found in the informative annexes.

3.1

accessories

device-specific tools that are required to assist in the implantation of the transcatheter heart valve substitute

3.2

adverse event

AE

untoward medical occurrence in a study subject which does not necessarily have to have a causal relationship with study treatment

NOTE An AE can be an unfavorable and unintended sign (including an abnormal laboratory finding), symptom or disease, temporary or permanent, whether or not related to the prosthetic valve implantation or procedure.

3.3

arterial end diastolic pressure

minimum value of the arterial pressure during diastole

3.4

arterial peak systolic pressure

maximum value of the arterial pressure during systole

3.5

back pressure

differential pressure applied across the valve during the closed phase

3.6

body surface area

A_{bs}

total surface area (m^2) of the human body

NOTE This can be calculated (Mosteller's formula) as the square root of product of the weight in kg times the height in cm divided by 3,600 (see Reference^[12]).

3.7

cardiac index

cardiac output (CO, l/min) divided by the body surface area (A_{bs} , m^2), in units l/min/ m^2

3.8

closing volume

portion of the regurgitant volume that is associated with the dynamics of the valve closure during a single cycle

NOTE See Figure 1.

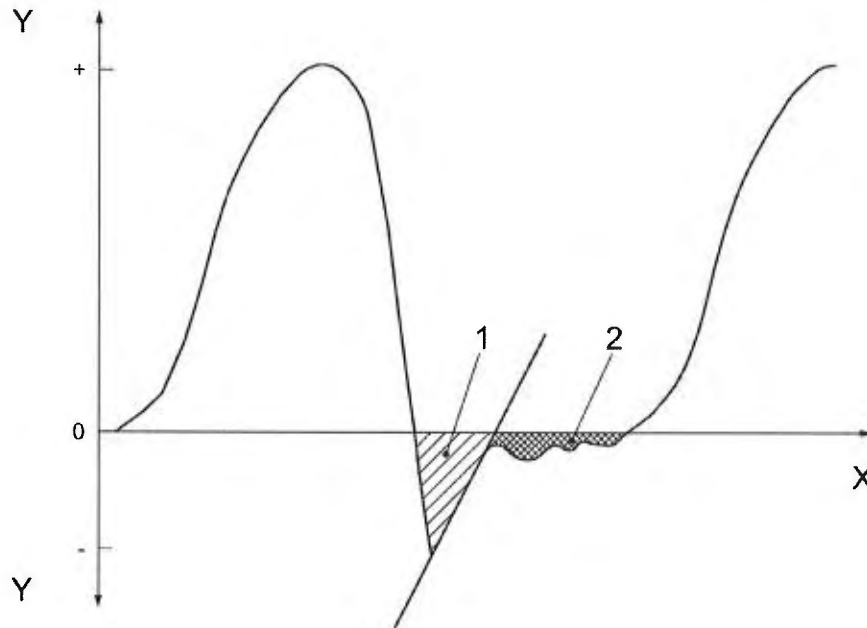

Key

X	time
Y	flowrate
1	closing volume
2	leakage volume

Figure 1 — Schematic representation of flow waveform and regurgitant volumes for one cycle

3.9

coating

thin-film material that is applied to an element of a heart valve substitute to modify its physical or chemical properties

3.10

compliance

relationship between change in diameter and change in pressure of a deformable tubular structure (e.g. valve annulus, aorta, conduit), defined in this part of ISO 5840 as

$$C = 100\% \times \frac{(r_2 - r_1) \times 100}{r_1 \times (p_2 - p_1)}$$

where

C is the compliance in units of % radial change/100 mmHg;

p_1 is the diastolic pressure, in mmHg;

p_2 is the systolic pressure, in mmHg;

r_1 is the inner radius at p_1 , in millimeters;

r_2 is the inner radius at p_2 , in millimeters.

NOTE See ISO 25539-1.

3.11

component-joining material

material, such as a suture, adhesive or welding compound, used to assemble the components of a heart valve substitute, thereby becoming part of the implant device

NOTE See examples in Annex B.

3.12

cycle

one complete sequence in the action of a heart valve substitute under pulsatile flow conditions

3.13

cycle rate

number of complete cycles per unit of time, usually expressed as cycles per minute (cycles/min)

3.14

delivery approach

anatomical access used to deliver the implant to the implant site (e.g. transfemoral, transapical, transeptal)

3.15

delivery system

catheter or other device-based system used to deliver the implant to the implant site

3.16

deployed valve diameter

outer diameter (mm) of the implantable device when deployed within the target implant site in an idealized circular configuration

3.17

device embolization

dislodgement from the intended and documented original position to an unintended and non-therapeutic location

3.18

device failure

inability of a device to perform its intended function sufficient to cause a hazard

3.19

device migration

detectable movement or displacement of the device from its original position within the implant site, without embolization

3.20

effective orifice area

EOA

orifice area that has been derived from flow and pressure or velocity data

3.21

failure mode

mechanism of device failure

NOTE Catastrophic support structure fracture, calcification and prolapse are examples of failure modes.

3.22

follow-up

continued assessment of patients who have received the heart valve substitute

3.23

forward flow volume

volume of flow ejected through the test heart valve substitute in the forward direction during one cycle

3.24

fracture

disruption, under the action of applied stress or strain, of any part of the transcatheter heart valve substitute that was previously intact

3.25

heart valve substitute

device used to replace the function of a natural valve of the heart

NOTE See examples in Annex B.

3.26

imaging modality

imaging method used to facilitate delivery and/or retrieval of the implant within the target implant site, as well as to assess valve performance after implantation

3.27

implant site

intended site of transcatheter heart valve substitute deployment

3.28

intended use

use of a product, process or service in accordance with the specifications, instructions and information provided by the manufacturer

3.29

leakage volume

component of the regurgitant volume that is associated with leakage during closed phase of a valve in a single cycle and is the sum of the transvalvular leakage volume and paravalvular leakage volume

NOTE 1 The point of separation between the closing and leakage volumes is obtained according to a defined and stated criterion (the linear extrapolation shown in Figure 1 is just an example).

NOTE 2 See Figure 1.

3.30

mean arterial pressure

time-averaged arithmetic mean value of the arterial pressure during one cycle

3.31

mean pressure difference

time-averaged arithmetic mean value of the pressure difference across a heart valve substitute during the forward flow phase of the cycle

3.32

non-structural valve dysfunction

abnormality extrinsic to the transcatheter heart valve substitute that results in valve dysfunction (stenosis, regurgitation or both)

3.33

occluder/leaflet

component that inhibits back flow

NOTE See examples in Annex B.

3.34

paravalvular leakage volume

component of the leakage volume that is associated with leakage around the closed heart valve substitute during a single cycle

3.35

reference valve

heart valve substitute with a known clinical experience used for comparative preclinical and clinical evaluations

3.36

regurgitant fraction

regurgitant volume expressed as a percentage of the forward flow volume

3.37

regurgitant volume

volume of fluid that flows through a heart valve substitute in the reverse direction during one cycle and is the sum of the closing volume and the leakage volume

NOTE See Figure 1.

3.38**repositioning**

change in implant position of a partially or fully deployed transcatheter heart valve substitute via a transcatheter technique, possibly requiring full or partial recapturing of the device

3.39**retrieval**

removal of a partially or fully deployed transcatheter heart valve substitute via a transcatheter technique

3.40**risk**

combination of the probability of occurrence of harm and the severity of that harm

NOTE Adapted from ISO 14971.

3.41**risk analysis**

systematic use of available information to identify hazards and to estimate the associated risks

NOTE Adapted from ISO 14971.

3.42**risk assessment**

overall process comprising a risk analysis and a risk evaluation

NOTE Adapted from ISO 14971.

3.43**root mean square forward flow****RMS forward flow**

square root of the integral of the volume flow rate waveform squared during the positive differential pressure interval of the forward flow phase used to calculate EOA

NOTE See Figure 2.

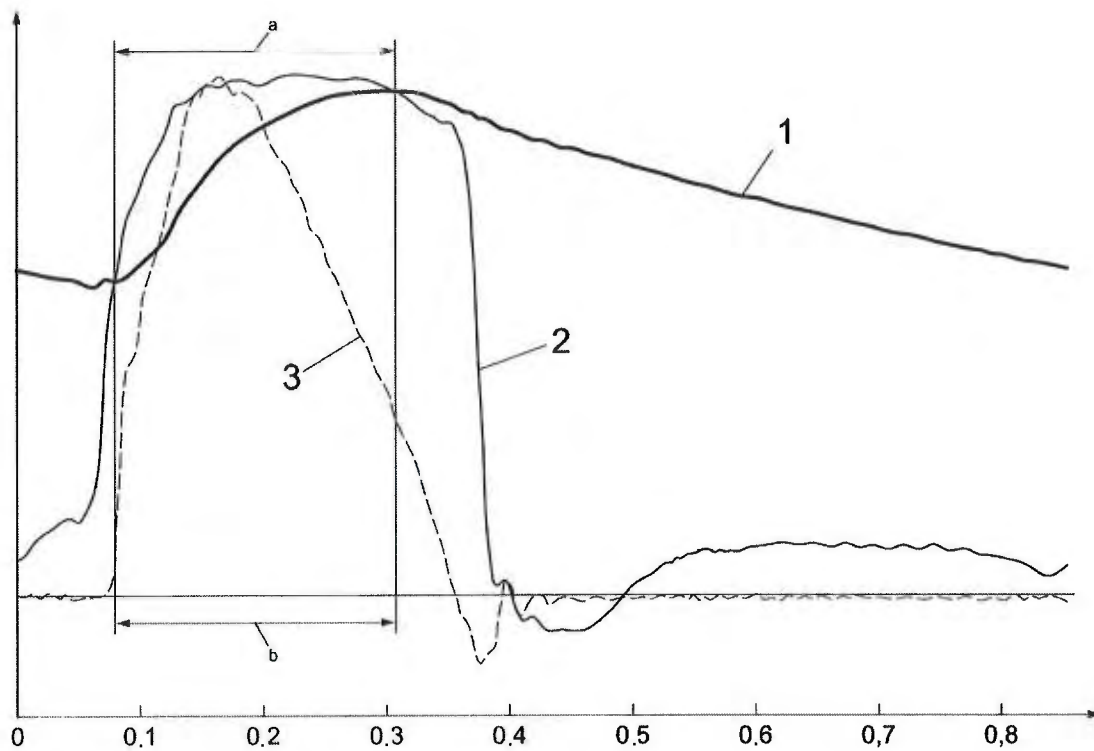

Key title

- 1 aortic pressure
- 2 left ventricular pressure
- 3 aortic flow rate
- a Positive pressure range.
- b Q_{rms} range.

Figure 2 — Schematic representation of the positive pressure period of an aortic forward flow interval

3.44

safety

freedom from unacceptable risk

NOTE Adapted from ISO 14971.

3.45

severity

measure of the possible consequences of a hazard

NOTE Adapted from ISO 14971.

3.46

special processes

processes for which the product cannot be fully verified by inspection or test

3.47

sterility assurance level

SAL

probability of a single viable microorganism occurring on an item after sterilization

NOTE The term SAL takes a quantitative value, generally 10^{-6} or 10^{-3} . When applying this quantitative value to assurance of sterility, an SAL of 10^{-6} has a lower value but provides a greater assurance of sterility than an SAL of 10^{-3} .

[ISO/TS 11139, definition 2.46]

3.48

sterilization

validated process used to render product free from viable microorganisms

NOTE 1 In a sterilization process, the nature of microbial inactivation is exponential and thus the survival of a microorganism on an individual item can be expressed in terms of probability. While this probability can be reduced to a very low number, it can never be reduced to zero.

NOTE 2 See **sterility assurance level** (3.47).

NOTE 3 Adapted from ISO/TS 11139.

3.49

structural component failure

degradation of structural integrity of the support structure (e.g. strut fractures) that results in the functional performance of the implant no longer being acceptable and/or that results in adverse events

3.50

structural valve dysfunction

structural abnormality intrinsic to the transcatheter heart valve substitute that results in valve dysfunction (stenosis and/or transvalvular and/or paravalvular regurgitation)

3.51

support structure

portion of the transcatheter heart valve substitute that transfers loads between occluder and implant site and anchors the device within the implant site

3.52

surgically implanted heart valve substitute

heart valve substitute generally requiring direct visualization and cardiopulmonary bypass for implantation

3.53

transcatheter heart valve substitute

heart valve substitute implanted in a manner generally not involving direct visualization, and generally involving a beating heart

3.54

transcatheter heart valve system

implantable device, delivery system, accessories, packaging, labeling and instructions

3.55

transvalvular leakage volume

component of the leakage volume that is associated with leakage through the closed valve during a single cycle

3.56

usability

characteristic of the user interface that establishes effectiveness, efficiency, ease of user learning and user satisfaction

3.57

valve loading

process to affix or attach a transcatheter heart valve substitute onto a delivery device and collapse the valve (e.g. reduce its diameter) for insertion via the delivery system (e.g. catheter), performed either during manufacture or in the clinic

4 Abbreviations

For the purposes of this part of ISO 5840, the following abbreviations apply.

AE	Adverse event
EOA	Effective orifice area
AWT	Accelerated wear testing
CFD	Computational fluid dynamics
ECG	Electrocardiogram
FEA	Finite element analysis
IFU	Instructions for use
LV	Left ventricle, left ventricular
MAP	Mean arterial pressure
MRI	Magnetic resonance imaging

5 Fundamental requirements

The manufacturer shall determine, at all stages of the product life cycle, the acceptability of the product for clinical use.

6 Device description

6.1 Intended use

The manufacturer shall identify the physiological condition(s) to be treated, the intended patient population, potential adverse events and intended claims.

6.2 Design inputs

6.2.1 Operational specifications

The manufacturer shall define the operational specifications for the device, including the principles of operation, intended device delivery approach/process, expected device lifetime, shelf life, shipping/storage limits, and the physiological environment in which it is intended to function. The manufacturer shall carefully define all relevant dimensional parameters that will be required to accurately select the size of device to be implanted. Table 1 and Table 2 define the expected physiological parameters of the intended adult patient population for transcatheter heart valve substitutes for both normal and pathological patient conditions.

Table 1 — Heart valve substitute operational environment for left side of heart — Adult population

Parameter	General condition			
Surrounding medium	Human heart/human blood			
Temperature	34 °C to 42 °C			
Heart rate	30 bpm to 200 bpm			
Cardiac output	3 l/min to 15 l/min			
Blood pressures and resultant pressure loads by patient condition	Arterial peak systolic pressure mmHg	Arterial end diastolic pressure mmHg	Peak differential pressure across closed valve ^a	
			Aortic Δp_A mmHg	Mitral Δp_M mmHg
Normotensive	120	80	100	120
Hypotensive	60	40	50	60
Hypertensive				
Mild	140 to 159	90 to 99	115 to 129	140 to 159
Moderate	160 to 179	100 to 109	130 to 144	160 to 179
Severe	180 to 209	110 to 119	145 to 164	180 to 209
Very severe	≥ 210	≥ 120	≥ 165	≥ 210
^a Peak differential pressure across closed aortic valve is estimated using the following relationship: — ΔP_{Aortic} approximately pressure associated with dicrotic notch assuming LV pressure is zero approximately arterial end diastolic pressure + 1/2(arterial peak systolic pressure – arterial end diastolic pressure). — Peak differential pressure across closed mitral valve estimated to be equivalent to arterial peak systolic pressure.				

Table 2 — Heart valve substitute operational environment for right side of heart — Adult population

Parameter	General condition			
Surrounding medium	Human heart/human blood			
Temperature	34 °C to 42 °C			
Heart rate	30 bpm to 200 bpm			
Cardiac output	3 l/min to 15 l/min			
Forward flow volume	25 ml to 100 ml			
Blood pressures and resultant pressure loads by patient condition	Right ventricle peak systolic pressure mmHg	Pulmonary artery end diastolic pressure mmHg	Peak differential pressure across closed valve ^a	
			Pulmonary Δp_P mmHg	Tricuspid Δp_T mmHg
Normotensive	18 to 35	8 to 15	13 to 25	18 to 35
Hypotensive	15	5	10	15
Hypertensive				
Mild	40 to 49	15 to 19	28 to 34	40 to 49
Moderate	50 to 59	20 to 24	35 to 42	50 to 59
Severe	60 to 84	25 to 34	43 to 59	60 to 84
Very severe	85 to 120	≥ 35	60 to 78	85 to 120
^a Peak differential pressure across closed pulmonary valve is estimated using the following relationship: — $\Delta P_{pulmonic}$ approximate pressure associated with dicrotic notch assuming RV pressure is zero approximately pulmonary artery end diastolic pressure + 1/2(right ventricle peak systolic pressure – pulmonary artery end diastolic pressure). — Peak differential pressure across closed tricuspid valve estimated to be equivalent to right ventricle peak systolic pressure.				

6.2.2 Performance specifications

The manufacturer shall establish (i.e. define, document and implement) the clinical performance requirements of the device and the corresponding device performance specifications for the intended use and device claims. The following list of desired clinical and device-based performance characteristics describe a safe and effective transcatheter heart valve substitute system.

6.2.2.1 Implantable device

The design attribute requirements of ISO 14630:2012, Clause 5, shall apply. The intended performance of the transcatheter heart valve substitute shall take into account at least the following:

- a) the ability to be consistently, accurately and safely loaded onto the delivery system;
- b) the ability to be consistently, accurately and safely deployed;
- c) the ability to be safely retrieved and/or repositioned (if applicable);

- d) the ability to ensure effective fixation within the target implant site;
- e) the ability to maintain structural and functional integrity during the expected lifetime of the device;
- f) the ability to conform with anatomical structures within the implant site (e.g. in the aortic position, there is potential for interaction with coronary ostia, anterior mitral leaflet, AV bundle branch);
- g) the ability to allow forward flow with acceptably small mean pressure difference;
- h) the ability to prevent retrograde flow with acceptably small regurgitation, including paravalvular leakage;
- i) the ability to resist migration and embolization during the expected lifetime of the device;
- j) the ability to minimize hemolysis;
- k) the ability to minimize thrombus formation;
- l) the ability to maintain its functionality for the intended application consistent with the target patient population.

6.2.2.2 Delivery system

The design attributes to meet the intended performance of the delivery system shall take into account at least the following:

- a) the ability to permit consistent, accurate and safe access, delivery, placement and deployment of the transcatheter heart valve substitute to the intended implant site;
- b) the ability to permit consistent and safe withdrawal of the delivery system prior to and after deployment of transcatheter heart valve substitute;
- c) the ability to minimize hemolysis;
- d) the ability to minimize thrombus formation;
- e) the ability to minimize blood loss (hemostasis);
- f) the ability to retrieve, reposition and/or remove the transcatheter heart valve substitute (if applicable).

6.2.2.3 Transcatheter heart valve system

The design attributes to meet the intended performance of the transcatheter heart valve system shall take into account at least the following:

- a) the compliance of the transcatheter heart valve system with the requirements of ISO 10993-1 and appropriate other parts of ISO 10993;
- b) the visibility of the transcatheter heart valve system under fluoroscopy or other imaging modalities;
- c) compatibility with magnetic resonance imaging (MRI);
- d) the ability of the transcatheter heart valve system to maintain its functionality and sterility for its specified shelf life prior to implantation.

6.2.3 Implant procedure

The entire system shall provide intended users with the ability to safely and effectively perform all required pre-operative, intra-operative and post-operative procedural tasks and achieve all desired objectives. This shall include all other tools and accessories that intended users will use to complete the procedure.

NOTE For guidance on how to determine and establish design attributes pertaining to the use of the system to conduct the implant procedure, see IEC 62366.

6.2.4 Packaging, labeling and sterilization

The transcatheter heart valve substitute system shall meet the requirements for packaging, labeling and sterilization contained within Annex C, Annex D and Annex E, respectively.

The manufacturer shall provide sufficient information and guidance in the labeling to allow for appropriate preparation of the implant site (e.g. balloon valvuloplasty), accurate selection of appropriate implant size and reliable implantation of the transcatheter heart valve substitute.

6.3 Design outputs

The manufacturer shall establish (i.e. define, document and implement) a complete specification of the transcatheter heart valve substitute system, including component and assembly-level specifications, delivery system, accessories, packaging and labeling. Annex F contains a listing of terms that may be used in describing various valve models. In addition to the physical components of the heart valve substitute system, the implant procedure itself should be considered an important element of safe and effective heart valve therapy.

6.4 Design transfer (manufacturing verification/validation)

The manufacturer shall generate a flowchart identifying the manufacturing process operations and inspection steps. The flowchart shall indicate the input of all components and important manufacturing materials.

As part of the risk management process, the manufacturer shall establish the control measures and process conditions necessary to ensure that the device is safe and suitable for its intended use. The risk management file shall identify and justify the verification activities necessary to demonstrate the acceptability of the process ranges chosen.

The manufacturer shall establish the adequacy of full scale manufacturing by validation of the manufacturing process. The manufacturer shall validate all special processes and process software, and document the results of the validation.

NOTE See ISO 13485.

6.5 Risk management

The manufacturer shall define and implement a risk management program in accordance with ISO 14971.

Annex G contains a list of potential hazards specific to heart valve substitutes that can serve as the basis for a risk analysis.

7 Design verification testing and analysis/design validation

7.1 General requirements

The manufacturer shall perform verification testing to demonstrate that the device specifications result in a transcatheter heart valve substitute system that meets the design specifications (design output meets design input). The manufacturer shall establish tests relating to hazards identified from the risk analysis. The protocols shall identify the test purpose, set-up, equipment (specifications, calibration, etc.), test conditions (with a justification of appropriateness to anticipated *in vivo* operating conditions for the device), acceptance criteria and sample quantities tested.

The manufacturer shall validate the design of the transcatheter heart valve substitute system.

7.2 *In vitro* assessment

7.2.1 Test conditions, sample selection and reporting requirements

7.2.1.1 Test specimens shall represent, as closely as possible, the finished product to be supplied for clinical use, including exposure to the maximum number of recommended sterilization cycles, process chemicals, aging effects, and any catheter loading and deployment steps (including repositioning and recapturing, if applicable) in accordance with all manufacturing procedures and IFU, where appropriate. Any deviations of the test specimens from the finished product shall be justified.

7.2.1.2 The specimens selected for testing shall fully represent the total implant size range. Depending on the particular test, testing might not necessarily have to be completed for each discrete valve size, but shall at least be completed for the largest and smallest sizes, each deployed to the largest and smallest deployed diameters as per the IFU. Sampling shall ensure adequate representation of the expected variability in the manufacture of devices. A rationale for device size selection shall be provided.

7.2.1.3 For all tests, the number of samples shall be justified based on the specific intent of the test. Additional recommendations regarding sampling and sample conditioning are included within each test method defined herein, as appropriate.

7.2.1.4 Where simulation of *in vivo* conditions is applicable to the test method, consideration shall be given to those operational environments given in Table 1 and Table 2 for the adult population. See Annex H for guidelines regarding suggested test conditions for the pediatric population. Where applicable, testing shall be performed using a test fluid of isotonic saline, blood, or a blood-equivalent fluid whose physical properties (e.g. specific gravity, viscosity at working temperatures) are appropriate to the test being performed. The test fluid used shall be justified. The testing shall be performed at the intended operating temperature as appropriate.

7.2.1.5 Test methods for verification testing shall be appropriately validated. Refer to applicable sections of ISO/IEC 17025.

7.2.1.6 Each test report shall include:

- a) rationale for the test;
- b) identification and description of the transcatheter heart valve substitute system elements tested (e.g. batch number);
- c) identification and description of the reference valve(s) where appropriate;

- d) number of specimens tested, and rationale for sample size;
- e) detailed description of the test method including preconditioning to simulate intended use;
- f) verification that appropriate quality assurance standards have been met (e.g. Good Laboratory Practice);
- g) test results and conclusions.

Statistical procedures, such as the ones described in Annex I, may be used to assist data analysis.

7.2.2 Material property assessment

7.2.2.1 General

Properties of the transcatheter heart valve substitute system components (e.g. support structure, valve leaflets) shall be evaluated as applicable to the specific design of the system as determined by the risk assessment. The materials requirements of ISO 14630:2012, Clause 6, shall apply. Additional testing specific to certain materials shall be performed to determine the appropriateness of the material for use in the design. For example, materials dependent on shape memory properties shall be subjected to testing in order to assess transformation properties.

7.2.2.2 Biological safety

The biocompatibility of the materials and components used in the transcatheter heart valve substitute system shall be determined in accordance with ISO 10993-1. The test plan recorded in the risk management file shall comprise a biological safety evaluation program with a justification for the appropriateness and adequacy of the information obtained. The documentation shall include a rationale for the commission of any biological safety tests carried out to supplement information obtained from other sources and for the omission of any tests identified by ISO 10993-1 but not performed. During the hazard identification stage of a biological safety evaluation, sufficient information shall be obtained to allow the identification of toxicological hazards and the potential for effects on relevant hematological characteristics. Where an identified hazard has the potential for significant clinical effects, the toxicological risk shall be characterized through evaluation of data on, for example, mode of action, dose-response, exposure level, biochemical interactions and toxicokinetics.

For transcatheter heart valve substitutes using animal tissue or their derivatives, the risk associated with the use of these materials shall be evaluated in accordance with ISO 22442-1, ISO 22442-2 and ISO 22442-3.

7.2.2.3 Material and mechanical property testing

The material properties of all constituent materials comprising the transcatheter heart valve substitute system and each element thereof shall be evaluated as applicable to its specific design. Scientific literature citations or previous characterization data from similar devices can be referenced; however, the applicability of the literature data to the transcatheter heart valve substitute shall be justified.

Mechanical properties shall be characterized at various stages of manufacture, as applicable: a) for the structural component raw materials, b) for the structural component in its final manufactured state, and c) for the finished device after applicable catheter loading and deployment states. Environmental conditions that might affect device or component performance or durability shall be evaluated and included in testing protocols (e.g. shelf life testing). Annex J provides potentially relevant physical, mechanical and chemical properties by material class and components. Annex K provides a list of standards that might be

applicable to the testing of materials and components. Annex L provides guidance on mechanical property characterization of raw and conditioned materials. Annex M provides guidance on corrosion assessment.

7.2.3 Device hydrodynamic performance assessment

Hydrodynamic testing shall be performed to provide information on the fluid mechanical performance of the transcatheter heart valve substitute and provide indicators of valve performance in terms of load to the heart and potential for blood stasis and damage. The implant shall be deployed into the test fixtures using the loading and deployment steps in accordance with the IFU. The test chamber shall be representative of the critical aspects of the target implant site (e.g. compliance, geometry) for the target patient population. The test chamber details shall be justified by the manufacturer. The measurement accuracy and repeatability of the test system shall be evaluated and documented.

A guideline for the performing and reporting of hydrodynamic tests is provided in Annex N. The detailed protocols shall be defined based on the findings of the risk assessment.

The minimum performance requirements provided in Table 3 and Table 4, provided as a function of deployed valve diameter (in mm), shall be used as a frame of reference for assessing transcatheter heart valve substitute performance. The parameters in Table 3 and Table 4 assume a circular deployed valve diameter; however, anticipated variation in deployed shapes shall be evaluated (e.g. round, out-of-round). For deployed valve diameters outside the ranges listed in Table 3 and Table 4, justification of performance parameters shall be provided by the manufacturer. When assessing retrograde flow, the manufacturer shall evaluate both the transvalvular regurgitant volume and the combined transvalvular and paravalvular regurgitant volume independently for comparison against the corresponding values listed in Table 3 and Table 4. EOA and regurgitant fraction values that do not comply with those listed in Table 3 and Table 4 shall be justified by the manufacturer. At a minimum, the performance shall be characterized at the smallest and largest intended deployed diameters; the deployed valve diameter within the relevant region of the implant site may be smaller than the unconstrained valve diameter. The minimum performance requirements correspond to the following pulsatile flow conditions: beat rate = 70 cycles/min, simulated cardiac output = 5.0 l/min, mean aortic pressure = 100 mmHg, and systolic duration = 35 %. These pulsatile flow conditions are based on a healthy normal adult and might not be applicable for pediatric device evaluation (see Annex H for pediatric parameters). The minimum performance requirements are based on values in the published scientific literature⁰⁰⁰.

Table 3 — Minimum device performance requirements, aortic

Parameter	Deployed valve diameter within implant site mm							
	17	19	21	23	25	27	29	31
A_{EO} (cm ²) greater than or equal to	0.70	0.85	1.05	1.25	1.45	1.70	1.95	2.25
Transvalvular regurgitant fraction (% of forward flow volume) less than or equal to	10	10	10	10	15	15	20	20
Total regurgitant fraction (% of forward flow volume) less than or equal to	15	15	20	20	20	20	25	25

Table 4—Minimum device performance requirements, mitral

Parameter	Deployed valve diameter within implant site mm					
	23	25	27	29	31	33
A_{EO} (cm ²) greater than or equal to	1.05	1.25	1.45	1.65	1.90	2.15
Transvalvular regurgitant fraction (% of forward flow volume) less than or equal to	15	15	15	20	20	20
Total regurgitant fraction (% of forward flow volume) less than or equal to	20	20	20	25	25	25

The total regurgitant fraction shall include closing volume, transvalvular leakage volume and paravalvular leakage volume.

$$EOA = \frac{q_{v,RMS}}{51.6 * \sqrt{\frac{\Delta p}{\rho}}}$$

where

EOA is the effective orifice area (cm²);

$q_{v,RMS}$ is the root mean square forward flow (ml/s) during the positive differential pressure period;

Δp is the mean pressure difference (measured during the positive differential pressure period) (mmHg);

ρ is the density of the test fluid (g/cm³).

NOTE 1 This formula is derived from a simplified version of the Bernoulli Equation and as such has limitations. The constant (51.6) is not dimensionless, thus this equation is only valid with the units shown.

NOTE 2 Defining the time interval for flow and pressure measurement as the positive pressure period of the forward flow interval for EOA computation provides repeatable and consistent results for comparison to the Table 3 and Table 4 reference values. It is recognized that this approach may not equate to the EOA computation approaches employed clinically.

NOTE 3 RMS forward flow is calculated using the equation

$$q_{v,RMS} = \sqrt{\frac{\int_{t_1}^{t_2} q_v(t)^2 dt}{t_2 - t_1}}$$

where

$q_{v_{RMS}}$	is root mean square forward flow;
$q_v^{(t)}$	is instantaneous flow at time t ;
t_1	is time at start of positive pressure;
t_2	is time at end of positive pressure.

NOTE 4 The rationale for use of $q_{v_{RMS}}$ is that the instantaneous pressure difference is proportional to the square of instantaneous flow rate, and it is the mean pressure difference that is required.

7.2.4 Structural performance assessment

An assessment of the ability of the implant to withstand the loads and/or deformations to which it will be subjected shall be performed in order to evaluate the risks associated with potential structural failure modes.

7.2.4.1 Device durability assessment

An assessment of the durability of the valve shall be performed in order to assess continued function over a reasonable lifetime. Unless the labeling for a particular device includes an explicit statement about anticipated *in vivo* device lifetime, testing shall be performed to demonstrate reasonable assurance that transcatheter heart valve substitutes will remain functional for at least 200 million *in vitro* test cycles. For materials without established clinical history as a valve leaflet/occluder, testing durations of greater than 200 million cycles shall be considered, and scientifically justified if not performed. If the labeling for a particular device includes an explicit statement about anticipated *in vivo* device lifetime, testing shall be performed to support the labeling claim.

The requirements of 7.2.1.1 shall apply. One equivalent size reference valve shall be tested under identical hydrodynamic loading conditions for each valve size tested. Tests shall be performed at a defined differential pressure consistent with normotensive conditions specified in Table 1 or Table 2. See Annex H for guidelines regarding suggested test conditions for the pediatric population. During the durability testing, the defined target peak differential pressure across the closed valve shall be maintained for 95 % or more of all the test cycles. Each test valve shall experience a differential pressure equal to or greater than the defined differential pressure for 5 % or more of the duration of each cycle. Cycle rates used for durability testing shall be justified based on the valve design, anticipated failure modes, and the behavior of time-dependent materials. Test valves shall experience the full range of leaflet/occluder motion associated with normotensive conditions (see Table 1, Table 2 and Annex H) during testing.

If transcatheter heart valve substitutes identical in design are intended for implant in multiple valve positions, testing shall include the differential pressure conditions defined for the worst case valve position. Consideration shall be given to variation in deployed valve shape (e.g. round, out-of-round) and intended operating temperature. In addition, test fixturing shall be designed to be representative of critical aspects of the target implant site (e.g. compliance, geometry).

The implant shall be deployed into the test fixturing using the loading and deployment steps in accordance with the IFU. Valves undergoing cycling in durability testers shall be observed at regular and frequent intervals (e.g. daily or weekly). Valves shall also be functionally evaluated at intervals of 50 million cycles or less for the duration of the test. A detailed description of the appearance of the heart valve and hydrodynamic performance shall be documented prior to testing, throughout the test at the established inspection intervals, and at the completion of test. The durability assessment shall be performed by characterization of the test valve in terms of the observed damage and the extent of

damage and by imposing pass/fail criteria for identified damage. The durability test setup parameters shall be verified by use of an appropriate reference valve. The failure modes to be considered and the pass/fail criteria for the test shall be determined based upon the risk assessment.

Dynamic failure mode testing shall be conducted. Guidelines for durability testing, including dynamic failure mode evaluation, are provided in Annex O.

7.2.4.2 Device structural component fatigue assessment

An assessment of the fatigue performance of the transcatheter heart valve substitute support structure shall be conducted; all components comprising the support structure, including anchoring features, shall be appropriately considered. Unless the labeling for a particular device includes an explicit statement about anticipated *in vivo* device lifetime, testing shall be performed to demonstrate reasonable assurance that the support structure will remain functional for a minimum of 400 million cycles for critical loading modes. If the labeling for a particular device includes an explicit statement about anticipated *in vivo* device lifetime, testing shall be performed to support the labeling claim. Failure criteria for fatigue testing shall be justified by the manufacturer based on the results of the risk assessment.

The manufacturer shall identify and justify the appropriate *in vivo* loading and environmental conditions used. Fatigue test and analysis shall, at a minimum, use conditions consistent with pressures associated with moderate hypertensive conditions listed in Table 1 and Table 2 and other relevant *in vivo* loading conditions. See Annex H for guidelines regarding suggested test conditions for the pediatric population. In addition, dynamic effects imparted by leaflet/occluder motion on resulting stress/strain magnitudes during valve closure shall be addressed.

Test specimens shall represent, as closely as possible, the finished product as supplied for clinical use, including exposure to the maximum number of recommended sterilization cycles, process chemicals, aging effects, and any catheter crimping, loading and deployment steps in accordance with manufacturing procedure and IFU. Consideration shall be given to anticipated variations in the deployed device shape. Devices shall be tested at the intended operating temperatures and environmental conditions. In addition, test fixtures shall be designed to be representative of critical aspects of the target implant site (e.g. compliance, geometry). The implant shall be deployed into the test fixtures using the loading and deployment steps in accordance with the IFU.

A validated stress/strain analysis of the structural components of the implant under simulated *in vivo* conditions shall be performed on all structural components. Loading from all valve components shall be considered. For example, where analysis is only required for the support structure, it might be necessary to include reaction loads associated with dynamic effects of leaflet/occluder closure in the analysis in order to simulate *in vivo* loading realistically. An appropriate validated constitutive model for each material shall be used in any stress analysis, including time-dependent, temperature-dependent and/or non-linear models.

Fatigue characterization and lifetime assessment of the structural components under simulated *in vivo* conditions shall be performed in order to evaluate risks associated with fatigue-related failure modes. The manufacturer shall determine and justify the fatigue assessment approach and associated characterization technique adopted in order to best determine the structural lifetime for the specific material and valve/component design. Suggested guidelines are provided in Annex P and Annex L.

7.2.4.3 Component corrosion assessment

An assessment of the corrosion resistance of all constituent materials comprising the transcatheter heart valve substitute system shall be conducted. It is well established that metal corrosion potential can be sensitive to variations in manufacturing processes (e.g. heat treatment, chemical etching,

electropolishing). Therefore, the corrosion resistance shall be characterized using the finished component. Annex M provides guidance on corrosion resistance characterization.

The manufacturer shall provide rationale for the selected test methods and justify that all corrosion mechanisms and conditions have been considered through testing or theoretical assessments.

7.2.5 Additional implant design evaluation requirements

The following implant design evaluation requirements shall apply as appropriate. Justification shall be provided for those requirements that are deemed not applicable to a particular design. Additional implant design evaluation requirements could be applicable as per ISO 25539-1. The manufacturer shall define all applicable requirements based on the results of the risk assessment for the specific device design.

7.2.5.1 Device migration resistance

The ability of the implantable device to remain in the target implant site under simulated operating conditions shall be assessed. Consideration shall be given to variation in deployed shape, deployed size, implant site characteristics (e.g. degree and distribution of calcification) and mechanical properties (e.g. compliance). The pressure conditions specified in Table 1 and Table 2, and other loading conditions, shall be considered as applicable. See Annex H for guidelines regarding suggested test conditions for the pediatric population. One suitable method to assess device migration resistance is to utilize a pulsatile test conducted by ramping up the pressure in a step-wise manner.

7.2.5.2 Device MRI safety

The manufacturer shall evaluate the safety and compatibility of the implant with the use of MRI as per ASTM standards F2052, F2213, F2182, F2119, and F2503.

7.2.5.3 Implant foreshortening (length to diameter)

The manufacturer shall determine the relationship between implant length and expanded implant diameter. Depending on the design, the length of a device might change with deployed diameter. The specific implant length could affect implant function.

7.2.5.4 Crush resistance

The manufacturer shall determine the ability of the support structure to resist deformation due to crushing loads over a diameter range that spans the recommended range of deployed diameters per the IFU. This is accomplished by the following evaluations:

- the crush resistance test with a radially applied load measures the ability of the non-self-expanding support structure to resist permanent deformation when subjected to a circumferentially uniform radial load;
- the crush resistance test using parallel plates measures the ability of the support structure to resist permanent deformation along the entire length of the device when subjected to a load uniformly applied over the length of the device.

7.2.5.5 Recoil (balloon expandable stents)

Determine the amount of device diameter elastic recoil (percent of device diameter reduction) after the deployment of the implant. Correlate this recoil to recommended sizing.

7.2.5.6 Dimensional verification

Determine the appropriate dimensions for conformance with design specifications.

7.2.5.7 Radial resistive force

For self-expanding support structures, the manufacturer shall characterize the force exerted by the support structure as it resists radial compression from its maximum diameter to its minimum crimp diameter per the IFU. See nitinol-specific definitions in Annex J.

7.2.5.8 Chronic outward force (COF)

For self-expanding support structures, the manufacturer shall characterize the force exerted by the support structure as it attempts to expand to its maximum unconstrained diameter after being radially compressed to its minimum crimp diameter as per the IFU. Depending on the support structure design, the COF might be different in different regions of the support structure and should be evaluated accordingly. See nitinol-specific definitions in Annex J.

7.2.6 Delivery system design evaluation requirements

ISO 25539-1 and ISO 10555-1 were used as a basis for defining delivery system design evaluation requirements specified herein. Justification shall be provided for those requirements that are not applicable. The manufacturer shall define all applicable requirements based on the results of the risk assessment for the specific delivery system design and delivery approach (e.g. transfemoral, transapical).

7.2.6.1 Implant interactions with delivery system

The manufacturer shall evaluate interactions between the implant and delivery system during use in accordance with the IFU to ensure no damage is induced to the implant or delivery system. The following aspects shall be evaluated as applicable:

- crimping/loading and attachment of the device to the delivery system;
- loading device into the delivery sheath;
- positioning/deployment of the device within the target implant site;
- repositioning/recapturing of the device (if applicable) including damage to the valve if intended for immediate re-use;
- withdrawal of the delivery system from the patient;
- component dimensional compatibility with ancillary devices.

7.2.6.2 Loading of the device into the delivery system

The manufacturer shall define all specific performance parameters to be evaluated to verify safe and reliable loading of the device into the delivery system. The manufacturer shall demonstrate that the implantable device can be reliably attached to the delivery system in accordance with the IFU and satisfy attachment performance requirements, such as:

- attachment strength between the device and the delivery system;
- no damage to the device or the delivery system;
- crimped diameter;

- crimped shape (uniform or non-uniform);
- proper orientation of the device into the delivery system;
- dislodgement force;
- device sterility;
- device rinsing;
- delivery system flushing (de-airing);
- component dimensional compatibility with ancillary devices.

7.2.6.3 Ability to access and deploy

The manufacturer shall demonstrate that the attachment between the device and the delivery system shall be sufficient to permit safe, repeatable and reliable delivery of the device to the intended implant site, release of the device from the delivery system and safe removal of the delivery system from the patient in accordance with the IFU. The manufacturer shall define all specific performance parameters to be evaluated to verify safe and reliable deployment of the device within the intended implant site, such as:

- force to deploy;
- all relevant forces required to reposition the device (if applicable);
- flex/kink resistance;
- bond strength (tensile and torque);
- torquability;
- pushability;
- trackability;
- access angle between apex and annular plane for trans-apical delivery approach;
- hemostasis;
- time to deploy, including time of flow restriction or blockage, and time to restore flow;
- component dimensional compatibility with ancillary devices;
- balloon characteristics (if applicable);
- inflation/deflation time;
- relationship between the implant diameter and balloon inflation pressure, including assessment of effects associated with over-inflation and under-inflation;
- mean burst pressure;
- rated burst pressure;
- rated fatigue.

7.2.7 Design-specific testing

In order to assess failure modes identified by the risk assessment that may not be related to durability or component fatigue, design-specific testing may be necessary. In some cases, design-specific testing may have direct implications for the overall structural lifetime of a component or valve and additional tests may be required e.g. support structure creep, static pressure test, particulate generation, burst/circumferential strength, leaflet kinematics, retrievability of device, repositionability of device, effects of device post-dilatation.

AAMI
Single user license provided to AAMI standards committee members.

7.2.8 Visibility

The ability to visualize the implanted device and delivery system during delivery, deployment and after delivery system withdrawal, using the manufacturer's recommended imaging modality [e.g. fluoroscopy, MRI, computed tomography (CT), echocardiography] shall be evaluated.

7.2.9 Simulated use

The ability to permit safe, consistent and accurate deployment of the transcatheter heart valve substitute within the intended implant site shall be evaluated using a model that simulates the intended use conditions. This assessment will include all elements of the transcatheter heart valve substitute system required to facilitate delivery and implantation of the implantable device. The model shall consider anatomical variation in intended patient population with respect to vasculature and intended implant site, temperature effects, pulsatile flow, etc. Justification for critical parameters of the simulated use model shall be provided. Potential hazards associated with inaccurate valve position and deployment and resulting effects on valve performance and unintended anatomical interactions (i.e. coronary occlusion, anterior mitral impingement) shall be documented within the risk assessment.

7.2.10 Human factors/usability assessment

In addition to conducting simulated use to evaluate the functionality of the transcatheter heart valve substitute, simulated use shall also be conducted as part of the required usability assessment (or "usability testing") as per IEC 62366. The main objective of the usability assessment is to validate that intended users of the device or system can use it safely and effectively to deliver and deploy the device in the patient. Usability assessment performance measurements shall be based on use error analysis results. The assessment shall primarily focus on whether or not the design attributes of the device or system used to conduct the implant procedure appropriately mitigate identified potential use errors that can occur. It is recommended that usability assessment be conducted throughout the design cycle.

7.3 Preclinical *in vivo* evaluation

7.3.1 Overall requirements

A preclinical *in vivo* test program shall be conducted in order to address transcatheter heart valve substitute system delivery, deployment and imaging characteristics and transcatheter heart valve substitute safety and performance. The preclinical program design should be based on risk management assessment. This program may involve the use of different species and implant durations to address the key issues identified in the risk assessment. The use of alternative implantation sites (e.g. chronic pulmonary valve replacement rather than aortic valve replacement), alternative implantation techniques (e.g. transapical delivery, surgical) and acute as well as chronic studies might be justified to accommodate specific transcatheter heart valve substitute design features and species-specific anatomic differences. Due to anatomic species differences and use of non-diseased animal models, in some cases more reliance on *in vitro* testing might be necessary to assess the potential for migration, embolization and the effect of heart valve substitute post-implantation changes in shape on hemodynamic performance.

The preclinical *in vivo* evaluation shall:

- a) evaluate the extent to which the hemodynamic performance of the transcatheter heart valve substitute reflects the intended clinical use;
- b) assess delivery deployment, implantation procedure and imaging characteristics of the transcatheter heart valve system. Consideration should be given, but not limited, to the following items:

AAMI
Single user license provided to AAMI standards committee members.

- 1) ease of use;
 - 2) delivery system handling characteristics (e.g. pushability, trackability);
 - 3) proper valve alignment relative to flow (e.g. note the presence of device angulation, bends, kinks);
 - 4) post-implantation changes in shape and structural components of the transcatheter heart valve;
 - 5) imaging characteristics;
 - 6) migration or embolization of the heart valve substitute;
 - 7) ability to recapture and re-deploy the heart valve substitute, if applicable;
- c) assess the *in vivo* response to the heart valve substitute. Consideration should be given, but not limited, to the following items:
- 1) healing characteristics (e.g. pannus formation, tissue overgrowth);
 - 2) effect of post-implantation changes in shape and structural components on hemodynamic performance;
 - 3) hemolysis;
 - 4) thrombus formation;
 - 5) embolization of material from the implant site, delivery device or heart valve substitute;
 - 6) migration or embolization of the heart valve substitute;
 - 7) proper alignment relative to flow (note the presence of angulations, bends, kinks);
 - 8) biological response (e.g. inflammation, rejection);
 - 9) calcification;
 - 10) structural and non-structural dysfunction;
- d) use the final clinical design and condition of the transcatheter heart valve substitute system. The system shall be prepared, deployed and imaged using the same procedures (e.g. preparation of the device for delivery and deployment) as intended for clinical use. Consideration shall also be given to effects of maximum allowable conditioning steps (e.g. maximum sterilization cycles, maximum crimp time, maximum crimp cycles):
- 1) if needed, ancillary short-term studies could be conducted to evaluate unique design and delivery aspects of the device;
 - 2) the manufacturer shall justify any modifications to the device or system that may be required for implantation in the animal model;
- e) investigate transcatheter heart valve substitute system in positions for which it is intended (e.g. aortic, mitral, pulmonic); if species-specific anatomic features or the use of a non-diseased animal model confound the ability to evaluate the transcatheter heart valve substitute in positions for which it is

intended, provide a justification for implantation in an alternative site or the use of alternative implantation procedures;

- f) subject comparably sized reference heart valve substitutes to identical anatomic and physiological conditions as the test device;
- g) be performed by appropriately experienced and knowledgeable test laboratories;
- h) address animal welfare in accordance with the principles provided in ISO 10993-2.

7.3.2 Methods

Guidance on the conduct of *in vivo* preclinical evaluation and a series of tests which can be used to address the relevant issues is provided in Annex Q. The intent of these studies is to mimic as closely as possible the clinical use and hemodynamic performance of the transcatheter heart valve system (delivery, deployment, imaging and test heart valve substitute). It is recognized that adverse events arising after valve implantation can be attributed to the implanted valve, the procedure, and/or the environment into which it is implanted, including interactions among these. Therefore, serious adverse events arising during or after valve implantation shall be carefully analyzed and interpreted in order to identify the cause of the adverse event.

The investigator should seek to control as many variables as possible within each study arm (e.g. species, gender and age). Animals suffering from periprocedural complications (e.g. endocarditis) may be excluded from the group of study animals, but they shall be reported.

The number of animals used for implantation of test and reference heart valve substitutes shall be justified for each test based on risk assessment.

For long-term studies, the specified duration of the observation period of the animals shall be justified according to the parameter(s) under investigation. The observation period shall be appropriately justified in each study protocol, but will not be less than 90 days.

A macroscopic, radiographic and histological post-mortem examination shall be performed, focusing on device integrity and delivery system/device related pathology. The report shall include this information from all animals that have been entered into the study.

The assessment shall provide at least the following:

- a) any detectable pathological consequences, including but not limited to: migration or embolization; valve alignment relative to flow noting the presence of angulations, bends or kinks; post-implantation changes in shape of structural components; thrombo-embolic phenomena; pannus formation; and inflammatory responses involving the transcatheter heart valve substitute and/or in the major organs;
- b) any macro- or microscopic or radiographic detectable structural alterations in the transcatheter heart valve substitute and macroscopic examination of the delivery system, (e.g. damage, material degeneration, changes in shape or dimensions);
- c) serial blood analyses performed pre-operatively, at appropriately justified intervals during the observation period, and at termination to assess hemolysis, abnormalities in hematology and clinical chemistry parameters;
- d) delivery and deployment characteristics, including but not limited to ease of use, handling characteristics, imaging, sizing technique, retrieval and redeployment;

- e) hemodynamic performance over a range of cardiac outputs (e.g. 2.5 to 6 l/min) in the same animal;
- f) serious adverse events (e.g. myocardial infarction, significant cardiac arrhythmias, embolization); refer to ISO 14155 for serious adverse events definitions;
- g) any other system or procedure-related complication or events.

7.3.3 Test report

The laboratory performing the preclinical *in vivo* study shall produce the test report, which shall include a description of the risk evaluation, the complete original study protocol, all data generated from the preclinical *in vivo* evaluation, and a summary of the data generated during the course of the investigation, addressing the results, including serious adverse events, deviations from the protocol and their significance, generated by evaluations described in Annex Q.

The test report shall include:

- a) identification of each of the system components (delivery system, transcatheter heart valve substitute and other auxiliary devices) used in the procedure (product description, serial number and other appropriate identification);
- b) detailed description of the animal model used, the rationale and justification for its use. The pre-procedural assessment of each animal shall include documentation of health status as well as gender, weight and age of the animal;
- c) description of the imaging technique(s), the implantation procedure, including delivery, deployment and sizing technique, valve position and any procedural difficulties;
- d) description of the pre-procedural and post-procedural clinical course of each animal including clinical observations, medication(s) and interventions used to treat serious adverse events. Describe anticoagulation or antiplatelet drug and regimen used as well as therapeutic level monitoring methods;
- e) any deviations from the protocol or amendments to the protocol and their significance;
- f) names of the investigators and their institutions along with information about the implanting personnel and the laboratory's experience with heart valve substitute implantation and animal care;
- g) interpretation of data and a recommendation relative to the clinical safety and performance of the transcatheter heart valve substitute system under investigation;
- h) the study pathologist's report that includes gross and radiographic examination and histopathology findings for each explanted heart valve substitute;
- i) detailed full necropsy reports for each animal enrolled in the study that includes an assessment of the entire body or such findings as thromboembolism or any other adverse effects putatively from the heart valve substitute;

Further details of the test report depend on the defined test protocol.

7.4 Clinical investigations

7.4.1 General

Clinical investigations shall be performed for new or modified transcatheter heart valve systems to investigate those risks and aspects of clinical performance that cannot be fully evaluated from pre-clinical or other available data. Clinical investigations shall be carried out in accordance with this part of ISO 5840 and ISO 14155. If a determination is made that clinical investigations are not required, justification shall be documented in the risk management file.

Clinical studies shall be designed to fully evaluate the transcatheter heart valve system in its intended uses. The studies shall include an assessment of adverse events related to risks arising from the use of the transcatheter heart valve system and from the procedure. The clinical investigation shall include pre-procedure, peri-procedure, and follow-up data from a specified number of patients, each with a follow-up appropriate for the device and its intended use. The clinical data shall provide substantial evidence of acceptable performance and safety (i.e. freedom from unacceptable risk).

The study protocols should specify primary and secondary end points as well as specific study related adverse events with consideration of Annex R and published definitions. The definitions of the outcome measures should be consistent with those employed in previous studies of heart valves, when appropriate. The study protocol shall include a data analysis plan and success criteria.

The manufacturer is responsible for ensuring collection of appropriate information. The design shall be consistent with the aims of the protocol. For a given study, data collection forms should be the same for each institution and investigator. The protocol shall ensure consistency between the study aims and the inclusion/exclusion criteria.

Studies should employ measures to minimize bias. The use of an independent clinical events adjudication committee to classify events against pre-established criteria, and core laboratories are recommended for outcome variables that might be prone to inter-observer variability.

To ensure patient safety, a safety monitoring plan shall be established. Study oversight may be provided by a data safety monitoring committee.

Study designs may vary depending on the purposes of the assessment (randomized/contemporaneously controlled superiority or non-inferiority, observational/registry, etc.), and the intended duration of implantation (e.g. bridge to next planned valve reoperation versus permanent implant). To the extent feasible, study populations shall be representative of the intended post-market patient population. If registries are a part of the study design, the registries shall be constructed to include consecutive series of patients. Further, studies shall be designed to ensure ascertainment of protocol specified follow-up information for a relevant duration in all patients entered into the study unless patients specifically withdraw consent for follow-up. In this case, follow-up in these patients will end at the time of the withdrawal, except that, depending on local legal requirement relevant to patient privacy, survival may still be followed.

7.4.2 Statistical considerations

The size, scope and design of the clinical trial shall be based on (i) the intended use of the device, (ii) the results of the risk analysis, (iii) measures that will be evaluated, and (iv) the expected clinical outcomes. The basis for the sample size shall be documented. The manufacturer is responsible for proposing and justifying the specific statistical methodology used. The methods may come from either a frequentist or Bayesian framework. If a Bayesian design is used, the prior information incorporated in the model should be prespecified. Designs may use fixed sample size or pre-specified adaptive methodology.

^AAMI
Single user license provided to AAMI standards committee members.

Prior to embarking on a large clinical trial, a feasibility study may be considered when the risks or clinical performance of the new device are not well understood.

A randomized controlled study, assessing superiority or non-inferiority as appropriate, should be considered to minimize bias when existing objective performance and safety metrics are inadequate. Depending on the scope and objectives of the clinical study, other designs might be appropriate; however, non-randomized study designs shall implement appropriate measures to minimize bias.

While double-blind randomized trials are ideal, blinding of patients and primary investigators might not be possible in studies of valves. In situations where randomization is possible but blinding is not, randomization of patients to treatments should be performed so that neither the patient nor the investigator knows the subsequent assignment. For both randomized and non-randomized studies, if the outcome measure cannot be measured objectively, blinded assessments are most appropriate. In these cases, methods shall be chosen to minimize bias to the greatest extent possible (e.g. using independent, blinded assessors to obtain the study outcome measures).

If a comparable device is not on the market, randomization against an appropriate alternative therapy should be considered.

If a comparable device is on the market, a non-inferiority design might be most appropriate. The requirements for a device that is a modification of an approved device might be less stringent depending on the risk analysis. If the study uses a non-inferiority design, the non-inferiority margin should be justifiable and, to the extent feasible, based on prior data from comparable devices.

7.4.3 Distribution of subjects and investigators

Clinical investigations shall be designed to include enough subjects, clinicians and institutions to be reasonably representative of the intended patient and user populations to provide generalizable results. The protocol shall specify the planned number of institutions and minimum and maximum number of subjects and investigators per institution.

7.4.4 Sample size

The sample size should be sufficient to enable assessment of the clinical performance of the system as well as to quantify the associated risk. When appropriate to the study aims, standard statistical methods should be used to calculate the minimum sample size with prior specification of the Type 1 error rate, the statistical power, and effect sizes to be detected.

7.4.5 Entry criteria

The inclusion and exclusion criteria shall be clearly established. The target population (i.e. those for whom the device is intended) and the accessible population (i.e. those who will enter the study) shall be specified and salient differences between those two populations justified. The study should only include patients who are willing and able to participate in the follow-up requirements.

7.4.6 Duration of the study

The protocol shall specify the duration of the study. The duration will depend on specific purposes of the study (e.g. bridge to a planned valve reoperation or a permanent implant) as identified by the risk assessment, the intended application and, if relevant, the type of device modification. The intended application includes the disease and population for which the device is intended, including the expected duration of survival in a parallel disease-free population.

7.4.7 Clinical data requirements

7.4.7.1 General

Clinical data, including adverse events, shall be recorded for all patients in the study as required by ISO 14155.

The investigational protocol shall include an explant pathology protocol with detailed instructions for the return of the explanted valves to the manufacturer or an independent laboratory for assessment. Whenever feasible, the explanted device shall be subjected to appropriate functional, imaging and histopathological investigations.

The data given in 7.4.7.2 and 7.4.7.3 shall be collected or a justification for not doing so shall be provided.

7.4.7.2 Baseline

- a) Demographics (e.g. age, gender, race/ethnicity).
- b) Baseline information (e.g. weight, blood pressure).
- c) Patient co-morbidities and co-existing medical conditions (e.g. liver, kidney and lung disease, substance abuse, diabetes, hypertension, and history of endocarditis).
- d) Diagnosis (e.g. valvular lesion and aetiology) and co-existing cardiovascular diseases (e.g. heart failure, cardiomyopathy, aneurysm, cerebral vascular disease, peripheral vascular disease, coronary artery disease, previous myocardial infarction), and cardiac rhythm.
- e) New York Heart Association (NYHA) functional class and, if relevant, Society of Thoracic Surgeons (STS) score or EuroSCORE, or both. Quality of life indicators or exercise tolerance tests should also be considered.
- f) Previous cardiovascular interventions [e.g. coronary artery bypass, coronary artery angioplasty, percutaneous valvuloplasty (position), operative valvuloplasty (position), valve repair (position), previous heart valve implantation (position), peripheral vascular interventions].
- g) Echocardiographic and other relevant imaging data to provide cardiac hemodynamic, geometric and functional information, to characterize the diseased valve and to assess implant site and annulus size.
- h) Relevant imaging data for assessment of potential delivery approach.
- i) Blood studies assessing hepatic, cardiac and renal status, and including hematologic/coagulation profile.

7.4.7.3 Peri-procedure data

- a) Any differences from original diagnosis.
- b) Any concomitant interventions or procedures.
- c) Date of procedure.
- d) Transcatheter heart valve system (e.g. type, models, sizes, and serial numbers).

- e) Assessment of implant site and annulus size, or other relevant sizing measure of patient.
- f) Implantation technique.
- g) List of all devices used.
- h) Removal of all or part (specify) of native valve structures, if relevant.
- i) Implant position (e.g. aortic or mitral), heart valve substitute positioning in relation to tissue annulus (e.g. supra-annular or intra-annular).
- j) Transcatheter heart valve substitute position relative to critical anatomy (e.g. with reference to coronary ostia, mitral valve leaflet).
- k) Assessment of handling, visualization, deployment, orientation, implant location and withdrawal of delivery system.
- l) Quantitative and qualitative assessment of deployed valve geometry and configuration.
- m) Details of procedure, including any adjunctive procedures performed (e.g. radiation dosage) and medications.
- n) Procedural complications, including subsequent interventions.
- o) Evaluation by echocardiography and/or other relevant imaging and hemodynamic modalities, as defined in the clinical protocol. At a minimum, pressure gradient and degree of regurgitation should be documented.

7.4.7.4 Follow-up data

Follow-up data shall be collected at 30 days, at least one specific time point between three and six months, at one year, and annually thereafter until the investigation is completed. The following evaluations should be performed at all follow-up assessments unless an adequate risk analysis justifies a less frequent interval. Depending on the trial design, additional data collection times might be appropriate.

NOTE Additional follow-up intervals might be appropriate to document early or long-term structural valve dysfunction or non-structural dysfunction.

The following data shall be collected or a justification for not doing so shall be provided:

- a) date and location of follow-up;
- b) New York Heart Association functional class;
- c) quality of life indicators and exercise tolerance tests should also be considered;
- d) device assessment (e.g. implant location, geometry, structural integrity, orientation);
- e) hemodynamic evaluation by Doppler echocardiography, or other relevant methodology (see Annex S);
- f) heart rate, conduction status and rhythm;

- g) tests for hemolysis (e.g. plasma-free hemoglobin) (other blood assessments may also be indicated);
- h) status of anticoagulant and/or antiplatelet therapy;
- i) adverse events as specified in Annex R, concomitant therapies that might include cardiac assist and need for pacing;
- j) reoperation reports;
- k) date and cause of death;
- l) autopsy report, if autopsy is performed.

7.4.8 Clinical investigation report

7.4.8.1 General

The clinical investigation report shall comply with ISO 14155. The report shall tabulate or otherwise summarize the data required by 7.4.7 and shall provide an analysis of the following, at a minimum:

- a) patient population by age and gender;
- b) pre-procedural versus post-procedural New York Heart Association functional class;
- c) pre-procedural versus procedural diagnoses of valvular and coexisting disease;
- d) system handling, visualization, deployment, orientation, implant location, procedural complications and subsequent procedures;
- e) pre-procedural versus post-procedural hemodynamic and blood study results;
- f) adverse events as defined in the study protocol.

7.4.8.2 Analysis and reporting

The clinical investigation report should include information on all patients for whom implantation was planned (the "intent-to-treat" population). For randomized studies, the groups should include all randomized patients, even those who did not receive the implant. Additional analyses should be performed on the patients who actually received the implant.

Specific analyses shall include:

- a) overall survival;
- b) occurrence of adverse events (see Annex R).

7.4.8.3 Post-market clinical follow-up

In addition to the follow-up of the original cohort of patients, post-market hypothesis driven clinical studies shall be initiated when indicated on the basis of the risk analysis to gather data from a larger population. Possible objectives for post-market clinical follow-up studies are to: a) provide longer term safety and performance data and b) assess whether the results of the pre-market clinical investigation can be generalized to the post-market population. In addition to post-market hypothesis driven clinical follow-up

studies, longer term post-market surveillance (registry) follow-up studies might also need to be conducted, particularly if the rate of enrolment in the post-market hypothesis driven studies is low (e.g. pediatric studies). Post-market surveillance (registry) studies should include a systematic review of data obtained from routine clinical procedures, always noting that consecutive patient series are highly desirable and, for defining absolute rates of adverse events, are imperative.

If a post-market clinical study is conducted, the follow-up evaluation shall be performed according to the following principles:

- a) the long-term follow-up cohort might include all patients in the pre-marketing studies, a subset of the original patients, or additional patients;
- b) a cohort assessment to evaluate whether the results of the pre-market clinical investigation can be generalized to the post-market population;
- c) the scope and duration of any post-market study will depend on the risk assessment;
- d) specifically for establishing adverse event rates, observational registries can be useful. They generally shall be designed to capture consecutively treated patients, and should be of sufficient size so that point estimates have acceptably narrow confidence intervals.

Annex A (informative)

Rationale for the provisions of this part of ISO 5840

A.1 Rationale for risk-based approach

The rationale for basing this part of ISO 5840 on risk management is that the traditional requirements-based model cannot keep up with the speed of technological innovation. With the requirements-based model, manufacturers have to spend their time looking for ways to comply with the requirements of this part of ISO 5840, rather than on developing new technologies that could lead to inherently safer products. The risk-based model challenges the manufacturer to continually evaluate known and theoretical risks of the device, to develop the most appropriate methods for reducing the risks of the device, and to implement the appropriate test and analysis methods to demonstrate that the risks have been reduced.

This part of ISO 5840 combines a requirement for implementing the risk-based model with a listing of best practice methods for verification testing appropriate to transcatheter heart valve system evaluation. The intent of the risk assessment is to identify the hazards along with the corresponding failure modes and causes in order to identify the requisite testing and analysis necessary to evaluate the risk associated with each specific hazard. The brainstorming/decision-making/documentation process inherent in risk management provides the opportunity for the manufacturer to evaluate the best practice methods included within this part of ISO 5840. The manufacturer may choose to follow the best practice method as defined within this part of ISO 5840, or may deviate from the method and provide a scientific justification for doing so. The risk management file required by ISO 14971 should document these decisions with rationale.

The risk-based model requires a collaborative environment between the device developer (the manufacturer) and the body responsible for verifying compliance with the applicable regulation regarding safety and performance of the device. The manufacturer should strive for continuous improvement in device design as well as test methodologies that can ensure safety and performance of a device with less reliance on years of patient experience for evidence of effectiveness.

A.2 Rationale for preclinical *in vivo* evaluation

The overall objective of preclinical *in vivo* evaluation is to test the safety and function of the transcatheter heart valve system in a biological environment with the closest practically feasible similarity to human conditions.

The preclinical *in vivo* evaluation is the final investigational step prior to human implantation. Therefore, it should provide the regulatory body with an appropriate level of assurance that the transcatheter heart valve system will perform safely.

No single uniformly acceptable animal model has been established. Therefore, the animal model(s) selected should be properly justified in order to ensure the highest degree of human compatible conditions for the delivery system and test valve pertinent to the issues being investigated. Since chronic studies are conducted to elucidate heart valve substitute hemodynamic performance, biological responses, structural integrity and delivery system and valve-related pathology in a specific anatomical

position, it is preferable to undertake this longer-term testing of the valves in anatomical positions for which it is intended.

The concurrent implantation of reference heart valve substitutes enhances the comparative assessment by providing a bridge to known clinical performance. In addition, such an approach facilitates the distinction between the complications related to the reference heart valve substitute versus those of the transcatheter heart valve system.

A.3 Rationale for design verification and design validation testing

Verification and validation testing includes materials testing, preclinical bench testing, preclinical *in vivo* evaluation and clinical investigations. Although clinical investigations are usually considered to be part of design validation, some of the requirements established under design input might be verifiable only under clinical conditions. The tests specified herein do not purport to comprise a complete test program; a comprehensive test program for the transcatheter heart valve system should be defined as part of the risk assessment activities. Where the manufacturer's risk assessment concludes that the safety and performance will be better demonstrated by other tests or by modifying the test methods included in this part of ISO 5840, the manufacturer should include in the risk assessment a justification of the equivalence or superiority of the alternative test or test method.

The manufacturer should validate the design of the transcatheter heart valve system, its packaging, labeling and accessories. For a new transcatheter heart valve system, design validation typically occurs in two phases. In the first phase, the manufacturer reviews the results of all verification testing and the manufacturing process validation, prior to the first human implant. The review might also include analysis of the scientific literature, opinions of clinicians and other experts who will be using the device, and comparisons to historical evidence from similar designs. The output of the review should be that the device is safe and suitable for human clinical investigations. The second phase of design validation occurs in conjunction with the outcomes of the pre-marketing approval of the clinical investigation. The data from the approval phase clinical investigation should be reviewed to ensure that the device, its packaging, labeling and accessories are safe and suitable for their intended use and ready for market approval. These validation activities should be documented.

For a modification to an existing transcatheter heart valve system design or manufacturing method, the concepts of verification and validation continue to be applicable but might be limited in scope. The risk analysis should define the scope of the verification and validation.

The use of clinical grade materials and components, as opposed to generic test samples, is important since fillers, additives and processing aids can have profound implications on material properties. Testing should be designed to evaluate areas where materials are joined (e.g. welded, sutured or glued) since these are potential areas for failure.

A.4 Rationale for Doppler echocardiographic assessment

Echocardiography and Doppler echocardiography are presently accepted as practical and available methods for evaluating human cardiac function and the function of heart valve substitutes. The accuracy of these diagnostic procedures depends upon the skill of the operator. All investigating institutions involved in the clinical evaluation of a specific transcatheter heart valve substitute should employ the same echocardiographic protocol.

A.5 Rationale for clinical evaluation reporting

Accepted guidelines for reporting end points are contained within Reference 0. The purpose of these guidelines is to facilitate the analysis and reporting of results of procedures on diseased cardiac valves. The definitions and recommendations are designed to facilitate comparisons among different clinicians, cohorts, delivery techniques and devices. A transcatheter heart valve substitute undergoing clinical evaluation should function as intended, with valve complication rates within broadly acceptable performance criteria limits, based on published follow-up studies. To enable appropriate risk assessment, preoperative, peri-operative and follow-up data should be collated, analyzed and reported.

The clinical evaluation of a transcatheter heart valve substitute after implantation requires documentation of specified complications (see 7.4). A new or modified transcatheter heart valve substitute should perform as well as existing heart valve substitutes. Where appropriate, randomized clinical trials should be conducted comparing the transcatheter heart valve substitute against surgically implanted heart valve substitutes and/or medical therapy. The clinical evaluation also requires formal statistical evaluation of the clinical data. Unanticipated valve-related complications will be reported and evaluated prior to the completion of the formal methods of overall performance evaluation. Statistical evaluation methods and assessment criteria of clinical data could be different between pediatric and adult study populations. Given the perceived significant risks associated with transcatheter heart valve substitutes, post-market surveillance protocols should be established.

A.6 Rationale for device sizing within labeling and instructions for use

In the past, problems have been reported with the labeling and instructions for use associated with size designations and sizing procedures for replacement heart valves. This has led to confusion among users about which size valve to implant in a particular patient. This has also led to confusion about how to compare results (published or otherwise) from one valve model to another. A solution to the problem can be achieved by providing more complete sizing information (e.g. deployed size range), which will ultimately benefit the clinician and the patient.

A.7 Rationale for human factors engineering

There is a published human factors standard: IEC 62366. Manufacturers should incorporate human factors engineering into their overall product development process in order to ensure the design and development of safe, effective and easy-to-use transcatheter heart valve systems.

Annex B
(informative)

Examples of transcatheter heart valve substitutes, components and delivery systems

B.1 Examples of transcatheter heart valve substitutes

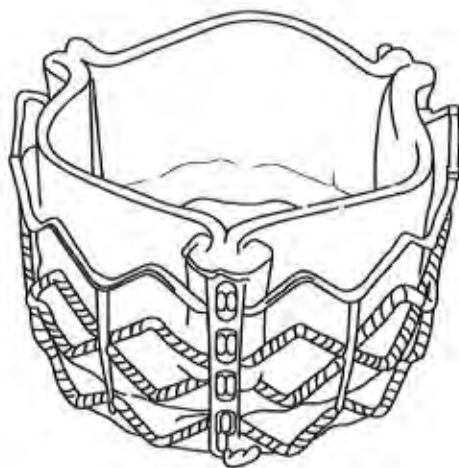

Figure B.1 — Example A

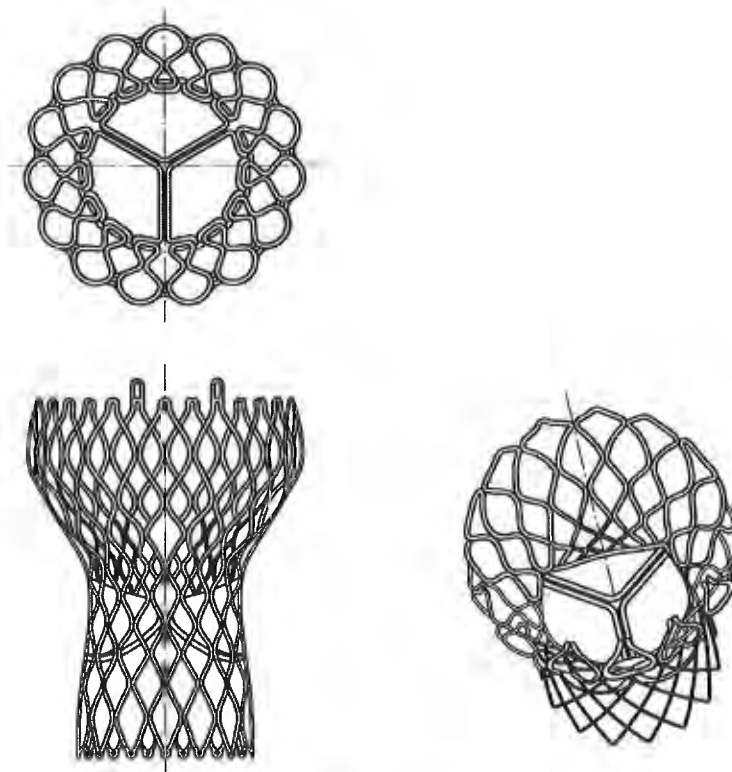
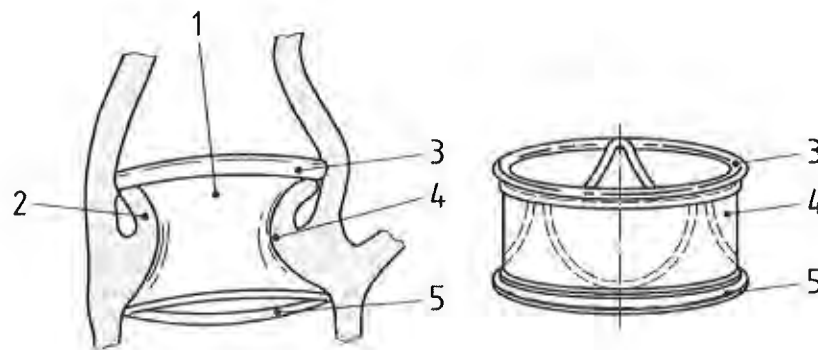

Figure B.2 — Example B



Key

1	implant
2	diseased valve, left ventricle
3	outflow end
4	mid-portion, used as diameter reference point
5	inflow end

Figure B.3 — Example C

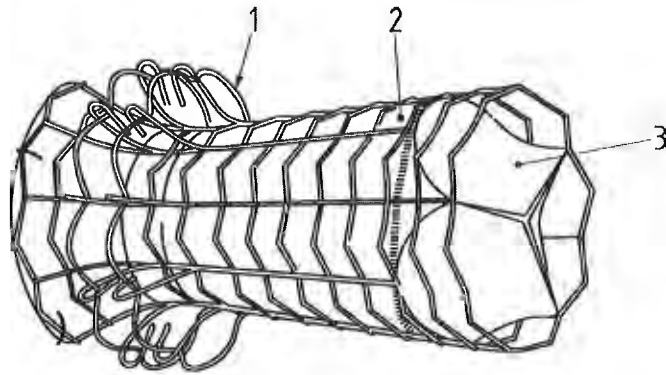

Key

1	annular clamp
2	diverging section, extends into aorta
3	prosthetic valve

Figure B.4 — Example D

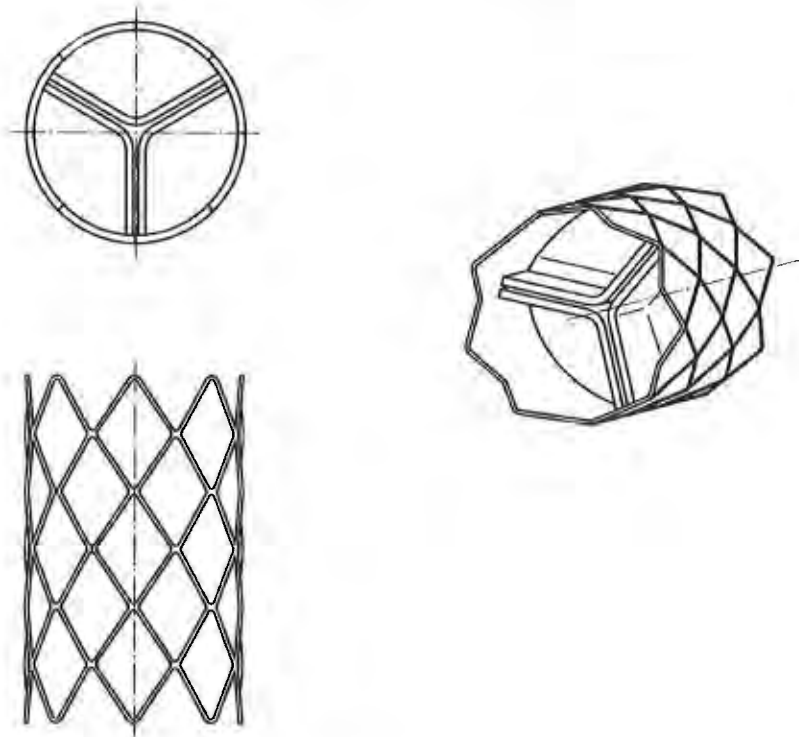
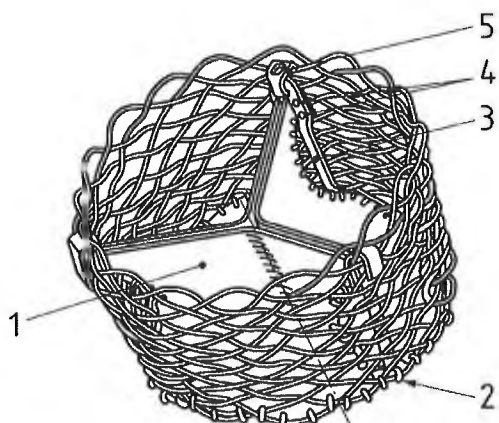

Figure B.5 — Example E



Key

1	replacement valve
2	anchor
3	post
4	holes, leaflet tissue can come through
5	buckle

Figure B.6 — Example F

B.2 Examples of delivery systems

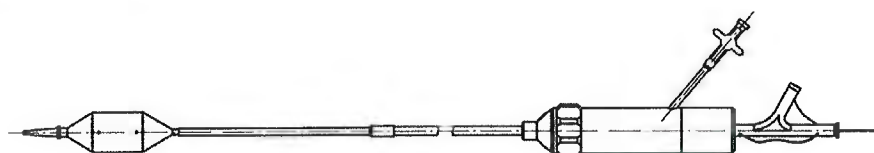
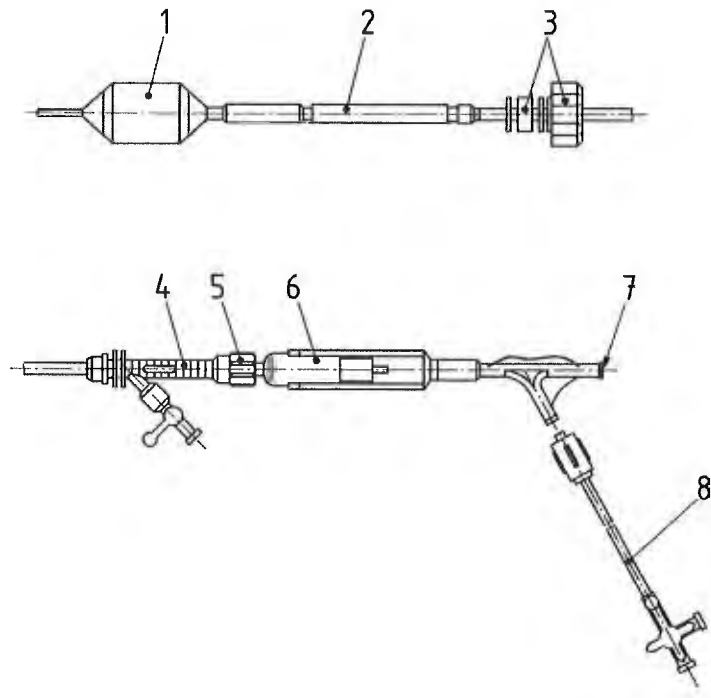

Figure B.7 — Example G



Key

- | | | | |
|---|------------------------|---|--------------------|
| 1 | deployment balloon | 5 | outer sheath seal |
| 2 | introducer sheath | 6 | articulation lever |
| 3 | introducer sheath seal | 7 | guidewire lumen |
| 4 | outer sheath | 8 | inflation port |

Figure B.8 — Example H

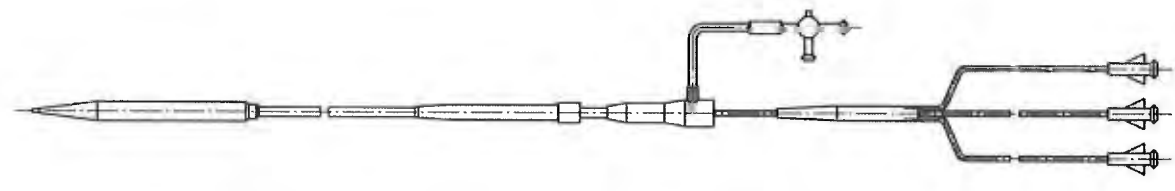

Figure B.9 — Example I

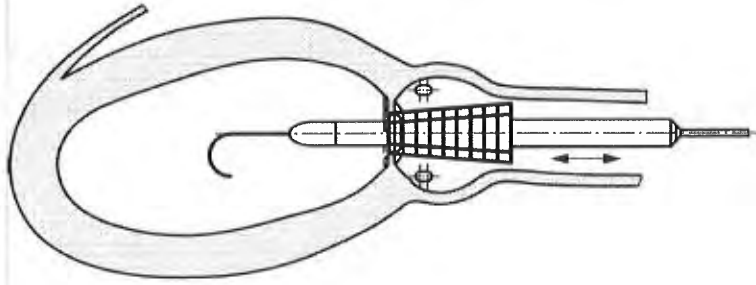

Figure B.10 — Example J

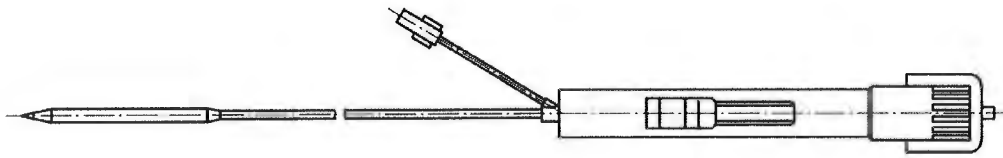

Figure B.11 — Example K

Annex C (normative)

Packaging

C.1 Requirements

The packaging requirements of ISO 11607 (all parts) and of ISO 14630:2012, Clause 10, shall apply.

C.2 Principle

Packaging shall be designed to ensure that the user is provided with a transcatheter heart valve substitute, delivery system and accessories whose characteristics and performance are unaltered by normal transit or storage. The packaging shall maintain the characteristics and performance of the package contents under normal conditions of handling, transit and storage, and shall permit the contents to be presented for use in an aseptic manner. There shall be a means to show if the packaging was exposed to abnormal conditions (e.g. freezing, excessive heat, container damage) during transit or storage that damage the transcatheter heart valve substitute.

C.3 Containers

C.3.1 Unit container(s)

The transcatheter heart valve substitute, delivery system and accessories shall be packaged in unit container(s) designed so that any damage to the unit container(s) seal is readily apparent. The unit container(s) shall meet the requirements of ISO 11607 (all parts).

C.3.2 Outer container

The unit container(s) shall be packaged in an outer container(s) (sales/storage package) to protect the unit container(s).

Annex D (normative)

Product labels, instructions for use and training

D.1 General

The labeling requirements of ISO 14630:2012, 11.2, shall apply.

Labels, IFU and training programs shall be designed to ensure that the user is provided with information on handling and implanting the transcatheter heart valve substitute, and shall be approved and reviewed as part of the risk and quality management systems. Labels and IFU shall meet country-specific language requirements.

D.1.1 Unit-container label

Each unit container shall be marked with the following information:

- a) name or trade name;
- b) model number;
- c) serial/lot number;
- d) size and device type if applicable (e.g. 21 mm, aortic);
- e) the word "sterile" if applicable and the method of sterilization;
- f) for sterile devices, the use by date or the expiration date;
- g) statement regarding single use only (if applicable);
- h) reference to see IFU for user information.

D.1.2 Outer-container label

In addition to applicable storage instructions, each outer container shall be marked with word(s), phrase(s) and/or symbol(s) for:

- a) name or trade name of device;
- b) name, address and phone number of manufacturer and/or distributor and other methods of contacting the manufacturer (e.g. facsimile number, email address). It might also be necessary to have the name and address of the importer established within the importing country or an authorized representative of the manufacturer established within the importing country;
- c) model number;
- d) serial/lot number;

- e) size and device type if applicable (e.g. 21 mm, aortic);
- f) net contents;
- g) the word "sterile" and method of sterilization if applicable;
- h) for sterile devices, the use by date or the expiration date;
- i) statement regarding single use only (if applicable);
- j) devices intended for clinical investigations shall bear identification that the device is intended for investigational use only;
- k) any special storage or handling conditions as indicated in the device specification;
- l) warning against use of the device if the unit container has been opened or damaged;
- m) reference to see IFU for user information.

D.1.3 Instructions for use

Each heart valve substitute shall be accompanied by IFU that shall include at least:

- a) name or trade name of device;
- b) name, address and phone number of manufacturer and/or distributor and other methods of contacting the manufacturer (e.g. facsimile number, email address). It might also be necessary to have the name and address of the importer established within the importing country or an authorized representative of the manufacturer established within the importing country;
- c) revision level of IFU and implementation date;
- d) net contents;
- e) indications for use and any known contra-indications;
- f) device description including available models and user required dimensions;
- g) a description of any accessories required and reference to instructions for their use;
- h) how the device is packaged/supplied;
- i) the word "sterile" and method of sterilization if applicable;
- j) statement that the device can or cannot be re-sterilized;
- k) statement regarding single use only (if applicable);
- l) devices intended for clinical investigations shall bear identification that the device is intended for investigational use only;
- m) any special storage or handling conditions;

- n) warning against use of the device if the unit container has been opened or damaged;
- o) any warnings regarding handling or implanting the device;
- p) any other warnings or precautions specific for the device, including but not limited to concomitant procedures of use with other devices;
- q) instructions for re-sterilization (if applicable) including the maximum number of reesterilization cycles, parameters which have been proven to be capable of achieving sterility of the device, and appropriate information relevant to other methods, apparatus, containers and packaging;
- r) specific instructions for device preparation (i.e. rinsing requirements for tissue valves);
- s) specific instructions for implanting or using the device;
- t) specific instructions for sizing target implant site and selecting appropriate device size;
- u) list of potential complications;
- v) summary of clinical experience if required;
- w) the appropriate MR safety designation (MR Conditional, MR Safe, or MR Unsafe) and a statement regarding MRI compatibility;
- x) any information or instructions which are intended to be communicated from the physician to the patient.

D.1.4 Labels for medical records

The manufacturer shall provide peel-off, self-adhering labels, or equivalent, with each transcatheter heart valve substitute that enables transfer of device information to the appropriate records. Each label shall contain: the name or model designation, size and serial number of the transcatheter heart valve substitute, and manufacturer identification.

The size of the labels shall be sufficient to display the required information in a legible format. Excessive size shall be avoided. The number of required labels may vary based on individual country policies.

D.2 Training for physicians and support staff

The manufacturer shall establish a structured training program for the physician and staff who will be involved in the peri-procedural care of the patient. The training program shall be designed to provide the physician and staff with the information and experience necessary to control user-associated risks when the device is used in accordance with the IFU. Training records shall be maintained as evidence that physicians have received appropriate training.

The training program shall include the following elements, where appropriate:

- a) description of all system components, including the valve and delivery system as well as a summary of the basic principle of operation;
- b) complete review of the IFU including the indications for use, patient selection, contra-indications, precautions, warnings, potential adverse events, pre-procedure set-up, sizing the valve, implant procedure and post-procedure patient care;

- c) review of imaging requirements for implanting the device such as fluoroscopy, computed tomography (CT), transthoracic echocardiography (TTE), magnetic resonance imaging (MRI) and transoesophageal echocardiography (TEE);
- d) hands-on bench top demonstration of the valve and delivery system in a simulated model;
- e) use of the device in an animal model or other appropriate models such as a robotic simulation system;
- f) a clinical training program, including proctored cases;
- g) user verification/validation, determined by pre-defined criteria.

Annex E (normative)

Sterilization

E.1 General

The sterilization requirements of ISO 14630:2012, Clause 9, shall apply, together with the following requirements.

For devices or accessories supplied sterile, sterilization shall occur by an appropriate method and shall be validated in accordance with internationally recognized criteria, as specified in ISO 17665 (all parts), ISO 11135 (all parts), ISO 11137 (all parts), ISO 14160 and ISO 14937. If the manufacturer states that the heart valve substitute can be re-sterilized prior to implantation, adequate instructions shall be provided by the manufacturer, including parameters that have been proven to be capable of achieving sterility of the device.

For any reusable devices or accessories, the IFU shall contain information on the appropriate processes to allow reuse, including cleaning, disinfection, packaging and, where appropriate, the method of sterilization and any restriction on the number of reuses.

Annex F (informative)

Valve description

F.1 Description of transcatheter heart valve substitute

The description of the transcatheter heart valve substitute should include, at a minimum, the information listed below. The verbal description should be supported by pictures or illustrations where appropriate.

- Components (e.g. leaflets, support structure, connections to leaflets, connections to annulus).
- Occluder/leaflet materials (e.g. pericardial, venous valve).
- Structural materials (e.g. stainless steel, nitinol).
- Component joining materials/methods (e.g. suture materials).
- Deployment mode (e.g. self-expanding, balloon expanding).
- Implant position (e.g. aortic, mitral, tricuspid, pulmonic, conduit).
- Deployed valve diameter or diameter range.
- How the device connects or interacts with the intended implant site.
- Retrievability.
- Orientability.

F.2 Description of delivery system

The description of the delivery system should include, at a minimum, the information listed below. The verbal description should be supported by pictures or illustrations where appropriate.

- Delivery approach (e.g. transfemoral, transapical).
- Delivery tools/catheters.
- Guidewire.
- Introduction sheath.
- Balloon.
- Crimping/loading tool.
- Access port.
- Accessories.

F.3 Chemical treatments, surface modifications or coatings

The description should include any chemical treatments, surface modifications or coatings used, including primary fixation of tissue and any anti-calcification, anti-infection or anti-thrombotic treatments.

F.4 Component description

Each of the components of the transcatheter heart valve substitute should be listed and the materials of construction should be documented. The components list should include packaging storage media (e.g. for tissue materials). An assembly sketch should be documented that includes all components, including joining materials, such as sutures.

F.5 Implant position

A brief description of the implant technique, including procedures for sizing the valve and the recommended implant procedure, should be documented.

F.6 Accessories

Any accessories that are to be used in conjunction with the heart valve substitute and its implantation (e.g. guidewires, introducer sheaths, balloon catheters) should be described and their materials of construction should be provided.

Annex G (informative)

Transcatheter heart valve substitute hazards, associated failure modes and evaluation methods

G.1 Hazards, failure modes and evaluation methods

Typical hazards, examples of their associated failure modes, and possible evaluation methods are given in Table G.1. This list is not intended to be all-inclusive but representative of hazards and failure modes that are applicable to transcatheter heart valve substitutes.

NOTE For guidance on how to identify and assess potential device-related use errors, and extensive information about use-related hazards, failure modes, and evaluation methods, see IEC 62366, which includes a figure of a comparison of the risk management process (ISO 14971) and the usability engineering process (IEC 62366), as well as an informative annex on categories of user action and an informative annex on examples of use errors, abnormal use and possible causes.

Table G.1 — Transcatheter heart valve substitute hazards, associated failure modes and evaluation methods

Potential hazard	Possible failure mode(s)	Possible evaluation methods
Stenosis	Pannus overgrowth, leaflet mineralization, excessive support structure deformation due to <i>in vivo</i> loading, support structure fracture, excessive support structure recoil, device migration, insufficient radial strength, crushing of the support structure during CPR, device embolization	Steady/pulsatile-flow pressure difference, support structure creep testing, wear/durability testing, support structure fatigue testing/analysis, support structure radial force testing, support structure recoil testing, pre-clinical <i>in vivo</i> evaluation with echocardiographic characterization, cadaver evaluations
Regurgitation	Leaflet tear, abrasion, delamination or shrinkage, leaflet prolapse, excessive support structure deformation, support structure fracture, suture breakage/pull out, suture hole elongation, out-of-tolerance condition, over-expansion of the support structure, paravalvular leakage, device embolization	Pulsatile flow regurgitation testing, valve prolapse testing, material characterization, durability testing, support structure fatigue testing/analysis, support structure creep testing, device distribution testing, pre-clinical <i>in vivo</i> evaluation with echocardiographic and fluoroscopic characterization, <i>in vitro</i> flow visualization
Embolization of debris – device or procedure related	Leaflet fragments due to leaflet tear or leaflet mineralization; debris resulting from: support structure fracture, generated during tracking of delivery system through vasculature, or delivery system balloon rupture	Material characterization, durability testing, support structure fatigue testing/analysis, leaflet prolapse testing, device distribution testing
Device embolization	Size mismatch	Clinical evaluation including imaging and possibly direct visualization, <i>in vitro</i> pulsatile migration testing

Potential hazard	Possible failure mode(s)	Possible evaluation methods
Hemolysis	Material or mechanical factors that cause elevated turbulence	<i>in vitro</i> flow visualization, <i>in vitro</i> whole blood studies in bench models, pre-clinical <i>in vivo</i> evaluation, clinical evaluation
Thrombosis, thromboembolism	Material or mechanical factors that cause flow stasis or adverse blood-material interaction	Material characterization, <i>in vitro</i> flow visualization, blood-material interaction characterization, pre-clinical <i>in vivo</i> evaluation, clinical evaluation
Bioincompatibility	Local or systemic toxicity, inappropriate tissue response or effect on coagulation, material degradation, leaching of component compounds	Biocompatibility safety evaluation as per applicable ISO standard, material characterization, blood material interaction characterization, biostability testing, corrosion testing, characterization of sterilization residuals, pre-clinical <i>in vivo</i> evaluation, clinical evaluation
Paravalvular leak	Incomplete support structure expansion, support structure fatigue fracture, inadequate sealing skirt, valve improperly sized (i.e. too small for implant site), valve malposition	<i>In vitro</i> models, <i>ex vivo</i> studies (e.g. cadaver hearts) pre-clinical <i>in vivo</i> evaluation, hydrodynamic characterization, clinical evaluation
MRI incompatibility	Device migration, device heating, image distortion, poor device visualization	Material characterization, MRI compatibility testing
Endocarditis	Non-sterile device, non-sterile accessories	Validation of sterility processes for device and accessories to a sterility assurance level of 10^{-6} , device package integrity testing
Inability to complete implant procedure; increased procedural time	Improper patient screening for vascular compatibility, delivery system failure, improper sizing, valve damaged during loading onto delivery system, device not compatible with accessories	Design validation with device, packaging, accessories, and IFU; tracking evaluation of valve and delivery system; in-process inspections, pre-clinical <i>in vivo</i> evaluation, usability and clinical evaluations
Virus, bovine spongiform encephalopathy or other transmissible agent	Tissue and/or tissue-derived source material contamination	Demonstrated compliance with all elements of ISO 22442 (all parts)
Bleeding	Perforation of vessel wall during valve deployment, perforation of vessel wall due to support structure fracture, perforation of vessel wall or cardiac chamber wall with delivery system, erosion of vessel wall	Design validation testing with device and delivery system, pre-clinical <i>in vivo</i> evaluation, clinical evaluation
Unintended anatomical interactions	Anterior mitral leaflet interference, coronary occlusion, conduction system interference, vascular or myocardial injury	<i>Ex vivo</i> evaluation (e.g. cadaver studies), pre-clinical <i>in vivo</i> evaluation, clinical evaluation
Plastic deformation of prosthesis support structure	User applies excessive force on prosthesis during crimping process	Usability assessment of representative intended users conducting prosthesis preparation, crimping, and loading tasks
Prosthesis is prematurely deployed	Design or user error	Usability assessment of representative intended users conducting simulated implant procedure tasks, clinical evaluation

G.2 Additional generic failure modes and causes

G.2.1 Potential hazards relating to the delivery system's "ability to access" include, but are not limited to, the following:

- a) guidewire not crossing the lesion;
- b) introducer and delivery systems not matching the access site (i.e. size mismatch);
- c) delivery system not advancing to target implant site;
- d) emboli generation;
- e) device embolization from the delivery system.

G.2.2 Potential hazards relating to the "ability to deploy the delivery system" include, but are not limited to, the following:

- a) inability to fully and properly deploy the device;
- b) disproportionate dimensions and properties, such as balloon compliance and burst pressure, of balloon relative to device and implant site (if applicable);
- c) device embolization from the delivery system;
- d) balloon failure (if applicable);
- e) damage of device components by other components;
- f) inadequate visualization;
- g) emboli generation.

G.2.3 Potential hazards relating to the "ability to withdraw the delivery system" include, but are not limited to, the following:

- a) improper balloon deflation (balloon expandable);
- b) balloon winging (cross-sectional shape of the balloon when deflated that can cause problems during withdrawal);
- c) lack of structural integrity;
- d) emboli generation;
- e) diameter mismatch;
- f) device embolization from the delivery system;
- g) damage of device system components by other components;
- h) delivery system snags on the device;

- i) inadequate visualization;
- j) device embolization.

G.2.4 Potential hazards relating to the “hemostasis of the delivery system” include, but are not limited to, the following:

- a) size mismatch;
- b) seal incompetence;
- c) other leakage.

G.2.5 Potential hazards relating to the “ability to accurately deploy the device” within the target implant site include, but are not limited to, the following:

- a) inaccurate positioning or orientation;
- b) improper deployment configuration;
- c) incomplete deployment;
- d) inadequate visualization;
- e) improper sizing of implant site.

G.2.6 Potential hazards relating to “effective fixation of the device” within the vasculature include, but are not limited to, the following:

- a) incomplete apposition to vessel wall;
- b) excessive or inadequate radial outward force;
- c) improper sizing of implant site;
- d) device migration;
- e) device embolization.

G.2.7 Potential hazards related to “structural integrity of the device” include, but are not limited to, the following:

- a) structural failure of implant;
- b) loss of complete apposition to vessel wall;
- c) leaking.

G.2.8 Potential hazards related to “durability of the device” include, but are not limited to, the following:

- a) potential failure modes, such as wear, strut fracture, delamination and suture breaks;
- b) radial and axial loads, and other *in vivo* loads.

G.3 Additional generic failure modes and causes

Additional generic failure modes and causes include:

- valve and delivery system cannot navigate tortuous anatomy;
- valve cannot be loaded onto the delivery system;
- valve inverted on the delivery system;
- valve cannot be released from the delivery system post-deployment;
- inadequate IFU;
- poorly designed delivery system user interface;
- inadequate labeling;
- inadequate warnings;
- use by unskilled personnel;
- packaging damaged during shipment;
- shelf life degradation;
- environmental damage during shipment and storage (excess heat or cold);
- improper re-use of device.

Annex H (informative)

In vitro test guidelines for pediatric devices

H.1 Introduction and pediatric definitions

Traditionally, heart valve substitutes have been designed, tested and labeled for the adult population. Many real and perceived scientific, marketing and regulatory barriers have limited the development of pediatric heart valve substitutes. These include the need for small device sizes, patient growth requiring multiple reoperations, problems with enhanced calcification of bioprosthetic tissue, a perceived small market size, and a lack of sufficient patients to fill a typical clinical trial. These questions were addressed at a pediatric heart valve workshop held in Washington, D.C. on January 12, 2010, which was attended by clinicians, device industry representatives, academicians and the US Food and Drug Administration. The following guidelines for *in vitro* testing of devices intended for the pediatric population are from a talk given at that workshop.

NOTE See Reference 0.

Some definitions of pediatrics (see Table H.1) include only four groups (newborn, infant, child, adolescent), but input from pediatric clinicians led to adding the "toddler" subpopulation.

Table H.1 — Pediatric definitions

Pediatric subpopulation	Approximate age range	Proposed definition
Newborn	Birth to 1 month	0 < age < 30 days
Infant	1 month to 1 year	30 days ≤ age < 1 year
Toddler	1 year to 5 years	1 year ≤ age < 5 years
Child	5 years to 13 years	5 years ≤ age < 13 years
Adolescent	13 years to 21 years	13 years ≤ age < 22 years

H.2 Pulsatile flow test conditions: left side

Table H.2 — Pulsatile flow test conditions: left side

Pediatric subpopulation	Systolic duration	MAP	Beat	Cardiac
	%	mmHg	rate (bpm) ^a	output ^b (l/min)
Newborn	50	45	60, 150, 200	0.5; 1; 1.5
Infant	50	55	60, 120, 200	1, 2, 3
Toddler	45	65	60, 100, 160	1.5; 3; 4.5
Child	40	80	60, 80, 140	2; 3.5; 5
Adolescent	35	100	45, 70, 120	2, 5, 7
^a See Reference 0.				
^b See Reference 0.				

H.3 Pulsatile flow test conditions: right side

Table H.3 — Pulsatile flow test conditions: right side

Pediatric subpopulation	Systolic duration	MAP	Beat	Cardiac
	%	mmHg	rate (bpm) ^a	output ^b (l/min)
Newborn	50	20	60, 150, 200	0.5; 1; 1.5
Infant	50	20	60, 120, 200	1, 2, 3
Toddler	45	20	60, 100, 160	1.5; 3; 4.5
Child	40	20	60, 80, 140	2; 3.5; 5
Adolescent	35	20	45, 70, 120	2, 5, 7
^a See Reference 0.				
^b See Reference 0.				

H.4 Steady back pressure and forward flow conditions: left side

Table H.4 — Steady back pressure and forward flow conditions: left side

Pediatric subpopulation	Steady back pressure ^a	Steady forward flow rates ^b
	mmHg	l/min
Newborn	40, 80	5, 10, 15
Infant	40, 80, 120	5, 10, 15, 20
Toddler	40, 80, 120	5, 10, 15, 20
Child	40, 80, 120, 160	5, 10, 15, 20, 25
Adolescent	40, 80, 120, 160, 200	5, 10, 15, 20, 25, 30
^a See Reference 0.		
^b See Reference 0.		

H.5 Steady back pressure and forward flow conditions: right side

Table H.5 — Steady back pressure and forward flow conditions: right side

Pediatric subpopulation	Steady back pressure ^a	Steady forward flow rates ^b
	mmHg	l/min
Newborn	5, 10, 20	5, 10, 15
Infant	5, 10, 20	5, 10, 15, 20
Toddler	5, 10, 20	5, 10, 15, 20
Child	5, 10, 20, 30	5, 10, 15, 20, 25
Adolescent	5, 10, 20, 30, 40	5, 10, 15, 20, 25, 30
^a See Reference 0.		
^b See Reference 0.		

H.6 AWT test conditions: left side

Table H.6 — AWT test conditions: left side

Pediatric subpopulation	Minimum mitral peak differential pressure ^a	Minimum aortic peak differential pressure ^b
	mmHg	mmHg
Newborn	75	50
Infant	90	60
Toddler	97	67
Child	105	75
Adolescent	120	90
^a See Reference 0.		
^b See Reference 0.		

H.7 AWT test conditions: right side

Table H.7 — AWT test conditions: right side

Pediatric subpopulation	Minimum tricuspid peak differential pressure ^a	Minimum pulmonary peak differential pressure ^b
	mmHg	mmHg
Newborn	30	10
Infant	30	10
Toddler	30	10
Child	30	10
Adolescent	30	10
^a See Reference 0.		
^b See Reference 0.		

H.8 FEA/life analysis conditions: left side

Table H.8 — FEA/life analysis conditions: left side

Pediatric subpopulation	FEA peak differential pressure/CO ^a	Life analysis cycle criterion
	mmHg/(l/min)	equivalent years
Newborn	70/1.5	5
Infant	90/3	7
Toddler	110/4.5	10
Child	135/5	10 ^b
Adolescent	160/7	10 ^b
^a See Reference 0.		
^b Reference 0 says 15 equivalent years, which comes from US FDA.		

H.9 FEA/life analysis conditions: right side

Table H.9 — FEA/life analysis conditions: right side

Pediatric subpopulation	FEA peak differential pressure/CO ^a	Life analysis cycle criterion
	mmHg/(l/min)	equivalent years
Newborn	30/1.5	5
Infant	30/3	7
Toddler	30/4.5	10
Child	35/5	10 ^b
Adolescent	40/7	10 ^b
^a See Reference 0.		
^b Reference 0 says 15 equivalent years, which comes from US FDA.		

Annex I (informative)

Statistical procedures when using performance criteria

I.1 General

Historically, mean pressure difference and leakage values for a given valve size have been reported as the mean and standard deviation of three samples. Because these sample sizes are very small, they lead to wide confidence intervals when comparing results to a reference valve or performance criteria.

I.2 Methods

The confidence interval can be effectively reduced by modeling the entire experiment in a way that accounts for both the valve size and flow rate (for the pressure difference) or valve size and back pressure (for the leakage)(see Reference 0). Suitable modeling methods include analysis of variance (ANOVA) and regression analysis. The performance criteria are then compared to the sample mean plus or minus a confidence interval. Additional information to report might include how well the model fits, and the statistical significance of the effects of the size and flow rate (or back pressure). Note that if the same valve is tested under more than one condition (e.g. under several flow rates), then the multiple measurements should be taken into account to reflect the fact that the measurements on the same valve are not independent. In such cases, a nested ANOVA could be performed. This approach leads to smaller standard errors and narrower confidence intervals than the estimate obtained if the correlations among measurements are ignored.

Annex J (informative)

Examples and definitions of some physical and material properties of transcatheter heart valve substitutes and their components

J.1 General

This annex provides examples and definitions of the physical and material properties that could be relevant in characterizing a transcatheter heart valve substitute and/or its components, and their definitions.

All measurements should be performed on materials or components as they would be found in the finished product. This includes all subsequent treatments after fabrication.

Examples of some standardized test methods that could be relevant for physical and material property characterization are provided in Annex K.

The risk analysis should play a role in the choice of determining the physical and material properties of the heart valve substitute and its components.

J.2 Bulk physical properties

J.2.1

chemical composition

measurement of the chemical composition and purity, including any processing aids

J.2.2

density

measurement of the mass per unit volume, i.e. the compactness of a material

J.2.3

liquid diffusivity (porosity and permeability)

measurement of the ability of a material to absorb or adsorb biological components from the surrounding tissues and fluid environments

NOTE This biological property could cause calcification and premature failure of some animal tissues under certain stresses.

J.2.4

material hardness

measurement of resistance to scratching or plastic deformation by indentation (generally related to wear resistance)

J.2.5

microstructure

measurement of the size and shape of the grains, defects, voids, etc. of which the material is composed

NOTE For tissue-derived materials, this should include, e.g. cellular or collagen morphology.

J.2.6

coefficient of thermal expansion

change in physical dimension as a result of a change in temperature

J.2.7

glass transition temperature

characteristic temperature of a polymer system below which long-chain mobility no longer exists

J.2.8

melt index

number of grams of thermoplastic resin at a specified temperature that can be forced through a specified orifice in an allotted time by a specified pressure

J.2.9

melting point

temperature at which a solid material turns liquid

J.2.10

hydraulic expansion

comparison of the dimensions of the material before and after exposure to water

J.2.11

biostability

change in chemical composition of a material after exposure to a physiologic-fluid environment

J.2.12

film thickness

thickness of a film deposited on a substrate, averaged over the surface of the film

NOTE Techniques for measuring thin-film thickness include profilometry and ellipsometry. In some cases, Auger depth profiling can be used.

J.2.13

film composition

analysis of the elemental composition of a film, expressed as a percentage

J.3 Surface physical properties

J.3.1 General

All measurements should be performed on materials or components as they would be found in the finished product. This includes all subsequent treatments after fabrication, e.g. sterilization.

J.3.2

critical surface tension

surface morphology of a biological implant

NOTE Surface roughness and chemical composition play a key role in how an implant interacts with the biological host. Critical surface tension is a useful attribute for characterizing the surface of a solid material. The measurement is affected by the surface's topology, chemistry and cleanliness. The measurements are related to the surface free energy of the material.

J.3.3

surface roughness

microtopology of the component surface

J.3.4

surface chemical composition

material composition within a few atomic layers of the surface

NOTE Variations in the chemicals present at the surface could affect how a material will react with the host. The chemical constituents of the surface can be altered by manufacturing processes such as grinding, polishing, cleaning, sterilizing and handling.

J.3.5

surface charge and surface charge density

type of charge (positive or negative) and the amount that can be bound to the surface of a material

NOTE It has been suggested that surface charge can play an important role in the biocompatibility of materials.

J.3.6

surface resistance, R

ratio of the bulk resistivity and film thickness:

$$R_{\text{sheet}} = \frac{\Omega}{\delta}$$

where

Ω is the bulk resistivity, expressed in ohm-centimeters;

δ is the sample thickness, expressed in centimeters

NOTE A typical method for determining the sheet resistance is the "four-point probe" method. Such measurements should be done at several places on the surface of the film to obtain an average sheet resistance value.

J.4 Mechanical and chemical engineering properties

J.4.1 General

The following are the materials' engineering properties that can be evaluated to assess the ability of a material or a component to function in the intended site.

J.4.2

wear resistance

rate of the systematic removal of material as two surfaces move past one another

J.4.3

coefficient of friction

energy expended in moving two components past one another that are in intimate contact

J.4.4

peel strength

adhesion between different layers of a material, usually a lamellar composite

NOTE Lamellae could include thin surface layers used to change the chemical boundary conditions of a material.

AAMI
Single user license provided to AAMI standards committee members.

J.4.5

flexural strength

stress level required to cause fracture in bending

NOTE There is usually considerable variation in the measured strength among specimens in these tests. To ensure that the data are representative of the true strength of the material, the results should be reported using an appropriate statistical method.

J.4.6

compressive strength

stress required to deform a material in a uniaxial compressive stress state

NOTE There can be considerable variation in the measured strength among specimens in these tests. To ensure that the data are representative of the true strength of the material, the results should be reported using an appropriate statistical method.

J.4.7

tensile strength

stress required to deform a material in a uniaxial tensile stress state

NOTE 1 The term "tensile strength" or "ultimate tensile strength" is usually used to define the load-carrying capability of a material in a uniaxial tensile stress state typically expressed as an engineering stress. This condition also defines the limit of uniform strain, after which plastic instability (necking) occurs.

NOTE 2 There is usually considerable variation in the measured strength among specimens in these types of tests. To ensure that the data are representative of the true strength of the material, the results should be reported using an appropriate statistical method.

J.4.8

tensile strain to failure (elongation)

total amount of strain or elongation that a material can tolerate just prior to fracture

J.4.9

strain energy to failure

energy needed to deform a material to breaking point

NOTE Strain energy is a measure of the toughness of a material, generally in the absence of a durability mechanism.

J.4.10

residual stress

stresses that remain in a material after it has been fabricated

J.4.11

fretting

surface damage that results when two surfaces in contact experience slight periodic relative motions

J.4.12

stress relaxation

gradual decrease in measured stress under a specified elongation or deformation

J.4.13

creep

temporal change in dimension of a material under a prescribed mechanical loading condition

J.4.14

fracture toughness

measure of the ability of a material to deform plastically in the presence of a notch

NOTE It is the stress intensity at which unstable crack growth will proceed.

J.4.15

crack growth velocity

speed and load conditions under which a crack will propagate through a material once it has been initiated

NOTE The rates can be influenced by the residual stresses in the material.

J.4.16

fatigue life

number of cycles or total time a material can be repeatedly loaded without fracture under specified loading conditions

NOTE In general, there are two independent time components to fatigue failure. First is the crack initiation phase, when repeated loading cycles weaken a material, usually through a defect coalescence process at a flaw site, until a critical flaw size is reached and fracture occurs. Once a crack is initiated, the second, or crack growth, phase of fatigue begins. The crack continues to grow under repeated loading conditions until the stress loading exceeds the fracture toughness, resulting in total failure.

J.4.17

general corrosion

uniform degradation of the surface of a metal due to chemical reactions with specific environments

J.4.18

fretting corrosion

form of corrosion in which two surfaces rubbing against each other produce small particles which oxidize to form an abrasive powder that exacerbates the destructive process, eventually forming a crack

NOTE The surface damage occurs between adjacent surfaces that are in close contact, under pressure, and are subjected to slight relative motions.

J.4.19

pitting corrosion

form of extremely localized corrosion that leads to the creation and propagation of small holes in the metal

J.4.20

crevice corrosion

corrosion occurring in spaces (crevices) to which the access of the working fluid from the environment is limited

J.4.21

galvanic corrosion

electrochemical process in which one metal corrodes preferentially when in electrical contact with a different metal and both metals are immersed in an electrolyte

J.4.22

intergranular corrosion

form of corrosion where the grain boundaries of a metal are more susceptible to corrosion than the matrix

J.4.23

stress corrosion cracking

failure of a metal from the combined effects of a corrosion environment and a static tensile stress

J.4.24

corrosion fatigue

simultaneous action of cyclic stress and chemical attack on a metallic part

J.4.25

void concentration

number of voids in a film (areas where the film did not cover the substrate) per unit area

AAMI
Single user license provided to AAMI standards committee members.

NOTE The void concentration is specific to the void size or range of sizes (e.g. a void concentration might be 100 voids of diameter 1 mm or less per square centimeter).

J.4.26

tear strength

force needed to initiate or continue tearing a sheet of fabric

J.4.27

Young's modulus

slope of the initial linear portion of the stress strain curve; a measure of the mechanical stiffness of a material

NOTE As a tensile or compressive stress is exerted on a piece of material, it tends to elongate or contract. The ratio of the applied stress to the percentage change in length (strain) is defined as Young's modulus. Young's modulus is needed in theoretical modeling of both the static and dynamic stress distributions anticipated in completed devices.

J.4.28

Poisson's ratio

ratio of change in dimensions in the transverse direction to the longitudinal direction

NOTE When a piece of material is stretched or compressed longitudinally under a uniaxial load, it changes shape transversely. As with Young's modulus, Poisson's ratio is needed to model the mechanical behavior of completed devices.

J.4.29

dynamic moduli

complex moduli (storage and loss moduli) that describe the mechanical behavior of viscoelastic materials

J.4.30

stress intensity factor, k

description of the intensity of the stress field ahead of a sharp crack under linear elastic loading conditions

J.4.31

critical stress intensity factor, k_c

stress intensity above which a crack will advance under monotonic, quasi-static loading conditions

NOTE k_c is a function of the mode of loading, chemical environment, microstructure, test temperature, strain rate and stress state.

J.4.32

fatigue

fracture of a material under repeated application of a stress or strain

J.5 Nitinol properties

J.5.1

austenite finish temperature, A_f

temperature at which the reverse martensite-to-austenite transformation is completed on heating in a single-stage transformation, or the temperature at which the R-phase-to-austenite transformation is completed on heating in a two-stage transformation

NOTE ASTM provides different methods for determining A_f (e.g. DSC or bend and free recovery).

J.5.1.1

bend and free recovery

test method to determine the A_f temperature of nitinol by measuring the rate of strain recovery as a function of temperature during heating of a previously deformed test sample

J.5.1.2

differential scanning calorimetry

DSC

test method to determine the A_f temperature of nitinol by comparing the enthalpy (heat evolved) of a test sample to a known standard during heating

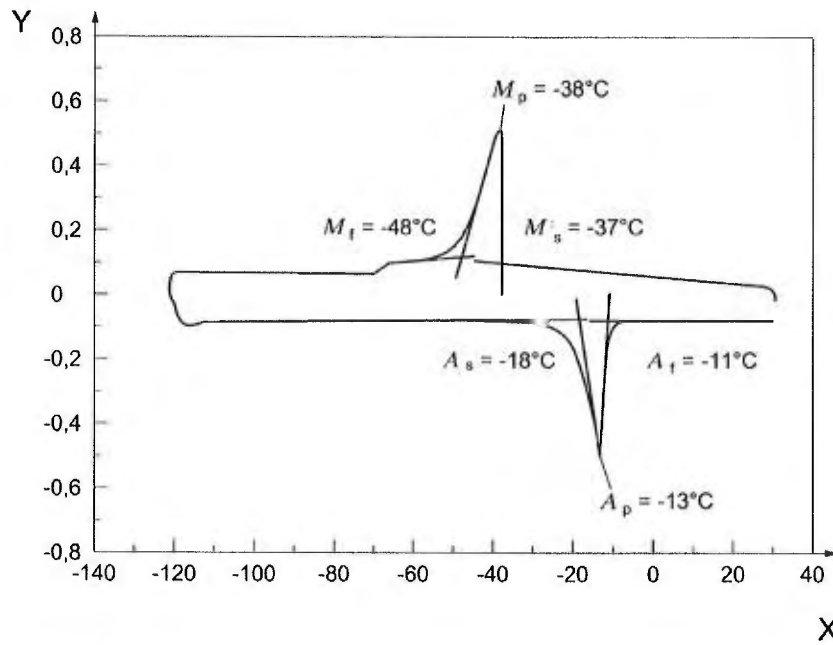

Key

X	temperature (°C)
Y	heat flow (W/g)
As	Austenite start temperature
Ap	Austenite peak temperature
Af	Austenite finish temperature
Ms	Martensite start temperature
Mp	Martensite peak temperature
Mf	Martensite finish temperature

NOTE Reprinted from ASTM F2005 with permission of ASTM International.

Figure J.1 — Example DSC graph for single-stage transformation nickel-titanium alloy

J.5.2

mechanical properties

J.5.2.1

lower plateau strength

LPS

stress at 2.5 % strain during unloading of the sample, after loading to 6 % strain

NOTE See ASTM F2516.

J.5.2.2

residual elongation, E_r , (%)

difference between the strain at a stress of 7.0 MPa during unloading and the strain at a stress of 7.0 MPa during loading

NOTE See ASTM F2516.

J.5.2.3

uniform elongation, E_u , (%)

elongation at the maximum force sustained by the test piece just prior to necking, or fracture, or both

NOTE See ASTM F2516.

J.5.2.4

upper plateau strength

UPS

stress at 3 % strain during loading of the sample

NOTE See ASTM F2516.

J.5.2.5

ultimate tensile strength

UTS

maximum load carrying capability of a sample tested in uniaxial tension

J.5.2.6

austenite modulus

steepest part of the initial loading stress-strain curve of a superelastic nitinol sample

NOTE Unlike most metals, the modulus of nitinol can exhibit significant temperature sensitivity and might be affected by the onset of a mechanically induced transition to the R-phase.

J.5.2.7

martensite modulus

steepest part of the unloading stress-strain curve of a superelastic nitinol sample

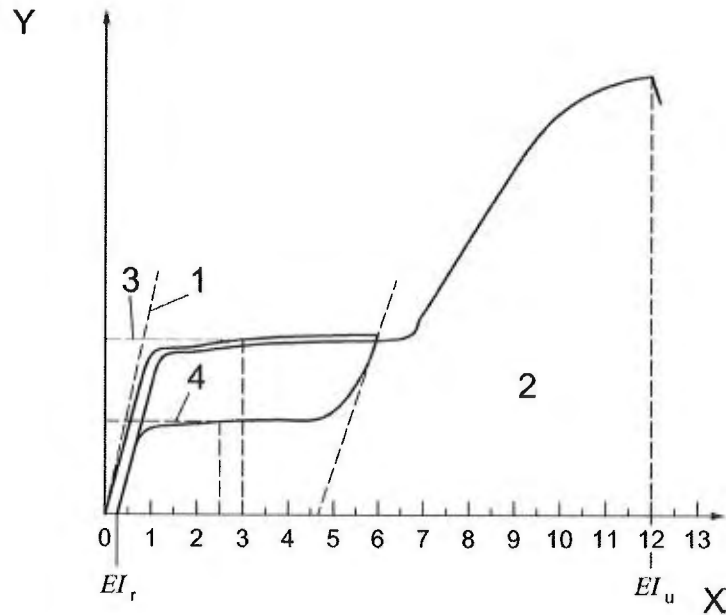

Key

- X strain (%)
- Y stress
- 1 Austenite modulus
- 2 Martensite modulus
- 3 UPS
- 4 LPS
- 5 UTS

NOTE Reprinted from ASTM F2516 with permission of ASTM International.

Figure J.2 — Typical stress-strain curve of superelastic (SE) nitinol indicating various reportable parameters

J.5.3

glossary of terms related to nitinol

J.5.3.1

austenite

high-temperature solid phase of approximately equiatomic composition in the Ni-Ti alloy system

NOTE After processing to obtain specific properties the austenite phase can undergo a reversible phase transformation to the martensitic or rhombohedral (R)-phases.

J.5.3.2

martensite

low-temperature solid phase of approximately equiatomic composition in the Ni-Ti alloy system that formed from the austenite or the rhombohedral phase with either B19 (orthorombic) or B19' monoclinic crystal structure

J.5.3.3

rhombohedral (R) phase

metastable phase of nitinol

J.5.3.4

nitinol

generic trade name for a Ni-Ti alloy (include typical composition range per ASTM) primarily used for its superelastic or shape memory behavior

J.5.3.5

shape memory alloy

metal which, after an apparent plastic deformation in the martensitic phase, undergoes a thermoelastic phase transformation when heated through its transformation temperature range resulting in a recovery of the deformation

J.5.3.6

radial resistive force

RRF

force exerted by a superelastic nitinol support structure as it resists radial compression from its relaxed diameter

NOTE See Figure J.3.

J.5.3.7

chronic outward force

COF

force exerted by the support structure as it expands to its relaxed diameter after being radially compressed

NOTE See Figure J.3.

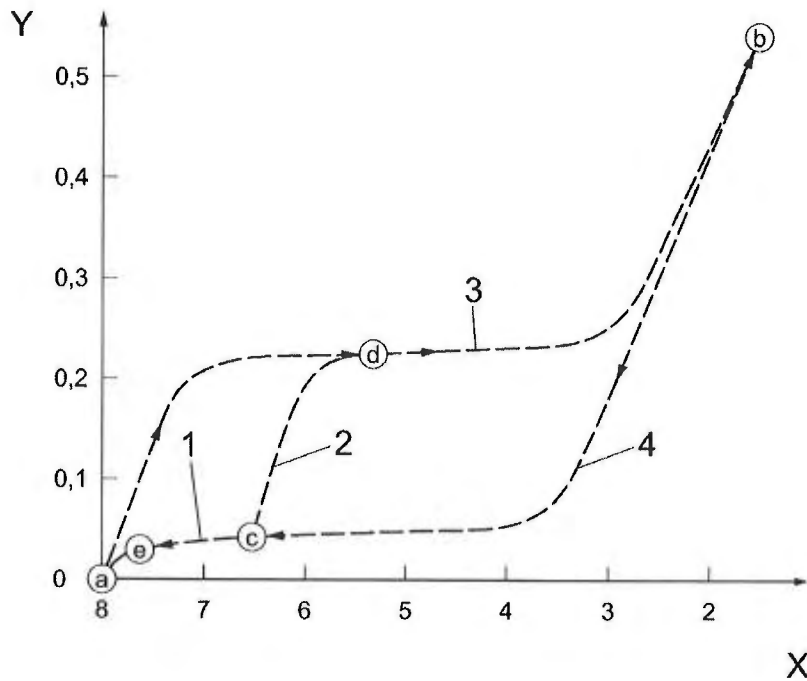

Key

- X stent diameter (mm)
- Y hoop force (N/mm)
- 1 COF
- 2 RRF
- 3 loading: crimping into catheter
- 4 unloading: release from catheter

NOTE © Cordis Corporation 2012.

Figure J.3 — Force-diameter curve of a superelastic (SE) nitinol support structure demonstrating chronic outward force (COF) and radial resistive force (RRF)

J.5.3.8

superelasticity

non-linear recoverable deformation behavior of Ni-Ti shape memory alloys at temperatures above the austenite finish temperature (A_f)

NOTE The non-linear deformation arises from the stress-induced formation of martensite on loading and the spontaneous reversion of this crystal structure to austenite upon unloading.

J.5.3.9

phase transformation temperatures related to nitinol

J.5.3.9.1

martensite start temperature, M_s

temperature at which the forward austenite-to-martensite or R-phase-to-martensite transformation begins

J.5.3.9.2

martensite finish temperature, M_f

temperature at which the forward austenite-to-martensite or R-phase-to-martensite transformation ends

J.5.3.9.3

austenite start temperature, A_s

temperature at which the reverse martensite-to-austenite or R-phase-to-austenite transformation begins

J.5.3.9.4

rhombohedral start temperature

R-phase start temperature

R_s

temperature at which the forward austenite-to-R-phase transformation begins

J.5.3.9.5

rhombohedral finish temperature

R-phase finish temperature

R_f

temperature at which the forward austenite-to-R-phase transformation ends

Annex K (informative)

Examples of standards applicable to testing of materials and components of transcatheter heart valve substitutes

K.1 Metals

K.1.1 Specifications for materials for metal surgical implants

ISO 5832-1, *Implants for surgery — Metallic materials — Part 1: Wrought stainless steel*

ISO 5832-2, *Implants for surgery — Metallic materials — Part 2: Unalloyed titanium*

ISO 5832-3, *Implants for surgery — Metallic materials — Part 3: Wrought titanium 6-aluminium 4-vanadium alloy*

ISO 5832-4, *Implants for surgery — Metallic materials — Part 4: Cobalt-chromium-molybdenum casting alloy*

ISO 5832-5, *Implants for surgery — Metallic materials — Part 5: Wrought cobalt-chromium-tungsten-nickel alloy*

ISO 5832-6, *Implants for surgery — Metallic materials — Part 6: Wrought cobalt-nickel-chromium-molybdenum alloy*

ISO 5832-7, *Implants for surgery — Metallic materials — Part 7: Forgeable and cold-formed cobalt-chromium-nickel-molybdenum-iron alloy*

ISO 5832-8, *Implants for surgery — Metallic materials — Part 8: Wrought cobalt-nickel-chromium-molybdenum-tungsten-iron alloy*

ASTM F2005, *Standard terminology for nickel-titanium shape memory alloys*

ASTM F2063, *Standard specifications for wrought nickel-titanium shape memory alloys for medical devices and surgical implants*

ASTM F2082, *Standard test method for determination of transformation temperature of nickel-titanium shape memory alloys by bend and free recovery*

ASTM F2004, *Standard test method for determination of transformation temperature of nickel-titanium shape memory alloys by thermal analysis*

ASTM F2516, *Standard test method for tension testing of nickel-titanium superelastic materials*

K.1.2 Tensile test with extensometer to failure

ASTM E8, *Standard test methods for tension testing of metallic materials*

ASTM E111, *Standard test method for Young's modulus, tangent modulus, and chord modulus*

K.1.3 Poisson's ratio

ASTM E132, *Standard test method for Poisson's ratio at room temperature*

K.1.4 Durability crack initiation and endurance limit; S-N curves

ASTM E466, *Standard practice for conducting constant amplitude axial fatigue test of metallic materials*

ASTM E468, *Standard practice for presentation of constant amplitude fatigue test results for metallic materials*

ASTM E739, *Standard practice for statistical analysis of linear or linearized stress-life (S-N) and strain-life (E-N) fatigue data*

K.1.5 Fatigue crack growth rate; crack growth velocity

ASTM E647, *Standard test method for measurement of fatigue crack growth rates*

K.1.6 Hardness

ISO 6508-1, *Metallic materials — Rockwell hardness test — Part 1: Test method (scales A, B, C, D, E, F, G, H, K, N, T)*

ISO 6507-1, *Metallic materials — Vickers hardness test — Part 1: Test method*

K.1.7 Microstructure

ASTM E3, *Standard guide for preparation of metallographic specimens*

ASTM E112, *Standard test methods for determining average grain size*

K.1.8 Thermal expansion

ASTM E228, *Linear thermal expansion of solid materials with a vitreous silica dilatomet*

K.1.9 Fracture toughness

ASTM E399, *Standard test method for plane-strain fracture toughness of metallic materials*

AS/TM 1820, *Standard test method for measurement of fracture toughness*

K.1.10 Fatigue life

ASTM E466, *Standard practice for conducting force controlled constant amplitude axial fatigue tests of metallic materials*

ASTM E468, *Standard practice for presentation of constant amplitude fatigue test results for metallic materials*

ASTM E739, *Standard practice for statistical analysis of linear or linearized stress-life (S-N) and strain-life (E-N) fatigue data*

K.1.11 Corrosion

ASTM F2129, *Standard test method for conducting cyclic potentiodynamic polarization measurements to determine the corrosion susceptibility of small implant devices*

ASTM G46, *Standard guide for examination and evaluation of pitting corrosion*

ASTM F746, *Standard test method for pitting or crevice corrosion of metallic surgical implant materials*

ASTM G61, *Standard test method for conducting cyclic potentiodynamic polarization measurements for localized corrosion susceptibility of iron-, nickel-, or cobalt-based alloys*

ASTM F746, *Standard test method for pitting or crevice corrosion of metallic surgical implant materials*

ASTM G192-08, *Standard test method for determining the crevice repassivation potential of corrosion-resistant alloys using a potentiodynamic-galvanostatic-potentiostatic technique*

ASTM G82, *Standard guide for development and use of a galvanic series for predicting galvanic corrosion performance*

ASTM G71, *Standard guide for conducting and evaluating galvanic corrosion tests in electrolytes*

ASTM G106-89, *Standard practice for verification of algorithm and equipment for electrochemical impedance measurements*

ASTM G161-00, *Standard guide for corrosion-related failure analysis*

ASTM G199-09, *Standard guide for electrochemical noise measurement*

ASTM G108-94, *Standard test method for electrochemical reactivation (EPR) for detecting sensitization of AISI type 304 and 304L stainless steels*

ASTM G44-99, *Standard practice for exposure of metals and alloys by alternate immersion in neutral 3.5 % sodium chloride solution*

ASTM A262-10, *Standard practices for detecting susceptibility to intergranular attack in austenitic stainless steels*

ASTM F1801-97, *Standard practice for corrosion fatigue testing of metallic implant materials*

ISO 16429, *Implants for surgery — Measurements of open-circuit potential to assess corrosion behavior of metallic implantable materials and medical devices over extended time periods*

K.2 Polymers

K.2.1 Viscosimetry

ASTM D20, *Standard test method for distillation of road tars*

ISO 61, *Plastics — Determination of apparent density of molding material that cannot be poured from a specified funnel*

K.2.2 Melt flow index

ASTM D1238, *Standard test method for melt flow rates of thermoplastics by extrusion plastometer*

K.2.3 Specifications for high molecular weight polyethylene

ISO 3834-1, *Quality requirements for fusion welding of metallic materials — Part 1: Criteria for the selection of the appropriate level of quality requirements*

ISO 3834-2, *Quality requirements for fusion welding of metallic materials — Part 2: Comprehensive quality requirements*

ISO 3834-3, *Quality requirements for fusion welding of metallic materials — Part 3: Standard quality requirements*

ISO 3834-4, *Quality requirements for fusion welding of metallic materials — Part 4: Elementary quality requirements*

K.2.4 Determination of breaking strength under static load

ISO 13934-1, *Textiles — Tensile properties of fabrics — Part 1: Determination of maximum force and elongation at maximum force using the strip method*

K.2.5 Tensile test with extensometer to failure (if possible)

ASTM D638, *Standard test method for tensile properties of plastics*

K.2.6 Tensile properties

ISO 527 (all parts), *Plastics — Determination of tensile properties*

K.2.7 Poisson's ratio

ASTM E132, *Standard test method for Poisson's ratio at room temperature*

K.2.8 Determination of dynamic mechanical properties

ISO 6721-1, *Plastics — Determination of dynamic mechanical properties — Part 1: General principles*

ISO 6721-2, *Plastics — Determination of dynamic mechanical properties — Part 2: Torsion-pendulum method*

K.2.9 Resistance to surface wear

ISO 4586-2, *High-pressure decorative laminates (HPL) — Laminates based on thermosetting resins — Part 2: Determination of properties*

K.2.10 Resistance to scratch

ISO 1518 (all parts), *Paints and varnishes — Determination of scratch resistance*

BS 3962-6, *Assessment of resistance to mechanical damage*

K.2.11 Flexural properties; determination of breaking strength under dynamic bending load

AAMI
Single user license provided to AAMI standards committee members.

ISO 178, *Plastics — Determination of flexural properties*

K.2.12 Fatigue crack initiation and endurance limit; S-N curves

ASTM E466, *Standard practice for conducting force controlled constant amplitude axial fatigue tests of metallic materials*

ASTM E468, *Practice for presentation of constant amplitude fatigue test results for metallic materials*

K.2.13 Fatigue crack growth rate

ASTM E647, *Test method for measurement of fatigue crack growth rates*

K.2.14 Determination of compressive properties

ISO 604, *Plastics — Determination of compressive properties*

K.2.15 Specification of surgical implants made from high-density silicone elastomer

BS 7253-3, *Non-metallic materials for surgical implants — Specification for surgical implants made of heat-vulcanized silicone elastomer*

K.2.16 Density

ASTM E792, *Standard guide for selection of a clinical laboratory information management system*

K.2.17 Liquid diffusivity (porosity and permeability; water absorption)

ASTM D570, *Standard test method for water absorption of plastics*

K.2.18 Hardness

ASTM D785, *Standard test method for Rockwell hardness of plastics and electrical insulating materials*

K.2.19 Wear resistance

ASTM D1044, *Standard test methods for resistance of transparent plastics to surface abrasion*

ASTM D4060, *Standard test method for abrasion resistance of organic coatings by the taber abraser*

K.2.20 Creep

ASTM D2990, *Test methods for tensile, compressive, and flexural creep and creep-rupture of plastics*

K.2.21 Fracture toughness

ASTM E399, *Standard test method for plane-strain fracture toughness of metallic materials*

AS/TM 1820, *Standard test method for measurement of fracture toughness*

K.2.22 Hydraulic expansion

ASTM F1087, *Test methods for linear dimensional stability of a gasket material to moisture*

K.3 Ceramics and carbons

K.3.1 Physical and chemical properties

ISO 6474 (all parts), *Implants for surgery — Ceramic materials*

K.3.2 Fatigue rate

ASTM E647, *Standard test method for measurement of fatigue crack growth rates*

K.3.3 Hardness

ASTM E92, *Standard test method for Vickers hardness of metallic materials*

K.3.4 Thermal expansion

ASTM E228, *Linear thermal expansion of solid materials with a vitreous silica dilatometer*

K.3.5 Fracture toughness

ASTM E399, *Standard test method for plane-strain fracture toughness of metallic materials*

K.4 Biological materials

K.4.1 Possible adaptation of tensile properties

ISO 527 (all parts), *Plastics — Determination of tensile properties*

K.5 Textiles

K.5.1 Determination of tear-out resistance

ISO 13937-2, *Textiles — Tear properties of fabrics — Part 2: Determination of tear force of trouser-shaped test specimens (Single tear method)*

K.5.2 Determination of water absorption

DIN 53923, *Testing of textiles — Determination of water absorption of textile fabrics*

K.6 MRI compatibility

ASTM F2052, *Standard test method for measurement of magnetically induced displacement force on medical devices in the magnetic resonance environment*

ASTM F2119, *Standard test method for evaluation of MR image artifacts from passive implants*

ASTM F2182, *Standard test method for measurement of radio frequency induced heating near passive implants during magnetic resonance imaging*

ASTM F2213, *Standard test method for measurement of magnetically induced torque on medical devices in the magnetic resonance environment*

ASTM F2503, *Standard practice for marking medical devices and other items for safety in the magnetic resonance environment*

Annex L (informative)

Raw and post-conditioning mechanical properties for support structure materials

L.1 Raw material properties

Raw material properties determine incoming material quality and uniformity and predict subsequent thermo-mechanical effects. Thermo-mechanical properties of the implanted device affect clinical performance, as well as stress (or strain) and fatigue behavior.

Typical mechanical properties listed below that should be specified for the raw material(s) used in the support structure include, but are not limited to:

- ultimate tensile strength (UTS);
- yield strength (YS);
- elongation;
- plateau stresses, for nitinol;
- elastic strain limits, for nitinol.

L.2 Post-conditioning mechanical properties

The stress-strain behavior of the support structure material after deployment should be reported. The stress-strain behavior should be presented in a plot or graph that shows both loading and unloading. Typical post-processing mechanical properties of the support structure material that should be reported include, but are not limited to, the following (see Annex J for other potentially relevant mechanical properties):

- UTS;
- YS;
- elongation;
- elastic modulus;
- Poisson's ratio;
- endurance limit (if applicable);
- plateau stresses, for nitinol;
- elastic strain limits, for nitinol.

L.3 Other mechanical properties

In addition, reporting other mechanical properties at previous stages of manufacture might allow characterization of the material for use in stress or strain analysis. The stress-strain response, endurance

AAMI
Single user license provided to AAMI standards committee members.

limit, and post-processing mechanical properties should be determined through physical experiments or computational models that simulate support structure material properties, manufacturing and deployment processes. The use of literature or handbook values should be justified. Standard test methods should be used whenever possible. Non-standard test methods should be described in detail and should be justified.

Annex M (informative)

Corrosion assessment

M.1 Rationale

Corrosion of the implantable device components can cause or contribute to structural component failure. In addition, corrosion by-products (e.g. metallic ion release) could cause biological and tissue responses. *In vitro* testing is performed to detect and measure metallic ion release.

Many types of corrosion mechanisms might act, often simultaneously, on the device over time. While some corrosion mechanisms are predominantly related to material properties, surface finish and manufacturing of the component (e.g. uniform corrosion, pitting corrosion and intergranular corrosion), others relate more to the device design (e.g. crevice corrosion and galvanic corrosion) or the operational conditions (e.g. fretting corrosion, corrosion fatigue and stress corrosion cracking). The planning, selection, design and execution of corrosion tests should ensure that all relevant corrosion mechanisms and their interactions are identified and assessed to obtain the information needed to evaluate the device performance during its service life.

Corrosion assessment can include a variety of electrochemical, microscopic and gravimetric methods. Often combinations of qualitative observations, quantitative measurements and statistical analyses are needed to provide an overall assessment of corrosion. Standard corrosion tests developed by ASTM, NACE and ISO address the technical requirements specified in the test method but might need to be modified to appropriately address conditions applicable to device applications. If a standard is followed where no acceptance criteria are prescribed, the manufacturer should justify the final acceptance criteria adopted.

NOTE See Reference 0.

M.2 General

Commonly used standard methods for medical device components include, but are not limited to, ASTM F2129 and ASTM F746. Non-destructive methods, such as electrochemical impedance spectroscopy (ASTM G106) and electrochemical noise measurements (ASTM G199) might be advantageous for monitoring corrosion properties and events during accelerated or real time testing.

The corrosion mechanisms described below are often applicable to materials and conditions representative of implantable heart valve substitutes, although other mechanisms are possible. The manufacturer should provide rationale for the selected test methods and justify that all applicable corrosion mechanisms and conditions have been addressed through testing or theoretical assessments.

M.3 Pitting corrosion

Pitting corrosion is a localized form of corrosion. It occurs when discrete areas of a material lose their passive state and undergo corrosion attack while the majority of the surface remains unaffected. The localized corrosion attack creates small holes (pits) which can rapidly penetrate the material and

AAMI
Single user license provided to AAMI standards committee members.

contribute to failure. Pitting of a material depends strongly on the presence of aggressive ionic species (e.g. chloride ions) in the environment having a sufficient oxidizing potential.

The assessment of the pitting corrosion susceptibility of the device is of relevance both for storage solution and in simulated *in vivo* conditions. Literature citations or previous experience with similar devices could be referenced; however, the materials, design and fabrication processes specific to the device under analysis may reduce or eliminate the applicability of generic literature. For example, the pitting corrosion resistance of nitinol is sensitive to processing variables such as heat treatment and electropolishing; therefore the pitting corrosion susceptibility of the finished nitinol support structure should be characterized. To capitalize on previous experience with similar devices it is necessary to show that their surface chemistries are equivalent.

Pitting corrosion can be assessed by electrochemical methods, such as potentiodynamic and potentiostatic measurements described in ASTM F2129 and ASTM F746. Crevice corrosion will occur at lower potentials than pitting and therefore interference from crevices on the test sample can lead to an underestimation of the pitting resistance. It is recommended to perform microscopic examination (e.g. as described in ASTM G161) of the samples after testing to evaluate the presence of pits and/or crevice corrosion, because it is difficult to mount a test sample without introducing a crevice at the sample/mount interface.

NOTE See Reference 0.

M.4 Crevice corrosion

Crevice corrosion is a form of localized corrosion which occurs in areas where parts of the material are in contact with small volumes of stagnant liquid. In short, the limited mass transfer within the stagnant liquid in the crevice creates a deoxygenized zone with increased salt and acid concentration compared to the rest of the liquid. This difference shifts the electrochemical potential within the crevice to a more negative value which causes passivity to breakdown and the onset of active dissolution (corrosion).

Crevice corrosion can result from the design of the component or from formation of deposits that introduce a critical crevice. This corrosion mechanism occurs mainly, but not exclusively, on materials which are protected by a passive oxide.

Literature citations or previous experience with similar devices can be referenced. However, as the presence of critical crevices is strongly related to device design, and the material passivity is affected by the specific fabrication processes, generic literature might not be applicable. To capitalize on previous experience with similar devices it is necessary to show that their surface chemistries and crevices are equivalent. Crevice corrosion can be assessed by immersion test methods as well as electrochemical methods under open circuit conditions or applied potential/current, such as described in ASTM F2129, ASTM F746 and ISO 16429.

M.5 Galvanic corrosion

Galvanic (or bimetallic) corrosion is a form of corrosion in which one metal corrodes preferentially when it is in electrical contact with a different metal. Enhanced corrosion of the more negative (less noble) metal will be experienced together with partial or complete cathodic protection of the more positive (more noble) metal.

If the device contains more than one type of metal, such as a support structure with marker bands, the manufacturer should demonstrate the design's resistance to galvanic corrosion. It is recommended that

AAMI
Single user license provided to AAMI standards committee members.

the risk of galvanic corrosion is addressed by theoretical methods, such as Evans Diagram and ASTM G82. If overlapping of devices is expected during clinical procedures, then the potential for galvanic corrosion of contacting dissimilar materials should be addressed. Test methods described in ASTM G71 or equivalent methods can be used or modified, by incorporating the experimental setup described in ASTM F2129.

M.6 Corrosion fatigue

Corrosion fatigue can be defined as a material failure mechanism which depends on the combined action of repeated cyclic stresses and a chemically reactive environment. One example is that localized corrosion-deformation interactions on smooth surfaces act as crack initiation sites at thresholds lower than estimated from linear elastic fracture mechanics. The total damage due to corrosion fatigue is usually greater than the sum of the mechanical and chemical components acting separately.

NOTE 1 See Reference 0.

Crack growth is often rate limited by one of the slow steps in the mass-transport and crack surface reaction sequence and, as a consequence, slow loading rates enhance corrosion fatigue damage. Hence, testing at low frequency might be necessary to adequately address the corrosion fatigue mechanisms acting on the device. ASTM F1801 outlines corrosion fatigue testing of standard material specimens for medical implant applications. Corrosion fatigue experiments follow directly from procedures for mechanical tests and can be assessed as part of the fatigue assessment of the device or in separately designed corrosion fatigue tests for the support structure component as justified by the manufacturer.

NOTE 2 See Reference 0.

M.7 Fretting (wear) and fretting corrosion

Fretting is defined as the wear process occurring between contacting surfaces having relative oscillatory motion. Fretting corrosion is caused by corrosion reactions which occur at the interface of two closely fitting surfaces when they are subjected to slight relative oscillatory motion with or without the abrasive effects of corrosion product debris between them.

The potential for fretting (wear) and fretting corrosion should be addressed in designs that allow micromotion between components (e.g. woven wires) that might disrupt an associated coating or passive film.

M.8 Post-fatigue corrosion evaluation

After completion of fatigue testing and/or device durability testing, corrosion evaluation of specimens should be considered. The manufacturer should justify the evaluation method used.

Annex N (informative)

Guidelines for verification of hydrodynamic performance

N.1 General

This annex provides guidance on test equipment, test equipment validation, formulation of test protocols and test methods for the hydrodynamic performance of transcatheter heart valves. Equipment and test procedures should be appropriate for the valve's intended indication, e.g. adult/pediatric, left/right-side. See Table 1 and Table 2, and Annex H.

N.2 Steady forward flow testing

Steady forward flow testing is not intended to characterize valve performance, but may be helpful in verifying the accuracy of the pulsatile flow testing. This is an optional study.

N.3 Steady back flow leakage testing

N.3.1 Measuring equipment accuracy

N.3.1.1 The steady flow leakage flowrate should have a minimum measurement accuracy of ± 1 ml/s.

N.3.1.2 All other items of measuring equipment should have a minimum measurement accuracy of ± 5 % of the full-scale reading.

N.3.2 Test apparatus requirements

N.3.2.1 The steady back flow leakage testing should be conducted in an apparatus that is capable of generating constant back pressures appropriate for the intended device application in accordance with Tables 1 and 2. See Annex H for guidelines regarding suggested test conditions for the pediatric population.

N.3.2.2 The heart valve substitute should be deployed with simulated conduits representative of the intended implant site and deployed device diameters.

N.3.2.3 A standardized nozzle can be used to characterize the back pressure, leakage volume flow rate and pressure measuring equipment.

N.3.2.4 The repeatability of the test system should be evaluated and documented.

N.3.3 Test procedure

N.3.3.1 Measure the static leakage across the test valve and the standard nozzle at five equidistant back pressures appropriate for the intended device application in accordance with Tables 1 and 2. Collect

at least five measurements at each level of back pressure. See Annex H for guidelines regarding suggested test conditions for the pediatric population.

N.3.4 Test report

The steady back flow test report should include:

- a) a description of the fluid used for the test, including its biological origin or chemical components, temperature, viscosity and specific gravity under the test conditions;
- b) a description of the steady flow apparatus;
- c) details of the mean, range and standard deviation of the performance test variables, at each simulated condition for each test heart valve substitute and standard nozzle, presented in tabular and graphic form; i.e. static leakage volume flow rate, expressed in l/min, as a function of back pressure.

N.4 Pulsatile-flow testing

N.4.1 Measuring equipment accuracy

N.4.1.1 The pressure measurement system should have a natural frequency of at least 50 times that of the test cycle rate and a measurement accuracy of at least ± 0.26 kPa (± 2 mmHg).

N.4.1.2 Regurgitant volume measurements should have a measurement accuracy of at least ± 2 ml.

N.4.1.3 All other measuring equipment should have a measurement accuracy of at least ± 5 % of the full-scale reading.

N.4.2 Test apparatus requirements

N.4.2.1 The pulsatile-flow testing should be conducted in a pulse duplicator which produces pressure and flow waveforms that approximate physiological conditions over the required physiological range appropriate for the intended device application in accordance with Tables 1 and 2. See Annex H for guidelines regarding suggested test conditions for the pediatric population.

N.4.2.2 The pulse duplicator should have had its properties and performance established by means of testing reference valves of different sizes in both the aortic and mitral positions.

N.4.2.3 The pulse duplicator should permit measurement of time-dependent pressures, volumetric flow rates, velocity fields and turbulent shear stress fields.

N.4.2.4 The repeatability of the test system should be evaluated and documented.

N.4.2.5 Relevant dimensions of the intended implant site should be simulated.

N.4.2.6 The conduit geometry and mechanical properties should be representative of the intended implant site.

N.4.2.7 The chamber should allow the observer to view and photograph the inflow and outflow aspects of the test heart valve substitute at all stages of the cycle.

N.4.3 Test procedure

N.4.3.1 Tests should be carried out on each valve in the position in which it is intended to be used. Qualitative and quantitative assessments should be made.

N.4.3.2 Pressure difference should be measured at four simulated cardiac outputs between 2 and 7 l/min (e.g. 2; 3.5; 5; 7 l/min), at a single simulated normal heart rate (e.g. 70 cycles/minute), or as appropriate for the intended device application in accordance with Tables 1 and 2. See Annex H for guidelines regarding suggested test conditions for the pediatric population.

N.4.3.3 Regurgitant volumes should be measured at three different mean (averaged over the cardiac cycle) back pressures [e.g. 10.4; 15.6 and 20.8 kPa, (80, 120 and 160 mmHg)], at three simulated low, normal, and high heart rates (e.g. 45, 70 and 120 cycles/minute) at a normal simulated cardiac output (e.g. 5 l/min), or as appropriate for the intended device application in accordance with Tables 1 and 2. See Annex H for guidelines regarding suggested test conditions for the pediatric population.

N.4.3.4 At least 10 measurements of each of the following variables should be obtained from either consecutive or randomly-selected cycles:

- a) mean pressure difference across the test heart valve substitute;
- b) mean and RMS flow rates through the test heart valve substitute;
- c) forward flow volume;
- d) cycle rate;
- e) mean arterial pressure over the whole cycle;
- f) duration of forward flow through the test heart valve substitute, as a percentage of cycle time;
- g) regurgitant volume, including the closing volume, the leakage volume (see Figure 1) and the corresponding mean pressure difference across the closed valve.

N.4.3.5 Assess the flow fields (velocity and shear) in the immediate vicinity of the heart valve substitute. Techniques for such measurements include, but are not limited to, laser Doppler velocimetry (LDV), digital particle image velocimetry (DPIV) and computational fluid dynamics (CFD). The CFD code should be verified to make sure that the right equations and physics are being modeled as applied to the valve design being evaluated. CFD results should be validated by comparison with experimental results.

N.4.3.6 Quantitatively assess the hemolytic and thrombogenic potential of the valve design in each position of intended use, either in the studies described in N.4.3.5, or other relevant *in vitro*, computational and/or *in vivo* studies. Measures such as shear rate magnitude versus duration and particle residence time should be considered.

N.4.4 Test report

The pulsatile-flow test report should include:

- a) a description of the fluid used for the test, including its biological origin or chemical components, temperature, viscosity and specific gravity under the test conditions;

- b) a description of the pulse duplicator, as specified in N.4.2, and its major components and associated apparatus, including a schematic diagram of the system giving the relevant chamber dimensions, chamber compliance (if a compliant chamber is used), details of the location of the pressure-measuring sites relative to the base of the leaflets of the heart valve substitute, pressure measurement instrumentation frequency response, and the appropriate representative pressure and flow waveforms at nominal conditions;
- c) an assessment, including appropriate documentation, of the opening and closing action of a test heart valve substitute and, if appropriate, its adjacent flow field under stated conditions;
- d) a permanent recording of at least 10 consecutive or randomly selected cycles of the time-dependent simultaneous pressures, proximal and distal to the heart valve substitute, and the volume flow through it. Details of mean, range and standard deviation of the following performance test variables at each simulated cardiac output for each test heart valve substitute and reference valve should be presented in tabular and graphic form;
 - e) simulated cardiac output;
 - f) cycle rate;
 - g) duration of forward flow phase, expressed as a percentage of the cycle time;
 - h) forward flow volume;
 - i) mean and RMS flow rates;
 - j) mean pressure difference;
 - k) effective orifice area (provide formula used);
 - l) regurgitant volume, closing volume and leakage volume, expressed in milliliters and as a percentage of stroke volume; and the corresponding mean pressure difference across the closed valve;
 - m) mean arterial pressure over the whole cycle;
 - n) appropriate qualitative photographic documentation and quantitative analyses of the opening and closing characteristics for the heart valve substitute;
 - o) appropriate documentation and quantitative analyses of the velocity and shear stress fields in the immediate vicinity;
 - p) appropriate qualitative and quantitative documentation for the hemolytic and thrombogenic potential.

N.4.5 Paravalvular leakage assessment

The methods described above for steady and/or pulsatile back flow leakage can be used for paravalvular leakage quantification. Testing of the valve deployed within the simulated conduit first without and then with sealing around the valve perimeter may be used to characterize paravalvular leakage. Other methods may be employed.

Annex O (informative)

Durability testing

O.1 General

This annex provides requirements for test equipment, formulation of test protocols and test methods for the durability assessment of heart valves. The heart valve substitutes should be tested under appropriate loads while simulating device function in an appropriate fluid environment to a specified number of cycles required to demonstrate *in vitro* device durability.

O.2 Measurement equipment accuracy

The pressure transducers located in the measurement system used to measure the transvalvular pressure difference should have a natural or resonant frequency 50 times the cycle rate being tested. Minimum measurement accuracy should be ± 0.65 kPa (± 5 mmHg) unless otherwise justified. The data sampling rate should be appropriate.

O.3 Test parameters

Tests should be performed at a defined differential pressure consistent with normotensive conditions specified in Table 1 or Table 2 for a minimum of 200 million cycles. The manufacturer should justify the cycle rate and load conditions. The test cycle rate should be established based on the device design and materials of construction as these might influence the results of durability tests. See Annex H for guidelines regarding suggested test conditions for the pediatric population.

O.4 Results evaluation

Some minor damage is expected on valves after completing durability testing. Failures, however, are characterized by excessive structural damage and/or functional impairment. A clear definition of "failure" should be established and be consistent with respect to the specific failure mode(s) identified by the risk analysis. Examples of structural deterioration include holes, tears, gross delamination, fraying, incomplete coaptation, fracture, excessive deformation, failure of any individual component, other mechanical breakdown and/or wear. Examples of functional impairment include excessive regurgitation and/or excessive transvalvular forward flow pressure difference.

If redundant leaflet material resulting from deployment of the device into an annulus at the low end of the indicated use range causes premature degradation of leaflet material due to localized bending or folding (e.g. buckling or "pinwheeling"), additional evaluations of leaflet material in the region of bending or folding should be conducted [e.g. histological evaluations, scanning electron microscopy (SEM)]. Results should be qualitatively compared to those from test valves tested at the maximum deployed valve diameter. See References 0, 0, 0 and 0.

NOTE "Pinwheeling" refers to twisting of leaflet free-edges resulting of excessive leaflet tissue.

Additional shorter duration testing at physiologic beat rates (<200 bpm) may be considered.

AAMI
Single user license provided to AAMI standards committee members.

O.5 Real time wear testing

In addition to accelerated wear testing, wear testing at physiologic conditions (e.g. beat rates < 200 bpm) to cycle counts less than 200 million cycles may be considered. The results of this testing may be used to evaluate the validity of accelerated durability test results.

O.6 Dynamic failure mode

Potential modes of failure associated with structural valve deterioration (Annex G) should be identified. A possible evaluation method is subjecting samples of valves that have survived 200 million cycles of durability testing to extended accelerated durability testing under the same or more severe conditions. Other evaluation methods may be employed depending on the device design, materials and construction. The method(s) used should be justified.

O.7 Report requirements

The durability assessment report should include:

- a) a list of the valves, including reference valves, used to conduct the testing;
- b) description and dimensions of deployed valve configuration;
- c) justification for the reference valve used;
- d) justification for cycle rates used;
- e) the pass/fail criteria and justification for the criteria;
- f) a description of the fluid used for the assessment, including biological origin or chemical components, temperature, viscosity, pH, and specific gravity under the simulation conditions;
- g) descriptions, specifications and validations of all test apparatus and references to and/or descriptions of any procedures used in order to complete the assessment;
- h) a list of pertinent test conditions (e.g. cycle rate, average peak closed pressure difference), sample pressure waveforms, and rationale for any deviations from those test conditions specified for durability testing;
- i) verification that targeted pressures across the closed valve were attained for at least 5 % of each cycle during at least 95 % of the test cycles;
- j) a detailed description of the appearance of the heart valve substitutes and hydrodynamic performance prior to test, at the completion of the test, at periodic intervals during the test of 50 million cycles or less, and upon the development of structural change and/or failure. Any damage should be characterized by using the appropriate means (e.g. histology or surface characterization). It should be indicated if the valves were intact for the length of the evaluation and if they met the pass/fail criteria.

Annex P (informative)

Fatigue assessment

P.1 General

A fatigue assessment (see Figure P.1) consists of:

- a stress/strain analysis of the components/valve under, at a minimum, simulated *in vivo* moderate hypertensive conditions, and other relevant loading modes;
- a fatigue characterization of the structural material/component;
- a fatigue lifetime assessment of the components/valve.

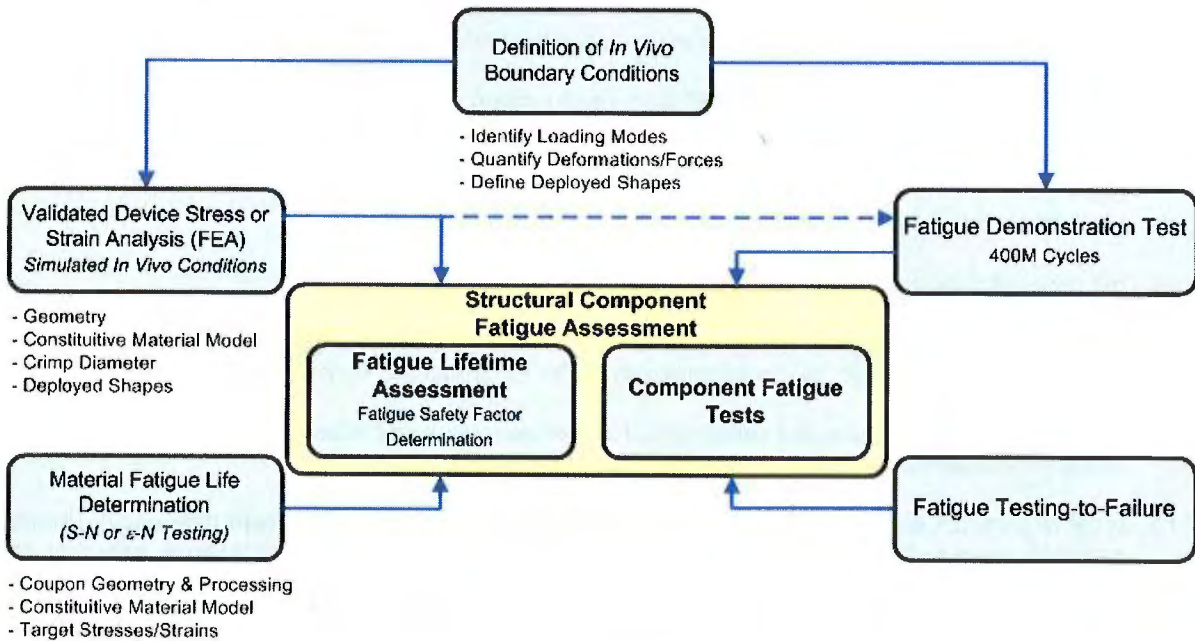

Figure P.1 — Example schematic of a structural component fatigue assessment using a stress-or strain-life approach

NOTE The selection of stress analysis or strain analysis should be employed depending on the material of the structural component.

P.2 Stress/strain analysis of structural components under simulated *in vivo* conditions

A validated stress/strain analysis of the transcatheter heart valve substitute under simulated *in vivo* conditions should be performed on all structural components such as support structures, mesh, and attachment parts. Other valve components such as leaflets, sutures or cloth should be considered for their reaction loads but would not necessarily require analysis.

The analyses should fully represent the range of deployed valve diameters and the loading conditions associated with the implantation site. If all deployed valve diameters are not analyzed, it is necessary to conduct an analysis to identify the size and deployed valve diameter of the device with the greatest potential for failure.

Stress/strain analysis should account for all physiologic loading conditions to which the device will be subjected. It might not be feasible to simulate all combined loading modes in a single analysis; however, any de-coupling or superposition of loading modes should be justified. Physiologic loading will depend on the implant site and device design, and may include, but is not limited to:

- differential pressures across the valve (minimum pressures associated with moderate hypertensive conditions);
- transient stresses occurring during opening and closing;
- radial dilatation and compression;
- torsion;
- bending;
- axial tension;
- axial compression;
- linear/transverse compression (e.g. crushing).

These items should be considered in the context of anatomic variability and pathologic changes within the implantation site.

The manufacturer should identify and justify the appropriate *in vivo* loading conditions. Pressures associated with normal, hypertensive and hypotensive conditions are given in Tables 1 and 2. See Annex H for guidelines regarding suggested test conditions for the pediatric population.

The entire stress/strain history of the device in each loading step should be included in the stress/strain analysis. The entire stress/strain history may include, but is not limited to:

- initial fabrication, expansion, manufacturing, test and inspection;
- crimping/loading onto the delivery system;
- deployment;
- retrieval and re-deployment (if applicable);
- physiologic loading conditions.

Residual stresses/strains resulting from manufacturing processes that were not included in test specimens (e.g. material coupons) and any stress concentrations associated with the manufacturing process should be included in the stress/strain analysis. Residual stresses/strains might result from the crimping process, loading the device onto the delivery system, and deployment.

Valve motion and closure geometry are not always symmetric. This is particularly true for flexible leaflet valves for which geometrical asymmetry can contribute to closure asymmetries. It is important to ensure that the maximum stresses are not underestimated. For this reason, stress/strain analyses should be performed on entire valve/component geometries unless it is demonstrated that the use of a simplified model with symmetry conditions is representative of the full analysis.

An appropriate constitutive model for each material should be used in any stress/strain analysis, including time-dependent, temperature-dependent and/or non-linear models as appropriate. Development of constitutive models or evaluation of appropriate constants for existing constitutive models should be based on testing of material that is representative of the actual structural component, including material processing and environmental exposures (e.g. sterilization). The geometry and mechanical properties of simulated implantation sites should be justified and included in the analysis.

Validation of any stress/strain analysis should be performed in order to demonstrate sufficient confidence in the predicted results. While it is left to the manufacturer to develop and justify such a validation, the validation should include comparison of predicted FEA results against actual experimental measurements. Note that the comparison should be made to independent measurement.

P.3 Fatigue characterization

P.3.1 General

Fatigue characterization generally falls into four main categories:

- a) stress/life (S/N) for use with classical stress/life assessment;
- b) strain/life (ϵ /N) for use with classical strain/life assessment;
- c) fatigue crack growth for use in damage tolerance analysis (DTA);
- d) component testing for use in demonstrating fatigue resistance.

The manufacturer should determine and justify the most appropriate characterization(s) and assessment approach(es) for the specific material and valve design. However, the particular characterization technique should be consistent with the subsequent lifetime assessment approach used. Fatigue characterization of each structural material/component should be performed so that all properties necessary for the fatigue analysis are appropriately determined.

Coupon test specimens used to determine material properties should be produced in such a way as to ensure the specimen is representative of the actual material in the heart valve component (e.g. microstructure, crystallinity, density). For example, material properties for nitinol components (e.g. A_f temperature) should be determined. Valve components used as test specimens should be representative of actual clinical components (e.g. fabrication methods, defect population). All test specimens should be exposed to all of the environments encountered in clinical valve fabrication. Stress or strain levels specified for the fatigue characterization will be justified by the manufacturer and should encompass the worst case anticipated stresses or strains experienced by the component *in vivo*. Cyclic test rates/frequencies should be justified by the manufacturer. Testing should be performed in an environment that is representative of the physiological environment with respect to its effect on fatigue behavior. The testing should fully represent the range of deployed valve diameters and the loading conditions associated within the implantation site. If all deployed valve diameters are not tested, it will be necessary to conduct an analysis to identify the size(s) of the device with the greatest potential for fatigue failure.

Note that fatigue testing should be performed in such a manner as to preserve the anticipated *in vivo* failure mechanism. For example, nitinol has been shown to be relatively insensitive to test frequency and environment for fatigue crack growth measurements. If an accelerated protocol is used (e.g. increased test frequency), the manufacturer should justify the appropriateness of the test frequency chosen.

P.3.2 Stress/life (S/N) characterization

Classical S/N characterization is performed by generating failure data at various cyclic stress levels and load ratios in order to determine the maximum allowable stress for a specified design lifetime.

Testing should be performed at stress levels, including both amplitude and mean values, at least as severe as those predicted by the FEA under moderate hypertensive pressures and other relevant *in vivo* loading conditions with a safety factor justified by the manufacturer. Test frequency and environment, including test temperature and physiologically representative fluid, should be specified and justified by the manufacturer. Note that an endurance limit, as classically defined, might not exist for all materials when exposed to corrosive environments.

P.3.3 Strain/life (ϵ/N) characterization

While stress has traditionally been the basis for controlling fatigue tests and as a means of monitoring fatigue performance and failure for conventional engineering materials, strain provides a more practical and appropriate means of analyzing materials such as nitinol given its superelastic properties. Strain life (ϵ/N) characterization is performed by generating failure data at various cyclic strain amplitude levels and mean strain levels in order to determine the maximum allowable strain for a specified design lifetime. In such cases where stress-life characterization for nitinol is preferred, this alternative approach should be justified by the manufacturer.

Testing should span a sufficient range of both amplitude and mean strain conditions in order to establish and characterize the fatigue response of the material. Strain levels specified for the fatigue characterization will be justified by the manufacturer and should encompass the worst case anticipated stresses or strains experienced by the component *in vivo*. Test frequency and environment, including test temperature and physiologically representative fluid, should be specified and justified by the manufacturer. Note that an endurance limit, as classically defined, might not exist for all materials when exposed to corrosive environments.

P.3.4 Fatigue crack growth (da/dN) characterization

Fatigue crack growth testing is used in association with damage tolerance analyses. This analysis employs a fatigue crack growth relation governing crack propagation from inherent flaws in the material/component. Thus, the fracture toughness and fatigue crack growth behavior relating the rate of crack growth, da/dN , to an appropriate measure of the cycling crack driving force (commonly taken as the cyclic stress intensity factor) are determined for the component material.

Fatigue crack growth testing can be performed on representative test specimens or actual components. In either case, an appropriate measure of the crack driving force should be known. It is often more convenient and common to use more standard fracture specimens whose crack driving force solutions are readily known and available. Because crack growth kinematics depend on the mode of loading (e.g. opening versus shear), testing should also be performed so as to simulate the anticipated *in vivo* mode of crack growth.

Unless plane strain conditions are ensured for the test specimen, testing should be performed on specimens whose thickness is at least as thick as the actual component. While machined notches may be used to aid and control the formation of a crack, it might be necessary to pre-crack the specimen prior to

generating acceptable crack growth and/or toughness data. However, care should be taken in pre-cracking so as not to overload the specimen. For example, for nitinol, overloads might cause large compressive stresses to develop near cracks, resulting in retarded growth and potentially non-worst case crack growth behavior. For the same reason, testing should generally be performed under increasing crack driving force in order to mitigate potential retardation effects.

Testing should span the range of crack driving force from threshold, or minimum anticipated driving force, to near toughness in order to adequately establish and characterize the fatigue crack growth behavior of the material. For example, normally nitinol does exhibit threshold behavior, below which no crack growth occurs. If a threshold is to be used in subsequent damage tolerance analyses, the manufacturer should establish and verify its existence.

P.3.5 Component testing

Fatigue testing of components may be used to demonstrate fatigue lifetimes under conditions that exceed those experienced by the component *in vivo*. Testing should produce stresses or strains that are representative of the worst case anticipated stresses or strains experienced by the component *in vivo* with a fatigue safety factor justified by the manufacturer. Because component testing might only approximate *in vivo* loadings, a validated stress analysis of the component testing might be required to demonstrate that testing is representative of the *in vivo* loadings.

A clear definition of “failure” should be established and be consistent with respect to the specific failure mode(s) identified by the risk analysis. Samples should be characterized and evaluated for failure prior to, during and after testing. Evaluation and documentation during testing should be performed, at intervals justified by the manufacturer, to distinguish fatigue-induced damage from testing artifacts. Testing artifacts should in no way influence the potential for the test to cause fatigue-induced damage.

P.4 Fatigue lifetime assessment

P.4.1 General

Based on fatigue characterization completed as per Clause P.3, a lifetime assessment of the structural components should be performed in order to evaluate risks associated with fatigue-related failure modes. While it is left to the discretion of the manufacturer to determine and justify the most appropriate lifetime assessment approach(es) for the specific material and valve design, the particular approach should be consistent with the appropriate supporting characterization technique. If a general material fatigue characterization (i.e. ϵ/N or fatigue crack growth) was developed, it could be used in fatigue lifetime assessments of several failure modes provided the material data are representative of the material and loadings of each particular failure mode. Deterministic or probabilistic approaches may be employed for fatigue life assessments. If fatigue safety factors are reported, the method by which safety factors were computed should be explained.

P.4.2 Stress-life (S/N) assessment

The S/N structural fatigue life is based on the S/N data in order to determine the predicted lifetime at the maximum stress as determined from the stress analysis. The stress-life assessment should reflect the inherent variability in the fatigue data as well as a measure of confidence in the stress analysis.

The stress-life assessment should identify and account for the effects of allowable variances such as dimensional tolerances and manufacturing-related defects, material variations (e.g. voids, impurities, material property variations), and assess whether the methodologies for assuring variances are maintained within the manufacturer’s justified acceptance criteria.

P.4.3 Strain-life (ϵ/N) assessment

The ϵ/N structural fatigue life is based on the ϵ/N data in order to determine the predicted lifetime at the maximum mean and alternating strains as determined from the strain analysis. The strain-life assessment should reflect the inherent variability in the fatigue data as well as a measure of confidence in the strain analysis.

The strain-life assessment should identify and account for the effects of allowable variances such as dimensional tolerances and manufacturing-related defects, material variations (e.g. voids, impurities, material property variations), and assess whether the methodologies for assuring variances are maintained within the manufacturer's justified acceptance criteria.

P.4.4 Damage tolerance analysis (DTA)

For many transcatheter heart valve substitutes, most parts have very small cross-section dimensions, on the order of a few hundred micrometers. For these small components, the typical critical cracks for fatigue are on the order of a few tens of micrometers, which are significantly less than the large-crack assumptions for DTA.

The DTA approach to small component device fatigue is appropriate only when the geometric size of the device is large enough to sustain stable crack growth for many thousands of cycles and over a long enough time period to retain functionality of the device. Contrary to large-crack fatigue crack growth, short-crack fatigue crack growth depends on additional parameters such as test sample geometry, initial crack size, and material microstructure. The computational methods for calculating stress intensity factors have not been validated for this crack size regime; experimental methods for deriving short-crack data have not been developed or standardized.

The application of traditional damage tolerant analysis to small components is not appropriate for use as the primary analytical method for predicting component fatigue life. However, DTA concepts may be useful for establishing inspection limits for quality assurance purposes.

P.4.5 Component demonstration assessment

Component demonstration assessments involve verification that component testing demonstrates sufficient survival with an appropriate confidence level.

Component testing is typically used to demonstrate probability of survival with associated confidence of components subjected to conditions that meet or exceed anticipated *in vivo* conditions. Unless testing is performed under several loading conditions, it might not be possible to extrapolate significantly beyond the duration of the component demonstration testing. As a result, component testing is often used to supplement other lifetime assessments. However, if component testing is performed over a sufficient range of conditions, it might be possible to predict the component lifetime at *in vivo* conditions.

Note that the confidence of the demonstration assessment should reflect the number of components tested and their representation of the actual component population, the ability to detect failures in the test, and a measure of confidence in the simulated *in vivo* and test stress analyses.

P.4.6 Test to failure

To compare the predicted areas of high stress or strain from computational analyses to the observed failure areas of the specimen, a selection of specimens that have survived fatigue testing should continue testing and/or a sample of new specimens should be subjected to exaggerated stress or strain levels (i.e. step-stress paradigm) to determine the manner in which they will fail. The manufacturer should justify the

number of samples and test conditions used. The manufacturer should use these specimen failures, if applicable, to demonstrate consistency with stress/strain analysis predictions.

P.4.7 Post-fatigue corrosion evaluation

After completion of fatigue testing, specimens should be subjected to detailed microscopic surface inspection for any evidence of corrosion.

Annex Q (informative)

Preclinical *in vivo* evaluation

Q.1 General

Based on the risk management assessment and in order to predict the safety and performance of clinical use, the study should be designed to provide a sufficient number of animals implanted with the test transcatheter heart valve substitutes and reference heart valve substitutes (rationale for animal model and justification for the use of alternative anatomic sites and implantation methods should be provided).

Evaluations listed in this annex (Table Q.1) are not intended as mandatory or all-inclusive. Each of the described evaluations includes the minimum parameters necessary to assess a specific issue. However, additional parameters might be relevant depending on specific study goals and/or manufacturer product claims. Acute testing of transcatheter heart valve substitutes can be performed under non-sterile conditions.

Q.2 Definitions

Q.2.1

acute assessment

short-term implants used to assess *in vivo* safety and performance

NOTE All animals entered into acute short-term assessment will remain under general anesthesia for the duration of the study.

Q.2.2

chronic assessment

long-term implants to assess chronic *in vivo* safety and performance after the animal has recovered from anesthesia

NOTE The endpoints and durations of these studies should be determined by risk analysis.

Table Q.1—Examples of evaluations

Evaluation	Acute	Chronic
Hemodynamic performance	X	X
Ease of use	X	X
Device migration/embolization	X	X
Interference with adjacent anatomical structures	X	X
Hemolysis		X
Thrombo-embolic complications		X
Calcification/mineralization		X
Pannus formation/tissue ingrowth/foreign body		X
Structural valve dysfunction and non-structural dysfunction		X

Q.3 Disposition of evaluations

The evaluations listed in Table Q.1 can be addressed as follows.

Q.3.1 Hemodynamic performance

Transvalvular mean pressure differential and regurgitation should be performed, at least on the day of elective euthanasia, at cardiac outputs across the range of 2.5 to 6 l/min. Transvalvular regurgitation measurement should be performed using a continuous flow measurement technique or other methods which do not require crossing the valve with a catheter. Multiple measurements of pressure and flow should be obtained.

Measuring equipment used to assess hemodynamic performance should be described and its performance characteristics documented.

Q.3.2 Ease of use

The ease of use should include a descriptive assessment of the handling characteristics of the transcatheter heart valve substitute system (e.g. steerability, trackability, pushability, visibility, ergonomic characteristics, reliability of deployment, ability to recapture and redeploy, procedure duration) and unique features of the system, compared to a reference system (if appropriate). Auxiliary procedures such as rapid pacing or balloon valvuloplasty should be described. Visualization of valve function and alignment should be performed intra- or post-operatively using appropriate imaging modalities. The performance characteristics of the selected equipment should be documented.

Q.3.3 Device migration or embolization

Describe and document using imaging or other techniques as appropriate to assess device migration or embolization.

Q.3.4 Interference with adjacent anatomical structures

Interference with coronary ostia, cardiac conduction system, mitral valve structures, etc. should be assessed and documented as appropriate.

Q.3.5 Hemolysis

At a minimum, the following laboratory analyses should be performed: red blood cell count, hematocrit, reticulocyte count, lactate dehydrogenase, haptoglobin and plasma-free hemoglobin. Additional hematology and clinical chemistry analyses should also be conducted to assess inflammatory response, platelet consumption, liver and renal function.

Q.3.6 Thrombo-embolic events

Thrombo-emboli should be evaluated in terms of macroscopic description, photographic documentation and a histologic description of the thrombotic material. A full post-mortem examination should be performed to disclose peripheral thrombo-emboli, both macro- and microscopically. Thrombo-emboli could originate from the implant site, delivery system or heart valve substitute.

Q.3.7 Calcification/mineralization

Calcification/mineralization should be evaluated in terms of macroscopic description, photographic and radiographic documentation and a histological description of any mineral deposits. The results should be compared to those of a reference valve, if available.

Q.3.8 Pannus formation/tissue ingrowth

At a minimum, the distribution and thickness of pannus formation/tissue ingrowth should be described using macroscopic and microscopic methods and photographic documentation. A description of the inflammatory response should also be included in the histologic description.

Q.3.9 Structural valve dysfunction and non-structural dysfunction

Structural and non-structural valve dysfunction should be macro- or microscopically documented and described. If deemed appropriate by the program and/or study director, any unused portion of the explanted transcatheter heart valve substitute should be retained in a suitable fixative for additional studies if needed.

Q.3.10 Assessment of valve and non-valve related pathology

Assessment of valve and non-valve related pathology not otherwise described above should be macroscopically described, histologically evaluated (if appropriate) and photographically documented.

Annex R (normative)

Adverse event classification during clinical investigation

R.1 General

The manufacturer shall ensure that investigators evaluate and report all relevant adverse events, for all study subjects, from the time the subject is enrolled (after signing the Informed Consent Form) to the end of the follow-up period. The manufacturer shall develop systems to ensure that all adverse events and device deficiencies are reported to the manufacturer in a timely manner and recorded appropriately, in accordance with ISO 14155.

R.2 Evaluation

Adverse events and device deficiencies shall be evaluated and communicated to interested parties in accordance with ISO 14155.

R.3 Data collection requirements

The manufacturer shall ensure the following information is documented on a case report form, for all observed adverse events (AEs):

- date of onset or first observation;
- description of the event;
- seriousness of the event;
- causal relationship of the event to the device;
- causal relationship of the event to the procedure;
- treatment required;
- outcome or status of the event.

R.4 Classification of serious adverse events

Each AE shall be categorized as either a serious adverse event (SAE) or non-serious adverse event according to the definitions in ISO 14155.

R.5 Adverse device effects

Adverse device effects shall be categorized as adverse device effects (ADE) and serious adverse device effects (SADE) in accordance with the definitions in ISO 14155. Device deficiencies shall also be identified in accordance with ISO 14155.

R.6 Classification of causal relationships

Causal relationship is the relationship of the AE to the study device, the implant procedure or the patient's condition. It should be established at least in line with the following categories.

- Device-related: any AE involving the function of the device, or the presence of the device in the body. Included in this category are events that are directly attributed to the device.
- Procedure-related: any AE that results from the implant procedure. Events in this category are directly related to the general procedural sequelae.
- Patient condition-related: any AE that results from the worsening of a pre-existing condition or cannot be attributed to the device or procedure.

Unknown: any AE that cannot be assigned to any of the above three conditions.

In addition to establishing this causal relationship, the probability of relationship should also be established by categorizing them as either definitely, possibly or not related to the device or procedure.

Independent adjudication of causality shall be conducted to assign the specific cause of an adverse event. Formal adjudication of adverse events is intended to manage the ambiguity and bias in assigning causality. The adjudication process should be performed by an independent, multi-participant committee of qualified experts.

R.7 Adverse events

R.7.1 General

Anticipated adverse events should be established based on the risk analysis for the specific technology. Risk analysis as defined by ISO 14971 is a systematic approach that uses available information to predict device-related hazards to estimate risk. ISO 14155 requires that the risk analysis shall include or refer to an objective review of published and available unpublished medical and scientific data and that the residual risks, as identified in the risk analysis, as well as risks to the subject associated with the clinical procedure required by the protocol, be balanced against the anticipated benefits to the subjects. Anticipated adverse events identified via the risk analysis shall be clearly specified in the clinical trial protocol prior to the initiation of the clinical study. Unanticipated adverse events that occur during a clinical trial that were not identified in the risk analysis shall be recorded as such and the causality appropriately adjudicated.

NOTE Risk is defined as the combination of the severity of the harm (or adverse event) and the probability of the occurrence of harm (see 3.40).

Where appropriate, the identified adverse event definitions used in the clinical protocol shall be consistent and aligned with the most applicable published guidelines, for example, the current Valve Academic Research Consortium (VARC)⁰. Adverse events identified by the risk analysis that are not included in the published guidelines should be defined based on relevant/contemporary references such as the Merck Manual, medical texts or other Academic Research Consortia.

All adverse events in addition to any relevant hazards (conditions that have the potential to lead to a harm or adverse event, e.g. strut fractures, valve migration or valve malposition) that have the potential to lead to future adverse events shall be recorded within the case report forms (CRFs). The CRFs shall also record all relevant information (e.g. any underlying evidence, such as imaging data, biomarkers) related to the incident to allow for complete analysis and any re-classification of events based on future changes to the published guidelines.

AAMI
Single user license provided to AAMI standards committee members.

Examples of adverse events are provided below. This list is not intended to be all-inclusive but representative of adverse events associated with transcatheter heart valves.

R.7.2 Examples of adverse events

- Arrhythmia
- Bleeding
- Cardiac tamponade
- Coronary obstruction
- Device embolization (valve or delivery system components)
- Endocarditis (transcatheter heart valve substitute)
- Hemodynamic instability
- Hemolysis
- Myocardial infarction
- Native valve dysfunction such as
 - regurgitation
 - stenosis
- Prosthetic valve dysfunction such as
 - regurgitation
 - stenosis
 - valve thrombosis
- Pulmonary embolism
- Renal compromise
- Stroke/Transient Ischaemic Attack (TIA)
- Systemic infection
- Thrombosis
- Vascular damage/trauma

R.8 Outcome severity rankings

Adverse events may lead to a variety of clinical outcomes. Examples of clinical outcomes resulting from an adverse event may include any of the following:

- death;
- new or prolonged surgery (e.g. coronary artery bypass, valve replacement);
- new or prolonged hospitalization;
- permanent impairment of body structure or body function;
- permanent pacemaker;
- required LVAD or transplant.

Certain outcomes such as death or prolonged hospitalization frequently have been classified as adverse events in various classification schemes and clinical trials. Consistent with ISO 14155, these shall be considered outcomes secondary to one or more adverse events. In addition, VARC includes a discussion of death/all cause mortality; however, this is used in context of study end points rather than adverse events.

Consistent with published guidelines such as VARC, potential clinical outcomes related to each adverse event identified by the guidelines shall be ranked by severity. Ranking the severities of clinical outcomes for each adverse event, consistent with recognized guidelines, allows for meaningful comparisons among different studies, clinicians, cohorts, delivery techniques and devices. Clinical outcome severity rankings included in the clinical protocol should be updated as necessary based on the most current published version of the relevant guidelines.

Examples of adverse events with their associated clinical outcome severity rankings are provided in Table R.1.

Table R.1—Examples of adverse events clinical outcome severity ranking

Adverse event	Clinical outcome severity ranking
Arrhythmia	1 Oral or parenteral medication; required observation, spontaneously resolved, no treatment needed
	2 Temporary pacemaker or cardioversion
	3 Permanent pacemaker, or defibrillation
	4 Death
Bleeding	1 Any bleeding worthy of clinical mention (e.g. access site hematoma) that does not meet severity 2, 3 or 4
	2 Overt bleeding either associated with a drop in the hemoglobin level of at least 3.0 g/dl or requiring transfusion of 2 or 3 units of whole blood/RBC, and does not meet criteria for severity 1
	3 Meets at least one of the following criteria — Bleeding in a critical area or organ, such as intracranial, intraspinal, intraocular, or pericardial necessitating pericardiocentesis, or intramuscular with compartment syndrome, or
	— Bleeding causing hypovolemic shock or severe hypotension requiring vasopresors or surgery, or
	— Overt source of bleeding with drop in hemoglobin of ≥ 5 g/dl or whole blood or packed RBCs transfusion ≥ 4 U
	4 Fatal bleeding
Endocarditis (transcatheter heart valve substitute)	1 Requiring oral or parenteral antibiotics; requiring observation, spontaneously resolved, no treatment needed
	2 Requiring IV or PO antibiotics associated with embolic complications
	3 Requiring valve replacement
	4 Death
Myocardial infarction, acute	1 Requiring IV diuretics, or oral treatment
	2 Requiring lytic agents, inotropic agents, vasoactive agents, percutaneous revascularization, or IABP
	3 Requiring LVAD, transplant
	4 Led to death
Renal compromise	1 Requiring change in medications, IV diurectics
	2 Requiring temporary dialysis
	3 Requiring transplant, or chronic dialysis
	4 Death
Structural valve deterioration	1 Requiring oral medication, or change of parameters on imaging with no symptoms
	2 Requiring IV inotropic or vasoactive agents or IABP
	3 Requiring valve replacement
	4 Death

AAMI
Single user license provided to AAMI standards committee members.

R.9 Follow up of SAEs

Any SAE shall be followed until it has resolved or in the investigator's opinion it is no longer clinically significant.

Annex S **(informative)**

Echocardiographic protocol

S.1 General

S.1.1 Echocardiography is the standard modality for the routine assessment of replacement heart valves both for research or regulatory studies and in clinical practice. Computed tomography (CT), or fluoroscopy may be used to image occluders in suspected obstruction of a replacement valve and magnetic resonance may be used in research studies notably for the assessment of LV mass and volumes.

S.1.2 Imaging facilities should be equipped with systems that have been validated for the intended applications in the assessment. They should also utilize personnel that have been specifically trained to conduct the required assessments.

S.1.3 Studies should be performed according to previously developed protocols. Additionally, study-specific training should be conducted prior to the study to ensure that all involved personnel clearly understand protocol objectives. The protocols should include procedures for assuring the quality of the acquired data.

S.1.4 When applicable, particularly in the case of the evaluation of primary study objectives, a third party "Core Lab" should be utilized to evaluate imaging studies. The Core Lab should be selected based upon its experience in conducting these types of evaluations as well as special expertise in the selected imaging modality. Utilization of a core lab can improve overall study quality by eliminating center bias, standardizing grading techniques and improving individual assessment quality.

S.1.5 Imaging studies should be recorded and archived for review. Data should be reviewed soon after recording a study so that deviations from the protocol can be detected early and, if necessary, a further study can be performed.

S.1.6 Centers should minimize the number of operators performing the protocol-required exams. Likewise, Core Labs should limit the number of observers evaluating studies.

S.1.7 For longitudinal analysis, consistent imaging methodologies should be used for all time points. For example, transoesophageal echocardiography (TEE) and transthoracic (TTE) echocardiography should not be mixed during follow-up. Likewise, particular images collected should remain consistent throughout the course of the study.

NOTE See Reference 0.

S.2 Echocardiographic studies

S.2.1 Echocardiographic studies should be conducted to capture protocol prescribed information to address study end points. Typically this involves standard imaging views in both 2D and Color Doppler modalities. Imaging planes will usually include: parasternal long-axis, parasternal short-axis at aortic, mitral and papillary muscle levels, apical 4-chamber, apical 2-chamber, apical long-axis. For adequate

AAMI
Single user license provided to AAMI standards committee members.

assessment of replacement heart valves it is often necessary to use off-axis views to minimize the effect of shielding. Spectral Doppler is essential.

S.2.2 Image sets of sufficient duration (3 cycle clips) should be collected to ensure a thorough evaluation. Typically, in addition to still images, video loops demonstrating the previous and following beats should be collected. In the case of patients with arrhythmias such as atrial fibrillation, longer image sets should be collected to allow for an assessment of the impact of the dysrhythmia on the indices being evaluated.

S.2.3 When possible, an ECG should be collected during the imaging study.

S.3 Data collected

S.3.1 Specific indices collected as part of echocardiography imaging studies should not only focus on the evaluation of the prosthetic device but should also, when applicable, generate data related to other aspects of cardiac function as well as characterizing the patient's overall clinical status and progress.

S.3.2 Specific methods for the collection of each index or image, as well as the method by which each image set is evaluated are variable and patient specific. Additionally, the methods by which calculations for each index are performed can also be case specific. As a result, specific information regarding the methods and techniques used to gather images and perform the required calculations are considered beyond the scope of this part of ISO 5840. It is therefore recommended that the assistance of appropriate medical professionals is enlisted to help select specific methodologies for the collection of required data.

S.3.3 Despite these issues, some consensus exists with regard to which indices are to be collected. The following describes data sets that should be considered when the clinical study is designed.

S.3.4 Indices for the characterization of the left ventricle:

- LV diameter in systole and diastole;
- LV wall thickness at the interventricular septum and posterior wall;
- LV volume in systole and diastole;
- LV ejection fraction;
- segmental wall motion analysis;
- LV mass and indexed LV mass.

S.3.5 Indices for the characterization of a replacement aortic valve:

- LV outflow tract peak velocity time velocity integral, and annular dimension;
- transaortic peak velocity, peak pressure gradient, mean pressure gradient, time velocity integral, ejection time;
- effective and indexed effective orifice area by the continuity equation using the ratio of velocity integrals. For this purpose, the outflow tract diameter should be assumed to be the diameter measurement immediately below the valve;
- transaortic flow, cardiac output and cardiac index;
- the presence and localization of regurgitant jets should be noted and the grade of regurgitation quantified. Additionally, each jet should be classified as paravalvular, transvalvular, both or uncertain.

S.3.6 Indices for the characterization of a replacement mitral valve:

- from the transmitral signal, peak velocity, peak pressure gradient, mean pressure gradient, diastolic velocity integral (DVI), pressure half-time;
- the Hatle Formula ($(220)/\text{pressure half-time}$) should not be applied;
- effective and indexed effective orifice area be calculated using the continuity equation although little normative data exist;
- cardiac output and cardiac index;
- the presence and localization of regurgitant jets should be noted and the grade of regurgitation quantified. Additionally, each jet should be classified as paravalvular, transvalvular, both or uncertain.

S.3.7 Indices for the characterization of the tricuspid valve:

- peak velocity, peak pressure gradient, mean pressure gradient, pressure half-time and velocity integral;
- the presence and localization of regurgitant jets should be noted and the grade of regurgitation quantified. Additionally, each jet should be classified as paravalvular, transvalvular, both or uncertain;
- tricuspid regurgitation peak velocity.

S.3.8 Indices for the characterization of a replacement pulmonary valve:

- peak velocity, peak pressure gradient, mean pressure gradient;
- the presence and localization of regurgitant jets should be noted and the grade of regurgitation quantified. Additionally, each jet should be classified as paravalvular, transvalvular, both or uncertain.

S.43D Echocardiography studies

When available, 3D echocardiography can be used to augment 2D studies. The data obtained can be particularly useful when volumetric data are desirable. If these methods are to be employed, care should be taken to ensure that the protocol dictates that the methods remain consistent through follow-up.

Bibliography

- [1] ISO/TS 11139, *Sterilization of health care products — Vocabulary*
- [2] American College of Cardiology/American Heart Association 2006 Guidelines from the Management of Patients with Valvular Disease
- [3] Duerig T.W., Tolomeo D.E. An overview of superelastic stent design. Proceedings of the Int'l Conference on Shape Memory and Superelastic Technologies SMST-2000; (eds.) S. Russell, A. Pelton. pp. 585-604)
- [4] EuroSCORE (see 7.4.7.2 e))
- [5] Gangloff R.P. "Environmental Cracking – Corrosion Fatigue", Chapter 18 in "Corrosion Tests and Standards – Application and Interpretation" 2nd edition, R. Baboian (editor) ASTM International (2005)
- [6] Mosby C.V. *Harriet Lane Handbook: a Manual for Pediatric House Officers*. St. Louis, 2002
- [7] Kelly R.G. "Pitting", Chapter 18 in Corrosion Tests and Standards – Application and Interpretation, 2nd edition, R. Baboian (editor) ASTM International (2005)
- [8] Knirsch W. et al. Cardiac Output in Children: Comparison of the Ultrasound Cardiac Output Monitor with Thermo dilution Cardiac Output Measurement. *Intensive Care Med.* 2008, 34 pp. 1060–1064
- [9] Kappetein A.P., Head S.J., Généreux P. et al. Updated standardized endpoint definitions for Transcatheter Aortic Valve Implantation. The Valve Academic Research Consortium-2 Consensus Document. *J. Am. Coll. Cardiol.* 2012, 60 pp. 1438–54
- [10] Magning T. "Corrosion Fatigue Mechanisms in Metallic Materials", Chapter 13 in Corrosion Mechanisms in Theory and Practice, 2nd edition, P. Marcus (editor), Marcel Dekker (2002)
- [11] Marquez S., Hon R.T., Yoganathan A.P. Comparative hydrodynamic evaluation of bioprosthetic heart valves. *J. Heart Valve Dis.* 2001, 10 pp. 802–811
- [12] Mosteller R.D. Simplified calculation of body-surface area. *N. Engl. J. Med.* 1987, 317 p. 1098
- [13] New York Heart Association functional class (see 7.4.7.2 e))
- [14] Schmidt P. Pediatric replacement heart valves: Proposed engineering and testing paradigm. Presented at the AdvaMed Pediatric Heart Valve Workshop: A new paradigm for obtaining marketing approval for pediatric sized prosthetic heart valves, Washington, DC, January 12, 2010
- [15] Shah S.R., Vyavahare N.R. The effect of glycosaminoglycan stabilization on tissue buckling in bioprosthetic heart valves. *Biomaterials.* 2008, 29 pp. 1645–1653
- [16] Silverman D.C. "Types of Data", Chapter 2 in Corrosion Tests and Standards – Application and Interpretation, 2nd edition, R. Baboian (editor) ASTM International (2005)
- [17] Society of Thoracic Surgeons score (see 7.4.7.2 e))

- [18] Stewart S.F.C., Bushar H.F. Improved statistical characterization of prosthetic heart valve hydrodynamics using a performance index and regression analysis. *J. Heart Valve Dis.* 2002, 11 pp. 270–274
- [19] Vahanian A., Alfieri O.R., Al-Attar N. et al. Transcatheter valve implantation for patients with aortic stenosis: a position statement from the European Association of Cardio-Thoracic Surgery (EACTS) and the European Society of Cardiology (ESC), in collaboration with the European Association of Percutaneous Cardiovascular Interventions (EAPCI). *Eur. J. Cardiothorac. Surg.* 2008, 34 pp. 1–8
- [20] Vesely I., Boughner D., Song T. Tissue buckling as a mechanism of bioprosthetic valve failure. *Ann. Thorac. Surg.* 1988, 46 (3) pp. 302–308
- [21] Vyavahare N., Ogle M., Schoen F.J., Zand R., Gloeckner D.C., Sacks M. et al. Mechanisms of bioprosthetic heart valve failure: fatigue e causes collagen denaturation and glycosaminoglycan loss. *J. Biomed. Mater. Res.* 1999, 46 pp. 44–50
- [22] Yoganathan A.P., Travis B. Fluid dynamics of prosthetic valves. In: *The practice of Clinical Echocardiography*, 2nd Edition: Otto. WB Saunders, Philadelphia, PA, 2002
- [23] Zegdi R., Ciobotaru V., Noghin M., Sleilaty G., Lafont A., Latrémouille C. et al. Is it reasonable to treat all calcified stenotic aortic valves with a valved stent? Results from a human anatomic study in adults. *J. Am. Coll. Cardiol.* 2008, 51 pp. 579–584
- [24] Zoghbi W.A., Chambers J.B., Dumesnil J.G., Foster E., Gottdiener J.S., Grayburn P.A. et al. American Society of Echocardiography recommendations for evaluation of prosthetic valves with two-dimensional and Doppler echocardiography. A report from the American Society of Echocardiography's Guidelines and Standards Committee and The Task Force on Prosthetic valves, developed in conjunction with the American College of Cardiology Imaging Committee, the European Association of Echocardiography of the European Society of Cardiology and The Japanese Echocardiography Society. *J Am Soc Echo.* 2009, 22 pp. 975–1014
- [25] ISO 8601, *Data elements and interchange formats — Information interchange — Representation of dates and times*
- [26] ISO 10555-1, *Intravascular catheters — Sterile and single-use catheters — Part 1: General requirements*
- [27] ISO 13485, *Medical devices — Quality management systems — Requirements for regulatory purposes*
- [28] ISO 25539-1, *Cardiovascular implants — Endovascular devices — Part 1: Endovascular prostheses*
- [29] ANSI/AAMI HE75, *Human factors engineering — Design of medical devices*
- [30] *Standardized end point definitions for transcatheter aortic valve implantation clinical trials: A consensus report from the Valve Academic Research Consortium in the Journal of American College Cardiology*
- [31] ISO 5840:2005, *Cardiovascular implants — Cardiac valve prostheses*¹
- [32] Merck Manual. available at <http://www.merckmanuals.com/professional/index.html>

¹ ISO 5840:2005 will be revised by ISO 5840-1 in future.